

THE
STONE - MILLIS
ARITHMETIC

ADVANCED

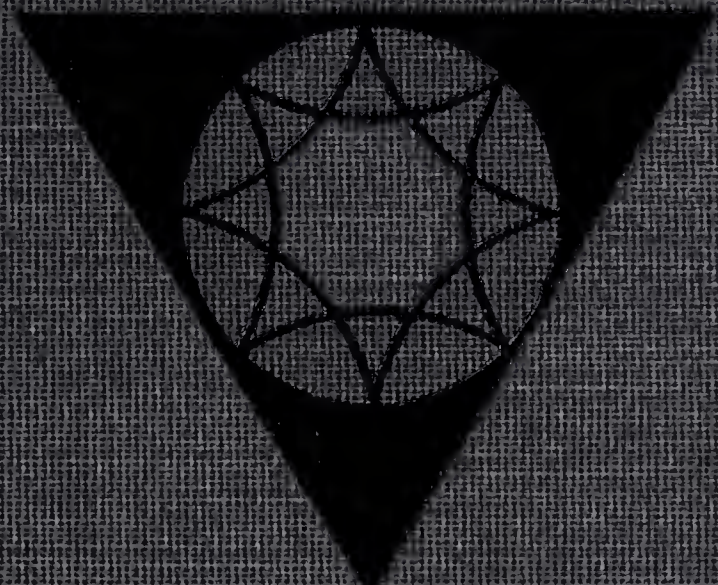

BENU. H. SANBORN
— & CO. —

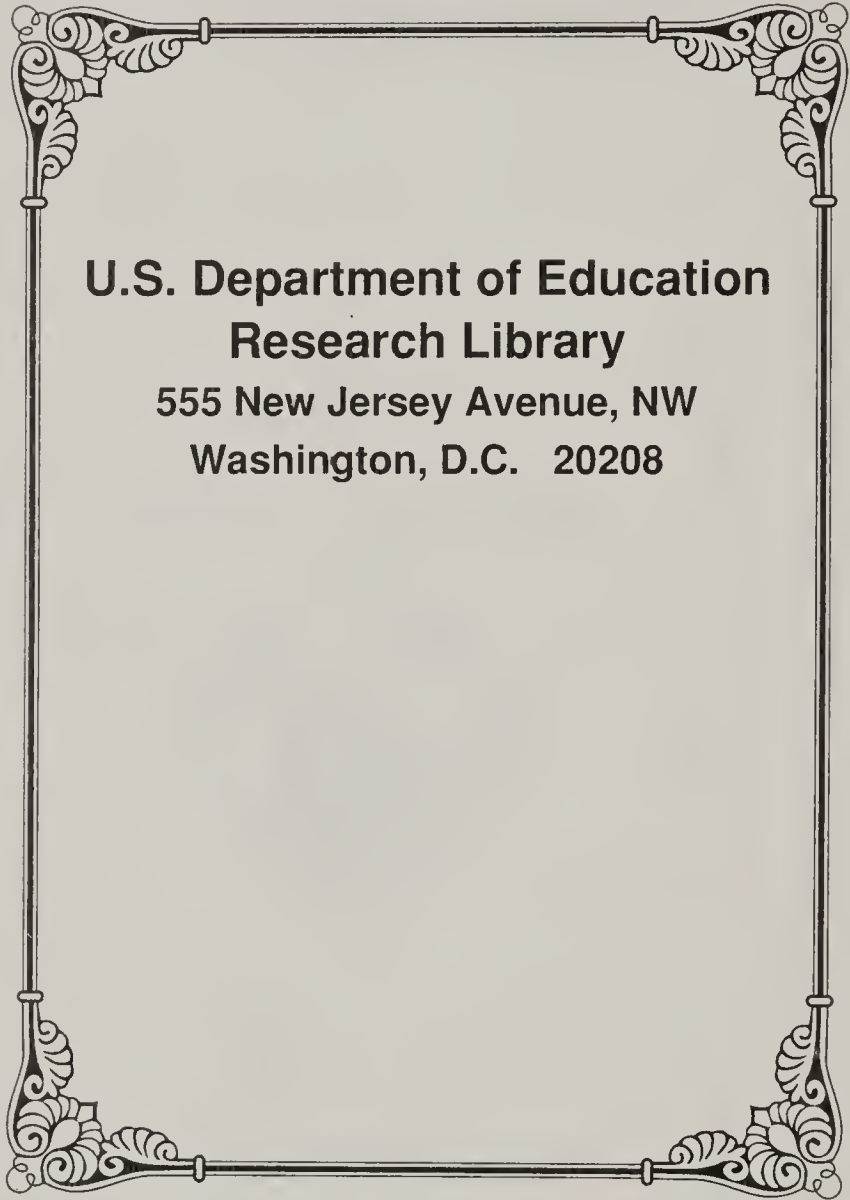

**U.S. Department of Education
Research Library
555 New Jersey Avenue, NW
Washington, D.C. 20208**

L V I S J

6-1132



✓ THE

STONE-MILLIS ARITHMETICS

ADVANCED

BY

Charles
JOHN C. STONE, A.M.

HEAD OF THE DEPARTMENT OF MATHEMATICS, STATE NORMAL SCHOOL,
MONTCLAIR, NEW JERSEY, CO-AUTHOR OF THE SOUTHWORTH-STONE
ARITHMETICS, THE STONE-MILLIS SECONDARY ARITHMETIC, ALGEBRAS,
GEOMETRIES, ETC.

AND

Franklin
JAMES F. MILLIS, A.M.

HEAD OF THE DEPARTMENT OF MATHEMATICS, FRANCIS W. PARKER
SCHOOL, CHICAGO, CO-AUTHOR OF THE STONE-MILLIS SECONDARY
ARITHMETIC, ALGEBRAS, AND GEOMETRIES

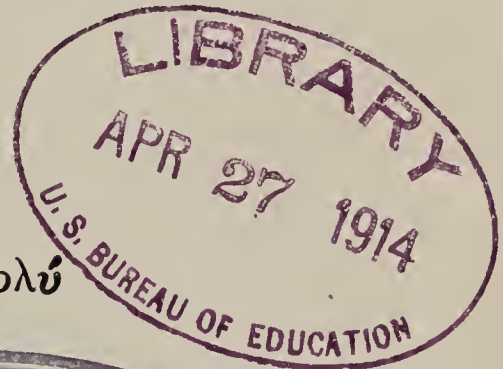

οὐ πόλλ' ἀλλὰ πολὺ

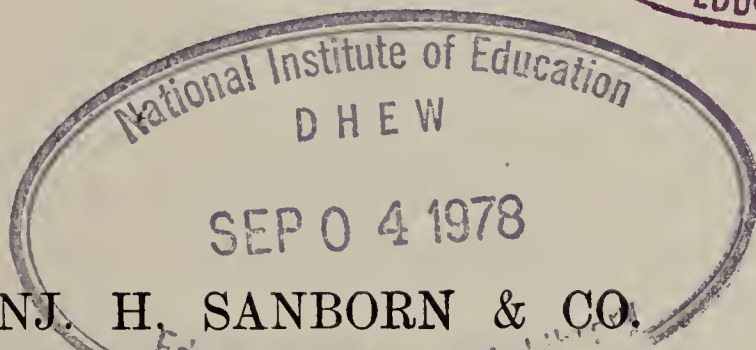

BENJ. H. SANBORN & CO.
BOSTON NEW YORK CHICAGO

1914

Call Number

LT QA 106 .586a v.3

Stone, John Charles.

The Stone-Millis Arithmetics

Date

9-04-78

78-

853000

Transferred from the Library
of Congress under Sec. 58,
Copyright Act of Mch. 4, 1909

COPYRIGHT, 1911, 1914,
By JOHN C. STONE AND JAMES F. MILLIS.

APR 11 1914

✓ © Cl. A 371326 *cl*

4105836

PREFACE

IN the preparation of this series of arithmetics the chief aims have been more adequately to adapt the subject matter to the experiences, interests, and immediate needs of children, and to provide means for a mastery of the formal phases of arithmetic through more scientifically organized drills.

The books are based upon the principles that knowledge to be real must be founded upon the actual experiences of the individual learner; that knowledge to be retained must be given opportunity for use, the more immediately the better; and that a necessary condition for true learning is that the process be self-actuated through motive or interest.

Hence, throughout the series an endeavor has been made not only to develop the principles and processes in a most economical and psychological order but to provide an adequate mental imagery as a basis for their rational understanding.

In the selection of problem material the utmost care has been exercised to use only problems that deal with the experiences of children. They deal with their chief occupation — play, with their constructive activities, with phases of the home and the local community life with which they come into direct contact. The problems of adult life, of interest only to adults, who have had a wider experience and in consequence interests foreign to the lives of children, have been painstakingly excluded from the lower grades. Many pages

of problems are grouped to tell a story, and they teach lessons valuable in themselves. Many are based upon and portray actual facts, as given in statistics, etc. By using problems touching the actual experiences of childhood we are assured of adequate imagery in the child's mind, upon which his success in the interpretation and solution of problems most depends. Such problems also provide opportunity for the pupil's arithmetical knowledge to function through use, for they give practice in solving the very problems which children actually encounter in their activities in and out of school. Evidently such problems furnish the maximum of motive or interest, the prerequisite for self-actuated study. This feature of the Stone-Millis Arithmetics manifests itself conspicuously throughout the series.

The play instinct has been appealed to throughout the series, especially in the work of the primary grades. In the work of the second and third grades numerous games have been introduced that have been found, by actual use in the classrooms of many schools, to be of deep interest to children. These provide an excellent basis of problems and a means for motivated drills.

Most of the commercial applications of arithmetic are foreign to the experiences of children. In order to provide in the school the experiences that are otherwise lacking, and that are necessary for the mastery of this phase of arithmetic, suggestions have been given at different points of the series showing how the business processes may be dramatized or acted out in make-believe activities in the schoolroom.

Motivated drills, for the mastery of the tables and formal processes of arithmetic, have been systematically and plentifully provided throughout the books, and should prove a strong feature of the series. The game element has been

introduced frequently in these drills, especially for the primary grades.

The series consists of three books: the *Primary*, *Intermediate*, and *Advanced*. The *Primary* book contains the work suggested for the second, third, and fourth grades; the *Intermediate*, the work for the fifth and sixth grades; and the *Advanced*, the work for the seventh and eighth grades.

In the preparation of this second edition, the authors have had the assistance of many teachers and educators, who have read the manuscript and proof critically and have offered valued constructive suggestions.

They are especially indebted to Supt. L. P. Bénézet of La Crosse, Wisconsin, and to Supt. Don C. Bliss of Montclair, New Jersey, and to their corps of principals and teachers, to all of whom they wish to acknowledge their deepest gratitude.

JOHN C. STONE,
JAMES F. MILLIS.

JANUARY, 1914.

SUGGESTIONS TO TEACHERS

IN using these books, the best results will be obtained by following carefully the order and method of development of topics in the text. There is a most economical and psychological, as well as logical, order of steps in the development of each of the formal processes, and they must be thoroughly developed and rationalized in the mind of every pupil. A thorough understanding of each process necessitates that underlying it there be built up in the mind of the pupil a clear body of imagery. Part of this imagery is developed through objective teaching, and part is mere picturing of the form of the process — keeping numbers in straight columns, etc. The text suggests many ways of providing this imagery through the use of objects, etc. Other objective means of providing adequate mental imagery will suggest themselves to the thinking teacher who fully grasps the principle involved. Do not continue with the concrete aids after their object is once attained, *i.e.* after making clear the meaning of the fact or process. Each formal process should become to the pupil a machine. Automatic control of this machine as such should be the ultimate aim. For this purpose much drill work is necessary. Supplement the drills of the text by cards, charts, games, etc.

In the solution of an applied problem, the essential thing is to see that there is a clear mental picture in each pupil's mind

of the situation involved in the problem. The reason that problems are hard, and that pupils fail with them, is because the mental imagery is not provided. It is wise, before sending pupils home to get a lesson, to see that every pupil in the class possesses adequate imagery for the interpretation of each problem in the lesson. This is the most essential thing in successful teaching.

If the problems used are only those that come within the range of the child's actual experiences and activities, the imagery required for their interpretation is apt to be possessed by the pupils. It is when we use problems from the world of adults, dealing with matter with which children have had no experience, that we ask the impossible of the pupils. The problems of this text deal, in so far as it is possible, with the experiences of childhood, yet some children in every class may be lacking in the particular imagery that is necessary for the interpretation of some of the problems. This the teacher must take care to supply.

The problems of the text should be supplemented in every community by the use of local problems drawn from the environment of the pupils. Apply every topic to problems which the pupils meet in their other school work, and in their own everyday lives in the home and in the larger community. The teacher and pupils together should collect the data for these problems. If in a rural school, where agriculture is taught, draw upon that subject for problems — the testing of seeds for planting, etc. Strive to make arithmetic a practical tool in the solution of the pupil's own personal problems.

In the text, problems have not been labeled "oral" or "written," an invariable custom among other books. We prefer, rather, that the pupil be encouraged to solve every problem as far as possible without a pencil, as in real life.

It is believed that such a procedure will tend toward a more spontaneous method of analysis, and hence lead away from the mechanical and deadening forms so often seen in the schoolroom.

Neither have many set forms of solution been given in the text. In most cases the teacher should not demand any particular form, but should encourage a pupil to study each problem and choose the method that seems to him to require the least figuring. Encourage short methods. Do not repress originality or individuality.

The play instinct of children should be utilized in the teaching of arithmetic, by the use of games in the primary grades, and by contests and dramatizations in the higher grades. Various types of games for the primary grades are suggested in the text. They afford motivated drills on the tables and processes. These games will suggest others that the teacher may invent. Some are well adapted for use by a large class in the classroom, some are suited for smaller groups of children, and some are good for two or more children to play at home. In the upper grades children enjoy drills in the form of contests or "number downs," where the class is divided into two opposing teams.

The dramatization of the commercial applications of arithmetic has been tried with remarkable success in many schools. Suggestions as to how this may be carried out are given at several points of the text. The pupils organize and "go through the motions" of a make-believe business, using real business forms and processes. This work makes the commercial processes realistic, appeals to the play instinct, utilizes the social motive, affords immediate applications of the arithmetic work, and applies the principle of learning to do by doing. Most of this activity may be carried on outside the regular

school hours, and only the checking up, summaries, and drills need consume the recitation time.

The tables of drills given throughout the text should be used carefully by teachers. Many are printed in script because of a number of evident advantages. Some of these tables, as those on pages 219, 220, and 221 of the Primary book, should be used for a short time each day, for several days in succession. In the use of such tables use a time limit, encouraging the pupils to work rapidly and accurately. Have the pupils score their results each day, as suggested in the text, and keep their scores for several days. They will thus be able to measure and observe their own progress from day to day, and will try to improve their records. Teachers who understand the graphing of statistics might show the pupils how to picture their progress by means of graphs of their daily scores. These drill tables, involving contest and the game element, have been used in this way with unbounded interest on the part of the pupils, and with gratifying results.

CONTENTS

ADVANCED ARITHMETIC

PART ONE: SEVENTH YEAR

	PAGE
I. GENERAL REVIEW	1
1. Whole numbers; fractions; decimals	1
II. DENOMINATE NUMBERS	42
2. Denominate numbers	42
3. Linear measure	42
4. Square measure	46
5. Cubic measure	52
6. Measurement of wood	56
7. Measurement of lumber	57
8. Liquid measure	61
9. Dry measure	63
10. Weight measures	66
11. Measurement of time	71
12. Angle and arc measure	72
13. Measurement of paper	75
14. Units in counting	77
15. Fundamental processes with compound numbers	77
16. Latitude and longitude	80
17. Standard time	83
18. Foreign money	85
III. MENSURATION	90
19. The circle	90
20. Ratio of circumference to diameter	91
21. The area of a circle	94
22. Rectangular prisms and their volumes	97
23. The surfaces of rectangular prisms	99
24. The cylinder	101

	PAGE
IV. PERCENTAGE	105
25. The meaning of per cent	105
26. Per cent changed to fractions	110
27. A relation expressed as per cent	113
28. Profit and loss	119
29. Commission	123
30. "Marking down" goods	126
31. Trade discount	129
32. Billing goods to "the trade"	131
33. Simple interest	137
34. Promissory notes	139
35. Security	140
36. A short method of finding interest	142

PART TWO: EIGHTH YEAR

V. PRACTICAL MEASUREMENTS	145
37. Surfaces	145
38. Areas of plane surfaces	145
39. Surfaces and volumes of solids	154
40. Measurement of the sphere	173
41. Indirect problems in measurement of surfaces	176
42. The need of a new process	177
43. Extracting the square root of any number	178
44. The Pythagorean Theorem	186
45. Isosceles and equilateral triangles	189
46. Additional applications of the Pythagorean Theorem	190
VI. APPLICATIONS OF PERCENTAGE	196
47. The meaning of percentage	196
48. General applications of percentage	198
49. Property insurance	204
50. Taxes	206
51. National revenues	209
52. Trade discount	213
53. Successive discounts	214
54. A single discount equivalent to two discounts	217
55. Giving discounts on goods bought at a discount	218
56. Simple interest	221

CONTENTS

xiii

	PAGE
57. Borrowing at a bank	226
58. Discounting notes	227
59. Computing interest by tables	230
60. Partial payments on a note	233
61. Compound interest	234
62. Stock investments	237
63. Bonds	242
64. Indirect problems of percentage	244
VII. PROPORTION	253
65. Meaning of proportion	253
66. Similar figures	253
67. Levers	257
68. The wheel and axle	259
69. The statement of a proportion	260
VIII. GENERAL REVIEW	263
APPENDIX	280
The metric system	280
Rules for reference	291
Tables for reference	296

ADVANCED ARITHMETIC

PART ONE: SEVENTH YEAR

I. GENERAL REVIEW

1. WHOLE NUMBERS ; FRACTIONS ; DECIMALS

1. What does *thirteen* mean ? *Fourteen* ?
2. Explain the meanings of all the numbers from 13 to 19.
3. What does the syllable *teen* mean ?
4. What does *twenty* mean ? *Thirty* ? *Forty* ?
5. What does *ty* mean ?
6. What do we call 10 *tens* ? 10 *hundreds* ? 10 *thousands* ?
7. How many different figures do we use in writing numbers ?
8. How is it that we can express all numbers, however large, by the use of nine figures and a zero ?
9. How does the value represented by 5 change in the following : 5 ; 50 ; 500 ; 5000 ; 50,000 ?
10. What value has the zero ? Why is it used ?
11. Then the value represented by a figure depends upon what *two* things ?

Each figure has a value denoted by its form, and also a value denoted by its position.

12. In 347, what does 7 represent? What does 4 represent? What does 3 represent?

The names of the orders, reading from right to left, are: ones, tens, hundreds, thousands, ten thousands, etc.

13. What is the largest number you can express with the figures 1, 4, 9, and 0, using each figure but once?

14. Explain why you placed them in the *orders* that you did.

15. How many units of any order does it take to make one unit of the next higher order?

Since ten units of any order make one unit of the next higher order, we call our system of writing numbers a decimal system.

Decimal comes from the Latin decem, meaning ten.

16. Read the following:

3,436,585; 17,309,607; 906,350,780; 100,040,065.

Each *period of three figures* is set off by commas so that it may be more easily read.

The names of the first six periods, reading from right to left, are: ones, thousands, millions, billions, trillions, and quadrillions.

17. Read the following:

3,709,068,345; 17,836,405,736,400; 15,040,048,304.

Do not use "and" in reading whole numbers.

18. Read without using the word "and" :

4,705	6,137,008	42,200,020	10,063,005,408
27,003	3,000,975	34,003,007	16,100,005,365
195,006	600,001	93,040,075	26,013,200,789

19. Write the above numbers as your teacher reads them.

*Our method of writing numbers is called the **Hindu** method, for it was invented by the Hindus.*

The ten symbols, 1, 2, 3, 4, 5, 6, 7, 8, 9, and 0, used in the Hindu notation, are called the ten digits.

The Roman Notation

1. Read : I, II, IV, V, VI, X, IX, XI, XII, XX.
2. Give the values of V, X, L, C, D, and M.
3. Read : XX, XXX, XII, XV, XVII, LX, CL, CLX.
4. When a letter is followed by the same letter or by one of less value, how is the value of the whole expression found?
5. Read : IV, IX, XL, CD.
6. When a letter is followed by one of greater value, how is the value of the whole expression found?
7. To write 1492, we write the symbols for
 $1000 + 400 + 90 + 2$, which are
 $M + CD + XC + II$, or MCDXCII.

In the Roman notation :

- I. Add the values of the letters when a letter is followed by the same letter or one of less value ; and
- II. Subtract the values of the letters when a letter is followed by one of greater value.

8. Write in Roman notation :

21	345	1280	1775
47	716	2345	1620

9. Write in Hindu notation :

XXIX	XXVII	MCDXX
LXVI	XXXIV	MDCIX
XLIV	CCXIX	MCCXL

A dash over a letter multiplies its value by 1000.

Thus, $\bar{X} = 10,000$; $\bar{C} = 100,000$; $\bar{L} = 50,000$.

Addition

1. Add 7 and 9. Add 3 ft. and 8 in. What change did you make before adding 3 ft. and 8 in.? Why?

Addition is the process of uniting two or more numbers (addends) into one number (sum).

Numbers expressed in unlike units cannot be added until the units are made alike.

See how quickly you can give the sums of the following :

2.	3.	4.	5.	6.	7.	8.	9.	10.	11.	12.	13.
9	8	7	3	5	46	29	94	48	83	385	846
7	8	8	9	8	21	78	47	97	79	476	974
8	9	9	4	9	87	67	29	38	46	987	486
6	7	9	7	7	64	44	84	46	28	498	798
5	6	3	8	2	49	59	36	85	74	546	964
9	8	6	9	8	87	86	89	97	87	879	781
7	4	8	6	5	64	78	77	48	96	796	436
2	3	2	7	9	38	42	46	59	87	847	894

Without copying, see how many sums you can get in 10 minutes.

	1.	2.	3.	4.	5.	6.	7.	8.
<i>A</i>	165	724	259	867	453	674	947	349
	847	589	518	498	146	496	686	756
	296	376	476	159	789	528	251	685
	734	458	697	624	975	719	439	924
	589	961	834	735	862	385	578	817
<i>B</i>	628	572	975	394	135	837	463	238
	549	839	617	745	657	465	975	846
	756	946	843	867	892	651	289	975
	384	681	298	218	764	289	847	469
	917	457	536	695	489	974	516	751
<i>C</i>	853	697	795	417	928	576	275	159
	967	859	463	548	546	649	463	728
	245	714	689	369	869	182	819	846
	786	246	425	876	417	498	957	975
	419	583	871	295	375	357	648	634
<i>D</i>	738	437	391	647	524	279	867	976
	496	571	685	978	178	316	394	859
	547	895	879	825	693	784	475	142
	689	624	246	396	845	598	658	685
	125	986	457	451	967	645	219	437
<i>E</i>	536	842	496	748	294	163	368	645
	698	167	287	529	876	679	987	317
	472	935	753	485	953	457	759	486
	785	786	861	693	641	824	645	759
	914	594	549	176	785	598	421	298
<i>F</i>	283	328	895	528	349	918	189	715
	495	615	428	967	756	364	457	379
	761	756	754	184	685	572	296	458
	578	489	617	375	924	497	548	926
	649	947	963	496	817	856	376	684

Give directions for five steps in adding :

I. Arranging the numbers.		20.
II. Beginning to add.	492	679,458
III. Setting down the sum.	864	340,276
IV. "Carrying."	793	950,673
V. Checking.	956	268,479
	<u>3105</u>	728,735
		629,876
		724,894

Add vertically; then horizontally :

	1.	2.	3.	4.	5.	
6.	\$3.47	\$14.69	\$193.67	\$4769.83	\$6483.47	829,386
7.	8.62	48.96	846.84	4392.16	8432.97	445,876
8.	9.46	37.81	932.71	8437.66	6432.98	377,872
9.	6.58	47.94	683.77	6989.84	8469.32	763,874
10.	7.39	82.66	765.75	4329.41	9396.48	689,983
11.	<u>9.88</u>	<u>68.43</u>	<u>392.50</u>	<u>6832.47</u>	<u>9375.58</u>	670,498
						988,875
12.	Find the sum of the five sums of the columns.					687,568
13.	Find the sum of the six sums of the lines.					994,693
14.	Why should these two sums be equal ?					849,376

Add and check :

15.	16.	17.	18.	19.	
\$475.21	\$648.93	\$719.63	\$963.94	\$679.83	917,966
649.85	973.26	834.56	738.42	759.94	279,976
837.64	387.92	784.97	697.18	678.90	681,437
246.89	814.78	469.38	346.32	543.21	195,603
937.48	687.34	847.86	923.76	783.94	806,466
742.37	968.47	952.78	768.93	989.76	721,149
896.48	706.34	298.73	376.87	768.92	305,844
					568,792

Subtraction

1. 5 apples taken from 9 apples leaves how many?
2. How many apples added to 5 apples make 9 apples?
3. If one plate contains 9 apples and another 5, how many more in the first plate?

Subtraction is the process of taking one number from another, of finding what number must be added to a given number to make a given sum, or finding the difference between two numbers.

4. *Subtract each of the following from 100 :*

<i>a.</i>	11	88	44	74	52	70	36	13	60	67	37	48	31	87
<i>b.</i>	35	61	82	14	91	33	22	65	42	53	15	59	69	47
<i>c.</i>	83	30	23	57	89	43	95	29	68	32	84	26	79	16
<i>d.</i>	55	81	73	72	21	94	56	99	17	93	41	66	58	51
<i>e.</i>	92	19	63	45	96	18	86	46	76	49	71	62	27	85
<i>f.</i>	64	77	24	28	34	39	78	38	80	25	97	54	98	40

5. Give the difference between each number and the one at its right.

6. Give the difference between each number and the one below it.

Subtract at sight :

7.	8.	9.	10.	11.	12.
700	3000	60503	65000	55111	86459
<u>325</u>	<u>800</u>	<u>40402</u>	<u>37892</u>	<u>46221</u>	<u>47560</u>

13. From 60,000 take 38,271; 19,069; 17,032; 38,065.

14. From 70,900 take 69,987; 46,908; 50,067; 21,906.

See how many you can subtract in 10 minutes :

	<i>A</i>	<i>B</i>	<i>C</i>	<i>D</i>	<i>E</i>	<i>F</i>	<i>G</i>	<i>H</i>
1.	5006	4036	9802	8003	4062	7604	9006	4881
	2678	2192	4359	5348	1253	4489	3247	1567
2.	7803	6502	2006	5060	8090	3046	9076	9002
	5275	4369	1278	2938	1306	1925	7231	6138
3.	2106	4002	7016	8501	5073	2060	4003	6701
	1357	2189	3420	2328	1438	1718	2891	2437
4.	9007	8075	9080	6003	7060	6092	9071	9086
	4565	7029	6234	3459	5128	1358	5219	2410
5.	6043	5620	7506	9002	7900	6031	8704	3062
	4192	1438	4321	1658	6423	2819	5471	2491
6.	9024	7083	8004	9020	3106	4950	3702	6003
	7231	5461	1329	2913	2084	3862	1389	4189
7.	8003	7064	6001	9201	6028	9048	7050	6290
	1628	4329	4128	5897	4593	2639	3415	3198
8.	6408	7021	8600	7603	9040	8002	7063	5006
	4399	3498	4378	3429	4329	3649	6357	3207
9.	4354	5438	6942	8008	7005	6070	4968	4360
	1276	4519	4651	7439	5128	1562	3499	2287
10.	6003	9006	5003	6843	5946	9872	5308	2004
	5134	8417	1625	4959	3728	6943	4239	1536
11.	5030	6060	7006	3485	6955	3294	6009	8516
	4348	5276	3197	2576	4869	2465	5567	7287
12.	2531	6848	5236	4963	3798	7631	3050	3942
	1740	4796	4972	3874	1895	4722	1283	2854

The Stone Industry

The quarrying, shipping, and use of stone is one of the large industries of the United States. The various kinds of stone quarried are classified as granite, limestone, sandstone, bluestone, marble, and trap rock. This stone is used for different purposes: for building, for monuments, for manufacture of cement, for chemical action — as in alkali works, sugar factories, carbonic-acid plants, paper mills, etc.

VALUE OF STONE PRODUCED IN THE UNITED STATES, 1900–1909

YEAR	GRANITE	LIMESTONE	MARBLE	SANDSTONE	BLUESTONE	TRAP ROCK
1900	\$ 10,969,417	\$ 13,556,523	\$ 4,267,253	\$ 5,272,865	\$ 1,198,519	\$ 1,706,200
1901	14,266,104	18,202,843	4,965,699	6,974,199	1,164,481	1,710,857
1902	16,083,475	20,895,385	5,044,182	9,430,958	1,163,525	2,181,157
1903	15,703,793	22,372,109	5,362,686	9,482,802	1,779,457	2,732,294
1904	17,191,479	22,178,964	6,297,835	8,482,162	1,791,729	2,823,546
1905	17,563,139	26,025,210	7,129,071	8,075,149	1,931,625	3,074,554
1906	18,562,806	27,327,142	7,582,938	7,147,439	2,021,898	3,736,571
1907	18,064,708	31,737,631	7,837,685	6,753,762	2,117,916	4,594,103
1908	18,420,080	27,682,002	7,733,920	5,831,231	1,762,860	4,282,406
1909	19,581,597	32,070,401	6,548,905	6,564,052	1,446,402	5,133,842

1. Find the total value of each kind of stone quarried during the ten years 1900–1909.
2. Find the total value of all stone quarried during each one of the ten years 1900–1909.
3. Find how much more of each kind was quarried in 1909 than in 1900.
4. The value of the limestone quarried in 1909 was how much greater than that of each of the other stones during that year?
5. The total value of the limestone quarried in the

United States in 1910 was \$ 34,603,678. What increase was this over the previous year ?

6. The states producing the greatest amount of limestone in 1910 were as follows: Pennsylvania, \$5,394,611; Indiana, \$4,472,241; Ohio, \$4,357,432; Illinois, \$3,847,715; New York, \$2,813,476; Missouri, \$2,360,604. Find the total value of the output of these six states.

THE FOLLOWING TABLE SHOWS THE VALUE OF THE STONE USED FOR VARIOUS PURPOSES IN 1909

KINDS	BUILDING	MONUMENT	FLAG-STONE	CURB-STONE	PAVING	CRUSHED
	\$	\$	\$	\$	\$	\$
Granite	6,532,872	4,347,992	47,230	1,030,568	3,064,010	2,743,117
Trap rock	33,529	—	—	—	226,663	4,749,086
Sandstone	3,349,519	—	955,283	937,767	600,200	1,212,931
Limestone	4,797,268	—	41,343	214,140	188,680	15,052,753
Marble	2,881,267	1,756,198	—	—	—	—

7. Which was of greater value in 1909 and how much, the building stone or the crushed stone ?

8. Compare the value of granite used for building purposes with that used for all other purposes.

9. Compare the value of crushed limestone with that used for all other purposes.

10. What is the greatest use of sandstone ? Compare the value of the stone in that use with that for all other purposes.

11. Indiana produces the largest amount of limestone for building purposes of all the states. The total value of the limestone used for building purposes in the United States in 1910 was \$5,272,024, of which Indiana produced \$3,270,704 worth. What was the value of that produced by the rest of the states ?

Multiplication

1. In combining unequal *addends*, as $9 + 6 + 8 + 7 = 30$, what is the process called?
2. In what two ways may equal addends, as $7 + 7 + 7 + 7 = 28$, be combined? How is the shorter process written? What is it called?
3. If you have forgotten the product of 4×7 , how can you find it?

Multiplication of whole numbers is a short way of adding equal numbers.

4. In $4 \times \$7 = \28 , which is the *multiplier*? What does it show? Which is the *multiplicand* or the number to be multiplied? Which is the *product*?
5. If you wish to know the product of 3×48 in. and have forgotten your multiplication tables, how can you find it?
6. From the examples given above observe that:

I. *The multiplier must be an abstract number, that is, one which is used without reference to some particular thing.*

II. *The multiplicand may be either an abstract number or a concrete number, that is, one that is associated with some particular thing.*

III. *The product must be the same kind of number as the multiplicand.*

Find the products of:

7. 9×376 . 8. 8×947 . 9. 9×845 . 10. 8×638 .

- | | | | | |
|--|---|---|--|--|
| $\begin{array}{r} A \\ 489 \\ \underline{7} \\ 63 \\ 56 \\ \underline{28} \\ 3423 \end{array}$ | <p>1. Under A what are added to get the result ?</p> <p>2. Explain the position of each product and its real value.</p> <p>3. Show how the same result was obtained under B without setting down the <i>partial products</i>.</p> <p>4. Compare the work under B and C, and tell how to multiply by any number of 10's, 100's, etc.</p> | <table style="width: 100%; border-collapse: collapse;"> <tr> <td style="width: 50%; vertical-align: top;"> $\begin{array}{r} B \\ 489 \\ \underline{7} \\ 3423 \end{array}$ </td> <td style="width: 50%; vertical-align: top;"> $\begin{array}{r} C \\ 489 \\ \underline{70} \\ 34230 \end{array}$ </td> </tr> </table> | $\begin{array}{r} B \\ 489 \\ \underline{7} \\ 3423 \end{array}$ | $\begin{array}{r} C \\ 489 \\ \underline{70} \\ 34230 \end{array}$ |
| $\begin{array}{r} B \\ 489 \\ \underline{7} \\ 3423 \end{array}$ | $\begin{array}{r} C \\ 489 \\ \underline{70} \\ 34230 \end{array}$ | | | |

In what time can you find the products of all?

- | | | |
|----------------------|-----------------------------|------------------------------|
| 5. 6×4763 . | 9. $80 \times 84,965$. | 13. $80 \times 72,397$. |
| 6. 8×4931 . | 10. $70 \times 12,039$. | 14. $70 \times 95,364$. |
| 7. 9×6989 . | 11. $300 \times 842,794$. | 15. $30,000 \times 91,000$. |
| 8. 7×5987 . | 12. $50 \times 1,203,900$. | 16. $20,000 \times 75,000$. |

Multiplying by an Integer

PROCESS

$$\begin{array}{r} 578 \\ \underline{346} \\ 3,468 = 6 \times 578 \\ 23,12 = 40 \times 578 \\ 173,4 = 300 \times 578 \\ \underline{199,988} = 346 \times 578 \end{array}$$

Give directions for :

- I. Arranging the factors.
- II. Beginning to multiply.
- III. Setting down and carrying.
- IV. Arranging partial products.
- V. Finding the entire product.
- VI. Checking the work.

Find the products :

- | | | | | | | | |
|-----------|-----------|-----------|-----------|-----------|-----------|-----------|-----------|
| 1. | 2. | 3. | 4. | 5. | 6. | 7. | 8. |
| 389 | 496 | 562 | 834 | 965 | 729 | 396 | 487 |
| <u>76</u> | <u>67</u> | <u>76</u> | <u>58</u> | <u>85</u> | <u>58</u> | <u>49</u> | <u>94</u> |
| 9. | 10. | 11. | 12. | 13. | 14. | 15. | 16. |
| 925 | 784 | 965 | 746 | 859 | 397 | 486 | 572 |
| <u>49</u> | <u>38</u> | <u>83</u> | <u>92</u> | <u>29</u> | <u>69</u> | <u>96</u> | <u>39</u> |

17. A farmer sold 325 lambs at \$7 each. How much did he receive for all?

WORK

$$\begin{array}{r} 325 \\ 7 \\ \hline 2275 \end{array}$$

Hence \$2275

I. Which is the true multiplicand?
The true multiplier?

II. Why find 7×325 instead of $325 \times \$7$?

III. Since $7 \times 325 = 325 \times 7$, work is saved by using abstract numbers and interchanging the multiplier and multiplicand in such problems. Why was the dollar sign omitted?

Explain what changes you make in the following and why:

18. Find the cost of 175 bbl. of apples at \$3 per barrel.
19. Find the cost of 365 T. of coal at \$4 per ton.
20. How much will 218 qt. of milk cost at 8¢ per quart?
21. How much will 516 cords of wood cost at \$7 per cord?
22. Find the cost of 819 lb. of sugar at 6¢ per pound.
23. Find the cost of 927 bu. of peaches at \$3 per bushel.

See how many products you can find in 10 minutes:

	1.	2.	3.	4.	5.	6.	7.	8.
A	3645	7983	6498	4596	8174	3769	2957	6589
	479	794	709	358	853	538	296	692
B	9768	8374	7965	5978	8096	7083	8039	7608
	926	708	187	781	259	952	509	648
C	7084	4039	5908	6085	8906	7480	9073	6480
	846	475	574	978	529	879	906	785
D	6307	7098	9605	7809	6452	5964	6438	7608
	924	379	928	765	867	587	297	546

Division

1. How many \$ 5 bills make \$ 30?
2. 60 yd. is how many times as long as 10 yd. ?
3. If \$ 30 is divided into 5 equal parts, how many dollars in each part?
4. If 60 yd. is divided into 10 equal parts, how long is each part?

Division is the process of finding how many times one number will contain another, or of separating a number into equal parts.

5. If you have 35 marbles, to how many boys can you give 5 marbles each?

35 marbles \div 5 marbles = 7, the number of boys.

*This problem illustrates the **measuring** idea of division.*

6. If you have 35 marbles and separate them into 5 equal groups, how many marbles in each group?

35 marbles \div 5 = 7 marbles, the number in each group.

*This problem illustrates the **partition** idea of division.*

7. If 20 books cost \$ 40, what *part* of this amount will one cost?

8. If I buy books at \$ 2 each, *how many* can I buy for \$ 40?

9. Which of the following are *partition* and which *measurement*?

(a) If one hat costs \$ 2, how many can be bought for \$ 20?

(b) If \$ 36 is divided among 9 boys, how much will each receive?

(c) If 2 T. of coal will last me 1 mo., how long will 20 T. last?

Exercises

1. Divide 64,170 by 186.

WORK

$$\begin{array}{r}
 345 \\
 186 \overline{)64170} \\
 \underline{558} \\
 837 \\
 \underline{744} \\
 930 \\
 \underline{930} \\
 0
 \end{array}$$

Give directions for the following steps in division :

- I. What number do we first divide?
- II. Where is the trial quotient figure placed?
- III. What product is then found? Where written?
- IV. What is subtracted?
- V. What shows whether the trial quotient is correct, too large, or too small?
- VI. What is the next step before further division?
- VII. How may the result be checked?

Find the quotients :

- | | | |
|------------------|--------------------|-------------------|
| 2. 759,470 ÷ 78. | 9. 89,175 ÷ 39. | 16. 183,974 ÷ 94. |
| 3. 624,798 ÷ 48. | 10. 284,603 ÷ 98. | 17. 265,371 ÷ 88. |
| 4. 182,347 ÷ 57. | 11. 99,134 ÷ 49. | 18. 104,288 ÷ 78. |
| 5. 96,343 ÷ 97. | 12. 108,264 ÷ 57. | 19. 139,267 ÷ 72. |
| 6. 192,462 ÷ 67. | 13. 346,271 ÷ 86. | 20. 204,306 ÷ 68. |
| 7. 236,475 ÷ 77. | 14. 937,441 ÷ 163. | 21. 307,961 ÷ 96. |
| 8. 187,931 ÷ 68. | 15. 784,267 ÷ 269. | 22. 198,001 ÷ 67. |

Drill Table

See how many you can divide in 10 minutes :

	<i>A</i>	<i>B</i>	<i>C</i>	<i>D</i>	<i>E</i>	<i>F</i>	
1.	263,816	530,997	465,043	571,377	623,871	398,416	÷ 673
2.	396,516	631,828	605,852	640,996	586,752	708,228	÷ 764
3.	732,615	828,852	773,364	677,127	345,066	418,761	÷ 867
4.	450,072	354,756	517,752	404,952	542,004	328,248	÷ 564
5.	403,172	462,264	545,292	296,956	632,808	440,572	÷ 748

Divisors Ending in Zeros

1. Divide 186,340 by 3800.

WORK

$$\begin{array}{r}
 49 \\
 3800 \overline{)186340} \\
 \underline{152} \\
 343 \\
 \underline{342} \\
 140, \text{ rem.}
 \end{array}$$

I. *Cutting off the last figure of a number divides it by 10. The figure cut off is the remainder.*

Cutting off two figures of a number divides it by what? What is the remainder?

II. By what were both dividend and divisor divided by cutting off the figures in the work in the margin?

Figures cut off in the dividend are annexed to the remainder.

Divide :

- | | |
|--------------------|-----------------------|
| 2. 368,450 ÷ 8600. | 7. 784,309 ÷ 8700. |
| 3. 197,642 ÷ 9300. | 8. 639,480 ÷ 7900. |
| 4. 846,175 ÷ 8700. | 9. 874,360 ÷ 3800. |
| 5. 347,360 ÷ 7600. | 10. 965,300 ÷ 36,000. |
| 6. 693,842 ÷ 6900. | 11. 873,400 ÷ 28,000. |

Factors

The factors of a number are those numbers that multiplied together make the number.

Thus, 3 and 2 are factors of 6, for $2 \times 3 = 6$.

If a number has no factor except itself and 1, it is a prime number.

Thus, 5, 7, 11, 13, 17, 19, 23, and 29 are *prime numbers*.

Give at sight two factors that make :

- | | |
|-----------------------|---------------------------|
| 1. 15 ; 24 ; 30 ; 49. | 5. 75 ; 60 90 ; 100. |
| 2. 16 ; 35 ; 28 ; 63. | 6. 81 ; 96 ; 110 ; 120. |
| 3. 18 ; 21 ; 32 ; 70. | 7. 72 ; 125 ; 150 ; 144. |
| 4. 20 ; 36 ; 42 ; 80, | 8. 105 ; 132 ; 160 ; 200. |

Tests of Divisibility

There are some easy tests of divisibility of certain numbers that should be known. They are as follows :

I. A number is divisible by 2 if it ends in 0, 2, 4, 6, or 8.

II. A number is divisible by 4 if the number represented by the two right-hand figures is divisible by 4.

III. A number is divisible by 5 if it ends in 5 or 0.

IV. A number is divisible by 3 if the sum of its digits is divisible by 3.

V. A number is divisible by 9 if the sum of its digits is divisible by 9.

Cancellation

1. If a farmer raises 1050 bu. of corn on a 15-A. field, how many bushels should he raise at this rate on 96 A. ?

WORK

$$\begin{array}{r} 32 \quad 210 \\ \cancel{96} \times \cancel{1050} = 6720 \\ \quad \cancel{1} \cancel{5} \\ \quad \quad \cancel{5} \end{array}$$

Hence 6720 bu.

EXPLANATION.— After indicating the division and multiplication as here shown, we see by the tests of divisibility that 96 and 15 may each be divided by 3, giving 32 and 5. We then see that 1050 and 5 may each be divided by 5, giving 210 and 1 (not written). Then $32 \times 210 = 6720$.

The division of 96 and 15 by 3, and of 1050 and 5 by 5, is called *cancellation*, cancellation marks being drawn through the numbers as they are divided.

Find by cancellation :

2.	3.	4.	5.	6.
$\frac{12 \times 100}{16}$	$\frac{24 \times 63}{36}$	$\frac{126 \times 42}{27}$	$\frac{250 \times 198}{180}$	$\frac{144 \times 185}{120}$
7.	8.	9.	10.	11.
$\frac{36 \times 200}{8 \times 30}$	$\frac{68 \times 324}{9 \times 72}$	$\frac{128 \times 75}{240 \times 5}$	$\frac{56 \times 120}{96 \times 35}$	$\frac{189 \times 330}{18 \times 45}$

FRACTIONS

1. If a whole is divided into a number of equal parts, each part is a **fractional unit** and is named according to the number of parts into which the whole is divided. A **fraction** is one or more fractional units. Draw a line and show three fourths of it.

2. What symbol is used to express three fourths?

3. The two numbers used to express three fourths are called the **terms** of the fraction. Give the name of each.

4. Which term shows *how many* fractional units the fraction contains?

5. Which term shows the *name* of the fractional units?

6. If you take two equal lines and cut one into three equal parts and one into four equal parts, what will the fractional units be called in each case?

7. Then which is larger, $\frac{2}{3}$ or $\frac{2}{4}$?

8. Name the largest possible fractional unit.

9. Name a very small fractional unit.

10. Tell how many fractional units in each, name the fractional unit, and tell how many make up a whole :

$$\frac{3}{4}; \quad \frac{5}{6}; \quad \frac{7}{8}; \quad \frac{9}{10}; \quad \frac{11}{14}; \quad \frac{17}{18}; \quad \frac{3}{11}; \quad \frac{9}{13}; \quad \frac{14}{15}.$$

The lower term *shows the name* of the fractional unit and is called the **denominator**.

The upper term *shows how many* of the fractional units are taken to make up the fraction and is called the **numerator**.

11. If you have three rods, each $\frac{3}{4}$ of a foot long, how long a rod will they form if placed end to end?

$$3 \times \frac{3}{4} \text{ ft.} = \frac{9}{4} \text{ ft.}$$

12. Draw two lines of equal length. Show $\frac{3}{8}$ of one and $\frac{3}{4}$ of the other. Compare $\frac{3}{4}$ with $\frac{3}{8}$.

13. In Problem 12, observe the lines that were drawn and tell the relation of $\frac{3}{8}$ to $\frac{3}{4}$.

- I. *Multiplying the numerator multiplies the fraction.*
- II. *Dividing the denominator multiplies the fraction.*
- III. *Multiplying the denominator divides the fraction.*
- IV. *Dividing the numerator divides the fraction.*

Multiply each of the following by 3 and tell how you did it:

14.	15.	16.	17.	18.	19.
$\frac{2}{5}$	$\frac{3}{5}$	$\frac{2}{7}$	$\frac{3}{10}$	$\frac{1}{6}$	$\frac{3}{4}$
$\frac{3}{7}$	$\frac{5}{8}$	$\frac{3}{11}$	$\frac{4}{9}$	$\frac{5}{18}$	$\frac{4}{11}$
$\frac{2}{9}$	$\frac{5}{6}$	$\frac{5}{12}$	$\frac{5}{14}$	$\frac{7}{11}$	$\frac{5}{21}$

Divide each of the following by 2 and tell how you did it:

20.	21.	22.	23.	24.	25.
$\frac{4}{5}$	$\frac{3}{4}$	$\frac{6}{11}$	$\frac{1}{5}$	$\frac{10}{19}$	$\frac{7}{9}$
$\frac{6}{7}$	$\frac{5}{6}$	$\frac{8}{15}$	$\frac{3}{7}$	$\frac{12}{13}$	$\frac{5}{21}$
$\frac{8}{9}$	$\frac{7}{8}$	$\frac{10}{11}$	$\frac{5}{8}$	$\frac{14}{15}$	$\frac{8}{29}$

Changing Fractions to Larger or Smaller Units

1. Draw a line and divide it into fourths. If you divide each fourth into three equal parts, each part is what part of the whole?

2. Then 1 fourth will make how many twelfths? 3 fourths will make how many twelfths?

$$\frac{3}{4} = \frac{9}{12}, \text{ hence } \frac{9}{12} = \frac{3}{4}.$$

Observe from this that:

Both terms of a fraction may be multiplied or divided by the same number without changing the value of the fraction.

Change to largest possible units (reduce to lowest terms) :

3.	4.	5.	6.	7.	8.
$\frac{12}{16}$	$\frac{21}{24}$	$\frac{64}{72}$	$\frac{40}{64}$	$\frac{15}{45}$	$\frac{14}{49}$
$\frac{14}{21}$	$\frac{16}{20}$	$\frac{56}{64}$	$\frac{32}{40}$	$\frac{15}{35}$	$\frac{63}{81}$
$\frac{9}{15}$	$\frac{15}{25}$	$\frac{35}{42}$	$\frac{48}{64}$	$\frac{18}{63}$	$\frac{14}{56}$
$\frac{10}{12}$	$\frac{21}{35}$	$\frac{21}{49}$	$\frac{54}{63}$	$\frac{24}{72}$	$\frac{21}{63}$
$\frac{8}{12}$	$\frac{18}{27}$	$\frac{28}{35}$	$\frac{55}{66}$	$\frac{36}{60}$	$\frac{24}{48}$

Change to 60ths :

9.	10.	11.	12.	13.	14.
$\frac{3}{4}$	$\frac{5}{6}$	$\frac{7}{15}$	$\frac{7}{10}$	$\frac{7}{20}$	$\frac{1}{2}$
$\frac{2}{5}$	$\frac{2}{3}$	$\frac{11}{30}$	$\frac{11}{12}$	$\frac{13}{30}$	$\frac{3}{5}$
$\frac{3}{10}$	$\frac{7}{12}$	$\frac{8}{15}$	$\frac{14}{15}$	$\frac{13}{15}$	$\frac{1}{4}$

Improper Fractions and Mixed Numbers

1. If you have one piece of ribbon $\frac{3}{4}$ yd. long and another $\frac{1}{2}$ or $\frac{2}{4}$ yd. long, together you have how many fourths of a yard?

2. How many fourths in a whole? Then $\frac{5}{4}$ yd. is how much more than a yard? $\frac{5}{4}$ yd. = $1\frac{1}{4}$ yd.

3. When a fraction is equal to more than a whole of anything, what is it called?

4. When a number is made up of a fraction and a whole number, as $3\frac{3}{4}$ ft., what is it called? Why?

5. How many 5ths in a whole? Then $\frac{13}{5}$ = what?

6. Give the values of: $\frac{11}{6}$; $\frac{14}{3}$; $\frac{15}{7}$; $\frac{21}{5}$; $\frac{43}{8}$; $\frac{36}{7}$.

7. Give a rule for changing improper fractions to whole or mixed numbers.

8. 1 = how many 5ths? Then $1\frac{3}{5}$ = how many 5ths?

9. $2\frac{3}{4}$ = how many 4ths? $3\frac{5}{8}$ = ? $4\frac{3}{4}$ = ? $2\frac{3}{5}$ = ?

Change to whole or mixed numbers :

10.	11.	12.	13.	14.	15.
$\frac{26}{7}$	$\frac{33}{8}$	$\frac{19}{5}$	$\frac{51}{8}$	$\frac{101}{16}$	$\frac{98}{12}$
$\frac{34}{9}$	$\frac{27}{4}$	$\frac{42}{8}$	$\frac{53}{16}$	$\frac{95}{17}$	$\frac{65}{15}$
$\frac{38}{5}$	$\frac{64}{9}$	$\frac{67}{7}$	$\frac{89}{15}$	$\frac{86}{13}$	$\frac{59}{9}$

Change to improper fractions :

16.	17.	18.	19.	20.	21.
$5\frac{3}{8}$	$9\frac{5}{6}$	$11\frac{2}{3}$	$11\frac{7}{8}$	$10\frac{4}{5}$	$24\frac{5}{6}$
$6\frac{5}{7}$	$7\frac{3}{4}$	$15\frac{5}{6}$	$9\frac{13}{16}$	$16\frac{2}{9}$	$31\frac{2}{7}$
$8\frac{2}{3}$	$9\frac{7}{8}$	$13\frac{2}{5}$	$8\frac{7}{9}$	$17\frac{1}{11}$	$53\frac{1}{5}$

Addition of Fractions

1. Tell which of the following are *like fractions* and why :

$$\frac{2}{3}; \frac{3}{4}; \frac{1}{4}; \frac{1}{3}; \frac{3}{8}; \frac{5}{7}; \frac{7}{8}; \frac{2}{7}; \frac{3}{9}; \frac{5}{8}.$$

2. Which of the above fractions can be added without changing the units?

3. Add $3\frac{3}{4}$, $5\frac{2}{3}$, $7\frac{5}{6}$.

WORK

$$\begin{array}{r} 3\frac{3}{4} \\ 5\frac{2}{3} \\ 7\frac{5}{6} \\ \hline 17\frac{1}{4} \end{array} \quad \begin{array}{r} \frac{9}{12} \\ \frac{8}{12} \\ \frac{10}{12} \\ \hline \frac{27}{12} \end{array} = 2\frac{1}{4}$$

Give the steps in adding mixed numbers :

- I. The change made in the fractions.
- II. The method of adding the fractions.
- III. The reduction of the sum of the fractions.
- IV. What is written down and what is carried?

Add :

4.	5.	6.	7.	8.	9.
$13\frac{3}{4}$	$24\frac{2}{3}$	$16\frac{7}{8}$	$34\frac{1}{5}$	$28\frac{3}{4}$	$32\frac{2}{3}$
$16\frac{5}{6}$	$17\frac{1}{6}$	$14\frac{3}{4}$	$16\frac{7}{15}$	$19\frac{7}{8}$	$28\frac{2}{9}$
$12\frac{7}{8}$	$22\frac{5}{9}$	$17\frac{5}{16}$	$28\frac{11}{30}$	$16\frac{2}{3}$	$16\frac{1}{2}$

10.	11.	12.	13.	14.	15.	16.
$12\frac{1}{2}$	$11\frac{15}{16}$	$16\frac{3}{4}$	$32\frac{5}{12}$	$82\frac{1}{3}$	$15\frac{1}{6}$	$22\frac{3}{4}$
$6\frac{3}{10}$	$9\frac{1}{2}$	$24\frac{7}{8}$	$84\frac{2}{3}$	$24\frac{3}{4}$	$23\frac{4}{5}$	$86\frac{1}{5}$
$8\frac{3}{4}$	$7\frac{3}{8}$	$42\frac{1}{2}$	$48\frac{5}{6}$	$86\frac{5}{8}$	$18\frac{1}{3}$	$86\frac{1\frac{4}{5}}{1\frac{5}{5}}$
$6\frac{7}{8}$	$5\frac{1}{2}$	$83\frac{5}{8}$	$34\frac{3}{4}$	$32\frac{2}{3}$	$32\frac{7}{12}$	$42\frac{1}{3}$
$1\frac{1}{2}$	$9\frac{11}{16}$	$92\frac{4}{16}$	$52\frac{2}{3}$	$84\frac{7}{8}$	$84\frac{1}{4}$	$43\frac{5}{12}$
$9\frac{1}{4}$	$8\frac{3}{4}$	$26\frac{1}{2}$	$69\frac{11}{12}$	$32\frac{11}{12}$	$46\frac{3}{8}$	$23\frac{1}{4}$
$3\frac{5}{8}$	$7\frac{5}{8}$	$82\frac{3}{4}$	$82\frac{1}{6}$	$13\frac{1}{2}$	$53\frac{3}{4}$	$48\frac{5}{6}$

Drill Table

	<i>a</i>	<i>b</i>	<i>c</i>	<i>d</i>	<i>e</i>	<i>f</i>	<i>g</i>	<i>h</i>
1.	$\frac{1}{2}$	$\frac{4}{5}$	$\frac{3}{16}$	$\frac{5}{18}$	$4\frac{1}{3}$	$12\frac{1}{2}$	$19\frac{7}{8}$	$341\frac{4}{9}$
2.	$\frac{1}{3}$	$\frac{5}{8}$	$\frac{5}{18}$	$\frac{9}{20}$	$6\frac{3}{4}$	$16\frac{2}{3}$	$19\frac{5}{12}$	$482\frac{5}{10}$
3.	$\frac{1}{4}$	$\frac{3}{7}$	$\frac{1}{20}$	$\frac{2}{3}$	$8\frac{5}{6}$	$18\frac{3}{4}$	$16\frac{1}{2}$	$386\frac{5}{12}$
4.	$\frac{1}{5}$	$\frac{8}{15}$	$\frac{4}{25}$	$\frac{5}{6}$	$7\frac{5}{12}$	$31\frac{1}{4}$	$24\frac{1}{8}$	$521\frac{3}{4}$
5.	$\frac{1}{6}$	$\frac{7}{8}$	$\frac{6}{7}$	$\frac{8}{9}$	$8\frac{5}{9}$	$33\frac{1}{3}$	$24\frac{3}{4}$	$287\frac{1}{6}$
6.	$\frac{1}{8}$	$\frac{7}{12}$	$\frac{4}{9}$	$\frac{7}{16}$	$9\frac{11}{18}$	$37\frac{1}{2}$	$41\frac{2}{3}$	$272\frac{1}{4}$
7.	$\frac{1}{9}$	$\frac{5}{6}$	$\frac{7}{8}$	$\frac{14}{15}$	$6\frac{7}{8}$	$43\frac{3}{4}$	$36\frac{11}{12}$	$316\frac{7}{16}$
8.	$\frac{1}{10}$	$\frac{3}{25}$	$\frac{9}{10}$	$\frac{4}{9}$	$7\frac{7}{10}$	$56\frac{1}{4}$	$45\frac{4}{5}$	$382\frac{7}{8}$
9.	$\frac{1}{12}$	$\frac{11}{16}$	$\frac{3}{15}$	$\frac{7}{9}$	$10\frac{2}{5}$	$62\frac{1}{2}$	$48\frac{9}{16}$	$681\frac{2}{3}$
10.	$\frac{4}{15}$	$\frac{3}{5}$	$\frac{4}{25}$	$\frac{3}{8}$	$11\frac{13}{15}$	$66\frac{2}{3}$	$52\frac{3}{4}$	$218\frac{4}{5}$

Suggestive exercises:

1-10. $a + b$.	41-50. $f + g$.	81-90. $g + h$.
11-20. $a + c$.	51-60. $e + h$.	91-100. $c + g$.
21-30. $a + d$.	61-70. $e + f$.	101-110. $a + b + c$.
31-40. $b + c$.	71-80. $d + f$.	111-120. $b + c + d$.

NOTE. — $a + b$ indicates that the adjacent fractions in columns a and b are to be added.

Subtraction of Fractions

1. From $34\frac{1}{6}$ subtract $16\frac{3}{4}$.

WORK

Give in detail each step in order :

$$\begin{array}{r} 34\frac{1}{6} \\ 16\frac{3}{4} \\ \hline 17\frac{5}{12} \end{array}$$

- I. Change made in the fractions.
- II. How was the $\frac{5}{12}$ found?
- III. What was the next step?

Subtract :

2.	4.	6.	8.	10.	12.
$63\frac{2}{3}$	$64\frac{1}{5}$	$101\frac{1}{8}$	$201\frac{5}{9}$	$190\frac{2}{7}$	$314\frac{3}{5}$
$17\frac{5}{6}$	$18\frac{3}{4}$	$86\frac{3}{4}$	$168\frac{2}{3}$	$164\frac{2}{3}$	$169\frac{5}{7}$
<hr/>	<hr/>	<hr/>	<hr/>	<hr/>	<hr/>
3.	5.	7.	9.	11.	13.
$58\frac{1}{4}$	$64\frac{3}{8}$	$96\frac{3}{16}$	$310\frac{2}{3}$	$280\frac{1}{4}$	$201\frac{1}{8}$
$17\frac{2}{3}$	$19\frac{5}{6}$	$49\frac{5}{8}$	$165\frac{4}{5}$	$196\frac{7}{8}$	$156\frac{2}{3}$
<hr/>	<hr/>	<hr/>	<hr/>	<hr/>	<hr/>

Subtract without rewriting :

14.	$215\frac{5}{6}$	20.	$112\frac{1}{5}$	26.	$3059\frac{1}{4}$	32.	$403\frac{1}{12}$
	$39\frac{1}{2}$		$46\frac{2}{3}$		$126\frac{5}{8}$		$231\frac{1}{5}$
	<hr/>		<hr/>		<hr/>		<hr/>
15.	$160\frac{2}{3}$	21.	109	27.	$2930\frac{1}{3}$	33.	$426\frac{1}{5}$
	$49\frac{11}{12}$		$26\frac{11}{12}$		$427\frac{5}{6}$		$108\frac{1}{3}$
	<hr/>		<hr/>		<hr/>		<hr/>
16.	$203\frac{5}{6}$	22.	$1096\frac{3}{8}$	28.	$734\frac{11}{16}$	34.	$117\frac{2}{3}$
	$98\frac{7}{8}$		$204\frac{3}{4}$		$246\frac{7}{8}$		$96\frac{7}{8}$
	<hr/>		<hr/>		<hr/>		<hr/>
17.	$106\frac{1}{8}$	23.	$4095\frac{2}{3}$	29.	$324\frac{1}{4}$	35.	$213\frac{5}{6}$
	$94\frac{11}{12}$		$738\frac{11}{12}$		$163\frac{3}{5}$		$108\frac{3}{4}$
	<hr/>		<hr/>		<hr/>		<hr/>
18.	$104\frac{1}{5}$	24.	$4152\frac{5}{7}$	30.	$610\frac{5}{9}$	36.	$261\frac{1}{8}$
	$26\frac{2}{3}$		$136\frac{2}{3}$		$138\frac{11}{12}$		$107\frac{15}{16}$
	<hr/>		<hr/>		<hr/>		<hr/>
19.	$1546\frac{2}{3}$	25.	$4012\frac{11}{16}$	31.	$341\frac{1}{11}$	37.	$230\frac{2}{3}$
	$119\frac{5}{8}$		$107\frac{7}{8}$		$103\frac{1}{2}$		$103\frac{5}{8}$
	<hr/>		<hr/>		<hr/>		<hr/>

Use the table on page 22 for drill in subtraction.

Multiplication of Fractions

- $3 \times \$5 = \--- ; $3 \times 5 \text{ ft.} = \text{--- ft.}$; $3 \times \frac{5}{8} = \frac{\quad}{8}$.
- $\frac{3}{4} \times 7 = \frac{3}{4}$ of 7 = $3 \times \frac{1}{4}$ of 7 = $3 \times \frac{7}{4} = \frac{\quad}{4}$.
- Tell how to multiply a fraction by a whole number, or a whole number by a fraction.
- $\frac{2}{3} \times \frac{4}{5} = 2 \times \frac{1}{3}$ of $\frac{4}{5} = 2 \times \frac{4}{3 \times 5} = \frac{2 \times 4}{3 \times 5} = \text{---}$.
- Give a short rule for multiplying one fraction by another.
- Multiply $3\frac{1}{2}$ by $2\frac{3}{4}$.

WORK

$$3\frac{1}{2} \times 2\frac{3}{4} =$$

$$\frac{7}{2} \times \frac{11}{4} = \frac{77}{8} = 9\frac{5}{8}$$

Give the steps:

- Changing the mixed numbers.
- Completing the work.

- Find $\frac{6}{7} \times \frac{2}{9}$.

WORK

$$\text{I. } \frac{6}{7} \times \frac{2}{9} = \frac{12}{63} = \frac{4}{21}$$

OR

$$\text{II. } \frac{\overset{2}{\cancel{6}}}{7} \times \frac{\underset{\underset{3}{\cancel{9}}}{2}}{9} = \frac{4}{21}$$

In I how was the product $\frac{12}{63}$ found? How was it reduced to $\frac{4}{21}$?

In II what common factor was canceled from both numerator and denominator before multiplying? Which method do you prefer?

At sight give the products:

- | | | | |
|-----------------------------|-------------------------------|--|--|
| 1. $4 \times \frac{2}{3}$. | 7. $\frac{3}{4} \times 8$. | 13. $\frac{2}{3} \times \frac{3}{4}$. | 19. $\frac{3}{5} \times \frac{5}{9}$. |
| 2. $2 \times \frac{3}{4}$. | 8. $\frac{2}{3} \times 9$. | 14. $\frac{3}{4} \times \frac{5}{6}$. | 20. $\frac{4}{5} \times \frac{3}{8}$. |
| 3. $5 \times \frac{2}{7}$. | 9. $\frac{3}{4} \times 5$. | 15. $\frac{2}{3} \times \frac{6}{7}$. | 21. $\frac{2}{3} \times \frac{9}{10}$. |
| 4. $3 \times \frac{5}{6}$. | 10. $\frac{2}{3} \times 7$. | 16. $\frac{5}{6} \times \frac{2}{3}$. | 22. $\frac{3}{4} \times \frac{8}{9}$. |
| 5. $4 \times \frac{5}{6}$. | 11. $\frac{4}{5} \times 15$. | 17. $\frac{3}{8} \times \frac{5}{9}$. | 23. $\frac{2}{5} \times \frac{15}{16}$. |
| 6. $3 \times \frac{5}{8}$. | 12. $\frac{4}{5} \times 9$. | 18. $\frac{3}{4} \times \frac{8}{5}$. | 24. $\frac{2}{7} \times \frac{7}{10}$. |

Find the products :

25. $\frac{10}{12} \times \frac{24}{35}$.

29. $\frac{25}{36} \times \frac{24}{35}$.

33. $\frac{2}{3} \times 7\frac{1}{2}$.

26. $\frac{9}{10} \times \frac{20}{27}$.

30. $\frac{3}{22} \times \frac{55}{63}$.

34. $2\frac{2}{3} \times 7\frac{5}{16}$.

27. $\frac{4}{11} \times \frac{22}{8}$.

31. $\frac{5}{13} \times \frac{65}{17}$.

35. $4\frac{4}{5} \times 15\frac{5}{8}$.

28. $\frac{13}{21} \times \frac{35}{39}$.

32. $\frac{11}{12} \times \frac{48}{15}$.

36. $\frac{4}{7} \times \frac{3}{8} \times 3\frac{1}{2}$.

37.
128
16 $\frac{3}{4}$

40.
268
24 $\frac{5}{6}$

43.
385 $\frac{1}{4}$
24

46.
426 $\frac{2}{3}$
19

38.
396
47 $\frac{2}{3}$

41.
345
17 $\frac{2}{5}$

44.
468 $\frac{1}{2}$
16

47.
574 $\frac{5}{6}$
15

39.
248
73 $\frac{3}{5}$

42.
368
47 $\frac{5}{6}$

45.
549 $\frac{2}{5}$
16

48.
874 $\frac{7}{8}$
26

Division of Fractions

1. \$8 ÷ \$2 = ? 8 ft. ÷ 2 ft. = ? 8 mi. ÷ 2 mi. = ?

$\frac{8}{9} \div \frac{2}{9} = ?$

2. When both dividend and divisor are expressed in like units, how is the division performed ?

At sight give the quotients :

3.

4.

5.

6.

$\frac{4}{5} \div \frac{2}{5}$.

$\frac{10}{11} \div \frac{2}{11}$.

$\frac{9}{10} \div \frac{4}{10}$.

$\frac{7}{8} \div \frac{3}{8}$.

$\frac{8}{11} \div \frac{4}{11}$.

$\frac{12}{16} \div \frac{3}{16}$.

$\frac{8}{9} \div \frac{5}{9}$.

$\frac{10}{13} \div \frac{4}{13}$.

$\frac{6}{7} \div \frac{2}{7}$.

$\frac{14}{15} \div \frac{2}{15}$.

$\frac{7}{10} \div \frac{3}{10}$.

$\frac{3}{8} \div \frac{5}{8}$.

$\frac{8}{15} \div \frac{2}{15}$.

$\frac{12}{13} \div \frac{4}{13}$.

$\frac{11}{8} \div \frac{3}{8}$.

$\frac{2}{9} \div \frac{7}{9}$.

7. Divide $\frac{3}{4}$ by $\frac{5}{7}$.

$$\frac{3}{4} \div \frac{5}{7} = \frac{3 \times 7}{4 \times 7} \div \frac{4 \times 5}{4 \times 7} = \frac{3 \times 7}{4 \times 5} = \frac{21}{20} = 1\frac{1}{20}.$$

Observe the following steps :

- I. Both terms of $\frac{3}{4}$ were multiplied by 7.
- II. Both terms of $\frac{5}{7}$ were multiplied by 4.
- III. This was to reduce both fractions to like units.
- IV. The numerators only were used in the division.
- V. Hence we divided 3×7 by 5×4 .
- VI. This could have been done by inverting the divisor and multiplying the dividend by it.

8. Divide $2\frac{2}{3}$ by $3\frac{1}{5}$.

WORK

$$2\frac{2}{3} \div 3\frac{1}{5} = \frac{8}{3} \div \frac{16}{5} = \frac{8}{3} \times \frac{5}{\cancel{16}_2} = \frac{5}{6}.$$

- | | | |
|--|---------------------------------------|--|
| 9. $\frac{7}{8} \div \frac{3}{5}$. | 12. $\frac{7}{8} \div 1\frac{3}{4}$. | 15. $6\frac{7}{8} \div 1\frac{1}{2}$. |
| 10. $2\frac{1}{2} \div \frac{3}{4}$. | 13. $3\frac{1}{2} \div \frac{7}{8}$. | 16. $8\frac{1}{4} \div 1\frac{3}{4}$. |
| 11. $1\frac{7}{8} \div 2\frac{1}{2}$. | 14. $4\frac{1}{2} \div \frac{3}{4}$. | 17. $7\frac{5}{8} \div 2\frac{1}{4}$. |

18. Divide $345\frac{1}{2}$ by $16\frac{3}{4}$.

WORK

$$\begin{array}{r} 16\frac{3}{4} \overline{)345\frac{1}{2}} = \\ \underline{204\frac{2}{67}} \\ 67 \overline{)1382} \\ \underline{134} \\ \underline{42} \\ \underline{42} \\ 0 \end{array}$$

SUGGESTION. — The quotient is not changed if both dividend and divisor are multiplied by the same number. Hence both dividend and divisor were multiplied by 4, the least common denominator of the fractions, in order to get numbers free of fractions.

Divide :

- | | | |
|---|---|--|
| 19. $362\frac{3}{4} \div 13\frac{1}{2}$. | 21. $495\frac{3}{4} \div 16\frac{7}{8}$. | 23. $984\frac{5}{6} \div 26\frac{1}{3}$. |
| 20. $875\frac{3}{5} \div 21\frac{2}{3}$. | 22. $630\frac{7}{8} \div 15\frac{3}{4}$. | 24. $1054\frac{3}{8} \div 17\frac{1}{2}$. |

Drill Table

	<i>a</i>	<i>b</i>	<i>c</i>	<i>d</i>	<i>e</i>	<i>f</i>	<i>g</i>	<i>h</i>
1.	$\frac{2}{3}$	$\frac{5}{9}$	$\frac{11}{12}$	$2\frac{3}{5}$	$6\frac{3}{8}$	$15\frac{5}{6}$	$316\frac{1}{2}$	\$100
2.	$\frac{3}{4}$	$\frac{2}{7}$	$\frac{3}{8}$	$7\frac{2}{3}$	$18\frac{1}{5}$	$28\frac{1}{3}$	$493\frac{2}{3}$	250
3.	$\frac{5}{6}$	$\frac{5}{8}$	$\frac{4}{9}$	$5\frac{3}{10}$	$9\frac{1}{12}$	$21\frac{3}{8}$	$741\frac{3}{4}$	500
4.	$\frac{7}{8}$	$\frac{2}{12}$	$\frac{7}{24}$	$6\frac{5}{6}$	$10\frac{3}{10}$	$64\frac{2}{9}$	$827\frac{4}{5}$	576
5.	$\frac{4}{5}$	$\frac{6}{35}$	$\frac{3}{14}$	$9\frac{6}{7}$	$15\frac{2}{3}$	$85\frac{3}{4}$	$936\frac{7}{8}$	600
6.	$\frac{8}{9}$	$\frac{3}{10}$	$\frac{11}{30}$	$8\frac{7}{8}$	$21\frac{5}{6}$	$90\frac{9}{10}$	$1464\frac{1}{6}$	640
7.	$\frac{7}{10}$	$\frac{9}{25}$	$\frac{13}{40}$	$4\frac{11}{15}$	$9\frac{7}{8}$	$16\frac{1}{2}$	$2525\frac{1}{10}$	720
8.	$\frac{11}{12}$	$\frac{3}{16}$	$\frac{5}{18}$	$9\frac{23}{24}$	$12\frac{4}{15}$	$72\frac{1}{4}$	$4769\frac{3}{8}$	800
9.	$\frac{5}{7}$	$\frac{3}{9}$	$\frac{7}{105}$	$10\frac{4}{21}$	$18\frac{3}{4}$	$36\frac{5}{7}$	$8461\frac{3}{7}$	960
10.	$\frac{14}{25}$	$\frac{19}{50}$	$\frac{23}{60}$	$3\frac{19}{20}$	$20\frac{14}{15}$	$25\frac{4}{5}$	$7550\frac{7}{10}$	1000

- | | | | |
|------------------------|------------------------------|--|---------------------|
| 1. $a + \frac{2}{3}$. | 10. $e + f + g$. | 19. $f - d$. | 28. $e \times f$. |
| 2. $b + \frac{3}{4}$. | 11. $20 - d$. | 20. $f - d - a$. | 29. $67 \times g$. |
| 3. $c + \frac{7}{8}$. | 12. $e - 5\frac{4}{5}$. | 21. $5 \times a$. | 30. $f \times h$. |
| 4. $a + b$. | 13. $a - b$. | 22. $12 \times b$. | 31. $a \div b$. |
| 5. $d + c$. | 14. $d - c$. | 23. $8 \times f$. | 32. $a \div c$. |
| 6. $a + b + c$. | 15. $e - d$. | 24. a of c . | 33. $a \div d$. |
| 7. $d + e$. | 16. $f - e$. | 25. $b \times c$. | 34. $d \div e$. |
| 8. $e + f$. | 17. $94\frac{7}{8} - f$. | 26. $a \times b \times c$. | 35. $e \div d$. |
| 9. $d + e + f$. | 18. $g - f$. | 27. $b \times c \times d$. | 36. $f \div e$. |
| 37. $g \div 9$. | 40. $h \div f$. | 43. b of $e \div d$. | |
| 38. $g \div 75$. | 41. $a + b - \frac{1}{2}c$. | 44. $f \div d \times e$. | |
| 39. $h \div d$. | 42. $f - (d + e)$. | 45. $(a \text{ of } d) \div (b \text{ of } c)$. | |

NOTE.—This table may be used if more abstract drill is desired. Each exercise above furnishes 10 examples, making 450 in all.

Practical Problems

1. A merchant bought 750 lb. of sugar at $4\frac{1}{3}\text{¢}$ a pound and sold it at $4\frac{3}{4}\text{¢}$ a pound. What was his profit?
2. If a dealer buys 6500 lb. of cotton at $11\frac{3}{4}\text{¢}$ a pound and sells it at $13\frac{1}{2}\text{¢}$ a pound, how much does he make?
3. A farmer cut three crops of alfalfa from his field in one season, as follows: $9\frac{3}{4}$ T., $8\frac{3}{8}$ T., and $6\frac{1}{2}$ T. Find the total yield for the season.
4. How many baskets, each containing $\frac{3}{8}$ bu. of pears, can a dealer fill from a barrel containing $2\frac{1}{4}$ bu.?
5. How many $\frac{1}{4}$ -lb. boxes of candy can be filled from a box containing $12\frac{1}{4}$ lb.?
6. On the remnant counter Marie found a piece of cloth containing $\frac{7}{8}$ yd., marked 49¢. How much did it cost per yard?
7. At the rate in Problem 6, at what price should a remnant containing $2\frac{3}{4}$ yd. be marked?
8. A remnant containing $5\frac{5}{8}$ yd. is marked 90¢. Which is cheaper, and how much, to buy the remnant or to buy the same amount of goods from the regular counter at 20¢ per yard?
9. If it takes $\frac{5}{8}$ yd. of ribbon to make the school colors for one pupil, how many yards will it take for 36 pupils? How many can be made from a bolt containing $12\frac{1}{2}$ yd.?
10. If a boy makes the 100-yd. dash in $11\frac{3}{8}$ sec., what is his speed per second?
11. Four boys in a relay race ran as follows: the first $9\frac{3}{8}$ sec., the second $8\frac{1}{2}$ sec., the third $10\frac{4}{5}$ sec., the fourth $9\frac{1}{2}$ sec. How long did it take to complete the race?
12. A drainage ditch 120 yd. long is to have a fall of $\frac{3}{8}$ in. per yard. Find the total fall of the ditch.

13. John gathered a bushel of walnuts and sold 20 qt. What fraction of the bushel did he sell? Express it in lowest terms.

14. A man had a farm containing 160 A. He sold 60 A. of it. What fraction of the farm did he sell? Express it in lowest terms.

15. A farmer had a herd of 240 sheep. He sold 180 of them. What fraction of the herd did he sell? Express in lowest terms.

16. From Chicago to Omaha is 492 mi., and from Chicago to Denver is 1062 mi. What fraction of the distance from Chicago to Denver is the distance from Chicago to Omaha? Express in lowest terms.

17. If you pay 35¢ for 6 pencils, how much is that for each?

18. Mary needs $\frac{1}{4}$ yd. of ruching for each sleeve of a dress and $\frac{3}{8}$ yd. for the neck. How much does she need altogether?

19. Mr. King cut $4\frac{1}{2}$ T. of hay from one field, $3\frac{3}{8}$ T. from another, and $5\frac{3}{4}$ T. from another. How many tons did he cut in all?

20. Rain fell to a depth of $2\frac{3}{4}$ in. one day, $1\frac{5}{16}$ in. the next day, and $1\frac{1}{2}$ in. the next day. Find the total rainfall for the three days.

21. The average rainfall in Indiana for a period of 36 yr. was $41\frac{1}{2}$ in. per year. If, during one year, the rainfall was only $36\frac{9}{16}$ in., this was how much less than the average?

22. During the same period the average rainfall in New Mexico was $14\frac{1}{4}$ in. per year. How much more was the annual rainfall in Indiana than in New Mexico?

23. The least rainfall was in Arizona, where the average was only $3\frac{1}{8}$ in. per year. The annual rainfall in Indiana was how many times as much as that in Arizona?

24. The state having the greatest average rainfall per year was Alabama, where the average was 62 in. The annual rainfall of Alabama was how many times that of Arizona?

25. Ice cutters who were storing ice in the winter found that the ice was $12\frac{3}{4}$ in. thick at night and the next morning $15\frac{5}{16}$ in. thick. How much did it freeze during the night?

26. John kept a record of his growth in height from the time that he was 9 yr. old until he was 12 yr. old. During the tenth year he grew $2\frac{5}{8}$ in., during the eleventh $1\frac{11}{16}$ in., and during the twelfth $\frac{21}{2}$ in. Find his growth during the three years.

27. If I nail two boards together, one $\frac{7}{8}$ in. and the other $1\frac{1}{4}$ in. thick, how long a nail will it take to just reach through them?

28. By how much does the thickness of a $1\frac{1}{2}$ -in. board exceed the length of a $\frac{7}{8}$ -in. screw?

29. From a barrel containing $31\frac{1}{2}$ gal. of vinegar a merchant sold on the different days of one week the following amounts: $3\frac{3}{4}$ gal., $4\frac{1}{8}$ gal., $3\frac{1}{2}$ gal., $4\frac{1}{4}$ gal., $2\frac{3}{4}$ gal., and $10\frac{3}{4}$ gal. How much remained in the barrel?

30. The record for the 100-yd. dash in a recent year was $9\frac{4}{5}$ sec. If you could run it in $14\frac{1}{2}$ sec., your time would be how much more than the record?

31. What does it cost to mail a package of newspapers weighing 12 oz., at $\frac{1}{4}\text{¢}$ per ounce?

32. If Harry grew $1\frac{3}{8}$ in. during a year, find how much he grew, on the average, per month.

33. How many pieces of ribbon each $\frac{3}{8}$ yd. long can be cut from a piece of ribbon $7\frac{1}{2}$ yd. long?

34. A grocer bought 2400 lb. of sugar at $4\frac{5}{8}\text{¢}$ per pound and sold it at $5\frac{1}{4}\text{¢}$ per pound. Find his profit.

DECIMAL FRACTIONS

1. What is meant by saying that our system of writing numbers is a "decimal system"?

2. Compare the values of the 2's in 222.

3. Compare the values of the 3's in 33; in 3.3; in 0.33; in 0.033.

4. Which of the preceding numbers are integers (whole numbers)? Which are decimals? Which are mixed decimals?

5. In our system of writing numbers the value of a figure depends upon what two things?

6. In the following number, which figure stands for tens? For tenths? For hundreds? For hundredths?

54321.2345

7. Compare the positions and values of the 3's. Of the 4's.

8. Of what orders are the 5's?

9. Of what use is the decimal point?

10. How is the denominator of a decimal determined?

11. Write the following with denominators:

0.8; 0.24; 0.175; 0.036; 0.008; 0.0025; 0.0017.

12. Write decimally the following:

$\frac{8}{10}$; $\frac{8}{100}$; $\frac{8}{1000}$; $\frac{8}{10000}$; $\frac{25}{100}$; $\frac{25}{1000}$; $\frac{25}{10000}$.

13. Compare the number of places taken up by each decimal with the number of zeros in the denominator.

14. In reading a *mixed decimal*, what part is read first? Where is "and" used?

15. Read: 145.45; 100.045; 0.145; 200.008; 0.208.

16. Read: 0.307; 0.0307; 330.03; 0.303; 0.71; 0.071.

17. Write decimally: $\frac{345}{1000}$; $\frac{12}{100}$; $\frac{817}{1000}$; $\frac{125}{1000}$; $\frac{25}{1000}$.
18. Write as mixed decimals: $1\frac{3}{10}$; $2\frac{7}{100}$; $1\frac{17}{1000}$; $16\frac{1}{100}$.
19. Write 0.8 and 0.80 as common fractions, and compare their values.
20. Compare the values of 0.9 and 0.90; of 0.250 and 0.25.
21. Annexing or removing a zero from the right of a decimal has what effect upon the value of the decimal?
22. Change the form without changing the value:
0.50; 0.800; 0.950; 0.700; 0.080; 0.0750.
23. Compare 0.8 and 0.08; 0.25 and 0.025; 0.017 and 0.17.
24. What is the effect upon the value when the decimal point is moved one place to the *left*? Two places? Three?
25. What is the effect upon the value when the decimal point is moved one place to the *right*? Two places? Three?
26. In the whole number 8, where is the decimal point supposed to be? If a zero is annexed to 8, has the decimal point been moved? Which way? What effect?
27. Tell what effect annexing a zero has upon each of the following:
75; 7.5; 1.2; 12; 3.5; 4.8; 56; 84; 6.2.
28. Then when does annexing a zero affect the value of a number, and when does it not?
29. Change to common fractions and reduce to lowest terms: 0.4; 0.80; 0.25; 0.50; 0.75; 0.125; 0.375; 0.050.
30. Change $\frac{7}{8}$ to a decimal.
- | | | | | |
|-----------------|-----------------------|-----------------------|-----------------------|-----------------------|
| WORK | 31. $\frac{7}{20}$. | 34. $\frac{27}{80}$. | 37. $\frac{15}{16}$. | 40. $\frac{3}{16}$. |
| 8) <u>7.000</u> | 32. $\frac{13}{40}$. | 35. $\frac{3}{40}$. | 38. $\frac{17}{25}$. | 41. $\frac{5}{32}$. |
| 0.875 | 33. $\frac{13}{20}$. | 36. $\frac{7}{16}$. | 39. $\frac{19}{20}$. | 42. $\frac{7}{125}$. |
43. Change to mixed decimals: $3\frac{7}{8}$; $5\frac{3}{16}$; $7\frac{3}{32}$; $1\frac{1}{25}$.

Adding and Subtracting Decimals

Add:

1.	96.475	2.	186.32	3.	0.4875	4.	0.648
	83.8		62.379		2.93		1.97
	5.42		4.8		8.479		2.9
	16.783		9.54		6.53		17.06
	<u>4.09</u>		<u>72.683</u>		<u>0.985</u>		<u>1.875</u>

Add each column, then each line:

	5.	6.	7.	8.	9.
10.	9.875	17.965	36.895	346.85	17.846
11.	6.35	187.35	175.45	17.395	9.38
12.	16.8	9.632	9.62	7.28	19.265
13.	5.48	8.7	18.385	34.652	3.8
14.	26.376	13.5	9.6	19.8	1.96

Subtract:

15.	3.85	16.	42.8	17.	8.96	18.	0.96	19.	0.85
	<u>1.685</u>		<u>19.368</u>		<u>1.097</u>		<u>0.398</u>		<u>0.186</u>

Write all as decimals and add:

20.	21.	22.	23.	24.
16.372	$8\frac{5}{8}$	79.42	$14\frac{1}{4}$	$86\frac{3}{4}$
$216\frac{1}{2}$	$34\frac{7}{8}$	19.365	$16\frac{3}{8}$	$97\frac{3}{10}$
$25\frac{1}{4}$	0.847	$96\frac{3}{16}$	29.3	0.8
<u>0.3</u>	<u>$87\frac{1}{2}$</u>	<u>$12\frac{1}{2}$</u>	<u>0.306</u>	<u>0.375</u>

Subtract:

25.	26.	27.	28.	29.
200	2.0856	9.65	6.3752	14
<u>17.38</u>	<u>1.43</u>	<u>1.7804</u>	<u>1.98</u>	<u>$3.86\frac{1}{3}$*</u>

* NOTE. — Such expressions are *complex decimals*. $3.86\frac{1}{3}$ is read “three and eighty-six and one third hundredths.”

Multiplication of Decimals

1. Multiply the following by 10 at sight :

3.45; 0.165; 2.15; 34.5; 16.02.

2. Find 8×0.1 ; 8×0.01 ; 8×0.001 ; 8×0.3 ; 8×0.03 .

3. Since $0.1 \times 3.5 = 0.35$, how much is 0.3×3.5 ?

Give the products :

4.	5.	6.	7.
0.2×0.4	0.6×0.8	0.06×300	0.5×0.5
0.02×0.4	0.06×0.8	0.08×400	0.05×0.05

The product contains as many decimal places as there are decimal places in both of the factors.

Exercises

1. Find 3.46×2.008 .

WORK	
2.008	2.008
3.46	3.46
<u>.12048</u>	<u>.12048</u>
.8032	.8032
<u>6.024</u>	<u>6.024</u>
6.94768	6.94768

EXPLANATION.—The first partial product is 0.06×2.008 or 0.12048, which may be written in either of the ways given. The important thing to remember is how to determine the number of decimals in the product and to put the decimal point where it belongs.

Find the products :

- | | | |
|--------------------------|-----------------------------------|--------------------------|
| 2. 0.89×5.076 . | 7. 0.037×12.50 . | 12. 0.08×45.6 . |
| 3. 8.47×9.432 . | 8. 1.87×0.360 . | 13. 0.24×9.60 . |
| 4. 0.84×19.60 . | 9. $0.36 \times 3.6 \times 36$. | 14. 0.17×34.6 . |
| 5. 2.65×0.48 . | 10. $0.5 \times 4.2 \times 45$. | 15. 0.65×82.4 . |
| 6. 9.06×1.25 . | 11. $4.8 \times 0.5 \times 1.2$. | 16. 3.45×0.09 . |

Some Special Decimals

There are certain decimal and common fractions that occur so frequently that one ought to be able to change instantly from one to the other.

Memorize this table of simple relations :

$0.50 = \frac{1}{2}$.	$0.66\frac{2}{3} = \frac{2}{3}$.	$0.62\frac{1}{2} = \frac{5}{8}$.
$0.25 = \frac{1}{4}$.	$0.33\frac{1}{3} = \frac{1}{3}$.	$0.87\frac{1}{2} = \frac{7}{8}$.
$0.12\frac{1}{2} = \frac{1}{8}$.	$0.16\frac{2}{3} = \frac{1}{6}$.	$0.14\frac{2}{7} = \frac{1}{7}$.
$0.06\frac{1}{4} = \frac{1}{16}$.	$0.08\frac{1}{3} = \frac{1}{12}$.	$0.11\frac{1}{9} = \frac{1}{9}$.
$1.25 = 1\frac{1}{4}$.	$0.37\frac{1}{2} = \frac{3}{8}$.	$0.83\frac{1}{3} = \frac{5}{6}$.

There are other relations that are readily seen from these. Thus,

$$0.28\frac{4}{7} = \frac{2}{7}; \quad 0.56\frac{1}{4} = \frac{9}{16}; \quad 0.58\frac{1}{3} = \frac{7}{12}; \quad \text{etc.}$$

Drill Exercises

Give at sight:

- | | | |
|-----------------------------------|------------------------------------|------------------------------------|
| 1. 28×0.25 . | 16. $51 \times 0.33\frac{1}{3}$. | 31. $480 \times 1.66\frac{2}{3}$. |
| 2. 0.75×84 . | 17. 12×3.50 . | 32. $49 \times 0.14\frac{2}{7}$. |
| 3. 32×1.25 . | 18. $54 \times 0.16\frac{2}{3}$. | 33. $12 \times 0.12\frac{1}{2}$. |
| 4. 96×0.75 . | 19. $24 \times 1.16\frac{2}{3}$. | 34. $24 \times 0.37\frac{1}{2}$. |
| 5. 12×2.25 . | 20. $0.12\frac{1}{2} \times 88$. | 35. $48 \times 0.62\frac{1}{2}$. |
| 6. 16×1.75 . | 21. $1.12\frac{1}{2} \times 24$. | 36. $80 \times 0.62\frac{1}{2}$. |
| 7. 24×2.50 . | 22. $72 \times 0.16\frac{2}{3}$. | 37. $56 \times 0.87\frac{1}{2}$. |
| 8. 36×1.25 . | 23. $96 \times 0.08\frac{1}{3}$. | 38. $16 \times 2.87\frac{1}{2}$. |
| 9. 14×2.50 . | 24. $48 \times 1.08\frac{1}{3}$. | 39. $32 \times 1.87\frac{1}{2}$. |
| 10. 3.5×42 . | 25. $24 \times 0.37\frac{1}{2}$. | 40. $40 \times 1.37\frac{1}{2}$. |
| 11. 1.25×64 . | 26. $16 \times 1.37\frac{1}{2}$. | 41. $48 \times 0.87\frac{1}{2}$. |
| 12. $24 \times 0.33\frac{1}{3}$. | 27. $0.83\frac{1}{3} \times 36$. | 42. $35 \times 1.14\frac{2}{7}$. |
| 13. $36 \times 1.33\frac{1}{3}$. | 28. $24 \times 0.83\frac{1}{3}$. | 43. $42 \times 2.33\frac{1}{3}$. |
| 14. $18 \times 0.66\frac{2}{3}$. | 29. $18 \times 1.83\frac{1}{3}$. | 44. $48 \times 1.87\frac{1}{2}$. |
| 15. $48 \times 1.66\frac{2}{3}$. | 30. $126 \times 1.33\frac{1}{3}$. | 45. $72 \times 1.11\frac{1}{9}$. |

Multiplying by the Method of Aliquot Parts

An aliquot part of a number is a number contained in the given number an exact number of times. Thus, 25 is an aliquot part of 100, for it is contained in 100 an exact number of times. So is 2.5 of 10; $3\frac{1}{3}$ of 10; $33\frac{1}{3}$ of 100, etc.

Certain aliquot parts of 10, 100, and 1000 occur so often that they should be instantly recognized and used to shorten work when possible.

Memorize this table :

$25 = \frac{1}{4}$ of 100.	$16\frac{2}{3} = \frac{1}{6}$ of 100.	$6\frac{1}{4} = \frac{1}{16}$ of 100.	$2\frac{1}{2} = \frac{1}{4}$ of 10.
$33\frac{1}{3} = \frac{1}{3}$ of 100.	$12\frac{1}{2} = \frac{1}{8}$ of 100.	$3\frac{1}{3} = \frac{1}{3}$ of 10.	$125 = \frac{1}{8}$ of 1000.

1. Multiply 4.2 by $16\frac{2}{3}$.

WORK

$$\begin{array}{r} 6 \overline{)420} \\ 70 \end{array}$$

EXPLANATION. — Since $16\frac{2}{3}$ is $\frac{1}{6}$ of 100, we may multiply by 100 (how?), then divide by 6.

2. Observe the above table, and tell how to multiply by 25. By $33\frac{1}{3}$. By $12\frac{1}{2}$. By 125.
3. How would you multiply by $6\frac{1}{4}$? By $3\frac{1}{3}$? By $2\frac{1}{2}$?

Give at sight :

- | | | |
|-------------------------------|--------------------------------|--------------------------------|
| 4. $33\frac{1}{3} \times 18.$ | 8. $16\frac{2}{3} \times 36.$ | 12. $25 \times 84.$ |
| 5. $25 \times 24.$ | 9. $33\frac{1}{3} \times 42.$ | 13. $12\frac{1}{2} \times 24.$ |
| 6. $16\frac{2}{3} \times 54.$ | 10. $12\frac{1}{2} \times 72.$ | 14. $16\frac{2}{3} \times 24.$ |
| 7. $25 \times 96.$ | 11. $25 \times 32.$ | 15. $12\frac{1}{2} \times 96.$ |

Find the products :

- | | | |
|-----------------------------------|------------------------------------|------------------------------------|
| 16. $3\frac{1}{3} \times 63.72.$ | 19. $16\frac{2}{3} \times 384.54.$ | 22. $33\frac{1}{3} \times 96.126.$ |
| 17. $2\frac{1}{2} \times 86.48.$ | 20. $25 \times 36.978.$ | 23. $33\frac{1}{3} \times 73.245.$ |
| 18. $16\frac{2}{3} \times 193.5.$ | 21. $25 \times 32.847.$ | 24. $25 \times 9.368.$ |

Division of Decimals: Divisor a Whole Number

1. Give the quotients: $\$8 \div 2$; $8 \text{ ft.} \div 2$; $0.8 \div 2$; $0.08 \div 2$.

Divide at sight:

2.	3.	4.	5.	6.
$3 \overline{)0.9}$	$3 \overline{)0.15}$	$3 \overline{)0.015}$	$4 \overline{)0.08}$	$4 \overline{)0.016}$

Observe that when any number is divided by an abstract whole number, we are finding the *size* of the parts into which the dividend is divided, hence the name of the units is not changed. Thus, if we divide hundredths, we have hundredths, etc.

7. Divide 20.21 by 86.

WORK

$$\begin{array}{r}
 0.235 \\
 86 \overline{)20.210} \\
 \underline{17 \ 2} \\
 3 \ 01 \\
 \underline{2 \ 58} \\
 430 \\
 \underline{430} \\
 0
 \end{array}$$

Three points to observe in division:

I. If the divisor is a whole number, the position of the first quotient figure is directly above the right-hand figure of the number first used, for both dividend and quotient are like units. (See observation above.)

II. The point in the quotient is directly above the point in the dividend.

III. Zeros may be annexed to the right of the decimal part of the dividend, or to the right of the decimal point if the dividend is a whole number.

The decimal point should be written for the quotient before the division is begun.

Divide:

- | | | |
|-------------------------|---------------------------|--------------------------|
| 8. $83.507 \div 113$. | 15. $84.3336 \div 7208$. | 22. $3.29832 \div 509$. |
| 9. $731.79 \div 173$. | 16. $769.986 \div 7938$. | 23. $7.31430 \div 315$. |
| 10. $5.7629 \div 143$. | 17. $72.5508 \div 8637$. | 24. $0.39346 \div 103$. |
| 11. $1778.7 \div 121$. | 18. $1701.00 \div 2700$. | 25. $0.19781 \div 131$. |
| 12. $19.740 \div 105$. | 19. $91285.8 \div 706$. | 26. $300.352 \div 608$. |
| 13. $288.41 \div 151$. | 20. $345.144 \div 394$. | 27. $1402.01 \div 893$. |
| 14. $14.688 \div 108$. | 21. $88.3666 \div 889$. | 28. $0.01728 \div 144$. |

Dividing a Decimal by a Decimal

1. Divide 4.797 by 2.46.

WORK

$$\begin{array}{r} 1.95 \\ 2.46 \overline{)4.79\underset{\wedge}{7}0} \\ \underline{2\ 46} \\ 2\ 337 \\ \underline{2\ 214} \\ 1230 \\ \underline{1230} \end{array}$$

Points to observe in dividing by a decimal :

I. Free the divisor of decimals by moving the point to the right of the right-hand figure.

II. Move the point in the dividend as many places to the right as it was moved in the divisor. Why is this necessary?

III. Place the point in the quotient above the new position of the point in the dividend.

Divide :

- | | | |
|------------------|---------------------|-----------------------|
| 2. 4.41 ÷ 0.42. | 8. 70.918 ÷ 0.059. | 14. 472.131 ÷ 6.27. |
| 3. 97.28 ÷ 3.2. | 9. 8.700 ÷ 0.087. | 15. 6.2222 ÷ 58.7. |
| 4. 752 ÷ 0.16. | 10. 20.976 ÷ 0.76. | 16. 1747.2 ÷ 0.312. |
| 5. 95.7 ÷ 2.9. | 11. 44.472 ÷ 1.02. | 17. 57.629 ÷ 0.0143. |
| 6. 25.11 ÷ 0.27. | 12. 0.7866 ÷ 85.5. | 18. 2898.75 ÷ 0.0125. |
| 7. 7.011 ÷ 5.7. | 13. 879.79 ÷ 0.907. | 19. 3.9346 ÷ 1.03. |

Approximate Quotients

1. Find the quotient of $3.45 \div 8.91$ correct to thousandths.

WORK

$$\begin{array}{r} 0.3872^+ \\ 8.91 \overline{)3.45\underset{\wedge}{0}000} \\ \underline{2\ 67\ 3} \\ 77\ 70 \\ \underline{71\ 28} \\ 6\ 420 \\ \underline{6\ 237} \\ 1830 \\ \underline{1782} \end{array}$$

EXPLANATION. — Since 2 ten thousandths is less than $\frac{1}{2}$ of one thousandth, the quotient 0.387 is correct to the nearest thousandth.

Had the answer been required to the nearest hundredth, it would have been 0.39, for 0.007 is more than $\frac{1}{2}$ of one hundredth. That is, if the next digit after the one required is less than 5, the required digit is unchanged. If it is equal to or greater than 5, the required digit is increased by 1.

Find quotients true to nearest thousandths :

- | | | |
|------------------------|------------------------|-------------------------|
| 2. $3.1416 \div 7.28.$ | 9. $160 \div 3.141.$ | 16. $0.615 \div 31.42.$ |
| 3. $0.86 \div 52.7.$ | 10. $7.68 \div 0.752.$ | 17. $7.421 \div 0.075.$ |
| 4. $64.3 \div 1.25.$ | 11. $39.1 \div 60.55.$ | 18. $93.08 \div 678.5.$ |
| 5. $174 \div 0.63.$ | 12. $5.85 \div 123.4.$ | 19. $1.818 \div 0.154.$ |
| 6. $2.69 \div 59.9.$ | 13. $610 \div 0.059.$ | 20. $72.83 \div 4.046.$ |
| 7. $0.88 \div 0.41.$ | 14. $0.47 \div 57.36.$ | 21. $1.806 \div 1728.$ |
| 8. $673 \div 8.04.$ | 15. $57.8 \div 0.914.$ | 22. $0.678 \div 3.667.$ |

Changing Fractions to Decimals

Since a fraction may also be considered an indicated division, a common fraction may be changed to a decimal by considering it a problem in division and dividing the numerator by the denominator according to the rules for division of decimals.

In case there is a remainder after the division is carried as far as required, it may be written as a common fraction, giving a *complex decimal*, or we may have an approximate quotient as in the above exercises, called an *incomplete decimal*. Thus, $\frac{3}{7} = 0.428\frac{4}{7}$ or 0.429, as required in the problem.

Change to complex decimals of three places :

- | | | | |
|--------------------|---------------------|----------------------|----------------------|
| 1. $\frac{7}{12}.$ | 5. $\frac{5}{9}.$ | 9. $\frac{46}{49}.$ | 13. $\frac{86}{53}.$ |
| 2. $\frac{9}{16}.$ | 6. $\frac{7}{30}.$ | 10. $\frac{83}{85}.$ | 14. $\frac{48}{35}.$ |
| 3. $\frac{4}{15}.$ | 7. $\frac{17}{16}.$ | 11. $\frac{19}{73}.$ | 15. $\frac{16}{91}.$ |
| 4. $\frac{3}{7}.$ | 8. $\frac{23}{18}.$ | 12. $\frac{43}{17}.$ | 16. $\frac{81}{93}.$ |

Change to incomplete decimals of three places :

- | | | | |
|----------------------|----------------------|----------------------|---------------------|
| 17. $\frac{11}{12}.$ | 19. $\frac{6}{11}.$ | 21. $\frac{7}{15}.$ | 23. $\frac{7}{18}.$ |
| 18. $\frac{5}{9}.$ | 20. $\frac{11}{60}.$ | 22. $\frac{1}{600}.$ | 24. $\frac{3}{13}.$ |

Problems Involving Decimals

1. If a gallon of milk weighs 8.6 lb., what will 100 gal. weigh?

2. If a cow gives 5164.8 lb. of milk a year, how many gallons does she give? (Allow 8.6 lb. to a gallon.)

3. A gallon of water weighs 7.5 lb. A gallon of milk is how many times as heavy as a gallon of water?

THIS TABLE SHOWS THE DIGESTIBLE NUTRIENTS IN 1 POUND

FEED	PROTEIN	CARBOHYDRATES	FAT	TOTAL
Corn	0.079 lb.	0.667 lb.	0.043 lb.	0.789 lb.
Oats	0.093 lb.	0.473 lb.	0.042 lb.	0.608 lb.
Cottonseed . .	0.372 lb.	0.169 lb.	0.122 lb.	0.663 lb.
Wheat bran . .	0.122 lb.	0.392 lb.	0.027 lb.	0.541 lb.

4-7. Find how much of each nutrient in a ton of each kind of feed.

8-11. Find the total amount of nutrient in a ton of each kind of feed.

12. How can you check your answers of Problems 8-11 from the results of Problems 4-7? Check them in this way.

13. When corn is \$21 per ton, find the cost of a pound of nutrients.

14. When wheat bran is selling at \$3.25 per 100 pounds, find the cost of a pound of nutrients.

15. Timothy hay has 47.6 lb. of digestible nutrients to every 100 lb., while alfalfa hay has 51.6 lb. When timothy is worth \$22 per ton, for how much should alfalfa sell?

16. Of every pound of beef loin 0.156 lb. is protein. A working man needs 0.24 lb. of protein daily. If he gets it wholly from beef, how much will he need daily?

17. A quart of oysters contains but 0.106 lb. of protein. If a man gets the protein needed entirely from oysters, how many quarts will he need daily?

18. Find how many times as expensive as beef at 20¢ per pound are oysters at 50¢ per quart. Carry the result to the third decimal place.

NUTRIENTS IN 1 POUND OF SOME COMMON FOODS

FOOD	PROTEIN	FAT	CARBOHYDRATES	REFUSE AND WATER
Beef	0.156 lb.	0.166 lb.	none	0.658 lb.
Pork	0.131 lb.	0.232 lb.	none	0.615 lb.
Fowl	0.138 lb.	0.317 lb.	none	0.630 lb.
Whole milk	0.032 lb.	0.038 lb.	0.051 lb.	0.870 lb.
Wheat bread	0.078 lb.	0.012 lb.	0.520 lb.	0.353 lb.
Dried beans	0.175 lb.	0.016 lb.	0.578 lb.	0.126 lb.
Raw eggs	0.127 lb.	0.088 lb.	none	0.767 lb.

19. If a man needs 1.12 lb. of carbohydrates daily, how many pounds of wheat bread would he need if he gets it wholly from bread? If he gets it wholly from beans?

20. Find how much of each of the articles in the table is required to yield as much protein as a quart (2 lb.) of milk.

21. When beef is selling at 22¢ per pound, find the cost of a pound of nutrients furnished by beef.

22. When beans are 5½¢ per pound, find the cost of a pound of nutrients furnished by beans.

23. A ton of field-cured corn fodder contains 127.6 lb. of nutrient, while a ton of clover hay contains 886.2 lb. When clover hay is worth \$18 per ton, how much is corn fodder worth?

II. DENOMINATE NUMBERS

2. DENOMINATE NUMBERS

Any number of the standard units of measure, such as 4 feet, 20 pounds, 8 gallons, is called a **denominate** number.

A denominate number expressed in terms of two or more units of measure is called a **compound denominate** number.

3. LINEAR MEASURE

The measures used in measuring length or distance are called linear measures.

1. For convenience, in measuring short and long distances, small and large units of length measure are employed. Name all of the units of length in common use.

2. These units bear definite relations to each other, expressed by the *table of linear measure*. If you do not know it already, learn thoroughly the following:

Table of Linear Measure

12 inches (in.) = 1 foot (ft.)
3 feet = 1 yard (yd.)
$5\frac{1}{2}$ yards = 1 rod (rd.)
320 rods = 1 mile (mi.)
5280 feet = 1 mile

- How many inches in a yard?
- How many feet in a rod? $5\frac{1}{2} \times 3 \text{ ft.} = \text{--- ft.}$
- How many yards in a mile? $320 \times 5\frac{1}{2} \text{ yd.} = \text{--- yd.}$
- Find, by measuring, the length and the width of the schoolroom, in feet. In yards.
- Is the room more or less than 3 rd. long?

8. Estimate the length of some object. Then measure it and see how nearly accurate your judgment is.

9. Estimate the length of a rod on the floor, and then measure the distance marked.

10. Estimate the distance of 10 rods out of doors, and then measure it.

11. What building is about a mile from your school?

12. How far do you live from school?

NOTE. — By measuring off a stout cord a rod long, or 50 ft. long, or any other desired length, a convenient means is secured for making long measurements out of doors. An expensive tape line is not necessary.

Pupils should make many estimates and measurements of short and long distances, as suggested in the preceding problems, to develop accuracy in judgment of distances.

Reduction in Linear Measure

Changing any number of units of one denomination to units of another denomination is called **reduction**. Changing a given unit to a smaller unit is called *reduction to a lower denomination*, as changing from feet to inches. Changing a given unit to a larger unit is called *reduction to a higher denomination*, as from feet to yards.

Exercises in Reduction to Lower Denominations

Reduce:

1. 6 ft. to inches; $8\frac{1}{2}$ ft. to inches; $10\frac{3}{4}$ ft. to inches.
2. 3 yd. to inches; 4 yd. to inches; $5\frac{1}{2}$ yd. to inches.
3. 2 rd. to yards; to feet.
4. 10 mi. to rods; to yards.
5. $8\frac{1}{2}$ mi. to feet.
6. State the method of reducing any number of units of one denomination to units of a smaller denomination.

7. Sweet peas are planted in a row 4 in. apart. How many seeds can be planted in a row 5 yd. 2 ft. 8 in. long?

SOLUTION: 5 yd. = 5×3 ft. = 15 ft.
 15 ft. + 2 ft. = 17 ft.
 17 ft. = 17×12 in. = 204 in.
 204 in. + 8 in. = 212 in.
 212 in. \div 4 in. = 53, no. of 4-in. spaces.
 Hence, 54 seeds, — for two seeds mark the first space, and there is one seed for each new space.

Reduce:

- | | |
|----------------------------|----------------------------|
| 8. 2 ft. 5. in. to inches. | 10. 1 mi. 248 ft. to feet. |
| 9. 2 yd. 2 ft. to feet. | 11. 2 mi. 18 rd. to rods. |

Exercises in Reduction to Higher Denominations

Reduce:

- 48 in. to feet ; 6 in. to feet.
- 27 ft. to yards ; 45 ft. to yards.
- 144 in. to yards ; 288 in. to yards.
- 33 ft. to rods ; 132 ft. to rods.
- 10,560 ft. to miles ; 23,760 ft. to miles.
- State the method of reducing a number of any denomination to a number of a higher denomination.
- A flower bed is 195 in. long. How many yards, feet, and inches is this?

SOLUTION: $195 \div 12 = 16$ with remainder 3.
 Hence 195 in. = 16 ft. 3 in.
 $16 \div 3 = 5$ with remainder 1.
 Hence 16 ft. = 5 yd. 1 ft.
 Hence 195 in. = 5 yd. 1 ft. 3 in.

Reduce:

- 182 in. to yards, feet, and inches.
- 64 ft. to rods, yards, and feet.

10. 1000 rd. to miles and rods.
11. Express 21 in. as feet, decimally to hundredths.
12. Express 20 ft. as yards, decimally to hundredths.
13. Express 12,000 ft. as miles, decimally to hundredths.

Applications of Linear Measure

1. A class of pupils wished to divide 20 yd. of ribbon into 48 equal parts for class colors. How many inches long must each piece be cut?

SOLUTION: $20 \text{ yd.} = 20 \times 36 \text{ in.} = 720 \text{ in.}$
 $\frac{1}{48}$ of 720 in. = 15 in.
Hence, each piece was 15 in. long.

2. How many badges, each containing 10 in., can be made from 15 yd. of ribbon?

3. How many books can be bound with 45 yd. of tape, if each book requires 9 in. of tape?

4. How many bolts, each 5 in. long, can be cut from a bar of iron 10 ft. long?

5. 60 ft. of a certain kind of wire weighs 1 lb. What is the weight of a mile of it?

6. Find the cost of constructing a ditch a half mile long at \$2.50 a rod.

7. How many feet of wire does a man need to build a fence 6 wires high around a lot 20 yd. wide and 28 yd. long?

8. A piece of land has a frontage of 80 rd. on a street. Into how many city lots with a frontage of 60 ft. each can it be divided?

9. A tight board fence 120 ft. long is to be made of 9-inch boards, nailed upright. How many boards will it require?

10. In a certain city one block is 440 ft. long. How many blocks are there to the mile?

11. In building a grape arbor 10 yd. 2 ft. long, a man set the posts 8 ft. apart. How many posts were needed for one row? (Draw a diagram.)

12. If three crosspieces were used between each pair of posts, how many were needed for one row of the arbor described in Problem 11?

13. How many posts 12 ft. apart are needed for an arbor 8 rd. long?

14. How many crosspieces will be needed if there are three between each pair of posts?

15. Geraniums are to be set 8 in. apart, in a row 6 yd. 2 ft. 8 in. long. The end plants are to be placed 4 in. from the ends. How many plants are required?

4. SQUARE MEASURE

1. Draw upon the blackboard a square foot. Draw lines dividing the square foot into square inches. How many square inches in the square foot?

2. Similarly, by drawing a figure, show how many square feet there are in a square yard.

3. Learn thoroughly the following:

Table of Square Measure

144 square inches (sq. in.) = 1 square foot (sq. ft.)
9 square feet = 1 square yard (sq. yd.)
$30\frac{1}{4}$ square yards = 1 square rod (sq. rd.)
160 square rods = 1 acre (A.)
640 acres = 1 square mile (sq. mi.)

4. How many square inches in a square yard?

5. How many square feet in a square rod?
6. A strip of ground 16 rods long and 10 rods wide contains an acre. Why?
7. Give other dimensions of a rectangular piece of ground that would contain an acre.
8. Measure off an acre of ground near the school, and mark the four corners of it.
9. How many square feet in an acre? $160 \times 30\frac{1}{4} \times 9$ sq. ft. = ——— sq. ft.

Reduction in Square Measure

1. How many square inches in 5 sq. ft.?
2. How many square feet in 8 sq. yd.?
3. How many square inches in 4 sq. yd.? $4 \times 9 \times 144$ sq. in. = ——— sq. in.
4. How many acres in 6 sq. mi.? In 20 sq. mi.? In 36 sq. mi.?
5. How many square rods in 10 sq. mi.?
6. Reduce 4 acres to square rods. To square feet.
7. Reduce 2 sq. yd. 7 sq. ft. 80 sq. in. to square inches.

SOLUTION: 2×9 sq. ft. = 18 sq. ft.
 18 sq. ft. + 7 sq. ft. = 25 sq. ft.
 25×144 sq. in. = 3600 sq. in.
 3600 sq. in. + 80 sq. in. = 3680 sq. in.

Reduce :

8. 5 sq. ft. 30 sq. in. to square inches.
9. 10 sq. yd. 6 sq. ft. to square feet.
10. 40 A. 80 sq. rd. to square rods.
11. 2 sq. mi. 420 A. to acres.
12. 121 sq. yd. to square rods.

13. Express 365 sq. in. as square feet, decimally to hundredths.

14. Express 860 sq. in. as square yards, decimally to hundredths.

15. Reduce 5160 sq. in. to square yards, square feet, and square inches.

SOLUTION: $5160 \div 144 = 35$ with remainder 120.

Hence, 5160 sq. in. = 35 sq. ft. 120 sq. in.

$35 \div 9 = 3$ with remainder 8.

Hence, 35 sq. ft. = 3 sq. yd. 8 sq. ft.

Hence, 5160 sq. in. = 3 sq. yd. 8 sq. ft. 120 sq. in.

Reduce:

16. 300 sq. in. to square feet and square inches.

17. 40 sq. ft. to square yards and square feet.

18. 425 sq. rd. to acres and square rods.

Applications of Square Measure

1. What is a rectangle? Name two kinds of rectangles.

2. Find the area, or number of square inches, in a rectangle 8 in. long and 4 in. wide.

SUGGESTION. — How many square inches in a rectangle 8 in. long and 1 in. wide?

A rectangle 4 times as wide will contain how many square inches? 4×8 sq. in. = — sq. in.

3. State the method of finding the area of a rectangle.

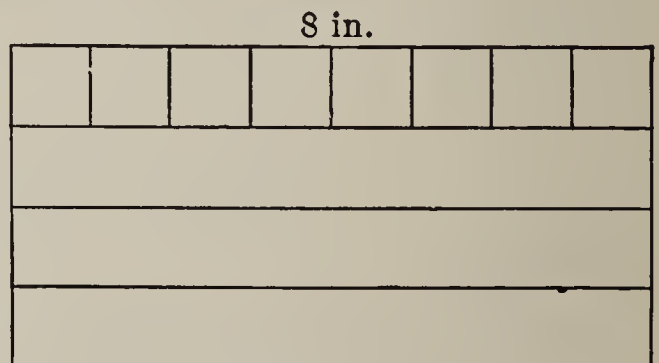

Scale $\frac{1}{4}$

4. If you have a garden 12 ft. wide and 16 ft. long, how many square feet does it contain? Is it as large as a garden 14 ft. square?

5. If your father wishes to build a cement road $5\frac{1}{2}$ ft. wide and 126 ft. long from the street to his garage, how much will it cost at \$1.35 a square yard?

6. James built a dock 36 ft. long and 4 ft. wide for a boat landing. Find the cost at 35¢ a square yard.

7. In making a tulip bed George estimated that he would need to buy 9 bulbs for each square foot. How many bulbs did he buy for a bed 2 yd. by 3 yd.?

8. Which would take more bulbs and how many, a bed 7 ft. by 9 ft. or one 8 ft. square? (Use 9 bulbs to the square foot.)

9. Sometimes city lots are sold by the square foot of area, and sometimes by the linear foot of frontage. If a lot has a frontage of 60 ft. and a depth of 175 ft., will it cost more at 18¢ a square foot or \$32 per linear foot across the front?

10. Compare the costs at 22¢ a square foot and \$35 a front foot for a lot 65 ft. front by 165 ft. in depth.

11. Glass is bought at wholesale by the box. A box contains 50 sq. ft. of glass. Find the number of panes of window glass 6 in. by 8 in. in a box.

12. If each pupil should have 16 sq. ft. of floor space, how many square yards of floor should there be in a room to accommodate 30 pupils?

13. A man has a lawn 50 ft. by 40 ft. How much will it cost him to have it sodded at 8¢ a square yard?

14. In front of a lot a cement sidewalk is constructed 5 ft. wide and 60 ft. long. How much will it cost at \$1.25 per square yard?

15. Find the cost per square yard of making a cement sidewalk in your town or a nearby town and find the cost of some walks that you can measure.

16. When the pressure of the wind is 0.06 lb. on a square inch, what is the total pressure against the side of a house 18 ft. high and 40 ft. long?

17. In a room 14 ft. by 17 ft., a rug 9 ft. by 12 ft. is placed centrally, and filling at 37¢ a square yard is used to cover the rest of the floor. What is the cost of the filling?

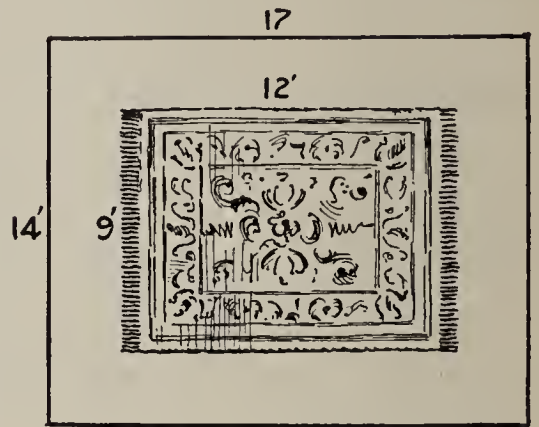

18. The diagram represents a farm 140 rd. square. How many acres in it?

19. How many acres of wheat?

20. How many acres of corn?

21. How many acres of oats?

22. How many acres of fruits?

23. The total forest area in the United States is approximately 677,735,000 acres. How many square miles is this?

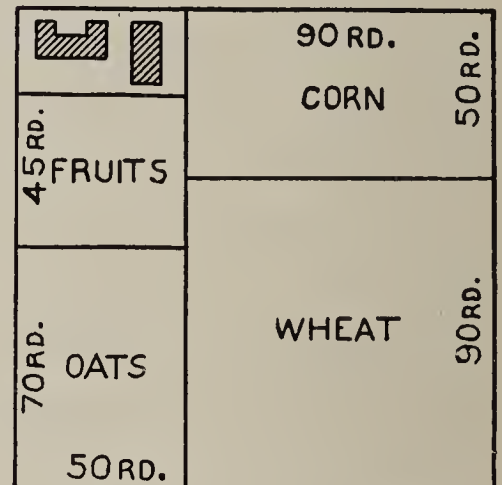

24. Where coffee is grown in South America, there are usually 5 coffee trees to every square rod. How many coffee trees are there to an acre?

25. The average yield of a coffee tree is 6 lb. per season. How many pounds will an acre produce? If this coffee brings 12¢ a pound at the plantation, what is the income from an acre?

26. A speculator bought a lot of land measuring 160 rd. by 40 rd. at \$2 a square rod, and sold it at 2¢ a square foot. Find his profit.

Division of Land

Most of the land in the Central and Western states has been surveyed and divided into **townships**, by a system of parallel lines running east and west and another system of parallel lines running north and south.

A township is 36 miles square.

Each township is subdivided into 36 equal squares, called **sections**. The sections are always numbered as in the figure.

The sections are divided into halves and quarters; the quarters into halves and quarters; etc.

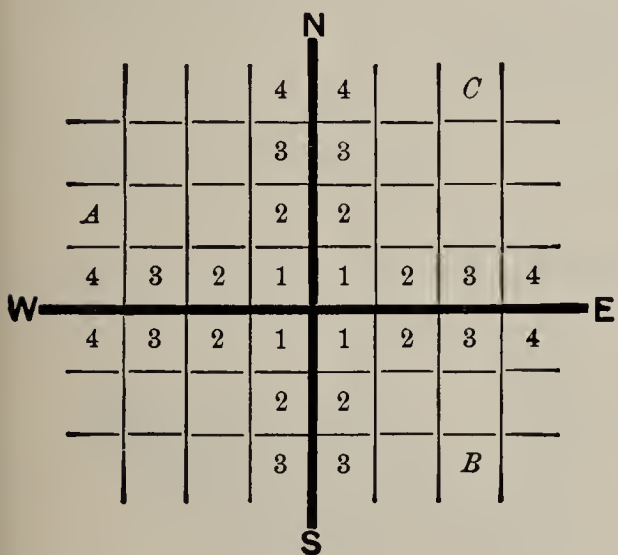

6	5	4	3	2	1
7	8	9	10	11	12
18	17	16	15	14	13
19	20	21	22	23	24
30	29	28	27	26	25
31	32	33	34	35	36

Township.

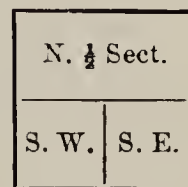

Section 15.

Exercises

1. How many square miles in a township?
2. How many square miles in a section?
3. How many acres in a section?
4. A man's farm is described as the southwest quarter of section 15. Locate his land on the figure. How many acres has he?
5. A farmer owns the north half of section 31. Locate it in the figure. How many acres has he?

6. A man owns all of section 23 and the northwest quarter of section 24. How many acres has he?

7. How much is the north half of the northeast quarter of section 6 worth at \$45 an acre?

8. A $\frac{1}{2}$ -mile square is what part of a section? How many acres does it contain?

9. A man owns 40 A. What part of a section does he own?

10. If his farm is square, how far is it along one side? How far around it?

5. CUBIC MEASURE

1. How many cubic inch blocks can be laid in one row 12 in. long?

2. How many of these rows can be placed upon one square foot of surface?

3. How many cubic inches in a layer of such blocks 1 ft. square?

4. How many such layers of blocks are required to make a cubic foot?

5. How many one-inch cubes are there in a cubic foot?

6. How many cubic blocks, each containing one cubic foot, can be laid in a layer 1 yd. square?

7. How many such layers are there in a cubic yard?

8. How many cubic feet in a cubic yard?

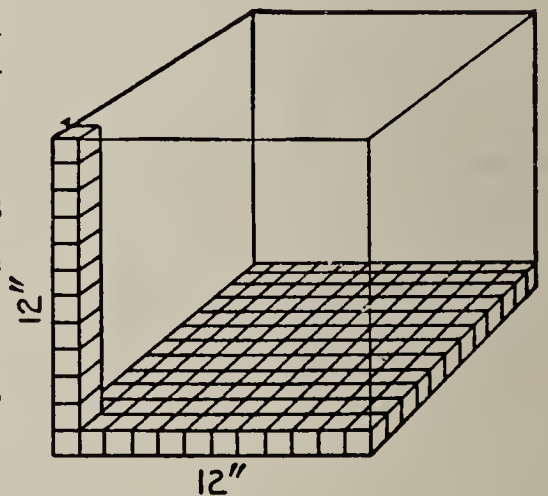

9. Learn thoroughly the following :

Table of Cubic Measure

1728 cubic inches (cu. in.) = 1 cubic foot (cu. ft.)
27 cubic feet = 1 cubic yard (cu. yd.)
128 cubic feet = 1 cord
$24\frac{3}{4}$ cubic feet = 1 perch
1 cubic yard = 1 load

NOTE. — The *cubic inch*, *cubic foot*, and *cubic yard* are the units of cubic measurement most frequently used in everyday life. The *cord* is used in measuring firewood; the *perch* in measuring stone; and the *load* in measuring earth removed for excavations, etc.

Exercises in Cubic Measure

Reduce :

1. 4 cu. ft. to cubic inches ; $12\frac{1}{2}$ cu. ft. to cubic inches.
2. 8 cu. yd. to cubic feet ; $3\frac{1}{3}$ cu. yd. to cubic feet.
3. 5 cords to cubic feet. 4. 24 perches to cubic feet.
5. 16 loads to cubic feet ; 40 loads to cubic feet.
6. 8.36 cu. yd. to cubic feet ; to cubic inches.
7. 5 cu. ft. 56 cu. in. to cubic inches.

SOLUTION: 5 cu. ft. = 5×1728 cu. in. = — cu. in.
 — cu. in. + 56 cu. in. = — cu. in.

8. 12 cu. ft. 256 cu. in. to cubic inches.
9. 7 cu. yd. 4 cu. ft. to cubic feet.
10. 1 cu. yd. 230 cu. in. to cubic inches.
11. 4 perches 16 cu. ft. to cubic feet.
12. 2 cords 94 cu. ft. to cubic feet.
13. 10,368 cu. in. to cubic feet.
14. 270 cu. ft. to cubic yards.
15. 896 cu. ft. to cords. 16. 297 cu. ft. to perches.

17. 7250 cu. in. to cubic feet, expressed decimally to hundredths.

18. 8 cu. ft. to cubic yards, expressed decimally to hundredths.

19. 103,470 cu. in. to higher denominations.

SOLUTION: $103,470 \div 1728 = 59$ with remainder 1518.

Hence, 103,470 cu. in. = 59 cu. ft. 1518 cu. in.

$59 \div 27 = 2$ with remainder 5.

Hence, 59 cu. ft. = 2 cu. yd. 5 cu. ft.

Hence, 103,470 cu. in. = 2 cu. yd. 5 cu. ft. 1518 cu. in.

20. 5680 cu. in. to cubic feet and cubic inches.

21. 1692 cu. ft. to cubic yards and cubic feet.

22. 4250 cu. in. to cubic feet, expressed decimally to hundredths.

23. 500 cu. ft. to cubic yards, expressed decimally to hundredths.

24. 124 cu. ft. to perches, expressed decimally to hundredths.

Applications of Cubic Measure

1. What name is given to a solid bounded by 6 rectangles? By 6 squares?

2. How many cubic inches in a rectangular solid 8 in. long, 4 in. wide, and 3 in. thick?

SUGGESTION.— On a rectangular surface 8 in. long and 1 in. wide a row of 8 inch-cubes may be laid; 4 such rows, or a layer, may be laid on a surface 4 in. wide; 3 of these layers will contain $3 \times$ — inch-cubes, or 96 inch-cubes or cubic inches.

3. Make a statement of the method of finding the contents or the volume of a rectangular solid.

4. What is the volume of a rectangular solid 4 in. high, 5 in. wide, and 6 in. long?

5. How many cubic inches in a brick 2 in. by 4 in. by 8 in.?
6. How many such bricks does it take to make a cubic foot?
7. What part of a cubic yard is a stone 1 ft. by 2 ft. by 3 ft.?
8. A cubic foot of granite weighs 165 lb. Find the weight of a granite monument containing $4\frac{1}{4}$ cu. yd.
9. What is the weight of a block of granite 5 ft. long, 2 ft. 6 in. wide, and 1 ft. 8 in. thick, if a cubic foot weighs 165 lb.?
10. A schoolroom 4 yd. high, 10 yd. wide, and 15 yd. long contains 60 pupils. How many cubic feet of air has each pupil?
11. Authorities agree that each pupil should be supplied with 75 cu. yd. of fresh air per hour. How many cubic feet per hour is this?
12. The loam in a box 4 in. by 8 in. by 9 in. is found to weigh 15 lb. Find the weight of a cubic foot of it.
13. Steel weighs 0.28 lb. per cubic inch. Find the weight of a steel beam 20 ft. long, 1 ft. wide, and $\frac{1}{4}$ ft. thick.
14. A gallon contains 231 cu. in. How many gallons in a cubic foot?
15. How many gallons does a tank 3 ft. deep, 4 ft. wide, and 6 ft. long hold?
16. Find the number of loads of earth removed in making an excavation 6 ft. deep, 15 ft. wide, and 40 ft. long. Find the cost at \$ 0.75 per load.
17. A trench 40 rd. long is dug 2 ft. deep and 18 in. wide. How many loads of earth are removed?

18. A man has a front lawn 40 ft. wide and 60 ft. long. He wishes to fill it to a depth of 4 in. with soil. How many loads of soil must he order? Find the cost at \$1 per load, a price paid at times in cities for putting soil on sandy places.

19. A school garden is 120 ft. by 80 ft. How many loads of earth will raise the whole surface 6 in.?

20. A street 1200 ft. long and 40 ft. wide is to be covered with crushed stone to a depth of 4 in. Find the cost of the stone at \$1.25 per cubic yard.

21. A cubic foot of water weighs 62.5 lb. Find the weight of water in a tank 90 in. long and 64 in. wide when the water is 52 in. deep.

22. Cast-iron weighs 450 lb. per cubic foot. Find the weight of a casting that contains 1260 cu. in.

23. I bought a square lot of land 300 ft. long. I laid out a 40-ft. street through the middle of it in each direction. What was the area of each of the four lots that remained?

24. If you cut a 6-in. square out of each corner of a square yard, what part of the latter remains?

25. What will a sheet of zinc 8 ft. long and 32 in. wide cost at $7\frac{1}{2}$ ¢ a pound, if every square foot weighs 8 oz.?

26. At 75 ¢ a yard, what will it cost to put a picket fence halfway around a corner lot measuring 72 ft. by 150 ft.?

6. MEASUREMENT OF WOOD

1. What is a cord of wood?

2. How long a pile of wood, cut 4 ft. long and piled compactly 4 ft. high, does it take to make a cord?



3. Firewood usually is cut in 4-foot lengths. How many cords of firewood in a rick 4 ft. high and 24 ft. long?
4. How many cords of 4-ft. wood in a rick 12 ft. high and 16 ft. long?
5. How many cords of 4-ft. wood in a rick 6 ft. high and 32 ft. long?
6. How much will a pile of wood 10 ft. by 6 ft. by 8 ft. cost at \$8 a cord?
7. 4-ft. wood is usually cut into 16 in. lengths for use in stoves. This is called *stove wood*. How many stove lengths can be cut from a stick of wood 4 ft. long?
8. A rick of stove wood 8 ft. long and 4 ft. high is called a *cord* of stove wood. How many cords of stove wood can be cut from a cord of 4-ft. wood?
9. How many cords of stove wood in a rick 16 ft. long, 8 ft. wide, and 6 ft. high?
10. A dealer buys 4-ft. wood at \$6 a cord, and has it sawed into stove wood. He then sells the stove wood at \$2.75 a cord. How much profit does he make on a cord of 4-ft. wood?

7. MEASUREMENT OF LUMBER

The unit of measure for boards, planks, joists, timber, etc., is generally the **board foot**.

A *board foot* is 1 ft. long, 1 ft. wide, and 1 inch thick.

In studying Section 4 we have learned to find the number of square feet in one face of a board. This number will also represent the number of board feet in a board 1 in. thick.

NOTE.—Lumber less than 1 in. thick is counted as if it were an inch thick. If the lumber is more than an inch thick, the thickness is taken into account.

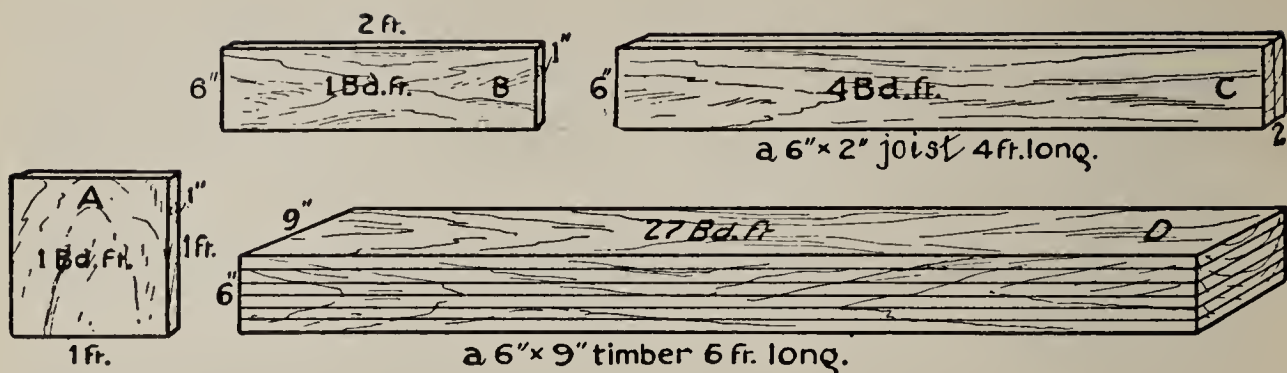

1. Compare the dimensions and contents of A and B in the illustration.

2. Find the area of the face of C. The number of board feet in C.

SUGGESTION. — $\frac{6}{12} \times 4 = \text{---}$; $2 \times \text{---} = \text{---}$.

3. How many 1-inch boards are equal to D? Show that D contains 27 board feet.

4. Make a statement of the method of finding the contents of a plank in board feet.

NOTE. — Without much regard to correctness of language, a lumberman would answer the last question by saying, "Multiply width and thickness in inches and length in feet together, and divide the result by 12." Show where the language here is not correct. He would also speak of a board foot simply as a "foot."

5. How many board feet make a cubic foot?

6. How many board feet in a board 1 ft. wide, 10 ft. long, and 1 in. thick?

7. How many board feet in a board 2 ft. wide, 8 ft. long, and 1 in. thick?

8. Find the number of board feet in a board 4 in. wide, 16 ft. long, and 1 in. thick.

9. Find the number of board feet in a board 2 in. thick, 1 ft. wide, and 14 ft. long. It is equivalent to how many boards 1 in. thick, of this width and length?

Find the contents in board feet of:

10. A board 12 in. wide, 8 ft. long, and 2 in. thick.
11. A board 8 in. wide, 6 ft. long, and 3 in. thick.
12. A board $\frac{1}{2}$ in. thick, 6 in. wide, and 10 ft. long.
13. A board $2\frac{1}{2}$ in. thick, 8 in. wide, and 12 ft. long.
14. A joist 15 ft. long, 4 in. wide, and 3 in. thick. (A $3'' \times 4''$ joist.)
15. A joist 20 ft. long, 5 in. wide, and 4 in. thick.
16. A joist 18 ft. long and 5 in. square.
17. A man measured a stack of lumber and found that it contained 1000 boards, each 1 in. thick, 6 in. wide, and 16 ft. long. How many board feet in the stack?

18. A boy undertook to make a mission table for a Christmas present to his mother.

The top was 3 ft. by $2\frac{1}{2}$ ft., and $1\frac{1}{2}$ in. thick. The legs were 27 in. long and 3 in. square. The four pieces mortised into the legs, to which the top was fastened, were each 1 in. thick

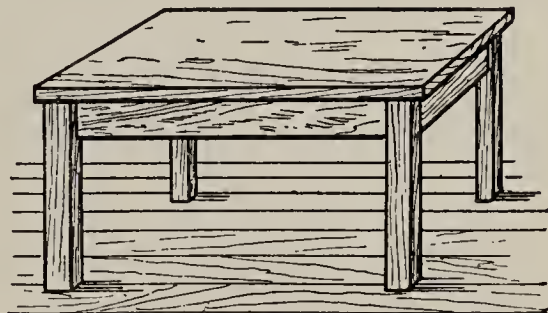

and 5 in. wide, two of them 28 in. long and two 22 in. long. How many feet of lumber did it take in all? How much did it cost him at 12¢ per board foot?

19. Find the cost of 2500 board feet of flooring at \$35 per thousand board feet.

NOTE. — Lumber is sold in quantities for so much per thousand (M) board feet.

Find how much must be paid for:

20. 3000 ft. of spruce at \$16 per M.
21. $2\frac{1}{2}$ M white pine at \$17.

22. 4500 ft. of hard pine at \$42 per M.

23. 800 ft. walnut at \$80 per M.

24. 750 ft. whitewood at \$38 per M.

25. 1600 ft. cherry at \$80 per M.

26. The diagram represents a barn. What is the area of the rectangular part of the end?

27. What is the area of the gable, or triangular part?

28. How many feet of 1-inch lumber will it take to cover the end? How much will it cost at \$20 per M?

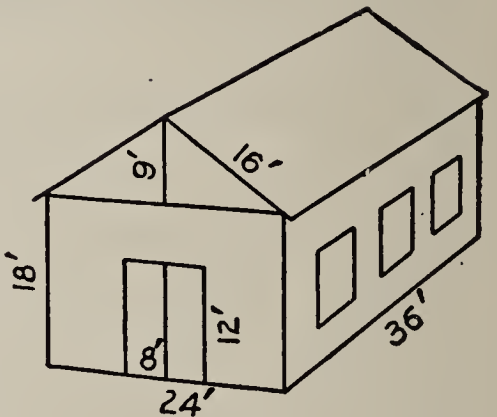

29. If the barn is 36 ft. long, what is the area of each side? Of both sides?

30. How many feet of 1-in. lumber will it take to side the barn? How much will it cost at \$20 per M?

31. For upright posts in the barn 16 joists are required, each 18 ft. long and 6 in. square. How much will they cost at \$25 per M?

32. Also 40 other joists, 14 ft. long, 3 in. thick, and 4 in. wide, are required. How much will they cost at \$25 per M?

33. 36 rafters, each 2 in. by 6 in. by 16 ft., are required. Find their cost at \$25 per M.

34. A driveway in the barn 12 ft. wide and 24 ft. long is floored with boards 2 in. thick. Find their cost at \$30 per M.

35. Find the cost of a board walk 4 ft. wide and 25 ft. long. The cross boards are nailed to three 3" \times 4" stringers and are 2" thick. The lumber costs \$28 per M.

8. LIQUID MEASURE

NOTE.—The school should have a set of liquid measures. These should be actually used by the pupils until the knowledge of their sizes and relations becomes a matter of experience.

1. Get a vessel of water, and by filling a gill measure and emptying the contents into a pint measure, see how many gills it takes to make a pint.

2. Find, in the same way, how many pints in a quart, and how many quarts in a gallon.

3. Learn thoroughly the following :

Table of Liquid Measure

4 gills (gi.) = 1 pint (pt.)
2 pints = 1 quart (qt.)
4 quarts = 1 gallon (gal.)
$31\frac{1}{2}$ gallons = 1 barrel (bbl.)
1 gallon = 231 cubic inches

4. How many gills in a quart? In a gallon?

5. How many pints in a gallon?

6. How many cubic inches in a quart? In a pint?

7. Estimate the number of gallons of water in some vessel. Then measure it with a gallon measure, and see how nearly accurate your judgment is.

8. Practice estimating in this way the quantity of liquids in vessels until you can estimate accurately at sight any given quantity of liquid.

Exercises in Liquid Measure

1. How many quart bottles can be filled from a 5-gallon can of milk?

Reduce:

2. $3\frac{1}{2}$ gal. to quarts; to pints.
3. $5\frac{1}{2}$ qt. to pints; to gills.
4. 6 gal. 3 qt. to quarts.
5. 2 qt. 1 pt. to pints.
6. 126 gal. to barrels; 1200 gal. to barrels.
7. 21 pt. to quarts and pints.
8. 35 qt. to gallons and quarts.
9. 18 gal. to barrels, expressed decimally to hundredths.

Applications of Liquid Measure

1. In cooking, a measure called a *cup* is sometimes used. It is equal to $\frac{1}{2}$ pt. How many cups in a pint? How many gills in a cup?
2. Milk is shipped in 10-gal. cans from farms to dairy stations in cities. There it is bottled by bottling machines and distributed to customers. How many quarts in one can?
3. How many pint bottles would one 10-gal. can fill?
4. The milk is hauled from the railroad station to the dairy in loads of 24 cans each. How many gallons in one load? How many quart bottles does one load fill?
5. This milk retails at 8¢ a quart. How much do the consumers pay for one 10-gal. can of milk?
6. If a family uses 2 qt of milk, how many families would one 10-gal. can supply?
7. When milk is bottled, it is placed in crates. There are 12 quart bottles to a crate. If the milkman has 9 crates, how many gallons has he? Find the cost at 18¢ a gallon.
8. If a retail wagon carries 8 crates of quart bottles and 12 crates of pint bottles, what is the retail value at 4¢ a pint? (Allow 12 bottles to a crate.)

9. A grocer pays 20¢ a gallon for milk, and retails it at 8¢ a quart. How much is his profit on a gallon? If he handles 30 gallons a day, how much is his profit?

10. How many $\frac{1}{2}$ -pt. bottles of mineral water can be filled from a tank holding 650 gallons?

11. A ship with 1200 persons aboard carries a supply of 12,000 gal. of fresh water. If a person, on the average, uses 2 qt. of water a day, how many days will the supply last?

12. A tank of a gasoline stove holds 2 qt. 1 pt. of gasoline. How many times can it be filled from a 5-gal. can of gasoline?

13. How many ink bottles, each holding $\frac{1}{2}$ gi., can be filled with 1 gal. of the fluid?

14. Some children made 3 gal. of lemonade. They sold it in glasses holding $\frac{2}{3}$ pt. each. How many glasses were there? How much did they receive from the sale of it at 5¢ a glass?

15. A dealer bought maple syrup in large quantities at 90¢ a gallon and sold it in quart bottles at 45¢ a quart. If the bottles cost 3¢ each, find the profit on 200 gal.

16. Find the profit on 750 gal.

17. A woman made 15 glasses of crab-apple jelly and 15 glasses of grape jelly. Each glass held $\frac{1}{2}$ pt. How many pints of jelly did she make? Quarts? Gallons?

9. DRY MEASURE

NOTE. — The school should have a set of dry measures, to be used by the pupils as suggested under liquid measure.

1. For what is dry measure used?

2. By filling a pint measure with beans, or other material easily obtained, and emptying the contents into a quart measure, show how many pints, dry measure, make a quart.

3. In a similar manner, show the number of quarts in a peck, and the number of pecks in a bushel.
4. Learn thoroughly the following :

Table of Dry Measure

<p style="text-align: center;">2 pints (pt.) = 1 quart (qt.) 8 quarts = 1 peck (pk.) 4 pecks = 1 bushel (bu.)</p>

NOTE.—The dry quart is larger than the liquid quart. The dry quart contains 67.2 cu. in., while the liquid quart contains only 57.75 cu. in.

Exercises in Dry Measure

Reduce :

1. 3 bu. to pecks; to quarts. 12 bu. to pecks; to quarts.
2. 5 pk. to quarts; to pints. $7\frac{1}{2}$ pk. to quarts; to pints.
3. 16 qt. to pecks; 41 qt. to pecks.
4. 21 pt. to quarts and pints. 5. 336 cu. in. to quarts.
6. 63,008 cu. in. to bushels.

Applications of Dry Measure

1. How many quart boxes will 2 bu. 3 pk. 1 qt. fill?
2. What is the cost of 2 pk. 3 qt. of nuts at 15¢ a quart?
3. If a half-peck basket of peaches sells for 25¢, how much is that per bushel?
4. A grocer buys onions at 80¢ a bushel. He then retails them at 5¢ a quart measure. How much profit does he make on a bushel?
5. A fruit dealer buys peaches at wholesale for \$2.25 a bushel. He then puts them in baskets holding 2 qt. each,

and sells them at 25¢ a basket, keeping the basket. How much is his profit on a bushel? If the baskets cost him 1¢ apiece, and he lets them go with the fruit, how much is his profit per bushel?

6. A fruit dealer buys pears at wholesale for \$2 a barrel. The barrel contains $2\frac{1}{2}$ bu. He puts them in half-peck baskets costing him 2¢ each, and retails them at 20¢ a basket. How much does he make on a bushel?

7. A gardener sold on one day 2 qt. of green beans to each of 22 customers, and 3 qt. to each of 18 customers. How many quarts did he sell in all? How many bushels?

8. The gardener received 10¢ a quart for the beans. How much was that per bushel? How much did he receive from the day's sales?

9. He sold also 2 bu. 3 pk. 2 qt. of sweet potatoes at 16¢ a quart. How much did he get for them?

10. A gardener sows peas in rows 90 ft. long, using 1 pt. of seed to 100 ft. How many quarts of seed does he need for 20 rows? How much does it cost him at 25¢ a quart?

11. A grocer bought 20 bu. of potatoes at 55¢ a bushel, plus cartage. The cartage was \$2. 1 bu. 2 pk. spoiled. He sold the rest at 30¢ a peck. How much was his profit on the lot?

12. Four people went on a trip and brought back a bushel and a half of crab apples, which they divided equally among them. How many quarts did each have?

13. A vegetable peddler started out with 3 bu. of beans. He sold a peck to one customer, a half peck to another, 3 qt. to another, and 2 qt. to another. How many had he left?

10. WEIGHT MEASURES

The system of weights used in ordinary measurements is called the system of *Avoirdupois weight*.

Table of Avoirdupois Weight Measure

16 ounces (oz.) = 1 pound (lb.)
100 pounds = 1 hundredweight (cwt.)
2000 pounds = 1 ton (T.)

A ton of 2000 pounds is sometimes called a *short ton*, in distinction from a ton of 2240 lb., called a *long ton*, which is used in measuring some mining products in wholesale transactions.

NOTE.—In addition to the above table of weights, there are other tables of weights used by people engaged in certain technical pursuits.

Goldsmiths, in weighing the precious metals and stones, use the system of *Troy weight*:

24 grains (gr.)	= 1 pennyweight (pwt.)
20 pennyweights	= 1 ounce (oz.)
12 ounces	= 1 pound (lb.)

Physicians and druggists, in prescriptions, use the system of *Apothecaries' weight*:

20 grains (gr.)	= 1 scruple (♃)
3 scruples	= 1 dram (℥)
8 drams	= 1 ounce (℥)
12 ounces	= 1 pound (lb.)

The pound of Troy and Apothecaries' weight is less than the pound Avoirdupois.

The learning of these two tables is part of a technical education.

Exercises in Weight Measure

Reduce:

1. $3\frac{1}{2}$ T. to pounds; $8\frac{1}{4}$ T. to pounds; 1.75 T. to pounds.
2. 1 T. to hundredweight; 7 T. to hundredweight; $2\frac{1}{2}$ T. to hundredweight.

3. 48 oz. to pounds ; 144 oz. to pounds ; 320 oz. to pounds.
4. 6000 lb. to tons ; 18,000 lb. to tons ; 3550 lb. to tons.
5. How many pounds in 4480 long tons ?
6. How many short tons in 100 long tons ?
7. How many long tons in 56 short tons ?

Applications of Weight Measure

1. A family pays 30¢ for 100 lb. of ice. How much is that per 1000 lb. ? How much per ton ?
2. An ice company stores 300 tons of ice from a pond in winter. How many families would this supply, if each family used, on the average, 1500 lb. a season ?
3. A refrigerator in a meat market holds 4 tons of ice. When 2860 lb. have been put in, how many more pounds are required to fill it ?
4. A market man has 7850 lb. of ice put into his refrigerator at one time. How much does it cost at \$3.90 a ton ?
5. A market man has his refrigerator filled with ice once a week. If 6500 lb. are put in each time, on the average, how many tons will be used in a year (52 weeks) ? How much will the ice cost for a year at \$4 a ton ?
6. A man living near a lake cut 150 cakes of ice averaging 80 lb. each. The total cost was \$4.80. How much a ton did his ice cost him ?
7. Allowing 4 lb. to the cubic foot, how many tons of hay in a mow 32 ft. long, 18 ft. wide, and 14 ft. deep ?
8. Find the cost of 27,000 lb. of timothy hay at \$18 a ton.
9. A farmer sold his hogs at \$7.50 per hundredweight. They weighed 8600 lb. What did he get for them ?

United States Postal Rates

Domestic mail matter is classified as first, second, third, and fourth class. The postage differs for the different classes of mail matter. The postal rates to foreign countries are in general different from the domestic rates.

1. The postage on first-class domestic mail matter is 2¢ an ounce. How much is the postage per pound?

2. Find the postage on each of the following first-class pieces of mail: a package weighing $2\frac{1}{2}$ lb.; one weighing $1\frac{3}{4}$ lb.; one weighing 1 lb. 8 oz.; one weighing 2 lb. 6 oz.

3. All classes of mail matter may be registered for safety at a cost of 10¢ in addition to the regular postage. How much is the postage on a first-class registered package weighing 1 lb. 3 oz.?

4. I received a package of first-class matter through the mail that had 52¢ postage on it. How many ounces did it weigh? How many pounds and ounces?

5. The rate of postage on second-class matter, when sent by the publisher, or by a news agency to regular subscribers, or to another news agency, is 1¢ a pound or fraction thereof. How much is the postage on a piece of second-class matter weighing 2 lb. 5 oz.?

6. If second-class matter is sent by persons other than the publishers or news agencies, the rate is 1¢ for each 4 oz. or fraction thereof. What is the rate per pound?

7. If you mail a bundle of newspapers (second class) weighing 2 lb. 8 oz., how much is the postage?

8. The rate of postage on third-class mail matter (books, photographs, etc.) is 1¢ for each 2 oz. or fraction thereof. How much is the postage on a package of third-class matter weighing 3 lb.? One weighing $2\frac{1}{4}$ lb.?

Problems in Buying and Selling Coal

Coal is found in commercial quantities in 27 states and territories of the United States and in Alaska.

1. The total land surface of the states and territories, including Alaska, is 3,547,746 sq. mi. How many acres?

2. Of this, 280,397 sq. mi. are coal fields. How many acres?

3. Illinois has the largest area of coal fields of all the states. There are 42,900 sq. mi. of coal fields in the state. What decimal part of the coal-field area of the United States is this?

4. In a recent year the output from the coal mines of Illinois was 41,480,104 short tons. How many carloads would this make, allowing 40,000 lb. to the load?

5. If a man can mine an average of 4 tons 500 lb. a day, how many miners, working 300 days of the year, would it require to mine a year's output in Illinois? (See Ex. 4.)

6. Coal dealers buy coal by the short ton from the mines. It is shipped to coal yards in the cities, and then retailed to the consumers. A dealer received one day a car containing 48,000 lb. of coal, one containing 42,800 lb., one containing 46,600 lb., and one containing 39,900 lb. How much did it cost him at \$2.75 a ton?

7. A man ordered 10 T. of coal from a coal dealer. It was delivered in loads as follows: 1 T. 850 lb., 1 T. 950 lb., 1 T. 1700 lb., 2 T. 100 lb., 1 T. 900 lb., 1 T. 1500 lb. Did he receive 10 T.?

8. A coal company delivered to a customer one load of coal of 2150 lb., one of 1950 lb., one of 2200 lb., and one of 2350 lb. How much was the bill at \$6.50 a ton?

The Products of a Farm

A farmer raises wheat, corn, oats, and hay, which he hauls to market and sells each year. He also raises hogs and cattle, which he ships to the city market.

1. He hauls his wheat, when threshed, and stores it in a large building called an *elevator*, which is situated by a railroad track. From the elevator it is reshipped later. The capacity of a certain elevator is 2,400,000 bu. Wheat weighs 60 lb. to the bushel. Find the capacity of the elevator in tons:

2. How many carloads, of 60,000 lb. each, does the elevator hold?

3. In one day the man delivers four loads of wheat at the elevator, weighing as follows: 2400 lb., 2700 lb., 2550 lb., and 2350 lb. How many bushels is this?

4. He hauls in all 90,000 lb. of wheat to the elevator. How many bushels?

5. He raises also 1000 bu. of oats. Of this he sells 12 loads of 1 T. each. One bushel of oats weighs 32 lb. How much does he get for the oats at 40¢ a bushel? How many bushels does he have left?

6. He sells 44,890 lb. of timothy hay at \$20 per ton, and 46,880 lb. of clover hay at \$16 per ton. How much does he get for the hay?

7. He sells 40 head of cattle, the total weight of which is 36,500 lb., at \$8.40 per hundredweight. How much does he receive for them?

8. He sells hogs, the total weight of which is 19,240 lb., at \$9.75 per hundredweight. How much does he receive for them?

11. MEASUREMENT OF TIME

Table of Time Measure

60 seconds (sec.) = 1 minute (min.)	12 months or } = 1 year (yr.) common 365 days } 366 days = 1 leap year 100 years = 1 century “Thirty days have September, April, June, and November.”
60 minutes = 1 hour (hr.)	
24 hours = 1 day (da.)	
7 days = 1 week (wk.)	
30 (31, 28, 29) days = 1 month (mo.)	

All the other months have 31 days except February, which has 28.

A true or solar year does not have exactly 365 days, but 365 da. 5 hr. 48 min. 49.7 sec., or nearly $365\frac{1}{4}$ da. Since 365 da. is not exact, in every fourth year, except the century years that are not divisible by 400, one day is added, making 366 da. or a **leap year**. The extra day in leap years is added to the month of February, making it 29 days long.

Two weeks are called a **fortnight**, 3 months or 13 weeks a **quarter**, and 10 years a **decade**.

Problems in the Measurement of Time

1. How many decades have passed since July 4, 1776?
2. Except century years not divisible by 400, years divisible by 4 are leap years. Which of the following were leap years: 1728, 1776, 1812, 1860, 1886, 1900, 1908?
3. Find the time from March 16, 1895, to July 5, 1910.

SOLUTION: Count by years as far as possible, then by calendar months, then by days.

From March 16, 1895, to March 16, 1910, is 15 yr.

From March 16, 1910, to June 16, 1910, is 3 mo.

From June 16 to July 5 is 19 da.

Hence the time is 15 yr. 3 mo. 19 da.

Find the time from :

4. April 12, 1904, to July 28, 1910.
5. August 10, 1890, to June 18, 1902.
6. February 6, 1897, to January 10, 1900.
7. January 1, 1903, to December 21, 1909.
8. October 8, 1907, to May 3, 1910.
9. Find your exact age to-day in years, months, and days.
10. Abraham Lincoln was born February 12, 1809. How many years, months, and days ago to-day was that?
11. Pennsylvania train, No. 18, which leaves Pittsburg at 4.50 P.M. (50 minutes after 4 in the afternoon), reaches Washington, D.C., at 8.40 A.M. the next day. How many hours and minutes are required for the trip?
12. Michigan Central train, No. 8, which leaves Detroit at 3.45 P.M., reaches New York at 9.03 A.M. next day. How many hours and minutes is that?
13. A train leaving Cincinnati at 9.30 P.M. arrives at Cleveland at 6.45 A.M. next day. The distance is 263 miles. How many miles an hour does the train run, on the average?

12. ANGLE AND ARC MEASURE

1. Draw two straight lines from the same point. These lines form an **angle**. The lines are its **sides**, and the point its **vertex**.

2. What is a right angle? Draw a right angle.

3. If a right angle is divided into 90 equal parts, each part is called a **degree**. Hence a right angle contains 90 degrees (90°). How many degrees in $\frac{1}{2}$ of a right angle? In $\frac{1}{6}$ of a right angle? In 4 right angles?

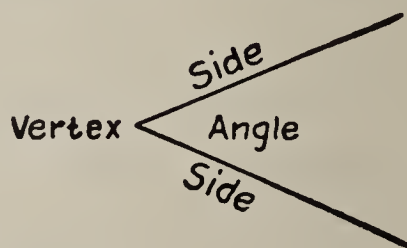

4. Draw two lines crossing each other at right angles. How many right angles do they form? How many degrees in all of the angles?

5. If these angles were divided into any number of smaller angles, how many degrees would there be in all of the angles together? How many degrees in all of the angles around a point?

6. The number of degrees in an angle is found by means of a **protractor**, shown in the figure.

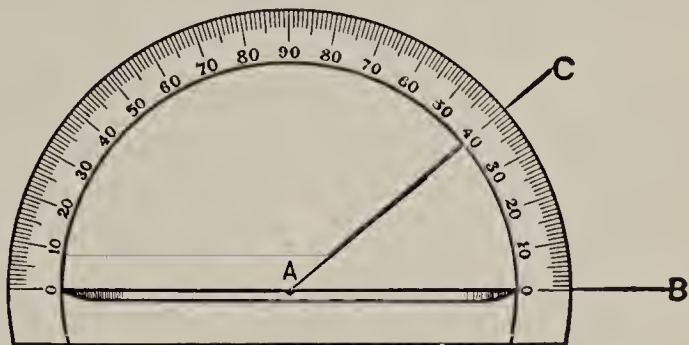

7. For accurate measurements in surveying, astronomy, etc., where angles are used, a degree is divided into 60 smaller units of measure, called minutes, and a minute into 60 smaller units, called seconds.

Table of Angle Measure

60 seconds (60'') = 1 minute (1')
60 minutes = 1 degree (1°)
90 degrees = 1 right angle

8. Draw a circle. Any part of the circumference is called an **arc**. Draw a right angle with its vertex at the center of the circle. The arc of the circumference cut off by the sides of the angle is called a **quadrant**. If the lines were drawn dividing the right angle into degrees, they would also divide the quadrant into how many equal parts? Each of these is called



a degree of arc. How many degrees of arc in a quadrant? How many in the whole circumference?

9. A degree of arc, as well as a degree of angle, is divided into minutes and seconds.

Table of Arc Measure

60 seconds ($60''$) = 1 minute ($1'$)
60 minutes = 1 degree (1°)
90 degrees = 1 quadrant
360 degrees = 1 circumference

NOTE.—It is evident that if the two radii are drawn joining the ends of an arc to the center of the circle, there will be just as many degrees, minutes, and seconds of angle in the angle formed as there are degrees, minutes, and seconds of arc in the arc.

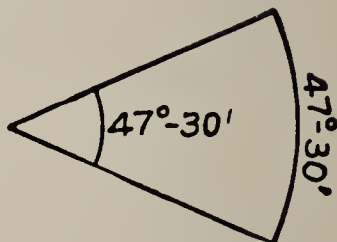

Problems in Angle and Arc Measurement

1. How many degrees in $\frac{1}{2}$ of a circumference? In $\frac{1}{6}$ of a circumference?
2. Reduce $42,895''$ to degrees, minutes, and seconds.
3. How many degrees between the hands of a clock at 1 o'clock? At 2 o'clock? At 4 o'clock? At 6 o'clock?
4. When a star is straight overhead, how many degrees is it from the western horizon?
5. What does it mean to say that two stars are 20° apart?
6. If a star is 25° from zenith (from straight overhead), how far is it above horizon?
7. A *sextant*, an instrument used for measuring angular distances, and especially by sailors for measuring the latitude and longitude of a ship at sea, has an arm bearing a scale in

degrees that is $\frac{1}{6}$ of a circumference long. How many degrees does it contain? (An illustration may be found in the dictionary.)

8. The angle of elevation of the sun above the horizon may be found by use of a simple instrument like the figure, called a *quadrant*, that the pupil can easily make out of cardboard, a pin, a string, and a weight. Cut out $\frac{1}{4}$ of a circle from cardboard, using a radius of about 8 in. Mark the arc in degrees. From a pin put through the cardboard at the center *A*, suspend a plumb line made of string and a small weight. To find the elevation of the sun, hold the instrument upright so that the plumb line is over the 90° mark. Note the point *C* when the shadow of the pin *A* made by the sun falls on the scale. The number of degrees from *O* to *C* is the elevation of the sun.

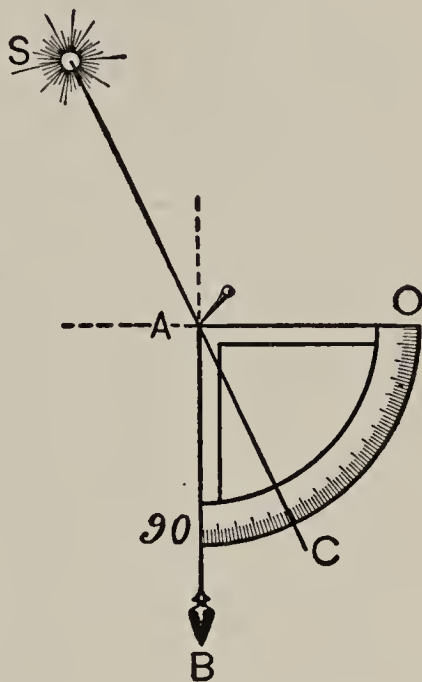

How may the same instrument be used to find the elevation of stars, by pointing the edge of *AB* towards the star?

NOTE. — The making of this quadrant has been found to be an interesting and valuable piece of hand work.

13. MEASUREMENT OF PAPER

Paper is bought and sold by the *sheet*, *quire*, and *ream*.

Table of Paper Measure

24 sheets = 1 quire
20 quires = 1 ream

NOTE. — The quire has practically gone out of use now, except in selling letter paper in boxes. When paper is bought of a wholesale house, it is usually put up in reams containing 500 sheets. Any quantity less than a ream is computed by sheets.

1. How many sheets in $\frac{1}{2}$ quire? In 2 quires? In 5 quires?
2. How many quires in $\frac{1}{2}$ ream? In 5 reams? In 10 reams?
3. How many quires in 48 sheets? In 96 sheets?
4. A man bought a box of letter paper containing 2 quires for 48¢. How much was that a sheet?
5. I paid 36¢ for a box of paper containing 1 quire. How much was that per sheet?
6. Which is cheaper, to buy a ream of 500 sheets at a wholesale house for \$2, or to buy 20 quires put up in boxes at 10¢ a quire? Why?
7. A man bought blotting paper at 72¢ a quire, and sold it at 5¢ a sheet. How much was his profit?
8. Letter paper is generally bought of a wholesale house by a printer in sheets 17 in. by 22 in. How many letter heads $8\frac{1}{2}$ in. by 11 in. can be cut from one sheet? Explain how. How many letter heads of this size will a ream of 500 sheets make?
9. A man wants 8000 letter heads $8\frac{1}{2}$ in. by 11 in. How many reams (500 sheets) of paper $17'' \times 22''$ must the printer order from the wholesale house for them?
10. A dealer bought 24,000 sheets of linen paper $17'' \times 22''$ at \$5 per 1000. He cut it into sheets $8\frac{1}{2}$ in. by 11 in., which he sold at 25¢ for 100. How much did he get for it? How much did he make?
11. A stationer buys 500 sheets of blotting paper $19'' \times 24''$. He cuts it into blotters $4'' \times 9''$. How many blotters will he have? What per cent of each sheet is wasted?
12. If he bought at 3¢ a sheet and sold at 5¢ a dozen blotters, how much did he gain?

14. UNITS IN COUNTING

Table

12 things = 1 dozen	12 gross = 1 great gross
12 dozen = 1 gross	20 things = 1 score

- How many things in a gross? In a great gross?
- What does it mean to say that one lived to the age of threescore and ten?
- How many pencils in 2 gross?
- How many gross in 1000 pencils?
- Find the cost of 1200 dozen penholders at \$2.50 a gross.

15. ADDITION, SUBTRACTION, MULTIPLICATION, AND
DIVISION OF COMPOUND NUMBERS

The principles and methods of simple numbers apply equally to the fundamental processes in compound numbers.

Problems in Addition

- The lengths of the blackboards in a schoolroom are 4 yd. 1 ft. 8 in., 3 yd. 9 in., and 2 yd. 2 ft. 5 in., respectively. Find the total length of the three boards.

WORK

$$\begin{array}{r}
 4 \text{ yd. } 1 \text{ ft. } 8 \text{ in.} \\
 3 \quad 0 \quad 9 \\
 2 \quad 2 \quad 5 \\
 \hline
 10 \text{ yd. } 1 \text{ ft. } 10 \text{ in.}
 \end{array}$$

EXPLANATION.— The like units are written in columns. The sum of the column of inches is 22 in. Reduced to feet and inches, this is 1 ft. 10 in. Write 10 in. and add 1 ft. to the next column. Similarly, reduce the sum of the column of feet to yards and feet, etc.

Add:

$$\begin{array}{r}
 2. \quad 3 \text{ yd. } 1 \text{ ft. } 6 \text{ in.} \\
 2 \quad 2 \quad 4 \\
 6 \quad 1 \quad 7 \\
 \hline
 \end{array}$$

$$\begin{array}{r}
 3. \quad 2 \text{ hr. } 13 \text{ min. } 27 \text{ sec.} \\
 4 \quad 25 \quad 32 \\
 1 \quad 27 \quad 10 \\
 \hline
 \end{array}$$

$$\begin{array}{r} 4. \quad 4 \text{ lb.} \quad 9 \text{ oz.} \\ \quad 3 \quad 6 \\ \quad 5 \quad 12 \\ \hline \end{array}$$

$$\begin{array}{r} 6. \quad 45^\circ \quad 18' \quad 12'' \\ \quad 32 \quad 43 \quad 51 \\ \quad 28 \quad 24 \quad 8 \\ \hline \end{array}$$

$$\begin{array}{r} 5. \quad 2 \text{ bu.} \quad 3 \text{ pk.} \quad 5 \text{ qt.} \\ \quad 4 \quad 2 \quad 7 \\ \quad 5 \quad 1 \quad 3 \\ \hline \end{array}$$

$$\begin{array}{r} 7. \quad 1 \text{ gal.} \quad 3 \text{ qt.} \quad 1 \text{ pt.} \\ \quad 3 \quad \quad \quad 1 \\ \quad 2 \quad 2 \\ \hline \end{array}$$

8. At the remnant counter a girl bought one piece of ribbon containing 1 yd. 16 in.; another containing 2 ft. 20 in.; and a third containing 1 yd. 2 ft. What was the total length of the three pieces?

9. A room is 4 yd. 2 ft. 6 in. wide and 5 yd. 1 ft. long. How much border is required to go around it?

10. If my garden is 24 ft. 8 in. wide and 30 ft. 4 in. long, how much will it cost to fence it at 45¢ a foot?

11. How many feet of weather molding are necessary to go around a door 6 ft. 10 in. by 3 ft. 4 in.? How many for a window 4 ft. 6 in. by 2 ft. 6 in.?

Problems in Subtraction

1. A piece of cloth contains 3 yd. 1 ft. 9 in. A piece 1 yd. 2 ft. 6 in. is used. How much remains?

$$\begin{array}{r} \text{WORK} \\ 3 \text{ yd.} \quad 1 \text{ ft.} \quad 9 \text{ in.} \\ 1 \quad 2 \quad 6 \\ \hline 1 \text{ yd.} \quad 2 \text{ ft.} \quad 3 \text{ in.} \end{array}$$

EXPLANATION.—Like units are written in columns. Since 1 ft. is less than 2 ft., change 1 yd. to 3 ft. and add the 1 ft. This gives 2 yd. 4 ft. Then 4 ft. - 2 ft. = 2 ft., and 2 yd. - 1 yd. = 1 yd.

Subtract:

$$\begin{array}{r} 2. \quad 4 \text{ yd.} \quad 2 \text{ ft.} \quad 6 \text{ in.} \\ \quad 2 \quad 1 \quad 8 \\ \hline \end{array}$$

$$\begin{array}{r} 4. \quad 10 \text{ gal.} \quad 2 \text{ qt.} \quad 1 \text{ pt.} \\ \quad 6 \quad 3 \quad 1 \\ \hline \end{array}$$

$$\begin{array}{r} 3. \quad 5 \text{ bu.} \quad 3 \text{ pk.} \quad 4 \text{ qt.} \\ \quad 2 \quad 1 \quad 7 \\ \hline \end{array}$$

$$\begin{array}{r} 5. \quad 7 \text{ sq. yd.} \quad 4 \text{ sq. ft.} \quad 80 \text{ sq. in.} \\ \quad 2 \quad 7 \quad 96 \\ \hline \end{array}$$

6. When a boy was 10 yr. old, he was 1 yd. 11 in. tall. When he was 12 yr. old, he was 1 yd. 1 ft. 7 in. tall. How much did he grow in the two years?

7. Measure the height of some of the tallest pupils in the class, in yards, feet, and inches. Let each pupil find the difference between his height and that of the tallest in the class.

8. A board is 2 yd. 1 ft. long. A boy cuts off a piece 2 ft. 8 in. long. How much is left?

9. From an iron rod 3 yd. 2 ft. 6 in. long a blacksmith cuts off a piece 1 yd. 1 ft. 10 in. long. How much is left?

Problems in Multiplication

1. A wire fence 5 wires high is 34 yd. 2 ft. 8 in. long. How much wire does it take to build it?

WORK	EXPLANATION. —
34 yd. 2 ft. 8 in.	$5 \times 8 \text{ in.} = 40 \text{ in.}; 40 \text{ in.} = 3 \text{ ft. } 4 \text{ in.}$ Write the 4 in.;
5	$5 \times 2 \text{ ft.} = 10 \text{ ft.}$
174 yd. 1 ft. 4 in.	$10 \text{ ft.} + 3 \text{ ft.} = 13 \text{ ft.}; 13 \text{ ft.} = 4 \text{ yd. } 1 \text{ ft.}$
	Write the 1 ft. $5 \times 34 \text{ yd.} = 170 \text{ yd.}; 170 \text{ yd.} + 4 \text{ yd.} = 174 \text{ yd.}$

Multiply:

2. 3 yd. 2 ft. 5 in. by 3. 4. 2 hr. 13 min. 10 sec. by 6.

3. 3 gal. 2 qt. 1 pt. by 4. 5. 3 sq. ft. 27 sq. in. by 8.

6. The desks in a school room are placed 2 ft. 10 in. apart. How long a row is required for 5 desks?

7. The side of a square lot is 24 yd. 2 ft. 4 in. What is the perimeter?

8. How much belting does it take to drive 20 machines in a factory, if it takes 21 ft. 5 in. for each machine?

9. In the wood shop a boy constructs a table 2 ft. 4 in. high. How long a piece of timber does he need for the four legs?

10. A machinist desires to cut 4 bars, each 3 ft. 2 in. long. How long must the bar be from which they are cut?

11. Find the cost of 24 sash curtain rods 3 ft. 10 in. long at 8¢ a foot. Allow 1 ft. 9 in. waste in cutting.

Problems in Division

1. A man has a lot of which the frontage is 26 yd. 2 ft. He wishes to set 5 shade trees along the lot, one at each end. How far apart must they be placed?

FORM	EXPLANATION.
$\begin{array}{r} 6 \text{ yd. } 2 \text{ ft.} \\ 4 \overline{)26 \text{ yd. } 2 \text{ ft.}} \end{array}$	$26 \text{ yd.} \div 4 = 6 \text{ yd.}$, with remainder 2 yd. Write the 6 yd. Reduce 2 yd. to feet, giving 6 ft. $6 \text{ ft.} + 2 \text{ ft.} = 8 \text{ ft.}$ $8 \text{ ft.} \div 4 = 2 \text{ ft.}$

Divide:

2. $3 \overline{)17 \text{ lb. } 4 \text{ oz.}}$ 4. $10 \overline{)13 \text{ bu. } 1 \text{ pk. } 6 \text{ qt.}}$

3. $5 \overline{)11 \text{ hr. } 21 \text{ min. } 10 \text{ sec.}}$ 5. $4 \overline{)9 \text{ sq. ft. } 120 \text{ sq. in.}}$

6. A coat rack is 15 ft. 8 in. long. It is to contain 9 hooks. The outer hooks are to be 2 in. from the ends. How far apart must the hooks be placed?

7. A fence 30 yd. 2 ft. 7 in. long is to be made with 12 posts. How far apart must the posts be set?

8. Three boys went nutting and gathered 2 pk. 3 qt. 1 pt. of nuts. They wished to divide the nuts equally among them. How many should each boy have?

16. LATITUDE AND LONGITUDE

NOTE.—A map should be used in teaching this topic. Practice should be given in finding the latitude and longitude of places, and of locating places in given latitude and longitude.

In the study of geography it is seen that the location of any point of the earth's surface is known by learning its distance north or south of the equator, called its **latitude**, and

its distance east or west of a given meridian, called its **longitude**. In measuring longitude, the meridian commonly used, called the **prime meridian**, is that of Greenwich, near London, England. The meridian of Washington is sometimes used.

Since the earth is practically a large sphere, distances on its surface are measured along arcs of circles, and hence are expressed in degrees, minutes, and seconds of arc.

To say that a place is in latitude 38° N. means that it is 38° north of the equator. And to say that a place is in longitude 117° E. means that it is 117° east of the meridian of Greenwich.

Exercises

1. By looking at a map, find the latitude and the longitude of each of the following: New Orleans; New York; Charleston, S.C.; Denver; Peking, China; Lima, Peru; Rio Janeiro, Brazil; Cape Town, Africa.

2. The following table gives the longitudes, to the nearest minute, of twelve cities.

How far is it in longitude between Boston and San Francisco?

PLACE	LONGITUDE	PLACE	LONGITUDE
Berlin, Germany . . .	$13^\circ 24'$ E.	Tokio, Japan . . .	$139^\circ 42'$ E.
Boston	$71^\circ 3'$ W.	London	6' W.
Calcutta	$88^\circ 20'$ E.	Paris, France . . .	$2^\circ 20'$ E.
Chicago	$87^\circ 37'$ W.	St. Petersburg . . .	$30^\circ 16'$ E.
Cincinnati	$84^\circ 26'$ W.	Manila, Philippines .	$120^\circ 58'$ E.
Cleveland	$81^\circ 40'$ W.	San Francisco . . .	$122^\circ 26'$ W.

3. Find the difference in longitude between Berlin and St. Petersburg.

4. Find the difference in longitude between Chicago and Paris.
5. Find the difference in longitude between Boston and Manila.
6. How far is Cleveland west of London?
7. How far is Tokio east of Calcutta?
8. Find the differences in longitude between other cities given in the above table.

Longitude and Time

1. How often does the earth turn on its axis? In what direction does it turn?

Table

2. Make a point on a ball or globe, turn the globe on its axis, and discover the figure described by the point when the globe makes a complete revolution.

The earth turns through 360° longitude in 24 hr. time 15° longitude in 1 hr. time 1° longitude in 4 min. time $15'$ longitude in 1 min. time $1'$ longitude in 4 sec. time
--

3. Through how many degrees does the point move? Through how many degrees of longitude does a point on the earth's surface move in 24 hours?

4. Since a point on the earth's surface moves through 360° in 24 hours, through how many degrees does it move in 1 hour?

Exercises

1. If your city is just passing under the sun, *i.e.* if it is just noon, has a point 15° west of you yet passed under the sun? When will it do so?

2. When you have noon, what time is it 15° west of you? What time 15° east of you?

3. When you have noon, what time is it 30° west of you? What time 30° east of you?
4. What time is it $7\frac{1}{2}^\circ$ west of you when you have noon?
5. When it is 10 A.M. in your city, what time is it 10° west of you? 40° east of you? 90° east of you?
6. When it is 1 P.M. in your city, what time is it 60° west of you? 105° west of you? 90° east of you?
7. When it is noon at Chicago, what time is it at Boston?

WORK

$$\begin{array}{r}
 87^\circ \quad 37' \quad 16 \times 4 \text{ min.} \quad = 64 \text{ min.} \\
 71^\circ \quad 3' \quad 34 \times 4 \text{ sec.} = 136 \text{ sec.} = \frac{2 \text{ min. } 16 \text{ sec.}}{66 \text{ min. } 16 \text{ sec.}} \\
 \hline
 16^\circ \quad 34'
 \end{array}$$

Hence it is 6 min. 16 sec. after 1 P.M. at Boston.

8. When it is noon at Chicago, find the time at San Francisco.
9. When it is 10 A.M. at Boston, find the time at Paris.
10. When it is midnight at Chicago, what time is it at Manila?
11. A boat race occurs on the Thames at 5 P.M. The result is known in Philadelphia at 1 P.M. Account for this.
12. When it is 5 A.M., October 22, at Manila, what time and what date is it at Boston?

17. STANDARD TIME

The time considered above is called **local time**. The fact that all places east of a given point have later local time, and all places west of it earlier local time, caused confusion in railroad travel. Hence, in 1883, the railroads of the United States adopted for their own convenience what is

known as **standard time**. At any particular place the time is reckoned as the local time of some specified meridian rather than the meridian through that place. The meridians used are 75° , 90° , 105° , and 120° west of Greenwich. Thus places within about $7\frac{1}{2}^{\circ}$ of any of these meridians use the local time of that meridian.

The line of division between standard meridians is not a straight line midway between them, but depends upon important railroad terminals. It was fixed by the roads. This is shown in the following map:

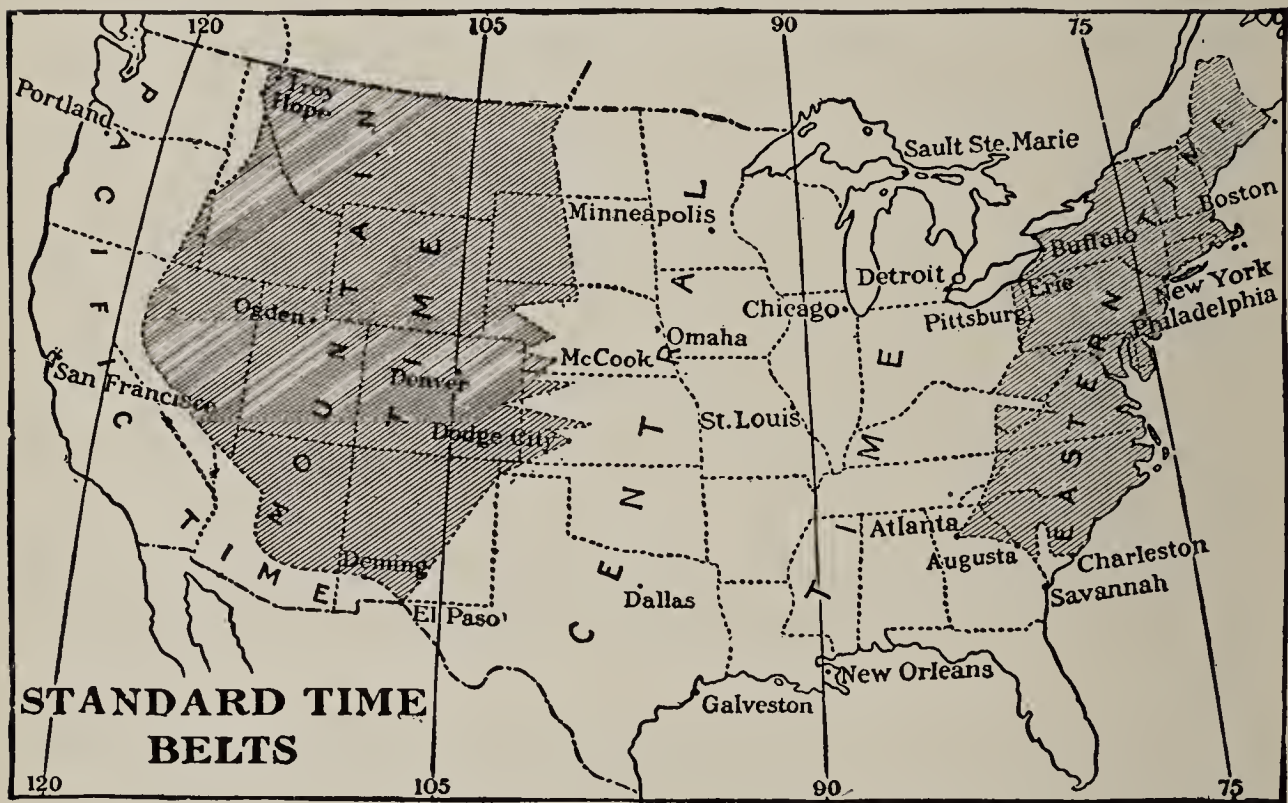

Exercises

1. From what meridian do you reckon time in your town or city? Has the meridian (a north and south line) through your place passed under the sun before or after this meridian does?
2. Do you live east or west of the meridian from which you reckon time?

3. How many degrees is your meridian from this meridian? Compare your local time with the standard time.

4. Suppose one lives 7° east of the 90th meridian. Is standard time fast or slow? How much?

The local time of the 75th meridian is **Eastern Time**, of the 90th, **Central Time**, of the 105th, **Mountain Time**, of the 120th, **Pacific Time**.

5. Which time do you use?

6. When it is 8 A.M. Eastern Time, what is it Pacific Time?

7. When it is 4 P.M. Mountain Time, what is it Eastern Time?

8. At noon by Central Time, what is it by each of the others?

9. If one is traveling from New York to Chicago, how will he change his watch as he changes into Central Time?

10. When it is noon in Chicago, what time is it in New York? Charleston? New Orleans?

11. When it is 3 P.M. in San Francisco, what time is it in St. Louis? Detroit? Boston?

12. Make and solve other problems about standard time.

18. FOREIGN MONEY

The money used by people of other nations is different from that used in the United States. Americans who buy goods in a foreign country, or who travel in a foreign country, must know the value of the different denominations of money used in that country.

The following tables give the denominations of money used in some countries of Europe, together with their equivalents in the money of the United States.

Table of English Money

1 pound (£)	= 20 shillings (s.)	= \$4.8665
1 shilling	= 12 pence (d.)	= \$0.243+

We think ordinarily of the pound as *about* \$5, of the shilling as *about* 25 cents, and of the penny as *about* 2 cents.

Canada uses the same denominations as the United States, although the coins have not quite the same values as those of our money.

Table of French Money

1 franc (fr.)	= 100 centimes (c.)	= \$0.193
---------------	---------------------	-----------

We think ordinarily of the franc as *about* 20 cents.

This system is used also by some other countries of Europe, as Belgium and Switzerland. Italy uses the *lira*, Spain the *peseta*, and Greece the *drachma*, all of which have the same value as the franc.

Table of German Money

1 mark (M.)	= 100 pfennigs (pf.)	= \$0.238
-------------	----------------------	-----------

We think ordinarily of the mark as *about* 25 cents, and of 4 pf. as 1 cent.

Find the values in dollars and cents of the following:

- | | | |
|----------------|------------------|--------------------|
| 1. £ 140. | 6. 1250 fr. | 11. 100 M. |
| 2. £ 500. | 7. 50 c. | 12. 546 M. |
| 3. £ 8 12s. | 8. 5 fr. 10 c. | 13. 60 pf. |
| 4. £ 5 8s. 6d. | 9. 120 fr. 50 c. | 14. 20 M. 50 pf. |
| 5. 10s. 8d. | 10. 34 fr. 15 c. | 15. 1642 M. 25 pf. |

16. Marshall Field & Co., Chicago, buy a bill of goods amounting to £ 1250 15s. How much American money do they pay in settlement of the bill?

17. John Wanamaker, New York, buys goods in Paris amounting to 1054 fr. 50 c. How much American money does it take to pay the bill?

18. An American firm buys toys made in Germany amounting to 2544 M. 25 pf. How much American money is paid in settlement of the bill?

19. Make and solve other problems about the purchase of goods in foreign countries by merchants in your own city.

20. Visit some merchant who deals in imported goods, and get from him statements of his bills of goods that he has actually bought. Let the class compute the cost to him, in American money, of these goods.

NOTE.—Part of the class may assume that they are English firms, French firms, etc., and the rest that they are American merchants buying goods from these firms.

A Summer Trip Abroad

One summer Robert Ellis spent his vacation on a trip with his parents to Europe. They went to New York, and from there sailed on a British steamer to Liverpool.

1. During the voyage his father paid out £ 4 8s. for fees on the ship. How many dollars was this?

2. When they landed at Liverpool, they took a train directly to London. The three tickets cost £ 3 5s. How many dollars was this?

3. They remained 10 days in London, stopping at a hotel that cost them £ 2 10s. a day. Find the amount of the hotel bill in American money.

4. They spent £ 1 12s. 6d. for cab hire during their stay in London. How much was that in American money ?

5. When they left London, they went first to Paris, France. They remained there 12 days. In Paris they paid out 30 fr. 25 c. for cab hire, and 480 fr. for hotel bill. How much was this in our money ?

6. While in Paris, Robert's mother went shopping, and spent 325 fr. 50 c. for different things. To how much American money was this equivalent ?

7. From Paris they went to Germany, stopping at a number of places. They spent four days in Berlin. There their average daily expenses for hotel bills, etc., amounted to 38 M. 50 pf. Find the amount of this for the four days. How much was it in United States money ?

8. Before leaving Berlin, Robert's father bought him some drawing instruments that cost in all 23 M. 75 pf. Find their cost in our money.

9. Their other expenses while in Germany amounted to 385 M. 20 pf. How much was this in our money ?

10. They spent a few days in Switzerland, and then went to Italy. At Naples Robert's father bought a painting for 492 lira. He had it packed for 6 lira, and shipped it home. What was the entire cost of the painting in American money ?

11. They sailed from Italy to New York on an Italian steamship. The tickets for the three cost 1100 lira. Find their cost in American money.

12. When they started from New York to Liverpool, Robert set his watch according to New York time. When they reached London, he found that his watch did not agree with the clocks there. Was his watch ahead or behind, and how much ?

Miscellaneous Problems

1. When potatoes are selling at 20¢ per $\frac{1}{2}$ peck, how much is that per bushel?

2. When potatoes are selling at 35¢ per peck, or $\$3.10$ for a $2\frac{1}{2}$ -bu. bag, how much is saved by buying a bag if you will use that many?

3. When navy beans are selling at 12¢ per quart, how much is that per bushel?

4. If a dealer buys beans at $\$2.80$ per bag of 2 bu., and retails them at 8¢ per quart, how much does he make per bag?

5. A man wishes to set posts for a wire fence along one side of his field. The length is 16 rd. and the posts are to be 12 ft. apart. How many will he need?

6. If the posts cost 16¢ each and the fencing wire costs $2\frac{1}{2}\text{¢}$ per foot, find the cost of the wire and posts.

7. At $\$24$ per M find the cost of rough flooring for a barn floor 18 ft. wide and 48 ft. long, if the boards are $1\frac{1}{2}$ in. thick.

8. A man bought a farm of 40 A. 120 sq. rd. at $\$60$ per acre. Find the cost.

9. A farmer sold six loads of ear corn averaging 2650 lb. each at 56¢ per bushel. Allowing 70 lb. to the bushel, find how much he got for the corn.

10. Upon a piece of land 16 rd. by 28 rd. a farmer gathered 42,000 lb. of potatoes. Allowing 60 lb. per bushel, find the yield in bushels per acre.

11. When a creamery pays 85¢ per hundred pounds for milk, how much is that a gallon, allowing 8.42 lb. to the gallon?

III. MENSURATION

19. THE CIRCLE

1. A curved line, all points of which are equally distant from a point within, called the *center*, is a **circle**.

Sometimes the surface inclosed by the curved line is called the *circle*, and the line itself is called the *circumference*.

2. The distance from the center to the curve is the **radius**. In the figure how many radii are drawn? Name them.

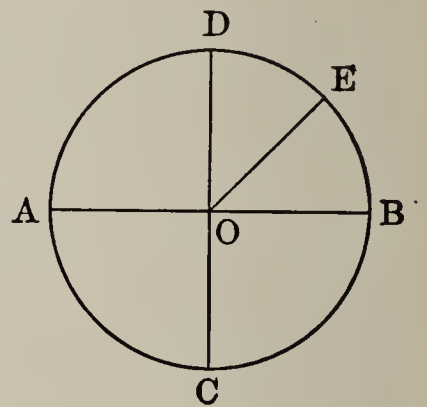

3. Any straight line through the *center* terminating in the *circumference* is a **diameter**. Is a diameter shown in the figure? Which lines are diameters?

4. Into how many equal parts does a diameter divide a circle? *One half* of a circle is called a **semicircle**.

5. Into how many equal parts do two perpendicular diameters divide the circumference? Such parts are called **quadrants**.

6. Any part of a circumference is called an **arc**. The figure bounded by two radii and an arc is a **sector**. Name some sectors in the figure.

7. For convenience in measuring arcs, every circumference, whether large or small, is divided into 360 equal parts, called degrees (360°). How many degrees in a semicircumference? In a quadrant?

8. Each degree is divided into 60 minutes ($60'$), and each minute into 60 seconds ($60''$). (See § 12.)

20. THE RATIO OF CIRCUMFERENCE TO DIAMETER

1. Cut circles of different sizes from stiff cardboard, or use large circular objects found in the home, such as circular tables, disk phonograph records, etc. Measure accurately the diameter and circumference of each.

NOTE.—To get an accurate measurement of a circumference, two pupils can work together to an advantage. Take two rulers, one standing edgewise on the other as a guide for the circular object. Mark a point on the circumference and roll through one complete revolution, noticing the distance passed over on the bottom ruler, and holding against the second ruler to get a straight path.

2. *Make a table of your measurements as follows :*

TABLE

	CIRCUMFERENCE	DIAMETER	RATIO OF CIRCUMFERENCE TO DIAMETER
1.	$25\frac{1}{8}$ in.	8 in.	3.140625
2.			
3.			

3. In each case divide the circumference by the diameter, carrying the result to several decimal places.

4. Take all the results that are about alike and find the average.

5. If you have measured and divided accurately, the quotient will be 3.1416 *nearly*. What does this show?

6. If the diameter of a circle is 10 ft., what is the circumference?

3.1416 is the ratio of the circumference to the diameter.
It is represented by the Greek letter π (π).

7. If $D =$ diameter, $R =$ radius, $C =$ circumference, read the following :

$$C = \pi \times D; D = C \div \pi, \text{ or } D = \frac{C}{\pi}; C = 2 R \pi, \text{ or } 2 \pi R.$$

Find the diameter or circumference or radius. Forecast the result.

8. $D = 20$ ft. ; $C = ?$

11. $C = 4$ ft. 8 in. ; $D = ?$

9. $C = 205$ ft. ; $D = ?$

12. $D = 16\frac{1}{4}$ in. ; $C = ?$

10. $R = 90$ ft. ; $C = ?$

13. $C = 2$ yd. $1\frac{1}{2}$ ft. ; $R = ?$

14. The diameter of a circle is 15 in. Find the circumference.

15. The circumference of a circle is 25 ft. Find to hundredths of a foot the length of the diameter.

Problems with Circles

1. Florence made a circular button bag. She cut a paper pattern, using a pair of compasses. Setting the legs of the compasses 5 in. apart, what was the diameter of the pattern?

2. For finishing, she turned down a half-inch hem, all around. What was the diameter of the finished bag?

3. How much narrow ribbon would she have needed for a binding if she had bound the bag instead of hemming it?

4. If she uses 5 rings on the edge of the bag, as shown in the picture, *about* how far apart are they?

5. Later she made this same style of bag as a collar bag for her father's suit case. She made the radius of her circle 10 inches. How many rings did she need, sewing them *about* 4'' apart?



6. How much lace is needed for the edge of a 27'' circular centerpiece, allowing 23'' for fullness?

(A 27'' centerpiece is one 27 in. in diameter.)

7. How much will the lace cost at 36¢ a yard?

8. If your bicycle wheel is 28 in. in diameter, how far around it? How far does it go when it turns once (makes a *revolution*)?

9. How many revolutions will it make in going a mile?

10. A circus ring is 135 ft. across. How far is it around? Except for three entrances, each 12 ft. wide, the seats extend entirely around it. How long is the highest row of seats? Allowing 24 in. to each person, how many seats in the row?

11. Some boys wish to lay off a circular running track so that four times around it will make a mile. They wish to tie a string to a stake in the center of the circle to be formed, and, holding the other end, mark out the track by walking around the stake. Tell them how long a string to use.

12. A boy going to a rural school walks each day half-way around a circular pond, a distance of $\frac{1}{2}$ mile. How much distance can he save when the pond is frozen so he can walk straight across?

13. The prize pumpkin at the county fair was 76 in. in circumference. Find its diameter.

14. How much bead fringe must I buy to go around the border of a circular lamp shade that is 16 in. in diameter?

15. The diameter of the top of a barrel is $17\frac{1}{2}$ in. How long must the strip of sheet iron be cut to make the hoop at the top of the barrel, allowing 2 in. for lap?

16. A wagon wheel is 46 in. in diameter. How long must the blacksmith cut the iron bar to make the tire, allowing $\frac{1}{2}$ in. for lap in welding?

17. An overshot water wheel is 8 ft. in diameter. It has 28 buckets on its rim. How far apart are the buckets placed?

18. The rim of a grindstone can move at a speed of 2500 ft. per second without bursting. How many revolutions per minute can a grindstone 3 ft. in diameter safely make?



21. THE AREA OF A CIRCLE

By the **area of a circle** is meant the area of the surface inclosed by the circle.

1. Draw a circle on stiff cardboard and cut it out. Draw diameters cutting the circle into at least sixteen equal sectors.

2. Take half of the circle and set the sectors as in the lower row of *B*. Use the other half as in the upper row of

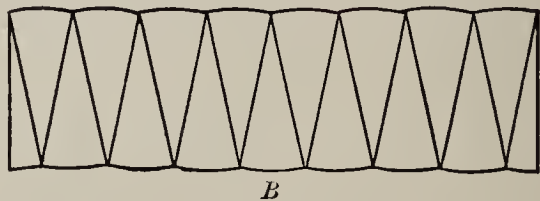
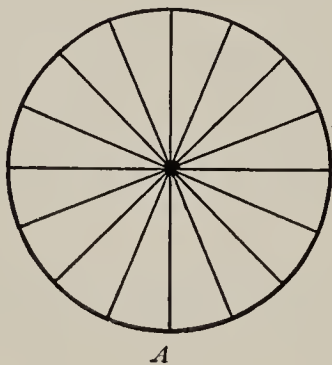

B, dividing one sector into two equal parts and using them as shown.

3. What figure that you have studied does *B* resemble?

4. If *B* were a perfect rectangle, what line of the circle would the base be?

5. What is the altitude of the figure that resembles a rectangle?

6. While the circle cannot be made into an exact rectangle, because the base is still made up of arcs of a circle, however small they are cut, it is proved in geometry that:

The area of a circle is the same as that of a rectangle having a base equal to one half the circumference and an altitude equal to the radius.

7. How is the area of a rectangle found? What is the area of a rectangle whose base is $\frac{1}{2}C$ and whose altitude is R ? State a rule for computing the area of any circle.

NOTE.— In the following problems, R stands for radius, D for diameter, and C for circumference.

8. Find the area of a circle whose diameter is 10 ft.

$$\text{SOLUTION: } C = 3.1416 \times 10 \text{ ft.} = 31.416 \text{ ft.}$$

$$R = \frac{1}{2} \text{ of } 10 \text{ ft.} = 5 \text{ ft.}$$

$$5 \times 31.416 \text{ sq. ft.} = 157.080 \text{ sq. ft.}$$

$$\frac{1}{2} \text{ of } 157.080 \text{ sq. ft.} = 78.54 \text{ sq. ft.}$$

NOTE.— We may use C and R as abstract numbers representing the number of units in performing the computation. The product will then be an abstract number showing the number of units in the area.

Find the areas of circles:

9. $R = 6 \text{ ft.}, C = \text{---}$.

11. $C = 100 \text{ ft.}, D = \text{---}$.

10. $D = 12 \text{ ft.}, C = \text{---}$.

12. $C = 50 \text{ ft.}, R = \text{---}$.

Since $\text{area} = \frac{C \times R}{2}$ and $C = 2 \times \pi \times R$, we may multiply by $2 \times \pi \times R$ instead of C . Then

$$\text{area} = \frac{2 \times \pi \times R \times R}{2} = \pi R^2.$$

NOTE.— $R \times R$ is written R^2 and is read “ R square.”

That is, to find the area of a circle, square the radius and multiply by 3.1416.

13. Cut from thick cardboard or sheet metal a circle whose radius is 4 in. Cut from the same material a square whose side is 4 in. Weigh both, and see if the weight of the circle is not approximately 3.1416 times the weight of the square. Show that the result agrees with the rule that the area of a circle equals πR^2 .

Find the areas of circles :

- | | | |
|-------------------|-----------------------------|-------------------|
| 14. $R = 15$ ft. | 17. $R = 22\frac{1}{2}$ rd. | 20. $C = 108$ ft. |
| 15. $D = 42$ ft. | 18. $R = 16\frac{1}{2}$ rd. | 21. $C = 1$ mi. |
| 16. $C = 400$ in. | 19. $D = 80$ yd. | 22. $D = 38$ rd. |

Problems involving Circles

1. The circular basin of a fountain is 20 feet in diameter. How many square feet in the bottom? What will it cost to cement the bottom at \$1.75 per square yard?

2. Around the fountain basin is a 4-ft. paved walk. How many square feet of paving are needed?

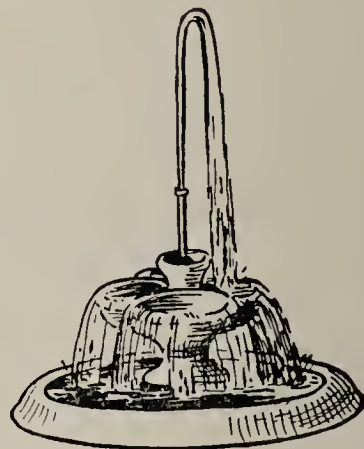

SUGGESTION.— You are to find the difference between the area of a circle whose radius is 14 ft. and one whose radius is 10 ft.

3. The earth is nearly 8000 miles in diameter. What is the approximate length of the equator?

4. From the result of Exercise 3, find at what velocity a person who is at the equator revolves through space.

5. A boy gets $\frac{1}{2}\text{¢}$ a square yard for cleaning the snow from a circular skating pond 300 ft. in diameter. How much does he earn?

6. What is the diameter of a circular sailor hat that requires 1 yd. 14 in. of velvet to bind it?

7. What part of a piece of buckram 10 in. square is left after cutting a circular piece 10 in. in diameter from it?

8. How many yards of lace will be required to trim 1 doz. plate doilies 6 in. in diameter, adding $\frac{1}{5}$ extra for fulling?

9. How many square feet of asbestos is used in making a table mat for a 54-in. circular table?

10. At 5¢ a foot, how much will it cost to put a fence around my circular tulip bed, if it is 8 ft. in diameter?

11. A hose will throw water 40 yd. in every direction from the hydrant. Over what area will it sprinkle?

12. Which is larger and how much, a circular tray 16 in. in diameter or a rectangular one 12 in. by 18 in.?

13. If a circular piece of boiler plate 34 in. in diameter is cut from a sheet 3 ft. square, how many square inches of the metal are wasted?

14. A belt runs over a pulley 28 in. in diameter, revolving at a speed of 216 revolutions a minute. How far does a point on the belt travel in a minute?

15. If you can ride around 20 times on a merry-go-round for 5¢, and your path is 20 ft. in diameter, how far do you ride for 5¢?

22. RECTANGULAR PRISMS AND THEIR VOLUMES

1. Describe a **right prism**.

2. Prisms are named from their bases: *square*, *rectangular*, *triangular*, *hexagonal*, etc. Name some objects that are square prisms; some that are rectangular.

3. Is a square prism also rectangular? What kind of prism is a cube?

4. To find the volume of a rectangular prism whose dimensions are 4 in., 5 in., and 9 in.

(1) First find the number of cubic inches in one row or a square prism 1 in. by 1 in. by 9 in.

(2) Then find the number of such rows in one tier or layer 4 in. wide.

(3) Then find the number of such layers in the prism, and explain the statement $5 \times 4 \times 9$ cu. in. = — cu. in.

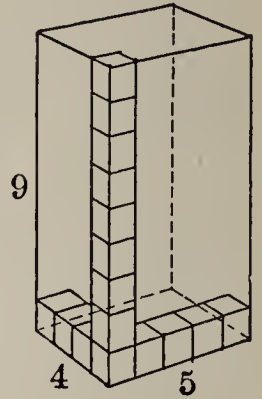

5. How many inch cubes may be put into a box 10 in. long, 8 in. wide, and 5 in. deep?

6. A trunk measures 3 ft. by 20 in. by 18 in. Find its volume.

Find the volumes of rectangular prisms of these dimensions:

	LENGTH	WIDTH	HEIGHT		LENGTH	BREADTH	DEPTH
7.	16 ft.	10 ft.	8 ft.	10.	$42\frac{1}{2}$ ft.	20 ft.	$13\frac{1}{3}$ ft.
8.	1 yd.	2 ft.	9 in.	11.	$12\frac{1}{2}$ yd.	10 ft.	16 in.
9.	24 ft.	16 ft.	4 yd.	12.	$20\frac{1}{2}$ ft.	$17\frac{1}{3}$ ft.	6 in.

13. If the base of a rectangular prism contains 30 sq. in., how many cubic inches in the bottom layer? If the prism is 10 in. high, how many cubic inches in the prism?

STATEMENT. — 10×30 cubic inches = — cubic inches.

14. The floor of a cellar contains 36 sq. yd. If the cellar is 8 ft. deep, find its cubical contents.

15. A square prism is 16 in. wide and 4 ft. long. Find the volume.

16. A 5-in. cube is cut from the corner of a 20-in. cube. What part remains?

17. A cellar is 40 ft. long, 30 ft. wide, and $7\frac{1}{2}$ ft. deep. How many cubic feet of earth were removed in its construction? How many loads (cubic yards)?

18. A freight car 36 ft. long and $8\frac{1}{2}$ ft. wide is loaded 5 ft. deep with wheat. How many bushels does it contain if 1 cu. ft. = 0.8 bu.?

19. How many tons of ice can be packed in an ice house $40' \times 24' \times 16'$, allowing 2' on each side and above and below for sawdust? (1 cu. ft. of ice weighs $56\frac{1}{4}$ lb.)

20. An ice pond is 260 ft. wide and 426 ft. long. If the ice is frozen to a depth of 14 in, how many tons can be cut from the pond?

21. My ice box will hold a piece of ice $32'' \times 24'' \times 14''$. How much will such a piece weigh?

22. A coal bin 12 ft. long and 8 ft. wide is filled to the depth of 5 ft. Allowing 80 lb. to a cubic foot, how many tons are in the bin?

23. A coal car $7\frac{1}{2}$ ft. wide and 30 ft. long is loaded to an average depth of 4 ft. How many tons of coal on the car?

23. THE SURFACES OF RECTANGULAR PRISMS

1. How many surfaces has a rectangular prism?

2. What name is given to a rectangular prism with equal faces?

3. Find the entire surface of a 5-in. cube.

Explain the statement: $6 \times 5 \times 5$ sq. in. = ——— sq. in.

4. The entire surface of a cube is 150 sq. in. How long is it?

Find the entire surface of: 5. A 9-in. cube.

6. A cube 10 in. long. 7. A 16-in. cube.

How long a cube has

8. An entire surface of 384 sq. in.?
9. An entire surface of 600 sq. ft.?
10. An entire surface of 294 sq. in.?
11. Compare the ends of a square prism with each other.
12. Compare its four sides.
13. Find the entire surface of a square prism 8 in. long and 3 in. wide. (What is the area of each square? How many? Of each rectangle? How many?)
14. Compare the opposite faces of *any* rectangular prism.
15. Give the dimensions in feet of each face in the figure at the right. What is its entire surface in square feet?

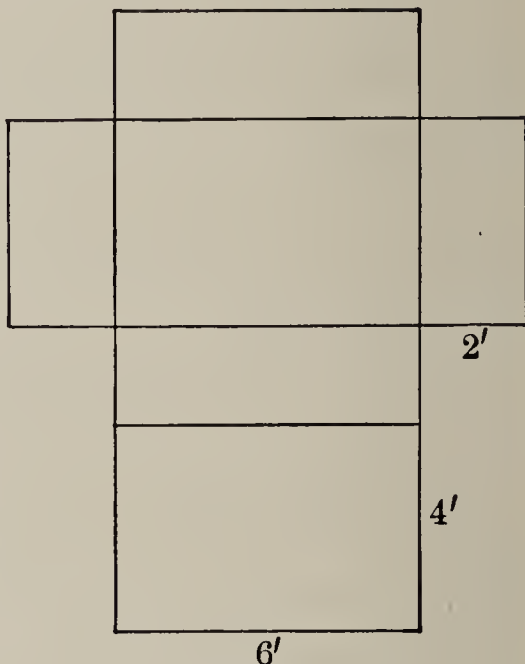

Find the entire surfaces of prisms:

16. 10 in. by 6 in. by 4 in.
17. 12 ft. long, 9 ft. wide, 6 ft. high.
18. 20 ft. long, 4 ft. wide, 8 ft. high.

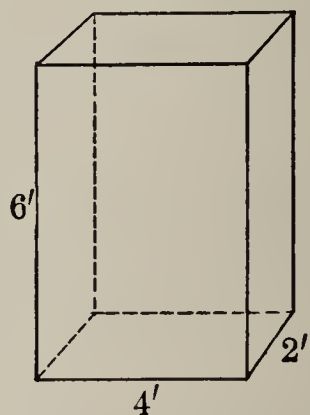

19. How many square yards of lath does it take for the walls and ceiling of a room 14 ft. wide, 18 ft. long, and 9 ft. high?

20. How many square feet of sheathing does it take for the two sides and two ends of a box car 8 ft. wide, 8 ft. high, and 34 ft. long?

21. A room is 14 ft. wide, 18 ft. long, and 9 ft. high. Making no allowance for windows or doors, find the cost of lathing and plastering the walls and ceiling at 55¢ a square yard.

22. Estimate the number of gallons of paint required to apply one coat to the outside of a house that is 36 ft. wide, 40 ft. long, and 18 ft. high to the eaves, if the gables contain in all 840 sq. ft. A gallon of paint covers 150 sq. ft.

23. An open rectangular tank 16 in. wide, 24 in. long, and 20 in. deep is to be lined with copper. How many square inches of sheet copper does it take?

24. THE CYLINDER

A round object such as a log, a round iron rod, etc., is a **cylinder**. The two ends which are equal circles in parallel planes are called the **bases**.

1. Mention some other common objects that are cylinders.

2. If a cylinder is cut as in Fig. A and arranged as in Fig. B, what does it nearly become?

3. If the circular end is the base, it has been changed into one nearly like a rectangle. Has the area of the base changed in B? Has the length of the cylinder changed?

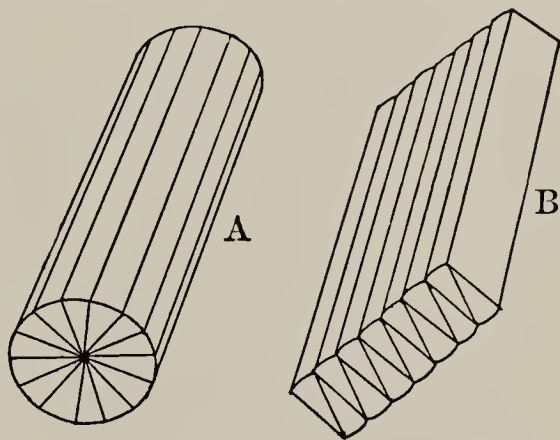

4. In B, if the base were a rectangle and its area known, how would its volume be found?

5. If the radius of A is 1 in., what is the area of its base or the base of B? If the length of B is 8 in., what is the volume?

6. The volume that we have found by considering that the cylinder is nearly a prism with an equal base and the same height is the volume that is found by geometry to be the true one, viz. :

The volume of a cylinder is the same as that of a prism having a base of the same area and having the same height. Hence, to find the volume of a cylinder, multiply the area of the base (πR^2) by the height.

7. Find the volume of a cylinder whose radius is 8 in. and whose height is 15 in.

Explain the statement: $(15 \times 3.1416 \times 8 \times 8)$ cu. in. =
— cu. in.

8. A cylindrical pail 6 in. in diameter inside, and 12 in. deep contains how many cubic inches?

Explain the statement: $(12 \times 3.1416 \times 3 \times 3)$ cu. in. =
— cu. in.

9. The volume of an irregular-shaped object, as a stone, may be found by submerging it in a cylindrical vessel of water. When a stone is submerged in a cylindrical vessel 8 in. in diameter, the water rises 4 in. Find the volume of the stone.



10. Find the volumes of 5 irregular bodies by the method of Problem 9.

11. How much will a 2-in. (diameter) iron bar 10 ft. long weigh? (1 cu. ft. weighs 480 lb.)

12. A hot-water tank is $4\frac{1}{2}$ ft. high and 15 in. in diameter. If 1 cu. ft. equals $7\frac{1}{2}$ gal., how much water will the tank hold?

13. A cylindrical tank for supplying water to a locomotive is 24 ft. in diameter and 16 ft. high. How many gallons will it hold? (1 cu. ft. = $7\frac{1}{2}$ gal.)

14. The tank on a sprinkling wagon is 10 ft. long and 4 ft. in diameter. How many gallons of water does it hold?

15. The cylinder of a steam pump is 14 in. in diameter, and the stroke of the piston is 18 in. How many gallons of water does it discharge at each stroke? If it makes 40 strokes a minute, how many gallons does it discharge in a minute? In an hour?

16. A gas tank is 250 ft. in diameter and 40 ft. high. How many cubic feet of gas does it hold?

17. Water runs through a sewer pipe 3 ft. in diameter at a speed of 60 ft. a minute. How many gallons does the sewer discharge in a minute?

18. A granite lawn-roller is 3 ft. long and 20 in. in diameter. What is its weight, the weight of granite being 165 lb. to the cubic foot?

The Surface of a Cylinder

1. In form, the ends or bases of a cylinder are equal to what? The rest of the surface is called the **convex surface**.

2. Suppose the diameter of a cylinder to be 4 in. Its circumference equals what?

3. The circumference of a cylinder is 8 in.; its diameter is what?

4. A cylinder is 4 in. in diameter. Find the area of its two ends or bases.

5. Roll an oblong paper to form a cylinder. Give the length and circumference of the cylinder thus made.

6. Unroll the paper and give the dimensions of a rectangle equivalent to the convex surface of the cylinder. Explain the diagram at the right.

7. The convex surface is equal to $C \times L$ square units, where C = circumference and L = length. Why is this?

8. A cylinder is 25 in. long, 4 in. in diameter. Find its convex surface. Explain: $(3.1416 \times 4) \times 25$ sq. in. = — sq. in.

9. A cylinder is 20 in. long, 5 in. in diameter. Find the area of the *entire* surface, or of the convex surface plus the surface of the ends.

10. A tin can is to be made 5 in. high and with a diameter of 4 in. Allowing $\frac{1}{4}$ in. for a seam, find the size of the rectangular sheet of tin from which the convex surface is to be made.

11. What is the area of the entire cooling surface of an ice-cream freezer 6 in. in diameter and 9 in. high?

12. How many square inches of sheet iron does it take to make a joint of stove pipe 6 in. in diameter and 18 in. long, allowing $\frac{1}{2}$ in. for the seam?

13. How much does it cost to paint a standpipe 16 ft. in diameter, and 120 ft. high at 3¢ a square foot?

14. At \$3 per 100 sq. ft., how much will it cost to paint the outer convex surface of a tank 22 ft. in diameter and 14 ft. high?

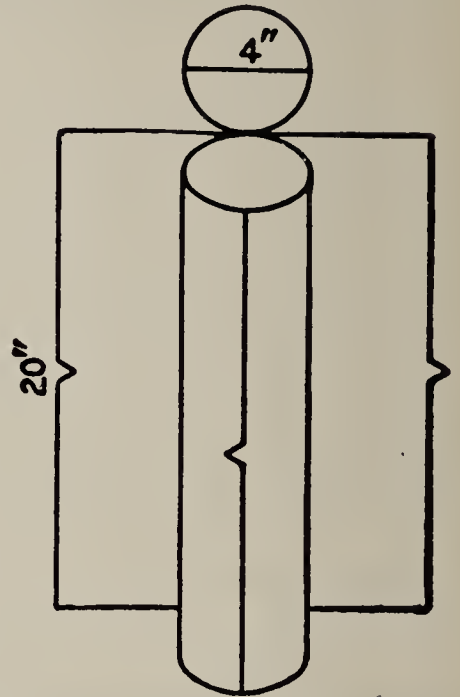

IV. PERCENTAGE

25. THE MEANING OF PER CENT

Per cent is only another name for hundredths. Thus, if 5% of the words in a spelling lesson were missed, 5 *words of every hundred* were missed.

Then 5%, 0.05, and $\frac{5}{100}$ all mean the same thing.

Per Cents changed to Decimals

In problems, per cents are changed to decimals. Thus,

$$15\% = 15 \text{ hundredths} = 0.15.$$

$$8\frac{1}{2}\% = 8\frac{1}{2} \text{ hundredths} = 0.08\frac{1}{2} = 0.085.$$

$$\frac{3}{4}\% = \frac{3}{4} \text{ of a hundredth} = 0.00\frac{3}{4} = 0.0075.$$

$$6\frac{2}{3}\% = 6\frac{2}{3} \text{ hundredths} = 0.06\frac{2}{3}.$$

$$175\% = 175 \text{ hundredths} = 1.75.$$

Exercises

Change to decimals:

- | | | | |
|---------|-------------------------|-----------------------|-------------------------|
| 1. 25%. | 8. $12\frac{1}{2}\%$. | 15. $\frac{1}{2}\%$. | 22. 225%. |
| 2. 38%. | 9. $17\frac{1}{2}\%$. | 16. $\frac{3}{5}\%$. | 23. 375%. |
| 3. 46%. | 10. $26\frac{1}{4}\%$. | 17. $\frac{1}{4}\%$. | 24. 400%. |
| 4. 57%. | 11. $3\frac{3}{4}\%$. | 18. $\frac{3}{8}\%$. | 25. $8\frac{1}{3}\%$. |
| 5. 30%. | 12. $6\frac{1}{4}\%$. | 19. $\frac{4}{5}\%$. | 26. $16\frac{2}{3}\%$. |
| 6. 70%. | 13. $20\frac{1}{2}\%$. | 20. $\frac{7}{8}\%$. | 27. 1750%. |
| 7. 90%. | 14. $15\frac{3}{4}\%$. | 21. $\frac{5}{8}\%$. | 28. 900%. |

Decimals changed to Per Cents

In finding what per cent one number is of another we shall have to change decimals to per cents. Thus,

$$0.14 = 14 \text{ hundredths} = 14\%.$$

$$0.325 = 32\frac{1}{2} \text{ hundredths} = 32\frac{1}{2}\%.$$

$$0.0225 = 2\frac{1}{4} \text{ hundredths} = 2\frac{1}{4} \%.$$

$$2.35 = 235 \text{ hundredths} = 235\%.$$

$$0.0075 = \frac{75}{100} \text{ of a hundredth} = \frac{3}{4} \%.$$

Exercises

Change to per cents:

- | | | | |
|----------|------------|-------------|-------------|
| 1. 0.26. | 7. 0.365. | 13. 0.045. | 19. 0.004. |
| 2. 0.38. | 8. 0.428. | 14. 0.025. | 20. 0.006. |
| 3. 0.45. | 9. 0.725. | 15. 0.0325. | 21. 0.005. |
| 4. 0.65. | 10. 0.896. | 16. 0.0625. | 22. 0.0075. |
| 5. 0.86. | 11. 0.783. | 17. 0.0775. | 23. 0.0015. |
| 6. 0.97. | 12. 0.847. | 18. 0.0875. | 24. 0.0035. |

Finding a Per Cent of a Number

To find 25 % of 600 is to find 0.25×600 , which is 150.

Exercises

Find:

- | | | |
|------------------|-------------------------------|-------------------------------|
| 1. 6 % of 150. | 11. 20 % of 140. | 21. $6\frac{1}{4}$ % of 800. |
| 2. 8 % of 200. | 12. 10 % of 2000. | 22. $8\frac{1}{2}$ % of 900. |
| 3. 7 % of 500. | 13. 12 % of 3000. | 23. $10\frac{1}{2}$ % of 700. |
| 4. 4 % of 120. | 14. 15 % of 6000. | 24. $9\frac{1}{2}$ % of 600. |
| 5. 15 % of 300. | 15. $7\frac{1}{2}$ % of 800. | 25. $7\frac{1}{2}$ % of 420. |
| 6. 15 % of 400. | 16. $3\frac{1}{2}$ % of 600. | 26. $5\frac{1}{2}$ % of 320. |
| 7. 12 % of 500. | 17. $8\frac{1}{3}$ % of 300. | 27. $8\frac{1}{3}$ % of 630. |
| 8. 9 % of 120. | 18. $5\frac{1}{2}$ % of 1000. | 28. $12\frac{1}{2}$ % of 800. |
| 9. 10 % of 750. | 19. $6\frac{1}{2}$ % of 1200. | 29. 20 % of 750. |
| 10. 15 % of 150. | 20. $7\frac{1}{2}$ % of 2000. | 30. 20 % of 950. |

Drill Exercises

1. How many times a number is 200 % of it?
2. What is 100 % of \$360? 200 % of \$360?
3. What is 1 % of \$3800? Of \$4200? Of \$6300?
4. What is 1 % of 1000 mi.? What is $\frac{1}{2}$ % of 1000 mi.?
5. What is 1 % of 2000 bu.? What is $\frac{1}{4}$ % of 2000 bu.?
6. What per cent of anything is 0.15 of it?
7. How many times a thing is 150 % of it?
8. Two times a thing is what per cent of it?

At sight give:

9.	10.	11.	12.
1 % of 300.	100 % of 500.	$\frac{1}{2}$ % of 400.	150 % of 400.
2 % of 600.	200 % of 600.	$\frac{1}{4}$ % of 800.	250 % of 200.
5 % of 200.	300 % of 700.	$\frac{1}{5}$ % of 1500.	350 % of 600.

At sight change to per cent:

13.	14.	15.	16.	17.
0.25.	0.3.	0.325.	$0.26\frac{1}{2}$.	1.25.
0.36.	0.4.	0.628.	$0.38\frac{1}{4}$.	1.38.
0.72.	0.7.	0.975.	$0.26\frac{1}{5}$.	2.25.

Change to hundredths, then to per cent:

18. $\frac{1}{5}$.	22. $\frac{3}{8}$.	26. $\frac{3}{7}$.	30. $\frac{17}{15}$.
19. $\frac{3}{4}$.	23. $\frac{72}{125}$.	27. $\frac{9}{11}$.	31. $\frac{16}{11}$.
20. $\frac{18}{25}$.	24. $\frac{175}{125}$.	28. $\frac{8}{9}$.	32. $\frac{38}{35}$.
21. $\frac{7}{10}$.	25. $\frac{11}{8}$.	29. $\frac{4}{15}$.	33. $\frac{42}{39}$.

Change to common fractions and reduce to lowest terms:

34. 25 %.	36. 80 %.	38. $37\frac{1}{2}$ %.	40. $16\frac{2}{3}$ %.
35. 75 %.	37. 60 %.	39. $82\frac{1}{2}$ %.	41. $66\frac{2}{3}$ %.

Problems in Percentage

1. My gas bill for August is \$4.60. I can save 10 % by paying it before September 10. How much will my gas bill for August cost me, if I pay the bill before September 10?

2. George bought a \$35 canoe. By paying cash he got a discount of 10%. How much did he save by paying cash? What was the cost of the canoe, by paying cash?

3. If a man's salary was \$64 a week, and then was increased $12\frac{1}{2}\%$, how much was it after the increase?

4. A grocer buys butter at wholesale, at 28¢ a pound, and retails it at a profit of 25%. What is his price?

5. If the living expenses of a family were \$80 a month two years ago, what are they now, if the cost of living has increased 20%?

6. A firm advertises its blankets as 60 % wool and the rest cotton. How much of each in 5-lb. blankets?

7. A firm sold \$7000 worth of goods one week. If 5 % is lost in bad debts, how much will be collected?

8. At a special sale all shoes were sold 20 % below the regular price. Give the sale prices of shoes, the regular prices of which were: \$3.50; \$4; \$4.50; \$5; \$5.25; \$5.75.

9. By paying cash for goods I get a reduction of 5 % from the regular price. How much can I save by paying cash for goods, the regular price of which is \$250?

10. At the "August Sale," Revell's gave a reduction of 10 % from the regular prices. Find how much is saved by buying any of the following in August:

- | | |
|-------------------------------------|--------------------------|
| (a) \$65 dining-room table; | (e) \$42 sofa; |
| (b) \$185 parlor suite; | (f) \$98 bed-room suite; |
| (c) \$56 set of dining-room chairs; | (g) \$36 library table; |
| (d) \$24 rocker; | (h) \$24 settle. |

11. A boy had \$80 in the bank. He withdrew 40 % of it to buy a canoe. How much remained?

12. The flooring for a hall cost \$250. The cost of labor to lay and dress it added 60 % more. Find the whole cost.

13. A farmer raised 1500 bu. of wheat one year. If fertilizing will increase the crop 40 %, how much will he then raise?

14. A salesman received $7\frac{1}{2}$ % of his sales as his pay. One month he sold \$6200 worth of goods. How much did he earn?

15. A man's house and lot cost him \$11,500. He has paid 70 % of it. How much remains unpaid?

16. A man delivered 2500 pounds of milk to the creamery. It tested 3.8 % butter fat. He was paid at the rate of 24¢ a pound for the butter fat. How much was this?

17. A dealer pays \$1 per bushel for onions. For how much a peck must he sell them to make a profit of 20 %?

18. For how much a $\frac{1}{2}$ peck must a dealer sell peaches costing \$3 per bushel to make a profit of 20 %?

19. If a grocer's average profits are 30 % of his sales, what are his weekly profits from sales of \$960 per week?

20. A dealer bought hats at \$24 per dozen, and marked them to sell at a profit of 50 %. At what price was each hat marked?

21. 45 % of fresh chestnuts is water. How much water in a bag of chestnuts weighing 28 lb.?

22. 78.3 % of potatoes is water. How much water in a bushel of potatoes weighing 60 lb.?

23. A crate of live chickens weighs 76 lb. The empty crate weighs 12 lb. If chickens shrink 29 % on being dressed, what will be the dressed weight of the lot?

24. A dealer pays 13¢ a pound for live chickens weighing 85 lb. The chickens are dressed, and sold at 22¢ a pound. Allowing 27% for shrinkage in weight when dressed, find his profit on the lot.

25. I place 360 eggs in an incubator. If 75% of them hatch, how many chickens shall I get?

26. At the same rate, how many chickens should I get from 840 eggs?

26. PER CENT CHANGED TO FRACTIONS

1. 50% of anything is what part of it?

$$50\% = 0.50 = \frac{50}{100} = \frac{1}{2}.$$

2. 25% of anything is what part of it?

3. $12\frac{1}{2}\% = \frac{1}{2}$ of 25%. Then $12\frac{1}{2}\%$ of anything is what part of it?

4. $6\frac{1}{4}\% = \frac{1}{2}$ of $12\frac{1}{2}\%$. Then $6\frac{1}{4}\%$ of anything is what part of it?

5. $3 \times 33\frac{1}{3}\% = 100\%$. Then $33\frac{1}{3}\%$ of anything is what part of it?

6. $66\frac{2}{3}\% = 2 \times 33\frac{1}{3}\%$. Then $66\frac{2}{3}\%$ of anything is what part of it?

7. $16\frac{2}{3}\% = \frac{1}{2}$ of $33\frac{1}{3}\%$. Express $16\frac{2}{3}\%$ as a fraction.

8. $5 \times 20\% = 100\%$. Express 20% as a fraction.

9. $40\% = 2 \times 20\%$. Express 40% as a fraction.

10. Express 60% as a fraction; express 80% in fractional form.

11. What part of anything is 25% of it? 75% of it?

A Table of Equivalents

To be memorized:

$\frac{1}{2} = 50\%$	$\frac{1}{3} = 33\frac{1}{3}\%$	$\frac{1}{5} = 20\%$	$\frac{4}{5} = 80\%$
$\frac{1}{4} = 25\%$	$\frac{2}{3} = 66\frac{2}{3}\%$	$\frac{2}{5} = 40\%$	$\frac{3}{4} = 75\%$
$\frac{1}{8} = 12\frac{1}{2}\%$	$\frac{1}{6} = 16\frac{2}{3}\%$	$\frac{3}{5} = 60\%$	$\frac{3}{8} = 37\frac{1}{2}\%$

OTHER EQUIVALENTS LESS IMPORTANT ARE :

$\frac{5}{6} = 83\frac{1}{3}\%$	$\frac{5}{8} = 62\frac{1}{2}\%$	$\frac{1}{12} = 8\frac{1}{3}\%$
$\frac{1}{7} = 14\frac{2}{7}\%$	$\frac{7}{8} = 87\frac{1}{2}\%$	$\frac{1}{16} = 6\frac{1}{4}\%$

Drill Exercises

Find:

- | | |
|-------------------------------------|-----------------------------------|
| 1. $12\frac{1}{2}\%$ of 96 lb. | 11. 50% of \$ 6200. |
| 2. 20% of 90 mi. | 12. 25% of \$ 5200. |
| 3. 50% of 2000 lb. | 13. 75% of \$ 1600. |
| 4. 25% of \$ 60. | 14. $\frac{1}{2}\%$ of 6200. |
| 5. 75% of 400 yd. | 15. $\frac{1}{4}\%$ of 5200. |
| 6. $33\frac{1}{3}\%$ of 24 hr. | 16. $\frac{3}{4}\%$ of 1600. |
| 7. 30% of 200 A. | 17. $37\frac{1}{2}\%$ of \$ 2400. |
| 8. $66\frac{2}{3}\%$ of 300 pupils. | 18. 60% of \$ 1500. |
| 9. 25% of 1200 men. | 19. $83\frac{1}{3}\%$ of \$ 3660. |
| 10. $16\frac{2}{3}\%$ of \$ 3000. | 20. $14\frac{2}{7}\%$ of \$ 2100. |

Problems

1. A man borrows \$1200, and at the end of the year repays it, together with 6% of it for the use of it. How much does he pay?

2. A man invests \$9660 in a business enterprise that makes a profit of $8\frac{1}{3}\%$ of his investment. How much is his profit?

3. In some of the states in the southwest men pay as high as $16\frac{2}{3}\%$ for the use of borrowed money. At this rate, how much would a man pay for the use of \$4290?

4. In Idaho, where land is increasing rapidly in value, a man paid \$29.50 an acre for 40 acres of land that was not under cultivation. After holding it one year, he sold it at an increase of $66\frac{2}{3}\%$ of what it cost him. At what price did he sell it?

5. A farmer had a piece of wet land which produced a crop worth \$25 an acre. By tiling it so as to drain the water off, he increased the value of the crop $83\frac{1}{3}\%$. What was the value of the crop per acre after the land was tilled?

6. A real estate dealer claimed that if I invested \$6000 in some Western land, it would yield me a profit of $33\frac{1}{3}\%$ in two years. How much would the profit be?

7. Of the 840 bu. of apples taken from an orchard, $14\frac{2}{7}\%$ were defective. How many bushels were marketable?

8. If $12\frac{1}{2}\%$ of the apples put into a large storage house spoil, and 1240 bu. are stored, how many bushels spoil?

9. If $33\frac{1}{3}\%$ of the weight of meat is lost in shrinkage when cooked, what ought a ham weighing 12 lb. when raw to weigh when baked?

10. If $37\frac{1}{2}\%$ of a chicken is waste, how much edible matter in a chicken weighing 4 lb. 8 oz.?

11. If $62\frac{1}{2}\%$ of a certain soil is fine sand, how much sand in a load containing 32 cu. ft.?

12. In a load of soil containing 28 cu. ft., $14\frac{2}{7}\%$ is fine sand, 25% coarse sand, and $12\frac{1}{2}\%$ gravel. Find the number of cubic feet of each in the load.

13. The percentage of nutritive matter in butternuts is $12\frac{1}{2}\%$. Find the amount of food in 12 lb. of butternuts.

14. Alfalfa hay contains about $14\frac{2}{7}\%$ protein, and red clover hay about $12\frac{1}{2}\%$ protein. How much more protein (the real nutritive part of the hay) in a ton of alfalfa than in a ton of red clover?

27. A RELATION EXPRESSED AS PER CENT

A *per cent*, like any other fraction, expresses a relation between two quantities. Likewise, the relation between two numbers, or their *ratio*, is often expressed in terms of *per cent*. Thus, instead of saying that $\frac{1}{4}$ of the cost was gained in selling an article, one may say that 25% of the cost was gained.

Exercises and Problems

1. Compare 2 and 4; thus, 2 is $\frac{1}{2}$ or 50% of 4; 4 is 2 times or 200% of 2.
2. Compare 3 and 6; 2 and 8; 3 and 12.
3. 5 is what part of 20? What per cent of it?
4. 16 is what part or per cent of 48? \$24 is what part of \$36? What per cent?
5. 12 ounces is what part of a pound? What per cent?
6. 800 lb. is what part of a ton? How many 100ths of a ton, or per cent, is it?
7. 16 is what per cent of 40?
8. 48 is what per cent of 64?
9. 90 is what per cent of 144?
10. 35 is what per cent of 105?
11. 20 is what per cent of 40? Of 60? Of 120? Of 400?
12. 45 is what per cent of 90? Of 180? Of 450? Of 900?
13. 60 is what per cent of 180? Of 300? Of 1200?

14. 30 is what per cent of 90? Of 120? Of 150? Of 210? Of 240?

15. George bought a \$32 canoe for \$28. What per cent of discount did he get?

16. When a man sells bananas for 20¢ a dozen that cost him 15¢, what per cent of the cost is he making?

17. When the cost of porterhouse steak is increased from 24¢ to 28¢ a pound, what is the per cent of increase?

DRILL TABLE

What per cent of:

1. 10 is 5?	9. 90 is 30?	17. 25 is $8\frac{1}{3}$?
2. 20 is 5?	10. 28 is 7?	18. 100 is 30?
3. 24 is 8?	11. 56 is 7?	19. 200 is 150?
4. 32 is 8?	12. 60 is 40?	20. 300 is 24?
5. 50 is 10?	13. 90 is 45?	21. 300 is 75?
6. 60 is 20?	14. 25 is $12\frac{1}{2}$?	22. 400 is 40?
7. 75 is 25?	15. $37\frac{1}{2}$ is $12\frac{1}{2}$?	23. 400 is 60?
8. 80 is 40?	16. $16\frac{2}{3}$ is $8\frac{1}{3}$?	24. 400 is 160?

Miscellaneous Problems in Percentage

1. A merchant sold a pair of shoes for \$5 that cost him \$3.50. What was his gain per cent?

SOLUTION

$$\begin{array}{r}
 \$5.00 \\
 \underline{\$3.50} \\
 \$3.50) \$1.50(0.428\bar{6} \\
 \underline{1.400} \\
 1000 \\
 \underline{700} \\
 300 \\
 \underline{350} = \frac{6}{7}
 \end{array}$$

EXPLANATION.—The ratio of the gain to the cost is found by dividing. Since the result is wanted in *per cent*, the quotient is carried to *hundredths*, and the remainder is expressed as a common fraction. Then the gain is $42\frac{6}{7}\%$. The division might have been carried to four decimal places thus, $0.4286-$
Then $0.4286- = 42.86-\%$.

2. The wages of the men in a certain factory are to be raised 20% from their present scale. How much will a man get after the advance who was getting \$2.25 before it?

3. The Tariff Act of 1909 placed a duty of 40% upon the value of imported kitchen utensils. What was the duty upon a bill valued at \$980?

4. A mason estimates that the material for a certain cement walk will cost \$75, and that the labor will cost 25% more than the material. At what price must he take the job to make 20% of the total cost of material and labor?

5. To find the number of "board feet" of lumber in any 3-in. flooring $33\frac{1}{3}\%$ of the area to be covered is added to allow for the waste in the "tongue-and-groove." Find how much flooring is required for the two floors of a building $36' \times 48'$.

6. From a sheet of straw board $22\frac{1}{2}'' \times 28''$ a boy cuts book covers $7\frac{1}{2}'' \times 5''$. How many can be cut from 1 sheet? What per cent of each sheet is waste?

SUGGESTION. — Compare the area wasted with the area of the sheet.

7. What per cent is waste when $5'' \times 7''$ covers are cut from sheets $21'' \times 28''$?

8. In making a hammered brass article, a piece of brass containing 17 sq. in. is cut from a sheet 4 in. wide and 5 in. long. What per cent of the material is wasted?

9. A copper ornament containing $8\frac{1}{2}$ sq. in. is cut from a sheet of copper 2 in. by 5 in. What per cent of the metal is wasted?

10. A class in clay work was provided with 15 lb. of plastina for use in modeling. When the work was finished and the plastina put away, it weighed only $12\frac{1}{2}$ lb. What per cent of it was wasted?

11. In his examinations in arithmetic a boy had 10 problems out of 12 right. His grade was what per cent?

12. In his history examination he answered 6 questions out of 8 correctly. What per cent was his grade in history?

13. In spelling, he had 27 words right out of 30. What per cent was his grade in spelling?

14. In a school of 320 children, 145 were boys. What per cent were girls?

15. In this school the average daily attendance was 305. What was the per cent of attendance?

16. The amount of raw silk produced by the whole world in one year was 48,634,000 lb. Of this Japan produced 14,043,000 lb. What per cent of the world's product did Japan produce?

17. The year that the wheat crop of the entire world was 3,624,418,000 bu., the United States produced 737,189,000 bu. What per cent of the world's wheat crop was produced by the United States?

18. The year that the corn crop of the entire world was 3,478,328,000 bu., the United States produced 2,668,651,000 bu. What per cent of the world's corn crop was produced by the United States?

19. A man invested \$18,500 in business and his profit for a year was \$2250. The profit was what per cent of the investment?

20. A farmer who had a farm valued at \$20,000 made from it in one year \$1700. What per cent of the value did it yield?

21. Which is the better investment, an investment of \$12,000 with a profit of \$960, or an investment of \$16,500 with a profit of \$1155?

22. In 1908 the amount of rice grown in the United States was 21,889,620 bu. Of this Louisiana produced 11,550,000 bu. What per cent of the whole crop did Louisiana produce?

23. In 1908–1909 the total amount of cane sugar produced by the world was 7,342,854 T. Of this, the United States produced 1,045,000 T. What per cent of the world's product did the United States produce?

24. The total amount of beet sugar produced by the world the same season was 6,889,218 T. The United States produced 380,000 T. of this. What per cent of the beet sugar did the United States produce?

25. In 1905 there were 3610 cheese factories in the United States. Of these 1454 were in Wisconsin. What per cent of all the cheese factories were in Wisconsin?

26. At the same time Wisconsin had 902 out of the 5235 butter factories in the United States. What per cent of these were in Wisconsin?

27. According to the Underwood-Simmons Tariff Law, which was passed in 1913, the duty on all decorated china-ware bought abroad by people of the United States is 40 % of its value. If Siegel & Cooper buy a set of china dishes in Europe for \$28, what duty must they pay on them to get them admitted to the United States? If they add \$10 to cover their expenses and profits, how much must you pay for that set of dishes?

28. The duty on undecorated chinaware is 35 %. A set of dishes of this kind bought in Europe for \$18 costs a merchant how much duty to get it into the United States? Allowing \$8.50 for profit, etc., how much must you pay him for these dishes?

29. The duty on opera glasses, telescopes, etc., is 35% of their value. What would be the duty on a pair of opera glasses costing \$2 in Europe?

30. The duty on imported automobiles is 30%. If your father bought an automobile in Paris for \$1650, what duty would he have to pay to get it into the United States?

31. The duty on pocket knives valued at more than \$1 a dozen is 35% of their cost abroad. Allowing the local merchant 10¢ for profit, etc., how much must you pay him for a knife that cost 25¢ in Dublin?

32. For a double-barreled shotgun valued at \$8 in Germany the duty is 35% of the value. Allowing the merchant of whom you buy it \$3 for handling it, how much must you pay for the gun?

33. The duty on Nottingham lace window curtains, made of cotton and other vegetable fiber, is 35%. What is the duty on curtains that cost \$7.50 per pair abroad?

34. The duty on toys is 35%. If a mechanical toy costs 20¢ in Germany, and you allow the merchant of whom you buy it 8¢ for profit, how much must you pay for it?

35. Find the saving in per cent by buying during this sale.

Parlor Suites

Saturday, Last Day
Of The Sale

One more chance left you to buy a beautiful, substantial, up-to-date parlor suite of three or five pieces away under the usual price.

\$55 Parlor Suites for . \$35	\$97 Parlor Suites for . \$58
\$60 Parlor Suites for . \$38	\$128 Parlor Suites for . \$75
\$68 Parlor Suites for . \$40	\$161 Parlor Suites for . \$100
\$94 Parlor Suites for . \$55	\$204 Parlor Suites for . \$125

36. The accompanying table gives the average weights of boys and girls at different ages, found from thousands of measurements. Find the per cent of increase in weight from year to year of both boys and girls.

AGE	WEIGHT IN POUNDS	
	Boys	Girls
9	50.0	47.1
11	59.8	56.6
13	75.8	72.7
15	96.4	89.0
17	116.6	104.4

37. Find the per cent of increase in the population of each of the following cities from 1900 to 1910 :

CITY	POPULATION IN 1900	POPULATION IN 1910
Cleveland, O.	381,768	560,663
New Orleans	287,104	339,075
Lowell, Mass.	94,969	106,294
Wilkesbarre, Pa.	51,721	67,105
Terre Haute, Ind.	36,673	58,157

28. PROFIT AND LOSS

It is common in any business transaction to compute the *profit or loss* as a certain per cent of the cost of the articles sold.

Thus, if a merchant makes 25% of the cost of a suit for which he paid \$16, his profit is \$4.

If he sold a suit for \$20 that cost him \$16, he made \$4, which is $\frac{1}{4}$ of the cost, or his gain is 25%.

Problems in Profit and Loss

1. A merchant bought a suit for \$12, and sold it at a gain of 30%. How much did he gain? For how much did he sell it?

2. A dealer gained \$3 upon goods that cost him \$15. His gain was what part of the cost? What per cent of it?
3. A book cost the dealer \$2, and he sold it at a gain of 40%. How much did he gain? For how much did he sell it?
4. If a dealer buys a book for \$3 and sells it for \$4.20, how much does he gain? What part of the cost is this? What per cent of it?
5. By selling a suit for \$24, a dealer made \$8. What did the suit cost? The gain was what part of the cost? What per cent of it?
6. A house and lot that cost \$8000 were sold for \$10,000. What per cent was gained?
7. A man sold a house and lot for \$6000, which was \$1000 more than it cost him. What per cent did he make?
8. By selling a stock of goods for \$8000 a merchant lost \$2000. What per cent did he lose?
9. A grocer paid 80¢ a bushel for potatoes and sold them for 30¢ a peck. What was his per cent of gain?
10. An article costing \$18.50 was sold at a gain of 20%. Find the gain and the selling price.
11. Mr. Ward bought a city lot for \$1600, but when he sold it he could get only \$1400 for it. What per cent did he lose?
12. If a dealer pays \$38.40 per dozen pairs for shoes, for how much a pair must he sell them to make 25% of the cost?
13. A merchant buys coal at \$6.25 a ton, including the cost of delivery, and sells it at \$7.50. If he loses 2% in bad debts, what is his net rate of gain?
14. A merchant's sales for the year amounted to \$75,000. His average gross gain was $12\frac{1}{2}\%$ of the sales. Clerk hire

was \$2400, and sundry expenses were \$1250. Find the net gain.

15. A grocer bought 2000 bu. of potatoes at 45¢ a bushel. $\frac{3}{4}$ of them were sold at a gain of 20%; the remainder at a loss of $11\frac{1}{9}\%$. Find the average rate of gain upon all.

16. A dealer bought 25 boxes of oranges of 144 each at \$3.50 per box. In all, he found 120 decayed ones. At what price per dozen must he sell the remainder to gain 25% of the total cost?

17. A grocer bought 250 pounds of raw coffee beans at $14\frac{1}{4}$ cents a pound. In roasting, it lost 25% of its weight. He sold the roasted coffee at 22 cents a pound. How much did he make? What per cent of the cost did he make?

18. A merchant bought 2000 pounds of sugar at $4\frac{1}{2}$ ¢. If the loss in drying out, down weights, etc., was 10% of the amount bought, what per cent did he make by selling at 6¢?

19. A merchant bought coffee at 22 cents a pound and sold it for 35 cents. What per cent does he make if he loses 5% in bad debts?

20. One year a merchant sold goods that cost him \$1500 at an average advance of $33\frac{1}{3}\%$ of the cost, but lost 2% from bad debts. Find his net rate of gain.

21. A man bought a farm for \$8000. He then ditched it at an expense of \$450. He built on it a house costing \$2600 and a barn costing \$1850. What was his total investment? At what price must he sell it if he wishes to make a profit of 8% of his investment?

22. A buyer bought a carload of hogs, weighing 14,500 lb., at \$8 a hundredweight, and shipped them to the city market. They lost 200 lb. in shipping. He then sold them at \$8.50 a hundredweight. What per cent did he gain?

23. A man bought some city lots for \$12,600. He paid taxes on them for two years, amounting to \$302.40. Then during a money panic he had to sell them for \$11,000. What per cent of the first cost was his loss?

24. The owner of a delicatessen shop buys 8 lb. of beef at 22¢ a pound. When he roasts it, it shrinks 30% of its weight. At what price must he sell it to gain 20%?

25. He buys a ham weighing 14 lb. at 20¢ a pound. When he bakes it, it loses 35% of its weight. At how much a pound must he sell it to make a profit of 25%?

26. Let each pupil make and give to the class an original practical problem in profit and loss.

By inspection, find the loss or gain:

	COST	RATE OF PROFIT OR LOSS	PROFIT OR LOSS		COST	RATE OF PROFIT OR LOSS	PROFIT OR LOSS
1.	\$ 3000	20 %		19.	\$ 4200	16 $\frac{2}{3}$ %	
2.	\$ 6500	40 %		20.	\$ 10,800	11 $\frac{1}{9}$ %	
3.	\$ 8200	10 %		21.	\$ 6500	50 %	
4.	\$ 9600	12 $\frac{1}{2}$ %		22.	\$ 7800	20 %	
5.	\$ 1250	30 %		23.	\$ 1800	25 %	
6.	\$ 1800	16 $\frac{2}{3}$ %		24.	\$ 4200	16 $\frac{2}{3}$ %	
7.	\$ 3690	33 $\frac{1}{3}$ %		25.	\$ 600	25 %	
8.	\$ 2400	66 $\frac{2}{3}$ %		26.	\$ 800	12 $\frac{1}{2}$ %	
9.	\$ 3200	12 $\frac{1}{2}$ %		27.	\$ 450	20 %	
10.	\$ 2400	37 $\frac{1}{2}$ %		28.	\$ 500	30 %	
11.	\$ 3200	62 $\frac{1}{2}$ %		29.	\$ 600	15 %	
12.	\$ 2700	66 $\frac{2}{3}$ %		30.	\$ 1200	25 %	
13.	\$ 8400	8 $\frac{1}{3}$ %		31.	\$ 1500	20 %	
14.	\$ 4800	6 $\frac{1}{4}$ %		32.	\$ 1600	10 %	
15.	\$ 2800	2 $\frac{1}{2}$ %		33.	\$ 2100	20 %	
16.	\$ 1600	15 %		34.	\$ 2500	8 %	
17.	\$ 9600	25 %		35.	\$ 3200	6 $\frac{1}{4}$ %	
18.	\$ 3500	14 $\frac{2}{7}$ %		36.	\$ 2400	12 $\frac{1}{2}$ %	

By inspection, find the rate of loss or gain :

	COST	PROFIT OR LOSS	RATE		COST	PROFIT OR LOSS	RATE
1.	\$10,000	\$1000		17.	\$7500	\$3750	
2.	\$1500	\$500		18.	\$9000	\$1500	
3.	\$2400	\$600		19.	\$8000	\$2000	
4.	\$1500	\$750		20.	\$1200	\$300	
5.	\$1200	\$600		21.	\$100	\$21	
6.	\$3600	\$600		22.	\$200	\$38	
7.	\$5000	\$600		23.	\$400	\$36	
8.	\$5000	\$750		24.	\$1000	\$120	
9.	\$9600	\$1600		25.	\$1200	\$120	
10.	\$6000	\$1500		26.	\$2000	\$600	
11.	\$9000	\$4500		27.	\$1500	\$450	
12.	\$2800	\$400		28.	\$750	\$150	
13.	\$6400	\$800		29.	\$600	\$150	
14.	\$7200	\$800		30.	\$800	\$160	
15.	\$6300	\$900		31.	\$900	\$72	
16.	\$7500	\$2500		32.	\$1800	\$360	

29. COMMISSION

The money paid by one person, called the *principal*, to another, called the *agent*, for transacting business, is called **commission**.

The commission is usually reckoned as a per cent of the money involved. Thus, an agent gets a per cent of the money received for goods sold, or of the cost of goods bought, or of the amount of money collected.

Commission is sometimes reckoned upon the quantity sold, as so much per bushel, car, pound, etc.

A merchant who sells and *handles* the goods sold on commission is called a **commission merchant**. If an agent merely arranges for purchases or sales of goods for another, *without actually receiving and delivering them*, he is called a **broker**.

Thus, if a commission merchant of Chicago sells for an apple grower in Colorado a carload of apples to a fruit firm in Chicago, he receives the apples and delivers them to that firm. But a Chicago *broker* will sell a carload of wheat for a St. Paul firm to another broker who represents a firm in Cleveland, and the wheat will be shipped directly to Cleveland, from St. Paul.

Problems and Exercises in Commission

1. A salesman sold \$75,500 worth of goods one year. His commission was $7\frac{1}{2}\%$ of his sales. What did he earn?
2. A salesman sold \$60,000 worth of goods one year, and received a commission of \$3600. What was his rate of commission?
3. What is the yearly income of a salesman who sells \$60,000 worth of goods at $7\frac{1}{2}\%$ commission? If his expenses are \$150 per month, what is his net income?
4. A salesboy was offered his choice of the following: \$8.50 a week; \$5 a week and 1% of his sales; or 4% of his sales. He chose the last: His sales averaged \$265 per week. How much better than \$8.50 a week is this? How much better is this for the year, if he worked 50 weeks?

DRILL TABLE

No.	SALES	RATE	COM.	No.	SALES	RATE	COM.
5.	\$85,000	4%		10.	\$345,000	2%	
6.	\$75,000	$8\frac{1}{3}\%$		11.	\$95,000	$12\frac{1}{2}\%$	
7.	\$96,000	$6\frac{1}{4}\%$		12.	\$42,000	5%	
8.	\$24,000	25%		13.	\$65,000	15%	
9.	\$36,000	20%		14.	\$72,000	8%	

15. An agent bought 500 barrels of apples for me at \$1.20 per barrel. Find his commission at 3%. How much per barrel did it add to the cost?

16. My agent bought a carload (720 bu.) of potatoes for me at 40 cents a bushel, commission $2\frac{1}{2}\%$. What was his commission? How much per bushel did it add to the cost? If freight, drayage, and other expenses are 9 cents a bushel, for how much a bushel must I sell them to make 30%?

17. A Chicago broker sold for a shipper in Minneapolis 8500 bu. of Minnesota wheat to a miller in Toledo. His commission or brokerage was $\frac{1}{8}\%$ a bushel. How much was his commission on the sale?

18. He sold for a shipper in Kansas City 7600 bu. of corn to a firm in Cincinnati at a commission of $\frac{1}{8}\%$ a bushel. What was his commission on this sale?

19. A commission merchant sold a consignment of Colorado apples to a firm for \$350, and charged 5%. What was his commission?

20. A real estate agent sold my house for me at $2\frac{1}{2}\%$ commission. What was his fee, if the house sold for \$9750?

21. During August and September, Jenkins & Marshall, real estate brokers, sold 5 houses for the following sums: \$9500; \$7750; \$11,500; \$8750; \$6750. How much did they make at $2\frac{1}{2}\%$ commission?

22. A man took orders for a grocery firm at $12\frac{1}{2}\%$ of his sales. One month his orders amounted to \$1436. How much did he earn? His orders averaged \$1020 per month for the year. How much did he make per year?

23. In Oklahoma a man drives through the country and small towns, and takes orders for coffee, tea, spices, etc., for a firm in Minneapolis, Minn. He receives 35% of his sales

for commission. One week his orders amounted to \$128. What was his commission?

24. If his sales amounted to an average of \$120 a week, what would he earn in a year of 52 weeks?

25. A lawyer charges $2\frac{1}{2}\%$ for collecting money from a debtor for a client. What would be his fee for collecting a debt of \$7000?

26. What would be his fee if he charged 3% for collecting a debt of \$1260?

27. For settling an estate a lawyer charges 2% of the amount of money involved in the estate. What would be his fee for settling an estate amounting to \$65,278?

30. "MARKING DOWN" GOODS

Sometimes goods are marked to sell at a certain per cent of profit, but for some reason must be sold at a reduction from the marked price. The problem in such cases is to find the net loss or gain.

Problems in "Marking Down" Goods

1. Goods costing \$250 were marked to sell at a gain of 40%, but were sold at 25% less than marked. Find the gain.

2. Shoes costing \$30 per dozen pairs were marked to sell at a gain of 50%, but were sold for "a quarter off," that is, at a reduction of 25% from the marked price. What was the gain or loss on each pair?

3. Boys' suits costing \$60 per dozen were marked to sell at a gain of 40%, and sold at "a quarter off." What was gained?

4. An article costing \$3.50 was marked at an advance of 20 % and marked down 10 %. Find the gain.

5. Goods costing \$80 were marked to sell at 40 % gain, but were marked down 10 %. What per cent of the cost was gained?

6. Goods costing \$350 were marked at 20 % above cost and then sold at 10 % off. What per cent was gained?

7. How much is lost by marking an overcoat that cost \$24 at 50 % above cost, then selling it at 40 % off?

8. What per cent is gained by marking a suit that cost \$18 at 40 % above cost and then selling it at 20 % off?

9. A merchant made \$1.50 when selling an \$18 overcoat at "a quarter off." At what per cent of profit had he marked it?

10. A milliner received a lot of untrimmed hats costing \$2.50 each, which she marked to sell at a profit of 50 %. She later marked them down 20 % for "a bargain sale." What was her profit on each? What per cent profit did she make?

11. A clothier made \$1.80 when selling a boy's suit marked \$12 at "a quarter off." At what per cent of profit had he marked it?

12. A dealer received an invoice of \$3500 worth of goods which he marked $33\frac{1}{3}$ % above cost. He then marked them down 10 % for "a bargain sale." What was his profit? What per cent of profit did he make?

13. Smith and Foster sold a set of table-ware marked at \$120 at 25 % less than the marked price and still made \$18. Required the cost price.

14. If the marked price of the table-ware had been \$150, what would the per cent above cost have been?

DRILL TABLE

Fill out this table:

No.	COST PRICE	RATE OF GAIN	PROFIT	MARKED PRICE	RATE OF REDUCTION	SELLING PRICE	NET LOSS OR GAIN
15.	\$ 3.50	20 %			10 %		
16.	\$ 7.60	25 %			$12\frac{1}{2}$ %		
17.	\$ 10.50	$33\frac{1}{3}$ %			$2\frac{1}{2}$ %		
18.	\$ 3.60	$33\frac{1}{3}$ %			10 %		
19.	\$ 9.60	$16\frac{2}{3}$ %			5 %		
20.	\$ 16.40	20 %			8 %		
21.	\$ 24.80	40 %			25 %		
22.	\$ 16.50	45 %			$16\frac{2}{3}$ %		
23.	\$ 17.20	50 %			$12\frac{1}{2}$ %		

24. What per cent profit do I make by marking goods at 50 % above cost and then discounting the marked price 20 % ?

SOLUTION

$$\begin{array}{r}
 5)150 \% \\
 \underline{30 \%} \\
 120 \% \\
 \underline{100 \%} \\
 20 \%
 \end{array}$$

EXPLANATION. — The goods were marked to sell at 150 % of the cost. They were marked down 20 %, or $\frac{1}{5}$ of the marked price. $\frac{1}{5}$ of 150 % of the cost is 30 % of the cost. Hence, the goods sold for 120 % of the cost, or at a gain of 20 %.

25. Do I make or lose by marking goods to sell at a profit of 50 % and selling at “one third off” ?

26. Some goods were marked 60 % above cost. At a bargain sale they were sold at “a quarter off.” What per cent did the dealer make ?

27. If a merchant marks his goods to sell at a gain of 30 %, but has to sell them at 30 % from the marked price, what per cent does he lose ?

DRILL TABLE

Give the rate of loss or gain :

No.	MARKED RATE OF GAIN	RATE OF REDUCTION	RATE OF LOSS OR GAIN	No.	MARKED RATE OF GAIN	RATE OF REDUCTION	RATE OF LOSS OR GAIN
1.	50 %	20 %		10.	30 %	20 %	
2.	40 %	10 %		11.	50 %	33 $\frac{1}{3}$ %	
3.	40 %	16 $\frac{2}{3}$ %		12.	40 %	25 %	
4.	50 %	16 $\frac{2}{3}$ %		13.	30 %	25 %	
5.	33 $\frac{1}{3}$ %	10 %		14.	20 %	8 %	
6.	20 %	12 $\frac{1}{2}$ %		15.	25 %	16 $\frac{2}{3}$ %	
7.	40 %	12 $\frac{1}{2}$ %		16.	33 $\frac{1}{3}$ %	20 %	
8.	50 %	8 %		17.	60 %	40 %	
9.	60 %	35 %		18.	60 %	25 %	

31. TRADE DISCOUNT

It is a custom among certain wholesale dealers, manufacturers, and publishers; to fix a price on their goods, called the *list price*, and then to allow a certain deduction from this price to purchasers. The list prices are generally printed in catalogues. A deduction is often made from a bill of goods if paid within a limited number of days. This deduction is called *trade discount*. The price after the amount of the discount is deducted is called the *net price*.

Problems in Trade Discount

1. What will a bill of goods listed at \$90 cost, if the discount is 20 %?
2. Goods listed at \$150 were sold for \$120. What was the rate of discount?
3. A bill of \$1600 was discounted at 30 %. What was the net price?

4. What is the rate of discount when a piano listed at \$800 sells for \$600?

5. By paying cash a merchant may save 5%. How much is this on a bill of \$2400?

6. I buy a bill of goods amounting to \$68.50. By paying the bill within 10 days I am allowed a discount of 2%. How much do I pay, if I pay within this time?

7. A bill for erasers and crayon bought by a school amounted to \$12.40. If a discount of 12% was allowed, what was the net price?

8. The ice company sells a 1000-pound ticket for \$3.50. If you pay for it in advance, you get it for \$3. What rate of discount do you get by paying in advance?

9. A bill of goods listed at \$375 was sold at 22% off. Find the net price.

10. I got a discount of \$294 from a bill of goods listed at \$840. What was the rate of discount?

11. I bought goods that were listed at \$1150 for \$920. What rate of discount was this?

DRILL TABLE A

Find the net price :

	LIST PRICE	RATE OF DISCOUNT	NET PRICE		LIST PRICE	RATE OF DISCOUNT	NET PRICE
1.	\$ 40	25 %		9.	\$ 240	$8\frac{1}{3}$ %	
2.	\$ 65	20 %		10.	\$ 640	$12\frac{1}{2}$ %	
3.	\$ 150	$33\frac{1}{3}$ %		11.	\$ 750	20 %	
4.	\$ 600	$16\frac{2}{3}$ %		12.	\$ 800	40 %	
5.	\$ 960	$16\frac{2}{3}$ %		13.	\$ 900	$11\frac{1}{9}$ %	
6.	\$ 175	10 %		14.	\$ 420	$14\frac{2}{7}$ %	
7.	\$ 450	$16\frac{2}{3}$ %		15.	\$ 1200	$16\frac{2}{3}$ %	
8.	\$ 960	$33\frac{1}{3}$ %		16.	\$ 720	25 %	

DRILL TABLE B

Fill out the table :

	LIST PRICE	RATE OF DISCOUNT	DISCOUNT	NET PRICE		LIST PRICE	RATE OF DISCOUNT	DISCOUNT	NET PRICE
1.	\$ 465	20 %			8.	\$ 950		\$ 96	
2.	\$ 970	33 $\frac{1}{3}$ %			9.	\$ 1050		\$ 175	
3.	\$ 1640	40 %			10.	\$ 1260			\$ 1050
4.	\$ 1830	5 %			11.	\$ 940		\$ 23.50	
5.	\$ 1960	2 $\frac{1}{2}$ %			12.	\$ 630			\$ 598.50
6.	\$ 3470	5 %			13.	\$ 126			\$ 108
7.	\$ 1698	16 $\frac{2}{3}$ %			14.			\$ 236.25	\$ 708.75

32. BILLING GOODS TO "THE TRADE"

The following problems show the forms of bills sent to purchasers where discounts are deducted.

Problems

1. Check the following bill :

				CHICAGO, ILL., May 1, 1910.	
W. D. Williams & Co.,					
Urbana, Ill.					
Bought of A. G. SPAULDING & BROS.					
ATHLETIC GOODS, 147 WABASH AVE., CHICAGO.					
TERMS: NET CASH.					
3	Doz. Tennis Rackets	\$18.00	54	00	
6	Doz. Tennis Balls	3.25	19	50	
$\frac{1}{2}$	Doz. Tennis Nets	17.60	8	80	
			82	30	
Less 10%			8	23	
				74	07

2. Complete the following :

INDIANAPOLIS, IND., July 6, 1911. Mr. R. H. Brabb, Springfield, Mo.					
Bought of HOLLWEG & REESE IMPORTERS OF CHINA, GLASS, AND QUEENSWARE					
TERMS: 60 days or 2% off 10 days.					
6	Doz. 5274 Plates	\$2.25	*	*	
6	“ “ Teas	2.50	*	*	
$\frac{7}{12}$	“ “ Coffee Cup Only	2.40	*	*	
6	“ “ Fruit	1.50	*	*	
2	“ “ Deep Coup. Soup	2.00	*	*	
1	Only “ Covd. Dish	1.65	*	*	
3	“ “ Casseroles	1.65	*	*	
			*	*	
	Less 10%		*	*	
					* *
2	Doz. 19,783 H. & Co. Fruit	3.19	*	*	
2	Only “ Baker	1.50	*	*	
2	“ “ Lobster Salad	1.69	*	*	
			*	*	
	Less 25%		*	*	
					* *
	Pkg.			50	* *
					* *

Make out bills for the following, using the name “Board of Education” of some town, and the name of some dealer. Supply dates. Acting as clerk for the dealer you may receipt the bill in proper form.

3. Permanent equipment for a class of 42 pupils in a primary school, discount 25 % :

42 pr. scissors	@ \$3.00	per doz.
42 compasses	@ 1.20	per doz.
42 rulers	@ 2.00	per 100
42 triangles	@ 0.09	
3 punches	@ 0.40	
paper cutter	3.00	
boxes, etc.	4.20	

4. Supplies for the same class, discount $12\frac{1}{2}\%$:

250 sheets cardboard	22 × 28	@ 90¢	per 100 sheets
400 sheets cover-paper		@ \$2.50	per 100 sheets
100 sheets strawboard	22 × 24	@ \$2	per 100
42 sheets pressboard	24 × 32	@ 70¢	per doz.
$\frac{1}{2}$ ream manila tag	22 × 28	@ \$7.50	per ream
1 roll leatheret	30 yd.	@ 25¢	per yard
50 tubes glue		@ 7¢	per tube
2 doz. tubes photo paste		@ \$1.00	per doz.

5. Bill the following supplies at a discount of 20%:

4 doz. Le Page's glue, 4-oz. cans	@ \$1.30
10 pkg. folding paper	4 × 4 @ 6¢
8 pkg. colored paper	6 × 9 @ 20¢
2 pkg. cartridge paper, assorted	14 × 18 @ 60¢
8 pkg. manila drawing paper, gray	8 × 10 $\frac{1}{2}$ @ 15¢
4 doz. rulers, 12-in. brass edge	@ 40¢
5 Higgins's liquid paste, 14-oz. jars	@ 28 $\frac{1}{2}$ ¢

6. Equipment for a class of 30 pupils in Sloyd work, discount 20%:

30 Sloyd knives	@ \$4.05	per doz.
30 6-in. try-squares	@ 1.58	per doz.
30 compasses	@ 1.00	per doz.
30 T-squares	@ 63¢	per doz.
30 45-degree triangles	@ 50¢	per doz.
30 30-60-degree triangles	@ 50¢	per doz.
30 rulers	@ 12¢	per doz.
30 pencils	@ 24¢	per doz.
30 trays	@ \$8.10	per doz.

7. The equipment for a class of 36 pupils in bent-iron work, discount $33\frac{1}{3}\%$:

36 flat-nose pliers, No. 5	@ \$2.00 per doz.
36 round-nose pliers, No. 5	@ 2.10 per doz.
1 cutting machine	4.75
36 rulers	0.36

8. Supplies for a class of 36 pupils in bent-iron work, discount $33\frac{1}{3}\%$:

3500 binders	@ 10 ¢ per 100
15 50-ft. coils $\frac{1}{4}$ inch iron	@ 20 ¢
3 tubes black paint	@ 25 ¢
50 pencils	@ 2 ¢

Workshop Problems

1. Make out a bill for the following set of tools, with 5% discount for cash:

1 work bench	@ \$9.00	1 2-foot rule	@ \$0.35
1 No. 5 jack plane	@ 2.09	1 7" try-square	@ .40
1 No. 2 smoothing plane	@ 1.66	1 8" bevel	@ .44
1 26" rip saw	@ 1.40	1 pair 6" dividers	@ .35
1 24" compass saw	@ .90	1 nail set	@ .10
1 set chisels, $\frac{1}{4}$ ", $\frac{1}{2}$ ", 1"	@ 1.44	1 marking gauge	@ .30
1 $\frac{1}{2}$ " gouge	@ .37	1 rubber mallet	@ .65
1 hammer	@ .65	1 coping saw	@ .20
1 hatchet	@ .56	1 oil stone	@ .35
1 ratchet brace	@ 1.76	2 No. 2 hand screws, each	@ .30
1 set auger bits $\frac{1}{4}$ ", $\frac{3}{8}$ ", $\frac{1}{2}$ "	@ 1.38	1 can glue	@ .25
2 gimlet bits, each	@ .10	1 drawknife	@ .55
1 counter sink	@ .23	1 sq. reamer	@ .20
1 5" screwdriver	@ .35	1 coes wrench	@ .50
1 plumb and level	@ .90	1 file	@ .27

2. The above set can be purchased complete for \$24. What per cent is saved in buying the complete set instead of paying the price found in Ex. 1?

3. The following is the cost of Le Page's liquid glue :

$\frac{1}{2}$ pt.	\$ 0.30	1 qt.	\$ 0.80	1 gal.	\$ 2.60
1 pt.	0.50	$\frac{1}{2}$ gal.	1.50	5 gal.	12.50

If large quantities of glue are used, what per cent is saved in buying in 1-pt. lots instead of $\frac{1}{2}$ -pt. lots? In $\frac{1}{2}$ -gal. lots instead of 1-pt. lots? In gallon lots instead of pint lots? In gallon lots instead of quart lots? In 5-gal. lots instead of quart lots? In 5-gal. lots instead of gallon lots?

4. No. 1 sandpaper costs \$ 3.38 per ream, \$ 0.20 per quire, \$ 0.10 per doz. Where large quantities of sandpaper are used, how much is saved per ream in buying in ream lots instead of quire lots? In quire lots instead of dozen lots? What is the percent of saving in each case?

NOTE.—24 sheets = 1 quire; 20 quires = 1 ream.

5. Emery paper costs \$ 4.63 per ream; emery cloth costs \$ 13.25 per ream. What is the difference in cost? What is the per cent of difference?

6. A No. 605 bed-rock plane costs \$ 2.09. The bed of a No. 605 plane costs \$ 1.50. In case the bed of the plane is broken, what per cent is saved in buying a new bed instead of having to buy an entire new plane?

7. A "frog" of a No. 605 plane costs \$ 0.30. If the frog should break, what per cent is saved in being able to buy a new frog instead of having to buy an entire new plane?

8. A $1\frac{1}{2}$ -lb. rubber mallet costs \$ 0.65. A 3-lb. rubber mallet costs \$ 1. What is the difference of cost in 12 of each? What per cent of difference?

9. 2-ft. wood-bar clamps with iron clamp screws sell for \$ 0.85 apiece or \$ 9 per doz. How much is saved in buying in dozen lots instead of single clamps? What is the per cent of saving?

10. A boy working with a dull plane can square up a board in 85 minutes, while a boy working with a sharp plane can do the same work in 40 minutes. What per cent of time is saved in working with a sharp plane?

Problems in Food Supplies

1. The weight of a live chicken is $4\frac{1}{4}$ lb. When dressed, it weighs only 3 lb. What per cent of live weight is waste?

2. The waste as follows is what per cent of the live weight; head and blood, 2 oz.; feathers, 4 oz.; feet, 2 oz.; entrails, 12 oz.?

3. The chicken described above, when boiled, weighed 1 lb. 12 oz. What per cent passed into broth?

4. Bones, skin, and surplus fat removed from cooked chicken weigh 14 oz. What per cent of the live weight are they? What per cent of edible solid remains?

5. At 15 cents per pound, live weight, what is the cost? At 18 cents, dressed, what is the cost?

6. At 15¢ a pound live weight, how much was the cost per pound of the solid, edible part remaining when cooked?

7. A lady keeping a delicatessen shop bought 60 lb. of dressed fowl at 18 cents a pound. They were cooked, bones were removed, and then were made into a "pressed chicken" loaf. If the loss in weight in cooking and pressing was 65%, at what price per pound must the chicken be sold to make $33\frac{1}{3}\%$? To make 25%? To make neither profit nor loss?

8. Potatoes contain 78% water; 2% proteid; 18% starch; 1% cellulose; 1% mineral salts.

In a bushel (weighing 60 lb.) what is the weight of each component part?

33. SIMPLE INTEREST

Money paid for the use of money is **interest**.

It is a certain *per cent* of the amount borrowed, called the **principal**. The **rate** quoted is for the use of the money for one year, even though the interest may be collected semi-annually or quarterly.

Drill

1. At 5%, how much is the interest of \$400 for 1 year? For 6 months? For 2 years? For 2 yr. 6 mo.?
2. At 6%, how much is the interest of \$500 for 1 year? For 2 years? For 2½ years? For 8 months, or ⅔ year?
3. At 5%, how much is the interest of \$800 for 1 year? For 6 months? For 3 months? For 9 months? For 1 yr. 3 mo.?

At 6%, what is the interest of:

- | | |
|---------------------|------------------------|
| 4. \$500 for 6 mo.? | 6. \$250 for 1 year? |
| 5. \$300 for 8 mo.? | 7. \$150 for 2½ years? |

At 5%, what is the interest of:

- | | |
|----------------------------|----------------------------|
| 8. \$800 for 1 yr. 6 mo.? | 11. \$400 for 2 yr. 3 mo.? |
| 9. \$200 for 2 yr. 6 mo.? | 12. \$800 for 1 yr. 9 mo.? |
| 10. \$300 for 2 yr. 8 mo.? | 13. \$700 for 4 years? |

Exercises

1. At 5%, what is the interest of \$540 for 2 yr. 7 mo.?

SOLUTION

$$\frac{31}{12} \times \frac{5}{100} \times \$540, \text{ or}$$

$$\frac{31 \times 5 \times \$540}{12 \times 100} = \$69.75$$

EXPLANATION. — $\frac{5}{100}$ of \$540 = the interest for 1 yr. Now 2 yr. 7 mo. = $\frac{31}{12}$ yr. Hence the total interest = $\frac{31}{12} \times \frac{5}{100} \times \540 .

Use cancellation when possible.

NOTE.—This is called the **general method** of finding interest.

Find the interest of:

2. \$5000 at 5% for 1 yr. 3 mo.
3. \$6040 at 4% for 1 yr. 8 mo.
4. \$7500 at 4% for 2 yr. 2 mo.
5. \$1240 at 6% for 1 yr. 9 mo.
6. \$4360 at 5% for 2 yr. 8 mo.
7. \$2500 at 4% for 1 yr. 4 mo.
8. \$6400 at 6% for 3 yr. 10 mo.
9. \$3785 at 6% for 4 yr. 6 mo.
10. \$7500 at 5% for 2 yr. 9 mo.
11. \$4850 at 4% for 3 yr. 1 mo.
12. \$1780 at 5% for 1 yr. 11 mo.

Interest for Years, Months, and Days

In computing interest for days, 30 days are considered an interest month, and 360 days an interest year.

Find the interest of:

1. \$4500 at 6% for 2 mo. 20 da.

SOLUTION

$$\frac{80}{360} \times \frac{6}{100} \times \$4500 = \$60.$$

EXPLANATION. — 2 mo. 20 da. =

80 da. · 80 da. = $\frac{80}{360}$ year.

2. \$9460 at 6% for 6 mo. 12 da.
3. \$1350 at 5% for 8 mo. 20 da.
4. \$3460 at 4% for 9 mo. 10 da.
5. \$4860 at 4% for 90 da.
6. \$6500 at 5% for 70 da.
7. \$1400 at 6% for 110 da.
8. \$3050 at 6% for 86 da.
9. \$5100 at 5% for 2 mo. 5 da.
10. \$1950 at 4% for 2 mo. 12 da.

11. \$2500 at 6 % for 1 yr. 2 mo. 20 da.
12. \$4675 at 4 % for 2 yr. 3 mo. 15 da.
13. \$3700 at 5 % for 1 yr. 8 mo. 8 da.
14. \$1280 at 6 % for 3 yr. 4 mo. 17 da.
15. \$6400 at 5 % for 2 yr. 1 mo. 21 da.

34. PROMISSORY NOTES

One who borrows money from another gives a written promise, called a **promissory note**, to repay the money at a given time. The rate of interest to be paid is also stated unless the interest is paid in advance.

A *promissory note* is used also in buying as well as in borrowing. It is used, too, in paying for services rendered. Thus, a man may buy a piece of machinery and give a promissory note to pay for it at some future time, say in six months or a year. In general, then, a promissory note is a written promise to pay for "value received," whether it is money, merchandise, or service.

The following is the common form of a promissory note :

<i>\$450</i>	<i>New York,.....Nov. 16,.....1910.</i>
<i>.....Six months.....after date...I...promise to pay to</i>	
<i>the order of R. M. Simpson.....</i>	
<i>Four Hundred Fifty.....Dollars.</i>	
<i>Payable at...Empire Bank.....</i>	
<i>Value received. Interest 6% per annum.</i>	
<i>---Henry Williams.---</i>	

Mr. Williams is called the **maker** of the note and Mr. Simpson the **payee**.

Exercises

1. Make out a promissory note in which you promise to pay William Robinson \$1250 in 3 yr. at 5%. Date it to-day.
2. Make out a promissory note for \$2500 at 6%, payable in 8 months, given by yourself to John Dowell. Date it to-day.
3. Make out such a promissory note as Richard Monroe would give you if you loaned him to-day \$5000 at 6%, to be repaid in 4 months.
4. Make out other notes, using whatever data you wish.

35. SECURITY

One who loans money or takes a note for property sold wishes, of course, to be reasonably secure from loss. That is, he wishes to be reasonably sure that the one owing the money will pay it when due.

Sometimes two or more sign the same note. Any one of those signing it thus becomes responsible for its payment. This method of securing a note is called **personal security**.

Sometimes the repayment is secured by the borrower making over certain *real estate* or *personal property* to the one of whom the money is borrowed. This is called a **mortgage**, and becomes void when the money is repaid.

When giving a note for property bought, a **lien**, or a form of mortgage, usually is given on the property.

Interest Exercises with Time to be Found

For method of finding the time between dates, see p. 71.

1. What is the interest of a note for \$275, dated July 27, 1909, and paid May 12, 1910, bearing interest at 6%?
2. What must I pay November 17, 1911, to take up my note for \$387, given March 25, 1910? Interest at 5%.

3. What is the value, on the 5th of January, 1910, of a 6 % note for \$475, dated June 18, 1909 ?

4. What must I pay on the 8th of December, 1910, to redeem my note for \$360, dated February 19, 1910 ? Interest at 6 %.

5. How much is due July 20, 1910, on a note for \$725, given October 6, 1909, with interest at 5 % ?

6. Find interest of \$7685, April 25 to November 11, 1910, at 5 %.

7. What is the amount of the principal and interest of \$2850 at 5 % from July 2, 1910, until December 25, 1910 ?

8. I took a 6 % mortgage of \$6000 on February 28, 1910. How much interest shall I receive by November 30, 1911 ?

9. If you loaned your father \$540 at 5 %, on March 12, 1911, and he paid it back to you on January 20, 1912, how much must he pay you in settlement ?

NOTE. — Pupils may pretend that they borrow money from each other and loan money to each other, a note being given in each case, and the interest being computed by both the pupil who loans and the one who borrows.

Problems in Interest

1. A man bought a city lot for \$2500, paying \$1000 cash and giving his note, secured by a mortgage on the property, at 6 %, payable in one year, for the balance. How much must he pay at the end of the year to cancel the note and mortgage?

2. A man bought a house for \$9500, paying \$3500 cash, and giving his note (and mortgage) for the balance at 5 %. How much a year is his interest ?

3. Instead of paying rent of \$40 a month, a man buys a house for \$6500. He pays \$2500 cash and gives his note at 6 % for the balance. If his taxes are \$70 a year, how much less are interest and taxes than rent ?

4. A man who is paying \$50 per month rent has \$3000 in the savings bank. The bank pays him 4% interest. Can he save money by buying a \$7000 house with the \$3000 and a 6% note, if taxes are \$65 a year, and repairs and other expenses are \$80? How much?

SUGGESTION.—How much a year is he now paying out in excess of the interest from the bank? How much will he pay out yearly in interest, taxes, and repairs? Which is more, and how much?

5. A man who has \$4000 invested in shares of a building and loan association that pays him 5% interest annually rents a flat for \$45 a month. Would he save money by buying a house for \$6500 with the \$4000 and a 6% note, if all expenses on the house amounted to \$175 a year? How much?

6. A bank pays 3% interest on money deposited in it, and loans this money at 6%. How much does it make in 2 years on deposits amounting to \$45,000?

36. A SHORT METHOD OF FINDING INTEREST

Money is often borrowed for short periods, say 30, 60, or 90 days, especially at banks. 6% is a very usual rate. In such cases, much time may be saved by observing that

The interest of any principal at 6%
For 360 days = 0.06 of the principal;
For 60 days = 0.01 of the principal;
For 6 days = 0.001 of the principal.

Find the interest of \$720 at 6% for 90 days.

\$7.20	EXPLANATION. — Since $\frac{1}{100}$ of \$720, or \$7.20, is the interest for 60 days, \$3.60 must be the interest for 30 days, and their sum the required interest.
3.60	
\$10.80	

NOTE. — This is called the aliquot part method or the 60-day method of computing interest.

Drill Exercises

At sight, give the interest at 6 % of :

- | | |
|----------------------|-----------------------|
| 1. \$540 for 60 da. | 10. \$305 for 90 da. |
| 2. \$600 for 90 da. | 11. \$1200 for 15 da. |
| 3. \$840 for 30 da. | 12. \$1600 for 75 da. |
| 4. \$720 for 10 da. | 13. \$2400 for 45 da. |
| 5. \$900 for 120 da. | 14. \$3600 for 10 da. |
| 6. \$540 for 90 da. | 15. \$4200 for 70 da. |
| 7. \$120 for 45 da. | 16. \$5400 for 50 da. |
| 8. \$750 for 40 da. | 17. \$6300 for 50 da. |
| 9. \$630 for 120 da. | 18. \$2100 for 20 da. |

Find the interest at 6 % of :

- | | |
|---------------------------------|------------------------|
| 19. \$720 for 87 da. | 30. \$4800 for 50 da. |
| \$ 7.20 = int. for 60 da. | 31. \$1250 for 90 da. |
| 2.40 = int. for 20 da. | 32. \$600 for 90 da. |
| 0.60 = int. for 5 da. | 33. \$750 for 120 da. |
| 0.24 = int. for 2 da. | 34. \$1200 for 45 da. |
| <hr/> \$10.44 = int. for 87 da. | 35. \$1600 for 15 da. |
| 20. \$965 for 117 da. | 36. \$360 for 20 da. |
| 21. \$1050 for 96 da. | 37. \$810 for 20 da. |
| 22. \$1360 for 33 da. | 38. \$1600 for 6 da. |
| 23. \$1540 for 54 da. | 39. \$2400 for 10 da. |
| 24. \$1680 for 93 da. | 40. \$3600 for 15 da. |
| 25. \$2750 for 63 da. | 41. \$8400 for 75 da. |
| 26. \$742 for 72 da. | 42. \$2600 for 90 da. |
| 27. \$960 for 84 da. | 43. \$7200 for 100 da. |
| 28. \$1432 for 36 da. | 44. \$960 for 110 da. |
| 29. \$1520 for 108 da. | 45. \$3200 for 75 da. |

46. \$4200 for 70 da.

48. \$1840 for 75 da.

47. \$2800 for 45 da.

49. \$1280 for 115 da.

NOTE. — This method may be used to advantage with other rates. The following illustrates the way to use it.

At 5%, find the interest of:

50. \$840 for 75 da.

$$\$8.40 = \text{int. at } 6\% \text{ for } 60 \text{ da.}$$

$$2.10 = \text{int. at } 6\% \text{ for } 15 \text{ da.}$$

$$\underline{6)10.50} = \text{int. at } 6\% \text{ for } 75 \text{ da.}$$

$$1.75 = \text{int. at } 1\% \text{ for } 75 \text{ da.}$$

$$\underline{\$8.75} = \text{int. at } 5\% \text{ for } 75 \text{ da.}$$

55. \$970 for 85 da.

56. \$450 for 20 da.

57. \$120 for 50 da.

58. \$830 for 45 da.

59. \$650 for 45 da.

51. \$820 for 70 da.

60. \$810 for 75 da.

52. \$950 for 63 da.

61. \$960 for 70 da.

53. \$720 for 93 da.

62. \$875 for 110 da.

54. \$875 for 72 da.

63. \$760 for 96 da.

Problems in Interest

1. I needed the use of \$800 for a short time, so I borrowed it for 90 days of a man who was in the business of loaning money. He charged 7% interest. What was the amount of the interest?

2. A man who was building a house borrowed \$3600 of a building and loan association at 6%, and gave the association a lien on the house as security. At the end of 95 days he sold the house, and with part of the money paid off the note. How much did it take to pay off the note?

3. A man bought a building lot for \$1200, paying one third cash, one third at the end of 90 days, with 5% interest, and the rest at the end of 6 months, with 5% interest. How much did the lot cost him?

PART TWO: EIGHTH YEAR

V. PRACTICAL MEASUREMENTS

37. SURFACES

A **surface** is the exterior part of an object and has length and breadth but not thickness.

A **plane surface** is a surface like the top of a desk, a table, or the blackboard. If a straight edge of a board is placed in any direction on a plane surface, all parts of the straight edge will touch the plane surface.

A **square unit**, which is a square a unit long and a unit wide, is the **unit of measure** in measuring surfaces.

To **measure** anything we find how many times it will contain the unit of measure.

The measure of a surface is called its **area**.

NOTE.—Other terms, such as *base*, *altitude*, *angle*, etc., have become familiar through use in former work.

38. AREAS OF PLANE SURFACES

The Rectangle

1. Find the area of a rectangle 6 in. long and 4 in. wide.

(a) How many square inches are there in the lower row?

(b) How many such rows?

(c) Then how many square inches in the four rows or the whole rectangle?

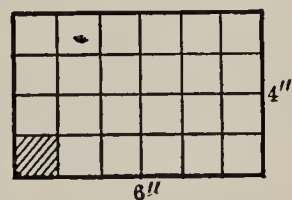

$$4 \times 6 \text{ sq. in.} = \text{---} \text{ sq. in.}$$

2. If a rectangle is 11 in. long, how many square inches make a row of this length? If it is 6 in. wide, how many such rows will there be? Then how do you find the area of the rectangle?

The number of square units in any rectangle is the product of the number of units in its length multiplied by the number of units in its width.

NOTE.—It is understood that the dimensions are both expressed in the same unit as the length of the square unit required in the answer.

Problems

1. Find the area of a rectangle 28 ft. wide and 32 ft. long.

2. Which has more floor surface, a room $16' \times 24'$ or one $18' \times 22'$?

3. Some contractors estimate the cost of houses from the size of the "floor plan." If a contractor estimates the cost of a small three-story house at \$6.50 for each square foot in the area of the first floor, find the cost of a house $34' \times 36'$.

4. Using the data given in Problem 3, find the cost of a house having a 36-ft. front, if the depth is 30 ft.

5. How much more would it cost to make the house described above 2 ft. wider and 2 ft. longer?

6. A farmer estimates 12 T. of silage to the acre from a field of corn. If the field is 22 rd. by 40 rd., how many tons does he expect?

7. Allowing 7 pk. of seed wheat for each acre, how many bushels will a farmer need for a field 40 rd. long and 22 rd. wide?

8. A city lot with a frontage of 60 ft. and a depth of 180 ft. sold at \$35 per front foot. How much was this per square foot?

9. Which is cheaper and how much, a lot with an 80-ft. front and a depth of 175 ft., at \$20 per front foot, or at 12¢ per square foot?

10. Which is cheaper, to buy linoleum for my $13\frac{1}{2}' \times 15'$ kitchen from a firm that quotes linoleum 6 ft. wide at \$1.10 per running yard, and $7\frac{1}{2}$ ft. wide at \$1.38 per running yard, or from a firm that quotes "60¢ per square yard" for the same quality?

11. For a room $18' \times 24'$ which width of the printed linoleum is most economical? Find the cost of 6-ft. linoleum running lengthwise, of both the printed and the inlaid, for the room.

12. Find the cost, for the same room, of 12-ft. linoleum running crosswise.

13. Which width of printed linoleum would you select for a room $15' \times 18'$? Why? Find the cost.

14. Find the cost, at $12\frac{1}{2}$ ¢ per square foot, of a 4-ft. cement walk across the front and one side of a corner lot $80' \times 196'$. The inner edge of the walk is the outer edge of the lot.

15. Find the cost of building cement sidewalks in your town, then measure a piece of walk and compute its cost.

16. Find the cost of inlaid linoleum and find the cost of enough for the floor of the kitchen in your home.

HEAVY PRINTED LINOLEUM

Width	Running Yard
6 ft.	\$1.20
$7\frac{1}{2}$ ft.	\$1.53
12 ft.	\$2.72

IMPORTED INLAID LINOLEUM

Width	Running Yard
6 ft.	\$2.70

The Parallelogram

A **parallelogram** has both pairs of its opposite sides parallel, but its angles need not be right angles.

1. Cut from paper or cardboard a parallelogram of some convenient size, as figure *A*. Draw a perpendicular line from one corner to the opposite side, as the line marked $3''$. This is the *altitude*, and the line to which it is drawn perpendicular is the *base* of the parallelogram.

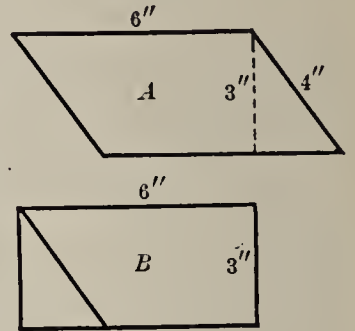

2. Cut along the altitude, and change the parallelogram into a rectangle, as in figure *B*.

3. Compare the length (base) and width (altitude) of the parallelogram *A* with those of rectangle *B*.

4. How many square inches in *B*? In *A*?

The area of a parallelogram is the same as that of a rectangle having the same length and width.

Hence, the area of a parallelogram is the product of the number of units of length in its base and the number of units of length in its altitude.

Exercises

1. Find the area of a parallelogram 18 in. long and 10 in. wide.

2. Find the area of a parallelogram whose base is 24 ft. and altitude 20 ft.

3. A strip of ground in the form of a parallelogram is 60 rd. long along one side and 36 rd. wide. How many square rods does it contain? How many acres?

The Triangle

1. Make two triangles exactly alike, as *A* and *B* in the figure. Place the two together so as to form a parallelogram, as in the figure. The *base* and *altitude* of triangle *A* are the same as those of the parallelogram, viz. 6'' and 3'' respectively.

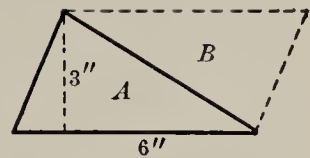

2. If the parallelogram thus formed is 6 in. long and 3 in. wide, what is the area? Then what is the area of each triangle?

The area of a triangle is one half of that of a parallelogram having the same dimensions.

Hence the area of a triangle is one half of the product of the number of units of length in its base and the number of units of length in its altitude.

3. Find the area of a triangle whose base is 12 in. and whose altitude is 7 in.

WORK

$$\frac{7 \times 12 \text{ sq. in.}}{2} = 42 \text{ sq. in.}$$

EXPLANATION. — Since the area of a parallelogram 12 in. long and 7 in. wide is 7×12 sq. in., the area of the triangle is but one half as large.

Exercises

Find the area of each of these triangles:

BASE	ALTITUDE	BASE	ALTITUDE
1. 14 ft.	10 ft.	5. 18 ft. 4 in.	12 ft.
2. 18 ft.	12 ft.	6. 20 ft. 8 in.	16 ft.
3. 20 ft.	15 ft.	7. 12 ft. 10 in.	20 ft.
4. 16 ft. 6 in.	14 ft.	8. 16 ft. 3 in.	16 ft.

9. How many square feet in the gable end of a house in the form of a triangle whose base is 24 ft. and height 10 ft. ?

10. The diagram is that of a field. AC represents 80 rd., BF 30 rd., and DE 35 rd. How many acres in it ?

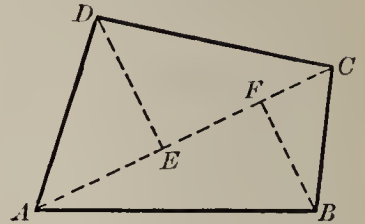

11. Draw a diagram $ABCD$ in which diagonal AC represents 24 in. and the perpendicular to it from D is 12 in. and from B is 10 in. Find the area.

The Trapezoid

A plane surface having four sides, two of which are parallel and the other two not parallel, is a **trapezoid**. Thus, figure A is a trapezoid. The parallel sides are called *bases*, and the perpendicular distance between them the *altitude*.

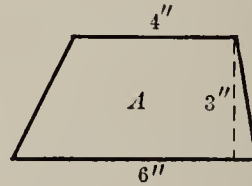

Make two trapezoids exactly alike. Place them as in the figure formed by A and B . From this, observe that:

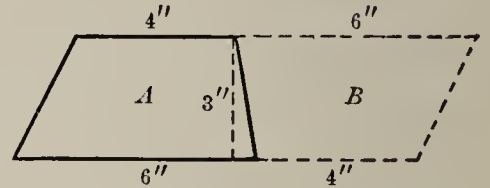

The number of square units in the area of any trapezoid is equal to one half of the product of the number of units in its altitude by the sum of the numbers of units in its two bases.

Exercises

Find the area of each of the following trapezoids :

UPPER BASE	LOWER BASE	ALTITUDE
1. 12 ft.	16 ft.	8 ft.
2. 10 ft. 6 in.	14 ft. 6 in.	10 ft.
3. 14 rd.	24 rd.	$9\frac{1}{2}$ rd.

4. This is a diagram of an irregular field. Find the number of acres in it. $AH = 20$ rd., $HG = 45$ rd., $GD = 15$ rd., $EF = 24$ rd., $GC = 24$ rd., $BH = 20$ rd.

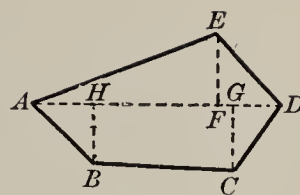

5. Find the area when $AH = 30$ rd., $HG = 70$ rd., $GD = 20$ rd., $EF = 50$ rd., $GC = 40$ rd., and $HB = 45$ rd.

Practical Problems in Areas

1. A farmer has a field 80 rd. long and 65 rd. wide. How many bushels of seed wheat will he need for it, allowing 7 pk. to the acre?

2. The athletic park of a school is 400 ft. wide and 600 ft. long. How many acres does it contain?

3. A city bought a plot of land 360 ft. wide and 420 ft. long for a public playground. How much did it cost at \$900 per acre?

4. How much will it cost to pave a street 42 ft. wide and 600 ft. long, at \$1.75 per square yard?

5. How many tiles 8 in. square will it take to cover a floor 38 ft. wide and 56 ft. long?

6. A grass plot $90' \times 110'$ is to be surrounded by a 4-ft. walk. A contractor constructs it with asphalt for 5¢ per square foot. How much does it cost?

7. Find the area of $ABCDE$, if $AC = 500$ yd.; $BG = 200$ yd.; $AF = 75$ yd.; $AG = 125$ yd.; $AH = 425$ yd.; $EF = 160$ yd.; $DH = 110$ yd.

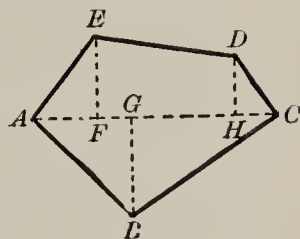

8. In $ABCDEF$, $AG = 100$ ft.; $GH = 100$ ft.; $HI = 400$ ft.; $IJ = 100$ ft.; $JD = 150$ ft.; $BG = 150$ ft.; $HF = 200$ ft.; $CI = 175$ ft.; and $JE = 150$ ft. Find the area.

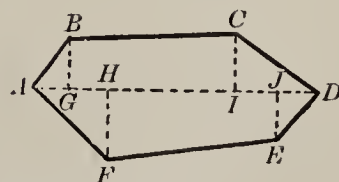

The Circle

The area of a parallelogram was found by changing it to a rectangle. Then the areas of triangles and trapezoids were seen to depend upon that of a parallelogram. It will be seen that the area of a circle may be found in the same way. Thus we see that all plane areas may be made to depend upon a parallelogram.

1. Cut a circle into a number of equal sectors, say 16, as shown in the figure to the left. Fit them together as in the figure to the right.

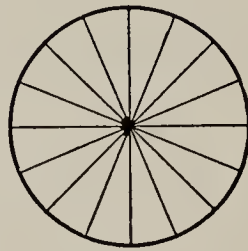

A

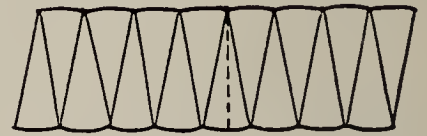

B

2. Of the figures studied in the preceding pages, which does this figure most resemble?

3. In what way does it differ from an exact parallelogram?

4. If you consider this figure a parallelogram, what line of the circle becomes the base? The altitude?

5. If the diameter of this circle is 10 in. what is its circumference?

The circumference of a circle is 3.1416 (π) times its diameter.

6. What is the base of the figure made from the circle? The altitude?

7. Then if it were an exact parallelogram whose base is 15.708 in. and whose altitude is 5 in., what would be its area?

The area of a circle has been found by geometry to equal that of a parallelogram whose base is one half of the circumference and whose width is the radius.

8. This principle is expressed by $A = \frac{C}{2} \times R$, where A stands for the area, C for the circumference, and R for the radius. But $C = \pi \times D$, where D stands for the diameter. So $C = 2 \times \pi \times R$. Then $A = \frac{C}{2} \times R = \pi \times R \times R = \pi \times R^2$.

The number of square units in the area of a circle is equal to 3.1416 times the square of the number of units in its radius.

NOTE. — When great accuracy is not required in the practical applications of the formulæ for the circle, $3\frac{1}{7}$ is used instead of 3.1416 for the value of π , in order to shorten the work.

Problems

1. How could you lay off a circle upon the floor or playground by the use of a string?
2. Some boys wish to lay off a circular running track that will be $\frac{1}{4}$ mi. around. How long a radius will they need?
3. Lay off a running track that will be $\frac{1}{20}$ mi. around.
4. Some boys walked around a lake known to be $2\frac{1}{2}$ mi. across. How far did they have to walk?
5. What is the length of the largest circular running track that can be laid out in a lot 196 ft. square?
6. How many times must you run around a 150-ft. circle to run $\frac{1}{2}$ mi. ? (A 150-ft. circle is a circle 150 ft. in diameter.)
7. How many square inches in the area of a 10-in. circle?
8. Compare the area of a 15-ft. circle with that of a 10-ft. circle.
9. A contractor agrees to build a basin for a fountain at the rate of 65¢ for each square foot in the bottom of the basin. How much will a basin 18 ft. in diameter cost?

10. Using the price in Problem 9, which will be cheaper and how much, two 15-ft. basins or one 22-ft. basin?

11. The 24-ft. basin for a fountain in a park is surrounded by a 5-ft. walk. How much did the walk cost at 20¢ per square foot?

39. SURFACES AND VOLUMES OF SOLIDS

A **solid** has length, breadth, and thickness.

A **prism** is a solid of which two of the bounding surfaces are parallel and equal, called the *bases*, and all of the others are parallelograms. The perpendicular distance between the bases is the *altitude*.

A **rectangular prism** is a solid bounded by six rectangular faces. If all six faces are squares, the solid is a **cube**.

A **cubic unit** is a cube a unit long. Thus, a cube 1 in. long is a cubic inch; a cube 1 ft. long is a cubic foot; etc.

To **measure** a solid we find how many times it will contain a **cubic unit**, called the *unit of measure*.

The measure of a solid is called its **volume**.

The surface of the sides of any solid is called its **convex surface**.

Rectangular Prisms

1. How many cubic inches in a rectangular prism 4 in. wide, 3 in. thick, and 5 in. high?

SUGGESTION.—How many cubic inches along the 3-in. edge? How many such rows will cover the base? How many such layers will make a pile 5 in. high?

$$5 \times 4 \times 3 \text{ cu. in.} = \text{---} \text{ cu. in.}$$

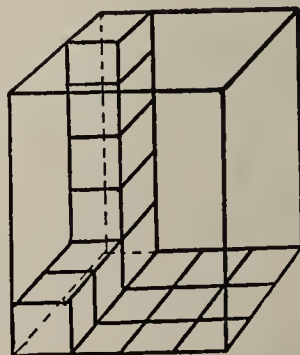

2. How many cubic feet in a rectangular prism 6 ft. by 5 ft. by 10 ft.?

3. How many cubic yards of space in a room 8 yd. by 10 yd. by 4 yd.?

The number of cubic units in a rectangular prism is equal to the product of the numbers of units in its three dimensions.

4. If there are 16 sq. in. in the base of a rectangular prism, how many 1-in. cubes will it take to make the bottom layer of the prism?

5. What is the volume of a rectangular prism whose base is 15 sq. in. and whose height is 12 in.?

6. Find the volume of a coal bin if the floor contains 120 sq. ft. and the height is 8 ft.

The volume of a rectangular prism may also be found by finding the product of the number of units in the area of the base by the number in the height or altitude.

7. Allowing 56 lb. of coal to the cubic foot, how many tons of coal may be stored in a bin 10 ft. by 12 ft. and 7 ft. deep?

8. A car 36 ft. long, and $8\frac{1}{2}$ ft. wide is loaded with wheat to a depth of 5 ft. Allowing 0.8 bu. to the cubic foot, how many bushels does the car contain?

9. Wheat weighs 60 lb. to the bushel. If the allowed capacity of the car described in Problem 8 is 80,000 lb., by how much does the load lack in reaching the capacity?

10. How much will the excavation for a cellar 30 ft. by 40 ft. and 6 ft. deep cost at 40¢ per cubic yard?

11. If a swimming pool is 60 ft. wide and 90 ft. long, and it is filled twice a week to an average depth of 6 ft., how many thousand cubic feet of water is used each year (52 wk.)? Find the cost of the water at 85¢ per 1000 cu. ft.

12. An ice car 36 ft. long, $8\frac{1}{2}$ ft. wide, and 7 ft. deep will hold how many tons of ice, allowing $56\frac{1}{4}$ lb. to the cubic foot? How much is the carload worth at \$4.25 per ton?

13. A man wishes to build a coal bin large enough to hold his winter's supply of 15 T. when filled to a depth of but 6 ft. How many square feet in the base?

SOLUTION

$$\begin{array}{r} 125 \\ 5 \ 1000 \\ \hline 15 \times 2000 = \frac{625}{7} = 89+ \\ \frac{56 \times 6}{7 \ 2} \end{array}$$

Hence, about 90 sq. ft.

EXPLANATION.— $15 \times 2000 =$ the number of pounds.

$$\frac{15 \times 2000}{56} = \text{number of cubic feet.}$$

Number of cubic feet divided by the number of feet in height = number of square feet in the base.

14. Find the floor area of a bin to hold 12 T. when filled to a depth of 5 ft. Give some dimensions of the floor that will make the required area.

15. A farmer built a watering trough 12 ft. long, 30 in. wide, and 20 in. deep. Allowing $7\frac{1}{2}$ gal. to the cubic foot, how many gallons will it contain?

16. Find the entire surface of a prism 4 in. by 2 in. by 6 in.

SUGGESTION.— The surface is equal to a rectangle 12 in. long and 6 in. wide, and two others each 2 in. by 4 in.

17. Tell how to find the area of the entire surface of any rectangular prism.

18. If the sides and bottom of a tank 40 in. by 30 in. and 16 in. deep are to be lined with copper, how many square inches will be used? (The bottom is 40 in. by 30 in.)

19. Not allowing for openings, how many square yards of calcimining in the walls and ceiling of a hall 24 ft. wide, 45 ft. long, and 10 ft. high?

20. We may get some idea of the meaning of the large number of bushels of grain raised each year by finding the size of prism it would form. Find how deep the 700,000,000 bushels of wheat raised in the United States in 1910 would be if stored in a bin one mile square. (1 cu. ft. = $\frac{4}{5}$ bu.)

$$\text{SOLUTION} \quad \frac{5}{4} \times \frac{700,000,000}{5280 \times 5280} = ?$$

EXPLANATION. — $700,000,000 \div \frac{4}{5} =$ number of cubic feet. This divided by the number of square feet in a mile, which is 5280×5280 , will give the depth. Why?

21. Corn in the ear averages about $\frac{2}{5}$ bu. to the cubic foot. Find the depth of the corn raised in 1910 (3,000,000,000 bu.) if stored in a bin 1 mi. square.

22. In a recent year the United States raised 1,000,000,000 bu. of oats. Find the depth if stored in a bin $\frac{1}{2}$ mi. square.

Measurement of Lumber

In the measurement of lumber the unit of measure used is a **board foot**. A *board foot* is 1 ft. square and 1 in. thick.

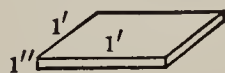
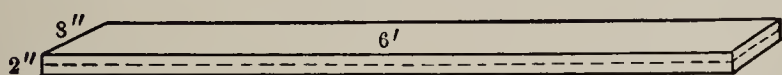

1. The figure shows a board 6 ft. long, 8 in. wide, and 2 in. thick; also a board foot. How many square feet in the top surface of the board? How many times does it contain the top surface of a board foot? If the board were only 1 in. thick, how many board feet would it contain? Since it is 2 in. thick, the number of board feet equals $2 \times \text{---}$ or --- .

2. Find the number of board feet in a board 16 ft. long, 9 in. wide, and 3 in. thick.

The number of board feet in a board equals the product of the number of feet of length, the number of feet of width, and the number of inches of thickness.

NOTE. — A board less than 1 in. thick is counted as 1 in. thick.

Find the number of board feet in the following :

3. A board 14 ft. long, 6 in. wide, 2 in. thick.
4. A board 12 ft. long, 10 in. wide, $1\frac{1}{2}$ in. thick.
5. A board 16 ft. long, 9 in. wide, $\frac{7}{8}$ in. thick.
6. A joist 16 ft. long, 4 in. wide, 2 in. thick.

Triangular Prisms

1. Find the volume of a triangular prism whose base is a right triangle 3 in. by 4 in. and whose height is 5 in.

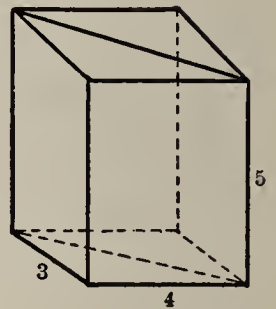

SUGGESTION. — It is evident that the triangular prism is equal to one half of a rectangular prism of the same dimensions. But the triangle is half of the rectangle, so the volume is half that of the rectangular prism. That is, the volume of a triangular prism equals the product of the area of its base and its height.

2. Find the volume of a triangular prism when the area of the base is 65 sq. in. and the height is 18 in.

3. Find the volume of a triangular prism when the area of the base is 216 sq. in. and the height $8\frac{1}{2}$ in.

4. The base of a prism is a right triangle of which the sides forming the right angle are 6 ft. and 8 ft. The altitude is $9\frac{1}{4}$ ft. Draw a diagram. Find the volume.

5. A glass prism has for its base a right triangle of which the sides forming the right angle are each 3 in. The altitude is $4\frac{1}{2}$ in. Find the volume.

6. Charles made a V-shaped trough for feeding his pigs, by nailing one board to the edge of another, so that they were at right angles, and then nailing boards

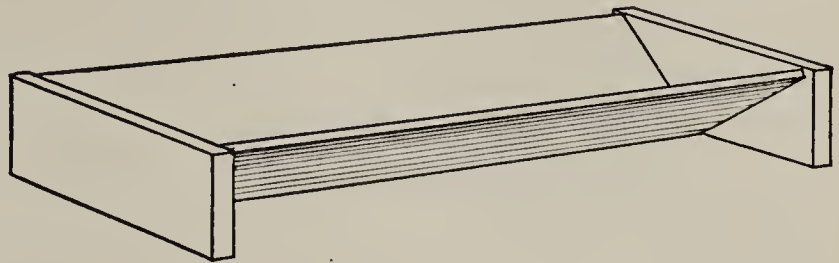

across the ends of these, as in the picture. The trough was 6 ft. long. Each end formed a right triangle, of which the sides forming the right angle were each 8 in. Allowing $7\frac{1}{2}$ gal. to a cubic foot, find how many gallons the trough would hold.

7. Water runs in a V-shaped trough at a velocity of 40 ft. per minute. A cross section of the stream is a right triangle of which the sides forming the right angle are each 6 in. How many gallons per minute does the trough deliver? (The water delivered per minute is a prism with altitude 40 ft.)

The Volume and Surface of Any Prism

NOTE. — All prisms discussed in this book are right prisms. That is, the sides are rectangles, whatever the shape of the bases.

Any prism may be divided into triangular prisms, as in the figure. Hence, it is clear that:

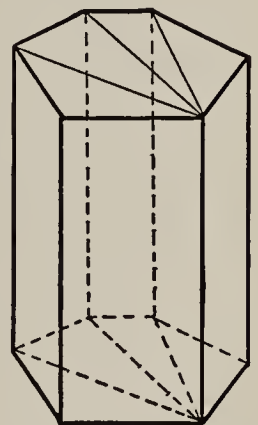

The volume of any prism equals the product of the altitude and the area of the base, and the area of the total surface is twice the area of the base, plus the area of a rectangle whose width is the perimeter and whose height is the height of the prism.

1. Area of base = 364 sq. ft. Height = 12 ft. Volume = ?
2. Area of base = 46.8 sq. in. Height = 9.2 in. Volume = ?

The Volume of a Cylinder

1. If a cylinder is cut as in Fig. *A* and arranged as in Fig. *B*, what does it nearly become?

2. If *B* were a rectangular prism, how would its volume be found?

3. If the radius of *A* is 1 in., what is the area of its base or the base of *B*? If the length of *B* is 8 in., considering it a prism, what is the volume?

4. It is found in geometry that:

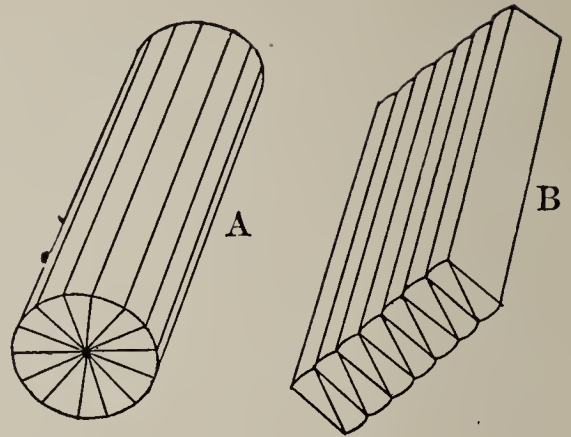

The volume of a cylinder is the same as that of a prism having a base of the same area and having the same height. That is, the volume is equal to the area of the base multiplied by the height.

5. Find the volume of a cylinder whose radius is 8 in. and whose height is 15 in.

Explain the statement: $(15 \times 3.1416 \times 8 \times 8)$ cu. in. = 3015.936 cu. in.

6. A cylindrical pail 6 in. in diameter inside and 12 in. deep contains how many cubic inches?

$(12 \times 3.1416 \times 3 \times 3)$ cu. in. = ——— cu. in.

7. Allowing $7\frac{1}{2}$ gal. to the cubic foot, how many gallons will a cistern 8 ft. in diameter and 12 ft. deep hold?

8. How many gallons will a hot-water tank 16 in. in diameter and 5 ft. long hold? (231 cu. in. = 1 gal.)

9. If you have a hot-water tank in your home, find its capacity.

The Surface of a Cylinder

1. Take a rectangular piece of paper and roll it to form a cylinder. Observe that the lateral surface of a cylinder is equal to that of a rectangle whose dimensions are the perimeter of the base and the height of the cylinder.

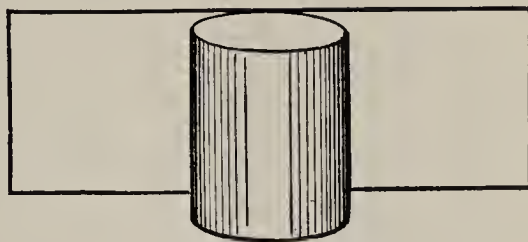

The area of the total surface of a cylinder is that of a rectangle and two circles.

2. Find the area of the total surface of a cylinder 10 ft. high and 8 ft. in diameter.
3. The radius of a cylinder is 15 in. and the height or altitude 40 in. Find the area of the total surface.
4. The diameter of one cylinder is 8 in. and the altitude 6 in., and the diameter of another is 6 in. and the altitude 8 in. Compare the areas of their lateral surfaces. Which has the greater area of total surface? How much?
5. A standpipe for city water is 96 ft. high and 18 ft. in diameter. A man contracts to paint it on the outside for \$1.60 a hundred square feet. How much does he get?
6. What does it cost to paint a smokestack 50 ft. high and 4 ft. in diameter at $1\frac{1}{2}$ ¢ a square foot?
7. A steam pipe is 40 ft. long and 4 in. in diameter. How much heating surface does it have?
8. The water in the boiler of an engine is heated by 36 pipes, each 3 in. in diameter and 10 ft. long, which carry the heat from the fire box through the water. It is necessary to know the total heating surface of the pipes. How much is it?

Prisms and Pyramids Compared

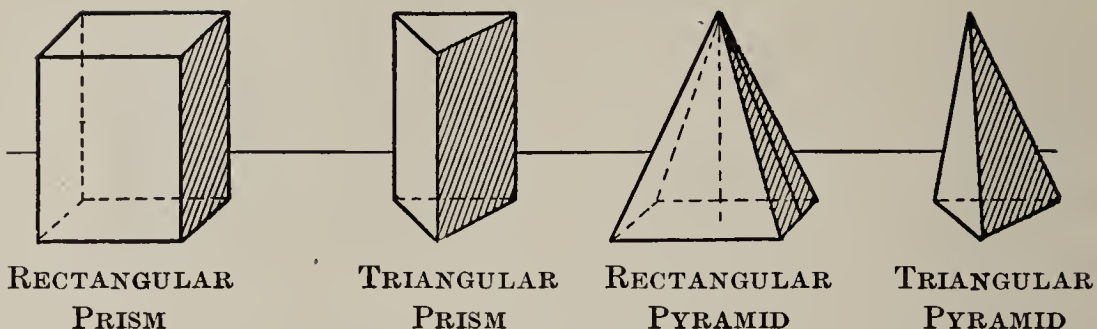

A **pyramid** is a solid whose base is a polygon (figure bounded by three or more straight lines) and whose sides or faces are triangles meeting at a common point called the **vertex** of the pyramid.

If the base is a regular polygon (having all sides equal and all angles equal), as a square, or an equilateral triangle, and the edges meeting at the vertex are all equal, the pyramid is a **regular pyramid**.

The distance from the vertex to any side of the base of a regular pyramid is the **slant height**.

1. Make a hollow prism and pyramid having the same dimensions. Fill the pyramid with dry sand and pour into the prism. What part is filled? How often must the pyramid be filled and poured into the prism to fill it?

2. What, then, would you say of the volume of the pyramid compared with that of the prism of the same dimensions?

3. If a prism contains 36 cu. in., what is the volume of a pyramid having the same dimensions?

4. What part of a square prism is whittled away by a boy who is making the largest possible pyramid of it?

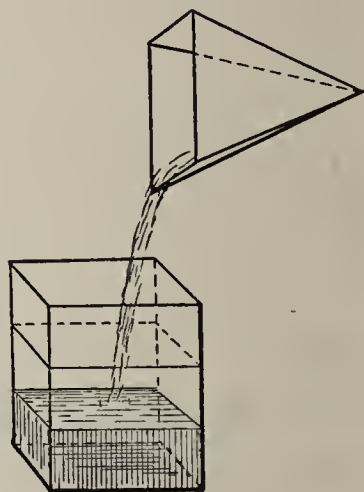

5. Make of clay, or cut from a large potato, a prism and a pyramid with equal bases and altitudes. Weigh them, and compare their weights.

The volume of a pyramid is $\frac{1}{3}$ of that of a prism having an equal base and an equal altitude. Hence the volume of a pyramid equals one third of the product of the altitude and the area of its base.

6. If the base of a pyramid contains 12 sq. ft. and the height is 9 ft., how many cubic feet in the volume?

7. The base of a pyramid is 4 ft. square and the height is 10 ft. Find the volume.

8. A farmer has a pile of corn in the form of a pyramid 6 ft. high and 12 ft. square at the bottom. Counting $2\frac{1}{2}$ cu. ft. to a bushel, how many bushels of corn in the pile?

9. The base of a pyramid is 8 ft. square and its slant height is 10 ft. Draw a diagram of the pyramid. How many triangles meet at the vertex? What is the area of each? Of all?

10. Show that the area of all of the triangles in Problem 9 is equal to one half of the product of the slant height and the perimeter of the base.

The area of the lateral surface of a regular pyramid equals one half of the product of the slant height and the perimeter of the base.

11. The slant height of a pyramid is 16 in. and the base is a triangle each side of which is 12 in. Find the area of the lateral surface.

Cones and Cylinders Compared

A solid having a circle for a base and tapering uniformly to a **vertex** is a **cone**.

The distance from the vertex to a point of the circumference of the base is the **slant height**.

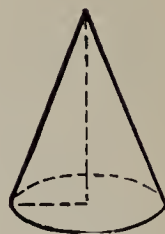

A CONE

While there are other kinds of cones, we shall consider only the kind described above. In this kind the altitude from the vertex passes through the center of the base. It is called a **right circular cone**.

1. If a hollow cone were filled with sand and emptied into a cylinder of the same base and height, it would fill one third of it. Then if the volume of a cylinder is 15 cu. in., what is the volume of a cone having the same base and altitude?

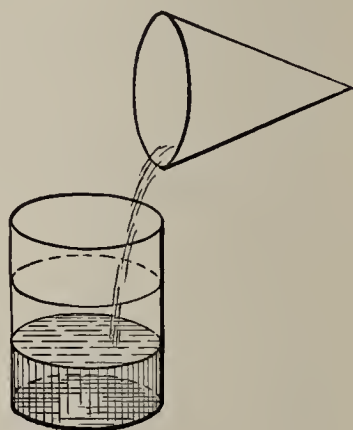

2. Find the volume of a cylinder whose base is 10 in. in diameter and whose altitude is 12 in. What is the volume of a cone of the same dimensions?

The volume of a cone is equal to one third of that of a cylinder having an equal base and the same height. Hence the volume of a cone equals one third of the product of the altitude and the area of the base.

3. Find the volume of a cone 12 in. high if the radius of the base is 8 in.

4. How many bushels in a conical pile of grain 5 ft. high and 8 ft. across the bottom, allowing 0.8 bu. to the cubic foot?

5. In one corner of a bin is a pile of wheat forming a fourth of a cone. The height is 4 ft. and the radius of the cone is 6 ft. How many bushels are there?

6. A farmer has a pile of apples 6 ft. high and 10 ft. across the bottom. How many bushels has he? Count 3 bu. to 4 cu. ft.

7. A pile of corn is 14 ft. in diameter and tapers to a point. The depth of the pile is $6\frac{1}{2}$ ft. Allowing $2\frac{1}{2}$ cu. ft. to a bushel, find how many bushels of corn the pile contains.

8. A building lot has a mound on it that is approximately a cone 42 ft. in diameter and 6 ft. high. How much will it cost at 75¢ a cubic yard to have the mound hauled away in leveling the lot?

The Surface of a Cone

1. Cut a pattern like the one in the margin and make a cone from it.

2. Observe that the convex surface is the sector of a circle. If this sector is cut into a large number of small sectors, they closely resemble triangles. If they are considered triangles, how is the area found?

3. What is the length of the arc of the sector? Considering it a triangle, what is the altitude? The area?

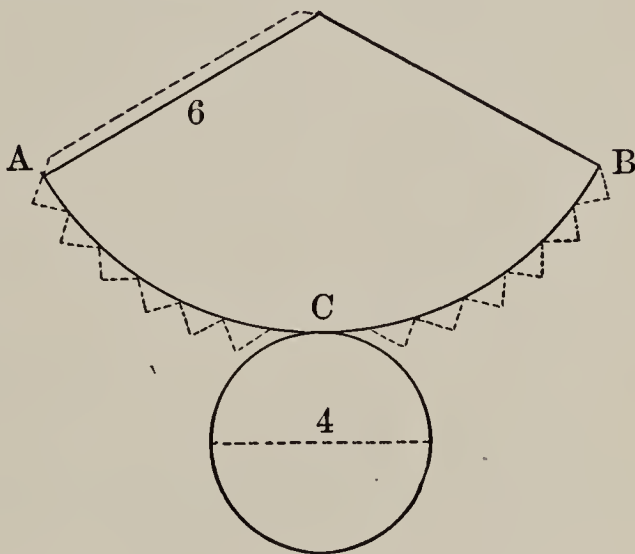

The area of the convex surface of a cone is the perimeter of the base multiplied by one half of the slant height.

4. What is the area of the entire surface of a cone whose base is 10 ft. in diameter, and whose slant height is 9 ft. ?

5. Find the area of the convex surface of a cone whose base is 12 ft. in diameter and whose slant height is 10 ft.

The Silo

A silo is used to “can” shredded corn fodder. It is built round so that there will be no corners that cannot be filled, for if a large quantity of air were left in a corner, mold and rot would start. Silos are built of boards, hollow tile, or cement.

While the silage is much more compact near the bottom, and while the weight of a cubic foot varies with the size of the silo, a ton requires from 40 to 50 cu. ft. of space.



In the following problems, consider that 50 cu. ft. of silage weighs 1 T.

Problems

1. How much surface is there to be painted, not counting the roof, in a silo 16 ft. in diameter and 38 ft. high ?

2. If the roof of this silo is shaped like a cone, with a base 19 ft. in diameter and a slant height of $10\frac{1}{2}$ ft., how many square feet in the roof ?

3. At \$1.75 per 100 sq. ft. for a double coat of paint, find the cost of painting this silo, including the roof.

4. How many tons of silage can be stored in a silo 18 ft. in diameter and 42 ft. high ?

5. Allowing 40 lb. per day for each head of cattle, how many tons of silage must be stored to provide for a herd of 24 cows for 200 da. ?

6. How high must a man build a silo 14 ft. in diameter to furnish the silage needed for the herd in Problem 5 ?

7. A man who has a herd of 60 cows builds two silos, each 16 ft. in diameter and 30 ft. high. Allowing 40 lb. of silage per day for each cow, how many days will it last ?

8. Considering that a crop of corn will yield 12 T. to the acre, how many acres should be planted to fill a silo 14 ft. in diameter and 38 ft. high ?

9. A farmer finds that one silo 14 ft. in diameter and 34 ft. high, or two small silos each 10 ft. in diameter and 30 ft. high, will be necessary for his herd of 25 cows. How much more 2-in. lumber will be needed for the walls of the two small ones than for the wall of the large one ?

10. If each of the silos in Problem 9 has cement floors costing $12\frac{1}{2}$ ¢ per square foot, how much more will the floors of the two small ones cost than the floor of the large one ?

11. Silage exposed to the air for several days spoils, so the diameter to be used depends upon the number of cattle in the herd. If it requires 10 cattle to keep the silage fresh in a 10-ft. silo, by feeding from the top surface of the silage, how many are required to keep fresh the silage in a 12-ft. silo ?

SUGGESTION. — Area of a 10-ft. circle = $100 \times \frac{\pi}{4}$ sq. ft. Area of a 12-ft. circle = $144 \times \frac{\pi}{4}$ sq. ft. Hence the larger circle is 1.44 times as large as the smaller. Hence it would require 14 or 15 cattle.

12. If it requires 10 cows to keep fresh the silage in a 10-ft. silo, how many head will be required to keep fresh the silage in a 20-ft. silo ? In a 25-ft. silo ?

Miscellaneous Problems

1. A prism has a base 4 ft. square, and is 7 ft. high. What is its volume?

2. A prism has an altitude of 16 in., and its base is a right triangle of which the sides forming the right angle are 4 in. and 5 in. Find its volume.

3. A square pyramid is 12 ft. high and measures 3 ft. along one side of its base. What is its volume?

4. The volume of a square prism is 36 cu. in. What is the volume of a square pyramid of the same base and altitude?

5. A square prism has a base 2 ft. long and an altitude of 10 ft. It is made of granite weighing 165 lb. to the cubic foot. What is the weight of the prism?

6. Find the lateral area of a prism whose altitude is 4 ft. and base 3 ft. square. Find the whole area.

7. The altitude of a triangular prism is 12 in., and the base is a right triangle whose sides, including the right angle, are 6 in. and 8 in. Find its volume.

8. A square pyramid has a slant height of 12 in. and a base with side 4 in. What is its convex surface?

9. An octagonal pyramid's slant height is 16 in., and the perimeter of its base is 48 in. What is its convex surface?

10. The altitude of a square pyramid is 15 in. and the side of its base is 12 in. Find its volume.

11. The wagon box most generally used in hauling dirt is 9 ft. by 3 ft. by 16 in. How many cubic feet will a load contain? How many cubic yards?

12. The excavation for a house is 38 ft. long, 30 ft. wide, and 5 ft. deep. How many cubic yards of earth are removed in making the excavation?

13. A freight car 36 ft. long and 8 ft. 6 in. wide, inside measurements, is filled with wheat to a depth of 5 ft. Allowing 0.8 bu. to a cubic foot, and 60 lb. to a bushel, find the weight of the load. If the capacity of the car is 80,000 lb., how much does it lack of being loaded to its full capacity?

14. How many cubic yards of stone are required to build a dam 300 ft. long, 15 ft. high, 10 ft. wide at the bottom, and 4 ft. wide at the top?

15. The Great Pyramid of Egypt, known as the pyramid of Cheops, is 764 ft. square, and its altitude is 480 ft. Find its volume.



Allowing 170 lb. to the cubic foot, find its weight in tons, if it were solid.

16. How many acres of ground does this pyramid cover?

17. The Washington Monument at Washington, D.C., is crowned with a pyramid $34\frac{1}{2}$ ft. square and 25 ft. high. Allowing 170 lb. to the cubic foot, find the weight of it in tons.

18. Find the volume of a cylinder whose altitude is 10 in. and radius of base 4 in.

19. If a cylinder weighs 3 lb. what will be the weight of a cone of the same material having the same base and altitude?

20. The largest possible cone is turned in a lathe out of a cylinder 6 in. long and 3 in. in diameter. What part of the cylinder goes into shavings? How many cubic inches in the cone?

21. The base of a cone is 6 sq. in. and its altitude is 12 in. Find its volume.

22. The diameter of the base of a cone is 4 feet. Its altitude is 9 feet. Find its volume.
23. A cylinder of ebony weighs 1 lb. 8 oz. What will an ebony cone of the same base and altitude weigh?
24. How many cubic yards of earth must be removed in digging a cistern 10 ft. in diameter and 10 ft. deep?
25. Allowing $7\frac{1}{2}$ gal. to a cubic foot, find how many gallons of water a cistern will hold that is 9 ft. in diameter and 10 ft. deep. Since $31\frac{1}{2}$ gal. = 1 barrel, how many barrels will it hold?
26. How many barrels will a standpipe hold that is 18 ft. in diameter and 80 ft. high?
27. The cylindrical tank of the large sprinkling car used by a city street car company in sprinkling the tracks is 6 ft. in diameter and 26 ft. long. How many gallons will it hold?
28. A cubic inch of brass weighs 0.303 lb. Find the weight of a brass tube 20 ft. long whose inner diameter is 1 in. and outer diameter $1\frac{1}{2}$ in.
29. The piston of a pump is 8 in. in diameter, and makes a stroke of 18 in. How many gallons of water will it deliver in an hour, if it makes 30 strokes a minute? (231 cu. in. = 1 gal.)
30. A boiler of an engine 4 ft. in diameter and 16 ft. long is traversed by 60 pipes, each 3 in. in diameter, which convey the heat through the water. How many gallons of water will the boiler hold?
31. A fruit raiser has a round pile of apples that is 6 ft. across at the bottom, and tapers to a point that is 4 ft. high at the middle. How many bushels in the pile? (Count 3 bu. to 4 cu. ft.)

32. A wash boiler 12 in. deep, 10 in. wide, and 20 in. long has round ends; *i.e.* each end is a half cylinder. How many gallons does it hold?

33. The figure represents a view of a “rain gauge,” an instrument used for measuring the amount of rainfall. The opening at the top is 12 in. in diameter, and the cylindrical stem 4 in. in diameter. Suppose that in a rain the stem is filled to a depth of 4 in. What is the precipitation? (That is, what is the depth of the rainfall on level ground?)

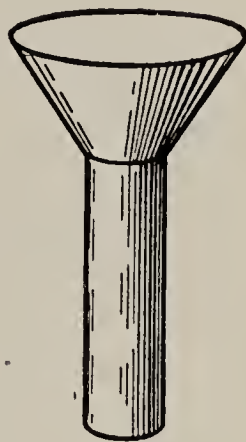

34. Suppose that in a rain the stem in the gauge in Exercise 33 is filled to a depth of 5 in. What is the precipitation?

35. A farmer has a pile of ear corn approximately in the form of a cone whose height is 8 ft. and width at the bottom 16 ft. How many bushels does it contain? (Count 2 bu. to 5 cu. ft.)

36. A farmer wishes to know how many tons of hay there are in a stack in the form of a cylinder 16 ft. in diameter and 7 ft. high, surmounted by a cone 8 ft. high. Allowing 512 cu. ft. to the ton, find the amount of hay in the stack.

37. In a steam boiler 94 flues, or cylindrical pipes, each 2 in. in outside diameter and 12 ft. long, convey the heat from the fire box through the water. How much heating surface do they apply to the water?

38. What is the lateral area of a cone whose slant height is 4 ft. and the diameter of whose base is 3 ft.?

39. The radius of the base of a cone is $3\frac{1}{2}$ ft. The slant height is 5 ft. Find the entire area, *i.e.* the area of the base plus the lateral area.

40. A horizontal oil tank is 24 ft. long and 8 ft. in diameter. Allowing $7\frac{1}{2}$ gal. to a cubic foot, find how many gallons it will hold.

41. Which will hold the more, two tanks 16 ft. long and 4 ft. in diameter, or one tank 16 ft. long and 8 ft. in diameter?

42. Allowing 45 cu. ft. of silage to a ton, how many tons will a silo hold that is 16 ft. in diameter and 35 ft. high?

43. A corn crib is 16 ft. long and 10 ft. wide. It is filled the entire length with ear corn to a depth of 10 ft. along the back side and to a depth of 7 ft. along the front side. Allowing $2\frac{1}{2}$ cu. ft. to a bushel, find how many bushels the crib contains.

44. A haystack is approximately a cylinder 14 ft. in diameter and 6 ft. high, surmounted by a cone 8 ft. high. Allowing 512 cu. ft. to a ton, find the number of tons of hay in the stack.

45. A haymow in a barn is 30 ft. wide, 40 ft. long, and 12 ft. high to the eaves of the roof. The gable is 30 ft. wide, and the highest point of the roof is 15 ft. above the level of the eaves. If the mow is filled to the roof with hay, how many tons does it contain?

46. A man feeds his hogs in a V-shaped trough that is 12 ft. long, 11 in. wide at the top, and $5\frac{1}{2}$ in. deep. Counting $7\frac{1}{2}$ gal. to a cubic foot, find how many gallons it will hold.

47. A railroad fill 300 ft. long is 9 ft. wide at the top, 17 ft. wide at the bottom, and 4 ft. deep. How many cubic yards of earth does it take to make the fill?

48. A cement wall is 60 ft. long, 2 ft. wide at the top, 4 ft. wide at the bottom, and 6 ft. high. How many cubic feet does it contain?

40. MEASUREMENT OF THE SPHERE

A **sphere** is a round solid bounded by a surface, all points of which are equally distant from a point within called the center. The distance from the center to any point of the surface is the **radius**, and the distance through the center of the sphere from surface to surface, which is twice the radius, is the **diameter**. The circle made by cutting a sphere by a plane through the center is called a *great circle of the sphere*.



1. Name some common objects that are spherical.

The curved surface of a hemisphere (a half-sphere) may be compared with its flat surface by placing a tack in the center of each and then carefully winding a hard cord completely over each surface as in the illustration.



Compare the lengths of these two cords and then show that the area of the curved surface of a hemisphere is just twice the area of a great circle of the sphere.

2. Then show that :

The area of the surface of a sphere is equal to 4 times the area of a great circle of the sphere.

3. How is the area of a circle found? Show that the area of the surface of a sphere whose radius is R is $4 \times \pi \times R^2$.

4. If a sphere should be dissected as in the illustration on next page, what solids would its parts most resemble?

5. What line in the sphere forms the altitude of each pyramid-like solid?

6. What forms the base of each?

7. Taken together, what will the bases of all the pyramid-like solids make?

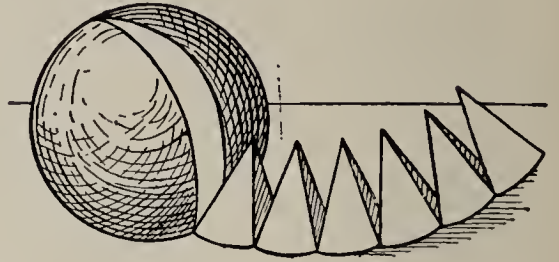

8. If these were perfect pyramids, how would the volume of any one be found?

While these solids are not pyramids, for their bases are not plane figures, yet it is proved in geometry that :

The volume of a sphere is the same as that of a pyramid whose base is the surface of the sphere and whose height is the radius of the sphere.

Hence, the volume of a sphere is equal to the area of its surface multiplied by one third of its radius.

9. Since the area of the surface of a sphere is equal to 4 times the area of a great circle, or $4 \times \pi \times R^2$, show that :

$$\text{The volume of a sphere} = \frac{1}{3} R \times 4 \times \pi \times R^2 = \frac{4}{3} \times \pi \times R^3.$$

Exercises

1. Find the area of the surface of a sphere whose radius is 4 in.

2. Find the area of the surface of a sphere whose radius is 10 in.

3. Find the area of the surface of a sphere whose diameter is 6 ft.

4. Find the volume of a sphere whose radius is 3 ft. and the area of the surface 113 sq. ft.

5. Find the volume of a sphere whose radius is 9 ft.

6. Find the volume of a sphere whose diameter is 16 ft.
7. Taking the radius as 4000 mi., find the area of the entire surface of the earth.
8. The surface of a tiled dome, in the form of a hemispherical surface, whose diameter is 24 ft., is made of tiles each 1 in. square. How many tiles are required to make it?
9. A gilded dome is in the form of a hemisphere whose diameter is 30 ft. How many square feet in its surface?
10. The dome of an astronomical observatory, which is in the form of a hemisphere, is 48 ft. in diameter. How many square feet of tin does it take to cover it?
11. A hemispherical skylight is 16 ft. in diameter. Not allowing for sash, how many square feet of glass are required to make it?
12. Steel weighs 490 lb. to the cubic foot. Find the weight of a steel ball 10 in. in diameter.
13. A bowl in the form of a hemisphere is 6 in. in diameter. How many cubic inches will it contain?
14. Find the weight of a cast-iron spherical shell 1 inch thick, with an outside diameter of 9 in., 1 cubic foot of cast iron weighing 450 lb.
15. A boiler is made in the form of a 4-foot cylinder 2 ft. in diameter, with hemispherical ends. How many gallons will it hold? (1 gal. = 231 cu. in.)
16. A haystack is approximately in the form of a cylinder 16 ft. in diameter and 8 ft. high, surmounted by a hemisphere. Allowing 512 cu. ft. to the ton, find the weight of the stack.
17. A brass spherical shell 1 inch thick and 10 inches in external diameter is found to weigh 77.422 lb. Find to three decimal places the weight of 1 cu. in. of brass.

41. INDIRECT PROBLEMS IN MEASUREMENT

1. What is the side of a square whose area is 81 sq. in.?

SOLUTION: Since 81, the number of square inches, is the product of two equal numbers, each of which is the number of inches in the length of the square, we know that the answer is 9 in., for $9 \times 9 = 81$.

2. What is the side of a square whose area is 1225 sq. in.?

WORK

$$\begin{array}{r} 5 \overline{)1225} \\ 5 \overline{)245} \\ 7 \overline{)49} \\ \underline{\quad\quad} \\ 7 \end{array}$$

$5 \times 7 = 35$, no of in.

EXPLANATION. — Since we are not likely to know the squares of numbers above 12×12 , we cannot give the answer at once as in Problem 1. Hence we must first factor the number. Since $1225 = 5 \times 5 \times 7 \times 7$, it must be the product of two equal numbers, each 5×7 or 35.

3. What is the side of a square having the same area as a rectangle 16 ft. wide and 36 ft. long?

SOLUTION: $16 \times 36 = 4 \times 4 \times 6 \times 6$. Hence the square is 24 in. long.

4. A lot 75 ft. wide and 147 ft. long has the same area as a square lot of what dimension?

5. What is the radius of a circle whose area is 314.16 sq. ft.?

SOLUTION: The area is the product of two factors. One is R^2 and the other is 3.1416. Dividing by 3.1416, the known factor, the other factor is found to be 100. Hence $R^2 = 100$. Then $R = 10$.

6. What is the radius of a circle whose area is 154 sq. in.?

SUGGESTION. — Use $\pi = \frac{22}{7}$. First divide 154 by $\frac{22}{7}$.

7. What must be the radius of a circular bottom of a silo if its area is to be 616 sq. ft.? (Use $\pi = \frac{22}{7}$.) The diameter?

Find the two equal factors that make the following:

- | | | |
|--------------|--------------|--------------|
| 8. 9216. | 11. 396,900. | 14. 176,400. |
| 9. 11,025. | 12. 360,000. | 15. 331,776. |
| 10. 194,481. | 13. 117,649. | 16. 275,625. |

42. THE NEED OF A NEW PROCESS

In the problems of the preceding page it was found that it sometimes is necessary to find *one of two equal factors* that make a number.

When a number is the product of two or more equal factors, it is called a **power** of one of the factors. When it is the product of *two* equal factors, it is called the **second power** or **square** of one of them, and when the product of *three* equal factors, it is called the **third power** or **cube** of one of them.

The power of a number is indicated by an **exponent**. Thus, $2 \times 2 \times 2$ is written 2^3 , where 3 is the *exponent*.

When a number is the product of two or more equal factors, one of the factors is called a **root** of the number. If there are *two* equal factors, one is called the **square root**, and if there are *three* equal factors, one is called the **cube root** of the number.

The square root of a number is indicated by the symbol $\sqrt{\quad}$, called a **radical sign**. Thus, the square root of 25 is written $\sqrt{25}$.

1. Find the radius of a circle whose area is 300 sq. ft.

SOLUTION: $300 \div 3.1416 = 95.5$, *nearly*. Now 95.5 is *less* than 10×10 and *greater* than 9×9 . Also, since $9.5 \times 9.5 = 90.25$, 95.5 is also greater than 9.5×9.5 . Then the radius is *greater* than 9.5 ft. but *less* than 10 ft.

2. Show that the square root of 240 is greater than 15.4 and less than 15.5.

While the approximate results found above might be sufficient for many practical problems, we need a **new process** by which more accurate results may be found when wanted. This new process is called **Square Root**. While the *exact* square root of a number cannot be found unless the number is made up of two equal factors, the process gives the root to any desired degree of accuracy.

43. THE PROCESS OF EXTRACTING THE SQUARE ROOT OF ANY NUMBER

Separating a number into two equal factors is the reverse of squaring one of these equal factors. A careful analysis of the process of squaring will enable us to reverse the process and find the square root of a number when it cannot be readily found by factoring.

The Process of Squaring a Number

1. Square 47.

PROCESS

$$\begin{array}{r} 47 \\ 47 \\ \hline 329 = 7^2 + 7 \times 40 \\ 1880 = 7 \times 40 + 40^2 \\ \hline 2209 = 7^2 + 2 \times 7 \times 40 + 40^2 \end{array}$$

Observe that in the process of multiplication we first find 7×7 or 7^2 ; next, 7×40 ; next, 40×7 ; and finally, 40×40 or 40^2 .

2. 83^2 in the same way is equal to $3^2 + 3 \times 80 + 80 \times 3 + 80^2 = ?$

3. Compare 3×80 with 80×3 . Then $3 \times 80 + 80 \times 3 = 2 \times 3 \times 80$. Hence, $83^2 = 3^2 + 2 \times 3 \times 80 + 80^2$.

4. Square 64 by this method.

WORK

$$\begin{array}{r} 64 \\ 64 \\ \hline 16 = 4^2 \\ 480 = 2 \times 4 \times 60 \\ 3600 = 60^2 \\ \hline 4096 = 64^2 \end{array}$$

5. Which of the partial products is the largest? From which digit was it obtained?

6. Which is the smallest of the partial products? From which digit was it obtained?

7. If 3600 were taken from the product, most of what remains is made from what factors?

8. State the rule for squaring numbers in this way.

Find by this method the squares of the following:

9. 35.

10. 62.

11. 84.

12. 58.

The number of periods of two figures each, beginning at ones, into which a whole number can be divided equals the number of figures in the square root.

10. Give the number of figures in the square roots of:
 9409 381 27,225 182,329 49,434,961.
11. Square 0.2; 0.02; 0.4; 0.12; 0.25; 0.03; 0.005.
12. Compare the number of decimal places in the square with the number in the root. Why can the square of a decimal never contain an odd number of decimal places?
13. State a principle for the number of periods in the decimal part corresponding to the principle given for integers.

Extracting the Square Root

Find the square root of 2809.

PROCESS

$$2809 \quad (50 + 3)$$

$$\underline{2500} = 50^2$$

$$\underline{309} = 2 \times 50 \times n + n^2 \text{ (why?)}$$

$$\underline{300} = 2 \times 50 \times 3$$

$$\underline{9} = 3^2$$

1. How many figures in this square?
2. Then how many in the root?
3. What is the square of 50? Of 60?
4. Between what two squares does 2809 come?
5. Then its root lies between what two numbers?
6. If the root lies between 50 and 60, the largest of the three partial products that make the square is what?
7. When 2500 is taken from 2809, what two partial products are contained in the 309 remaining? Most of the 309 is made from which of the partial products?
8. Then since 309 is more than 2×50 times the number that we are yet to find, about what must the number be?

10. When $2 \times 50 \times 3$ is taken from 309, what one of the three partial products remains?

11. Is 9 equal to 3^2 ? Then the second number must be 3, and the entire root is $50 + 3$ or 53. Prove by squaring.

12. Give the complete process of finding the root of a number containing three or four figures.

13. Find the square root of 8836.

SHORT PROCESS

$$\begin{array}{r} 88'36(94 \\ 81 \end{array}$$

$$2 \times 90 = 180 \begin{array}{|l} \hline 736 \\ \hline 4 \\ \hline 184 \end{array} \begin{array}{|l} \hline 736 \\ \hline \end{array}$$

We may omit the zeros in the square of 90, also the zero of the 90.

14. Compare $4 \times 180 + 4 \times 4$ with 4×184 .

Thus we see that we may also save work by adding the 4 to 180 before multiplying by 4.

Solve by both processes and show what you save by the shorter:

- | | | | |
|---------------------|---------------------|---------------------|---------------------|
| 15. $\sqrt{784}$. | 18. $\sqrt{3136}$. | 21. $\sqrt{5329}$. | 24. $\sqrt{7569}$. |
| 16. $\sqrt{3364}$. | 19. $\sqrt{6889}$. | 22. $\sqrt{4489}$. | 25. $\sqrt{2809}$. |
| 17. $\sqrt{8464}$. | 20. $\sqrt{2704}$. | 23. $\sqrt{9801}$. | 26. $\sqrt{9409}$. |

The process is the same for larger numbers. Study the following and describe the process.

27. Find the square root of 2,137,444.

PROCESS

$$2'13'74'44(1462$$

Find the square root of:

$$\begin{array}{r} 1 \\ 2 \quad \begin{array}{|l} \hline 113 \\ \hline 24 \quad 96 \\ \hline 28 \quad 17 \quad 74 \\ \hline 286 \quad 17 \quad 16 \\ \hline 292 \quad 5844 \\ \hline 2922 \quad 5844 \end{array} \end{array}$$

- | | |
|----------------|----------------|
| 28. 283,024. | 34. 529,984. |
| 29. 299,209. | 35. 484,416. |
| 30. 404,496. | 36. 638,401. |
| 31. 556,516. | 37. 725,904. |
| 32. 755,161. | 38. 294,849. |
| 33. 6,017,209. | 39. 1,739,761. |

The Square Root of a Fraction

To find the square root of 0.501.

$0.7^2 =$	0.49	$0.501(0.707 +$
$\underline{1.4}$	$\left[\begin{array}{l} 0.0110 \\ 0.009849 \\ 0.001151 \end{array} \right.$	
$\underline{\quad .007}$		
$\underline{1.407}$		

EXPLANATION. — As the square of *tenths* gives *hundredths*, to get the first root figure we take the first two figures at the right of the point or 0.50, the root of which is nearly 0.7. Each new quotient figure is determined by division, as in the case of integers. Since the square of a decimal cannot give an odd number of figures, this decimal must be an *imperfect* power, and the root cannot be *exactly* determined. This is indicated by a + or - after the last root figure.

This is indicated by a + or - after the last root figure.

Find the square root of:

- | | | | |
|--|------------|-----------|----------------|
| 1. 0.5625. | 4. 0.783. | 7. 824.9. | 10. 1932.4. |
| 2. 0.9216. | 5. 0.89. | 8. 0.64. | 11. 225.9009. |
| 3. 42.225. | 6. 19.467. | 9. 0.064. | 12. 0.8. |
| A. $\sqrt{\frac{320}{405}} = \sqrt{\frac{64}{81}} = \frac{8}{9}.$ | | | 13. 234.7024. |
| B. $\sqrt{\frac{3}{8}} = \sqrt{0.375} = 0.612 +.$ | | | 14. 2,044,900. |
| C. $\sqrt{7\frac{1}{9}} = \sqrt{\frac{64}{9}} = \frac{8}{3} = 2\frac{2}{3}.$ | | | 15. 76.3876. |
| D. $\sqrt{4\frac{4}{9}} = \sqrt{\frac{40}{9}} = \frac{6.3245 +}{3} = 2.108 +.$ | | | 16. 0.3. |
| E. $\sqrt{6\frac{3}{8}} = \sqrt{6.375} = 2.52 +.$ | | | |

In finding the roots of fractions :

- I. First change them to simplest form, as in A or C.
- II. Use the method in A or C when both terms are perfect powers.
- III. Use B or E when both terms are imperfect powers.
- IV. D may be used when the denominator is a square.

- | | | | |
|-------------------------------|------------------------------|---------------------------------|------------------------------|
| 17. $\sqrt{\frac{147}{432}}.$ | 19. $\sqrt{6\frac{19}{25}}.$ | 21. $\sqrt{82\frac{4}{5}}.$ | 23. $\sqrt{151\frac{7}{8}}.$ |
| 18. $\sqrt{\frac{5}{16}}.$ | 20. $\sqrt{5\frac{2}{3}}.$ | 22. $\sqrt{\frac{1905}{6480}}.$ | 24. $\sqrt{2\frac{3}{16}}.$ |

Some Applications of Square Root

1. Find the side of a square whose area is 178 sq. in. Carry the computation to tenths of an inch.
2. Find the side of a square whose area is 2764 sq. ft.
3. A square field contains 8 acres. How many rods long and wide is it?
4. A square board is to be cut that shall contain 92 sq. in. in its surface. How large a square must be made?
5. How many feet of fence does it take to go around a square lot containing 2 acres?
6. The area of a circle is 216 sq. in. Find its radius. Its diameter. Carry the computation to tenths of an inch.
7. The area of a circle is 27 sq. ft. Find its radius to tenths of a foot. Its diameter.
8. The cross section of a pipe is 7.5 sq. in. Find its diameter to tenths of an inch.
9. Two drain pipes in a house unite and discharge into one pipe with the same capacity as the two pipes together. The diameter of one small pipe is 2 in. and that of the other 3 in. Find the diameter of the large pipe into which they discharge.
10. Two sewer pipes, each 3 ft. in diameter, are to discharge into a large pipe whose capacity is equal to the two pipes together. How large must the large pipe be made?
11. What should be the diameter of the smokestack for a boiler which has 160 flues, each 2 in. in diameter?
12. A water main is 18 in. in diameter. It is to be replaced by a pipe with 3 times the capacity. What must be the diameter of the new pipe? Compute to tenths of an inch.

13. The area of the base of a cylinder is 184 sq. in. Find the diameter of the cylinder to tenths of an inch.

14. The bottom of a silo is to contain 364 sq. ft. Find its diameter to tenths of a foot.

15. A farmer wishes to build one silo with the same capacity as two silos of the same height, one with diameter 16 ft. and the other with diameter 20 ft. Find the diameter for the new silo.

16. A farmer wishes to build a silo 40 ft. high that will hold 250 tons of silage. Allowing 50 cu. ft. to a ton, find the diameter of the required silo.

17. If a silo is to be built 36 ft. high and to hold 200 tons of silage, what must the diameter be? Allow 50 cu. ft. to a ton.

18. Allowing 40 lb. of silage per day for each head of cattle, how many tons of silage must a farmer store to provide a herd of 30 cows for 180 days of the winter?

19. If he makes his silo 30 ft. high, what must be the diameter of the silo which the farmer builds to store the silage for the herd in Problem 18? Allow 50 cu. ft. to a ton.

20. To keep silage fresh it has been found that about 9 sq. ft. of surface to each cow of the herd must be allowed. Find the diameter, to the nearest foot, of a silo best suited to a herd of 22 cows. (Use $\pi = 3\frac{1}{7}$.)

SOLUTION: $9 \times 22 \div 3\frac{1}{7} = 63$. $\sqrt{63} = 8$, *nearly*. Hence, 16 ft.

21. In the same way find the diameter when there are 14 cows in the herd. When there are 56 cows.

22. A silo 12 ft. in diameter is built for a herd of 14 cows. What diameter would be necessary for a silo for a herd of 56 cows, if each cow is to be allowed as many square feet of feeding surface as in the first silo?

23. I wish to build a tank 4 ft. high that will hold 850 gal. What must be the diameter? (Use 1 cu. ft. = $7\frac{1}{2}$ gal.)

24. A square prism 50 in. high contains 57,800 cu. in. Find the dimensions of the base.

25. A square pyramid 15 in. high contains 1445 cu. in. Find the dimensions of the base.

26. A rectangular field twice as long as wide contains 7.2 A. Find its dimensions.

27. The depth of a city lot is three times the frontage, and the lot contains 12,675 sq. ft. Find the frontage.

28. If a metal plate 10 in. in diameter weighs 2 lb., what is the diameter of a plate of the same material that will weigh 5 lb.?

29. Instead of two circular flower beds each 12 ft. in diameter, George wishes to make a single bed that will be as large as the two. What diameter must it have?

30. Two reservoirs each 30 ft. in diameter and 60 ft. high are to be replaced by a single one of the same height that will hold as much as the two. Find what diameter the new one must have.

31. If a cylindrical tank 12 ft. long is to hold 2500 gal., what must be its diameter? (1 cu. ft. = $7\frac{1}{2}$ gal.)

32. The altitude of a cone is 16 in. and its volume is 1496 cu. in. Find the radius of the base. The diameter.

33. The base of a prism is a square. The altitude is 8 in. and the volume is 96 cu. in. Find to tenths of an inch the side of the base.

34. The volume of a pyramid is 360 cu. in., the altitude is 9 in., and the base is a square. Find to tenths of an inch the side of the base.

44. THE PYTHAGOREAN THEOREM

1. Draw a right triangle with the sides which form the right angle 3 inches and 4 inches respectively.

2. Measure the length of the other side, or hypotenuse.

3. Draw a square on each of the three sides as base.

4. Compare the square on the hypotenuse with the sum of the squares on the other sides.

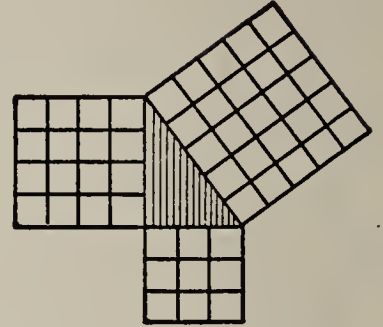

Pythagoras proved about 500 B.C. that the fact that we find true here is true for *any* right triangle, viz. that

The square on the hypotenuse of a right triangle is equal to the sum of the squares on the other two sides.

5. Carpenters make use of this fact in laying out the foundation for a building, when they want to form a right angle. A line 8 feet long is taken in one direction along which the foundation is to be made. Another line 6 feet long is fastened to one extremity of the first line and moved until a 10-foot rod will just reach the outer extremities of the two lines. Draw such a figure, and show that this gives a right triangle.

6. Use the test in Exercise 5, and find whether the walls of your schoolroom are perpendicular to the floor.

7. If the square on the hypotenuse is 100 sq. in. and on one of the sides 36 sq. in., what is the length of each side of the triangle?

8. Find the diagonal of the ceiling of your room by measuring the length and breadth of the room.

Denoting the hypotenuse by H , the base by B , and the perpendicular by P , when these are abstract numbers representing the *number* of units in the dimensions, we may state from the above principle the following formulæ:

$$H = \sqrt{B^2 + P^2}$$

$$B = \sqrt{H^2 - P^2}$$

$$P = \sqrt{H^2 - B^2}$$

9. Explain the formulæ.

10. If $H = 15$ and $P = 14$, $B =$ what?

11. If $B = 15$ and $P = 16$, $H =$ what?

12. If $H = 25$ and $B = 20$, $P =$ what?

The truth of the Pythagorean theorem may be seen by drawing, or cutting from cardboard, figures like the following:

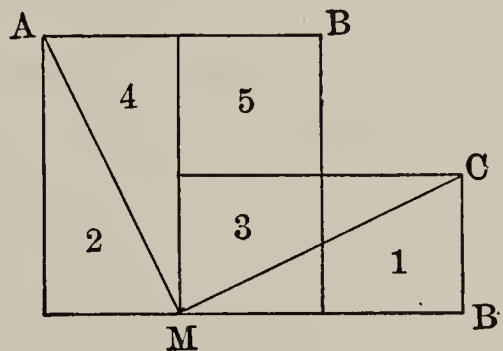
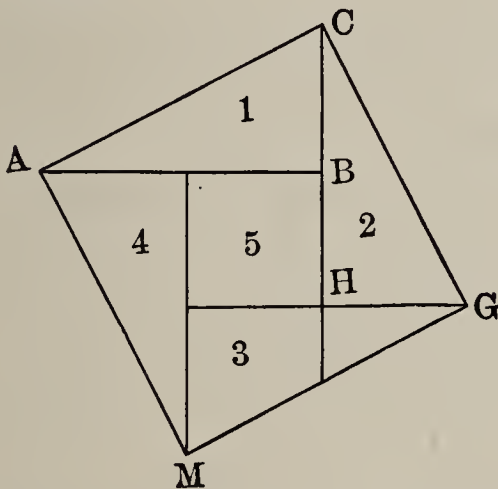

Let ABC be the right triangle. The square on the hypotenuse AC is equal to the four triangles, 1, 2, 3, and 4, and the small square, 5. Now put 1 and 2 in the position of the figure at the right, and the figure is equal to a square on AB and one on CB .

Problems

1. The base of a right triangle is 48 feet and the perpendicular is 36 feet. What is the hypotenuse?

2. The hypotenuse is 85 feet and the perpendicular is 51 feet. What is the base?

3. The base is 76 feet and the hypotenuse is 95 feet. What is the perpendicular?
4. What is the diagonal of a rectangle 92 ft. long and 69 ft. wide?
5. What is the diagonal of a 30-ft. square?
6. What is the longest line that can be drawn on a sheet of paper 16 inches wide and 20 inches long?
7. What is the diameter of the largest wheel that can be got through a doorway measuring 7 feet by 5 feet?
8. What is the distance between the opposite corners of a field 200 rods long and half as wide?
9. If a window is 18 ft. from the ground, how long must a ladder be to reach to the window if the foot of the ladder is placed 6 ft. out from the building?
10. In decorating a room two ribbons are stretched, connecting the opposite corners. If the room is 30 ft. wide and 40 ft. long, how many yards of ribbon does it take?
11. A baseball diamond is 90 ft. square. How far is it from first to third base?
12. A derrick is 48 ft. high, and is supported by three steel cables, each reaching from the top of the derrick to a stake in the ground 45 ft. from the foot of the derrick. How much steel cable does it take, allowing 10 ft. for fastening all three cables?
13. The gable of a house is 24 ft. wide and 12 ft. high from the plate to the ridgepole. How long must the carpenters cut the rafters, if they are to project one foot over the eaves?
14. There are 16 steps to a stairway. The rise of each is 8 in. and the tread 10 in. How long must the timber be cut that runs from one floor to another to support the steps?

45. ISOSCELES AND EQUILATERAL TRIANGLES

A triangle having two equal sides is **isosceles**. One having all of the sides equal is an **equilateral** triangle.

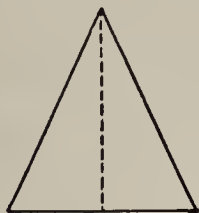

ISOSCELES TRIANGLE

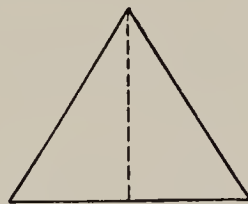

EQUILATERAL TRIANGLE

Prove by cutting or measuring that :

(1) *The altitude of an isosceles triangle divides the base into two equal parts.*

(2) *The perpendicular from any vertex of an equilateral triangle to the opposite side divides that side into two equal parts.*

Since an equilateral triangle is also isosceles whatever side is taken as base, (2) could have been inferred from (1).

1. If the base of an isosceles triangle is 12 in. and the equal sides 10 in., what is the altitude?

2. Find the altitude of a triangle 10 in. on each side.

3. Find the area of an isosceles triangle whose base is 10 in. and whose equal sides are each 12 in.

4. Find the area of an equilateral triangle each of whose sides is 14 in.

5. A *regular hexagon* is made up of six equilateral triangles. Study the figure and discover how to inscribe one in a circle.

6. Find the area of a regular hexagon each of whose sides is 10 in.

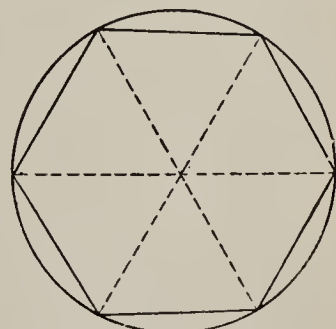

A REGULAR HEXAGON

46. ADDITIONAL APPLICATIONS OF PYTHAGOREAN THEOREM

1. Find the volume of a pyramid whose slant height is 10 in. and whose base is 12 inches square.

SOLUTION

$$\sqrt{10^2 - 6^2} = 8$$

Hence $AB = 8$ in.

$$\frac{8 \times 12 \times 12}{3} = 384$$

Hence vol. = 384 cu. in.

EXPLANATION. — The height AB must be known before the volume can be found. AB is seen to be the altitude of right triangle ABC .

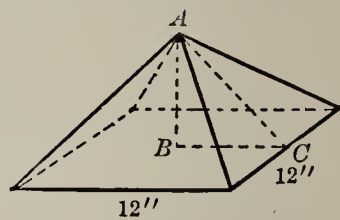

$AC = 10$ in. and $BC = \frac{1}{2}$ of 12 in. = 6 in.

2. The slant height of a square pyramid is 15 inches, and the side of the base is 10 inches. Find the volume.

3. A square pyramid has a base whose side is 4 ft., and the altitude is 6 ft. Find the slant height.

4. What two lines of an isosceles triangle must be known to find the area? Find the area of an isosceles triangle whose equal sides are each 10 ft. and whose base is 8 ft.

5. The altitude of a pyramid whose base is an equilateral triangle is 8 inches. The sides of the base are each 6 inches. Find the volume.

6. If the slant height of a cone is 12 inches and the diameter of the base 10 inches, find the altitude.

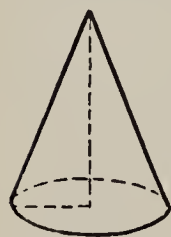

7. Find the altitude of a cone when the diameter of the base is 16 in. and the slant height is 15 in.

8. Find the volume of a cone when the radius of the base is 6 in. and the slant height 10 inches.

9. A pile of grain in the shape of a cone is 12 ft. in diameter at the bottom and the slant height is 9 ft. Find how many bushels it contains. (1 cu. ft. = 0.8 bu.)

Miscellaneous Problems in Mensuration

1. The volume of a pyramid is what part of the volume of a prism having the same dimensions? What is the volume of a pyramid 10 ft. high, the area of whose base is 56 sq. ft.?
2. Compare the rule for finding the volume of a cone with that for finding the volume of a pyramid.
3. Compare the surface of a sphere with that of one of its great circles.
4. How is the volume of a sphere shown?
5. Explain the meaning of the following formulæ:
(a) $V = \frac{1}{3} Ah$; (b) $V = \frac{1}{3} h\pi r^2$; (c) $S = 4\pi r^2$; (d) $V = \frac{4}{3}\pi r^3$.
6. If a square prism weighs 2 lb. 4 oz., what will be the weight of a square pyramid of the same base and altitude?
7. The contents of a square prism are 36 cu. in. How many cubic inches in a square pyramid of the same dimensions?
8. A bar of iron 12 in. by 2 in. by 3 in. will make how many pyramids of the same dimensions?
9. The largest possible cone is turned in a lathe out of a cylinder. What part goes to shavings?
10. If a sphere 3 inches in diameter is carefully turned out of a 3-inch cube, what part of the cube will go into shavings, and what part will remain in the sphere?
11. If a sphere is 0.5236 of a cube of the same diameter, what will be the contents of a sphere 4 inches in diameter?
12. If a cubic foot of iron weighs 450 pounds, what is the weight of an iron sphere 12 inches in diameter?
13. A cubic foot of ivory weighs 114 pounds. What is the weight of a set of 4 billiard balls 2 inches in diameter?

14. How many cubic miles in the moon, if we call its diameter 2000 miles?

15. If we call the diameter of the earth exactly 8000 miles, how many moons will be equal in volume to the earth? Shorten your work by cancellation.

16. Two 4-inch spheres are dropped into a pail even full of water and holding 864 cubic inches. How many cubic inches of water are displaced?

17. How does the curved surface of a hemisphere compare with its flat surface?

18. What is the surface of four great circles of a 5-inch sphere? What is the circumference of one of these circles?

19. Find the number of square inches in the surface of a 6-inch sphere.

20. A cubic foot of water weighs 1000 ounces, and gold is about 19 times as heavy. What would a sphere of gold 3 inches in diameter weigh?

21. How many square miles in the surface of the moon? Call its diameter 2000 miles.

22. A farmer has a wheat bin 12 ft. wide and 14 ft. long. He wishes to store 672 bu. of wheat in it. To what depth must he fill it? (1 cu. ft. = 0.8 bu.)

23. In estimating the cost of plastering a room, a contractor usually makes no allowance for openings. Find the cost of plastering the walls of a room 22 ft. by 33 ft. and 12 ft. high, at 7¢ per square foot. How much will the ceiling add to the cost at 8¢ per square foot?

24. Coal weighs a ton to 35 cu. ft. A man has 64 acres of coal land, the coal bed under it being 12 ft. thick. How many tons of coal in the bed? How much is it worth at \$1.95 a ton in the ground?

25. A man has a town lot 50 ft. wide and 120 ft. long that is $4\frac{1}{2}$ ft. below the level of the street. How much will it cost him, at 50¢ a load, to have earth hauled with which to fill it to the level of the street?

26. Water is flowing into a cylindrical tank whose diameter is 16 ft. at a rate of 20 cu. ft. a minute. How long will it take to fill the tank to a depth of 6 ft.?

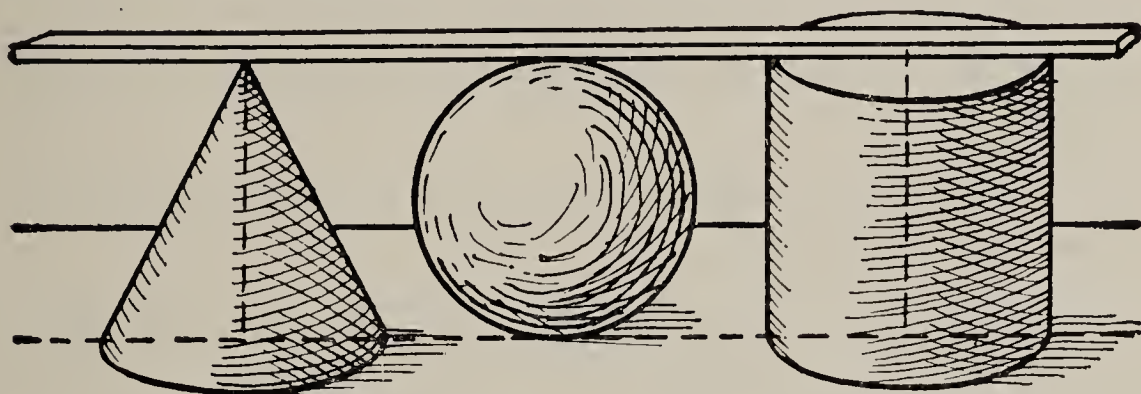

27. Compare the volumes of a cone, a cylinder, and a sphere, all having the same height and the same diameter. Suppose the diameter is 2 ft. and the height 2 ft.

Problems in Specific Gravity

SPECIFIC GRAVITIES, REFERRED TO WATER

Alcohol . . . 0.79	Gold . . . 19.3	Sea water . . 1.025
Brass . . . 8.4	Granite . . . 2.7	Silver . . . 10.5
Cast iron . . . 7.2	Ice . . . 0.92	Steel . . . 7.8
Cork . . . 0.24	Mercury . . . 13.6	Sulphur . . . 2.
Glass . . . 2.5	Petroleum . . 0.7	Zinc . . . 7.2

NOTE. — The *specific gravity* of a substance is the ratio of the weight of that substance to the weight of an equal volume of some substance taken as a standard. For the specific gravity of solids and liquids, distilled water is usually taken as the standard substance. For gases, either air or hydrogen is taken as the standard.

1 cu. ft. of water weighs 1000 oz., or 62.5 lb.

1. Find the weight of a cubic foot of each of the following: cast iron; granite; glass; gold; silver.
2. A piece of zinc weighs 1125 lb. How many cubic feet are there?
3. How many cubic feet of glass weigh 1572.5 lb.?
4. Find the weight of 1 cu. ft. of cork; of sulphur.
5. Find the weight of 10 gal. of sea water.
6. Find the weight of one gallon of alcohol; of one gallon of petroleum.
7. What is the weight of a block of ice 12 in. thick, 18 in. wide, and 36 in. long?
8. How many tons of ice will an ice-house hold that is 24' by 30' by 20', allowing $2\frac{1}{2}$ ft. on all sides and above and below for sawdust?
9. The specific gravity of good milk is 1.032. If 28 cu. in. of the milk taken from a can in a certain dairy wagon are found by the inspector to weigh just 1 lb., is the milk good?
10. One cubic foot of a certain kind of limestone is found to weigh 187.5 lb. What is the specific gravity?
11. One cubic foot of copper is found to weigh 556.25 lb. What is the specific gravity of copper?
12. A steel beam 16 ft. long, $2\frac{1}{4}$ in. wide, and 8 in. thick weighs how much?
13. A steel beam is 16 ft. long, $2\frac{2}{5}$ in. thick, and 14 in. wide. What is its weight?
14. An iceman delivered a block of ice 1 ft. long, $\frac{5}{6}$ of a foot wide, and $\frac{3}{4}$ of a foot thick, and charged for 50 lb. What was the shortage in weight?
15. What is the weight of a block of ice $6\frac{1}{2}$ ft. \times $1\frac{1}{4}$ ft. \times $4\frac{2}{3}$ ft.?

16. Find the weight of a cast-iron pipe 1.3 ft. long, 10 in. outside diameter, and $\frac{7}{8}$ in. thick.

17. What is the weight of a hollow steel pillar 10 ft. long, whose external diameter is 5 in., and internal diameter 4 in.? What is the diameter of a solid pillar of the same weight and length?

18. A grindstone when new is 6 ft. in diameter and has a 14-in. face. What has it lost in weight when the diameter is worn down 4 in.? (The specific gravity of sandstone is 2.42.)

19. What weight of brass is cut off in turning a cylinder 1 in. in diameter and 1 ft. long from a bar $1\frac{1}{4}$ in. square and 1 ft. long?

20. A tank car has a tank 7 ft. 9 in. inside diameter and 34 ft. long. What weight of petroleum will it carry?

21. Find the weight of a pane of plate glass $36'' \times 54''$ and $\frac{1}{8}$ of an inch thick.

22. Find the weight of a granite paving block $6'' \times 6'' \times 12''$.

23. In a laboratory a bottle 3 inches in diameter is filled with mercury to the depth of 4 inches. Find the weight of the mercury.

24. A steel rod $1\frac{1}{2}$ in. in diameter and 3 ft. long will weigh how much?

25. A kerosene can 14 in. in diameter and 18 in. high will weigh how much when full, allowing 3 lb. for the weight of the can?

26. A pane of plate glass for a large window is 6 ft. wide and 10 ft. high. If it is $\frac{3}{8}$ in. thick, how much will it weigh?

27. Make other applied problems, based upon the above table of specific gravities, and let the class solve them.

VI. APPLICATIONS OF PERCENTAGE

47. THE MEANING OF PER CENT

Per cent means *hundredths*.

Thus, 6 % of anything means 0.06 or $\frac{6}{100}$ of it.

25 % of anything means 0.25, $\frac{25}{100}$ or $\frac{1}{4}$ of it.

100 % of anything means $\frac{100}{100}$ of it, or *all* of it.

Exercises

What part of anything is :

- | | | |
|----------------|----------------|------------------------------|
| 1. 3 % of it? | 5. 50 % of it? | 9. $8\frac{1}{3}$ % of it? |
| 2. 8 % of it? | 6. 75 % of it? | 10. $12\frac{1}{2}$ % of it? |
| 3. 30 % of it? | 7. 80 % of it? | 11. $16\frac{2}{3}$ % of it? |
| 4. 60 % of it? | 8. 90 % of it? | 12. $37\frac{1}{2}$ % of it? |

How many times anything is :

- | | | |
|------------------|------------------|------------------|
| 13. 200 % of it? | 17. 250 % of it? | 21. 125 % of it? |
| 14. 300 % of it? | 18. 450 % of it? | 22. 225 % of it? |
| 15. 400 % of it? | 19. 750 % of it? | 23. 375 % of it? |
| 16. 800 % of it? | 20. 950 % of it? | 24. 625 % of it? |

What per cent of anything is :

- | | | |
|--------------------------|---------------------------|---------------------------|
| 25. $\frac{1}{2}$ of it? | 29. $\frac{1}{6}$ of it? | 33. $\frac{3}{4}$ of it? |
| 26. $\frac{1}{3}$ of it? | 30. $\frac{1}{8}$ of it? | 34. $\frac{2}{5}$ of it? |
| 27. $\frac{1}{4}$ of it? | 31. $\frac{1}{9}$ of it? | 35. $\frac{7}{10}$ of it? |
| 28. $\frac{1}{5}$ of it? | 32. $\frac{1}{10}$ of it? | 36. $\frac{7}{8}$ of it? |

What per cent of anything is :

- | | | |
|-----------------|-----------------|------------------|
| 37. 0.35 of it? | 40. 0.8 of it? | 43. 0.125 of it? |
| 38. 0.84 of it? | 41. 0.08 of it? | 44. 0.785 of it? |
| 39. 0.17 of it? | 42. 0.06 of it? | 45. 0.075 of it? |

What per cent of a number is :

- | | |
|--------------------------|-----------------------------|
| 46. 2 times the number ? | 49. 2.3 times the number ? |
| 47. 3 times the number ? | 50. 3.08 times the number ? |
| 48. 4 times the number ? | 51. 5.7 times the number ? |

At sight give the equivalent in per cent :

52.	53.	54.	55.	56.
0.35	1.25	0.235	0.5	1.2
0.28	3.75	0.685	0.6	3.4
0.07	6.85	0.725	$0.3\frac{1}{2}$	1.9
0.09	1.95	0.016	$0.2\frac{1}{2}$	8.2
$0.12\frac{1}{2}$	3.08	0.085	$0.6\frac{1}{2}$	4.3

What per cent is :

57.	58.	59.	60.
2 of 4 ?	4 of 10 ?	7 of 42 ?	4 of 2 ?
3 of 9 ?	6 of 50 ?	3 of 24 ?	9 of 3 ?
4 of 16 ?	8 of 40 ?	8 of 48 ?	8 of 2 ?
5 of 25 ?	10 of 20 ?	9 of 45 ?	12 of 3 ?

Find :

- | | |
|--------------------------------|----------------------|
| 61. 8% of 965. | 73. 1.34% of 3600. |
| 62. 15% of 386. | 74. 2.47% of 98,000. |
| 63. 35% of 768. | 75. 6.13% of 75,000. |
| 64. 85% of 398. | 76. 16.4% of 86,000. |
| 65. $6\frac{1}{2}$ % of 480. | 77. 125% of 9600. |
| 66. $8\frac{1}{4}$ % of 640. | 78. 250% of 7200. |
| 67. $9\frac{1}{2}$ % of 920. | 79. 350% of 5600. |
| 68. $16\frac{1}{4}$ % of 840. | 80. 7.5% of 4200. |
| 69. $36\frac{1}{2}$ % of 1150. | 81. 6.25% of 1600. |
| 70. 2.5% of 1200. | 82. 208% of 1450. |
| 71. 3.4% of 876. | 83. 16.5% of 2400. |
| 72. 5.2% of 960. | 84. 19.2% of 3200. |

48. APPLICATIONS OF PERCENTAGE

The Purchasing Power of Farm Products

The following table gives the average prices, in cents per bushel, that farmers received in 1899 and in 1911:

PRODUCTS	PRICE 1911	PRICE 1899	PRODUCTS	PRICE 1911	PRICE 1899
Corn	61.8	30.3	Barley	86.9	40.3
Wheat	87.4	58.4	Rye	83.2	51.0
Oats	45.0	24.9	Potatoes . . .	79.9	39.0

1-6. Find the per cent of increase in the price of each.

7. Find the average of the per cents found in Ex. 1-6.

The following table gives the average prices that farmers paid for their supplies in 1899 and in 1911:

SUPPLIES	PRICE 1911	PRICE 1899	SUPPLIES	PRICE 1911	PRICE 1899
Coffee	\$0.27	\$0.172	Muslin	\$0.094	\$0.072
Flour	\$6.08	\$4.76	Barb wire . . .	\$3.07	\$2.96
Lard	\$0.14	\$0.101	Nails	\$3.08	\$2.98
Sugar	\$6.75	\$5.33	Shovels	\$0.774	\$0.70
Brooms	\$0.50	\$0.28	Harness	\$15.50	\$12.34
Fruit jars . . .	\$0.80	\$0.728	Mowers	\$47.90	\$46.01
Stoves	\$28.56	\$24.75	Wagons	\$74.40	\$60.72

8-21. Find the per cent of increase in the price of each.

22. Find the average of the per cents found in Ex. 8-21.

23. By how much did the average increase in the price of products exceed the average increase in the cost of supplies?

24. From these results would you say that "the times" are growing better or worse for the farmer?

Scientific Farming

Up to the present time, as the population of our country has increased, the food supply of the nation has been increased chiefly by increasing the area cultivated. But soon the tillable land will all be taken up, and the increased food supply necessary for the increasing population will have to be produced through increasing the yield per acre by more scientific methods of using the soil. Germany has already used scientific farming with great success.

The following table gives the average annual yield per acre for certain crops produced in Germany during a period of years, and the yield of corresponding crops during a period of years beginning twenty years later:

CROP	YIELD FIRST PERIOD, BUSHELS PER ACRE	YIELD SECOND PERIOD, BUSHELS PER ACRE
Wheat	21.2	31.2
Rye	16.6	28.3
Oats	34.1	57.5
Barley	24.5	37.2
Potatoes	130.0	210.1

- 1-5. Find the per cent of increase in the yield of each crop.
6. Considering wheat worth 90¢ per bushel, the increase in the crop increased the income from the land how much per acre?
7. How much money loaned at 6% would yield a yearly interest equal to this increase?

NOTE.—It should be noticed that the result may be considered the increase in the actual value of the land.

8. Following the suggestion in the note, find the increase in the value of the land, if potatoes are worth 60¢ per bu.

9. In the same way compute the increase in the value of the land due to the increase in the oats crop. Allow 40¢ per bushel for the oats.

The following table gives the corresponding figures for the United States, except that here the second period began eighteen years after the first.

CROP	YIELD FIRST PERIOD, BUSHELS PER ACRE	YIELD SECOND PERIOD, BUSHELS PER ACRE
Wheat	12.7	14.7
Rye	12.7	16.4
Oats	25.6	29.0
Barley	22.6	24.6
Potatoes	73.2	96.9

10-14. Compute the per cent of increase in the yield per acre for each crop in the table of crops in the United States.

15. Compare the per cent of increase in yield per acre of each crop in Germany to the corresponding per cent of increase in the United States. That is, find the ratio and express it as per cent.

SUGGESTION.—It was found that the increase in the wheat crop of Germany was 47.17%, while in the United States it was only 15.75%. The ratio is $47.17 \div 15.75$, or 2.995. Hence 299.5%.

Plant Food

Do you know how the German farmer is able to make the soil produce so much more than the American farmer? The increase of yield of crops is produced by recognizing the fact that plants to grow need food just as animals do. Some of the most important of these foods that plants take from the soil and which farmers must restore to the soil to keep it from becoming less fertile are potassium, magnesium, calcium,

phosphorus and nitrogen. Failure to return these has worn out millions of acres of the older farm lands of the United States. Potassium, phosphorus, and nitrogen are the chief foods that need to be returned.

1. In an experiment in England, in which plant foods were supplied regularly to the soil for sixty years, the average yield of wheat per acre at the end of sixty years was 36.9 bu. On adjoining land where no plant food was applied, the yield was but 12.6 bu. per acre. Find the per cent of increase in the yield due to plant feeding.

SUGGESTION. — $36.9 \text{ bu.} - 12.6 \text{ bu.} = 24.3 \text{ bu.}$ Then 24.3 bu. is what per cent of 12.6 bu.?

2. Soil that when unfertilized yielded only 10 bu. of barley per acre yielded 33.4 bu. when fertilized. Find the per cent of increase of yield through fertilization of the soil.

3. Similarly, soil that when unfertilized yielded only 1949 lb. of clover per acre, yielded 8590 lb. after sixty years of application of plant foods. Find the per cent of increase.

PER CENTS REMOVED FROM THE SOIL BY CROPS

CROP	NITROGEN	PHOSPHORUS	POTASSIUM
Wheat (grain)	2.4 %	0.9 %	0.6 %
Corn	1.9 %	0.7 %	0.4 %
Oats	2.1 %	0.8 %	0.6 %
Timothy	1.3 %	0.5 %	0.9 %
Potatoes	0.2 %	0.1 %	0.3 %
Wheat straw	0.6 %	0.1 %	0.5 %

4. How much of each of the three foods of the above table is taken from an acre of soil that produces 40 bu. of wheat and $1\frac{3}{4}$ tons of straw? (A bu. of wheat weighs 60 lb.)

5. When a field of corn produces 50 bu. per acre, how much of each food is taken from the soil, not counting stalks and cobs? (Shelled corn weighs 56 lb. to the bushel.)

6. The analysis of a certain soil showed that there were 3200 lb. of nitrogen, 4350 lb. of phosphorus, and 17,200 lb. of potassium per acre in the upper 8 inches of the soil. How many crops of wheat of 20 bu. per acre, returning the straw, will the nitrogen supply? The phosphorus? The potassium?

7. It has been found that plants can take from the soil in one season about $\frac{1}{4}$ of 1% of the potassium that it contains. If a farmer takes a sample of his soil to an experiment station to be analyzed, and finds that an acre, to the depth that he plows it, contains 20,000 lb. potassium, how many pounds per acre can the plants take up in a season?

8. To produce the grain and stalks for a corn crop of 100 bu. to the acre requires about 70 lb. of potassium to the acre. How many bushels of corn per acre may the farmer in Problem 7 expect to grow on his farm, assuming that there are sufficient quantities of other plant foods?

9. A farmer finds that his soil contains 18,400 lb. potassium to the acre, to the depth that he plows it. If $\frac{1}{4}$ of 1% of this is available for the crop in one season, how many pounds are available?

10. For the grain and straw in a wheat crop of 50 bu. to the acre, 58 lb. of potassium per acre are required. How many bushels of wheat per acre will his soil produce?

11. Two per cent of the nitrogen in the soil to the depth plowed can be taken up by a crop in one season. To produce a crop of 100 bu. of corn per acre would require 148 lb. nitrogen. If an Iowa farmer finds that his soil contains 4420 lb. nitrogen to the acre, how many bushels of corn per acre should it produce?

Statistics of Important Farm Products

1. In ten years — from 1899 to 1909 — the wheat crop increased from 658,500,000 bu. to 683,400,000 bu. Find the per cent of increase. What was the average per cent of increase per year?

2. The value of the wheat crop increased in ten years (1899 to 1909) from \$370,000,000 to \$657,700,000. Find the per cent of increase in value. What was the average per cent of increase per year?

3. Does a comparison of the results in Problems 1 and 2 indicate that the price per bushel has gone up or down?

4. The average yield in 1899 was 12.5 bu. per acre. In 1909 it was 15.4 bu. per acre. Find the per cent of increase.

5. Some claim that the crop can be increased 125% by more scientific farming. If a crop of 683,400,000 bu. should be increased by this per cent, how much would it then be?

6. There are 5,850,000 farms in the United States, of which 34.9% grow wheat. How many farms grow wheat?

7. The production of cotton lint increased from 9,435,000 bales in 1899 to 10,640,000 bales in 1909. Find the per cent of increase.

8. The value of the cotton crop increased from \$323,800,000 in 1899 to \$703,600,000 in 1909. Find the per cent of increase.

9. What do the results of Problems 7 and 8 show as to the increase or decrease in the price per pound?

10. The total yield of corn in 1899 was 2,656,000,000 bu. In 1900 it was 2,552,000,000 bu. Find the per cent of decrease.

11. The Irish potato crop of 1909 was 367,520,000 bu. The crop of 1899 was 18.8% less than this. Find the crop of 1899.

49. PROPERTY INSURANCE

In order that I may not have to bear the total loss in case my house is damaged or destroyed by fire, I pay an **insurance company** a certain per cent or **premium** for the **insurance** of the property.

Thus, the insurance company agrees to make good my loss to the extent of the sum named in the **policy**, which is their *agreement*, or *contract*, with me, in case my house accidentally is burned during the period specified in the policy.

NOTE. — Bring before the class expired policies written upon buildings in your town or neighborhood. Find from them the local insurance rate. Also compare the rates for one-year with the rates for three-year policies.

1. I have my house insured for \$5000 for 3 years. I have to pay the insurance company \$25 for this. What is the face of the policy? What per cent of the face of the policy is the premium? This is what per cent a year?

2. If you insure your house for \$6000 for 5 years at $1\frac{1}{4}\%$, how much is the premium? How much will you receive from the insurance company if your house is totally destroyed?

3. Is property usually insured for its full value? Why?

4. I value my house at \$8000. How much will it cost me to insure it for 3 years at half its value at $\frac{3}{4}\%$ of the face of the policy?

5. If I have my yacht insured for \$3000, which is only $\frac{3}{4}$ of its value, what is my loss if it is totally destroyed and I have paid a premium of $1\frac{3}{8}\%$ of the face of the policy?

6. A merchant insured a stock of goods worth \$40,000 at $\frac{3}{4}$ of their value at a premium of $\frac{1}{2}\%$. What was the cost of the insurance?

7. A hotel costing \$50,000 is insured for 3 years for half of its value at 1% a year. What is the total premium?

8. A church is insured for \$5000 in each of five different companies. The total premium is \$500. What is the rate of insurance?

9. What is the premium on a \$12,000 policy at $1\frac{3}{4}\%$?

10. Goods worth \$9000 are insured for $\frac{2}{3}$ of their value. What is the rate if the premium is \$75?

11. A factory worth \$60,000 is insured for $\frac{3}{4}$ of its value at $1\frac{7}{8}\%$. The possible loss to the owner, including the premium, is how much?

12. A stock of goods costing \$250,000 is insured for $\frac{3}{5}$ of the cost. The rate is $1\frac{3}{4}\%$. In case they are totally destroyed, what is the entire loss to the owner? How much does the insurance company lose?

13. A wooden tenement house valued at \$24,000, two miles from a fire engine, is insured for half of its value at $\frac{3}{4}\%$ a year. How much is the total premium for 5 years?

14. When the premium is \$36 on a \$4800 policy, what is the rate?

15. It is quite common to speak of the cost of insurance in terms of a certain number of dollars per thousand dollars. Thus, a man may insure his property for 1 year for \$20 per \$1000. What per cent is this?

16. How much will it cost me to insure my household goods 1 year for \$4000 at \$16 per \$1000?

17. A schoolhouse valued at \$250,000 is insured at the rate of \$12.50 per \$1000. What is the premium?

18. A factory worth \$162,500 is insured for $\frac{3}{4}$ of its value at \$16.50 per \$1000. What per cent is the rate? What is the premium?

19. A firm insures its building, valued at \$28,000, at \$12 per \$1000; the first floor contents, valued at \$12,000, at \$14 per \$1000; and the contents of the other floors, valued at \$35,000 at \$16 per \$1000. If the policies are written for $\frac{3}{4}$ of the value in each case, what is the premium on the building and the entire contents?

20. A vessel is insured for \$15,000 and its cargo for \$9000. What is the premium at $\frac{5}{8}\%$?

Give the premiums on the following policies at the rates named:

- | | | |
|--------------------------------|----------------------------------|----------------------------------|
| 21. \$2400, $1\frac{1}{2}\%$. | 25. \$12,000, $1\frac{1}{2}\%$. | 29. \$26,000, $1\frac{3}{4}\%$. |
| 22. \$5000, $1\frac{3}{4}\%$. | 26. \$45,600, $1\frac{1}{4}\%$. | 30. \$65,400, $1\frac{1}{2}\%$. |
| 23. \$3600, $1\frac{1}{4}\%$. | 27. \$84,000, $1\frac{1}{2}\%$. | 31. \$18,500, $1\frac{3}{4}\%$. |
| 24. \$6000, $2\frac{1}{8}\%$. | 28. \$16,000, $1\frac{7}{8}\%$. | 32. \$44,000, $1\frac{3}{4}\%$. |

NOTE. — Other kinds of property insurance, in addition to insurance against fire, are insurance against loss by tornado, by theft, by disaster at sea (called marine insurance), etc. In these the premium is computed as in fire insurance.

50. TAXES

Most of the expenses of towns, cities, counties, and states are met by **taxes** levied by the proper officers upon the property of the town, city, county, or state.

Property is divided into two classes for taxation:

I. **Real Estate**, regarded as immovable, as land and buildings, including mines, quarries, forests, railroads, etc.; and

II. **Personal Property**, which is movable.

Besides the property tax, in some states all male citizens over 21 years old are required to pay a *poll tax*.

The rate of taxation is often stated as a certain number of mills on \$1, or as a certain number of cents on \$100. Sometimes it is stated as a per cent of the assessed value of the property.

1. Name some things for which the state needs money. Some things for which the county needs money. Name some things for which cities and villages need money.

2. If taxes are 16 mills on \$1, what rate per cent are the taxes? How much are the taxes on a valuation of \$16,000?

3. At \$1.25 on \$100 what is the per cent of tax rate? What is the amount of taxes upon property assessed at \$16,000?

4. How large a tax on property is assessed in your city or town?

Suppose a town has to raise a certain sum of money for the expenses of the coming year. Officers, called **assessors**, first estimate the value of the property to be taxed, and then **assess** each owner in proportion to what he has.

5. If the amount to be raised is \$20,000, and the poll tax amounts to \$1600, how large a property tax must be assessed?

6. The assessed valuation of the property of a certain town is \$200,000. The tax to be raised is \$4000. What is the *rate of taxation*?

7. What shall Mr. Smith pay, who owns \$5000 worth of property in the town?

8. My property is assessed at \$3000. The tax rate is $1\frac{1}{2}\%$. What is my tax if I pay a poll tax of \$2?

9. The tax to be raised is \$15,000. There are 250 polls, that is, male citizens over 21. What must be raised by a property tax if the poll tax is \$2 each?

10. If the tax is \$16 on every thousand dollars of the valuation of my property, how large will my tax be if I am assessed for \$5000?

Find the tax to be raised on the property under the following conditions :

	TOTAL TAX	NO. OF POLLS	SINGLE POLL TAX		TOTAL TAX	NO. OF POLLS	SINGLE POLL TAX
11.	\$28,000	218	\$1.50	14.	\$740,000	9,287	\$2.00
12.	\$27,500	960	\$1.75	15.	\$752,000	10,426	\$2.50
13.	\$76,400	2580	\$2.00	16.	\$427,000	7,315	\$2.15

In the following express the tax rate as (a) mills on \$1; (b) cents on \$100; (c) dollars on \$1000; (d) as a per cent:

	ASSESSED VALUATION	TAX TO BE RAISED ON PROPERTY		ASSESSED VALUATION	TAX TO BE RAISED ON PROPERTY
17.	\$48,000	\$1,200	21.	\$51,000,000	\$750,000
18.	\$650,000	\$13,000	22.	\$49,000,000	\$630,000
19.	\$1,650,000	\$28,875	23.	\$135,000,000	\$900,000
20.	\$2,470,000	\$30,875	24.	\$215,000	\$2,700

25. The valuation of property in a certain town is \$2,306,000. The tax to be raised on the property is \$39,202. What must the rate be?

26. What will a man's property tax be if he owns \$11,500 worth of property in this town?

27. If you live in a town, find the assessed valuation of the property of the town and the tax to be raised. Then find the tax rate.

28. Is property assessed for its full cash value in your town? If not, for about what per cent of its value is it assessed?

29. What is the tax in your town upon property assessed at \$15,400? At \$5800?

30. Is there a poll tax in your town? If so, how much is it?

51. NATIONAL REVENUES

The people are not taxed directly upon the property they own to support the national government as they are to support state, county, and local governments. The chief sources of income are : (1) **tariffs, duties, or customs** which are levied upon certain articles imported into the United States from foreign countries; (2) **internal revenue taxes** which are levied upon certain things made in this country, chiefly upon alcoholic liquors and tobacco products; (3) and an **income tax** levied upon incomes in excess of certain fixed amounts.

Some goods are on the *free list*, *i.e.* not subject to duty.

Some goods are subject to an *ad valorem* duty, which is a per cent of the value of the goods at the place of purchase.

Some goods are subject to *specific* duty, which is a certain amount per pound, per bushel, etc.

And some goods are subject to both duties.

Prior to 1913 there was no income tax, but the tariff rates were higher than under the new law of that year known as the Underwood-Simmons tariff law.

TABLE SHOWING A FEW CHANGES IN TARIFF RATES

ARTICLES	PAYNE LAW	UNDERWOOD LAW
Wool blankets	33 ¢ per lb. and 50 %	25 %
Beef, lamb, pork	25 %	free
Brooms	40 %	15 %
Cotton stockings	30 %	20 %
Woolen yarn	27½ ¢ per lb. and 35 %	18 %
Kitchen utensils	40 %	25 %

Problems

1. Ink and ink powders are subject to an *ad valorem* duty of 15 %. Find the duty on ink costing \$4000.

2. Olive oil is subject to a specific duty of 20 ¢ a gallon when bought in large holders. What is the duty on 850 gal. of olive oil?

3. Perfumery, if containing alcohol, is subject to an *ad valorem* duty of 60 % and a specific duty of 40 ¢ a pound. What is the duty on a shipment of perfumery weighing 250 lb. and purchased abroad for \$590?

4. The duty on decorated chinaware is 55 %. Find the duty on a set of china dishes costing \$18.50 in Germany. If you allow the merchant \$15 for expenses, profits, etc., how much must you pay him for these dishes?

5. The duty on imported automobiles is 30 %. What is the duty on a machine costing \$4600 in Paris?

6. The duty on hooks and eyes is 15 %. Find the duty on hooks and eyes valued at \$20.

7. The duty on watch and clock movements is 30 %. Find the duty on a watch movement costing \$8.50 in Europe.

8. The total value of watch and clock movements imported in a recent year was \$2,556,635. Find the duty.

9. The duty on feathers, flowers, etc., used for decorations is 60 %. During a recent year the total value of these importations was \$11,660,084. Find the duty.

10. The duty on copper wares was reduced by the Underwood-Simmons law from 45 % to 20 %. This country imported \$29,271,540 worth during a recent year. By how much is the duty lessened by the new law upon such an amount?

11. Ready-made clothing composed of cotton or vegetable fiber is subject to a duty of 30 %. Find the duty on \$750 worth of boys' suits.

12. Find the duty on a fur coat costing \$95 at a rate of 15 %.

13. The average duty upon jewelry is 60 %. If this country imports yearly jewelry valued at \$31,112,110, as it did in a recent year, how much income does the government get from this source?

14. We import an average of \$4,869,000 worth of toys yearly. The duty is 35 % of the value. Find the total duty paid upon toys yearly.

15. Under the Payne-Aldrich tariff law the duty on combed wool or tops was $24\frac{3}{4}$ ¢ per pound and 30 %. Under the new Underwood-Simmons law it is 8 %. During a recent year we imported 266,409,304 pounds of wool valued at \$45,171,994. By how much is the income to the government lessened upon such an importation?

16. The duty upon all ready-made woolen clothing is 35 %. What is the duty upon a suit costing \$36 abroad?

17. The duty upon Brussels carpet was 44 ¢ per square yard and 40 % under the Payne-Aldrich law. It is 25 % under the Underwood-Simmons law. Find the difference in duty upon a rug $9' \times 12'$ valued at \$36.80.

18. The duty upon Oriental and Axminster rugs was 90 ¢ per square yard and 40 % under the old law, and is 50 % under the new. Find the difference in duty on each of the following:

3 $8' \times 10\frac{1}{2}'$ Oriental rugs valued at \$78 each.

2 $9' \times 13'$ Oriental rugs valued at \$198 each.

4 $9' \times 12'$ Axminster rugs valued at \$56 each.

19. If a dealer imports an Oriental rug costing \$98 abroad, for how much must he sell it to make 30 % of the cost, including duty? (Use the rate in Problem 18.)

20. If this rug was $8' \times 11'$, for how much must he have sold it to make 30 % under the old duty.

The Income Tax

The income tax consists of a **normal** and an **additional tax**.

The *normal tax* is 1% of the net income in excess of \$3000, except in case of a married man, in which case it is on the net income in excess of \$4000.

The *additional tax* is as follows:

- 1% additional upon all amounts from \$20,000 to \$50,000;
- 2% additional upon all amounts from \$50,000 to \$75,000;
- 3% additional upon all amounts from \$75,000 to \$100,000;
- 4% additional upon all amounts from \$100,000 to \$250,000;
- 5% additional upon all amounts from \$250,000 to \$500,000;
- 6% additional upon all amounts above \$500,000.

1. Find the income tax of a bachelor having a net income of \$60,000.

SOLUTION

Normal tax,	1% of \$57,000	(\$60,000 - \$3,000) =	\$570
Additional tax,	1% of \$30,000	(\$50,000 - \$20,000) =	300
Additional tax,	2% of \$10,000	(\$60,000 - \$50,000) =	200
		Total tax =	\$1070

2. Find the income tax of a bachelor having a net income of \$90,000.

3. Find the income tax of a married man if his net income is \$15,000. If it is \$25,000.

4. Find the income tax of a bachelor having a net income of \$150,000. Of one having a net income of \$300,000.

5. Find the income tax yet to be paid by a bachelor having a net income of \$60,000, when the tax of 1% has already been paid on \$19,000 at the source from which the income was derived.

SUGGESTION. — Here the *normal tax* is found upon \$33,000. That is, upon \$60,000 less \$3000 and less \$19,000 upon which 1% has already been paid.

6. A certain bachelor is said to have an annual income of \$335,000. Find his income tax.

7. A married man has an annual income of \$58,000. Find his income tax.

52. TRADE DISCOUNT

1. Show the difference between grower or producer and importer ; wholesaler and retailer.

2. Do you buy from wholesalers or retailers ?

3. With whom do wholesalers have to deal ?

It is the general custom of wholesale dealers, manufacturers, and publishers to fix a price, called the **list price**, on their goods and then allow a certain per cent **discount** from this price to "the trade," as we have seen before.

4. A dealer bought a bill of hardware listed at \$360, but got a trade discount of $33\frac{1}{3}\%$ from this price. How much did the hardware cost him ?

5. A dealer in chinaware paid \$450 for a bill of dishes listed at \$600. What was the rate of discount ?

6. A dinner set listed at \$48 was sold to a dealer at a discount of 40 %. How much did it cost him ?

7. Find the net price of a piano listed at \$450, but sold at a discount of 20 %.

Give the discount :

	LIST PRICE	DISCOUNT		LIST PRICE	DISCOUNT		LIST PRICE	DISCOUNT
8.	\$ 600	20 %	13.	\$ 720	$8\frac{1}{3}\%$	18.	\$ 1450	20 %
9.	\$ 750	$33\frac{1}{3}\%$	14.	\$ 900	$66\frac{2}{3}\%$	19.	\$ 1700	40 %
10.	\$ 840	$12\frac{1}{2}\%$	15.	\$ 1200	$33\frac{1}{3}\%$	20.	\$ 1800	25 %
11.	\$ 960	25 %	16.	\$ 1600	25 %	21.	\$ 900	30 %
12.	\$ 1200	10 %	17.	\$ 900	10 %	22.	\$ 800	40 %

Give the rate of discount:

	LIST PRICE	DISCOUNT		LIST PRICE	DISCOUNT		LIST PRICE	DISCOUNT
23.	\$ 800	\$ 200	28.	\$ 1800	\$ 450	33.	\$ 8000	\$ 1000
24.	\$ 900	\$ 300	29.	\$ 2000	\$ 500	34.	\$ 4800	\$ 1600
25.	\$ 1000	\$ 250	30.	\$ 2400	\$ 600	35.	\$ 5400	\$ 900
26.	\$ 1200	\$ 400	31.	\$ 3500	\$ 700	36.	\$ 6400	\$ 800
27.	\$ 1500	\$ 1000	32.	\$ 4200	\$ 700	37.	\$ 7200	\$ 900

Copy and fill the following table:

	LIST PRICE	RATE OF DISCOUNT	DISCOUNT	NET PRICE		LIST PRICE	RATE OF DISCOUNT	DISCOUNT	NET PRICE
38.	\$825	20 %			45.	\$1900		\$190	
39.	\$640	33 $\frac{1}{3}$ %			46.	\$1050		\$87.50	
40.	\$1860	40 %			47.	\$2520			\$2100
41.	\$2730	5 %			48.	\$640		\$51.20	
42.	\$1280	2 $\frac{1}{2}$ %			49.	\$1260			\$1197
43.	\$3470	8 %			50.	\$252			\$216
44.	\$4298	16 $\frac{2}{3}$ %			51.			\$472.50	\$1417.50

53. SUCCESSIVE DISCOUNTS

When wholesale houses wish to increase the discount already given, they usually add another discount to be taken from the former discounted, or *net* price, rather than give a new *single* discount.

Thus, if goods are quoted at \$600, less 25 % and 10 %, it means that \$600 is to be discounted 25 %, and the remainder, \$450, is then to be discounted 10 %, leaving a net cost of \$405.

Secure, if possible, the catalogue of some dealer, together with his discount sheet, and examine both carefully.

Problems

1. A bill of goods quoted at \$400 is sold at 25 % and 10 % off. What is the net cost?
2. After receiving discounts of 20 % and 10 % from goods listed at \$1000, how much will they cost me?

By inspection give the net price:

	LIST PRICE	DISCOUNTS	NET PRICE		LIST PRICE	DISCOUNTS	NET PRICE
3.	\$ 600	20 %, 10 %		8.	\$ 2400	25 %, 10 %	
4.	\$ 900	33 $\frac{1}{3}$ %, 10 %		9.	\$ 3600	33 $\frac{1}{3}$ %, 12 $\frac{1}{2}$ %	
5.	\$ 1000	40 %, 15 %		10.	\$ 1600	25 %, 5 %	
6.	\$ 1200	16 $\frac{2}{3}$ %, 20 %		11.	\$ 3500	14 $\frac{2}{7}$ %, 2 %	
7.	\$ 1800	33 $\frac{1}{3}$ %, 20 %		12.	\$ 6000	10 %, 10 %	

13. A bill of hardware was listed at \$ 96, 40 % and 10 % off. Find the net price.
14. Find the net cost of a bill of \$85, 40 % and 5 % off.
15. Find the net cost of 8 doz. drip pans listed at \$4.45 per dozen, and 15 coal hods listed at \$2.10 per dozen; discounts 60 % and 10 %.
16. Find the net cost of 24 doz. basting spoons at \$3 per dozen, and $\frac{1}{4}$ gross galvanized buckets at \$58 per gross; discounts 75 % and 10 %.
17. A dealer received a bill of window glass listed at \$730, but the discounts were 90 % and 15 %. Find the net cost.
18. Find the net cost of a bill of \$850, 50 % and 15 % off.
19. A bill of chinaware listed at \$736 had discounts of 66 $\frac{2}{3}$ % and 10 %. Find the net price, including \$8.36 for boxing, freight, and drayage.

20. One third of the gross amount of a bill of silverware amounting to \$846 was discounted at 40 %, 10 %, and 10 %, and the remainder at 40 % and 15 %. Find the net amount of the bill. If the dealer retails the entire bill at an average of 90 % of the list price, what does he make? What per cent of the net cost is this?

21. A dealer receives a bill the gross amount of which is \$334. The discounts are 40 % and 10 %. The freight, drayage, and sundry expenses amount to \$12.50. If the dealer receives an average of 85 % of the list price, what per cent does he make on the net cost?

22. A dealer received the following invoice of wagons : 3 listed at \$79 each ; 2 listed at \$81 each ; 4 listed at \$103 each ; and one listed at \$85. The discounts were 40 % and 5 %. Find the net invoice. If a further discount of 5 % for cash is given, what will he save by paying cash?

23. A department store bought a lot of toys amounting to \$850, discount 20 %, 10 %, and 5 %. What was the net cost?

24. A publishing house sold a lot of books to a bookstore amounting to \$1240, with 15 % off, and an additional 2 % for cash. How large a check paid the bill?

25. A school bought of J. L. Hammett, Boston, the following supplies for number work :

6 tin thermometers, 12-inch	@ \$0.15
4 clock faces, cardboard	@ 0.25
2 sets dry measures	@ 1.75
2 sets liquid measures	@ 1.25
1 set sphere, cone, cylinder	@ 0.75
36 boxes toy money	@ 0.15
22 boxes inch cubes	@ 0.50

A discount of 20 % and an additional discount of 2 % for cash were allowed. How much was the bill?

26. A Boys' Club bought the following games for their club room :

2 Reversible Game Boards	@ \$ 2.85 each
4 Checkerboards and Checkers	@ .58 each
3 Sets Bone-faced Dominoes	@ 1.95 each
2 Games of Rook	@ .50 each
2 Folding Tables	@ 3.45 each

A 10% discount and a further discount of 2% for cash were allowed. What was the amount of the bill?

27. Find the amount of the following bill for school supplies:

12 doz. Higgins's inks	@ \$3.75
12 doz. water colors	@ 0.35
4 doz. scissors	@ 1.50
5 lb. Boston erasers	@ 0.80
3 doz. Dennison's paste	@ 0.85

Discounts, 10%, 15%, 5%.

54. A SINGLE DISCOUNT EQUIVALENT TO TWO DISCOUNTS

A merchant may wish to know the single discount equivalent to two or more discounts. For example, he may wish to know which is better, 40% and 10%, or 45%.

SOLUTION: $40\% + 10\% \text{ of } 60\% = 46\%$.

EXPLANATION. — A single discount of 40% leaves the cost 60% of the list price. A further discount of 10% of 60% of the list price is 6% of the list price. Hence the total discount is $40\% + 6\%$, or 46%.

Problems

1. Which is better, discounts of 40% and 20%, or of 50% and 10%?

SOLUTION: $40\% + 20\% \text{ of } 60\% = 52\%$.

$50\% + 10\% \text{ of } 50\% = 55\%$.

Hence the second is better.

2. One dealer offers me 60% and 10% off. Another offers me 50% and 25% off. Another offers me a single discount of 65%. Which is the best offer?

By inspection, give the single discount equivalent to :

- | | |
|--------------------------------|--------------------------------|
| 3. 10% and 10%. | 16. 20% and $12\frac{1}{2}$ %. |
| 4. 20% and 10%. | 17. 40% and 15%. |
| 5. $33\frac{1}{3}$ % and 10%. | 18. 50% and 5%. |
| 6. 40% and 25%. | 19. 50% and 25%. |
| 7. 40% and $33\frac{1}{3}$ %. | 20. 50% and 40%. |
| 8. 50% and 10%. | 21. 60% and $12\frac{1}{2}$ %. |
| 9. $66\frac{2}{3}$ % and 10%. | 22. 60% and 25%. |
| 10. 20% and 25%. | 23. 55% and $33\frac{1}{3}$ %. |
| 11. 40% and 20%. | 24. 40% and 30%. |
| 12. 60% and 20%. | 25. 25% and $33\frac{1}{3}$ %. |
| 13. 60% and 25%. | 26. 36% and $12\frac{1}{2}$ %. |
| 14. 30% and 10%. | 27. 52% and $8\frac{1}{3}$ %. |
| 15. 40% and $16\frac{2}{3}$ %. | 28. 28% and $16\frac{2}{3}$ %. |

55. GIVING DISCOUNTS ON GOODS BOUGHT AT A DISCOUNT

A merchant may wish to know what discount he can give from the *list price* from which he bought at a discount, and still make a profit.

For example, a merchant may buy goods at a discount of 40% and wish to know what discount he can give from the same list price and still make 25%.

SOLUTION AND ANALYSIS

The cost = 60% of the list price.

The gain = 25%, or $\frac{1}{4}$ of 60% of the list price, or 15% of the list price.

The selling price = 60% + 15%, or 75% of the list price.

Hence, he can give a discount of 25% ($100\% - 75\%$) of the list price.

Problems

1. If I can buy an article at a discount of 50%, what discount can I give and still make 20%?

2. I wish to make $33\frac{1}{3}\%$ on goods bought at 40% below the list price. What discount can I give?

Find the discounts that can be given:

	DISCOUNT	GAIN		DISCOUNT	GAIN		DISCOUNT	GAIN
3.	60%	25%	7.	40%	$8\frac{1}{3}\%$	11.	30%	20%
4.	40%	20%	8.	80%	50%	12.	$33\frac{1}{3}\%$	10%
5.	70%	10%	9.	60%	50%	13.	$66\frac{2}{3}\%$	40%
6.	20%	$12\frac{1}{2}\%$	10.	50%	40%	14.	75%	50%

A Game: Buying, Selling, and Canceling Indebtedness

To make more concrete the work of discounts, etc., as well as of methods of sending money to pay for goods bought, let the pupils play "Going into business." Take the class to a local bank. Study the method of depositing money in a bank. Get samples of a *deposit slip* and a page from a *bank book*.

Get also some *checks* and show the method of checking out money from a bank.

Also discuss other forms of paying off indebtedness, as *drafts*, *postal money orders*, *express money orders*, etc. Get blanks of each of these, and discuss the methods of *indorsement*, which becomes a receipt for the money received.

Let pupils represent large wholesale houses in some large city. Let others be retail merchants buying from them. The wholesale merchants will send bills, with discounts. The retailers will check up the bills and pay by draft, check, or money order.

Problems

NOTE.— The study of this set of problems is to follow a trip to a bank suggested on the preceding page.

1. Suppose you bought of E. L. Holmes & Co., St. Louis, Mo., a bill of hardware as follows :

26 doz. axes at \$4.80; 32 doz. files at \$1.20; 36 doz. saws at \$3.40. Discounts, 40 % and 10 %. Terms: 2 % discount for cash in 10 days; net 60 days.

Make out a bill such as E. L. Holmes & Co. would send you, showing net price.

Send a draft in payment. What is the face of the draft? Where will you get it? To whom will you have it made payable? If made payable to yourself, how will you indorse it before sending it?

2. Suppose you bought of M. E. Dawson & Co., New York, the following :

4 kitchen cabinets at \$13.25; 3 kitchen cabinets at \$15.25; and 1 kitchen cabinet at \$17.75. Terms: 2 % off for cash in 10 days; net 30 days.

Make out the proper bill. Find the net cash price. Send them your check for the payment. What will Dawson & Co. do with this check when they receive it? What will a postal money order to settle the bill cost?

3. F. R. Smith & Sons, Peru, Ind., bought of J. L. Morris & Co., Chicago, the following :

2 safes at \$12.50; 3 armchairs at \$9; 2 rockers, leather, at \$25; 1 couch at \$8; 3 couches at \$6.50; 2 rockers at \$9. Terms: net 60 days.

Make out the proper bill, finding the price in 60 days. Pay by check.

4. A. L. Morgan of Salem, Ill., bought of Reed, Murdock, & Co., Chicago, the following:

86 lb. tea at 43 ct.; 280 lb. of coffee at 28 ct.; 250 lb. prunes at $11\frac{1}{2}$ ct.; 116 lb. raisins at 14 ct.; 144 cans salmon at 15 ct.; 86 lb. apricots at 18 ct. Terms: 60 days net; 2% off for cash in 10 days.

Make out the proper bill. Make out the proper form of draft. What would Reed, Murdock, & Co. do with this draft?

5. I. C. Carpenter bought of the Van Cleve Glass Co. the following:

Three boxes 7×9 , single, at \$26.75; 5 boxes 10×14 , single, at \$28.25; 2 boxes 16×20 , single, at \$30; 5 boxes 12×20 , single, at \$28; 6 boxes 18×24 , single, at \$31.75. Discounts 85% and 10%. Terms: 60 days net or 2% off in 10 days.

Write out a check for the cash payment.

6. R. L. Stevens & Sons sold to J. H. Boyce the following:

Two rockers at \$13.50; 1 rocker at \$8.25; 2 Morris chairs at \$15; 3 chairs at \$3.75; 1 hall tree at \$11.50; 1 hall tree at \$13.75. Terms: net 90 days.

Make out the proper bill. The proper draft. The proper check.

56. SIMPLE INTEREST

General Method of finding Interest

1. If I pay 6¢ for a year's use of a borrowed dollar, what is the rate of interest?
2. What does the expression "6 per cent interest" mean?
3. At 6%, what is a year's interest of \$300?

4. What part of a year is 2 months? If the interest for 1 year is \$18, what should it be for 2 months?

5. What is the interest of \$400 for 1 year and 6 months at 5%?

6. At 7%, what is the interest of \$200 for 2 years, 6 months?

7. What is the first step in finding the interest of any principal? The second step?

8. At 5%, what is the interest of \$720 for 2 yr. 5 mo.?

SOLUTION

$$\frac{29}{12} \times \frac{5}{100} \times \$720 = \$87.$$

EXPLANATION. — $\frac{5}{100}$ of \$720
 = int. for 1 yr. 2 yr. 5 mo. = $\frac{29}{12}$
 yr. Hence the total interest = $\frac{29}{12}$
 $\times \frac{5}{100} \times \$720.$

Find the interest of:

9. \$6000 at 5% for 1 yr. 4 mo.
10. \$4800 at 6% for 2 yr. 8 mo.
11. \$7500 at 5% for 3 yr. 7 mo.
12. \$9640 at 6% for 2 yr. 9 mo.
13. \$4575 at 6% for 4 yr. 2 mo.
14. \$5280 at 4% for 1 yr. 11 mo.
15. \$6800 at 6% for 2 mo. 12 da. ($\frac{72}{360}$ yr.)
16. \$12,000 at 5% for 1 mo. 27 da.
17. \$28,400 at 5% for 2 mo. 10 da.
18. \$1890 at 6% for 3 mo. 14 da.
19. \$7630 at 5% for 4 mo. 24 da.
20. \$1200 at 6% for 90 da.
23. \$9600 at 4% for 67 da.
21. \$3500 at 6% for 35 da.
24. \$1450 at 6% for 24 da.
22. \$4850 at 5% for 75 da.
25. \$5260 at 5% for 45 da.

Two Special Methods of Finding Interest

1. Find the interest of \$ 750 at 6 % for 117 days.

SOLUTION

$$\frac{117}{360} \times \frac{6}{100} \times \$750 = ?$$

EXPLANATION. — Since 360 days make an interest year for time less than one year, 117 days make $\frac{117}{360}$ of a year. Hence $\frac{117}{360} \times \frac{6}{100} \times \$750 = \text{Interest}$.

2. A study of the solution will show that :

To find the interest of any principal at 6 % for any number of days, multiply the principal by the number of days, point off three more decimal places and divide by 6.

3. Find the interest of \$ 940 at 6 % for 65 days.

WORK

Find the interest at 6 % of :

$$\begin{array}{r} \$ 940 \\ \quad 65 \\ \hline 4700 \\ \quad 5640 \\ \hline 6)61.100 \\ \underline{\$ 10.18} \end{array}$$

- | | |
|-----------------------|------------------------|
| 4. \$ 780 for 95 da. | 10. \$ 1650 for 36 da. |
| 5. \$ 860 for 117 da. | 11. \$ 1920 for 47 da. |
| 6. \$ 950 for 216 da. | 12. \$ 1730 for 82 da. |
| 7. \$ 845 for 86 da. | 13. \$ 1360 for 76 da. |
| 8. \$ 1250 for 72 da. | 14. \$ 1620 for 49 da. |
| 9. \$ 1340 for 64 da. | 15. \$ 1980 for 18 da. |

16. The same method may be used for interest at 5 % if $\frac{1}{6}$ of the result is deducted. Why ?

17. To use the same method for interest at $4\frac{1}{2}$ %, $\frac{1}{4}$ of the result must be deducted. Why ?

At 5 %, find the interest of :

- | | |
|------------------------|------------------------|
| 18. \$ 1900 for 45 da. | 22. \$ 850 for 112 da. |
| 19. \$ 2400 for 86 da. | 23. \$ 975 for 118 da. |
| 20. \$ 3600 for 75 da. | 24. \$ 948 for 132 da. |
| 21. \$ 5600 for 36 da. | 25. \$ 890 for 89 da. |

At $4\frac{1}{2}\%$ find the interest of:

- | | |
|-----------------------|-----------------------|
| 26. \$1540 for 26 da. | 29. \$2450 for 70 da. |
| 27. \$1620 for 32 da. | 30. \$3460 for 80 da. |
| 28. \$1980 for 46 da. | 31. \$9640 for 50 da. |

This method is sometimes called the **Banker's Method**.

The Second Special Method

1. Find the interest of \$1250 at 6% for 60 da.

SOLUTION

$$\frac{\cancel{60}}{\cancel{360}} \times \frac{\cancel{6}}{100} \times \$1250 = \$12.50$$

2. Study the solution and tell what numbers cancel out.

3. What remains for a divisor? How do you divide by 100?

To find the interest of any principal at 6% for 60 days, move the decimal point two places to the left.

At 6% find the interest of:

4. \$196 for 115 da.

5. \$119 for 89 da.

WORK

$$\text{Int. for } \left\{ \begin{array}{l} 60 \text{ da.} = \$1.96 \\ 30 \text{ da.} = .98 \\ 20 \text{ da.} = 0.6533 + \\ 5 \text{ da.} = 0.1633 + \\ \hline 115 \text{ da.} = \$3.7566 + \\ \text{Hence, } \$3.76 \end{array} \right.$$

WORK

$$\text{Int. for } \left\{ \begin{array}{l} 60 \text{ da.} = \$1.19 \\ 20 \text{ da.} = 0.3966 + \\ 6 \text{ da.} = 0.1190 \\ 3 \text{ da.} = 0.0595 \\ \hline 89 \text{ da.} = \$1.7651 \\ \text{Hence, } \$1.77 \end{array} \right.$$

This is sometimes called the **Aliquot Part Method**.

Find the interest at 6% of:

- | | |
|---------------------|----------------------|
| 6. \$780 for 67 da. | 8. \$920 for 86 da. |
| 7. \$640 for 93 da. | 9. \$940 for 200 da. |

At 5 % find the interest of:

10. \$ 840 for 75 da.

\$ 8.40 = int. at 6 % for 60 da.

2.10 = int. at 6 % for 15 da.

6)10.50 = int. at 6 % for 75 da.

1.75 = int. at 1 % for 75 da.

\$ 8.75 = int. at 5 % for 75 da.

11. \$ 820 for 70 da.

12. \$ 950 for 63 da.

13. \$ 720 for 93 da.

14. \$ 875 for 72 da.

15. \$ 970 for 85 da.

16. \$ 450 for 20 da.

17. \$ 120 for 50 da.

18. \$ 830 for 45 da.

19. \$ 650 for 45 da.

20. \$ 810 for 75 da.

21. \$ 960 for 70 da.

Interest on Notes

1. What is a promissory note?

2. In computing the interest on a note, how is the time between dates found? Find the time between March 6, 1908, and September 2, 1909.

\$ 1500--- Baltimore, Md., ---August 15, ---1910.
 ---Sixty days---after date---I---promise to pay to the
 order of---Thomas Simpson-----
 Fifteen Hundred-----Dollars
 Payable at State Bank. Interest 6% per annum.
 Value received. -----Gordon Bradford.-----

3. Find the interest on the above note when due. What is the amount that Gordon Bradford must pay in settlement?

4. A note given May 3, 1910, for \$850, at 5 %, was paid off July 18, 1910. How much was paid in settlement?

5. A note given August 25, 1909, for \$2400, at 6 %, was paid off June 16, 1910. How much was the interest?

6. If you gave a note for \$ 650 at 6 % for 90 da., what amount would it take to pay it off?

7. Ask some banker to fill out a note for you showing that John Doe has borrowed \$ 1275 of Richard Roe to-day at 6 % for 90 da. Ask him to show you his method of finding the interest.

8. Prepare notes showing that you have borrowed money to-day from different members of the class, filling in the dates, lengths of periods that the notes are to run, and rates of interest, as you wish. Have the persons to whom the notes are given compute the interest on them. Check their work.

57. BORROWING AT A BANK

When borrowing at a bank, the interest, called **Bank Discount**, is paid in advance. Hence no rate of interest is named in the note. The balance left after deducting the discount is called the **proceeds**. Notes given to banks usually are made for 30, 60, or 90 days, and then are renewed if desired.

Problems

<i>Montclair, N. J., --- Dec. 10, --- 1910.</i>	
<i>-----Ninety days-----after date, I promise to pay to the</i>	
<i>order of R. W. Hemphill, Cashier.-----\$ 600.</i>	
<i>Six Hundred and $\frac{\text{no}}{100}$-----Dollars</i>	
<i>at Montclair Savings Bank, Montclair, N. J.</i>	
<i>Value received.</i>	<i>Residence---314 Elm St.---</i>
<i>Due-----Discount-----</i>	<i>-----Henry Wilson.-----</i>

1. When is the above note due?
2. At 6%, what is the discount?
3. What are the proceeds?
4. If you borrow \$875 at a bank for 60 days, at 6%, what will be the discount? What will the proceeds be, *i.e.* how much money will you actually receive from the bank? How much must you pay back at the end of 60 days?
5. If you borrow \$1250 at a bank for 90 days, at 5%, what will be the discount? How much will you actually receive from the bank?
6. I can borrow \$500 for 60 days, at 6%, from an individual or from a bank. Compare the interest in the one case with the discount in the other. In which case do I get the use of the greater amount of money for the same interest?

Fill out the following table :

	PRINCIPAL	RATE	TIME	BANK DISCOUNT	PROCEEDS
7.	\$2500	6%	60 da.		
8.	\$1600	6%	90 da.		
9.	\$1860	5%	60 da.		
10.	\$6500	5%	30 da.		
11.	\$4250	6%	90 da.		
12.	\$2150	6%	30 da.		
13.	\$5000	5%	90 da.		
14.	\$8430	6%	60 da.		

58. DISCOUNTING NOTES

It often happens that the holder of a promissory note desires to use the money promised in the note before it is due to be paid. In such a case, he can sell the note to a bank. This is called **discounting the note**. The compensation

charged by the bank is *bank discount*, being computed on the value of the note at maturity at a certain rate per cent for the time from the date when the note is discounted until it is due. The maturity value of the note less the discount is the *proceeds*.

NOTE. — Banks usually compute the time in the exact number of days in discounting a note. In some parts of the country, both the day that the note is discounted and the day that it is due are included. The pupil should ascertain and follow the local custom.

Problems

1. A note for \$800, at 5%, dated March 6, 1910, and due June 6, 1910, was discounted at a bank April 15, 1910, at 6%. How much did the bank pay for the note, *i.e.* what were the proceeds?

	SOLUTION	
Face =	\$ 800.00	EXPLANATION. — From March 6 to June 6 = 3 mo. From April 15 to June 6 = 52 da. The interest for 3 mo. at 5% is added to the principal to get the maturity value. The discount on the maturity value is found for 52 da. at 6%.
Int. 3 mo., 5%	10.00	
Maturity value	<u>\$ 810.00</u>	
Discount, 52 da., 6%	7.02	
Proceeds	<u>\$ 802.98</u>	

NOTE. — Local customs vary. Visit a bank in your city and find how the cashier would discount this note.

2. A note for \$1200, without interest, due September 1, is discounted at 6% July 6. What are the proceeds?

3. A note for \$450, without interest, due May 10, is discounted at 6% April 1. Find the proceeds.

4. A merchant sold \$350 worth of goods, and took the purchaser's note for the amount at 5%, due in 60 days. Needing the cash, he took the note 10 days later to a bank and sold it at a discount of 6%. How much did he receive for it?

5. A dealer bought \$1250 worth of goods, and gave his note on February 5 for 90 days, at 6%. On February 12 the holder of the note discounted it at a bank at 6%. What were the proceeds?

6. If you were to buy an automobile for \$1600 on April 20, and give your note for the amount at 5%, due in 90 days, and the automobile company discounted the note at a bank at 6% the day it was made, how much cash would the company receive for the machine?

Find proceeds of notes under these conditions :

	FACE	RATE	DATE OF NOTE	RUNS	DISCOUNTED AT 6%
7.	\$450	4%	May 10	60 da.	28 da. after date.
8.	\$720	5%	Aug. 15	90 da.	48 da. before maturity.
9.	\$850	6%	June 1	90 da.	15 da. after date.

10. Find the proceeds of a note for \$958, without interest, dated October 12, 1910, and having 45 days to run, if discounted at date at 7 per cent.

11. A note of \$600, dated May 3, 1910, interest 6%, to run 4 months, was discounted May 20 at 6%. Find the proceeds.

12. A note of \$560, to run 3 months, dated August 4, 1910, bearing 5% interest, was discounted at 6% on September 19. Find the discount and the proceeds.

13. A man sold his farm for \$6500, taking a note due in 6 months, interest 5%. He at once sold the note to a bank, discount 6%. What did he get in cash for his farm?

14. A certain wholesale house sells goods on 90 days' time, taking in payment a 90-day note without interest. What does the house get for an invoice of \$820 discounted at 6% 5 days after the date of the note?

15. Some firms date their bills for certain kinds of goods two or three months ahead of the actual date of making out the invoice. A bill of wall paper amounting to \$540 was billed December 15, 1909, but dated March 1, 1910. If this bill is paid before March 1, a discount equal to 6% interest may be deducted. What will settle the bill December 15? What will settle it January 1, 1910? What February 1?

59. COMPUTING INTEREST BY TABLES

We have found that bank discount usually is computed for the exact number of days that a note has to run from the date that it is discounted. This time is quickly found by the use of the following table :

THIS TABLE SHOWS THE NUMBER OF DAYS FROM ANY DAY OF ANY MONTH TO THE SAME DAY OF ANY MONTH NOT MORE THAN ONE YEAR LATER

FROM	TO											
	JAN.	FEB.	MAR.	APR.	MAY	JUNE	JULY	AUG.	SEPT.	OCT.	NOV.	DEC.
Jan.	365	31	59	90	120	151	181	212	243	273	304	334
Feb.	334	365	28	59	89	120	150	181	212	242	273	303
March	306	337	365	31	61	92	122	153	184	214	245	275
April	275	306	334	365	30	61	91	122	153	183	214	244
May	245	276	304	335	365	30	61	92	123	153	184	214
June	214	245	273	304	334	365	30	61	92	122	153	183
July	184	215	243	274	304	335	365	31	62	92	123	153
Aug.	153	184	212	243	273	304	334	365	31	61	92	122
Sept.	122	153	181	212	242	273	303	334	365	30	61	91
Oct.	92	123	151	182	212	243	273	304	335	365	31	61
Nov.	61	92	120	151	181	212	242	273	304	334	365	30
Dec.	31	62	90	121	151	182	212	243	274	304	335	365

Thus, the number of days from June 13 to November 27 of the same year is found as follows :

By the table, from June 13 to November 13 = 153 days.

From Nov. 13 to November 27 = 14 days.

Total = 167 days.

INTEREST TABLE. INTEREST AT 6%

DA.	\$ 100	\$ 200	\$ 300	\$ 400	\$ 500	\$ 600	\$ 700	\$ 800	\$ 900	\$ 1000	DA.
1	0.017	0.033	0.050	0.067	0.083	0.100	0.117	0.133	0.150	0.167	1
2	0.033	0.067	0.100	0.133	0.167	0.200	0.233	0.267	0.300	0.333	2
3	0.050	0.100	0.150	0.200	0.250	0.300	0.350	0.400	0.450	0.500	3
4	0.067	0.133	0.200	0.267	0.333	0.400	0.467	0.533	0.600	0.667	4
5	0.083	0.167	0.250	0.333	0.417	0.500	0.583	0.667	0.750	0.833	5
6	0.100	0.200	0.300	0.400	0.500	0.600	0.700	0.800	0.900	1.000	6
7	0.117	0.233	0.350	0.467	0.583	0.700	0.817	0.933	1.050	1.167	7
8	0.133	0.267	0.400	0.533	0.667	0.800	0.933	1.067	1.200	1.333	8
9	0.150	0.300	0.450	0.600	0.750	0.900	1.050	1.200	1.350	1.500	9
10	0.167	0.333	0.500	0.667	0.833	1.000	1.167	1.333	1.500	1.667	10
11	0.183	0.367	0.550	0.733	0.917	1.100	1.283	1.467	1.650	1.833	11
12	0.200	0.400	0.600	0.800	1.000	1.200	1.400	1.600	1.800	2.000	12
13	0.217	0.433	0.650	0.867	1.083	1.300	1.517	1.733	1.950	2.167	13
14	0.233	0.467	0.700	0.933	1.167	1.400	1.633	1.867	2.100	2.333	14
15	0.250	0.500	0.750	1.000	1.250	1.500	1.750	2.000	2.250	2.500	15
16	0.267	0.533	0.800	1.067	1.333	1.600	1.867	2.133	2.400	2.667	16
17	0.283	0.567	0.850	1.133	1.417	1.700	1.983	2.267	2.550	2.833	17
18	0.300	0.600	0.900	1.200	1.500	1.800	2.100	2.400	2.700	3.000	18
19	0.317	0.633	0.950	1.267	1.583	1.900	2.217	2.533	2.850	3.167	19
20	0.333	0.667	1.000	1.333	1.667	2.000	2.333	2.667	3.000	3.333	20
21	0.350	0.700	1.050	1.400	1.750	2.100	2.450	2.800	3.150	3.500	21
22	0.367	0.733	1.100	1.467	1.833	2.200	2.567	2.933	3.300	3.667	22
23	0.383	0.767	1.150	1.533	1.917	2.300	2.683	3.067	3.450	3.833	23
24	0.400	0.800	1.200	1.600	2.000	2.400	2.800	3.200	3.600	4.000	24
25	0.417	0.833	1.250	1.667	2.083	2.500	2.917	3.333	3.750	4.167	25
26	0.433	0.867	1.300	1.733	2.167	2.600	3.033	3.467	3.900	4.333	26
27	0.450	0.900	1.350	1.800	2.250	2.700	3.150	3.600	4.050	4.500	27
28	0.467	0.933	1.400	1.867	2.333	2.800	3.267	3.733	4.200	4.667	28
29	0.483	0.967	1.450	1.933	2.417	2.900	3.384	3.867	4.350	4.833	29
Mo.	\$ 100	\$ 200	\$ 300	\$ 400	\$ 500	\$ 600	\$ 700	\$ 800	\$ 900	\$ 1000	Mo.
1	0.500	1.000	1.500	2.000	2.500	3.000	3.500	4.000	4.500	5.000	1
2	1.000	2.000	3.000	4.000	5.000	6.000	7.000	8.000	9.000	10.000	2
3	1.500	3.000	4.500	6.000	7.500	9.000	10.500	12.000	13.500	15.000	3
4	2.000	4.000	6.000	8.000	10.000	12.000	14.000	16.000	18.000	20.000	4
5	2.500	5.000	7.500	10.000	12.500	15.000	17.500	20.000	22.500	25.000	5
6	3.000	6.000	9.000	12.000	15.000	18.000	21.000	24.000	27.000	30.000	6
7	3.500	7.000	10.500	14.000	17.500	21.000	24.500	28.000	31.500	35.000	7
8	4.000	8.000	12.000	16.000	20.000	24.000	28.000	32.000	36.000	40.000	8
9	4.500	9.000	13.500	18.000	22.500	27.000	31.500	36.000	40.500	45.000	9
10	5.000	10.000	15.000	20.000	25.000	30.000	35.000	40.000	45.000	50.000	10
11	5.500	11.000	16.500	22.000	27.500	33.000	38.500	44.000	49.500	55.000	11
Yr.	\$ 100	\$ 200	\$ 300	\$ 400	\$ 500	\$ 600	\$ 700	\$ 800	\$ 900	\$ 1000	Yr.
1	6.00	12.00	18.00	24.00	30.00	36.00	42.00	48.00	54.00	60.00	1
2	12.00	24.00	36.00	48.00	60.00	72.00	84.00	96.00	108.00	120.00	2
3	18.00	36.00	54.00	72.00	90.00	108.00	126.00	144.00	162.00	180.00	3
4	24.00	48.00	72.00	96.00	120.00	144.00	168.00	192.00	216.00	240.00	4
5	30.00	60.00	90.00	120.00	150.00	180.00	210.00	240.00	270.00	300.00	5

When men have much computing of interest or bank discounts to do, time is saved by using an interest table like the one on the preceding page.

Exercises in using Interest Tables

1. Find the bank discount on \$240, at 6%, from March 12, 1910, to July 25, 1910.

By the tables, from March 12 to July 12 = 122 days.

From July 12 to July 25 = 13 days.

Total = 135 days, or 4 mo. 15 days.

By the tables, Int. of \$200 for 15 days = \$0.500

Int. of 40 for 15 days = 0.100

Int. of 200 for 4 mo. = 4.000

Int. of 40 for 4 mo. = 0.800

\$5.40

By the tables, find the interest, at 6%, of:

- | | |
|------------------------|-----------------------|
| 2. \$850 for 18 da. | 11. \$7840 for 69 da. |
| 3. \$970 for 33 da. | 12. \$645 for 27 da. |
| 4. \$680 for 42 da. | 13. \$837 for 39 da. |
| 5. \$910 for 47 da. | 14. \$972 for 41 da. |
| 6. \$780 for 68 da. | 15. \$895 for 111 da. |
| 7. \$3400 for 71 da. | 16. \$908 for 117 da. |
| 8. \$5600 for 83 da. | 17. \$675 for 175 da. |
| 9. \$7200 for 91 da. | 18. \$861 for 134 da. |
| 10. \$8600 for 113 da. | 19. \$276 for 142 da. |

Find the bank discount and proceeds of:

20. \$450 from August 6, 1909, to November 15, 1909, at 6%.
21. \$960 from January 3, 1910, to June 18, 1910, at 6%.
22. \$4300 from March 18, 1910, to June 3, 1910, at 6%.

23. \$1850 from October 1, 1909, to January 19, 1910, at 6%.

24. \$3800 from May 30, 1910, to July 3, 1910, at 6%.

60. PARTIAL PAYMENTS ON A NOTE

In general, modern business custom will not allow an advance payment upon a note unless it is so stipulated in the note. Such stipulations are usually to the effect that such payments are to be made at the end of interest-paying periods. There was a time, however, when borrowing among individuals was more common than now, and when the payments of interest and any other payments were more irregular. To govern the final settlements in such transactions, the United States Supreme Court decreed that —

Partial payments of notes must first be used to cancel the interest due. Any balance remaining may be used to lessen the principal. If, however, the payment is too small to pay the interest due, the unpaid interest must not be used to increase the principal, which must never represent more than the money actually and previously due.

NOTE.—It is customary in partial payment notes to indorse the payments on the back of the note when made.

Problems

1. What is due January 16, 1908, on a note of \$1600 drawing 6% interest, given May 3, 1904, the following payments having been made: May 3, 1905, \$200; December 18, 1905, \$80; June 25, 1906, \$300; April 16, 1907, \$450?

2. What is due July 23, 1908, on a note of \$2400 drawing 5% interest, given January 4, 1903, the following payments having been made: September 4, 1903, \$300; July 19, 1904, \$50; January 4, 1905, \$300; April 16, 1906, \$250; December 26, 1907, \$500?

NOTE. — Since the payment on July 19, 1904, was insufficient to pay the interest then due, the principal left on September 4, 1903, will have to be used again. Work will be saved by finding the amount from September 4, 1903, to January 4, 1905, and then deducting \$350, or both payments.

3. A note of \$3500, dated August 15, 1905, interest 6%, has the following indorsements: August 15, 1906, \$500; February 15, 1907, \$100; July 10, 1907, \$400; December 15, 1907, \$1500. What is due August 15, 1908?

4. A note of \$7500, dated May 3, 1905, interest 5%, has the following indorsements: May 3, 1906, \$2500; August 3, 1906, \$3500; February 18, 1907, \$50; May 3, 1907, \$500. What is due May 3, 1908?

5. I paid a note that had been running just 5 years. It drew 6 per cent interest, and its face was \$900. It was given Dec. 11, 1907, and \$300 had been paid on it 2 yr. 8 mo. after date. What sum cancelled it?

61. COMPOUND INTEREST

When interest due at the end of any interest period is added to the principal, and thus draws interest for the next interest period, and so on, we have **compound interest**. Thus, in a savings bank, the interest due at any interest-paying date is credited to one's account, and thus draws interest, giving *compound interest*.

In most states the collection of compound interest on a note is illegal. In modern practice, then, the subject is merely of use to large investors, as building and loan associations, life insurance companies, banking corporations, etc., who wish to compute the final incomes from reinvesting all interest as it falls due. Such computations are made by the use of compound interest tables.

A SECTION OF A COMPOUND INTEREST TABLE

PERIODS	1 PER CENT.	1½ PER CENT.	2 PER CENT.	2½ PER CENT.	3 PER CENT.	PERIODS
1	1.010000	1.015000	1.020000	1.025000	1.030000	1
2	1.020100	1.030225	1.040400	1.050625	1.060900	2
3	1.030301	1.045678	1.061208	1.076891	1.092727	3
4	1.040604	1.061364	1.082432	1.103813	1.125509	4
5	1.051010	1.077284	1.104081	1.131408	1.159274	5
6	1.061520	1.093443	1.126162	1.159693	1.194052	6
7	1.072135	1.109845	1.148686	1.188686	1.229874	7
8	1.082857	1.126493	1.171660	1.218403	1.266770	8
9	1.093685	1.143390	1.195093	1.248863	1.304773	9
10	1.104622	1.160541	1.218994	1.280085	1.343916	10
11	1.115668	1.177949	1.243374	1.312087	1.384234	11
12	1.126825	1.195618	1.268242	1.344889	1.425761	12
13	1.138093	1.213552	1.293607	1.378511	1.468534	13
14	1.149474	1.231756	1.319479	1.412974	1.512590	14
15	1.160969	1.250232	1.345868	1.448298	1.557967	15
16	1.172579	1.268985	1.372786	1.484506	1.604706	16
17	1.184304	1.288020	1.400241	1.521618	1.652847	17
18	1.196147	1.307341	1.428246	1.559659	1.702433	18
19	1.208109	1.326951	1.456811	1.598650	1.753506	19
20	1.220190	1.346855	1.485947	1.638616	1.806111	20

PERIODS	3½ PER CENT.	4 PER CENT.	4½ PER CENT.	5 PER CENT.	6 PER CENT.	PERIODS.
1	1.035000	1.040000	1.045000	1.050000	1.060000	1
2	1.071225	1.081600	1.092025	1.102500	1.123600	2
3	1.108718	1.124864	1.141166	1.157625	1.191016	3
4	1.147523	1.169859	1.192518	1.215506	1.262477	4
5	1.187686	1.216653	1.246181	1.276281	1.338226	5
6	1.229255	1.265319	1.302260	1.340096	1.418519	6
7	1.272279	1.315932	1.360861	1.407100	1.503630	7
8	1.316809	1.368569	1.422100	1.477455	1.593848	8
9	1.362900	1.423312	1.486095	1.551328	1.689479	9
10	1.410600	1.480244	1.552969	1.628895	1.790848	10
11	1.459970	1.539454	1.622853	1.710339	1.898299	11
12	1.511069	1.601032	1.695881	1.795856	2.012197	12
13	1.563956	1.665074	1.772196	1.885649	2.132928	13
14	1.618695	1.731676	1.851945	1.979931	2.260904	14
15	1.675348	1.800944	1.935282	2.078928	2.396558	15
16	1.733986	1.872981	2.022370	2.182875	2.540351	16
17	1.794676	1.947901	2.113376	2.292018	2.692773	17
18	1.857489	2.025817	2.208478	2.406619	2.854339	18
19	1.922501	2.106849	2.307860	2.526950	3.025600	19
20	1.989789	2.191123	2.411714	2.653298	3.207136	20

Problems in Compound Interest

1. If you deposit \$400 in a savings bank which pays 4% interest, payable semiannually, how much will you have at the end of two years?

WORK, WITHOUT TABLES

<u>\$ 400</u>	
8	int. for $\frac{1}{2}$ yr.
<u>\$ 408</u>	amt. at end of $\frac{1}{2}$ yr.
8.16	int. for $\frac{1}{2}$ yr.
<u>\$ 416.16</u>	amt. at end of 1 yr.
8.32	int. for $\frac{1}{2}$ yr.
<u>\$ 424.48</u>	amt. at end of $1\frac{1}{2}$ yr.
8.49	int. for $\frac{1}{2}$ yr.
<u>\$ 432.97</u>	amt. at end of 2 yr.

EXPLANATION. — Int. of \$400 for $\frac{1}{2}$ yr. at 4% = \$8. This was added to \$400 to give the amt. due. Next, \$408 for $\frac{1}{2}$ yr. at 4% = \$8.16. This was added to \$408, giving \$416.16, etc.

WORK, USING TABLES

\$ 1.082432
400
\$ 432.972800

EXPLANATION. — Since 4%, payable yearly, is 2% for $\frac{1}{2}$ yr., or each period, we find the amt. of \$1 for 4 periods at 2%. Since amt. of \$1 = \$1.082432, amt. of \$400 = $400 \times \$1.082432$.

2. Find in both ways the amount of \$600 for 4 years at 3%, payable semiannually.

3. If a man deposits \$500 semiannually in a savings bank, what amount will he have to his credit at the end of 5 years, interest 3%, payable semiannually?

SUGGESTION. — The first \$500 is compounded for 5 yr. at 3%, hence for 10 periods at $1\frac{1}{2}$ %. The next for 9 periods, the next for 8 periods, etc. By adding the amounts of \$1 for each of these 10 periods at $1\frac{1}{2}$ % we get \$10.863263. Hence on \$500 the amount is 500 times as great.

4. How much can one accumulate in 10 years by depositing \$800 annually, interest 4%, compounded annually?

62. STOCK INVESTMENTS

When a number of individuals form an organization under the laws of a state to conduct business, the organization is called a **Company, Stock Company, or a Corporation.**

The money contributed to carry on the business of the company is its **Capital or Stock.**

The stock of a company is divided into **shares.** The holder of one or more shares is known as a **stockholder** of the company.

When one buys one or more shares of stock in a company, he receives a **stock certificate,** which is a formal statement issued by the company showing the number of shares of which the holder is owner.

No. <u>268</u>	<u>100</u> SHARES
INCORPORATED UNDER THE LAWS OF THE STATE OF NEW JERSEY	
Flemington Pressed Brick Company	
CAPITAL STOCK, \$200,000	
<i>Flemington, N.J., 3/8/11</i>	
<i>This certifies that J. R. Simms is the owner of One Hundred shares, of One Hundred Dollars each, of the capital stock of the Flemington Pressed Brick Company.</i>	
Transferable only on the books of the Company in person or by attorney upon surrender of this certificate.	
<i>A. L. Simpson,</i>	<i>H. L. Berry,</i>
SECRETARY.	PRESIDENT.

The value named in the stock certificate is the **par value** of the stock. The par value is determined by the company when it organizes, and depends upon the number of shares into which it seems desirable to divide the stock.

The price for which stock sells is its **market value**.

The earnings of a company that are divided among its stockholders are called the **dividends**. The dividends are designated as a certain per cent of the par value of the stock.

Market value, January 11, 1911

Am. Express	225
Am. Tel. & Tel.	141½
Balt. & Ohio	106
Chi. Gt. Western.....	22¾
Ill. Cent.....	134
U. S. Steel.....	74
Utah Copper.....	45½

There are two kinds of stock, **common** and **preferred**. The rate of dividend paid upon the preferred is stated in the stock certificate. The rate paid upon the common depends upon the net earn-

ings; that is, upon the part left after all expenses, including the dividends upon the preferred stock, are paid.

In general, one wishing to buy stock in a certain company does not know who has such stock for sale; or if he wishes to sell, does not know a buyer. Hence, he buys or sells through an agent called a **stock broker**. The broker usually gets $\frac{1}{8}\%$ of the par value of the stock for selling and the same for buying.

Exercises and Problems

1. What is the name of the company issuing the stock certificate on the preceding page?
2. From whom did the company get its right to organize to carry on business?
3. What is the entire capital of the company?
4. How many shares of stock in this company?

5. Who owns this stock certificate? How many shares does he own?

6. What is the par value of each share? Of the whole certificate?

7. If the market value of this stock is 135, this means that each share is selling for \$135. At this price, what are the 100 shares worth?

8. If Mr. Simms bought this at $145\frac{1}{8}$, through a broker, paying him $\frac{1}{8}\%$ of the par value for buying it, how much did each share cost? The 100 shares?

9. If Mr. Simms sells this stock at $151\frac{1}{4}$, through a broker, paying him $\frac{1}{8}\%$ of the par value for his services, how much does he receive *net* for each share? That is, how much is left after paying brokerage? How much will he receive for the 100 shares?

10. If you buy stock at $98\frac{1}{2}$, through a broker (brokerage $\frac{1}{8}\%$), how much does a \$100 share cost you? If you sell it for 102, through a broker, how much do you really get for each share? How much is gained?

11. When stock is quoted at $142\frac{1}{8}$, how much will a \$100 share cost if bought through a broker? How much will 100 shares cost?

NOTE. Always consider brokerage $\frac{1}{8}\%$ of the par value.

12. In a daily paper find the market value of the stock quoted on page 238. Suppose that you bought 50 shares of each on Jan. 11, 1911, through a broker, and sold yesterday. How much did you make or lose on each?

13. Get an old daily paper and one of yesterday. Compare the prices shown in them, on the two dates, of the following: Chicago, Milwaukee, and St. Paul; New York Central; United States Rubber; Wisconsin Central.

14. When a 6% dividend is paid, how much is that on a \$100 share? On 10 shares? On 50 shares?

15. If I own 100 shares of United States Steel and an 8% dividend is paid, how much do I receive?

16. When a company whose capital stock is \$400,000 pays a 12% dividend, how much is paid out in dividends?

17. When you get a 9% dividend upon stock, how many dollars do you get per \$100 share? If you paid \$150 per share for this stock (including brokerage), your dividends are what per cent of your investment?

18. If you can buy 10 \$100 shares of stock at 140 and get an 8% dividend each year, how much more income will you have yearly than if you loan the same money at 5%?

19. When stock costing \$80 per \$100 share pays a 4% dividend, the dividend is equal to interest at what per cent on the investment?

20. Find the difference in incomes from 10 \$100 shares of each of the following, and from the market value of the stock invested at $5\frac{1}{2}\%$ interest:

Market value . . .	80	225	198	145	75	60	210	340
Rate of dividend . .	4%	12%	12%	8%	4%	3%	10%	20%

21. From the table in problem 20, find what per cent the dividend is of the market value in each case.

NOTE. This is called the rate of income from the investment.

22. When stock bought at $134\frac{1}{4}$ pays an 8% dividend, what is the rate of income?

23. When a corporation whose capital stock is \$200,000 divides \$12,000 among its stockholders, what is the rate of dividend? How much will a man receive who has 50 shares of \$100 each?

24. If you own 100 shares of \$50 each in a corporation paying a dividend of 8%, how much will you receive?

25. \$20,000 of the stock of a certain corporation is 7% preferred stock. What are the dividends upon the preferred stock?

26. If the total capital of the corporation referred to in problem 25 is \$270,000, how much is common stock?

27. In the same corporation, if \$16,400 in dividends are distributed to the stockholders of both kinds of stock, how much do the common stockholders get? What per cent of the common stock is this?

28. If I buy 10 \$100 shares of stock at $125\frac{1}{4}$ (through a broker), receive a dividend of 12%, and sell in a year for $131\frac{1}{8}$ (through a broker), how much do I make?

29. How much does one lose, besides the interest upon the money that he invests, if he buys 100 \$100 shares of stock at $80\frac{3}{4}$, receives two 5% dividends, and sells in two years at 65, both transactions through a broker?

30. If you buy 50 \$100 shares of New York Central when it is selling at $108\frac{1}{2}$, hold it until you have received three 8% dividends, and then sell it at $116\frac{5}{8}$, both transactions through a broker, how much do you make?

NOTE. It will be found interesting and of great value in making the study of stocks concrete, for the class to play "Stock Exchange." A few pupils may act as brokers, and the rest play that they are investors. The investors prepare make-believe certificates of stock, either stock of fictitious companies or stock quoted in the daily papers, which they place on sale through their chosen brokers. The market prices asked may be taken from daily papers, if the stocks are quoted there, or regulated in some other way. Each of the pupils also buys stocks through the broker handling the kind that he wants. Payments may be made by checks on a make-believe school bank or otherwise, the brokers receiving their fees. Play that a day or a week is a year. Pay dividends once a year. Details of the game will suggest themselves readily to the teacher.

63. BONDS

When corporations, or national, state, or city governments, borrow large sums of money, they usually give a series of **bonds** or **promissory notes**, for one or more hundred or thousand dollars each, and to run several years at a fixed rate of interest. Instead of finding some one that will lend the money needed, the bonds are issued and offered for sale.

Registered bonds are recorded by number on the books of the corporation, with the names and addresses of the holders. They can change owners only through the office of the treasurer. The interest is sent to the holder when due.

One of several interest coupons attached to a bond.

<p>Mexican Mutual Planters' Company OF NEW YORK</p> <p><i>Will pay to bearer at the office of the Company-----Fifty-----Dollars on the--15th--day of--April---, 1911, being--one year's--interest on coupon bond No.---137---</i></p> <p>---A. L. Smith,--- Secretary.</p>

Coupon bonds bear small, detachable coupons or certificates of the amount of interest regularly due. These coupons are paid by the treasurer on presentation, or they may be deposited at one's

bank for collection. Bonds are bought and sold like stocks.

Problems

1. If the coupon shown above is one attached to a 5 % bond, what is the face value of the bond?
2. When is the next payment of interest due?
3. Where can it be collected, and by whom?

4. If the bonds sell at 108, what would this one cost, including $\frac{1}{8}\%$ brokerage?

5. My $4\frac{1}{2}\%$ bonds yield me \$180 annually. What is their par value?

6. If a \$2000 bond was bought when quoted at $103\frac{7}{8}$ (\$103 $\frac{7}{8}$ for \$100 of par value), brokerage $\frac{1}{8}$, what did it cost? What is it worth at maturity? How much less than it cost is this?

7. When bonds are quoted at $97\frac{3}{8}$, what will a \$1000 bond cost, if bought through a broker? What is it worth when due?

8. A corporation is bonded for \$200,000. The bonds bear $4\frac{1}{2}\%$ interest. What yearly interest does the corporation pay?

9. What income will one receive yearly from six \$500 5% bonds?

10. A \$30 coupon was detached from a 6% bond, being the interest for one year. What was the face of the bond?

11. How many \$1000 4% bonds are necessary to yield an annual income of \$1200?

12. When one buys a \$1000 5% bond, due in 3 years, at $96\frac{7}{8}$, brokerage $\frac{1}{8}\%$, what does he make besides the interest if he holds it until maturity?

13. Give the cost of a \$1000 bond in each of the following corporations, allowing $\frac{1}{8}$ for brokerage, the quotations being for \$100 par value. (5s = 5% interest.)

Argentine	5s	$95\frac{7}{8}$	C. B. & Q.	4s	$96\frac{1}{2}$
Rep. of Cuba	5s	$103\frac{1}{8}$	C. M. & St. P.	4s	$100\frac{1}{8}$
U.S. of Mexico	4s	$94\frac{1}{2}$	Iowa Cent.	5s	$106\frac{7}{8}$
Am. Tobacco	6s	$106\frac{7}{8}$	P. & M.	4s	$78\frac{3}{4}$
Armour & Co.	$4\frac{1}{2}$ s	$94\frac{3}{8}$	St. P. & M. M.	$4\frac{1}{2}$	$89\frac{1}{4}$
Balt. & Oh.	4s	$92\frac{1}{2}$	St. L. & S. W.	4s	$93\frac{1}{8}$
Cent. of N.J.	5s	$124\frac{1}{2}$	Va. & S. W.	5s	98

14. Give the year's income from a \$1000 bond in each of the corporations listed in problem 13.

15. I wish to secure an income of \$1200. How much shall I spend for 4% bonds bought at par to do this? How much at 102?

16. A father gives his son sufficient 5% bonds to pay his college expenses with their income. His expenses amount to \$800 a year. What is the face value of the bonds? What did they cost through a broker at 110?

64. INDIRECT PROBLEMS OF PERCENTAGE

There is a class of problems in percentage, much less common in business than those already given, that will be discussed in this section, viz.: *to find all or any required per cent of a given number when some known per cent of it is given.*

Problems

1. A dealer lost 20% when selling an overcoat for \$16. How much did it cost him?

SOLUTION

80% of the cost = \$16.
 1% of the cost = \$.20.
 100% of the cost = \$20.

ANALYSIS

Since 20% is lost, the \$16 is only 80% of the cost. Then 1% of the cost is $\frac{1}{80}$ of \$16, or 20¢. And all of the cost or 100% of it is \$20.

A SECOND SOLUTION

80% of the cost = \$16.
 $\frac{20\%}{100\%}$ of the cost = $\frac{\$16}{80}$
 100% of the cost = \$20.

ANALYSIS

Since 80% of the cost = \$16, then 20% of the cost = $\frac{1}{4}$ of \$16, or \$4. Adding, 100% of the cost = \$20.

2. A dealer marked a suit to sell for \$28. This was a gain of 40%. Find the cost of the suit.

SUGGESTION. 140% of the cost is known and 100% of it is wanted.

3. My rent is \$720 a year. This is 10 % of the value of the property. Find the value of the property.
4. By selling a house for \$12,000 I gained 20 % of the cost. Find the gain.
5. After using a canoe one season, I sold it for \$28.80, which was 20 % less than it cost me. How much did it cost me?
6. A dealer sold a chair for \$32. If his gain was $33\frac{1}{3}$ % of the cost, how much did it cost him?
7. After allowing a discount of 25 %, a bill of goods cost \$1395. Find the list price.
8. A man sold a buggy for \$190, which was a loss of 5 %. For how much must he have sold it to make 25 %?
9. \$28.35 will settle a bill on which a discount of 10 % is given for cash. How much is saved by paying cash?
10. After deducting 4 % for his commission, an agent remitted \$3072 from a sale of goods. For how much did he sell the goods?
11. A merchant sold goods for \$240, thereby losing 20 %. For how much should he have sold them to gain 20 %?
12. A speculator sold two houses for \$10,000 each. On one he made 25 % of the cost, and on the other he lost $16\frac{2}{3}$ % of the cost. Compare the gain on one with the loss on the other.
13. After gaining 50 % of his original capital, a man had a capital of \$18,000. Find the original capital.
14. A yacht cost a dealer \$448. He wishes to know how to mark it so that he may deduct 20 % from the marked price and still make 25 % of what it cost him. Can you tell him?
15. A merchant sold tea at 42 ¢ a pound. This was 20 % more than it cost him. How much did he make on 350 lb.?

16. A real estate dealer sold a lot for \$1500, which was 25 % more than it cost him. How much did he make, not considering that he incurred any expense in the transaction?

17. How much a bushel must a dealer pay for potatoes, if he wishes to sell them for 65¢ a bushel and make 30 %?

18. A dealer sold a lot of unwashed wool at 25¢ a pound. He made a profit of 10 % after paying out 3¢ a pound for expenses in marketing it. How much did he pay for it?

19. A dealer sold hogs in the city market at \$9.75 per hundred pounds. The cost of delivery was \$1.15. How much must he have paid to make a profit of 20 %?

20. By selling a bill of goods for \$282 an agent made 20 % of the cost. Find the gain.

WORK

$$\begin{array}{r} 6)\$282 \\ \underline{\quad\quad} \\ \$47, \text{ the gain.} \end{array}$$

ANALYSIS

The selling price, \$282, was 120 % of the cost. The gain was 20 % of the cost or only $\frac{1}{6}$ of the selling price. Hence $\frac{1}{6}$ of \$282 is gained.

NOTE. When one reasons from the given number of per cent to 1 %, then from 1 % to the required number of per cent, the method is called **Unitary Analysis**. When one compares the required per cent directly with the given per cent, as in the solution given above, the method is called **The Ratio Method**. Use the latter method when it will save work.

21. Solve problems 3, 4, 5, 6, 7, 11, 12, 15, and 16 by the "ratio method" without a pencil.

22. A merchant marked an overcoat to sell for \$21. This was 40 % more than it cost. The coat was afterward sold for \$18. Find the per cent of gain.

WORK

$$\begin{array}{l} \frac{6}{7} \text{ of } 140 \% = 120 \% \\ \text{Hence the gain was } 20 \% \end{array}$$

NOTE. This is another example of the ratio method.

ANALYSIS

The coat was sold for $\frac{6}{7}$ of the marked price, which was 140 % of the cost. Then the coat sold for $\frac{6}{7}$ of 140 % of the cost or 120 % of the cost. Then it sold for 20 % above cost, or at a gain of 20 %.

23. I bought books for 20 % less than the list price. At what price were books listed that cost me \$56.80?

24. A hardware dealer got a bill of goods that cost him net, \$372. The discount was $33\frac{1}{3}$ %. At what price were the goods listed?

25. Shoes were marked to sell at \$4.80 a pair; this was 60 % more than they cost. If they were sold at a "bargain sale" at $\frac{1}{4}$ off, how much was made on each pair?

26. Give a short method of finding the gain when the selling price is known and the rate of gain on the cost is 20 %. When it is 25 %. When it is $33\frac{1}{3}$ %. When it is 50 %. When it is $16\frac{2}{3}$ %. When it is 10 %.

At sight give the gain:

	SELLING PRICE	RATE OF GAIN		SELLING PRICE	RATE OF GAIN		SELLING PRICE	RATE OF GAIN
27.	\$16,400	$33\frac{1}{3}$ %	31.	\$15,630	50 %	35.	\$78,100	10 %
28.	\$27,600	25 %	32.	\$98,400	20 %	36.	\$19,500	20 %
29.	\$54,300	20 %	33.	\$45,500	$16\frac{2}{3}$ %	37.	\$63,420	$33\frac{1}{3}$ %
30.	\$29,400	$16\frac{2}{3}$ %	34.	\$17,525	25 %	38.	\$156,900	50 %

39. Mr. Brown paid \$72 for a buggy. The retailer who sold it to him made 25 % profit. The wholesaler made 10 % when he sold it to the retailer. The manufacturer made 15 % when he sold it to the wholesaler. How much more than cost to the manufacturer did it cost Mr. Brown?

40. A merchant sold tea for 70¢ a pound, thereby making 40 % of what it cost him. How much will he make on 384 lb.?

41. How much can a grain dealer pay farmers for wheat if he gets but \$1.13 a bushel and wishes to make 8 % profit?

42. One year a dealer sold \$28,500 worth of coal. He failed to collect 2 % of it. Find the total cost to him if he yet cleared 20 % of the cost.

Miscellaneous Problems in Percentage

1. A man owing \$85,000 failed, and paid but 52¢ on the dollar. What per cent did he pay? How much did he pay? What was my loss if he owed me \$4500?
2. My household expenses this month were \$108.35. This was 10% more than the average monthly expenses for the year. Find my yearly household expenses.
3. A merchant insured his goods for $\frac{4}{5}$ their inventory value at $1\frac{1}{2}\%$. What was their value if the premium was \$75?
4. I bought a piano listed at \$650, but received a discount of 30% and 10%. How much did it cost me?
5. A man bought 50 shares of mining stock at $87\frac{1}{2}$, received an 8% dividend, and sold it at $92\frac{7}{8}$. How much did he make, considering brokerage $\frac{1}{8}\%$ in each transaction?
6. A father left $66\frac{2}{3}\%$ of his estate to a son and the remainder, \$75,400, to a daughter. What was the value of the estate? How much did the son receive?
7. A merchant failing in business finds his resources to be but \$40,950, while his liabilities are \$65,000. What per cent of his indebtedness can he pay? What will a man lose to whom he owes \$4200?
8. I forwarded to my agent enough money to make an investment for me and to pay his commission of 3%. If his commission was \$72, what was my investment?
9. A house worth \$6300 was insured for $\frac{2}{3}$ its value at $1\frac{3}{4}\%$. Find the premium.
10. A man buys 200 stoves at \$27.50. The trade discount is 20%, with 10% off for cash. For how much cash could he pay for his stoves?

11. If 95% of a ship is valued at \$49,970, what is 67½% of it worth?

12. If you buy at 40% below list price and sell at 20% below the same list price, what per cent do you make?

13. A commission merchant sold 1560 lb. of butter at 25¢ a pound. What was his commission at 10%?

14. For selling 600 yd. of carpet at \$1.20 a yard an agent received \$36. What rate per cent was his commission?

15. I buy goods at discounts of 20%, 25%, and 10% from the list price. For what per cent of the list price do I buy?

16. A bill of books amounting to \$250 is reduced to what net amount by discounts of 20% and 10%?

17. A house valued at \$4800 is insured for $\frac{3}{4}$ of its value at 1½%. What is the amount of the premium?

18. At 30¢ a dozen and 30% *ad valorem*, find the duty on 500 doz. linen collars valued at \$1.20 a dozen.

19. A dealer bought 380 long tons of coal at \$4.20 per long ton and sold it at \$5.75 per short ton. What was his gain if 1% is allowed for waste in weight, 7¢ a 100 lb. for freight, and \$114 for hauling, etc.?

20. A man received \$1560 as the annual 12% dividend on stock that he owned. He afterward sold 35 shares at 142¼ per share and the remainder at 143 per share, brokerage $\frac{1}{8}$ % on each sale. What were the net proceeds of each sale?

21. A man pays \$14.40 for a grate; the retailer sold it to him at 25% gain, the wholesaler to the retailer at 10% gain, and the manufacturer to the wholesaler at 15% gain. How much more than the actual cost to the manufacturer does the consumer pay?

22. A New York importer bought 1800 yd. Brussels carpet, $\frac{3}{4}$ of a yard wide, invoiced at £ 300 (\$1459.95 United States money). The specific duty is 28¢ per square yard, *ad valorem* duty 40%. What is the total duty? Ocean freight and charges on this side amount to \$278.25. At what price per yard must he sell the carpet to gain 20%?

23. Coffee costing $19\frac{1}{2}$ ¢ per pound lost 10% in roasting. For how much must it sell in order to gain $16\frac{2}{3}$ %?

24. A farm was bought for \$11,360: fencing cost \$675, breaking \$745, a house \$2590, and barns \$1310. The farm was sold at a profit of 20% on the investment; 65% was paid in cash and the balance by a note. What was the amount of the note?

25. A commission merchant sold for a consignor 650 lb. of butter at 30¢ a pound. His charges were freight \$4.43 and commission $2\frac{1}{4}$ %. He invested the proceeds in coffee @ 28¢ a pound. How many pounds did he buy if he charged $1\frac{1}{2}$ % for buying?

26. A note for \$1080, dated Jan. 10, 1910, payable in 90 days, with interest at 6%, is discounted Feb. 27 at 6%. Find the bank discount and the proceeds at 360 days to the year.

27. A. Morton bought of Grant Bros., Feb. 18, 1910, terms 2% off if paid in 10 days, net 30 days, 900 ft. iron pipe at 32¢ less 25% and 10%; 65 elbows at 20¢ less 20% and 10%; 145 yd. asbestos at 54¢. Make out the bill of Grant Bros. payable Feb. 28, 1910.

28. Tape needles that cost $\frac{2}{5}$ ¢ each sold for 2¢ each. Find the per cent of profit.

29. In 1830 the total cost of labor to produce an acre of wheat was \$3.83. In 1906 the cost was \$2.02. Find the per cent of decrease due to improved machinery.

30. A field of wheat yielded 21 bu. an acre, and it was sold at 98¢ a bushel. The cost of cultivation and harvesting was \$2.02 an acre. Find the net gain per acre.

31. In Problem 30, it was estimated that 20% more expended in cultivation would have increased the yield 30%. What would the net gain then have been?

32. If an agent remits his principal \$625.38 as the net proceeds from the sale of goods, after deducting \$18.72 for freight and 5% for commission, how much was the commission?

33. When an article bought at \$25, less discounts of 20%, 10%, and 5%, is sold for \$22.23, what is the gain per cent upon the net cost?

34. How much shall a dealer ask for cloth costing \$2.40 a yard so that he may make a profit of 10% when selling it at a discount of $33\frac{1}{3}\%$ from the asking price?

35. A boy sold his bicycle for \$28 after using it one year. This was 20% less than it cost him. How much did he lose?

36. A man was offered \$9000 for a house. He afterwards sold it for but \$6800, which was 15% less than it cost him. What per cent would have been made if the first offer had been accepted?

37. When a dealer buys rabbits for \$1.50 a dozen and sells them for 35¢ a pair, what per cent is he making?

38. When a dealer buys coal at the rate of \$5 for a ton of 2240 lb. and sells it at \$6.25 for a ton of 2000 lb., find the gain per cent.

39. If the iceman pays \$5 per ton for ice and retails it at 50¢ per 100 lb., and if delivery costs \$2 per ton and the loss is 20% by melting, what per cent does he make?

40. Careful farmers test their seed corn before planting it, in order to select only seed that will grow, and thus increase the yield. From different parts of each of the finest looking ears that can be found, grains are taken and placed in a seed germinator to sprout. Only those ears are used for planting the fields whose grains sprout in the germinator. A man put 540 grains of corn in a germinator. Only 486 of the grains sprouted. What per cent sprouted?

41. By planting only selected seed, all of which grew, he raised 80 bu. per acre. Allowing the per cent found in Problem 40 of grains that would not grow, if he had used seed not selected, what would have been the yield per acre?

42. If he planted 75 acres of corn, how many bushels did he gain by testing the seed?

43. Allowing 60¢ per bushel, how much did he gain on the crop by testing the seed?

44. If he spent only $2\frac{1}{2}$ days testing the seed for the entire crop, how much did he get for each day's work? Would it pay for every farmer to test his seed corn?

45. If a man put 7380 grains of corn in his germinator, and only 6790 grains sprouted, what per cent sprouted?

46. If a farmer tested 5220 grains of corn, and only 4594 of the grains sprouted, what per cent sprouted?

47. By testing his seed corn a farmer found that 7% of the grains did not germinate. By planting the selected seed, his yield was 85 bu. per acre. How many bushels per acre did he gain by testing the seed?

48. A farmer found that $8\frac{1}{2}\%$ of the corn tested would not sprout. By planting only selected seed, the yield was 78 bu. per acre. How many bushels per acre did he gain by testing the seed?

VII. PROPORTION

65. MEANING OF PROPORTION

When two ratios are equal, they form a **proportion**.

Thus, the ratio of the cost of two similar pieces of cloth is the same as the ratio of their length. That is, if 10 yards cost \$4, 15 yards will cost \$6, or

$$\frac{\$4}{\$6} = \frac{10 \text{ yd.}}{15 \text{ yd.}}$$

It is read \$4 is to \$6 as 10 yd. is to 15 yd.

When quantities are in proportion they are said to be **proportional**.

66. SIMILAR FIGURES

1. Similar figures have exactly the same shape. That is, *their corresponding sides are proportional*.

2. Make two similar triangles. Are their corresponding angles equal?

3. Draw a triangle, ABC , as in the figure. Draw EF parallel to AB . By the use of a protractor compare the angles FEC and BAC . Also angles CFE and CBA .

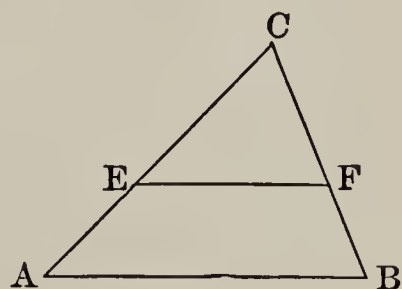

4. Are triangles ABC and EFC similar; that is, do they have the same shape?

5. Make a triangle in which AC is 6 inches and CB 3 inches. Mark off CE equal to 4 inches and CF 2 inches. Are the two triangles similar?

6. What is the ratio of CA to CE ? Of CB to CF ?

7. Cut similar triangles from cardboard. Measure their sides and prove the statement on the next page.

In similar triangles the ratios of the corresponding sides are equal, and the ratio of any two sides of one is equal to the ratio of the corresponding sides of the other.

8. Inaccessible distances may be found by the principle of similar triangles. Suppose we are to find the distance AB across a small lake. By measuring from A to C , and from B through O to D , making the ratio of OC to OA the same as of OD to OB , we have similar triangles.

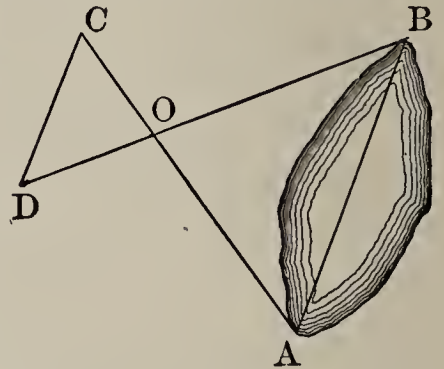

If $OC = \frac{1}{2} OA$, and CD measures 20 rods, what is AB ?

NOTE.— Make OC any convenient part of OA , and then OD the same part of OB . In the figure $OC = \frac{1}{2} OA$, and $OD = \frac{1}{2} OB$.

9. I wish to find the distance AB . AC is 15 rods and OC is 5 rods. I measure from B through O to D . If BO is 8 rods, what shall I make OD ? Why?

I find DC to be $7\frac{1}{2}$ rods. How far from A to B ?

10. A boy, wishing to find the height of a pole CE , made a piece of apparatus which he called his "surveying instrument." It consisted of a right triangle whose two legs were equal. It stood 3 feet from the ground. He moved it along until the point C could just be seen along the hypotenuse of the triangle

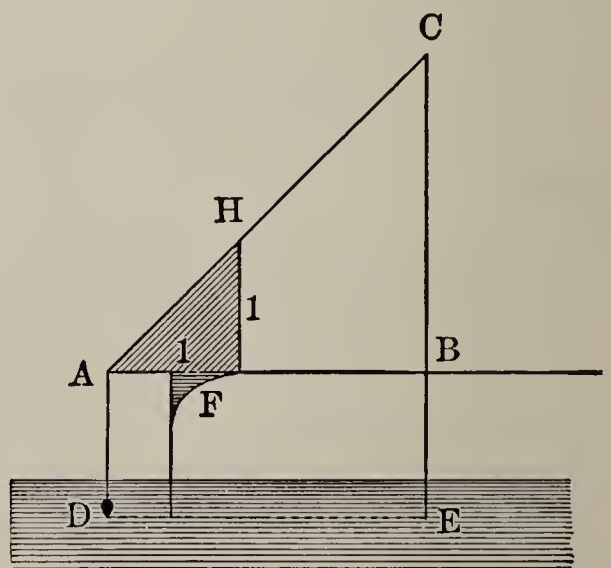

when the base of the triangle AF was parallel to the ground. A line with a weight (a plumb line) hung from A . If DE was 27 feet, how high was the pole? (Triangles AFH and ABC are similar. Why?)

11. If HF had been twice AF , and DE had been 40 feet, what would CE have been?

12. Make such an instrument, and find the height of trees, telegraph poles, etc.

13. Make one with the triangle having one leg twice the other, and measure the same heights. Do your results check?

14. Two triangles are similar. One has sides 4, 5, and 7 inches, respectively. The long side of the other is 21 inches. What are the other sides? What if the short side of the latter were 2 inches?

15. In this way measure distances on your school lot.

16. Thales, a Greek philosopher and mathematician, about 600 B.C., is said to have amazed the Egyptians by measuring the heights of the pyramids by the length of the shadows which they cast. Measure the height of a tree as follows:

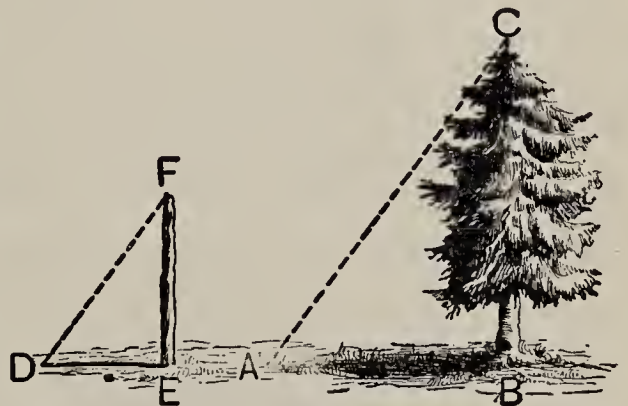

Hold a stick, whose length is known, in a vertical position, and mark the end of its shadow. Measure the length of the shadow of the stick and also of the shadow of the tree. From these measurements compute the height of the tree.

17. When a vertical rod 6 feet high casts a shadow 9 feet long, a tree casts a shadow of 150 feet. How high is the tree?

18. The distance across a stream may be estimated as follows: Find two points A and B , directly opposite each other on the two banks of the stream. Measure off a line AC , several yards long, along the bank (at right angles to AB). At C measure off a distance CD at right angles to AC . By sighting from D to B , locate a stake at a point E of AC in line with D and B . Get the lengths of AE and EC . Triangles ABE and DEC are similar right triangles. Why? From the measurements of AE , EC , and CD , the length of AB may be computed.

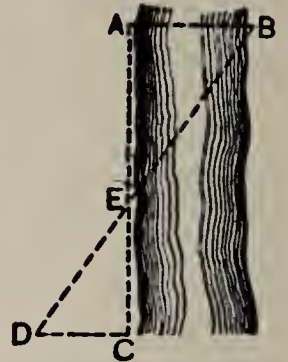

Suppose that AE is 100 yd., EC 80 yd., and CD 40 yd. How wide is the stream?

With a tape line, measure some distance in the neighborhood in this way.

19. Sailors and others use the following method of estimating the distance DA to an object A . With the left eye closed, the finger is pointed, at arm's length, towards A . Then the right eye is closed and the left eye opened, when the object appears to have moved through the distance AB . The distance AB , being transverse to the line of sight, is estimated. The distance CD between the eyes is about one tenth of the distance from the eye to the end of the outstretched finger. If AB is 500 ft., what is the distance of A ? If AB is apparently 12 ft.? Estimate in this way the distances to objects about you.



20. If the distance from the eyes to the end of the finger is 8 times the distance between the eyes, how would you find the distance to an object by the method of Problem 19?

67. LEVERS

In every simple machine there are two forces involved: the **resistance**, or force to be overcome, and the **effort**, or force necessary to overcome the resistance. The relation between the resistance and effort depends upon the nature of the machine and upon the dimensions of its parts.

In the **lever**, the resistance W and the effort W' are applied at different points of a rigid bar which revolves freely about a point of support called the **fulcrum**. There are three classes of the lever as shown in the figures. The distances l and l'

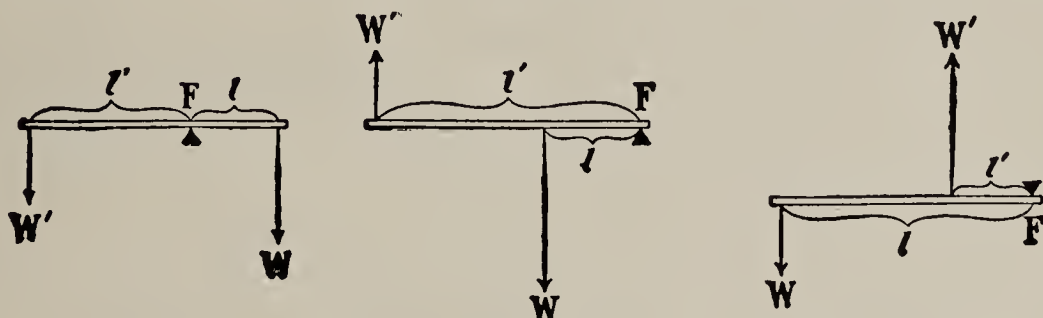

from the fulcrum to the points of the lever where the resistance and effort, respectively, are applied are called the *arms* of the lever. It is shown that

The resistance and effort are inversely proportional to their distances from the fulcrum; that is, $\frac{W}{W'} = \frac{l'}{l}$.

Thus, if two children are playing at "see-saw," the *heavier*-child must sit *nearer* the point of support. If John weighs 60 lb. and Harry 80 lb., John weighs $\frac{3}{4}$ as much as Harry; hence he must sit $\frac{4}{3}$, or $1\frac{1}{3}$, times as far from the point of support.



The beam balance, common steelyard, scissors, pincers, crowbar, etc., are familiar examples of levers.

Problems

1. With a "jack," as shown in the figure, a man wishes to raise 1200 lb. How much weight must he use on the long end of the lever?

SOLUTION: Since the long arm is 6 times the short one, but $\frac{1}{6}$ of the weight is needed. Hence, $\frac{1}{6}$ of 1200 lb., or 200 lb., is needed.

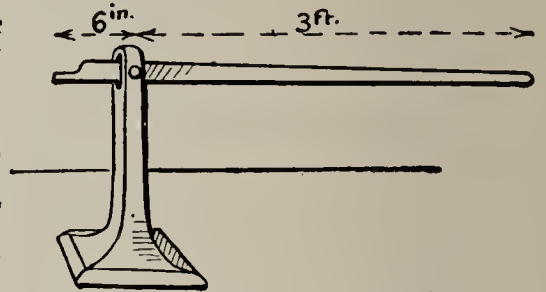

2. The figure shows heavy shears used in cutting sheet metal or heavy wire. When the wire is 2'' from the fulcrum (the point where the two parts are joined) and the hand 8'' from this point, what is the cutting force of a squeeze of 10 lb.?

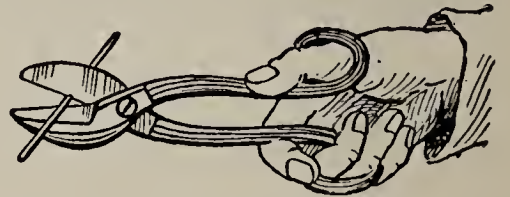

3. Will the wire be more easily cut if it is moved toward the tip of the blade or toward the fulcrum? Why?

4. For cutting heavy wire would you choose shears with long or short arms (the handles grasped by the hand)? Why?

5. This figure shows a pair of steelyards, used in weighing. Would a heavy package to be weighed require the weight a to be far from or near to the fulcrum?

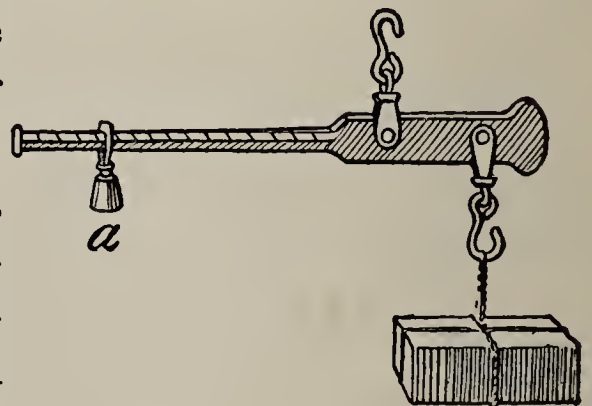

6. Suppose the weight a is 1 lb. How far from the fulcrum must it be placed to balance a weight of 4 lb. placed 4 in. from the fulcrum?

7. Suppose a weighs $2\frac{1}{2}$ lbs., 10 in. from the fulcrum. What weight 2 in. from the fulcrum will it balance?

8. In this nut-cracker the hand is 6'' from the fulcrum and the nut but 1''. A pressure of 5 lb. with the hands gives what pressure upon the nut?

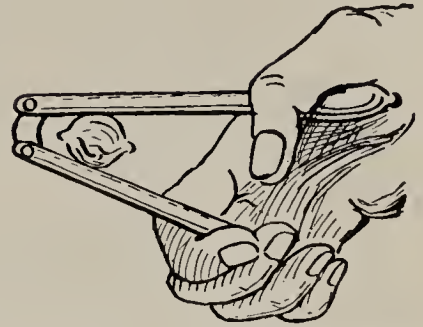

9. Two boys are carrying a weight of 150 lb. suspended upon a 9-foot pole between them. The weight is 6 ft. from one boy and 3 ft. from the other. How much does each boy carry?

68. THE WHEEL AND AXLE

The wheel and axle consists of a wheel fastened rigidly to a cylinder (axle) so that both turn together about the same axis. The power, or effort, is applied to the rim of the wheel. The weight, or resistance, is applied to the cylinder by means of a rope or cable.

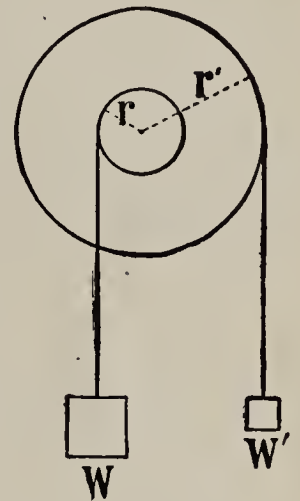

It is found that this simple machine gives the same advantage as the lever. That is, if the radius of the wheel is two times that of the axle, 1 lb. applied at the rim of the wheel will lift 2 lb. How much will 5 lb. lift? If the radius of the wheel is 5 times that of the axle, how much will 1 lb. lift? How much will 10 lb. lift? 20 lb.?

The resistance and effort are inversely proportional to the radii of the axle and the wheel, respectively.

Problems

1. The crank to the windlass of a well is 18 in. long, and the cylinder upon which the rope is wound 9 in. in diameter. What force is needed to raise 48 pounds of water?

2. Two men working at a capstan walk in a circle 8 ft. in diameter, and each exerts a force of 60 lb. The diameter of the axle is 9 inches. What pull is exerted along the rope?



3. A horse walking in a circle 15 ft. in diameter moves a house by means of a capstan 18 in. in diameter. The horse exerts a pull of 1200 lb. What is the resistance of the house?

69. THE STATEMENT OF A PROPORTION

Sometimes a proportion is stated with colons (:) instead of in the fractional form. Thus the fact that "3 is to 4 as 9 is to 12" is stated " $3:4 = 9:12$."

In such a statement the first and last terms (3 and 12) are called the **extremes**. The other two (4 and 9) are called the **means**. Observe that in this proportion $3 \times 12 = 4 \times 9$.

Exercises

1. Are these ratios equal? Do they form a proportion?

$$2:4 = 4:8 \qquad 4:12 = 3:9 \qquad 3:9 = 6:18$$

$$3:6 = 6:12 \qquad 5:10 = 2:4 \qquad 5:15 = 4:12$$

2. In each of the above exercises, see whether the product of the means equals the product of the extremes.

In any proportion the product of the means equals the product of the extremes.

3. $x:6 = 9:12$. Find the value of x .

SUGGESTION: This means that $12 \times \text{some number} = 6 \times 9$. Hence the number is $6 \times 9 \div 12 = 4\frac{1}{2}$. This is usually stated $12x = 54$; $x = \frac{1}{12}$ of $54 = 4\frac{1}{2}$.

Find the missing term :

4. $x : 5 = 12 : 4.$ 7. $x : 40 = 5 : 8.$ 10. $x : \frac{2}{5} = \frac{2}{3} : \frac{1}{2}.$
 5. $x : 9 = 3 : 4.$ 8. $x : 75 = 6 : 150.$ 11. $x : \frac{2}{3} = \frac{7}{8} : \frac{5}{12}.$
 6. $x : 12 = 2 : 18.$ 9. $x : 3 = 90 : 6.$ 12. $x : \frac{3}{4} = \frac{5}{6} : \frac{2}{3}.$

Problems Solved by Proportion

1. If 14 tons of straw cost \$ 65, find the cost of 56 tons.

SOLUTION

$$\begin{array}{r} 4 \\ \cancel{56} \times \$65 \\ \hline 14 \end{array} = \$260$$

EXPLANATION. — Since the ratio of the numbers of tons must equal the ratio of the cost, we get the proportion written. The missing term is found as above.

2. Find the cost of 85 yd., when 17 yd. cost \$ 1.25.
 3. If 19 gal. of alcohol cost \$72, what will 114 gal. cost?
 4. If a bicyclist runs 18 mi. in $2\frac{1}{4}$ hr., how long will he require to cover 162 mi. at the same rate?
 5. If 13 cars will carry 275 T. of coal, how many tons will 91 cars carry?
 6. When \$ 120 is paid for 15 bbl. of flour, what shall be paid for 79 bbl.?
 7. \$5.88 purchases 7 gal. molasses. At the same rate, what will 27 gal. cost?
 8. A yachting party sails 319 mi. in 11 da. At the same rate, how far will it travel in a 47-day trip?
 9. If a person 5 ft. 6 in. tall, walking in the sunshine, casts a shadow 6 ft. long, how high is a tree that casts, at the same time, a shadow 54 ft. long?
 10. Two men purchase a boat. One furnishes 13 parts of the purchase money, and the other furnishes 17 parts. They sell it at a profit of \$960. Divide it equitably.

11. Two friends agree to share the expenses of an outing trip in the ratio of 3:5. The expenses are \$24. What ought each to pay?

12. What is the ratio of a square foot to a square yard? What is the ratio of 2 sq. ft. to 2 sq. yd.? What is the ratio of 3 sq. ft. to 3 sq. yd.?

13. Two partners share the year's profits of \$1500 in the ratio of 7:8. What is the difference between their shares?

14. A cog wheel having 8 cogs plays into another having 24 cogs. When the small wheel has made 42 revolutions, how many has the larger wheel made?

15. If a block of marble weighs 6930 lb., and is 7 ft. long, 3 ft. wide, and 2 ft. thick, what will a block 10 ft. long, 4 ft. wide, and 3 ft. thick weigh?

SOLUTION

$$7 \times 3 \times 2 : 10 \times 4 \times 3 = 6930 \text{ lb.} : x$$

$$\frac{10 \times 4 \times 3 \times 6930 \text{ lb.}}{7 \times 3 \times 2} = 19,800 \text{ lb.}$$

EXPLANATION. — Since the ratio of the weights must equal the ratio of the volumes, we get the proportion written.

16. If a bin 12 ft. long, $4\frac{1}{2}$ ft. wide, and $7\frac{1}{2}$ ft. deep holds 324 bu. of grain, how many bushels will a bin 16 ft. long, 5 ft. wide, and $6\frac{1}{2}$ ft. deep hold?

17. If \$240 are paid for building a wall 75 ft. long, 10 ft. high, and $1\frac{1}{2}$ ft. thick, at the same rate, how much should be paid for building a wall 90 ft. long, 12 ft. high, and $1\frac{1}{2}$ ft. thick?

18. If a field 40 rd. by 65 rd. produces 750 bu. of wheat, how much will a field 30 rd. by 95 rd. produce at the same rate?

19. If a piece of lumber $3'' \times 8'' \times 12'$ is worth \$1.20, what is a piece $4'' \times 9'' \times 15'$ worth at the same rate?

VIII. GENERAL REVIEW

1. If $\frac{5}{7}$ of a farm is worth \$8750, how much is $\frac{3}{8}$ of the remainder worth?

2. (a) The sum of two fractions is $1\frac{5}{13}$; one of them is $\frac{5}{7}$. What is the other?

(b) The product of two fractions is $\frac{1}{6}\frac{5}{3}$; one of them is $\frac{3}{7}$. What is the other?

3. A house worth \$8250 was insured for $\frac{2}{3}$ of its value at $\frac{3}{4}\%$. Find the premium.

4. A firm had $\frac{1}{4}$ of its capital invested in goods, $\frac{2}{3}$ of the remainder in land, and the remainder, \$1224, in cash. What was the capital of the firm?

5. What will it cost to paint the walls and ceiling of a hall 48 ft. long, 27 ft. wide, and 18 ft. high at \$1.20 per square yard, no allowance being made for openings?

6. If gunpowder contains 75% saltpeter, 10% sulphur, and 15% charcoal, how many pounds of each are there in a ton of powder?

7. Find the interest of :

(a) \$875 for 1 yr. 11 mo. 19 da. at $5\frac{1}{2}\%$.

(b) \$1250 for 117 da. at 6% by *Bankers' Method*.

(c) \$1800 for 90 da. at 5% by *Aliquot Method*.

8. A merchant having a debt of \$7540 due him agrees to accept 80% of the amount due. How much will he lose if he pays his agent $2\frac{1}{2}\%$ for collecting the money?

9. A grain elevator has a bin $7\frac{1}{4}$ ft. square and 80 ft. deep. How many bushels will it hold, allowing $1\frac{1}{4}$ cu. ft. to the bushel?

10. At what price per pair must a merchant buy gloves to retail them at \$1.25 a pair and make a profit of 20%?

11. A dealer bought goods at 20% below the regular list price and sold them at 20% above the list price. What per cent did he make?

12. If an agent is paid \$750 as his commission at $2\frac{1}{2}\%$, how much does his employer receive?

13. If the premium on an insurance policy is \$19.50 and the rate is $\frac{1}{2}\%$, what is the face of the policy?

14. A boy buys apples at the rate of 5 for 2¢ and sells them at the rate of 8¢ a dozen. How many must he buy and sell to make \$2?

15. A 50-ft. ladder leans against a wall. The foot of the ladder is 14 ft. from the base of the wall. To what height from the ground does the upper end of the ladder extend?

16. Compare the *areas*, and also the *circumferences* of a 100-ft. circle and a 50-ft. circle. (One 100 ft. in diameter and one 50 ft. in diameter.)

17. A man bought two houses at \$4500 each. He sold one for \$6300, but he sold the other at a loss of 37%. How much did he gain or lose on both?

18. What is the difference between a discount of 45% on a \$500 bill of goods, and three successive discounts of 20%, 15%, and 10%?

19. How much must be invested in 5% bonds at 108, brokerage $\frac{1}{8}\%$, to yield an annual income of \$2050?

20. A merchant bought 2000 yd. of silk at $87\frac{1}{2}\%$ a yard. He marked it \$1.10 a yard and sold 950 yd. at that price. He then sold 750 yd. at 10% off from the marked price, and the rest at 50% off. Did he make or lose, and how much?

21. Find the interest of \$1650 for 3 yr. 9 mo. 15 da. at $5\frac{1}{2}\%$.

22. A room 18' \times 12' is 10' high. At 25¢ a square yard, find the cost of plastering, making no allowance for openings.

23. Mr. G. H. Smith bought of Hammett, Brown, & Co., April 7, 1910, 2 lb. veal at 16ϕ , 3 lb. sirloin steak at 25ϕ , $2\frac{1}{2}$ lb. ham at 18ϕ , $2\frac{1}{4}$ lb. chops at 24ϕ ; April 21, 5 lb. chops at 25ϕ , $3\frac{1}{2}$ lb. tenderloin steak at 30ϕ . Make out the bill.

24. The list price of a bill of hardware was \$8750, but the discounts were 20% and 10%. Find the net cost.

25. If I bought stock selling at $131\frac{7}{8}$, brokerage $\frac{1}{8}\%$, at a total cost of \$5280, how much is my dividend when an 8% dividend is declared?

26. A house is assessed at \$9500 in a town where the rate of taxation is \$16.40 on a thousand dollars. How much taxes must the owner pay on the house?

27. Hardware listed at \$8.40 sold with discounts of 15% and 10%. Find the net cost.

28. In the following, discount the list price by the method you think will make the least computation:

(a) An invoice of \$1750, discounted at 20% and 10%;

(b) An invoice of \$1750, discounted at 8% and 6%;

(c) An invoice of \$1750, discounted at 28% and 35%.

29. Find the cost of a carpet 30 in. wide, at \$1.25 per yard, for a room 18 ft. by 14 ft., the strips to run lengthwise, no allowance for matching.

30. A house costing \$11,250 rents for \$1200 a year. The taxes and other expenses are \$300 per year. Find the per cent of net income on the investment.

31. A lawyer collected a debt of \$1260, and charged 5% commission on the sum collected. How much did the creditor receive?

32. How many board feet of lumber 1 inch thick will be required to build a tight board fence $4\frac{1}{2}$ ft. high, inclosing a lot 110 ft. wide and $8\frac{1}{2}$ rd. long?

33. At \$6.50 a ton, how much will 5500 lb. of coal cost?
34. How much will it cost to dig a cellar 38 ft. long, 30 ft. wide, and $7\frac{1}{2}$ ft. deep, at 45¢ a cubic yard?
35. A merchant bought gloves at \$4.50 a dozen pairs, and sold them at 50¢ a pair. What per cent did he gain?
36. A house is worth \$8000 and the furnishings \$2400. The house was insured for $\frac{4}{5}$ of its value at 2%, and the furniture for $\frac{3}{4}$ of its value at $1\frac{1}{2}$ %. Find the total premium.
37. A merchant received a shipment of \$1950 worth of goods which he marked to sell at a gain of $\frac{3}{5}$ of the cost, but reduced the marked price $\frac{1}{3}$ for a "bargain sale." How much did he make?
38. My coal bin is 12' long, $8\frac{1}{2}$ ' wide, and 6' high. Allowing 56 lb. to a cubic foot, how much will it cost to fill it at \$6.75 a ton?
39. A car contains 72,060 lb. of wheat. How much is it worth at $87\frac{1}{2}$ ¢ a bushel?
40. A dealer buys apples at \$2.50 a barrel ($2\frac{1}{2}$ bu.). At what price per peck must he sell them to make 20% of the cost?
41. Assuming that a cubic foot of hay weighs 5 lb., how much in a mow $14' \times 14' \times 22'$?
42. At \$5.75 a ton, how much are four loads of coal worth, weighing respectively 4230 lb., 4120 lb., 4300 lb., and 3900 lb.?
43. A bill of goods was bought for \$280. The freight was \$17.50. For how much must they be sold to gain 12% of the total cost?
44. How many tons of silage can be placed in a round silo 14' in diameter and 30' deep, assuming that a cubic foot of silage weighs 40 lb.?

45. How much must I invest in 5% bonds at $104\frac{1}{4}$, brokerage $\frac{1}{8}$ %, to have a yearly income of \$1500 from them?

46. If I should invest \$27,000 in $4\frac{1}{2}$ % bonds at 90, no brokerage, what would be the yearly income from them?

47. Which gives the lower net price for a piano listed at \$600 — a direct discount of 45%, or successive discounts of 25%, 15%, and 5%? How much lower?

48. The amount of tax to be assessed in a certain city is \$44,382. The assessed valuation of the taxable property is \$2,850,800. There are 1080 polls each assessed \$1.50. Find the rate of taxation.

49. A factory worth \$32,000 is insured for $\frac{3}{4}$ of its value at 2%. In case of total loss of the property by fire, how much would the owner lose, including the premium paid out?

50. Find the net amount of a bill of \$1240 subject to successive discounts of 10%, 14%, and $12\frac{1}{2}$ %.

51. A tax of \$11,000 is to be levied in a town. The property is assessed at \$500,000. If there are 500 polls each paying \$2, what will be the taxes, including his poll tax, of a man whose property is assessed at \$12,500?

52. Which is cheaper and how much on a bill of \$500 — 25% and 15% off, or 20% and 20%?

53. How much will it cost to dig a cellar 36 ft. square and $7\frac{1}{2}$ ft. deep at $66\frac{2}{3}$ ¢ a cubic yard?

54. A ladder 55 ft. long may be so placed in a street as to touch a window 44 ft. high on one side, and on being turned without changing its base, it will reach another window 33 ft. high on the opposite side of the street. Find the width of the street.

55. One year a farmer raised 300 bu. of apples. From the same orchard he raised 450 bu. the next year. What was the per cent of increase?

56. Make a receipted bill of the following items bought of Frank Jones by William French: 26 lb. of sugar at $5\frac{1}{2}\phi$; 24 lb. of lard at $16\frac{1}{2}\phi$; 15 bu. of potatoes at 85ϕ ; 8 lb. of coffee at 32ϕ ; and 5 bu. 3 pk. of apples at \$1.20 a bushel.

57. Two ships sailed from the same harbor, one 150 mi. east and the other 200 mi. south. How far apart were they then?

58. If a map is 10 in. by 16 in. and made to the scale of 50 mi. to the inch, what is the area represented?

59. A grain bin is $8' \times 6' \times 11'$. Allowing $1\frac{1}{4}$ cu. ft. to the bushel, how many bushels will it contain?

60. Find the simple interest of \$986 for 2 yr. 5 mo. 18 da. at $5\frac{1}{2}\%$.

61. I sold 50 shares of stock at $106\frac{1}{2}$. I bought it at 105. Counting brokerage $\frac{1}{8}\%$, how much did I make?

62. My 12% dividend from some stock was \$180. How many \$100 shares have I?

63. How long a ladder is required to reach to a window 20 ft. high, if the base of the ladder must be placed 5 ft. from the building?

64. How many feet of fencing are required to inclose a square field containing 8100 sq. ft.?

65. A certain town is taxed \$10,999. The real estate of the town is valued at \$500,000 and the personal property at \$300,000. There are 666 taxable polls, each assessed \$1.50. What is one's tax whose real estate is valued at \$4000 and personal property at \$8000, and who pays a poll tax?

66. A house and lot cost \$5000. The insurance is \$25, taxes are \$50, and repairs \$65 annually. What rent must be received in order to realize a net 6% on the investment?

Give the cost of, including $\frac{1}{8}\%$ brokerage, and the income from 10 thousand-dollar bonds in each of the following:

NOTE. — 4s means that the bond is paying 4% interest upon its face value.

67. Adams Exp. Co. 4s at $93\frac{5}{8}$. 71. N.Y. city $4\frac{1}{2}$ s at $101\frac{3}{4}$.

68. C. & O. R. R. $4\frac{1}{2}$ s at $96\frac{3}{8}$. 72. Tide Water 6s at $102\frac{7}{8}$.

69. Cuban Gov. $4\frac{1}{2}$ s at $98\frac{1}{4}$. 73. Miami C. 6s at $140\frac{1}{2}$.

70. N.Y. Tel. $4\frac{1}{2}$ s at $96\frac{1}{2}$. 74. Utah Copper 6s at $103\frac{1}{4}$.

75. Find cost of 1185 lb. of hay at \$19.50 per ton.

76. Find cost of 275 ft. of lumber at \$47 per M (thousand).

77. At 35¢ per cubic yard find the cost of excavating a trench 6 rd. long, $1\frac{1}{2}$ yd. wide, and 1 ft. 6 in. deep.

78. The price of gas is 11¢ per hundred cubic feet, with a discount of 20% if paid within 5 da. of the end of the month. My meter reading at the end of May was 67,300 cu. ft. The April reading was 64,800 cu. ft. I paid my May bill June 2. What sum did I pay?

79. A garden 145 ft. long and 120 ft. wide is surrounded by a tight board fence 6 ft. high. At 8¢ a square yard, find the cost of painting both sides of the fence.

80. A field of 40 A. yielded 24 bu. of wheat per acre. It sold for 92¢ a bushel. The total cost of growing and marketing was \$296. The profit was what per cent of the cost?

81. The average yield of a certain field was 36 bu. of corn per acre. It was estimated that 2 da. more per acre spent in cultivation would have increased the yield to 45 bu. per acre. If corn was worth 45¢ a bushel, how much per day would the farmer have received for his extra work?

82. A man's holdings in U.S. 4s bring him an annual income of \$1000. If he bought the bonds at a 10% premium, what did they cost him, brokerage $\frac{1}{8}\%$?

83. If a coal dealer buys coal at \$5 a ton of 2240 lb., and sells it at \$6 a ton of 2000 lb., what is his per cent profit?

84. A farmer has a herd of 12 dairy cows that average 22 lb. each of milk per day. The milk tests 3.8% butter fat, and butter fat is worth 28 cents per pound. What is the daily income from the herd?

85. The surface of a pond contains 3 A. of commercial ice. The water is frozen so that the ice is 15 in. thick. If ice is 0.92 as heavy as an equal volume of water, find the weight of the crop of ice in tons.

86. A man wishes to put a water tank in his attic. The tank is 28 in. long, 24 in. wide, and allows 20 in. for the depth of the water. How many gallons will the tank hold?

87. If $1\frac{3}{4}$ barrels of lime are required for plastering 50 sq. yd., how many barrels would be required for a job of plastering equivalent to wall surface 150 ft. by 12 ft.?

88. Find the cost of lining the sides and bottom of a tank 5 ft. 8 in. long, 4 ft. wide, and 5 ft. deep with zinc, weighing 0.5 lb. to the square foot, at 12 cents a pound.

89. How many cubic yards of earth would have to be removed to lower the grade of a street 15 in., the street being 20 rd. long and 60 ft. wide?

90. A house cost \$5500. The average annual necessary expenditures are: repairs, \$120; taxes, \$52; insurance, \$12.50. The house rents for \$35 a month. What per cent, net, does the owner realize on his investment?

91. A man has a claim of \$15,775 against a corporation. He pays a collector 5% of the amount collected. What is his

total loss, including the collector's fee, if but 65 % of it is collected ?

92. By selling goods for \$4176, my gain was 20 %. By selling them for \$3132, what would my per cent of loss have been ?

93. I bought \$12,500 worth of goods (list price) at a discount of $33\frac{1}{3}$ % and 10 % from the list price, and sold them at a discount of 25 % from the same list price. What per cent did I make ?

94. A dealer bought 600 tons of coal at \$5 per ton and sold it at a gain of 25 %. Find his net profit if he loses 3 % in bad debts and is out \$120 for freight, delivery, etc.

95. Find the selling price of goods listed at \$1150, discounts $33\frac{1}{3}$ % and 10 %, sold at a profit of 40 % on the cost.

96. A sugar factory contracts to pay \$4.25 per ton for beets which test 14 % or less of sugar, and to pay 20 cents extra per ton for each additional per cent above 14 %. A man has 12 acres of beets yielding 15 tons per acre that test 14 %, and 10 acres yielding $13\frac{1}{2}$ tons per acre that test 15 % sugar. What is the value of his crop ? If he spends \$400 for labor to produce the crop, what is his average net profit per acre ?

97. What is the cost of paving and curbing a street 2640 ft. long and 42 ft. wide, if the contract price is \$1.25 a square yard for paving and 45 cents a linear foot for curbing ?

98. A bin is to be constructed to occupy a space 10 ft. long and 6 ft. wide, and is to hold 9 tons of coal (2000 lb. to a ton). If there are 56 lb. in a cubic foot of coal, what must be the depth of the bin ?

99. A bin 8 ft. long, 6 ft. wide, and 5 ft. deep contains 150 bu. of oats. What per cent of the bin is filled ?

100. A total tax of \$383,780 is raised in a town having 1015 polls each assessed at \$2. The assessed valuation of the property is \$25,450,000. What is the tax rate upon the property?

101. If I buy goods at 30 % discount from the list price, what discount can I give from the same list price to make 20 %?

102. A rope 73 ft. long is fastened to the top of a boat's mast, and when drawn taut, it touches a point on the deck 55 ft. from the foot of the mast. Find the height of the mast.

103. The composition of one kind of Babbitt's metal is 4 parts copper, 8 parts antimony, and 88 parts tin. Find the amount of each material necessary to produce 175 lb. of the metal.

104. Write out a note in which you promise to pay John Jones \$560, 6 months after date, with interest at 5 %.

105. What will you pay him at the end of 6 months in settlement of the note?

106. Write out a check on the Continental National Bank for \$35.77, payable to Henry Thompson, and signed by yourself. If, instead of cashing the check at the bank, he wishes to turn it over to William Hart in payment of a debt and let him cash it at the bank, what must he do?

107. Pretending that you are cashier of the First National Bank of your town or city, write a draft on the Corn Exchange Bank of New York, payable to Charles Hanes, for \$224.25.

108. Name all of the different ways in which you could pay a debt that you owe to a person in a distant city. Describe the steps in the procedure in each case.

109. If you had a note for \$850 bearing 6 % interest, made

February 14, 1911, and due in 6 months, and you discounted it at a bank February 25, 1911, at 5 %, what proceeds would you receive?

110. A note for \$475, bearing 6 % interest, dated June 6, 1908, and due in 90 days, was discounted at a bank on June 26, 1908, at 6 %. What were the proceeds of the note?

111. If I am a merchant, and sell to a customer a bill of goods amounting to \$670, which is the better proposition for me, to take his note for the amount for 90 days at 5 %, and discount it at a bank at 6 % the day that it is made in order to get the cash, or to give him a 2 % discount for cash?

112. A bill of goods amounted to \$275. Discounts of 5 %, 10 %, and 20 % were allowed. What did it take to pay the bill?

113. A farmer has a stack of hay in the form of a rectangular prism 30 ft. long, 16 ft. wide, and 8 ft. high, surmounted by a pyramid 10 ft. high. How many cubic feet in the stack? Allowing 512 cu. ft. to the ton, how many tons in this stack?

114. A farmer has a haystack in the form of a cylinder 15 ft. in diameter, and 7 ft. high, surmounted by a cone 10 ft. high. Allowing 512 cu. ft. to the ton, find the number of tons in the stack.

115. A farmer has a crib 30 ft. long and 12 ft. wide, in which the corn is piled throughout its length to a depth of 10 ft. on one side, and slopes to a depth of 8 ft. on the other side. Allowing 2 bu. to 5 cu. ft., find the number of bushels in the crib.

116. A gardener has a round pile of potatoes that is 10 ft. across at the bottom, and tapers to a point that is 6 ft. high at the center. Allowing 3 bu. to 4 cu. ft., find the number of bushels in the pile.

117. From four trees a man got a round pile of apples that was 6 ft. across at the bottom and tapered to a point 3 ft. high at the center. Allowing 3 bu. to 4 cu. ft., how many bushels did he get?

118. How many barrels does a cistern hold that is 10 ft. in diameter and 11 ft. deep?

119. A city sewer pipe 3 ft. in diameter discharges at a velocity of 2 ft. a second when running full. How many gallons does it deliver in a second? How many in a minute?

120. A steam pump delivers water at a rate of 400 gal. a minute. How long will it take for it to fill a reservoir 12 ft. in diameter and 16 ft. deep?

121. Two pipes each 6 in. in diameter empty into a larger pipe. How large must this larger pipe be, if it is to have the same carrying capacity as the two smaller pipes together?

122. A plumber wishes to drain three pipes, each 1 in. in diameter, into one pipe whose capacity shall be equal to the combined capacities of the three drain pipes. Find to the nearest $\frac{1}{4}$ in. the diameter of the larger pipe that he must use.

123. A man installing a furnace in a house had one pipe 12 in. in diameter which was to deliver the warm air to two pipes of equal size that were to carry the air to different rooms. If the two small pipes were to equal in capacity the 12-in. pipe, find to the nearest $\frac{1}{2}$ in. the diameter of the small pipes that must be made.

124. If apples weighing $3\frac{3}{8}$ lb. weigh only $\frac{9}{16}$ lb. when dried, what per cent of the apples originally was juice?

125. If a piece of beef weighing $4\frac{5}{16}$ lb. weighed only $3\frac{3}{8}$ lb. when roasted, what per cent of the weight was lost in roasting?

126. A wall 25 in. thick, 9 ft. high, and 60 ft. long is to be built of bricks 2 in. by 4 in. by 8 in. Allowing 10 % of the space for mortar, find how many thousand bricks must be ordered.

127. How many tons of silage in a silo 16 ft. in diameter, filled to a depth of 28 ft., if it weighs 40 lb. to the cubic foot?

128. If a dealer buys hats at \$27 per dozen and sells them at a gain of $33\frac{1}{3}$ %, what is the selling price for each?

129. If \$15,000 is invested so as to yield $5\frac{1}{2}$ % interest, what is the yearly income?

130. How much must be invested in $4\frac{1}{2}$ % bonds at par to give an annual income of \$1890?

131. A bill of glassware was invoiced at \$620. The discounts were 20 % and 10 %. For what must it be sold to yield a net gain of 25 %?

132. A bill of goods costing \$960 was sold at a gain of 25 %, but 4 % of the sales was not collected. Find the rate of net gain.

133. Mr. Brown has an acre of land that will produce 240 bu. of potatoes worth 45 ¢ a bushel at a total expense of \$75 for seeding, cultivating, and marketing. How much money loaned at $5\frac{1}{2}$ % will it take to yield the same income?

134. A piece of land near New York produces garden truck valued at \$500 per acre. The total cost of growing and harvesting the crop is \$175 per acre. How much money must be loaned at 5 % to yield as great a net income?

135. The value of milk depends upon the amount of butter fat which it contains. When milk containing 4.5 % of butter fat is selling for 9 ¢ a quart, how much is milk containing 3 % butter fat worth?

136. A man has a lawn $120' \times 200'$ covered with black dirt to the average depth of $2\frac{1}{2}''$. Deducting $36' \times 40'$ for the house, how much did it cost him at 90ϕ a load (cubic yard)?

137. A house $30' \times 36'$ covers what per cent of a lot $60' \times 175'$?

138. When Illinois Central stock pays a dividend of 6% , what is the income from 250 \$100-shares?

139. What is the annual income from 50 \$1000 New York City $4\frac{1}{2}\%$ bonds?

140. When a cotton plantation of 400 acres produces 350 lb. to the acre, how many 500-lb. bales in the whole crop? How much is the crop worth at $11\frac{3}{4}\phi$ a pound?

141. If a dealer sells goods at a profit of 50% , but fails to collect 10% of the sales, what per cent of profit is he really making?

142. A man bought a city house for \$11,500. He paid \$6000 cash and gave a mortgage for the rest, interest $5\frac{1}{2}\%$. How much a year is the interest?

143. A man was offered \$500 cash for a team of horses or a 6-mo. note of \$550 without interest. He chose the latter and discounted it at a bank at 6% . How much more than the cash offer did he receive?

144. How many tons of ice can be packed in an ice house 50 ft. long, 40 ft. wide, and 16 ft. high, allowing 2 ft. on all sides, above, and below, for sawdust? (1 cu. ft. = $57\frac{1}{2}$ lb.)

145. A farmer has land that will produce 65 bu. of corn per acre by an expenditure of \$11.50 per acre in fertilizer, labor, and seed. If the corn is worth 45ϕ a bushel, how much capital invested at 6% will it take to give the same net earnings?

146. If the "ash man" can haul 3 cubic yards at a load, about how many ash cans 18 in. in diameter and 30 in. high may be emptied into one load?

147. A solid cast-iron cylinder 2 in. in diameter is to weigh 8 lb. How long must it be? (A cubic inch of cast iron weighs 0.26 lb.)

148. Some silver solder is made of 1 part copper to 2 parts silver. At 18¢ a pound for copper and 54¢ an ounce for silver, how much will 24 oz. of silver solder cost?

149. Find the cost of digging a well 40 ft. deep and 6 ft. in diameter at \$2.25 per cubic yard.

150. How many gallons of water will a cylindrical tank 16 ft. in diameter and 14 ft. high contain?

151. A clothes boiler has semicircular ends. How many gallons will a boiler contain whose extreme length is 20'', height 14'', and width 12''?

152. A tank 12 ft. in diameter is filled at the rate of 180 gal. a minute. How many inches per minute does the water rise in the reservoir?

153. A farmer has a round pile of potatoes that is 8 feet across at the bottom, and tapers to a point 5 feet high at the center. If there are 3 bu. to 4 cu. ft., how much is the pile worth at 45¢ a bushel?

154. Find the interest of \$750 at 6% for 126 days in two ways.

155. Find the interest of \$2480 at 5% for 90 da. in two ways.

156. Find the interest of \$1600 at $4\frac{1}{2}\%$ for 1 yr. 5 mo. 16 da.

157. Find the time from August 2, 1914, to May 14, 1916.

158. Find the interest of a note for \$860 at 6% given March 10, 1914, and paid off January 20, 1915.

159. If I give a note April 20, 1913, at 5% interest, for \$450, and pay it off November 8, 1913, how much do I pay in settlement?

160. I borrow \$1200 from a bank for 90 days. The bank charges 6% interest. When is the interest paid? What is it called? To what does it amount? What are the proceeds?

161. If you borrow \$350 from a bank for 60 days, and the bank charges 6%, how much money do you get?

162. What advantage does a bank have in loaning money that an individual loaning money does not have?

163. John Adams bought goods from Simmons and Company, and gave his note for \$800 for the goods, at 6%, for 90 days. Ten days after receiving the note Simmons and Company took it to their bank and discounted it (sold it to the bank) at 6%. How much did Simmons and Company get for the note?

164. If you were in business and sold a customer a bill of goods amounting to \$480, which would yield you the greater income, to allow the customer a discount of 2% for cash, or to take his note for the amount of the bill at 5% for 90 days and immediately discount it at the bank at 6%? How much?

165. What must be paid for a bill of goods amounting to \$125, if discounts of 20%, 10%, and 2% are allowed?

166. What is the actual cost of a bill of goods listed at \$280, with discounts of 10%, 25%, and 1%?

167. Which is greater, three successive discounts of 20%, 10%, and 5%, or a single discount of 35%?

168. I pay \$250 dues semiannually on running stock in a Building and Loan Association which allows 8% interest. The interest is "set over" or added to the value of the stock semiannually. The payment of dues is made each time, after the first, just before the interest for the half year is "set over," and draws interest during the next half year. What is the stock worth just after the tenth payment of dues is made?

169. If you deposit \$80 in a savings bank that allows 3% interest, compounded semiannually, what will you have in the bank at the end of 5 years?

170. A boy puts \$16 in a postal savings depository, which pays 2% interest. The interest is allowed and entered to his credit once each year. Interest is not allowed on fractions of a dollar. To what does the account amount in 5 years?

171. If a high school boy deposits \$25 in a postal savings depository at the beginning of each of the four years that he is in high school, and is allowed 2% interest which is entered to his credit annually, to how much will his account amount at the end of the fourth year?

172. A man bought 100 shares of railroad common stock at $156\frac{3}{8}$, held it for two years, then sold it at $172\frac{7}{8}$, both transactions through a broker. He received two 8% dividends from the stock. How much did he make on the transaction?

173. A man borrowed \$1200 of a neighbor and gave his note for the amount June 10, 1912, at 6%. He made a partial payment on the note October 16, 1912, of \$500, and another partial payment April 10, 1913, of \$450. How much more did he have to pay in settlement of the note November 10, 1913?

APPENDIX

THE METRIC SYSTEM

The **English system of weights and measures**, the system in common use in the United States, lacks a uniform scale of relation. For example, 12 in. = 1 ft., 3 ft. = 1 yd., $5\frac{1}{2}$ yd. = 1 rd., etc.; and 2 pt. = 1 qt., 4 qt. = 1 gal.

The United States system of money has a uniform decimal scale, and thus any part of a dollar can be expressed as a decimal fraction. Thus 3 dollars, 5 dimes, and 7 cents can be expressed \$3.75.

The **metric system of weights and measures** grew out of an attempt by the French government to supply a system of weights and measures that would have a uniform decimal scale of relation that would thus facilitate computation.

The committee appointed to report upon a *standard unit* thought to make this unit, which was to be the **unit of length**, some part of some well-defined portion of the earth's circumference. A careful computation of the length of the earth's quadrant through Paris was made, and 0.0000001 of this distance was taken and called the **meter**. The meter is about 39.37 inches in length.

NOTE. While a slight error was made in fixing the standard unit, this does not affect the usefulness of the system.

From the meter, all units of length, surface, volume, capacity, and weight are derived.

The **unit of weight** is the weight of a cube of water 0.01 of a meter on an edge. This is the **gram**.

The **unit of capacity** is a cubical vessel 0.1 of a meter on an edge. This is a **liter** (lē'ter).

NOTE. The metric system is in general use by nearly all civilized nations except Great Britain and the United States. It is used by some

departments of the United States government, and in the sciences. It was legalized in France in the early part of the nineteenth century.

The metric system is a *decimal system*, ten units of one denomination making *one unit* of the next higher.

Since the metric system is a decimal system, units may be changed to those of a higher or lower denomination by moving the decimal point.

Decimal parts of the standard or principal unit are denoted by **Latin prefixes**; multiples of the same, by **Greek prefixes**.

FROM THE LATIN	FROM THE GREEK
Milli means 0.001	Myria means 10,000
Centi means 0.01	Kilo means 1000
Deci means 0.1	Hekto means 100
	Deka means 10

In the tables units in common use are in **bold-faced type**.

NOTE. There is no uniformity as to the abbreviations used. The ones given here are in general use.

UNITS OF LENGTH

Standard unit, the **Meter**

TABLE	EQUIVALENTS
10 millimeters (mm.) = 1 centimeter (cm.)	= 0.3937079 inch
10 centimeters = 1 decimeter (dm.)	
10 decimeters = 1 meter (m.)	= 39.37079 inches
10 meters = 1 dekameter (Dm.)	
10 dekameters = 1 hektometer (Hm.)	
10 hektometers = 1 kilometer (Km.)	= { 3280.9 feet
10 kilometers = 1 myriameter (Mm.)	0.621382 mile



1 DECIMETER,

10 CENTIMETERS,

OR 100 MILLIMETERS

UNITS OF SURFACE

Principal unit, the Square Meter

NOTE. As the units of surface are squares whose dimensions are the corresponding linear units, it takes 10^2 or 100 units of one denomination to make one of the next larger.

TABLE		EQUIVALENTS
100 sq. millimeters (sq. mm.)	= 1 sq. centimeter (sq. cm.)	= 0.155 sq. in.
100 sq. centimeters	= 1 sq. decimeter (sq. dm.)	
100 sq. decimeters	= 1 sq. meter (sq. m.)	= 10.764 sq. ft.
100 sq. meters	= 1 sq. dekameter (sq. Dm.)	
100 sq. dekameters	= 1 sq. hektometer (sq. Hm.)	
100 sq. hektometers	= 1 sq. kilometer (sq. Km.)	= 247.114 acres

When used in measuring land the square meter is called a **centare** (ca.); the square dekameter an **are** (a.); and the square hektometer a **hektare** (Ha.).

UNITS OF VOLUME

Principal unit, the Cubic Meter

NOTE. As the units of volume are cubes whose edges are the corresponding linear units, it takes 10^3 or 1000 units of one denomination to make one of the next higher.

TABLE		EQUIVALENTS
1000 cu. millimeters (cu. mm.)	= 1 cu. centimeter (cu. cm.)	= 0.06102 cu. in.
1000 cu. centimeters	= 1 cu. decimeter (cu. dm.)	
1000 cu. decimeters	= 1 cu. meter (cu. m.)	= 35.314 cu. ft.

In measuring wood the cubic meter is called a **stere** (st.); a **decister** (dst.) is one tenth of a stere. 1 stere = 0.2759 cord.

UNITS OF CAPACITY

Principal unit, the **Liter** = a cu. decimeter

TABLE		EQUIVALENTS
10 milliliters (ml.)	= 1 centiliters (cl.)	= 0.6102 cu. inch
10 centiliters	= 1 deciliter (dl.)	
10 deciliters	= 1 liter (l.)	= { 1.0567 liquid quarts 0.908 dry quart
10 liters	= 1 dekaliter (Dl.)	
10 dekaliters	= 1 hektoliter (Hl.)	= { 26.417 gallons 2.8375 bushels
10 hektoliters	= 1 kiloliter (Kl.)	

The **liter** is used in measuring liquids and small fruits; the **hektoliter** in measuring grain, vegetables, and liquids in larger quantities.

UNITS OF WEIGHT

Principal unit, the **Gram**

TABLE		EQUIVALENTS
10 milligrams (mg.)	= 1 centigram (cg.)	= 0.15432 grain
10 centigrams	= 1 decigram (dg.)	
10 decigrams	= 1 gram (g.)	= 15.432 grains
10 grams	= 1 dekagram (Dg.)	
10 dekagrams	= 1 hektogram (Hg.)	
10 hektograms	= 1 kilogram (Kg.)	= 2.20462 pounds
10 kilograms	= 1 myrogram (Mg.)	
10 myrograms	= 1 quintal (Q.)	
10 quintals	= 1 metric ton (T.)	= 2204.621 pounds

The **gram** is the weight of a cubic centimeter, the **kilogram** of a cubic decimeter, and the **metric ton** of a cubic meter, of distilled water at its greatest density.

The *gram* is used in mixing medicines, and in weighing jewels, precious metals, letters, etc. Ordinary articles are weighed by the *kilogram* (commonly called *kilo*) and heavy articles by the *metric ton*.

TABLE OF EQUIVALENTS

<i>Common</i>	<i>Metric</i>	<i>Common</i>	<i>Metric</i>
1 inch	= 2.54 cm.	1 cu. foot	= 28.317 cu. dm.
1 foot	= 30.48 cm.	1 cu. yard	= 6.7645 cu. m.
1 yard	= 0.9144 m.	1 cord	= 3.624 st.
1 rod	= 5.029 m.	1 liquid quart	= 0.9463 l.
1 mile	= 1.6093 Km.	1 gallon	= 3.785 l.
1 sq. inch	= 6.452 sq. cm.	1 dry quart	= 1.101 l.
1 sq. foot	= 9.2903 sq. dm.	1 bushel	= 0.3524 Hl.
1 sq. yard	= 0.8361 sq. m.	1 grain	= 0.0648 g.
1 sq. rod	= 0.2529 a.	1 ton	= 0.9072 met. ton
1 sq. mile	= 2.59 sq. Km.	1 troy ounce	= 31.1035 g.
1 Acre	= 0.4047 Ha.	1 av. ounce	= 28.35 g.
1 cu. inch	= 16.378 cu. cm.	1 av. pound	= 0.4536 Kg.
<i>Metric</i>	<i>Common</i>	<i>Metric</i>	<i>Common</i>
1 meter	= 3 ft. 3 $\frac{3}{8}$ in.	1 liter	= 1.06 liq. qt. or $\frac{9}{10}$ dry qt.
1 kilometer	= $\frac{5}{8}$ mile	1 hektoliter	= 2 $\frac{5}{8}$ bushels
1 are	= 4 sq. rd.	1 gram	= 15 $\frac{1}{2}$ grains
1 hectare	= 2 $\frac{1}{2}$ acres	1 kilogram	= 2 $\frac{1}{5}$ av. pounds
1 stere	= $\frac{1}{4}$ cord	1 metric ton	= 2200 pounds

Oral Exercises

- How many mm. in a m. ? In a Km. ?
- How many cm. in a m. ? In a Km. ?
- Reduce 25 Km. to m.
- Reduce 0.03 m. to mm.
- Reduce 0.37 Km. to m.
- How many m. in 1.22 Dm. ? In 2 Hm. ? In 0.004 Km. ?
- How many cm. in 2.45 mm. ? In 3 m. ?
- How many Hm. in 426.25 m. ? How many Km. ?
- Reduce 4.25 sq. cm. to sq. m. ; to sq. mm.
- How many sq. cm. in 25 sq. m. ? In 4286 sq. mm. ?
- How many sq. m. in 36,284 sq. mm. ? In 12.34 sq. cm. ?

12. Reduce 0.0286 sq. Km. to sq. Dm.; to sq. m.; to sq. dm.; to sq. cm.; to sq. mm.
13. How many cu. m. in 1 cu. cm.? In 1 cu. mm.?
14. How many cu. m. in 1 cu. Dm.? In 1 cu. Km.?
15. Reduce 26.814 cu. m. to cu. dm.; to cu. cm.; to cu. mm.
16. Reduce 5.123 cu. m. to cu. Dm.; to cu. cm.
17. How many a. in 5.268 Ha.? How many ca.? How many sq. m.?
18. How many cu. dm. in 12 steres? How many cu. Dm.?
19. How many ft. in 2.5 m.? In 327 cm.?
20. How many sq. in. in 100 sq. cm.? In 326.8 sq. mm.?
21. How many in. in 2.5 cm.? In 500 mm.?
22. How many mi. in 15 Km.?

Problems

1. In 847.2 Kg., how many grams? How many pounds?
2. Change 75 bushels to hektoliters.
3. How many square meters in a rectangle 18 ft. by 10 ft.?
4. An importer pays duty on 1200 m. of cloth. How many yards?
5. How many square rods in a square hektometer?
6. How many liters in a cubic meter?
7. An importer buys 250 l. of liquor at \$0.75 a liter. He sells it for \$3 a gallon. What does he gain or lose?
8. A rectangular stone is 1 m. long, 5 dm. wide, and 24 cm. thick. How many kilograms does it weigh, being eight times as heavy as water?
9. How many kilograms of flour in a barrel? (1 bbl. = 196 lb.)

10. Add 18.32 Km., 648 m., 94.8 Hm., 38.4 dm.
11. What will a stere of stone cost at \$12 a cord?
12. How many hectares in a field 14 Hm. long and 40 Dm. wide? How many acres?
13. How many gallons in a cubic meter of water?
14. How many times is 16 dm. contained in 1.28 Km.?
15. If American goods are bought at \$2.35 per yard, at what price per meter must they be sold in Paris to gain 25%?
16. A hektoliter of fruit weighs 63 kilograms, and 32 liters of sirup can be obtained from it. How many kilograms of fruit will it take to make a hektoliter of sirup?
17. The distance between two places on a map is 12.5 centimeters. What is the actual distance between the places if the scale of the map is 1 to 60,000?
18. Coal weighing 2450 lb. weighs how many kilograms?
19. A tank 9 m. long, 8 m. wide, and $3\frac{1}{2}$ m. deep is filled with water. How many kiloliters does it contain? What is the weight of the water in kilograms? In metric tons?
20. The distance between two German cities is 320 Km. What is the distance in miles?
21. A Paris paper gives the speed of a train at 72.46 Km. per hour. What is the speed of the train in miles per hour?
22. A Paris firm places with an American foundry an order for a cargo of steel bridge frames 17.128 m. in length. What is the required length in feet and inches, correct to a hundredth?
23. A Chicago picture dealer wishes to order from Paris a frame for a canvas $42'' \times 38''$. Required the dimensions of the frame in centimeters, correct to a hundredth.

24. A bolt of imported silk is marked 72.28 m. A dress-maker purchased it at \$1.25 per yard. What is the amount of the bill?

25. If the distance between two cities is 120 mi., how far is it in kilometers?

26. Estimating that two of your ordinary steps make a meter, how far is your home, in meters, from the school?

27. A 200 liter cask of oil is purchased in Paris at 1.5 francs per liter, and retailed in New York at \$1.95 per gallon. Allowing \$12.95 for duties and transportation, what sum is gained?

28. An importer bought an invoice of 137.4 kilos of gum at 27.5 francs per kilo. After adding \$28.75 for duties and transportation charges, what is the cost per pound in United States money?

29. The dome of the capitol at Washington is 287 ft., 6 in. high, surmounted by a statue of Liberty 19 ft., 6 in. high. What is the whole height in meters?

30. From Heidelberg to Strassburg, Germany, is given in a railroad guide as 136 Km. How many miles is it?

31. A German railroad guide gives the distances from Berlin to other cities as follows: To Bremen 339 Km., to Dessau 132 Km., to Dresden 175 Km., to Frankfurt a. Main 541 Km., to Hamburg 280 Km., to Leipzig 164 Km., to Potsdam 26 Km., to Wiesbaden 578 Km. Express these distances in miles.

32. The distance from Wittenberg to Leipzig is 69 Km. The railroad fare between the two points, first class, is 3 M. 40 pf. What is the fare in cents per mile?

33. The fare, second class, between Wittenberg and Leipzig is 2 M. 20 pf. How much is that in cents per mile?

34. A train leaving Berlin at 5:25 A.M. reaches Wittenberg at 7:46 A.M. The distance is 95 Km. What is the speed in miles per hour?

35. A train leaving Berlin at 8:35 A.M. reaches Potsdam at 9:00 A.M. The distance is 26 Km. What is the speed in miles per hour?

36. A German liner is 338 meters long, and an American liner 827 ft. long. Which is the longer, and how much?

37. On a running track 10 hurdles are placed 25 meters apart. How many yards is it from the first hurdle to the last?

38. The tire of an automobile of French make is 7.5 cm. thick. How many inches?

39. A Frenchman flew in his aeroplane a distance of 85 Km. in 1 hr. 15 min. How many miles an hour did he fly?

40. An American traveling in France wished to ship his automobile on a freight car from one point to another. The width of the machine was 58 inches, and the width of the car 2.15 meters. Would the machine go into the car?

41. Mt. Everest is approximately 8842 meters high. Find its height in feet. In miles.

42. An American bought a piece of French velvet containing $32\frac{1}{2}$ meters for \$9.25. What did it cost per yard?

43. An American dealer bought cloth in Paris at 38¢ per meter. What did it cost per yard? The ad valorem duty that he paid on it was 40%. If expenses for shipping, etc., amounted to 8¢ per yard, for how much must he retail it to make a profit of 25%?

44. An American tourist in Europe traveled on one trip 8750 meters by rail. How many miles?

45. If an American woman shopping in Paris wanted 65 inches of ribbon, how many meters must she ask for?

46. A certain street in Paris is 20 meters wide. How many feet and inches in the width?

47. John Wanamaker, New York, wished to order 40 gal. of perfume in France. How many liters did he order?

48. If 2 Hl. 10 l. of perfume were ordered, how many gallons was it?

49. A German manufacturer filled bottles, each holding 5 dl., from a tank holding 2.5 Hl. How many bottles did it require?

50. A French merchant paid 26 fr. for 1 Hl. of apples, and retailed them at 50c. a liter. What was his profit on 1 Hl.?

51. A New York merchant imports 3 Kl. of olive oil. How many quart cans will it fill?

52. In weighing an object in a science laboratory, 3 gram weights, 4 decigram weights, and 7 centigram weights were placed on the scales to make them balance. Express the weight of the object in grams.

53. In weighing an object, 1 kilogram weight, 6 gram weights, and 3 centigram weights were placed on the scales. Express the weight of the object in grams.

54. If an object weighs 43,262 grams, what different weights would have to be placed on the scales to balance it?

55. If the school has any metric weights and scales, practice weighing objects and expressing the weights in grams.

56. A manufacturing firm in Germany ordered 120 metric tons of wood pulp from a shipper in the United States. How many pounds did it take to fill the order? How many tons?

57. A firm in Paris ordered 250 Hl. of rice from an American firm. How many bushels must be shipped?

58. An American importer received a shipment of 850 Kg. of Limburger cheese from Germany. How many pounds was it?

59. If the cheese in the above problem cost the importer 90 pf. per kilo, how many cents was that per pound?

60. One of the most interesting industries of St. Etienne, France, is the manufacture of Roquefort cheese, of which the United States imports large quantities. The industry consumes annually 349,000 liters of sheeps' milk. How many gallons is this?

61. From this milk 3797 metric tons of Roquefort cheese are made annually. How many pounds is that?

62. An average of 100 liters of sheeps' milk will produce about 24 kilos of fresh cheese. How many quarts of sheeps' milk does it take to make a pound of cheese?

63. In other parts of France where imitation Roquefort cheese is made, it takes 100 liters of cows' milk to make 15 kilos of cheese. How many quarts of cows' milk does it take to make a pound of cheese?

64. Roquefort cheese is matured and mellowed in large caves or excavations hollowed out in the steep sides of the rocky mountains. Some of these caves are as large as 57 meters long, 9 meters wide, and 14 meters high. Express these dimensions in feet.

NOTE. If a German or French map can be secured, much interesting work may be done with it in determining the distances between points from measurements, by using the scale to which it is drawn. Similarly, a topographic map may be used in determining the heights of European mountains, etc., in terms of the metric system. Changes may be made to our units of measure.

RULES FOR REFERENCE

A **rule** in arithmetic gives directions for performing the operations necessary to obtain a desired result.

A clear understanding of subjects and principles will make rules unnecessary. The following are given for reference. Quantities described concretely must often be considered as abstract.

FACTORING

Least Common Multiple. (1) *Reject from the given numbers all that are divisors of any of the rest.* (2) *Separate each of the remaining numbers into its prime factors.* (3) *Multiply the largest of the given numbers by all the prime factors of the other numbers that are not found among its own.* *This product will be the L.C.M. required.*

FRACTIONS

To Lowest Terms. *Divide both terms of the fraction by all factors common to both.*

To a Required Denominator. (1) *Divide the required denominator by the given denominator.* (2) *Multiply each term of the given fraction by the quotient.*

To Mixed Numbers. *Divide the numerator by the denominator.*

Mixed Numbers to Improper Fractions. *Multiply the integer by the denominator, and to the product add the numerator. Write the sum over the denominator.*

To a Common Denominator. (1) *Find the L.C.M. of the denominators of the given fractions.* (2) *Divide this by the denominator of each fraction and multiply both terms of the fraction by the quotient thus found.*

Addition. (1) *Change the fractions to a common denominator.* (2) *Find the sum of the numerators.* (3) *Write the sum over the common denominator.* (4) *Simplify the result.*

Add integers and fractions separately in adding mixed numbers.

Subtraction. *Proceed as in addition of fractions, excepting that the difference of the numerators is to be taken instead of their sum.*

Multiplication. I. When one factor is an integer. *Either (a) multiply the numerator by the integer, or, (b) divide the denominator by it.*

II. When one factor is an integer and the other a mixed number. (1) *Multiply the integer first by the fractional part, then by the integral part of the multiplier.* (2) *Add the partial products.*

III. When the factors are mixed numbers or fractions. (1) *Change integers and mixed numbers to improper fractions.* (2) *Write the product of the numerators over that of the denominators.* (3) *Simplify the result.* (*The process may often be shortened by cancellation.*)

Division. I. A fraction by an integer. *Either (a) divide the numerator, or, (b) multiply the denominator by the integer.*

In general. II. (1) *Change dividend and divisor to fractional form, and then (2) to a common denominator.* (3) *Find the quotient of the numerators;* or, III. *Multiply the dividend by the divisor inverted.*

DECIMALS

To Common Fractions. *Express the denominator and change the fraction to smallest terms.*

Common Fractions to Decimals. *Make a decimal point after the numerator, then annex zeros and divide by the denominator.*

Addition and Subtraction. *Write in columns with the decimal points under each other, then proceed as with integers.*

Multiplication. (1) *As with integers.* (2) *Give the product as many decimal places as there are in all the factors.*

Division. (1) *Make the divisor an integer by removing the decimal point.* (2). *Move the decimal point in the dividend an equal number of places in the same direction.* (3) *Divide as with integers.* (4) *Give the quotient as many decimal places as have been used in the dividend.*

MEASUREMENTS

NOTE. — In the following rules, dimensions are spoken of as abstract numbers.

OF LINES

To find —

The Perimeter of a Polygon. *Take the sum of its bounding lines.*

One Dimension of a Rectangle. *Divide its area by the given dimension.*

One Dimension of a Rectangular Prism. *Divide its volume by the product of the two given dimensions.*

The Side of a Square. *Take the square root of its area.*

The Diagonal of a Square. *Take the square root of twice its area.*

The Diagonal of a Rectangular Prism. *Take the square root of the sum of the squares of its three dimensions.*

The Circumference of a Circle or Sphere. *Multiply the diameter by 3.1416.*

The Diameter of a Circle or Sphere. *Divide the circumference by 3.1416.*

The Hypotenuse of a Right Triangle. *Take the square root of the sum of the squares of the short sides of the triangle.*

One of the Short Sides of a Right Triangle. *Take the square root of the difference of the squares of the given sides.*

OF SURFACES

NOTE. — Before multiplying, dimensions must be changed to like numbers.

To find the Area of —

A Parallelogram. *Find the product of base and altitude.*

A Triangle. *Find half the product of base and altitude.*

A Trapezoid. *Multiply the altitude by half the sum of its parallel sides.*

Other Polygons. *Divide into triangles and find the sum of their areas.*

A Sector. *Find half the product of arc and radius.*

A Circle. *Multiply the square of the radius by 3.1416.*

The Lateral Surface of a Prism or Cylinder. *Multiply the perimeter of the base by the altitude.*

The Lateral Surface of a Pyramid or Cone. *Multiply the perimeter of the base by half the slant height.*

A Sphere. (1) *Multiply circumference by diameter; or, (2) multiply the square of the diameter by 3.1416.*

OF SOLIDS

To find the Volume of a —

Rectangular Solid. *Find the product of its three dimensions.*

Prism or Cylinder. *Multiply the area of the base by the altitude.*

Pyramid or Cone. *Multiply the area of the base by one third the altitude.*

Sphere. (1) *Multiply the cube of the diameter by 0.5236; or, (2) take $\frac{4}{3}$ of the cube of the radius multiplied by 3.1416.*

To find —

The Number of Board Feet in a Piece of Lumber. *Multiply the product of its length and width in feet by its thickness in inches. (Disregard thickness when it is one inch or less.)*

PERCENTAGE

To find a —

Per Cent of a Number. *Multiply by the rate expressed as a decimal or as a common fraction.*

Rate Per Cent. *Express the relation as a common fraction. Change to a decimal. Express the quotient as a per cent.*

INTEREST

General Method. *Find the product of the principal, rate per cent, and time in years. (The time may be taken in months or in days, provided the product is divided by 12 or 360, as the case may be.) Use cancellation.*

Principal and interest added will give the amount.

Banker's Method. *Multiply the principal by the number of days. Move the decimal point three places to the left in the product (divide by 1000). Divide by 6. This gives the interest at 6%.*

Aliquot Part Method. *Move the decimal point two places to the left in the principal. This gives the interest at 6% for 60 days. Then take such parts or multiples of this as the given time may require.*

To find the Amount due on a Note on which Partial Payments have been made. United States rule: *Find the amount of the principal to the time when a payment or the sum of several payments shall equal or exceed the interest due at the time. Subtract such payment or sum of payments from the amount, and with the remainder as a new principal, proceed as before to the time of settlement.*

Compound Interest. *Find the amount of the principal for the first period of time. Treat this amount as a new principal, and find its amount for the second period, and so on for the entire time. The last amount less the given principal will be the compound interest.*

Bank Discount. *Compute bank discount as if it were simple interest on the maturity value of the note for the term of discount. The maturity value of the note less the bank discount will be the proceeds. (Use the exact number of days that the note has to run after day of discount.)*

SQUARE ROOT

Extracting the Square Root.

I. *Beginning at the decimal point, separate the given number into groups of two figures each.*

II. *Find the greatest square in the left group and place its root at the right; subtract the square of this root from the left group, and to the remainder annex the next group for a dividend.*

III. *Divide this dividend, omitting the last figure, by double the root already found, and annex the quotient to the root, and also to the divisor.*

IV. *Multiply the divisor as it now stands by the last root figure and subtract the product from the dividend.*

V. *If there are more groups to be brought down, proceed in the same manner as before.*

*60 pounds	= 1 bushel	{ wheat or potatoes
*56 "	= 1 "	corn or rye
*32 "	= 1 "	oats
196 "	= 1 barrel	flour
200 "	= 1 "	beef or pork

* In most States.

Troy Weight.

(For precious metals, jewels, etc.)

24 grains	{ = 1 pennyweight (pwt.)
20 pennyweights	= 1 ounce
12 ounces	= 1 pound

437½ grains	= 1 ounce	} Av.
7000 "	= 1 pound	
480 "	= 1 ounce	} Troy.
5760 "	= 1 pound	

Apothecaries' Weight.

20 grains	= 1 scruple (sc. or Ⓢ)
3 scruples	= 1 dram (dr. or ℥)
8 drams	= 1 ounce (oz. or ℥)
12 ounces	} = 1 pound (lb. or ℔ .)
5760 grains	

Length.

12 inches (in.)	= 1 foot (ft.)
3 feet	= 1 yard (yd.)
16½ feet or 5½ yards	} = 1 rod (rd.)
320 rods	
5280 feet	} = 1 mile (m.)
63,360 inches	

4 inches	= 1 hand
6 feet	= 1 fathom

6086.7 feet or 1.15 + com- mon miles	} = { 1 knot 1 nautical mile 1 geographic mile
3 knots	

Circular Measure.

60 seconds (")	= 1 minute (')
60 minutes	= 1 degree (°)
360 degrees	= 1 circumference
69⅙ miles or 60 geographic miles	} = { 1° of latitude; or 1° of longitude on the equator

Surface or Square.

144 square inches (sq. in.)	} = { 1 square foot (sq. ft.)
9 square feet	
30¼ square yards 272¼ square feet	} = { 1 square rod (sq. rd.)
160 square rods 43,560 square feet	
640 acres	= { 1 square mile (sq. m.)
1 square mile	= 1 section
36 square miles	= 1 township
100 square feet	= { 1 square (in roofs, floors, etc.)

Solid or Cubic.

1728 cubic inches (cu. in.)	} = { 1 cubic foot (cu. ft.)
27 cubic feet	
	= { 1 cubic yard (cu. yd.)

Wood Measures.

16 cubic feet	= 1 cord foot (cd. ft.)
128 cubic feet	} = 1 cord (cd.)
8 cord feet	

METRIC SYSTEM

UNITS OF LENGTH

	TABLE	EQUIVALENTS
10 millimeters (mm.)	= 1 centimeter (cm.)	= 0.3937079 inch
10 centimeters	= 1 decimeter (dm.)	
10 decimeters	= 1 meter (m.)	= 39.37079 inches
10 meters	= 1 dekameter (Dm.)	
10 dekameters	= 1 hektometer (Hm.)	
10 hektometers	= 1 kilometer (Km.)	= { 3280.9 feet 0.621382 mile
10 kilometers	= 1 myriameter (Mm.)	

UNITS OF SURFACE

	TABLE	EQUIVALENTS
100 sq. millimeters (sq. mm.)	= 1 sq. centimeter (sq. cm.)	= 0.155 sq. in.
100 sq. centimeters	= 1 sq. decimeter (sq. dm.)	
100 sq. decimeters	= 1 sq. meter (sq. m.)	= 10.764 sq. ft.
100 sq. meters	= 1 sq. dekameter (sq. Dm.)	
100 sq. dekameters	= 1 sq. hektometer (sq. Hm.)	
100 sq. hektometers	= 1 sq. kilometer (sq. Km.)	= 247.114 acres

When used in measuring land the square meter is called a *centare* (ca.), the square dekameter an *are* (a.), and the square hektometer a *hektare* (Ha.).

UNITS OF VOLUME

	TABLE	EQUIVALENTS
1000 cu. millimeters (cu. mm.)	= 1 cu. centimeter (cu. cm.)	= 0.06102 cu. in.
1000 cu. centimeters	= 1 cu. decimeter (cu. dm.)	
1000 cu. decimeters	= 1 cu. meter (cu. m.)	= 35.314 cu. ft.

In measuring wood the cubic meter is called a *stere* (1 st. 0.2759 cd.) ; a *decistere* (1 dst.) is one tenth of a stere.

UNITS OF CAPACITY

Principal unit, the **Liter** = a cu. decimeter.

	TABLE	EQUIVALENTS
10 milliliters (ml.)	= 1 centiliter (cl.)	= 0.6102 cu. inch
10 centiliters	= 1 deciliter (dl.)	
10 deciliters	= 1 liter (l.)	= { 1.0567 liquid quarts 0.908 dry quart
10 liters	= 1 dekaliter (Dl.)	
10 dekaliters	= 1 hektoliter (Hl.)	= { 26.417 gallons 2.8375 bushels
10 hektoliters	= 1 kiloliter (Kl.)	

UNITS OF WEIGHT

	TABLE	EQUIVALENTS
10 milligrams (mg.)	= 1 centigram (cg.)	= 0.15432 grain
10 centigrams	= 1 decigram (dg.)	
10 decigrams	= 1 gram (g.)	= 15.432 grains
10 grams	= 1 dekagram (Dg.)	
10 dekagrams	= 1 hektogram (Hg.)	
10 hektograms	= 1 kilogram (Kg.)	= 2.20462 pounds
10 kilograms	= 1 myriagram (Mg.)	
10 myriagrams	= 1 quintal (Q.)	
10 quintals	= 1 metric ton (T.)	= 2204.621 pounds

TABLE OF EQUIVALENTS

<i>Common</i>	<i>Metric</i>	<i>Common</i>	<i>Metric</i>
1 inch	= 2.54 (cm.)	1 cu. foot	= 28.317 (cu. dm.)
1 foot	= 30.48 (cm.)	1 cu. yard	= 0.7645 (cu. m.)
1 yard	= 0.9144 (m.)	1 cord	= 3.624 (st.)
1 rod	= 5.029 (m.)	1 liquid quart	= 0.9463 (l.)
1 mile	= 1.6093 (Km.)	1 gallon	= 3.785 (l.)
1 sq. inch	= 6.452 (sq. cm.)	1 dry quart	= 1.101 (l.)
1 sq. foot	= 9.2903 (sq. dm.)	1 bushel	= 0.3524 (Hl.)
1 sq. yard	= 0.8361 (sq. m.)	1 grain	= 0.0648 (g.)
1 sq. rod	= 0.2529 (a.)	1 ton	= 0.9072 (met. ton)
1 sq. mile	= 2.59 (sq. Km.)	1 troy ounce	= 31.1035 (g.)
1 Acre	= 0.4047 (Ha.)	1 av. ounce	= 28.35 (g.)
1 cu. inch	= 16.387 (cu. cm.)	1 av. pound	= 0.4536 (Kg.)

APR 20 1914

