

ALGEBRAIC EXPRESSIONS OF DEAF STUDENTS: CONNECTING VISUO-GESTURAL AND DYNAMIC DIGITAL REPRESENTATIONS

Solange Hassan Ahmad Ali Fernandes, Lulu Healy

Anhanguera University of São Paulo

This paper explores the algebraic expressions of deaf learners as they explore and construct sequences using the digital microworld Mathsticks. More specifically, it attempts to identify how the deaf students coordinated bodily, discursive and digital resources in order to attribute their own personal senses to the notion of variable. Examples of their interactions with the tasks and tools are analysed to identify evidence of the presence of the three conditions of algebraic thinking, indeterminacy, denotation and analyticity. Our findings suggest that the creation of a shared sign “secret number” to represent the idea of variable was central in facilitating the students to adopt algebraic rather than arithmetic approaches and to appropriate the idea of a general term.

DISCURSIVE MODES, LEARNING AND ALGEBRAIC THINKING

Our research with students with disabilities focuses on how the specific ways in which they experience and interact with the world mediate their learning. In the case of deaf learners, for example, we are interested in better understanding how the visuo-gestural expressions of signed languages, as well as the interactional practices associated with their use, shape the appropriation of mathematical knowledge. In this paper, we concentrate on the participation of Brazilian deaf students, whose first language is Libras (Brazilian Sign Language), in activities involving the construction of algebraic generalisations to represent the mathematical structure of visually presented sequences.

Our approach has been strongly influenced by the work of Vygotsky and especially by his ideas concerning the mediating role of material and semiotic tools, which emerged initially from his studies with people with disabilities (Vygotsky, 1997). For Vygotsky, language is a broad concept which encompasses, as well as the communicative function, the function of organising and developing the processes associated with thinking. In the case of the deaf learner, his view was that in order to overcome the barriers related to the absence of an oral language, from a very early age the deaf child develops “habits of mimic-gestures” that represent more than a way of expressing their emotions, becoming also a vital mode of discursive communication (Vygotsky, 1997, p. 119).

In Vygotsky’s view, both thought and language result from the interactions between individuals within the context of their socio-historic culture (Vygotsky, 1962; Leontiev, 1978; Luria, 1992). Adopting a contemporary version of this position,

Radford (2006) describes thinking as a result of a reflective praxis mediated by the body, signs and tools – a dialectic movement between a historically and culturally constituted reality and the individual who reflects upon it (Radford, 2006). Following the steps of Leontiev, Radford and Roth (2011) stress the *personal senses* that emerge in instructional situations as individuals attribute their own subjective meanings for the objective meanings of the objects under study. Although subjective, these meanings are necessarily social, in that they are moulded by shared cultural signs of those who participate in the situation.

We concur with this view, but believe it is important to recognise that in the socio-historic practices that have come to characterise most mathematics classrooms, dialogues based on visuo-gestural forms of expression have only recently been considered and valued. In fact, for many years, deaf students were discouraged or even forbidden from using sign languages as a medium for learning. It is hence critical that we begin to investigate how the discursive practices of deaf learners might favour the process of transforming conceptual objects of culture (algebraic objects in this case) into objects of consciousness.

In this article, we focus on the interactions between a group of deaf students, their hearing teacher, an interpreter and hearing researchers that occurred as the students worked on activities involving generalisation. In each of the episodes we present, we attempt to identify evidence of algebraic thinking in the expressions of the students, using Radford's (in press) characterisation of algebraic thinking as comprised of three interrelated conditions, *indeterminacy*, *denotation* and *analyticity*. Indeterminacy refers to the condition that thinking algebraically involves problems with unknown, or undetermined, elements, in our case numbers. Denotation involves the need to name or symbolize the indeterminate numbers. For Radford, denotation does not necessarily involve the use of standard alphanumeric signs, “indeterminate quantities can also be symbolized through natural language, gestures, unconventional signs or even a mixture of these” (p. 4). The third condition, analyticity, implicates the treatment of the indeterminate elements as if they were known. That is, a student thinking algebraically will not need to assign a specific value to, say, an unknown number in order to operate with it.

With these three conditions in mind, in the remainder of the paper we present episodes from a series of tasks involving generalisation and consider aspects of the discursive practices of the deaf students that contributed to the production of generalisations and indicated the personal senses attributed to the notion of variable.

THE EMPIRICAL PROCEDURE

Drawing from the methods associated with *Design Experiments* (Cobb *et al.*, 2003), the activities we have developed for deaf learners seek to privilege visual representations as starting points from which to motivate engagement in reflective and discursive practices. The activities discussed in this article represent the third and fourth sessions of a series of five, each of which occurred on a separate day and lasted

for approximately 90 minutes. The group of six deaf students, aged between 18 and 31 years, composed a 9th grade class who studied in the evenings at a school that was part of the public system of the municipal of Barueri, a town on the outskirts of the São Paulo conurbation. This school attends both deaf and hearing students, who usually study together, although for historical reasons this particular class included only deaf students.

During the research sessions, in addition to the teacher and interpreter, four other researchers were present. Three cameras were positioned in the classroom to record the interactions of all the participants. Additionally, in the three sessions involving the use of digital tools, three laptops were available and the on-screen activity was also recorded. In the first two sessions, the students worked on paper and pencil tasks involving visually presented sequences. Although the students successfully completed the activities, our analyses suggested that in terms of the sense of indeterminacy, one of the critical conditions of algebraic thinking, none of the tasks provoked in students a need to denote or operate with an unknown element. That is, the students were able to generate generalisations that they could use to locate any given term of the sequence, but for them it only made sense to do so once the value of the specific term required was identified. We might say that the idea of a general term did not figure in the shared dialogue (for more details on these two sessions, see Fernandes and Healy, 2013).

From the third session on, we decided to adopt a different approach. With the intention of encouraging students to identify the visual structure of a general term, we chose to work with the Mathsticks microworld, created in the Imagine version of the Logo programming language (Figure 1 presents an English version, the Portuguese version used in our study is available at www.matematicainclusiva.net.br).

This microworld, originally described in Noss, Healy and Hoyles (1997), is designed to encourage students to produce a variable procedure (in the **history box**) that can be used to generate the set of terms for a given sequence. The elements of the sequence are mathsticks, created by clicking on the respective icons and positioned through four jump icons. When the **history box** is activated (turned **on**), a reusable symbolic trace of the users' actions is recorded in symbolic form as Logo commands. Sets of the commands can be repeated in a way that corresponds to how the sequence grows and the box labeled **n** can be used as a variable, allowing the same **history** to produce different terms in the same sequence (in Figure 1, the value of **n** is 5, hence the 5th term in the sequence is generated).

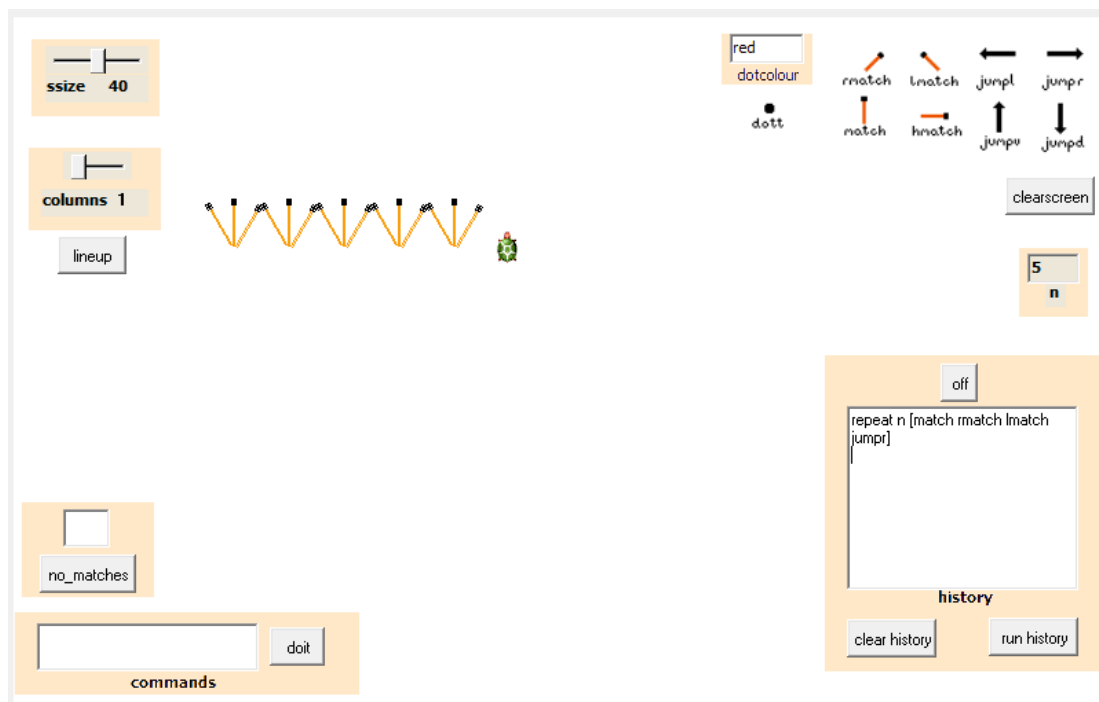

Figure 1: The Mathsticks Microworld

STUDENTS' INTERACTIONS WITH THE MATHSTICKS MICROWORLD

The participating students had never used the Logo programming language before, nor were they accustomed to interacting with digital tools in their mathematics lessons. The first activity (Figure 2) hence had the aim of familiarising students with the microworld tools and their functions.

Program a history that draws all these figures

Write your history

Figure	5	3	16	14	n
Number of sticks					

Figure 2: The “L” task

To introduce the activity, the screen from the microworld was reproduced on the blackboard and, as the functions of the different tools were explained, the students experimented with them in pairs on the laptops. After seeing how a matchstick “L” could be produced, the students were shown how commands could be repeated in the **history box** to produce the 6th term of the sequence. At this point the **history box** on the blackboard contained the commands **repeat 6 [match hmatch junpr]**.



Figure 3: Changing the number of repeats the board. (Figure 3).

The next step was to introduce variables, or more specifically the microworld variable **n** represented as a box on the screen. To illustrate its use, the commands in the **history box** were altered to **repeat n [match hmatch jump]**. Having explored the effect of changing the value of **n**, the students began to work in pairs to complete the table presented in the “L” task in Figure 2. They progressed without difficulty until the moment that they came to the column in which the number of matches in the n^{th} term was requested. Although they knew that each “L” shape was made up of two matches and found it straightforward to calculate the cases in which either the number of the term or the number of matches was known, faced with a (our) denotation of a variable they were unsure as to what was expected. We might say that although they had varied the value of **n** in their interactions with Mathsticks, their thinking was still predominantly arithmetic, and they were still operating only with known quantities. After having discussed their results and with a consensus that to determine the number of matches in any term it was necessary *always* to multiply the number of “Ls” by two, one of the researchers completed the table, writing $n \times 2$. Almost immediately, reflecting on this inscription, one of the students, Elaine, offered a new interpretation for **n**, signing “*n is a secret number*” (Figure 4).

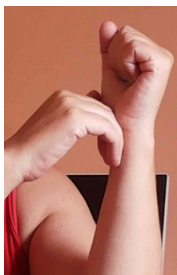

Figure 4: The Libras sign for “secret”

Our interpretation is that the denotation of the variable offered by Elaine was indicative of her developing personal sense of indeterminacy and the idea that it is possible to work with numbers without knowing their values. Indeed the sign for “secret” is itself suggestive of hiding something down one’s sleeve and only perhaps later revealing its value – a kind of bodily expressed metaphor for an unknown.

In creating the sign “secret number”, Elaine simultaneously expressed and shared her sense of the variable **n**. The creation of such signs is a common part of communicating in Libras, especially as official signs for mathematical terms such as “variable” do not always exist or, at least, are not widely known. Elaine’s sign was hence adopted forthwith as a means of referring to variables.

In the following session, the students worked on similar activities in which the structure of the terms became gradually more complex, Figure 5 presents an example, that we will call the “rectangle task”.

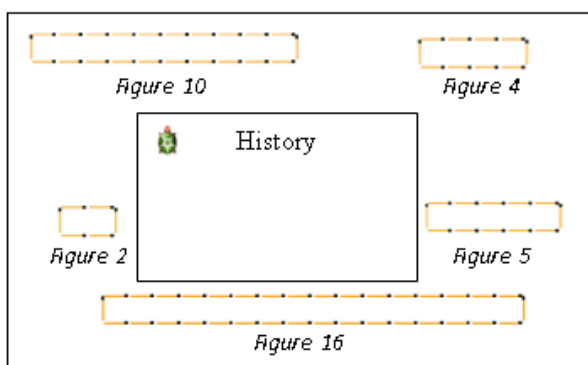

Figure 5: The rectangle task

In the activities that preceded this task, the general term could be written in the form **repeat n [procedure]**. In this task, however, while the number of horizontal matches varies as the sequence changed, there are always 2 vertical matches. Perhaps not surprisingly, all the student pairs began first by seeking a generalisation using the repeat structure that had worked in the previous activities.

Téo, for example, noticed how the number of horizontal matches increased and in his first attempt he wrote **repeat n [hmatch jumpu hmatch jumpd jumpv]**. When he tested the commands in the **history box**, using 12 as the value for **n**, he saw that the term was incomplete (Figure 6). He added the command **match** to the **history box** and, after considerable thought, completed the figure with the commands **repeat 12 [jumpv] match**. (Figure 7). He was very satisfied with the result.



Figure 6: First attempt



Figure 7: Completing the figure

When asked to explain why this addition had worked, he confidently signed the following answer

Téo: *12 here in n (pointing to the **box n** on the screen). So r e p e t i r (spells out the word letter by letter) 12 (pointing to the **repeat 12** in the **history box**). It has to be equal to n. An example, if it was 9 (points again to the **repeat 12**), it wouldn't work. It has to be 12 to be the same.*

To further illustrate his explanation, and what happens when “*n is different*” Téo changed **n** to 20 (Figure 8).



Figure 8: **n** equals 20

He immediately resolved the problem by changing the 12 to 20 and was then, asked if he could change commands in the **history box** so it was not longer to alter manually on each change to **n**.

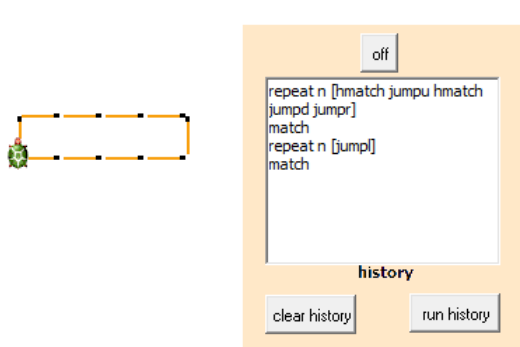

Figure 9: A general history

This intervention led to the replacement of **repeat 20** with **repeat n** and the new **history** was checked with different values for **n** (Figure 9 shows the term drawn when **n** is 4). In this construction procedure, we see traces of the analyticity proposed by Radford as the third condition for algebraic thinking, although, given the nature of the task, in this case it involves relating specific and general terms, rather than, say, operating on unknowns to locate particular values.

DEAF LEARNERS' EXPRESSIONS OF MATHEMATICAL GENERALITIES

Marschark and Hauser (2008, p. 9), reflecting on instructional approaches appropriate to include deaf learners, remark that “the use of dynamic visual displays to accompany instructors’ verbal descriptions are especially helpful for learning”. The choices of the mediational elements in this study – the microworld, the tasks, and the language used – were made with this in mind: to respect but also to diversify the discursive practices preferred by deaf students. The dynamic representations of the Mathsticks microworld enabled the students to explore the visual structures of the sequences they encountered and the possibility to generate a symbolic representation of a general term by using a Logo variable appeared to serve as a meaningful introduction to indeterminacy and to favour the emergence of algebraic thinking.

In the examples presented in this article we have tried to show how the interactions of the students with the microworld, with each other and with us involved them in a process of coordinating bodily resources with visual, dynamic and linguistic signs in order to attribute meanings to mathematical objects. Their expressions during this process contain traces of the three conditions for algebraic thinking, indeterminacy, denotation and, albeit to a lesser degree, analyticity. For example, as Elaine offered a sign to denote her personal sense of the variable **n**, she also offered a means, that was shared and understood by the group, to reflect about the condition of indeterminacy and the sign “secret number” came to represent an as yet unknown (or unrevealed) number. The use of this sign was particularly important since these students were not yet familiar with more conventional semiotic systems used to represent indeterminate numbers, nor were they (or we) aware of signs in Libras for terms such as “variable”.

It is also interesting to focus on the form of the sign itself. Like many signs in Libras, there is a certain iconicity associated with the sign for “secret”, it evokes the idea of something being hidden up ones’ sleeve. The sign “secret number” expresses in a visuo-gestual form a particular incarnation of an algebraic variable that seemed to make sense to this student group. As we seek to better include deaf students in school mathematics, we believe that we need to attend more closely to the practice of communicating mathematics in this visuo-gestual form.

Acknowledgements

We are grateful for the funding received from CAPES (Coordenação de Aperfeiçoamento de Pessoal de Nível Superior) which is contributing to the ongoing programme of research entitled *Towards an Inclusive Mathematics Education* (No. 23038.019444/2009) and for the grant received by Lulu Healy from CNPq (Conselho Nacional de Desenvolvimento Científico e Tecnológico). We would also like to thank Heliel Ferreira dos Santos, Fabiane Guimarães Vieira Marcondes and Kauan Espósito da Conceição who collaborated with us in the design and execution of the Mathsticks sessions.

References

- Cobb, P., Confrey, J., Disessa, A., Lehrer, R., & Schauble, L. (2003). Design experiments in educational research. *Educational Researcher*, 32(1), 9-13.
- Fernandes, S. H. A. A., & Healy, L. (2013). Expressando generalizações em Libras: álgebra nas mãos de aprendizes surdos. *Caderno CEDES*, 33(91), 349-368.
- Leontiev, A. (1978). Marxism and psychological science. In *Activity, consciousness, and personality* (Chapter 1). (M. Hall, Trans.). Upper Saddle River, NJ: Prentice-Hall.
- Luria, A. R. (1992). The child and his behavior. In *Ape, primitive man, and child: Essays in the history of behaviour* (Chapter 3). (E. Rossiter, Trans.). Harlow, Essex: Harvester Wheatsheaf. (Originally published 1930)
- Marschark, M., & Hauser, P. (2008). Cognitive underpinnings of learning by deaf and hard-of-hearing students: Differences, diversity, and directions. In M. Marschark & P. C. Hauser (Eds.), *Deaf cognition: Foundations and outcomes* (pp. 3-23). New York: Oxford University Press.
- Noss, R., Healy, L., & Hoyles, C. (1997). The construction of mathematical meanings: Connecting the visual with the symbolic. *Educational Studies in Mathematics*, 33(2), 203-233.
- Radford, L. (2006). Elementos de una teoría cultural de la objetivación. *Relime—Revista Latinoamericana de Investigación en Matemática Educativa, Número Especial*, 103-129.
- Radford, L. (in press). The progressive development of early embodied algebraic thinking. *Mathematics Education Research Journal*.
- Radford, L., & Roth, W.-M. (2011). Intercorporeality and ethical commitment: an activity perspective on classroom interaction. *Educational Studies in Mathematics*, 77(2-3), 227-245.
- Vygotsky, L. S. (1997). *Obras escogidas V – Fundamentos da defectología*. (J. G. Blank, Trad.). Madrid: Visor.
- Vygotsky, L. S. (1962). The genetic roots of thought and speech. In E. Hanfmann & G. Vakar (Eds.), *Thought and language* (Chapter 4). (E. Hanfmann & G. Vakar, Trans.). Massachusetts: The MIT Press.