

**What Does Engineer**  
**Office Manager** **It** **Really**  
**Lab Technician** **Mean**  
**Teacher** **to Be** **Biotechnology**  
**Criminal Justice** **Nursing** **College**  
**General Studies** **Programmer** **IT and** **Nurse** **Automechanic**  
**Accounting**  
**Business** **Work** **Researcher**  
**Auditor** **Ready?** **Early Childhood Education**

*The English Literacy Required of  
First Year Community College Students*





# What Does It Really Mean to Be College and Work Ready?

*The English Literacy Required of  
First Year Community College Students*

---

A Report from the National Center on Education and the Economy

*May 2013*



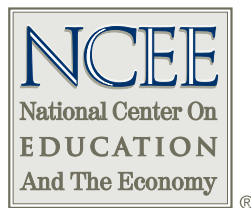

The National Center on Education and the Economy was created in 1988 to analyze the implications of changes in the international economy for American education, formulate an agenda for American education based on that analysis and seek wherever possible to accomplish that agenda through policy change and development of the resources educators would need to carry it out.

**National Center on Education and the Economy**

2000 Pennsylvania Avenue, NW  
Suite 5300  
Washington, DC 20006  
(202) 379-1800  
[www.ncee.org](http://www.ncee.org)

Copyright © 2013 by the National Center  
on Education and the Economy



# PREFACE

---

In the fall of 2009, the National Center on Education and the Economy initiated a series of research programs designed to support our high school reform program, *Excellence for All*, based on our more than 20 years of research on the school reform programs of the countries with the most successful education programs worldwide.

---

The design of *Excellence for All* entails the use of some of the world's best instructional programs, with high quality curriculum and high quality matching examinations. To make this program work as designed, we had to be sure that the performance standards we identified as “passing” on the lower division exams we had selected in English and mathematics were sufficiently challenging that students passing these examinations were likely to be successful in the first year of a typical community college program.

We asked the association of community colleges what that standard might be. They did not know. There was no shortage of opinion about what it might be, much of it based on asking panels of community college faculty for the answer. But this method of determining education standards is notoriously faulty, because educators, job foremen and others presumably in a position to know typically answer in terms of what they would like students and workers to know and be able to do, not in terms of what the program of study or the work *actually* requires. We quickly discovered that no one had done in-depth research on what was needed to be successful in our community colleges.

So we set in motion two empirical studies, one focused on English and the other on mathematics requirements. Each of these studies was guided by a panel of leading experts in that subject matter area, including key figures from the community colleges themselves, as well as leading subject matter experts and researchers. Both studies were overseen by the *Excellence for All* Technical Advisory Committee, whose members include many of the nation's leading psychometricians, cognitive scientists, curriculum experts and testing experts. I am deeply indebted to both the subject matter committees and the Technical Advisory Committee for the time and careful attention they have given to these studies over the two-and-a-half years it has taken to conduct them. Special appreciation goes to the English Panel co-chairs, Richard P. Durán, Sally Hampton and Catherine E. Snow, for their leadership, thoughtfulness and creativity in steering the Panel through the challenging tasks we set before them.

Most of the work, as is usually the case, was done by the staff. Betsy Brown Ruzzi, NCEE's Vice-President for Programs, produced the original research design and has continued to be deeply involved in the work. Jackie Kraemer, Senior Policy Analyst, conducted the research. Jennifer Crow,

Production Designer, assembled and aggregated all the data coding and developed the data displays. David R. Mandel, Director of Research and Policy Analysis, oversaw the whole process and played a key role in drafting the reports.

This entire effort also enjoyed the support and encouragement of the Bill & Melinda Gates Foundation as part of their College Ready Education strategy.

The nation is, at long last, engaged in serious discussion of what it means to be College and Career Ready. We believe that this research program will make an important contribution to that debate by cutting through strongly expressed opinions on the matter that turn out to be just plain wrong in the light of our findings, findings that may surprise many observers. We find, for example, that although challenging texts are used in community colleges, the reading tasks that are set before students are not especially demanding. Even so, many students attending community colleges fall short of the rather minimal literacy demands made upon them, casting an even harsher light on the failings of U.S. high schools.

But these findings will not surprise all. As the facts presented in these reports came to light in the course of our research, I shared them with people very close to the institutions we were researching. Few of them were surprised. Most told me that the emerging picture corresponded closely to what they saw every

day in the field. They had long ago concluded that the debate about standards was unhinged from the realities in our community colleges.

We offer these research reports in the hope that our findings will make an important contribution to the larger debate about what it means to be college and career ready and what our schools should be doing to provide curricula and instruction that will help all students be ready for college and careers when they graduate from high school.

Some may charge that our findings constitute an argument to lower high school leaving standards. That would be a gross misreading of our findings. A large fraction of high school leavers cannot now do the work required of them in the first year of the typical community college program. Our first priority should be to reduce that fraction greatly by teaching all high school students what they will need to succeed in college. But we do not teach what they need, while demanding of them what they don't need; furthermore, the literacy skills that we do teach and that they do need, we teach ineffectively. Many high school graduates cannot meet the typically limited literacy demands of community college programs. Perhaps that is the place to begin our deliberations.

**Marc Tucker, President**

*National Center on Education and the Economy*



# ENGLISH PANEL

---

**Richard P. Durán, Co-Chair**

Professor, Gervitz Graduate School of Education  
University of California, Santa Barbara  
Santa Barbara, CA

**Sally Hampton, Co-Chair**

Senior Fellow  
Pearson - America's Choice  
Fort Worth, TX

**Catherine E. Snow, Co-Chair**

Patricia Albjerg Graham Professor of Education  
Graduate School of Education  
Harvard University  
Cambridge, MA

**Paul Carney**

English Instructor  
Minnesota State Community and Technical College  
Fergus Falls, MN

**Mark W. Conley**

Professor of Literacy  
University of Memphis  
Memphis, TN

**David D. Haynes**

Associate Professor of English and Director,  
Creative Writing  
Southern Methodist University  
Dallas, TX

**George Hillocks, Jr.**

Emeritus Professor of English  
University of Chicago  
Chicago, IL

**Tanya M. Hodge**

English Teacher and English Department Chair  
South High School  
Minneapolis, MN

**John McMillan**

President  
Inquiry By Design  
Fort Worth, TX

**Danielle S. McNamara**

Professor of Psychology and Senior Scientist,  
Learning Sciences Institute  
Arizona State University  
Tempe, AZ

**Sandra Murphy**

Professor Emerita, School of Education  
University of California, Davis  
Walnut Creek, CA

**Maricel G. Santos**

Associate Professor of English  
San Francisco State University  
San Francisco, CA

**Howard B. Tinberg**

Professor of English  
Bristol Community College  
Fall River, MA

# TECHNICAL ADVISORY COMMITTEE

---

## **Howard T. Everson, *Co-Chair***

Executive Director and Professor  
Center for Advanced Study in Education Graduate  
School & University Center  
City University of New York  
New York, NY

## **James W. Pellegrino, *Co-Chair***

Liberal Arts and Sciences  
Distinguished Professor  
Distinguished Professor of Education  
Co-Director, Learning Sciences Research Institute  
University of Illinois at Chicago  
Chicago, IL

## **Lloyd Bond**

Consulting Scholar  
Carnegie Foundation for the Advancement  
of Teaching  
Vacaville, CA

## **Philip Daro**

Director, Strategic Education Research Partnership –  
San Francisco  
Senior Fellow, Mathematics  
Pearson - America's Choice  
Berkeley, CA

## **Richard P. Durán**

Professor  
Gevirtz Graduate School of Education  
University of California, Santa Barbara  
Santa Barbara, CA

## **Edward H. Haertel**

Jacks Family Professor of Education, Emeritus  
Graduate School of Education  
Stanford University  
Stanford, CA

## **Joan Herman**

Director  
National Center for Research on Evaluation,  
Standards and Student Testing  
University of California, Los Angeles  
Los Angeles, CA

## **Robert L. Linn**

Distinguished Professor Emeritus of Education  
University of Colorado  
Ouray, CO

## **Catherine E. Snow**

Patricia Albjerg Graham Professor  
Graduate School of Education  
Harvard University  
Cambridge, MA

## **Dylan Wiliam**

Emeritus Professor of Educational Assessment  
Institute of Education  
University of London  
London, England

# TABLE OF CONTENTS

---

I	<i>Summary</i> .....	1
II	<i>Background</i> .....	5
III	<i>Methodology</i> .....	6
IV	<i>Findings: Text Complexity</i> .....	7
V	<i>Findings: Reading Task Complexity</i> .....	10
VI	<i>Findings: Writing</i> .....	17
VII	<i>Conclusion</i> .....	24
VIII	<i>Bibliography</i> .....	26

## APPENDICES

A	<i>English Panel Biographical Sketches</i> .....	30
B	<i>Text Complexity Report</i> .....	36
C	<i>Community College 101 Courses: Student Assessment Instruments and Test/Exam Formats Used</i> .....	58
D	<i>Example 3 - Business Plan Excerpt</i> .....	64
E	<i>Example 4 - Criminal Justice Final Exam Essay Question</i> .....	74
F	<i>Example 5 - Argument Essay</i> .....	80

---



# I. SUMMARY

**THERE IS A STRONG CONSENSUS** that students ought to leave high school ready for both college and careers. And there is little disagreement that being college and career ready ought to include being able to communicate clearly—to speak grammatically, write well and read the required materials with understanding.

A large and growing fraction of our high school graduates go to community college either to launch their careers or to prepare for transfer to a four-year college. If a student leaves high school unable to succeed in the initial credit-bearing courses of the local community college, that student is ready neither for work nor college. And the fact is that a large proportion of our high school graduates are indeed unable to succeed in their first year in community college, and those who are assigned to remedial courses have a painfully low rate of college completion.

So this report addresses a simple question: what kind and level of literacy is required of a high school graduate if that student is going to have a good chance of succeeding in the first year of a typical community college program?

One would think that the answer to that question would be well known, but it is not. Community college staff have been asked for their opinions on that point, but people who study the process of setting standards of this sort know that people who are asked such questions typically answer based on what they would like students to know and be able to do, rather than on what the actual work demands.

We present here an empirical analysis of the literacy skills needed in a range of initial required community college English and introductory courses in a diverse range of programs of study.<sup>1</sup>

We began this research by randomly selecting a community college from each of seven states and then focusing on eight of the most popular and diverse programs in those colleges — Accounting, Automotive Technology, Biotech/Electrical Technology, Business, Criminal Justice, Early Childhood Education, Information Technology/Computer Programming<sup>2</sup> and Nursing — plus the General Track.<sup>3</sup> We collected materials, including graded student assignments, tests and examinations from each college to allow us to analyze the reading and writing skills that are required in the initial credit-bearing courses in those programs, and in the first year English Composition course required by each program. We also analyzed the reading levels needed to understand the material in the textbooks used in those courses.

---

<sup>1</sup> A parallel study has been completed by NCEE analyzing the mathematics needed for success.

<sup>2</sup> While there are distinct differences in the curricula of the Information Technology and Computer Programming courses we encountered, the character of the texts they employ are quite similar so they have been joined together for analytical purposes.

<sup>3</sup> About one-third of community college students who graduate choose to major in the liberal arts and sciences, general studies and/or humanities, a figure that has remained steady over the last decade. The next most popular majors are in the health professions and related clinical sciences, which encompass about 21% of all associate degrees granted. Business is another popular major, drawing 15.7% of community college students, followed by engineering at 6.5%. Security and protective services and computer and information services round out the most popular majors with 4.4% and 3.8% of students choosing these fields, respectively. While health fields have experienced an increase in graduates between the 1999–00 and 2009–10 school years (from 15.3% to 20.9%), engineering has dropped from 10.5% of graduates to just 6.5%. Most other fields have remained fairly stable. (NCES, *Condition of Education, 2012*, (2012). Washington, DC).

We found that the reading and writing currently required of students in initial credit-bearing courses in community colleges is not very complex or cognitively demanding. While the information load of texts students encounter in community colleges is considerably more demanding than of those assigned in high school, students are not expected to make much use of those texts. The requirements for writing are marginal at best and the performance levels students are expected to meet with respect to reading are in many cases surprisingly modest.

It turns out that the reading complexity of college texts used in initial courses is somewhere between the level of grade 11 and grade 12. One would think that this means that the level of the community college texts is comparable to the level of a student's high school text and would therefore present no challenge to their reading ability. But that does not seem to be the case. Two things point in this direction. First, the high failure rates that students experience in community college suggest that these texts are too difficult for many of them to handle. Second, there are an accumulating number of studies of high school texts that point to their diminished level of challenge over the past half century at the same time as the demands of college texts are holding steady or increasing.<sup>4</sup> Taken together they suggest that high school students typically confront texts that fall short of those rated at grade 11 or 12.

Our text complexity study noted that students who will be successful readers of information-rich texts written at the 11<sup>th</sup> or 12<sup>th</sup> grade level must possess the following capacities:

- The ability to read complex texts in unsupported environments;
- The capacity to process, retain and synthesize large amounts of new information;

- Significant reading experience in a wide range of content areas; and
- The ability to read and understand tables, charts, maps, lists and other documents that supplement the prose in many college texts.

Many students emerge from high school without these capacities and experiences because reading for in-depth subject matter comprehension is not formally taught in our high schools and the reading that is required more often than not demands little more than searching for basic facts as opposed to trying to make sense of complex or conflicting ideas or both. The reading that is assigned in high schools is also drawn from much less complex texts than are found in community college, particularly in college courses focusing on technical areas such as information technology and automotive technology. Texts in these fields require the ability to read and understand technical vocabulary, charts and other visual representations of physical and mechanical phenomena not typically taught in high school outside of career and technical education courses. In many cases it is not that students might not come across such material, it is that they are rarely called on to engage with it. This disconnect between high school and college reading demands is particularly troubling and suggests a need to reexamine what is taught in high school. The Common Core State Standards in English Language Arts (CCSS) address reading in history/social studies as well as science and technical subjects, and in so doing may increase the relevance of high school instruction.

While the reading complexity of first-year community college texts is between 11<sup>th</sup> and 12<sup>th</sup> grade levels, we found that community college instructors typically make limited use of the texts they assign and use many aids (e.g., *PowerPoint* presentations, videos, outlines, flashcards) to help students understand the key points of the sections of the text they are asked to read. It would appear that students' inability to read texts of the level assigned does not inhibit their success in their programs. Is this because the material in the texts is irrelevant to later success in education and careers, or because

---

<sup>4</sup> ACT, *ACT National Curriculum Survey* (Iowa City, IA: ACT, 2009). Common Core State Standards Initiative (2011). *Common Core State Standards for English Language Arts & Literacy in History/Social Studies, Science, and Technical Subjects, Appendix A: Research Supporting Key Elements of the Standards*. Washington, DC: National Governors Association Center for Best Practice and Council of Chief State School Officers.

the instructors offer workarounds, recognizing their students' limited reading ability?<sup>5</sup>

The Programme for International Student Assessment (PISA) analytical framework used by the Panel to analyze the level of reading challenge makes a distinction between retrieval tasks – those that require a reader simply to find information and make basic interpretations of it – and analytic/synthetic tasks, that require the reader to reflect on and evaluate what they have read. Overall, we found that most of what first-year community college students are required to do falls in the former category. Only the English Composition classes reliably assign tasks that require students to reflect on and evaluate what they have read.

The study also analyzed the reading and writing requirements found in tests and examinations in initial credit bearing community college courses. In this case, we found that most assessments in community colleges come in the form of multiple-choice questions that demand very little in the way of complex reading skills and no writing.

Our analysis of the writing required to succeed in initial credit bearing courses in community college revealed that most introductory college classes demand very little writing; when writing is required, instructors tend to have very low expectations for grammatical accuracy, appropriate diction, clarity of expression, reasoning and the ability to present a logical argument or offer evidence in support of claims.

To the extent that writing is required, it typically takes the form of informational writing or marshaling evidence for taking a particular course

of action tied to a course-relevant profession. For example, filling in an auto repair order form, completing a pre-school class observation form, reporting engine analysis findings, writing up treatment notes for a nursing patient, or making an argument for taking a particular action on the basis of criminal justice system data. But this kind of writing gets the most modest attention in high schools, where literary analysis plays a significant role. However, even more worrying than how the balance is struck between different forms of writing in high school is that so little writing of any kind is assigned. Across various content area classes the default is short form assignments that require neither breadth nor depth of knowledge. Furthermore, the quality of instruction, especially with regard to argument, falls far short of what students need.<sup>6</sup> The good news here is that the CCSSE has recognized this problem and set out to address it by spelling out a much more ambitious approach to teaching writing, starting in the elementary grades and extending into secondary schools. But applauding new standards is not the same as enacting them. Serious attention at the state and local level to bridging the gap between where we are and where we need to be must follow and this should include greater attention to writing in teacher education across the board.

With the exception of English Composition classes, complex writing plays a minor role in community college student exams. When writing is assigned in exams, the emphasis in grading is on the least cognitively demanding aspects of writing. At almost every turn one finds the weakness of high school writing being reinforced in community colleges when just the obverse ought to be the order of the day. Taken together this suggests that community

---

<sup>5</sup> One explanation of what is occurring is that there has been an element of “pedagogical surrender” occurring on college campuses. Where once (mid-80’s to late 90’s) they taught to “the middle,” now they teach to “the base.”

---

<sup>6</sup> Applebee, A. N. and Langer, J. A. (2011). A Snapshot of Writing Instruction in Middle Schools and High Schools, *English Journal*, 100.6” 14–27.

college could be a much more rewarding experience for students were it not for the weak preparation that precedes college and the modest expectations students encounter during their stay.

We have noted that community college instructors do not expect their students to be able to read at the level of their texts or to write very much at all, suggesting that those instructors have very low expectations for their students, expectations so low as to deny many, if not most, students the opportunity to learn skills essential to the careers they have chosen to pursue. Conversely, we have also pointed out that nothing in the high school curriculum prepares students for some of what is expected in our community colleges.

The response that many of our readers would no doubt expect from the Panel is a demand that community colleges raise their expectations for student reading and writing at least to the point that students be expected to read the texts they are given and to write material appropriate to the careers they have chosen at a level that goes beyond the simplest recall of facts to embrace the kinds of analysis expected of them on the job, and further, that the high schools be expected to prepare these students to meet such standards and to provide the foundation

skills required for their graduates to exercise the skills for which currently no foundation is provided in high school.

Yes, but a note of caution is in order. We need to bear in mind that a very large fraction of high school graduates cannot meet the very low expectations that community colleges currently have of them. The nation may have to learn to walk before it runs, which means that it is important, first, to enable our high school students to meet the current very low standards before we ratchet those standards up. Nothing in that stance, however, should prevent the high schools from providing the skills needed to do the kinds of reading and writing now demanded by our community colleges for which no foundation is currently provided. Nor should it prevent community colleges from beginning now to assign more writing in those cases in which it now assigns none or from asking students to read material which is vital to their mastery of the initial skills their future employers will require. But, as they do this, they will also have to provide the support those students may need to succeed on these tasks. The aim here must be not to raise the standards come what may, but to increase student success on more demanding tasks that are vital to their success in their chosen fields.



# II. BACKGROUND

**THIS REPORT SUMMARIZES** one of several research initiatives the National Center on Education and the Economy (NCEE) is undertaking as part of its *Excellence for All* initiative. *Excellence for All* aims to bring what are known as aligned instructional systems to American high schools. Such aligned instructional systems are characterized by: 1) programs comprised of courses that constitute a coherent core curriculum, typically consisting, at a minimum, of courses in one's native language, mathematics, the sciences, history and the arts, each of which is framed by a detailed syllabus; 2) instructional materials custom-tailored to support each curriculum; 3) teacher professional development that trains teachers to teach the curriculum and organize instruction so that the broad range of students likely to encounter it will succeed; 4) high quality examinations (typically dominated by essay and constructed response questions) that are designed to assess the extent to which the student has command of the material described in the syllabus and can apply it to unfamiliar problems; and 5) professional scoring of the examinations.

For more than 20 years NCEE has been benchmarking the national education systems that perform at the top of the international league tables and get large percentages of their students ready to be successful in college. A key finding from this research is that the nations that have overtaken the U.S. in student achievement have powerful, coherent and aligned instructional systems. This finding is no longer a secret, and in fact many researchers have converged on this conclusion. As NCEE has shared these results with states and localities it has found good numbers of them interested in putting such coherent, aligned systems into place, and in Fall 2011 they began doing so.

NCEE is now working in four states to pilot two different systems, ACT's *QualityCore* program and the University of Cambridge's International General Certificate of Secondary Education (IGCSE) program, in 39 high schools. One of the key provisions of the pilot is that students who succeed in these "lower division" (9<sup>th</sup> and 10<sup>th</sup> grade) programs and do well on their examinations will have the option to enter open admissions colleges without remediation. They could also stay in high school and complete a demanding "upper division" program that will prepare them for selective colleges and universities.

Critical to this plan is to set trustworthy qualification scores on the English and mathematics examinations that certify that students are ready to succeed in initial credit-bearing courses at open admissions colleges and universities. This study was designed to support this effort by identifying what knowledge and skills in the English Language Arts are actually required in such courses.

Within this broader effort, the specific goals for this project were:

- To describe the literacy tasks in the initial required English course and the initial courses in a variety of program areas in open admissions colleges and universities;
- To describe what the prerequisite literacy skills are for students to be successful in these courses given the demands of these courses; and
- To inform the process of setting qualification scores on the aligned instructional systems examinations to enable students to succeed in credit-bearing courses at open admissions colleges and universities, given current demands.

# III. METHODOLOGY

**IN ORDER TO ADDRESS THESE ISSUES**, NCEE collected course materials (syllabi, required texts, graded mid-term and final exams and, in some cases, graded assignments) from seven community colleges randomly selected from within each of seven states that are interested in this work. These colleges are in Arizona, Connecticut, Kentucky, Mississippi, New Hampshire, New Mexico and New York. They serve a mix of rural, urban and suburban populations and their enrollments range from 3,000 to 30,000.

The standard way of determining what students need to know and be able to do to succeed in college is to put this question to highly regarded faculty. What they usually report, however, is their sense of what would be desirable rather than what is currently needed. To make sure we are reporting on what is actually required to do the work, rather than on the aspirations of community college faculty, NCEE gathered and analyzed actual evidence to determine the reading and writing knowledge and skills needed to succeed. This was done in eight highly popular and diverse program areas (Accounting, Automotive Technology, Biotech/Electrical Technology, Business, Criminal Justice, Early Childhood Education, Information Technology/Computer Programming and Nursing), as well as the initial mathematics and English courses required by each of these programs. We did not analyze any certificate programs, only programs that led to an AA, AAS, or AS degree, or that allowed students to transfer to a four-year institution

to continue studying for a BA or BS degree. In each case, the required courses for the general track were covered in the set of courses we analyzed.

In order to analyze the literacy demands in the courses we selected (i.e., the first required English course as well as the introductory or 101 courses for each program), a panel of literacy experts drawn from community colleges as well as from four-year institutions and high schools was assembled (see the Biographical Sketches of the panel members in Appendix A).

To review and analyze the evidence, three different studies were undertaken:

- An analysis of the complexity of the texts used in the English Composition and initial introductory courses;
- An analysis of the complexity of reading tasks based on texts used in these classes in order to understand what students are asked to do with respect to their assigned reading; and
- An analysis of a sample of graded writing assignments collected from these classes in order to understand what kind of work generally receives grades of A, B and C.

# IV. FINDINGS

## *Text Complexity*

**THE FIRST READING STUDY** was an analysis of the complexity of textbooks commonly in use in entry-level community college courses, using four readability measurement tools to analyze and compare representative texts.<sup>7</sup> These measures included three of the leading quantitative tools (Flesch Kincaid, Dale-Chall and Gunning Fog) as well as the Dale-Chall qualitative tool. In order to do the qualitative analysis, a small panel of high school and community college instructors was recruited to review a selection of samples from each of eighty-six textbooks that were collected from the seven colleges in this study. The Dale-Chall qualitative tool included rubrics for each of six text types (Literature, Popular Fiction, Life Sciences, Physical Sciences, Narrative Social Studies and Expository Social Studies). The Panel was faced with a decision about the Information Technology, Auto Mechanics and Mathematics texts that did not map neatly onto any of these text types. They decided that Auto Technology was similar enough to Life Sciences to take advantage of the Life Sciences rubric but decided that Information Technology and Mathematics should be left out of this qualitative analysis as none of the rubrics fit the characteristics of the texts used in these courses.<sup>8</sup>

The study found that, across the disciplines, the textbooks present comparable and significant challenges for students who will be using them in largely unassisted environments (i.e., assigned

readings outside of class as opposed to supported readings in the classroom environment). The texts are laden with content and are otherwise characterized by extensive specialized vocabulary, sophisticated text structures and long, relatively complicated sentences. Texts in many of the disciplines studied require significant amounts of background and concept knowledge for comprehension, and complex concepts and information are often presented in tables, charts, maps and lists that supplement the prose.

Chart 1 on the next page shows the average grade level of texts on each of the four tools in each of the program areas. The Gunning Fog tool, although correlated with the other tools, shows a higher complexity level consistently across all areas as it overweighs sentence and word length as the key measure of complexity and takes less account of vocabulary and word frequency levels. As a result the analysis team decided to set the Gunning Fog measures aside and focus on the others. Among the remaining three tools the overall average level was about grade 11.5, with Criminal Justice, Biotechnology and Nursing rated as high as grade 13 and English Composition and Early Childhood Education as low as 9.5. The study noted that several of the fields analyzed are highly technical (e.g., Auto Technology and Accounting) and none of the tools available for text analysis take into account the specialized technical vocabulary and the visual representations that are typically found in these texts. Consequently, they surmised that these texts would have scored higher in complexity if these factors were taken into account and also observed that these types of texts are not found in most high school curricula.

<sup>7</sup> Specifics on the selection and application of the measurement tools are found in the full Text Complexity Report, Appendix B.

<sup>8</sup> It turned out that the absence of this data was likely of modest consequence as the findings across the three non-Gunning Fog measures tended to be quite close to one another within each program of study.

**CHART 1** *Text Difficulty Comparison: Grade Ratings for Texts in Introductory Courses in Select Programs of Study<sup>9</sup>*

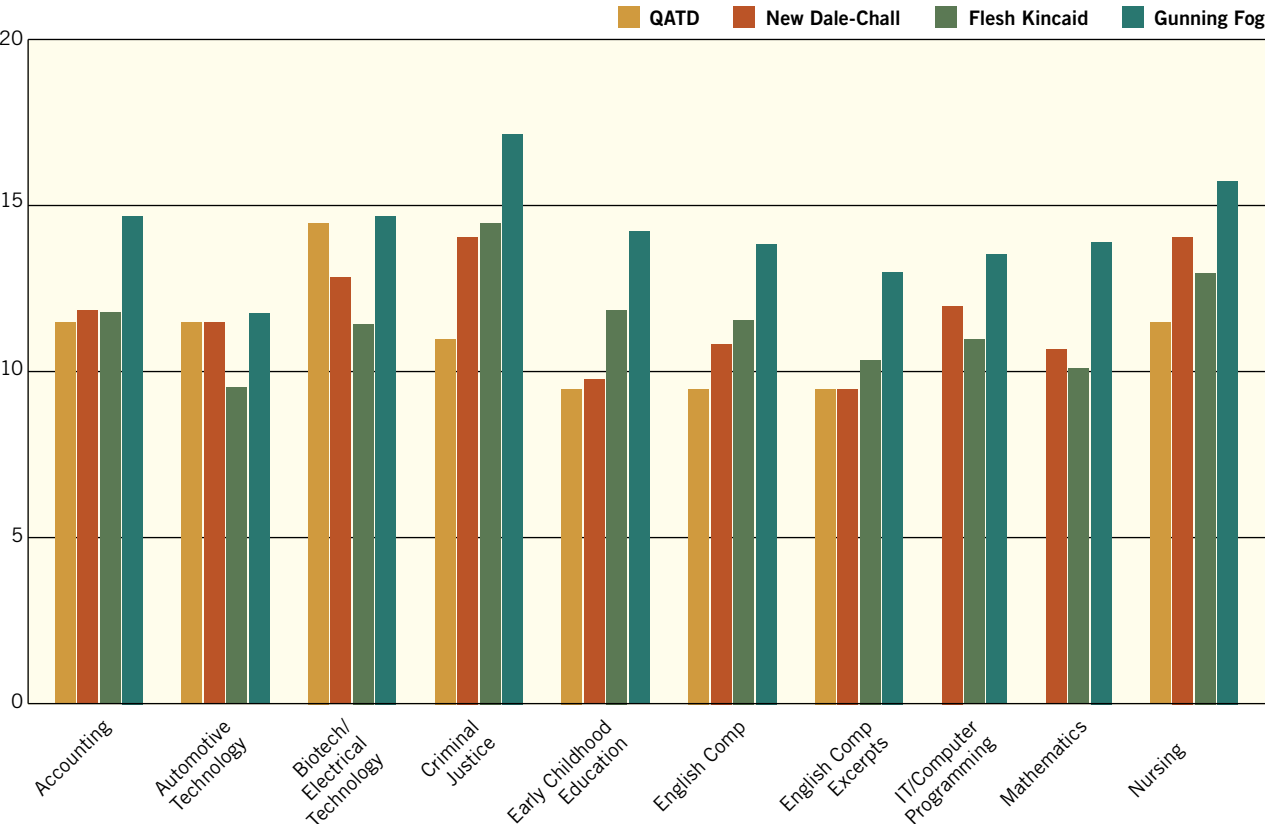

<sup>9</sup> English Composition texts were rated on two different grounds. First, they were based on the text complexity in the body of the textbook texts. Second, they were based on excerpts found in these texts (from literature, sample letters, etc.) employed to illustrate important ideas.

We concluded that students who will be successful readers of these texts must possess the following capacities:

- The ability to read difficult texts in unsupported environments;
- The capacity to process, retain and synthesize large amounts of new information;
- Significant reading experience in a wide range of content areas; and
- The ability to read and understand tables, charts, maps, lists and other documents that supplement the prose in many college texts.

Many students emerge from high school without these capacities and experiences. And it is no wonder as reading in subject matter areas is not formally taught in high schools, and the reading that is assigned is typically from much less complex texts that have seen their challenge levels decline for the past several decades at a time when the workplace is trending in just the opposite direction. Consequently, we are witnessing a difficult situation only getting worse when a sharp course correction is urgently needed. Today's high school texts also suffer by rarely including the types of charts and

visual representations common in many college texts in technical fields. Taken together this disconnect between high school and college reading demands is stark and points to reexamining what is taught in high school. The CCSS could play a constructive role in this process as they address graphic literacy as part of their *Standards for Literacy for History/Social Studies, Science and Technical Subjects* but not as part of their *Standards for English Language Arts*. This is probably as it should be as it is in the sciences, technology courses and in the social sciences and mathematics as well where there are naturally occurring authentic opportunities to provide students with more encounters with charts and visual representations of the natural and built worlds.

It is notable that college instructors in our study described different ways that they addressed the lack of preparation among their students for reading. Their strategies include creating *PowerPoints* and outlines, treating the text as a review resource for foundational information covered in class, and even making the texts optional. While these approaches can be seen as understandable, even commendable efforts to promote student learning, the end result is that many of our college students are likely left without the skills to handle the reading demands in the classes they will take subsequently, and very likely in the workplace as well.

# V. FINDINGS

## *Reading Task Complexity*

**THE SECOND READING STUDY** attempted to answer the question: what are students asked to do with what they read? To approach this question the panel looked at a set of reading tasks assigned in community college courses. Instructors were asked to supply a set of three tasks, if available, one from early in the semester, another from mid-semester, and one that they considered the most challenging of the semester. Panelists were provided with the sample of the background reading for each task (if available), a copy of the actual assignment, and samples of student work produced in response to the task (if available). They were also provided for background purposes with whatever other class materials had been supplied, including syllabi and transcripts of interviews with instructors.

The panel rated the complexity of these tasks using an adaptation of the Programme for International Student Assessment (PISA) reading scales, which organize task complexity in three categories - Retrieve and Access, Integrate and Interpret, and Reflect and Evaluate. This system of categorization was selected because it is widely known and has widespread credibility. The PISA rubric, that distinguishes seven levels of complexity within each task category, was designed to classify items on a literacy assessment, and thus it crossed two

dimensions – text burden and task burden – into a single rubric.

Given that the application here was somewhat different, a number of modifications to the PISA rubric were needed to make it usable for our purposes. First, the seven complexity levels were collapsed to five, to sharpen the distinctions between levels.<sup>10</sup> In the course of the review it became clear that the demands of the texts that framed the tasks were not related in any simple way to the complexity of the tasks themselves, but this is a built-in characteristic of the PISA scales. This led the panel to develop a context level progression scale (derived from the PISA reading scales), to reflect how demanding was the challenge of finding and understanding the information to be retrieved, integrated or evaluated. Adding this in as a second dimension independent of the challenge of the retrieval, integration or evaluation task allowed an unconstrained analysis of these two aspects of reading. We thus ended up with two rubrics to employ for this analysis (see scales on the next page).

---

<sup>10</sup> It should also be noted that the PISA rubric, elegant as it is, was designed for test items, not tasks based on lengthy or multiple passages, so some adaptation was needed to use it for these purposes.

**READING TASK COMPLEXITY SCALE (ADAPTED FROM PISA)**

Level	Access and Retrieve	Integrate and Interpret	Reflect and Evaluate
<b>5</b>	Combine multiple pieces of independent information in an accurate and precise sequence or structure.	Demonstrate a full and detailed understanding of the whole text or specific sections. Make multiple inferences, comparisons and contrasts that are both detailed and precise even in the face of unfamiliar abstract ideas or competing information. Generate abstract categories for interpretations.	Hypothesize about or critically evaluate a text, taking into account multiple criteria or perspectives, and applying sophisticated understandings from beyond the text – i.e., bringing a situation model to bear on the textual interpretation. In service of evaluation, refer to appropriate dimensions of text (e.g., genre, presupposed expertise, appropriateness for specific audiences).
<b>4</b>	Locate and possibly combine several pieces of information, some of which may be outside the main body of the text.	Demonstrate a full and detailed understanding of a text even in the face of ideas that are contrary to expectations. Construe the meaning of nuanced language. Apply criteria to examples, using high-level inference. Generate categories to describe relationships between parts of a text.	Hypothesize about a text, drawing on specialized knowledge (a situation model) and on deep understanding. Critically analyze and evaluate potential or real inconsistencies, either within the text or between the text and ideas outside the text.
<b>3</b>	Locate several pieces of information, each of which may need to meet multiple criteria. May need to combine information of different kinds (e.g., verbal and graphical).	Use text-based inferences to construe the meaning of a section of a text by taking into account the text as a whole, and/or to extract and understand categories relevant to the textual inferences.	Use formal or public knowledge (a widely shared, nontechnical situation model) to hypothesize or critically evaluate a text, thus showing accurate understanding of the text.
<b>2</b>	Locate several pieces of information, each of which may need to meet multiple criteria. Combine pieces of information within a text.	Integrate several parts of a text in order to identify the main idea, understand a relationship, or construe the meaning of a word or phrase. Compare, contrast or categorize taking several criteria into account.	Make connections or comparisons, give explanations, or evaluate a feature of a text. Demonstrate a detailed understanding of the text by relating it to familiar, everyday knowledge (a simple situation model) or a less detailed understanding that draws on less common knowledge (a more sophisticated situation model).
<b>1</b>	Locate one or more independent pieces of explicitly stated information meeting a single criterion, by making a literal or synonymous match. May make simple connections between adjacent pieces of information.	Recognize the main idea or author’s purpose in a text, making low-level inferences.	Make a simple connection or comparison between information in the text and common, everyday knowledge (personal knowledge schemas), or explain a feature of the text by drawing on personal experiences or attitudes.

## CONTEXT LEVEL PROGRESSION SCALE

Level	Description
5	Target information has all the challenges spelled out in 4 and, in addition, comes from different parts of a text and/or from different sources within a text (e.g., tables, graphs, glossaries), and is likely to be unfamiliar to the reader.
4	Target information is deeply embedded in the text, and competing information is strongly distracting. The text is long, complex and contains claims contrary to expectations, including potential or real inconsistencies.
3	Target information is not prominent in the text that may include ambiguities, is complex or long, and competing information is extensive and prominent and/or distracting.
2	Target information is relatively accessible, but the text includes competing information.
1	Target information may not be prominent in the text, but is easily found, there is little or no competing information, nor is abstruse discipline-specific knowledge required.

There were 54 tasks to be analyzed. Each was assigned to two panelists and panelists were asked to rate each task on each category of the PISA scale that fit the task. They assigned a 0 for any category they found that did not apply to a particular task. If a reading sample was provided (or if the assignment asked for students to choose a text of a certain type that panelists were familiar with, such as song lyrics or an article from a specific magazine), they were asked to assign a context level to the text as well.

If panelist ratings were divergent, they discussed their reasoning to see if they could agree on a common rating. In cases where they did not agree, a third rating provided by one of the three co-chairs became the rating of record.

Chart 2 shows the average complexity level for the analyzed tasks by program area.<sup>11</sup> The ratings average

<sup>11</sup> Ratings of zero were not included in the averages.

**CHART 2** *Average Reading Task Complexity Ratings by Type and Program*

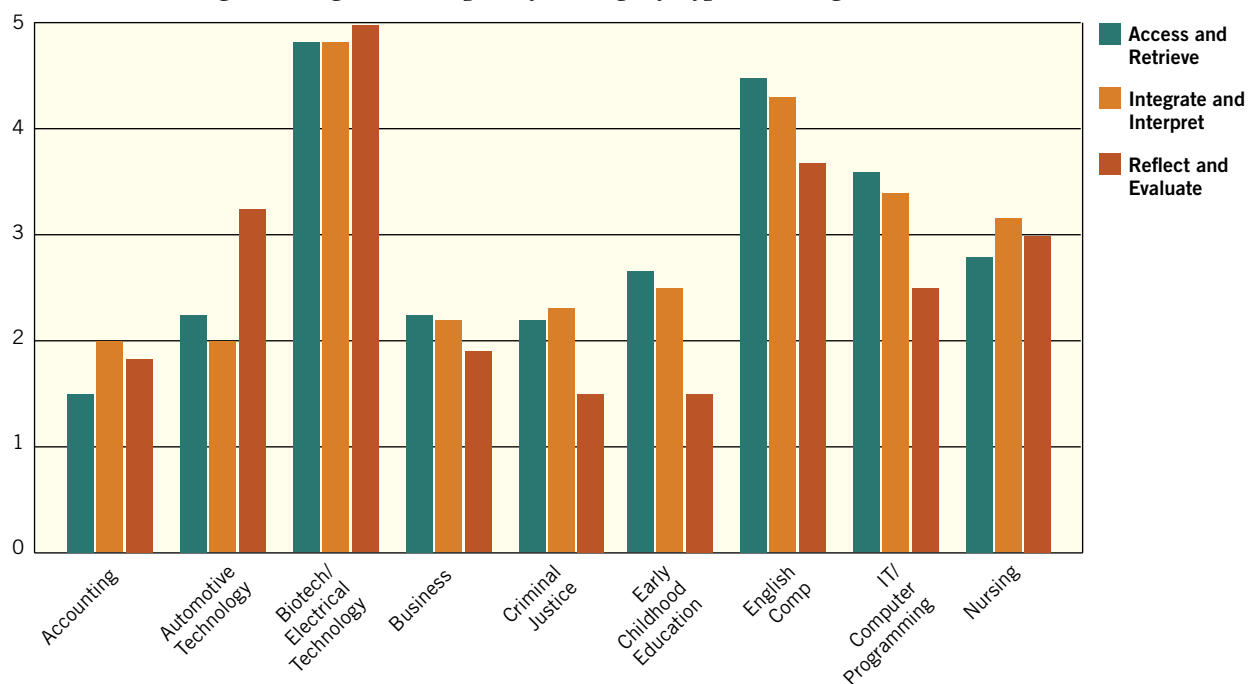



at about a level 2 of 5 save for English Composition and Biotechnology where higher ratings were found.

What this chart does not show (but what is clear from the program by program charts) is that many tasks have a Reflect and Evaluate rating of 0, with the notable exception of English Composition tasks and the few tasks collected from a Biotechnology course. This divide between the English Composition tasks and the introductory course

tasks was consistent (see Chart 3, next page). The following examples of an introductory course task and an English Composition course task are typical. Example 1 is from an IT class. It asks students to access and retrieve information from multiple sources and perhaps integrate information at a rudimentary level. But the nature of the assignment precludes deep reflection or evaluation. Example 2 is from an English Composition course. It asks the students to write a “blog entry” that analyzes the

## EXAMPLE 1

### CIS111 LAB FALL 2010 PASSWORDS

1. Think of a catchy phrase or word to encrypt into a password. Using the heuristics outlined in chapter 12 convert your password into one that another user may not guess. Use at least three changes. Obviously, do not use one that is an active password.
2. You are a manager in a business department coordinating a password security plan for the Network Administrator. Consider, password format guidelines, expirations, entry lockouts, password disclosures and any other important details. Source your resources. Write a one-page summary detailing your plan.
3. What antivirus software is installed on your computer? How do you update the software to download the newest virus protection? Do a complete system check. Answer: How long did it take? How many files were checked? Were any viruses found?

## EXAMPLE 2

### BLOG #2: ANALYSIS PRACTICE

Review the lyrics and corresponding cover art for The White Stripe’s “Blue Orchid,” Bruce Springsteen’s “Born in the U.S.A.,” and Lady Gaga’s “Paparazzi.” Select ONE of the three and complete the following steps in writing:

1. Analyze the written text and interpret the song’s meaning, referring directly to the lyrics. Do not summarize.
2. Analyze the visual image and interpret the album cover’s meaning, referring directly to the artwork. Do not summarize.
3. Analyze the relationship between the text and the visuals. In what ways is the album cover a representation or misrepresentation of the song lyrics? How do they influence one another and your experience of them? What deeper understanding do you now have about the visual and text when experience together?

*Note: You do not have to have prior knowledge of any of the artists or songs provided. In fact, you should avoid using any research or prior knowledge about the music and instead see what conclusions you can draw by studying only the text and visual with your current life experience. Your blog response must be AT LEAST 250 words long.*

**CHART 3** *Average Reading Task Complexity Ratings for English Composition Courses and Introductory Courses*

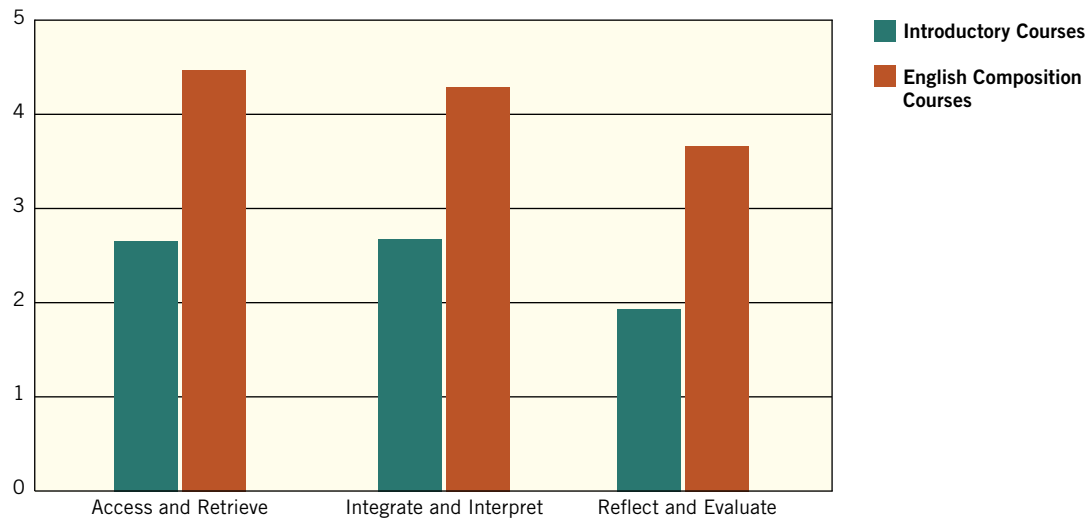

lyrics and cover art for an album and reflect on the relationship between them. This assignment clearly asks students to reflect on and evaluate information.

English Composition tasks were not only notable for including far more reflect and evaluate tasks but overall had much higher scores on the task complexity scale than the introductory courses. It was suggested by panel members that English Composition courses, unlike introductory program courses, tended to focus on analysis of text rather than straightforward information retrieval. Some of the panelists noted that the assignments for many introductory classes were not especially detailed

regarding expectations for students and left room for students to take a less analytic stance. Often the panelists said they were not clear what the instructors were expecting until they saw the student samples that instructors deemed acceptable. On the other hand, the English Composition courses often included detailed rubrics for each assignment.

To provide another angle on the demands of the reading tasks that students encounter in their first year of community college, assuming they are not in developmental courses, we have created three charts (4A, B and C, below) that display how the ratings were distributed over the PISA inspired 1–5 scale for

**CHART 4A** *Distribution of Reading Tasks by Complexity Rating for Criminal Justice Courses*

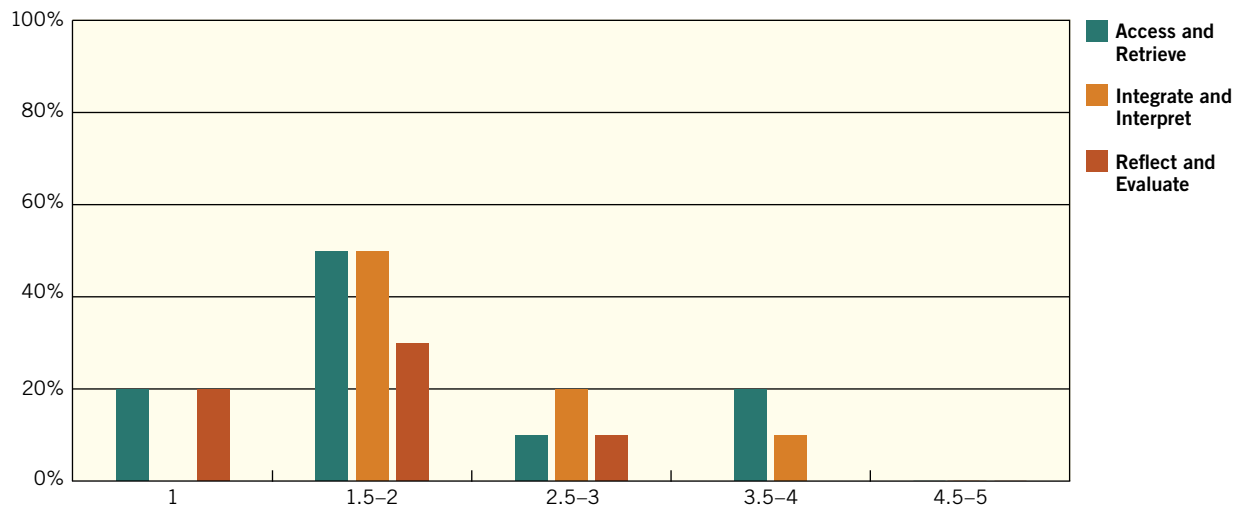

**CHART 4B** *Distribution of Reading Tasks by Complexity Rating for Early Childhood Education Courses*

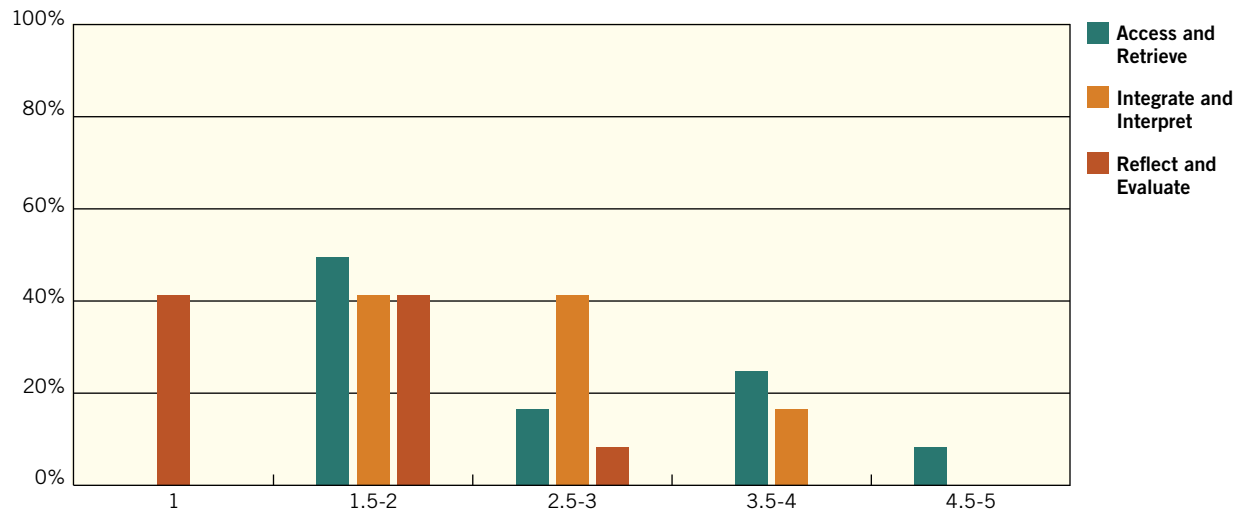

**CHART 4C** *Distribution of Reading Tasks by Complexity Rating for English Composition Courses*

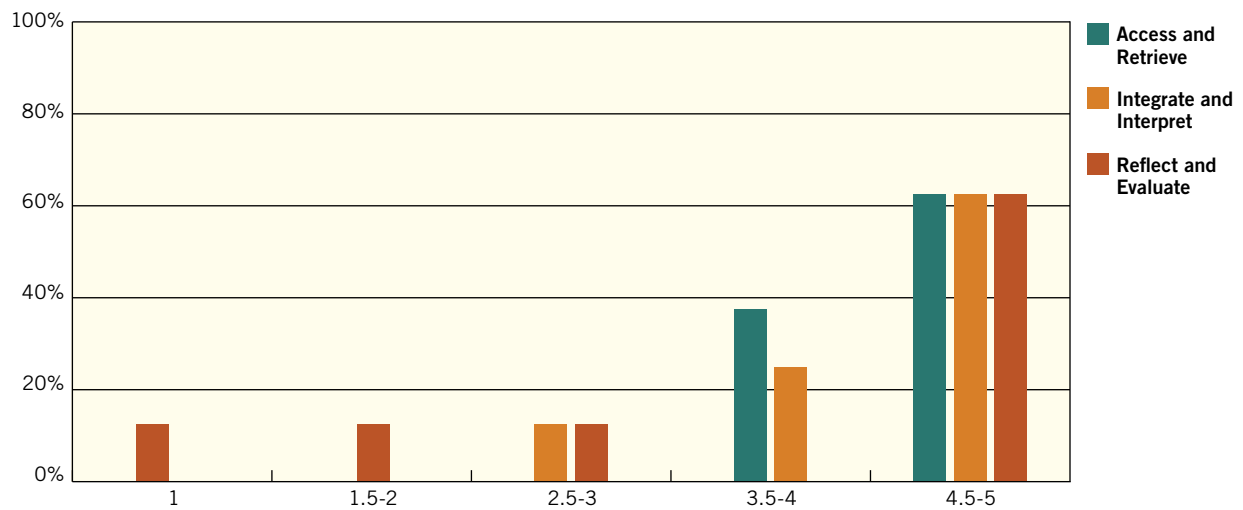

English Composition courses and two other sectors, Criminal Justice and Early Childhood Education, to provide an illustration of what was found in the courses other than English Composition.

Here again the sharp distinction between English Composition and everything else is readily apparent as are the modest demands students encounter in courses other than English Composition.

In addition to the divide between the English Composition and introductory courses, we also looked at the relationship between the context level of the texts and the complexity of the tasks. Not surprisingly, we found that tasks were more complex as the demands posed by the texts they are linked to, their context levels, increased. This is shown in Chart 5 (next page) where we see evidence of a clear trend of context level rising

as reading task complexity rises for “Access and Retrieve” and “Integrate and Interpret” tasks. The same phenomenon was also found for “Reflect and Evaluate” tasks for every interval but the first.

Overall, this analysis suggests that college students are rarely asked to do complex analyses of texts, except in English Composition classes and in a few

of the Technology and science-oriented classes. With access and retrieve and integrate and interpret tasks found in 101 courses receiving an average rating at or slightly above 2, it appears that students in these courses are hardly being challenged at all to learn what such courses could offer. This can't serve them well as they continue their studies, apply to transfer to a four-year college, or enter the workplace.

**CHART 5** *Average Reading Task Complexity Rating by Context Level*

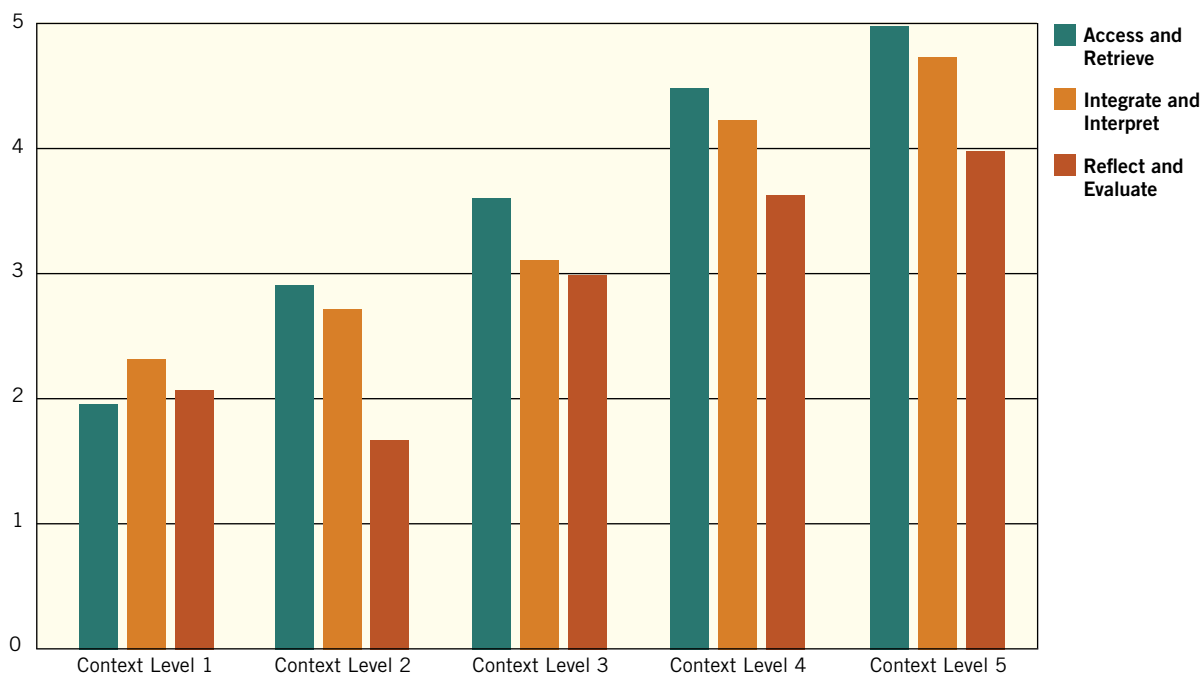

# VI. FINDINGS

## *Writing*

**FOR THE ANALYSIS** of writing demands in community college, the panel analyzed samples of student writing from English Composition classes and other classes that required writing. In this analysis of writing that is assigned to students versus other forms of writing they may undertake on their own, it is notable that there was very little writing required in several of the program areas such as Auto Technology, Nursing and Accounting. In several other areas, like Criminal Justice, Information Technology/Computer Programming and Business some classes at some colleges required papers or essays on exams but many classes required only multiple choice midterm and final exams with no written work. Overall, 14 (33 percent) of the 43 introductory courses we examined had exclusively multiple choice or true/false exams and assignments. A good many more were primarily assessed using multiple-choice items, with the addition of a very limited set of short answer questions or a single essay aimed at no more than measuring a student's ability to recall isolated concepts.<sup>12</sup>

We collected a set of varied writing samples. While the English Composition courses, from which most of the essays were collected, assign fairly traditional essays, many of the introductory courses assign specialized writing that is focused on a particular vocational area, such as a car repair form for an Auto Technology class, a case study form reporting a home visit to a preschool student in an Early Childhood Education class, or a business plan from a Business course.<sup>13</sup> In addition, across most of the program areas we also encountered writing

samples from timed final exams; but these were hard to compare to essays that students could revise and spend more time on. There was discussion of whether or not the “essay” rubrics could be used for this type of writing. It was decided the essay rubrics could be used but would be adapted as needed for different writing formats. For example, the panelists did not use the “introduction” category for a case study or technical form. There was also a question raised whether students’ handling of the content of the course carried significantly more weight than the quality of their writing to such an extent that it might distort the grading of writing from introductory program classes. This does not appear to be the case. The panelists, none of them specialists in the content area courses, likely valued writing quality more than content correctness across all the writing topics. Nonetheless, when we compared panel vs. instructor “grades” in these courses, the relationship was not different from that found for English Composition courses.

The panelists analyzed the writing samples using a rubric they developed that drew on the CCSS in English Language Arts and the Cambridge IGCSE English First Language rubric that was seen by the Panel as being especially well crafted. The Panel developed three versions of the rubric representing the types of writing most commonly assigned in college: narrative, information and argument. All three rubrics use the same categories: Introduction; Organization; Development; Vocabulary; Closure; and Other. For timed essays and other specialized formats panelists did not include any category (like Introduction) that did not apply. Each rubric includes 4 score point levels (see rubrics below).

---

<sup>12</sup> See Appendix C for a chart detailing evaluation and exam formats used by the 101 courses.

<sup>13</sup> See Appendix D for an excerpt of a business plan that received a high grade.

The three rubrics were used to serve multiple purposes. First, to understand and describe the kind and quality of writing that is being produced in community college entry-level courses. Second, to determine what level of writing is required to earn grades that signal success in college and suggest that a student has a good chance to complete a program that will yield a certificate or degree. This, in turn, promised to generate a strong signal about the literacy level students need to be college ready.

To move forward with this college-ready analyses two decisions had to be taken: what score points on the writing rubrics could be equated with college-readiness; and what instructor grades signaled college success? The answer to the first question was judged to be 2.5 on each of the 4-point scales as performance at 2 was viewed as inadequate, 3 was viewed as successful, and there is the possibility that some performances south of 3 yet north of 2 might

lead to success in subsequent courses. On the second there was general agreement that college success would most likely require student performance at a GPA of 2.75 or above. This score was based, in part, on the NCEE Technical Advisory Committee's (TAC) choice of B- as a qualification score for likely success in college. The TAC's choice of this performance level was strongly influenced by the college readiness benchmark research conducted by the College Board and ACT correlating students' scores on their college readiness exams with grades in college that would indicate a good likelihood (a 67% chance) of students achieving in their first semester at college an average GPA of B-.<sup>14</sup>

---

<sup>14</sup> Andrew Wiley, Jeffrey Wyatt and Wayne J. Camara, *The Development of a Multidimensional College Readiness Index*; (New York, NY: The College Board, 2010). Jeff Allen & Jim Scoring. *Using ACT Assessment Scores to Set Benchmarks for College Readiness*, (Iowa City, IA: ACT, 2005).

## SCORE POINTS – ARGUMENT

	Score Point 4	Score Point 3	Score Point 2	Score Point 1
<b>Introduction</b>	The introduction to the paper's claims builds context for the argument by presenting data, employing narrative, or through the use of other rhetorical strategies.	The paper at the outset engages and orients the reader by taking a stance or presenting a dilemma or conflict to be resolved.	The paper contains an introductory statement or section that makes a claim(s).	At the beginning there is an attempt to make a claim but meaning is hampered by lack of language control.
<b>Organization</b>	The organizing structure and transitions between the essay's ideas and sections enhance the essay's argument. (One idea builds upon the next; the flow of the argument is clear and logical.)	A logical organizing structure links the claim(s), reasons and evidence. Transitions effectively convey the relationships among ideas and link the major sections of the text.	Reasons and evidence are provided but may not be presented in an orderly manner that links the evidence to the claim(s). Appropriate transitions are used between paragraphs.	The overall structure is inadequate with organizational problems obscuring the central idea.
<b>Development:</b> • <b>Claims</b> • <b>Reasons</b> • <b>Evidence</b>	Sound reasons and sufficient relevant evidence support the claim. Each component is employed in support of the essay's argument. The essay may address counterarguments to its central claim.	For the most part, appropriate reasons and sufficient relevant evidence support the claim. The paper contains no extraneous information.	There is variable development of the logic line. Minimal and sometimes irrelevant material is presented.	The paper may provide a simple list that mixes facts and reasons or just lists reasons.
<b>Vocabulary</b>	The paper contains clear, appropriate and precise language. Issue specific language is used with accuracy and in a way that supports the authority of the paper's argument.	The paper contains clear, appropriate and precise language and some issue specific vocabulary.	The paper contains mostly everyday language, but also includes some precise language related to the development of the argument.	The paper contains everyday language related to the topic.
<b>Closure</b>	The concluding section attempts to synthesize the essay's ideas in a way that reinforces its central arguments or opinions.	A concluding statement or section that supports the arguments or opinions found in the essay.	A concluding statement is presented, although it may not flow logically from the argument or opinions in the essay.	The paper simply ends without attention to a conclusion or closing thought.
<b>Other</b>	Punctuation and grammar are used competently and sometimes with a flair that enhances the voice of the essay. A range of complex and varied sentence structures enhance the paper and reflect the writer's voice	Punctuation and grammar are used competently. Although there may be some distracting errors, meaning is clear. Sentence structures are for the most part complex and varied.	There may be frequent and significant errors, but they do not inhibit understanding. Simple sentences are the dominant syntactic form, although there is some evidence that the writer has tried to write more sophisticated structures without success.	The paper contains frequent and significant errors in spelling, punctuation and grammar, but some meaning is intelligible. The paper contains a minimal number of grammatically accurate sentences. Lack of language control is evident throughout.

## SCORE POINTS – INFORMATIONAL WRITING

	Score Point 4	Score Point 3	Score Point 2	Score Point 1
<b>Introduction</b>	The paper at the outset engages and orients the reader by announcing the topic; strategies for setting a context for the essay are present and integrated with the material that follows.	The paper at the outset engages and orients the reader by announcing the topic and the (perhaps general) context for what follows.	The paper contains an introductory statement that announces the topic.	The paper may provide a simple generalization about the topic or simply begin abruptly.
<b>Organization</b>	Complex ideas, concepts and information are organized into categories that reflect a solid engagement with the subject. Across the major sections of the text, ideas are connected in ways that enhance the reader's understanding.	Complex ideas, concepts and information are organized into categories. Transitions effectively convey the relationships among ideas and link the major sections of the text.	Related ideas are grouped. Appropriate transitions are used between paragraphs.	The ideas may be organized as a simple list. Ideas may be linked within sentences and paragraphs.
<b>Development</b>	The topic is developed with well-chosen, significant and sufficient details, facts, definitions or other examples. There is appropriate (to the content) and well articulated, explanation, elaboration or comparative development across the essay.	The topic is developed with significant and sufficient details, facts, definitions or other examples, and offers explanation, elaboration or comparison across the essay.	Uses facts, details, definitions, quotations or other examples to develop the topic through synthesis, explanation, elaboration or comparison, but development is uneven.	The paper is somewhat developed, but may not provide the most significant or relevant facts or examples. Expected syntheses, explanation, elaboration or comparison difficult to discern.
<b>Vocabulary</b>	The paper contains precise language and domain specific vocabulary. The domain specific language is used with control.	The paper contains precise language and domain specific vocabulary. The domain specific language is used with uneven control.	The paper contains some precise language related to the topic.	The paper contains everyday language related to the topic.
<b>Closure</b>	The conclusion presents a synthesis by logically connecting the facts and ideas addressed in the development of the essay.	The conclusion moves toward a synthesis by logically connecting the facts and ideas addressed in the development of the essay, but the logic may be less than sound, and the attempted synthesis flawed.	The paper contains a concluding statement or section.	The paper simply ends without attention to a finding, conclusion or closing thought.
<b>Other</b>	Competent use of punctuation and grammar is evident, with few if any errors. Sentence structures are complex and varied. Formatting and graphics (if included) enhance comprehension.	Competent use of punctuation and grammar is evident, although there may be some distracting errors. Sentence structures are for the most part complex and varied. Formatting and graphics may be provided to aid comprehension.	Knowledge of basic punctuation and grammar is in evidence. Although there are frequent and distracting errors, they do not inhibit understanding. Simple sentences are the dominant syntactic form although there is some evidence that the writer has tried to write more sophisticated structures without success.	There are weaknesses in spelling, punctuation and grammar, but some meaning is intelligible. The paper contains a minimal number of grammatically accurate sentences. Lack of language control is evident throughout.



## SCORE POINTS – NARRATIVE

	Score Point 4	Score Point 3	Score Point 2	Score Point 1
<b>Introduction</b>	The paper engages and orients the reader by presenting a context, by introducing a narrator or character, or by entering immediately into the action strategically or dramatically. An engaging narrative voice is immediately present on the page.	The paper engages and orients the reader by presenting a context, by introducing a narrator or character, or by entering immediately into the action strategically or dramatically. There is the presence of a narrative voice in the opening.	The paper presents a context for what is to follow and introduces a character or narrator.	The paper may provide a simple generalization about the experience or simply begin abruptly.
<b>Organization</b>	The sequencing of events is varied in ways that enhances the richness of the narrative.	Events are sequenced logically with a variety of techniques.	The sequence of events is clear.	Attempts have been made to sequence events, but control is occasionally lost.
<b>Development</b>	The use of dialogue further enriches characterization, and detailed description and effective pacing supports the development of the narrative. The presentation of events or characterization keeps the reader engaged in the story.	Narrative techniques such as dialogue, description, and pacing are used to develop events and/or characters.	Minimal descriptive details are used to develop characters and/or events; descriptive language is rudimentary, employs clichés and reflects a limited range of techniques.	An attempt may have been made to develop characters and/or events through description, but the descriptions are scant, if present at all.
<b>Vocabulary</b>	Figurative language and precise detail creates vivid images of characters and events.	Words, phrases and details that present a vivid picture of characters and events are used.	Some precise language is used to describe characters and events.	Everyday language related to characters and events is used.
<b>Closure</b>	The conclusion fulfills the expectations set by the introduction and may offer a clever twist or surprise.	The conclusion is clearly stated and follows logically from the event sequence.	A closure statement is presented related to the events in the writing.	The paper ends abruptly without a generalization about the experience or attention to a conclusion.
<b>Other</b>	Punctuation and grammar are used competently. Sentence structures are complex and varied. Formatting and graphics may be provided to enhance comprehension.	Punctuation and grammar are used competently. Although there may be some distracting errors, meaning is clear. Sentence structures are for the most part complex and varied. Formatting and graphics may be provided to aid comprehension.	Knowledge of basic punctuation and grammar is in evidence. However, there are frequent and significant errors though they do not inhibit understanding. Simple sentences are the dominant syntactic form used by the writer.	There are weaknesses in spelling, punctuation and grammar, but some meaning is intelligible. Lack of language control is evident throughout.

NCEE asked instructors to provide a range of student writing samples, including an A, two Bs and one C. When colleges graded the essays differently (e.g., high, medium or low), we created a common letter scale for all of the essays. The instructors' grades were obscured on the copies of student work the panelists used so that their scoring would not be influenced by instructor grades. It is worth noting that the majority of essays we received from colleges were argument or informational, with only one college sending narrative essays from an English Composition class.

While there was much agreement between the instructors' and the panelists' scores at the lower end of the grading scale, there was some notable disagreement at the mid-range of the scale. Chart 6 shows the difference in what the panel and the instructors considered college ready (i.e., 2.5 on the

rubrics for the panelists and a GPA of 2.75 for the instructors). While 20 percent of essays that the panel considered college ready were scored not college ready by the instructors, almost half (48 percent) of those considered college ready by the instructors were given scores of 2 or below by the panel.

Chart 7 that contrasts instructor grades with panel ratings makes this point even more starkly. Over seventy-five percent of the essays given a B by the instructors were marked 2 or below by the panel. This was an issue in particular in the argument essays, which often received Bs without including well-supported claims. No obvious pattern emerged to suggest why the panelists graded the writing aspect of the subject matter essays more harshly than did the instructors. See Example 4 (in Appendix E) for a typical case of disagreement. This essay was scored an A by

**CHART 6** *Panel Ratings of Essays Scored College Ready and Not College Ready by Instructors*

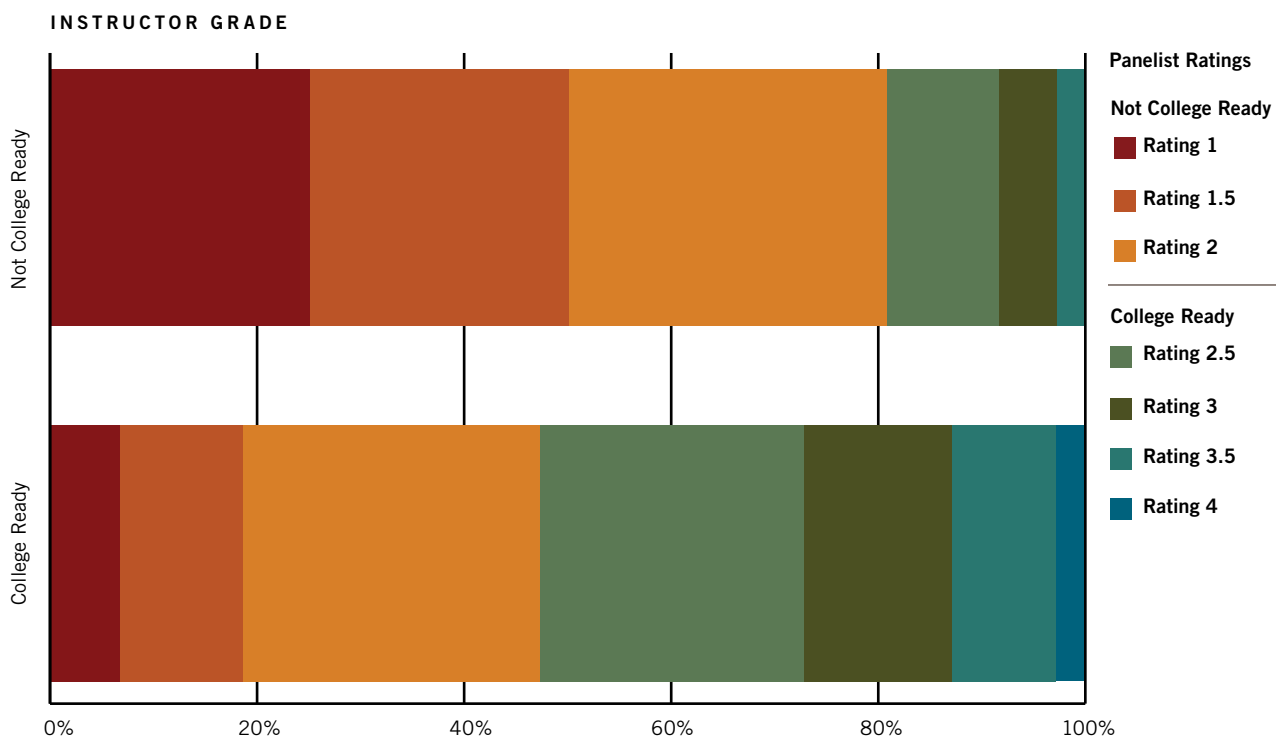

the instructor and was given a 1.5 by the panel. The panelists' notes suggest that they did not believe the author developed an argument. They agreed with the instructor that the grammar and vocabulary were reasonable. In fact, most of the essays where the panel scored the essays lower than the instructor involved similar rationales: failure of the essay to sufficiently develop the theme or argument according to the norms of that genre. It seemed that instructors sometimes gave students a pass on organization, especially if spelling and punctuation were largely correct. It should also be noted that there were many examples of agreement on the scoring, particularly at the higher scores. See Example 5 (in Appendix F) from an English class. This essay was given an A by the instructor and 3s by the panelists.

We conclude that a significant share of the writing that is considered acceptable by community college instructors is found wanting on the CCSS-based rubric, particularly writing that requires reasoned arguments supported by evidence. We also found the lack of writing in many of the programs a cause for concern. It seems that students are required to learn college writing in English Composition and then rarely asked to write again. Further, on those few occasions when they are asked to write outside of English Composition, the standard for what is considered acceptable is considerably lower than in English Composition. This deprives students of the opportunity to build a critical communications skill and also suggests that much of the assigned work required much less complex analysis and thought than might initially be suggested by the tasks at hand.

**CHART 7** *The Distribution of Panel Ratings of Student Essays by Instructor Grades*

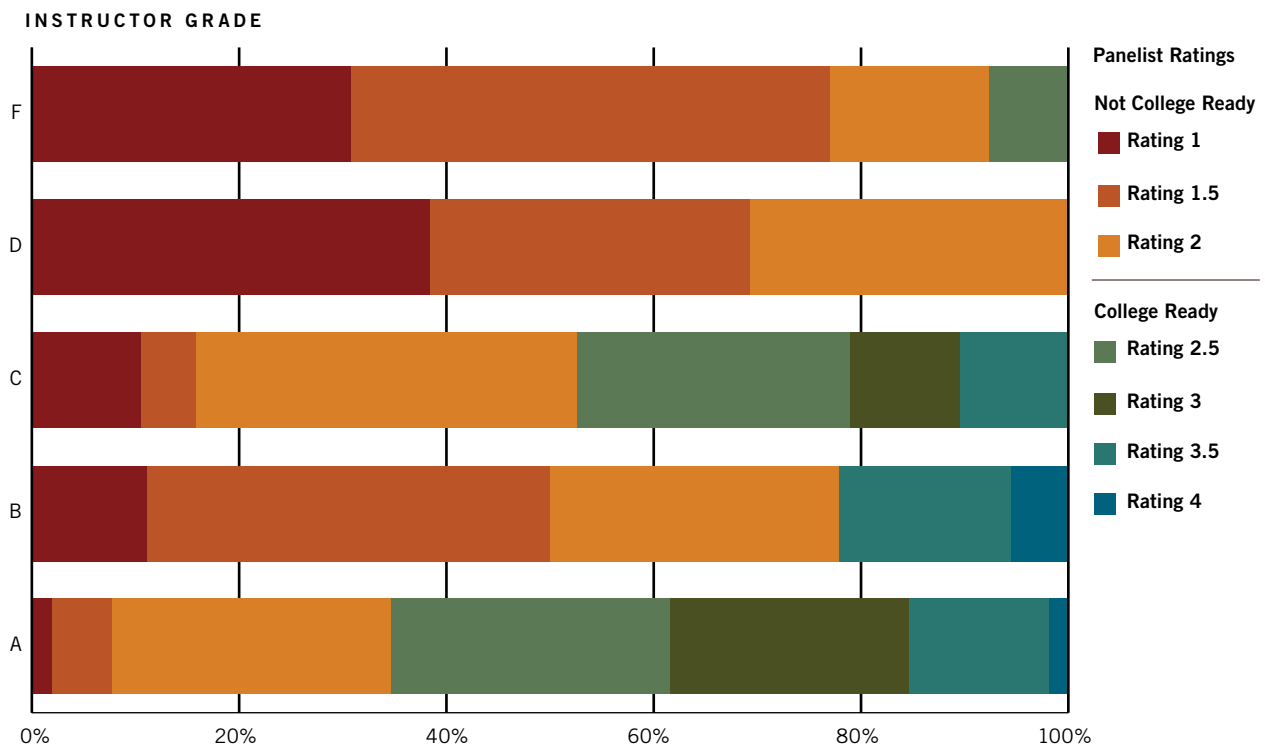

# VII. CONCLUSION

**THIS STUDY** of initial credit-bearing courses in community colleges suggests that only modest reading and writing demands are placed on students in these courses. While texts assigned include content at about an 11<sup>th</sup>–12<sup>th</sup> grade reading level, which is significantly more challenging than what they typically encounter in high school, the level of processing of those texts required by the assigned tasks is, at best, only modestly challenging in most courses. The one exception was English Composition, where high challenge levels are common. Students in the community colleges we studied are asked to retrieve information and sometimes integrate information from different texts in their writing, but only a few courses, outside of English Composition classes, ask students to reflect on and analyze what they read.

Reading and understanding technical vocabulary is a necessary skill in many of the initial credit bearing courses analyzed. While students will not likely encounter such vocabulary in high school, experience in high school with navigating texts in unfamiliar subjects, including texts that contain technical vocabulary of some type, would better prepare them for the demands of college. Consistent with this idea is identification by the CCSSE of reading in technical subjects as an important learning objective. Consequently, placing some greater emphasis on literacy with graphical representations and other technical means of communication seems like a sensible strategy for high schools to consider.

English Composition courses in our community colleges focus on teaching students the different genres of writing needed in college, but many of the courses specific to the industry clusters never give any writing assignments or assign types of writing that might help students develop the writing

skills needed for that industry. In addition, far too many of the industry classes rely primarily on multiple choice tests to assess students' command of knowledge, thus communicating that writing ability is not really needed. Aside from sending a false signal to students, this shouldn't be read as an excuse for anyone being satisfied with the meager amount of writing students are assigned in high school. In the first instance, most students will be taking an English Composition course and not giving adequate attention to writing in high school is a recipe for trouble in this course and in subsequent college courses students might take. Secondly, it is a recipe for trouble in the workforce and for participation in civil society.

For far too many students, the reading and writing done in high school do not match either the complexity level or the task types they will need in their college classes and in many career pathways. We found considerable evidence suggesting that many of the deficits of secondary school language arts instruction are being replicated rather than remedied in community college teaching. The writing tasks assigned in these community college programs are of low challenge, students' writing skills are rarely assessed, and expectations for student writing, especially of arguments, are low. Our students clearly need better instruction in constructing arguments and in laying out their thinking logically and persuasively. Such writing is at the heart of learning in college to say nothing of its essential role in many workplaces. It pushes students to gain command of the subjects they are studying, to think critically about the strengths and weaknesses of different points of view, to anticipate counterarguments, and to express their findings clearly and persuasively. The target for student competence in this aspect of literacy in both our

high schools and colleges needs to be raised if our students are to have a future with promise that they all deserve. The call of the Common Core State Standards for strengthened instruction in this area is a sound first step in this direction.

The Panel's concern with community college faculties' low expectations for the literacy levels of their students could reasonably be read as a call for raising those expectations to much higher levels. But we suspect that those expectations are as low as they are in part because so many of their incoming students cannot achieve even at these low levels. To raise the standards in our community colleges without concurrently doing what is necessary to enable our graduating high school students to meet the minimal standards currently in place would be irresponsible. Such a policy stance will only make a tough situation worse. So action on both fronts is clearly urgent. Once the nation has succeeded in bringing the literacy levels of our graduating high school students up to the current (low) standards of our community colleges, we suspect the community colleges will be as eager as anyone else to raise those standards. But we would hope they would not wait for all the evidence to roll in and use the weakness of our high schools as an excuse for inaction.

The issues revealed by this study are clearly not limited to the low standards for English literacy in our high schools. There is a striking mismatch between the kind of English literacy skills demanded for success in college and careers and the curriculum in our schools. Some of this mismatch is addressed by the new Common Core

State Standards for English literacy. As such they represent a promising first step in righting this ship, but their faithful implementation will likely be a heavy lift for our schools, and even if successfully executed offer no guarantee of fully addressing the many shortcomings identified by this study. Parallel initiatives on the community college front are also in order as is a commitment to build on this initial research to deepen our understanding of the issues at hand and to track the results of the most promising efforts that may be mounted to address the shortcomings identified here.

This report will be jarring for many. Our findings paint a very different picture of the actual standards for success in our community colleges than many have been carrying around in their heads. While we are confident that our research techniques have enabled us to produce a much more accurate picture of those standards than the nation has ever had before, we do not regard this report as the last word on the subject. We would welcome studies that include a much larger random sample of colleges, take a closer look at colleges with outstanding reputations and gather a larger sample of the materials used in courses as well as student work. We think it would be worthwhile to do case studies of community colleges, looking in more detail at classroom practices and interviewing instructors to better understand why they are not making full use of the texts they assign and gauge their own sense of their students' needs and limitations. It is not unusual for researchers, in their reports, to call for more research, but we do believe that, in this case, more research could pay large dividends.

# VIII. BIBLIOGRAPHY

ACT, *ACT National Curriculum Survey* (Iowa City, IA: ACT, 2009)

Jeff Allen and Jim Sconing. *Using ACT Assessment Scores to Set Benchmarks for College Readiness*, (Iowa City, IA: ACT, 2005).

Arthur N. Applebee and Judith A. Langer, “A Snapshot of Writing Instruction in Middle Schools and High Schools”, *English Journal*, 100.6 (2011): pp. 14–27.

Common Core State Standards Initiative, *Common Core State Standards for English Language Arts & Literacy in History/Social Studies, Science, and Technical Subjects, Appendix A: Research Supporting Key Elements of the Standards*. (Washington, DC: National Governors Association Center for Best Practice and Council of Chief State School Officers, 2011)

NCES, *Condition of Education 2012*, (Washington, DC: U.S. Department of Education, 2012).

Andrew Wiley, Jeffrey Wyatt and Wayne J. Camara, *The Development of a Multidimensional College Readiness Index*; (New York, NY: The College Board, 2010).







# APPENDICES

---

A *English Panel Biographical Sketches* ..... 30

B *Text Complexity Report*..... 36

C *Community College 101 Courses: Student Assessment Instruments  
and Test/Exam Formats Used* ..... 58

D *Example 3 - Business Plan Excerpt* ..... 64

E *Example 4 - Criminal Justice Final Exam Essay Question*..... 74

F *Example 5 - Argument Essay*..... 80

---

### Richard P. Durán – Co-Chair

Richard P. Durán is a professor at the Gevirtz Graduate School of Education, University of California, Santa Barbara (UCSB). Prior to joining UCSB, he served as a research scientist at Educational Testing Service where he conducted studies on the validity of the SAT for use in predicting Latino students' college achievement, the validity of the GRE test, and the validity of the Test of English as Foreign Language. Since joining UCSB Dr. Durán has conducted and published research on assessment validity and education policy, and educational interventions serving English language learners preparing for college. He has investigated how more effective instruction could be designed to improve the academic outcomes of culturally and linguistically diverse students who don't perform well on standardized tests and who come from low-income families, and how students' self awareness of their performance can lead to new notions of assessment. Most recently he has been conducting research on student learning in after-school computer clubs.

Dr. Durán has served as a member of the National Research Council's (NRC) Board on Testing and Assessment, and as a member of the NRC Committee on Appropriate Test Use that authored a congressionally mandated report on the validity of tests for high school graduation purposes. He currently serves as a member of the NAEP Validity Studies Panel and on the Technical Advisory Committees for the state assessment systems of Washington and California.

### Sally Hampton – Co-Chair

Sally Hampton is a Senior Fellow for Pearson-America's Choice. Recently, she served on the English Language Arts work group of the Common Core State Standards Initiative and was a Senior

Scholar at the Carnegie Foundation for the Advancement of Teaching. Previously, she was the Director of English Language Arts for the National Center on Education and the Economy and also served as its Deputy Director of Research and Development. Dr. Hampton has taught in both urban and rural classrooms, directed a National Writing Project site, and developed a K–12 research-based writing program and the staff development materials to support this program.

### Catherine E. Snow – Co-Chair

Catherine E. Snow is the Patricia Albjerg Graham Professor of Education at the Harvard Graduate School of Education. She received her PhD in psychology from McGill and worked for several years in the linguistics department of the University of Amsterdam. Her research interests include children's language development as influenced by interaction with adults in home and preschool settings, literacy development as related to language skills and as influenced by home and school factors, and issues related to the acquisition of English oral and literacy skills by language minority children. She has co-authored books on language development (e.g., *Pragmatic Development* with Anat Ninio) and on literacy development (e.g., *Is Literacy Enough?* with Michelle Porche, Patton Tabors and Stephanie Harris), and published widely on these topics in refereed journals and edited volumes.

Dr. Snow's contributions to the field include membership on several journal editorial boards, co-directorship at the origin of the Child Language Data Exchange System, and editorship for many years of *Applied Psycholinguistics*. She served as a board member at the Center for Applied Linguistics and a member of the NRC's Committee on Establishing a Research Agenda on Schooling for Language Minority Children. She chaired the NRC's Committee on Preventing Reading Difficulties in

Young Children, which produced a report that has been widely adopted as a basis for reform of reading instruction and professional development. She has also served on the NRC's Council for the Behavioral and Social Sciences and Education, and as president of the American Educational Research Association. A member of the National Academy of Education, Dr. Snow has held visiting appointments at the University of Cambridge, England, Universidad Autonoma in Madrid, and The Institute of Advanced Studies at Hebrew University in Jerusalem, and has guest taught at Universidad Central de Caracas, El Colegio de Mexico, Odense University in Denmark, and several institutions in The Netherlands.

### Paul Carney

Paul Carney is an instructor at Minnesota State Community and Technical College – Fergus Falls where he has taught courses in composition, literature, humanities, men's studies, criminology and creative writing. He has served two terms as president of the Minnesota Council of Teachers of English, is a former fellow and board member of The Minnesota Writing Project, and has participated in the Minnesota Department of Education's Quality Teaching Network in Language Arts. He also served as co-chair of Minnesota's P-16 Collaborative sub-committee on college and workplace readiness for writing and currently serves on the Minnesota Department of Education's Assessment Advisory Committee. His research interests include writing assessment, college readiness standards alignment, and general education assessment in higher education. He is the developer and coordinator of *Ready or Not Writing*, an online diagnostic program funded by the Minnesota State Colleges and Universities System. The program invites high school students to submit their writing electronically to college English instructors for assessment and feedback. In 2009 he was selected to serve on the English Language Arts Work Team for the

Common Core State Standards. In 2012 he was named Educator of the Year by the Minnesota State Colleges and Universities Board of Trustees. He received his BA from Southern Methodist University and earned Masters Degrees in English and Sociology from The University of Texas at El Paso.

### Mark W. Conley

Mark W. Conley is professor in literacy and teacher education at the University of Memphis. Previously, he was a professor at Michigan State University for 21 years, specializing in teacher education and adolescent literacy. At Michigan State, he developed a tutoring program for teacher preparation students working with 250 adolescents each year at five local urban middle schools. Since coming to Memphis, he wrote the curriculum and is a part of the team effort to implement the Memphis Literacy Corps, an intensive tutoring program to boost the literacy skills of over-age grades 4, 5 and 6 students in the Memphis City Schools. The Memphis Literacy Corps is the largest, research-based tutoring instructional intervention ever attempted in the United States, involving 900 tutors and almost 3000 children.

Dr. Conley is author of numerous articles about literacy for adolescents, appearing in the *Journal of Adolescent and Adult Literacy* and the *Harvard Educational Review*. He has written texts on adolescent literacy and assessment as well as edited several volumes summarizing research on adolescent literacy. His research focuses on literacy and subject matter connections, examining literacy demands experienced by students in content area classrooms. Most recently, he has been researching the uses of computer-based tutoring approaches for students struggling to learn complex topics in mathematics and science. He holds a certified flight instructor certificate with an instrument rating and teaches acoustic guitar building in his spare time as part of his passion for teaching and learning.

### David D. Haynes

David D. Haynes is an associate professor of English at Southern Methodist University where he is Director of Creative Writing. For the past sixteen years he has also taught in the top-rated Warren Wilson MFA program for writers in Asheville, NC. Recently, he was selected to serve on the Associated Writing Programs' board. His early career was spent in urban schools, mostly teaching middle grade students in St. Paul. He served on the planning teams for numerous school reform efforts, including the Longfellow Humanities Magnet School and the Saturn School of Tomorrow, where he served as Associate Teacher for Humanities. He has been actively involved in efforts to improve the teaching of writing and has worked to bring a variety of innovative programs to students. He had a critical role in the work of the National Board for Professional Teaching Standards (NBPTS), serving as a member of the National Board's Early Adolescence/Generalist standards committee and as a Teacher-in-Residence/Teacher Consultant. At NBPTS he worked to develop standards in the fields of social studies, vocational education, art, early childhood education and for teachers of students whose first language is not English. He also served as the designer and principal presenter for the National Board's Institutes.

Mr. Haynes is the author of six novels for adults and six books for children. *Right by My Side* was published by New Rivers Press in 1993 and was nominated for a Minnesota Book Award for best novel and also selected by the American Library Association as one of 1994's best books for young adults. *Somebody Else's Mama*, published by Milkweed Editions in 1995, was nominated for a Minnesota Book Award and was selected as the best adult fiction by Friends of American Writers in 1996. Also published in 1996 were *Heathens* (New Rivers Press) and *Live at Five* (Milkweed), which was also nominated for the Minnesota Book Award. His

children's books include the four novels in "The West Seventh Series," written specifically for reluctant middle readers. His most recent adult novel is *The Full Matilda* (Doubleday/Broadway Books). Several of his stories have been recorded for the National Public Radio Series "Selected Shorts." In 1996, *Granta Magazine* selected him as one of the Best of the Young American Novelists.

### George Hillocks, Jr.

George Hillocks, Jr. is emeritus professor of English at the University of Chicago. He received his BA in English in 1956 and began his teaching career in the Euclid (Ohio) Public Schools where he taught grades 7-12 over the next nine years. In 1959, he received his MA in English from Case Western Reserve University and a Diploma in English Studies from the University of Edinburgh. In 1963, he became the director of the U. S. Office of Education sponsored Demonstration Center for Junior High English, one of four federally sponsored demonstration centers, but the only one providing curriculum materials and on-the-spot observation of classes and discussions with teachers. In 1965, he moved to Bowling Green State University where he served as director of Freshman English Programs from 1969-1971. He received his PhD in English from Case Western in 1970.

He moved to the University of Chicago in 1971 where he served as professor of education and English language and literature, and director of the Master of Arts of Teaching English program until 2002. He has published nine books and over ninety articles. His most recent book is *Teaching Argument Writing: Supporting Claims with Relevant Evidence and Clear Reasoning* (Heinemann, 2011). He is a member of the National Academy of Education, a Fellow of AERA and the recipient of the National Conference for Research on Language and Literacy "Lifetime Distinguished Researcher Award 2010."

**Tanya M. Hodge**

Tanya M. Hodge is an English Language Arts teacher at South High School in Minneapolis. She has taught incoming freshmen language arts students through Advanced Placement literature and composition, has served as English Department Chair and mentored students in several programs, from an Advancement Via Individual Determination (AVID) Team for college-readiness, to an All Nations Team offering high expectations and strategic support for Native American students. Ms. Hodge is now the faculty advisor for the National Honor Society chapter at South High as well as the Chair of the Liberal Arts Program. She teaches Advanced Placement Language and Composition and V.O.I.C.E.S, an interdisciplinary video production class (Values, Options, Issues and Choices Explored in Society).

Earlier this year she was part of the International Leaders in Education Program (ILEP) Review Panel, scoring and ranking applications for teachers applying to participate in the program. She has previously been an ILEP fellow in Kuala Lumpur, Malaysia where she taught at St. Johns, an all-boys school. In 2010 Ms. Hodge taught an AP demonstration lesson and facilitated professional development workshops for the English department at the Beijing Royal School. She received her Bachelor of Arts in English and her Master of Education, both from the University of Minnesota.

**John McMillan**

John McMillan is the President of Inquiry By Design. He has been involved in school reform efforts on a district and national level since 1993. He has worked on secondary national literacy projects, including the Harvard PACE Project, the New Standards Project's Reference Exam and Performance Standards initiatives, and the Ramp Up to Literacy and Ramp Up to Advanced Literacy programs at the National Center on Education and the Economy. Dr. McMillan was a member of the Disciplinary Literacy team for English at the University of Pittsburgh's Institute for Learning and is currently working with Stanford University to develop Common Core State Standards-aligned performance assessments for high school English Language Arts classrooms. He holds a doctorate in English from Texas Christian University, has taught at secondary and university levels, and consults widely on various literacy-related projects.

**Danielle S. McNamara**

Danielle S. McNamara is a professor in the Psychology Department and senior scientist in the Learning Sciences Institute at Arizona State University. Her academic background includes a Linguistics BA (1982), a Clinical Psychology MS (1989), and a PhD in Cognitive Psychology (1992) from the University of Colorado-Boulder. Her research involves the study of learning and cognitive sciences and the development of educational technologies. The overarching theme of this work is to better understand cognitive processes involved in memory, knowledge acquisition, reading and writing, and to apply that understanding to educational practice by creating and testing educational technologies (e.g., Coh-Metrix, the iSTART Reading Strategy tutor, Writing Pal the writing strategy tutor).

A focus of her work is on developing methods to improve success for struggling high school students. Along those lines, she contributed to the writing of the English Language Arts College Board Standards for College Success, which had a focus on including reading strategies within the standards. She has served on the editorial boards of Discourse Processes, Memory & Cognition, and JEP:LMC and currently serves as associate editor for three journals, *topiCS*, the Cognitive Science Journal, and the Journal of Educational Psychology. She has served on numerous review panels for the Institute of Education Sciences, National Science Foundation and National Institute of Child Health and Human Development and currently serves on the National Institute of Health's standing review panel for cognition and perception. She also serves on the governing boards for the Society for Text and Discourse and the Cognitive Science Society.

### Sandra Murphy

Sandra Murphy is professor emerita at the University of California, Davis' School of Education. She has written widely on the teaching and assessment of writing and has co-authored several books on writing assessment, including *Designing Writing Tasks for the Assessment of Writing* (with Leo Ruth), *Writing Portfolios: A Bridge from Teaching to Assessment* (with Mary Ann Smith), and *Portfolio Practices: Lessons from Schools, Districts and States* (with Terry Underwood). She currently serves as a member of the editorial boards of *Research on the Teaching of English* and the *Journal of Writing Assessment*. Previously she served on the advisory board for the *Handbook for Writing* and as a member of the boards of *Assessing Writing* and *Educational Assessment*. Areas of special interest in her research and scholarship include writing assessment and its impact on teachers and curriculum, reading comprehension and critical perspectives on literacy.

Dr. Murphy is active as an educational consultant who specializes in writing assessment and the development of curriculum standards. She co-chaired the Steering Committee for the development of the new framework for the National Assessment of Educational Progress (NAEP) in Writing and served on the work group for the development of the Common Core State Standards in English Language Arts and the Common Core State Standards for Literacy in History, Social Studies, Science and Technical Writing. She received her PhD in Language and Literacy Education from the University of California, Berkeley.

### Maricel G. Santos

Maricel G. Santos is an associate professor of English at San Francisco State University, where she teaches in the MA in TESOL Program and the EdD in Educational Leadership Program. She teaches courses in second language acquisition, ESL methodology, community-based ESL, curriculum development, immigrant literacies, and research methods. Dr. Santos also is a research scholar supported by a Research Infrastructure in Minority Institutions (RIMI) grant from NIH's National Center for Minority Health and Health Disparities. Her RIMI research explores adult ESL participation as a health-protective factor in transnational immigrant communities, as well as the ways that adult ESL learners can serve as agents of change in health care. In collaboration with the California Diabetes Program, she is studying the effects of peer support networks and innovative curricula on diabetes prevention and awareness among beginning-level adult ESL learners (a study supported by a 5-year grant from the Centers for Disease Control and Prevention).

Dr. Santos has published a co-edited volume with Dr. Kathleen M. Bailey entitled *Research on ESL in U.S. Community Colleges: People, Programs, and*



Potential (2009, University of Michigan Press). She also has authored several adult ESL teacher training materials (including study circles for the National Center for the Study of Adult Learning and Literacy) and articles in *Global Health Promotion*, *Focus on Basics*, and the *Harvard Education Newsletter*. She serves on the editorial board of the *Modern Language Journal* and previously served on the board of the *Harvard Educational Review*. Prior to coming to San Francisco State, she worked on various research projects with the National Center for the Study of Adult Learning and Literacy. Dr. Santos has an EdD in Human Development and Psychology, with a focus on Language and Literacy, from the Harvard Graduate School of Education, an MA in TESOL from the Monterey Institute of International Studies, and a BA in English Literature from Swarthmore College.

### Howard B. Tinberg

Howard B. Tinberg is professor of English at Bristol Community College in Fall River, Massachusetts, where he has taught for more than two decades. His major interest over the years has been to promote the scholarship of teaching and learning, both within English studies and across disciplines. He is the author of three books, *Border Talk: Writing and Knowing at the Two-Year College* (NCTE, 1997), *Writing with Consequence: What Writing Does in the Disciplines* (Longman, 2003), and (with JP Nadeau) *Community College Writers: Exceeding Expectations* (SIU Press, 2010). He is co-editor, with Patrick Sullivan, of *What is College-Level Writing?* (NCTE, 2006) and, with Patrick Sullivan and Sheridan Blau, of *What is College-Level Writing? II* (NCTE, 2010). He is past editor of the journal *Teaching English in the Two-Year College* (published by NCTE).

Dr. Tinberg has published articles in *College English*, *College Composition and Communication*, *Teaching English in the Two-Year College*, *Pedagogy*, *ADE*

*Bulletin*, *English Journal*, *Change*, *Journal of Basic Writing* and *Community College Review*. He was the 2004 recipient of the Carnegie/CASE Community College Professor of the Year and served as a Carnegie Scholar in 2005-2006. He was recently elected assistant chair of the Conference on College Composition and Communication, the premier national organization for college and university teachers of rhetoric and composition. He received his PhD in English from Brandeis University.

BY JOHN MCMILLAN & SALLY HAMPTON

MARCH 21, 2011

With Race to the Top and the rise of the Common Core State Standards, issues related to text complexity are at the forefront of the national conversation about literacy and schooling. The pressures of international competition have amplified concerns that students across states might not experience equitable and rigorous literacy tasks featuring texts that are comparably difficult. Unfortunately, consensus determinations about levels of complexity in texts are difficult to make. The world of readability is a highly contested one so there are a large number of disparate tools available to schools, teachers, publishers, and testing companies interested in assessing difficulty or, conversely, crafting texts for specific ages or skill levels.

Almost all readability metrics insist on reducing measures of difficulty to a single score, one that accounts for some combination of vocabulary difficulty, syntactic complexity, and text structure and that purports to be useful across genres and for both literary and informational texts. The consequences of this are an inevitable reductionism because single score metrics inevitably oversimplify the nature and dimensions of difficulty. The classic example of this is found in the way most readability measures overpredict the difficulty of informational texts while underpredicting the difficulty of narrative or literary texts.

This study was undertaken to inform the work the National Center on Education and the Economy is conducting with states in the Consortium on Board Examination Systems (SCOBES). These states—which include Arizona, Connecticut, New Mexico, New York, Kentucky, Maine, Vermont, and New Hampshire—indicated strong interest in piloting board exams in their high schools. Related to the pilot, NCEE has assembled a technical advisory

committee whose work it will be to recommend cut scores on those examinations that will certify readiness for entry-level credit courses at open-admissions postsecondary institutions in the COBES states. To inform that work, we set out to conduct a survey of entry-level textbooks collected from entry level credit courses at a random set of open admissions postsecondary institutions in the eight COBES states. These were gathered from eight popular and diverse program areas. We set out to learn something about the kinds and levels of text complexity in-coming college students are likely to encounter in entry-level courses in an effort to determine where high school students need to be in terms of their ability to deal with levels and kinds of text complexity.

To accomplish this, we aimed to apply—and compare across—a core set of readability measurement tools that are widely considered as best correlating to scores on comprehension tests<sup>1</sup>. Our objective was to use this set of readability metrics to analyze and evaluate a set of entry-level postsecondary textbooks in order to inform the current conversation about the skill set and experiences high school students need to successfully transition from secondary to post-secondary education.

Determining the complexity levels of a large set of texts is no easy matter. Pinpointing the exact challenge level of materials necessary for a student to be successful in a high school biology or literature course or in an entry-level course at a technical school—for example, in an IT course or a class on automotive repair—requires negotiating several problematic factors:

---

<sup>1</sup> Different tests measure comprehension in different ways, though all measure subskills that correlate with comprehension. Measuring subskills is not the same as measuring comprehension itself. This is a critical point in the conversation about text complexity and readability.



- The specific constructs different readability formulas measure;
- Discrepancies, the result of different definitions or conceptions of seemingly straightforward constructs such as “vocabulary” and “sentence length,” that account for differences between formulas measuring the same passages;
- Determining which among the myriad of readability metrics currently represent the gold standards in measurement and why these measures are granted this status, including how they correlate with tests of reading comprehension;
- How non-prose text elements such as maps, tables, and graphs (referred to as “documents” by Mosenthal and Kirsch) influence complexity and are accounted for by readability metrics.

### On Readability Formulas

Critics of readability formulas often point to the discrepancies that exist between the disparate scores different readability formulas assign to the same texts. They contend that such discrepancies are indications of the lack of precision of the formulas. Critics also point out that these measures only take into account the surface features of a text, that they ignore features such as content and organization.

Defenders of readability formulas contend that it is not how the instruments agree or disagree with one another on a particular text, but their degree of consistency in predicting difficulty over a range of graded texts. And that while readability measures do largely focus on surface features such as vocabulary and sentence length, *these features have been shown to be the best predictors of text difficulty as measured by reading comprehension measures.*

In either case, the range of scores provided by different formulas remind us that they are not perfect predictors. They provide probability statements or, rather, rough estimates of text difficulty that, in most cases, correlate closely with one another. All readability formulas primarily account for variations in vocabulary, syntax, and text structure. The problem is that these formulas measure these constructs in often very different ways. Some examples:

- A measurement of the *vocabulary challenges* posed by a given text might address one or more of the following things *and define it as “vocabulary”*: word familiarity, word difficulty, number of letters per word, or the number of syllables per word.
- Measures of *syntactic complexity* might count the number of words per sentence, the number of words prior to the verb in the main clause, or at levels of cohesion in a text as indicated by cohesive links in a text, e.g. conjunctions, adversatives, and other transition words.
- Accounting for the difficulties posed by different *text structures* might address the predictability or accessibility of different narrative and nonnarrative structures, including the way authors indicate relationships between parts and ideas in a text and the degree to which those relationships.

Perhaps the most highly regarded tool for evaluating the difficulty level of texts for assisted instructional environments (e.g. a secondary school classroom) is the *Qualitative Assessment of Text Complexity* created by Jeanne Chall, Glenda Bissex, Sue Conrad, and Susan Harris-Sharple. This assessment supplies readers with graded passages from a range of published works, as well as a method for matching texts to those passages in order to rank texts by

difficulty. After training and calibrating, judges complete worksheets as they match new passages to those in the assessment book. There are a total of 52 passages in the QATD that are arranged by grade-level across the following six “scales”:

- Literature
- Popular fiction
- Life Science
- Physical science
- Narrative Social Studies
- Expository Social Studies.

The authors of the QATD selected passages for each scale based on the following grade-related requirements for the reader:

- Knowledge of vocabulary,
- Familiarity with sentence structure,
- Subject related and cultural knowledge,
- Technical knowledge,
- Density of ideas, and
- Level of reasoning.

Hence, the *QATD* is informed by, but goes well beyond, computer-based readability formulas although it does take into account both vocabulary and sentence length. For this reason, even though it is limited to six text type categories and a narrow band of content areas, it is widely regarded as the gold standard in the readability world.

William DuBay, in his book *Smart Language*:

*Readers, Readability, and the Grading of Text*, used the *QATD* passages to determine the overall validity of various readability formulas. To do this, he used the computer program “Readability Calculations,” available from Micro Light and Power at <http://www.micropowerandlight.com> and the 52 normed passages in the *Qualitative Assessment of Text Difficulty* tool. The results listed here show the correlations between the general-purpose readability formulas and the normed passages:

Formula	Correlation	Standard Error
Dale-Chall	.93	1.76
Flesch-Kincaid	.91	1.9
Gunning Fog	.91	2.00
McLaughlin Smog	.88	2.28
Flesch Reading Ease	.88	2.44
Fry Graph	.86	2.31
FORCAST	.66	3.61

To appreciate the work undertaken to create a valid readability measure, consider DuBay’s account of the original Dale-Chall formula (1948), DuBay’s strongest correlator and widely regarded as perhaps the most consistent and valid formula for determining readability:

The original Dale-Chall formula uses a sentence length variable plus a percentage of “hard words” not found in Dale’s long list of 3,000 easy words. It was updated in 1995 (the New Dale-Chall) and was validated against a variety of criteria, including the following:

- 32 passages tested by Bormuth (1971) on 4th to 12th-grade students.
- 36 passages tested by Miller and Coleman (1967) on 479 college students.
- 80 passages tested by MacGinitie and Tretiak (1971) on college and graduate students.
- 12 technical passages tested by Caylor et al. (1973) on 395 Air Force trainees.
- Nursing
- Business/Accounting
- Automotive Technology
- Information Technology
- Criminal Justice
- Early Childhood Education

The new version of the Dale-Chall formula (1995) was also cross-validated with:

- The Gates-MacGinitie Reading Test.
- The Diagnostic Assessments of Reading and Trial Teaching Strategies (DARTTS).
- The National Assessment of Reading Progress.
- The Spache Formula.
- The Fry Graph.
- Average judgments of teachers on the reading level of 50 passages of literature.

The new formula correlates .92 with the Bormuth Mean Cloze Scores, making it the most valid of the popular formulas. (Dubay 94-95)

### *What We Did*

For this project, we analyzed and evaluated passages selected from 86 textbooks across a selection of popular areas of study used in entry-level courses in eight community colleges and open admissions universities. The areas of study were:

- Biotech/Electrical Technology

In addition to these textbooks, we also looked at textbooks used in required initial mathematics and English Composition courses required for these programs. To evaluate the difficulty levels posed by these texts, we used the *Qualitative Assessment of Text Difficulty* and the three readability programs that, according to William DuBay, correlated most strongly with the *QATD* scale passages:

- The New Dale-Chall
- The Gunning-Fog
- Flesch Kincaid

We selected passages from each textbook for scoring in the following way: From each book, five 100 word passages were selected at random approximately one every 100 pages. Ten selections were chosen from the composition textbooks: five passages that gave directions or provided commentary and five that contained model texts for different writing types featured in a particular textbook. The rationale for sampling composition textbooks in this way was simple: directions and commentary in a composition textbook are ubiquitous and yet substantially different from the genre models students are likely to encounter elsewhere in a reader.

Passages were and saved in Microsoft Word and plain text formats. The Word documents were used for the QATD scoring and for the reporting of the scores after the readability formulas (New Dale-Chall, Flesch Kincaid, and Gunning-Fog) were run. Plain text files were required for running the readability formulas. For each readability formula, the five passages for each textbook were scored in aggregate, providing a single score that accounted for all the selections in a given text. We ran all 86 textbooks through the three computer-based readability programs.

Next, we created a subset of 46 textbooks that mapped to the scale passages in the QATD tool. (The remaining 40 texts—for example, mathematics and Information Technology texts—did not correlate closely enough to any of the QATD scales and so were not included in this portion of the study.) This subset included humanities and sciences texts and textbooks from other disciplines that utilized text structures and conceptual taxonomies similar to those in the life and physical sciences scale passages. For example, automotive technology textbooks organized information in the domain in connected sequences according to function and relationships between systems in ways quite similar to biology or anatomy; hence, they were scored using the QATD scale for Life Sciences where knowledge was similarly structured by system and function.

Next, we convened a QATD scoring session with group of educators with secondary and post-secondary experience<sup>2</sup>. The group went through an initial training and calibration seminar that focused on a shared set of texts and scales. After calibration,

---

<sup>2</sup> QATD scoring committee: Sally Hampton (America's Choice), John McMillan (Inquiry By Design), Christi Duque (Instructor, Tarrant County College, Fort Worth, TX), Manuel Alvear (High School English teacher, Country Day School, Fort Worth, TX), Adrienne Richardson (Instructional Coach, Fort Worth ISD), Faye Richardson (Secondary English and Reading teacher, Fort Worth ISD), Aimee Shimamoto Hunter (educational consultant), and Bonnie Dickinson (America's Choice).

the large group separated into three smaller groups and scored the remaining texts.

### *The Qualitative Assessment of Text Difficulty*

The QATD is a judgment-based tool used for estimating reading difficulty. It was created by Jeanne Chall and three of her doctoral students: Glenda Bissex, Sue Conard, and Susan Harris-Sharpley. The QATD was written during a time, like now, in which there was renewed enthusiasm for holistic scoring to assess student writing and to estimate the readability of texts.

The QATD presents “a method for the qualitative assessment of text difficulty—a method that relies on total impression rather than on an analysis of text features” (1). The QATD method involves mapping passages selected from texts to sets of exemplar passages that have been scaled for comprehension difficulty. The exemplar passages are sorted into six types: Literature, Popular Fiction, Life Sciences, Physical Sciences, Narrative Social Studies, and Expository Social Studies. The QATD provides scale passages for each type rated by grade level from 1<sup>st</sup> to 16+ (graduate school). The following criteria were used to scale each passage:

- Vocabulary (general and content-related)
- Sentence structure
- Prior knowledge of general and subject-related concepts, including life experiences and cultural/literary knowledge for the fiction scales.
- For the sciences and social studies scales, attention was also paid to the conceptual load or density of ideas within a passage, as well as the level of reasoning (including drawing inferences and a sense of how knowledge is

constructed in a discipline) required for a reader to comprehend the text.

To use the QATD, a reader or group of readers samples representative passages from a text they are evaluating and compares them to the scale passages in the QATD. To do this, a reader first makes a decision regarding the content of the text: Is it literature? Popular fiction? Narrative Social Studies? Expository Social Studies? If it is in the sciences, is it a life science or a physical science? Once a determination is made, the reader takes selections of approximately 100 words from the text she is evaluating and compares it to the scale passages in the QATD<sup>3</sup>. In making this comparison, the reader looks for similarities in the challenges posed by vocabulary, the length and structures of sentences featured in the text sample and the scale passage, and the level of reasoning required to comprehend the text. For example, here are **two** scale passages from the Life Sciences category of the QATD:

## LEVEL 2

Frogs and toads are amphibians without tails.

You can tell frogs apart by the pattern on their skins.

Some frogs have stripes.

The Swamp Tree frog has dark stripes down its back.

The Green Tree frog has a light stripe down each side and along its legs.

The Sheep frog has a light stripe down the middle of the back.

Which is which?

Sometimes size is a clue.

The Bullfrog is big. It can be 8 inches long. The Green frog is smaller. It gets to be only 3½ inches long.

## LEVEL 11-12

Frogs and toads have an aquatic larval stage, the familiar tadpole. The fishlike tadpole has gills which are later lost in metamorphosis. The moist skin of frogs and other amphibians contains mucous glands that assist in maintaining the moisture. Moreover, the eggs of amphibians, laid in water or other moist areas, are usually covered with a gelatinous substance. Thus amphibians remain dependent on aquatic (or at least wet) environments in many ways.

This group also shows adaptations for living on land. Most importantly, adults have lungs adapted for air breathing and are therefore no longer dependent on water for gas exchange. (It can occur through the skin when amphibians are in water.) Furthermore, the two nostrils are connected to the mouth cavity to facilitate breathing through the lungs. Almost all amphibians have two pairs of jointed appendages that permit locomotion both on land and in water. Frogs and toads also have sound-sensitive membranes (“external eardrums”) on their bodies; such specialized sense organs are essential for land dwellers, because air does not transmit sound waves as

<sup>3</sup> For this study, we took five 100 word samples from each text, the first near the beginning of the book (within the first 100 pages) and the remaining four passages approximately every 100 pages thereafter. This was a necessary variation on the QATD protocol (given the number and size of the texts in the study) which suggests that “for books of 150 pages or longer, select one sample from every 50th page. The first sample should be taken from the beginning section of the book (but not the first page), and systematically thereafter, from every 50th page” (15).

efficiently as water. Finally, amphibians have a more efficient type of circulatory system than fish, including a heart with three chambers rather than two.

Here is a selection from *Inquiry Into Life* by Sylvia S. Mader, a textbook we evaluated for the project that readers determined best matched the Life Sciences 11-12 scale passage:

A **covalent bond** results when two atoms share electrons in such a way that each atom has an octet of electrons in the outer shell. In a hydrogen atom, the outer shell is complete when it contains two electrons. If hydrogen is in the presence of a strong electron acceptor, it gives up its electron to become a hydrogen ion (H<sup>+</sup>). But if this is not possible, hydrogen can share with another atom and thereby have a completed outer shell. For example, one hydrogen atom will share with another hydrogen atom. Their two orbitals overlap, and the electrons are shared between them. Because they share the electron pair, each atom has a completed outer shell. (25)

Readers of this passage determined that the passages were comparable in terms of:

- Sentences: sentences in both passages were similar in length and complexity.
- Vocabulary: passages contained comparable amounts of difficult words and specialized terminology
- Level of reasoning: required reader to make connections between ideas that were not always explicit. For example, the lack of cohesive links between first two sentences in *Inquiry Into Life* is challenging because a reader must determine that sentences two through seven are

illustrating scenarios for the creation of covalent bonds using the hydrogen atom as a case.

- Comparable levels of idea density with similar levels of support through transition words. The shifting in Mader's text ("if this, then this," "but if this (then) this" maps to signpost words in the scale passage ("moreover," "furthermore," "finally"). In both passages a reader must use these words to track connections and relationships between sentences and ideas in order to grasp the overall coherence of the selections.

One of the challenges we faced in this project was created by the limited number of scale types in the QATD. After all, we were looking at textbooks from automotive mechanics, accounting, and criminal justice, as well as at textbooks from disciplines that mapped directly to the scale content categories: biology, narrative passages from composition readers, and selections from history textbooks. To use the QATD across a wider range of content areas, we made judgments about texts according to the ways we observed them organizing knowledge in a field. For example, we used the life sciences scale to score passages from automotive mechanics because both were "descriptive/technical," primarily factual and at the highest levels of difficulty becoming more microscopic, detailed, and technical (QATD 60). Indeed, the challenges posed by a college-level biology textbook and an automotive mechanics text used in a community college are in many ways similar: seemingly massive amounts of information, often organized by systems and in hierarchies, using precise, technical vocabulary and featuring many, often highly detailed visuals that supplement the print text. Here is a selection from Stockel, Stockel, and Johanson's *Auto Fundamentals*, a text that readers scored at 11-12 using the Life Sciences scale:

Air operated shock absorbers have hydraulic dampening systems which operate in the same



manner as those on conventional shocks. In addition, they contain a sealed air chamber, which is acted on by pressure from a height control sensor. Varying the pressure to the air chamber causes the air shock to increase or decrease its length or operating range.

Air pressure is delivered to the air shocks through plastic tubing. The tubing connects the shocks to an air valve. Air pressure for raising the shocks is generally obtained from an outside source, such as a service station compressor, and is admitted through the air valve. To deplete the shocks of unwanted air (lower vehicle curb height), the air valve core is depressed, allowing air to escape. (459)

Like the scale passage and the selection from Mader's *Inquiry Into Life* described above, this passage also features sentences of relatively long and complex construction and a large number of specialized, discipline-specific vocabulary. The passage is dense with ideas and provides some support for readers through words and phrases such as "which" and "in addition," though the burden is largely on the reader to make clear the implicit connections between sentences.

### Content Area Findings

On the whole, all of the textbooks we reviewed present significant challenges for students using them in *largely unassisted* environments. Among the greatest challenges is the development of the capacity to comprehend and process large amounts of declarative knowledge that very often appear to have distant and unclear connections to real contexts. Summaries of the findings for each discipline are provided below.

### Nursing

QATD	NDC	FK	GF
11-12	13-15 (14.075)	12.99	15.76

*Nursing textbooks were among the most difficult texts according to all of the complexity metrics.* Compared to texts in the other disciplines, nursing texts featured perhaps the widest range of text types, including documents (e.g. table and graphs), procedural passages, technical passages featuring dense and specialized concept loads, as well as descriptive passages featuring non-technical vocabulary. Technical passages also featured complex syntactic structures that also significantly escalate difficulty levels for readers. The three samples below (from *Fundamentals of Nursing*, by Harkreader, Hogan, and Thobaben) provide glimpses of procedural, technical, and descriptive (non-technical) passages:

### Procedural

Preventing needlestick injuries is a vital concern in the health care industry. The Occupational Safety and Health Administration (OSHA) mandates the use of standard precautions, which include proper handling and disposal of sharp instruments including needles. After administering an injection, discard the syringe and needle, without recapping the needle, in a rigid container that has been specifically labeled and provided for that purpose (Figure 21-8). The container should be leakproof and puncture-proof. Rigid containers are kept on medication cards in all client care settings and are wall-mounted in client rooms and treatment areas in many acute care institutions. To prevent the risk of needlestick injury, do not try to place a used syringe into an overfilled container. (459)

### Technical

The electrolytes that are most plentiful inside the cells are potassium, magnesium, phosphate, and protein. Sodium, calcium, chloride, hydrogen, and bicarbonate are the most plentiful electrolytes in the extracellular fluid. Electrolytes exert a major influence on the movement of water between compartments, on enzyme reactions, on neuromuscular activity, and on acid-base regulation. The specific functions of protein, hydrogen, bicarbonate, and other electrolytes as they affect acid-base balance will be discussed later.

It is through complex regulatory systems that the body maintains electrical neutrality. This means that the number of negative ions (anions) equals the number of positive ions (cations) in the body. Table 26-1 lists the functions and regulators of ions important in the body. (615)

### Descriptive non-technical

Personal hygiene consists of those activities that an individual undertakes to maintain body cleanliness and freedom from disease—namely bathing, oral hygiene, and hair care. It is essential to both physical and psychological well-being that hygiene needs be adequately met. If the body is not kept clean, the skin is compromised and the body can be threatened by infection or disease. The individual's comfort, self-esteem, and body image are also enhanced by cleanliness of the body. When illness or injury prevents the client from meeting self-care needs, it is your responsibility to assist clients in a culturally sensitive manner to be as independent as possible, and to provide clients with information and resources needed to resume self-care abilities to the extent that physical and mental capacities allow. (785)

### Early Childhood Education

QATD	NDC	FK	GF
9-10	9-10 (9.78)	11.87	14.24

*Early childhood textbooks were among the least difficult of the texts scored.* Concept loads were generally minimal in comparison to other disciplines that featured often significantly greater amounts of specialized vocabulary and concepts. Documents in early childhood textbooks were mostly simple lists or maps that lacked embedded elements and which required very little if any outside knowledge for comprehension.

Below is a sample passage from *Beginning Essentials in Early Childhood Education*, by Gordon and Browne. This selection exemplifies some of the typical characteristics of these texts: relatively uncomplicated sentence structures, low concept loads, and non-technical vocabulary (not to mention broad and suspect generalizations):

Gifted children have long attention spans, learn rapidly, and have good memories and advanced vocabularies. They ask a lot of questions and are able to express their ideas easily. Independent and imaginative, gifted children may be bored by normal activities. Socially, the gifted child is sought after by peers, yet may be uneasy about relationships with other children. (109)



## Automotive Technology

QATD	NDC	FK	GF
11-12	11-12	9.54	11.77

Although not the most difficult according to the computer-based programs, *Auto texts were considered to be among the most challenging by QATD judges who all agreed that prior knowledge was essential for comprehension given the amount of specialized vocabulary and the sheer amount of systems-specific information that accumulates across the different texts.* Two of the three computer-based metrics, as well as the QATD scoring group, scored these texts as upper high school level texts—though it is important to note that none of these metrics accounted for the frequency and complexity of the “documents” (e.g. maps, charts, graphs) included in these texts. Our survey of documents using the PMOSE/IKIRSCH tool rated the documents in automotive technology texts as the most complex across all the disciplines, a finding that suggests that these are college-level texts that pose significant challenges for readers. Below are sample passages from automotive texts that illustrate different characteristics of these texts:

### *Highly specialized and dense vocabulary loads*

Diodes are used where alternating current (ac) must be rectified (changed) to direct current (dc). They are used in alternators, which charges the battery and operates other vehicle systems. Alternator diodes are arranged to permit the current to leave the alternator in one direction only. Modern alternators contain six diodes to allow all of the alternator output to be processed into direct current. Diodes are also used in air conditioning compressor and other vehicle circuits.

Another type of diode is the *Zener diode*, which will not allow current to flow until a certain voltage is reached. When the triggering voltage is reached, the diode will become a conductor, allowing current to pass. Zener diodes are often used in electronic voltage regulators. (Stockel et al, 117)

### *Vocabulary loads are sometimes mitigated by simpler sentence structures*

Air operated shock absorbers have hydraulic dampening systems which operate in the same manner as those on conventional shocks. In addition, they contain a sealed air chamber, which is acted on by pressure from a height control sensor. Varying the pressure to the air chamber causes the air shock to increase or decrease its length or operating range.

Air pressure is delivered to the air shocks through plastic tubing. The tubing connects the shocks to an air valve. Air pressure for raising the shocks is generally obtained from an outside source, such as a service station compressor, and is admitted through the air valve. To deplete the shocks of unwanted air (lower vehicle curb height), the air valve core is depressed, allowing air to escape. (Stockel et al, 459)

### *Descriptive passages that assume prior knowledge for comprehension*

On older pressurized cooling systems, the cooling system could never be completely filled, since coolant expelled through the pressure cap was replaced by air when the engine cooled off. This meant that the cooling system could never be operated at full capacity. The closed cooling system, which had the addition of a coolant recovery system, provided vehicles with a cooling system that could be operated at

full capacity. The major features are a coolant reservoir and a different pressure cap design. Some systems use the coolant reservoir as part of the actual cooling system. The pressure caps in these systems are mounted on the reservoir itself. (Stockel et al, 203)

### Criminal Justice

QATD	NDC	FK	GF
11-12 (10.5)	13-15 (14.08)	14.5	17.17

Overall, the Criminal Justice texts were identified as the most challenging by the computer-based metrics. QATD judges did not agree with this assessment, although the group still scored these texts at upper high school levels. Difficult vocabulary and significant amounts of discipline-specific concepts (e.g. see below: “precedent,” “applied,” “mala prohibita,” and “mala in se”) characterize these texts, though textbook authors often made efforts to define some of these terms in context. Criminal Justice texts also frequently featured long sentences with sophisticated syntactic structures (for an example, see the last sentence in the passage below).

The present English system of law came into existence during the reign of Henry II (1154-1189), when royal judges began to publish their decisions in local cases. This allowed judicial precedents to be established and a national law to accumulate. Other judges began to use these written decisions as a basis for their decision making, and eventually a fixed body of legal rules and principles emerged. If the new rules were successfully applied in a number of different cases, they would become precedents, which would then be commonly applied in all similar cases. This unified system evolved into

a common law of the country that incorporated local custom and practice into a national code. Crimes that were mala in se, inherently evil and depraved (such as murder, burglary and arson), and were the cornerstone of the common law, were joined by new mala prohibita crimes such as embezzlement, which reflected existing social and economic conditions. (Siegel 88)

### Information Technology

QATD	NDC	FK	GF
n/a	11-12 (12)	10.99	13.54

The IT texts were not scored using the QATD tool because the judges agreed that the texts did not map well to any of the scale passages used in the QATD tool.

Like the automotive technology texts, the IT textbooks were marked by wide use of documents (e.g. charts, maps, graphs, and annotated screenshots) that required significant amounts of prior knowledge to comprehend.

Only a small number of operations, such as arithmetic and assignment operations, are explicitly defined in C + + . Many of the functions and symbols needed to run a C + + program are provided as a collection of libraries. Every library has a name and is referred to by a header file. For example, the descriptions of the functions needed to perform input/output (I/O) are contained in the header file iostream. Similarly, the descriptions of some very useful mathematical functions, such as power, absolute, and sine, are contained in the header file cmath. If you want to use I/O or math functions, you need to tell the computer where to find the necessary code. You

use preprocessor directives and the names of header files to tell the computer the locations of the code provided in libraries. Preprocessor directives are processed by a program called a preprocessor. (Malik, 75)

### *Business/Accounting*

QATD	NDC	FK	GF
11-12	11-12 (11.86)	11.8	14.7

*Sometimes dense and marked by very specialized language, difficulties in these texts were occasionally ameliorated by authors' intentional use of examples and anecdotes to illustrate difficult concepts.* Even so, selections such as those below from Weygandt, Kieso, and Kimmel's *Accounting Principles* and Rich, Jones, Heitger, Mowen, and Hansen's *Cornerstones of Financial and Managerial Accounting* still required significant amounts of background and concept knowledge for comprehension.

When the seller elects not to offer a cash discount for prompt payment, credit terms will specify only the maximum time period for paying the balance due. For example, the invoice may state the time period as n/30, n/60, or n/10 EOM. This means, respectively, that the buyer must pay the net amount in 30 days, 60 days, or within the first 10 days of the next month.

When the buyer pays an invoice within the discount period, the amount of the discount decreases Merchandise Inventory. Why? Because companies record inventory at cost and, by paying within the discount period, the merchandiser has reduced that cost. To illustrate, assume Sauk Stereo pays the balance due of \$3,500 (gross invoice price of \$3,800

less purchase returns and allowances of \$300) on May 14, the last day of the discount period. The cash discount is \$70 ( $\$3,500 \times 2\%$ ), and Sauk Stereo pays \$3,430 ( $\$3,500 - \$70$ ). The entry Sauk makes to record its May 14 payment decreases (debits) Accounts Payable by the amount of the gross invoice price, reduces (credits) Merchandise Inventory by the \$70 discount, and reduces (credits) Cash by the net amount owed. (Weygandt, Kieso, and Kimmel 200)

In addition, the trial balance is used to *prove the equality of debits and credits*. If debits did not equal credits, the accountant would quickly know that an error had been made. The error could have been in the journalizing of the transaction, the posting of the transaction, or in the computation of the balance in the ledger. However, *a word of caution is necessary* here: A trial balance whose debits equal credits does *not* mean that all transactions were recorded correctly. A trial balance will not detect errors of analysis or amounts. Sometimes the wrong account is selected for a journal entry or an incorrect amount is recorded for a transaction. In other cases, a journal entry is omitted or entered twice. As long as both the debit and credit portions of the journal entry or posting reflect the incorrect information, the debit and credit totals in a trial balance will be equal. (Rich, Jones, Heitger, Mowen, and Hansen 80)

*Biotech/Electrical Technology*

QATD	NDC	FK	GF
13-15	13-15 (12.58)	11.46	14.7

This small group of texts was comprised of only three texts: *Thinking Like an Engineer* by Gerrish, Dugger, and Roberts, *Electric Circuits* by Nahvi and Edminister, and *Electricity and Electronics* by Stephan, Bowman, Park, Sill and Ohland. All metrics scored these texts at the upper levels of difficulty. *QATD scores of these texts marked them as the most challenging of all the disciplines.* Passages (see below for a sample from *Electricity and Electronics* by Gerrish, Dugger, and Roberts) from these texts were marked by content-specific vocabulary and conceptually dense passages that sometimes featured shorter sentences that while perhaps offsetting some of the difficulty, still posed—according to three of the four metrics—post-high school level challenges for readers.

A ground fault interrupter provides protection by monitoring and comparing the current through the hot and neutral conductors. A complete circuit has the same current in the hot and neutral conductors. If a ground fault occurs, part of the current will flow to ground. When part of the current flows to ground, the comparator circuit detects an unbalanced condition between the hot and neutral currents. If the difference between the hot and neutral conductor exceeds 5 mA, the comparator circuit will energize the trip coil and cause a contact to open in the hot conductor circuit. This stops the flow of current through both the outlet and the person holding a device that is plugged into the outlet. Electric shock is stopped almost instantaneously. After the GFI is tripped, the red reset button needs to be pressed to reset the GFI trip mechanism once more. See Figure 2-22. Be aware of a condition known as nuisance trip, which occurs when there is excessive moisture in the device area. (47)

*Mathematics (including Statistics)*

QATD	NDC	FK	GF
n/a	11-12 (10.69)	10.11	13.92

The mathematics texts were not scored using the QATD tool because the texts did not map well to any of the scale passages used in the QATD tool. *The New Dale Chall and Flesch Kincaid indicated that on average the passages in math texts were in the upper high school range. Consistent with scoring in the other disciplines, the Gunning Fog rated them higher.*

The connection with the first interpretation is that if we sketch the curve  $y = f(x)$ , then the instantaneous rate of change is the slope of the tangent to this curve at the point where  $x = a$ . This means that when the derivative is large (and therefore the curve is steep, as at the point  $P$  in Figure 12), the  $y$ -values change rapidly. When the derivative is small, the curve is relatively flat and the  $y$ -values change slowly.

In particular, if  $s = f(t)$  is the position function of a particle that moves along a straight line, then  $f'(a)$  is the rate of change of the displacement  $s$  with respect to the time  $t$ . In other words,  *$f'(a)$  is the velocity of the particle at time  $t = a$ .* The speed of the particle is the absolute value of the velocity, that is,  $|f'(a)|$ .

In the following example we estimate the rate of change of the national debt with respect to time. Here the function is defined not by a formula but by a table of values. (Stewart 79)

## English Composition

	QATD	NDC	FK	GF
<b>Composition–Anthologies</b>	9-10	9-10 (9.5)	10.36	13.02

	QATD	NDC	FK	GF
<b>Composition–Texts</b>	9-10	11-12 (10.85)	11.58	13.86

Passages in composition textbooks were sorted into two kinds: anthologies and texts. This distinction seemed important given the widely different function of these passages in the books. “Anthologies” are those model texts that the authors selected as examples of writing of the different genre students were expected to write in in a composition course. These texts covered a wide range of narrative and nonnarrative genre.

“Texts” were those passages composed by the textbook authors to introduce or provide commentary or advice on writing in different genre. These passages frequently had an informal tone and were marked by a “how-to” spirit intended to support students understanding and work in a particular form. The two passages below are from Lunsford, Ruzkiewicz, and Walters’ *Everything’s an Argument*. *On the whole, composition textbooks were among the least difficult of those reviewed in this study.*

### Models

One hundred and twenty correctional officers at the Louisiana State Penitentiary at Angola and Holman State Prison in Alabama were interviewed anonymously in order to understand broad areas of the execution process. The one to two hour interviews were conducted over the summers of 2000 and 2001.

During 2000, interviews were conducted of fifty of fifty-two members of the Louisiana execution team. During 2001, fifty interviews were conducted of security officers who either work on Death Row or a part of the execution process in Louisiana. An additional twenty interviews were carried out involving correctional officers who have worked with executions in Alabama. In addition to gathering demographic and background information, a number of questions were asked about the following topics: (1) The execution experience, including roles, reactions, preparations, emotions experienced, and changes over time; (2) Stresses related to their job and methods to cope with stress; (3) Support network and influence of work on relationships; (4) Aftermath of execution experience for the officer. Based on our interviews, we were able to recreate the step-by-step process of carrying out an execution. The process was largely similar in the two states, but differed due to both situational factors with the two facilities as well as the mode of execution employed in each state. (Louisiana uses lethal injection while Alabama is one of two remaining states still employing the electric chair as its sole means of execution.) (205)

### Directions

Most readers won’t accept this assumption as principle worth applying generally. It would produce a chaotic or arbitrary world, like that of the Queen of Hearts in *Alice’s Adventures in Wonderland* (“Off with the heads of anyone I don’t like!”). So far, so good. But how does understanding warrants make you better at writing arguments? The answer is simple: warrants tell you what arguments you have to make and at what level you have to make them. If your warrant isn’t controversial, you can immediately begin to defend your claim.

But if your warrant is controversial, you must first defend the warrant—or modify it or look for better assumptions on which to support the claim. Building an argument on a weak warrant is like building a house on a questionable foundation. Sooner or later, the structure will crack. (155)

### General Findings

*Correlation of Metrics* Chall et al’s findings regarding the relative comparability of complexity ratings across the different metrics held true. In other words, there was wide agreement between all the metrics about which texts were most difficult and which posed challenges that weren’t as significant to readers. In short, our findings (summarized below in Table One) concurred with Chall’s point that

“different methods of estimating difficulty tend to produce similar results. That is, tested reading comprehension, judgments of teachers, judgments of readers, and scores from readability formulas on the same materials produced essentially the same estimates of the difficulty of the texts” (ix).

And with few exceptions, scoring using the QATD also largely mapped to ratings on the computer-based tools. Given its prevalent use in schools, it seems worthwhile to determine whether Lexile scoring of these texts would map to our findings. Among the metrics, the Gunning Fog skewed consistently high with scores two to three levels above the others. This is not an issue though, given that Gunning Fog scores largely correlated with the other metrics, e.g. texts deemed as difficult on the Gunning Fog were by and large deemed difficult on the other metrics. Gunning Fog uses a higher standard for comprehension than the other formulas so the higher scores are typical for this tool.

*Comparable Levels of Text Complexity* The difficulty levels and kinds of challenges posed by textbooks for academic and technical disciplines used in community colleges and open admissions universities *are comparable across disciplines*. This means that the amount and kind of technical vocabulary, the sentence and text structures, levels of cohesion, and the importance of background knowledge for comprehension are similar. This seems a critical point, one that is generally not acknowledged or appreciated. A few scored lower (e.g. Composition and Early Childhood), a few were higher (e.g., Criminal Justice and Nursing), but on the whole reading in all the disciplines present similar and comparable challenges to students.

*Disciplinary Demands* On the whole, all the textbooks we reviewed pose serious challenges for students, *especially in college classrooms where they will be largely unassisted*. Perhaps the greatest among these is cultivating the capacity to retain, account for, and apply large amounts of declarative knowledge that very often appear to have distant and unclear connections to real contexts. Disciplines featuring less difficult texts (e.g. Early Childhood and Composition) by and large lacked the dense passages featuring large amounts of discipline-specific vocabulary that marked the more difficult texts (e.g. Accounting, Criminal Justice, and Automotive Mechanics). Textbooks in math, computer science, and automotive mechanics featured large numbers of often very complicated “documents”—tables, graphs, maps, and lists that were used to amplify, summarize, or illustrate information provided in prose. These documents impact the complexity of a text. It is important to note that none of the standard complexity metrics have the capacity to account for document complexity. This gap obscures, for instance, the fact that automotive technology texts, which all the metrics marked as difficult but less so than other disciplines, might in fact pose significant challenges for readers unrecognized by traditional readability metrics. (During our work on this report



we conducted a cursory exploration of the PMOSE/IKIRSCH tool, a metric that allows a reader to distinguish between different “documents” and to surmise the impact they might have on readers. This work is summarized in Appendix II).

## Conclusions

Text complexity at the college level—in other words, the challenge level presented to students by entry-level textbooks—is distinguished by the following factors: heavy content, lots of specialized vocabulary, sophisticated text structures (including the relationships between parts and subparts in a text), and long and relatively complicated sentences. *All of the textbooks analyzed in this study are marked to some degree by these features.* Students who will be successful readers of these textbooks, even the ones identified as least difficult, must have the following capacities:

1. *Students must be able to read difficult texts in unsupported environments:* The search for a definitive response to the question “is this text high school level or college level according to this metric” must be informed by the following realities:
  - The biggest difference between high school and College reading is that in high school a students’ reading of text is largely supported through instructional activities and regular interactions with a teacher.
  - The reading volume in college is significantly greater in college. College students are expected to read significantly greater amounts of material without support.

The implications of these points are significant: if a text used in a community college classroom is written at a “high school level,” a student who might

be able to read that text successfully in a high school classroom where they receive instructional support that aids comprehension is likely struggle with that text in the less-supported college environment.

2. *Students must be able to negotiate or process large amounts of new information:* Students need capacities for building mental models of disciplines, for managing the conceptual loads required of that work. The density of ideas in texts in many disciplines—from Auto Mechanics to Nursing to Criminal Justice—suggests that students must be equipped with both the stamina and skills to absorb and retain large amounts of declarative knowledge and to be able—presumably—to apply that knowledge in academic, clinical or laboratory settings. High school teachers should imagine that one of their responsibilities is to help students learn to process large amounts of new material *independently*.
3. *Students must have sophisticated academic vocabularies:* A student’s ability to negotiate texts with large proportions of difficult words is often regarded as the best predictor of comprehension. Students need to be able to negotiate difficult, often technical vocabulary. It is important to note that these are not word recognition challenges in which a reader is faced with terms they would likely encounter in everyday life, but word identification challenges which often entail familiarity with concepts and knowledge contexts that would be quite disorienting to someone who lacks appropriate prior knowledge or experience.
4. *Students must read a lot and in multiple genres:* Reading volume and breadth is very important. Familiarity with text structures and size of reading vocabulary directly corresponds to success on reading achievement tests. Regular reading experience also leads to the development of a kind of stamina that would likely be important a student’s ability

to negotiate long and complicated texts. Self-selected reading is important, though the unique demands posed by nonnarrative texts suggests that schools should pay careful attention to providing students with regular and deep access to informational materials in a wide range of content areas.

5. *Students must have experience working with difficult academic texts in classroom settings:*

The implications for teaching and learning are not to be minimized. By and large, a student's ability to manage and make sense of complex texts is directly impacted by their experience of those texts in classroom settings. Teachers of all content areas should take care to make the structures of knowledge in their disciplines explicit to students. The importance of professional development for teachers focused on helping them teach students to read texts in their disciplines cannot be underestimated. One question to consider is whether a tool like Cohmetrix—which offers a much more nuanced picture of the challenges posed by a given text—could be used to help teachers spot and appreciate difficulty in texts in ways that would help them more precisely prepare students for difficult reading by equipping them with information and insights that allow them to coach students through specific kinds of difficulty. A student's experience with a text is also directly and powerfully shaped by the task or purpose for which the student is reading.

6. *Students must know how to recognize and use text structures to scaffold their comprehension:* This ability will directly impact a student's ability to comprehend complex texts in content-area classes. The extent to which students can see and understand connections between parts and subparts, paragraphs, and sentences within paragraphs directly affects their abilities to organize that information in ways that allow

them to access or apply it in both academic and real-world contexts. Students would benefit from explicit instruction about text structure, including the ways in which knowledge in different disciplines is organized and how those different organizational structures inform the way a reader moves through a text.

7. *Students must be able to read and comprehend "documents":* Document literacy is very

important. Reading texts in college is not exclusively a question of students' ability to read prose. Students must be able to read and understand the tables, charts, maps, and lists that supplement prose if they are to be successful, especially in courses or disciplines that require students to internalize large amounts of factual information. It is important to remember that the complexity of documents increases difficulty in ways that are currently not captured by most readability metrics. Our brief foray into work with the PMOSE/IKIRSCH tool suggests that the challenges posed by documents in different disciplines is not the same—textbooks in some disciplines use more and more complex versions of these non-prose texts than others. We do not report on the findings of this exercise as it was the first time we used the tool and our purpose was to see how it worked and whether it would be a useful tool for this project. We do think it was information and would recommend doing a broader scan of the texts through this lens. This work is summarized in Appendix II of this report.



**TABLE 1** *Text Difficulty Comparison: Grade Ratings for Texts in Introductory Courses in Select Programs of Study*

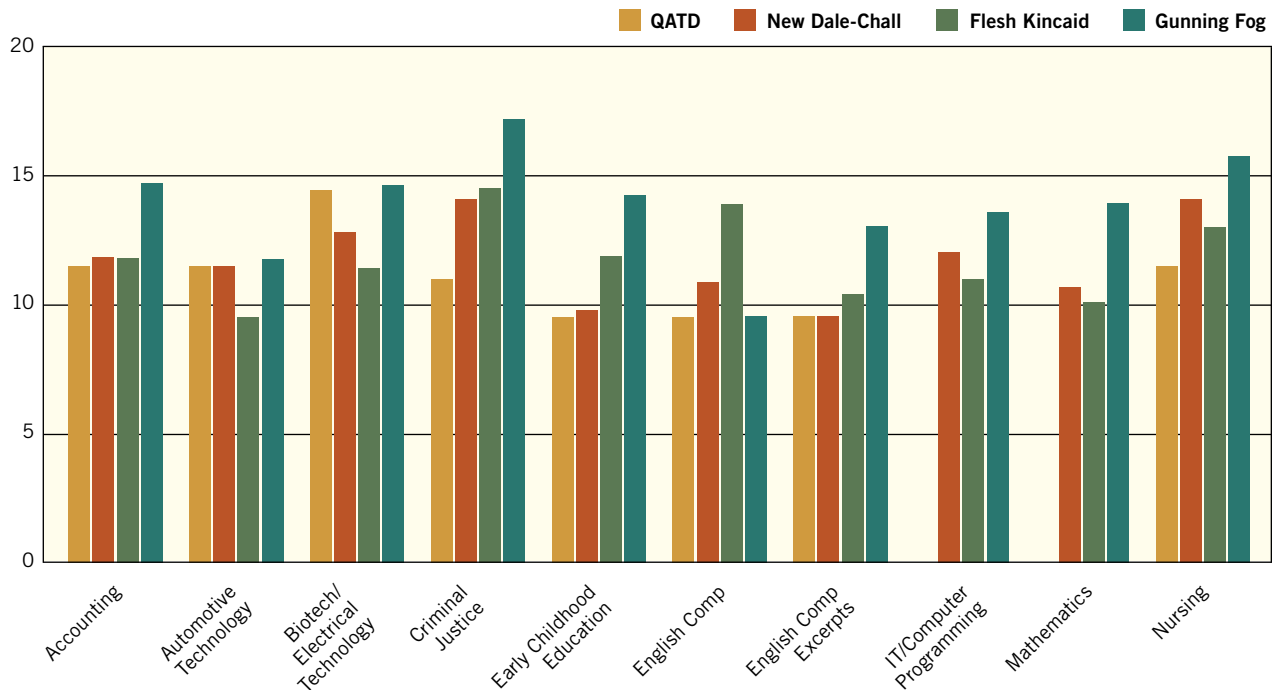

## Works Cited

Chall, Jeanne S., Glenda L. Bissex, Sue S. Conrad, and Susan Harris-Sharple. Qualitative Assessment of Text Difficulty: A Practical Guide for Teachers and Writers. Cambridge, MA: Brookline Books, 1996.

DuBay, William H. Smart Language: Readers, Readability, and the Grading of Text. Costa Mesa, CA: Impact Information, 2007.

Mader, Sylvia S. Inquiry Into Life. Boston: McGraw-Hill, 2008.

Malik, D.S. C++ Programming- From Problem Analysis to Program Design. Florence, KY: Course Technology, 2010

Mosenthal, Peter and Irwin Kirsch. 1998. "A new measure for assessing document complexity: The PMOSE/IKIRSCH document readability formula." *Journal of Adolescent and Adult Literacy*, 41, 638–657.

Siegel, Larry J. Essentials of Criminal Justice. Belmont, CA: Wadsworth, 2011.

Stewart, James. Essential Calculus. Florence, KY: Cengage, 2011.

Stockel, Martin W., Martin T. Stockel, and Chris Johanson. Auto Fundamentals. Tinley Park, IL: Goodheart-Willcox, 2005. Weygandt, Kieso, Kimmel. Accounting Principles. Hoboken, NY: Wiley, 2008.

## APPENDIX 1 Individual Text Tables

*Automotive Technology*

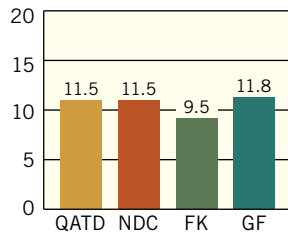

*Business/Accounting*

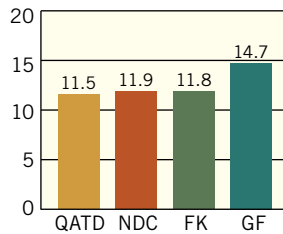

*Criminal Justice*

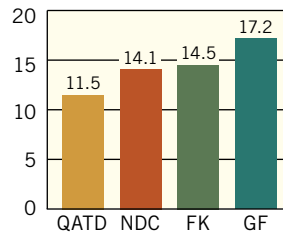

*Early Childhood Education*

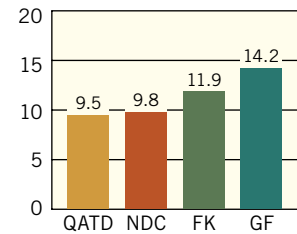

*English Composition - Anthologies*

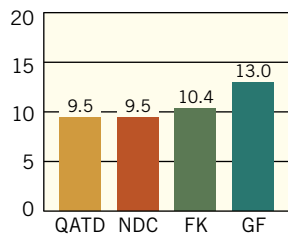

*English Composition - Texts*

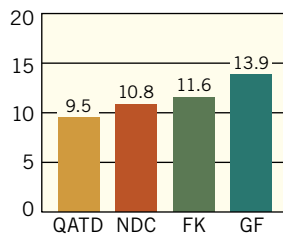

*IT*

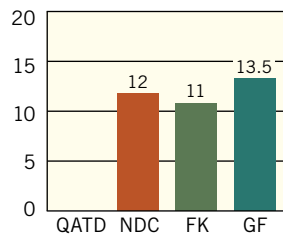

*Mathematics*

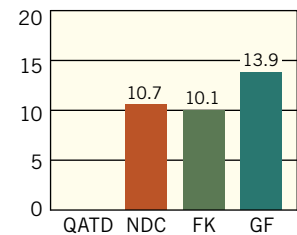

*Nursing*

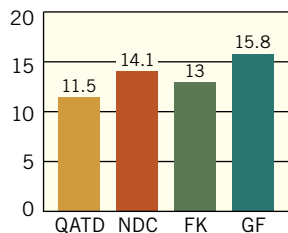

*Biotech/Electrical Technology*

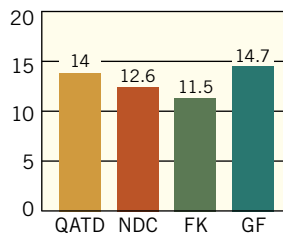

## APPENDIX 2 Documents and Text Difficulty

During another meeting, we used the PMOSE/IKIRSCH Document Readability formula to score graphics selected from a small sampling of textbooks (one to two texts per subject area, not including mathematics) from each discipline.

The PMOSE/IKIRSCH Document Readability Formula offers a way to measure and compare print material *not* written in prose format. The rationale for using the PMOSE/IKIRSCH tool was that all metrics of text difficulty are defined (and limited)

by the constructs they define and measure. Most readability formulas ignore one of the most pervasive characteristics of textbooks: the tables, charts, graphs, maps, and lists that Mosenthal and Kirsch call “documents.” According to Mosenthal and Kirsch, documents are “print materials structured as lists, charts, or graphic displays.” These graphics pose additional challenges for readers, challenges that are the result of density and structure. The PMOSE/IKIRSCH tool rates a text via three different criteria:

1. Structure: What is the design of the document? Different structures or displays (list, table, pie

FIGURE ONE Document from Auto Fundamentals, by Stockel, Stockel, and Johanson

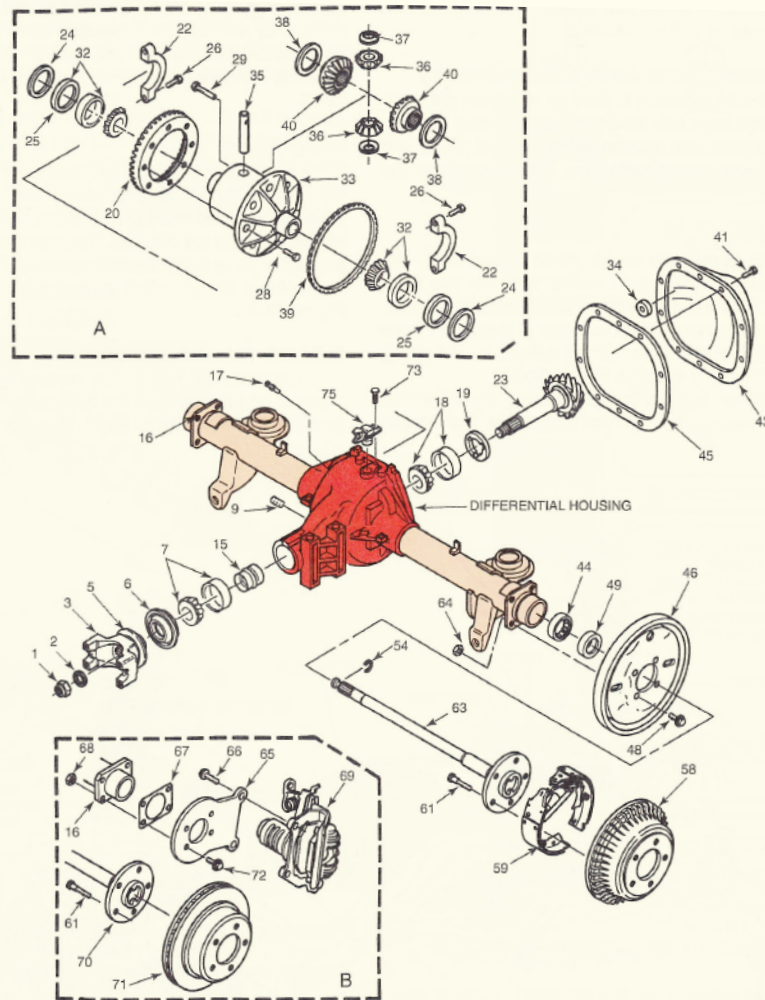

**Figure 22-29.** An exploded view of a semi-floating, hypoid type, rear axle assembly. This unit has an integral ring and pinion carrier (differential) housing. A—Exploded view of the differential assembly. B—Exploded view of the optional disc brake assembly. 1—Differential drive pinion gear nut. 2—Differential drive pinion gear washer. 3—Differential drive pinion gear yoke. 5—Differential drive pinion gear dirt deflector. 6—Differential drive pinion gear seal. 7—Differential drive pinion gear outer bearing assembly. 9—Rear axle housing drain plug. 15—Differential drive pinion gear spacer. 16—Rear axle housing assembly. 17—Rear axle vent. 18—Differential drive pinion bearing assembly. 19—Shim differential drive pinion gear. 20—Gear differential ring. 22—Differential carrier bearing cap. 23—Differential drive pinion mounting gear. 24—Differential bearing shim. 25—Differential bearing spacer. 26—Differential bearing cap bolt/screw. 28—Differential ring gear bolt/screw. 29—Differential pinion gear shaft bolt/screw. 32—Differential bearing assembly. 33—Differential case. 34—Rear axle housing chip collecting magnet. 35—Differential pinion gear shaft. 36—Differential pinion gear. 37—Differential pinion gear thrust washer. 38—Differential side gear thrust washer. 39—Rear wheel speed sensor reluctor wheel. 40—Differential side gear. 41—Rear axle housing bolt/screw. 43—Rear axle housing cover. 44—Rear axle shaft bearing assembly. 45—Rear axle housing cover gasket. 46—Rear brake backing plate. 48—Rear axle housing bolt/screw. 49—Rear axle shaft bearing seal. 54—Rear axle shaft lock. 58—Rear brake drum. 59—Rear brake assembly. 61—Rear wheel bolt/screw. 63—Rear axle (drum brake assemblies) shaft. 64—Rear brake backing plate nut. 65—Rear brake caliper assembly plate. 66—Caliper assembly mounting bolt/screw. 67—Axle tube flange shim. 68—Rear brake caliper mounting plate nut. 69—Rear brake caliper assembly. 70—Rear axle (disc brake assemblies) shaft. 71—Rear brake rotor. 72—Rear brake backing plate bolt/screw. 73—Sensor plug mounting bolt/screw. 75—Wheel speed sensor assembly. (Pontiac)

chart, maps) are given different scores according to overall difficulty and sophistication: are they simple lists? Combined lists? Intersecting lists? Nested lists?

2. *Density*: How many titles and items are presented to the reader in the document?
3. *Dependency*: Does the reader need to look outside the document for important information required to make sense of the document?

The PMOSE/IKIRSCH tool is designed to help a reader determine the complexity of a given document by using a simple point system for each of the criteria above. Figure One and Figure Two below are examples of documents that can be scored using the PMOSE/IKIRSCH Document Readability Formula. Both are examples of print materials that are not in sentence and paragraph format.

**FIGURE TWO** *Document from Introduction to Early Childhood Education, by Marian Marion*

### **FIGURE 10.5** *Guiding Principles of Early Childhood Curriculum Development*

**Principle 1:** Plan a curriculum reflecting all developmental domains

**Principle 2:** Develop a curriculum with intellectual integrity and regarded as appealing and important to children

**Principle 3:** Plan a comprehensive and integrated curriculum focusing on recognized content areas

**Principle 4:** Plan a curriculum encouraging children's social interaction

**Principle 5:** Plan a curriculum with appropriately challenging and novel learning activities

**Principle 6:** Plan a curriculum to meet the needs of all children

Figure One is an example of a map that contains a large number of nested labels. It is not uncommon to see many documents like this in an automotive mechanics textbook—or for that matter in a biology or anatomy textbook. According to the PMOSE/IKIRSCH tool, one of the things that makes this document particularly difficult is the sheer number of labels and items in the map. In addition, the map requires that the reader possess a deep subject-specific knowledge-base to make sense of the map.

This also increases the complexity of the document. Our readers determined that this document's complexity level was "high" according to the PMOSE/IKIRSCH scale—a scale that ranged from "Very Low" to "Very High." Figure Two, on the other hand, received a score of "Very Low." It has a simple list structure and features only a few items and labels and does not require discipline-specific content knowledge for comprehension.



## C Community College 101 Courses: Student Assessment Instruments and Test/Exam Formats Used

The evaluation instruments that are listed here are drawn from each course's syllabus, with each row representing a different course at a different community college. The weight each instrument is assigned in the determination of a student's final grade is captured in the percentage that appears adjacent to each one.

### ACCOUNTING

Student Assessment Instruments	Test/Exam Formats Used
Average of homework marks Average of 4 multi-chapter tests, midterm exam and final exam*	Tests/exams are multiple choice and constructed response
Quizzes (15%) Homework (15%) 2 Exams (30%) Final (40%)	Exams are multiple choice and constructed response
4 Multi-chapter exams Final exam Challenge problems*	Exams are multiple choice and constructed response
Final exam and multi-chapter tests (48%) Single chapter quizzes (18%) Textbook materials (16%) Group project (12%) Class participation (6%)	Tests/exams are multiple choice
Exams 1-3 (60%) Final exam (25%) Class participation (10%) Assignment (5%)	Tests are multiple choice and constructed response
Group exercises, quiz and project (30%) Homework (25%) 3 Chapter exams (10% each)	Final exam and quiz are multiple choice
Quizzes, homework, projects Midterm exam Final exam*	Final exam is multiple choice and constructed response

\*Weighting of instruments unknown

\*\*As presented in the syllabus, does not add to 100%.

**AUTO TECHNOLOGY**

Student Assessment Instruments	Test/Exam Formats Used
Homework (10%) WorkKeys Assignment (5%) Communication exercise (5%) Lab exercises (30%) Quizzes (10%) Midterm exam (10%) Written final exam (10%) Hands-on final exam (20%) Portfolio (5%)*	Quizzes and exercises are constructed response or short activities Final written exam is constructed response and multiple choice
Tests (50%) Daily grade which includes homework and in-class work (25%) Final Exam (25%)	Tests/exams are multiple choice
Quizzes and exams (40%) Homework (10%) Labs (40%) Research paper (10%) Class participation (+/- 10%)**	Final exam is true/false, multiple choice and essays

**BIOTECH/ELECTRICAL TECHNOLOGY**

Student Assessment Instruments	Test/Exam Formats Used
Exams (40%) Lab reports and practicals (30%) Homework and quizzes (15%) Student project (10%) Notes and notebooks (5%)	Exams are multiple choice, constructed response, and essay
Tests/exams* Other instruments - unknown	Test/exams are multiple choice and fill in the blank

**BUSINESS**

Student Assessment Instruments	Test/Exam Formats Used
Midterm exam (30%) Final exam (40%) Oral presentations (15%) ePortfolio (5%) Overall (participation, homework) (10%)	Final exam is multiple choice and essay

\*Weighting of instruments unknown

\*\*As presented in the syllabus, does not add to 100%.

## C Community College 101 Courses: Student Assessment Instruments and Test/Exam Formats Used

Student Assessment Instruments	Test/Exam Formats Used
Quizzes and exams (50%) 3 Projects (30%) Homework (20%)	Final exam is multiple choice
Quizzes (25%) Team project (20%) 5 Tests (40%) Participation (15%)	Quizzes and tests are multiple choice
Tests (30%) Final exam (40%) Project (30%)	Format of tests/exams unknown

### COMPUTER PROGRAMMING

Student Assessment Instruments	Test/Exam Formats Used
Final exam (20%) Midterm midterm (20%) Quizzes (20%) Homework (15%) ePortfolio (15%) Participation (10%)	Midterm exam is a paper Final exam is a programming assignment
Quizzes (20%) Assignments (30%) Participation/homework (10%) Midterm exam (15%) Final exam (25%)	Midterm exam and final exam are constructed response

### CRIMINAL JUSTICE

Student Assessment Instruments	Test/Exam Formats Used
3 tests (75%) Final exam (25%)	Tests/exams are multiple choice.
Assignments (30%) Class participation/papers (20%) Midterm exam (20%) Final exam (20%) WorkKeys pretest (10%)	Exams are true/false and multiple choice



Student Assessment Instruments	Test/Exam Formats Used
Midterm (25%) Final exam (25%) Term paper (15%) Syllabus test (4%) Presentation (4%) Quizzes (8%) Participation (10%)**	Final exam is multiple choice
2 Exams (20%) Final exam (30%) 3 Papers (30%)**	Final exam is multiple choice, short answer, and essay
Midterm exam (25%) Final exam (25%) 2 Assignments (40%) Participation (10%)	Final exam is short answer and essay
Chapter tests (40%) Final exam (20%) In-class assignments (20%) Quizzes/other (20%)	Final exam is multiple choice and essay
Tests (40%) Discussion assignments (30%) Group project (20%) Attendance/participation (10%)	Tests are multiple choice and short essays

### EARLY CHILDHOOD EDUCATION

Student Assessment Instruments	Test/Exam Formats Used
Attendance and class participation (24%) Observations of early childhood classrooms (20%) Self-assessment (6%) Class presentations (15%) Journal reflections (15%) Midterm review (10%) Final review (10%)	Format of midterm and final review unknown
Fieldwork Tasks (25%) Quizzes (20%) Orientation training for Childhood Development Associate (CDA) certificate (7.5%) CDA Portfolio (autobiography, competency statement and collection of resources) (30%) Personal philosophy of education (2.5%) Class participation (10%)	Format of quizzes unknown

*\*\*As presented in the syllabus, does not add to 100%.*

## C Community College 101 Courses: Student Assessment Instruments and Test/Exam Formats Used

Student Assessment Instruments	Test/Exam Formats Used
Term paper (20%) 3 Exams (30%) In-class writing assignments (10%) Final exam (25%) Class participation (15%) Extra credit writing assignments (+10%)	Exams are essay exams
3 Tests (60%) Observation project (20%) In-class papers (20%)	Tests include multiple-choice, true/false and short answer
3 Exams (40%) Quizzes (20%) Term research project (13%) Final exam (27%)	Exams and quizzes are multiple choice
Exams Other instruments unknown*	Exams are multiple choice
3 Tests (60%) Journal critique (10%) Oral summary of newspaper article (5%) Written classroom observations (20%) 2 One-page reaction papers (5%) Extra credit book chapter notes (3%)	Tests are multiple choice, true/false and matching

### INFORMATION TECHNOLOGY

Student Assessment Instruments	Test/Exam Formats Used
14 Chapter quizzes (25%) Lab assignments (40%) Midterm exam (10%) Final exam (20%) Honor's project (5%)	Exams are multiple choice
Final exam (20%) Midterm exam (20%) Quizzes (20%) Homework (15%) ePortfolio (15%) Participation in Blackboard discussions (10%)	Exams are constructed response
40 Class and lab assignments (67%) 3 Exams (33%)	Exams are multiple choice

Student Assessment Instruments	Test/Exam Formats Used
4 Exams (40%) 10 Quizzes (30%) 20 Assignments (30%) 3 Blackboard discussions (5% bonus)	Exams are multiple choice
Assignments (25%) Concept exams (20%) 3 Microsoft exams (10%) Final exam (15%)	Exams are short answer, fill in the blank or multiple choice

**NURSING**

Student Assessment Instruments	Test/Exam Formats Used
Unit quizzes/exams (40%) Comprehensive Theory and Clinical final exam (25%) Exit exam (5%) Oral presentation (5%) Written assignments (5%) Outside assignments (10%) Lab Practicum (10%)	Exams and quizzes are multiple choice
Exams/tests Other instruments - unknown*	Exams/tests are multiple choice
Chapter exams (76%) Final exam (16%) Quizzes/projects (8%)	Exams are multiple choice, true/false or matching with occasional essay questions
6 Exams, 2 lab practical exams, and final exam (70%) Medical terminology quizzes and homework (30%)	Exams are multiple choice
3 Unit exams (20% each) Final exam (40%)	Exams are multiple choice
Tests (75%) Final exam (25%) Lab is pass/fail	Tests/exams are multiple choice

*\*Weighting of instruments unknown*

*\*\*As presented in the syllabus, does not add to 100%.*

**Business Plan for an Startup Business**

Page 1 of 26



NB: ONLY PARTS I-IV ARE INCLUDED IN THIS EXCERPT

**Business Plan for an Startup Business**

Page 2 of 26

**I Table Of Content**

I.	Table Of Contents.....	2	✓
II.	Executive Summary.....	3	
III.	General Company Description.....	4	
IV.	Products and Services.....	8	
V.	Marketing Plan.....	9	
VI.	Operational Plan.....	23	
VII.	Management and Organization.....	25	

Business Plan for an Startup Business

II Executive Summary

Owners:



*Good!*

Product:

- ❖ We operate an On-line service to handle Firearms and accessories for the Sportsman and Collector. We will assist in the legal transfer as a Federal Firearm License holder for those purchasing firearms. ✓✓

Customers:

- ❖ Our customers will be Sportsmen and Collectors who appreciate fine firearms.

Growth in the Industry:

- ❖ The industry will continue to grow as more women—51 percent of the adult populations as of the 2000 census—take advantage of the services the industry offers. As the number of women living alone continues to increase so has their demand for the products and training provided by the industry.
- ❖ New government regulations applying to the transfer of firearms between individuals will serve to grow the number of FFL holder needed. As more states adopt Canceled Carry Permits the demand for the services and products provided by the industry will also continue to grow. *Good.*
- ❖ The explosion of Internet use in America increases the number of possible clients daily. The Internet has proved invaluable in showcasing the products and services offered by the industry and will continue to do so.

Funding:

- ❖ We are able to self fund the Startup of this business. ✓

Business Plan for an Startup Business

Page 4 of 26

**III General Company Description**

**General Company Description:**

- ❖ We will handle the legal responsibilities for the transfer of sporting arms from the seller to the buyer. We will order and locate firearms for the sportsman or collector. We will sell firearms we acquired or accepted on consignment. We will provide estimates of value for insurance or sale purposes. Good

**Mission Statement:**

- ❖ To provide our customers with a trusted and reliable avenue for the acquisition and transfer of sporting arms. To accurately place a value on collections for insurance and estates purposes. To reinforce the positive and family friendly values of the sport. To educate users in the safe handling and use of firearms. Good

**Company Goals and Objectives:**

- ❖ Goals:
  - I. To grow an on-line business supplying firearms to the sportsman and collector. ✓
  - II. To grow this business—by expanding the product line—to a level capable of generating profits in excess of \$100,000.00 annually ✓
  - III. To grow this business to a level that will justify expansion to a brick and mortar operation. ✓

## Business Plan for an Startup Business

Page 5 of 26

### ❖ Objectives

#### I. Prepare for startup:

- Establish an LLC ✓
- Obtain FFL—application process can run 6 months or longer—and any necessary permits needed to conduct this type of business. ✓
- Obtain Gun Safe and digital storage equipment. ✓
- Move from DSL to a Cable Internet connection. *Very good*
- Obtain necessary equipment and setup accounts with a provider of Master Card and Visa services.

#### II. Make final adjustments to Business Plan in preparation—to coincide with or follow shortly after my Graduation from CNM and finding employment and Linda's retirement—for a launch date of April, 2011. ✓

#### III. Establish a presence on-line—using the services of Guns America and Guns International—listing new products. *WEBSITE!*

#### IV. Within six months of startup establish a Web ordering site separate from Guns America and Guns International. Direct customers to this site within the listing posted on Guns America and Guns International.

#### V. Within twelve months of startup begin listing—used and collector firearms—items related to the secondary market. ✓

#### VI. Within twenty-four months begin listing new products that have been purchased new and enhanced by—Gunsmith—John Farner of Eagle Machine-Gunsmithing & Machining Services. ✓



Business Plan for an Startup Business

Page 6 of 26

**Business Philosophy:**

- ❖ To provide quality service to the customer; establishing a working relationship that is enjoyable to both the customer and me.

Good

***Our products and services will be marketed to firearm enthusiasts, collectors, or their estates.***

**Industry Description:**

The procurement and collection of firearms has changed drastically since the gun control act of 1968 was adopted. In the not too distant future I believe the government will impose restrictions on the transfer of firearms between individuals. These restrictions will force transfers to be handled by a Federal Firearm License holder. Collectors are aging and the changing economy is and will continue to force many to sell their collections. A growing segment of the society, women, have begun to seek training in the use of firearms. By obtaining a FFL we are able to satisfy the legal duties involved in the procurement and transfer of firearms. As a NRA certified instructor we will be able to participate in educated recommendations to new enthusiasts.

✓ Good

#### IV Products and Services

*Good!*

We will act as a dealer for several of the large firearm distributors. In this capacity, we will receive the firearm from the distributor and handle the legal transfer to the individual. We will list on-line any firearms we acquire or accept on consignment. When a firearm is purchased on-line we will handle the legal transfer to a FFL holder in the buyer's home state. We will provide written estimates of collections or individual items. All estimates will be based on wholesale value. We will offer free of charge recommendations for firearm selection and recommended training facilities.

##### Strengths:

- ❖ By operating as an On-line service the costs associated with a brick and mortar establishment are avoided. ✓
- ❖ We possess a comprehensive knowledge of the products to be provided.
- ❖ Because we are a Home Bases operation there is very little overhead.
- ❖ Acting as a Dealer for the larger Wholesalers eliminates the burden of new product inventory.
- ❖ Operating as an On-line service allows the customer to place orders 24 hours a day 7 days a week.
- ❖ By not holding new product inventory funds can be directed to the acquisition of secondary—used and collector firearms—market inventory. This segment of the market offers an opportunity for a greater profit margin.

##### Disadvantages:

- ❖ Lack of a brick and mortar facility. ✓

## Business Plan for an Startup Business

Page 9 of 26

**Pricing:**

There is no licensing fee to act as a dealer for any of the large firearms distributors. Our fee for a transfer will be \$35.00. The price of ordered firearms will be cost plus 30 percent. The price on consignment firearms will be wholesale value plus 30 percent. The cost of an appraisal will be on an individual basics starting at \$10. A locator fee of 30 percent of the retail value, or \$50.00 per research hour, will be applied for the location of collector firearms.

**V Market Research**

In 2000 the United States Census Bureau projected a population of 300,000,000 to be reached in 2006. Of that 300 million, 200 million are of Adult age and potentially able to purchase a firearm. If 50 percent of that 200 million are excluded by choice, criminal activity, or due to mental illness the number of possible firearm owners falls to 100 million. This number is born-out by research preformed by the Gallup Poll. In September, 2000, the Gallup Poll placed the number of gun owners in America at between 77 million and 90 million. Research preformed by the Pew Research Center and published in June, 2008, placed the number of adult Americans with Internet access at 110 million. Therefore, by marketing our services on the Internet we will directly reach approximately 55 million of the 100 million gun owners in America today. With the continuing growth of the Internet the number of potential clients will continue to grow.

FANTASTIC

**Economics:**

The United States Census Bureau projected a population of 300,000,000 to be reached in 2006. Of that population 1/3 would be 21 years old and younger. Currently 50% of the adult population own firearms. Based on these numbers there is a potential market between 50,000,000 and 100,000,000 buyers for this product.

✓  
1000 }

Business Plan for an Startup Business

Page 10 of 26

**Current Demand in Target Market:**

Currently there is a very high demand in the market for this product. The fear of government regulation has created an artificial shortage, brought about by the hording of firearms and ammunition. ✓

**Trends in Target Market:**

Demand for this product, particularly those with a military appearance, will remain high for the foreseeable future. I expect it to fall to reasonable levels, upon the exit of the current administration, in 2012. ✓

**Growth potential:**

The potential for growth in the business is enormous.

The changing Federal regulations of this industry have driven many brick and mortar shops out of business. This situation has been amplified by the aging of current shop owners. Many current shops were founded by World War II and Korean War veterans. While many of their sons chose to continue the business; their grandchildren have chosen more glamorous and more politically correct career paths. ☺

Many former and current owners failed and continue to fail in adapting to newer business models. Use of the Internet and modern shipping methods could have saved many older shops. It is no longer necessary to hold large inventors on-site. Use of the Internet and modern shipping methods allow the client to view the product and delivery can accrue in as little as three day. Inventory that is on site can be displayed to millions by way of the Internet.

Very Good



## E Example 4 - Criminal Justice Final Exam Essay Question

Essay Prompt..... 74  
Essay Rubric ..... 74-75  
Student Reponse..... 76-79

### CJ101 FINAL EXAM, ESSAY QUESTION

Give the pros and cons to the death penalty; after that give your opinion.

Your paper will use 12 point font, the same size as these letters. WRITE AN APA STYLE PAPER, cover sheet, APA page numbering & USE A SEPARATE SHEET TO LIST YOUR REFERENCES. For example:

#### References

- American Psychological Association (2010). Free tutorial on the basic APA style. Retrieved April 19, 2010, from <http://www.apastyle.org/apa-style-help.aspx>
- Inciardi, J. A. (2010). *Criminal justice* (9<sup>th</sup> ed.). New York: McGraw-Hill

---

Show direct quotes such as, Inciardi (2010) said, "On January 20, 1864, William Barnet and Sandy Kavanagh were executed in the Vermont State Prison for the crime of murder" (p. 383). Notice there was only one period and that was after the page number. For longer quotes such as, Inciardi (2010) said:

On January 20, 1864, William Barnet and Sandy Kavanagh were executed in Vermont State Prison for the crime of murder. During the next 100 or so years, through 1967, a total of 5,707 state-imposed death sentences were carried out across the country. (p. 383)

Notice on this indentation that the page number is after the quote. The period comes at the end of the sentences and since the quote is indented, **quotation marks are not used**.

---

I will be looking at:

- (1) Content; is it even, balanced information (**THE CONTENT SHOULD BE AT LEAST 1 PAGE**)
- (2) Organization; the ideas are arranged logically
- (3) Purpose; the writer's purpose is readily apparent
- (4) Use of references; compelling evidence is given (**YOU MAY USE YOUR TEXTBOOK, PROFESSIONAL JOURNALS, EDUCATIONAL MOVIES**). HOWEVER, ONLY ONE

**REFERENCE IS REQUIRED.**

- (5) Voice; writing is compelling
- (6) Tone; the tone is consistently professional
- (7) Sentence structure; are well phrased and varied in length (**NO EXCEPTIONALLY LONG SENTENCES**).
- (8) Word choice; is consistently precise (**SAME TENSE IN A SENTENCE: PAST, PRESENT, OR FUTURE. ALL WORDS IN THE SAME SENTENCE ARE SINGULAR OR PLURAL**)
- (9) Grammar, spelling and mechanics; are free of errors (**AVOID USING "YOU" AND USING "BUT" IN THE MIDDLE OF A SENTENCE. THE WORD "HOWEVER" IS A BETTER WORD TO USE**).
- (10) Critical thinking; accurately interprets evidence
- (11) **Your paper will be titled** The Pros and Cons of the Death Penalty
- (12) **Your page numbering will be** Death Penalty 1, Death Penalty 2, Death Penalty 3, etc.
- (13) **Direct quotes ARE NOT REQUIRED.**
- (14) **Use Spell Check and Grammar Check**
- (15) **Have someone else who is a good writer to READ YOUR PAPER.**
- (16) **THIS ESSAY/PAPER IS WORTH 20% OF YOUR FINAL EXAM**
- (17) No more than 20% of your paper should be direct quotes. **However, direct quotations are not required.**

The Pros and Cons of the Death Penalty

By

CJ, 101, Introduction to Criminal Justice



Death Penalty 2

The Pros and Cons of the Death Penalty

The Inciardi (2007) said, "The death Penalty Debate, historically the arguments for or against capital punishment have revolved around the issues of economics, retribution, public opinion, community protection, deterrence, irreversibility, discrimination, protection of the criminal justice system, brutalization, and cruel and unusual punishment" (p. 440). There are different ways to execute someone who has been given the death penalty.

From many decisions from 1878 through 1953, the Supreme Court upheld different types of executions such as; hanging, shooting, electrocution, and the use of lethal gas.

There are many different Pros and Cons for capital punishment. First, the Pros are usually the victims of the crime, and the cons are usually the convicted and family members. The first execution by electrocution took place at Auburn Prison, Auburn, New York on August 6, 1890. The prisoner, William Kemmler, was executed for murder.

The cases that follow stated in Inciardi (2007):

**Lockhart v. McCree**, decided in 1986, the court asserted that even if juries that support the death penalty are "conviction prone," this in itself does not violate any constitutional provisions (p. 446). **McCleskey v. Kemp**, decided in 1987, the Court held that statistical evidence of racial discrimination in death sentencing could not, in and of itself, establish a violation of the Eighth and/or Fourteenth Amendments. The court further held that to obtain relief, a defendant must prove either (1) that decision makers in his or her case acted with discriminatory purpose or (2) that the legislature enacted or maintained the death penalty statute because of an anticipated racially discriminatory effect (p. 446).

The cons for the argument is as follow; Inciardi (2007) said," In the fall of 1971, **Furman v. Georgia**, **Jackson v. Georgia**, and **Branch v. Texas** were brought before the court on the ground that the death sentences ordered were "cruel and unusual" because of the arbitrary and

Death Penalty 3

discriminatory manner in which such sanctions had been imposed in the past for the crimes of murder and rape” (p. 433).

For every pro, there is a con against the death penalty. For me, it will always be Pro, if someone can stand and take a life, then he or she should be ready to lose their own. If they have so much contempt and disrespect for life then they will commit murder again, and next time it could be a family member, a close friend, or even yourself.

Death Penalty 4

References

Inciardi, J. A. (2007) *Criminal Justice*. New York: McGraw-Hill

## F Example 5 - Argument Essay

*Essay Prompt* ..... 80  
*Essay Rubric* ..... 81  
*Student Reponse* ..... 82-83

### Argument Essay

Imagine that a congressman has introduced this new bill to Congress:

“The United States government shall guarantee all American citizens a minimum income of \$10,000 a year for a single person, \$12,000 a year for a married couple, and \$15,000-20,000 a year for a family with children (depending on the number of children). Every adult citizen who makes more than the minimum income shall pay taxes on the surplus. Every citizen who makes less than the minimum income shall receive a refund from the government to bring their income up to the minimum.”

In your essay, argue that the government should, or should not, pass this bill.

In the columns below, brainstorm supporting arguments for your thesis, opposing arguments, and your rebuttals to the opposing argument.

Thesis: \_\_\_\_\_  
\_\_\_\_\_

Supporting Arguments

Opposing Arguments

Rebuttals

ENG 101/107

ESSAY COVER SHEET

Name \_\_\_\_\_

Assignment \_\_\_\_\_ Due Date \_\_\_\_\_

Essay Grade

To receive a grade, the topic and mode must be appropriate for the assignment, and the essay must be typed in Standard Form.

Content (100 points possible):

	Possible Points	Your Points
1. There is a short, clear title.	5 points	_____
2. The first paragraph attracts the reader's interest and introduces the topic well.	20 points	_____
3. The thesis is well written and clearly stated in the first paragraph.	20 points	_____
4. The body is well organized and supports the thesis well.	40 points	_____
5. The conclusion effectively ends the essay	15 points	_____

Total Points \_\_\_\_\_

Point Scale for Editing

+ 5 points	0	-5 points	-10 points	-20 points	-40 points
0 errors	1-3 errors	4-5 errors	6-7 errors	8-9 errors	10 or more

Your Editing Score \_\_\_\_\_

Point Scale for Length

0	-10 points	-20 points	-30 points	-40 points	-50 points
480-500	450-479	400-449	350-399	300-349	Less than 300

Your Length Score \_\_\_\_\_

Your Essay Grade \_\_\_\_\_

Comments:

October 27, 2010  
ENG 101

### Minimum Income

In the U.S. there are many people in need of help, but there are also people who take advantage of the help our government offers. Many people like to rely on government funding because they know they can have it easy that way. There is a new bill that states that the U.S. should give a yearly income of \$10,000 to a single person, \$12,000 for a married couple, and \$15,000 - \$20,000 for a family depending on how many children they have. Giving families a minimum wage will help them at least to survive and be able to bring themselves back up to a more settled situation. The United States government must guarantee all American citizens a minimum income.

Many people would be against this bill because they say that this allows people to be lazy and want to just receive the money. I believe that most people don't want to just barely survive in this world. Here in our country, there is a drive to want to persevere and do the most you can with your life and your family's life. The majority doesn't want to have the least, they want to be wealthy and this just helps those get a good start to becoming economically better. The minimum income would help people barely survive and there would not be as many homeless people and families out there.

This bill helps our government with unnecessary spending. Having this minimum income means that there will be no programs people used for economic issues. There are many cases of people lying just to be able to receive the funding from the government, which meant they were giving money away to ones who didn't need it. The minimum income forces people to use

October 27, 2010  
ENG 101

that money wisely because when that's gone there is nowhere else to face. Others might say that this isn't true because they had ways to know that people actually need the help from these programs, but we all know that people find any way possible to get fake proof of needing help of the government. That is why a minimum income helps immensely.

There are also many against the minimum income because the bill states that citizens who make more than the minimum income shall pay taxes on the surplus. Whether there is a minimum income or not, we all have to pay taxes either way. Taxes have always been there to help out the country in what is needed. What is being misunderstood is that this helps the country greatly economically since they are not going to have to pay for all the programs that gave free food and money.

In the end, I believe that everybody receiving a minimum income will benefit our country greatly. They will not have to pay for all of these programs and we will have less families struggling just to survive and be able to feed their families. That is what we are here for, to be able to live a good life and be able to achieve the "American Dream."









2000 Pennsylvania Avenue, NW  
Suite 5300  
Washington, DC 20006

202-379-1800 | [www.ncee.org](http://www.ncee.org)

Find us on Facebook | Follow us on Twitter @CtrEdEcon