

DOCUMENT RESUME

ED 481 372

SE 068 362

TITLE Optics: Light, Color, and Their Uses. An Educator's Guide with Activities in Science and Mathematics.

INSTITUTION National Aeronautics and Space Administration, Huntsville, AL. George C. Marshall Space Flight Center.

REPORT NO EG-2000-10-64-MSFC

PUB DATE 2000-00-00

NOTE 96p.

PUB TYPE Guides - Classroom - Teacher (052)

EDRS PRICE EDRS Price MF01/PC04 Plus Postage.

DESCRIPTORS *Color; Elementary Secondary Education; Hands on Science; *Light; *Optics; Science Activities; Space Sciences

ABSTRACT

This educator's guide from discusses optics, light, color and their uses. Activities include: (1) "Reflection of Light with a Plane (Flat) Mirror--Trace a Star"; (2) "Reflection of Light with Two Plane Mirrors--Double Mirrors Placed at a 90-Degree Angle"; (3) "Reflection of Light with Two Plane Mirrors--Double Mirrors Placed at a Number of Angles"; (4) "Making a Kaleidoscope--Construction of a Large Kaleidoscope Using PVC Pipe"; (5) "Making a Periscope"; (6) "Constructing a Spectroscope"; (7) "Exploring Diffraction with a Spectroscope--The Electromagnetic Spectrum"; (8) "Diffraction of Light by Very Small Apertures"; (9) "Discovering Color with a Prism--Fabrication of a Prism from Acrylic Plastic"; (10) "Light and Color--Color Spinners"; (11) "Light and Color--Filters"; (12) "Light and Color--Hidden Messages"; (13) "Simple Magnifiers"; (14) "Focusing Light with a Lens"; (15) "Building a Telescope--Diagrams of Reflector and Refractor Telescopes"; (16) "Building a Microscope--Construction of a Microscope--A File Folder Microscope"; (17) "Interference Fringes"; and (18) "Polarization of Light. (MVL)

Reproductions supplied by EDRS are the best that can be made from the original document.



National Aeronautics
and Space Administration

Educational Product

Teachers

Grades K-12

EG-2000-10-64-MSFC

ED 481 372

OPTICS

Light, Color, and Their Uses

An Educator's Guide With Activities In Science and Mathematics



U.S. DEPARTMENT OF EDUCATION
Office of Educational Research and Improvement
EDUCATIONAL RESOURCES INFORMATION
CENTER (ERIC)

This document has been reproduced as
received from the person or organization
originating it.

Minor changes have been made to
improve reproduction quality.

• Points of view or opinions stated in this
document do not necessarily represent
official OERI position or policy.

OPTICS
Light, Color, and Their Uses

seaworld



BEST COPY AVAILABLE



NASA Spacelink

Optics: Light, Color, and Their Uses—An Educators Guide With Activities In Science and Mathematics is available in electronic format through NASA Spacelink— one of the Agency’s electronic resources specifically developed for use by the educational community.

**The system may be accessed at the following address:
<http://spacelink.nasa.gov>**

Light, Color, and Their Uses

Optics:

Light, Color, and Their Uses

An Educator's Guide With Activities in Science and Mathematics

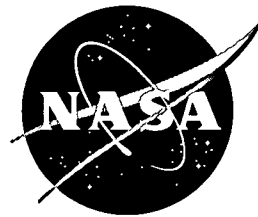

National Aeronautics and Space Administration

**Space Optics Manufacturing Technology Center
Marshall Space Flight Center**

**Customer Employee Relations Directorate /
Education Programs Department
Marshall Space Flight Center**

This publication is in the Public Domain and is not protected by copyright.
Permission is not required for duplication.

EG-2000-10-64-MSFC



Optics: Light, Color, and Their Uses

An Educator's Guide With Activities in Science and Mathematics

Acknowledgments

Pat Armstrong
Curriculum Development Coordinator
Huntsville City Schools
Huntsville, AL

Era Jean Mann
Computer Specialist
Retired from NASA Marshall Space
Flight Center
Huntsville, AL

P. Derryl Evans
Optical Physicist
Retired from NASA Marshall Space
Flight Center
Huntsville, AL

Vicki Smith
IPA/Huntsville City Schools
Education Program Specialist
NASA Marshall Space Flight Center
Huntsville, AL

Vinson B. Huegele
Optical Physicist
Space Optics Manufacturing
Technology Center
NASA Marshall Space Flight Center

On the Cover

Replicated X-ray Mirror

The reflective tube is an x-ray telescope mirror made as a shell cast from a mold called a mandrel. The cylindrical mandrel is carefully shaped and polished until it has the proper optical surface. Then gold, followed by nickel, is electroplated onto the mandrel. The electroplated metal then comes off the mandrel and the shell formed is a high-precision mirror on the inside. The mandrel can be used again to replicate many mirrors with the same shape.

The x-ray mirrors in the Chandra Observatory are made of glass. Metal mirrors replicated from a mandrel are much lighter and cheaper than glass, so they are desirable for space applications. The Marshall Space Flight Center (MSFC) is advancing replicated optics technology.

Shown in the picture are students Colton Guthrie and Laquita Hurt, with MSFC optical physicist Vince Huegele.





Chandra X-Ray Observatory

X rays are a high-energy wavelength in the electromagnetic spectrum. Many stars, supernova, quasars and galaxies emit x rays, so observing these objects in that wavelength will reveal much about them.

The Chandra Observatory (formerly called the Advanced X-ray Astrophysics Facility—AXAF) the world's most powerful x-ray telescope, was launched on July 23, 1999, to view x-ray sources from space. Astronomers must have this observatory in space because the Earth's atmosphere absorbs and blocks celestial x-ray radiation from reaching the ground.

Chandra flies 200 times higher than the Hubble Space Telescope and its orbit takes it one-third of the way to the Moon. The cylindrical glass mirrors in the Chandra are the largest of their kind and the smoothest ever created. Chandra and its upper stage was the heaviest payload ever launched on the Shuttle.

The Chandra design and development program was managed by MSFC. The observatory's telescope was tested and certified at the MSFC X-Ray Calibration Facility.

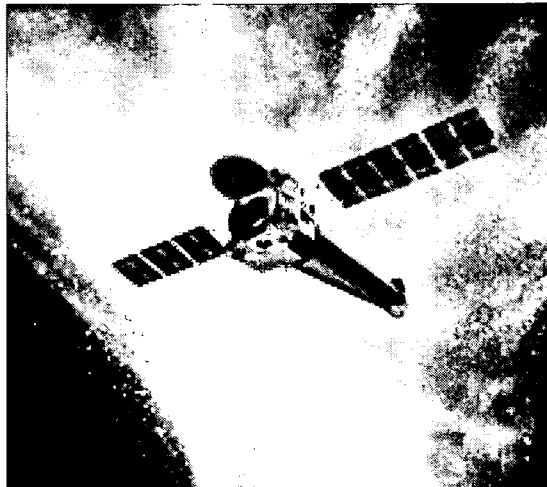

Light, Color, and Their Uses





The Hubble Space Telescope

A new era in astronomy began as Shuttle astronauts released the Hubble Space Telescope into orbit on April 26, 1990. With its vantage point above Earth's atmosphere Hubble has shown the birth and death of stars, colliding galaxies, stellar plumes, gas rings, nebula clouds, comet impacts on Jupiter, and storms on Saturn, all with greater clarity and brightness than humans have ever seen before. Hubble is fulfilling its mission to collect knowledge and discover a new perspective of the universe.

The Hubble telescope uses a Cassegrain reflector system that has a hyperbolic-shaped mirror. The design is optimized for focusing the visible spectrum. The development and assembly of the Hubble was directed by MSFC.

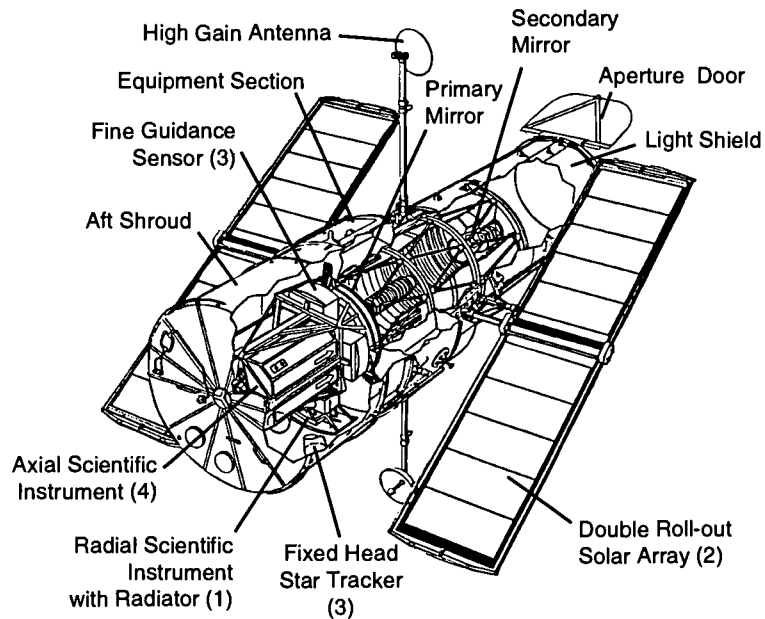



Investigating Laser Light Craft

The futuristic idea of a small laser-propelled spacecraft like the model shown here is being studied at MSFC.

The laser on the ground fires up under the specially shaped craft. The focused infrared laser beam is absorbed by the air inside the engine, creating a laser supported detonation. The high-pressure, high-temperature plasma created by the laser absorption cools and expands out the rear of the vehicle producing the thrust which propels the lightcraft into the sky.

MSFC is fabricating lightcraft bodies, developing beam directors, and investigating improved vehicle and laser concepts.

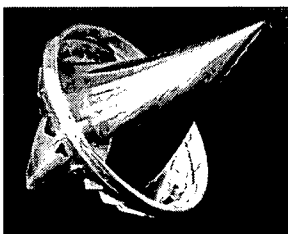

Next Generation Space Telescope

The next space telescopes larger than Hubble will have to be made with special lightweight mirrors. MSFC is testing new materials and assembly techniques to make giant reflectors that will fold up for launch and then open in space. These telescopes will be big enough to allow scientists to see Earth-like planets around other stars.

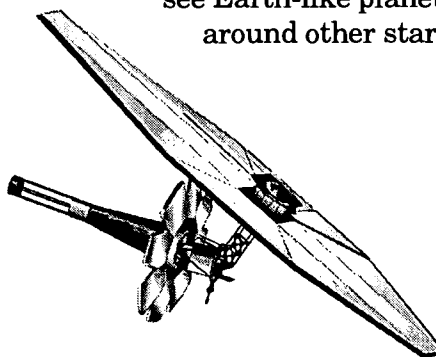

Improving Observatory Alignment

The Hobby-Eberly telescope (HET) near Ft. Davis, Texas, is a 9-meter diameter telescope tailored for spectroscopy. It has a special mirror with 91 segments and features an innovative, low-cost tracking system. MSFC is designing a mirror Segment Alignment Maintenance System on the HET to improve the mirror performance.

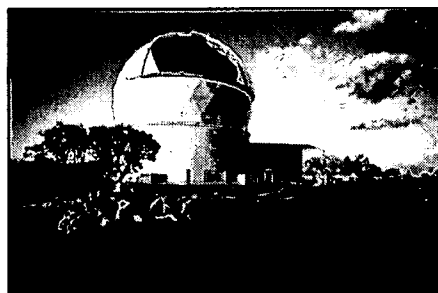

Light, Color, and Their Uses



NASA Projects, MSFC, Optics



Besides working with the large space observatories Hubble and Chandra, the MSFC optics group has done design, assembly or testing on the following projects.

Space Station Windows

The windows in the Space Station are for the crew to view external operations. MSFC designed the frames for the windows and tested the transmission quality of the glass.

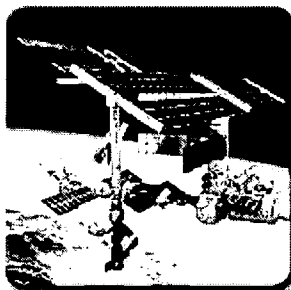

Composite Infrared Spectrometer (CIRS) for the Cassini Saturn Spacecraft

The CIRS is a set of interferometers designed to measure infrared emissions from atmospheres, rings, and surfaces to determine their compositions and temperatures. MSFC made and tested the mirrors for the CIRS



instrument. Cassini was launched on October 6, 1997, and will arrive at Saturn on July 1, 2004.

Soft X-Ray Imager (SXI)

SXI is designed to obtain a continuous sequence of corona x-ray images from the Sun to monitor solar activity for its effects on the Earth's upper atmosphere. It uses a Wolter grazing incidence mirror similar to the type in Chandra. SXI was assembled and tested at MSFC and will be launched as part of a Geostationary Operational Environmental Satellite (GOES) weather satellite.

Lightning Imaging System (LIS)

The LIS is a space-based instrument used to detect the distribution and variability of lightning on Earth. The measurements are being used to study

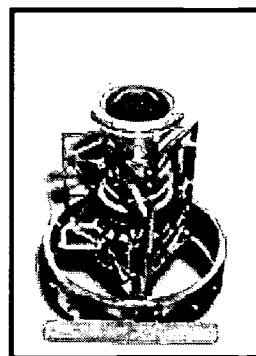

storm convection and global precipitation. LIS was made at MSFC and launched on November 28, 1997, in a weather satellite.



Classroom Activities

This material has been developed to provide a guide to hands-on experiences in science and mathematics. The activity plans are written to be used by the students in groups of two to four people in a lab-type setting.

Each lab session should begin with a brief discussion of the theory section of each lesson plan. The teacher should feel free to adjust the information and activities to meet the needs of the students. For the very young student, the teacher may want to lead the experience activity and adapt the questions.

Pat Armstrong

Activities for Grades K–4

- Activity 1: Reflection of Light With a Plane (Flat) Mirror
- Activity 2: Reflection of Light With Two Plane Mirrors
- Activity 7: Exploring Diffraction With a Spectroscope
- Activity 10: Light and Color-Color Spinners
- Activity 11: Light and Color-Filters
- Activity 12: Light and Color-Hidden Messages
- Activity 13: Simple Magnifiers

Activities for Grades 5–8

- Activity 1: Reflection of Light With a Plane (Flat) Mirror
- Activity 2: Reflection of Light With Two Plane Mirrors
- Activity 3: Reflection of Light With Two Plane Mirrors-Double Sided
- Activity 5: Making a Periscope
- Activity 6: Constructing a Spectroscope
- Activity 7: Exploring Diffraction with a Spectroscope
- Activity 10: Light and Color-Color Spinners
- Activity 12: Light and Color-Hidden Messages
- Activity 13: Simple Magnifiers

Activities for Grades 9–12

- Activity 4: Making a Kaleidoscope
- Activity 5: Making a Periscope
- Activity 8: Diffraction of Light by Very Small Apertures
- Activity 9: Discovering Color With a Prism
- Activity 14: Focusing Light With a Lens
- Activity 15: Building a Telescope
- Activity 16: Building a Microscope
- Activity 17: Interference Fringes
- Activity 18: Polarization of Light

Light, Color, and Their Uses



Table of Contents

Light, Color, and Their Uses

Activity / Lesson

	National Science Standards	1
	National Mathematics Standards	2
	Introduction to Light and Color	3
	Introduction to Mirrors and Lenses	5
1	Reflection of Light With a Plane (Flat) Mirror—Trace a Star	13
2	Reflection of Light With Two Plane Mirrors — Double Mirrors Placed at a 90-Degree Angle	17
3	Reflection of Light With Two Plane Mirrors — Double Mirrors Placed at a Number of Angles	19
4	Making a Kaleidoscope	23
	Construction of a Large Kaleidoscope Using PVC Pipe	25
5	Making a Periscope	27
6	Constructing a Spectroscope	29
7	Exploring Diffraction With a Spectroscope	31
	The Electromagnetic Spectrum	34
8	Diffraction of Light by Very Small Apertures	35
9	Discovering Color With a Prism	37
	Fabrication of a Prism From Acrylic Plastic	40
10	Light and Color — Color Spinners	41
11	Light and Color — Filters	43
12	Light and Color — Hidden Messages	45
13	Simple Magnifiers	47
14	Focusing Light With a Lens	49
15	Building a Telescope	53
	Diagrams of Reflector and Refractor Telescopes	56
16	Building a Microscope	57
	Construction of a Microscope — A File Folder Microscope	59
17	Interference Fringes	61
18	Polarization of Light	63



Teachers' Resource Materials	65
Answer Booklet	65
Glossary	73
General Information for Educators and Students	77
NASA Online Educational Resources	79
Education Home Page	79
NASA Spacelink	79
Educator Resource Center and CORE	80
NASA Television (NTV)	81
List Of Catalogs	82
Educator Reply Card	83

Light, Color, and Their Uses





Light, Color, and Their Uses

National Science Standards

Activity/Lesson	Science as Inquiry	Physical Science
1. Reflection/Plane Mirror	<input checked="" type="checkbox"/>	<input checked="" type="checkbox"/>
2. Reflection/2 Mirrors	<input checked="" type="checkbox"/>	<input checked="" type="checkbox"/>
3. Reflection/Double Mirrors	<input checked="" type="checkbox"/>	<input checked="" type="checkbox"/>
4. Making a Kaleidoscope	<input checked="" type="checkbox"/>	<input checked="" type="checkbox"/>
5. Construction of a Kaleidoscope	<input type="checkbox"/>	<input checked="" type="checkbox"/>
6. Making a Periscope	<input checked="" type="checkbox"/>	<input checked="" type="checkbox"/>
7. Constructing a Spectroscope	<input type="checkbox"/>	<input checked="" type="checkbox"/>
8. Exploring Diffraction	<input checked="" type="checkbox"/>	<input checked="" type="checkbox"/>
9. Electromagnetic Spectrum	<input checked="" type="checkbox"/>	<input checked="" type="checkbox"/>
10. Diffraction of Light	<input checked="" type="checkbox"/>	<input checked="" type="checkbox"/>
11. Discovering Color/Prism	<input checked="" type="checkbox"/>	<input checked="" type="checkbox"/>
12. Fabrication of a Prism	<input checked="" type="checkbox"/>	<input checked="" type="checkbox"/>
13. Color Spinners	<input checked="" type="checkbox"/>	<input checked="" type="checkbox"/>
14. Filters	<input checked="" type="checkbox"/>	<input checked="" type="checkbox"/>
15. Hidden Messages	<input checked="" type="checkbox"/>	<input checked="" type="checkbox"/>
16. Simple Magnifiers	<input checked="" type="checkbox"/>	<input checked="" type="checkbox"/>
17. Focusing Light With a Lens	<input checked="" type="checkbox"/>	<input checked="" type="checkbox"/>
18. Building a Telescope	<input checked="" type="checkbox"/>	<input checked="" type="checkbox"/>
19. Building a Microscope	<input checked="" type="checkbox"/>	<input checked="" type="checkbox"/>
20. Construction of a Microscope	<input type="checkbox"/>	<input checked="" type="checkbox"/>
21. Interference Fringes	<input checked="" type="checkbox"/>	<input checked="" type="checkbox"/>
22. Polarization of Light	<input checked="" type="checkbox"/>	<input checked="" type="checkbox"/>

ses U jneqll pure 'joloC 'tugil



National Mathematics Standards

Activity/Lesson	Problem Solving	Communication	Connection	Computation/Estimation	Measurement
1. Reflection/Plane Mirror	<input type="checkbox"/>	<input checked="" type="checkbox"/>	<input type="checkbox"/>	<input type="checkbox"/>	<input checked="" type="checkbox"/>
2. Reflection/2 Mirrors	<input type="checkbox"/>	<input checked="" type="checkbox"/>	<input type="checkbox"/>	<input type="checkbox"/>	<input checked="" type="checkbox"/>
3. Reflection/Double Mirrors	<input checked="" type="checkbox"/>	<input checked="" type="checkbox"/>	<input type="checkbox"/>	<input checked="" type="checkbox"/>	<input checked="" type="checkbox"/>
4. Making a Kaleidoscope	<input type="checkbox"/>	<input checked="" type="checkbox"/>	<input checked="" type="checkbox"/>	<input type="checkbox"/>	<input type="checkbox"/>
5. Construction of a Kaleidoscope	<input type="checkbox"/>	<input checked="" type="checkbox"/>	<input checked="" type="checkbox"/>	<input checked="" type="checkbox"/>	<input checked="" type="checkbox"/>
6. Making a Periscope	<input type="checkbox"/>	<input checked="" type="checkbox"/>	<input checked="" type="checkbox"/>	<input checked="" type="checkbox"/>	<input type="checkbox"/>
7. Constructing a Spectroscope	<input type="checkbox"/>	<input checked="" type="checkbox"/>	<input checked="" type="checkbox"/>	<input type="checkbox"/>	<input checked="" type="checkbox"/>
8. Exploring Diffraction	<input type="checkbox"/>	<input checked="" type="checkbox"/>	<input type="checkbox"/>	<input type="checkbox"/>	<input type="checkbox"/>
9. Electromagnetic Spectrum	<input type="checkbox"/>	<input checked="" type="checkbox"/>	<input type="checkbox"/>	<input type="checkbox"/>	<input type="checkbox"/>
10. Diffraction of Light	<input type="checkbox"/>	<input checked="" type="checkbox"/>	<input type="checkbox"/>	<input type="checkbox"/>	<input type="checkbox"/>
11. Discovering Color/Prism	<input type="checkbox"/>	<input checked="" type="checkbox"/>	<input type="checkbox"/>	<input type="checkbox"/>	<input type="checkbox"/>
12. Fabrication of a Prism	<input type="checkbox"/>	<input checked="" type="checkbox"/>	<input type="checkbox"/>	<input type="checkbox"/>	<input checked="" type="checkbox"/>
13. Color Spinners	<input checked="" type="checkbox"/>	<input checked="" type="checkbox"/>	<input type="checkbox"/>	<input checked="" type="checkbox"/>	<input checked="" type="checkbox"/>
14. Filters	<input type="checkbox"/>	<input checked="" type="checkbox"/>	<input type="checkbox"/>	<input checked="" type="checkbox"/>	<input type="checkbox"/>
15. Hidden Messages	<input type="checkbox"/>	<input checked="" type="checkbox"/>	<input type="checkbox"/>	<input checked="" type="checkbox"/>	<input type="checkbox"/>
16. Simple Magnifiers	<input type="checkbox"/>	<input checked="" type="checkbox"/>	<input type="checkbox"/>	<input type="checkbox"/>	<input type="checkbox"/>
17. Focusing Light With a Lens	<input checked="" type="checkbox"/>	<input checked="" type="checkbox"/>	<input type="checkbox"/>	<input type="checkbox"/>	<input type="checkbox"/>
18. Building a Telescope	<input type="checkbox"/>	<input checked="" type="checkbox"/>	<input checked="" type="checkbox"/>	<input type="checkbox"/>	<input type="checkbox"/>
19. Building a Microscope	<input type="checkbox"/>	<input checked="" type="checkbox"/>	<input checked="" type="checkbox"/>	<input type="checkbox"/>	<input type="checkbox"/>
20. Construction of a Microscope	<input type="checkbox"/>	<input checked="" type="checkbox"/>	<input checked="" type="checkbox"/>	<input checked="" type="checkbox"/>	<input checked="" type="checkbox"/>
21. Interference Fringes	<input type="checkbox"/>	<input checked="" type="checkbox"/>	<input type="checkbox"/>	<input type="checkbox"/>	<input type="checkbox"/>
22. Polarization of Light	<input type="checkbox"/>	<input checked="" type="checkbox"/>	<input type="checkbox"/>	<input type="checkbox"/>	<input type="checkbox"/>

Introduction to Light and Color

Introduction to Light

Light is a form of radiant energy or energy that travels in waves. Since Greek times, scientists have debated the nature of light. Physicists now recognize that light sometimes behaves like waves and, at other times, like particles. When moving from place to place, light acts like a system of waves. In empty space, light has a fixed speed and the wavelength can be measured. In the past 300 years, scientists have improved the way they measure the speed of light, and they have determined that it travels at nearly 299,792 kilometers, or 186,281 miles, per second.

When we talk about light, we usually mean any radiation that we can see. These wavelengths range from about $16/1,000,000$ of an inch to $32/1,000,000$ of an inch. There are other kinds of radiation such as ultraviolet light and infrared light, but their wavelengths are shorter or longer than the visible light wavelengths.

When light hits some form of matter, it behaves in different ways. When it strikes an opaque object, it makes a shadow, but light does bend around obstacles. The bending of light around edges or around small slits is called diffraction and makes patterns of bands or fringes.

All light can be traced to certain energy sources, like the Sun, an electric bulb, or a match, but most of what hits the eye is reflected light. When light strikes some materials, it is bounced off or reflected. If the material is not opaque, the light goes through it at a slower speed, and it is bent or refracted. Some light is absorbed into the material and changed into other forms of energy, usually heat energy. The light waves make the electrons in the materials vibrate and this kinetic energy or movement energy makes heat. Friction of the moving electrons makes heat.



Introduction to Color

Color is a part of the electromagnetic spectrum and has always existed, but the first explanation of color was provided by Sir Isaac Newton in 1666.

Newton passed a narrow beam of sunlight through a prism located in a dark room. Of course all the visible spectrum (red, orange, yellow, green, blue, indigo, and violet) was displayed on the white screen. People already knew that light passed through a prism would show a rainbow or visible spectrum, but Newton's experiments showed that different colors are bent through different angles. Newton also thought all colors can be found in white light, so he passed the light through a second prism. All the visible colors changed back to white light.

Light is the only source of color. The color of an object is seen because the object merely reflects, absorbs, and transmits one or more colors that make up light. The endless variety of color is caused by the interrelationship of three elements: Light, the source of color; the material and its response to color; and the eye, the perceiver of color.

Colors made by combining blue, yellow, and red light are called additive; and they are formed by adding varying degrees of intensity and amounts of these three colors. These primary colors of light are called cyan (blue-green), yellow, and magenta (blue-red).

Pigment color found in paint, dyes, or ink is formed by pigment molecules present in flowers, trees, and animals. The color is made by absorbing, or subtracting, certain parts of the spectrum and reflecting or transmitting the parts that remain. Each pigment molecule seems to have its own distinct characteristic way of reflecting, absorbing, or transmitting certain wavelengths. Natural and manmade colors all follow the same natural laws.

Light, Color, and Their Uses



Introduction to Mirrors and Lenses

Introduction to Mirrors

As we look around the room, we see most objects by the light that is diffusely reflected from them.

Diffuse reflection of light takes place when the surface of the object is not smooth. The reflected rays from a diffusely reflecting surface leave the surface in many different directions.

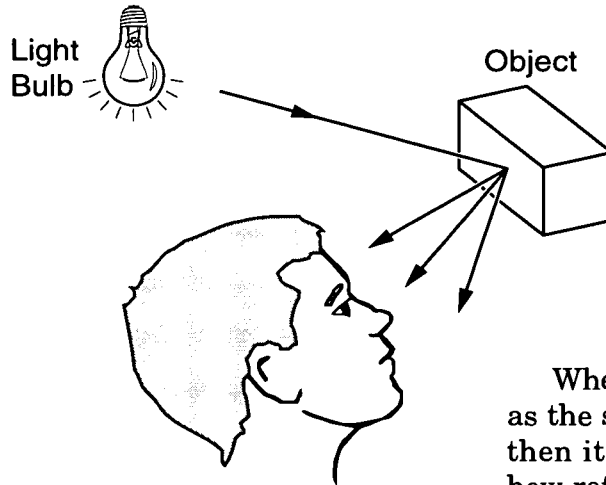

When the surface is smooth, such as the surface of glass or a mirror, then it can be easily demonstrated how reflected rays always obey the law of reflection as illustrated below.

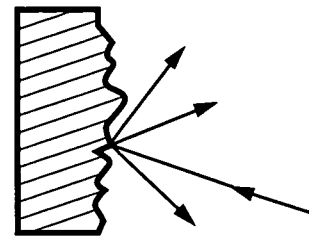

Law of Reflection

The angle of incidence is equal to the angle of reflection.

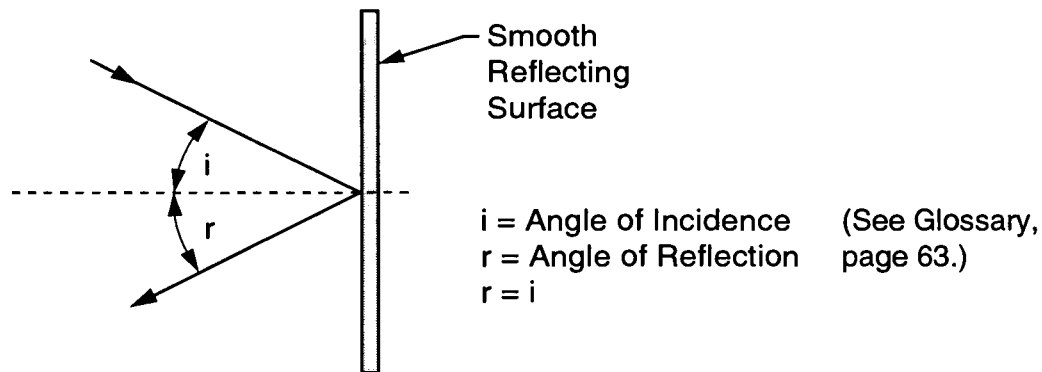

The Image Formed by Reflection in a Flat Mirror

Every object we see has many rays of light coming from it either by reflection or because it is a light source such as a light bulb, the Sun, a star, etc. Each point on that object is a source of light rays. In the illustration below, the tip of the arrow is used as an example of a point on the object from which rays of light would be coming. As the rays from the object

are reflected by the mirror, the reflected rays appear to come from the image located behind the mirror at a distance equal to the object's distance from the mirror. The image is called a virtual image since the rays do not actually pass through or come from the image; they just appear to come from the image as illustrated below.

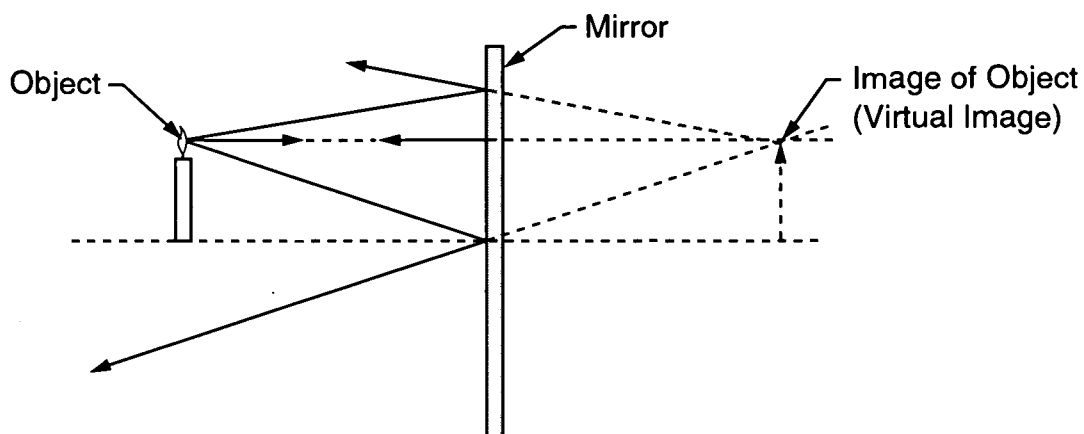

The Image Formed by a Concave Mirror

A concave mirror that is part of a ball or hollow sphere (that is, it has a circular cross section) is a spherical mirror. The focal length is approximately one-half the radius of curvature. A ray that is both parallel and very close to the optical axis will be reflected by the mirror so that it will cross the optical axis at the "paraxial focal point." The paraxial focal point is located a distance of one-half the radius of curvature from the point on the mirror where the optical axis intersects the mirror. The word "paraxial" comes from the Greek "para" or "par" meaning "at the side of, or beside, and axial." Thus paraxial means beside the axis.

Another ray that is parallel to the optical axis, but not close to the axis, will be reflected by the mirror so that it crosses the optical axis, not at the paraxial focus, but a small distance

closer to the mirror. This difference in the axis cross-over points is called spherical aberration.

If the mirror has a cross section that is a parabola instead of a circle, all of the rays that are parallel to the optical axis will cross at the same point. Thus, a paraboloidal mirror does not produce spherical aberration. This is why the astronomical telescope known as the Newtonian (invented by Isaac Newton) uses a paraboloidal primary mirror.

For demonstration purposes in the classroom, it works out that we can make the approximation that spherical mirrors behave almost like paraboloidal mirrors and determine that the focal length of a spherical mirror is about one-half the radius of curvature of the mirror.

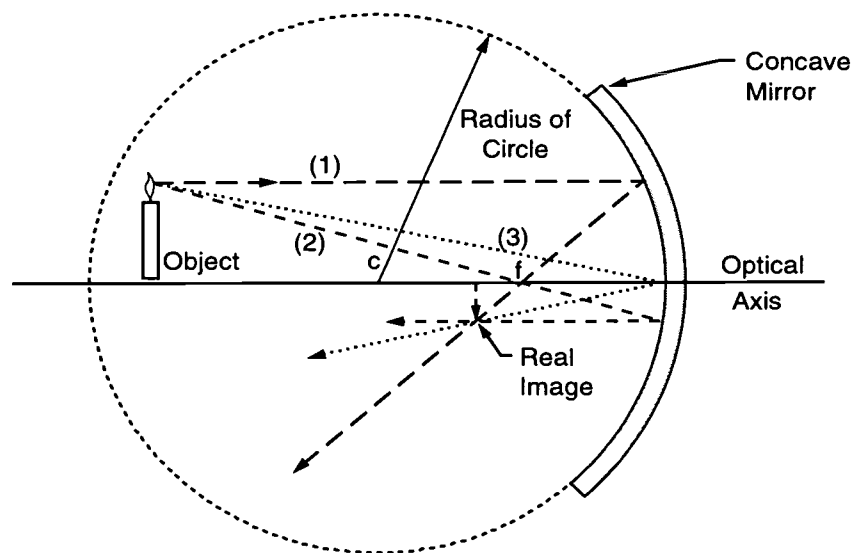

In the case where the object is located between the focal point and the mirror, such that the object distance is less than the focal length of the mirror, a virtual, upright, and enlarged image is obtained. This is the case when looking at yourself in a concave “make-up” mirror, which is described below.

A ray (1) appearing to come from the focal point strikes the mirror and is reflected parallel to the optical axis. A ray (2) parallel to the optical axis is reflected by the mirror so that it goes through the focal point. A ray (3) striking the mirror at the optical axis is reflected so that the angle of reflection is equal to the angle of incidence.

The ray diagram below uses three reflected rays to illustrate how the image can appear to be enlarged and upright. The image formed is a virtual image.

The Image Formed by a Convex Mirror

The image formed by a convex mirror is virtual, upright, and smaller than the object. This is illustrated by the ray diagram on the following page. The diagram depicts the three rays that are discussed in the following paragraph.

A ray (1) parallel to the optical axis is reflected as if it came from the focal point (f). A ray (2) directed toward the focal point is reflected parallel to the optical axis. A ray (3) striking the mirror at the optical axis is reflected at an angle equal to the angle of incidence.

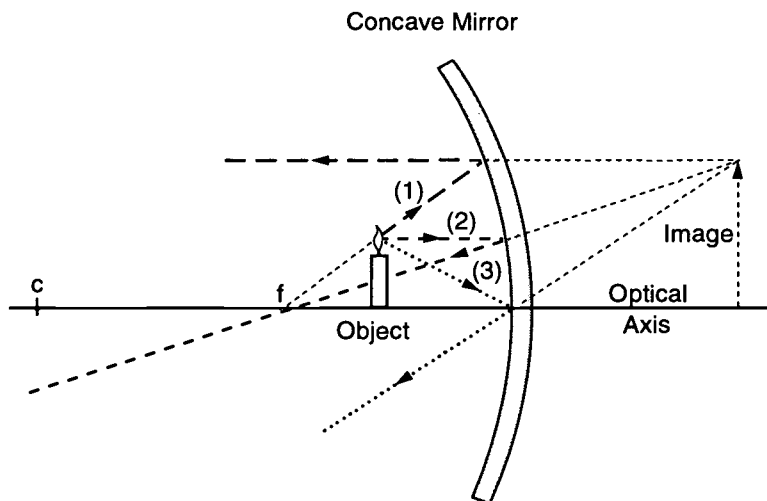

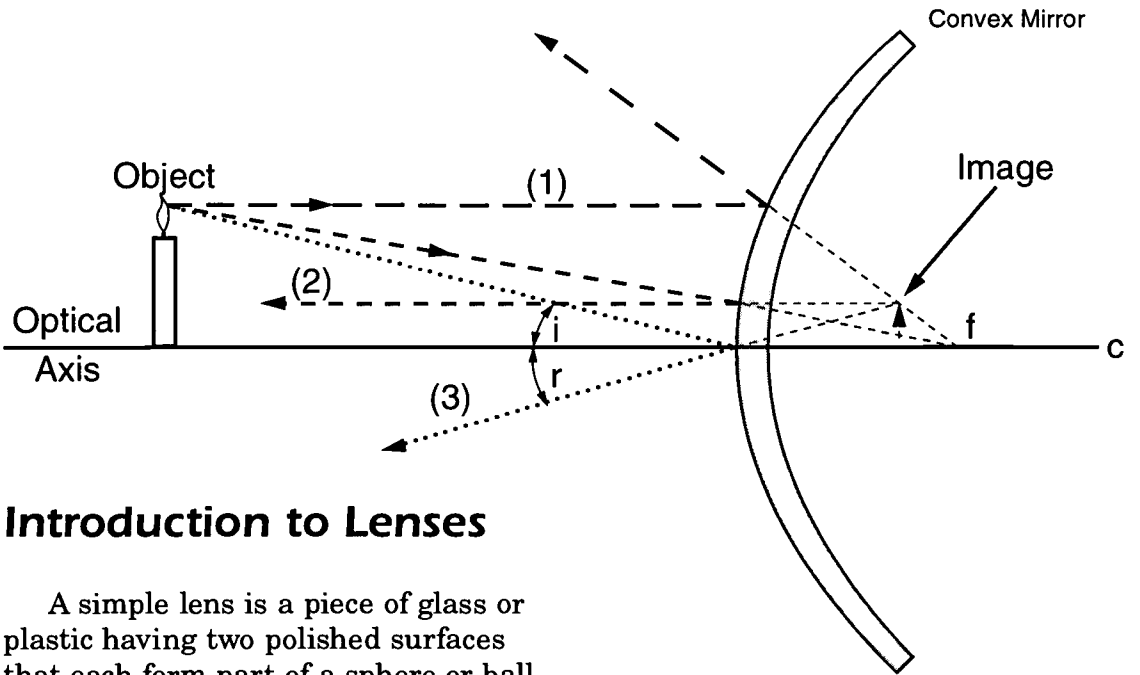

Introduction to Lenses

A simple lens is a piece of glass or plastic having two polished surfaces that each form part of a sphere or ball. One of the surfaces must be curved; the other surface may be curved or flat. An example of a simple lens would be obtained if a piece of a glass ball were sliced off as shown in the following illustration.

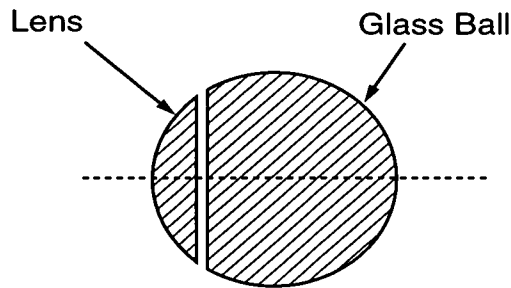

The piece of the ball sliced off would be a lens with a spherical side and a flat side. Lenses can be made in a variety of shapes for various applications. Some examples of lens shapes are illustrated here.

A lens thicker in the center than at the edge is called a converging or positive lens. A lens thinner at the center than at the edge is called a diverging or negative lens. In the illustration shown, lenses 1, 2, and 3 are converging or positive lenses. Lenses 4 and 5 are diverging or negative lenses.

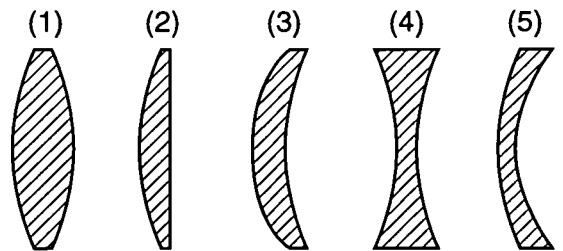

The Image Formed by a Converging Lens

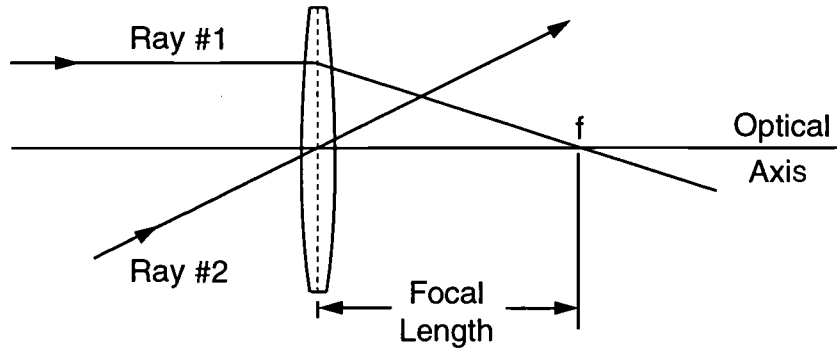

When using a thin lens, that is, the thickness at the center of the lens is not too great, a thin lens mathematical approximation can be used. This approximation assumes the bending of light occurs in one plane inside the lens.

A ray of light coming from a very distant object, such that the ray is parallel to the optical axis, will be bent by refraction at the two surfaces of the lens and will cross the optical axis at the focal point (f) of the lens, as seen in the illustration below. A ray passing through the center of the lens will pass through the lens undeviated.

The size and location of an image formed by a lens can be found by using the information from these two rays which is shown in the illustration below.

The following illustration depicts two rays, which are defined in the following text. A ray (1) parallel to the optical axis passes through the focal point (f). A ray (2) passing through the center of the lens is undeviated.

The image is real, smaller than the object, and upside down. If a piece of paper is placed at the image location, a real image can be seen on the paper. An example of this is taking a picture with a camera, where the photographic film is located at the image position.

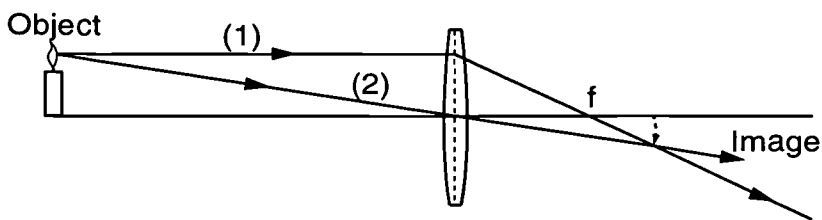

A Simple Magnifier

When the object lies between the lens and the focal point, a virtual, upright, and enlarged image is obtained, as seen in the illustration below.

Three rays are included in the illustration. Following are descriptions of these rays. A ray (1) leaving the object parallel to the optical axis will bend at the lens and go through the focal point (f). A ray (2) leaving the object going through the center of the lens will be undeviated. A ray (3) leaving the object as if it came from the front focal point of the lens will bend at the lens and travel in a line parallel to the optical axis.

After passing through the lens, the three rays described above will appear to come from an enlarged and upright image. Any other ray leaving the tip of the object will appear to come from the tip of the image after passing through the lens. The three rays used in the illustration below were chosen because their paths are always known. Two rays are actually enough to locate the image, while the third ray is used for an additional check of the location of the image.

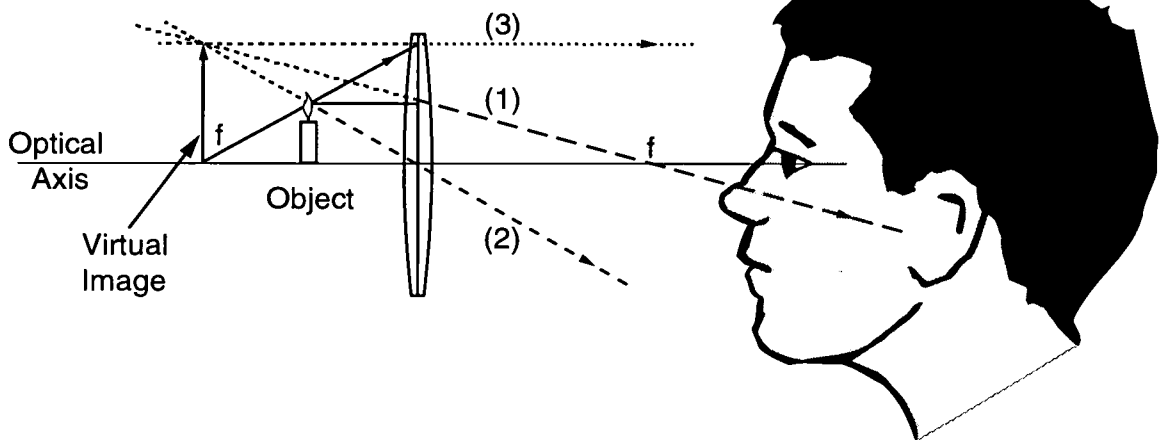

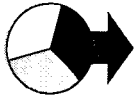

Reflection

Reflection of Light With a Plane (Flat) Mirror—Trace a Star

Objective



The student will experiment with reflection by using a plane mirror.

Theory



Flat mirrors are also called plane mirrors. Light rays that fall upon a surface are called incident rays. The angle at which light strikes a plane mirror from an object is called the angle of incidence. The angle at which light is reflected from the mirror is called the angle of reflection.

Science and Mathematics Standards



Science Standards

- Science as Inquiry
- Physical Science

Mathematics Standards

- Problem Solving
- Communication
- Connection
- Computation/Estimation
- Measurement

Materials



- 2 blocks of wood 8 inches long
- 1 piece of cardboard 8 inches × 5 inches
- 1 mirror tile (1 foot square backed with heavy cardboard sealed on the edges with thick tape)
- thick tape (duct tape)
- heavy cardboard
- tracing patterns (on page 15)
- pencil
- paper, white





Procedures

1. Stand the mirror at 90 degrees to the surface of the table.
2. Stand the two wooden blocks on the ends. Position them parallel to each side of the mirror and 10 inches from the face of the mirror.
3. Place the cardboard horizontally across the top of the two wooden blocks. Place a paper tracing pattern on the flat surface between the two blocks of wood.
4. Place your finger or pencil at the starting point on the pattern.
5. Look only in the mirror and trace the star pattern found on page 5. Now trace the swirl pattern also on page 5.

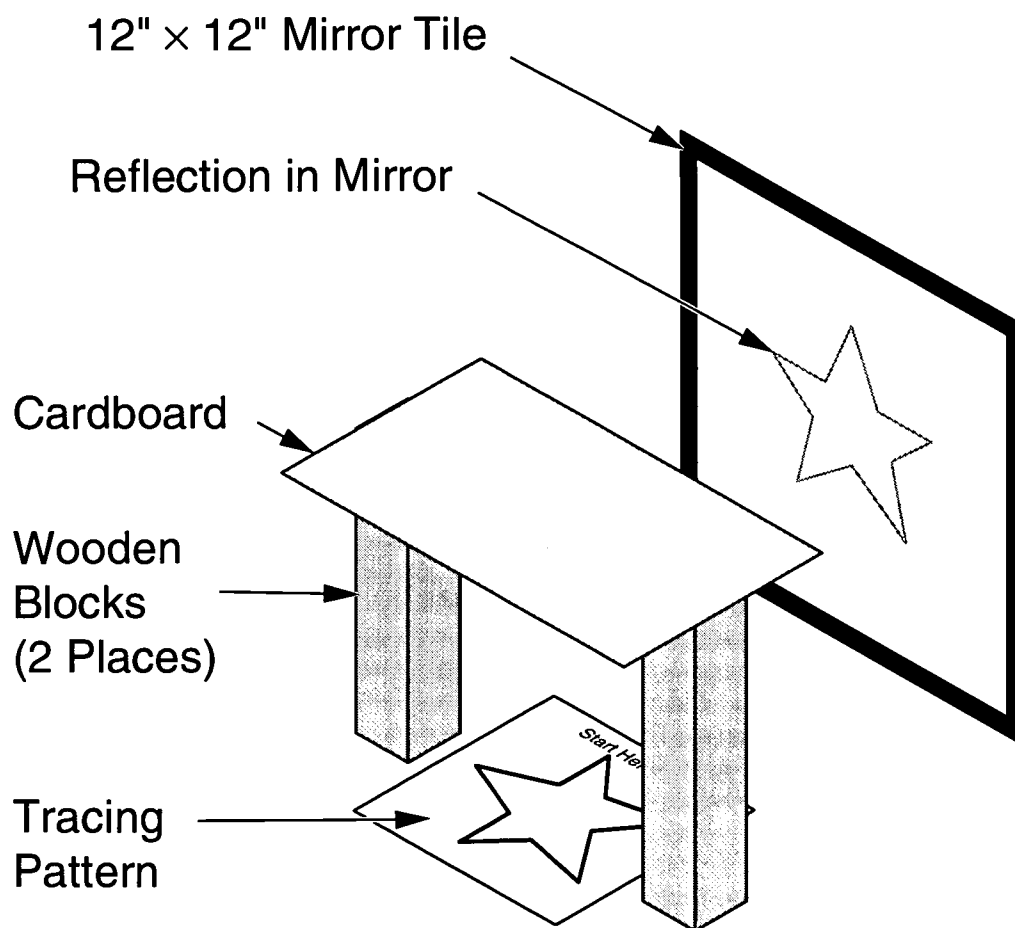

Light, Color, and Their Uses



Tracing Pattern #1

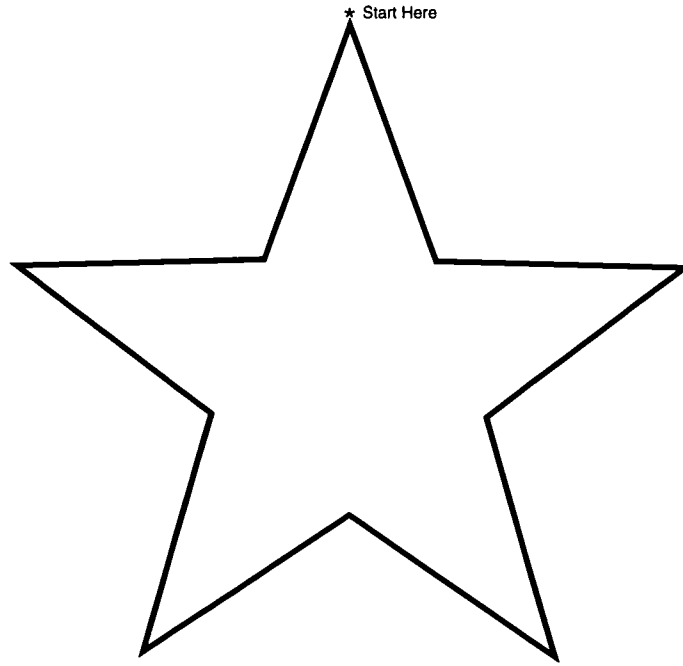

Tracing Pattern #2

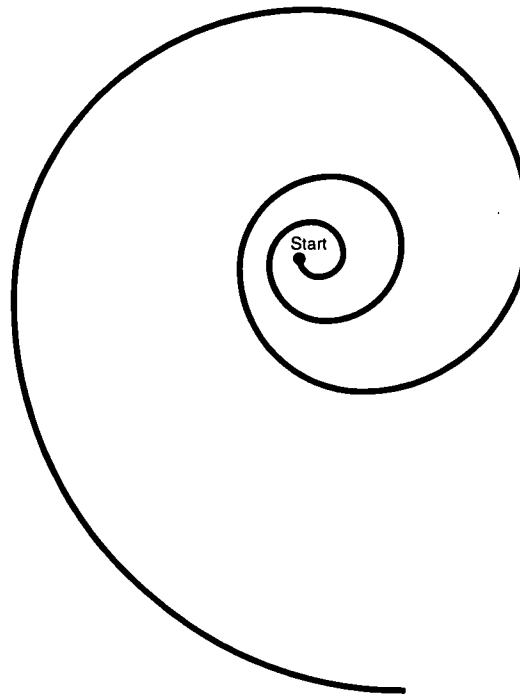

Observations, Data, and Conclusions



1. What did you learn after tracing the two patterns?
2. What information did your eyes give you?
3. What information did your brain or body give you?
4. Where did the hand in the mirror seem to be located when you looked in the mirror?
5. Is it harder to trace a pattern with your finger or with a pencil? Why?
6. What characteristic of light did you learn about when you did this activity?
7. After completing these questions, draw some designs of your own. Exchange your designs with another student and trace their designs.

Design Page

Light, Color, and Their Uses



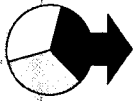

Reflection of Light With Two Plane Mirrors—Double Mirrors Placed at a 90-Degree Angle

Objective



The student will experiment with reflections of two plane mirrors placed at a 90-degree angle to see what will be reflected.

Theory



When you place two plane mirrors at a 90-degree angle, the image of the first mirror is reflected in the second mirror so that the reversed mirror image is reversed again, and you see a *true image*. (See Glossary, page 73.) The placement of images in the mirror will vary with the distance of the person or object in front of the mirror.

Science and Mathematics Standards



Science Standards

- Science as Inquiry
- Physical Science

Mathematics Standards

- Problem Solving
- Communication
- Connection
- Computation/Estimation
- Measurement

Materials



- 1 protractor
- 2 plane mirror tiles 12 inches square (These mirrors should be backed with heavy cardboard and sealed around the edges with thick tape. The mirrors should then be taped together to form two to four hinges. You now have framed mirrors that can stand alone.)
- cardboard
- tape



Procedures



1. Place the mirrors at a 90-degree angle.
2. Place yourself in front of the mirrors.
3. Look into the mirror and follow the instructions. All instructions should be followed while looking into the mirror, not at your body.
 - A. Raise the right hand that you see in the mirror.
 - B. Turn your head to the left.
 - C. Touch your right ear with your left hand.
 - D. Look into the mirror and wink your left eye.
 - E. Raise both hands with your palms facing the mirror.
 - F. Touch one little finger to the thumb on the other hand.
 - G. Bring both hands together until your fingers touch.
 - H. Raise the left hand with the palm facing the mirror and the right hand with the palm turned away from the mirror.
 - I. Touch your right shoulder with your left hand.
 - J. Choose a partner and give five instructions of your own.

Observations, Data, and Conclusions



1. What did you observe during this activity?
2. What information did your eyes give you?
3. Why was this activity difficult?
4. What characteristic of light did this activity use or demonstrate?

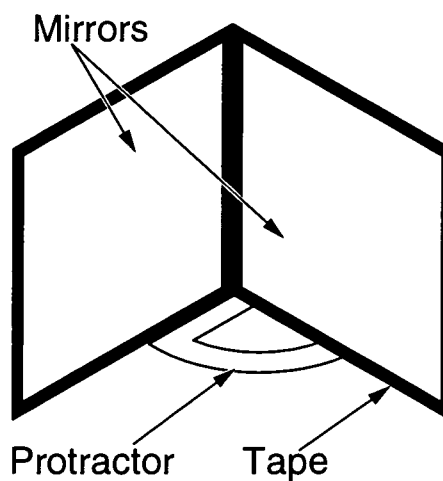

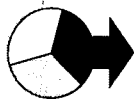

Reflection of Light With Two Plane Mirrors—Double Mirrors Placed at a Number of Angles

Objective



The student will experiment with reflections of two plane mirrors placed at different angles.

Theory



As the angle between two mirrors is increased and decreased, the number of reflected images increases and decreases. At some angles, you will see all complete images. At other angles, you will see some complete images and some parts of images. There is also a relationship between the size of the angles and the number of edges of the mirrors that are visible. Placement of the images in the mirrors depends on the distance from the surfaces of the two mirrors.

Science and Mathematics Standards



Science Standards

- Science as Inquiry
- Physical Science

Mathematics Standards

- Problem Solving
- Communication
- Connection
- Computation/Estimation
- Measurement

Materials

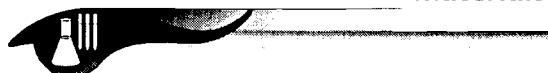

- 1 protractor
- 2 plane mirror tiles 12 inches square (These mirrors should be backed with heavy cardboard and sealed around the edges with thick tape. The mirrors should then be taped together to form two to four hinges. You now have framed mirrors that can stand alone.)
- cardboard
- tape



Procedures



1. Place the protractor on a table and stand the two mirrors on top of it at a 90-degree angle. The mirrors should be placed so that you can readily measure the angle as you open and close the mirrors.
2. Place the mirrors at a 90-degree angle. How many mirrors do you see? How many complete images do you see? How many parts of images do you see? Record your observations in the chart on page 21.
3. Change the mirrors to a 10-degree angle and count the whole images and the parts of images that you see. Repeat step 2.
4. Continue to change the degrees of the angle from 0 through 180 degrees and repeat step 2.

HINT: When you look into the mirrors, place your face between the two mirrors or as close to the edges as possible. Keep your face perpendicular to the space or hinge between the two mirrors.

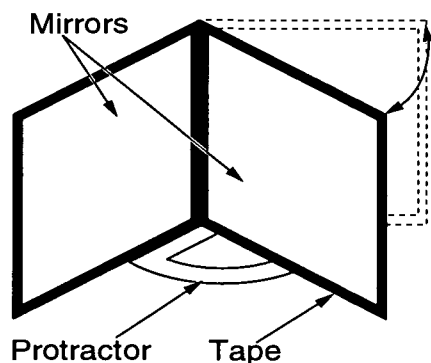

Observations, Data, and Conclusions

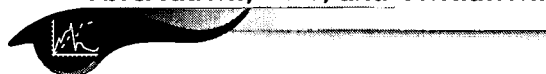

1. Make your observations as you complete the table on the following page. (Refer to question No. 4 below.)
2. At what degrees or angles do you seem to see whole images and no partial images?
3. How does the number of degrees seem to be related to the number of mirrors that you count?
4. Using the following formula, compute each angle measured and compare your answers to what you see in the mirror. Because you are using simple materials, your observations may differ slightly with the computations.

Number of images observed in mirror equals 360 degrees divided by angle indicated on the protractor.

Example: $360^\circ \div 90^\circ = 4$ images

Perform the math computations and complete the table in question No. 1 above.

5. Are the number of observed images and the computed math answers the same? Why or why not?



Reflection

Angle	Number of Mirrors Observed	Number of Images Observed	Computations
10°			
20°			
30°			
40°			
50°			
60°			
70°			
80°			
90°			
100°			
110°			
120°			
130°			
140°			
150°			
160°			
170°			
180°			



Math Computations:

Light, Color, and Their Uses



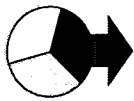

Making a Kaleidoscope

Objective



The student will experiment with multiple reflections in mirrors.

Theory



When three rectangular mirrors that are the same size are arranged in an *equilateral triangle* (See Glossary, page 73), rays of light from an object form multiple images due to reflections from the mirrors. The equilateral triangle formed by the mirrors has three equal angles of 60 degrees, and the sides have equal lengths.

Science and Mathematics Standards



Science Standards

- Science as Inquiry
- Physical Science

Mathematics Standards

- Problem Solving
- Communication
- Connection
- Computation/Estimation
- Measurement

Materials



- 3 flat rectangular mirrors of equal size
- rubber bands
- Transparent tape
- small items to put in the kaleidoscope (glitter, confetti, ect.)
- a piece of white cardboard
- resealable bag



Procedures

A-B
C-D

1. Place the three mirrors together as shown, using the long side of each mirror. Put a few pieces of tape on the backs of the mirrors to hold them together.
2. Put two of the rubber bands around them to hold them securely together.
3. Use this simple kaleidoscope to do the following activities.
 - A. Hold the kaleidoscope in your hand and look through it at objects around the room.
 - B. Hold the kaleidoscope above the white cardboard and look down inside it. Put some object such as a coin, or the small pieces of colored paper in the resealable bag (keep them in the bag) on the white cardboard inside the kaleidoscope. Observe the images reflected in the mirrors.

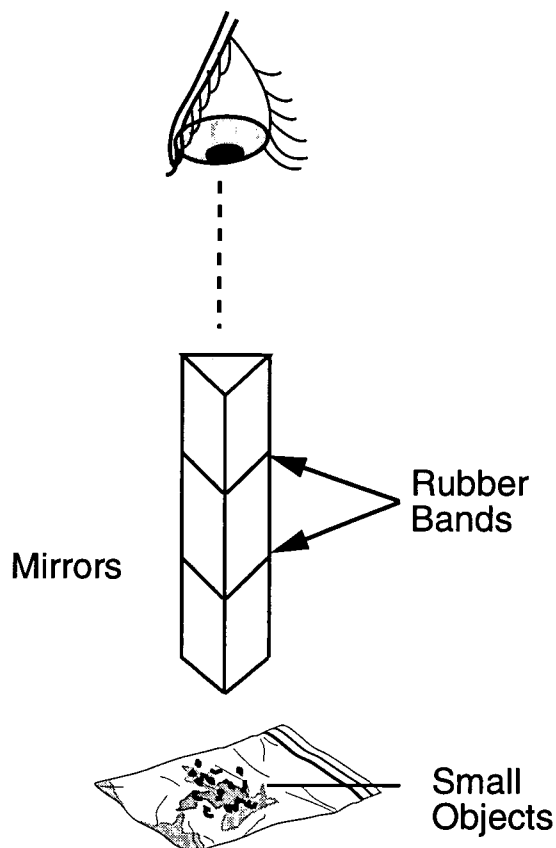

Observations, Data, and Conclusions

K-K

1. How many images did you see?
2. Did the images appear to be the same size as the object?
3. How were the objects oriented with respect to the reflected images?

Light, Color, and Their Uses



Junior Home Scientist Project



Construction of a Large Kaleidoscope Using PVC Pipe (Adult Supervision Is Required at All Times)

Materials



- 1 piece of PVC pipe 10 centimeters (about 4 inches) in diameter and about 16 inches long
- 12-inch mirror tile
- hack saw with fine blade
- 1 glass cutter
- sandpaper
- flat black spray paint
- white glue
- epoxy glue
- cardboard
- foam rubber used for packing and shipping
- scissors or utility knife
- thick leather gloves
- red, blue, or yellow paint (optional)
- contact paper (optional)

Procedures



1. Buy or cut to size the 16-inch length of PVC pipe. Sand the edges and corners of the pipe until they are smooth.
2. Use the flat black paint and spray the inside of the pipe. Leave the paint to dry overnight. Later, paint the outside of the pipe any color or design that you desire. Contact paper could also be used.
3. While wearing leather gloves, cut the 12-inch square mirror tile into 3-inch strips. Sand the edges of the mirrors.
4. Position the three strips of glass close to one end of the PVC pipe. Place the mirrors to form three 60-degree angles.
5. Use the epoxy to glue the mirrors inside the pipe. Pack foam behind each mirror to provide stability.
6. Cut a circular piece of cardboard to fit the inside diameter of the pipe. Cut a 1-inch hole in the middle of the cardboard.



7. Position this circular cardboard piece into the end of the PVC pipe and glue it with white glue to form the eye piece of the kaleidoscope.
8. Now cut another circular cardboard piece to fit the opposite end of the pipe. In the center of the cardboard cut a triangle with three 60-degree angles.
9. Match this triangular opening with the opening formed by the three mirrors and use the white glue to glue the cardboard into place.

Variations:

It is also possible to make a kaleidoscope using two mirrors positioned at a 20-degree angle. You may fill in the third side with a piece of mirror tile. Experiment with various angles of the mirrors and locations of the eyepiece holes. Kaleidoscopes made with smaller angles are more interesting.

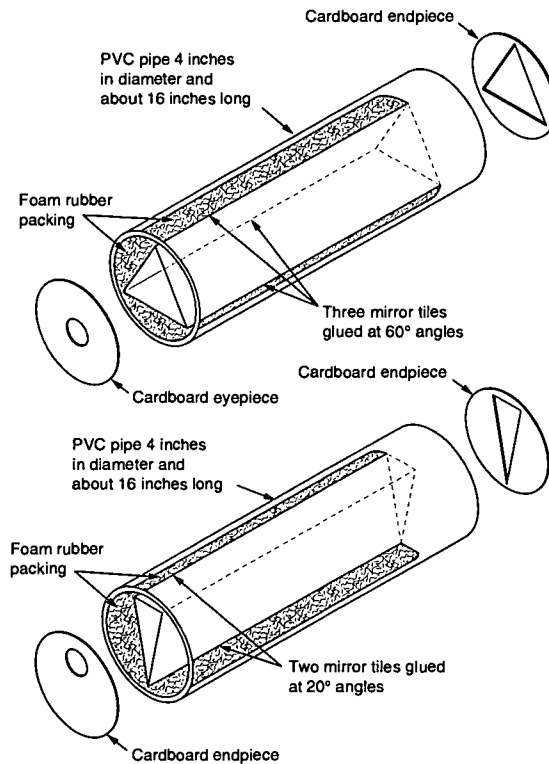

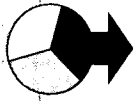

Making a Periscope

Objective

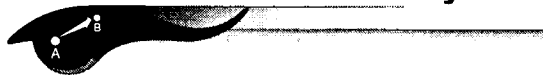

The student will experiment with a simple periscope to see how it reflects light.

Theory

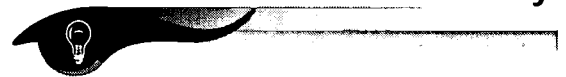

A periscope is an optical instrument that uses a system of prisms, lenses, or mirrors to reflect images through a tube. Light from a distant object strikes the top mirror and is then reflected at an angle of 90 degrees down the periscope tube. At the bottom of the periscope, the light strikes another mirror and is then reflected into the viewer's eye. This simple periscope uses only flat mirrors as compared to the periscopes used on submarines, which are usually a complex optical system using both lenses and mirrors.

Science and Mathematics Standards



Science Standards

- Science as Inquiry
- Physical Science

Mathematics Standards

- Problem Solving
- Communication
- Connection
- Computation/Estimation
- Measurement

Materials



- 2 flat mirrors
- a cardboard tube with openings on each end
- wooden supports
- tape



Procedures



Insert both flat mirrors into the periscope viewing tube as shown. The mirrors must be facing each other. When the mirrors are inserted correctly each mirror will be resting on the wooden supports. As each mirror is inserted, place a small piece of Scotch tape over the mirror slots on the outside of the viewing tube. Hold the periscope so the mirrors are resting on the wooden supports, then look through it.

NOTE: The mirrors will fall out if you turn your periscope upside down.

Observations, Data, and Conclusions



1. Draw a diagram of the path a ray of light follows as it travels from an object, through the periscope, and into your eye.
2. Do you think the periscope would work if the mirrors were at some angle other than 45 degrees?

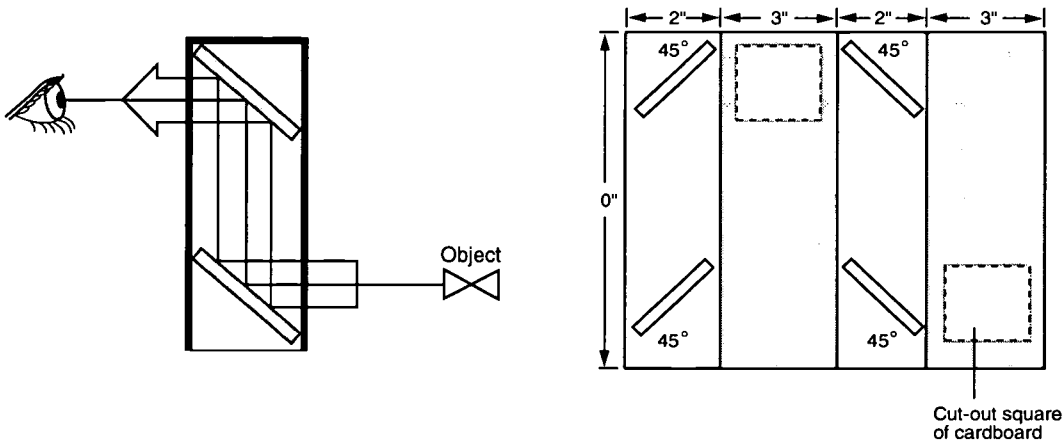

Junior Home Scientist



A periscope can easily be made from materials that you can find at home. The drawing above gives you an example to use. Mirrors of any size will do, as long as they are flat.

Light, Color, and Their Uses



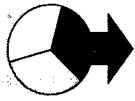

Constructing a Spectroscope

Objective



With adult supervision the student will construct a simple spectroscope.

Theory



All elements or pure substances, such as gold, silver, neon, or hydrogen, give off a set of wavelengths of light when they are heated. Scientists can study the light given off by stars and other objects in space or heated substances here on Earth and identify the kinds of elements that are present. In fact, the element helium, which is a very light gas, was discovered by studying the spectral lines of the Sun. Later, helium was found here on Earth. Scientists who study light use very complicated spectroscopes to observe and measure wavelengths given off by light sources.

Science and Mathematics Standards



Science Standards

- Science as Inquiry
- Physical Science

Mathematics Standards

- Problem Solving
- Communication
- Connection
- Computation/Estimation
- Measurement

Materials



- 1 cardboard box with lid
- sharp knife or blade
- 1 double-edged razor blade
- scissors
- black marker
- tape
- 1 manila file folder
- commercially purchased diffraction grating (plastic material with 13,440 grooves per square inch). (See List of Catalogs, page 83.)



Procedures

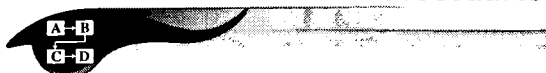

1. Make or adapt a box that is about 10 inches long, 6 inches wide, and 2 inches deep. The box must have a tight lid.
2. Use a black marker and color the inside of the box and lid.
3. Choose one end of the box and measure $\frac{1}{4}$ inch from the corner. **WITH ADULT HELP OR SUPERVISION**, cut out a 1-inch square hole.
4. Next cut a piece of diffraction grating $1\frac{1}{2}$ inches square.
5. Cut a frame of manila paper for the diffraction grating. The side measurements should be $1\frac{1}{2}$ inches square, and inside measurements for the hole in the frame should be 1 inch square.
6. Frame the diffraction grating and tape it inside the box to cover the 1-inch square hole cut in step No. 3, with lines of the diffraction grating vertical.
7. Directly opposite the diffraction grating on the other end of the box, measure and mark $\frac{1}{2}$ inch from the corner of the box and $\frac{1}{4}$ inch from the bottom. **WITH ADULT HELP OR SUPERVISION**, cut a hole 1-inch high and $\frac{1}{2}$ -inch wide.
8. Cut a rectangle of manila paper $1\frac{1}{2}$ inches by 2 inches. In the center of the manila rectangle, cut a small rectangular hole $\frac{3}{4}$ -inch high and $\frac{1}{4}$ -inch wide.

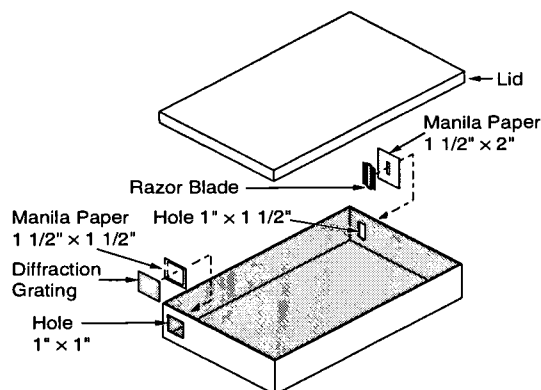

9. **WITH ADULT SUPERVISION**, break the razor blade into two pieces along the long hole in the blade. Place the sharp edges of the blade together to form a long narrow slit.
10. Mount the razor blade slit so that the long slit is parallel to the lines of the diffraction grating.
11. **WITH ADULT SUPERVISION**, center the slit in the double-edge razor blade over the opening in the large manila rectangular frame. Tape pieces of the blade in place.
12. Tape the framed razor blade to the outside of the box on the end opposite from the diffraction grating.
13. Place the lid securely on the box. Find a light source. Aim the razor blade at the light and look through the diffraction grating.
14. Observe the emission spectrum emitted by the light source.

Light, Color, and Their Uses





Diffraction

Exploring Diffraction With a Spectroscope

Objective

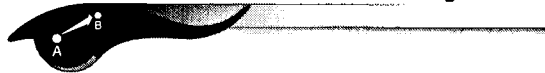

The student will be able to see what happens to light when it passes through a spectroscope.

gives off the same group of wavelengths. This group is called the emission spectrum of the element.

Science and Mathematics Standards



Science Standards

- Science as Inquiry
- Physical Science

Mathematics Standards

- Problem Solving
- Communication
- Connection
- Computation/Estimation
- Measurement

In the visible wavelengths of the electromagnetic spectrum, red, with the longest wavelength, is diffracted most; and violet, with the shortest wavelength, is diffracted least. Because each color is diffracted a different amount, each color bends at a different angle. The result is a separation of white light into the seven major colors of the spectrum or rainbow. A good way to remember these colors in order is the name Roy G. Biv. Each letter begins the name of a color: red, orange, yellow, green, blue, indigo, and violet. (Reference Electromagnetic Spectrum page 34.)

Theory

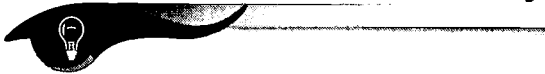

A spectroscope is a device that can be used to look at the group of wavelengths of light given off by an element. All elements give off a limited number of wavelengths when they are heated and changed into gas. Each element always

Materials

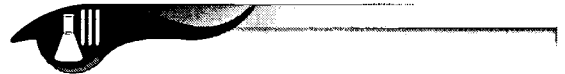

- spectroscope (one spectroscope for four students)
- light sources (sunlight, incandescent, fluorescent, cadmium, sodium, neon, mercury, helium, etc.) (See List of Catalogs, page 83.)
- diffraction grating
- compact disc



--	--	--	--	--	--	--	--

R O Y G B I V
 Red Orange Yellow Green Blue Indigo Violet

(Students should color these boxes with their crayons.)

Procedures



Use a spectroscope and look at different kinds of light. View bulbs with different gases inside.

3. When you look at the different light sources through the spectroscope, observe the stripes of color. Do they fade or blend into each other? Describe the bands of color.
4. Does each light source produce the same group of colors or spectrum?
5. Each group of colors for each different light source is called the emission spectrum for that source. How are the spectra or groups of colors alike? Different?
6. Why are the groups of color for each light source different?

Observations, Data, and Conclusions



1. Observe each source of light. Explain what you see.
2. Observe the colors. Start with the first color on the left and list them in the table in the order that you see them.

Light Source	Colors

Light, Color, and Their Uses



Additional Activities



White light can be separated into all seven major colors of the complete spectrum or rainbow by using a diffraction grating or a prism. The diffraction grating separates light into colors as the light passes through the many fine slits of the grating. This is a transmission grating. There are also reflection gratings. A reflection grating is a shiny surface having many fine grooves. A compact disc makes a good reflection grating.

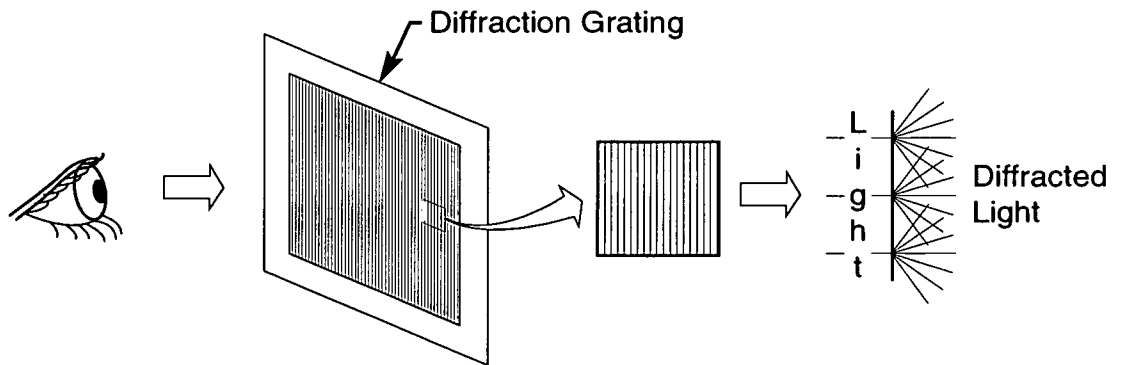

The prism separates light into colors because each color passes through the prism at a different speed and angle. The angles of reflection of the light, upon entering and leaving the prism, vary with the wavelength or color of the light.

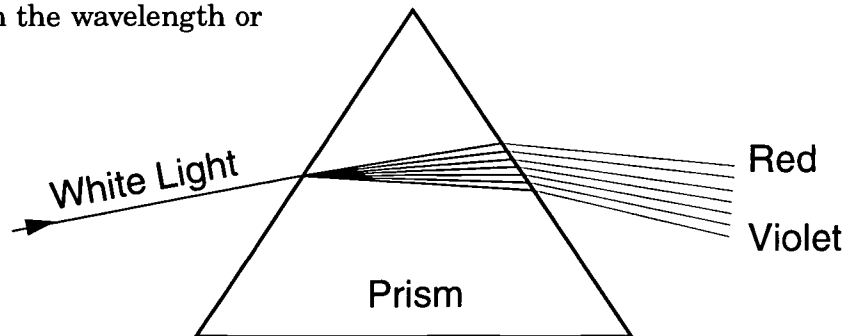

The Electromagnetic Spectrum

For hundreds of years, scientists believed that light energy was made up of tiny particles which they called "corpuscles." In the 1600's, researchers observed that light energy also had many characteristics of waves. Modern scientists know that all energy is both particles, which they now call *photons*, and waves.

Photons travel in *electromagnetic waves*. These waves travel at different *frequencies*, but all travel at the speed of light. The *electromagnetic spectrum* is the range of wave frequencies from low frequencies (below visible light) to high frequencies (above visible light). (See figure below.)

The *radio wave* category includes radio and television waves. These low-frequency waves bounce off many materials.

Microwaves pass through some materials but are absorbed by others. In a microwave oven, the energy passes through the glass and is absorbed by the moisture in the food. The food cooks, but the glass container is not affected.

Like other wavelengths, *infrared* or heat waves are more readily absorbed by some materials than by others. Dark materials absorb infrared waves while light materials reflect them. The Sun emits infrared waves, heating the Earth and making plant and animal life possible.

Visible light waves are the very smallest part of the spectrum and are the only frequencies visible to the human eye. Colors are different within this category, ranging from the red wavelengths, which are just above the invisible infrared, to violet. Most of the Sun's energy is emitted as visible light.

The Sun also emits many *ultraviolet* waves. High-frequency ultraviolet wavelengths from the Sun cause sunburn.

X rays can penetrate muscle and tissue but are blocked by bone, making medical and dental x-ray photographs possible.

Gamma-ray waves, the highest frequency waves, are more powerful than x rays and are used to kill cancerous cells.

The atmosphere protects Earth from dangerous ultraviolet, x-ray, and gamma-ray radiation.

The Electromagnetic Spectrum

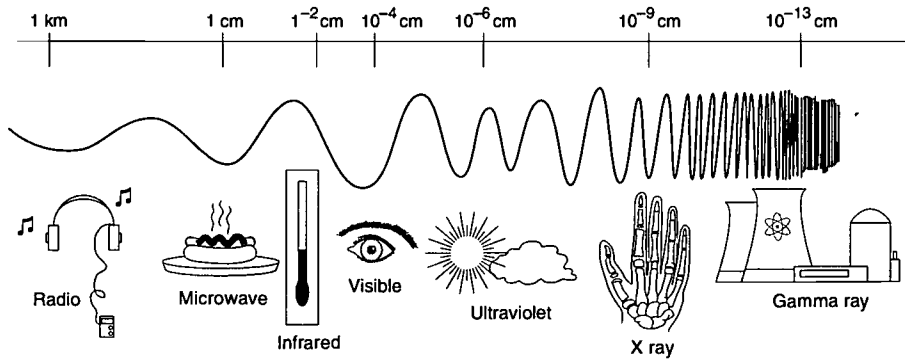



Diffraction

Diffraction of Light by Very Small Apertures

Objective



The student will observe that when light passes through a small hole, it no longer travels in a straight line. The observed light pattern illustrates the wave behavior of light. The student will determine what light pattern is created by light passing through each diffraction screen.

Theory



When light passes through a small hole or a narrow slit, the light waves spread out. The hole or slit must be extremely small for the effect of this spreading to be seen. Each point of the hole or slit acts like a source of a spherical wave. At certain angles, the spherical waves from all the points will be in phase and will add to form a bright spot. At other angles the waves will be out of phase and will cancel to form a dark spot. The pattern of light and dark is called the diffraction pattern. The diffraction pattern depends on the shape of the aperture (square or slits). (See Glossary, page 73).

Science and Mathematics Standards



Science Standards

- Science as Inquiry
- Physical Science

Mathematics Standards

- Problem Solving
- Communication
- Connection
- Computation/Estimation
- Measurement

Materials



- 2 diffraction screens, one of narrow parallel slits and one of square apertures (See List of Catalogs, page 83.)
- a distant or point light source



Procedures



Use both diffraction screens, one at a time.

1. Hold one diffraction screen by its edges and place it in front of your eyes. Look through it at a point source of light several feet away from you.

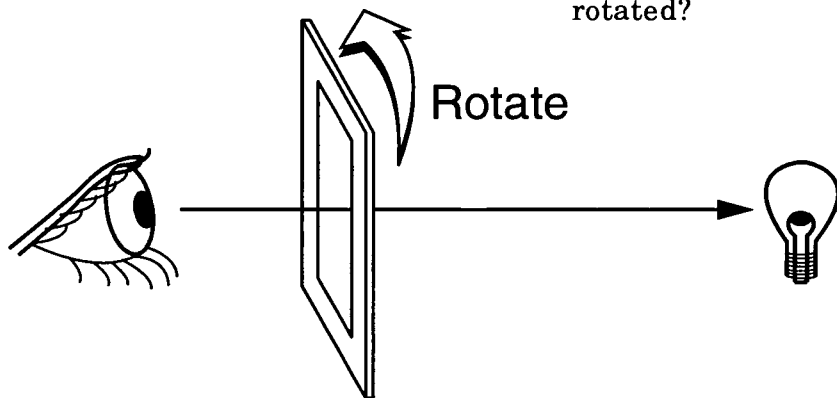

2. Slowly rotate the diffraction screen while continuing to look through it at the light source.
3. Repeat steps 1 and 2 with the other diffraction screen.

Observations, Data, and Conclusions



1. Draw or describe the pattern you observed through each diffraction screen the first time you looked at the light source.
2. How did the pattern change as each diffraction screen was slowly rotated?

Junior Home Scientist



You can observe the same square aperture diffraction pattern using a point source of light at home. Find a window with sheer curtains and observe a street light through the curtains. This experiment will need to be done at night when the street light is lit. To observe the diffraction pattern, turn the room light off and look at the street light through the sheer curtain. The street light serves as the light point source and the curtain provides the diffraction screen.



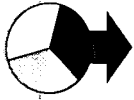

Discovering Color With a Prism

Objective



The student will observe what happens to light as it passes through a prism. The student will experiment with white light that is composed of a continuous band of colors. The band of colors appears in the same pattern as the colors of a rainbow.

Theory



This experiment was first done by Sir Isaac Newton (1642–1727). Newton let a beam of sunlight pass through a glass prism and observed the white light spectrum. In a vacuum, light of all colors travels at the same speed. When light passes through a material, such as glass or water, the red light at one end of the spectrum travels faster than the violet light at the other end of the spectrum. This difference in speed causes a change in the direction of light when going from air to glass and from glass to air. This change of direction is called refraction, and is greater for violet light than for red light. The speed of light in the glass depends on the color; thus we get a continuous band as in the rainbow.

Science and Mathematics Standards



Science Standards

- Science as Inquiry
- Physical Science

Mathematics Standards

- Problem Solving
- Communication
- Connection
- Computation/Estimation
- Measurement

Materials



- glass or plastic prism
- light sources, including an incandescent lamp, fluorescent lamp, cadmium lamp
- a prism made out of acrylic plastic (see page 40) (optional)



Procedures



1. Hold the small prism with one finger at the top and one finger at the bottom. Position the prism 2 to 3 inches in front of your eye. Look through one side of it in the direction of the light source as shown below.
2. First, look at the incandescent lamp. Observe the colors that are visible as you view this lamp.
3. Next, view the fluorescent lamp and then the cadmium lamp. (The kinds of light source may vary.)
4. Record your observations in the next section.

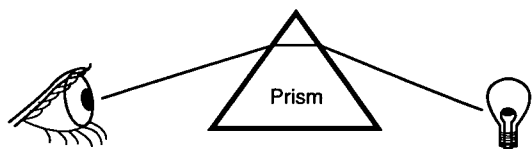

Observations, Data, and Conclusions



1. Observe the colors from the three different light sources and list them in order in the chart below. Start with the first color on the left and list them as you see them. (Hint: ROY G. BIV—red, orange, yellow, green, blue, indigo, violet)
2. What differences and/or similarities did you observe in each light source when looking through the glass, plastic or acrylic plastic?
3. Were the colors always in the same order?
4. Were the colors always in bands?
5. Did the bands always form the same shapes?

Hint: An artificial light source will not transmit the complete spectrum unless it is a white light source.

Light Source	Colors
Incandescent Lamp	
Fluorescent Lamp	
Cadmium Lamp	

Light, Color, and Their Uses



Additional Activities



Repeat the previous activities with a high quality prism (highly dispersive). What differences do you observe between the acrylic plastic or plastic prism and the prism made out of optical quality glass?

Junior Home Scientist



You can make a prism at home by placing a flat mirror in a shallow pan of water. Put the pan of water in a window where the Sun can shine into the water. (See the figure below.) The sunlight reflected from the mirror can be seen as a rainbow of colors reflected on a wall.

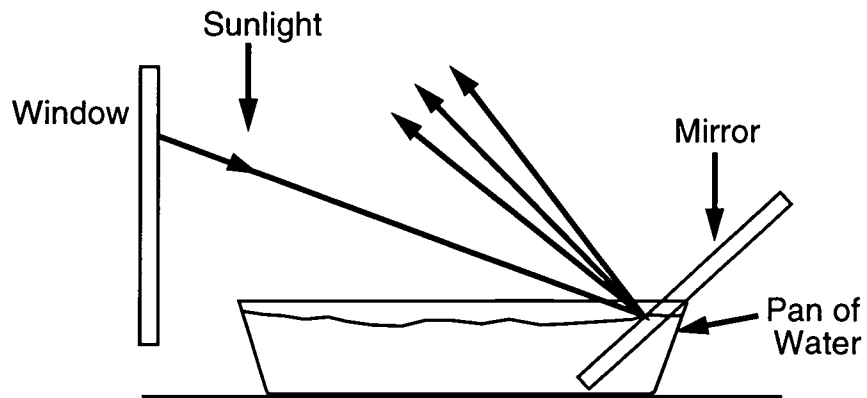

Fabrication of a Prism From Acrylic Plastic

Materials

- acrylic plastic about one-half inch thick.
- Hacksaw with fine blade or band saw, very fine sandpaper (400 or 600 grit, possibly available at auto paint stores or auto body repair shops), very fine file, craft felt, silver polish, one small board with two tacks (optional).

Procedures

1. Place the plastic in a bench vise and cut it to shape with a fine-blade hacksaw. The angles should be as near 60 degrees as possible. File the cut edges smooth.
2. Put a piece of fine sandpaper (400 or 600 grit) on a flat surface. Rub the cut face or edge of the prism on the sandpaper holding the face or cut edge flat against the paper in order to get a nice flat face. Continue sanding and using finer and finer sandpaper until the surface is smooth, free of scratches, and has a translucent appearance.

3. Now the plastic is ready to polish to make the surface transparent. The polishing pad is a 2-inch \times 4-inch piece of craft felt. Tack the felt to a board or hold it stretched on a flat surface. Wet the felt with water and put a small amount of silver polish on the felt. Rub the plastic on the felt strip. Expect to spend one-half hour or more to polish a single edge or face of the plastic. When finished, wet the plastic with water and pat it dry so the surface will not be scratched.

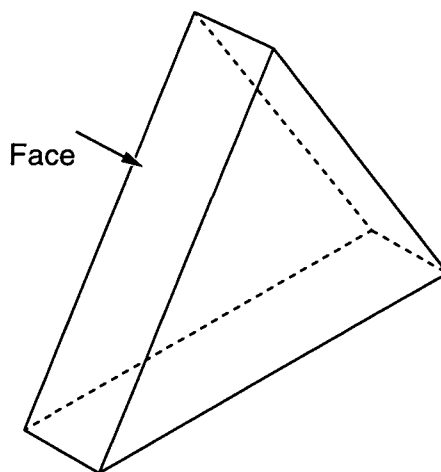

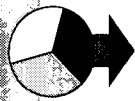

Light and Color—Color Spinners

Objective



The student will observe the effects of rapid movement using colors. The student will observe how colors change and how different colors can be made.

Theory



Some colors are made by adding or subtracting parts of the colors in the spectrum. When designs of more than one color are moved rapidly, the human eye sees these colors blended or mixed.

Science and Mathematics Standards



Materials



Science Standards

- Science as Inquiry
- Physical Science

Mathematics Standards

- Problem Solving
- Communication
- Connection
- Computation/Estimation
- Measurement

- strong string such as kite string
- white cardboard circles 2 to 4 inches in diameter
- magic markers or washable paint
- scissors



Procedures



1. Color the circles with the magic markers. You may color each section a different color or draw a colorful design.
2. When you have colored the circle on both sides, punch two holes in the center of the circle about one-half to one-quarter inch apart.
3. Cut a piece of string about 36 to 48 inches long. Thread the string through the two holes and tie the two ends together.
4. Now hold a piece of the string in each hand and twist it. Pull the string and make the paper circle spin.

Observations, Data, and Conclusions



1. Observe the pattern on the spinning circle. What did you see?
2. What colors did you see?
3. Did the colors seem to mix and become other colors?
4. How can you make green?
5. How can you make orange?
6. How can you make gray or white?
7. How can you make brown?
8. Can you make stripes? How?
9. What else can you make? Keep experimenting!

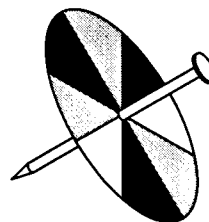
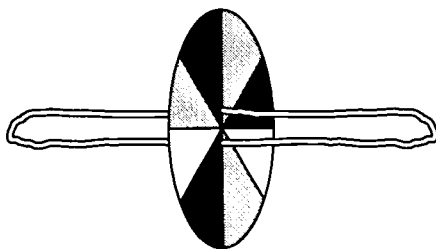
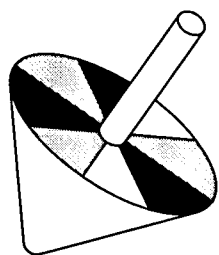

Light, Color, and Their Uses



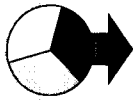

Light and Color—Filters

Color

Objective



The student will experiment with color by using a variety of filters.

Theory



Light is the only source of color. Color pigments (paints, dyes, or inks) show color by absorbing or subtracting certain parts of the spectrum, and reflecting or transmitting the parts that remain. The visual sensation of all the colors can be created by adding different intensities or amounts of the three primary colors—red, green, and blue. Filters subtract or absorb a band of wavelengths of color and transmit the other wavelengths. A yellow filter transmits yellow and a red filter transmits red.

Science and Mathematics Standards



Science Standards

- Science as Inquiry
- Physical Science

Mathematics Standards

- Problem Solving
- Communication
- Connection
- Computation/Estimation
- Measurement

Materials



- a variety of transparent filters or cellophane of different colors (See List of Catalogs, page 83.)
- light source such as a window
- slide projector or overhead projector



Procedures



Place a filter in front of the light source. Combine two colored filters. Now combine three colors. Experiment with many different combinations.

Observations, Data, and Conclusions



1. What colors can you make with two different filters?
2. What colors can you make with three different filters?
3. How many different colors can you make?
4. What did you learn about color filters?

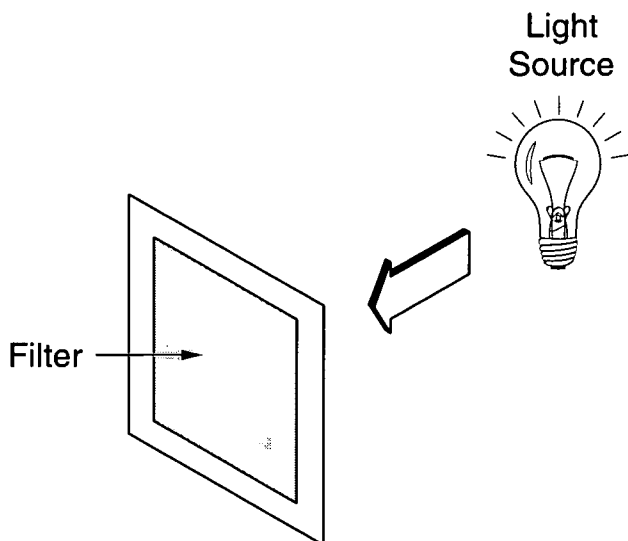

Light, Color, and Their Uses



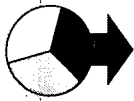

Light and Color—Hidden Messages

COLOR

Objective



The student will construct, experiment, and observe with designs viewed through color filters.

Theory



A totally transparent piece of glass transmits all wavelengths of light. An opaque object will transmit no light at all. A red filter transmits red, a blue filter transmits blue, and a yellow filter transmits yellow; so that all other colors are absorbed or subtracted. Some manmade sources of light, such as fluorescent bulbs, cause objects to appear to be different colors because they do not generate all the wavelengths of white light.

Science and Mathematics Standards



Science Standards

- Science as Inquiry
- Physical Science

Mathematics Standards

- Problem Solving
- Communication
- Connection
- Computation/Estimation
- Measurement

Materials



- white paper
- highlight or pastel magic markers (three or more colors)
- transparent color filter or cellophane in a variety of colors
- a card with several hidden messages of different colors (handmade)



Procedures



1. Using at least 3 different magic marker colors, draw a design. Think in terms of space and astronomy designs.
2. Use magic markers to draw more designs, be sure to include at least one hidden message in your designs. Can you hide three or more messages in one design?

(Students should use a space or astronomy word as their hidden message and then draw designs over it.)

3. View the design through several filters.

Observations, Data, and Conclusions



1. When you viewed the designs without a filter, what did you see?
2. What did you see when you looked at your design with each colored filter?
3. What did you see when you used two different filters together?
4. Why did you see different things with each different filter?
5. If possible, exchange designs with another person and read their secret message.

Light, Color, and Their Uses



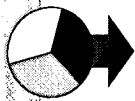

Lenses

Simple Magnifiers

Objective



The student will experiment with magnifiers.

Science and Mathematics Standards



Simple double-convex lenses can make good magnifiers. Some transparent bottles and jars bend light and magnify print. They may also reverse the print. Water in a jar or a drop of water can also serve as a magnifier.

Science and Mathematics Standards

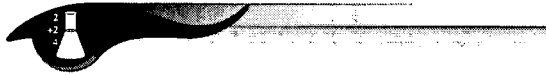

Science Standards

- Science as Inquiry
- Physical Science

Mathematics Standards

- Problem Solving
- Communication
- Connection
- Computation/Estimation
- Measurement

Materials



- photographic slide frame or thin piece of cardboard with a 1-inch square hole
- transparent tape
- small transparent sauce or condiment bottles
- jars of different shapes
- water
- old magazine or newspaper



Procedures



1. Place a piece of transparent tape across the opening of the slide or cardboard. Wet one finger and place one small drop of water onto the tape.

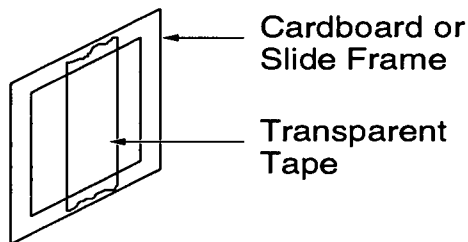

2. Position the water drop above the newspaper or numbers. Can you read the letters or numbers?
3. Continue to experiment. Use a big drop of water. Use a tiny drop of water. Hold the drop very close to the letters and words. Move the drop slowly away from the words. Keep experimenting.
4. Now place the edges of the bottles close to the words. Do all of the bottles magnify? Do some of them magnify? Do they magnify better if you put water in them? Experiment with bottles of all shapes. Do some jars of water reverse letters?

Observations, Data, and Conclusions



Water Drop Magnifier

1. What did you see when you looked through the drop of water?
2. Could you read the letters? Did the letters and numbers appear larger?
3. How did you focus the water drop magnifier?
4. Which water drop magnified more, the large drop or the small drop? Why? Hint: How does the size of the water drop effect the way light is bent or refracted?

Bottles and Jars that Magnify

5. What shape bottle or jar magnifies best?
6. What parts of bottles magnify best?
7. Do these bottles or jars magnify better with water in them?
8. Why do bottles magnify objects?

Light, Color, and Their Uses



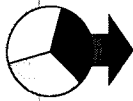

Lenses, Refraction

Focusing Light With a Lens

Objective



The student will experiment with a converging lens that has a focal point which can be easily measured. Using a lens, the student will observe the image of an object through a lens and will determine the magnification of that lens.

focus at the focal point of the lens. Since it is inconvenient to get infinite distances in the classroom, the following lens equation is used to compute the focal length of a lens:

$$\frac{1}{f} = \frac{1}{D_o} + \frac{1}{D_i}$$

Science and Mathematics Standards

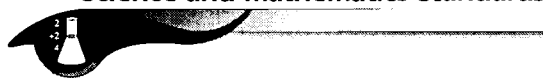

Science Standards

- Science as Inquiry
- Physical Science

Mathematics Standards

- Problem Solving
- Communication
- Connection
- Computation/Estimation
- Measurement

The measured distance of the object, D_o , from the lens, and the measured distance of the image, D_i , are used to compute the focal length, f , of a converging lens. A more convenient form of this equation is

$$f = \frac{D_i D_o}{D_i + D_o}$$

Theory



When light from a source that is an infinite distance away passes through a converging lens, the light will come to a

Materials

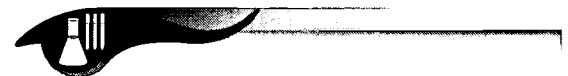

- 2 converging lenses
- a white cardboard imaging screen
- a meter stick or metric ruler
- a 12-inch ruler
- a light source (flashlight)
- an object such as an arrow made of tape on the flashlight lens cover



Procedures

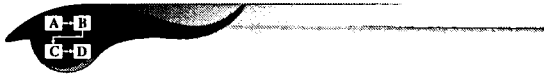

Using both lenses, one at a time, complete all the activities in **Part 1**; then complete **Part 2**.

at which you can see objects clearly is 10 inches. Use the estimated focal length measurement of each lens, D_1 and D_2 , that was measured in the procedure above.

Procedures



Part 1

1. Experiment with the lenses. Hold each lens above a surface such as your hand, the writing on this page, the fabric of your clothes, etc. Adjust the lens until the surface is in focus and you can see the object clearly. At this point, we are using the lens as a magnifier. Details of the object should be sharp.

2. With the 12-inch ruler, measure the distance from the edge of each lens to the image that you have in focus on the paper, as shown. This distance will be known as D_1 for lens No. 1 and D_2 for lens No. 2.

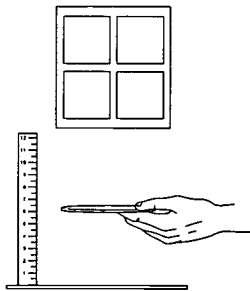

3. Calculate an estimated magnification power for each lens. The magnification of a lens can be explained simply as how many times larger the lens makes the object appear. To perform this calculation, assume that the nearest distance

Observations, Data, and Conclusions



- Using the following equation, calculate an estimate of the magnification for each lens:

$$M = \frac{10}{D}$$

(inches) near distance
for clear vision

(inches) estimated
focal length of lens

- Using the previous equation, compute the magnification (M) of each lens using the distance (D) for each lens.

D_1 for lens No. 1

D_2 for lens No. 2

$$M_1 = \frac{10}{D_1}$$

M_1 for lens No. 1

$$M_2 = \frac{10}{D_2}$$

M_2 for lens No. 2

- Which lens has the greater magnification?

Light, Color, and Their Uses



Lenses, Refraction

Procedures



Part 2

In **Part 2**, a more precise measurement of the focal length of the lenses will be made.

1. For this experiment, the object to be focused is a circle of frosty plastic sheet with a geometrical shape on it. This object should be put on the inside of the flashlight lens cap. Turn the flashlight on and place it along the meter stick pointed toward the zero end of the meter stick.
2. Place the white cardboard imaging surface at the zero end of the meter stick.
3. Hold each lens, one at a time, between the light source (flashlight) and the white cardboard imaging surface as shown below.
4. When you have a sharp image of the object on the imaging surface, you will have found the point at which the lens focuses. When you have found a sharp image, hold things still and measure the distances.

5. Measure the object distance (D_o) and the image distance (D_i) of each lens. To find the object distance (D_o), measure the distance from the black arrow on the surface of the flashlight cover glass to the edge of the lens you are holding. To find the image distance (D_i), measure the distance from the white cardboard imaging surface to the edge of the lens you are holding.

Observations, Data, and Conclusions



1. Record the object distance (D_o) and the image distance (D_i) of lens No. 1 and lens No. 2.

(D_o) of lens No 1 _____ centimeters (cm)

(D_i) of lens No 1 _____ centimeters (cm)

(D_o) of lens No 2 _____ centimeters (cm)

(D_i) of lens No 2 _____ centimeters (cm)

2. How does the focused image compare with the object?

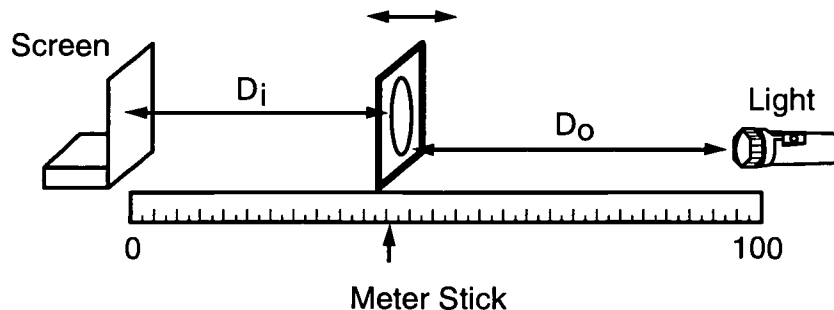

3. If you found two clear images, what was different about them? Why were there two images? (optional)

Which may be written as:

$$f = \frac{D_i D_o}{D_i + D_o}$$

4. Using the following equation, calculate the focal length of each lens using the measurements that you have just made.

Use this equation twice, once for each lens.

$$f_1 = \frac{D_i \times D_o}{D_i + D_o}$$

The following equation describes how the object distance, the image distance, and the focal length are related for a lens.

Focal length lens No. 1 _____ centimeters (cm)

f = focal length
D_o = object distance
D_i = image distance

$$f_2 = \frac{D_i \times D_o}{D_i + D_o}$$

$$\frac{1}{f} = \frac{1}{D_o} + \frac{1}{D_i}$$

Focal length lens No. 2 _____ centimeters (cm)

Math Computation:

Light, Color, and Their Uses



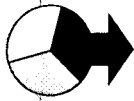

Building a Telescope

Objective



The student will construct a simple refracting telescope and calculate the magnification.

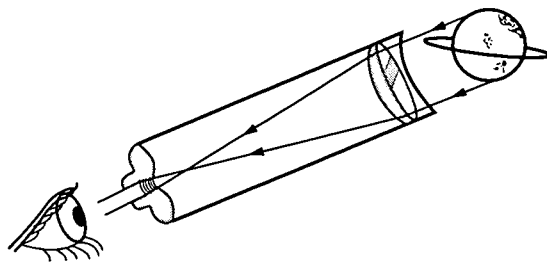

Theory



In a telescope, the lens held next to your eye is called the eyepiece and is usually a short focal length lens or a combination of lenses. The lens at the other end of the telescope is called the objective lens. Light from a distant object is focused by the objective lens to form an image in front of the eyepiece. The eyepiece acts as a magnifier and enlarges that image. The magnification of the telescope can be found by dividing the focal length of the objective by the focal length of the eyepiece.

Science and Mathematics Standards



Science Standards

- Science as Inquiry
- Physical Science

Mathematics Standards

- Problem Solving
- Communication
- Connection
- Computation/Estimation
- Measurement

Materials



- 2 converging lenses (convex lenses)
- telescoping tubes (mailing tubes)
- manila file folder
- scissors
- knife or saw
- glue
- 1 white poster board
- red and black tape



Procedures



This telescope will be constructed using the same lenses that were used in the experiment named, "Focusing Light With a Lens," page 49.

1. The mailing tubes will be the body of the telescope with the smaller one sliding inside the larger one. The length of the assembled telescope will be a little longer than the sum of the focal lengths of the two lenses. Add the value of the focal lengths of the short and long lens together. Divide that length by two and then add another inch. Cut both of the tubes to that length with a knife or saw.
2. Use the scissors to cut out two circles from the manila paper that are the same size as the diameter of the mailing tube. These circle frames will mount and center the lenses on the tube. With a knife, cut out circles that are slightly smaller than the
3. Slide the two cardboard tubes together. You have now assembled a simple refracting telescope. Look through the eyepiece of your telescope and focus it on a distant object. Slide the two cardboard tubes in and out until you have a clear image. What do you observe?
4. Use the red and black tape to make stripes on the white posterboard (see illustration on page 55) to use as a chart.

diameter of the lenses in the center of the paper frame circle. Glue the lenses to the center of the frame. The shorter focal length lens will be the eyepiece. Glue that framed lens to the end of the smaller tube. Glue the other framed lens to the end of the larger tube.

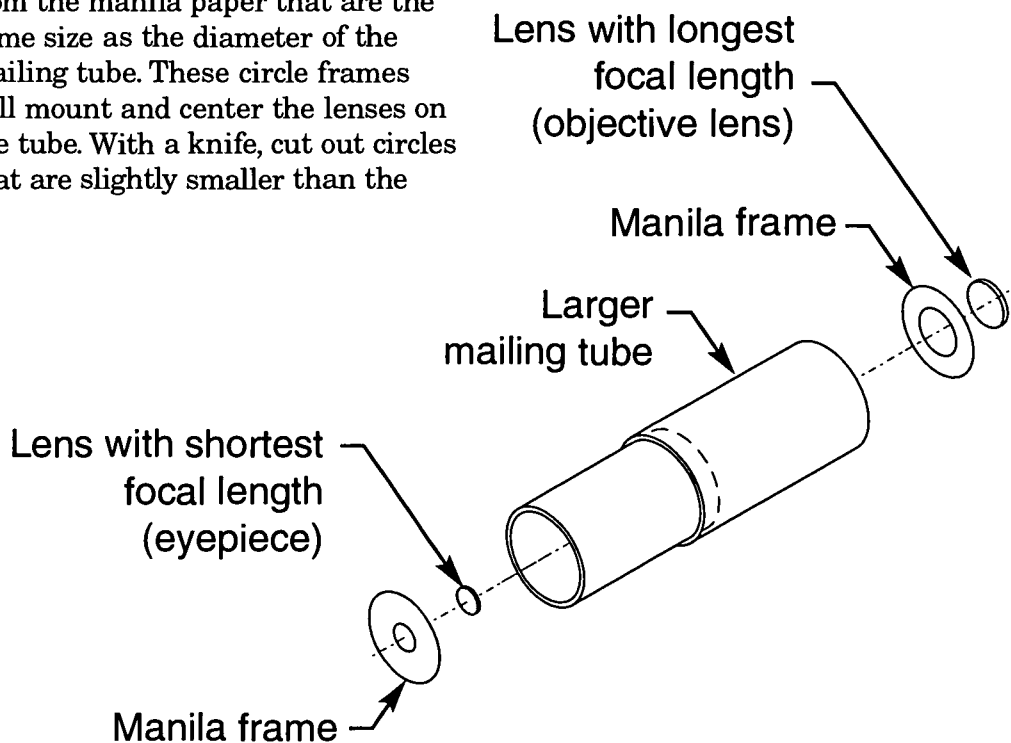

Light, Color, and Their Uses



Observations, Data, and Conclusions

- To compute the power or magnification (**M**) of your telescope, you will use the focal lengths computed in the experiment named, "Focusing Light With a Lens," page 49. Insert the number for each previously computed focal length into the following equation:

M = power or magnification

F_e = focal length of the eyepiece

F_o = focal length of the objective

$$M = \frac{F_o}{F_e}$$

The magnification of my telescope is _____

- Evaluate your calculated magnification. Stand at one end of the room and look at the chart with red and white stripes, and black and white stripes. Look directly at the chart with one eye and look through the telescope with the other eye. This may be a little difficult at first, but with a little practice you will find that you can do it.
- How much is the chart magnified?

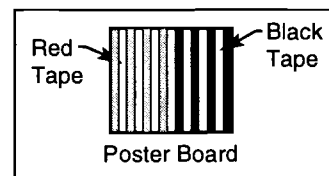
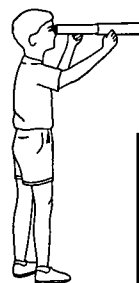

- Do you think the amount of magnification observed through your telescope matched the magnification you computed for your telescope?
- In observing objects through your telescope, did the image appear clear?
- How was the observed image oriented?

Comment: The useful magnification of a telescope is limited by diffraction. This diffraction limit is about 10 times magnification per inch of diameter of the objective lens.

Example: an objective lens 2 inches in diameter will provide a realistic telescope power of 20 times.



Junior Home Scientist



Converging lenses can be found in many of the everyday items we see in our homes. How many can you find? Here are a few examples: Paperweights, fish bowls with water in them, bottoms of soda bottles, etc.

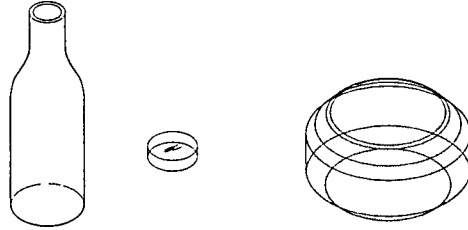

Newtonian Reflector Telescope

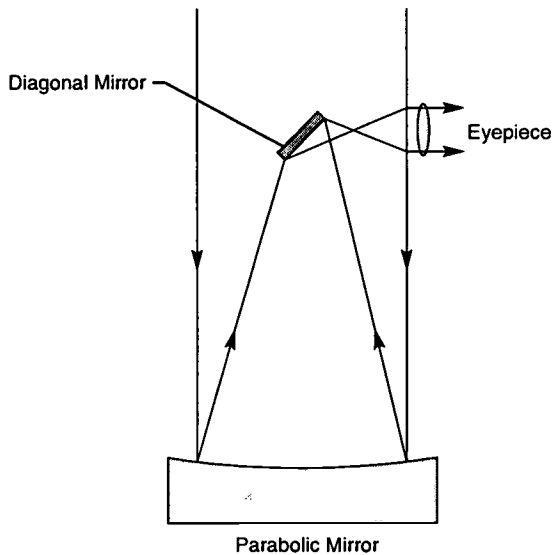

Refractor Telescope

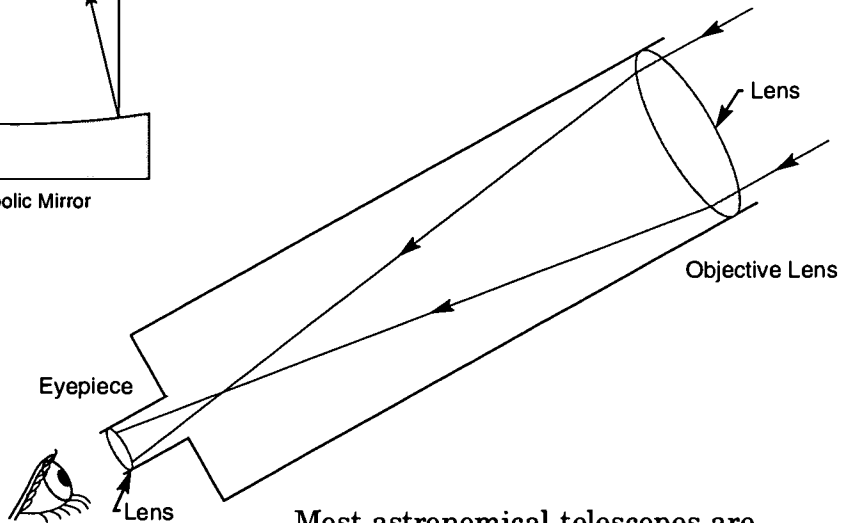

Most astronomical telescopes are reflectors. Objective mirrors are easier to make than objective lenses. Large mirrors are structurally easier to design and less expensive to build than large lenses.

Light, Color, and Their Uses





Lenses

Building a Microscope

Objective

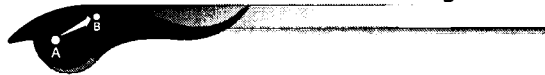

The student will construct a simple low-power microscope from two converging lenses. See pages 59-62. The student will be able to see how a microscope works.

Theory



In a microscope, the lens, placed next to the object to be magnified, is called the objective lens, while the lens held next to the eye is called the eyepiece. The eyepiece should have a focal length of about 25 millimeters, while the objective should have a focal length of 25 millimeters or less to be suitable for building a microscope. The distance to the enlarged image formed by the objective lens is 160 millimeters. The enlarged image formed by the objective lens is magnified by the eyepiece.

Science and Mathematics Standards

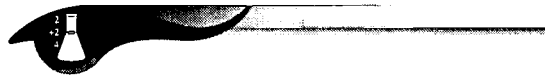

Science Standards

- Science as Inquiry
- Physical Science

Mathematics Standards

- Problem Solving
- Communication
- Connection
- Computation/Estimation
- Measurement

Materials

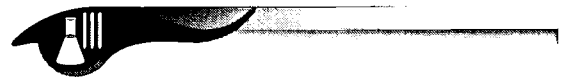

- 2 converging lenses (convex lenses)
- telescoping tubes (mailing tubes)
- a selection of materials to view with the microscope
- a laboratory microscope



Procedures

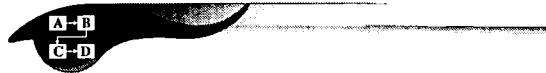

This microscope will be constructed using two converging lenses of short focal length suitable for a microscope as described in the theory section on the previous page. Two cardboard telescoping tubes that fit snugly one inside the other will be the body of the microscope.

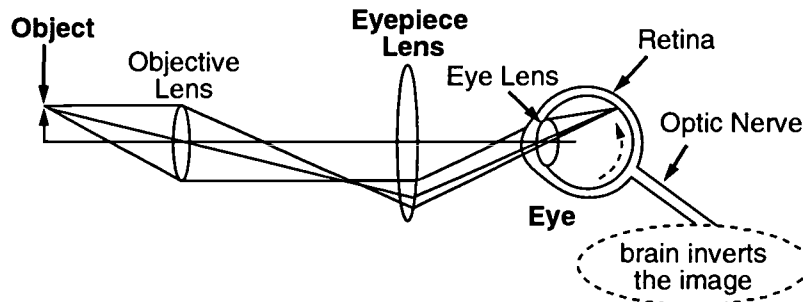

1. To build your microscope, place the lens identified as the eyepiece (ocular) lens on the end of the cardboard tube having the smallest diameter.
2. Take the other lens, the one identified as the objective lens, and place it on the end of the cardboard tube having the largest diameter.
3. Slide the two cardboard tubes together. You have now assembled a simple microscope. View several items. Slide the two cardboard tubes in and out until you have a clear image.

Observations, Data, and Conclusions



1. List the various objects that you examined through your microscope. Find two additional items to examine.
2. Take two of the objects that you examined through your microscope and look at them through the laboratory microscope.
3. What differences did you observe when you looked through the microscope you made and the laboratory microscope?
4. Which is the better microscope?
5. What makes that microscope better?





Construction of a Microscope— A File Folder Microscope

Materials



- 2 lenses (one 46 mm and one 28 mm)
- 2 manila file folders
- carpenter's wood glue
- dowel
- small wooden block
- screw with wing nut
- scissors
- black liquid shoe polish or dye
- rubber bands
- small piece of pipe
- clear varnish (optional)

Procedures



1. From the manila file folder, cut the biggest piece of uncreased paper possible. Pull the piece of folder back and forth over the sharp edge of a desk so that the paper will curve or curl. After the entire piece of folder has begun to curl, take the small piece of pipe and roll the paper around it. As the paper is rolled onto the pipe apply the glue to the entire inside surface of the paper. When the first roll is complete, secure it with rubber bands until it is dry.
2. After the paper roll is dry, remove the pipe, and then drip black liquid shoe polish inside the paper tube to coat the entire inside surface of the tube.
3. Next, cut a smaller piece of paper and roll and glue it around the first tube of paper. (For all other instructions, see the illustration on the following page.)



Light, Color, and Their Uses

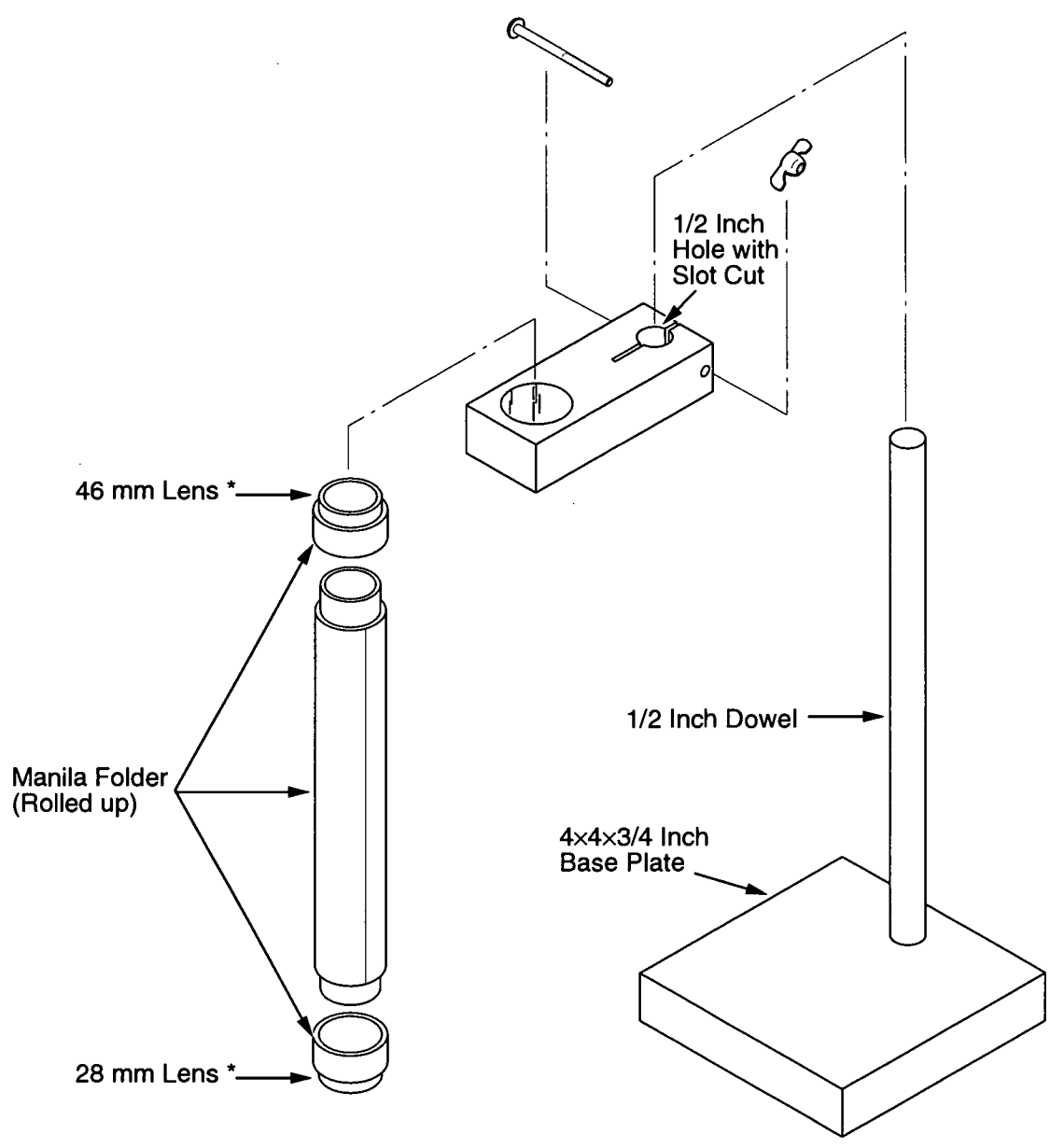

* Lenses may be obtained from school supply store.



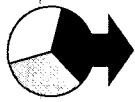

Interference Fringes

Interference Fringes

Objective



The student will observe interference fringes formed by a layer of air between two pieces of glass.

Science and Mathematics Standards



Science Standards

- Science as Inquiry
- Physical Science

Mathematics Standards

- Problem Solving
- Communication
- Connection
- Computation/Estimation
- Measurement

Theory



When light of a single color (or wavelength) passes through the layer of air between two flat pieces of glass, part of the light is reflected by the

glass-to-air boundary and part is reflected from the air-to-glass boundary. If the difference in the paths of the two rays is equal to a multiple of whole wavelengths, the light amplitude will add to form a bright band. The dark bands are formed by rays that cancel each other. A good source of light that has some single colors is a fluorescent light. The light looks white to your eyes even though it contains a bright green component caused by the mercury vapor in the tube. This is called the mercury green line and has a wavelength of 5,461 angstroms, which is 0.5461 millimeters (0.5461 E-6 meters). See the illustration on page 62.

Materials



- 2 glass flats (glass microscope slides) (see List of Catalogs, page 83.)
- sheet of black construction paper
- a light source such as an overhead fluorescent light
- 1 set high-quality flats (optional) (see List of Catalogs, page 83.)



Procedures



1. Stack the two glass flats one on top of the other. Put the flats on the black construction paper or cardboard provided. Place the flats under a fluorescent light.
2. View the flats at an angle so the fluorescent light can be seen in the reflection as shown below. Observe the interference fringes. They will appear as contour lines or concentric rings that are somewhat irregular.
3. Press on the glass flats with your finger and observe the effect on the interference fringes.

Observations, Data, and Conclusions

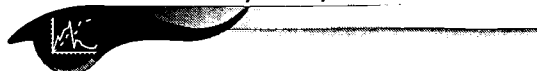

1. Were you able to observe the interference fringes? What did they look like?
2. What happens when the glass flats are pressed?

Use of high-quality glass vs. low-quality glass in this experiment



Straight, parallel lines are seen when high-quality glass flats are used.



Uneven, wavy lines are seen when low-quality glass flats are used.

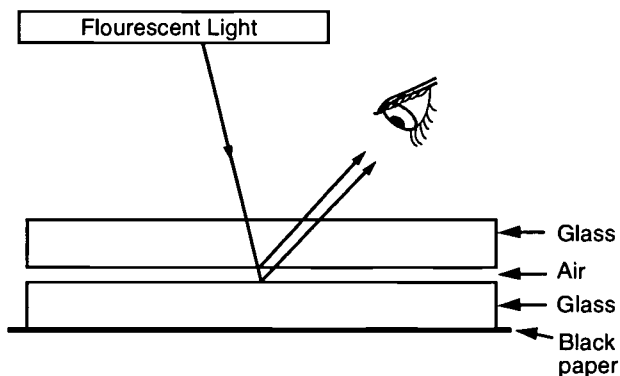

Light, Color, and Their Uses



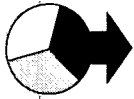

Polarization

Polarization of Light

Objective



The student will observe polarized light and how it is affected when it passes through stressed transparent plastic materials.

made of film material will pass light in only one plane. If we have two Polarizing filters whose planes of polarization are rotated 90 degrees with respect to each other, then no light gets through. Some materials can rotate the plane of polarization as light passes through them. If we place this material between crossed polarizers, then some light can get through. An example of a material that rotates the plane of polarization is clear plastic under stress. (Stress patterns can be produced by applying a force to the plastic. They can also be generated during the manufacturing process and frozen into the plastic.)

Science and Mathematics Standards



Science Standards

- Science as Inquiry
- Physical Science

Mathematics Standards

- Problem Solving
- Communication
- Connection
- Computation/Estimation
- Measurement

Materials



- 2 sheets of Polarizing material for filters
- small metal or cardboard frames
- a light source such as a fluorescent light
- samples of flat molded plastic objects such as a protractor
- transparent tape

Theory



If the electric field of light (a transverse wave) moves in a fixed plane, then the light is said to be polarized in that plane. A polarizer



Procedures

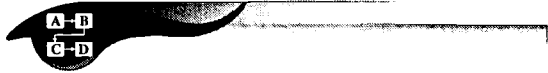

1. Place one Polarizing filter on top of the other filter. Look through both of them toward a light source such as a fluorescent light or a window. Rotate one of the filters with respect to the other one until no light passes through them.
2. Place a flat molded plastic object between the two filters and look toward the light source. Some light will now pass through the two Polarizing filters as illustrated. Observe the pattern of light created by the transparent piece of plastic; note the corners.
3. Using the metal or cardboard frame provided, cover the frame with overlapping layers of transparent tape. Use no more than three layers of tape at any overlapping place on the frame. Place the frame with the transparent tape between the two Polarizing filters. Rotate the filters again so that the light is blocked out and look at the light source.

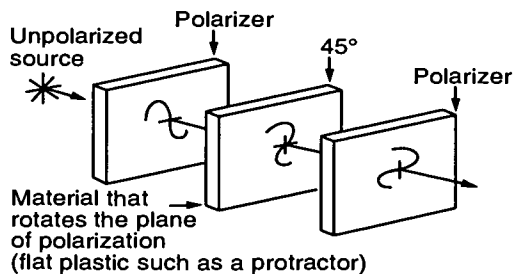

Observations, Data, and Conclusions

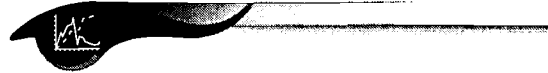

1. Why does light not pass through the two Polarizing filters turned at 90 degrees to each other?
2. Why does light pass through the molded transparent plastic?
3. What effect do the layers of transparent tape have on the light as it passes through them and the Polarizing filters?

Junior Home Scientist



Experiment with polarized light at home. Find an old pair of Polarizing sunglasses and carefully remove each lens from the frame. These two lenses will provide you with two Polarizing filters to use to examine other materials. Corn syrup in water is another material that has the ability to rotate the plane of polarization of light between two Polarizing filters. For best results, the water and syrup solution should be put in a clear container with flat sides.

Light, Color, and Their Uses



Answer Booklet

Reflection of Light With a Plane (Flat) Mirror—Trace a Star Observations, Data, and Conclusions

Page 16

1. The individual students will complete the activity with varying degrees of difficulty.
2. The student will see the images reversed left to right.
3. The brain and the senses, especially touch, tend to get confused and the brain will try to correct for the reversal of the images.
4. The hand will appear to be located behind the mirror at a distance equal to the distance of the object from the front of the mirror.
5. It tends to be easier to trace with a finger because the body gets additional feedback through the sense of touch.
6. This activity deals with reflection.
7. At the end of the lesson, the students might share their designs with the class. If a computer is available the students could design and compile a booklet of class designs on the computer.

Reflection of Light With Two Plane Mirrors— Double Mirrors Placed at a 90-Degree Angle Observations, Data, and Conclusions

Page 18

1. When the mirrors are placed at 90 degrees, the image is not reversed and this is called a true image.
2. The eyes see a true image or they see the student as other people see the student.
3. Over the years, the student has adjusted to a reversed image in the mirror. Also, the activities ask the student to use the hand to cross midline of the body. The right brain controls the left side and the left brain controls the left side and this adds another variable which the student must consider.
4. Reflection



Reflection of Light With Two Plane Mirrors— Double Mirrors Placed at a Number of Angles

Observations, Data, and Conclusions

Page 20

1. Computation.
2. You will see whole images at 60, 90, and 180 degrees.
3. The number of images and the number of mirror frames that are reflected will be equal.
4. The number of images equals 360 degrees divided by the angle indicated on the protractor.
5. The number of observed images and the computed images should be equal, but the observed images may be one or two less because of the crude equipment used.

Making a Kaleidoscope

Observations, Data, and Conclusions

Page 24

1. There is no exact number of images because the equipment being used is very crude. The activity is included to encourage the student to observe more carefully.
2. The objects appear to be the same size, but they are reflected in parts or pieces.
3. In some segments of the kaleidoscope, the images are reversed left to right or even upside down.

Making a Periscope

Observations, Data, and Conclusions

Page 28

1. The lines are the same as those shown in the illustration at the top of page 17.
2. No, the periscope will not function if the mirrors are positioned at different angles.



Exploring Diffraction With a Spectroscope

Observations, Data, and Conclusions

Page 32

1. The student will see a spectrum or bands of color like a rainbow. Each bulb will also have a set of distinct vertical lines. Each different element has its own distinct set of vertical lines, or signature.
2. If the light observed is a white light source, the student will observe the seven major colors in a continuous spectrum. The name Roy G. Biv will help the student to remember the names of the colors in order—red, orange, yellow, green, blue, indigo, and violet. If the light observed is not a white light source, some of the colors of the spectrum will not be seen.
3. The bands of color fade or blend into each other. Depending on the spectroscope, the student may observe very distinct vertical lines of color. You might also see some black lines which are absorption lines.
4. No, each light source has its own unique pattern of colored vertical lines.
5. There are bands of color, but they also tend to fade together. With some spectroscopes, the students will see very distinct and precisely spaced vertical lines. These lines are the signature of that particular element. The black lines (Fraunhofer lines) are the absorption lines of certain elements. For more information, see an encyclopedia.
6. Though light bulbs may look the same, they are filled with different elements or gases. Each gas or element has its own emission spectrum or bands of colors.

Diffraction of Light by Very Small Apertures

Observations, Data, and Conclusions

Page 36

1. This activity is intended to encourage the student to observe more carefully.
2. The shape, direction, or number of pattern may change as the screen is slowly rotated. A varying combination of patterns and colors will appear.



Discovering Color With a Prism

Observations, Data, and Conclusions

Pages 38

1. By refraction, a prism can break white light up into its seven major colors. Some of the suggested light sources will appear to be white light to the eye, but a prism will show that some wavelengths are not present.
2. The acrylic plastic or plastic prism will refract and break the light into color, but the quality of the plastic or glass will determine the sharpness of the colors.
3. Colors always come out of a prism in the same order. Some colors will be omitted if the light source is not white light.
4. The colors blend or shade into each other.
5. The bands of color do not always have the same shape or width. The shape or width of the color band depends on the type of light source.

Light and Color—Color Spinners

Observations, Data, and Conclusions

Page 42

1. The colors seem to blend and form other colors. The perception of color is determined by light, the source of color; material and its response to color; and the eye of the perceiver of color.
2. The colors seen by the student will depend on the design, the kind of pigment used, and the speed of the movement.
3. While spinning, the colors seem to mix and become other colors. The mixing of the colors is a function of the eyes and brain.
4. Combine blue and yellow pigments to make green.
5. Combine red and yellow pigment to make orange.
6. If all colors are equally combined in design, they should make white or gray. The kind of pigment used will affect the colors.
7. Most of the time, brown can be made by adding red, yellow, and blue.
8. Color one side of the circle and add a few lines or dots on the other half of the circle. Experiment.



9. Color varies a great deal with the type of pigment used. The colors in light also combine differently than pigment.

Light and Color—Filters

Observations, Data, and Conclusions

Page 44

1. The students will record what they observe. Answers will vary depending on the filters used.
2. Answers will vary.
3. Answers will vary.
4. Filters subtract or absorb some colors. Two filters may be used to transmit a third color.

Light and Color—Hidden Messages

Observations, Data, and Conclusions

Page 46

1. The student should see a confusion of lines, letters, and shapes of varying colors.
2. If a red filter is used, red will not be seen and yellow may appear to be orange. Green will appear to be dark blue. If a yellow filter is used, all the yellow designs will not be seen. The colors will vary with the pigments and filters used.
3. Answers will vary depending on the pigment and filters used.
4. Each filter absorbs and transmits different wavelengths of light.
5. A booklet of secret messages might be a nice class project.

Simple Magnifiers

Observations, Data and Conclusions

Page 48

1. The letters are magnified.
2. The magnification is better with smaller drops of water.
3. The water drop magnifier is focused by moving it back and forth from the surface of the print or picture.



4. The smaller water drop magnifies more because of the way it bends or refracts light. The focal length of the small drop is shorter because the curvature of the surface of the water drop is greater. The shorter the focal length of a lens, the greater the magnification.
5. Bottles with curved edges magnify better.
6. The bottom or curved side of a bottle magnifies best.
7. The water acts as a lens and refracts or bends light to a focal point.
8. Some bottles serve as converging or convex lenses, and they bend or refract the light to focus it.

Focusing Light With a Lens

Observations, Data, and Conclusions

Pages 50 (Part 1)

1. Answers will vary depending on the lenses provided.
2. Answers will vary depending on the lenses provided.
3. The lens of the eyepiece of a telescope will have the shorter focal length and the greater magnification. The object lens will have the longer focal length and less magnification.

Pages 51–52 (Part 2)

1. Answers will vary depending on the lenses provided.
2. With a single lens, the focal image will generally be smaller than the object. The focal image may be the same size as the object, but it will never be larger.
3. If you found two distinct images, one will be large and one will be small. One may also be reversed. There are two distinct images because the object distance is different. The object distance is the distance between the object and the lens. The student must consistently use the same object distance when measurements are made.
4. Answers will vary depending on the lenses provided.



Building a Telescope

Observations, Data, and Conclusions

Pages 55

1. Answers will vary with the lenses used.
2. The student will observe with and without the telescope. After observing the striped chart, or some other object provided, the student will make a judgment about the amount the telescope magnifies. Generally, simple telescopes constructed by students will have a magnification of less than five.
3. Answers will vary with the lenses used.
- 4–5. These questions were included to encourage the student to observe carefully.
6. This is a refracting telescope and the image will appear upside down. For more information, see telescopes in an encyclopedia.

Building a Microscope

Observations, Data, and Conclusions

Page 58

- 1–2. Answers will vary.
3. The microscope with the better set of lenses will have a clearer, sharper image.
4. The purchased microscope will be better.
5. The purchased microscope is better because the glass in the lenses is a better quality and has been ground and polished more carefully. It is also mounted and aligned more precisely.

Interference Fringes

Observations, Data, and Conclusions

Page 62

1. See the top left figure on page 62.
2. See the bottom left figure on page 62.



Polarization of Light

Observations, Data, and Conclusions

Page 64

1. Polarized material allows light to pass through it only in one direction or plane. See the figure on page 64.
2. The plastic is transparent and it will allow the light to pass through it, but the student should notice the bands of color around areas of stress. As the object was molded into shape, there were areas that were pulled and pushed, and these stress marks were molded into the plastic. The stressed areas interrupt the light rays entering the plastic and change the plane or direction of that light.
3. The transparent tape changes the plane or direction of polarization. The tape may also act as a filter and absorb some wavelengths. Layering the tape may also reinforce the light waves that are in or out of phase. Two or more light waves that exactly match or overlap at the crests and troughs of the waves are said to be in phase. When the crests and troughs of two or more waves do not match or overlap, the waves are said to be “out of phase.”



Glossary

additive color

A primary light color—red, blue, or green; these three colors produce white light when added together.

angle of incidence

The angle between a wave striking a barrier and the line perpendicular to the surface.

angle of reflection

The angle between a reflected wave and the normal to the barrier from which it is reflected.

angstrom

An angstrom is $1/100,000,000$ of a centimeter.

concave lens

A lens that is thinner in the middle than at the edges; used to correct nearsightedness.

convex lens

A lens that is thicker in the middle than at the edges; used to correct farsightedness.

diffraction grating

A piece of transparent or reflecting material, which contains many thousands of parallel lines per centimeter; used to produce a light spectrum by diffraction.

electromagnetic wave

A wave that does not have to travel through matter in order to transfer energy.

electromagnetic spectrum

Transverse radiant energy waves, ranging from low frequency to very high frequency, which can travel at the speed of light.

element

A substance that cannot be broken down into simpler substances by ordinary means.

equilateral triangle

A triangle with three equal angles of 60 degrees and sides of equal length.

filter

A screen that allows only certain colors to pass through it; a transparent material that separates colors of light.

focal length

The distance between the principal focus of a lens or mirror and its optical center.



focal point/focus

The point that all light rays from a mirror or lens pass through.

frequency

The number of waves that pass a point in a given unit of time.

gamma ray

High-energy wave of high frequency and with a wavelength shorter than an x ray; released in a nuclear reaction.

image

The reproduction of an object formed with lenses or mirrors.

in phase

When two or more light rays overlap exactly at the crest and the trough, they are said to be "in phase."

index of refraction

The amount that light is refracted when it enters a substance; given as the ratio of speed of light in a vacuum to its speed in a given substance.

infrared radiation

Invisible radiation with a longer wavelength than red light and next to red light in the electromagnetic spectrum; used in heat lamps, to detect heat loss from buildings, and to detect certain tumors.

interference

The addition by crossing wave patterns of a loss of energy in certain areas and reinforcement of energy in other areas.

kaleidoscope

A toy in which reflections from mirrors make patterns. It was invented in 1819 by David Brewster.

laser (light amplification by stimulated emission of radiation)

A device that produces a highly concentrated, powerful beam of light which is all one frequency or color and travels only in one direction.

law of reflection

Angle of incidence equals the angle of reflection.

lens

A curved, transparent object; usually made of glass or clear plastic and used to direct light.



light

Light is a form of energy, traveling through the universe in waves. The wavelengths of visible light range from less than 4,000 angstroms to more than 7,000 angstroms.

normal

A line perpendicular to a surface.

opaque

Not transparent; no light passes through the material.

optical axis

The line straight out from the center of a parabolic mirror; straight line through the center of a lens.

optical fiber

A thin strand of glass that transmits light down its length.

optical telescope

A tube with magnifying lenses or mirrors that collect, transmit, and focus light.

out of phase

When the crest of one wave overlaps the trough of another they are said to be "out of phase."

parabola

A curved line representing the path of a projectile; the shape of the surface of a parabolic mirror.

parabolic mirror

A curved mirror.

pigment

A material that absorbs certain colors of light and reflects other colors.

plane mirror

A mirror with a flat surface.

polarized light

Light in which all waves are vibrating in a single plane.

prism

A transparent material with two or more straight faces at an angle to each other.

real image

An image that can be projected onto a screen; formed by a parabolic mirror or convex lens.



reflection

The light or image you see when light bounces off a surface; bouncing a wave or ray off a surface.

reflecting telescope

A telescope in which magnification is produced by a parabolic mirror.

refraction

Bending of a wave or light ray caused by a change in speed as it passes at an angle from one substance into another.

scattering

The spreading out of light by intersecting objects, whose size is near the wavelength.

spherical

Surface of a lens or mirror that is part of a sphere.

subtractive color

One of the three pure pigment colors—magenta, yellow, cyan; these pigment colors produce black when mixed.

translucent

Semitransparent; a material that admits some light.

transparent

See-through; light can go through.

true image

A true image is the way other people see us. It is the opposite of the image that is seen in a mirror.

ultraviolet radiation

Radiation that has a shorter wavelength than visible light; next to violet light in the electromagnetic spectrum.

virtual image

An image formed by a mirror or lens that cannot be projected onto a surface.

visible light spectrum

Band of visible colors produced by a prism when white light is passed through it.

wavelength

The total linear length of one wave crest and trough.

x ray

Invisible electromagnetic radiation of great penetrating power.



NASA Resources for Educators

NASA Educational Materials

NASA publishes a variety of education resources suitable for classroom use. Educational materials are available from the NASA Educators' Resource Center Network (ERCN). Posters, lithographs, and some other printed materials are in limited supplies; the publication of new materials is ongoing. Contact the Educator Resource Center in your area, or NASA Central Operation of Resources for Educators (CORE), for the current list of available resources. (See next page for CORE and ERCN addresses.)

NASA Television

NASA Television (NTV) features Space Shuttle mission coverage, live special events, live interactive educational shows, electronic field trips, aviation and space news, and historical NASA footage. Programming has a 3-hour block—Video (News) File, NASA Gallery, and Education File beginning at noon Eastern and repeated three more times throughout the day.

The NASA Education File features programming for educators and students highlighting science, mathematics, geography, and technology-related topics. Viewers are encouraged to tape the programs.

The NTV Education File can be accessed at
<http://spacelink.nasa.gov/education.file>

Via satellite—GE2, Satellite, Transponder 9C at 85 degrees West longitude, vertical polarization, with a frequency of 3880.0 megahertz (MHz) and audio of 6.8 MHz—or through collaborating distance learning networks and local cable providers.

Please visit
<http://www.nasa.gov/ntv/ntvweb.html>
to learn about NTV on the web.

Live feeds preempt regularly scheduled programming. Check the internet for program listings at:

NTV Home Page:
<http://www.nasa.gov/ntv>

Select "Today at NASA" and "What's New on NASA TV":
<http://www.nasa.gov>

Select "TV Schedules":
<http://spacelink.nasa.gov/NASA.News/>



NASA Educator Resource Center Network

To make additional information available to the education community, the NASA Education Division has created the NASA Educator Resource Center (ERC) network. ERC's contain a wealth of information for educators: Publications, reference books, slide sets, audio cassettes, videotapes, telelecture programs, computer programs, lesson plans, and teacher guides with activities. Because each NASA Field Center has its own areas of expertise, no two ERC's are exactly alike. Phone calls are welcome if you are unable to visit the ERC that serves your geographic area. A list of the centers and the geographic regions they serve starts on the next page.

Regional Educator Resource Centers (RERC's) offer more educators access to NASA educational materials. NASA has formed partnerships with universities, museums, and other educational institutions to serve as RERC's in many states.

Teachers may preview, copy, or receive NASA materials at these sites. A complete list of RERC's is available through CORE.

ERC and regional ERC locations:
<http://spacelink.nasa.gov/ercn>

NASA CORE was established for the national and international distribution of NASA-produced educational materials in audiovisual format. Educators can obtain a catalog and an order form by one of the following methods:

- NASA CORE
Lorain County Joint Vocational School
15181 Route 58 South
Oberlin, OH 44074
- Phone (440) 774-1051, Ext. 249 or 293
- Fax (440) 774-2144
- E-mail: nasaco@lecca.org
- Home Page: <http://core.nasa.gov>

Light, Color, and Their Uses



Teacher's Resource

If you live in:	Precollege Officer:	Educator Resource Center:
Alaska Arizona California Hawaii Idaho Montana Nevada Oregon Utah Washington Wyoming	Mr. Garth A. Hull Special Assistant, Educational Programs NASA Ames Research Center Mail Stop 204-12 Moffett Field, CA 94035-1000 Phone: (650) 604-5543	NASA Research Center: NASA Ames Educator Resource Center NASA Ames Research Center Mail Stop 253-2 Moffett Field, CA 94035-100 Phone: (650) 604-3574
California (Regions near NASA Dryden Flight Research Center)	Dr. Marianne McCarthy Education Specialist NASA Dryden Flight Research Center Mail Stop D4839A P.O. Box 273 Edwards, CA 93523-0273 Phone: (661) 258-2281	NASA Dryden Flight Research Center: NASA Dryden Educator Resource Center 45108 N. 3rd Street East Lancaster, CA 93535 Phone: (661) 948-7347
Connecticut Delaware District of Columbia Maine Maryland Massachusetts New Hampshire New Jersey New York Pennsylvania Rhode Island Vermont	Dr. Robert Gabrys Chief, Education Office NASA Goddard Space Flight Center Mail Code 130.3 Greenbelt, MD 20771-0001 Phone: (301) 286-7207	NASA Goddard Space Flight Center: NASA Goddard Educator Resource Center Mail Code 130.3 NASA Goddard Space Flight Center Greenbelt, MD 20771-0001 Phone: (301) 286-8570
Colorado Kansas Nebraska New Mexico North Dakota Oklahoma South Dakota Texas	Ms. Billie A. Deason Education Team Lead Education & Community Support Branch NASA Johnson Space Center Mail Code AP2 2101 NASA Road One Houston, TX 77058-3696 Phone: (281) 483-8646	NASA Johnson Space Center: NASA JSC Educator Resource Center 1601 NASA Road One Houston, TX 77058-3696 Phone: (281) 244-2129



If you live in:	Precollege Officer:	Educator Resource Center:
Florida Georgia Puerto Rico Virgin Islands	Dr. Steve Dutzak Chief, Education and Services Branch NASA Kennedy Space Center Mail Code AB-G1 Kennedy Space Center, FL 32899-0001 Phone: (407) 867-4444	NASA Kennedy Space Center: NASA KSC Educator Resource Center Mail Code ERC Kennedy Space Center, FL 32899-0001 Phone: (407) 867-4090
Kentucky North Carolina South Carolina Virginia West Virginia	Dr. Bill Williams Precollege Officer NASA Langley Research Center Mail Stop 400 Hampton, VA 23681-0001 Phone: (757) 864-9728	NASA Langley Research Center: NASA Langley Educator Resource Center Virginia Air and Space Center Hampton, VA 23669-4033 Phone: (757) 727-0900 Ext.757
Illinois Indiana Michigan Minnesota Ohio Wisconsin	Ms. Jo Ann Charleston Chief, Office of Education Programs NASA Lewis Research Center Mail Stop 7-4 21000 Brookpark Road Cleveland, OH 44135-3191 Phone: (216) 433-2957	NASA Lewis Research Center: NASA Lewis Educator Resource Center Mail Stop 8-1 21000 Brookpark Road Cleveland, OH 44135-3191 Phone: (216) 433-2017
Alabama Arkansas Iowa Louisiana Missouri Tennessee	Alicia Beam Education Program Specialist NASA Marshall Space Flight Center Mail Code CD60 Huntsville, AL 35812-0001 Phone: (256) 544-8811	NASA Marshall Space Flight Center: NASA Marshall Educator Resource Center One Tranquility Base Drive Huntsville, AL 35807-7015 Phone: (256) 544-5812
Mississippi	Wanda F. DeMaggio Education Programs Manager NASA Stennis Space Center Bldg. 1100 Mail Code AA10 Stennis Space Center, MS 39529-6000 Phone: (228) 688-1107	NASA Stennis Space Center: NASA Stennis Educator Resource Center Building 1200 Stennis Space Center, MS 39529-6000 Phone: (228) 688-3338
The Jet Propulsion Laboratory (JPL) serves inquiries related to space and planetary exploration and other JPL activities.	Mr. David M. Seidel Manager, Educational Affairs Office NASA Jet Propulsion Laboratory Mail Code T1709 4800 Oak Grove Drive Pasadena, CA 91109-8099 Phone: (818) 354-9313	NASA Jet Propulsion Laboratory: NASA JPL Educator Resource Center Mail Code 601-107 NASA Jet Propulsion Laboratory 4800 Oak Grove Drive Pasadena, CA 91109-8099 Phone: (818) 354-6916

Light, Color, and Their Uses



On-Line Resources for Educators

NASA Education Home Page

NASA's Education Home Page serves as a cyber-gateway to information regarding educational programs and services offered by NASA for educators and students across the United States. This high-level directory of information provides specific details and points of contact for all of NASA's educational efforts and Field Center offices.

Educators and students utilizing this site will have access to a comprehensive overview of NASA's educational programs and services, along with a searchable program inventory that has cataloged NASA's educational programs.

NASA Education Home Page:

<http://education.nasa.gov>

NASA Spacelink

NASA Spacelink is one of NASA's electronic resources specifically developed for the educational community. Spacelink is a "virtual library" in which local files and hundreds of NASA World Wide Web links are arranged in a manner familiar to educators. Using the Spacelink search engine, educators can search this virtual library to find information regardless of its location within NASA. Special events, missions, and intriguing NASA web sites are featured in Spacelink's "Hot Topics" and "Cool Picks" areas.

Spacelink may be accessed at: <http://spacelink.nasa.gov>

NASA Spacelink is the official home to electronic versions of NASA's Educational Products. NASA educator guides, educational briefs, lithographs, and other materials are cross-referenced throughout Spacelink with related topics and events. A complete listing of NASA Educational Products can be found at the following address:

<http://spacelink.nasa.gov/products>

"Educator Focus" is comprised of a series of Spacelink articles, which offers helpful information related to better understanding and using NASA educational products and services. Visit "Educator Focus" at the following address:

<http://spacelink.nasa.gov/focus>

Join the NASA Spacelink EXPRESS mailing list to receive announcements of new NASA materials and opportunities for educators. Our goal is to inform you as quickly as possible when new NASA educational publications become available on Spacelink:

<http://spacelink.nasa.gov/express>



NASA Aeronautics Centers' Education Home Pages

NASA Marshall Space Flight Center
<http://www.msfc.nasa.gov/education>

NASA Ames Research Center
<http://www.arc.nasa.gov/kids.html>

NASA Dryden Flight Research Center
<http://trc.dfrc.nasa.gov/trc/>

NASA Langley Research Center
<http://edu.larc.nasa.gov>

NASA Lewis Research Center
<http://www.grc.nasa.gov/www/oep>

Light, Color, and Their Uses



List of Catalogs for Science Equipment K-12

Carolina Biological Supply Co.
2700 York Road
Burlington, NC 27215
1-800-334-5551

Central Scientific Co. (CENCO)
11222 Melrose Avenue
Franklin Park, IL 60131
1-800-262-3626

Delta Education, Inc.
P.O. Box 950
Hudson, NH 03051
1-800-442-5444

Dick Blick Art Materials
P.O. Box 1267
Galesburg, IL 61401
1-800-447-8792

Edmund Scientific Company
*(Specialty Optics)
101 E. Gloucester Pike
Barrington, NJ 08007-1380
1-609-5647-8880

Flinn Scientific, Inc.
(Chemical Catalog)
P.O. Box 219
131 Flinn Street
Batavia, IL 60510-9906
1-708-879-6900

Fisher Scientific Co.
Educational Materials Division
4901 W. LeMoyné Street
Chicago, IL 606512
1-800-621-4769

Frey Scientific Co.
P.O. Box 8101
905 Hickory Lane
Mansfield, OH 44901-8101
1-800-25-FREY

Hubbard
P.O. Box 104
Northbrook, IL 60065
1-800-323-8368

NASCO
901 Janesville Avenue
Fort Atkinson, WI 53538
1-800-558-9595

Oriental Trading Company, Inc.
P.O. Box 3407
Omaha, NE 68103
1-800-875-8480

Science Kit and Boreal Labs
777 E. Park Drive
Tonawanda, NY 14150
1-800-828-7777

Scienceware
Grau-Hall Scientific
6501 Elvas Avenue
Sacramento, CA 95819
1-800-331-4728

S&S Arts and Crafts
Colchester, CT 06415
1-800-243-9232

Stumps Decorations for
Special Occasions
Box 305
South Whitley, IN 46787-0305
1-800-992-9251

Triarco Arts & Crafts
14650 28th Avenue N.
Plymouth, MN 55447
1-800-328-3360





Optics—An Educator’s Guide with Activities in Science, Mathematics, and Technology Education

To achieve America’s goals in Educational Excellence, it is NASA’s mission to develop supplementary instructional materials and curricula in science, mathematics, geography, and technology. NASA seeks to involve the educational community in the development and improvement of these materials. Your evaluation and suggestions are vital to continually improving NASA educational materials.

Please take a moment to respond to the statements and questions below. You can submit your response through the internet or by mail. Send your reply to the following internet address:

http://ehb2gsfc.nasa.gov/edcats/educator_guide

You will then be asked to enter your data at the appropriate prompt.

Otherwise, please return the reply card by mail. Thank you.

1. With what grades did you use the educator’s guide?

Number of Teachers/Faculty: _____ K-4 _____ 5-8 _____ 9-12 _____ Community College
 College/University: _____ Graduate _____ Undergraduate

Number of Students: _____ K-4 _____ 5-8 _____ 9-12 _____ Community College
 College/University: _____ Graduate _____ Undergraduate

Number of Others: _____ Administrators/Staff _____ Parents _____ Professional Groups
 _____ General Public _____ Civic Groups _____ Other

2. What is your home 5- or 9-digit zip code? _____

3. This is a valuable educators guide.
 Strongly Agree Agree Neutral Disagree Strongly Disagree
4. I expect to apply what I learned in this educator’s guide.
 Strongly Agree Agree Neutral Disagree Strongly Disagree

5. What kind of recommendation would you make to someone who asks about this educator’s guide?
 Excellent Good Average Poor Very Poor

6. How did you use this educator’s guide?
 Background Information Critical Thinking Tasks
 Demonstrate NASA Materials Demonstration
 Group Discussions Hands-On Activities
 Integration Into Existing Curricula Interdisciplinary Activity
 Lecture Science and Mathematics
 Team Activities Standards Integration
 Other: Please specify: _____

7. Where did you learn about this educator’s guide?
 NASA Educator Resource Center
 NASA Central Operation of Resources for Educators (CORE)
 Institution/School System
 Fellow Educator
 Workshop/Conference
 Other: Please specify: _____

8. What features of this educator’s guide did you find particularly helpful?

9. How can we make this educator’s guide more effective for you?

10. Additional comments:

Today’s Date: _____

Fold along the line and tape closed

Please Place
Stamp Here
Post Office
Will Not Deliver
Without Proper
Postage

National Aeronautics and Space Administration
Education Division
Mail Code FE
Washington DC 20546-0001

————— Fold along the line and tape closed —————





*U.S. Department of Education
Office of Educational Research and Improvement (OERI)
National Library of Education (NLE)
Educational Resources Information Center (ERIC)*

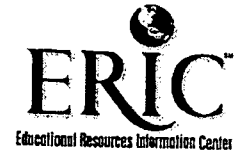

NOTICE

Reproduction Basis

- This document is covered by a signed "Reproduction Release (Blanket)" form (on file within the ERIC system), encompassing all or classes of documents from its source organization and, therefore, does not require a "Specific Document" Release form.
- This document is Federally-funded, or carries its own permission to reproduce, or is otherwise in the public domain and, therefore, may be reproduced by ERIC without a signed Reproduction Release form (either "Specific Document" or "Blanket").