

## DOCUMENT RESUME

ED 472 094

SE 066 379

AUTHOR Simmt, Elaine, Ed.; Davis, Brent, Ed.; McLoughlin, John Grant, Ed.

TITLE Canadian Mathematics Education Study Group = Groupe Canadien d'Etude en Didactique des Mathematiques. Proceedings of the Annual Meeting (24th, Montreal, Quebec, Canada, May 26-30, 2000).

INSTITUTION Canadian Mathematics Education Study Group.

PUB DATE 2000-00-00

NOTE 193p.; For individual plenary papers, see SE 066 382 and SE 066 384.

PUB TYPE Collected Works - Proceedings (021)

LANGUAGE English, French

EDRS PRICE EDRS Price MF01/PC08 Plus Postage.

DESCRIPTORS \*Professional Development; Concept Formation; Curriculum Development; Elementary Secondary Education; Equal Education; Foreign Countries; Instructional Development; Learning Activities; \*Mathematics Instruction; \*Mathematics Teachers; Teacher Education Programs

IDENTIFIERS Canada

## ABSTRACT

This document contains the proceedings of the annual meeting of the Canadian Mathematics Education Study Group (CMESG) held at the University of Quebec in Montreal, Canada, May 26-30, 2000. The proceedings consist of two plenary lectures, five working groups, four topic sessions, new Ph.D. reports, and panel discussions. Papers include: (1) "Manipulating Combinatorial Structures" (Gilbert Labelle); (2) "The Theoretical Dimension of Mathematics: A Challenge for Didacticians" (Maria Bartolini Bussi); (3) "Mathematics Courses for Prospect Elementary Teachers" (Caroline La Joie and Ed Barbeau); (5) "Crafting an Algebraic Mind: Intersections from History and the Contemporary Mathematics Classroom" (Louis Charbonneau and Luis Radford); (6) "Mathematics Education et Didactique des Mathematiques: Is There a Reason for Living Separate Lives?" (Tom Kieren and Anna Sierpiska); (8) "Teachers, Technologies, and Productive Pedagogy" (David A. Reid and Rosamund Sutherland); (9) "Calculus Reform: A Critical Assessment" (Sylvie Desjardins and Harald Proppe); (10) "A Proof Ought to Explain: A Classroom Teacher-Researcher, a Mathematics Educator, and Three Cohorts of Fifth Graders Seek to Make Meaning of a Non-Obvious Algebraic Equation" (Vicki Zack and David A. Reid); (11) "Assessment for All" (Leigh N. Wood and Geoffrey H. Smith); (12) "Mathematics--By Invitation" (Ralph T. Mason); (13) "Math Central: An Internet Service for Teachers and Students" (Mhairi (Vi) Maeers and Harley Weston); (14) "Mathematical Conversations within the Practice of Mathematics" (Lynn Gordon Calvert); (15) "The Word Problem as Genre in Mathematics Education" (Susan Gerofsky); (16) "How Visual Perception Justifies Mathematical Thought" (Dennis Lomas); (17) "Folding Back and Growing Mathematical Understanding" (Lyndon Martin); (18) "La Place et les Fonctions de la Validation Chez les Futures Enseignants des Mathematiques au Secondaires" (Claudine Mary); (19) "Mathematics Knowing in Action: A Fully Embodied Interpretation" (Elaine Simmt); (20) "Pourquoi Enseigner les Mathematiques a Tous?" (Bernard R. Hodgson); (21) "Why Teach Mathematics to Everyone?" (Bernard R. Hodgson); (22) "Why Teach Mathematics to All

Students?" (Sandy Dawson); (23) "Why Teach Mathematics to All Students?" (Brent Davis); and (24) "Why Teach Mathematics to Everyone?" (Nadine Bednarz). (KHR)

CANADIAN MATHEMATICS EDUCATION  
STUDY GROUP

GROUPE CANADIEN D'ÉTUDE EN DIDACTIQUE  
DES MATHÉMATIQUES

PERMISSION TO REPRODUCE AND  
DISSEMINATE THIS MATERIAL HAS  
BEEN GRANTED BY

*E. Simmt*

PROCEEDINGS  
2000 ANNUAL MEETING

TO THE EDUCATIONAL RESOURCES  
INFORMATION CENTER (ERIC)

1

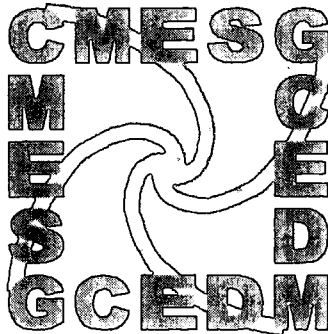

Université du Québec à Montréal  
May 26 – 30, 2000

**BEST COPY AVAILABLE**

EDITED BY:  
Elaine Simmt, *University of Alberta*  
Brent Davis, *University of Alberta*  
John Grant McLoughlin, *Memorial University*

U.S. DEPARTMENT OF EDUCATION  
Office of Educational Research and Improvement  
EDUCATIONAL RESOURCES INFORMATION  
CENTER (ERIC)

*[Signature]* This document has been reproduced as  
received from the person or organization  
originating it.

Minor changes have been made to  
improve reproduction quality.

• Points of view or opinions stated in this  
document do not necessarily represent  
official OERI position or policy.

CANADIAN MATHEMATICS EDUCATION  
STUDY GROUP

GROUPE CANADIEN D'ÉTUDE EN DIDACTIQUE  
DES MATHÉMATIQUES

PROCEEDINGS  
2000 ANNUAL MEETING

Université du Québec à Montréal  
May 26 – 30, 2000

EDITED BY:  
Elaine Simmt, *University of Alberta*  
Brent Davis, *University of Alberta*  
John Grant McLoughlin, *Memorial University*

**24<sup>th</sup> Annual Meeting**  
**Canadian Mathematics Education Study Group /**  
**Groupe Canadien d'Étude en Didactique des Mathématiques**  
Université du Québec à Montréal, 2000

**PROCEEDINGS**

**Table des matières / Contents**

	<i>v</i>	<i>Acknowledgements</i>
	<i>vii</i>	<i>Schedule</i>
MALGORZATA DUBIEL	<i>ix</i>	<i>Introduction</i>
<b>PLENARY LECTURES</b>		
GILBERT LABELLE	3	<i>Manipulating Combinatorial Structures</i>
MARIA BARTOLINI BUSSI	21	<i>The Theoretical Dimension of Mathematics: A Challenge for Didacticians</i>
<b>WORKING GROUPS</b>		
CAROLINE LAJOIE & ED BARBEAU	35	A • <i>Des cours de mathématiques pour les futurs enseignants et enseignantes du primaire</i>
	43	<i>Mathematics Courses for Prospective Elementary Teachers</i>
LOUIS CHARBONNEAU & LUIS RADFORD	47	B • <i>Crafting an Algebraic Mind: Intersections from History and the Contemporary Mathematics Classroom</i>
TOM KIEREN & ANNA SIERPINSKA	61	C • <i>Mathematics education et didactique des mathématiques : y a-t-il une raison pour vivre des vies séparées?</i> <i>Mathematics education et didactique des mathématiques: Is there a reason for living separate lives?</i>
DAVID A. REID & ROSAMUND SUTHERLAND	81	D • <i>Teachers, Technologies, and Productive Pedagogy</i>
SYLVIE DESJARDINS & HARALD PROPPE	87	E • <i>Calculus Reform: A Critical Assessment</i>
<b>TOPIC SESSIONS</b>		
VICKI ZACK & DAVID A. REID	95	<i>A Proof Ought to Explain: A Classroom Teacher-Researcher, a Mathematics Educator, and Three Cohorts of Fifth Graders Seek to Make Meaning of a Non-Obvious Algebraic Equation</i>
LEIGH N. WOOD & GEOFFREY H. SMITH	103	<i>Assessment for All</i>

RALPH T. MASON	109	<i>Mathematics—By Invitation</i>
MHAIRI (VI) MAEERS & HARLEY WESTON	115	<i>Math Central: An Internet Service for Teachers and Students</i>

#### NEW PhD REPORTS

LYNN GORDON CALVERT	123	<i>Mathematical Conversations within the Practice of Mathematics</i>
SUSAN GEROFSKY	129	<i>The Word Problem as Genre in Mathematics Education</i>
DENNIS LOMAS	135	<i>How Visual Perception Justifies Mathematical Thought</i>
LYNDON MARTIN	141	<i>Folding Back and Growing Mathematical Understanding</i>
CLAUDINE MARY	147	<i>La place et les fonctions de la validation chez les futurs enseignants des mathématiques au secondaires</i>
ELAINE SIMMT	153	<i>Mathematics Knowing in Action: A Fully Embodied Interpretation</i>

#### PANEL DISCUSSION

BERNARD R. HODGSON	163	<i>Pourquoi enseigner les mathématiques à tous?</i>
SANDY DAWSON	165	<i>Why teach mathematics to all students?</i>
BRENT DAVIS	167	<i>Why teach mathematics to all students?</i>
NADINE BEDNARZ	173	<i>Pourquoi enseigner les mathématiques à tous?</i>
	181	<i>Why teach mathematics to everyone?</i>

#### APPENDICES

191	A • <i>Working Groups at Each Annual Meeting</i>
195	B • <i>Plenary Lectures at Each Annual Meeting</i>
197	C • <i>Proceedings of Annual Meetings</i>
199	D • <i>List of Participants</i>

## Acknowledgements

On behalf of the members, the CMESG/GCEDM executive would like to take this opportunity to thank our local hosts for their contributions to the 2000 Annual Meeting and Conference. Specifically, thank you to: Lesley Lee, chair of local organizing committee; Caroline Lajoie, electronic equipment; Bernadette Janvier and Carolyn Kieran, meals; Nadine Bednarz, coffee; Nathalie Prévost and Jeanne Laporte-Jobin, registrations; Asuman Oktaç and Astrid Defence, walking tours; Hassane Squalli and Rina Herscovics, email.

Supplementary materials to some of the contributions in these *Proceedings* are posted on the CMESG website (<http://www.cmesg.math.ca>), maintained by David Reid.

Thank you to Darren Stanley for proofreading assistance.

## Schedule

	<b>Friday May 26</b>	<b>Saturday May 27</b>	<b>Sunday May 28</b>	<b>Monday May 29</b>	<b>Tuesday May 30</b>
<b>AM</b>		<b>8h30 - 9h00</b> Registration <b>9h00 - 12h15</b> WGA WGB WGC WGD WGE <b>10h30 - 11h00</b> Coffee Break	<b>9h00 - 12h15</b> WGA WGB WGC WGD WGE <b>10h30 - 11h00</b> Coffee Break	<b>9h00 - 12h15</b> WGA WGB WGC WGD WGE <b>10h30 - 11h00</b> Coffee Break	<b>9h00 - 9h30</b> Ad hoc sessions <b>9h30 - 11h00</b> Special Panel Discussion <b>11h00 - 11h15</b> Coffee Break <b>11h15 - 12h15</b> Closing Session
<b>Lunch</b>		<b>12h15 - 13h30</b>	<b>12h15 - 13h30</b>	<b>12h15 - 13h30</b>	
<b>PM</b>	<b>15h45</b> Friends of FLM <b>16h00 - 17h00</b> Registration <b>17h00-18h00</b> Opening Session	<b>13h30 - 14h20</b> Topic Groups <b>14h30 - 15h00</b> Small group discussion of Plenary I <b>15h00 - 15h15</b> Coffee Break <b>15h15 - 16h15</b> Questions for Labelle	<b>14h00 - 15h00</b> Plenary II: Bartolini Bussi <b>15h10 - 16h00</b> Topic Groups <b>16h00 - 16h30</b> Coffee Break <b>16h30 - 16h55</b> New PhDs <b>17h00 - 17h25</b> New PhDs	<b>13h30 - 14h00</b> Small group discussion of Plenary II <b>14h10 - 15h10</b> Questions for Bartolini Bussi <b>15h10 - 15h30</b> Coffee Break <b>15h30 - 15h55</b> New PhDs <b>16h00 - 16h30</b> Ad hoc sessions <b>16h45 - 17h45</b> General Meeting	
<b>Supper</b>	<b>18h00 - 19h15</b>	Walking Tours	<b>19h00</b> Restaurant Le Caveau	<b>19h00</b> Restaurant La Rotonde	
<b>Evening</b>	<b>19h30 - 20h30</b> Plenary I: Labelle <b>20h25</b> Social				



## Introduction

Malgorzata Dubiel - President, CMESG/GCEDM  
*Simon Fraser University*

It is a great pleasure to write an introduction to the *CMESG/GCEDM Proceedings* from the 2000 meeting held at the Université du Québec à Montréal (UQAM).

A necessary part of the introduction to the *CMESG/GCEDM Proceedings* is an attempt to explain to readers, some of whom may be newcomers to our organization, that the volume in their hands cannot possibly convey the spirit of the meeting it reports on. It can merely describe the content of activities without giving much of the flavour of the process.

To understand this, one needs to understand the uniqueness of both our organization and our annual meetings.

CMESG is an organization unlike other professional organizations. One belongs to it not because of who one is professionally, but because of one's interests. And that is why our members are members of mathematics and education departments at Canadian and other universities and colleges, and school teachers, united by their interest in mathematics and how it is taught at every level, by the desire to make teaching more exciting, more relevant, more meaningful.

Our meetings are unique, too. One does not simply attend a CMESG meeting the way one attends other professional meetings, by coming to listen to a few chosen talks. You are immediately part of it; you live and breathe it.

Working Groups form the core of each CMESG meeting. Participants choose one of several possible topics, and, for three days, become members of a community which meets three hours a day to exchange ideas and knowledge, and, through discussions which often continue beyond the allotted time, create fresh knowledge and insights. Throughout the three days, the group becomes much more than a sum of its parts—often in ways totally unexpected to its leaders. The leaders, after working for months prior to the meeting, may see their carefully prepared plan ignored or put aside by the group, and a completely new picture emerging in its stead.

Two plenary talks are traditionally part of the conference, at least one of which is given by a speaker invited from outside Canada, who brings a non-Canadian perspective. These speakers participate in the whole meeting; some of them afterwards become part of the group. And, in the spirit of CMESG meetings, a plenary talk is not just a talk, but a mere beginning: it is followed by discussions in small groups, which prepare questions for the speaker. After the small group discussions, in a renewed plenary session, the speaker fields the questions generated by the groups.

Topic Groups and Ad Hoc presentations provide more possibilities for exchange of ideas and reflections. Shorter in duration than the Working Groups, Topic Groups are sessions where individual members present work in progress and often find inspiration and new insight from their colleagues' comments.

Ad Hoc sessions are opportunities to share ideas, which are often not even "half-baked"—sometimes born during the very meeting at which they are presented.

A traditional part of each meeting is the recognition of new PhDs. Those who completed their dissertations in the last year are invited to speak on their work. This gives the

group a wonderful opportunity to observe the changing face of mathematics education in Canada.

In 2000, the Tuesday morning panel discussion on curriculum reform was a new feature. Lively and exciting, it created a lot of interest, and so we invited the panelists to submit brief summaries of their presentations for the proceedings, to preserve some of the flavour of the discussion.

Our annual meetings are traditionally set on university campuses with participants staying in dormitories rather than hotels, both to make the meetings more affordable and to allow for discussions to continue far beyond the scheduled hours. The 2000 Annual Meeting was no exception. It was hosted on the campus of the Université du Québec à Montréal, and the participants stayed in the UQAM residence. A successful, working meeting in the middle of Canada's most exciting city, in early Summer—is it possible? Can you keep people in? The executive had been worrying about this before the meeting. But the exciting program, excellent organization and great food (probably the best of all our meetings!) all contributed to one of the largest and most successful meetings ever. Thanks to Lesley Lee and her team for their hard work!

Editing the *Proceedings* of the meeting is a formidable task, one we tend to take for granted. I would like therefore to extend our gratitude to the editors of this volume: John Grant McLoughlin, Brent Davis and Elaine Simmt. Special thanks to Elaine and Brent, who started their work earlier than expected to give a hand in difficult circumstances.

## Plenary Lectures

---

## Manipulating Combinatorial Structures

Gilbert Labelle  
*Université du Québec à Montréal (UQAM)*

A combinatorial structure is a finite *construction* made on a finite set of *elements*. In real-life situations, combinatorial structures often arise as "skeletons" or "schematic descriptions" of concrete objects. For example, on a road map, the elements can be cities and the finite construction can be the various roads joining these cities. Similarly, a diamond can be considered as a combinatorial structure: the plane facets of the diamond are connected together according to certain rules.

Combinatorics can be defined as the mathematical analysis, classification and enumeration of combinatorial structures. The main purpose of my presentation is to show how the manipulation of combinatorial structures, in the context of modern combinatorics, can easily lead to interesting teaching/learning activities at every level of education: from elementary school to university.

The following pages of these proceedings contain a grayscale version of my (color) transparencies (two transparencies on each page). I decided to publish directly my transparencies (instead of a standard typed text) for two main reasons: my talk contained a great amount of figures, which had to be reproduced anyway, and the short sentences in the transparencies are easy to read and put emphasis on the main points I wanted to stress.

The first two transparencies are preliminary ones and schematically describe: a) the importance and relations of combinatorics with science/social activities, b) how analytic/algebraic combinatorics is similar to analytic/algebraic geometry. The next 7 transparencies (numbered 1 to 7) contain drawings showing basic combinatorial structures together with some terminology. Collecting together similar combinatorial structures give rise to the concept of *species of structures* (transparencies 8 to 12). A power series is then associated to any species of structures enabling one to count its structures (transparencies 13 to 15). Each operation on power series (sum, product, substitution, derivation) is reflected by similar operations on the corresponding species of structures (transparencies 16 to 18). The power of this correspondence is illustrated on explicit examples (transparencies 18 to 26) where the structures are manipulated (and counted) using various combinatorial operations. Transparencies 27 to 30 suggest some general teaching/learning activities (from elementary to advanced levels) that may arise from these ideas. I hope that the readers will agree that manipulating combinatorial structures constitutes a good activity to develop the mathematical mind.

### References

The main references for the theory of combinatorial species are:

- Joyal, A. (1981). Une théorie combinatoire des séries formelles, *Advances in Mathematics*, 42, 1–82.  
Bergeron, F., Labelle, G., & Leroux, P. (1998). Combinatorial Species and Tree-like Structures. *Encyclopedia of Math. and its Applications*, Vol. 67, Cambridge University Press.

**PRELIMINARIES**

The dynamic connections between combinatorial / discrete mathematics and science / social activities will greatly increase during the coming decades :

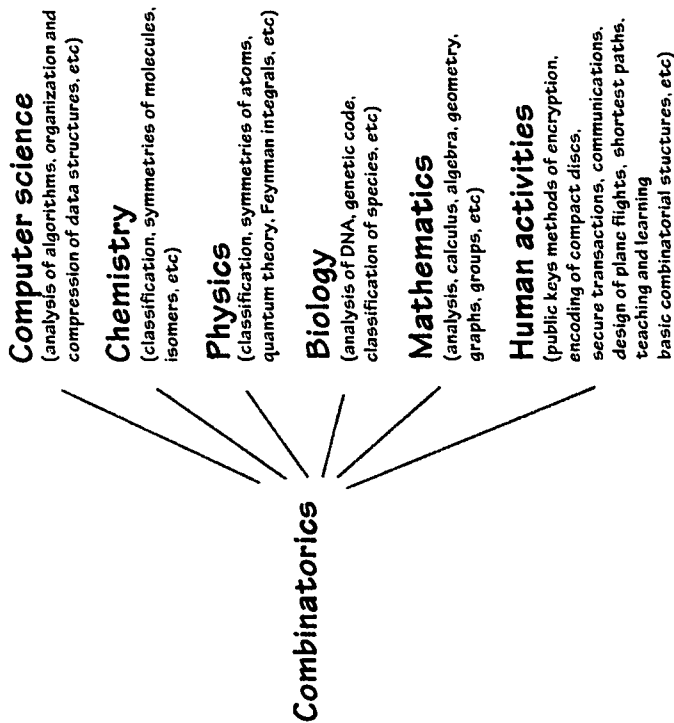

**ANALYTIC / ALGEBRAIC GEOMETRY**

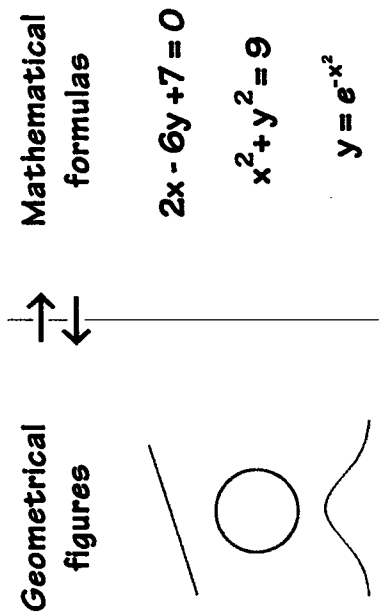

**ANALYTIC / ALGEBRAIC COMBINATORICS**

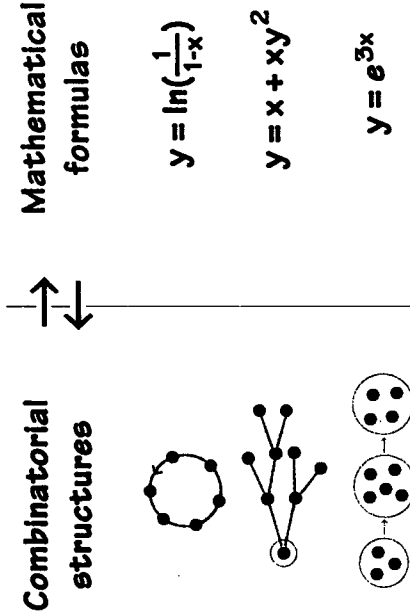

**Example 2.** A rooted tree on  $U = \{a, b, c, \dots, z, y, s, t\}$



**Example 3.** An oriented cycle on  $U = \{1, 2, \dots, 9\}$

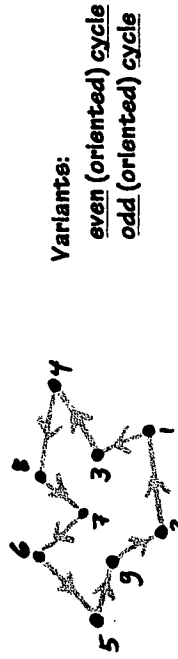

Variante:  
even (oriented) cycle  
odd (oriented) cycle

**Example 4.** A subset on (of)  $U = \{\square, \Delta, \circ, \star, \perp, \top\}$   
 (or bicoloration)



**MANIPULATING COMBINATORIAL STRUCTURES**

Gilbert Labelle / LaCIM - UQAM

In Combinatorics, a structure, s, is a finite construction made on a finite set U.

- We say that : U is the underlying set of s
- or : U is equipped with (the structure) s
- or : s is (built) on U
- or : s is labelled by the set U

**Example 1.** A tree on  $U = \{a, b, c, \dots, x, y, z, t\}$

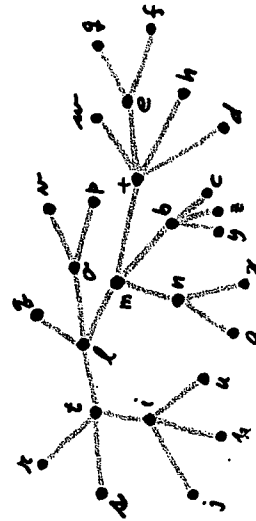

4

**Example 8.** A partition on  $U = \{\square, \star, 1, 2, 3, a, b, \dots, p\}$

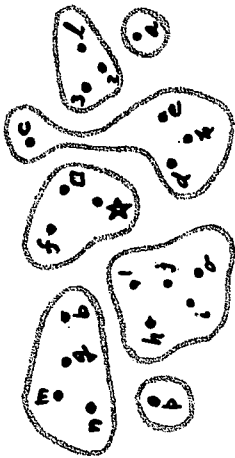

3

**Example 5.** A (the) set structure on

$$U = \{\square, \circ, \Delta, \star, \perp, \bullet\}$$

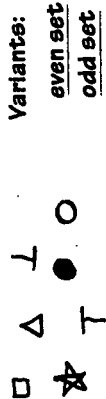

**Example 6.** A permutation on

$$U = \{1, 2, 3, 4, 5, a, b, \dots, n\}$$

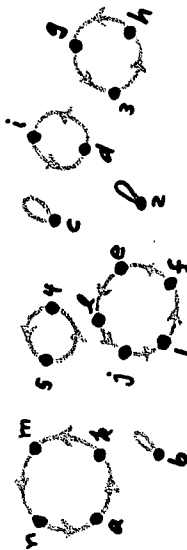

**Example 7.** A linear order on  $U = \{u, v, w, x, y, z\}$



**Example 9.** An endofunction on  $U = \{1, 2, \dots, 62\}$

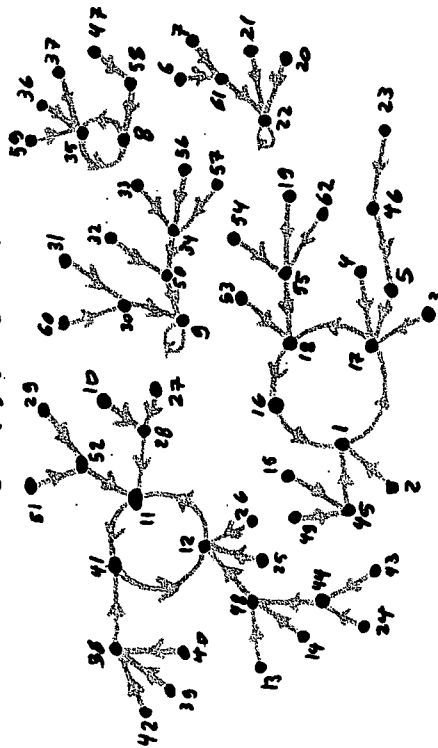

**Example 13.** A singleton on  $U = \{a\}$



(There is no singleton structure on  $U$  if  $|U| \neq 1$ )

**Example 14.** An empty set structure on  $U = \emptyset$



(There is no empty set structure if  $U \neq \emptyset$ )

**Example 15.** An involution on  $U = \{a, b, \dots, l\}$

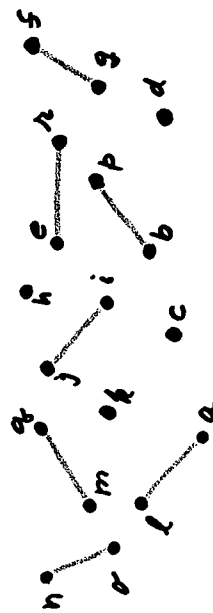

**ETC, ETC, ETC, ...**

**Example 10.** A bicolored polygon on

$U = \{a, b, c, d, e, f\}$



**Example 11.** A graph on  $U = \{1, 2, \dots, 46\}$

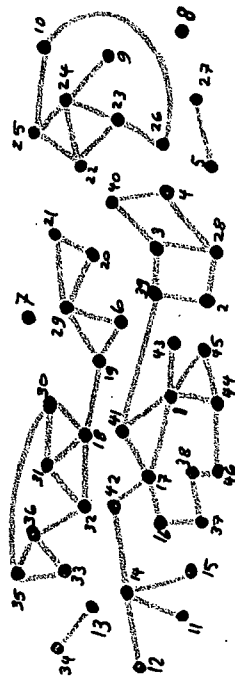

**Example 12.** A connected graph on  $U = \{1, 2, \dots, 19\}$

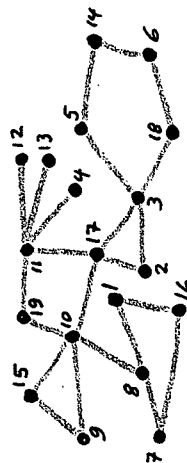



For example, we can consider

- the species  $\mathcal{A}$  of all trees (arbres),
- the species  $\mathcal{A}$  of all rooted trees (arborescences),
- the species  $\mathcal{C}$  of all cycles,
- the species  $\mathcal{C}_{\text{even}}$  of all even cycles,
- the species  $\mathcal{P}$  of all subsets (of sets),
- the species  $\mathcal{E}$  of all sets (ensembles),
- the species  $\mathcal{E}_{\text{even}}$  of all even sets,
- the species  $\mathcal{E}_{\text{odd}}$  of all odd sets,
- the species  $\mathcal{S}$  of all permutations,
- the species  $\mathcal{L}$  of all linear orders,
- the species  $\mathcal{B}$  of all partitions,
- the species  $\mathcal{E}nd$  of all edofunctions,
- the species  $\mathcal{P}^{bic}$  of all bicolored polygons,
- the species  $\mathcal{G}ra$  of all graphs,
- the species  $\mathcal{G}ra^c$  of all connected graphs,
- the species  $\mathcal{X}$  of all singletons,
- the species  $\mathcal{I}$  of the empty set,
- the empty species  $\mathcal{O}$  (containing no structure),
- the species  $\mathcal{I}nv$  of all involutions,
- ⋮
- the species  $\mathcal{F}$  of all F - structures.

CONVENTION: An arbitrary structure

$\mathcal{A}$  on  $\mathcal{U}$

will sometimes be represented by



Here,  $\mathcal{U} = \{a, b, c, d, e, f\}$

A structure  $\mathcal{A}$  on  $\mathcal{U}$  is said to be even (odd) if  $\mathcal{U}$  contains an even (odd) number of elements.

Two structures  $\mathcal{A}$  and  $\mathcal{C}$  are said to be disjoint if their underlying sets are disjoint.

Structures can be studied and classified by collecting them into SPECIES OF STRUCTURES:

By convention, for any finite set  $U$  we write

$F[U] :=$  the set of all  $F$ -structures on  $U$

Example. If  $F = C =$  the species of cycles, then



is a  $C$ -structure

and if  $U = \{m, n, p, q\}$ , then

$$C[\{m, n, p, q\}] = \{ \text{cycle}(m, n, p, q), \text{cycle}(n, p, q, m), \text{cycle}(p, q, m, n), \text{cycle}(q, m, n, p) \}$$

Fundamental properties satisfied by the preceding example :

PROPERTY 1. For every finite set  $U$ , the set  $C[U]$  is always finite.

PROPERTY 2. Every bijection

$$\begin{array}{ccc} U & = & \{m, n, p, q\} \\ \beta \downarrow & & \downarrow \tau \\ V & = & \{a, b, c, d\} \end{array}$$

induces another bijection,

$$\begin{array}{ccc} C[U] = \{ \text{cycle}(m, n, p, q), \text{cycle}(n, p, q, m), \text{cycle}(p, q, m, n), \text{cycle}(q, m, n, p) \} \\ \downarrow C[\beta] & & \downarrow \tau \\ C[V] = \{ \text{cycle}(a, b, c, d), \text{cycle}(b, c, d, a), \text{cycle}(c, d, a, b), \text{cycle}(d, a, b, c) \} \end{array}$$

which relabels via  $\beta$  each  $C$ -structure on  $U$  to form a corresponding  $C$ -structure on  $V$ .

CONVENTION. An arbitrary  $F$ -structure  $\mathcal{A}$  on  $U$  can be represented by diagrams like

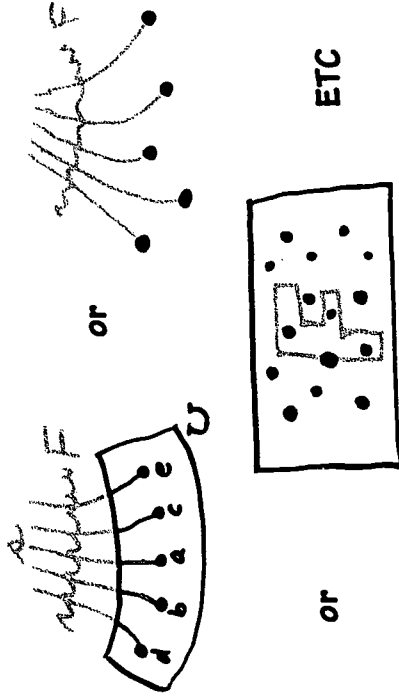

Counting structures of a given species

The properties of relabellings imply that the number of  $F$ -structures on  $U$  depends only on the number of elements of  $U$ .

- That is,  $|F[U]|$  depends only on  $|U|$ .

Note. Two successive relabellings via  $\beta$  and  $\beta'$  amounts to a single relabelling via  $\beta' \circ \beta$ :

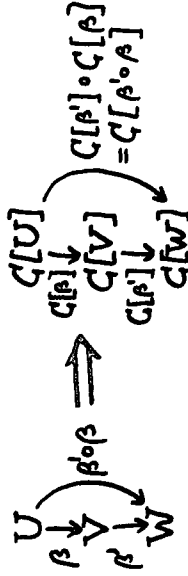

DEFINITION (André Joyal, UGAM, 1979)

A combinatorial species is a rule  $F$  which

- 1) generates, for each finite set  $U$ , another finite set  $F[U]$ ,
- 2) generates, for each bijection

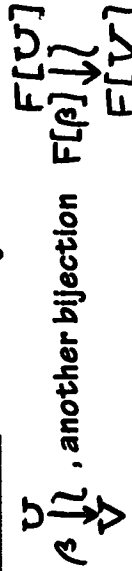

in a coherent way:  $F[\beta'] \circ F[\beta] = F[\beta' \circ \beta]$ .

- Any  $\mathcal{A}$  in  $F[U]$  is called a  $F$ -structure on  $U$ .
- Any bijection  $F[\beta]$  is called  $F$ -relabelling via  $\beta$ .

13

Hence, if we want to simply count  $F$ -structures, it is sufficient to consider only the cases

$$U = \underline{n} = \{1, 2, \dots, n\}, \quad n = 0, 1, 2, \dots.$$

DEFINITION. Let  $F$  be a species and

$$\begin{aligned} f_n &= |F[\underline{n}]| \\ &= \text{number of } F\text{-structures} \\ &\quad \text{labelled by } \{1, 2, \dots, n\}. \end{aligned}$$

The generating series of the species  $F$  is

$$F(x) = \sum_{n=0}^{\infty} f_n \frac{x^n}{n!}.$$

NOTE. We will see that generating series give rise to a dynamic connection between

COMBINATORICS and ANALYSIS.

14

$$F(x) = \sum_{n=0}^{\infty} f_n \frac{x^n}{n!}$$

Example 1.  $S$  : the species of permutations

$$S(x) = \sum_{n \geq 0} n! \frac{x^n}{n!} = \sum_{n \geq 0} x^n = \frac{1}{1-x}$$

Example 2.  $\mathcal{P}$  : the species of subsets

$$P(x) = \sum_{n \geq 0} 2^n \frac{x^n}{n!} = e^{2x}$$

Example 3.  $E$  : the species of sets

$$E(x) = \sum_{n \geq 0} 1 \frac{x^n}{n!} = e^x$$

Example 4.  $E_{\text{even}}$  : the species of even sets

$$E_{\text{even}}(x) = 1 + \frac{x^2}{2!} + \frac{x^4}{4!} + \dots = \cosh x$$

Example 5.  $E_{\text{odd}}$  : the species of odd sets

$$E_{\text{odd}}(x) = \frac{x}{1!} + \frac{x^3}{3!} + \frac{x^5}{5!} + \dots = \sinh x$$

**COMBINING and MANIPULATING SPECIES**

We know how to add, multiply, substitute, and differentiate series to obtain other series:

$$\text{if } F(x) = \sum_{n \geq 0} f_n \frac{x^n}{n!}, \quad G(x) = \sum_{n \geq 0} g_n \frac{x^n}{n!}$$

$$\text{and } H(x) = \sum_{n \geq 0} h_n \frac{x^n}{n!}$$

then we have the following table

OPERATION	COEFFICIENT $h_n$
$H(x) = F(x) + G(x)$	$h_n = f_n + g_n$
$H(x) = F(x) \cdot G(x)$	$h_n = \sum_{0 \leq k \leq n} \frac{n!}{k!(n-k)!} f_k g_{n-k}$
$H(x) = F(G(x))$ $G(0) = g_0 = 0$	$h_n = \sum_{\substack{0 \leq k \leq n \\ n_1 + n_2 + \dots + n_k = n}} \frac{n!}{k!n_1! \dots n_k!} f_k g_{n_1} \dots g_{n_k}$
$H(x) = \frac{d}{dx} F(x)$	$h_n = f_{n+1}$

This table suggests corresponding combinatorial operations for species :

Example 6.  $L$  : the species of linear orders

$$L(x) = \sum_{n \geq 0} n! \frac{x^n}{n!} = \sum_{n \geq 0} x^n = \frac{1}{1-x}$$

Example 7.  $C$  : the species of cycles

$$C(x) = \sum_{n \geq 1} (n-1)! \frac{x^n}{n!} = \sum_{n \geq 1} \frac{x^n}{n} = \ln\left(\frac{1}{1-x}\right)$$

Example 8.  $C_{\text{even}}$  : the species of even cycles

$$C_{\text{even}}(x) = \sum_{\substack{n \text{ even} \\ n \geq 1}} (n-1)! \frac{x^n}{n!} = \sum_{k \geq 1} \frac{x^{2k}}{2k} = \ln\sqrt{\frac{1}{1-x^2}}$$

Example 9.  $End$  : the species of endofunctions

$$End(x) = \sum_{n \geq 0} n^n \frac{x^n}{n!}$$

Example 10.  $X$  : the species of singletons

$$X(x) = 0 + 1 \frac{x}{1!} + 0 \frac{x^2}{2!} + 0 \frac{x^3}{3!} + \dots = x$$

Example 11.  $Gra$  : the species of graphs

$$Gra(x) = \sum_{n \geq 0} 2^{\binom{n}{2}} \frac{x^n}{n!}$$

**THEOREM.** If  $F$  and  $G$  are species, then

$$\begin{aligned} (F+G)(x) &= F(x) + G(x), \\ (F \cdot G)(x) &= F(x) \cdot G(x), \\ (F \circ G)(x) &= F(G(x)), \quad (\text{if } G[\emptyset] = \emptyset) \\ F'(x) &= \frac{d}{dx} F(x). \end{aligned}$$

**EXAMPLES / APPLICATIONS**

1)  $E = E_{\text{even}} + E_{\text{odd}} \Rightarrow E(x) = E_{\text{even}}(x) + E_{\text{odd}}(x)$   
 that is,  $e^x = \cosh x + \sinh x$

2) Let  $D$  be the species of derangements,  
 i.e., permutations without fixed points, then

$$S = E \cdot D$$

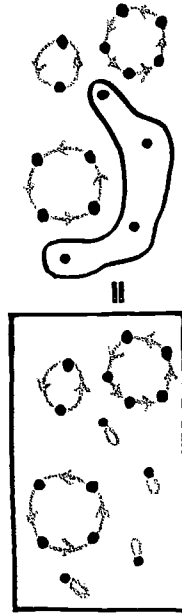

$$\begin{aligned} \Rightarrow S(x) &= E(x) \cdot D(x) \quad \text{i.e., } \frac{1}{1-x} = e^x D(x) \\ \Rightarrow D(x) &= e^{-x} \frac{1}{1-x} \\ \Rightarrow d_n &= \text{number of derangements of } n \text{ objects} \\ &= n! \left( \frac{1}{0!} - \frac{1}{1!} + \frac{1}{2!} - \frac{1}{3!} + \dots + (-1)^n \frac{1}{n!} \right) \end{aligned}$$

**DEFINITION.** From given species  $F$  and  $G$   
 other species can be built:

The species  $F+G$   
 $A (F+G)$ -structure is  $\left[ \begin{array}{l} \text{a } F\text{-structure} \\ \text{or (distinct copies)} \\ \text{a } G\text{-structure} \end{array} \right]$

The species  $F \cdot G$   
 $A (F \cdot G)$ -structure is  $\left[ \begin{array}{l} \text{an ordered pair} \\ \text{of a } F\text{-structure and a} \\ \text{disjoint } G\text{-structure} \end{array} \right]$

The species  $F \circ G = F \circ G$   
 $A (F \circ G)$ -structure is  $\left[ \begin{array}{l} \text{a } F\text{-structure} \\ \text{built on a finite set of} \\ \text{disjoint } G\text{-structures} \end{array} \right]$  (here,  $G[\emptyset] = \emptyset$ )

The species  $F'$   
 $A F'$ -structure on  $U$  is  $\left[ \begin{array}{l} \text{a } F\text{-structure} \\ \text{on } U + \{*\} \end{array} \right]$

3)  $End = S \circ A$

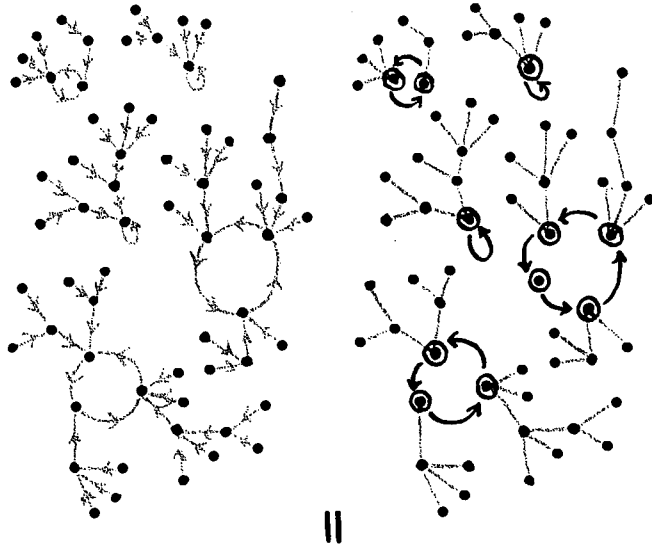

$$\Rightarrow End(x) = S(A(x)) \Rightarrow \sum_{n \geq 0} n^n \frac{x^n}{n!} = \frac{1}{1-A(x)}$$

$$\Rightarrow A(x) = \frac{\sum_{n \geq 1} n^n \frac{x^n}{n!}}{\sum_{n \geq 0} n^n \frac{x^n}{n!}}$$

4a)  $S = E \circ C$

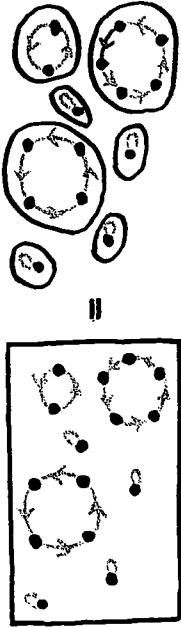

$$\Rightarrow S(x) = E(C(x)) \Rightarrow \frac{1}{1-x} = e^{C(x)}$$

$$\Rightarrow C(x) = \ln\left(\frac{1}{1-x}\right), c_n = (n-1)!$$

4b) Let  $S^{<k>}$  be the species of permutations having  $k$  cycles

and  $E_k$  be the species of  $k$ -sets,

then  $S^{<k>} = E_k \circ C, E_k(x) = \frac{x^k}{k!}$

$$\Rightarrow S^{<k>}(x) = E_k(C(x)) = \left[ \ln \frac{1}{1-x} \right]^k / k!$$

$\Rightarrow A_n^{<k>} =$  number of permutations of  $n$  points having  $k$  cycles

$=$  absolute value of Stirling number of the first kind

$$= \frac{1}{k!} \sum_{n_1 + \dots + n_k = n, n_i > 0} \frac{n!}{n_1! n_2! \dots n_k!} = |s(n, k)|$$

5a)  $B = E \circ E_+$

Where  $E_+$  is the species of non-empty sets.

$$E_+(x) = e^x - 1 \Rightarrow B(x) = E(E_+(x)) = e^{e^x - 1} = \frac{1}{e} e^{e^x}$$

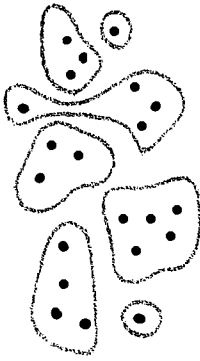

It follows that

$b_n =$  number of partitions of a set of  $n$  elements

$$= \frac{1}{e} \sum_{i=0}^n \frac{i^n}{i!} \quad \left( \begin{array}{l} \text{This is Dobinski's formula} \\ \text{for the } n \text{th Bell number} \end{array} \right)$$

5b) Let  $B^{\langle k \rangle}$  be the species of partitions having  $k$  classes

and  $E_k$  be the species of  $k$ -sets,

$$\Rightarrow B^{\langle k \rangle} = E_k \circ E_+ \Rightarrow B^{\langle k \rangle}(x) = [e^x - 1]^k / k!$$

$\Rightarrow b_n^{\langle k \rangle} =$  number of partitions of  $n$  points into  $k$  classes = Stirling number of the second kind

$$= \frac{1}{k!} \sum_{n_1 + \dots + n_k = n} \frac{n!}{n_1! n_2! \dots n_k!} = S(n, k)$$

6)  $P = E \cdot E$

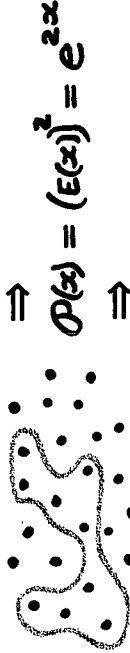

$p_n =$  number of subsets of a set of  $n$  elements =  $2^n$  (known!)

7) Let  $\hat{S}$  be the species of permutations having only even cycles:  $\hat{S} = E \circ C_{\text{even}}$

$$\Rightarrow \hat{S}(x) = e^{C_{\text{even}}(x)} = e^{\sum_{k \geq 2} \frac{x^k}{k}} = \frac{1}{\sqrt{1-x^2}}$$

$$\Rightarrow \hat{A}_n = \begin{cases} 1 \cdot 3 \cdot 5 \dots (2k-1)^2 & \text{if } n = 2k \\ 0 & \text{otherwise} \end{cases}$$

8)  $L' = L^2$



$$\Rightarrow L^2(x) = (L(x))^2 \Rightarrow \frac{d}{dx} \frac{1}{1-x} = \left( \frac{1}{1-x} \right)^2 \quad (\text{known!})$$



12)  $A = X \cdot (E \circ A)$



$\Rightarrow A(x) = X(x) \cdot E(A(x)) = x e^{A(x)}$   
 $\Rightarrow A(x) e^{-A(x)} = x \Rightarrow a_n = n^{n-1}$

13) Let  $\mathcal{V}$  be the species of vertebrates  
 (a vertebrate is a pointed rooted tree)

$\mathcal{V} = L \circ A$



$\Rightarrow \mathcal{V}(x) = L(A(x)) = \frac{x}{1-A(x)} = \text{End}(x)$   
 $\Rightarrow n_n = n a_n = \text{number of endofunctions on } n \text{ elements}$   
 $= n^n \Rightarrow a_n = n^{n-1} \text{ (Joyal)}$

9)  $C' = L$



(again!)

$\Rightarrow \int \frac{dx}{1-x} C(x) = L(x) \Rightarrow C(x) = \int \frac{dx}{1-x} = \ln\left(\frac{1}{1-x}\right)$

10)  $P^{\text{bic}} = L_{\text{odd}} = C'_{\text{even}}$

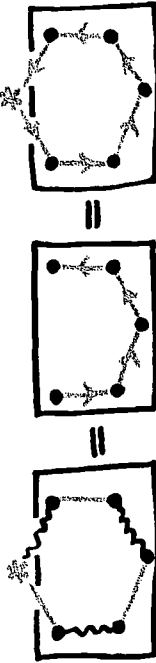

but  $P^{\text{bic}} \neq C'_{\text{even}} !!!$

11)  $B' = E \cdot B$



$\Rightarrow \int \frac{dx}{1-x} B(x) = E(x) B(x) = \sum_{k=0}^n \binom{n}{k} b_k$

16) Let  $Bal$  be the species of ballots.

$$Bal = L \circ E_+$$

$$\Rightarrow Bal(x) = L(E_+(x)) = L(e^x - 1)$$

$$= \frac{1}{1 - (e^x - 1)} = \frac{1}{2(1 - \frac{1}{2}e^x)} = \frac{1}{2} \sum_{k=0}^{\infty} (\frac{1}{2}e^x)^k$$

Hence, the number of ballot outcomes for  $n$  candidates is

$$\sum_{k=0}^{\infty} \frac{k^n}{2^{k+1}} \quad (\text{always an integer!!})$$

17)  $Inv = E \circ (X + E_2)$

$$\Rightarrow Inv(x) = e^{x + \frac{1}{2}x^2} = e^x \cdot e^{\frac{1}{2}x^2}$$

$\Rightarrow$  the number of involutions on  $n$  elements is

$$\sum_{0 \leq k \leq \lfloor n/2 \rfloor} \binom{n}{2k} 1 \cdot 3 \cdot 5 \cdots (2k-1)$$

18) Classical formulas of Calculus hold

For example:  $(F \circ G)' = (F' \circ G) \cdot G'$  [chain rule]



14)  $\mathcal{F}$  = the species of forests of rooted trees

$$\mathcal{A}' = \mathcal{F}$$

$$\Rightarrow \mathcal{F}(x) = \frac{d}{dx} \mathcal{A}(x) = \frac{d}{dx} \sum_{n \geq 1} n^{n-2} \frac{x^n}{n!}$$

$$\Rightarrow \mathcal{F}_n = \text{number of forests of rooted trees on } n \text{ points}$$

$$= (n+1)^{n-1}$$

15)  $\mathcal{Ara} = E \circ \mathcal{Ara}^c$



$$\Rightarrow \mathcal{Ara}(x) = e^{\mathcal{Ara}^c(x)}$$

$$\Rightarrow \mathcal{Ara}^c(x) = \ln \mathcal{Ara}(x) = \ln \sum_{n=0}^{\infty} 2^{\binom{n}{2}} \frac{x^n}{n!}$$

To find, build or draw combinatorial structures from real-life situations or from concrete / abstract objects.

Rivers making a (plane) tree

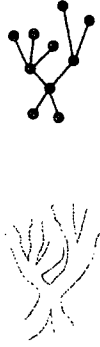

Ladders



Flowers



Sitting around a round table



**POSSIBLE TEACHING / LEARNING ACTIVITIES**  
( from elementary to advanced )

To find, build or draw combinatorial structures from real-life situations or from concrete / abstract objects.



To decide whether two structures of a given species are equal or not.



To make a complete and non-repetitive list of structures belonging to a given species, labelled by a given (small) set.



To make a complete and non-repetitive list of unlabelled structures belonging to a given species on n indistinguishable elements (n small).



To find combinatorial equations associated to species (and vice-versa).



To find enumerative or structural properties of species from their combinatorial equations (via series expansions, for example).



To find combinatorial equations associated to species (and vice-versa).

To find enumerative or structural properties of species from their combinatorial equations (via series expansion, for example).

To decide whether two structures of a given species are equal or not.

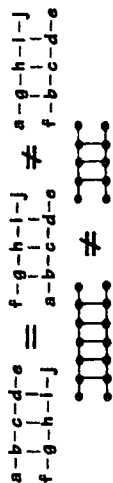

To make a complete and non-repetitive list of structures belonging to a given species, labelled by a given (small) set.

The 16 trees labelled by  $\{a, b, c, d\}$ :

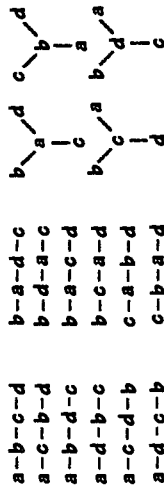

To make a complete and non-repetitive list of unlabelled structures belonging to a given species on n indistinguishable elements (n small).

The 2 unlabelled trees on 4 identical elements:



# The Theoretical Dimension of Mathematics: A Challenge for Didacticians

Maria G. Bartolini Bussi  
*University of Modena and Reggio Emilia - Italy*

## Introduction

The aim of this presentation is to discuss some findings of a few research studies developed in Italy about the approach to theoretical knowledge. Four different teams have worked in a coordinated way for years, namely the teams directed by F. Arzarello (at the University of Turin), M. Bartolini Bussi (at the University of Modena), P. Boero (at the University of Genoa) and M. A. Mariotti (at the University of Pisa).<sup>1</sup>

The set of studies is based on the strict interlacement of several kinds of analysis, for designing purposes and for modeling the processes as well:

- first, the historic-epistemological analysis of ways of mathematical reasoning (with a special focus on proofs);
- second, the didactical analysis of the interaction processes developed in the classroom within suitable teaching experiments;
- third, the cognitive analysis of the processes underlying the production of reasoning and of arguments in proofs.

Whilst the first kind of studies might be considered as an heritage of the Italian tradition of studies on the foundations of mathematics and on the didactical implications, the second and the third are more related to the development of the international literature on the field.

To keep under control the complexity of the system, some theoretical constructs were assumed and/or produced in the research development. The early theoretical constructs concerned the setting of students' activity (*field of experience*<sup>2</sup>) and the quality of classroom interaction (*mathematical discussion*<sup>3</sup>). Exploratory studies were produced at very different school levels.

The teaching experiments of the coordinated project were aimed at creating suitable settings for most of learners (from primary to secondary and tertiary education) being able to develop a theoretical attitude and to produce proofs. The experiments shared some common features from the design phase to the implementation in the classroom:

- the selection, on the basis of historic-epistemological analysis, of fields of experience rich in concrete and semantically pregnant referents (e.g., perspective drawing; sun shadows; Cabri-constructions; gears; linkages and drawing instruments);
- the design of tasks within each field of experience, which require the students to take part in the whole process of production of conjectures, of construction of proofs and of generation of theoretical organization;
- the use of a variety of classroom organization (e.g., individual problem solving, small group work, classroom discussion orchestrated by the teacher, lectures);
- the explicit introduction of primary sources from the history of mathematics into the classroom at any school level.

Teacher participation helped to determine activity in each phase (design, implementation, collection of data and analysis). Their sensitivity and competence proved to be essential

not only in the careful management of classroom activity but also in the elaboration of analytical tools and of the theoretical framework: in a word, they have become *teacher-researchers*. Last but not least, while taking part in the design of experiments, the teachers were put in the condition of deepening some issues concerning the theoretical dimension of mathematics and its relationship with experiential reality. In other words, the theoretical dimension of mathematics became part of the intellectual life of teachers, an essential condition, as they were expected to be able to foster the development of similar attitudes in their pupils.

The outcomes of the teaching experiments were astonishing, if compared with the general plea about the difficulty (or the impossibility) of coping with the theoretical dimension of mathematics. Just to quote a case, most of students even in compulsory education (e.g., Grades 5-8) succeeded in producing conjectures and constructing proofs (Bartolini Bussi et al., 1999) in the setting of the modeling of gears. Were these studies action research based, the process could have stopped here with the production and documentation of facts, i.e., paradigmatic examples of improvement in mathematics teaching. But an additional aim of 'research for innovation' concerned the study of the conditions for realization as well as the possible factors underlying effectiveness; in other words, this success had to be treated as a didactic phenomenon (Arzarello & Bartolini Bussi, 1998). This created the need of framing in an explicit way the existing studies within a theoretical framework, that might have interpreted them in a unitary way and might have suggested issues for a research agenda. The general framework was enriched by two specific additional theoretical constructs, elaborated on the basis of epistemological and cognitive analysis: the idea of *mathematical theorem*<sup>4</sup> and the idea of *cognitive unity*.<sup>5</sup>

In this presentation two examples will be discussed in more details:

- a classroom discussion concerning the shift from 'empirical' to 'theoretical' compass in primary school (5th grade);
- the scheme of a teaching experiment about overcoming conceptual mistakes by an original recourse to Socratic dialogue (5th - 7th grades).

Both examples concern young pupils, to emphasize also the need of starting quite early to nurture the theoretical approach to mathematics.

### First Example: From 'Empirical' To 'Theoretical' Compass (5th Grade)

#### The Protocols

The pupils have been given the following individual problem on an A4 sheet: *Draw a circle, with radius 4 cm, tangent to both circles. Explain carefully your method and justify it.*

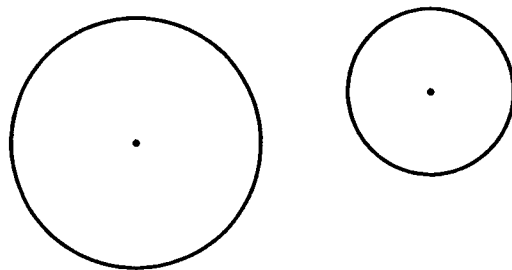

**FIGURE 1** [The circles have radii 3 cm and 2 cm and the distance of their centres is 7 cm.]

All the pupils of the classroom have produced a solution by trial and errors, adjusting a compass to produce a circle that looks tangent to both. Some of them have found two solutions (symmetrical). The teacher (Mara Boni) collects all the individual solutions, analyses them and, a week later, and gives all the pupils a copy of Veronica's solution. Then she introduces the theme of discussion.

Veronica's solution:

*The first thing I have done was to find the centre of the wheel C;*

*I have made by trial and error, in fact I have immediately found the distance between the wheel B and C. Then I have found the distance between A and C and I have given the right 'inclination' to the two segments, so that the radius of C measured 4 cm in all the cases. Then I have traced the circle.*

Veronica's justification:

*I am sure that my method works because it agrees with the three theories we have found:*

- i) the points of tangency H and G are aligned with ST and TR;*
- ii) the segments ST and TR meet the points of tangency H and G;*
- iii) the segments ST and TR are equal to the sum of the radii SG and GT, TH and HR.*

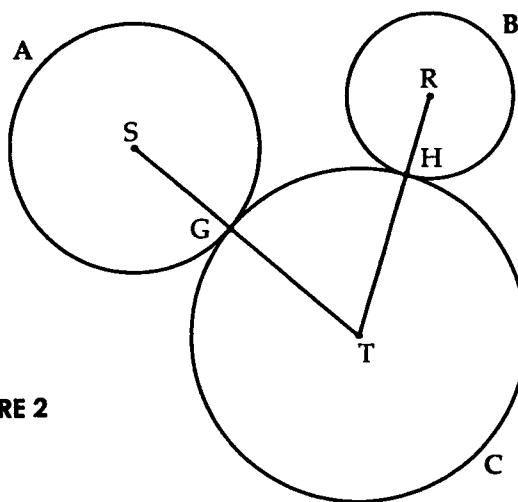

FIGURE 2

The classroom discussion:

Teacher: *Veronica has tried to give the right inclination. Which segments is she speaking of? Many of you open the compass 4cm. Does Veronica use the segment of 4cm? What does she say she is using?*  
[Veronica's text is read again.]

Jessica: *She uses the two segments ...*

Maddalena: *.. given by the sum of radii*

Teacher: *How did she make?*

Giuseppe: *She has rotated a segment.*

Veronica: *Had I used one segment, I could have used the compass.*

[Some pupils point with thumb-index at the segments on Veronica's drawing and try to 'move' them. They pick up an ideal segment as if it were a stick and try to move it.]

Francesca B.: *From the circle B have you thought or drawn the sum?*

Veronica: *I have drawn it.*

Giuseppe: *Where?*

Veronica: *I have planned to make RT perpendicular [to the base side of the sheet] and then I have moved ST and RT until they touched each other and the radius of C was 4cm.*

Alessio: *I had planned to take two compasses, to open them 7 and 6 and to look whether they found the centre. But I could not use two compasses.*

Stefania P.: *Like me ; I too had two compasses in the mind.*

Veronica: *I remember now: I too have worked with the two segments in this way, but I could not on the sheet.*

[All the pupils 'pick up' the segments on Veronica's drawing with thumb-index of the two hands and start to rotate them. The shared experience is strong enough to capture all the pupils.]



Elisabetta [excited]: *She has taken the two segments of 6 and 7, has kept the centre still and has rotated: ah I have understood !*  
 Stefania P.: *... to find the centre of the wheel ...*  
 Elisabetta: *... after having found the two segments ...*  
 Stefania P.: *... she has moved the two segments.*  
 Teacher: *Moved? Is moved a right word?*  
 Voices: *Rotated .. as if she had the compass.*  
 Alessio: *Had she translated them, she had moved the centre.*  
 Andrea: *I have understood, teacher, I have understood really, look at me ...*  
 [The pupils continue to rotate the segments picked up with hands.]  
 Voices: *Yes, the centre comes out there, it's true.*  
 Alessio: *It's true but you cannot use two compasses*  
 Veronica: *you can use first on one side and then on the other.*  
 Teacher: *Good pupils. Now draw the two circles on your sheet.*  
 [All the pupils draw the two circles on their sheet and correctly identify the two possible solutions for the centres.]

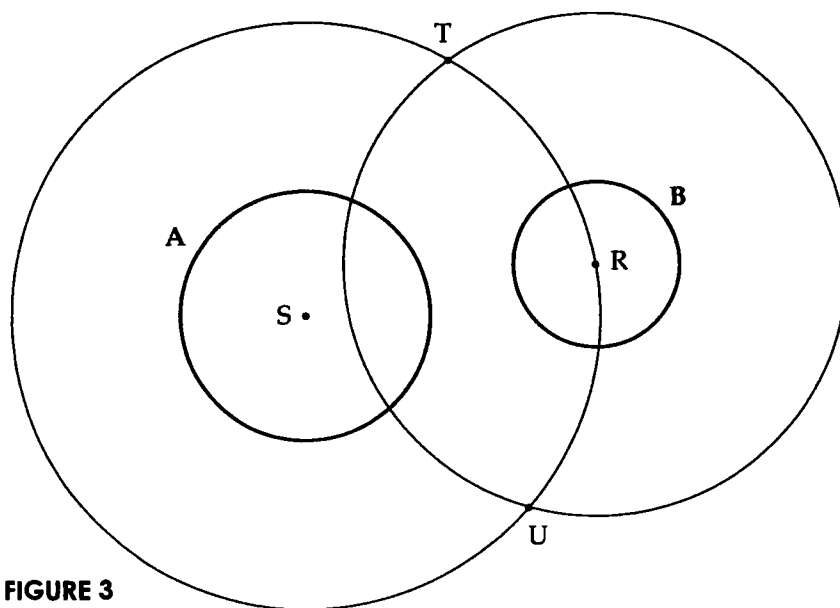

FIGURE 3

### Discussion of the Protocols

The reader might be astonished to think that this problem is given in primary school; s/he might be even more astonished if s/he knew that this classroom is in a district with a very low socio-cultural level. We might offer some elements to understand better, before starting the discussion of the protocols.

First, the classroom is taking part in a long term teaching experiment from the 1st grade, concerning the modeling of gears. The project has two aspects: the (algebraic) modeling of functioning (Bartolini Bussi et al., 1999) and the (geometrical) modeling of shapes (Bartolini Bussi et al., to appear). For the pupils, (toothed) wheels have been naturally modeled by circles and wheels in gear with each other have been modeled as tangent circles (the evocation of wheels appears also in Veronica's protocol). They have discovered by experiments and transformed into fundamental statements some elementary properties of tangent circles, such as the alignment of the two centres and the point of tangency and the related relation between the distance of centres and the sum of radii.



Second, the pupils are capable to discuss effectively with each other, as their teacher is a member of the research team on *Mathematical Discussion*, which analyses the limits and advantages of different types of discussion orchestrated by the teacher (Bartolini Bussi, 1996; 1998) and has introduced in that classroom mathematical discussion since the 1st grade. The pupils are also accustomed to produce detailed individual written protocols, with a clear explanations of their processes: this custom too is the outcome of a very special classroom culture, where individual tasks and discussions on the individual strategies are systematically interlaced with each other.

Third, the pupils are acquainted with the use of the compass to draw circles more precisely than freehand. Between the 2nd and the 3rd grade they have worked for some sessions on the compass, first trying to invent their own instruments to draw circles and then appropriating the existing instrument 'compass' and the manual procedure (not so easy for young pupils) to use it effectively. They have used often the compass to produce round shapes, also in art lessons with the same teacher (to imitate some drawings by Kandinsky).

In this background, we may now discuss the protocols. In this episode we are real time observing the emergence of an enriched use of the compass, that is entering the classroom culture. The compass is going to be used not to produce a fair round shape, but to find a point (or better, two points) that are at a given distance from two given points. The way of using the compass (i. e. the gesture of handling and tracing the curve) is the same when a pupil wishes to produce a round shape and when s/he wishes to find a point at a given distance, but the senses given by the pupils to the processes (gestures) and to the products (drawings) are very different. When the compass is used to produce round shape, its main goal is communication; when the compass is used to find the points which satisfy a given relationship, it becomes an instrument of semiotic mediation (Vygotsky, 1978), that can control - from the outside - the pupil process of solution of a problem, by producing a strategy that (i) can be used in any situation, (ii) can produce and justify the conditions of possibility in the general case and (iii) can be defended by argumentation referring to the accepted theory. We shall reconsider this point later.

The geometric compass, embodied by the metal tool stored in every school-case, is no more a material object only: it becomes a mental object, whose use may be substituted or evoked by a body gesture (rotating hands or arms) or even by the product of the gesture, i. e. the drawn curve. Even if the link with the body experience is not cut (it is rather emphasized), the loss of materiality allows to take a distance from the empirical facts, transforming the empirical evidence of the drawing that represents a solution (whichever is the early way of producing it) into the external representation of a mental process. The (geometrical) circle is not an abstraction from the perception of round shapes, but the reconstruction, by memory, of a variety of acts of spatial experiences (a 'library' of trajectories and gestures, see Longo 1997).

### **A Short Interlude: Towards Semiotic Mediation**

In the above episode we observed the integration of two ways of thinking of circles. Recalling the history of geometry, it is the integration of the mechanical/dynamic/procedural approach of Hero ('a circle is the figure described when a straight line, always remaining in one plane, moves about one extremity as a fixed point until it returns to its first position') with the geometrical/static/relational approach of Euclid ('a circle is a plane figure contained by one line such that all the straight lines falling upon it from one point among those lying within the figure are equal to one another'). In this case the standard compass is only the prototype of a larger class of instruments (drawing instruments) which were used for centuries to prove the existence of and to construct the solutions of geometrical problems and of algebraic equations as well (Lebesgue, 1950). The experience of the continuity of motion was in the place of the still lacking theoretical foundation of mathematical continuity.

Hence, exploring the relationships between these two ways of thinking of circles and the role played by the compass is an epistemologically correct way to approach very early the problem of continuum. Even if the flow of the discussion is natural and fluent, the process is not spontaneous at all: it is evident the care of the teacher in choosing an effective protocol and in encouraging the use of gestures and the interaction between pupils with a deep exploration of the mental processes.

These are young pupils, yet the difficult relationship between the two ways of thinking of circles emerges also with elder students. We may quote a very interesting clinical interview (Mariotti et al. 2000), carried out with an 12th grade student, Giulia, familiar with the Cabri environment.

**Problem**

Two intersecting circles  $C1$  and  $C2$  have a chord  $AB$  in common. Let  $C$  be a variable point on the circle  $C1$ . Extend segments  $CA$  and  $CB$  to intersect the circle  $C2$  at  $E$  and  $F$ , respectively. What can you say about the chord  $EF$  as  $C$  varies on the circle? Justify the answer you provide.

Giulia has produced a right conjecture (if  $K$  is the centre of  $C2$  and  $M$  is the midpoint of  $EF$  the segment  $KM$  does not vary in length) and justified it. In particular, she has proved, in standard way that, while  $C$  is dragged on the circle  $C1$ , the triangle  $EKF$  does not change in size. A very brief excerpt of the last part of the interview follows. The complete protocol with a detailed epistemological and cognitive analysis is in the quoted paper.

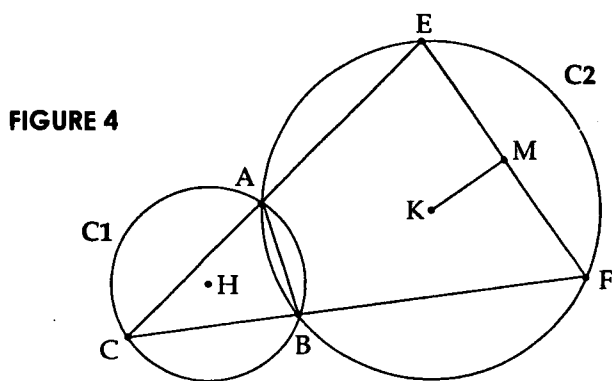

Giulia: What is the geometric locus of the midpoint of  $EF$  as  $C$  moves on the circle? The geometric locus of the midpoint of  $EF$  .. the midpoint of  $EF$ ... if it doesn't vary in length... can I draw? [referring to the drawing with Cabri]

Int.: Sure...

G.: This is the midpoint ... when  $C$  ... well.. what does it mean? When  $C$  moves on the circle the midpoint [ $M$ ] draws a circle around the centre, another circle with the same centre as the bigger one... shall I say why? If I need to say that it is a circle I must prove that it is always equidistant from the centre ... because.. well... I must prove that it is always equidistant from the centre ... well... at this point this distance here... why? ....

Int.: Try and use what you already know ... what you have just proved.

G.: Yes, if this segment has to be always.... it is always equal to ... it has always the same distance from the centre, because if you change the segment ... I mean... equal segments are those for which... I don't remember exactly the theorem, but equal segments are.... have the same distance from the centre ... equal segments on the same circle have the same distance from the centre... therefore if I prove ..I mean.. no I have already proved that that segment is always constant. [...] I haven't proved it because I haven't proved that this one rotates ...or something like that....[...] Now I must also say why the geometric locus is a circle, mustn't I? Shall I prove it?

Int.: Haven't you done it? you said that one always stays constant...

- G.: *stays constant....*  
 Int.: *How do you define a circle?*  
 G.: *I define it as locus.. you are right... locus of points equidistant from the centre... it crossed my mind that I had to prove also.... no.. maybe it is stupid ... that I had to prove that it was rotating around the centre....*  
 Int.: *Oh, right... that it was rotating....*  
 G.: *I mean, wasn't it something ...? if I say ... it is fine that it forms a ... but the circle... I can see that it forms a circle when I drag the point C and drag it around the circle [...]*  
 G.: *Mustn't I prove that it [M] rotates?*  
 Int.: *How can you prove that it rotates?*  
 G.: *Well.. I don't know.. actually that is the problem....*  
 Int.: *The fact is that once you proved that as C varies the triangle which has the chord as one side is always a constant triangle, you have proved that that one is a circle because it is the locus of points equidistant....*  
 G.: *Is that enough? Is that enough to show that it is a circle?*

Giulia feels that the dynamic features of the locus cannot be taken on board with the standard proof. Also the rotation of the chord EF is perceived as something to be proved. Giulia is not happy with the simple visual perception of the movement and she seems to feel the need to 'translate' it into a mathematical statement to be justified in some way. There is a sort of gap between Euclid's definition of circle Giulia knows and the perceived rotation of the line KM. The definition of circle as a locus of points having the same distance from a given point is perceived as detached from what happens in the Cabri screen: there is a point C whose movement directs the movement of the point M. The situation is similar to the one experienced by using a drawing instrument, where the directing point control the motion of the tracing point (Bartolini Bussi, 2000). The relationship of pointwise generation of curves by means of geometrical constructions to continuous generation of curves by means of instruments was debated for centuries (in ancient Greece and in the 17th century Europe as well) and enlightened when the meaning of continuity was clarified, in geometry and in calculus. It is worthwhile to remind that, until then, the continuous generation of a curve by a drawing instrument was used to prove the existence of and to construct the solutions of geometrical problems and of algebraic equations as well (Lebesgue, 1950).

Hence, the activity of the 5th graders who were building the link between pointwise and continuous generations of circles was very relevant from an epistemological perspective. After revisiting the standard compass, we might wonder whether other artifacts may be used effectively by teachers to nurture a theoretical attitude towards mathematics. The analysis of other artifacts is surely beyond the scope of this presentation. If the compass (and other drawing instruments) may be oriented towards the problem of continuum, the abacus may be oriented towards the polynomial representation of natural number and the perspectograph towards the projective extension of the euclidean plane and the roots of projective geometry. These examples concerns very intrusive old physical artifacts which explicitly require a physical (gesturing/handling) activity of the pupils. Other examples are offered by the recent development of 'virtual' microworlds: we may quote the approaches developed by Mariotti (and coworkers) in the Cabri setting (Mariotti et al., 2000) and in L'Algebrista, a symbolic manipulator created within Mathematica to introduce pupils to algebra theory (Cerulli & Mariotti, 2000).

All these examples are relevant cases of psychological tools or tools of semiotic mediation, as meant by Vygotsky<sup>6</sup>. It is worthwhile to remind that Vygotsky himself quotes, as examples, language, various systems for counting, mnemonic techniques, algebraic symbol systems, works of art, writing, schemes, diagrams, maps and *mechanical drawing* (including the use of drawing instruments). All these tools are, coherently with the cultural - historical approach of Vygotsky, taken from the history of mankind and are to be introduced into the life of young learners by an interactive practice guided by adults. This observation hints at the possible differences between these psychological tools and those teaching aids that are,

very often, produced and sold by commercial agencies (think for instance of the multibase material for the representation of numbers): first the cultural - historical relevance; second the not obvious transparency of concepts to be conveyed, rather dependent of the practices realized by adults and young learners together (see Meira, 1994).

The power of the theoretical construct of semiotic mediation, borrowed from Vygotsky's work, is evident if we apply it to analyze briefly another teaching experiment, aimed at developing metacognition as the consciousness of the ways of overcoming conceptual mistakes.

### Second Example:

#### Overcoming Conceptual Mistakes by Imitating a Socratic Dialogue (5th - 7th Grades).

This study has been carried out by a group of teachers-researchers coming from two different teams (Genoa and Modena), under the direction of P. Boero (see Garuti et al., 1999). It concerned the capacity to detect conceptual mistakes and overcome them by general explanation. The object of the experiment was a well known piece of the Plato's dialogue *Meno*, that concerning the problem of doubling the area of a given square by constructing a suitable square (this means overcoming the mistake which consists of doubling the side length). The crucial mediational tool is the Socratic dialogue, i.e., a dialogue intended to provoke crisis and then allow it to be overcome. In this framework, the excerpt concerning doubling the area of a given square is crucial as a practical demonstration. The dialogue consists of three different phases:

- A. Socrates asks Meno's slave to solve the problem of doubling the area of the square by constructing a suitable square; the slave's answer (side of double length) is opposed by Socrates through direct, visual evidence (based on the drawing of the situation).
- B. Then the slave is encouraged to find a solution by himself—but he only manages to understand that the correct side length must be smaller than three halves of the original length.
- C. Socrates interactively guides the slave towards the right solution (achieved through a construction based on the diagonal of the original square).

Drawing on the text of the dialogue, a teaching sequence was organized as follows:

1. students were briefly informed about the whole activity to be performed; then they individually tried to solve the same problem posed by Socrates to the slave.
2. students, under the teacher's guidance, read and tried to understand the three phases of the dialogue; then they read the whole dialogue aloud (some students playing the different characters); finally, they discussed the content and the aim of the whole dialogue, trying to understand (under the teacher's guidance) the function of the three phases. After negotiation with students, a wall poster was put up summarizing the three phases in concise terms.
3. the teacher presented the students with some, possible mistakes that could become the object of a dialogue similar to Plato's, and they were invited to propose other mistakes.<sup>7</sup>
4. students discussed about the chosen mistake, trying to detect (under the teacher's guidance) good reasons explaining why it is a mistake, then trying to find partial solutions, and finally arriving to a general explanation.
5. students individually tried to produce a "Socratic dialogue" about the chosen mistake;
6. students compared and discussed (under the teachers' guidance) some individual productions.

It is beyond the scope of this paper to detail the findings, that are, by the way, framed by an original 'voices and echoes game', that cannot be described here. It is enough to say that 86 pupils (out of 114) showed to be aware that appropriate counter-examples can reveal a conceptual mistake. More than 50 pupils tried to give a general explanation of the mistake or to find a general rule, showing to be aware of the necessity of doing it. Last but not least, 19 pupils showed to be conscious of the way to overcome the chosen mistake and were able to guide the slave towards a general solution.

The results were astonishing for the exceptional ability in keeping the roles of Socrates and of the slave in the dialogue and for the good choice of counterexamples.



### Comparison of the Two Examples

Beyond the young age of the pupils, the originality of the tasks and the astonishing results, is there any relationships between the two examples we have considered?

The relationship emerges if we compare them as tools of semiotic mediation.

The aims of the two activities concern higher psychological processes: what is into play is, for the compass, the theoretical nature of actions with a physical instruments and, for the Socratic dialogue, the overcoming of conceptual mistakes. For these aims original tasks are chosen: the task is, for the compass, the production of a method to find points according to the standard of geometric construction, and, for the dialogue, the production of a dialogue according to Plato's model. The tools introduced are rather standard: the compass is included in every school bag from primary school, and this excerpt of *Meno* is often used to introduce the problem of doubling the cube. However, what is original is the intentional and carefully designed kind of social practice, where the use of the tools is introduced. What is asked is not an instrumental use of them, rather it is the internalization of the activity with the concrete compass and of the model of the Socratic dialogue (that has the potentiality to transform them into psychological tools). The semiotic mediation is started in the collective phases (discussions orchestrated by the teacher, after or before the individual task), with a strong emphasis on imitation of gestures, words and, in the case of the dialogue, of the structure of the text itself. The teacher's role in guiding the whole process is essential. Hence, in spite of the big difference between the two artifacts, strong and deep similarities can be envisaged in the management of school activity. They can be summed up by three keywords: social interaction; teacher's guide and imitation. The resulting processes draw on a careful a priori analysis of the potentialities of the activity towards the development of the higher psychological process, required by the approach to theoretical knowledge.

### Concluding Remarks

In this presentation, we have discussed two examples which are provocative for both teachers and researchers. The 'good' functioning of the above experiments might be analyzed by means of different tools:

- epistemological (to enlighten the nature of mathematics itself);
- historical (to clarify the process of constitution of a piece of knowledge to be taught);
- anthropological (to uncover hidden conceptions);
- cognitive (to interpret the nature of individual processes and the weight of students and teachers conceptions in shaping them);
- didactical (to elucidate the function of contexts and tasks and on the role of the teacher in classroom interaction ).

The above list might be enlarged to enclose other issues. It is trivially clear that, on the one hand, every factor offers only a particular perspective and, on the other hand, a global analysis is needed for educational purposes.

We believe that the process of building a theoretical attitude towards mathematics is quite long and can last for years. In our framework, this process is developed under the guide of a cultured adult (the teacher), who, on the one hand, selects the tasks and, on the other hand, orchestrates the social interaction before or after the individual solution. For the learners, gaining a theoretical attitude does not cut the link with concrete (and bodily) experience, but rather gives a new sense to 'the same' concrete experience.

From a research perspective, this set of studies opens a lot of interesting questions. For instance, they concern the analysis of distinctive features of theoretical knowledge, at least when the didactical purpose is in the foreground; the listing of a larger and larger set of artifacts analysed as tools of semiotic mediation and the study of the effective introduction of these artifacts in the classroom; the study of the relationships between individual and collective processes in selected cases.

The discussion in Montreal has shown that linking material activity with theoretical reasoning and emphasising the teacher's guide and the role of imitation may clash against the deep beliefs of some mathematics educators. This is what happens when different classroom cultures meet each other.

## Notes

1. The project was directed by F. Arzarello and funded by the MURST (Ministry of University and Research in Science and Technology).
2. *field of experience*: a system of three evolutive components (external context, the student's internal context and the teacher's internal context) referred to a sector of human culture which the teacher and students can recognize and consider as unitary and homogeneous (Boero et al., 1995)
3. *mathematical discussion*: a polyphony of articulated voices on a mathematical object, which is one of the motives of the teaching - learning activity (Bartolini Bussi, 1996)
4. *mathematical theorem*: the system of three interrelated elements: a statement (i.e., the conjecture produced through experiments and argumentation), a proof (i.e. the special case of a discourse that is accepted by the mathematical community) and a reference theory (including postulates and deduction rules); this conception emphasizes the importance that students are confronted with this complexity rather than with the mechanical repetition of given proofs (Mariotti et al., 1997).
5. *cognitive unity*: the continuity between the processes of conjecture production and proof construction. During the production of the conjecture, the student progressively works out his/her statement through an intensive argumentative activity functionally intermingled with the justification of the plausibility of his/her choices. During the subsequent statement proving stage, the student links up with this process in a coherent way, organising some of the previously produced arguments according to a logical chain' (Garuti et al., 1996). The cognitive unity is recognisable in the close correspondence between the nature and the objects of the mental activities involved. This theoretical construct was the base of further developments, playing different roles: a formidable tool for designing activities within the reach of students (Bartolini Bussi et al., 1999); a pointer of the difficulty, for analyzing activities and understanding some reasons for success and failure (Bartolini Bussi & Mariotti, 1999); a key for understanding the deep nature of proving tasks, as far as the immediacy of the solution is concerned (Mariotti et al., 2000). In the ongoing research, the issue of mental processes underlying the production of proofs and more generally the genesis of (abstract) mathematical objects is at the very core (see Bartolini Bussi et al., 1999, Arzarello, 2000).
6. A long quotation from Vygotsky may be useful here:

Every elementary form of behavior presupposes direct reaction to the task set before the organism (which can be expressed with the simple S - R formula). But the structure of sign operations requires an intermediate link between the stimulus and the response. This intermediate link is a second order stimulus (sign) that is drawn into the operation where it fulfils a special function: it creates a new relation between S and R. The term 'drawn into' indicates that an individual must be actively engaged in establishing such a link. The sign also possesses the important characteristic of reverse action (that is, it operates on the individual, not the environment).

Consequently, the simple stimulus-response process is replaced by a complex, mediated act, which we picture as:

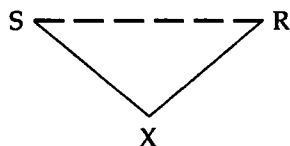

FIGURE 5

In this new process the direct impulse to react is inhibited, and an auxiliary stimulus that facilitates the completion of the operation by indirect means is incorporated.

Careful studies demonstrate that this type of organization is basic to all higher psychological processes, although in much more sophisticated forms than that shown above. The intermediate link in this formula is not simply a method of improving the previously existing operation, nor is a mere additional link in an S - R chain. Because this auxiliary stimulus possesses the specific function of reverse action, it transfers the psychological operation to higher and qualitatively new forms and permits humans, by the aid of extrinsic stimuli, to control their behavior from the outside. The use of signs leads humans to a specific structure

- of behavior that breaks away from biological development and creates new forms of a culturally-based psychological process. (Vygotsky, 1978)
7. Here is a sample of the three mistakes that were chosen in the six classes (5th or 7th grades):
    - a. "By dividing an integer number by another number, one always gets a number smaller than the dividend" (7th grade)
    - b. "By multiplying an integer number by another number, one always gets a number bigger than the first number" (5th grade)
    - c. "By multiplying tenths by tenths, one gets tenths" (5th grade) (Garuti et al., 1999).

## References

- Arzarello, F., & Bartolini Bussi, M. (1998). Italian trends in research in mathematics education: A national case study in the international perspective. In J. Kilpatrick & A. Sierpiska (eds.), *Mathematics education as a research domain: A search for identity*, vol. 2 (pp. 243–262). Dordrecht: Kluwer Academic Publishers.
- Arzarello, F. (2000). Inside and outside: Spaces, times and language in proof production. To appear in the *XXIV PME Proceedings*.
- Bartolini Bussi, M., & Mariotti M.A. (1999). Semiotic mediation: From history to mathematics classroom. *For the Learning of Mathematics*, 19(2), 27–35.
- Bartolini Bussi, M. (1996). Mathematical discussion and perspective drawing in primary school. *Educational Studies in Mathematics*, 31(1–2), 11–41.
- Bartolini Bussi, M. (1998a). Verbal interaction in mathematics classroom: A Vygotskian analysis. In H. Steinbring, M. Bartolini Bussi, & A. Sierpiska (eds.), *Language and communication in the mathematics classroom* (pp. 65–84). Reston, VA: NCTM.
- Bartolini Bussi, M. (1998b). Joint activity in the mathematics classroom: A Vygotskian analysis. In F. Seeger, J. Voigt, & U. Waschesho (eds.), *The culture of the mathematics classroom: Analyses and changes* (pp. 13–49). Cambridge, UK: Cambridge University Press.
- Bartolini Bussi, M., Boni, M., Ferri, F., & Garuti, R. (1999). Early approach to theoretical thinking: Gears in primary school. *Educational Studies in Mathematics*, 39(1–3), 67–87.
- Bartolini Bussi, M. (2000). Drawing instruments: Cultural, epistemological and cognitive issues. In B.K. Selvik, C. Kirfel, & M.J. Hoines (eds.), *Matematikk i samfunnsmessig, historisk og kulturelt perspektiv (Mathematics in perspective of history, culture and society)* (pp. 19–47). Hogskolen i Bergen: Skriftserien rapport n 2/2000, ISBN 82-7709-033-1.
- Bartolini Bussi, M., Boni, M., & Ferri, F. (to appear). Construction problems in primary school: A case from the geometry of circle. In P. Boero (ed.), *Theorems in school: From history and epistemology to cognitive and educational issues*. Dordrecht: Kluwer Academic Publishers.
- Boero, P., Dapuzeto, C., Ferrari P., Ferrero, E., Garuti, R., Lemut, E., Parenti, L., & Scali E., (1995). Aspects of the mathematics—Culture relationship in mathematics teaching-learning in compulsory school. In the *XIX PME Proceedings* (vol. 1, pp. 151–166).
- Cerulli, M., & Mariotti, M.A. (2000). *A symbolic manipulator to introduce pupils to algebra theory*. Montreal: ITS 2000.
- Garuti, R., Boero, P., & Chiappini, G. (1999). Bringing the voice of Plato in the classroom. *XXIII PME Proceedings*, vol. 3 (pp. 9–16).
- Garuti, R., Boero, P., Lemut, E., & Mariotti, M.A. (1996). Challenging the traditional school approach to theorems: a hypothesis about the cognitive unity of theorems. *XX PME Proceedings*, vol. 2 (pp. 113–120).
- Lebesgue, H. (1950). *Leçons sur les constructions géométriques*. Paris: Gauthier-Villars.
- Longo, G. (1999) (<http://www.dmi.ens.fr/users/longo/geocogni.html>)
- Mariotti, M.A., Bartolini Bussi, M., Boero, P., Ferri, F., & Garuti R. (1997). Approaching geometry theorems in contexts: From history and epistemology to cognition. *XXI PME Proceedings*, vol. 1 (pp. 180–195).
- Mariotti, M.A., Mogetta, C., & Maracci, S. (2000). *Linking conjecture, justification and analytical proof in a dynamic geometry environment*. Chicago: NCTM pre-session 2000.
- Meira, L. (1995). Mediation by tools in the mathematics classroom. *XIX PME Proceedings*, vol. 1 (pp. 102–111).
- Vygotsky, L.S. (1978). *Mind in society: The development of higher psychological processes*. Cambridge, MA: Harvard University Press.

**Working Group Reports**

---



## Des cours de mathématiques pour les futurs enseignants et enseignantes du primaire

Caroline Lajoie, *Université du Québec à Montréal*  
Ed Barbeau, *University of Toronto*

### Participants et participantes

Ed Barbeau	Bernard R. Hodgson	Richard Pallascio
Pat Barnson	Marty Hoffman	Medhat Rahim
Lynda Colgan	Isabelle Jordi	Jean-Luc Raymond
Mary Crowley	Ann Kajander	David Robitaille
Brent Davis	Caroline Lajoie	Anne Roy
Sandy Dawson	Michèle Coache-Lessard	Peter Taylor
Roz Doctorow	Dave Lidstone	Jennifer Thom
Malgorzata Dubiel	Lyndon Martin	Jo Towers
Doug Franks	John Grant McLoughlin	Harley Weston
George Gadanidis	Eric R. Muller	

Les mathématiques occupent une place importante dans les programmes d'enseignement de l'école primaire. On constate cependant que de nombreux enseignants et enseignantes du primaire n'ont pas un bagage suffisant en mathématiques et/ou n'ont pas confiance en leurs capacités dans le domaine. Certaines universités portent une attention particulière à ces problèmes : elles dispensent des cours, ou parfois même offrent des programmes, pour aider les futurs enseignants et enseignantes à mieux comprendre les mathématiques, à améliorer leur expertise dans le domaine et à se sentir davantage en confiance avec les mathématiques. Ce groupe de travail était l'occasion de prendre connaissance des différents cours offerts dans les universités canadiennes et de discuter à savoir si de telles activités devraient être une partie intégrante de tout programme de formation des maîtres du primaire.

Nous souhaitions, par ce groupe de travail, dresser un portrait de la situation actuelle dans les universités canadiennes et échanger sur nos expériences respectives afin de faire ressortir les orientations retenues par les collègues, les fondements sous-jacents aux cours dispensés, les objectifs visés, les pratiques mises en place, les questions et défis qui se posent. Trois questions étaient proposées initialement aux participants et participantes :

- Pourquoi devrions-nous enseigner les mathématiques aux futurs enseignants et enseignantes du primaire ?
- Que devrions-nous leur enseigner ?
- Comment devrions-nous leur enseigner ?

Notre groupe de travail était composé d'une trentaine de personnes intervenant dans la formation mathématique des maîtres du primaire au Canada. Parmi ces personnes se trouvaient :

- Des mathématiciens, provenant de départements de mathématiques, et intervenant soit dans des programmes de formation des maîtres du primaire, soit dans des programmes

précédant les programmes de formation des maîtres, dépendant de leur province d'appartenance et de la politique de formation des maîtres en vigueur dans leur province.

- Des didacticiens et didacticiennes des mathématiques, provenant surtout de départements d'éducation (il existe certaines exceptions, comme à l'UQAM, où les personnes intervenant en didactique des mathématiques sont rattachées pour la grande majorité au département de mathématiques de leur institution), et intervenant soit dans des cours de mathématiques, soit des cours de didactique des mathématiques.
- Des personnes intervenant dans la formation pratique des futurs maîtres du primaire (maîtres associés et superviseurs de stages).

Notre groupe a beaucoup échangé au cours de ces trois demi-journées de travail, mais il n'est pas parvenu à établir un consensus et à répondre aux trois questions précédentes d'une seule et même voix. Notre discussion a même permis de soulever un certain nombre d'autres questions que nous avons jugées tout aussi fondamentales que les précédentes, et pour lesquelles il ne nous a pas été davantage possible de répondre en nous mettant d'accord ! Cependant, en discutant de ces diverses questions, nous nous sommes tous et toutes engagés dans une réflexion sérieuse sur nos pratiques de formation, et c'est sans doute ce que nous retiendrons le plus de nos rencontres de travail. En particulier, nous avons pu préciser chacun et chacune nos constats, nos intentions, nos contraintes, nos préoccupations, nos présupposés, etc. à l'égard de la formation des maîtres du primaire en mathématiques.

### Compte-rendu de nos travaux – jour 1

La première journée, tous les participants et participantes de notre groupe de travail se sont présentés. Un des objectifs d'un tel exercice était de dresser un portrait d'ensemble de nos contextes respectifs. Nous avons tôt fait de constater que ces contextes sont très variés.

Dans la province même de Québec, les contextes varient d'une université à l'autre. En fait, tous les programmes de formation des maîtres du primaire ont ceci de commun qu'ils sont offerts sur une période de quatre ans à des personnes ayant en main un diplôme d'études collégiales (DEC) ou l'équivalent, mais la répartition des cours varie sensiblement d'une université à l'autre. Par exemple, certaines universités, comme l'Université Laval et l'Université du Québec à Montréal, imposent au moins un cours de mathématiques et des cours de didactique des mathématiques, alors que d'autres n'incluent dans la formation obligatoire des futurs maîtres du primaire que des cours de didactique des mathématiques. Aussi, dans certaines universités québécoises, la formation mathématique et la formation en didactique des mathématiques sont assurées toutes les deux par des personnes provenant d'un seul et même département, alors que dans d'autres elles sont assurées par des personnes provenant de deux départements distincts.

La situation se complexifie encore bien davantage lorsqu'on visite les autres provinces canadiennes. Après leur cours secondaire, qui dure généralement six ans, les étudiants et étudiantes qui souhaitent devenir des enseignants et enseignantes au primaire doivent obtenir un diplôme d'études post-secondaires dans un domaine de leur choix, puis un diplôme universitaire en formation des maîtres. Les programmes de formation des maîtres au primaire, qui peuvent être suivis après le programme préalable, mais qui peuvent l'être aussi en parallèle avec celui-ci, sont généralement sous la responsabilité des facultés d'éducation et ils sont d'une durée totale d'une ou deux années, dépendant de la province. Dans un tel contexte, les facultés d'éducation disposent de très peu de temps pour former les futurs maîtres, et elles se concentrent surtout sur la formation à l'enseignement des disciplines, au détriment d'une formation dans les disciplines elles-mêmes. De plus, rares sont les universités qui obligent les étudiants et étudiantes à suivre des cours de mathématiques avant de s'inscrire à un programme de formation des maîtres du primaire. Ainsi, il arrive très souvent que les étudiants et étudiantes se présentent dans les cours de didactique des mathématiques avec comme dernière expérience en mathématiques celle de l'école secondaire.

**Portrait des programmes de formation des maîtres au Canada**  
(selon les informations dont disposait notre groupe de travail)

<i>Province</i>	<i>Nombre d'années pré-universitaires</i>	<i>Nombre d'années pour le programme de formation des maîtres</i>	<i>Exigence d'un cours de mathématiques à l'intérieur du programme ou avant d'entrer dans le programme</i>
<i>Colombie-Britannique</i>	12	1 année continue après un autre programme	1 cours non-spécifique exigé
<i>Alberta</i>	12	2 années continues après un autre programme	Aucun
<i>Saskatchewan</i>	12	1 année après un autre programme ou en parallèle avec un autre programme	Aucun
<i>Manitoba</i>	12	1 année après un autre programme ou en parallèle avec un autre programme	Aucun
<i>Ontario</i>	13 (Modification à 12)	1 année après un autre programme ou en parallèle avec un autre programme	Variable (à Queen's par exemple, 1 cours exigé)
<i>Québec</i>	13 (incluant les 2 années de CÉGEP)	4 années consécutives immédiatement après le CÉGEP	Variable (entre 0 et 2 cours de mathématiques obligatoires)
<i>Nouveau-Brunswick</i>	12	1 année après un autre programme ou en parallèle avec un autre programme	Variable
<i>Nouvelle-Écosse</i>	12	2 années consécutives après un autre programme	En changement : un cours qui demande d'intégrer les mathématiques, les sciences et la langue.
<i>Île du Prince-Édouard</i>	12	1 année après un autre programme. Changement prévu : 2 années plutôt que 1	Aucun
<i>Terre-Neuve</i>	12	1 année après un autre programme	2 cours de mathématiques exigés

Un autre objectif des présentations de chacun et de chacune était d'identifier un certain nombre de préoccupations communes. Nous avons pu en repérer quelques-unes. D'abord, un grand nombre de personnes s'inquiètent de l'anxiété vécue par plusieurs de leurs étudiants et étudiantes à l'idée de devoir faire des mathématiques, et à l'idée aussi de devoir les enseigner. Plusieurs personnes déplorent aussi la faiblesse de leurs étudiants et étudiantes en mathématiques, une faiblesse qui se manifeste souvent avec des contenus très simples, dont ceux enseignés au primaire, et qui se manifeste plus particulièrement au moment de raisonner, expliquer, justifier, etc. Plusieurs personnes remarquent aussi que beaucoup d'étudiants et d'étudiantes ont une vision réductrice des mathématiques, laquelle s'avère à leur avis inappropriée pour des futurs enseignants et enseignantes du primaire. Tous et toutes semblent s'entendre enfin sur le fait que le temps alloué par leurs universités pour préparer adéquatement les futurs maîtres du primaire à enseigner les mathématiques au primaire est insuffisant.

## Compte-rendu de nos travaux – jour 2

La deuxième journée, pour faciliter les échanges, nous nous sommes séparés en trois sous-groupes. Chaque sous-groupe choisissait une ou des questions parmi celles ressorties de la discussion amorcée au jour 1 : Pourquoi devrions-nous enseigner les mathématiques aux futurs enseignants et enseignantes du primaire ? Que devrions-nous leur enseigner ? Comment devrions-nous leur enseigner ? Comment évaluer leurs apprentissages ? Comment intégrer de tels cours dans les programmes de formation des maîtres ? Quelle place laisser aux réformes du système éducatif dans ces cours ?

## Compte-rendu de nos travaux – jour 3

Après avoir fait un compte-rendu des discussions vécues en sous-groupes au jour 2, le groupe de travail a identifié parmi les questions ayant retenu son attention au cours des derniers jours celles qui lui apparaissent les plus importantes. Le groupe est d'avis que toutes les personnes impliquées dans la formation des maîtres du primaire devraient examiner chacune de ces questions en profondeur, puisqu'elles permettent, comme cela a été le cas pour nous, d'amorcer une réflexion sérieuse sur les pratiques actuelles de formation des maîtres du primaire en mathématiques au Canada.

### Question 1

*Qu'attendons-nous d'un bon enseignant ou d'une bonne enseignante de mathématiques au primaire ?*

Cette question nous apparaît fort importante puisqu'en y répondant nous répondons aussi en partie à la suivante : " pourquoi dispenser des cours de mathématiques aux futurs enseignants et enseignantes du primaire " ? Aux yeux des participants et participantes, un bon enseignant ou une bonne enseignante de mathématiques au primaire est une personne passionnée, cultivée, compétente, débrouillarde, autonome, à l'écoute de ses élèves, et intéressée à parfaire sa formation mathématique une fois sa formation universitaire terminée.

Ainsi, il convient de se demander si notre enseignement en formation des maîtres va en ce sens... Malheureusement, par manque de temps, nous n'avons pas pu creuser davantage cette question, du moins pas en grand groupe.

### Question 2

*Quel devrait être le contenu d'un cours de mathématiques pour les futurs maîtres du primaire ?*

Toutes les personnes qui ont participé à notre groupe de travail n'ont pas la même idée de ce que devrait être un cours de mathématiques pour futurs maîtres du primaire. Par exemple, certains des exemples de cours qui ont été mentionnés comportent des occasions de réfléchir sur l'enseignement au primaire, des préparations d'activités, des expérimentations avec des élèves, etc., alors que d'autres consistent essentiellement en une opportunité pour les étudiants et étudiantes de faire des mathématiques, de vivre eux-mêmes une activité mathématique.

En ce qui concerne le contenu mathématique lui-même, les avis des participants et participantes sont encore là passablement partagés. En fait, pour un grand nombre d'entre eux, il ne fait aucun doute qu'un enseignant ou une enseignante du primaire a besoin d'une formation mathématique plus avancée pour bien exploiter les situations qu'il ou elle aura mises en place avec ses élèves, mais les contenus spécifiques à aborder ne font pas l'unanimité. En fait, pour certains participants et participantes, il importe non seulement que les contenus mathématiques soient plus avancés de ceux enseignés au primaire mais aussi il faut qu'ils soient différents de ceux qui leur ont été enseignés précédemment au cours de leur cheminement scolaire (par exemple les géométries non euclidiennes, les classes résiduelles modulo  $n$ , les bases de numération autres que la base dix, etc.). Pour d'autres, il importe surtout que ces contenus plus avancés soient enseignés différemment de la manière dont les mathématiques leur ont été enseignées précédemment, en ayant recours à des approches

auxquelles ils sont moins habitués pour apprendre les mathématiques - résolution de problèmes, travail en équipe, rédaction d'un journal, utilisation des nouvelles technologies, jeux de rôles, etc.

Même si une majorité de participants et participantes sont d'avis que les contenus enseignés dans les cours de mathématiques pour futurs maîtres du primaire doivent " dépasser " les contenus de l'école primaire, un certain nombre de personnes défendent l'idée inverse, à savoir que les professeur/e/s d'université devraient enseigner à leurs étudiants et étudiantes en formation des maîtres du primaire les mêmes contenus que ces derniers devront enseigner à leurs élèves, en ayant recours aux mêmes approches qu'ils seront appelés à utiliser dans leurs classes. Cette opinion a toutefois fait surgir chez certaines personnes une interrogation : en donnant ce type de cours, peut-on s'attendre à ce que les étudiants et étudiantes développent les différentes compétences nécessaires à la profession enseignante ?

Quelques points sur lesquels nous nous sommes entendus tout de même, eu égard au contenu des cours de mathématiques ou plutôt aux approches à privilégier, est que les étudiants et étudiantes doivent pouvoir faire des mathématiques, qu'ils doivent pouvoir vivre des succès en mathématiques mais aussi surmonter des difficultés et relever des défis. Nous nous sommes entendus aussi sur le fait qu'un des moyens à privilégier pour y parvenir est la résolution de problèmes, individuellement et en équipes.

Nous nous sommes questionnés enfin sur la place à laisser au formalisme mathématique dans les cours de mathématiques pour futurs enseignants et enseignantes du primaire, de même que sur l'utilisation à faire des NTIC dans ces cours, mais nous n'avons pas vraiment creusé ces questions. Aussi, l'idée de proposer aux étudiants et étudiantes en formation des maîtres des cours de mathématiques à contenus variables, qui pourraient être précisés en fonction de leurs besoins, a été lancée mais plusieurs objections ont été formulées.

### *Question 3*

*Qui devrait enseigner les cours de mathématiques aux futurs enseignants et enseignantes du primaire ?*

Plusieurs participants et participantes sont d'avis que les futurs enseignants et enseignantes du primaire devraient avoir le point de vue du mathématicien ou de la mathématicienne sur les mathématiques du primaire pour pouvoir aborder eux-mêmes les mathématiques avec des yeux d'adultes.

D'autres personnes sont plutôt d'avis que les cours de mathématiques doivent être donnés uniquement par les didacticiens et didacticiennes. Certaines personnes craignent fort que les cours enseignés dans les départements de mathématiques jouent le rôle de filtres, et elles sont d'avis qu'ils feraient moins de tort s'ils étaient donnés dans les départements d'éducation plutôt que dans les départements de mathématiques. Un petit nombre de personnes ont même suggéré que ce devrait être des enseignants et enseignantes du primaire qui enseignent les mathématiques aux futurs maîtres, et que les expériences mathématiques des futurs enseignants devraient se faire dans le contexte de leur enseignement.

Aux dires de toutes les personnes qui s'opposent à ce que les mathématiciens et mathématiciennes interviennent en formation des maîtres du primaire, les cours donnés par les professeurs dans les départements de mathématiques sont souvent de niveau trop élevé pour les étudiants et étudiantes, de niveau trop élevé en fait si on considère les mathématiques dont ils auront besoin pour leur enseignement ... En fait, le problème est que les participants et participantes ne s'entendent pas sur les mathématiques dont auront besoin les futurs maîtres du primaire pour enseigner les mathématiques à ce niveau ! D'ailleurs, il n'est pas certain que nous ayons tous et toutes la même idée non plus des mathématiques qui devraient être enseignées au primaire.

Dans la majorité des provinces canadiennes, les seuls cours de mathématiques suivis par les futurs enseignants et enseignantes du primaire ne sont pas des cours adaptés à cette



clientèle, et ils sont généralement suivis non seulement par des futurs maîtres du primaire mais aussi par d'autres personnes nullement intéressées par l'enseignement primaire. Aussi, il peut arriver que les personnes qui enseignent ces cours ne soient pas particulièrement intéressées elles non plus à l'enseignement des mathématiques au primaire. On comprend donc un peu mieux les réticences de certaines personnes à l'idée de laisser la formation mathématique des futurs maîtres du primaire se poursuivre de cette façon. Au Québec, la situation est sensiblement différente. En effet, les universités qui offrent des cours de mathématiques à leurs futurs enseignants et enseignantes du primaire offrent des cours généralement adaptés à ces clientèles et réservés de plus à ces mêmes clientèles.

La majorité des participants et participantes semblent s'entendre sur le fait que nous avons tous et toutes un rôle à jouer dans la préparation des futurs maîtres du primaire à enseigner les mathématiques mais que ce rôle n'est pas le même pour tout le monde. Il faut donc préciser nos rôles respectifs et apprendre à se parler, à collaborer ensemble, et ce tant au moment d'élaborer les programmes que par après.

#### *Question 4*

*Comment intégrer les cours de maths à la formation des futurs enseignants et enseignantes ?*

Actuellement, dans plusieurs des universités canadiennes, les étudiants et étudiantes qui s'inscrivent en formation des maîtres du primaire n'ont pas à suivre de cours de mathématiques, ni avant d'entrer dans le programme, ni après y être entrés. La majorité des participants et participantes déplorent cette situation et souhaiteraient que les futurs maîtres suivent un ou des cours de mathématiques. Outre le contenu de tels cours, la question se pose à savoir comment ils doivent être articulés aux programmes de formations des maîtres. Plusieurs options sont possibles : des cours de mathématiques isolés préalables aux programmes de formation des maîtres, des cours de mathématiques préalables aux programmes de formation mais mieux articulés à ces programmes, des cours de mathématiques à l'intérieur du programmes de formation des maîtres et préalables aux cours de didactique des mathématiques, des cours de mathématiques à l'intérieur du programmes de formation des maîtres offerts en parallèle avec les cours de didactique, etc.

Aux dires des participants et participantes, il semble qu'une formation issue de cours de mathématiques isolés, non adaptés à la clientèle des futurs maîtres du primaire, et souvent suivis aussi par d'autres clientèles, est souvent décevante puisque les étudiants et étudiantes ne parviennent pas à faire des liens par eux-mêmes avec les cours suivants. Ainsi, les participants et participantes penchent davantage vers une suite cohérente de cours de mathématiques et de didactique des mathématiques où, en particulier, les cours de mathématiques sont adaptés à la clientèle, et où les cours de mathématiques et les cours de didactique sont bien arrimés ensemble. Ici encore, une telle solution suppose que les personnes qui interviennent dans ces cours, peu importe leur provenance, discutent entre elles ...

#### *Question 5*

*Quelle forme devrait prendre l'évaluation dans ces cours ?*

Nous avons très peu discuté de cette question. Nous avons surtout entendu quelques exemples d'épreuves utilisées par les collègues : quiz, résolution de problèmes, journaux de bord, etc.

#### *Question 6*

*Est-ce que tous les étudiants et étudiantes qui s'inscrivent en formation des maîtres au primaire doivent nécessairement passer à travers tout le programme ?*

Un des participants a fait remarquer qu'il semblait y avoir dans notre groupe de travail un a priori important, à savoir que tous les étudiants et étudiantes qui s'inscrivent en formation des maîtres au primaire à l'université pourront enseigner les mathématiques au primaire.

Cette personne était plutôt d'avis que les étudiants et étudiantes qui éprouvent d'énormes difficultés en mathématiques, de même que ceux qui ont développé une véritable " phobie " des mathématiques—ce à quoi on a référé comme étant la " mathophobie "—devraient être orientés vers d'autres programmes de formation. Cette proposition a soulevé des réactions très vives chez d'autres participants et participantes, qui ont demandé, par exemple, qui pourrait réellement décider d'avance si les étudiants et étudiantes en formation des maîtres seront de bons enseignants et enseignantes de mathématiques, et surtout sur quelles bases ! Quelques personnes ont mentionné que certains de leurs " bons " étudiants et étudiantes en mathématiques se sont avérés en fait de bien mauvais enseignants et enseignantes une fois rendus dans les écoles, ou encore ont réalisé qu'ils n'aimaient pas enseigner cette matière, alors que d'autres moins doués semblent avoir développé avec les années une appréciation différente des mathématiques, et de l'enseignement des mathématiques, et semblent être devenus de très bon enseignants et enseignantes de mathématiques.

#### *Question 7*

*Quelle place faire aux réformes ?*

Cette question a été très peu touchée dans notre groupe de travail mais elle a été retenue comme étant une question importante. Les personnes qui sont intervenues ont exprimé une idée à l'effet que les futurs maîtres devraient être formés de manière à ce qu'ils puissent intervenir à l'intérieur de différents contextes, de manière à ce qu'ils puissent en particulier s'adapter aux changements de curriculum. Aussi, pour plusieurs, nos étudiants et étudiantes devraient pouvoir devenir des agents de changement dans leurs milieux scolaires respectifs.

#### *Question 8*

*Quel devrait être le rôle de notre groupe, le GCEDM/CMESG ?*

Le GCEDM/CMESG devrait-il devenir pro-actif dans le but de favoriser la mise en place d'une réforme dans les programmes de formation des maîtres au Canada ? Ou devrions-nous plutôt, chacun et chacune, agir individuellement, à l'intérieur de nos milieux respectifs ? Notre groupe de travail semble tendre vers la dernière alternative. Aussi, il est d'avis qu'une discussion comme celle que nous avons eue lors de nos trois rencontres devrait avoir lieu aussi dans nos différents milieux, entre les personnes qui interviennent en formation des maîtres du primaire en mathématiques ou entre celles qui seraient susceptibles de le faire.

### **Conclusion**

Nous sommes tous et toutes conscients que les étudiants et étudiantes en formation des maîtres du primaire ont besoin de vivre une expérience positive en mathématiques. Nous devons contribuer à enlever la peur que peuvent avoir certains et certaines des mathématiques, et nous devons leur donner le goût des mathématiques ! Cependant, nous nous entendons pour dire que la réussite de nos étudiants et étudiantes ne doit pas se faire au détriment d'une formation de qualité.

Aussi, un des points sur lequel tout le groupe était en accord est que les étudiants et étudiantes doivent être prêts à s'engager à poursuivre leur formation mathématique après être passés par l'université, soit dans leur milieu professionnel, soit à l'université. Aussi, il faudrait faire en sorte qu'une meilleure cohésion s'installe entre les différents intervenants et intervenantes en formation des maîtres, mais aussi entre les écoles et les universités.

Nous avons réalisé suite à nos trois demi-journées de travail qu'il serait vain de chercher un modèle unique de formation des maîtres du primaire en mathématiques au Canada. Il faut plutôt faire ressortir ce qui fonctionne bien dans nos contextes respectifs, et partager nos expériences avec les autres. À partir de là, il faut chercher ensemble une diversité de solutions.

## Mathematics Courses for Prospective Elementary Teachers

Caroline Lajoie, *Université du Québec à Montréal*  
Ed Barbeau, *University of Toronto*

### Participants

List provided on page 35.

### 0. Introduction

Rather than provide a detailed account of the programs that were available or might be offered, the rather large working group (of about thirty mathematicians, education researchers and didacticians) focussed on sharing perspectives, delineating the issues and formulating some essential questions that would need more detailed consideration.

A complete consensus was not possible. However, there was substantial agreement on many points. Marty Hoffman pointed to the need to give education students a new view of the nature of mathematics, while Bernard Hodgson emphasized the desirability of elementary teachers having the viewpoint of a mathematician. What these amount to are very much open to discussion, but John Grant McLoughlin mentioned the difficulty that what students are taught at college is not validated by their experiences in the classroom.

### 1. Selective Survey of Teacher Training

In Canada, there is an essential difference between the regime in Quebec and the regime in other provinces.

In Quebec, while details of the programs vary, the formation of teachers is much better integrated than elsewhere in the country. The typical path leading to university education is as follows: pupils have seven years of elementary school (K-6), followed by five years of high school, which they enter at the age of twelve, and two years at the CEGEP level (CEGEP is an acronym for "Collège d'enseignement général et professionnel"). Undergraduate university education generally lasts three years, but the programs for both primary and secondary teachers preservice education are four-year programs that combine discipline courses with courses in education, including the equivalent of one year of practicum. (The discipline courses for secondary teachers amount to two years of mathematics and science.) One drawback of this approach is that it does require students to decide to go into teaching fairly early, at the time of their graduation from CEGEP.

The pattern in other provinces is that students take an undergraduate degree, and then, having decided to enter the teaching profession, attend a faculty of education for usually one year and sometimes two. Time is very short at the education faculty to do much more than briefly look at the disciplines, with the focus on methodology. There is generally no requirement that the students will have studied any mathematics at all at the college level. Consequently, it is highly likely that many new teachers will feel ill-prepared to handle the teaching of elementary mathematics.

Specifically, in British Columbia, the University of British Columbia requires one tertiary mathematics course outside of the education program. In Alberta, students spend two



years in a faculty of education, and need no tertiary mathematics course for admission. Saskatchewan and Manitoba have a similar regime. In Ontario, the normal education program lasts for one year, but there are some universities for which a concurrent BSc/BA-BEd program is available. The tertiary mathematics requirement for admission varies. In New Brunswick, there is a choice of consecutive and concurrent programs. Nova Scotia requires two years at a faculty of education after completion of the BSc; there are disciplinary requirements at university for mathematics, English, social science and science at university. Prince Edward Island currently requires one year in an education program, but plans to change this to two years. In Newfoundland, there is a consecutive program that requires two university mathematics courses.

Lyndon Martin, who has taught in the United Kingdom, told the group that since the National Curriculum came into force, the government prescribes in detail how teachers are to be prepared, with an emphasis on technical knowledge; teachers are tested before going into the field. According to the UK National Literacy/Numeracy Standard, each school pupil receives one hour each of mathematics and English; teachers are recommended to use a whole-class interactive approach.

Bernard Hodgson described the situation in France. Recent reforms have sought to raise the status of primary teachers, who have three years of formation after their first university degree.

## 2. Questions

On the second day of deliberations, the working group broke into three subgroups to formulate and concentrate on key questions. It reunited on the final day to hear reports on these discussions, and to draw up a list of issues requiring attention.

### (a) *What do we want teachers to be?*

Some characteristics are competence, autonomy, resourcefulness, passion, and sensitivity to the learner and broad in outlook. The teacher should continue to be a learner. These are the goals to keep in mind in designing courses and programs, so that we require of teachers some intimacy with and understanding of mathematics. However, before this can occur, they need to be confident in the subject, and this requires in some cases that we vanquish a deep-seated phobia.

### (b) *What is the scope of the syllabus of courses for teachers?*

It is agreed that these courses should in some way go beyond covering the material that they are expected to teach; the students need an adult view of elementary mathematics. Accordingly, this may entail giving them experiences quite distinct from ones they had in their own schooling. Many of the courses described within the group embodied individual and group problem solving, opportunities to reflect on both the subject and pedagogy, and a component that requires some planning and execution of lessons. It is not clear to how high a level mathematics should be taught to inform the elementary curriculum, or when and how formalism should be engaged. For example, while modular arithmetic might not be taught in schools (there was some demurral about this), it can be a useful conceptual tool for the teacher. Should there be some courses that are completely open-ended, without a syllabus at all? One radical suggestion was to have a course with no prescribed content that would evolve according to the characteristics of the students. This was a point of disagreement within the group. Because of the trepidation felt by many students about mathematics, courses should be designed to enable students to quickly experience success in tackling a mathematical problem flexibly without a "recipe" mentality.

Teachers will be expected to use technology in their practice, and their mathematics courses should reflect this. What is the role of spread sheets? graphing calculators?

software packages, such as Geometer's Sketchpad or Mathematica?

Certainly, an important ingredient in any course is encouragement for students to reflect on mathematics, learning and teaching, and on their own experiences, thus broadening their worldview. This can be achieved, for example, through keeping logs and doing projects.

(c) *Who should give such courses?*

A majority of the group felt that prospective teachers should take suitable mathematics courses before they begin the pedagogical part of their formation; this would allow them to get some experience before they do their practicum. A minority view was that mathematics should be taught in conjunction with their training program, as this will provide a context and a focus for teachers. Apart from the difficulty of shortage of time, it seems difficult to see how this might allow teachers to have a broader view of mathematics that goes beyond the exigencies of their teaching. However, there was the fear that the university level mathematics might be inappropriate or may turn candidates away from teaching.

(d) *How particular to elementary teachers should university courses be?*

It may be that some courses could be given in common to teachers at all levels, secondary as well as elementary, or that certain courses would be suitable to a variety of students, such as mathematics appreciation courses for nonspecialists or courses in the history of mathematics or science. Certain geometry courses might also fall into this category.

(e) *How should courses be packaged?*

One or two courses of a special character are available at some universities, and enrolment is voluntary. Peter Taylor argued for incorporating courses into a unified program. Certainly, universities might look at preferred paths for prospective elementary teachers that might involve mathematics courses combined with certain courses in other areas. To avoid the danger of having only courses that do not take into account special characteristics of future elementary teachers, one might, as in Quebec, have courses designed and reserved for this population.

(f) *Should university-level courses in mathematics be required for entry into a faculty of education?*

The affirmative argument recognizes that elementary teachers will be required to teach mathematics. Being able to count on some background in mathematics will enable faculties of education to focus more on methodology. The negative argument points to the danger that such courses might act as a filter (is this necessarily a bad thing?). If we were to take this route, then a much stronger consensus will be needed as to what the university courses should involve. However, most participants deplored the lack of mathematical background among future teachers and would like to work towards an effective compromise.

(g) *How can we ensure a coherent mathematical experience for students as they pass from school to university, through a faculty of education and then out into the field?*

A current problem is that students get conflicting impressions of mathematics, and the school regime does not always support a broad approach to the subject. So teachers need to have an understanding of the contexts in which mathematics appears, and to be sensitive to the best approach for each context.

An important ingredient in getting this coherence is the follow-up available for novice teachers. The planning for each of inservice and preservice training should take the other into account. Perhaps a conference can be organized for new teachers to dis-

cuss their practice, or a website can be set up. John Grant McLoughlin has offered to organize such a website and Harley Weston to mount and maintain it.

(h) *How should students be evaluated in university courses and programs?*

While the pass/fail approach might be appropriate in a faculty of education where the final decision is a binary one—whether or not to certify, this might not be suitable for university courses, where one would like to compare candidates. Should there be final examinations? If so, what should they involve?

The group heard of a number of options. In the program at York University, there were quizzes and final examinations; in the examination, students were expected to respond to issues. Another possibility for an examination is that it include problems selected from a list that students prepare in advance. The advantage of quizzes was that they helped to focus what went on in the class. Anne Roy mentioned that at UQAR (Rimouski), teams of four had to prepare a lesson, that students had to select problems and prepare a book on them, that there was a final examination, and that the students had to pursue a research program; this allowed for a variety of ways of understanding where the students were at. In Queen's College in New York, students worked on open-ended problems, first in pairs, then two explained to two, then four to four, and so on until the class was involved.

(i) *Should all elementary teachers be expected to teach mathematics?*

Most people took for granted that all prospective teachers should be prepared to teach mathematics. What about those who evince enormous difficulty or revulsion for the discipline? Should they be directed into a different regime? This question elicited a lively response among participants, some of whom pointed to the practicalities of identifying such students. Often students who are good at mathematics may find it hard to teach it effectively, while others who may fear or detest the subject confront their feelings and end up not only with a much better appreciation and competence, but with a good deal of effectiveness in the classroom.

(j) *How much should courses reflect the status quo, and how much should they support reform?*

Teachers have to deal with the situation in which they find themselves, but at the same time, we would like them to be agents of reform.

### 3. Other Issues

There were a number of other issues that were briefly touched upon in the discussion.

- (a) We seem to have some hidden assumptions about the mathematics that should be taught to elementary children. Perhaps this needs to be reviewed.
- (b) EQAO in Ontario surveys how much pupils like mathematics. They have found that dislike for mathematics among children of both sexes is already widespread at the Grade 3 level; although the girls perform better. This phenomenon needs further study. Does it reflect the demeanour of the teachers? or pressures of testing?
- (c) What is the role of CMESG in ameliorating the situation with respect to the formation of teachers? Should it provide direct feedback to other organizations, such as the Canadian Mathematical Society, which might propose and lobby for changes? How broadly should its proceedings be disseminated? Should it make a presentation to the Council of Ministers? It seems out of keeping with the traditions of CMESG to enunciate a position; rather, it seeks to ensure that issues are thoroughly aired in a knowledgeable way.

## Crafting an Algebraic Mind: Intersections from History and the Contemporary Mathematics Classroom

Louis Charbonneau, *Université du Québec à Montréal*  
Luis Radford, *Université Laurentienne*

### Participants

Katherine Borgen	Gila Hanna	Roberta Mura
Benoît Côté	Joel Hillel	Alfred Nnadozie
Gord Doctorow	Bernadette Janvier	Hassane Squalli
Susan Gerofsky	Lesley Lee	Darren Stanley
Frédéric Gourdeau	Dennis Lomas	Dalene Swanson
José Guzman	Ralph Mason	Leigh Wood

### Introduction

The working group sessions were organised around three activities. The first one dealt with the history of algebra. A text was distributed to all participants who were then asked to answer the questions appearing at the end of each section. This report reproduces the said text and includes the salient small group comments as well as excerpts from our discussions.

For the second activity, Luis Radford summarised a part of his classroom research in which he, along with some other teachers, planned a teaching sequence having in mind some historical considerations. A video showing some of these students at work was then presented. A copy of their productions and a transcript of their discussions were also made available to the workshop participants. These documents are not included in the report. The second part of our report will, nevertheless, summarise our discussion that revolved around the semiotic and conceptual limits and possibilities of two models (the use of the balance model and the two-containers model) intended as pedagogical artefacts to help novice students deal with linear equations.

The last activity consisted of sharing our views on the use of history in the classroom.

## PART 1: MEDIAEVAL AND RENAISSANCE ALGEBRA

### I. The numerical tradition in mediaeval algebra—First degree equations

#### *Liber augmentis et diminutionis*

The text *Liber augmentis et diminutionis*, a mathematical text of a Hindu origin and dealing with first degree equations, was translated by Abraham ben Ezra during the 11<sup>th</sup> Century. The author of the text seems to have been Ajjub al-Basri, “the first Arab who mastered the Hindu technique of solving equations” (Hughes 1994, p. 31). We find in this text some problems solved using different techniques. Two of them are false position and *regula infusa*.

*Regula infusa* consists of operations performed on the “positive coefficient” of the un-

known and the constant term. Of course, there are no definitions; the *regula infusa* is learnt through examples. The problems involve fractional parts of the unknown and, in the complex variants, sums of linear expressions and fractional parts of them. The main problem consists in bringing all the fractional parts to integer terms.

The problems solved by *regula infusa* arose probably in the context of division of fortunes left by a person to the family (the terms of the division of the fortune being stated through fractional parts). Certainly, the problems in the *Liber augmenti and diminutionis* go beyond the requirement of practical situations. This mathematical text and its *regula infusa* method have to be seen as a pedagogical attempt to teach techniques to solve linear equations whose difficulty resided in the handling of fractional parts.

One of the problems is the following (Libri 1838–1841, p. 321):

English	Français
A treasure is increased by a third [of it]. Then a fourth of this aggregated is added to the first sum. The new sum is 30. How much was the treasure originally?	Un trésor (censu) est augmenté de son tiers. Alors une quatrième partie de cet agrégat est ajoutée à la première addition. La nouvelle addition est 30. Combien le trésor originel était-il ?

In modern notation, the problem is the following:

$$t + \frac{1}{3}t + \frac{1}{4}(t + \frac{1}{3}t) = 30$$

*Census* (treasure) and *res* (thing) were two different terms used in mediaeval algebra. In later texts the relation between them became standardized. It was that of a number to its square (the square of the *res* was the *census*). Here, however, their relation is different. We are symbolizing here treasure as  $t$ .

The solution is as follows:

Assume *res* and add its fourth to it and you have a *res* and a fourth of a *res*. How much less will bring *res* and fourth of *res* to a *res*? You will find that what that is, is its fifth. Subtract therefore from thirty its fifth and twenty-four will remain. Then take the second *res* and add it to its third part and you will have *res* and its third. How much less therefore will bring *res* and third of *res* to a *res*? You will find in truth that how much that is, is its fourth. Therefore subtract from twenty-four its fourth and 18 will remain. (Libri, op. cit.)

As we see, the text starts by dividing the original problem into two sub-problems. By taking  $t + \frac{1}{3}t$  as a *res*, that is, in modern notations, by making  $x = t + \frac{1}{3}t$ , the first sub-problem is:

$$x + \frac{1}{4}x = 30.$$

Then, the left side of the equation  $x + \frac{1}{4}x = 30$  gives  $\frac{5}{4}x = 30$  and in order to reduce this to one  $x$ ,  $\frac{1}{5}$  of  $\frac{5}{4}$  of  $x$  has to be subtracted from each side. This gives:

$$(\frac{5}{4}x - \frac{1}{5})(\frac{5}{4}x) = 30 - \frac{1}{5}(30); \text{ that is, } x = 30 - 6 = 24.$$

Now the text deals with the equation  $t + \frac{1}{3}t = 24$ . The method is the same. The new equation is hence  $\frac{4}{3}t = 24$ . To get one  $t$ , we need to subtract  $\frac{1}{4}$  of  $\frac{4}{3}t$  from  $\frac{4}{3}t$ . Thus, the problem is now:

$$(\frac{4}{3}t - \frac{1}{4})(\frac{4}{3}t) = 24 - \frac{1}{4}(24); \text{ that is, } t = 18.$$

### Exercise 1

Solve the following problem using the *regula infusa* method:

A treasure is increased by a third of itself and four dragmas. Then a fourth of this sum was added to the first sum. The result was forty. (Libri 1838–1841, p. 322)



### Question 1

- 1.1 What are the key algebraic concepts used in the *regula infusa* method?
- 1.2 The concept of equality is one of the more important concepts in algebra. What are the properties of the equality that were required in the *regula infusa* method?

### Question 2

Problems such as the first one shown above were also solved by the method of *false position*. To solve the first equation  $x + \frac{1}{4}x = 30$ , and in order to avoid fractional parts, one may assume that  $x = 4$ . The act of assuming a value for  $x$  was referred to as making position, and since the assumption was known to be false a priori the method was called false position.

If  $x = 4$  is substituted in the equation, one gets 5 instead of 30. So, in those cases, the author of *Liber augmentis and diminutionis* asks the same type of question: "Tell me then: by how much must you multiply 5 until you get 30". The answer is obviously by 6. Hence the answer is 6 times the false position, that is  $x = 6 \times 4 = 24$ .

- Using the method of false position, solve the second equation involved in the first problem, namely,  $t + \frac{1}{3}t = 24$

### Question 3

Do you think that the method of false position is "more algebraic" than the *regula infusa* method? Explain!

### Discussion

The discussion was mainly related to question 3.

In a certain way, the *regula infusa* method is more restrictive than the method of *false position*. Indeed, from the point of view of the scope of the method, this first method applies to a more specific type of problem, that is, those problems whose equations are of the general form  $x + \frac{x}{n} = k$ .

However, the method of *false position* seems less algebraic than the other method. The equality is treated differently in these two methods. In the *regula infusa*, the equality is seen more like a statement of the equivalence between two ways of seeing the same quantity. The manipulations used to solve the problem show that  $k$  is interpreted as the  $n + 1$   $n$ th parts of the *unknown*. In the method of *false position*, the "equality" indicates the result of an operation. The result of the calculation  $x + \frac{x}{n}$  gives  $k$ . So, one tries to calculate the value of this operation by substituting the unknown by a concrete number. If one doesn't get the expected result, one modifies the number, taking into account what happened in the first calculation. The notion of equality used in *regula infusa* then seems closer to the one used in algebra.

Some noticed that, in general, students don't feel at ease with the method of false position.

## II. The geometric tradition in mediaeval algebra – Second degree equations

### *Abû Bekr's Liber Mensurationum*

One of the interests of Abû Bekr's *Liber Mensurationum* (ca. 9<sup>th</sup> Century) for the study of the conceptual development of algebra is that this book contains several problems solved using two different methods. One of the methods is referred to as belonging to the people of *al-gabr* (that is, the people of algebra: to be read, people practicing algebra). The other method does not bear any specific name. Following Høyrup (1990) the method shall be identified as belonging to the "cut-and-paste geometry".

In what follows, one problem from Abû Bekr's *Liber Mensurationum* is presented. It comes from the edition made by Busard in 1968, an edition based on the translation to Latin by Gerardo de Cremona in the 12th Century.

**Problem 25**

If in truth he will say to you: the area is 48 and you have added two sides and what results was 14, what then is the quantity for each side?

The solution according to the "cut-and-paste geometry" is the following:

This will be the way to solve it: when you halve fourteen, it will be seven, the same then multiply by itself and what will result, will be 49. Then deduct from it 48 and one will remain, of which obtain the root, which is one; if you will have added to it half of 14, that what will result will be the longer side. And if you will have deducted it from the half of 14 that what will result is the shorter side."

**Comments**

Although it is not explicitly stated, the problem deals with a rectangle. The question is to find the length of the sides.

The colloquial style of the text evokes unambiguously the oral setting in which the mathematical discussions were held and makes us sensitive to the characteristics of teaching in oral traditions. In all likelihood, the solution was accompanied by some drawings that were not inserted in the text. The text, indeed, rather has the value of an aide-mémoire, and not that of an autonomous item in the mediaeval market of manuscripts' circulation.

As to the solution, the idea underlying the problem-solving procedure is to start from a square whose side is half of the sum of the sides of the sought after rectangle, that is to start with a square having a side equal to half of 14. This procedure is a kind of false position method in that the problem-solver knows that by taking the side as equal to half of 14 some adjustments will be required later.

**Question 1**

Try to make sense of the solutions using the following reconstructed sequence of drawings:

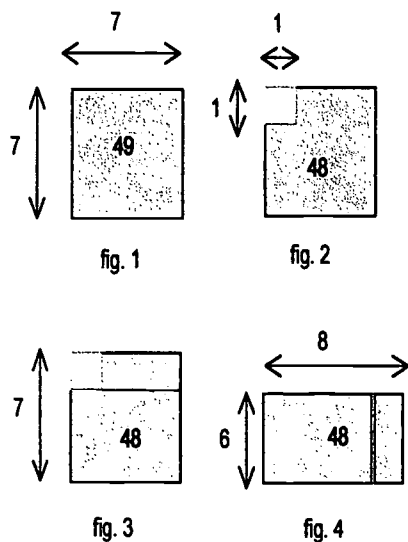

The text presents another method to solve the same problem, which is the method of algebra. As we will see, the algebraic solution is given following a kind of a discursive protocol which seems strange to us. But not to Abû Bekr's students! The text does not use letters as we do now. However an abstract terminology was already in place. Two of the basic terms were the thing (*res* in Latin) and its square, *census*. We have edited the text using numbered lines to make references to the text easier.

### Question 2

Read the algebraic solution (lines 1–7) and find out what is the equation solved in the text. Provide some explanations of the following key terms:

- To confront;
  - To restore.
1. There is another way for it, according to algebra, that is: put one side as one thing (*res*) and the second 14 less thing.
  2. Then multiply the thing with 14 less thing and the result will be 14 things less the *census*.
  3. Confront then (*opponere ergo*) the area, that is, you restore 14 things with census subtracted and add [the restoration] to 48.
  4. It will therefore be census and 48 dragmas that equal 14 things.
  5. You will therefore have after the confrontation *censo* and 48 dragmas that equal fourteen things.
  6. Then do according to what was given in the fifth question of algebra which is, when you halve 14 things and multiply them by themselves and deduct from it 48 and you will obtain the root of that which remains.
  7. Afterwards, if you will have added half of 14, that which will result will be the longer side and if you subtract it, it will be the shorter one.

### Question 3

- Write in modern symbolism the equation in line 5. Then follow the instructions given in line 6.
- Follow the instructions given in line 7 and verify the result. We will come back later to the justification of this algorithm, when we shall read an excerpt of Al-Khwarizmi's work.
- What is the role of number 48 in the problem?

### Question 4

We saw that the unknown was represented by *res* (thing). Did Abû Bekr operate on/with the unknown? Explain!

### Question 5

What are the main differences in both methods, the cut-and-paste geometry and the algebraic one? Explain the differences in terms of the kind of symbolization and meanings on which each solution relies.

*Note:* Abû Bekr's "Problem 25" has a long story. It appears in a different formulation and conceptualization in Diophantus' *Arithmetic* (see Radford 1991/92, 1993, 1996) at the end of Antiquity. But in all likelihood the problem was known and solved by Babylonian scribes around 1600 B.C.



*Al-Khwarizmi and the geometric proof of canonical equations*

Al-Khwarizmi gave, in an explicit manner, a geometrical proof of the procedure solving second degree equations. He distinguished three kinds of objects: numbers, the unknown (*jidhr*, i.e., *root*, which the abacus masters will translate as *thing*) and *Mal* (the square of the unknown). One of the six types of equations which he studied was: squares and numbers equal to roots. Al-Khwarizmi says:

For instance, "a square and twenty-one in numbers are equal to ten roots of the same square." That is to say, what must be the amount of the square, which when twenty-one dirhems are added to it, becomes equal to the equivalent of ten roots of that square.

This type of equation corresponds to the equation for which Abû Bekr gave the steps leading to the solution in the problem seen above. Al-Khwarizmi provided a geometrical proof for the particular equation stated above ( $x^2 + 21 = 10x$ ) (see Rosen 1831, p. 16 ff). We will give it here for the equation of problem 25 of Abû Bekr (details in Radford 1995a), that is, the equation:  $x^2 + 48 = 14x$ .

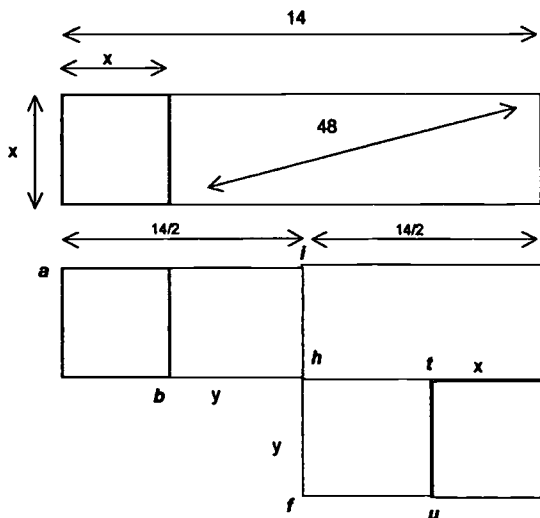

Let  $i$  be the middle of  $ag$ . Construct  $hf$  such that  $bh = hf$ . Let  $td$  be equal to  $hi$ . The rectangles  $bi$  and  $ud$  are equal. Hence, square  $fg$  minus rectangle  $bg$  is equal to square  $ft$ . That is, area square  $ft = (14/2)(14/2) - 48$ . Its side is obtained by taking the square root of the area and  $x$  is found by subtracting the square root from  $14/2$ . This is the small side in Abu Bekr problem. The big side is obtained by subtracting the small side from 14.

**III. A problem from Fibonacci's *Liber Abaci***

Leonardo Pisano or Fibonacci was instrumental in the introduction of Arabic algebra into the West. His *Liber Abaci* (1202) was a sort of encyclopedia containing an exposition of several methods to solve a variety of commercial and non-commercial problems. In the *Liber abaci* there is no algebraic symbolism yet. And Fibonacci and the mathematicians of the 13<sup>th</sup>, 14<sup>th</sup> and 15<sup>th</sup> centuries were still using only one unknown to solve problems—even if most of the time in the statement of the problems the question was to find several numbers (see Radford 1997, in press). This is the case in the following problem.

Divide 10 into two parts, add together their squares, and that makes  $62\frac{1}{2}$ .

**Exercise 1: Becoming rhetoric!**

Using the mediaeval algebraic technique, find the second-degree equation corresponding to this problem. (If needed, make transformations so that the "coefficient" of censo be one). As the mathematicians of that period, you will use one unknown only (which you will represent by 'thing' and its square by 'censo'). In the problem-solving process indicate the passages where 'restoration' was needed.

**Exercise 2**

Instead of solving the equation by the usual modern formula, solve it using the geometric argument explained in the previous section.

## Exercise 3

Compare your solution to Fibonacci's:

## Fibonacci's Solution

Let the first part be one thing, and this multiplied by itself makes a censo.

In the same way, multiply the second part, which is 10 minus one thing, by itself; for the multiplication you do this: 10 times 10 equals 100; a subtracted thing multiplied by a subtracted thing makes a censo to add. And twice 10 multiplied by a subtracted thing makes 20 subtracted things. And so for 10 minus 1 thing multiplied by itself makes 100 and a censo diminished by 20 things. Adding this to the square of the first part, that is, to the censo, there will be 100 and two censi minus twenty things, and this equals  $62\frac{1}{2}$  denarii.

Add therefore, twenty things to each part, there will be 100 and two censi equal to 20 things and  $62\frac{1}{2}$  denarii. Take away, therefore,  $62\frac{1}{2}$  from each part, there will remain two censi and  $37\frac{1}{2}$  denarii that equal 20 roots; this investigation has thus been brought to the third rule of mixed cases, that is, censi and numbers are equal to roots.

In order to introduce the rule, divide the numbers and roots by the number of censi, that is by 2, and it will make one censo and  $18\frac{3}{4}$  denarii equal to 10 roots. Therefore ... (According to Boncompagni's edition of *Liber Abaci*; 1857, p. 411. The problem is fully discussed in Radford 1995a.)

## Discussion

At the beginning, the discussions focused on the nature of numbers and their relation with geometry. But quickly, it evolved toward ways of solving Fibonacci's problem. Frédéric Gourdeau presented his own solution.

## Frédéric's Solution

The square has an area of 100. The two squares (grey) have a total area of  $62\frac{1}{2}$ .

Therefore, the two remaining equal rectangles are left with a total area of  $100 - 62\frac{1}{2}$ , that is  $\frac{75}{2}$ , and thus one of those rectangles has an area of  $\frac{75}{4}$ .

The problem is then to find a rectangle of which half of the perimeter is 10 and the area is  $\frac{75}{4}$ .

This is the type of problem solved by Abû Bekr.

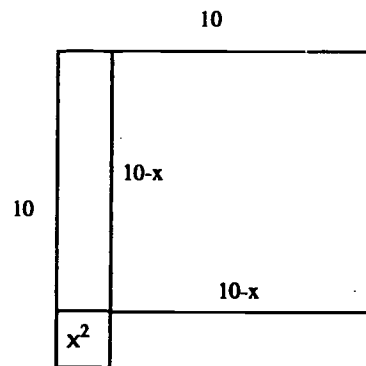

We also noticed that writing an expression such as  $x^2 - 2x + 100$  is misleading. This expression is the area of the square of sides  $(10 - x)$ . In the context of Fibonacci's epoch, it would be impossible to have a negative number, even a virtual one, since this expression represents an area which is necessarily positive. In the expression  $x^2 - 2x + 100$ , it may happen that  $x$  be such that  $x^2 - 2x$  becomes negative. So, we should write instead  $x^2 + 100 - 2x$ . This shows the danger of using algebraic symbolism while studying the early history of algebra or while using concrete material such as algebraic tiles.

The fact that, at that time, memory was of paramount importance while solving mathematical problems was also discussed. In the Middle Ages, writing was a lot less widely spread than today. The high cost of paper limited the availability of support for writing. Also, students, and society in general, developed many ways of using memory. With the widespread use of writing and other cultural means to keep track of things and events, those abilities have been transformed and required to a lesser extent.

**IV. Operating with and on the unknown**

In Section I we encountered a first type of operation with the unknown: addition of the unknown and fractional parts of it (e.g.,  $x + \frac{1}{4}x = \frac{5}{4}x$ ). In Section II, we encountered a different type of operation with the unknown. Indeed, in this case, the unknown (or its square) appeared as a subtractive term (i.e. a term that is provisionally lacking from another term. More specifically  $x^2$  was seen as being absent from 14 in the left expression of the equation  $14x - x^2 = 48$ ). So, the expression  $14x - x^2$  was repaired or restored by adding  $x^2$  to both sides of the equality. In this section we will see another type of operation with the unknown by referring to a problem from R. Canacci's *Ragionamenti d'algebra*. This book belongs to the tradition of algebra books of the Renaissance. With the increase of economic activity in the 13<sup>th</sup> Century onwards, exchange of merchandise and money were the main means to acquire goods. But cash money was not always available. Sometimes, to do business required more money than merchants could afford. So small companies developed and with this a systematic study of mathematical techniques to calculate gains. In teaching settings, problems were ideated in such a way that merchants and their sons were trained to cope with calculations and problem-solving needs—merchants' daughters were not usually involved in commercial activity (a contextual analysis of commercial mathematics and its relation to the humanistic thinking of the Quattrocento can be found in Radford 2000).

The following problem is a kind of pedagogical effort to provide training to use algebra in a non-realistic setting. The difficulty resides in finding the equation and handling it.

Two men have a certain amount of money. The first says to the second: if you give me 5 denarii, I will have 7 times what you have left. The second says to the first: if you give me 7 denarii, I will have 5 times what you have left. How much money do they each have?

*Exercise 1*

Using one unknown only, write an equation for this problem. Then solve it justifying the algebraic actions.

Compare your solution to Canacci's.

Canacci's Solution	Comments
<p>The first man has 7 things minus 5; the second man has one thing and 5 D[enarii].</p> <p>The second [gives] to the first 5D. He is left with a thing. The first will have 7 things.</p> <p>Therefore, the first has 7 things minus 5D. He gives 7 to the second who has one thing and 5D, for which he asked, and the first will have 7 things minus 12D. This is equal to 5 times the [amount] of the first. Therefore, multiply the amount of the first by 5 and that gives 5 times 7 things minus 12, that which gives 35 things minus 60D. This is equal to one thing plus 12. Even up the parts by adding to each 60D and subtracting a thing from each part this will give 34 things equal to 72D. Divide the things, as the rule says, and the thing is <math>2 \frac{2}{19}</math> [the text is incorrect: the division gives <math>2 \frac{2}{17}</math> — L.R.] Therefore, since the thing is <math>2 \frac{2}{19}</math>, come back to the beginning of the problem. The first man had 7 things minus 5D, the second man had a thing and 5D. Therefore, the first had ...</p>	<p>First man = <math>7x - 5</math>                      Second man = <math>x + 5</math>.</p> <p>After the second person gives the 5 denarii, the amount are <math>7x</math> and <math>x</math>, respectively.</p> <p>After the first person gives 7 denarii, the amounts are <math>7x - 12</math> and <math>x + 12</math>, respectively.</p> <p>The equation is:  <math>x + 12 = 5(7x - 12)</math>  <math>x + 12 = 35x - 60</math>,                      operating <math>x</math> leads to:  <math>34x = 72</math> and <math>x = 2 \frac{2}{17}</math></p>

(This problem is fully discussed in Radford 1995a.)

### Discussion

Two original solutions have been given to Canacci's problem.

While playing with real pieces of money, cents and obviously not dinarii, Darren Stanley found the following solution. It seems that working with concrete money played an important role in the making of Darren's solution. We may speculate, and it is pure speculation, that Canacci's solution may have been found the same way.

#### Darren's Solution

Let's say, at the beginning of the discussion, that the second man has  $x + 5$  denarii. But, since if you (the second man) give me (the first man) 5 denarii, I will have 7 times what you have left, after this exchange, the second man has  $x$  denarii, since he gave 5 denarii to the first man, and the first has  $7x$  denarii, 7 times what the second has. Thus, the first man having gotten 5 denarii in this exchange, before it, at the beginning, he had  $7x - 5$  denarii.

	First man	Second Man
At the beginning	$7x - 5$	$x + 5$

Let's now analyze the second exchange. The second says to the first: if you give me 7 denarii, I will have 5 times what you have left. Then, after the exchange, the first man has  $(7x - 5) - 7$  denarii, and the second has 5 times this amount, that is  $5(7x - 12)$  denarii. Then, before this exchange, the second man had  $5(7x - 12) - 7$  denarii, since he got 7 denarii from the first man during the exchange.

	First man	Second Man
At the beginning	$7x - 5$	$5(7x - 12) - 7$

Therefore, the amount the second man had at the beginning may be expressed in two different ways,  $x + 5$  and  $5(7x - 12) - 7$ . Thus,

$$x + 5 = 5(7x - 12) - 7.$$

So  $x = 2^{2/17}$  denarii. Then, the first has  $9^{14/17}$  denarii, and the second one,  $7^{2/17}$  denarii.

Ralph Mason proposed another solution.

#### Ralph's Solution

Let's resolve this problem using ratios, with a graphical representation.

With the first exchange, the first man has seven times more money than the second one. Thus, the first man has  $7/8$  of all the money. At the beginning, the first man had then seven eighths of the total, less 5.

With the second exchange, the second man has five times more money than the first one. Thus, the first man has  $1/6$  of all the money. At the beginning, the first man had then one sixth of the total, plus 7.

Therefore, if one says that the res is the total amount of money, and we look at what the first man had at the beginning, one has:

$$\frac{7}{8} \text{ res} - 5 = \frac{1}{6} \text{ res} + 7.$$

From there, it is easy to find the actual amounts each man has.

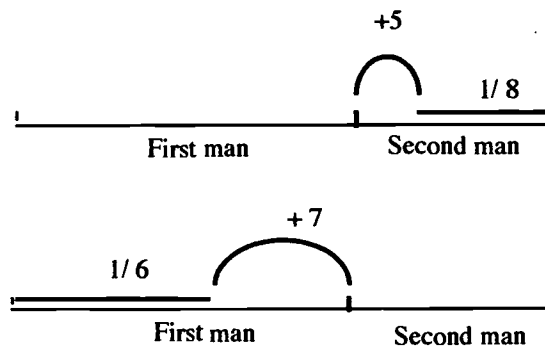

## PART 2: A TEACHING SEQUENCE

The second part of the working group was devoted to the analysis of a video. This video showed two groups of three Grade 8 students each working with manipulatives trying to solve some problems related to linear equations. The members of the working group had the verbatim discussion of one of the groups of three students who participated in an experiment described in Radford and Grenier's papers (1996a, 1996b). The part we saw focused on the way the students dealt with the question of the equality between the two parts of what could be an equation. The stage at which the students were, they hadn't yet seen any symbolism. The problems on which they had worked were given in terms of hockey cards and envelopes containing an unknown number of hockey cards, the question being how many hockey cards does each envelope contain. One of the ideas was to have the students consider the unknown as an "occult" quantity, as Mazzinghi wrote during the second half of the 14<sup>th</sup> Century. The students had actual envelopes and hockey cards in their hands.

In the working group, the discussion rapidly focused on the analogy between an equation and a balance model. Is this idea of a scale really helping students to understand how to manipulate and transform an equation? Three main objections were raised.

First, it was noted that two-plate scales are not common in our students' environment. Usually, the students don't have any experience with such scales. Can we then say that an analogy between such an instrument and a symbolic equation may help a student to know what to do to manipulate an equation?

Second, the common situation in which the balance model is used in the introduction to algebra refers to discrete quantities only, i.e., hockey cards.

Third, the equality corresponds to the fact that there is the same number of cards on "both sides" of the equation. However, in a balance, it is not the number of objects in each plate that is equal, but the weight of those objects.

In light of the previous objections, another different approach was proposed by one of the workshop participants. This approach is based on the use of two identical containers and was illustrated with reference to the following problem. In the first container, there is already 1 dl of liquid, and in the other, there are 4 dL. There is a third, smaller container of an unknown capacity, called a "cup".

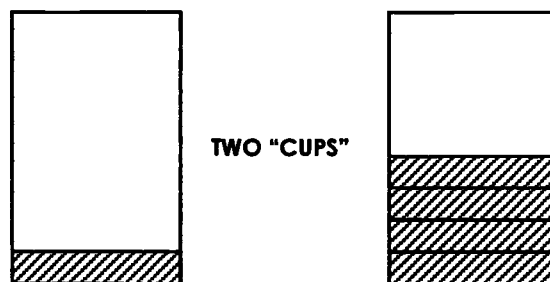

The containers are such that if we add the liquid of two "cups" to the first container and then add one "cup" to the second container, the liquid in both containers will be at the same level. In such a situation, the equality is *visible*. She argued that this situation is more natural than the one based on a balance model and that a research process is probably more likely to be engaged by the children themselves and that when one uses a real object to represent the unknown, the actions to be executed are more natural.

The presentation of the two-container model was followed by a discussion. Some objections were made, among them the following.

First, it is not clear that the two-container model is more visible than the balance model. Indeed, while it is true that you can see that both of the containers have the same amount of liquid, what you see is the total of the liquid. Once the water has been poured, it is impos-



sible to visually discern what you had before and what was added. In a real setting, what one sees is not a diagram like the one provided above. The dividing lines are not there. The students lose track of the different components of which the total is made up and can easily forget how many dl were in each container at the beginning—something that can unnecessarily complicate the problem-solving procedure. This problem with the liquid, it was argued, is a common problem of objects with a fuzzy referent. (Actually this is why, in natural language, the plural of objects such as liquid and sand functions differently from the plural of discrete objects: if you add water to water you still have water—and not waters). In contrast to what happens in the two-container model, the discrete objects of the balance model allow the students to clearly keep track of what they add or remove from the scale (cards and envelopes are visually different).

Second, the above-mentioned intrinsic difficulty with the two-container model renders it very unlikely to make it appear more natural than the balance model. Furthermore, as to the familiarity of students with balance artefacts, it was noticed that contemporary students in primary school learn about the relations "X is lighter than Y", "X is heavier than Y", "X is as heavy as Y", etc., through the use of plastic balances.

Third, the two-container model requires that the students add and remove amounts of liquid that need to be measured. Since here we are dealing with liquid, measures will always be approximative. Unavoidable errors in measures complicate the students' hands-on procedure and filter unnecessary sources of problems into the learning process.

Fourth, from the concrete demands of the teaching setting, it has to be pointed out that as a result of playing with liquid, the chances are that the students will end up making a mess in the classroom.

Fifth, in the end, the unknown in the two-container model is the amount of liquid held by the "cup". You add (or remove) one, two, three cups. Upon closer examination, as in the case of the balance model, you are handling whole quantities. Hence, there is not much to be gained from this point of view.

During the comparison of the two models, it was noticed that both of them bear the risk of not making clear for the student the distinction between the signifier and the signified. In the balance model, the unknown is the number of cards in the envelope. The students, however, tend to identify the unknown with the envelopes. In the two-container model, the confusion arises by taking the cup as the unknown instead of the amount of liquid in the cup.

These considerations led some members of the group to ask if in using too much concrete material we are not led to a situation where, like in the Middle Ages, negative numbers would not be accepted.

Luis Radford then expressed the view that it is important to distinguish hard uses of the balance model (based on the weight of objects) from metaphorical uses of it (based on a descriptive general idea of quantities that are equal) and explained that, in his research, the metaphorical model is a way to help students make sense of the comparison of quantities required in algebra (his students are not provided with any scale). In his approach, this kind of comparison—that past mathematicians referred to as "confrontation"—is possible by a division of the space in which the concrete actions occur. The desk becomes the space on which actions unfold. As it was possible to see in different parts of the classroom episodes presented in the video, the desk is divided by the students (in general, mentally) into two parts, each one containing the cards and envelopes according to the problem. The algebraic concept of unknown becomes conceptually related to the concrete actions that the students perform on the objects and that underlie the algebraic techniques. A metaphorical approach referring obliquely to a balance is intended to invite students to participate in a kind of language game (in Wittgenstein's sense) that, as experimental data shows, they easily join and that gives them an opportunity to conceive the idea of "confrontation" in a concrete way. Radford emphasised the fact that the originality in his approach is to be found not only in the metaphorical recourse to a balance but, over all, in the recourse to three distinct (but

related) semiotic layers in which students have the chance to produce meanings for symbols. The differentiated semiotic layers constitute an important difference to other hands-on approaches (e.g., in terms of the role of symbols and the source of their meaning).

Thus, one of the fundamental differences between the two models previously discussed was located in the source of meaning for the concept of unknown and the correlated actions carried out on it (addition, subtraction, etc., of known and unknown terms of the "confronted" quantities). In the metaphorical balance model, the meaning of concepts arises from the hands-on step, based on the students' gestures and concrete actions on concrete objects. In this model, there is an important step (systematically placed after the hands-on step and before the symbolic one) in which the students make drawings. No more manipulatives are required. Reasoning on the drawings, an iconic type of algebraic thinking is generated. In this stage, meaning is produced from actions on indirect objects—icons of concrete objects. This step is followed by a symbolic one in which symbols are introduced as abbreviations of those gestures and actions on icons. Spatially, the equation mimes the iconic objects. In this step, the actions are characterised by new symbols on the page which then becomes a semiotic space endowed with the meaning of the actions undertaken on the iconic layer. The three-step methodology developed by Radford and Grenier is such that each semiotic layer (concrete, iconic and symbolic) functions at different times. In the two-container model, in contrast, because of the difficulty involved in keeping track of the amount of water added or removed, the actions have to be written down or referred to the equation (let's suppose a student who removes, say, 3 dL and a cup from each container and puts the removed liquid into another recipient, which may already contain some liquid, and then forgets the actions previously undertaken. It will be almost impossible for him or her, by merely looking into the recipient, to identify what was removed from each container). This is why, to keep track of actions (something required in any heuristic process), these have to be written down somewhere. As a result, two semiotic layers enter simultaneously into the scene and it may be unclear for the students where to focus their attention—the containers or the written actions? Furthermore, the necessity of keeping track of actions may lead the teachers to prematurely introduce the symbolic equation, which thereby becomes a focus of attention and the source of meaning.

Despite the theoretical and semiotic principles underpinning the two models, both allow students to construct (although probably not with the same intensity), little by little, complex symbolic representations. For instance, in one of the classroom episodes, discussed in the working group, it was possible to see how the group of students, after solving some word-problems about hockey cards through the balance model, succeed in symbolising a word-problem about pizzas into an equation as follows:

$$3P - 6 = 1P - 2 + 18.$$

The problem dealt with pizzas having two missing slices. The number of slices in one of those pizzas was represented by the students as '1P - 2'. Thus, the left side of the equation indicates the number of slices in three of those pizzas. The sense of the equation and the meaning of the actions were such that they added 6 slices on the left side to complete the pizzas and, to maintain the 'confrontation', the students added 6 slices on the right side of the equation. Two of the 6 slices were used to complete the pizza on the right side of the equation. Symbolically, these actions were written as follows:

$$\begin{array}{r} 3P - 6 = 1P - 2 + 18, \\ + 6 \quad + 2 + 4. \end{array}$$

The resulting equation was then  $3P = 1P + 22$ ; then they proceeded to remove 1P from both sides, and so on.

This is reminiscent of what they had done in a previous stage when they were using concrete material.

The longitudinal nature of the research ensured a close follow-up allowing one to see how the concrete actions progressively lose their contextual root and become more and

more autonomous vis-à-vis the specific situation of the problems.

The working group participants seemed to agree that, despite the differences in the discussed models, both of them are based on cultural artefacts (containers and scales) that as any artefact, are not "good" or "bad" in themselves. What is important, from a pedagogical point of view, is that, suitably used in the classroom, they can serve as a means to promote mathematical understanding.

### PART 3: USING HISTORY IN THE CLASSROOM

At the beginning of this last part of our work, we saw an extract of a video done under the supervision of Leigh Wood (*Balancing the equation: The concepts of algebra*. University of Technology, Sydney and the Open Training Education Network). This video was aimed at students being introduced to algebra. The extract showed a discussion between two characters involved in the resolution of a traditional problem from India and another one from China.

This led us to a discussion about the main reasons for which the members of the working groups used history in their mathematics classroom. Different categories of reasons surfaced. The most often mentioned one was the desire to show to students that mathematics is a human activity. To do that, one may focus on multicultural aspects of the history of mathematics, choosing for example to study Islamic patterns. Another way is to focus on the fact that the history of mathematics is full of controversies and discussions. Opinions played an important role in the evolution of mathematics. It is why the history of mathematics is a rich source of problems for problem solving activities. Having students solve problems and, at the same time, be informed of historical discussions aroused by this same problem may be a very enriching experience for students. A last way of giving students the feeling of mathematics as a human activity is to relate the evolution of mathematics to the fulfilment of human needs, practical needs, related to the economy, the daily life, the military, etc., as well as other needs related to aesthetic or intellectual pursuits.

History is often fascinating for students. Using history often allows teachers to get their attention. History gives then a way to motivate students, even if just for a short period of time. Anecdotal extracts from the life of mathematicians are often used in that way.

It has been noticed, on the other hand, that putting too much emphasis on the life and works of great mathematicians may give the students the impression that mathematics is only accessible to a small group of very bright persons. It is therefore essential to have a healthy diversity of historical intrusions in the mathematical classroom.

### References

- Høyrup, J. (1990). Algebra and naive geometry: An investigation of some basic aspects of old Babylonian mathematical thought. *Altorientalische Forschungen*, 17, 27–69, 262–354.
- Hughes, B. (1994). Problem-solving by Ajjub al-Basri, an early algebrist. *Journal for the History of Arabic Science*, 10(1 & 2), 31–39.
- Libri, G. (1838–1841). *Histoire des sciences mathématiques en Italie*. Paris: Jules Renouard, Vol I.
- Radford, L. (1991/92). Diophante et l'algèbre pré-symbolique. *Bulletin AMQ* (Association Mathématique du Québec), 31/32, (4/1), pp. 73–80. Reprint: L'ouvert, IREM de Strasbourg, No. 68, 1–13.
- Radford, L. (1993). Le raisonnement algébrique. Une réflexion épistémologique. *Actes du Colloque Élève, école, société: pour une approche interdisciplinaire de l'apprentissage*. Montréal: CIRADE, Université du Québec à Montréal, 33–45.
- Radford, L. (1995a). Before the other unknowns were invented: Didactic inquiries on the methods and problems of mediaeval Italian algebra. *For the Learning of Mathematics*, 15(3), 28–38.
- Radford, L. (1995b). Helping students to construct and link problem-solving models. *Ontario Mathematics Gazette*, 34(2), 15–18.
- Radford, L. (1995c). L'Émergence et le développement conceptuel de l'algèbre (III siècle–XIV



- siècle), in: *Actes de la première Université d'été européenne. Histoire et Épistémologie dans l'éducation Mathématique*, F. Lalonde, & F. Jaboeuf (éds.), IREM de Montpellier, 69–83.
- Radford, L. (1996). The roles of geometry and arithmetic in the development of elementary algebra: Historical remarks from a didactic perspective. In N. Bednarz, C. Kieran, & L. Lee (eds.), *Approaches to algebra: Perspectives for research and teaching* (pp. 39–53). Dordrecht: Kluwer.
- Radford, L. (1997). L'invention d'une idée mathématique : la deuxième inconnue en algèbre, *Repères (Revue des instituts de Recherche sur l'enseignement des Mathématiques)*, juillet, 28, 81–96.
- Radford, L. (2000). *Savoir mathématique, processus de signification et pratiques sociales : le cas de l'algèbre à la Renaissance*. Communication présentée au colloque «L'importance du langage dans l'enseignement et l'apprentissage», ACFAS, Université de Montréal, 16–18 mai 2000.
- Radford, L. (in press). The historical origins of algebraic thinking. In R. Sutherland, T. Rojano, A. Bell, & R. Lins Eds.), *Perspectives in school algebra*. Dordrecht: Kluwer.
- Radford, L. & Grenier, M. (1996a). Entre les idées, les choses et les symboles — Une séquence d'enseignement d'introduction à l'algèbre. *Revue des sciences de l'éducation*, 22, 253–276.
- Radford, L. & Grenier, M. (1996b). On the dialectical relationships between symbols and algebraic ideas. In L. Puig & A. Gutiérrez (eds.), *Proceedings of the 20th international conference for the psychology of mathematics education*, vol. 4 (pp. 179–186). Spain: Universidad de Valencia.
- Rosen, F. (1831). *The algebra of Mahammed ben Musa*. London: Oriental Translation Fund.

**Mathematics education et didactique des mathématiques : y a-t-il  
une raison pour vivre des vies séparées?**

**Mathematics education & didactique des mathématiques: Is there a  
reason for living separate lives?**

Tom Kieren, *University of Alberta*  
Anna Sierpinska, *Concordia University*

**Participants**

Mariolina Bartolini Bussi	Claude Gaulin	Tom O'Shea
Richard Barwell	Rina HersHKovitz	Asuman Oktaç
Nadine Bednarz	William Higginson	Elaine Simmt
Laurinda Brown	Carolyn Kieran	Margaret Sinclair
Lynn Gordon Calvert	Stan Manu	Vicki Zack
Olive Chapman	John Mason	Rina Zazkis
Lucie DeBlois	Joan Moss	

Note: In the report that follows, the pronoun 'we' refers to the leaders of the working group.

The aim of the working group, as announced in the program of the meeting, was 'to build bridges between the "two solitudes": mathematics education and *didactique des mathématiques* in Canada, while respecting the distinct character of each'. We hoped that the bridges will be built on 'an identification of and a discrimination between the distinctive *problématiques* (i.e., research questions, techniques of research, preferred methodologies and theoretical frameworks), and a synthesis of the main findings and a cautious generalization in terms of possible future developments'.

The format of the activity being that of a working group and not of a lecture, we aimed at finding a situation that would provoke the participants to make explicit their approaches to or understandings of the problems of the teaching and learning of mathematics, and engage in discussing the differences. Given the variety of *worlds brought forth*<sup>1</sup> by the participants, the leaders had no doubt that differences would inevitably appear. These worlds could be those of a mathematics or mathematics education student, of a mathematics teacher or teacher educator, researcher in mathematics education using this or that learning and instructional theory, textbook writer, and other.

The idea was to choose a mathematical topic and look at it from the point of view of its teaching and learning. We chose the operation of division, because (a) it is an elementary mathematical notion, so it could be assumed that all participants had an established experience with it, and (b) it is a notion which is notorious for its difficulty for the students. Its difficulty can be analyzed from many points of view: mathematical, epistemological, cognitive, socio-cognitive, cultural-anthropological, didactic. The point of view that a person would choose may reflect his or her role in the domain of mathematics education and the *problématique* in which he or she situates his or her work.

We planned two activities related to the division operation to trigger off the discussions. Both had to do with school problems or exercises. The first one was meant to be a task that a teacher or a textbook writer could be faced with; we expected the second to more likely engage a researcher's mind.

Here is how the first task was formulated, both in French and English.

### Task 1

*The French version:*

Inventez un problème qui exigerait l'utilisation de l'opération de division.

*The English version:*

Develop a problem in which a person would use division in its solution. Here is an example of such a problem. It was written in the form of a song:

*We have some pizza,  
We have some pizza,  
We have  $\frac{3}{4}$ !  
We have  $\frac{3}{4}$ !  
We want to make shares,  
We want to make shares of size  $\frac{1}{2}$ !  
Of size  $\frac{1}{2}$ !  
How many shares?*

Upon the posting of the task on a transparency, the participants' attention was drawn to the subtle differences in meaning between the two formulations: First of all, the English version contained an example, there was no example in the French version. Moreover, the French version was very concise, written in a school exercise style, and it used the mathematical term 'operation of division' instead of just saying 'division' as in the English version. In English, the necessity of using division was made to be subjective: 'in which a person would use division'. In French, it was assumed that the problem itself would be such that division would be necessary, no matter who would attempt its solution. Thus different kinds of necessity were evoked in the two versions: a 'psychological necessity' in English, and an 'epistemological necessity' in French. Moreover, the French version asked the participants to 'invent' a problem which could suggest that the expected answer was just a statement of a problem. The English version asked the participants to 'develop' a problem which opened a possibility of a response in the form of a longer essay, comprising an account of the process of finding the problem rather than just the statement of a problem.

The French version was written by Anna, who then asked Tom to express the task in English. The two had not discussed the translation beforehand and did not make a conscious effort of bringing up the above mentioned differences. We consider the differences, noticed *post factum*, to reflect our minds as individuals (at that particular time) and we do not think they should be interpreted as pointing to some more general structural distinction between '*didactique des mathématiques*' and 'mathematics education'.

The participants formed 7 small groups of 2 to 3 people. The groups were asked to write their responses on transparencies for presentation to other groups. All groups except for one wrote their transparencies in English. All English written responses contained more than one problem; the single French response contained only one problem.

We reproduce below the written responses of the groups as displayed on transparencies. To the extent that we remember it, we shall give some information about how the representatives of the groups explained their thinking about the tasks in the groups. The reader will have to understand that it has been sometimes very difficult for us to distinguish our memory of the presentations from our interpretations of what has been said. The only 'facts', therefore, are what participants wrote on the transparencies.

## Response 1

*Anna has 36 sweets. She likes to have them in small boxes of 5 sweets each. Help Anna.*

• • •

*Mummy has 36 sweets and she likes to spread them between 5 girls. Help Mother.*

• • •

*Bob has some amount of money. He likes to give the same amount of money to his sons. Help Bob.*

The group looked at the meaning of the operation of division in school word problems and how different it can be from the mathematical operation of division. In school word problems the operation is performed on real or imagined quantities of objects; in early education it can even be performed on objects themselves. In this context, there are two kinds of division: grouping ( $n$  objects are grouped into sub-collections of  $k$  objects; how many groups are obtained?), and sharing ( $n$  objects are shared among  $k$  people; how many objects does each person get?). In the sequence of problems that are proposed, the first one is, seemingly, about grouping, the second and third are about sharing. But, although in the first two concrete numbers of objects to be grouped or shared are proposed, the result is not a whole number. The division of one candy into 5 little pieces is impractical, and so it appears that the first two problems involve Euclidean division:  $36 = 7 \times 5 + 1$ . Noticeably, the questions in the problems are not of the standard type, 'how many candies in a box?', or 'how many candies for each girl', but 'Help Anna/Mother'. This may cause the children worry about the remainder in the practical terms of what should Anna or Mom do with the candy that is left over. Anna could be allowed to either keep one box with only one candy in it, or simply eat the candy. With the sharing of the candies among 5 girls, the problem of fairness is brought up: cutting one candy into five equal pieces can be quite a difficult task in practice, so some other solution has to be thought of. Maybe Mom can be rewarded for her kindness with the remaining candy, or the girls could be drawing lots for it. The third problem sounds like a problem of sharing, but, in fact, it is very different from the previous two. It is a class of problems and not a single problem because no concrete data are given. The quantities involved are not sets of objects but amounts of money, which can therefore be expressed in decimal form. While the previous two problems could be, in principle, solved without using the mathematical operation of division on numbers (one could enact the grouping and sharing of candies using counters or some pictorial representation of the collection), in the case of the third problem, one has to propose and discuss an operation to be performed on any amount of money and any number of sons of Bob. The discussion must be conducted in hypothetical terms, (if Bob has  $b$  dollars, and  $n$  sons, he has to give  $b \div n$  dollars to each). This problem could lead the students to discuss what happens if the result of the division  $b \div n$  is a decimal with more than 2 decimal digits. It must be rounded off, because there are no coins of less than 1 cent. Who gains, who loses and how much in such transactions?

## Response 2

*To force division ... "breaking up"*

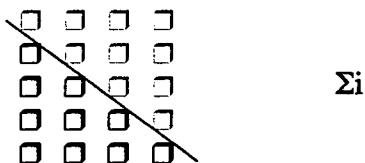

*That's where the 'divided by 2' comes from.*

• • •

*12 ÷ 4 ... Not a problem ... Discussion of methods*

• • •

*24 ÷ 1/2 ... Problem (for some!)*

This group understood the task as one, indeed, of *developing* a problem that would 'force' the operation of division. It evoked in them the idea of a long-term collaborative process between a practicing teacher and a researcher. The presenter referred the audience to the Topic Group A2 led by Vicki Zack and David Reid for more details about this collaboration and the kind of teaching-learning situation that had been developed in the process. Discussing the task proposed in the present WG, the group posed themselves the question of students' understanding of the operation of division at some early stage. How could the operation of, say, dividing by 2 be understood? They thought that this operation could be 'forced' upon the students in a situation of 'breaking up' something in two, say a  $5 \times 4$  squared board (an activity leading, eventually, to the formula of the sum of  $n$  consecutive numbers—but this went beyond the task given in the WG). The group then started to think about what makes a division task of the type  $a \div b$  a problem; for example  $12 \div 4$  is not a problem, but  $24 \div 1/2$  can be a problem for some students.

Response 3

- *Divide a given line segment into 4  $2/3$  pieces of equal size.*
- *Divide \$(Aus) 1800 among 3 people in ratio 3 : 2 : 1.*
- *Find continued fraction for  $\sqrt{3}$ .*
- *Graph  $f(x) = \begin{cases} 6 & \text{for } x = 3 \\ \frac{x^2 - 9}{x - 3} & \text{for } x \neq 3 \end{cases}$  on the interval  $[-10, 10]$ .*
- *A dozen apples cost \$2.40. What does 1 apple cost? What do 15 apples cost?*

The first two problems were presented as challenging the students' typical procedures for solving problems of division of segments in a given ratio and sharing money among people. The first requires to divide a segment not in a given *ratio* but into *a number of pieces* of equal size, and, moreover, the given number of pieces is not a whole number. The students would have to first try to understand what it might mean to divide something into a non-whole number of pieces. This problem might indeed lead the students to generalize the notion of division beyond the 'grouping' and 'sharing' conceptions applied to whole numbers. The second problem is about dividing an amount among people not equally, as usual, but in a certain ratio. Between the problems 1 and 2, the operations have switched their customary contexts, thus inviting the students to de-contextualize or de-compartmentalize some of their knowledge.

The whole set of problems also hints at the ambiguity of the term 'operation of division' in mathematics: there is the operation of division in rational numbers, the division of a number in a given ratio, the Euclidean division (as used in finding the continued fraction for  $\sqrt{3}$ ), the division in the ring of polynomials, the division in decimals with a fixed number of decimal digits (which could involve taking approximations).

Response 4

- *Fred has 10 chocolate bars and needs to distribute them among 5 friends. How many does each get?*
- *Jane is driving 520 km/h. How long will the drive take?*
- *Paula is making a cake. The recipe calls for 2  $1/2$  cups of flour. She only has a  $1/2$  cup measure. How many times will she need to fill the measure?*
- $362.5 \overline{) 4789146}$

In a way which could be seen as dual to Response 3, this group aimed at illustrating the variety of contexts in which a student may be required to use the operation of division: sharing and grouping, speed-time-distance, ratio and proportion, computational exercises.

## Response 5

- $(2\frac{1}{7}x^3 + 28x^2 - 156x + 319) \div (x^2 - 16)$
- *How many different CMESG working groups of size 19 can you get from a group of 99 participants?*
- *Divide a banana into 3 equal parts.*

The problems were presented with the intent of illustrating the complexity of interpretation that arises when a particular interpretation of the meaning of the operation of division is not clearly stated. The first example explicitly requires division, as shown by the division symbol, although the students may not see any other purpose of it than to arrive at an answer, as is the case for most high school algebra problems.

The second example also requires division: The task is to determine how many different groups of size 19 can be formed and this requires partitioning the set into two groups, one of size 19 and the other of size 80. It is a task in combinatorics.

In the third example the word 'equal' was a key aspect of the problem. How would students attack the problem? Perhaps by estimating, and taking into account the narrowing of the ends. Perhaps by weighing pieces. Somebody in another group suggested a banana naturally separates longitudinally into three equal pieces. What a nice challenge instead of dividing pizzas into three equal parts.

## Response 6

*The Stack of Paper Sheets problems*

1. *You want to share a stack of papersheets among a given number of persons. How would you go about deciding on the number of sheets per person? (or: How would you do it?)*
2. *You have in front of you a full package of paper. What is the thickness of each sheet? (or: You have 150 sheets of paper in a stack. The stack has a thickness of 5 cm. What is the thickness of each sheet?)*

These problems were inspired by a situation proposed by Guy Brousseau for the teaching of rational numbers (Brousseau, G., 1997: *Theory of Didactical Situations in Mathematics*. Dordrecht, Holland: Kluwer Academic Publishers, pp. 195–212). In the situations proposed by Brousseau, children had to estimate the relative sheet thickness of several kinds of paper. The specificity of this situation is that children have to build a mathematical model for the solution of a practical problem, because it is impossible to directly measure the thickness of a sheet of paper. The operation of division may appear as an efficient/economical tool in solving the problem.

## Response 7

*On veut construire une banderolle pour accueillir le groupe canadien. Cette banderolle doit mesurer 125 dm. On la construit à partir de bandes de tissu de même longueur et de différentes couleurs. Chaque bande de tissu mesure 5 dm. De combien de tissu aura-t-on besoin?*

*(English translation: A 125 dm welcome banner is to be made for the opening of the CMESG conference. It is to be made of strips of material of different color but the same length equal to 5 dm. How much material is needed?)*

*Le groupe a surtout discuté des réponses des étudiants dans les cours de didactique des mathématiques au programme de formation des enseignants, niveau bac, lorsqu'on leur demande d'inventer des problèmes de division. Les étudiants proposent presque toujours des problèmes de partage de bonbons. L'effort des instructeurs va alors dans la direction d'un élargissement du répertoire des futurs maîtres dans le domaine des situations pouvant exiger l'opération de division. Les situations impliquant des quantités continues et non seulement discrètes en sont une des voies. Une autre est la prise en*



*compte du contexte des données du problème. Par exemple, dans le problème ci-dessus, la solution n'est pas obtenue, comme on pourrait le croire, par la division de 125 par 5, car en cousant ensemble les bandes on perd au moins 1 cm sur une bande interne et .5 cm sur les bandes des bouts.*

(English translation: The group's discussion focused mostly on the responses of pre-service teachers in courses in 'didactics' in the Bachelor of Education program, when they are confronted with tasks of inventing problems on division. Most of the time, the students propose problems about sharing candies. The instructors attempt to broaden the future teachers' repertoire in the domain of situations that could require the use of division. Situations involving continues and not only discrete quantities are one of the directions taken. Another is the taking into account of the context of the givens in the problem. For example, in the problem above, the solution is not obtained, as one could think, by dividing 5 into 125, because in sawing together the strips one loses at least 1 cm in the inside strips and .5 cm in the outside strips.)

• • •

In the discussions following the presentations of the responses to Task 1, the participants wondered at the variety of 'enactive division' operations which could all be represented by one mathematical notation. But some participants pointed out to the variety of division operations also in mathematics (the 'fair division' algorithm was mentioned as a way of contrast with the usual, school situations, where 'equal shares' are always required). Looking at 'division' from a linguistic and cultural point of view, the participants were able to outline the large semantic field related to the idea of division: Divide and conquer!, divorce, separation, separatism, equity, demarcation, allocation, concatenation, the equi-division of the Inuits, cutting out (e.g., the largest square out of a rectangle)....

Given this variety, some participants questioned the possibility of devising problems that would make the use of division in any one of its meanings 'necessary'.

The moral of this discussion was meant to be: school mathematics concepts are not a given. On the contrary, they are problematic and have to be studied. This assumption and a purposeful study of the meanings of mathematical concepts chosen to be taught at different levels of schooling distinguishes the domain of mathematics education both as research and practice from the domain of general education. And this common focus on the mathematical meanings unites all mathematics educators, no matter what language they speak or use in their work and no matter what their epistemological assumptions about mathematics are, or what learning and instructional theories they bring into their ways of looking at the phenomena of teaching and learning. Our aim in this working group was to bring these assumptions to the awareness of the participants.

The focus on mathematical meanings notwithstanding, mathematics educators around the world still find ways of getting 'divided' over what they see as they look at the mathematical subject matter of the phenomena of teaching and learning. This could already be noticed during the first round of discussions about the meaning of the operation of division in school mathematics, in research mathematics, in language and culture. In order to bring the participants to further articulate their standpoints in front of the mathematical subject matter, and start seeing where the possible differences may lie, a second task was offered. This time, the groups were not formed in a spontaneous manner, but we tried to ensure that in each group a sufficient variety of points of view is represented. The task was inspired by a situation proposed, experimented and analyzed by G. Brousseau.<sup>2</sup>

## Task 2

The participants were given a list of 31 problems taken from 'chapters on division' of two high school textbooks.<sup>3</sup> The list can be found in the Appendix. The participants were asked to agree on a set of criteria to classify the given division problems.

A priori, the task of classification of division problems could be conducted from many points of view: epistemological, cognitive, sociological, linguistic, didactic. We hoped that the task would bring forward these different perspectives and trigger a discussion about

the differences between research paradigms. Research paradigms could be differentiated by the weight attributed to these foci. *Didactique des mathématiques*, especially in Brousseau's Theory of Didactic Situations edition, gives special importance to the epistemological analysis. In a way, everything else is subordinated to the results of this analysis.

A more general division of perspectives could occur along the distinction between empirical and rationalistic methodologies. This, indeed, happened in one of the groups where some people wanted to start from a set of criteria and classify the problems on that basis while others wanted to first look at the problems, find what is involved in them, and categorize them on this basis. These are two opposed approaches: from a theory to an analysis of data versus from the sorting out of data to the building of a model. The variables chosen a priori for the classification were: types of numbers, types of relations between data, context, complexity of strategies used, social influence, type of contract/expectation, emotional aspects.

After the groups had been working for about an hour, they were asked to prepare presentations of their work, along the following questions:

- *What was the nature of your classification of the problems?*
- *Looking back, what were your reasons for selecting these criteria (or this criterion) for classifying these items?*
- *In what way did your scheme or criteria relate to or take into account that these were "division" items?*

The presentations of the work in small groups demonstrated the difficulty and sometimes the reluctance of the participants to engage with the task of classification. One person asked the leaders, 'What the problems of division have to do with the theme of this group?'. Most often the issues discussed in the groups were of a general nature, e.g., Is it possible to look at a school problem in abstraction from the didactic situation in which it is involved? Shouldn't sequences of problems be considered rather than isolated problems? Are these problems requiring division in themselves, because they cannot be solved without this operation, or is it the didactic contract in which they are embedded (by being included in a chapter on division or by explicit instruction from the teacher)? Isn't the didactic contract always present in classroom situations and therefore is it at all possible to generate a 'cognitive' or 'epistemological' necessity of a mathematical concept at school? Isn't the necessity always institutional?

Some persons focused on the linguistic aspects of the problems and pointed to the ambiguities in the formulation of some of them. There were also remarks about the structure of the problems, in particular, in relation to the closed form of many of them. In one of the groups, the discussion was related to a possible reformulation of the problems in the direction of a greater openness and flexibility in using solving strategies and mathematical operations. It was said that there are, in general, two ways of looking at a problem: 'What do I do?', and 'What does it mean?', and students in the classroom should be encouraged to engage with both rather than with the only the first one, as is usually the case.

One group came up with a variety of possible criteria, e.g.,

- *items that 'force' the use of division and those that do not;*
- *items that are conceptually rich and those that are mere exercises;*
- *items using natural language besides the mathematical notation and items using only the mathematical notation;*
- *straightforward items and items involving a subtlety;*
- *items leading the students to develop an algorithm and those that ask him or her to apply a ready made one.*

By the time the group reports were done, the frustration of the group participants had grown considerably, most people sympathizing with the person who asked 'What the problems of division have to do with the theme of this working group?', and all wanting to finally sit down all together and explicitly address the issue of the differences between mathematics education (ME) and *didactique des mathématiques* (DM).



Anna tried to use the common experience of the group (frustration with Task 2 included) to point to the distinctive feature of DM, namely its insistence on epistemological analyses of mathematical concepts, based on the study of their history both in the domain of research mathematics and in the school institutions (the so-called didactic transposition). This insistence may point to an implicit epistemological assumption that knowledge has some kind of objective existence and life, independent from the individual cognizing subjects. The belief in the importance of the history of a concept for its teaching in the sense of creating the optimal conditions for its 'artificial genesis' in the classroom, may be based on the Marxist assumption of the so-called 'historical necessity': certain socio-cultural conditions necessarily lead to certain changes in the mental reality of those who participate in them. DM has thus the ambition to be able to 'engineer' didactic situations that would create optimal conditions for the artificial geneses of the basic mathematical concepts. These are very strong rationalistic and dialectic-materialistic assumptions that are not easily accepted by the mathematics educators coming from the more Baconian, empiricist tradition in science.

Tom, on the other hand, presented the approach of Les Steffe with whom he had collaborated recently. This brief discussion well illustrated another attempt to deal with a conclusion which was derived from earlier group discussions and reported above: 'school mathematics concepts are not a given; they are problematic and have to be studied. This assumption and a purposeful study of the meanings of mathematical concepts chosen to be taught at different levels of schooling distinguishes the domain of mathematics education both as research and practice from the domain of general education'. Les and his group at the University of Georgia have approached the development of the concepts of school mathematics from a different point of view. In their work they take seriously the activities of children, engaged in what an observer sees as legitimate mathematical actions, as a source for the development of mathematical ideas for a researcher (or a teacher). In fact, Steffe has been engaged in the development of what he terms a 'mathematics of children' which he sees a co-creation of children engaged in mathematical actions and an interpreting researcher, and which has led him to develop a systematized collection of such concepts particularly for natural numbers and the additive operations on them. (He is continuing work on multiplicative operations and on rational number concepts.) In this case the researcher (usually in an inter-active group whose members have varying areas of expertise and interest related to the study) is engaged in the study of children's actions and interactions (with a small group of peers and a teaching researcher or a researching teacher) which occur in a carefully developed mathematical setting or which occur as children engage with carefully developed mathematical prompts. In their work the children can use various tools which in recent cases have been computer based 'tool' kits. For example his group has created such tool kits for the study of pluralities and unities and unifying compositions and for studying multiplicative situations. From a careful recursive study of the children in action, from interactions with children over an extended period of time and from the detailed multi-leveled study of videos of actions and interactions, Steffe derives and constructs this 'mathematics of children'. Teacher/researchers again acting with children in teaching experiments attempt to 'transpose' the 'mathematics of children' into a 'mathematics for children'—that is into legitimate and useful curriculum elements, classroom practices as well as materials through which teachers might gain insight into both how children come to know important mathematical ideas and how one uses such knowledge of children mathematical knowing and the 'mathematics of children' to inform one's teaching practices. (In this aspect Steffe's work is related to the Cognitively Guided Instruction work of, say, Carpenter and Fennema at Wisconsin or to the socio-mathematical work of Cobb and Yackel.) Notice that this approach shares with Brousseau's work the notion that one needs to have a very clear notion of key mathematical ideas and that a transposition of these key ideas is needed for the purposes of teaching and learning. But a key source of those ideas is different in the two cases. In Steffe we see the researcher as developing a mathematics of children which is derived from the legitimate actions of children themselves as filtered through the eyes of a researcher who

brings to bear a deep knowledge of mathematics in his observing, interpreting and constructing. This view of mathematics knowing and the provision for it is consistent with and driven by Steffe's current ideas of radical constructivism. (Such an approach has the flavour of Kant and Vico.) This provides a very different basis for studying the problems of school mathematics concepts than that of Brousseau and to a different programme of research and development as well (even if the proponents of either program might be willing to borrow ideas from the other in one way or the other).

The working group spent a small amount of time discussing the contrasts and the inter-relationships among these two approaches to the study of mathematical concepts and mathematical knowing and its development in young persons.

• • •

Most of the last session of the working group C was spent on a general discussion which was fuelled by more focused questions from the participants concerning the types of research topics and methodologies that could be accepted as legitimate in DM but not in EM and vice versa. This discussion was fueled, in particular, by a contribution of Elaine Simmt, who told the group about her research on teaching practices (Simmt, E. 1998, *The Teaching Practices Project*. Unpublished Report, University of Alberta). We reproduce below a summary of this contribution, written by Elaine after the conference:

The purpose of the project was to inform teachers, and mathematics education leaders about the teaching practices of teachers in schools whose students perform well on the 9th grade Alberta provincial achievement test. To learn what the teachers were doing in those schools we observed the teachers at work in their classes, we interviewed them and the school administrators and we surveyed students and parents. The report consists of 15 case studies each focused on a different teacher. From observing teachers in their classrooms we learned about some of their teaching practices. Specifically, these teachers' practices included:

- making mathematics real and relevant for their students;
- making connections within mathematics and between mathematics and the world outside of school;
- caring about students' mathematics knowing;
- practicing demanding instruction, both in terms of classroom behaviour and the level of mathematical thinking;
- proposing challenging content;
- engaging in highly interactive instruction;
- being well prepared for teaching<sup>4</sup>;
- reflecting on their own practices and assessing their own instruction;
- taking ownership of the curriculum.

It was very evident that these teachers cared about their students' mathematics knowing. Not only did they demand of the students suitable classroom behavior but they demanded mathematical thinking about challenging content. These teachers understood their primary task to be teaching students *mathematics* (with an emphasis on mathematics). They did so by practicing highly interactive instruction built from teachers and students questioning and explaining their way through a lesson. Rather than focusing simply on skill development, problem solving, or concept development, the teachers in our study were adept at balancing these in their instruction. The teachers taught processes such as communication and problem solving as they taught particular skills and concepts. As well, the teachers in our study were very good at being able to adjust the difficulty of the tasks they assigned students, providing adequate scaffolding and highlighting relevant cues to enable students to get into the mathematical activity and participate. Considering the teachers practices as a totality, we noted that the place and ownership of the curriculum stands out. These teachers and many of their students behaved in ways that led us to see them as taking ownership of the curriculum. They

talked about mathematics as if it were their own. Teachers selected examples, explanations and concepts to develop based on who their students were, how the teacher understood the mathematics and based on the teachers' understanding of the expected outcomes of the program of studies.

We concluded from this study that we could not identify or write a prescription for good teaching because not only is it a highly personal and interpersonal act but good teaching could take many forms. (Elaine Simmt)

### Task 3

At the end, we asked the participants to write what they thought they would like the readers of the conference proceedings to know about what happened in the group. We reproduce their responses below. Some participants referred to Elaine Simmt's contribution in their responses.

#### Response 1. (unsigned)

##### *Comment on Working Group*

*The discussion that went on during the sessions made me realize how eclectic research in mathematics education is in Canada and how ignorant the majority of us are about the existence and the characteristics of the main schools of research in that area. Because of that, the work done tended to be superficial and unfocussed. Perhaps in a future CMESG conference a Working Group should be organized in which research questions should be looked at and considered using different paradigms and perspectives.*

#### Response 2. Laurinda Brown

Purpose of research: *Seeing more... about something.  
Explicit about something. Sharing.*

Where I'm coming from? *Methodological issues.  
Being clearer (process) about how I see ...  
Questioning assumption*

Where I'm going? *Tracking transformations of seeing/questioning/raising new assumptions, questions*

*(a) Within a culture (gatekeepers?) possible to see theoretically in more detail ... peer review, community, etc....*

*(b) Personally—in action—through action—seeing more holistically—complex decision-making in the classroom*

*Affordances and constraints of strength of culture in supporting (a) and (b) above?*

*I do not see (a), (b) as different/dichotomous.*

*2nd order questions relate to the processes rather than particulars (Mariolina). Each individual act is necessarily contingent/different (context, etc., etc....)*

*How explicit can I be?*

*[Categories of] complex, complicated, difficult mean more to me in relation to allowing me to make decisions in practice (take actions as a teacher), contingent upon student/pupils' practices.*

*How much this would be useful for anyone outside our subgroup remains in question.*

*However, engaging at the 2nd order level would say things about the skills (?) of the individuals in the group which allowed the coemergence of these ideas which (inevitably?) we interpret differently even in the subgroup. There was a sense of those ideas being validated within the subgroup across 'didactique' and other approaches.*

## Response 3. Vicki Zack

*I would like to reflect on Tom O'Shea's question further. I do not recall the wording of it, but the sense of it for me was, (1) Would the 'didacticien' take on the type of project Elaine Simmt was asked to take on?, and, also, (2) How would the European researcher approach the question? Please ignore my poor phrasing and overgeneralization of the 'European researcher'. In considering these questions (perhaps as a microcosm of our theme) I would say that I see substantive differences between the perspective of the person who comes out of the didactique tradition and one who would broach the question from Elaine's vantage point. I do not claim to describe adequately either the (stereotyped) didacticien, or Elaine. That being said, I will state that I would hesitate to say either that the two sides are diametrically opposed, or that there are no differences. They are looking at different aspects and there is much in the 'holistic' approach which is not considered at all by the 'didacticien' and much in the detailed consideration of the mathematics that Elaine would not do.*

*In Elaine's case, it is possible, indeed highly likely, that there are many intangibles which she senses but which she cannot put her finger on. Jennifer Lewis, a doctoral student working with Deborah Ball at the University of Michigan, is trying to tease out some of these aspects. Often, there is no language to describe them. Elaine's teacher may be 'setting her students up for success' by knowing the mathematics, knowing how her students learn, knowing the bumps along the way in regard to the specific subject matter for that/these lessons over the three days, etc., and how it all fits into the whole, etc. She/he is sensitive to the individual student, has in mind the history of the student in the class, with her peers, and the teacher also knows that one should move the lesson along at a pace that will meet the needs of most of the students while the students know that time will be provided either then or after class to try to fill in the gaps.*

*Having the rulers available is but one example of the teacher putting the emphasis where it should be, on getting on with the subject at hand, without wasting time 'disciplining' students who may not have a ruler, or pencil. Singling that student out (i.e. being unkind), having that student be out of class retrieving his ruler and thus losing valuable time, is counter to the ethic the teacher and her students share. The teacher and the students are there to use every moment to their advantage. Nel Noddings has spoken about caring. Caring is vital. It is of course not the only element, but without it the positive dynamic may not be there. Teaching well and helping each child to fulfill his or her potential is at the root of what one does, and so it is about being adept with the content, etc., of course. It takes such a lot of effort and caring to attend to each child's needs ... therein lies the burden of responsibility.*

*The 'didacticien' also cares deeply about the mathematics, is careful to delve and explore in profound ways, and works very hard to be thorough in mapping out the theoretical, epistemological, and cognitive dimensions. I feel we can do more in North America to have a far more detailed and informed picture in this regard — informed by research as well as by classroom practice. However, I do think that the European researcher needs to broaden her perspective to consider all the other elements which make the picture complex ... the child's history, the aspect of culture, the emotional dimensions, the history of that classroom across that year, etc.*

*I will not go further now, but thank you both, Anna and Tom, for the invigorating questions and for the haziness. Haziness is necessary for growth. I also thank Elaine for sharing that quote, that episode. It is a memorable one for me.*

## Response 4. Nadine Bednarz

*La première séance sur la division a permis de faire ressortir des dimensions multiples du concept de division, très riches, débordant la vue souvent restreinte à laquelle celle-ci est souvent associée. Celle-ci a fait ressortir les multiples points de vue qui nécessairement guident une telle analyse: si je me positionne comme enseignant au primaire, ou formatrice d'enseignants à l'université, ou chercheuse visant à mettre en place une séquence visant par exemple, à tester certains aspects de situations, ma façon de poser un problème de division et de valider celui-ci serait nécessairement différente.*



*La deuxième séance en sous-groupe est apparue très riche dans la mesure où elle a permis une explicitation, une action et une confrontation de multiples perspectives. Les membres du groupe venant d'horizons divers (Alberta, Québec, Angleterre, Italie, Israël), la situation d'action mise en place forçait nécessairement une explicitation de différentes perspectives ancrées dans des pratiques sociales différentes. En ce sens, l'on pourrait dire, dans les termes de Brousseau, qu'elle nous a permis de vivre une situation d'action/formulation.*

*La discussion globale de la fin montra toute la complexité de s'attaquer au problème abordé dans ce groupe de travail, mais en même temps sa nécessité.*

*(English translation: The first session, about division, allowed to bring up the multiple dimensions of the concept of division, very rich and going beyond the usually restricted perspective from which it is seen. This brought forth also the different points of view that necessarily influence this kind of analysis: if I position myself as a primary school teacher, or as a teacher educator at the university, or as a researcher who aims at testing certain aspects of a designed teaching situation, my way of posing a division problem and of validating it would be, necessarily, different.*

*The second session in sub-groups appeared as very rich to the extent in which it allowed an explicitation, an action and a confrontation of multiple perspectives. The members of the sub-group coming from diverse horizons (Alberta, Québec, England, Italy, Israel), the situation of action thus set up necessarily implied an explicitation of the different perspectives anchored in different social practices. In this sense, one might say, in Brousseau's terms, that the setting allowed us to live a [didactic] situation of action/formulation.*

*The global discussion in the final session showed all the complexity of wanting to attack the theme of the Working Group, as well as it underscored the need for it.)*

#### Response 5. Lynn Gordon Calvert

*Mathematics Education (and/embedded in/embeds/all of the above) Didactique des Mathématiques*

*If we think about what is research—even what is research from these two paradigms—we are trying to find meaning and coherence for the questions and concerns of the teaching/learning of mathematics that arise for us. These questions and concerns do not arise from autonomous individuals and observers but from observers-embedded-in-a-(research)-culture. What is posed and what is accepted is a reflection of the individual's own history which induces the history, not just of this individual, but an ancestral history of interactions.*

*Are we all attempting to integrate the paradigms? No, perhaps we wish only to be informed so that we may broaden our understanding (expand our cognitive domains) of the concerns and the explanations used for addressing the concerns within the paradigms. To look at mathematics from a new perspective with new eyes. Viewing the epistemological analysis allowed this to occur.*

*Although we have focused on the contrasts/comparisons between mathematics education and didactique (at a national level) we recognized that the same contrasts/comparisons regarding how and what research questions are posed, how these questions are addressed/analyzed and the interpretations created/validated do not stay at this national level but filter down to various perspectives, say, within mathematics education (or didactique des mathématiques) (e.g., cognitive, socio-cultural perspectives) and filtered further still, over and over and over again so that two researchers, sitting side by side watching the same video will 'notice' different aspects and will explain them differently depending on the history that person brings to that moment. Therefore, the original question/concern regarding mathematics education and didactique moves back and forth from the broad 'whole' to the very local level. A fractal image! (Of course, this reflection is very much a reflection of the history I bring to this moment. What I observed, noticed... .)*

#### Response 6. (unsigned)

*It is very difficult to attempt to distinguish the research culture of one country or community from another. First of all, no matter how cohesive a community may appear to be, there are always individual differences and personal interpretations. Nevertheless, the sharing of a common theo-*

retical framework and its associated discourse makes for communication among its members. But the very specialized discourse they share creates boundaries. Outsiders find entry difficult. The cultural history of a community and its artifacts are neither transportable to outsiders nor understandable by them. Thus, attempting to synthesize the research perspectives of another community is fraught with 'danger'. Even synthesizing the perspective of one's own community requires caution—for it tends to mask the individual in its highlighting of general features. In fact, the very act of creating this synthesis can change to a certain degree the nature of the research culture being described.

#### Response 7. Tom O'Shea

Dear Leora,

Well, here it is, the end of the final day of the workshop on 'mathematics education and didactique des mathématiques'. I came seeking understanding of 'didactique' as viewed in Québec, partly because of previous presentations at CMESG by Québécois participants. I remember last year leading a workshop on teaching practices where Linda Gattuso described some of her work and I really didn't know what she was talking about. The phrase that caught my eye for this session referred to 'two solitudes'—an expression coined by Hugh MacLennan in the 1950s to describe the separate lives of the English and the French in Québec. So I expected to gain an appreciation of the differences between the two camps.

We struggled on the first day on a group task related to division and it was not clear how this might connect to the issue. On the second day, Anna gave a detailed demonstration of the mathematical analysis which helped to see how didactique applies in a particular instance. The third day moved into a group discussion that seemed to cover the whole spectrum of mathematics education and attendant research.

So what do I leave with? My sense is that the metaphor is not 'two solitudes' but 'converging desires'. The contribution from international participants helped to shape my thoughts and my conceptual understanding of the issue. The end result for those of us coming from two traditions is quality of scholarship. Both need to be grounded in theory and guided by consideration for student, teacher, and content. I look forward to reading Anna's notes and sharing ideas with my graduate students in my course next year on Foundations of Mathematics Education.

Hope you and the kids are well.

Love

Tom

#### Response 8. Rina Zazkis

We (I) struggled to understand the differences and the common features of two traditions—Math Ed and didactique des mathématiques.

From the final remarks of the discussion it is my understanding that researches in both traditions may explore very similar research questions and the important difference will be in the presentation/reporting of the results. 'French' will have long theoretical explanations, while this part will be overlooked or minimized by anglophones. In the end, 'French' would be 'apologetic', maybe more aware of the scope of the claims made in the report.

To put things bluntly in my own terms, the 'bottom line' observation is 'the French have a longer foreplay'. The rest is pretty much the same (and lots more recrimination in the end).

In my still childish wishful thinking I wanted to come out of the discussion with 'answers'. The outcome is 'more questions'. Maybe this was expected as well.

#### Response 9. Margaret Sinclair

There were so many ideas in the three days that I found I needed to ground them in my research interest to make sense. The activity with division informed my understanding of task development. This thread ran through the discussion—that I must contrast results with expectations,



*that the task is critical to what happens... to the response of the students. At the same time, since I am in a relatively new field (looking at technology) I needed to hear about some other ideas—that research starts from the limitations of reality, that situations you design will become richer as you develop a growing understanding of children's cognitive responses to the (technological—in this case) task.*

*As a doctoral student I appreciated the clarification of the various traditions, and the contrasts elaborated between the Italian, French, American and Canadian traditions. Laurinda's comment about assumptions needing to be clearly stated so that the reader can 'enter and learn' takes on new importance now that I have a better understanding of the differences.*

*The discussion on focus was also helpful. As I look at my data, the ideas of '2nd order variables', my focus 'at the moment', and Elaine's 'fuzzy answers' will inform my decisions about what to communicate about my findings and how to communicate those ideas.*

#### Response 10. John Mason

*We were offered a task of classifying some 31 'tasks' taken from an old and a recent text. The effect of the task was to raise questions about how tasks arise and are used within different approaches to research. I appreciated the consistency of being engaged in a task in order to bring an awareness-perspective-orientation to the surface, as, it seems, is the aim of the school of situations didactiques, as well as my own.*

*What emerged was an attempt to articulate similarities and differences in different approaches. We found it helpful to use the commonplace triad of Mathematics—Student—Teacher within a macro- and micro environment (institutions, socio-cultural-historical-political and personal concerns-propensities-sensitivities). Different approaches stress different aspects to different degrees, but perhaps more importantly, are more or less explicit about assumptions and structures underlying different components.*

*No-one likes to be 'put in a pigeon-hole', so a natural response to being told that one's approach stresses some aspects and ignores others is to put more emphasis on less stressed aspects. This is one way in which we helped each other approach and maintain complexity.*

*A contrast was made between depth and breadth, though I am not entirely convinced, because neither necessarily denies the other, especially when a part may be fractal-like, similar to the whole or, hologrammatically, the part contains information concerning the whole.*

*Useful quotation: We hope our theories are as observation based as our observations are theory based (Goodman, 'Ways of Worldmaking', 1997).*

*I offer the conjecture that the more precise you want to be about observations, the more precisely you learn about (the sensitivities of) the researcher (cf. Heisenberg's Uncertainty Principle) which connects to a perspective in which an event consists of all the stories told about that event.<sup>5</sup>*

*The challenge for me is making explicit assumptions being made, exposing theoretical underpinnings (à la Goodman).*

*Additional thought: I came away feeling I appreciate more fully some of the social-psychological-cultural forces which are part of the autopoietic creation of academic-scholarly identity. Distinction making can exacerbate differences rather than clarifying similarities.*

*Conjecture: Behind the technical terms which create and support identity, there is more in common than adherents like to admit, since few people like to be classified, pigeon-holed, or having their terms re-cast in other terms.*

#### Response 11. (unsigned)

*As our group attempted to analyze/categorize the division problems, I was first struck by the different backgrounds, interests and research questions that our group brought to the table. As we proceeded with the task, I then became aware of the differences in our willingness to proceed with the task. Although this statement may stand alone as an observation and serve as a metaphor for the multi-perspective and inter-disciplinary nature of the mathematics education community, it*

also led me to feel frustrated and worried for our ability as a community to move forward and contribute to our field in the beautiful and optimistic way that Bill Higginson has proposed. That said, participating in this group has been a totally (?) experience. I have been absolutely engaged throughout the entire 3 days.

#### Response 12. Rina Hershkovitz

I left with the feeling that we were dancing around a few poles and may be not with them, and there were more than 2 poles. At the end I think that the way of 'dancing around' rather than 'dancing with' is better because:

- 1) The 'poles' were, in a way, present in these 3 days. For me especially when we were 'classifying' the division problems. The debates and the ways each of us expressed our thoughts revealed these different poles.
- 2) This way of dancing around leaves room for each of us to be 'creative' in the interpretation of the (hidden) poles and then to integrate it with his or her 'knowledge', beliefs, experience.
- 3) The opportunity to listen to the different participants' 'poles' (culture, etc.) made these poles richer.

This way is a good trigger to want to read and know more.

#### Response 13. Asuman Okaç

For me what was most striking was not the particular topic in question, because I feel that we drifted from it in many ways, but it was how the participants responded to the tasks, how they formulated questions and reflected on the discussion.

I do think that it would be difficult to classify the whole group into the two solitudes, as there were many international participants, and even the ones that presumably belong to these groups were different. I think the 'didactique des mathématiques' camp was not very well represented.

I am probably writing down my impressions the way I feel them rather than describing what happened which might point out to the difficulty in focusing. I think that when Anna suggested the task of classifying division problems she was quite focused herself. But when it comes to the application level involving so many people, we ran into the issue of expectations of the designer of the activity vs the interpretations given by the participants.

#### Response 14. Richard Barwell

How is it possible to communicate across cultures? Before we can discuss similarities or differences between Math Ed and didactique, it is necessary to understand the two positions, but this is not really possible or meaningful since our different understandings are informed by our individual histories so that we make our own versions of Math Ed or didactique (or semiotics, or Piaget or ...). This is not to say that such a discussion is unhelpful, but that its value is in its doing rather than in its conclusions: in dialogue. So the things that I take away from the Working Group is some thoughts about the nature of didactique—some ideas of what it might be or more of how it might be done (and equally some thought about Math Ed and ... and ...). One aspect which I liked was the participation in some activities which were informed by the didactique perspective. Even where these activities caused dissonance and confusion amongst some participants this was still valuable as it informed the ensuing personal reflections. The discussion in the final meeting developed into a fruitful sharing of approaches to research, to questioning, to looking and seeing which I can engage with from my own perspective.

#### Response 15. Mariolina Bartolini Bussi

At the beginning I was not sure to be in the right place. I was talking about division and yet I was expecting to take part in the comparison of different research traditions. In the second task all became clear. We 'naturally' shifted from classifying problems to wondering about the 'sense' of

*this task, without knowing more about the didactic situation. And this made clear to me that in our small group we were contrasting at least two approaches.*

*At the beginning I had wished to be allowed to jump from one group to another to know more about the Canadian community. At the end I was happy to have taken part in the process of shifting from a particular task to more general yet contextualized discussions.*

#### Response 16. William Higginson

*The Two Solitudes Concern: A CMESG working group in the full sense of the term ... rich images, diverse interpretations, short term confusion, ground shifting insights, personal assimilation/accretions of formerly encountered colleagues, glimpses of newcomers coming on stream, a sense of personal and community evolution. Another reminder of the challenges and rewards of imaginative classification. And in the end an awareness of the non-solitude of unity coexisting with a multiplicity of 'communitudes'.*

### Final plenary session Report of Working Group C

Tom's account of what happened in the working group was the following:

#### *Catching the Evolutionary Drift*

*The general task of our group was to contrast various North American approaches to research (and development?) in mathematics education with elements of the theory of didactic situations approach. Each of us brought our own lived histories and structures (or relevant parts thereof) to the task. We were asked in a 'naïve' way to engage in reflective 'actions' and 'reformulations' kinds of tasks with elements of the theory of didactic situations approach. Because these tasks engaged us in talking about division and division of fractions and we were asked to engage in these experiences without elaborate theoretical discussions first, we all individually (and in our groups sometimes with one notable group exception) lost our way from time to time because we confused our 1st order (division of fractions) task with our 2nd order (build up didactical situations ideas) task.*

*Much thinking, ideas and questioning arose on day one and two as well as sense of confusion. On day 3 we engaged the contrasting task directly, especially taking our research structures and experiences as a basis. This session evolved in such a way that we came to build on one another's offerings and to be occasioned by them. Unlike days 1 and 2 to a certain extent we 'caught the evolutionary drift'. We made more contrasts among our research ideas and positions.*

*Aside from very general re-remembering and contrasting much of the extensionive action/reflections of days 1 and 2 was 'lost' in this discussion. Explicit features which may have been folded back to and restructured were 'lost' as we moved through this new period of action guided by perhaps a different question of contrast than that which we started on.*

*For me this rather inter-active, structure(s) determined, occasioning drift had its points of growth and development. But many ideas which were excellent but not 'good enough' (for our group) went without further examinations. We made much, gained and grew, but did not do as much of the contrasting with DS ideas as we might have had (some of) the day 1 and 2 ideas (which could be observed to have been available but not taken up) been followed in a different way. Of course, this is only my research view of the multiverse in which we exist(ed).*

For the closing session, as a reaction to her being dead serious over the three days of work, Anna chose to take a humoristic slant in her report of the events.

*You are expecting me to give a report of the proceedings of WG C. But it is impossible for me to tell you what actually happened in the group. There were about 18 to 20 people there and just as many different accounts could be given of the events. At the end of yesterday's session, Tom and I asked participants to describe their experiences in writing. What we obtained was exactly that: 16 different stories, to which then Tom added his own, yet different, story. For the final report, rather*

than summarizing them all, I decided to pick, at random, the 18th story and read it to you. Here it is:

Anything can be learned the easy way, by listening to lectures and being told what is what and what is not what we think it is, or the hard way, by problem solving. Group C learned about the differences between Didactique and Mathematics Education research the hard way. The sessions started by a research activity, inspired by one of Guy Brousseau's papers about the theory of didactic situations. After one session and a half of hard labor several frustrated participants refused to produce any more research findings and started asking questions about the purpose of all this, and the relevance of the activity to the theme of the working group. Some of the More Radical Constructivists called for a lecture on the theory of didactic situations and a clear definition of the difference between didactique and mathematics education. But the followers of Activity Theory objected that this would be against the teachings of Marx, who, as you know, was quite stubborn in his claim that any intellectual assimilation of reality must arise, whether you like it or not, from labor and material production. This statement provoked loud protests from a group of Enactivists, seconded by Eclecticists, who put up a banner with slogans such as 'Keep your envelopes sealed!' and 'Epistemology, cognition and didactics, unite!' The first slogan was met with a hearty applause: participants finally had the feeling of understanding something. But several members of the group did not agree especially with the last word, 'unite', and demanded immediate division, separation, splitting and uneven yet fair allocation of demarcation lines. The discussion was getting more and more impassioned and I don't know where it would have led the group, if two wise men with long memories hadn't suddenly made their appearance. They revealed to the dazed audience that there is absolutely no reason for discord, because all differences stem from bad translation. For example, 'epistemological analysis' is normally translated into 'analyse épistémologique', while the correct translation should be 'analyse des conceptions spontanées des enfants'. Or something like that—they were not too sure. Anyway, the wise men postulated that, in order to discard all possibility of discord in the future, Latin be used universally as the one and only language of science. The proposal was accepted by acclamation. The meeting was then adjourned among general expressions of joy and optimism.

*Gaudeamus igitur!*

## Appendix

List of problems given to the participants in Task 2.

The 1936 textbook

1. Alice, Ruth and Mary were the Pop-corn Committee for the Pearson School Halloween party. The girls bought  $\frac{3}{4}$  of a quart of pop-corn and divided it equally among themselves to pop. Each girl took what fraction of a quart of corn to pop?
2. Tom and Jimmy were to make a box for a game to be played at the Halloween party. They needed 4 boards each  $\frac{3}{4}$  ft. Long. The janitor gave the boys a board 3 ft. Long. How many boards each  $\frac{3}{4}$  ft. long could they have cut from the 3-foot board?
3. Henry brought  $\frac{3}{4}$  of a bushel of walnuts to the party. He divided the nuts into 50 equal shares. Each share was what fraction of a bushel?
4. The children had a peanut relay race. Each team ran  $\frac{7}{8}$  of a block, and each pupil on the team ran  $\frac{1}{8}$  of a block. How many pupils were on each team?
5. Each of the girls on the Refreshment Committee served  $\frac{1}{2}$  of a pumpkin pie at the party. The pies had been cut so that each piece was  $\frac{1}{8}$  of a whole pie. Into how many pieces was each half-pie cut?
6.  $\frac{9}{10} + \frac{15}{16}$
7.  $\frac{5}{8} + \frac{15}{16}$
8. The cookie recipe that Mrs. White planned to use called for  $\frac{3}{8}$  cup of chocolate. She had only  $\frac{1}{4}$  cup of chocolate. What fraction of the full recipe could she have made with that amount?
9. Divide and put your answer in simplest form:  $\frac{9}{10} \div \frac{3}{5}$ .



10. On Halloween the Pine Hill School had some Hard Luck races. The route for the races was in three laps. The first lap was from the school to Five Corners:  $\frac{1}{4}$  mile. The second lap was from Five Corners to Orr's Sawmill:  $\frac{7}{8}$  mile. The third lap was from Orr's Sawmill to the school:  $\frac{3}{4}$  mile. Hellen said that the second lap of the route was  $3\frac{1}{2}$  times as long as the first. Jane said that it was  $3\frac{3}{8}$  times as long. Which girl was correct?
11. Divide: (a)  $76 \overline{)912}$  (b)  $431 \overline{)35351}$
12. Woods family went to the State fair. Father and Andy drove to the fair in the truck, taking some cattle to be entered for prizes. Mother and Ruth drove the family car. On the way to and from the Fair, Father used a total of 24 gallons of gasoline and 5 quarters of oil for the truck. The gasoline cost 18 cents per gallon, and the oil cost 30 cents per quart. Father drove the truck  $107\frac{7}{10}$  miles in going to the fair and  $108\frac{3}{10}$  mile in returning. Besides the cost of the gasoline and oil, the expenses for the truck were \$1.00 for repairing a tire. To the nearest cent, what was the cost per mile for the truck for the round trip?
13. Divide  $\frac{3}{4}$  by  $\frac{5}{9}$ .
14. Nancy earned her Christmas money making Christmas cards. She bought 2 sheets of cardboard at 5 cents each, a bottle of drawing ink for 25 cents, and some watercolors for 25 cents. (A) How much did all these things cost? (B) The cardboard sheets were 22 inches by 28 inches in size. She cut each sheet into strips 22 inches long and  $5\frac{1}{2}$  inches wide. How many of the  $5\frac{1}{2}$  inch strips did she cut from the 2 sheets? How many pieces were too narrow for her to use?
15. Sally and Ruth decided to make some valentines which would be different from those they could buy in the stores. They bought a sheet of red paper 22 inches by 28 inches. Each girl took  $\frac{1}{2}$  of it. How many hearts could each girl have cut from her share, if each heart used up to 1 square inch of paper?
16.  $2 \overline{)155.8}$
17.  $32 \overline{)5.12}$
18.  $6 \overline{).828}$
19. During 8 hours on Tuesday there was .96 inch of rainfall. This was an average of what decimal fraction of an inch per hour.
20. Mr. Burns and his family drove their car and trailer to Arrow Head camp to spend a few days. They drove 297.5 miles in 8.5 hours in travelling to the camp. How many miles per hour did they average?
21.  $7.8 \overline{)7581.6}$
22. Mr. Mills told Ned and Alice that they could sell vegetables during the summer and keep half of the profits. Mr. Mills helped Ned build a stand. To make the boards below the shelf, they sawed up some 14-foot boards. How many boards 3.5 ft. Long could they have sawed from each 14-foot board?
22.  $1.25 \overline{)3}$

*The 1988 textbook*

1. Look at the two series of operations. How do the divisors and results change? Can you find the missing results?

$8 \div 8 = 1$	$\frac{3}{16} \div 8 = \frac{3}{128}$
$8 \div 4 = 2$	$\frac{3}{16} \div 4 = \frac{3}{64}$
$8 \div 2 = 4$	$\frac{3}{16} \div 2 = \frac{3}{32}$
$8 \div 1 = 8$	$\frac{3}{16} \div 1 = \frac{3}{16}$
$8 \div \frac{1}{2} = ?$	$\frac{3}{16} \div \frac{1}{2} = ?$
$8 \div \frac{1}{4} = ?$	$\frac{3}{16} \div \frac{1}{4} = ?$
$8 \div \frac{1}{8} = ?$	$\frac{3}{16} \div \frac{1}{8} = ?$

- Add two more operations to each column.
- What should  $\frac{3}{16}$  be multiplied by in order to obtain  $\frac{3}{128}$ ?

- What should  $\frac{3}{16}$  be multiplied by in order to obtain  $\frac{3}{64}$ ?
  - What operations could replace each of these divisions? Can you see a rule?
  - Write a similar series of operations.
2. Mom said to Johnny: "I have 6 liters of honey. I'd like to keep it in  $\frac{1}{2}$  liter jars. Could you bring the jars from the cellar?" (A) How many jars should Johnny bring? (B) How many  $\frac{1}{4}$  L jars would he have to bring? (C) And—how many jars of  $\frac{3}{4}$  liter?
  3. A quotient is equal to the divisor and it is 4 times larger than the dividend. What is the dividend?
  4. Find a number which is 4 times larger from the quotient of the numbers  $3\frac{1}{2}$  and  $2\frac{4}{5}$  enlarged by 1.
  5.  $2\frac{1}{3} + \frac{3}{4} \div \frac{1}{2}$
  6.  $-12.8 \times (-0.2)$
  7.  $3\frac{1}{3} \div (-\frac{5}{6}) \div (-2)$
  8. Decide which product is less expensive
    - (a) Margarine sold in 250 g cups for \$1.32 or margarine sold in 500 g cups for \$2.49.
    - (b) Yogurt sold in 150 g cups for \$0.93 or yogurt sold in 500 g cups for \$2.60.

### Notes

1. We are using Maturana & Varela's expression here.
2. Brousseau, G., 1988: Représentation et didactique du sens de la division. In G. Vergnaud, G. Brousseau, & M. Hulin (eds.), *Didactique et acquisition des connaissances scientifiques*. Actes du Colloque de Sèvres, mai 1987. Grenoble: La Pensée Sauvage éditions, pp. 47–64.
3. Knight, F.B., Studebaker, J.W., & Ruch, G.M. (1936). *Study Arithmetics, Grade Six*. Chicago: Scott, Foresman and Company.  
Zawadowski, W. et al. (1998). *Matematyka 2001. Podrecznik do klasy 6 szkoły podstawowej*. Warszawa: WSiP.
4. Elaine illustrated this point by recalling how one of the teachers she observed had the rulers available during a geometry lesson in case some students forgot to bring their own. This allowed her to save time on classroom management and concentrate on the mathematical content of the lesson.
5. We have adopted this perspective in putting together the report of Working Group C.



## Teachers, Technologies, and Productive Pedagogy

David A. Reid, *Acadia University*  
Rosamund Sutherland, *University of Bristol*

### Participants

Donald Cudmore  
Astrid Defence  
Gary Flewelling  
Pierre Gauthier  
Frank Gruen

Dave Hewitt  
Vi Maeers  
Claudine Mary  
Douglas McDougall  
David Pimm

Medhat Rahim  
David Reid  
Geoffrey Roulet  
Nathalie Sinclair  
Rosamund Sutherland

The working group would like to thank Caroline Lajoie for her technical support during the conference.

### Introduction

This report attempts to re-present nine hours of discussion by fifteen participants in a single report of a few pages. Inevitably the richness of our work in Montréal has been diminished in this transformation, but we hope that we can at least provide a record of the issues we raised, the ideas we generated, and a few conclusions we drew. We have not attempted a blow-by-blow account, instead choosing to reorganise the discussion into sections dealing with questions we raised that guided our work, the two examples we considered at length, the beliefs about learning that seemed to be implicit in the discussion of the teaching potential of those examples, the characteristics of rich learning environments that were mentioned in our discussions, possible implications for designing of technology and important issues that were raised that we felt had to be addressed if technology is to play a useful role in the teaching of mathematics.

### Questions

Our opening discussions raised many of the questions that guided our discussions. They can be seen as falling into three groups around three general questions.

Perhaps the most fundamental of the three concerned the meaning of the phrase “productive pedagogy” that appeared in the title of the working group. Related questions referred to issues like the kinds of problems students are offered, the source of motivation, and the kinds of learning we hope to motivate students towards.

We recognised that pedagogy is based on beliefs concerning the nature of learning, and so a question arose around the beliefs we had brought to the group, and what implications those had for pedagogy. Related questions concerned the relationship between motivation to learn and constraints that limit learning, the role of social interaction in learning, what we felt was important about learning mathematics and what different ways of learning might exist.

Our third question referred specifically to identifying design principles for software intended to be compatible with productive pedagogy. Given our beliefs/theories about what

constitutes a “good” mathematical learning environment (teacher plus students plus technology) can we imagine/analyse what a technological environment affords from the point of view of mathematical learning? What features might push students to a more mathematical way of thinking? What affordances should be built in for teacher involvement?

### Two Examples to Think With

The two examples we used to focus our discussions came from Nathalie Sinclair and Dave Hewitt. They have since described their work in the pages of *For the Learning of Mathematics*. See Sinclair (2001) and Hewitt (2001).

Part of our discussion centred around the intents Dave and Nathalie had in developing their technological tools for learning. Dave outlined that he had based his design on very young children’s learning of language. He wanted to provide a context for students to explore the contexts in which words appear, and to abstract from those contexts. The software provides names and conventions, freeing the students to work on relationships and properties.

Nathalie was trying to create tension for the student so that she or he would see that there was something to be resolved. She wanted the student to be able to use existing perceptions (e.g., of direction) to explore the co-ordinate system. It is important to consider what kind of mathematical action is possible. Working with equations versus dragging a vertex—is that a different kind of mathematical action? What does “mathematical action” mean? Numbers and equations? What else?

In the context of both examples we discussed the idea of scaffolding the learner. For example, in Nathalie’s environment an algebraic symbolism is provided which maps to actions but students can also act on the symbolism themselves and chose to do this.

### Beliefs About Learning

We recognised that any description of rich learning environments and principles for design we might come up with would have to be, implicitly or explicitly, based on our beliefs about the nature of learning. While this is equally true of any aspect of teaching, for us it was especially important to recall that theories/beliefs about learning have to come before we introduce technology. The characteristics of a rich mathematical learning environment are the same whatever the technology being used, and exploring our beliefs provided one way to explore what characteristics might be shared by the kinds of technological environments in which we were interested.

Some of the beliefs that were articulated included the following. We did not attempt to be exhaustive or unanimous in our discussion of these beliefs, instead using them to clarify our consideration of learning environments and technology design.

- Learning takes place without deliberate intent by a teacher or a learner.
- Learning comes from active doing/working. Active involvement in learning is an important element in motivating the student. Asking questions, making conjectures, reporting, and structuring are important to learning.
- Human beings come with ways of acting on the world, ways of being acted on by the world (e.g., senses), and needs that support learning about some aspects of their environment.
- Being able to observe the consequences of one’s actions is a powerful part of learning.
- What human beings learn changes them and so changes what/how they can learn.
- Students construct, explore, etc., but not independently of social contexts (peers, teacher, and culture). The social and physical world a learner perceives constrains what they can learn. It does not determine what the student will learn but does affect it and is affected by it.
- In any situation we stress some things and ignore others. What we focus on is constrained by what is available. So more limited environments “force” more focus. Different situations allow for different foci.

### Characteristics Of Rich Mathematical Learning Environments

Implicitly or explicitly, much of our work revolved around the question, “What are the characteristics of rich environments for learning mathematics?” We agreed that we could imagine such environments involving the examples offered by Dave and Nathalie. It remained to see if we could tease out some characteristics so that we could discuss how technology might support them.

Perhaps the most general characteristic of a mathematically rich learning environment is that it is transformative. Students should walk out feeling that they are a different person with new skills or new confidences. In addition to the concepts and procedures of the discipline, the students should also learn what it is to act like a mathematician, learn about the nature/pervasiveness/power of mathematics and learn to think with the tools/habits of mind/perspectives of mathematics.

Such an environment must include complex and messy problems about which students can develop their own understanding of a new (for them) piece of institutionally accepted mathematical knowledge. The students engage in situations that they don’t understand, in which bringing unfinished ideas is part of the agenda. In addition to complexity, the problems must be open, in the sense that there is space for students’ voices, dialogue, and “good-enough” (as opposed to complete and correct) understanding.

Motivation is important in a learning environment in which students are expected to go straight in and figure things out. Several sources of motivation were mentioned by members of the group. Three that received the most attention were the role of an audience that values the students’ work, and whose opinion the students value, the joy inherent in the study of mathematics for its own sake, and the positive feeling associated with learning.

We recognised the importance of multiple representations and approaches in allowing students with differing backgrounds to be successful. The different algebraic notations in the case of Nathalie’s software offered one stimulus to this aspect of our discussions. The presence in a learning environment of different tools for expressing ideas (paper & pencil, software, etc.) and tools for moving between different representations (language/graphical/numerical/algebraic) were also recognised as important.

The last characteristic of a rich learning environment, but certainly not the least based on frequency of mention in the discussion, is the presence of a teacher. While one aspect of the teacher’s role is that of a co-learner, the attentions of teacher and students are placed differently.

### Possible Implications For Designing Of Technology

In the design of technology for productive pedagogy, we moved quickly to reject the idea that technology can be pedagogical in and of itself. We emphasised the pedagogical role of the teacher using software in a classroom, and of the designer of software, websites, and other technological tools. We recognised that the potential effectiveness of computer-based environments, as with any other resources, will partly depend upon the activity offered by a teacher and the choice of freedom/constraints which comprise that activity. Such decisions about freedom/constraints are pedagogic in nature.

Keeping these things in mind, we proposed a range of design principles for technology that could be used by a teacher to produce a mathematically rich learning environment.

An important question that gave rise to design principles was “Why use technology?—Is there anything qualitatively different between working with paper and pencil and working within a computational environment?” Three answers to this question led to productive discussion: We lose agency when we work with computers, that is, we give over some of the agency to the computational tool; technology provides opportunities to rethink our approaches (e.g., dynamic geometry, approaches to classifying quadrilaterals); the feedback from a computer is more neutral than from a human.

Using a technology involves submitting oneself to the requirements that technology makes for its use. Computers only respond to typed commands in a particular syntax, or

offer only a limited range of buttons to push. This means that the special notations of mathematics can be required not by the seeming whim of a teacher, but instead by the design of a technology. The need to communicate a mathematical command to a computer makes mathematical activity (which is normally occurring invisibly in the mind of a learner) visible to others, and makes it possible to record that activity. Technologies can also limit the kind of mathematical activity that is possible, so that geometric methods or algebraic methods are used to solve a problem because the technology makes one or the other easy. Paradoxically the constraints imposed by technology can contribute to the openness we identified as being an important feature of a mathematically rich learning environment, as technologies such as computer increase the number of choices/opportunities for what freedom/constraints can be included within an activity.

Technologies make some things easy that were difficult. Visualising geometry as dynamic is one, as the effort of making the diagrams move is transferred from the learners' imagination to the computer's graphical display. Exploring iterative functions is another, as the time taken to calculate a hundred iterations is reduced from hours to seconds. Dave's example offers another possibility, a new representation of the existing system of classifying quadrilaterals that shifts the emphasis to the categories that overlap or exclude each other.

When computers refuse to do what their users think they have asked of them it is not a judgement of the request, any more than the refusal of a stone to move when insufficient force is applied in pushing it is a judgement on the person pushing. This means that the shift of agency mentioned above can occur without an interpersonal power struggle developing. In addition the way in which technology misbehaves can offer insight into the task itself. If a calculation takes more time than expected, or produces an error, that indicates something about that calculation that might not be apparent from its algebraic expression.

Another question that gave rise to some design principles was "Is there such a thing as mathematical technology?" We saw that there might be nothing essential about a particular technology from the point of view of mathematics, but nevertheless we can talk of mathematical affordances of a piece of technology. There are some technologies that allow you to act mathematically more easily than others. And some that make it very difficult. We recognised that affordances depend not only on the technology but also on the user. More mathematically sophisticated or technologically adept users there might be more mathematical affordances in a particular technology than for more typical users of it. In design it is important not to consider what the designer can make the technology do, but rather what someone with no prior knowledge of the technology can make it do. It is possible to hammer nails with a plastic bottle (by filling it with water and freezing it) but giving a novice a plastic bottle as an introduction to hammering would be misguided.

Another guiding question for design is the anticipated user of the technology. The dominant image of a single user with a teacher's guidance much be broadened to consider use by groups (perhaps networked groups), by students working at home, and by students working at a distance.

The intent of the designer was a focus for our deliberations, but at the same time we were not sure how important it was to make those intents known to users. A user is likely to construct their own set of implicit intents that they imagine guide the design, and the intents that they would be interested in might differ depending on whether they were using the technology as a student, as a teacher, as a researcher, and a parent, or in some other role. It was suggested that it would be useful to make the designers' intents available, perhaps in different forms intended for different audiences, but with restricting who could read what. For teachers this is especially important as they make decisions and define their own intentions when they chose to use technology in certain ways in their classrooms.

In summary, some of the principles we mentioned for technology design were: Openness, Constraints, Focus, Allowing user(s) to operate comfortably, but not too comfortably, Affording the teacher control over the technology, Providing feedback, Including multiple representations (e.g., graph, equations, properties, shape, and name), and Including opportunities for sharing work with an audience.

### Important Issues and Questions for Further Research

Inevitably more issues were raised than could be addressed in the time we had. Some of these important but neglected issues are:

- Do we want the mathematics class to take over the home? (e.g., via the web)
- Is this a critical approach to technology? Is there a need for a critical pedagogy?
- What does appropriate use of technology mean?
- Can we use technology as a political lever to force change in classes? (I.e., Can we use technology as a Trojan Horse to introduce our pedagogical principles into schools?)
- Does the technology change what mathematics can be taught in schools and what mathematics exists?

### References

- Hewitt, D. (2001). Arbitrary and necessary: Part 2 assisting memory. *For the Learning of Mathematics*, 21(1), 44–51.
- Sinclair, N. (2001). The aesthetic is relevant. *For the Learning of Mathematics*, 21(1), 25–32.



## Calculus Reform: A Critical Assessment

Sylvie Desjardins, *Okanagan University College*  
Harald Proppe, *Concordia University*

### Participants

Marie-Jane Haguél  
Jacqueline Klasa

Gilbert Labelle  
Manuel Santos

George Smith  
Gervais Tremblay

### Day 1: Introduction

The first objective of this working group was to review and analyze the reform approach to the teaching of calculus. Our second objective was to explore the role of technology, from graphing calculators to computer labs to the internet. The intention was to understand how reform, coupled with the best features of the emerging technological tools, could be deployed to improve the transmission of the principles of calculus.

The group was small, but it covered a wide spectrum of views and expertise. During the first session, each participant was asked to describe his own experience with calculus reform or the use of technology in the classroom. While some of the participants were not directly involved with the teaching of freshman calculus, and only a few had used the standard reform text of Hughes-Hallet Gleason et al., most had some degree of familiarity with the basic idea of calculus reform, and all were using some form of technology—such as graphing calculators, or computers with either symbolic algebra software like Maple, or geometric softwares like Cabri—in their own classrooms.

Following the introduction of the participants, there were some informal discussions on subjects ranging from the definition of calculus and how certain topics should be taught, to the nature of calculus courses 10 years from now. There was general consensus that the way we teach calculus has changed since the introduction of graphing calculators, computers, and other aides, and that it will continue to change as a result of continuous improvements in technology.

What kind of technological tools will exist in 2010? Because so many of the ideas of calculus can be put into pictures, or involve approximations, we all agreed that students will likely have access to very sophisticated tools. As a result, calculations will be made simpler, and graphing calculators as we know them will become virtually obsolete.

We took the generally accepted view that in the traditional approach much of the effort is concentrated on the symbolic representation. That is, students are expected to gain a certain level of algebraic skill, so that they can learn to apply well-known calculus techniques to solve problems. The reform approach, on the other hand, maintains that the concepts should be presented according to the rule of three, which demands symbolic, graphical, and numerical representations. Motivation for the concepts is provided in word problems, and it involves extensive use of technology.

But are these changes being driven by technology for the sake of technology? Is technology-based reform truly improving the state of mathematics education?

The participants agreed that students in both traditional and reform courses continue



to have difficulties understanding real-life modeling situations. Moreover, while most of the participants were willing to see the merits of the graphical and numerical representations, they believed that, in order to bring these elements to the classroom, it would be necessary to eliminate some traditional topics. Whether this should be done, and whether it can be accomplished without somehow weakening the content of a freshman calculus course, is where the usual debate between the traditional and the reform approach begins. Our initial discussion of reform was, in this sense, very traditional.

There was concern about the skills left undeveloped when there is too much reliance on technological tools. The ability to manipulate algebraic symbols, for example, is critical in solving problems and in understanding ideas. Therefore, we should not ignore the possibility that, just as the calculator can compromise students' arithmetic reflexes, the graphing calculator and symbolic algebra computers could compromise the development of basics algebraic skills, and ultimately hinder the students' ability to move on to more sophisticated concepts.

In an attempt to legitimize technology, an analogy was drawn with statistics, where the availability of statistical software has significantly changed the content of introductory statistics courses. In statistics, there is now less emphasis on the ability to perform certain algebraic computations. Rather than simply make the courses easier or compromise anything, however, this has allowed the early introduction of difficult ideas, and freed valuable class time so that realistic applications can now be explored efficiently. The students more quickly gain practical knowledge and develop skills that can readily be put to work in a modern environment.

Generally, we adopted the view that we shouldn't refuse the advantages offered by technology just to preserve old and trusted ways. But, having done so, we quickly rejected the option of eliminating certain topics from the calculus curriculum to make room for qualitative and geometric interpretations. Reform should not mean selecting fewer chapters from a text; the appropriate strategy is to build a new course from the ground up, starting with the basic skills deemed necessary for our students. These basic skills should include not only problem-solving skills, but also general thinking and communication skills.

Much of the remaining time was spent brainstorming to identify ways in which these skills could be developed within the context of a calculus course. At the end of the first day there was, among the participants, a sense that true reform would require substantive changes.

## **Day 2: Presentations**

On the second day there were two key presentations. Sylvie, using material developed for the single and multivariable calculus courses at Okanagan University College, demonstrated how technology, combined with the key features of reform, can be used to streamline and enhance the delivery of a mathematic's course. Then Geoff, one of the participants, agreed to present the innovative treatment that has been used to teach calculus to engineering and science students at the University of Technology Sydney, Australia. We have tried to encapsulate the content of each of these presentations.

### *1. Effective Use of Technology*

Why develop a course website? First, the website provides a convenient platform for the distribution of class material. Since any document produced on a computer can be converted into a portable document format (pdf) file, class material such as review sheets, sample tests, or solutions for homework, quizzes, or tests, can be posted for easy access. Moreover, the site can also contain class information, such as an outline or syllabus, a list of suggested homework problems, a series of worksheets for Maple or graphing calculators, and a detailed timetable that can be updated as required.

The information on the website is therefore current and accessible at any time, from

anywhere. To demonstrate how the internet can expedite some of the administrative concerns of teaching mathematics, Sylvie took us on a tour of a course website. (Most of the material explored during this presentation is accessible from Sylvie's homepage.<sup>2</sup>)

Technological tools, such as graphing calculators or computers, can be used as teaching tools. The calculus course at OUC is made up of three hours of lecture per week, and one hour of computer lab. The Maple-based labs usually consist of two or three questions complementing material covered during lectures. The necessary Maple commands are provided through examples in the students' lab manual or in Maple worksheets posted on the website. Group work is encouraged, but each student must submit individualized solutions that include comments and explanations.

There are many benefits associated with a computer-based lab for a first-year calculus course. First, because working with symbolic algebra software means that students can easily obtain graphical, numerical, and algebraic representations of a given problem, more of their time is devoted to understanding how to use these various representations to obtain a solution. In addition, since students learn to use Maple early on, they will be ready to use the software to tackle more complex problems in later courses. But, perhaps the most important advantage for the students is the opportunity to explore mathematics hands-on in a group setting. During the lab, students can apply their knowledge of calculus to solve problems, and discuss among themselves how and why certain methods work. Most scientific disciplines already enjoy the benefits of a course-based lab; the availability of symbolic algebra software means that we too can offer our students the same kind of learning environment.

Students need to know how to use the technological tools to get an accurate representation of the problems they are trying to solve. They must also be able to understand the information contained in these new representations. To this end, they must be able to talk about mathematics so that they can formulate questions, explain ideas, and store concepts in a mode that is most familiar to them. To ensure that students verbalize mathematics, their work should always include written explanations, and a significant portion of the grade should be set aside for the required explanations. To illustrate the sort of material covered in a reform-based course, tests and assignments, including

Maple-based projects, were offered as examples of the graphical and numerical treatment of various topics. Here is a typical exam question:

Consider the two curves below (Figure 1). One designates the rate of snowfall (in  $\text{m}^3/\text{hour}$ ),  $S(t)$ , that fell on a section of the Coquihalla highway during a storm last winter. The other shows the rate of snow removal,  $R(t)$ , in the same section.

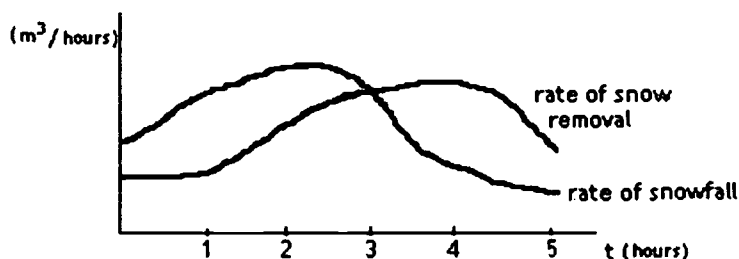

**FIGURE 1.**  
Rates of Snowfall and  
Snow Removal

- When was the quantity of snow on the road the greatest? Explain.
- When was the quantity of snow increasing most rapidly? Explain.
- Use the fundamental theorem of calculus to write a formula for the the quantity of snow,  $Q(t)$ , at any given time. Assume that there was no snow before the start of the storm.

Finally, students should still be able to solve problems without the help of technology. To make sure that they acquire the more conventional algebraic skills, students at OUC are

expected to write a technical test. Before taking the test, they are given an extensive list of standard practice problems. Calculators are not allowed during this test, and students can repeat the test to improve their score. This encourages them to devote as much time as they need to become familiar with the basic algebraic techniques.

Thus, by providing students with the necessary tools, technical and otherwise, and the ability to use them properly, a reform-based calculus course aims to help students develop mathematical survival skills so that they can better understand the concepts encountered in any mathematics course.

## II. Motivation and Relevance

Geoff and his colleague believe that special care must be taken to tailor mathematics to the needs of the audience. In particular, any new approach must recognize the fact that students come to university with certain preconceived notions about mathematics. By the time they finish high-school, for example, students generally think about functions in terms of formulas, and they view mathematics as the formal manipulation of symbols. For them, calculus is nothing more than the set of rules that govern this manipulation. This oversimplification can be detrimental since, on the one hand, students often feel they know all there is to know about calculus even though they might not understand much about it, and on the other hand, they fail to recognize the relevance of calculus to real-life applications.

Formulas are but one representation for a function and, since most functions do not have nice formulation, it is misleading to restrict ourselves to the traditional treatment of elementary transcendental functions. A more useful form for a function is one that allows you to perform accurate computations. To help students progress beyond the notion of functions as formulas, we challenge the traditional picture by basing our course on "constructive learning." In this context, motivation means that nothing is introduced unless it is required in the solution of a problem.

We start from the premise that only real problems, that is, "those people are willing to pay for," are worth solving. The course, designed by Geoff and his colleague L. Wood, focuses on three real-life problems: the noise resulting from the vibrations of the cables of a suspension bridge in Sidney, the design of a roller coaster amusement park ride called the Tower of Terror, and the consequences of the blow-out of a pressurized door on an aircraft.

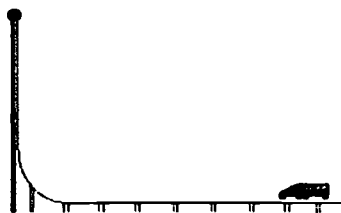

**FIGURE 2.**  
The Tower of Terror

First, we construct a mathematical model for the problem at hand. This model usually involves a differential equation whose solution is obtained by means of power series. Thus, trigonometric and exponential functions first appear as power series. Since the values and properties of these functions can easily be deduced from the series representation, this approach can help demystify the formulas associated with these functions.

In addition, our approach provides a fresh presentation of the concepts of calculus. Continuity and differentiability are introduced by means of sequences and series. Thus, the difficult notions of limits and convergence become meaningful and therefore more easily understood. Integration is developed to provide solutions for certain differential equations. This means that both numerical methods and integration techniques are introduced because they can be useful in trying to understand these solutions. Proofs need not always be given, but, in order to maintain the mathematical integrity of calculus, all results should be stated correctly.

The problem-motivated approach is hands-on, so Mathematica is used to provide numerical answers. Therefore, technology is used in a practical way and in a context in which the answers have significant relevance for the students. Furthermore, the emphasis placed on the ideas of convergence and error bounds prepares the students for many modern applications in computing.

### Day 3: Conclusions

When asked to comment on the presentations, many of the participants admitted that they had changed their perceptions of the role of technology in the classroom. The fact is that, when the focus is taken away from the algebraic struggle experienced by many of our students, there is more opportunity to challenge them with new ideas and concepts. Indeed, the examples introduced in Sylvie's presentation provide a good illustration of the ways in which technology is changing the knowledge that can be transmitted in a freshman calculus course. Moreover, the ability to easily do numerical computations means that we can be more flexible in our approach to teaching calculus. Geoff's presentation demonstrates the possibilities when technology removes constraints and makes advanced material more accessible to students.

We spent most of the last day discussing how to get the most from technology. As a result, we have highlighted two important issues that must be addressed in developing the curriculum for a technology-based calculus course.

First, since we can nurture understanding only by ensuring the participation of the student, we should use technology to promote "constructive learning." To this end, we need to design problems that can be explored easily, using the technology at hand, to generate mathematical ideas. The following exercise, provided by one of the participants, illustrates how high-school students can take advantage of dynamic software, such as Cabri-Geometry, to explore the graphic, algebraic, and numerical representations of a simple task:

Initially, students are asked to graph the equation  $y = -2x + 8$ , and draw a rectangle so that one of its vertices lies at the origin of the coordinate system, and another touches the graph of the equation. (Figure 3)

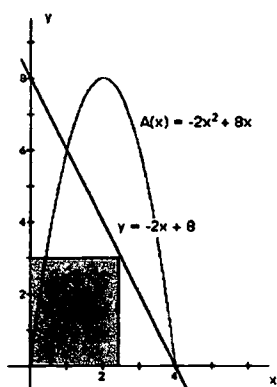

FIGURE 3

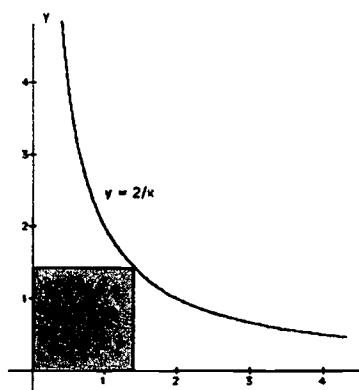

FIGURE 4

They are then asked to discuss a set of questions:

- How is a point on the line determined?
- Is there enough information to draw a rectangle with the required conditions?
- How many more rectangles can you draw with the same conditions?
- Show how you can calculate the area and perimeter of the rectangles. Explain how you determined the information needed to calculate those areas.

- How can you express the area and perimeter as a function of  $x$ ?
- Draw a graph that corresponds to the area. Describe the behaviour of the graph in terms of the side and area of the rectangle.
- Make a table for the area of various rectangles and their dimensions. Can you indicate which rectangle has the largest area?
- What would happen to the area, if the vertex that lies on the line now rests on  $y = 2/x$ ? (Figure 4)

Second, as we try to adjust to the new technology, we must be careful to ensure that, rather than throw away the traditional methods, we enrich them. The ability to think and understand requires an open and flexible mind. Flexibility depends on familiarity with the symbolic, visual, and numerical aspects of the material. These are, of course, manifestations of the same thing, but they provide different perceptions, and thus facilitate understanding. We need to see things in different ways, but we should not favour one representation over another. That is, we must try to integrate and balance the different registers of representations.

At the beginning of the workshop, Gilbert made us all smile with his vision of the classroom 10 years from now:

Each student would come to class equipped with a small device that could fit into a shirt pocket. This computer-like device would unroll into a virtual screen that could respond to a finger's motion, and execute any of the advanced functions now available with Maple.

Our students can already acquire hand-held calculators capable of doing sophisticated symbolic algebra, and powerful mathematical software packages are now available on their home computers. The fact is that, while many of us might choose to question or criticize such developments, it is unlikely that much can be done to prevent them.

The most important conclusion that has emerged from this workshop is that we need to develop new course material to ensure that technology is used to construct knowledge rather than simply provide short-cuts. To this end, much can be gained if we are willing to combine the traditional and reform points of view.

## References

1. Hughes-Hallett, D., Gleason, A.M., & McCallum, W.G. (1998). *Calculus: Single variable* (2<sup>nd</sup> edition). New York: John Wiley & Sons, Inc.
2. <http://www.ouc.bc.ca/staff/sdesjard/>
3. Smith, G.H. & McLelland, G.J. (1999). *On the shoulders of giants. A course in single variable calculus*. Sydney: University of Technology.
4. Santos, M. (2000). *Exploring variation via a routine task*. Preprint.

## Topic Sessions

---



## **A Proof Ought to Explain: A Classroom Teacher-Researcher, a Mathematics Educator, and Three Cohorts of Fifth Graders Seek to Make Meaning of a Non-Obvious Algebraic Expression**

Vicki Zack, *St. George's Elementary School, Montreal, Quebec*  
David A. Reid, *Acadia University*

This paper details one aspect of the collaboration between a classroom teacher and researcher (Vicki) and a university mathematics educator and researcher (David) who have been working over a number of years (in particular 1995-1996, 1998-1999, 1999-2000) with Vicki's fifth grade students on a variant of the chessboard task, and on the inquiry which has arisen therefrom. Vicki's original challenge to her students was that they construct a general procedure, which some succeeded in doing. In the midst of seeking to encode the general procedure into an algebraic expression, the fifth graders were blocked; teacher and children together bumped up against the realisation that they could not do so given the state of their current knowledge. Reciprocal adult-child nudging and challenges were in evidence. Vicki sought out and offered the students a 'non-obvious expression' which worked— $n(n + 1)(2n + 1) \div 6$  (Anderson, 1996). The children, in 1996, in turn raised the bar: they saw *that* it worked but asked *why* it worked as it did (Zack, 1997), a question Vicki could not answer. The students' challenge evoked a longstanding search, namely our (Vicki and David's) search for an explanation which made sense to fifth graders, in answer to their need to understand *why* the non-obvious expression worked as it did.

The paper will deal for the most part with the 'tri-tower pyramid' proof presented by David to two groups of fifth grade students in May 1999 and in May 2000, and with whether it answered the question posed by the fifth grade cohort in 1996.

### **Establishing the context: The school and classroom setting, the task, and the trajectory of the inquiry by adults and children**

The school is private and non-denominational, with a population that is ethnically, religiously and linguistically mixed. Most students come from English speaking, middle class backgrounds. Non-routine problem solving is central to the mathematics curriculum at all grade levels. The school and classroom learning site is one in which the children are expected to publicly express their thinking, and engage in mathematical practice characterized by conjecture, argument, and justification (Cobb, Wood, & Yackel, 1993, p. 98).

Mathematics is studied for 45 minutes each day (and twice a week extended to 90 minutes), and extended investigations of non-routine problems take up the entire lesson three times a week. There are usually about 25 students enrolled in the class, but mathematics is done as a half class of 12 or 13. The students are grouped heterogeneously in groups of four or five. When working on a problem they first work in twos and threes, then come together in their groups to compare solutions, then report to the half-class. (Other episodes and interpretations involving some of the same children can be found in Zack, 1997, 1999.)

The students were videotaped throughout their group and half-class discussions. In addition, their written work in their "math logs" was photocopied, written responses to questions focussed on particular aspects of their activity were collected, and they were interviewed and videotaped reflecting on their past activity.

**The trajectory of this inquiry: Vicki nudges the children, and the children in turn nudge her**

One part of this investigation, that of the search for a visual proof, originated in the first CMESG meeting Vicki attended, in Halifax, in May 1996. In her working group Bill Higginson asked the participants to think of an idea they wanted to share, and she chose to speak about one of the 30-some non-routine problem-solving assignments she has assigned to her students — namely a variant of the chessboard problem. However, she had never appreciated the richness inherent in that task until she heard the responses of CMESG members, among them, Bill Higginson, Harry White, and others. Due to the plenary address given by Celia Hoyles that year on proof, Vicki began thinking about young children and their notions of proof. Serendipity led her to select this task and present it at that CMESG working group session that year, but her study of this mathematical task and of questions about proving has since exploded into investigations into children's notions of proof (Zack, 1997), their use of everyday and mathematical language in their arguments about proving (Zack, 1999), and the linguistic coherence in the students' arguments (Zack, 1998).

**The task**

The task and its extensions, Vicki's own questions and personal confusion, and the children's challenges and questions, led us (Vicki and David) and the children to push forward in our investigation in unanticipated but fruitful ways.

Here (Fig. 1) was the task as Vicki presented it to the class in the first year (May, 1994):

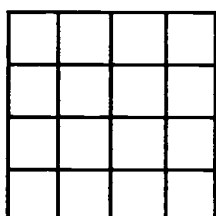

Find all the squares in the figure on the left. Can you prove that you have found them all?

**FIGURE 1.** The Count the Squares Problem

Vicki expanded the process each year, adding extensions in order to see whether and how the children could see and generalize various patterns, primarily the sum of squares. The problem evolved in terms of extended questions posed and class time spent from the first year, 1994 (one 90-minute session) to the most recent, 1999 (three 90 minute sessions, then a full week of interviews: children responding to segments of videotape featuring themselves discussing the tasks and talking about some aspect of proving, discussions about proving with small group of 2, 3, 4, to 6 people, then David presenting two visual proofs to small and larger groups).

Originally, Vicki's expectation was that some children might see the pattern of the sum of the squares—and express their hypothesis that the pattern would continue, i.e.,  $1^2 + 2^2 + 3^2 + 4^2 + 5^2 + \dots$ . Thus, if the children were able to generalize and say that the pattern would continue thus, that was good enough; indeed she felt that was sufficient for fifth graders. When she posed the "What if it were a 60 by 60 square?" question in 1996, what she expected the children to say was that 'the pattern just continues'. Vicki did not expect, nor did she want, the children to work out the actual numerical answer. She even tried to stop them from working it out. They ignored her. This unexpected development actually led to a number of surprises. In one instance the interaction between the members of two teams holding opposing positions about the answer to the 60 by 60 led to a discussion about proving, and prompted one of the teams to construct three counter-examples in order to try to convince the other team that their position was untenable (Zack, 1997). In another instance, rather than working with the numbers, thinking that there must of course be an 'easier way' than working through to the 60 by 60, a few children endeavored to construct an algebraic

expression but came up empty (Alan and Keiichi in 1996, and Walt in 1999). Vicki was not aware in 1995/6 that it was not possible for the children to derive an algebraic expression for this generalization, and so this occurrence was a surprise for her as well. She was pushed to seek out other sources, people as well as book sources.

Vicki was pleased to discover, and brought back to the children, the Johnston Anderson (1996) formula— $n(n + 1)(2n + 1) \div 6$ —which Anderson himself called a ‘non-obvious expression’. Her expectation was that she and the class would use it and see that it fit all of the examples which the children had calculated concretely. That was good enough for Vicki as she did not know *why* the expression worked; she only knew *that* it did. However, the students raised the bar again; they wanted to know *why* it worked as it did (Zack, 1997). They also wanted to know how anyone could come up with that expression. It did not fit the kind of algebraic expression which some of them had been able to derive in other instances, where there was a meaningful connection and transition between the concrete examples, and the general algebraic expression (Zack, 1995; Graves & Zack, 1996). Seeking an explanation to bring back to the students, Vicki was told that fifth graders could not construct or understand the mathematical approach to the construction of Anderson’s algebraic expression given the state of their current mathematical knowledge. It seemed at that time a dead end. Thus, in 1997, the paper written for the PME conference of that year ended with a list of the children’s emergent definitions of what they felt proof ought to be, among them that the proof must make sense and that the person presenting it must say why it works. When asked “What do you think of Johnston Anderson’s rule?”, the children responded that explanations and proofs should make sense. Ross, for example, said that Anderson’s rule was “brilliant, but he should explain why it works.” Lew said that “if the Johnston rule had evidence, if Johnston himself explained why it worked it would be more convincing.” And Rina felt that Anderson’s expression was “a great way to figure out the problem but it doesn’t make sense. . . . I think a mathematical proof is when you say why it works and if it works for everything show why” (Zack, 1997, p. 297). Perhaps due to the in-classroom emphasis on explaining oneself, the children pushed to know the whys, and hows. Hanna has suggested that proofs which explain ought to be favoured above those which merely prove (1995, p. 48). All but one of the fifth graders polled (of a total of 10 that year) stated unequivocally that a proof ought to explain.

Their questions in turn pushed David and Vicki to embark on an investigation to find an explanation, in response to the children’s need to know *why*. Over the next while (1996–2000), David, building on his long-standing interest in proof (e.g., Reid, 1992, 1995, 1997, 1998) explored and deliberated, at times with others (Cf, e-mail communication with Tommy Dreyfus), but most often alone. He decided on three possibilities and at various times showed and discussed with the children one of three visual proofs, each meeting with some measure of success and a number of unanswered questions: See Figures 2, 3, 4.

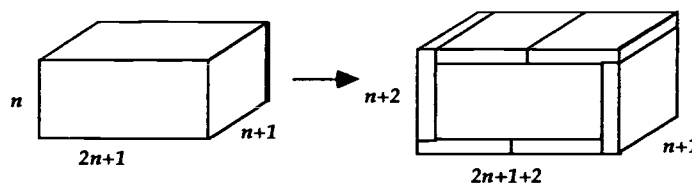
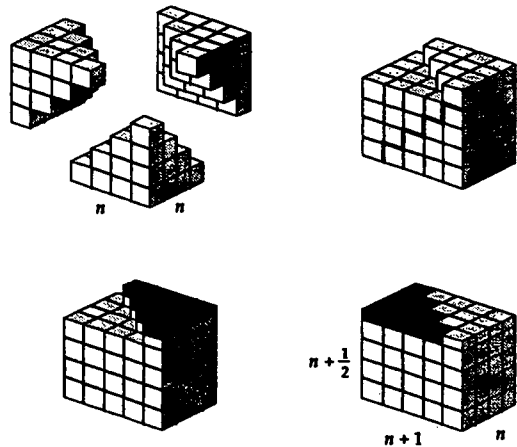

FIGURE 2. The wrapping proof presented to small groups in November 1996

Having summarized what brought us to this point, the next part of this paper will deal with the tri-tower visual proof presented in 1999 and 2000 (akin to Figure 3 and as shown in the photos below), and a number of challenging ideas embedded therein (see the “tri-tower proof,” below). We will also reflect upon whether David’s proof did or did not answer the question posed by the students in 1996, namely that a proof ought to explain.



$$1^2 + 2^2 + \dots + n^2 = \frac{1}{3}n(n+1)(n + \frac{1}{2})$$

**FIGURE 3.** Man-Keung Siu's visual proof (from Nelsen, 1993, p. 77), the basis for the tri-tower visual proof presented in 1999 and 2000

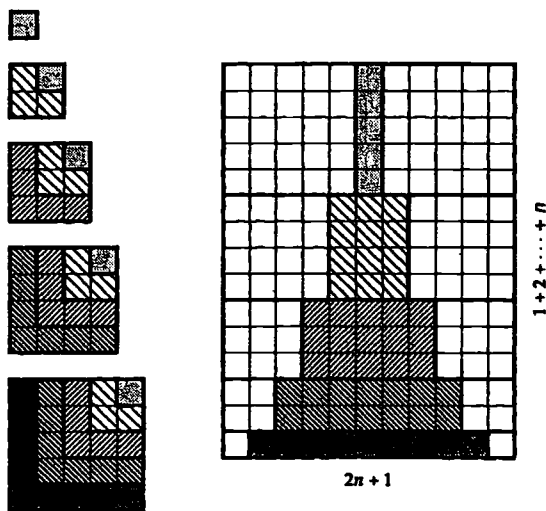

$$3(1^2 + 2^2 + \dots + n^2) = (2n+1)(1+2+\dots+n)$$

**FIGURE 4.** Martin Gardner and Dan Kalman's visual proof (from Nelsen, 1993, p. 78), the basis for the odd number visual proof presented to small groups in 1999 and 2000

**David's presentation of the tri-tower proof, presented in May 1999 and May 2000**

Begin by representing the sum of the square numbers as a set of squares made from multi-link cubes:

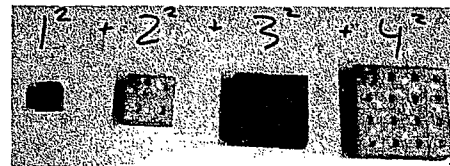

These squares are put together to make a "pyramid":



Two more pyramids are assembled:

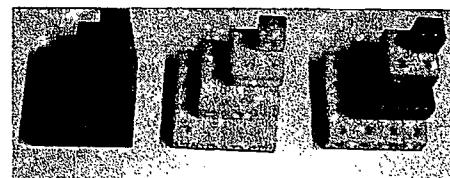



The pyramids are put together with the aim of making something as close to a rectangular block as possible:

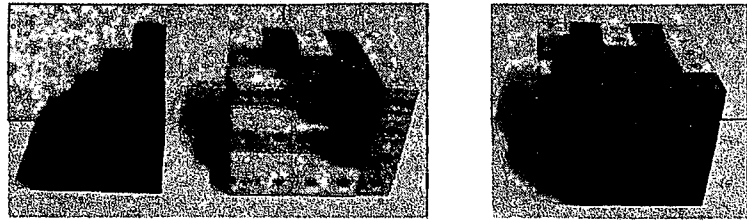

The block is then examined to see how many cubes are in each layer, and how many layers there are:

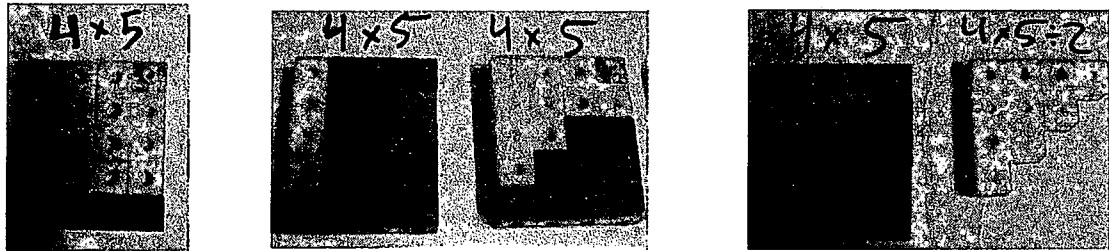

There are 4 and a half layers, each of which is 4 by 5. (Note that it is easy to see that if pyramids of size 5 had been used the resulting block would be 1 larger in all three dimensions, because a 5 by 5 square would be added onto the bottom of each size 4 pyramid.)



Finally note that three pyramids were used, so the number of cubes in one pyramid is the number of cubes in the block, divided by 3:

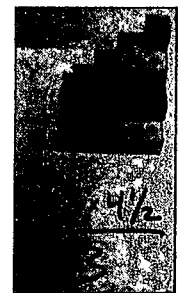

The number of cubes in one pyramid is the same as the sum of the square numbers, which establishes this formula (and because it is easy to see how the same construction would be done with pyramids of any size, the generalization of the formula is established as well).

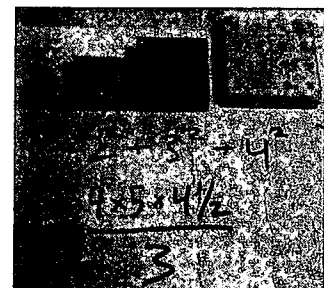

For some students the connection between the two formulae is clear. For others it isn't but that doesn't undermine the formula derived in the explanation.

$$\frac{n(n+1)(n+\frac{1}{2})}{3} \stackrel{?}{=} \frac{n(n+1)(2n+1)}{6}$$

### Crucial ideas

There are a number of crucial ideas (see Chart 1) that must be understood in order to understand the explanation as a whole. Not all the children understood all these ideas, and those that did understand them did not all understand them at the same time. Nonetheless, they were able to attain partial understandings of the explanation that were good enough to support their continuing engagement in the mathematical activity of the class.

#### CHART 1.

Crucial ideas that they might not understand but hold and wait for understanding.

1. To count squares you add  $1 + 4 + 9 + 16 + \dots$ . These numbers are SQUARE numbers in the sense of being  $N \times N$ .
2. The NUMBER of blocks in a pyramid of height  $N$  is the SAME AS the NUMBER of squares in a  $N \times N$  grid ( $1 + 4 + 9 + \dots + N \times N$ ).
3. Assembling three pyramids always produces the same three dimensional object. (Note: I used induction, Jackie does better in 9.1.)
4. One face of the object is made up of an entire  $N \times N$  square, plus the edge of another one, forming an  $N \times (N + 1)$  rectangle.
5. The top layer contains HALF as many blocks as the other layer, which is the same as a FULL layer of HALF blocks.
6. Arrays: That a three dimensional box is composed of  $A \times B \times C$  little cubes.
7. If you use three pyramids you have to divide by 3 later.
8. You can use a letter to stand for a variable in a formula.

### Is this proving?

Did David's visual proof answer the question posed by the students in 1996, namely that a proof ought to explain? When working with the fifth graders in the May 2000 cohort, in the discussion following the presentation the question was raised: Is this proving? The question can be rephrased and then answered in a number of ways.

### Did the children feel that it was a proof?

In the class of May 2000, nine students responded "No" to the question "*Think of what David did yesterday with the block towers. Was it proving?*", fifteen responded "Yes," and three responded "Yes, partly". On the face of it this indicates that most of the children did feel that the manipulation of the blocks and the accompanying commentary constituted proving or a proof. It should be noted however that their *reasons* for feeling so varied widely, as did their personal definitions of "proof" and "proving".

Among those who responded "No" reasons included:

- He was just showing us a way that it worked but he didn't prove that it worked.
- He wasn't proving he was finding out the answer. (4 similar responses)
- I don't think it was proving because we were not trying to prove the answer.
- It didn't prove the answer was right.
- It's a formula not a way to prove.

Among those who responded "Yes" reasons included:

- When he was using the blocks he showed evidence that his answer was correct. (2 similar responses)
- *Yes, it was proving because we got the answer for the 4 by 4 and for the 5 by 5.* (3 similar responses)
- *Yes, it was proving because it was make a math sentence and show what I did.* (2 similar responses)



responses)

- Yes, it was proving because he was showing us how you get all the squares. (3 similar responses)
- He showed us an easier way to do the problems and he proved that it works when we tested it. Also he showed us why it worked.
- He showed how he did it and why it worked.
- He showed exactly what he was doing and because he explained why he was doing it.

The range of reasons for accepting or rejecting the argument using blocks as a proof leave us in the situation of claiming that in some cases a child who accepted the argument as a proof, in fact did not understand it to be a proof for the kinds of reasons we would like, and so we might assert that it *wasn't* a proof for that child. For example, the children who said it was a proof because a couple of examples were shown ("Yes, it was proving because we got the answer for the 4 by 4 and for the 5 by 5.") seem only to have seen the argument as the production of some empirical evidence, not as a generic example that could apply to any number of squares. Similarly, those who emphasized the production of a formula ("Yes, it was proving because it was make a math sentence") seem also to have missed the point we would have liked them to have understood.

This raises the question of what *we* feel is a proof. Our research, while focussed on the children, tells us about ourselves. By considering that responses that do not fit our expectations we can identify some of those expectations, specifically that we expect a proof to be:

- General, applicable to all the elements in a family of specific statements.
- Explanatory, or at least demonstrating conclusively *that* something is the case.
- Reasoned, based on statements that are accepted and logically connected.

### Would a mathematician accept the argument as a proof?

As with the children the answer depends on the mathematician you ask. Presumably, Man-Keung Siu, creator of the visual proof on which the blocks demonstration was based, Roger Nelsen, editor of the book in which it was found (Nelsen, 1993) and Phillip J. Davis (1993), who asserts that such arguments should play a more significant role in mathematics education, are three mathematicians who would call it a proof. But others might disagree.

### Do we accept the argument as a proof?

Yes and no. In the abstract, it is a proof, but in practice it matters how the audience reacts. Is a play a comedy if no one laughs, even if the author expected them to?

### References

- Anderson, J. (1996). The place of proof in school mathematics. *Mathematics Teaching* 155, 33–39.
- Cobb, P., Wood, T., & Yackel, E. (1993). Discourse, mathematical thinking, and classroom practice. In E. Forman, N. Minick, & C. A. Stone (Eds.), *Contexts for learning: Sociocultural dynamics in children's development* (pp. 91–119). New York: Oxford University Press.
- Davis, P.J. (1993). Visual theorems. *Educational Studies in Mathematics* 24, 333–344.
- Graves, B., & Zack, V. (1996). Discourse in an inquiry math elementary classroom and the collaborative construction of an elegant algebraic expression. In L. Puig & A. Gutiérrez (Eds.), *Proceedings of the XX Conference of the International Group for the Psychology of Mathematics Education (PME 20)* (pp. 27–34). Valencia, Spain.
- Hanna, G. (1995). Challenges to the importance of proof. *For the Learning of Mathematics* 15(3), 42–49.
- Nelsen, R. (1993). *Proofs without words: Exercises in visual thinking*. Washington, DC: Mathematical Association of America.
- Reid, D.A. (1992). *Mathematical induction: An epistemological study with consequences for teaching*. Unpublished master's thesis. Montreal: Concordia University.
- . (1995). *The need to prove*. Unpublished doctoral dissertation. Edmonton: University of Alberta.

- (1997). Constraints and opportunities in teaching proving. In E. Pehkonen (Ed.), *Proceedings of the XXI Annual Conference of the International Group for the Psychology of Mathematics Education*, Vol. 4 (pp. 49–55). Lahti, Finland.
  - (1998). Why is proof by contradiction difficult? In A. Olivier & K. Newstead (Eds.), *Proceedings of the XXII Annual Conference of the International Group for the Psychology of Mathematics Education*, Vol. 4 (pp. 41–48). Stellenbosch, South Africa.
- Zack, V. (1995). Algebraic thinking in the upper elementary school: The role of collaboration in making meaning of 'generalisation'. *Proceedings of the XIX Conference of the International Group for the Psychology of Mathematics Education*, Vol. 2 (pp. 106–113). Recife, Brazil.
- (1997). "You have to prove us wrong": Proof at the elementary school level. In E. Pehkonen (Ed.), *Proceedings of the XXI Conference of the International Group for the Psychology of Mathematics Education*, Vol. 4 (pp. 291–298). Lahti, Finland.
  - (1998). *Coherence in five fifth grade boys' argumentation about proof: A sociolinguistic study of the role of repetition and logical structure in the boys' talk*. Paper presented at the Research Pre-session of the National Council of Teachers of Mathematics (NCTM) 76th Annual Meeting, Washington, DC, April 2–4, 1998.
  - (1999). *Everyday and mathematical language in children's argumentation about proof*. *Educational Review*, 51(2). Special issue: "Culture and the mathematics classroom." Guest editor: L. Burton, 129–146.

## Assessment for All

Leigh N. Wood & Geoffrey H. Smith  
*University of Technology, Sydney*

Assessment is an area of mathematics education worth revisiting. Technology has moved into the curriculum and into the working lives of mathematicians, adding extra dimensions to mathematics. Questions about who should learn mathematics and what constitutes mathematics learning are evolving and changing. Flexibility and student choices are important issues, particularly in post-secondary education. Our thesis is that flexible assessment is not mandatory or essential to learning but that it should be considered as a component in the overall design of the curriculum. The reasons for the use or non-use of flexible assessment by lecturers are investigated by giving examples from a survey of academic teaching staff.

Flexible assessment is assessment that involves some kind of choice on the part of the student. We will use assessment to mean assessment of the students' learning in a subject; that is the tasks that are graded. Flexible assessment may be associated with flexible delivery but may occur in conventional delivery. In this paper we are considering post-secondary education but the principles apply to other educational situation. There are many publications with examples of different assessment practices (Angelo & Cross, 1994), examples of peer teaching (Houston & Lazenbatt, 1996, Houston, 1998), changing examination questions (Ball et al., 1998; Smith et al., 1996) and using language-teaching techniques in assessment (Wood & Perrett, 1997). These do not directly address the issue of choice.

In general the more data you have about learning, the more accurate the assessment of a student's learning. However, what is achieved in accuracy costs significantly in lecturer time. This is discussed in Angelo & Cross (1994). Another consideration with assessment is the idea that "assessment drives learning" (Ramsden, 1992). Assessment forms a critical part of a student's learning, especially at tertiary level.

Technology has changed the learning of mathematics but it has also changed the administration of assessment. It is possible to set up assignments and solutions on the Web and keep in email contact with students. Students can submit assignments by email and so on. It has become easier to keep track of large amounts of data from students. It is also easier to communicate with students. New communications technology encourages flexibility. Inviting students to participate in mathematics encourages active learning.

### **Calculating the amount of flexibility** (adapted from Wood & Smith, 1999)

It is useful to have a tool to calculate the amount of flexibility of assessment in subjects or over the whole curriculum. We have devised a table (Table 1) that enables the overall amount of flexibility to be easily calculated by circling and adding the appropriate numbers. Low totals indicate a large amount of student choice and high totals indicate little student choice.

### **Assessment parameters**

There are a number of parameters that occur in any assessment scheme, and it is the amount of choice that a student has in setting these parameters that contributes to the overall flexibility of the scheme.

**Components:** Assessment is made up of a number of components. These could include tests, assignments, projects and examinations. The lecturer may insist that the total assessment consist of a certain minimum number of components.

**Timing:** Students may be able to negotiate the timing of submission of assignments or tests within a semester or, occasionally, over a longer period of time. Generally assessment schemes that involve a final examination will have constraints on the timing of the final examination.

**Style:** Students may be able to choose the style or format of the their assessment. They may be able to write a report, write an essay, give a talk, produce a video or construct a poster presentation.

**Tools:** Students may be able to choose which tools they are able to use to complete an assessment task. This can include computer tools such as *Mathematica*, *Maple*, *Minitab*, *SPSS*, *Excel*, library resources or Internet sites. Examinations and tests may be open book, restricted open book, with or without calculator and so on. Practical considerations come into play here. It may be impractical to have some students choosing open book and others choosing closed book examinations.

**Grouping:** Students may work in groups. There are many possibilities here. There can be student choice as to the number of people in a group, who is in the group and what roles each person takes in a group. Students may be able to work alone if they prefer, or the lecturer may insist on a minimum group size.

**Weighting:** There are many different ways of choosing the weight to give to each component of assessment. Students may be given complete freedom to vary weights of various components between 0% and 100%. Most lecturers would probably feel that this is too flexible. There would almost certainly be some components of the assessment that a lecturer feels are essential to meet the objectives of the subject, in which case some restrictions would be imposed to ensure that these are adequately represented.

**Content:** Students may be given a choice of topics for projects, assignments and examinations. Students may be able to choose from a range of topics or suggest a topic themselves. Again a lecturer may choose to impose restrictions on the choice if he or she feels that certain topics are essential.

Assessment Parameters	Student chosen	25% student chosen	Approx. half student chosen	25% assigned	Lecturer assigned
Components	1	2	3	4	5
Timing	1	2	3	4	5
Style	1	2	3	4	5
Tools	1	2	3	4	5
Grouping	1	2	3	4	5
Weighting	1	2	3	4	5
Content	1	2	3	4	5
Marking	1	2	3	4	5
Feedback	1	2	3	4	5

TABLE 1. Calculation of degree of flexibility in assessment

**Marking:** Students can be given a choice of who marks their work: their peers, self-marking, lecturer or a mixture of these modes. Again it may be necessary to have the whole subject group decide on the marking mode and the lecturer may impose restrictions.

**Feedback:** Students may choose the form of feedback. Some may prefer written solutions, others may prefer a 10-minute interview with the lecturer. Student feedback was one of the areas that mathematics performed badly in graduate survey data. With our limited resources, we need to look at effective ways of giving feedback on work and this may be different for different students.

### Survey on flexible learning

In 1999, lecturers at the University of Technology, Sydney were surveyed as to their use of flexible assessment. The survey was optional and conducted using email. What emerged was an interesting array of assessment procedures across the University.

*Why do you use flexible assessment?*

When asked why teaching staff use flexible assessment the answers fell into several categories. One common response was "Why not?" The quotes were categorized as to the lecturers' aim. Selected quotes from lecturers are compiled below with the teaching area in brackets. You will notice only one from mathematics.

Flexible assessment allows for the student to show their achievement:

- *I use flexible assessment to better meet the needs of students and to create an environment in which a student's final results are a reasonable reflection of their achievement of the objectives of the subject. (Mathematics)*
- *I believe one form of assessment does not suit all needs nor accurately reflect capabilities. (Law)*
- *Because not all forms of assessment suit all students. (Science)*
- *I use flexible assessment to allow students to respond in ways that will allow them to reach their potential and gain learning experiences most meaningful to them. (Education)*

Flexible assessment to cater for the family or work commitments of their students:

- *It suits students' needs and work/life commitments. (Education)*
- *Flexibility allows many students to successfully complete the subject who would otherwise fail it due to work pressures, ...family/personal problems etc. (Business)*

Flexible assessment as a learning tool:

- *To allow students to learn about scheduling their work to suit their requirements and other deadlines. (Computing)*
- *To enhance learning autonomy. (Education)*
- *It teaches students that along with rights (i.e. self-determination) there are responsibilities. They are responsible for their own learning. It helps me move from the role of policeman and judge into a more participatory role. It is much nicer to be a teacher. The outcomes for the student are in the end far superior. I do not think they learn much more about the subject. However, they learn so much more about themselves. (Business)*

Flexible assessment to encourage higher learning:

- *Because the work that students appear to put in it appears to be of a higher order than when the topic is merely given to them. (Law)*

- *It gives students ownership and control over their learning path. (Education)*

Flexible assessment to cater for different abilities:

- *To allow an extension or challenge additional assessment. (Business)*
- *To be fair to students.... I want to provide multiple opportunities for triers. (Computing)*
- *To make learning relevant to each individual. (Nursing)*
- *To allow for different competencies (e.g., some like IT, some do not). (Business)*
- *It allows students with different levels of background preparation to reach the objectives of the subject at their own pace. (Computing)*

Flexible assessment encourages interest:

- *There is more commitment to learning. (Computing)*
- *I think that this encourages student interest in the subject ... are able to pursue special interests. (Law)*
- *Students enjoy it. (Law)*

*Has it been successful? Are there any problems? How have students reacted?*

The overwhelming response from lecturers was that the flexible assessment was a success. They backed up their assertions with positive student surveys. These lecturers were, however, the group who used flexible assessment regularly.

Flexible assessment has some problems and lecturers have refined their assessment over the years. One of the particular problems is to communicate the different assessment scheme to the students many of whom have never had choice before in their learning. Typical quotes are: "It has been successful but hard work", "It does take a lot of explanation at the start of the semester, especially to some students", "At the start of the year, the students have doubts about the system, but they soon adapt ...."

Other problems can occur if the lecturer is the only one with a flexible approach "because my subject is the only flexible subject that students are doing at the time, some students let it slip." Also one lecturer of a class of 300 found that only 90 chose different assessment, the rest chose a default mode.

A few students react badly to choice: "some students feel that they are unfairly treated by choice" and "some students take too long to decide what options to take, or decide that ... another choice would be easier," and so on. A few staff and students believed that all students should have the same assessment otherwise it is unfair.

*Why are you not using flexible assessment?*

There were many reasons.

1. Numbers. Many lecturers felt that flexible assessment would be too difficult with large classes and had generally only used it with smaller groups.
2. Equity. Different students doing different tasks can be considered unfair. It is noticeable that lecturers in computing, engineering and sciences believe this more than humanities and social science lecturers.
3. Maturity. Flexible assessment is much more common in senior years and postgraduate study.
4. Administration. For some lecturers the administration difficulties of keeping track of students following different assessment patterns have proved a major deterrent.
5. Learning. Lecturers who had a defined area of content that they wanted the students to master generally did not use flexible assessment.



## Conclusion

Lecturers and students are using flexible assessment for many reasons. Positive student surveys showed that students responded well to the use of flexible assessment. However, lecturers were selective in its use. Giving students choice in their assessment requires maturity and self-knowledge of their learning style. As students progress through their degree programs, greater flexibility in assessment can be implemented. Initially, students require some support to assist their transition to university. Too much choice at the early stages can be difficult to communicate.

As we consider the invitation to participate in mathematics learning, flexible assessment can promote participation and active learning. From the survey results, it appears that mathematics lecturers rarely use flexible assessment. Perhaps it is time to experiment.

## Acknowledgement

Thanks to all the staff at the University of Technology, Sydney who participated in the flexible assessment survey.

## References

- Angelo, T.A. & Cross, K.P. (1994). *Classroom assessment techniques: A handbook for college teachers*. San Francisco: Jossey-Bass Publishers.
- Ball, G., Stephenson, B. Smith, G.H., Wood, L.N., Coupland, M., & Crawford, K. (1998). Creating a diversity of experiences for tertiary students. *International Journal of Mathematics, Science, and Technology Education* 29, 827–841.
- Crawford, K., Gordon, S., Nicholas, J., & Prosser, M. (1993). Learning mathematics at university level: Initial conceptions of mathematics. *Proceedings of the Sixteenth Annual Conference of the Mathematics Education Research Group of Australia*.
- Houston, S.K., & Lazenbatt, A. (1996). A peer-tutoring scheme to support independent learning and group project work in mathematics. *Assessment and Evaluation in Higher Education* 21, 251–266.
- Houston, S.K. (1998). Get students to do the teaching! In P. Galbraith, W. Blum, G. Booker, & I. Huntley (Eds.), *Mathematical modelling—Teaching and assessing in a technology rich world* (pp. 45–54). Chichester: Horwood Publications.
- Ramsden, P. (1992). *Learning to teach in higher education*. New York: Routledge.
- Smith, G.H., Wood, L.N., Coupland, M., Stephenson, B., Crawford, K., & Ball, G. (1996). Constructing mathematical examinations to assess a range of knowledge and skills. *International Journal of Mathematics, Science, and Technology Education* 27, 65–77.
- Wood, L.N., & Perrett, G. (1997). *Advanced Mathematical Discourse*. Sydney: UTS.
- Wood, L.N., & Smith, G.H. (1999). Flexible assessment. In W. Spunde, P. Cretchley, & R. Hubbard (eds.), *The challenge of diversity* (pp. 229–236). Laguna Quays: University of Southern Queensland Press.

## Mathematics—By Invitation Only

Ralph T. Mason  
*University of Manitoba*

Why should students do their math? Why should they learn it? Perhaps on one level, these questions don't matter: *if they do it, if they learn it*, then surely why they do so is not significant. However, as students do their math, as they learn it, the intentions which bring them to mathematics are going to shape their engagement with it. Their engagement, in turn, shapes the nature of their experience. And the nature of their experience will determine what they think math is. For instance, if a student does her math because she believes that good marks in math are essential to getting to university, then she will believe in mathematics as long as it serves as a means to the end with which she links it. If a student does his math because he is forced to do so, by either threats of consequences if he does not or promises of rewards if he does, he will see mathematics as a tool of power, relevant only to the extent that the structure (often, the school as institution) holds power of relevance to the student.

Could students develop reasons for doing mathematics, reasons for learning mathematics, which are related to the qualities of mathematics that we as mathematicians value? Could the beauty of mathematics or the joy of mathematics or the power of mathematics be why students learn math? Alternatively, or perhaps supplementally, could the reasons students do math be for the values they hold for the processes of doing them—the interactions, the activities, the progress that can be inherent to mathematics? This paper explores the possibility of answering these questions in the affirmative. If students can be brought to mathematics without promise of reward or threat of diminished opportunity, could mathematics be seen as worth doing, in itself and for itself?

### The Siren Call of Mathematical Thinking

Here is some inviting mathematics. In figure one below, you see a hundreds board. It is most often seen in elementary classrooms, used when a sequential list of numbers organized into rows of ten can help students engage with a concept. (It is also seen behind the Snakes and Ladders in the popular board game, although the orientation is different.) This activity, however, is more appropriate for middle-years students: it involves thinking within the context of divisibility, but its mathematical content lends itself well to algebraic notations, thus offering a context in which variables can be used by the students to express their conjectures and rationales. But I am ahead of myself—I have not yet offered you an invitation.

Beside the hundreds board (Figure 1, next page) you see some pentominoes (Figure 2), arrangements of five squares. Select one, and cover any five cells of the hundreds board with it. When you add up the five numbers, the total might or might not be divisible by five. If it doesn't divide by five, I don't know what your total's remainder might be. However, I do know that if you move the pentomino to cover a different five numbers, you will get exactly the same divisibility. How about that?

I find that students are usually reluctant to add up their five numbers. I invite them to be as lazy as possible about it. Instead of adding up the five numbers, what if they just pick

1	2	3	4	5	6	7	8	9	10
11	12	13	14	15	16	17	18	19	20
21	22	23	24	25	26	27	28	29	30
31	32	33	34	35	36	37	38	39	40
41	42	43	44	45	46	47	48	49	50
51	52	53	54	55	56	57	58	59	60
61	62	63	64	65	66	67	68	69	70
71	72	73	74	75	76	77	78	79	80
81	82	83	84	85	86	87	88	89	90
91	92	93	94	95	96	97	98	99	100

FIGURE 1. Hundreds Board

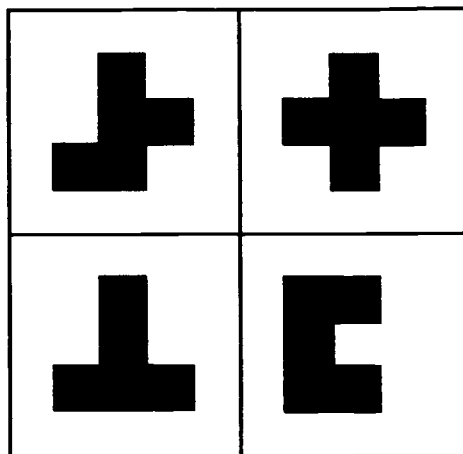

FIGURE 2. Some Pentominoes

a key cell (I have marked a suggestion on some of the pentominoes), and multiply it by five? They might be off by a little, but they can adjust appropriately. For instance, the first pent, if we multiplied the *K value* by five, would be quite close. The top cell is actually ten less than the key cell, but below the key cell is one that is ten more. The right cell is one more, and the final cell is nine more. So we'd just have to *add ten* to the results of *keycell times five*, to get the actual total. And hey, that pentomino (in that orientation) is always divisible by five. The total is always *ten more than five times the key cell*, and it's always divisible by five. Is there a relationship between the two ideas? Let's try another pentomino—or see what happens if we use the same one and change orientations. (A partial answer may be invitational for some readers: Of the four pentominoes in the positions given below, three will always yield a total divisible by five, and the other will always have a remainder of two. However, three of the four will change their divisibility if rotated. There are eight pentominoes not shown.)

If we recognize that we could encourage students to engage in this mathematics without coercion or compulsion, what is it that can be the reason for that engagement? It could be that they are being compliant, or obedient, or perhaps they are responding to the teacher's appealing personality. There are surface-appeal features, including the chance to do some easy examples and some easy arithmetic as a first step. However, there is clearly something more than simple arithmetic with weirdly shaped pieces, luring students into deeper engagement. Beyond the introductory arithmetic, there is room for curiosity, an opportunity to wonder, and a chance for intellectual attainment. In other words, it is the math in the activity that is likely to form the greatest source of reward for the participants. The activity invites people into the math which is, in its turn, rewarding.

**Invitational Packaging**

My teacher-education students are often concerned about making their lessons appealing to students. Two ideas tend to predominate: one, the content must be embedded in contexts which the students will value, such as an application (buying a car) or an interesting format (making a poster advertising bank loans); two packaging the math content in a game. For instance, before a test they might suggest dividing their class into three teams and asking review questions, using a Jeopardy approach. Because the game is fun, perhaps the students will see the math as fun, too. At least they won't find it unpalatable. In a single period of review, the only math is perhaps 30 short-answer one-right-answer questions. The math to which the game invites the students is narrow and constricting, and, in reality, not even mathematical in nature. The invitational packaging diminishes the overall package, and an appealing invitation draws students toward an activity without the mathematical qualities that might sustain interest.

A game can, however, be an invitation to mathematics. In other words, a game can be a way to draw people toward meaningful and rewarding mathematical thinking (pattern noticing, analysis, justification). For instance, the game of Nim can be such an invitation: Two persons face a pile of toothpicks: perhaps there are 18. Each person takes one, two, or three toothpicks in their turn. Whoever takes the last one loses. Who should win?



The game as outlined may be enough of an invitation. However, we want *all* to engage, and we want them all to engage *mathematically* rather than just socially or competitively or empirically. (This last word points toward the finding of good strategies by building an extensive set of examples, rather than by using a few examples to enable the learner to identify structures which can be analyzed.) We are likely to need to help some students to find a place to begin to notice patterns. For them, some hints can lead them to focus on the end-game, the part of the game when there are only a few toothpicks left. We may have to help some students see a cycle of two turns as an element that can be considered: helping them to see that a cycle of two turns has a maximum and a minimum change could help, without giving away the opportunity to discover the ideal cycle. We may have to help all students find ways to express the patterns they find (maybe even ways that use mathematical notations, or at least the logical language of if-then). And we may have to invite students to extend the mathematics by adapting the game slightly, and thus having at their disposal an extended playground for analysis and generalization. In other words, we must do more than invite people to our mathematical game—we will have to play host to ensure all our guests feel the pleasure of addressing an intellectual challenge.

### Planning the Party

It's bad form to invite people to a party, and then not have anything rewarding planned for them to do. If you do plan some rewarding activities for guests, they are more likely to accept your next invitation. What does that mean to invitational mathematics teaching? Here is an example.

Imagine students dealing with the following questions:

- a) 0.355 divided by 2 = \_\_\_\_
- b) 2.0 divided by 0.355 = \_\_\_\_
- c) Dividing makes smaller, so of course the answer to question A is less than the original 0.355. However, the answer to question B is more than the original 2.0! How is that?

We all know that question C above is much harder than the previous questions. In fact, it is seldom asked of students, to see what they understand about division of decimals. Yet, it's in the third question that more than arithmetic takes place: the structure of numbers and of the operation of division is open for analysis, pattern-noticing, and communicating. In other words, the only thing really worth inviting students to engage with is in question C. We need to make the first elements more inviting by making them both more appealing and more valuable. Let's begin again. Pretend you can go to the fridge or the convenience store for some supplies.

- a) Here's a can of pop, and two glasses. How much pop can go in each glass? (The pop-can says that it holds 355 ml.)
- b) Here's a two-litre bottle of pop. That's two thousand ml. How many of these pop-cans could we fill with that pop?
- c) Answer the two questions again, but use litres (that means decimal numbers).
- d) The answer to question B is between 6 and 7, whether we use ml or litres. Can you explain why?

- e) How does the answer to question B (between 6 and 7) compare in meaning to the first value (2) in the question?

There is more going on here than context providing interesting packaging for some arithmetic questions. The invitation begins with mathematics that is both accessible and meaningful for all the students. Even a person weak in arithmetic could perform the tangible and/or image-based acts of pouring and counting/measuring. Then, when the mathematics includes some arithmetic that is typically less success-based, the students still have ways to check the correctness of their answers. They can compare to their mental images of the objects (and actions on those objects) to check the sense of their answers, and they can compare to the answers they developed in the preliminary questions. Finally, they will have a variety of ways of addressing each of the final questions, all of which will enable them to make and express personal versions of the meanings of the experience. It is math that they can all learn (especially at the beginning), and it is math that is (eventually) complicated enough that they can all be glad they learned. With invitational mathematics, we can attract more students toward mathematics—and it's more mathematics. In fact, it *has* to be more mathematics, for it is the quality of the mathematics on which we are relying.

### Inviting the Reluctant Guest

Readers may well be asking, "Can it work in high school?" There are some advantages built in to high school math for anyone taking an invitational approach. For instance, I believe that the mathematics of high school is already potentially richer, potentially more rewarding as intellectual challenge. However, an invitational approach will have some reluctant students to invite: students constrained by their presumptions that math is hard, perhaps too hard for them. Considerations of invitational mathematics at the high school level may also be constrained by the effectiveness of marks and credentials with high school students, and the readiness of teachers and students alike to accept that math need not succeed with all students. Is invitational math feasible in high school?

Here is an example. It suggests that invitational math may need different packaging, different starting points, and different kinds of values to students when those students are in high school or beyond. For a topic, let us consider exponential functions. Whether it is taught to feature an exponential formula or a recursive sequence or both, it is often done with the real-life applications of compound interest for a mortgage or new car loan or investments of \$10 000, or else with radioactive decay. The contexts make it apparent that the arithmetic of the topic is applied to important aspects of adult life. But does adult life interest all our students? And is the math behind the exponential formula or the spreadsheet recursion accessible in those contexts, or rewarding to come to understand? The answers are no and maybe. Is there a more invitational alternative? Perhaps there is. What if we used examples that enabled our students to question their own status, and framed it in ways that engaged them with the mathematics behind the arithmetic? Below is an example, rewriting a 5% radioactive decay example.

In Manitoba, 84% of students graduate from high school, but fewer than half of those students get university-entrance mathematics qualifications. In the spreadsheet below, there is a list of steps along the journey toward mathematics success in high school. The numbers pretend that there is a 5% loss at each stage of the journey. You have one question, and two jobs:

1. Why do nine stages each removing 5% of the population NOT remove 45% total? Try a 10% decay—nine stages won't create a 90% loss.
2. Change the rate of decay to get a more realistic final success rate.
3. Say something important about one of the steps in the decay you see as more significant than others.



	rate of decay per stage =	5%
	original population =	100
dropped out before grade 10	survivors =	95
entered a non-academic math stream in grade 10		90
dropped out during or after grade 10		86
failed, or dropped to a non-academic stream for grade 11		81
dropped out during or after grade 11		77
failed, or dropped to a non-academic stream for grade 12		74
dropped out during 12 or were talked out of writing the final exam		70
failed the grade 12 exam		66
passed the grade 12 exam, but had less than a university level mark		63

I hope this example suggests that the mathematics of high school continues to be worth understanding, not just learning by practice and application. It is also possible to package it in contexts that bring its potential as a thinking tool into topics of relevance to the learners. It remains to be seen to what extent this possibility could apply to all higher-level math—but the possibility may not be available to us if we continue to engage students through our institutional authority.

### Mathematics—An Open Invitation

Imagine a student trying to remember his divisibility rules for 6 and 9. Is she going to be able to tell if she has remembered well? She could, of course, test her recall with some examples. But divisibility is only one or two questions on the test. It might not be worthwhile to make sure she has it right. For some, of course, marks matter enough that they will not miss such a detail in their last-minute studying. The invitation to do well on math tests by cramming the details back into short-term memory is one that only a portion of the students accept. It is sad, in my opinion, that many teachers too accept that only a portion of students will remember such details as divisibility, and fewer still will understand them, and fewer yet again (shades of radioactive decay!) will enjoy engaging with them.

Could a specific topic such as divisibility by 6 and by 9 be made inviting to all the students? We know that failure or risk of failure prevents some students from engaging. Could success, and expectation of success, cause those students to engage? Surely that could only be so, if the success was real, and meaningful, and well-earned. How could that be accomplished, with a narrow mathematical topic such as divisibility?

Let us start with what students of divisibility can already do. They probably can't all divide (not accurately). They probably can't all think multiplicatively—the additive context of skip-counting may be the closest they can come. Let's begin there. On the same hundreds board used above, we could have students skip count by twos. They would put red tiles on 2, 4, 6, and 8, and so on. What if they were told to skip-count by threes? If they do it right, they will put green tiles on 3, 6, 9, and 12, and so on. With help the students will see that the skip-counting numbers for 2 or 3 are the multiples of 2 or 3, and the multiples of 2 or 3 are divisible by 2 or 3. The students will also see that some numbers have both red and green tiles. They can make a connection between divisibility by six and divisibility by both two and three. We could then ask them to check out (with different results) skip counting by twos and by fives, or by threes and fours, or by threes and sixes. Each example gives them the chance to think, to see and express patterns—in other words, to succeed and accomplish the natural reward of doing so.

What about skip-counting by nines? Could we just get at the rule for divisibility by 9 by laying tiles on the nines numbers? It's probably worth doing, but it doesn't get the students too close to the rule. For that, we might have to teach them more directly. Can we get them to see why the remainder when 8000 or 800 or 80 is divided by 9 is always 8, or why the remainder when 3000 or 300 or 30 is divided by 9 is always 3? That's not hard: for 1000



or 100 or 10 we always seem to miss by one. We can divide 999 or 99 or 9 by 9 without remainder, so for 1000 or 100 or 10 we miss by one. A good teacher will know when sufficient examples and discussion of examples have developed that idea. Then it will be time to move on: If we have many thousands or hundreds or tens to divide by nine, we'll miss by one (have a remaining single) for every single one of them. So all we have to do is keep track of how many singles we'll have left. For instance, 4320 would have 4 left over from the 4000 divided by 9 (remember there are 4 groups of 999 there), and 3 left over from the 300 divided by nine, and 2 left over from 20 divided by 9. Aha—we have enough left-over singles to make another group of nine. How many slow-motion examples such as this will learners need? Good teachers know how to find that out, as they teach. The rule for divisibility by nine can be built by students from guided engagement with examples and by making sense of those examples.

What does all this mean? One, I am suggesting that mathematical ideas can be presented in rich visual ways, ways that often enable students to connect the new ideas to the prior areas of competence which all students in a grade-level have. In this case, skip-counting was a connection from counting to divisibility. Two, I am suggesting that mathematical ideas can be taught as being sensible, with reasons for rules, reasons that can be built from examples with guidance. Making sense of complex ideas is rewarding enough to make students want to come back for more.

However, there is a deeper idea at play here. Where will teaching ideas like the above divisibility lesson ideas come from? They will come from people who believe that math is in itself worth learning—sensible, rich and rewarding. They will come from such people searching for ways to make that same math accessible and attractive to many more students than now have successful access. In other words, it will come from people who believe in mathematics as something that can be taught by invitation only.

#### **Note**

This paper is a synopsis of a fuller presentation. The examples that are used here are only those which can be presented in the less interpersonal form of printed proceedings.

## **Math Central: An Internet Service for Teachers and Students**

Mhairi (Vi) Maeers & Harley Weston  
*University of Regina*

In the summer of 1995 Denis Hanson, Vi Maeers and Harley Weston of the University of Regina began work at the University of Regina on an Internet service for people involved in mathematics education from Kindergarten to Grade 12. This service is called Math Central, and it went on the net in September of 1995. Funding was subsequently obtained from the University of Regina, the Provincial Department of Education, and SchoolNet. Math Central was moved to its present site in the summer of 1996, <http://MathCentral.uregina.ca/>.

In the period 1994-1995 the Province of Saskatchewan was just beginning to implement a new mathematics curriculum which uses a problem solving, resource-based approach. In implementing this curriculum teachers were faced with the challenge of finding accessible and suitable resources. It was our intention that Math Central be a source of teaching materials and aid for teachers in the implementation of the new curriculum.

There were three initial objectives of this project: to devise a vehicle for teachers, and student teachers to share resources and discuss concerns, to give students a way to demonstrate to teachers some potential uses of this Internet/communications technology through a service that is a direct aid to their day-to-day teaching and lesson planning.

Since its inception in 1995 the usage patterns of Math Central have changed substantially. At the moment approximately 2% of the hits come from Saskatchewan, 10% from Canada, 80% from the USA and 5% from other places primarily France, Australia and the United Kingdom.

### **Services**

Math Central has four main services, The Resource Room, Quandaries and Queries, Teacher Talk and The Bulletin Board.

#### *The Resource Room*

The Resource Room is a facility where mathematics educators can store and retrieve resources on mathematics and the teaching of mathematics. It is a place where teachers can share notes, ideas, lesson plans, or any other resource on the teaching of mathematics.

The resources are categorized in a database by level—elementary, middle or secondary, and then by curriculum strand. A user can browse using these categories or search by keyword, author, or title. In the database are resources written by teachers, preservice teachers, and university faculty as well as links to teaching materials maintained by Statistics Canada.

For example browsing at the middle level in the *Numbers and Operations* strand you find, among others, a resource called *Operations Activities* by *Debbie Penner*, a teacher in Regina. Two of the resources that are found by searching for the keyword *geometry* are *Tantalizing Tessellations*, written by three University of Regina students and *Allison's Star Balls*, an origami

activity that will be familiar to anyone who attended the CMESG Annual Meeting in 1999 at Brock University.

The Resource Room also has a mathematics glossary at the middle level in English and at the elementary and middle levels in French.

### *Quandaries and Queries*

Quandaries and Queries is a question and answer service. Mathematics questions sent to Quandaries and Queries are automatically forwarded to a group of teachers and university faculty called the Quandaries and Queries consultants. Input from the consultants is then formulated into a response which is returned to the poser of the question. As in the Resource Room the questions and answers are stored in a database that can be searched by keyword, author, or title. Questions come from students, teachers, parents, grandparents, business people, researchers, ... and range from difficulties with elementary number facts

*I'm in a 5th grade class, please explain what whole numbers are ...*

to stimulating mathematical questions

*A man goes out in time between 5 and 6 and when he comes back he observes that two hands have interchanged position. Find when the man did go out?*

to, at times, questions from the corporate world

*I have a roll of paper, wrapped around a corrugate core, whose diameter is 10.750 in. The outer diameter of the roll is approx. 60 in. The thickness of the paper is .014 in. I am trying to find out how much linear feet of paper is left on the roll, given only the diameter of paper remaining on the core.*

### *The Bulletin Board*

This is Math Central's information board. Our intention here is to provide a link to the mathematics teachers' organizations and conferences in the various provinces and territories in Canada, and to online newsletters and periodicals of interest to mathematics teachers and students.

### *Teacher Talk*

Teacher Talk is an electronic mailing list for mathematics teachers. It provides a facility for an open discussion on mathematics education, with the topics as varied as the participants wish.

### **Survey**

Prior to the survey being posted on Math Central we had many discussions with colleagues about the learning curve in learning *about* technology to learning *with* technology—to being able to *use* technology in interesting, thoughtful and appropriate ways in the mathematics teaching/learning environment. The rapid rise of the use of the Internet, both as a source of information for teachers and students and as a learning tool in the classroom, has given rise to questions concerning its use. We recognized that a current argument in relation to technology is in regard to what it can offer a learner—can it raise achievement in mathematics (as evidenced by mathematics test scores)? We felt from our own experience that interactive web-based technology can enhance mathematics learning and achievement—depending on how it is used, by whom, in what context, and that web resources in the hands of an effective teacher can indeed become effective learning resources. Beliefs about teaching and learning and common classroom teaching practices emerging from these beliefs and from learning theory influence the manner in which any resource is used in a classroom, in this case web-based resources. Web-based technology used as a tool or as a resource in a constructivist classroom would look quite different from technology used in a traditional classroom, both in the type of technology used and in how it was used. We wanted to determine how teachers were using the web, in particular Math Central. Thus, in the Fall of 1998 a questionnaire

was posted on Math Central in an attempt to answer some of these questions. The purposes of this survey were to determine how the resources on Math Central were being used, to explore the connection between web resources and understanding/achievement, to find what type of resources were being sought and how they were used, and to ask the participants if they believe that web resources can make a difference to math achievement.

In total 159 people responded to the survey within a specified time frame, resulting in 142 usable responses. Responding to the survey were 86 teachers, 24 preservice teachers, 13 parents, and 21 other. Some of the qualitative responses are recorded below (original questions are in italics), followed by an explanation:

*What is an example of something you have found on Math Central which you have used in some way in your teaching or learning?*

*Has this resource extended the mathematical understanding or mathematical achievement of your students? [yes/no/no opinion/explain]*

- Problem solving—makes students think
- Other URLs—new ways to present mathematics topics to students
- New resources—extends teaching ideas and teacher understanding on a concept
- Specific resources (e.g., Tessellations)—new language, new ideas for activities, help visualize
- Various—helped students understand concepts

Responses to this part of the survey focused on (a) understanding of concepts (teacher and student); (b) enabling thinking; (c) finding new teaching methods/ideas.

*What kind of material are you looking for?: A: The teacher*

- Lesson plans
- Classroom-ready activities (e.g., worksheets)
- Problems
- Background on mathematics topics
- Software freeware
- Other websites
- Specific topic resource (e.g., Tessellations)
- Creative/unusual materials

*What kind of material are you looking for?: B: The Preservice Teacher*

- Lesson plans
- Hands-on (fun) activities
- Help with my coursework (e.g., background on mathematics topics; ideas for assignments)
- Material related to Pan Canadian Framework
- Specific topic resource (e.g., Tessellations)

The following chart illustrates how teachers and preservice teachers use the Math Central web resources:

	Teacher	Preservice Teacher
<b>Long Range Plans</b>	43	4
<b>Daily Planning</b>	54	8
<b>Interactive Resource</b>	61	12
<b>Assessment</b>	25	5
<b>Other</b>	3	1
<b>Total</b>	86	24

*Can the world wide web make a difference in teaching and learning in mathematics?*

- Increase interest and motivation in learning mathematics—creates active learners
- Comparison (with other countries)
- Instant and current results (e.g., Stats)—good source of information; also currency of teaching approaches & classroom-tested activities
- People who are excited about math put exciting things on the web!!
- Extension of teaching
- The web enables sharing of teachers' and of students' work (so that others can benefit)
- The web is a place to go to find answers (e.g., Quandaries & Queries) or to talk to other teachers (e.g., Teacher talk)
- Enables students to work more independently and creatively
- The web (math sites) is like a math lab outside the classroom—an alternative learning/teaching tool
- A great resource for special education
- Enables access to a great variety of material
- Need to be web literate (i.e., how to search, what you're looking for & how to evaluate)

A summary of the views that respondents had towards the impact of the web on teaching and learning mathematics are:

- Helps understanding
- Promotes interest/motivation in learning
- Provides current, easily-accessible resources
- Access of material for remote areas and special teaching situations
- Fosters sharing of ideas/questions
- Fosters creativity & independent learning
- Need to be web-literate and have good search/retrieval skills

There is no evidence to claim a direct link between the use of web resources and mathematics achievement (as indicated by test scores). But we can conclude, based on the results of this study that:

- Web-based technology engages students' interest and provides the occasion for learning (mathematics)
- Teachers who use web resources (appropriately) in teaching may well provide a rich learning environment for students
- Good teaching is just that—good teaching; good teachers who use web resources use them effectively.

**Our Final Thoughts**

Some teachers tend to focus ON technology, as an object which can perform miracles in teaching and learning (mathematics)—just because it's there. Technology, especially computer-related technology (and more specifically web-based technology) is only as effective as the user (teacher or learner). Different choices are made regarding which form/type of technology to use for which purpose by teachers who hold different ideologies about teaching. Technology is NOT the problem. Blame should not be cast ON technology, nor should claims be made FOR or OF technology. People who teach mathematics should first ask the mathematics curriculum question (what mathematics needs to be taught/learned and by whom?) and then use the best resource to enhance learning of that question. That resource may or may not involve technology. If technology is to be used we reckon it should be used to develop higher-order thinking; it should not shut down thinking, but offer learners a way to learn mathematics differently, or a new way to learn old mathematics, or to make possible the learning of an abstract concept which would be impossible or close to impossible without it. We claim that technology should be used appropriately in careful, thoughtful, child-centred, and curriculum-driven ways.

Technology is ever present in transformative ways. J.S. Brown writes in "Growing up Digital: How the Web Changes Work, Education, and the Ways People Learn" (*Change*, March/April 2000) that . . . "the world wide web will be a transformative medium, as important as electricity." We need to spend time understanding how technology can liberate, not how it can inhibit. We need to understand the flexibility technology offers and the distributed nature of how learning occurs. We need to understand how to create knowledge communities that were simply not available to the learner before. We need to participate in the technology revolution whether we like it or not."

We invite you to explore Math Central and we invite you to think about how you use technology in teaching mathematics. If concrete manipulatives can offer learners a rich hands-on environment and enable them to learn mathematical concepts, then can technology provide a better medium for the exploration of mathematical ideas?



**New PhD Reports**

---

## Mathematical Conversations within the Practice of Mathematics

Lynn Gordon Calvert  
*University of Alberta*

### Introduction

*Mathematical Conversations within the Practice of Mathematics* is offered as a means to question underlying assumptions and broaden current perceptions of practice and discourse in mathematics education. The focus of this dissertation is to explore the place for conversation within the practice of mathematics. However, accepting a discourse of mathematical conversation requires alternate images of practice, intelligent action, acceptable explanation, and of the nature of mathematics. This work begins to shape these alternate images while describing and interpreting mathematical conversations within the whole of doing and coming to know mathematics with others.

Our reasons, as teachers, for becoming aware of alternative discourses and legitimate practices are not because we are striving to find a discourse that eventually 'works' or a practice which prescribes what we should do as educators. Rather, questioning our assumptions about how mathematical knowing is generated and accepted by the discipline is essential for revealing the nature of mathematical knowing and understanding how these assumptions have been woven into classroom practice.

*Mathematical Conversations* attempts to build on recent reforms in mathematics education by pushing the present boundaries of mathematical practice and interaction. Readers are invited to enter into conversation with the text, to question their own assumptions and expectations regarding discourse and practice, the nature of mathematics, and mathematics teaching and learning. It is hoped that by doing so, we can continue the conversation about mathematical discourse and practice as it occurs in our classrooms.

### Mathematical Discourse and Practice

In recent years discourse and language have become a major focus in mathematics education research. This focus is consistent with a current sociocultural emphases in educational research which attends to how discourse and language are cultural and cognitive mediators of learning (Hicks, 1996a). Our current reform image of mathematics instruction has been derived from references to disciplinary practices and has emphasized a discourse of argumentation. For instance, teachers are asked to promote classroom discourse in which students "initiate problems and questions," "make conjectures and present solutions," "try to convince themselves and one another of the validity of particular representations, solutions, conjectures, and answers" and "rely on mathematical evidence and argument to determine validity" (NCTM, 1991, p. 45). These statements reveal the extent to which current reforms promote mathematics as a practice of *problem solving* and as a discourse of *argument*.

One of the difficulties of a problem solving perspective that is revealed in this work is that the goal for problem solving, as it was for drill and practice exercises, remains on completing tasks as quickly and as efficiently as possible so that the students can be 'released' from their relationship with the mathematics. I question whether it is wise or sufficient to equate mathematics or mathematical practice solely with problem solving. I also wonder

whether there are other forms of legitimate practice that may encourage students to maintain their relationship with the mathematics. However, for an alternative practice to be accepted it must be viewed as appropriate and intelligent by persons in the mathematical community.

Similarly, argumentation brings with it a set of assumptions that reveal underlying societal beliefs and values. Western Culture appears to have created a deep-seated connection between argumentation and knowledge acquisition. This is particularly true in the field of mathematics. Mathematics generally emphasizes a methodology of doubt which is congruent with an argumentative discourse in mathematics education. An argumentative approach is based on convincing the other of the correctness of one's thinking. This continues to be a source of difficulty in mathematics learning as the image of mathematics is often presented as step-by-step, linear and error-free. As a result, students are often left with the impression that mathematics arises from one's mind in a finished and polished form; errors, tangents and uncertainty are thought not to occur if one is a knowledgeable mathematician. The lack of acknowledgement of narrative aspects and experiential ways of engaging in mathematical activity have upheld the mystery surrounding mathematics inquiry.

Conversation is explored in this work as a possible alternative mode of discourse which recognizes more formative aspects of mathematical reasoning. However, conversation and doing mathematics may be viewed by many people as incompatible activities. Doing mathematics is often perceived as independent, linear and goal-directed behaviour, while a conversation rarely proceeds in a linear progressive manner with clear direction and purpose. Its character is more circular, weaving its way around and through the topic at hand (Smith, 1991). The participants themselves do not know where they are going or even what they are talking about in some absolute sense. Throughout this work there is a question as to whether the activities within a mathematical conversation would be viewed by the community as acceptable mathematics.

### **Theoretical Framework**

Conversation is not defined here as simply a verbal exchange or informal talk. Instead, conversation is viewed as our primary mode of being and interacting in the world. The theoretical framework for this research is based on an enactivist perspective. Enactivism is a theory of knowing based primarily on the work of biologists Maturana and Varela (Maturana & Varela, 1987; Varela, Thompson & Rosch, 1991). It interrelates contemporary cognitive science with philosophy, psychology, and ecological perspectives. The enactivist framework presented here also draws on Gadamer's 'philosophical hermeneutics' (Gadamer, 1989) and Bakhtin's 'philosophical anthropology' (1981, 1986). Enactivism attempts to blur the distinction between knowing and action by focusing on the *interaction* between a person and his or her environment. Enactivism suggests that mathematical understanding should be studied not through its products or mental structures in and of themselves, but rather, as understanding occurs in the interaction between persons and their environment in the process of bringing forth a world of mathematical significance (Maturana & Varela, 1987; Varela, Thompson & Rosch, 1991). Enactivism suggests that knowledge is not stored in the head or in the world. Rather, it only arises in interaction in which both persons and the environment are mutually responsive. As individuals, we do not simply react to a static environment around us, nor are we isolated, contained individuals who manipulate our surroundings; instead, reality is brought forth on a moment to moment basis through our actions and interactions with others and with the environment.

### **Methodology**

Data for over 15 pairs of participants have been collected for this study. The participants include students in classroom and clinical situations from grades 3 to grade 10, undergraduate students in education, and parents and children involved in an extracurricular mathematics program. The number of mathematical sessions that each pair participated in varied from one to six. All sessions followed the same general format: a mathematical prompt was posed

and it was expected that participants would continue to engage in it for as long as it held their interest. There was an expectation that this would be approximately one hour. The prompts were frequently found in problem solving books (e.g., Mason, Burton & Stacey, 1985; Stevenson, 1992) and made use of concrete manipulatives, paper and pencil, and computer software. The prompts were potentially rich in mathematics and allowed students with a variety of skills and experiences to participate in various ways. The mathematical prompts provided a starting point for inquiry into mathematical activity. While some outcomes were anticipated, it was not expected that all students would engage in similar activities. The pairs engaged in the mathematical environment in ways they determined appropriate and personally relevant.

The dissertation itself provides three illustrative examples of mathematical conversations focusing on (1) mathematical explanations in the process of understanding, (2) relationships within mathematical conversations and (3) lingering in a mathematical space. While the interpretations made are directly related to the context of the illustrative example provided in each chapter, these interpretations were informed by observations made of all participants in this study—including sessions that were viewed as having qualities that were not consistent with mathematical conversations. The sessions selected for this dissertation provide a broad basis from which to discuss the interdependent features of mathematical conversations.

The reporting of this data cannot be thought of as presenting a correct view of what 'is' or what 'was,' for no such view is possible (Shotter, 1993). My descriptions and interpretations are necessarily incomplete and open to further interpretation. Their incompleteness is not because they stand as only a partially correct match to a universally objective truth, but because they "initiate and guide a search for meanings among a spectrum of possible meanings" (Bruner, 1986, p. 25). Interpretation and explanation allow us to enter into the creation of meaning and are purposeful within their incompleteness to shape expectations and provide meaning and coherence for experiences related to mathematical interactions. It is expected that a reader will expand upon these explanations further so that an even broader understanding of the experiences may be shared.

### **Mathematical Explanations in the Process of Understanding**

The two participants in this narrative were both undergraduate students, Tamera and Kylie, majoring in mathematics. Rather than presenting this research as how people *should* come to know mathematics through interaction, this chapter suggests how, at least some people *do* come to know mathematics through mathematical acts of explanation and reasoning within a context of conversation.

The form of mathematical explanations offered by Tamera and Kylie's interaction were described as *explanations in action*. Explanations in action are an offering or invitation to oneself and to the other. They often invite images, models, metaphors, and narratives of the topic of concern. Kylie and Tamera's explanations were not attempts to convince the other, but were offerings which expanded their understanding of the phenomenon. These explanations did not attempt to satisfy a criterion of correctness or completeness nor were they attempting to convince the other of a particular truth as an end-point. Instead, their explanations in action allowed them to say or to experience a feeling that they could "go on" (Wittgenstein, 1953). They were offered as plausible, sufficient and believable for the moment. Such explanations subsequently defined a domain of legitimate actions and practices from within which they acted.

However, mathematics as a discipline has had difficulty acknowledging the role that formative explanations play in learning mathematics and in expanding fields of study within mathematics. While the criterion for acceptance of mathematical explanations in action are based on whether it expands the participants understanding of a phenomenon in that moment, in mathematics the criteria for explanations has been based on its perceived accuracy, completeness and whether it is a convincing argument. Explanations from this perspective are an end point in the discussion. The contradiction has implications for what we have

**FEATURES OF MATHEMATICAL CONVERSATIONS**

Orienting Gestural Domains	Features within a Mathematical Conversation
<p><b>ADDRESSIVITY TOWARDS THE OTHER</b></p> <p><i>What response is expected from and offered to the other?</i></p> <p><i>What emotional predisposition is chosen?</i></p> <p><i>How are conflicts dealt with?</i></p>	<p><i>Oriented towards relationships among persons in interaction.</i></p> <ul style="list-style-type: none"> <li>• The listener has an ethical responsibility to respond to and address the other through questions, clarifications, or continuations and extensions of previous gestures.</li> <li>• The mutual acceptance of self and of the other supports ongoing interpersonal relations.</li> <li>• Alternative explanations and counterexamples are offered and perceived to assist in expanding understanding.</li> </ul>
<p><b>ADDRESSIVITY TOWARDS OTHERNESS</b></p> <p><i>What response is expected from and offered by the participants and by the mathematical otherness?</i></p> <p><i>What emotional predisposition is chosen?</i></p>	<p><i>Oriented towards relationships among persons and the mathematical environment.</i></p> <ul style="list-style-type: none"> <li>• Participants seek insight and understanding by responding to and addressing otherness through questions, predictions, conjectures, and explanations.</li> <li>• Otherness responds to the participants' gestures by bringing forth alternative and shifting mathematical landscapes.</li> <li>• Curiosity and a structure of play support ongoing mathematical relations.</li> </ul>
<p><b>THE LIVED CURRICULUM</b></p> <p><u>Directing the Course</u> <i>Who or what is responsible for directing the path of mathematical activity?</i></p> <p><i>What mechanisms set the boundaries of the lived curriculum?</i></p> <p><u>Mathematical Explanations</u> <i>How are mathematical explanations posed?</i></p> <p><i>What criteria are used to accept explanations?</i></p>	<p><i>Interactions between persons and mathematical environment lay a path of mathematical activity.</i></p> <ul style="list-style-type: none"> <li>• The direction of activity is led by no one and no thing. The path is oriented by emotionally charged mutual concerns arising in the moment.</li> <li>• Proscriptive logic sets the boundaries: whatever is allowed by the mathematical situation and by the participants' experiences is acceptable.</li> <li>• <i>Explanations in action</i> arise in the course of ongoing interaction and are open to revision at any time.</li> <li>• <i>Explanations as re-presentation</i> arise in moments requiring a summary of interactions.</li> <li>• Criteria of acceptance: When explanations are perceived to broaden understanding in that moment and are plausible, coherent with previous experiences and good enough for now; they allow participants to continue on.</li> <li>• Explanations are observed to be accepted when they become part of the participants' subsequent actions.</li> </ul>



accepted as mathematical in our classrooms. If mathematical explanations in action are to be accepted by the mathematics community as mathematical, the community must alter its criteria for acceptance. Until then, 'mathematical explanations in action' will not be viewed as mathematical or as an acceptable mathematical practice in and of itself—only as a precursor to 'real' mathematics.

### **Relationships within Mathematical Conversations**

Stacey, a mathematics major in education, volunteered to participate with her friend Ken, a business student, as her partner. This chapter focuses on the relationships Stacey and Ken form between themselves and also between themselves and the mathematics brought forth as they engaged in a mathematical conversation.

Stacey and Ken maintained their relationship with one another and with the mathematics for an extended period of time. Their mathematical activities were playful, creative and unexpected. Although their work may be viewed as a spontaneous and random creation, such a view would belie the experience and history that both Stacey and Ken bring to this situation. As this mathematical conversation unfolded—as they laid down the path of their exploration—who they are, what they believe, and what mathematical skills, and interests they have brought are recognizable in what they do, what they say, and in the roles that they play.

Inviting mathematical conversations into the classroom requires an acknowledgement of the emotional aspects of interpersonal and mathematical relationships. The members of the community need not only tolerate but must invite ambiguity and uncertainty into their play-space. Rather than being tied to a specific goal, a perceived utility or a final destination, the importance of play for the purpose of continuing to play becomes a key feature of mathematical conversations, but more importantly, it is a feature of the ongoing practice of mathematics.

### **Lingering in a Mathematical Space**

In this chapter Calvin, who was twelve years of age, and his mother Jolene participated in an extra-curricular mathematics program for children ages 8 – 14 and their parents. They are not working in a tutor-tutee relationship, but are both engaged in the mathematical activity together. The path of their mathematical activity cannot be viewed as being directed towards a future goal or as an attempt to solve a predetermined problem. Instead, it is described as lingering; that is, a mode of being or living in which questions and concerns are raised and addressed in the moment as part of their ongoing interactions with each other and with the environment. Such concerns cannot be viewed as discrete nor do they ever appear to be completely resolved; rather, they overlap, are revisited and lead to other concerns.

Because of the less goal-directed nature of lingering it may be viewed with skepticism as a useful mode of mathematical activity. Although Calvin and Jolene engaged in mathematical actions for an extended period of time, would such mathematical lingering be observed as intelligent behavior or as random wanderings? An alternative image of intelligence based on an ongoing and evolutionary notion rather than on a finite problem solving perspective is used to analyze their interactions. This perspective of intelligence suggests that we exist within a mode of lingering. The goal of living is not to find one's way to the other side of life, but to experience living through a series of meaning-making actions—actions through which "one's world stands forth" (Johnson, 1987, p. 175).

If viewed as an appropriate and intelligent activity, lingering in a mathematical space allows its participants to maintain their relationships and stretch the boundaries of their activities so that new ideas, concerns and understandings can be incorporated. There is recognition that a complete understanding of a problem is never obtained, but one's understanding continues to expand as he or she maintains relationships with the mathematical world brought forth.



## Conclusions

The features of mathematical conversation drawn from the illustrative examples provided are summarized into three observational domains of discourse: (1) *Addressivity towards the other* highlights the ethical responsiveness and responsibility of persons in conversation and their mutual acceptance of one another to support ongoing mathematical interactions. (2) *Addressivity towards otherness* emphasizes the reciprocal relationship between the conversants and the mathematics brought forth. That is, participants not only respond to the mathematics, but the mathematical field of play responds to the conversants' interactions. (3) *The lived curriculum* is the path of mathematical activity laid as the addressivity interactions unfold. The lived curriculum in conversation is not directed from within any individual nor is it simply random. The path is oriented by the mutual concerns raised within the ongoing interactions and is bounded by the possibilities for mathematical action and by the participants' experiential histories drawn into the moment.

Mathematical conversation as presented here does not attempt to prescribe or even describe how mathematical conversations should be implemented into the classroom by defining the teacher's and students' roles in discourse, the tasks, or the learning environment. This work does, however, point to features of mathematical conversations and suggest ways in which they can be observed within the classroom. Mathematical conversation also points to the potential consequences for the choices educators make in terms of discourse and acceptable mathematical practices.

The present research raises a number of pedagogical concerns for choosing argumentation as an exclusive form of discourse and problem solving, as it is currently perceived, as an exclusive form of practice. I offer mathematical conversations, not as a replacement, but as an alternative. I do not suggest that every interaction in mathematics should be an occasion for mathematical conversation. Mathematical conversation is one potential and possible path within the practice of mathematics requiring further exploration and explanation within mathematics education.

## References

- Bakhtin, M.M. (1981). *The dialogic imagination*. Edited by M. Holquist. Translated by M. Holquist & C. Emerson. Austin: University of Texas Press.
- Bakhtin, M.M. (1986). *Speech genres and other late essays* Edited by C. Emerson & M. Holquist. Translated by V.W. McGee. Austin: University of Texas Press.
- Bruner, J. (1986). *Actual minds, possible worlds*. Cambridge, MA: Harvard University Press.
- Gadamer, H.-G. (1989). *Truth and method* (2nd Rev. ed.). Translated by J. Weinsheimer & D.G. Marshall. New York: Continuum.
- Hicks, D. (1996a). *Discourse, learning, and schooling*. Cambridge, UK: Cambridge University Press.
- Johnson, M. (1987). *The body in the mind: The bodily basis of meaning imagination, and reason*. Chicago: The University of Chicago Press.
- Mason, J., Burton, L., & Stacey, K. (1985). *Thinking mathematically* (revised edition). Wokingham, UK: Addison-Wesley Publishing Company.
- Maturana, H.R., & Varela, F.J. (1987). *The tree of knowledge: The biological roots of human understanding* (revised edition). Boston: Shambhala.
- National Council of Teachers of Mathematics. (1991). *Professional standards for teaching mathematics*. Reston, VA: NCTM.
- Shotter, J. (1993). *Conversational realities: Constructing life through language*. London: Sage.
- Smith, D. G. (1991). Hermeneutic inquiry: The hermeneutic imagination and the pedagogic text. In E.C. Short (Ed.), *Forms of curriculum inquiry* (pp. 187-209). Albany, NY: State University of New York Press.
- Stevenson, F.W. (1992). *Exploratory problems in mathematics*. Reston, VA: NCTM.
- Varela, F.J., Thompson, E., & Rosch, E. (1991). *The embodied mind: Cognitive science and human experience*. Cambridge, MA: The MIT Press.
- Wittgenstein, L. (1953). *Philosophical investigations*. Translated by G.E.M. Anscombe. New York: Macmillan.

## The Word Problem as Genre in Mathematics Education

Susan Gerofsky  
Simon Fraser University

My thesis looks at the word problem in mathematics education as a genre, seen from a number of points of view: from the standpoints of linguistics, literary theory, pedagogic intentions, and the history of the genre. The central questions asked are: What *are* word problems? What other genres are they *like*? What do we think they are for? and Where do they come *from*?

This study is *not* intended to find ways to teach students to be more efficient solvers of mathematical word problems. Neither is it intended to use linguistic analysis to recommend better or more efficient ways to write word problems aimed at students of particular school grade levels or reading levels. Rather than ask, "How can we make better word problems?" or "How can we make our students better solvers of word problems?", I ask, "What *are* word problems?"

### The word problem genre seen from the points of view of linguistics, narrative theory, pedagogy and history of mathematics

My answers to this question follow from my observation that mathematical word problems can be seen as a linguistic and literary *genre* that forms part of the traditional pedagogy of mathematics.

Considering a set of disparate texts as a genre is to view this set as a conceptual *object* (similar to a "mathematical object"). In metaphorical terms, my aim in this project is to see "the mathematical word problem" as a figure set against a variety of different backgrounds.

Since mathematical word problems are texts written in natural languages (although some would question how "natural" their language really is), I begin my "walk" around the word problem from the point of view of linguistics, in particular the branch of linguistics called pragmatics, the study of language in use. From this point of view, word problems can be seen as a form of linguistic utterance, set against the background of all other forms of linguistic utterance. Certain oddities or particularities about the language of word problems can be seen from this point of view, including unusual forms of reference, an anomalous use of verb tense, and a particular discourse structure.

Word problems are also *story problems*, and pose mathematical questions in the form of stories. So mathematical word problems can also be seen from the point of view of literature and narrative theory, and can be viewed against a background of stories in general. Again certain peculiarities become evident, this time in terms of plot and character, the positioning of the narrator and reader, the placement of the narration in time and place—and these peculiarities are closely linked to word problems' linguistic features. I analyze mathematical word problems from the related points of view of linguistics and literary/narrative theory and find cohesion in the singular "object" seen from these two vantage points. The word problem genre does indeed seem to be a unified, distinctive object, and this analysis provides suggestions as to which other genres it may be related to in terms of its linguistic and literary features.

A description of genre requires us to ask not only, "What is it?" but also, "What is it for?" and "Who is it for?" Considerations of genre, at least since Bakhtin (1986), inevitably lead to questions of addressivity and intention. Addressivity refers to the author's real or imagined audience for a particular utterance or piece of writing. Bakhtin writes:

Both the composition and, particularly, the style of the utterance depend on those to whom the utterance is addressed, and the force of their effect on the utterance. Each speech [or written] genre in each area of ... communication has its own typical conception of the addressee, and this defines it as a genre. (1986, p. 95)

In the case of word problems, intention includes educators' conscious, stated intentions when writing or teaching word problems, but also intentions carried by the word problem genre itself and students' uptake of their teachers' intentions, of which educators may not be aware. In a small-scale empirical study, I interviewed some teachers, students and curriculum writers in primary, secondary and tertiary mathematics education in order to begin to understand their intentions, or uptake of others' intentions, around the word problem genre in mathematics education.

I saw this part of the study as a way of testing my analytic findings about word problems in conversation with others—students, teachers, writers—people who are intimately involved in the use of word problems in mathematics education. Again, there are many resonances with linguistics, since the study of linguistic pragmatics is deeply involved in questions of intentionality in language in use. As part of a "walk around" the word problem genre, I took a standpoint in the practical, day-to-day world of mathematics pedagogy in schools, and viewed the word problem genre against a background of other pedagogic forms and intentions.

The last viewpoint in this study is a historical one. My question here is, "What are the origins of the genre?" and "How has it changed over the course of its history?" Mathematical word problems have very ancient origins, and a very long continuous history of use in the teaching and learning of mathematics. Following on earlier analysis, I look at the history of forms and intentions related to the word problem genre. There is difficulty in ascribing particular intentions to written texts which span a very long history and wide-ranging cultural geography, and which we are often obliged to read in translation. Nonetheless, there are at least some likely conjectures and intriguing suggestions to be gained from this point of view, looking at the word problem genre as an object set against other historical texts in mathematics education.

Finally, I suggest that an exploration of genre in mathematics teaching and learning can be a source for innovation and renewal in mathematics education practices. I propose that identifying and describing the *genres*, or forms, of teaching can be a creative step toward improving teaching. Knowing more about educational genres allows us to take a more playful or artful attitude towards the forms that we have inherited. This aspect of playing with forms is in contrast to the overwhelmingly moralizing tone which has traditionally been central to educational writing. A primarily moral stance tends to foreclose on the possibilities of a genre with a stern "yea" or "nay" ("Use nothing but word problems!" or "Never again use word problems!") without ever taking the time to investigate what the genre is and why it is that way.

Knowing more about what a genre *is* in descriptive terms can allow us to play with the boundaries of the genre, changing or emphasizing its typical features and pushing it to the edge of its genre boundaries to create new forms. Knowing what a genre *is like* (i.e., what other genres it reminds us of or is structurally similar to) allows us to treat one genre *as if* it were another, to recontextualize it, and by placing an old genre in new settings, to give it new meanings by using analogy to other, similar genres.

Knowing some of the *intentions* encoded within a generic form, knowing *who* it is addressing and some of what it is striving to say to its intended audience, allows us to know what a particular genre will or will not allow us to say by its very form. An awareness of codified intentions allows us to play with various ways of saying what (we think) we intend.

Finally, understanding something of the history of a genre, knowing where a genre *comes from*, allows us to retrieve cultural memories, to revive old meanings in new settings and make new meanings in old settings. Revisiting archaic forms and intentions can give inspiration and energy in the present.

### Conclusions

In offering some background to genre theory from linguistics, literary studies and film studies, I make the following assertions:

- Genres are sets of cultural conventions. Genres are defined by cultural recognition and consensus, and do not necessarily satisfy a defining list of clearly-stated characteristics;
- Addressivity is an important feature to investigate in any genre. A particular genre addresses a particular imagined audience;
- Examples of a certain genre are made in imitation, not of life, but of other exemplars of the genre (so word problems are made not in imitation of life but of other word problems);
- To quote rhetorician Carolyn Miller, "What we learn when we learn a genre is not just a pattern of forms or even a method of achieving our own ends. We learn, more importantly, what ends we may have" (Miller, 1984, p. 165). The genres of our culture define us, our identities and desires, in relation to our culturally-mediated worlds;
- Genres carry their own generic intentions, which may or may not be our intentions as users of the genre. These meanings, inherent in the very form of the genre, may have historical or archaic roots.

Looking at word problems from the point of view of linguistics and of literary theory, I asked two questions: what is the word problem genre and what other genres is it *like*?

Linguistic analysis of the word problem genre found the following features typical of word problems as a genre:

- a 3-component narrative structure (set-up, data, question);
- indeterminate deixis of nouns and pronouns;
- a non-deictic use of metalinguistic verb tense;
- strong, unambiguous illocutionary force (along the lines of, "Turn this into a mathematical problem of the type you have just been taught, and find the right answer!"). This illocutionary force rests on a series of tacit assumptions—for example, that the word problem contains sufficient information for its solution, that contingencies of our lived lives cannot be invoked nor extraneous information requested, that the word problem can be turned into a symbolic mathematical problem, that a right answer exists, that word problems are meant as exercises to practice mathematical methods, etc.;
- "no truth value"—that is, as with fiction, it is inappropriate to ascribe truth or falsity to the statements in a word problem;
- a flouting of the "Gricean maxim of quality" (which states that, in order to make conversation possible, we agree not to say what we believe to be false).

Literary analysis of word problems suggests that they are *like* religious or philosophical parables in their non-deictic, "glancing" referential relationship to our experienced lives, and in the fact that the concrete images they invoke are interchangeable with other images without changing the essential nature of the word problem or parable. The nouns and verbs in both word problems and parables point to a non-material world (the world of mathematical objects or philosophical entities) rather than to their usual referents in our material, lived lives. For this reason, both parables and mathematical word problems feature odd, often fanciful, elliptical and inconclusive story elements, an anomalous use of verb tense, and a lack of concern with the contingencies of day-to-day life.

Where the two genres differ is in their use. While parables are meant to be lingered



over, because they resonate with the deepest concerns of human life and teach through paradox and perplexity, mathematical word problems are typically offered to students for quick translation into symbolic form, correct solution by familiar methods as an exercise, and immediate disposal.

In the empirical portion of this study, I looked at the word problem genre as an object of pedagogy, and at gaps between pedagogic intentions consciously ascribed to by teachers and writers, those inherent in the genre, and those taken up by students in their role as cultural interpreters. In interviews with teachers and curriculum writers, a variety of stated pedagogic intentions were found. A pattern that emerged was that educators involved in elementary schooling valued practical, contextualized, open-ended problems over abstractly mathematical ones, while those in tertiary education valued abstract mathematical interpretations, in which students were encouraged to “see through” the apparent story to a mathematical structure (or alternately, to “project” the desired mathematics onto the story situation), rather than dwell on the given story. The only secondary teacher interviewed seemed to be in an uncomfortable middle position, pulled by the expressed aims of both elementary and tertiary mathematics education cultures. This teacher expressed conflicting desires to do “real” problem solving of the type favoured by the elementary teachers, and to acculturate students to see the abstract mathematical structures favoured by tertiary education teachers.

Students’ uptake of their teachers’ intentions seemed quite accurate—that is to say, the students were skilled readers of their teachers. Those with the highest levels of tertiary mathematics education were most consistently willing and able to “see through” word problems to mathematical structures, and, although some initially stated that word problems were meant to prepare them for practical job situations, a look at some examples from their own textbook led them to other conclusions.

Elementary and junior secondary students, although capable of “seeing through” story as well, more often looked at word problems in terms of their real-life applications, in terms of their holistic meanings and lived-life contingencies. They criticized particular problems on practical or moral grounds. Those students whose teacher enjoyed the pleasurable riddling tradition affiliated historically with word problems also expressed enjoyment at solving puzzles. Students valued the interest and memorability of word problem imagery, and saw the question component as a point of entry to become involved in playing with the problem.

Looking at the history of the word problem genre, I focused on issues of intentionality. I found that mathematical word problems have a continuous history going back more than 4000 years, to ancient Babylon and ancient Egypt, and spanning cultures as diverse as ancient China, medieval India, the medieval Islamic world, and medieval and Renaissance Europe. What is more, the form of mathematical word problems appears nearly unchanged throughout its long history.

It was established that, from the earliest citations of word problems on Babylonian clay tablets, these problems were never simply applications of mathematics to practical, real-life problems. Mathematical methods and concepts have always come prior to the stories of word problems, and there has always been ambiguity in the referents for the words in these stories. In a tangential way, the words used refer to the concrete objects that are their usual referents in natural language; however, their primary referents are the objects and methods of a mathematical world, although these are only spoken of in the coded clothing of story.

I speculated that the purpose of mathematical word problems may have changed at the time when algebra was introduced. In a pre-algebraic culture, the only way to express mathematical generality may be through repeated exemplars—that is, through a series of stories which point to similar mathematical structures and methods. Algebra, on the other hand, can easily express generality using variables. My conjecture is that, once algebra had been introduced, the long tradition of word problems was preserved by attaching new meaning to the genre, that of useful, practical problems. The pretext of practicality and usefulness has justified the use of word problems in mathematics education; and since most school students are either pre-algebraic or novices at algebra, word problems may continue to serve the purpose of expressing generality through repeated exemplification for them.

### Some implications for teaching

Is there a distinction between riddles, recreational puzzles and school word problems? Since the same problems can be found contextualized in all three settings, the difference seems to lie mainly in the intentions surrounding the problem. Riddles are contextualized in a setting of pleasurable social interaction. They can be part of a process of building social solidarity and, simultaneously, a source of competition, as in the village riddling contests. Although riddles have been collected in written form, their primary use is in oral culture, and good riddlers can draw from a large memorized repertoire upon which a certain degree of improvisation is possible.

In contrast, word problems in school mathematics are traditionally assigned as a sort of bitter medicine that will make you better. In North American mathematics textbooks, they usually come at the end of a series of “easier” numerically or algebraically-stated problems related to a mathematical concept introduced in the preceding chapter. The word problems represent a final test of students’ competence in recognizing problem types related to that chapter and translating those problems into tractable diagrams and equations which can be solved using taught algorithmic methods. School word problems are not social events nor part of an oral culture. They are ideally meant to be solved silently, individually, using pencil and paper. Students are certainly not encouraged to memorize a repertoire of word problems for later enjoyment. On the contrary, once solved, they are generally discarded by teacher and students.

Riddles often retain strong links to folktales and parables and other teaching tales in their invocation of paradox and ambiguity, through their use of puns, hyperbole, nonsense, etc. Like parables and word problems, they point to two worlds at once—the world of their literal referents and another world invoked by word play or unexpected associations and structures. In riddles and parables, this ambiguity is embraced as essential to the enjoyment and philosophical import of the genre.

Contemporary writers of mathematical word problems, on the other hand, work hard to make their problems realistic, relevant and unambiguous. In this pursuit of singleness of meaning and relevancy, they are stymied by the genre’s history and form, which carry with them the intention to create paradox and at best a shifting relationship to everyday reality.

What if we treated word problems in mathematics classes as if they were parables, or riddles? Would this alter our intentions as mathematics educators, or our students perceptions of those intentions?

For example, if word problems were not considered disposable exercises (as they often are now) but as parables worthy of longer and deeper contemplation, we might spend a week considering a single word problem in all its considerations and implications. Students might be asked to comb older textbooks or even historical sources for word problems pointing to the same mathematical structures as the “parabolic” story under consideration. They might consider changing certain features of the word problem while holding others unchanged, and seeing whether this altered the mathematical relationships pointed to in the problem. They might try to project real-life situations in which recalling the word problem “parable” might be instructive, or helpful, or comforting.

And what if word problems were considered as riddles? First of all, a playful and perhaps competitive spirit would be invoked. Word play and double meanings would be welcomed rather than banned. A pleasurable, oral culture approach to a recreational use of word problems would take the place of our present, very serious approach to evaluation of student written knowledge.

Perhaps the simple suggestion that mathematical word problems be considered *as parables* or *as riddles*—the shift to the “as if” point of view that characterizes play and drama—may begin to engender a shift in thinking and in educational practice. Playing with genre, and even pushing its elements beyond genre limits may lead to unexpected insights. Why not take a playful approach to the traditional genres of mathematics education, and what is more, why not let our students in on what we know about these genres and give them a



chance to play with them too? Rather than forcing a choice for teachers, either to embrace traditions unthinkingly or discard traditional forms in a fever of reform, we could "try on" new contexts for old forms, and encourage an awareness of the forms themselves. By playing with unfamiliar intentions for familiar forms, we may find renewed meanings and resonances for the genres of mathematics education.

### Acknowledgements

Many thanks to faculty and colleagues in the Faculty of Education at Simon Fraser University and to members of CMESG for their ongoing support, challenges and stimulation. Thanks to the teachers, students and curriculum writers who agreed to be interviewed for this thesis. Thanks to all the members of my committee for their unfailing interest and guidance. A special and heartfelt "thank you" to David Pimm for his very thoughtful mentorship, excellent editorial advice, and for all the time he contributed throughout this project.

### References

- Bakhtin, M.M. (1986). *Speech genres and other late essays*. Translated by V.W. McGee. Austin, TX: University of Texas Press.
- Grice, H.P. (1975). Logic and conversation. In P. Cole & J.L. Morgan (Eds.), *Syntax and semantics 3: Speech acts* (pp. 41–58). New York: Academic Press.
- Høyrup, J. (1994). *In measure, number, and weight: Studies in mathematics and culture*. Albany, NY: State University of New York Press.
- Jamieson, K.M. (1975). Antecedent genre as historical constraint. *Quarterly Journal of Speech* 61, 406–415.
- Kafka, F. (1961). *Parables and paradoxes*. New York: Schocken Books.
- Keitel, C. (1989). Mathematics education and technology. *For the Learning of Mathematics* 9 (1), 7–13.
- Lamarque, P., & Olsen, S.H. (1994). *Truth, fiction and literature: A philosophical perspective*. Oxford, UK: Clarendon Press.
- Lave, J. (1992). Word problems: A microcosm of theories of learning. In P. Light & G. Butterworth (Eds.), *Context and cognition: Ways of learning and knowing* (pp. 74–92). New York: Harvester Wheatsheaf.
- Levinson, S. (1983). *Pragmatics*. Cambridge, UK: Cambridge University Press.
- Miller, C.R. (1984). Genre as social action. *Quarterly Journal of Speech* 70, 151–67.
- Olivastro, D. (1993). *Ancient puzzles*. New York: Bantam.
- Singmaster, D. (1988). Some early source in recreational mathematics. In C. Hay (Ed.), *Mathematics from manuscript to print 1300–1600* (pp. 195–208). Oxford, UK: Clarendon Press.
- Sobchack, T. (1975). Genre films: A classical experience. Reprinted in In B.K. Grant (Ed.) (1986), *Film genre reader* (pp. 102–113). Austin, TX: University of Texas Press.
- Swales, J.M. (1990). *Genre analysis*. Cambridge, UK: Cambridge University Press.
- Tropfke, J. (1980). *Geschichte de Elementarmathematik, 4. Auflage: Band 1: Arithmetik und Algebra*. Berlin: De Gruyter.

# How Visual Perception Justifies Mathematical Thought<sup>1</sup>

Dennis Lomas

*Ontario Institute for Studies in Education/University of Toronto*

Visual perception has been cast in many roles. Some philosophers of mathematics regard perception as an essential constituent of mathematical intuition.<sup>2</sup> According to some psychologists, visual perception is directly involved in problem solving.<sup>3</sup> A traditional view in mathematics in effect charges that visual perception provides misleading information.<sup>4</sup> On this showing, diagrams are relegated to what is considered to be a minor and suspect role as "aids to intuition".

My PhD thesis attempts to show that visual perception helps to justify a significant range of mathematical beliefs, including those pertaining to the mathematics taught in school. There is not enough time to present my whole thesis in the allotted time. Instead, I present a core argument. Although my presentation of this argument is not as fleshed out as it is in my thesis, it should give you a good idea of one of the central ideas of my thesis. This is that visual perception significantly helps to justify (provide an objective foundation for) some mathematical propositions, in particular, geometric propositions.

A few caveats are in order at the outset. I do not deny that visual perception can sometimes prompt incorrect inference. My claim is that visual perception *in general* supplies correct information with which to reason. This is especially so in geometry. Neither do I hold that visual perception is the only way in which mathematical knowledge is justified. A full account of such justification would need to include, among other things, how activities and practices such as refereeing sanction new mathematical results, and how the success of scientific and engineering practices warrant the mathematics employed in these enterprises.<sup>5</sup> As a final caveat, I do not attempt here (nor in my thesis) to show that visual perception justifies all mathematical propositions or propositions from all branches of mathematics. I do not claim, for example, that visual perception justifies the continuum hypothesis.

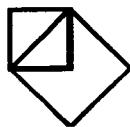

FIGURE 1

My argument begins with an examination of the utility of diagrams in geometric thought. Diagrammatic reasoning goes back a long way. There is an ancient description of geometric reasoning with diagrams in Plato's dramatization in the *Meno* (81e-86b) where a boy, under Socrates's questioning, figures out how to double a square, that is, how to construct a square exactly twice the area of a given square. The boy learns that a square with a side equal to the diagonal of the given square is twice its area. This proposition is illustrated in Figure 1. The larger square, whose side is a diagonal of a smaller square, is twice the area of the smaller square. By Socrates's lights, the boy's learning is "remembering" from past lives.<sup>6</sup> Even though Plato uses this scene to develop a theory of "reminiscence" from past lives, the scene is an even-handed portrayal of diagrammatic reasoning. The linguistic prerequisites for solving the problem are implicitly given at the beginning of the scene. The boy is proficient in Greek and of course considerable language understanding is required to follow Socrates's questions.<sup>7</sup> Meno: Very much so. He was born in my household" (*Meno*,

82b). In fact, Socrates and the boy share many concepts; otherwise they could not converse with each other. The boy knows some mathematics. He knows, for example, what a square is<sup>8</sup> and he knows four is double two.<sup>9</sup>

Relying on the particular figures in the sand, after a few false starts which he corrects under Socrates's careful questioning, the boy learns how to double any square. The diagrams in the sand are crucial for solving the problem. For example, once the boy examines a diagram something like that shown in Figure 2<sup>10</sup> and after Socrates asks him a few more questions, he realizes how to double a square. The solution in essence is this. The square formed by the diagonals, illustrated by shading in the diagram below, is twice the area of any of the four smaller inside squares, one of which is illustrated by stripes in Figure 3. The shaded square is composed of four small triangles, whereas the striped square is composed of two small triangles. (All the small triangles have equal area.) Consequently, the shaded square has twice the area of the striped square. Furthermore, a side of the shaded square is a diagonal of the striped square. This solves the doubling a square problem because it demonstrates that a square (as indicated by the shaded square above) with a side that is the diagonal of another square (as indicated by the striped square above) is double its area. This scene suggests that diagrams can play a central role in some geometric proofs.

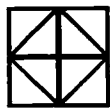

FIGURE 2



FIGURE 3

This assessment might be challenged by disputing the role of diagrams. In fact, diagrammatic proofs are held in disrepute by many mathematicians and logicians. Diagrams are considered at best as mere "aids to intuition" and not legitimate constituents of mathematical proofs mainly because of the danger of generalizing from accidental features of diagrams. Logician Neil Tennant adheres to this view:

[The diagram] is only an heuristic to prompt certain trains of inference: ... it is dispensable as a proof-theoretic device; indeed, ... it has no proper place in the proof as such. For the proof is a syntactic object consisting only of sentences arranged in a finite and inspectable array. (Tennant 1986, taken from Barwise and Etchemendy 1991, p. 8)

Philosophers and logicians Jon Barwise and John Etchemendy correctly contend that this stance is mistaken, provided care is taken not to use accidental features of diagrams in proofs. In challenging the dogma that all sound reasoning must be exclusively sentential, they draw on the work of psychologists<sup>11</sup> who similarly have challenged this dogma.

After presenting a standard diagrammatic proof of the Pythagorean Theorem, Barwise and Etchemendy argue:

It seems clear that this is a legitimate proof of the Pythagorean theorem. Note, however, that the diagrams play a crucial role in the proof. We are not saying that one could not give an analogous (and longer) proof without them, but rather that the proof as given makes crucial use of them. To see this, we only need note that without them, the proof given above makes no sense.

This proof of the Pythagorean theorem is an interesting combination of both geometric manipulation of a diagram and algebraic manipulation of nondiagrammatic symbols. Once you remember the diagram, however, the algebraic half of the proof is almost transparent. This is a general feature of many geometric proofs: Once you have been given the relevant diagram, the rest of the proof is not difficult to figure out. It seems odd to forswear nonlinguistic representation and so be forced to mutilate this elegant proof by constructing an analogous linguistic proof, one no one would ever discover or remember without the use of diagrams. (Barwise and Etchemendy 1991, p. 12)

So Barwise and Etchemendy rightly dispute Tennant's contention that a diagram is dispensable and is "only an heuristic to prompt certain trains of inference". Instead, diagrams take centre stage in many geometric proofs, so much so that algebraic manipulation is "almost transparent" once the relevant diagram is recalled.<sup>12</sup> An objection may be that alterna-

tive proofs may not utilize diagrams. However, that does not undermine the full-fledged role of diagrams in proofs that utilize them, as Barwise and Etchemendy point out.

Visual perception supplies shape information that is used in solving problems. In the case of perceiving a diagram of a square, we become consciously aware of shape properties of the diagram: its number of sides, the equality of angles and sides, and various symmetries. This information is needed in order to solve the doubling-a-square problem. Presumably, it is perceived *shapes* that assist us in figuring out the solution because, in a geometric diagram, information about shape is the only type of information that is relevant to solving geometric problems.

Geometry is generally concerned with abstract geometric objects (for example, perfect or ideal squares), which cannot be perceived because they are immaterial. It might, then, seem that visual perception cannot play a role in geometric reasoning because visual perception cannot give us cognitive access to abstract geometric objects. However, as already shown, the utility of diagrams in geometric reasoning can be explained only by supposing that visual perception supplies conscious shape information. How, then, does visual perception supply this information? One suggestion is this. Visual perception gives us access to concrete diagrams, which we then non-perceptually construe to be representations of abstract geometric objects. This seems to be part of the answer because in order to reason about abstract geometric objects, we need a way to represent them. This is not the full answer, however, because in order to facilitate geometric reasoning, a diagram typically needs to mimic, in a significant way, the shape of the abstract geometric object (or objects) that the diagram represents. Why should this be so; that is, why should the shape of a diagram matter in this way?

The answer to this last question seems to be a variation on what has already been argued: visual perception of a concrete diagram in a way supplies conscious information about the shape properties of the abstract object, shape properties which the diagram mimics in some significant way. But how is visual perception able to do this? To understand what is going on we need to observe, first, that geometric reasoning (about abstract geometric objects) takes place within the context of our having acquired the concept abstract geometric object. (This is not to say that we know everything about an *abstract* geometric object that we are studying. In fact, the aim of geometric reasoning is often to discover more properties of *abstract* geometric objects. We do know, however, that the object is abstract and in what sense it is abstract.) In this context, visual perception greatly contributes to our conscious awareness of the shape properties of abstract geometric objects even though we visually perceive only shape properties of concrete diagrams that depict abstract objects and have similar shapes to these objects. That is to say, the perception of shape properties of concrete diagrams is a *surrogate* for conscious awareness of shape properties of abstract geometric objects depicted in the diagrams.<sup>13</sup> This surrogate consciousness can arise for a subject only if the subject knows what an abstract geometric object is, in particular, knows that its shape can be only approximated by a diagram. As an example of the surrogate role of visual perception, consider perception of Figure 4, a depiction of an abstract geometric object (a depiction used in trying to solve the problem of doubling an *abstract* square). The configuration of lines, edges, angles, etc., in this diagram is similar to the configuration of lines, etc., in the abstract object that the diagram depicts. Visual perception of this configuration can then be used as a surrogate for conscious awareness of a similar configuration obtaining in the abstract geometric object that the diagram depicts.

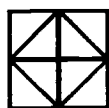

FIGURE 4



FIGURE 5

In what sense is the configuration of lines, edges, and angles, etc., in a diagram *similar* to the depicted abstract geometric object? To address this question we consider a simpler diagram (in Figure 5) and suppose that it represents a perfect square. Evidently, this dia-



gram is relatively precise. Likely, the lines are within one tenth of an inch of being equal and the angles are within a couple of degrees of being equal. So if our eyesight is working properly, we probably perceive a diagram that is similar in shape to a perfect square in the sense of being within the mentioned tolerances. This means that our visual experience of shape properties of the concrete diagram can become a surrogate for conscious awareness of the shape properties of an abstract square. In perceiving, for example, the above diagram we experience the same number and the same connectivity of lines as occurs in an abstract square. Visual perception plays a conceptual role by supplying a surrogate for conscious awareness of the properties of abstract squares.<sup>14</sup>

A diagram need not be accurately drawn in order for perception of its shape properties to act as a surrogate for conscious awareness of shape properties of the abstract object depicted in the diagram. For example, the diagram in Figure 6, if taken as a depiction of the abstract geometric object used in the doubling-a-square problem, is inaccurate. Nonetheless, perception of its shape properties can still act as a surrogate (for conscious awareness of the shape properties of the depicted abstract geometric object) in much the same way as does perception of the shape properties of the more accurate depiction. For example, although the angles and line lengths in this diagram are quite inaccurate, aside from this the configuration of lines is still the same. Perception of this configuration, then, can be a surrogate for conscious awareness of the same configuration in the abstract geometric object.

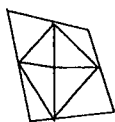

FIGURE 6

I have established that visual perception of diagrams is a surrogate for conscious awareness of the abstract shape properties of geometric objects. It follows from this that if visual perception of these diagrams is accurate, it helps to justify the mathematical propositions arising from diagrammatic reasoning. In general, visually perceiving objects of a simple type (such as the diagrams involved in proving the Pythagorean theorem) is veridical. In fact, provided lighting conditions are adequate, we are quite good at veridically perceiving most objects, especially those which we encounter in our day-to-day lives.<sup>15</sup> Visual perception, thus, can play a role in justifying the Pythagorean theorem and other geometric propositions.

Accordingly, it is no surprise that diagrams are ubiquitous in many areas of science. Perceiving diagrams is a reliable (and often convenient) way to supply information with which to reason.

Viewing visual perception as justifying a significant portion of school mathematics answers relativistic and sceptical theories within mathematics-education discourse. It is alleged in one quarter<sup>16</sup> that mathematical knowledge is insecure because its justification depends exclusively on historically contingent sanctioning activities and practices within the mathematics enterprise. Historical shifts in these mathematical activities and practices can overturn even well-established mathematical propositions. Recognizing the role of visual perception in objectively justifying many mathematical propositions serves as an antidote to such relativism. Visual perception does not justify all of mathematics (as I have made clear in this talk). It does, however, serve in helping to justify our belief in the truth of some mathematics, including that taught and learned from childhood to highschool graduation.

In many circles, empirical justification counts for little or nothing. At best it is considered a stepping stone to real justification. My stance on the justificatory role of visual perception puts me in agreement with those who think that empirical justification counts for a lot in mathematics,<sup>17</sup> especially in the mathematics taught in school.

My argument for the perceptual justification of a significant portion of mathematics is the main offshoot of my assessment of the role of visual perception in diagrammatic reasoning. For the future, I have in mind an exploration of the philosophical, theoretical, and policy questions posed for mathematics and science education by the introduction of graphics-based learning and teaching software.

## Notes

1. This presentation is based on part of my PhD thesis *Eye's Mind* (2000).
2. See, for example, Charles Parsons (1980).
3. See, for example, Rock Irwin (1983).
4. See, for example, Neil Tennant (1986).
5. Some of these issues are addressed in my thesis.
6. "[T]here is no teaching but recollection...." (*Meno*, 82a).
7. "Socrates: Is he a Greek? Does he speak Greek?"
8. "S: Tell me now, boy, you know that a square figure is like this?—I do." (*Meno* 82b)
9. See *Meno* 85b.
10. This diagram is indicated by Socrates at 85a.
11. Keith Stenning (1977) and Stephen M. Kosslyn (1980) are two psychologists from whose work Barwise and Etchemendy have drawn.
12. They also observe:  
We want to suggest that the search for any universal scheme of representation—linguistic, graphical, or diagrammatic—is a mistake. Efficient reasoning is, we believe, inescapably heterogeneous (or "hybrid") in nature. (1996, p. 180)
13. A similar conclusion is drawn by Marcus Giaquinto in his discussion of the role of perception in the proof of doubling a square set down by Plato in the *Meno*:  
[V]ision was a means of getting information about things that were not before one's eyes. Seeing the diagram as a geometrical figure of a certain sort, seeing parts of it as related in certain geometrical ways and visualizing motions of the parts, enabled us to tap our geometrical concepts in a way which feels clear and immediate. (Giaquinto, 1993, p. 95)
14. How do we come to comprehend or intuit abstract geometric objects such as perfect square? One approach involves imagining a process of successive, unending refinements to a concrete square. A perfect square is considered to be the ultimate product of these refinements. This is the approach of Bernard Lonergan (1957, pp. 31–32). I comment on how we come to comprehend or intuit abstract geometric objects in Chapter 6 of my thesis.
15. It is no surprise that diagrams are ubiquitous in many areas of science. Perceiving diagrams is a reliable (and often convenient) way to supply information with which to reason.
16. See, for example, Paul Ernest (1998).
17. See, for example, Philip Kitcher (1988).

## References

- Barwise, J., & Etchemendy, J. (1991). Visual information and valid reasoning. In W. Zimmerman & S. Cunningham (Eds.), *Visualization in teaching and learning mathematics*. Washington, DC: Mathematical Association of America.
- Barwise, J., & Etchemendy, J. (1996). Heterogeneous logic. In G. Allwein & J. Barwise (Eds.), *Logical reasoning with diagrams*. New York: Oxford University Press.
- Ernest, P. (1998). *Social constructivism as a philosophy of mathematics*. New York: State University of New York Press.
- Giaquinto, M. (1993). Diagrams: Socrates and Meno's slave. *International Journal of Philosophical Studies* 1(1): 81–97.
- Kitcher, P. (1988). Mathematical Naturalism. In W. Aspray & P. Kitcher (Eds.), *History and philosophy of modern mathematics*. Minneapolis: University of Minnesota Press.
- Kosslyn, S.M. (1994). *Image and brain*. Cambridge, MA: The MIT Press.
- Lomas, D. (2000). *Eye's mind*. Unpublished doctoral dissertation. Toronto: University of Toronto.
- Lonergan, B. (1957/1992). *Insight: A study of human understanding*. Toronto: University of Toronto Press.
- Parsons, C. (1980). Mathematical Intuition. *Proceedings of the Aristotelian Society* LXXX: 145–168.
- Plato. *Meno*. In G.M.A. Grube (Trans.) (1981), *Plato: Five dialogues*. Indianapolis, IN: Hackett.
- Rock, I. (1983). *The logic of perception*. Cambridge, MA: The MIT Press.
- Stenning, K. (1977). On remembering how to get there: How we might want something like a map. In A.M. Lesgold, J.W. Pellegrino, S.W. Fokkema, & R. Glaser (Eds.), *Cognitive psychology and instruction*. New York: Plenum Press.
- Tennant, N. (1986). The withering away of formal semantics. *Mind and Language* 1: 302–318.



# Folding Back and Growing Mathematical Understanding

Lyndon C. Martin  
*University of British Columbia*

## Introduction

This study is concerned with the nature of mathematical understanding, and with the process through which mathematical understanding grows and develops. The work is rooted in the Dynamical Theory for the Growth of Mathematical Understanding, developed by Susan Pirie and Thomas Kieren. It is on one aspect of this theory that the research focuses, the phenomenon of 'folding back'. Folding back is a key feature of the Pirie-Kieren model and is an action through which mathematical understanding can grow and develop. The study extends the work of Pirie and Kieren through examining in detail the process of 'folding back'. From video data, a number of categories, providing a language for fully describing the phenomenon of folding back are proposed and illustrated. These suggest that folding back can be categorised in a number of different ways, forming parts of three inter-related aspects of folding back, termed 'source', 'form' and 'outcome'. The study considers the links and relationships between these aspects and categories and discusses the ways in which source, form and outcome interact and relate. Through this the process of folding back as a holistic action and mechanism for growth is elaborated. The implications of folding back for those involved in the teaching and learning of mathematics are also considered.

## The Pirie-Kieren theory for the dynamical growth of mathematical understanding

The theory developed by Pirie and Kieren (1994) to offer a language and way of observing the dynamical growth of mathematical understanding contains eight potential levels for understanding for a specific person and for a specified *topic*. These are named Primitive Knowing, Image Making, Image Having, Property Noticing, Formalising, Observing, Structuring and Inventising. The model and the theory have been presented and discussed at a number of previous CMESG meetings and documented there and elsewhere. (See for example Pirie and Kieren 1991; Pirie and Kieren, 1992; Towers, 2000). For reasons of space it is not therefore intended to discuss the theory in detail here.

## Focusing on folding back

A key feature of the Pirie-Kieren theory is the idea that a person functioning at an outer level of understanding will repeatedly invocatively return to an inner level. Such a shift has been termed 'folding back' by Pirie and Kieren (1991). In this paper they define folding back:

A person functioning at an outer level of understanding when challenged may invoke or **fold back** to inner, perhaps more specific local or intuitive understandings. This returned to inner level activity is not the same as the original activity at that level. It is now stimulated and guided by outer level knowing. The metaphor of folding back is intended to carry with it notions of superimposing ones current understanding on an earlier understanding, and the idea that understanding is somehow 'thicker' when inner levels are

revisited. This folding back allows for the reconstruction and elaboration of inner level understanding to support and lead to new outer level understanding. (p. 172)

This definition suggests then that an individual will, when faced with a problem at *any* level that is not immediately solvable, return to an inner level of understanding. The result of this 'fold back' is that the individual is able to extend their current inadequate and incomplete understanding by reflecting on and then reorganising their earlier constructs for the concept, or even to generate and create new images, should their existing constructs be insufficient to solve the problem. However, the person now possesses a degree of self-awareness about his or her understanding, informed by the operations at the higher level.<sup>1</sup>

Thus, the inner layer activity cannot be identical to that originally performed, and the person is effectively building a 'thicker' understanding at the inner layer to support and extend their understanding at the outer layer that they subsequently return to. It is the fact that the outer layer understandings are available to support and inform the inner layer actions which gives rise to the metaphor of *folding* and *thickening*. Although a learner may well fold back and be acting in a less formal, more specific way, these inner layer actions are not identical to those performed previously.

Folding back can be visualised as the folding of a sheet of paper in which a thicker piece is created through the action of folding one part of the sheet onto the other. The learner has a different set of structures, a changed and changing understanding of the concept, and this extended understanding acts to inform subsequent inner layer actions.

Folding back then is a metaphor for one of the processes of actions through which understanding is observed to grow and through which the learner builds and acts in an ever-changing mathematical world. Folding back accounts for and legitimates a return to localised and unformulated actions and understandings in response to and as a cause of this changing world.

The question then arises of why it was decided, in this study, to explore and develop the notion of folding back as a phenomenon. Although Pirie and Kieren have frequently provided a definition of folding back, they have rarely elaborated on this, either through providing examples of folding back occurring in learners, or theoretically through further developing the language for describing the phenomenon. Bearing in mind that folding back is held by Pirie and Kieren to be a key mechanism for enabling the continuing growth of mathematical understanding, and thus perhaps the most vital element of their model, it seems that there is a need to explore folding back further and in greater detail. Folding back, with its consideration of the way in which learners work with, utilise, and build on existing knowledge also seemed to offer a powerful tool for teachers to use in considering the growing understanding of their students, and their effect on this. However, the existing definition of the phenomenon was inadequate to provide a really useful and specific language for teachers to recognise folding back, and to be able to consider how the phenomenon might have implications for their teaching.

### Methods and Methodology

The research employed video-recording as both a tool of data collection, and as a tool of data analysis. This was supplemented by written work and observational notes. A wide range of students, of different ages, working on a range of mathematical topics, in a variety of settings were observed for differing period of times. Use was made of selective, appropriate elements of the Pirie-Kieren theory to identify examples of folding back, which were then examined in detail. These data were categorised through a process which drew on the microanalytic techniques of Erickson (1992) and the 'constant comparative method' of Glaser and Strauss (1967) although the study did not aim to generate 'grounded theory' as such. Instead, the method was used to facilitate the elaboration of a part of an existing theory in a way similar to that suggested by Woods (1986) and detailed by Vaughan (1992). The analysis of the data generated a framework for describing and categorising any observed act of folding back. This is presented on the following page.

### The framework for describing folding back

#### 1. "SOURCE"

*Encompassing four main categories:*

**Invocative Teacher Intervention**  
**Invocative Peer Intervention**  
**Invocative Material Intervention**  
**Self Invoked**

*Each of these interventions can be divided into two sub-categories:*

Intentional  
 Unintentional

*An Intentional Intervention can be further divided into two sub-categories:*

Explicit  
 Unfocused

#### 2. "FORM"

*Encompassing four main categories:*

**Working at an inner layer using existing understanding**  
**Collecting at an inner layer**  
**Moving out of the topic and working there**  
**Causing a discontinuity**

#### 3. "OUTCOME"

*Encompassing two main categories:*

**Uses extended understanding to work on overcoming an obstacle—i.e., effective**  
**Cannot use extended understanding to work on solving problem—i.e., ineffective**

*The first of these was also divided into two further sub-categories:*

Returns to outer layer with external prompt  
 Returns to outer layer without external prompt

**A special case: 'Not taken as invocative' as an outcome**

### Commenting on the categories

Whilst it is not possible here to describe and discuss in detail all of the categories which form the framework, I would like to elaborate on those which contributed to the key findings of the study and which were especially significant in elaborating the role of folding back in the growth of mathematical understanding.

#### 1. *The unfocused intentional teacher intervention*

Unfocused intentional interventions by the teacher occur as a result of the teacher perceiving a need for the student to fold back and work at an inner layer in some way. However, in contrast to explicit interventions, the unfocused intervention does not directly tell the student to fold back nor does it flag a particular earlier understanding for the student to work with. Instead an unfocused intervention highlights for the student what the problem may be with his or her existing understanding without directly suggesting a solution. The language of such interventions is less closed and more open-ended in nature, consisting of phrases like: 'Try thinking of another way of...' or 'Are you sure...?' or 'What if...?'. Such comments and questions allow for a variety of responses and for the learner to explore his or her thinking rather than giving a particular single response.

## 2. *Collecting at an inner layer*

Folding back to collect entails retrieving previous knowledge for a specific purpose and reviewing or 'reading it anew' in light of the needs of current mathematical actions. Thus collecting is not simply an act of recall, it has the 'thickening' effect of folding back. This phenomenon occurs when students know that they know what is needed, and yet their understanding is not sufficient for the automatic recall of usable knowledge.

The data yielded a number of cases where following a shift by the learner to an inner layer of understanding, there was not actually any observable learning activity, in the sense of any developing and thickening of existing constructs nor was there any generation of wholly new understandings. However, what had occurred had certainly involved the calling into play of current knowing actions and already existing concepts and constructs. Instead of working on these existing ideas, the inner layer activity had been more a process of 'collecting' an earlier construct or understanding and then using this at the outer layer. Collecting seems to involve the learner having a sense of knowing and being aware that he or she has the necessary understandings, but that they are just not immediately accessible. This extends the notion of reflection to involve not only the recognition by the learner of the inadequacy of his or her present thinking but also this self aware sense of knowing that he or she already has the understanding needed to solve the problem. The collecting process further incorporates a high degree of self-monitoring as the learner checks what he or she is collecting against what he or she thinks they need to know.

Although initially in such cases it may appear that the learner has a lack of understanding, this is not always the case, often it is the inability to instantly recall the required concept that is the only problem. The activity then involves the finding and remembering of this understanding rather than any act of modification or construction. Hence whereas folding back and using one's existing understanding involved reflection and some kind of thickening action, folding back and collecting involves reflection but then remembering rather than reworking. It is important to note that folding back and collecting is not the same as the instant recalling of a fact or formula where folding back does not take place.

## 3. *Cannot use extended understanding to work on solving problem*

Where the learner cannot use his or her extended understanding he or she may well have folded back and worked at the inner layer in any of the specified ways. However, despite this activity having taken place and the learner having modified his or her existing understanding in some way, he or she is unable to apply his or her extended understanding to the original problem. This inability to use extended understanding may have many causes such as inappropriate or insufficient activity at the inner layer possibly due to a lack of identified purpose to the folding back where the learner has reacted to a teacher intervention without fully appreciating the need to do so. In such cases although the learner may have broadened or modified some aspect of his or her understanding at an inner layer he or she has not and is not able to extend it and thus the particular local instance of folding back has not facilitated his or her growth of understanding in a more global sense.

## **Folding back and teaching and learning**

Again here it is only possible to give a brief sense of some of the conclusions of the study. Whilst there are many implications of the research for the teaching and learning of mathematics, I will comment mainly on the three categories detailed above.

For a teacher aiming to help his or her students to progress mathematically, there seems to be a real danger of the teacher attempting to provide too much guidance, through explicit, intentional interventions, which often do not result in an extended understanding although they may of course result in the continued 'doing' of mathematics. Instead, it is the subtle and exploratory interventions, intentional yet unfocused which seem to provide the kind of guidance needed to aid the growth of understanding and so assist the learner in achieving his or her potential level of growth. The study highlighted the importance of the



provision of a 'thinking space' for learners to develop their self-awareness, and for the teacher intervention to be a trigger for this rather than merely a directive about what to do. Also, the teacher often has a part to play in ensuring that the learner can apply his or her extended understanding to the original problem. Although here, the intervention is considered to be provocative in form there is still a need for the teacher to be closely 'attuned' to the actions of his or her students and to be able to make appropriate interventions as needed and to clearly be aware of the purpose of these.

The depiction of the action of 'collecting from an inner layer' is a significant contribution of this study, and is a form of folding back which has particular implications for the teacher. The notion of a learner 'reading anew' some aspect of his or her inner layer understandings, in light of a newly encountered need, provides a way of accounting for what might initially appear to be a lack of understanding. The need of a learner to fold back and to re-evaluate what he or she already knows, as opposed to being able to instantly recall the required understanding is important both for the learner and teacher.

A recognition that a learner who is engaged in collecting is not necessarily stuck, that he or she does know *how* to proceed, but does not have the necessary understanding immediately accessible, provides teachers with an opportunity to consider the appropriateness of their actions in facilitating the process of collecting and of making this effective for the learner. A teacher who can legitimise and help to facilitate collecting in his or her students would seem able to help their mathematical understanding to continue to grow. Certainly, collecting is for some students a particularly powerful mechanism for enabling growth, and one which they seem to depend on. One participant in the study, Ann, a student of relatively lower ability in terms of the mathematics she is working on, constantly needs to fold back and collect relevant earlier understandings to use in new more sophisticated ways. For her, collecting often involves the physical act of looking through a book, of searching through papers, and of articulating the context in which she last used the appropriate piece of mathematics. Without the legitimacy to do such things, it would seem that Ann would frequently be unable to collect successfully and would become mathematically stuck. However, a teacher who actively encourages the use of books, notes and the accompanying discussion and talk can help students to make collecting an effective act, and possibly a more efficient one.

There is no suggestion in this study that a teacher should 'stand back' from the workings of a learner and deliberately not be involved. Indeed enactivism recognises that the teacher is already implicated in the growing understandings of the learner. This research suggests that it is important for the teacher to actively participate in acts of folding back, but to recognise the possible effects of his or her interventions. In many of the cases of collecting identified in this study, an intervention to help identify where a student might find the mathematics he or she seeks to collect (a 'mathematical signpost') could make the process more efficient and perhaps less frustrating for him or her. Set beside this though must be an awareness of the possible danger of telling, and the potential for occasioning not collecting but a discontinuity in the growth process.

Folding back, through the notion of different kinds of interventions, provides a way of talking about how learners can be helped both to engage in an act of folding back and to make this act an effective one. The notion of effective folding back is a key idea of this research. The fact that to merely engage in folding back is not necessarily a guarantee of continuing growth is significant and has implications for the teacher and learner of mathematics. The definition for folding back includes the notion of the learner being 'self-aware' of his or her understanding and of this awareness informing the subsequent actions. This research strongly supports the importance of the learner being self-aware of the nature of his or her existing understandings if the folding back is to be effective. A learner must not only recognise, or be made aware of the need to fold back, but must also be able to fold back in an appropriate form and then engage in appropriate inner layer actions. Finally, he or she must be able to use this thickened understanding to work on the original problem. To fold back with an effective outcome is potentially demanding for the learner, and as this research has demonstrated, he or she may encounter difficulties at any stage of the process. For folding

back to be effective, in all of the different aspects, the facility of a learner to continually be aware of what he or she is doing, and why, is of crucial importance. This awareness can inform every action of the learner while folding back, and help to keep these actions related to, and applicable to, the initial problem. Where this awareness, at any stage, is not present, although folding back can still occur, it is often ineffective, or 'thin' rather than 'thick', to extend the language of Pirie and Kieren. In such situations there is again clearly a role for the teacher. Carefully worded questions or suggestions, perhaps simple and subtle in form can help to make ineffective acts of folding back become effective.

## Conclusion

Mathematical understanding and its growth will always be a complex and perhaps unpredictable phenomenon, yet if we are to teach children mathematics effectively we owe it to them to understand as much about the ways they are thinking as we can. As Pirie (1996) writes:

We can assess with ease the "what" but not the "how" of the learning taking place as students struggle to construct a path to understanding. We have standardized and accepted ways to photograph their arrival, but not the means to film their journey. Yet if we seek effective teaching we need ways of recognizing the paths that the students are laying down and a willingness to explore with them and to implicate ourselves in their constructing. (Pirie, in Davis 1996, p. xv)

This study offers a way of looking at and thinking about at least a part of the mathematical journey of a learner. It focuses on the 'how' of learning and de-constructs one element of the struggle of the learner. It provides a way of clearly recognising and identifying some steps on the path of understanding and offers to teachers some ways to consider their own implicated involvement in the journey.

## Note

1. Von Glasersfeld (1987) talks about 'operative awareness' and 'self-reflection' and suggests that 'what the mathematics teacher is striving to instill into the student is ultimately the awareness of a dynamic program and its execution.'

## References

- Davis, B. (1996). *Teaching mathematics: Toward a sound alternative*. New York: Garland.
- Erickson, F. (1992). Ethnographic microanalysis of interaction. In M.D. LeCompte, W.L. Millroy & J. Preissle (Eds.), *The handbook of qualitative research in education* (pp. 201-225). San Diego, CA: Academic Press.
- Glaser, B.G., & Strauss, A.L. (1967). *The discovery of grounded theory: Strategies for qualitative research*. New York: Aldine de Gruyter.
- Pirie, S.E.B., & Kieren, T.E. (1991). Folding back: Dynamics in the growth of mathematical understanding. In F. Furinghetti (Ed.), *Proceedings of the XV Annual Meeting of the International Group for the Psychology of Mathematics Education*, vol. 3 (pp. 169-176).
- Pirie, S.E.B., & Kieren, T.E. (1992). Watching Sandy's understanding grow. *The Journal of Mathematical Behavior* 11, 243-257.
- Pirie, S.E.B., & Kieren, T.E. (1994). Growth in mathematical understanding: How can we characterise it and how can we represent it? *Educational Studies in Mathematics* 26, 165-190.
- Towers, J. (2000). Teachers' interventions and the growth of students' mathematical understanding. In J.G. McLoughlin (Ed.), *Proceedings of the 1999 Annual Meeting of the Canadian Mathematics Education Study Group* (pp. 161-168).
- Vaughan, D. (1992). Theory elaboration: The heuristics of case analysis. In C.C. Ragin & H.S. Becker (Eds.), *What is a case? Exploring the foundations of social inquiry*. Cambridge: Cambridge University Press.
- Von Glasersfeld, E. (1987). Learning as a constructive activity. In C. Janvier (Ed.), *Problems of representation in the teaching and learning of mathematics* (pp. 3-17). Hillsdale, NJ: Erlbaum.
- Woods, P. (1986). *Inside schools: Ethnography in educational research*. London: Routledge.



# La place et les fonctions de la validation chez les futurs enseignants des mathématiques au secondaire

Claudine Mary  
Université du Québec à Montréal (UQAM)

## 1. Problématique et objectifs de recherche

Une recherche préalable à celle que nous rapportons ici, à laquelle nous avons participé, a montré qu'un programme de formation de futurs enseignants des mathématiques pouvait amener les étudiants à envisager les mathématiques et leur enseignement sous un angle moins formel et moins procédural (Bednarz, Gattuso, Mary, 1996). Les auteures pouvaient constater que les étudiants étaient devenus particulièrement sensibles à donner du sens à l'activité mathématique et à faire comprendre. Toutefois, plusieurs recherches soulignent des difficultés de futurs enseignants relativement à la preuve, non seulement leur peu d'habiletés en démonstration, mais aussi le recours à des vérifications empiriques et leur acceptation comme preuve (Knuth & Elliot, 1997; Moore, 1994; Martin et Harel, 1989). Il nous est apparu alors pertinent de nous interroger sur la rigueur qui accompagnait le projet de sens que semblaient avoir les futurs enseignants, objets de l'étude citée plus haut. Nous nous sommes posé la question suivante: quelle place et quelles fonctions ces étudiants donnaient-ils à la preuve ou à toute autre forme de validation? Pour répondre à cette question posée, nous avons analysé les leçons de quinze étudiants, préparées lors de leur stage d'enseignement. Notre objectif était de caractériser la validation dans leurs leçons, d'après

- 1) sa place, lieu et importance,
- 2) ses fonctions, et
- 3) les arguments utilisés.

Nous identifions une étape ou un argument de validation dans une leçon quand l'enjeu de l'étape ou de l'argument est l'acceptation d'une règle, d'un résultat ou d'un énoncé.

Les stagiaires devaient présenter par écrit au moins trois leçons consécutives et filmer au moins une leçon en classe. Ce sont ces planifications et prestations que nous avons analysées. Nous nous sommes limitée aux leçons portant sur des objectifs identifiés comme algébriques ou préparant à l'algèbre dans le programme d'études du Ministère de l'éducation, au premier cycle du secondaire. Nous voulions étudier la validation avant que la preuve, démonstration, ne soit introduite comme méthode. Nous avons choisi l'algèbre parce que le domaine est peu exploré. La recherche apporte donc aussi un éclairage particulier sur la validation en algèbre, en classe.

## 2. Grille d'analyse

Pour analyser les leçons, nous avons jumelé les idées maîtresses de plusieurs didacticiens. Margolinas (1989) fait l'hypothèse de l'existence de divers projets de validation dans la classe de mathématiques. Balacheff (1988) identifie différents types d'arguments chez les élèves et envisage des niveaux. Joshua et Joshua (1987) caractérisent la validation qui accompagne la transmission ou la construction d'un modèle en sciences expérimentales et, en parallèle, considèrent la validation en classe de mathématiques. Barbin (1989), Hanna (1989) et de

Villiers (1990), entre autres, identifient différentes fonctions de la preuve. Ces auteurs ont caractérisé la validation et plus spécialement la preuve selon des points de vue différents. Le nôtre a consisté à caractériser la validation dans les leçons des étudiants, à la lumière des caractérisations déjà faites, mais aussi à la lumière des intentions des stagiaires, énoncées dans leurs planifications, et des interactions de classe.

### 3. Résultats : projet de vraisemblance et fonctions didactiques

Dans ce qui suit, nous présenterons quelques résultats à partir de trois exemples illustrant trois types d'activités de classe à objectifs très différents. Dans le premier exemple, une stagiaire introduit une règle de manipulation d'expressions algébriques, à l'aide de matériel concret.

#### *Argumentation lors de l'introduction d'une règle*

La règle suivante est extraite de la planification d'une stagiaire:

Pour additionner des expressions algébriques, il suffit d'additionner les termes constants et les termes contenant la même variable ensemble. Ces termes sont appelés termes semblables. Cela revient à additionner les coefficients numériques des termes semblables et additionner les termes constants.

Le déroulement planifié se résume comme suit. Il faut effectuer l'opération  $(4x + 5) + (2x + 3)$ . Les deux binômes sont illustrés avec des jetons de formes différentes (Figure 1).

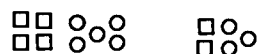

FIGURE 1

La stagiaire ayant précédemment présenté ce que représentait chacun des jetons, les élèves constatent qu'on a  $6x + 8$ . L'égalité  $(4x + 5) + (2x + 3) = 6x + 8$  est écrite au tableau. L'expérience est répétée pour d'autres sommes à effectuer comme  $(x + 9) + (3x + 2) = 4x + 11$  et  $(3x + 3) + (x + 6) = 4x + 9$ . Les nouvelles égalités sont écrites sous la première. Puis, à partir des égalités écrites au tableau, les élèves doivent trouver la règle énoncée plus haut. Lors de la prestation, le déroulement est semblable.

Le mode de validation utilisé ici consiste en expériences répétées. C'est le mode le plus utilisé par les stagiaires. Il est accompagné ou non d'une représentation visuelle. Ces expériences ont un potentiel de preuve, dans la mesure où elles illustrent les propriétés des objets mathématiques en jeu. Toutefois, nous pensons que ces expériences sont utilisées pour leur efficacité à produire des résultats et non pour leur potentiel de preuve.

Dans le cas présenté, que constatons-nous? Le matériel permet de trouver la réponse à l'opération d'addition des deux binômes et de poser l'équivalence algébrique. La règle, qui est énoncée après, semble résulter de la comparaison des expressions composant l'égalité, le but visé étant alors de faire constater ce qui se passe avec les lettres et les chiffres dans les expressions. La répétition des exemples est alors nécessaire pour que soit envisagée cette règle. Si le matériel permet d'illustrer les propriétés des opérations, celles-ci ne jouent aucun rôle explicite dans l'argumentation. C'est comme si le matériel ne servait qu'à trouver le résultat dont on a besoin pour produire la règle, qui elle n'est que constat sur ce qui arrive aux "x" et aux chiffres. Mais, le recours au matériel appelle à l'évidence et rend inutile le recours à une argumentation d'un autre niveau!

Toutefois, nous avons surtout cherché à voir si les propriétés des opérations guidaient le choix des illustrations ou si les propriétés des opérations étaient en filigrane des choix didactiques effectués. Nous avons constaté que les étudiants référaient généralement peu aux propriétés des opérations dans leurs planifications et dans leurs prestations et que les

règles de manipulations des expressions algébriques étaient souvent traitées indépendamment de celles-ci, sauf en ce qui concerne la distributivité de la multiplication sur l'addition, vue comme une procédure de calcul. Dans les planifications, la majorité des stagiaires a formulé explicitement le projet de donner du sens aux règles de manipulations algébriques. Certains parlent même de fonder ces règles. Les observations que nous venons de rapporter, nous laissent penser que les étudiants poursuivent alors un projet de vraisemblance. De plus, si l'étape de production de la règle vise son acceptation, elle vise surtout à ce que les élèves y arrivent.

Le deuxième exemple que nous présentons illustre un autre type de leçons que celui qui vient d'être décrit partiellement. Dans ces leçons, les élèves ont comme tâche de construire une formule. Les validations que nous observons alors sont diverses. Le cas décrit ci-dessous, montre des validations différentes jouant vraisemblablement des rôles différents.

### *Argumentation lors d'une activité de construction de formule*

Voici le problème que propose le stagiaire aux élèves:

Mon oncle Guy est propriétaire d'un restaurant. Il cherche une façon plus efficace et rapide de compter le nombre de chaises autour d'un agencement de tables. Sa méthode habituelle consiste à les compter une par une. Les tables sont toujours disposées en lignes droites et collées les unes aux autres. Elles ne forment jamais de "L" ou de "T". Tu dois aider mon oncle en lui donnant une méthode pour compter le nombre de chaises qu'il y a si on connaît le nombre de tables. (...)

Les extraits qui suivent proviennent de la prestation, enregistrée sur bande vidéo. Les élèves exposent les formules trouvées à tour de rôle.

Échange avec un élève:

Stagiaire: *Dis-moi ce que tu as comme message? En mots.*

Élève: *T'as 39 tables, là tu multiplies.*

Stagiaire: *Non, non, il faut que ce soit général, ça c'est un cas particulier.*

Élève: *Nombre de tables fois 2 parce que 2 tables de chaque côté plus 2 parce que tout le temps 1 de chaque côté.*

Stagiaire: *Comment tu écrirais ça avec des symboles?*

Élève: *m fois 2 .*

Stagiaire: *m fois 2 . [...] plus 2.*

Échange avec un autre élève:

Élève: *J'ai fait m fois x moins 2*

Stagiaire: *m c'est quoi*

Élève: *39*

Stagiaire: *m c'est quoi? ton nombre de tables?*

Élève: *oui*

Stagiaire: *x c'est quoi*

Élève: *le nombre de chaises ... +2 ...*

Stagiaire: *Le nombre de chaises est-ce que tu sais combien il y en a?*

Élève: *Ils disent qu'il y en a 4*

Stagiaire: *As-tu fait un dessin?*

Élève: *Si on prend l'exemple de 3 tables, il y en a 1 à chaque bout, il y en a une à chaque table d'un côté et d'l'autre bord avec. T'imagines qu'il y en a 39 comme ça.*

Stagiaire: *39 c'est quoi?*

Élève: *Le nombre de tables*

Stagiaire: *en mots, 39, c'est ton nombre de tables.*

Élève: *C'est ça 39 fois 2 plus 2*

Stagiaire: *en mots ... ton nombre de tables*

Élève: *fois 2 plus 2*

Dans ces extraits, nous constatons que les élèves expriment leur formule de manière générale, en les justifiant. Par exemple, dans le deuxième échange, l'élève fournit une explication générale (caractère gras), bien qu'articulée sur le cas particulier de 39: l'élève part d'un exemple de trois tables pour changer tout à coup pour 39 tables. Le nombre de tables, 3 ou 39, n'est pas important. Les explications des élèves s'appuient sur les propriétés générales de la situation et, dans ce sens, peuvent constituer une preuve de la validité de la formule. Il n'est pas sûr, toutefois, que le stagiaire accorde un statut de validation à ces explications. En fait, nous voyons bien que le stagiaire veut une formulation générale de la méthode utilisée mais il ne s'agit pas encore de valider cette méthode. En effet, ce n'est qu'une fois toutes les formulations produites que le stagiaire annonce une vérification des formules. Cette vérification apparaît alors en rupture avec les explications des élèves, comme le montre l'extrait qui suit.

Deux formules ont été produites par les élèves. La vérification a d'abord été effectuée pour une table. Elle se poursuit ensuite pour 3 tables:

Le stagiaire dessinant 3 tables: *J'ai 3 tables, ici. Est-ce que ça fonctionne?*

Un élève: *3 tables ça fait 8 personnes*

Un autre élève: *n fois 2.*

Stagiaire: *n vaut quoi ?*

Le même élève: *n, nombre de tables.*

Stagiaire: *Ça fait combien?*

Le même élève: *3 ? 2*

Un autre élève: *3 fois 2, 6, plus 2, 8. (...)*

Stagiaire: *Celle-là fonctionne. Est-ce que celle-là fonctionne?*

Les élèves effectuent le calcul: *Oui !*

Le stagiaire montrant le dessin de 3 tables au tableau: *On a obtenu 8 ici. Ça fonctionne aussi. Avec ça, ça marche, mais avec ce que t'as obtenu, 3 par tables ça fonctionne pas.*

La vérification consiste à comparer la réponse obtenue par calcul, à l'aide de la formule, avec la réponse obtenue préalablement par un autre calcul ou en regardant sur le dessin. Lors de cette vérification, la régularité qui permet de généraliser la formule n'est pas mise en évidence par le stagiaire et la vérification n'a pas de valeur générique, contrairement aux justifications des élèves dans l'étape qui précède cette vérification. Alors que les élèves utilisaient une explication générale, à partir d'un exemple générique ou d'une expérience mentale, le stagiaire compare des réponses. C'est le "8", dans l'extrait ci-dessus, obtenues par calculs ou sur dessin, qui est vérifié. D'une part, il semble que le stagiaire ne reconnaisse pas dans les explications des élèves des arguments de validation. D'autre part, on peut penser que ces deux validations, celles des élèves et celle du stagiaire, n'ont pas la même fonction! Outre le fait que les arguments utilisés soient différents, ces validations n'ont pas les mêmes caractéristiques: l'une appartient à l'étape de formulation et l'autre explicitement à l'étape de vérification; l'une se passe entre le stagiaire et un élève, l'autre est collective; l'une appartient à l'élève et l'autre est sous le contrôle du stagiaire; l'une rend compte de la démarche de construction de la formule et l'autre, explicitement, sert à déterminer les formules à retenir en éliminant celles qui ne produisent pas le résultat désiré.

L'étape de vérification était prévue par le stagiaire, dans sa planification, mais, la vérification se rapproche alors de celle utilisée par les élèves lors de la prestation. Il y a donc un glissement d'arguments de validation reposant sur les propriétés générales dans la planification, vers des arguments reposant sur des vérifications ponctuelles de réponses, dans la prestation. Ce glissement nous laisse penser que l'étape de vérification n'a pas que la fonction de valider les formules; elle contribue aussi à la gestion de l'activité mathématique en permettant de disposer collectivement des productions individuelles des élèves.

Un troisième type d'activités a été analysé. Dans ces activités, les élèves ont comme tâche de se prononcer sur la vérité d'un énoncé.

### Argumentation pour déterminer si un énoncé est vrai

Ci-dessous, nous présentons deux énoncés qui ont été proposés aux élèves; ceux-ci devaient décider si ces énoncés étaient vrais ou faux. Les élèves présentent leur solution au tableau.

Énoncé: *Pour tout nombre  $s$ ,  $s + s = s^2$ .*

Élève1: *On a  $s + s = s^2$ .*  
 $2 + 2 = 2 \times 2$   
 $4 = 4$

Stagiaire: *C'est vrai. Mais on dit bien "pour tout nombre". Ici on a un exemple où c'est vrai. Est-ce qu'il n'y aurait pas un autre exemple où ce serait faux?*

Élève: *Si on remplace  $s$  par 6...  $12 = 36$*

Stagiaire: *... Non, c'est faux. Quelle aurait dû être la vraie réponse pour  $s + s$ ?*

Elève: *2s.*

Stagiaire: *On va vérifier:  $2 \times 6 = 12$ ,  $12 = 12$  donc c'est vrai!*

Énoncé: *Pour tout nombre  $t$ ,  $2t + 3 = 3 + 2t$ .*

L'élève n'a pas fait d'exemple.

Stagiaire: *Oh! C'est pas complet, on n'a pas remplacé par un ...*

La stagiaire s'interrompt et poursuit: *On pourrait dire que c'est vrai dès le départ. Pourquoi c'est vrai? Par quelle propriété?*

Élèves: *la commutativité ...*

Stagiaire: *On peut remplacer par 2,  $2 + 3 = 3 + 2$ ,  $5 = 5$ . Vrai.*

Comme dans le cas précédent, nous constatons une validation par la réponse. Nous constatons que l'énoncé est reconnu comme vrai une fois la vérification exécutée sur un cas particulier et que cette vérification suffit pour conclure. Nous constatons que la vérification numérique a un statut privilégié par rapport aux propriétés et que les élèves ne sont pas interrogés sur la généralité du résultat lorsque l'énoncé est vrai. Nous avons observé, à quelques reprises, que des stagiaires utilisent un exemple pour justifier un énoncé de la même manière qu'ils utilisent un contre-exemple pour l'invalider et que les contre-exemples ne sont pas l'occasion de comprendre. La fonction de ces validations est bien plus d'invalider que de valider. Par ailleurs, l'analyse du manuel utilisé et la situation de l'exercice présenté, dans la séquence des exercices proposés, nous laissent penser que l'exercice devient une occasion d'améliorer les habiletés des élèves à évaluer numériquement des expressions algébriques, bien plus que de développer un esprit critique.

## 4. Conclusion

L'analyse des résultats montrent que le projet de sens des stagiaires est, pour plusieurs, un projet de vraisemblance. De plus, ces exemples montrent que l'étape de validation peut poursuivre d'autres objectifs que celui de valider les règles, résultats ou énoncés. Pour l'ensemble des leçons, nos analyses nous ont permis d'identifier deux catégories de fonctions pour ces étapes: il y a des fonctions plus strictement liées au besoin de validation de l'objet mathématique et des fonctions liées davantage à la présentation des contenus et à la progression du groupe-classe. Ces fonctions de la validation peuvent varier selon la place des étapes dans le déroulement de la leçon.

Par exemple, les validations qui ont lieu dans une période d'introduction à un concept pourraient davantage vouloir faire comprendre et faire partager la compréhension alors que celles qui ont lieu en conclusion pourraient se préoccuper surtout d'efficacité. L'identification de fonctions didactiques de la validation nous a permis d'apporter des explications à certains phénomènes observés en classe, notamment aux glissements des arguments de validation dont nous avons parlé plus haut. La reconnaissance de ces fonctions enrichit notre réflexion sur les contraintes qui pèsent sur la validation en situation de classe.



## Références

- Balacheff, N. (1988). *Une étude épistémologique du processus de preuve en mathématiques au collège*. Thèse. Grenoble: Université National Polytechnique.
- Barbin, E. (1989). Trois démonstrations pour un théorème élémentaire de géométrie. Sens de la démonstration et objet de la géométrie. In Commission Inter-IREM Histoire et Épistémologie des Mathématiques, *La démonstration mathématique dans l'histoire, Actes du 7ème colloque inter-IREM épistémologique et histoire des mathématiques* (pp. 57–79). Besançon.
- Bednarz, N., Gattuso, L., & Mary, C. (1996). Changes in student teacher views of the mathematics teaching/learning process at the secondary school level. In L. Puig & A. Gutiérrez (Eds.), *Proceedings of the XX International Conference for the Psychology of Mathematics Education* (pp. 59–66). Valence, Espagne.
- De Villiers, M. (1990, December). The role and function of proof with sketchpad. *South African Mathematics Magazine PYTHAGORAS*.
- Hanna, G. (1989). Proofs that prove and proofs that explain. In G. Vergnaud, J. Rogalski, & M. Artigue (Eds.), *Proceedings of the International Group for the Psychology of Mathematics Education*, vol. II (pp. 45–51).
- Joshua, M.-A., & Joshua, S. (1987). Les fonctions didactiques de l'expérimental dans l'enseignement scientifique (première partie), *Recherche en Didactique des Mathématiques* 8, 231–266.
- Knuth, E.J., & Elliot, R.L. (1997). Preservice secondary mathematics teachers' interpretations of mathematical proof, *Proceedings of the XIX Conference Group for the Psychology of Mathematics Education of North America* (pp. 545–551).
- Margolinas, C. (1989). *Le point de vue de la validation: essai de synthèse et d'analyse en didactique des mathématiques*. Thèse. Grenoble: Université Joseph Fourier.
- Martin, W.G., & Harel, G. (1989). Proof frames of preservice elementary teachers. *Journal for Research in Mathematics Education* 20, 41–51.
- Mary, C. (1999). *Place et fonctions de la validation chez les futurs enseignants des mathématiques au secondaire*. Thèse. Montréal: Université de Montréal.
- Moore, R.C. (1994). Making the transition to formal proof. *Educational Studies in Mathematics* 27, 249–266.



## Mathematics Knowing in Action: A Fully Embodied Interpretation

Elaine Simmt  
*University of Alberta*

Within the North American education system metaphors of mind and human understanding are commonly derived from our understanding of computers and information processing (Sawada, 1991). In the last three decades, much of the educational research about cognition has focused on questions about the input and output of information, problem solving, transfer of knowledge to new domains and expert/ novice knowledge. In contrast, this study, *Mathematics Knowing in Action*, is a view of mathematics cognition as a coemergent phenomena which arises through the perceptually guided action of humans in interaction with their environment. This view has been called enactivism (Maturana and Varela, 1992; Varela, Thompson and Rosch, 1991). Unlike theories that view cognition as information-processing and that suggest the goal of cognition is problem solving (Fodor, 1975, 1983; Guilford, 1967), an enactivist theory of cognition explains how cognition is fully embodied action that brings forth a world of significance. As well, enactivism explicitly rejects representational views of knowledge and cognition that are assumed in most cognitivist and information-processing models of the mind. Enactivism, as interpreted in education, is related to radical constructivism (von Glasersfeld, 1995), in that it examines the embodied structural dynamics of individuals and reflects a view of constructed realities, and enactivism is related to social constructivism (Ernest, 1995) in that it explores the ways in which knowing is a social act. However, enactivism differs from both forms of constructivism in its emphasis on the *coemergence* of knower and knowledge through perceptually guided action (Varela et al., 1991; Davis, Sumara and Kieren, 1996).

### Purpose of the Research

Guided by an enactive theory of cognition, my research sought to characterize and explain mathematics knowing-in-action and in doing so elaborate on enactivism as a theory for understanding mathematics knowing. Over the course of the research a number of questions were posed:

- Where is mathematics knowing observed?
- What are the sites of interaction and sources of perturbations for mathematics knowing?
- What characterizes the mathematics that is brought forth in mathematical activity?
- In what ways is the knower brought forth in doing mathematics?
- What implications does an enactivist view of mathematics knowing have for educators?

My doctoral dissertation is an expression of my understanding of mathematics knowing as it was shaped through researching these questions. The dissertation includes both accounts of my observations of people's knowing in action and models for understanding mathematics knowers and knowing. The dissertation begins with a story about how the research developed out of a non-traditional mathematics education setting. In the second chapter, the research methods are discussed with an elaboration of a "fractal" model for understanding research of complex phenomena. In Chapter 3 an illustration of the mathematical

actions and interactions of two parent-child pairs and interpretations from a number of theoretical perspectives found in the educational research literature are offered as a way of demonstrating the multiple ways in which a researcher or teacher might interpret such mathematical activity. Enactivism, the theoretical framework for this study is introduced in Chapter 4. Chapter 5 is used to make a distinction between understanding behaviour as caused by features or constraints in the environment to thinking about understanding as "occasioned" by the person's interactions with the environment. In the sixth chapter, various sites of interaction in which mathematics knowing can be observed are discussed. Chapter 7 is an exploration of the ways in which the knower is brought forth in mathematics knowing. Finally, Chapter 8 discusses how the researcher is implicated in the research and the dissertation by discussing how this study is a fully embodied interpretation of mathematics knowing in action. The purpose of the remaining sections of this paper is to briefly discuss the significant elements of the research as developed in the dissertation.

### Research Site and Methods

Data for my study were gathered from an extra-curricular mathematics program for parents and children. The program consisted of ten 1.5 h sessions and was repeated six times over four years. During that time, more than 40 children worked on variable-entry mathematics prompts (Simmt, 1997) with one of their parents. I collected data in a variety of forms from the parent-child sessions, including video and audio records, participants working papers and researcher field notes. These data were transformed through the creation of transcripts from audio tapes, still pictures from video tapes, and the integration of these with the participants' working papers and researcher's field notes. Then, I considered and interpreted the verbal utterances through line-by-line analysis of the transcripts; studied body language and intonation by viewing video tapes and still photos; and inferred mathematical forms and objects from the participants' actions, utterances and notations. As part of the validation process, a group of researchers, who shared an interest in students' mathematical understanding, offered their interpretations of both the primary and transformed data and of my interpretations of the mathematical actions and interactions of the participants.

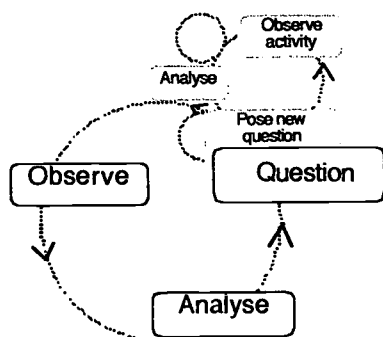

FIGURE 1. Model of the fractal-like research methodology

The interpretive analysis and model building was a dynamic, recursive and coemergent process. As I made observations and interpretations, models and pieces of the theory were shaped; as those models and pieces of theory emerged I revisited the data and new observations were made. A methodological feature of this study was a "fractal" metaphor for understanding the research process. A fractal model illustrates features of the research process that cyclic, spiral or pyramidal metaphors do not; that is, the research is layered, recursive, quasi-cyclic and self-similar at various levels of scale (see figure 1). This model proved to be useful because the theoretical framework of enactivism demanded a method with which I could attend to a "whole" in all of its complexity, at the same time as acknowledging that I could observe only fragments of that whole at any point in time (Simmt and Kieren, 1999). Fractals offer a way out of this dilemma since they point out the self-similar features of an "object" at various levels of scale.

### Interpreting Mathematics Knowing-in-action

In this dissertation, illustrative cases of parents and children, who together engaged in mathematical activity, were used to study mathematics knowing in action. The research demonstrated that students are more than problem solvers; they are fully embodied knowers (Simmt, 1999) who bring forth worlds of significance through their actions and interactions (Simmt, 1996a). Specifically, mathematics knowing is found in personal thought, social relationships, and cultural forms, all at once.

Because it is difficult in such a brief paper to report on a study like this one, which was constructed from extensive qualitative data, without presenting some of that data, a vignette created from the interactions of a parent-child pair is included here. In the vignette, the actions and interactions of a mother and her son from one session of the parent-child mathematics program are revealed. The parent-child pair worked for over an hour trying to solve the "problem" posed in a story that was read to them. The vignette serves two purposes: the first is to offer an illustration of the nature of the parent-child activity that informed this study, and the second is to contextualize the observations and explanations made in the subsequent discussion.

### The Mathematical Actions and Interactions of a Mother and Her Son

The night this event took place, we read from a children's story, *The Token Gift*, written by Hugh William McKibbin and illustrated by Scott Cameron (1996). It is a story about how the game of chess (Chaturanga as it was called in the story) was invented, and the pleasure it brought the king and his people. In the story, the king was so grateful for the game that he insisted the man who invented it name a reward. The man ask for one grain of rice to represent the first square of the game board, two for the second, four for the third, eight for the fourth and so on, doubling each time until all of the sixty-four squares were accounted for. At this point in the story, the children and parents were asked to figure out how much rice the king would need to fulfill the request. Each participant had a sheet of 2 cm x 2 cm graph paper and I suggested they mark off an 8 x 8 grid to represent the chess board.

Desie, and her son, Joss, worked together as they considered the prompt offered by the story. They shared the task quite simply; to begin with, Desie asked Joss for the number that should be written on each of the squares. He quickly computed each double, *in his head*, and she recorded it on the graph paper.

- "So the first one is — How many grains of rice go here?" the mother asked her son as she pointed to the square at the top left corner of their 'chess board'.*
- 5 *"One," replied the boy.*
- "Okay. How many go here, if we are doubling it?" She asked pointing to the next square.*
- "Two."*
- "So what is doubling two?"*
- 10 *"Four."*
- "What's doubling four?"*
- "Eight."*
- "Double of eight?"*
- "Sixteen."*
- 15 *"Double of sixteen?"*
- "Um, thirty-two."*
- "Good. And double of thirty-two?"*
- "I have this idea." Their rhythm was interrupted.*
- 20 *"Oh. Are you trying to figure something out," his mom responded.*
- "Sixty-four," said the boy after just a brief pause.*
- "Good! And the double of that?"*
- 25 *"We are in the hundreds."*
- "We are. We are," his mom nodded.*
- The boy hesitated, "Do you have a calculator?"*
- It didn't take long and the doubling was even too much for the calculator. Desie and Joss spent the next 40 minutes trying to make sense of big numbers and the nature of the big number that would be needed for the 64th square.*
- 30

Using a calculator triggered Joss's first difficulty with the task. His mom's response was to explain the difference between how to multiply with a calculator and how to add with one.

"Times?" Joss frowned as he examined the calculator.

"Times 2," she replied.

"I don't know what a times looks like."

"This one right here," she said as she reach over and touched the calculator. "You haven't started times in school yet have you?"

"No," said Joss as he pressed the keys and continued. "1 2 8 times 1 2 8—"

"No, no, sweetie. If you are doing— It can't be that. It has to be 128 times 2 or 128 plus 128." She turned the calculator toward herself and pressed the keys.

"That's what I had."

"You didn't times though." Without laboring the point she continued to compute the sums, "256 plus 256 is 512. So 512 plus 512..."

Joss leaned over and watched his mom intently as she operated the calculator. "This is a neat calculator. If I had something like this I would carry it everywhere."

"We're in the thousands," Joss wiggled in his chair and laughed. "And soon we will be in the millions!"

"16 384 plus 16 384 is 32 768."

"I can wait until we get right there," he giggled as he pointed to the last position on the calculator display.

When they did get to a million it was Desie who commented, "We just hit a million."

They both could see that the numbers were getting bigger and bigger—in fact too big for the calculator—but Joss did not want to stop. He suggested to his mom that she continue in the same way. So Desie worked on the next one. As she was writing [13, 1072] she realized she had put the comma in the wrong position.

"No. One hundred and thirty-one thousand," she said out loud as she marked the comma in the correct place.

Joss crawled up on his chair to get a closer look over his mom's shoulder. "Mom, we don't use those," he said as he pointed to her number written with a comma. "The teacher told us not to use marks like that."

"But they make it easier to tell what you are

doing," she replied.

"I know, but that is what the teacher said. She said, 'if you see your mom and dad doing it. They are just old fashioned'." Joss giggled again.

"Yea, but if you didn't divide the numbers then it is hard to tell what you are looking at."

"No. I think they put— like— Instead they use spaces," he said as he sat back.

With only a few more computations Desie and Joss came up against the calculator's capacity for displaying numbers and they were left trying to figure out how they might proceed.

"If we had [the numbers computed] up to there," Desie pointed to the 32nd square, "we would have half of it right?" She conjectured that if she knew the values for the first half of the chess board she could multiply by some number and she would be able to compute with just one computation the 64th square. However, she realized she was still stuck—the 64th number would still be too large to compute.

Desie asked Joss again if he had any ideas how to proceed. But Joss did not respond with a strategy, instead he said to his mom. "Know what? Chris [by Joss's assessment the smartest boy in his class at school] taught us this math question that is a regular math question. Chris said, 'You think this is hard. I think this is easy. I'm like, 'Chris. We might think it is easy too.' Then he writes down, 2 times 24. I'm like, 'Chris that is easy.'"

"So he thought you didn't know it, hey?" Desie replied. "It's 48 Chris! He's like, 'Oh.'" Joss said with a grin.

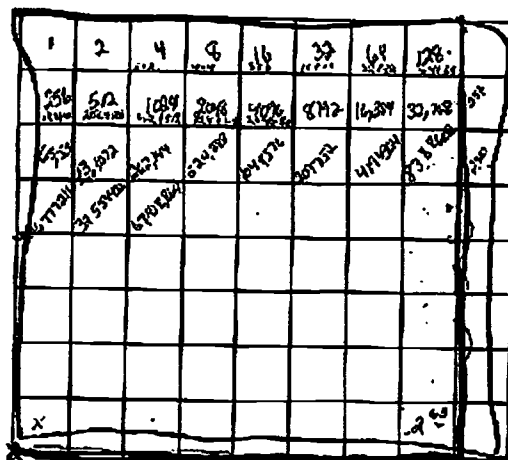

FIGURE 2. Desie and Joss's working paper

If the mother and son's actions described above are observed simply from the point of view that they were solving the particular problem posed in the story, then there is a risk that the complexity, complicity and contextuality of their knowing will be overlooked. On the other hand, an enactivist interpretation of this mother and son's mathematics knowing demonstrates that, at once, their knowing involves personal thought (for example, lines 20–50), social relationships (lines 106–117) and cultural forms (lines 54–86). Their bodies are both the source and intersection of the multiple dimensions of their experience; indeed, their mathematics knowing is a fully embodied phenomenon (Simmt, 1998).

### Fully Embodied Knowing

In this exploration of the mother and son's mathematics knowing, the prominence of the body as both a physical structure as well as an experiential one is striking. The tone of their voices, their utterances (line 26, 66), their giggles and laughter (58–60), the position of their bodies (54–55, 77), and the use of their hands to point and gesture (lines 62–64) reveal the significance of their physicality of their mathematics knowing. At the same time, the invitations to each other to participate (lines 1–4, 69–70, 105), the boy's references to others (84–86, 106–117), and their respect for the actions and utterances of the other (18–21, 22–26, 54) suggest that their mathematics knowing is not separate from their social being. In part, their relationship with each other is fostered and challenged through mathematical activity. Finally, the ways in which their behaviours are co-referenced to the patterns of acting that we call mathematics indicate that they are brought forth as members of a culture at the same time as they bring forth that culture. The numbers that are significant for them (lines 25, 58 and 66), the notation that they used (lines 70–90) and the technologies that are valued (lines 54–57) are all cultural forms. Through observing the mother and son's various mathematical actions and interactions, it is clear that doing mathematics is much more than simply solving a math problem, it is the bringing forth of their worlds of significance which is made possible through the personal, social and cultural dimensions of their experience.

### Models for Observing Mathematics Knowing

#### *Interactional Dynamics*

As the actions of the people in the vignette indicated, a person's structure determines any world building actions which he or she takes but it is the coupling with the environment (recurrent inter-action) which constitutes the space for such actions and provides the possibilities for them (figure 3). Together, the person and the environment co-determine any interaction between them; then, out of the interaction between them, there is a possibility for modification to the person and/or the environment. With a modification to either the person or the environment, a new sphere of behavioural possibilities arises for the person.

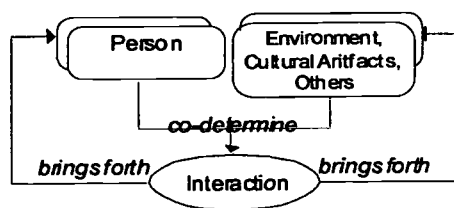

FIGURE 3. Interactional Model

One of the key elements of an enactivist perspective is that in interaction there is potential for *both* the person and the environment to change (or learn). In enactivist terms, interaction brings forth a worlds of significance which includes both knower and known and those worlds of significance intersect the worlds brought forth by others. This has significant ethical implications. Our knowledge, our knowing (as it has been cast in this work), changes



the world in which we exist. Because we are social beings, the worlds we bring forth are intertwined with the worlds of others. Hence, when we act, our actions have the potential to alter the worlds and possibilities of others.

### *Sites of Interaction and Sources of Perturbations*

Given that the role of interaction between a person and his or her environment was a significant feature of the mathematics knowing-in-action observed in the study, it was important for me to identify the "sites" of interaction because they were the sources of potential perturbations. From the study, four sites of interaction were observed: the interaction among people (see for example, lines 0–25); a person's interaction with his or her physical environment (lines 70–76); a person's interaction with his or her own thoughts (lines 96–104); and a person's interaction with the interactions of others (lines 77–91).

Observing mathematics knowing in these various sites might lead one to suggest that mathematics knowing is caused by the things found in these sites (be it an utterance, a thought, an image or some *thing* else). However, my interpretations of the data suggest that this does not offer a satisfactory explanation for the observations. Knowing does not seem to be *caused* (in the predictive sense) by some feature or aspect of the environment. Clearly, the environment both makes possible some actions and constrains others—the mother and child cannot do just anything (doubling is a possibility but counting is not). However, the mother and child themselves constrain and make possible certain actions—they cannot do what they do not *know* (the boy cannot multiply, since he does not *know* how). An interpretation of the "causes" of such observed behaviours suggest that, when taken in context, behaviours are better understood as "occasioned" by the person's interactions with the environment. *Occasioning* is a mechanism by which a person interacts with relevant possibilities in the environment. That interaction involves a selection of that which is relevant and the transformation and integration of the relevant to become part of the person's lived history (Simmt, 1996b).

### **Knower and Known Co-emerge**

From observing the actions and interactions of this mother and son, we have learned that knowing-in-action can be understood as enacting personal thought, social relationships and cultural forms. Each of these dimensions of experience, at once, constrain and make possible human mathematics knowing. At the same time, these dimensions come together in the human body and transform it. As the knower changes, the context of which he or she is a part changes hence potentially transforming the worlds he or she brings forth with others.

My research suggests that when we humans engage in mathematical activity, that activity intersects with our personal, social and cultural domains of our lives. In action, we bring forth a world of significance, which in this case is called mathematics and, in doing so we bring forth ourselves. In each act of bringing forth a world of significance and our "selves", we anticipated the future as our spheres of behavioural possibilities expand making possible our next utterance, movement, action, and thought. Further, because we bring forth worlds of significance with others, what we do, what we say, and what we know makes a difference, not only for ourselves, but for the other.

### **Significance to Mathematics Educators**

As discussed, this research suggests that mathematics knowing-in-action is much more than problem-solving. In fact, the people who were observed specified moment-by-moment that which was relevant for them to attend to and problems arose out of the act of specifying the relevant. It is significant to educational researchers that out of interactions with the environments, mathematical knowers are observed to specify the problems which have relevance to them—they bring forth a world of significance. Just as important as solving problems is



specifying them in the first place. Hence, placing an emphasis on “problem-solving” in school mathematics, that is looking for the solution to a pre-specified problem, misses this key aspect of human cognition observed in my research. The teacher needs to provide students not with problems to solve but with prompts for mathematical activity. These prompts can be as simple as: How many different ways can you show that  $28 \times 35 = 980$ ? Which would you rather have for allowance, a dollar a day for a month or a cent today, two cents tomorrow, four cents the next day doubling the amount received on each consecutive day? It is in the students’ interactions with such prompts and with each other and the teacher that problems will be posed and resolutions sought.

My research has led me to observe the significance of the multiple dimensions involved as mathematics and mathematics knowers coemerge. A person’s thoughts, social relationships and community are fostered through mathematical activity. At the same time, mathematics is created by communities of mathematics knowers through their interactions with each other, their own thoughts and the interactions of others. This view has important implications for mathematics education because it recognizes the significance of the classroom as a source of mathematics and mathematics knowers. This view suggests to educators that the mathematics classroom is an important site of community; a community which coemerges from the relationships created among students and with the teacher as members of the class share in mathematical experiences and develop their personal mathematical understanding.

## References

- Davis, B., Sumara, D., and Kieren, T. (1996). Cognition, coemergence, and curriculum. *Journal of Curriculum Studies* 28(2), 151–169.
- Ernest, P. (1995). The one and the many. In L. Steffe & J. Gale (Eds.), *Constructivism in education* (pp. 459–486). Hillsdale, NJ: Lawrence Erlbaum Associates.
- Fodor, J. (1975). *The language of thought*. Cambridge, MA: Harvard University Press.
- Fodor, J. (1983). *The modularity of mind: An essay on faculty psychology*. Cambridge, MA: MIT Press.
- Glieck, J. (1987). *Chaos: Making a new science*. New York: Viking.
- Guilford, J. (1967). *The nature of human intelligence*. New York: McGraw-Hill.
- Maturana, H., & Varela, F. (1992). *The tree of knowledge: The biological roots of human understanding* (rev. ed.). Boston: Shambhala.
- Sawada, D. (1991). Deconstructing reflection. *The Alberta Journal of Educational Research* 37(4), 349–366.
- Simmt, E. (1996a). *Parents and children doing mathematics: Bringing forth a world of significance*. Paper presented at the International Council of Psychologists Annual Convention, Banff, AB.
- Simmt, E. (1996b). *Parents and children and mathematics: Occasioning in mathematical cognition*. Paper presented at the American Educational Research Association Annual Conference, New York.
- Simmt, E. (1997). Reflections on a parent child mathematics program. *Delta-K* 35(1), 56–60.
- Simmt, E. (1998). The fractal nature of a mother and son’s mathematics knowing. *Journal of Curriculum Theorizing* 14(3), pp. 12–20.
- Simmt, E. (1999). *Fractal spaces of mathematics knowing: Collecting personal thought, collective process and cultural form as events of cognition*. Paper presented at the American Educational Research Association Annual Conference, Montreal, QC.
- Simmt, E. and Kieren, T. (1999). Expanding the cognitive domain: The roles and consequences of interaction in mathematics knowing. In F. Hitt & M. Santos (Eds.), *Proceedings of XXI Annual Meeting of Psychology of Mathematics Education*, volume 1 (pp. 298–305). Columbus, OH: Eric Clearing House for Mathematics Science and Environmental Education.
- Varela, F., Thompson, E., and Rosch, E. (1991). *The embodied mind: Cognitive science and human experience*. Cambridge, MA: MIT Press.
- von Glasersfeld, E. (1995). *Radical constructivism: A way of knowing and learning*. Washington, DC: The Falmer Press.

**Panel Discussion**

---

## Pourquoi enseigner les mathématiques à tous?

Bernard R. Hodgson  
*Université Laval*

Quand je pense à la nécessité d'enseigner les mathématiques à tout le monde, je pense bien sûr aux mathématiques en tant qu'outil, un outil d'une «efficacité déraisonnable», pour reprendre l'aphorisme célèbre du physicien Wigner. Un outil au service de tant de domaines de l'activité humaine, depuis les sciences naturelles jusqu'aux sciences sociales, en passant par l'administration, l'ingénierie ou les techniques. Les mathématiques y jouent un rôle vital non seulement en tant que langage de communication ou instrument de modélisation, mais surtout comme véhicule de conceptualisation de notions difficilement saisissables, voire carrément impénétrables, autrement. Elles constituent également un outil essentiel pour le citoyen, afin qu'il puisse fonctionner au quotidien en tant que consommateur avisé ou encore apprécier à sa juste valeur l'information quantitative dont on le bombarde sous forme de sondages, de graphiques, de tableaux numériques.

Mais quand je pense à la nécessité d'enseigner les mathématiques à tout le monde, je ne m'arrête pas qu'à leur aspect utilitaire. Je pense aux mathématiques pour tous en vue du développement d'aptitudes qui, à défaut d'être l'apanage des mathématiques, ne se retrouvent nulle part ailleurs mises en évidence de façon aussi claire et aussi percutante. Je pense aux mathématiques comme facilitant l'acquisition d'une saine rigueur de pensée et le déploiement d'un esprit attentif aux liens—déductifs ou autres—pouvant exister entre des concepts *a priori* disjoints. Les mathématiques soutiennent le citoyen qui, face à toutes sortes de situations plus ou moins complexes, est appelé à analyser, comprendre, prendre des décisions, ce qui exige des habiletés à formuler et à résoudre des problèmes. Elles rendent naturelles l'observation de régularités et l'émergence de structures, là où pouvait régner l'informe. En favorisant l'identification des hypothèses et l'explicitation de leurs conséquences, elles combattent la confusion ainsi que la rhétorique fallacieuse qui pourrait s'y nourrir. Loin de brimer la créativité, cette nécessité de la rigueur en mathématiques en constitue au contraire un ferment, la contrainte de la justification de ce qu'on avance forçant à aller au delà de l'intuition première.

Mais quand je pense aux mathématiques pour tout le monde, je n'ai pas à l'esprit que leurs applications multiples ou encore l'hygiène de l'esprit. Je pense aux mathématiques comme un élément charnière dans l'évolution de l'humanité, élément qui prend ses racines dans la plus haute Antiquité et qui se retrouve dans toutes les civilisations, parfois à des stades de développement variés. Mais je pense aussi aux mathématiques en tant que composante cruciale du cheminement de l'individu et comme un atout dans une carrière professionnelle pouvant s'étaler sur quelque trente-cinq années, nécessitant par le fait même de grandes capacités d'adaptation et d'évolution. À l'opposé d'une compétence spécifique à courte vue ne visant que les besoins immédiats, les mathématiques se présentent comme un élément robuste dans une formation de longue portée.

Quand je pense aux mathématiques pour tous, j'ai à l'esprit une métaphore riche et puissante de la réalité. Non que les mathématiques soient la seule façon de saisir l'univers, ni la plus importante ou la meilleure. Mais les ignorer revient à se couper d'une vision fondamentale et essentielle. Je pense aux mathématiques comme un médium absolument

unique pour voir les choses autrement, pour les mettre plus clairement en perspective les unes par rapport aux autres. Je pense aux mathématiques pour voir des choses imperceptibles autrement, des choses ne pouvant être appréhendées que par le biais d'une approche mathématique. Je pense aux mathématiques comme permettant d'atteindre l'inaccessible, tel Thalès ramenant la hauteur de la pyramide de Chéops à celle de son ombre, accessible à la mesure.

Quand je pense aux mathématiques pour tout le monde, je pense aux mathématiques comme antidote par excellence contre l'absolutisme, forme extrême de la violence. Je pense aux mathématiques pour contrer la certitude crasse, malgré que la vérité mathématique soit perçue, non sans une certaine raison d'ailleurs, comme la quintessence de la certitude. Je pense aux mathématiques nous montrant certaines vérités, telles les vérités euclidiennes, perdre leur caractère dogmatique et devenir des réalités parmi d'autres. Je pense aux mathématiques comme un laboratoire d'une «culture du conditionnel», comme lieu d'élaboration de vérités sous conditions, de vérités relatives à la présence ou non de certaines prémisses. «Si ceci était, alors ...; mais si cela était, alors ...» Je pense aux mathématiques comme permettant de cultiver la nuance et le doute, de développer le jugement et l'esprit critique, d'aller au cœur des choses. Je pense aux mathématiques comme alimentant en fin de compte le rêve, qui toujours, par delà les savoirs et les savoir-faire, distinguera l'homme de la machine.

Quand je pense à la nécessité d'enseigner les mathématiques à tout le monde, je pense à leur transformation, plusieurs siècles avant notre ère, par les penseurs grecs qui en ont fait essentiellement les mathématiques telles que nous les connaissons. Et à la façon dont ces penseurs se sont démarqués de leurs prédécesseurs par le rôle central accordé dans la démarche mathématique à l'argumentation. Mais pourquoi cela s'est-il passé «en Grèce et pas ailleurs, au VI<sup>e</sup> siècle et pas à une autre époque?», demande Léa, la jeune héroïne du roman *Le théorème du perroquet*, à son mentor.

«[Parce que les penseurs grecs], répond M. Ruche, ne sont ni esclaves ni fonctionnaires d'État, comme les mathématiciens-calculateurs babyloniens ou égyptiens qui, eux, appartenaient à la caste des scribes ou à celle des prêtres, détenant le monopole de la connaissance et du calcul. Les penseurs grecs n'ont de comptes à rendre à aucune autorité. Il n'y a ni roi ni Grand Prêtre pour décider quelle sera la nature de leur travail ou pour poser des limites à leurs études. *Les penseurs grecs sont des hommes libres!*» (Denis Guedj, *Le théorème du perroquet*, Éditions du Seuil, 1998, p. 179)

## Why teach math to all students?

Sandy Dawson  
*Pacific Resources for Education and Learning*

Why teach math to all students?

My response is that I'm not sure that we should. It **DEPENDS!** and **PERHAPS!** seem to be appropriate answers. The answer I am giving now has changed since I moved to Honolulu, and have started working in the Pacific region. This move has made me question assumptions that I had long accepted.

What was it about the Pacific region that caused me to question my assumptions, you might well ask:

- a. In 6 of 10 island nations, grade 8 is the upper limit of schooling.
- b. In one of those states, no English, and no formal counting is undertaken until grade 4/5, because of the cultural values of the nation. For that nation, native languages and cultural traditions are more important than knowing western mathematics.

It seems to me that the answer to the question of why teach math is a values question, and involves issues of value and culture. The answer usually given is so that people can function in an increasingly technological world. But in the region where I work, many islands are only reachable after a boat ride of 4 to 5 days. These islands have no electricity. In the island nation of Chuuk, for example, there are 87 schools, and 63 of those are on outer islands only accessible by boat. What the Director of Education for Chuuk said to me on my recent trip there was that if we teach mathematics, it must be practical, it must be related to the crafts and customs and activities children can relate to on their home island.

There is nothing in the nature of mathematics that would give an answer to the question of why teach mathematics, so it comes down to what the culture values and what it sees as important. Could mathematics be taught to all students, even those on remote Pacific islands? Of course it could, but whether it should or not is an entirely different question, and one much more difficult to answer.



## Why teach mathematics to all students?

Brent Davis  
York University

In January 2000, Elaine Simmt asked me if I'd like to be part of a panel to address the question, Why teach mathematics to all students? That left more than four months between my enthusiastic "Yes!" and the conference.

I set to work immediately. As is my usual practice, I proceeded by writing notes to myself whenever a relevant idea crossed my mind, stuffing them all into a folder that I intended to consult shortly before the conference.

Unfortunately, when I finally sat down to sort through the file, it was clear that my thinking around the issue was anything but consistent or coherent. The issues, the arguments, and the rationales that had collected weren't all compatible, and some were flatly contradictory. And so, unable to pull things together into a unified response, I chose to frame my conference contribution as three distinct engagements with Elaine's question.

### 1. Why do we teach mathematics to all students?

The question, "Why *do we* teach mathematics to all students?" prompts me to look for explanations and justifications. It's a query that I've encountered often, in policy statements, texts, curriculum documents, and so on. It seems to be one for which there is an accepted 'right answer.'

Sometimes that answer is presented through reference to the history of school mathematics. And, in fact, I think that such reference is vital if the purpose of the question is to get at why we teach mathematics the way we teach mathematics. Senses of the co-implicated historical structures of capitalism, industrialization, urbanization, and modern science are necessary to make sense of such curriculum emphases as quadratic equations and carpet sales.

Alternatively, the question is often answered in terms of the current social and technological contexts. Mathematics is argued to be useful to the individual: It is thought to support reasoning skills (and so contributes to the development of well-rounded citizens); it is associated with competencies that are seen as necessary to the workplace (and, hence, it makes sense to require calculus of potential pharmacists); it ensures that university-based mathematicians will always have someone to teach; and so on.

The more cynically and critically minded often take issue with such rationales—at least insofar as these lines of thought are tethered to 'traditional' classroom practices and emphases. Concerns for personal subjugation, social engineering, and cultural imperialism are common themes among the critical education group. Even so, critics often seem to be working from a conception of school mathematics that is strikingly similar to traditional versions. The difference is that traditional programs of study tend to be attached to a revised conception of mathematical literacy—one that is more focused on flexible thought, communication, social critique, and the like, without letting go of the cultural capital of traditional mathematical competence.

However, these more radical responses to the question of "Why *do we* teach math?"

may not be so different as they appear. While they clearly represent different ideological takes on the issue, their critiques are generally aimed at pedagogy, not at the broader project of school mathematics. That is, they offer different rationales—ones that are delivered with a different passion, even urgency—but those rationales seem to rely on an assumption that the *manner* of instruction (seen as problematic) can be separated from *topics* of instruction. We are thus thrust into a left-versus-right, liberal-versus-conservative, personal-empowerment-versus-social-responsibility subterfuge whenever the issue of teaching mathematics is engaged.

Whichever side is taken, however, the response seems to land in the same place.

Why *do we* teach mathematics to all students?

Because we have to: There are historical and cultural reasons that operate in the social and societal realms, albeit that most of these reasons are often all but forgotten. Whatever the reason, though, knowledge of mathematics is necessary for every citizen of today's world. It's useful.

## 2. Why would we teach mathematics to all students?

The tendency to frame discussions and debates of why mathematics is taught in terms of oppositional dyads might be interpreted as a sort of capitulation: Collectively, we seem to be resigned to the thought that school mathematics is a permanent fixture—that is, that this practice is not going away and, hence, the best we can do is tinker with it as it moves along.

This manner of assertion often prompts different takes on the issue of why we teach mathematics, away from efforts to specify purpose and toward more reflective examinations of the phenomenon—that is, to ask, Why teach *would we* teach mathematics to all students?

This is a question that hints that we humans just might not be completely conscious of everything that we do ... that some—and maybe most—of what we do emerges from personal and collective habit. That is, it could be taken as tacit acknowledgment that we humans are not principally reasoning beings.

It strikes me that this suspicion is at the root of the public school student's question, "Why are we doing this?", so often posed in the middle of mathematics lessons. Unfortunately, such inquiries tend to be answered with deflections to other times (e.g., "You'll need this someday.") and other places (e.g., "It's in the curriculum."). However, the fact that such answers are rarely satisfying—either to the interrogator or to the respondent—should give us pause. Perhaps our children are onto us, aware that mathematics instruction is in a rut. "Why are we doing this?" may in effect be one way of announcing an awareness that the teaching of mathematics, along with most of modern schooling, is being carried along by a momentum so great and that it has cut a swath so wide that it reduces all involved to quiet complacency as they immersed themselves in its less-than-mindful activity. "Why *would we* teach mathematics to all students?", then, operates on the collective level in much the same way that "Why would I do/think this?" operates for anyone who is dealing with a habit or obsession that has lost much of its original meaning. In brief, ours is a culture that is obsessed with and utterly reliant on mathematics.

Perhaps, even, 'obsession' and 'reliance' are not strong enough. It might be more appropriate to describe the situation in terms of 'addiction.' For example, in terms of symptoms, consider the way that mathematics courses through the veins of virtually all cultural activity. Try, for example, to find one item in the daily newspaper where some mathematized notion isn't explicitly invoked—let alone the more subtle uses of comparison, logical assertion, and linear narrative that are so privileged in Western mathematized culture ... and set aside the pervasive presence of electronic and other technologies, so utterly reliant on mathematized technologies, that make it possible for the items to be collected by the newspaper and for the newspaper to be brought to us. Mathematics is so present as to be like the air around us.

This silent and invisible addiction has, over the past few centuries, supported a false

security and a sense of great superiority—even invulnerability—in Western knowledge. Such troubling self-assurance as much derives from as it engenders particular partialities. To wring just one bit more from the analogy, our cultural addiction to mathematics is perhaps most evident in the tell-tale sign that, in spite of abundant evidence to the contrary (in, for example, the overburdening of planetary systems through mathematics-enabled technologies), there is a persistent denial that there is a problem.

The point here is not that mathematics is bad, nor that Western society is uniquely guilty of narrow perspectives. It is, rather, that singular epistemic (or religious, or philosophical) frames cannot encompass the spectrum of possible human lives. As Rorty (2000) puts it, a specific frame is “a projection of some particular choice among those possibilities, a working out of one particular fantasy, a picture of human existence drawn from one particular perspective” (p. 14).

I am, like everyone is, caught up in this fantasy, even as I attempt to consider the complex question, “*Why would we teach mathematics to all students?*” It is a query that isn’t really about what it seems to be asking. It is one way of expressing a suspicion of forces unseen and a frustration at the veils and the dust that prevent any hope of a truly satisfying answer.

On this count, there is a problem with the question that orients this writing. To pose a question that begins with *why* is in some ways to suggest that we have a choice in the matter.

We don’t. Even when not made an explicit topic of instruction, our mathematics is knitted through the structures of our being(s), and perhaps most readily apparent in our habits of perception. The linearities, rectangularities, crisp distinctions, tidy orders, etc. of our living spaces, narratives, interactions, hopes, etc. hint that our mathematics is one of the most pervasive and powerful of human technologies and, hence, one of the most pervasive and powerful constraints on Western conceptualization.

*Why would we teach mathematics to all students?*

Because we have to: We are creatures of habit who are caught up in complex flows of events that are dependent on but not determined by what we do—and, in terms of what we Westerners do, mathematics is at the core of the explanatory fantasy that is currently preferred to organize and structure experience.

### 3. *Why should we teach mathematics to all students?*

Perhaps, then, our efforts to answer the question should begin by breaking with the fantasy that prompts it—which is *not* to say that we should give up on mathematics, but that we might seek to interrogate the common sensibility that supports and that is supported by modern mathematics. This common sensibility, this collective fantasy, it that our civilization (and, as part of civilization, our knowledge) has a developmental structure.

An alternative fantasy might be that we do not (and can not) know where we’re going, that we are not converging onto a totalized knowledge of the universe, and that unambiguous linearized accounts of how we got here are convenient fictions. And, just as classic mathematics has played such a key role in the myth of a fully knowable universe, recent disciplinary developments may help to structure a perhaps-more-contextually-appropriate myth.

Over the past few centuries, the contributions of mathematics (and the mathematized sciences) to Western habits of perception have been dramatic. From the subatomic to the supergalactic, a range of phenomena have become perceptible mainly because mathematics has helped to predict their existence and, as such, have prompted us to look for them. Such is the key element to perception: expectation. Most of what the reaches consciousness is already interpreted, already selected by habits of perception, already fitted into the frames of expectation.

It is thus not surprising that we would locate mathematics at the core of public schooling. All formal education begins with one group’s desire to have another group perceive things in the same way. And mathematics is a primary enabler of current perceptual habits.

Discussions of the question, “*Why should we teach mathematics to all students?*”, then,

belong in the realms of obligation and mindfulness, in the spaces of the ethical and the moral. These are domains that, in terms of the manners in which mathematics teaching is usually rationalized, are not always visited—a tendency that is in keeping with the privilege afforded the acquisition of knowledge over the development of wisdom.

Such avoidance certainly has much to do with the character of modern mathematics. As a domain of inquiry, mathematics has for centuries failed to consider its place in the moral and ethical fabrics of human existence. In fact, following the Platonic separation of the worldly from the ideal, mathematics has most often been cast as detached from, even superior to such worries. It cloaks itself in a rhetoric of ideality and certainty, occasionally justifying its pursuits by touching the soil of utility. However, such acts seem to come with (at least tacit) qualifications that mathematics should not be held responsible for its applications and misapplications.

Even when discussions get past this troublesome separation of knowing from doing—that is, when matters of moral import are allowed to surface—there almost always continues to be an assumption of an inherent purity of formal knowledge. It follows that the project of mathematical inquiry tends to be cast in terms of goodness, with some acknowledgment given to the baser concerns of usefulness and cultural need. And the fact that discussions rarely go further doubtlessly contributes to the unproblematized history of imposing mathematics not only onto our children, but onto the children in other cultures.

And it seems even more rare that discussions of mathematical study are framed in terms of its complicity in a range of crises that extend (at least) from the microbial to the planetary. Even less is it discussed for its potential to support mindfulness awareness of such matters. In terms of the day-to-day life of a typical citizen of the Western world, mathematics has become part of the thrum of existence, an inextricable aspect of humanity. Represented to the masses as a more-or-less finished set of procedures, mathematics plays a vast and shaping role in the collective unconscious ... common sense ... the 'way things are.' Consider such pervasive phenomena as straight roads through undulating terrains, stripped forest ecosystems replenished with single species, the conception of time and linear and uniform, and on and on. Such phenomena betray a conception of the universe as subject to singular, linearizable interpretation.

That is, to a conception of the universe as essentially Euclidean. This usually transparent worldview served as the 'neutral' backdrop of anthropologists' studies of other cultures until only recently, when it was finally noticed that their reports were more expressions of their own cultures than of the cultures they thought they were describing. In the past few decades, there has been an emergent recognition that different worldviews are just that: different. Not wrong or primitive or naive. Different. And there is a dawning realization that this diversity is vital—an insight that is now commonly expressed in terms of the tremendous loss of knowledge that accompanies the extinction of a language.

Such events should compel us to ask "What else are we not seeing?", not just in terms of other societies, but, more importantly, with regard to the more-than-human world.<sup>1</sup> And that is a question that should make us constantly suspicious of the habits of mind that frame our current perceptions. In terms of the central concern of this writing, we need to be suspicious of our mathematics, especially at this historical moment. We need to suspect that domain which, at least since Descartes' proclaimed it as the sole route to unimpeachable truth, has been popularly regarded at the cornerstone of solid knowledge rather than an impediment to mindful participation in the universe. Faced, for example, with environmental events that continuously and dramatically illustrate the participatory nature of our activities, it seems that is time for a more humble, tentative, and attentive conception of truth. In terms of the contribution of mathematics, I would argue that we need to become more aware of how perceptions, forms, beliefs, activities, and so on are profoundly mathematized—and that can only happen by knowing something about mathematics.

More bluntly: If humanity, as a species, is to survive, we need to learn new habits of perceiving the world. And that won't happen unless we are better aware of what has been

allowed to slip into transparency. We owe it to the world (and to ourselves, as part of the world) to make an effort to restore a little of the hope and the wonder that were lost when Enlightenment thinkers condemned imagination and dismissed wisdom with the imposition of the deductive argument onto all claims to truth. To return to the analogy between personal addiction and our cultural obsession with mathematics, what is involved here is taking that first critical step toward recovery from an addiction: admitting that we have a problem.

Such assertions take us out of the “epistemology only” frame announced by Descartes, maintained by analytic philosophy, and enacted in our schools. It pushes the discussion back to the realm of *being* ... existence ... enchantment ... spirituality—the ontological. It is a realization that matters of knowing and doing are always and already matters of being.

Why *would we* teach mathematics to all students?

Because we have to: There are moral and ethical imperatives that operate in the human and in the more-than-human realms.

### Note

1. ‘More-than-human’ is borrowed from David Abram (1996). He develops it as an alternative to the more popular terms ‘non-human’ or ‘natural.’ In contrast to such terms, ‘more-than-human’ does not separate humanity from the rest of the universe.

### References

- Abram, D. (1996). *The spell of the sensuous: Perception and language in a more-than-human world*. New York: Pantheon Books.
- Rorty, R. (2000, October 22). Freud KO’s Plato. *New York Review of Books*, p. 14.



## Pourquoi enseigner les mathématiques à tous?

Nadine Bednarz,  
*Université du Québec à Montréal (UQAM)*

La question posée peut être reformulée dans les termes suivants, à travers trois questions que j'aborderai successivement: Faut-il enseigner les mathématiques à tous? Pourquoi les mathématiques devraient-elles faire partie de la formation que devrait recevoir tout élève, tout adulte? et, en supposant que l'on prenne pour acquis qu'il faille viser une telle formation, son enseignement à tous est-il viable?

### 1) Faut-il enseigner les mathématiques à tous?

On peut, a priori, répondre positivement à cette question en invoquant le fait que, sans cet apprentissage des mathématiques, c'est tout un mode d'appréhension du monde qui nous échapperait, et avec lui une certaine manière d'analyser les données, de juger de la validité de celles-ci, de raisonner (de manière analytique ou synthétique, inductive, deductive ...), d'argumenter, de généraliser, ou encore d'abstraire... Cependant, même si l'on peut reconnaître le bien fondé de cette activité mathématique, plusieurs rapports montrent que tel n'est pas le cas pour beaucoup d'élèves. Après avoir suivi à l'école une formation mathématique de plusieurs années, beaucoup d'adultes sont en ce domaine des analphabètes fonctionnels. Pour employer ici une métaphore, empruntée à mon collègue François Lalonde, si un apprentissage de la musique se limitait à l'apprentissage de gammes, arpèges, sonorités ... l'enfant, l'adolescent pourrait-il apprécier la beauté de la musique, appréhender le monde musical? Si, de manière analogue, les élèves abordent les mathématiques, en passant des heures et des heures à des exercices qui ressemblent fort à l'apprentissage de gammes et de techniques, sans jamais entendre de concerto ou de symphonie, peuvent-ils percevoir la pertinence de cette activité, lui donner un sens?

La musique que les mathématiciens entendent est sublime! Il est bien dommage que seuls les mathématiciens puissent assister à ces concerts (Lalonde, 2000, p 13)

Les mathématiques valent-elles dans ces conditions la peine d'être enseignées à tous? Notre question de départ ne peut donc être abordée sans considérer la nature même de l'activité mathématique à laquelle est confronté l'élève au cours de la formation de base.

L'école a, de tout temps, considéré que les mathématiques devaient faire partie de la formation fondamentale que devrait avoir tout enfant, tout élève, au moins pour la formation de base<sup>1</sup>, de sorte que le curriculum a toujours intégré les mathématiques dans son corpus obligatoire. Autrement dit, l'institution scolaire ne s'est jamais posée la question du caractère nécessaire de cet enseignement, alors qu'une telle question se pose par exemple pour l'enseignement de la musique, du théâtre, ou encore de la philosophie, même si à bien des égards ils peuvent être tout aussi pertinents. Nous sommes donc amenés à constater que l'enseignement des mathématiques occupe dans la hiérarchie des savoirs scolaires un statut privilégié.

Poser la question du «pourquoi enseigner les mathématiques à tous» revient ainsi à interroger ce présupposé, autrement dit à se demander quelle est la pertinence de cet enseignement qui semble pour beaucoup aller de soi.



La question initiale peut alors être reformulée de la manière suivante:

## **2) Pourquoi les mathématiques devraient-elles faire partie de la formation que devrait avoir tout élève, tout adulte?**

Je me suis amusée à analyser brièvement, dans les différents curriculums d'études qui sont apparus au Québec, ou encore à travers ce qu'en disaient les didacticiens<sup>2</sup> de l'époque, comment on justifiait la pertinence de cet enseignement des mathématiques. La brève analyse qui suit nous montre que la réponse à cette question, à caractère très idéologique, varie à travers le temps, en fonction des priorités sociales accordées à l'institution qu'est l'école.

*Quelques éléments de réponses données par les programmes successifs à la question de la nécessité d'un enseignement pour tous*

Pour rendre compte adéquatement de la façon dont on a justifié la nécessité d'un enseignement des mathématiques à tous, il serait juste de conduire une analyse systématique des programmes, en situant le contexte social plus large qui donne sens à leur évolution<sup>3</sup>. Notre intention est ici simplement d'évoquer, un peu de manière impressionniste, quelques unes de ces justifications, avant tout à titre indicatif.

Voici comment l'on justifiait au début du siècle l'enseignement de l'arithmétique, dont on reconnaissait la nécessité pour tous.

On enseigne les mathématiques à l'école primaire pour apprendre à l'enfant à calculer facilement et sûrement toutes les questions de nombre qui se présentent dans le cours ordinaire de la vie. (Mgr Ross, 1919, p. 278)

C'est ici, avant tout, l'utilité pratique de l'arithmétique qui apparaît un élément décisif. Cette visée «utilitaire» se reflétera dans les pratiques que l'on cherchera à favoriser dans l'enseignement, à la fois dans le contenu privilégié (le contenu mathématique abordé est limité à l'apprentissage de l'arithmétique, de la mesure, de la comptabilité; les problèmes sont avant tout pratiques, leurs données doivent être exactes et variés ...), et dans la manière dont on propose de l'appréhender (voir Bednarz, sous presse).

Toutefois, lorsqu'on s'attarde aux propos des pédagogues de cette époque, on retrouve également mis en évidence, même si c'est de manière moins prépondérante, un autre avantage éducatif accordé à l'enseignement des mathématiques, celui d'un lieu possible où exercer la réflexion et le raisonnement. Ainsi Mgr Rouleau parle de développer le raisonnement juste, de cultiver ce raisonnement, de fortifier le jugement ...

L'étude de l'arithmétique développe toutes les facultés, mais elle a pour but particulier d'habituer l'intelligence à raisonner juste. Le maître doit donc s'adresser plus particulièrement à la raison, suivre la méthode et employer les procédés propres à cultiver le raisonnement. C'est ce qui ne se fait pas très souvent. On s'adresse surtout à la mémoire. (L'Abbé Rouleau, Magnan et Ahern, 1904, pp.117-118)

Une certaine fonction culturelle associée à l'enseignement des mathématiques, détachée de son caractère utilitaire et pratique, est ainsi portée à l'attention.

Il y aurait pourtant intérêt à fixer la juste portée de l'arithmétique au point de vue de la seule culture générale; à démontrer que, si elle exerce et développe les facultés qu'on indique, et d'autres qu'on n'a pas nommées: la mémoire, l'imagination, la volonté, elle ne le fait que si on l'enseigne d'une façon raisonnable et rationnelle, c'est-à-dire, à la grande lumière de certaines théories générales. (L'abbé Maurice, 1925-1926, pp. 4-5)

et plus loin, il reprendra cette même idée

Je tiens donc à dire, d'une façon explicite, qu'on ne doit pas négliger de soigner la culture générale des élèves qui est grandement aidée, favorisée, par l'étude de l'arithmétique. Je n'exige pas qu'on pense sans cesse à cette fin indirecte, médiate: je ne demande pas qu'on en fasse un but principal, mais simplement qu'on ne l'oublie pas, qu'on ne fasse rien qui

puisse empêcher de l'atteindre, qu'on s'impose même de louables efforts pour y arriver. (L'abbé Maurice, 1925-1926, p. 7)

D'ailleurs il est intéressant à ce propos de lire ce que l'on disait à cette époque sur l'algèbre et son enseignement.

Peu de personnes dans notre province ont besoin d'une connaissance, même élémentaire, de l'algèbre pour remplir les devoirs de leurs charges, et, cependant, il n'est permis à personne de commencer l'étude d'une profession avant d'avoir subi avec succès l'examen sur cette matière. Pourquoi exige t-on ainsi de ceux qui se destinent aux professions la connaissance d'un sujet qui ne paraît avoir aucune utilité pratique? Parce qu'on suppose que pour réussir dans une profession, il faut avoir une intelligence cultivée et qu'il est généralement admis que l'étude de l'algèbre (si elle est enseignée de manière rationnelle) est un des puissants moyens de fortifier le jugement (Mgr Rouleau, Magnan et Ahern, 1909, p. 250)

On voit dans ce qui précède apparaître un double langage, celui d'une part d'un enseignement des mathématiques à tous, valorisé surtout pour son caractère utile (faire en sorte que tous puissent se débrouiller avec les questions de la vie courante), et celui d'autre part d'un enseignement, malheureusement réservé à une petite partie de la population, qui met l'accent sur le développement du jugement, sur la valeur non plus utilitaire mais éducative de cet enseignement.

La réponse à la question pourquoi enseigner les mathématiques prend donc, à travers ce qui précède, une double forme.

L'arithmétique est nécessaire

- 1) pour son utilité pratique: à la rigueur, on se passe de savoir lire, mais on ne peut se passer de savoir compter; l'homme le plus ignorant calcule ce qu'on lui doit et ce qu'il doit payer;
- 2) pour son avantage éducatif: cette étude force l'attention et exerce à un haut degré la réflexion, le jugement et le raisonnement suivi. (Mgr Ross, 1919, p. 278)

Cette double fonction de la formation mathématique restera présente dans le nouveau programme mis en place après la guerre. Ainsi, si l'on enseigne les mathématiques, c'est pour que l'enfant puisse résoudre des problèmes d'arithmétique (il aura à en résoudre dans toute sa vie d'adulte).

L'enseignement de l'arithmétique à l'école élémentaire doit faire acquérir à l'élève les connaissances utilisées dans la vie courante en cette matière: faire comprendre la valeur des nombres, assurer l'exactitude des calculs, établir le fondement des connaissances arithmétiques, développer l'attitude mentale convenable en face d'un problème, donner les connaissances pratiques des affaires courantes de la comptabilité domestique. (programme de 1959, p. 410)

Mais si on enseigne les mathématiques, c'est aussi parce qu'elles sont un lieu de formation intellectuelle.

L'enseignement de l'arithmétique doit aussi contribuer à la formation de l'enfant. Le travail bien fait en cette matière développe l'attention, la souplesse et la rapidité en même temps que la sûreté et la précision rigoureuse; on lui fait constater l'importance de l'exactitude des calculs et des mesures dans un travail exact et bien fait; il requiert une juste appréciation des faits, des quantités; il habitue au calme, à la maîtrise de soi, à l'esprit de suite dans les idées, à la logique en même temps qu'au sens pratique. (programme de 1959, p. 410)

Cette contribution à la formation mathématique qu'apporte l'étude de l'arithmétique est discutée par les pédagogues. Si on reconnaît son apport au développement du raisonnement, on doute beaucoup du «transfert» possible à d'autres domaines. Autrement dit la vertu quasi universelle du développement du raisonnement provenant d'un apprentissage des mathématiques, et ce dans tous les domaines, est quelque peu contestée. Dans cette fin éducative attribuée à l'enseignement des mathématiques, l'accent est moins mis sur l'intérêt

qu'il présente pour le développement du jugement que sur les habitudes méthodologiques de travail qu'il instaure.

Cette question de la formation intellectuelle que l'étude de l'arithmétique est censée donner à l'enfant, a été et est encore très discutée par les auteurs de pédagogie: on doute beaucoup du transfert. Aujourd'hui, il est presque généralement admis que l'enseignement de l'arithmétique n'a pas toute la valeur formatrice qu'on lui attribuait autrefois. Il développe certes l'esprit et le raisonnement mathématiques mais il n'est pas sûr qu'il entraîne au juste raisonnement dans d'autres matières. Toutefois, il développe également des habitudes de travail et d'ordre; il exerce l'attention et la précision. Cette formation peut probablement avoir des répercussions générales. (Beaudry, 1950, p. 344)

Récemment, le programme des années 1980<sup>4</sup> dénote un souci explicite de rendre l'enseignement des mathématiques accessibles à tous. Les justifications sous-jacentes apparaissent ici toutefois fort différentes de ce que l'on pouvait trouver dans le passé.

Un enseignement qui viserait à faire comprendre le mieux possible et au plus grand nombre possible de citoyens ce que sont et ce que ne sont pas les mathématiques devrait aboutir aux trois éléments majeurs de formation suivants: une façon de penser qui fournit un instrument extrêmement puissant pour analyser ses expériences, un complément de culture qui peut améliorer l'intérêt et le plaisir de vivre, et enfin un langage important, essentiel à la communication des idées et à l'expression des buts de la société. (MEQ, 1980, p. 6)

Dans ce qui précède apparaissent des fonctions nouvelles associées à l'enseignement des mathématiques: celles-ci constituent un puissant instrument de pensée pour l'individu, un langage essentiel à la communication des idées. Elles fournissent à l'individu les outils qui lui permettront d'avoir une prise sur le monde qui l'entoure.

Cette idée d'accessibilité à tous, qui correspondait aux besoins de la société des années 70, fera place, à l'aube du 21<sup>ème</sup> siècle, à celle de formation d'une personne autonome. On voit apparaître alors l'idée d'une nécessaire adaptation à une société en évolution.

L'évolution rapide de la société constitue un défi gigantesque pour notre système d'éducation quant à la préparation des jeunes à la société de demain. Il est aujourd'hui difficile de prévoir les connaissances exhaustives dont l'élève aura besoin demain; nous devons nous assurer qu'il acquière une solide formation de base, des habiletés et des attitudes essentielles à son adaptation afin qu'il puisse réinvestir ses connaissances pour acquérir celles dont il aura besoin au cours de sa vie. (MEQ, 1993, p.15)

L'enseignement des mathématiques mettra à cette fin l'accent sur des habiletés et attitudes à développer, dont l'habileté à résoudre des problèmes (MEQ, 1993) puis sur le développement de compétences (MEQ, 2000): compétence à résoudre des problèmes, à actualiser des concepts (les mathématiques sont un puissant outil d'abstraction, il faut non seulement acquérir des outils conceptuels appropriés, mais encore pouvoir les mobiliser, faire des liens); compétence à communiquer à l'aide du langage mathématique; à apprécier la contribution de la mathématique aux différentes sphères de l'activité humaine. La mathématique devient un moyen essentiel d'assurer, pour l'individu, son rôle dans une société de plus en plus exigeante, une société scientifique et technologique.

La mathématique est un moyen de formation intellectuelle. Elle contribue au développement des capacités intellectuelles des élèves, consolide leur autonomie et facilite la poursuite de leur formation postsecondaire. Elle leur permet d'acquérir des outils conceptuels appropriés pour assurer leur rôle dans une société de plus en plus exigeante. La mathématique est considérée comme un langage universel de communication et un outil d'abstraction. (MEQ, 2000)

À travers ce bref survol des programmes et des discours qui y sont tenus, on peut voir que les réponses à la question «Pourquoi la formation mathématique devrait-elle faire partie de la formation que devrait avoir tout élève?» sont multiples. Ainsi même si tous reconnaissent l'importance des mathématiques dans la formation d'un personne (la volonté

de faire apprendre les mathématiques est constante), ils ne réfèrent pas aux mêmes mathématiques. Ancrées dans une certaine vision de l'école et de son rôle, les argumentations développées sont diverses. On parle de développer le raisonnement, l'esprit logique, l'argumentation, bref une certaine rationalité, on attribue aux mathématiques une utilité pratique, ou encore une valeur formatrice du point de vue des habitudes de travail, ... on parle de développer l'habileté à résoudre des problèmes, la capacité d'abstraction, la capacité de communication à l'aide du langage mathématique, ....

À travers ces multiples réformes transparaît donc une certaine vision structurante des mathématiques qui donne sens à cet «enseignement pour tous».

En supposant maintenant que l'on prenne pour acquis qu'il faille viser cet enseignement pour tous, la question qui se pose est la suivante:

### 3) Un tel enseignement à tous est-il viable ? Et si oui à quelles conditions?

Pour rejoindre le plus grand nombre possible d'élèves, l'école va souvent chercher, on l'a vu à travers ce qui précède, à leur montrer l'apport des mathématiques. Ainsi, au début du siècle, on a le souci de montrer l'utilité des mathématiques, son application à la vie courante et, à l'aube du 21<sup>ème</sup> siècle, le souci de faire voir sa possible contribution aux différentes sphères de l'activité humaine (compétence à développer). Une telle orientation renvoie à un examen attentif de la notion d'application.

#### *L'enseignement des mathématiques: utilité, contribution?*

Lorsqu'on aborde la question d'un enseignement des mathématiques à tous, il me semble important d'éviter le piège, dans lequel on pourrait facilement tomber, celui des applications. Un réexamen de cette notion apparaît capital à bien des égards, pour dépasser le niveau des besoins immédiats et l'idée que les mathématiques de l'école ont un intérêt pour les autres domaines, le milieu du travail ou la vie courante. Ce que requière un réinvestissement des connaissances mathématiques dans d'autres sphères de la vie humaine est rarement une simple application de ce que le milieu de l'enseignement a mis au point, souvent en vase clos. C'est ce que nous montrent bien les travaux de Lave (1988) sur l'arithmétique des travailleurs en entrepôt, des vendeurs itinérants de bonbons ou des tailleurs: l'arithmétique utilisée diffère de celle introduite en classe, autant par les procédures de calcul élaborées que par les stratégies de résolution de problèmes mises en oeuvre. Ces travailleurs se sont construits des méthodes particulières de calcul, fonctionnelles, viables en contexte. Les jeunes brésiliens, vendeurs de la rue, réussissent au marché à résoudre des problèmes qu'ils échouent à résoudre le lendemain à l'école.

Ces observations révèlent l'existence d'une arithmétique contextuelle qui fonctionne dans un environnement particulier, dans lequel les nombres, les opérations ont un sens rattaché à une situation ou à une classe de situations.

Les travaux, à un autre niveau, menés par Claude Janvier et Michel Baril (1992) auprès de techniciens en poste dans une entreprise montrent que les particularités de la pratique professionnelle ajoutent des connotations si profondes et si distinctes qu'il est quasiment impossible de retrouver dans la connaissance particulière mise en oeuvre en contexte, la connaissance générale qui devrait en être la source.

Entrevoir l'enseignement des mathématiques sous l'angle de sa contribution pose donc un certain nombre de problèmes, et questionne, au plan épistémologique, la manière dont nous concevons cette contribution: mathématiques apprises dans la classe de mathématiques pour ensuite être appliquées, versus mathématiques construites en contexte qui modifient en retour la nature même des mathématiques construites.

Indeed, the aim of enabling competence in particular applications to develop must be reassessed. In fact, comments made so far in this article have shown that using mathematics is more akin to contextualizing mathematics than to applying it. In other words,



the actual practice of many «users» is not simply a particular case of a general method learned at school. Consequently, the whole notion of mathematical foundation has to be revised. (Janvier, 1990, p. 189)

On peut percevoir dès lors tout ce qu'implique, si on la retient, la mise en oeuvre éventuelle d'une telle vision structurante de l'enseignement des mathématiques.

Au delà des conséquences que la discussion précédente fait apparaître sur la nature même des mathématiques abordées, il faut enfin se poser la question de la viabilité d'un tel enseignement. Autrement dit, en prenant pour acquis que les mathématiques doivent être enseignées à tous, la véritable question qui se pose, sur un plan didactique, est la suivante: les mathématiques peuvent-elles être enseignée à tous et, si c'est le cas, quelles sont les conditions à mettre en place pour que cet enseignement puisse fonctionner?

*Des contraintes incontournables à prendre en compte pour aborder la question de l'enseignement des mathématiques pour tous*

L'examen des programmes et des discours qui les accompagnent fait abstraction des contraintes de terrain. Le caractère idéologique de ces orientations est avant tout attaché à une volonté sociale qui, dans les faits, apparaît extrêmement complexe à maintenir. On assiste ici à l'expression d'un décalage entre les discours sur cet enseignement (la didactique normative, celle des programmes, ...) et la didactique de terrain (la didactique praticienne).

The extent to which teaching and learning in a classroom community are productive depends on the habitus of participants, a set of dispositions that incline individuals to act and interact in particular ways ... cultural capital of different minority groups and characteristics of the discipline to be taught and learned. (Tobin, 1998, p. 196)

Autrement dit, l'examen de la question d'un enseignement des mathématiques pour tous ne peut échapper à l'analyse des contraintes du système didactique. Le travail conduit par nous-mêmes et d'autres chercheurs auprès de classes faibles nous renvoie en effet vite au problème de l'échec de beaucoup d'élèves, notamment de milieux défavorisés, et pose la question de l'enseignement possible des mathématiques auprès de ces élèves. Il ne suffit pas d'avoir confiance dans les possibilités des élèves, ni de s'interroger sur les mathématiques à enseigner, avec un désir de développer un enseignement des notions avec un sens aussi proche que possible de celui qu'elles ont en mathématiques, il s'agit aussi dans ce cas de comprendre le fonctionnement des élèves et des enseignants dans de telles classes. Les élèves vivent ici de nombreuses difficultés imbriquant de multiples dimensions, les problèmes d'enseignement des mathématiques ne se posent pas de la même façon, les contraintes de fonctionnement rendent les situations extrêmement difficiles à gérer pour l'enseignant (Perrin Glorian, 1992).

L'étude des conditions de fonctionnement de ces classes où beaucoup d'élèves rencontrent des difficultés scolaires, notamment de celles qui sont issus de milieux socioculturels défavorisés, nous apparaît donc un problème central pour aborder la plausibilité d'un enseignement des "mathématiques pour tous". Autrement dit, on ne peut aborder cette question d'un enseignement des mathématiques s'adressant à tout citoyen, sans s'interroger sur les conditions particulières à mettre en place dans ces classes, sur leurs contraintes de fonctionnement, sur la nature même des mathématiques qui peuvent être abordées dans ces classes ou d'autres.

Enfin un tel questionnement renvoie également à une nécessaire prise en compte des praticiens dans la mise en place d'un tel enseignement. En effet, malgré l'ampleur, par exemple dans les années 70, des réformes mises de l'avant en enseignement des mathématiques et des sciences (on peut penser par exemple à l'élaboration de programmes et de matériel didactique novateurs, aux mouvements d'intégration des mathématiques et des sciences tels USMES ...), on ne peut que constater l'échec de leur implantation (Bentley, 1998).

Or, le constat d'échec des réformes précédentes interpelle la conception implicite qu'on a du rôle des praticiens dans la mise en place des curriculums: les développements de ces

programmes nient le rôle important du praticien dans l'implantation de tout changement des pratiques éducatives, et ce en le plaçant dans un rapport d'application de la réforme, plutôt que dans un rapport de partage de sens.

Des approches doivent donc, selon nous, être mises en place privilégiant l'étude de significations partagées par les chercheurs et les praticiens (Bednarz, 2000). L'idée est peut-être plus de tenter d'identifier avec les enseignants, à partir de leurs expériences de classe, des descriptions de stratégies d'enseignement fécondes sur le plan des apprentissages des élèves, mais également viables en contexte, permettant de documenter une perspective diversifiée d'enseignement cherchant à rejoindre tout élève.

## Notes

1. La fréquentation scolaire obligatoire est pour les élèves du Québec de 6 à 14 ans relativement récente (1943). Ainsi en 1929, seulement 24% des élèves francophones poursuivaient des études au delà de l'école primaire, et après la guerre seulement 46% des élèves atteignaient la 7<sup>ème</sup> année. Ce n'est qu'en 1961 qu'une obligation est faite aux Commissions scolaires d'assurer l'enseignement jusqu'en 11<sup>ème</sup> année.
2. On ne parlait pas de didactique à cette époque, mais de pédagogie ou méthodologie spéciale.
3. Voir à ce sujet Bednarz (sous presse).
4. Nous passons par dessus le programme-cadre de 1970 et la vision unificatrice des mathématiques qui le sous-tendait, fortement influencée, comme ce fut le cas dans plusieurs pays, par les mathématiques modernes. Le vent de réformes qui souffla sur le Québec dans les années 70–80 fut marqué par un effort visant à rendre l'éducation accessible à tous, et ce à tous les niveaux scolaires et dans toutes les régions.

## Références

- Beaudry, G. (1950). Arithmétique. Dans *Méthodologie spéciale, sous la direction de Roland Vinette* (pp. 341–482). Montréal: Le Centre de psychologie et de pédagogie.
- Bednarz, N. (sous presse). *Pourquoi, pour qui enseigner les mathématiques? Une mise en perspective historique de l'évolution des programmes au XX<sup>e</sup> siècle au Québec*. Actes du colloque EM 2000, L'enseignement des mathématiques dans les pays francophones au XX<sup>e</sup> siècle et ses perspectives pour le début du XXI<sup>e</sup> siècle, Grenoble, 15, 16, 17 juillet 2000.
- Bednarz, N. (2000). Formation continue des enseignants en mathématiques: une nécessaire prise en compte du contexte. Dans P. Blouin & L. Gattuso (Dir.), *Didactique des mathématiques et formation des enseignants* (pp. 61–78). Montréal: Éditions Modulo.
- Bentley, M. (1998). Constructivism as a referent for reforming science education. In M. Larochelle, N. Bednarz, & J. Gagnon (Eds.), *Constructivism and education* (pp. 233–249). Cambridge, UK: Cambridge University Press.
- Lave, J. (1988). *Cognition in practice: Mind, mathematics and culture in everyday life*. Cambridge, UK: Cambridge University Press.
- Janvier, C., Baril, M., & Mary, C. (1992). *Contextualized reasoning in electrical technicians*. Draft Copy. CIRADE, UQAM.
- Janvier, C. (1990). Contextualization and mathematics for all. In T.J. Cooney & C.R. Hirsch (Eds.), *Teaching and learning in mathematics in the 1990s* (pp. 183–193). Reston, VA: The National Council of Teachers of Mathematics.
- Lalonde, F. (2000). Mathématiques et physique. Dualité et résonances. Dans *Mathématiques An 2000. Un aperçu de la recherche à l'occasion de l'année mathématique mondiale* (pp. 12–14). Montréal: Institut des sciences mathématiques et l'Association mathématique du Québec.
- L'Abbé J.O. Maurice D. Th, LL.L (1925–1926). *Causeries pédagogiques aux instituteurs de la Commission des Écoles Catholiques de Montréal*. Montréal: Imprimerie des sourds-muets.
- MEQ (1980). *Programme d'études en mathématiques au primaire*.
- MEQ (1993). *Programme d'études en mathématiques au secondaire* (mathématiques 116).
- MEQ (2000). *Programme d'études en mathématiques au primaire*.
- Perrin-Glorian, M.J. (1992). *Aires de surfaces planes et nombres décimaux. Questions didactiques liées aux élèves en difficultés aux niveaux CM-6<sup>ème</sup>*. Thèse de doctorat d'état, Université Paris 7, février.



- Programme d'études des écoles élémentaires.* (1959). Commission des Programmes et des manuels. Comité catholique du Conseil de l'Instruction publique.
- Mgr F.X. Ross (1919). *Manuel de pédagogie théorique et pratique*, 2ème édition. Québec: Imp. Charrier et Dugal, Limitée.
- L'Abbé Th.G. Rouleau, C.J. Magnan et J. Ahern (1904). *Pédagogie pratique et théorique à l'usage des candidats au brevet d'enseignement et des élèves des écoles normales.* Québec: Imprimerie Darveau.
- L'Abbé Th.G. Rouleau, C.J. Magnan et J. Ahern (1909). *Pédagogie pratique et théorique.* Québec: Imprimerie Langlais, Limitée.
- Tobin, K. (1998). Sociocultural perspectives on the teaching and learning of science. In M. Larochelle, N. Bednarz, & J. Garrisson (Eds.), *Constructivism and education* (pp. 195–212). Cambridge, UK: Cambridge University Press.

## Why teach mathematics to everyone?

Nadine Bednarz

*Université du Québec à Montréal (UQAM)*

The question appearing in the title could be reformulated according to the following terms, that is in the form of three questions that I will take up in order: Should mathematics be taught to everyone? Why should mathematics be a part of the education that every student and every adult receives? And, assuming that a mathematics education is indeed a worthy aim at, is mathematics teaching for all actually viable?

### 1) Should mathematics be taught to everyone?

In principle, this question can be answered in the positive by invoking the fact that without this mathematical education, an entire way of apprehending the world would escape us, and with this, a certain way of analyzing and judging the validity of data, reasoning (analytically, synthetically, inductively or deductively, etc.); arguing; generalizing or abstracting; etc. However, even though there are grounds for acknowledging the value of this mathematical activity, a number of reports have shown that such ends are not met for many students. After receiving schooling in mathematics for several years, many adults are functionally illiterate in this field. To borrow a metaphor from my colleague François Lalonde, if a musical education was limited to learning scales, arpeggios, tone and harmony, etc. would a child or teenager be able to appreciate the beauty of music, to appreciate the musical world? Likewise, and to pursue the analogy, if students' contact with mathematics amounted to spending hours and hours doing exercises that strongly resemble training in scales and techniques, without ever hearing a concerto or a symphony, would they then be able to perceive the relevance of this activity and ascribe a meaning to it?

The music that mathematicians hear is sublime! It is unfortunate that only mathematicians attend these concerts. (Lalonde, 2000, p. 13; translated by author)

Under these conditions, is teaching mathematics to all worth the effort? Thus, our initial question cannot be taken up without also considering the very nature of the mathematical activity with which students are confronted during their basic education.

At all times, schools have considered that mathematics should be part of the minimum, fundamental education that every schoolchild, every student should receive,<sup>1</sup> with the result that mathematics has always been included in core, compulsory curriculum. In other words, institutions of learning have never raised the question of whether this teaching was necessary, whereas such a question has been raised in the case of music, theatre and philosophy, even though in many respects such subjects could be just as relevant as mathematics. I am thus led to conclude that mathematics teaching holds a privileged status in the hierarchy of school knowledge. Putting the question of "why teach mathematics to all" thus amounts to throwing this assumption open to challenge—in other words, to wondering about the relevance of this instruction, which seem to be self-evident for many.

Thus, the initial question could be reformulated as follows:

## 2) Why should mathematics be a part of the education that every student and every adult receives?

Using various curricula that appeared in Québec or the related comments by 'didactics' specialists<sup>2</sup> of that time, I amused myself by briefly analyzing the grounds used to justify the relevance of mathematics teaching. The following brief analysis shows that the highly ideological answers given to this question vary over time, according to the social priorities ascribed to the institution of schools.

*Fragments of answers provided by a succession of curricula to the question of why mathematics teaching for all is necessary*

In any serious account of the grounds used to justify the necessity of mathematics teaching for all, it would be appropriate to make a systematic analysis of curricula, in particular by means of identifying the broader social context from which they derived their meaning.<sup>3</sup> In the present case, I intend more simply to somewhat impressionistically touch on a number of these grounds, which are offered primarily for their illustrative value.

Thus, the following example presents the grounds used in the early 20th century to justify teaching arithmetic, which was acknowledged as being a necessity for everyone.

Mathematics are taught in primary school so that children will learn to easily and reliably calculate all questions of figures that may arise over the ordinary course of a lifetime. (Mgr. Ross, 1919, p. 278)

In the above excerpt, the practicality of arithmetic is stressed more than anything else. This 'utilitarian' objective was to be reflected in the practices that tended to be favoured in teaching, in terms both of the prioritized content (the mathematics topics taken up were limited to arithmetic, measuring, accounting, etc.; the problems were primarily practical in nature; and the related data had to be precise and accurate), and of the proposed way of apprehending the subject (see Bednarz, in press).

However, if some attention is devoted to the comments of educators of that time, evidence also emerges, albeit less obviously so, of another educational benefit ascribed to mathematics teaching—a potential locus for practising reflection and reasoning ability. Thus, Mgr. Rouleau also mentions developing and cultivating sound reasoning as well as strengthening judgment.

The study of arithmetic develops all faculties, but it is specifically intended to accustom the mind to reason soundly. Teachers must specifically address reason, adhere to method and employ methods appropriate to cultivating reasoning ability. These are things that are not done very often. Rote [learning] is the main thing emphasized. (Mgr. Rouleau, Magnan and Ahern, 1904, pp. 117–118)

A certain cultural function associated with mathematics teaching, held separate from its utilitarian or practical side, also comes in for comment:

It would be worthwhile establishing the true scope of arithmetic in terms of *general culture alone*; and demonstrating that if indeed it exercises and develops the faculties indicated, and those that have not been named—memory, imagination, determination—it does so only if it is taught in a reasonable, rational manner—that is, in light of a number of general theories. (Father Maurice, 1926)

Further on, he returns to this same idea:

I also wish to explicitly mention that efforts should be made to develop students' general culture, which is significantly aided and fostered by the study of arithmetic. I do not insist on continually thinking about this indirect, mediate end. I do not require making it a chief objective. I simply request that it not be forgotten, that nothing be done to prevent us from achieving it, and that worthy efforts be summoned to accomplish it. (Father Maurice, 1925–1926, p. 7)

Furthermore, in that connection, it is interesting to read period comments concerning algebra and algebra teaching.

Few people in our province need even elementary knowledge of algebra to perform their duties, and yet, no one is allowed to commence the study of a profession without first having passed an examination on this subject. Why, then, are those who are called to the professions required to have knowledge of a subject that apparently has no practical application? Because it is assumed that in order to succeed in a profession, one must have a cultivated mind and because it is generally admitted that the study of algebra (if it is taught in a rational manner) is a powerful means of strengthening judgment. (Mgr. Rouleau, Magnan and Ahern, 1909, p. 250)

The preceding excerpt provides evidence of a kind of double language. On the one hand, there is mathematics teaching for all, which is valued for its utilitarian aspect (its capacity to ensure that everyone can manage with the questions of everyday life), and on the other there is an approach to teaching which unfortunately is reserved for a small segment of the population and which places emphasis on developing judgment and on the non-utilitarian but educational value of this teaching.

In light of the preceding excerpts, the answer to the question of why mathematics should be taught thus takes on a dual form. Arithmetic is necessary on account of:

- 1) its practical uses: strictly speaking, the ability to read can be dispensed with, but one can do without knowing how to count; even the most ignorant calculate what they owe and are owed;
- 2) its educational application: this type of study compels attention, exercises reflection, judgment and sustained reasoning to a high degree. (Mgr. Ross, 1919, p. 278)

This dual function of mathematics education will remain present in the new curriculum established following World War II. Thus, for example, if mathematics is taught, it is so that children may solve arithmetic problems (they will have to solve such problems in their adult lives).

Arithmetic education in primary schools should inculcate in students the knowledge of this subject that is used in everyday life—that is, promote understanding of the value of numbers, foster accuracy in calculations, establish the basis of arithmetical knowledge, develop a mental attitude that is appropriate to the problem at hand and provide practical knowledge of the usual subjects of household accounting. (Curriculum of 1959, p. 410)

However, if mathematics is taught, it is also because the subject represents a locus of intellectual development.

Mathematics teaching should also contribute to the development of the child. Work well done in this subject develops attention, agility and rapidity as well as reliability and rigorous precision. Children are made to observe the importance of accurate calculations and measurements as part of a precise, well-done job. [Mathematics education] requires an accurate appraisal of facts and quantities. It accustoms children to quiet, self-control, consistency of thinking, and a combination of logic and practicality. (Curriculum of 1959, p. 410)

The benefits of studying arithmetic as part of a mathematical education is the subject of debate among educators. While the contribution of arithmetic to reasoning ability is recognized, many doubts are raised over the potential for 'transfer' to other fields. In other words, the practically universal virtues of the development of reasoning ability resulting from mathematics education, regardless of the field, is thrown open to challenge to a certain extent. In descriptions of the educational end ascribed to mathematics teaching, emphasis is laid less on its value for developing judgment than on the work methods and habits implemented by it:

This question of the intellectual formation supposedly provided children via the study of arithmetic is still much debated among the teaching methods authors: [The notion of]

transfer appears quite dubious to them. Today, it is almost generally admitted that arithmetic does not possess all the formative value previously ascribed to it. It obviously develops a mathematical mind and reasoning ability, but it is not clear that it provides training in sound reasoning in other subjects. However, it also develops habits of work and method. This education probably could have general repercussions. (Beaudry, 1950, p. 344)

More recently, the curriculum of the 1980s<sup>4</sup> evidences an explicit concern for making mathematics teaching accessible for all. However, the underlying justifications appear quite different from those that were likely to be encountered in the past.

A type of teaching designed to produce understanding—to the fullest extent and among the greatest number of people possible—of what mathematics is and is not should produce the following three main educational results: a way of thinking that provides an extremely powerful instrument for analyzing one's experiences; an addition to one's culture that can improve and enhance the enjoyment of life; and finally an important language that is essential to communication and the expression of society's objectives. (Ministère de l'Éducation du Québec, 1980, p. 6)

The preceding excerpt provides evidence of the new functions associated with mathematics teaching: together, they represent a powerful intellectual for individuals, a language essential to communicating ideas. Mathematics supplies individuals with the tools for grasping the world around them.

At the dawn of the 21st century, this notion of universal accessibility, which dovetailed with the needs of society during the 1970s, would be supplanted by that of educating the autonomous individual. At that point, the idea of a necessary adaptation to an evolving society came to the fore.

The rapid evolution of society represents a huge challenge... Today it is difficult to foresee the exhaustive knowledge students will require tomorrow; it is our duty to ensure that they acquire a solid basic education and the skills and attitudes necessary to their adaptation, so that they may reinvest this knowledge and thereby acquire the knowledge that they will need during their lifetime. (Ministère de l'Éducation du Québec, 1993, p. 15)

Toward that end, mathematics teaching was to emphasize the development of skills and attitudes, including problem-solving skills (MEQ, 1993), and thereafter the development of 'competencies' (MEQ, 2000)—that is: competency in problem-solving and actualizing concepts (mathematics are a powerful tool of abstraction; not only must a person acquire the appropriate conceptual tools, he or she must also be able to mobilize them, establish relationships, etc.); competency in communicating using mathematical language; competency in appreciating the contribution of mathematics to various spheres of human activity. For the individual, mathematics thus became an essential means to taking up his or her "role in an increasingly demanding society," a scientific and technological society.

Mathematics is a means of intellectual preparation and training. It contributes to the development of students' intellectual capacities, consolidates their autonomy and facilitates their pursuit of postsecondary education. It enables them to acquire the conceptual tools appropriate to assuming their role in an increasingly demanding society. Mathematics is viewed as a universal language of communication and a tool of abstraction. (MEQ, 2000)

On the basis of this brief survey of curricular and their underlying discourses, it is clear that the answers to the question "Why should mathematics be part of the education that every student should receive?" are manifold. Thus, even though it is universally acknowledged that mathematics plays an important role in the education of an individual (the determination to make students learn mathematics is constant throughout), the various actors do not refer to the same type of mathematics. A certain underlying vision of the school and its role means that the lines of argument thus developed are diverse. Mention is made of developing reasoning ability, a logical mind, argumentative capacity—in short, a



certain kind of rationality. Mathematics is ascribed a range of practical uses, or a formative value in terms of work habits. Other actors refer to developing problem-solving skills, the capacity for abstraction, or the capacity for communication using mathematical language. These various reforms thus offer a glimpse of a certain structuring vision of mathematics which endows such "education for all" with meaning.

Assuming at this point that this "[mathematics] teaching for all" is an agreed-on objective, the question that then arises can be framed as follows:

### **3) Is such a type of teaching viable? If so, under what conditions?**

As was seen in the above excerpts, in order to reach out to the greatest number of students possible, schools attempted to show them the benefits of mathematics. Thus, at the turn of the century, educators went to some length demonstrating mathematics' utility and applicability to everyday life. At the dawn of the 21st century, they have strived to bring out the possible contribution of mathematics to various spheres of human activity (competency to be developed). In turn, an orientation of this kind implies examining the notion of application attentively.

#### *Mathematics teaching: its utility, its contribution?*

In my opinion, whenever the question of mathematics teaching for all is taken up, it is important to avoid the particularly deceptive trap represented by applications. Reexamining this notion appears crucial from many standpoints if we are to go beyond the level of immediate needs and the idea that school mathematics are valuable for other sectors, the workplace or everyday life. The re-investment of mathematical knowledge in other spheres of activity rarely entails simply applying what the teaching sector has concocted in isolation from the world. That much has been clearly shown in the work of Jean Lave (1998) concerning the arithmetic of warehouse workers, itinerant candy vendors, tailors, etc. The type of arithmetic practised by these people differs from the variety presented in the classroom, in terms not only of calculation procedures but also of the problem-solving strategies implemented. These merchants, tailors, etc. have devised for themselves specific methods of calculation that are functional and viable in context. Thus, for example, young Brazilian street vendors manage to solve problems in the marketplace that they fail to solve in school the following day.

These observations reveal the existence of a contextual type of arithmetic—that is, a type of mathematics that works in a particular context where numbers, operations, etc. have a meaning in connection with a situation or class of situations.

Research of another kind conducted by Claude Janvier and André Baril among technicians in the employ of a company provides illustration of how the particularities of professional practice add connotations that are so deep and so distinct that it is practically impossible to locate the general knowledge that ought presumably to be the source of this particular knowledge.

Conceptions of mathematics teaching in terms of its contribution thus raises a number of issues. And, epistemologically speaking, it challenges the way we view this contribution: the mathematics learned in the classroom for subsequent application versus the type of mathematics constructed in context and which modifies the very nature of the mathematics being constructed.

Indeed, the aim of enabling competence in particular applications to develop must be reassessed. In fact, comments made so far in this article have shown that using mathematics is more akin to contextualizing mathematics than to applying it. In other words, the actual practice of many 'users' is not simply a particular case of a general method learned at school. Consequently, the whole notion of mathematical foundation has to be revised. (Janvier, 1990, p. 189)

At that point, it becomes a bit clearer just how much is entailed by the potential implementation of this type of structuring vision of mathematics teaching, if indeed such an option is opted for.

Beyond the implications of the preceding discussion with respect to the very nature of the mathematics to be developed, the question of the viability of this teaching must also be addressed. In other words, assuming that mathematics should be taught to all, the real question that should be raised, in terms of mathematics education (didactics) is: can mathematics be taught to all, and if so, what conditions must be implemented in order for this teaching to work?

*Inescapable constraints that must be accounted for in any attempt at addressing the question of mathematics education for all*

The examination of curricula and their underlying discourses does not account for constraints occurring in the field. The ideological character of these orientations stems primarily from a social intention or will, which, in terms of the facts, is apparently complex to maintain. At this point, we are witness to a gap between the discourse concerning mathematics teaching for all (normative educational approaches—i.e., that of curricula, etc.) and teaching methods, as actually practised in the field.

The extent to which teaching and learning in a classroom community are productive depends on the habitus of participants, a set of dispositions that incline individuals to act and interact in particular ways...cultural capital of different minority groups and characteristics of the discipline to be taught and learned. (Tobin, 1998, p. 196)

In other words, an examination of the question of mathematics teaching for all cannot dispense with an analysis of the constraints under which the teaching system operates. Research by other researchers and myself among weaker classes presents us with the problem of the failure of many students, particularly those from disadvantaged environments, and raises the question of the possibility of mathematics teaching among these students. It is not merely a question of having confidence in the potential of students, or of inquiring into the type of mathematics to be taught out of a desire to develop a teaching of notions having a meaning as close as possible to that ascribed to mathematics by these students. In this case, it is also a matter of understanding the ways students and teachers manage to operate in such classes. These students experience numerous, multifaceted difficulties, the problems of mathematics teaching are framed differently, and the operating constraints make classroom situations extremely difficult for teachers to manage (Perrin-Glorian, 1992).

Thus, in my opinion, studying the operating conditions of these classrooms, in which schooling difficulties are the lot of many students, particularly those from disadvantaged socio-cultural environments, is a central issue in the process of addressing the plausibility of "mathematics education for all." In other words, the question of devising a type of mathematics education with every citizen in mind cannot be taken up without also examining the particular conditions that should be established in these classes, the operating constraints to which they are subjected, and the very nature of the mathematics that can be covered in these classes or others.

Furthermore, this type of questioning process also necessarily implies that the implementation of this type of teaching approach must take practitioners into consideration. In that connection, there can be no denying that despite the scope of the reforms previously put forward in mathematics and science teaching (for example, in science during the 1960s, the development of innovative programs and teaching materials, movements for integrating mathematics and science such as *USMES*, etc.), such initiatives have failed since the time of their implementation.

Now, once the failure of previous reforms has been admitted, we are forced to rethink the conception that we have of the role of practitioners in working up curricula: the ways in which academic programs are developed deny the major role that practitioners have to play

in introducing any type of change in educational practices, notably by placing practitioners in an implementation- or execution-type relationship with respect to the reform rather than a relationship based on the sharing of meaning.

In my view, a series of approaches should be developed which emphasize studying or investigating the meanings shared between educational researchers and practitioners (Bednarz, 2000). The main idea is perhaps more one of identifying and describing—in collaboration with teachers and on the basis of their classroom experiences—teaching strategies that are not only fruitful in terms of students' learnings but that are also viable in context. Such a process would also serve to document a diversified perspective on mathematics teaching aimed at reaching out to every student.

## Notes

1. Compulsory school attendance for students ages 6 to 14 is relatively recent in Québec (1943). Thus, in 1929, only 24% of francophone students pursued studies beyond primary school, and after World War II, only 46% entered Grade 7. It was only in 1961 that school boards were required by law to provide instruction until Grade 11.
2. At that time, didactics was not the term in use. Instead, educational science and special teaching methods were referred to.
3. See on this subject, Bednarz (in press).
4. I will skip over the 1970 core curriculum and the unifying vision of mathematics underlying it. As was the case in several countries, this vision was strongly influenced by modern mathematics. The sweeping reforms occurring in Québec during the 1970s and 1980s were marked by an attempt at making education accessible for all, at all levels of instruction and in all regions.

## References

- Beaudry, G. (1950). Arithmétique. Dans *Méthodologie spéciale, sous la direction de Roland Vinette*. (pp. 341–482). Montréal: Le Centre de psychologie et de pédagogie.
- Bednarz, N. (in press). Pourquoi, pour qui enseigner les mathématiques? Une mise en perspective historique de l'évolution des programmes au XX<sup>e</sup> siècle au Québec. *Actes du colloque EM 2000, L'enseignement des mathématiques dans les pays francophones au XX<sup>e</sup> siècle et ses perspectives pour le début du XXI<sup>e</sup> siècle*. Grenoble, July 15–17, 2000.
- Bednarz, N. (2000). Formation continue des enseignants en mathématiques: une nécessaire prise en compte du contexte. Dans P. Blouin & L. Gattuso (Dir.), *Didactique des mathématiques et formation des enseignants* (pp. 61–78). Montréal: Éditions Modulo.
- Bentley, M. (1998). Constructivism as a referent for reforming science education. In M. Larochelle, N. Bednarz, & J. Gagnon (Eds.), *Constructivism and education* (pp. 233–249). Cambridge, UK: Cambridge University Press.
- Lave, J. (1988). *Cognition in practice: Mind, mathematics and culture in everyday life*. Cambridge, UK: Cambridge University Press.
- Janvier, C., Baril, M., & Mary, C. (1992). *Contextualized reasoning in electrical technicians*. Draft Copy. CIRADE, UQAM.
- Janvier, C. (1990). Contextualization and mathematics for all. In T.J. Cooney & C.R. Hirsch (Eds.), *Teaching and learning in mathematics in the 1990s* (pp. 183–193). Reston, VA: The National Council of Teachers of Mathematics.
- Lalonde, F. (2000). Mathématiques et physique. Dualité et résonances. Dans *Mathématiques An 2000. Un aperçu de la recherche à l'occasion de l'année mathématique mondiale* (pp. 12–14). Montréal: Institut des sciences mathématiques et l'Association mathématique du Québec.
- Maurice, Father J.O., D. Th, LL.L (1925-1926). *Causeries pédagogiques aux instituteurs de la Commission des Écoles Catholiques de Montréal*. Montréal: Imprimerie des sourds-muets.
- MEQ (1980). Programme d'études en mathématiques au primaire.
- MEQ (1993). Programme d'études en mathématiques au secondaire (mathématiques 116).
- MEQ (2000). Programme d'études en mathématiques au primaire.
- Programme d'études des écoles élémentaires* (1959). Commission des Programmes et des manuels.

Comité catholique du Conseil de l'Instruction publique.

- Perrin-Glorian, M.J. (1992). *Aires de surfaces planes et nombres décimaux. Questions didactiques liées aux élèves en difficultés aux niveaux CM-6ème*. PhD thesis, Université Paris 7, February.
- Rouleau, Mgr. Th. G., C.J. Magnan and J. Ahern (1904). *Pédagogie pratique et théorique à l'usage des candidats au brevet de l'enseignement et des élèves des écoles normales*. Québec: Imprimerie Darveau.
- Rouleau, Mgr. Th. G., C.J. Magnan and J. Ahern (1909). *Pédagogie pratique et théorique*. Québec: Imprimerie Langlais, Limitée.
- Ross, Mgr. F.X. (1919). *Manuel de pédagogie théorique et pratique*, second edition. Québec: Imp. Charrier et Dugal, Limitée.
- Tobin, K. (1998). Sociocultural perspectives on the teaching and learning of science. In M. Larochelle, N. Bednarz, & J. Garrisson (Eds.), *Constructivism and education* (pp. 195–212). Cambridge, UK: Cambridge University Press

## Appendices

---



## APPENDIX A

### Working Groups at Each Annual Meeting

- 1977 *Queen's University, Kingston, Ontario*
- Teacher education programmes
  - Undergraduate mathematics programmes and prospective teachers
  - Research and mathematics education
  - Learning and teaching mathematics
- 1978 *Queen's University, Kingston, Ontario*
- Mathematics courses for prospective elementary teachers
  - Mathematization
  - Research in mathematics education
- 1979 *Queen's University, Kingston, Ontario*
- Ratio and proportion: a study of a mathematical concept
  - Minicalculators in the mathematics classroom
  - Is there a mathematical method?
  - Topics suitable for mathematics courses for elementary teachers
- 1980 *Université Laval, Québec, Québec*
- The teaching of calculus and analysis
  - Applications of mathematics for high school students
  - Geometry in the elementary and junior high school curriculum
  - The diagnosis and remediation of common mathematical errors
- 1981 *University of Alberta, Edmonton, Alberta*
- Research and the classroom
  - Computer education for teachers
  - Issues in the teaching of calculus
  - Revitalising mathematics in teacher education courses
- 1982 *Queen's University, Kingston, Ontario*
- The influence of computer science on undergraduate mathematics education
  - Applications of research in mathematics education to teacher training programmes
  - Problem solving in the curriculum
- 1983 *University of British Columbia, Vancouver, British Columbia*
- Developing statistical thinking
  - Training in diagnosis and remediation of teachers
  - Mathematics and language
  - The influence of computer science on the mathematics curriculum

- 1984 *University of Waterloo, Waterloo, Ontario*
- Logo and the mathematics curriculum
  - The impact of research and technology on school algebra
  - Epistemology and mathematics
  - Visual thinking in mathematics
- 1985 *Université Laval, Québec, Québec*
- Lessons from research about students' errors
  - Logo activities for the high school
  - Impact of symbolic manipulation software on the teaching of calculus
- 1986 *Memorial University of Newfoundland, St. John's, Newfoundland*
- The role of feelings in mathematics
  - The problem of rigour in mathematics teaching
  - Microcomputers in teacher education
  - The role of microcomputers in developing statistical thinking
- 1987 *Queen's University, Kingston, Ontario*
- Methods courses for secondary teacher education
  - The problem of formal reasoning in undergraduate programmes
  - Small group work in the mathematics classroom
- 1988 *University of Manitoba, Winnipeg, Manitoba*
- Teacher education: what could it be?
  - Natural learning and mathematics
  - Using software for geometrical investigations
  - A study of the remedial teaching of mathematics
- 1989 *Brock University, St. Catharines, Ontario*
- Using computers to investigate work with teachers
  - Computers in the undergraduate mathematics curriculum
  - Natural language and mathematical language
  - Research strategies for pupils' conceptions in mathematics
- 1990 *Simon Fraser University, Vancouver, British Columbia*
- Reading and writing in the mathematics classroom
  - The NCTM "Standards" and Canadian reality
  - Explanatory models of children's mathematics
  - Chaos and fractal geometry for high school students
- 1991 *University of New Brunswick, Fredericton, New Brunswick*
- Fractal geometry in the curriculum
  - Socio-cultural aspects of mathematics
  - Technology and understanding mathematics
  - Constructivism: implications for teacher education in mathematics
- 1992 *ICME-7, Université Laval, Québec, Québec*
- 1993 *York University, Toronto, Ontario*
- Research in undergraduate teaching and learning of mathematics
  - New ideas in assessment
  - Computers in the classroom: mathematical and social implications
  - Gender and mathematics
  - Training pre-service teachers for creating mathematical communities in the classroom

- 1994 *University of Regina, Regina, Saskatchewan*
- Theories of mathematics education
  - Pre-service mathematics teachers as purposeful learners: issues of enculturation
  - Popularizing mathematics
- 1995 *University of Western Ontario, London, Ontario*
- Anatomy and authority in the design and conduct of learning activity
  - Expanding the conversation: trying to talk about what our theories don't talk about
  - Factors affecting the transition from high school to university mathematics
  - Geometric proofs and knowledge without axioms
- 1996 *Mount Saint Vincent University, Halifax, Nova Scotia*
- Teacher education: challenges, opportunities and innovations
  - Formation à l'enseignement des mathématiques au secondaire: nouvelles perspectives et défis
  - What is dynamic algebra?
  - The role of proof in post-secondary education
- 1997 *Lakehead University, Thunder Bay, Ontario*
- Awareness and expression of generality in teaching mathematics
  - Communicating mathematics
  - The crisis in school mathematics content
- 1998 *University of British Columbia, Vancouver, British Columbia*
- Assessing mathematical thinking
  - From theory to observational data (and back again)
  - Bringing Ethnomathematics into the classroom in a meaningful way
  - Mathematical software for the undergraduate curriculum
- 1999 *Brock University, St. Catharines, Ontario*
- Information technology and mathematics education: What's out there and how can we use it?
  - Applied mathematics in the secondary school curriculum
  - Elementary mathematics
  - Teaching practices and teacher education

## APPENDIX B

### Plenary Lectures at Each Annual Meeting

1977	A.J. COLEMAN C. GAULIN T.E. KIEREN	The objectives of mathematics education Innovations in teacher education programmes The state of research in mathematics education
1978	G.R. RISING A.I. WEINZWEIG	The mathematician's contribution to curriculum development The mathematician's contribution to pedagogy
1979	J. AGASSI J.A. EASLEY	The Lakatosian revolution* Formal and informal research methods and the cultural status of school mathematics*
1980	C. CATTEGNO D. HAWKINS	Reflections on forty years of thinking about the teaching of mathematics Understanding understanding mathematics
1981	K. IVERSON J. KILPATRICK	Mathematics and computers The reasonable effectiveness of research in mathematics education*
1982	P.J. DAVIS G. VERGNAUD	Towards a philosophy of computation* Cognitive and developmental psychology and research in mathematics education*
1983	S.I. BROWN P.J. HILTON	The nature of problem generation and the mathematics curriculum The nature of mathematics today and implications for mathematics teaching*
1984	A.J. BISHOP L. HENKIN	The social construction of meaning: A significant development for mathematics education?*
1985	H. BAUERSFELD H.O. POLLAK	Contributions to a fundamental theory of mathematics learning and teaching On the relation between the applications of mathematics and the teaching of mathematics
1986	R. FINNEY A.H. SCHOENFELD	Professional applications of undergraduate mathematics Confessions of an accidental theorist*
1987	P. NESHER H.S. WILF	Formulating instructional theory: the role of students' misconceptions* The calculator with a college education

1988	C. KEITEL L.A. STEEN	Mathematics education and technology* All one system
1989	N. BALACHEFF D. SCHATTSNEIDER	Teaching mathematical proof: The relevance and complexity of a social approach Geometry is alive and well
1990	U. D'AMBROSIO A. SIERPINSKA	Values in mathematics education* On understanding mathematics
1991	J. J. KAPUT C. LABORDE	Mathematics and technology: Multiple visions of multiple futures Approches théoriques et méthodologiques des recherches Françaises en didactique des mathématiques
1992	ICME-7	
1993	G.G. JOSEPH J CONFREY	What is a square root? A study of geometrical representation in different mathematical traditions Forging a revised theory of intellectual development: Piaget, Vygotsky and beyond*
1994	A. SFARD K. DEVLIN	Understanding = Doing + Seeing ? Mathematics for the twenty-first century
1995	M. ARTIGUE K. MILLETT	The role of epistemological analysis in a didactic approach to the phenomenon of mathematics learning and teaching Teaching and making certain it counts
1996	C. HOYLES D. HENDERSON	Beyond the classroom: The curriculum as a key factor in students' approaches to proof* Alive mathematical reasoning
1997	R. BORASSI P. TAYLOR T. KIEREN	What does it really mean to teach mathematics through inquiry? The high school math curriculum Triple embodiment: Studies of mathematical understanding-in-inter-action in my work and in the work of CMESG/GCEDM
1998	J. MASON K. HEINRICH	Structure of attention in teaching mathematics Communicating mathematics or mathematics storytelling
1999	J. BORWEIN W. WHITELEY W. LANGFORD J. ADLER  B. BARTON	The impact of technology on the doing of mathematics The decline and rise of geometry in 20 <sup>th</sup> century North America Industrial mathematics for the 21 <sup>st</sup> century Learning to understand mathematics teacher development and change: Researching resource availability and use in the context of formalised INSET in South Africa An archaeology of mathematical concepts: Sifting languages for mathematical meanings

**NOTE**

\*These lectures, some in a revised form, were subsequently published in the journal *For the Learning of Mathematics*.



## APPENDIX C

### Proceedings of Annual Meetings

Past proceedings of CMESG/GCEDM annual meetings have been deposited in the ERIC documentation system with call numbers as follows:

<i>Proceedings of the 1980 Annual Meeting</i> .....	ED 204120
<i>Proceedings of the 1981 Annual Meeting</i> .....	ED 234988
<i>Proceedings of the 1982 Annual Meeting</i> .....	ED 234989
<i>Proceedings of the 1983 Annual Meeting</i> .....	ED 243653
<i>Proceedings of the 1984 Annual Meeting</i> .....	ED 257640
<i>Proceedings of the 1985 Annual Meeting</i> .....	ED 277573
<i>Proceedings of the 1986 Annual Meeting</i> .....	ED 297966
<i>Proceedings of the 1987 Annual Meeting</i> .....	ED 295842
<i>Proceedings of the 1988 Annual Meeting</i> .....	ED 306259
<i>Proceedings of the 1989 Annual Meeting</i> .....	ED 319606
<i>Proceedings of the 1990 Annual Meeting</i> .....	ED 344746
<i>Proceedings of the 1991 Annual Meeting</i> .....	ED 350161
<i>Proceedings of the 1993 Annual Meeting</i> .....	ED 407243
<i>Proceedings of the 1994 Annual Meeting</i> .....	ED 407242
<i>Proceedings of the 1995 Annual Meeting</i> .....	ED 407241
<i>Proceedings of the 1996 Annual Meeting</i> .....	ED 425054
<i>Proceedings of the 1997 Annual Meeting</i> .....	ED 423116
<i>Proceedings of the 1998 Annual Meeting</i> .....	ED 431624
<i>Proceedings of the 1999 Annual Meeting</i> .....	not available

#### NOTES

1. There was no Annual Meeting in 1992 because Canada hosted the Seventh International Conference on Mathematical Education that year.
2. The *Proceedings of the 2000 Annual Meeting* have been submitted to ERIC.

## APPENDIX D

### List of Participants

Barbeau, Edward  
*University of Toronto*  
barbeau@math.utoronto.ca

Barnson, Pat  
*University of Manitoba*  
umbarns3@cc.umanitoba.ca

Bartolini Bussi, Mariolina  
*Universita di Modena*  
Bartolini@unimo.it

Barwell, Richard  
*University of Bristol*  
richard.barwell@bristol.ac.uk

Bednarz, Nadine  
*Université du Québec à Montréal*  
Descamps-Bednarz.nadine@uqam.ca

Borgen, Katharine  
*University of British Columbia*  
kborgen@interchange.ubc.ca

Brown, Laurinda  
*University of Bristol*  
Laurinda.Brown@bris.ac.uk

Byers, Bill  
*Concordia University*  
Wpbyers@vax2.concordia.ca

Chapman, Olive  
*University of Calgary*  
Chapman@ucalgary.ca

Charbonneau, Louis  
*Université du Québec à Montréal*  
Charbonneau.louis@uqam.ca

Coache-Lessard, Michele  
*Université du Québec à Montréal*  
clau. lessard@pwc.ca

Colgan, Lynda  
*Queen's University*  
colgan@educ.queensu.ca

Côté, Benoît  
*Université du Québec à Montréal*  
cote.benoit@uqam.ca

Crowley, Mary  
*Mount St. Vincent University*  
mary.crowley@msvu.ca

Cudmore, Donald  
*Ontario*  
Dcudmore@canada.com

Davis, Brent  
*York University*  
bdavis@edu.yorku.ca

Dawson, Sandy  
*PREL, Honolulu*  
dawsons@prel.org

Deblois, Lucie  
*Université Laval*  
lucie.deblois@fse.ulaval.ca

Defence, Astrid  
*Concordia University*  
astrid@vax2.concordia.ca

Desjardins, Sylvie  
*Okanagan University College*  
sdesjard@okanagan.bc.ca

Doctorow, Gordon  
*Toronto District School Board*  
doctor2@sympatico.ca

Doctorow, Roz  
*Ontario*  
doctor2@sympatico.ca

Dubiel, Malgorzata  
*Simon Fraser University*  
 dubiel@cs.sfu.ca

Flewelling, Gary  
*Ontario*  
 flew@sentex.net

Franks, Doug  
*Nipissing University*  
 dougf@unipissing.ca

Gadanidis, George  
*University of Western Ontario*  
 gadanidis@sympatico.ca

Gaulin, Claude  
*Université Laval*  
 Claude.Gaulin@fse.ulaval.ca

Gauthier, Pierre  
*École Eulalie-Dorocher*  
 gauthierp@csdm.qc.ca

Gerofsky, Susan  
*Simon Fraser University*  
 gerofsky@sfu.ca

Giroux, Jacinthe  
*Université du Québec à Montréal*  
 Giroux.jacinthe@uqam.ca

Gordon Calvert, Lynn  
*University of Alberta*  
 lynn.gordon@ualberta.ca

Gourdeau, Frédéric  
*Université Laval*  
 fredg@mat.ulaval.ca

Grant McLoughlin, John  
*Memorial University of Newfoundland*  
 johngm@math.mun.ca

Gruen, Frank  
*British Columbia Institute of Technology*  
 fgruen@bcit.ca

Guzman, José  
*Cinvestav, Mexico*  
 Jguzman@mail.cinvestav.mx

Haguel, Marie-Jane  
*Collège de Sherbrooke*  
 Haguelma@collegesherbrooke.qc.ca

Hanna, Gila  
*OISE/University of Toronto*  
 ghanna@oise.utoronto.ca

Hershkovitz, Rina  
*Weizmann Institute*  
 rina.hershkovitz@weizmann.ac.il

Hewitt, Dave  
*University of Birmingham*  
 D.P.Hewitt@bham.ac.uk

Higginson, William  
*Queen's University*  
 higginsw@educ.queensu.ca

Hillel, Joel  
*Concordia University*  
 jhillel@alcor.concordia.ca

Hodgson, Bernard  
*Université Laval*  
 bhodgson@mat.ulaval.ca

Hoffman, Martin  
*Queens College*  
 hoffman@forbin.qc.edu

Janvier, Bernadette  
*Université du Québec à Montréal*  
 dufour-janvier.bernadette@uqam.ca

Jordi, Isabelle  
*Québec*  
 Rbourr@dsuper.net

Kajander, Ann  
*Lakehead University*  
 ann.kajander@lakeheadu.ca

Kieran, Carolyn  
*Université du Québec à Montréal*  
 kieran.carolyn@uqam.ca

Kieren, Tom  
*University of Alberta*  
 tom.kieren@ualberta.ca

Klasa, Jacqueline  
*Dawson College*  
 Jklasa@dawsoncollege.qc.ca

Labelle, Gilbert  
*Université du Québec à Montréal*  
 labelle.gilbert@uqam.ca

Lajoie, Caroline  
*Université du Québec à Montréal*  
 lajoie.caroline@uqam.ca

Lee, Lesley  
*Université du Québec à Montréal*  
 lee.lesley@uqam.ca

Lidstone, Dave  
*Langara College*  
 Dlidston@langara.bc.ca

Lomas, Dennis  
*OISE/University of Toronto*  
 Dlomas@oise.utoronto.ca

Manu, Stan  
*University of British Columbia*  
 Ssmanu@interchange.ubc.ca

Martin, Lyndon  
*University of British Columbia*  
 lyndon.martin@ubc.ca

Mary, Claudine  
*Québec*  
 Maryc@netc.net

Mason, John  
*The Open University*  
 j.h.mason@open.ac.uk

Mason, Ralph  
*University of Manitoba*  
 Masonrt@ms.umanitoba.ca

Maeers, Vi  
*University of Regina*  
 Maeers@uregina.ca

Marchand, Patricia  
*Québec*  
 Pamarchand@videotron.ca

McDougall, Douglas  
*OISE/University of Toronto*  
 Dmcdougall@oise.utoronto.ca

Moss, Joan  
*University of California, Berkeley*  
 Jmoss@uclink4.berkeley.edu

Muller, Eric  
*Brock University*  
 Emuller@spartan.ac.brocku.ca

Mura, Roberta  
*Université Laval*  
 Zorta.mura@fse.ulaval.ca

Nnadozie, Alfred  
*Concordia University*  
 Alfred@chek.com

Oktaç, Asuman  
*Concordia University*  
 oktac@alcor.concordia.ca

O'Shea, Thomas  
*Simon Fraser University*  
 oshea@sfu.ca

Pallascio, Richard  
*Université du Québec à Montréal*  
 Pallascio.Richard@uqam.ca

Pimm, David  
*Michigan State University*  
 pimm@msu.edu

Proppe, Hal  
*Concordia University*  
 proppe@alcor.concordia.ca

Radford, Luis  
*Laurentian University*  
 Lradford@nickel.laurentian.ca

Rahim, Medhat  
*Lakehead University*  
 medhat.rahim@lakeheadu.ca

Raymond, Jean-Luc  
*Université du Québec à Montréal*  
 raymond.jean-luc@uqam.ca

Reid, David  
*Acadia University*  
 david.reid@acadiau.ca

Robitaille, David  
*University of British Columbia*  
 david.robitaille@ubc.ca

Roulet, Geoffrey  
*Queen's University*  
 rouletg@educ.queensu.ca

Roy, Anne  
*Québec*  
 RoyAnne@globetrotter.net

Santos, Manuel  
*Cinvestav, Mexico*  
 Msantos@mail.cinvestav.mx

Swanson, Dalene  
*University of British Columbia*  
 dalene@interchange.ubc.ca

Sierpinska, Anna  
*Concordia University*  
 sierp@vax2.concordia.ca

Taylor, Peter  
*Queen's University*  
 taylorp@post.queensu.ca

Simmt, Elaine  
*University of Alberta*  
 elaine.simmt@ualberta.ca

Thom, Jennifer  
*University of British Columbia*  
 jthom@richmond.sd38.bc.ca

Sinclair, Margaret  
*OISE/University of Toronto*  
 masinclair@fcis.oise.utoronto.ca

Towers, Jo  
*University of Calgary*  
 towers@ucalgary.ca

Sinclair, Nathalie  
*Queen's University*  
 nathsinc@educ.queensu.ca

Tremblay, Gervais  
*Collège de Sherbrooke*  
 Tremblge@collegesherbrooke.qc.ca

Smith, Geoffrey  
*University of Technology, Sydney*  
 Gsmith@maths.uts.edu.au

Weston, Harley  
*University of Regina*  
 weston@math.uregina.ca

Squalli, Hassane  
*Université Laval*  
 Hsqualli@fse.ulaval.ca

Wood, Leigh  
*University of Technology, Sydney*  
 leigh.wood@uts.edu.au

Stanley, Darren  
*York University*  
 R.\_Darren\_Stanley@edu.yorku.ca

Zack, Vicki  
*St. George's School*  
 edvz@musica.mcgill.ca

Sutherland, Rosamund  
*University of Bristol*  
 ros.sutherland@bristol.ac.uk

Zazkis, Rina  
*Simon Fraser University*  
 zazkis@sfu.ca

**ERIC/CSMEE**  
1929 Kenny Road  
Columbus, OH 43210 – 1080  
USA



SE 066379



U.S. Department of Education  
Office of Educational Research and Improvement (OERI)  
National Library of Education (NLE)  
Educational Resources Information Center (ERIC)



# REPRODUCTION RELEASE

(Specific Document)

## I. DOCUMENT IDENTIFICATION:

Title: CANADIAN MATHEMATICS EDUCATION STUDY GROUP PROCEEDINGS 2000 ANNUAL MEETING	
Author(s): ELAINE SIMMT, BRENT DAVIS (Eds).	
Corporate Source: Canadian Mathematics Education Study Group	Publication Date: 2002

## II. REPRODUCTION RELEASE:

In order to disseminate as widely as possible timely and significant materials of interest to the educational community, documents announced in the monthly abstract journal of the ERIC system, *Resources in Education* (RIE), are usually made available to users in microfiche, reproduced paper copy, and electronic media, and sold through the ERIC Document Reproduction Service (EDRS). Credit is given to the source of each document, and, if reproduction release is granted, one of the following notices is affixed to the document.

If permission is granted to reproduce and disseminate the identified document, please CHECK ONE of the following three options and sign at the bottom of the page.

The sample sticker shown below will be affixed to all Level 1 documents

The sample sticker shown below will be affixed to all Level 2A documents

The sample sticker shown below will be affixed to all Level 2B documents

PERMISSION TO REPRODUCE AND DISSEMINATE THIS MATERIAL HAS BEEN GRANTED BY

*Sample*

TO THE EDUCATIONAL RESOURCES INFORMATION CENTER (ERIC)

**1**

Level 1

Check here for Level 1 release, permitting reproduction and dissemination in microfiche or other ERIC archival media (e.g., electronic) and paper copy.

PERMISSION TO REPRODUCE AND DISSEMINATE THIS MATERIAL IN MICROFICHE, AND IN ELECTRONIC MEDIA FOR ERIC COLLECTION SUBSCRIBERS ONLY, HAS BEEN GRANTED BY

*Sample*

TO THE EDUCATIONAL RESOURCES INFORMATION CENTER (ERIC)

**2A**

Level 2A

Check here for Level 2A release, permitting reproduction and dissemination in microfiche and in electronic media for ERIC archival collection subscribers only

PERMISSION TO REPRODUCE AND DISSEMINATE THIS MATERIAL IN MICROFICHE ONLY HAS BEEN GRANTED BY

*Sample*

TO THE EDUCATIONAL RESOURCES INFORMATION CENTER (ERIC)

**2B**

Level 2B

Check here for Level 2B release, permitting reproduction and dissemination in microfiche only

Documents will be processed as indicated provided reproduction quality permits. If permission to reproduce is granted, but no box is checked, documents will be processed at Level 1.

I hereby grant to the Educational Resources Information Center (ERIC) nonexclusive permission to reproduce and disseminate this document as indicated above. Reproduction from the ERIC microfiche or electronic media by persons other than ERIC employees and its system contractors requires permission from the copyright holder. Exception is made for non-profit reproduction by libraries and other service agencies to satisfy information needs of educators in response to discrete inquiries.

Signature: <i>Elaine Simmt</i>	Printed Name/Position/Title: editor
Organization/Address: c/o E. SIMMT 341. Education South University of Alberta Edmonton, AB Canada	Telephone: 780.492.6889 E-Mail Address: Elaine.Simmt@ualberta.ca
	FAX: 780.492.9402 Date: Dec 12/02

### III. DOCUMENT AVAILABILITY INFORMATION (FROM NON-ERIC SOURCE):

If permission to reproduce is not granted to ERIC, or, if you wish ERIC to cite the availability of the document from another source, please provide the following information regarding the availability of the document. (ERIC will not announce a document unless it is publicly available, and a dependable source can be specified. Contributors should also be aware that ERIC selection criteria are significantly more stringent for documents that cannot be made available through EDRS.)

Publisher/Distributor:
Address:
Price:

*not applicable*

### IV. REFERRAL OF ERIC TO COPYRIGHT/REPRODUCTION RIGHTS HOLDER:

If the right to grant this reproduction release is held by someone other than the addressee, please provide the appropriate name and address:

Name:
Address:

*not applicable*

### V. WHERE TO SEND THIS FORM:

Send this form to the following ERIC Clearinghouse:

However, if solicited by the ERIC Facility, or if making an unsolicited contribution to ERIC, return this form (and the document being contributed) to:

**ERIC Processing and Reference Facility**  
4483-A Forbes Boulevard  
Lanham, Maryland 20706

Telephone: 301-552-4200  
Toll Free: 800-799-3742  
FAX: 301-552-4700  
e-mail: [ericfac@inet.ed.gov](mailto:ericfac@inet.ed.gov)  
WWW: <http://ericfacility.org>

EFF-088 (Rev. 2/2001)