

DOCUMENT RESUME

ED 465 913

CG 031 808

AUTHOR Parizek, Deborah; Kesavan, Sandy  
TITLE From Classrooms to Careers: The Senior Mastery Process at Henry Ford Academy.  
PUB DATE 2002-07-00  
NOTE 14p.; In: Careers across America 2002: Best Practices & Ideas in Career Development Conference Proceedings (Chicago, IL, July 7-10, 2002); see CG 031 801.  
PUB TYPE Reports - Descriptive (141) -- Speeches/Meeting Papers (150)  
EDRS PRICE MF01/PC01 Plus Postage.  
DESCRIPTORS \*Career Exploration; Charter Schools; \*Curriculum Design; Employment Interviews; \*High School Seniors; High Schools; \*Internship Programs; \*Job Shadowing; Program Descriptions

ABSTRACT

The Henry Ford Academy is the nations first charter school developed jointly by a global corporation, public education, and a non-profit cultural institution. The Senior Mastery Process at Henry Ford Academy is an innovative, challenging program of career exploration and research project for high school seniors. Beginning with initial job shadowing and interviewing experiences in the ninth grade, Academy students gradually gain an awareness of career demands and opportunities through a curriculum designed to open their eyes and provide them with the chance to experience first hand the world of work. By their senior year, they have researched careers, developed a professional portfolio, assessed their personal strengths, participated in an extended internship, researched a topic of interest related to their career of interest, developed a project which naturally fits with that career and defended their research findings in a formal presentation to an evaluation committee. (GCP)

Reproductions supplied by EDRS are the best that can be made  
from the original document.

# From Classrooms to Careers: The Senior Mastery Process at Henry Ford Academy

by

Deborah Parizek  
Sandy Kesavan

U.S. DEPARTMENT OF EDUCATION  
Office of Educational Research and Improvement  
EDUCATIONAL RESOURCES INFORMATION  
CENTER (ERIC)

- This document has been reproduced as received from the person or organization originating it.
- Minor changes have been made to improve reproduction quality.

- Points of view or opinions stated in this document do not necessarily represent official OERI position or policy.

# From Classrooms to Careers: The Senior Mastery Process at Henry Ford Academy

**Deborah Parizek**

*Staff Development Coordinator*

*Henry Ford Academy*

**Sandy Kesavan**

*Practicum Director*

*Henry Ford Academy*

---

## Introduction and Rationale

The Henry Ford Academy is the nation's first charter school developed jointly by a global corporation, public education and a non-profit cultural institution. Designed to prepare students to be contributing members of society in the 21<sup>st</sup> century, the Academy opened its doors in the fall of 1997 on site at the Henry Ford Museum & Greenfield Village. Henry Ford Academy was conceived, developed and implemented by Ford Motor Company and Henry Ford Museum & Greenfield Village, and chartered by Wayne County Regional Educational Service Agency. In its first year, the Academy welcomed the first class of 100 ninth grade students representing more than 23 communities throughout Wayne County. This year there are 412 students enrolled in 9<sup>th</sup> through 12<sup>th</sup> grades. The Academy graduated its first senior class on June 3, 2001. This past spring the Academy received its North Central Accreditation.

The Senior Mastery Process stands out as a one-of-a-kind program because of the full support of the learning community, including the Academy and its partners, its mission to create a challenging Senior Year as the culminating event in a student's life, its integration into the four-year curricular plan of the Academy and its connections to research-based methods of teaching and learning. The primary purpose of the Senior Mastery Process (SMP) is to provide students with the opportunity to learn through experience in an environment where they make valuable connections between learning in the classroom and learning beyond school. As such, the sum of the student's experiences throughout the SMP has the potential to encourage dramatic student growth, both personal and academic.

During the student's senior year the SMP culminates in an intensive work-based internship in a career of interest, an academically rigorous research project, and a formal defense of the overall experience and individual research findings to a formal review committee. This series of experiences is preceded by prerequisites, which prepare students to succeed at each phase. While the SMP formally begins during a student's Junior Year, ninth graders gain their initial exposure to career options through an extensive Job Shadowing Project, which will be used as a foundation for further investigation in the tenth grade.

The staff of Henry Ford Academy firmly believes that all students should be held to high academic and learning standards. Therefore, all graduates of the Academy must

successfully complete the Senior Mastery Process. We also recognize that all students are at different levels of development and have different learning and work styles. For this reason, we incorporate a variety of ways for students to meet those expectations, a significant commitment of staff time and resources to support individual needs, and the positive, active involvement of every member of the instructional staff in the process. We also realize that many students select careers which are popular in the media or with which they have a personal connection. To open their eyes truly to exploration, we have all Juniors work with the Michigan Occupational Information Survey program, considering their current interests, academic background, strengths and interests in further education as they select a career on which to focus. Finally, since the Senior Practicum is a direct extension of the Academy curriculum, all liability issues compare to those associated with students on campus and the placement is not compensated.

The foundation partners of the Senior Mastery Process include Ford Motor Company (FMC), Henry Ford Museum (HFM) & Greenfield Village (GV), and the Wayne County Regional Educational Services Agency (WCRESA). These partners have demonstrated their support in a variety of ways which reflect their individual resources, but which also demonstrate their absolute commitment to improving the educational opportunities for young people in their community. FMC and HFM & GV provide direct financial and staff support, have assisted with the concept and design of the overall program, participate in the implementation of the program at their sites, offer critical feedback and are facilitating with the evaluation and dissemination of the SMP. WCRESA has assisted with the development and dissemination of the program ideas to local administrators and curriculum directors.

In addition, the SMP draws on the diverse opportunities offered by a large group of Adult Partners, which includes members from myriad career fields and locations in the community. So far, we have placed 176 Academy seniors in each of our two graduating classes in individual placements with over 150 partners. As developing networking skills is a requirement for all students, many bring their Adult Partners into the program themselves. Other students work with Adult Partners associated with the foundation partners or introduced by the Practicum Coordinator.

While the SMP has been specifically designed to benefit Academy students, we believe that it is not exclusive to our particular situation or combination of partners. After having met with a variety of people from different groups and organizations, we have identified three groups that are most likely to benefit from an introduction to the program and its benefits for the learning community. The most obvious audience is educators currently involved in delivering curriculum to students. This may include superintendents, principals, teachers, vocational education coordinators, and technical and career preparation directors. The second key group is centered in the local business community: the local Chamber of Commerce, branch offices of regional or national corporations, government agencies, owners and employees of area businesses to name just a few. Finally, a third key group is university educators interested in partnering with local education agencies or in adapting the program to fit their own curricular needs.

## **The Senior Mastery Process: Background and Description of the Program**

Prior to the first days of class, the Academy's curriculum design team researched existing programs which challenged the traditional approach to secondary school education and which encouraged students to engage in profound, rigorous and individualized educational experiences. Two sources had a significant impact on the development of the original vision for the Academy and continue to inform our efforts to create a quality learning community for students. First, the team read and discussed *Horace's School*, by Ted Sizer. From it we drew our focus on designing a smaller learning community in which all students would be engaged, would undertake significant, individualized research projects and authentic assessment, and would therefore be active participants in their own growth. The second source, *The Power of Their Ideas*, by Deborah Meier, influenced the development of the Academy overall and the Senior Mastery Process most directly. We adapted several of the components of the third phase of the curriculum of the Central Park East Secondary School for inclusion in the SMP. Additionally, we were inspired by the stories of personal commitment and dramatic effort on the part of the entire staff to build a school that provided a quality educational and personal experience for all students who came through the doors. As we have come to realize, the work never ends.

In June 2000, the National Commission on the High School Senior Year was created. The following year the Commission issued the first draft of a report, which outlined several problems associated with the traditional senior year in high school and which was summarized in "Rethinking the Senior Year" by David Conley in the National Association of Secondary School Principals Bulletin, May 2001. He wrote that students have lost interest in school by their senior year. They spend more time working and socializing than studying, despite claiming to understand the importance of a good education. These adolescent tendencies are exacerbated by the significant challenges of the traditional educational system itself: limited capacity for change, lack of qualified teachers and counselors, widespread student tracking, low expectations for student achievement, inadequate assessment systems and a sense that learning needs to happen in the classroom during the academic school year (Conley, 2001). This report and others with similar conclusions reconfirmed that the Senior Mastery Process responded to our own conclusions from empirical evidence—seniors tend to be bored and waste their time at the very moment when they need to stay focused on their long-term goals and life plans.

### **The Senior Mastery Process**

The Senior Mastery Process was developed based on the belief that students must have opportunities to link what they are learning in school to the real world. This belief has been a strong conviction of the staff of the Henry Ford Academy since its inception. The primary purpose of the SMP is to provide students with an opportunity to learn through experience in an environment where they can make valuable connections between learning in the classroom and learning beyond school. The goal is to enable them to become self-initiating learners by:

- Gaining an awareness of various career and educational opportunities;
- Investigating their career interests and individual learning and work styles;
- Developing their own Senior Mastery Research and Product plans;
- Networking in the community to identify a challenging, supportive Practicum Placement;
- Gathering hard and empirical data related to their research question in a supervised, work-based learning experience;
- Evaluating what they learned “on-the-job” and through their research in a final reflection paper;
- Presenting their findings and defending them to a committee of peers and involved adults from the staff and the community.

This experience is designed to assist students in developing an awareness of the skills and attitudes required to function as productive, contributing members of the community. It enables students to be involved in real-life problem solving, in which they are regarded as valuable and contributing individuals whose ideas, opinions and suggestions are respected and taken seriously.

The Senior Mastery Process is a four-part program, which includes the Junior Workshop, the Senior Practicum, the Senior Workshop and the Senior Defense. It is designed to be taught in ten-week seminars for a 4x4 block schedule but can easily be adapted to a more traditional schedule with a twenty-week semester.

### **Junior Workshop**

The Junior Workshop is a ten-week course that is required for all Juniors. It is an individualized seminar to help students develop the focus, materials, skills and plan for completing the Senior Practicum, Senior Workshop and the Senior Defense. Successful completion is a pre-requisite for entering the Senior Practicum. There are four components: Learning about Self, Learning about Careers, Learning Job Search Skills and Developing a Professional Portfolio.

- In *Learning about Self*, students explore their personal character traits and discover how those can impact their performance in school and in their future endeavors. They also explore the effectiveness of various methods of communication.
- In *Learning about Careers*, students investigate possible career choices using the Michigan Occupational Information Services (MOIS). Through their research, students identify a career of interest and design a timeline of the requirements for seeking a job in a particular career pathway.
- In *Learning Job Search Skills*, students write an effective, professional resume and participate in an “interview by committee” with members of the local business community who then debrief the experience with the students. Networking for potential Adult Partners for the Practicum Placement completes this segment.
- In *Developing a Professional Portfolio*, students create a comprehensive portfolio, which contains many of their reflective and descriptive papers,



their autobiography, a personal mission statement, their resume and other documents developed throughout the term.

### **Senior Practicum**

The Senior Practicum is the second part of the program and the pre-requisite for Senior Workshop. Students complete 75 hours of field work over a ten-week period in a career area they have researched and identified as a possible future career. Students work with Adult Partners in the workplace who provide meaningful learning opportunities for the students.

During this time students are required to write daily/weekly reflections on their work experience and its connection to their individual research question developed in Junior Workshop. They are also to gather specific data through a survey of their colleagues or through individual interviews. Students document their participation and attendance in the Senior Practicum Portfolio, shared weekly with the Practicum Coordinator and other students in the seminar. Finally, students review traditional sources of information for additional research and begin designing and developing their Senior Mastery Product which will help them communicate their findings from their research during their Defense.

### **Senior Workshop**

After successfully completing the Senior Practicum, students enter Senior Workshop. This ten-week course has three major components: the Senior Mastery Process Paper, the development of the Senior Mastery Product and preparation for the Senior Defense. The SMP Paper is an 18-20 page self-reflection essay in which students are asked to reflect on their preparation during Junior Workshop, the learning and challenges they experienced in the Senior Practicum, the results of their research process, and the impact of the SMP on them. In their SMP Product students develop a creative product, which demonstrates what they have learned during the entire Senior Mastery Process. Students can draw on their unique talents to present their learning and findings through a model, developed software or programs, dramatic presentations, explanatory video.

Students also prepare for their formal Defense by developing their overall presentation, any technological support, practicing their presentation with other students for feedback and setting the time and place of the Defense with their Committees. Successful completion of the elements of the Senior Workshop is required before students can schedule their Defense.

### **Senior Defense**

The Senior Defense is the culminating experience of the Senior Mastery Process. Before a committee of 6-8 adults, students give a 20-minute presentation in which they discuss their Practicum, the experiences they had with their Adult Partners, present their research findings and exhibit their Senior Mastery Product. The committee then questions the student on his/her methodology, conclusions and personal reflections having come through the SMP. Members of the Defense Committee typically include the Adult Partner, the Senior Practicum Coordinator and Senior Workshop Teacher, a teacher of choice, and student peers.

The experience concludes with a reception to honor the students' successful completion of the Senior Mastery Process.

### **Results of the Implementation**

Students are changed in a number of ways by their participation in the SMP. They:

- Demonstrate an increased level of independence, responsibility and self-confidence;
- Develop a more informed understanding of their selves
- Possess several important professional documents including a formal resume and portfolio;
- Recognize the elements of strong work-place etiquette and its importance to success;
- Have a realistic knowledge of what “work” is and the expectations of employers;
- Develop greater understanding of the importance of effective networking, communication, and on-the-job learning;
- Make informed decisions regarding post-secondary school education and employment.

The Senior Mastery Process is clearly aligned to meet the Career Content Standards as well as Michigan's career preparation goals and objectives as defined by the Department of Education. Through a series of authentic projects and experiences throughout the course of the SMP students are exposed to each of the nine stated standards and are expected to achieve a significant level of mastery as a requirement for graduation from the Academy. Choice is present at each stage of the Process with students selecting careers on which to focus their investigation and eventual research, networking to identify an Adult Partner in a Practicum of personal interest, creating an individualized manner in which to present their research findings and learning, and selecting their Defense Committee members. Students have identified such diverse Practicum Placements as modeling, cosmetology, dee-jaying at a radio station, media production, events planning, counseling, teaching, robotics, engineering, neurosurgery, construction management, fashion design, interior design, culinary arts and restaurant management, to name but a few.

There are three major outcomes to this program: first, the students come out of the experience having greater knowledge about potential careers and the daily responsibilities of professionals in those careers. Second, they are able to make informed decisions about whether or not to pursue a particular career or educational path. In many cases students find that they very much enjoy their first career choice and begin the process of actively preparing to enter that career. They seek out college programs or post-secondary opportunities related to that field. In other cases, students discover that they need to consider a different future; they may lack certain academic preparation, find that the daily grind is not interesting or identify a career they had not yet considered because of a lack of exposure. Third, they have gained experience in real-world problem solving with reasoned professional adults where they are treated as true members of the team.

We know this program is effective for several reasons. Several companies have



hired students for summer positions following the completion of their Practicums or have offered others paid internships often reserved for college students. We have had excellent and consistent feedback from our partners about what they liked and what they felt needed to be changed to improve the program. Parents and students have also communicated their positive opinions and constructive criticisms about the SMP overall and their recognition of the individual growth each has experienced with this process. This feedback is especially important since the SMP continues to be a work in progress. Finally, students utilize their awareness of what employers want, labor market trends and workplace expectations immediately as they continue their extra-curricular jobs and seek out further opportunities in their fields of interest. They have also incorporated their new knowledge and experience into their research for appropriate college and/or university programs, community service opportunities, public service appointments or immediate employment.

The SMP is designed to meet a wide variety of student and partner needs in ways, which draw on the unique strengths that each brings to the entire experience. Early in the process, those who participate gain a shared understanding of what work means to each and the ways in which professionals move from school to work. Later, students and Adult Partners alike develop meaningful relationships in the context of the Practicum, share their unique perspectives on work and school, increase each other's comfort level and understanding of the other as well as promote strong ties within the community. Many of the employers of the Adult Partners also gain the opportunity to enhance their corporate citizenship, play a significant role in the development of the future work force and further their commitment to the community as a whole.

### **Replication of the Senior Mastery Process**

The Henry Ford Academy explicitly considers replication of unique elements of its curriculum to be an inherent part of its mission. Currently, the staff at Henry Ford Academy is actively involved in preparing for the replication of the Senior Mastery Process. This past summer, we developed the specific curriculum materials—an Introduction, a Teacher Handbook with lesson plans and master copies for all student materials and a Student Handbook—and began defining the potential audience for our program. Currently we are formatting the content and materials for distribution on CD-ROMs in partnership with Ford Motor Company. We have also been working with the FAMS program (Ford Academies of Manufacturing Sciences) to facilitate their potential adoption of the program as an addition to their curriculum and with Wayne County RESA to gain an understanding of the needs other schools would have in putting such a program in place. Those discussions have addressed implementing the entire SMP as well as possibly using only the initial phases of our program. Finally, we are exploring grants and other sources of funding which would help us provide staff and resources for the express purpose of helping other teachers and schools adopt the Senior Mastery Process.

### **Summary and Conclusions**

The Senior Mastery Process at Henry Ford Academy is an innovative, challenging program of career exploration and research project for high school seniors. Beginning with

initial job shadowing and interviewing experiences in the ninth grade, Academy students gradually gain an awareness of career demands and opportunities through a curriculum designed to open their eyes and provide them with the chance to experience first hand the world of work. By their senior year, they have researched careers, developed a professional portfolio, assessed their personal strengths, participated in an extended internship, researched a topic of interest related to their career of interest, developed a project which naturally fits with that career and defended their research findings in a formal presentation to an evaluation committee.

The SMP thus encourages students to take charge of their education so that they can ultimately achieve their individual goals for further education and/or employment. Students are fully supported in their efforts to achieve the high expectations at every step of the way by the carefully developed curriculum, the teachers instructing the courses, the Practicum Coordinator, the entire staff of the Academy as mentors and coaches, the Adult Partners, parents and peers. Through the SMP students gain a sense of both personal achievement and academic success at an individualized level. While there continue to be obstacles to implementing this complex and demanding program, we feel that the benefits far outweigh those challenges.

The true test of the program however lies in its impact on student growth and achievement. With only two classes of students having completed the major components and successfully matriculated, we have to rely on empirical data, observations and personal comments to evaluate the SMP initially. The wide range of careers experienced, the positive reflections from students in their final evaluations, the obvious skill development demonstrated in the final Defenses and the clear sense of personal pride in a challenge met and a job well-done confirm the value of the Senior Mastery Process.

The Senior Mastery Process is the capstone experience for all students at Henry Ford Academy. Incorporating many of the skills and content Academy students are expected to master in order to graduate from the Academy, the SMP transforms the senior experience into one that is academically and personally challenging. Interning, writing, researching, product creation, formal presentation and reflection all combine in a personalized program that starts and ends with the student himself/herself. Students who have successfully completed the SMP—all graduates of the Academy—have demonstrated tremendous affective growth as well. All have gained increased levels of personal responsibility, significant on-site career/work experience, strong decision making skills, a sense of pride in themselves and their accomplishments, greater comfort with adults and new or unfamiliar situations, and an understanding of the true need for life-long learning.

In addition to reinforcing students' self concept, completing the SMP has also helped create an awareness of the value of being a well-rounded and well-educated person with many and varied skills. The individualized nature of the SMP means that all students challenge themselves in ways that are appropriate to their strengths and weaknesses. They also receive commensurate support to ensure that they experience success in meeting those challenges. The work-based components of the program show that all learning does not happen in classrooms and is not the restricted privilege of academically successful students. For those students with that history of good grades on tests and positive feelings about class, it encourages them to achieve in new, more authentic, ways. For those students whose

strengths lie in interpersonal communication, creative problem solving, development of new ideas and projects, to name a few, the SMP reinforces the value of those skills and talents in the larger society outside of school.

### References and Resources

Conley, David T. (2001). Rethinking the senior year. *NASSP Bulletin*, 85, 625.

Meier, D. (1995). *The power of their ideas: Lessons for America from a small school in Harlem*. Boston, MA: Beacon Press.

Sizer, T. R. (1992). *Horace's school: Redesigning the American high school*. Boston, MA: Houghton Mifflin.

Deborah Parizek, Henry Ford Academy, Staff Development Coordinator, Co-Designer of the Senior Mastery Process, Junior Workshop  
dparizek@hfa.spfs.k12.mi.us

Sandy Kesavan, Henry Ford Academy, Practicum Director, Co-Designer of the Senior Mastery Process, Senior Practicum  
skesavan@hfa.spfs.k12.mi.us

Tracy Speaker, Henry Ford Academy, English Instructor, Co-Designer of the Senior Mastery Process, Senior Workshop  
tspeaker@hfa.spfs.k12.mi.us

Shannon Clements, Henry Ford Academy, Special Grants and Projects Coordinator  
sclements@hfa.spfs.k12.mi.us

### Student Reflections on the Senior Practicum

"I truly enjoyed my Practicum. I think this makes people really follow their dreams and see what it is really all about....I was treated like part of the team and I will continue to work with them."

Felicita, Recording Artist, Senior, 2002

"I feel that I am very lucky to have had the chance to work in the field of Pharmacy....At first I was scared to try anything because I was afraid that I would mess something up. With the help of my Adult Partner and the people that worked there, I overcame my fear."

Madona, Pharmacist, Senior, 2002

"In my senior practicum there are things that I liked, disliked, and within that there are many

things that I learned which will have a great impact on me in the future. (At times) I felt that I may have been missing something (at my practicum), however upon reflection I did not go to my practicum to do someone’s work, I went to learn and it was a learning experience indeed.”

Joe, Automotive Engineer, Senior, 2002

“When I first heard about senior practicum, I was very intimidated. I thought it seemed too difficult and some of the strictest teachers in the school were overseeing it...I enjoyed my practicum experience very much.”

Andrea, Physical Therapist, Senior, 2002

“It was a rewarding experience. An all around great endeavor.”

Adult Partner, 2002

“Time is always an issue. If students could have the chance to spend more “full” days or “half” days on the job, they may get a truer picture of on-the-job responsibilities.”

Adult Partner, 2002

“I think the program is well-thought out. I would have enjoyed more flexibility on schedule days since my schedule is unpredictable. I know the student’s are still doing a regular school day.”

Adult Partner, 2002

“It was a dream come true. I now have contacts for the future, and I plan to use what I learned to someday have a full time job at Ford Motor Company.”

Neil, Marketing, Senior 2001

### Primary Career Pathways for Seniors

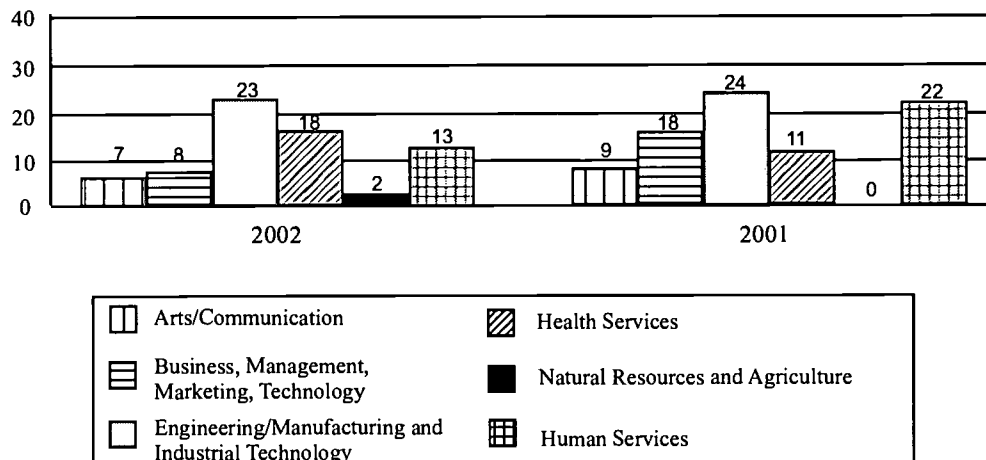

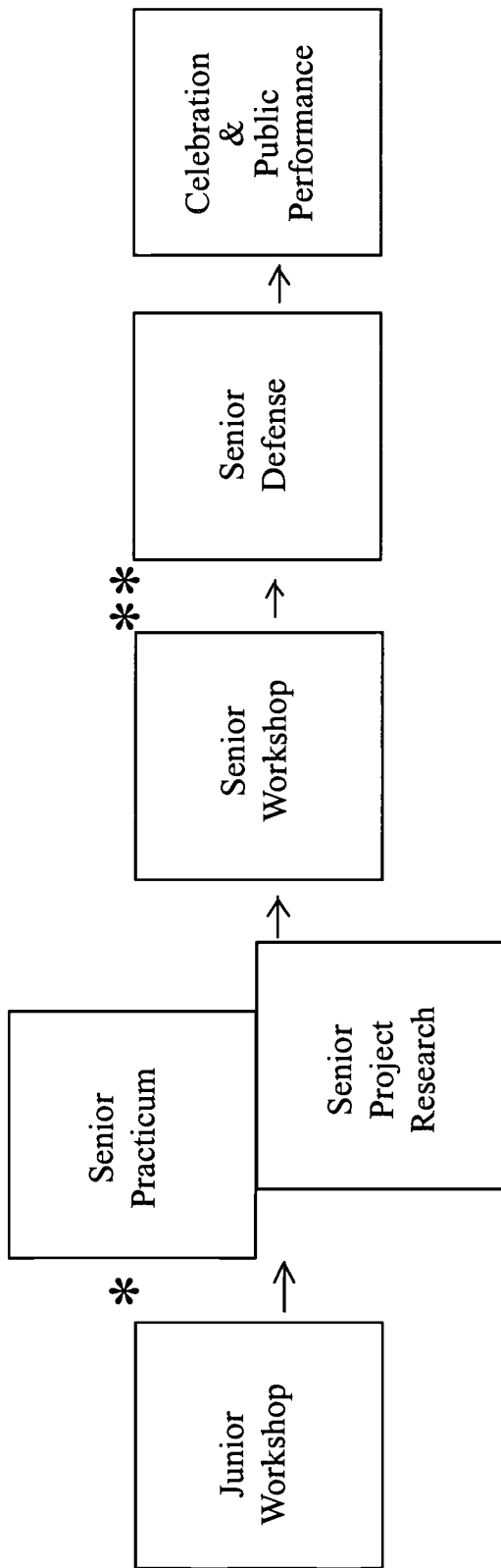

- Investigation of self, educational interests.
- Development of professional portfolio and job search skills
- Determination of Senior Practicum Placement
- Out of school, work-based, learning experience
- Developed experience of research focus question and data collection
- Required Reflection Journal and work site documentation
- Academic exploration on self chosen research question
- Analysis of collected data/info from research and Practicum
- 18-20 page reflection paper on research process
- Design and creation of senior mastery product to demonstrate learning
- Preparation for Senior Defense
- Presentation of Senior Mastery product and learning to Defense Committee for final evaluation and acceptance
- Public display or performance of Senior Mastery Products to larger audience
- Recognition and celebration of tremendous accomplishment

\* Mandatory Practicum Orientation  
 \*\* Mandatory Defense Practice Presentation



**U.S. Department of Education**  
*Office of Educational Research and Improvement (OERI)*  
*National Library of Education (NLE)*  
*Educational Resources Information Center (ERIC)*



## NOTICE

### Reproduction Basis



This document is covered by a signed "Reproduction Release (Blanket)" form (on file within the ERIC system), encompassing all or classes of documents from its source organization and, therefore, does not require a "Specific Document" Release form.



This document is Federally-funded, or carries its own permission to reproduce, or is otherwise in the public domain and, therefore, may be reproduced by ERIC without a signed Reproduction Release form (either "Specific Document" or "Blanket").

EFF-089 (3/2000)