

DOCUMENT RESUME

ED 462 272

SE 065 382

TITLE Geometry and Algebra: The Future Flight Equation. A Lesson Guide with Activities in Mathematics, Science, and Technology. NASA CONNECT.

INSTITUTION National Aeronautics and Space Administration, Hampton, VA. Langley Research Center.

REPORT NO EG-2001-09-30-LARC

PUB DATE 2001-00-00

NOTE 30p.; Accompanying videotape not available from ERIC.

AVAILABLE FROM For full text: <http://spacelink.nasa.gov/products>.

PUB TYPE Guides - Classroom - Teacher (052)

EDRS PRICE MF01/PC02 Plus Postage.

DESCRIPTORS \*Aerospace Education; Algebra; Aviation Mechanics; Aviation Technology; \*Design; Geometry; \*Integrated Activities; Learning Activities; \*Mathematics Activities; Mathematics Education; \*Science Activities; Science Education; Secondary Education; Technology Education

ABSTRACT

This activity, part of the NASA CONNECT Series, is designed to help students in grades 6-8 learn how NASA engineers develop experimental aircraft. It consists of an overview of the program, details of the hands-on activity, a series of blackline master student worksheets, teacher materials, and a guide to further resources. (MM)

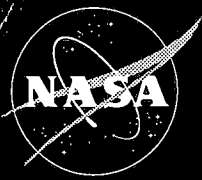

National Aeronautics and Space Administration

Langley Research Center  
Hampton, VA 23681-2199

Educational Product

Educators

Grades 6-8

EG-2001-09-30-LARC

ED 462 272

NASA CONNECT

# Geometry and Algebra: The Future Flight Equation

A Lesson Guide with Activities in Mathematics, Science, and Technology

U.S. DEPARTMENT OF EDUCATION  
Office of Educational Research and Improvement  
EDUCATIONAL RESOURCES INFORMATION  
CENTER (ERIC)

This document has been reproduced as received from the person or organization originating it.

Minor changes have been made to improve reproduction quality.

Points of view or opinions stated in this document do not necessarily represent official OERI position or policy.

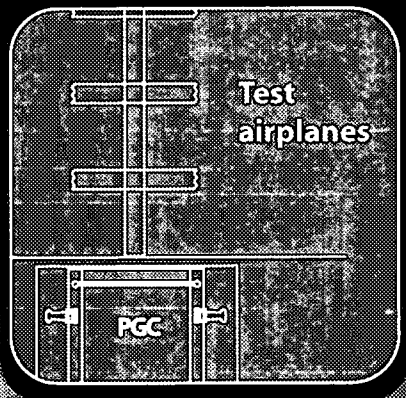

Test  
airplanes

PGC

EROS300





*Geometry and Algebra: The Future Flight Equation* is available in electronic format through NASA Spacelink - one of NASA's electronic resources specifically developed for the educational community. This publication and other educational products may be accessed at the following address: <http://spacelink.nasa.gov/products>

A PDF version of the lesson guide for NASA CONNECT can be found at the NASA CONNECT web site: <http://connect.larc.nasa.gov>

# ***Geometry and Algebra: The Future Flight Equation***

**A Lesson Guide with Activities in Mathematics, Science, and Technology**

## **Program Overview**

Summary and Objectives .....	5
Student Involvement .....	5
Cue Card Questions .....	5
Hands-On Activity .....	5
Instructional Technology Activity .....	5
Resources .....	5

## **Hands-On Activity**

Background .....	6
National Standards .....	6
Instructional Objectives .....	7
Vocabulary .....	8
Preparing for the Activity .....	8
Student Materials .....	8
Teacher Materials .....	8
Time .....	8
Focus Questions .....	8
Advance Preparation .....	8
The Activity .....	9
Extensions .....	12

## **Student Worksheets**

Data Chart .....	13
Wing Chart .....	14
Experimental Data and Wing Charts .....	15
Delta Wing Template .....	16
Oblique Wing/Stabilizer Template .....	17
Straight Wing/Stabilizer Template .....	18
Swept-Back Wing Template .....	19
Graph Paper .....	20
Fuselage Template .....	21
Cue Cards .....	22

## **Teacher Materials**

Cue Card Answers .....	23
------------------------	----

## **Instructional Technology Activity**

Description .....	24
National Standards .....	24
Instructional Objectives .....	25

## **Resources**

Books, Pamphlets, and Periodicals .....	26
Web Sites .....	26

**Acknowledgments:** Special thanks to Summer 2001 Educators in Residence, Jennifer Pulley, Chris Giersch, Bill Williams, and NCTM.



# Program Overview

## SUMMARY AND OBJECTIVES

In *Geometry and Algebra: The Future Flight Equation*, students will learn how NASA engineers develop experimental aircraft. They will learn about the Hyper-X Research Vehicle, an experimental plane that uses scramjet engine technology to propel itself to ten times the speed of sound. Students will understand how the Hyper-X is part of the Future

Flight Equation. They will observe NASA engineers using geometry and algebra when they measure and design models to be tested in wind tunnels. By conducting hands-on and web activities, students will make connections between NASA research and the mathematics, science, and technology they learn in their classrooms.

## STUDENT INVOLVEMENT

### Cue Card Questions

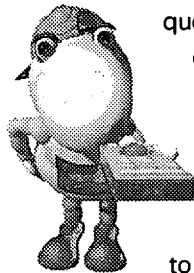

Norbert, NASA CONNECT's animated cohost, poses questions throughout the broadcast. These questions direct the instruction and encourage students to think about the concepts being presented. When viewing a videotaped version of NASA CONNECT, educators have the option to use Norbert's Pause, which gives students an opportunity to reflect and record their answers on the Cue Cards (p. 22). Norbert appears with a remote to indicate an appropriate time to pause the videotape and discuss the answers to the questions.

### Hands-On Activity

The hands-on activity is teacher-created and is aligned with the National Council of Teachers of Mathematics (NCTM) standards, the National Science Education (NSE) standards, the International Technology Education Association (ITEA) standards, and the National Educational Technology (NET)

standards. Students are designated as Aeronautical Engineers in Training (AET). They will analyze wing geometry based on measurements and observations. Students will use geometry and algebra to design, construct, and test an experimental wing.

### Instructional Technology Activity

PlaneMath, the instructional technology activity, is aligned with the National Council of Teachers of Mathematics (NCTM) standards, the National Science Education (NSE) standards, the International Technology Education Association (ITEA) standards, and the National Educational Technology (NET) standards. This online interactive activity lets students learn, design, and test experimental aircraft. The students will learn about the forces of flight, wing shape, propulsion, experimental design, and several other topics. To access PlaneMath, go to Dan's Domain on NASA CONNECT's web site at <http://connect.larc.nasa.gov/dansdomain.html>.

## RESOURCES

Teacher and student resources (p. 26) support, enhance, and extend the NASA CONNECT program. Books, periodicals, pamphlets, and web sites provide teachers and students with background information and extensions. In addition to the resources listed in this lesson guide, the NASA CONNECT web site,

<http://connect.larc.nasa.gov>, offers online resources for teachers, students, and parents. Teachers who would like to get the most from the NASA CONNECT web site can visit the Lab Manager, located in Dan's Domain, <http://connect.larc.nasa.gov/dansdomain.html>.

# Hands-On Activity

## BACKGROUND

Aeronautical research usually begins with computers, wind tunnels, and flight simulators, but eventually the theories must fly. That is when flight research begins, and aircraft are the primary tools of the trade. There are four stages in the development of new aircraft: mission (purpose), design (aerodynamics, propulsion, stability, control), computer modeling, and testing.

Flight research involves doing precision maneuvers in either specially built experimental aircraft or in an existing production aircraft that has been modified. All research aircraft are able to perform scientific experiments because of the onboard instruments that record data about its systems, aerodynamics, and the outside environment.

NASA pilots work closely with engineers to conduct carefully constructed flight programs that gradually probe an aircraft's capability; edging toward the speed, altitude, and structural limits that will define the final performance of an aircraft. This procedure furnishes answers that will verify, extend, and perhaps correct the inputs from computer studies, wind tunnel tests, and simulations. It is the last step in the developmental process and leads the way for designs that can be put into production. It also delivers the final word on a most crucial question: How well does it fly?

Experimental research aircraft are tools of exploration, incorporating the newest ideas in every aspect of aerospace flight. For this reason they come in many shapes and sizes. They have short wings, delta wings, swept wings, moveable wings, and no

wings. They fly with jet engines, rocket engines, piston engines, solar-electric engines, and even without engines. Some research planes are too small for a pilot; some are as large as an airliner.

The first experimental planes designed exclusively for research were the XS-1 and the D-558-1. They were made in 1946 to enable scientists to study flight near the speed of sound. Custom-made planes were the only way to accomplish this objective because supersonic wind tunnels were not accurate enough, and no other planes had flown that fast. The supersonic era began when the XS-1 broke the "sound barrier" in 1947.

In the 1950s the famous "X-Planes" continued to take people to higher altitudes and greater speeds. They were the first aircraft to fly at Mach 2 and Mach 3, and the studies performed with them influenced the designs of all supersonic planes.

In the 1960s, the X-15 rocket plane became the first aircraft to fly into space. The projects done on this aircraft benefited not only NASA's Apollo Lunar Landing Program, but also the Space Shuttle, nearly 15 years later.

Since the 1970s, NASA flight research has become more comprehensive with flights involving everything from Space Shuttles to ultralight aircraft. NASA now flies not only the fastest airplanes, but some of the slowest as well. Flying machines continue to evolve with new wing designs, propulsion systems, and flight controls. As always, a look at today's experimental research aircraft is a preview of the future.

## NATIONAL STANDARDS

### Mathematics (NCTM) Standards

- Compute fluently and make reasonable estimates
- Understand measurable attributes of objects and the units, systems, and processes of measurement
- Apply appropriate techniques, tools, and formulas to determine measurements
- Develop and evaluate inferences that are based on data
- Build new mathematical knowledge through problem solving
- Apply and adapt a variety of appropriate strategies to solve problems

- Recognize, use, and learn about mathematics in contexts outside of mathematics
- Analyze characteristics and properties of two- and three-dimensional geometric shapes and develop mathematical arguments about geometric relationships
- Use visualization, spatial reasoning, and geometric modeling to solve problems
- Understand and use metric systems of measurement
- Formulate questions that can be addressed with data and collect, organize, and display relevant data to answer them
- Solve problems that arise in mathematics and in other contexts
- Monitor and reflect on the process of mathematical problem solving
- Make and investigate mathematical conjectures
- Select and use various types of reasoning and methods of proof
- Organize and consolidate mathematical thinking through communication
- Recognize and use connections among mathematical ideas
- Understand how mathematical ideas interconnect and build on one another to produce a coherent whole

#### Science (NSE) Standards

- Abilities necessary to do scientific inquiry
- Understanding about scientific inquiry

- Physical Science
- Motions and forces
- Science and Technology
  - Abilities of technological design
  - Understanding about science and technology

#### Technology (ITEA) Standards

##### The Nature of Technology

- Develop an understanding of the characteristics and scope of technology
- Develop an understanding of the core concepts of technology

##### Design

- Develop an understanding of the attributes of design
- Develop an understanding of engineering design
- Develop an understanding of the role of troubleshooting, research and development, invention and innovation, and experimentation in problem solving

#### Technology (NET) Standards

- Technology tools to enhance learning, increase learning, and promote creativity
- Use technology resources for solving problems and making informed decisions
- Select and use appropriate tools and technology resources to accomplish a variety of tasks and solve problems

## INSTRUCTIONAL OBJECTIVES

The student will

- use algebra to calculate wing area, wingspan, chord length, and aspect ratio.
- use a portable glider catapult to analyze wing geometry based on measurement (distance rating) and observations (glide rating and speed rating).
- design, construct, and test an experimental wing to achieve maximum distance.
- incorporate collaborative problem-solving strategies in a real-life application.

**VOCABULARY**

**aspect ratio** - wingspan length divided by the average chord length

**chord** - straight line distance joining the leading and trailing edge of an airfoil

**fuselage** - the part of the airplane to which the tail and wings are attached. The fuselage holds passengers and cargo and is streamlined to produce the least possible drag.

**horizontal stabilizer** - the horizontal part of the tail. The horizontal stabilizer helps to increase the stability of the aircraft.

**lift** - a force that is perpendicular to the air flow around the aircraft

**thrust** - a force created by the engines that pushes an aircraft through the air

**weight** - the force of gravity acting on an object. The weight force pulls an aircraft toward the Earth and must be overcome by a combination of lift and thrust.

**wingspan** - distance from wing tip to wing tip

**PREPARING FOR THE ACTIVITY**
**Student Materials (per 4-student group)**

20 straight pins                      calculator  
 4 small binder clips              masking tape  
 Student Worksheets (p. 13 - 21)  
 10 meat trays (suggestion: 28 cm x 23 cm - size 12)  
 meter stick or measuring tape  
 4 scissors (optional: plastic knife, box cutter)  
 fine sand paper or emery board

**Teacher Materials**

4 small binder clips              2 thumbtacks  
 rubber band (size 64)            cardboard (28 cm x 40 cm)  
 2 wooden rulers or paint sticks

**Time**

Discussion of the activity.....5 min  
 Preparing aircraft.....25 min  
 Conducting the activity.....60 min

**Focus Questions**

1. What are some common geometric shapes used in wing design?
2. Why is the geometric shape of a wing important in aircraft design?
3. What are some tools engineers need to design aircraft?
4. Why is it essential for engineers to work in teams when designing aircraft?

**Advance Preparation**

The teacher should construct a Portable Glider Catapult (PGC) for each student group.

- A. Cut out a 28-cm by 40-cm piece of cardboard.
- B. Place two wooden rulers or paint sticks on top of the cardboard and attach them to the board with small binder clips, as shown in Figure 1.

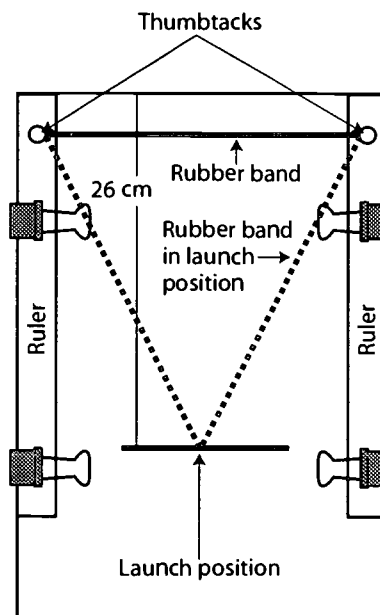

- C. Cut a size 64 rubber band. Attach the rubber band to each of the rulers with thumbtacks as shown in Figure 1. Fold (double) the ends of the rubber band once before pinning the thumbtack





through it to prevent the rubber band from tearing at the thumbtack.

- D. Construct a horizontal line 26 cm from the top. This line is called the launch position and indicates how far back you pull the rubber band.

The following area formulas will be used to calculate the wing area:

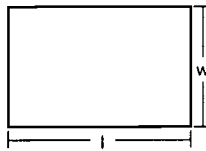

#### Rectangle

$$A = lw$$

$l$  = length,  $w$  = width

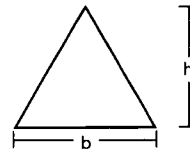

#### Triangle

$$A = (1/2)bh$$

$b$  = base,  $h$  = height

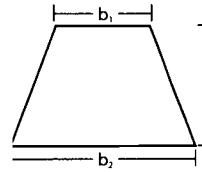

#### Trapezoid

$$A = (1/2)(b_1 + b_2)h$$

$b_1$  = base 1,  $b_2$  = base 2

$h$  = height

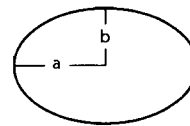

#### Ellipse

$$A = \pi ab$$

$$\pi = 3.14$$

$a$  = semimajor axis

$b$  = semiminor axis

## THE ACTIVITY

### Step 1: Introducing the Activity

- Announce: NASA has designated the class as Aeronautical Engineers in Training (AET). Your job is to test current wing designs based on distance traveled, glide rating, and speed rating. From your analysis of the data that you collect, you will have the task of designing and testing an experimental wing to achieve maximum distance traveled.
- Organize students into groups of four.
- Distribute a Portable Glider Catapult to each group along with the necessary materials.
- Have students cut out the templates for the fuselage, wings, and horizontal stabilizers.
- Have students place the templates on the meat trays and trace around the templates. Each group should make four different fuselages and one set of wings for each fuselage. Students should make a fifth fuselage to be used in conjunction with their experimental wing (Part III of the activity).

**Tip:** To avoid wasting meat trays, we suggest students follow the guideline:

- One meat tray will yield two fuselages.
- One meat tray will yield one fuselage and three horizontal stabilizers.
- Use one meat tray for each of the wings.

- Have students tape a piece of masking tape to the nose of the fuselage to prevent it from breaking.

### Step 2: Conducting the Activity - Part I: Preflight

- Have students calculate the wing area (in  $\text{cm}^2$ ) for each wing. Students have two options for calculating wing area: 1. the teacher may provide formulas found in the lesson guide (students may need to divide wings into shapes to calculate the area) 2. students can count the number of squares on the wing templates. If students count the number of squares on the wing templates, they will have to estimate the number of squares around the edges of the wings. Record the wing area on the data chart.
- Have students calculate the wingspan (in cm) for each wing. The wingspan is the linear distance from wing tip to wing tip. See Figure 2. Record the value on the data chart.

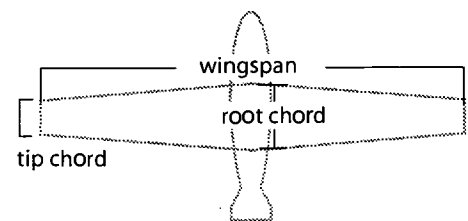

Figure 2

- Have students measure the root chord, the width of the wing at the line of intersection with the fuselage, for each wing. See Figure 2. Record the value on the data chart.
- Have students measure the tip chord, the width



of the tip of the wing, for each wing. See Figure 2. Record the value on the data chart.

**Note:** The measure of the tip chord for a Delta Wing and an Oblique Wing is 0.

- E. Have students calculate the average chord by using the formula:  $(\text{root chord} + \text{tip chord}) / 2$ . Record the value on the data chart.
- F. Have students calculate the aspect ratio for each wing by using the formula:  $(\text{wingspan}) / (\text{average chord})$ . Record the value on the data chart.
- G. Have students use masking tape to mark the launching point for each team. From the launching point, have students put down a piece of masking tape 12 meters long. Have students measure and mark the tape at 1-meter intervals. See Figure 3.

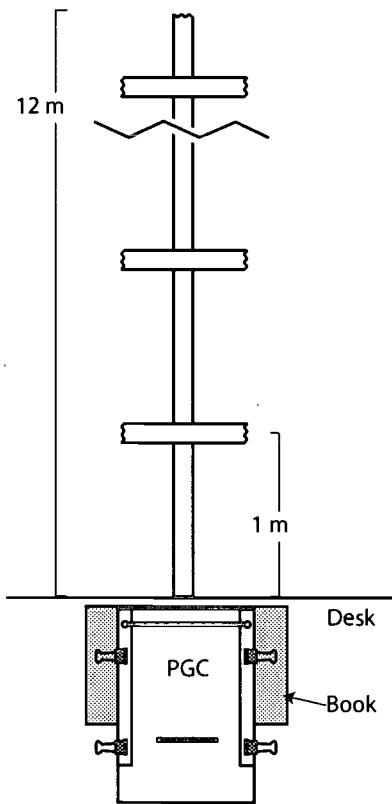

Figure 3

- H. Have students place a desk or table at the launching line to elevate the PGC. Place a book with a height of approximately 5 cm under the front portion of the PGC.
- I. Have students select a wing shape to test.

Students should adhere to the following guidelines for corresponding wing shape and horizontal stabilizer:

Oblique wing . . . . .Oblique horizontal stabilizer  
 Delta wing . . . . .No horizontal stabilizer  
 Straight wing . . . . .Straight horizontal stabilizer  
 Swept-back wing . . . . .Swept-back horizontal stabilizer

Have students construct each aircraft by placing the corresponding wing and horizontal stabilizer into the fuselage. Have students secure each wing and horizontal stabilizer with straight pins. See Figure 4.

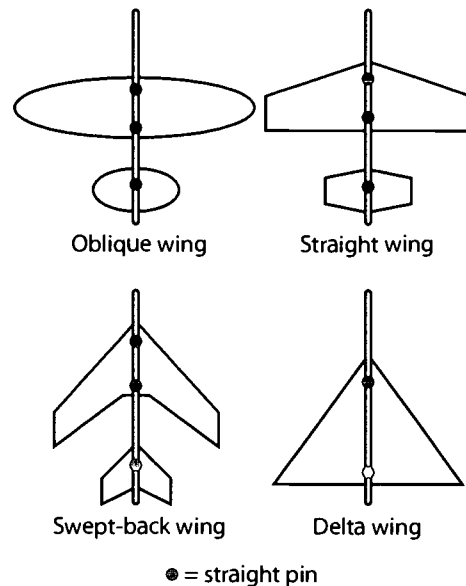

Figure 4

**Note:** Two straight pins for the wing and one straight pin for the horizontal stabilizer are sufficient to secure the aircraft.

**Caution:** Remind students to use straight pins safely.

**Step 3: Conducting the Activity - Part II: Test Flight**

- A. In each group, one student should be in charge of launching the aircraft, one student in charge of stabilizing the Portable Glider Catapult, one student in charge of marking where the aircraft hit the ground, and one student in charge of recording the data. Have students take their stations.

**Note:** Have students rotate duties so that each student can launch an aircraft.

- B. Have students conduct practice runs to become familiar with the aircraft and PGC. Have students attach a small binder clip to the aircraft to give it some weight. See Figure 5. The binder clip can be adjusted either closer to the nose or closer to the tail anytime during the test flights to ensure that the aircraft is achieving maximum flight.

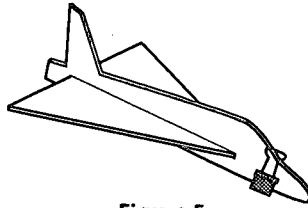

Figure 5

- C. Students should position the aircraft on the PGC as shown in Figure 6. The rubber band must always be below the fuselage and wings. Have students pull back the aircraft to the launch position. Make sure the bottom of the fuselage is resting on the PGC before the aircraft is launched. Have a student announce: "Clear the flight deck for aircraft catapult!" Have students launch aircraft.

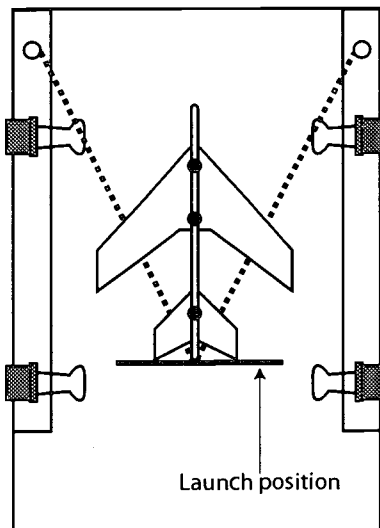

Figure 6

- D. Once students have conducted a few practice runs, Announce: "Clear the flight path, set up for testing."
- E. Have students use the oblique wing aircraft for the first test. Students will conduct five trials for each wing shape. Have students perform trial 1 for the oblique wing aircraft.
- F. Have students measure the distance traveled

(in cm) and record the value on the wing chart under "distance".

- G. Have students make some flight observations based on glide rating and speed rating. Use the following scale to assign a glide rating and speed rating for the aircraft:

Glide Scale	Speed Scale
5 - Excellent	5 - Extremely Fast
4 - Very good	4 - Very Fast
3 - Good	3 - Fast
2 - Fair	2 - Slow
1 - Poor	1 - Very slow

Record the glide rating and speed rating for trial 1 under the observation section on the data chart.

- H. Have students repeat Steps E - G for trials 2 - 5.
- I. Have students calculate the average distance traveled, glide rating, and speed rating. Record all values on the wing chart.
- J. Have students use the delta wing aircraft for the second test. Repeat Steps F, G, and I for trials 1 - 5.
- K. Have students use the straight wing aircraft for the third test. Repeat Steps F, G, and I for trials 1 - 5.
- L. Have students use the swept-back wing aircraft for the fourth test. Repeat Steps F, G, and I for trials 1 - 5.

#### Step 4: Analysis

- A. Based on the distance traveled, the glide rating, and the speed rating, have students determine which wing shape had the best overall rating.
- B. Have students determine which wing flew the farthest.
- C. What conclusions can be drawn from the wing's aspect ratio and wing area with respect to distance traveled?

#### Step 5: Conducting the Activity - Part III: Experimental Flight

- A. Using the data collected from the test flights, have each group design an experimental wing on graph paper. The objective is to design a wing which will achieve a greater distance than the four test wings. The only design constraint is that the experimental



- wing must fit into the fuselage.
- B. Using scissors, have students cut out the experimental wing template.
  - C. Have students put the experimental wing template on a meat tray and trace around the template. Cut out the template.
  - D. Have students calculate the wing area, wing span, root chord, tip chord, and aspect ratio. Record all values on the experimental data chart.
  - E. Have students construct the experimental aircraft by placing the experimental wing into the fuselage. Students may choose any horizontal stabilizer. Have students secure each aircraft with straight pins.
  - F. Have students attach a small binder clip to the aircraft to give it some weight. Students should position the aircraft on the PGC. Have students pull back the aircraft to the launch position (horizontal line of the PGC). Have students announce: "Clear the flight deck for aircraft catapult!" Have students launch the aircraft.
  - G. Have students measure the distance the experimental aircraft traveled. Record the value on the experimental data chart.
  - H. Have students use the glide scale and speed scale to determine the glide and speed ratings. Record the values on the data chart.
  - I. Have students repeat steps F - H for trials 2 - 5.
  - J. Have students determine the average distance, glide rating, and speed rating.

**Step 6: Discussion**

- A. How did you use the data from the test aircraft to create your experimental design?
- B. Evaluate the success of your experimental design. What factors support your findings?
- C. Your design was based on achieving maximum distance. How would your design change if you considered other factors such as fuel efficiency, cargo, or speed?
- D. Why is the use of geometry and algebra essential in the design of future aircraft?



**Extensions**

1. Invite an aeronautical engineer to participate in the activity with the students. After the activity is conducted, have the aeronautical engineer lead a discussion on aircraft design.
2. Have the students experiment with different materials in constructing the gliders. Compare and contrast the various materials used.
3. Have students use geometry and algebra to construct more aerodynamic fuselages.

# Student Worksheets

Name: \_\_\_\_\_ Date: \_\_\_\_\_

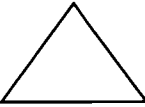
## Data Chart

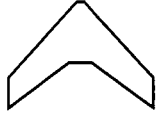
Oblique Wing	Wing Area (cm <sup>2</sup> )	Wing Span (cm)	Root Chord (cm)	Tip Chord (cm)	Average Chord (cm)	Aspect Ratio
						
Delta Wing	Wing Area (cm <sup>2</sup> )	Wing Span (cm)	Root Chord (cm)	Tip Chord (cm)	Average Chord (cm)	Aspect Ratio
						
Straight Wing	Wing Area (cm <sup>2</sup> )	Wing Span (cm)	Root Chord (cm)	Tip Chord (cm)	Average Chord (cm)	Aspect Ratio
						
Swept-Back Wing	Wing Area (cm <sup>2</sup> )	Wing Span (cm)	Root Chord (cm)	Tip Chord (cm)	Average Chord (cm)	Aspect Ratio
						

### Notes

---

---

---

---

---

---

---

---

---

---

---

---

---

---

---

---

---

---

---

---

---

---

---

---

---



Name: \_\_\_\_\_ Date: \_\_\_\_\_

### Experimental Data Chart

Experimental Wing	Wing Area (cm <sup>2</sup> )	Wing Span (cm)	Root Chord (cm)	Tip Chord (cm)	Average Chord (cm)	Aspect Ratio

### Experimental Wing Chart

Experimental Wing	Measurement	Observations		Overall Rating
	Distance	Glide Rating	Speed Rating	
Trial 1				
Trial 2				
Trial 3				
Trial 4				
Trial 5				
Average				

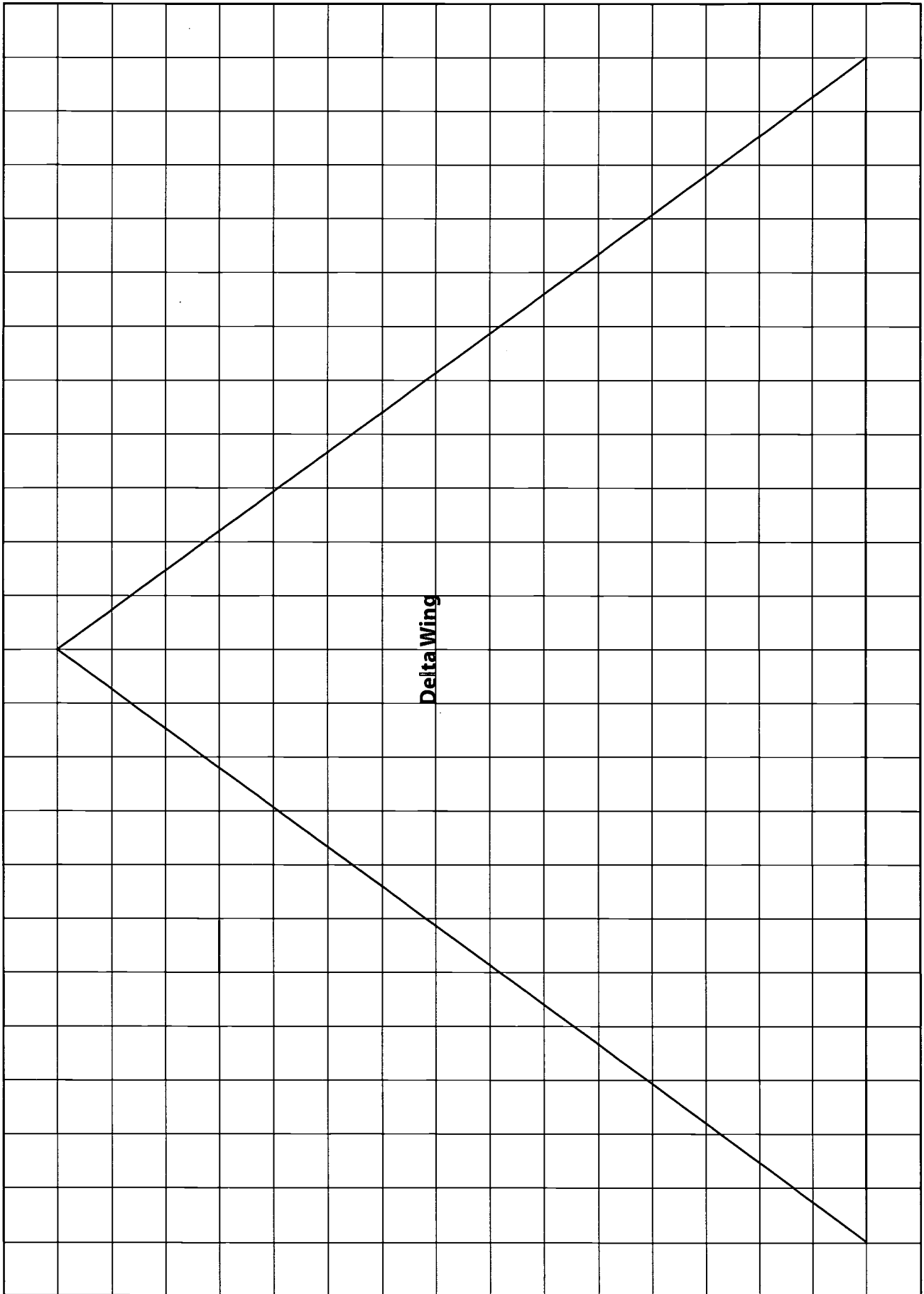



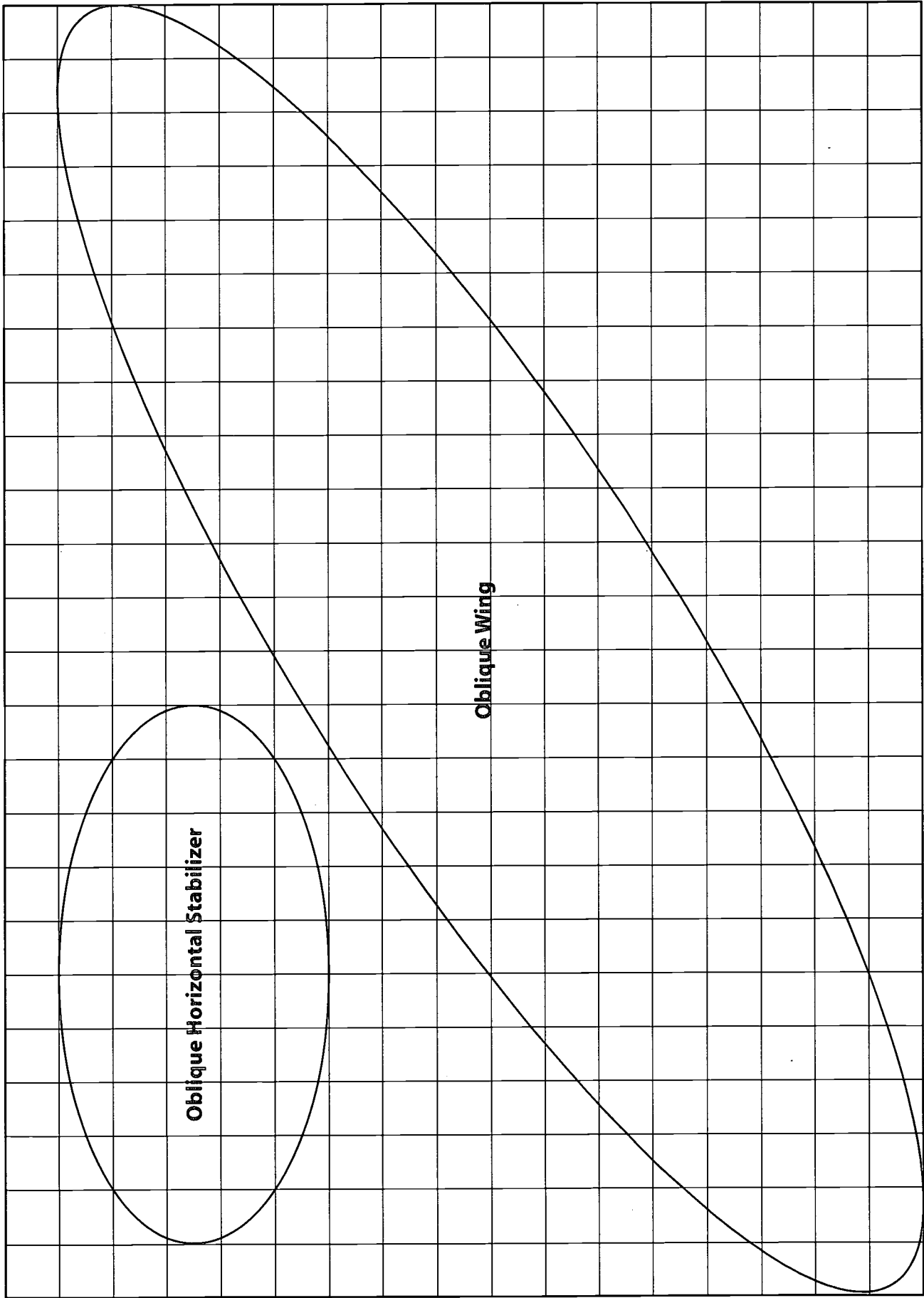

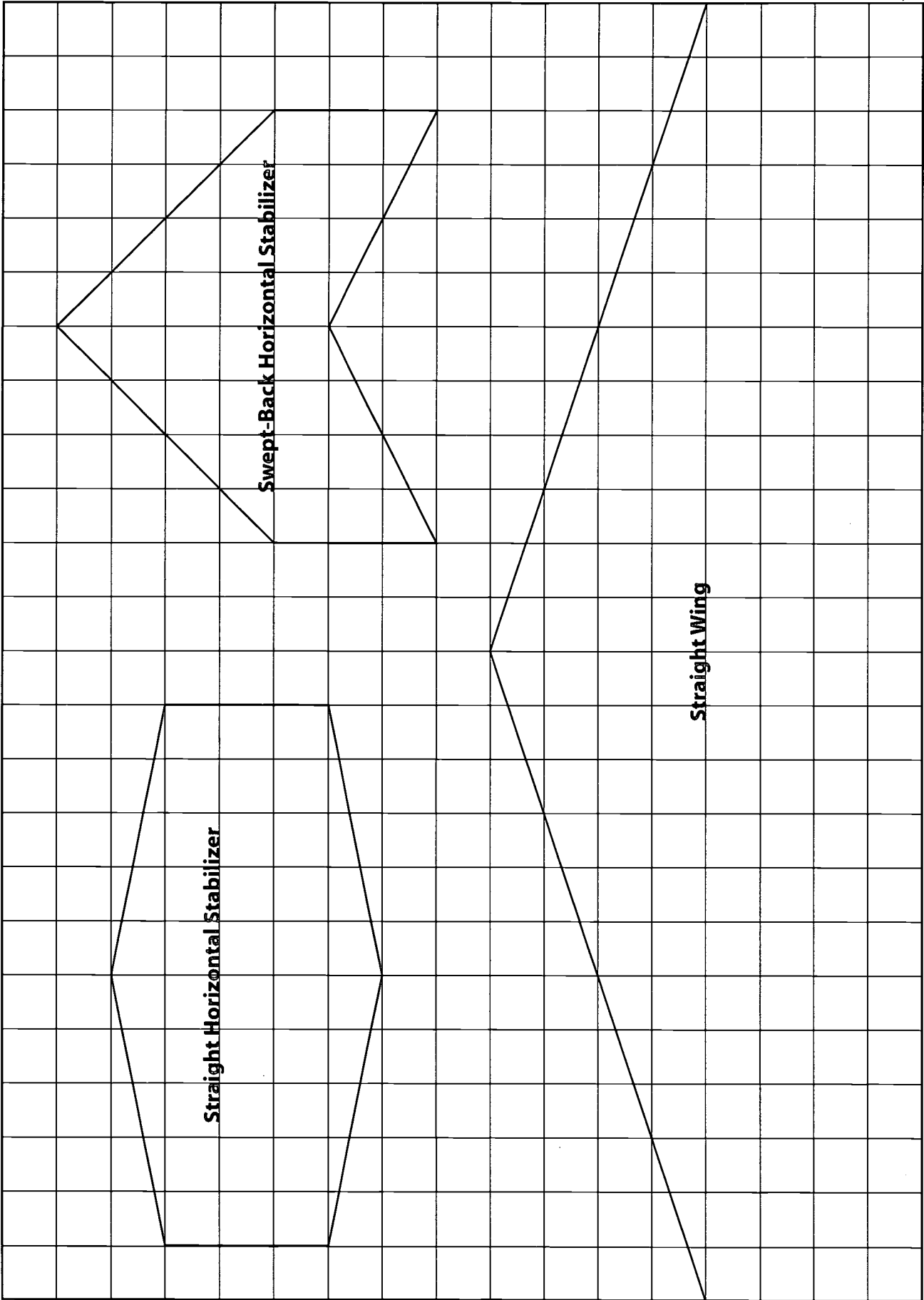

Straight Horizontal Stabilizer

Swept-Back Horizontal Stabilizer

Straight Wing

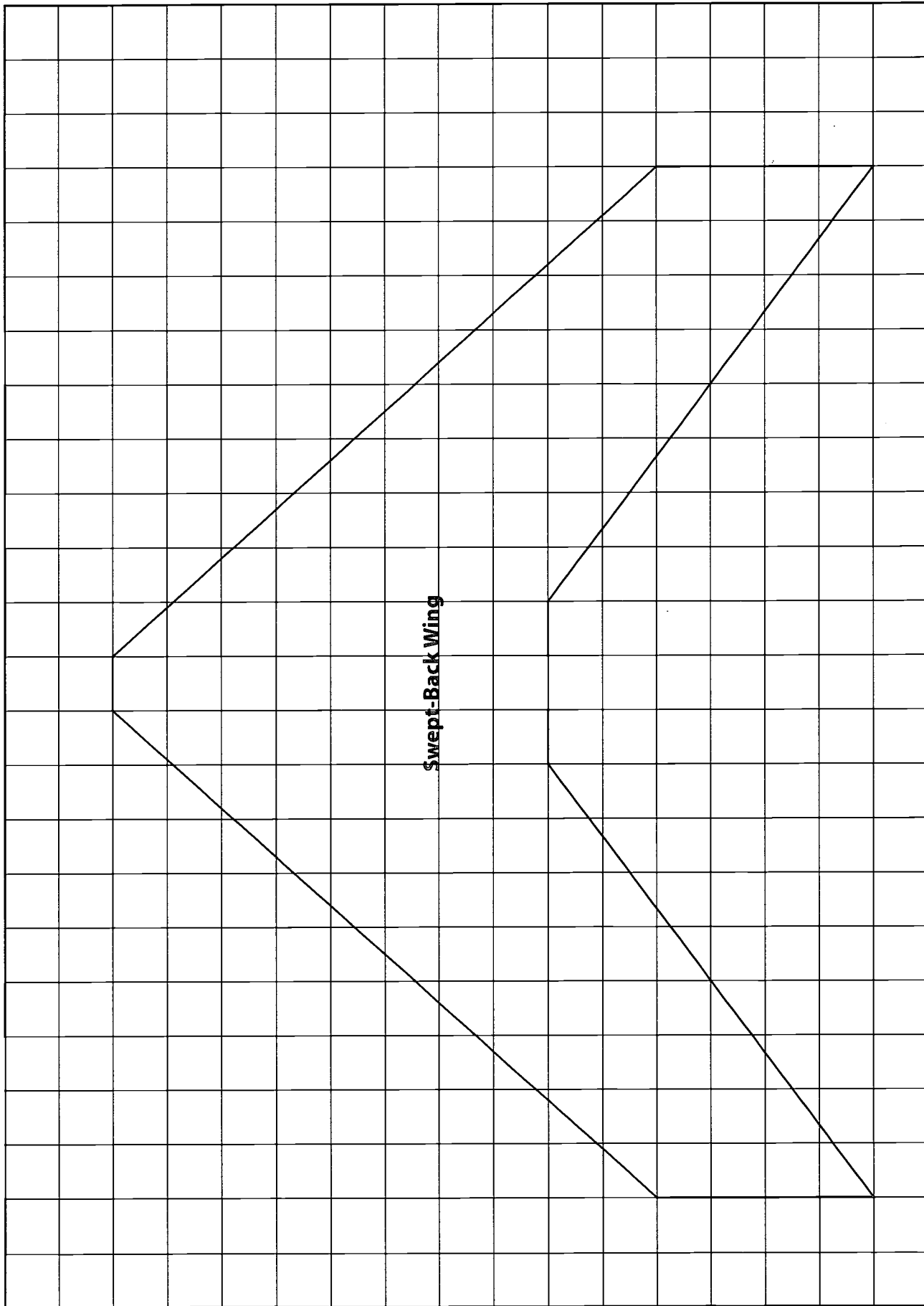

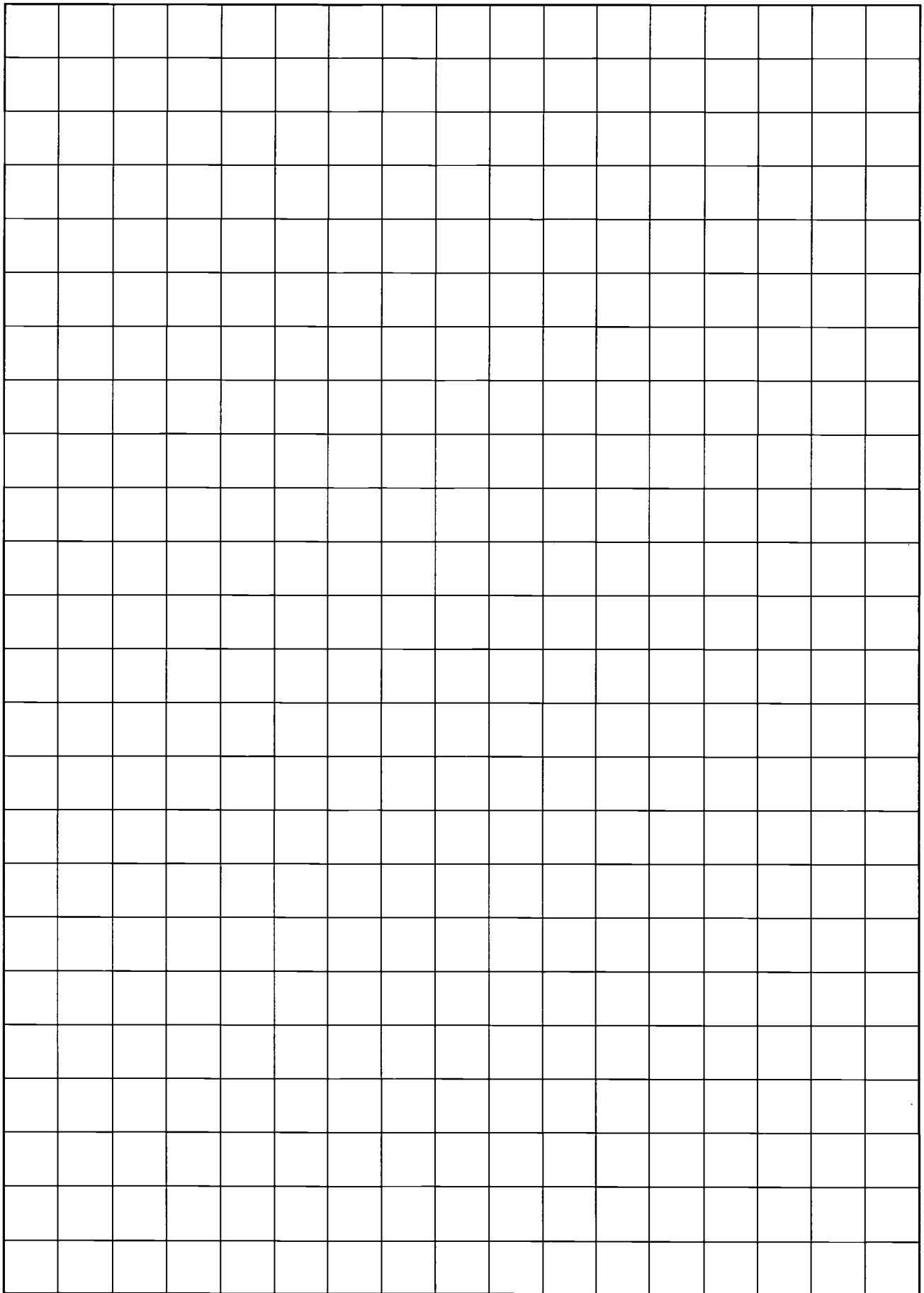



**FUSELAGE TEMPLATE**

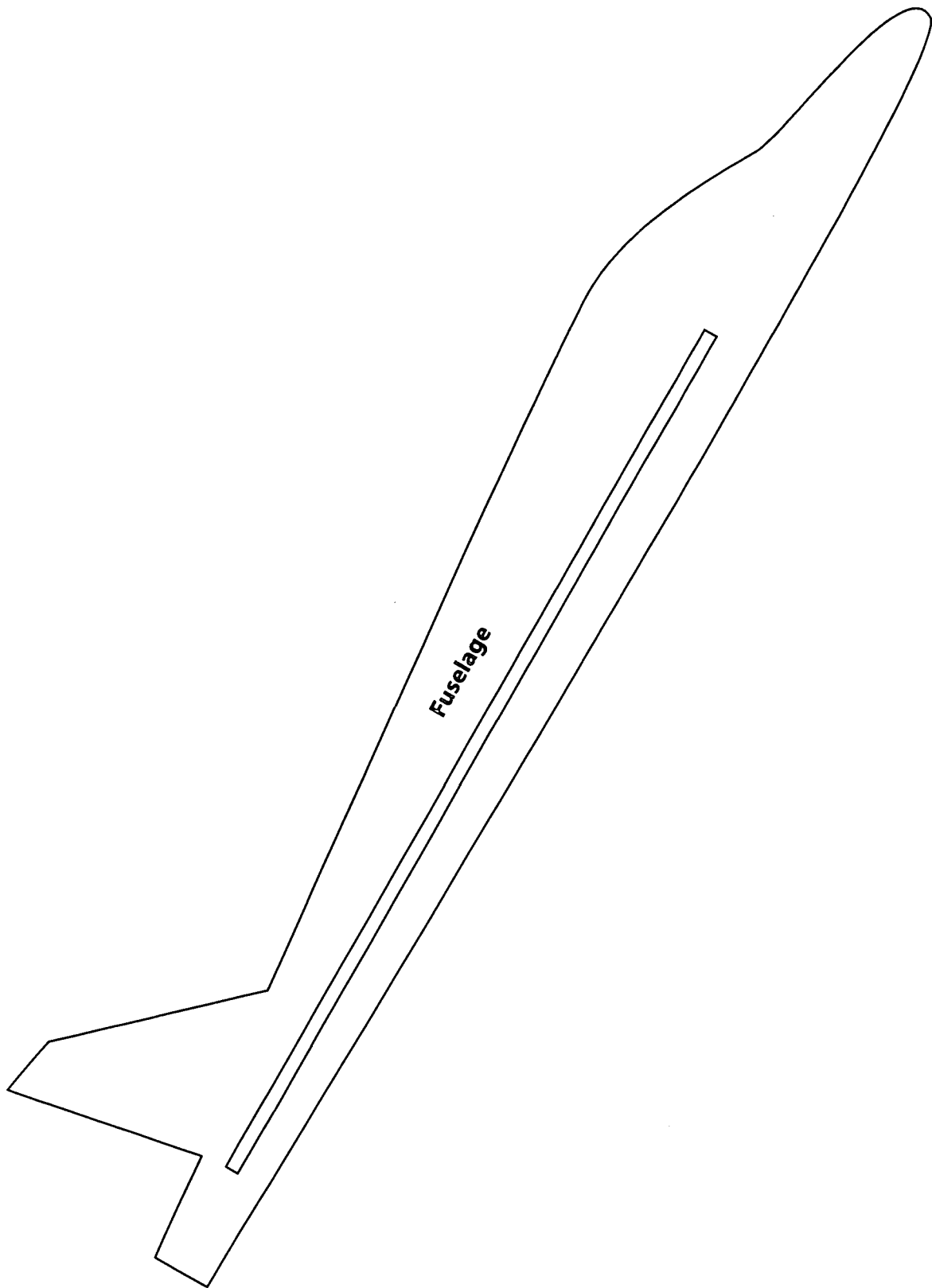

Name: \_\_\_\_\_  
Date: \_\_\_\_\_

# Cue Cards

**Scott Holland, Ph.D., Fluid Dynamics Team Leader,  
Aerothermodynamics Branch, NASA Langley Research Center**

1

What are the steps in designing an aircraft?

---

---

---

---

2

How do the mission requirements of an aircraft determine its shape?

---

---

---

---

3

Why are wind tunnels important in testing aircraft designs?

---

---

---

---

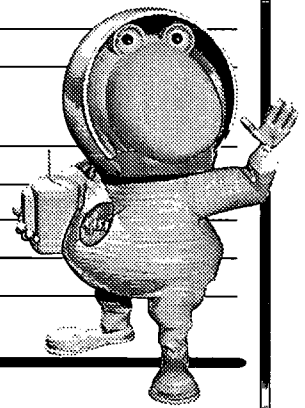

**Laurie Marshall, Aerospace Engineer, NASA Dryden Flight Research Center**

1

How will the Hyper-X reach its test altitude?

---

---

---

---

2

How do the Hyper-X engineers collect their research information?

---

---

---

---

3

Why is algebra important to Hyper-X research?

---

---

---

---



# Teacher Materials

## Cue Card Answers

**Scott Holland, Ph.D., Fluid Dynamics Team Leader,  
Aerothermodynamics Branch, NASA Langley Research Center**

**1** What are the steps in designing an aircraft?

**Possible answers:** Mission, Design, Computer Modeling, Testing

**2** How do the mission requirements of an aircraft determine its shape?

**Possible answers:** Some planes are short, some are long and slender, some fly slowly and some fly fast. They look and perform differently because they were designed to satisfy different missions.

**3** Why are wind tunnels important in testing aircraft designs?

**Possible answers:** Wind tunnel testing helps engineers determine the best aircraft design and shows how the vehicle will fly.

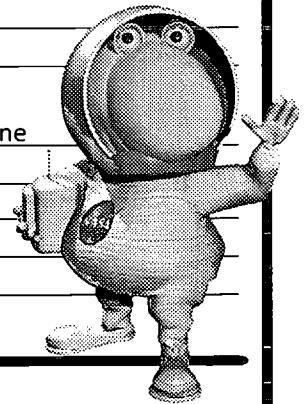

**Laurie Marshall, Aerospace Engineer, NASA Dryden Flight Research Center**

**1** How will the Hyper-X reach its test altitude?

**Possible answers:** The B-52 jet takes the Hyper-X, which is attached to the rocket, up to a preset altitude and speed and releases it. The rocket ignites and flies to an altitude of almost 100,000 ft, traveling to Mach 7.

**2** How do the Hyper-X engineers collect their research information?

**Possible answers:** The Hyper-X generates over 600 measurements that are sent to the control room during the flight. These measurements allow the research engineers to determine the success of the experiment during the flight.

**3** Why is algebra important to Hyper-X research?

**Possible answers:** Algebra is the foundation to analyze all data that are measured. Algebra is used throughout the design, flight testing, and postflight analysis phases of the experiment.





# Instructional Technology Activity

## DESCRIPTION

Info Use, in cooperation with NASA, presents PlaneMath, an online interactive activity that lets your students learn, design, and test experimental aircraft. Your students will be hired as airplane design engineers for PlaneMath Enterprises. As new employees, they will visit eight training departments. The students will learn about the forces of flight, wing shape, propulsion, experimental design, and several other topics. After students complete their training, they will go to the

Design Department to receive their first project. Here students will design and test an aircraft that will fly from San Francisco to New York. Students will take into consideration time in flight, total budget, and operating cost per flight.

To access PlaneMath, go to Dan's Domain on NASA CONNECT's website at <http://connect.larc.nasa.gov/dansdomain.html>.

## NATIONAL STANDARDS

### Technology (ITEA) Standards

#### The Nature of Technology

- develop an understanding of the characteristics and scope of technology
- develop an understanding of the core concepts of technology
- develop an understanding of the relationships among technologies and the connections between technology and other fields of study

#### Technology and Society

- develop an understanding of the role of society in the development and use of technology
- develop an understanding of the influence of technology on history

#### Design

- develop an understanding of the attributes of design
- develop an understanding of engineering design
- develop an understanding of the role of troubleshooting, research and development, and invention
- innovation and experimentation in problem solving

#### Abilities of a Technological World

- develop abilities to apply the design process
- develop abilities to assess the impact of products and systems

### Technology (NET) Standards

- use content-specific tools, software, and simulations (e.g., environmental probes, graphing calculators, exploratory environments, web tools) to support learning and research
- design, develop, publish, and present products (e.g., web pages, video tapes) using technology resources that demonstrate and communicate curriculum concepts to audiences inside and outside the classroom
- select and use appropriate tools and technology resources to accomplish a variety of tasks and solve problems

### Science (NSE) Standards

- Abilities necessary to do scientific inquiry
- Understanding about scientific inquiry

#### Physical Science

- Motions and forces

#### Science and Technology

- Abilities of technological design
- Understanding about science and technology

#### Science in Personal and Social Perspectives

- Science and technology in society



**Mathematics (NCTM) Standards**

- Understand patterns, relations, and functions
- Represent and analyze mathematical situations and structures using algebraic symbols
- Use visualization, spatial reasoning, and geometric modeling to solve problems
- Understand measurable attributes of objects and the units, systems, and processes of measurement
- Apply appropriate techniques, tools, and formulas to determine measurements
- Build new mathematical knowledge through problem solving
- Make and investigate mathematical conjectures

**INSTRUCTIONAL OBJECTIVES**

Students will

- learn basic components of aircraft design.
- understand mathematical concepts involved in the aircraft design process.
- design and test an aircraft given several parameters.





# Resources

## BOOKS, PAMPHLETS, AND PERIODICALS

Abbott, Ira H., Van Doenhoff, Albert E.: *Theory of Wing Sections*, Dover Publications, New York, 1980.

Ashley, Holt: *Engineering Analysis of Flight Vehicles*, Dover Publications, New York, 1992.

Ashley, Holt, Landahl, Marten: *Aerodynamics of Wings and Bodies*, Dover Publications, New York, 1985.

Committee of High Speed Research, Aeronautics and Space Engineering: *US Supersonics Commercial Aircraft: Assessing NASA's High Speed Research Program*, National Academy Press, 1997.

Crouch, Tom D., Jakab, Peter L.: *Visions of a Flying Machine: The Wright Brothers and Process of Inventions* (Smithsonian History of Aviation Series), Smithsonian Institution Press, 1997.

Lombardo, David A.: *Advanced Aircraft Systems*, Tab Books, 1993.

Niu, Michael Chen-Young: *Airframe Structural Design: Practical Design Information and Data on Aircraft Structure*, Technical Book Co., 1999.

Raymer, Daniel P.: *Aircraft Design: A Conceptual Approach*, American Institute of Aeronautics, 1999.

Smith, Zeke: *Understanding Aircraft Composite Construction: Basics of Materials and Techniques for the Non-Engineer*, Pathway Book Service, 1996.

## WEB SITES

### Aeronautics / General Information

<http://quest.arc.nasa.gov/aero/planetary/atmospheric/Atmos5-8read.html>

<http://educate.si.edu/resources/lessons/siyc/flight/start.html>

### Aeronautical Interactive and Hands-On Activities

<http://www.aero.hq.nasa.gov/edu/>

<http://kids.msfc.nasa.gov/Rockets/Airplanes/>

<http://www.massinteraction.org/html/nasa/redesign/activities/index.html>

<http://www.lmasc.com/kids/index.htm>

<http://www.allstar.fiu.edu/aero/princ1.htm>

<http://www.nasm.edu/galleries/gal109/NEWHTF/RESROOM/RESOURCE.HTM>

<http://www.patprojects.org/glider/index.htm>

### Interactive Airplane Design Activities

<http://www.planemath.com>

<http://www.desktopaero.com/adw/adw.html>

### Aeronautical Related Lesson Plans for Educators

<http://www.vasc.org/teacher.html>

<http://educate.si.edu/resources/lessons/siyc/flight/start.html>

<http://www.vasc.org/erc/index.html>

### Figure This!

Offers Mathematics Challenges that middle school students can do at home with their families to emphasize the importance of a high-quality mathematics education for all.

<http://www.figurethis.org>

### Engineer Girl

Part of the National Academy of Engineering's Celebration of Women in the Engineering project. The project brings national attention to the opportunity that engineering represents to people of all ages, but particularly to women and girls.

<http://www.engineergirl.org>

### GetTech

Through its web site and collateral materials, GetTech helps prepare students in fun ways for tomorrow's great jobs.

<http://gettech.org>



**U.S. Department of Education**  
*Office of Educational Research and Improvement (OERI)*  
*National Library of Education (NLE)*  
*Educational Resources Information Center (ERIC)*



## **NOTICE**

### **Reproduction Basis**



This document is covered by a signed "Reproduction Release (Blanket)" form (on file within the ERIC system), encompassing all or classes of documents from its source organization and, therefore, does not require a "Specific Document" Release form.



This document is Federally-funded, or carries its own permission to reproduce, or is otherwise in the public domain and, therefore, may be reproduced by ERIC without a signed Reproduction Release form (either "Specific Document" or "Blanket").