

DOCUMENT RESUME

ED 461 910

EA 028 055

TITLE Crashworthiness of Small Poststandard School Buses: Safety Study.

INSTITUTION National Transportation Safety Board (DOT), Washington, DC.

REPORT NO NTSB-SS-89/02

PUB DATE 1989-10-11

NOTE 243p.

PUB TYPE Reports - Evaluative (142)

EDRS PRICE MF01/PC10 Plus Postage.

DESCRIPTORS Accidents; *Bus Transportation; *Design Requirements; Elementary Secondary Education; Federal Regulation; Injuries; *School Buses; *School Safety; *Standards; Student Transportation

ABSTRACT

In 1977, a series of Federal Motor Vehicle Safety Standards (FMVSS) for school buses became effective, mandating different performance standards for school buses compared to other buses. Because data on the crash performance of school buses built to these standards were lacking, the National Transportation Safety Board conducted a series of in-depth accident investigations from 1984 to 1988. The study sought to determine how well federal school bus standards were working to protect passengers from injury and whether changes in the standards were needed. This paper reports on the crash performance of small poststandard (manufactured after April 1, 1977) school buses and vans used for school transportation. Occupants of the small school buses generally fared well in the accidents investigated. As a result of this safety study, recommendations were issued to the National Highway Traffic Safety Administration, manufacturers of small school buses, and various associations of school-transportation officials and contractors. The recommendations include: conduct research on the design of restraining barriers; determine the feasibility of requiring lap/shoulder belts or other restraints with upper torso support for passengers; collect data on roof and joint strength; amend federal performance standards for school bus windshield retention; develop performance standards for boarding door controls in certain small buses; and correct improper installation and use of lapbelts and other restraints. Appendices contain case summaries and indexes of cases, bus-design information, data on injuries and accidents, and a list of FMVSS standards mentioned in the recommendations. (LMI)

ENTIRE DOCUMENT:
POOR PRINT QUALITY

Reproductions supplied by EDRS are the best that can be made
from the original document.

Crashworthiness of Small Poststandard School Buses: Safety Study

U.S. National Transportation Safety Board
Washington, DC

October 11, 1989

NTSB Number SS-89/02

EA 028 055

BEST COPY AVAILABLE

U.S. DEPARTMENT OF EDUCATION
Office of Educational Research and Improvement
EDUCATIONAL RESOURCES INFORMATION
CENTER (ERIC)

This document has been reproduced as received from the person or organization originating it.

Minor changes have been made to improve reproduction quality.

• Points of view or opinions stated in this document do not necessarily represent official OERI position or policy.

PB89-917003

Crashworthiness of Small Poststandard School Buses: Safety Study

(U.S.) National Transportation Safety Board. Washington, DC

11 Oct 89

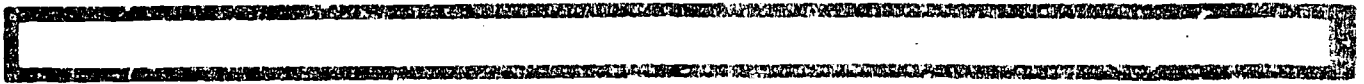
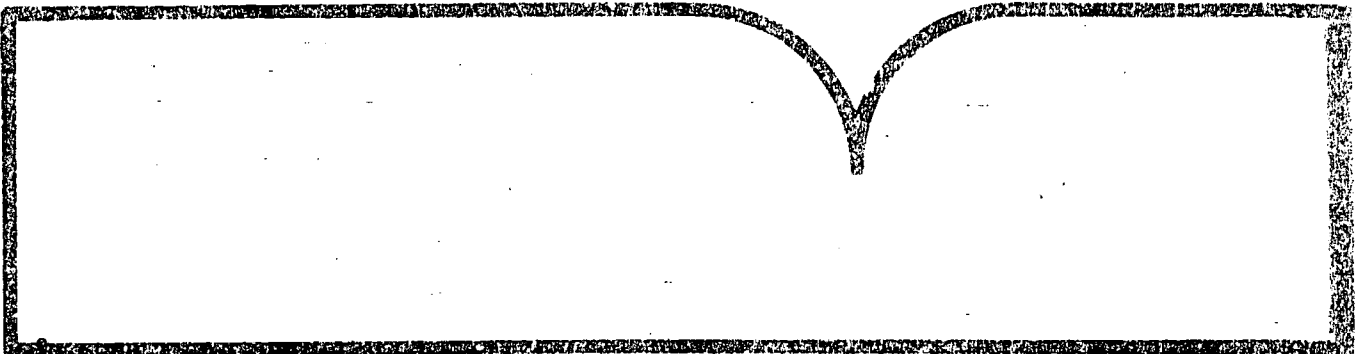





The National Transportation Safety Board is an independent Federal agency dedicated to promoting aviation, railroad, highway, marine, pipeline, and hazardous materials safety. Established in 1967, the agency is mandated by the Independent Safety Board Act of 1974 to investigate transportation accidents, determine the probable cause of accidents, issue safety recommendations, study transportation safety issues, and evaluate the safety effectiveness of government agencies involved in transportation.

The Safety Board makes public its actions and decisions through accident reports, safety studies, special investigation reports, safety recommendations, and statistical reviews. Copies of these documents may be purchased from the National Technical Information Service, 5285 Port Royal Road, Springfield, Virginia 22161. Details on available publications may be obtained by contacting:

**Public Inquiries Section
National Transportation Safety Board
800 Independence Avenue, S.W.
Washington, D.C. 20594
(202)382-6735**

TECHNICAL REPORT DOCUMENTATION PAGE

1. Report No. NTSB/SS-89/02		2. Government Accession No. PB89-917003		3. Recipient's Catalog No.	
4. Title and Subtitle Safety Study: Crashworthiness of Small Poststandard School Buses				5. Report Date October 11, 1979	
				6. Performing Organization Code	
7. Author(s)				8. Performing Organization Report No.	
				10. Work Unit No. 5139A	
9. Performing Organization Name and Address National Transportation Safety Board Bureau of Safety Programs Washington, D.C. 20594				11. Contract or Grant No.	
				13. Type of Report and Period Covered Safety Study 1974-80	
12. Sponsoring Agency Name and Address NATIONAL TRANSPORTATION SAFETY BOARD Washington, D. C. 20594				14. Sponsoring Agency Code	
				15. Supplementary Notes	
16. Abstract This study reports on the crash performance of small poststandard (manufactured after April 1, 1977) school buses and vans used for school transportation. Occupants of these small school buses generally fared well in the accidents investigated. As a result of this safety study, recommendations were issued to the National Highway Traffic Safety Administration, manufacturers of small school buses, and various associations of school transportation officials and contractors. The recommendations focus on the following safety issues: design of restraining barriers; feasibility of providing lap/shoulder belts or other restraints with upper torso support for passengers; deficiencies in roof and joint strength; lack of Federal performance standards for school bus windshield retention; design of the boarding door controls in certain small school buses; and the need to correct improper installation and use of lapbelts and other restraints.					
17. Key Words School buses; school vans; restraining barriers; joint strength; Federal standards; lapbelts; restraints			18. Distribution Statement This document is available through the National Technical Information Service Springfield, VA 22161		
19. Security Classification (of this report) UNCLASSIFIED		20. Security Classification (of this page) UNCLASSIFIED		21. No. of Pages 228	22. Price A11



CONTENTS

EXECUTIVE SUMMARY.....	v
INTRODUCTION.....	
Definition of Small Versus Large School Bus.....	1
Why This Study Was Conducted.....	2
Previous Studies of Large School Buses.....	6
Studies of Passenger Car Crashes.....	7
Accident Selection Criteria.....	10
How the Investigations Were Conducted.....	12
DIFFERENCES IN FEDERAL MOTOR VEHICLE SAFETY STANDARDS FOR SMALL AND LARGE SCHOOL BUSES.....	14
Lapbelts.....	14
Vehicle Structure.....	14
Seating.....	14
OVERVIEW OF RESTRAINT USE AND INJURY ANALYSIS.....	18
RESTRAINT USE.....	
Deficiencies in Official Reports of Restraint Use.....	20
Restraints Incorrectly Coded as Lapbelts.....	21
Improper Use of Lapbelts.....	21
Unusual Configuration and Installation of Restraints.....	22
INJURY OUTCOME.....	
Overall Passenger Outcome.....	28
Minor Injuries.....	28
Moderate and Above Injuries.....	28
Importance of Seating Position.....	28
Differences Between Safety Board and Police Accident Report Data on Injury Severity.....	30
Uniform School Bus Accident Reporting Form.....	31
RESTRAINING BARRIERS.....	
Crash Performance of Barriers.....	33
Consequences of Barrier Design.....	34
Risk of Head Injury.....	34
Canadian Crash Tests on Risk of Head Injury.....	38
Anchorage Strength for Restraining Barriers.....	39
Criteria for Head Protection.....	40
Lack of Criteria for Thorax or Abdominal Injury.....	40
Possible Solutions to the Problem of Restraining Barrier Design.....	43
Removal of Restraining Barrier.....	44
Redesign of Barrier.....	44
Installation of Lap/Shoulder Belts.....	44
Rear-Facing Seats.....	46
Summary.....	48
	49

STRUCTURAL INTEGRITY.....	51
Windshields.....	51
Inadvertent Door Opening.....	52
Joint Separations.....	55
EVACUATION.....	61
Fire and Fuel Tank Leaks.....	63
Emergency Exits.....	63
Special Students.....	64
Lapbelt Release.....	64
CONCLUSIONS.....	66
RECOMMENDATIONS.....	69
REFERENCES.....	72
APPENDIXES.....	75
A Index to Safety Board Study Case: Involving School Vehicles Built to Federal School Bus Standards.....	75
B Case Summaries of School Buses Built to Federal School Bus Standards.....	79
C Summary of Safety Issues by Case Number.....	160
D Index to and Case Summaries of Small School Vehicles Not Built to Federal School Bus Standards.....	164
E Examples of Conflicting Classifications of School Buses.....	181
F Data on Public School Transportation, 1986-87.....	185
G School Bus Sales by Body Type, 1974-88.....	186
H School Bus Type Designations.....	187
I Abbreviated Injury Scale (AIS).....	189
J Comparison of KABCO and AIS Injury Scales.....	191
K Limitations of the KABCO Injury Codes.....	194
L Data on Fatal School Bus Accidents.....	196
M Federal Motor Vehicle Safety Standards (FMVSS) Mentioned in Safety Recommendations.....	197

EXECUTIVE SUMMARY

In 1977, a series of Federal Motor Vehicle Safety Standards (FMVSS) for school buses became effective, mandating different performance standards for school buses compared to other buses. Data on the crash performance of school buses built to these standards were lacking, so the National Transportation Safety Board conducted a series of indepth accident investigations from 1984 to 1988 to determine how well Federal school bus standards are working to protect passengers from injury and whether changes in the standards are needed.

Federal standards for the design and operation of school buses differ according to the passenger capacity and gross vehicle weight rating of the bus. The Safety Board, therefore, studied the performance of large and small school buses separately, and two reports were planned.

The first report, published in 1987, examined the crash performance of large school buses built after the new standards for school buses became effective. The Safety Board found, overall, that large poststandard school buses provided excellent crash protection to their passengers but issued recommendations to further refine the safety of these school buses. The Safety Board concluded that the first priority for improving the safety of school bus passengers should be the rapid retirement of prestandard school buses, followed by expenditure of funds toward accident prevention in the form of improved driver training and equipment to reduce the number of student fatalities occurring during the loading and unloading of large school buses. Two to three times as many students are killed each year in the loading zones as are killed while riding on the school buses.

This is the second report on school bus safety; it focuses on the performance of small school buses and vans used for school transportation. The report is based on review of past research, crash tests, and the Safety Board's investigation of accidents involving vehicles used for school transportation manufactured after April 1, 1977. Safety Board highway investigators, working out of eight Regional Offices, established notification networks with State and local police, hospitals and emergency personnel, and safety groups, and asked to be alerted when a crash meeting the Safety Board's criteria occurred. To be investigated for the study, the crash had to meet at least one of the following criteria: damage to the school vehicle that required it be towed from the scene, the school vehicle rolled over, or one or more bus passengers was seriously injured or killed. Accidents in which these elements occur put passengers at risk of injury. As a result, the design of the bus, in terms of occupant protection, can be evaluated. The typical school bus accident, which results in property damage only and in which the bus is driven from the accident scene, does not "test" the crashworthiness of the vehicle.

The Safety Board found that occupants of the small school buses built to Federal school bus standards generally fared well in the accidents investigated. Injuries, when sustained, were generally minor and were primarily to the face, head, or lower limbs. Unrestrained and lapbelted passengers showed similar patterns of minor injuries, and seating position, more than restraint status,

appeared to influence the severity of injuries. Passengers seated in the front rows of certain types of small school buses appeared to be at increased risk of head or facial injuries because of the absence or peculiar design of a restraining barrier. Lapbelted passengers, in particular, appeared to be at risk of injury from interaction with the restraining barriers.

Lapbelt use did not appear to hamper emergency evacuation of passengers, primarily because adults on the scene rapidly released the passengers from their belts. No postcrash fires or leaks from the school bus fuel tanks occurred. In many accidents, however, school bus passengers were limited in the number of emergency exits available: after the crash, exits were often blocked or inoperable.

Other issues addressed in this report include: inaccurate reporting of restraint status and injuries; improper use and installation of lapbelts; windshield dislodgement; inadvertent opening of the boarding door during the crash; and separation of body joints.

As a result of this safety study, recommendations were issued to the National Highway Traffic Safety Administration, manufacturers of small school buses, and various associations of school transportation officials and contractors. The recommendations focus on the following safety concerns:

- design of restraining barriers in small school buses;
- feasibility of providing lap/shoulder belts or other restraints with upper torso support for passengers;
- deficiencies in roof and joint strength;
- lack of Federal performance standards for school bus windshield retention;
- design of the boarding door controls in certain small school buses; and
- need to correct improper installation of lapbelts and other restraints and to use restraints properly.

NATIONAL TRANSPORTATION SAFETY BOARD
WASHINGTON, D.C. 20594

SAFETY STUDY

CRASHWORTHINESS OF SMALL POSTSTANDARD SCHOOL BUSES

INTRODUCTION

The driver of a school bus transporting six students to school lost control when negotiating a right curve. The school bus traveled onto the left shoulder of the road, struck two utility poles, rolled onto its right side and came to rest. The initial impact was a Delta V of 10 mph.¹ Of the six passengers, ages 5 to 18, four were uninjured and two sustained minor contusions and abrasions. (Case 11, Denville, New Jersey.)

The good outcome of this school bus accident is not unusual. Most school bus passengers involved in a crash are either uninjured or receive minor injuries at most, even in accidents in which rollover occurs.² This school bus, however, was not a typical big, yellow school bus. It was a 16-passenger school van, painted yellow, equipped (as all vans are required to be) with a lapbelt for every passenger. At the time of the crash, four of the six passengers were wearing their lapbelts; one of the passengers who was wearing a lapbelt and one who was unrestrained received minor injuries.³

The typical school bus used in the United States to transport students is a large, yellow bus with seating capacity for more than 50 passengers, with a gross vehicle weight rating (GVWR)⁴ of more than 10,000 pounds, and is equipped

¹ The severity measure used in the Safety Board's cases is Delta V, considered by most crash researchers to be the best single measure of collision severity. Delta V, as used in the investigations of these cases, is the instantaneous rate of speed change undergone by a vehicle at impact. The Delta V estimates were generated primarily from measurements of both the location and extent of the vehicles' structural deformation, along with the vehicles' weights.

² According to the National Safety Council (NSC), about 80 percent of all school bus accidents involve no injuries to passengers on the bus. If injuries do occur, NSC estimates that about 89 percent of the injuries in nonfatal accidents are minor and about 10 percent are moderate. These figures are based on 16 years of data including school vehicles of all types.

³ In this case, seating position, more than restraint status, influenced injury outcome. The other unrestrained passenger and the other lapbelted passengers were uninjured.

⁴ The gross vehicle weight rating (GVWR) is used by the federal government in its motor vehicle safety standards. GVWR is the value specified by the manufacturer as the loaded weight of a single vehicle. One school bus can be designed to carry fewer passengers than another school bus but still have a higher gross vehicle weight rating. In other words, passenger capacity does not determine if a school bus is built to "large" or "small" school bus performance standards set by the federal government.

with a seatbelt for the driver only.⁵ Obviously, not all vehicles used for school transportation fit this description. School districts also use passenger cars, station wagons, minivans, and smaller school buses (including van conversions) to transport students.

Schools typically use a small vehicle rather than large school bus for special purposes such as transporting special education and handicapped students, Head Start students, and athletic teams to out-of-town meets, and for activity trips by school-sponsored clubs. Smaller school buses are preferred for a variety of reasons: (1) lower purchase price; (2) lower operating costs; (3) bus routes with fewer students; (4) ease of handling in an urban environment where door-to-door service is required;⁶ (5) closer pupil supervision (because of fewer passengers); (6) ability to retrofit additional exits, such as wheelchair lifts; and (7) ability to provide extra leg room between seats.

The Safety Board was interested in documenting the crash performance of small school buses but faced two immediate questions: what is a school bus, and what distinguishes a large school bus from a small school bus?

Definition of Small Versus Large School Bus

There is no general agreement on what a school bus is or what distinguishes a small school bus from a large one. The term "school bus" has no common definition, unlike the terms "passenger car" or "truck." The only consensus is that a school bus cannot be a public carrier, such as a municipal bus, or be the family's private vehicle.

There are two basic approaches for defining a vehicle as a school bus: by use, or by body type. The most common approach is by use. Using this definition, the term "school bus" describes any vehicle, regardless of body type, used to transport students. Thus, buses and vans built to Federal school bus standards as well as other types of vehicles--such as converted airport transit buses, and minivans and station wagons (other than the family car)--used to transport students can be called school buses. Most statistics about school buses of this type relate only to vehicles used to transport students at public expense; vehicles used by private schools are excluded. For example, school bus statistics from the National Safety Council (NSC), the most widely referenced data, include only vehicles used for public school transportation (National Safety Council 1987).

A school bus can also be any vehicle with a school bus-type body, regardless of its use. Under this definition, the term "school bus" would include school buses used by public and private schools along with vehicles with

⁵ Only a few of the Nation's 15,480 school districts have ordered large school buses equipped with passenger lapbelts.

⁶ Many school districts are required by State or local statutes to provide special students with door-to-door service and/or to limit the time the students are in transit between home and classroom. These requirements result in a need for small vehicles.

school bus bodies used by day camps, churches, private activity groups--such as Boy Scouts, migrant workers, and community shelter programs--as well as school buses converted to motor homes. Any vehicle with other than a bus body would be excluded; van-conversion school buses, for example, would not be included in such data.

The Federal Government uses both of these definitions of school bus, and other definitions, in its standards, operational guidelines, and accident data collection. Perhaps the most important definition is that used in the U.S. Department of Transportation's Federal Motor Vehicle Safety Standards (FMVSS), which vehicle manufacturers must follow. The definition of school buses used for the FMVSS's has both passenger capacity requirement and use qualifications. For a vehicle to be defined as a school bus, it must first be a "bus"--that is, "a motor vehicle with motive power, except trailer, designed to carry more than 10 persons." Further, a "school bus" is "a bus sold or introduced in interstate commerce, for purposes that include carrying students to and from school and related events." Under this definition, both a van-based vehicle and a bus, if built to FMVSS for school buses, would be termed a school bus.

In this study, the Safety Board used the FMVSS definition of school bus because it was interested in documenting the crashworthiness of vehicles built to the Federal school bus performance standards. In addition, the Safety Board investigated four cases involving vehicles that were not built to Federal school bus standards because some States permit use of such school vehicles. Discussions in the text and appendixes A-D distinguish between vehicles built to school bus FMVSS and those that were not.

The problems inherent in defining a small versus large school bus were even more difficult. A uniform definition, based on either vehicle weight or passenger capacity, does not exist. School districts, States, school bus manufacturers, and the Federal Government have their own and different methods of classifying school buses. The size of a school bus can be based on passenger capacity (for example, 16 passengers or less, or more than 16 passengers--the source of some Type I versus Type II school bus classifications), vehicle configuration (for example, van-type body versus bus body), gross vehicle weight rating (GVWR of 10,000 pounds or less, or more than 10,000 pounds), or a combination of these factors (for example, school bus Types A, B, C, and D as used by school bus manufacturers; see fig. 1).

The size designations and definitions of school buses overlap and conflict with one another, making it impossible to compare data sets with one another (appendix E). Deciding how to differentiate between a small versus large school bus for the study was difficult. At first, the Safety Board believed it could restrict case vehicles in the study to those with a GVWR of 10,000 pounds or less, the basis for the FMVSS size distinctions. However, another Federal guideline, Highway Safety Program Standard No. 17, which currently distinguishes between school buses by passenger capacity, complicated matters. A school vehicle could be a "large" bus under one set of Federal requirements and a "small" bus under another (passenger capacity does not always correspond with GVWR). The Commercial Motor Vehicle Safety Act of 1986 (P.L. 99-570) also distinguishes between school buses by passenger capacity; the Act, administered



A Type A school bus is a conversion or body constructed on a van-type compact truck or a front-section vehicle, with a gross vehicle weight rating of 10,000 pounds or less, designed for carrying more than 10 persons.



A Type B school bus is a conversion or body constructed and installed on a van or front-section vehicle chassis, or stripped chassis, with a gross vehicle weight rating of more than 10,000 pounds, designed for carrying more than 10 persons. Part of the engine is beneath and/or behind the windshield and beside the driver's seat. The entrance door is behind the front wheels.

Figure 1.--These models of one manufacturer are classified by the industry-wide system of school-bus type definitions.



A Type C school bus is a body installed on a flat back cowl chassis with a gross vehicle weight rating of more than 10,000 pounds, designed for carrying more than 10 persons. All of the engine is in front of the windshield and the entrance door is behind the front wheels. (Type C school buses are also sometimes referred to as "conventional" school buses.)



A Type D school bus is a body installed on a chassis, with the engine mounted in the front, midship, or rear, with a gross vehicle weight rating of more than 10,000 pounds, designed for carrying more than 10 persons. The engine may be behind the windshield and beside the driver's seat, at the rear (behind the rear wheels), or midship (between the front and rear axles). The entrance door is ahead of the front wheels. (Type D school buses also are sometimes referred to as "transit-style" school buses.)

Figure 1 (continued).

under the responsibility of the Federal Highway Administration, applies only to vehicles "designed to transport more than 15 passengers, including the driver." Then too, States and school districts routinely refer to school buses as either Type I or Type II, a designation loosely based on passenger capacity. Most available school bus data use this Type I or Type II designation.

In this study, the Safety Board sized school buses using the school bus industry system of classifying school buses as either Type A, B, C, or D, a system that takes into account GVWR and vehicle configuration (definitions and examples are given in figure 1). This report presents data for school bus Types A and B. Types A and B are referred to in State and industry statistics as Type II ("small") school buses. Only Type A is a small school bus as defined by the FMVSS because of its GVWR. A Type B school bus is a small school bus that is built to the large school bus FMVSS because of its GVWR. This report distinguishes between Type A and Type B school buses in discussions of vehicle crash performance and seatbelt installation. Most cases were Type A school buses.

Why This Study Was Conducted

In 1977, a series of new and modified FMVSS relating to school buses became effective, mandating different performance standards for school buses compared to other buses. Data on the crash performance of school buses built to these standards were lacking, so the Safety Board conducted a series of accident investigations from 1984 to 1988 to determine how well the standards are working to protect passengers from injury and whether changes in the standards are needed. Two reports were planned because Federal standards and guidelines differentiate between school buses by size.

The first report, published in 1987, examined the crash performance of Type C and Type D school buses (the types commonly called large or Type I school buses) built to Federal school bus standards (National Transportation Safety Board 1987b). The Safety Board found, overall, that these large poststandard school buses provided excellent crash protection to their passengers but issued recommendations to further refine the safety of these school buses. The Safety Board concluded that the first priority for improving the safety of school bus passengers should be the rapid retirement of prestandard school buses, followed by expenditure of funds toward accident prevention in the form of improved driver training and equipment to reduce the number of student fatalities occurring during the loading and unloading of large school buses. Two to three times as many students are killed each year in the loading zones as are killed while riding on the school buses.

This is the second report on school buses; it focuses on the crash performance of Type A and Type B school buses, the types referred to in some statistics as Type II or small school buses. In the report, both vehicles with bus bodies and van conversion bodies are referred to as school buses. Discussions distinguish between types of vehicles when appropriate.

Type A and Type B school buses combined constitute about 15 percent of the public school bus fleet (about 41,000 of the 362,000 public school vehicles⁷), but sales of these smaller school vehicles in the school bus fleet have increased every year for the last 5 years (appendixes F and G). These small school buses frequently carry passengers who are the most vulnerable of all school bus passengers, very young students or passengers with some form of disability (that is, emotional, physical, or learning disability).

It is important to note that small school buses are not simply miniature versions of large school buses. Small school buses differ from large school buses not only in size and weight--important factors in the magnitude of crash forces acting on school bus passengers--but also in structural configuration and interior features. These differences are especially pronounced in Type A school buses, which represent most of the accidents discussed in this report.

Previous studies of large school buses.-- Because of these differences, the conclusions drawn by the Safety Board regarding the crashworthiness of large school buses (National Transportation Safety Board 1987b) do not necessarily apply to small school buses. For example, the Safety Board did not recommend that States or school districts allocate funds to retrofit or purchase large school buses with lapbelts because it found that passengers on large school buses would, overall, receive no net benefit from lapbelt use. That conclusion did not consider the possibility of lapbelt-induced injuries; had this possibility been included, the overall net effect of lapbelts would have been negative for large school buses. This conclusion does not necessarily mean that passengers on small school buses would not benefit from lapbelts. The advantages or disadvantages of lapbelt use may well be different in a school bus designed for 16 or fewer passengers compared with a school bus designed for 54 passengers. A separate analysis was needed for small school buses because they may perform more like a car than a bus in a crash. Certainly a small school bus is closer in size and weight to a passenger car than to a large school bus (figs. 2 and 3).

Studies of passenger car crashes.--Accidents involving small school buses have been of interest to groups advocating the installation of passenger lapbelts on large school buses and to those concerned that the same types of lapbelt-induced injuries that have occurred in rear seats of passenger cars (National Transportation Safety Board 1986) would occur to lapbelted passengers in school buses.

As previously stated, the disparate size and mass of a small school bus compared with a large school bus means that findings about the advantages or disadvantages of passenger lapbelts on large school buses have little relevance to whether or not passenger lapbelts are needed on small school buses. For similar reasons, studies of the crash performance of lapbelts in the rear seat of a passenger car are not necessarily applicable to lapbelts in a small school bus. The differences in size and interior features between a passenger car and school bus are too great.

⁷ The number of small school buses and vans used by private schools is not known.

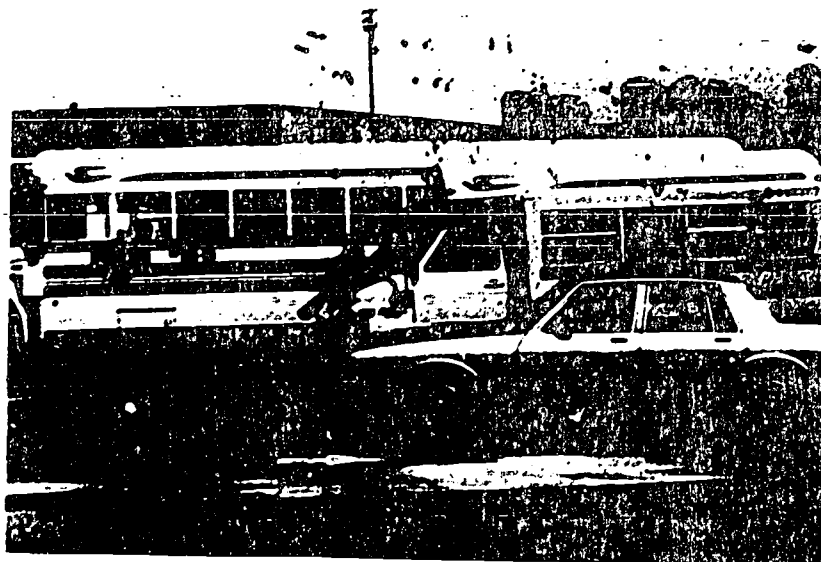

Figure 2.--A small school bus is closer in size and weight to a passenger car than to a large school bus. In this photo, a 66-passenger school bus and a 22-passenger school bus are parked alongside a Chevrolet Caprice. If a school bus is involved in a collision with a car, the crash forces experienced by passengers riding on the small school bus will be much more severe than if they had been riding on the large school bus.

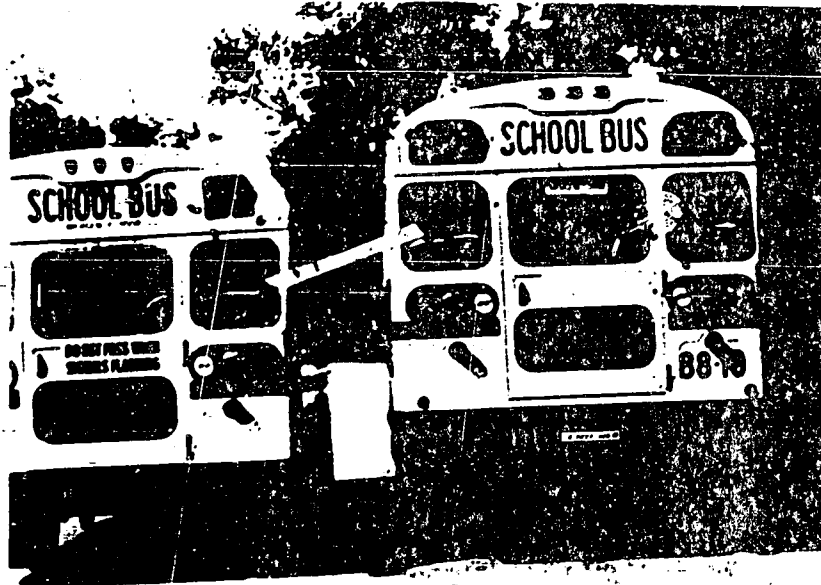

Figure 3.--Passengers seated in a small school bus are closer to the ground, and closer to the level at which a passenger car would impact, than passengers seated in a large school bus. (A school van is pictured at left; a large school bus is at right. The difference in heights of seatbacks from road level is indicated.)

For example, General Motors (GM) recently estimated that use of a lap-only belt in the rear seat of a passenger car can reduce fatalities by 18 percent \pm 9 percent⁸ (Evans 1989). "The effectiveness of lapbelts in preventing fatalities in rear seats flows mainly from ejection prevention," GM concluded. Lapbelts were able to reduce collisions between occupant and vehicle interior only 1 percent \pm 9 percent.⁹ In other words, lapbelts were unable to prevent most interior contacts, and their effectiveness was mainly due to ejection prevention. Considering the differences between a passenger car and school bus, the effectiveness of lapbelts is likely to be even less on the school bus because ejection is less possible from the bus. Occupants of passenger cars are ejected most often through the car side door, followed in frequency by ejection through the adjacent window or through the windshield. Unrestrained passengers on a school bus are less likely to be ejected than occupants of passenger cars because they are not seated next to a door, windows are usually partitioned, seatbacks are usually closer and higher, and passengers are farther from the windshield.

Accident Selection Criteria

The purpose of this safety study was to determine how well small school buses protect their student passengers from injury. The purpose of the study was not to document how well adults were protected in a small school bus or the problems of transporting physically handicapped passengers.¹⁰

Investigations were limited to vehicles built after April 1, 1977, the date when all Federal school bus standards were in effect, and that met the industry-wide definition of a Type A or a Type B school bus^{11,12} (school bus models are

⁸ That is, the overall effectiveness of a lapbelt could be as high as 27 percent or as low as 9 percent.

⁹ According to the GM research, lapbelts, at best, can prevent 10 percent of interior contacts, and in the worst case, be a negative factor, increasing harmful interior contacts by 8 percent. The estimates by GM are based on comparing the outcome of "matched pairs" (restrained versus unrestrained occupants) of passenger cars from data in the Fatal Accident Reporting System (FARS) for 1975-85. FARS, a data base maintained by the National Highway Traffic Safety Administration (NHTSA), is derived from police accident reports; data on restraint use and injury outcome are not comprehensive and contain inaccuracies. Estimates about the effectiveness of rear seat lapbelts are not uniform. Prior to his 1989 study, Evans reported lower estimates for the effectiveness of lapbelts in reducing fatalities: 7 percent \pm 12 percent, based on FARS data for 1975-83. Other research, notably by NHTSA, has estimated the effectiveness of rear seat lapbelts to be as high as 40 percent.

¹⁰ Wheelchair restraints and restraints for the handicapped, and how to secure them to a school bus interior, are exempt from meeting federal standards. The evaluation of such restraints is beyond the scope of this study.

¹¹ Type A and Type B school buses are commonly equipped with lapbelts for passengers.

¹² Some States (including Connecticut, Michigan, New Hampshire, and Vermont) appear to allow vans not built to federal school bus standards to be used to transport students on regular routes. Most are stock vans bought from a dealer's lot. Other States allow such vans to be used for student activity trips or other special transportation purposes. The Safety Board, since 1983, has urged that only vehicles built to federal school bus standards be used for student transportation. The Safety Board also investigated four accidents involving vehicles that were not built to federal school bus standards (appendix D). Some passengers were fatally injured in these crashes, sometimes by lapbelt-induced injuries. The crashes involving the nonstandard vehicles were so much more severe that in some cases the differences in vehicle performance and injury outcome could be due to higher crash forces rather than the lack of crashworthiness of the vehicle.

identified in appendix H and fig. 1). The case vehicle had to be primarily occupied by preschool or school-age children (not all of whom were in wheelchairs), and the accident had to meet at least one of the following criteria:

- the case vehicle was involved in a moderate speed collision¹³ that disabled the bus (occupant injuries need not have resulted); or
- the case vehicle overturned; or
- one or more of the case vehicle's passengers was seriously injured or killed, regardless of the type of accident.

The cases presented in this report are not a census or a statistical sample of all accidents involving Type A and B small school buses in the United States during the investigation period. The number of crashes involving poststandard small school buses occurring nationwide during the span of the Safety Board's study is unknown.¹⁴ This report is a "case" study, based on investigations of accidents meeting specified criteria to collect accurate and complete data on crash performance and injury outcome for those accidents.

The accident criteria specified allowed the Safety Board to examine the crash performance of small school buses in accidents that put the occupants at risk of injury. This type of accident is not typical, however. According to available data, the typical school bus accident is minor, a "fender bender," and does not result in injury. Consequently, such an accident would not "test" the crashworthiness of the vehicle and would preclude an evaluation of whether the vehicle's design offers adequate protection for the occupants. Likewise, such an accident would not be useful for evaluating the benefits of a passenger restraint system (such as lapbelts) because the passengers, regardless of restraint status, are at little risk of injury. In addition, a school bus accident resulting in minor injuries to unrestrained passengers does not yield data useful for analyzing the benefit of lapbelt use. Seatbelt use does not guarantee that an individual will be unharmed, nor does it eliminate minor (AIS 1) injuries. The National Highway Traffic Safety Administration (NHTSA) has estimated that lapbelts and lap/shoulder belts in passenger cars are only 10 percent effective in preventing minor (AIS 1) injuries.

¹³ The phrase "moderate speed" was included to preclude the Safety Board being notified of a minor accident, such as a bus that backed into an object or struck another vehicle when both were nearly at a standstill. The term "collision" had to appear in the accident report because the criteria also specified "no injury need to have resulted."

¹⁴ Available accident statistics combine all types of school vehicles and prestandard and poststandard buses together. Nationwide, an estimated 5,000 injury-producing accidents involving all types of school vehicles occurred during the 1986-87 school year. This total includes accidents resulting in injuries only to occupants of the other vehicle and pedestrians. According to 16 years of National Safety Council data, most injuries to school bus occupants probably were minor.

This report, unlike others, also distinguishes between types of small school buses, an important distinction because Type A school buses meet a different set of FMVSS requirements than Type B school buses, which in terms of FMVSS requirements, are "large" school buses.

Data about the accidents and vehicles investigated in this study are presented in table 1.

How the Investigations Were Conducted

The investigations for this study were conducted by Safety Board headquarters staff and staff in eight Regional Offices during 1984-88.¹⁵ At the beginning of the study, each Safety Board Regional Office set up an accident notification plan, involving a network of law enforcement and medical authorities in the multi-State region surrounding the office. Local and State authorities in each region agreed to notify the Safety Board investigators of a crash meeting the Safety Board's criteria as soon as they became aware of it. Upon notification, the investigators determined if the crash, in fact, met the selection criteria, and if so, began a detailed investigation.

Damage to the exterior or interior of the school bus was documented and analyzed, especially in relationship to each passenger's seating position. Information on each occupant (age, weight, and height) and seating location was determined to the extent possible. For each occupant, the investigators attempted to determine whether a restraint system was used, whether it was used correctly, the probable source of each injury, and the nature and severity of each injury sustained, expressed in terms of the Abbreviated Injury Scale (AIS) (appendix I).

Throughout this report, occupants are frequently described in terms of his or her maximum AIS level injury (MAIS). Use of the AIS injury coding system helps eliminate individual bias when discussing injuries; a "serious" injury to one person may be a "moderate" to another person. Under the AIS system, all injuries are listed in a coding manual and only one code per specific injury can be assigned.

¹⁵ The Safety Board has highway investigators in the following Regional Offices: Atlanta, Chicago, Denver, Fort Worth, Kansas City, Los Angeles, New York, and Seattle.

Table 1.--Data about accidents and vehicles investigated for study on crashworthiness of 24 small poststandard school buses, 1984-88

Item	Number	Item	Number
<u>Type of vehicle:^a</u>		<u>Other vehicle(s) or object(s) involved:^c</u>	
Type A school bus ^b	19	Passenger car or van	9
Type B school bus	5	Light truck	3
		Heavy truck	2
		Other school bus	1
		Other object	7
<u>Manufacturer of school bus body:</u>		<u>Type(s) of accident:</u>	
Collins Bus Corp.	3	Collision	21
T.P.I. (Sturdivan)	3	Noncollision ^d	3
Wayne Corp.	3		
Blue Bird Body Co.	2	Rollover ^e	12
Carpenter Body Works		Nonrollover	12
Coach & Equipment (Fortivan)	2		
Van-Con, Inc.	2		
Sheller-Globe	1		
Superior Coach Int'l.	1		
Thomas Built Buses	1		
AnTran (Vanguard)	1		
Other	5		
		<u>Principal direction of impact in collision accidents:^f</u>	
		Frontal	9
		Side	5
		Rear	1
		Multiple	6
<u>Manufacturers of school bus chassis:</u>			
Chevrolet	13		
Dodge	6		
GMC	2		
Ford	3		

^a Vehicles are classified by the school bus industry system (adopted at the National Minimum Standards Conference 1980) that takes into account both gross vehicle weight rating (GVWR) and vehicle configuration.

^b Includes school vans. Type A school vehicles have a GVWR of 10,000 pounds or less and must therefore meet federal standards for small school buses.

^c Some accidents did not involve other vehicles or an object, and some accidents involved multiple vehicles or objects.

^d All noncollision accidents were rollovers.

^e All but three of the rollovers were precipitated by a collision. Safety Board accident criteria undoubtedly resulted in a higher proportion of rollover accidents than would be found in accidents involving small school buses nationwide.

^f Includes head-on collision and front angle.

DIFFERENCES IN FEDERAL MOTOR VEHICLE SAFETY STANDARDS FOR SMALL AND LARGE SCHOOL BUSES

Federal Motor Vehicle Safety Standards (FMVSS) specify for school buses with a GVWR of 10,000 pounds or less, different performance standards and, in some respects, less stringent standards than those required for larger school buses. Type A school buses are the only type of school bus considered "small" or "light" school buses by FMVSS. NHTSA proposed a "combination of requirements for light school buses that differ from those for heavier buses, because the crash pulse experienced by smaller vehicles is more severe than that of larger vehicles in similar collisions" (41 FR 4016, January 28, 1976). Three of the most substantial differences between Type A school buses and other types of school buses are outlined below.

Lapbelts

Type A school buses, like all passenger cars and multipurpose vans, are required by FMVSS to be manufactured with at least a lapbelt at every occupant seating position. In the preamble to FMVSS 222, "School Bus Seating and Crash Protection," NHTSA stated "such restraints are necessary to provide crash protection in small vehicles" (41 FR 4016, January 28, 1976). Other types of school buses (Type B, C, and D) are not required by FMVSS to have passenger lapbelts installed and, if they do, they need not meet Federal seatbelt standards.

Vehicle Structure

Type A school buses are not required by FMVSS to have the same level of structural integrity as larger school buses. They are exempt from the Federal standards that specify joint strength, and a less stringent test of roof strength is applied. In 1973, during rulemaking connected with FMVSS 221, "School Bus Body Joint Strength," NHTSA found "no evidence that the mode of (joint) failure found in larger traditional school buses also occurs in smaller, van-type school buses currently manufactured by automobile manufacturers for use as 11- to 17-passenger schoolbuses...Until information to the contrary appears or is developed, these vehicles should not be covered by the requirement" (41 FR 3872, January 27, 1976). The Safety Board believes this report presents such information. The application plate used in roof performance tests in small school buses was increased in size when some industry commenters stated they would find it necessary to discontinue production of small school buses if the same testing requirements as for larger school buses were imposed (41 FR 3874, January 27, 1976).

Seating

Seating standards are also different for Type A school buses than for other school buses: compartmentalization is incomplete. When Federal rulemaking regarding school bus seating was first proposed, the seats of all size school buses were required to meet identical requirements in terms of seat spacing and seat performance. Several commenters objected to the applicability of the

standard to school buses with a GVWR of 10,000 pounds or less, asserting that the special requirements of the standard for small buses were inappropriate, or unachievable, within the 9-month lead time for compliance mandated by Congress. Since NHTSA had "specified adequate numbers of seatbelts for the children that the vehicle would carry," different requirements for seating in small school buses were considered "reasonable," and NHTSA exempted seats of Type A school buses from certain requirements. (41 FR 4016, January 28, 1976).

These are not the only differences in standards for Type A school buses and other types of buses. Figure 4 provides additional examples.

Exterior Requirements

Small School Bus

Emergency Exits (FMVSS 217) — Rear emergency exit must comply with provisions of standard for small school buses. Dimensions and clearance of side emergency exits not specified.

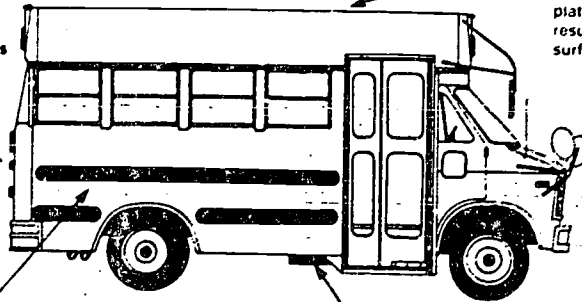

Rollover Protection (FMVSS 220) — Test requires a vertical force equal to 1½ times the unloaded vehicle weight be applied to roof. Force application plate is wider and longer than roof, resulting in large load-absorbing surface.

Joint Strength — Not required to meet any Federal Standard; exempt from school bus joint strength standard (FMVSS 221).

Fuel Tank Integrity (FMVSS 301) — Same performance and test requirements as that required for all buses and multipurpose vehicles: a frontal barrier crash test, a rear moving flat barrier test, a lateral moving flat barrier test, and a static rollover test, with fuel spillage not to exceed certain limits.

Large School Bus

Emergency Exits — Same number of exits required as small school bus, but rear exit must have twice the clearance and be slightly larger. Dimensions and clearance of side emergency exit specified.

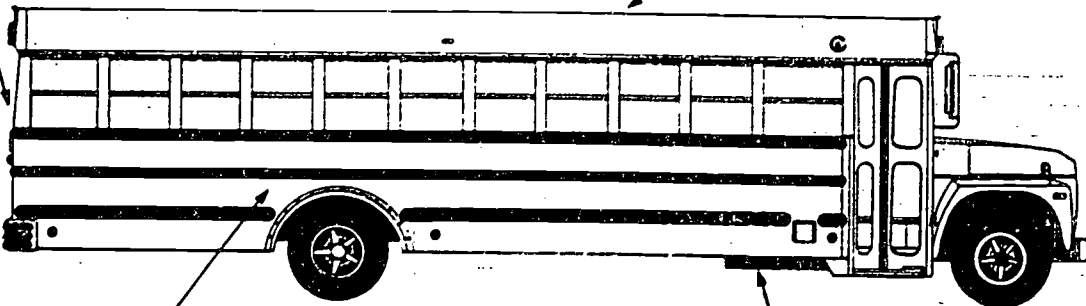

Rollover Protection — More stringent test requirements result in greater roof strength. Force application plate is narrower and shorter than roof; the latter aspect stresses the roof structure more than the test for small school buses.

Joint Strength — Must meet Federal school bus joint strength standard (FMVSS 221).

Fuel Tank Integrity — Standard specifies different testing requirement: one test only, a moving contoured barrier crash. Same fuel spillage limitations.

(Note: FMVSS distinguish school buses on the basis of gross vehicle weight rating. Small school buses have a GVWR = 10,000 lbs.; large school buses = 10,000 lbs.)

Figure 4.--Structural differences affect both the exterior and interior of small and large school buses.

Seating Requirements (FMVSS 222)

Small School Bus

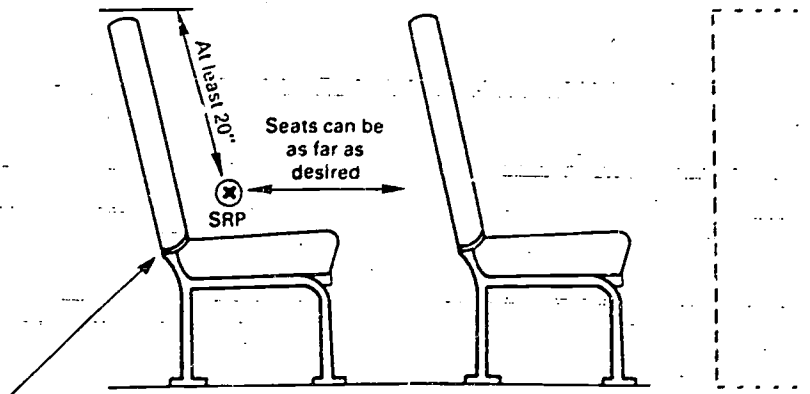

At least a lapbelt required at every occupant seating position. Must meet same standards as belts in multipurpose passenger vehicles (FMVSS 208, 209, 210).

Frontal barrier(s) not required. If installed, no spacing or size requirements or any of the restraining barrier requirements of FMVSS 222 apply. Head protection zone requirements in force, though.

Large School Bus

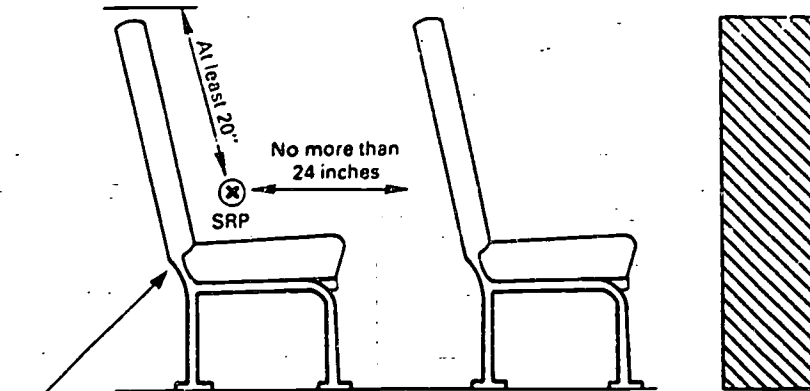

No seatbelts of any kind required for passengers. If installed, do not have to meet any Federal requirements.

Frontal barriers required. Must meet specific requirements for size, spacing and crash performance.

Note: SRP is the Seating Reference Point, pivot point of hip.

Figure 4 (continued).

BEST COPY AVAILABLE

OVERVIEW OF RESTRAINT USE AND INJURY ANALYSIS

A case study, like this report, can provide data that are not usually available and that are needed before discussion of the injury outcome for restrained or unrestrained passengers on small school buses can be discussed. Before analysis can begin, certain questions must be answered:

- Where was the occupant seated in relation to crash forces and deformation of the vehicle?
- Was the occupant restrained at the time of the crash?
- If restrained, what kind of restraint was used?
- Was the restraint correctly installed and worn properly?
- What was the severity and location of injury?
- What was (were) the agent(s) of injury?

Police accident records or media reports of school bus crashes generally cannot supply answers to these questions, and the reliability of data they can supply is sometimes questionable. Table 2 illustrates differences between data collected by the Safety Board and the data available from official reports of a school bus accident.

There are several reasons for the discrepancies between severity of injuries reported in police accident records and the severity determined by Safety Board investigators. The priority of police at the accident scene is to have the injured transported to hospitals as quickly as possible and to establish traffic control, not to code injury severity. Police generally receive little training in coding and evaluating injuries, and the injury scales they use are simplified. In addition, certain types of injuries may not be readily apparent immediately after the accident.

Reports of belt use are usually higher than actual use. Nearly all States and local school districts have statutes or regulations requiring the school bus driver to be restrained when the bus is in motion. Failure to wear the available belt, especially if involved in an accident, may be grounds for dismissal. Some school districts also require that passengers of school buses equipped with lapbelts be buckled up whenever the school bus is in motion. Federal Highway Safety Program Standard No. 17 currently recommends that passengers in school vehicles that carry 16 or fewer pupils shall be required to wear lapbelts when available and whenever the vehicle is in motion. Furthermore, some school buses have adult aides on board charged with ensuring that students buckle-up.

Analyses of restraint use and injury outcome are discussed in the following chapters. The analyses also discuss differences between the Safety Board's findings and official accident reports.

Table 2.--Differences in restraint use and injury status coded for case 15, Perrysburg, Ohio

Item coded	Coded on State police accident form	Determined by investigators of the National Transportation Safety Board ^a
<u>Restraint use:</u>		
Passengers	17 were wearing lapbelts	1 was unrestrained 14 were wearing lapbelts ^b 1 was restrained in a misused child safety seat ^c 1 status undetermined ^d
Driver	Was wearing lapbelt	Restrained by a loosely adjusted lap/shoulder belt (the only belt available at the seating position)
<u>Injury status:</u> ^e		
Passengers	1 was uninjured 15 received minor injuries 1 received serious injuries	1 was uninjured 11 received minor injuries 2 received moderate injuries 3 received serious injuries
Driver	Received minor injuries	Received moderate injuries (including two fractured ribs)

^a Based on physical evidence, reconstruction of the accident, and statements of witnesses and vehicle occupants.

^b All but one of the lapbelts were adjusted with excessive slack considering the small size of the occupants. The lapbelts thus provided little restraint.

^c The police report indicated the passenger was lapbelted and received minor injuries. The passenger was actually restrained in an improperly secured child safety seat with half of the safety seat's harness around her body. The child received a serious injury, a fractured femur.

^d The police report indicated this 5-year-old passenger was wearing a lapbelt. The passenger's seating position was actually occupied by an unsecured child safety seat lying on its side. The lapbelt at the position showed no physical evidence of having been in use at the time of the accident.

^e The Ohio State police use the KABCO injury scale, which provides five injury codes from which to choose: fatal, serious, minor, no visible injury, or not injured. National Transportation Safety Board investigators use the AIS injury scale, which provides nine classifications: uninjured, minor, moderate, serious, severe, critical, maximum (virtually unsurvivable), injured (unknown severity), unknown if injured. The differences in injury severity shown in the table are not necessarily the result of inaccurate coding by the police; they may just reflect the limitations of the KABCO injury scale compared with the AIS scale.

RESTRAINT USE

Restraint use was high among the drivers of school vehicles in this study. Nearly three-fourths of the drivers were wearing the lap or lap/shoulder belt available at their seating positions at the time of the crash.¹⁶

Restraint use among passengers in the study was lower than that of the drivers, but still high. Two-thirds of the passengers with restraints available at their seating positions were determined by the Safety Board to have been restrained in some fashion at the time of the crash. (Restraints included child safety seats; properly and improperly used lapbelts and lap/shoulder belts; and substandard, jury-rigged "belts" and secured wheelchairs.) Data were collected on 111 lapbelted passengers (97 on vehicles built to Federal school bus standards; 14 on vehicles not built to these standards).

The level of restraint use among passengers in this study was far greater than that reported in a survey conducted in New York State in 1988, the only State to require that all new school buses, regardless of size, be equipped with lapbelts for passengers.¹⁷ The survey found that in the school districts with formal policies mandating seatbelt use, fewer than 25 percent of passengers on the belt-equipped buses wore the available belts. The lapbelts on some buses had been vandalized.¹⁸

Many of the school vehicles in the Safety Board's study are the type in which belt use is required by State or local policies, contributing to the higher belt use rate in this study compared to the New York survey. The higher rate also occurred because the school buses carried few passengers, passengers were usually young (grade school age or younger),¹⁹ or handicapped, or because aides were aboard vehicles to encourage passengers to buckle-up. Not surprisingly, restraint use was higher in the six buses with aides aboard than in buses without aides. Only one of the seven aides, however, was restrained at the time of the accident.

¹⁶ Of the 20 restrained school bus drivers, 11 wore lapbelts and 9 wore lap/shoulder belts. This was a much higher belt use rate than observed in the Safety Board's study of large school buses: of 43 crashes, nearly half the school bus drivers were unrestrained.

¹⁷ Large school buses ordered for use in New York State are also required to have more seatback padding and, since 1968, higher seatbacks than required by Federal standards. Seatbacks in New York school buses are 28 inches from the Seating Reference Point; Federal standards specify a minimum of 20 inches.

¹⁸ Only 13 percent of the school districts reported no problems with seatbelts. Of the districts reporting problems, 15 percent had cut belts, 19 percent had buckles removed, 12 percent had broken buckles, 18 percent had improper adjustment, 30 percent had belts tied together, and 34 percent had multiple problems. According to the survey, repair costs and down time related to seatbelts on buses has created added expense including replacement parts, labor, and loss of vehicle use. This cost factor is projected to exceed \$1,000,000 per year across the State.

¹⁹ Grade school pupils are more likely to buckle up than high school pupils (U.S. Department of Transportation, National Highway Traffic Safety Administration 1986).

Deficiencies in Official Reports of Restraint Use

In most accidents, Safety Board investigators did not rely solely on statements regarding belt use of witnesses or vehicle occupants or on the restraint status in the police report, but rather looked for physical evidence of use. Reconstruction of the crash events, information on the fit of the belt and size of the occupant, and medical records on the injuries sustained assisted the Safety Board investigators in evaluating restraint use. In some cases, the restraint status reported by the school bus occupant was directly contradicted by physical evidence; in others, the status reported was questionable. Four examples follow:

1. The school bus driver's lap/shoulder belt was found pinned behind his deformed seat, with its latchplate splattered with blood. The opening where the latchplate would fit in the buckle stalk was filled with asphalt, which had spilled into the bus when it was struck by a truck transporting hot asphalt. (Case 25.)
2. All lapbelts on the school bus were unusable; they either had been vandalized or were stowed beneath the bottom seat cushions. (Case 4.)
3. The 5-foot 2-inch, 190-pound driver's aide was found in the stairwell following the crash; her pelvis was fractured. The adjusted length of the lapbelt at her seating position was 22 inches. (Case 15.)
4. The school bus driver refused to start the bus unless all passengers were lapbelted, so to give the appearance of being belted, the passenger inserted the buckle into his latchplate, but not far enough to engage the buckle. He slipped from his seat during the crash. (Case 5.)

Police accident reports indicated that these school bus occupants were restrained. Many of the occupants had told law enforcement officials on the scene that they had been using the available restraint at the time of the crash. Safety Board investigators determined from evidence, however, that all were unrestrained. Deficiencies in accident reports of other cases are documented in the case summaries (appendixes B and D).

Police may be inclined to take occupant statements about restraint use at face value, or to list uninjured occupants as restrained and injured occupants as unrestrained. In cases 4 and 24, for example, all passengers were listed as lapbelted in the police report although there were no lapbelts available for use at their seat on the bus. Restraint use is probably overstated in most of the official reports.

Restraints incorrectly coded as lapbelts. --Not all lapbelts reported in use were actually lapbelts. Police reported other devices as lapbelts: a child safety seat, a lap/shoulder belt, a large belt formed by joining the latchplate of the aisle-side lapbelt with the latchplate of the lapbelt at the window seating position, and a jury-rigged "restraint" consisting of two car lapbelts tied together and slipped over the top of a bench seat.

Improper use of lapbelts.--Police reports do not indicate whether the lapbelt was being worn properly. The Safety Board investigators found instances of lapbelts that were being worn improperly rather than snug and low on the abdomen as recommended. The design of lapbelts commonly installed for passenger use on school buses may encourage misuse.

Nearly all lapbelts installed for passengers on school buses are "static" lapbelts, the type commonly found in airplanes and the center seating position of cars. Static belts are not equipped with retractors that automatically tighten the belt around the occupant; instead, the school bus passenger must manually adjust the belts--shorten or lengthen them--to ensure proper fit.

Safety Board investigators often found that the lapbelts had excess slack (cases 2, 5, 13, 15, 17, 19, and 25). A loosely worn lapbelt cannot provide the same level of protection as a snugly worn belt and exposes the occupant to injury: in the Safety Board's cases, passengers slipped out from the restraint in a crash, incurring injuries from contact with components of the vehicle interior normally not reachable.²⁰ Loose fit also increases the chance of ejection, and an occupant with a loosely fitted lapbelt may be at more risk of abdominal or spinal injury.

Unusual Configuration and Installation of Restraints

Some of the restraints reported in use were improperly installed or of such a design that they would not meet Federal standards. Federal safety standards for seatbelt design and installation (FMVSS 208, 209, and 210) apply only to belts provided by the manufacturer in motor vehicles required by FMVSS to be provided with seatbelts.²¹ The owner can alter the seatbelts, even cut them out of the vehicle, and not be in violation of any Federal standards. (They may, however, be in violation of a State law.) The restraints described in table 3 violate established installation guidelines and some basic tenets of seatbelt design.

The "lapbelts" and jury-rigged restraints described in table 3 provide school bus passengers with a degraded level of protection at best. Moreover, some of them expose the occupant to danger of injury from the belt itself, as in the loopbelt held together by a metal plate with exposed bolts (fig. 5). The unrestrained child seated on the bench seat next to the two children encircled by this belt could have been harmed in an accident by contact with the metal plate and protruding bolts. The children within the loopbelt also were in danger of injury caused by their bodies slipping around in this large belt and interacting forcefully with one another. Moreover, because the loopbelt was not secured to the seat or floor, it could move upward, beyond the children's chests, and position itself near the neck.

²⁰ See case 15, for example.

²¹ The Type A school buses in the study originally were equipped by the manufacturer with lapbelts meeting federal standards, as required by federal regulations. The Type B school buses in the study were not required by federal regulations to have factory-installed lapbelts; if lapbelts were installed by the school district, they did not have to meet federal seatbelt standards.

Table 3.--Examples of unusual passenger restraints and installations in small school buses

Type of school bus and case number	Unusual restraints and installations
<u>Type A:</u> ^a	
Case 3	Lapbelts were available for every passenger, but two types had been installed. Some lapbelts had pushbutton release latchplates, like those commonly found on passenger cars; others had lift-type release buckles like those in airplanes. This mix was found throughout the vehicle, even on the same bench seat.
Case 15	A child safety seat was improperly installed and misused: the right side shoulder strap of the harness was not attached to the safety seat, and the vehicle lapbelt was improperly routed around the restraint.
Case 17	Two lapbelts had been shortened by looping over the webbing, punching a hole through the looped-over webbing, and then remounting the belt to the seat using a bolt. The "adjustment" had been done to meet parents' complaints that the belts were too large to fit small children.
<u>Type B:</u> ^b	
Case 21	The driver had "knotted" the webbing of two of the available lapbelts, in an attempt to shorten the belts. One belt was too long because it was anchored to the wheel well rather than to the floor on one side, adding 9 inches to the belt webbing (the wheel well was higher than the floor); this effectively prevented the child from securing the belt snugly around his body. A child safety seat was also secured by a knotted belt. (Other cases in the study also had knotted belts.)
Case 22	A passenger was restrained by a lapbelt and an improperly installed E-Z-ON vest: only the two upper loops of the vest were secured to the school bus floor. The lower loops were loose.

Table 3.--Examples of unusual passenger restraints and installations in small school buses (continued)

Type of school bus and case number	Unusual restraints and installations
<u>Type B (cont'd):</u> Case 24	<p>Passenger seatbelts were not installed, but the school bus contractor had jury-rigged two unusual restraints on two of the six bench seats. The first consisted of two lapbelt assemblies, joined together by two metal plates and secured with four bolts. The plates were exposed and the bolts protruded 1 3/8 inches. The restraint was looped around the junction of the seat-back and seat cushion and was designed to be placed around three children. Two children shared this "loopbelt" and an unrestrained child sat next to them on the same bench seat.</p> <p>The second restraint consisted of two belts: one was a form of shoulder strap and the other a large loopbelt. The shoulder strap was wrapped horizontally around the seat; the other belt was placed over it, like a large lapbelt encircling the seat. The lap portion of the restraint fit across the occupant's upper torso.</p> <p>Neither restraint was anchored to the seat frame or floor: they were merely wrapped around the seat frames.</p>
<u>Van not built to Federal school bus standards:</u> Case 27	<p>Lapbelts demonstrated a variety of unconventional installations: two belts shared an anchor point; lapbelts were all different lengths; and buckle-to-latch configurations were irregular.</p>

^a Type A school buses are required by Federal standards to be manufactured with at least a lapbelt at every passenger seating position.

^b Type B school buses are exempt from the lapbelt requirement. Type B buses, however, often are ordered with passenger lapbelts or are retrofitted with belts.

^c The National Transportation Safety Board has urged that only vehicles built to Federal school bus standards be used to transport pupils.

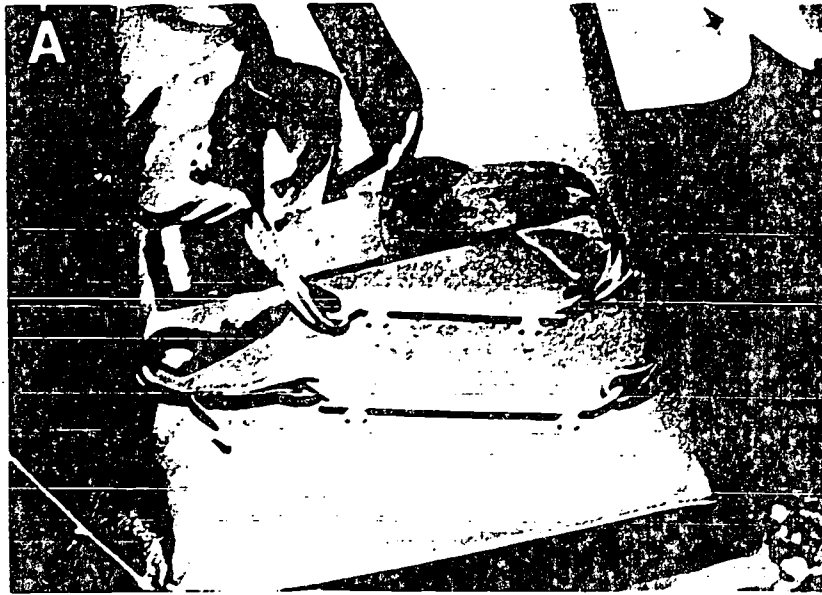

B

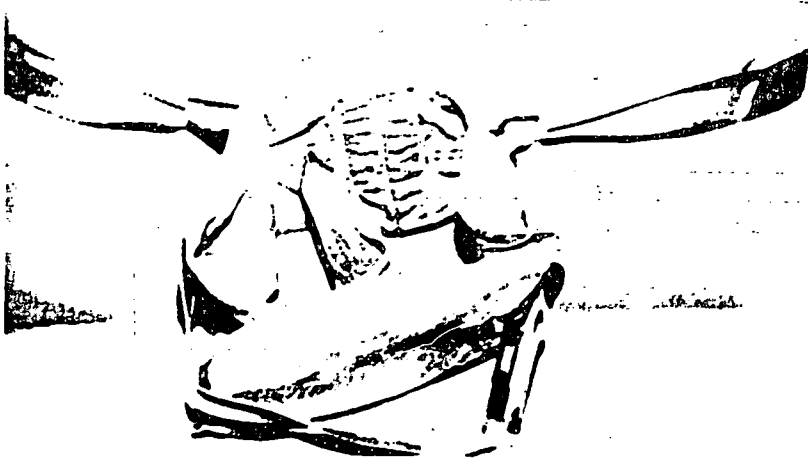

Figure 5.--Such "restraints" pose danger to the occupants. The jury-rigged loopbelt (A) and unusual three-point restraint (B and C) were found in case 24. Neither was secured to the seat or floor. Other examples of improper installation were shared seatbelt anchorages (D) and unusual configuration of buckles and latchplates (E).

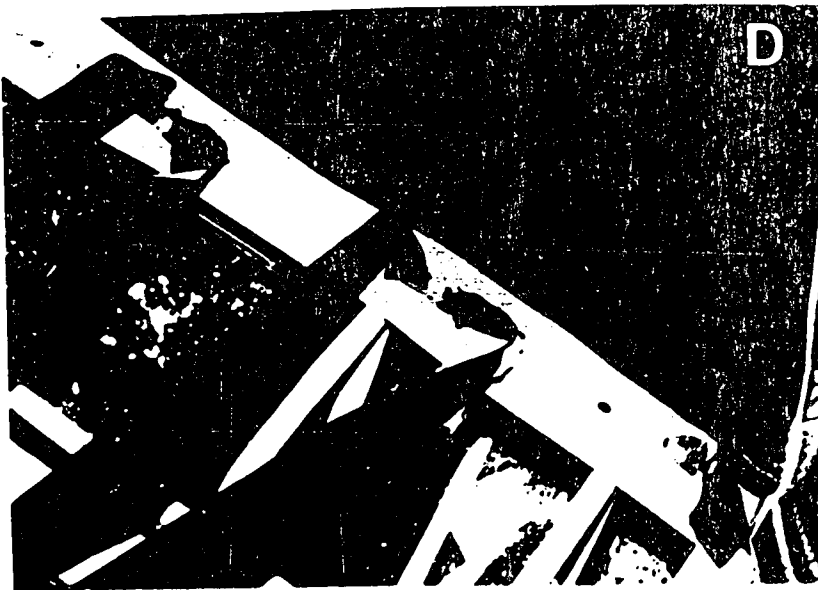
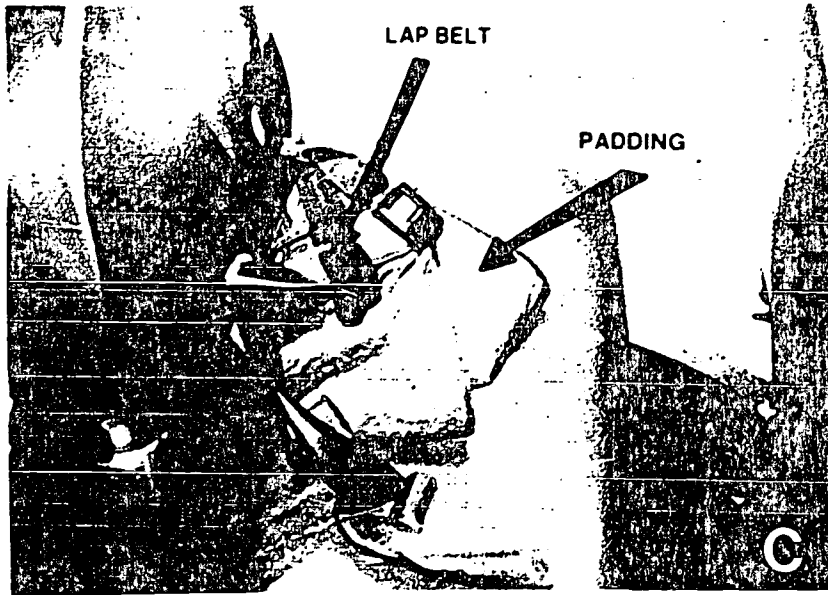

Figure 5 (continued).



Figure 5 (continued).

A restraint, by definition, is designed for use by one person only. Crash tests performed at University of Michigan Transportation Research Institute (Weber and Melvin 1983) have demonstrated a substantial increase in injury potential to occupants who share a seatbelt as they collide violently with one another. With a shared restraint, proper fit--crucial for good restraint performance--is impossible: the loopbelt cannot be properly positioned over the pelvic areas of two children.

Prior to this study, the Safety Board investigated cases involving large school buses (both prestandard and poststandard) that had been retrofitted with a form of these loopbelts. Regardless of the size of vehicles on which such belts are found, they are not restraints. They pose a danger to occupants and should be removed from the school bus.

Based on the occurrence and potential dangerous crash consequences of the unusual restraints and installations documented in these cases, the Safety Board believes that the National Association of State Directors of Pupil Transportation, the National Association of Pupil Transportation, and the National School Transportation Association should alert their members to the dangers of such systems and urge them to correct the installations. Students also need to be instructed in the proper use of restraints.

INJURY OUTCOME

Overall Passenger Outcome

Restraint use cannot guarantee that an occupant will be uninjured in a crash. Although restraint use was high in the Safety Board's cases, two-thirds of the passengers in small school buses built to Federal school bus standards were injured. Those who were unharmed included restrained and unrestrained passengers (cases 2, 3, 11, 12, 21, and 23). In some accidents, an unrestrained passenger was the only uninjured occupant in the vehicle; in others, a restrained passenger was uninjured.

Fortunately, when school bus passengers were injured, minor injuries were usually all that they received. For example, 122 of the 167 passengers in the case vehicles built to Federal school bus standards were known to be injured, but of these 122, 100 sustained minor injuries only. Few passengers, regardless of their restraint status, received more than moderate injuries (table 4).²²

Minor Injuries

The most common minor injury was a facial laceration, followed by contusion to leg or arm. Minor head and facial injuries were especially common among lapbelted passengers. Because a lap-only belt does not provide upper torso restraint, the upper body of the lapbelted passenger is free to move, in some situations more violently than an unrestrained passenger due to the jackknife effect. Lapbelted children also received minor abdominal contusions from the belt in several cases (cases 5, 6, 7, 12, 13, 17, and 22) (see footnote 22).

Moderate and Above Injuries

Only 22 of the 167 passengers received more than a minor injury. Moderate injuries accounted for half of these injuries. Unrestrained passengers were not overrepresented in these injuries. Of the 12 passengers sustaining moderate injuries, 7 were restrained, 4 were unrestrained, and restraint status was unknown for 1. The same pattern held true for the 8 passengers with serious injuries: 6 were restrained and 2 were unrestrained.

For more detailed analysis of the differences in injury outcome for restrained versus unrestrained passengers, the reader is referred to the case summaries in appendix B. The Safety Board did not conduct further numerical comparisons because of the small numbers of passengers in the study and the importance of crash severity in injury outcome. For example, one accident involved 2 1/4 revolutions in which 11 passengers were unrestrained; another case involved a minor head-on collision and 9 lapbelted passengers. These cases are too dissimilar in severity and crash dynamics to draw any comparisons about the

²² This outcome was not true in the cases involving school vehicles not built to Federal school bus standards (see appendix D). These crashes were generally more severe than those in which vehicles were built to school bus standards, and lapbelted students fared worse, sometimes incurring fatal lapbelt-induced injuries (case 26).

Table 4.--Injury outcome of passengers on vehicles built to Federal school bus standards investigated for this study^a

(By number of passengers)

Case number	Uninjured	Minor (AIS 1)	Moderate (AIS 2)	Serious (AIS 3)	Severe and above (AIS 4-6)	Unknown severity and unknown if injured (AIS 7)	Total
1		2					2
2	2	4					6
3	2	3					5
4	1	5	1				7
5	2	4	2				8
6		9					9
7		4	2	1			7
8	2						2
9	3						3
10	2	8	1				11
11	4	2					6
12	1	9	1				11
13		9					9
14	6	4	1				11
15	1	11	2	3			17
16	2	2	2	3			9
17		7			2 ^b		9
18	4						4
19	4	4					8
20	2	3					5
21	3						3
22	1	5		1			7
23	2	3					5
24	1	2					3
TOTAL	45	100	12	8	2	0	167

^a The school bus driver was fatally injured in two cases: 7 and 8. Drivers are not included in the table because their seat and surrounding environment is far more hostile than that of the passengers. The school bus driver, for example, has no passive protection and is exposed to the windshield, steering wheel, gear shift, and dashboard.

^b These two passengers were fatally injured: one passenger sustained MAIS 5 injuries that proved fatal; the other, MAIS 6 that proved fatal.

effect of restraint use. A more useful comparison is to look at the outcome for restrained versus unrestrained passengers in the same vehicle. Even within a single accident, comparisons based on restraint status can be misleading if the occupant's seating position and its relationship to the crash forces, intrusion, or other causes of injury are not considered.

Importance of Seating Position

Seating position, more than restraint status, appeared to influence injury outcome in most of the accidents investigated for this study.²³ Lapbelt use, however, appeared to have contributed to head injuries sustained by occupants of the front rows who faced a restraining barrier. In a frontal crash, a lapbelted passenger will jackknife over the belt and strike the barrier. Barrier design, or absence of a barrier, also may have led to injury for unrestrained passengers. In the cases investigated, two passengers in vehicles built to Federal school bus standards died from their injuries (case 17). One was lapbelted; the other was not. Interaction with an abbreviated restraining barrier aggravated their injuries.

Differences Between Safety Board and Police Accident Report Data on Injury Severity

Many law enforcement officials use injury classification systems that have very broad classifications for injuries, such as the KABCO scheme. In KABCO, for example, a broken arm and a broken skull are both coded as "A" (incapacitating) injuries, despite their vastly different threat to life. Internal injuries, such as intra-abdominal lacerations, are not likely to be coded at all.

Accident reports examined for this study that were filed by police or schools sometimes underestimated the severity of injuries sustained. In case 19, for example, the lapbelted school bus driver was listed in police records as having sustained minor injuries; the driver stated such to police immediately following the accident. These "minor" injuries ultimately prevented the driver from working for 48 days. Safety Board investigators determined that the driver had sustained at least moderate (AIS 2) injuries.²⁴

The KABCO coding classification also obscured important differences in injury severity among passengers. For example, in case 16, all nine passengers were listed in the police accident report as receiving "A" level (incapacitating) injuries. The Safety Board determined that the severity of injuries varied widely; two passengers were uninjured, two received minor injuries only, two sustained moderate injuries, and three were seriously injured.

²³ This study collected data on lapbelt performance in the crashes investigated for the study; it did not attempt to determine whether lapbelts could cause or prevent injury in noncrash situations. The 1989 survey of New York State school districts found that lapbelts can cause injuries in noncrash situations: 204 injuries resulted from seatbelt use: seatbelts were used as weapons, used to trip passengers, and metal splinters caused injuries. Seatbelt-related injuries increased 460 percent since the 1988 New York survey while the number of buses with seatbelts increased 38.6 percent.

²⁴ The driver had sustained deep contusions on her face from contact with the rearview mirror and deep contusions on her abdomen induced by the lapbelt (she had slipped off her seat during rollover but remained suspended by the belt webbing; the school bus had come to rest on its right side).

Safety Board investigators found that injuries, particularly minor injuries, often went unreported by the police. In case 10, for example, the police accident report listed 8 of the 10 students on the bus as uninjured. The Safety Board investigator determined that only two students were injured. In other cases, injury information on the police reports was inconsistent with the evidence: cases 1, 2, 5, 12, 13, 15, and 16. Minor injuries sustained by lapbelted passengers often were not reported.

Limitations of the KABCO injury coding system are illustrated in table 2 and in appendixes J and K.

School accident records also are not complete and do not provide detailed data on location or severity of injuries. Most school districts have an established policy that all school bus passengers involved in a crash, regardless of observed injury status, must be transported to an emergency room for examination. The hospital emergency room records then become the source of injury information. The Safety Board found instances when some parents, alerted by local news reports of the accident, drove to the crash site and took their child home or to the family physician for examination; injury information for such instances may not find its way into official school records. Then too, some injuries, such as muscle sprains or abdominal bruising, may not manifest themselves until days after the accident.

Uniform School Bus Accident Reporting Form

The reporting problems documented in this study are part of a larger concern: school bus accident and injury statistics, overall, are less than adequate for research purposes and hamper analysis of what safety countermeasures are needed and would prove most effective. For example, there is no standard definition of "school bus accident" or "school bus-related accident." Injury reporting is also widely divergent. For example, in 1987, Maryland reported that less than 10 percent of all school bus accidents resulted in injury. New York State, however, reported that 60 to 66 percent resulted in injury.

These shortcomings are not new. As a Congressionally funded Transportation Research Board study (Transportation Research Board, National Research Council 1989) pointed out, the Secretary of the U.S. Department of Transportation outlined the problem in 1977:

Wholly reliable information on school bus accidents is not readily available on a national basis. This is particularly true for nonfatal injury accidents, and even more so for accidents in which no injury is present. The information deficiency exists with respect to descriptive statistics as well as to accident-injury causation data; and it stems from both inadequate investigations at the accident site and the lack of a formal and systematic data collection and synthesis process to produce aggregated information.

Solutions do exist to some of the problem. The 1985 National Conference on School Transportation--a conference of State Pupil Transportation Directors, local school district personnel, contract operators, and advisors from the school bus industry--proposed a uniform school bus accident report form that would provide standardized reporting of school bus accident data throughout the school bus transportation industry. The Conference has adopted this form, but it is too soon to determine if school districts will use the standard form and generate the type of data useful to determine what types of accidents, nationwide, produce serious injuries to school bus passengers. (It will be vital that trained personnel complete the accident forms to generate accurate data.) Had this form been in use throughout the United States, the Safety Board would have been able to compare the performance of the Type A and Type B school buses in its investigations to the universe of accidents involving school buses of those types.

RESTRAINING BARRIERS

The forward portion of the interior of a school bus has many elements that can cause injury if contacted in a crash, including the stairwell, dashboard, windshield, and boarding door mechanism. The area immediately around the school bus driver is particularly hostile: the gearshift and steering wheel have the potential to inflict serious injury.

To prevent front row passengers from being thrown into this hostile environment, Federal standards mandate a restraining barrier, sometimes called a modesty panel, to be installed on a school bus with a GVWR more than 10,000 pounds. These restraining barriers are to serve the same function as seatbacks: to provide a form of built-in crash protection called compartmentalization.

A compartment is formed by the occupant's own seat and the back of the seat directly in front; the seats are required to cushion the passenger's body in a crash by "giving" in a controlled deformation and are required to remain firmly attached to the floor and sidewall. For occupants of front seats, a restraining barrier is substituted for the back of a seat in front. The barrier must meet the same requirements as seatbacks; that is, have the same spacing and dimensions and the same performance requirements under testing conditions specified in the standard.

Compartmentalization has been required on all Type B, C, and D school buses manufactured since April 1, 1977. Because compartmentalization is supposed to provide the crash protection needed by passengers, these buses are not required by Federal regulations to have lapbelts installed.

At least a lapbelt, however, is required to be installed by the vehicle manufacturer at every seating position in Type A school buses. Compartmentalization is not required on Type A school buses, and hence is incomplete or lacking on many Type A school buses. According to Federal standards, for example, a restraining barrier is not required in front of the first row seats. Seatbacks must meet the same requirements for height and head impact protection zone as do larger school buses, but there is no restriction on the maximum amount of space between seats.

In contrast, Canadian school bus safety standards require that all school buses, regardless of size, meet the same compartmentalization standards. All school buses must have front seat restraining barriers installed that meet all the requirements for seatbacks--padding, dimensions, and forward deflection performance. Occupant crash protection on all school buses is provided entirely by means of compartmentalization, and seatbelts for passengers are not required on any size school bus.²⁵

The result of the U.S. standard is that front seat occupants of Type A school buses have little, if any, built-in crash protection. Some Type A school buses have no frontal restraining barriers. Some manufacturers provide one or more barriers,²⁶ but without Federal standards, the barriers can vary in height, width, padding (or have no padding at all), and attachment strength.

²⁵ Canada does not recommend that lapbelts be installed for passengers. Crash tests conducted for Transport Canada in 1984 and 1986 suggest that lapbelt use by passengers, in all sizes of school buses, increases the chance of head injuries (Transport Canada 1985; Davis Engineering Limited 1986).

²⁶ Restraint barriers are required by many States and are written into their school bus specifications.

The Safety Board's 19 cases involving Type A school buses provided a variety of barrier configurations. Some buses had only one barrier, on the right side; passengers seated in the left front row faced directly into the driver's seatback.²⁷ Other buses had barriers on both sides of the aisle. Barriers differed widely in design, sometimes even on the same bus: some were free standing, others had stanchions reaching to the ceiling, still others consisted of a guardrail and stanchion only. Barriers also differed in the amount and location of padding (some were not padded, others were padded only on the lower portion of the barrier or on the guardrail only) and in size and shape (some barriers were narrower and lower than the seats)²⁸ (fig. 6). The presence of such objects directly in front of a seated passenger--either unrestrained or lapbelted--can present a hazard (and did in some of the accidents investigated for this study).

Crash Performance of Barriers

Consequences of barrier design.--Data are available in the case summaries in appendix B of the injury outcome for 47 front seat occupants of Type A school buses. The design of the frontal barrier is most crucial when frontal impact is involved because this is the crash configuration during which the body of the passenger in the front seat will most likely interact with the barrier. This study provided data on the body movements and injuries sustained by 30 passengers seated in the front rows of Type A school buses in accidents where frontal impact was the principal event. Of these passengers, 19 were restrained, and 11 were unrestrained.²⁹ In only one accident (case 17) were unrestrained and restrained passengers seated next to one another on the same front seat. Thus, other than in this case, the Safety Board was not able to compare directly the experience of lapbelted versus unrestrained passengers on the same front seat regarding interaction with the barrier.

When frontal barriers were present in Type A school buses, their design and placement allowed closed head injuries, sometimes of a serious nature, to occur to both lapbelted and unrestrained passengers in frontal crashes.³⁰ Furthermore, when barriers were not present, unrestrained front row passengers were thrown into the driver's seatback or into the front of the bus, sustaining injuries. Appendix C indicates the cases in which the absence or design of the restraining barrier was a factor in occupant injuries.

The recent school bus study issued by the Transportation Research Board estimated that only two to three passengers are killed annually while riding on a small school bus (Transportation Research Board, National Research Council 1989) (appendix L). The Safety Board's study presents data for six fatally injured passengers of small school vehicles, only two of whom were being transported by school buses built to Federal school bus standards. Both of these fatalities occurred on a Type A school bus and both involved interaction with a frontal restraining barrier. Details of the accident follow.

²⁷ In such a case, the driver's seatback would have to meet performance requirements for the head protection zone.

²⁸ In some Type A school buses with two restraining barriers, the barriers were of different heights (case 16, for example).

²⁹ Restraints included lapbelts and child safety seats.

³⁰ Closed head injury is the most common serious neurologic disorder in the United States, and even minor or moderate head trauma can cause long-lasting symptoms (Fisher 1985).

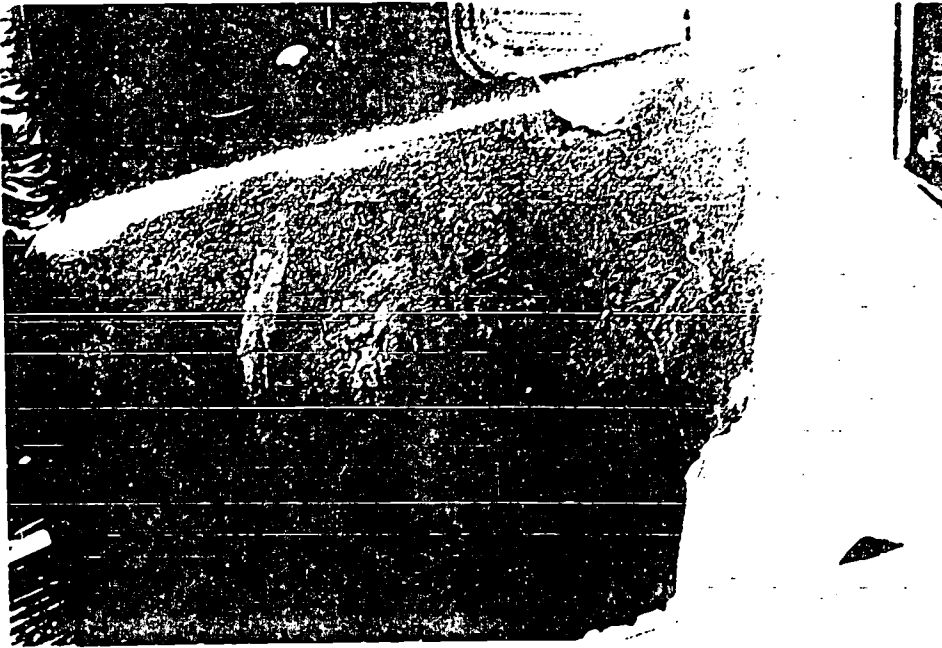

Figure 6.--The types of restraining barriers found in Type A school buses vary widely. Note the exposed bolts in the top photograph (case 3), and exposed metal guardrail near wall anchor in the bottom photograph (case 5). Both lapbelted and unrestrained passengers seated directly behind these barriers received facial and head injuries.

Both fatalities occurred in the same accident (case 17). A lapbelted and an unrestrained passenger³¹ were seated next to one another in the right front row, facing an abbreviated restraining barrier, which consisted of only a metal panel surrounded by a lightly padded, tubular steel frame. The barrier was about 9 inches away from the seat and was considerably lower and narrower than the seat it faced. The barrier measured 29 1/2 inches from the floor; the seatback was 41 1/2 inches from the floor. The barrier was 28 inches wide; the seat was 39 inches wide. A barrier so designed would not meet Federal standards for large school buses.³²

The small school bus had been slowly climbing a hill when it was struck head-on by an out-of-control truck that was overturning at an estimated speed of 40 mph. The bus was struck again on its left side as the truck rotated (fig. 7). During the crash, a 7-year-old in the front seat by the right window jackknifed over his lapbelt and struck the left side of his head and neck on the tubular frame of the modesty panel. He sustained maximum (AIS 6) injuries, including a lacerated larynx, a fractured and dislocated cervical spine, crushed spinal cord, and brain hemorrhage. He died instantly. A 17-year-old boy in the center front seat received critical (AIS 5) injuries, including a head injury and fractured left femur and right tibia. He died several days later. This passenger was found in the stairwell by rescuers; Safety Board investigators determined that he had struck the left side of the restraining barrier while moving forward and to his left, catching his right leg on the abbreviated barrier and pivoting around it. The barrier could not contain him. He then continued forward into the boarding door control, fracturing his left femur, and into the windshield header, where he sustained a fatal head injury (fig. 8).

The school bus also had a restraining barrier on the left side, of different design. It had no panel but only a lightly padded stanchion post and horizontal bar, level with the top of the driver's seatback. An unrestrained 3-year-old sitting directly behind the driver was propelled against the driver's seatback during the crash and was found lying on the floor underneath the driver's seat following the crash. Fortunately, the child received only minor injuries.

Case 17 was the only accident investigated by the Safety Board in which the design of the restraining barrier contributed to fatal injuries. However, survivors in other cases were injured by interaction with the barrier as well. For example, the design of an abbreviated restraining barrier on the right side of the Type A school bus in case 15 may have allowed an unrestrained adult aide

³¹ Throughout this report, discussion is based on the restraint status and body movements of injured students as determined by the Safety Board investigators. Restraint status frequently differed from that reported by police and the media. For example, in case 17, one of the fatally injured passengers, originally reported in official accounts as unbelted, was determined by the Safety Board as restrained. The coroner reported lapbelt-induced bruises on the victim's pelvis. In addition, this fatally injured 7-year-old was reported by media as being found in the stairwell; he was actually found seated in a bench seat, restrained by his lapbelt.

³² Restraining barriers in Types B, C, and D school buses are required to be equal to, or larger, than the facing seat.



Figure 7.--Damage to the small school bus in case 17 was mainly to the left front, yet the fatally injured passengers were seated on the right. Passengers on the left side received minor or no injuries; restraint status did not influence the injury outcome for passengers on the left side.

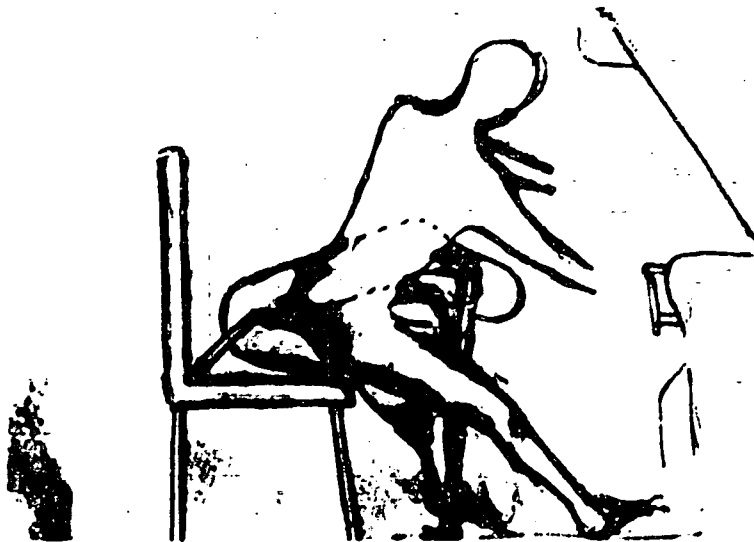

Figure 8.--Artist's sketch of body movements of the two fatally injured passengers in case 17 at the moment of initial impact.

to sustain a fractured pelvis. Like the 17-year-old boy in case 17, the driver's aide was found in the stairwell following the crash. A metal panel, framed by lightly padded tubular steel, was positioned between the right front seat and the stairwell, but it did not extend far enough to prevent the unrestrained aide, seated on the aisle seat of the right front row, from being thrown forward during the frontal impact. She struck the boarding door control and fell into the stairwell.

Risk of head injury.--In the Safety Board's cases, lapbelted passengers appeared to be at risk of more serious head injuries from barrier contact than did unrestrained passengers. This finding is consistent with the crash dynamics for a lapbelted passenger versus an unbelted passenger in a frontal crash. In a frontal crash, the lapbelted passenger, restrained by the belt around the pelvis, will pivot forward, striking the barrier with head or neck as he or she jackknives forward. In contrast, the whole body of an unrestrained passenger would move forward and impact the barrier. In general, when forces of impact are spread out rather than concentrated on one area of the body, they are less injurious.

In addition to the fatal head injury in case 17, nonfatal head injuries were also sustained by lapbelted passengers in Type A school buses involved in frontal crashes. Examples follow:

Case 15. A lapbelted 5-year-old passenger seated in the right front row, by the window, sustained a serious (AIS 3) closed head injury, and contusions to his forehead and left side of face from contact with the restraining barrier. He jackknifed into the abbreviated barrier in front of him when the small school bus struck a passenger car with its left front, at an estimated speed of 50 mph (fig. 9). A lapbelted 5-year-old passenger seated on the left front row sustained moderate (AIS-2) closed head injury, probably from contact with the driver's seat back; no barrier was present.

Case 12. Both restraining barriers were closer in size and appearance to the type of barriers in large school buses, but only an inch of styrofoam padding covered the wooden frame on the side facing the passengers. When the school van struck a fixed object head-on (21.7 mph Delta V) and then rolled onto its side, a 5-year-old lapbelted passenger seated on the aisle in the right front row jackknifed forward and struck the barrier, sustaining a moderate concussion. This injury was the worst sustained by any passenger, restrained or unrestrained, in the van. A lapbelted passenger seated next to him, by the window, received abrasions and contusions to his head, and one of the two lapbelted passengers in the left front row also sustained minor head injuries from contact with the barrier.

Case 5. When the school van, traveling 29 mph, struck a passenger car head-on, the two lapbelted passengers, ages 10 and 11, in the right front seat pivoted forward and hit the lightly padded crossbar of the barrier. The barrier consisted of a panel supported by stanchion and crossbars (see figure 6). One passenger received a concussion, and the other, a closed head injury.

In still other accidents, lapbelted and unrestrained passengers sustained minor head and facial injuries from contact with the restraining barriers. Most involved minor crash forces, as in case 3 (Delta V 9.5 mph).

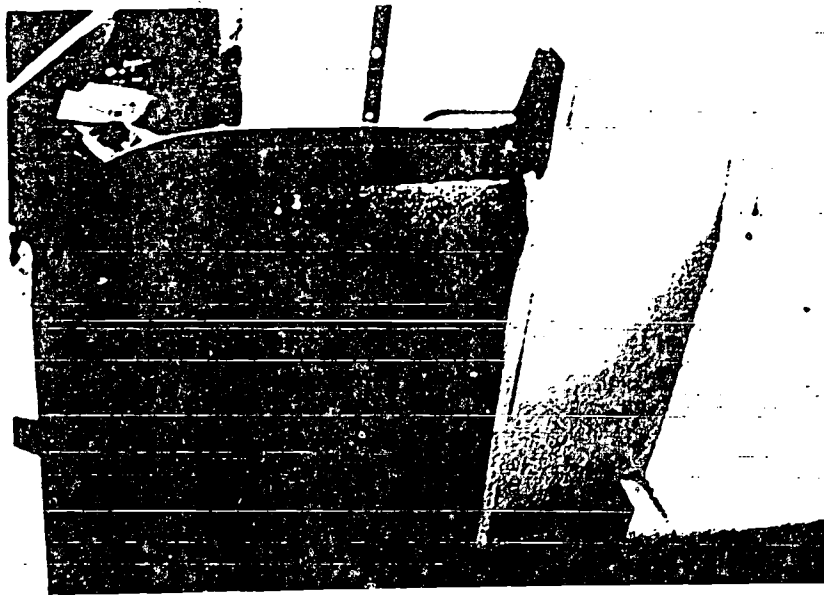

Figure 9.--This abbreviated restraining barrier was on the right side of the Type A school bus in case 15. No barrier was on the left side. The passenger seated behind the barrier next to the window sustained a serious concussion when he jackknifed over his lapbelt, striking his head on the barrier. The unrestrained passenger seated next to him on the aisle was not contained by the short barrier and was flung forward, fracturing his pelvis.

Canadian crash tests on risk of head injury.--Crash tests conducted for Transport Canada also suggest that lapbelted passengers seated behind a restraining barrier, regardless of whether it meets large school bus standards or not, would be at increased risk of head injury compared to unrestrained passengers in the same vehicle (Transport Canada 1985; Davis Engineering Limited 1986). The 1984 tests used three different sizes of school buses in 30-mph frontal crashes. Lapbelted anthropomorphic dummies registered higher head injury scores (usually three times higher) than unbelted dummies, especially on the smaller school vehicles. The difference was particularly marked for anthropomorphic dummies in the front row, the positions that had restraining barriers facing them. (Because the tests used Canadian buses, the restraining barriers on small buses also met the same standards for barriers in large school buses.) The lapbelted anthropomorphic dummies also showed severe rearward neck flexure after striking the seatbacks or restraining barriers with their heads.

Two of the three school vehicles tested were Type A school buses. The lapbelted anthropomorphic dummy in the front row of the Type A school van conversion registered a head injury criteria (HIC) of 2,016 compared to 369 for the unbelted anthropomorphic dummy next to it.³³ In the Type A small school bus, the lapbelted anthropomorphic dummy in the front seat measured a HIC of 2,505 compared to 893 for the unbelted anthropomorphic dummy (fig. 10).

Almost all of the crashes investigated by the Safety Board involving Type A school vehicles were probably lower in severity than those in the Canadian crash tests, but the accident investigations as a whole do suggest that lapbelted passengers in the front seat run the risk of head injury from contact with a restraining barrier.

Anchorage strength for restraining barriers.--In the Transport Canada crash tests, researchers documented that the frontal barriers in Type A school buses tore loose from their anchorages or became dislodged (Transport Canada 1985).³⁴ In the Safety Board's study on small school buses, this occurred in cases 7, 10, 16, and 17 (fig. 11). The anchor points of restraining barriers in Type A school buses in the United States do not have to meet any Federal performance standards.

Criteria for head protection.--Because head injuries potentially have serious consequences on a child's cognitive and behavioral development, the Federal Government has established performance requirements for passenger head and face protection as they pertain to school bus seats and restraining barriers. These requirements are written in FMVSS 222 and apply to all sizes of school buses. Hence, front seat passengers of Type A school buses in the Safety Board's study faced barriers that satisfied Federal head protection requirements.

The standard head protection test consists of a head form device weighing 11 1/2 pounds striking any "contactable surface" within the "head protection zone" at one of two specified velocities for impact. (See figure 12 for the dimensions of this zone. The sidewall, window, and door structure are excluded from the head protection zone.) At the high impact velocity (22 feet per second, close to Delta V 15 mph), the deceleration of the center of gravity must be such that the HIC value is less than 1,000.

³³ HIC is a measure of the forces the head experiences during the crash. It does not measure injury to the neck or facial laceration. The higher the HIC score, the greater the likelihood of serious or fatal injuries. The Federal Government requires that cars equipped with automatic restraints not exceed a HIC of 1,000 in 30 mph crash tests. Individuals, however, have a wide range of tolerance to injury. Consequently, although there are relationships between dummy test results and actual injuries, there is no single cutoff point for serious injury or death. Higher scores indicate a higher potential risk and lower scores indicate a lower potential risk. In addition, even a moderate head injury can have long-term effects on memory and learning ability.

³⁴ The anthropomorphic dummy in the school van used in the tests contacted the forward restraining barrier, the barrier's anchorage bolts pulled out of the floor, and the dummy was then hurled forward into the dash and windshield, and came to rest in the stairwell. Transport Canada concluded the dummy would have been contained within the seating compartment had the barrier not pulled loose from its anchors.

BEST COPY AVAILABLE

DUMMY NUMBER	LOCATION IN BUS	SEAT SPACING (inch)	LAP BELTED	UNBELTED	MIC	CHEST ACCELERATION (g)	
1	Front LH	21	X		2,505	40.1	SMALL SCHOOLBUS (less than or equal to 10,000 GVWR) THOMAS MINOTOUR 22 PASSENGER Vehicle Wt. 8,874 lbs. Vehicle Velocity 29.42 MPH Vehicle Decel. 19.5 g Dynamic Crush 28.7 in. Body Slide 15 in.
2	Front RH	21		X	893	47.9	
3	Centre LH	26 1/2	X		1,144	30.6	
4	Centre RH	26 1/2	/	X	741	39.0	
5	Rear LH	24	X		1,173	42.4	
6	Rear RH	24		X	494	44.9	
1	Front LH	21 1/2	X		2,016	32.5	SCHOOL VAN BUILT RE SCHOOLBUS STANDARDS (van conversion) CAMPWAGON 10 PASSENGER Vehicle Wt. 6724 lbs. Vehicle Velocity 29.44 MPH Vehicle Decel. 49 g Dynamic Crush 19.5 in. Body Slide 0
2	Front RH	20 1/2		X	349	21.1	
3	Centre LH	26 1/2	X		2,195	32.2	
4	Centre RH	27		X	846	42.0	
5	Rear LH	24 1/2	X		1,711	37.5	
6	Rear RH	24 1/2		X	607	24.4	

MIC is a measure of the forces the head experiences during the crash. It does not measure injury to the neck or facial laceration. The higher the MIC score, the greater the likelihood of serious or fatal injuries. The Federal government requires that cars equipped with automatic restraints not exceed a MIC of 1,000 in 30 mph crash tests. However, individuals have a wide range of tolerance to injury. Consequently, although there are relationships between dummy test results and actual injuries, there is no single cutoff point for serious injury or death - higher scores indicate a higher potential risk and lower scores indicate a lower potential risk.

Chest deceleration is a measure of the amount of force the belted dummy's chest experiences during the crash impact. Higher chest deceleration scores indicate that it is more likely that occupants will sustain serious internal injuries. The score is given in gravitational units (G's). Cars equipped with automatic restraints must not exceed 40 G's in the 30 mph compliance tests.

Figure 10.--Summary of Transport Canada 1984 frontal crash tests involving Type A school buses. (Adapted from Transport Canada 1985.)

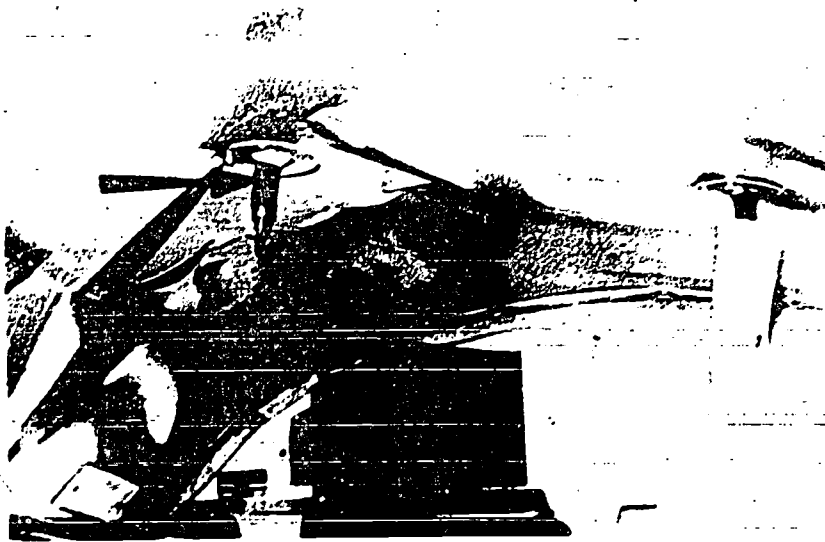

Figure 11.--A sharp projectile was exposed (arrow) when the anchor point for a restraining barrier in the Type A school van separated (case 10). No unrestrained passenger, fortunately, struck the area of the roof during the 270° rollover (10 of the 11 passengers were not using the available lapbelts at the time of the crash).

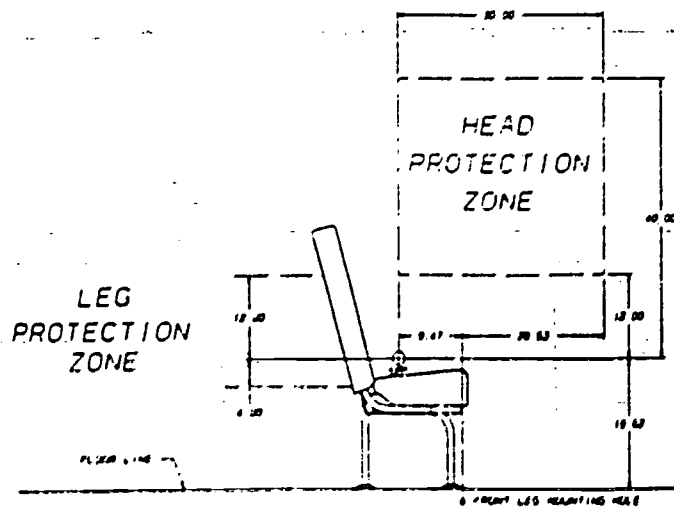

Figure 12.-- The dimensions of the head and leg protection zones apply to all sizes of school buses.

A study done for Transport Canada, however, indicates that the validity of this criterion is questionable (St. Laurent 1983). Earlier research, in 1979, reported on tests in which prestandard school bus seats with and without any extra padding were struck in a manner conforming to the test requirements of FMVSS 222. All impacts directly against the metal crossbar also produced results of HIC values less than 1,000. The Safety Board believes the head protection criteria may need to be revised.

Lack of criteria for thorax or abdominal injury.--In contrast to head injuries, the Federal Government currently has no criteria for abdominal, spinal, or thorax injuries. Researchers do not know what the thresholds for these injuries are; that is, how much force and at what duration to these regions of the body will result in serious or fatal injuries. The Hybrid III dummy can measure thoracic forces, but what it means in terms of human injury is unknown. No dummy currently has been approved by the Federal Government for recording abdominal pressure. The lack of appropriate anthropomorphic dummies and injury criteria hampers researchers in discussion of neck, spinal, and abdomen injuries in relationship to lapbelt use and barrier design. For example, the fatal neck injury sustained by the lapbelted passenger in case 17 probably could not have been predicted from available crash data: the Canadian crash tests did not measure thoracic forces.

One manufacturer, Thomas Built Buses, has conducted a series of crash tests using a Type A school bus that suggest lapbelts on small school buses may have the potential to inflict serious abdominal injuries, whereas lap/shoulder belts do not. In May 1986, Calspan, the company Thomas contracted to conduct the tests, crashed a 1986 Minotour bus into a frontal barrier at about 30 mph. In this test, two 6-year-old dummies and one 5th-percentile adult dummy were used. One of the 6-year-old dummies was secured only by a lapbelt; the other 6-year-old dummy and the adult dummy were secured by lap/shoulder belts. Load cells were placed on the belts to record the forces exerted on the abdomen and pelvis.

On the 6-year-old dummy wearing the lapbelt only, tension forces in the lapbelt during the crash translated into "direct lap abdominal total pressures of 1,768 pounds at peak and in excess of 1,200 pounds on the lap or abdomen for a significant time period" according to Calspan (Calspan 1986). For comparison, the director of engineering for Thomas Built Buses offered an auto investigation involving a 128-pound adult female in which 1,573 pounds of abdominal pressure resulted in injuries which included tearing of the liver and lacerations of the colon (Césari and Ramet 1979). The dummy wearing the lap/shoulder belt, registered much lower belt forces. The belt forces translated into "lap abdominal pressure 44G at peak and above 300 pounds for a significant period of time."

In the Safety Board's cases involving school buses built to Federal school bus standards, no lapbelted passenger sustained more than a minor abdominal injury from the lapbelt. This was not the case, however, in the few accidents involving school vehicles not built to Federal school bus standards investigated as part of this study. These accidents were all of greater crash severity than those involving school buses built to Federal standards. It may be that higher crash forces, not the difference in vehicle configuration, were responsible for the lapbelt-induced abdominal and spinal injuries. Cases are too limited in number to draw conclusions. The crash test conducted for Thomas Built Buses using a Type A school bus with abdominal sensor on the belted anthropomorphic dummy suggests that further testing is needed.

Possible Solutions to the Problem of Restraining Barrier Design

The interior (that is, the seating design) of a small school bus must provide crash protection to both lapbelted and unrestrained passengers. A basic problem occurs, however: many approaches to ameliorate the chance of more-than-minor head injuries sustained by lapbelted passengers from interaction with the restraining barrier (or seatbacks) appear to compromise or negate the compartmentalization that protects unrestrained passengers. Some options to resolve this problem appear more promising than others; a variety of approaches appear below.

Removal of restraining barrier.--Although removing the barrier may appear, at first glance, to be the easiest solution, the Safety Board does not consider this an option. Unrestrained passengers need a barrier for crash protection, and there will be unrestrained passengers in small school buses despite the availability of seatbelts. Some passengers in the front rows will not wear the available lapbelts or the lapbelts may be vandalized. In case 4, for example, an unrestrained passenger seated in the left front row was thrown forward into the stairwell, fracturing his leg. The school van had no restraining barriers and the lapbelt at his seating position had been vandalized by students and was inoperable. This accident occurred in California, but data from New York and other States suggest that vandalism is not an isolated occurrence.³⁵

If a school district has school buses without frontal restraining barriers in its fleet, it is imperative that district personnel ensure that front seat passengers wear the available seatbelts. School bus drivers and aides should place special emphasis on the need for front seat passengers to be restrained whenever the bus is in motion; the lapbelt is their only crash protection.

Redesign of barrier.--The 1984 Canadian crash tests suggest that merely requiring the restraining barriers in Type A small school buses to meet the same standards required for restraining barriers in larger school buses (essentially the same performance and design requirements as for seatback) will not suffice. Lapbelted passengers sustained unacceptable head injury scores. The Safety Board's accidents involving Type B school buses do not shed light on the problem. The Safety Board investigated only five accidents involving Type B school buses, small school buses built to standards for large school buses and hence have restraining barriers identical to those found in large school buses. The small number of accidents, only two of which did not involve rollover, did not yield data for comparison. The design of the restraining barrier, in terms of crash consequences for lapbelted passengers, will be most crucial in a frontal crash because of the "jackknifing" reaction of lapbelted passengers.

Changes in Spacing. Changes in seat spacing conceivably would lessen the possibility of harmful interaction for lapbelted passengers, but compartmentalization, which relies on closely spaced seats and closely spaced restraining barriers to provide built-in protection to unrestrained passengers, could be compromised. It is not clear by how much distance the spacing could be increased.

³⁵ Fairfax County, Virginia, for example, reported the vandalization of seatbelts and the theft of buckles as a major problem: "Hundreds of belts have already been replaced, over 500 in the last two months alone." (Letter from C. Frank Dixon, Director of Transportation Services, Fairfax County Public Schools to the Transportation Research Board, October 2, 1987.)

Increasing seat spacing to 40 inches, as originally proposed by the Department of Transportation (DOT) for use with lapbelts and suggested by some studies as the minimum spacing needed for lapbelted passengers on a school bus, would negate the protection compartmentalization provides to unrestrained passengers. Increasing the seat spacing by smaller increments, with the intent of maintaining compartmentalization, may also not ameliorate the problem. The 1984 Canadian crash tests experimented with various seat spacing (20, 21, 24, 26, and 27 1/2 inches), but found that in all practical seat spacing, lapbelted passengers still sustained higher and unacceptable head injury scores than did unrestrained passengers (Transport Canada 1985).

The relevancy of the Canadian school bus crash tests have been criticized, and dismissed by some, on several grounds, including the facts that the tests did not use a Hybrid III anthropomorphic dummy with its greater biofidelity and that researchers used the adult Head Injury Criterion (HIC) of 1,000 as the threshold for serious and above head injuries. The Safety Board is not comfortable dismissing the Canadian test results on these grounds.

The anthropomorphic dummy used in the Canadian tests was a reasonable facsimile of student bodies, and the type of dummy was similar to those currently used in U.S. car crash tests. The Hybrid III dummy is currently an option only in certifying compliance with FMVSS 208; no date has been set by which the Hybrid III must be the standard dummy.

No Hybrid III dummies approximating a school-age child have been accepted by DOT for compliance testing; scaled-down adult dummies are used (5th-percentile adult female dummies are used because they have body mass apportionment closer to child; that is, top heavy).

Critics of the Canadian tests have suggested that a HIC of 2,000, instead of 1,000, would have been more reasonable for children (Transportation Research Board 1989). The U.S. Government currently uses a HIC of 1,000 as injury threshold in its testing of child safety seats and in all occupant protection tests. There is no agreement as to what a suitable HIC for children may be because children have thresholds to head injury that vary dramatically according to age (Dejeammes and others 1984, Foust and others 1977, Snyder 1969, Snyder and others 1977, Stürtz 1980). Allowing a higher HIC than 1,000 could have potentially fatal consequences to teenage passengers who have adult tolerances; adult aides on board school buses also would be at risk of head injury. The Safety Board also notes that New York--the only State to mandate that all school buses, regardless of size, be equipped with lapbelts for passengers--has required extra padding in the seats such that when tested, the HIC must not exceed 800, a lower, not higher, threshold.

Increased Padding. Additional padding on restraining barriers (and seats) may ameliorate chances of head injury. What thickness, material, and location of padding is necessary is not clear. In 1986 tests for Transport Canada, the thickness of energy absorbing foam in the head impact area was increased to see if increased padding would reduce the severity of head impacts for lapbelted passengers (Transport Canada 1987). Two foam densities were used: a denser, high energy absorbing foam was used around the seat frame, and a less dense foam between the inner foam and seatback upholstery. The extra foam was localized at the top of the seat and part way down the back.

The performance of these contoured padded seatbacks was tested using instrument-equipped lapbelted anthropomorphic dummies (5th-percentile adult female dummies). Head-on and oblique sled tests were conducted at 30 mph. The HIC results were essentially the same for the standard, unaltered seatback (Transport Canada 1987) (fig. 13).

Less Aggressive Barrier. Another possible approach to reducing head injuries from interaction with a barrier is to design the barrier to be more "forgiving"--that is, to deform more readily when struck. Research is necessary to determine if this approach has promise. The 1986 Canadian sled tests tested a less aggressive seatback in combination with a lapbelted anthropomorphic dummy and found the HIC remained essentially the same (Transport Canada 1987) (see figure 13). (Peak head acceleration was, however, substantially lower and chest acceleration also somewhat lower than for the unaltered seat.)

Height. Height of the barrier is another factor that needs to be re-examined. Perhaps the barrier must be 28 inches from the Seating Reference Point; certainly it should not be lower in height than the seat it faces, as some frontal barriers were in the Safety Board's cases.

Examination of Entire Seating System. The entire seating system must be examined as a unit to provide maximum protection for a passenger. The Transportation Research Board study (Transportation Research Board, National Research Council 1989) summarized the problem as follows:

Any attempt to characterize the safety of school bus seats by a single factor (e.g., seat back height or seat spacing) is overly simplistic.

FMVSS 222, as now written, does not appear to provide the same level of protection for passengers in the front seats on a Type A school bus as it provides for passengers in the front seats on larger school bus (Types B, C, and D). This holds true whether the passenger is lapbelted or unrestrained. The 1984 and 1986 Canadian tests suggest to the Safety Board that all aspects of restraining barriers--location, size, spacing, and anchorage strength--should be reconsidered in light of their interaction with the body movements of lapbelted passengers (see figures 10 and 13).

Research clearly is needed to determine the optimum design of restraining barriers in Type A school buses. In the meantime, if school districts order small school buses with barriers, they are advised to order buses with barriers more closely approximating those currently installed in a larger school bus. These barriers probably provide protection superior to the exposed metal rail, poorly padded, or abbreviated barriers seen in the Safety Board's cases. Restraining barriers also should be provided for both the left and right front seats.

Installation of Lap/Shoulder Belts.--Installation of lap/shoulder belts, instead of lapbelts, for passengers in the front row, or at all seating positions, would immediately lessen the chance of injurious head contact with the barrier or seatback, regardless of seating design. Lap/shoulder belts provide upper torso restraint that lapbelts do not. A lap/shoulder-belted passenger will not jackknife forward in a frontal crash: the upper body is restrained. Lap/shoulder belt use would also lessen the chance of abdominal injury compared to lapbelt use, because the restraining force is spread out over a larger portion of the body.

HEAD AND CHEST ACCELERATIONS AND HIC VALUE

SEAT SERIES	HEAD ON IMPACT			OBLIQUE IMPACT		
	Resultant Peak Head Accel (g)	Resultant Peak Chest Accel (g)	HIC	Resultant Peak Head Accel (g)	Resultant Peak Chest Accel (g)	HIC
Unaltered	199.8	1116.6	58.9	227.6	1181.4	79.8
Contoured Padded	200.4	1082.0	71.6**	92.1	1154.9	68.2
Less Aggressive	114.9	1079.8	48.6	145.4	1423.8	65.0
Rearward Facing	59.1	275.6	35.1	58.8	309.2	35.4
Three point	58.2*	634.6	60.3	88.5*	917.6	72.2**
Multi point	184.3*	558.8	63.3**	217.7*	834.5	68.7**

Notes: * Peak acceleration occurs in secondary impact.
 ** Value exceeded 60 g for more than 3 milliseconds.

MAXIMUM SEAT BELT LOADS (lbs)

SEAT SERIES	HEAD ON IMPACT				30° OBLIQUE IMPACT			
	Left Lap	Right Lap	Left Shoulder	Right Shoulder	Left Lap	Right Lap	Left Shoulder	Right Shoulder
Unaltered	1967	1953	-	-	2070	2221	-	-
Contoured Padded	2126	1396	-	-	2608	1838	-	-
Less Aggressive	1505	1509	-	-	2030	1626	-	-
Rearward Facing	85	76	-	-	116	142	-	-
Three-Point	1930	1324	-	1147	2257	1279	-	N/A
Multi-Point	1373	1669	724	840	1534	1710	616	1163

MAXIMUM FEMUR LOADS

SEAT SERIES	HEAD ON IMPACT		30° OBLIQUE IMPACT	
	Left Femur Load (lbs)	Right Femur Load (lbs)	Left Femur Load (lbs)	Right Femur Load (lbs)
Unaltered	397	334	313	588
Contoured Padded	714	1555	831	708
Less Aggressive	594	1685	869	497
Rearward Facing	518	522	313	395
Three Point	2350	1456	1389	346
Multi Point	2324	2181	1647	508

Figure 13.--Results of Transport Canada 1986 sled tests.
 (Source: Transport Canada 1987.)

Rulemaking is underway that may result in lap/shoulder belts being available for certain school bus passengers. In response to the Safety Board's lapbelt study (National Transportation Safety Board 1986), the National Highway Traffic Safety Administration (NHTSA) has issued an Advance Notice of Proposed Rulemaking to require lap/shoulder belts at all outboard seating positions in passenger vehicles. This requirement would include Type A school buses. The Safety Board is pleased that rulemaking is underway. If lap/shoulder belts are installed and used, some of the danger of interacting with school bus restraining barriers (and seatbacks) will be lessened for window seat passengers. Passengers sitting in the middle or the aisle positions, however, will still have only a lapbelt available.

Research is needed to explore whether it is technically feasible to install lap/shoulder belts at all seating positions. It may be that current Federal standards mandating school bus seat design, seatbelt anchorage and installation, and school bus joint strength will have to be somewhat modified to permit installation of lap/shoulder belts. Certain questions will have to be answered, including:

- Where can the shoulder harness be mounted?
- If the shoulder harness must be attached to the seatframe, can added padding compensate for the increased "stiffness" of the frame Canadian researchers and U.S. manufacturers believe will be necessary?
- Can proper geometry of the shoulder belt attachment points be maintained?
- Will bus seating capacity be altered?

Multipoint restraining systems--that is, four- or five-point harnesses--do not, at first glance, appear to be suitable alternatives to lap/shoulder belts in terms of restraint for able-bodied passengers. Installation problems would exist and passengers may be less likely to use the restraint because harnesses can be cumbersome and difficult to put on and adjust properly. Transport Canada reported instances of submarining out of four-point harness systems during its 1986 sled tests of different seating concepts in frontal and oblique (30 degrees from head-on) impacts (Transport Canada 1987). A new development, a form of restraining bar manufactured by Transportation Equipment Corp., offers promise. The chest-high padded restraining bar functions as a "mechanical air bag" and appears to offer increased protection against head injury for lapbelted and unrestrained passengers in a frontal crash.

Rear-facing seats.--Rear-facing seats, perhaps with slightly more padding and higher seatbacks than currently mandated by U.S. or Canadian standards, appear to be a promising solution to problem of providing crash protection to both lapbelted and unrestrained passengers. In a frontal crash, lapbelted and unrestrained passengers in rear-facing seats would accelerate backward at initial impact into the seatback, absorbing crash forces over their entire back. Although lapbelted passengers might experience head contact with the seatback in front of them on rebound, this force is considerably less than the initial impact.

No revision in Federal standards would be necessary to implement this option. Small school buses (GVWR of 10,000 pounds or less), unlike larger school buses, are not required to have forward-facing seats. Therefore, States and school districts can order Type A school buses with rear-facing seats, either throughout the bus or for front rows only. Furthermore, because Federal standards set the minimum requirements only, seats can be ordered that have higher seatbacks or more padding than currently mandated.

The 1986 Canadian sled tests showed a substantial reduction for rear-facing seats in all recorded injury criteria compared to the standard, unaltered school bus seat (Transport Canada 1987) (see figure 13). Indeed, head injury scores were very low (a HIC of about 300), below all other test conditions.

Partly from the results of these sled tests, the Canadian government began a demonstration program that involved three school buses equipped with rear-facing seats. The buses were operated in four cities during the 1987-88 school year. Each school district using the buses was asked to record acceptance of, and attitudes toward, the rear-facing seats, as well as other pertinent information from students or parents that might aid in the evaluation of the system. The published findings from these field tests are not yet available.

Discussions with representatives of Transport Canada indicate that the two major concerns associated with rear-facing seats--motion sickness and pupil management--did not become major problems. Although some of the older children complained of motion sickness when riding in rear-facing seats, the younger children did not, which suggested that rear-facing seats might be phased into school bus fleets beginning with buses serving elementary grades.

Summary

This study cannot provide a clear answer for how to resolve the restraining barrier problem. The accidents investigated for this study document that a problem exists in Type A school buses, but they do not provide enough data for the solution. A case study provides accurate and comprehensive data on each case in contrast to other data sources. However, because of the limited number of cases and many variables that influence injury outcome (for example, crash configuration and severity, barrier design, restraint status, seating position, passenger size and age), a case study cannot isolate the variables. All variables interact to influence injury outcome.

For example, this report provided data on 19 accidents involving Type A school buses. Limited data on the relationship between restraining barriers and injuries became available. Some of these vehicles had no frontal barriers; others had only one. If two barriers were present within the vehicle, they often varied widely in design. Barriers differed in configuration, height, width, spacing from the front seat, and amount of padding. The front seat often is not the first choice of student passengers as a desired seating position, so few passengers faced the restraining barrier. Even if the Safety Board continued to conduct in-depth investigations of Type A school bus accidents, the lack of data would persist.

Accident data files maintained at the State or Federal level will not provide needed data. Aside from the inaccuracies of restraint and injury status noted in this report, such files do not record seating position (hence, the researcher has no way of knowing what passengers were seated in the front rows), nor do they record whether the school bus was a Type A vehicle. Without tracing the Vehicle Identification Number (VIN), a researcher cannot know what type of frontal barrier, if any, was present in the bus. Even determining the make and model of the small school bus will not reveal this information because States and local school districts often order small school buses with custom options; for example, a specific type of frontal barrier.

Hence, the Safety Board believes that the NHTSA should conduct research to determine the relationship between restraining barrier design and injuries to unrestrained and lapbelted passengers of different sizes. Research should focus on the height, width, location, and anchorage strength of the barrier, and the spacing between the barrier and front seats. (Resultant data should help determine the optimum design for seating throughout the bus.)

Computer simulation may be needed to manipulate the many variables that influence injury outcome. Researchers will be hindered by the lack of accurate real world injury data and data from crash tests using instrument-equipped anthropomorphic dummies on which to model injury outcome. However, variables such as barrier spacing, height and width, and passenger restraint status and size can be easily manipulated in computer simulation.

Little crash test data are available for poststandard school buses of any size. The Safety Board acknowledges the high cost of conducting full-scale bus crash tests using instrument-equipped anthropomorphic dummies. Sled tests offer a less costly alternative and an opportunity to test whatever barrier design appears most promising. Hybrid III dummies should be used in any sled tests conducted to provide state-of-the-art biofidelity, and force readings should include thorax and abdominal loading in addition to HIC, chest acceleration, and femur loading. Test results can influence future rulemaking on occupant seating and crash protection for all sizes of school buses.

The Safety Board also believes that NHTSA should determine the feasibility of installing some form of restraint that provides upper torso restraint on school buses. Current Federal regulations applicable to Type A school buses require that at least a lapbelt be provided for each passenger, and other Federal guidelines state that these belts should be worn. If student passengers must be belted, they should have the option of the superior protection afforded by a lap/shoulder belt or another form of restraint that provides upper torso protection. If States and school districts wish to order large school buses with restraint systems, they also should be able to provide upper torso restraints. Finally, if lapbelts prove to be the only seatbelt system that can be installed, NHTSA should actively research the possibility of requiring rear-facing seats for small school buses. Additional requirements for mirrors may be necessary to allow the school bus driver to observe passenger behavior.

STRUCTURAL INTEGRITY

An occupant's chances of surviving a school bus crash are enhanced if he or she remains within the vehicle. The primary defense against ejection is the structural integrity of the vehicle; floor, roof, and side panel joints must not separate, and bus windows and doors must not open during a crash. Any opening in the school bus body offers opportunity for occupants to be ejected. Another defense would be seatbelt use, but ejection is still possible if the belt is worn loosely, or if the seat or seatbelt anchors are compromised. In addition, available seatbelts are not always worn.

In the cases investigated for this study, the Safety Board documented that the front windshields in school buses became dislodged, side boarding doors opened, roofs deformed, and body joints separated. Not only did this damage expose passengers to the possibility of ejection, but the deformation and exposed metal edges created potential for injury if contacted.

Windshields

Regardless of the size of the school bus, all windows, except windshields, in the vehicle must meet specific retention standards set by the Federal Government. These standards were established to minimize the likelihood an occupant would be thrown from the bus because the window opened or was dislodged from its mounting. (The glazing materials used in a school bus windshield, however, must satisfy FMVSS 205, "Glazing Materials," which was established to minimize the possibility of occupants being thrown through the windows.)

Windshields in large school buses (GVWR more than 10,000 pounds) are specifically exempted from the retention performance criteria set by FMVSS 217, "Bus Window Retention and Release." In the Safety Board's study on Type C and Type D large school buses, windshields had popped out or broken out in six cases (National Transportation Safety Board 1987b). In two of the six cases, school bus occupants were ejected out of the windshield opening. In one (Hecla, Oklahoma), the unrestrained school bus driver was found lying inside the engine compartment following the crash; the engine hood had opened during the crash. In another crash (Swink, Oklahoma), four students reported they were ejected out of the open windshield. All survived, most with minor or moderate injuries only.

The Safety Board is currently investigating a fatal rollover school bus crash that occurred on May 14, 1989, near Boulder, Colorado, in which a student seated in the front row apparently was ejected through the windshield opening and killed; the windshield had been dislodged during the rollover. The ejected passenger struck a boulder, dislocating his neck and sustaining a head injury. The accident bus was a poststandard large (Type D) school bus (NTSB field case DEN-89-FH003).

The windshields of small school buses with a GVWR of 10,000 pounds or less also are exempt from window retention standards set by FMVSS 217. By virtue of their GVWR, however, Type A school buses fall under another Federal standard: FMVSS 212, "Windshield Mounting." This standard, which applies to passenger cars, multipurpose vehicles, and buses with a GVWR of 10,000 pounds or less, was designed to "reduce crash injuries and fatalities by providing for retention of the vehicle windshield during a crash...and preventing the ejections of occupants

from the vehicle." However, almost all Type A school buses are exempt from FMVSS 212 because they are "forward control vehicles," as defined by the standard,³⁶ a type of vehicle specially excluded from this standard. (Note: Type A school buses are built on the same type of chassis as many multipurpose vans. The windshield is part of the chassis.)

The Safety Board does not agree that forward control vehicles should be exempt from FMVSS 212. During a series of special investigations involving forward control vans, the Safety Board found that the windshields of 10 of the 19 vans were not retained during the crash. Two drivers were ejected through the windshield and a third was partially ejected. Two passengers in front seats and a passenger in a rear seat were also ejected through the windshield. As a result of its safety study on multipurpose vans (National Transportation Safety Board 1979), the Safety Board recommended that NHTSA consider extending FMVSS 212 to forward control vans. NHTSA did not agree, and FMVSS 212 still exempts forward control vehicles.

Hence, most small school buses are not required to meet Federal standards for windshield retention, although some may voluntarily do so.

In this study, the front windshield was dislodged or shattered during the crash in seven cases.³⁷ Fortunately, no occupant was ejected through the large opening created in the front of the bus. In a few cases, the opening served as an emergency exit for the driver and some passengers after the crash.³⁸ Windshields, however, are not designated emergency exits and are not required to meet any of the emergency provisions of FMVSS 217.

Because of the documented cases of windshield dislodgement and the accompanying danger of occupant ejection, the Safety Board believes that the NHTSA should amend FMVSS 217, "Bus Window Retention and Release," to include a performance standard for the minimum retention of windshields in school buses. Windshields, as well as windows, in a school bus should be required to withstand crash forces intact. If windshields are to function as emergency exits, then they should be required to meet Federal standards for emergency exits.

Inadvertent Door Opening

If a school bus door opens during a crash, unrestrained or improperly restrained occupants seated nearby can be ejected through the opening created. The controls for opening and closing the right front door in some small school buses appear to be poorly designed, allowing the door to open during a crash.

³⁶ The NHTSA defines a forward control vehicle as "a configuration in which more than half of the engine length is rearward of the foremost point of the windshield base and the steering wheel hub is in the forward quarter of the vehicle length."

³⁷ Cases 10, 12, 13, 14, and 24 in appendix B; also cases 25 and 28 in appendix D.

³⁸ In public hearings connected with a 1988 church bus accident in Carrollton, Kentucky, the NHTSA mentioned use of the windshield area as an emergency exit; it, however, is not designated as an emergency exit in Federal standards.

BEST COPY AVAILABLE

This led to the partial ejection and death of the driver of the school van in case 8. In that accident the unrestrained school bus driver lost control of the bus on a wet gravel road; the bus rotated 180° and overturned onto its right side in a ditch. The driver was partially ejected and then crushed under the frame of the boarding door as the bus came to rest on its side. In three other cases (5, 11, and 23), investigators documented that the right front boarding door either opened during the crash or was found with damaged controls after the crash.

The design of the opening control appeared to be relatively similar in all cases in which the boarding door was a safety issue (fig. 14). The door control in case 8 was described in the investigator's report as follows:

The passenger loading door latch consists of a handle near the center of the vehicle which is connected to the door by a long rod. The handle latches the door closed by being swung past center in an arc. This handle is easily bumped past center, allowing the door to open--several other drivers in the school district stated that, on rough roads, the latch did not keep the door from opening. The unrestrained school bus driver may have either bumped or grabbed the door handle of the passenger boarding door as she fell against the door. The door handle on the accident bus moved easily out of the locked position. A positive latch on the door handle could prevent this occurrence.

A driver restrained by a lapbelt can also inadvertently open a door control without a positive latch. Because it provides no upper torso restraint, a lapbelt will allow the torso of a restrained driver to strike the door handle during the accident and inadvertently open the door. The driver could also grab the door handle for support during rollover and inadvertently open the door. A driver restrained by a lap/shoulder belt also could, in certain accident configurations, open the door by sliding out from under the shoulder harness and striking the controls. In the Safety Board's cases, the right front boarding door opened in crashes in which the school bus driver was restrained. In two cases, Safety Board investigators also documented that unrestrained passengers seated in the front rows of the bus moved forward, struck, and deformed the door controls (cases 15 and 17):

The DOT has identified boarding door latches as a school bus safety problem. A report issued in 1973 stated the following:

With buses in motion, when brakes are applied, children standing in the area of the first step have been thrown against the door latch connecting rod. As a result of a child's momentum, the "over center" latches have, in some cases, unlatched, allowing doors to open. Better operating door mechanisms are available and new ones are being developed by at least three manufacturers under contract to UMTA [Urban Mass Transportation Administration] in its transit bus program.

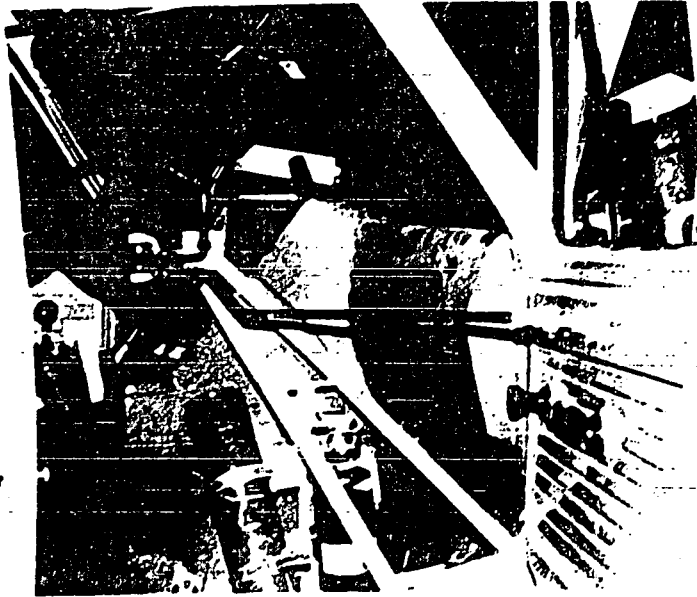

Figure 14.-- A boarding door control of such design can be opened inadvertently.

A trade-off study of service door operation could be combined with emergency door studies to determine the optimum door that should be required. A demonstration of the various door concepts would be a valuable tool in determining the parameters to be traded. (U.S. Department of Transportation, National Highway Traffic Safety Administration 1973.)

In the 1984 frontal crash tests conducted for Transport Canada, the right front door of the small school bus (Type B) "opened early during the collision event and remained open after the vehicle had come to a standstill (Transport Canada 1985)."³⁹

³⁹ A school van (a Type A vehicle) tested for Transport Canada did not exhibit this problem. The boarding door was operable after the crash.

Not only can an open door be dangerous during a crash, it can jeopardize evacuation. For example, if a door opens even partially during the crash, it creates not only an avenue for ejection, similar to a dislodged windshield, but it can easily be crushed or jammed, thus eliminating the door's use as an emergency exit after the accident. In seven cases involving Type A school buses, the right boarding door could not be used as an emergency exit because it was jammed, in some manner.⁴⁰ The school bus usually had experienced a frontal impact followed by rollover.

Some of the Safety Board's cases also contained examples of a related safety concern: the stairwell area, immediately in front of the boarding door, was deformed following the accident. The crash performance of the boarding door and related structures may need to be re-examined as a unit.

Because of these documented safety problems associated with the boarding door control, the Safety Board believes that the NHTSA, the School Bus Manufacturers Institute, and manufacturers of van-conversion school buses should work together to develop performance standards for the opening control mechanism on school vehicles with a GVWR less than 10,000 pounds that will eliminate the possibility of inadvertent door opening during a frontal or rollover crash. A positive latch would eliminate this problem.

School buses currently are exempt from FMVSS 206, "Door Locks and Door Retention Components," which sets performance requirements for side doors in passenger cars, multipurpose passenger vehicles, and trucks.

Joint Separations

Deficiencies in school bus joint strength were among the safety shortcomings Congress directed the DOT to correct in the 1970s. In 1977, DOT enacted FMVSS 221, "School Bus Body Joint Strength," to establish the minimum strength of body panel joints. However, small school buses with a GVWR of 10,000 pounds or less were exempt from this standard. As a result of this exclusion, Type A school buses do not have to meet Federal standards for joint strength, which were instituted to "reduce deaths and injuries resulting from the structural collapse of school bus bodies during crashes."

The Safety Board is concerned about this exclusion for three primary reasons. First, in most crash scenarios, the body joints of a small school bus will be tested far more than those of a large school bus. Size and mass of a motor vehicle are extremely important considerations in crash severity. For example, in a collision between a school bus weighing 20,000 pounds and passenger car weighing 4,000 pounds,⁴¹ the crash forces acting on the school bus and its occupants will be far less than if the school bus weighs 6,000 pounds. Similarly, if a small school bus collides with a heavy truck, the crash will stress the small school bus far more a large school bus.

⁴⁰ Cases 5, 8, 11, 13, 15, 17, and 19 in appendix B; also see case 23, which involved a Type B school bus. In case 14, the rear emergency door opened during the crash and was torn from its hinges. This was the only study case involving inadvertent rear door opening. In case 6, both the left and right front doors jammed.

⁴¹ Because passenger cars are the most common type of motor vehicle on the road, this kind of accident would be the typical multi-vehicle crash involving a school bus.

Second, the degree of compartmentalization required in a Type A school bus by Federal standards is far less than that required in a larger bus. Passengers of a small school bus, especially one without restraining barriers, will be able to move about the bus more freely in a crash. Third, not all school bus occupants wear the available seatbelts, or wear them snugly. Joint separation or an opening caused by roof deformation is consequently a concern even in school buses equipped with lapbelts. Federal tests for roof rollover strength are less stringent for a school bus with a GVWR of 10,000 pounds or less (fig. 15). In addition, such school buses are exempt from Federal requirements for school bus joint strength.

Joint separations were documented in six accidents involving Type A school vehicles (cases 10, 11, 13, 14, and 16);⁴² five of the six were van conversions (fig. 16).⁴³ In two of the cases (cases 13 and 14), the joint separations probably still would have occurred if the vehicles had been required to meet the joint strength standards for large school buses. One of the accidents involved an 810° rollover and multiple impacts, events that are outside the parameters of Federal test requirements. The other case involved separation of a maintenance access panel, and such panels are exempt from compliance with FMVSS 221.⁴⁴

Safety Board investigators found joint separations in one of the five cases investigated involving a Type B school vehicle. Type B school buses, although considered small (Type II) school vehicles, are required to be built to Federal standards for large school buses. In case 24, the small school bus sustained a rear-end impact followed by 90° rollover. One of the six panel seams in the ceiling toward the back of the bus separated in two places; the separations were 6 inches long and 1/4 inch wide.

Passenger injuries were attributed to joint separations in only one accident (case 16). In the other accidents, the separations clearly had the potential to cause injury, but occupant kinematics were such that the occupants' bodies did not contact the sharp metal edges that were exposed when the joints separated (fig. 16; cases 10, 11, 13, 14, 16, and 24). Separated joints have injury potential to restrained and unrestrained occupants alike, and because the integrity of the structure is thereby compromised, they increase the chance of ejection for unrestrained passengers and for passengers with loosely fitted belts.

⁴² Joint separation may have also occurred in case 17.

⁴³ Separations of restraining barrier attachment points are discussed in the section "Restraining Barriers."

⁴⁴ Even for large school buses, maintenance access panels are specifically excluded from current Federal standards for joint strength. As a result of a fatal accident involving a large school bus in St. Louis, Missouri, in 1985, the Safety Board recommended that the NHTSA include maintenance access panels in the joint strength standard (National Transportation Safety Board 1987a). Rulemaking to amend FMVSS 221 is under consideration.

FMVSS 220
FORCE APPLICATION PLATE SIZE
SMALL SCHOOL BUSES

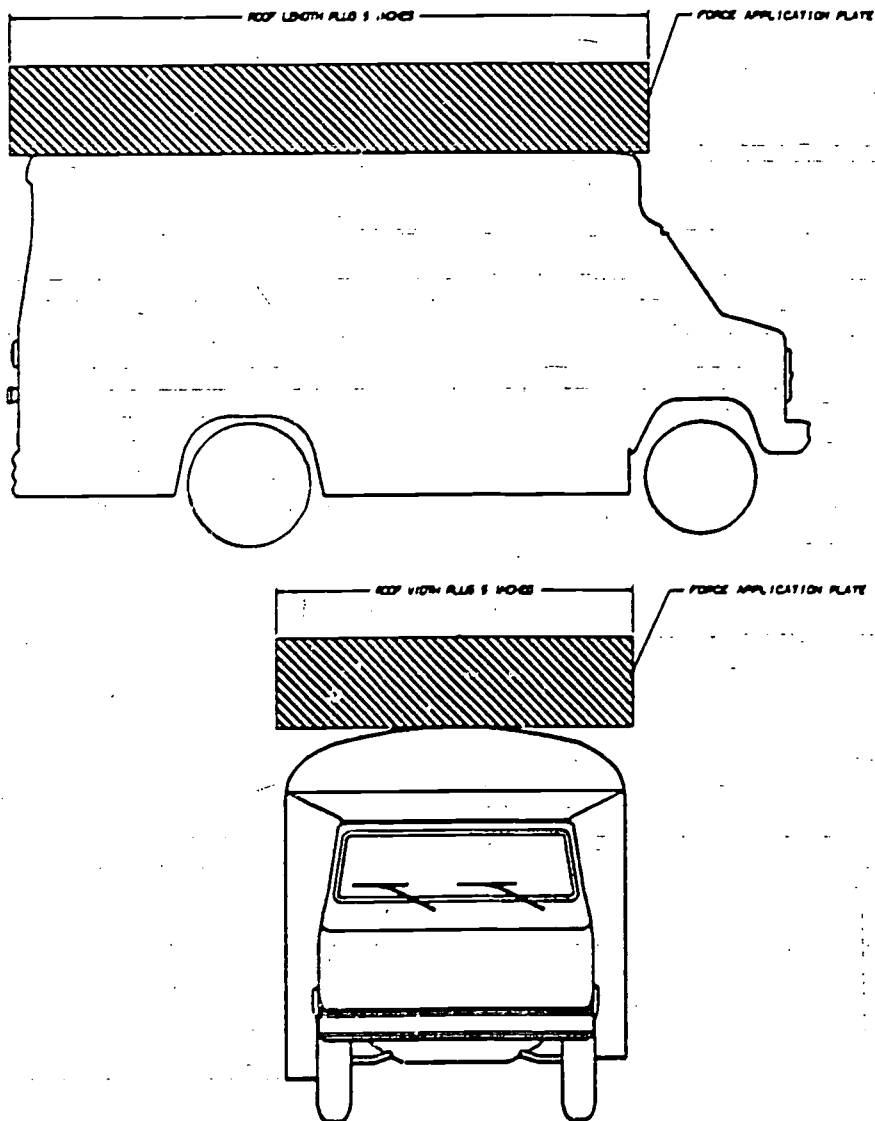

Figure 15.--A larger force application plate is used to test roof strength in small school buses compared to that used in tests of larger school buses. The result is that the roof of a small school bus must pass a less stressful test of roof rollover performance. (Source: School Bus Manufacturers Institute 1999.)

FMVSS 220
FORCE APPLICATION PLATE SIZE
LARGE SCHOOL BUSES

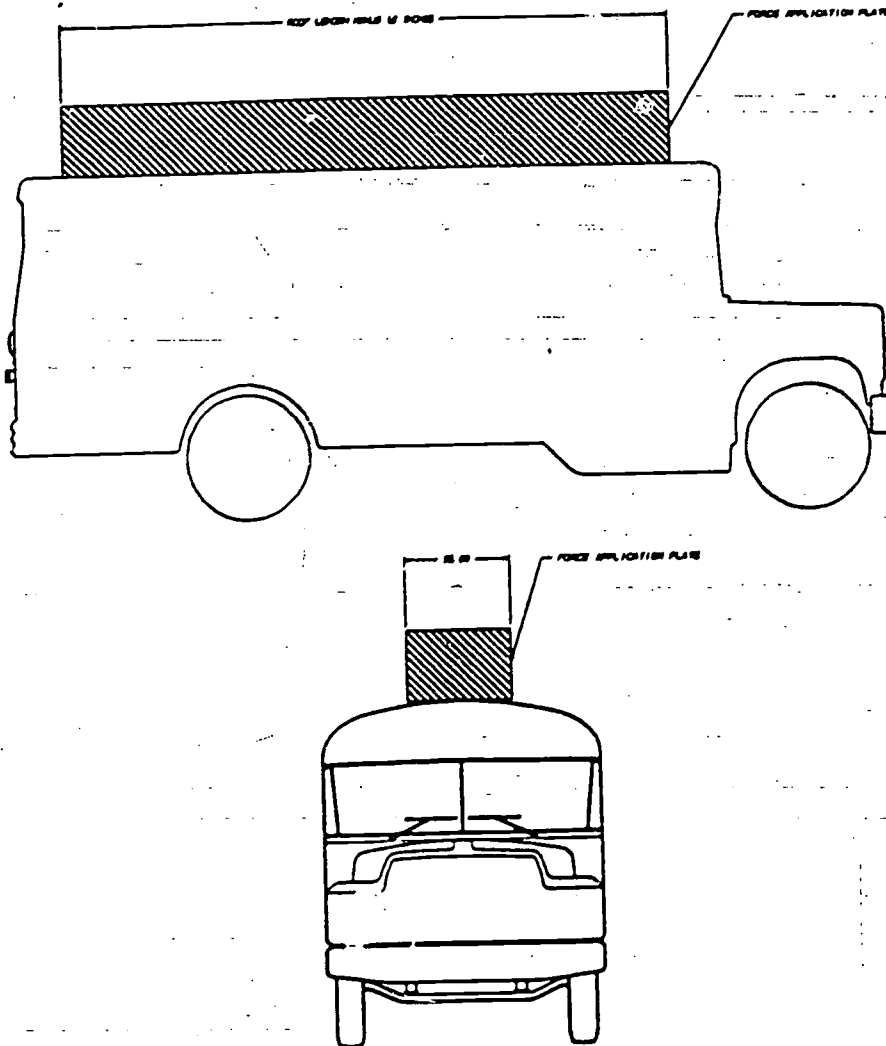

Figure 15 (continued).

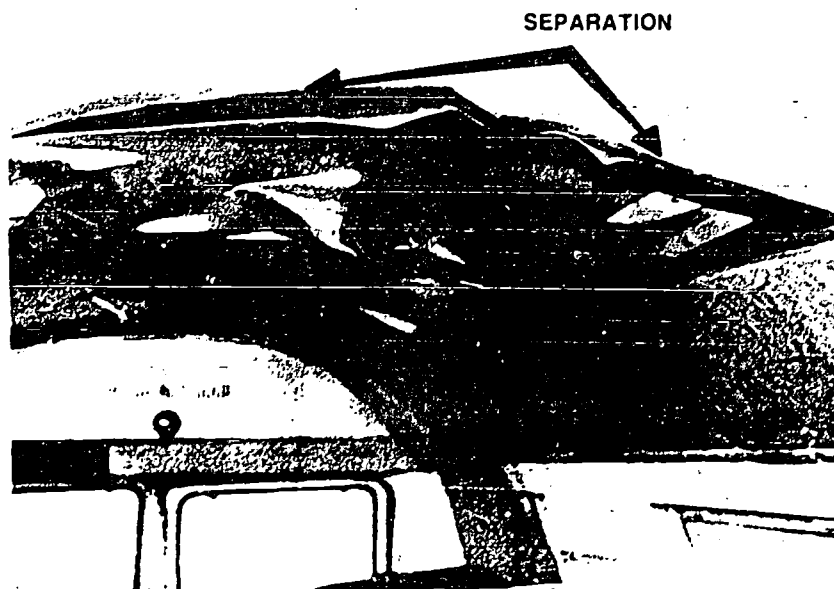

Figure 16.--Sharp metal edges were exposed in the roof of the Type A school van, posing a safety hazard (case 10). Interior roof of the vehicle looking toward the rear: arrows indicate separation of sheet metal panels where 13 rivets broke loose.

In case 16, the only accident in which joint separation caused injury, the Type A school bus impacted an unsecured concrete barrier. The sheet metal from the B-pillar to the left rear axle was peeled back and extended well outside of the original width of the bus (fig. 17). The left side structural supports for the roof were torn away, allowing the roof on the left side to collapse down to near the tops of the seatbacks. The body of the bus was torn loose from the chassis along the right side and across the rear. The left sidewall next to rows 1-3 was torn away or crushed. The anchor of the left side restraining barrier was dislodged, and the barrier was displaced rearward into contact with the front row seat. Had the passengers been in a large school bus, they would have been seated higher off the ground and the concrete barrier would have contacted the bus below their seating positions.

Lapbelt use could not prevent the passengers' injuries, and may have contributed to the severity of some injuries, as lapbelted passengers pivoted forward around their belts, striking the seatbacks before them with their heads.

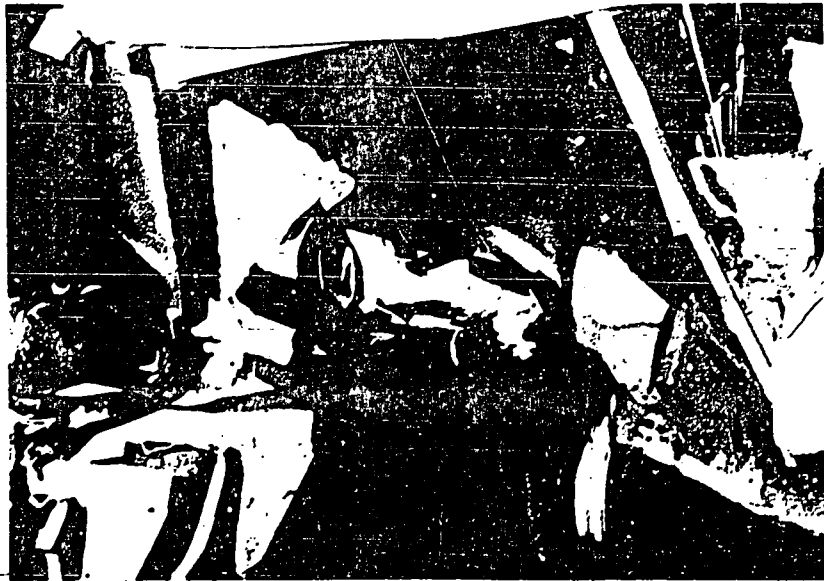

Figure 17.--Joint separation occurred on the left side of the small school bus in case 16.

The Safety Board investigator, however, determined that at least two of these four passengers were prevented by their lapbelts from being ejected. They had been sitting by the outside of the bus and had clear, open spaces to their left. The other two were not ejected because the side panels of the school bus body were deformed around them, blocking their access to the outside. Whether their injuries would have been more severe had they been ejected is not known.

Because of the increased stress subjected to body joints (including roof) of a small school bus compared to a large school bus in most crash scenarios (that is, the small bus lacks the advantage of larger size and mass) and the risk of injury joint separation poses for passengers, the Safety Board believes that the NHTSA during its ongoing review of school bus FMVSS, should review FMVSS 220, "School Bus Rollover Protection," to determine if roof performance tests of small school buses should be identical to the tests required of large school buses. Similarly, NHTSA should consider extending FMVSS 221, "School Bus Body Joint Strength," to small school buses.

EVACUATION

School bus evacuation has emerged as a topic of increased concern following the May 14, 1988, fatal crash of a church bus near Carrollton, Kentucky (National Transportation Safety Board 1989). Twenty-six passengers, all but two of whom were school-aged children, died in the fire that broke out following the crash; the passengers could not exit the bus in time. The vehicle was a 66-passenger, large, Type C, retired school bus, owned and operated by a church.

Since that crash, the Safety Board has investigated two additional cases involving school bus fires. The first case, occurring in March 1989, involved a Type A school bus (NTSB field case ATL-89-FH001). A fire started in the engine compartment of a school van outside Memphis, Tennessee, that was transporting wheelchair-bound students. Because of the van's configuration, the engine was partially within the passenger compartment, near the driver's seat. The fire was not contained within the engine, spread to the van's interior, and was fed by the material used for seat construction. The forward portion of the bus was engulfed in flames. Evacuating the students was difficult: the electrical system controlling the wheelchair lift was damaged by the fire. Only with the help of passersby were the students evacuated before the fire consumed the interior of the van. The other case, also occurring in March 1989, involved a large poststandard school bus near Kansas City, Missouri, damaged when it struck a stopped tractor-trailer (NTSB field case DCA-89-SH-001). The impact pushed the fuel tank rearward and the fuel lines of the school bus fuel tank pulled loose; a fire started. The interior of the school bus was consumed. Fortunately, no students were aboard; however, the driver was pinned in and sustained burn injuries over 10 percent of her body and suffered smoke inhalation.

Fire was also involved in an earlier investigation conducted by the Safety Board involving a small school bus in 1981, outside Hermanville, Mississippi (National Transportation Safety Board 1982). A school van transporting Head Start students ran off a bridge and rolled over. The side door could not be opened, and not all of the occupants could be evacuated in time; 5 of the 32 occupants (the van was overloaded) perished in the fire. As a result of the accident, the Safety Board issued the following safety recommendation to the NHTSA:

H-82-33

Examine the crash performance of vans in rollovers and all accident types, through its crash testing and accident investigation programs, to determine if there is any tendency for doors and other escape areas to unnecessarily jam or be blocked in low-speed crashes. If necessary, establish additional crash performance standards for van escape areas, especially those used for public transportation.

The NHTSA responded that it could not identify any specific instances of exits jamming because of crash damage; the Safety Board closed the recommendation (Closed--Acceptable Action). In its 1979 study of the performance of multipurpose vans, the Safety Board had previously asked NHTSA to "study the extent to which doors jam in collisions and to determine if corrective action is

needed to prevent ejection and enhance escape (National Transportation Safety Board 1979). In this study on small school buses, the Safety Board has documented instances of exit doors being jammed from crash damage and doors opening inadvertently. Emergency exit availability remains a concern.

Proposals to amend Federal school bus standards for emergency exits, fuel tank integrity, and interior flammability have focused on large school buses since the fatal crash in Carrollton, Kentucky, which prompted media attention and re-examination of these issues by DOT. Large school buses (Types C and D) comprise the majority of school vehicles in the public school bus fleet. Nonetheless, small school buses, by virtue of their design and use, deserve special attention. Emergency evacuation issues connected with a small school bus should be examined separately from large school buses for the following reasons:

1. Fuel tanks on some small school buses are exempt from Federal fuel system integrity standards for school buses; tank guards are usually not present; and the fuel tanks are located on a different portion of the chassis than on a large school bus. Fuel tanks found on Type A and Type B school buses are almost never located on the right side of the school bus, near the boarding door, as is the case with most large school buses. Instead, the fuel tank of a small school bus is located between the chassis rails, a safer location. The tanks do not have protective tank guards or "cages" as are found on large school buses. In addition, the fuel tanks of Type A school buses must meet the same performance tests required of a passenger car, multipurpose passenger vehicle, or truck van, not the performance tests specified for a school bus.
2. Small school buses may have a smaller ratio of passengers to emergency exits than do large school buses, but the vehicle itself is not required to meet the same structural integrity requirements as a large school bus. Hence, the exits on a small school bus may be more likely to be jammed after the crash, due to body deformation, than those on larger school buses. Although the crash pulse experienced by a school bus in a multivehicle collision will always be greater for a small school bus than for a large school bus in a similar crash, the body of a Type A school bus is not required to be built to Federal school bus standards for joint strength, and the roof must withstand a less stringent test for rollover strength. In addition, side emergency exits are not required to have the same clearance as found on large school buses, and the boarding door may be more likely to open in a crash. The Federal Government also specifies a smaller minimum access area for the rear emergency door in a Type A school bus compared to larger school buses: only a 6- by 22-inch unobstructed clearance compared to 12 by 22 inches in a larger school bus.
3. Small school buses are often used for special transportation purposes, which include transport of preschoolers and of the physically and mentally handicapped. In these cases, more time for evacuation may be needed than the number of passengers may suggest.

Evacuation training becomes more difficult, especially if wheelchair-restrained or mentally disabled students are involved. (The Safety Board investigated a survivable accident occurring in March 1988 in which a wheelchair-bound student died when her bus overturned [NTSB field case FTW-88-HFR05]).

4. Small school buses customarily are equipped with at least a lapbelt at every passenger seating position; large school buses are not. If passengers are wearing lapbelts at the time of the crash, the belt must be released before evacuation can proceed. Depending on the crash configuration and the age and ability of the passengers, school officials have worried this could slow evacuation.

With these factors in mind, the Safety Board closely examined evacuation in its study cases. Little, if any, postcrash data on school bus accidents are routinely available; for example, through what door(s) the students evacuated, how many were injured during the evacuation itself, and what exits were inaccessible or jammed. Evacuation data are not available from State or national school bus accident data banks, and accident reports filed by local school districts rarely include such information. This report supplies such data.

Fire and Fuel Tank Leaks

Fires in school buses, regardless of the vehicle's size, appear to be relatively infrequent events. When they do occur, fires are most likely not to be connected with a crash, but rather associated with fire in the engine compartment resulting from poor maintenance or from vandalism by students on the bus. Available data suggest that when a fire does occur in connection with a school bus accident, the fire more often results from a fuel leak from the other vehicle involved than from the school bus itself. An analysis of 10 years (1977-1987) of data on fatal accidents found that no fatalities of occupants of school bus-type vehicles were attributed to fire or smoke inhalation. The accident in Carrollton, Kentucky, changed that record.

In the Safety Board's cases investigated for this study, fuel tanks of small school buses did not leak following the crash, and there were no postcrash fires.

Emergency Exits

Small school buses frequently have more exits than large school buses have, although they generally transport fewer passengers. Some small school buses may have a door on the left side by the driver or a side exit, sometimes with double doors or equipped with a wheelchair lift. The additional exits are fortunate: in about half of the study cases, occupants reported that one of the school bus exits could not be opened. The right boarding door was the exit most often reported as being jammed or unusable (7 out of 24 cases); the rear emergency door and the driver's door on the left side were rarely cited (2 and 3 cases, respectively). These findings may reflect the crash configurations represented by the study cases--mainly frontal, involving rollover--as well as deficiencies in boarding door design, roof, and joint strength.

The rear emergency door was the most commonly used exit (more than three-fourths of the cases). The boarding door on the right side was rarely used.

Special Students

Four cases in the study involved school buses transporting Head Start or physically handicapped students. Seven other cases involved school buses transporting passengers classified as emotionally disturbed or learning disabled. These types of children could have more problems in evacuation because of their age and disabilities.

Few evacuation problems were encountered, however. The one notable exception involved transport of deaf students in case 13. The driver--who had received minor injuries only--was removed from the accident scene first; but because he was the only adult who knew sign language, emergency personnel were unable to communicate with the children aboard the bus. Safety Board investigators found that the bus carried no identification to alert rescuers that deaf children were aboard. Fortunately, no passenger received more than minor injuries, so no one suffered because of delays in treatment.

Successful evacuation in most cases was not a result of frequent evacuation practice--indeed, some pupils told the Safety Board investigators they had never practiced evacuation (cases 8 and 23)--but rather resulted from the presence of aides on the bus and the swift assistance rendered by adult passersby and emergency rescue personnel. In two cases (cases 1 and 21), the school bus drivers had instructed passengers to remain in their seats until rescue personnel arrived.

Lapbelt Release

Some school authorities have expressed concern about whether lapbelt use by school bus passengers would hinder evacuation, specifically, if lapbelted school bus passengers would be able to release themselves from their belts. Not all school buses have adult aides on board, and the driver is often the only adult. Rollover crashes have been of particular interest, because students on the "high side" of the bus would be suspended by their belts or might be afraid (or even unable) to release their belts and fall to the lower side.

In the Safety Board's study cases, most passengers did not release themselves from their lapbelts. Adults, either bus occupants or rescuers, released the belts for the children (cases 1, 9, 13, 16, and 19). This may reflect the type of passengers often carried by small school buses--the handicapped or the very young.

In four cases (cases 12, 19, 22, and 23), students were held suspended by their belts after a rollover crash and required assistance releasing their belts.⁴⁵ In two cases, students were injured when they released their belts and fell to the lower side of the bus, striking seatbacks; only minor injuries resulted.

⁴⁵The school bus driver in case 23 was also suspended by his belt.

BEST COPY AVAILABLE

Lapbelt use substantially delayed passenger evacuation in only one accident investigated, a nonrollover accident.⁴⁶ A student was unable to release his lapbelt because hot asphalt, from the dump truck that collided with the school van, had spilled onto his seat, burying the seatbelt latchplate. The lapbelt was subsequently cut by the truck driver and the student was freed.

⁴⁶ Case 25, appendix D.

CONCLUSIONS

1. Because of the differences (size, mass, exterior and interior features) between a small school bus and large school bus, findings based on investigations of accidents involving large school buses cannot be extrapolated to smaller school vehicles.
2. The small school buses involved in the 24 accidents investigated for the Safety Board's study generally provided good crash protection to both restrained and unrestrained passengers.
3. If student passengers were injured, injuries usually were minor, regardless of their restraint status. The head and face were the body parts most commonly injured among both lapbelted and unrestrained passengers.
4. Seating position was a more important factor than restraint status in determining injury severity.
5. Accidents in this study offered examples of both the advantages and disadvantages of lapbelt use.
6. Restraint status, injury severity, and seating location of occupants often were not accurate in official police reports of the school bus accident. Evaluation of lapbelt performance based on these sources may be misleading.
7. Restraint use was high among school bus occupants in the study, probably reflecting that States or local school districts have policies requiring that occupants of small school vehicles wear the available seatbelts, the limited number and youth of the passengers, and presence of adult aides on some buses. Nearly three-fourths of the school bus drivers and two-thirds of the passengers were restrained.
8. Restraint use was low among adult aides on board the school bus. Only one of seven adult aides, who were charged with ensuring passenger belt use, was wearing a seatbelt at the time of the crash.
9. The school bus drivers and passengers sometimes did not wear their seatbelts properly. The most common mistake was failure to adjust the manual lapbelt to fit snugly. Almost one-third of the lapbelted passengers were wearing their belts improperly.
10. In some passenger lapbelts and other restraints had been installed or after initial purchase of the vehicle by employees of the school or bus contractor in a manner inconsistent with Federal standards for seatbelts, diminishing crash protection and increasing the potential to induce injury.

11. Passengers seated in the front rows of Type A school buses are at special risk of injury in a frontal crash. Type A school buses are not required to have a restraining barrier forward of the front seats, and if they do, these barriers do not have to meet the same standards as those found in other types of school buses. The Safety Board has documented the danger of being unrestrained in a school bus without a frontal barrier as well as the danger of being lapbelted and interacting with a barrier in a frontal crash.
12. Restraining barrier supports and anchors in Type A school buses sometimes came loose during the crash. Sharp metal edges were sometimes exposed, and the separations allowed the barrier to move rearward into passenger seating space.
13. Data from Canadian crash tests suggest that merely requiring that Type A school buses have frontal restraining barriers identical to those mandated in larger schoolbuses (Types B, C, and D) will not provide a solution for head protection. Lapbelted anthropomorphic dummies seated in the front seats of Type A school buses equipped with large school bus barriers registered unacceptable head injury scores, more than twice the allowable limit.
14. The Federal Government currently has no injury criteria for abdominal, spinal, or thorax injuries. Researchers do not know how much force and at what duration will result in fatal or serious injuries to these regions of the body of lapbelted and unrestrained occupants. Hence, performance standards for restraining barriers and seatbelts regarding abdominal, spinal, or thorax injuries do not exist.
15. In multivehicle crashes and other crash scenarios, small school buses lack the built-in crash advantage of superior size and weight provided by large school buses. Current Federal standards allow Type A school buses to be built with roofs less able to withstand rollover forces than larger school buses. Body joints in Type A school buses are exempt from Federal joint strength standards.
16. Joint separations were documented in 6, possibly 7, of the 19 cases involving Type A school vehicles; 5 of the 6 were van conversions. Joint separations were documented in 1 of the 5 cases investigated involving Type B school buses.
17. In some accidents, the right side boarding doors opened inadvertently during the crash, and front windshields were displaced. Retention within the vehicle is advantageous to survival, so any opening in the school bus body poses danger to an unrestrained or improperly restrained occupant.
18. School bus windshields are exempt from FMVSS 217, "Bus Window Retention and Release."
19. The boarding door controls of some small school buses have no positive latch locking mechanism.

20. In 7 out of 24 cases, the passenger boarding door was unavailable for use as an emergency exit because of damage sustained during the accident due to poor design of door control, structural weakness near the door area, or deformation of the roof above the door.
21. For a variety of reasons, student passengers rarely released themselves from their lapbelts after the crash. Adults at the scene usually released the student passengers.
22. Lapbelt use usually did not hinder evacuation efforts, even in rollover crashes when the school bus came to rest on its side.
23. In the Safety Board's cases, the fuel tanks of the small school buses (both Type A and B) did not leak after the crash, and there were no postcrash fires.
24. The definitions of "small" versus "large" school bus used in the Federal Motor Vehicle Safety Standards, in Federal program guidelines, by Congress, by State and local school transportation officials, and by the school bus industry, are not uniform.

RECOMMENDATIONS

As a result of this study, the National Transportation Safety Board recommends:

--to the National Highway Traffic Safety Administration:

Determine the feasibility of requiring lap/shoulder belts or other restraint systems that provide upper torso restraint at front seat passenger seating positions on Type A school buses (gross vehicle weight rating of 10,000 pounds or less). Amend Federal Motor Vehicle Safety Standard (FMVSS) 222, "School Bus Passenger Seating and Crash Protection," and FMVSS 210, "Seat Belt Assembly Anchorages," or any other standards, as needed, should standards prove incompatible. (Class II, Priority Action) (H-89-46)

Conduct research, including computer simulation and sled crash tests using Hybrid III dummies if needed, to determine the relationship between restraining barrier design and injuries to unrestrained and lapbelted passengers of different sizes on small school buses (gross vehicle weight rating of 10,000 pounds or less). Research should focus on the height, width, padding, location, and anchorage strength of the barrier, and the spacing between the barrier and front seats. Amend Federal Motor Vehicle Safety Standard 222, "School Bus Passenger Seating and Crash Protection," as needed. (Class II, Priority Action) (H-89-47)

Amend Federal Motor Vehicle Safety Standard 217, "Bus Window Retention and Release," to include a performance standard for the minimum retention of windshields in all sizes of school buses. (Class II, Priority Action) (H-89-48)

Collect and evaluate accident data on the crash performance of the roof and emergency exits on small school buses (gross vehicle weight rating of 10,000 pounds or less) in rollovers. Data should not be limited to van-based buses. Based on analysis, ascertain whether it is appropriate to amend Federal Motor Vehicle Safety Standard 220, "School Bus Rollover Protection," to make roof performance tests for small school buses (gross vehicle weight of 10,000 pounds or less) to be identical in all aspects to those now required of large school buses (gross vehicle weight rating of more than 10,000 pounds). If such tests are not appropriate, modify the test for small school buses to stress the roof more than the present force application plate test does. (Class II, Priority Action) (H-89-49)

Collect and evaluate accident data involving small school buses to ascertain whether school buses with a gross vehicle weight rating of 10,000 pounds or less should be required to meet joint strength requirements of Federal Motor Vehicle Safety Standard 221, "School Bus Body Joint Strength." (Class II, Priority Action) (H-89-50)

Specify in new rulemaking or in an amendment to Federal Motor Vehicle Safety Standard 206, "Door Locks and Door Retention Components," a requirement for a positive latch locking mechanism on the passenger loading doors of small school buses (gross vehicle weight rating of 10,000 pounds or less) to eliminate the possibility of inadvertent door opening during a frontal crash or rollover. Work with school bus and school van manufacturers to develop the performance standards. (Class-II, Priority Action) (H-89-51)

Urge manufacturers to provide means to retrofit positive latch locking mechanisms on existing door controls of small school buses (gross vehicle weight rating of 10,000 pounds or less). (Class II, Priority Action) (H-89-52)

--to members of the School Bus Manufacturers Institute and manufacturers of van conversion school buses:

Work with National Highway Traffic Safety Administration to develop performance standards for a locking mechanism for the boarding doors of school buses with a gross vehicle weight rating of 10,000 pounds or less to eliminate the possibility of inadvertent door opening during frontal or rollover crash. (Class II, Priority Action) (H-89-53)

Provide retrofit kits for small school buses (gross vehicle weight rating of 10,000 pounds or less) currently without positive latch door control locking mechanisms. (Class II, Priority Action) (H-89-54)

--to the National Association of State Directors of Pupil Transportation, the National Association of Pupil Transportation, and the National School Transportation Association:

Alert your members to the dangers inherent in improper installation of seatbelts and/or installation of restraint systems not meeting Federal standards or guidelines in school buses and urge them to correct such installations. Also alert your members of the need to instruct students to wear lapbelts properly. (Class II, Priority Action) (H-89-55)

BY THE NATIONAL TRANSPORTATION SAFETY BOARD

/s/ JAMES L. KOLSTAD
Acting Chairman

/s/ JIM BURNETT
Member

/s/ JOHN K. LAUBER
Member

/s/ JOSEPH T. NALL
Member

/s/ LEMOINE DICKINSON, JR.
Member

October 11, 1989

REFERENCES

- American Association for Automotive Medicine. 1985. The abbreviated injury scale. Arlington Heights, IL. 80 p.
- Calspan. 1986. Crash testing of Thomas Minotour vehicle, 1986 Thomas bus, intermediate school bus. Buffalo, NY; Rep. 7481-1; final report for Thomas Built Buses. [Not paged].
- Carpenter, K. 1973. Injury reporting reliability. Report from the New York State Department of Motor Vehicles, Albany. [Pages not known].
- Carroll, P.S.; Scott, R.E. 1971. Acquisition of information on exposure and on non-fatal crashes. In: Vol. 2--Accident data inaccuracies. Report from the Highway Safety Research Institute, University of Michigan. [Pages not known].
- Césari, D.; Ramet, M. 1979. Evaluation of human tolerance in frontal impacts. In: Proceedings of the 23d Stapp car crash conference. Pap. 791032. Warrendale, PA: Society of Automotive Engineers: 873-911.
- Davis Engineering Limited. 1986. School bus seat development study. Ottawa, ON; final report; Transport Canada contract OS285-00139. 186 p.
- Dejeannes, Maryvonne; Tarrière, Claude; Thomas, Christian; Kallieris, Dimitrios. 1984. Exploration of biomedical data towards a better evaluation of tolerance for children involved in automotive accidents. In: Advances in belt restraint systems: design, performance and usage: Proceedings of the international congress and exposition; 1984 February 27-March 2; Detroit, MI. P-141. Warrendale, PA: Society of Automotive Engineers: 427-440.
- Evans, Leonard [Operating Sciences Department, General Motors Research Laboratories]. 1989. Restraint effectiveness, occupant ejection from cars, and fatality reductions. Pap. No. 880596. Presented at the 68th annual meeting of the Transportation Research Board; 1989 January 22-26; Washington, DC. 15 p.
- Fisher, Jerid M. 1985. Cognitive and behavioral consequences of closed head injury. In: Seminars in neurology. Pap. 85-010. Southborough, MA: National Head Injury Foundation. 4 p.
- Foust, David R.; Bowan [Bowman], Bruce M.; Snyder, Richard G. 1977. Study of human impact tolerance using investigations and simulations of free-falls. In: Proceedings of the 21st Stapp car crash conference. Pap. 770915. Warrendale, PA: Society of Automotive Engineers: 3-51.
- Huang, L.C.; March, J.C. 1978. AIS and threat to life. In: Huelke, D.F., ed. Proceedings of the American Association for Automotive Medicine 22nd conference, and the International Association for Accident and Traffic Medicine 7th conference. Morton Grove, IL: American Association for Automotive Medicine. Vol. 1: 242-254.

- Hutchinson, T.P. 1987. Severity classification by American police. In: Road accident statistics. Adelaide, South Australia: Rumsby Scientific Publishing (p. 190-191). 292 p.
- National Safety Council. 1987. Accident facts. Washington, DC. 104 p.
- National Transportation Safety Board. 1979. Special study: safety of multipurpose vans. NTSB/HSS-79/1. Washington, DC. 44 p.
- National Transportation Safety Board. 1982. Highway accident report: Pattison Head Start Center school van run-off bridge and fire near Hermanville, Mississippi, December 17, 1981. NTSB/HAR-82/5. 24 p.
- National Transportation Safety Board. 1986. Safety study: performance of lap belts in 26 frontal crashes. NTSB/SS-86/03. Washington, DC. 236 p.
- National Transportation Safety Board. 1987a. Highway accident report: Schoolbus loss of control and collision with guard rail and sign pillar, U.S. Highway 70 near Lucas and Hunt Road, St. Louis County, Missouri, November 11, 1985. NTSB/HAR-87/02. 45 p.
- National Transportation Safety Board. 1987b. Safety study: Crashworthiness of large poststandard schoolbuses. NTSB/SS-87/01. Washington, DC. 474 p.
- National Transportation Safety Board. 1989. Highway accident report: Pickup truck/church activity bus head-on collision and fire near Carrollton, Kentucky, May 14, 1988. NTSB/HAR-89/01. 87 p.
- School Bus Fleet. 1989. [School bus statistics]. Redondo Beach, CA: Bobit Publishing; 34(6): 11, 14, 58, 60.
- School Bus Manufacturers Institute. 1989. Congressional briefing for the House Surface Transportation Subcommittee. May 17.
- Scott, R.E. 1972. Evaluation of severity codes in accident data. HIT Lab Reports. Ann Arbor: Highway Safety Research Institute, University of Michigan. [Pages not known].
- Shinar, D.; Treat, J.R.; McDonald, S.T. 1983. The validity of police reported accident data. Accident Analysis and Prevention. 15: 175-191.
- Snyder, Richard G. 1969. Impact injury tolerances of infants and children in free-fall. In: Proceedings of the 13th annual conference of the American Association for Automotive Medicine; 1969 October 16-17; Minneapolis, MN. [Place of publication unknown]: [Publisher unknown]: 131-164.
- Snyder, Richard G.; Foust, David R.; Bowman, Bruce M. 1977. Study of impact tolerance through free-fall investigation. UM-HSRI-77-8. Ann Arbor, MI: The University of Michigan, Highway Safety Research Institute. 140 p. plus appendixes.

- St. Laurent, Andre. 1983. School bus accidents and passenger injuries: a literature review. Ottawa, ON: Biokinetics and Associates; Doc. R83-14; prepared for TES Limited. 40 p.
- G. 1980. Biomechanical data of children. In: Proceedings of the 24th car crash conference. Pap. 801313. Warrendale, PA: Society of Automotive Engineers: 514-559.
- Transport Canada. 1985. School bus safety study. TP 6222E. [Place of publication unknown]. 2 vol.
- Transport Canada [Farr, G.N.]. 1987. School bus seat development study. TP 8445E. [Place of publication unknown]. 37 p.
- Transportation Research Board, National Research Council. 1989. Improving school bus safety. Spec. Rep. 222. Washington, DC. 214 p.
- U.S. Department of Transportation, National Highway Transportation Safety Administration. 1973. Pupil transportation safety program plan. DOT HS-820-267. Washington, DC (p. 30). [Total pages not known].
- U.S. Department of Transportation. National Highway Traffic Safety Administration. 1986. School bus safety belts: their use, carryover effects and administrative uses. DOT-HS-806-965. Washington, DC. 60 p.
- Weber, K.; Melvin, J.W. 1983. Injury potential with misused child restraining systems. In: SAE child injury and restraint conference proceedings; 1983 October 17-18; San Diego, CA. SAE/P-83/135. Warrendale, PA: Society of Automotive Engineers: 53-59.

APPENDIX A

INDEX TO SAFETY BOARD STUDY CASES INVOLVING SCHOOL VEHICLES
BUILT TO FEDERAL SCHOOL BUS STANDARDS

This appendix lists the 24 case summaries in appendix B by type of school vehicle. The types are classified by the school bus industry system that takes into account the gross vehicle weight rating (GVWR) and configuration of the vehicle. The classifications and definitions were adopted at the National Minimum Standards Conference of 1980. Both Type A and Type B school buses were formerly referred to as Type II school buses.

Type A school buses are grouped by van conversions and small school buses. Within each group, nonrollover accidents are listed first, then rollover accidents, in order of increasing severity. The list also identifies the accident location and date, chassis manufacturer of the school vehicle, make and model of the body, and the type of accident in terms of the school vehicle.

Type A School Vehicles (19 cases)

A Type A school vehicle is a van conversion or body constructed on a van-type compact truck or front-section vehicle with a GVWR of 10,000 pounds or less, designed for carrying more 10 persons.

Van conversions (Type A)

Number of cases: 14

Type of accident: Nonrollover 7 (all frontal impact)
Rollover 7 (3 noncollision)

Case numberData

- | | |
|---|---|
| 1 | Bedford, New York
September 23, 1986
1983 Dodge chassis with 16-passenger body by Ram Van
Left front impact |
| 2 | Laurel Hollow, New York
February 5, 1987
1980 Chevrolet chassis with 16-passenger body by
Van Con, Inc.
Left front impact |
| 3 | New Castle, New York
February 2, 1987
1983 GMC chassis with 16-passenger Sturdivan body by
T.P.I.
Left front impact |

- 4 Carson, California
May 18, 1987
1981 Dodge chassis with 16-passenger body by
Collins Bus Corporation
Multiple frontal impacts
- 5 Lake Zurich, Illinois
October 10, 1985
1984 Chevrolet chassis with 16-passenger Fortivan body by
Coach and Equipment Manufacturing Corporation
Head-on collision
- 6 Pomona, California
June 11, 1987
1987 Dodge chassis with 16-passenger Bantam body by
Collins Bus Corporation
Frontal impact
- 7 Allegan, Michigan
December 5, 1984
1978 Chevrolet chassis with 16-passenger body by
Shaller-Globe Corporation
Head-on collision
- 8 Fort Dodge, Iowa
March 15, 1984
1980 Chevrolet chassis with 16-passenger body by
Superior Coach International
Noncollision rollover (90°)
- 9 Los Angeles, California
April 8, 1987
1976 Ford school van configured for 16 passengers
Noncollision rollover (90°)
- 10 New York, New York
April 19, 1985
1978 Dodge chassis with 16-passenger Fortivan body by
Coach and Equipment Manufacturing Corporation
Noncollision rollover (170°)
- 11 Denville, New Jersey
March 9, 1987
1986 Chevrolet chassis with 15-passenger body by
Van Con, Inc.
Multiple frontal impacts, followed by rollover (90°)
- 12 Gresham, Oregon
January 14, 1987
1979 Dodge chassis with 14-passenger Sturdivan body by
T.P.I.
Frontal impact, followed by rollover (90°)

- 13 Houston, Texas
February 25, 1986
1980 Dodge chassis with 16-passenger body by
Collins Bus Corporation
Frontal impact, followed by rollover (360°)
- 14 Westchester, New York
March 25, 1987
1982 Ford chassis with 16-passenger Sturdivan body by
T.P.I.
Rollover (810°), followed by multiple impacts

Small School Buses (Type A)

Number of cases: 5

Type of accident: Nonrollover 3
Rollover 2

- | <u>Case number</u> | <u>Data</u> |
|--------------------|--|
| 15 | Perrysburg, Ohio
April 6, 1987
1981 Chevrolet chassis with 23-passenger Busette Body by
Wayne Corporation
Left front collision, followed by secondary impact. |
| 16 | Elmhurst, Illinois
February 7, 1986
1982 Chevrolet chassis with 23-passenger Vanguard body by
American Transportation Corporation
Left side impact, followed by secondary impact |
| 17 | Chester County, Pennsylvania
February 26, 1988
1983 Ford chassis with 22-passenger Busette body by
Wayne Corporation
Head-on collision, followed by secondary side impact |
| 18 | Vista, California
December 3, 1986
1985 Chevrolet chassis with 20-passenger Micro-Bird body
by Blue Bird Body Company
Left side impact, followed by rollover (90°) |
| 19 | San Antonio, Texas
February 5, 1985
1981 Chevrolet chassis with 20-passenger Busette-body by
Wayne Corporation
Left side impact, followed by rollover (90°) |

Type B School Vehicles (5 cases)

A Type B school bus is a van conversion or body constructed and installed on a van or front section vehicle chassis or stripped chassis, with a GVWR of more than 10,000 pounds, designed for carrying more than 10 persons. Part of the engine is beneath and/or behind the windshield and beside the driver's seat. The entrance door is behind the front wheels. Note: Type B vehicles must meet the Federal standards for large school buses although they also are considered small (Type II) school buses. The gross vehicle weight of these vehicles may be under 10,000 pounds but their GVWR is over 10,000 pounds. The rating includes passenger load.

Number of cases: 5

Type of accident: Nonrollover 2 (all multiple collision)
Rollover 3 (all collision rollovers)

<u>Case number</u>	<u>Data</u>
20	Clarkston, Georgia May 8, 1987 1982 Chevrolet chassis with 18-passenger Cadet body by Carpenter Body Works, Inc. Head-on collision, followed by rear-end collision
21	Williston, Vermont November 21, 1987 1979 Chevrolet chassis with 18-passenger Mini-Bird body by Blue Bird Body Company Multiple collision: sideswipe, followed by head-on impact
22	Greensboro, North Carolina January 14, 1986 1980 Chevrolet chassis with 20-passenger Mighty Mite body by Thomas Built Buses (bus reconfigured to 10-passenger capacity) Right side impact, followed by rollover (90°)
23	Little Rock, Arkansas May 2, 1983 1981 Chevrolet chassis with 15-passenger Cadet Body by Carpenter Body Works Head-on collision, followed by rollover (90°)
24	Flower Hill, New York January 24, 1986 1979 GMC chassis with 14-passenger Coachette body Rear-end collision, followed by rollover (90°)

APPENDIX B

CASE SUMMARIES OF SCHOOL BUSES
BUILT TO FEDERAL SCHOOL BUS STANDARDS

Case No. 1	Safety Board Investigation No. NYC-87-H-SB02
Location of Accident	Pea Pond Road; outside Bedford, New York
Date and Time	September 23, 1986; 8:04 a.m.
Description of School Vehicle	Type A van conversion: 1983 Dodge chassis with 16-passenger body by Ram Van
Type of Accident	Left front impact
Severity of Accident	Delta V estimated to be less than 10 mph

Summary of Events

A school van was transporting two students to school on a two-way, asphalt county road on a rainy day. All occupants of the van were restrained. As the school van negotiated a left curve, a 1984 Buick LeSabre station wagon, traveling in the opposite direction, crossed the centerline and struck the left front of the school van head-on.

After the crash, the school van driver and two students remained in their seats until emergency personnel arrived. The driver and one passenger exited the bus unassisted. The remaining passenger was removed from the van by emergency response personnel. The passengers were treated for injuries and released by the hospital.

Damage to the poststandard school van was minor; damage was confined to the exterior of the bus, except for a radial fracture of the left front passenger window. Slight rearward deformation was found at the left front bumper, and grill.

Outcome of Occupants of School VehiclePassengers

Of the 2 passengers, ages 7 and 10:
2 sustained MAIS 1 (minor) injuries.

Both passengers were wearing static lapbelts anchored to the seatframes. Each restraint system was equipped with adjustable, cinching latchplates and pushbutton release buckles.

The lapbelted passenger seated on the left side in the front seat next to the window received a contusion on the bridge of his nose, from contact with the left side window. At impact, he most likely pivoted around the belt, moved forward

and then to the side, striking the window. He also complained of pain in his abdomen, probably from the lap belt, and in his right leg. Had this passenger been unrestrained, he probably still would have sustained minor injuries only.

The lapbelted passenger sitting on the right side in the front seat next to the window received a contusion on his lower abdomen, caused by the lapbelt. Had he been unrestrained, he probably still would have received only minor injuries. The use of lapbelts, like all forms of seatbelts, cannot assure that the occupant will be uninjured.

Driver

The driver of the school van was wearing the available lap/shoulder belt; it was equipped with an emergency locking retractor, a cinching latchplate, a sidewall-mounted D-ring, and a pushbutton release buckle mounted to a flexible stalk. Although the driver was not injured, she complained of pain to the right knee. Had she not been wearing the three-point belt, she probably would have been thrown forward and to the left and could have received at least minor injuries. The school van driver is seated in a more hostile environment than are the passengers.

Notes About the Accident

The interior of the school van had a padded roof.

Bedford, New York
Case Number 1

Principal Direction
of Force

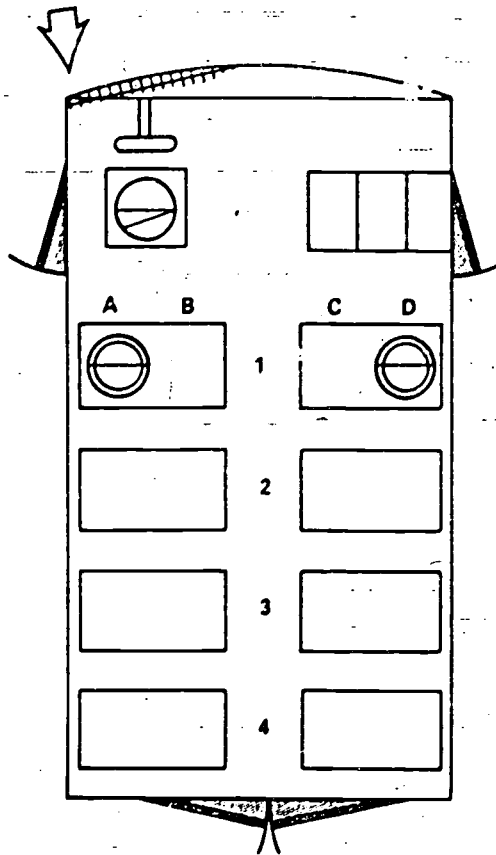

Left Side of Bus
Driver
F-44, MAIS 0
Row 1A
M-7, MAIS 1

Right Side of Bus
Row 1D
M-10, MAIS 1

LEGEND	
○ Uninjured	⊖ Lap Belt Used
⊖ Injured	⊖ Lap/Shoulder Belt Used
⊖ Fatally Injured	⊖ Lap Belt Used
⊖ Unknown if Restrained	⊖ Air Seat
	⊖ Child Safety Seat

Example: M-17, Age 17, Male. MAIS 2 listed for injured occupants seat. Maximum AIS* injury was a moderate AIS 21 injury.

AIS Code and Injury Severity

0 Uninjured	5 Critical
1 Minor	6 Maximum injury
2 Moderate	7 Injured, unknown severity
3 Serious	8 Unknown if injured
4 Severe	

* American Association for Automotive Medicine Abbreviated Injury Scale (AIS)

The school bus shown
is representational only.

Case No. 2	Safety Board Investigation No. NYC-87-H-SB04
Location of Accident	Intersection of State Route 25A and Mooreshill Road; Laurel Hollow, New York
Date and Time	February 5, 1987; 3:40 p.m.
Description of School Vehicle	Type A van conversion: 1980 Chevrolet chassis with 16-passenger body by Van Con, Inc.
Type of Accident	Left front impact
Severity of Accident	Delta V 13 mph for school van

Summary of Events

A school van transporting six students home from school, was making a left turn when it collided with a 1977 Chevrolet Malibu. After impact, the van rotated counterclockwise and came to rest upright. Safety Board investigators determined that all of the students and the driver were unrestrained at the time of the crash; two students and the driver claimed they were restrained, but evidence proved otherwise.

A 13-year-old student made an unsuccessful attempt to open the rear emergency exit. All passengers evacuated the bus through the right side door. The school van driver lay unconscious in the aisle; students had to step over her. The driver was taken to the hospital; all of the students were released to their parents at the scene and were later examined by private physicians.

The left front bumper and sheet metal of the van were displaced rearward and inboard from their normal position. The left front wheel and A-frame assembly were displaced rearward into the inner fender well, causing them and the left door to be deformed. The floor beneath the driver's seat buckled but did not present a hazard. The poststandard vehicle remained intact and provided good crash protection to the passengers.

Outcome of Occupants of School Vehicle

Passengers

Of the 6 passengers, ages 7 to 13:
 2 were uninjured, and
 4 sustained MAIS I (minor) injuries.

No passenger was wearing the lapbelt available at the seating position. Although the two students in the front row claimed they were wearing lapbelts and they had "popped open," the Safety Board investigators found no evidence to support the claims. When the lapbelts were examined, they worked properly and had no force loading scars or defects. The adjustment lengths, 42 inches for the 9-year-old girl and 41 inches for the 8-year-old boy, would be too loose to provide proper fit for the two passengers.

Four of the students received minor contusions and lacerations to their faces and upper limbs. Had the passengers been lapbelted, these injuries would still have occurred because each student could easily have reached the same contact points. Lapbelts provide no upper torso restraint.

Driver

A lap/shoulder belt was available at the driver's position. The driver claimed to have been wearing the restraint, but two passengers reported that the driver was lying in the aisle of the passenger area following the crash, indicating she had not been restrained. Her position reportedly blocked evacuation routes, and the passengers had to step over her to exit the vehicle through the right side passenger loading door. In addition, the driver received moderate (AIS 2) injuries (a cerebral concussion and a large laceration to the right side of the head), which are not consistent with lap/shoulder belt use in a frontal crash. Had the driver been wearing the lap/shoulder belt, injuries would probably have been less severe.

Notes About the Accident

The van conversion was equipped with heavily padded modesty panels forward of both the left and right front seats; no stanchions were present.

The student who attempted to open the rear emergency door did so by trying to push down on the door release handle with her right hand. In her position, the right side of her body would have been in front of the instruction decal affixed to the lower portion of the left door, blocking it from her view. The instruction decal affixed to the right rear door was also hidden from her view by the right seatback. She did not attempt to lift the door release handle, which would have opened the door.

The instruction decals had been affixed to the rear doors when the van conversion was done by Van Con, Inc. Van Con was notified of the circumstances of this accident and agreed to place decals in the immediate vicinity of the door handles on future conversions. They also agreed to implement a retrofit program for their school vans currently in use.

Laurel Hollow, New York
Case Number 2

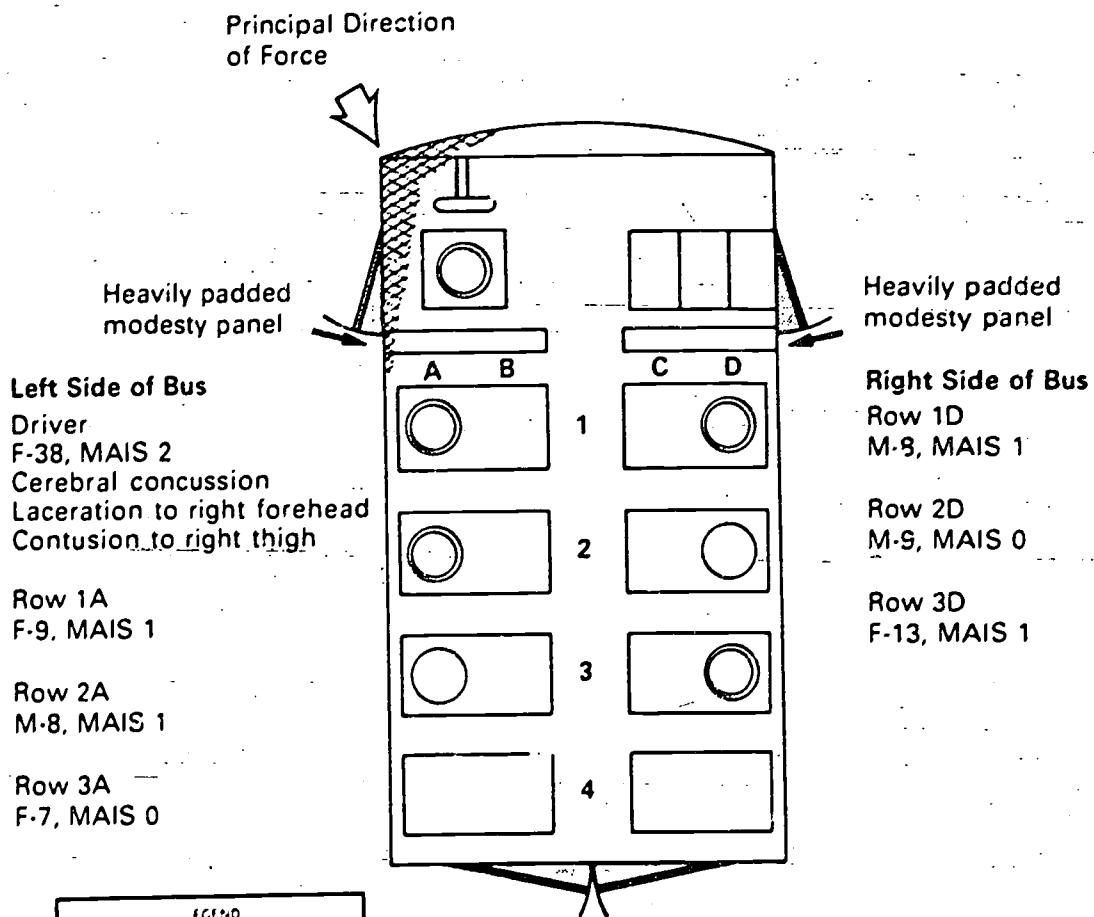

LEGEND

- Uninjured
- ⊙ Injured
- ⊙ Safety Restraint
- ⊙ Unrestrained
- ⊙ Restrainted
- ⊙ Lap Belt Used
- ⊙ Lap-Shoulder Belt Used
- ⊙ Latch Belt Used
- ⊙ Wheel Chair
- ⊙ Child Safety Seat

Example: M-11, Age 11

MAIS 2 used for injured occupants only

Maximum AIS 2 injury was a moderate AIS 2 injury

AIS Code and Injury Severity

0 Uninjured	5 Critical
1 Minor	6 Maximum injury
2 Moderate	7 Injury with permanent disability
3 Serious	8 Unrestrained or injured
4 Severe	

* American Association for Automotive Medicine
Adapted from the Scale AIS.

The school bus shown is representational only.

Case No. 3	Safety Board Investigation No. NYC-87-H-SB03
Location of Accident	Whippoorwill Road; outside New Castle, New York
Date and Time	February 2, 1987; 7:46 a.m.
Description of School Vehicle	Type A van conversion: 1983 GMC chassis with 16-passenger Sturdivan body by T.P.I.
Type of Accident	Left front impact
Severity of Accident	Estimated Delta V 5 mph

Summary of Events

A school van transporting five students to school was traveling along a road with patches of snow and ice. The driver was wearing the available lap/shoulder belt; only one of the student passengers was wearing the available lapbelt. As the van approached a cross street, an oncoming 1978 Ford sedan crossed the centerline and collided with the left front of the van. The school van came to rest in its lane near the shoulder, and the Ford was angled toward the van with its rear axle on the centerline.

After the crash, the school van driver unbuckled his belt and the lapbelt worn by one of the passengers. He led all passengers to the rear of the bus, opened the emergency exit door, and then assisted each student out of the vehicle. Three students were treated for injuries and released by the hospital.

The left front of the van was crushed inward; the maximum deformation measured 10 inches at extreme left corner. The driver's door was buckled, the left front tire was flat, the wheel was pushed rearward, and the van body was scratched along the left side behind the driver's door. This poststandard school van performed well in this collision: all of the damage was confined to the exterior, and there was no intrusion into the passenger compartment.

Outcome of Occupants of School Vehicle

Passengers

Of the 5 passengers, ages 7 to 13:

- 2 were uninjured, and
- 3 sustained MAIS 1 (minor) injuries.

Two unrestrained passengers were seated on the left: one in the front seat next to the window, and the other in the third seat from the front next to the window. Both received minor injuries, probably from contacting the sidewall. Most likely they still would have made contact had they been wearing the available lapbelts because lapbelts provide no upper torso restraint.

The only restrained passenger was sitting on the left side in the second seat from the front, next to the window. She sustained no injuries. The passenger seated directly across the aisle from her was unrestrained and sustained no injuries. Hence, evaluating the benefit of lapbelt use is difficult in this collision.

Two unrestrained passengers were sitting on the right side of the van next to the window. The one in the front seat received a laceration on the forehead, while the one in the second seat from the front was uninjured. Had the passenger in the front seat been wearing the available lapbelt, her injuries would most likely have been the same because the lapbelts are not designed to prevent minor (MAIS 1) injuries. Seating position, more than restraint use, appears to be important in this collision.

Driver

The driver of the van was restrained with a lap/shoulder belt and received a bruised left forearm and a laceration on his left knee, both minor (AIS 1) injuries. Had he not been wearing the restraint, he would have been thrown forward and to the left. Because the area surrounding the driver's seat is more hostile than that provided for the students, he might have received more serious injuries if unrestrained.

Notes About the Accident

The passengers' bench seats were equipped with manually adjustable lapbelts; some belts had pushbutton release buckles, and others had lift release type buckles. This mix of buckle releases was sometimes found installed on the same bench seat. The belts were anchored to the seatframes and were routed between the seat cushions and the seatbacks.

The school van was equipped with a padded restraining barrier with lightly padded stanchions in front of both front seats. The unrestrained passenger seated in the left front seat sustained a laceration to the lower gum and a contusion to the left eyebrow, both from contact with the barrier. The unrestrained passenger in the right front seat sustained a small triangular laceration to her forehead from contact with the barrier. Had these passengers been wearing lapbelts at the time of the crash, the same injuries, as well as other facial or head injuries, could have been sustained. Head and face injuries are not eliminated by lapbelt use. In a frontal crash, lapbelted passengers would jackknife over their lapbelts, and contact the restraining barrier.

New Castle, New York
Case Number 3

LEGEND

○ Uninjured	⊖ Leg Restraint
⊖ Injured	⊖ Leg Restraint / Belt Used
⊖ Fatigue Injured	⊖ Leg Restraint
⊖ Unrestrained Restraint	⊖ Wheel Guard
	⊖ Child Safety Seat

Example: MA 12
Male Age 12 - MAIS 2 (Seated but injured - moderate injury)
MAIS 2 (Seated but injured - moderate injury)
MAIS 2 (Seated but injured - moderate injury)
MAIS 2 (Seated but injured - moderate injury)

MAIS Code and Injury Severity

0 Uninjured	5 Critical
1 Minor	6 Maximum Injury
2 Moderate	7 Unrestrained passenger severely injured
3 Severe	8 Unrestrained passenger severely injured
4 Severe	

* American Society of Mechanical Engineers
MAIS #2000-1000-1000-1000

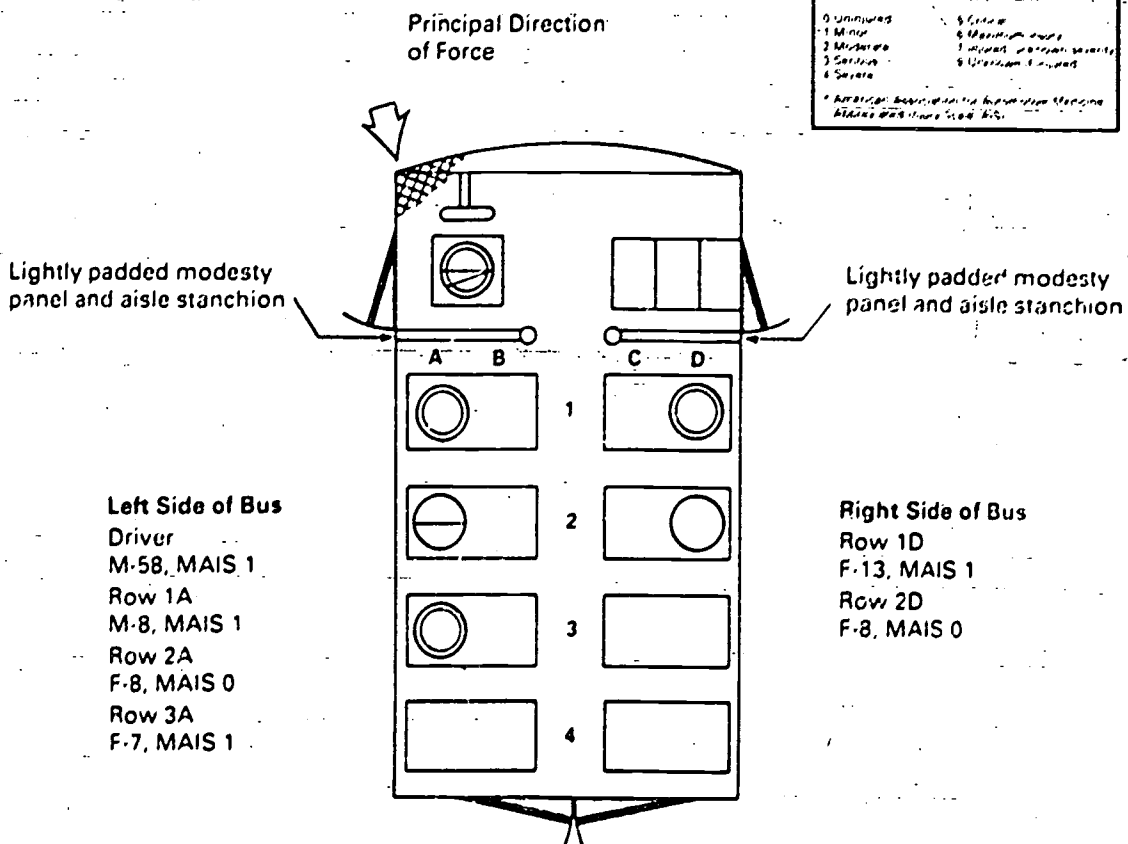

The school bus shown is representational only

APPENDIX B

88

Case No. 4	Safety Board Investigation No. LAX-87-H-SB11
Location of Accident	Normandie Avenue; Carson, California
Date and Time	May 18, 1987; 7:59 a.m.
Description of School Vehicle	Type A van conversion; 1981 Dodge chassis with 16-passenger body by Collins Bus Corporation
Type of Accident	Multiple frontal impacts
Severity of Accident	Delta V unknown

Summary of Events

A school van traveling about 45 mph was transporting seven special education students to school. The van was equipped with seatbelts for only some seats. All students were unrestrained. The driver lost control of the vehicle, which left the road and mounted the sidewalk. As the van traveled along the sidewalk, it impacted and sheared a 16-inch-diameter wooden power pole with its right front, then sheared a 5-inch-diameter light standard before striking and coming to rest against a second wooden power pole.

No information was available on exits or evacuation. The damage to the van was concentrated on the right front, with a maximum deformation of 33 inches of rearward crush. Most of the damage to the interior was in the area of the stairwell. No interior panel separations were noted. No passenger seats were within the area of deformation. This poststandard van performed well considering the severity of the collision.

Outcome of Occupants of School Vehicle

Passengers

Of the 7 passengers, ages 8 to 22:

- 1 was uninjured,
- 5 sustained MAIS 1 (minor) injuries, and
- 1 sustained MAIS 2 (moderate) injuries.

All passengers were unrestrained. Lapbelts were not available at all seating positions; only the two front benches had lapbelts installed, which had either been vandalized or stowed beneath the seat cushion.

The passenger sitting on the left side in the front seat next to the window received only minor (AIS 1) injuries: contusions and abrasions to right head, right knee, and elbow. These or similar minor injuries might also have been sustained had the passenger been wearing a lapbelt.

The passenger sitting on the right side in the front seat next to the window received a fractured leg (probably AIS 2) and multiple contusions and abrasions; detailed descriptions of the injuries were unavailable. Because the impact was from the front and concentrated on the right front corner, the passenger was probably thrown forward; no barrier (modesty panel) was present to limit forward movement. Had the passenger been wearing a lapbelt, or had a frontal barrier been present, he probably would not have fractured his leg.

The passenger seated on the left side in the fourth seat next to the aisle was uninjured. The remaining passengers (all seated adjacent to windows), received minor injuries: lacerations, abrasions, and contusions. Had lapbelts been available and been worn, these passengers would probably still have sustained minor injuries; the lapbelts would not have prevented their contact with the sidewalls and windows.

Driver

The driver was not wearing the available lapbelt. He complained of pain to the chest and right leg; the injuries could not be coded due to lack of medical diagnosis. Deformation of the upper steering wheel rim was noted. The outcome for the driver would unlikely have been much different had he been restrained because the lapbelt would not have restrained his upper torso.

Notes About the Accident

Only the driver's seat and the two front seats were equipped with any form of seatbelt. Two of the four lapbelts on the two front seats had been disabled by students. Of the eight possible attachment points for the four lapbelts, six had been rendered unsafe by tampering. Students had removed the webbing stitching that attached the latchplates.

The school van was not equipped with restraining barriers.

Carson, California
Case Number 4

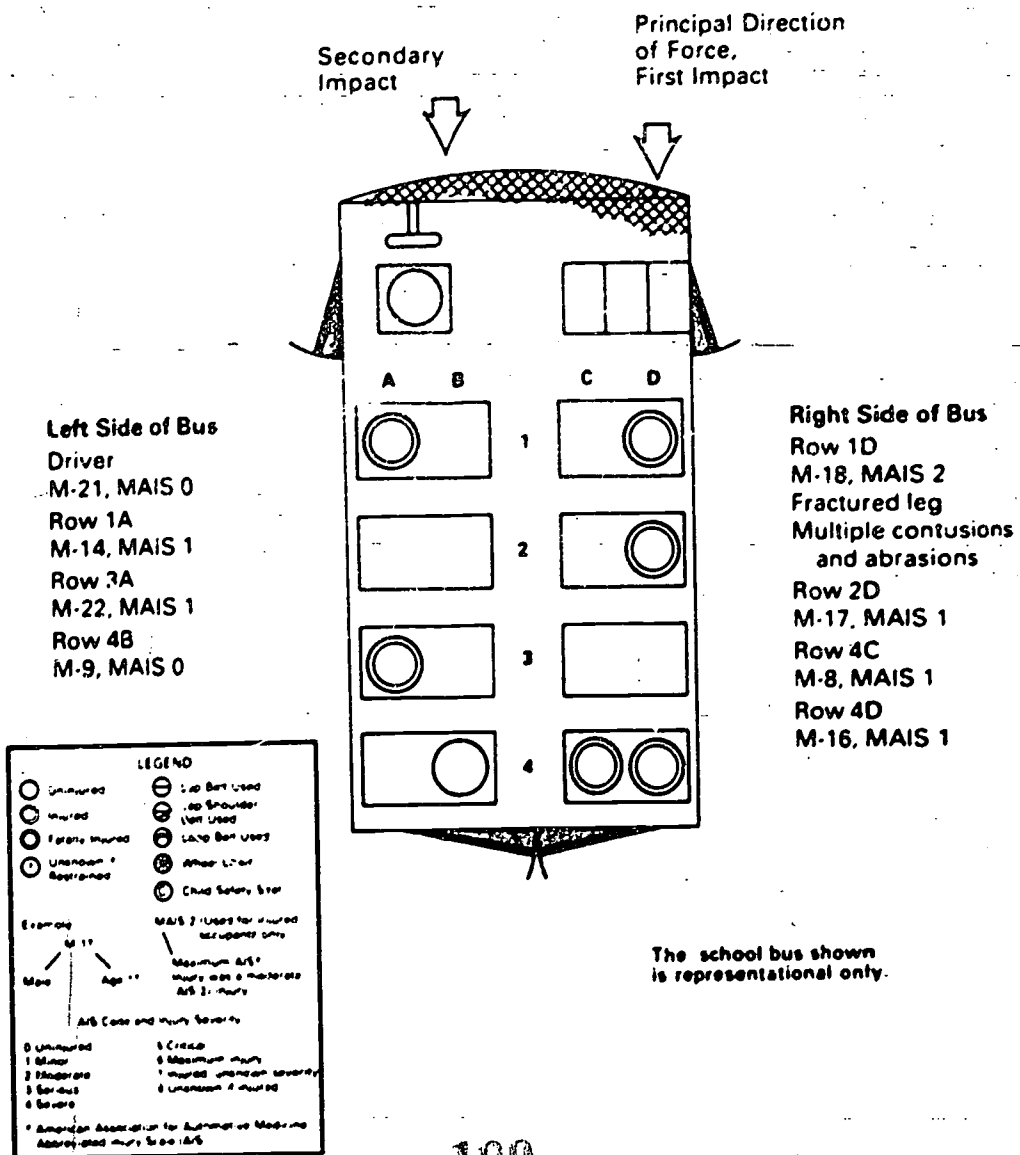

Case No. 5	Safety Board Investigation No. CHI-86-H-ORC1
Location of Accident	Midlothian Road; Lake Zurich, Illinois
Date and Time	October 10, 1985; 8:29 a.m.
Description of School Vehicle	Type A van conversion: 1984 Chevrolet chassis with 16-passenger Fortivan body by Coach and Equipment Manufacturing Corporation
Type of Accident	Head-on collision, with principal direction of force at about the 1 o'clock position
Severity of Accident	Delta V unknown

Summary of Events

A school van, equipped with lapbelts for all passengers and a lap/shoulder belt for the driver, was transporting eight elementary students to school. The driver and all but one passenger were restrained. One of the restrained passengers was misusing the lapbelt at his seat. The van was traveling about 40 mph on an urban, two-lane, two-direction wet road when, to avoid a vehicle stopped in her travel lane, the school van driver veered to the right onto the gravel shoulder. When the driver attempted to steer back onto the road, she lost control of the van on the rain-slicked pavement, and the van entered the opposite lane into oncoming traffic. The school van, traveling at a tachograph-recorded speed of 29 mph, struck the front of a Honda Civic CRX traveling toward the van. After impact, the school van traveled about 40 feet before coming to rest upright.

The driver of the van exited through the left side door. All eight passengers exited the van through the rear emergency exit without assistance.

The school van received extensive damage to its exterior right front structure, with rearward collapse reaching over 20 inches at the bumper level. The frame, axle, suspension, and sheetmetal moved rearward. The right side service door was jammed shut by damage, and the floor at the entrance step was buckled. No significant interior damage was noted within the passenger seating area of the van. The poststandard school van chassis and body performed well in this moderate speed collision, dissipating the crash forces without serious injuries to its occupants.

Outcome of Occupants of School Vehicle

Passengers

Of the 8 passengers, ages 8 to 12:
 2 were uninjured,
 4 sustained MAIS 1 (minor) injuries, and
 2 sustained MAIS 2 (moderate) injuries.

The lapbelts were equipped with pushbutton release buckles. One of the restrained passengers, however, had created a huge lapbelt by combining the latchplate from one belt system with the buckle of another on the same seat.

Both passengers sitting on the left side in the front seat were wearing lapbelts; they received minor (AIS 1) contusions and abrasions. Had neither been wearing his restraint, each probably would still have received at least minor injuries. The principal direction of force came from the 1 o'clock direction; both of these passengers would have been thrown into the modesty panel and stanchion crossbar in front of them. All components were padded, but some minor injuries probably would still have resulted. (Note: The passenger seated next to the window indicated to medical personnel that his belt came loose. The statement is not supported by the types of injuries sustained.)

Both passengers sitting on the right side in the front seat were wearing lapbelts; they received moderate (AIS 2), unspecified closed head injuries from pivoting forward at the hips and hitting their heads on the stanchion crossbar that provides the upper frame for the modesty panel. Had neither been restrained, each would have been thrown forward into the modesty panel and probably would have received at least some minor injuries. However, because most of the impact would have been spread out over the entire body, rather than concentrated on their heads, their injuries might well have been lessened.

The two passengers sitting on the left side in the second seat claimed to be wearing lapbelts; neither was injured. However, the passenger next to the aisle told the Safety Board investigator he had not actually buckled his belt; he had inserted the "tongue" of the belt into the buckle latchplate, but not far enough to engage the buckle. He also stated that as the belt opened, the passenger seated adjacent to the window grabbed him and held him in place.

The passenger sitting on the left side in the third seat next to the window was wearing a lapbelt. His only injury was a bruise from the lapbelt.

The passenger sitting in the last seat on the right side was next to the window and was misusing the restraint furnished at his seat. He had fastened the buckle from the lapbelt at one side of the seat to the latchplate from the lapbelt on the other side of the seat, forming a large lapbelt with excessive slack. He received minor (AIS 1) injuries (two bruises and a laceration to his head), from pivoting forward at the hips and striking his head on the seatback in front of him. Had he not been wearing the restraint, he probably still would have received some minor injuries from being thrown against the seatback in front of him.

Driver

The driver of the schoolbus was wearing a lap/shoulder belt equipped with dual retractors and a windowshade tension relief feature. She received minor (AIS 1) contusions and abrasions. From the driver's description, it appears that the lapbelt portion of the restraint was properly adjusted, but the shoulder strap was worn loosely over the driver's left chest, sagging to an area probably lower than that usually considered proper. Had the driver not been restrained by the lap/shoulder belt, she would have been thrown forward into the steering wheel and instrument panel, probably receiving additional minor and perhaps moderate injuries.

Notes About the Accident

Although most passengers in the school van apparently were restrained, they may not have been wearing the lapbelts correctly. These students had behavior disorders and required constant supervision. The school district furnishes no formal direction or education regarding the proper placement or snugness of restraints. The students are told by the driver to use the lapbelts and pull them "tight."

This school van was equipped with restraining barriers forward of both front seats. The panels were supported by stanchions and crossbars which, though padded, present a contact surface to passengers in the front seats.

Lake Zurich, Illinois
Case Number 5

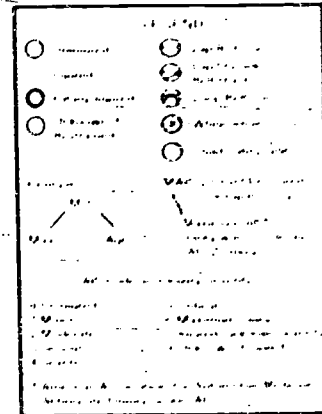

Principal Direction of Force



Lightly padded modesty panel and aisle stanchion

Lightly padded modesty panel and aisle stanchion

Left Side of Bus

- Driver
- F 51, MAIS 1
- Row 1A
- M 9, MAIS 1
- Row 1B
- M 9, MAIS 1
- Row 2A
- M 11, MAIS 0
- Row 2B
- M 11, MAIS 0
- Row 3A
- M 8, MAIS 1

Right Side of Bus

- Row 1C
- M 11, MAIS 2
- Closed head injury, unconscious less than 15 minutes
- Contusion on both knees
- Row 1D
- M 10, MAIS 2
- Cerebral concussion
- Contusion on right knee
- Row 4
- M 12, MAIS 1

Special Notes:

Passenger in Row 4 between C&D was using the buckle from one position and the latchplate from the other position

The school bus shown is representational only

Case No. 6	Safety Board Investigation No. FTW-87-F-SB15
Location of Accident	Intersection of Garey Avenue at Grand; Pomona, California
Date and Time	June 11, 1987; 2:40 p.m.
Description of School Vehicle	Type A van conversion: 1987 Dodge chassis with 16-passenger Bantam body by Collins Bus Corporation
Type of Accident	Frontal impact
Severity of Accident	Delta V unknown

Summary of Events

A small school van was transporting nine special education students on a five-lane city street. The driver and all nine student passengers were restrained by the lapbelts installed in the van. Witnesses stated that the van was traveling at about 35 mph when it veered from the second traffic lane and struck the curb. The students reported that the 72-year-old driver grasped his chest, and then slumped behind the steering wheel. The van rode along the curb for about 250 feet before overriding the curb and striking front first into an 18-inch-diameter utility pole.

No information is available on evacuation.

The poststandard school van received substantial damage to the front and left front. The 18-inch utility pole penetrated more than 20 inches into the driver's seating area. The steering column was displaced rearward, and the floor and firewall around the driver's seat were buckled. The driver's seat was also forced rearward and displaced from its mounting tracks. Induced damage was found all about the van's body; both the left and right front doors were jammed. The rear emergency exit doors and the double doors on the right side remained operational.

Outcome of Occupants of School Vehicle

Passengers

Of the 9 passengers, ages 6 to 12:
9 received MAIS I (minor) injuries.

All passengers reportedly were wearing the lapbelts available at their seating positions at the time of the crash. The Safety Board investigator was not able to confirm their restraint status, however.

All passengers reported minor (AIS 1) contusions, abrasions, and lacerations. Most of the injuries were to the face or lower limbs, with two complaints of abdominal trauma. The pattern of injuries, especially complaints of abdominal pain, are consistent with lapbelt use. Most passengers probably would have sustained injuries of similar severity had they been unrestrained, except for the passengers in the front seats. This van conversion did not have barriers installed forward of the front seats; even in this moderate speed collision, the passengers in the front seats could have suffered additional injuries if they had been thrown forward into the frontal interior and stepwells.

Driver

The lapbelt-restrained driver received critical (AIS 5) injuries that proved fatal: flailed chest, laceration of the left lung, a cardiac contusion, and multiple abrasions and lacerations. Because of the severe intrusion into the driver's compartment, the use of a lap/shoulder belt probably would not have reduced his injury level.

Notes About the Accident

This school van was not equipped with padded restraining barriers, or any type of barrier, forward of the front seats. Consequently, unrestrained passengers would be free to be move forward into the frontal interior and door stepwells. On the other hand, had restraining barriers been present, lapbelted passengers could have sustained neck and head injuries from contact with the barrier as they jackknifed forward during the frontal collision.

A review of the 22-year-old driver's medical history revealed that he had been diagnosed in 1979 as having chronic pulmonary obstruction and atherosclerotic heart disease. The autopsy report revealed 85 percent occlusion of the anterior descending branch of the left coronary artery, 75 percent occlusion of the right coronary artery, and 10-15 percent occlusion of the circumflex coronary artery.

At the time of the accident, the driver possessed a valid medical certificate for driving a school bus

Pomona, California
Case Number 6

LEGEND

○ Uninjured	⊖ Lap Belt Used
⊖ Injured	⊖ Lap Shoulder Belt Used
⊖ Fatally Injured	⊖ Loop Belt Used
⊖ Unrestrained/Restrained	⊖ Wheel Chair
	⊖ Child Safety Seat

Example: Male, 5ft 11", Age 17
 MAIS 3 (Used for injured occupants only)
 Maximum AIS* Injury: Moderate
 *AIS 2 injury

AIS Code and Injury Severity

0 Uninjured	5 Critical
1 Minor	6 Maximum Injury
2 Moderate	7 Injured, Unrestrained
3 Serious	8 Unrestrained Injured
4 Severe	

* American Association for Automotive Medicine
 Abbreviated Injury Scale (AIS)

Principal Direction of Force

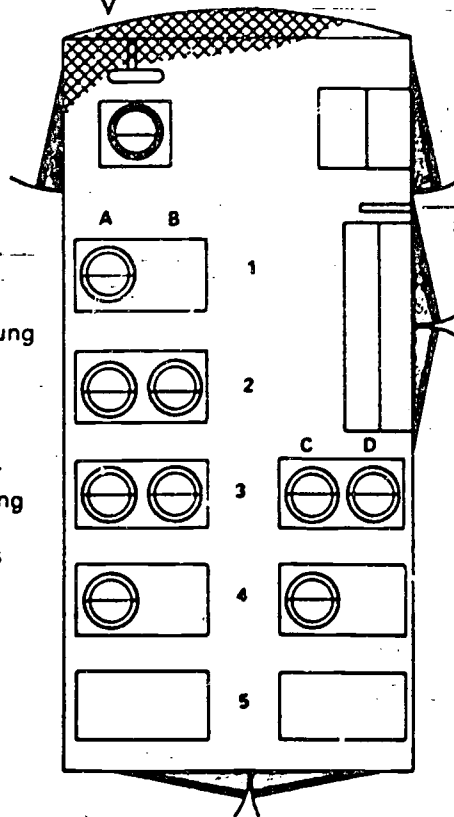

Left Side of Bus

Driver
 M-72, MAIS 5
 Lacerations of left lung with hemothorax
 Cardiac contusion
 Flail chest
 Fracture - sternum
 Fracture - left femur
 Contusion - right lung
 Multiple abrasions
 Multiple lacerations

Row 1A
 F-12, MAIS 1

Row 2A
 F-11, MAIS 1

Row 2B
 F-8, MAIS 1

Row 3A
 M-7, MAIS 1

Row 3B
 M-13, MAIS 1

Row 4A
 M-9, MAIS 1

Right Side of Bus

Row 3C
 F-9, MAIS 1

Row 3D
 M-6, MAIS 1

Row 4C
 M-8, MAIS 1

Special Notes:
 The restraint status of all passengers could not be confirmed.

The school bus shown is representational only.

Case No. 7	Safety Board Investigation No. CHI-85-H-0R06
Location of Accident	128th Avenue and 26th Street; Allegan, Michigan
Date and Time	December 5, 1984; 12:15 p.m.
Description of School Vehicle	Type A van conversion: 1978 Chevrolet chassis with 16-passenger body by Sheller-Globe Corporation
Type of Accident	Head-on collision
Severity of Accident	Delta V unknown

Summary of Events

A school van was transporting seven Head Start students. All passengers were restrained: three by lapbelts and four by child safety seats. The driver was wearing the available lapbelt. The van was traveling on a two-lane, two-way rural highway when an oncoming tractor/trailer combination unit (27,710 pounds) crossed over the centerline into the school van's lane. When the truckdriver braked, attempting to get out of the path of the school van, the trailer unit jackknifed and rotated counterclockwise. The van struck the trailer head-on with its extreme left front, striking the right drive axle of the tractor and crushing in the entire front structure of the van. At impact, the van rotated counterclockwise 90 degrees, traveled 38 feet backward, and came to rest upright.

The driver of the van was pinned in the wreckage and was unable to assist with evacuation of the passengers. At least two of the passengers were removed from the van by passersby; the rest were removed by emergency response personnel and other persons assisting at the accident scene.

The front structure of the school van was destroyed, with structural collapse reaching a depth of more than 35 inches at the exterior left front, past the driver's compartment, ending just forward of the first row of passenger seats. No major damage was noted to the passenger seat framework or to the van interior behind the restraining barrier. Restraining barriers mounted just behind the driver's seat and the loading door were displaced rearward at their bottom attachments due to the buckling of the passenger compartment floor. This rearward displacement probably increased the severity of contact for passengers in the front seats.

Most of the damage to the poststandard school van in this severe crash was sustained at the driver's compartment. The integrity of the passenger compartment was not violated and, considering the impact forces involved, the passengers fared well. From severity of the crash and difference in vehicle weights, the van driver had little chance of survival; she was fatally injured.

Outcome of Occupants of School Vehicle

Passengers

Of the 7 passengers, ages 3 to 4:

- 4 sustained MAIS 1 (minor) injuries,
- 2 sustained MAIS 2 (moderate) injuries, and
- 1 sustained MAIS 3 (serious) injuries.

Three of the passengers were restrained by lapbelts; four others were in child safety seats secured to the bench seats by lapbelts.

The major impact forces of this collision acted at the extreme front of the van. While the front stopped in a very short distance, the rear rotated very rapidly away from the direct force line. This increased the distance over which the rear of the van decelerated, in effect, greatly reducing the G forces at the seating positions nearer the rear of the van.

The most seriously injured passengers were seated in the front area of the van; all moderately injured passengers were seated along the left side. Injuries to the children in the front seats were a direct result of the collapsing front structure; the other passengers in the van were injured by contact with the seats in front of them. Most of the passengers who sustained minor injuries were seated at the rear and right rear of the van, the portion of the passenger compartment that experienced less crash forces.

The passenger on the left side in the front seat next to the window, in a Ford Tot Guard child safety seat, sustained serious (AIS 2) injuries: fractures of left arm and leg. The passenger on the right side in the front seat next to the window, also in a Ford Tot Guard child safety seat, sustained serious (AIS 3) injuries: displaced fractures of left leg. Had these two passengers not been restrained, they probably would have been propelled into the collapsing sheetmetal and would have sustained more serious injuries.

The passenger on the left side in the second seat next to the window, restrained by a lapbelt, sustained minor (AIS 1) injuries: contusions and abrasions, attributed principally to the lapbelt. This passenger might have been more seriously injured had the restraint not been used.

The lapbelted passenger seated on the left side in the third seat next to window sustained a moderate (AIS 2) injury (fracture of the left wrist) and minor contusions from the lapbelt. This passenger could have been more seriously injured had she been unrestrained.

The lapbelted passenger on the right side in the third seat next to the window sustained minor (AIS 1) injuries: contusions and abrasions. His injuries might have been more serious had he been unrestrained.

The passengers of both fourth row seats next to the windows were in Ford Tot Guard child safety seats. Both received minor (AIS 1) injuries: contusions and abrasions. The child safety seats worked well in preventing additional or more serious injuries.

Driver

The driver used the available lapbelt. Because of the structural collapse that occurred at impact, the driver received multiple traumatic injuries that proved fatal. Specific injuries listed by emergency room records included near amputation of the left arm and left leg (AIS 3), multiple lacerations about the abdomen and face, and facial contusions. Restraint use was irrelevant for the driver because no survivable space remained at his seating position.

Notes About the Accident

This school van was equipped with well-padded restraining barrier forward of both front bench seats.

Allegan, Michigan
Case Number 7

LEGEND

○ Uninjured	⊖ Lap Belt Used
⊖ Injured	⊖ Lap/Shoulder Belt Used
⊖ Fatally Injured	⊖ Wide Belt Used
⊖ Injured & Restrained	⊖ Air Seat
	⊖ Child Safety Seat

Example: M-11, Age 11
 Maximum AIS
 Injured was a Moderate AIS 2 injury

AIS Code and Injury Severity

0 Uninjured	5 Critical
1 Minor	6 Maximum Injury
2 Moderate	7 Injured, unknown severity
3 Serious	8 Unavailable/Injured
4 Severe	

* American Association for Automotive Medicine Approved Injury Scale & S*

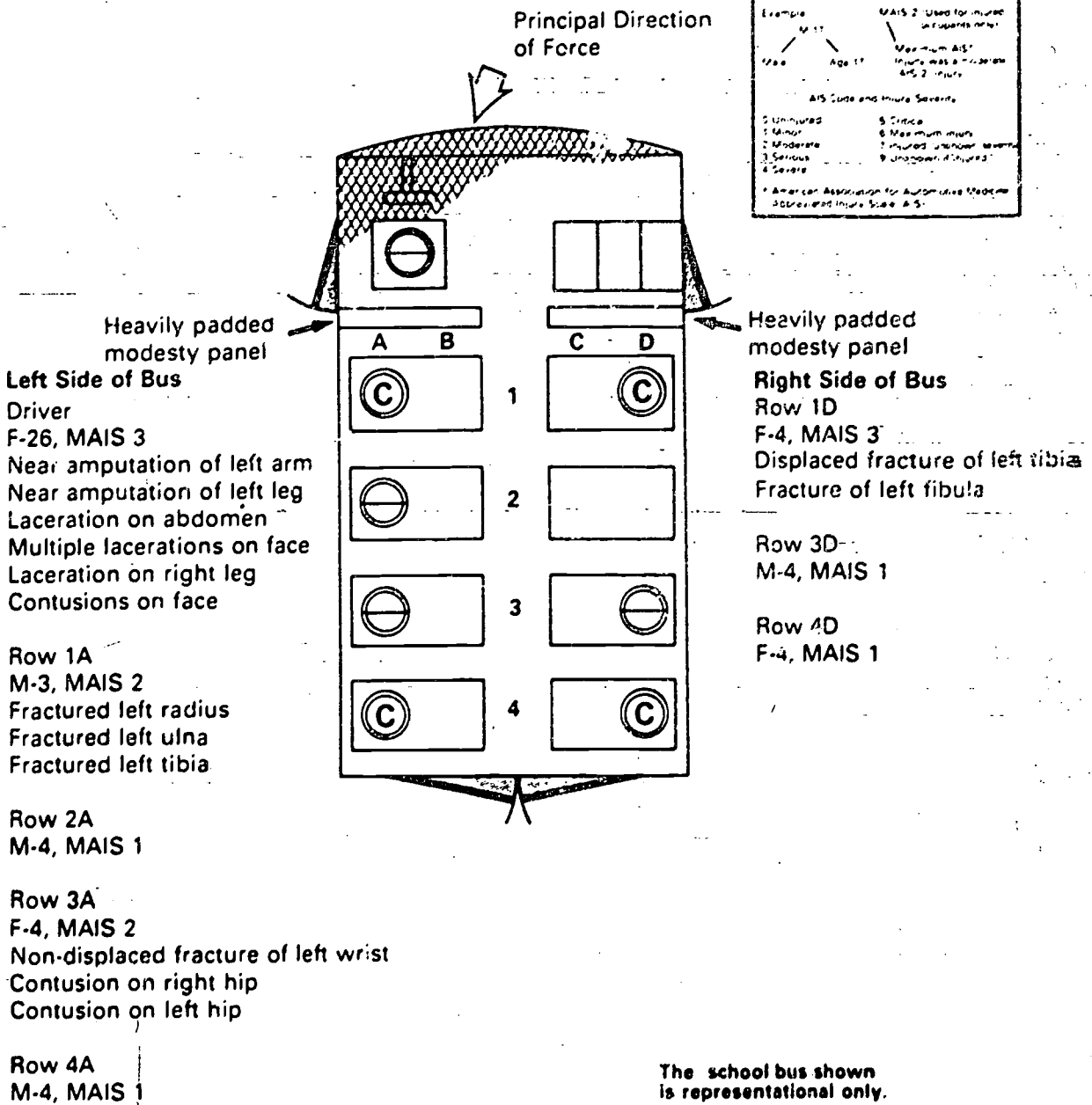

Case No. 8 Safety Board Investigation No. MKC-84-H-SB21

Location of Accident An unnumbered Webster County road; outside Fort Dodge, Iowa

Date and Time March 15, 1984; 12:25 p.m.

Description of School Vehicle Type A van conversion: 1980 Chevrolet chassis with 16-passenger body by Superior Coach International

Type of Accident Noncollision rollover (90°)

Severity of Accident Delta V not calculable

Summary of Events

A school van, equipped with lapbelts for all occupants, was transporting two kindergarten students home from school on a wet, two-lane, two-way gravel road. All occupants were unrestrained. The driver allowed the van to travel to the left edge of the road and then back across the road to the right edge. The van then veered back to the left, rotating counterclockwise 180°, and overturned onto its right side in a ditch. The driver was partially ejected and crushed.

The two passengers opened the rear emergency door and exited the van.

The interior of the poststandard school van was not damaged, and only minor damage occurred to the exterior. The boarding door, which had been partially open as the bus rolled over, was damaged as was the right rear corner of the school van. The structure of the van held up well in the rollover. Crush forces were minor. No panel separations occurred, and the vehicle body was not distorted.

Outcome of Occupants of School Vehicle

Passengers

Of the 2 passengers, age 6:
2 were uninjured.

One passenger had been on the right side in the second row next to the window; the other was on the left in the third row next to the window. The passenger in row 3 probably slid to the right side during the rollover. Neither of them was wearing the available lapbelts. The passengers told the Safety Board investigators they had never been instructed or encouraged to use the available belts. (The school district policy, as stated by the bus supervisor, is that if a seatbelt is available, it is to be worn.) Because both passengers were uninjured, their lapbelt use in this accident would not have been of benefit.

Driver

The driver of the school van received injuries that proved fatal: chest compression syndrome. As the van rolled to the right, the unrestrained driver probably fell out of her seat and against the boarding door. The driver was partially ejected and then crushed under the door frame as the bus came to rest on its right side. If the driver had worn the available lapbelt, her ejection and resulting death could have been prevented.

Notes About the Accident

The school van was equipped with padded restraining barriers forward of the front row of seats.

The passenger loading door latch consisted of a handle near the center of the vehicle that is connected to the door by a long rod. The handle latches the door closed by being swung past center in an arc. The handle is easily bumped or jarred past center, allowing the door to open; several other drivers in the school district stated that, on rough roads, the latch did not keep the door from opening. The Safety Board found that the door handle on the accident van moved easily out of the locked position. A positive latch on the door handle could prevent this occurrence.

The unrestrained driver either may have bumped or grabbed the door handle of the passenger boarding door as she fell against the door. Thus, she may have unlocked the door, permitting her ejection.

See also cases 11, 15, 17, and 19.

Fort Dodge, Iowa
Case Number 8

Rollover

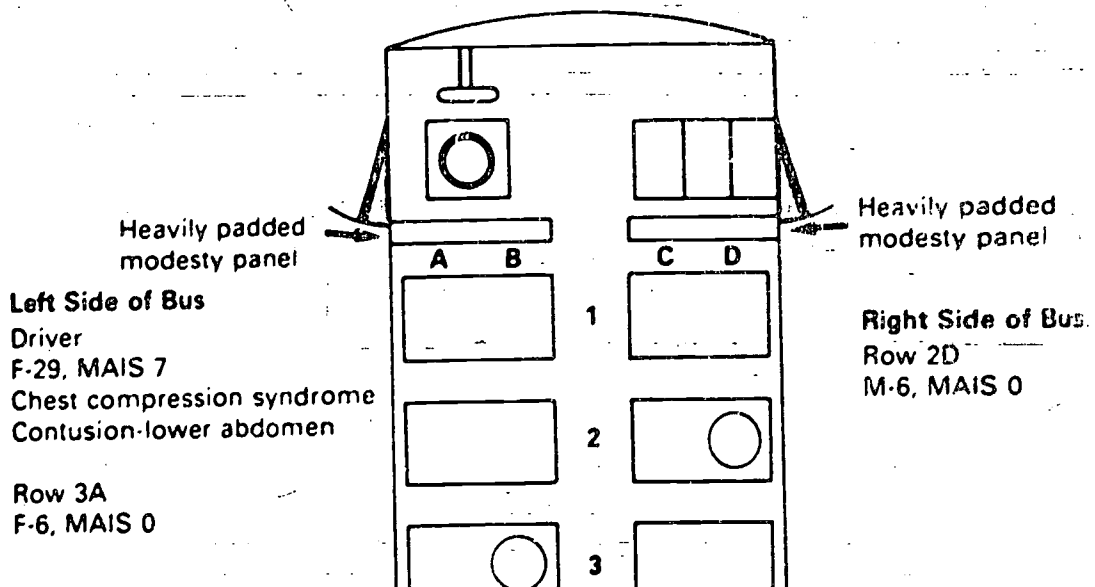

Left Side of Bus
 Driver
 F-29, MAIS 7
 Chest compression syndrome
 Contusion-lower abdomen

 Row 3A
 F-6, MAIS 0

Right Side of Bus:
 Row 2D
 M-6, MAIS 0

LEGEND

○ (empty)	○ (filled)	○ (filled)	○ (filled)
○ (empty)	○ (filled)	○ (filled)	○ (filled)
○ (empty)	○ (filled)	○ (filled)	○ (filled)
○ (empty)	○ (filled)	○ (filled)	○ (filled)

Example:
 M-11
 Male
 Age 11

MAIS 2 - used for injured
 MAIS 0 - used for uninjured

Maximum AIS
 MAIS 6 - 6 or more AIS
 MAIS 7 - 7 or more AIS

AIS Code and Injury Severity

0 Uninjured	3 Critical
1 Mild	4 Maximum
2 Moderate	5 Injured (Permanent)
3 Serious	6 Permanent (Severe)
4 Severe	

* American Association of Motor Vehicle Administrators
 Addressed: 4400 North Lincoln Ave., Schaumburg, IL 60196

The school bus shown is representational only.

Case No. 9	Safety Board Investigation No. LAX-87-H-SB08
Location of Accident	State Route 134; Los Angeles, California
Date and Time	April 8, 1987; 8:30 a.m.
Description of School Vehicle	Type A van conversion; 1976 Ford school van configured for 16 passengers
Type of Accident	Noncollision rollover (90°)
Severity of Accident	Delta V not calculable

Summary of Events

A school van, transporting three special education students, was traveling on a four-lane freeway at a driver-estimated speed of 35 mph. All occupants were reported to be restrained by the lapbelts available at each seating position. The driver had to brake suddenly, the van skidded forward, and the driver made a sharp right turn to avoid collision with a vehicle ahead. The school van rotated 180° clockwise and overturned onto its left side.

The driver exited through the right door of the bus. Two of the passengers were able to release their lapbelts and extricate themselves. One passenger was unable to release the belt and was helped by the driver. A passerby also helped the passengers exit the bus through the right front door.

Damage to the poststandard school vehicle was slight and was limited to minor denting at the D pillar, displacement of the overhead signs and the left side mirror, and minor sheet metal scraping. The driver's door window and the front section of a left side adjustable window shattered. No interior damage was evident. The van performed well in this low speed rollover.

Outcome of Occupants of School Vehicle

Passengers

Of the 3 passengers, ages 12 to 15:
3 were uninjured.

Although no one was injured, one passenger complained of leg pain.

Reliable information was not available about the exact seating position of the passengers; the lapbelts displayed no force loading marks to confirm restraint use. Had the passengers been unrestrained, the injury outcome probably would have been similar in this low speed rollover, but analysis is hindered by lack of information about seating position.

Driver

The lapbelt-restrained driver was not injured, but she did experience neck pain. Had she not been restrained, injury outcome probably would have been similar.

Los Angeles, California
Case Number 9

Rollover

Driver
F-36, MAIS 0

Seating position of
passengers is unknown

All reported wearing lap
belts, and all were uninjured

M-12, MAIS 0

M-14, MAIS 0

M-15, MAIS 0

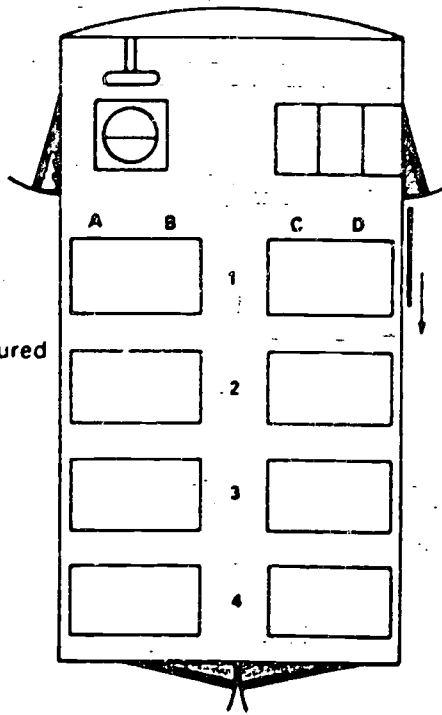

LEGEND

○ Uninjured	⊕ Lap Belt Used
○ Injured	⊕ Lap/Shoulder Belt Used
⊙ Fatally Injured	⊕ Lap Belt Used
○ Uninjured & Reprimanded	⊕ Child Seat
	⊕ Child Safety Seat

Example: M-11
Max Age 11
MAIS 2 Used for injured occupants only
Maximum AIS 1
None, use a moderate AIS 2 None

AIS Code and Injury Severity

0 Uninjured	6 Critical
1 Minor	7 Maximum Injury
2 Moderate	8 Injured, unknown severity
3 Serious	9 Unknown Injury
4 Severe	

* American Association for Automotive Medicine
Approved July 1, 1985

The school bus shown
is representational only

Case No. 10	Safety Board Investigation No. NYC-85-H-SB10
Location of Accident	Southern State Parkway; outside New York City, New York
Date and Time	April 19, 1985; 3:30 p.m.
Description of School Vehicle	Type A van conversion: 1978 Dodge chassis with 16-passenger Fortivan body by Coach and Equipment Manufacturing Corporation
Type of Accident	Noncollision rollover (270°)
Severity of Accident	Delta V not calculable (driver reported she was traveling 45 mph before loss of control)

Summary of Events

A school van was transporting 10 learning-disabled students and an adult aide home from school on a rainy day. Only one passenger and the driver were restrained. As the van negotiated a curve, at a driver-estimated speed of 45 mph, the driver lost control and the van struck the curb of the center median. The van rolled over onto its left side in the median, continued to roll until it completed three-quarters of a revolution, and came to rest on its right side.

The 10 students were evacuated through the rear emergency door; the driver and aide evacuated the van through the front windshield area (the windshield had been dislodged).

The top portion of the poststandard van was shifted slightly to the right and showed scratch marks from the rollover. Two sections of sheet metal on the midsection of the inside roof had separated, exposing the edges of the metal. The seats on the right side were undamaged. The seatbacks on the left side were pushed slightly inboard. The left side window frames were displaced toward the center about 7 inches and were up against the seatbacks. The padded restraining barriers were dislodged from their anchors.

Outcome of Occupants of School Vehicle

Passengers

Of the 11 passengers, a 26-year-old aide and 10 students, ages 9 to 13:
 2 were uninjured,
 8 sustained MAIS 1 (minor) injuries, and
 1 sustained MAIS 2 (moderate) injuries.

Only 1 of the 11 passengers was restrained although a lapbelt was available at every seating position. The lapbelted passenger was seated on the right side in the second row next to the window, and reportedly was uninjured.

Of the 10 unrestrained passengers, only one received more than minor injuries: the student seated in row 1 on the left aisle received a moderate (AIS 2) injury (a fractured left clavicle, contact point unknown) and a contusion on the left shoulder (AIS 1) from contact with a window frame. Lapbelt use might have reduced the moderate injury to a minor one, because the fractured clavicle most likely occurred when the passenger fell from the left to the right side of the van during rollover.

Difference in the minor injuries sustained by the other unrestrained passengers would have been unlikely had lapbelts been used. In a rollover of more than 180°, passengers sitting next to the windows will likely strike their heads, arms, and legs against the vehicle interior, even if lapbelted.

The adult aide received the most extensive assortment of minor (AIS 1) injuries of any passenger: lacerations to the right side of head, abrasions on left wrist, contusion to left leg, contusion near right eye, and laceration to left elbow. She had been seated on the right side in the first row next to the window.

The initial ground contact was on the left side, near the top of the windows. Passengers seated on the left side of the poststandard van would have sustained more severe initial impact.

Driver

The driver of the school van was wearing the available lapbelt and received minor (AIS 1) injuries: contusions on abdomen (from lapbelt) and laceration on bridge of nose (contact unknown). It is difficult to determine whether the injuries would have been different had the driver not been wearing the belt.

Notes About the Accident

Analysis of injuries based on official police reports can be misleading. The New York police accident report filed with the Department of Motor Vehicles lists 8 of the 10 students in the bus as having no visible injury. The Safety Board investigator however, determined that two students were uninjured, seven had minor injuries, and one sustained moderate (AIS 2) injuries.

An adult aide had been provided by the school district to ride the school van to assist the driver with the special education students. One of the aide's duties is to instruct the children to buckle up (the aide is not asked to physically fasten their seatbelts). Despite this charge, the aide and 9 of the 10 students were unrestrained at the time of the accident. Because the lapbelts on this bus were manually adjustable, students would have to adjust the belts before they would fit properly.

One of the poles supporting the restraining barriers came loose, leaving an exposed anchor point in the ceiling that could have caused injury to the passengers. One unrestrained passenger is known to have struck the ceiling, but not at this location.

This van, retrofitted to Federal school bus standards, held up relatively well during the rollover. Although the roof panels separated, exposing edges of sheet metal, they apparently did not injure any of the passengers. Such panel separations pose a hazard to passengers.

Nassau County, New York
Case Number 10

LEGEND

○ Uninjured	⊖ Lap Belt Used
⊖ Injured	⊖ Lap Shoulder Belt Used
⊖ Fatally Injured	⊖ Loop Brake Used
⊖ Unknown or Restrained	⊖ Wheel Coat
	⊖ Child Safety Seat

Example: M 17 (Male) Age 17
 - MAIS 2 - Used for injured occupants only
 - Maximum AIS* Injury was a moderate AIS 2 injury

AIS Code and Injury Severity

0 Uninjured	5 Critical
1 Minor	6 Maximum injury
2 Moderate	7 Injured, unknown severity
3 Serious	8 Unknown injury
4 Severe	

* American Association for Automotive Medicine Abbreviated Injury Scale (AIS)

Rollover

Lightly padded modesty panel with aisle stanchion

Lightly padded modesty panel with aisle stanchion

Left Side of Bus

- Driver
- F-38, MAIS 1
- Row 1A
- F-12, MAIS 1
- Row 1B
- F-11, MAIS 2
- Fractured left clavicle
- Contusion on left shoulder
- Row 2A
- F-9, MAIS 1
- Row 3A
- F-12, MAIS 0
- Row 4A
- M-11, MAIS 1
- Row 4B
- M-10, MAIS 1

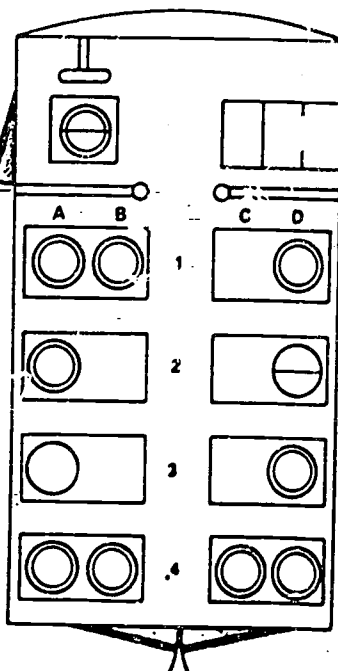

Right Side of Bus

- Row 1D
- F-26, MAIS 1
- Row 2D
- F-12, MAIS 0
- Row 3D
- M-13, MAIS 1
- Row 4C
- M-11, MAIS 1
- Row 4D
- F-10, MAIS 1

The school bus shown is representational only.

Case No. 11	Safety Board Investigation No. NYC-87-H-SB05
Location of Accident	Palmer Road; Denville, New Jersey
Date and Time	March 9, 1987; 8:40 a.m.
Description of School Vehicle	Type A van conversion: 1986 Chevrolet chassis with 16-passenger van body by Van Con, Inc.
Type of Accident	Multiple frontal impacts, followed by rollover (90°)
Severity of Accident	Delta V 10 mph for initial pole impact.

Summary of Events

A school van, transporting six students to school, was negotiating a right curve on a two-lane roadway when the driver lost control of the vehicle. The van traveled onto the left shoulder, struck two utility poles, rolled over onto its right side, and came to rest. Four of the passengers were restrained by lapbelts; the driver was restrained by a lap/shoulder belt.

After the crash, the driver unbuckled his lap/shoulder belt and walked over the passenger seats to the rear of the van, opened the emergency exit door, and assisted each student out of the van. The driver and students then waited at the side of the road for the police to arrive.

The poststandard van sustained moderate damage to the left and right front fenders from contact with the utility poles. Only minor damage occurred to the van body from the rollover. There was a minor separation of the inner sheet metal from the window frame of the rearmost window on the right side and at the right front behind the passenger loading door. The boarding door had opened during rollover. The flooring was buckled underneath the driver's seat and the engine cover. The instrument panel between the engine cover and steering column was cracked, and the right side passenger door control arm was deformed. Blood and hair were embedded in the second window frame on the right side.

Outcome of Occupants of School Vehicle

Passengers

Of the 6 passengers, ages 5 to 18:
 4 were uninjured, and
 2 sustained MAIS 1 (minor) injuries.

Four of the six student passengers were restrained with static lapbelts. Of the two passengers that were injured, one was wearing a lapbelt and one was unrestrained. Both were seated on the right side, and both received minor (AIS 1) contusions and abrasions to the right side of their bodies. Passengers on the left side of the vehicle (the high side of the vehicle during the rollover), were uninjured; two were lapbelted and one was unrestrained.

There appears to be no correlation between belt use or nonuse and the injuries sustained in this accident.

Driver

The driver, who was restrained by a lap/shoulder belt, sustained a minor (AIS 1) contusion to his left knee. This injury was probably caused by the deceleration when the bus struck the first utility pole. The lap/shoulder belt may have prevented additional injuries to this driver.

Notes About the Accident

The passenger seats were equipped with manually adjustable lapbelts that had cinching-type, lift release-type buckles. The belts were anchored to the seat frames and were routed between the seat cushions and seatbacks.

It appears that the right side passenger loading door opened during the collision; the door control arm did not have locking mechanism. Although the open door did not result in additional injuries in this accident, it did present a potential hazard by creating an opening through which an occupant could have been ejected. (See case 8, Fort Dodge, Iowa.)

Denville, New Jersey
Case Number 11

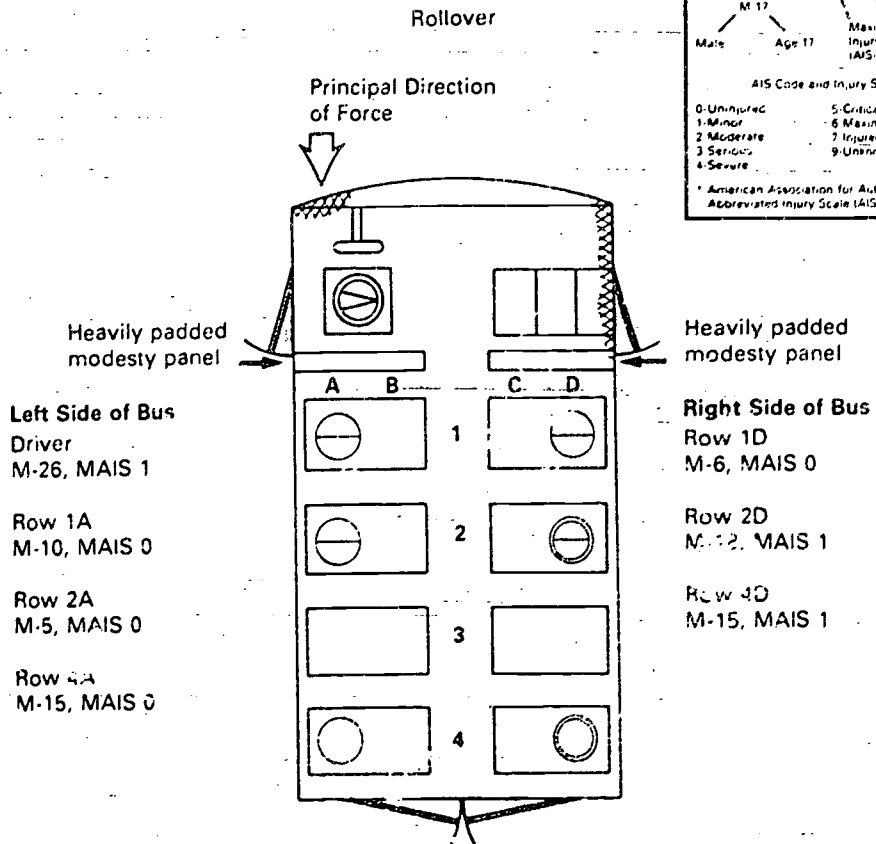

LEGEND

○ Uninjured	⊖ Lap Belt Used
⊖ Injured	⊖ Lap Shoulder Belt Used
⊖ Fataally Injured	⊖ Long Belt Used
⊖ Unknown if Restrained	⊖ Wheel Chair
	⊖ Child Safety Seat

Example: M 17 Male, Age 17, MAIS 2 (Used for injured occupants only). Maximum AIS* Injury was a moderate (AIS 2) injury.

AIS Code and Injury Severity

0 - Uninjured	5 - Critical
1 - Minor	6 - Maximum injury
2 - Moderate	7 - Injured, unknown severity
3 - Serious	8 - Unknown if injured
4 - Severe	

* American Association for Automotive Medicine Abbreviated Injury Scale (AIS)

The school bus shown is representational only.

Case No. 12	Safety Board Investigation No. SEA-87-H-S805
Location of Accident	West Powell Boulevard; Gresham, Oregon
Date and Time	January 14, 1987; 1:08 p.m.
Description of School Vehicle	Type A van conversion: 1979 Dodge chassis with 14-passenger Sturdivan body by T.P.I. (van was painted brown)
Type of Accident	Frontal impact, followed by rollover (90°)
Severity of Accident	Delta V 21.7 mph

Summary of Events

A school van, equipped with lapbelts for all occupants, was transporting 11 Head Start students home from school, traveling at a witness-estimated speed of 40 mph. Of the 11 passengers, 10 were wearing lapbelts; the driver was unrestrained. The driver lost control of the van on a two-lane asphalt road; the vehicle crossed over into the opposing lane, left the road, and jumped a curb. After it struck a large brick and concrete pillar, the van slowly rolled over onto its left side and came to rest.

A passerby saw the van turn over, went to the bus, entered through the front windshield (which had been displaced), and began helping students out of the van. She handed them to another passerby standing outside the bus. She later recalled finding one student dangling from the belt but could not recall if other students were in such position.

The van sustained most of its damage to the front end, just to the right of center, with the maximum crush measuring 29 inches. Minor scratches and dents were noted on the left side. Considering the severity of the impact, this poststandard school van performed well. All of the damage was confined to the exterior of the vehicle. The entire windshield was displaced during the accident.

Outcome of Occupants of School Vehicle

Passengers

Of the 11 passengers, ages 4 to 5:
 1 was uninjured,
 9 sustained MAIS 1 (minor) injuries, and
 1 sustained MAIS 2 (moderate) injuries.

Of the 11 passengers, 10 were wearing lapbelts; the unrestrained passenger was the only one uninjured.

The two lapbelted passengers on the left side in the first seat received minor injuries. Both had bruises on their abdomens from the lapbelts; the passenger next to the window had bruises and abrasions on her face, most likely caused by hinging forward at her hips and striking the restraining barrier with her head; the other, seated next to the aisle, received a laceration on his left hand and abrasions on his left hand and right knee. He probably hit the restraining barrier and his knee. Had these passengers not been wearing lapbelts, their injuries probably still would have been minor.

The front seat on the right side was occupied by two lapbelted passengers. The 5-year-old next to the aisle was the only passenger who received a moderate injury, a concussion, the worst injury sustained in this crash. His head injuries were probably caused when he "jackknifed" forward at the hips and his head struck the restraining barrier in front of him. His other injuries consisted of bruises on his face, a laceration on the inside of his lower lip, and a bruise on his right arm. He also had abrasions on his abdomen from the lapbelt. Had he not been wearing the lapbelt, he most likely would have hit the restraining barrier with his entire body. The forces would have been distributed over a larger portion of his body, and his injuries might have been only minor (MAIS 1).

The other passenger in the front seat on the right side, next to the window, sustained bruises and a minor abrasion to the head and complained of abdominal pain for 5 days after the accident, probably from the lapbelt. Had this passenger been unrestrained, the injuries might have been different but probably still would have been minor.

Both lapbelted passengers in the second seat on the left side received minor injuries. The passenger next to the window had abrasions on the right side of his head, probably from hitting the back of the seat in front of him. The passenger next to the aisle received a small laceration on the left ear, an abrasion on her chin, and a bruise on her right shin. Both complained of abdominal pain. Had neither of these passengers been wearing the lapbelts, they most likely would have been thrown forward into the seat in front of them and still would have received at least minor injuries.

The only unrestrained passenger, sitting in the second seat on the right side next to the aisle, was the only passenger not injured. Although he told the investigator he was wearing his lapbelt, two other passengers stated he was not. He also had no abdominal bruises or pain. Had he been wearing the available lapbelt, he might have experienced some abdominal pain or bruising.

The other passenger in the seat, next to the window, received abrasions on the right side of her head and contusions from the lapbelt. The head injuries were probably caused by hitting the seatback in front of her as she hinged forward from her hips. Had she not been wearing the lapbelt, her injuries might have been different but still would have been minor.

The remaining lapbelteD passengers were sitting in the third seat: one on the left side next to the window, and two on the right side. All three received bruises around the abdomen, caused by the lapbelts. Other injuries were contusions and abrasions on the face, most likely caused by striking the back of the seat in front as they jackknifed forward from their hips. Had they not been wearing the lapbelts, the energy of impact with the seatback in front of them would not have been concentrated on their faces and heads, but they probably still would have received minor injuries.

Driver

The driver was not wearing the available lapbelt. She was thrown forward on impact and most likely contacted the windshield and/or steering wheel, causing AIS 1 abrasions, lacerations, and bruises on her face. The contact with the steering wheel and the bruise on her right thigh could have been resulted from hitting the engine cover. Had she been wearing the lapbelt, she probably still would have received some minor injuries.

Notes About the Accident

The driver told the Safety Board investigator that she had been distracted by the students' behavior immediately before the accident. She said she was playing a tape on school bus safety at the time of the accident. She also related that this group of students was the most unruly of the groups she drove, and that no parents ride on this run (on other runs, parents ride along, which helps with discipline). This van was equipped with lapbelts and all passengers but one were belted at the time of the accident. The driver, however, was not wearing her lapbelt.

The school van was equipped with padded restraining barriers.

Gresham, Oregon
Case Number 12

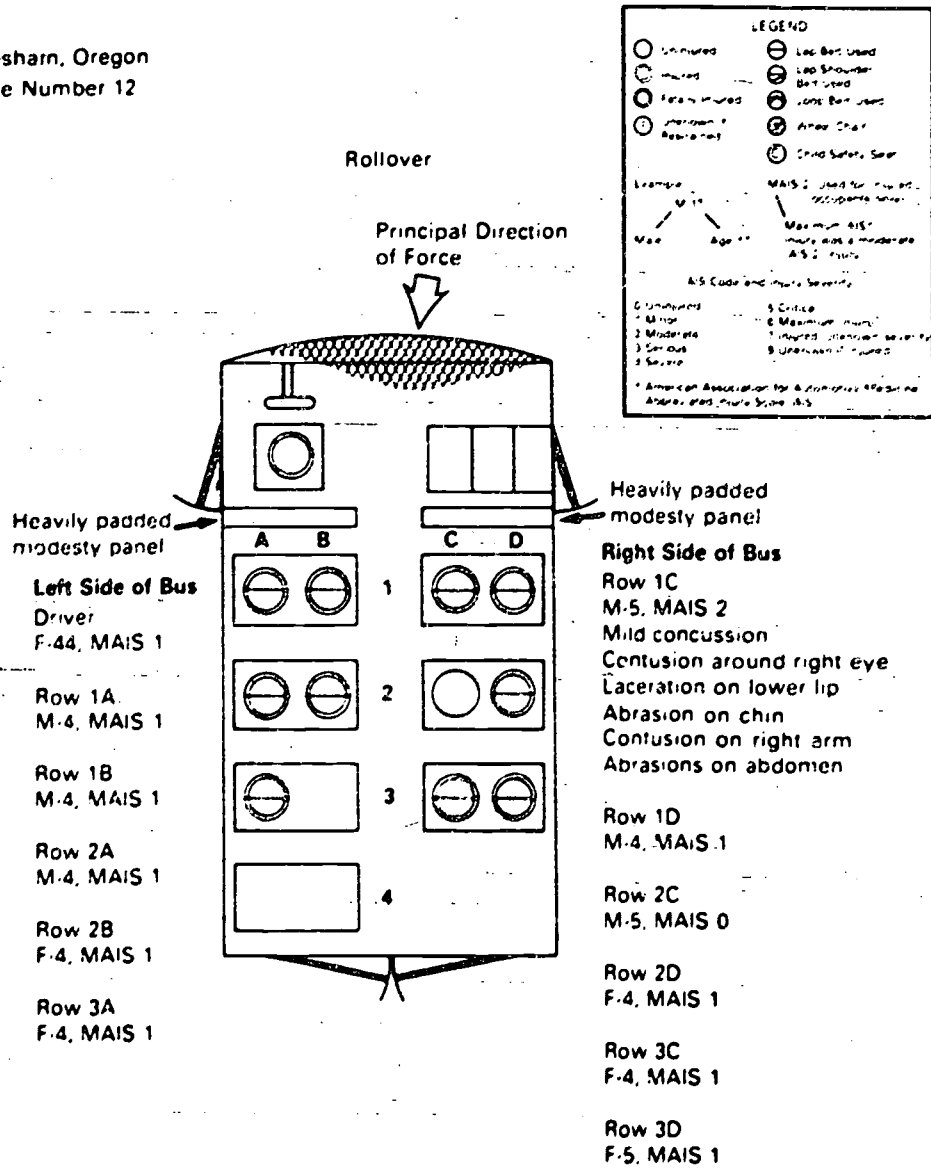

The school bus shown is representational only

Case No. 13	Safety Board Investigation No. FTW-86-H-SB03
Location of Accident	Alternate U.S. Highway 90; Houston, Texas
Date and Time	February 25, 1986; 3:35 p.m.
Description of School Vehicle	Type A van conversion: 1980 Dodge chassis with 16-passenger body by Collins Bus Corporation
Type of Accident	Frontal impact, followed by rollover (360°)
Severity of Accident	Delta V not calculable (van was probably traveling less than 25 mph when it vaulted from the guardrail into 360° rollover)

Summary of Events

A school van, equipped with lapbelts for all occupants, was transporting nine deaf students home from school. All occupants were restrained. As the vehicle was traveling a divided section of four-lane highway, the driver lost control. The van left the roadway, struck and overrode a metal W-beam guardrail, and rotated 90° clockwise over about 30 feet. It then vaulted from the guardrail, rotated 180° degrees about its vertical axis and landed on its roof, continuing a 180° rotation before coming to rest upright.

Evacuation from the van occurred through the rear emergency exit because the front door was jammed by impact forces during the rollover. The older students reportedly kicked open the emergency exit and assisted the younger students and driver. The aisle contained no displaced seat cushions or other obstructions. The driver and students reported no problems in disconnecting their lapbelts.

The van body sustained exterior damage to the left front, extending 24 inches laterally with approximately 6 inches of rearward crush. The roof was collapsed inward and down 8 inches at the right front and 12 inches at the left front. Buckling of the roof and door frame above the passenger loading door rendered the door inoperative. The windshield was displaced from its frame during the rollover. The interior of the bus body sustained moderate crushing damage during the rollover and ground impact.

The panel above the rear emergency exit door was distorted, with five attachment screws displaced, but the door remained fully operational. The steering wheel was deformed forward and downward approximately 2 inches, and the driver's rearview mirror was shattered. A maintenance access panel, on the interior left side just to the rear of the driver's seat, was displaced about 2 inches, posing a potential hazard to passengers.

The poststandard van performed well in this moderate speed impact and full rollover. The only major structural failure occurred at the right front and resulted in the disablement of the passenger loading door.

Outcome of Occupants of School Vehicle

Passengers

Of the 9 passengers, ages 14 to 19:

9 sustained MAIS I (minor) injuries.

All passengers were restrained by lapbelts. Only one passenger, on the left side in the front seat on the aisle, received an abdominal contusion attributed to lapbelt use.

Injury outcome in this accident, in which every passenger was restrained, was similar to accidents investigated by the Safety Board in which passengers were unrestrained. The lapbelted passengers were prevented from being thrown about the bus interior but were not prevented from interior contacts that caused their minor (AIS I) injuries: abrasions and contusions. Lapbelts are not designed to prevent, nor are they capable of preventing, minor (AIS I) injuries. In this particular accident, however, lapbelt use probably prevented additional injuries during the vault and subsequent 360° rollover.

Driver

The lapbelted driver received minor (AIS I) injuries: a laceration of the lip from contact with the rearview mirror and multiple contusions of the left arm. The driver probably would have been more seriously injured had she been unrestrained. The driver, however, apparently had her lapbelt loosely adjusted, because she came up off her seat and contacted the rearview mirror. Measurements from the driver's seating position indicated that the latchplate was adjusted out 25 inches and that the buckle was adjusted out 30 inches.

Notes About the Accident

The driver was the first person to be taken from the scene by rescue personnel. This hampered rescue personnel because she was the only person who knew sign language; without her, rescue personnel could not communicate with the deaf students to determine the nature of their injuries.

Houston, Texas
Case Number 13

Rollover

Principal Direction
of Force

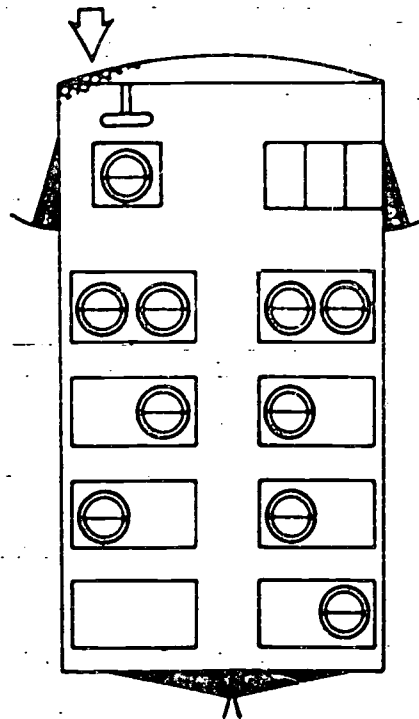

Driver
F-31, MAIS 1

F-14, MAIS 1

F-19, MAIS 1

F-16, MAIS 1

M-19, MAIS 1

F-19, MAIS 1

F-18, MAIS 1

F-17, MAIS 1

F-18, MAIS 1

M-18, MAIS 1

LEGEND

○ Uninjured	⊖ Use Seat Belt
○ Injured	⊖ Use Shoulder Belt Used
○ Fatally Injured	⊖ Use Seat Belt Used
○ Laceration / Replaced	⊖ Air Bag Used
	⊖ Child Safety Seat

Example: M-19, M-18, M-17, M-16, M-15, M-14, M-13, M-12, M-11, M-10, M-9, M-8, M-7, M-6, M-5, M-4, M-3, M-2, M-1

MAIS 1 Used for incident occupants only

Maximum AIS 19 (not a multiplier A & 2) rule

AIS Code and Injury Severity

0 Uninjured	5 Critical
1 Minor	6 Moderate Injury
2 Moderate	7 Injured (potential severity)
3 Serious	8 Unsurvivable Injury
4 Severe	

* American Association for Automotive Medicine Abbreviated MAIS Scale (AIS)

The seating pattern on the bus was determined, but the exact location of individual students is unknown.

The school bus shown is representational only.

Case No. 14	Safety Board Investigation No. NYC-87-H-SB06
Location of Accident	Saw Mill River Parkway; Westchester, New York
Date and Time	March 25, 1987; 8:30 a.m.
Description of School Vehicle	Type A van conversion: 1982 Ford chassis with 16-passenger Sturdivan body by T.P.I.
Type of Accident	Rollover (810°), followed by multiple impacts
Severity of Accident	Delta V unknown

Summary of Events

A school van was transporting 11 unrestrained, learning-disabled students on a scheduled route from Bedford to Irvington, New York. The van was traveling a straight and level section of a four-lane divided highway, at an estimated speed of 62 mph, when it departed the right side of the road, rolled 2 1/4 times, struck a signpost and two trees, and came to rest on its left side. A 14-year-old passenger who had been seated in the left front aisle seat was partially ejected through a left side window and was pinned under the bus.

After the crash, all of the passengers, except the student who was partially ejected, walked unassisted out of the vehicle through the rear emergency exit and waited at the side of the road for the police. Rescue personnel cut the seatbelt restraining the driver and assisted her from the vehicle. They were also able to pull the partially ejected boy from underneath the overturned van without having to lift the vehicle.

The tops of both front fenders of the poststandard van were pushed downward. The front of the roof, both A pillars, and the window frames of both side doors were pushed downward and rearward. The remainder of the roof was dented and scraped, and both side doors were buckled; the windshield, right side door window, and second passenger window on the left side were all shattered. The right rear emergency exit door was detached from the vehicle, its hinges still attached to the door but pulled from the door frame anchors. Both rear passenger seats were twisted and pushed rearward, whereas the right front passenger seat had pulled away from its sidewall anchor and was tilted leftward. The front ceiling had been pushed down into the driver's compartment, and it was buckled with several seam separations.

Outcome of Occupants of School Vehicle

Passengers

Of the 11 passengers, ages 13 to 17:
 6 were uninjured,
 4 sustained MAIS 1 (minor) injuries, and
 1 sustained MAIS 2 (moderate) injuries.

All passengers were unrestrained. The passenger who was partially ejected out the second passenger window on the left side sustained a fractured pelvis (AIS 2). Had the passenger been wearing the available lapbelt, he would not have been ejected and possibly would have sustained a lesser injury; his specific injury, a fractured pelvis, could not have occurred. Had he been unrestrained but not ejected, he might have sustained injuries more comparable in severity to those sustained by other passengers: six were uninjured and four sustained only minor (AIS 1) injuries.

Driver

The driver was wearing the available lap/shoulder belt and sustained only minor (AIS 1) injuries. Had the driver not been restrained, she could have sustained more serious injuries from being propelled into the sheet metal of the collapsing roof.

Notes About the Accident

A witness stated that the van "weaved"; the driver stated that the van "wobbled" until she lost control.

During the rollover, the right rear emergency exit door opened and was subsequently torn from its hinges. This provided another for a possible passenger ejection. No substantial deformation occurred to the door frame or to the left rear door; hence, the two rear emergency doors should have remained closed throughout the crash sequence.

The driver had been hired 5 days before the crash and had not previously driven a school van. She had received no training in operating the van, and had driven the van only once 2 days before the accident. When hired, she passed a six-question written test and a road test administered by another company employee.

Westchester, New York
Case Number 14

Rollover

Direct crush force
on top from rollover

Modesty panel
type unknown

Left Side of Bus

- Driver
- F-35, MAIS 1
- Row 1A
- M-14, MAIS 0
- Row 1B
- M-15, MAIS 2
- Fractured pelvis
- Abrasion on left knee
- Row 2A
- M-16, MAIS 0
- Row 3A
- M-15, MAIS 1
- Row 3B
- M-17, MAIS 1
- Row 4A
- M-17, MAIS 0

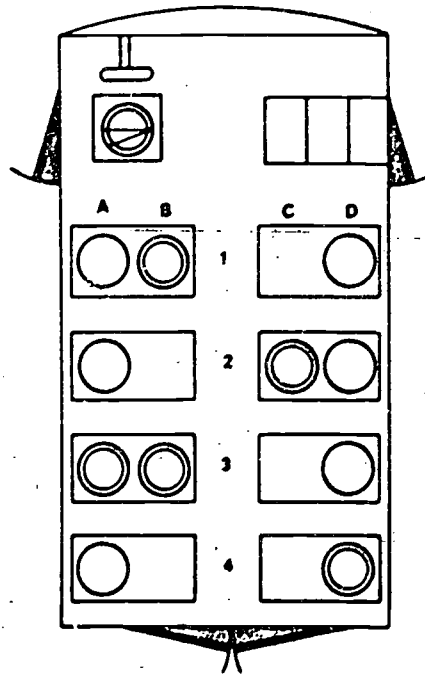

LEGEND

○ Uninjured	⊖ Leg Rest Used
⊖ Injured	⊖ Leg Rest, No Rest Used
⊖ Fracture Injured	⊖ Leg Rest Used
⊖ Injurious to Restraint	⊖ Rest Seat
	⊖ Child Safety Seat

Example: M-17
Age 17
MAIS 2 Injured for injuries
Maximum AIS 2
Injury was a moderate
AIS 2 injury

AIS Codes and Injury Severity

0 Uninjured	6 Critical
1 Minor	7 Maximum Injured
2 Moderate	8 Injured, Uninjured Severe
3 Severe	9 Injurious to Restraint
4 Severe	

* American Board of Fire and Accident Investigation
Address: 10000, Suite 600

Right Side of Bus

- Row 1D
- M-14, MAIS 0
- Row 2C
- M-16, MAIS 1
- Row 2D
- M-14, MAIS 0
- Row 3D
- M-13, MAIS 0
- Row 4D
- M-17, MAIS 1

The school bus shown
is representational only.

Case No. 15	Safety Board Investigation No. CHI-87-H-SB12
Location of Accident	State Route 199 at Dunbridge Road; Perrysburg, Ohio
Date and Time	April 6, 1987; 11:55 a.m.
Description of School Vehicle	Type A small school bus: 1981 Chevrolet chassis with 23-passenger Busette body by Wayne Corporation
Type of Accident	Left front collision, followed by secondary impact
Severity of Accident	Delta V unknown

Summary of Events

A small school bus was transporting 15 students and 2 aides home from a Head Start day-care program. Of the 15 preschoolers, 13 were wearing loosely adjusted static lapbelts, 1 was seated in a misused child safety seat, and restraint status for the other was unknown. One of the aides was restrained by a lapbelt, and the driver was wearing the available lap/shoulder belt. As the school bus crossed an intersection, at a driver-estimated speed of 50 mph, it struck a passenger car with its left front. The bus continued about 110 feet before veering to the left into a drainage ditch and striking a dirt embankment. The bus came to rest upright.

The occupants were evacuated through the right front passenger loading door and the rear emergency exit door.

The poststandard bus received substantial damage on the left front and left front side from the impact with the passenger car. Damage was also noted from the secondary collision with the dirt embankment. The combination of impacts resulted in 30 inches of rearward crush at the left front of the bus. The collapsed structure intruded 20 1/2 inches into the driver's compartment, pushing the instrument panel and steering assembly into contact with the driver. The floor in front of the driver's position buckled, rotating the top of the driver's seat rearward.

Outcome of Occupants of School Vehicle

Passengers

Of the 17 passengers, a 16-year-old aide, a 35-year-old aide, and 15 students, ages 4 and 5:

- 1 was uninjured,
- 11 sustained MAIS 1 (minor) injuries,
- 2 sustained MAIS 2 (moderate) injuries, and
- 3 sustained MAIS 3 (serious) injuries.

Reports indicated that all occupants were wearing some type of restraint at the time of the accident. Safety Board investigators, however, determined that one of the aides was probably unrestrained and that most of the lapbelts used by passengers were not adjusted properly.

The 4-year-old passenger on the left side in the front seat next to the window was in a Kantwet Safeguard model 301 child safety seat. Inspection of this seat and the lapbelt used for attachment found that the lapbelt was not routed in accordance with the instructions provided with the seat. The right side shoulder strap of the safety seat was not attached to the system. The passenger received a serious (AIS 3) fracture of her left femur and multiple minor (AIS 1) contusions. The serious injury probably occurred as a direct result of the misuse of the child seat, because it allowed the passenger sufficient forward movement to contact the left side bulkhead at the junction of the van chassis and the school bus body. Had the seat been properly secured to the bench seat, the passenger's injuries would likely have been reduced.

The 5-year-old passenger seated on the left side in the front seat next to the aisle was reportedly wearing a static lapbelt. Inspection of the lapbelt found the cinching latchplate adjusted to 22 inches from the function of the seat cushions--an excessive distance for the passenger's size. The passenger received a moderate (AIS 2) closed head injury, probably from contact with the driver's seatback as it rotated rearward. The absence of abdominal contusions or other trauma indicates that the lapbelt probably provided little restraint; excessive slack was found in the webbing. An unsecured child safety seat was found in this passenger's seating position, thus the restraint status is unknown.

The adult aide on the right side in the front seat next to the aisle stated she was restrained by the static lapbelt available at her position. The driver, however, reported that the aide was thrown forward from her seat at impact into the stairwell of the passenger loading door. The driver's account appears correct, because major forward deformation was found to the door's opening hardware. That damage was also consistent with the serious (AIS 3) fractured pelvis and moderate (AIS 2) lacerations sustained by the aide. It's unlikely that the lapbelt's adjusted length of 22 inches would have fit the aide, who, according to medical records, was 65 inches tall and weighed 190 pounds. The Safety Board believes the aide was unrestrained.

The 5-year-old passenger on the right side in the front seat next to the window was reportedly wearing the static lapbelt available at his position. The adjustment of the lapbelt, however, was probably very loose: the cinching latchplate was 22 1/2 inches from the junction with the seat cushions. The passenger's serious (AIS 3) closed head injury likely resulted from contact with the lightly padded frame of the restraining barrier forward of this seating position. Considering the contact points involved, severity of injury would unlikely have changed with a properly adjusted lapbelt.

The 4-year-old passenger on the left side in the second seat next to the window was also wearing a lapbelt with excessive slack: the cinching latchplate was adjusted to 18 1/2 inches from the junction with the seat cushions. The passenger received a moderate (AIS 2) fracture of his right lower leg, probably from contact with the lower framework of the seat in front of him. It is unknown what difference a properly adjusted lapbelt would have made. At 41 inches in height, the passenger would have been decelerated entirely by the 2-inch-wide webbing of the lapbelt; serious injuries might have resulted.

The 4-year-old on the left side in the second seat in the center position was reportedly wearing a lapbelt. The latchplate was adjusted to 23 inches from the junction with the seat cushion, much too great a distance for effective restraint of this 37-inch-high, 45-pound passenger.

The remaining passengers received minor (AIS 1) contusions, abrasions, and lacerations. All were reportedly wearing the available lapbelts. Safety Board investigators found, however, that all but one of the lapbelts were adjusted with excessive slack, for the passengers' sizes. Latchplate adjustment lengths varied from over 18 inches to 25 inches. The single exception was the lapbelt of 16-year-old aide. The latchplate adjustment length of 20 1/2 inches probably provided some degree of restraint to this person.

Driver

The driver was restrained by a lap/shoulder belt equipped with dual emergency locking retractors, a sewn-in latchplate, and a stalk-mounted buckle attached to the side of the pedestal seat. The driver received moderate (AIS 2) fractures of three adjacent ribs on her left side and her maxilla, primarily from the instrument panel and steering assembly crushing rearward into her space. She also sustained multiple minor (AIS 1) contusions and lacerations of her face and limbs. Considering the intrusion into her compartment, the lap/shoulder belt performed as well as could be expected. Had this driver been unrestrained, greater injuries might have resulted.

Notes About the Accident

This small bus had no restraining barrier between the front seat on the left side and the driver's seat. An abbreviated metal panel, framed by lightly padded tubular steel, was positioned between the front seat on the right side and the stairwell; however, this barrier did not extend far enough forward in the center of the bus to prevent the aide from traveling forward into the door components. Some of the serious (AIS 3) injuries sustained by the passengers in the front seats might have been prevented had larger, padded barriers been installed in the bus.

The floor of the bus forward of and underneath the driver's seat buckled from the impact, resulting in the rearward rotation of the driver's seat at its top. The rotation was beneficial to the driver, because it moved her rearward away from the collapsing structural components.

The lapbelts on the bus had pushbutton release latchplates and were anchored to the seatframes.

Perrysburg, Ohio
Case Number 15

Principal Direction of Force

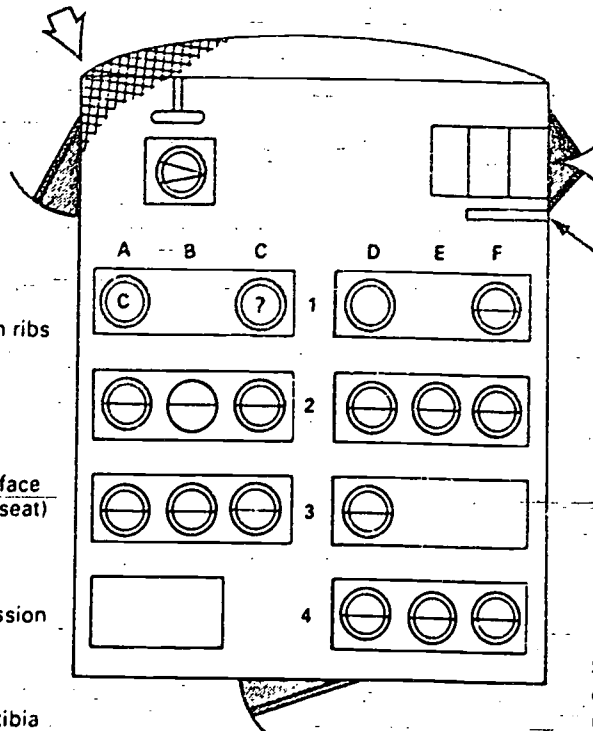

LEGEND

- Uninjured
- ⊖ Injured
- ⊙ Fatally Injured
- ⊖ Unrestrained
- ⊖ Restrainted
- ⊖ Lap Belt Used
- ⊖ Lap Shoulder Belt Used
- ⊖ Urns Belt Used
- ⊖ Wheel Chair
- ⊖ Child Safety Seat

Example: Male, Age 17, MAIS 2 (used for injured occupants only). Maximum AIS* Injury was a moderate AIS 2 injury.

AIS Codes and Injury Severity

0 Uninjured	5 Critical
1 Minor	6 Maximum Injury
2 Moderate	7 Injured, Unrestrained
3 Serious	8 Unrestrained Injured
4 Severe	

* American Association for Automotive Medicine, Abbreviated Injury Scale (AIS)

Left Side of Bus

Driver
F-43, MAIS 2
Fracture, left 7, 8, & 9th ribs
Maxilla fracture

Row 1A
F-4, MAIS 3
Fracture - left femur
Multiple contusions - face (misused child safety seat)

Row 1C
M-5, MAIS 2
Cerebral concussion

Row 2A
M-4, MAIS 2
Fracture - right tibia

Row 2B
F-5, MAIS 0

Row 2C
F-5, MAIS 1

Row 3A
F-5, MAIS 1

Row 3B
F-5, MAIS 1

Row 3C
F-16, MAIS 1

Row 2D
F-4, MAIS 1

Row 2E
F-5, MAIS 1

Row 2F
F-4, MAIS 1

Row 3D
M-4, MAIS 1

Row 4D
M-5, MAIS 1

Row 4E
M-4, MAIS 1

Row 4F
M-5, MAIS 1

Right Side of Bus

Row 1D
F-35, MAIS 3
Fractured pelvis
Large laceration above left eye
Laceration above right eye
Multiple contusions

Row 1F
M-5, MAIS 3
Serious concussion
Contusion - forehead
Contusion - left side of face
Abrasion - left leg
Contusion - left pelvis

Special Notes:
All lapbelts worn, except the one worn by the passenger in 3C, were so loosely adjusted relative to the occupant's size that they provided little restraint.

The school bus shown is representational only.

Case No. 16 Safety Board Investigation No. CHI-86-H-SB07

Location of Accident Interstate 294; outside Elmhurst, Illinois

Date and Time February 7, 1986; 2:30 p.m.

Description of School Vehicle Type A school bus: 1982 Chevrolet chassis with 23-passenger Vanguard body by American Transportation Corporation

Type of Accident Left side impact, followed by secondary left side impact

Severity of Accident Delta V unknown

Summary of Events

A small school bus, equipped with restraints for all occupants, was transporting an adult aide and eight emotionally disturbed students home from school. The aide was the only unrestrained occupant. The driver lost control of the vehicle and swerved to the left, striking a section of eight unanchored New Jersey-style concrete median barriers. The unanchored barriers were pushed out of their positions, allowing the bus to strike the end of the permanently anchored section. Witnesses reported that as the bus was deflected to the right, back into traffic, it was struck near the rear axle on the left side by a 1981 Dodge St. Regis.

According to the aide, two of the students opened the right front passenger loading door and exited onto the roadway following the accident. One student was trapped between deformed seats for a time, but all other passengers were either evacuated from the bus by emergency personnel or were able to leave the bus without assistance. The aide stated that she was not able to open the rear emergency exit.

Contact damage occurred from the left front corner of the bus back to the rear axle. The sheet metal from the B pillar to the left rear axle was peeled back to the rear axle and extended well outside the original width of the bus. The left side structural supports for the roof were torn away, allowing the roof on the left side to collapse downward to near the tops of the seatbacks. The body of the bus was torn loose from the chassis along the right side and across the rear. The seats in this bus were attached to the sidewalls on the outboard ends and supported by two pipe legs per seat at the inboard end. All four seats on the left side of the bus were torn loose from their outboard anchor points and rotated counterclockwise. The left side modesty panel was displaced rearward to contact the front seat on the left side.

The portions of the poststandard bus that contacted the exposed end of the anchored barriers were badly damaged. Most of the left side to the rear of the B pillar was torn away, destroying the outboard anchor points for all of the left side seats and exposing those occupants to greater hazards. Of the five passengers seated on the left, four received moderate (AIS 2) to serious (AIS 3) injuries and one had minor (AIS 1) injuries. Of the four seated on the right, two were not injured, one had minor (AIS 1) injuries, and one had moderate (AIS 2) injuries.

Outcome of Occupants of School Vehicle

Passengers

Of the 9 passengers, ages 9 to 21:

- 2 were uninjured,
- 2 sustained MAIS 1 (minor) injuries,
- 2 sustained MAIS 2 (moderate) injuries, and
- 3 sustained MAIS 3 (serious) injuries.

All passengers except the adult aide were restrained by lapbelts. Passengers on the left side in the first two rows next to the window were prevented from ejection by use of the lapbelts. Use of their lapbelts, however, resulted in some head and facial injuries and did not prevent other serious injuries.

The lapbelted passenger on the left side in the front seat next to the window sustained a serious (AIS 3) injury. She was seated at the beginning of the major intrusion. When the side of the bus and seat anchor points were torn away, this passenger may have had direct contact with the barrier and the sheet metal. The frame for the restraining barrier in front of her seat was found protruding back into her seating position. The fractured femur was probably caused by either contact with the side wall as it was torn away or by the restraining barrier as it was pushed into her position. The fractured and the dislocated wrist likely resulted from contact with the displaced components. Her concussion and the minor facial injuries probably occurred as she "jackknifed" over her lapbelt; her head contacted the frame of the restraining barrier as it was moving back toward her. Had she not been restrained, she could have been ejected because the sidewall had been torn away. Had she been ejected, her injuries might have been more severe.

The lapbelted passenger on the left side front seat next to the aisle received a moderate (AIS 2) concussion and abrasions on her face. At impact, she also would have "jackknifed" forward, exposing her head to greater injury. She probably struck the frame of the restraining barrier in front of her. Because she was not seated directly next to the area of impact, she did not come in contact with the sheet metal as it was torn away. Had she not been wearing the lapbelt, she would have been thrown forward into the restraining barrier and probably still would have received minor to moderate injuries. She could have been ejected but with less likelihood than for the passenger on her left.

The lapbelted passenger sitting on the left side in the second seat next to the window was also in the area of major intrusion. She received open fractures of the left tibia, right tibia, and femur (all serious, AIS 3 injuries), which probably contacted the moving sheet metal and possibly the concrete barrier. The closed fracture of her left femur could have resulted when the seat in front of her pushed back into her seating area. She could have been ejected and sustained even more serious injuries had she not been wearing the lapbelt.

The lapbelted passenger on the left side in the third seat next to the window received a fractured left femur and a closed head injury that left him unconscious for more than an hour (both serious, AIS 3 injuries). He was in the area of major impact, and sheet metal from the side had been pushed back to his seat. His head injury probably occurred as he violently pivoted forward from the

hips over the lapbelt and struck the back of the seat in front of him. The fractured left femur could have resulted from the displaced metal around him. He probably would not have been ejected had he been unrestrained because he was not next to the opening. Without the restraint, he probably would have received some minor to moderate injuries, but his head injury probably would not have been as severe: the impact forces would have been more evenly distributed over his entire body rather than concentrated on his head.

The lapbelted passenger on the left side in the last seat next to the window was just beyond the area of major impact. His injuries were not serious: a laceration on his scalp and on his left leg. Had he not been wearing the lapbelt, he probably would have received some minor injuries.

Two lapbelted passengers were on the right side in the front seat. The passenger next to the aisle was uninjured, and the one next to the window received only abrasions. These passengers were seated out of the area of intrusion and impact. Had they not been wearing the lapbelts, they might have received some minor injuries.

No injuries were reported for the lapbelted passenger on the right side in the second seat next to the window. Because she was not in the area of intrusion, she was not exposed to the deforming sheet metal. She might have sustained some minor injuries had she not been wearing the lapbelt.

A 21-year-old aide was on the right side in the third seat next to the window. One of her duties was to make certain that all of the students were wearing their lapbelts. Although she stated that she was wearing the available lapbelt, she also stated that she fell onto the floor, which resulted in a dislocated left shoulder. Safety Board investigators determined that an occupant in that seating position could not have fallen to the floor, even with an improperly adjusted lapbelt. A properly worn lapbelt might have prevented the dislocated shoulder, but moderate injuries could still have resulted.

Driver

The driver, restrained with a lap/shoulder belt, received a moderate (AIS 2) concussion. Even though he was in front of the area of intrusion, the roof collapsed above him and probably came into contact with his head, producing the concussion. Without the restraint, he probably would have been thrown forward and to the left, sustaining minor to moderate injuries.

Ermhurst, Illinois
Case Number 16

LEGEND

○ Uninjured	⊖ Mild Concussion
○ Injured	⊖ Moderate Concussion
⊖ Mild Concussion	⊖ Severe Concussion
⊖ Moderate Concussion	⊖ Head Injury
⊖ Severe Concussion	⊖ Skull Fracture
⊖ Head Injury	⊖ Spinal Cord Injury

Example: **MAIS 3** (Mild Concussion, Moderate Concussion, Skull Fracture)

MAIS 1-4 are based on the following:

1. Loss of consciousness	5. Loss of consciousness
2. Memory loss	6. Maximum 15 minutes
3. Moderate	7. Impaired motor function
4. Severe	8. More than 15 minutes
9. Skull fracture	

* American Standard for Automotive Markings
Attributed to the American Society of Mechanical Engineers

Principal Direction of Force

Heavily padded modesty panel

Heavily padded modesty panel

Left Side of Bus
Driver

M-34, MAIS 2
Moderate concussion
Multiple abrasions
Multiple contusions

Row 1A
F-16, MAIS 3
Comminuted fracture of left femur
Fracture: dislocation of left wrist
Cerebral concussion
Hematoma on right forehead
Abrasions on right hand
Possible skull fracture

Row 1C
F-17, MAIS 2
Moderate concussion
Abrasions on head

Row 2A
F-18, MAIS 3
Open fracture of right tibia
Open fracture of left tibia
Closed fracture of left femur

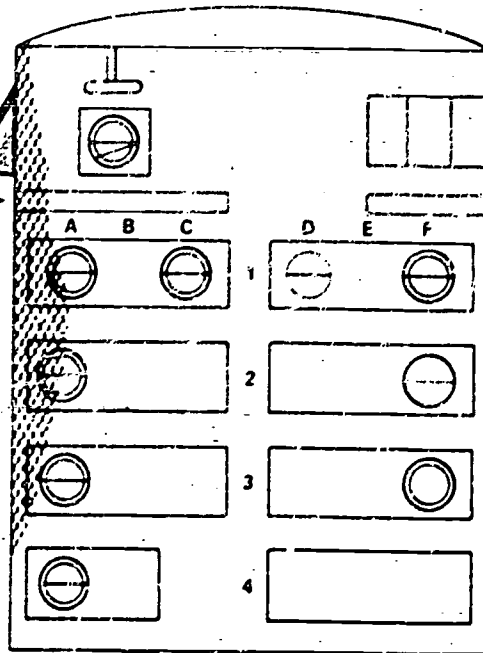

Row 3A
M-15, MAIS 3
Closed head injury, unconscious more than 1 hour
Closed fracture of left femur
Contusion on the nose

Row 4A
M-16, MAIS 1

Right Side of Bus

Row 1D
F-14, MAIS 0

Row 1F
M-11, MAIS 1

Row 2F
F-9, MAIS 0

Row 3F
F-21, MAIS 2
Dislocated left shoulder

The school bus shown
is representational only

Case No. 17	Safety Board Investigation No. NYC-88-H-SB08
Location of Accident	Route 113, West Pikeland Township; Chester County, Pennsylvania
Date and Time	February 26, 1988; 9:10 a.m.
Description of School Vehicle	Type A school bus; 1983 Ford chassis with 22-passenger Busette body by Wayne Corporation
Type of Accident	Head-on collision, followed by secondary left side impact
Severity of Accident	Delta V unknown

Summary of Events

A small school bus, equipped with lapbelts for all occupants, was transporting eight students and the driver's 3-year-old son to school on a two-lane highway. Four of the nine passengers were restrained by lapbelts, and the driver was wearing a lap/shoulder belt. As the small school bus traveled southbound, it was struck in the front by a northbound truck that was out of control and overturning. The initial impact was followed by a secondary impact at the left side of the school bus as the truck rotated counterclockwise on its right side. The collision sequence pushed the school bus rearward for several feet before it came to rest on the west shoulder against a metal guardrail. Four vehicles were involved in this accident; however, only the truck collided with the school bus.

The driver of a passenger car involved in the accident entered the school bus through the rear emergency door, released several of the students' lapbelts, and assisted the students with minor injuries from the bus. He was assisted by passing motorists. Both the fatally injured and the critically injured passengers were left onboard until evacuated by emergency rescue personnel. The driver was trapped from a massive structural collapse at her seating position; the right front passenger loading door was jammed by crush damage. The driver was freed after several hours by fire rescue personnel.

The front structure of the poststandard school bus was destroyed, with more than 41 inches of rearward collapse at the left front. Additionally, the left side of the bus body was crushed 24 inches inboard at the second and third rows of bench seats.

The integrity of the passenger compartment was affected by the structural collapse. The forward roof area and left side A pillar were pushed rearward and down into the driver's compartment, and the instrument panel and steering assembly were pushed rearward toward the driver's seat. Buckling of the floor occurred in the forward area of the bus. The support leg of the right modest panel was displaced from its lower mounting bracket, and the wall mounting bracket for the panel was partially displaced. Control components for the right front passenger door were deformed, caused by occupant contact and structural collapse. The inboard collapse of the left side of the bus resulted in substantial deformation to the seatback and frame assembly of the second and third bench seats on the left side.

Outcome of Occupants of School Vehicle

Passengers

Of the 9 passengers, 8 students and the driver's son, ages 3 to 18:

- 7 sustained MAIS 1 (minor) injuries,
- 1 sustained MAIS 5 (critical) injuries that proved fatal
- 1 sustained MAIS 6 (maximum injury, virtually unsurvivable) injuries that proved fatal

Four of the passengers were wearing the static lapbelts available at their seating positions. The lapbelts were mounted to the individual seat frames and were furnished with pushbutton release buckles. An inspection revealed that one of the lapbelts in use had been altered by the school district; the alterations-- which compromised the belt--did not, however, affect the outcome of injury. Another lapbelt not in use also had been modified.

Six of the passengers received only minor (AIS 1) contusions, abrasions, lacerations, and strains. Of that number, three were restrained and three were unrestrained. All were seated behind the front seats and thus were afforded compartmentalization by the high backed, padded seats in front of their positions.

The other passenger with minor injuries was the 3-year-old son of the driver seated directly behind the driver on the front bench seat next to the window. An attorney for the child's family indicated that the driver had lapbelted him in seat 45 minutes before the accident. A witness found the boy on the floor behind the driver's seat when the bus was entered only seconds after the crash. Examination of the latchplate portion of the belt revealed that the cinching type latchplate was adjusted to 26 1/2 inches from its anchor point on the seat frame, and that the belt was tucked into the area between the seat cushion and the seat back. Based on this evidence, Safety Board investigators determined that the child was not wearing the lapbelt at the time of the crash. Given the minor injuries sustained by this child, neither restraint use nor a padded modesty panel could have improved the outcome. The child's forward travel was contained by the rear of the driver's seatback, thus allowing him to decelerate into a "friendly" surface.

The two fatally injured passengers were seated next to each other on the right side in the front seat. The 7-year-old next to the window and wearing a static lapbelt received AIS 6 injuries from contact with an abbreviated modesty panel in front of his seating position. He died from these injuries. An unrestrained 17-year-old, in the center of the seat, received critical (AIS 5) injuries, which also were fatal. The 17-year-old struck the left side of the modesty panel while moving forward and to the left; the amount of barrier deflection is unknown. He was found in the stairwell; Safety Board investigators determined that after striking the left side of the restraining barrier with his right leg, he pivoted around the barrier and continued forward. He hit the boarding door control, fracturing his left leg, and continued into the windshield header where he sustained a fatal head injury.

The 7-year-old seated next to the window probably jackknifed over the lapbelt and struck the left side of his head and neck on the tubular frame of the modesty panel. He sustained a lacerated larynx, a fractured and dislocated cervical spine, crushed spinal cord, and brain hemorrhage. The modesty panel was about 1 1/2 inches shorter than those installed in large, poststandard school buses; it was also much lower.

Driver

The lap/shoulder belted driver received severe (AIS 4) injuries, all resulting from the collapsed structure surrounding her seating position. Given the extreme intrusion that occurred, the driver might have been fatally injured had she not been restrained by the lap/shoulder belt.

Notes About the Accident

This small bus was furnished with a lightly padded stanchion post and horizontal bar, at the level of the driver's seatback top, between the front seat on the left side and the driver's seat. There was no modesty panel on the left side. An abbreviated modesty panel was located on the right side of the bus, placed between the front seat and the stairwell. This barrier was surrounded by a lightly padded, tubular steel frame.

Examination of the lapbelts installed at the left front window seat and the second right window seat revealed that both had been altered. The webbing for the buckle side had been shortened by looping the belt over, making a hole through the webbing, and then remounting it to the seat frame. These altered lapbelts were used to restrain smaller and younger students after parents had commented to the school about the difficulty in properly adjusting the belts around smaller children. The after-market alteration, performed by employees of the school district, was not consistent with mounting guidelines outlined in FMVSS 209, "Seat Belt Assemblies."

Chester Co., Pennsylvania
Case Number 17

LEGEND

○ Uninjured	⊖ Leg Belt Used
⊖ Injured	⊖ Leg Shoulder Belt Used
⊖ Forearm Injured	⊖ Leg Belt Used
⊖ Uninjured/Retained	⊖ Arm Injured
	⊖ Head Safety Bar

Example:
 M-17, M-18, M-19, M-20, M-21, M-22, M-23, M-24, M-25, M-26, M-27, M-28, M-29, M-30, M-31, M-32, M-33, M-34, M-35, M-36, M-37, M-38, M-39, M-40, M-41, M-42, M-43, M-44, M-45, M-46, M-47, M-48, M-49, M-50, M-51, M-52, M-53, M-54, M-55, M-56, M-57, M-58, M-59, M-60, M-61, M-62, M-63, M-64, M-65, M-66, M-67, M-68, M-69, M-70, M-71, M-72, M-73, M-74, M-75, M-76, M-77, M-78, M-79, M-80, M-81, M-82, M-83, M-84, M-85, M-86, M-87, M-88, M-89, M-90, M-91, M-92, M-93, M-94, M-95, M-96, M-97, M-98, M-99, M-100

All Data and Injury Severity

1 Uninjured	2 Minor
3 Moderate	4 Severe
5 Major	6 Maximum Injury
7 Fatal	8 Uninjured/Retained
9 Fatal	10 Fatal

American Association of Motor Vehicle Physicians
Abbreviated Injury Scale - AIS

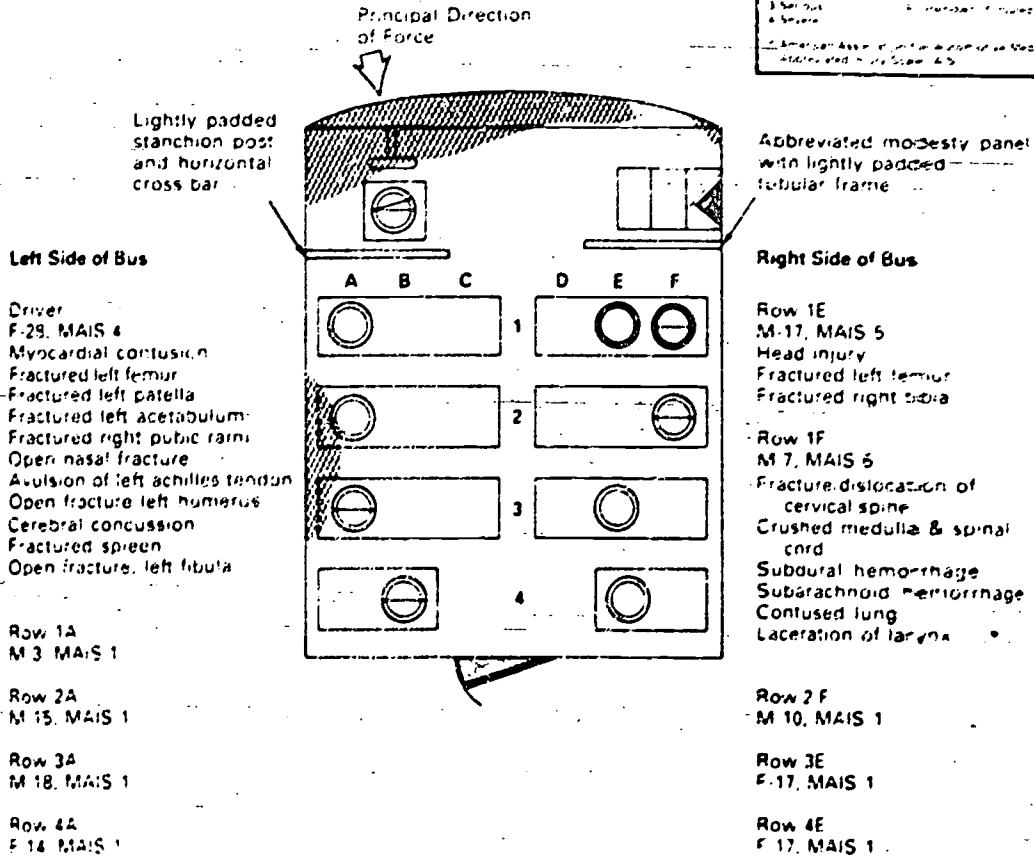

The school bus shown is representational only

Case No. 18 Safety Board Investigation No. LAX-87-H-SB03

Location of Accident Intersection of Escondido Avenue and Pala Vista Drive; Vista, California

Date and Time December 3, 1986; 1:15 p.m.

Description of School Vehicle Type A small school bus; 1985 Chevrolet chassis with 20-passenger Micro-Bird body by Blue Bird Body Company

Type of Accident Left side impact, followed by rollover (90°)

Severity of Accident Delta V unknown

Summary of Events

A small school bus transporting four Head Start students home from school was crossing an urban intersection when it was struck at its left rear tire by a 1979 Volkswagen Rabbit. The four passengers were restrained by the available lapbelts; the driver was wearing a lap/shoulder belt. After impact, the van rotated counterclockwise about 45° before slowly overturning onto its right side and coming to rest.

The driver reported that a passerby released the passengers from their lapbelts and assisted the children out of the van through the rear emergency exit.

The collision produced some slight sheet metal deformation at the left rear of the van and also some scrapes on the left rear wheel rim. The only other damage on the van resulted from the 90° rollover. The mirrors and some of the metal joints on the right side had been deformed. No evidence of any interior damage was found. The poststandard van held up well in the collision and rollover. Most of the repair cost was to fix damage to the bus that resulted from the tow truck righting the bus after overturn.

Outcome of Occupants of School Vehicle

Passengers

Of the 4 passengers, age 4:
4 were uninjured.

The driver and a witness confirmed that all four passengers were wearing the available lapbelts; the passengers' seating positions were unknown. All passengers reportedly were uninjured, but the Safety Board was able to locate and interview only one. The passengers may have been bruised. Because seating positions were unknown, the Safety Board could not analyze the value of lapbelts in this crash. For example, had the passengers been seated on the right side of the bus, the side that impacted the ground, the outcome of injuries would have been the same, regardless of lapbelt use.

Driver

The driver of the van was wearing a lap/shoulder belt and received no injuries. Had the driver not been wearing the restraint, she might have been injured as the van rolled to its right side. She would have fallen out of her seat, hit the gear box, and fallen to the right side into the stairwell. The driver's environment is more "hostile" than that of the passengers because no containment is provided.

Notes About the Accident

There was no barrier between the driver and the front passenger seat on the left side. On the right side, between the door stairwell and the front seat, was a metal modesty panel and stanchion. The cross support bar and stanchion were lightly padded; the panel itself was bare metal. In a frontal crash, these design aspects could significantly affect injury outcome of both unrestrained and restrained passengers.

Vista, California
Case Number 18

LEGEND

○ Uninjured	⊖ Lap Belt Used
⊖ Injured	⊖ Lap/Shoulder Belt Used
⊖ Severely Injured	⊖ Loose Belt Used
⊖ Unrestrained or Restrained	⊖ Wheel Chair
	⊖ Child Safety Seat

Example: M 17 / Male / Age 17 / Maximum AIS 2 (Used for injured occupants only) / Injury was a moderate AIS 2 injury

AIS Code and Injury Severity

0 Uninjured	5 Critical
1 Minor	6 Maximum Injury
2 Moderate	7 Injured (unknown severity)
3 Serious	8 Unrestrained Injured
4 Severe	

* American Association for Automotive Medicine Accredited Injury Scale - AIS

Rollover

Driver
F-67, MAIS 0

Principal Direction
of Force

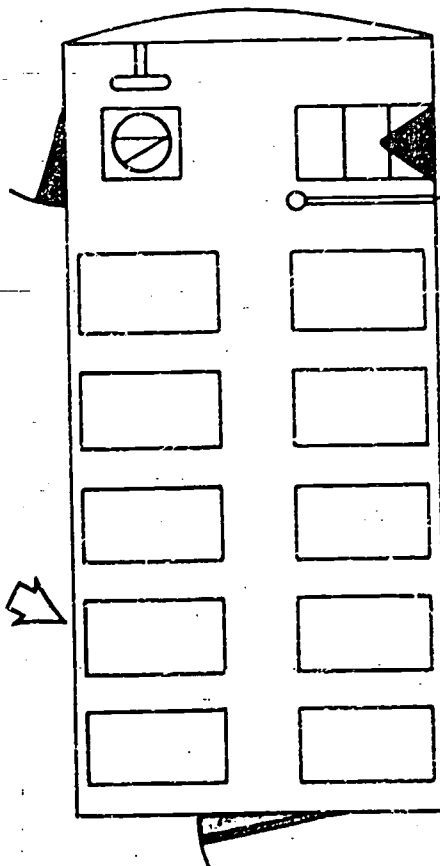

Modesty panel with lightly padded aisle stanchion and cross support; panel was bare metal.

All passengers were wearing lap belts; seating positions unknown. Injury status could be confirmed for only one passenger.

F-4, MAIS 0
M-4, MAIS 0
M-4, MAIS 0
F-4, MAIS 0

The school bus shown is representational only.

Case No. 19	Safety Board Investigation No. FTW-85-H-OR20
Location of Accident	Intersection of Groos Street at Hermitage Street; San Antonio, Texas
Date and Time	February 5, 1985; 3:25 p.m
Description of School Vehicle	Type A small school bus; 1981 Chevrolet chassis with 20-passenger Busette body by Wayne Corporation
Type of Accident	Left side impact, followed by rollover (90°)
Severity of Accident	Delta V 11.5 mph, followed by rotation, then by slow rollover

Summary of Events

A small school bus, equipped with lapbelts for all occupants, was transporting seven handicapped students and an aide home from school on a two-way residential street. All occupants were restrained. A 1978 Ford F-150 pickup truck (4,300 pounds) ran a stop sign and collided into the left side of the school bus. The school bus rotated 70° counterclockwise, continued another 34 feet, before striking the concrete curb with its right rear tires, and turned over onto its right side. The school bus then slid 31 feet before coming to rest.

The driver of the school bus related that unidentified persons opened the rear emergency exit door and assisted in evacuating the passengers. This assistance was reportedly provided quickly, with only one passenger having time to release his lapbelt independently. One passenger's parent reported that the boy, excited by the rescue efforts, released his own belt and fell from the high side of the overturned bus into contact with the lower side seats; facial abrasions resulted. No other difficulties during evacuation were reported.

The poststandard bus received moderate damage on the left side near the rear dual wheels and moderate damage on the right side where the bus slid on its side. Much of the damage occurred during the rollover. Several of the interior seat cushions were displaced into the aisle during the rollover sequence. Another seat cushion, although it remained on the seat, was completely freed from its mounting brackets.

The integrity of the passenger compartment was not affected by impact or rollover, and the rigid framework placed to protect the fuel tank performed as designed by preventing any penetration to the tank.

Outcome of Occupants of School Vehicle

Passengers

Of the 8 passengers, an adult aide (age unknown) and 7 students, ages 3 to 10:
4 were uninjured, and
4 sustained MAIS 1 (minor) injuries.

All passengers reportedly were wearing the lapbelts available at their seating positions at the time of the crash.

Injuries, if sustained, were minor (AIS 1), and primarily occurred during the rollover. Restraint use was of greatest benefit during the rollover, especially to passengers seated on the left side of the bus: they were not flung to the right side when that side contacted the ground.

Driver

The lapbelted driver received moderate injuries: AIS 2 contusions on her face when she contacted the rearview mirror, and AIS 2 contusions on her abdomen induced by the lapbelt. She also sustained AIS 1 contusions on her shoulder and arm from contact with the steering wheel and on her wrist from contact with the door control.

The lapbelt was equipped with dual automatic retractors. From the appearance and length of damaged webbing on the latchplate side of the system, the retractor apparently allowed 5 to 6 inches of webbing to spool out. The driver reported she slipped off her seat but remained suspended by restraint webbing.

Had a three-point lap/shoulder belt been available and used, the driver's injuries would have been reduced. Had she not used the lapbelt, her injuries would probably have remained the same, or been less serious because her upper torso would not have pivoted forcefully over the lapbelt. The lapbelt-induced abdominal contusions caused the driver to miss 48 days of work.

Notes About the Accident

This small bus was furnished with a lightly padded stanchion post and horizontal bar, at the level of the driver's seatback top, between the front seat on the left side and the driver's seat. The left side had no restraining barrier. An abbreviated restraining barrier was located on the right side of the bus, placed between the front seat and the stairwell. The barrier was surrounded by a lightly padded tubular frame.

The driver and all passengers were restrained according to school district policy. The driver told Safety Board investigators that she normally did not wear a seatbelt in her private vehicle but did follow the district's policy while on the job. Responsibility for enforcing the policy is shared by the driver and by the aide who is furnished for each bus.

The lapbelts on the bus had pushbutton release latchplates and were anchored to the seatframe. Loading marks were found on some the lapbelts to substantiate use.

The driver told police that she had sustained minor injuries; this information was entered in the police report. These "minor" injuries resulted in the driver losing weeks of work. During an interview conducted the second day following the accident, Safety Board investigators determined that the driver had sustained moderate or greater injuries.

San Antonio, Texas
Case Number 19

Rollover

LEGEND

○ Uninjured	⊖ Lap Belt Used
⊖ Injured	⊖ Lap Shoulder Belt Used
⊖ Fatally Injured	⊖ Loop Belt Used
⊖ Unknown if Restrained	⊖ Wheel Chair
	⊖ Child Safety Seat

Example: M 17, Male, Age 17
 MAIS 2 (Used for injured occupants only)
 Maximum AIS Injury was a moderate (AIS 2) injury

AIS Code and Injury Severity

0-Uninjured	5-Critical
1-Minor	6-Maximum injury
2-Moderate	7-Injured, unknown severity
3-Serious	8-Unknown if injured
4-Severe	

* American Association for Automotive Medicine Abbreviated Injury Scale (AIS)

Lightly padded stanchion post and horizontal cross member

Left Side of Bus

Driver
F-22, MAIS 2
Large facial contusion
Large contusion on abdomen
Contusion on left shoulder
Contusion on left elbow
Abrasion on right lower arm

Principal Direction of Force

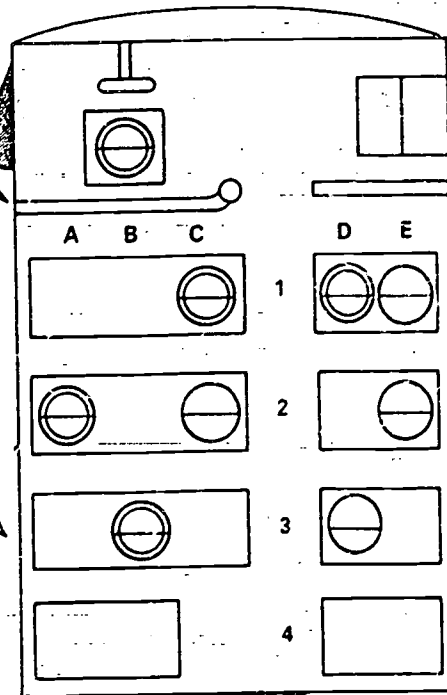

Modesty panel with lightly padded tubular frame

Right Side of Bus

Row 1D
F-3, MAIS 1

Row 1E (adult aide)
F-age unknown, MAIS 0

Row 2E
F-4, MAIS 0

Row 3D
M-5, MAIS 0

Row 1C
M-10, MAIS 1

Row 2A
M-10, MAIS 1

Row 2C
F-6, MAIS 0

Row 3B
M-6, MAIS 1

The school bus shown is representational only.

Case No. 20	Safety Board Investigation No. ATL-87-H-SB17
Location of Accident	North Indian Creek Drive; Clarkston, Georgia
Date and Time	May 8, 1987; 3:00 p.m.
Description of School Vehicle	Type B school bus: 1982 Chevrolet chassis with 18-passenger Cadet body by Carpenter Body Works, Inc.
Type of Accident	Multiple impacts: head-on collision, followed by rear-end secondary collision
Severity of Accident	Delta V unknown

Summary of Events

A small school bus was transporting five deaf students to their homes. The driver and all passengers were reportedly wearing the lapbelts installed on the bus. As the bus traveled northbound at a driver-estimated speed of 10 mph, a southbound 1-ton truck veered across the centerline and struck the bus head-on. Following this collision, the bus was struck in the rear by a 28-passenger school bus. The second collision did not produce passenger injuries.

Information on evacuation is not available.

The poststandard school bus received damage primarily to its front structure: the front bumper, right side frame, grill, hood, and radiator were deformed. The interior of the bus was undamaged.

Outcome of Occupants of School Vehicle

Passengers

Of the 5 passengers, age 6 to 11:
 2 were uninjured, and
 3 received MAIS_1 (minor) injuries.

The passengers were restrained by static lapbelts equipped with pushbutton release buckles.

The passengers who received minor (AIS 1) injuries were reportedly seated in the two front seats and the second seat on the left side. Information on specific seating positions, injury descriptions, and restraint adjustment is not available. The seating positions of the two uninjured passengers is not available. Use or nonuse of lapbelts in this relatively low speed collision likely had little effect on injury outcome for the passengers. All passengers had the additional benefit of well-padded barriers, either restraining barriers or seatbacks, in front of their seating positions.

Driver

The driver of the school bus was restrained by a lapbelt and received minor (AIS 1) contusions and abrasions about her abdomen, shoulder, and limbs.

Notes About the Accident

This school bus was equipped with padded restraining barriers in front of the first row of seats.

The lapbelts provided for the student passengers were mounted to the seatframes and passed between the upper and lower seat cushions. Pushbutton release buckles were furnished.

Clarkston, Georgia
Case Number 20

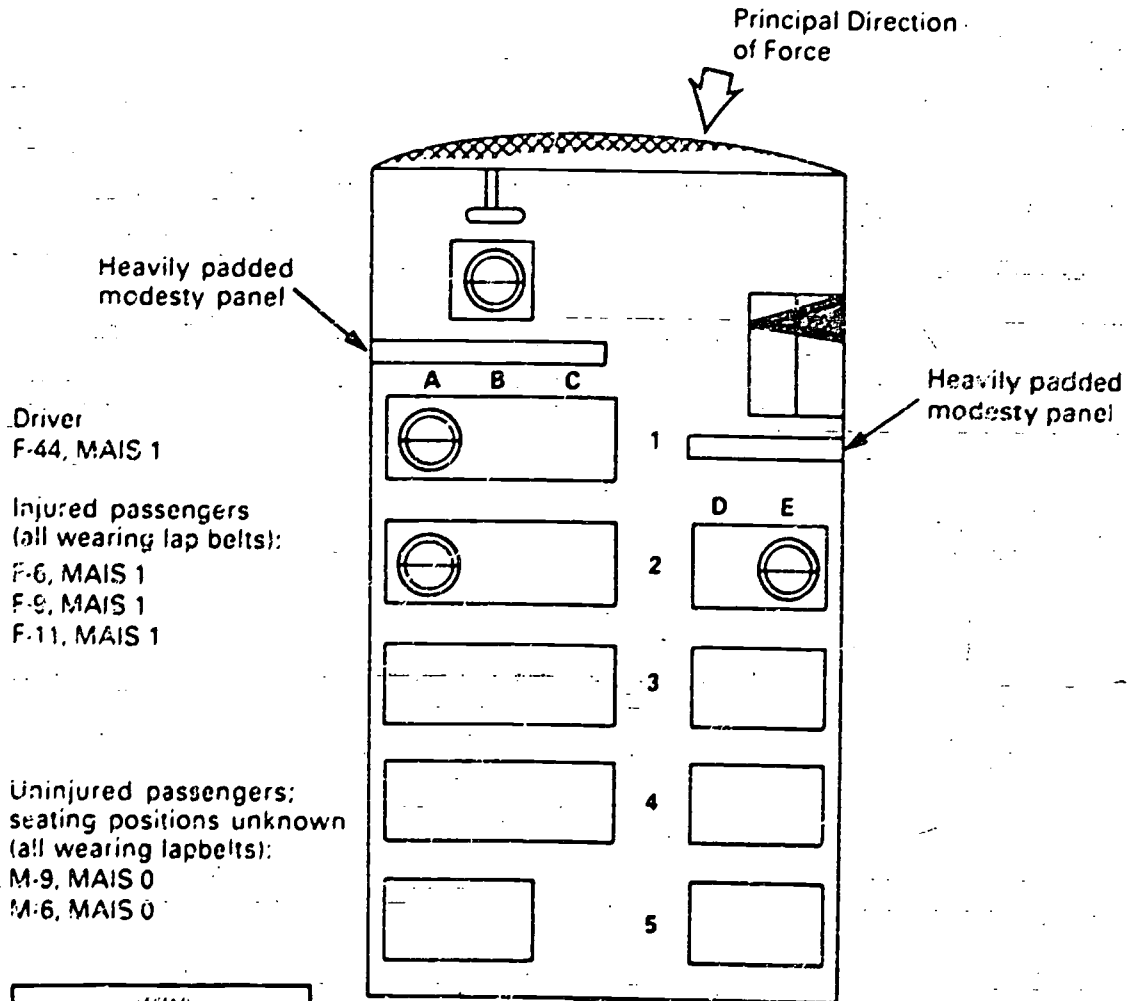

LEGEND

○ Injured	⊕ Lap Belt used
⊖ Injured	⊕ Lap Shoulder belt used
⊙ Injured, restrained	⊕ High Back seat
⊙ Injured, not restrained	⊕ Child Seat
	⊕ Child Safety Seat

Example:
 M-11
 Male Age 11
 Maximum AIS* Maximum AIS*
 Injured and a maximum AIS of 1 injury

AIS Grade and Injury Severity

5 Uninjured	6 Critical
4 Minor	5 Maximum Injury
3 Moderate	4 Injured, position unclear
2 Serious	3 Unknown Injury
1 Severe	

* American Association for Automotive Medicine classification (see SAE J845)

Special Notes:
Seating pattern for injured passengers is known, but not the specific locations of the individuals.

The school bus shown is representational only

Case No. 21	Safety Board Investigation No. NYC-87-H-SB01
Location of Accident	West Oak Hill Road; Williston, Vermont
Date and Time	November 21, 1987; 7:50 a.m.
Description of School Vehicle	Type B school bus: 1979 Chevrolet chassis with 18-passenger Mini-Bird body by Blue Bird Body Company
Type of Accident	Multiple collision: sideswipe, followed by head-on impact
Severity of Accident	Delta V estimated at 10 to 15 mph for head-on impact

Summary of Events

A small school bus, transporting three learning-disabled students to school, was traveling at a driver-estimated speed of 30 mph on a two-way, snow-covered road. The driver and two of the three passengers were restrained in some fashion. A 1984 Chevrolet Citation, traveling in the opposite direction, crossed the centerline and sideswiped the left side of the bus. The bus then veered to the right, left the road, and struck a tree head-on before coming to rest.

After the crash, the passengers remained in their seats until checked by ambulance personnel. The bus driver then unlatched the lapbelt securing the child safety seat used to restrain one passenger and carried the child, still in his safety seat, from the bus. The driver also unbuckled the other restrained passenger from her lapbelt; this passenger and the unrestrained passenger exited through the side door.

The left front corner of the bus had an inward crush of 10 inches. The front left side of the body was deformed toward the center from 3 to 5 inches. Damage from the tree was found near the center of the front of the bus where the bumper was pushed back 6.5 inches. All window glass was intact.

The poststandard school bus performed well. Damage was confined to the exterior body panels and front bumper.

Outcome of Occupants of School Vehicle

Passengers

Of the 3 passengers, ages 4 to 15:
3 were uninjured.

Two of the three passengers were restrained: one in a child safety seat and one by a static lapbelt. Determining the value of restraint use is difficult because all passengers were uninjured. The passenger in the child safety seat probably benefitted most from restraint use because he was not thrown forward into the restraining barrier or onto the floor. Use or nonuse of lapbelts probably had little effect on the injury of the other passengers.

Driver

The only injured occupant in the bus was the lapbelted driver who received a minor abrasion (AIS 1) on the right side of his hip, most likely caused by the lapbelt.

Notes About the Accident

The lapbelts on this bus were an aftermarket addition by the school district. Safety Board investigators determined that the lapbelt used by the passenger in the second seat on the right side was installed and used improperly. The webbing with the buckle end was anchored to the wheel well instead of the floor. The wheel well was much higher than the floor, adding 9 inches of extra length and preventing the belt from properly fitting the child. To take up the slack, the driver had knotted the belt webbing. Had this collision been more violent, the knot might have caused an injury because the passenger would have "jackknifed" over the belt and the knot. The child safety seat was also secured with a knotted lapbelt.

Williston, Vermont
Case Number 21

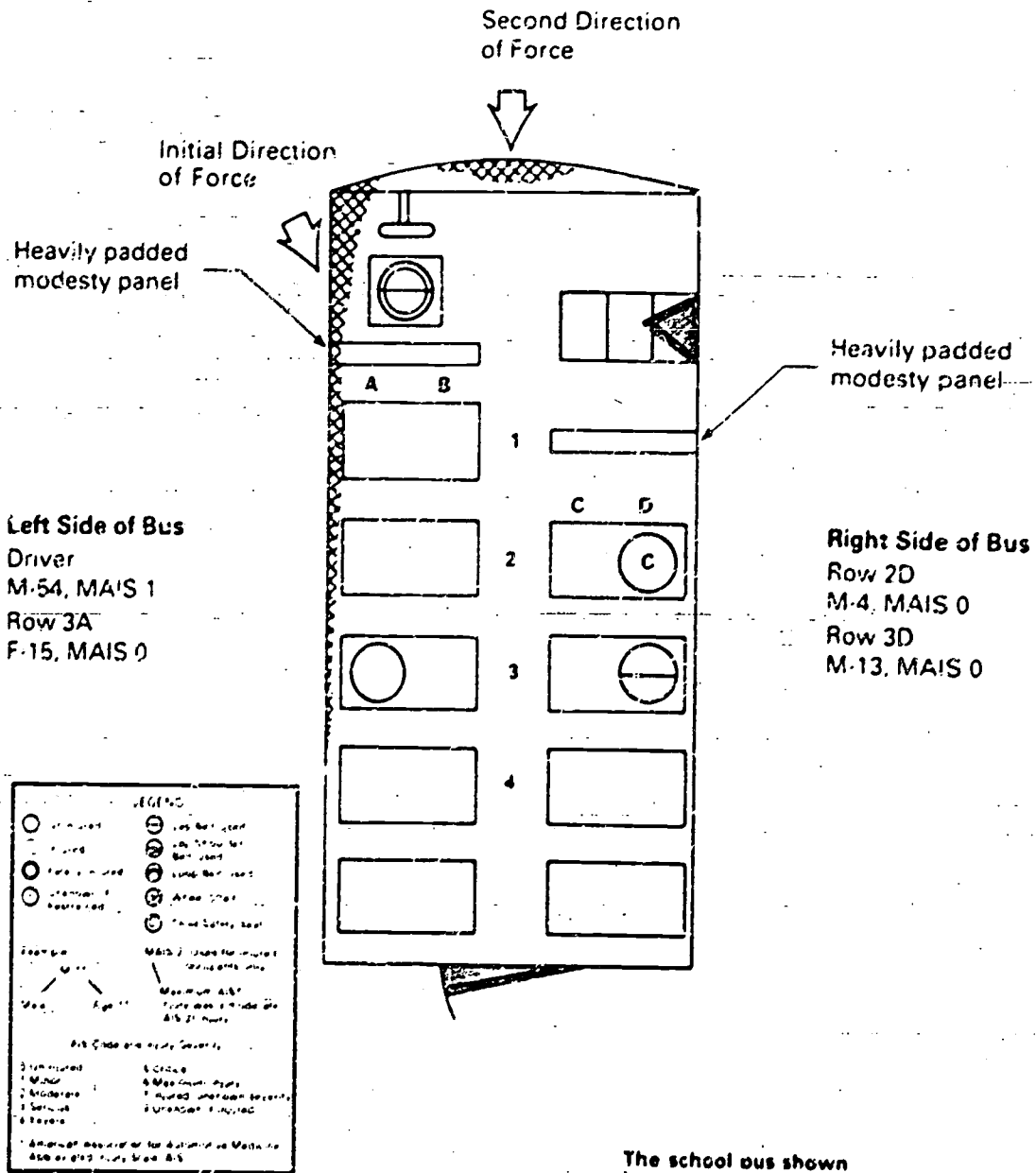

The school bus shown is representational only.

Case No. 22 Safety Board Investigation No. ATL-86-H-SB04

Location of Accident Intersection at Wautuga and Cascade Drive;
Greensboro, North Carolina

Date and Time January 14, 1986; 3:30 p.m.

Description of School Vehicle Type B school bus: 1980 Chevrolet chassis with 20-passenger Mighty Mite body by Thomas Built Buses. The bus had been reconfigured to 10-passenger capacity.

Type of Accident Right side impact, followed by rollover (90°)

Severity of Accident Delta V unknown (bus speed estimated at 25 mph; and car speed estimated at 5 mph)

Summary of Events

A school bus, transporting six students (some mentally disabled, others physically disabled) and a driver's aide, was traveling on an urban street. All but one of the occupants were restrained in some fashion (restraints included a misused harness, secured wheelchair, and lapbelts). As the bus crossed an intersection, a 1980 Oldsmobile 98 sedan struck the bus on its right side. The right rear dual tires of the bus rode up over the front of the car, lifting the bus up and starting the clockwise rotation of the bus as it continued to travel away from the impact. After a 95° clockwise rotation over 60 feet, the bus overturned onto its left side and came to rest.

The driver unlatched her lapbelt and began to organize the evacuation, assisted by the aide. Paramedics, the driver, the aide, and an unidentified passerby assisted some of the students to release their restraints; the two students on the right side of the bus remained suspended for only a few minutes. The rear emergency door was easily opened by a passerby; all entries and exits were made through this door during the rescue.

The poststandard school bus received minor exterior damage on its right side and moderate damage to its drive axle. Minor buckling of the interior roof occurred at the left side; however, no panel separations occurred.

Outcome of Occupants of School Vehicle

Passengers

Of the 7 passengers, a 39-year-old aide and 6 students, ages 5 to 13:
 1 was uninjured,
 5 sustained MAIS 1 (minor) injuries, and
 1 sustained MAIS 3 (serious) injuries.

Six of the seven passengers were restrained in some fashion; the unrestrained passenger was the driver's aide who was squeezed onto the third seat on the right side, which was already filled to capacity, so she could assist the handicapped student seated next to her. Because the aide was not in a designated seating position (the bench seat was designed for only one person), no lapbelt was available for her. The unrestrained aide received the most serious (AIS 3) injuries: a displaced fracture of her right wrist, which occurred when she struck the left side of the bus, possibly contacting the wheelchair secured to the left side, as the bus overturned. She also sustained abdominal trauma that threatened her pregnancy.

Of the six passengers who were restrained, four were secured by lapbelts, one was secured by the upper torso straps of an E-Z-ON vest and lapbelt, and another was in a special wheelchair equipped with several straps. The wheelchair was secured by two lapbelts.

The lapbelted passenger on the left side in the front row next to the window was reportedly not injured. The lapbelted passenger on the left side next to the window in the second seat received minor injuries: a small bruise on left knee from contact with the side wall or another passenger. The lapbelted passenger on the left side in the second seat next to the aisle received a small abrasion on the left side of his abdomen from the lapbelt. Passengers on the left side of the bus probably received less benefit from their restraints during the rollover than those seated on the right side: the bus came to rest on its left side.

The passenger seated on the right side of the bus in the second seat was restrained in a special harness, an E-Z-ON vest, but the harness was improperly used. Although designed to be secured to the floor by four loops, only the two upper loops were secured. The available lapbelt was used instead of the other attachments. The passenger received a minor injury: a small bruise on his right forehead from hitting the seatback in front of him. Had he not been restrained, he would have been thrown to the left during the rollover and probably could have received additional minor injuries.

One passenger was in a special wheelchair secured to the third seat on the left side with specially adapted straps. The passenger was severely disabled and could not sit or hold his head erect; the restraint device was necessary to keep the passenger in an upright position. He received a minor contusion: a bruise on his eyelid. Had he not been restrained, he could have received additional injuries.

The lapbelted passenger on the right side in the third seat next to the window received minor injuries: small bruises to her thigh from flexing over the lapbelt, and a lower leg abrasion from contact with the seatframe. Had she not been restrained, she might have fallen to the left during the rollover and received other injuries.

Driver

The lapbelted driver received multiple minor (AIS 1) bruises and abrasions from contact with the steering assembly, interior sidewall, and window area. The lapbelt-induced deep bruises on her left hip at the groin indicated that the impact was forceful. She also complained of soreness in her back and headaches.

Notes About the Accident

The school bus had been reconfigured for the transportation of disabled students; its original 20-passenger seating capacity was reduced to allow only 10 bench positions. The design left space at the extreme left rear for securing one conventional wheelchair. Three bench seats, all 26 inches wide, were installed on the right side of the bus; three 39-inch-wide and one 26-inch-wide seats were installed on the left side. The reduced width of the seat at the left rear position allowed greater access to an automated wheelchair lift installed on the right side of the bus.

The improper installation of the E-Z-ON vest did not result in injuries in this accident but might have in other accidents. Extrapolating injury outcome of a passenger in a specially designed harness or wheelchair restraint from the outcome of a passenger in a conventional restraint, such as a lapbelt, cannot be done with certainty.

Greensboro, North Carolina
Case Number 22

Rollover

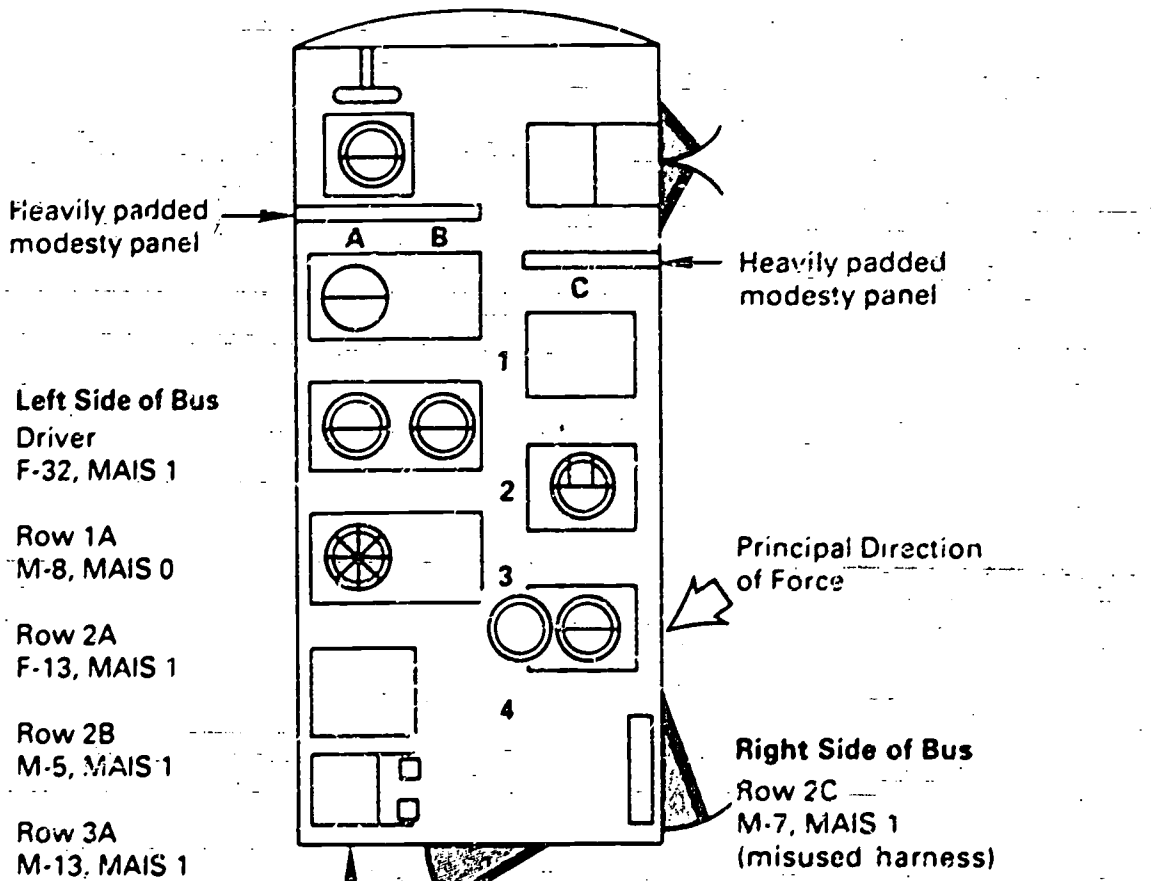

<ul style="list-style-type: none"> ○ Uninjured ○ Minor ○ Moderate ○ Severe ○ Fatal 	<ul style="list-style-type: none"> ○ Low Back Injury ○ Low Back Strain ○ Low Back Sprain ○ Wheel Chair ○ Child Safety Seat
<p>MAIS 1</p> <p>MAIS 2</p> <p>MAIS 3</p> <p>MAIS 4</p> <p>MAIS 5</p> <p>MAIS 6</p> <p>MAIS 7</p> <p>MAIS 8</p> <p>MAIS 9</p> <p>MAIS 10</p> <p>MAIS 11</p> <p>MAIS 12</p> <p>MAIS 13</p> <p>MAIS 14</p> <p>MAIS 15</p> <p>MAIS 16</p> <p>MAIS 17</p> <p>MAIS 18</p> <p>MAIS 19</p> <p>MAIS 20</p>	<p>MAIS 21</p> <p>MAIS 22</p> <p>MAIS 23</p> <p>MAIS 24</p> <p>MAIS 25</p> <p>MAIS 26</p> <p>MAIS 27</p> <p>MAIS 28</p> <p>MAIS 29</p> <p>MAIS 30</p> <p>MAIS 31</p> <p>MAIS 32</p> <p>MAIS 33</p> <p>MAIS 34</p> <p>MAIS 35</p> <p>MAIS 36</p> <p>MAIS 37</p> <p>MAIS 38</p> <p>MAIS 39</p> <p>MAIS 40</p> <p>MAIS 41</p> <p>MAIS 42</p> <p>MAIS 43</p> <p>MAIS 44</p> <p>MAIS 45</p> <p>MAIS 46</p> <p>MAIS 47</p> <p>MAIS 48</p> <p>MAIS 49</p> <p>MAIS 50</p>

MAIS 1: Maximum 65% injury, moderate & 57% injury

MAIS 2: Maximum 65% injury, moderate & 57% injury

MAIS 3: Maximum 65% injury, moderate & 57% injury

MAIS 4: Maximum 65% injury, moderate & 57% injury

MAIS 5: Maximum 65% injury, moderate & 57% injury

MAIS 6: Maximum 65% injury, moderate & 57% injury

MAIS 7: Maximum 65% injury, moderate & 57% injury

MAIS 8: Maximum 65% injury, moderate & 57% injury

MAIS 9: Maximum 65% injury, moderate & 57% injury

MAIS 10: Maximum 65% injury, moderate & 57% injury

MAIS 11: Maximum 65% injury, moderate & 57% injury

MAIS 12: Maximum 65% injury, moderate & 57% injury

MAIS 13: Maximum 65% injury, moderate & 57% injury

MAIS 14: Maximum 65% injury, moderate & 57% injury

MAIS 15: Maximum 65% injury, moderate & 57% injury

MAIS 16: Maximum 65% injury, moderate & 57% injury

MAIS 17: Maximum 65% injury, moderate & 57% injury

MAIS 18: Maximum 65% injury, moderate & 57% injury

MAIS 19: Maximum 65% injury, moderate & 57% injury

MAIS 20: Maximum 65% injury, moderate & 57% injury

MAIS 21: Maximum 65% injury, moderate & 57% injury

MAIS 22: Maximum 65% injury, moderate & 57% injury

MAIS 23: Maximum 65% injury, moderate & 57% injury

MAIS 24: Maximum 65% injury, moderate & 57% injury

MAIS 25: Maximum 65% injury, moderate & 57% injury

MAIS 26: Maximum 65% injury, moderate & 57% injury

MAIS 27: Maximum 65% injury, moderate & 57% injury

MAIS 28: Maximum 65% injury, moderate & 57% injury

MAIS 29: Maximum 65% injury, moderate & 57% injury

MAIS 30: Maximum 65% injury, moderate & 57% injury

MAIS 31: Maximum 65% injury, moderate & 57% injury

MAIS 32: Maximum 65% injury, moderate & 57% injury

MAIS 33: Maximum 65% injury, moderate & 57% injury

MAIS 34: Maximum 65% injury, moderate & 57% injury

MAIS 35: Maximum 65% injury, moderate & 57% injury

MAIS 36: Maximum 65% injury, moderate & 57% injury

MAIS 37: Maximum 65% injury, moderate & 57% injury

MAIS 38: Maximum 65% injury, moderate & 57% injury

MAIS 39: Maximum 65% injury, moderate & 57% injury

MAIS 40: Maximum 65% injury, moderate & 57% injury

MAIS 41: Maximum 65% injury, moderate & 57% injury

MAIS 42: Maximum 65% injury, moderate & 57% injury

MAIS 43: Maximum 65% injury, moderate & 57% injury

MAIS 44: Maximum 65% injury, moderate & 57% injury

MAIS 45: Maximum 65% injury, moderate & 57% injury

MAIS 46: Maximum 65% injury, moderate & 57% injury

MAIS 47: Maximum 65% injury, moderate & 57% injury

MAIS 48: Maximum 65% injury, moderate & 57% injury

MAIS 49: Maximum 65% injury, moderate & 57% injury

MAIS 50: Maximum 65% injury, moderate & 57% injury



The school bus shown is representational only.

Case No. 23	Safety Board Investigation No. FTW-83-F-H001
Location of Accident	Colonel Glenn Road; outside Little Rock, Arkansas
Date and Time	May 2, 1983; 3:50 p.m.
Description of School Vehicle	Type B school bus: 1981 Chevrolet chassis with 15-passenger Cadet body by Carpenter Body Works
Type of Accident	Head-on collision followed by rollover (90°)
Severity of Accident	Delta V unknown (bus speed at impact was about 30 mph; pickup speed at impact 20 mph)

Summary of Events

A small school bus, equipped with lapbelts for all occupants, was transporting five physically handicapped students from school. Four of the five passengers and the driver were restrained. The bus was traveling 30 mph in a heavy rain on a two-lane road. When the bus approached a sharp right curve, the driver applied the brakes; the rear began to sideslip, and the bus rotated clockwise out of control. The school bus slid across the road center and collided right front to right front with a 1977 Chevrolet pickup truck. The collision pushed the pickup truck back and caused it to rotate 45° clockwise. As the bus forced the pickup rearward, the right front wheel of the bus overrode the right front wheel of the pickup, causing the bus to lean to the left and overturn slowly onto its left side.

Evacuation of the school bus went smoothly, although the passengers had never practiced evacuation. Two passengers required assistance releasing their lapbelts. One student was hanging from the upper side of the bus and was reluctant to release his latchplate until the bus driver was there to cushion his fall; another student needed assistance to walk, so he waited for help. After assisting the passengers, the driver opened the emergency door, and the passengers helped each other out. A passerby held the door open.

The right front corner of the poststandard school bus was crushed rearward a maximum of 28 inches, and the crumpled metal extended rearward to the side exit door. This door was jammed and the students were evacuated through the rear exit, which was not damaged.

No interior damage occurred.

Outcome of Occupants of School Vehicle

Passengers

Of the 5 passengers, ages 14 to 18:
 2 were uninjured, and
 3 sustained MAIS I (minor) injuries.

Four of the five passengers were wearing lapbelts.

Two of the four passengers wearing lapbelts and the unrestrained passenger sustained minor (AIS 1) contusions and abrasions. Lapbelt use made little difference in this accident: both restrained and unrestrained passengers received minor injuries. Both of the uninjured passengers, however, were wearing lapbelts. No student complained of soreness from the lapbelt.

Driver

The 35-year-old lapbelted driver received minor (AIS 1) contusions to her hip, attributed to the lapbelt because she was suspended by the webbing before releasing the belt. The use of the lapbelt likely helped to reduce the number and severity of her injuries.

Notes About the Accident

This bus was equipped with 29-inch-high restraining barriers in front of both front row seats.

The bus was transporting a deaf-mute passenger and a passenger who, although able to move with crutches, normally used a wheelchair. All passengers were seated on the bench seats at the time of the accident; no passenger was in a wheelchair.

Little Rock, Arkansas
Case Number 23

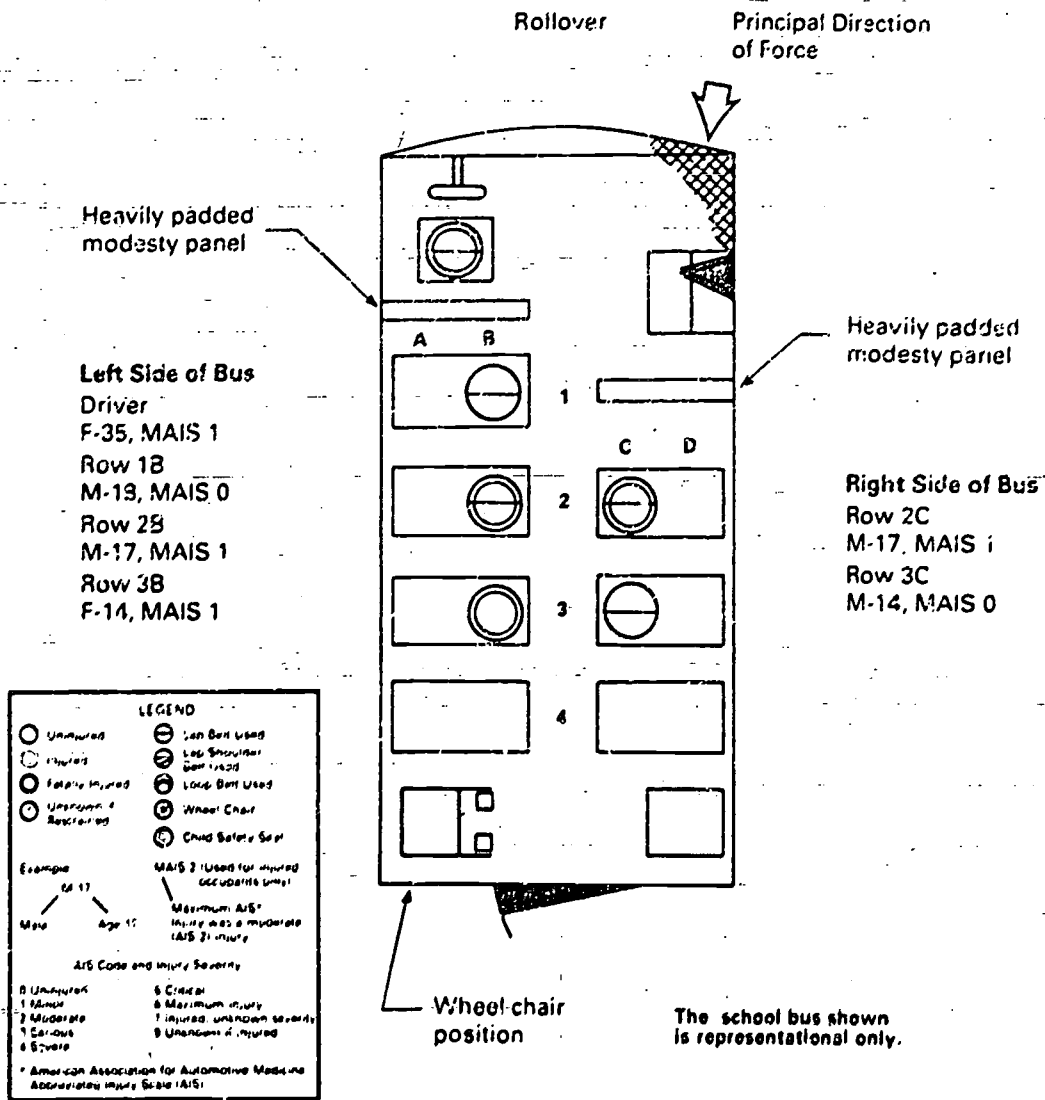

Case No. 24	Safety Board Investigation No. NYC-86-H-SB04
Accident Location	Intersection of Port Washington Boulevard and Bonnie Heights Road; Flower Hill, New York
Date and Time	January 24, 1986; 8:45 a.m.
Description of School Vehicle	Type B school bus; 1979 GMC chassis with 14-passenger Coachette body
Type of Accident	Rear-end collision, followed by rollover (90°)
Severity of Accident	Delta V unknown (bus was just accelerating from stop.)

Summary of Events

A small school bus was transporting three preschool and elementary students to school. Two of the three passengers were sharing a substandard belt. The school bus stopped at an intersection and then proceeded across a four-lane, two-way, divided highway when it was struck in the right rear by a passenger car. At impact, the school bus rotated clockwise and rolled over onto its left side.

After the schoolbus came to rest, the driver unbuckled his belt and went to the passengers. The unrestrained boy was lying on his left side by the window frame and ceiling, conscious and alert. The driver unbuckled the belt shared by the two other children; they were also conscious and alert and remained calm. They stood up on their own and the driver assisted the passengers out of the rear emergency exit.

The body of the poststandard school bus remained relatively intact; however, the left side of the body, from the windows to the roof, was displaced inward about 1 inch. The padded restraining barrier and the three rows of seats behind the driver's seat abutted the sidewall because of this displacement. One ceiling seam separated in two places; the separations were 6 inches long and one-fourth inch wide. The windshield cracked and was dislodged from its frame. The doors on the right rear for the wheelchair lift were rendered inoperative.

Outcome of Occupants of School Vehicle

Passengers

Of the 3 passengers, ages 5 to 6:
 1 was uninjured, and
 2 sustained MAIS 1 (minor) injuries.

Two of the passengers were restrained by one large, substandard form of seatbelt, jury-rigged in the bus (see description of belt under "Notes About the Accident"). These passengers were seated on the left side in the front seat at the window and center positions. One received a bone bruise (AIS 1), and one was

uninjured. Use of the substandard belt unlikely affected their injury outcome because of their proximity to the side onto which the bus rolled. The nature of the substandard belt, however, increased the chance of greater injuries. The passenger on the left side in the front seat next to the aisle was unrestrained; he received a minor laceration (AIS 1) to his chin from the window frame. Had he been restrained, his injuries probably would have been about the same because of the dynamics of the bus and his close proximity to the side onto which the bus rolled.

Even if all of the passengers had been restrained by properly installed lapbelts, injury outcome would not have improved over the minor to no injuries that were actually sustained.

Driver

The lapbelted driver received minor (AIS 1) injuries. The contusions to the driver's left shoulder could have been caused by the clockwise rotation of the bus when it was stuck in the right rear or by the driver striking the left inside wall of the bus as it overturned onto its left side.

Notes About the Accident

The jury-rigged restraints, erroneously reported to be lapbelts, were installed by employees of the bus company, not the school bus manufacturer. Bus company policy for the last 5 years states that the driver is to fasten the belt around prekindergarten passengers and to suggest to kindergarten and older passengers that they wear the belt.

Each of the six passenger seats had a 29-inch-tall seatback. Only two belts were provided: for the first and third seats on the left side. Both improvised belts created potential injury-producing hazards.

The belt on the front seat was made up from two sets of lapbelts joined together by two metal plates, each about 7 inches long, and four bolts, each about 1 3/8 inches long. The belt was looped around the junction of the seatback and seat cushion rather than anchored to the floor or seatframe. The installation allowed up to three children to be restrained by the belt. The exposed metal plates and protruding bolts presented a hazard for any occupant coming in contact with them. A passenger restrained by the device would probably sustain a serious injury during a crash if the bolts and plates were in front of or alongside the passenger's torso.

The device on the third seat had been installed in a manner similar to the one on the front seat. It consisted of two belts: one wrapped horizontally around the seatback about 8 inches above the top of the seat cushion, and one looped around the cushion. The looped belt, with padding stitched to it, served as the lapbelt. This device also compromised the safety of an occupant restrained by it. The lap portion of the belt would fit around the upper torso, not low and across the hips. Because the lap portion of the belt wrapped around the belt on the seatback, it could slide to the inboard and outboard positions of the seat.

According to the label on the belts, the webbing latches and buckles conform to Federal Motor Vehicle Safety Standards 209 and 302. Neither of the belts however, conform to the Federal standards. For example, FMVSS 210 stipulates that "anchorage for an individual seatbelt assembly shall be located at least 6.50 inches apart laterally, measured between the vertical centerline of the hole holes"; the jury-rigged restraints were not anchored at all. Section 571.209 of the FMVSS states that "a seatbelt assembly shall be designed for use by one, and only one, person at any one time," and that the seatbelt shall be capable of adjustment to fit the occupant. The devices did not meet these requirements.

In the Society of Automotive Engineers book entitled "Motor Vehicles Seat Belt Assembly Installations," section SAE-J800C states that attachment parts shall be spaced laterally so that the lapbelt portion of the seatbelt assembly essentially forms a "U"-shaped loop when in use. The standard states that in no case shall both ends of one assembly be connected at the same anchorage or attachment point.

APPENDIX C
SUMMARY OF SAFETY ISSUES BY CASE NUMBER

Case number	Inaccurate reporting of restraint status	Improper use or unusual installation of available restraints	Involvement of stanchion/ frontal barrier in occupant injuries (includes absence of frontal barriers) or anchor dislodgement	Joint or maintenance access panel separation	Crushed roof or other intrusion into passenger compartment	Floor buckled	Jammed/ blocked exit or exit unable to open	Boarding door/control component/ door jammed shut	Other
1									
2	x	x					x		
3		x	x				x (driver's door)		
4	x	x (vandalized belts)	x (absent)						Mix of pushbutton latch plates and lift release latch plates on same seat. Lapbelts not available at all seating positions; stairwell deformed.
5	x	x	x			x	x	x (jammed)	Floor at entrance step buckled.
6						x	x		Driver with chronic heart condition
7		x	x (moved by floor buckle)			x			

Case number	Inaccurate reporting of restraint status	Improper use or unusual installation of available restraints	Involvement of stanchion, frontal barrier in occupant injuries (includes absence of frontal barriers) or anchor dislodgement	Joint or maintenance access panel separation	Crushed roof or other intrusion into passenger compartment	Floor buckled	Jammed/ blocked exit or exit unable to open	Boarding door/control door jammed shut	Other
8								^a (opened)	Children not instructed on belt wearing/ evacuation
9									
10			^a (dislodged from anchor)	^a					Windshield dislodged
11				^a			^a (opened)	^a	
12									Driver distracted by lapbelting students; windshield displaced
13				^a			^a	^a (inoperable)	Evacuation of deaf students hampered when driver, the only person knowing sign language, was removed; windshield displaced

Case number	Inaccurate reporting of restraint status	Improper use or unusual installation of available restraints	Involvement of barrier in occupant injuries (includes absence of frontal barriers or anchor dislodgement)	Joint or maintenance access panel separation	Crushed roof or other intrusion into passenger compartment	Floor buckled	Jammed, blocked exit or exit unable to open	Boarding door/control component door jammed shut	Other
14							(side doors buckled)		Windshield shattered, rear emergency door opened and torn from hinges during rollover. New driver had never driven a van. Seats detached from anchorage.
15	x	x	x			x		(injuries to aide from contact with components)	
16	x		(dislodged from anchor)	x (left side peeled back)	x		x		Sheet metal torn away; seats torn loose.
17	x	x	(dislodged from anchor)	x	x	x	x	(jammed)	Bench seats deformed.
18			x	x					

Case number	Inaccurate reporting of restraint status	Improper use or unusual installation of available restraints	Involvement of stanchion/ frontal barrier in occupant injuries (includes absence of frontal barriers) or anchor dislodgement	Joint or maintenance access panel separation	Crushed roof or other intrusion into passenger compartment	Floor buckled	Jammed/ blocked exit or exit unable to open	Boarding door/control/ door jammed shut	Other
19		x					x	x (injuries to driver from contact with control)	Seat cushions detached
20									
21		x							
22		x			Minor roof buckle	x			
23							x	x (jammed)	Evacuation never practiced.
24	x	x		x			x		Lapbelts not available at all seating positions. windshield dislodged.
25	x	x			x				Belts anchored to seats and floor, windshield fractured.
26									Seat deformed.
27		x							
28									All glass out.

APPENDIX D

INDEX TO AND CASE SUMMARIES OF SMALL SCHOOL VEHICLES
NOT BUILT TO FEDERAL SCHOOL BUS STANDARDS

Number of cases: 4
 Type of accident: Nonrollover 3
 Rollover 1

<u>Case number</u>	<u>Data</u>
25	Wallingford, Connecticut -- November 10, 1987 1985 Ford E-350, 15-passenger van (not built to Federal school bus standards) Frontal collision
26	Schaumburg, Illinois April 5, 1985 1984 Ford 19-passenger Econoline van (not built to Federal school bus standards) Head-on collision
27	Bedford, New Hampshire October 1, 1985 1981 Dodge Van Space Porter Custom SE (previously used for airport service; retrofitted to meet New Hampshire school bus standards; van not built to Federal school bus standards) Left side impact
28	Odessa, Texas June 23, 1984 1980 Ford Superwagon, 15-passenger van (not built to Federal school bus standards) Noncollision rollover (720°)

Case No. 25	Safety Board Investigation No.: NYC-88-H-SB04
Accident Location	Durham Road; Wallingford, Connecticut
Date and Time	November 10, 1987; 2:45 p.m.
Description of School Vehicle	1985 Ford E-350, 15-passenger van (painted blue, not school bus yellow). The van was not built to Federal school bus standards.
Type of Accident	Frontal collision
Severity of Accident	Delta V 13 mph

Summary of Events

A Ford van being used as a school vehicle was transporting 14 passengers (an adult aide and 13 junior high school students) home from school on a rural road. Some form of belt system was available at each seating position, but at least four passengers and the driver were unrestrained. As the van entered a left curve, a 1972 Chevrolet dump truck, traveling in the opposite direction, lost control on the snow-covered road and crossed into the van's lane. The dump truck, which was rotating counterclockwise, struck the left front of the van with its left side. Impact forces caused the dump truck's load of hot asphalt to spill onto the van's roof and into the van through the broken side windows.

Of the 14 passengers, 13 safely evacuated the bus. The passenger seated directly behind the driver was unable to release his lapbelt because hot asphalt had spilled onto his seat, burying the latchplate. The lapbelt was subsequently cut by the truck driver, and the student was freed. The unrestrained driver of the school van was trapped in the vehicle until extricated by rescue personnel.

The left front of the van was crushed rearward 17 inches and 13 inches rightward at maximum collapse. The windshield was fractured at the left A pillar, and the driver's door and the middle left side window were broken. The dashboard and steering wheel were pushed rearward towards the driver's seat. The roof buckled rearward of the B pillar.

Considering the difference in mass between the dump truck and the van, the van performed well in the crash. Most injuries were caused by the spillage of hot asphalt into the van, not by the crash itself.

Outcome of Occupants of School Vehicle

Passengers

Of the 14 passengers, one adult and 13 students, ages 11 to 15:
 13 sustained MAIS 1 (minor) injuries, and
 1 sustained MAIS 2 (moderate) injuries.

Of the 14 passengers, 8 were wearing lapbelts, 1 was wearing a lap/shoulder belt available at his seating position, and restraint use for 1 was undetermined. The adult aide was unrestrained.

The passenger wearing the lap/shoulder belt was seated in the bucket seat to the right of the driver. The shoulder portion of the belt was equipped with an emergency locking retractor; the lap portion was equipped with an automatic locking retractor. The passenger received minor (AIR 1) injuries: nose laceration from contact with the dashboard, first degree burns on top of his head from hot asphalt, and contusions to midchest and right hip from the shoulder harness. Had this student not been restrained by the lap/shoulder belt, he probably would have contacted the dashboard more forcibly and sustained more serious injuries. Information was not available on the adjustment of his lap/shoulder belt; some slack probably was present in the shoulder portion because he contacted the dashboard in this Delta V 13 mph collision.

The lapbelted passenger by the window in the front row of bench seats received the worst injury (moderate, AIS-2) sustained by a passenger: a fractured cheekbone from contact with the door frame on the driver's side, which was dislodged during the crash. He also sustained minor forehead and lip lacerations (AIS 1) from contact with the door frame and first-degree burns on hands and upper legs from hot asphalt. Because the lapbelt offered no upper torso restraint, it could not prevent his upper body from swinging forward at impact and hitting the door frame.

The lapbelted passenger seated in the middle of the front row received minor (AIS 1) injuries: contusions on his left knee from contact with the seatback in front of him and multiple minor burns from hot asphalt. The outcome probably would have been similar had he been unrestrained.

The adult aide seated next to him, on the right side of the front row, was not using the available lapbelt and sustained minor (AIS 1) injuries: contusions on her left shoulder, her chest, right knee, and left foot. If lapbelted, she still probably would have sustained minor injuries.

The lapbelted passenger by the window in the second row of bench seats sustained minor (AIS 1) contusions on her head, left knee, and shin from contact with the seatback in front of her and first-degree burns on her chin and hands from asphalt. Lapbelt use could not prevent these injuries because upper and lower extremities are free to flail about in a crash.

Lapbelt use also did not prevent the passenger in the middle of the second row from straining his left wrist or from sustaining first-degree burns on his hands, forearms, and left cheek from hot asphalt. Lapbelt use did not prevent the passenger on the right side of the second row from spraining his left ankle.

At least two of the three passengers on the third bench seat wore the available lapbelts. The passenger in the middle claimed to have been restrained, but examination of the belt's latchplate adjustment indicated that, if worn, the webbing would have provided no restraint: the belt was extended to its maximum length. All three sustained minor (AIS 1) injuries: contact-induced contusions,

strains, and burns from the asphalt. The occupant in the middle also sustained nose and forehead abrasions and knee abrasions from contact with the seatback, and abrasions to the hip area. The other two sustained neck or back sprains, origin unknown.

The fourth bench seat was equipped with lapbelts for the four seating positions. Only one of the four students seated on the bench was restrained at the time of the crash. All four students, however, received only minor injuries.

Driver

The driver was unrestrained, but restraint status probably had little effect because of the intrusion at his seating position. He sustained moderate (AIS 2) injuries: a fractured left knee and fractured five adjoining ribs on his left side when he contacted the left door and steering wheel during the collision. He also received a kidney injury of unknown severity (AIS 7). Hot asphalt caused first-degree burns of both hands, left forearm, back, and left thigh.

The driver was trapped in the vehicle as a result of the vehicle collapse at his seating position and the hot asphalt that had spilled on top of him. He was freed by fire rescue personnel.

Notes About the Accident

Passenger injuries, for the most part, were caused by the hot asphalt that spilled into the van through the broken windows. Restraint use could have provided little benefit in those circumstances. Seating position, rather than restraint status, was the major factor in injury outcome. The two passengers receiving the worst injuries were seated in the impact zone.

Although the driver stated he was wearing the lap/shoulder belt available at his position, Safety Board investigators determined that he probably was unrestrained. The shoulder portion of the three-point belt was found wedged behind the driver's seat with blood splattered on the latchplate, and asphalt concrete filled the buckle latchplate slot.

The lapbelts provided at 13 of the 14 passenger seating positions were General Motor lapbelts, with pushbutton release latchplates, requiring manual adjustment to ensure a snug fit. Safety Board investigators suspect at least one of these lapbelts had not been adjusted properly: the student seated in the third bench seat, middle position, claims to have been wearing the available lapbelt but slid forward under the seat in front of her during the crash. The lapbelt at her seating position was found extended to its maximum length. If worn, it probably had not been adjusted to fit properly and allowed the student to slide under the belt and onto the floor.

The lapbelts on the four bench seats were equipped with pushbutton release latchplates. Latchplates on the rear bench seat were anchored to the floor; the others were anchored to the seatframe.

Wallingford, Connecticut
Case Number 25

LEGEND

○ Uninjured	⊖ Lap Belt Used
⊖ Injured	⊖ Lap/Shoulder Belt Used
⊙ Fatally Injured	⊖ Long Dist. Used
⊖ Unrestrained	⊖ Air Bag Used
⊖ Restricted	⊖ Child Safety Seat

Example: M-11, Male, Age 17, Maximum AIS# Injury was a Moderate (AIS 2) Injury.

AIS Codes and Injury Severity

1 Uninjured	5 Critical
2 Minor	6 Maximum Injury
3 Moderate	7 Injured, Unknown Severity
4 Serious	8 Unknown Injury
5 Severe	9 Unknown Injury

© American Association for Automotive Medicine
Abbreviated Injury Scale (AIS)

Principal Direction
of Force

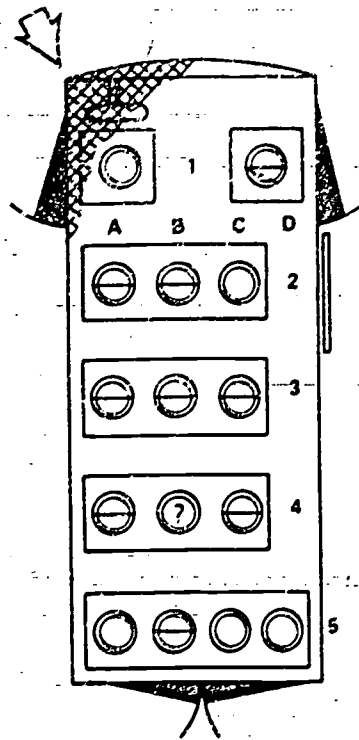

Left Side of Van

Driver
M-68, MAIS 2
Fracture of left knee
Fracture of five adjacent ribs on left.
Kidney injury, unknown severity
First degree burns on both hands, left forearm, lower back, and left thigh

Row 2A

M-11, MAIS 2
Fracture of left cheek bone
Laceration of forehead and lips
First degree burns on hand and both upper thighs

Row 2B

M-13, MAIS 1

Row 3A

F-12, MAIS 1

Row 3B

F-11, MAIS 1

Row 4A

F-12, MAIS 1

Row 4B

F-13, MAIS 1
(restraint status unknown)

Row 5A

M-14, MAIS 1

Row 5B

M-13, MAIS 1

Right Side of Van

Row 1D

M-11, MAIS 1

Row 2C

F-53, MAIS 1

Row 3C

M-13, MAIS 1

Row 4C

F-13, MAIS 1

Row 5C

M-15, MAIS 1

Row 5D

M-15, MAIS 1

The van shown is
representational only.

Case No. 26	Safety Board Investigation No. CHI-85-H-OR18
Accident Location	Schaumburg Road and Plumgrove Road; Schaumburg, Illinois
Date and Time	April 5, 1985; 12:49 p.m.
Description of School Vehicle	1984 Ford 19-passenger Econoline van. The van was not built to Federal school bus standards.
Type of Accident	Head-on collision
Severity of Accident	Delta V 25-28 mph

Summary of Events

A van used as a school vehicle was transporting 12 students on an activity trip. While traveling eastbound on a four-lane roadway divided by a 16-foot-wide flush divider island, the driver lost control. The van crossed over the median divider, entered the opposing traffic lanes, and struck a 1984 Lincoln Continental sedan head-on. After impact, both vehicles came to rest in the westbound left lane still engaged in the impact position.

Of the 12 passengers in the van, 7 were wearing lapbelts and 5 were unrestrained. The driver was also unrestrained.

Collision damage was found across the entire front of the van, with maximum rearward crush reaching 20 inches at the right front. There was no intrusion into the passenger compartment of the van. Interior damage occurred to the steering assembly and instrument panel forward and inboard of the driver's seat position. The lower framework and the seatback of each bench seat were substantially deformed. A spare tire and wheel, stored but unsecured beneath the rearmost bench seat, was displaced forward during the impact.

The van performed well in this crash, allowing the passenger compartment to maintain its structural integrity without contributing to passenger injury. Although the vehicle did not conform to Federal school bus standards, this does not appear to have affected the crash outcome. Many injuries were attributable to lapbelt use rather than to the interior features of the van.

Outcome of Occupants of School Vehicle

Passengers

Of the 12 passengers, ages 6 to 7:

- 5 sustained MAIS 1 (minor) injuries,
- 3 sustained MAIS 3 (serious) injuries,
- 3 sustained MAIS 5 (critical) injuries (the injuries for one proved fatal),
- and
- 1 sustained MAIS 7 (unknown severity) injuries.

Although the passenger in the front bench seat (bench 1) next to the left window said that he was wearing the lapbelt provided, evidence indicated that he was unrestrained. He received minor (AIS 1) abrasions and a laceration. Considering the injuries sustained by the lapbelted passengers in this van, this passenger might have received a greater level of injuries had he been restrained.

The passenger in bench 1 in the second seat from the left was restrained by a static lapbelt and sustained a bilateral pelvic fracture (AIS 2), contusions and abrasions on and above the bridge of his nose (AIS 2), a closed head injury with neuralgic defect (AIS 3), and abrasion of the left and right flanks (AIS 1). The passenger's injuries can be attributed directly to his wearing the lapbelt. Considering the location and type of his pelvic injuries, the lapbelt was apparently worn in what is usually considered to be a proper manner. The bilateral pelvic fracture was caused by decelerating into the belt webbing while the upper torso jackknifed over belt causing head contact with the rigid base of the driver's seat. Had a lapbelt not been worn, this child's deceleration would have been into the rear cushion of the driver's seat, the driver's body, and the surface of the engine cover, with the deceleration forces distributed over more of his body; some level of moderate to serious injury could have occurred.

The passenger in bench 1 in the right seat was restrained by a lapbelt and sustained a serious (AIS 3) comminuted fracture of the left iliac wing and minor (AIS 1) contusions and abrasions to his abdomen and limbs. Because his height was much greater than that of the passenger on his left, his head was directed into the upper area of the seatback in front of him (the right front seat). The seatback deformed forward, allowing a controlled or contained deceleration. Although the serious pelvic injury was the result of his wearing the lapbelt, the passenger did not receive a serious head injury, unlike his seatmate.

The passenger in bench 2 next to the left window was not wearing the static lapbelt available and sustained a minor (AIS 1) contusion to his lower left leg, which did not require medical attention. He was fully contained by the seatback directly in front of him. Extensive forward displacement occurred in the seatback along with multiple scuffed areas.

The passenger in bench 2 next to the right window was not wearing the static lapbelt available at that position and also sustained only minor (AIS 1) injuries: abrasions and contusions. Extensive forward deformation occurred to the lower framework of bench 2 along with the seatback at this position. The seatback directly in front was pushed forward several inches, with scuffed areas on the upholstered rear surface.

The passenger in bench 3 next to the left window was wearing the static lapbelt available at that position and sustained serious (AIS 3) injuries that included a fracture of the left iliac crest, a head injury, and a bladder contusion. The passenger was hospitalized for 4 days. Her serious injuries can be attributed to her wearing the lapbelt. The location and nature of her pelvic injuries strongly suggest proper belt placement. The bench seat directly in front was extensively deformed: the lower framework was displaced forward several inches and the back cushion was pushed forward into contact with the lower cushion. Scuffed areas were observed on the upholstered rear surface of the back cushion.

The passengers in bench 3 in the second seat from the left and the right seat were not wearing the static lapbelts available at the positions. Both passengers sustained minor (AIS 1) contusions and abrasions, and were both contained by the seatbacks in front, allowing them to "ride down" the impact forces without serious injury.

The passenger in bench 4 next to the left window was wearing the static lapbelt available at that position and sustained critical (AIS 5) injuries that proved fatal. This passenger suffered a contusion (6 x 6 inches) on the left hip (AIS 2), bilateral pulmonary contusions (AIS 3), retroperitoneum hematoma (AIS 3), subarachnoid hemorrhage (AIS 3), serosal tear (AIS 4), torn mesentery (AIS 4), subdural hematoma (AIS 4), laceration of the, colon (AIS 5), laceration of the small bowel (AIS 5), and loss of consciousness (AIS 5). The passenger never regained consciousness following the crash. She was treated with the aid of life support equipment for 3 days before being pronounced dead. The injuries resulted from lapbelt use. The severity of the injuries was increased by the presence of an unsecured spare tire and wheel that moved forward at impact to a position beneath and forward of the passenger. The jackknifing action over the lapbelt accelerated her head into violent contact with the tire and wheel, resulting in brain and spinal injury. The lapbelt itself penetrated her abdomen, resulting in massive internal trauma. The movement of the spare tire blocked the downward collapse of the lower seat cushion, presenting a rigid surface that resulted in compression of the passenger's chest and pulmonary contusions. Had the lapbelt not been worn, the passenger's head would not have accelerated downward into the spare tire and wheel or into the lower framework of bench 3.

The passenger in bench 4 in the second seat from the left was wearing the static lapbelt available and sustained critical (AIS 5) injuries: a bilateral fracture of iliac crests (AIS 2), a subarachnoid hemorrhage (AIS 3), and severe brain stem injury (AIS 5). The passenger received initial care at an area hospital for 2 days before being transferred for long-term care. His injuries, like those of the passenger to the left, are attributed to the lapbelt being worn. These injuries probably would have been less severe had the passenger not been lapbelled.

The passenger in bench 4 in the second seat from the right was also wearing the static lapbelt available and sustained critical (AIS 5) injuries: a contusion with hematoma of the forehead (AIS 2), abrasion/contusion of the lower abdomen (AIS 3), contusion with hematoma of the cecum (AIS 3), subarachnoid hemorrhage of the cranial/cervical junction (AIS 3), subarachnoid hemorrhage of the posterior fossa (AIS 3), perforation of small bowel (AIS 5), and a spinal cord contusion (quadriplegic) (AIS 5). The passenger spent extended time at a local hospital and was then transferred to an extended-care facility. The passenger would not have received such serious injuries had he not been lapbelled.

The passenger in the bench 4 next to the right window seat was wearing the static lapbelt available. Several inches of forward deformation occurred at the right side lower framework of bench 4. The tubular frame members were bent forward to a point of contact between the bench's leading edge frame and the inner fender of the right rear tire. The back cushion of the bench was displaced forward by several inches at its top. This passenger sustained a moderate (AIS 2) injury. a

full-depth laceration of the tongue. She was afforded some degree of deceleration by the interior sidewall of the van and the forward deformation of the lower framework of the seat; she did not sustain serious to critical injuries comparable to the other lapbelteed-passengers.

Driver

The driver of the van, who was not wearing the available lap/shoulder belt, sustained severe injuries: a large laceration of the left thigh (AIS 2), contusion of the upper left chest (AIS 2), multiple facial contusions (AIS 2), concussion with amnesia (AIS 3), avulsion fracture of the right elbow (AIS 3), and a bilateral pulmonary contusion (AIS 4).

Witnesses stated that the driver apparently passed out just before to the collision and leaned over to the right. Had the driver had been wearing the lap/shoulder belt, her leaning to the right would have taken her out of the shoulder belt and left her restrained by the lapbelt only.

Schaumburg, Illinois
Case Number 26

Driver
F-24, MAIS 4
Bilateral pulmonary contusions
Concussion
Avulsion fracture of right elbow
Multiple contusions to the face
Contusion - upper left chest
Large laceration - left thigh
Multiple small lacerations - face
Fractured - left side 1st & 2nd ribs
Contusion - right clavicle area
Multiple contusions - left leg
Multiple contusions - right leg
Abrasions - right hand
Abrasions - left hand

Row 1A
M-6, MAIS 1
Row 1B
M-7, MAIS 3
Closed head injury with neurological defect
Contusion - abrasion - bridge of nose and above
Bilateral pelvic fractures
Abrasion - left flank
Abrasion - right flank

Row 1D
M-7, MAIS 3
Comminuted fracture - left iliac wing
Contusion - upper forehead
Contusion - lower abdomen - right to left side
Abrasion - lower left leg
Abrasion - left calf

Row 2A
M-6, MAIS 1
Row 2D
M-5, MAIS 1

Row 3A
F-6, MAIS 3
Closed head injury
Bladder contusion
Fracture right iliac crest
Contusion - right hip
Contusion - left iliac crest
Abrasions - contusions - lower right leg
Contusions - lower left leg
Contusions - right hand
Contusions - left hand

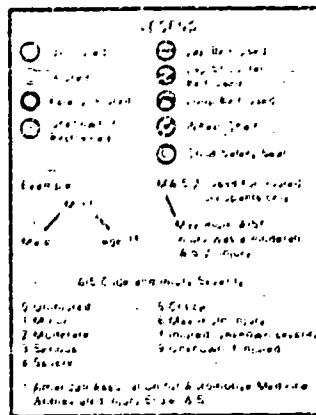
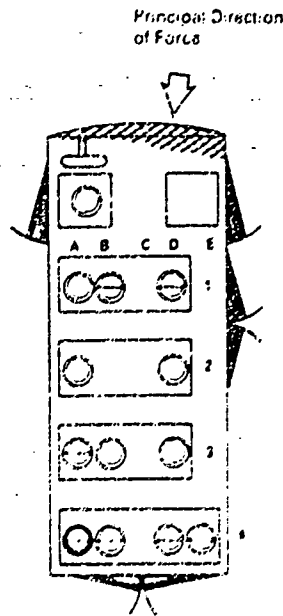

Row 3B
F-6, MAIS 1
Row 3D
M-6, MAIS 1
Row 4A
F-6, MAIS 5
Cervical axial dislocation
Closed head injury
Laceration - small bowel
Laceration - colon
Subdural hematoma
Torn mesentery
Serosal tear
Subarachnoid hemorrhage
Retroperitoneum hematoma
Bilateral pulmonary contusions
Contusion - 6" x 6" - left hip
Contusion - left cheek
Contusion - lower pelvic area
Contusion - left arm
Contusion - lower left leg
Abrasion - lower right leg
Row 4B
M-6, MAIS 5
Severe brain stem injury
Subarachnoid hemorrhage
Bilateral fracture - iliac crest
Contusion with hematoma to forehead
Contusion - lower left abdomen
Contusion - lower right abdomen
Contusion - right ankle
Abrasion - right tibia area
Abrasion - left tibia area
Row 4D
M-6, MAIS 5
Spinal cord contusion
Perforation of small bowel
Subarachnoid hemorrhage - posterior fossa
Subarachnoid hemorrhage - cranial cervical junction
Contusion with hematoma - cecum
Contusion with hematoma - forehead
Abrasion contusion - lower abdomen
Row 4E
F-7, MAIS 7
Unspecified leg injury
Full depth laceration of tongue
Abrasion - right side of forehead
Abrasion - right side of face
Contusion - right side of pelvis
Contusion - left side of pelvis

The van shown is representational only

Case No. 27 Safety Board Investigation No. NYC-85-H-SB01

Accident Location Route 101 at Wallace Road; Bedford, New Hampshire

Date and Time October 1, 1985; 6:50 a.m.

Description of School Vehicle 1981 Dodge Van Space Porter Custom SE. The van, previously used for airport limousine service, met New Hampshire standards for a multi-purpose school bus; it had not been retrofited to meet Federal school bus standards. (The van was painted white, not school bus yellow.)

Type of Accident Left side impact, with principal direction of force at the 10 o'clock position

Severity of Accident Delta V unknown

Summary of Events

A van, equipped with some form of seatbelt at all seating positions, was transporting two unrestrained students to school. The driver was restrained by a lap/shoulder belt. When the driver attempted to turn from one roadway to another in heavy fog, it was struck in the left front side by a dump truck, which was traveling at 35 mph. The dump truck pushed the van across the center of the road, where the truck struck a 1984 Chevrolet sedan.

The van received extensive damage on the left side, with maximum inward crush reaching 39 inches at the driver's door. The bench seat behind the driver's seat was displaced rearward and to the right.

The van was not built according to the requirements of the Federal Motor Vehicle Safety Standards (FMVSS) for school buses; therefore it cannot be evaluated by these standards. The van, which was rated at less than 10,000 pounds gross vehicle weight rating, was struck on the left side by a loaded dump truck that weighed 51,900 pounds traveling at about 35 mph. The differences in weight and in structural rigidity between the two striking vehicles makes irrelevant any discussion of crash performance of vans conforming to federal school bus standards versus nonstandard conforming vans.

Outcome of Occupants of Vehicle

Passengers

Of the 2 passengers, ages 15 and 18:
 1 sustained MAIS 3 (serious injuries), and
 1 sustained MAIS 5 (critical injuries).

The unrestrained passenger in the right front seat received critical (AIS 5) injuries: interventricular and intercerebral hemorrhages; he was unconscious for more than 24 hours. The contact points for the passenger were not confirmed. The dynamics of the collision moved him forward and to the left at impact, into the area of maximum intrusion. The use or nonuse of restraint probably did not affect the injury outcome for this passenger because of the massive intrusion into the forward area of the van.

The other unrestrained passenger was in one of the three rows of bench seats; the exact position is not known. The passenger was ejected out of a left side window. (The windows did not conform to federal school bus standards). She sustained serious (AIS 3) injuries: a comminuted pelvic fracture, closed head injuries, and a massive lower leg injury that necessitated amputation of the limb. The type and severity of the lower leg injury indicate that the limb was run over by the dump truck tires following the ejection. The pelvic fracture and head injuries could have occurred from contact with the pavement. The intrusion on the school van was on the left front, away from this passenger's seating area. The forces, however, would remain extreme, and had she been lapbelled, she would probably have still sustained serious injuries.

Driver

The driver was wearing the lap/shoulder belt provided. She sustained severe (AIS 4) injuries that proved fatal: skull fractures; brain hemorrhage; fractured ribs, femur, and pelvis; and lacerated liver, spleen, kidney, and lung. The injuries were caused by impact forces and severe intrusion into the driver's seating area. The impact force and penetration by the dump truck into the driver's door, at belt line height, resulted in an unsurvivable crash for the driver, belted or not.

Notes About the Accident

Lapbelts were installed in the van, but the installation and configuration was unusual and not in compliance with the Federal Motor Vehicle Safety Standards. The lapbelts were different lengths, ranging from 9 to 20 inches to the cushion junction. The Safety Board investigator sat in various seats in the van and tried to fasten the seat belts; belts often would not fit around his body.

In the rearmost seat, buckle-to-latch configurations were irregular. Two buckles lay next to each other on one side of the seat, two latchplates together on the other side, and a buckle/latchplate combination on each of the outboard locations (the configuration should be buckle/latchplate across the rear seat). At another position, two belts were anchored by one bolt. Federal Motor Vehicle Safety Standard 209 specifies that seatbelt anchorages for an individual belt assembly shall be located at least 6.5 inches apart laterally, measured between the bolt holes. A passenger restrained in such a belt in a frontal collision would pivot forward and would be forced to the left or right, depending on the side of the bus he or she was sitting on.

The Dodge van was previously used for airport limousine service. The school district leased the van and made certain modifications so it could be certified as a multipurpose school vehicle. The modifications, according to the State's regulations regarding school transportation, do not require the vehicles to conform to Federal school bus standards.

Bedford, New Hampshire
Case Number 27

Principal Direction
of Force

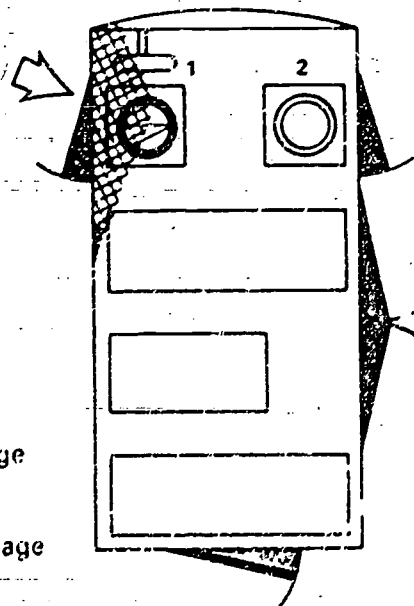

Left Side of Van
Driver
F-40, MAIS 4
Subdural hematoma
(right cerebral)
Laceration of liver
Laceration of left kidney
Subarachnoid hemorrhage
Laceration of spleen
Collapsed left lung
Retroperitoneal hemorrhage
Fracture of right femur
Skull hairline fracture
(left temporal)
Skull hairline fracture
(right temporal)
Fractured pelvis (left ischium)
Fractured pubis
Fractured left 7th and 8th ribs
Fractured left tibia

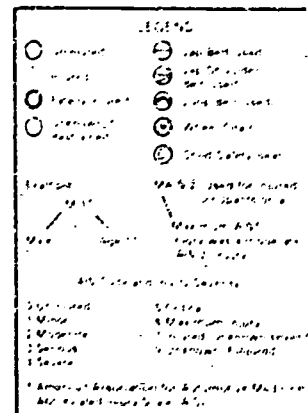

Right Side of Van
Seat 2
M-15, MAIS 5
Concussion-unconscious
more than 24 hours
Multiple inter-ventricular and
inter-cerebral hemorrhages
Laceration on back of head
Abrasion on left front temple
Laceration on right hand

Seating position unknown
F-18, MAIS 3
(Unrestrained)
Comminuted pelvic fracture
Compound fracture of left tibia
Compound fracture of left fibula
Fractured acetabular
Compound fracture of
left metatarsal toes
Fracture of left tarsus
Fractured right radius
Fractured left phalanges
Laceration of right cheek
Abrasion and contusion on central
forehead

The van shown
is representational only.

Case No. 28	Safety Board Investigation No. FTW-84-H-SB11
Accident Location	State Highway 158; outside Odessa, Texas
Date and Time	June 23, 1984; 5:15 p.m.
Description of School Vehicle	1980 Ford Superwagon. 15-passenger van. The van was not built to Federal school bus standards.
Type of Accident	Noncollision rollover (720°)
Severity of Accident	Delta V not calculable

Summary of Events

An overloaded church van, not built to school bus standards, was transporting 21 passengers to a youth revival; the van was built for 15 passengers. Some form of restraint was provided at each of the 15 seating positions, but none of the passengers was restrained. The driver was also unrestrained. As the van traveled at about 50 mph on a two-lane, two-way, straight and level rural road, the left rear tire blew out and the driver lost control of the vehicle. The van continued 660 feet, veering onto the shoulder and back into opposing traffic lanes. When the van rotated clockwise about 110°, the exposed left rear wheel rim dug into the asphalt, causing the van to turn over onto its left side. The van completed two revolutions (720°) covering a distance of 90 feet before it came to rest on its wheels. Three passengers were ejected and fatally injured during the rollovers.

Damage to the van was typical of a vehicle rollover, confined principally to the sheet metal body with little structural deformation. Striations found on the van body were consistent with ground scars found at the accident scene, indicating two complete rollovers. All glass areas of the van, except on the left side, were broken out and missing. The roof and side pillars were pushed toward the left as a result of the rollover. The van's body structure performed well in the double rollover. The occupants' injuries were not caused by the structure deformation or collapse.

Outcome of Occupants of School Vehicle

Passengers

Of the 21 passengers, ages 3 to 40:

- 3 were uninjured.
- 11 sustained MAIS 1 (minor) injuries.
- 4 sustained MAIS 3 (serious) injuries or greater, and
- 3 sustained fatal injuries (AIS coding not possible due to lack of medical records).

No passenger was restrained. Lapbelts were available at each designated seating position, but the van was carrying more passengers than it was designed for ("more" in number, not weight). Six passengers were not in a designated seating position; they were either sitting in the aisle or squeezed onto a bench seat that was already full.

Proper use of the lapbelts would have prevented or reduced some of the injuries received in this accident. The three fatally injured passengers were ejected from the vehicle as it rolled over. These ejections and the fatal injuries would have been prevented had the restraints been worn. No major structural collapse of the vehicle occurred; the passengers not ejected received injuries mainly due to their freedom to be thrown about the interior of the vehicle.

Driver

The driver of the van was not wearing the lap/shoulder belt provided at his position. The driver sustained at least minor injuries, but specific information is not available. He was not hospitalized. Medical information is not available so he is coded as injured, unknown severity (AIS 7).

Notes About the Accident

Of the 15 lapbelts furnished by the vehicle manufacturer, 7 were lying on the floor of the van, out of position for passenger use.

The van, with the exception of its left rear tire, was in good mechanical condition. The tire probably had been used as a spare until recently. An inspection before the trip would have identified the poor condition of the tire.

Odessa, Texas
- Case Number 28

Rollover

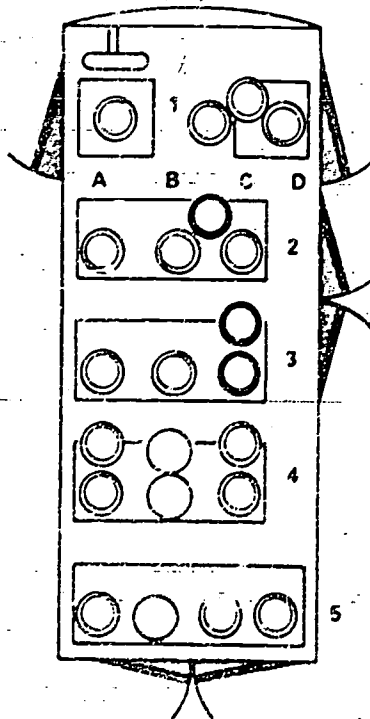
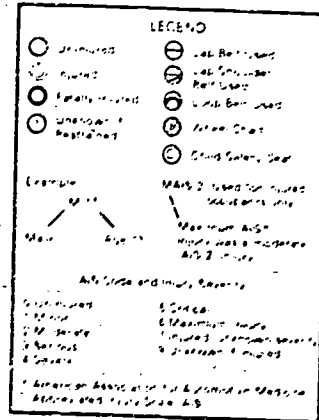

- Driver
- M-20, MAIS 7
- Row 1B
- F-16, MAIS 1
- Row 1C
- F-9, MAIS 1
- Row 1D
- F-21, MAIS 1
- Row 2A
- M-18, MAIS 1
- Row 2B
- F-21, MAIS 1
- Row 2C
- M-32, MAIS 1
- Row 2 B C
- F-29, MAIS 7
- Specific injuries unknown
- Row 3A
- M-8, MAIS = 3
- Specific injuries unknown
- Row 3B
- F-11, MAIS = 3
- Specific injuries unknown
- Row 3C
- F-40, MAIS 7

- Row 3CX
- M-2, MAIS 7
- Row 4A
- M-13, MAIS 1
- Row 4B
- M-27, MAIS 0
- Row 4C
- M-11, MAIS 1
- Row 4AX
- M-6, MAIS = 3
- Specific injuries unknown
- Row 4BX
- M-3, MAIS 0
- Row 4CX
- M-4, MAIS 1
- Row 5A
- M-11, MAIS 1
- Row 5B
- M-17, MAIS 0
- Row 5C
- M-14, MAIS = 3
- Specified injuries unknown
- Row 5D
- M-12, MAIS 1

The van shown
is representational only.

APPENDIX E

EXAMPLES OF CONFLICTING CLASSIFICATIONS OF SCHOOL BUSES

Case 16 (Elmhurst, Illinois)

School Vehicle: 1982 Chevrolet van chassis with 23-passenger Vanguard body by American Transportation Corporation.

Classifications: Federal Motor Vehicle Safety Standards.--Classified as a small school bus because its gross vehicle weight rating is less than 10,000 pounds. At least a lapbelt for every passenger is required at manufacture; the lapbelts must meet all Federal standards for belts on multipurpose vehicles. The bus is required to meet Federal requirements for small school buses: no minimum joint strength is specified, and no frontal barrier is required. The bench seats do not have to meet any seat spacing requirements.

Federal Highway Safety Program Standard No. 17.--Classified as a Type I large school bus because its passenger capacity is more than 15. Passengers of Type I school buses are not required to wear their seatbelts (if seatbelts are present).

National Minimum Standards Conference (School Bus Industry).--Classified as a Type A small school bus (formerly called a Type II) because its gross vehicle weight rating is less than 10,000 pounds and its passenger capacity is more than 10.

Case 23 (Little Rock, Arkansas)

School Vehicle: 1981 Chevrolet chassis with 15-passenger Cadet body by Carpenter Body Works.

Classifications: Federal Motor Vehicle Safety Standards.--Classified as a large school bus because its gross vehicle weight rating is over 10,000 pounds. Lapbelts for passengers are not required; if installed, they do not have to meet Federal requirements for seatbelts. The school bus must meet all design and performance standards for large school buses, including compartmentalization.

Federal Highway Safety Program Standard No. 17.--Classified as a Type II small school bus because its passenger capacity is less than 16. Passengers on a Type II school bus must wear their lapbelts whenever the vehicle is in motion.

National Minimum Standards Conference (School Bus Industry).--Classified as a Type B small school bus (formerly called a Type II) because its gross vehicle weight rating is more than 10,000 pounds and its capacity is more than 10 persons.

Table 5. Classifications and definitions of school buses by organization or entity, 1988

Organization or entity and vehicle classification	Former classification	Gross vehicle weight rating (GVWR)	Passenger capacity	Other	Pounds	
					Number	
Federal Motor Vehicle Safety Standards (FMVSS) ^a						
Small school bus		10,000 or less	10 or more (designed to transport more than 10 persons)			A bus that is sold or introduced in interstate commerce for purposes that include carrying students to and from school or related events, but does not include a bus designed and sold for operation as a common carrier.
Large school bus		More than 10,000	10 or more			A bus that is sold or introduced in interstate commerce for purposes that include carrying students to and from school or related events, but does not include a bus designed and sold for operation as a common carrier.
Federal Highway Safety Program (FHSP) No. 17 ^b						
Small school bus (Type II)		--	16 or fewer			Any motor vehicle used to carry pupils to or from school. Excludes private motor vehicles used to carry members of the owner's household.
Large school bus (Type I)		--	More than 16			A motor vehicle with motive power, except a trailer, used to carry pupils to and from school. Includes vehicles that are at any time used to carry school children and school personnel exclusively. Excludes common carriers.

See footnotes at end of table.

Table 5.---Classifications and definitions of school buses by organization or entity, 1988 (continued)

Organization or entity and vehicle classification	Former classification	Gross vehicle weight rating (GVWR)	Passenger capacity	Other	Number	
					Pounds	Members
<u>School bus industry:^c</u>						
<u>Small school bus--</u>						
Type A	Type II	10,000 or less	10 or more	Van conversion or school bus body constructed on a van-type compact truck or front-section vehicle.		
Type B	Type II	More than 10,000	10 or more	Van conversion or school bus body constructed on a van-type compact truck, front-section vehicle, or stripped-chassis. Part of the engine is beneath or behind the windshield and beside the driver seat. Entry door is behind front wheels.		
<u>Large school bus--</u>						
Type C (conventional style)	Type I	More than 10,000	10 or more	Body installed on a flat back cowl chassis. All of the engine is in front of the windshield, and entry door is behind the front wheels.		
Type D (transit style)	Type I	More than 10,000	10 or more	Body installed on a chassis. Engine may be mounted in front (behind the windshield and beside the driver seat), midship (between front and rear axles), or in the rear (behind the rear wheels). Entry door is ahead of front wheels.		

^cFor footnotes at end of table.

Table 5.--Classifications and definitions of school buses by organization or entity, 1985 (continued)

Organization or entity and vehicle classification	Former classification	Gross vehicle weight rating (GVWR)	Passenger capacity	Other	Number
					Founds
National Safety Council (NSC)					
The NSC does not distinguish between large and small school buses.					
National Highway Traffic Safety Administration (NHTSA)					
National Accident Sampling System (NASS)--					
The NASS distinguishes only between van-type school buses and other school buses.					
Fatal Accident Report System (FARS)--					
Data can be retrieved two ways, by:					
Function					
or					
Body type (bus body versus van-based bus)					
<p>Any vehicle reported in State statistics on school buses. Includes regular school buses and other nonfamily-owned vehicles used to transport pupils (vans, station wagons, and buses other than school buses).</p> <p>School buses are defined by function.</p> <p>A school bus, as distinguished by function, is not necessarily built to Federal standards for school buses.</p> <p>A school bus, as distinguished by body type, does not have to be used solely for school transportation; it can be a church bus, day camp bus, or a mobile home.</p>					

* Not applicable or criterion not established.

The NHTSA manual aspects of vehicle design and crash performance. The standards are part of the Code of Federal Regulations.

Effective December 1988. Standard No. 17 is being revised by the Department of Transportation.

Can be used at the National Highway Traffic Safety Administration Conference of 1985.



APPENDIX F

DATA ON PUBLIC SCHOOL TRANSPORTATION, 1986-87

The following table presents data for school buses classified as Type I and Type II school buses. Type I buses are classified by the school bus industry (National Minimum Standards Conference of 1980) as Type C and Type D large school buses. Type II buses are classified by the school bus industry as Type A and Type B small school buses. Type II also includes other types of small vehicles used for school transportation.

State	Pupils Transported at Public Expense	Bus Ownership						Total Number of Buses	Total Miles of Service	Transportation Expenditures(\$) Including Capital Outlay
		District			Contractor					
		Type I	Type II	Total	Type I	Type II	Total			
Alabama	441,115	6,360	176	6,536	0	0	0	6,536	53,815,195	565,681,208
Alaska	41,576	107	5	112	454	86	540	652	5,805,000	23,131,275*
Arizona	205,001	370	3,085	3,455	67	0	67	3,522	32,961,720	50,189,410
Arkansas	254,474	N/A	N/A	N/A	N/A	N/A	N/A	4,179	38,222,000	48,635,060*
California	1,094,367	10,969	2,586	13,555	3,447	3,314	6,761	20,316	277,969,06	649,325,855
Colorado	226,563	4,023	399	4,422	N/A	N/A	N/A	4,422	44,615,987	53,736,778
Connecticut	348,763	N/A	N/A	N/A	3,654	1,002	4,656	4,656	8	110,000,000
Delaware	83,645	339	30	369	898	41	939	1,308	18,427,596	27,742,101*
Florida	759,356	8,642	300	9,342	649	0	649	6,991	123,190,130	228,351,067
Georgia	1,564,802	N/A	N/A	10,331	N/A	N/A	9	10,340	68,119,060	681,859,685
Hawaii	40,237	15	0	15	508	240	748	763	7,240,558	17,654,717
Idaho	122,400	1,476	10	1,486	528	10	538	2,084	20,965,380	25,651,630
Illinois	328,200	N/A	N/A	8,782	N/A	N/A	12,450	21,230	250,004,393	338,233,257
Indiana	46,431	7,307	160	7,467	2,484	N/A	2,484	9,951	65,798,194	86,240,880
Iowa	244,618	5,815	830	6,645	276	16	292	6,087	62,384,262	58,342,409
Kansas	182,633	558	3,452	4,010	N/A	N/A	1,261	5,271	41,671,097	51,560,957
Kentucky	454,501	7,164	472	7,636	174	11	185	7,819	78,837,900	87,033,965
Louisiana	536,765	3,237	121	3,358	3,742	140	3,882	7,240	65,168,564	123,170,963
Maine	170,240	198	1,738	1,936	56	403	459	2,395	29,436,474*	30,448,508
Maryland	447,399	2,478	14	2,492	2,587	47	2,634	5,125	79,450,533	113,379,689
Massachusetts	405,588	N/A	N/A	2,298	N/A	N/A	5,208	7,496	56,531,103	150,652,577*
Michigan	781,874	N/A	N/A	13,480	N/A	N/A	100	13,580	128,520,000	260,500,000
Minnesota	854,347	3,819	787	4,606	4,566	995	5,565	10,210	116,473,000*	171,611,078
Mississippi	361,580	N/A	N/A	5,200	2	0	2	5,202	41,322,249	55,436,819
Missouri	456,156	4,813	1,129	5,942	3,375	792	4,167	10,109	107,787,264	155,074,325
Montana	80,105	432	48	480	993	48	641	1,321	16,678,152*	17,568,680
Nebraska	263,588	N/A	N/A	N/A	N/A	N/A	N/A	3,952	29,927,872	32,534,090
Nevada	40,478	139	827	966	0	0	0	966	13,513,522	26,125,464*
New Hampshire	162,005	291	29	320	1,327	253	1,680	2,000	13,500,000	26,650,347*
New Jersey	619,246	3,547	1,747	5,294	2,205	3,336	7,940	13,234	118,191,000	284,285,262*
New Mexico	136,792	503	71	574	1,240	303	1,543	2,117	29,280,071*	53,072,143
New York	1,917,619	11,529	3,053	15,202	N/A	N/A	12,000*	27,202	300,000,000*	906,258,716
North Carolina	586,089	13,153	0	13,153	0	0	0	13,153	118,429,680	118,538,141*
North Dakota	49,619	1,271	168	1,439	448	61	509	1,908	25,476,000	24,343,508*
Ohio	1,296,808	10,866	154	11,020	440	38	478	11,568	162,371,000	268,958,262*
Oklahoma	298,862	6,701	67	6,768	N/A	N/A	N/A	6,768	58,129,408	60,295,089
Oregon	215,831	2,642	354	2,996	1,515	125	1,640	4,630	43,170,484*	71,473,317
Pennsylvania	1,337,637	4,915	232	5,147	12,578	2,934	15,442	20,589	252,957,603	382,454,715
Rhode Island	10,000	N/A	N/A	270	N/A	N/A	1,080	1,350	N/A	N/A
South Carolina	438,783	5,950	13	5,963	10	338	356	6,319	67,309,575	54,652,863
South Dakota	47,468	1,138	101	1,239	391	27	418	1,657	18,707,420	19,607,477
Tennessee	522,896	4,860	151	5,011	1,380	150	1,540	6,561	74,273,780	77,013,202
Texas	1,010,000	22,832	1,558	24,490	631	25	656	25,146	200,899,300	166,110,486
Utah	153,273	4,429	67	4,496	78	2	80	1,576	16,176,656	28,988,428*
Vermont	71,587	467	50	517	477	126	603	1,848	11,531,429	16,667,088
Virginia	735,583	8,866	410	9,276	281	0	281	9,557	84,184,110	153,056,838
Washington	365,920	5,204	385	5,589	660	151	811	6,400	99,293,757	132,882,016
Washington DC	5,161	N/A	N/A	N/A	N/A	N/A	N/A	148	2,020,000	N/A
West Virginia	278,380	2,721	286	3,017	0	63	63	3,080	37,748,950	84,132,950
Wisconsin	488,413	N/A	N/A	1,971	N/A	N/A	5,112	7,083	73,508,025*	120,252,425
Wyoming	42,203	1,183	327	1,510	32	14	46	1,556	15,145,940	28,208,211*
TOTAL	22,682,499	178,138	28,822	246,960	54,868	15,128	108,663	361,888	3,608,888,622	61,388,976,828

SOURCE: The National Association of State Directors of Pupil Transportation Services and Bobit Publishing Research Department.
 * Data not tabulated; % of state over 7.5 estimates by NDOT range from 40% to 50% of all school buses are contractor owned. * one year's sale shown

Source: Reproduced from School Bus Fleet magazine, December/January 1989 issue, with permission from Bobit Publishing Co., Redondo Beach, California

APPENDIX G

SCHOOL BUS SALES BY BODY TYPE, 1974-88

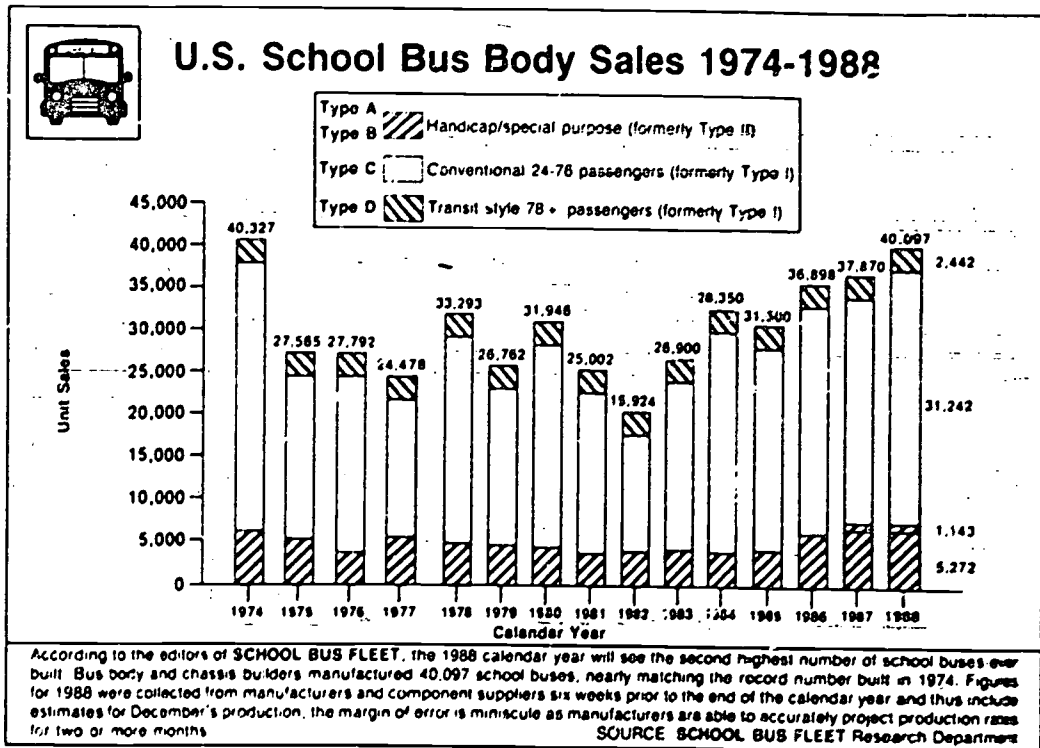



Source: Reproduced from School Bus Fleet magazine, December/January 1989 issue, with permission from Bobit Publishing Co., Redondo Beach, California

APPENDIX H
SCHOOL BUS TYPE DESIGNATIONS

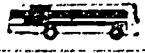

School Bus Type Designations

As the 1973 Federal Motor Vehicle Standards Committee on School Transportation in 1960 the definitions for school buses were changed to Type A, Type B, Type C, and Type D from Type I and Type II. These new standards are intended to apply primarily to new vehicles. It should be noted vehicles with a capacity for more than 10 passengers cannot be certified as school buses under federal regulations.

COMPANY	 TYPE A	 TYPE B	 TYPE C	 TYPE D
Amtran				
Vanguard			•	
Dixie			•	
Vanguard	•			
President				•
Blue Bird Body Co.				
Mini Bus	• (Small)			
Mini Bus		•		
Conventional			•	
Type D				•
All American				•
Fast Pass				•
All American				•
Fast Pass				•

(continued)

School Bus Type Designations (Continued)

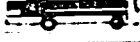
COMPANY				
	TYPE A	TYPE B	TYPE C	TYPE D
Carpenter Body Works				
Clipper	• (Dual)			
Cadet		•		
Conventional			•	
Corsair				•
Cavalier				•
Collins Bus Corp.				
Super Bantam	•			
Bantam	•			
Econobus	•			
Crown Coach Int'l				
Supercoach				•
Gillig Corp.				
Advanced Design Bus				•
Midbus				
Superior	•			
Minuteman	•			
National Coach				
16-20 Pass	•			
The New Bus Co.				
Chickasha				•
Superior Coach Int'l				
Partner	•			
Thomas Built Buses				
Minotaur	• (Dual)			
Mighty Mile		•		
Conventional			•	
Jet-Liner				•
Westcoaster				•
MVP				•
TPI				
Sturdivan	•			
Super Sturdivan	•			
SturdiBus	• (Dual)			
Van-Con Inc.				
16 Pass	•			
Wayne Corp				
Lester				•
Lifeguard			•	
Chaperone	• (Dual)			
Buvelle	• (Dual)			
Chaperone II	• (Dual)			

TYPE A: Type A school bus is a conversion of body constructed upon a van-type compact truck or a more serious vehicle, with a gross vehicle weight rating of 10,000 pounds or less, designed for carrying more than 10 persons.

TYPE B: A Type B school bus is a conversion of body constructed and installed upon a van or light section vehicle chassis, or stripped chassis, with a gross vehicle weight rating of more than 10,000 pounds, designed for carrying more than 10 persons. Part of the engine is beneath and/or behind the windshield and beside the driver's seat. The entrance door is behind the front wheels.

TYPE C: A Type C school bus is a body installed upon a full size conventional chassis with a gross vehicle weight rating of more than 10,000 pounds, designed for carrying more than 10 persons. All of the engine is a part of the windshield and the entrance door is behind the front wheels.

TYPE D: A Type D school bus is a body installed on a chassis with the engine mounted in the front, middle, or rear, with a gross vehicle weight rating of more than 10,000 pounds designed for carrying more than 10 persons. The engine may be behind the windshield and beside the driver's seat, it may be at the rear of the bus, behind the rear wheels or midway between the front and rear axles. The entrance door is ahead of the front wheels.

Source: Reproduced from School Bus Fleet magazine, December/January 1989 issue, with permission from Bobit Publishing Co., Redondo Beach, California

APPENDIX I

ABBREVIATED INJURY SCALE (AIS)

Injuries of school bus occupants were coded in this study according to the 1985 Abbreviated Injury Scale (AIS) (American Association for Automotive Medicine 1985).¹ Injuries are described in the case summaries (appendixes B and D) in terms of the maximum AIS injury (MAIS) sustained by an occupant. Hence, if an individual sustained two AIS 3 injuries, one AIS 2, and seven AIS 1 injuries, the individual is assigned an MAIS 3 injury.

A University of Michigan study substantiated that approximately 98 percent of the people sustaining multiple injuries would be properly assessed using their most severe injury as an index (Huang and March 1973). Identification of each injury incurred by a school bus occupant with an MAIS 2 or more is included on the bus seating charts in the case summaries.

<u>AIS Code</u>	<u>Description</u>	<u>Examples</u>
0	Uninjured	
1	Minor	Bruises, abrasions, superficial lacerations (less than 2 inches on face or 4 inches on body, provided they do not extend into subcutaneous tissue), fractured finger, sprained wrist, fractured nose.
2	Moderate	Deep laceration, mild concussion, head injury with amnesia about accident and no neurological damage, fractured clavicle, sprained knee, fractured foot, fractured ulna.
3	Serious	Fractured femur, dislocated hip, brain swelling, contused bladder, fractured pelvis, crushed forearm, hand amputation, head injury with prior unconsciousness with neurologic deficit.
4	Severe	Ruptured spleen, amputation of leg above knee, brain hematoma less than 100 cc.

(Continued)

¹ AIS is a standardized, universally accepted system for assessing the severity of injuries from impacts by coding individual injuries. The first AIS was published in 1971 under sponsorship of a joint committee of the American Medical Association, the American Association for Automotive Medicine, and the Society of Automotive Engineers. Since 1973, the American Association for Automotive Medicine has been the sponsoring organization.

AIS Scale (continued)

<u>AIS Code</u>	<u>Description</u>	<u>Examples</u>
5	Critical	Pulmonary artery laceration, complete spinal cord lesion (quadriplegia or paraplegia), ruptured liver, unconsciousness more than 24 hours or penetrating skull injury, brain hematoma more than 100 cc.
6	Maximum injury	Torso transection, massive skull crush, spinal cord crush with total transection C-3 or above, crushed brain stem.
7	Injured, unknown	Insufficient information is available or outcome rather than injury is described; i.e., arm trauma, closed head injury, kidney injury.
9	Unknown, if injured	Medical report states "redness over eye," "suspicion of _____" or no information is available.

APPENDIX J

COMPARISON OF KABCO AND AIS INJURY SCALES

The KABCO injury scale is commonly used in police accident reports. The AIS scale is used by accident investigators with the National Transportation Safety Board and by highway researchers.

KABCO Scale

The KABCO system has 5 options for coding injuries:^a

<u>Code</u>	<u>Description</u>
K	Dead before report was made
A	Bleeding wound, distorted member, or had to be carried from scene
B	Other visible injury or bruises, abrasions, swelling, or limp
C	Possible injury
O	No indication of injury

AIS Scale

The AIS system has 9 options:

<u>Code</u>	<u>Severity</u>
0	Uninjured
1	Minor
2	Moderate
3	Serious
4	Severe
5	Critical
6	Maximum, virtually unsurvivable
7	Injured, unknown severity
9	Unknown if injured

^a Definitions as used in Illinois police reports.

An injury can be coded differently, depending on the injury scale used. The KABCO system has broad classifications that can be misleading about the actual severity of injury. The following examples, using cases from this study on small poststandard school buses, illustrate differences in coding. The full summary of each case is given in appendix B or D.

Case 13 (Houston, Texas): 9 passengers

KABCO Scale ^b		AIS Scale	
Number of passengers	Injury code	Number of passengers	Injury code
2	A	9	AIS 1
7	C		

Case 16 (Elmhurst, Illinois): 9 passengers

KABCO Scale		AIS Scale	
Number of passengers	Injury code	Number of passengers	Injury code
9	A	2	AIS 0
		2	AIS 1
		2	AIS 2
		3	AIS 3

^b The KABCO system is defined differently in Texas police reports: K = Killed. A = Incapacitating injury--severe injury that prevents continuation of normal actions; includes broken or distorted limbs, internal injuries, and crushed chest. B = Nonincapacitating injury--evident injury such as bruises, abrasions, minor lacerations that do not incapacitate. C = Possible injury--injury that is claimed, reported, or indicated by behavior without visible wounds.

Case 26 (Schaumburg, Illinois): 12 passengers

KABCO Scale		AIS Scale	
<u>Number of passengers</u>	<u>Injury code</u>	<u>Number of passengers</u>	<u>Injury code</u>
1	K	5	AIS 1
10 ^c	A	3	AIS 3
1	C	3	AIS 5
		1	AIS 7

^c The 10 passengers coded as receiving "A" injuries did not actually receive injuries of the same severity. Under the AIS scale, these 10 passengers were coded as follows: 4, AIS 1 (minor); 3, AIS 3 (serious); 2, AIS 5 (critical); 1, AIS 7 (injured, unknown severity).

APPENDIX K
LIMITATIONS OF THE KABC0 INJURY CODES

The following discussion about the KABC0 injury coding system has been excerpted from a University of Adelaide publication (Hutchinson 1987).

8.10.1 The codes

Most American police forces use the K, A, B, C, 0 code recommended by the National Safety Council. The wording of the definitions of these codes varies in minor ways from place to place. Very brief descriptions are as follows:

- K Fatal.
- A Incapacitating injury.
- B Non-incapacitating (evident) injury.
- C Possible injury.
- 0 No indication of injury.

8.10.2 Inter- and intra-state variations in usage

Carroll and Scott (1971) and Scott (1972) noticed enormous differences between states of the U.S.A. as to the proportions in which the A, B, C codes were used: the proportion of A injuries varied from 13% to 65%, and the proportion of C injuries varied from 9% to 75%, in a sample of 17 states. The authors thought that much of the variation must be attributed to non-uniformity of scale interpretation and use. I have compiled some more recent data--see Table 8.22.

* * * * *

The K, A, B, C, 0 scheme permits rapid evaluation under adverse circumstances and with minimal examination of the victim. But obviously many injuries in the A category are minor, such as superficial lacerations accompanied by moderate but easily controlled bleeding, and conversely the C category could include severe and potentially life-threatening injuries such as a ruptured spleen. Further doubt is cast on the validity of this classification by the finding (Carpenter, 1973) that insurance payments (in what was admittedly a small sample) for severity C were higher than for B which in turn were higher than for A. In the course of a wider investigation, Shinar et al (1983) found that a substantial number of injury accidents in Indiana were recorded by the police as damage-only (grade 0).

Table 8.22: Percentage distribution of severity of injury in thirteen states.

	A	B	C
South Carolina 1985	36	22	42
Massachusetts 1981	32	32	36
Illinois 1983	27	26	47
South Dakota 1983	20	47	33
Idaho 1983	17	40	44
Washington 1982-83	15	41	45
Michigan 1983	14	31	55
Delaware 1983	13	48	39
Texas 1983	12	44	44
States that may not be comparable:			
Alabama 1983*	59	26	15
Arizona 1983#	20	47	33
Ohio 1984+	8	41	51
California 1983+	5	46	49

* Rural accidents only.

U.S. and state highways only.

+ These states use the term "severe" in describing the most serious category. Thus in California it is called a "severe wound", though the definition of this is very similar to the usual definition of code A: "Injury which prevents the injured party from walking, driving, or performing activities he/she was normally capable of before the accident." In the Ohio data table it is called "severe", but in the definitions it is called "serious visible injury", and is defined as "An injury other than fatal that prevents the injured person from working, driving, or continuing normal activities that he (she) was capable of performing prior to the accident."

APPENDIX L

DATA ON FATAL SCHOOL BUS ACCIDENTS

The table that follows is from a study on school bus safety published in 1989 by the Transportation Research Board, National Research Council. The values are derived from FARS, the fatal accident reporting system of the U.S. Department of Transportation, National Highway Traffic Safety Administration.

TABLE 3-2 ESTIMATED ANNUAL SCHOOL BUS ACCIDENT FATALITIES (FARS 1982-1986)

Persons	Vehicle Type			Total
	School Buses ^a	Vehicles Used as School Buses ^b	Other Vehicles	
Fatally Injured				
Drivers	1.6	0.8	62.6	65.0
Pedestrians				
Students ^c	24.0	1.8	11.6	37.4
Adults ^d	4.4	1.0	1.8	7.2
Passengers				
Students	9.6	2.4	8.0	20.0
Adults	2.4	0.6	11.6	14.6
Bicyclists				
Students	1.8	0.4	1.0	3.2
Adults	1.2	0.2	0.2	1.6
	45.0	7.2	96.8	149.0

NOTES: Average values derived from 5 years of fatal accident data. Drivers and passengers were occupants of the vehicle type indicated. Pedestrians and bicyclists were struck by the vehicle type indicated.

^a"School bus" refers to a vehicle designed and built as a school bus, excluding van-based buses. These vehicles are predominantly Type I buses with GVWRs greater than 10,000 lb.

^b"Vehicle used as a school bus" refers to a vehicle that is externally identifiable as a school bus, but not originally designed and built as a school bus, for example, station wagons, standard vans, and vans modified to serve as school buses.

^cStudents are defined as persons under 20 years old.

^dAdults are defined as persons 20 years old or older.

Source: Transportation Research Board, National Research Council (1989, p. 35).

APPENDIX M

FEDERAL MOTOR VEHICLE SAFETY STANDARDS (FMVSS)
MENTIONED IN SAFETY RECOMMENDATIONS

§ 571.206

49 CFR Ch. V (10-1-88 Edition)

§ 571.206 Standard No. 206; Door locks and door retention components.

S1. *Purpose and scope.* This standard specifies requirements for side door locks and side door retention components including latches, hinges, and other supporting means, to minimize the likelihood of occupants being thrown from the vehicle as a result of impact.

S2. *Application.* This standard applies to passenger cars, multipurpose passenger vehicles, and trucks.

S3. *Definitions.* "Cargo-Type Door" means a door designed primarily to accommodate cargo loading including, but not limited to, a two-part door that latches to itself.

"Side front door" means a door that in a side view, has 50 percent or more of its opening area forward of the rearmost point on the driver's seat-back, when the driver's seat is adjust-

382

National Highway Traffic Safety Admin., DOT

§ 571.206

ed to its most vertical and rearward position.

"Side rear door" means a door that, in a side view, has more than 50 percent of its opening area to the rear of the rearmost point on the driver's seatback, when the driver's seat is adjusted to its most vertical and rearward position.

S4. Requirements. Components on any side door leading directly into a compartment that contains one or more seating accommodations shall conform to this standard. However, components on folding doors, roll-up doors, doors that are designed to be easily attached to or removed from motor vehicles manufactured for operation without doors, and side doors which are equipped with wheelchair lifts and which are linked to an alarm system, consisting of either a flashing visible signal located in the driver's compartment or an alarm audible to the driver which is activated when the door is open, need not conform to this standard.

S4.1 Hinged Doors, Except Cargo-Type Doors.

S4.1.1 Door Latches. Each door latch and striker assembly shall be provided with two positions consisting of—

- (a) A fully latched position; and
- (b) A secondary latched position.

S4.1.1.1 Longitudinal Load. The door latch and striker assembly, when in the fully latched position, shall not separate when a longitudinal load of 2,500 pounds is applied. When in the secondary latched position, the door latch and striker assembly shall not separate when a longitudinal load of 1,000 pounds is applied.

S4.1.1.2 Transverse Load. The door latch and striker assembly, when in the fully latched position, shall not separate when a transverse load of 2,000 pounds is applied. When in the secondary latched position, the door latch and striker assembly shall not separate when a transverse load of 1,000 pounds is applied.

S4.1.1.3 Inertia Load. The door latch shall not disengage from the fully latched position when a longitudinal or transverse inertia load of 30g is applied to the door latch system (including the latch and its actuating

mechanism with the locking mechanism disengaged).

S4.1.2 Door Hinges. Each door hinge system shall support the door and shall not separate when a longitudinal load of 2,500 pounds is applied. Similarly, each door hinge system shall not separate when a transverse load of 2,000 pounds is applied.

S4.1.3 Door Locks. Each door shall be equipped with a locking mechanism with an operating means in the interior of the vehicle.

S4.1.3.1 Side Front Door Locks. When the locking mechanism is engaged, the outside door handle or other outside latch release control shall be inoperative.

S4.1.3.2 Side Rear Door Locks. In passenger cars and multipurpose passenger vehicles, when the locking mechanism is engaged both the outside and inside door handles or other latch release controls shall be inoperative.

S4.2 Hinged Cargo-Type Doors.

S4.2.1 Door Latches.

S4.2.1.1 Longitudinal Load. Each latch system, when in the latched position, shall not separate when a longitudinal load of 2,500 pounds is applied.

S4.2.1.2 Transverse Load. Each latch system, when in the latched position, shall not separate when a transverse load of 2,000 pounds is applied. When more than one latch system is used on a single door, the load requirement may be divided among the total number of latch systems.

S4.2.2 Door Hinges. Each door hinge system shall support the door and shall not separate when a longitudinal load of 2,500 pounds is applied, and when a transverse load of 2,000 pounds is applied.

S4.3 Sliding Doors. The track and slide combination or other supporting means for each sliding door shall not separate when a total transverse load of 4,000 pounds is applied, with the door in the closed position.

S5. Demonstration Procedures.

S5.1 Hinged Doors, Except Cargo-Type Doors.

S5.1.1 Door Latches.

S5.1.1.1 Longitudinal and Transverse Loads. Compliance with paragraphs S4.1.1.1 and S4.1.1.2 shall be demonstrated in accordance with para-

§ 571.206

49 CFR Ch. V (10-1-88 Edition)

graph 4 of Society of Automotive Engineers Recommended Practice J839b, "Passenger Car Side Door Latch Systems," May 1965.

S5.1.1.2 Inertia Load. Compliance with S4.1.1.3 shall be demonstrated by approved tests or in accordance with paragraph 5 of SAE Recommended Practice J839b, May 1965.

S5.1.2 Door Hinges. Compliance with S4.1.2 shall be demonstrated in accordance with paragraph 4 of SAE Recommended Practice J934, "Vehicle Passenger Door Hinge Systems," July 1965. For piano-type hinges, the hinge spacing requirements of SAE J934 shall not be applicable and arrangement of the test fixture shall be altered as required so that the test load will be applied to the complete hinge.

S5.2 Hinged Cargo-Type Doors.

S5.2.1 Door Latches. Compliance with S4.2.1 shall be demonstrated in accordance with paragraphs 4.1 and 4.3 of SAE Recommended Practice J839b, "Passenger Car Side Door Latch Systems," May 1965. An equivalent static test fixture may be substituted for that shown in Figure 2 of SAE J839b, if required.

S5.2.2 Door Hinges. Compliance with S4.2.2 shall be demonstrated in accordance with paragraph 4 of SAE Recommended Practice J934, "Vehicle Passenger Door Hinge Systems," July 1965. For piano-type hinges, the hinge spacing requirement of SAE J934 shall not be applicable and arrangement of the test fixture shall be altered as required so that the test load will be applied to the complete hinge.

S5.3 Sliding Doors. Compliance with S4.3 shall be demonstrated by applying an outward transverse load of 2,000 pounds to the load bearing members at the opposite edges of the door (4,000 pounds total). The demonstration may be performed either in the vehicle or with the door retention components in a bench test fixture.

(36 FR 22902, Dec. 2, 1971, as amended at 27 FR 284, Jan. 8, 1972; 50 FR 12031, Mar. 27, 1985)

§ 571.210

49 CFR Ch. V (10-1-88 Edition)

§ 571.210 Standard No. 210: Seat belt assembly anchorages.

S1. Purpose and scope. This standard establishes requirements for seat belt assembly anchorages to insure their proper location for effective occupant restraint and to reduce the likelihood of their failure.

S2. Application. This standard applies to passenger cars, multipurpose passenger vehicles, trucks, and buses.

S3. Definition. "Seat belt anchorage" means the provision for transferring seat belt assembly loads to the vehicle structure.

S4. Requirements.**S4.1 Type.**

S4.1.1 Seat belt anchorages for a Type 2 seat belt assembly shall be installed for each forward-facing outboard designated seating position in passenger cars other than converti-

bles, and for each designated seating position for which a Type 2 seat belt assembly is required by § 571.208 in vehicles other than passenger cars.

S4.1.2 Seat belt anchorages for a Type 1 or a Type 2 seat belt assembly shall be installed for each designated seating position, except a passenger seat in a bus or a designated seating position for which seat belt anchorages for a Type 2 seat belt assembly are required by S4.1.1.

S4.1.3 Notwithstanding the requirement of paragraph S4.1.1, each vehicle manufactured on or after September 1, 1987, that is equipped with an automatic restraint at the front right outboard designated seating position that cannot be used for securing a child restraint system or cannot be adjusted by the vehicle owner to secure a child restraint system solely through the use of attachment hardware installed as an item of original equipment by the vehicle manufacturer, shall have, at the manufacturer's option, either anchorages for a Type 1 seat belt assembly at that position or a Type 1 or

National Highway Traffic Safety Admin., DOT

§ 571.210

Type 2 seat belt assembly at that position. The anchorages shall consist of, at a minimum, holes threaded to accept bolts complying with S4.1(f) of Part 571.209 of this chapter.

S4.2 Strength.

S4.2.1 Except for side-facing seats, the anchorage for a Type 1 seat belt assembly or the pelvic portion of a Type 2 seat belt assembly shall withstand a 5,000-pound force when tested in accordance with S5.1.

S4.2.2 The anchorage for a Type 2 seat belt assembly shall withstand 3,000-pound forces when tested in accordance with S5.2.

S4.2.3 Permanent deformation or rupture of a seat belt anchorage or its surrounding area is not considered to be a failure, if the required force is sustained for the specified time.

S4.2.4 Except for common seat belt anchorages for forward-facing and rearward-facing seats, floor-mounted seat belt anchorages for adjacent designated seating positions shall be tested by simultaneously loading the seat belt assemblies attached to those anchorages.

S4.3 Location. As used in this section, "forward" means in the direction in which the seat faces, and other directional references are to be interpreted accordingly. Anchorages for automatic and for dynamically tested seat belt assemblies that meet the frontal crash protection requirement of S5.1 of Standard No. 298 (49 CFR 571.208) are exempt from the location requirements of this section.

S4.3.1 Seat belt anchorages for Type 1 seat belt assemblies and the pelvic portion of Type 2 seat belt assemblies.

S4.3.1.1 In an installation in which the seat belt does not bear upon the seat frame, a line from the seating reference point to the nearest contact point of the belt with the hardware attaching it to the anchorage for a non-adjustable seat, or from a point 2.50 inches forward of and 0.375 inch above the seating reference point to the nearest contact point of the belt with the hardware attaching it to the anchorage for an adjustable seat in its rearmost position, shall extend forward from the anchorage at an angle with the horizontal of not less than 20° and not more than 75°.

S4.3.1.2 In an installation in which the belt bears upon the seat frame, the seat belt anchorage, if not on the seat structure, shall be aft of the rearmost belt contact point on the seat frame with the seat in the rearmost position. The line from the seating reference point to the nearest belt contact point on the seat frame shall extend forward from that contact point at an angle with the horizontal of not less than 20° and not more than 75°.

S4.3.1.3 In an installation in which the seat belt anchorage is on the seat structure, the line from the seating reference point to the nearest contact point of the belt with the hardware attaching it to the anchorage shall extend forward from that contact point at an angle with the horizontal of not less than 20° and not more than 75°.

S4.3.1.4 Anchorages for an individual seat belt assembly shall be located at least 6.50 inches apart laterally, measured between the vertical centerlines of the bolt holes.

S4.3.2 Seat belt anchorages for the upper torso portion of Type 2 seat belt assemblies. With the seat in its full-rearward and downward position and the seat back in its most upright position, the seat belt anchorage for the upper end of the upper torso restraint shall be located within the acceptable range shown in Figure 1, with reference to a two dimensional manikin described in SAE Standard J826 (November 1962) whose "H" point is at the seating reference point and whose torso line is at the same angle from the vertical as the seat back.

S5. Test procedures. Each vehicle shall meet the requirements of S4.2 when tested according to the following procedures. Where a range of values is specified, the vehicle shall be able to meet the requirements at all points within the range.

S5.1 Seats with Type 1 or Type 2 seat belt anchorages. With the seat in its rearmost position, apply a force of 5,000 pounds in the direction in which the seat faces to a pelvic body block as described in Figure 2, restrained by a Type 1 or the pelvic portion of a Type 2 seat belt assembly, as applicable, in a plane parallel to the longitudinal cen-

§ 571.210

terline of the vehicle, with an initial force application angle of not less than 5° nor more than 15° above the horizontal. Apply the force at the onset rate of not more than 50,000 pounds per second. Attain the 5,000-pound force in not more than 30 seconds and maintain it for 10 seconds.

85.2 *Seats with Type 2 seat belt anchorages.* With the seat in its rearmost position, apply forces of 3,000 pounds in the direction in which the seat faces simultaneously to pelvic and upper torso body blocks as described in Figures 2 and 3, restrained by a Type 2 seat belt assembly, in a plane parallel to the longitudinal centerline of the vehicle, with an initial force application angle of not less than 5° nor more than 15° above the horizontal. Apply the forces at the onset rate of not

49 CFR Ch. V (10-1-88 Edition)

more than 30,000 pounds per second. Attain the 3,000-pound forces in not more than 30 seconds and maintain them for 10 seconds.

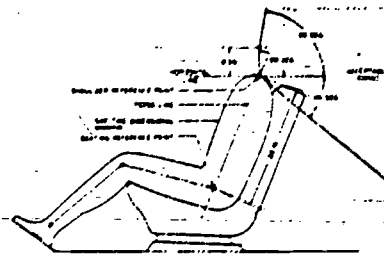

FIGURE 2. ILLUSTRATION OF OCCUPANT FOR UPPER TORSO RESTRAINT

National Highway Traffic Safety Admin., DOT

§ 571.210

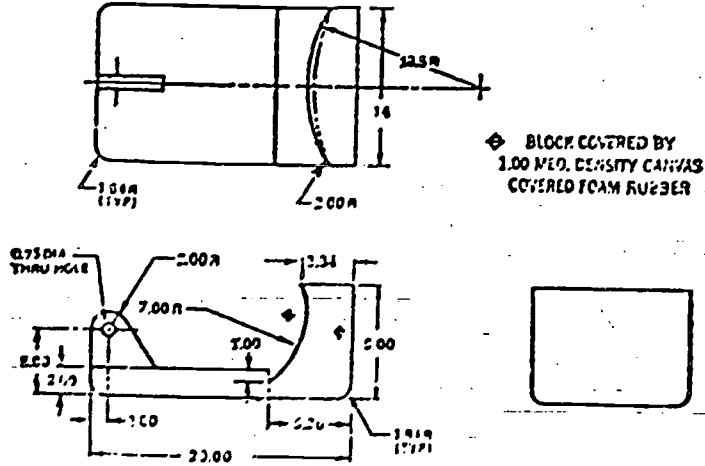

FIGURE 2—BODY BLOCK FOR LAP BELT ANCHORAGE

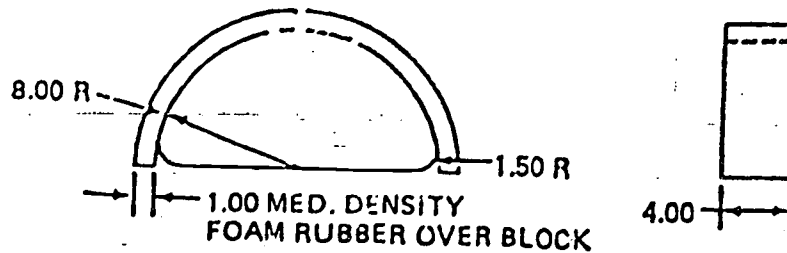

FIGURE 3 - BODY BLOCK FOR COMBINATION SHOULDER AND LAP BELT ANCHORAGE

86. *Owner's Manual Information.* The owner's manual in each vehicle with a GVWR of 10,000 pounds or less manufactured after September 1, 1987 shall include:

(a) A section explaining that all child restraint systems are designed to be secured in vehicle seats by lap belts or the lap belt portion of a lap-shoulder belt. The section shall also explain that children could be endangered in a

crash if their child restraints are not properly secured in the vehicle.

(b) In a vehicle with rear designated seating positions, a statement alerting vehicle owners that, according to accident statistics, children are safer when properly restrained in the rear seating positions than in the front seating positions.

(c) In each passenger car, a diagram or diagrams showing the location of the shoulder belt anchorages required

§ 571.210

by this standard for the rear outboard designated seating positions, if shoulder belts are not installed as items of original equipment by the vehicle manufacturer at those positions.

S7. Installation Instructions. The owner's manual in each vehicle manufactured on or after September 1, 1987, with an automatic restraint at the front right outboard designated seating position that cannot be used to secure a child restraint system when the automatic restraint is adjusted to meet the performance requirements of S5.1 of Standard No. 208 shall have:

(a) A statement that the automatic restraint at the front right outboard designated seating position cannot be used to secure a child restraint and, as appropriate, one of the following three statements:

(1) A statement that the automatic restraint at the front right outboard designated seating position can be adjusted to secure a child restraint system using attachment hardware installed as original equipment by the vehicle manufacturer;

(2) A statement that anchorages for installation of a lap belt to secure a child restraint system have been provided at the front right outboard designated seating position; or

(3) A statement that a lap or manual lap or lap/shoulder belt has been installed by the vehicle manufacturer at the front right outboard designated seating position to secure a child restraint.

(b) In each vehicle in which a lap or lap/shoulder belt is not installed at the front right outboard designated seating position as an item of original equipment, but the automatic restraint at that position can be adjusted by the vehicle owner to secure a child restraint system using an item or items of original equipment installed in the vehicle by the vehicle manufacturer, the owner's manual shall also have:

(1) A diagram or diagrams showing the location of the attachment hardware provided by the vehicle manufacturer.

(2) A step-by-step procedure with a diagram or diagrams showing how to modify the automatic restraint system to secure a child restraint system. The

49 CFR Ch. V (10-1-88 Edition)

instructions shall explain the proper routing of the attachment hardware.

(c) In each vehicle in which the automatic restraint at the front right outboard designated seating position cannot be modified to secure a child restraint system using attachment hardware installed as an original equipment by the vehicle manufacturer and a manual lap or lap/shoulder belt is not installed as an item of original equipment by the vehicle manufacturer, the owner's manual shall also have:

(1) A diagram or diagrams showing the locations of the lap belt anchorages for the front right outboard designated seating position.

(2) A step-by-step procedure and a diagram or diagrams for installing the proper lap belt anchorage hardware and a Type 1 lap belt at the front right outboard designated seating position. The instructions shall explain the proper routing of the seat belt assembly and the attachment of the seat belt assembly to the lap belt anchorages.

(38 FR 22902, Dec. 2, 1971, as amended at 37 FR 9323, May 9, 1972; 43 FR 21892, May 22, 1978; 43 FR 53442, Nov. 16, 1978; 50 FR 41359, Oct. 10, 1985; 51 FR 9813, Mar. 21, 1986; 51 FR 29555, Aug. 19, 1986)

§ 571.217

49 CFR Ch. V (10-1-88 Edition)

§ 571.217 Standard No. 217: Bus window retention and release.

S1. Scope. This standard establishes requirements for the retention of windows other than windshields in buses, and establishes operating forces, opening dimensions, and markings for pushout bus windows and other emergency exits.

S2. Purpose. The purpose of this standard is to minimize the likelihood of occupants being thrown from the bus and to provide a means of readily accessible emergency egress.

S3. Application. This standard applies to buses, except buses manufactured for the purpose of transporting persons under physical restraint.

S4. Definitions. "Push-out window" means a vehicle window designed to open outward to provide for emergency egress.

"Adjacent seat" means a designated seating position located so that some portion of its occupant space is not more than 10 inches from an emergency exit, for a distance of at least 15 inches measured horizontally and parallel to the exit.

"Occupant space" means the space directly above the seat and footwell, bounded vertically by the ceiling and horizontally by the normally positioned seat back and the nearest obstruction of occupant motion in the direction the seat faces.

S5. Requirements.

S5.1 Window retention. Except as provided in S5.1.2, each piece of window glazing and each surrounding window frame when tested in accordance with the procedure in S5.1.1 under the conditions of S6.1 through S6.3, shall be retained by its surrounding structure in a manner that prevents the formation of any opening large enough to admit the passage of a

4-inch diameter sphere under a force, including the weight of the sphere, of 5 pounds until any one of the following events occurs:

(a) A force of 1,200 pounds is reached.

(b) At least 80 percent of the glazing thickness has developed cracks running from the load contact region to the periphery at two or more points, or shattering of the glazing occurs.

(c) The inner surface of the glazing at the center of force application has moved relative to the window frame, along a line perpendicular to the undisturbed inner surface, a distance equal to one-half of the square root of the minimum surface dimension measured through the center of the area of the entire sheet of window glazing.

S5.1.1 An increasing force shall be applied to the window glazing through the head form specified in Figure 4, outward and perpendicular to the undisturbed inside surface at the center of the area of each sheet of window glazing, with a head form travel of 2 inches per minute.

S5.1.2 The requirements of this standard do not apply to a window whose minimum surface dimension measured through the center of its area is less than 8 inches.

S5.2 Provision of emergency exits. Buses other than schoolbuses shall provide unobstructed openings for emergency exit which collectively amount, in total square inches, to at least 67 times the number of designated seating positions on the bus. At least 40 percent of the total required area of unobstructed openings, computed in the above manner, shall be provided on each side of a bus. However, in determining the total unobstructed openings provided by a bus, no emergency exit, regardless of its area, shall be credited with more than 536 square inches of the total area requirement. School buses shall provide openings for emergency exits that conform to S5.2.3.

S5.2.1 Buses with GVWR of more than 10,000 pounds. Except as provided in S5.2.1.1, buses with a GVWR of more than 10,000 pounds shall meet the unobstructed openings requirements by providing side exits and at least one rear exit that conforms to

National Highway Traffic Safety Admin., DOT

§ 571.217

S5.3 through S5.5. The rear exit shall meet the requirements when the bus is upright and when the bus is overturned on either side, with the occupant standing facing the exit. When the bus configuration precludes installation of an accessible rear exit, a roof exit that meets the requirements of S5.3 through S5.5 when the bus is overturned on either side, with the occupant standing facing the exit, shall be provided in the rear half of the bus.

S5.2.1.1 A bus with GVWR of more than 10,000 pounds may satisfy the unobstructed openings requirement by providing at least one side door for each three passenger seating positions in the vehicle.

S5.2.2 Buses with a GVWR of 10,000 pounds or less. Buses with a GVWR of 10,000 pounds or less may meet the unobstructed openings requirement by providing:

(a) Devices that meet the requirements of S5.3 through S5.5 without using remote controls or central power systems;

(b) Windows that can be opened manually to a position that provides an opening large enough to admit unobstructed passage, keeping a major axis horizontal at all time, of an ellipsoid generated by rotating about its minor axis an ellipse having a major axis of 20 inches and a minor axis of 13 inches; or

(c) Doors.

S5.2.3 School buses.

S5.2.3.1 Each school bus shall comply with either one of the following minimum emergency exit provisions, chosen at the option of the manufacturer:

(a) One rear emergency door that opens outward and is hinged on the right side (either side in the case of a bus with a GVWR of 10,000 pounds or less); or

(b) One emergency door on the vehicle's left side that is in the rear half of the bus passenger compartment and is hinged on its forward side, and a push-out rear window that provides a minimum opening clearance 16 inches high and 48 inches wide. This window shall be releasable by operation of not more than two mechanisms which are located in the high force access region as shown in Figure 3C, and which do not

have to be operated simultaneously. Release and opening of the window shall require force applications, not to exceed 40 pounds, in the directions specified in S5.3.2.

S5.2.3.2 The engine starting system of a school bus shall not operate if any emergency exit is locked from either inside or outside the bus. For purposes of this requirement, "locked" means that the release mechanism cannot be activated by a person at the door without a special device such as a key or special information such as a combination.

S5.3 Emergency exit release.

S5.3.1 Each push-out window or other emergency exit not required by S5.2.3 shall be releasable by operating one or two mechanisms located within the regions specified in Figure 1, Figure 2, or Figure 3. The lower edge of the region in Figure 1, and Region B in Figure 2, shall be located 5 inches above the adjacent seat, or 2 inches above the armrest, if any, whichever is higher.

S5.3.2 When tested under the conditions of S6., both before and after the window retention test required by S5.1, each emergency exit not required by S5.2.3 shall allow manual release of the exit by a single occupant using force applications each of which conforms, at the option of the manufacturer, either to (a) or (b). The release mechanism or mechanisms shall require for release one or two force applications, at least one of which differs by a 90° to 180° from the direction of the initial push-out motion of the emergency exit (outward and perpendicular to the exit surface).

(a) Low force application.

(1) Location. As shown in Figure 1 or Figure 3.

(2) Type of motion. Rotary or straight.

(3) Magnitude. Not more than 20 pounds.

(b) High force application.

(1) Location. As shown in Figure 2 or Figure 3.

(2) Type of motion. Straight, perpendicular to the undisturbed exit surface.

(3) Magnitude. Not more than 60 pounds.

§ 571.217

49 CFR Ch. V (10-1-88 Edition)

S5.3.3 When tested under the conditions of S6., both before and after the window retention test required by S5.1, each school bus emergency door shall allow manual release of the door by a single person, from both inside and outside the bus passenger compartment, using a force application that conforms to paragraphs (a) through (c) except a school bus with a GVWR of 10,000 pounds or less does not have to conform to paragraph (a). Each release mechanism shall operate without the use of remote controls or tools, and notwithstanding any failure of the vehicle's power system. When the release mechanism is not in the closed position and the vehicle ignition is in the "on" position, a continuous warning sound shall be audible at the driver's seating position and in the vicinity of the emergency door having the unclosed mechanism.

(a) Location: Within the high force access region shown in Figure 3A for a side emergency door, and in Figure 3D for a rear emergency door.

(b) Type of motion: Upward from inside the bus; at the discretion of the manufacturer from outside the bus.

Buses with a GVWR of 10,000 pounds or less shall provide interior release mechanisms that operate by either an upward or pull-type motion. The pull-type motion shall be used only when the release mechanism is recessed in such a manner that the handle, lever, or other activating device does not protrude beyond the rim of the recessed receptacle.

(c) Magnitude of force: Not more than 40 pounds.

S5.4 Emergency exit extension.

S5.4.1 After the release mechanism has been operated, each push-out window or other emergency exit not required by S5.2.3 shall, under the conditions of S6., before and after the window retention test required by S5.1, using the reach distances and corresponding force levels specified in S5.3.2, be manually extendable by a single occupant to a position that provides an opening large enough to admit unobstructed passage, keeping a major axis horizontal at all times, of an ellipsoid generated by rotating about its minor axis an ellipse having

a major axis of 20 inches and a minor axis of 13 inches.

S5.4.2 School bus emergency exit extension.

S5.4.2.1 School bus with a GVWR of more than 10,000 pounds. After the release mechanism has been operated, the emergency door of a school bus with a GVWR of more than 10,000 pounds shall, under the conditions of S6., before and after the window retention test required by S5.1, using the force levels specified in S5.3.3, be manually extendable by a single person to a position that permits—

(a) In the case of rear emergency door, an opening large enough to permit unobstructed passage of a rectangular parallelepiped 45 inches high, 24 inches wide, and 12 inches deep, keeping the 45-inch dimension vertical, the 24-inch dimension parallel to the opening, and the lower surface in contact with the floor of the bus at all times; and

(b) In the case of a side emergency door, an opening at least 45 inches high and 24 inches wide. A vertical transverse plane tangent to the rear-most point of a seat back shall pass through the forward edge of a side emergency door.

S5.4.2.2 School bus with a GVWR of 10,000 pounds or less. A school bus with a GVWR of 10,000 pounds or less shall conform to all the provisions of S5.4.2, except that the parallelepiped dimension for the opening of the rear emergency door or doors shall be 45 inches high, 22 inches wide, and 6 inches deep.

S5.5 Emergency exit identification.

S5.5.1 In buses other than school buses, except for windows serving as emergency exits in accordance with S5.2.2(b) and doors in buses with a GVWR of 10,000 pounds or less, each emergency door shall have the designation "Emergency Door" or "Emergency Exit" and each push-out window or other emergency exit shall have the designation "Emergency Exit" followed by concise operating instructions describing each motion necessary to unlatch and open the exit, located within 6 inches of the release mechanism.

National Highway Traffic Safety Admin., DOT

§ 571.217

EXAMPLES

- (1) Lift to Unlatch, Push to Open
- (2) Lift Handle and Push out to Open

When a release mechanism is not located within an occupant space of an adjacent seat, a label meeting the requirements of S5.5.2 that indicates the location of the nearest release mechanism shall be placed within the occupant space.

EXAMPLE

Emergency exit instructions located next to seat ahead.

EXAMPLE "EMERGENCY EXIT INSTRUCTIONS LOCATED NEXT TO SEAT AHEAD"

S5.5.2 In buses other than school buses. Except as provided in S5.5.2.1, each marking shall be legible, when the only source of light is the normal nighttime illumination of the bus interior, to occupants having corrected visual acuity of 20/40 (Snellen ratio) seated in the adjacent seat, seated in the seat directly adjoining the adjacent seat, and standing in the aisle location that is closest to that adjacent seat. The marking shall be legible from each of these locations when the other two corresponding locations are occupied.

S5.5.2.1 If the exit has no adjacent seat, the marking must meet the legibility requirements of S5.5.2 for occupants standing in the aisle location nearest to the emergency exit, except for a roof exit, which must meet the legibility requirements for occupants positioned with their backs against the floor opposite the roof exit.

S5.5.3 *School Bus.* Each school bus emergency exit provided in accordance with S5.2.3.1 shall have the designation "Emergency Door" or "Emergency Exit," as appropriate, in letters at least 2 inches high, of a color that contrasts with its background, located at the top of or directly above the emergency exit on both the inside and outside surfaces of the bus. Concise operating instructions describing the motions necessary to unlatch and open the emergency exit, in letters at least three-eighths of an inch high, of a color that contrasts with its background, shall be located within 6 inches of the release mechanism on the inside surface of the bus.

EXAMPLE

- (1) Lift to Unlatch, Push to Open
- (2) Lift Handle, Push Out to Open

S6. Test conditions.

S6.1 The vehicle is on a flat, horizontal surface.

S6.2 The inside of the vehicle and the outside environment are kept at any temperature from 70° to 85° Fahrenheit for 4 hours immediately preceding the tests, and during the tests.

S6.3 For the window retention test, windows are installed, closed, and latched (where latches are provided) in the condition intended for normal bus operation.

S6.4 For the emergency exit release and extension tests, windows are installed as in S6.3, seats, armrests, and interior objects near the windows are installed as for normal use, and seats are in the upright position.

§ 571.217

49 CFR Ch. V (10-1-88 Edition)

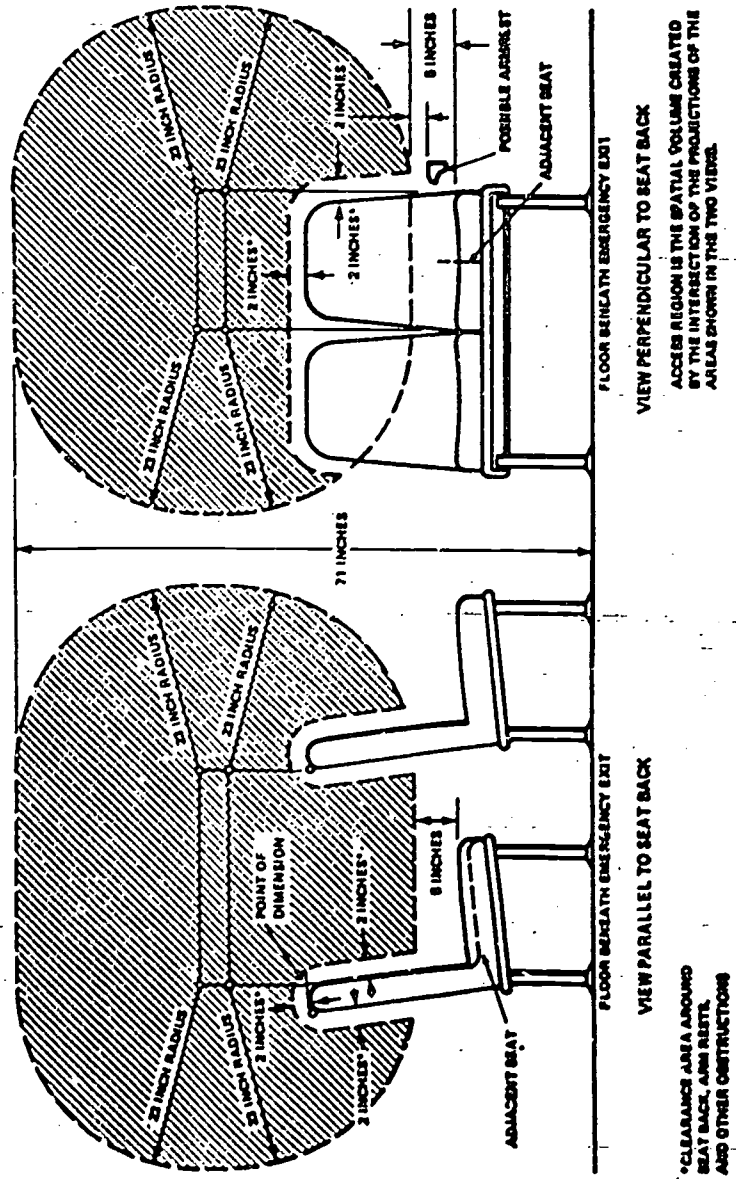

FIGURE 1 LOW-FORCE ACCESS REGION FOR EMERGENCY EXITS HAVING ADJACENT SEATS

National Highway Traffic Safety Admin., DOT

§ 571.217

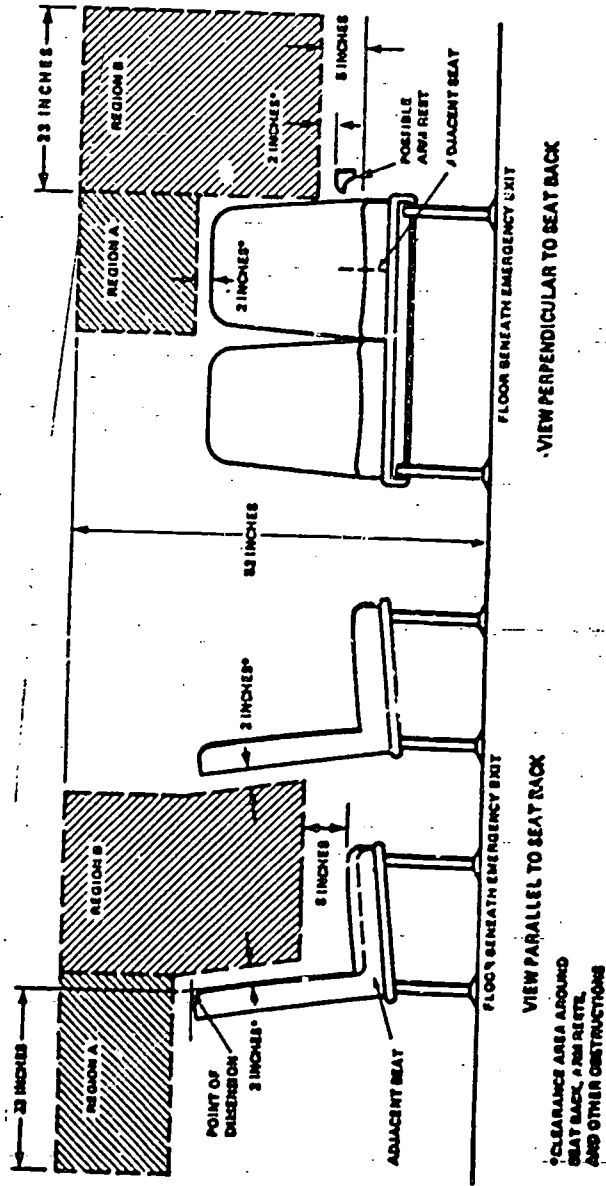
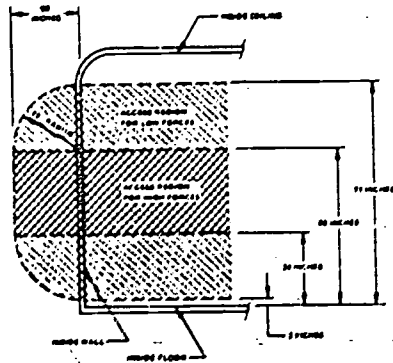

FIGURE 2 HIGH-FORCE ACCESS REGIONS FOR EMERGENCY EXITS HAVING ADJACENT SEATS

§ 571.217

49 CFR Ch. V (10-1-88 Edition)



3A. SIDE EMERGENCY EXIT

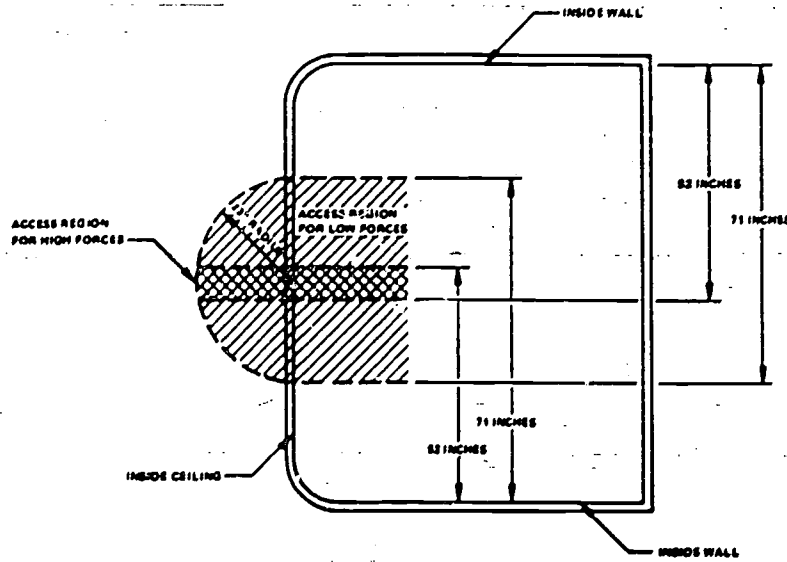

3B. ROOF EMERGENCY EXIT

National Highway Traffic Safety Admin., DOT

§ 571.217

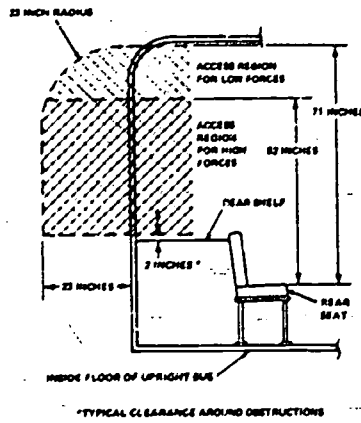

3C. REAR EMERGENCY EXIT WITH REAR OBSTRUCTION

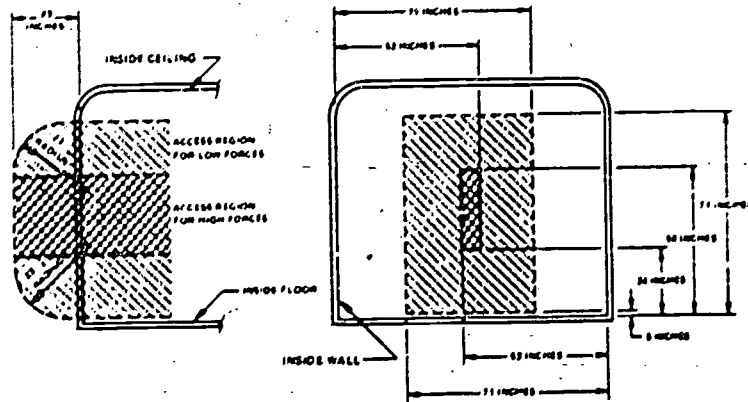

3D. REAR EMERGENCY EXIT WITHOUT REAR OBSTRUCTION

FIGURE 3 LOW AND HIGH-FORCE ACCESS REGIONS FOR EMERGENCY EXITS WITHOUT ADJACENT SEATS

§ 571.217

49 CFR Ch. V (10-1-88 Edition)

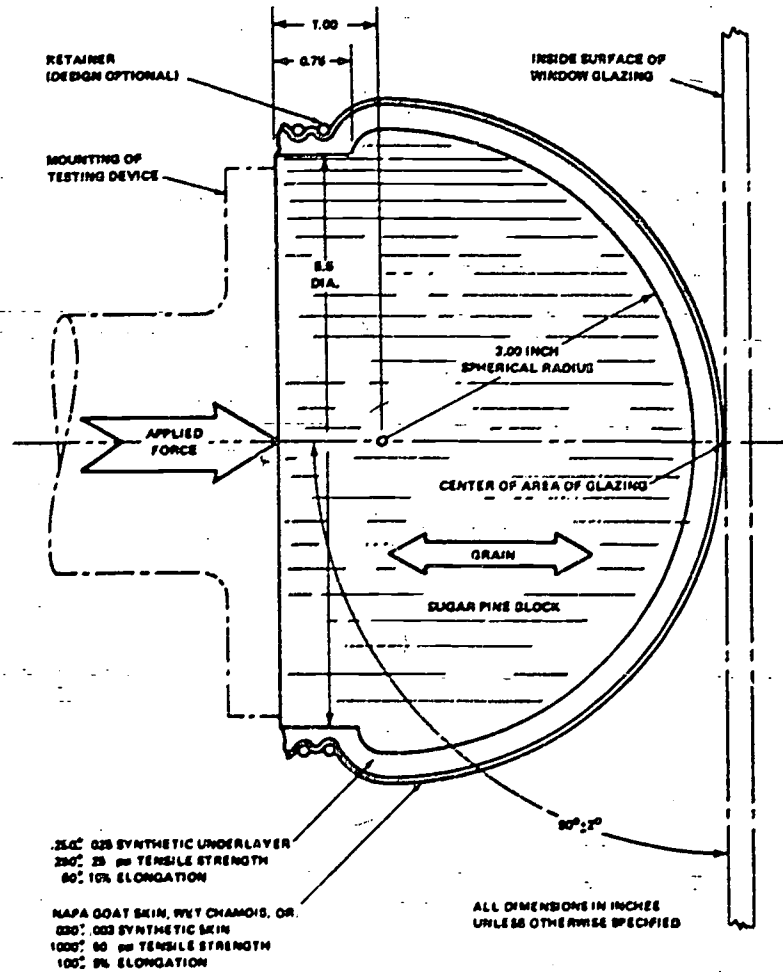

FIGURE 4 HEAD FORM

(37 FR 9395, May 10, 1972, as amended at 37 FR 18035, Sept. 6, 1972; 38 FR 6070, Mar. 5, 1973; 38 FR 7562, Mar. 23, 1973; 39 FR 15274, May 2, 1974; 40 FR 48512, Oct. 18, 1975; 41 FR 3872, Jan. 27, 1976; 41 FR 22357, June 3, 1976; 41 FR 24592, June 17, 1976; 41 FR 36027, Aug. 26, 1976; 47 FR 7256, Feb. 18, 1982; 47 FR 37555, Aug. 26, 1982)

National Highway Traffic Safety Admin., DOT

§ 571.220

§ 571.220 Standard No. 220: School bus rollover protection.

S1. Scope. This standard establishes performance requirements for school bus rollover protection.

S2. Purpose. The purpose of this standard is to reduce the number of deaths and the severity of injuries that result from failure of the school bus body structure to withstand forces encountered in rollover crashes.

S3. Applicability. This standard applies to school buses.

S4. Requirements. When a force equal to $1\frac{1}{2}$ times the unloaded vehicle weight is applied to the roof of the vehicle's body structure through a force application plate as specified in S5., Test procedures—

(a) The downward vertical movement at any point on the application plate shall not exceed $\frac{5}{16}$ inches; and

(b) Each emergency exit of the vehicle provided in accordance with Standard No. 217 (§ 571.217) shall be capable of opening as specified in that standard during the full application of the force and after release of the force, except that an emergency exit located in the roof of the vehicle is not required to be capable of being opened during the application of the force. A particular vehicle (i.e., test specimen) need not meet the emergency exit opening requirement after release of force if it is subjected to the emergency exit opening requirements during the full application of the force.

S5. Test procedures. Each vehicle shall be capable of meeting the requirements of S4. when tested in accordance with the procedures set forth below.

S5.1 With any non-rigid chassis-to-body mounts replaced with equivalent rigid mounts, place the vehicle on a rigid horizontal surface so that the vehicle is entirely supported by means of the vehicle frame. If the vehicle is constructed without a frame, place the vehicle on its body sills. Remove any components which extend upward from the vehicle roof.

S5.2 Use a flat, rigid, rectangular force application plate that is measured with respect to the vehicle roof longitudinal and lateral centerlines.

(a) In the case of a vehicle with a GVWR of more than 10,000 pounds, 12

inches shorter than the vehicle roof and 36 inches wide; and

(b) In the case of a vehicle with a GVWR of 10,000 pounds or less, 5 inches longer and 5 inches wider than the vehicle roof. For purposes of these measurements, the vehicle roof is that structure, seen in the top projected view, that coincides with the passenger and driver compartment of the vehicle.

S5.3 Position the force application plate on the vehicle roof so that its rigid surface is perpendicular to a vertical longitudinal plane and it contacts the roof at not less than two points, and so that, in the top projected view, its longitudinal centerline coincides with the longitudinal centerline of the vehicle, and its front and rear edges are an equal distance inside the front and rear edges of the vehicle roof at the centerline.

S5.4 Apply an evenly-distributed vertical force in the downward direction to the force application plate at any rate not more than 0.5 inch per second, until a force of 500 pounds has been applied.

S5.5 Apply additional vertical force in the downward direction to the force application plate at a rate of not more than 0.5 inch per second until the force specified in S4. has been applied, and maintain this application of force.

S5.6 Measure the downward movement of any point on the force application plate which occurred during the application of force in accordance with S5.5.

S5.7 To test the capability of the vehicle's emergency exits to open in accordance with S4.(b)—

(a) In the case of testing under the full application of force, open the emergency exits as specified in S4.(b) while maintaining the force applied in accordance with S5.4 and S5.5; and

(b) In the case of testing after the release of all force, release all downward force applied to the force application plate and open the emergency exits as specified in S4.(b).

S6. Test conditions. The following conditions apply to the requirements specified in S4.

S6.1 Temperature. The ambient temperature is any level between 32° F. and 90° F.

§ 571.221

S6.2 Windows and doors. Vehicle windows, doors, and emergency exits are in the fully-closed position, and latched but not locked.

(41 FR 3875, Jan. 27, 1976, as amended at 41 FR 36026, 36027, Aug. 26, 1976)

§ 571.221 Standard No. 221: School bus body joint strength.

S1. Scope. This standard establishes requirements for the strength of the body panel joints in school bus bodies.

S2. Purpose. The purpose of this standard is to reduce deaths and injuries resulting from the structural collapse of school bus bodies during crashes.

S3. Application. This standard applies to school buses with gross vehicle weight ratings of more than 10,000 pounds.

S4. Definitions. "Body component" means a part of a bus body made from a single piece of homogeneous material or from a single piece of composite material such as plywood.

"Body panel" means a body component used on the exterior or interior surface to enclose the bus' occupant space.

"Body panel joint" means the area of contact or close proximity between the edges of a body panel and another body component, excluding spaces designed for ventilation or another functional purpose, and excluding doors, windows, and maintenance access panels.

"Bus body" means the portion of a bus that encloses the bus's occupant space, exclusive of the humpers, the chassis frame, and any structure forward of the forwardmost point of the windshield mounting.

49 CFR Ch. V (10-1-88 Edition)

S5. Requirement. When tested in accordance with the procedure of S6., each body panel joint shall be capable of holding the body panel to the member to which it is joined when subjected to a force of 60% of the tensile strength of the weakest joined body panel determined pursuant to S6.2.

S6. Procedure.

S6.1 Preparation of the test specimen.

S6.1.1 If a body panel joint is 8 inches long or longer, cut a test specimen that consists of any randomly selected 8-inch segment of the joint, together with a portion of the bus body whose dimensions, to the extent permitted by the size of the joined parts, are those specified in Figure 1, so that the specimen's centerline is perpendicular to the joint at the midpoint of the joint segment. Where the body panel joint is not fastened continuously, select the segment so that it does not bisect a spot weld or a discrete fastener.

S6.1.2 If a joint is less than 8 inches long, cut a test specimen with enough of the adjacent material to permit it to be held in the tension testing machine specified in S6.3.

S6.1.3 Prepare the test specimen in accordance with the preparation procedures specified in the 1973 edition of the Annual Book of ASTM Standards, published by the American Society for Testing and Materials, 1916 Race Street, Philadelphia, Pennsylvania 19102.

S6.2 Determination of minimum allowable strength. For purposes of determining the minimum allowable joint strength, determine the tensile strengths of the joined body components as follows:

National Highway Traffic Safety Admin., DOT

§ 571.222

FIGURE 1

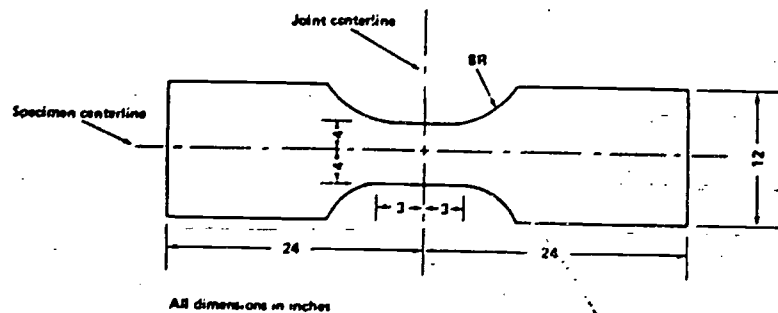

(a) If the mechanical properties of a material are specified by the American Society for Testing and Materials, the relative tensile strength for such a material is the minimum tensile strength specified for that material in the 1973 edition of the Annual Book of ASTM Standards.

(b) If the mechanical properties of a material are not specified by the American Society for Testing and Materials, determine its tensile strength by cutting a specimen from the bus body outside the area of the joint and by testing it in accordance with S6.3.

S6.3 Strength test.

S6.3.1 Grip the joint specimen on opposite sides of the joint in a tension testing machine calibrated in accordance with Method E4, Verification of Testing Machines, of the American Society for Testing and Materials (1973 Annual Book of ASTM Standards).

S6.3.2 Adjust the testing machine grips so that the joint, under load, will be in stress approximately perpendicular to the joint.

S6.3.3 Apply a tensile force to the specimen by separating the heads of the testing machine at any uniform rate not less than $\frac{1}{8}$ inch and not more than $\frac{1}{4}$ inch per minute until the specimen separates.

141 FR 3872, Jan. 27, 1976, as amended at 41 FR 36077, Aug 28, 1976)

§ 571.222 Standard No. 222; School bus passenger seating and crash protection.

S1. *Scope.* This standard establishes occupant protection requirements for school bus passenger seating and restraining barriers.

S2. *Purpose.* The purpose of this standard is to reduce the number of deaths and the severity of injuries that result from the impact of school bus occupants against structures within the vehicle during crashes and sudden driving maneuvers.

S3. *Application.* This standard applies to school buses.

S4. *Definitions.* "Contactable surface" means any surface within the zone specified in S5.3.1.1 that is contactable from any direction by the test device described in S6.6, except any surface on the front of a seat back or restraining barrier 3 inches or more below the top of the seat back or restraining barrier.

"School bus passenger seat" means a seat in a school bus, other than the driver's seat or a seat installed to accommodate handicapped or convalescent passengers as evidenced by orientation of the seat in a direction that is more than 45 degrees to the left or right of the longitudinal centerline of the vehicle.

S4.1 The number of seating positions considered to be in a bench seat is expressed by the symbol W, and calculated as the bench width in inches

§ 571.222

divided by 15 and rounded to the nearest whole number.

S5. Requirements. (a) Each vehicle with a gross vehicle weight rating of more than 10,000 pounds shall be capable of meeting any of the requirements set forth under this heading when tested under the conditions of S8. However, a particular school bus passenger seat (i.e., test specimen) in that weight class need not meet further requirements after having met S5.1.2 and S5.1.5, or having been subjected to either S5.1.3, S5.1.4, or S5.3.

(b) Each vehicle with a gross vehicle weight rating of 10,000 pounds or less shall be capable of meeting the following requirements at all seating positions other than the driver's seat: (1) The requirements of §§ 571.208, 571.209, and 571.210 (Standard Nos. 208, 209, and 210) as they apply to multipurpose passenger vehicles; and (2) the requirements of S5.1.2, S5.1.3, S5.1.4, S5.1.5, and S5.3 of this standard. However, the requirements of Standard Nos. 208 and 210 shall be met at W seating positions in a bench seat using a body block as specified in Figure 2 of this standard, and a particular school bus passenger seat (i.e., a test specimen) in that weight class need not meet further requirements after having met S5.1.2 and S5.1.5, or having been subjected to either S5.1.3, S5.1.4, S5.3, or § 571.210 (Standard No. 210).

S5.1 Seating requirements. School bus passenger seats shall be forward facing.

S5.1.1 [Reserved]

S5.1.2 Seat back height and surface area. Each school bus passenger seat shall be equipped with a seat back that, in the front projected view, has a front surface area above the horizontal plane that passes through the seating reference point, and below the horizontal plane 20 inches above the seating reference point, of not less than 90 percent of the seat bench width in inches multiplied by 20.

S5.1.3 Seat performance forward. When a school bus passenger seat that has another seat behind it is subjected to the application of force as specified in S5.1.3.1 and S5.1.3.2, and subsequently, the application of additional

49 CFR Ch. V (10-1-88 Edition)

force to the seat back as specified in S5.1.3.3 and S5.1.3.4:

(a) The seat back force/deflection curve shall fall within the zone specified in Figure 1;

(b) Seat back deflection shall not exceed 14 inches; (for determination of (a) and (b) the force/deflection curve describes only the force applied through the upper loading bar, and only the forward travel of the pivot attachment point of the upper loading bar, measured from the point at which the initial application of 10 pounds of force is attained.)

(c) The seat shall not deflect by an amount such that any part of the seat moves to within 4 inches of any part of another school bus passenger seat or restraining barrier in its originally installed position;

(d) The seat shall not separate from the vehicle at any attachment point; and

(e) Seat components shall not separate at any attachment point.

S5.1.3.1 Position the loading bar specified in S6.5 so that it is laterally centered behind the seat back with the bar's longitudinal axis in a transverse plane of the vehicle and in any horizontal plane between 4 inches above and 4 inches below the seating reference point of the school bus passenger seat behind the test specimen.

S5.1.3.2 Apply a force of 700W pounds horizontally in the forward direction through the loading bar at the pivot attachment point. Reach the specified load in not less than 5 nor more than 30 seconds.

S5.1.3.3 No sooner than 1.0 second after attaining the required force, reduce that force to 350W pounds and, while maintaining the pivot point position of the first loading bar at the position where the 350W pounds is attained, position a second loading bar described in S6.5 so that it is laterally centered behind the seat back with the bar's longitudinal axis in a transverse plane of the vehicle and in the horizontal plane 18 inches above the seating reference point of the school bus passenger seat behind the test specimen, and move the bar forward against the seat back until a force of 10 pounds has been applied.

National Highway Traffic Safety Admin., DOT

§ 571.222

S5.1.3.4 Apply additional force horizontally in the forward direction through the upper bar until 4,000W inch-pounds of energy have been absorbed in deflecting the seat back (or restraining barrier). Apply the additional load in not less than 5 seconds nor more than 30 seconds. Maintain the pivot attachment point in the maximum forward travel position for not less than 5 seconds nor more than 10 seconds and release the load in not less than 5 nor more than 30 seconds. (For the determination of S5.1.3.4 the force/deflection curve describes only the force applied through the upper loading bar, and the forward and rearward travel distance of the upper loading bar pivot attachment point measured from the position at which the initial application of 10 pounds of force is attained.)

S5.1.4 *Seat performance rearward.* When a school bus passenger seat that has another seat behind it is subjected to the application of force as specified in S5.1.4.1 and S5.1.4.2:

(a) Seat back force shall not exceed 2,200 pounds;

(b) In the case of a school bus manufactured on or after April 1, 1978, seat back deflection shall not exceed 10 inches; (For determination of (a) and (b) the force/deflection curve describes only the force applied through the loading bar, and only the rearward travel of the pivot attachment point of the loading bar, measured from the point at which the initial application of 50 pounds of force is attained.

(c) The seat shall not deflect by an amount such that any part of the seat moves to within 4 inches of any part of another passenger seat in its originally installed position;

(d) The seat shall not separate from the vehicle at any attachment point; and

(e) Seat components shall not separate at any attachment point.

S5.1.4.1 Position the loading bar described in S5.5 so that it is laterally centered forward of the seat back with the bar's longitudinal axis in a transverse plane of the vehicle and in the horizontal plane 13.5 inches above the seating reference point of the test specimen, and move the loading bar

rearward against the seat back until a force of 50 pounds has been applied.

S5.1.4.2 Apply additional force horizontally rearward through the loading bar until 2,800W inch-pounds of energy has been absorbed in deflecting the seat back. Apply the additional load in not less than 5 seconds nor more than 30 seconds. Maintain the pivot attachment point in the maximum rearward travel position for not less than 5 seconds nor more than 10 seconds and release the load in not less than 5 seconds nor more than 30 seconds. (For determination of S5.1.4.2 the force/deflection curve describes the force applied through the loading bar and the rearward and forward travel distance of the loading bar pivot attachment point measured from the position at which the initial application of 50 pounds of force is attained.)

S5.1.5 *Seat cushion retention.* In the case of school bus passenger seats equipped with seat cushions, with all manual attachment devices between the seat and the seat cushion in the manufacturer's designed position for attachment, the seat cushion shall not separate from the seat at any attachment point when subjected to an upward force of five times the seat cushion weight, applied in any period of not less than 1 nor more than 5 seconds, and maintained for 5 seconds.

S5.2 *Restraining barrier requirements.* Each vehicle shall be equipped with a restraining barrier forward of any designated seating position that does not have the rear surface of another school bus passenger seat within 24 inches of its seating reference point, measured along a horizontal longitudinal line through the seating reference point in the forward direction.

S5.2.1 *Barrier-seat separation.* The horizontal distance between the restraining barrier's rear surface and the seating reference point of the seat in front of which the barrier is required shall not be more than 24 inches measured along a horizontal longitudinal line through the seating reference point in the forward direction.

S5.2.2 *Barrier position and rear surface area.* The position and rear surface area of the restraining barrier shall be such that, in a front projected

§ 571.222

49 CFR Ch. V (10-1-88 Edition)

view of the bus, each point of the barrier's perimeter coincides with or lies outside of the perimeter of the seat back of the seat for which it is required.

S5.2.3 Barrier performance forward. When force is applied to the restraining barrier in the same manner as specified in S5.1.3.1 through S5.1.3.4 for seating performance tests:

(a) The restraining barrier force/deflection curve shall fall within the zone specified in Figure 1;

(b) Restraining barrier deflection shall not exceed 14 inches; (For computation of (a) and (b) the force/deflection curve describes only the force applied through the upper loading bar, and only the forward travel of the pivot attachment point of the loading bar, measured from the point at which the initial application of 10 pounds of force is attained.)

(c) Restraining barrier deflection shall not interfere with normal door operation;

(d) The restraining barrier shall not separate from the vehicle at any attachment point; and

(e) Restraining barrier components shall not separate at any attachment point.

S5.3 Impact zone requirements.

S5.3.1 Head protection zone. Any contactable surface of the vehicle within any zone specified in S5.3.1.1 shall meet the requirements of S5.3.1.2 and S5.3.1.3. However, a surface area that has been contacted pursuant to an impact test need not meet further requirements contained in S5.3.

S5.3.1.1 The head protection zones in each vehicle are the spaces in front of each school bus passenger seat which are not occupied by bus sidewall, window, or door structure and which, in relation to that seat and its seating reference point, are enclosed by the following planes:

(a) Horizontal planes 12 inches and 40 inches above the seating reference point;

(b) A vertical longitudinal plane tangent to the inboard (aisle side) edge of the seat;

(c) A vertical longitudinal plane 3.25 inches inboard of the outboard edge of the seat, and

(d) Vertical transverse planes through and 30 inches forward of the reference point.

S5.3.1.2 Head form impact requirement. When any contactable surface of the vehicle within the zones specified in S5.3.1.1 is impacted from any direction at 22 feet per second by the head form described in S6.6, the axial acceleration at the center of gravity of the head form shall be such that the expression

$$\left[\frac{1}{(t_2 - t_1)} \int_{t_1}^{t_2} a dt \right] \leq (t_2 - t_1)$$

shall not exceed 1.000 where a is the axial acceleration expressed as a multiple of g (the acceleration due to gravity), and t_1 and t_2 are any two points in time during the impact.

S5.3.1.3 Head form force distribution. When any contactable surface of the vehicle within the zones specified in S5.3.1.1 is impacted from any direction at 22 feet per second by the head form described in S6.6, the energy necessary to deflect the impacted material shall be not less than 40 inch-pounds before the force level on the head form exceeds 150 pounds. When any contactable surface within such zones is impacted by the head form from any direction at 5 feet per second, the contact area on the head form surface shall be not less than 3 square inches.

S5.3.2 Leg protection zone. Any part of the seat backs or restraining barriers in the vehicle within any zone specified in S5.3.2.1 shall meet the requirements of S5.3.2.2.

S5.3.2.1 The leg protection zones of each vehicle are those parts of the school bus passenger seat backs and restraining barriers bounded by horizontal planes 12 inches above and 4 inches below the seating reference point of the school bus passenger seat immediately behind the seat back or restraining barrier.

S5.3.2.2 When any point on the rear surface of that part of a seat back or restraining barrier within any zone specified in S5.3.2.1 is impacted from

National Highway Traffic Safety Admin., DOT

§ 571.222

any direction at 16 feet per second by the knee form specified in S6.7, the resisting force of the impacted material shall not exceed 600 pounds and the contact area on the knee form surface shall not be less than 3 square inches.

S6. Test conditions. The following conditions apply to the requirements specified in S5.

S6.1 Test surface. The bus is at rest on a level surface.

S6.2 Tires. Tires are inflated to the pressure specified by the manufacturer for the gross vehicle weight rating.

S6.3 Temperature. The ambient temperature is any level between 32 degrees F. and 90 degrees F.

S6.4 Seat back position. If adjustable, a seat back is adjusted to its most upright position.

S6.5 Loading bar. The loading bar is a rigid cylinder with an outside diameter of 6 inches that has hemispherical ends with radii of 3 inches and with a surface roughness that does not exceed 63 micro-inches, root mean square. The length of the loading bar is 4 inches less than the width of the seat back in each test. The stroking mechanism applies force through a pivot attachment at the centerpoint of the loading bar which allows the loading bar to rotate in a horizontal plane 30 degrees in either direction from the transverse position.

S6.5.1 A vertical or lateral force of 4,000 pounds applied externally through the pivot attachment point of the loading bar at any position reached during a test specified in this standard shall not deflect that point more than 1 inch.

S6.6 Head form. The head form for the measurement of acceleration is a rigid surface comprised of two hemispherical shapes, with total equivalent weight of 11.5 pounds. The first of the two hemispherical shapes has a diameter of 6.5 inches. The second of the two hemispherical shapes has a 2 inch diameter and is centered as shown in Figure 3 to protrude from the outer surface of the first hemispherical shape. The surface roughness of the hemispherical shapes does not exceed 63 micro-inches, root mean square.

S6.6.1 The direction of travel of the head form is coincidental with the straight line connecting the center-

points of the two spherical outer surfaces which constitute the head form shape.

S6.6.2 The head form is instrumented with an acceleration sensing device whose output is recorded in a data channel that conforms to the requirements for a 1,000 Hz channel class as specified in SAE Recommended Practice J211a, December 1971. The head form exhibits no resonant frequency below three times the frequency of the channel class. The axis of the acceleration sensing device coincides with the straight line connecting the centerpoints of the two hemispherical outer surfaces which constitute the head form shape.

S6.6.3 The head form is guided by a stroking device so that the direction of travel of the head form is not affected by impact with the surface being tested at the levels called for in the standard.

S6.7 Knee form. The knee form for measurement of force is a rigid 3-inch-diameter cylinder, with an equivalent weight of 10 pounds, that has one rigid hemispherical end with a 1½ inch radius forming the contact surface of the knee form. The hemispherical surface roughness does not exceed 63 micro-inches, root mean square.

S6.7.1 The direction of travel of the knee form is coincidental with the centerline of the rigid cylinder.

S6.7.2 The knee form is instrumented with an acceleration sensing device whose output is recorded in a data channel that conforms to the requirements of a 600 Hz channel class as specified in the SAE Recommended Practice J211a, December 1971. The knee form exhibits no resonant frequency below three times the frequency of the channel class. The axis of the acceleration sensing device is aligned to measure acceleration along the centerline of the cylindrical knee form.

S6.7.3 The knee form is guided by a stroking device so that the direction of travel of the knee form is not affected by impact with the surface being tested at the levels called for in the standard.

S6.8 The head form, knee form, and contactable surfaces are clean and dry during impact testing.

§ 571.222

49 CFR Ch. V (10-1-88 Edition)

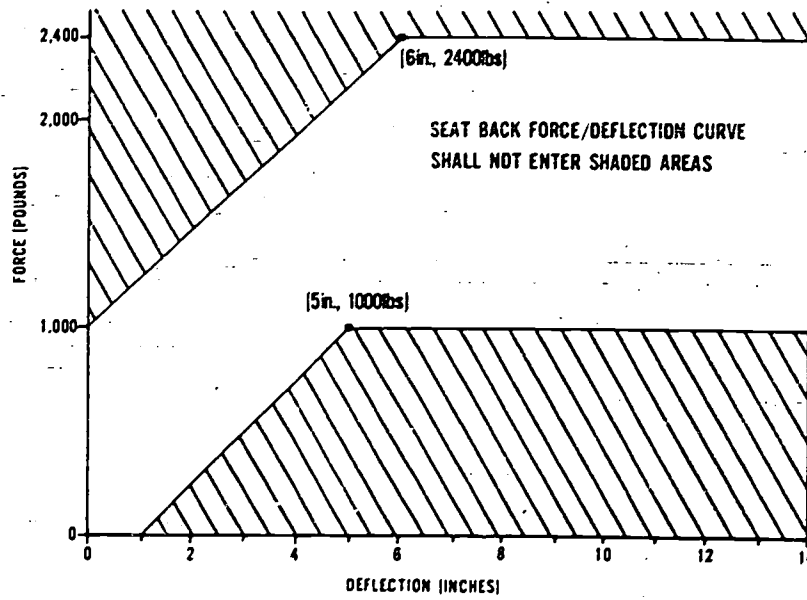
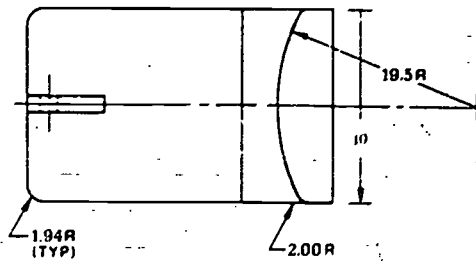

FIGURE 1 - FORCE/DEFLECTION ZONE

National Highway Traffic Safety Admin., DOT

§ 571.222



⊕ BLOCK COVERED BY
1.00 MED. DENSITY CANVAS
COVERED FOAM RUBBER

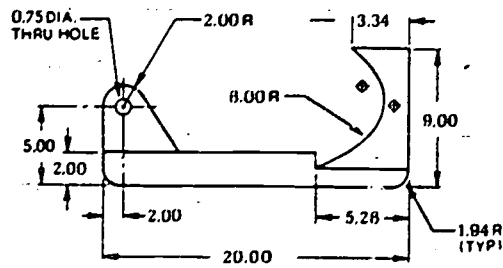

FIGURE 2 - BODY BLOCK FOR LAP BELT

§ 571.222

49 CFR Ch. V (10-1-88 Edition)

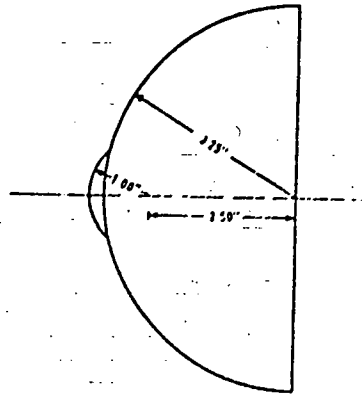

FIGURE 3

(41 FR 4018, Jan. 28, 1976, as amended at 41 FR 28528, July 12, 1976; 41 FR 36027, Aug. 26, 1976; 41 FR 54245, Dec. 16, 1976; 42 FR 84120, Dec. 22, 1977; 43 FR 9150, Mar. 6, 1978; 44 FR 12975, Mar. 29, 1979; 48 FR 12386, Mar. 24, 1983)



U.S. DEPARTMENT OF EDUCATION
Office of Educational Research and Improvement (OERI)
Educational Resources Information Center (ERIC)



NOTICE

REPRODUCTION BASIS

This document is covered by a signed "Reproduction Release (Blanket)" form (on file within the ERIC system), encompassing all or classes of documents from its source organization and, therefore, does not require a "Specific Document" Release form.

This document is Federally-funded, or carries its own permission to reproduce, or is otherwise in the public domain and, therefore, may be reproduced by ERIC without a signed Reproduction Release form (either "Specific Document" or "Blanket").