

DOCUMENT RESUME

ED 461 578

SO 029 606

AUTHOR Frese, Millie K., Ed.
TITLE "I" Is for Iowa Inventors!
INSTITUTION Iowa State Historical Society, Iowa City.
ISSN ISSN-0278-0208
PUB DATE 1998-00-00
NOTE 34p.; Published quarterly. Theme issue.
AVAILABLE FROM State Historical Society of Iowa, 402 Iowa Avenue, Iowa City, IA 52240-1806 (\$3). Tel: 319-335-3916.
PUB TYPE Collected Works - Serials (022)
JOURNAL CIT Goldfinch: Iowa History for Young People; v20 n1 Win 1996
EDRS PRICE MF01/PC02 Plus Postage.
DESCRIPTORS Elementary Education; Elementary School Students; Family History; *Inventions; *Local History; *Patents; Social History; *Social Studies; *State History
IDENTIFIERS *Iowa

ABSTRACT

"The Goldfinch" is a magazine oriented toward young children and intended to introduce said audience to many different aspects of Iowa history. Each issue focuses on a different topic, and features a number of articles that discuss the topic in more depth. The topic for this issue is Iowa Inventors. Featured articles highlight women inventors, young inventors, and patents. The articles include "Iowa Inventors from A to Z"; "Patent That"; "Write Women Back into History"; "Nicholas Schrunck: Kid Inventor"; and "Fort Madison: Inventor 'Pens' History." Additional activities include a crossword puzzle, a history mystery, and a story. (RH)

"I" is for Iowa Inventors!

Millie K. Frese, Ed.

The Goldfinch: Iowa History for Young People
Volume 20 Number 1 Winter 1996

U.S. DEPARTMENT OF EDUCATION
Office of Educational Research and Improvement
EDUCATIONAL RESOURCES INFORMATION
CENTER (ERIC)

- This document has been reproduced as received from the person or organization originating it.
 - Minor changes have been made to improve reproduction quality
-
- Points of view or opinions stated in this document do not necessarily represent official OERI position or policy.

PERMISSION TO REPRODUCE AND
DISSEMINATE THIS MATERIAL HAS
BEEN GRANTED BY

D. Gore

TO THE EDUCATIONAL RESOURCES
INFORMATION CENTER (ERIC)

1

2

BEST COPY AVAILABLE

THE Goldfinch

Iowa History for Young People

Volume 20, Number 1 • Fall 1998 • \$3



“I” is for
Iowa

Inventors!



Rebecca Johnson

p. 7

Dear Readers,

What do you think an inventor looks like? Today's image of inventors is a lot different than old stereotypes of people with thick glasses, wild hair, and white lab coats! An inventor looks like any woman, man, girl, or boy who can identify a problem and look for new or improved ways to solve it.

Iowa's history is full of inventive people. Each light bulb on the map on the next page marks the spot where a creative Iowan turned bright ideas into inventions. Their stories are packed into this issue of *The Goldfinch*. But we ran out of pages before we could tell you about the radio-related inventions of Arthur Collins of Cedar Rapids, or about the doctors at the University of Iowa who invented buffered aspirin, or about a synthetic blood patented by the U of I for use in surgery, or about Iowa State University researchers who developed a part used in all fax machines...

This issue is just the beginning of a fascinating journey through Iowa's creative heritage!

—The Editor

R.S. Maybe today's inventor looks just like you! Do you have an inventive idea you'd like to tell me about? I'd love to hear from you! My address: 402 Iowa Ave., Iowa City, IA, 52242. E-mail: mfrese@blue.weeg.uiowa.edu.

Jenny Plagman and Abby Rosenthal demonstrated their invention, Stink Stopper, at the 1998 *Invent, Iowa!* state competition. Read more about young inventors on p. 26!

THE Goldfinch

Volume 20, Number 1 • Winter 1996



Member, Educational Press Association of America

Winner of a 1998 Parents' Choice Silver Honor Award

INTERIM EDITOR: Millie K. Frese
PUBLICATIONS DIRECTOR: Shaner Magalhães
ILLUSTRATION: Mary Moye-Rowley
PUBLICATIONS INTERN: Bonnie Wilmesmeier

CONSULTING EDITORS: John Anderson, associate director, University Relations, Iowa State University; Skip Derra, science writer in University Relations, Iowa State University; Dianne Haas and Mary Ann Reiter, co-chairpersons, Wapello County Sesquicentennial Committee; and Timothy J. Zarley, attorney at law.

CONTRIBUTING WRITERS: Jen Golay, Katherine House, Lin Ly, Diane Nelson, Melinda Padley, Brian Page, Nicholas Schrunck, Jean Strong, and Jan Wolbers.

EDUCATORS' ADVISORY BOARD: Carol Dighton, West Delaware Middle School, Manchester; Janice L. Gobble, Danville Elementary School, Danville; and Clen A. Lincoln, Fair Oaks Middle School, Fort Dodge.

CHILDREN'S ADVISORY BOARD: Leah Bergman, Iowa City; Sarah Frese, Danville; Emily Johnson, Fort Dodge; Jessica Myers, Coralville; and Jeff Zittergruen, Van Horne.

SPECIAL THANKS TO: Alexia Abernathy; Linda Blakesley, administrator, Legal/Patent Department, Sheaffer Pen Corporation; Countree Store, Winfield, Iowa; and Karon Moll, State Library of Iowa, Des Moines.

CREDITS: The characters Wild Rosie and Goldie created by SHSI exhibit designer Jerry Brown.

The Goldfinch (ISSN 0278-0208) is published quarterly by the State Historical Society of Iowa, 402 Iowa Avenue, Iowa City, Iowa 52240-1806 (319/335-3916). Second-class postage paid at Iowa City, Iowa. Subscriptions are \$9.95 for four issues.

Postmaster: Send address changes to: Carol Carey, subscriptions coordinator, *The Goldfinch*, State Historical Society of Iowa, 402 Iowa Avenue, Iowa City, Iowa 52240-1806. © State Historical Society of Iowa, 1998. No portion of *The Goldfinch* may be reproduced without prior permission except for classroom use.



The Goldfinch is also available on cassette tape for the blind, the visually impaired, the physically handicapped, and the learning disabled. For more information contact the Iowa Department for the Blind, 1-800-362-2587. Or write to the Iowa Department for the Blind Library, 524 4th St., Des Moines 50309.



Allen Johnston

p. 8

On the Cover

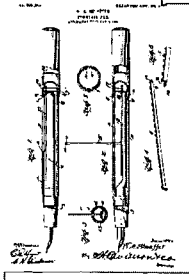

Walter Sheaffer's fountain pen p. 22

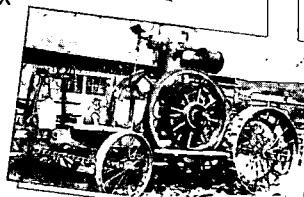

John Froelich's tractor—p. 6



Features

- 4 Iowa Inventors from A to Z
- 15 Patent That!
- 20 Write Women Back into History
- 21 Nicholas Schrunk: Kid Inventor
- 22 Fort Madison Inventor "Pens" History

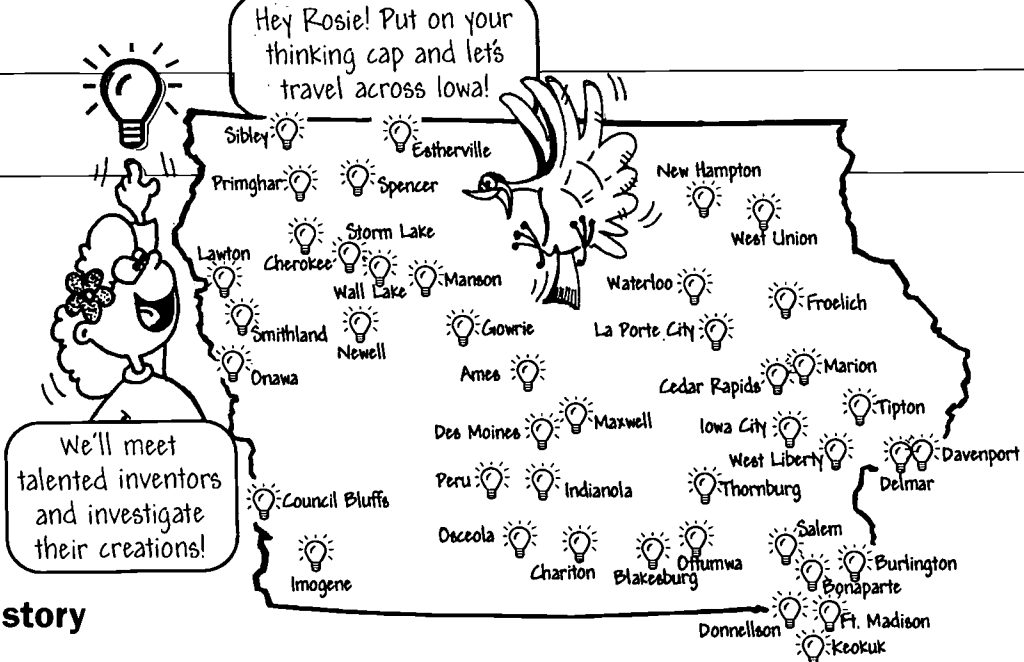

Calling All Historians:

This issue of *The Goldfinch* might help generate ideas for your

1999 History Day project!

Science, Technology, Invention in History: Impact, Influence, and Change

Competition Dates:

Districts: February – March 1999

State: Junior Division – April 26, 1999

Senior Division – May 3, 1999

National: June 13-17, 1999

Competition open to students in grades 6 through 12.

For more information, contact Crystal Bailey, SHSI,

600 E. Locust, Des Moines, Iowa 50319.

Departments

- 2 On the Cover
- 24 Dear Diary
- 26 History Makers
- 28 *Goldfinch* fiction: The Dream Computer

Activities

- 16 Inventor's Crossword Puzzle
- 17 History Mystery
- 25 Be a Diary Detective!

Iowa Inventors and Inventions

from
A to Z

An invention begins with someone's good idea. Sometimes those ideas happen by accident. More often, inventions result when creative people work hard to solve a problem or to make life's chores a little easier.

A Air-tight Mailbag

Bags stuffed with letters were piled atop stagecoaches to travel between stage stop post offices in the 1850s.

The problem: Dust and dirt blown into the bags soiled the mail. Rain and snow leaked in, reducing letters to a soggy mess.

The solution: Charles A. Robbins and Harvey Allen designed an air-tight mailbag to protect mail from dust and water. Robbins constructed

the prototype by crimping in elastic material at the mouth of the bag. He was one of the first Iowa City residents to apply for a patent, which was granted on September 7, 1852.

Robbins's inventions didn't stop when he solved the soggy mail problem. He also patented a ditching and excavating plow for turning prairie sod.



Stagecoaches carried people and mailbags!

B Basic Skills Tests

Sharpen your #2 pencil and blacken the oval of the correct answer:

Everet F. Lindquist, a professor of education at the University of Iowa, devised:

- (a) the Iowa Tests of Basic Skills in 1935
- (b) the Iowa Tests of Educational Development in 1942
- (c) the first electronic scoring machine
- (d) all of the above

The correct answer is (d) all of the above.

Born in Gowrie, Lindquist earned national recognition for his innovations in testing. Schools across the nation used tests he developed, sending them in by the thousands for grading. Scoring them one by one was a tedious job. Lindquist dreamed of an easier way—then invented the first electronic scoring machine in 1952, even though he had no special training in electronics.

Now, when your teacher tells you it's time for basic skills tests, you'll know whom to thank!

Corn Picker



Patrick J. Lawler was a farm kid who didn't like the hard work of farming. Picking corn by hand left him exhausted. But he liked tinkering with machines and dreamed of an easier way to get the job done.

By 1880, Lawler had drawn his ideas for a corn picking machine on paper. With the help of John F. Barry, a lawyer from Chicago, Lawler built a working model of his dream. Then, on a sunny afternoon in 1885, a crowd gathered at the Lawler farm near Wall Lake to watch the strange machine pick corn. Neighbors were amazed as the horse-drawn picker poured out a stream of husked ears.

A Chicago manufacturing company offered Lawler money for the rights to produce his machine, but he and Barry wanted to manufacture the corn picker themselves. They purchased a blacksmith shop and built two machines but were unable to sell them. Lawler's first corn picker was sold for scrap in 1932.

A little boy standing in Christian Nelson's ice cream shop in Onawa in 1920 couldn't make up his mind. Should he buy ice cream or a chocolate bar?



Nelson's sweet treat has been in production for almost 80 years!

Inspired by the child's dilemma, Nelson experimented with chocolate and cocoa butter until he found just the right mixture for a coating that would freeze on a slice of ice cream. He patented the creation, originally called the "I-Scream-Bar."

Delicious Apple

Delicious Apple

Jesse Hiatt was a farmer who experimented with new varieties of apples, berries and flowers. He could do curious things like grafting several varieties of fruit on one tree. He planted a new type of red raspberries that bore fruit even in hot summer months. Then he discovered what would become the most popular apple variety in the world—by accident.

Hiatt found the unusual seedling in his orchard near Peru in Madison County. Each time he tried to chop it out, the stubborn seedling grew back. So he let it grow, later discovering qualities he liked in the fruit. Hiatt called the apple variety "Hawkeye" and entered it in a fruit show at the 1893 Missouri State Fair. When a judge bit into the apple and proclaimed it "delicious," the name stuck. A descendant of the original tree still stands just north of Peru.



Hiatt's tree in 1922

Eskimo Pie

E

Soon he teamed up with Russell Stover to produce what became known as the Eskimo Pie.

The Eskimo Pie became a national sensation. More than one million sold daily at the height of its popularity. Demand for the frozen treat was so strong that it helped lift cocoa- and chocolate-producing countries out of an economic depression.

Not bad for a simple idea from an inventor in Onawa!

"Kids used to hang around, just to eat his failures."

—Mrs. Fred Otto, January 1955, recalling Nelson's ice cream shop.

F

Frank-A-Matic

~~Do you like hot dogs?~~ Did you know that most of the frankfurters and sausages consumed around the world today are produced on a machine created by an Iowa inventor?

Ray Townsend introduced the "Frank-A-Matic" in 1964. His invention stuffed and linked 30,000 frankfurters and sausages per hour.



This Frank-A-Matic is in the SHSI (Des Moines) Collection.

This machine was one of Townsend's many innovations to boost the meat-packing industry. Born in Des Moines in 1913, Townsend is the inventor or co-inventor listed on more than 70 U.S. patents.

Gasoline Tractor

In 1892, John Froelich built the first gasoline-powered tractor that propelled itself backward and forward. His invention helped pave the way for modern farming.

John grew up in Froelich, a Clayton County town named after his father, Henry. John ran a feed mill and elevator, and tinkered with machines. Mounting a gasoline engine on a well-drilling rig gave him the idea to mount an internal combustion engine on a tractor. A few weeks later, the tractor—a forerunner of today's John Deere tractors—was shipped to South Dakota, where it threshed

G



John Froelich

72,000 bushels of wheat in 52 days.

Froelich, with other investors, founded the Waterloo Gasoline Traction Engine Company in 1893. This company eventually became the John Deere Tractor Works.

Like many inventors, Froelich received little recognition for his work during his lifetime while others profited from his creations.

H

Helicopter

August Werner had a vision. He wanted to be the first person to invent a heavier-than-air craft that could actually fly—with a person in it!

In 1880, Werner and his wife, Martha (Mattie), moved to Imogene, a settlement with fewer than 200 people. Werner built and operated a boarding-house and a restaurant. He also served as the town's furniture dealer, cabinet maker, and undertaker—occupations that often went together in the 1880s since the town cabinet maker had the skills needed to also make coffins.

But Werner lost interest in his work. He didn't finish coffins time, the restaurant ran short of food, and he neglected orders for cabinets. Instead, his attention was focused on the small model helicopters he designed and built in his carpenter shop. Werner believed he could build a full-sized helicopter that would carry him into the air.

Driven by a wooden crank and spring that powered a propeller, the helicopter models flew up to the ceiling of his workshop. For months, Werner secretly worked on his inventions. Finally, early in 1886, he announced plans to build a full-



August Werner

sized helicopter and fly to Washington D.C. to have lunch with the president of the United States!

On July 4, 1886, Werner and a passenger, Imogene resident John Barker, got into the helicopter. As they worked the hand cranks and foot pedals, the helicopter blade began to rotate faster and faster. Finally, according to several witnesses, the machine rose about four feet off of the ground before one of the wooden cogs gave way and the helicopter crashed into a heap. Depressed and humiliated, Werner never again attempted to fly.

Although Werner's flight did not take him to see the president, it represented a great accomplishment. His four-foot flight took place **seventeen years** before the Wright brothers took their historic first flight at Kitty Hawk. Werner's vision and courage made him a pioneer in aviation.

—by Jan Wolbers

Incubator

When Rebecca Johnson's husband died, the Maxwell

woman had to support three young children on her own. Cleaning houses and sewing did not pay enough, so Johnson used her small inheritance to buy a house, eight acres of land, two cows, a few pigs, and several dozen hens. She raised chickens year-round, paying careful attention to their needs. She built a hen house that was so warm her hens laid eggs all winter. She later wrote, "I fed them cabbage, beets, turnips, squash, onions, for I knew to produce eggs in winter I would have to make conditions as near like those of the warmer months as possible.... I never let them out on cold days."

Soon she made enough money selling eggs for 18 cents per dozen to pay her living expenses and feed her animals. In the late 1800s Johnson made her first **incubator**.

Using incubators, Johnson hatched 5,000 chickens in one season. Later in her poultry career, she hatched half that amount in a single day! Eventually, she made \$300 monthly during the busy part of the year. Newspapers wrote about her skills. She received so many letters asking for advice that she wrote a book. Johnson published *How to Hatch, Brood, Feed and Prevent Chicks from Dying in the Shell* in 1906.

In 1907, Johnson received U.S. Patent No. 894,835 for an incubator alarm. The device alerted farmers to changing temperatures within the incubator. Later, she refined her invention so the thermostat raised and lowered the wick of a heat lamp.

—by Katherine House

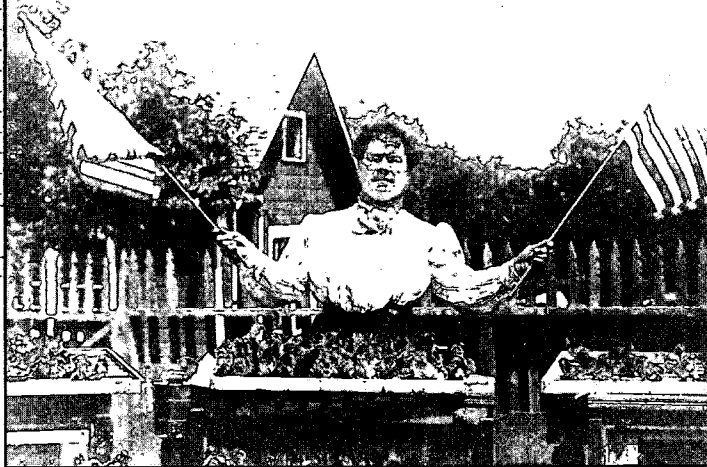

Rebecca Johnson's poultry business (and inventiveness!) supported her family PHOTO: SHSI (DES MOINES)

incubator: a container that is kept warm for hatching eggs.



Johnston's Sewing Machine Attachments

Allen Johnston sold sewing machines to earn his way through dental apprenticeship in the 1860s. He experimented with ruffler and embroidery attachments in his spare time, creating devices that would make his sewing machines better than those sold by competitors. Seamstresses used his attachments to decorate clothing and curtains with ruffles and fancy stitching popular after the Civil War. His gadgets saved hours of tedious handstitching and earned Johnston recognition as an inventor. But it was his childhood that had prepared him for his career.

Johnston grew up on a farm in Wapello County near Blakesburg. His family didn't have money for toys, so Johnston built them himself. He fashioned sleds, ice skates, wagons, and bows and arrows from materials he found around home. When Johnston needed a baseball he wound yarn in a tight ball then used squirrel skin he tanned himself for the cover. If he didn't have the tools he needed, he made them, too.

Allen Johnston's childhood prepared him for a career as an inventor.



PHOTO COURTESY: WAPELLO COUNTY HISTORICAL MUSEUM

Johnston built a machine for cracking hazelnuts (hulling them by hand was slow, hard work), turned his mother's spinning wheel into a drill to bore holes in metal and wood, then adapted the spinning wheel again for use as a lathe.

"Many a night have I sat up and sewed a ball cover together so that I could take it to school the next day," Johnston wrote. It's not surprising that this child became an inventor who received 129 patents from 1870 to 1925.

Locomotive Cow Catcher

Obstacles on railroad tracks created collision hazards for trains speeding across the countryside. James Mitchell of Osceola patented this early development in locomotive cow catchers. The device, mounted on the front of the engine, helped remove livestock or debris from the tracks without derailing the train.

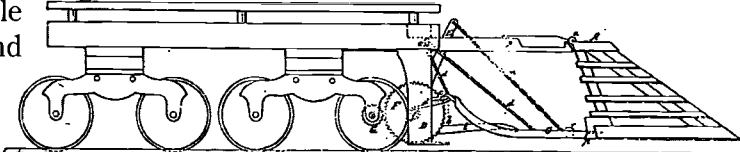

Kitchen Table

Josephine Bliss of Primghar must have been a very organized woman—or at least she wanted to be! In 1878, she was granted a patent for a kitchen table that

had a series of boxes with hinged lids, a reversible molding board for shaping pastries, sliding end pieces, and front storage drawers.

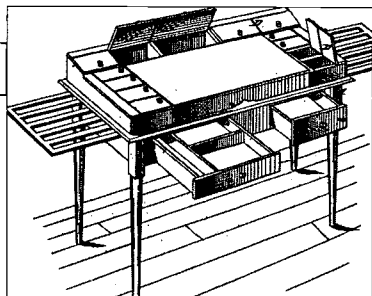

Bliss submitted this drawing with her patent application.

M

Merry-go-round

On July 25, 1871, Wilhelm Schneider of Davenport was issued a patent for his merry-go-round design. His invention attracted crowds of children but wasn't successful financially.

Schneider built a two-story merry-go-round for public demonstration shortly after receiving his patent. Kids crowded aboard. They especially loved the second-story seats!

"Within each compartment may be placed a sofa, imitation horse, or other suitable seat," Schneider wrote in his patent. A staircase led to the second level. Schneider's carousel could be pushed by hand from a platform in the upper level (an awful job!) or powered by horses. Eventually gas and steam engines were adapted to power amusement devices like Schneider's.

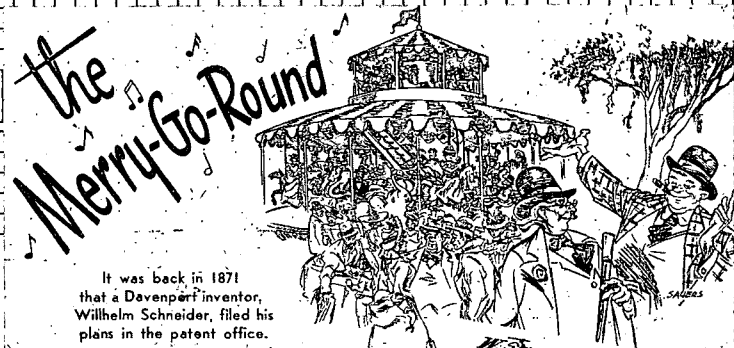

These drawings appeared in the Des Moines Morning Register on August 21, 1949, illustrating an article which described Wilhelm Schneider's invention. Schneider's patent (bottom left) was issued for an improvement in carousels.

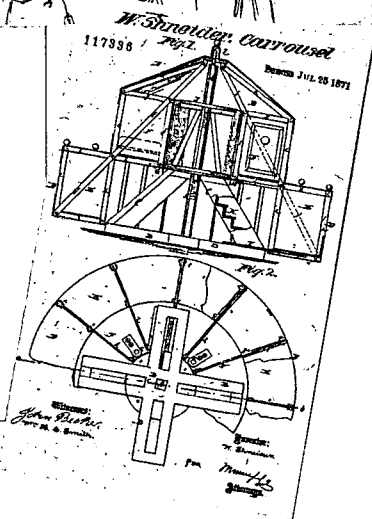

UNITED STATES PATENT OFFICE.

WILHELM SCHNEIDER, OF DAVENPORT, IOWA.

IMPROVEMENT IN CARROUSELS.

Specification forming part of Letters Patent No. 117,530, dated July 25, 1871.

To all whom it may concern,
Be it known that I, WILHELM SCHNEIDER, of Davenport, in the county of Scott and State of Iowa, have invented a new and Improved Carrousel, and I do hereby declare that the following is a full, clear, and exact description thereof, which will enable others skilled in the art to make and use the same, reference being had to the accompanying drawing forming part of this specification, in which—

Figure 1 represents a vertical central section of my improved carrousel, the lines a, Fig. 2, indicating the plane of section. Fig. 2 is a portion of an inverted plan view of the same.

Similar letters of reference indicate corresponding parts.
This invention relates to a new arrangement of "carrousel" or rotary pavilion used in public parks and other places of amusement, and has for its object to provide ample accommodation for occupants, a substantial mode of construction, and a convenient method of guiding it during motion. The invention consists in making the carrousel in two stories, and in providing a statione within the central supporting frame to enable persons to reach the second story.

In the drawing represents the stationary supporting post of my improved carrousel. It projects from an suitable cross-shaped or other base B, which sustains it in the upright position. Lines G D extend from the base B to the upper part of the post, and steady it. They also serve to hold a disk or circular platform, a, which encloses the post, as shown, and which supports platform d. D is the rotary frame of the carrousel. It is constructed of a series of upright lines e, f, horizontal beams g, h, inclined rods j, j, and roof timbers k, all disposed substantially

Fig. 1, to constitute two stories, under a single roof. The lower level or tier B extends to the height of the

platform a. Its inner diameter is equal to the outer diameter of the upper chamber or story F, whose lower is in line with and its ceiling in line with the platform d. The center of the roof, considered as an inverted zedder, l, which the small upper end of the post enters, as shown. G G are friction-suffers, applied to the floor of the chamber B, and working against the edge of the platform c, to steady the carrousel in its rotation.

The persons or occupants for turning the carrousel are placed upon the platform d and rotate the outer case B. Radial partitions may be arranged within the inner chambers to divide the same into series of small apartments. Within each compartment may be placed a sofa, imitation horse, or other suitable seat. Entrances H H are built along the braces O of the stationary support to enable persons to enter and leave the upper story. K is a ball, applied to the base B, to lock into an eye or staple at the bottom of the carrousel, to prevent rotation of the same whenever it is desired to leave it at rest. The interior of each apartment may be furnished and embellished in suitable manner, and also the outside of the carrousel.

Having thus described my invention, I claim as new and desire to secure by Letters Patent—

1. The carrousel, made in two stories, E and F, the lower embracing the upper, as specified.

2. The abutments H, applied to the stationary frame of the two-story carrousel, substantially as and for the purpose herein shown, and described.

3. The post A, provided with the platform a and staircase B, to constitute the support of a carrousel, in the manner described.

WILHELM SCHNEIDER.

Witnesses:
J. W. WYER,
F. H. HARRIS.

N

Nylon

Dr. Wallace Hume Carothers was born in Burlington on April 27, 1898. He died April 29, 1937—just 20 days after applying for Patent 2,130,948 covering the production of nylon yarn.

Carothers taught at the University of Illinois and at Harvard before joining the DuPont Company in 1928. He researched polymers (long chain molecules) and contributed to work on synthetic rubber. In 1937, Carothers patented the material that would become known as nylon and different methods for creating it. Carothers died before the new material was named.

Nylon hosiery first went on sale in May 1940. Today nylon is used in many more products.

Can you name some nylon products you use?

Obstacles

Inventors face many obstacles along the road of discovery. Sometimes their ideas are ahead of their time and no one will listen. Or worse, everyone laughs.

Sometimes it's hard to turn a good idea into something that really works. Often inventors have to fight court battles to protect their creations. Inventors are people who overcome obstacles.

George Washington Carver knew all about obstacles. You may know that he developed 300 uses for peanuts and that his innovations revitalized the dying agricultural industry of the South. But did you know he was born a slave?

George was an infant when he and his mother were kidnapped near the end of the Civil War. His mother was never found, but a rescue party exchanged him for a racehorse owned by Moses Carver. Moses and his wife raised George (who adopted the Carver's last name). They taught him to read and write and later sent him to school. He earned a college scholarship—but when he arrived on campus, he was denied admission because his skin was black.

Carver was discouraged, but he didn't give up. He worked and saved money for his education. In 1890, Simpson College in Indianola welcomed Carver. The following year he transferred to what is now Iowa State University to pursue an education in science. He earned an undergraduate degree in 1894 and was appointed to the faculty to teach agriculture and botany while studying for a master's degree, which he received in 1896.

Carver left Iowa State to head the agriculture department at Tuskegee Institute in Alabama, where he conducted the plant research that made him famous.

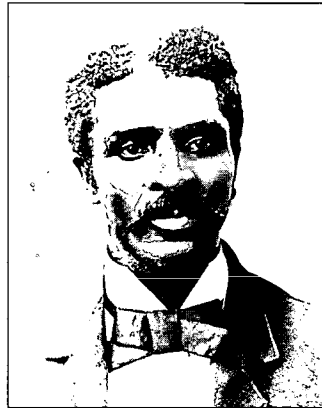

George Washington Carver

PHOTO COURTESY: IOWA STATE UNIVERSITY



Power Lift

The Goldfinch asked Jean Strong, who grew up on a farm near Marion in the 1930s, to recall the invention with the greatest impact on her childhood. Here's what she said:

The power lift on our tractor was the most memorable invention of my young life. The farm where I grew up, one mile from Marion, had electricity long before most Iowa farms. But the power lift became popular during my 1930s childhood and was a marvel.

The power lift empowered me—a mere child and a girl at that—to cultivate corn, two rows at a time, when I was 12.

Before this advance in farm machinery, my father used a single-row, two-wheel cultivator drawn by a team of horses. My legs and arms were not strong enough to push the plow shares into the ground on either side of a corn row and, at the same time, guide the team across the field like my father did.

Our two-row corn cultivator was attached to a Case tractor, and could be lowered into the soil at one end of the corn rows and pulled back up at the other end. This marvelous feat was activated

by Jean Strong

by the touch of a boot heel to the power-lift button, located beneath the operator's seat, while steering the tractor. I was able to help my father "lay by" (cultivate) our corn acres during the growing season. Weather permitting, we hoped to defeat the weeds and see knee-high corn by the Fourth of July.

With the tractor's hydraulic device, farmers completed heavy work with speed and ease. Unlike horses, the tractor did not get tired nor need frequent rest stops.

Like many farming implements, the device had its down side. Power lifts could be dangerous. Before protective power-drive guards were installed, many children were maimed or killed when clothing caught in the mechanism.

Tractors in those days did not have cabs to protect the operator from the scorching sun. My dad, who once suffered heat stroke in the barn hayloft during haying season, created his own shade. He attached a frame of wood to the fenders, then nailed burlap to the frame. Dad pioneered his "invention" long before air-conditioned cabs became options.



Jean, Doris, George, and Eileen Strong with their pony, Lady. Jean was 11 years old when this photo was taken on their farm near Marion in 1936.

Quest

Q

Q is for the QUEST that challenges inventive minds to do things in a new way or to improve current methods for getting things done. According to Allen B. Sharp,

“There are plenty of things left to invent. We just haven't thought of them yet.”

Sharp is co-founder of Al-jon, an Ottumwa company that produces car-crushing and recycling equipment. He is also the great-grandson of another famous Ottumwa inventor: Allen Johnston.

Rice Krispies Treats™

R

Maybe you don't recognize the name Mildred Day. But you've probably tasted her invention. Day developed Rice Krispies™ bars in the late 1920s as a fund-raiser for a Campfire Girls group. Kids of all ages still enjoy the gooey blend of cereal, marshmallows, and butter she created.

Born in Marion County, Day was a 1928 graduate of Iowa State University in Ames. She worked at Kellogg Co. in Battle Creek, Michigan. Rice Krispies™ cereal went on the market in 1928, but Rice Krispies Treats™ weren't introduced to the public until the 1940s. The recipe first appeared on cereal boxes in 1941. Today, you can make them yourself—or buy them prepackaged.



Soy Ink

In 1988, artist Sharen Brower of Newell was experimenting in her studio. She tested a new type of ink made from soybean oil. Unfortunately, this ink did not dry at all and was hard to clean up. Next, Brower visited scientists at Iowa State University and other labs. After more experimentation, she created a formula for faster drying soy ink. Brower liked using this ink because farmers grow soy beans throughout Iowa.

After some publicity, Brower received phone calls from printers wanting to know more about her discovery. "As an artist, I didn't intend to invent anything," she said. "I think that's how inventions happen out of necessity. I was trying to do something different." She talked to officials of a large ink company about producing her invention, but they were not interested.



Sharen Brower

In 1991, Brower obtained patents for formulas for soy newspaper ink, artist's ink, paint, and other products. Later, she learned the ink company that hadn't been interested in her invention was selling a product a lot like hers. The company told her they wanted to negotiate a licensing agreement so they could continue to manufacture the ink. When they couldn't reach an agreement, the company sued Brower claiming her patent was invalid.

Brower fought back. The lawsuit took so much of her time that she closed her studio in 1993. Finally, in 1997, the lawsuit was settled out of court. Brower cannot discuss how much money she received from the ink company, but she is "very happy with the settlement." She now lives on a ranch in Wyoming with her family and has resumed painting.

Your local newspaper might be printed with soy ink. Many printers place a special seal on their products to show readers that they use soy ink. The SoySeal is available from the National Soy Ink Information Center in Urbandale. Soy inks are better for the environment than petroleum-based inks because they have fewer volatile organic compounds which react with other pollutants to form smog. Also, experts say it's easier to remove soy inks from paper when recycling.

I Trampoline

Cedar Rapids native George F. Nissen loved to bounce. And he knew that most kids do, too. As a kid, Nissen's heroes were circus acrobats. As a college student in the 1930s, Nissen was a national intercollegiate tumbling cham-

pion. Nissen invented the modern trampoline, building his first model in 1931. By 1940, he produced trampolines full-time at his home. The business grew, and Nissen moved production to a Cedar Rapids factory site in 1947. Nissen sold his trampoline manu-

facturing business to a New Jersey company in 1981.

In the mid-1980s, Nissen formed a research firm to develop athletic products. In 1991, at age 76, Nissen was back in the business of inventing with new developments in bleacher seating.

-by Katherine House

PHOTO COURTESY: THE STORM LAKE TIMES



Under the Weather

Sometimes ideas for inventions splash down with the rain. Just ask Maggie Boyd, 12, of Burlington. As a sixth-grader at Oak Street Middle School, Maggie demonstrated the Rain Rider Helmet for Invention Convention judges on March 12, 1998. Weather was her inspiration—she came up with the idea while riding her bicycle and trying to hold an umbrella at the same time.



Maggie Boyd

PHOTO: JOHN LOVRETTA/BURLINGTON HAWKEYE

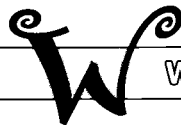

Washing Machine

Washing clothes used to be back-breaking work. Water had to be hauled in buckets and heated. Then clothes were rubbed against a washboard by hand, rinsed in a tub of clean water, and hung out to dry.

By 1873, more than 2,000 patents had been granted for machines to lighten the burden on wash day. One of those patents

Smithland. Would you have recognized this contraption as a washing machine?

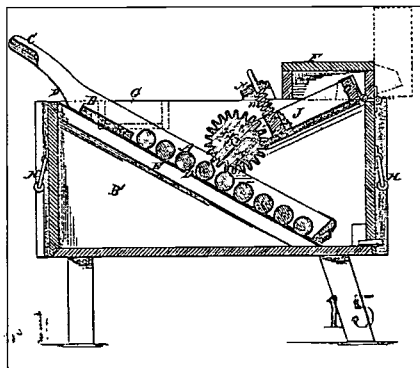

Vending Machine

Need a snack? Plug some change into a vending machine and you'll be using an Iowa inventor's creation.

In 1931, F. A. Wittern invested his last \$12.50 to buy some used tools and start a company that became one of the nation's biggest vending machine manufacturers. Today, Fawn Engineering Co. is located in Clive.

Wittern was always good at turning ideas into mechanical models. He was 16 when, during World War I, he came up with the idea of magnetic mines. Impressed with Wittern's ideas, President Woodrow Wilson offered the young inventor a position in the War Department's experimental division.

Wittern held 30 patents by the time he opened his business in a Des Moines garage in 1931. The first machine his company produced was a coin-operated baseball game. Wittern always looked for new and better ways to build his machines. Soon Fawn Engineering earned the reputation for producing the best designed machines available.

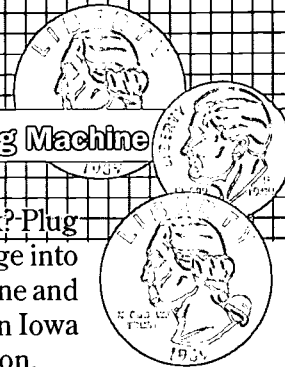

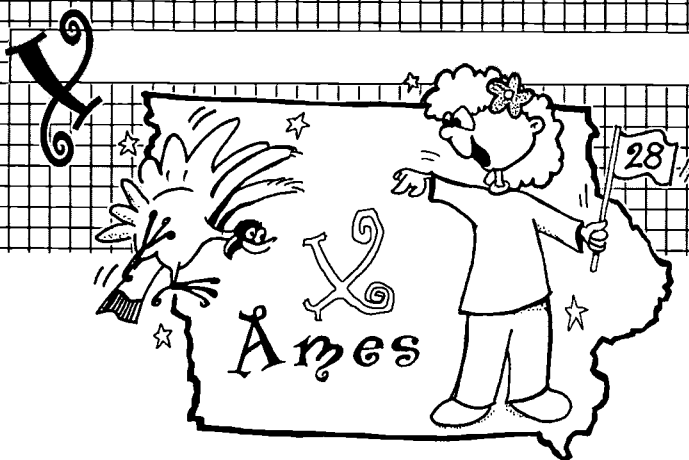

“X” marks the spot where Professor John Vincent Atanasoff developed the first digital computer in the 1930s while teaching at Iowa State University. Read “The Dream Computer” beginning on page 28 to learn more about his invention!

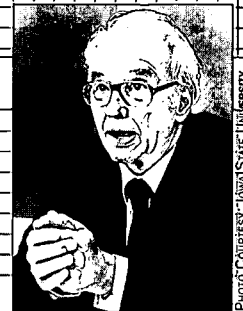

PHOTO COURTESY IOWA STATE UNIVERSITY

Y Young Inventors!

Alexia Abernathy of Cedar Rapids was 14 years old when she was among the first inventors chosen for the National Gallery for America’s Young Inventors in 1996.

Her invention, the Oops! Proof No-spill Feeding Bowl, began as a project for *Invent, Iowa!* when she was a fifth-grader at Johnson Elementary School in Cedar Rapids.

The Oops! Proof bowl has an 8-oz. inner bowl which fits into a 16-oz. outer bowl. A rim fits over the outer bowl, directing potential spills into it. She got the idea while watching a 2-year-old who often spilled his cereal.

Alexia convinced Little Kids, Inc., of East Providence, Rhode Island, that her invention was a marketable idea. Little Kids produced the bowl from 1994 to 1998. “They just took it out of production,”

Alexia explained, “when the company went to all toys.” The license to produce the Oops! Proof bowl will return to Alexia. But she’s headed for college in the fall and hasn’t decided whether or not she’ll try to find another company to manufacture her invention.

“When I invented (the Oops! Proof bowl), it wasn’t to market and make money from it. It was for fun,” Alexia said.

Alexia Abernathy in 1994



Z
Z is for zillions of Iowa ideas, inventors, and inventions throughout history—and even more to

e. Want to know more? *Keep Reading!*

Patent *That!*

by Brian Page

Sixty thousand. That's about how many Iowans have received patents for their inventions since 1836. For the nation as a whole, the number of patents granted stands at about six million and counting!

The United States began issuing patents in 1790 under the direction of Thomas Jefferson, then Secretary of State. In 1836, Congress revised the patent application process and established the U.S. Patent and Trademark Office (PTO) to administer the new system. The main type of patent issued by the PTO is a utility patent. Utility patents are granted to persons who invent new industrial processes (that is, new ways of making things, new machines, new manufactured items, or new chemical compositions). To be patented, such inventions must also be useful—they must actually work! One cannot receive a patent on merely a good idea.

A patent application involves several parts. An inventor must:

- submit a written document describing the invention in detail along with a claim for why it is new and distinct,

- make an oath as to the truthfulness and accuracy of all statements made in the application,
- provide drawings of the invention, and
- pay filing-related fees ranging from a few hundred to a thousand dollars.

Many inventors hire specialized patent agents or attorneys to search patent records and prepare documents for filing with the PTO. It takes the PTO about a year to examine the patent application and make a decision.

Ever heard the term “patent pending?” It indicates that an inventor or company has an application on file with the PTO and is waiting for a decision to be made. Patents are granted to about two out of every three applicants. Once an invention is patented, inventors must pay additional periodic maintenance fees amounting to several thousand dollars over the life of the patent.

Obtaining a patent gives an inventor the right to exclude others from making, using, or selling the invention in the United States for 17 years from the date

of application. These rights allow inventors to profit from their inventions, either by putting them to use themselves or by selling their patents to others. In return, inventors are required to disclose their inventions so that society may benefit through other inventors' attempts to improve upon or design around the inventions.

It is important to remember, however, that a patent does not guarantee the commercial success of an invention. There are over 130,000 patents issued every year. Many of the new inventions never make enough money to cover the costs of applying for patents! It is also important to remember that revolutionary inventions are extremely rare. In fact, most patents are issued for very small improvements to existing technologies. Economically successful inventions like automobiles or computers, for example, were not patented in their entirety. Such technologies seldom emerge fully developed from the mind of a single inventor at a single point in time. Instead, they are built up gradually from a broad range of smaller inventions coming from hundreds, even thousands, of creative people. 

Inventor's Crossword Puzzle

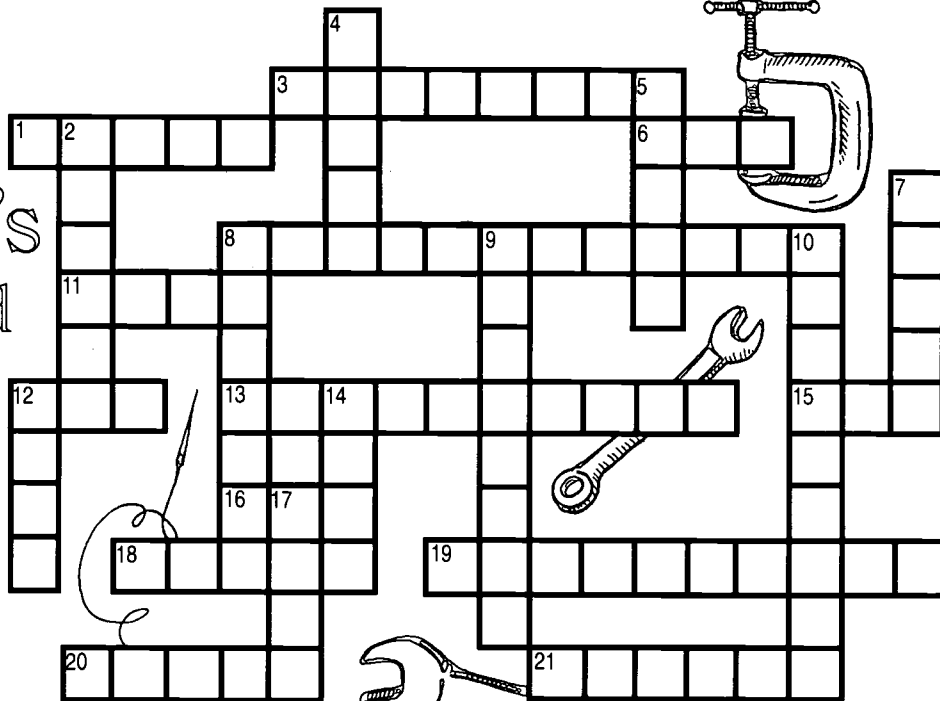
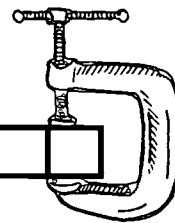
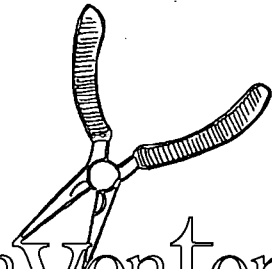
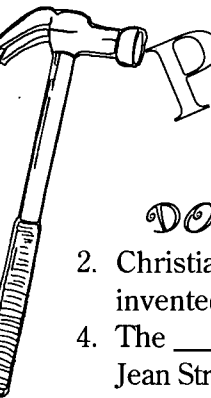

DOWN

2. Christian Nelson invented the ____ pie.
4. The ____ lift empowered Jean Strong to cultivate corn.
5. The man who invented ____ died before he could name his discovery.
7. Get a ____ from F.A. Wittern's invention.
8. Charles A. Robbins invented a better ____.
9. John Froelich built the first ____ tractor.
10. Hiatt's apple.
12. Phebe R. Lamborn patented a fly-screen attachment for this.
14. Patrick Lawler invented a machine to pick this crop.
17. Invent, ____! is a contest for creative kids.

ACROSS

1. E.F. Lindquist invented the Iowa ____ of Basic Skills.
3. Walter Sheaffer patented a lever-fill ____ pen.
6. The next great Iowa inventor could be ____!
8. Wilhelm Schneider was issued an early patent for a ____.
11. Inventions often start with one person's ____.
12. Thank Ray Townsend next time you eat a hot ____!
13. Patent 18,348 went to James Mitchell for the ____ cow catcher.
15. Sharen Brower patented a formula for soy ____.
16. August Werner's flying machine was heavier than ____.
18. One of the toys Allen Johnston built for himself as a kid.
19. Rebecca Johnson tinkered with ____.
20. Iowa town with a famous ice cream shop.
21. Mildred Day invented the recipe for Rice Krispies ____.

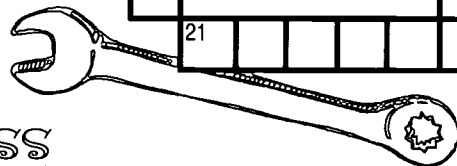
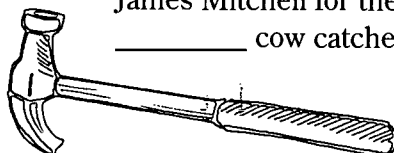

History

Mystery!

-by Diane Nelson

More than 50 Iowa women received patents in the 1800s. Can you match the women listed with their inventions?

- | | |
|-----------------------------------|---|
| Lucinda Humphrey, Tipton | <input type="checkbox"/> Attachment for pants (1881) |
| Matilda Fletcher, Des Moines | <input type="checkbox"/> Fly-screen-door attachment (1884) |
| Annis Hurd, Waterloo | <input type="checkbox"/> Clothes drainer (1891) |
| Mary R. Barhydt, Burlington | <input type="checkbox"/> Milk-can elevator (1884) |
| May A. Start, Cherokee | <input type="checkbox"/> Portable trunk (1874) |
| Viola J. Augir, Spencer | <input type="checkbox"/> Toasting device for stoves (1891) |
| Phebe R. Lamborn, West Liberty | <input type="checkbox"/> Road cart (1891) |
| Mary Couplin, Thornburg | <input type="checkbox"/> Bunk for railway cars (1887) |
| Mary E. Tisdale, Cedar Rapids | <input type="checkbox"/> Hair-puffing pins (1876) |
| Louisa J. Schelley, Keokuk | <input type="checkbox"/> Band-cutter and feeder (1893) |
| Dora Mitchell, Ottumwa | <input type="checkbox"/> Skirt protector (1862) |
| Cornelia C. Wood, Sibley | <input type="checkbox"/> Egg-boiler and caster (1885) |
| Ida Smith, West Union | <input type="checkbox"/> Apparatus for cooking, broiling, baking, etc. (1894) |
| Anna L. Eversmeyer, La Porte City | <input type="checkbox"/> Chart for drafting garments (1882) |
| Annie R. Chittenden, Osceola | <input type="checkbox"/> Plow (1891) |
| Elma M. Mitchell, Salem | <input type="checkbox"/> Guard for bedsteads (1885) |
| Nell O. Westberg, Sanborn | <input type="checkbox"/> Vegetable-slicing machine (1894) |
| Annie C. Cook, Council Bluffs | <input type="checkbox"/> Album for photographs (1883) |
| Margaret E. Jehu, Estherville | <input type="checkbox"/> Picture-hanger (1886) |

Need help?
Turn the page!

History Mystery!

Iowa women mixed creativity and imagination with the desire to solve problems and make life easier in the 1800s. Their efforts often produced useful inventions—and more than 50 patents. One example:

Mary Potts was a 20-year-old homemaker in Ottumwa in 1871 when she made a difficult chore easier for herself—and women around the world—by improving the sadiron.

Before Potts' invention, the entire sadiron, including the attached metal handle, was heated on a stove. Women used pot holders to keep from burning their hands as they ironed. Potts designed a wooden handle that detached while the iron heated on the stove, keeping the handle (and her fingers!) cool. Her invention, available through the Sears, Roebuck & Co. catalog, remained popular until electric irons became popular in the early 1900s.

MRS. POTTS' SAD IRONS With Forged Stretcher Handle.

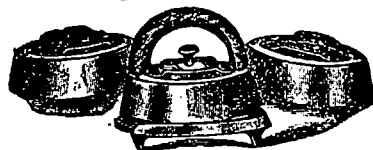

The only Potts' sads having forged stretcher handle. Admitted by all to be the best sad iron made. Set consists of one iron with rounded end, weight 4 pounds; two with regular ends, one weighs 5½ pounds and one 5½ pounds; one detachable wood handle with forged stretcher. This handle will not break if you happen to drop it on the floor; one iron stand.

No. 23R345 The original genuine Mrs. Pott's Sad Iron, in sets of three, with detachable wood handle, having forged stretcher as described above and iron stand, finely polished. Price, per set..... 67c

No. 23R346 Set of three genuine Mrs. Potts' Sads, as above, finely polished and nickel plated. Price, per set..... 73c

No. 23R350 Extra handle with forged stretcher, won't break, if you happen to drop it on the floor. Price, each..... 15c

No. 23R353 Extra handle with cast stretcher. Price, each..... 5c

If by mail, postage extra, 10 cents.

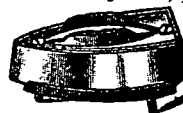

No. 23R360 Mrs. Potts' Solid Sad Iron, nickel plated without handle. Handle No. 23R350 or 23R353 fits this iron.

Weight, lbs....	4	5	6	7	8	9	10
Price, each....	18c	23c	27c	32c	36c	41c	45c

This ad for Mrs. Potts' sadirons appeared in the 1902 Sears, Roebuck & Co. catalog.

Now back to the History Mystery: Case Solved!

Lucinda Humphrey (Tipton) may have been the first Iowa woman to receive a patent. Her *skirt protector* was registered in April 1862.

We don't know if Matilda Fletcher (Des Moines) liked to travel, but we do know she received a patent for a *portable trunk* in 1874.

Women in the 1870s didn't have electric hair-puffing gadgets. Perhaps

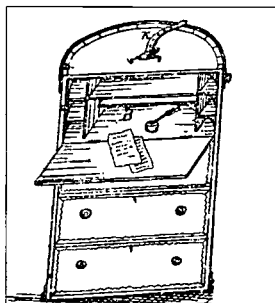

portable trunk

some of them used the *hair-puffing pins* patented by Annis Hurd (Waterloo) in 1876.

No doubt many women devised new methods for their sewing tasks. Mary R. Barhydt (Burlington) combined elastic strips and buttonholes in what she called an *attachment for pants*. It received a patent in 1881. May A. Start (Cherokee) patented her *chart for drafting ladies' and children's clothes* in 1882.

As photography became more popular, people looked for creative ways to display their photos.



hair-puffing pins

Viola J. Augir (Spencer) patented her *photograph album* five years before George Eastman introduced his simple box camera. Metal clips held the photos in place.

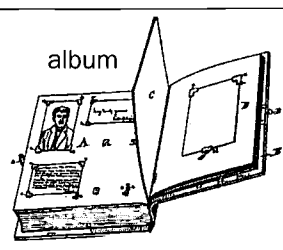

Phebe R. Lamborn (West Liberty) didn't want the flies and other insects that sat on her door to come inside when the door was opened. Her *fly-screen-door attachment* received a patent in 1884.

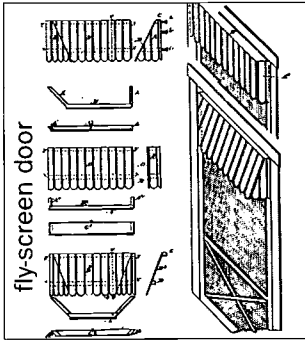

When **Mary Couplin** (Thornburg) patented her *milk-can elevator* she included a six-step description of how the rollers, pivot arm, and shaft worked.

Mary E. Tisdale (Cedar Rapids) patented an *egg boiler and caster* in 1885. A handle on the central stem allowed the two rings fitted with egg-holding cups to be lowered into and then raised from a kettle of boiling water.

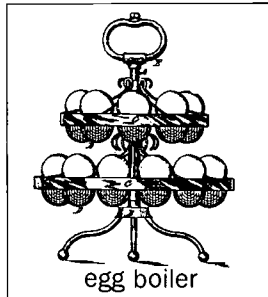

To avoid falling out of bed, you might want to try the *guard for bedsteads* patented by **Louisa J. Schelley** (Keokuk) in 1885.

If you've ever struggled to reach the nail when hanging a picture, you might appreciate the *picture-hanger* patented by **Dora Mitchell** (Ottumwa) in 1886.

Only 17 years after the first settlers reached her county, **Cornelia C. Wood** (Sibley) registered her patent for a *bunk for railway cars*.

Decades before electric toasters became available, **Ida Smith** (West Union) received a patent for

her *cooking, toasting, and shielding device for stoves*. It had an adjustable toasting rack and a removable shielding plate.

To make it easier to remove clothes from the wash water, **Anna L. Eversmeyer** (La Porte City) patented a *clothes drainer* in 1891. The lidded vessel had holes in the sides, handles, and a removable support system.

Many people experimented with different types and shapes of *plows*. In the early 1890s, **Elma M. and John E. Mitchell** (Salem) patented at least four. The first, in 1891, had a series of parallel curved bars with disconnected lower points.

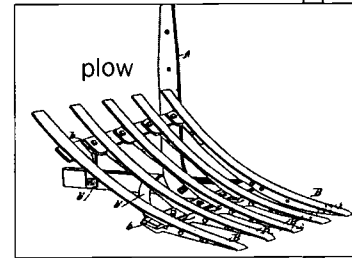

Later that year, **Annie R. Chittenden** (Osceola) received a patent for a *road cart* in which the seat and footbox were connected to a spring.

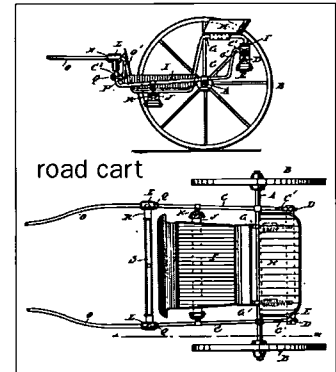

Trying to find an easier way to do a routine task, **Nell O. Westberg** (Sanborn) devised a complicated-looking *band-cutter and feeder* intended for use with a threshing machine.

Margaret E. Jehu (Estherville) received a patent for her *apparatus for cooking, broiling, baking, etc.* The separable parts included two hot air chambers with open tops and bottoms, a deflector, a griddle, a broiler, and a lid.

In 1894, **Annie C. Cook** (Council Bluffs) received a patent for a *vegetable-slicing machine* that used a rotary platform and a disk carrying radial cutters attached to a shaft with a handle.

Write Women Back into History

Melinda Padley won first place in the Women in Science and Engineering category of the 1998 Write Women Back into History Contest with this essay about her innovative great-great-aunt.

Gertrude Sunderlin, my great-great-aunt, was born in Delmar, Iowa, on August 27, 1884.

She started school in 1899 and graduated in 1913 as valedictorian of Ames High School. After that, she entered Iowa State University. In college she belonged to Kappa Delta, the literary society, and was in a play, too. Before she graduated from ISU she taught in Marathon, Iowa, and West Branch. In 1919, she graduated from ISU, where she was the honor student of the College of Home Economics.

Gertrude received free tuition to go to any Iowa college as a prize for being Ames High School Valedictorian. Money was always a problem in her family, and she was very generous with the money she made from teaching. She even helped put her two sisters through college. Later, it is believed by the family, she provided funds anonymously for Gertrude Mae (her niece and my grandmother) to go to Iowa Wesleyan College when Gertrude Mae's Purdue scholarship was lost due to illness.

In 1921, she went to a Garrett Theological Institute, but she got ill and couldn't continue her studies there. After recovering, she taught at a college in Brookings, South Dakota. In 1926, she got a Master of Science degree in household bacteriology from ISU. Then in 1928, she became the first woman to receive a Ph.D. in bacteriology and food and nutrition from the College of Home Economics at ISU. While getting her Ph.D., she received funding from the Ball Fruit Jar Company.

After that she taught at Louisiana State University from 1928 to 1931. In 1931, she went to teach at the Purdue College of Home Economics. She taught and experimented with foods while she was there.

In 1948, she and one of her students invented



Melinda Padley, 14, is a student at Linn-Mar High School in Marion. Her English teacher, Susan Huffman (left), and State Representative Rosemary Thomson (center) were with Melinda when she received her award from Governor Branstad.

Master Mix. This was the first mix of this kind (it is a lot like Bisquick now). Her students and she published 1,500 copies of the Master Mix book and traveled around the world distributing the books and food made from Master Mix. This mix was the forerunner for all mixes. She didn't want to patent this idea, so Purdue University sold it to different food companies.

After the Master Mix, she worked on recipes for freezing jams, jellies, batters, and dough. In 1958, she was given the Centennial Citation from the Alumni Association of ISU. One of her students invented Stove Top Stuffing.

Gertrude was a master weaver, an excellent bridge player and enjoyed gardening. She was very active after retiring in 1954 and moved to Iowa City, quietly helping some young people financially through college.



Nicholas Schrunk: Kid Inventor



Nicholas Schrunk, 13, of Spirit Lake described his inventive interests for *The Goldfinch*.

I got interested in inventing because of a guinea pig named Freckles.

It all started during first grade when a teacher announced the *Invent, Iowa!* competition. My parents said they would help me if I came up with an idea. I knew that all inventors start out with a problem to solve. My first step, then, was to come up with a problem.

My guinea pig, Freckles, needed exercise. But my mom didn't like the idea of Freckles running all over our house. I used a construction set that included motors, gears, and batteries to invent a solution. After working out balance problems and adding new features (such as my mom's kitchen timer), I came up with my first invention: the Motorized Guinea Pig Walker. The battery-operated machine rolled across the kitchen floor. Lettuce (his favorite food) on a hook lured Freckles to follow. I prepared a poster, practiced my oral presentation, and entered the local *Invent, Iowa!* contest. I advanced to state competition with my Motorized Guinea Pig Walker and won! I received an honorary patent, signed by the governor, and a \$500 savings bond. That was great!



Nicholas and Freckles

Some of my friends ask me how I come up with so many ideas. For me it's always easiest when I can just identify an everyday problem and just go from there. I add to or modify my ideas until I'm satisfied. I keep a detailed notebook as I go along. I like to build my inventions, but often I sketch and label them as I think of new things. For the *Invent, Iowa!* competition, it is important to be able to present your invention well—that's part of the judging. I role-play my presentations with my dad or mom before the competition. I always try to shake the judge's hand, speak clearly, and be organized. Prior to judging, I always take my inventions around to businesses and get opinions about whether or not my ideas would sell. I include that information in my presentation.

Support from my family helps a lot. My dad is always willing to help me build my inventions. My mom helps me with materials for making posters. My whole family (my three sisters are inventors, too) bounces ideas off each other when we're in the car or eating dinner together.

For anyone even a little bit interested in inventing, I would strongly encourage you to try. It can be a lot of fun!



Read more about *Invent, Iowa!* on page 26!

WALTER SHEAFFER'S PEN HISTORY

Ft. Madison Inventor "Pens" History

Walter Sheaffer didn't like the messy job of refilling fountain pens. It took a steady hand and either an eye dropper or a coin pressed into a slot in the barrel to add ink to most fountain pens of the day. There had to be a simple, clean solution to this inky dilemma. Sheaffer was determined to find it.

While flipping through a newspaper one evening in 1907, Sheaffer got an idea for a new kind of pen. Working in the back room of his Fort Madison jewelry store, he invented a lever mechanism that fit smoothly into the pen's barrel. A single stroke of this slim, metal lever filled the pen's internal reservoir with ink directly from the bottle. No more eyedroppers or coins!

Sheaffer worked on a model of the first practical self-filling fountain pen, and on August 25, 1908, he obtained U.S. Patent No. 896,861 for his revolutionary design.

His instinct and experience as a salesman convinced Sheaffer that he had a great idea. He assembled extra models of an improved design, patented in 1912, and had friends try them out. They loved the pens—but advised him against going into the pen business.

Why take a chance on losing everything? they cautioned. Sheaffer was 45 years old and supported his family through a successful jewelry business. He'd have to risk his business and borrow money to compete with at least 58 companies already in the field. If his pen company failed, he'd lose everything.

In the spring of 1912, the jewelry store workshop became a pen factory. Seven employees, including Sheaffer's son, Craig, crowded inside to fashion the first Sheaffer pens.

Sheaffer's company fought life-and-death legal battles to protect his patents and product designs. The company survived the Great Depression and World Wars (Craig shifted manufacturing from pens to military supplies during World War II). When Sheaffer died in 1946, his pens were in the hands of people around the world.

Control of Sheaffer Pen stayed in Fort Madison until the company was sold in 1966. Sales declined in the 1960s as consumers chose cheap, disposable pens over more expensive Sheaffer designs. The company struggled financially while it continued producing top-



Unless it's SHEAFFERS it isn't a Lifetime* - know the Pen by the White Dot

This ad appeared in *The Saturday Evening Post* on August 24, 1940.

Sheaffer Pen

- 1913:
- Owner:** Walter A. Sheaffer
- Factory:** 10' x 14' workshop in the back of Sheaffer's Fort Madison jewelry store.
- Employees:** 7
- Sales:** \$100,000

Did you know? Sheaffer workers produced 8,890,000 writing instruments in 1997!

of-the-line products, but slowed in introducing new items.

The Goldfinch visited Sheaffer Pen in the midst of a \$5 million renovation by the company's new owners—Bic Corporation.

"Our product line did not change much for many years," said Owen Jones, Sheaffer's chief executive officer. "Now we have introduced new designs, and more new products are being developed."

The company's New Product Development Group is back in the business of invention. Employees from production lines help identify problems, generate solutions and develop new products and ideas. Customers also share their ideas for new products.

In addition to Sheaffer's more expensive models, the company is producing more pens priced from \$2.50 to \$10, including inexpensive pens for kids. Some come in fluorescent colors, and others, like the *School™* pen, are clear so you can see how they work without taking them apart!

Today, almost all Sheaffer pens are produced in Fort Madison, then distributed to more than 150 countries. Company headquarters returned to Fort Madison in 1990, where it all began with Walter Sheaffer's big idea. 



Walter A. Sheaffer

Born: July 27, 1867 in Bloomfield to Jacob Royer and Anna Eliza (Walton) Sheaffer.

Siblings: 4

Died: 1946

Occupations: jeweler, salesman

(he sold pianos, organs and sewing machines in addition to watches and jewelry), farmer, chicken breeder, inventor and entrepreneur.

As a kid: Sheaffer went to work when he was 11 to help support his family. He worked as a printer's devil (a helper who often did the messy work!) for \$1 a week then for a local grocer for \$7.20 a month. He dropped out of high school to work in a jewelry store in Centerville, earning \$15 per month plus meals and a place to stay. Sheaffer's bed was on a shelf under a counter in the store, so he doubled as the store's night watchman!

Corp. at a glance

1998:

Owner: Bic Corp. acquired Sheaffer in 1997

Factory: 259,000 square feet, located at 301 Avenue H, Fort Madison.

Employees: 450

Sales: more than \$50 million

Expensive pen: \$5,200

Inexpensive pen: \$2.49

ERIC
Full Text Provided by ERIC



Top Secret:

Sheaffer's **Gold Melter** has been preparing their secret 14- and 18-karat gold alloys for 20 of his 35 years with the company. He is one of only six people in Sheaffer's history who have melted and poured gold for fountain pens and pen nibs. Skilled workers perform more than 300 steps to create each Sheaffer fountain pen.

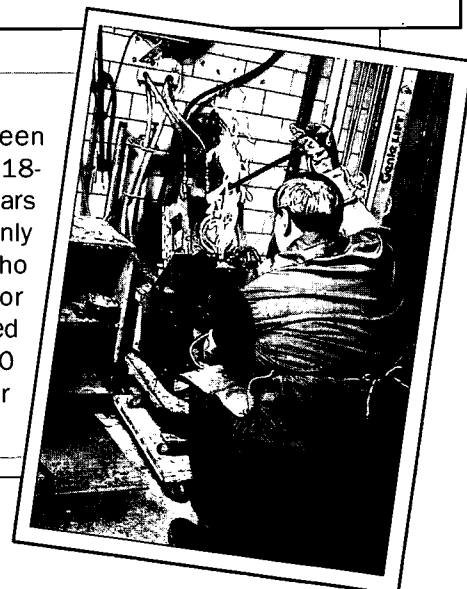

Dear Diary...

*M*ary Eleanor Armstrong was 16 years old when she started keeping a diary. "I thought I would keep memoranda of my doings," says her first entry, dated October 19, 1891. She described daily life in rural Jones County, where she cooked, sewed, raised chickens, picked and husked corn by hand, and attended church, school, and dances. She records births, deaths, her marriage to Claude Peet, and stories of their family in notebooks and tablets (with a few interruptions) until 1961.

Mary wasn't an inventor, but she wrote about inventions. Read her diary to find out how one innovation—the telephone—changed her life!

Sunday, Aug. 19th, 1900
Our phones have come.

Monday, Aug. 20th, 1900
Picked two pails full tomatoes. Canned 4 qts. Terrible warm & I worked hard all day. Roy Peet called this morning.

Wed, Aug. 22nd, 1900
About 1 o'clock the telephone men ... came and put in our phone & let in a handful of flies... The phone is "just all right." Claude talked to Harry awhile and I talked to Katie. We listened awhile in the eve. Heard Drummont's clock strike 8 o'clock and heard music.

Thursday, Aug. 23rd, 1900
I have got over being afraid of

talking at the phone. A good many rung up our phone this a.m. but couldn't hear us for someone else would talk too. We could hear them telling each other how they had tried to get us but failed. At last Mrs. Roy Peet telephoned to me and we talked. They wanted her to let us know that Matt would thresh at Kohl's ... & someone else clicked in and began to call Mary! Mary! Oh, Mary!

I washed this forenoon, the biggest washing I have had. My lines all full & some on the fence & grass. Mrs. Roy came running down ... to tell me that some woman at Martelle wanted to talk to me & as I was out doors & in the wood house I couldn't hear the ring. So I went

& rung up Willis. He had heard someone ringing for me but didn't know who it was.

Friday, Oct. 19th, 1900
Listened to the phone awhile. Played I was central. I talked with Lizzie this p.m. Mixed bread at night.

Friday, Nov. 23rd, 1900
I am 25 years old today. Ironed and worked a cross-stitch. Claude finished picking corn. I baked a cake. Cora telephoned to me.

January 3, 1901
Something wrong with this telephone line. The bells won't all ring.



Mary (Armstrong) and Claude Peet,
December 22, 1915

Be a diary detective!

by Millie Frese

Mary (Armstrong) Peet's diary often names people who called or whom she called—even before her August 22, 1900, entry noting their phone had been installed. It's just one of the mysteries Mary's diary raises for *Goldfinch* diary detectives! Read these entries from Mary's "memoranda" again, then see if you can answer the following questions!

1. How did people *call* before they had telephones?

(Here's a hint from another entry:

Saturday, August 25, 1900...Ma, Eve and Lorene came up for a call after supper.

Does a different wording help you figure it out?)

2. Have you ever lived without a telephone? Now, imagine having a phone in your home for the first time. Would you be afraid of it? Why do you think Mary was afraid at first?

3. Why could Mary hear other people talking on the line during phone conversations?

4. List some of the new uses of words that the telephone added to Mary's vocabulary. Are they words that you still use when talking about telephones?

5. What did Mary mean when she wrote about "listening" to the phone? To learn more about party lines, ask a grandparent or older friend!

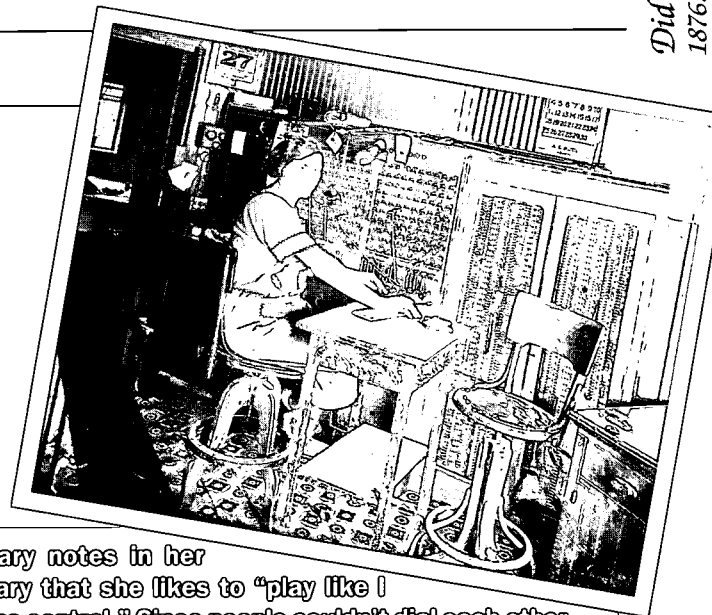

Mary notes in her diary that she likes to "play like I was central." Since people couldn't dial each other directly, a central operator connected callers. This ca. 1920 photo is of the Rockwell telephone switchboard.

Did you know? The telephone was invented in 1876. By 1900, 1.4 million were in use!

History Makers

What's your problem?

Invent, Iowa! wants to know.

Invent, Iowa! is a state-wide program that teaches creative thinking and problem solving through the invention process. This year, local and regional conventions attracted 38,000 inventors in grades four through eight. Winners advanced to the state convention at the Polk County Convention Center on April 18. The state convention featured 275 inventions. Young inventors represented more than 100 Iowa cities.

"It's very much a homegrown program," said Debra Johnson, *Invent, Iowa!* coordinator.

Inventors keep journals tracing the development of their inventions. They start with a problem, then brainstorm solutions, build and test models, and do research to make sure the product does not already exist. As some inventors found out, even solutions have problems of their own.

Rusty Ross, Lawton, invented an electronic toilet paper dispenser. Rather than pulling on the toilet paper roll, you push a button that used to be a doorbell. Rusty, 11, named his invention the Ross Roller.

"There was another button besides the doorbell one," Rusty

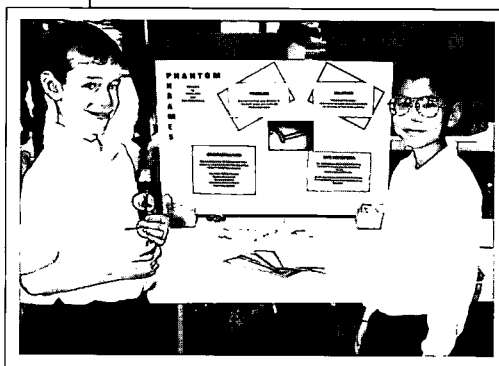

Dan Haverkamp and Philip Shiu introduce *Phantom Phrames*.

said. "It was like an on-off switch like a light. The problem with that was it wouldn't shut off fast enough and it'd always give you too much. But it was just enough for me to win in the contest at school, then I changed it for this one."

Iowa City residents Dan Haverkamp, 9, and Philip Shiu, 10, found a way to keep track of eye glasses in the dark. Their invention, *Phantom Phrames*, re-

quires putting glow-in-the dark craft paint on the frames of glasses.

"First we had the idea to put a magnet so it would stick to your

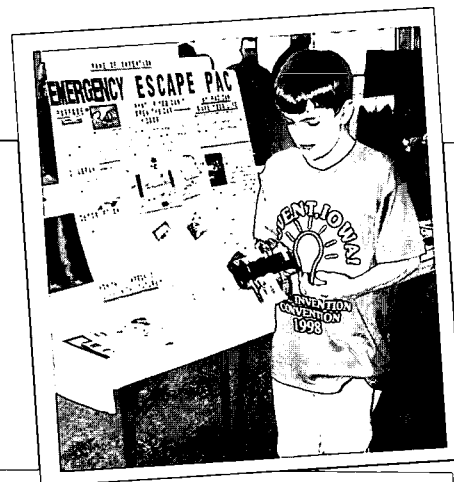

The *Emergency Escape Pac* for vehicles includes scissors, fuses, a flashlight, and glow stick.

"I've learned how to be safer."

—Chris Stanford, 10, Bonaparte

table but then it looked really tacky," Dan said. "And then it might fall."

Breanne Hunold, 12, and Jessica Mueller, 12, invented *Secura Calf-eteria*, a bottle feeding station for calves. They added a chain and hook to a regular bottle holder. The chain loops

around fence rows and hooks to secure the bottle holder to a fence.

“When you go to feed the bottle calves, normally you have

Breanne Hunold and Jessica Mueller, Donnellson, have competed in *Invent, Iowa!* for three years.



“It’s really fun. You get to stay in a hotel with your friends and go swimming ... you meet a lot of new people. It’s fun to come back the next year and see somebody you recognize.”

—Breanne Hunold

to hold onto it so it takes longer to do chores,” Jessica said. “Normally the bottle calves just suck it off. With this invention, you can go do other chores and it won’t fall off.”

“If [the bottle] falls off, it can get into manure and calves can step on it and break it, or if it gets

dirty, they can get sick from it,” Breanne explained. “[Secura Cafeteria] cuts down on vet bills and the cost of supplies.”

Jenny Plagman, 10, and Abby Rosenthal, 10, made their Cedar Rapids homes more pleas-

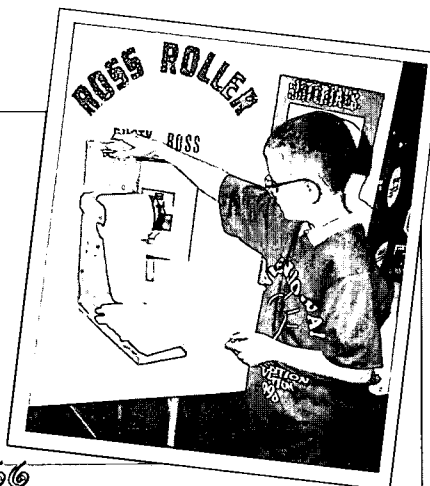

“It can be used in public restrooms or in hospitals for people with disabilities.”

—Rusty Ross

ant with Stink Stopper. The invention attaches air freshener to the toilet.

“Sometimes the bathroom stinks and you can’t really dare to go in there,” Abby said. Their invention automatically sprays air freshener when the toilet flushes. “You don’t have to go searching for the air freshener,” she contin-

ued. “It’s really convenient to use.”

Some *Invent, Iowa!* participants thrive on the competition. Others, like 11-year-old Chris Wienhold from Manson, enjoy creating inventions and getting them to work.

Chris’s invention, Lazy Desk, adds some conveniences to the regular school desk. It includes an arm that raises (so you don’t have to raise yours), a water bottle holder and a fan.

Many of the young inventors understand the role that inventions play in history.

History shows how people have “gotten smarter over the years and figured things out,” Chris said.

“[An invention] could be part of history, I think, because if people need to use it, then they’re going to be using it from century to century until it just dies down and nobody knows what it is anymore,” Jenny said.

“It has a really big impact because everything was invented at one time or another and if it hadn’t been, we’d all be living in caves,” Breanne said.



PHOTOS: MATTHEW J. PALMIOTTO

The Dream Computer

by Jen Golay

"I'm never going to get this done!" sighed fourteen-year-old Alysia Duncan. She stared blankly at the computer screen in front of her. Its bluish light cast an eerie glow around her room. Alysia's algebra book lay open on her

desk. The spreadsheet on the screen blurred as her tired eyelids began to sink. "Why does my computer have to be such a dinosaur? If I had a newer one, I could finish this assignment!" Alysia dropped her head onto her

folded arms. As she lay on her textbook looking up at the computer screen, she felt hypnotized by the blinking cursor.

Moments later, Alysia jumped. The screen was no longer the grid of numbers that made up her spreadsheet assignment; instead, it had become a mass of

twinkling red and blue lights. Alysia shook her mouse trying to get her work back on the screen. She pounded the enter key. "What's the matter with this dumb

and took a swallow of the warm pop sitting on her desk.

"I must be really tired," she said to herself.

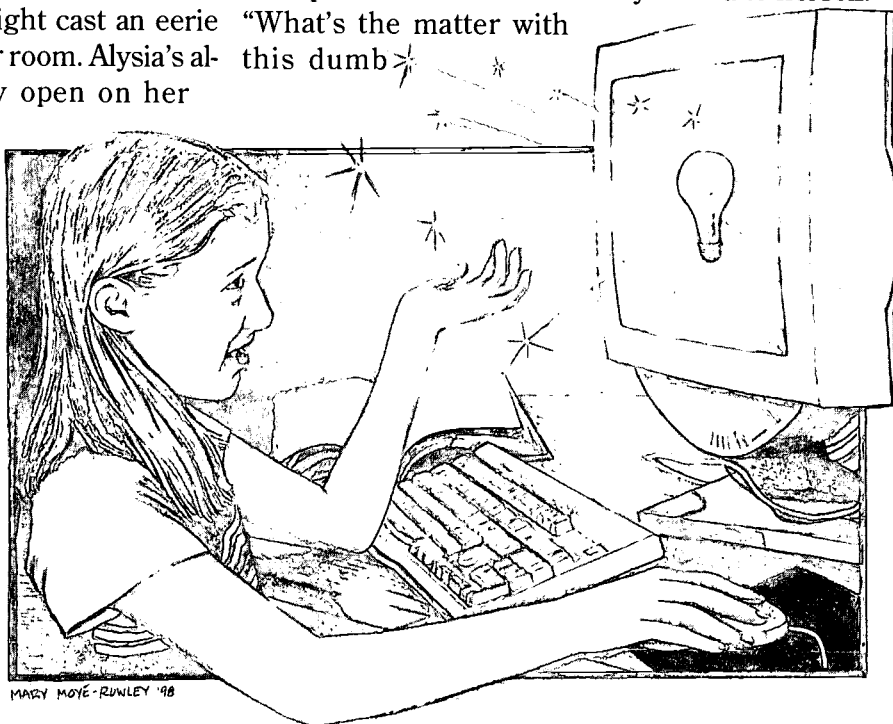

Still the computer beckoned to her, "Follow me. Follow me. Follow me." Alysia sat down in front of her computer once again. Hesitantly, she put her hand on the mouse. The arrow on her computer screen moved toward the flashing bulb. Slowly she double clicked.

thing?" she cried. Just when she was about to flip the power switch, one white light bulb appeared in the center of her screen.

"Follow me," an electronic, monotone voice repeated. "Follow me. Follow me."

Alysia shook her head, got up and walked around her room,

The room became dark as the blinking lights on the computer screen faded.

"What is happening?" Alysia whispered to herself.

"Clifford, did you wire that last circuit?" someone asked. Alysia didn't recognize the man's voice



In this 1941 photo, Clifford E. Berry holds vacuum tubes that were part of the ABCComputer's memory.

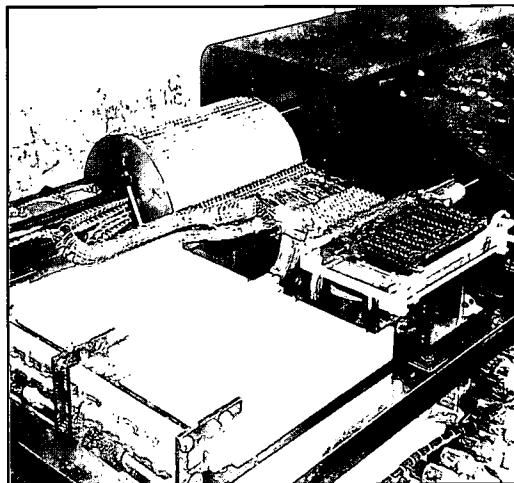

The original ABCComputer was produced at Iowa State University from 1939 to 1942.



John Vincent Atanasoff in the classroom on May 22, 1981.

"Yes, Dr. Atanasoff," replied another man's voice.

"Let's try another equation," the first voice said. Alysia squinted into the darkness. Slowly, light illuminated a small, cool room. All around her, Alysia saw tables and shelves with wires, tools, glass tubes, and small paper cards. At one end of the room, two men stood with their backs to Alysia. One of them stood next to a machine the size of Alysia's desk; the other one was kneeling near the bottom of the machine and jiggling some wires. The man
ling next to the machine

flipped a switch. The whirring sound of a motor reached Alysia's ears. The man fed a paper card into the machine. Alysia stared with fascination as minutes later, the second man watched a small device click and reveal a number.

"That's it! It's correct!" shouted the second man. "It works!" The two men heartily shook hands.

"What works?" Alysia heard herself ask. The two startled men turned to face her. Alysia was surprised as well. She hesitantly moved toward the machine. "What works?" she repeated, in-

trigued by the maze of knobs, dials and glass tubes. "What kind of machine is that?"

"Our computing machine," replied the first man slowly. "Who are you?"

"I'm Alysia Duncan," she replied with a grin. "Who are you, and where am I?"

"I'm John Vincent Atanasoff, and this is my assistant Clifford Berry," replied the first man. "You are in the basement of the physics building at Iowa State University. It's 1942."

Alysia's eyes got big. "Oh boy," she whispered.

“Would you like to see our project?” Professor Atanasoff asked. “We’re pretty proud of it. We can use it to calculate algebra problems. It’s much faster than doing it by hand.”

Alysia’s brow wrinkled in confusion. “You mean like a calculator or a computer?” she asked.

“Yes, I guess you could call it something like that,” said Mr. Berry. “Let me show you how it works.” Mr. Berry led Alysia over to the machine.

“This machine is special because it uses electricity to solve mathematical equations, not just simple ones like $5 + 5$, but complex ones that require a person several hours to figure out.”

“We tell the machine what we want it to calculate,” said Professor Atanasoff. “It converts the numbers into a form of mathematics that uses only 1’s and 0’s. This is easier and faster electronically than the numbers you use to do math.”

“The machine can ‘think and remember’ by burning small spots on these cards,” said Mr. Berry. “The machine

reads these cards using electric impulses. And when the calculation is complete, the answer, converted back to regular numbers appears on these dials.” Mr. Berry pointed to a small read-out panel that looked like the odometer in Alysia’s parents’ car.

“Can I try it?” asked Alysia.

“Go ahead,” replied Professor Atanasoff smiling.

“Ask it to figure $9 - (3 \times 2) = X$,” said Alysia remembering part of her homework assignment. Professor Atanasoff and Mr. Berry gave the machine Alysia’s request. Minutes later, the dials in the read-out panel clicked to the correct answer—3. Alysia was surprised

it took the machine as long as it did to figure the simple equation, but she noticed some pretty long and hard looking equations on a sheet of paper next to the machine. Suddenly, her homework didn’t seem so difficult, and her computer didn’t seem so ancient.

“We hope this machine will help our college students save time on long, hard math problems,” said Dr. Atanasoff.

Alysia smiled, “Oh, I think you can be sure it will help even more people than that.”



Atanasoff’s computer wasn’t used much—but he introduced fundamentals that are the foundation for every computer in the world today.

Stephen Frese, 9, studies a replica of the Atanasoff-Berry Computer on display at the State Historical Building in Des Moines. To find out where you can see the ABC replica, check out

this web site:

<http://www.scl.ameslab.gov/ABC>



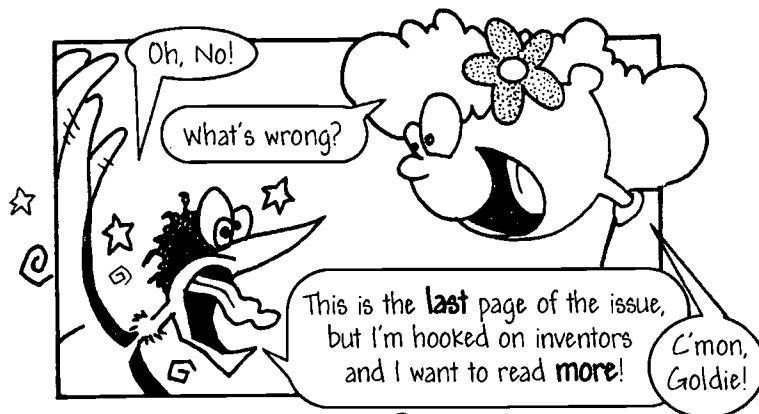

Now it's your turn! Head to the library with Wild Rosie and Goldie and read more about your favorite inventors and inventions, or look up some of the inventors we didn't have room to cover. Or pick a common item (don't forget: you are surrounded by inventions!) and find out who invented it and learn the stories behind the invention. Take the toothbrush, for instance. You use one every day, but do you know who invented it? Imagine life without one! How would you clean your teeth? I don't know who invented the toothbrush, but I do

know that the bristles are made of nylon fibers and that nylon was invented by someone from Burlington, Iowa. An invention (like nylon) may begin as one person's idea, but it doesn't stop there. Other people make improvements on an invention or find new uses for the product. History is full of creative Iowans whose innovations left their marks on our state—and the world! Their stories are waiting to inspire the next generation of curious minds. Who knows? Maybe one of the next great, life-changing inventions will be **YOURS!** 

—The Editor

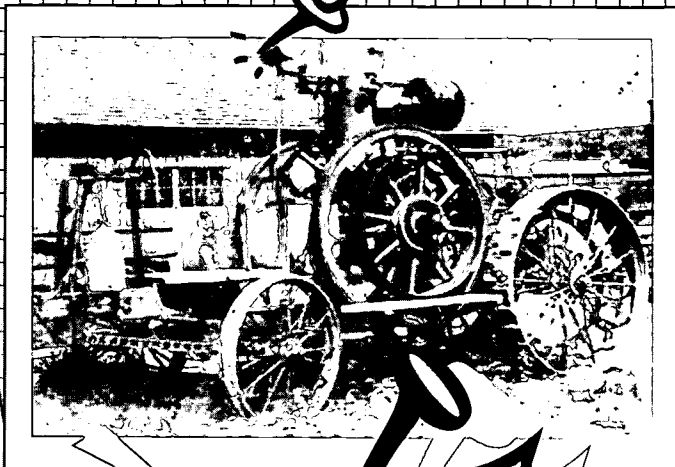
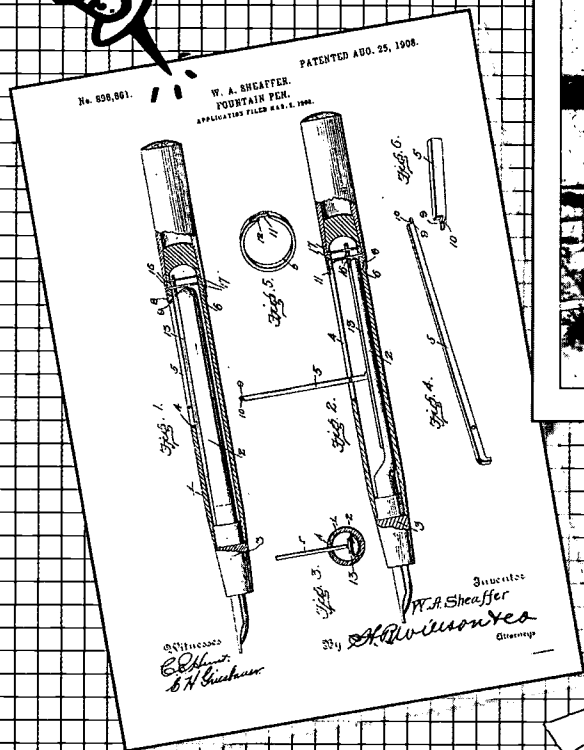

Inventions
 are ideas
 that have
 come to life
 to change
 our lives.

THE Goldfinch

US ISSN 0278-0208

State Historical Society of Iowa

402 Iowa Avenue

Iowa City, Iowa 52240-1806

Second-class
 postage paid at
 Iowa City, Iowa



U.S. Department of Education
Office of Educational Research and Improvement (OERI)
National Library of Education (NLE)
Educational Resources Information Center (ERIC)



NOTICE

REPRODUCTION BASIS



This document is covered by a signed "Reproduction Release (Blanket) form (on file within the ERIC system), encompassing all or classes of documents from its source organization and, therefore, does not require a "Specific Document" Release form.



This document is Federally-funded, or carries its own permission to reproduce, or is otherwise in the public domain and, therefore, may be reproduced by ERIC without a signed Reproduction Release form (either "Specific Document" or "Blanket").