

DOCUMENT RESUME

ED 460 830

SE 061 935

TITLE Scientific American Frontiers Teaching Guides for Shows 701-705, October 1996-April 1997.

INSTITUTION Connecticut Public Television, Hartford.; Public Broadcasting Service, Washington, DC.

PUB DATE 1996-00-00

NOTE 81p.; Hosted by Alan Alda. Underwritten by GTE Corporation. Series produced by The Chedd-Anglier Production Company with "Scientific American" magazine. Classroom materials produced by Media Management Services, Inc.

AVAILABLE FROM Scientific American Frontiers Program, 105 Terry Drive, Suite 120, Newtown, PA 18940. Tel: 800-315-5010 (Toll Free); Fax: 215-579-8589; e-mail: saf@pbs.org; Web site: <http://www.pbs.org>.

PUB TYPE Guides - Classroom - Teacher (052)

EDRS PRICE MF01/PC04 Plus Postage.

DESCRIPTORS Animal Behavior; *Artificial Intelligence; Biomechanics; *Brain Hemisphere Functions; Cognitive Processes; *Educational Television; Elementary Secondary Education; *Robotics; *Science and Society; Science Instruction; Technological Advancement

IDENTIFIERS Massachusetts Institute of Technology; Scientific American Frontiers; *South Africa

ABSTRACT

These teaching guides are meant to supplement the seventh season (1996-97) of the PBS Series "Scientific American Frontiers". Episode 701 is entitled "Inventing the Future: A Tour of the MIT Media Lab" and the teaching guide contains information and activities on a virtual pet dog, computers of the future, a smart car designed to prevent accidents, wearable computers, and an interactive opera using hyperinstruments. The teaching guide for Episode 702, entitled "Science Safari: A Scientific Expedition through South Africa", includes information and activities on controlling malaria, hominid fossils found in South Africa, a 16th-century royal burial site, wildlife management in South African nature parks, and attempts to save wild plants from extinction. Episode 703 is entitled "Pieces of Mind: Inside the Human Brain" and features information and activities on split-brain patients, the emotional aspects of memory, false memory, REM sleep, and language learning. Episode 704 is entitled "Going to Extremes: Testing Nature's Limits" and contains information and activities on funnel web spiders, the physiology of mountain sickness, the biomechanics and physiology of the cheetah and the pronghorn antelope, frogs and fish that survive extremely cold temperatures, and new ocean species discovered by the Monterey Bay Aquarium Research Institute. Episode 705 is entitled "Robots Alive! Robots with Minds of Their Own" and presents information and activities on robots that navigate mazes and clean tennis courts, a van that drives itself, teaching a robot to walk on two legs, the attempt to create artificial intelligence, and the Aerial Robotics Competition. (WRM)

Reproductions supplied by EDRS are the best that can be made
from the original document.

**Scientific American Frontiers
Teaching Guides for Shows 701-705
October 1996-April 1997**

- **Inventing the Future**
- **Science Safari**
- **Pieces of Mind**
- **Going to Extremes**
- **Robots Alive!**

Hosted By Alan Alda

GTE

PBS

U.S. DEPARTMENT OF EDUCATION
Office of Educational Research and Improvement
EDUCATIONAL RESOURCES INFORMATION
CENTER (ERIC)

- This document has been reproduced as received from the person or organization originating it.
- Minor changes have been made to improve reproduction quality.

• Points of view or opinions stated in this document do not necessarily represent official OERI position or policy.

2

PERMISSION TO REPRODUCE AND
DISSEMINATE THIS MATERIAL HAS
BEEN GRANTED BY

J. Gordon

TO THE EDUCATIONAL RESOURCES
INFORMATION CENTER (ERIC)

1

EO61935

SCIENTIFIC
AMERICAN
FRONTIERS

SHOW 701 TEACHING GUIDE • OCTOBER 23, 1996 • 8-9 PM

Inventing the Future

A Tour of the MIT Media Lab

GTE

Underwritten by
GTE Corporation

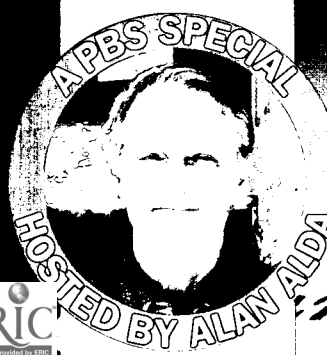

1996-97 PROGRAM
SCHEDULE ENCLOSED

FOR YOUR INFORMATION

WELCOME TO THE FUTURE!

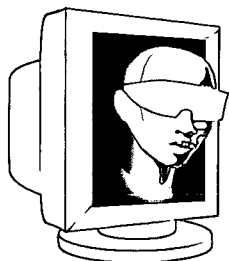

Imagine a computer that would recognize faces of people and prompt you to remember their names or a smart car that could sense when you're falling asleep at the wheel. Scientists at the MIT Media Lab believe all this and more is possible. Host Alan Alda and the crew of SCIENTIFIC AMERICAN FRONTIERS take you there to meet scientists who are literally inventing the future.

Be sure to visit our Web site (<http://www.pbs.org/saf/>) and try our online activities (see pp. 14-15 in this guide). You can also visit us on America Online (**keyword: frontiers**). You and your students can enter the **Viewer Challenge** (p. 4) and have a chance to win one of our terrific FRONTIERS T-shirts! As always, the activities (and all other pages) in this guide may be photocopied for use in different courses and grade levels; please feel free to adapt them for your students.

FRONTIERS is always interested in hearing about your successful science-related online projects. Send your creative ideas to the address in the box below and we'll include your ideas in future teaching guides.

FRONTIERS ON VIDEOTAPE

Videotapes of past shows are available through the School Program. If you missed a show or want to complete your FRONTIERS tape library, call 800-315-5010. Tapes are \$19.97 each, including shipping and handling. (Orders accepted with purchase order, credit card or check.)

NEXT TIME ON FRONTIERS

Stay tuned November 20, 1996, when SCIENTIFIC AMERICAN FRONTIERS travels to South Africa on a science safari for this season's International Special.

Dear Science Educator,

We are delighted to present you with this teaching guide, which corresponds to **Inventing the Future**, an exciting television special that kicks off the 1996-97 season of SCIENTIFIC AMERICAN FRONTIERS. Airing on PBS, the season premiere is scheduled to broadcast nationally on Wednesday, October 23, and will feature technological research and wizardry at MIT's famous Media Lab.

Over the past six years, thousands of educators across America have come to count on the FRONTIERS teaching guides for invaluable ideas and interactive classroom activities, all designed to stimulate students' interest in science. This season, as in the past, educators who are enrolled in the FRONTIERS School Program will receive a free teaching guide for each of the five specials. Look for your guide about two to three weeks before each show airs.

The five-part FRONTIERS series entertains and educates young and old viewers alike, showing us interesting and life-changing science while profiling the men and women who make it all happen. Alan Alda, a long-time science buff, is returning for his fourth season as series host and will take us on location to exciting destinations, including South Africa in November.

GTE and *Scientific American* are involved with SCIENTIFIC AMERICAN FRONTIERS for two key reasons: it provides intelligent television for the home and, just as important, FRONTIERS brings science to life in the classroom. Let us take this opportunity to thank you for using FRONTIERS in your classroom and for helping shape the lives of America's young students.

If you have been with FRONTIERS over the years, it's nice to have you back. If you are new to the series, welcome. We hope you'll find many uses for this resource in your classroom this year and beyond.

Sincerely,

Chuck Lee

Charles R. Lee
Chairman and CEO
GTE Corporation

John J. Hanley

John J. Hanley
President and CEO
Scientific American

SCIENTIFIC AMERICAN FRONTIERS is closed-captioned for the hearing-impaired and is narrated by Descriptive Video Service (DVS) for visually impaired audiences. The series and School Program are endorsed by the National Science Teachers Association (NSTA) and the National Education Association (NEA).

TAPING THE SHOW

- Always check TV listings to confirm air date and time.
- As a teacher, you have off-air taping rights in perpetuity for classroom use.
- If you can't find the show in your TV listings, call your local PBS station.
- Do you need help? Call the FRONTIERS School Program at 800-315-5010.
- Videotapes of past shows can be purchased (\$19.97 each). Call 800-315-5010.

FREE VIDEOTAPING & PHOTOCOPYING RIGHTS

GTE Corporation, the series underwriter, makes available complete off-air taping rights in perpetuity for classroom use of SCIENTIFIC AMERICAN FRONTIERS. Educators may record each show when it airs on PBS and keep the tapes to use in the classroom year after year. Educators may also photocopy all materials in this guide for classroom use. If you know of other educators interested in receiving these guides, they may sign up by calling the SCIENTIFIC AMERICAN FRONTIERS School Program at 800-315-5010.

LET US HEAR FROM YOU!

We appreciate and welcome your questions, comments, compliments and constructive criticism. Please contact us . . .

BY MAIL:

SCIENTIFIC AMERICAN FRONTIERS
105 Terry Drive, Suite 120
Newtown, PA 18940-3425

BY PHONE: 800-315-5010

BY FAX: 215-579-8589

BY E-MAIL: saf@pbs.org

TABLE OF CONTENTS

SHOW 701 • OCTOBER 23, 1996 • 8 PM ON PBS

INVENTING THE FUTURE

6 VIRTUALLY REAL

Meet Silas, the MIT Media Lab's virtual pet dog . . . Software agents that could help you navigate cyberspace and the real world

Activities:

An overview of the show and this guide . . . Exercise your brain with thoughtful activities and questions

8 BODY TALK

In the future, computers may take the form of animated characters like Gandolf or even a smart desk . . . Alan Alda hosts a cooking show using a smart camera

Activities:

A design challenge invites students to create their own intelligent devices . . . Graphing pixels

10 SMART CAR

A smart car that could wake up the driver and prevent accidents is already in the making . . . Find out more about the human brain

Activity:

Experimenting with artificial intelligence

11 PRIVATE EYES

Computers may turn up in your shoes, your glasses or your jewelry

Activity:

Debating the role of computers and technology in society today and tomorrow

12 BRAIN MUSIC

High-tech hyperinstruments meet opera in a new kind of interactive performance medium

Activities:

Learn about the physics of music by making low-tech instruments



DEPARTMENTS

4 VIEWER CHALLENGE

5 THE BIG PICTURE

14 SAF ONLINE

COVER PHOTO: ©LUCIANO GAGLIARDI/THE STOCK MARKET

SCIENTIFIC AMERICAN FRONTIERS is made possible by an underwriting grant from GTE Corporation. The series is produced by The Chedd-Angier Production Company in association with *Scientific American* magazine and presented to PBS by Connecticut Public Television. Some materials produced by Media Management Services, Inc.



STORY	RUNNING TIME	COMPUTER SCIENCE	GENERAL SCIENCE	MATH	MUSIC	PHYSICAL SCIENCE	TECHNOLOGY
VIRTUALLY REAL	13:24	•	•				•
BODY TALK	9:15	•	•	•			•
SMART CAR	11:23	•	•	•			•
PRIVATE EYES	11:44	•	•				•
BRAIN MUSIC	7:04	•	•	•	•	•	•

*CHECK LOCAL TIME



Student's Name _____
 Teacher's Name & Course _____

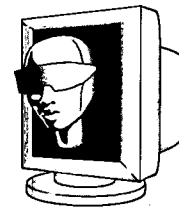

Watch **SCIENTIFIC AMERICAN FRONTIERS** Show 701, "Inventing the Future," for answers to questions on this page. Answer the ten questions correctly and you'll be eligible to win a **FRONTIERS** T-shirt!

Virtually Real

- What game does Alan Alda play in the smart room?
 a. Myst b. SimCity c. Doom d. Qin
- How are virtual animals like Silas different from robots, in terms of the computer world?

Body Talk

- In the future, the character called Gandolf will be able to recognize the content of:
 a. emotions b. gestures c. faces d. books
- How does a smart camera system know how to find the right shots?

Smart Car

- List one thing a smart car might do if it senses the driver is getting sleepy.

- The part of the brain that Roz Picard says "functions like the fire alarm in your house" is called the:

- a. amygdala b. cortex
 c. hippocampus d. neocortex

Private Eyes

- MIT students are experimenting with computers built into all of the following *except*:

- a. eyeglasses b. clothing
 c. shoes d. watches

- What happens when you walk on a shoe computer?

Brain Music

- What is the sensor chair designed to measure?

- The rhythm tree, digital baton and sensor chair are examples of:

- a. notation systems b. new bands
 c. hyperinstruments d. musical scores

For Teachers Only

When completed, this page can become an entry to the **FRONTIERS** T-shirt contest; 20 winners (10 students, 10 teachers) will be drawn at random for each show. To enter the T-shirt drawing, send all completed challenges *in one envelope* with a cover sheet to: **Viewer Challenge**,

SCIENTIFIC AMERICAN FRONTIERS, 105 Terry Drive, Suite 120, Newtown, PA 18940-3425. Mail completed entries by **November 22, 1996**.

TIP: You can also download these questions on the **FRONTIERS** online sites on the Web and AOL (see pp. 14-15).

Important!! Please include a separate cover sheet and tell us:

- number of challenges submitted
- teacher's name
- grade and course
- school name, address and phone number
- where your students watched the show — at home, at school or both
- the name of your students' favorite story in this show (conduct a quick poll to find out)

Thank you!

ANSWERS TO VIEWER CHALLENGE 701: 1. c 2. animals juggle multiple goals, while robots focus on one thing at a time 3. b 4. follows descriptions of actions in the script 5. turn on air-conditioner, sound warning, spray peppermint 6. a 7. d 8. as you walk, you generate power; power builds up with each step 9. body's electric current or electric field 10. c

The Evolution of Thinking Machines

What we think of as the computer started out as a bank of wired machines that filled a 30-by-50-foot room and weighed 30 tons. Today, a handheld calculator has more computing power than the first true electronic brain of the 1940s. As you see on this episode of FRONTIERS, the trend toward miniaturization continues. Computers in the future may be carried in your shoe or worn as part of

your eyeglasses or clothes. They may also be quite different in brain power and applications from what we use today. You will probably talk to your future computer and it may even remind you of appointments and assignments or the names and faces of people you meet.

17th Century

In 1642, the French philosopher Blaise Pascal invented a mechanical adding machine at the age of 19 to help his father, a tax collector. Pascal's calculator is considered a forerunner of the digital computer.



Ancient Times

The earliest computing device in the world (after fingers and toes) is believed to have been a primitive abacus, invented about 5,000 years ago.

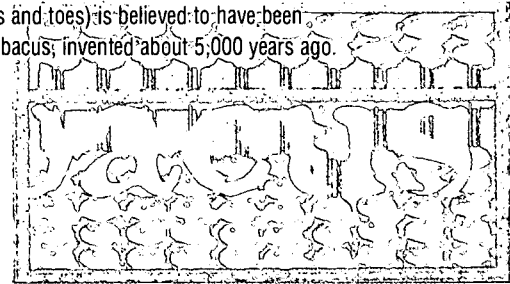

19th Century

In the 1830s, British mathematician Charles Babbage designed mechanical calculating machines (Difference Engine and Analytical Engine) that used punched cards to solve math problems. American statistician Herman Hollerith invented a machine that used perforated cards to tabulate data for the 1890 U.S. Census.

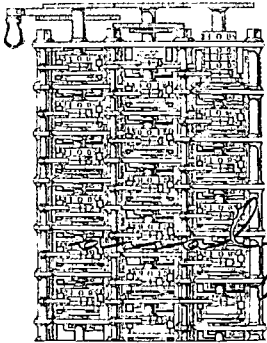

Analytical engine

Early 1940s

British mathematician Alan Turing put his theories about computers into practice during World War II, when he helped build the Colossus to crack enemy codes. In 1944, U.S. scientists built the Mark I, an automatic digital computer. By today's standards, these two machines would seem slow, but they could do math calculations faster than a person.

1940s and 1950s

Wartime research launched the Information Age in 1946, with the first electronic computer built to compute artillery trajectories. The 30-ton Electronic Numerical Integrator and Computer or ENIAC, powered by 18,000 vacuum tubes, could do in a day what it took one person a year to calculate. The invention of the transistor in 1947 made smaller and more reliable computers possible. In 1952, UNIVAC became the first computer to accurately predict the results of a U.S. presidential election.

1960s and 1970s

The third generation of computers put thousands of transistors on a board, called the integrated circuit. In the 1960s, the Cold War generated research into a communications network that could operate in the event of nuclear attack — the foundations for today's Internet. Putting all the components on chips of silicon in the fourth generation enabled computers and electronic devices to become smaller, faster, cheaper and more efficient.

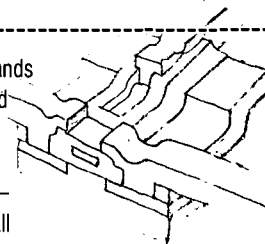

1980s and 1990s

Continued miniaturization made the microprocessor and personal computer possible; computers continued to shrink in size but grow in brain power. In 1982, the word "Internet" appeared for the first time. Internet usage has grown exponentially in the 1990s as millions of people rush onto the Information Superhighway. Office and home computing networks link people around the globe, while scientists tinker with the next generation of computers.

mouse

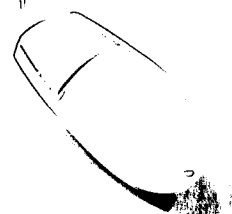

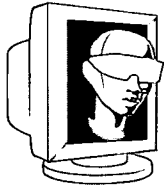

**RUNNING
TIME:**

13:24

**CURRICULUM
LINKS:**

**COMPUTER
SCIENCE**

artificial
intelligence,
programming

LITERATURE

science fiction

PSYCHOLOGY

learning

TECHNOLOGY

inventions

VIRTUALLY REAL

Go behind the scenes at the MIT Media Lab and preview tomorrow as you meet some of the country's visionary computer pioneers. MIT professors Alex (Sandy) Pentland and Pattie Maes and graduate student Bruce Blumberg demonstrate their projects, which range from smart rooms to software agents that help users navigate cyberspace. You'll also meet the lab's virtual pet dog and find out how computers of the future might look and behave.

WELCOME TO THE FUTURE . . . GETTING STARTED

The MIT Media Lab is a unique facility where scientists and students play with technology. The lab explores such concepts as virtual reality, artificial intelligence, communications and other computer applications, from education to entertainment. Computer wizard Nicholas Negroponte is the founder and director of the lab, which commemorated its tenth anniversary in October 1995. Research is supported by federal contracts and many corporations.

Scientists and engineers at the lab are among the visionary leaders of the digital revolution. Their projects are the subject of this special show, from an intelligent agent posing as a virtual dog to smart cars, smart rooms and a smart desk that acts like a good office assistant.

This guide features a variety of activities to accompany this futuristic show. Some activities apply to computer technology, but many can also

be used to explore various technologies and discuss and debate the role computers play in our lives.

Activities on these two pages require very few materials — just the creativity of the most powerful thinking machine on Earth, your brain.

You may wish to use these activities as part of an integrated approach to technology. We hope you will share the materials and tell others on your team or in your school about FRONTIERS. "Inventing the Future" provides terrific opportunities for discussion.

Anywhere You Go, There You Are

How close are we now to being continually reachable? What devices allow us to stay in touch or to do our work anywhere we happen to be? How do companies gather information about us? (E-mail, cellular phones, pay-per-view, grocery store scanning cards and credit cards are just some of the ways.)

Now, imagine a world completely connected by electronics for instant information exchange, a world where you are always reachable. Imagine that the accessibility is accomplished by even smaller computer chips than we have available today and that a chip becomes your identification. Doctors implant the chip in your wrist when you are born and it carries all your personal data.

Describe a day in this world. How would the chip change our money system, our identification system, our health care system, our buying power, our reachability? What would the advantages and disadvantages be?

Design a Smarter Desk

Work with a partner or group to design a "smart" school desk. How would it recognize you? What would it

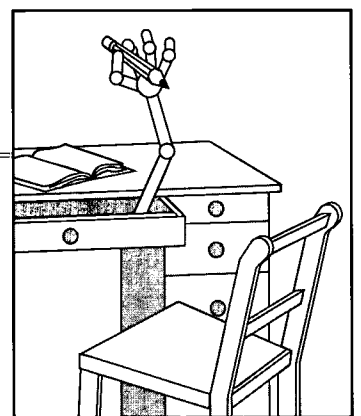

be able to do? How could your classroom or school building also become smart? What parts of traditional school would become obsolete? How would the desk change your study and learning habits? Include an agent or helper like Silas (the virtual dog seen on FRONTIERS). What would the agent do?

See page 8 for more design challenges.



Sandy Pentland and Pattie Maes, seen in this segment, answer your questions online.

See pp. 14-15 for information.

Technology Timeline

List ten devices developed since 1900 that have changed how we communicate and transmit information.

Select a focus: information, music, images, mixed media, print materials, message delivery, etc.

Make a timeline of your devices and highlight how each innovation improved on the last. You may include the personal computer, the videophone, satellites, television, CDs, etc. Use the timeline on page 5 as a starting point.

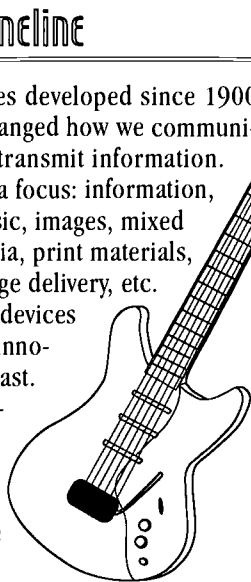

A Day in Cyberspace

Observe and keep track of all the ways you use computers or computer technology in a single day. Don't forget the microwave oven that pops your popcorn, or the card you use at school for ID, or the bank card you or your parents use at the cash machine, or the greeting card that plays music! Make a list and compare it with lists made by your classmates. Who can create the longest list? Identify how many items on your list use semiconductors.

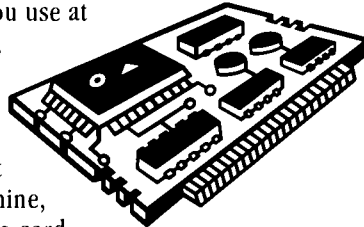

Model a Neural Network

Your loan has been denied — not by a person or a business, but by a computer. How is that possible? One of the more successful applications for artificial intelligence (AI) determines what sort of a credit risk you are by using a series of if/then/else rules based on specific reasoning provided by a business expert or by a neural network. In a neural network, a computer has access to many case studies and, using reasoning similar to statistical analysis, “learns” to make decisions. Your brain uses rules to make decisions and is itself a neural network, with many more connections than a computer.

As part of a group, make a list of eight popular CDs, then write a set of rules to determine whether a particular CD should have a prime position in a national retail music store. When you have finished, exchange your rules and CD list with another group. Compare rules to make a decision about which three CDs should be on the featured display.

See page 10 for another activity that uses rules in artificial intelligence.

Resources

- ▷ *Scientific American*:
 - “Smart Cards,” August 1996;
 - “The Culture Machine: Science and Art on the Web,” August 1996;
 - “Smart Rooms,” April 1996;
 - “Intelligent Agents” and other articles in the special issue *Key Technologies for the 21st Century*, September 1995.
- ▷ *Being Digital* by Nicholas Negroponte (Vintage Books, 1995).
- ▷ *Silicon Snake Oil* by Clifford Stoll (Anchor Books, 1995).
- ▷ *The Turing Option* by Harry Harrison and Marvin Minsky (Warner Books, 1992).

Would you trade
a live pet
for a virtual one?

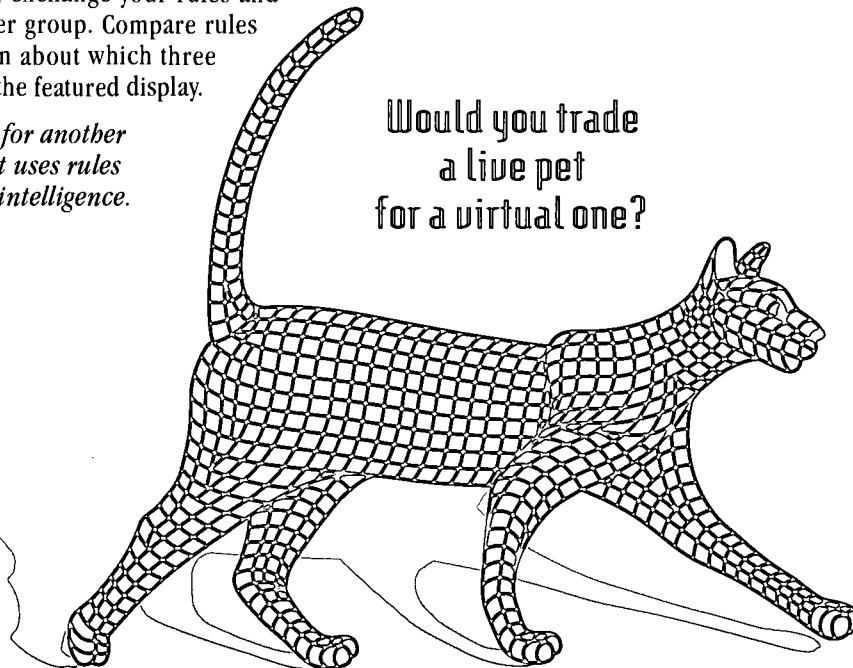

SCIENTIFIC
AMERICAN
FRONTIERS

SHOW 701

INVENTING
THE FUTURE

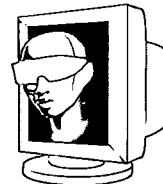

VIRTUALLY REAL

FOR FURTHER
THOUGHT

- ▷ Why would you want a computer to perform a quick and simple task like making coffee or reading the newspaper out loud to you? Who would benefit from these technological developments?
- ▷ Why would you want a smart room or a wearable computer?
- ▷ Is the technology age leading to the no-privacy age?
- ▷ Agents might help you remember people's names or help you get around town. Can you think of other useful applications?
- ▷ Besides security or a warning system that could alert parents to what their children are doing, can you think of other ways a smart room might be used?

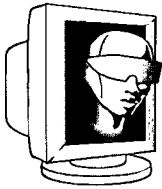

BODY TALK

**RUNNING
TIME:**

9:15

**CURRICULUM
LINKS:**

**COMPUTER
SCIENCE**

artificial
intelligence

MATH

graphing,
vectors

TECHNOLOGY

design,
inventions

BODY TALK

If computers as we know them disappear, what will future computers look like? The Media Lab is developing some intriguing possibilities to take computers out of the box. They include Gandolf, a character that interacts with the user; a smart desk that helps the user; and a smart camera that can film a TV show without an operator. Host Alan Alda shows how the smart camera works when he hosts a cooking show to demonstrate one of his favorite recipes.

ACTIVITY 1: Designing the Future, Bit by Bit

OBJECTIVE

Apply principles and concepts from the research projects at the MIT Media Lab to alternative designs.

In this episode of FRONTIERS, you see a preview of how scientists at the MIT Media Lab are inventing the future. Projects like smart rooms, wearable computers, intelligent agents and the *Brain Opera* may contain the seeds of future innovations that will force us to make a paradigm shift in the way we think about computers today.

Using some of the concepts explored in "Inventing the Future," here's a chance to design your own vision of tomorrow. Brainstorm a computer application or an invention that will make life safer, easier, healthier or simply more fun. Include a drawing of your invention and a brief description. You may want to work with a partner or in small groups. You can use some of the suggested applications below, or come up with your own ideas.

Here are some questions to focus your creative thinking on:

- ▷ What is the purpose of your invention?
- ▷ In what ways would it help people?
- ▷ How would you market it?

Design a Smart House

A smart house might be made up of many smart rooms. The smart rooms at MIT use cameras, microphones and other sensors; the rooms in your house need not be limited to this hardware.

Make a Thing That Thinks

In this project, scientists want to move away from designing the computer as a passive box on your desk by adding intelligence to objects or appliances. Choose an everyday object and make it "smarter." How will it interact with the user? How will it be helpful?

Build Your Dream Machine

Use any of the concepts seen on FRONTIERS, from wearable computers to autonomous agents, to create your own personal assistant in the form of a machine or appliance or . . . (use your imagination!).

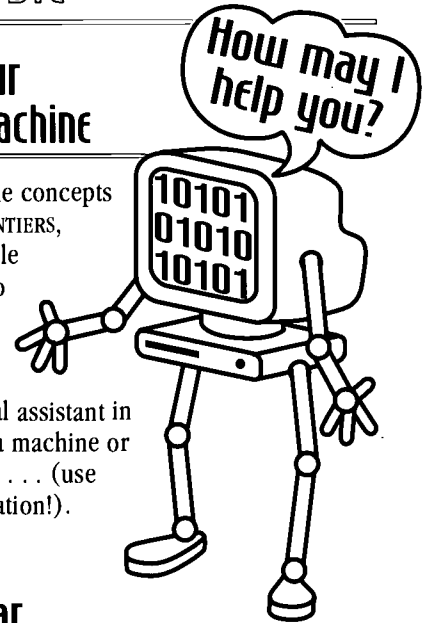

Invent a Smart Car

Think about the car you'd like to be driving in the next century. If you could select or invent any features for this vehicle, what would they be? Describe the interior and exterior.

Early in the next millennium your right and left cuff links or earrings may communicate with each other by low-orbiting satellites and have more computer power than your present PC. Your telephone won't ring indiscriminately; it will receive, sort and perhaps respond to your incoming calls like a well-trained English butler.

— from *Being Digital*
by Nicholas Negroponte



Justine Cassell, seen in this segment, answers your questions online. See pp. 14-15 for information.

ACTIVITY 2: What's in a Dot? Computer Imaging Games

SCIENTIFIC AMERICAN FRONTIERS

SHOW 701

INVENTING THE FUTURE

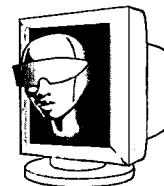

BODY TALK

Use a magnifying glass to examine images on a television or computer screen. You'll notice that these graphics are composed of individual dots or pixels. (You can get a similar effect by looking at images in a magazine.) In order to render these images, microprocessors must approximate them as collections of dots or lines positioned on a grid. It's not as smooth as a photograph, but it's clear enough to tell a visual story.

- MATERIALS**
- ✓ magnifying glass
 - ✓ chalkboard
 - ✓ chalk
 - ✓ pencil
 - ✓ graph paper

Images on a computer screen are produced by one of two modes — a vector (lines) or raster-type display (dots). In a vector display, an electron beam creates a straight line between two points, making a line drawing. In the raster, or television-type display, the electron beam aims for pixels near lines traced by a horizontal scanner to form the picture. Raster graphics have become the accepted mode of operation.

OBJECTIVE

Students will play drawing games to learn about how computers generate images that are recognizable to humans.

PROCEDURE

A. DRAWING WITH DOTS GAME

Divide into teams. One student from team A goes to the board with an image in mind. She draws the image with dots, using one dot at a time. She makes a dot every five or ten seconds.

The first person on team B to guess what she is drawing wins. Try adding new rules to see how they affect the game. Limit the category to a narrow topic, such as animals, letters, playing card suits, etc.

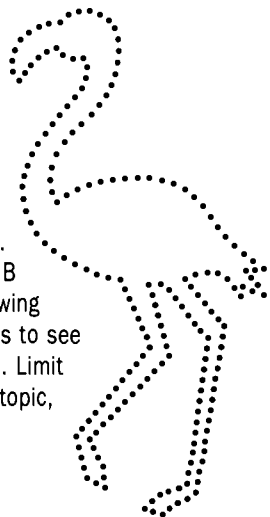

B. GRAPHING GAME

1. Divide into pairs. On a piece of graph paper with a fine grid, label coordinate axes and draw an object near the origin. *Don't reveal it to your partner.*
2. Plot points on the coordinate intersections that fall closest to the object. No points can be between lines; you are "forcing" the dots to specific coordinate points.
3. Make a table of X,Y coordinates.

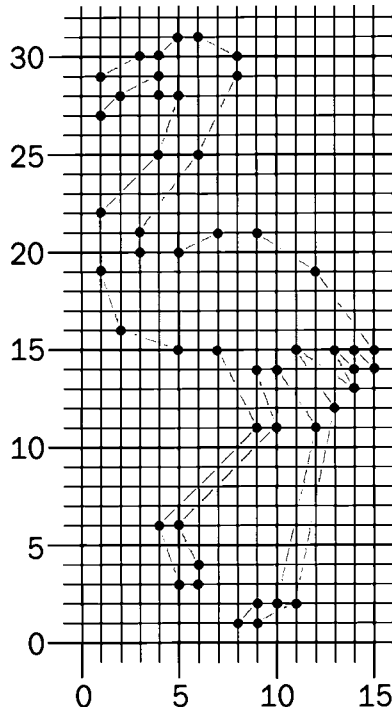

4. Give just your table of coordinates to your partner. Have him/her plot the points on a fresh piece of graph paper and try to identify the object.

What you have just done modeled the traditional raster, or television-type, display used by computer monitors. The dots represent computer pixels. A typical 15-inch color computer monitor renders images in red, green and blue signals over a resolution of 640 x 480 pixels; each dot is only a quarter of a millimeter in size. That means a single image can have more than a quarter-million dots! Imagine all the ones and zeros representing these dots in the binary language of the processor.

QUESTIONS

1. How does this suggest to you that computers:
 - a. view and interpret images?
 - b. produce graphics on paper and on screen?
2. How does the Drawing with Dots game change when you limit it to specific categories?
3. How does using fixed coordinate points (as used in the Graphing Game) affect your ability to recognize an image?
4. Considering your answers, what kinds of challenges and limitations do computer engineers and programmers face in designing their products?
5. Why do you think it might be harder for a computer to recognize faces than to read text?

FOR FURTHER THOUGHT

- ▷ See if you can find out more about raster-type and vector-type images. Based on what you know, which system would work better for a computer that has to resize graphics by scaling them up or down by a certain percentage?
- ▷ Find examples of recent movies or TV commercials that use morphing or other special effects. If you have morphing software, try some experiments.

ACTIVITIES ON PAGES 9 AND 11 WERE DEVELOPED BY MARC ROSNER, SCIENCE TEACHER AT PORT CHESTER MIDDLE SCHOOL, PORT CHESTER, N.Y. ROSNER IS ALSO A SCIENCE EDUCATION CONSULTANT AND WRITER.

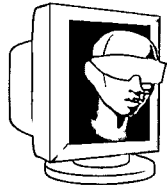

SMART CAR

SMART CAR

A car that could alert drivers to potential problems or wake up sleepyheads at the wheel seems like a futuristic fantasy, but the MIT Media Lab is working to make this dream a reality. The car's computer could recognize impending signs of trouble and help prevent accidents. Also in this segment, MIT's Professor Rosalind Picard talks about how she is teaching the computer to know how people are feeling. Part of her research includes learning more about the human brain.

ACTIVITY: Digital Messages

RUNNING TIME:

11:23

CURRICULUM LINKS:

BIOLOGY

cellular differentiation

COMPUTER SCIENCE

artificial intelligence

MATH

computers, logic

TECHNOLOGY

computer simulations

For a library of resources about Artificial Life, visit the FRONTIERS Web site at:

<http://www.pbs.org/saf/>

One of the intriguing areas being explored in the field of Artificial Intelligence (AI) is Artificial Life. This field grapples with such questions as: How does a computer learn? Do machines evolve? And even, why do birds flock?

Scientists working with Artificial Life have devised a model they call "cellular automata" to understand living systems. This model states that behavior is based on a set of rules. Simply put, each cell determines its behavior based on what neighboring cells do.

Cellular automata is derived from automata theory, conceptualized in the 1950s as an abstract branch of mathematics to deal with automatic machines. Linguists and computer scientists became interested in the theory to explore the idea of thinking computers. Mathematician John von Neumann described cellular automata as mathematical "cells" — like squares on a chessboard — that change their state according to simple rules.

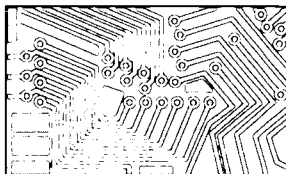

Experiments in this field help us synchronize traffic patterns and understand behavioral patterns in humans and animals. Cellular automata research has simulated biological processes and behaviors, including swarming and flocking behaviors and cellular differentiation.

The following activity uses a series of simple mathematical rules to demonstrate the concept of cellular automata. It uses eight students or cells because eight bits usually make up a byte in computer programs; a single character is usually made up of one byte.

In the following activity, read over the rules before starting. At the beginning, go slowly. While it may seem complicated at first, it will become easier as students learn the rules. Designate a leader to shout "go" before each change. You may want to rehearse the game with a group of eight students and present it as a class demonstration.

OBJECTIVE

Students will model cellular automata using simple rules and make connections to biological and mathematical systems.

PROCEDURE

Select eight students to stand in a circle with their backs to the outside. Students represent "cells" of information and will have two positions, standing or sitting. Each student will look at his/her neighbor on the right to determine what to do next based on these two rules:

If the person to your right is up, sit down.

If the person to your right is down, stand up.

Sound simple? Give it a try.

Start the circle in this configuration:

D D D D D U D D

Each student looks to the right and makes a decision about what to do when the leader yells "go." All eight cells (students) make the change **at the same time**. The second configuration should be:

U U U U D U U U

Does every cell change? (No)

The third configuration should look like this:

D D D U D D D D

Continue the process until the pattern begins to repeat.

TEACHER'S NOTE: The pattern will begin to repeat after the eighth configuration. Try UUUUUUUU, UUUUUUUU, UUUUUUUU or other combinations. The resulting oscillating pattern is called a "blinker."

THESE ACTIVITIES AND SEVERAL OTHERS IN THIS GUIDE WERE DEVELOPED BY KELLY WEDDING, BIOLOGY TEACHER AT ROUND ROCK HIGH SCHOOL NEAR AUSTIN, TEXAS.



Sandy Pentland and Rosalind Picard, seen in this segment, answer your questions online. See pp. 14-15 for information.

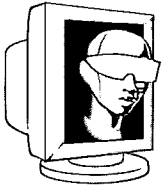

PRIVATE EYES

RUNNING TIME:

11:44

CURRICULUM LINKS:

COMPUTER SCIENCE
artificial intelligence

CURRENT ISSUES

TECHNOLOGY
inventions

RELATED FRONTIERS ACTIVITY:

SHOW #403 TEACHING GUIDE

"The Electronic Brain" (p. 10)



Thad Starnor, seen in this segment, answers your questions online. See pp. 14-15 for information.

PRIVATE EYES

Computers in your shoes and clothing may seem like science fiction, but on the MIT campus, it's already happening. In fact, some MIT students wear their computers all the time. Such wearable computers can access a personal database to recall names, faces, even conversations from the past. One day soon, you may put on your computer instead of working at a desk. In some visions of the future, keyboards and the passive boxes that house the microprocessor will completely disappear.

ACTIVITY: Debating Artificial Intelligence

As technology evolves, machines are becoming more "intelligent" and the boundaries between humans and machines are becoming less distinct. On this episode of FRONTIERS, you see examples of very smart computers and some intelligent applications, like smart rooms and autonomous agents.

The development of increasingly advanced technology in computers and robotics has sparked serious debate among scientists regarding the possible existence of artificial intelligence. Scientists divide into two basic factions. One group believes such development is possible in the relatively near future; the other disagrees, arguing that computers and machines will never achieve the equivalent of human intelligence.

How smart *are* smart rooms? Can a computer really be "smart" at all? Consider the possible answers to this question and debate the positions scientists held about artificial intelligence.

OBJECTIVE

Investigate issues about computer technology by debating or role-playing various approaches.

PROCEDURE

Divide into two groups, each with the task of defending one of the following positions:

- ▷ Humans can, or will at some point, build machines that are intelligent, thinking and conscious.
- ▷ Machines can never truly have intelligence, thought and consciousness.

TIPS

Before jumping into your roles, spend some time reasoning out your argument. How are computers/

machines similar to the human brain/body? How are they different? What is intelligence? When is something alive? You may wish to do some additional research to support your position.

It is not necessary for you to personally believe the opinion you are defending. As an exercise in debate, the point here is to take a position and articulate it as logically as you can. Afterwards, you can discuss your real feelings on the matter and analyze the strengths of the argument posed by each team.

For more ideas, see the resources listed on page 7.

We cannot think realistically any more of the human species without machines. Human nature is now absolutely and indissolubly connected to the machines we create.

— Bruce Mazlish, MIT history professor, as quoted in *Fortune*

Computers have been programmed to succeed at human games like chess, checkers and Scrabble. In 1996, the IBM computer Deep Blue beat world chess champ Garry Kasparov in several games, but Kasparov prevailed to win, despite the computer's advantage of 32 microprocessors that could calculate 200 million chess positions per second. Although Kasparov concedes it is inevitable that a machine will beat a human in chess, for now the human brain proved it could outwit the machine strategically. A rematch has been scheduled for 1997.

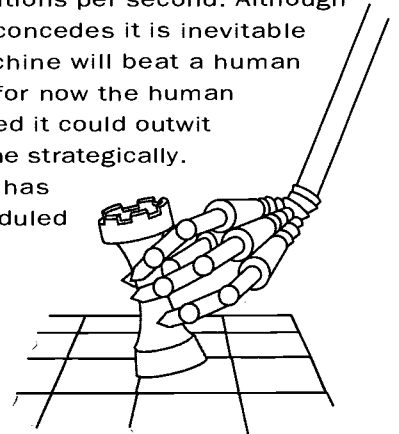

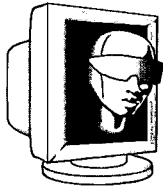

BRAIN MUSIC

RUNNING TIME:
7:04

CURRICULUM LINKS:

COMPUTER SCIENCE
artificial intelligence

MATH
ratios

MUSIC
composition and theory

PHYSICAL SCIENCE/PHYSICS
acoustics, pitch, sound waves

PSYCHOLOGY
brain

TECHNOLOGY
inventions

BRAIN MUSIC

Blending opera and computer technology, the *Brain Opera* is a unique, interactive musical event created by composer Tod Machover and a team of artists and scientists at the MIT Media Lab. A synthesis of art, music and technology, the opera invites the audience to make music on hyperinstruments, which is incorporated into the performance. MIT musician-scientists performed the opera at the Lincoln Center Festival in New York City during the summer of 1996; it is currently on international tour.

ACTIVITY 1: Bottled Sounds

As you see on **FRONTIERS**, the *Brain Opera* uses high-tech hyperinstruments to create musical compositions. But low-tech instruments like the glass harmonica can also be used to make music. The sounds produced with these homemade instruments can be used to find out more about sound and pitch. The Bottled Sounds extension is a simplified version of Ben Franklin's glass harmonica, an instrument using a series of graduated glasses or glass bowls that produce different tones when the edges are rubbed with a wet finger.

- ✓ 5 identical glass beverage bottles
- ✓ water
- ✓ metal spoon

OBJECTIVE

In these activities (pp. 12-13), students will operationally define the relationship between the length of a vibrating air column and the pitch of the sound produced.

PROCEDURE

1. Work with a partner. Fill one bottle to the top with water. Fill the second bottle 3/4 full, the third bottle 1/2 full and the fourth 1/4 full. Leave the fifth bottle empty.
2. Gently strike the side of each bottle with a metal spoon. Observe the pitch of each note.
3. Adjust the amount of water in each bottle to make notes in a recognizable musical phrase.



4. Now blow across the top of each bottle. Observe the pitch of each bottle's note.

QUESTIONS

1. How does the pitch of the bottle relate to the level of water when the bottle is struck by a spoon?
2. How does the pitch relate to the level of water when air is blown across the top of the bottle?
3. Compare and contrast the two sound-making techniques. What material vibrates to produce the note when the bottle is struck? What material vibrates when air is blown across the top?
4. Would changing the size of the spoon affect the pitch? How?
5. Does the height of the strike affect the pitch? Explain.

ANSWERS: 1. more water, lower pitch 2. more water, higher pitch 3. the water within the bottle; the air within the bottle 4. No. It would change the amount of energy added to the system. Although the pitch would remain the same, the loudness would vary with the size of the striking mallet. 5. No. It doesn't matter where the strike occurs. The energy of impact is transferred through the glass to the liquid.

EXTENSION

Fill a glass halfway with water. Wet your finger by dipping it into the water. Slowly circle the moist finger around the rim of the glass. Keep moving your finger at a steady rate. Make sure your finger remains moist. When the friction between the moving finger and the glass rim is correct, the glass will begin to "sing."

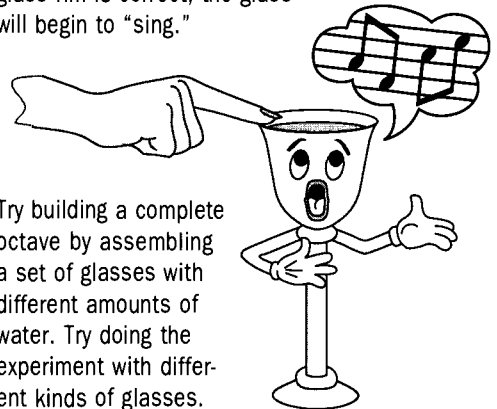

Try building a complete octave by assembling a set of glasses with different amounts of water. Try doing the experiment with different kinds of glasses.



Tod Machover, seen in this segment, answers your questions online. See pp. 14-15 for information.

ACTIVITY 2: Straw Pipes

The linear body of a wind instrument, like a flute, contains a column of air. When this air is set in motion, it vibrates. These vibrations travel outward and reach our ears as notes of a scale.

- ✓ 8 identical plastic straws per group
- ✓ permanent markers
- ✓ rulers
- ✓ scissors

The pitch of the notes depends upon the length of the vibrating air column. If the column stretches along the entire length of the flute, its note is low. When the instrument's holes open, the column is shortened. The air now vibrates from the mouthpiece to the open hole; the pitch becomes shrill.

Most of us are familiar with a basic (diatonic) scale: *do - re - mi - fa - sol - la - ti - do*. The difference in pitch between the same two notes from one scale to another is called an octave. The notes within an octave have a mathematical arrangement, shown in the table at the right.

PITCH	LENGTH RATIO
C	1
D	8/9
E	4/5
F	3/4
G	2/3
A	3/5
B	8/15
C	1/2

If, for example, a length of tube 30 cm long produced a low C, then a tube half its length (15 cm) would produce a C one octave higher.

A tube $\frac{4}{5}$ of the length (20 cm) would produce an E. In the following activity, you'll construct a set of air columns to produce the eight notes of an octave. (Note: the notes of this scale are arbitrary and are not intended to match true notes.)

PROCEDURE

1. Work with a partner. Each of you will construct four of the eight straw instruments.
2. Measure the length of one straw. Record the length as the low "C" note in the chart below (the top box represents the low "C"). Use the ratios shown above to determine the length of straw needed to produce each of the eight notes. Record values in the table at the right.
3. Mark the lengths on the eight straws so that you and your partner will have a complete set of eight notes. Trim each straw with scissors to the exact length. You may want to write the name of the note on each straw that you cut.

PITCH	STRAW LENGTH
C	_____cm
D	_____cm
E	_____cm
F	_____cm
G	_____cm
A	_____cm
B	_____cm
C	_____cm

4. Flatten one end of each straw. Use scissors to make two cuts on the flattened end as shown here. The cuts should produce reed-like mouthpieces on all eight straws.

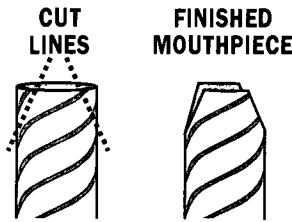

5. Chew down on the mouthpiece end of your straw to flatten it (do not exchange straws with your partner). If chewing or cutting has closed the trimmed end, open it.
6. Place this trimmed end in your mouth and blow lightly. The end should be far enough in your mouth that the flaps are free to vibrate. As you blow, the reed flaps will vibrate, producing a buzzing note. Compare the pitches of the notes produced by straws of different lengths.

(Note: If a straw doesn't produce a sound, chew the trimmed end to soften the reed flaps.)

EXTENSIONS

- ▷ Design and build an instrument that produces all eight notes in an octave, using only a single straw.
- ▷ Work with your partner to find out which notes sound pleasant (harmonious) when played together using different straws. Record those note combinations. Also, record the note combinations that do not sound pleasant (discordant).
- ▷ Work with the entire class to produce a "musical story" or opera of pipes with your instruments. The story should include unison notes, harmonious note combinations and discordant note combinations.



The curved shape within the tube represents the smallest standing wave that can form in a straw pipe.



This longer straw segment has a longer standing wave. The longer waveform produces a sound that is detected as lower in pitch.

ACTIVITIES ON THESE PAGES CONTRIBUTED BY MASSACHUSETTS SCIENCE WRITER MICHAEL DISPEZIO, AUTHOR OF CRITICAL THINKING PUZZLES (STERLING, 1996).

SCIENTIFIC AMERICAN FRONTIERS

SHOW 701

INVENTING THE FUTURE

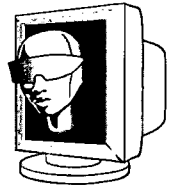

BRAIN MUSIC

FOR FURTHER THOUGHT

- ▷ Do you remember the last time you filled a jug or bottle with water? If so, did the sound produced by the water rising in the jar get lower or higher in pitch? Think about it. Then, from what you've learned, explain your observation.

FRONTIERS ONLINE

Visit MIT's Media Lab with FRONTIERS Online!

Ask the Scientists

After you watch "Inventing the Future" you can learn more about the intriguing research at MIT from the scientists you see on the show. We invite you to send your questions to the six scientists featured on this page. They will be available to answer viewers' questions from **October 23 to November 8, 1996**, via FRONTIERS on the World Wide Web at <http://www.pbs.org/saf/>.



VIRTUALLY REAL

Professor Alex (Sandy) Pentland (left), academic head of the Media Laboratory, combines reality with virtual reality. One example is Silas, an intelligent virtual dog that responds to its environment.

Also in this segment, **Professor Pattie Maes** (right) explains how software agents, like the Firefly project she developed, can help match people with their interests and with others who share those interests. Send in your questions to find out more about these fascinating projects.



PRIVATE EYES

If you can imagine a computer that acts almost like an auxiliary brain and can be worn as easily as a pair of eyeglasses, you'll be intrigued by the work of **Thad Starner** and his Wearable Computing Project. This self-styled cyborg is ready to answer your questions about "wearing" a computer and the capabilities of these amazing devices.

BRAIN MUSIC

The *Brain Opera* allows an audience to generate hypermusic on hyperinstruments, and then incorporates the sounds into a live performance. The creator of the *Brain Opera*, **Tod Machover**, will tell you more about this collaborative event. Machover is scheduled to be in France and Germany during this question-and-answer session, so he'll also field questions about his latest projects in Europe.



BODY TALK

Are computers as we know them disappearing? This segment shows how computers are "coming out of the box" to see and hear more like people and to respond to our gestures. The next generation of computers may look completely different and take on a more

active role in our world. If you'd like to discover more, **Professor Justine Cassell** will answer your questions about Gandolf and the computers of the future.

SMART CAR

Could "smart" cars interpret drivers' actions and warn them of impending danger? You'll find out when **Sandy Pentland** (pictured above in Virtually Real) invites Alan Alda to take his driving simulator for a test ride. Also in this segment, **Associate Professor of Media Technology Rosalind Picard** (right) shows how she's trying to give computers the human-like ability to recognize emotional cues and use them in interactions. Find out more about the amazing new capabilities of computers by sending your questions to these scientists.



HERE'S HOW TO "ASK THE SCIENTISTS":

- ▷ Watch "Inventing the Future" and review this classroom guide to prepare your question(s) and decide which scientist(s) you'd like to contact.
- ▷ Visit SCIENTIFIC AMERICAN FRONTIERS on the World Wide Web at <http://www.pbs.org/saf/>. Click on the "Ask the Scientists" icon on the welcome screen to find the e-mail form for sending your question(s). Scientists will answer as many questions as possible, and their answers will be posted for all FRONTIERS viewers to read.
- ▷ Note that the Media Laboratory offers several Web sites where you can learn more about the projects featured on "Inventing the Future." You may want to visit the sites listed on the next page before preparing your questions.
- ▷ Remember to e-mail your questions by November 8, 1996.

"Inventing the Future" airs on PBS on Wednesday, October 23, 1996 at 8 pm*.

* Check your TV listings to confirm local air time and date.

Welcome to FRONTIERS Online 1996-97

This season FRONTIERS continues to bring you and your students an array of exciting online activities and resources, both on America Online and the World Wide Web. Below is a sampling of FRONTIERS cyberspace features planned for this season.

 America Online	 PBS Online
---	---

Library of Online Resources and Related Sites Explore these online sites for further learning.	•	•
E-Mail FRONTIERS (saf@pbs.org) Send us feedback . . . ask for help. We're listening!	•	•
Send a Message to Alan Alda Write a note to the host of FRONTIERS.	•	•
Ask the Scientists Send questions to scientists featured on "Inventing the Future."		•
Science Scavenger Hunt Answer correctly for a chance to win a FRONTIERS T-shirt!		•
Instant Poll Share your opinion about topics on FRONTIERS.	•	•
Vote for Your Favorite Segment Tell us what story you like best on each show.		•
Teaching Guides Download resources for using FRONTIERS in your classroom.	•	•
Transcripts Access the complete text for each FRONTIERS show.	•	•
Viewer Challenge Questions Use this quiz to test students' viewing skills.	•	•

Explore the Future Online

Check out these sites provided by the MIT Media Laboratory and visit the FRONTIERS Web site for additional resources related to "Inventing the Future."

▷ <http://www.media.mit.edu>

Visit **MIT's Media Lab** and explore its advanced research into a broad range of technologies including digital TV, computer music and vision, electronic publishing, artificial intelligence and education-related technologies.

▷ <http://www-white.media.mit.edu/vismod/demos/smartroom/>

Investigate how smart rooms act like invisible butlers. Their cameras, microphones and other sensors receive and use information to interpret what people are doing and try to help them.

▷ <http://www.sciam.com/WEB/0496issue/0496pentland.html>

Learn more about smart rooms from this *Scientific American* magazine article. Sandy Pentland explains how computer systems that identify people and interpret their actions are bringing researchers closer to building helpful homes and work environments.

▷ <http://www-white.media.mit.edu/vismod/demos/smartdesk/>

Discover how a cyberdesk can create a personal work environment that responds to you to increase your comfort and productivity.

▷ <http://wearables.www.media.mit.edu/projects/wearables/>

Learn how the Wearable Computing Project hopes to shatter myths about how a computer should be used.

▷ <http://brainop.media.mit.edu>

Find out more about the *Brain Opera*, an interactive musical journey into your mind created by Tod Machover.

At press time, the online features and sites listed here were current. Due to the rapidly changing online world, some may have changed or may no longer be available.

WATCH IT ON PBS

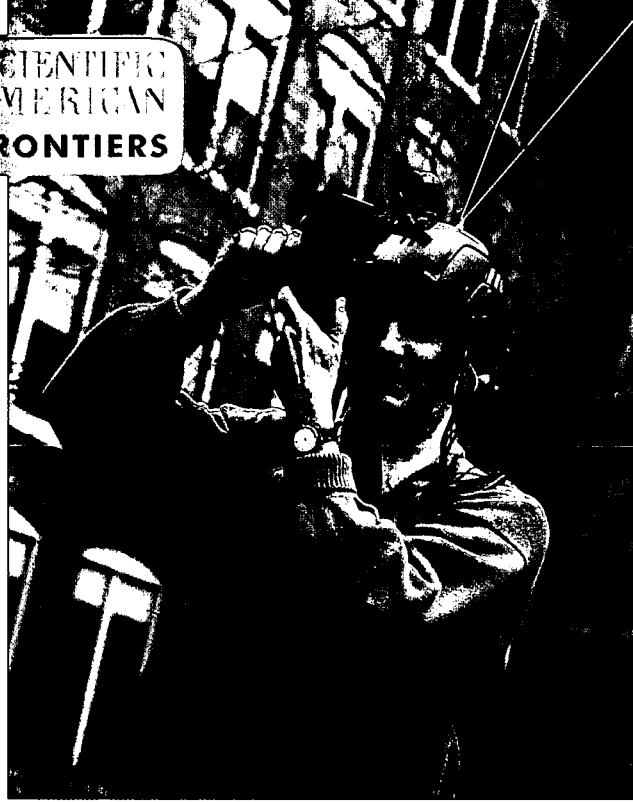

SCIENTIFIC AMERICAN FRONTIERS airs monthly on PBS – October and November 1996 and January, February and April 1997. Each hour-long special includes a variety of fascinating science stories based on a single theme.

INVENTING THE FUTURE (Show 701)

Wednesday, October 23, 1996 8 pm

Leap forward into the future when FRONTIERS visits the MIT Media Lab to test out smart cars, smart rooms and wearable computers. Scientists here are redefining the computer as we know it, from a box that sits on your desk to an intelligent personal information appliance that might be with you at all times.

SCIENCE SAFARI (Show 702)

International Special

Wednesday, November 20, 1996 8 pm

Travel on a science safari to South Africa and meet some of the world's largest animals; then trek to sites once inhabited by early humans. Find out how technology is helping combat malaria.

PIECES OF MIND (Show 703)

Wednesday, January 22, 1997 8 pm

Spend the night in a sleep laboratory and find out more about how your brain works to create memories, dreams and language.

GOING TO EXTREMES (Show 704)

Wednesday, February 19, 1997 8 pm

Join scientists as they track the fastest animal on earth and investigate survival mechanisms of animals in desert and arctic environments.

ROBOTS ALIVE! (Show 705)

Wednesday, April 9, 1997 8 pm

Meet some autonomous robots with minds of their own. Host Alan Alda catches up with Flaky, the most capable robot that exists today.

HOSTED BY
ALAN ALDA

SCIENTIFIC AMERICAN FRONTIERS takes viewers on a futuristic tour of the MIT Media Lab in its 1996-97 season premiere. Host Alan Alda sings, composes melodies on hyperinstruments in the *Brain Opera*, plays with a virtual dog, tries out a shoe computer and test drives a smart car. Remember, teachers may videotape the show to use year after year. GTE Corporation, the series underwriter, grants educators free off-air taping rights in perpetuity for classroom use.



ASK THE SCIENTISTS!

Pattie Maes and other scientists seen on *Inventing the Future* answer your questions online. See pp. 14-15.



Underwritten by GTE Corporation



SCIENTIFIC
AMERICAN
FRONTIERS

Connecticut Public Television
P.O. Box 260240
Hartford, CT 06126-0240

1996-97
PROGRAM
SCHEDULE
ENCLOSED

INSIDE:

Requested Teaching Materials for INVENTING THE FUTURE

Airing October 23, 1996 on PBS

NON PROFIT
U.S. POSTAGE
PAID
Permit No. 51
Bristol, PA



Printed on recycled paper

SCIENTIFIC
AMERICAN
FRONTIERS

SHOW 702 TEACHING GUIDE • NOVEMBER 20, 1996 • 8-9 PM

Science Safari



GTE

Underwritten by
GTE Corporation



A Scientific
Expedition Through
South Africa

FOR YOUR INFORMATION

SCIENCE IN SOUTH AFRICA



Join FRONTIERS for a special science safari to South Africa, the location for this season's International Special. As South Africa emerges from the shadows of apartheid, find out what scientists are doing to solve some ancient problems (malaria) and modern dilemmas (balancing life in a wildlife park).

Be sure to visit our Web site (<http://www.pbs.org/saf/>) and try our online activities (see pp. 14-15 in this guide). You can also visit us on America Online (keyword: **frontiers**). You and your students can enter the **Viewer Challenge** (p. 4) and have a chance to win one of our terrific FRONTIERS T-shirts!

GTE GIFT GRANTS

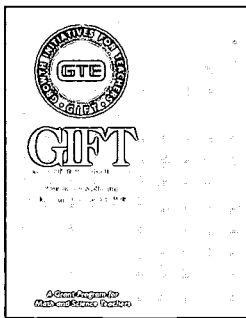

There's still time to apply for a GTE Growth Initiatives for Teachers (GIFT) grant. Each year, GTE Corporation awards grants of \$12,000 to 60 teams of one math and one science teacher from the same school. Teachers of grades 6-12 from selected states may apply for these grants, which are designated for school-enrichment projects and professional development. Participating states include: AL, AR, AZ, CA,

CO, CT, DC, FL, GA, HI, IA, ID, IL, IN, KY, MA, MD, ME, MI, MN, MO, NC, NE, NH, NM, OH, OK, OR, PA, SC, TN, TX, VA, WA, WI and WV. Winning educators have used their grants to fund exciting projects, from weather stations to aquafarms, robotics labs and much more. It's a great way to develop original projects that connect math, science and technology.

For an application, call 800-315-5010. **Applications must be postmarked by January 17, 1997.**

Scientific American FOR EDUCATORS

You'll find fascinating articles in each month's issue of *Scientific American* magazine, with multiple tie-ins to your curriculum and to episodes of FRONTIERS. For example, "The Global Positioning System" and "The Loves of the Plants" in the February 1996 issue link to stories in South Africa, as does "Rock Art in Southern Africa" in the November 1996 issue.

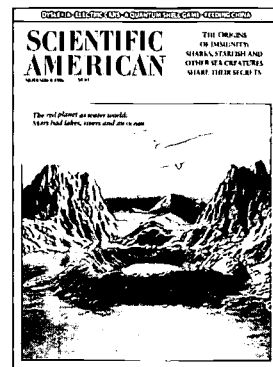

Educators and students can take advantage of special educational rates — \$24.97 for 12 monthly issues. To order, write to: *Scientific American*, Dept. SAF, 415 Madison Ave., New York, NY 10017. You can also access the magazine directly on the World Wide Web (<http://www.sciam.com/>) and on America Online (keyword: Sciam).

AERIAL ROBOTICS FOR HIGH SCHOOL

In 1997, the Association for Unmanned Vehicle Systems International (AUVSI) will sponsor a high school version of the collegiate International Aerial Robotics Competition seen last season on FRONTIERS (Flying High, Show #603, "RoboFlyers"). If your school is interested in learning more or participating in this event, please visit the aerial robotics competition Web page for the contest rules and an application (<http://avdil.gtri.gatech.edu/AUVS/IARCLaunchPoint.html>). Applications are due on December 1, 1996.

NEXT TIME ON FRONTIERS

Tune in January 22, 1997, when SCIENTIFIC AMERICAN FRONTIERS explores the workings of the human brain on **Pieces of Mind**. (See back cover for season schedule.)

SCIENTIFIC AMERICAN FRONTIERS is closed-captioned for the hearing-impaired and is narrated by Descriptive Video Service (DVS) for visually impaired audiences. The series and School Program are endorsed by the National Science Teachers Association (NSTA) and the National Education Association (NEA).

TAPING THE SHOW

- Always check TV listings to confirm air date and time.
- As a teacher, you have off-air taping rights in perpetuity for classroom use.
- If you can't find the show in your TV listings, call your local PBS station.
- Do you need help? Call the FRONTIERS School Program at 800-315-5010.
- **Videotapes of past shows** can be purchased (\$19.97 each). Call 800-315-5010.

FREE VIDEOTAPING & PHOTOCOPYING RIGHTS

GTE Corporation, the series underwriter, makes available complete off-air taping rights in perpetuity for classroom use of SCIENTIFIC AMERICAN FRONTIERS. Educators may record each show when it airs on PBS and keep the tapes to use in the classroom year after year. Educators may also photocopy all materials in this guide for classroom use.

If you know of other educators interested in receiving these guides, they may sign up by calling the SCIENTIFIC AMERICAN FRONTIERS School Program at 800-315-5010.

LET US HEAR FROM YOU!

We appreciate and welcome your questions, comments, compliments and constructive criticism. *Please contact us . . .*

BY MAIL:

SCIENTIFIC AMERICAN FRONTIERS
105 Terry Drive, Suite 120
Newtown, PA 18940-3425

BY PHONE: 800-315-5010

BY FAX: 215-579-8589

BY E-MAIL: saf@pbs.org

VISIT US ONLINE:

<http://www.pbs.org/saf/>

TABLE OF CONTENTS

SHOW 702 • NOVEMBER 20, 1996 • 8 PM ON PBS

SCIENCE SAFARI

6 FIGHTING MALARIA

Find out what South Africa is doing to control malaria — and how the insects are fighting back.

Activities:

Learn more about the life cycle of mosquitoes . . . Explore surface tension and ways of combating malaria

8 THE FIRST PEOPLE

Archaeologists discover hominid fossils at a site in South Africa and locate rock art painted thousands of years ago.

Activities:

Making inferences about fossil finds . . . Interpreting ancient art



10 CITY OF GOLD

The burial site of a 16th-century king and queen is found at a site called Thulamela, which means “place of giving birth” . . . Meet one of the present-day kings of the Venda.

Activities:

To dig or not to dig: current issues in the field . . . Some background and perspective

12 WAYS OF THE WILD

Scientists at parks within KwaZulu-Natal deal with complex issues of balancing life in an enclosed ecosystem.

Activity:

Role-playing issues involved in wildlife management

13 MR. CELE'S GARDEN

Many of the plants traditional African healers depend on for their medicines have been brought to the edge of extinction — the solution could be very non-traditional.

Activity:

Challenges of germinating mustard seeds

DEPARTMENTS

4 VIEWER CHALLENGE

5 THE BIG PICTURE

14 SAF ONLINE

Note: This Table of Contents does not reflect the actual order of the show's stories. The At-A-Glance box below reflects the actual order.

AT-A-GLANCE	SCIENCE SAFARI SHOW 702 • 11/20/96 8 PM* ON PBS		BIOLOGY	EARTH SCIENCE	GENERAL SCIENCE	LIFE SCIENCE	PHYSICAL SCIENCE	TECHNOLOGY
	STORY	RUNNING TIME						
	CITY OF GOLD	9:00	•		•	•	•	•
	WAYS OF THE WILD	14:00	•	•	•	•		
	MR. CELE'S GARDEN	9:00	•	•	•	•		•
	FIGHTING MALARIA	10:00	•	•	•	•	•	•
	THE FIRST PEOPLE	11:00	•	•	•	•		

*CHECK LOCAL TIME

SCIENTIFIC AMERICAN FRONTIERS is made possible by an underwriting grant from GTE Corporation. The series is produced by The Chedd-Angier Production Company in association with *Scientific American* magazine and presented to PBS by Connecticut Public Television.



19B

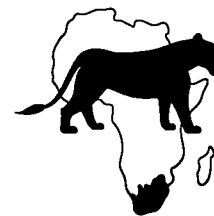

Student's Name _____
 Teacher's Name & Course _____

Watch **SCIENTIFIC AMERICAN FRONTIERS "Science Safari" (Show 702)** for answers to questions on this page. Answer the ten questions correctly and you'll be eligible to win a **FRONTIERS T-shirt!**

City of Gold

1. Archaeologists found all of the following at Thulamela *except*:
 a. iron b. diamonds c. copper d. gold
2. In what way do the Venda people tell a story or express a part of their history?

Ways of the Wild

3. The process of natural selection in Mkuze Park is influenced by all of the following *except*:
 a. drought b. fire c. genetics d. poachers
4. What species of African wildlife was saved from extinction by good wildlife management?

Mr. Cele's Garden

5. Why have some medicinal plants been driven to near-extinction in South Africa?

6. Which one of the following plants almost became extinct in South Africa?
 a. wild ginger b. pepperbark tree
 c. peppermint d. ginseng

Fighting Malaria

7. Malaria is primarily being brought to South Africa by people coming from what country?
 a. Ghana b. Tanzania c. Mozambique d. Kenya
8. What are two methods South Africa is using to control malaria?

The First People

9. Fossils found at the Saldanha site are representative of what kind of hominids?
 a. modern humans b. Cro-Magnons
 c. archaic humans d. Neanderthals
10. Much of the rock art in South Africa was painted with what pigment?

For Teachers Only

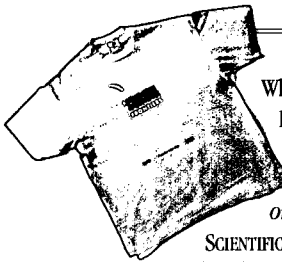

When completed, this page can become an entry to the **FRONTIERS T-shirt contest**; 20 winners (10 students, 10 teachers) will be drawn at random for each show. To enter the T-shirt drawing, send all completed challenges *in one envelope* with a cover sheet to: **Viewer Challenge**, SCIENTIFIC AMERICAN FRONTIERS, 105 Terry Drive, Suite 120, Newtown, PA 18940-3425. Mail completed entries by **December 20, 1996**.

TIP: You can also download these questions on the **FRONTIERS** online sites on the Web and AOL (see pp. 14-15).

Important!! Please include a separate cover sheet and tell us:

- number of challenges submitted
- teacher's name
- grade and course
- school name, address and phone number
- where your students watched the show — at home, at school or both
- the name of your students' favorite story in this show (conduct a quick poll to find out)

Thank you!

ANSWERS TO VIEWER CHALLENGE 702: 1. b 2. songs, dance 3. d 4. white rhino 5. growing population increased the demand 6. b 7. c 8. spraying walls inside houses, visits by health workers, mass screenings 9. c 10. ochre

THE BIG PICTURE

SOUTH AFRICA AT A GLANCE

South Africa is a vast and diverse land that has made significant contributions to history and science, from the origin of humans, to gold and diamond exploration, to the first human heart transplant and more, as you'll see on this episode of FRONTIERS.

▽ **POPULATION:** 45,095,459 people, or about 1/5 the population of the U.S.

▽ **AREA:** 472,281 sq. mi. (slightly larger than Texas, New Mexico and Oklahoma put together).

▽ **CURRENCY:** Rand (exchange rate 1.00 = \$.28 U.S.).

▽ **LANGUAGES:** There are 11 official languages: English, Afrikaans, Ndebele, Northern Sotho, Southern Sotho, Swati, Tsonga, Tswana, Venda, Xhosa and Zulu.

▽ **ETHNIC GROUPS:** Blacks: 74%, whites: 14%, mixed race: 9%, Asian: 3%.

▽ **LAND:** Less than 12% is arable; most is semi-desert. Topography varies and includes mountains, deserts, farmlands, savannah and coastal areas.

▽ **CLIMATE:** Average summer temperature: low 68°, high 89°; average winter temperature: low 34°, high 62°. Average annual rainfall: 18 inches.

▽ **TIME ZONE:** 7 hours ahead of Eastern Standard Time.

▽ **GOVERNMENT:** Federal republic (since the repeal of apartheid in 1994, the nation has undergone historic change).

▽ **PRIMARY INDUSTRIES:** Gold (South Africa is the world's largest producer), diamonds, other minerals; tourism.

▽ **TRAVEL TO:** A journey of 8,000 miles from New York to Johannesburg takes 14.25 hours by air.

THIS MAP HIGHLIGHTS THE LOCATIONS OF THE VARIOUS SITES WE VISIT ON FRONTIERS.

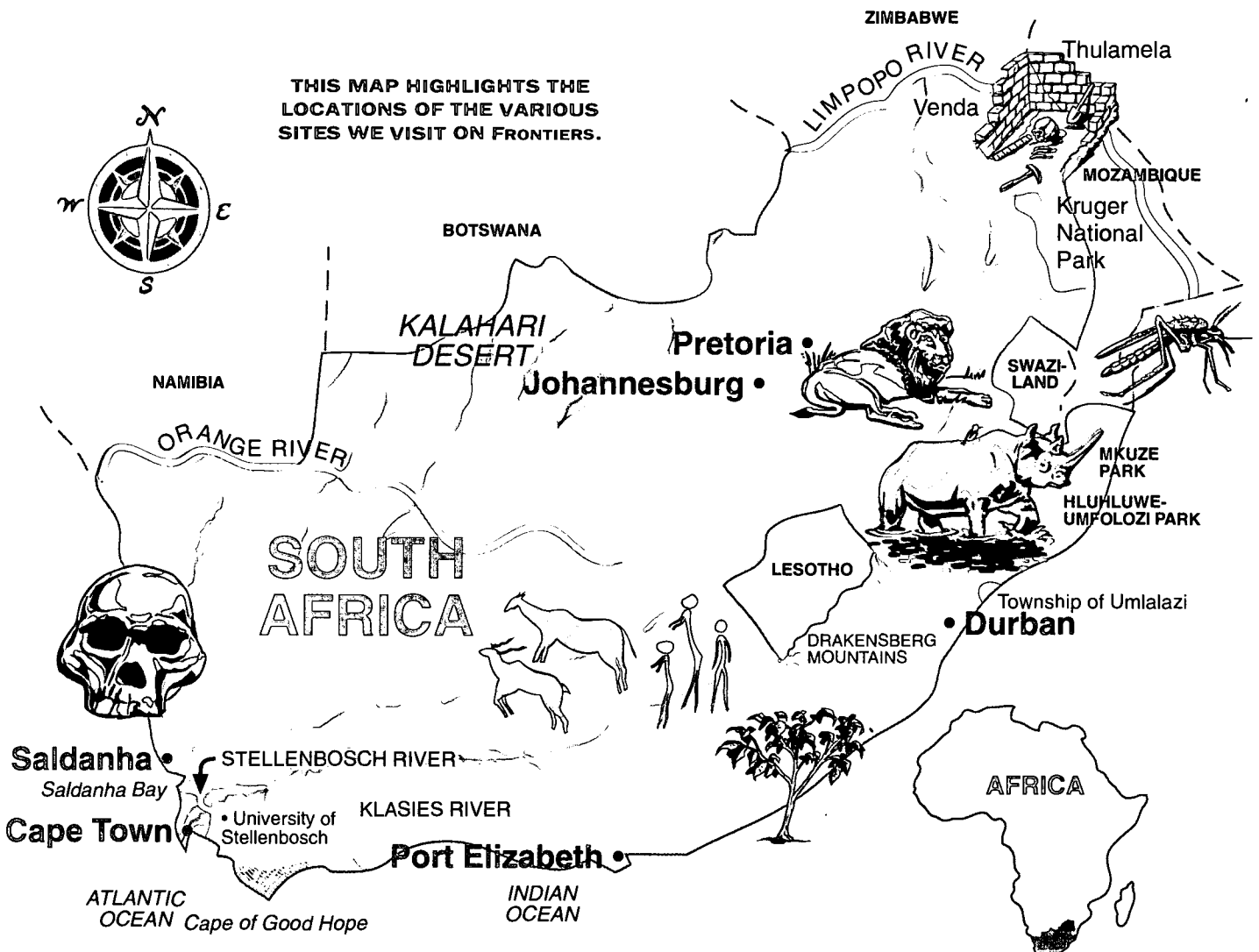



FIGHTING MALARIA

**RUNNING
TIME:**

10:00

**CURRICULUM
LINKS:**

BIOLOGY

insects, migration

**COMPUTER
SCIENCE**

databases

GENERAL SCIENCE

invertebrates

HEALTH

disease, micro-organisms, parasites

MATH

graphing

SOCIAL STUDIES

FIGHTING MALARIA

Each year, more than 400 million people in the world become infected with malaria transmitted from Anopheles mosquitoes. Over two million people, mostly in Africa, die. Although South Africa has been vigilant about malaria control, this disease continues to kill. FRONTIERS takes viewers through the laborious task of trying to control malaria, made even more challenging by mosquitoes that have developed a resistance to insecticides. One new technique involves the high-tech Global Positioning System (GPS).

Menacing Mosquitoes

Mosquitoes are an amazingly prolific relative of flies and gnats that need nothing more than a sip of blood and a bit of brackish (stagnant) water to set up a nursery teeming with squirming larvae (wigglers). Discarded tires, bird baths, clogged gutters and even cupped leaves serve as a haven for baby mosquitoes after a spring or summer rain.

Roughly 2,700 species of mosquitoes are classified into 35 groups; each group is called a genus. Mosquitoes in three main genera attack people.

A minor player in the food chain, mosquitoes serve no useful purpose except as food for bats and birds. They range in length from 6.4 mm to 12.7 mm — almost half an inch long. No wonder bumper stickers from Minnesota to Louisiana proclaim the insect their “state bird.”

As you see in this episode of FRONTIERS, malaria is often fatal. The female Anopheles mosquito transmits the parasites that cause malaria into the bloodstream. The parasite infects and destroys red blood cells. Only 76 new cases of locally acquired malaria in the U.S. were reported to the Centers for Disease Control and Prevention (CDC) from 1957 through 1994; but outside the U.S. malaria is still a killer — especially in Africa, where 90% of cases occur.

The mouth of a mosquito contains a full complement of serious tools. The proboscis, or lower lip, is a thin sheath hiding half a dozen razor-sharp implements. The mosquito does not really “bite” its victim, but stabs it with needle-like stylets at the center of its proboscis.

After the mosquito pierces the skin of its victim, it injects a mixture of saliva and anticoagulant into the opening. (The malaria parasite is transmitted at this stage.) When the victim’s blood has thinned

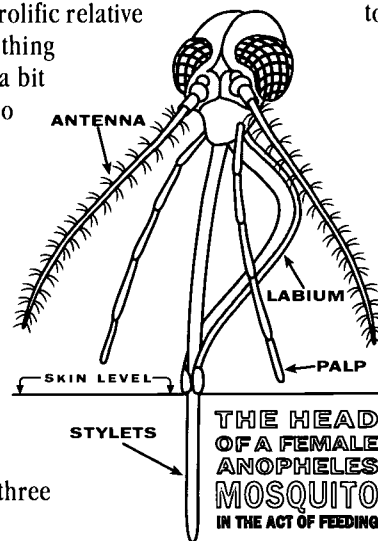

to a feeding consistency, the mosquito plunges in a straw-like digestive tube and begins to feed on the blood. Most people are allergic to the mosquito’s saliva, which causes the familiar itching and swelling.

Male mosquitoes feed off plant sap, as do females, but only adult females are blood-suckers; a meal of blood is essential to producing a healthy brood of eggs. Depending on the species, eggs are laid singly or in “rafts” on standing or stagnant water containing organic material on which the larvae will feed. Air trapped under the eggs keeps them afloat.

ACTIVITY 1: Floating Nurseries

Surface tension allows the surface of water to behave like “skin.” Insects like mosquitoes are able to walk on it. In some species, the larva’s breathing tube has water-repellent hairs that break through the surface tension.

You can investigate surface tension to better understand how the egg rafts stay afloat and how mosquitoes are able to stand on the water’s surface. Carefully float a sewing needle on the surface of a clean container of water and look at it with a magnifying glass. What do you see? Try floating other objects on the surface. How does shape affect the object’s ability to successfully rest on the surface? Using aluminum foil, create a “raft” with air trapped under a convex floor. Use paper clips, staples or pennies to see how much weight the raft can hold before it sinks.



<http://www.pbs.org/saf/>



Sipho Ngxongo,
seen in
this segment,
answers your
questions online.
See pp. 14-15
for information.

ACTIVITY 2: Real-World Connections

As more landfills refuse to accept scrap tires, illegal tire dumps have proliferated across the U.S. and resulted in major sites of mosquito breeding. In 1992, authorities located a pile of tires only seven miles from Walt Disney World in Florida, where billions of mosquitoes had taken up residence. Many were infected with the deadly Eastern equine encephalitis.

In late summer of 1996, residents of the Northeast became concerned when mosquitoes infected with Eastern equine encephalitis were captured and identified. Officials ordered the spraying of pesticides to prevent a possible epidemic.

Conduct a Public Health Campaign

As the head of public relations for your city, you are asked to design a campaign to persuade residents to dispose of tires properly and to identify mosquito breeding grounds. You realize the urgency of the job because a neighboring state has identified a potentially fatal virus transmitted by mosquitoes.

Work in teams to plan your strategies. Some questions to consider:

- ▷ How can you make people aware of the potential dangers of mosquitoes without causing panic?
- ▷ Pesticides, vaccines and biological controls (spraying spores of a bacterium to kill the larvae) have been used effectively. What methods would you recommend to control the mosquitoes?
- ▷ What are you going to do with the tires and how will you get citizens to cooperate?

Math Connection

Mosquitoes develop into adults and leave the water about seven days after the female lays her eggs. Depending on the species, a female can lay between 100 and 400 eggs in one brood and produce a new brood every two to three days (or about 3,000 eggs in a lifetime). Most eggs are lost to predators who find them an easy snack.

Assuming that one adult female produces a new brood every three days, but only 10% of the eggs survive to become adults, how many offspring might one female mosquito produce in one week (providing the female remains alive that long)? Now assume that half of the offspring are female; how many mosquitoes could be born in the next generation? Why are controls in the early spring the most important?

Literature Connection

In his poem *The Mosquito*, D.H. Lawrence describes the sound of the mosquito as "a small, high, hateful bugle in my ear." He calls the creature a "ghoul on a wing." Look up the poem and the West African folk tale, "Why Do Mosquitoes Buzz in People's Ears?" (it can be found in the children's book of the same title by Verna Aardema). Then write your own poem or story about this unpopular insect. Don't forget illustrations!

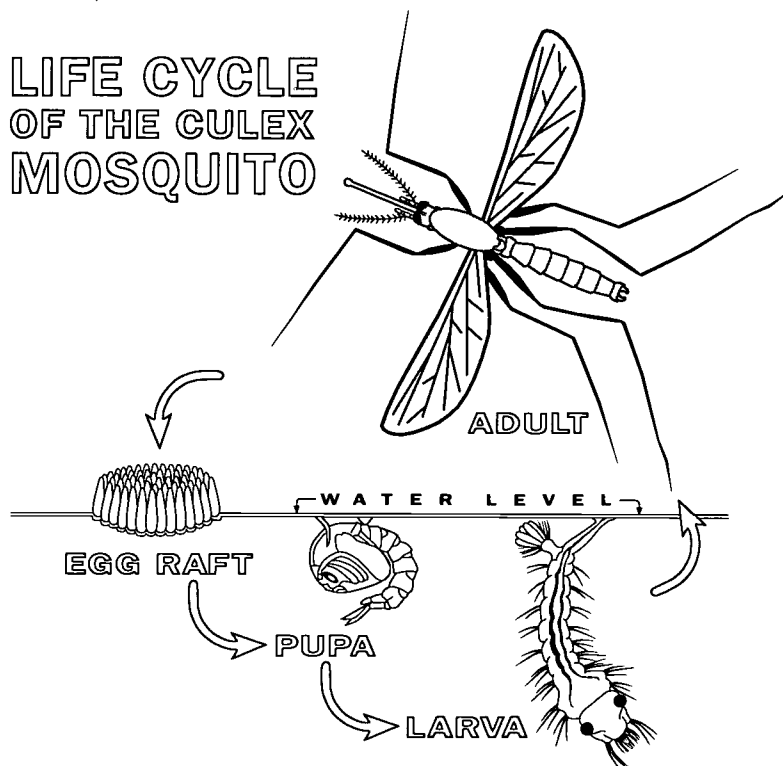

SCIENTIFIC
AMERICAN
FRONTIERS

SHOW 702

SCIENCE
SAFARI



FIGHTING MALARIA

FOR FURTHER THOUGHT

- ▷ What other diseases are transmitted by mosquitoes? Map the areas in the world where malaria, dengue and other mosquito-borne diseases are still a problem. Identify which species carries the disease.
- ▷ Find out what mosquito control methods are used in your community. What is the cost to maintain this program?
- ▷ If mosquitoes are a "minor player in the food chain," why not just eradicate them as a species? Explain your answer.
- ▷ Explain and demonstrate why running water in a stream or pond would be a poor choice for where to lay mosquito eggs.



THE FIRST PEOPLE

RUNNING TIME:

11:00

CURRICULUM LINKS:

AFRICAN HISTORY & CULTURE

ARCHAEOLOGY/ PALEONTOLOGY

ART

BIOLOGY

evolution, natural selection, population genetics

GENERAL SCIENCE

fossils, geological time scale, prehistoric man

MATH

ratios

SOCIAL STUDIES

THE FIRST PEOPLE

Most scientists believe that modern humans originated in Africa. For decades scientists have discovered incredible finds from different areas of Africa; fragments of bone and human-like fossil remains are giving us tantalizing clues to our past. Ancient rock art created by people who inhabited this land thousands of years ago provides another window into the past. In this episode, FRONTIERS visits Hilary Deacon and other archaeologists working in South Africa to solve the riddles of human evolution.

ACTIVITY 1: Calculating Clues from Bones



Much of our knowledge about early humans is based on inferences. Inferences are “best guesses” that connect an observation with an established fact or association.

Behavioral and anatomical features of early humans are often inferred from partial skeletons or scattered bone fragments. Rarely is an entire skeleton ever discovered by a paleontologist. Sometimes a single bone can be used to uncover a person’s or animal’s complex biological and social characteristics.

In the following activity, you’ll infer a person’s height from the length of one bone. By applying a simple calculation to the observed length, you’ll develop a “best guess” for body height.

OBJECTIVE

Evaluate mathematical relationships.

PROCEDURE

1. The formulas below illustrate the relationships between bone lengths and a person’s height.

MALES (HEIGHT IN INCHES)

$$\text{Height} = (\text{length of radius} \times 3.3) + 34$$

$$\text{Height} = (\text{length of humerus} \times 2.9) + 27.8$$

FEMALES (HEIGHT IN INCHES)

$$\text{Height} = (\text{length of radius} \times 3.3) + 32$$

$$\text{Height} = (\text{length of humerus} \times 2.8) + 28.1$$

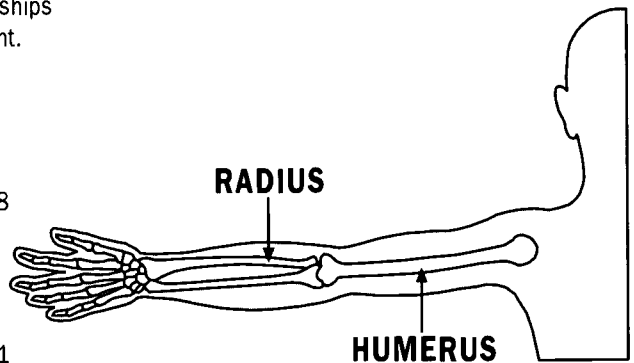

<http://www.pbs.org/saf/>



Hilary Deacon, seen in this segment, answers your questions online. See pp. 14-15 for information.

	BONE LENGTH	CALCULATED HEIGHT	MEASURED HEIGHT
RADIUS			
HUMERUS			

ANALYSIS

1. Compare your calculated and measured heights. How accurate were your inferences? (Answers will vary.)
2. Which was a more accurate bone length to base your inference upon? (Answers will vary; however, many students will find it easier to measure the length of the humerus.)
3. Measure the length of your foot. Is this length closer to the length of your radius or humerus? (In most, it will be surprisingly close to the length of the radius.)

EXTENSIONS

- ▷ Pool and average the class data collected above. Graph the relationship between radius length and height. Use separate curves for males and females.
- ▷ Work with a partner to determine if you can find a correlation between height and the length of a person's tibia, or shinbone. Can you find a correlation between height and the length of a person's femur (thighbone)? Once you arrive at the relationship, have other student groups test out your calculation method.

**SCIENTIFIC
AMERICAN
FRONTIERS**

SHOW 702

SCIENCE
SAFARI



THE FIRST PEOPLE

ACTIVITY 2: Painting Rituals

What are the rituals in your daily life? Do your evening rituals depend on the lineup of sky objects or the lineup of nightly television shows? What can someone learn about you and your society by studying rituals?

MATERIALS

- ▽ non-toxic finger paints
- ▽ paper

PROCEDURE

1. Identify three ritual activities you share with members of your family. Identify three different rituals you share with friends.
2. Obtain a set of non-toxic finger paints from your instructor. Fingerpaint each of the rituals identified above. Use straight lines and the fewest strokes possible to simulate schematic images or the "stick figures" typical of some ancient art.
3. Display your illustrations. Have other students interpret your rituals.

OBJECTIVE

Identify and communicate present-day rituals through ancient art techniques.

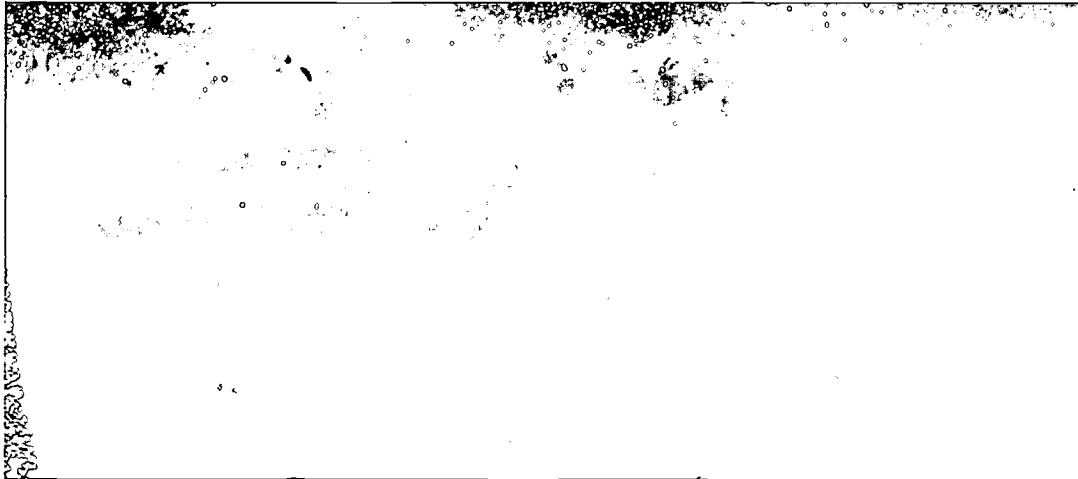

ANNE SOLOMON

This rock painting, found in the Drakensberg Mountains, shows a rain ceremony painted in red ochre. An animal is being captured by rainmakers or shamans. For more about the South African rock art, see "Rock Art in Southern Africa" in the November 1996 issue of *Scientific American* magazine.

ACTIVITY 3: Interpreting an Ancient Drawing

Suppose you are the scientist who discovered the cave painting to the right. Critically analyze the image. Then write a short caption that describes the complete event.

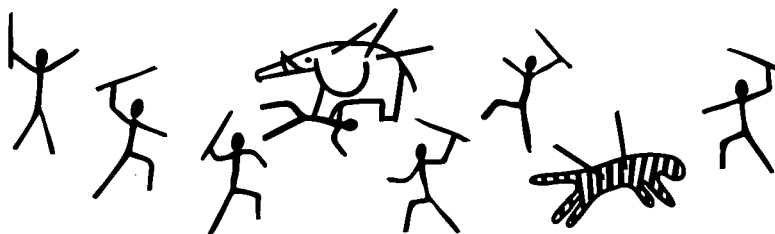

FOR FURTHER THOUGHT

- ▷ In Activity 1, why do the formulas contain different calculations for determining male and female heights? (Skeletons of males and females have different proportions.)
- ▷ Do you think archaeologists of the future might interpret the graffiti of today similarly to the way we interpret ancient rock paintings or petroglyphs?
- ▷ Much rock art in Paleolithic times in various areas of the world was painted in red or yellow ochre. What is this pigment and why was it used by so many different cultures?



CITY OF GOLD

**RUNNING
TIME:**

9:00

**CURRICULUM
LINKS:**

**AFRICAN HISTORY
& CULTURE**

ARCHAEOLOGY

BIOLOGY

evolution,
musculoskeletal
system

GENERAL SCIENCE
geological time scale

SOCIAL STUDIES

TECHNOLOGY

tools

**RELATED
FRONTIERS
ACTIVITY:**

**CREATURES
OF THE DEEP
(SHOW 604)
TEACHING GUIDE**

"Investigate a
Midden" (p. 11)

<http://www.pbs.org/saf/>



Sidney Miller,
seen in
this segment,
answers your
questions online.
See pp. 14-15
for information.

CITY OF GOLD

Centuries before the Dutch ever landed near Cape Town, what is now South Africa was a bustling trading center. Archaeologists in the new South Africa are only just beginning to uncover the history of this ancient land. Viewers accompany Alan Alda and the FRONTIERS crew to a site where a 16th-century king and queen were buried inside the walled citadel of Thulamela. Clues buried in the earth may help today's descendants of the people who once lived here understand and connect to their past.

ACTIVITY: To Dig or Not to Dig: Debating the Issues

In centuries past, a victorious conquering army frequently claimed antiquities and artifacts as prizes of war and hauled them back to their own country. Sometimes the artifacts were restored to their native land many years later. Similarly, fossil finds were often taken from the site where they were found and no records were kept of the finds, thus depriving future scientists of important historical information. Artifacts and fossilized bones might even be sold on the black market. Such activities are now considered highly unprofessional and are usually illegal.

In recent times, archaeologists, paleontologists and other scientists on digs or at excavations have been much more sensitive to both science and the rights of native peoples. As you see on FRONTIERS, a committee of local people is overseeing the excavation of a site that may tell them more about their own culture and ancestors at Thulamela.

Not everyone is convinced of the need to respect the rights of property. In fact, these issues raise questions for discussion among scientists and others concerned. Just who owns an artifact or a fossil found buried in the earth? And what is the best way to remain sensitive to the past yet mindful of the need to share information?

Sometimes historic preservation takes an extreme point of view, and old buildings are maintained simply because they are old. Other times there is a rush to develop and build on land where artifacts are found.

In such situations, who decides what is right? And under the circumstances, what *is* the right course of action? What would *you* do, for example, if artifacts were found on your property?

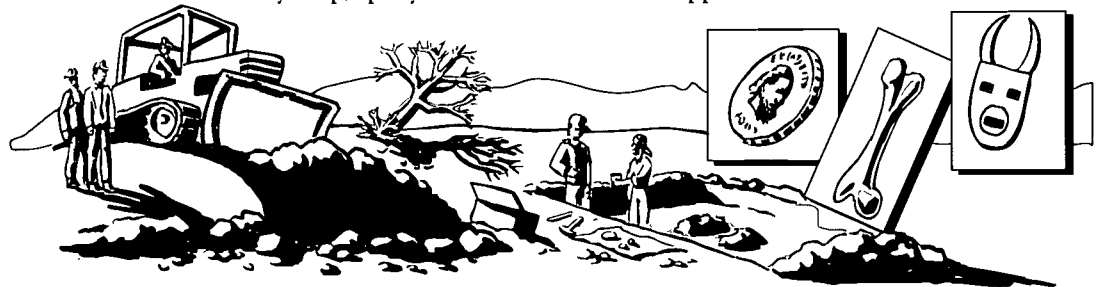

OBJECTIVE

Apply critical thinking to current issues. Present arguments in an organized, coherent fashion.

PROCEDURE

Below are several scenarios that raise pertinent issues for discussion. Discuss, debate or role-play the situation. Or, write a position paper defending your perspective. Some roles to play might include:

- ▷ the archaeologist or paleontologist who made the discovery,
- ▷ a representative from a scientific association,
- ▷ a person with commercial interests, such as a developer or antique dealer,
- ▷ a museum official,
- ▷ a descendant of the native people who lived on the site in earlier times,
- ▷ a person who owns the property on which the artifacts are found.

Artifacts Under a House

In the process of razing a house and surrounding buildings for a new development, builders find some artifacts buried beneath the hearth of what was once a kitchen. Local archaeologists determine that the artifacts — pieces of bone, coins, buttons — may have belonged to former slaves. Developers are impatient and want to proceed with the new development, but a local museum wants to continue to look for other items. What should happen?

A Mummy Is Found

Excavators in a western state find a long-buried mummy. Present-day Native Americans want to bury the remains on their land, following traditional ceremonies. They have requested that the mummy not be photographed. A museum wants

the mummy to be part of an exhibit on early people. And scientists object to the no-photography rule, saying they need to document and share information about the find. What should happen here?

Pottery in the Backyard

A woman digging in woods near her house finds pottery shards and other bits and pieces — probably from what was once a kitchen midden where people dumped their trash. She takes all the finds into her house to clean them, then sells them at flea markets. When members of a local archaeology association find out, they are horrified and demand she stop digging in public woods. They claim the artifacts should be retrieved for study or placement in a museum. Who owns the artifacts? Should they be given to a museum?

EXTENSION

A controversy is raging right now over who owns some bones found in Washington State. Samples indicate that the skeleton might be more than 9,000 years old. Leaders of the Umatilla Indian tribe claim the remains belong to them because they are those of an ancestor. They plan to rebury the bones without allowing further analysis. Anthropologists say the bones might be Caucasian and want more opportunity to study them. Who owns the remains and what should happen to them?

Timeline of Fossil Finds and Paleolithic Art

A.D.	
1652	Dutch found Cape Town
c. 1300	Great Zimbabwe is major trading center
c. 1250 to 1700	Walled city of Thulamela flourishes
B.C.	
c. 600	Bantu people move into southern Africa; Africa's Iron Age begins
c. 5000	Farming introduced into northern Africa
c. 10,000	Last Ice Age ends
c. 17,000	Cave paintings created at Lescaux (France), Altamira (Spain) and other sites in Europe
c. 26,000	Earliest surviving examples of rock art created by Bushmen (San people)
c. 75,000	Last European Ice Age begins; Earliest Australian rock art created
c. 100,000 to 120,000	Evidence of early humans at Klasies River in South Africa
c. 120,000	Modern <i>Homo sapiens</i> emerge
c. 300,000	Archaic <i>Homo sapiens</i> live at Saldanha
c. 200,000 to 500,000	Archaic <i>Homo sapiens</i> emerge

A leading theory today holds that modern *Homo sapiens* emerged in what is now Africa 150,000 to 100,000 years ago and then spread to the rest of the world. Paleontologists and archaeologists continue to find pieces of the puzzle of human origins. New technologies and dating procedures push back the years and revise theories. Dating of fossil finds and artifacts is not precise and can provide only estimates.

SCIENTIFIC
AMERICAN
FRONTIERS

SHOW 702

SCIENCE
SAFARI



CITY OF GOLD

FOR FURTHER THOUGHT

➤ Local residents who may be descendants of Thulamela's people are participating in the excavation of the Thulamela site. They have requested that the site be reconstructed as it was in the 16th century, when the walled city thrived. Not all archaeologists favor this approach. Why do you think there might be disagreement?

➤ Do you think rock art indicates that "modern humans" occupied a site? How much credence should be given to the symbolism and modern interpretations of work created thousands of years ago?

➤ What would your artifacts say about your culture? For more on the subject, read *Motel of the Mysteries* by David Macaulay. This book imagines what future archaeologists might interpret about our civilization.



WAYS OF THE WILD

**RUNNING
TIME:**

14:00

**CURRICULUM
LINKS:**

BIOLOGY

biomes, vertebrates

GENERAL SCIENCE

ecology

LANGUAGE ARTS

current issues,
debate, speech

LIFE SCIENCE

mammals

**SCIENCE,
TECHNOLOGY
& SOCIETY**

SOCIAL STUDIES

TECHNOLOGY
monitors, tagging
devices

WAYS OF THE WILD

What happens when wild animals accustomed to living in wide open spaces have to live within restricted boundaries? Find out when FRONTIERS travels to Hluhluwe-Umfolozi and Mkuze Parks in South Africa, which serve as a model for other African countries. Scientists have been dealing with complex issues of water, fire and vegetation problems for over a decade. Their experiences offer lessons in advanced wild-life management and hint at what the future holds for wildlife everywhere.

ACTIVITY: Wildlife Challenge

Read the following hypothetical scenario and prepare your response.

OBJECTIVE

Apply critical thinking skills to a decision-making scenario and strategically communicate information.

THE SCENARIO:

People in your town have voted to replace an old zoo — the free Municipal Zoo — with a new conservation park that is considered by educators and animal rights activists to be more “humane to animals.” Not everyone agrees with the decision, and many people have argued in favor of keeping the old zoo, if only to preserve fond memories.

Nevertheless, the citizens passed legislation to build new structures and replace old ones. The conservation park will be built on a tract of land that is currently the site of closed but re-toolable factories. The entire project will cost taxpayers about \$25 million and take five years to complete.

Upon completion, the park will offer a protected and natural habitat for animals currently housed in the Municipal Zoo. The park will also maintain breeding populations of several endangered species.

Owners of the new park would like to save money by reducing the staff, if that is possible. Funds needed for this project will be “trimmed” from a variety of ongoing social projects in the town and raised from a bond issue in the upcoming election. Additional money will be obtained by introducing an admission price of \$5 per person. The developers of the new park hope to raise much of the money to keep the costs down, and also provide educational classes and other opportunities for local students.

YOUR ASSIGNMENT:

Imagine that you are employed as a speech writer for a mayoral candidate. The candidate informs you that she wishes to gain support for establishing the new park as part of her platform.

Your job is to write a speech she can deliver to various audiences.

The mayoral candidate first wants you to evaluate the different audiences she will face in her upcoming campaign. To each group, she must present as much of the above scenario as possible. Your first assignment is to critically analyze the list of audiences and prepare three to four points the candidate can make in support of the new conservation park, with the particular audiences in mind.

Another part of your job is to assist with raising funds for the new park; you have been promised a bonus if your candidate gets into office and another bonus if you are successful in raising money. How will you make your pitch to these audiences?

POTENTIAL AUDIENCES:

- unemployed factory workers
- local tourism committee
- conservationists
- animal rights activists
- low-income families
- science teachers
- investors in local manufacturing
- workers currently employed at the Municipal Zoo

EXTENSIONS

- Design an advertisement that could be published in the local newspaper that would encourage support for this project. Alternatively, design a home page for the park’s new Web site.
- Suppose you were allowed to redesign this zoo project. Describe the five most important parts of your new zoo’s philosophy. Which things about the current proposal would you keep? Which things would you get rid of? How? Present your design and policy statements and any pertinent research and interviews in a display (use a presentation board if you wish).

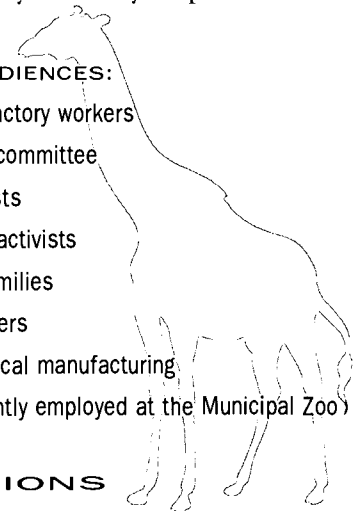

<http://www.pbs.org/saf/>



Pete Goodman,
seen in
this segment,
answers your
questions online.
See pp. 14-15
for information.



MR. CELE'S GARDEN

**RUNNING
TIME:**

9:00

**CURRICULUM
LINKS:**

BIOLOGY

botany, taxonomy

EARTH SCIENCE

ecosystems

GENERAL SCIENCE

classification,
plants

HEALTH

alternative
medicines, herbs

LIFE SCIENCE

disease, medicine,
plants

**RELATED
FRONTIERS
ACTIVITY:**

**DRAGON SCIENCE
(SHOW #602)
TEACHING GUIDE**

"How Much Do
You Know About
Medicine?" (p. 11)

<http://www.pbs.org/saf/>



Richard Symmonds,
seen in
this segment,
answers your
questions online.
See pp. 14-15
for information.

MR. CELE'S GARDEN

A*fricans have always relied on traditional medicines — even now they* use a mix of old and new. Traditional healers once gathered the wild plants they needed to make healing remedies. But today they are often gathered by traders and many of the wild plants and trees are in danger of dying out due to the increasing demand. Botanists have become alarmed and are working with traditional healers like Mr. Cele to cultivate plants and save them from extinction.

ACTIVITY: Improving the Odds

MATERIALS

- ▽ mustard seeds (located in the spice section of grocery stores)
- ▽ paper towels
- ▽ 4 petri dishes
- ▽ 4 small zipper-type plastic bags
- ▽ small magnifying glass
- ▽ 60-watt bulb
- ▽ power source
- ▽ thermometer
- ▽ boxes
- ▽ ice chest
- ▽ ice
- ▽ source of refrigeration
- ▽ water

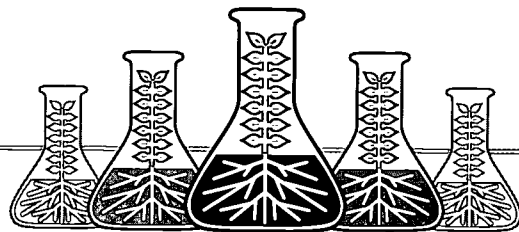

As botanists and gardeners know, many factors play a role in plant growth. A supply of water and appropriate temperatures trigger an internal mechanism that causes a plant to begin to put down roots. The roots seek nutrients and the plant pushes toward the light with a stem and tiny energy-grabbing seed leaves.

OBJECTIVE

Investigate factors affecting seed germination and graph the results.

PROCEDURE

I. GERMINATION RATE

Work with a partner or in small groups.

1. Cut four layers of paper towel to fit in each petri dish.
2. Select 200 mustard seeds and divide them into groups of exactly 50 each. Use an index card to help separate and count seeds.
3. For each dish, place two circles of paper towel in the bottom and spread 50 seeds evenly on top. Place two more paper towel circles on top of the seeds.
4. Label the plastic bags 1, 2, 3, 4 and add your group name.
5. Carefully saturate, but don't drench, the paper towels with water. Place each dish in a labeled plastic bag and seal.

II. PLACE EACH OF THE FOUR PACKAGES IN A DIFFERENT ENVIRONMENT . . .

1. . . in a closed box on the counter or desktop in the classroom. Measure and record the air temperature inside the box.

2. . . in a closed box about two inches from a 60-watt bulb that is left on during the day (or in a warm spot in the room). Measure and record the air temperature in the box after the bulb has been on for 15 minutes.
3. . . in an ice chest that contains a small amount of ice. Measure and record the air temperature inside the chest after it has been closed for 15 minutes.
4. . . in a box to be placed in a refrigerator. Measure and record the air temperature inside the refrigerator.

III. OBSERVATIONS AND MEASUREMENTS

On a daily basis for the next three to four days:

1. CAREFULLY open the packages and record the number of seeds that have germinated (split the seed coat) and sketch what you observe. Use the magnifying glass to provide details. Graph the results.
2. Measure and record the temperatures of the different environments so you can compute an average daily temperature for each environment.
3. At the end of the experiment record your observations for the entire experiment and address the following questions:
 - ▷ What percentage of seeds germinated in each collection?
 - ▷ Based on your results, what is the optimum environment for germination?

EXTENTIONS

- ▷ How are botanists seen on FRONTIERS bringing back nearly extinct plant species?
- ▷ Mustard plants belong to the family of crucifers. Find out what other plants belong to this family.
- ▷ Some crucifers are being used in cancer research. Can you find examples of other herbs and plants being used as medicine?
- ▷ Look up <http://fastplants.cals.wisc.edu/> on the Web and locate where species of Brassicas grow in the world. Plot the sites on a map.

FRONTIERS ONLINE

Take a Science Safari with FRONTIERS Online!

Ask the Scientists

After you watch **Science Safari** you can learn more about science in South Africa from the scientists you see on the show. We invite you to send your questions to the scientists featured on this page. They will be available to answer your

questions from **November 20 to December 6, 1996**, via FRONTIERS on the World Wide Web at <http://www.pbs.org/saf/>.

CITY OF GOLD

An extraordinary find at an excavation near the border of Mozambique and Zimbabwe helps piece together South Africa's pre-colonial history. Archaeologist **Sidney Miller** has discovered the burial site of a 16th-century king and queen of the Venda, former rulers of an ancient people whose culture we glimpse through the evocative dances performed by modern-day Venda in this story. If you'd like to know more, send your questions about this discovery to Sidney Miller.



FIGHTING MALARIA

Although South African health authorities once considered malaria intensively controlled, it has emerged again as the biggest threat to human health in the developing world. **Sipho Nxongo**, a regional director for the Department of Health, directs efforts to combat malaria in the province of KwaZulu-Natal. Find out more about the strategies to combat malaria by sending your questions to Mr. Nxongo.



WAYS OF THE WILD

The animals of South Africa evolved to migrate over large areas in search of food and water. Today, the expanding human population means that wide open spaces no longer exist. The management of South Africa's wildlife is a challenge for ecologists like **Pete Goodman** of the Natal Parks Board.

What is the future for rhinoceros, elephants and other animals in South Africa? Pete Goodman will provide the latest information about this crucial question.



THE FIRST PEOPLE

Extraordinary archaeological discoveries are helping piece together the evolution of human life in sub-Saharan Africa. Explore the past as FRONTIERS visits **Hilary Deacon**, professor of archaeology at the University of Stellenbosch. Deacon, an expert on African archaeology and the emergence of modern humans, will answer your questions about these intriguing topics.

HERE'S HOW TO "ASK THE SCIENTISTS":

MR. CELE'S GARDEN

Indigenous plants provide important materials for South Africa's traditional healers, who have routinely gathered plants in the wild. Now that many plant species, like the pepperbark tree, are becoming scarce, **Richard Symmonds**, a horticulturalist with the Silver Glen Nursery, works with traditional healers to encourage the cultivation and preservation of wild species. Learn more about these conservation measures by sending your questions to Richard Symmonds.



▷ Watch **Science Safari** and review this classroom guide to prepare your question(s) and decide which scientist(s) you'd like to contact.

▷ Visit SCIENTIFIC AMERICAN FRONTIERS on the World Wide Web at <http://www.pbs.org/saf/>. Click on the "Ask the Scientists" icon on the welcome screen to send your question(s). Scientists will answer as many questions as possible, and their answers will be posted for all FRONTIERS viewers to read.

▷ Remember to e-mail your questions by December 6, 1996.

"Science Safari" airs on PBS on Wednesday, November 20, 1996, at 8 pm*.

* Check your TV listings to confirm local air time and date.

Please note that **Khotso Mokhele, Ph.D.**, president of South Africa's Foundation for Research Development (FRD), is also available to answer your questions. You can read more about Mokhele on the opposite page.

Meet Khotso Mokhele



While on "Science Safari" in South Africa, Alan Alda took time out from a busy filming schedule to interview Khotso Mokhele, Ph.D., President of the Foundation for Research Development (FRD). The Foundation is South Africa's funding agency for research in science, engineering and technology. In this role, Dr. Mokhele is deeply committed to uplifting disadvantaged communities in South Africa.

Dr. Mokhele spoke with Alan Alda at length about the role of education in the "new" South Africa. Here is an excerpt from his comments:

"I don't believe we will have any democracy to speak of until black people in South Africa start to feel they can be architects of this democracy — not

just the social aspects, but the education and economic aspects as well. For us — for black people — and for the total society, we must have unhindered access to those careers upon which an economy is built. And you don't easily do that by producing lots of accountants, lawyers and medical doctors. You do it by producing engineers, physicists and chemists. To create a new society we must open the door that makes mathematics and science education available to everyone in this country."

Born in 1955 in South Africa, Dr. Mokhele matriculated from a rural school and obtained a B.Sc. degree in agriculture. Then, on a Fulbright-Hays Scholarship, he studied at the University of California-Davis, earning an M.Sc. (food science) and a Ph.D. (microbiology) in 1986. Subsequently, he was awarded postdoctoral fellowships and worked in the laboratory of Nobel Prize-winner Dr. Hamilton O. Smith at Johns Hopkins University School of Medicine. Dr. Mokhele returned to South Africa in 1987 and held teaching and research positions before joining the FRD.

Dr. Mokhele will be available to answer your questions about science in South Africa on the "Ask the Scientists" forum. Please refer to the opposite page for details about how to submit your questions.

Science in Cyberspace

In each issue of this guide, look for news about innovative Web sites researched and recommended by FRONTIERS staff. We hope you'll find them helpful.

▷ <http://www.biology.com>

 The *Biology Place* is designed to put the Web to work for your general biology course. Led by Neil Campell of the University of California — Riverside, The *Biology Place* faculty provides resources for instructors and students, including inquiry-based activities and selections from *Scientific American* magazine. The *Biology Place* is a new service from Peregrine Publishers, Inc.

For a full description of membership options, go to *Membership* at

▷ <http://www.biology.com>, or call toll-free 888-TBP-SITE.

○ And coming soon from Peregrine Publishers . . .

○ *The Chemistry Place*, scheduled to launch in February 1997.

○ ○ ○

LET US CITE YOUR FAVORITE SITE!

○ Tell us about your favorite science sites on the information superhighway. If we recommend your site in this guide, you'll receive a FRONTIERS T-shirt. Please send your suggestions to: saf@pbs.org.

Web Sites for South Africa

Looking for more about science in South Africa? Put on your digital pith helmet and check out these sites — and don't forget to take a short safari to the FRONTIERS Web site for additional resources about science in South Africa.

▷ <http://whyfiles.news.wisc.edu/016skeeter/index.html>

Discover hundreds of mosquito "bytes," including facts about malaria, illustrations of the mosquito's life cycle, even a contest for the best "skeeter nightmare."



▷ <http://www.mc.maricopa.edu/academic/cultsci/anthro/Africa.html>

Find out more about how the history of Africa is marked by the rise of complex societies, migrations, agriculture and diversity.

▷ <http://www.geocities.com/Athens/6398/>

Experience how the past speaks to the future in this site that reports on archaeology and excavations in South Africa. Click on the "Thulamela Story" for maps, photos and reports from the Thulamela excavation.

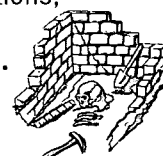

▷ <http://www.southafrica.net/tourism/wildlife.html>

Travel to this site to see colorful illustrations and learn more about South Africa's animals and wildlife habitats.



▷ http://www.panda.org/research/facts/fct_medical.htm

Check this site for an overview of plant use in traditional and modern medicine, as well as facts about conservation issues and biodiversity.



▷ <http://rodie.animal.uiuc.edu/Documents/RSA.html>

Visit the South Africa home page and discover a vast and varied land. Find maps, statistics, links and much more.

At press time, the online features and sites listed here were current. Due to the rapidly changing online world, some may have changed or may no longer be available.

WATCH IT ON PBS

SCIENTIFIC AMERICAN FRONTIERS airs monthly on PBS – October and November 1996 and January, February and April 1997. Each hour-long special includes a variety of fascinating science stories based on a single theme.

INVENTING THE FUTURE [Show 701]

Wednesday, October 23, 1996 8 pm

Leap forward into the future when FRONTIERS visits the MIT Media Lab to test out smart cars, smart rooms and wearable computers. Meet scientists who are redesigning the look and role of computers.

PIECES OF MIND [Show 703]

Wednesday, January 22, 1997 8 pm

Spend the night in a sleep laboratory and find out more about how your brain works to create memories, dreams and language.

GOING TO EXTREMES [Show 704]

Wednesday, February 19, 1997 8 pm

Join scientists as they track the fastest animal on earth and investigate survival mechanisms of animals in desert and arctic environments.

ROBOTS ALIVE! [Show 705]

Wednesday, April 9, 1997 8 pm

Meet some autonomous robots with minds of their own. Host Alan Alda catches up with the inventor of Flaky, Alan's robot friend from a previous season.

SCIENCE SAFARI [Show 702]

International Special

Wednesday, November 20, 1996 8 pm

Travel on a science safari to South Africa and meet scientists who are conserving wildlife; then trek to sites once inhabited by early humans. Find out how technology is helping combat malaria and what archaeologists are learning about ancient cultures.

SCIENTIFIC AMERICAN FRONTIERS



HOSTED BY ALAN ALDA

SCIENTIFIC AMERICAN FRONTIERS takes viewers on a trip to South Africa, where old meets new in a land of amazing beauty and diversity. Remember, teachers may videotape the show to use year after year. GTE Corporation, the series underwriter, grants educators free off-air taping rights in perpetuity for classroom use.



ASK THE SCIENTISTS!

Hilary Deacon and other scientists seen on Science Safari answer your questions online. See p.14. <http://www.pbs.org/saf/>



Underwritten by GTE Corporation



Connecticut Public Television
P.O. Box 260240
Hartford, CT 06126-0240

NON PROFIT
U.S. POSTAGE
PAID
Permit No. 51
Bristol, PA

INSIDE:

Requested Teaching Materials for SCIENCE SAFARI

Airing November 20, 1996, on PBS



Printed on recycled paper

SCIENTIFIC
AMERICAN

FRONTIERS

SHOW 703 TEACHING GUIDE • JANUARY 22, 1997 • 8-9 PM

PIECES OF MIRO

Inside the Human Brain

GTE

Underwritten by
GTE Corporation



ERIC
Full text provided by ERIC

FOR YOUR INFORMATION

INSIDE THE BRAIN

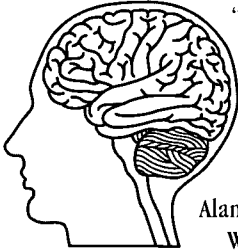

"We've gone to extraordinary places and done extraordinary things in making SCIENTIFIC AMERICAN FRONTIERS. But there's nowhere we visited that is more extraordinary than our destination now: inside the human brain." With these words, host Alan Alda introduces **Pieces of Mind**.

We still know relatively little about how the brain works. In this show, we meet researchers who are now able to see inside the human brain while it is thinking, remembering, learning, sleeping and dreaming.

FRONTIERS meets scientists exploring the inner workings of the human mind, using a combination of technology and psychological studies to find out more about how the brain works.

Join them as they take you on a fascinating journey, exploring the questions humankind has pondered for millennia. The remarkable and revolutionary findings you see here are perhaps only the beginnings of a larger understanding of the amazing and complex human brain of the late 20th century.

Be sure to visit our Web site (<http://www.pbs.org/saf/>) and try our online activities (see pp. 14-15 in this guide). You and your students can enter the **Viewer Challenge** (p. 4) and have a chance to win one of our terrific FRONTIERS T-shirts.

FRONTIERS NOW AVAILABLE IN DVS

With a grant from GTE, the underwriter of FRONTIERS, the blind and visually impaired can once again enjoy Descriptive Video Service (DVS) narration of FRONTIERS. Broadcast via the second audio program (SAP) channel on stereo television or stereo VCRs, DVS narration describes key visual elements without interfering with the existing dialogue or soundtrack. DVS, now broadcast by 129 television stations, does for the visually impaired what closed-captioning

has done for the hearing-impaired. For more information on DVS, call 617-492-2777, ext. 3490.

FRONTIERS ON VIDEOTAPE

Videotapes of past shows are available through the FRONTIERS School Program. If you missed a show or want to complete your FRONTIERS videotape library, call 800-315-5010. Tapes are \$19.97 each, including shipping and handling. (Orders accepted with purchase order, credit card or check.) Teaching guides for many past shows are available on the FRONTIERS Web site.

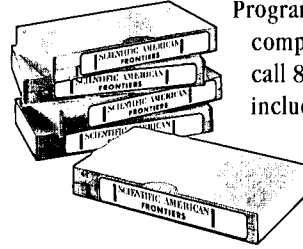

FREE KIT FOR TEACHERS

Looking for free materials? *Scientific American* magazine offers a free kit for educators. The kit, designed for grades nine and higher, contains a sample issue of the magazine, plus tips for using the magazine in the classroom. **To request a kit, call 800-377-9414.**

CORRECTION

In the teaching guide for **Science Safari** (Show 702), we inadvertently put the drawings of the stages of the mosquito life cycle (p. 7) in the wrong order. The "larva" stage of the mosquito's life cycle should come before the "pupa" stage. We regret the error. If you would like to receive a corrected illustration of the mosquito life cycle, please call 800-315-5010 or visit our Web site.

NEXT TIME ON FRONTIERS

Tune in February 19, 1997, when SCIENTIFIC AMERICAN FRONTIERS goes to extremes, looking at spiders that adapt to the desert and frogs that freeze. Watch **Going to Extremes** for more about unusual environments on the planet. (See back cover for season schedule.)

SCIENTIFIC AMERICAN FRONTIERS is closed-captioned for the hearing-impaired and is narrated by Descriptive Video Service (DVS) for visually impaired audiences. The series and School Program are endorsed by the National Science Teachers Association (NSTA) and the National Education Association (NEA).

TAPING THE SHOW

- Always check TV listings to confirm air date and time.
- As a teacher, you have off-air taping rights in perpetuity for classroom use.
- If you can't find the show in your TV listings, call your local PBS station.
- Do you need help? Call the FRONTIERS School Program at 800-315-5010.
- Videotapes of past shows can be purchased (\$19.97 each). Call 800-315-5010.

FREE VIDEOTAPING & PHOTOCOPIING RIGHTS

GTE Corporation, the series underwriter, makes available complete off-air taping rights in perpetuity for classroom use of SCIENTIFIC AMERICAN FRONTIERS. Educators may record each show when it airs on PBS and keep the tapes to use in the classroom year after year. Educators may also photocopy all materials in this guide for classroom use.

If you know of other educators interested in receiving these guides, they may sign up by calling the SCIENTIFIC AMERICAN FRONTIERS School Program at 800-315-5010.

LET US HEAR FROM YOU!

We appreciate and welcome your questions, comments, compliments and constructive criticism. *Please contact us . . .*

BY MAIL:

SCIENTIFIC AMERICAN FRONTIERS
105 Terry Drive, Suite 120
Newtown, PA 18940-3425

BY PHONE: 800-315-5010

BY FAX: 215-579-8589

BY E-MAIL: saf@pbs.org

VISIT US ONLINE:

<http://www.pbs.org/saf/>

TABLE OF CONTENTS

SHOW 703 • JANUARY 22, 1997 • 8 PM ON PBS

PIECES OF MIND

6 THE MAN WITH TWO BRAINS

Studies with so-called "split-brain" patients yield fascinating information about how the brain works.

Activity:

What happens when the left hand does not know what the right hand is doing?

7 REMEMBERING WHAT MATTERS

Why do we remember experiences that are emotionally significant? A neurobiologist shares his findings.

Activity:

Learn more about PET scans and how they work.

8 TRUE OR FALSE?

A noted brain researcher explores false memory.

Activities:

Improve your memory with mnemonic devices.

10 WHAT'S IN A DREAM?

Join host Alan Alda as he spends the night in a sleep lab . . . Find out what happens during REM sleep and why.

Activities:

Keep a sleep and dream journal . . . Find allusions to sleep and dreams in popular culture.

12 OLD BRAIN/NEW TRICKS

Is there a critical window to learning language? One neuroscientist's work suggests that very early learning is best.

Activities:

An experiment in sensory competition . . . Graphing the relationship between language and age.

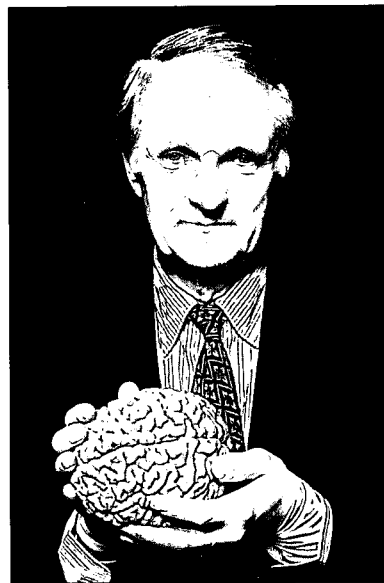

DEPARTMENTS

4 VIEWER CHALLENGE

5 THE BIG PICTURE

14 SAF ONLINE

VIEWER CHALLENGE	PIECES OF MIND SHOW 703 • 1/22/97 8 PM* ON PBS		BIOLOGY	GENERAL SCIENCE	LIFE SCIENCE	PSYCHOLOGY	TECHNOLOGY
	STORY	RUNNING TIME					
	The Man with Two Brains	10:05	•	•	•	•	•
	Remembering What Matters	8:35	•	•	•	•	•
	True or False?	8:57	•	•	•	•	•
	What's in a Dream?	13:28		•	•	•	•
	Old Brain/New Tricks	10:50		•	•	•	•

*CHECK LOCAL TIME

SCIENTIFIC AMERICAN FRONTIERS is made possible by an underwriting grant from GTE Corporation. The series is produced by The Chedd-Angier Production Company in association with *Scientific American* magazine and presented to PBS by Connecticut Public Television.





Student's Name _____
 Teacher's Name & Course _____

Watch **SCIENTIFIC AMERICAN FRONTIERS Pieces of Mind (Show 703)** for answers to questions on this page. Answer the 10 questions correctly and you'll be eligible to win a **FRONTIERS T-shirt!**

The Man with Two Brains

1. Why did surgeons cut the man's corpus callosum?

2. What is the role of the corpus callosum?

- a. stores memories
- b. directs motor functions
- c. warns brain of impending danger
- d. connects the two hemispheres

Remembering What Matters

3. What hormone enhances memory?

- a. estrogen
- b. adrenaline
- c. cortisol
- d. ACTH

4. What part of the brain is activated by emotions?

True or False?

5. According to Daniel Schacter's theory, where is memory located in the brain?

6. According to Schacter, what is the role of the hippocampus?

- a. creates memories
- b. indexes memories
- c. deletes bad memories
- d. creates dreams

What's in a Dream?

7. What does REM refer to in sleep?

- a. routine eye motion
- b. random excess memory
- c. rapid eye movement
- d. resting energy momentum

8. Why do Carlyle Smith and other researchers believe dreams are important?

Old Brain/New Tricks

9. According to Neville's studies, where is grammar processed in an adult's brain?

- a. cortex
- b. hippocampus
- c. left hemisphere
- d. midbrain

10. What is the main difference in how adults' and children's brains process language?

For Teachers Only



When completed, this page can become an entry to the **FRONTIERS T-shirt contest**; 20 winners (10 students, 10 teachers) will be drawn at random for each show. To enter the T-shirt drawing, send all completed challenges *in one envelope* with a cover sheet to: **Viewer Challenge, SCIENTIFIC AMERICAN FRONTIERS, 105 Terry Drive, Suite 120, Newtown, PA 18940-3425. Mail completed entries by February 14, 1997.**

TIP: You can also download these questions on the **FRONTIERS Web site** (*see pp. 14-15*).

Important!! Please include a separate cover sheet and tell us:

- number of challenges submitted
- teacher's name
- grade and course
- school name, address and phone number
- where your students watched the show — at home, at school or both
- the name of your students' favorite story in this show (conduct a quick poll to find out)

Thank you!

ANSWERS TO VIEWER CHALLENGE 703: 1. to prevent epileptic seizures 2. d 3. b 4. amygdala 5. all over the brain 6. b 7. c 8. This sleep state helps us consolidate memories and process information in various regions. 9. c 10. In adults, language is processed in specific areas; very young children process language all over the brain.

THE BIG PICTURE

ANATOMY OF THE BRAIN

Every aspect of our lives — from breathing and sleeping to personality, likes and dislikes — is governed by the brain. This artist's rendition depicts some of the parts of the brain and explains how they affect our functions.

Weighing in at about 1,450g and containing 100 billion neurons, the human brain is the most complex structure we know. The human brain is made up of three major regions: the forebrain or cerebrum (13); the mid-brain (5); and the hindbrain, which consists of the medulla oblongata (2) and the cerebellum (11).

The cerebrum is divided into two hemispheres, left and right, each consisting of four lobes; the lobes are named after the bones of the skull that protect them (frontal, parietal, occipital, temporal).

The surface of the cerebrum is the cerebral cortex (12), which is composed of neuron cell bodies collectively known as gray matter. The many folds of the cerebral cortex provide more surface area and more room for neuron cell bodies than a smooth surface.

Here are some other important parts of the human brain:

- 1. SPINAL CORD:** Conveys impulses to and from the brain.
- 2. MEDULLA OBLONGATA:** Helps regulate basic functions like breathing, blood pressure, sneezing, sleep.
- 3. PONS:** Links cortex with cerebellum; associated with facial expression.
- 4. AMYGDALA:** Activated by emotions; see p. 7 of this guide.
- 5. MIDBRAIN:** Forwards impulses from the spinal cord; controls certain reflex responses.
- 6. OLFACTORY BULB:** Forwards sensory information from nose to cortex and amygdala.
- 7. HIPPOCAMPUS:** Keeps track of memories; see pp. 8-9 of this guide.
- 8. THALAMUS:** Associated with all senses except smell; relays sensory impulses to the cerebral cortex.
- 9. HYPOTHALAMUS:** Regulates many body functions, such as heart rate, body temperature, sleep cycles, hormone levels, libido, hunger, thirst.
- 10. CORPUS CALLOSUM:** Links left and right hemispheres of the brain, allowing them to communicate; see p. 6 of this guide.
- 11. CEREBELLUM:** Controls muscle coordination and sense of balance; also involved in learning of motor skills.
- 12. CEREBRAL CORTEX:** Wrinkled outer layer of the cerebrum; controls our higher-level, advanced abilities like speech and reasoning.
- 13. CEREBRUM:** Serves as the center for speech, reasoning, emotions and personality; interprets sensory information and controls motor impulses.
- 14. SEPTUM:** Associated with feelings of pleasure.

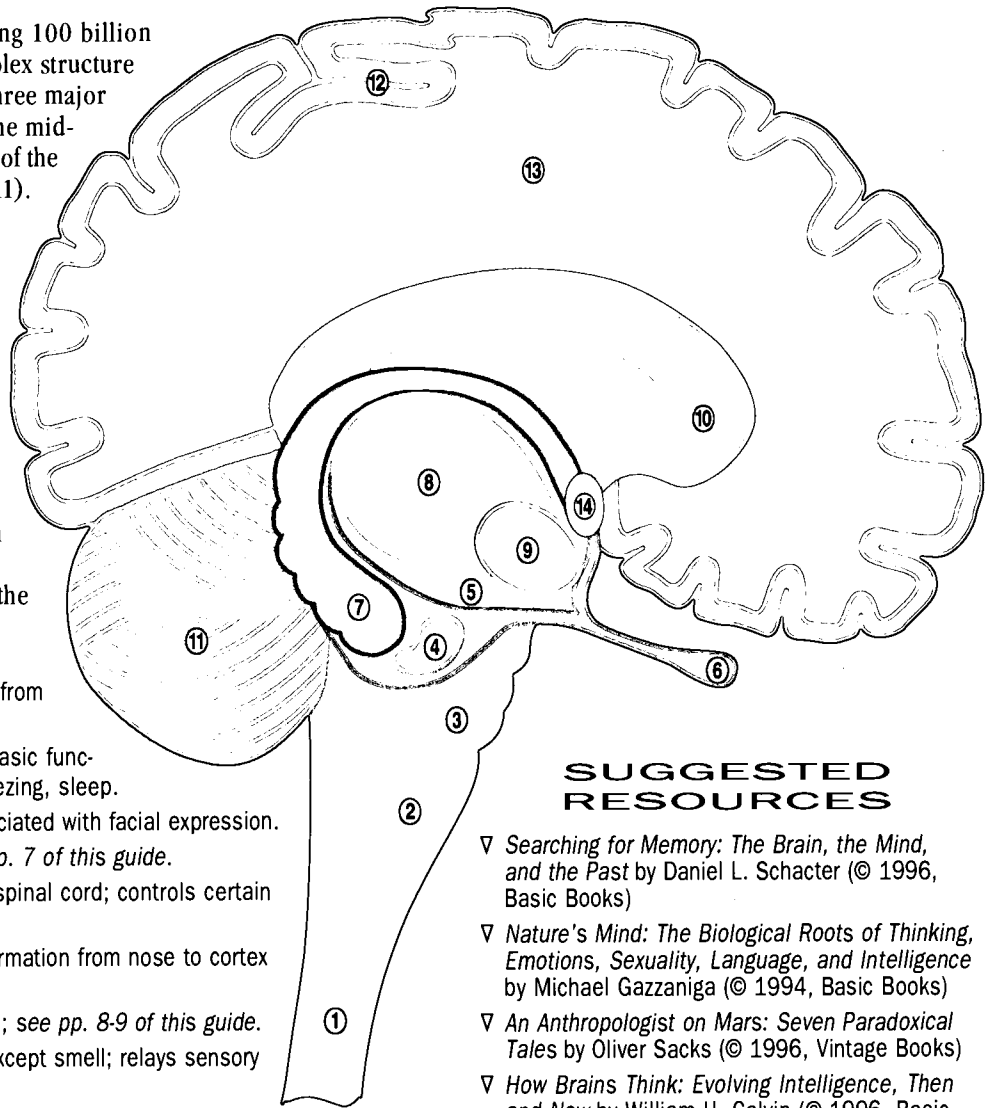

SUGGESTED RESOURCES

- ▽ *Searching for Memory: The Brain, the Mind, and the Past* by Daniel L. Schacter (© 1996, Basic Books)
- ▽ *Nature's Mind: The Biological Roots of Thinking, Emotions, Sexuality, Language, and Intelligence* by Michael Gazzaniga (© 1994, Basic Books)
- ▽ *An Anthropologist on Mars: Seven Paradoxical Tales* by Oliver Sacks (© 1996, Vintage Books)
- ▽ *How Brains Think: Evolving Intelligence, Then and Now* by William H. Calvin (© 1996, Basic Books)
- ▽ *The Brain Pack: An Interactive Three-Dimensional Exploration of the Mysteries of the Mind* by Ron Van der Meer and Ad Dudink (© 1996, Running Press)
- ▽ *Sleep Thieves: An Eye-opening Exploration Into the Science and Mysteries of Sleep* by Stanley Coren (© 1996, The Free Press)
- ▽ *The Brain* (© 1990, *How Things Work* series, Time-Life Books, Inc.)
- ▽ *Scientific American* magazine:
 - "Dyslexia," November 1996
 - "The Puzzle of Conscious Experience," December 1995

SOURCES FOR ILLUSTRATION: A PICTORIAL HANDBOOK OF ANATOMY AND PHYSIOLOGY BY DR. JAMES BEVAN (© 1994, REED INTERNATIONAL BOOKS LIMITED) AND MIND AND BRAIN (© 1993, JOURNEY THROUGH THE MIND AND BODY SERIES, TIME-LIFE BOOKS, INC.)



THE MAN WITH TWO BRAINS

The *corpus callosum* acts as a bridge between the two hemispheres of your brain. What happens when the two halves no longer connect? For more than a decade, Dartmouth neuroscientist Michael Gazzaniga has followed the cognitive experiences of a man with severe epilepsy whose connection between his brain's two hemispheres was severed to stop his seizures. Gazzaniga's work with so-called "split-brain" patients has given him a unique perspective into how the brain perceives and communicates.

ABOUT YOUR BRAIN

Inside your head, you possess three pounds of the most complex structure that we know of: your brain. The human brain has evolved over several million years to become the incredibly complex organ that it is in humans today. You might say the brain has come a long way from its hominid ancestors on the African savannas.

Still, we share many brain activities with our distant ancestors — dreams, memory, sleep and some form of language or communication have long characterized humans and made us individuals. The fight-or-flight response, for example, helped our ancestors defend and survive attacks by predators. Although we don't have to fight predators

today, the same response is activated every day in modern humans.

The brain of three million years ago found food, later learned to cook it, eventually learned to farm, make tools, build great cities — and invent the computer. Over the course of those three million years, both cranial capacity and brain size have expanded. The human brain has become increasingly complex, enabling us to enjoy a high level of problem-solving abilities.

This show takes you inside the human brain and shows you what fascinating questions scientists are exploring today about perception, memory, sleep, dreams and language.

RUNNING TIME:

10:05

CURRICULUM LINKS:

BIOLOGY

brain organization, learning, memory

GENERAL SCIENCE

brain, human body, nervous system

HEALTH

disease

LIFE SCIENCE

human evolution, vision

PSYCHOLOGY

cognition, perception

TECHNOLOGY

computers, imaging

ACTIVITY: Left and Right Brains

The corpus callosum connects both hemispheres of the brain and enables the left and right sides of the brain to communicate. As you see in this episode of FRONTIERS, when this bridge is disconnected, the person functions quite well but experiences perceptual and cognitive dysfunction. If the corpus callosum is severed, the right hand truly does not know what the left hand is doing.

For the vast majority of us, the right hemisphere of the brain controls the left side of the body, and the left hemisphere controls the right side. What your left eye perceives registers in your right brain; what your right eye sees registers in your left brain. The right brain sends messages to the left, and vice versa, via the corpus callosum.

When the corpus callosum is severed, as it is in the patient's brain as seen on FRONTIERS, there is perception but no messages travel back and forth between the brain's two hemispheres. Thus, although both eyes "see" an image, each hand drawing the figure does only what its half of the brain perceives. The left hemisphere, which handles language in most people, does not receive or send messages about what the two halves see. The brain is, indeed, divided.

TRY THIS YOURSELF

After watching the show, try to replicate what Alan Alda does and draw figures or geometric shapes with your left and right hands simultaneously. You might try setting up a screen like Alda does on the show so that you do not see what your hands are drawing. What happens? How is what you draw different from what the patient on FRONTIERS does? Explain.

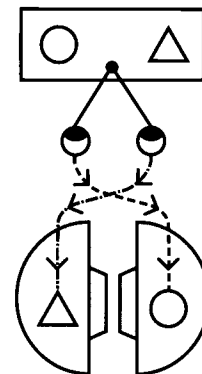

Signals from nerves on one side of the body arrive at the brain and cross over to the opposite side via the corpus callosum, which links the left and right hemispheres. The corpus callosum shown here is severed.

EXTENSION

Using your biology text and any other resources, can you trace the pathway of a signal from a nerve to your brain? Some situations to map might be: what happens when you stub your toe, when you taste a piece of chocolate or when you worry about an exam.

<http://www.pbs.org/saf/>



Michael Gazzaniga, seen in this segment, answers your questions online. See p. 14 for information.



**RUNNING
TIME:**
8:35

**CURRICULUM
LINKS:**

BIOLOGY
brain organization

GENERAL SCIENCE
human brain

HEALTH
mental disorders

LANGUAGE ARTS

LIFE SCIENCE
human brain

PSYCHOLOGY
emotions

TECHNOLOGY
imaging
techniques

REMEMBERING WHAT MATTERS

Neurobiologist James McGaugh is sometimes called “Mr. Amygdala” for his work with this almond-shaped structure in the forebrain. Intrigued by questions of how memories are made, he has studied the brain for more than 40 years. Through his experiments, McGaugh has found that an emotional response can enhance memory retention. Using PET scans to look inside the brain as memories are formed, McGaugh has discovered that the amygdala helps the brain remember what matters.

What Is a PET Scan?

A PET scan is not an x-ray of your pet — though perhaps it would be interesting to find out how the brains of cats and dogs and other animals work while sleeping and dreaming!

As you see on *Pieces of Mind*, the use of PET (positron emission tomography) imaging has given researchers a tool to look inside the brain. Researchers can study the brain while we are learning, talking, remembering, thinking.

The PET technique uses radioactive elements to produce images of the inside of the body or brain. The person whose brain will be scanned drinks a simple glucose (sugar) solution tagged with a radioactive element. As the solution moves into the brain, it gives off particles like x-rays that allow the computer to trace their location on a color monitor. The more active the brain is, the more it uses the sugar solution. The greater the use of glucose, the brighter those areas glow. During a PET scan, the researchers may vary the person’s exposure to sound or sight to watch for changes in the brain’s image.

PET scans are featured in several stories in *Pieces of Mind*, including this one on James McGaugh’s work, which investigates the role of

the amygdala. McGaugh uses the PET scan technique to actually peek inside the brain as memories are formed!

PET scans are now used to identify different areas of the brain used for sight, sound and speech, so researchers can actually “see” what a thought looks like. PET scans are also being used to help explain what is happening inside the brains of people with Alzheimer’s, schizophrenia and other diseases. A PET scan of a person with severe Alzheimer’s indicates diminished brain activity.

ACTIVITY

After you watch the show, brainstorm brain activities you think a PET scan could be used for. Perhaps your idea will one day be part of an experiment, as we continue to learn more about the human brain.

EXTENSIONS

- ▷ What might be the evolutionary advantages of memories enhanced by an emotional response?
- ▷ How many of your experiences today can you recall? Of those you remember, are there some with greater emotional significance?

CURRENT RESEARCH PROJECTS

You can find out more about sleep and dream research, as well as other topics featured on this episode of *FRONTIERS*, by using the World Wide Web. Here are some projects of interest:

- ▷ Essay Contest: The Sleep Research Society, a professional scientific organization, sponsors an annual high school Essay Awards Program. For contest rules and an entry form, contact Sleep Contest Inquiry, Sleep Research Society, 1610 14th Street NW, Suite 300, Rochester, MN 55901, or visit their Web site (<http://www.websciences.org/trainee/EssayIntro.htm>). Entries must be postmarked by March 15, 1997.
- ▷ Students at the University of California, Santa Cruz, are working on a quantitative analysis of dream content. You can visit their Web site (<http://zzyx.ucsc.edu/~dreams>) and download a “DreamSAT,” a spreadsheet that will help you analyze dream data.
- ▷ For more about the true meaning of Native American dream catchers, visit the Native American Technology and Art site (<http://www.lib.uconn.edu/NativeTech/dreamcat/dreamcat.html>).

<http://www.pbs.org/saf/>



James McGaugh,
seen in
this segment,
answers your
questions online.
See p. 14
for information.



**RUNNING
TIME:**

8:57

**CURRICULUM
LINKS:**

ART

BIOLOGY

brain organization

GENERAL SCIENCE

human brain

HEALTH

emotions,
mental health

LANGUAGE ARTS

LIFE SCIENCE

human brain

PSYCHOLOGY

learning, memory

TECHNOLOGY

imaging techniques

To learn more
about Daniel
Schacter's memory
research, visit
his Web site:
<http://www.wjh.harvard.edu/~dls>

TRUE OR FALSE?

Noted brain researcher **Daniel Schacter of Harvard** wondered if memories are located in a certain region of the brain. His work convinced him that memories are not fixed, but malleable, and scattered as bits and pieces in different areas of the brain. Schacter also wondered if false memories can be implanted in the brain. Alan Alda volunteers to be the research subject of an experiment that studies whether we "remember" events that did not happen.

ACTIVITY 1: Visual Recall

Draw a picture of a familiar setting like a living room, classroom or playground. Do not fill the set with objects. Photocopy the scene and set the copy aside. To the original sketch, add drawings of furniture and other objects normally found in the setting. When you've finished adding objects to your scene, exchange completed scenes with a partner. Study each other's furnished scenes for 60 seconds. Then exchange the original, unfurnished scenes and try to sketch in as many of the missing objects as you can remember.

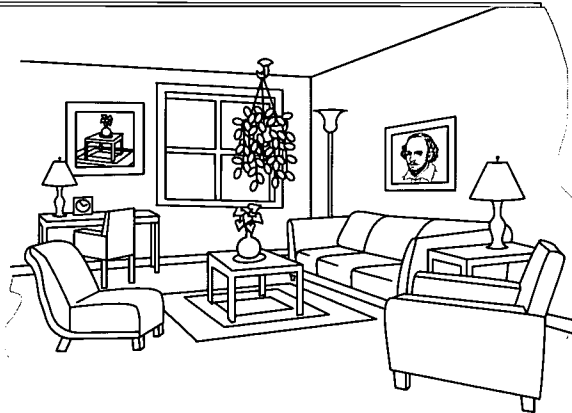

ACTIVITY 2: Mnemonic Devices

Mnemonics, or the science or art of aiding memory, is an ancient concept. Many people rely on mnemonic devices to help remember what they've learned or need to recall, from grocery lists to people's names to kings and queens or the presidents.

What works for one person may not work for another. The six devices described below suggest ways to help improve memory. Each device is followed by a challenge.

Memory Maps

This technique depends on visualizing a journey in which objects to be recalled are placed in familiar locations. For example, suppose you had to remember such unrelated items as a tuba, ice skate, pen, walrus, coffee cup and airplane. You can visualize a walk through the rooms of your house in which each item is placed in a different room. This technique is useful for memorizing bones or muscles of the body or other lists of related terms.

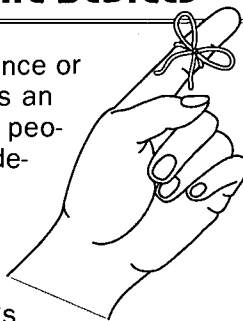

CHALLENGE:

Write a list of 15 objects. Exchange lists with a partner. Allow a few minutes to create memory maps of your partner's list based on a familiar location or path. Then remove the lists and proceed on your visual journey, writing down all the objects you can recall from your partner's list.

Associations

Developing associations is a familiar strategy used to recall information by connecting it to other, more familiar pieces of information. For example, memorizing a sequence of seemingly random digits is easy when that number series is your birth date or street address. Developing associations is also a helpful way to remember new information.

CHALLENGE:

Develop a 10- or 15-digit random number that does not repeat and figure out associations to help you memorize it. Use each type of association only once (only one date or one phone number, etc.). Exchange numbers with a partner and memorize, using associations.

Rhyming

Rhymes and jingles are powerful memory devices. Just think how often you have used the rhyme, "Thirty days has September . . ." to recall the number of days within a month.

CHALLENGE:

Compose a list of 15 objects to memorize. Exchange lists with a partner. Set a time limit of five minutes to create a rhyme that incorporates the words on the list. Then use your rhyme to recall the memorized words.

Chunking

When reciting a telephone or Social Security number, most people are apt to speak it in three chunks. For example, the first and second chunks of a phone number consist of three digits and the third chunk contains four digits. Chunking the numbers makes a meaningless series easier to remember. Can you think of other series of numbers that are frequently chunked?

CHALLENGE:

Try memorizing a series of nine random numbers. Then break up the series into three chunks. Does chunking help to recall the numbers?

Acronyms and Acrostics

Acronyms and acrostics are mnemonic devices used to recall concepts or information. The two devices are different, but they work similarly in creating an easy-to-remember association of words.

An acronym is a word formed from the initial letter or letters of each of the parts of a name or organization. For example, the acronym LASER stands for Light Amplification by Stimulated Emission of Radiation. Some other familiar acronyms are RADAR, REM sleep, SCUBA, SONAR, NASA, ZIP code, etc.

Though we usually think of acronyms as names of organizations or terms created by the scientific or medical community, you can also make up acronyms to help you remember information. Think of an acronym as a "fun" word or phrase in which each letter stands for the first letter of the item to be recalled. For example, Roy G. Biv stands for the colors of the spectrum. Psychology students made up the acronym WIRES to remember kinds of memory (Working, Implicit, Remote, Episodic, Semantic).

By contrast, an acrostic is a memory strategy that takes the first letters of a series of words, lines or verses to form a memorable phrase. An acrostic is probably more well known as a kind of crossword puzzle or poetry game.

Sometimes the phrase is nonsense, which may help you remember it! Here are two: King Philip Came Over For Great Spaghetti or Kings Play Cards On Fat Green Stools. Each acrostic stands for the biological classification hierarchy (Kingdom, Phylum, Class, Order, Family, Genus, Species).

CHALLENGES:

- ▷ Create acronyms to describe each of your school subjects. Or, devise a quiz to see how many official acronyms you can spell out.
- ▷ Create an acrostic to help you remember the planets in the solar system in order or some other concept, like the 10 most abundant elements in the universe.
- ▷ Survey people to see what mnemonic devices they have used to remember things.

EXTENSIONS

- ▷ Repeat the picnic experiment seen on FRONTIERS, but script a different scene. Use a Polaroid to take photos.
- ▷ Devise an experiment using word lists like what you see on the show. Does your mind want to make associations to other words?
- ▷ This is an experiment often done in law school: act out a scene and then see how many observers remember what actually took place.

ACTIVITIES ON THESE PAGES CONTRIBUTED BY MASSACHUSETTS SCIENCE WRITER AND CONSULTANT MICHAEL DISPEZIO, AUTHOR OF *CRITICAL THINKING PUZZLES* (STERLING, 1996).

SCIENTIFIC
AMERICAN
FRONTIERS

SHOW 703

PIECES
OF MIND



TRUE OR
FALSE?



THE TERM 'MNEMONIC' COMES
FROM THE NAME FOR THE GREEK
GODDESS OF MEMORY, MNEMOSYNE.

FOR FURTHER
THOUGHT

- ▷ Do you think imaging techniques similar to those shown on this episode of FRONTIERS should ever be used as evidence in a trial? Why or why not?
- ▷ In what ways do photographs enhance our memories?
- ▷ What do you think memory was like in the long history of humans before photography?



RUNNING TIME:

13:28

CURRICULUM LINKS:

ART

BIOLOGY

brain organization, nervous system

GENERAL SCIENCE

scientific method

HEALTH

emotions, mental health

LIFE SCIENCE

LITERATURE

MATH

data analysis

PSYCHOLOGY

dreams, learning, sleep

TECHNOLOGY

computers, imaging

<http://www.pbs.org/saf/>



Robert Stickgold, seen in this segment, answers your questions online.

See p. 14 for information.

WHAT'S IN A DREAM?

What happens when we sleep, and why, are questions that intrigue scientists and laypeople. Two scientists — Robert Stickgold of Harvard and Carlyle Smith of Ontario's Trent University — invite viewers to spend some time in their sleep labs, along with Alan Alda. Their sleep experiments help illuminate what goes on in our minds while we're dreaming. Stickgold's research looks at what happens during REM (dream) sleep, while Smith explains why.

"TO SLEEP, PERCHANCE TO DREAM ..."

The scientists you see in this episode of SCIENTIFIC AMERICAN FRONTIERS are researching what seems to be an inherent human fascination with sleep and dreams. With modern technology and new tools for unlocking "Sleep's Dark and Silent Gate" (title of

a song by Jackson Browne), scientists have extended and are redefining some of our understanding about sleep and dreams. Recent findings have implications for learning. In these activities you will explore more about sleep and dreams.

ACTIVITY 1: The Sleep Journal

Although you can't measure changes in brain chemistry or track subtle variations in an electroencephalogram (EEG) to study REM sleep, you can use one of the tools sleep and dream scientists have used for many years: the sleep journal. By keeping a sleep journal, you can track your sleep patterns to see if the quantity and quality of your sleep affects your performance in school or sports. A sleep journal also allows you to record your dreams and consider their content to see if they relate to events during your waking hours.



OBJECTIVE

Keep a journal to track sleep and dream activity.

PROCEDURE

To keep a sleep journal you must get into the habit of writing down information at three key times: when you go to bed, when you wake up during the night and when you wake up in the morning. (You may adapt the study and track just your nighttime and morning routines.) Establish a time period for your study (one week is suggested). When you have completed the study, examine your data and answer the questions that follow. Summarize your findings.

1. AS YOU GO TO BED. Write down the date, the time you go to bed and key events that happened to you during the day. Note your resting pulse rate. Later you will use this information to determine the total time you slept, how well you slept and if the day's events seem to have influenced your sleep patterns and dreams.

2. WHEN YOU WAKE UP AT NIGHT. Often when you wake during the night it is right after a period of REM sleep and therefore, most likely, right after a dream. It is better to try to recall any dreams and write them down when you wake up rather than to turn over and figure you'll remember to write them down in the morning. When you wake at night, write down the time. If you recall a dream, write down as many details as you can remember. (Hint: keep a notepad, pen and flashlight by your bed.)

3. WHEN YOU WAKE UP IN THE MORNING. Write down the time you wake up, the number of hours you slept and whether you feel rested or still tired. Record your pulse when you wake up and compare it with your resting pulse from the night before. This data gives you an idea about how well your sleep has helped you recover from the previous day's exertions. Scientists believe that deep sleep has a critical restorative effect on the body. In general, if you slept well, your pulse should be lower in the morning than it was the night before. Lastly, record any dreams you remember from the night before.

QUESTIONS

1. Do the previous day's activities seem to interfere with your ability to get a good night's sleep? If you go to bed worried, does that cause you to have a restless night's sleep?
2. Do your dreams seem to be related to what happened during the previous day? What other factors might affect your dreams — worries, experiences, people you've met or seen on TV?
3. Do the number of hours and the quality of your sleep — whether you are rested or still tired when

you wake up — seem to affect how well your day goes? Does a good night's sleep help you have a better day?

4. Is there a difference in your ability to recall details of dreams recorded when you wake up at night versus those recalled in the morning?
5. Does your ability to remember your dreams seem to improve as you track them in your journal?
6. Do you notice a change in your ability to solve problems or think creatively after a good night's sleep?

ACTIVITY 2: Sleep and Dreams in Our Culture

Dream and sleep images are everywhere in popular culture. You can probably think of many references to sleep and dreams in movies, TV shows, books, poetry and songs (Sheryl Crow's album *Ordinary Morning* contains allusions to sleep and dreams, for example). Going back in time, Shakespeare used many references to dreams, such as these lines from *Romeo and Juliet*: "True, I talk of dreams; Which are the children of an idle brain."

OBJECTIVE

Find examples of ways sleep and dreams are used as images in popular culture.

PROCEDURE

Divide into teams and list as many movies or songs as you can think of that use sleep or dreams as part

of their imagery. Be as specific as possible and write down the exact title of the song or movie, and the lyrics in the song or scenes in the movie that use these images. Explain what the songwriter or screenwriter was trying to say.

EXTENSIONS

- ▷ Find additional references to dreams and sleep in cartoons, books, advertisements, etc.
- ▷ Look for examples of dream images and what they might convey in works of art, like paintings by Marc Chagall.
- ▷ Dreams play different roles in various cultures. Consider the concept of dreamtime in the mythology of Australian Aborigines or the dream catchers of Native Americans.

What Happens When You Sleep?

An EEG (electroencephalogram) shows what happens to our brains during sleep. Most people experience several stages of sleep during an ordinary night. If you were to spend the night in a sleep lab connected to an EEG like the subjects do on *FRONTIERS*, the EEG would give a portrait of your brain during the night. The electrical activity indicated by brainwave patterns would fluctuate through stages of non-REM and REM sleep. Sleep cycles through five stages:

- ▷ Stage 1: This "alpha" stage is the transition from wakefulness to real sleep.
- ▷ Stage 2: Generally considered the first true sleep state and still light sleep.
- ▷ Stages 3 and 4 are characterized by deep, slow-wave sleep. Stage 3 might be described as moderately deep sleep and Stage 4 as very deep sleep. Stage 4, the "delta" stage, is restorative sleep and can be affected by caffeine, drugs, noise, etc. People with sleep-related disturbances or sleep deprivation show a lack of Stage 4 sleep.

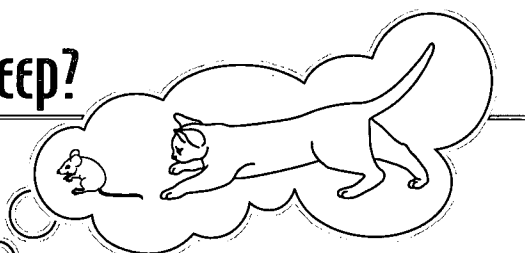

- ▷ REM sleep: In the 1950s, scientists discovered that the eyes of sleeping subjects fluttered back and forth under their eyelids at various times. They identified this stage as rapid-eye-movement or REM sleep. As you see on *FRONTIERS*, REM sleep plays a role in the consolidation of memories and processing information. So "sleeping on it" may serve a vital function in problem solving for humans. In addition, many great discoveries in science and other creative endeavors have been initiated by dreams.

Humans spend about 30 percent of their sleep time dreaming and about 20 percent in deep sleep, with the remaining time in light sleep. Perhaps you can observe a sleeping dog to see if it shows rapid eye movements.

THESE ACTIVITIES WERE CONTRIBUTED BY JAMIE LARSEN, A SCIENCE TEACHER AND TUFTS UNIVERSITY WRIGHT FELLOW CURRENTLY LIVING NEAR SEDONA, ARIZONA.

SCIENTIFIC
AMERICAN
FRONTIERS

SHOW 703

PIECES
OF MIND



WHAT'S IN
A DREAM?

FOR FURTHER THOUGHT

- ▷ It is estimated that millions of Americans — especially teenagers — experience sleep deprivation. What has contributed to this phenomenon in our culture? Consider the impact on driving, learning, jobs. Are you getting enough sleep?
- ▷ Scientists believe that REM sleep helps consolidate memories. What implications does this have for learning?
- ▷ Some chronic diseases are associated with either a loss of Stage 4 sleep or some form of sleep disturbances. Use the Internet to find out more about current research into sleep disturbances like narcolepsy, sleep apnea, insomnia.
- ▷ Why did early humans fall into the habit of sleeping at night?



RUNNING TIME:

10:50

CURRICULUM LINKS:

BIOLOGY

brain organization

GENERAL SCIENCE

brain

LANGUAGE ARTS

LIFE SCIENCE

MATH

graphing

PSYCHOLOGY

language development

TECHNOLOGY

imaging techniques

RELATED FRONTIERS ACTIVITY:

IT'S A KID'S WORLD (Show 505) Teaching Guide

"Born to Talk" (p. 11) and "A Change of Mind" (p. 12)

<http://www.pbs.org/saf/>



Helen Neville, seen in this segment, answers your questions online.

See p. 14 for information.

OLD BRAIN/NEW TRICKS

Is there a critical window for learning language? Neuroscientist Helen Neville of the University of Oregon, Eugene, believes there is — whether the language is spoken or signed. Through her work Neville has been able to find out what regions of the brain process language. In adults different parts of the brain do specialized jobs, but very young children process language all over the brain, suggesting that optimized learning occurs early in life.

ACTIVITY 1: Sensory Competition

Helen Neville, the scientist featured on this segment of FRONTIERS, studies where in the brain we process language. She also is interested in various cognitive functions and the plasticity of the brain. In this activity, we'll explore what happens when you try to learn something through one sense but experience competing input from another.

Try this activity with a partner. Read the entire activity first and set up your data table before you begin the experiment.

MATERIALS

- ▽ paper
- ▽ pen or pencil
- ▽ stop watch
- ▽ boom box (optional)

OBJECTIVE

Conduct an experiment to find out how various senses compete during the learning experience.

PROCEDURE

1. Write a series of six random, two-digit numbers, like this: **47 09 15 66 31 14**.
2. Give the list to your partner. Allow your partner 30 seconds to memorize the numbers. Keep the environment as quiet as possible. Close all doors and windows. Instruct those around you to speak softly or not at all.
3. After 30 seconds, put the list of numbers away. Wait another 30 seconds.
4. Ask your partner to write down the numbers.
5. Check how many numbers your partner remembered correctly.
6. Repeat Steps 1 through 5 using a new set of numbers. This time, in Step 2, introduce some "auditory competition." That is, make noise. Talk to your partner. Sing or say a poem. Tell about your last birthday, what day it was and what you did. Play some music if you have it.
7. Using new numbers each time, repeat both trials two more times, so you have three "quiet" trials and three "noisy" ones.

8. For each study, record data in the following tables.

SILENT TRIAL	# OF CORRECT ANSWERS
1	
2	
3	
TOTAL	

NOISY TRIAL	# OF CORRECT ANSWERS
1	
2	
3	
TOTAL	

9. How do the scores compare (silent vs. noisy)? Propose a hypothesis about learning that might account for the differences. You may want to consider such information as which noises were most distracting.

10. Tally data for the class as a whole. Did different individuals demonstrate different learning styles?

QUESTIONS

What are the implications of this experiment for:

- ▷ a teacher preparing a lesson or teaching a class?
- ▷ an architect designing a conference room?
- ▷ an air traffic controller?
- ▷ students studying for an exam?
- ▷ a library?

ACTIVITY 2: Language Development

Even at a young age, children can talk and their language has meaning. As they grow older, they exhibit increasing grammatical complexity. Developmental psychologists are interested in the way the brain acquires, stores and retrieves information.

For this activity, you'll need several willing subjects of different ages ranging from young children to teenagers or adults. For example, your younger brother, age 8; your cousin, 4; friend, 10; friend, 14 or 15; parent, 42. This study can be done individually, in pairs or in teams.

OBJECTIVE

Explore the relationship between age and language by employing research methods of interviewing, transcription and statistical analysis.

PROCEDURE

1. Choose a photograph or work of art that contains a simple, recognizable scene. It should have some details, but not be too complex or abstract. A farmer in a field or a ship docked in a bay would be good examples.
2. Explain to your subject that you want him/her to look at the image and describe it verbally for one minute. Explain that you will tape record the description. Before you begin, try to make your subject comfortable. Answer any questions he/she has about the study before you begin and explain that there is no "right answer" expected. (All you have to say about your study is that you are researching the way people describe things.)
3. Your subject should say as much as he/she feels like saying in a minute. Don't force or pressure your subject into saying more than what comes naturally.

MATERIALS

- ▽ tape recorder
- ▽ pen or pencil
- ▽ writing paper
- ▽ photographs or illustrations

ANALYSIS

Transcribe your interviews by listening to the tape and writing down the name, age and recorded comments of each subject. Analyze the passage:

1. Count the total number of words.
2. Circle the nouns and underline the verbs.
3. Count the total number of nouns and verbs.
4. Calculate the average number of words per sentence.
5. Calculate the average number of letters per word.
6. Graph one or all of the following data as a function of age:
 - a. words per minute
 - b. words per sentence
 - c. letters per word
 - d. any other relationships you feel might be important to your study.

Make a line or bar graph and put age on the X or horizontal axis — this is the independent variable. Data about language, the dependent variable, goes on the Y or vertical axis.

7. What can you conclude about language from this study? What do your graphs show about the development of language? Can you form any hypotheses about how people learn?

EXTENSION

Compare different languages rather than age levels. Interview a person whose native language is English, and then repeat the experiment in a second language. Of course, analyzing your data could be tricky without an interpreter!

MARC ROSNER, WHO TEACHES PHYSICAL AND EARTH SCIENCE AT PORT CHESTER MIDDLE SCHOOL IN PORT CHESTER, NEW YORK, CONTRIBUTED THIS ACTIVITY.



SCIENTIFIC
AMERICAN
FRONTIERS

SHOW 703

PIECES
OF MIND



OLD BRAIN/
NEW TRICKS

FOR FURTHER THOUGHT

- ▷ What might be the implications of these studies for learning a second language?
- ▷ What would be the most effective way for a deaf child to learn a language?

Explore the Mind with FRONTIERS Online!

Ask the Scientists

Pieces of Mind profiles intriguing research about memory, dreams and language. If you'd like to learn more about these topics, we invite you to send your questions to the four scientists from the show featured on this page. They

will be available to answer questions from **January 22 to February 7, 1997**, via the FRONTIERS Web site: <http://www.pbs.org/saf/>.

THE MAN WITH TWO BRAINS

Michael Gazzaniga of Dartmouth University studies patients with hemispheric disconnection, also called "split brains." When the corpus callosum is severed, the two halves of the brain no longer communicate and, although these patients function normally, Gazzaniga's experiments reveal that the two sides of their brains interpret and organize information differently. Find out more by sending your questions to Gazzaniga.



WHAT'S IN A DREAM?

At Harvard University's sleep lab, **Robert Stickgold's** research involves waking up his subjects — including Alan Alda — and giving them a test. Stickgold's experiments are trying to establish how REM sleep and dreaming affect mental activities and the learning process.



If you'd like to know more about discoveries at the sleep lab, send your questions to Stickgold.



REMEMBERING WHAT MATTERS

James McGaugh is director of the Center for Neurobiology of Learning and Memory at the University of California, Irvine. He has found a strong relationship between emotional experiences and memory and discovered that memory

may be enhanced and manipulated. McGaugh answers viewers' questions about his research and the implications of his findings.



OLD BRAIN/NEW TRICKS

Is there a critical window of opportunity for children to learn language — and what happens if the brain is not exposed to language at the appropriate time? Neuroscientist **Helen Neville** of the University of Oregon researches

language acquisition and its relationship to the developing brain. Learn more about these topics by sending your questions to Neville.

ONLINE LEARNING LINKS

Understanding Emotional Memory Using the Web: An interactive online activity for Pieces of Mind

Here's an opportunity to use the Web to introduce your students to the anatomy and physiology of emotional memory. This interactive exercise, designed for student participation after watching **Pieces of Mind**, simulates an experiment on emotional states and memory.

To find this activity, visit the FRONTIERS Web site (<http://www.pbs.org/saf/>). Click on Guides and Resources and then select Guides and Resources for the Current Show to link to the activity.

Many thanks to *The Biology Place* (<http://www.biology.com>) for creating this activity. *The Biology Place*, a service of Peregrine Publishers, Inc., provides resources and inquiry-based activities for science educators. For more information, visit *Membership* at <http://www.biology.com> or call toll-free 888-TBP-SITE.



HERE'S HOW TO "ASK THE SCIENTISTS"

- ▷ Watch **Pieces of Mind** and review this classroom guide to prepare your question(s) and decide which scientist(s) you'd like to contact.
- ▷ Visit SCIENTIFIC AMERICAN FRONTIERS on the World Wide Web at <http://www.pbs.org/saf/>. Click on the "Ask the Scientists" icon on the opening screen to send your question(s). Scientists' answers will be posted online for FRONTIERS viewers to read. Depending on the volume of questions received, only selected questions may be answered.
- ▷ Remember to e-mail your questions by February 7, 1997.

Pieces of Mind airs on PBS on **Wednesday, January 22, 1997, at 8 pm***.

* Check your TV listings to confirm local air time and date.

Meet Jamie Larsen



"As we encourage our students to get on the information highway, it's important that we teach them to evaluate the resources they find there," says Jamie Larsen. Unlike more traditional resources in the library, cyberspace offers very little to help students "screen" the science sites they discover there. "As a result," Larsen believes, "we need to really work on training our kids to move beyond critical thinking into becoming 'skeptical inquirers.'"

Like many science educators, Larsen is concerned about the proliferation of "psuedo-science" generally and, most recently, the explosion of psuedo-science on the Web. To help students navigate the Web intelligently,

Larsen has developed an activity that encourages skeptical inquiry, teaches students to recognize psuedo-science and helps them determine any bias shown on a particular site. In Larsen's activity, students watch a video called "Alien Autopsy," which originally aired on the Fox network and that Larsen found on sale at his local video store. Then students use the Web to research information that supports or questions what the video presents as "actual footage of an alien autopsy." Larsen describes this activity as a discussion-based approach for using pseudo-science as a catalyst for scientific thought. This concept could work equally well using print or video coverage of other controversial science topics related to your curriculum. Teachers can visit Larsen's activity at <http://www.tufts.edu/~jlarsen/>.

Jamie Larsen has been a science teacher at Verde Valley School in Sedona, Arizona. Most recently, he has been on a Wright Fellowship for Science Education at Tufts University, where he developed Slam Dunk Science and MicroMentary projects and designed interactive activities for science classrooms to construct a sports research lab.

Science in Cyberspace

In each issue of this guide, look for news about innovative Web sites researched and recommended by FRONTIERS staff. We hope you'll find them helpful.

▷ <http://www.exploratorium.edu> Imagine a site where you can see satellite images of Earth, hear the Doppler effect and follow a step-by-step dissection of a cow's eye. You'll find all this and much, much more at the Web site for the Exploratorium in San Francisco.

The Exploratorium was founded by Dr. Frank Oppenheimer to showcase science, nature, art and technology. Its exciting exhibits are actually a very carefully devised science curriculum, appropriate for the informal and formal teaching of science.

Even if you and your students

○ can't visit San Francisco, you can still
○ access lots of fascinating science at
○ the Exploratorium online. Teachers
○ will especially enjoy "Hands-on Science," a teacher's guide to student-built experiments designed to help
○ you and your students succeed in
○ science — and have fun doing it.

LET US CITE YOUR FAVORITE SITE!

○ Tell us about your favorite science
○ sites on the information superhighway. If we recommend your site in
○ this guide, you'll receive a FRONTIERS
○ T-shirt. Please e-mail your suggestions to saf@pbs.org.

Find More About the Mind

Check out these sites for more about the scientists and topics covered on **Pieces of Mind**:

▷ <http://www.med.harvard.edu:80/AANLIB/home.html>

Explore the Whole Brain Atlas, a site with actual images that illustrate parts of the brain and show physiological differences between a normal brain, an aging brain and a brain with various diseases.

▷ <http://www.wjh.harvard.edu/~dis>

Visit the home page for Daniel Schacter, seen on "True or False?" You'll find more about his research and publications as well as reviews of his recent book, *Searching for Memory: The Brain, the Mind, and the Past*, published by Basic Books.

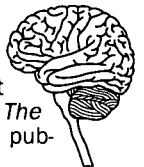

▷ <http://cogsci.vcsd.edu/cogsci/faculty/neville/html>

Explore Helen Neville's home page and find out more about this scientist featured on "Old Brain/New Tricks" in **Pieces of Mind**.

▷ <http://neuroscience.ucdavis.edu/faculty/gazzaniga.html>

Find out more about Michael Gazzaniga, seen on "The Man with Two Brains." His home page reports on his research and publications and gives an overview of his latest book, *The Cognitive Neurosciences*, from MIT Press.

▷ <http://www.lthaca.edu/hs/psych/psych1/curriculum/gep/sleepdreaming.html>

Find facts and definitions related to sleep at the Sleep and Dreaming Class Notes site from the department of psychology at Ithaca College.

▷ <http://www.uchsc.edu/sm/sm/surgery/neurosurg/science.htm>

Discover an extensive list of Web-based neuroscience resources prepared by the division of neurosurgery at the University of Colorado Health Sciences Center.



At press time, the online features and sites listed here were current. Due to the rapidly changing online world, some may have changed or may no longer be available.

WATCH IT ON PBS

SCIENTIFIC AMERICAN FRONTIERS

SCIENTIFIC AMERICAN FRONTIERS airs monthly on PBS — once in each of these months: October and November 1996 and January, February and April 1997. Each hour-long special includes a variety of fascinating science stories based on a single theme.

INVENTING THE FUTURE

[Show 701]

Wednesday, October 23, 1996 8 pm

Leap forward into the future when FRONTIERS visits the MIT Media Lab to test out smart cars, smart rooms and wearable computers. Meet scientists who are redesigning the look and role of computers.

SCIENCE SAFARI

[Show 702]

International Special

Wednesday, November 20, 1996 8 pm

Travel on a science safari to South Africa. Meet some of the world's largest animals, then trek to sites once inhabited by early humans. Find out how scientists combat malaria today.



ASK THE SCIENTISTS!

Helen Neville and other scientists seen on Pieces of Mind answer your questions online. See p. 14. <http://www.pbs.org/saf/>

PIECES OF MIND

[Show 703]

Wednesday, January 22, 1997 8 pm

Spend the night in a sleep laboratory and find out more about how your brain works to create memories, dreams and language. Find out how technology is helping scientists understand more about when and how the human brain learns language, processes and recalls information and dreams dreams.

GOING TO EXTREMES

[Show 704]

Wednesday, February 19, 1997 8 pm

Join scientists as they investigate survival mechanisms of animals that inhabit extreme climates — and how humans cope with high altitudes when climbing mountains.

ROBOTS ALIVE!

[Show 705]

Wednesday, April 9, 1997 8 pm

Meet some autonomous robots with minds of their own. Host Alan Alda catches up with the inventor of Flaky, Alan's robot friend from a previous season.



HOSTED BY ALAN ALDA

SCIENTIFIC AMERICAN FRONTIERS accompanies host Alan Alda to the Harvard sleep lab, where he is connected to a machine that will monitor his sleep and dreams.

Remember, teachers may videotape the show to use year after year. GTE Corporation, the series underwriter, grants educators free off-air taping rights in perpetuity for classroom use.



Underwritten by GTE Corporation



Connecticut Public Television
P.O. Box 260240
Hartford, CT 06126-0240

NON PROFIT
U.S. POSTAGE
PAID
Permit No. 51
Bristol, PA

INSIDE:
Requested Teaching Materials for **PIECES OF MIND**
Airing January 22, 1997, on PBS



Printed on recycled paper

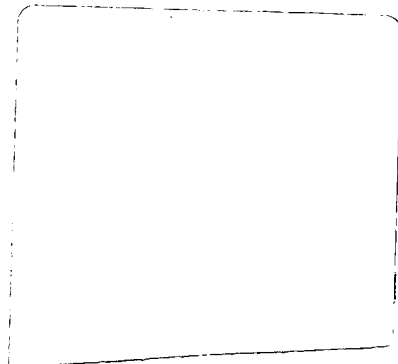

SCIENTIFIC
AMERICAN
FRONTIERS

SHOW 704 TEACHING GUIDE • FEBRUARY 19, 1997 • 8-9 PM

Going to Extremes

Testing Nature's Limits

GTE

Underwritten by
GTE Corporation



ERIC
Full Text Provided by ERIC

FOR YOUR INFORMATION

GOING TO EXTREMES

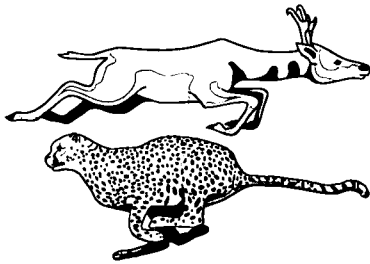

Join FRONTIERS on a journey to various places on Earth to see how animals and humans adapt to extreme environments.

Some of the adaptations may seem extreme in themselves: frogs that freeze and

thaw, sea creatures living in regions of very low oxygen and light, spiders whose behavior may indicate an evolutionary adaptation in the making and more, including the human body's response to high altitudes.

Be sure to visit our Web site (<http://www.pbs.org/saf/>) and try our online activities (see pp. 14-15 in this guide). You and your students can enter the **Viewer Challenge** (p. 4) and have a chance to win one of our terrific FRONTIERS T-shirts.

A LOOK BACK

You first met evolutionary biologist and paleontologist Geerat (Gary) Vermeij in **Creatures of the Deep** (Show 604) last season on FRONTIERS. Vermeij, who is blind, uses his sense of touch to "read" the biology and history of shells and the mollusks that once inhabited them. His ideas have caused other scientists to reconsider the roles of predator and prey in evolution. Vermeij tells his story in a new book, *Privileged Hands: A Scientific Life* (W.H. Freeman and Co., 1997). In his book, Vermeij recounts how an early interest in shells turned into a "burning curiosity — and set the course for my life." Check your local bookstore, library or Amazon Books (<http://www.amazon.com>).

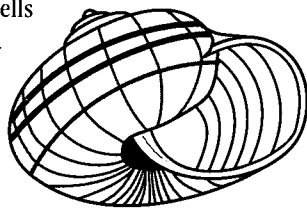

SCIENTIFIC AMERICAN EDUCATOR RATES

SCIENTIFIC AMERICAN magazine is an excellent resource for teachers; many articles relate directly to your science curriculum or to stories seen on FRONTIERS. For example: "Flight of Fancy" in the January 1997 issue and "Light in the Ocean's Midwaters" in the July 1995 issue will enrich the story on mid-ocean depths in **Going to Extremes**. The magazine offers a special rate to educators — \$24.97 for 12 monthly issues. To order, write SCIENTIFIC AMERICAN, Dept. SAF, 415 Madison Ave., New York, NY 10017.

THEY GO TO EXTREMES

FRONTIERS is produced by The Chedd-Angier Production Company in Watertown, Massachusetts, whose producers and camera crews often go to extremes to film the stories you see. Over the years, they have climbed the Alps, braved Arctic waters, trekked into deserts, explored unfamiliar countries and captured exciting but challenging footage. Along the way they've also wrestled with sharks, captured bears, risked attacks by scorpions and other critters, climbed the side of an active volcano and ventured into the unknown, all in the name of creating excellent science television.

Producing the story about mountain climbing seen in this episode meant experiencing the rigors of life at 15,000 feet above sea level. Different challenges arose for the crew and Host Alan Alda as they ventured beneath the surface of the water when exploring mid-ocean depths.

Finding cooperative cheetah and pronghorn to film was no easy matter, either. Several days before taping was to begin, the cheetah to be filmed suffered an unrelated injury. Luckily, at the last minute the producers were able to locate another cheetah to film.

NEXT TIME ON FRONTIERS

Stay tuned April 9, 1997, for **Robots Alive**, the season finale of SCIENTIFIC AMERICAN FRONTIERS, which features autonomous robots with minds of their own.

SCIENTIFIC AMERICAN FRONTIERS is closed-captioned for the hearing-impaired and is narrated by Descriptive Video Service (DVS) for visually impaired audiences. The series and School Program are endorsed by the National Science Teachers Association (NSTA) and the National Education Association (NEA).

TAPING THE SHOW

- Always check TV listings to confirm air date and time.
- As a teacher, you have off-air taping rights in perpetuity for classroom use.
- If you can't find the show in your TV listings, call your local PBS station.
- Do you need help? Call the FRONTIERS School Program at 800-315-5010.
- Videotapes of past shows** can be purchased (\$19.97 each). Call 800-315-5010.

FREE VIDEOTAPING & PHOTOCOPYING RIGHTS

GTE Corporation, the series underwriter, makes available complete off-air taping rights in perpetuity for classroom use of SCIENTIFIC AMERICAN FRONTIERS. Educators may record each show when it airs on PBS and keep the tapes to use in the classroom year after year. Educators may also photocopy all materials in this guide for classroom use. If you know of other educators interested in receiving these guides, they may sign up by calling the SCIENTIFIC AMERICAN FRONTIERS School Program at 800-315-5010.

LET US HEAR FROM YOU!

We appreciate and welcome your questions, comments, compliments and constructive criticism. *Please contact us . . .*

BY MAIL:

SCIENTIFIC AMERICAN FRONTIERS
105 Terry Drive, Suite 120
Newtown, PA 18940-3425

BY PHONE: 800-315-5010

BY FAX: 215-579-8589

BY E-MAIL: saf@pbs.org

VISIT US ONLINE:

<http://www.pbs.org/saf/>

TABLE OF CONTENTS

SHOW 704 • FEBRUARY 19, 1997 • 8 PM ON PBS

GOING TO EXTREMES

6 SPIDER CANYON

Long-term observations of funnel web spiders in a natural laboratory suggest a surprising theory.

Activity:

Trade observations of animal adaptations.

7 HIGH ANXIETY

FRONTIERS climbs to 15,000 feet to see if a test can predict who will succumb to mountain sickness.

Activity:

Learn about the physiology of mountain sickness.

8 ULTIMATE SPEED

Science explores the physiology and biomechanics of the two fastest runners in the animal kingdom.

Activities:

Measure your VO₂ max . . . Videotape biomechanics of running.

10 FROZEN ALIVE

Wood frogs that freeze and winter flounder that don't are the subjects of fascinating research activities.

Activities:

Chill out with organic antifreeze and frozen yeast.

12 HIDDEN DEPTHS

Underwater explorations of the ocean's middle depths turn up some bizarre species never seen before.

Activity:

Design and build a mini-ecosystem.



DEPARTMENTS

4 VIEWER CHALLENGE

5 THE BIG PICTURE

14 SAF ONLINE

Note: The order of the activities in this guide does not reflect the actual order of the stories in the show. The At-A-Glance box below reflects the story sequence on the show.

COVER PHOTO: © T/MAKER® — BRODERBUND SOFTWARE.

NOTE: THE PHOTOGRAPH OF ALAN ALDA HOLDING THE HUMAN BRAIN WHICH APPEARED ON THE TABLE OF CONTENTS IN THE **PIECES OF MIND** (SHOW 703) TEACHING GUIDE WAS TAKEN AND COPYRIGHTED BY STANLEY ROWIN.

SCIENTIFIC AMERICAN FRONTIERS is made possible by an underwriting grant from GTE Corporation. The series is produced by The Chedd-Angier Production Company in association with SCIENTIFIC AMERICAN magazine and presented to PBS by Connecticut Public Television. Some materials produced by Media Management Services, Inc.



STORY	RUNNING TIME	AT-A-GLANCE					
		BIOLOGY	EARTH SCIENCE	GENERAL SCIENCE	LIFE SCIENCE	PHYSICAL SCIENCE	TECHNOLOGY
Spider Canyon	12:09	•		•	•		
Frozen Alive	10:45	•		•	•	•	•
Ultimate Speed	10:54	•		•	•		•
Hidden Depths	9:04	•	•	•	•	•	•
High Anxiety	10:00	•	•	•	•		•

*CHECK LOCAL TIME

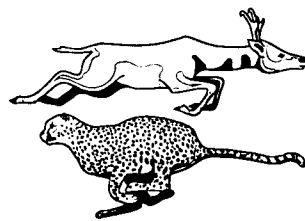

Student's Name _____
 Teacher's Name & Course _____

Watch **SCIENTIFIC AMERICAN FRONTIERS Going to Extremes (Show 704)** for answers to questions on this page. Answer the 10 questions correctly and you'll be eligible to win a **FRONTIERS T-shirt!**

Spider Canyon

1. How does the female funnel web spider identify its prey?

2. The hybrid spider offspring of aggressive males from the desert and the less aggressive spiders from the river are:

- a. very timid. b. super-aggressive.
 c. not very bright. d. confused.

Frozen Alive

3. What enables the winter flounder to survive the cold temperature of sea water?

4. What chemical enables the wood frog to freeze and thaw?

- a. glucose b. glyceric acid
 c. glycerol d. nitroglycerin

Ultimate Speed

5. When the cheetah is running, it gets extra power from energy stored in its:

- a. legs. b. feet. c. muscles. d. back.

6. How do pronghorn and cheetah differ in the ways they run?

Hidden Depths

7. What is "marine snow"?

8. The ocean at the middle depths contains low levels of (choose two):

- a. oxygen. b. phosphorus.
 c. nitrogen. d. light.

High Anxiety

9. The air at high altitudes causes problems for climbers because it contains:

- a. less nitrogen. b. more oxygen.
 c. less oxygen. d. more carbon dioxide.

10. What is the most dangerous time on the mountain for climbers susceptible to altitude sickness?

For Teachers Only

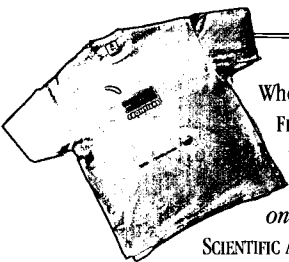

When completed, this page can become an entry to the **FRONTIERS T-shirt contest**; 20 winners (10 students, 10 teachers) will be drawn at random for each show. To enter the T-shirt drawing, send all completed challenges *in one envelope* with a cover sheet to: **Viewer Challenge**, SCIENTIFIC AMERICAN FRONTIERS, 105 Terry Drive, Suite 120, Newtown, PA 18940-3425. Mail completed entries by **March 21, 1997**.

TIP: You can also download these questions on the **FRONTIERS Web site** (*see p. 14*).

Important!! Please include a separate cover sheet and tell us:

- number of challenges submitted
- teacher's name
- grade and course
- school name, address and phone number
- where your students watched the show — at home, at school or both
- the name of your students' favorite story in this show (conduct a quick poll to find out)

Thank you!

ANSWERS TO VIEWER CHALLENGE 704: 1. senses vibration patterns of the prey when it touches her web 2. b 3. antifreeze proteins in its blood 4. a 5. d 6. cheetah — sprinter, anaerobic; pronghorn — long-distance runner with great endurance, aerobic 7. junk, detritus and dust from the upper layer of ocean that drifts down 8. a, d 9. c 10. night

THE BIG PICTURE

A FIELD GUIDE TO GOING TO EXTREMES

This episode of SCIENTIFIC AMERICAN FRONTIERS takes you to some of the extreme places on Earth and introduces you to a few of the inhabitants who live there. You'll meet animals that live in cold places and in hot places like the deserts of the American Southwest and in the savannas of Africa. You'll travel to the middle depths of the ocean off Monterey Bay, California and climb the Alps in Germany. Here are profiles of the animals and places featured on **Going to Extremes**.

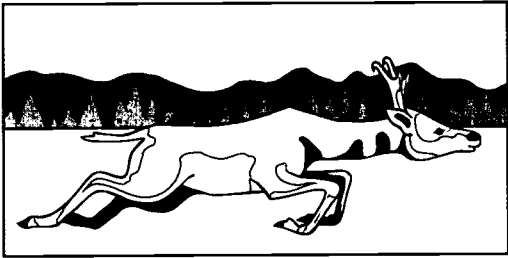

THE PRONGHORN ANTELOPE (*Antilocapra americana*), not a true antelope, lives in grasslands and deserts from northern Mexico to southwestern Canada. Native to the Great Plains of North America, pronghorn were once as populous as bison. Clocked at speeds of more than 60 mph, the pronghorn is the fastest New World mammal and can run at 45 mph for several miles.

about 10,000 years ago), is losing the race for survival. Cheetah are great sprinters and can run at speeds of 70 mph for distances of about 300 yards. The cheetah can accelerate from 0 to 45 mph in less than two seconds!

THE CHEETAH (*Acinonyx jubatus*) is built for speed. Sadly, the cheetah, once found in abundant numbers on African savannas (and in North America until

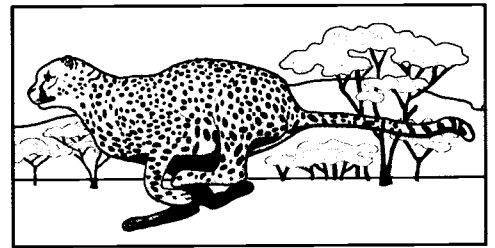

Found in the Atlantic Ocean from Newfoundland to Georgia and heavily concentrated in the northern regions, **THE WINTER FLOUNDER** (*Pleuronectes americanus*) has antifreeze proteins in its blood that keep it from freezing. The winter flounder is one species of right-eyed flatfish. When this fish is young,

its eyes are on both sides of its head; but as it matures, the eyes migrate to the right side.



THE WOOD FROG (*Rana sylvatica*) is found across many regions of northern North America and can live in habitats north of the Arctic Circle. Its freeze tolerance is made possible by glucose produced by its liver, which enables it to survive cold temperatures for weeks, with as much as 67 percent of its total body water turning to ice. When temperatures warm, the frog thaws.

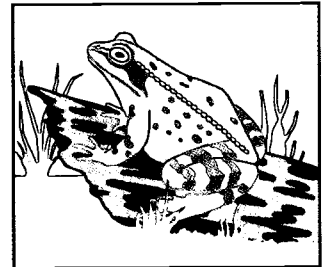

THE FUNNEL WEB SPIDER (*Agelenopsis aperta*) spins its web in the shape of a funnel (tube) on one end, where it retreats to get out of the sun and to await prey that lands on the web. The funnel is oriented so that the sun shines into the recess only in the late afternoon, which permits a longer time to hunt for food and cooler funnel temperatures in the daytime.



THE MIDDLE DEPTHS OF THE OCEAN — from a few hundred to 12,000 feet below the surface — is one of few unexplored regions on Earth. Scientists only recently discovered the strange forms of life that inhabit this region, where there is very little sunlight or oxygen. From fang fish to bioluminescent sea creatures and hundreds of other unique species, the inhabitants of this region have adapted to an extreme environment.



MOUNTAIN CLIMBING AT HIGH ALTITUDES can be hazardous to your health. Because of the atmospheric changes at this height and above, climbers must take special precautions to acclimate to the extremes before making the trek to the top. The tallest peaks of Mt. Everest reach higher than 29,000 feet; the FRONTIERS crew ascends to 15,000 feet in the Alps.

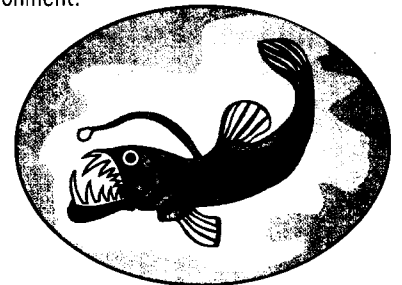

YOUR TURN: WHERE ON EARTH . . . ? Locate the following places on our planet: HOTTEST AND COLDEST SPOTS • HIGHEST MOUNTAIN PEAK • DEEPEST PART OF THE OCEANS • LONGEST RIVER

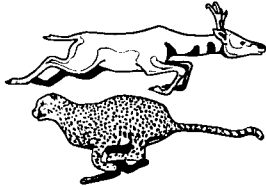

SPIDER CANYON

RUNNING TIME:

12:09

CURRICULUM LINKS:

BIOLOGY

arachnids, genetics

EARTH SCIENCE

biomes, desert

GENERAL SCIENCE

adaptation, evolution

GEOGRAPHY

American Southwest

LIFE SCIENCE

complex invertebrates, predator & prey

RELATED FRONTIERS ACTIVITY:

Show 303 Teaching Guide

"Luv to Catch Spiders" (pp. 13-14)

<http://www.pbs.org/saf/>



Susan Riechert, seen in this segment, answers your questions online.

See p. 14 for information.

SPIDER CANYON

Some spiders will go to any extremes to find a partner. But for the male funnel web spider in one area of Arizona, such behavior may not be in the best interests of the species. Arachnologist Susan Riechert has discovered that the union of aggressive males from the desert with timid spiders from the river is producing a super-aggressive hybrid spider with very low survival rates. Selection pressure should eventually prevent desert and river spiders from interbreeding, causing a new species to emerge.

ACTIVITY: Nature's Tools Trading Cards

MATERIALS

- ▽ paper
- ▽ pencils
- ▽ clipboard
- ▽ blank 3" x 5" index cards

The funnel web spider has evolved many adaptations that enable it to survive. From behavioral changes like hiding in its web to escape the heat of the day to physical modifications like those needed to spin a funnel-shaped web, adaptations are "nature's tools" for survival. In this activity, you will build a set of Nature's Tools Trading Cards. These cards, like sports and other trading cards, are a good way for you to apply your observation skills.

OBJECTIVE

Observe and write about adaptations in nature.

PROCEDURE

1. **OBSERVATIONS.** Select a quiet area to observe organisms. (If weather prevents outdoor observation, you can observe a dog, cat, hamster or other pet.) Choose an organism to study and draw it. Identify a feature or adaptation you think helps the organism survive and draw a close-up of it. Take notes on how you think the adaptation works. For example, the web of the black widow uses sticky threads in a random pattern to trap its prey.
2. **TRADING CARDS.** Using blank index cards, draw a vertical line down the middle of each side. On the front, left side of the card, redraw the picture of the organism you sketched in your initial observation. On the right side write the common name of the organism, the scientific name and a brief description of its habitat.
On the left side of the back of the card, draw one of the adaptations you

noted. On the right side write the name of the adaptation (if you know it) and a brief description of how it helps the organism survive. Start your cards with pictures of local animal species. As you get used to observing and creating cards, follow up with library or online research to support your observations. Once the cards are complete, you may wish to laminate them.

3. **GO ONLINE.** Take photos of plants and animals and substitute them for the drawings on the trading cards. A digital camera (or pictures you download from online sources) will let you import the pictures straight into a computer. You can also build your trading cards and make them available on your school's Web site.

SAMPLE TRADING CARD

FRONT

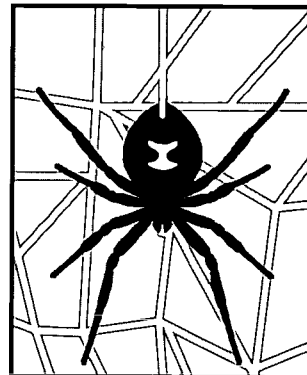

COMMON NAME:
black widow spider

SCIENTIFIC NAME:
Latrodectus mactans

HABITAT:
Found in southwestern deserts. Prefers dark, undisturbed places where it can build its web and wait for prey. Builds webs in crevices, rocks or buildings and wood piles. Hides during the day.

BACK

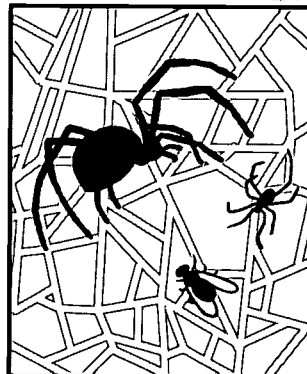

ADAPTATION OBSERVED:

The web of the black widow seems to be different from other spiders. It does not have a particular pattern; it consists of random threads that are attached to whatever is handy.

HOW IT WORKS:

The web seems to be sticky and traps insects that stumble into it. Once insects are trapped, the spider comes out and bites the prey. I saw that if I tap on the web the spider comes out as if an insect were caught.

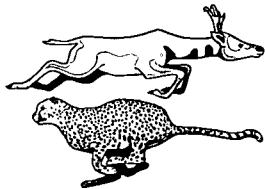

HIGH ANXIETY

Mountain climbing can be hazardous to your health. And with more and more adventurers participating in sports that take them to higher altitudes, the potential for disasters is increasing. In this episode, a German research team heads for the Alps to see if a test can predict who will adjust successfully to reduced levels of oxygen. Even though the volunteers are aware of the risks, the situation nearly turns fatal for one of them.

Mountain Climbing and Human Physiology

**RUNNING
TIME:**

10:00

**CURRICULUM
LINKS:**

BIOLOGY

circulatory system,
respiratory system

EARTH SCIENCE

atmosphere

GENERAL SCIENCE

blood cells,
human brain

HEALTH

aerobic breathing,
fitness, hypoxia

LIFE SCIENCE

gas exchange,
lung capacity,
physiology

FOR FURTHER THOUGHT

- ▷ What is the altitude where you live?
- ▷ Compare the atmospheric pressures at various altitudes, from sea level to 29,000'.
- ▷ Investigate the effects on the body of deep-sea diving at depths comparable to high altitudes. How are the "bends" like altitude sickness?
- ▷ For more details on the physiology of the human body at high altitudes, see "Mountain Sickness" in the October 1992 issue of *Scientific American*.

Two thousand years ago, Chinese travelers climbing the Himalayas called them the "Headache Mountains." And little wonder. The high peaks of the Himalayas have caused more than a few headaches for even the most experienced mountain climbers over the centuries.

The ancient Chinese who ascended those lofty peaks had one advantage modern travelers often do not: climbers in previous centuries were forced to acclimate slowly to any change in height, since they could not be flown in to a mountain resort and expect to be on the slopes or out hiking on the same day.

In a modern scenario, tourists fly from their homes at sea level to a mountain resort at 7,000 or 8,000 feet. The adventurous traveler then decides to take a tram or hike to the ski slopes, or climb a mountain trail, which might be closer to 9,000 or 10,000 feet. By nightfall, the traveler may experience severe headaches, shortness of breath, nausea, mental confusion and great fatigue.

This form of altitude sickness is known as acute mountain sickness. It can occur when people accustomed to living at sea level ascend to altitudes higher than 8,000 feet too rapidly for the body to adjust. At higher altitudes, changes in the atmospheric air pressure cause oxygen levels to drop. Mountain sickness is the body's response to falling concentrations of oxygen. It is remedied by rest or descent.

Not everyone who travels above 8,000 feet will experience symptoms of acute mountain sickness. It was once thought that more physically fit people would have an easier time adjusting to altitude. But that is not always the case, as you see on **FRONTIERS** when scientists try to predict who will experience the more severe form of mountain sickness. Some people are not as susceptible to any form of mountain sickness.

The case of mountain sickness in this episode of **FRONTIERS** is more extreme than that experienced by the occasional traveler. This more dangerous form of mountain sickness is high-altitude

pulmonary edema, which can be fatal. Experienced climbers and skiers know that the key to preventing problems at altitude is to climb slowly, allowing the body to acclimate. As a rule of thumb, climbers can avoid perils by ascending 2,000 feet a day above 7,000 feet and by climbing at a comfortable pace, allowing time for rest.



At High Altitudes

Even altitudes of 5,000 feet can literally take your breath away. If you live at an elevation of less than 3,000 feet, be aware that a rapid change in altitude can occasionally cause problems. Altitude sickness is highly unpredictable and can strike people in the best of health. Be aware of these symptoms:

- ▷ listlessness, drowsiness, apathy
- ▷ prolonged or severe headache, extreme thirst
- ▷ sleep disturbances, mental confusion
- ▷ slowed reflexes, fatigue

To cope with altitude sickness and its potentially unpleasant or dangerous effects when hiking, skiing or snowboarding, acclimate yourself slowly, drink plenty of water and avoid vigorous exercise until you've adjusted to the higher elevation.

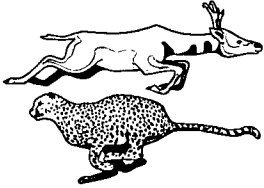

ULTIMATE SPEED

RUNNING TIME:

10:54

CURRICULUM LINKS:

BIOLOGY

blood gases, respiration

GENERAL SCIENCE

mammals, vertebrates

LIFE SCIENCE

life processes, respiration

PHYSICAL SCIENCE

force plate analysis, gases

PHYSICS

acceleration, velocity

RELATED FRONTIERS ACTIVITY:

SCIENCE OF SPORTS

(Show 405)

Teaching Guide

"Spring Man" (p. 7)

<http://www.pbs.org/saf/>



Rodger Kram, seen in this segment, answers your questions online.

See p. 14 for information.

ULTIMATE SPEED

The cheetah and the pronghorn antelope are the world's fastest land animals, but each achieves its success in locomotion because of very different biomechanics. The cheetah is a sprinter, built for speed with a flexible body and a large stride. By contrast, the pronghorn's body is built for endurance and long distances; it has evolved an aerobic ability that enables it to utilize oxygen at a very high rate. Both the cheetah and the pronghorn have been clocked at speeds higher than 60 mph.

DO THE LOCOMOTION . . .

Researchers interested in the physiology of locomotion look at how the body's systems — respiratory, cardiovascular, musculoskeletal — work when animals move.

As you see on FRONTIERS, physiologists use

NEEDS

ACTIVITY 1:

- ∇ stopwatch
- ∇ calculator

ACTIVITY 2:

- ∇ video camera
- ∇ meter stick

ACTIVITIES 1 & 2:

- ∇ writing materials
- ∇ graph paper

different tools and devices to study the science of running. Gas analyzers of O₂ and CO₂ concentrations and flowmeters can determine how efficiently an organism uses oxygen; high-speed videos record and analyze components of movement. The same techniques can be applied to human physiology and fitness.

You can set up your own research activities to find out more about the physiology and biomechanics of locomotion.

ACTIVITY 1: Calculate VO₂ Max

OBJECTIVE

Collect and analyze data to calculate human aerobic capacity.

The two fastest land animals, the pronghorn and cheetah, have evolved different solutions to the need for speed. Each animal is perfectly designed to run at top speed. One difference is in the ways the two use oxygen. The cheetah, like any sprinter, is anaerobic, while the pronghorn relies on aerobic endurance, similar to marathon runners.

Several tests have been developed to measure aerobic capacity in people and in animals. A popular test measures VO₂ (volume of oxygen) max — the more efficiently the oxygen is used, the more fit the runner. The higher the VO₂ max, the greater the aerobic capacity. The longer the run, the more accurate the measurement. Less than a mile is anaerobic running, not aerobic.

Physiologists have found a high aerobic capacity or ability to use oxygen in the pronghorn. As you see on FRONTIERS, physiologists monitor the O₂ and CO₂ concentrations in expired gases from the pronghorn.

You can measure VO₂ max yourself, by following these steps. Work with the physical education teacher or a track coach. You may want to ask for volunteers from various sports teams or set aside a block of time for a special physical education/

science project. Non-runners can handle the timing and calculations for the runners.

PROCEDURE

Use this equation to calculate VO₂ max for a distance of one mile:

$$VO_2 \text{ max} = 133.61 - (13.89 \times \text{time})$$

Time is equal to the number of minutes it takes to run one mile. VO₂ max is usually given in milliliters of oxygen per kilogram of body weight per minute (ml/kg/min). This equation, from *Inside Running: Basics of Sports Physiology* by David Costill, is just one example of many prediction equations. For a two-mile test, use: VO₂ max = 128.81 - (5.95 x time).

QUESTIONS

1. Graph the data you collect and examine it in different ways. For example, does VO₂ max differ by age or gender? Does VO₂ max differ among students involved in different sports?
2. VO₂ max can be influenced by exercise. What kind of exercise might help improve VO₂ max?
3. Why might we see more variation in aerobic capacity in humans than in animals?
4. Compare and contrast the physiology and biomechanics of the cheetah and pronghorn.

ACTIVITY 2: Biomechanics of Running

OBJECTIVE

Find out how different speeds affect stride rate and length.

When animals want to run faster, they increase either their stride rate or stride length. As you see on **FRONTIERS**, measuring the stride of a galloping pronghorn is challenging!

A stride is a complete movement from the point of one foot striking the ground, leaving it, then striking the ground again. Stride length is the distance traveled in one stride. A horse has a maximum stride length of about seven meters, a stride rate of about 2.25 strides/second and a top speed of about 70 km/hr. A cheetah, which is much smaller than a horse, has a stride length that is about the same as that of the horse; but the cheetah has a stride rate of about 3.5 strides/second and a top speed of about 110 km/hr. Where does the difference in speed come from? Consider the cheetah's physiology as explored in the activity on page 8.

Physiologists studying the mechanics of movement look at how anatomy contributes to speed by running animals at different speeds and filming them. They use high-speed cameras that can film at speeds greater than 1,000 images per second. Even though a video camera can shoot only 30 images per second, not fast enough to capture the details researchers need to see, you can use it to begin studying the biomechanics of running.

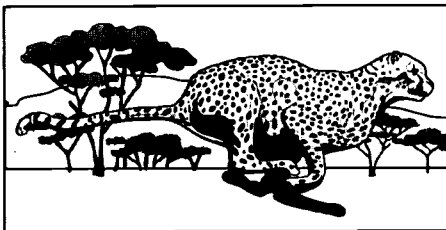

PROCEDURE

1. Position the video camera (an 8mm camera is best) in a well-lit area and against a backdrop that will let you capture a runner passing in front of the camera. Make sure you keep a detailed research journal with information on time, date and details of the data collection. You should also record the position of the camera setup so you can duplicate it if you have to take down your equipment.
2. Frame the picture so that you can capture about two full strides without having to move the camera while your subject is running.
3. Place a meter stick or mark the background with meter increments to give you a frame of reference to measure. To get a time reference, have the camera's time and date stamp feature turned on.

4. Start your camera and have the subject walk slowly in a straight line past the camera. Record at least two trials.
5. Next have your subject run at a jogging pace and record two trials. Repeat this at faster paces until, for the last trial, you have the subject sprint in front of the camera.
6. Once you've collected your data, examine the video to see how stride length and stride rate vary with pace. You may want to set up a data table to record the pace, stride length and stride rate.

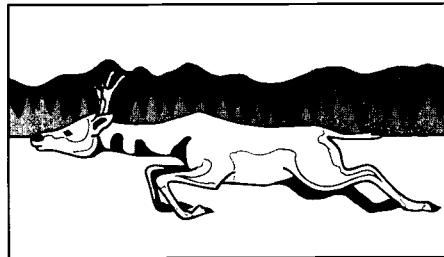

QUESTIONS

1. How do stride rate and stride length vary between males and females? Among runners of different ages?
2. Set up experiments that study the stride rate and length of different animals, or of different breeds of animals. How do they compare?

EXTENSIONS

- ▷ If your videotape player has a pause feature, you can stop the video at key times to trace the outline of the legs in a stride. Try to superimpose the bones of the leg over your drawing. What is the movement of the bones in the leg and foot over the course of a stride cycle?
- ▷ Reset your camera to get a close-up of the foot during running. How does the movement of the foot vary at different speeds? Does a different part of the foot hit the ground first? Does this vary among different people?
- ▷ Research other running animals. What bones do they use to run? How do they differ from the bones in a human's leg and foot? How does the ankle spur and bone structure help pronghorn run?
- ▷ If you have access to a software program like *Avid Cinema*, try making a movie of animals or people running, perhaps for your school's Web page, or just for fun.
- ▷ You can measure your VO_2 max on a treadmill. See *Bicycling Medicine — Cycling Health, Fitness & Injury Explained* by Arnie Baker, M.D.

THIS ACTIVITY AND THAT ON PAGE 6 WERE CONTRIBUTED BY JAMIE LARSEN, A SCIENCE TEACHER AND TUFTS UNIVERSITY WRIGHT FELLOW CURRENTLY LIVING NEAR SEDONA, ARIZONA.

SCIENTIFIC
AMERICAN
FRONTIERS

SHOW 704

GOING TO
EXTREMES

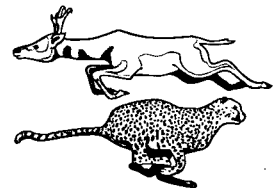

ULTIMATE SPEED

FOR FURTHER
THOUGHT

▷ Cheetah and other large mammals inhabited parts of North America until the end of the Pleistocene era, about 10,000 years ago. Find out where they lived and why they died out in these regions.

▷ The cheetah is greatly endangered. Find out how many cheetah are living, where they live and the reasons for their critical status.

▷ The pronghorn's speed may be an evolutionary adaptation in response to a predator chasing it. Today there is no creature living in the pronghorn's habitat that is capable of pursuing the chase. So why do pronghorn continue to run so fast? Some scientists have suggested that they are being chased by "ghosts" of predators. In other words, according to this theory pronghorn exhibit behavior appropriate for the wild but no longer necessary for survival. Can you find other examples of relict behavioral adaptations?

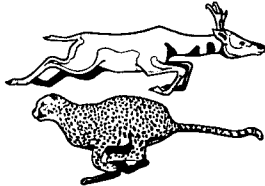

FROZEN ALIVE

**RUNNING
TIME:**

10:45

**CURRICULUM
LINKS:**

BIOLOGY

hibernation,
regulation

CHEMISTRY

change of phase,
glucose

EARTH SCIENCE

freezing & thawing,
water cycle

GENERAL SCIENCE

amphibians, fish

LIFE SCIENCE

cold-blooded
animals, cryogenics,
yeast

PHYSICAL SCIENCE

freezing point
depression
(supercooling)

TECHNOLOGY

antifreeze

<http://www.pbs.org/saf/>



**Kenneth and
Janet Storey**, seen
in this segment,
answer your
questions online.

See p. 14
for information.

FROZEN ALIVE

Two cold-blooded creatures have evolved very different physiologies to cope with the extreme cold of their environments. The winter flounder can live in sea water of -1.8°C . The wood frog actually freezes — its heart stops beating and its liver converts glycogen to glucose, thereby lowering the temperature at which ice crystals form and protecting its cells from the ice when freezing does occur. Scientists hope further understanding of these mechanisms might be used to preserve human organs for transplants.

ACTIVITY 1: Chill Out: Organic Antifreeze

MATERIALS

- ▽ basin or container
- ▽ thermometer
- ▽ 2 small plastic cups
- ▽ ice
- ▽ stirring rod
- ▽ graduated cylinder
- ▽ water
- ▽ salt
- ▽ sugar packets
- ▽ marker

As a substance (solute) dissolves in another substance (solvent), it produces a mixture called a solution. The relative amounts of solute and solvent can affect the physical properties of the solution. For example, glucose acts as a solvent to lower the freezing point of water.

When this happens, it is known as *freezing point depression* or *supercooling*.

An automobile's engine is cooled by jackets of water. In winter, water in these channels can freeze and expand. The expansion is so forceful it can crack an engine block. Antifreeze is a liquid solute (ethylene glycol) that dissolves easily in water. In solution and added to a car's engine, it lowers the freezing point of water, preventing it from freezing and ruining the engine.

Glucose, like the antifreeze ethylene glycol, dissolves in water. In this activity, think of the sugar solute as a form of glucose that depresses the freezing point of water. In cells, the lowering of the freezing point of the liquid cell contents protects the living system from freezing and ripping open with fatal results. The wood frog's liver

converts glycogen to glucose, which is able to actually prevent ice crystals from forming in the frog's cells through freezing point depression.

OBJECTIVE

Investigate the role of glucose (sugar solution) when used as an antifreeze.

PROCEDURE

1. Fill a small basin with about 500 mL of an ice-and-water mixture. Use a thermometer to measure the temperature of this mixture until it reaches 0°C .
2. Once the temperature has stabilized, add $\frac{1}{4}$ cup of salt to the mixture. Stir well. After five minutes remeasure the temperature of the solution. Did it change? If so, how?
3. Add 10 mL of ice-cold water (no ice) to two small cups labeled A and B.
4. Mix $\frac{1}{2}$ packet of sugar into cup B.
5. Place both cups into the large basin that has been filled with salted ice-water.
6. After ten minutes, compare the contents of the two cups.

QUESTIONS

1. What happened to the water in cups A and B?
2. What might account for any observed differences in the final appearance of the cup contents?



ACTIVITY 2: Cryogenics: The Big Chill

As you observe on FRONTIERS, some organisms withstand frigid temperatures by shutting down their energy needs. In a "suspended state," their cells, tissues and organs require very little energy. The demands of such a "quasi-living" state can be satisfied by a very slow metabolic rate.

Metabolism refers to the physical and chemical processes that make energy available to an organism.

Metabolism is affected by temperature. The colder the temperature, the slower the reaction rate. When the rate of these life-sustaining reactions drops beneath a critical level, the organism will die.

In this activity, you'll observe the relationship between temperature and metabolism. The subjects for this experiment are *Saccharomyces cerevisiae* — one-celled organisms more commonly known as baker's yeast. These cells have been specially packed, treated and stabilized so they can remain in a "suspended" but viable state for several months. When placed in warm water, the cells activate. As the metabolism awakens, the cells generate carbon dioxide gas. By observing the presence of this gas, you'll be able to make inferences about metabolism. You'll see that both the yeast and the multicellular organisms seen on FRONTIERS can survive states of suspended animation or low metabolic activity.

OBJECTIVE

Observe the relationship between temperature and metabolism.

PROCEDURE

1. Open a package of baker's yeast and carefully remove several small granules. Examine the grains of pressed dried yeast with a hand lens. Does the yeast appear alive? Explain.
2. Divide the contents of this opened package into two equal portions (about $1\frac{1}{8}$ teaspoons each).

MATERIALS

- ▽ 4 16-ounce clear beverage containers
- ▽ 8" to 10" balloons
- ▽ 2 packages of dry baker's yeast (or dried yeast in jars)
- ▽ warm water
- ▽ small basin filled with ice water
- ▽ small basin filled with warm water (about 40° C)
- ▽ thermometer
- ▽ sugar
- ▽ spoon
- ▽ magnifying glass

Place one portion into a small clean, dry beverage container labeled A and the other portion into a similar container labeled B.

3. Open and divide the contents of a second yeast package into two equal portions. Place one portion into a beverage container labeled C and the other portion into a container labeled D.
4. Do not activate the yeast in container A. The yeast in containers B, C and D should be activated according to the instructions printed on the yeast package, including adding about $\frac{1}{2}$ teaspoon of sugar per container.
5. Stretch and secure a balloon over the mouth of each of the four containers.
6. Set containers A and B on a desktop. Place container C in a basin filled with warm water. Place container D in a basin filled with ice water.
7. Examine the setups after 15 minutes. Record any change in the balloons' appearance.

Note: You can use dried yeast either in packets or in less expensive jars. The experiment will work even if amounts of yeast are not precise. You might want to try varying amounts of yeast to see what happens. Most instructions call for the use of sugar to activate the yeast; try variations of the instructions to see what happens.

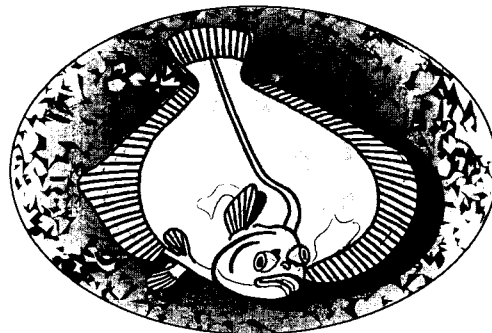

QUESTIONS

1. Did any of the balloons change in appearance? If so, how?
2. What caused this change?
3. What happened to the yeast in container A? Explain.
4. After 15 minutes, how did the appearance of the yeast change?
5. How is the yeast metabolism similar to the metabolism of the organisms shown in this segment of FRONTIERS?

ANSWERS TO QUESTIONS: ACTIVITY 1: 1. The water in cup A froze; the solution in cup B remained liquid. 2. The dissolved sugar lowered the freezing point of the water, thus preventing it from freezing. **ACTIVITY 2:** 1. Balloons over containers B, C and D inflated. 2. Yeast became activated and released CO₂ gas that inflated the balloons. 3. Since this yeast wasn't activated, it remained in its suspended state and did not produce a detectable amount of CO₂. 4. Yeast in warm water had the most froth; in room temperature it had a middle amount of froth; in ice water it had the least froth. 5. Metabolism is affected by temperature. In addition, both the yeast and multicellular organisms can survive in a "suspended state" of low metabolic activity.

ACTIVITIES ON THESE PAGES WERE CONTRIBUTED BY SCIENCE WRITER MICHAEL DISPEZIO, AUTHOR OF THE BOOK *THE SCIENCE OF HIV*, PART OF A NEW VIDEO AND ACTIVITIES CURRICULUM PACKAGE AVAILABLE FROM NSTA.

SCIENTIFIC
AMERICAN
FRONTIERS

SHOW 704

GOING TO
EXTREMES

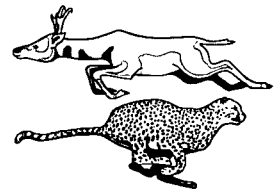

FROZEN ALIVE

FOR FURTHER
THOUGHT

- ▷ Apply the results of this activity to the role of glucose solution as an animal antifreeze.
- ▷ When making ice cream, flavored cream is placed in a container surrounded by salted ice. Why?
- ▷ Why do people put rock salt on icy sidewalks in the winter?
- ▷ Is your metabolism temperature-dependent? Does it change at all in summer or winter?
- ▷ How is the metabolism of cold-blooded animals different from that of warm-blooded animals?
- ▷ Can you think of other applications for the winter flounder and wood frog discoveries?
- ▷ Investigate the supercooling mechanisms of the Arctic ground squirrel, a mammal that is able to survive very cold temperatures.

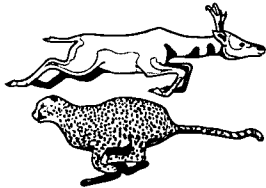

HIDDEN DEPTHS

**RUNNING
TIME:**

9:04

**CURRICULUM
LINKS:**

BIOLOGY

invertebrates

EARTH SCIENCE

biomes, ecology,
oceans

GENERAL SCIENCE

ecosystems

LIFE SCIENCE

bioluminescence,
classification,
ecosystems

TECHNOLOGY

submersibles

**RELATED
FRONTIERS
ACTIVITY:**

**THE WILD WEST
(Show 601)
Teaching Guide
"Model Planet"
(pp. 6-7)**

HIDDEN DEPTHS

Bioluminescent fish, gelatinous sea creatures 120 feet long, archaic cephalopods and other strange organisms are among the new species discovered by the Monterey Bay Aquarium Research Institute (MBARI) in the midwaters of the Pacific Ocean near the California coast. This region of the ocean presents an exciting and challenging realm to explore. Join FRONTIERS as the crew accompanies the *Ventana* ROV on a fascinating journey down to the middle depths to this unexplored ocean canyon.

ACTIVITY: Build a Biosphere

As you see on FRONTIERS in **Going to Extremes**, the middle depths of the ocean are a unique ecosystem, home to some bizarre creatures never before seen. In this activity, you will design and build your own biosphere based on a single ecosystem.



OBJECTIVE

Design and observe a mini-ecosystem.

An ecosystem is a system that has input and output by living and nonliving things knit together as an organized unit. Input can be in the form of energy from the sun or rainwater introduced into the ecological unit. Output is what the ecological unit produces, such as heat, carbon dioxide, oxygen or waste products.

To make your biosphere habitable for life, start with soil, air and water — the media that support the “bios” (life) in the biosphere. You will also need to provide food for the inhabitants inside their enclosed environment.

If you throw a bunch of plants, soil, water and creatures into a glass container and seal it, you’ll end up with a pretty wild project. However, it probably will last only a little while. If you want to build a biosphere that will support life, you first need to research and plan. Here’s how:



PROCEDURE

PLAN THE BIOSPHERE

1. Pick an ecosystem to build or replicate. It can be from your area or from another place on the planet.

Try to find a similar experiment or environmental problem in the news to use as a model for your experiment. Maybe you can solve the problem.

- 2.** Determine the needs of the ecosystem. Air, water and soil are important. So is selection of the flora and fauna (plants and animals). You can purchase seeds and plants, then research the needs of insects, fungi and microorganisms.
- 3.** When you determine the species you want, research the type of food and amount needed to sustain life in your biosphere. Figure out which members of the food web should be in the ecosystem to keep everything alive. You may need to provide “imported” food, like worms, for an animal higher on the food chain.
- 4.** Research the size of your biosphere. Size is relevant to food production. If your biosphere has a large consumer, like a mouse, turtle or fish, make sure there are enough plants, animals or both to meet that animal’s food needs. For example, a field mouse needs to eat 10 to 100 times its biomass in grass each day.
- 5.** Research the environmental needs of the biosphere. How much water will it need? What is the pH of the soil? What about temperature? Lighting?
- 6.** State a hypothesis about your project.
- 7.** Put the facts together and figure out where to get the species for the project and how to contain them. Your plan should include: the biosphere design, the materials, soil, water and air, as well as the plants and animals that will live inside.



TO LEARN MORE
ABOUT THE
**MONTEREY BAY
AQUARIUM
RESEARCH
INSTITUTE,**
VISIT ITS
WEB SITE AT:
[http://www.
mbari.org](http://www.mbari.org)

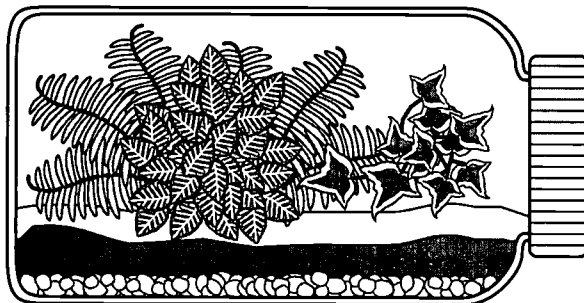

BUILD THE BIOSPHERE

Use a clear container with a "sample" taken from a local ecological unit or your own carefully selected ecological unit. Try grown seedlings or plants, a healthy water supply, soil with microorganisms and other life — everything you think you'll need based on your research and plan. Here are some hints:

- ▷ Glass jars (with lids) can be used for small biospheres. Make sure the glass is very clean before you build the biosphere. An aquarium tank is another way to contain your biosphere project. To create a closed aquarium, secure a tight-fitting lid and seal it with tape.
- ▷ Collect the species according to your plan.
- ▷ Insects can be captured in nets or by hand. Make sure they meet your ecosystem needs.
- ▷ Be humane to all living things you use. Do not use endangered or threatened species.

MONITOR THE BIOSPHERE

Monitor your experiments and write each observation; data collection is important in science. As part of the scientific research you are performing in this project, record as much as you can about the state of the biosphere at the beginning of the experiment. Make a final check at the end of the experiment to compare aspects of your biosphere "before" and "after."

- ▷ Take temperature readings at the same time each day or several times a day.
- ▷ Check soil and water quality. Inexpensive and simple kits to test nutrient contents can be bought in hardware and gardening stores. Try the pH test. It's fun!
- ▷ Population check: count the plants and animals by species. Record the numbers.
- ▷ Measure the heights of the plants. Draw illustrations to document physical changes.

Biosphere 2: An Update

Biosphere 2, a three-acre, glass-and-steel structure in Oracle, AZ, was created to help us better understand Biosphere 1 — the Earth. In Biosphere 2, scientists created seven ecosystems, including a rain forest and an ocean. The first experiment in 1991 involved eight scientists (and more than 3,000 species of plants, insects and animals) who lived in the sealed enclosure for two years. They had planned to grow their own food and study the earth's ecology in miniature. However, levels of CO₂ became life-threatening, food was insufficient to meet the needs of the inhabitants and the experiment was deemed one of mixed results.

Today, Biosphere 2 is a research and educational center affiliated with Columbia University; scientists are using the model biosphere to study

MAKE CALCULATIONS

To measure the results of your experiment, take the data (observations, pictures, temperatures, population records, pH or water quality tests, etc.) and see what has changed or stayed the same in the biosphere. The measurements and recordings you make will help define the change. For example:

1. Calculate growth in plants (from measurements).
2. Calculate declining populations (from counting and recording).
3. Calculate increasing populations (from counting and recording).
4. Calculate percentages of surviving species.
5. Graph and compare changes in temperature, lighting, pH and water quality.

DEVELOP A CONCLUSION

Based on your data, you will reach a conclusion about your hypothesis. You might:

- ▷ Explain results using data, facts and observations.
- ▷ Explain the scientific concepts at work in your biosphere.
- ▷ Explain similarities and differences between your research and the environmental research scientists are doing locally or worldwide.
- ▷ Explain what your team learned from the project.
- ▷ Look at reasons your biosphere plan worked or did not work.
- ▷ Identify any "cause and effect" relationships to explain changes that occurred during the experiment.
- ▷ Present facts on the changes that occurred or process you saw (water cycles, decomposition of materials, etc.).

THIS ACTIVITY IS ADAPTED BY PERMISSION FROM CURRICULUM MATERIALS PRODUCED BY THE BIOSPHERE PRESS.

timely issues like climate change, biodiversity, water resources and rising temperatures in hopes of applying the lessons to the real world. College students from different schools may spend a semester doing research at the facility.

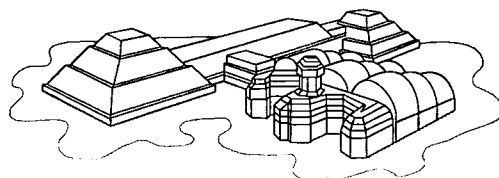

To find out more about Biosphere 2 or to take a virtual tour, go to the Web site <http://www.bio2.edu> and explore the various ecosystems. Or, find out how you can visit Biosphere 2, now open to the public.

SCIENTIFIC
AMERICAN
FRONTIERS

SHOW 704

GOING TO
EXTREMES

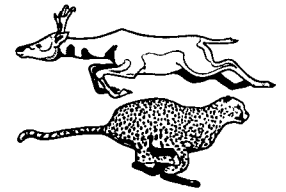

HIDDEN DEPTHS

FOR FURTHER
THOUGHT

▷ What physical features characterize the middle depths of the ocean? How is this region different from the shallows or ocean floor?

▷ Describe some of the adaptations different species have evolved to exist in these unusual conditions.

FRONTIERS ONLINE

Take Learning to the Limit with FRONTIERS Online!

Ask the Scientists

Going to Extremes investigates how animals — and humans — react to extremes in their environments. After you watch this program, send your questions about survival mechanisms to the experts on the show. The scientists on this page will answer viewers' questions from **February 19 to March 7, 1997**, via the FRONTIERS Web site: <http://www.pbs.org/saf/>.

SPIDER CANYON

Susan Riechert, a professor at the University of Tennessee, Knoxville, may be the world's foremost authority on spider behavior. After 20 years, Riechert's study of how desert spiders and river spiders adapt to their environments in southern Arizona has led to new insights about the nature of evolution. Send in your questions to find out more about Riechert's ground-breaking work.



ULTIMATE SPEED

Rodger Kram of the University of California at Berkeley studies the motion of cheetah at the Phoenix Zoo. He's learning that this species has several key adaptations that allow it to achieve speeds of more than 40 miles per hour in less than two seconds. Kram will answer your questions about the cheetah and why it's the fastest animal in the world.



FROZEN ALIVE

Kenneth and Janet Storey of Carleton University in Ottawa, Canada, search the woods for the wood frog, a species that freezes in the winter and thaws when spring arrives. At their lab, the Storeys put the



frog through MRIs to reveal how the frog freezes and survives this process. Send in your questions to the Storeys to learn more about this frog's amazing survival skills.

HIDDEN DEPTHS

This story, a repeat from FRONTIERS' 1995-96 season, takes you deep into the midwaters off Monterey Bay, California, where you'll encounter some of the most bizarre sea animals in the world. We will post online a complete transcript of the "Ask the Scientists" activity from this story, in which viewers' questions were answered by a team of scientists from the Monterey Bay Aquarium Research Institute (MBARI).

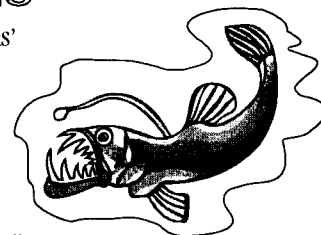

ONLINE LEARNING LINKS

Visit the SCIENTIFIC AMERICAN FRONTIERS Web site (<http://www.pbs.org/saf/>) for an array of exciting activities and resources for you and your students. Here are highlights of the cyberspace features you'll find when you visit FRONTIERS online:

Library of Online Resources and Related Sites

Explore FRONTIERS' suggestions for further learning.

Science Scavenger Hunt

Answer questions for a chance to win a prize!

Instant Poll

Share your opinions about topics on FRONTIERS.

Vote for Your Favorite Story

Tell us which story you like best on each show.

Teaching Guides and Transcripts

An online version of this guide, plus the complete transcript of each show.

HERE'S HOW TO "ASK THE SCIENTISTS"

- ▷ Watch **Going to Extremes** and review this classroom guide to prepare your question(s) and decide which scientist(s) you'd like to contact.
- ▷ Visit SCIENTIFIC AMERICAN FRONTIERS on PBS Online at <http://www.pbs.org/saf/>. Click on the "Ask the Scientists" icon on the opening screen to send your question(s). Scientists' answers will be posted online for FRONTIERS viewers to read. Depending on the volume of questions received, only selected questions may be answered.
- ▷ Remember to e-mail your questions by March 7, 1997!



Going to Extremes airs on PBS on **Wednesday, February 19, 1997, at 8 pm.**

Check your TV listings to confirm local air time and date.

WATCH IT ON PBS

SCIENTIFIC AMERICAN FRONTIERS airs on PBS once in each of these months - October and November 1996 and January, February and April 1997. Each hour-long special includes a variety of fascinating science stories based on a single theme.

INVENTING THE FUTURE (Show 701)

Wednesday, October 23, 1996 8 pm

Leap forward into the future when FRONTIERS visits the MIT Media Lab to test out smart cars, smart rooms and wearable computers. Meet scientists who are re-designing the look and role of computers.

SCIENCE SAFARI (Show 702)

International Special

Wednesday, November 20, 1996 8 pm

Travel on a science safari to South Africa. Meet some of the world's largest animals, then trek to sites once inhabited by early humans. Find out how scientists combat malaria today.



ASK THE SCIENTISTS!

Susan Riechert and other scientists seen on *Going to Extremes* answer your questions online. See p. 14.
<http://www.pbs.org/saf/>

PIECES OF MIND (Show 703)

Wednesday, January 22, 1997 8 pm

Spend the night in a sleep laboratory and find out more about how your brain works to create memories, dreams and language.

GOING TO EXTREMES (Show 704)

Wednesday, February 19, 1997 8 pm

Imagine a live frog that actually freezes and thaws! Join scientists as they investigate survival mechanisms of animals that inhabit unique climates from the desert to Canada. Join the crew on a mountain climb in the German Alps and on a dive beneath the sea as FRONTIERS goes to extremes on Earth.

ROBOTS ALIVE! (Show 705)

Wednesday, April 9, 1997 8 pm

Meet some autonomous robots with minds of their own, as well as inventors who are working on the robots of tomorrow.

SCIENTIFIC AMERICAN FRONTIERS



HOSTED BY ALAN ALDA

In this episode of SCIENTIFIC AMERICAN FRONTIERS, Host Alan Alda meets the two fastest animals on Earth, the cheetah and pronghorn antelope. The crew also explores life at nature's extremes, to see how people and animals cope.

Remember, teachers may videotape the show to use year after year. GTE Corporation, the series underwriter, grants educators free off-air taping rights in perpetuity for classroom use.



Underwritten by GTE Corporation



SCIENTIFIC AMERICAN FRONTIERS

Connecticut Public Television

P.O. Box 260240

Hartford, CT 06126-0240

NON PROFIT
U.S. POSTAGE
PAID
Permit No. 51
Bristol, PA

INSIDE:

Requested Teaching Materials for **GOING TO EXTREMES**

Airing February 19, 1997, on PBS



Printed on recycled paper

SCIENTIFIC
AMERICAN
FRONTIERS

SHOW 705 TEACHING GUIDE • APRIL 9, 1997 • 8-9 PM

1996-97
SEASON INDEX
INSIDE

Robots Alive!

GTE

Underwritten by
GTE Corporation

SEE IT ON PBS



ERIC
Full Text Provided by ERIC

65

Robots with Minds of Their Own

38061935

FOR YOUR INFORMATION

ROBOTS ALIVE!

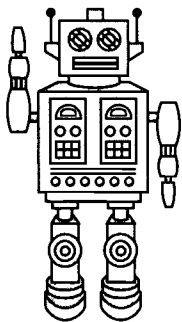

Robots that walk, talk and think for themselves are the featured subjects in the season finale of *SCIENTIFIC AMERICAN FRONTIERS*. This episode also includes a test ride in a van that drives itself and competitions with very intelligent robot contestants. Host Alan Alda meets with inventors of these autonomous robots to find out more about their works in progress and what we might expect to see in the near future.

Be sure to visit our Web site (<http://www.pbs.org/saf/>) and try our online activities (see pp. 14-15 in this guide). You and your students can enter the **Viewer Challenge** (p. 4) and have a chance to win one of our terrific *FRONTIERS* T-shirts.

RESOURCES YOU CAN USE

▷ Articles in *Scientific American* bring you current developments in the fields of robotics and artificial intelligence. Some examples include the special report on the Internet in the March 1997 issue; "A Cricket Robot," Dec. 1996; "Controlling Computers with Neural Signals," Oct. 1996 and "Will Robots Inherit the Earth?" Oct. 1994. See also "The Global Positioning System," Feb. 1996, for more on GPS technology. In September, look for a special issue of *Scientific American* about advances in travel and transportation.

You can access the magazine directly on the Web (<http://www.sciam.com/>) and on America Online (keyword: Sciam). To subscribe (a one-year subscription costs \$24.97), write to *Scientific American*, Dept. SAF, 415 Madison Ave., New York, NY 10017.

▷ Books of interest include: *HAL's Legacy: 2001's Computer as Dream and Reality*, edited by David G. Stork (MIT Press, 1997); and *Galatea 2.2* by Richard Powers (HarperPerennial, 1995).

CELEBRATE NATIONAL SCIENCE & TECHNOLOGY WEEK

April 20-26 is National Science & Technology Week (NSTW), a great time to promote science and technology with students, parents and the public. Why not use your videotaped copies of *FRONTIERS* and

teaching guide activities as part of a science fair display at your school? Or create a lending library of your classroom tapes that students can watch at home with their families. Visit the National Science Foundation's NSTW home page for more ideas on how to celebrate NSTW '97 and a list of organizations that can provide further resources: <http://www.nsf.gov/od/lpa/nstw/start.htm>.

\$12,000 GRANT OPPORTUNITY

If you missed applying for a GTE Growth Initiatives for Teachers (GIFT) grant this year, you can put your name on the mailing list to receive an application for next year's program by calling **800-315-5010**. Each year, GTE Corporation awards grants of \$12,000 to 60 teams of one math and one science teacher from the same school. Teachers of grades 6-12 from selected states may apply for these grants, which are designated for school enrichment projects and professional development. Educators in the following states are eligible: AL, AR, AZ, CA, CO, CT, DC, FL, GA, HI, IA, ID, IL, IN, KY, MA, MD, ME, MI, MN, MO, NC, NE, NH, NM, OH, OK, OR, PA, SC, TN, TX, VA, WA, WI and WV.

Applications will be mailed out in early fall. The deadline for completed applications will be mid-January 1998.

NEXT SEASON ON FRONTIERS

We'll return to PBS in October 1997. Be sure to tune in when *SCIENTIFIC AMERICAN FRONTIERS* brings you five new shows — covering topics that range from science in Scandinavian countries, to zoo research, pseudoscience and the connections between art and science. We'll also take a special trip to explore science in Panama, the tropical isthmus that connects the Americas. Until next season, watch for reruns of the 700 series on your local PBS station this summer.

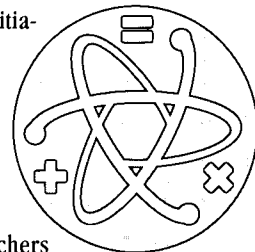

SCIENTIFIC AMERICAN FRONTIERS is closed-captioned for the hearing-impaired and is narrated by Descriptive Video Service (DVS) for visually impaired audiences. The series and School Program are endorsed by the National Science Teachers Association (NSTA) and the National Education Association (NEA).

TAPING THE SHOW

- Always check TV listings to confirm air date and time.
- As a teacher, you have off-air taping rights in perpetuity for classroom use.
- If you can't find the show in your TV listings, call your local PBS station.
- Do you need help? Call the *FRONTIERS* School Program at 800-315-5010.
- Videotapes of past shows** can be purchased (\$19.97 each). Call 800-315-5010.

FREE VIDEOTAPING & PHOTOCOPYING RIGHTS

GTE Corporation, the series underwriter, makes available complete off-air taping rights in perpetuity for classroom use of *SCIENTIFIC AMERICAN FRONTIERS*. Educators may record each show when it airs on PBS and keep the tapes to use in the classroom year after year. Educators may also photocopy all materials in this guide for classroom use. If you know of other educators interested in receiving these guides, they may sign up by calling the *SCIENTIFIC AMERICAN FRONTIERS* School Program at 800-315-5010.

LET US HEAR FROM YOU!

We appreciate and welcome your questions, comments, compliments and constructive criticism. *Please contact us . . .*

BY MAIL:

SCIENTIFIC AMERICAN FRONTIERS
105 Terry Drive, Suite 120
Newtown, PA 18940-3425

BY PHONE: 800-315-5010

BY FAX: 215-579-8589

BY E-MAIL: saf@pbs.org

VISIT US ONLINE:

<http://www.pbs.org/saf/>

TABLE OF CONTENTS

SHOW 705 • APRIL 9, 1997 • 8 PM ON PBS

ROBOTS ALIVE!

6 MAZES AND SQUIGGLES

Autonomous robots compete to see which ones can navigate a maze and clean up a tennis court.

Activities:

Define and write an algorithm . . . Take the robot challenge.

8 LOOK, NO HANDS!

A van that drives itself is taking shape at Carnegie Mellon University.

Activity:

Build a pizza-cutting robot.

9 TODDLER'S FIRST STEPS

Teaching a robot to walk on two legs is not as easy as it sounds, but a project at the University of New Hampshire is doing just that.

Activity:

Find the center of gravity.

10 ALMOST HUMAN

Building a robot that will match humans is the dream of robotics guru Rodney Brooks.

Activity:

Design a robot.

12 ROBOFLYERS

College students build and race flying robots at the Aerial Robotics Competition.

Activities:

What goes up must come down . . . Helicopter aviation.

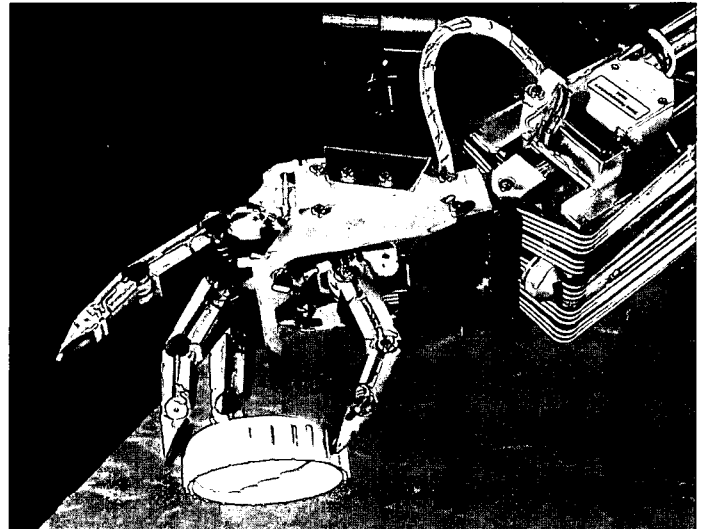

DEPARTMENTS

4 VIEWER CHALLENGE

5 THE BIG PICTURE

14 SAF ONLINE

COVER PHOTO OF COG: © SAM OGDEN/BOSTON.

SCIENTIFIC AMERICAN FRONTIERS is made possible by an underwriting grant from GTE Corporation. The series is produced by The Chedd-Angier Production Company in association with *Scientific American* magazine and presented to PBS by Connecticut Public Television.

om materials produced by Media Management Services, Inc.



STORY	RUNNING TIME	COMPUTER SCIENCE	GENERAL SCIENCE	PHYSICAL SCIENCE	PSYCHOLOGY	TECHNOLOGY
Mazes and Squiggles	14:41	•	•		•	•
Look, No Hands!	8:52	•	•	•		•
Toddler's First Steps	6:23	•	•	•	•	•
Almost Human	11:12	•	•		•	•
Roboflyers	11:44	•	•	•		•

*CHECK LOCAL TIME



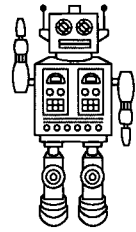

Student's Name _____
Teacher's Name & Course _____

Watch **SCIENTIFIC AMERICAN FRONTIERS Robots Alive! (Show 705)** for answers to questions on this page. Answer the 10 questions correctly and you'll be eligible to win a **FRONTIERS T-shirt!**

Mazes and Squiggles

- What strategy enables SRI to win the maze contest?
 - a. radar
 - b. multiple robots
 - c. remote sensors
 - d. motion detectors
- In the tennis ball contest, what kinds of robots are favored to do best?

Look, No Hands!

- If lane markers are missing, what does the experimental van's system do?
 - a. stops running
 - b. adapts to identify other features on the road
 - c. alerts the driver
 - d. sends signals to satellites
- Name two potential applications of the Carnegie Mellon Navlab project.

Toddler's First Steps

- How is the robot built by the University of New Hampshire different from earlier walking robots?

- What is the first thing the robot nicknamed "Toddler" learns?
 - a. how to walk
 - b. how to balance on one leg
 - c. how to hop
 - d. how not to fall over

Almost Human

- With Cog, Rodney Brooks and his colleagues at MIT hope to build a robot with the intelligence and capabilities of a(n):
 - a. six-month-old baby.
 - b. ten-year-old child.
 - c. adult.
 - d. Star Fleet commander.
- Compared to robots like IT, Cog is a more advanced system because it:

RoboFlyers

- Describe the task the aerial robot must complete.

- Which of these devices enables the Stanford team to win the contest?
 - a. sensors
 - b. motion detectors
 - c. vision system
 - d. GPS (Global Positioning System)

For Teachers Only

When completed, this page can become an entry to the **FRONTIERS T-shirt contest**; 20 winners (10 students, 10 teachers) will be drawn at random for each show. To enter the T-shirt drawing, send all completed challenges *in one envelope* with a cover sheet to: **Viewer Challenge**, SCIENTIFIC AMERICAN FRONTIERS, 105 Terry Drive, Suite 120, Newtown, PA 18940-3425. Mail completed entries by **May 1, 1997**.

TIP: You can also download these questions on the **FRONTIERS Web site** (*see p. 14*).

Important!! Please include a separate cover sheet and tell us:

- number of challenges submitted
- teacher's name
- grade and course
- school name, address and phone number
- where your students watched the show — at home, at school or both
- the name of your students' favorite story in this show (conduct a quick poll to find out)

Thank you!

ANSWERS TO VIEWER CHALLENGE 705: 1. b 2. small, agile robots 3. b 4. navigate hazardous environments, make highways safer, alert sleepy truck drivers 5. robot is modeled on humans; it learns from past experiences 6. d 7. a 8. learns from experiences 9. fly across a barrier, pick up puck and drop it at a designated site 10. d

THE BIG PICTURE

A SHORT HISTORY OF ROBOTS AND THINKING MACHINES

Although robots are considered a 20th-century invention, their origins lie in the distant past. From the earliest times, people have created myths about mechanical beings built in their own likeness with superhuman powers. The ancient Egyptians and Greeks built mechanical automatons to perform simple tasks. In modern times, mechanical toys entertained and ever-more-complicated machines were invented. The idea of a lifelike mechanical humanoid influenced both art and science; in 1818, Mary Shelley's

Frankenstein explored what happens when a man-made monster is given life by a well-meaning scientist. As computer technology became more advanced, scientists became more interested in building intelligent machines that could eventually think for themselves. Today, robots of all kinds populate our world and are used for varied applications in space exploration, the military, medicine, industry, research, police work and, of course, the movies. Here are some highlights of robot invention in the 20th century.



In 1921, the Czech dramatist Karel Capek coins the word robot in his play *R.U.R.* from a Czech word meaning "compulsory labor."

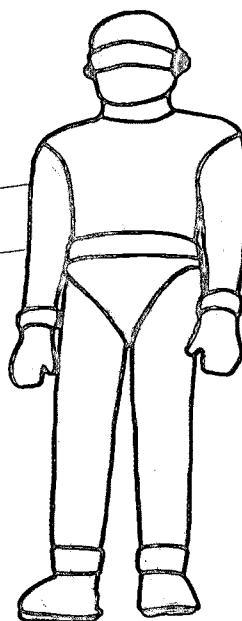
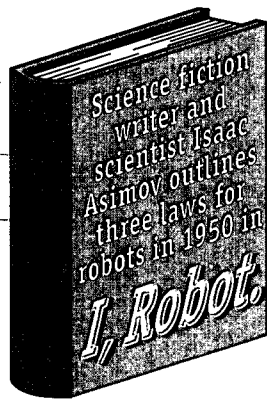

Classic sci-fi movies like *The Day the Earth Stood Still* and *Forbidden Planet* in the 1950s and '60s show robots in various roles, from advanced saviors to malevolent monsters.

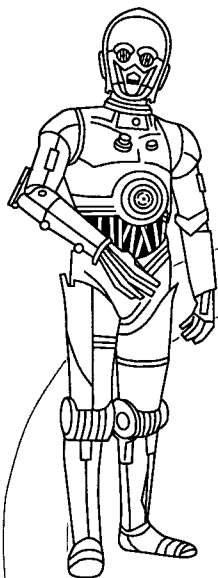

Beginning in 1977 (and re-released in 1997), the *Star Wars* trilogy captures the popular imagination of several generations of moviegoers.

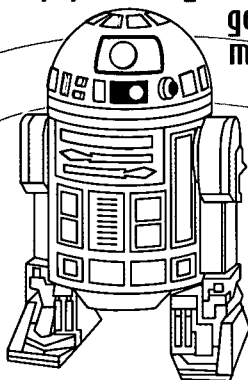

According to Arthur C. Clarke's popular 2001: A Space Odyssey, published in 1968, the homicidal computer HAL 9000 "becomes operational January 12, 1997."

Though this novel was written before computers became as powerful and popular as they are today, some of Clarke's predictions ring true.

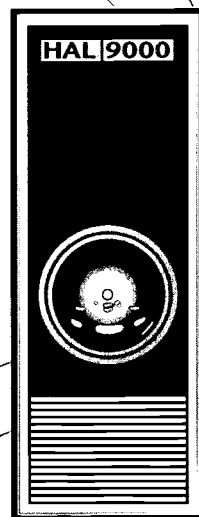

Since 1984, the U.S. Census has kept track of the robot population. Today, more than 70,000 robots are in use in the U.S., mostly for manufacturing and industrial purposes.

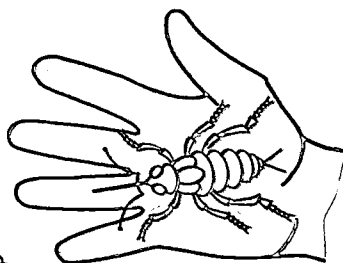
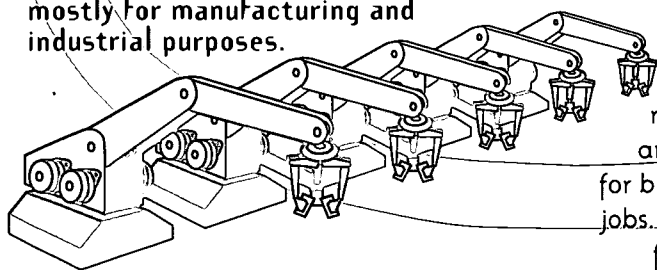

Today, robotics researchers build machines that are learning to walk, think, search for bombs and perform other dangerous jobs. Some robots are modeled on other forms of life, especially insects.

The Mars rover Sojourner (below), now on its way to Mars, is expected to land on July 4, 1997; the robot Dante explores volcanoes; robots even assist with surgery.

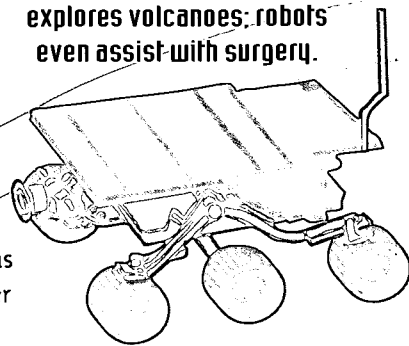

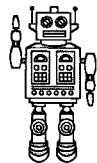

MAZES AND SQUIGGLES

Calling a meeting and cleaning up a tennis court are not hard jobs — for people. But for robots? Contests at the annual meeting of the American Association of Artificial Intelligence (AAAI) in 1996 challenged robots to do just that. Competing robots had to navigate a maze of offices in one contest and locate and collect tennis balls in the other. Join FRONTIERS in the fun to see how the latest generation of autonomous robots complete the assignments almost as if they were alive!

DEFINING ALGORITHMS

The robot contest at the annual meeting of the American Association of Artificial Intelligence is designed to demonstrate the best efforts from the fields of artificial intelligence (AI) and robotics. Contestants must design a robot with enough intelligence and capabilities to participate in a challenge event like these: "Call a Meeting" required robots to navigate a maze of offices and corridors and summon a meeting at a specific time; "Clean Up a Tennis Court" challenged robots to find and sweep up tennis balls.

As humans, we might look at the events' descriptions and wonder why robots are asked to complete such seemingly easy jobs. We would outline a procedure (steps) necessary to accomplish the task, then do it. Defining the steps, or making an algorithm, is also one of the first tasks a robotics researcher would take. The algorithm lays the groundwork the researcher will use to develop a robot and controlling program that will complete the challenge.

As you see on FRONTIERS, defining a procedure, or algorithm, even for a seemingly simple task is much more difficult than it appears. A paradox of artificial intelligence is that the easier a task is for humans to perform, the harder it is to create a computer program to model it.

In the first activity below, you will design an algorithm and "program" a human "robot" to complete the task. For these activities, you will want to work in teams. To add a little fun to this activity, have the teams in your class compete against each other to see which can complete the event in the fastest time. The second activity is based on one of the events you'll see in this episode.

OBJECTIVE

Understand a programmer's job by writing instructions for a robot to perform specific tasks.

RUNNING TIME:

14:41

CURRICULUM LINKS:

COMPUTER SCIENCE

artificial intelligence, programming

GENERAL SCIENCE

computer tech

PHYSICAL SCIENCE

TECH ED

inventions, robotics

Related FRONTIERS Shows and Activities Include:

Inventing the Future. Show 701: "Virtually Real" (pp. 6-7) / **Life's Big Questions.** Show 501: "Will Robots Take Over?" (p. 14) / **Special! Science Contests.** Show 403: "The Turing Test" (pp. 9-10)

<http://www.pbs.org/saf/>



Kurt Konolige, whose autonomous robot appears in this segment, answers your questions online.

See p. 14.

ACTIVITY 1: Picking Up a Cup

Work in teams of three or four students each to define an algorithm, write a "program" for a "robot" to follow, have your robot execute the program to see how effective your algorithm is and "debug" your program to improve it. The team will collaborate on writing the program; then one of the members will act as the robot that executes it. You'll want waterproof aprons or coveralls or even a change of clothes for this event.

CHALLENGE

Place two cups, one filled with water, the other empty, on a table in front of a chair. Your "robot" must sit in the chair and pour the cup of water into the empty cup. Oh, by the way, your robot will be blindfolded and won't be able to see!

1. BRAINSTORM. As a class, brainstorm what steps a robot must follow to pour water from one cup to

another. List on the board as many steps as you can. Be specific.

2. DESIGN AN ALGORITHM. Using the steps listed on the board, people on each team should write down, in order, the steps that will allow their robot to accomplish the challenge. (See example on p. 7.)

3. WRITE THE PROGRAM. Write down specific instructions your robot will carry out to complete each step. Your robot will follow these instructions as

they are read by a team member, while another person or your teacher makes sure they are followed exactly.

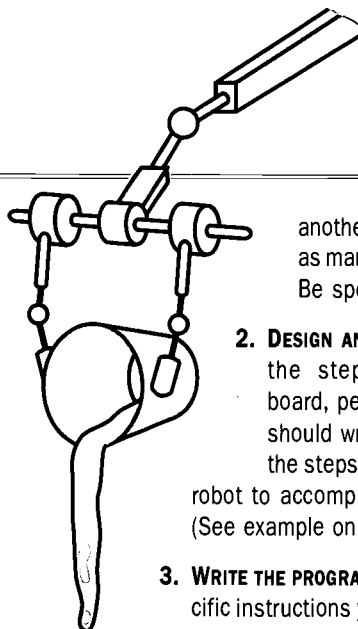

SAMPLE ALGORITHM AND PROGRAM

1. Reach for cup.

- a. lift arm
- b. move arm forward
- c. grab cup

2. Lift the cup.

- a. raise arm six inches
- b. move arm to left slowly

3. Pour water into cup.

- a. stop arm movement over cup
- b. turn wrist

4. TEST YOUR ROBOT. Blindfold your robot and have it sit in a chair. One team member will read the program and the robot will execute the instructions. The other team members should take notes on any problems that occur as your robot follows the instructions. (The team member who reads the instructions should also be careful the robot does not accidentally get hurt.)

5. REVISE THE PROGRAM. Now you must debug your program by revising the instructions your robot will

follow. Make sure you include any changes the team noted when testing your robot.

6. TEST THE UPDATED ROBOT. Have members of the team exchange roles so the new program is run on a robot that has not "learned" from previous attempts.

Note that the sample algorithm and program shown at left, if executed exactly, should not work unless the robot "cheats"! For example, such things as which arm to lift and how high, how far forward to move the arm and how to determine if the robot has grabbed the cup containing the water are not defined. *Question: How does the robot know which cup contains the water?*



ALTERNATE SUGGESTIONS:

Other programs you can write for your robot might include:

- ▷ Making a peanut butter and jelly sandwich.
- ▷ Tying a shoe.
- ▷ Putting on a pair of boots.
- ▷ Opening an umbrella.

**SCIENTIFIC
AMERICAN
FRONTIERS**

SHOW 705

**ROBOTS
ALIVE!**

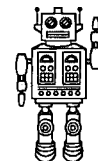

**MAZES AND
SQUIGGLES**

ACTIVITY 2: The AAI Challenge Event: Clean Up a Tennis Court

Once you have successfully programmed your robot for the simple challenge above, you are ready to attempt a larger challenge. Below you will find a brief description of one of the robot challenges at the 1996 AAI meeting, the tennis court cleanup contest seen on FRONTIERS. Design a program for a human robot to execute that will solve the challenge. Follow the steps above to help you program your robot. You may provide your robot with tools that will help execute your program. Good luck!

MATERIALS

- ▽ tennis balls
- ▽ Squiggle balls*
- ▽ cardboard

* Battery-powered Squiggle balls are available at science or toy stores. You can substitute Ping-Pong balls or even crumpled up paper for tennis balls and leave out the Squiggle ball to make the task simpler. Or, to challenge students further, use more than one Squiggle ball!

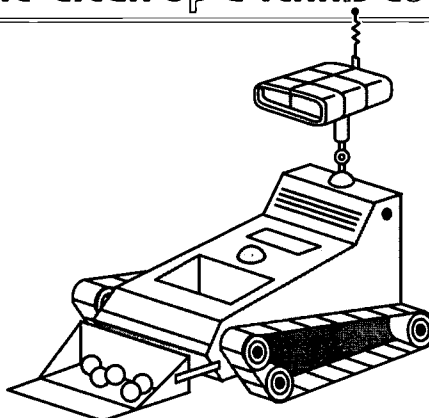

QUESTIONS

1. What limitations in performing the tennis court challenge might a robot have that a human would not have?
2. Can you think of ways to revise your program to make the number of instructions as small as possible? What would be the advantage of this? Do artificial intelligence (AI) researchers have to worry about the size of their programs?

NOTE TO TEACHER ON SETTING UP THE CHALLENGE: To conduct this challenge, block off a section of your room with a cardboard barrier that will allow students to observe the robot performing the task but will limit the space so the task is not impossible. A cardboard box with an opening cut in the side can serve as a pen.

THESE ACTIVITIES AND THOSE ON PAGES 10-11 WERE DEVELOPED BY JAMIE LARSEN, A SCIENCE EDUCATOR AND CONSULTANT IN SEDONA, ARIZONA.

FOR FURTHER THOUGHT

- ▷ Do you think a human would always be superior to a robot in performing certain jobs? If so, which jobs and why?
- ▷ Are there tasks robots would perform better than humans? If so, what tasks and why?
- ▷ For a complete description of both contests, instructions to robots and more about the competitions seen on FRONTIERS, go to <http://www.aai.org/Conferences/National/1996/robot.html>.
- ▷ The designer of the winning robots in the maze contest is Kurt Konolige, who also built the robot Flakey, seen on FRONTIERS in an earlier season. For more on Flakey and Konolige, go to <http://www.ai.sri.com/people/flakey>.

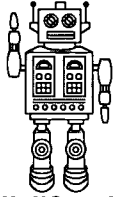

RUNNING TIME:

8:52

CURRICULUM LINKS:

COMPUTER SCIENCE

artificial intelligence, neural networks, programming

GENERAL SCIENCE

computer tech

PHYSICAL SCIENCE

machines

TECH ED

engineering, inventions, robotics

Related FRONTIERS Shows and Activities Include:

Inventing the Future, Show 701: "Smart Cars" (p. 10) / *Dragon Science*, Show 602: "Driven to the Wall" (p. 10) / *Life's Big Questions*, Show 501: "Will Robots Take Over?" (p. 14) / *Scientific Breakthroughs in Germany*, Show 402: "A Car That Drives Itself" (p. 7)

<http://www.pbs.org/saf/>



Chuck Thorpe, seen in this segment, answers your questions online. See p. 14 for information.

LOOK, NO HANDS!

Driving without putting your hands on the steering wheel is not usually recommended, but today it's possible to ride in an experimental van that does the driving for you. For more than ten years, robotics engineer Chuck Thorpe of Carnegie Mellon University in Pittsburgh has been working on a project called Navlab, with the ultimate goal to design and produce a vehicle that drives itself. Using sensors and video cameras, the van navigates highways without a human driver.

ACTIVITY: Robot Pizza Cutter

A robot is a device made of two main parts: a mechanical or machine part, and a control device or brain. In simple terms, the Navlab vehicle also consists of these components: a machine (van) and computerized components that read the road and tell the van what to do.

Among the more positive applications of robotics are the many high-tech devices that help disabled people function normally. A few years ago, a design team at Carnegie Mellon University invented Pizzabot, a robotic arm that could make a pizza. With the help of this high-tech chef, a disabled person used voice commands to tell the robot which toppings to put on a pizza.

Surprisingly, a pizza is a complicated product to make. Each step in the pizza-making process must be programmed. Using the algorithm procedure on pages 6-7 of this guide, describe the sequence of steps involved in making a simple pizza.

Now, try to build a pizza using just your voice. By using verbal commands, you will guide a mechanical device over a "pizza" target. The machine is a radio-controlled car with a marking pen attached to it. Since an electronic voice-activated circuit would be too difficult to build and too expensive to buy, we'll use the next best thing — a human voice. Work in teams of four.

OBJECTIVE

Simulate programming a robotic device.

PROCEDURE

1. Assign each person in the group one of these roles: *Engineer* — figures out how to attach the marker to the R/C car. *Timer* — times each person's turn. *Operator* — directs the movements of the R/C car by voice command; can give only

- ✓ radio-controlled car with controller unit
- ✓ large sheets of newsprint, each with a circle 2 feet in diameter drawn on it
- ✓ permanent marking pen
- ✓ tape

four commands: forward, stop, right, left. *Controller* — the only team member allowed to work the controls of the R/C car; responds only to commands issued by the operator.



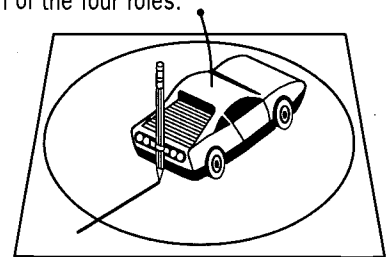







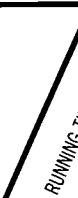
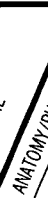

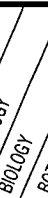





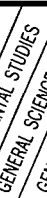

2. Have the *engineer* attach the marker to the R/C car so that the marker's point extends beneath the car and makes contact with the floor surface. If attached properly, the marker will leave a trace of the car's path.
3. The *timer* should tape the pizza target to the floor. The *engineer* should place the modified R/C car in the center of the newsprint circle, making sure the marker remains in contact with the newsprint surface.
4. The *controller* (person holding the control unit) should stand about ten feet from the target, facing in the opposite direction.
5. The *operator*, while facing the target, then gives commands to move the R/C car. The object is for the operator to have the car trace "cuts" onto the pizza target that will result in four equal slices.
6. The *timer* gives the operator three minutes to complete the objective. At the end of three minutes, team members should exchange places, making sure everyone has a chance to perform each of the four roles.

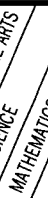
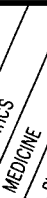

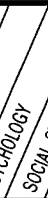
EXTENSION

➤ In 1995, researchers from the Robotics Lab at CMU "drove" the van seen in this segment (Navlab 5) from Pittsburgh, Pa., to San Diego, Calif., as part of the "No Hands Across America" project. You can read about their trip on the Web (http://www.cs.cmu.edu/afs/cs/usr/tjochem/www/nhaa/nhaa_home_page.html).

SEASON INDEX 1996-97

																								
SHOW 701 • OCTOBER 1996 INVENTING THE FUTURE	Virtually Real	13:24						•	•					•							•		•	
	Body Talk	9:15						•	•							•							•	
	Smart Car	11:23	•		•			•							•	•						•		•
	Private Eyes	11:44						•	•					•									•	
	Brain Music	7:04	•		•			•						•					•	•	•			•
SHOW 702 • NOVEMBER 1996 SCIENCE SAFARI	City of Gold	9:22	•	•					•	•					•							•		
	Ways of the Wild	14:25			•				•	•	•	•	•		•	•						•		•
	Mr. Cele's Garden	7:58			•	•	•		•	•	•	•	•			•	•					•		
	Fighting Malaria	8:55	•		•			•	•	•	•	•	•		•	•	•					•	•	•
	The First People	10:28	•	•	•		•					•	•		•	•	•	•				•		
SHOW 703 • JANUARY 1997 PIECES OF MIND	The Man with Two Brains	10:05	•		•				•				•		•	•					•		•	
	Remembering What Matters	8:35	•		•				•				•	•	•	•					•		•	
	True or False?	8:57	•		•								•	•	•	•					•		•	
	What's in a Dream?	13:28	•		•								•	•	•	•	•				•		•	
	Old Brain/New Tricks	10:50	•		•								•	•	•	•	•				•		•	
SHOW 704 • FEBRUARY 1997 GOING TO EXTREMES	Spider Canyon	12:09			•				•		•	•			•							•		•
	Frozen Alive	10:45	•		•		•			•	•	•	•		•	•	•				•		•	
	Ultimate Speed	10:54	•		•		•								•	•	•	•					•	
	Hidden Depths	9:04			•				•	•	•	•	•		•					•	•		•	•
	High Anxiety	10:00	•		•		•			•	•	•	•	•		•	•	•	•		•		•	
SHOW 705 • APRIL 1997 ROBOTS ALIVE!	Mazes and Squiggles	14:41						•	•					•							•		•	
	Look, No Hands!	8:52						•								•			•			•		•
	Toddler's First Steps	6:23	•		•				•						•				•	•	•		•	
	Almost Human	11:12	•					•	•					•	•					•		•		•
	RoboFlyers	11:44						•								•			•	•			•	

For more information on the SCIENTIFIC AMERICAN FRONTIERS School Program, write to: 105 Terry Drive, Suite 120, Newtown, PA 18940-3425 or call 800-315-5010. Videotapes of past shows may be purchased (\$19.97 per one-hour show). Call 800-315-5010.



SCIENTIFIC AMERICAN FRONTIERS is made possible by an underwriting grant from GTE Corporation. Produced by The Chedd-Angier Production Company in association with Scientific American magazine. Classroom materials produced by Media Management Services, Inc. Permission is granted to teachers to reproduce this index for classroom use. © 1997, GTE Corporation.



SCIENTIFIC AMERICAN FRONTIERS 700 SERIES

Inventing the Future Show 701

ORIGINAL AIR DATE: OCTOBER 1996

Leap into the future when FRONTIERS visits the MIT Media Lab to test out smart cars, smart rooms and wearable computers. Scientists here are redefining the computer as we know it, from a box that sits on your desk to an intelligent personal information appliance that might be with you at all times.

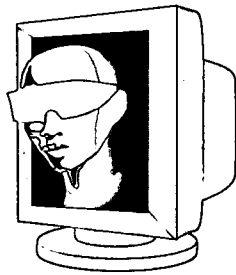

works to create memories, dreams and language. Find out how technology is helping scientists understand more about when and how the human brain learns language, processes and recalls information and dreams dreams.

Going to Extremes Show 704

ORIGINAL AIR DATE: FEBRUARY 1997

Imagine a live frog that actually freezes and thaws! Join scientists as they investigate survival mechanisms of animals that inhabit unique climates from the desert to Canada. Join the crew on a mountain climb in the German Alps and on a dive beneath the sea as FRONTIERS goes to extremes on Earth.

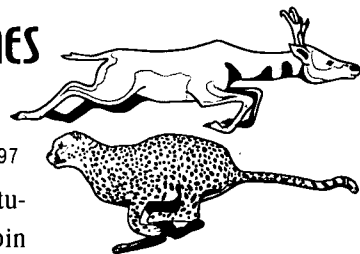

Science Safari Show 702 International Special

ORIGINAL AIR DATE: NOVEMBER 1996

Travel on a science safari to South Africa and meet scientists who are conserving wildlife; then trek to sites once inhabited by early humans. Find out how technology is helping combat malaria and what archaeologists are learning about ancient cultures.



Robots Alive! Show 705

ORIGINAL AIR DATE: APRIL 1997

Meet some autonomous robots with minds of their own, as well as inventors who are working on the robots of tomorrow. Robots that walk, talk and think are the subjects of this episode. Join FRONTIERS to see who wins a variety of robotics contests and take a ride in a van that drives itself! Visit MIT's Cog Shop, where the world's most sophisticated robot is being assembled.

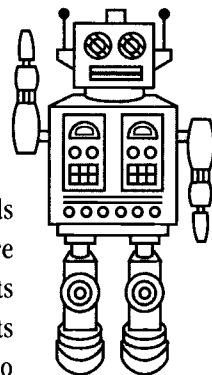

Pieces of Mind Show 703

ORIGINAL AIR DATE: JANUARY 1997

Spend the night in a sleep laboratory and find out more about how your brain

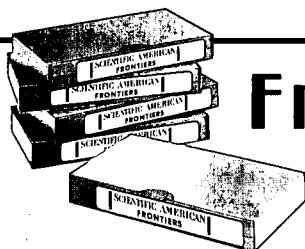

FRONTIERS on Videotape

Videotapes of past shows are available through the FRONTIERS School Program. If you missed a show or want to complete your FRONTIERS videotape library, call 800-315-5010. Tapes are \$19.97 each. (Orders accepted with purchase order, credit card or check.) Teaching guides for many past shows are available on the FRONTIERS site on PBS ONLINE: <http://www.pbs.org/saf/>.

Let us hear from you!

We appreciate and welcome your questions, comments, compliments and constructive criticism. *Please contact us . . .*

- **By mail:** SCIENTIFIC AMERICAN FRONTIERS, 105 Terry Drive, Suite 120, Newtown, PA 18940-3425
- **By phone:** 800-315-5010
- **By fax:** 215-579-8589
- **By e-mail:** saf@pbs.org
- **Or Visit Us Online!:** <http://www.pbs.org/saf/>

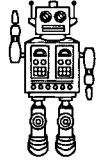

RUNNING TIME:

6:23

CURRICULUM LINKS:

COMPUTER SCIENCE

artificial intelligence, programming

LIFE SCIENCE

biological equilibrium

LITERATURE

science fiction

PHYSICAL SCIENCE

biomechanics, center of mass, dynamic balance

TECH ED

inventions, robotics

Related FRONTIERS Shows and Activities Include:

21st Century Medicine, Show 605: "Center of Gravity" (p. 8)

<http://www.pbs.org/saf/>



Thomas Miller, seen in this segment, answers your questions online. See p. 14 for information.

TODDLER'S FIRST STEPS

Walking is hard to learn to do, especially when you're a robot. Robotics engineers have been trying to teach robots to walk for several decades. Some of the earliest robots took steps, but every move they made was programmed. And they were likely to fall over. Enter the University of New Hampshire's biped walking robot, "Toddler," which is programmed to learn from its experiences. Before it starts to walk, it will learn how to stay in balance.

ACTIVITY: A Balancing Act

Engineers who design machines like the biped robot seen on FRONTIERS must address a variety of physical considerations in their design, including moment of force and center of mass. But the key consideration is balance. The robot (with its computer-based "brain") has the difficult task of perceiving itself in space and balancing in Earth's gravitational field.

Earlier walking robots like the six-legged walker seen on FRONTIERS employed static balance; if one of these robots stopped walking and went out of balance, it would fall over. By contrast, the strategy used with the current generation of walking robots, like "Toddler," is that of dynamic balance. Modeled on the human body, Toddler takes advantage of momentum to move forward.

OBJECTIVE

Study the physics involved in balancing.

Center of Mass

The center of mass (center of gravity) is the point at which the whole weight of an object balances. The center of mass might be considered the "average" point of all the matter in the object. You're probably not aware of it, but adjustments when you move affect your center of gravity and help you stay in balance. Tightrope walkers, for example, adjust their arms, hips and other body parts in order to move their center of gravity and stay atop the rope.

You can use cardboard cutouts to explore the effects of center of mass, as follows:

1. Draw various shapes on a piece of cardboard and cut them out.
2. Pierce each shape with a hole punch.
3. Allow the cutout to hang freely on a nail that is mounted on a ring stand.
4. Hang a plumb line and trace the line along the cutout.

5. Repeat the procedure with a hole somewhere else on the cutout.
6. The point where the lines intersect is the center of mass! You can test by piercing at this intersection. The object will spin freely about that point, remaining in balance.
7. Repeat with other shapes.

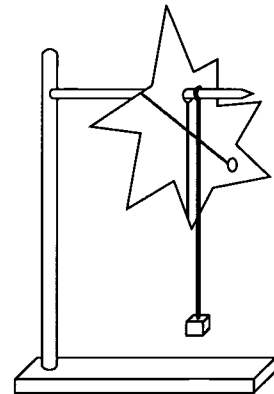

QUESTIONS

1. The center of mass in people varies, depending on height and weight. Because the biped robot has a lot of weight in its legs, its center of mass is lower than it is on a person. Where is your center of mass? How does your center of mass help you stay balanced and not fall over?
2. Explore more about dynamic balance and how we use it when we walk. For example, when you walk and lift one leg off the floor, your body is making adjustments so that you don't fall over. The next time you are walking, think about the work your body must do to stay balanced.
3. How do other animals stay in balance? Cats, for example, can flip themselves over during a fall and land on all four feet — a neat balancing act.
4. What biological systems help vertebrates stay in equilibrium? Consider the vision system, vestibular system (inner ear) and the brain and muscles (proprioception).

SCIENCE WRITER AND EDUCATOR MARC ROSNER CONTRIBUTED TO THIS ACTIVITY.

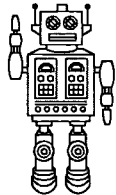

**RUNNING
TIME:**

11:12

**CURRICULUM
LINKS:**

COMPUTER SCIENCE
artificial intelligence,
programming

GENERAL SCIENCE
computer tech

LITERATURE
science fiction

PHYSICAL SCIENCE
biomechanics

TECH ED
inventions, robotics

**Related FRONTIERS
Shows and
Activities Include:**

Inventing the Future, Show
701: "Virtually Real" (pp. 6-
7) / **21st Century Medi-
cine**, Show 605: "Cyber-
surgery" (pp. 10-11)

<http://www.pbs.org/saf/>



Rodney Brooks,
seen in
this segment,
answers your
questions online.

See p. 14
for information.

ALMOST HUMAN

Building a robot that will mimic a human being is the ambitious goal of Rodney Brooks, MIT professor and artificial intelligence guru. For two years, Brooks has been working on Cog, a robot capable of learning from its experiences, the way people do. If Brooks is successful, Cog will become the most advanced robot in existence. Ultimately, Brooks envisions creating robots that can operate in the world like human beings and even outperform them.

ACTIVITY: Designing Robots

"The motivation behind creating Cog," according to researchers in the Cog Shop at MIT's Artificial Intelligence Lab, is the hypothesis that "humanoid intelligence requires humanoid interactions with the world."

In other words, the researchers behind Cog are trying to duplicate the human form and its functions. To do this, they draw on resources from a variety of fields, from developmental psychology to functional morphology. The researchers are studying not only what it means to act human, but also to look human.

An interesting aspect of their research (aside from all the cool science that is going on behind designing, building and debugging their various systems) is the humanoid appearance of Cog.

Just as nature seems to focus on specific forms to fill certain niches, Cog's creators also focus on a form that has proven itself in a niche in the real world. Does it follow that for robots to perform specific jobs they must have forms that are a reflection of organisms that fill a niche similar to that job?

In the making of *Star Wars*, George Lucas and the designers at Industrial Light & Magic (ILM) must have had this idea in mind when they developed many of their robots. From human-like C-3PO to the mouse-like robots scurrying around in the ships of the Imperial Fleet, the robots of *Star Wars* could be argued to have forms that fit their functions. An Internet search turns up many researchers in artificial intelligence (AI) and robotics who are taking a similar tactic and designing a menagerie of robots with forms that mimic real-world animals.

OBJECTIVE

Design robots for specific tasks with forms that fit their functions.

In this activity you will design and draw a robot that will search out deposits of underground minerals. Its form must fit its function. Your design should include details of the sensory and motor

functions of the robot, as well as reflect the form of an organism that functions in a similar manner in the real world. Follow the steps listed here to develop and draw the robot. Work in small groups or teams.

PROCEDURE

- 1. BRAINSTORM.** First identify what jobs this robot must perform to complete the mining task (function). Then brainstorm the design, including features you want to include (form). For example, a mining robot will have to dig; it will have to find and bring back a small sample; it will have to remember where it found the sample. List the jobs and corresponding design features on the board.
- 2. IDENTIFY ANALOGOUS ORGANISMS.** Next to the jobs you've listed on the board, identify organisms with a form that might fit the task.
- 3. DRAW YOUR ROBOT.** Use the notes on the board to design your robot. Your drawing may be a hybrid of the organisms listed or it may be totally different from the suggestions. Remember, however, that your drawing must reflect the mechanical nature of the parts that will make up your robot. ("Nailbot," for example, is a robot given the task of hammering nails into inaccessible places.)
- 4. LABEL YOUR ROBOT.** Label the major features and parts of your robot and briefly describe how they function.

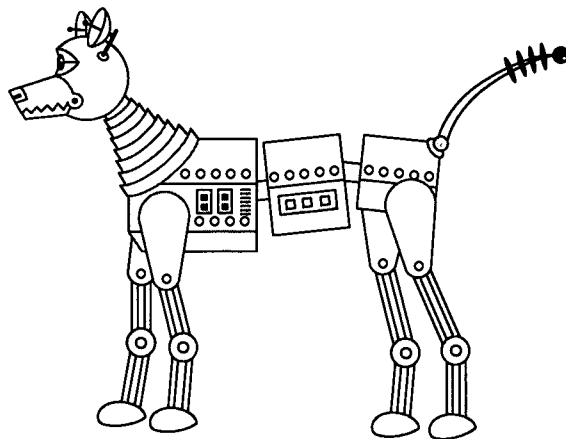

QUESTIONS

1. Do you think Rodney Brooks will achieve his goal of creating a robot capable of doing more than humans? Will this ultimate robot be created in a human likeness?
2. The scientists at the Cog Shop believe that to better interact with a human and to get humans to react "easily" and "naturally" around Cog, Cog needs to be as human-looking in its form and actions as possible. Do you agree or disagree with this assumption?
3. What kinds of sensors are available now to help you build the robot you have designed? A good place to start is the Cog Shop at MIT (<http://www.ai.mit.edu/projects/cog/>).

EXTENSIONS

- ▷ Search the Internet for artificial intelligence (AI) and robotics projects to see what designs researchers are using and building. See p. 15 for a listing of some sites to get started. You will probably want to narrow your search, as entering the word "robot" on a search engine will give you thousands of sites!
- ▷ Watch the *Star Wars* movies and note all the robots you can. Do their forms fit their functions?
- ▷ Compare HAL 9000 as seen in *2001: A Space Odyssey* to the computer technology that exists today. What could HAL do that computers cannot yet do (for example, read lips)?

**SCIENTIFIC
AMERICAN
FRONTIERS**

SHOW 705

**ROBOTS
ALIVE!**

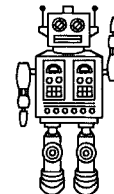

ALMOST HUMAN

NAME: NAILBOT

**FUNCTION: TO PLACE AND
HAMMER NAILS IN
INACCESSIBLE PLACES**

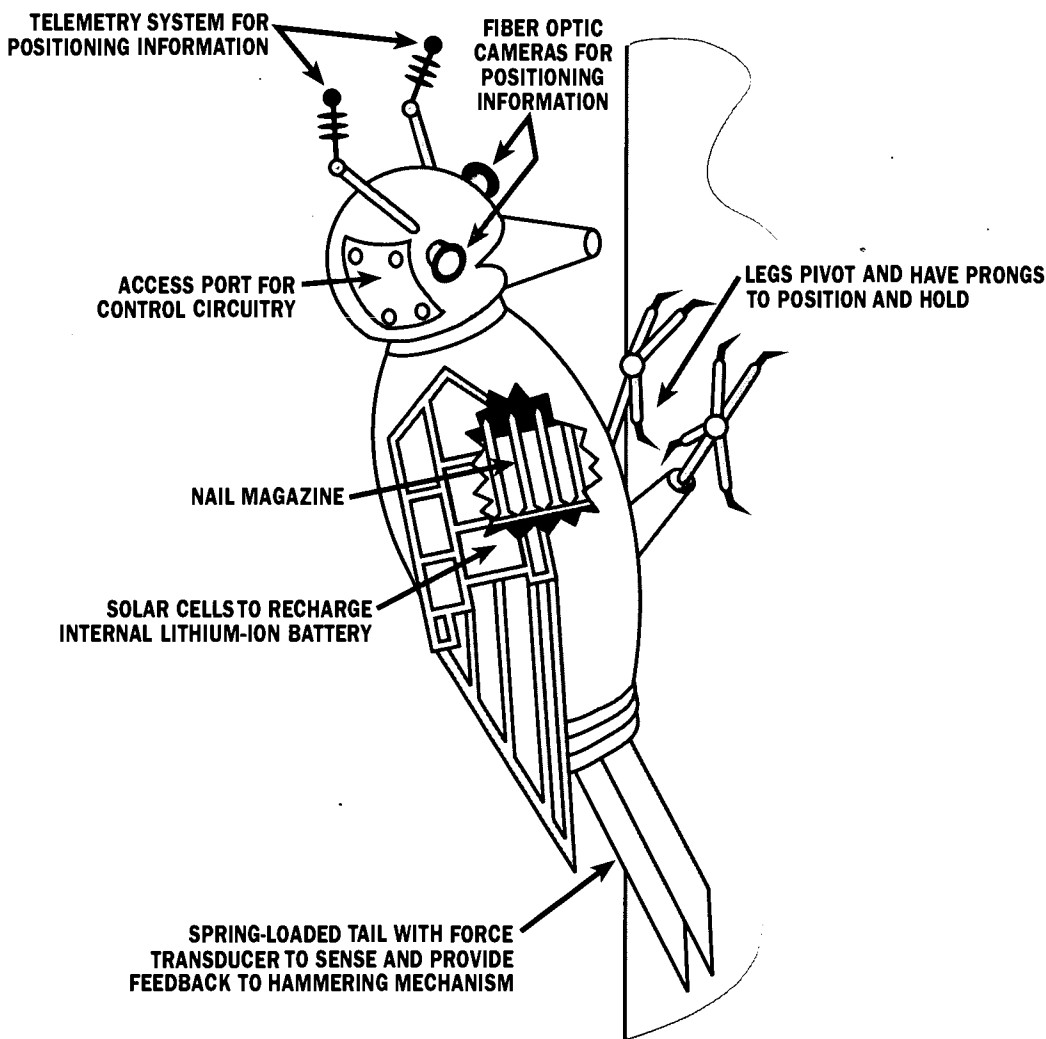

**FOR FURTHER
THOUGHT**

- ▷ Science fiction writer Arthur C. Clarke, in his Rama series of books, includes many robots with forms based on animals. He also suggests an interesting alternative: bioengineered organisms that perform specific tasks. Read the series and discuss the pros and cons of robots versus bioengineered organisms.
- ▷ Build your own insect-like robot! Get information on a small, six-legged, inexpensive robot called Stiquito from the Computer Science Department, Indiana University, 215 Lindley Hall, Bloomington, IN 47405. Or go to <http://grouchy.cs.indiana.edu/robotics/stiquito.html> for information on the colonies of Stiquito robots being used today.

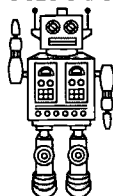

ROBOFLYERS

Motorized balloons, gas-powered model helicopters, tail sitters and other unusual designs were among the contenders in the Fifth International Aerial Robotics Competition. The challenge? Have the robot locate and pick up a metal puck and drop it off at a designated spot. Student teams tried their best to achieve success (in previous years, robots flew but could not pick up the pucks). As you see on FRONTIERS, the U.S. Department of Defense Global Positioning System (GPS) provides a strategic edge.

ACTIVITY 1: Rotating Wing: Going Up?

RUNNING TIME:

11:44

CURRICULUM LINKS:

COMPUTER SCIENCE
computer-assisted design, three-dimensional imaging

GENERAL SCIENCE
flight, scientific method

PHYSICAL SCIENCE
light, navigation

PHYSICS
projectile motion, trajectories

TECH ED
flying machines, robotics

Related FRONTIERS Shows and Activities Include:

Flying High, Show 603: "Build and Race a LTAV" (p. 12) and "The Ultimate LTAV Challenge" (p. 13)

Unlike most aircraft, a helicopter does not have a stationary or fixed wing. Instead, the spinning rotor blades atop the craft function as a lift-generating wing. As the blades turn, they produce the upward force needed to counter-balance the downward pull of gravity. When the lift is greater than the weight of the craft, the helicopter rises.

Using a straw and a small strip of paper, you can build a simple rotary-wing craft, similar to an ancient toy propeller designed by the Chinese centuries ago. Customize your wing to produce the most efficient rotary blades.

OBJECTIVE

Observe how rotating wings produce lift.

PROCEDURE

1. Cut out a thin strip of cardboard about 2 1/2 cm wide by about 12 1/2 cm long.

2. Make two small snips in the cardboard strip as shown here.

3. Use a hole punch or modeling knife to carefully make a small hole in the center of the cardboard strip (rotor).

- MATERIALS**
- ✓ thin cardboard or poster board
 - ✓ straws or small round dowels
 - ✓ tape (if necessary)
 - ✓ modeling knife or a hole punch
 - ✓ scissors

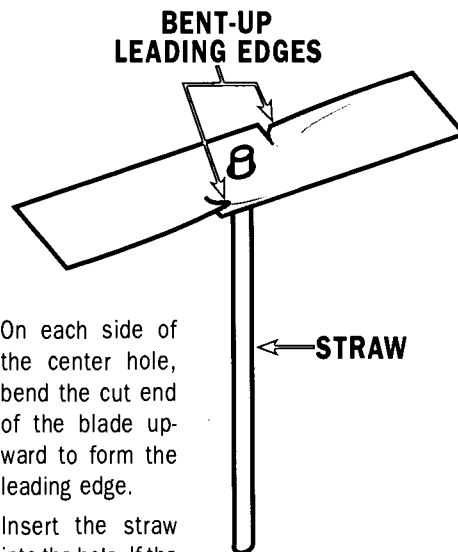

4. On each side of the center hole, bend the cut end of the blade upward to form the leading edge.
5. Insert the straw into the hole. If the fit is not snug, use tape to secure the straw to the blade. (But remember, tape will add weight.)
6. Place the straw (blades on the top) between the palms of your hands. Rapidly move one palm across the other and release the spinning prop. What happens? (**Note:** If the prop dives, change the direction in which you move your palms.)

EXTENSIONS

- ▷ Can you create a better rotor design? Experiment with the different variables in the construction of this device (rotor size, shape, placement of cuts, number of cuts, angle of bends, length of straw, etc.) to develop the highest-flying rotor blades.
- ▷ What is the effect of different angles (pitch) on real helicopter blades?
- ▷ Explain more about the ways helicopters produce lift; compare to the way a fixed-wing plane produces lift.

CLASSROOM CONTEST

Hold a contest to test your designs. Which designs produce the highest- and longest-flying craft? Draw "blueprints" of the winning aircraft and use these illustrations to discuss effective aviation design.

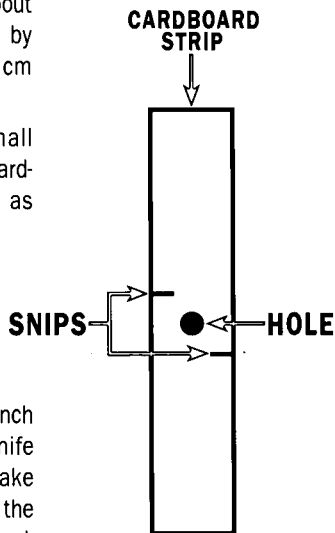

Visit the FRONTIERS Web site (<http://www.pbs.org/saf/>) for a transcript of a dialogue with Professor Robert Michelson of the Georgia Tech Research Institute, creator of the RoboFlyer contest.

ACTIVITY 2: Spinning Stability: Going Down?

The teams of college students participating in the Aerial Robotics Competition used sophisticated (and, in some cases, expensive) technology. They spent many months creating and perfecting their designs. But even with the most high-tech devices, their designs required an understanding of the basic principles that govern helicopter flight. These simpler activities provide an opportunity to learn more about rotating wings — without having to program a flying helicopter.

- ✓ sheets of 8½" x 11" paper
- ✓ small paper clips
- ✓ scissors

OBJECTIVE

Experiment with rotating wings and helicopter aviation. Observe the relationship between stability and spin.

If you've ever spun a top, you know that rotating objects gain stability from their twirling motion. This type of balance is also seen in objects that spin as they fall through the sky. You can observe this gyroscope-like stability in a rotating glider made with a sheet of paper and a paper clip.

PROCEDURE

1. Cut one sheet of paper lengthwise into thirds. Each strip (about 28 cm by about 7 cm) becomes a "wing."

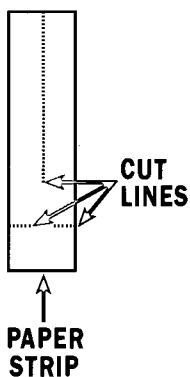
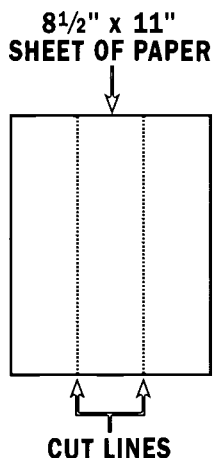

2. Cut about two-thirds of the way down the center of each strip (wing) as shown by the dotted line.
3. Make two horizontal cuts about 2 cm deep along the dotted lines as shown.

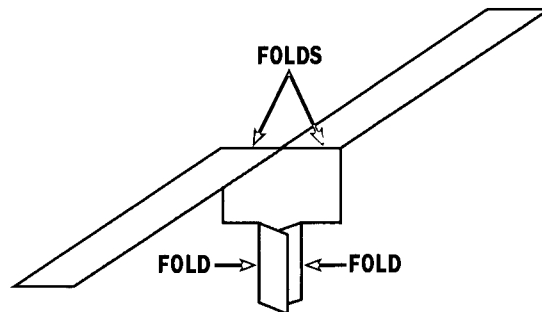

4. Fold and crease the wings in opposite directions as shown in the drawing.
5. Fold in the bottom leaves as shown. Secure the three-layer fold with a paper clip.

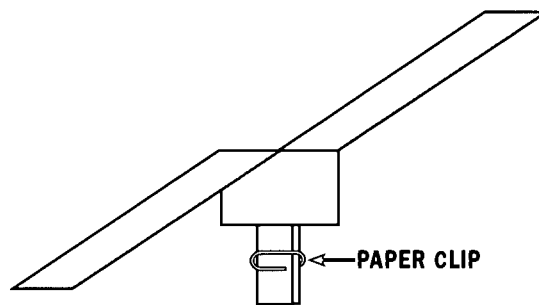

6. While holding the wings out, release the glider from a height of about six feet.
7. Experiment with using different weights of paper or shorter or longer wings, and releasing the rotating glider from various heights.

CHALLENGE 1:

Observe the direction of the rotation. Alter the craft so that it spins in the opposite direction.

CHALLENGE 2

Change the design so that the craft rotates as fast as possible.

**SCIENTIFIC
AMERICAN
FRONTIERS**

SHOW 705

ROBOTS
ALIVE!

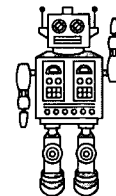

ROBOFLYERS

FOR FURTHER
THOUGHT

▷ You can read about the Aerial Robotics Competition in "Magnificent Men (Mostly) and Their Flying Machines," *Scientific American*, September 1995.

▷ A flying propeller toy like the one illustrated on p. 12 can be purchased from Edmund Scientific.

▷ For rules, videos of the competition and to see what other schools are doing in the "ultimate collegiate competition," go to the Association of Unmanned Vehicle Systems International (AUVSI) Web site at <http://avdil.gtri.gatech.edu/AUVS/IARCLaunchPoint.html>.

▷ AUVSI also sponsors a high school contest. Any interested robotics clubs should see the contest description and rules at <http://avdil.gtri.gatech.edu/AUVS/97IARC/1997HSOpenRules.html>.

▷ Find out more about the winning entry and how it used GPS technology at <http://www.gtri.gatech.edu/80/res-news/AERROB.html>.

MASSACHUSETTS-BASED SCIENCE WRITER MICHAEL DISPEZIO CONTRIBUTED THESE ACTIVITIES. DISPEZIO IS THE AUTHOR OF SEVERAL RECENT BOOKS OF SCIENCE ACTIVITIES, INCLUDING *VISUAL FOOLERY* (PLANET DEXTER DIVISION OF ADDISON-WESLEY, 1995), *CRITICAL THINKING PUZZLES* (STERLING, 1996) AND *THE SCIENCE OF HIV*, PART OF A CURRICULUM PACKAGE FOR NSTA.

FRONTIERS ONLINE

Learning comes alive with FRONTIERS Online!

Ask the Scientists

On **Robots Alive!** you'll meet some autonomous robots with minds of their own. Although they're not yet advanced enough to field queries from FRONTIERS viewers, you can send your questions about these robots to the researchers who developed them. The scientists featured on this page will answer your questions from **April 9 to 18, 1997**, via the FRONTIERS Web site: <http://www.pbs.org/saf/>.

MAZES AND SQUIGGLES

FRONTIERS viewers first met **Kurt Konolige** and his robot Flakey several seasons ago. We catch up with Konolige and his research on this program, where he takes first place in the fifth annual robotics contest sponsored by the American Association of Artificial Intelligence. The technology Konolige uses in competition is completely different from that used to develop Flakey. Find out more about Konolige's winning strategy by sending him your questions.



TODDLER'S FIRST STEPS

At the University of New Hampshire, robots are learning to walk in Professor **Thomas Miller's** lab. Miller, chair of the department of electrical and computer engineering, focuses his research on the dynamic balance of legged walking robots. Instead of being programmed, his robots actually "learn" to walk themselves. Find out more about Miller and his robots by sending your questions to "Ask the Scientists."



ALMOST HUMAN

Is it possible to create a computer that mimics a human being? That's the goal of **Rodney Brooks**, a professor of computer science and engineering and associate director of the Artificial Intelligence Laboratory at the Massachusetts Institute of Technology. Brooks hopes his robot Cog will have the intelligence of a six-month-old human baby. Send in your questions to learn more about how Brooks is working toward his goal.



LOOK, NO HANDS!

Chuck Thorpe's Navlab project at Carnegie Mellon University is dedicated to creating safer highways. Thorpe, a senior research scientist at CMU's Robotics Institute, has created a prototype van that analyzes the road ahead and steers itself along the highway. Thorpe answers your questions about Navlab 5 and how this technology may help drivers in the future.

FRONTIERS SITE GOES PLATINUM

We've received many positive comments about our expanded Web site — thank you. It's rewarding to hear that educators are turning to FRONTIERS on PBS Online for resources to expand learning before and after the show. We're also pleased to let you know that our site was recently recognized for excellence with a Platinum Award from NetGuide, which screened over 100,000 URLs and reviewed more than 50,000 sites before presenting its awards. Here's NetGuide's review of FRONTIERS online:

"The clear and simple layout of the SCIENTIFIC AMERICAN FRONTIERS site belies a wealth of learning resources. Accenting education, the features here allow you to delve into recent broadcasts using transcripts, teacher's guides, contests, quizzes and QuickTime video clips of upcoming episodes. If you prefer to exchange views with some of the show's participants, go to 'Ask The Scientists' area. The 'Related Sites' supplement directs you to further explore issues raised in each show. This is a great place for students and science mavens alike."

HERE'S HOW TO "ASK THE SCIENTISTS"

- ▷ Watch **Robots Alive!** and review this classroom guide to prepare your question(s) and decide which scientist(s) you'd like to contact.
- ▷ Visit SCIENTIFIC AMERICAN FRONTIERS on PBS Online at <http://www.pbs.org/saf/>. Click on the "Ask the Scientists" icon on the opening screen to send your question(s). Scientists' answers will be posted online for FRONTIERS viewers to read. Depending on the volume of questions received, only selected questions may be answered.
- ▷ Remember to e-mail your questions by **April 18, 1997!**



Robots Alive! airs on PBS on Wednesday, April 9, 1997, at 8 pm.*

*Check your TV listings to confirm local air time and date.

WATCH IT ON PBS

SCIENTIFIC AMERICAN FRONTIERS airs on PBS with five new programs each season, October through April. Each hour-long special includes a variety of fascinating science stories based on a single theme.

INVENTING THE FUTURE [Show 701]

Wednesday, October 23, 1996 8 pm

Leap forward into the future when FRONTIERS visits the MIT Media Lab to test smart cars, smart rooms and wearable computers. Meet scientists who are redesigning the look and role of computers.

SCIENCE SAFARI [Show 702]

International Special

Wednesday, November 20, 1996 8 pm

Travel on a science safari to South Africa. Meet some of the world's largest animals, then trek to sites once inhabited by early humans. Find out how scientists combat malaria today.



ASK THE SCIENTISTS!

Rodney Brooks and other scientists seen on Robots Alive! answer your questions online. See p.14.
<http://www.pbs.org/saf/>

PIECES OF MIND [Show 703]

Wednesday, January 22, 1997 8 pm

Spend the night in a sleep laboratory and find out more about how your brain works to create memories, dreams and language.

GOING TO EXTREMES [Show 704]

Wednesday, February 19, 1997 8 pm

Join scientists as they investigate survival mechanisms of animals that inhabit extreme climates, from the desert to the Arctic.

ROBOTS ALIVE! [Show 705]

Wednesday, April 9, 1997 8 pm

Meet some autonomous robots with minds of their own, as well as inventors who are working on the robots of tomorrow. Robots that walk, talk and think are the subjects of this episode. Join FRONTIERS to see who wins a variety of robotics contests and take a ride in a van that drives itself!

SCIENTIFIC AMERICAN
FRONTIERS

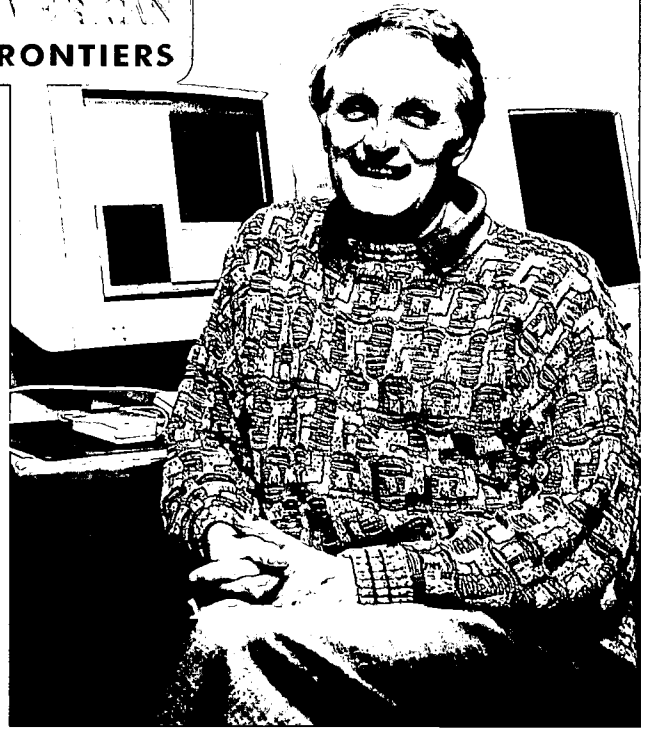

HOSTED BY
ALAN ALDA

Join Host Alan Alda for the season finale of SCIENTIFIC AMERICAN FRONTIERS, as he visits scientists working on new developments in the twin frontiers of computer technology—robotics and artificial intelligence.

Remember, teachers may videotape the show to use year after year. GTE Corporation, the series underwriter, grants educators free off-air taping rights in perpetuity for classroom use.



Underwritten by GTE Corporation



SCIENTIFIC AMERICAN FRONTIERS

Connecticut Public Television
P.O. Box 260240
Hartford, CT 06126-0240

NON PROFIT
U.S. POSTAGE
PAID
Permit No. 51
Bristol, PA

1996-97
SEASON INDEX
MAGAZINE

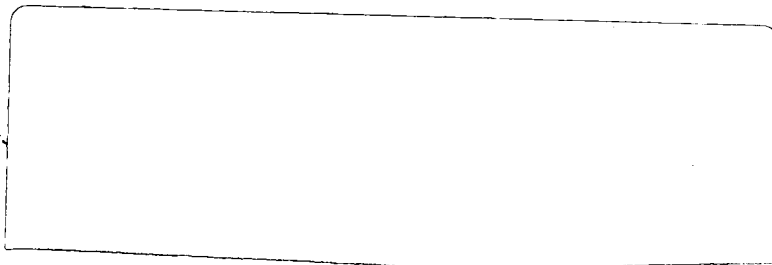

INSIDE:

Requested Teaching Materials for Robots Alive!

Airing April 9, 1997, on PBS



U.S. Department of Education
Office of Educational Research and Improvement (OERI)
Educational Resources Information Center (ERIC)

CE001935
ERIC

REPRODUCTION RELEASE

(Specific Document)

I. DOCUMENT IDENTIFICATION:

Title: Scientific American Frontiers Teachers Guides	
Author(s): Media Management Services	
Corporate Source: Media Management Services & GTE	Publication Date: 1997 - 2000

II. REPRODUCTION RELEASE:

In order to disseminate as widely as possible timely and significant materials of interest to the educational community, documents announced in the monthly abstract journal of the ERIC system, *Resources in Education (RIE)*, are usually made available to users in microfiche, reproduced paper copy, and electronic/optical media, and sold through the ERIC Document Reproduction Service (EDRS) or other ERIC vendors. Credit is given to the source of each document, and, if reproduction release is granted, one of the following notices is affixed to the document.

If permission is granted to reproduce and disseminate the identified document, please CHECK ONE of the following two options and sign at the bottom of the page.



Check here
For Level 1 Release:
Permitting reproduction in microfiche (4" x 6" film) or other ERIC archival media (e.g., electronic or optical) and paper copy.

The sample sticker shown below will be affixed to all Level 1 documents

PERMISSION TO REPRODUCE AND DISSEMINATE THIS MATERIAL HAS BEEN GRANTED BY

_____ *Sample* _____

TO THE EDUCATIONAL RESOURCES INFORMATION CENTER (ERIC)

Level 1

The sample sticker shown below will be affixed to all Level 2 documents



Check here
For Level 2 Release:
Permitting reproduction in microfiche (4" x 6" film) or other ERIC archival media (e.g., electronic or optical), but not in paper copy.

PERMISSION TO REPRODUCE AND DISSEMINATE THIS MATERIAL IN OTHER THAN PAPER COPY HAS BEEN GRANTED BY

_____ *Sample* _____

TO THE EDUCATIONAL RESOURCES INFORMATION CENTER (ERIC)

Level 2

Documents will be processed as indicated provided reproduction quality permits. If permission to reproduce is granted, but neither box is checked, documents will be processed at Level 1.

"I hereby grant to the Educational Resources Information Center (ERIC) nonexclusive permission to reproduce and disseminate this document as indicated above. Reproduction from the ERIC microfiche or electronic/optical media by persons other than ERIC employees and its system contractors requires permission from the copyright holder. Exception is made for non-profit reproduction by libraries and other service agencies to satisfy information needs of educators in response to discrete inquiries."

Sign here → please

Signature: Jessam Gordon	Printed Name/Position/Title: Jessam Gordon Project Manager, Scientific American Frontiers
Organization/Address: Media Management Services 105 Terry Dr. Suite 120 Newtown, PA 18940	Telephone: 800-523-5948
	FAX: 215-579-8589
	Date: 1/2/98
	E-Mail Address: jhgordon@edumedia.com