

## DOCUMENT RESUME

ED 452 680

EF 005 903

AUTHOR Williamson, Beech, Ed.; Watson, Lucy, Ed.  
TITLE Modern Foreign Languages Accommodation: A Design Guide.  
Building Bulletin 92.  
INSTITUTION Department for Education and Employment, London (England).  
Architects and Building Branch.  
ISBN ISBN-0-11-271093-X  
PUB DATE 2000-00-00  
NOTE 61p.; Contributions by Andy Thompson, Neville Morgan, and  
Christine Banks.  
AVAILABLE FROM The Stationery Office, P.O. Box 29, Norwich, NR3 1GN England  
(19.95 British pounds). Tel: 0870-600-5522; Fax:  
0870-600-5533; Web site: <http://www.thestationeryoffice.com>.  
PUB TYPE Guides - Non-Classroom (055)  
EDRS PRICE MF01/PC03 Plus Postage.  
DESCRIPTORS \*Classroom Design; \*Educational Facilities Design;  
Guidelines; Public Schools; School Construction; \*Second  
Language Instruction; \*Secondary Education; \*Space  
Utilization

## ABSTRACT

This document offers school design guidance for accommodating the needs for teaching modern foreign languages (MFLs) in secondary education. Section 1 outlines the range of spaces in a typical MFL suite and describes how to calculate the number of timetabled spaces required. It includes guidance on planning the suite and what to consider if there is to be community use. Section 2 describes the teaching and non-teaching spaces that might be found in the MFL suite. It gives guidance on the size and shape of spaces and shows typical furniture layouts. Section 3 describes typical MFL equipment and how it can be used most effectively. It also provides guidance on choosing and using furniture. Section 4 outlines the process of setting up and implementing a building project, from briefing to on-site construction. Section 5 presents case studies showing the issues covered in the rest of the document applied to real school projects. Appendices contain a glossary of terms and a 17-item bibliography. (GR)

This document has been reproduced as received from the person or organization originating it.

Minor changes have been made to improve reproduction quality.

Points of view or opinions stated in this document do not necessarily represent official OERI position or policy.

PERMISSION TO REPRODUCE AND  
DISSEMINATE THIS MATERIAL HAS  
BEEN GRANTED BY

John Birch

TO THE EDUCATIONAL RESOURCES  
INFORMATION CENTER (ERIC)

## Building Bulletin 92

# Modern Foreign Languages Accommodation

## A Design Guide



2

Architects and Building Branch  
Department for Education and Employment

D/EE

BEST COPY AVAILABLE

# **Modern Foreign Languages Accommodation**

A Design Guide

Architects and Building Branch  
Department for Education and Employment

# Acknowledgements

This publication has been prepared by the following team of DfEE Architects and Building (A&B) professionals, under the Head of Branch, Mukund Patel.

Executive editors:

Beech Williamson

Lucy Watson

With contributions from:

Andy Thompson

Neville Morgan

Christine Banks

This work was carried out in consultation with subject specialists from the Office for Standards in Education (OFSTED). The Department would like to thank the authorities and school staff who were so helpful on school visits and the following people who made up a working group throughout the project:

Alan Dobson HMI

Anna Marples Central Bureau for International Education (CBEVE)

Glenis Shaw (CILT)

The Languages, Arts and Sports Colleges Team, DfEE

and

Pam Haezewindt (The Leicestershire Comenius Centre)

Published with the permission of DfEE on behalf of the Controller of Her Majesty's Stationery Office.

© Crown Copyright 2000

All rights reserved.

Copyright in the typographical arrangement and design is vested in the Crown. Applications for reproduction should be made in writing to the Copyright Unit, Her Majesty's Stationery Office, St Clements House, 2-16 Colegate, Norwich NR3 1BQ.

First published 2000

ISBN 0 11 2713099 X

Printed in the United Kingdom for the Stationery Office.  
TJ2388 C20 09/00

# Contents

<b>Preface</b>	i
<b>Introduction</b>	iii
<b>Section 1: The MFL Suite</b>	1
Range of Spaces	2
Timetabled Classrooms	2
Untimetabled Teaching Spaces	6
Non-Teaching Support Spaces	7
Planning the Suite	8
Servicing and Environmental Design	9
Community Use	9
<b>Section 2: Individual Spaces</b>	12
Classroom Size and Classroom Planning	12
The Language Laboratory	16
ICT Cluster	17
Local Resource Area	18
Role Play Area	18
Servicing Teaching Spaces	20
Non-Teaching Support Spaces	20
<b>Section 3: Furniture and Equipment</b>	22
Tables and Chairs	22
Storage and Display	23
Audio Recording Facilities	23
Computers	25
Other Communications Equipment	27
<b>Section 4: Running a Project</b>	28
Setting up the Project	28
Implementing the Project	31
<b>Section 5: Case Studies</b>	33
The Willink School, Reading	33
Standish Community High School, Wigan	37
St Bede's RC School, Lanchester	41
Kettlethorpe School, Wakefield	45
<b>Glossary</b>	49
<b>Bibliography</b>	50
<b>Key to Symbols</b>	inside back cover

# Preface

The provision of modern foreign languages (MFLs) in secondary schools has undergone significant changes in the last decade. The subject is now compulsory for pupils aged 11-16 and the range of MFLs taught has been diversified so that more pupils are studying languages other than French, notably German and Spanish.

The National Curriculum has had a major impact on the teaching and learning of MFL since 1992 and its implementation continues to have implications for methodology and for the accommodation of the subject. It requires pupils to be given a wide range of opportunities for learning and therefore a greater variety of activities than before, including the use of information and communications technology. Above all, the curriculum is expected to be delivered mainly through the target language. The range of activities required in the sixth form has experienced similar developments in recent years.

This bulletin deals with the design, setting up and running of a building project for MFLs in a secondary school (some of the advice will also be relevant to similar projects in other departments). It covers a broad range of issues, from furniture and equipment to new building work.

The bulletin provides guidance for all those involved in a building project, from the teaching staff to the design consultants. Although the book can be read as a whole, cross-referencing throughout the document allows the reader to 'dip-in' to those parts which are most relevant to them. The contents of each section are summarised below. The Introduction, which briefly outlines the nature of MFL teaching and its accommodation need, will be useful to all readers.

**Section 1: The MFL Suite** outlines the range of spaces in a typical MFL suite and describes how to calculate the number of timetabled spaces required. It includes guidance on planning the suite and what to consider if there is to be community use. This section will be of particular interest to those compiling the initial schedule of spaces and developing a scheme design.

**Section 2: Individual Spaces** describes in more detail the teaching and non-teaching spaces that might be found in the MFL suite. It gives guidance on the size and shape of spaces and shows typical furniture layouts. This section will be most useful to those at the detailed design stage or those only considering the refurbishment of individual spaces.

**Section 3: Furniture and Equipment** describes typical MFL equipment and how it can be used most effectively. It also provides guidance on choosing and using furniture. This section will be particularly valuable to those dealing only with the provision of furniture and equipment.

**Section 4: Running a Project** outlines the process of setting up and implementing a building project, from briefing to on-site construction. It will be useful to school governors or teachers who have no knowledge or experience of the procedure.

**Section 5: Case Studies** show the issues covered in the rest of the document applied to real school projects. This section is likely to be of interest to all readers.

A glossary and bibliography are included.

In modern foreign languages (MFL) pupils may work as a whole class, in small groups or individually. They are taught predominantly in the target language and in the context of the relevant country's culture, learning through a number of different activities including:

- role play and improvised drama;
- using audio equipment;
- using computers;
- reading foreign language newspapers.

These and other activities can be accommodated in various ways but a typical department will include:

- **timetabled teaching spaces** including classrooms and possibly seminar rooms for smaller sixth form groups;
- **partially timetabled and untimetable teaching spaces** such as a language laboratory or a small group room (often used for working with a foreign language assistant (FLA));
- **non-teaching spaces** including staff areas, storage and display.

Some facilities, such as a drama studio or information and communications technology (ICT) room, may be shared with other departments.

In order to provide a flexible environment that caters for a range of activities, the size and shape of these spaces, their location and how they are serviced, furnished and equipped all need to be considered.

The starting point for any design is the brief which sets out the client's requirements. The brief is a working document which is developed by the staff involved in discussion with any building consultants appointed. The briefing process is described further in paragraph 4.14. The points raised below, in the form of a series of questions, can be used as the basis for developing a brief. The questions assume that the project will be for an existing school, but most of the issues and references to further information in this bulletin, will also apply to new schools.

## Are There Enough Classrooms?

In an existing MFL department, the first step when considering changes is to analyse the current (and future) situation to find out whether the accommodation meets the requirements of the curriculum, the number of pupils studying foreign languages and the teaching methods chosen. The curriculum analysis method can be used to calculate the number of timetabled teaching spaces (usually classrooms) required. This assessment should be done as part of a whole school analysis since an increase in spaces in one subject is likely to result in a decrease in another. See paragraph 1.9.

## Are There Enough Support Spaces?

Teaching methods, including role-play and the use of more sophisticated ICT equipment, may require access to more non-timetabled teaching areas such as a shared role play area or an ICT cluster. Foreign language assistants may need space to take small groups. See paragraph 1.21.

## Are Spaces the Right Size?

All teaching spaces need to be large enough to accommodate the maximum group size taking part in a range of activities, bearing in mind the furniture and equipment that will be needed.<sup>1</sup> If the total area of all spaces (teaching and non-teaching) is too small, the MFL department may need to expand into adjacent areas. If no suitable areas exist nearby, it may be worth considering moving the entire department to a more suitable position rather than splitting it. See paragraph 1.18.

It is sensible to try to achieve a close match between group sizes and room sizes. If, following an analysis of the existing facilities, it is found that some spaces are too large, it may be possible to make more effective use of the area by doing some minor adaptations. In some cases the need for new building work may be avoided saving both capital and running costs (see **Is New Building Necessary?** on the next page).

### Note

<sup>1</sup> The maximum group size likely to use the room will need to be assessed. If group sizes vary widely, not all classrooms in a suite need to be furnished for the largest group size. However, if accommodation allows it, this can maximise flexibility.

## Are the Spaces in the Right Place?

Facilities and resources can be used most efficiently by clustering MFL classrooms and support spaces together. The choice of the suite's location will be influenced by a number of factors including:

- the likelihood of spaces being shared with other departments;
- the need to have good sound insulation to the MFL teaching rooms;
- the need to minimise solar heat gain in areas where several computers are used.

See paragraph 1.34 on planning the suite.

## Is New Furniture and Equipment Required?

The furniture and equipment provided should allow a range of activities to take place and their condition and suitability should be sufficient for foreseeable future needs. Furniture that can be moved easily to allow for changing activities is an advantage. Resources such as audio equipment and ICT may be needed, in the main classroom or elsewhere (the location of computer equipment should be carefully considered to ensure effective use by all pupils). International projects will require easy access to e-mail, fax, the Internet and perhaps video-conferencing equipment.

Section 2 shows furniture and equipment used in a variety of room layouts. Section 3 discusses the equipment available and the type of furniture needed.

## Are the Spaces Suitably Serviced?

A MFL space should be adequately serviced to cater for the range of equipment (overhead projector (OHP), audio, video and ICT) to be used. If any changes are to be made, such as extending power and network cabling to service new equipment, it may be worthwhile and cost effective to design in some flexibility and to allow for changes in the future. See paragraph 2.24.

## Is the Environment Appropriate?

The requirements for heating and lighting a MFL classroom are similar to other general teaching spaces and are not therefore covered in detail in this document.<sup>2</sup> However, particular attention should be paid to acoustics to ensure attentive listening and understanding. The two main aspects are adequate sound insulation (the location of a teaching space should be considered) and sound quality within each space (influenced by room shape and surface finishes). If the sound quality in any of the MFL teaching spaces is poor, simple measures such as carpets or ceiling tiles can often alleviate the problems. See paragraph 2.26.

## Is New Building Necessary?

Improvement projects can range from updating resources or redecoration to a new building. If, following a curriculum analysis, additional area is considered necessary, it is important to explore the option of adaptation of the existing buildings before deciding on new work. New buildings involve not only initial capital cost but future recurrent costs (heating, lighting, cleaning and rates).

The total (or gross) area of all the school's buildings should be checked against the area ranges given in Building Bulletin 82: Area Guidelines for Schools.<sup>3</sup> If the gross area is well above the upper limit, it is likely that some area is not being used as efficiently as possible, and internal adaptations should accommodate the extra space required for MFL within the existing building envelope. The flow chart in Figure I/1 will help in deciding whether the existing MFL suite should be retained, refurbished or extended/replaced. More detailed discussion on assessing the type of project is discussed in paragraph 4.12.

### Notes

<sup>2</sup> See 'Guidelines for Environmental Design in Schools' (BB87), DfEE, 1997 for guidance on this matter.

<sup>3</sup> 'Area Guidelines for Schools' (BB82), DfEE 1996, gives the following gross area formulae range in square metres.

11-16 schools:  
 $1200+5.5N$  to  $1300+6N$

11-18 schools:  
 $1200+5.5N+2.5n$  to  
 $1300+6N+3n$ .

$N$  = total number on roll (incl. sixth form)

$n$  = number on roll in the sixth form.



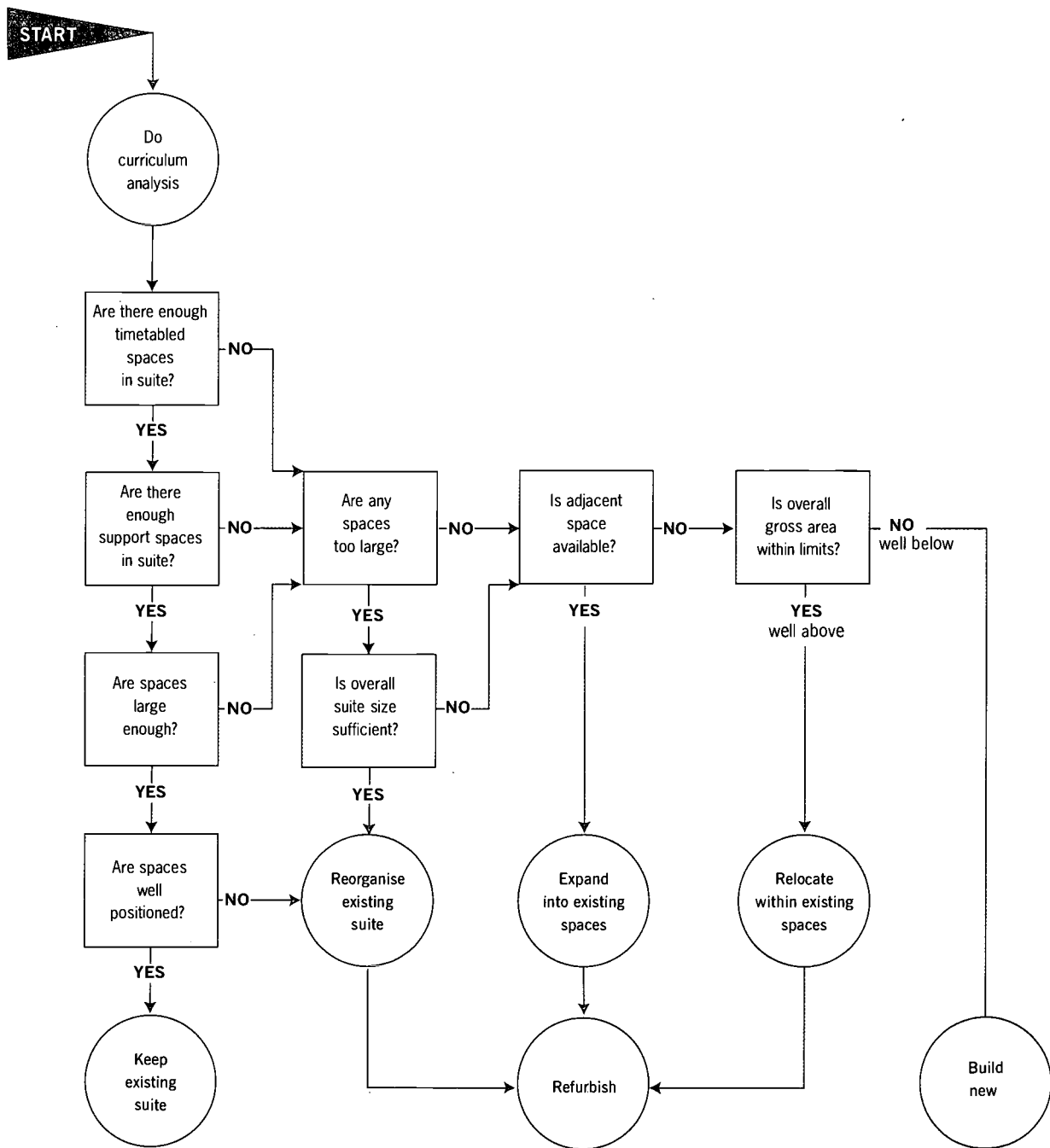

Figure I/1  
Flow chart for assessing need to change the MFL suite.

# Section 1: The MFL Suite

This section covers briefing and early design stage issues. It looks at the range of modern foreign languages (MFL) spaces, outlines a method to identify the number and size of rooms required, and considers some key planning issues including shared community use. The section begins with a description of MFL activities for those unfamiliar with how the subject is taught.

## Note

<sup>1</sup> There are four attainment targets in the National Curriculum: listening and responding, speaking, reading and responding and writing.

## Activities

1.1 A variety of teaching and learning methods are needed to deliver the National Curriculum and other courses, such as those in the sixth form, so that pupils will experience and learn from listening, speaking, reading and writing.<sup>1</sup> Pupils are taught predominantly in the target language and in the context of the relevant country's culture. They learn through a range of activities (some are shown in Figures 1/1 to 1/4) including:

- teacher presentations;
- pupils' presentations;
- role play or drama;

## Figures 1/1 to 1/4

MFL activities. Clockwise from top left: teacher presentation; various activities (carousel); role play; discussion with foreign language assistant.



- discussions, perhaps with a foreign language assistant (FLA) or other native speaker;
- reading from 'authentic' materials such as newspapers, magazines and books;
- using audio equipment;
- watching TV programmes and videos and listening to radio broadcasts from the relevant country;
- using computers;
- using communications technologies such as e-mail, telephone and fax;
- activities outside the school such as surveys;
- work experience;
- travel/pupil exchanges.

1.2 Depending on the methods chosen, these activities can be successfully tackled in a number of ways:

- whole class teaching;
- small group study or pair work;
- individual independent study (possibly using Information and Communications Technology (ICT)).

A carousel format is often used whereby a class of pupils is divided into groups each working on a different activity for a short time before moving on to the next.

1.3 Dictionaries and reference books are used as well as computers to access databases and the Internet. Computers are also used for textual exercises and to redraft written work to improve its accuracy and presentation. Both written and oral examinations take place, the latter often being recorded.

1.4 The way in which these activities are accommodated will have an effect on the number, type and size of spaces that are provided. This is discussed further below.

## Range of Spaces

1.5 Most MFL activities take place in a timetabled classroom which can accommodate a whole class group. Other activities may require access to a specialist space, i.e. one that is highly equipped or serviced, either as a whole class or smaller group. There may also be occasional use of spaces that are more suited to particular activities than a classroom. A range of spaces is identified in the Introduction:

- timetabled teaching spaces;
- partially timetabled and untimetable teaching spaces - such as a language laboratory or ICT cluster;
- non-teaching spaces.

1.6 The number, type and size of spaces for a particular school will depend on a number of factors. These include the amount of curriculum time spent on MFL courses now and in the future, group sizes and the way in which the school chooses to accommodate the range of activities described in paragraph 1.1. The choices to be made include whether:

- resources are kept in a shared area **or** in individual classrooms;
- ICT equipment is housed in a shared area, a language laboratory **or** in individual classrooms;
- work with foreign language assistants takes place in the classroom **or** in smaller areas in the suite;
- role-play or small group work is carried out in the classroom (by moving furniture) **or** in spaces shared with other subjects or uses.

1.7 In practice, there is likely to be a wish for all of these options to be possible. However, the constraints of budget and existing buildings may dictate the final decision. There may be considerable overlap between the use of certain spaces, particularly where a single use would leave an area underused. Whatever the schools particular arrangement, a variety of teaching contexts should be achievable within the MFL suite with sufficient space for activities to take place effectively and safely.

## Timetabled Classrooms

1.8 The most important issue to address is the number of timetabled teaching spaces, as this relates directly to the number of MFL lessons to be taught. This will depend on:

- the amount of timetabled teaching;
- the number of teaching groups.

It may be problematic to assume that specialist areas can be highly timetabled, as this may not suit the pattern of study at the time, so the *frequency of use* should be looked at carefully. The demand for timetabled spaces can be determined from an analysis of the curriculum proposed.

### Calculating the Number of Timetabled Classrooms (Curriculum Analysis)

1.9 The average number of teachers teaching MFL at any one time is equal to the number of timetabled rooms required if they are used 100% of the time. This *calculated number of spaces* can then be rounded up to give the actual number of rooms, with a reasonable frequency of use. For instance, if the total number of teaching periods for MFL in a 40 period week is 180, the number of teachers teaching at any one time would be, on average,  $180/40 = 4.5$ . This figure rounded up would be 5 teaching spaces, with a frequency of use of 90% (this frequency of use is determined by dividing the calculated number of spaces by the rounded up number of spaces).

1.10 The number of teaching periods can be identified by analysing the school timetable. In a new school or where the curriculum is changing, the calculated number of spaces may be more usefully identified by multiplying the average curriculum time for MFL, as a percentage, by the number of groups being taught in each year. So, for instance, if one group is taught MFL for 20% of the timetable, the calculated number of spaces required would be 0.2 for that group. The total for all groups can then be rounded up as above to identify the number of timetabled classrooms required.

MODEL A: 40 periods per cycle				
Year	Average curriculum time	Course structure		
		Proportion of year group	Subject	Curriculum time
7	10.0%	100%	French	10%
8 & 9	12.5%	100% + 50%	French Spanish	10% 5%
10 & 11	11.5%	100% + 15%	French Spanish	10% 10%
12 & 13	N/A			

MODEL B: 40 periods per cycle				
Year	Average curriculum time	Course structure		
		Proportion of year group	Subject	Curriculum time
7	10.0%	100%	French	10%
8 & 9	12.5%	50% + 50% 50%	French French German	10% 7.5% 7.5%
10 & 11	11.5%	65% + 50%	French German	10% 10%
12 & 13	20.0%	Total groups in sixth from 2 2	French German	20% 20%

MODEL C: 50 periods per cycle				
Year	Average curriculum time	Course structure		
		Proportion of year group	Subject	Curriculum time
7	12.0%	100%	French	12%
8 & 9	18.0%	100% + 50% + 25%	French Spanish German	12% 8% 8%
10 & 11	12.0%	100% + 12% + 8%	French Spanish German	10% 10% 10%
12 & 13	N/A			

MODEL D: 50 periods per cycle				
Year	Average curriculum time	Course structure		
		Proportion of year group	Subject	Curriculum time
7	12.0%	100%	German	12%
8 & 9	18.0%	100% + 60% + 20%	German French Spanish	10% 10% 10%
10 & 11	12.0%	100% + 7% + 7% + 6%	German French Spanish Urdu	10% 10% 10% 10%
12 & 13	20.0%	Total groups in sixth from 2 2 1 1	German French Spanish Urdu	20% 20% 20% 20%

1.11 MFL classrooms belong to a category known as general teaching spaces. These are rooms that are not heavily serviced or equipped that can be used for subjects such as English, mathematics and humanities. In order to be used efficiently, these spaces need to have a relatively high frequency of use and some overlap between subjects is usually accepted. A frequency of use of around 90% should generally be aimed for. A MFL suite requiring 4.8 calculated spaces could therefore contain:

- six spaces used 80% of the time for MFL lessons, with other subjects also timetabled in them (for a further 10% each on average); or
- five timetabled spaces used 90% of the time, with remaining lessons timetabled

in other classrooms predominantly used for other subjects; or

- five timetabled spaces used 90% of the time, and one specialist space such as a language laboratory, timetabled for 30% of the time, and used as a bookable resource at other times.

1.12 Figure 1/5 shows curriculum data for four models reflecting typical schools. Models A and C refer to 11-16 schools and models B and D include sixth form courses. Models A and B have a limited MFL provision and a 40 period week and while the average curriculum time for each (7-11) year is the same for both models, the course structure varies. In model A all pupils do one language (French) with a second as an option chosen by some in

**Figure 1/5**  
Four MFL curriculum models

<b>MODEL A: 750 places 11-16</b>		
<b>example with larger group sizes</b>		<b>teacher periods</b>
Year 7	5 groups of 30 @ 4 ppw =	20 = 20
Years 8 & 9	5 groups of 30 @ 4 ppw =	20 x 2 = 40
(in each year)	3 groups of 25 @ 2 ppw =	6 x 2 = 60
Years 10 & 11	6 groups of 25 @ 4 ppw =	24 x 2 = 48
(in each year)	1 groups of 23.5 @ 4 ppw =	4 x 2 = 8
	total	<b>128</b>
	calculated number of spaces	<b>3.2</b>
<b>example with smaller group sizes</b>		<b>teacher periods</b>
Year 7	5 groups of 30 @ 4 ppw =	20 = 20
Years 8 & 9	6 groups of 25 @ 4 ppw =	24 x 2 = 48
(in each year)	3 groups of 25 @ 2 ppw =	6 x 2 = 12
Years 10 & 11	8 groups of 19 @ 4 ppw =	32 x 2 = 64
(in each year)	2 groups of 11 @ 4 ppw =	8 x 2 = 16
	total	<b>160</b>
	calculated number of spaces	<b>4</b>

**Figure 1/6**  
Calculating the number of spaces needed; model A, 750 place school.

**Notes**  
<sup>2</sup> For the purposes of these examples, a maximum frequency of use of 93% is assumed.  
<sup>3</sup> Figures omitted because models unlikely to occur with these school and/or group sizes.  
<sup>4</sup> The frequency of use multiplied by the occupancy rate is referred to as the *utilisation factor* (also used in capacity calculations). This is effectively the average proportion of workplaces in use at any one time. It should usually be at around 75%. A suite of rooms with a high frequency of use could afford a low occupancy (such that, for instance, all groups are taught in standard classrooms for 30). A low frequency of use could allow more flexibility of timetabling but groups might need to be taught in appropriately sized rooms to give a higher occupancy rate.

year 8. In model B, pupils have the option of taking one or two languages. This variation can result in differences in the number of teaching periods and in average group sizes in a year group. Group sizes in model A, for example, may average higher than model B because a whole year group can be divided into average groups of 30 more easily. Models C and D have a higher MFL curriculum time than the other two models and a 50 period cycle. As with models A and B, the average curriculum time is the same for both but the courses are different.

1.13 Figure 1/6 shows how the curriculum information can be used to calculate the number of spaces needed. The example shows a 750 place school teaching curriculum model A. Two versions are shown, one with larger average group sizes than the other, reflecting differences in organisation. For example, a year group of 150 can be divided into 5 groups of 30 or 6 groups of 25. Groups are smaller in KS4 to allow for option groups.

1.14 Figures 1/7 and 1/8 show the number of spaces needed for all four models, for a variety of school sizes; larger

and smaller group size options are given. The number of spaces required for a typical number of sixth form courses is also shown for models B and D. Similar increases could be added to model A and C if they were 11-18 schools, effectively adding 0.2 to the calculated number of spaces for every group taught in the sixth form.

## Group Sizes and Occupancy

1.15 The curriculum analysis can be used to identify the average group size of classes, and from this a likely maximum group size. When comparing the maximum group size to the average, care should be taken to avoid too large a gap, as this can lead to uneconomic occupancy of rooms. Classrooms will typically be designed to house a maximum of 30 pupils, but the average group size may be around 25. This is a reasonable 'occupancy rate' (an average group size of 25 divided by a maximum group size of 30) of around 83.3%. assuming a frequency of use of around 90%.<sup>4</sup>

1.16 While a significantly lower occupancy rate can offer flexibility in timetabling, the spare workplaces created will often stand idle and the associated area could have been used towards resource areas or other unmetabled teaching spaces that could be used more effectively. This is particularly true when computer workstations are provided at the back of the room, possibly increasing the capacity to 33 or 34.

1.17 Sixth form groups are usually much smaller than those in KS3 and 4, so it is often worth having one room predominantly for use by small groups to avoid very low occupancy rates in a standard classroom. These spaces may also be used for smaller option groups in KS4 such as those in model D (Figure 1/5). See also paragraph 2.12.

MODEL A: 11-16 school					
Number on roll	Teacher periods	Average group size	Calculated number of spaces (100% usage)	Spaces required rounded	Frequency of use <sup>2</sup>
600	104	27	2.6	3	87%
	or 124	23	3.1	4	78%
750	128	27	3.2	4	80%
	or 160	22	4.0	5	80%
900	148	28	3.7	5	74%
	or 168	25	4.2	5	84%
1050	180	27	4.5	5	90%
	or 212	23	5.3	6	88%
1200	200	28	5.0	6	83%
	or 236	24	5.9	7	84%
1350	224	28	5.6	7	80%
	or 272	23	6.8	8	85%

MODEL B: 11-18 school						
Number on roll (11-16 only)	11 to 16 teacher periods	Average group size	11 to 16 calculated number of spaces (100% usage)	11 to 18 calculated number of spaces (includes 4 groups at 0.2 each)	Spaces required rounded	Frequency of use <sup>2</sup>
600	104	31	2.6	3.4	4	85%
	or 132	25	3.3	4.1	5	82%
750	136	30	3.4	4.2	5	84%
	or 152	27	3.8	4.6	6	77%
900	156	31	3.9	4.7	5	78%
	or 192	25	4.8	5.6	7	80%
1050	188	30	4.7	5.5	7	79%
	or 212	27	5.3	6.1	7	87%
1200	200	32	5.0	5.8	7	83%
	or 244	27	6.1	6.9	8	86%
1350	232	31	5.8	6.6	8	83%
	or 264	28	6.6	7.4	9	82%

**Figure 1/7**  
Number of spaces needed for a range of school sizes, for curriculum models **A** and **B** (Figure 1/5).

**Figure 1/8**  
Number of spaces needed for a range of school sizes, for curriculum models **C** and **D** (Figure 1/5).

MODEL C: 11-16 school					
Number on roll	Teacher periods	Average group size	Calculated number of spaces (100% usage)	Spaces required rounded	Frequency of use <sup>2</sup>
600	N/A <sup>3</sup>				
	162	20	4.0	5	81%
750	N/A				
	or 192	21	4.8	6	80%
900	189	25	4.7	6	79%
	or 235	20	5.9	7	84%
1050	224	25	5.6	7	80%
	or 266	21	6.6	8	83%
1200	254	25	6.4	7	91%
	or 301	21	7.5	9	84%
1350	290	25	7.2	8	91%
	or 331	22	8.3	10	83%

MODEL D: 11-18 school						
Number on roll (11-16 only)	11 to 16 teacher periods	Average group size	11 to 16 calculated number of spaces (100% usage)	11 to 18 calculate number of spaces (includes 6 groups at 0.2 each)	Spaces required rounded	Frequency of use <sup>2</sup>
600	N/A <sup>3</sup>					
	N/A					
750	N/A					
	N/A					
900	N/A					
	229	21	5.7	6.9	8	87%
1050	242	23	6.0	7.2	8	91%
	or 274	20	6.8	8.0	9	89%
1200	262	24	6.6	7.8	9	86%
	or 310	20	7.8	9.0	10	90%
1350	299	24	7.5	8.7	10	87%
	or 339	21	8.5	9.7	11	88%

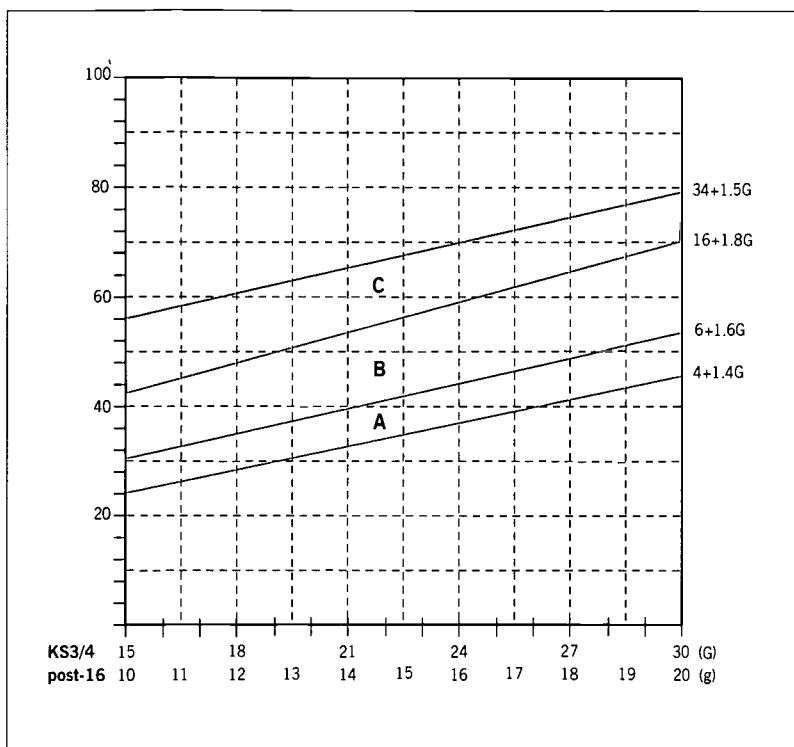

**Figure 1/9**  
Graph showing area ranges for MFL spaces according to group size<sup>5</sup>.

## Size of Timetabled Classrooms

1.18 Figure 1/9 shows recommended ranges for standard (zone A) and large (zone B) general teaching spaces, related to group size. The range reflects differences in teaching approach between schools. It also takes account of variations in the dimensions of (particularly existing) rooms.

1.19 The size of a MFL classroom will vary depending on the school's particular way of accommodating activities - some of which involve equipment - across the suite (see paragraph 1.1). In most cases, an area from the **upper half of zone A** will be suitable.

1.20 It is important to decide early on how different activities are to be accommodated but to allow some flexibility for change in the future. Planning the furniture and equipment layout of the classrooms is a useful way of assessing the suitability of its size and shape. This is equally important in new and existing suites. The size and the layout of MFL classrooms is discussed further in Section 2.

**Note**

<sup>5</sup> The graph is based on the formulae shown alongside, where G (or g) = group size. It is extracted from Area Guidelines for Schools (BB82) DfEE 1996.

## Untimetabled Teaching Spaces

1.21 Most schools are likely to have some rooms or areas which are partially timetabled and bookable. They may be for whole class groups (e.g. to use specialist equipment), or for small groups or individuals learning away from the class group in self-supported study or with a FLA.

1.22 The size of these spaces will depend on the number of pupils using them, the activities taking place and the furniture and equipment they contain. The area graph shown in Figure 1/9 can be used as a guide. Small group rooms used for conversation, reading or audio work are likely to fall into **zone A** while larger spaces with specialist equipment will be in **zone B** or **C**. The following untimetabled areas are described in Section 2:

- language laboratory - for work with audio, video or computer equipment;
- ICT cluster;
- small group room, e.g. for work with a FLA;
- resource area;
- role play area - somewhere that may be more suited to the activity than the classroom.

1.23 If untimetabled support spaces are used specifically for one task they may become underused and, particularly if they do not contain specialist equipment, may have more than one use. The same room, for example, may be used for oral examinations as well as a FLA's base. Some of these spaces can also be shared with other users (for example the role play area also being used by the drama department). This is discussed further in paragraph 2.13.



## Shared Spaces

1.24 Teaching spaces used predominately by other subjects can be used at some times by MFL pupils, either through timetabling or more informal arrangements. Such areas could include:

- a drama studio for role play and playlets;
- a specialist business studies space for office based simulations;
- a social area that can be used for role play or display;
- a recording studio (normally used by music or media studies) for complex recordings or oral examinations.

1.25 Some spaces are for the whole school to use. For example, an external area such as a courtyard can offer wider opportunities for teaching. An ICT space may be a whole school resource (with relevant MFL applications). In all these cases, it is preferable for shared areas to be close to the MFL suite.

## Non-Teaching Support Spaces

1.26 The provision of non-teaching support spaces will vary between schools but it is likely to include the areas discussed below. There may be overlap between teaching and non-teaching spaces particularly where individual spaces would otherwise be underused (for example a staff work room could also be used for oral examinations). Further details including example furniture layouts are given in Section 2.

## Staff Rooms

1.27 A departmental staff base for the preparation and storage of work can be useful, especially if it is centrally located to the suite of classrooms, to allow economical storage and movement. In some schools, it may be shared with another subject (e.g. English). If justified by the level of equipment, there may be a technician's room for the support and maintenance of ICT and other equipment.

## Storage

1.28 The following types of teaching storage should be considered:

- central secure storage - for valuable equipment, confidential paperwork and long term storage;
- local storage - for resources that need to be readily accessible during a lesson.

1.29 A total area of between **0.08 and 0.09m<sup>2</sup>** of full height storage, or its equivalent, should be provided for each workplace, the majority of it local. Storage can be provided by walk-in store rooms or cupboards or a combination of the two. This is discussed further in paragraph 2.32.

1.30 Space should also be allowed for storing pupils' coats and bags, either in clusters of lockers or coat and bag parks in each classroom. These arrangements are now more common than central cloakrooms in most schools.

## Services

1.31 In new accommodation, an allowance may need to be made for boiler plant rooms as well as meter and other service cupboards. As such spaces are usually difficult and expensive to move, their position needs to be carefully considered. In some cases they act as an acoustic 'buffer' between teaching spaces but, in addition to the point made above, this is not advisable if the service area itself generates noise that could cause disturbance (see paragraph 1.34).

## Circulation

1.32 In order to use space effectively, the design of circulation routes should be carefully considered. If rooms can be accessed from both sides of a corridor, this will save valuable area. Circulation through one teaching space to another should be avoided wherever possible, as the space required to move through the teaching space may not be easily usable. Routes to staff areas may be acceptable, but ideally all spaces should be directly accessible from a circulation route.



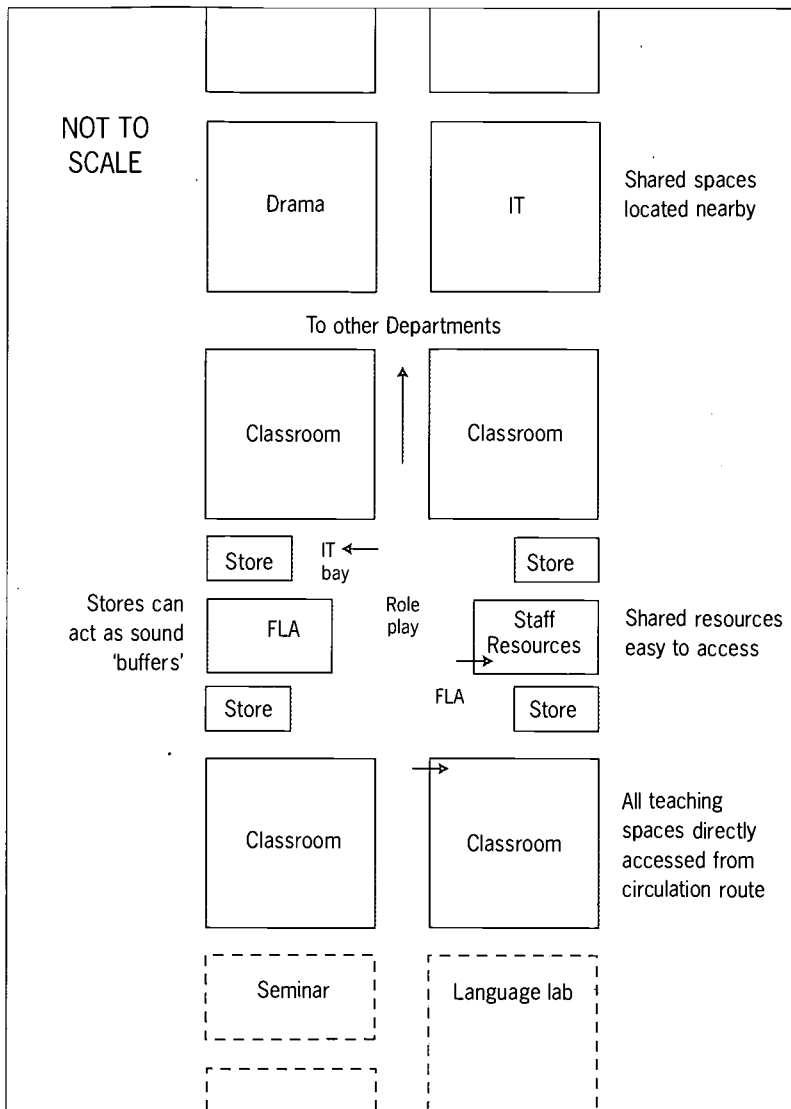

**Figure 1/10**  
Diagrammatic plan of MFL suite showing planning issues to be considered.

1.33 Corridors can act as vital display areas stimulating interest in foreign cultures and encouraging the use of the language studied.<sup>6</sup> Signs in the relevant language can provide a distinctive environment. The circulation area can even be used as role play space (see paragraph 2.23). It may also accommodate a small foyer or reception area for use by outside bodies and businesses if the suite is designed for non-school use (see paragraph 1.37).

**Note**  
<sup>6</sup> Reference should be made to part B2 of the Building Regulations where display occurs along a means of escape route.

## Planning the Suite

1.34 Most secondary schools organise their teaching spaces into departments or faculties. Locating MFL accommodation together on the same floor may be more economical in terms of staff time and may result in a more efficient use of resource areas and storage space. The identity of the suite can be reinforced through displays in the target language and colour co-ordinated finishes and furnishings. The choice of location and other planning issues to be considered when planning a MFL suite include those listed below (see also Figure 1/10).

- Position the suite so that related spaces such as a shared ICT room or drama facility are located nearby.
- Any resources shared with other departments (for example, a school may decide to teach business studies through a foreign language) should be readily accessible.
- Resources shared within the suite (e.g. an ICT cluster) should be easily accessed.
- The suite should ideally be located away from noisy areas (see paragraph 1.35).
- Stores and other such spaces can be used as sound 'buffers' between teaching spaces (but using stairs, plant or toilets as a buffer will reduce the subsequent adaptability of the building).
- The security of expensive equipment can be improved by keeping high concentrations of ICT or audio equipment on upper floors and in spaces that cannot easily be accessed from an adjacent flat roof.
- South facing ICT rooms are best avoided in case of excessive heat gain (see paragraph 3.23).

## Servicing and Environmental Design

1.35 All teaching spaces should be designed to provide an appropriate internal environment.<sup>7</sup> In the teaching of languages, particular attention will need to be given to the acoustic qualities of the spaces provided to ensure attentive listening and understanding. The quality of sound in a classroom is governed by both the insulation from background noise outside the room and the characteristics of the room itself (volume, shape and, most particularly, its surfaces). Acoustic requirements will therefore have to be borne in mind when designing the building fabric (e.g. windows and internal partitions), when planning the suite (see paragraph 1.34 above) and when specifying finishes. The acoustic design of individual teaching spaces is discussed in paragraph 2.26.

1.36 The servicing needs of MFL are similar to other general teaching spaces but particular attention should be given to the requirements of ICT and audio equipment. It is worthwhile designing the system to give some flexibility and to allow for future change. The servicing needs of individual spaces are covered in paragraph 2.24. The networking of computers is discussed in paragraph 3.31.

## Community Use

1.36 The use of MFL facilities by the local adult or business community, partner schools or other outside organisations (for instance in a Language College), will raise issues which will need to be addressed especially if this use takes place outside the normal school day. Creating a sense of identity to a suite of language facilities is important not just within the school context but also when marketing the resource to outside community, business or other users (Figure 1/11). The main issues to be considered are summarised below but more detailed guidance can be found in 'Raising Standards: Opening Doors'.<sup>8</sup>

## Security and Access

1.38 Ideally the MFL facilities should be separated in such a way that they can be easily accessed without compromising the security of the rest of the school complex. In a new stand-alone block this is usually easy to achieve but if the department is part of a larger building it may be more difficult. The aim, however, should always be to minimise access to other parts of the school whilst ensuring that all necessary provisions for the means of escape in case of fire are maintained at all times. Equipment and resources that are to be used by other groups during an extended day, or used in other schools, should be security marked, logged in and out and kept in a secure store.

## Car Parking

1.39 Parking provisions will need to be assessed to ensure that it is suitably located from a security point of view and will cope with the additional demand arising from community use. In most situations the existing school car parking should suffice. In exceptional cases, depending on access arrangements and site layout, it may be necessary to make modifications or additions to the existing arrangements.



**Figure 1/11**

Creating a sense of identity is important when marketing MFL facilities.

### Notes

<sup>7</sup> See Guidelines for Environmental Design in Schools (BB87) DfEE, 1997.

<sup>8</sup> See Bibliography.

## Running Costs

1.40 The ability to monitor the costs of heating, lighting and power associated with community use is desirable. It may make economic sense to heat the facilities independently from the rest of the school through zone control. Provision for a separate meter may also need to be considered.

1.41 Other additional running costs may include those for insurance, caretaking and cleaning. All recurrent costs incurred in making the facilities available outside school hours should be covered by the income from community and other uses if lettings are to be cost effective. These costs should be considered carefully within a business plan before including extra items specifically for community use such as car parking, kitchenettes or reception areas.

## Considering the Whole School

1.42 The design of MFL accommodation should not be considered in isolation from the rest of the school (see example in Figure 1/12). After initial identification of area needs, the gross area of the whole school should be checked against Building Bulletin 82: 'Area Guidelines for Schools'(see Bibliography). A certain amount of overlap between subject departments may have to be accepted. In an existing school, planned changes should form part of the school development plan<sup>9</sup> for the whole school site. This will ensure that maintenance and capital development work can be linked and that all areas of the school are considered.

**Note**

<sup>9</sup> Schools are required to prepare a School Development Plan.



When Queen Mary's High School in Walsall became a Language College, the MFL department required further accommodation. The school initially proposed to accommodate the additional classrooms on the floor below the existing teaching spaces, involving major adaptations to existing structural walls. However, this left existing, unsuitable MFL rooms and the department still not located together. Shortcomings in other subjects such as art and science were not addressed.

The final design rationalised languages, science and art into distinct areas by incorporating another project for science. The MFL department - adapted from existing good sized rooms - comprises five classrooms and a language laboratory. Although the solution initially appeared more disruptive than the original one, the advantages gained include:

- the language suite is on one floor;
- the corridor spinal link acts as a resource area;
- the art classrooms are larger and contain an area for display;
- the science suite is located mainly in one block rather than three separate buildings.

**Figure 1/12**  
 Queen Mary's High School, a  
 MFL adaptation considering the  
 whole school.

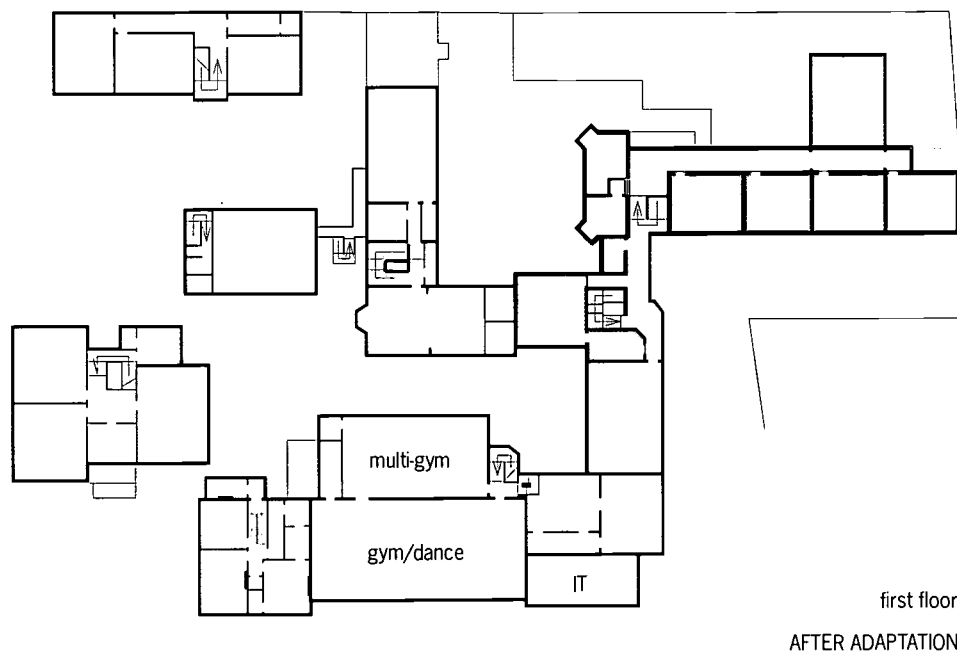

# Section 2: Individual Spaces

This section discusses the factors that need to be considered for each of the spaces in the modern foreign languages (MFL) department, expanding on the information given in Section 1. These spaces fall into three main categories: timetabled classrooms, partially or untimetabled teaching areas and non-teaching support spaces.

2.1 It is important to plan the furniture and equipment (F&E) layouts of each space at an early stage in the design process in order to check the viability of the room size and to help in F&E ordering. This section suggests a way of going about this and shows examples of furnished plans. Guidance on the furniture and equipment itself can be found in Section 3.

2.2 The shape of all teaching spaces should allow pupils to see the whiteboard and overhead projector (OHP) screen clearly, and to see and hear the teacher and any audio-visual aids such as a TV. The possible range of furniture layouts and teaching activities should not be restricted by the shape of the room. The most successful shape is usually rectangular and in the proportion range 1:1 to 4:5. This enables good supervision of pupils and allows for flexibility in furniture layouts if the area is appropriate for the group size (see Figure 1/9).

## Timetabled Spaces

### Classroom Size

2.3 Section 2 suggests an area range from the **upper half of zone A** (i.e. around 50 - 54m<sup>2</sup> for 30 pupils) for a typical MFL classroom. An area from the middle of zone A will allow a number of activities (see paragraph 1.1) to take place in the classroom itself with space for some portable audio equipment, a TV/video and bookshelves for readers and dictionaries. If fixed information and communications technology (ICT) or audio equipment is to be used in the classroom in addition to the above, further area will be needed. A small

amount of fixed equipment can be accommodated in an area from the top of zone A but anything more extensive will require an area from the **bottom half of zone B**. The school's decision on the location of equipment is therefore significant, whether it be:

- a little in each classroom;
- all in a specialist space, such as a language laboratory (see paragraph 2.14);
- some in larger classrooms and none in others, with the opportunity to swap or timetable such that all groups have access to both types of room;
- a variation of any or all of the above.

2.4 The recommended range does not allow for all the local storage (see paragraph 1.28) to be provided by furniture in the classroom. If such an option is chosen, the area will need to increase. Figures 2/2 to 2/4 show classrooms in the upper half of zone A. Examples of classrooms in zone B can be seen in the case studies.

## Classroom Planning

2.5 It is likely that all classrooms will need to accommodate a variety of activities. The furniture and equipment layout should relate to the teaching methods used while being flexible enough to be changed when required. Teachers should be able to move smoothly from one activity to another within a lesson and pupils should have the opportunity to practise and develop their skills.

2.6 The classroom plans shown in this section are based on the following criteria which can be used as a guide to ensure the space can be effectively and safely used. Each space accommodates up to 30 pupils.

- Each pupil has a work surface sufficiently large for equipment and text books, particularly where computers or fixed audio equipment are used (see paragraph 3.4).

- All pupils are able to see and hear the teacher clearly.
- Pupils can face the teacher and the white board or OHP screen whenever necessary.
- There is space for a TV/video at the front of the class, if required.
- Computer monitors, television screens and wall mounted white boards are positioned at right angles to window walls to reduce reflections and avoid daylight glare both of which reduce visibility.<sup>1</sup>
- Coat hooks are positioned close to the room entrance.
- There is enough suitable display space.
- Local storage is provided for items such as tape recorders and headsets.<sup>2</sup>
- Computer workstations, where provided, are located at the back of the room to maximise flexibility.
- The space between tables follows the recommendation of Figure 2/1 to ensure easy and safe circulation.

It is important to allow sufficient space for pupils and staff to work in comfort and to move around and between items of furniture safely and with reasonable ease. This is particularly important at the start and end of a lesson when around thirty pupils are likely to be making their way to or from their work places. More space will be required between tables and a wall than between one row of tables and another, and for longer rows or tables with back to back seating. The dimensions shown in Figure 2/1 can be used as a guide.

2.7 It should be possible to locate equipment requiring electrical or network connections in such a way as to avoid trailing leads constituting a trip hazard (see paragraph 2.24).

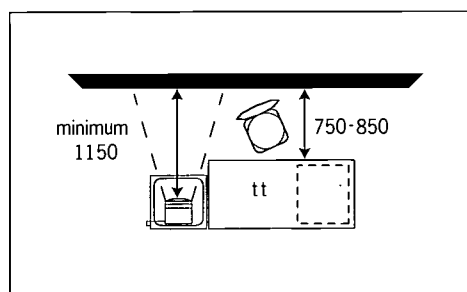
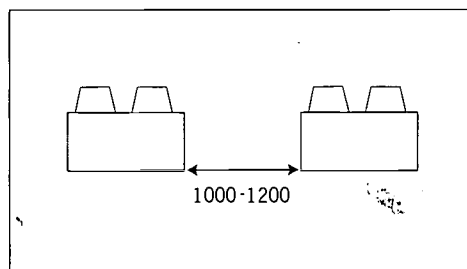
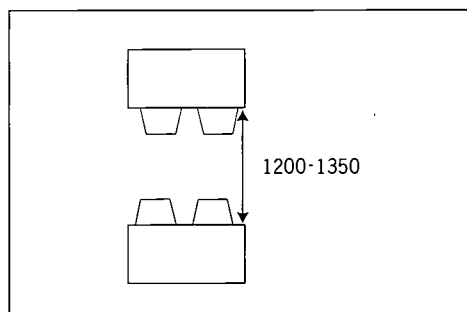
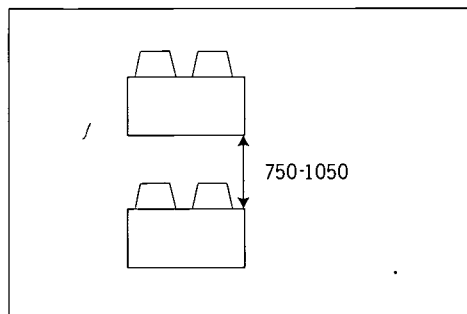
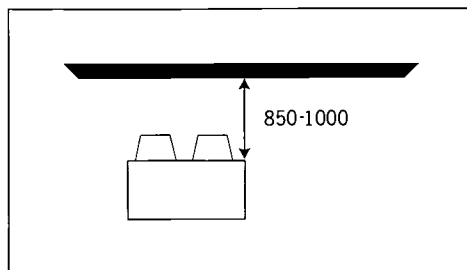

**Figure 2/1**  
Space between tables  
(dimensions shown in  
millimetres).

**Notes**

<sup>1</sup> A screen or board with a reflective surface may be difficult to view if it reflects a light source. A view of a bright window beyond a screen or whiteboard can cause discomfort as well as reducing visibility.

<sup>2</sup> In these plans, a walk in store is shown. Other options are discussed in paragraph 2.32.

## Section 2: Individual Spaces

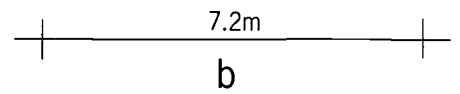
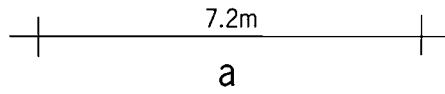

**Figure 2/2**

Rows of tables.

a: 51m<sup>2</sup> plan.

b: 54m<sup>2</sup> plan.

c: Typical view (opposite page).

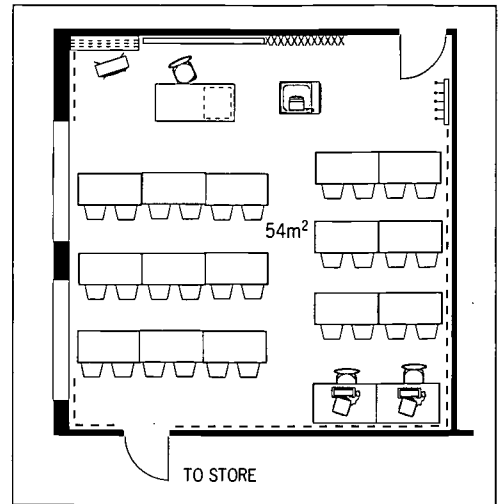
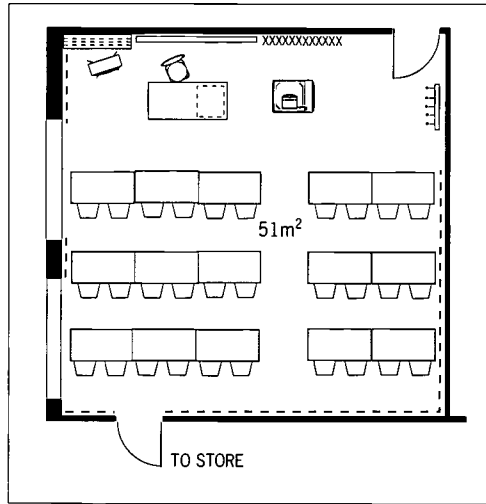

a

b

**Figure 2/3**

Horseshoe.

a: 51m<sup>2</sup> plan.

b: 54m<sup>2</sup> plan.

c: Typical view (opposite page).

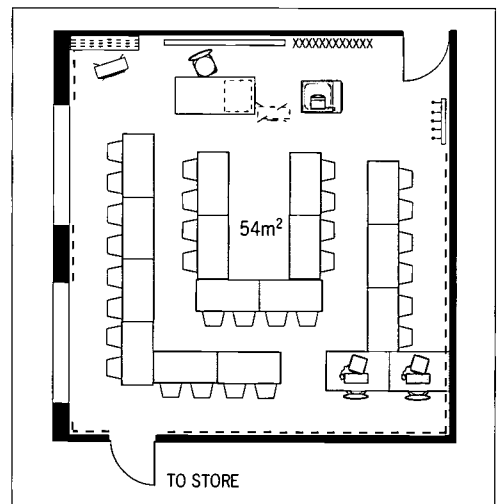
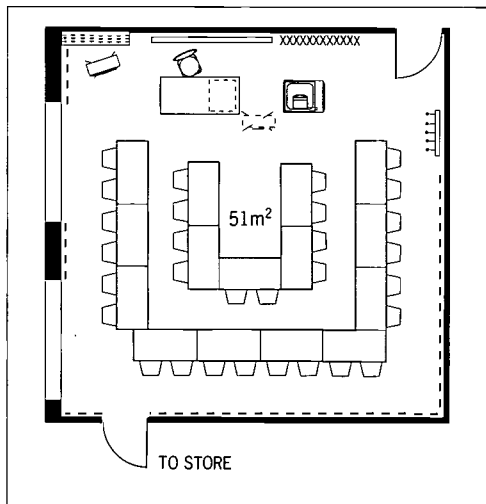

a

b

**Figure 2/4**

Cluster.

a: 51m<sup>2</sup> plan.

b: 54m<sup>2</sup> plan.

c: Typical view (opposite page).

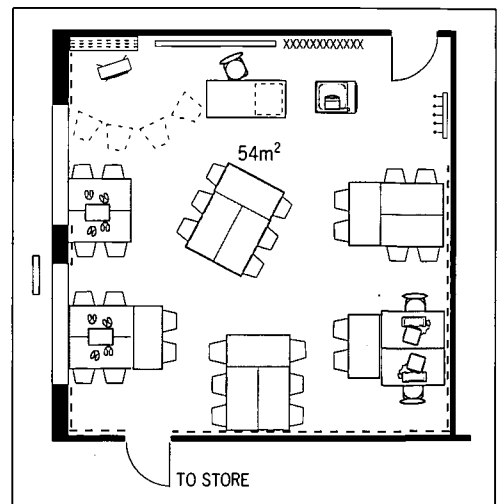
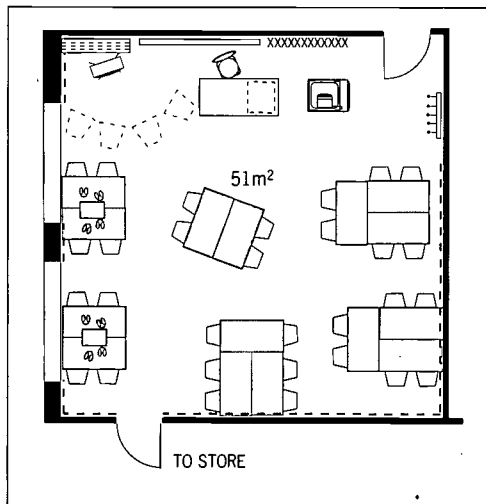



2.8 Figures 2/2 to 2/4 illustrate how a range of activities can be accommodated in a classroom. The plans (for up to 30 pupils) show two sizes of space: 51m<sup>2</sup> and 54m<sup>2</sup>. The larger space includes ICT at the back of the room. In both cases, all standard tables are 1200 x 600mm but in the 54m<sup>2</sup> room, there are two additional tables (1200 x 750mm) and chairs provided for using ICT or fixed audio equipment (see paragraph 3.4). The plans are described below. The photographs on this page show the 3 arrangements.

2.9 Rows of tables (Figures 2/2 a-c). This arrangement can be achieved in a variety of room dimensions. All pupils have a good view of the whiteboard and screen.

2.10 Horseshoe arrangement (Figures 2/3 a-c). This is favoured by many MFL teachers as it allows more pupils in the group to see each other during whole class oral work. The 7.2m room width (internal dimension) is key to the success of this layout, if reasonable distances between tables are to be achieved.

2.11 Cluster (Figures 2/4 a-c). This shows an arrangement for small group working. Activities include working with audio equipment (kept in the adjacent store), discussing in the MFL with books and resources to hand and using a TV and video. In the larger room there is also a group using the ICT equipment.

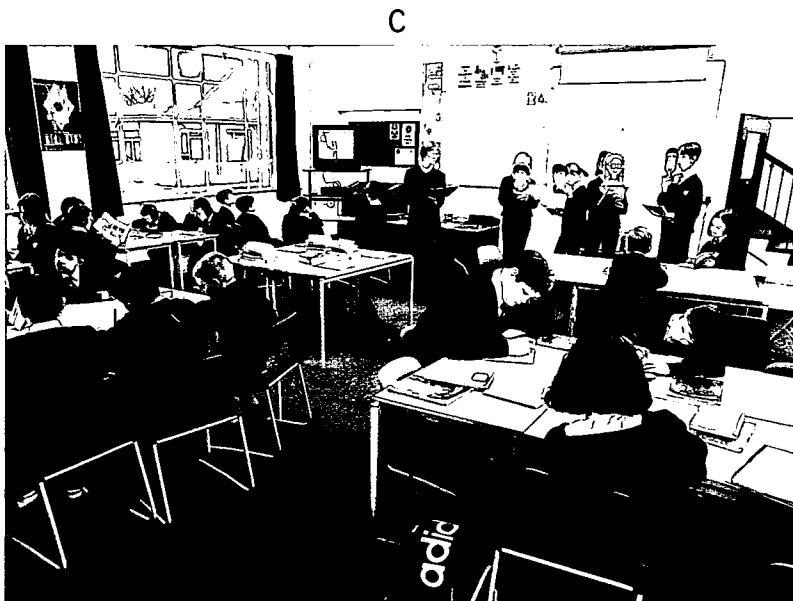
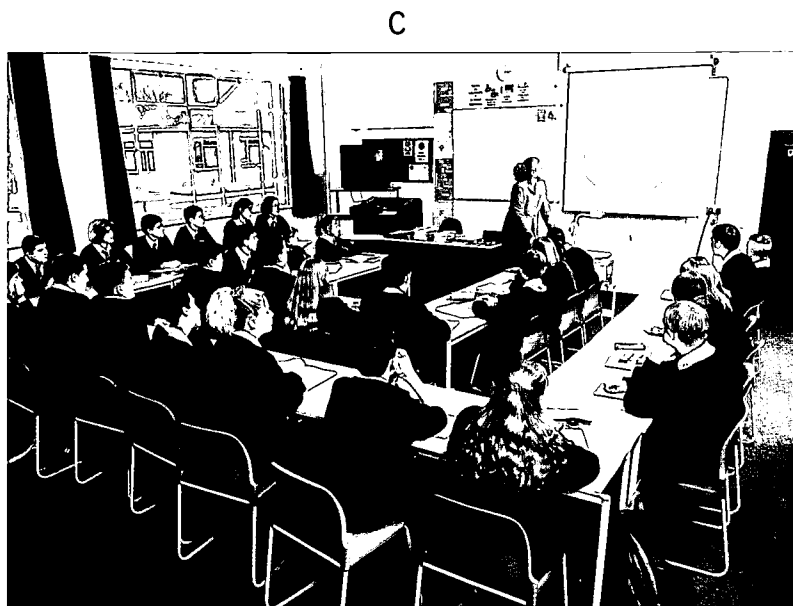
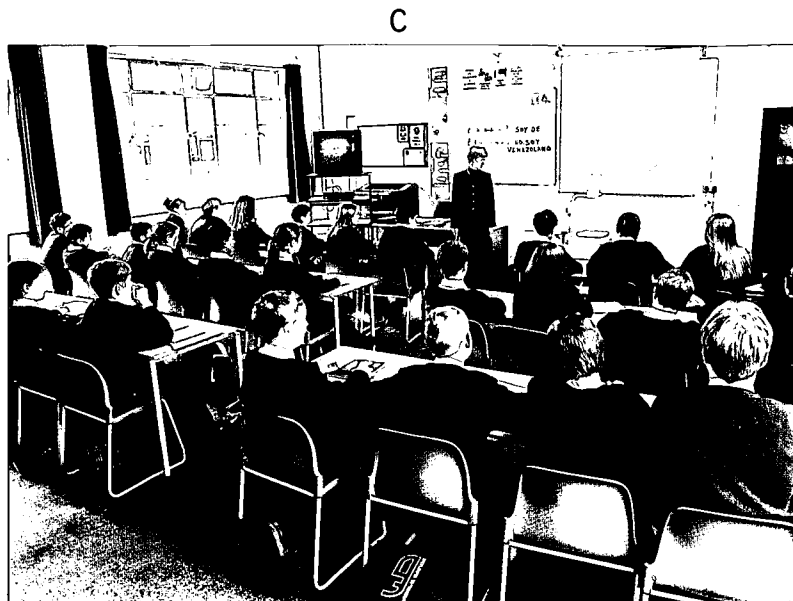



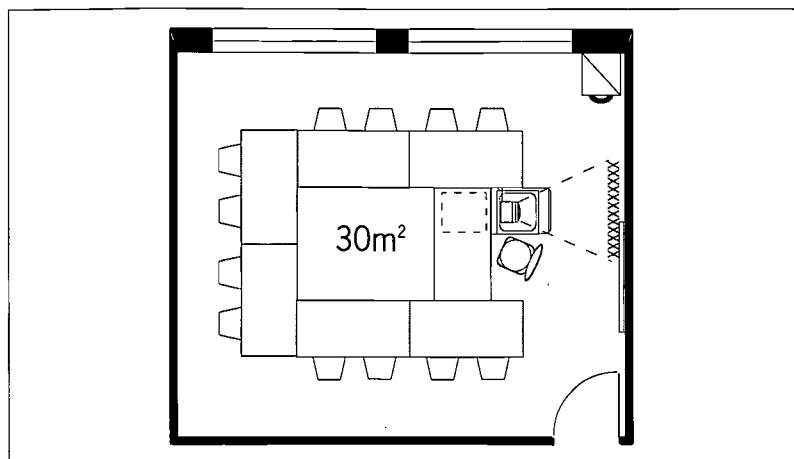

**Figure 2/5**  
Typical seminar room of 30m<sup>2</sup>, laid out with furniture for a sixth form group of twelve.

### Seminar Room

2.12 If the school has a sixth form or if small option groups are taught in KS4, one or two smaller classrooms for a group of up to about 16 may be usefully timetabled. Figure 2/5 shows a possible layout assuming predominant use by sixth formers (hence a larger 1500 x 750 table, see paragraph 3.4).

### Partially Timetabled and Untimetabled Areas

2.13 This category includes a variety of size and type of space. Some of the most typical are described here. Some of the smaller spaces can be used for more than one purpose in order to maximise their use; examples are given below. The more furniture and equipment there is in an area, the more specific its use and the less easily it

**Figure 2/6**  
Glazed screens allow views into an ICT cluster.



can be shared (for example an ICT cluster). In some cases teaching and non-teaching use can overlap. Sometimes one area can be divided into zones for different functions. For example, a staff base may be separated by screens from a resource area. In these cases, thought must be given to the possibility of one activity disturbing another.

### The Language Laboratory

2.14 Specialist language laboratories have been a feature of some secondary schools since the 1970s, with fixed tables and inset audio-recorders, linked to a central teacher's console (as described in paragraph 2.6). Many schools have since found the need for a language laboratory insufficient to justify the full-time use of a specialist room. The original format of the language laboratory, with rows of fixed tables and fixed screens between each workstation, was very difficult to use for other class activities. Some schools have opted for smaller systems in a number of classrooms, while others have introduced a more informal arrangement such that other activities can be undertaken in the room.

2.15 With the development of more sophisticated ICT, some MFL departments are choosing to accommodate audio, video and computer equipment in one room, similar to a language laboratory but in a more open environment. The options for ICT equipment are discussed in Section 2, but effectively comprise computers, audio systems and video systems (recorders and televisions) or a mixture of all three. The extent to which these are mixed in one room needs to be carefully considered. If both a computer and an audio or video system of tape deck and headphones is fitted at one workstation, it can be used effectively for some of the time. However, it is more often the case that only one of the available media is used, while the other remains under-used and unusable by others because of its location.

2.16 If shared ICT rooms are available nearby for timetabled and bookable use by the whole school, computers in the language laboratory are unlikely to be warranted in any great quantity and an audio-visual system only can be used. This is particularly true if computers are based in MFL classrooms or clusters in the suite. The following points are worth considering when planning a language laboratory:

- if there are enough flat topped tables the space can also be used as a classroom;
- it is useful if at least a majority of the class can see the video or whiteboard screen without discomfort;
- if individual pupils from other groups are to use equipment in the room, they must be able to do so without disturbing the main class group.

2.17 Figure 2/7 shows a language laboratory of 73m<sup>2</sup> which provides a combination of teaching methods for individuals, groups and whole classes (up to 32 pupils). It is also used by local primary school pupils. Four workstations at the back of the room are not connected to the master console. The position of the door allows pupils from other classes or sixth formers to reach this equipment (if it is available) without disturbing the main lesson.

2.18 The size of a language laboratory will depend on the quantity and type of equipment provided but an area range from the **middle of zone B** to the **middle of zone C** is likely.

## ICT Cluster

2.19 A suitable area may be designed into the suite to accommodate a small number of computers. The space should be visually linked to adjacent teaching spaces to allow partial supervision (Figure 2/6), but pupils from nearby classes would generally use the area individually or in small groups without teacher support. This has the advantage that all the computers are easily accessible and can be used at all times. The space can be linked to a local information resource area (also paragraph 2.21).

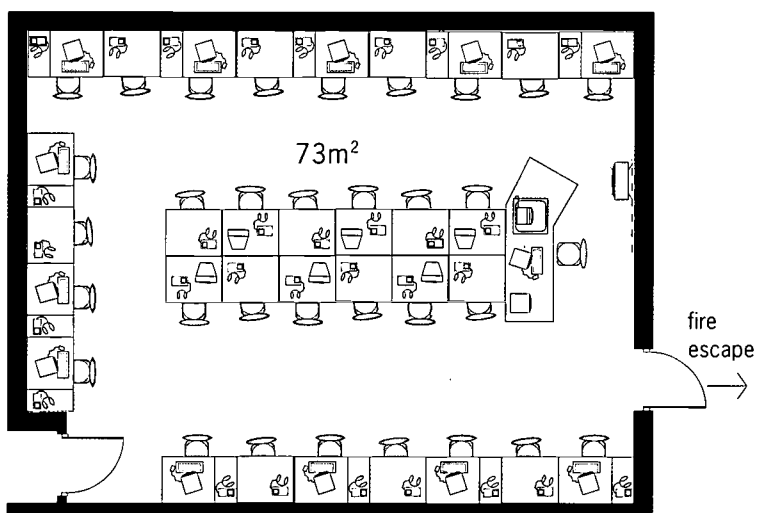

The following equipment is included in the language laboratory:

- cassette recorders at all 32 workplaces with microphone headset linked to a master console;
- 6 video/TV units in the central island linked to teachers console;
- 12 multi-media computers at perimeter tables linked into school network (access to CD-ROM, video and satellite).

A video recorder and large screen television at the teacher's end of the room allow all pupils to speak and listen to audio tapes related to action seen and heard on the video.

**Figure 2/7**  
Language laboratory at Queen Mary's Language College, Walsall.

**Figure 2/8**

Typical small group room.  
**a:** furniture layout  
**b:** conversation with a foreign language assistant

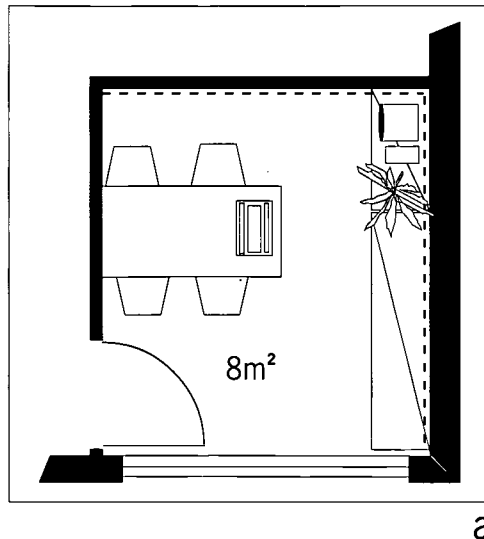

### Small Group Room

2.20 A small room or discrete area for about 4-6 pupils can be effectively used by foreign language assistants (FLAs) for individual conversations or small group teaching. If this becomes a room specifically for this one task, however, it may become under-used unless it has other uses. In an 11-18 school, it may be used for teaching very small sixth form groups. When not timetabled, it may also double as a local resource area (paragraph 2.21) or sixth form study area. If it is acoustically separate from other areas, it can be used for oral examinations. Figure 2/8 shows a typical layout of a space of 7.5m<sup>2</sup> for up to four pupils and a FLA.

### Role Play Area

2.23 Although role play and simulations can take place in a MFL classroom or a shared drama space, some schools have an area in the language suite which conveys something of the atmosphere of the country being studied through display, artefacts and 'scenery'. Places such as a 'street' of shops, a pavement café or a travel agent's booth can provide a more realistic environment for role playing than a classroom. The language of the signs can be changed to suit the country concerned. Because such an area will not be highly utilised even if it is shared or used by the community, businesses or other schools, it will not warrant a dedicated space. It may therefore be set in a wide corridor (see Figure 2/10), or in a room used for other activities, such as a social area (see Figure 2/11), or it might 'double' as a space for small groups and FLAs. As discussed in Section 1, other specialist spaces can be

### Local Resource Area

2.21 A local resource area for easy access by pupils can act as a focus for the department housing books, artefacts and other materials which are not needed often enough to require replication in each teaching space. It may serve as a reading area as well as being used by FLAs.

2.22 If it is only used by the MFL department, a resource area is best placed centrally to the suite, particularly if it contains central storage or shared equipment such as a photocopier. If shared with other subjects, it may be part of the whole school's central library resource facility. Figure 2/9 shows a typical resource area.

**Figure 2/9**

Local resource area.

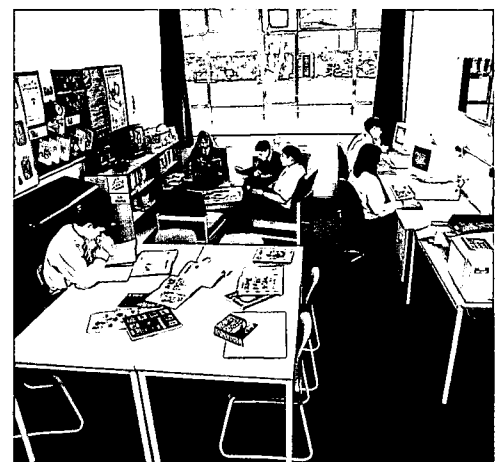



**Figure 2/10**  
Role play area at Standish  
Language College, Wigan.

A wide central spine flanked by classrooms and resource areas links the languages suite to drama and forms an economical circulation route. It also acts as an authentic street scene for role play through the use of small shops, bank and passport control and as a social area for the school. Where the corridor widens further a 'street side' cafe is set out next to a small kitchen area. The 'street' is a bookable space available to both Standish pupils and other local schools. The café area will accommodate 6 to 10 pupils and other 'commercial' outlets along the 'street' groups of 2 or 4. Teachers can observe independent work groups from the classroom, through glazed screens. This department is described further in Section 5.

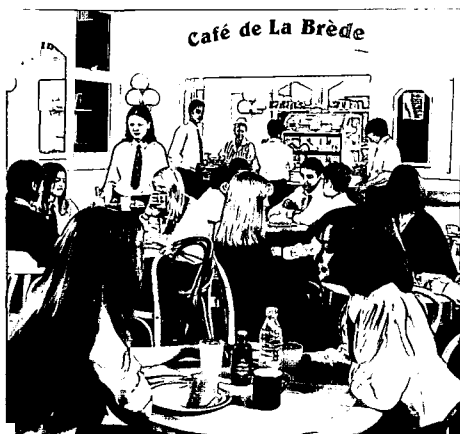

An existing social area was used to create the 'Café de la Brède' which conveys something of the atmosphere of the country through display, artefacts and 'scenery'. The café looks out onto an external courtyard which can be used as an extension of the café during suitable weather. The space continues to act as a social base for the school as well as being used by the nearby drama department, thus ensuring reasonable utilisation (see paragraph 1.15).

**Figure 2/11**  
Role play area at Kettlethorpe  
School, Wakefield.

used occasionally for role playing. Useful settings could include a business studies room which has an office style layout or even the school canteen.

### Servicing Teaching Spaces

2.24 All MFL teaching spaces should be adequately serviced to facilitate the use of relevant equipment, whether portable or fixed. The location of outlets should be co-ordinated with the room plan, taking into account the desirability of being able to move furniture and equipment to suit different activities. The following summarises the main requirements.

- It is important to provide sufficient service outlets at the teaching wall for equipment used for whole class teaching such as a television or OHP.
- A number of socket outlets may be needed for portable equipment. These can be distributed around the perimeter as position is usually not critical.
- Where portable equipment is connected to an outlet, measures should be taken to avoid trailing leads becoming a tripping hazard.
- Where future flexibility is required, a trunking system on two or three walls will allow electrical outlets to be repositioned or added where necessary. Separate compartments can be used for computer cabling or other wiring.

2.25 Large quantities of fixed equipment (such as in a language laboratory) can either be serviced from the perimeter with cables passing through specialist tables (see paragraph 3.5) or from the floor. Perimeter servicing is generally more suitable for existing rooms.

### Environmental Design of Teaching Spaces

2.26 A good acoustic environment is essential when learning a MFL. Acoustic characteristics in any room can be optimised through its volume and shape, as well as the sound absorption of furniture and the occupants. In existing classrooms, changing

the surface finishes can be the most effective means of altering the acoustic properties of the room. In rooms with low acoustic absorption and long reverberation times, sound quality tends to be poor. Classrooms can benefit particularly from having absorbent material on the floor and perhaps the rear wall, while the ceiling area and the wall behind the teacher can be acoustically reflective to allow the teacher's voice to be reflected to all the pupils. Hard, smooth finishes such as plaster on blockwork are highly reflective while carpet, acoustic ceiling tiles and soft pin-board can provide absorbency.

2.27 Appropriate lighting conditions are needed so that visuals, essential in MFL to underpin the use of the target language, can be seen clearly. Window blinds are useful for dimming the room when using the OHP or the electronic whiteboard, they also reduce glare and reflection on computer screens (see also paragraph 2.6 on positioning equipment). Where a number of computers are used, light fittings that are designed for use with computers (i.e. to reduce screen reflections and glare) should be considered.

### Non-Teaching Support Spaces

2.28 The provision of non-teaching support spaces will vary between schools but the following areas need to be considered.

#### Staff Base

2.29 A space where staff can prepare and store work securely and hold meetings is useful. A staff base can also be a central point for file servers, video recorders and a satellite TV receiver, which might then connect to computers and TV screens in the classrooms. It can also include an area to prepare audio or visual work using the appropriate equipment. Items often used by a number of language staff, such as a photocopier or fax, may be best situated here. The room may also be used by a FLA for small group work. Access for pupils will



need to be considered if they are to use any of the equipment, or if the room might occasionally be used for oral examinations. Figure 2/12 shows a typical departmental staff base of 22m<sup>2</sup>.

## Technician's Base

2.30 A space is usually needed for a technician to support or maintain ICT and other equipment associated with the language suite. The need will depend on the school's policy for networking and ICT support around the school generally but if such an area is required, it should ideally be located so that the technician can also easily supervise the main ICT area. It can also provide an alternative location to the staff base for housing centrally controlled equipment such as file servers.

## Teaching Storage

2.31 Teaching storage will be needed for items such as books, maps and brochures as well as portable tape recorders and other equipment. Paragraph 1.28 refers to two kinds of storage: central and local. Central storage is useful for valuable equipment, confidential paperwork and the department's long term stationery needs. Local storage includes items such as dictionaries, reference books and maps used for independent or small group study as well as tape recorders used for listening and speaking work in groups.

2.32 Central storage should be equally accessible to all MFL staff and can be in walk-in stores opening off the corridor or in cupboards in the staff base. Local storage can be either in a walk-in store (usually) opening off the classroom or in furniture in the room itself. Walk-in stores have the advantage that they can be locked and can house large items such as TVs or equipment trolleys. Storage furniture is not easily moveable and this can restrict the options for classroom layouts. If storage is provided in the classroom itself, the size of the room will have to increase to allow for this. Storage cupboards are discussed further in

agraph 3.8.

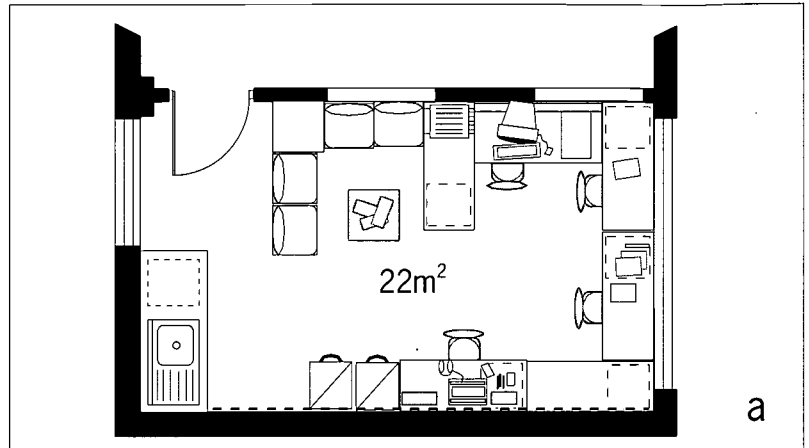

2.33 Store rooms should be designed to maximise the ratio of storage volume to floor area. In a small store in particular this may mean having an outward opening door but care should be taken to avoid the door opening into a circulation area. Long stores with continuous doors, in a 'wardrobe' style should generally be avoided as the area required for door opening can be wasteful and obstructive.

**Figures 2/12 a&b**

Staff resource area for between 4 and 8 staff. It is used for lesson preparation (including editing), meetings, making refreshments and storage. Informal seating can be used by a foreign language assistant and 1 or 2 pupils,



**Figure 2/13**

Technician at work.

# Section 3: Furniture and Equipment

This section describes the range of furniture and equipment (F&E) generally associated with modern foreign languages (MFL) learning and gives guidance on how to make the best use of it. Computer equipment is covered in particular detail.

3.1 A co-ordinated range of furniture and equipment - with matching dimensions, finishes and colours - gives flexibility because furniture and equipment can be used within and between rooms without restricting its use. All furniture and equipment should adhere to current British Standards.<sup>1</sup>

3.2 Furniture and equipment within the classroom should be portable, to allow it to be re-arranged for activities which are likely to include carousel work, language games and drama. Heavier or serviced furniture and equipment (F&E) should preferably be able to be moved without damaging the building fabric, so that layouts can be adapted to respond to changes in staff and in teaching methods. The use of portable audio equipment on loose tables rather than integral units on fixed tables is one way of allowing for future change. This principle is relevant to even the smallest project in any area of the school.

## Furniture

### Tables and Chairs

3.3 The size and design of furniture should always help users (adults and pupils) to adopt a correct posture for the task being carried out. This is particularly important where long periods can be spent in one position, as for example in using a computer or other information and communications technology (ICT) equipment (Figure 3/1). Tables must provide adequate clearance for the movement of pupils' thighs, knees, lower legs and feet. The work surface and front rails should have a thickness no more than 75mm in total to enable thigh clearance.

3.4 Basic movable tables allow for a range of activities. The classroom plans in

Section 2 show standard tables (1200 x 600mm for two people) in a variety of arrangements. This is suitable for rooms used by all age groups but if a space is predominantly used by sixth form students, wider tables of 1500mm will be more suited to their size. If audio visual (AV) and ICT equipment is to be used then a larger table is needed. The work surface should allow for the flexible arrangement of ICT equipment and be sufficiently deep (at least 750mm) to allow the keyboard to sit in front of the screen and for pupils to sit with their heads at least 600mm away from it. A 1500mm x 750mm table will allow two people to share one set of equipment. A sitting height of about 700mm is recommended.

3.5 Specialist tables, available with various designs of metal under-frame, are for use with computers and other serviced equipment. Some of these designs incorporate a cable tray for wire management which can be used to organise and tidy network and power cables as well as providing a means of routing cables from a wall outlet to one table via another. Tables with very glossy surfaces should be avoided as they can cause discomfort by reflecting light sources into pupils' eyes. They can also reflect light onto a computer screen reducing its visibility.

3.6 The use of adjustable chairs allows individual pupils to sit at the correct height in relation to the screen (i.e. the eye line should coincide with the top of the screen). These chairs also help to ensure that correct posture is achieved for a wide age range of pupils using ICT equipment.



#### Note

<sup>1</sup> The main British Standard is BS 5873: Educational Furniture, BSI 1988. For information on this and other issues to be considered when purchasing furniture and equipment, see 'F&E Purchasing; a Guide for Governors and Head Teachers', DfEE, 2000.

#### Figure 3/1

Furniture should be designed to allow adults and pupils to adopt a correct posture.

## Storage and Display

3.7 The school should have a clear policy with regard to the storage of coats and bags. This is especially important where access to the classroom is directly from outside. If coat hooks or coat and bag racks are provided in the classroom, they should be positioned next to the classroom door.

3.8 Sets of dictionaries and other reference materials, including newspapers, magazines, books and films will need to be stored. The options for storage are discussed in Section 2. If local storage is to be provided by cupboards, they can be below worktop height with shelving above or full height. The former arrangement provides a useful additional work and display surface but the latter provides a higher ratio of volume to floor area. Full height cupboards in particular are difficult to move, which can restrict furniture layout options.

3.9 Displays of posters and pupils' work are useful in classrooms and circulation areas to create a background or context to learning about the culture of the country. Pupils' foreign travel (schools trips or work experience) is often the subject of display in the MFL suite or elsewhere in the school. In busy circulation areas it is worthwhile considering some protection to the material such as placing it behind glass.<sup>2</sup> Portable divider screens can be used for display purposes in open plan areas. Screens can also be used to create discrete areas within a space, offering flexibility and providing some acoustic insulation. Figure 3/2 shows screens in a shared area used for staff, resources and small teaching groups (as in paragraph 2.29). Screens which have protruding 'feet' that can be a tripping hazard should be avoided.

## Equipment

3.10 In common with many teaching spaces, there is a whiteboard, screen and overhead projector (OHP) in every MFL classroom (Figure 3/3). Both the OHP screen and the whiteboard should be set



**Figure 3/2**

Portable divider screens create discrete areas for small groups within a larger space.

up so that they are on the eye-line of all pupils. To achieve this, the screen can be set up at an angle and/or pulled down around half way across the width of a whiteboard (see Figure 2/2). The specialised equipment that is more specific to MFL teaching is described below.

## Audio Recording Facilities

3.11 Equipment such as recorders and tape decks are commonly used in the teaching of foreign languages to allow pupils to listen to spoken languages and to record and play-back their own voices. They are available in three basic forms:

- desktop recorders;
- audio systems;
- multi-media equipment.

## Desktop Recorders

3.12 Small, mobile cassette tape decks allow pupils to listen to pre-recorded tapes and work with them. Multiple headset outlets allow up to five pupils to listen at the same time. They are easily stored and

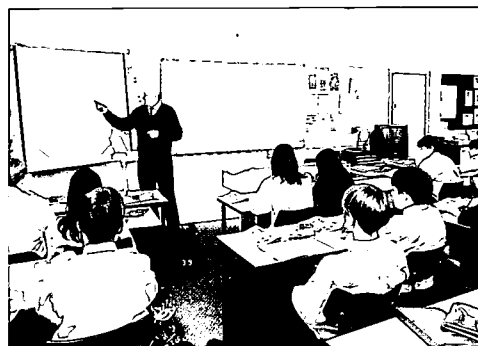

**Figure 3/3**

Typical classroom equipment.

### Note

<sup>2</sup> Refer to Part B of the Building Regulations where display is used along a means of escape route.



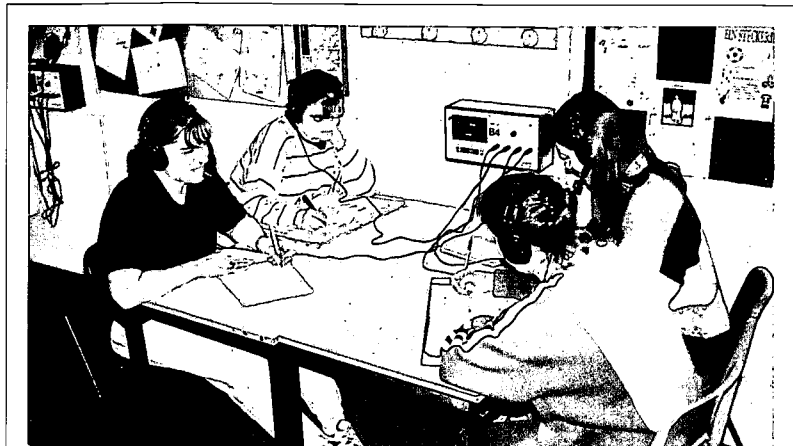

As the system can be used with loose tables, furniture can be more easily re-arranged for changing activities (role play, pupil presentations etc.) The head of MFL feels this type of teaching system is particularly suitable for mixed ability groups. Up to four pupils of similar ability can learn independently or as a group at one of the units. The teacher can discreetly monitor oral skills and progress through the console.

**Figure 3/4**

Wall mounted perimeter audio system at Bullers Wood School, Kent.

**Figure 3/5**

Fixed audio system built into tables.



**Figure 3/6**

Powerful multi-media computers with interactive software can be effective for pupils learning independently.



can be used on any work surface. Some types will need to be connected to a nearby power socket, while others are battery operated.

### Audio Systems

3.13 A range of equipment is available which incorporates either wall mounted equipment (Figure 3/4) or specialist tables with inset recording machines (Figure 3/5). Linking to a control console allows a teacher or assistant to talk to pupils through headsets or to 'listen in' to their self-recorded speech.

3.14 Tables housing serviced equipment may be purchased individually or purpose made by equipment suppliers. Groups of these tables have to be fixed together and (if they are serviced from the perimeter) to the wall, to avoid cables being pulled out of position. As they are unlikely to be moved frequently, their position in a room should be carefully considered to minimise inflexibility of the room layout.

### Multi-media Equipment

3.15 Some language laboratory systems use audio or video tape recording and computer technology together to enhance the facility (Figure 3/6). Although the two systems may be housed together on one workstation, they tend to remain separate. Small clusters of multi-media computer hardware may be used more effectively (see paragraph 3.21).

3.16 The latest high powered multi-media computer systems can digitally record and playback sound and offer interactive video on disc, with no need for tapes. This involves high memory machines with audio facilities and can include a camera fixed above the screen to allow video-conferencing and video recording. This kind of hardware is ideal for individual or small group learning, in other subjects as well as languages. However, as control and monitoring through a central console is not possible without costly additions, it may be less appropriate for larger groups.

## Computers

3.17 A range of activities required by MFL will need access to computers. Generally, these remain relatively large units possibly requiring connection to a network. Their position can therefore be fairly permanent and needs to be considered carefully.<sup>3</sup> Laptop computers offer flexibility, particularly if they are not networked (or can use a wireless connection) but they will require secure storage. Wherever laptops are stored, there needs to be a power supply for recharging (this needs to be done less frequently than it once did).

### Where Should Computers Be Positioned?

3.18 One or two computers can be used in the classroom as a learning tool during carousel work or for individual research work. Similar use can be made of a small cluster of five or six computers situated in a shared area between classrooms. A central ICT room which will take a full class is equally useful for concurrent individual or group work.

3.19 Ideally, depending on the working practices of the school and the size and type of accommodation, there should be access both to a nearby ICT room for whole class groups and either one or two computers in classrooms or a shared ICT cluster between classes. This arrangement allows a flexibility of approach such that, for instance, pair work started in the computer room can be added to in the classroom or cluster and vice-versa.

3.20 Where there is considerable funding available, a language laboratory may be considered which uses multimedia computers with consoles to monitor pupil performance in all four National Curriculum skills (see paragraph 2.14 for a description of this type of space).

3.21 Wherever computers are located they should be used as efficiently as possible. If they are installed in a language laboratory, the same

workstation may be used for audio work for most of the time while the computer is underused. In a classroom, they may stand idle for much of the time while whole class teaching takes place. Clusters of computers in shared areas can be used more efficiently because unused computers are always accessible. Computer clusters can have additional advantages including:

- the group using computers can vary in size;
- existing small classrooms need not be made larger to accommodate ICT equipment;
- a position can be established for printers, a phone connection or Internet link (see paragraph 3.30);
- older pupils may help younger pupils and a technician can easily access the equipment.

3.22 Supervision may be seen as a problem, but glazing in the partition walls can give partial supervision from adjacent teaching or staff areas.

3.23 As computers generate heat it is best to avoid locating large numbers of computers in rooms with large areas of (particularly south facing) glazing. If this is not possible, external shading devices can be used to control direct sunlight entering the room. Internal blinds can be used but they are less effective at preventing overheating and they restrict views of the outside which allow the eyes to rest.



**Figure 3/7**

Computer cluster situated in shared areas within MFL suite allows independent access by pupils.

#### Note

<sup>3</sup> Further advice and guidance on the accommodation implications of computers in schools is available in the Architects and Building (A&B) video and associated leaflet 'Making IT Fit', DfEE, 1995, see Bibliography.

3.24 Where the security of ICT equipment cannot be achieved through room location (see paragraph 1.34) other security measures (such as closed-circuit television, bars or shutters on windows, alarms or indelible marks on equipment) should be taken.<sup>4</sup>

3.25 Where and how computers are positioned in a room will make an impact on the activities that can be carried out. The most important consideration is the avoidance of problems due to glare and reflections which are generally caused by the position of the computer monitor (see paragraph 2.6). Computers are best positioned at 90° to the window wall but where this is not possible window blinds will help. If a small number of computers are in a classroom, they should be located at the back of the room since they are less easy to move than other furniture when the room is re-arranged to suit a different activity. If they are to be used by others during a lesson, they should be positioned so that pupils can reach them easily and use them without disrupting the main class.

### Specifications

3.26 A wide range of computer software is available for pupils to communicate and handle information, including generic 'tool kit' programs such as word processing, databases, spreadsheets, desktop publishing and multi-media presentation software.

3.27 As well as having access to this software on hard disks or a network, computers used by the MFL department should aim to have sound cards to allow sound and text files to be created by both teachers and pupils, as well as software to support MFL including a minimum of one text manipulation program which should serve most languages.

3.28 CD-ROM drives should be accessible, either on individual machines or via a network. When choosing CD-ROMs, the hardware system and network they are to run on and their running requirements should be thoroughly checked prior to purchase.

3.29 If existing ICT rooms are shared with other subjects, good access for MFL pupils must be assured and equipment must be suited to MFL learning. An audit of existing equipment may point to some simple upgrades, such as installing:

- soundcards in machines without them;
- spellcheckers for target languages;
- a good text manipulation package if required;
- MFL software;
- relevant versions of word processing software to suit, for instance, any community languages that are taught;
- network access to the Internet or an intranet system.

### Networking

3.30 Computers may be networked, either locally or generally. General networking allows pupils to connect to whole school resources such as library-based CD-ROMs from anywhere in the school. The ability to have access to the computer network for one or two workstations in each class base can be a useful and economic way of introducing a degree of flexibility into the ICT arrangements. Other fixed and portable equipment may also be networked.

3.31 Where a school opts for a computer network this will usually be linked across the school via cables in underground channels or ceiling voids. Within rooms, the network cables will normally be run from computer to computer. Some form of cable management will be needed (see paragraph 3.5). A secure area, such as an ICT technician's room will be needed to house the network file server(s).

3.32 Wireless networking, using radio or microwaves is starting to be used in schools. This has the advantage that a portable computer can access the network from anywhere in the school but costs are currently high.

#### Note

<sup>4</sup> For further information on security in schools, see 'Improving School Security' (Managing School Facilities), DfEE 1996.

## Other Communications Equipment

3.33 A wide variety of facilities are available for audio, visual and hard-copy communication to a wider field. These may be particularly useful for language students, linking with other institutions both in this country and abroad.

3.34 Modern telephone systems offer e-mail links between computers as well as video-conferencing facilities. Access to the World Wide Web through the Internet will supply constantly updated material in target languages, from shopping catalogues and tourist information to school sites with authentic texts and foreign news services in target languages. Any major use of this facility will mean that an ISDN line needs to be installed to ensure satisfactory speeds for the downloading of information. The connection can be through a number of Internet Service Providers, and the latest information should be sought to ensure an efficient connection, preferably with filtered access to safeguard against access to undesirable sites. If there is to be a connection to the Internet in the department, an early decision needs to be made as to the number and position of the machines with access.

3.35 TV sets may also be used with video recorders, connected either directly or through cabling from a central

position. Small groups may use TV sets with headphones (see Figure 2/6) or a large screen may be used with a whole class group.

3.36 Satellite TV receivers allow programmes from around the world to be viewed directly or recorded and played back during lessons. There are a number of different types of satellite dish available as well as cable TV. Advice should be sought from a number of different specialist suppliers to ensure the needs of the school are met within the available budget.

## Electronic Whiteboards

3.37 An electronic whiteboard (see Figure 3/8) is used in conjunction with a computer to display a range of information whether in the form of text, illustrations or video. Special 'pens' allow teachers and pupils to add information to the screen as well as control the images.

3.38 The whiteboards can be fixed or mobile. If a fixed whiteboard is provided in one room (installing one in every classroom is likely to be expensive) pupils can be timetabled into the space. A mobile whiteboard can be moved to any classroom. Servicing the equipment (bearing in mind the possible hazard of trailing leads) must be considered carefully.



**Figure 3/8**  
An electronic whiteboard in use.

# Section 4: Running a Project

This section summarises the process of carrying out a capital project from the initial ideas stage to occupying the completed accommodation.<sup>1</sup> It concentrates on alterations to existing schools but most of the advice is also relevant to the setting up of a suite in a new school.

## Note

<sup>1</sup> 'A Guide for Governors: Developing School Buildings', RIBA, 2000, provides a more comprehensive guide to this process.

4.1 The process of any project will fall into two parts: **setting up and implementation**. The first stage will involve:

- agreeing the aims, funding and time-scale of the project;
- creating a project team (and appointing consultants if required);
- developing a brief.

Having agreed that it needs to go ahead and can be funded, the implementation of the project will then involve:

- scheme design and estimated costs;
- tendering and contracts;
- site operations;
- occupation and use of the facilities.

These stages are described in more detail below. Figure 4/1 shows how they relate to the Royal Institute of British Architects (RIBA) stages of work.

## Setting Up the Project

### Agreeing the Aims

4.2 The need for any work should be explored thoroughly at the start. The first step will be to analyse the current situation to find out whether the existing accommodation meets the requirements of the curriculum, the number of pupils

studying modern foreign languages and the teaching methods chosen. The guidance in this document will help in this process, the questions in the Introduction providing a useful checklist.

4.3 Whatever changes are agreed for the modern foreign languages (MFL) department, they should be looked at in the context of the School Development Plan and the Local Education Authority's (LEA's) Asset Management Plan (AMP) (see Glossary). Short-term improvements may turn out to be a false economy if the entire department is likely to be moved, for instance, in conjunction with other changes in the school. A condition survey and suitability assessment should be available on all the school's accommodation as part of the AMP.

## Establishing the Budget

4.4 Once sources of finance and funding have been established, a budget for the project can be prepared. Initially, it will establish the elements of the project, which might include:

- loose furniture and equipment;
- fixed specialist equipment such as built-in Information Communications and Technology (ICT) wiring and units;
- building works, if any, including fixtures and fittings;
- external works such as paths or car-parking, if necessary;
- a contingency allowance for unforeseen work, of around 5%;
- professional fees on the building work up to about 15%;<sup>2</sup>
- VAT if applicable.<sup>3</sup>

**Figure 4/1**  
Project stage titles used here compared to RIBA work stages.

Pre-Appointment	A Appraisal	B Strategic Brief	C Outline Proposal	D Detailed Proposals	E Final Proposals	F Production Information	G Tender Documentation	H Tender Action	I Mobilisation	J To practical Completion	K After practical Completion
<b>SETTING UP THE PROJECT</b> • Agreeing the Aims • Establishing the budget • Programming the work • Creating a project team • Developing a brief			<b>IMPLEMENTATION</b> • Scheme design and estimated costs			• Tendering and Contracts			• Site operations		• Occupation



The case studies in Section 5 include breakdowns of project costs.

4.5 If professional consultants have been appointed (see paragraph 4.12), they will be able to draw up more detailed estimates based on the designs or proposals agreed. The budget should be constantly monitored and kept under review.

## Programming the work

4.6 The overall programme for the project should be considered at an early stage. Completion dates may be governed by the need to have the accommodation brought into use to suit the requirements of the academic year and/or to spend grants by a certain date. Practical problems and additional costs can arise if a project overruns its programme (for example because alternative temporary accommodation has to be found).

## Creating a Project Team

4.7 If the project involves anything more complex than the renewal of some equipment, it will be important to have a project team including all those who will be affected by the new proposals. The following people are likely to be involved from the outset:

- the Head and perhaps governors;
- a project co-ordinator;
- MFL teaching staff.

Others joining the team, either initially or at a later stage could include:

- professional consultants;
- an LEA officer;
- a Diocesan (or relevant religious body) officer.

4.8 All members will need to be aware of how they fit into the overall team structure and understand the roles of the other personnel involved. The roles of the principle players are described below.

## Head and Governors

4.9 The head of the school and the governors will need to be involved, particularly at the early stages, to agree the requirements of the MFL department, in relation to the priorities of the School Development Plan, the budget and the programme of work.

## Project Co-ordinator

4.10 It is important that one person on the project team (who has enough time available) has overall responsibility for co-ordinating the project, on behalf of the school, to ensure that all the information required is available and disseminated on time to the relevant parties. A project co-ordinator should ensure that there are clear lines of responsibility and channels of communication from the outset.

## Teaching Staff

4.11 The staff of the MFL department will need to decide on the brief for the project and specify the items needed. They should continue to check that these needs are met, if agreed, by the solutions proposed. The head of department is likely to take on this responsibility, involving other staff as necessary. Teaching staff from other departments may also need to be involved and will wish to be informed of the progress of the project.

## Professional Consultants

4.12 Consultants may be appointed in the initial stages of the project, helping with analysis of the school's current accommodation, the early budget plans and brief preparation. Alternatively they can be appointed once an initial brief and a budget have been discussed. The decision as to whether to appoint building consultants will partly depend on the nature of the work.<sup>4</sup> Thus while consultants should be involved with a major refurbishment for some minor refurbishment projects it may be possible to rely on the advice of LEA and (where relevant) Diocesan officers or the

### Notes

<sup>2</sup> Fees vary depending on the type of project. The DfEE takes the view that fees should not generally exceed 15%, not including planning charges.

<sup>3</sup> VAT is payable on all building work except new detached buildings at schools with charitable status. However, local authorities can recover VAT payable on community and foundation schools. Advice should be sought from the local HM Customs and Excise office.

<sup>4</sup> Who makes the decision will depend on the arrangements that have been made between LEA/Diocese and client. See 'A Guide for School Governors: Developing School Buildings', RIBA, 2000.

Following the previous flow chart (Figure 1/1)

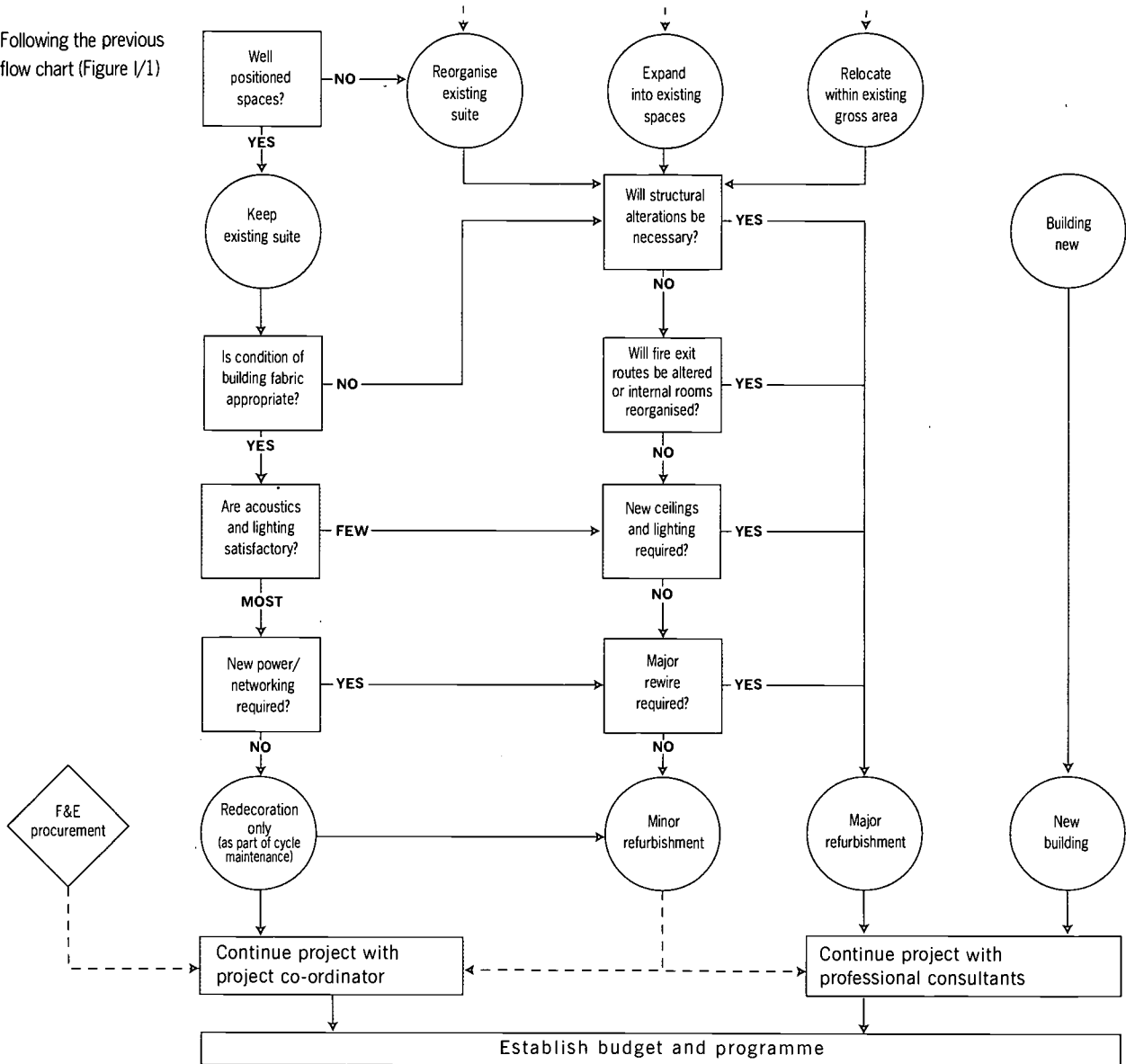

Figure 4/2

Flow chart to establish project type linking with the use of professional consultants. If in doubt, professional expertise should always be sought.

Notes

<sup>5</sup> All designs must take into account the School Premises Regulations, the Building Regulations where applicable and the current DfEE Constructional Standards. DfEE Building Bulletin 87 'Guidelines for Environmental Design in Schools' gives guidance on lighting, heating, ventilation and acoustics.

<sup>6</sup> Guidance can be found in 'F&E Purchasing: a Guide for Schools and Head Teachers',

contractors or suppliers involved. This should not be universally applied, however, and the option of employing consultants should be carefully considered whatever the type and size of the projects. The fee for an architect or other consultant can pay dividends in that they may suggest simple options for solving problems that the school may have assumed to be beyond their control. If building work is involved even minor works will require a knowledge of health and safety issues and relevant Building Regulations.<sup>5</sup> The flow chart in Figure 4/2 outlines some broad criteria for determining project type as one of the factors in deciding whether professional consultants will be required.

4.13 Where the building work element of a project is being handled by consultants, it may still be better for the school (in consultation with the LEA unless responsibility has been devolved to the school) to handle some or all of the furniture and equipment procurement directly. In these cases it is vital that the project co-ordinator liaises fully with the consultant to ensure the smooth integration into the scheme of those items being purchased directly by the school.<sup>6</sup>

## Developing a Brief

4.14 A comprehensive brief will help to ensure the successful outcome of any capital project, whatever its size or complexity. Wide ranging consultation and adequate time allocated to compiling the brief will help ensure that proposals bring maximum benefit to all potential users as well as complementing the School Development Plan.

4.15 The brief should explain the department's functions and identify the main requirements of the MFL suite, including numbers and types of spaces and any equipment that may have space or servicing implications. The brief should not be finalised before professional consultants have been appointed. It should be a working document that forms the basis of a dialogue between the consultant and the rest of the project team. The needs of the brief can then be compared with a variety of 'feasibility' options and the project team can decide which provides the most satisfactory and cost-effective solution. The solution that seems the most obvious initially may become less satisfactory as other options are explored. The same approach can be adopted even where consultants are not involved, the brief being finalised following discussions with LEA officers and suppliers.

## Implementation

4.16 The detailed arrangements for implementing the project will vary depending on budget, type of building work (if any) and whether consultants (or others such as procurement agents) are involved. The information on page 32 describes the main responsibilities of project team members at each stage of the job. Two types of project are shown:

- building work where professional consultants are employed;
- building work of a minor nature or furniture and equipment purchases where a professional consultant is not involved.

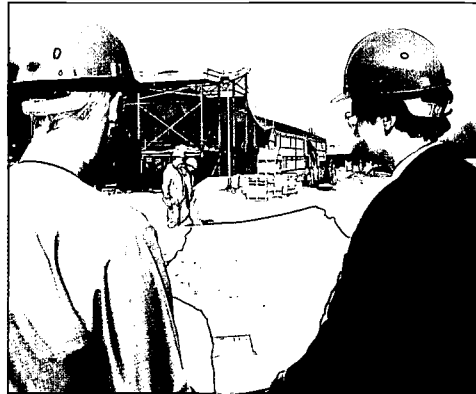

**Figure 4/3**  
Consultants overseeing the project on site

4.17 Large orders of furniture and equipment may be best dealt with by a procurement agent, who will organise many of the steps covered here. They will not provide the independent advice of a consultant, but as they are involved in bulk orders, they may bring savings.

4.18 Whatever the type of project, the project co-ordinator should:

- ensure that estimated costs are obtained for all elements of the project so that it can be established that the total cost of the scheme falls within the overall budget;
- agree any necessary savings as works proceed to ensure that the scheme remains within budget;
- inform staff and pupils of any health and safety issues connected with the site operations;
- arrange for any relevant insurance policies or cleaning and maintenance contracts.

4.19 On all projects it is beneficial to carry out some type of feedback exercise once the new facilities have been in use for a period of time. This exercise can:

- indicate modifications that would help to optimise the use of the new facilities;
- assess any educational or other benefits that have resulted from the project;
- highlight successful and unsuccessful parts of the design and the project process, providing a useful benchmark for similar projects at other schools.

This process should in any case be carried out as part of the LEA's AMP post-project analysis.



**Summary of the main responsibilities of project team members**

**Building Projects with Professional Consultants**

**Scheme Design and Estimated Costs**

The project team will finalise the brief during this stage. It is the responsibility of the consultants to prepare scheme proposals and estimated costs based on the brief, including alternative solutions where appropriate. In order to ensure that the total estimated cost falls within budget, the project co-ordinator should ensure that the costs of all elements of the scheme have been taken into account when assessing whether any savings are necessary.

**Tendering and Contracts**

The professional consultants will be responsible for the development of detailed specifications, drawings, Bills of Quantities (where appropriate), and all other information required for tendering purposes. They will also advise on and be responsible for obtaining and analysing tenders and letting contracts as agreed with the school.

**Site Operations**

The consultants will be responsible for overseeing the work carried out on site and agreeing the monthly valuations to be paid by the school. Any variations required to the works will need to be agreed by the project co-ordinator.

**Occupation**

The consultants will be responsible for agreeing hand-over and practical completion with the contractor. They will also agree arrangements for completing outstanding items (snagging items) and dealing with any defects that become apparent.

A period may be required for equipping and fitting out after the hand-over of the building.

**Minor Works and Furniture and Equipment**

**Scheme Design and Estimated Costs**

Budget estimates should be sought by the project co-ordinators from three contractors.

Before making decisions on the type or specification of furniture and equipment, it is prudent to seek advice and get budget estimates at an early stage, from a range of manufacturers and suppliers.

**Tendering and Contracts**

The project co-ordinator will be responsible for ensuring that written specifications and invitations to tender are drawn up. In all cases six firms should be invited to tender to ensure that at least three tenders (required to establish value for money) are returned. All tenders should be invited on the same basis to ensure fairness of competition and to enable direct comparison. In all cases the relevant financial and standing orders will need to be complied with when obtaining and letting tenders.

**Site Operations**

The project co-ordinator will need to ensure that all work is carried out and payments made in accordance with the terms and conditions of the various contracts entered into.

**Occupation**

For items purchased by the school, the project co-ordinator is responsible for arranging suitable delivery dates to ensure the efficient handling and installation of items and the avoidance of unnecessary storage charges.

# Section 5: Case Studies

This section describes four real projects where modern foreign languages (MFL) facilities have been refurbished in line with the guidance in this bulletin. They also illustrate the different stages involved in taking a capital project through to completion. While other schools may not feel the need to provide all the facilities shown here they should find something of interest in every solution.

5.1 The studies show a variety of approaches to designing and implementing MFL projects. For example, Standish and Kettlethorpe schools have created interesting role play areas. Willink School organised its small project without consultants but all the other schools used architects. Three of the schools are specialist language colleges and as part of their setting up process they received advice from Architects and Building (A&B)Branch at the DfEE.

## The Willink School, West Berkshire

5.2 The school, set in semi-rural surroundings on the Berkshire/Hampshire border, was designed in the late 1950s and significantly extended twenty years later. Before the school was awarded Language College status in September 1996, the accommodation for MFL was split between two floors of a three storey block and another classroom elsewhere in the school (see Figure 5/1).

## The Brief

5.3 The school wanted to bring all MFL teaching into one suite with accommodation that could be used as flexibly as possible. Their main requirements can be summarised as:

- four timetabled classrooms (determined from curriculum analysis, see paragraph 1.9);
- one partially timetabled information and communications technology (ICT) language room which can also serve as a traditional classroom;

## DATA SHEET

Type:	LEA mixed comprehensive
Age Range:	11 -18
No on roll:	700
Project:	Relocation and refurbishment of MFL Department with addition of ICT room.

### Project Cost

New build:	None
Adaptations:	£42,000
F&E:	£100,000
Fees:	None
Total:	£142,000

### Project Area

Teaching area:	322m <sup>2</sup>
Non-teaching area:	87m <sup>2</sup>

### Project Team (school)

- Mrs Barbara Wynn (headteacher)
- Mr Malcolm Summers (deputy head: project co-ordinator)
- Mrs Wendy Rumbol (head of MFL)

- each classroom to be equipped with the core basics of television (with access to satellite programmes), video, cassette player and a computer link to the department network;
- a sixth form study area;
- the possibility of accommodating video conferencing facilities and Internet access at a later date;
- a staff base.

## The Design Solution

5.4 The school used the Language College capital grant and matched sponsorship to relocate the department to a refurbished two storey block. This necessitated a chain of movement and gave the school the added benefit of being able to rationalise the suiting of four other departments within the school (see Figure 5/1). The MFL accommodation now comprises:

- four classrooms;
- an ICT room (the Languages Centre);

- a study and resource area for sixth form students;
- a staff base (for teachers, foreign language assistants (FLAs) and the technician);
- an office nearby for the head of department.

5.5 Three of the classrooms are larger than the areas recommended in Section 1. However, a through-route in two of these spaces effectively reduces the usable area. The largest room (MFL1) has enough space to include a role play area and quiet reading corner.

5.6 All MFL groups are timetabled into the Languages Centre once every two weeks with slots available for other subject areas to book time. Students also have access to the technology at lunchtimes and after school hours. The Centre is equipped with computers, an audio suite, satellite television, a video recorder and a laser disc player. A range of cassette, laser disc, video and CD-ROM resources are available for students to work on either independently,

in small groups or as a whole class. The overall area can also be used for conferences out of school hours with a whiteboard, overhead projector and flip chart provided.

5.7 Each member of the MFL staff has a workstation with access to the network. A laser printer and a dual deck cassette recorder are provided exclusively for staff use. The technician oversees the computer network and advises on future improvements to the system. When the network was installed, cabling and ducting was put in place to allow for future expansion.

5.8 Each teaching space is carpeted. All rooms have an overhead projector and screen, cassette recorder, colour television and video, audio system, satellite access and whiteboard. Fixed furniture has been minimised to ensure both that rooms can be rearranged easily and that demands arising from future changes can be accommodated more easily. Co-ordinated furniture and decor help to create a cohesive identity to the suite.

**Figure 5/1**  
Willink School, before and after adaptation.

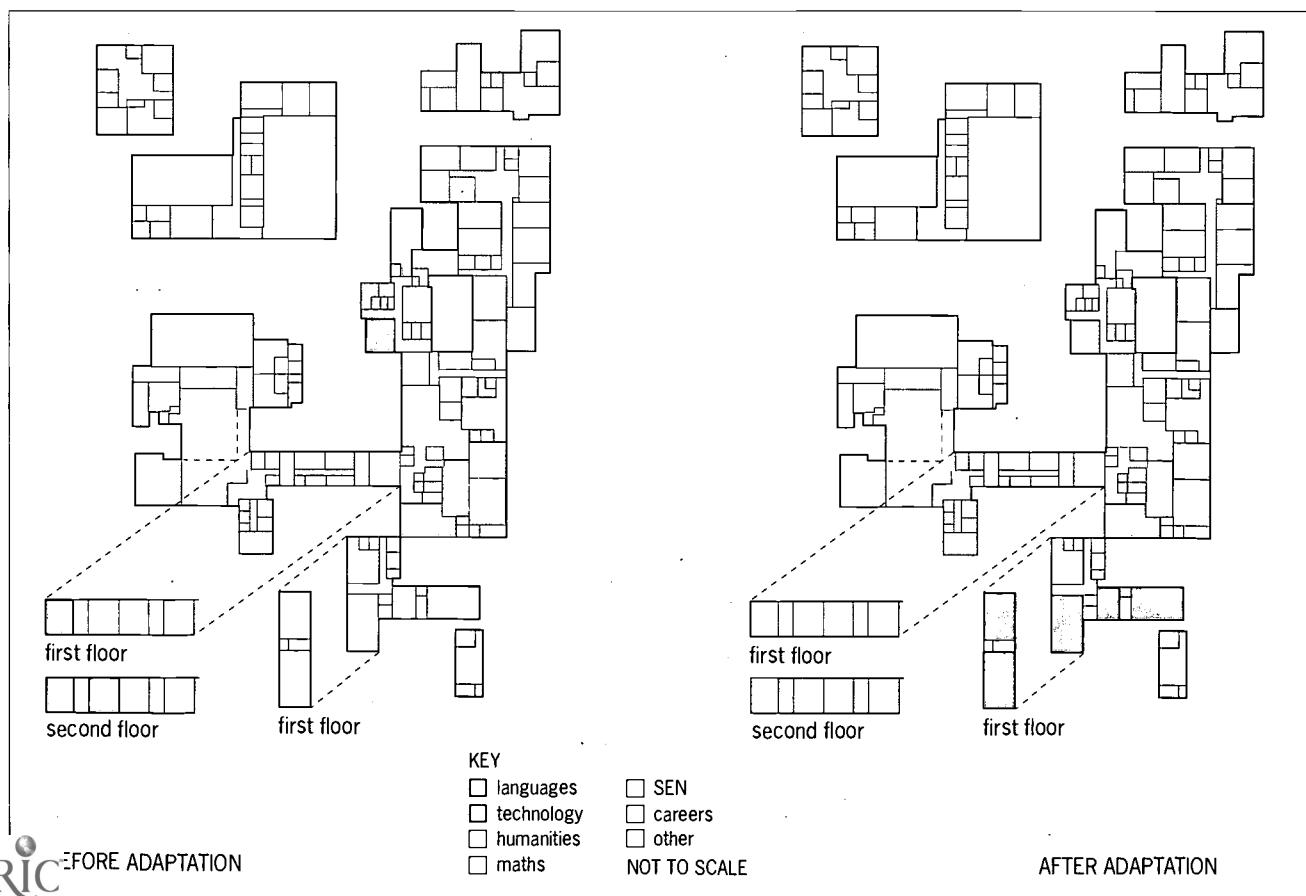

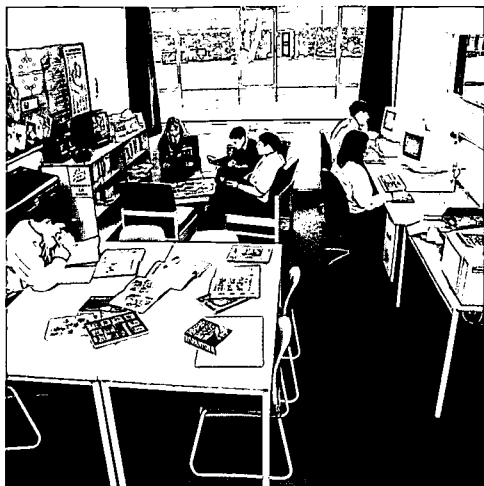

Figure 5/2  
Willink School resource area.

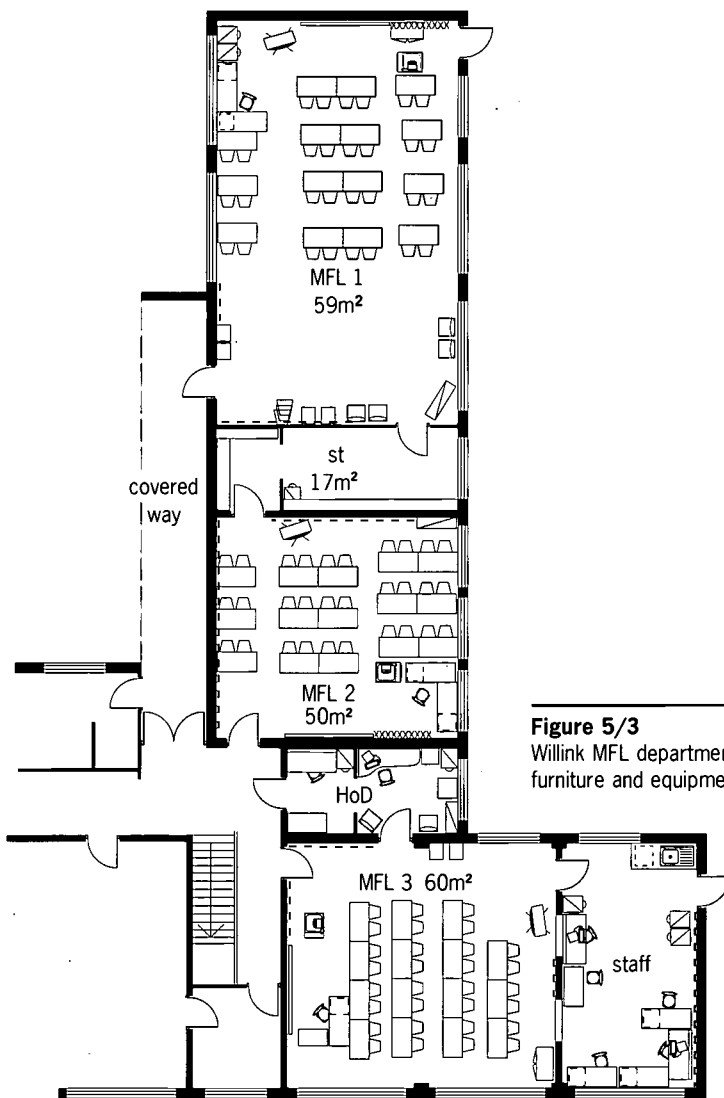
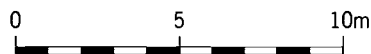
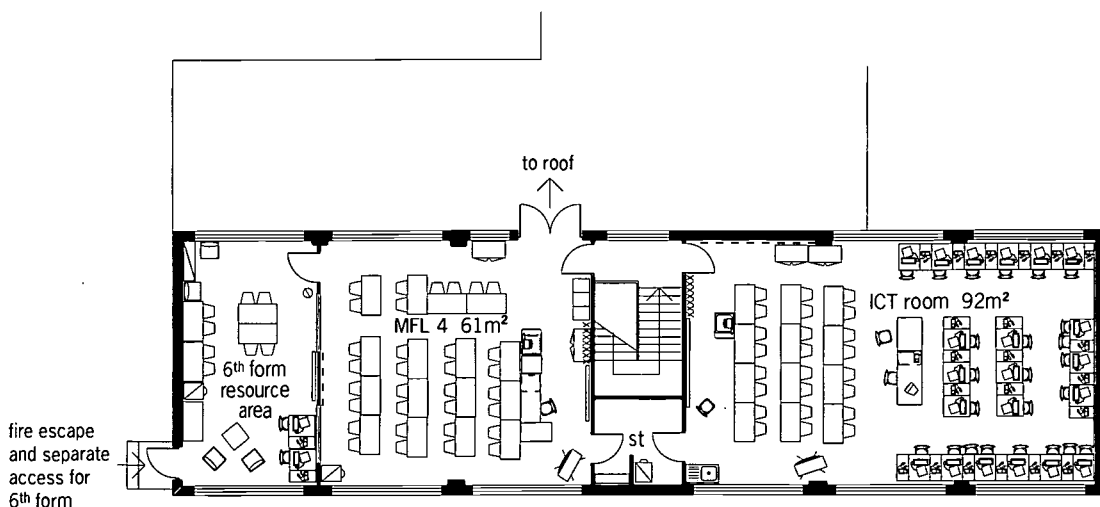

Figure 5/3  
Willink MFL department,  
furniture and equipment plan.

ground floor



first floor

### Willink School: The Project Team and the Process

The project team included the deputy head acting as project co-ordinator, the head and the head of MFL. Consultations with governors, MFL departmental staff and other school staff were carried out at all stages of the project development. An overall programme showing key dates was drawn up by the project co-ordinator to ensure that the scheme would be completed within the time scale available.

#### Appointing Consultants

As the scope of the project did not include any significant building work or affect the means of escape it was agreed, after consulting the appropriate LEA officers, that the appointment of professional building consultants would not be necessary. However, the project team sought advice from suppliers and manufacturers before making decisions on the specification for both ICT equipment and classroom furniture.

#### Scheme Design and Estimated Costs

Plans and specifications for the building work and re-decorations were drawn up in-house and amended after consultation with both the LEA and DfEE designers. A budget cost was allocated for this work. Budget estimates were obtained from a variety

of manufacturers and suppliers for the equipment and furniture. The project co-ordinator's task was to ensure that agreement was reached on all the choices that had to be made and that the overall cost remained within the total budget available.

#### Tendering and Contracts

Once the scope of the project and the budget had been agreed the project co-ordinator was responsible for drawing up written specifications and obtaining tenders for the various components of work. Where possible, up to six firms were invited to submit tenders for each element of the work. The school sought guidance from the LEA on dealing with tenders.

#### Site Operations and Occupation

The relocation and refurbishment works were planned to take place across the summer holiday to minimise disruption within the school. The timing of the procurement, delivery and installation of furniture and equipment had to be co-ordinated with the building and decoration works to ensure that work was carried out efficiently and in the appropriate sequence.

Early priority was given to departmental staff training so that the new facilities and equipment could be used as effectively and imaginatively as possible.

## Standish Community High School, Wigan

5.9 Standish Community High School was originally built in the 1970s. The school undertook a major building and remodelling programme in 1989, and in 1992 opened new facilities for science, design and technology, visual arts and IT. The school also made the entrepreneurial decision to commission a purpose-built conference centre (see Figure 5/4). The school was awarded Language College status in 1996.



**Figure 5/4**  
The new extension at Standish School.

### DATA SHEET

Type:	LEA mixed community comprehensive
Age range:	11 - 16
No. on roll:	985
Project:	New build and refurbishment works to create an MFL suite with drop-in language learning facility and business conference centre.

#### Project Cost (new build and adaptations)

Total	£394,138
-------	----------

#### Project Area

Teaching area:	781m <sup>2</sup>
Non teaching area:	91m <sup>2</sup>

#### Project Team (school)

• Mr Geoff Ashton (head) + Team of 5

## The Brief

5.10 The school wanted to re-organise the MFL suite which had classrooms of varying sizes (often awkwardly shaped) and very poor circulation (see Figure 5/5). They also wanted to create a suite that would provide excellent language teaching facilities not only for school pupils but also for the wider community. They perceived a need for greater competence in languages in the commercial sector and a demand for language learning among adults and 'second chance' learners. This led to the concept of a 'drop-in' language learning

centre. Such a facility had to be designed to satisfactorily accommodate a wide range of users, possibly simultaneously. It needed to be attractive to adult users and have suitable administrative facilities, particularly as the centre was intended ultimately to be run on a semi-commercial basis.

**Figure 5/5**  
Standish School, MFL department as existing.

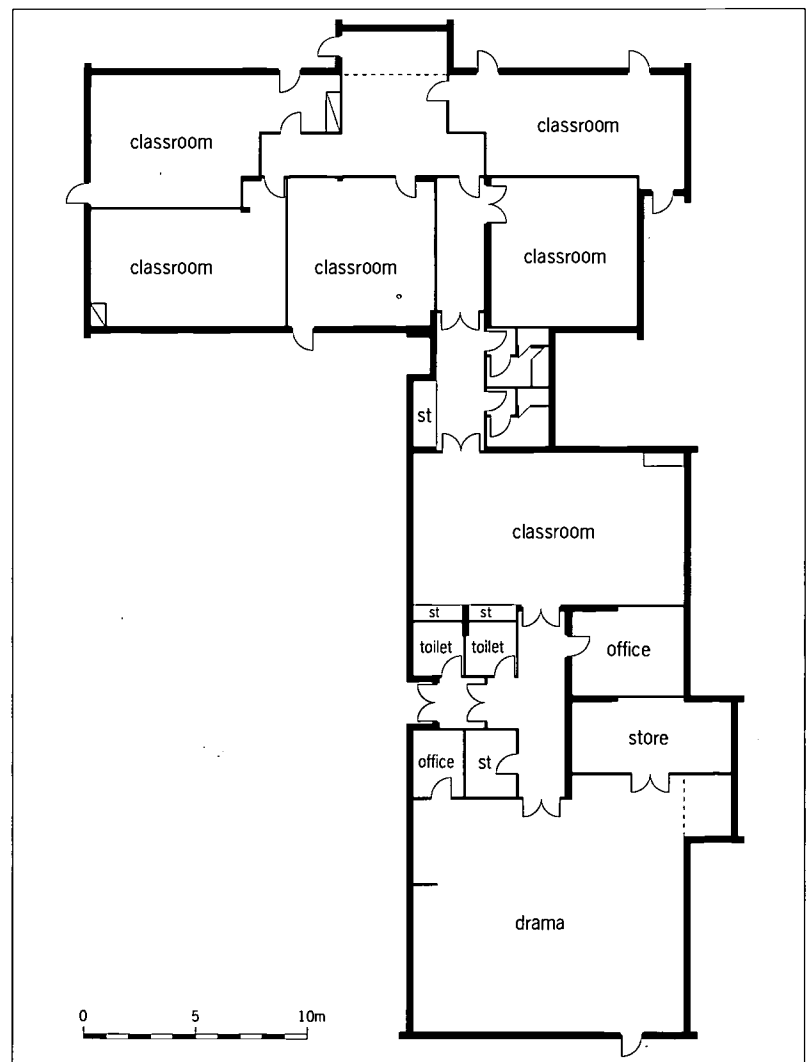

**Figure 5/6**  
Standish School, the role play 'street'.

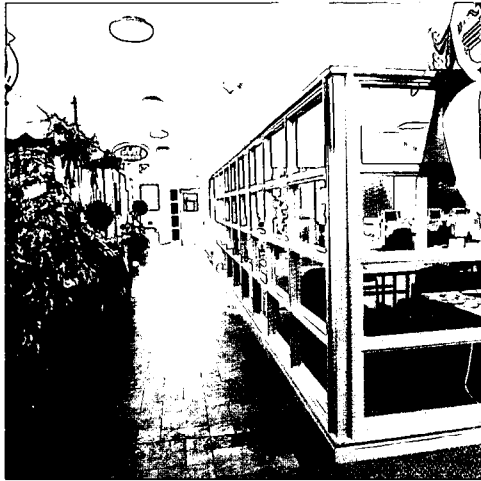

### The Design Solution

5.11 The comprehensive brief resulted in a scheme which involved a combination of remodelling and new building work. The MFL suite provides the following accommodation.

- Five fully refurbished classrooms.
- **A role play area:** an 'international' street setting with authentic accessories and changeable signs in four languages (Figure 5/6). The street (a corridor with a series of small rooms opening off it) has 'scene sets' for passport control, a bank (see Figure 5/7), a café, a hotel, sports and gift shops, a travel agent, a post office and a supermarket. It provides an authentic

language learning environment for pupils of the school and visitors and also functions as an original meeting venue in which commercial organisations can role play in four languages.

- **Multi-media room:** a twenty four-station interactive language learning space used throughout the school day as part of the normal teaching delivery. It is also available to pupils at lunchtimes and outside school hours to adults and businesses.
- **A meeting and conference room:** for up to 100 people, with a range of audio and video technology including video conferencing and an inter-active electronic whiteboard.

5.12 A movement area adjacent to the suite which is used by the Performing Arts and PE departments is also available as an additional role play area for language classes or community use.

5.13 As most of the accommodation was adapted from an existing building, some compromises were inevitable. MFL 2, at 39m<sup>2</sup>, can only accommodate 24 pupils and is timetabled for KS4 classes. The multi-media room is a very awkward shape but this is less of an issue in this room where pupils spend most of their time working individually.

**Figure 5/7**  
Pupils using the 'bank' for role play.





**Figure 5/8**  
Standish MLF department, F&E plan.

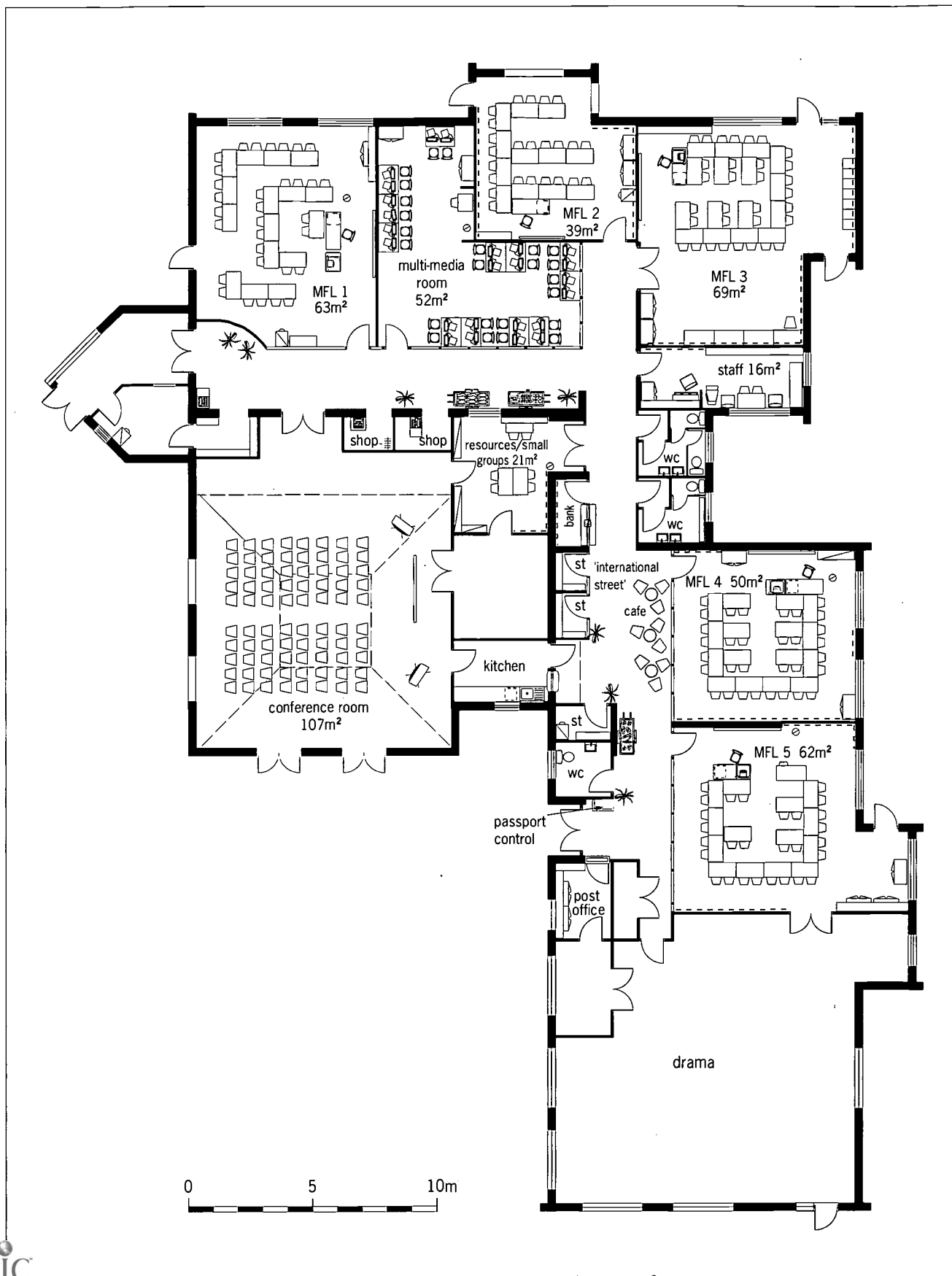

## **Standish School: The Project Team and The Process**

The project team consisted of five members of staff with the head acting as project co-ordinator. The need to employ professional building consultants was recognised at the outset.

### **Appointing Consultants**

The architects, who had experience of educational building design and had worked for the school before, were employed to advise on the formulation of the brief and to carry the project through to completion.

### **Scheme Design and Estimated Costs**

Following the formulation of the brief and the establishment of the overall budget, the architects produced a number of alternative designs with budget costs for consideration by the school. A detailed consultation exercise involving DfEE architects, the school's architect and teaching staff resulted in the agreed final design.

### **Tendering and Contracts**

The architects produced detailed design drawings and specifications so that competitive tenders based on a standard form of building contract could be obtained from a number of contractors. Following the architects' analysis of returned tenders, cost savings had to be agreed with the project team. Negotiations with the lowest tenderer were carried out by the architects on behalf of the school.

Contracts for furniture and equipment were obtained through a separate

competitive tendering process, some being handled directly by the school rather than by the consultant architects. At all times there was close liaison through the project co-ordinator between the school and the consultants to ensure the proper co-ordination of all the elements of the project and to avoid duplication or conflicting actions. The project co-ordinator's role at all times was to ensure that the parties were kept informed of all relevant actions and that the project proceeded to programme and within budget.

### **Site Operations and Occupation**

The architects were appointed to administer the building contract and oversee the works carried out on site on behalf of the school.

Once the building works had been completed and handed over to the school a period of time was allowed for furnishing and equipping the building before occupation and use. The project co-ordinator was responsible for ensuring that, where orders were being handled directly by the school, delivery was arranged to fit in with the handover date. This avoided the possibility of handling and temporary storage arrangements becoming problematic and expensive. During this period, account was also taken of the demands on and the disruption to staff and pupils.

The project as completed and occupied was inevitably modified to some degree as a natural result of the design process. The school continues to monitor and assess how the completed project is comparing with the criteria that were set at the briefing stage (see paragraph 4.19).

## St Bede's RC School, Lanchester, Co Durham

5.14 St Bede's was built in the mid 1960s and has expanded considerably since. The school was awarded Language College status in 1998 and at about the same time received a grant to replace three of its temporary huts which were used as general teaching classrooms. The MFL department had enough timetabled classrooms (six) of reasonable size but they were not organised into a suite (Figure 5/9).

### The Brief

5.15 As part of its Language College proposal for an enhanced curriculum, the school wanted to create two specialist spaces: one equipped with an interactive whiteboard and facilities for whole class video-conferencing and another containing ICT facilities. There was also a need for small group rooms where sixth form lessons and sessions with the FLA (a key part of the school's teaching) could take place.

### DATA SHEET

Type:	VA RC Comprehensive
Age Range:	11 -18
No on roll:	1020 + 195 VltH
Project:	Relocation and adaptation to provide specialist language rooms, linked to new MFL classroom block.

#### Project Cost

New build:	£168,832
Adaptations:	£43,420
External Works:	£14,832
Demolition:	£6,604
F&E:	£40,000
<i>(including computer hardware, software and cabling)</i>	
Fees:	£32,529
Total (excluding VAT):	£306,217

#### Project Area (new build and adaptations)

Teaching area:	474m <sup>2</sup>
Non-teaching area:	148m <sup>2</sup>

#### Project Team (school)

- Mr George Dunn (head)
- Mr Ian Merrington (school administrative officer and project co-ordinator)
- Mrs Hill (language college co-ordinator)

**Figure 5/9**

St Bede's School, before and after the project.

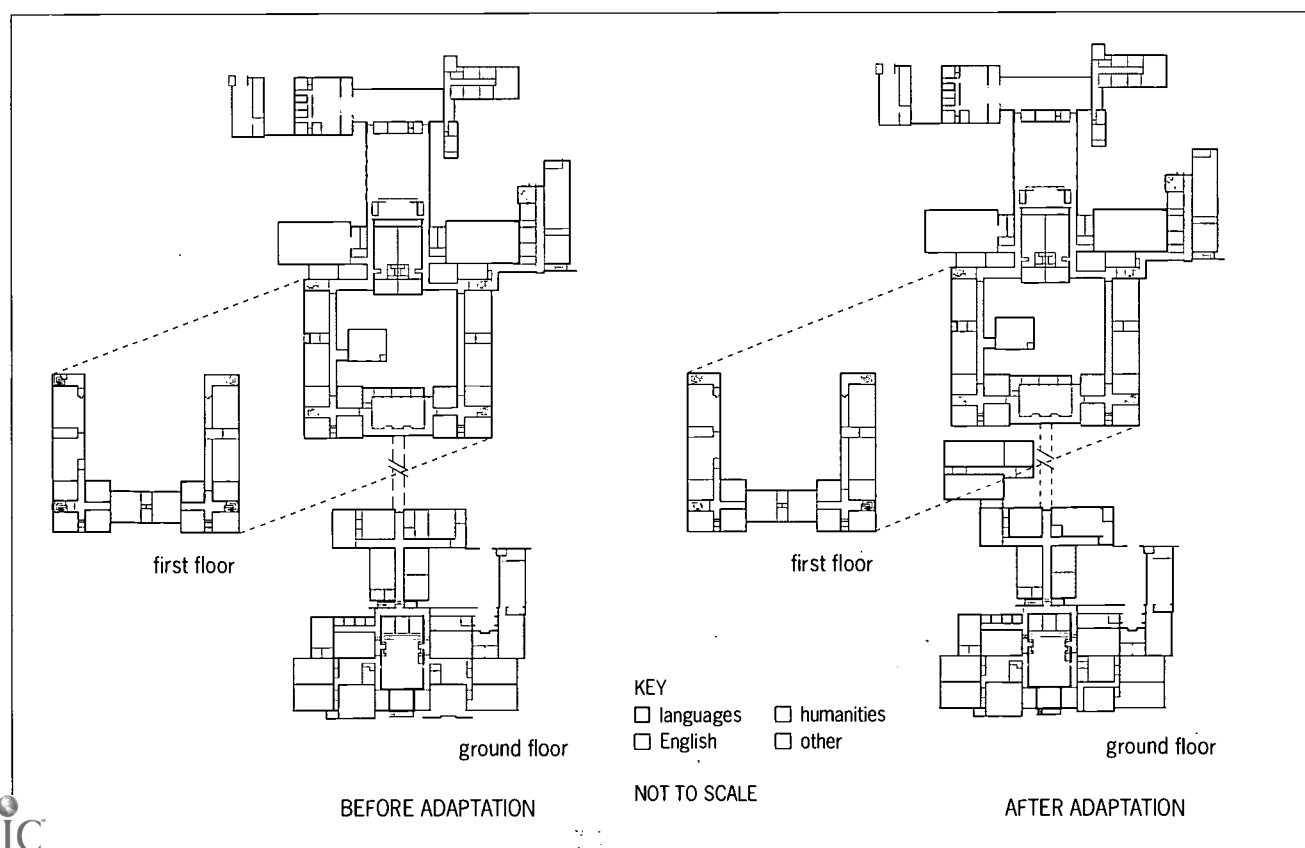

## The Design Solution

5.16 After consultation with the DfEE, it was agreed that the most effective solution would be achieved by combining the language college proposal with the project to replace the demountable classrooms. The MFL suite now comprises:

- six timetabled classrooms;
- an ICT space;
- a classroom equipped with inter-active whiteboard and video-conferencing equipment;
- three small group rooms;
- a staff base.

The two specialist spaces and one classroom have been adapted from an existing building, part of which is occupied by the history department with which MFL has strong links. The remaining five classrooms are housed in a new block which is linked to the existing building by a covered way. The plan allows for a corridor to be added in the future (see plan).

5.18 The specialist rooms are timetabled on a rota basis by the MFL department but a small amount of time is available for

other departments to use the facilities. The three small group rooms are all used by the FLA but they also have other uses. One doubles as a staff office, one is used as a study room by sixth form students and the third is equipped for small group video conferencing. The staff base is used by MFL and history teachers as well as the MFL technician. All these spaces are therefore used as effectively as possible (see paragraph 1.15).

5.19 The six classrooms are all equipped with an overhead projector (OHP), tape recorders, a video cassette recorder (VCR) and TV as well as a computer which is linked into the school network. A range of activities can take place (by re-arranging the furniture if necessary) including role playing. Cable trunking to all walls gives flexibility. Full height cupboards<sup>1</sup> and/or walk in stores in each classroom provide local storage to supplement the main departmental store room. Both specialist rooms are furnished for whole class groups although the video conferencing equipment limits the group size to 22 for that activity. The school has purchased a mobile inter-active whiteboard which can be used in all rooms, releasing the main room for greater use by the rest of the school.

**Figure 5/10**

A small group with the FLA at St Bede's School.



**Note**

<sup>1</sup> Full height cupboards can have disadvantages, see paragraph 3.8.

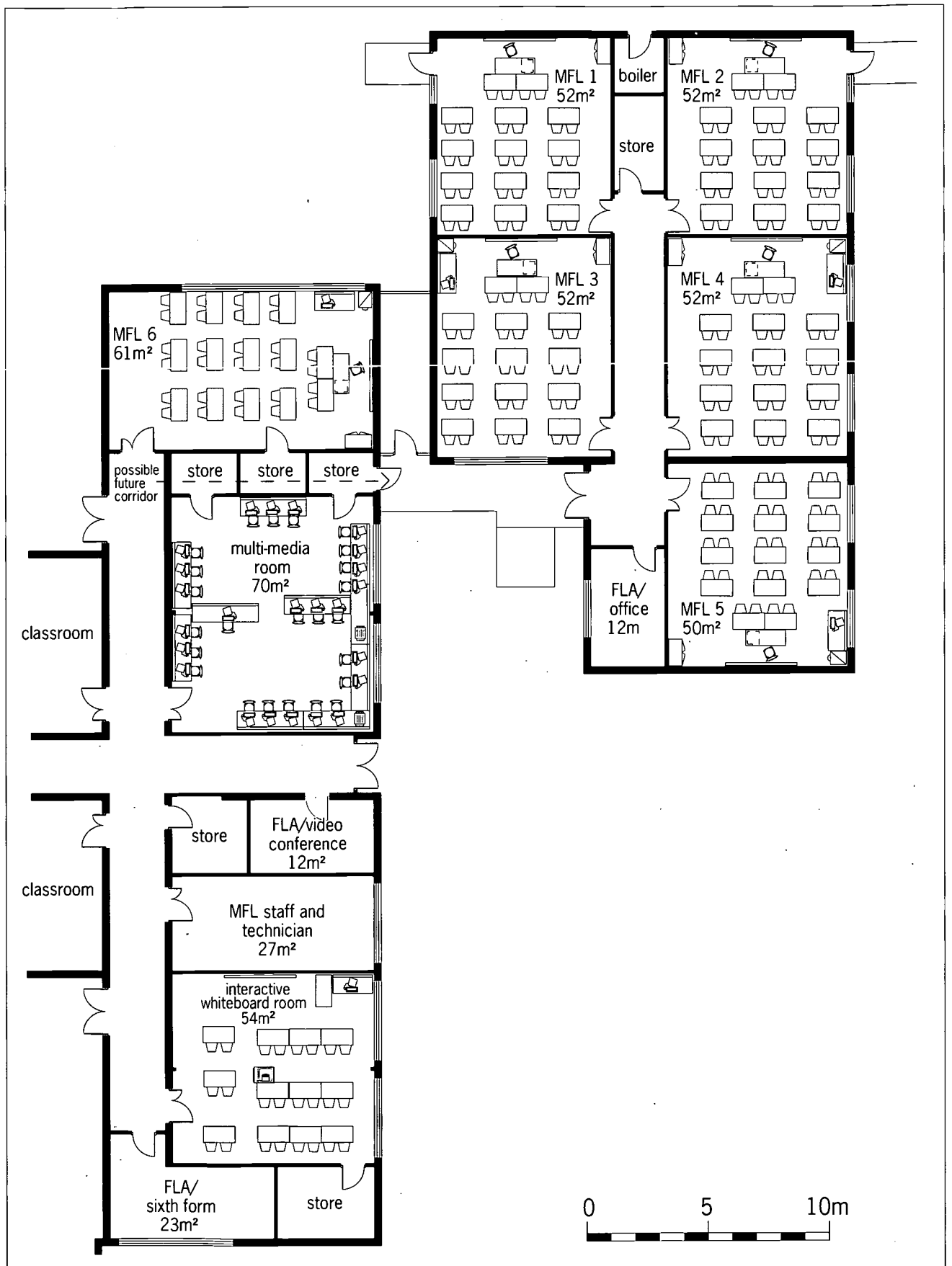

Figure 5/11  
St Bede's MFL department,  
F&E plan.

52

## St Bede's: The Project Team and the Process

The project was complicated by the dual funding arrangement but this provided a more satisfactory and better value solution in the end. The initial brief was compiled by MFL staff and the school manager acted as day to day project co-ordinator.

### Scheme Design and Estimated Costs

The architect worked with the school on a number of options before the final solution was reached. It was decided to build a separate block rather than an extension to minimise the payment of VAT thus maximising the available budget. The school used some of its delegated funds to pay for some of the fittings. Economies were made by re-using furniture wherever possible. The new furniture and equipment was purchased directly by the school with advice from the LEA and specialist sponsors.

### Tendering and Contracts

The architect prepared bills of quantities on which tenders were based. Five tenders were received.

### Site Operations and Occupation

As much work as possible was carried out during the school holidays but it was still necessary to vacate the area to be refurbished and adjust the school timetable to suit. A safe route had to be created for pupils to reach the technology block adjacent to the site area. Careful co-ordination between the contractor and the school's project co-ordinator ensured that particularly hazardous building operations and material deliveries took place outside the school timetable.

As the project team had agreed the scheme and gained the necessary approval before starting, there were no significant design changes during the construction process. However, persistent heavy rainfall resulted in some delays.

Occupation was phased with the refurbished area completed in April and the new block in July 1999. The temporary huts were kept until the end of the project to make up for the loss of space during construction.

**Figure 5/12**  
St Bede's School, the multi-media centre.





## Kettlethorpe School, Wakefield

5.20 The original school was built in 1965. Following a review of the provision of education in the area, the school was reorganised from a 13 to 16 school to an 11 to 16 school in September 1993. The LEA funded a programme of works to accommodate the expansion in numbers, including a refurbishment of modern foreign languages accommodation.

### The Brief

5.21 The MFL department was already in a suite but the increase in pupil numbers required an additional three timetabled spaces. The school also wanted to provide an area for role playing exercises that could be shared with the drama department. It was decided that all classrooms would have some audio

### DATA SHEET

Type:	Community Comprehensive
Age Range:	11 -16
No on roll:	1417
Project:	Adaptation to provide additional classrooms and role playing area. Part of major whole school reorganisation.

#### Project Cost

Total approximate cost of whole school project: £3.7m.

#### Project Team (school)

- Mr Brian Tapson (head)
- Mr John Clancy (head of MFL)
- Mr Peter Ellis (senior teacher and project co-ordinator)

recording equipment but that one designated as the 'master' classroom would house a central control unit linked up to all other spaces.

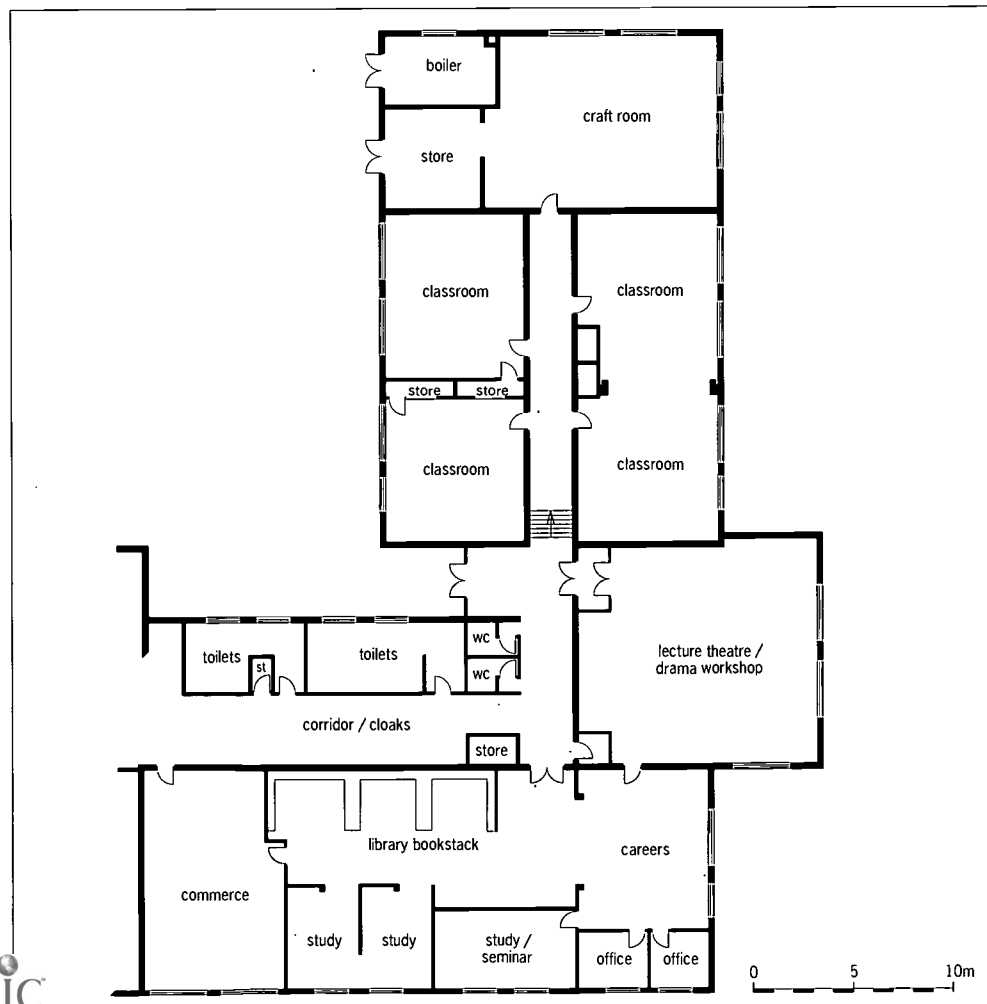

**Figure 5/13**

Kettlethorpe School, before adaptation.

## The Design Solution

5.22 Three of the existing MFL classrooms were retained and the fourth was enlarged to provide a social area which can be used for role play activities. Re-organisation in other areas of the school released adjacent spaces for MFL use, allowing the department to remain as a suite. The accommodation now comprises:

- 7 timetabled classrooms;
- a seminar room (for small GCSE groups and SEN teaching);
- a resource area;
- a staff base;
- a social area (shared with drama).

5.23 The social area is fitted out as the 'Café de la Brède', emulating the atmosphere of a French café for role play exercises and offering snacks and drinks to pupils at breaks and lunch. An adjacent courtyard is used as a performance space and extension to the café in fine weather.

5.24 Each classroom has 4 - 6 (depending on room size) specialist tables with inset recording machines. The tables are serviced from perimeter trunking via cable ducting which has been laid across the floor and covered by carpet. Serviced side benching allows computers to be used in any classroom, if necessary. Purpose made units beneath provide local storage. The rest of the classroom contains basic moveable tables allowing a range of activities to take place.

5.25 The staff base is serviced for cabled audio and TV signal distribution. The installation of a microphone enables tapes to be played in any or all of six rooms which is useful for classwork as well as for exams. It is hoped that later developments will include the control of videos and satellite television programmes from this base.

**Figure 5/14**

Kettlethorpe School  
**a:** View of a classroom;  
**b:** 'Café de la Brède'.

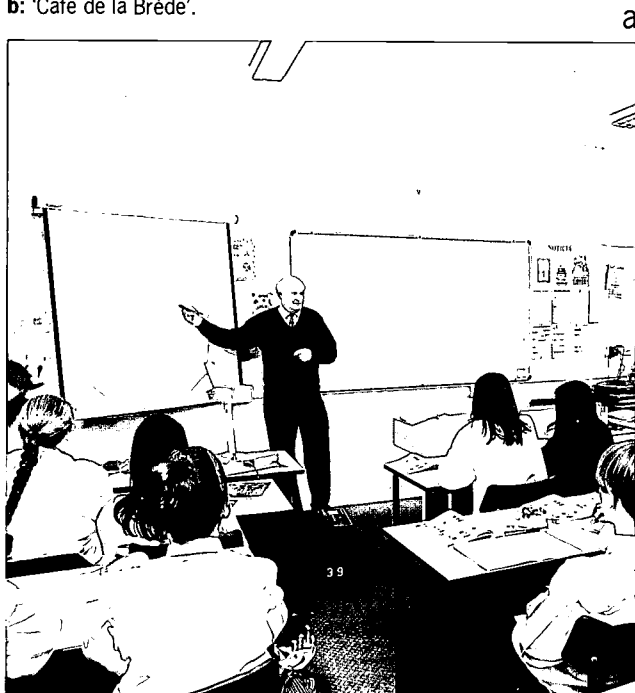

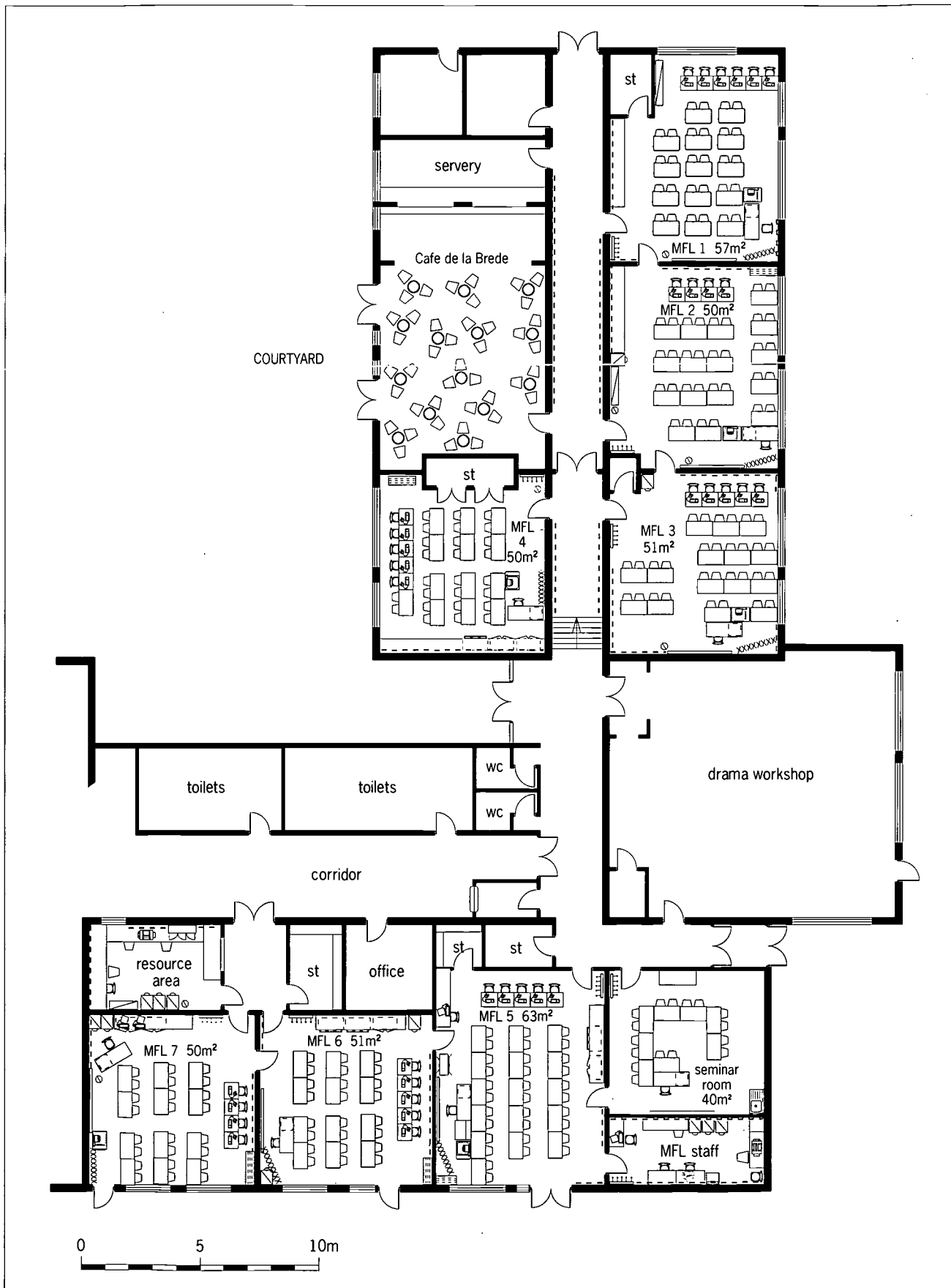

**Figure 5/15**  
Kettlethorpe MFL department,  
F&E plan.

## **Kettlethorpe School: The Project Team and the Process**

The scheme, which was designed by the LEA's own multi-disciplinary team, was part of a much larger project for the whole school. As it was decided not to decant the pupils, it was necessary to carry out the work in 17 overlapping phases, each with very tight deadlines, to minimise disruption to the school.

The LEAs project officer, project architect and schools project co-ordinator formed a management team for the whole project. The school's co-ordinator who was a senior art teacher had a good understanding of the technical aspects of building design and was able to use sketches to communicate the school's concepts to the consultants. His appointment was a key element in the success of the design.

### **Scheme Design and Estimated Costs**

The basic disposition of MFL rooms was agreed by the project management team in consultation with the school's management team and the head of MFL. In order to keep to the tight programme, details were agreed in time for the MFL section of work to start on site.

The use of stud partitions and suspended ceilings gave flexibility allowing for the possibility of changes of service routes. A great deal of effort was made to establish the right character for the 'café' using a number of detailed sketches.

## **Tendering and Contracts**

Tenders, based on bills of quantities, were invited for the building work. The furniture and equipment was procured separately using a purchasing organisation and specialist subcontractors. The project management team had to ensure that deliveries were carefully co-ordinated with the main building programme. Some of the existing furniture was re-used.

## **Site Operations & Occupation**

Between September 1993 and November 1994, twenty temporary classrooms and toilets housed pupils whilst works took place, often simultaneously on four areas of the site. Occupying the site during the project meant dealing with construction noise and having to re-organise the school circulation.

Co-ordination meetings with fitting out and services sub-contractors, design engineers and the general contractor took place throughout the construction period, dealing with general layouts and details. The school's project co-ordinator was involved in all this co-ordination work.

Although there were some problems on site these were resolved and the project was completed on time, despite a very tight and complex schedule. Good relations in the project management team and between the contractors and the school were key to this achievement. While the school has experienced some equipment problems the project has generally worked well.

# Glossary

**AMP:** Asset Management Plan. Document prepared by every local education authority (LEA) setting out priorities and the approaches agreed locally for tackling them, based on the school's estate.

**AV:** Audio Visual.

**BESA:** British Educational Supplies Association, London 020 7537 4997

**BILL OF QUANTITIES:** An itemised description of building works used as a basis for tendering.

**BRIEF:** Description of clients requirements, used as a basis for design and specification.

**BS:** British Standard.

**CAROUSEL:** A class divided into groups each working on a different activity for a short time before moving on to the next.

**CD-ROM:** Compact Disc Read Only Memory - computerised reference material.

**CONTINGENCY:** A sum of money, usually a percentage, included in the budget for a building project to allow for unforeseen events.

**FLA:** Foreign Language Assistant. A native speaker (often a student) who works alongside teachers in the classroom or with small groups in another space.

**FILE SERVER:** Central computer controlling network.

**FREQUENCY OF USE (%):** The average amount of time that a space is used, expressed as a percentage of the total number of teaching periods available.

**GROSS AREA:** The total floor area of all a school's buildings, measured to the inside face of external walls.

**ICT:** Information and Communications Technology.

**ISDN:** Integrated Services Digital Network. A telecommunications network which uses digital transmission.

**KEY STAGE (KS):** The statutory school years are divided into four phases which mark stages of development. These approximate to age as follows.

- KS1: age 5 - 7
- KS2: age 7 - 11
- KS3: age 11 - 14
- KS4: age 14 - 16

**LANGUAGE COLLEGE:** A secondary school that has received DfEE approval to specialise in modern foreign languages (MFL). Capital funding is shared between school and DfEE.

**LEA:** Local Education Authority.

**MFL:** Modern Foreign Languages.

**MULTI-MEDIA:** Equipment with more than one medium e.g. sound and vision.

**NETWORK:** Cable link between computers and other associated hardware.

**OHP:** Overhead Projector.

**PRACTICAL COMPLETION:** Stage in building project when users can occupy building.

**PROCUREMENT AGENT:** One who buys furniture and equipment on behalf of the client.

**ROLE PLAY:** Acting out real life scenes in the target language.

**SCHOOL DEVELOPMENT PLAN (SDP):** A document outlining a school's plans (for education, building and management) for raising educational achievement.

**SOUNDCARD:** Computer insert that allows it to produce sound.

**SUITE:** In this publication a suite refers to an identifiable group of same-subject spaces.

**TEACHING PERIOD:** Schools divide up the week in different ways. For example, 40 periods of 35 minutes.

**VCR:** Video Cassette Recorder.

**VDU:** Visual Display Unit, i.e. the computer screen.

**VIDEO-CONFERENCING:** Using video technology to enable groups of people to communicate at a distance (in MFL with foreign schools).

**WORKPLACE:** A place to work, ie. table space and seat, for one pupil (if applicable to activity).

**WORKSTATION:** A computer position.

**YEARS 7 TO 11:** Secondary school years are numbered from 7 (first year) to 11 (end of statutory schooling). The sixth form is sometimes referred to as years 12 and 13.

# Bibliography

## **Building, Furniture and Equipment**

*The Education (School Premises) Regulations, 1999.* (Statutory Instrument 1999 No. 2). London: The Stationery Office, 1999. ISBN: 0 11 080331 0.

*Department for Education and Employment. Constructional Standards for New School Buildings.* London: DfEE, 1997.

*Department of the Environment and The Welsh Office. The Building Regulations 1991. Approved Document B: fire safety.* London: HMSO, 1991. ISBN: 0 11 752313 5.

*Department for Education and Employment. Area Guidelines for Schools (Building Bulletin 82).* London: HMSO, 1996. ISBN: 0 11 270921 4.

*Department for Education and Employment. Guidelines for Environmental Design in Schools (Revision of Design Note 17). (Building Bulletin 87).* London: The Stationery Office, 1997. ISBN: 0 11 271013 1.

*British Standards Institution. BS 5873: Educational Furniture.* Milton Keynes: BSI, 1980 - 1988. In 5 parts.

*British Standards Institution. BS 6396: 1995. Specification for electrical systems in office furniture and office screens.* Milton Keynes: BSI, 1995. ISBN: 0 58 024736 8.

*Department for Education. Educational Furniture Database: Setting the Standards.* (Broadsheet 31). DFE, 1994.

*Royal Institute of British Architects. A Guide for School Governors: Developing School Buildings.* London: RIBA, 2000.

Web address: <http://site.yahoo.net/client-forums/ag.html>

*Department for Education and Employment. Improving Security in Schools (Managing School Facilities, Guide 4).* London: HMSO, 1996. ISBN: 0 11 270916 8.

*Department for Education and Employment. Raising Standards: Opening Doors.* London: DfEE, 1999.

## **Forthcoming Publications**

*Department for Education and Employment. F&E Purchasing: a Guide for Governors and Head Teachers.* London: The Stationery Office.

## **Video**

*Department for Education and Employment. Making IT Fit.* London: COI, 1995.

## **Education**

Modern Foreign Languages. The National Curriculum for England, Key Stages 3-4, [www.nc.uk.net](http://www.nc.uk.net)

GCSE core criteria (QCA) and Examination Board specifications.  
Telephone QCA: 020 7509 5555.

AS/A level core criteria (QCA) and Examination Board specifications.

CILT publications: Pathfinder series for MFL methodology; Infotech series for MFL and ICT methodology.  
Telephone CILT: 020 7379 5110



# Key to symbols



side bench  
600 deep x 850 high

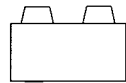

rectangular table  
1200x600x700 high

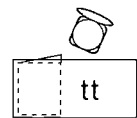

teachers table and pedestal  
1500x750x725 high



adjustable computer chair



polypropelene chair



upholstered chair



coffee table / table with  
magazines



stool



underbench tray unit  
1010x455x800 high



free-standing cupboard  
1010x455x800 high



4 drawer filing cabinet



bookcase / shelf



locker



coat hooks

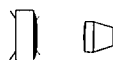

television & video/  
portable television



ohp/ohp on trolley



ohp screen



whiteboard



specialist table with  
inset recording machine

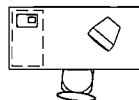

teacher's console for  
audio system

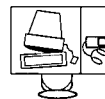

multi-media table (audio & IT)



multi-media table (audio & video)



portable desktop recorder



computer table  
1500x750x700 high



scanner



photocopier



printer/ printer on trolley



bin



display board

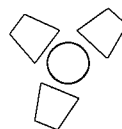

cafe table/ chairs



heater

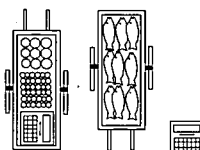

role play equipment



sink



INVESTOR IN PEOPLE

Published by The Stationery Office and available from:

**The Stationery Office**

(mail, telephone and fax orders only)

PO Box 29, Norwich, NR3 1GN

Telephone orders/General enquiries 0870 600 5522

Fax orders 0870 600 5533

[www.thestationeryoffice.com](http://www.thestationeryoffice.com)

**The Stationery Office Bookshops**

123 Kingsway, London WC2B 6PQ

020 7242 6393 Fax 020 7242 6412

68-69 Bull Street, Birmingham B4 6AD

0121 236 9696 Fax 0121 236 9699

33 Wine Street, Bristol BS1 2BQ

0117 926 4306 Fax 0117 929 4515

9-21 Princess Street, Manchester M60 8AS

0161 834 7201 Fax 0161 833 0634

16 Arthur Street, Belfast BT1 4GD

028 9023 8451 Fax 028 9023 5401

The Stationery Office Ortel Bookshop

18-19 High Street, Cardiff CF1 2BZ

029 2039 5548 Fax 029 2038 4347

71 Lothian Road, Edinburgh EH3 9AZ

0870 606 5566 Fax 0870 606 5588

**The Stationery Office's Accredited Agents**

(see Yellow Pages)

and through good booksellers





**U.S. Department of Education**  
Office of Educational Research and Improvement (OERI)  
National Library of Education (NLE)  
Educational Resources Information Center (ERIC)



## **NOTICE**

### **REPRODUCTION BASIS**



This document is covered by a signed "Reproduction Release (Blanket) form (on file within the ERIC system), encompassing all or classes of documents from its source organization and, therefore, does not require a "Specific Document" Release form.



This document is Federally-funded, or carries its own permission to reproduce, or is otherwise in the public domain and, therefore, may be reproduced by ERIC without a signed Reproduction Release form (either "Specific Document" or "Blanket").