

DOCUMENT RESUME

ED 452 679

EF 005 901

AUTHOR Holt, Diane; Watson, Lucy; Wadsworth, Alison
TITLE Science Accommodation in Secondary Schools: A Design Guide.
Building Bulletin 80 (Revised 1999).
INSTITUTION Department for Education and Employment, London (England).
Architects and Building Branch.
ISBN ISBN-0-11-271039-5
PUB DATE 1999-00-00
NOTE 66p.; Produced with assistance from Richard Daniels, Alan
Jones, Geoff Wonnacott, and Cliff Gould.
AVAILABLE FROM Stationery Office Publications Centre, P.O. Box 29, Norwich
NR3 1GN England (18.95 British pounds). Tel: 0870-600-5522;
Fax: 0870-600-5533; Web site:
<http://www.thestationaryoffice.com>.
PUB TYPE Guides - Non-Classroom (055)
EDRS PRICE MF01/PC03 Plus Postage.
DESCRIPTORS *Educational Facilities Design; Guidelines; Public Schools;
School Construction; *Science Facilities; *Secondary
Education; *Space Utilization

ABSTRACT

This document offers guidance in the accommodation needs for teaching the sciences in secondary education, either through new construction or the adaptation of existing buildings. Section 1 outlines the range of spaces usually required and examines planning options in new and adapted departments. Section 2 describes the planning of an individual laboratory, covering services distribution, servicing systems, and room layouts. A number of furnished plans are illustrated. Section 3 provides guidance on the teaching and non-teaching spaces supporting the laboratories. Section 4 covers items used in the laboratory and preparation room. Section 5 gives general guidance on services in the science department. Information on appropriate flooring is also included. Section 6 describes adaptation studies in three existing schools, based on the guidance in other sections. Section 7 provides general building cost guidance as well as more detailed information on the cost of servicing systems and fume cupboards. A cost analysis of two adaptation studies are included. Appendices contain a checklist, 42-item bibliography, and glossary of terms. (GR)

SCIENCE ACCOMMODATION IN SECONDARY SCHOOLS

A Design Guide

PERMISSION TO REPRODUCE AND DISSEMINATE THIS MATERIAL HAS BEEN GRANTED BY

John Birch

TO THE EDUCATIONAL RESOURCES INFORMATION CENTER (ERIC)

1

U.S. DEPARTMENT OF EDUCATION
Office of Educational Research and Improvement
EDUCATIONAL RESOURCES INFORMATION
CENTER (ERIC)

This document has been reproduced as received from the person or organization originating it.

Minor changes have been made to improve reproduction quality.

• Points of view or opinions stated in this document do not necessarily represent official OERI position or policy.

ED 452 679

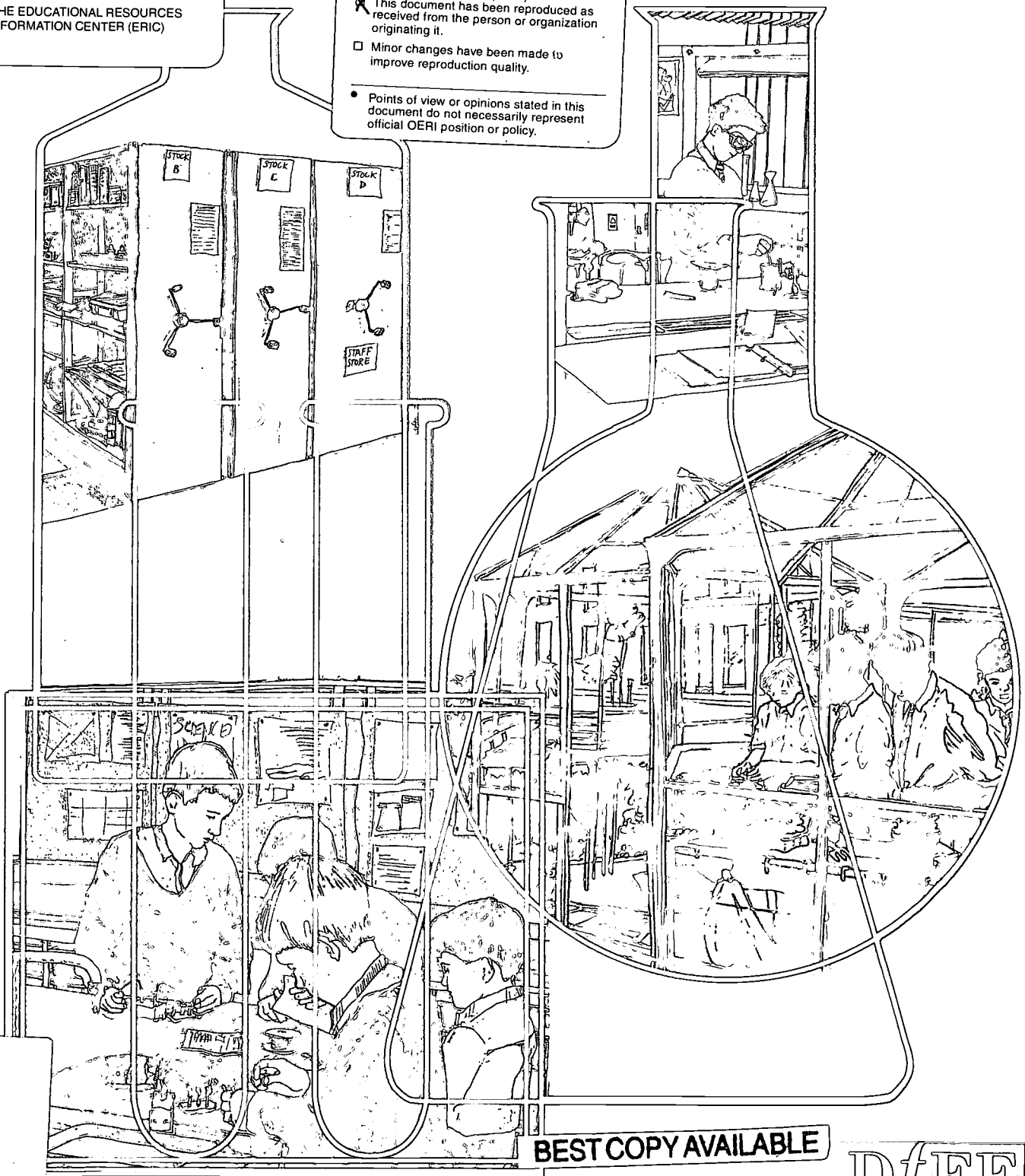

F 005 901

ERIC

BEST COPY AVAILABLE

D/EE

Architects & Building Branch

2

Department for
Education and Employment

BUILDING BULLETIN 80 (Revised 1999)

Science Accommodation in Secondary Schools

A Design Guide

Architects and Building Branch
Department for Education and Employment

Acknowledgements

This publication has been prepared by the following team in the Architects and Building Branch of the Department for Education and Employment.

Principal Architect: Diane Holt

Principal Architect: Lucy Watson

Senior Designer: Alison Wadsworth

with assistance from:

Senior Engineer: Richard Daniels

Principal Quantity Surveyor: Alan Jones

Principal Quantity Surveyor: Geoff Wonnacott

Her Majesty's Inspectors at Ofsted were also closely involved, led by Cliff Gould.

The Department would like to thank the authorities and school staff who were so helpful on the many school visits that were made and the advisers and furniture manufacturers who contributed information and comment.

Crown Copyright 1999. Published with permission of the DfEE on behalf of the Controller of Her Majesty's Stationery Office

Applications for reproduction should be made in writing to:

The Copyright Unit,
Her Majesty's Stationery Office,
St Clements House,
2-16 Colegate,
Norwich NR3 1BQ

ISBN 0 11 271039 5

Contents

Introduction	1
Section 1: Planning the Suite	2
Section 2: The Laboratory	10
Section 3: Support Spaces	24
Section 4: Furniture and Equipment	30
Section 5: The Environment/Health and Safety	36
Section 6: Adaptations: Three Furnished Case Studies	38
Section 7: Cost Guidance	46
Appendix 1: Checklist	54
Appendix 2: Glossary	57
Bibliography	58
Key to Symbols	Inside back cover

This publication offers guidance to those concerned with the provision of science accommodation, either through new construction or the adaptation of existing buildings. It is aimed at teachers, governors, local education authority advisers, building professionals and others who may be involved in the briefing and design process.

Science is a core National Curriculum subject at all key stages (KS). Post-16 courses are widely taught in schools. The science curriculum requires practical work at all levels. Most lessons contain a mixture of activities, which may include teaching exposition and questioning, practical work by pupils, teacher demonstrations, reading text books, writing notes, using computers, and evaluating practical work.

Science is normally taught in serviced laboratories, although some lessons may not require access to services, especially those for sixth form pupils. Nevertheless, access to serviced laboratories is needed for the majority of lessons for KS3 and KS4.

The amount of curriculum time spent and the way in which the subject is delivered varies from school to school. The guidance in this publication is not, therefore, prescriptive. It illustrates a variety of different approaches and it will assist schools in assessing how best their science accommodation can serve current and future curriculum needs in a flexible and adaptable way.

The accommodation needs of any individual subject should be considered in the context of the curriculum as a whole. It is recommended that this be done in partnership with either local education authority or other specialist advisers and building professionals. It is important to set planning targets to suit available resources and to look for value for money in all solutions.

The publication is chiefly concerned with provision for 11 to 16 year olds in secondary schools and does not include detailed information on sixth form accommodation. However, much of the

general guidance is equally applicable to older pupils and sixth form requirements are touched on in some of the examples.

There are no specific middle school plans illustrated although part of the KS3 curriculum will be taught in these schools. However, many of the planning principles described in Section 1 and the detailed information on servicing and furniture systems in other sections will apply.

The information in this publication begins with a broad outline of accommodation requirements, followed by more detailed guidance; a summary of the content is given here.

Section 1: Planning the Suite outlines the range of spaces usually required and looks at planning options in new and adapted departments.

Section 2: The Laboratory describes in detail the planning of an individual laboratory, covering services distribution, servicing systems and room layouts. A number of furnished plans are illustrated.

Section 3: Support spaces provides guidance on the teaching and non-teaching spaces supporting the laboratories.

Section 4: Furniture and Equipment covers items used in the laboratory and preparation room. The information complements that given in Section 2 on servicing systems.

Section 5: The Environment/Health and Safety gives general guidance on services in the science department. Information on appropriate flooring is also included.

Section 6: Furnished Case Studies describes adaptation studies in three existing schools, based on the guidance in other sections.

Section 7: Cost Guidance provides general building cost guidance as well as more detailed information on the cost of servicing systems and fume cupboards. A cost analysis of two adaptation studies are included.

Appendices include a Check List, Bibliography and Glossary of terms.

Section 1. Planning the Suite

This section outlines the main points to be considered when planning a suite of science spaces. Most schools will not be able to build a totally new science block, some schools may be adding one or two new spaces and others will be adapting their existing accommodation. The information provided here may form a useful guide when planning new or adapted spaces.

1.1 The range of teaching and non-teaching spaces is listed and a series of generic plan types indicate the key relationships between them. Three examples of adaptations illustrate typical situations in existing science suites.

1.2 This publication is mainly concerned with 11 to 16 schools with non specialist laboratories teaching a combined, coordinated or integrated science course. However, two of the adaptations are for 11 to 18 schools.

1.3 All the illustrations show individual laboratories in enclosed rooms. This is the most typical pattern in existing schools although there will be alternative arrangements, for example a science suite which includes one or more large double laboratories with an associated small lecture room, where two teachers 'team teach' a group of up to about forty pupils. This can be a successful combination for part of a suite of spaces.

The Suite of Spaces

1.4 The range of spaces required for teaching science will include laboratories, supplementary teaching spaces and non-teaching support spaces. The following may be used as a general guide when assessing the requirements of a particular school.

Number of Laboratories

1.5 Whether a new science block is being considered or existing accommodation adapted, the school's current and planned curricular, timetabling and staffing arrangements will need to be analysed in order to assess the number of laboratories that are required.

1.6 Figure 1/1 shows, for a range of school sizes, the number of spaces that are generated by two curriculum models reflecting a typical range of 11 to 16 schools. The number of teaching periods available will depend on the availability and deployment of science teachers. Decisions on this and on the proportion of pupils' time to be spent on science, will determine the average size of the teaching groups.

1.7 Group sizes and the amount of curriculum time spent on science will vary from school to school. Where the average group size is relatively small (e.g. KS3 groups of 25 and KS4 groups of 20), the number of lessons will increase and thus the number of laboratories, although these will be correspondingly smaller. Curriculum time may range from 10-15% at KS3¹ (the current average is 12.5%). At KS4 curriculum time may range from 10-30% with a current average of 20%.² In an 11 to 18 school, account must be taken of any A-level or vocational courses that are offered.

1.8 Figure 1/1 shows the average frequency of use of the spaces, that is its timetabled use compared to its availability. Schools will probably find it difficult to achieve a frequency of use higher than 85%/90% for Science because of the complexities of timetabling.

Size of Laboratory

1.9 The size of a laboratory will depend on the maximum expected group size rather than the calculated average. Figure 1/2 shows suggested area ranges according to group size.³ For a group of 30 KS3/4 pupils, a range of 79-91m² is given (Zone D). Laboratories from Zone C may be possible but will limit the activities and choice of furniture used. The range of activities being undertaken, the level of storage kept in the laboratory and the type of furniture system used can all affect area requirements. Section 2 provides further information on the size and shape of the laboratory and illustrates a number of spaces of 85m² for a maximum group size of 30 pupils.

Notes

¹ The final report by Sir Ron Dearing. 'The National Curriculum and its Assessment' recommended 90 hours per year for KS3 as a minimum. This is equivalent to 10% in most schools.

² 10% for single science, 30% for separate sciences and 20% for double science (taken by the majority of pupils).

³ The graph is based on the formulae shown alongside, where G (or g) = group size. It is extracted from Area Guidelines for Schools (BB82), DfEE 1996.

Model 1 15.2% pupil time spent on science	School size	KS ⁴	TP	Total TP	No. spaces calculated	Rounded number ⁵	F/use %	
Total PPW: 25 Science PPW KS3: 3(12%) KS4: 5(20%)	600	KS3	36					
		KS4	50	86	3.44	4	86%	
	750	KS3	45					
		KS4	70	115	4.6	5/6	92/76%	
	900	KS3	54					
		KS4	80	134	5.36	6	89%	
	1050	KS3	63					
		KS4	90	153	6.12	7	87%	
1200	KS3	72						
	KS4	100	172	6.88	8	86%		
Model 2 17% pupil time spent on science	600	KS3	72					
		KS4	80	152	3.8	5	76%	
	750	KS3	90					
		KS4	112	202	5.05	6	84%	
	900	KS3	108					
		KS4	128	236	5.9	7	84%	
	1050	KS3	126					
		KS4	144	270	6.75	8	84%	
1200	KS3	144						
	KS4	160	304	7.6	9	84%		

Figure 1/1
Numbers of Spaces for a Typical Range of Schools

Notes
⁴ Where possible group sizes at KS3 are no bigger than 30 and at KS4 no bigger than 24.
⁵ Where rounding up to the nearest whole number will result in a frequency of use greater than 90%, the next highest number of rooms is given. The practicalities of a frequency of use greater than 85/90% will need careful thought however. KS4 group sizes slightly higher than 24 could achieve a lower frequency of use.

1.10 If all the laboratories in a suite are the same size, there should be no restrictions on timetabling them. Schools will generally be able to timetable their spaces most flexibly if all the laboratories can accommodate the likely maximum group size, if necessary. However, in some situations, for example where a school has a large sixth form, it may be appropriate to provide some smaller specialist laboratories. Two examples of this are illustrated in the case studies.

- **A greenhouse and/or an animal room.** These spaces may be used for teaching or they may be used only by a technician. Animal rooms are rarely seen in schools these days but are sometimes used for insects such as locusts.

Figure 1/2
Area Guidelines

Supplementary Teaching Spaces

1.11 Certain supplementary teaching areas can be valuable additions to the suite where space allows (see Section 3). The following examples may be found.

- **A small resource area.** This space can provide a focus to the department, with displays of pupils' work and new scientific developments. A small network of computers can be a valuable resource, especially if there is good access from laboratories.
- **A small science project room** may be desirable in schools with sixth forms where older pupils can set up long term experiments.

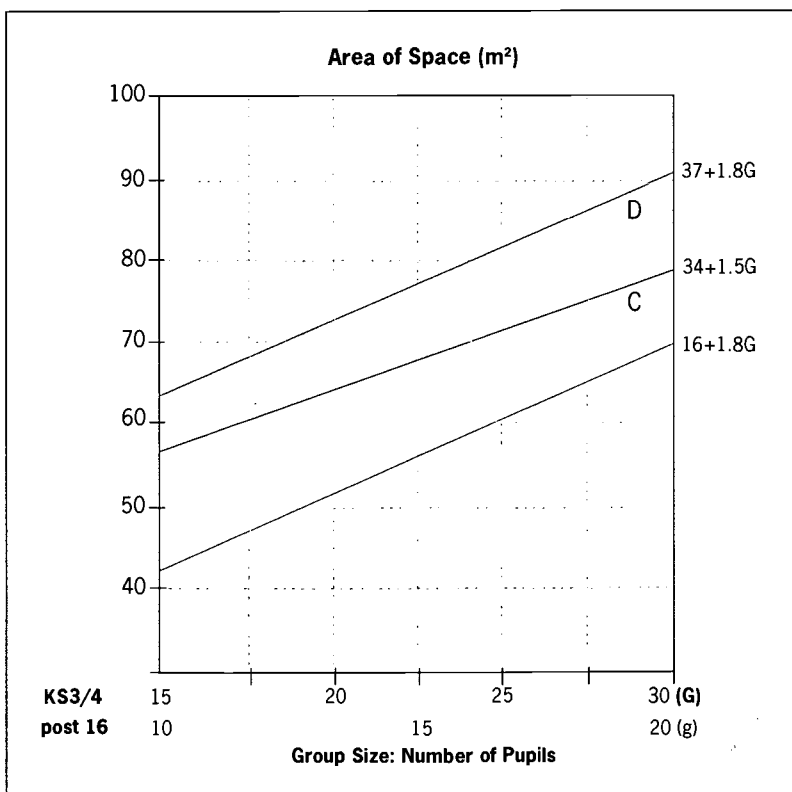

Non Teaching Support spaces

1.12 **Preparation and storage areas** are needed to support the teaching spaces. A total area of **0.4 - 0.5m²** per workplace (a figure based on an analysis of a number of existing schools) can be used as a guide. Where the laboratories are dispersed or on two floors this figure may need to be increased to allow for some duplication of resources.

1.13 A shared **staff base** can be useful for meetings and preparation work and the secure storage of paperwork such as pupils' records.

Circulation

1.14 Principal circulation routes should allow for the adequate movement of equipment, trolleys and pupils. Access by those in wheelchairs will also need to be considered.

Planning Principles

1.15 Figures 1/3 to 1/6 show four plan types: linear, grouped around a preparation room, and linear on two floors. These reflect typical organisational patterns, each one conforming to the following principles which aim to provide an efficient and integrated suite of spaces.

- **Laboratories are grouped together.** This enables common resources to be shared, and gives easier access to ancillary spaces.
- **There is only one preparation area for each floor of laboratories.** This provides a more economical use of space, equipment and technicians' time. If a preparation room is centrally positioned, travel distances to the laboratory are minimised.
- **Ancillary teaching spaces are located for ease of access.** The animal room is alongside the preparation room for convenient technician use and the resource area is located so that it provides a focus to the department and can be easily accessed by the whole suite.

The key features of the four generic plan types are outlined below.

Linear Plan (Figure 1/3)

1.16 This plan suits the smaller school with up to six laboratories where they are close enough together to feel like a suite and technicians can reach the rooms easily. For a school with more than seven laboratories the distance between the preparation room and some of the laboratories becomes inconvenient and the suite may be too dispersed.

1.17 The advantage of this plan type is that it can facilitate links with adjoining departments. Teaching spaces and resources may be shared; for example, a PECT space (see Glossary) could be used for both science and design and technology. Staff and display areas can also be shared.

Figure 1/3
Linear Plan

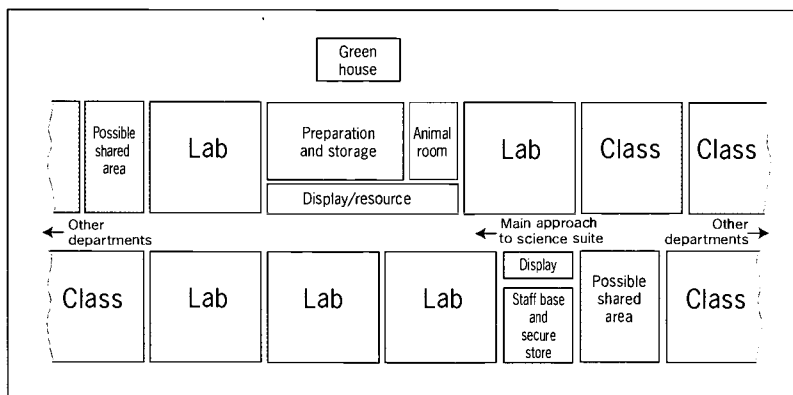
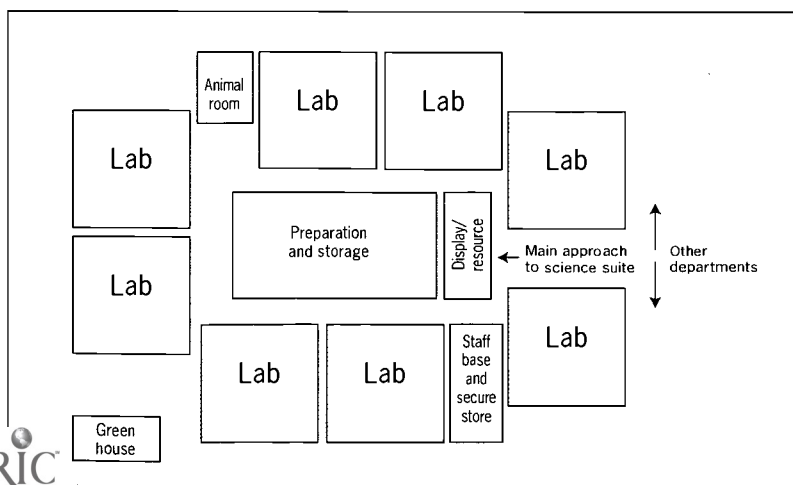

Figure 1/4
Central Preparation Room



Central Preparation room (Figure 1/4)

1.18 This plan is most suitable for schools with more than seven laboratories. It is convenient for the technicians because the preparation room is central to the suite, but there is no view out and in a two storey building there may be no daylight.

1.19 The disposition of the plan makes the suite easy to define but it may be less easy to establish links with other departments or to expand in the future.

1.20 The central resource area can be supervised easily from the preparation room, and the display can form part of the resource area.

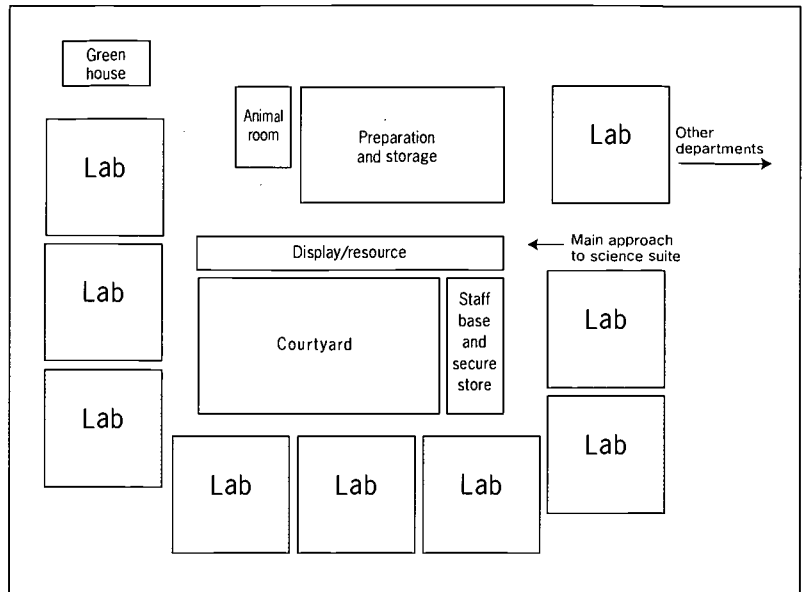

Figure 1/5
Central Courtyard

Central Courtyard (Figure 1/5)

1.21 This plan is less compact than the previous one with greater distances from preparation room to laboratory. The technicians enjoy a view of the outside and the enclosed and secure courtyard can be used for some practical activities, becoming an integral part of the suite of teaching spaces.

1.22 A variation of this plan is to have an atrium in place of a courtyard. This can provide a central teaching space, possibly available for use by other departments and could be considered for a central IT resource.

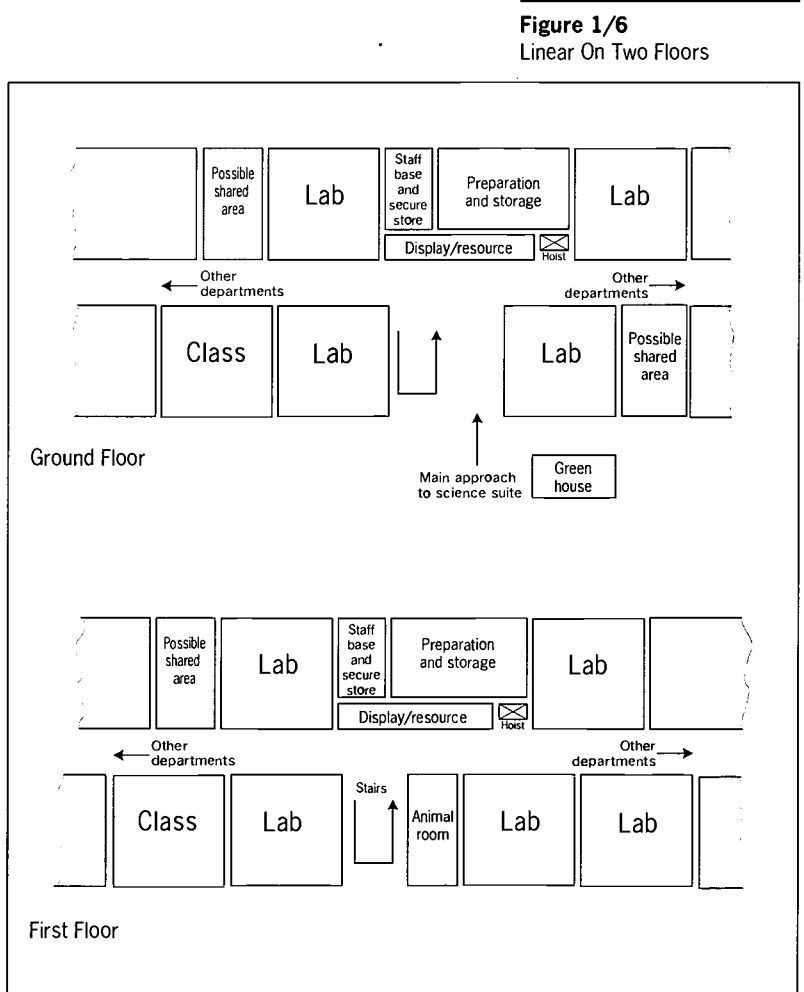

Figure 1/6
Linear On Two Floors

Linear On Two Floors (Figure 1/6)

1.23 Extending the suite on to two floors may be the best solution in some buildings, and it does share some of the advantages of the linear plan (ease of inter-departmental links and ease of extension). In a large school it may also help to break down the scale of the suite.

1.24 The main disadvantage of this plan is that preparation and storage facilities are divided between the floors and a hoist may be required. Any lift provided for disabled access may also be used for transporting heavy pieces of equipment as gas cylinders or computers.

1.25 A small resource bay has been shown on each floor so that pupils do not have to leave their floor to use the available resources.

Section 1. Planning the Suite

	CASE STUDY 1			CASE STUDY 2 ⁶			CASE STUDY 3 ⁶		
	E	A	N	E	A	N	E	A	N
Laboratories (no.)	5	5	5	7	9	9	8	9	9
Workplaces (no.) ⁷	122	134		185	242		147	171	
Total TA (m ²)	422	403		543	718		518	607	
Total TA/WP (m ²)	3.45	3.01	2.63 – 3.03	2.94	2.97	2.86 – 3.29	3.52	3.55	3.15 – 3.63
Total PA (m ²)	46	54		85	111		77	85	
Total PA/WP (m ²)	0.38	0.40	0.4 – 0.5	0.46	0.46	0.4 – 0.5	0.52	0.50	0.4 – 0.5
Total (TA+PA)/WP (m ²)	3.83	3.41		3.40	3.43		4.04	4.05	

Figure 1/7
Analysis of 3 Case Studies

Key

- E = Existing
- A = Adapted
- N = Notional
- TA = Teaching Area
- PA = Preparation Area
- WP = Workplace

Examples of Adaptations

1.26 The following three case studies show how existing science accommodation can be adapted using the area guidelines and planning principles already described. The examples reflect some typical situations.

- **Case Study 1:** a small school with two undersized laboratories.
- **Case Study 2:** a medium sized school with an insufficient number of laboratories.
- **Case Study 3:** a medium sized school with a large sixth form and an insufficient number of laboratories.

1.27 These case studies, which are all based on existing schools, show the adaptation of complete suites, although in reality the work may be phased over a period of years. Details of the furniture layouts for Case Studies 1 and 3 are described in Section 6, and a breakdown of both building and furniture and equipment costs is given in Section 7.

1.28 All three adaptations follow the same brief but in each case there are compromises made because of the nature of the existing buildings. None of the adaptations includes new building work although two involve expansion of the suite within existing accommodation. These plans show that although the sizes of spaces are sometimes less than ideal, valuable improvements can be made with minimal changes.

1.29 Figure 1/7 summarises the changes in each study and compares the areas per workplace with a notional plan which is based on the area guidance given earlier in this section (see paragraphs 1.9 and 1.12).

Notes

⁶ Case Studies 2 & 3 include some laboratories timetabled only for sixth form pupils. This is taken into account in the calculations.

⁷ The number of workplaces is based on the lower line of Zone D in Figure 1/2. This allows all pupils including sixth formers to engage in a full range of activities including practical work.

Case Study 1

As Existing (Figure 1/8)

1.30 Case study 1 is an 11-16 school with 600 pupils on roll. The existing science accommodation may be compared with the two storey generic plan in Figure 1/6. On the ground floor there are two large laboratories and a very small preparation room. On the first floor there are two small laboratories, neither of which is large enough for 30 pupils; one large laboratory and a small preparation room. Technicians carry equipment up and down the stairs and do much of their preparation work in the teaching spaces. The chemical store is accessed via one of the laboratories.

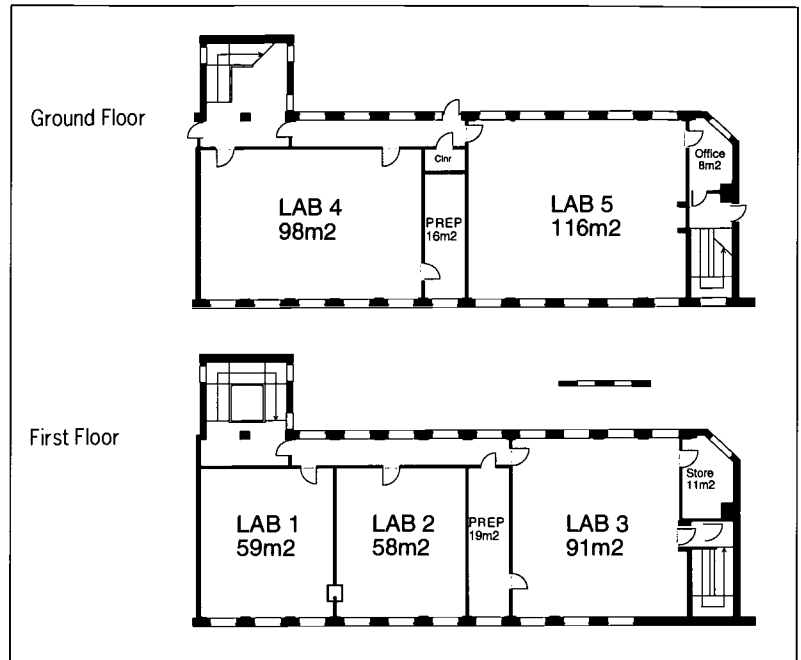

Figure 1/8
Floor Plans as Existing

The Adaptation (Figure 1/9)

1.31 The science curriculum taught in this school and the way in which it is organised requires five laboratories and adequate preparation facilities. Therefore, one of the small laboratories remains and the second one is enlarged sufficiently to accommodate 30 pupils. The large laboratory on the ground floor is reduced in size and the preparation room is enlarged. Below are the main features of the proposal.

- The suite provides more flexibility with four spaces for up to 30 pupils allowing a KS3 year group to be divided into four groups.⁸ The fifth laboratory can, if necessary, accommodate up to 24 pupils and is most likely to be used for KS4 pupils when a year group could be divided into five. The total number of workplaces (based on zone D in Figure 1/2) is increased from 122 to 134.
- The preparation and storage facilities are increased from 0.38m² to 0.40m² per workplace. Additional storage can continue to be provided in the largest laboratory. A separate ventilated chemical store is added with direct access from the preparation room. A hoist enables equipment to be transported between the two floors.

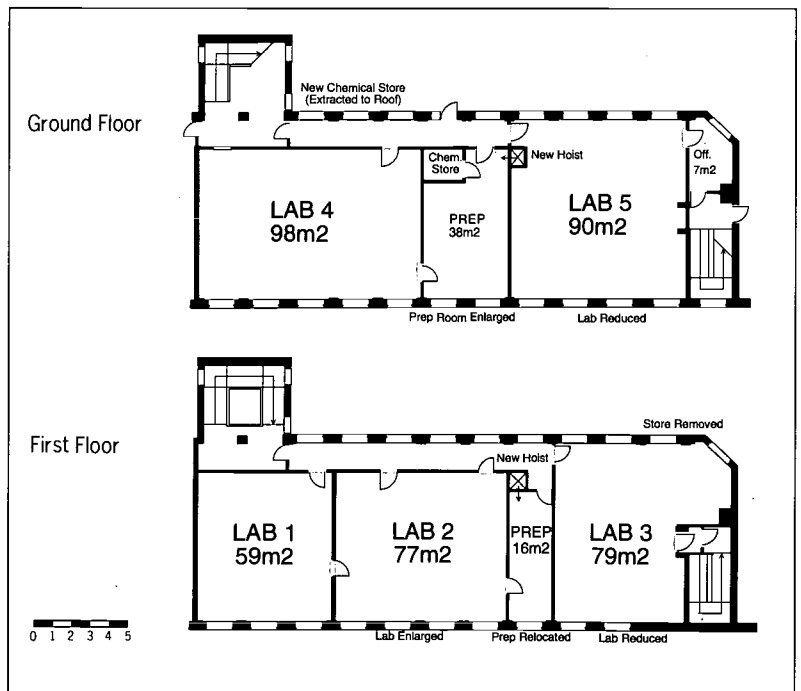

Figure 1/9
Floor Plans as Adapted

- As the alternative means of escape from the corridor is via laboratory 3, its door would have to remain unlocked. This situation is acceptable in an existing school if properly managed, but not in new buildings. The integrity of the main stairway has been secured by filling in the door opening from laboratory 4.

Note

⁸ An area from Zone C in Figure 1/2 (such as laboratory 2 in Case Study 1) is below the recommended area range for 30 KS3/4 pupils and would not be ideal in a new building. See Section 2, paragraph 2/7 for further discussion.

Case Study 2

As Existing (Figure 1/10)

1.32 Case Study 2 is an 11-18 school with 770 pupils from 11-16 and 250 sixth form pupils on roll. The amount of science curriculum time taught by the school and the timetabling organisation requires a minimum of nine laboratories with a planned frequency of use of 90%.

1.33 The existing science accommodation consists of seven spaces in one single storey building. Six of the laboratories are 79m² or more and the seventh is a small sixth form laboratory of

Figure 1/10
Floor Plans As Existing

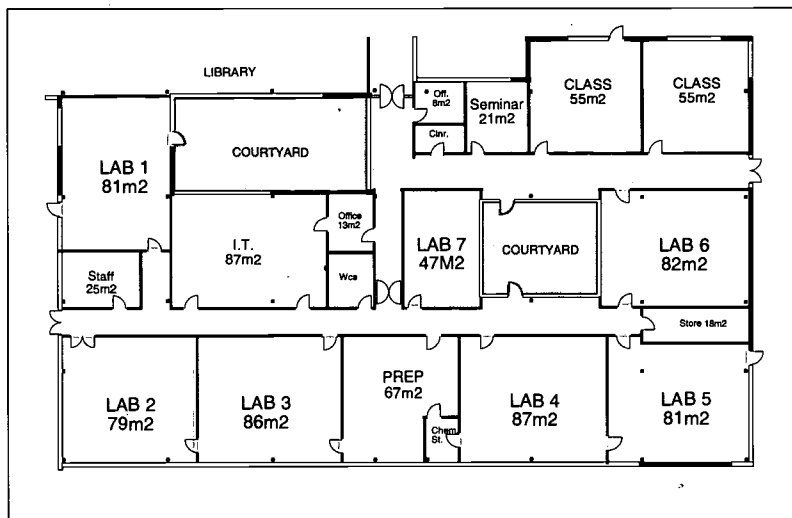
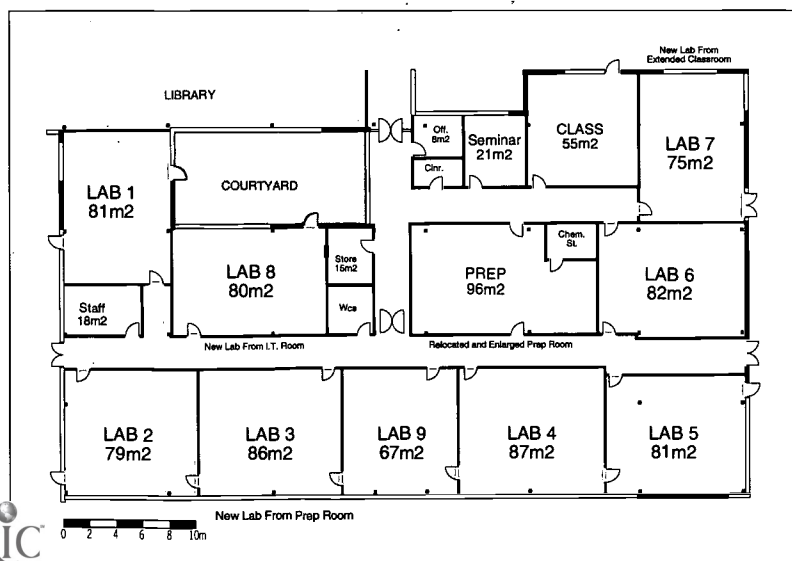

Figure 1/11
Floor Plans As Adapted



47m² providing a total of 185 workplaces. There is a centrally located preparation room and a separate chemical store providing a total area of 0.46m² per workplace. Within the same block there are two general teaching rooms and an IT room which can be brought into the adaptation.

The Adaptation (Figure 1/11)

1.34 Two further science spaces are created by adapting the IT room and the preparation room. The small sixth form laboratory is replaced by a space of 75m², created by extending one of the general teaching spaces. The preparation room, which needs to be larger to serve nine laboratories, is relocated to the centre of the suite, adapted from the small laboratory and the adjacent courtyard. The suite can be compared with the generic plan illustrated in Figure 1/4. The main points to note are summarised below.

- The adapted suite provides 7 laboratories which are large enough for 30 pupils, and two (laboratories 7 and 9) which are more suitable for sixth form groups.
- The total number of workplaces for science is increased to 242, assuming laboratories 7 and 9 are used as specialist sixth form laboratories.
- The area provided for storage and preparation is still 0.46m² per workplace.
- The internal preparation room may need to be daylit by rooflights and mechanically ventilated.
- The main corridor is widened to better accommodate the increased through-traffic of pupils and trolleys.

Case Study 3

As Existing (Figure 1/12)

1.35 Case Study 3 is an 11-18 school with 600 pupils from 11 to 16 and 328 sixth form pupils on roll. The science accommodation is all on the first floor of a 1930's building.

1.36 The science teaching and the timetabling of this school suggests a total of 9 spaces and this results in an average frequency of use of 87%. There are at present eight laboratories but only three are more than 70m² and three are 48-50m². General teaching rooms on other floors are currently used for some lessons.

1.37 There are three storage/preparation rooms which together provide an area of 0.52m² per workplace. Two general teaching rooms are available to be brought into the adaptation.

The Adaptation (Figure 1/13)

1.38 Five of the laboratories need to be large enough to hold 30 KS3/4 pupils. This is possible in the three largest existing laboratories (nos. 1, 4 and 7). A fourth laboratory (no. 5) is extended to 73m². A fifth Laboratory (no. 2) is extended to 67m² and can accommodate 28 or, if absolutely necessary, 30 KS 3/4 pupils. In some of these cases an area from zone C (Figure 1/2) is acceptable as a compromise.⁹ The remaining four spaces will be used for sixth form pupils. The main features of the adaptation, which is limited by the overall existing floor area, are listed below.

- The adapted suite provides seven fully serviced laboratories and two partly serviced science classrooms. The total number of workplaces has increased from 147 (with 3 spaces timetabled for sixth form groups) to 171.
- Four teaching spaces (nos. 3, 6, 8 and 9) are suitable for sixth form groups. Two of these are fully serviced, the other two can be used for non-practical lessons.

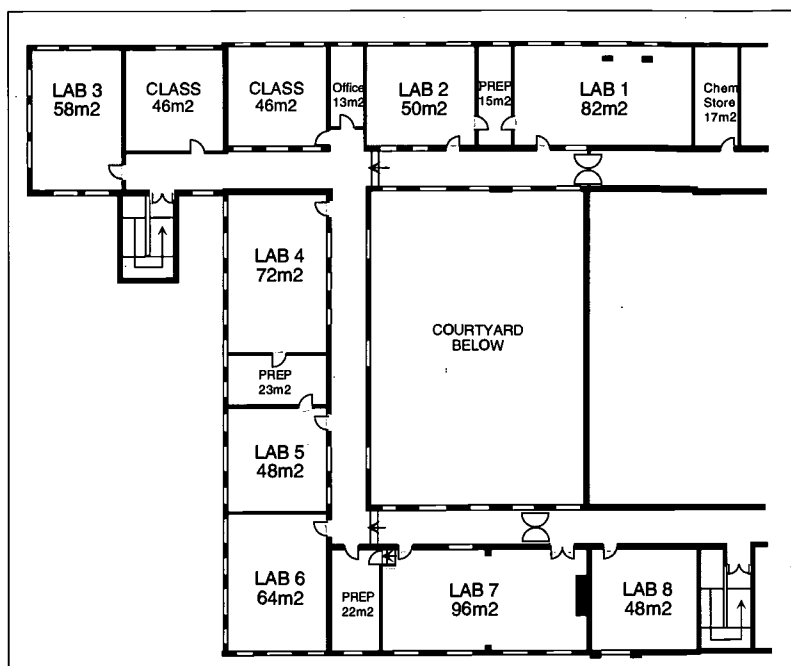

Figure 1/12
Floor Plans As Existing

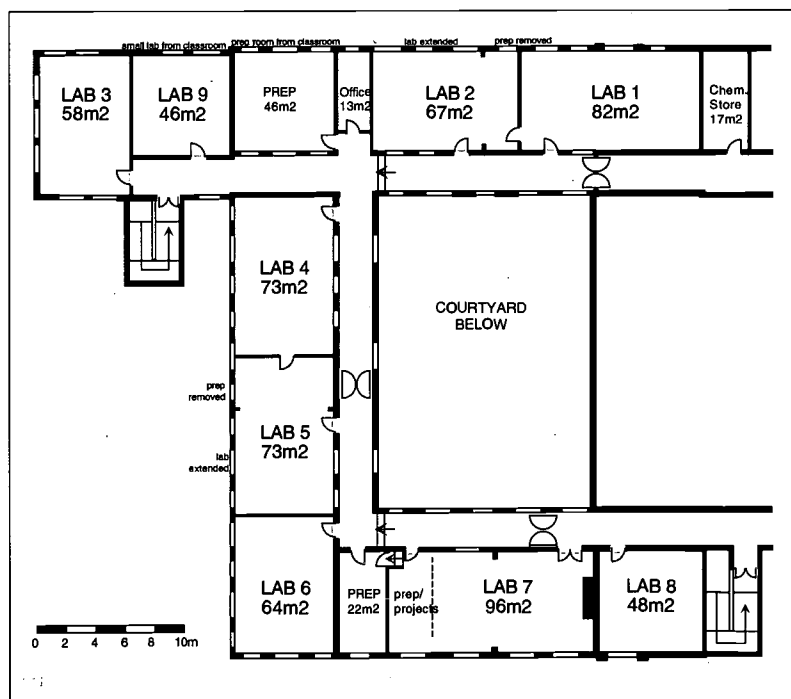

Figure 1/13
Floor Plans As Adapted

- The preparation and storage facilities are improved by converting one of the small classrooms into a main preparation room. The floor area provided for storage outside the laboratory is increased from 77m² to 85m² (0.50m² per workplace). This is further supplemented by storage within the laboratories.

Note

⁹ See Section 2, paragraph 2/7 for further discussion on laboratory size.

Section 2: The Laboratory

A laboratory should be flexible enough to respond to a wide and varying range of activities. The size of the space, the method of distributing services, and the choice of furniture systems will all affect the way in which it can be used.

2.1 This section provides guidance on all the main aspects of planning a laboratory. It is divided into five parts.

- Activities in the Laboratory.
- The Size and Shape of the Laboratory.
- A Planning Strategy.
- Services Distribution.
- Servicing Systems.

2.2 This is followed by examples of furnished layouts using a variety of serviced systems.

Figure 2/1
Briefing and Demonstration

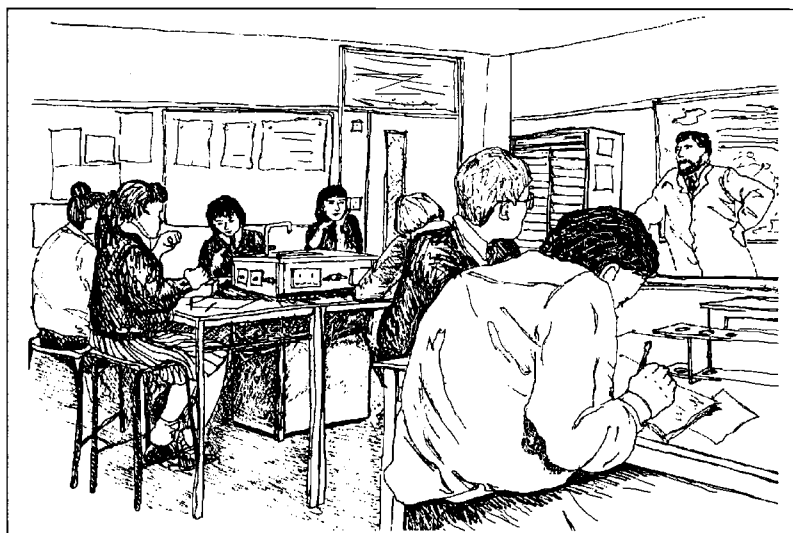
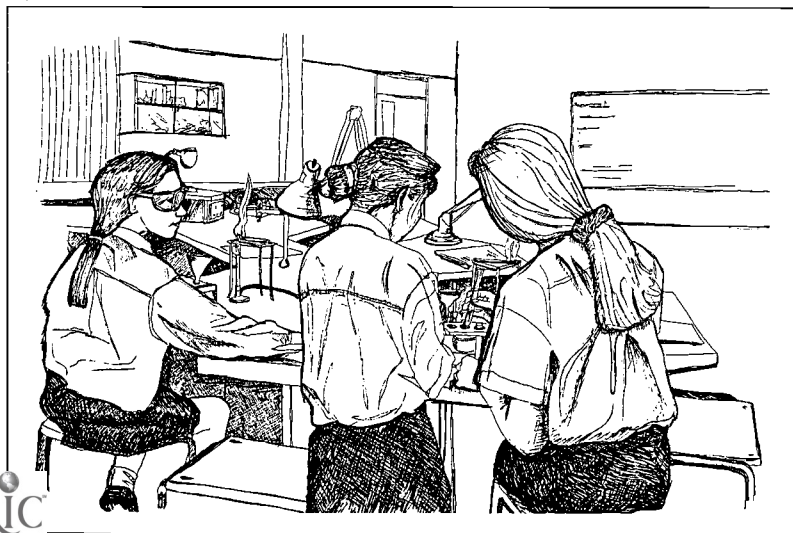

Figure 2/2
Pupils' Experiments



Activities in the Laboratory

2.3 There are certain basic activities common to all areas of science which may be identified as having an effect on the design of the laboratory. These activities can be categorised into three main areas.

- Briefing and teacher demonstration of experiments.
- Pupils' supervised experiments.
- Evaluation exercises, which includes independent research and recording by pupils, and class discussion and pupil presentations.

Briefing and demonstration (Figure 2/1)

2.4 Increased scientific investigation by pupils is now commonplace in laboratories. However the teacher may also need to address the whole class either in the form of briefing or discussion, possibly with the aid of a video or overhead projector. Demonstration of experiments may require pupils to gather around a serviced area, often the teacher's own table or a serviced unit within the classroom area. A fume cupboard is sometimes used for whole class demonstrations.

Pupils' supervised experiments (Figure 2/2)

2.5 Pupils will often carry out experiments, either individually, in small groups of two or three, or occasionally in larger groups. A full range of services may be needed and sufficient space must be provided for pupils to work safely at serviced units. Pupils may need ready access to a range of basic resources, such as bunsen burners, mats and tripods. They may need occasional access to a computer to obtain information and log and analyse data from experiments. CD ROM (see Glossary) and interactive video may also be used in certain situations.

Evaluation exercises (Figure 2/3)

2.6 Evaluation activities can include writing up experiments, class discussion, and pupil presentations, often with the use of an OHP (see Glossary) or computer.

The size and shape of the laboratory

2.7 Figure 1/2 in Section 1 shows an area range of 79-91m² (Zone D) for a group of 30 KS3/4 pupils. This will allow a class to undertake activities involving both practical and theory work. It should also allow for a reasonable level of local storage. An area from the upper end of the range may be appropriate where a small central preparation area necessitates an increase in local storage or where the quantity of equipment is greater than average (this may be the case where sixth form pupils are timetabled into main school laboratories). At the lower end of the range the choice of servicing system becomes more critical and some compromises may have to be made in the provision of equipment. As the size of the laboratory reduces, it becomes increasingly important to ensure careful supervision of practical work to maintain safe working practices. A laboratory of 70-79m² (Zone C in Figure 1/2) may accommodate 30 KS3/4 pupils but there is likely to be a reduced level of furniture and equipment. The range of activities taking place may also be limited.

2.8 All the laboratories shown in this section (Figures 2/11 to 2/25) are from the middle of area Zone D, 85m². Section 6 illustrates examples of laboratories for 30 pupils of between 70m² and 98m² as well as smaller spaces for groups of less than 30.



Figure 2/3
Evaluation Exercises

2.9 The shape of the space is almost as important as its size. A simple rectangular shape allows for flexibility of layout and enables good supervision of pupils. Rooms that are too long and narrow are difficult to arrange. Viewing distances may be too long or viewing angles too wide (see Figure 2/4). In a space of 85m², a depth of between 8m and 9m (ie. proportions from 1:1.0 to 1:1.2) suits a variety of furniture systems and avoids most of the problems listed above. Consideration must be given to ventilation and lighting in deeper spaces.

Figure 2/4
Viewing Distances

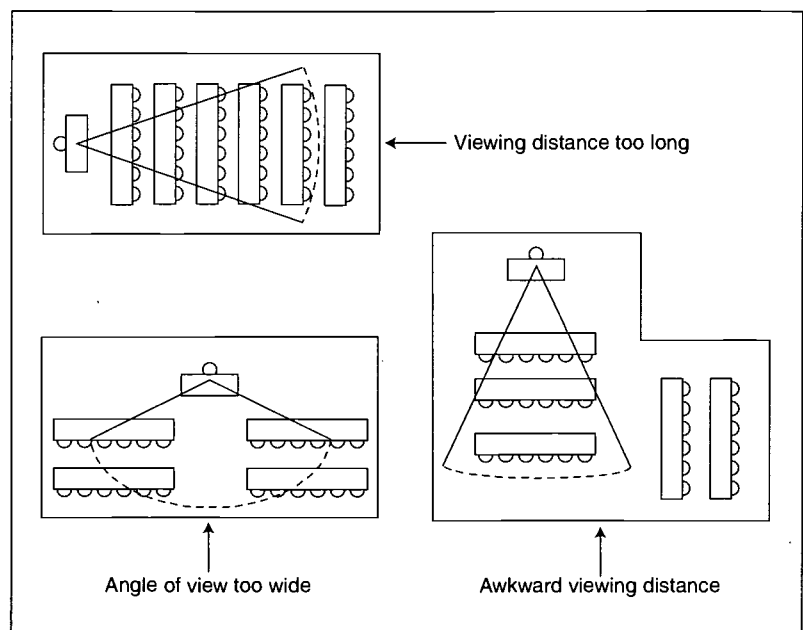

Notes

¹ Department for Education and Employment 'Fume Cupboards in Schools' (Revision of DN 29). BB 88, 1998.

² In these plans a position for a mobile fume cupboard is shown near to the teacher. When pulled from the wall it is accessible on all sides for demonstration purposes. A fume cupboard may not be required in all laboratories.

³ In these plans the teacher is assumed to demonstrate experiments that do not require a fume cupboard from the main serviced units.

Planning strategy

2.10 Schools may find it useful to establish a planning strategy for the laboratory. They may want to ensure that, regardless of the servicing system used, a suitable environment will be provided that is capable of responding in a flexible way to the activities taking place.

2.11 The furnished plans in this section are based on the zoning diagram illustrated in Figure 2/5 and the planning strategy outlined below. A group size of around 30 pupils is assumed (although the general principles apply to other group sizes too).

- A work surface area of at least 0.3m² is allowed for each pupil, allowing a maximum number of 30 pupils in the laboratory.
- All circulatory areas follow the planning guidelines outlined in BS 3202 and Figure 2/6.
- Each pupil has good access to a full range of services, with a minimum of one gas tap, one socket outlet per pupil and one sink per 6 pupils.
- Pupils face the teacher and the whiteboard whenever possible; alternative seat positions are shown around the teacher where this is not possible.
- A storage facility is included for pupils' coats and bags (if brought into the laboratory) adjacent to the door and the teacher.

Figure 2/5
Zoning Diagram

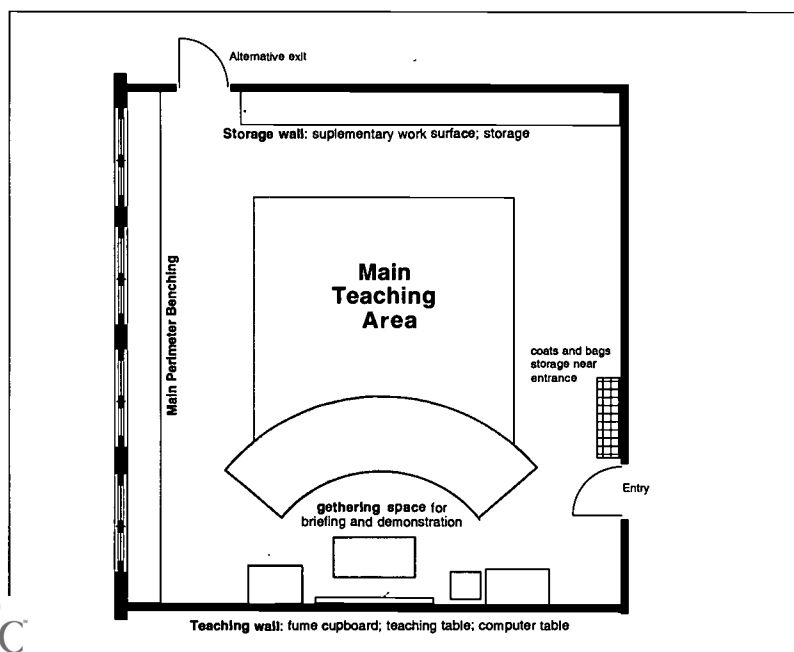

- Perimeter benching is kept to one wall where possible and is used as an additional shared work surface, containing a wash-up sink with hot and cold water.
- A fume cupboard¹ is shown which, for Health and Safety reasons, is positioned away from the fire exit or main circulation routes with good access for groups of pupils during demonstrations.²
- Where possible, the teaching wall is placed at 90° to the external wall, to allow good side lighting and avoid direct glare from the window.
- A computer position is provided close to the teacher to enable supervision, and to maximise the potential for shared pupil/teacher use. By placing the computer at 90° to the external wall problems of glare will be minimised.
- Storage of between 4m³ and 6m³ is provided for local resources and display and is concentrated above and below the perimeter benching. A separate preparation area is assumed within the overall science accommodation.
- There is adequate floor space at the perimeter for additional mobile storage units such as a general purpose trolley or tray units.
- A clear area is provided to allow pupils to gather together for briefing sessions and the safe demonstration of fume cupboard experiments.³ It is important to consider each pupil's ability to see and hear the teacher clearly.
- A clear floor length of around 3m is allowed within the circulation route for runway experiments.

Safe distances

2.12 Figure 2/6 provides a guide to the distances required between furniture in a laboratory. The information is based on BS 3202 (Part 3) with additional dimensions given for space around doors etc. Space allocation should fall within the range illustrated and will depend on the amount of circulation required, and the type of layout and activities envisaged. Safe distances around fume cupboards are given in Building Bulletin 88.¹

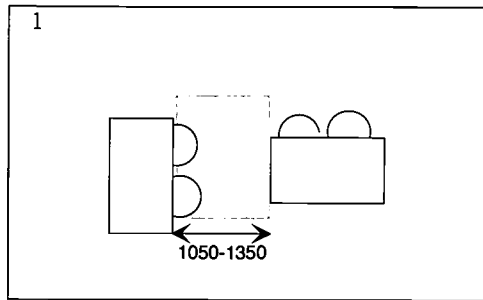
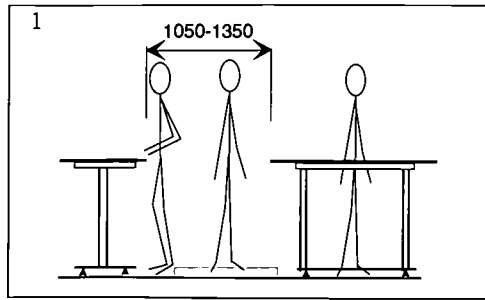
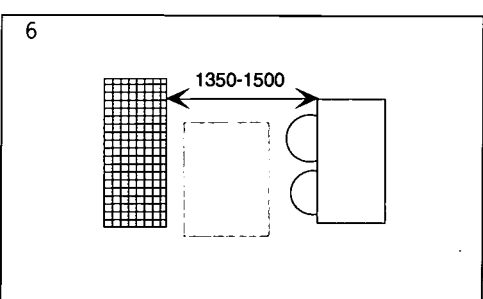
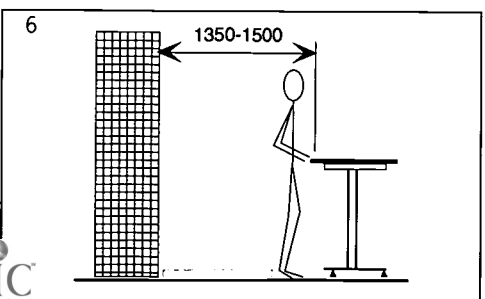
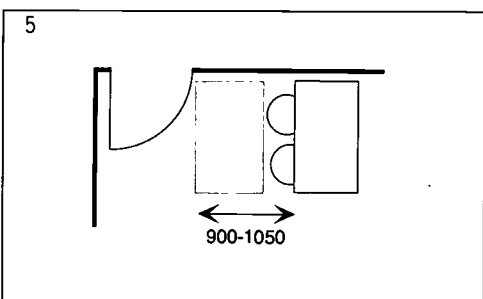
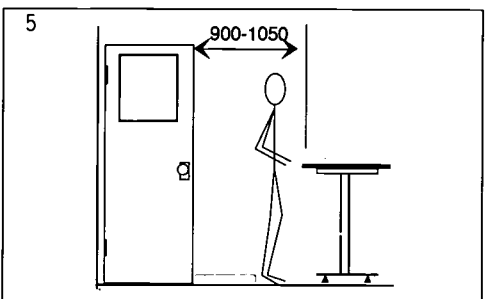
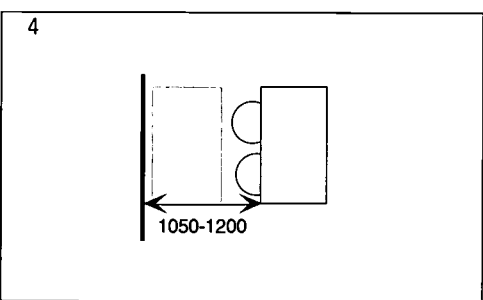
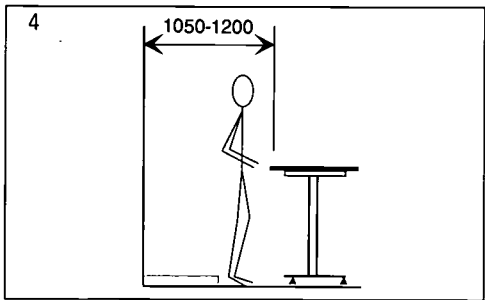
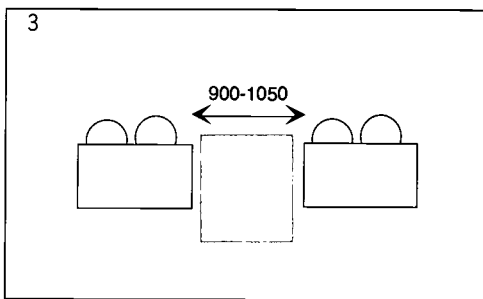
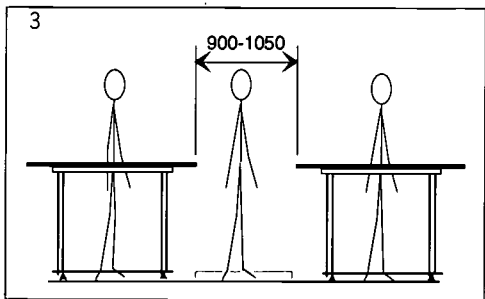
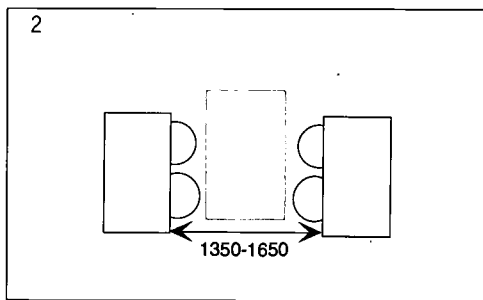
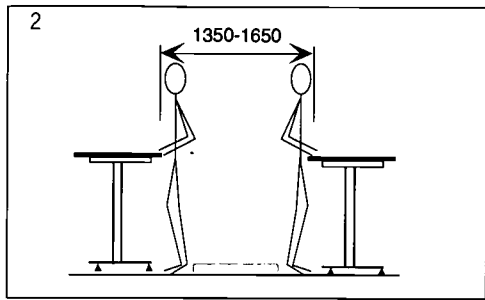

Figure 2/6
Safe Distances



Key

circulation



pupil table

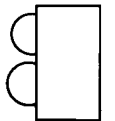

pupil



coats and bags storage

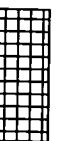

Services distribution

2.13 Services distribution within a laboratory can have a significant effect on future building adaptations, maintenance and the choice of furniture that can be accommodated. There are three main options for the distribution of services within a laboratory:

- overhead (Figure 2/7);
- underfloor (Figure 2/8);
- perimeter (Figure 2/9).

Within each option there are variations and sometimes two systems may be combined.

Figure 2/7
Overhead Servicing

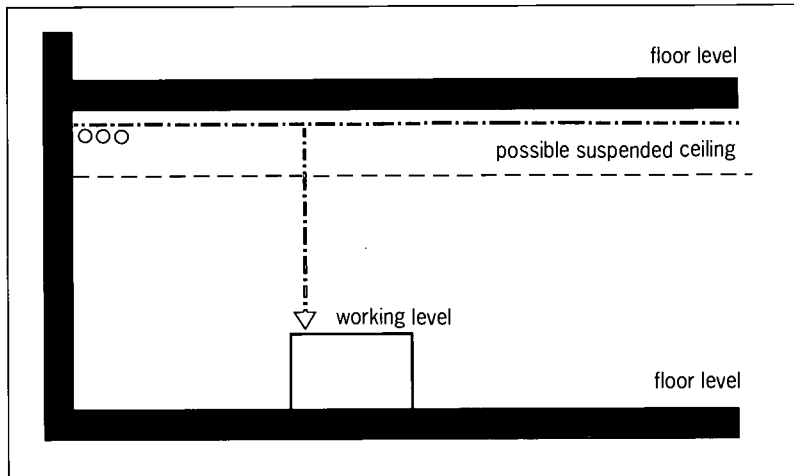
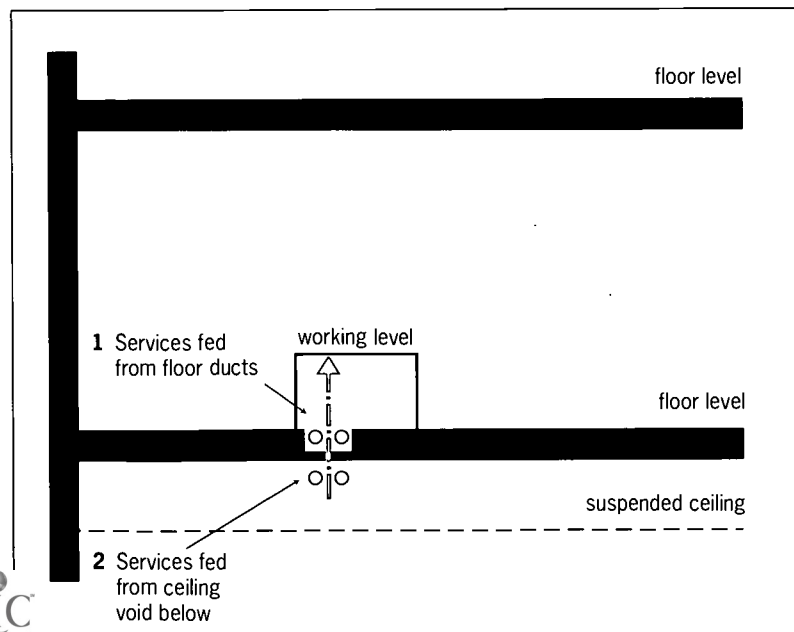

Figure 2/8
Underfloor Servicing



Overhead

2.14 In this option services run at high level, in trunking which is suspended below ceiling level or in a recessed ceiling duct, or in the ceiling void with a network of outlets set into the finished surface. Services are distributed to the furniture below by means of flexible pipes or cables. Generally, overhead supplies are combined with a gravity drainage system incorporating a network of floor outlets, although pumped or vacuum drainage systems which run in the overhead ducts are also a possibility.

2.15 Overhead systems can have the following advantages:

- perimeter, peninsular and island benching layouts can be serviced in a variety of configurations;
- there is flexibility in the location of furniture;
- services are readily accessible from within the laboratory which simplifies maintenance and allows adaptations to be carried out without disrupting other spaces.

2.16 The disadvantages of the system include:

- the servicing connections from ceiling to the working surface below can obstruct sight lines to the teacher's position;
- the vertical service 'droppers' can look untidy, particularly if there are a number of them, and may be vulnerable to damage;
- currently available pump and vacuum systems of drainage involve floor standing units which take up space and require regular and specialist maintenance (they may also be noisy).

Underfloor

2.17 In this option, services may either be run in ducts set into the floor with varying degrees of accessibility or they may be located in the ceiling void of the room below. Services reach bench top level via rigid or flexible connections.

2.18 The advantages of this system include:

- perimeter, peninsular and island benching layouts can be serviced;
- the laboratory looks neat with no exposed servicing cables or pipes.

2.19 The disadvantages of the system are:

- water supplies and drainage need careful separation from electrical services in floor ducts;
- if services are distributed in the ceiling void of the room below, modifications and maintenance will disrupt this room;
- as serviced units have to be located over floor outlets, there is limited scope for re-positioning.

Perimeter

2.20 Perimeter service ducts are usually located at bench level or below with drainage at a low level.

2.21 The advantages of this system are:

- all services, including drainage, are accessible from the space they serve simplifying maintenance and future changes;
- services are less likely to be damaged since they can be concealed by benching, the appearance of the laboratory is also more tidy;

2.22 The disadvantages of the system are:

- island benching cannot be serviced directly;
- services may have to be routed around door openings etc;
- where services are fixed to internal partitions this can restrict future planning changes.

2.23 This method is particularly appropriate for conversion work because installation is fairly straightforward, involving minimal disturbance of the existing structure.

Servicing Systems

2.24 There are several furniture systems which distribute services locally within the laboratory. Systems which are flexible enough to accommodate change are highly desirable. For example, it may be advantageous to be able to move tables to create a clear floor area for certain activities. A flexible servicing system also allows individual teachers to reorganise a space to suit their requirements. The choice of system will depend partly on the servicing method that is chosen, and on the level of available resources. The variety of systems can be divided broadly into the following four generic types.

- Serviced spines
- Serviced bollards
- Service pods
- Serviced furniture

2.25 Each system is described in the following examples and variations within each type is illustrated in detail. All the laboratories are the same size (85m²) showing the effect that different systems may have on an identical space. The effect of room shape is also demonstrated by showing each system laid out in two depths of space (8m and 9m).

Figure 2/9
Perimeter Servicing

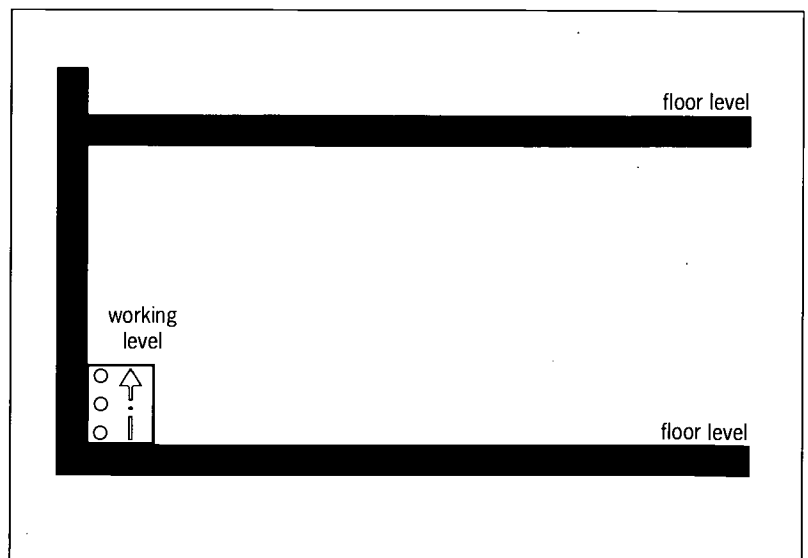
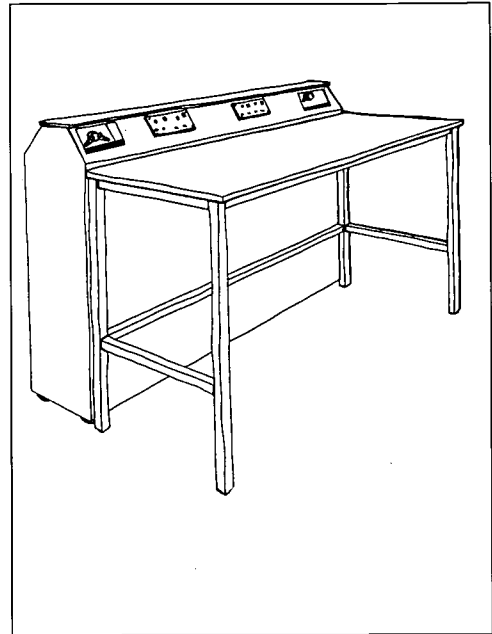

Figure 2/10
Typical Serviced Spine

Examples of Furnished Layouts

Serviced Spines

2.26 A Serviced Spine is a freestanding component incorporating (usually horizontal) services distribution duct with a number of outlets. A spine may provide both dry and wet services, including drainage, and may be fed from overhead, under the floor or from the perimeter. Spines serving island or perimeter benching layouts are not normally fixed to the floor, but their underframes are often clamped to the benches they serve. Most perimeter serviced spines must be clamped to the wall.



Notes To Plans

A: These illustrations are not prescriptive. The actual design and layout of school laboratories will depend on a number of factors, including the level of available resources.

B: Refer to the furniture key at the back of the publication.

C: Where pupils do not directly face the whiteboard, stools are shaded black.

Labkit Workstation (Figure 2/11)

2.27 The Labkit Workstation system is a relocatable kit of components which incorporates all required services including vacuum drainage. Piped and electrical supplies, together with drainage runs, are linked back to a control unit through integrated trunking at doorhead height. The control unit, containing switchgear, pumps and safety devices, is the only part of the system connected to the main services of the building. Loose tables - giving a work area per pupil of 0.36m^2 - are arranged around the workstations and storage components and sinks may be hung off the framework.

2.28 In both the 8m and 9m deep rooms an area is provided at the front of the laboratory for note taking and briefing which is a useful facility in a system where clear sightlines for pupils can sometimes be a problem.

2.29 In this particular layout the system appears to work more efficiently in the 8m deep room, with the control box being sited next to the teacher. This is because the greater width allows better circulation and more space around the teacher for class gatherings.

Figure 2/11
Labkit Workstation

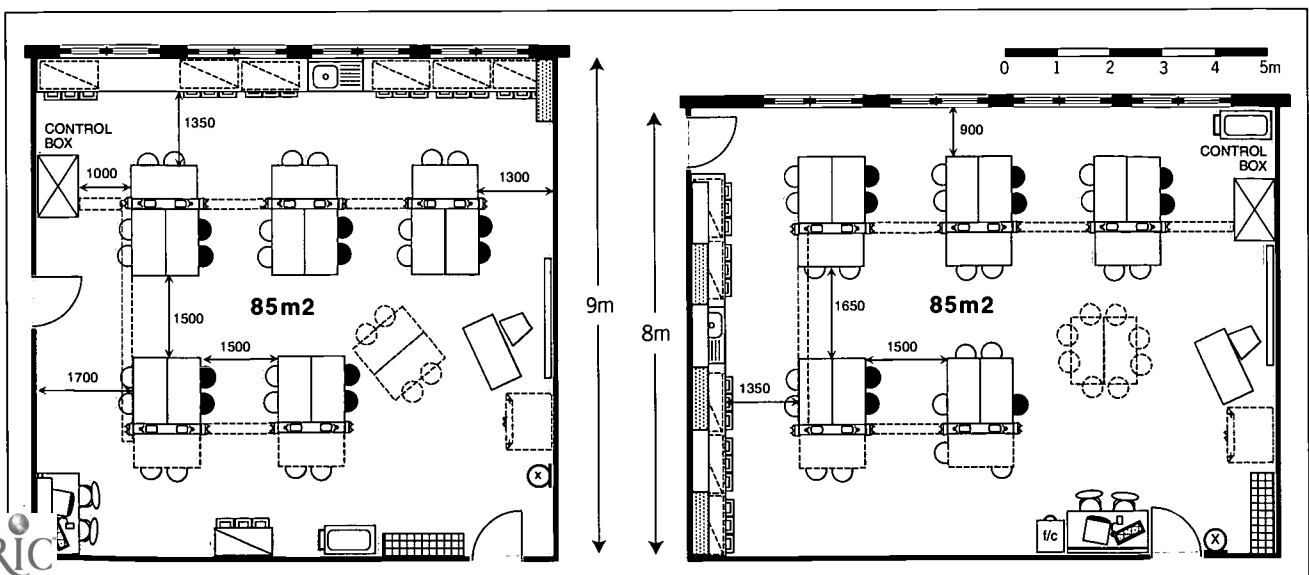

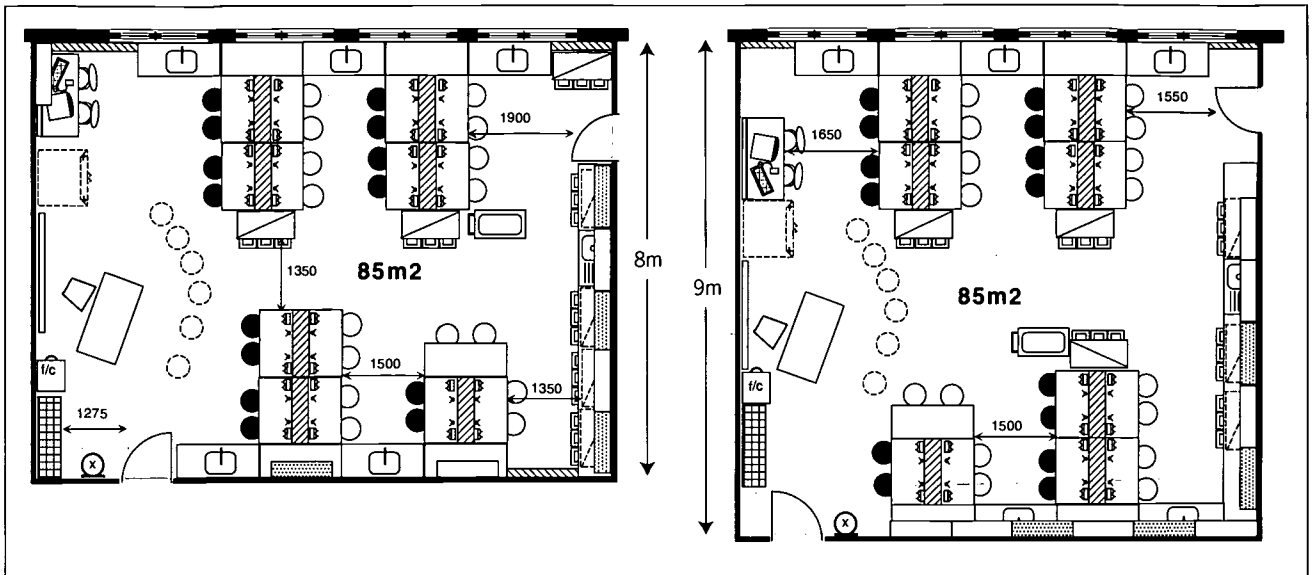

Spine & Perimeter Sink (Figure 2/12)

2.30 A 1200 x 300mm spine carrying gas and power serves a series of 1200 x 600mm and 1500 x 600mm tables clamped around it, giving an average of 0.36m² of work surface area per pupil. Water is provided by 1500 x 600mm sink tables. This system can be serviced from the perimeter, the floor or the ceiling. In these particular layouts services are assumed to be fed from the perimeter.

2.31 This system is generally efficient in its use of space but, due to its peninsular type arrangement, some of the perimeter work surface may be inaccessible and therefore wasteful of space. To avoid disruption to pupils working alongside the perimeter the sinks are positioned in the centre of the table.

2.32 Peninsular systems often work better in shallower rooms. In the 8m deep laboratory shown here, for example, there is more space at the front of the room and around the teacher and less underused space in the centre of the room than in the 9m deep version.

Figure 2/12
Spine & Perimeter Sink

Spine & Island Sink (Figure 2/13)

2.33 A similar spine system to Figure 2/12 but in this case the spines, in addition to providing gas and power, carry water and drainage to and from 1500 x 600mm sink tables. The sink tables are more accessible than those in Figure 2/12. Servicing can be from above or below but in this example is assumed to be from the perimeter with shelf ducts carrying the main service pipes around the room.

Figure 2/13
Spine & Island Sink

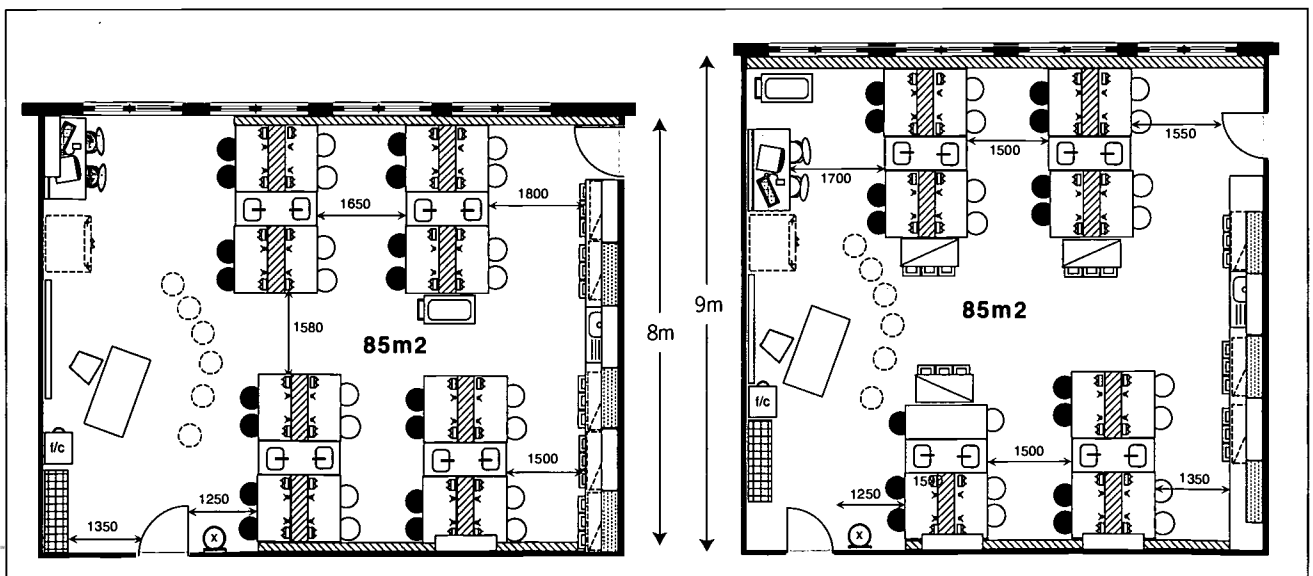
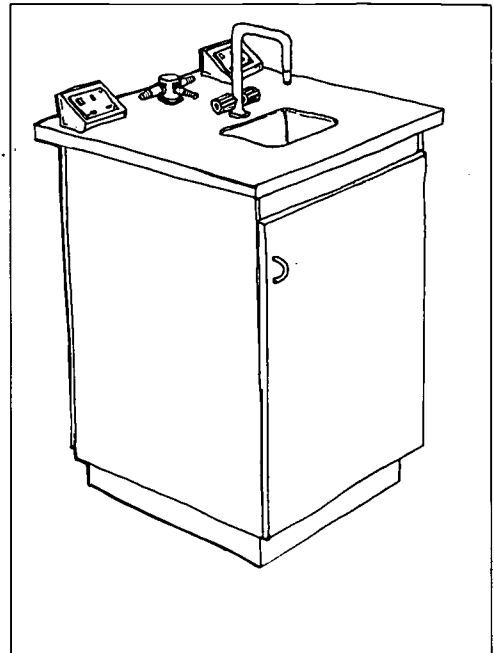

Figure 2/14
Typical Serviced Bollard

Serviced Bollards

2.34 Wet and dry services may be provided in separate serviced bollards but are usually combined in one unit. They are often designed to connect to underfloor services but some units may be linked to overhead or perimeter servicing systems. Bollards are usually located as island units surrounded by loose tables, usually 1200 x 600mm offering a work area per pupil of 0.36m². Many types have to be bolted to the floor for stability. Tables may be positioned in a variety of ways around the units, but the location of individual bollards is determined by the position of floor outlets. The system is best used where servicing can be provided beneath the floor to island units.



6 Person Bollard (Figure 2/15)

2.35 A series of six floor serviced 600 x 600mm bollards (or pedestals) provide water, gas and electricity for up to six pupils each. The work surface area is provided by loose tables which may be moved to create a variety of layouts.

2.36 In the 8m deep example pupils work in six clearly defined groups facing the whiteboard; therefore the lack of space around the teacher is less of a problem than it could be in other layouts. In both layouts the bollards are arranged in two parallel lines (under-floor service

routes) which permits a variety of table arrangements with convenient circulation and teacher supervision. Careful consideration should be given to the positioning of the bollards in order to maximise layout possibilities.

2.37 The circulation is better in the 8m deep laboratory, although the viewing distance from the whiteboard to the tables at the back of the room, as in many of the 8 x 10.5m plans, is rather long.

Figure 2/15
6 Person Bollard

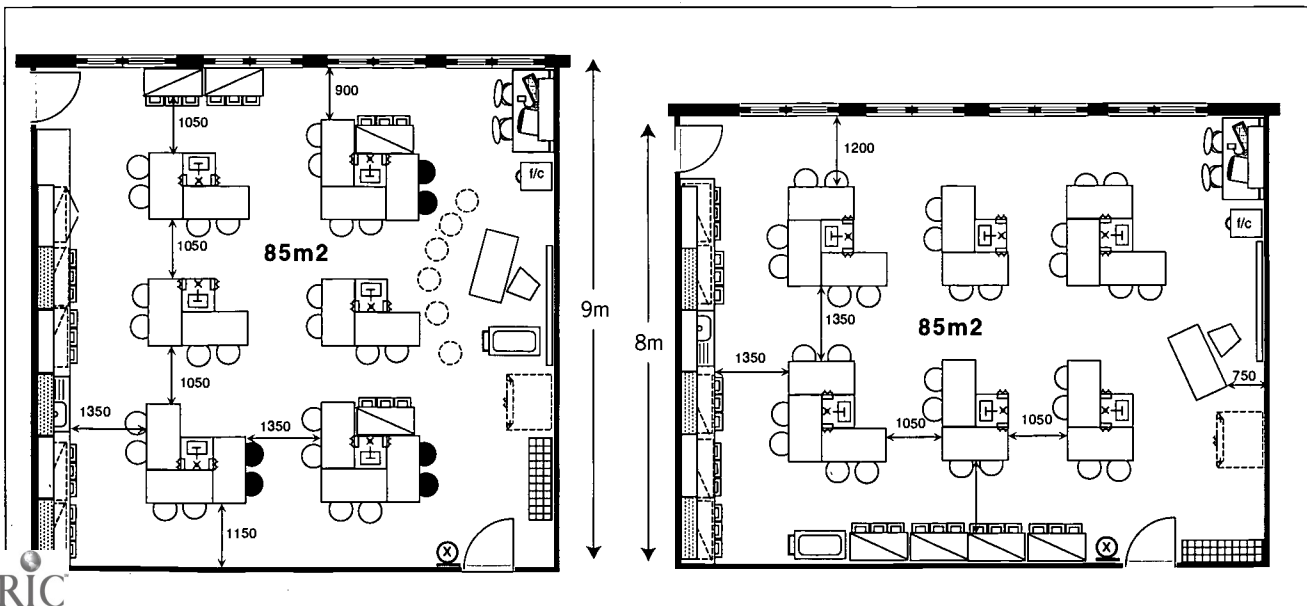

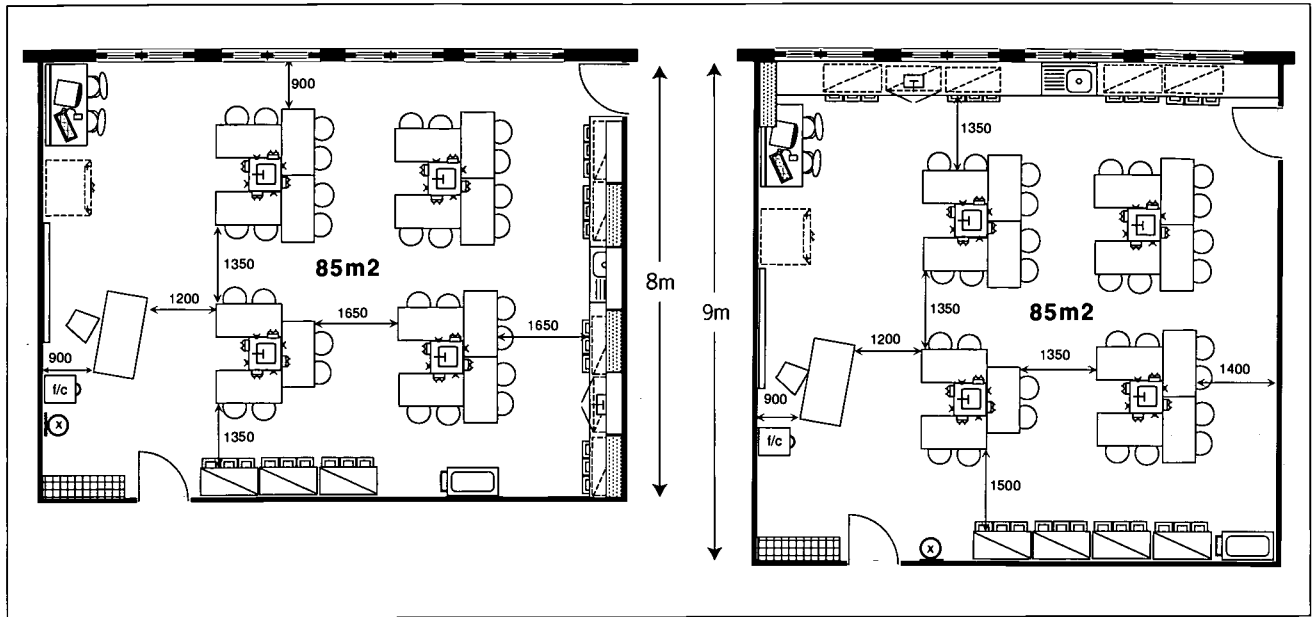

Figure 2/16
8 Person Bollard Option A

**8 Person Bollard Option A
(Figure 2/16)**

2.38 Four 600 x 600mm bollards provide services for up to eight pupils each. The reduced number of bollards results in a simple layout with generous free floor area. A distance of 2.4m between bollards allows two tables to fit between and enhances layout flexibility.

2.39 The layout of four bollards and surrounding tables is inherently square in form and therefore works more satisfactorily in the 9m deep room which is closer to a square. A useful tip for

planning 'island' layouts is to look upon the group of serviced units as a simple four sided shape which can be related to the room shape. This helps to identify remaining space which is available for side benching and storage.

**8 Person Bollard Option B
(Figure 2/17)**

2.40 These plans show the same rooms with the tables rearranged into a horseshoe for class discussions. Both depths of space result in a regular layout but the circulation works better in the 9m deep room.

Figure 2/17
8 Person Bollard Option B

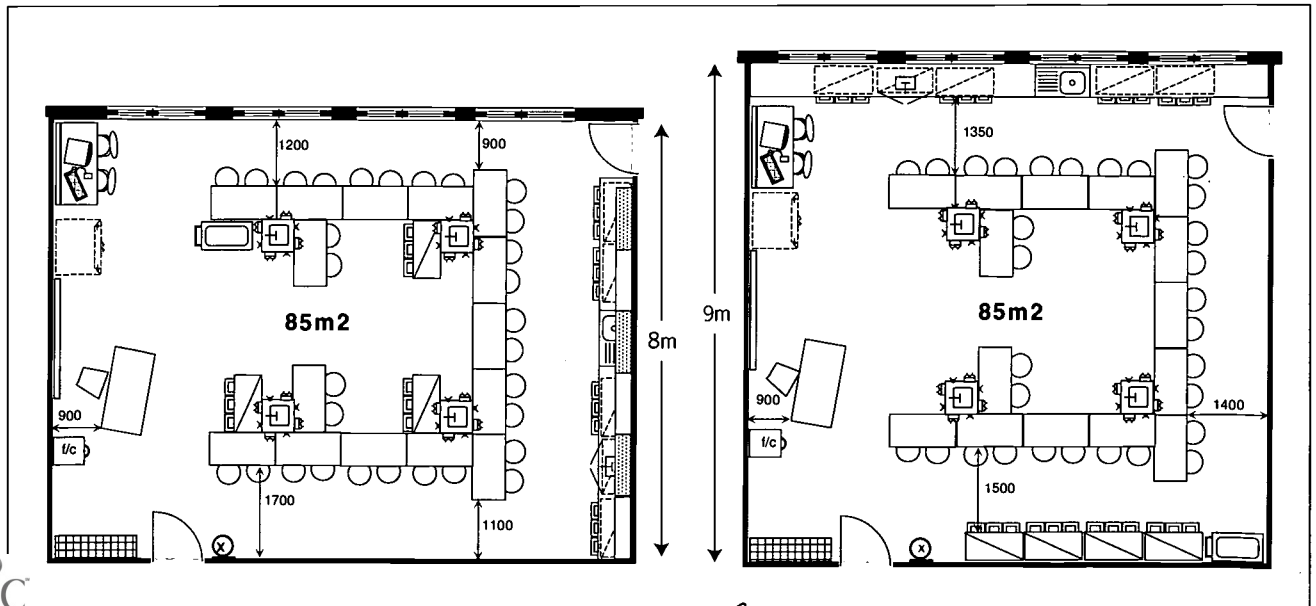

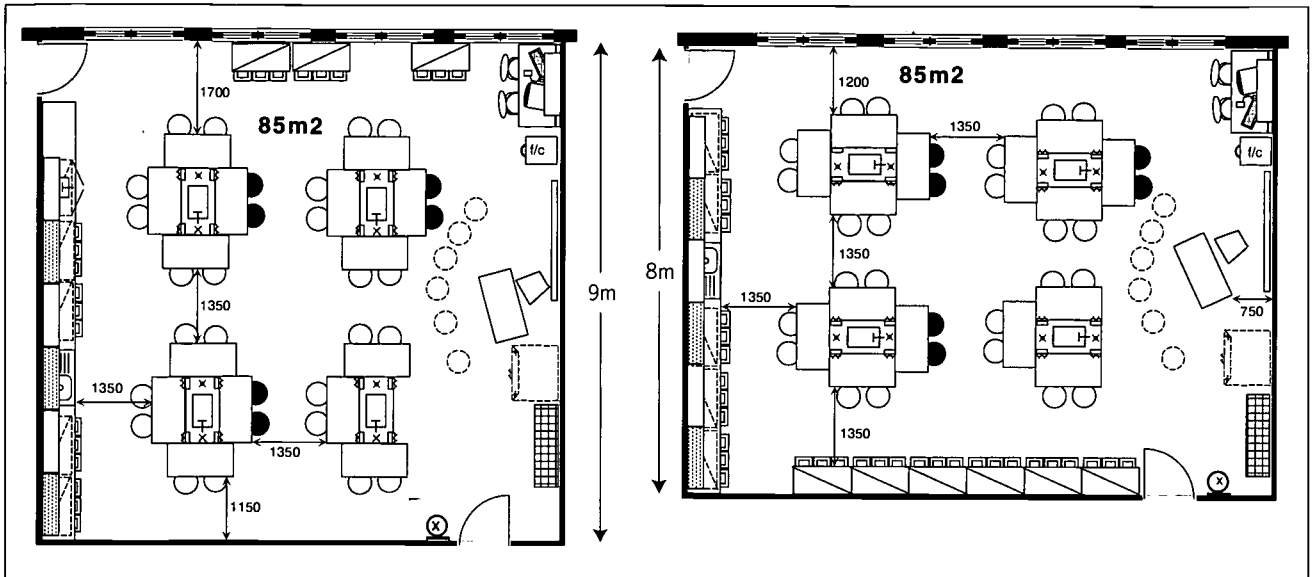

Figure 2/18
1200 x 600 Bollard

1200x600 Bollard (Figure 2/18)

2.41 This plan shows four 1200 x 600mm bollards serviced from below, providing gas, water and electrical outlets for up to eight pupils. Although the bollards are larger than those in Figures 2/16 and 2/17, the servicing provision is assumed to be the same (although the sink is larger).

2.42 Both depths of space work effectively and although some pupils do not directly face the teacher, alternative table layouts can overcome this. The 8m deep room works slightly better, allowing a long run of mobile storage units.

2.43 If servicing provision were increased, an arrangement of five tables for 10 pupils could be positioned around this larger bollard.

Bollard & Perimeter Servicing (Figure 2/19)

2.44 Four 1200 x 600mm bollards provide a full range of services. This bollard can be serviced from above or below. However, this particular layout shows a perimeter fed system. A 1200 x 1200mm table which is clamped or fixed to perimeter service ducting and the bollard carries services from the perimeter to the bollard. The tables on the other side of the bollard are loose and can be moved into the centre of the laboratory which is often underused space with peninsular systems.

2.45 The 8m deep room has less space in the centre. However, loose tables may be moved around to create alternative layouts.

Figure 2/19
Bollard & Perimeter Servicing

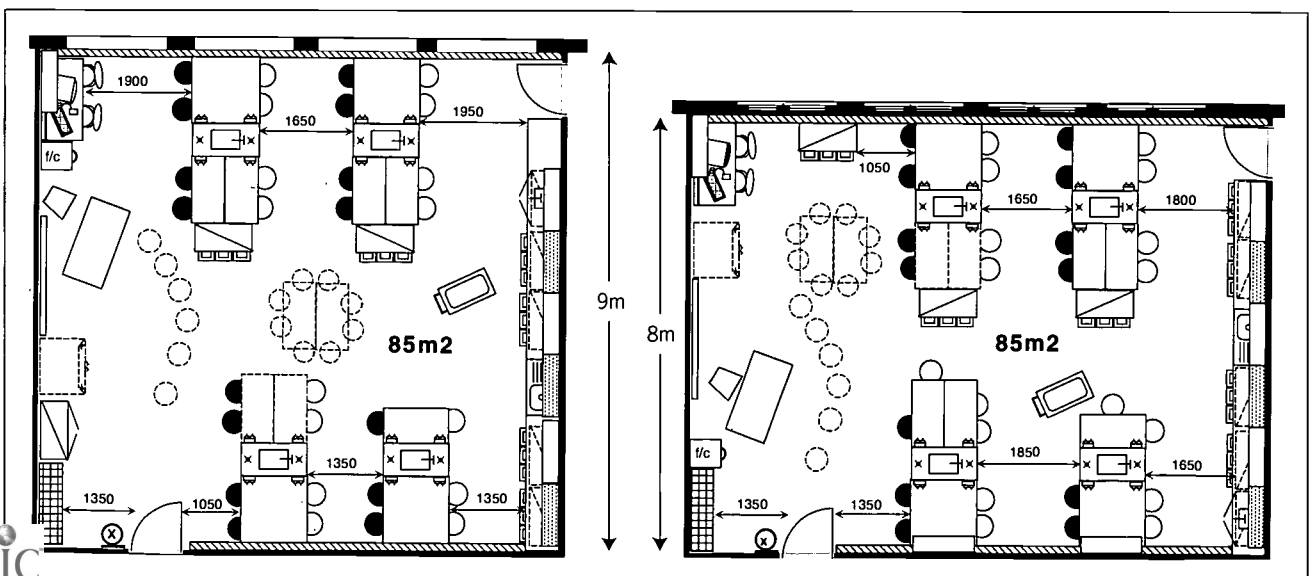

Service pods

2.46 Service pods (sometimes called bollards) are boxes containing outlets for electricity and gas which are clamped to bench tops. They are fed from underfloor or overhead servicing systems. Separate tap assemblies are used to provide water to sinks or drainage troughs. Pods and taps can be fixed to perimeter or island table layouts (usually 1200 x 600mm tables offering the pupil 0.36m² of work area).⁴ The main advantage of this system is that relocating the service unit is easy. When the laboratory is served by an overhead boom, cables may be 'plugged in' at various points along its length.

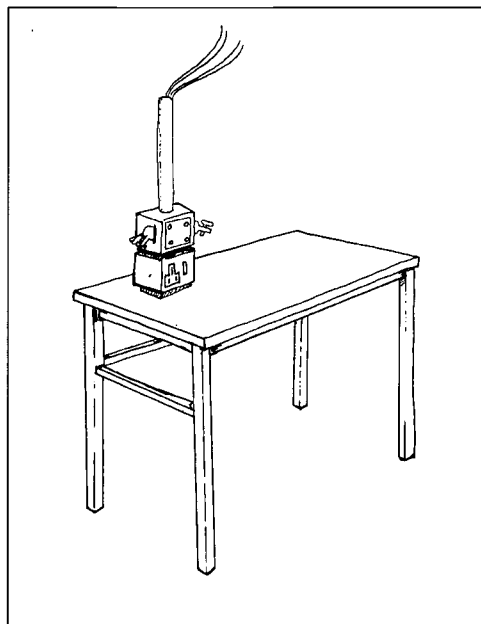

Figure 2/20
Typical Service Pod Serviced from Above

Pod & Perimeter Sinks (Figure 2/21)

2.47 This system works with either overhead or underfloor services. As pods are serviced via flexible connections tables may be moved within the limits of the connection length, giving a variety of layouts.

2.48 As the pods only provide gas and electricity the sinks are placed at the perimeter thus increasing the total length of benching required. Positioning sinks away from other services can pose difficulties, particularly when pupils are conducting experiments where access to water is required. As in all layouts it is necessary for a school to prioritise features of individual systems discussed in this publication and to choose accordingly.

2.49 Both depths of spaces work well in terms of circulation and, although not all pupils face the teacher, there is sufficient space to gather around for lectures or demonstrations.

2.50 A variation of this system is where sink tables are positioned alongside pods and tables in the centre of the room. Water and pumped drainage may be connected to the two overhead service booms at various points.

Note
⁴ A table which houses a pod will provide less work area for the pupil sitting by the pod.

Figure 2/21
Pod & Perimeter Sink

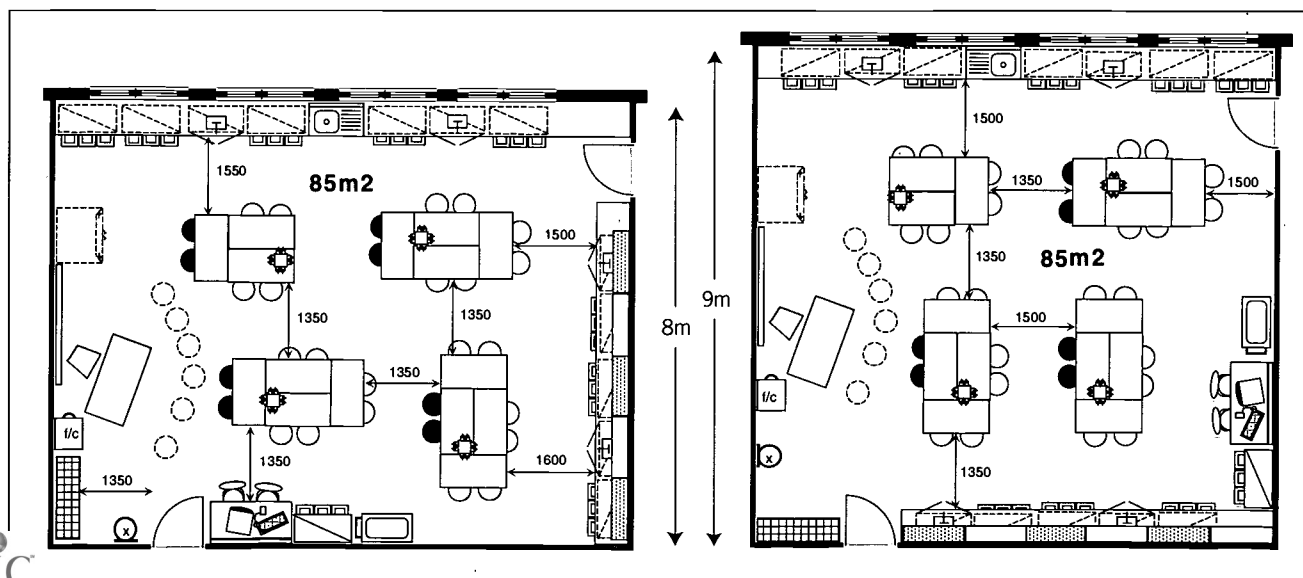
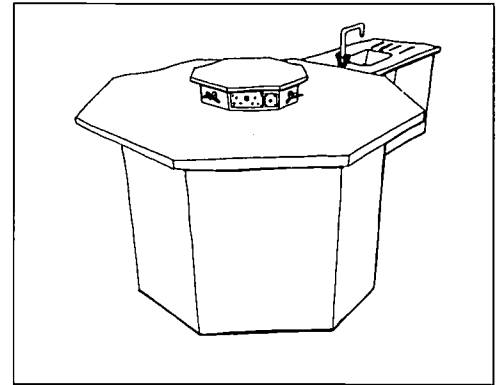

Figure 2/22
Typical Serviced Furniture

Serviced Furniture

2.51 In this type of system, services run within the furniture. Tables can be linked together allowing services to supply a group of work places. Installations are connected to the main services at one or more points, usually at the perimeter of the room. The advantage of this system is that a whole laboratory may be serviced from one perimeter supply point. The system is particularly suitable for conversion or upgrading work because services are kept separate from the building fabric. The disadvantage of systems with hard servicing connections is that tables may still need to be fixed to the floor thus limiting adaptability. In addition, a teacher's direct access to pupils may be restricted where a long chain of fixed linking furniture is formed.



of the units. Rather like serviced bollards, octagons are fixed to the floor and this may again limit flexibility.

2.53 The system may have a central turret which provides additional work surface for books, tasklights or computer screens. The turret can sometimes affect visual supervision of pupils sitting at the units.

Perimeter Serviced Octagon (Figure 2/23)

2.52 Fixed octagonal units, 1800mm in width, provide gas and power for up to eight pupils with a work area per pupil of 0.3m². The units in this example are linked to services at the perimeter via a 1000 x 600mm sink unit. Links at 90° or 45° increase planning options but can create 'triangles' of space which are difficult to use effectively. The system allows clearly organised groups of pupils to work together and teacher demonstration can take place around one

2.54 In both layouts the octagonal units seat a total of 27 pupils and for additional pupils a length of serviced perimeter benching is required. Circulation around the laboratory may be restricted by the linking sink units. For this reason generous distances are allowed between each of the octagonal units.

2.55 The 8m deep space has fewer unusable 'triangles' of floor space but the 9m deep space has a better teaching focus and has a more generous area for the fume cupboard and class gatherings.

Figure 2/23
Perimeter Serviced Octagon

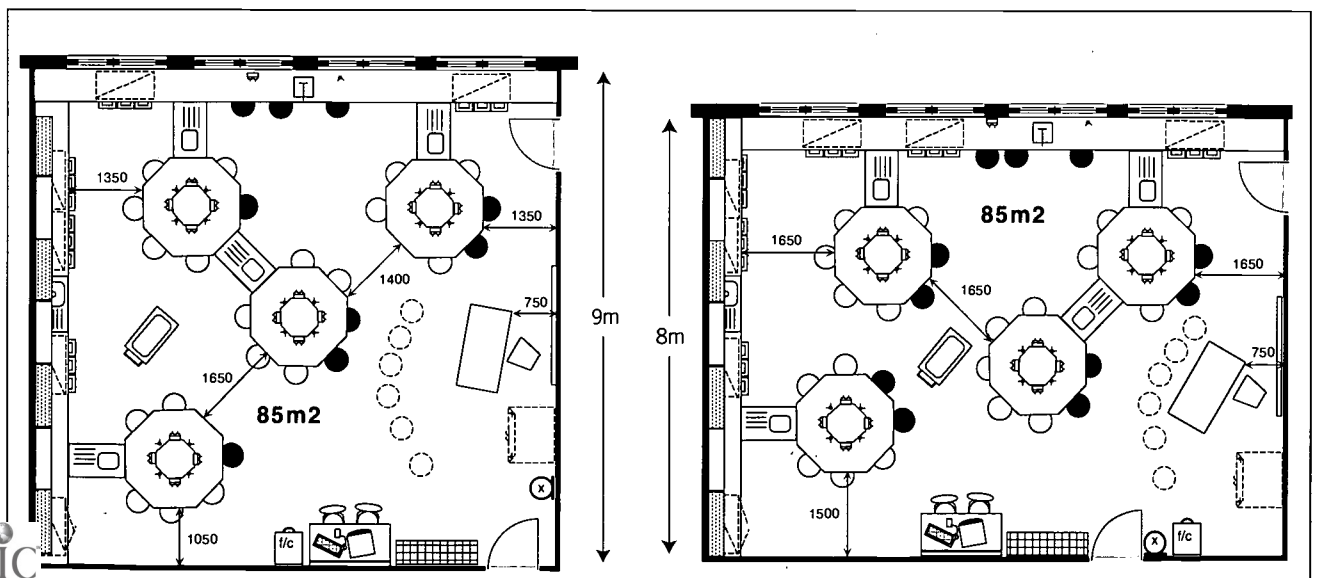

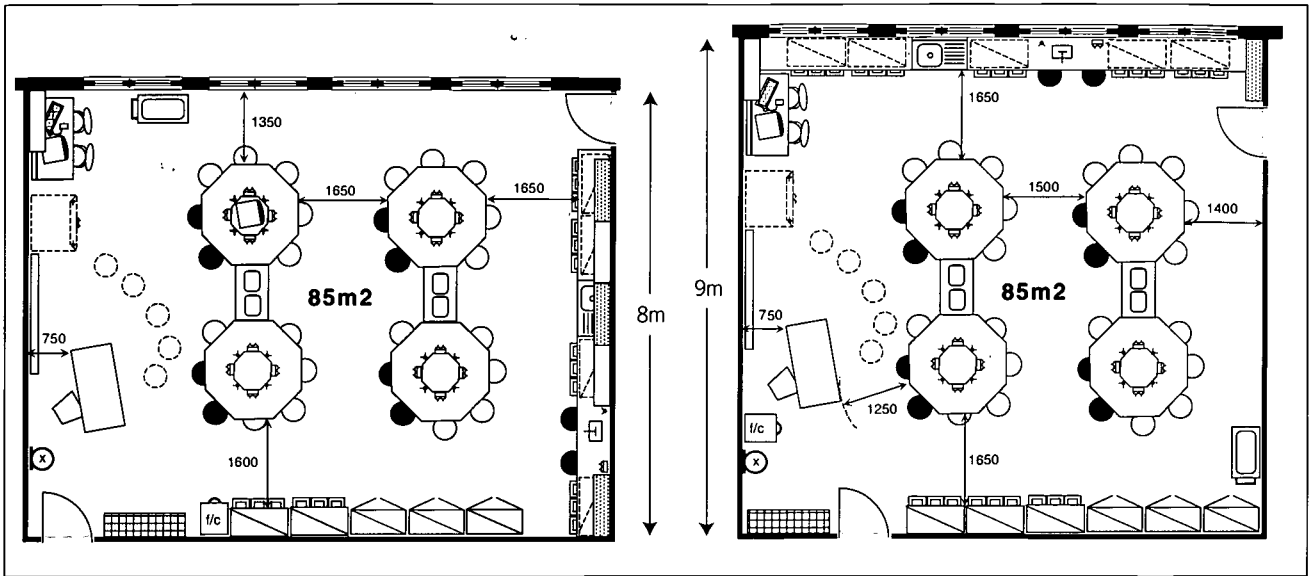

Island Octagon (Figure 2/24)

2.56 Here octagonal units are serviced from below and are therefore isolated from the perimeter of the room. Two pairs of octagons with a shared double sink sit centrally in the laboratory. This arrangement is space efficient and follows most of the planning guidelines laid out earlier in this section.

2.57 Circulation is similar between the two spaces. However, as the two pairs of octagons create a basic square shape the layout works better in the deeper 9m space.

Perimeter Serviced Tables (Figure 2/25)

2.58 A serviced furniture system using various components: a 1500 x 750mm table providing each pupil with 0.56m² of work area, a 750 x 750mm sink table and a

loose unserviced semi-circular table is shown. The rectilinear tables carry services in trays clipped to their underframes. Pyramid-shaped service pods at the corners of the tables provide gas and electrical outlets. The system offers a good deal of flexibility as tables can be unclamped and re-arranged. However, planning in 750mm modules can sometimes be restrictive.

2.59 Circular computer consoles may be attached to any of the tables and allow computers to be positioned anywhere. Being raised, the computer does not encroach on a pupil's working space, although the keyboard may.

2.60 In the 8m deep space there is more space around the teaching base but some pupils' viewing distances are long from the back of the laboratory.

Figure 2/24
Island Octagon

Figure 2/25
Perimeter Serviced Tables

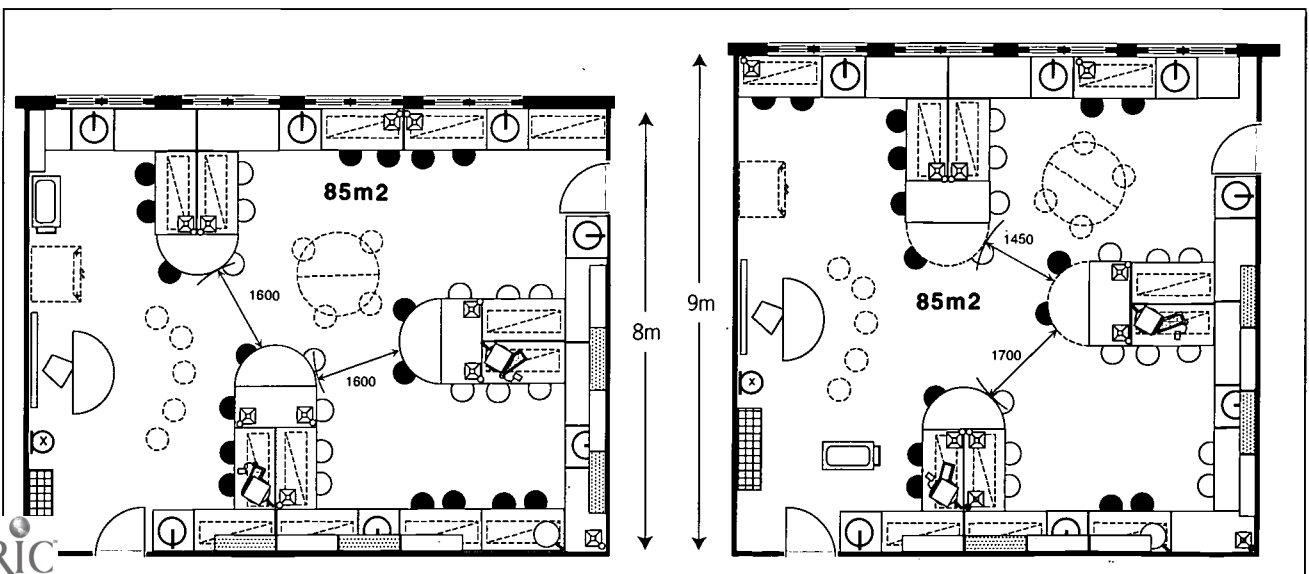

Section 3: Support Spaces

This section looks at spaces which support the main timetabled teaching spaces. It is divided into two parts: Supplementary Teaching Spaces and Non Teaching Spaces. Figure 3/1 indicates the relative location of these spaces in the context of one of the generic suites described in Section 1. The number and type of support facilities varies greatly between schools; the examples shown here are not the only solutions.

Figure 3/1
Key Plan

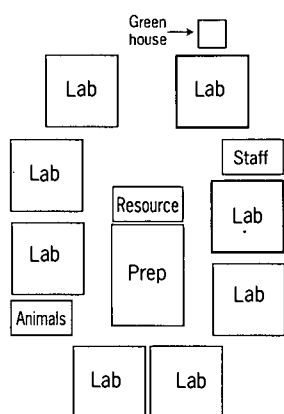

Note

¹ Department of Education and Science, 'The Outdoor Classroom'. BB71, London: HMSO, 1990.

Figure 3/2
IT/ Resource Area

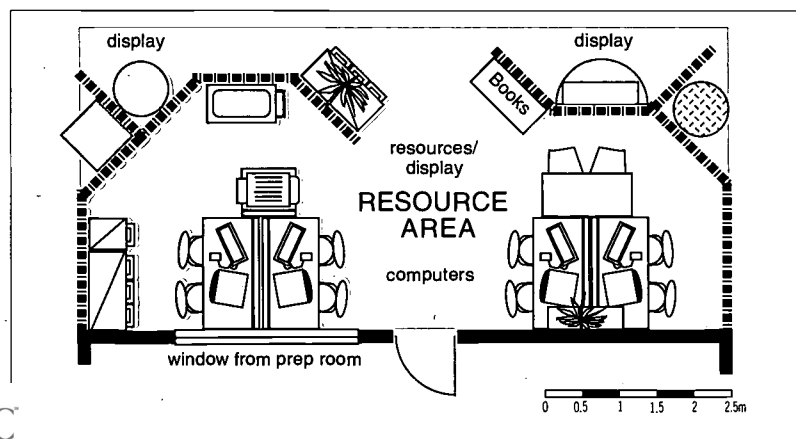

Supplementary Teaching Spaces

3.1 The three ancillary spaces described below are often associated with science suites: the Resource area, the Greenhouse and the Animal Room. They are all categorised here as teaching spaces but in some schools the animal room and greenhouse may be used only by staff.

The Resource Area

3.2 A useful facility is an IT and resource area which may need to be supervised. This space, which should be located as centrally as possible, acts as a resource base to the whole suite. If it is next to laboratories or the preparation room, this can help supervision when the area is used by small groups of pupils. In refurbished accommodation it may be possible to use part of an oversized laboratory as a resource area (see Section 6, Case study 1).

3.3 The example shown in Figure 3/2 includes a bank of computers and other resources such as books which are kept centrally to avoid unnecessary duplication. The space is kept as flexible as possible by

using mobile furniture and screens which divide up the space. Pupils can either come to this area to work on a regular basis or computers and resource trolleys can be wheeled into a laboratory as the need arises. There is provision for both horizontal and vertical display arranged so that pupils' work and scientific information can be seen on entry to the suite.

The Greenhouse

3.4 If a greenhouse is to be provided it can form an interesting and attractive extension to a science department. A small conservatory or Wardian window, a secondary glazing unit which provides a self sustaining environment, may be considered as an alternative.

Location

3.5 A greenhouse is best located fairly close to the science suite to encourage its use and allow easy maintenance and supervision. The site will need to receive plenty of sunlight and be protected from the wind.¹ If it is over-looked by other buildings the possibility of vandalism will be minimised.

Form and Material

3.6 The size of the greenhouse depends very much on the use that will be made of it. The structure can be of timber or aluminium, the latter requiring less maintenance. The glazing can be of glass, polycarbonate or acrylic. Polycarbonate is more expensive than acrylic although it is more hard-wearing, less brittle and does not discolour. Glass, although more easily broken, is better at transmitting light and does not deteriorate in the same way as acrylic.

Environment and Services

3.7 The greenhouse will need to be ventilated and various automatic window opening devices are available. It may be heated although this will add to the cost. Free standing heaters should never be used because of the danger of fire.

3.8 An automatic watering device is not essential but there should be access to water within the greenhouse. Any electrical socket outlets must be waterproof.

The Animal Room

3.9 Animals are kept less in schools today because of the problems of caring for them during school holidays. Animals must be properly housed and the Animals (Scientific Procedures) Act 1986 must be adhered to. This section provides a brief guide to housing small animals but more detailed guidance, including information on larger animals that are kept outside, can be found in more detailed publications.^{2&3}

Size and Location of Space

3.10 The size of the space will depend on the number of animals being kept and whether pupils are to be allowed into the room to observe them, but the width should at least allow for a 600mm deep work surface on either side with adequate circulation for trolleys in between (see Figure 3/3).

3.11 The room should be sited in a secure part of the suite and in an area where the animals will not be disturbed by excessive noise.

Environment and Services

3.12 The temperature should be kept at a fairly steady level of about 16 - 22°C, including during holiday periods. There should be some means of controlling direct sunlight, although it is not necessary to provide natural daylight. Background electric lighting should provide an illuminance of about 200 lux.

3.13 The space must be well ventilated but not draughty and provide 6-12 air changes per hour away from any window openings. There must not be any recirculation of air, and extracted air must be exhausted to the outside. Any external vents should be covered with insect proof mesh. Recommended humidity levels vary according to species from 40 to 60%.³

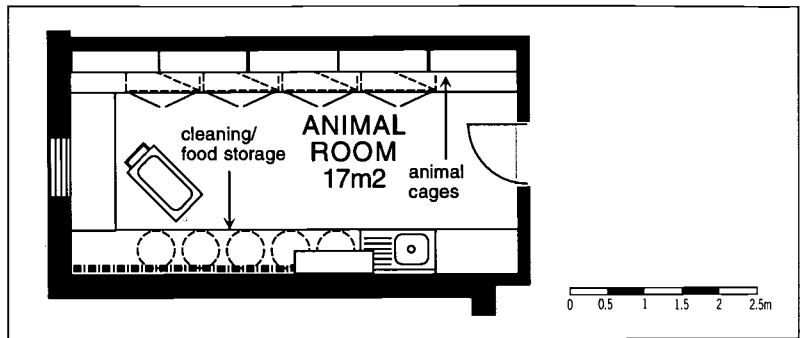

Fittings and Finishes

3.14 There will need to be a length of benching, a wash-up sink with hot and cold water, shelves for the animal cages and floor space for food bins. Shelves (approx. 400mm to 600mm deep) may be of metal or sealed timber and should be 100mm from the wall to allow air to circulate. Metal (corrosion resistant) supports are preferable to avoid problems with gnawing. Adjustable shelving will accommodate cages of varying sizes.

3.15 Generally surfaces should be designed to minimise the number of dust and dirt traps. Skirtings should be coved and there should be drainage channels to allow the floor to be washed down. Walls should be smooth with a washable surface.

Non-Teaching Spaces

The Preparation Room

3.16 In the past preparation rooms have been designed to serve one or two laboratories, often with an emphasis on physics, chemistry or biology. However more efficient use can be made of floor area and staff time if a central preparation room is provided to serve a number of laboratories. This is particularly the case as more laboratories become multi-purpose to suit an integrated approach to the science curriculum. This section outlines the basic requirement for a central preparation room (or two if there is more than one floor). The furniture layouts of two typical preparation rooms are illustrated in detail.

Figure 3/3
Animal Room

Notes

² RSPCA Education Department, 'Animals in Schools', Horsham: RSPCA, 1985.

³ Wray JD and Gaitens JF. 'Animal Accommodation In Schools', Schools Council. Educational Use Of Living Organisms Series, London, English Universities Press, 1974.

Section 3: Support Spaces

Note

⁴ These figures are based on a study of a number of existing preparation rooms.

3.17 An analysis of existing preparation rooms has shown that the use of the space can be broken down as follows.⁴

- fixed storage (including chemicals) 20-30%;
- mobile storage (including equipment trolleys) 8-10%;
- working area (including sitting/standing space) 25-30%;
- circulation 40-45%.

3.18 The examples shown in this section provide a total of 0.5m² of floor area for each science workplace, and assume that only a small amount of local storage is provided in the laboratories. The area breakdown roughly equates with the percentages given in paragraph 3.17.

3.19 The preparation room in a middle school will be simpler than the room(s) described in this section. It will probably serve only one or two laboratories, but it may also be used to prepare trolleys of equipment for teaching pupils in years five and six in their classroom bases.

Planning The Preparation Room

3.20 A central preparation room can act as the main store room for a suite of laboratories as well as a workroom for the technicians. Five main zones of activity can be identified: main storage; preparation, dispensing and cleaning; trolley park; the clean working area and chemical storage. These five zones and the relationship between them are

Figure 3/4
Zoning of Activities in the Preparation Room

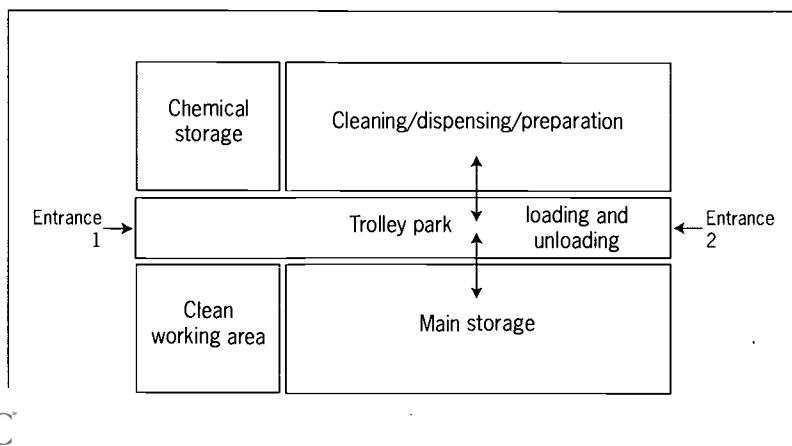

illustrated in Figure 3/4. This diagram forms the basis of all the preparation room layouts in this publication. Each zone is described in detail below.

The Main Storage Area

3.21 Items of equipment used frequently by all pupils (such as tripods, bunsen burners and goggles) are usually kept in the laboratory. All other equipment is best kept in a central preparation room where it can be checked regularly by a technician. The main storage area may be best concentrated in one place, preferably located alongside the preparation and cleaning area.

3.22 Storage is often in the form of freestanding timber or metal racks providing flexible storage systems which can be re-arranged to suit the available space.

3.23 An alternative method of bulk storage is the rolling unit system sometimes seen in library stockrooms. This system is very economical in its use of space because circulation is reduced, often providing approximately 30% more volume than a conventional system. However, it is expensive. The system is probably most appropriate for a large school with at least seven laboratories where it can be used for longer term storage while more frequently used materials can be kept on shelving or racking. Further details of storage systems can be found in Section 4.

The Preparation, Dispensing and Cleaning area

3.24 This is the main working area for technicians. It is where glassware is washed, equipment is sorted after being returned on trolleys from lessons, practical experiments are prepared and small items of equipment are repaired. There needs to be enough free bench space for technicians to carry out these activities. This is in addition to any space that is taken up with small bench mounted apparatus such as an autoclave or distillation unit. Gas taps and electrical

outlets should be provided and at least one sink in addition to the wash-up sink (which should have double bowl and drainer). Floor mounted equipment may include a fridge-freezer and dishwasher.

3.25 In order to dispense chemicals it may be convenient to position a serviced run of benching and the fume cupboard as near as possible to the chemical store. A fixed fume cupboard may be preferable to a mobile one because of the frequency of use by technicians. In a middle school, however, a mobile fume cupboard may be advantageous as it can be used for teaching as well as preparation. Fume cupboards should always be positioned away from circulation routes.⁵

The Trolley Park

3.26 To facilitate loading and unloading the trolley park should ideally be located between the main storage zone and the preparation/cleaning area. The space needs to be wide enough to park the maximum number of trolleys (eg. up to two per laboratory) and to allow circulation alongside. Additional parking space for trolleys may be needed at the entrance to the preparation room or adjacent to a hoist.

3.27 Gas cylinders will need to be clamped safely to a wall or bench within the preparation room.

The Clean Work Area

3.28 A discrete technicians' work area allows administrative tasks to be completed, and may be positioned next to the main doors of the preparation room forming a 'reception' area.

3.29 Furniture and equipment in this area may include a computer, filing cabinets, lockers for technicians' belongings, a local task light and a telephone. TV programmes may be recorded in this area.

The Chemical Store

3.30 The storage of chemicals is controlled by the 'COSHH' (see Glossary) regulations⁶ which state that employers should follow recommended procedures based on risk assessments when dealing with hazardous substances.

3.31 If bulk chemicals are kept by the school these are usually kept in a separate store in the school grounds. Smaller quantities are best kept in a separate locked chemical store within the preparation room, and should be accessible only to technicians and teachers.

3.32 The chemical store must be well ventilated to the outside air either by natural means or by mechanical extraction; full air conditioning is not necessary. The store requires protection from frost, and the door should open outwards. The floor should be bunded (see Glossary) with a slope to a collection area. The flooring material, eg. quarry tiles, should be impervious to chemicals.

3.33 There are recommended ways of arranging chemicals on shelves according to type.⁷ It is an advantage if all shelves are shallow to avoid hidden bottles and shelving above head height is best avoided. Shelves should be made of a non-corrosive material such as wood in case of leaks and corrosive liquids should be kept on the lowest shelves.

3.34 A separate chemical store within the preparation room is preferable. However, where this is not possible there should be at least a separate fire resistant cupboard for the highly flammable liquids, and another locked cupboard for highly toxic chemicals. The total volume per school of highly flammable liquids should not exceed 50 litres.⁸

3.35 Radioactive materials must be stored separately from highly flammable materials in a locked cupboard or store. Such materials should be stored and used in accordance with AM 1/92⁹ which states that in order to limit exposure time these materials should be stored in an area not used regularly by the same people.

Notes

⁵ Department for Education and Employment 'Fume Cupboards in Schools' (Revision of DN 29). BB 88,S0 1998.

⁶ Health and Safety Commission. COSHH: Guidance for Schools. London. HMSO,1989.

⁷ The Association For Science Education. 'Topics in Safety'. Hatfield: ASE, 1988.

⁸ The Highly Flammable Liquids and Liquefied Petroleum Gases Regulations, 1972.

⁹ AM 1/92: The Use of Ionising Radiations in Education Establishments. London: DFE, 1992.

Figure 3/5

Example A: Central Preparation Room to Serve 7 Laboratories

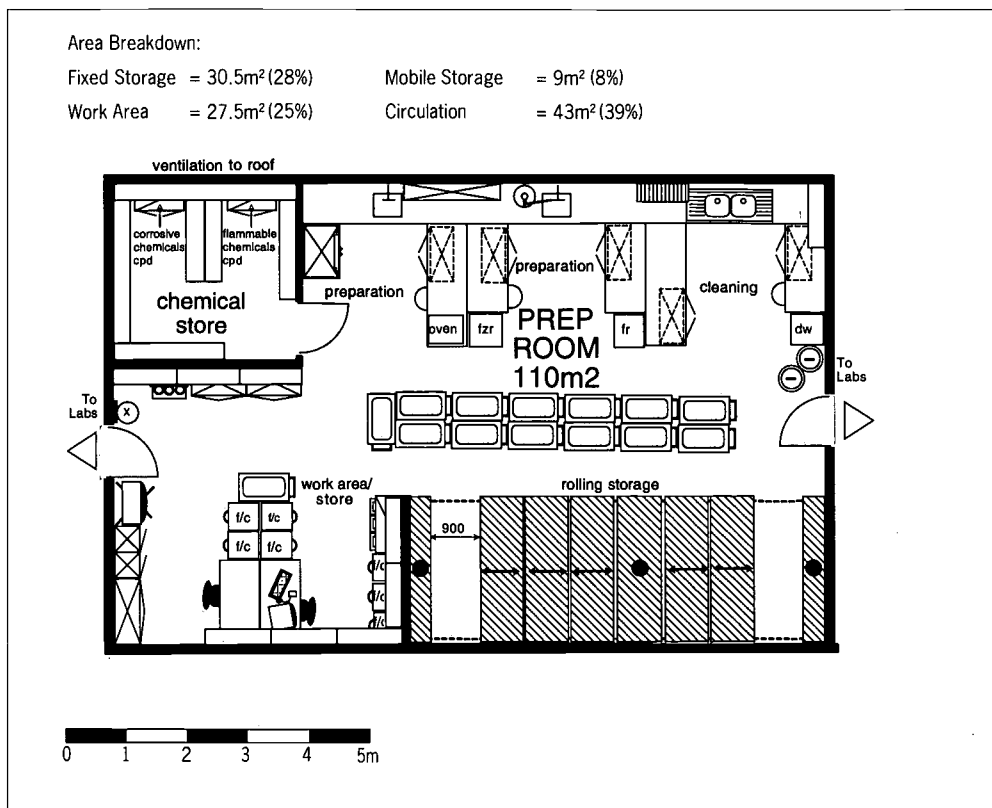

Example A: A Central Preparation Room.

3.36 Figure 3/5 shows a central preparation room serving a suite of seven laboratories. The layout is based on the zoning principles described earlier. Below are some particular points to note about the plan.

- Access is from each end of the room, opening directly onto the central trolley park.
- A rolling storage system is shown, divided into two halves by a fixed unit allowing two technicians to have access to different units at the same time.
- The main work area is divided into 3 zones: cleaning, general preparation and chemical preparation. The latter zone includes a fume cupboard adjacent to the chemical store.
- The cleaning area is separated from the preparation area and positioned next to one of the entrances.
- This room provides 8m³ of storage for each laboratory¹⁰, ie. 56m³ in total.

Example B: Preparation on Two Floors.

3.37 Figure 3/6 illustrates the preparation facilities for seven laboratories, divided across two floors (as illustrated in Section 1, Figure 1/6). There are particular points to note about these two plans.

- The size of each preparation room relates to the number of laboratories it serves. The larger preparation room also contains the chemical store.
- The facilities are generally divided according to the number of laboratories served on that floor. There are some duplications; in each preparation room there is a fridge, a TV and video recorder on a trolley, a wash-up sink, a science sink, a distillation unit and fire fighting equipment.
- Less frequently used items, such as the dishwasher and the fume cupboard, are not duplicated.

Notes

¹⁰ The volume calculated assumes a maximum storage height of 2 metres.

- The hoist enables equipment to be transported conveniently between the two floors. It is assumed that the hoist will have at least one door to prevent the spread of fire up the shaft.
- As these preparation rooms are on an external wall the technicians have an outside view but the different activity zones cannot be as efficiently organised as in the previous example.
- Simple racking units are shown for storage since the size of each preparation room does not warrant a rolling storage system. As a result, the total volume of storage is 7m^3 per laboratory (49m^3 in total), a little less than that provided in Example A.

The Staff Base

3.38 The requirements for local staff accommodation will vary from school to school. Figure 3/7 shows a possible arrangement for a staff base serving seven laboratories. There is sufficient space for up to seven members of staff to prepare work, hold meetings, or make refreshments. Facilities shown here include a computer, photocopier, telephone and sink. An adjacent lockable store may hold pupils' work retained for assessment purposes, record cards or any other items needing secure storage.

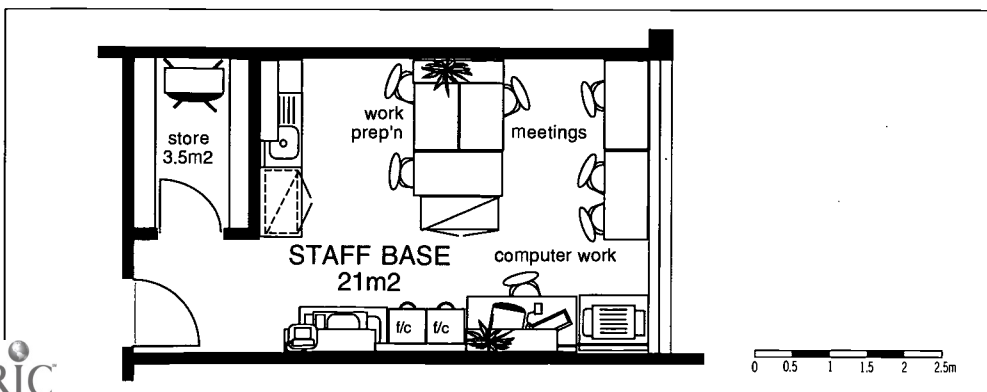
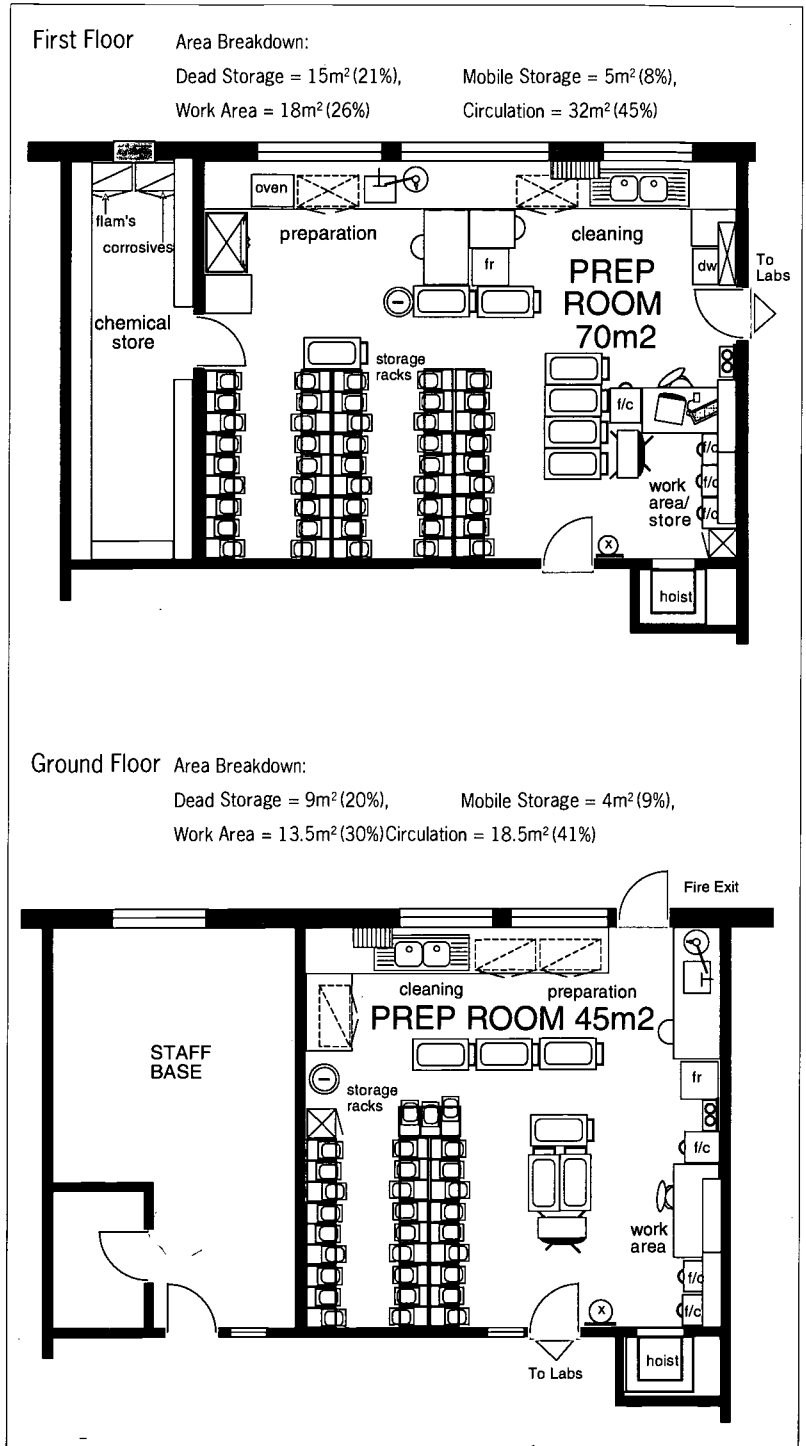

Figure 3/6
 Example B: Preparation on Two Floors in 7 Laboratory Suite

Figure 3/7
 Staff Base

Section 4: Furniture and Equipment

This section provides general guidance on the furniture and equipment shown in the layouts illustrated in Sections 2 and 6. It is worth noting however that each of the servicing systems outlined in Section 2 has its own particular furniture requirements whether loose or fixed.

4.1 Any science furniture that will be used in a school laboratory should ideally comply with all the relevant and current British Standards (BS). BS 3202 is a wide ranging standard which deals mainly with the construction of science research laboratory furniture, but is a useful reference. The standard is in four parts. Part Three covers mainly dimensional standards, the information on the safe distances between furniture forms the basis of the dimensions given in Section 2. BESA (see Glossary) have a list of member manufacturers whose products meets the relevant British Standards.

Figure 4/1
Co-ordinating Furniture and Services

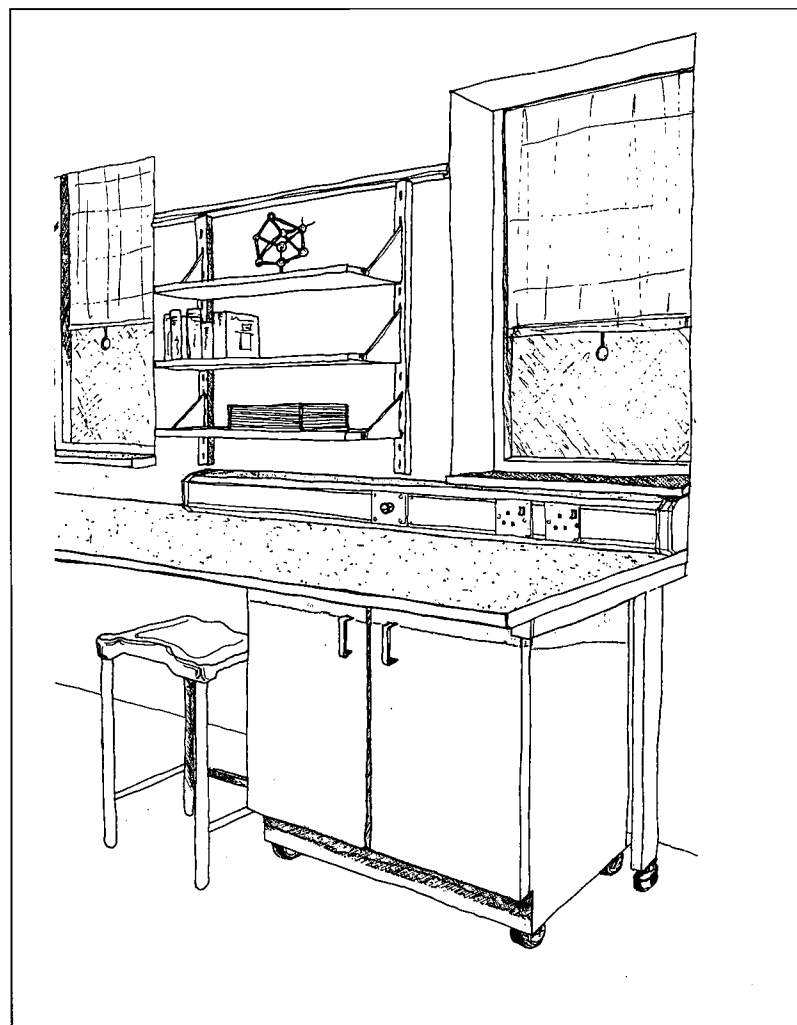

Tables and Benching

Dimensions

4.2 When designing with safety in mind it is important to consider both the smaller and taller pupil. 850mm is generally considered a suitable height for a laboratory work surface for KS3 and 4 science. Stools must correspond in height to the worktop. A measurement of 240-270mm from the top of the stool to the underside of the worktop allows sufficient thigh clearance for the pupil to sit comfortably at the work surface.

4.3 For benching there may need to be a working depth of 600mm. In any situation service outlets should be positioned not further than 600mm from the front of the bench. There should be sufficient depth underneath to allow stools to be safely tucked away during experiments. The computer and its wiring may often require a greater depth than 600mm; a computer table or trolley of 750mm deep may be preferable.

4.4 Separate trunking containing gas, electrical and water services, may run around the perimeter of the room sited above or below the side benching. Careful co-ordination will be needed where fitted workbenching and trunking runs above a radiator or where trunking runs beneath a window (see Figure 4/1). A well organised system of services which run along the benching will avoid services running along the wall and can ensure that there is sufficient free wall space for display boards and shelving.

Frames

4.5 Various frames in both wood and metal are available for side benching, fixed science furniture and loose tables. Frame shapes vary but metal frames are generally cantilevered whilst wooden frames are the more traditional four-legged shape. Four-legged frames are more suitable for systems where tables may be rearranged as they allow pupils to sit at the end of the table.

4.6 Cantilevered frames can be useful with wall benching/tables as there are no legs at the front to prevent pupils sitting anywhere along the bench. Figure 4/2 shows frame shapes used in various science systems installed in schools today.

Work Surface Materials

4.7 Resistance to water penetration, chemical attack, heat and impact are critical to work surfaces. BS 3202 sets down standards for surface strength and resistance based on a number of tests. CLEAPSS (see Glossary) have carried out tests based on this British Standard on a range of bench materials.¹

4.8 Manufacturers sometimes use different finishes for the perimeter work surface and the main serviced furniture system. The suitability of these finishes should therefore be carefully checked.

4.9 Below is a brief description of the most widely available materials and their properties divided into their two main categories of Wood and Synthetics. Section 7 gives a guide to the relative cost of these materials.

Wood

4.10 Iroko is often used for bench and table tops. It is a very durable wood and if correctly sealed it has good resistance to water and most chemicals, although it can be marked by heat. All seals, however, need to be adequately maintained to prevent water or chemicals reaching the wood itself. Wood has the advantage that it may be sanded and re-polished during refurbishment.

4.11 Iroko comes from trees in tropical rain forests and partly for this reason it is less used than it once was. Schools may wish to purchase iroko which has come from a sustainable source. An alternative is a recently developed material made up of small sections of iroko laminated together. These small sections come from younger trees helping the development of a sustainable resource.

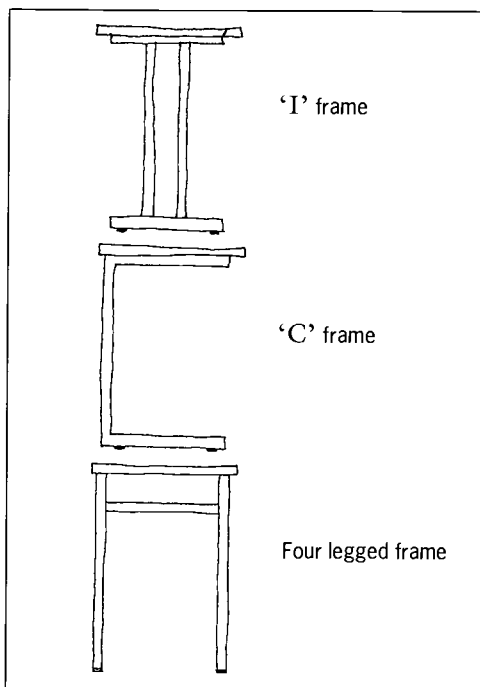

Figure 4/2
Frame Shapes for Laboratory
Tables

Synthetics

4.12 There are two main types of plastic used for worktops: homogeneous and laminated. Homogeneous synthetics include:

- cast epoxy resins;
- polymethacrylates;
- polyesters.

4.13 Laminated plastics are made up of layers of paper impregnated with resins. There are two main types:

- solid laminates;
- laminates on a chipboard base (laminated in a variety of thicknesses).

4.14 All the homogeneous synthetics have good all-round resistance but cast epoxy resin is the strongest material. The polymers may be stained by certain chemicals or excessive heat. The mottled surface finish of some of these materials can help to mask stains. Using a grinder on certain materials can help remove stains, a resin filler can then be used to fill in the 'hole', however a certain degree of skill is required to re-sand to a similar smooth finish as before. Solid laminates have a similar resistance to the polymers. Laminates which are on a chipboard or similar base are less suitable for laboratory use (particularly when the laminate is thin) because the layer of laminate can be damaged exposing the porous base layer.

Note

¹ CLEAPSS. 'Bench Materials for School Laboratories', School Science Service, 1991.

Service Outlets

Gas

4.15 Gas taps must be securely fixed in such a way that they cannot rotate, thereby preventing pupils from twisting the pipes and fracturing the gas connections. Taps should also have a clearly defined on and off position controlled by a double action method (eg. depressing and turning) to avoid pupils turning them on by accident. Drop lever taps are preferable as teachers are able to see from a distance whether taps are on or off.

Power

4.16 Double socket electrical outlets should be switched. Sockets should not be positioned horizontally and should ideally either be angled or protected by an overhanging work surface with non-drip groove. The way in which sockets are positioned near to sinks should be considered. All pipework to sinks should be crossbonded.

Water

4.17 Non-rotating sink taps avoid splashing and pupil misuse, and are advisable with high swan-necks to allow tall glassware to be filled. Various tap materials are available but an epoxy coat is suggested due to its overall resistance to corrosion.

Sinks

4.18 Wash up sinks are usually manufactured in stainless steel. The steel must be of an acid resistant grade

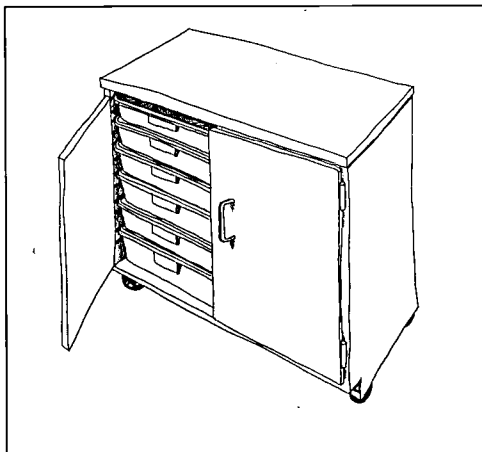

adequate for laboratory use although undiluted chemicals should never be poured into these sinks. Small sinks which are used for science practical work are generally available either in fireclay or a synthetic material. Fireclay has good resistance to most chemicals and heat, is easy to maintain and has a long life, but it is a hard material and glassware is more likely to break if dropped into this than a sink in one of the following synthetic materials.

- Cast epoxy: the same properties of high resistance as a worktop in the same material. Sink units are either inset into the bench top and the joint is sealed with a sealant, or form a complete unit with a drainer.
- Polymethacrylate: used where this is the bench material and a continuous joint-free surface is achieved. Staining may be caused by certain chemicals.
- Polypropylene: these sinks are inset and lipped and although they have good chemical resistance they can be damaged by heat.

4.19 Bottle traps to sinks will allow easy clearance in the case of blockage. If regulations concerning the disposal of chemicals are followed, dilution traps should not be necessary. Non-corroding polypropylene waste pipes are recommended.

Storage

Resources and Equipment

4.20 The laboratory layouts in Section 2 provide from 4m³ to 6m³ of storage. This allows for basic resources for up to 30 pupils and is additional to the storage in the preparation area. The majority of storage cupboards, with either adjustable shelving or trays, are shown stored under worktops. Adjustable shelving providing storage above the benching is also shown. Underbench storage units should ideally be mobile (see Figure 4/3). This also allows units to be re-arranged within the laboratory, moved to another laboratory or to the preparation area. Mobile storage units allow laboratory

Figure 4/3
Mobile Storage Units

floors to be cleaned more effectively and, when stored under benching, may be moved to create 'knee holes' when pupils wish to sit at the perimeter benching (see Figure 4/1).

4.21 Equipment trolleys are widely used for storing and moving resources. 1000 x 500mm is a typical size which is compatible with standard storage units. Trolleys may carry trays or shelves. Trays are particularly useful because they are also used in storage cupboards in the preparation area and the laboratory. Tray storage can be useful as resources can be stored in the preparation area on trays, placed on a trolley to be taken to a laboratory for transfer into a tray unit in the laboratory. A tray full of resources can be taken from a storage unit in the preparation room onto a trolley and transferred to a storage unit in the laboratory.

4.22 Where storage in the preparation area is minimal, full height cupboards may be used in the laboratories to increase storage capacity. They can be compatible with other lower height cupboards and trolleys and are often more economical in overall cost. However, they are not usually mobile, they do not provide a horizontal work surface and, if there are several, they can reflect sound from their laminate or metal doors.

4.23 The bulk of science equipment is generally stored in the preparation room. Storage systems which offer a range of interchangeable containers are particularly useful because science equipment comes in a variety of shapes and sizes. The racking system shown in Figure 4/4 can accommodate shelves, wire baskets or plastic trays. Baskets and trays are available in different depths and can be taken from racks and fitted onto trolleys (trolleys are usually included in the same range). Science equipment can often be heavy and it is advisable to place trays carrying this equipment on shelves. Figure 4/5 shows the rolling unit system described in Section 3, paragraph 3.23. If this furniture is used, the floor must be designed to allow trolleys to run smoothly between units. The floor must also be strong enough to take the additional weight of the system.

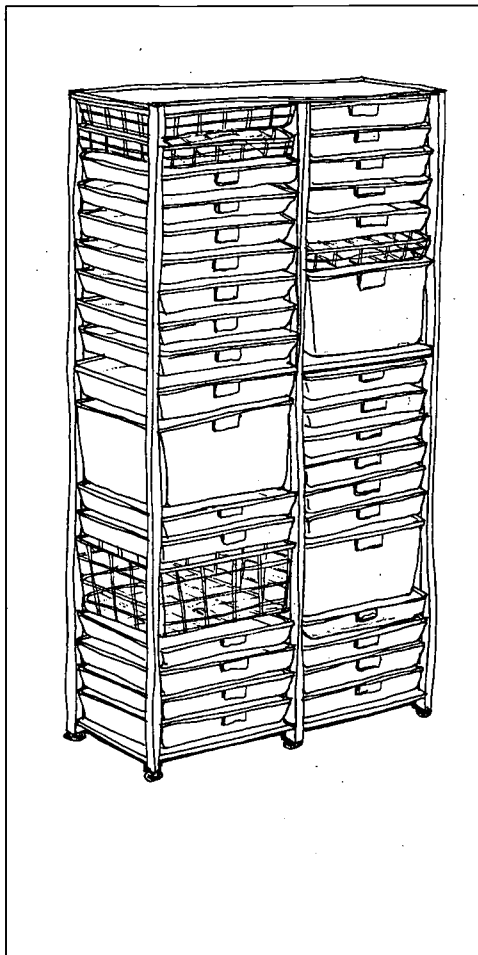

Figure 4/4
Racking Storage System

Figure 4/5
Rolling Storage System

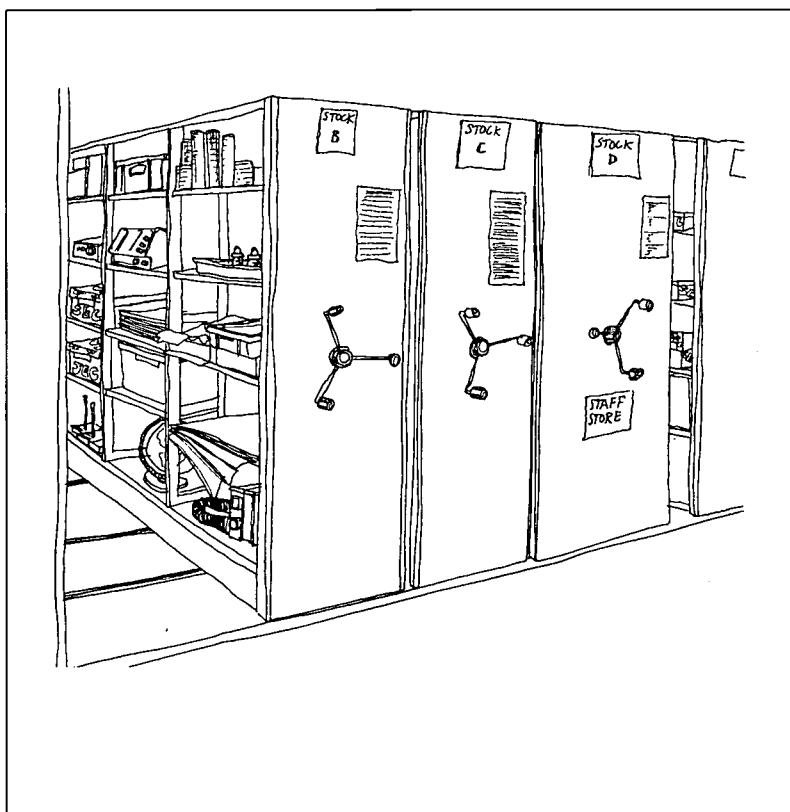

Figure 4/6
Wall Rail Systems

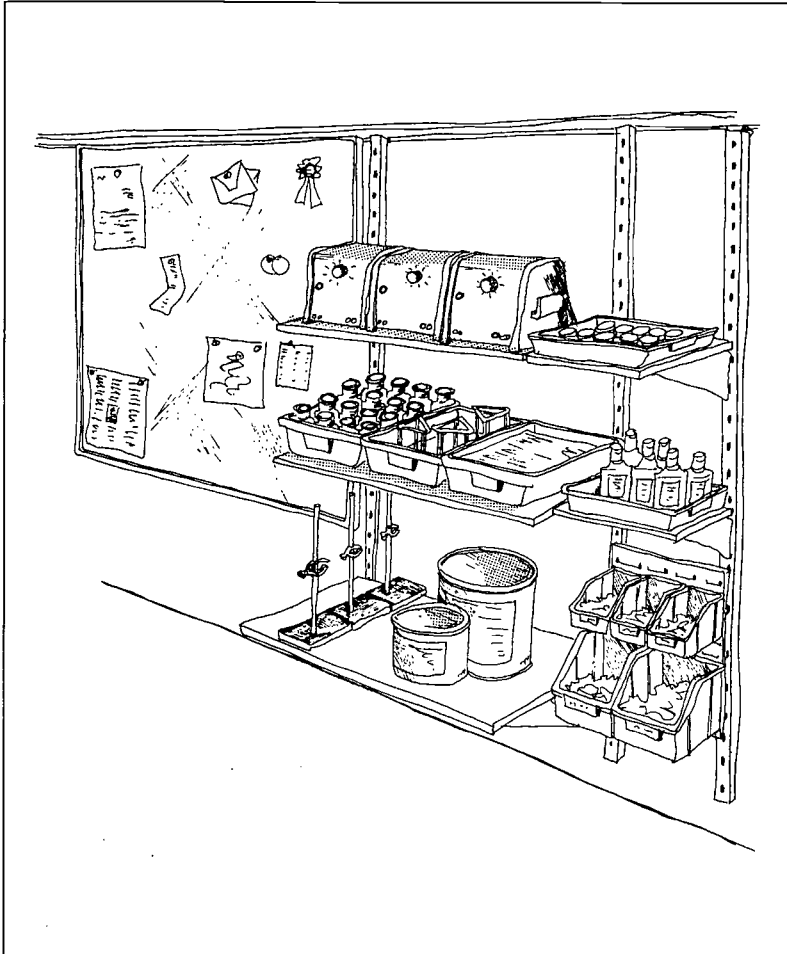
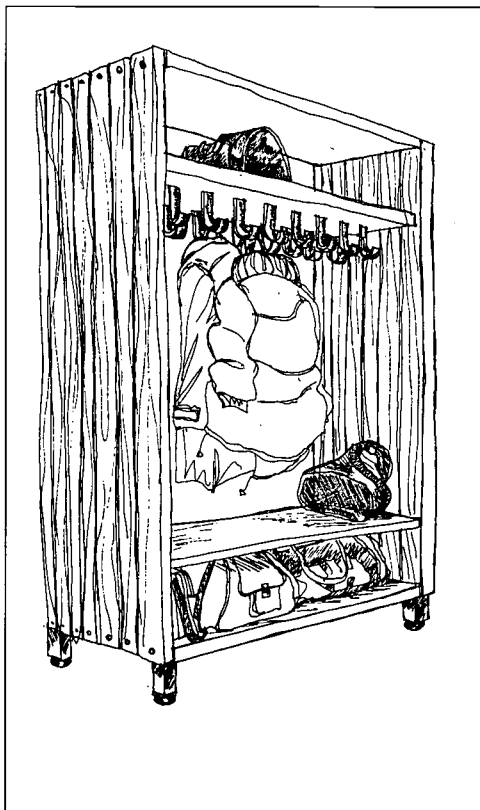

Figure 4/7
Pupils Coat and Bag Storage



4.24 Care must be taken in the storage of items which are fragile (such as glassware or eye-protective goggles) and which may require specialised storage units. The storage of large or heavy items should also be considered. The flexibility of each storage system should be borne in mind.

4.25 Wall rail systems are sometimes used in laboratories. Metal uprights hung from any point along the length of a horizontal shaped metal section carry cupboards or shelving brackets. Whiteboards can be hung directly from the wall rail. This system allows units to be positioned anywhere along a wall and changed (if required) at a later date (see Figure 4/6).

Pupils' coats and bags

4.26 If pupils' coats and bags are to be brought into the laboratory they must, for Health and Safety reasons, not cause obstruction. In all the laboratory layouts in Section 2, an area is shown near to the entrance for storing outdoor coats, bags and laboratory coats. Figure 4/7 shows one example of a storage unit designed for this purpose.

Display

4.27 Display is an important aspect of any classroom environment providing both visual stimulation and a sense of achievement to pupils. Vertical display may be in the form of loose boards or permanent pinboard wall covering. Work surfaces and cupboard tops provide excellent horizontal surfaces for displaying three dimensional objects. Delicate objects may need to be kept in glass fronted wall hung cupboards.

4.28 The flexible wall rail system illustrated in Figure 4/6 can be used for display as well as storage. This system enables the teacher to choose how the classroom environment should function.

Stools

4.29 Stools are available with a wooden or metal frame. The finish of the seats should be carefully considered, sealed wood or polypropylene are particularly useful. Shaped seats are generally more comfortable for students. Plastic end caps or bungs must be firmly positioned as, if removed, the metal legs can scrape and damage floor surfaces.

Fume Cupboards

4.30 Fume cupboards may be either fixed (Figure 4/8) or mobile (Figure 4/9). BB 88² looks in detail at the pros and cons of different types of fume cupboard (as well as containing valuable guidance on specifications, maintenance and commissioning). The main advantages of a mobile fume cupboard are ease of access for demonstration purposes and economy of use (one unit can be shared between a number of laboratories). The room layouts in Section 2 indicate a position for a fume cupboard (assumed to be mobile) in every lab.

4.31 Mobile fume cupboards may be of the ducted or recirculatory type. The ducted type has to be attached to a fixed extraction system whereas the recirculatory type, being self contained, can be used anywhere, making it particularly useful in conversion schemes.

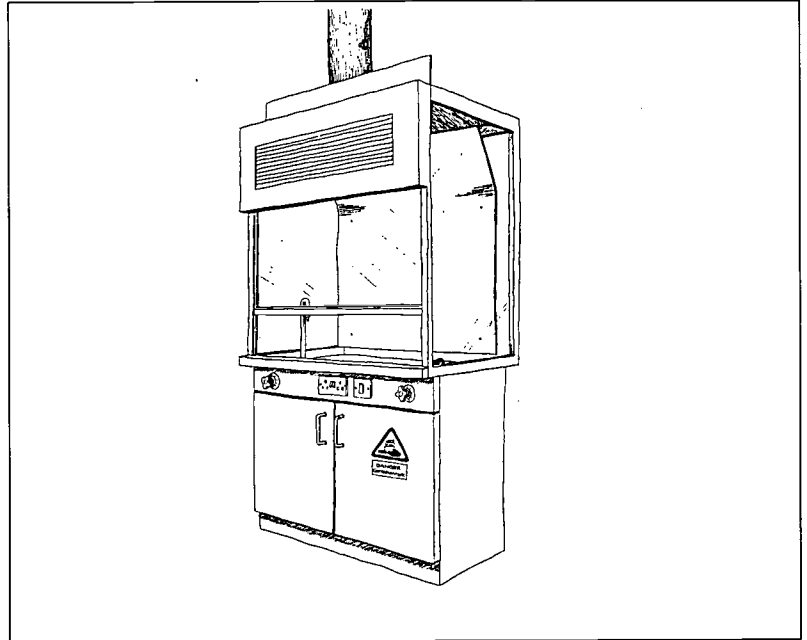

Figure 4/8
Fixed Fume Cupboard
with vented corrosives cabinet
underneath

4.32 Recirculatory fume cupboards contain filters which need to be changed at regular intervals. They are legally required to be tested for saturation. Testing filters is, in many cases, a skilled job and schools will need to invest in specialist equipment if they wish to do it themselves.

4.33 To ensure flexibility, the overall size of a mobile fume cupboard may need to be checked against door opening sizes. There are a number of documents providing information on all types of fume cupboard (see Bibliography).

Note
² Department for Education and
Employment 'Fume Cupboards
in Schools' (Revision of DN 29).
BB 88, SO 1998.

Figure 4/9
Mobile Fume Cupboards-
Ducted and Recirculatory

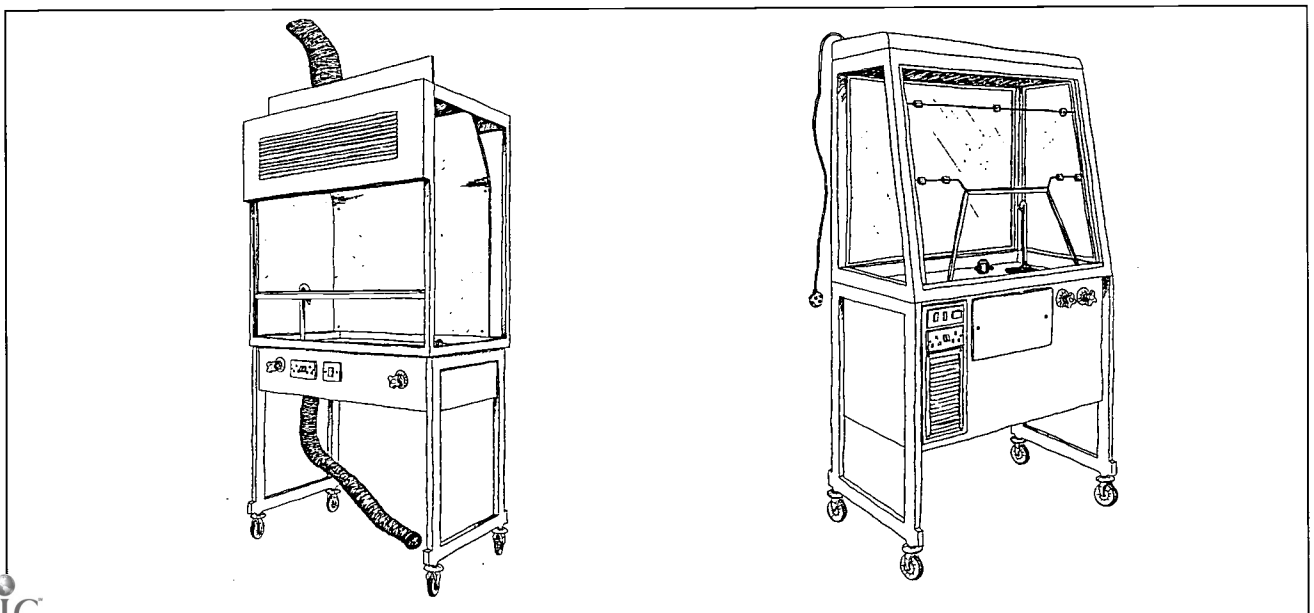

Section 5: The Environment/Health and Safety

As science is essentially a practical subject, Health and Safety regulations and environmental conditions are particularly important. Science laboratories are heavily serviced rooms and the design and coordination of all services must be considered at the outset. This section describes some of the main issues to be considered but reference should be made to all the relevant statutory documents and additional guidance listed here and in the bibliography.

Environmental Services

Ventilation

5.1 Ventilation of science laboratories must be designed to provide the normal background and rapid ventilation rates described in the School Premises Regulations¹ for all teaching spaces. These require that "Controllable ventilation should be provided at a minimum rate of 3 litres of fresh air per person per second for each of the maximum number of persons the area will accommodate" and that, "the spaces should be capable of being ventilated at a minimum rate of 8 litres of fresh air per second for each of the usual number of people in the space". The Workplace Regulations² also apply during use and require that "The fresh air supply rate should not normally fall below 5 to 8 litres per second, per occupant. Factors to be considered include the floor area per person, the processes and equipment involved, and whether the work is strenuous." Natural ventilation will need to be carefully designed to give the necessary ventilation rates.

5.2 Ventilation will be required for pollutant loads due to chemical experiments, heat gains from bunsen burners and other equipment and solar gains. The risk assessments for pollutants generated by science experiments conducted in the open laboratory assume a room volume of 200m³ and at least 2 air changes per hour for a typical science laboratory.³ This implies that if the ceiling height is low a higher ventilation rate will be required. Because of the possibility of 30 pupils doing chemical experiments local exhaust ventilation is usually required in

science laboratories where chemical experiments are conducted. Mechanical ventilation may be necessary where natural ventilation cannot be relied upon to provide the necessary ventilation. Heat recovery on local extract fans and on supply and extract systems is recommended to minimise ventilation heat losses. Windows which partially open are useful for natural ventilation during the winter months.

5.3 Where ducted fume cupboards are used, there needs to be an adequate supply of incoming air to compensate for the extraction when the cupboard is in use. The extracted air should ideally be discharged at a minimum height of one metre above the highest part of the building. All fume cupboards should be installed and used according to the guidelines laid down in Building Bulletin 88.⁴

Lighting

5.4 A good general level of illuminance (eg. 300 lux) is recommended for all teaching rooms in Building Bulletin 87.³ Additional local task lights may be useful for certain experiments. Dark shiny work surfaces are best avoided as they can cause glare. Very dark colours may provide too great a visual contrast. Further details can be found in 'Lighting Design for Schools'.⁵

5.5 Laboratories may need some form of blinds to reduce the daylight in the room when the OHP or video are in use or to control reflections on computer screens. One laboratory may need black-out facilities for light experiments; a dimming facility is also useful.

Heating

5.6 As with all services the position of heating outlets should be coordinated at an early stage with the furniture and equipment layout of the room. This is particularly important where heating units occur under worktops. Detailing must allow for adequate air movement which may mean leaving space in front of the unit and designing the worktop to allow for an air grille above each one.

Notes

¹ School Premises Regulations 1999. SI 1999/360. HMSO.

² Workplace Regulations (Health, Safety and Welfare). Approved Code of Practice. 224. 1993.

³ Department of Education and Employment, 'Guidelines for Environmental Design in Schools' (Revision of Design Note 17). BB 87, SO 1997.

⁴ Department for Education and Employment 'Fume Cupboards in Schools' (Revision of DN 29). BB 88, SO 1998.

⁵ Department for Education and Employment, 'Lighting Design for Schools', BB 90, 1999.

Health and Safety

Electricity

5.7 All installations must comply with the latest regulations from the Institute of Electrical Engineers (IEE).⁶ The safety of the electrical system should not be compromised by the electrical wiring in the furniture system and particular care must be taken with correct earthing and the safe isolation of electrical faults. This is especially important when adapting existing accommodation. Where servicing systems include flexible cables there must be some form of physical restraint.

5.8 Most laboratories are now fitted with mains supply and transformers are used locally for low voltage experiments. Protection by residual current devices (RCDs) is recommended. The current is switched off automatically in the case of a fault. One circuit usually controls one laboratory. A central push button isolator is also useful and should be positioned near the main laboratory entrance, easily accessible to the teacher.

Gas

5.9 Reference should be made to 'Guidance Notes on Gas Safety in Educational Establishments' (IM25).⁷

5.10 There will need to be a manual shut-off valve at the pipe entry to each laboratory. Where this valve is not easily accessible an automatic shut-off system can be used which will also shut down the supply in the event of a leak. This can be restored manually by a switch which should be located near the teacher's position or near the door.

5.11 Gas pipes should be installed in accordance with the Gas Safety (Installation and Use) Regulations 1998 and the Approved Code of Practice.⁸ With a few exceptions, the regulations require gas pipes to be ventilated along their run either by being exposed or by the enclosure being punctuated to provide adequate ventilation to avoid explosion due to a build-up of gas in the case of leakage.

5.12 Gas pipes need to be well supported particularly where they are part of a flexible overhead servicing system or at a height accessible to pupils. IM25⁷ gives guidance on gas supply to portable equipment such as mobile fume cupboards and recommends detailed inspection of such equipment at least once a year. It also recommends annual inspection of all gas pipework and controls.

Fire

5.13 The design of both new and adapted laboratory accommodation should be in accordance with the DfEE Constructional Standards.⁹ If the room exit door is not in a hazardous position a second exit is not essential. However, in new laboratory buildings an alternative exit is desirable and where the rooms are on the ground floor this can have the added advantage of giving access to an external learning space. A second exit can also lead to an adjacent laboratory in which case it is important that the door is left unlocked. Such an arrangement is shown in most of the plans in this publication.

Flooring

5.14 Flooring should have a minimum number of joints, be resistant to commonly used chemicals and be slip resistant even when wet.

5.15 Vinyl, which is often used for laboratory flooring, has good resistance to grease and oil and most chemicals although it can be damaged by hot cinders. As staining is likely to occur in time because of spillage, very light colours are best avoided. The versions with abrasive chips are slip resistant but more difficult to clean, and may damage the plastic feet on chairs and stools which then in turn, further damage the floor. Vinyl sheet must conform to BS 3261 and manufacturers recommendations for cleaning and maintenance should be adhered to carefully to avoid either damaging the surface or reducing the slip resistant quality.

5.16 Wood block flooring can be used if the surface is fully sealed and it is essential that a slip resistant polish continues to be used.

Notes

⁶ Institution of Electrical Engineers. 'Regulations for electrical installations': IEE wiring regulations. Stevenage: Institution of Electrical Engineers, 1991.

⁷ British Gas and Department of Education and Science 'Guidance Notes on Gas Safety in Educational Establishments' (IM 25). London: British Gas 1989.

⁸ 'Safety in the installation and use of gas systems and appliances', Guidance on the Gas Safety (Installation and Use) regulations 1998 and Approved Code of Practice, HSE Books, 1998, £10.95.

⁹ Department for Education and Employment. Letter to Chief Education Officers etc. 19 September 1997. Annex: the 1999 Constructional Standards. See also 'School Building Information Centre' website: www.dfee.gov.uk/schbltdgs/reg.

Section 6: Adaptations: Three Furnished Case Studies

This section illustrates the furnished adaptations of three existing schools reflecting some typical situations. The examples show rooms of different sizes and shapes as well as a variety of servicing options.

6.1 The information shown differs for each case study.

Case Study 1. The adaptation of a suite of science spaces (see Section 1, Figures 1/8 and 1/9) is shown refurnished and re-equipped using three different furniture systems. The advantages and disadvantages of each are outlined.

Case Study 2. One 6.5m deep laboratory is shown furnished in four different ways in order to give some guidance on the layout of narrow spaces, which are often the result of combining two general teaching rooms. A comparative analysis of the facilities provided by each option is shown in Figure 6/11.

Case Study 3. Three of the five laboratories from the project described in Section 1 (Figures 1/12 and 1/13) are illustrated, each furnished with a different system.

6.2 All the furniture layouts follow the principles outlined in Sections 2 and 3. However, with limited space some compromises are inevitable. As in Section 2, where pupils do not directly face the whiteboard, stools are shown shaded black.

Case Study 1: Furnishing a Suite of Laboratories

6.3 This two storey adaptation is described in Section 1 (Case Study 1) and a breakdown of the building, furniture and equipment costs is given in Section 7. Figure 6/1 shows the location of existing services. All the first floor laboratories are serviced at the perimeter only. On the ground floor, laboratory 4 has fully serviced tables and perimeter benches. Laboratory 5 has tables with gas and electricity and sinks in the perimeter benches. In these two rooms in particular the services and the furniture are in poor condition.

6.4 Figures 6/2 to 6/4 show the adapted suite of five laboratories laid out with three different furniture systems, all chosen to suit the dimensions of each space and the existing services. Four of the five laboratories (nos. 2, 3, 4 and 5) are furnished for up to 30 pupils. The fifth laboratory is furnished for a group of 24 pupils (probably KS4). On each floor one mobile (recirculatory) fume cupboard is shared between laboratories with a position shown in every laboratory except for the smallest.

6.5 In each example the preparation room layouts are identical. The larger room has a technicians' wash up area provided near the window wall while storage in the form of full height tray units is kept to the back of the room. An extraction system, taking foul air from the fume cupboard and chemical store to the outside, runs at high level.

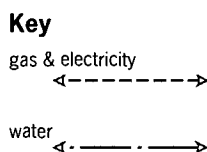
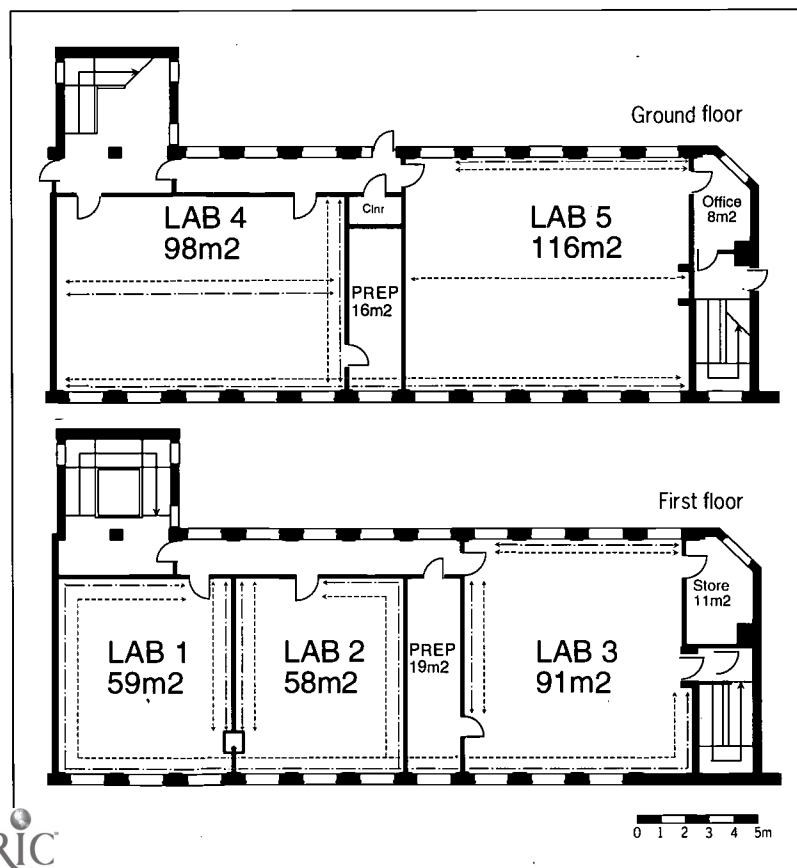

Figure 6/1
Case Study 1, Servicing arrangement of existing building



Option A (Figure 6/2)

6.6 In this option a serviced furniture system is shown.¹ On the first floor, services run through the furniture from the perimeter to the centre of the room. On the ground floor, because there are existing central services, an island version of the same system is used. The following points are of particular note.

- The octagonal units allow pupils to work in groups of up to 7 although in all the laboratories some pupils have to sit at the perimeter bench.
- In laboratory 1, which allows only 2.4m² per workplace, a smaller version of the octagon unit (1650mm diameter)

is used. A shelf duct on the side wall houses the service runs where a full depth bench would take up valuable space.

- The geometry of the octagonal units is suited to irregularly shaped rooms such as laboratory 3.
- In laboratory 5 where existing wet services are restricted to the perimeter, the units are 'dry' and pupils use sinks in the side benches.
- In laboratory 4 there is a small resource area which may be used by pupils from other classes. The continuous run of the work surface may present problems of circulation and access.

Note

¹ See Section 2, para 2.52, for a description of this type of system.

Figure 6/2
Case Study 1, Option A

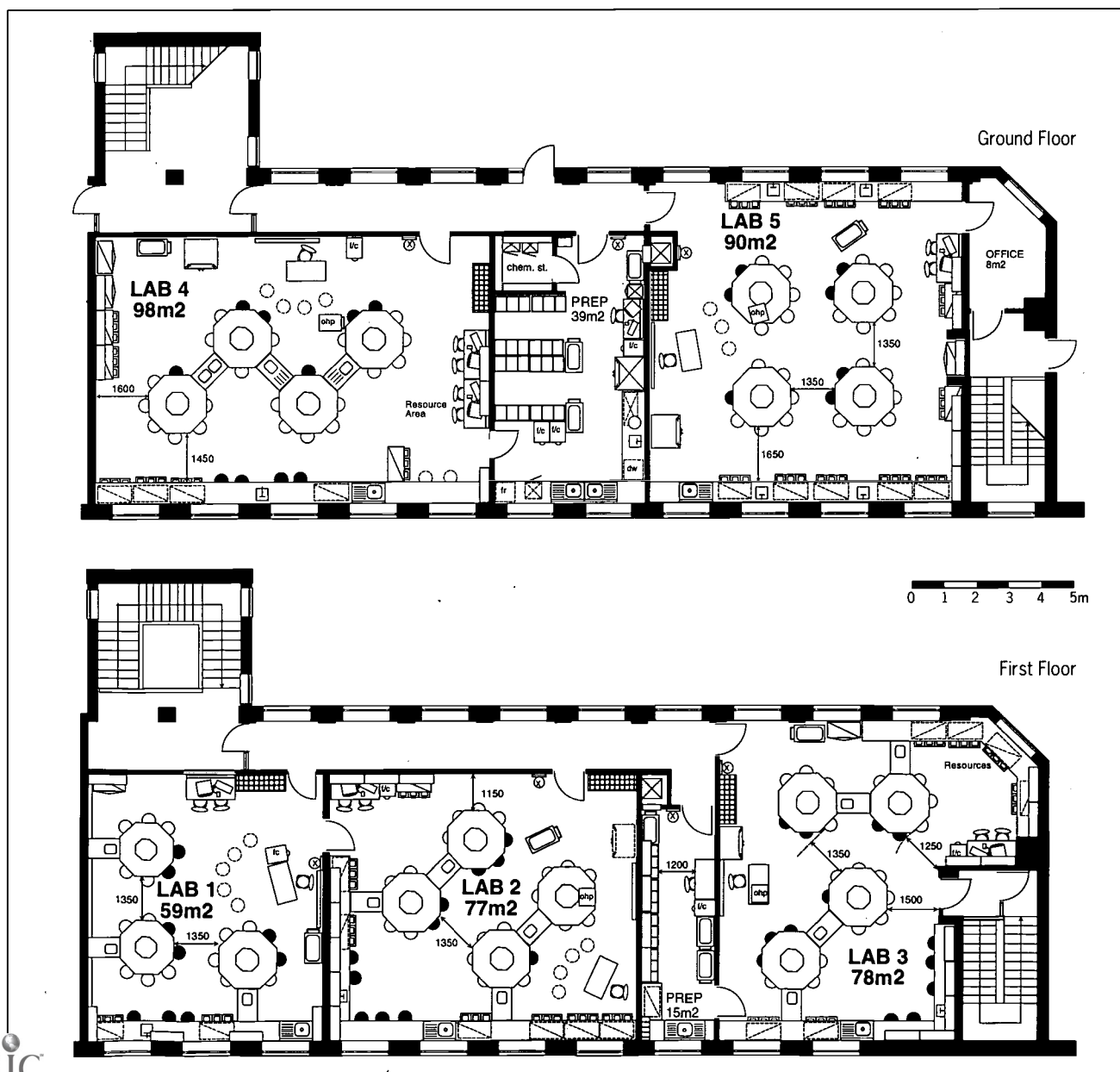

Note

² See Section 2, para 2.58, for a description of this type of system

Option B (Figure 6/3)

6.7 In this option another example of a serviced furniture system is shown² which is serviced exclusively from the perimeter. There are several points to note about this option.

- This system leaves more floor area free so that groups of pupils can gather easily around the teacher.
- In laboratory 2 the position of the whiteboard may cause problems with glare but this can be overcome by using blinds.
- Laboratory 4 on the ground floor has a resource area similar to that shown in Option A, resources may be replenished by technicians in the adjacent preparation room.

Option C (Figure 6/4)

6.8 This option is based on a bollard system. Island bollards provide wet and dry services in laboratory 4 (where wet services already run to the centre of the room) and dry services only in laboratories 2, 3 and 5. This involves more work to the existing services and building fabric than options A and B because gas pipes and electrical conduits have to be fitted beneath the floor in laboratories 2 and 3. In laboratory 1 a peninsular bollard system is used. Particular points to note are given opposite.

Figure 6/3
Case Study 1, Option B

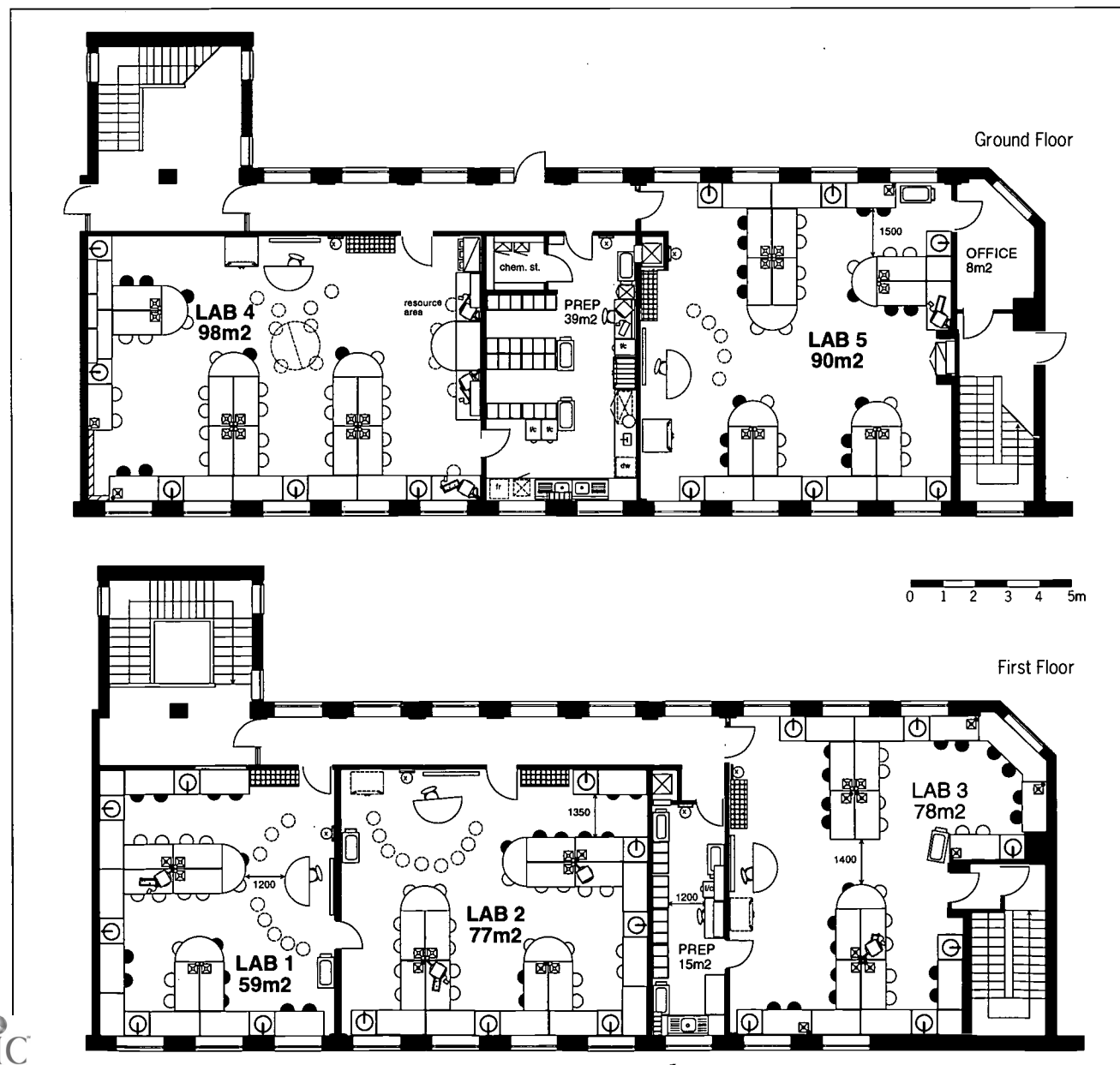

Section 6: Adaptations: Three Furnished Case Studies

- This system provides a very compact layout particularly in a small space such as laboratory 1.
- Where the bollards are fixed centrally (laboratories 2, 3, 4 & 5), the tables are loose and can be rearranged. In laboratory 2, for example, tables can be rearranged to allow all pupils to see the whiteboard (see Section 2, Figure 2.17).
- In laboratory 1 tables adjacent to the wall are clamped to a 1200 x 600 bollard, forming peninsular units under which services run. The other tables are loose and can be rearranged.
- In laboratory 2 the whiteboard faces the window wall and as with option B, blinds may be needed.
- In laboratories 2, 3 and 5 pupils sit at tables around the central bollards and use the sinks in the perimeter benches. The sinks are located along the same 'run' as the central bollards for easy access.
- In the large laboratory 4 a bank of resources is shown at the back of the room. There is space at the front for pupils to group around the teacher.

Figure 6/4
Case Study 1, Option C

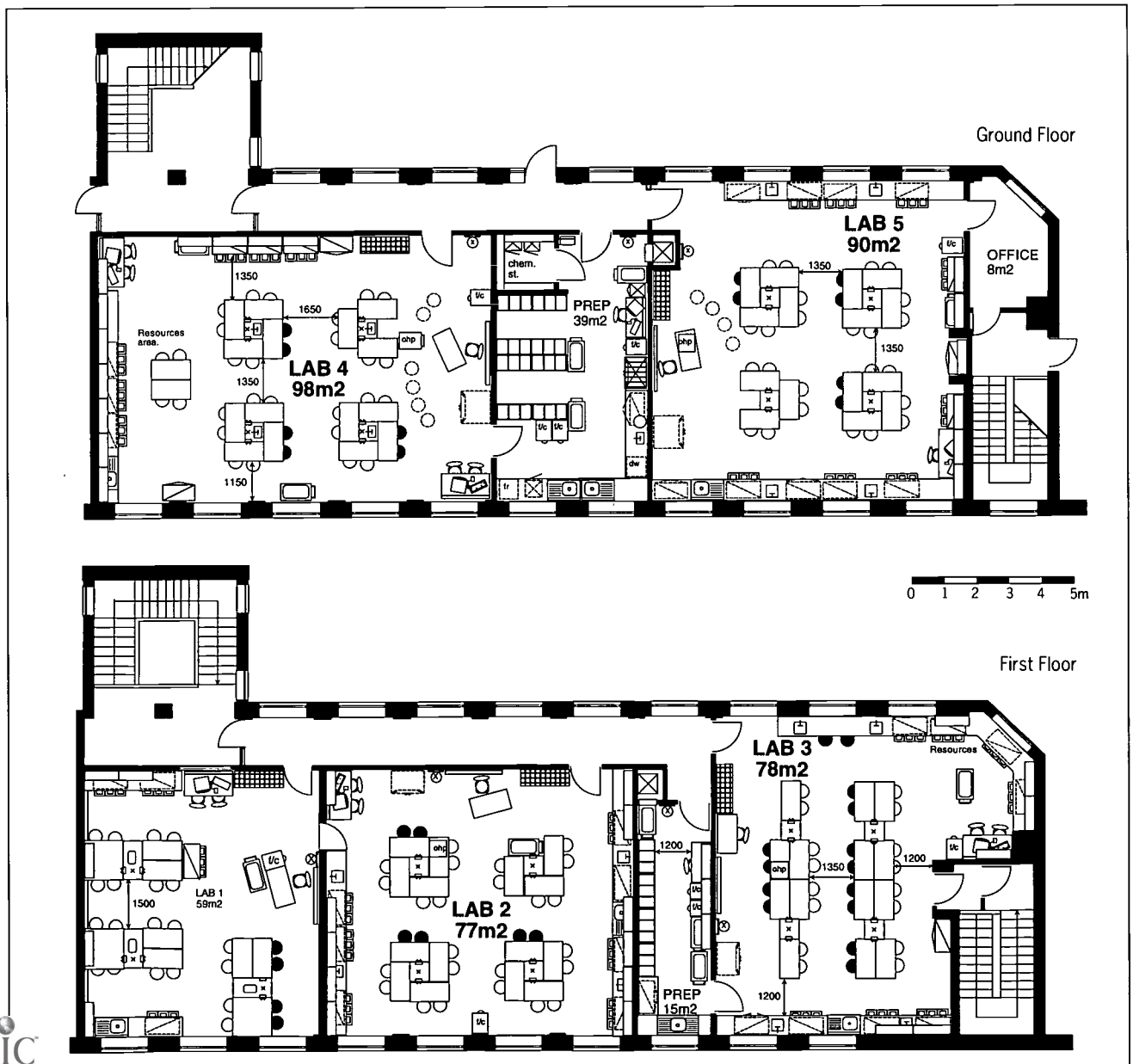

Case Study 2: The Furniture Layout of a Narrow Space

6.9 A common method of providing an extra laboratory is to combine two general classrooms which often results in a very narrow space which is difficult to plan. Figure 6/5 shows two 6.5m deep general classrooms of 49m² located adjacent to an existing science suite. The dividing wall is removed to provide one laboratory of 84m² and an adjacent store room. There is no gas and water in the room but existing services can be extended to the perimeter of the space.

Figure 6/5
Case Study 2, As Existing

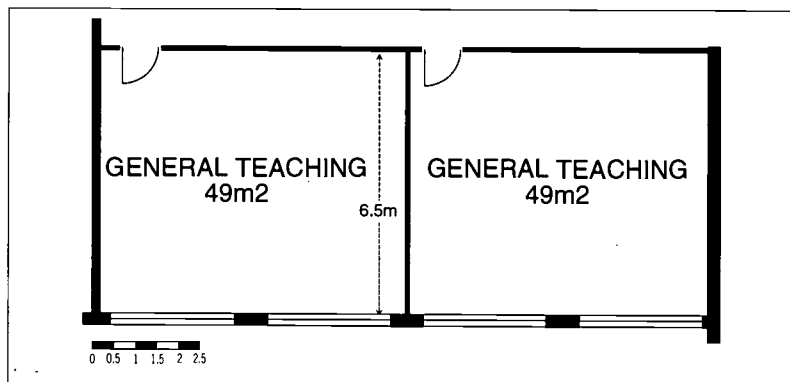

Figure 6/6
Case Study 2, Option A

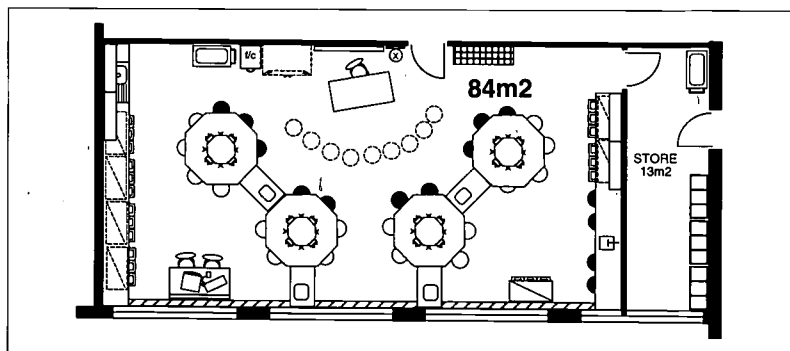
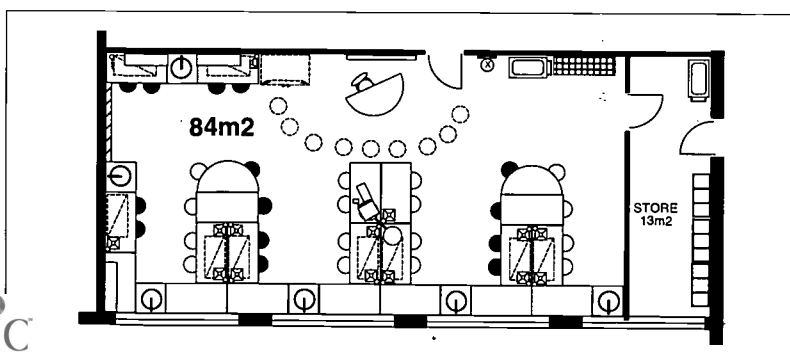

Figure 6/7
Case Study 2, Option B



6.10 Figures 6/6 to 6/10 show the laboratory fitted with five different systems to illustrate a variety of solutions appropriate for a narrow laboratory. Figure 6/11 shows an analysis of facilities offered by each system. In the first two options serviced furniture is used, in the third a spine, in the fourth underfloor services to central bollards and in the last option overhead booms service bench level pods.

6.11 The new laboratory is large enough to provide a full range of facilities, including a mobile fume cupboard. In every option the best position available for the whiteboard is opposite the window wall, blinds would therefore be needed to control glare. The proportions of the room can result in pupils having an oblique view of the teacher and whiteboard.

Option A (Figure 6/6)

6.12 This option shows an octagonal furniture system where the services run within the units (see Section 2, paragraph 2.52). The following points are of particular note.

- The arrangement of the octagonal units allows for an open central area where pupils and the teacher can gather for briefing or discussion.
- The door is placed in the centre of the room where the floor area is least obstructed.
- A shelf duct conceals the services running along the external wall.
- The position of the computer trolley is not ideal due to glare but this could be controlled by window blinds.

Option B (Figure 6/7)

6.13 This option shows another serviced furniture system (see Section 2, paragraph 2.58). Here tables form peninsular units along the long window wall. The following points are of particular note.

- Six pupils have to sit directly facing a wall rather than into the centre of the room, and this may be less easy for a teacher to supervise.

- There is no computer trolley shown as this system incorporates a monitor shelf.
- The area of work surface per pupil is higher than in other options, although the computer may take up some of this area.

Option C (Figure 6/8)

6.14 In this option tables are arranged around a 'wet' service bollard and a 'dry' service spine forming three peninsular units along the window wall. This system is described in more detail in paragraph 2.33, Section 2. A shelf duct along the window wall contains the services. This system shares some of the characteristics of option B but there are some differences.

- All pupils can be seated at the peninsular units.
- Pupils have ready access to sinks.

Option D (Figure 6/9)

6.15 In the first three options services are carried from the perimeter within serviced furniture or spines. In this option gas and electrical services run in underfloor ducts to dry bollards (this may not always be possible in an existing building). Sinks are provided at the perimeter. The following are the main features of this arrangement.

- The teacher has easy access to every side of each pupil group.
- The tables are loose and can be rearranged.
- There is less space at the front of the class than in the peninsular layouts.

Option E (Figure 6/10)

6.16 In this option the services are carried by an overhead boom to four table-mounted pods. As in option D the tables are loose and pupils use perimeter sinks. The following points are of interest.

- The free floor area is greater than in option D because the service pods sit on the tables and do not take any floor space. However, work surface areas are slightly reduced.
- One overhead boom serves all tables.
- As in option D, all the pupils can sit at the central tables.

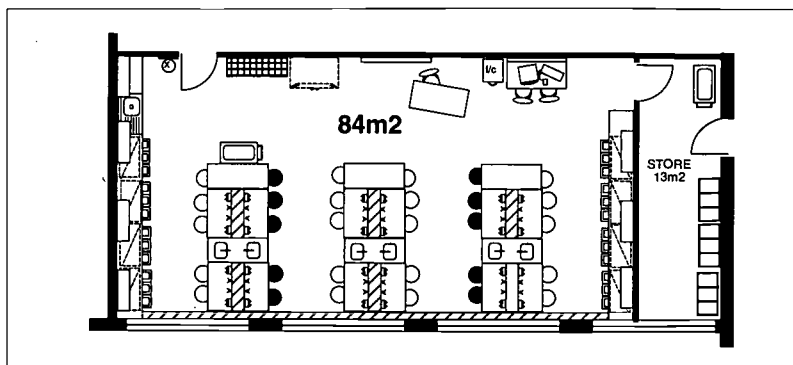

Figure 6/8
Case Study 2, Option C

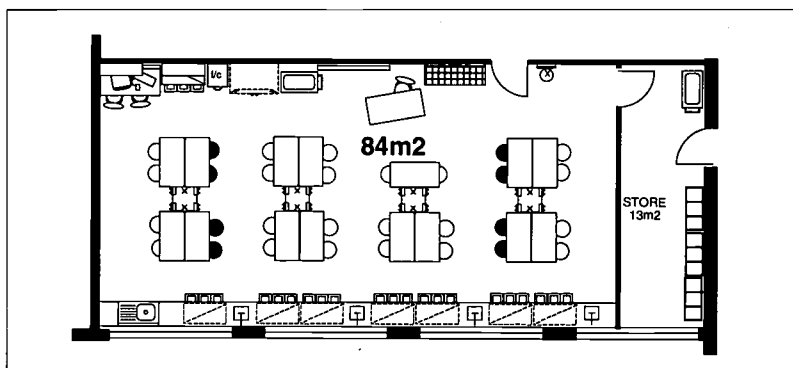

Figure 6/9
Case Study 2, Option D

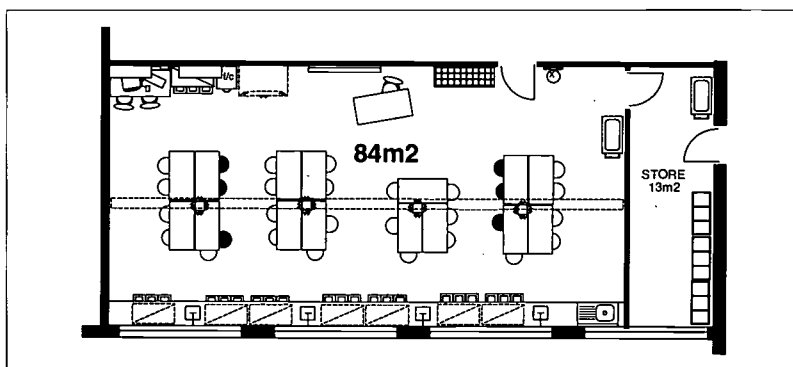

Figure 6/10
Case Study 2, Option E

Figure 6/11
Comparative Analysis of Case Study 2

Options	A	B	C	D	E
Serviced work area (m ²)	9	16.9	10.8	11.3	10.8
Ancillary work area (m ²)	4.7	7.8	6	6.3	6
Small sinks	5	5	4	6	4
Storage (m ²)	4	4.3	4	5.2	4.4
Service outlets	40	45	40	56	38
Computer table	1	0	1	1	1
Wash up sink	1	1	1	1	1
Fume cupboard	1	1	1	1	1
Whiteboard	1	1	1	1	1
Teacher's table	1	1	1	1	1

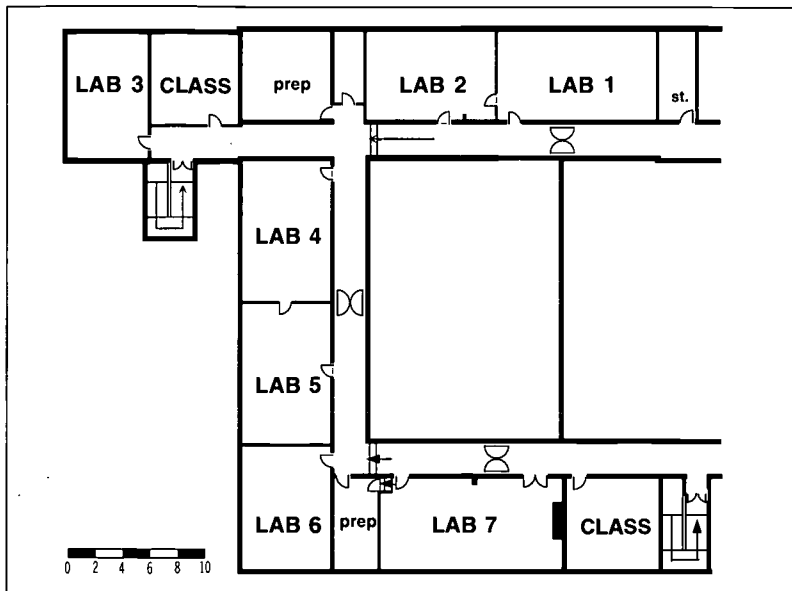

Figure 6/12
Key Plan

Figure 6/13
Case Study 3, Laboratory 2

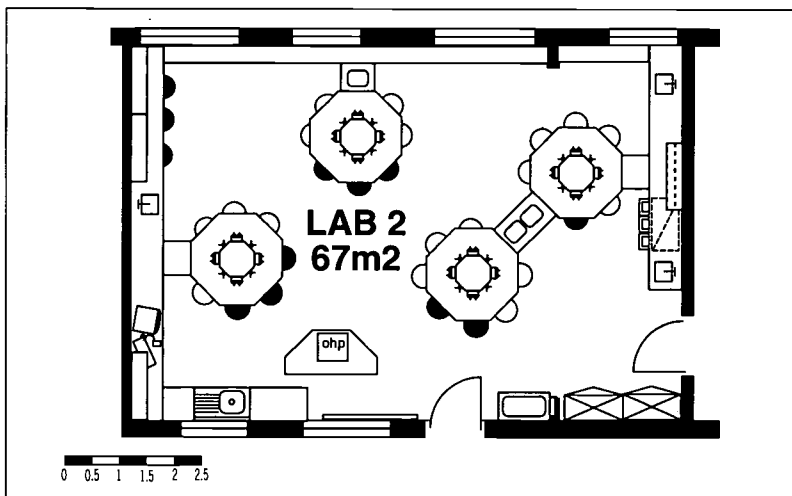
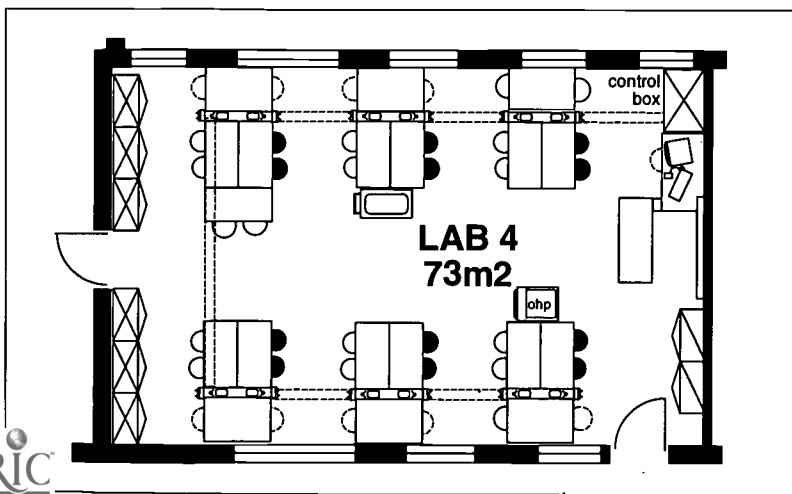

Figure 6/14
Case Study 3, Laboratory 4



Case Study 3: Three Different Systems

6.17 The adaptation of this first floor science suite is described in Section 1 (Case Study 3). The existing furniture has not been changed since the 1930s. Three of the five refurbished laboratories are illustrated showing differently furnished examples. Services are restricted to the perimeter of each space.

6.18 Each laboratory has sufficient work surface for 30 pupils although there is less side benching than in the larger spaces shown elsewhere and the level of equipment is reduced. There are two existing fume cupboards in laboratory 1 and a mobile fume cupboard is shared between other laboratories. Each laboratory includes some full height storage units. Figure 6/12 shows the location of the laboratories described. Points to note about the layout of each laboratory are listed below.

Laboratory 2 (Figure 6/13)

6.19 In this laboratory an octagonal serviced furniture system is shown with perimeter services masked along the external wall by a 300mm deep shelf. 27 pupils sit at the central units and three at one of the side benches.

6.20 Because of space restrictions, a smaller octagonal unit (1650mm diameter) and a small linking unit (500mm long) are used. The teacher's table is a special mobile unit based on the standard octagon.

Laboratory 4 (Figure 6/14)

6.21 The 'Labkit Workstation' system is shown (see paragraph 2.27, Section 2 for a description). Additional tables are used in place of perimeter benching.

6.22 All the tables are freestanding and can be rearranged to suit the activities in the lesson. The additional tables allow all pupils to sit 'inside' the overhead service boom enabling them to see the whiteboard more easily.

Laboratory 5 (Figure 6/15)

6.23 This laboratory is also serviced from above but only dry services are carried by the boom. Tables which surround a services spine are clamped together for stability. A similar system is described in paragraph 2.30, Section 2. Water services run along the perimeter wall beneath a 300mm deep shelf which also keeps units clear of existing radiators.

6.24 The proportion of the room limits the view of some pupils but there is enough clear space for pupils to gather around for demonstration or discussion.

6.25 As in all these laboratories a computer trolley is not shown because of the limited size of the space. In this case if a computer is required it sits on one of the tables.

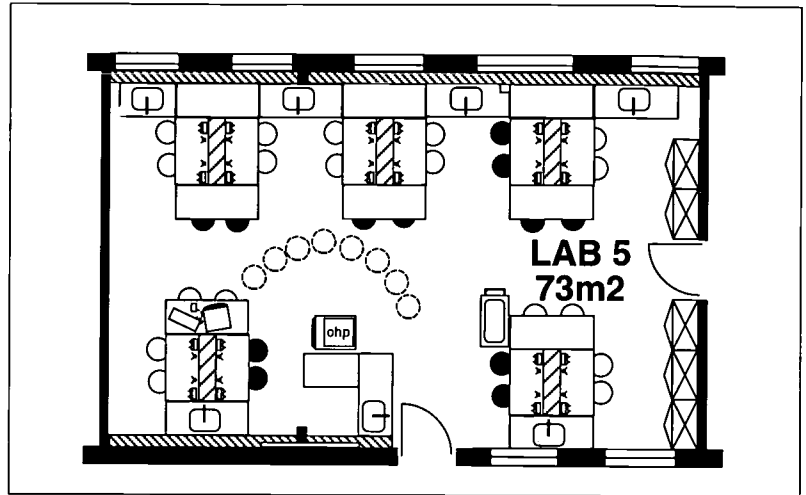

Figure 6/15
Case Study 3, Laboratory 5

Section 7: Cost Guidance

This section gives guidance on capital cost aspects of providing and fitting out science accommodation in secondary schools. It is divided into 3 parts: General Cost Matters, Furniture and Equipment Costs and Case Study Analyses. The Case Studies are taken from those illustrated in Section 6.¹

General Cost Matters

Building consultants' fees.

7.1 Major new building work and extensions, or substantial adaptations of existing accommodation, will normally be managed and supervised by a team of professional building consultants employed directly by the building owner. Depending on the nature of the work this service will usually cost between 10% and 15% of the value of the building contract, although higher fees may be payable in exceptional circumstances. The fee will cover the cost of employing - where appropriate - architects, engineers and surveyors. Consultants' services should be procured, like those of building contractors, on a competitive basis wherever possible. The respective professional institutions will supply details of the services that can be provided as well as information on fee scales.

7.2 The fee percentages will usually also apply to the value of any fixed furniture and fittings, eg. shelving, benching, cupboards etc, included within the main building contract whose design, procurement and installation has involved a reasonable degree of professional input by the consultants. Care however should be taken to ensure that fees are not paid on the value of items which, whilst forming part of the main building contract, have been independently designed, procured and fixed by a specialist contractor who has already included for the cost of providing these services within his price, eg. fitted laboratory furniture. Consultants may, however, claim fees in respect of any necessary co-ordination and liaison work

between the main project team and the specialist contractor.

7.3 In many local education authorities the procurement of furniture and equipment (sometimes both fixed and loose) is managed by the authority's supplies organisation. As an authority-wide service the cost of providing it may not always be attributed to individual projects and can therefore remain as a hidden cost. For projects at self-governing and other schools which do not automatically receive support from a local education authority supply organisation it may instead be necessary to employ the project architect or another agency to provide this service. This may cost up to 6% of the value of the furniture and equipment supplied and be additional to the normal professional fees described above. In smaller projects this work may be undertaken, possibly at no cost, by the school itself.

Value Added Tax

7.4 Under current regulations all building work will attract VAT at the standard rate except in the case of new detached buildings provided at schools which have charitable status, such as voluntary aided schools, in which case the work may be zero rated. Extensions to existing buildings will usually be standard rated, although in some instances, depending on the way the extension is linked to the existing buildings, it is possible for most of the work to be zero-rated. Furniture and equipment and professional fees are standard rated whatever the type of project. In local education authority school building projects any VAT payable is normally recoverable by the local authority.

7.5 Given the considerable impact that VAT can have on the total cost of a project, particularly in relation to extensions which may or may not attract VAT for the reason mentioned, advice should be sought from the local HM Customs and Excise Office at an early stage in the planning process.

Note

¹ Costs given are at first quarter 1999 prices (unless otherwise indicated) and may be updated to current price levels using appropriate tender price indices available from the Indices group of the Department of the Environment, Transport and the Regions, see also Note ³, page 50.

Building project phasing

7.6 For a number of reasons, it may be necessary to consider phasing the work over a period of time. The diseconomies associated with carrying out a number of small building projects instead of a single large one will need to be allowed for when the initial budget is set. Funding for phased educational projects will usually be contingent upon each phase providing fully operational accommodation in the event that further funds do not become available.

Comparative costs of new buildings and adaptation/refurbishment

7.7 Constructing and fitting out a new science building can cost between £1,000 and £1,400 per m² of gross floor area provided. These costs include for building work, furniture, equipment, site works and professional fees, but exclude land purchase costs and VAT. Factors influencing the cost include the size of the building contract, briefing requirements and standard of specification, site condition and ease of access and whether the building is single or multistorey.

7.8 Adaptation and refurbishment costs of existing buildings are usually more variable and depend on the degree to which the existing structure and services need to be altered and on the level of re-use of existing furniture and equipment. In the case of refurbishment requiring, for instance, only redecoration and a few extra services outlets and where there is substantial re-use of existing furniture and equipment the costs may be less than 10% of the cost of new. In larger projects involving extensive structural remodelling and renewal of services and where all new furniture and equipment is provided, the costs can approach those of providing a completely new building.

7.9 Generally where there is a choice between building new and adapting/refurbishing existing accommodation, the latter will provide the more economic solution as the capital costs are likely to be lower. Furthermore, as the amount of area in use remains the same there will not be the extra recurrent servicing costs associated with additional new building area, ie. heating, lighting, cleaning, maintenance, rates etc. These can cost up to £40 per m² of gross floor area annually. In addition adaptation/refurbishment may enable better suiting between existing curriculum areas than would a separate new building. Costs for the adaptation case studies described in Section 6 are given overleaf.

Temporary accommodation costs

7.10 The typical outright purchase and installation cost of temporary science laboratory buildings fully fitted with furniture and equipment is between £600 and £850 per m² (excluding VAT). This is about 50% to 75% of the cost of equivalent new permanent accommodation. Although cheaper than permanent accommodation, temporary science buildings generally have a shorter life expectancy. They may also be less convenient if they are isolated from the rest of the science department, making the sharing of resources and equipment more difficult. When hired for short periods, however, they can provide a cost effective solution to short term accommodation needs, eg. during building work, or to accommodate a short term peak in a school's roll. A typical six month hire charge for a 100 m² fully fitted and serviced temporary science laboratory building, inclusive of delivery, installation and removal, is between £20,000 and £24,000 (excluding VAT).

Furniture and Equipment Costs

Comparative costs of serviced furniture systems.

7.11 The Department has recently examined typical fitting-out costs for a range of model laboratory types incorporating some of the different serviced furniture systems that are available to schools. A number of manufacturers were invited to provide budget costs for completely fitting out two sizes of laboratory - a small one of 72m² and a larger one of 84m² - using their own proprietary furniture system and, if possible, a range of worktop materials.²

7.12 Because the choice of furniture system depends largely on the arrangement of services within the laboratory, the manufacturers were also asked to cost two servicing arrangements. The first had the main services entering the room and terminating at one point above the floor. This suggested a system in which the services after this point were carried within the furniture itself. The second arrangement had services running under the floor (see Figure 7/1). This

suggested a system of isolated serviced units, or bollards, in the centre of the room.

7.13 The results of the exercise are summarised in Figure 7/2. Not all the manufacturers submitted costs for all situations as they do not all produce systems applicable to each servicing arrangement.

7.14 The costs in Figure 7/2 also include the manufactures' budgets for furniture and equipment based on a standard schedule of items appropriate to a group size of 30 pupils. It was recognised at the outset that some of the schedule items were not produced by the manufacturers themselves and that they would have to obtain costs from other suppliers. This, however, is consistent with the growing market requirement for manufacturers in this sector to provide a complete service to supply, deliver and fix a wide range of products. Although most of the proposed furniture and equipment items were the same for both laboratories, some items were not included in the smaller one due to space constraints.

7.15 Although the figures include for the supply, delivery and fixing, they exclude the cost of any associated builders' work or for service installations up to the outlet points to which the

Figure 7/1
Laboratory Plans Used for Comparative Cost Study

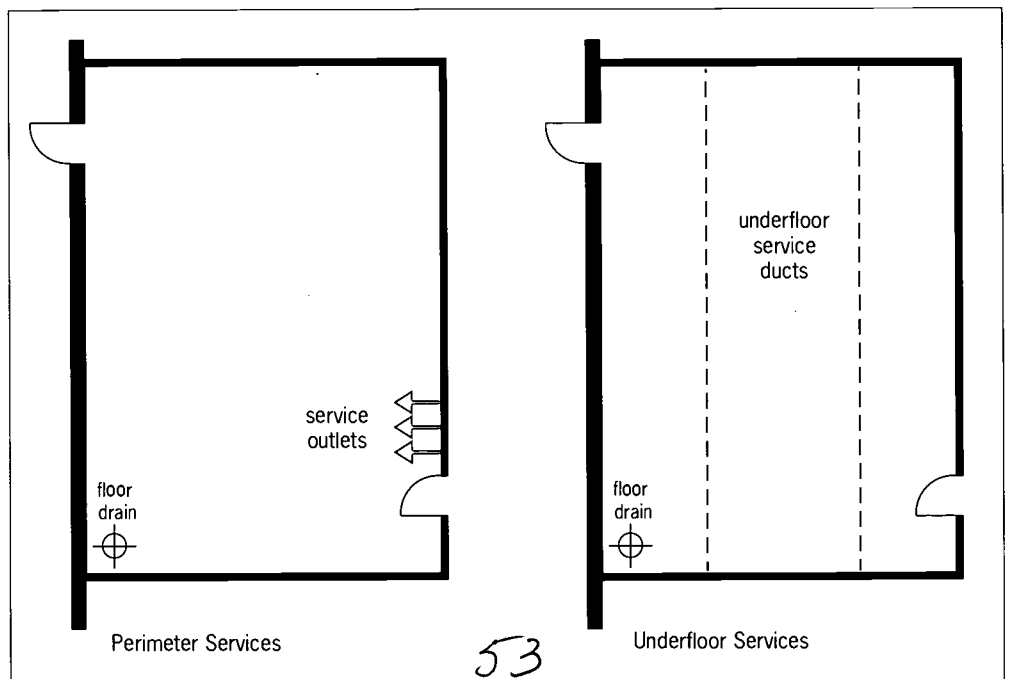

services in the furniture would connect. The following were included in the furniture and equipment schedule:

- serviced work surface for 30 pupils, which included 15 double socket outlets, 15 double gas taps and 5 small sinks with high level cold water taps;
- side benching provision and associated servicing;
- 1 no. wash up sink with hot and cold taps;
- mobile demonstration fume cupboard (in 84m² laboratory only);
- stools;
- teacher's table (unserviced) and chair;
- computer table/trolley;
- coats and bags storage (in 84m² laboratory only);
- storage (5m³ for the 84m² laboratory, 3m³ for the smaller laboratory);
- 4 drawer filing cabinet;
- whiteboards.

7.16 The first conclusion to be drawn from this exercise is that the type of worktop material was the main factor influencing overall costs. Although costs for the 'newer' materials are generally less expensive than they once were there is still a significant difference in the costs of systems finished in the new finishes compared to systems finished in more traditional materials such as iroko. The exercise shows the approximate order of costs (lowest first).

1. iroko.
2. solid laminate.
3. cast epoxy.
4. polyester.
5. polymethacrylate.

7.17 Section 4 analyses the non-financial advantages and disadvantages of these materials which need to be taken into account alongside the costing considerations when choosing a worktop.

7.18 Secondly, there was very little cost difference between manufacturers for the same generic systems (see paragraph 7.28). Despite the broad similarity in overall

84m² Laboratory

Above floor services	Worktop material		
	Iroko	Solid laminate	Polymethacrylate
Type of system	Iroko	Solid laminate	Polymethacrylate
Serviced bollards	£21,000		
Serviced spines		£21,000-£28,000	
Serviced pods		£21,000	
Serviced furniture	£22,000	£18,000	£26,000
Under floor services	Worktop material		
	Iroko	Solid laminate	Polymethacrylate
Type of system	Iroko	Solid laminate	Polymethacrylate
Serviced bollards	£22,000-£24,000	£17,000-£22,000	
Serviced spines	£21,000	£17,000-£20,000	
Serviced pods		£15,000	
Serviced furniture	£21,000		£28,000-£30,000

71m² Laboratory

Above floor services	Worktop material		
	Iroko	Solid laminate	Polymethacrylate
Type of system	Iroko	Solid laminate	Polymethacrylate
Serviced bollards	£13,000-£14,000		
Serviced spines	£21,000	£17,000-£20,000	
Serviced pods		£15,000	
Serviced furniture		£12,000	
Under floor services	Worktop material		
	Iroko	Solid laminate	Polymethacrylate
Type of system	Iroko	Solid laminate	Polymethacrylate
Serviced bollards	£12,000-£14,000	£12,000	
Serviced spines			
Serviced pods			£14,000
Serviced furniture	£11,000-£14,000		£18,000-£23,000

costs, manufacturer's individual charges for delivery and fixing varied greatly as a percentage of the furniture ex-works cost. None of the systems could be identified as being more costly, although some of the most recently developed systems appeared to attract the more expensive worktop materials.

7.19 Thirdly, the exercise shows that although both laboratory sizes are designed to accommodate 30 pupils, actual costs seem to reduce roughly proportionately with the reduction in floor area.

Figure 7/2
Comparative Budget Costs of Servicing Systems

However, because a major cost element relates to the provision of the basic serviced units - the quantity of which are determined by pupil numbers rather than floor area - there is likely to be a threshold below which furniture costs are unlikely to go for this number of pupils and at this level of specification.

7.20 Finally, the method of supplying services, either from below or above floor level, seems to have little effect on overall furniture costs. It is worth noting however whether the costs for particular systems include the costs of the services themselves (this may be particularly likely in the case of serviced furniture and serviced spines, see Section 2, paragraph 2.26 and 2.51).

Comparative costs of fixed and mobile fume cupboards

7.21 Fume cupboard costs can form a significant element of laboratory furniture and equipment costs. There are three main types: fixed, mobile re-circulatory and mobile ducted (described in Section 4). The supply and installation cost of a typical fixed fume cupboard is likely to be between £1,500 and £2,500 (excluding VAT) to which must be added the extract system cost of between £1,000 and £2,500.

7.22 Where a unit has to be situated a considerable distance from the exterior of the building, external extraction costs may be prohibitively high because of the need for more powerful fans and long duct lengths together with their associated builders' work. In such instances there may be advantages in using a mobile re-circulatory fume cupboard. At between £2,500 and £4,000 per installation these cost somewhat less than fixed fume cupboards with their associated extract systems. However, they do need regular filter changes which cost between £200 and £300 each; the change frequency depends on intensity of use but once a year is typical. The cost of a mobile ducted fume cupboard is likely to be between £1,500

and £2,500, plus the cost of the extract system as before.

7.23 Shared use of mobile fume cupboards between a number of laboratories can be a more economical solution than fixed units in each space.

Case Study Cost analyses

7.24 Figure 7/3 provides model cost analyses (based on typical budget prices) of the building adaptation work and furniture and equipment provision for each of the three furnishing options shown in Case Study 1, described in Section 6. Figure 7/4 provides a similar analysis of the project described in Case Study 3, although these reflect the true costs of a real project carried out by various manufacturers and contractors.³ In both tables the costs are attributed to each of the main building work elements in terms of the total cost, the percentage of total cost and the cost per m² of gross floor area affected by the building work. Furniture and equipment costs for Case Study 1 are further analysed on a room by room basis in Figure 7/3.

7.25 Building costs include for: minor structural changes to internal walls; some new doors and windows; new and upgraded mechanical and electrical services installations; new floor and ceiling finishes where necessary; full internal redecoration in areas affected by building work and modification of external drainage and service runs. No allowance is made for the cost of making good existing defects or for work arising from deferred maintenance.

7.26 Costs in these studies allow for entirely new furniture and equipment. In most adaptation and extension projects however it is likely that there will be considerable scope for re-use of existing items and it may be possible to achieve the kind of solutions shown here at considerably lower cost. However the Health and Safety implications of re-use will need to be considered as older items of furniture and equipment may no longer meet with current standards.

Note

³ For this reason it was felt to be unreliable to update costs, particularly as increases in F&E costs do not necessarily relate to any specific indices.

Note: Gross floor area affected by adaptation work = 461m².
Costs at first quarter 1999 prices.

Figure 7/3
Case Study 1: Cost Analysis of
3 Options

Option A: octagonal serviced furniture

ANALYSIS OF TOTAL COSTS				Analysis of furniture and equipment costs			
	Cost £	%	Cost £ per m ²		Fixed furniture £	Loose furniture £	Equipment £
Building adaptations	9,975	5.88%	21.6	Laboratory 1	6,181	2,425	863
Finishes	9,240	5.45%	20.0	Laboratory 2	8,903	3,285	4,007
Mech. & Elec. services adaptations	31,350	18.5%	68.0	Laboratory 3	8,721	3,115	3,719
External work and drainage	460	0.27%	0.99	Laboratory 4	7,974	3,685	4,087
(a) Building works sub totals	51,025	30%	110.7	Laboratory 5	6,510	4,135	3,895
Furniture (from boxes opposite)	65,143	38.4%	141.3	Preparation rooms	3,105	7,104	3,814
Equipment (from box opposite)	20,385	12%	44.2	Total	41,394	23,749	20,385
(b) Sub total	136,553	80%	296.2				
Profession fees @ 15% on (a)	7,650	4.5%	16.6				
(c) Sub totals	144,203	84.5%	313.0				
VAT @ 17.5% on (c)	25,235	14.9%	54.7				
TOTAL	169,438	100.00%	367.54				

Option B: serviced furniture

ANALYSIS OF TOTAL COSTS				Analysis of furniture and equipment costs			
	Cost £	%	Cost £ per m ²		Fixed* furniture £	Loose furniture £	Equipment £
Building adaptations	9,430	5.65%	20.45	Laboratory 1	8,350	1,466	411
Finishes	9,150	5.5%	19.85	Laboratory 2	11,440	1,502	4,001
Mech. & Elec. services adaptations	21,830	13.1%	47.3	Laboratory 3	11,000	1,548	3,431
External work and drainage	460	0.2%	0.99	Laboratory 4	14,440	1,571	3,434
(a) Building works sub totals	40,870	24.45%	88.7	Laboratory 5	13,450	1,525	3,365
Furniture (from boxes opposite)	76,501	45.6%	165.9	Preparation rooms	3,105	7,104	3,814
Equipment (from box opposite)	18,456	11.1%	40.0	Total	61,785	14,716	18,456
(b) Sub total	135,827	81.15%	294.6				
Profession fees @ 15% on (a)	6,130	3.7%	13.3				
(c) Sub totals	141,957	84.85%	307.9				
VAT @ 17.5% on (c)	24,842	14.9%	53.9				
TOTAL	166,799	100.00%	361.81				

Option C: serviced bollards

ANALYSIS OF TOTAL COSTS				Analysis of furniture and equipment costs			
	Cost £	%	Cost £ per m ²		Fixed* furniture £	Loose furniture £	Equipment £
Building adaptations	14,320	8.41%	31.0	Laboratory 1	7,039	2,803	1,199
Finishes	7,340	4.31%	15.9	Laboratory 2	4,634	6,030	3,975
Mech. & Elec. services adaptations	31,170	18.3%	67.6	Laboratory 3	4,424	6,200	3,911
External work and drainage	460	0.27%	0.99	Laboratory 4	3,662	6,430	4,199
(a) Building works sub totals	53,290	31.29%	115.6	Laboratory 5	4,354	6,880	3,815
Furniture (from boxes opposite)	62,665	36.8%	135.9	Preparation rooms	3,105	7,104	3,814
Equipment (from box opposite)	20,913	12.3%	45.3	Total	27,218	34,447	20,913
(b) Sub total	136,868	80.39%	296.8				
Profession fees @ 15% on (a)	7,995	4.69%	17.34				
(c) Sub totals	144,863	85.1%	314.2				
VAT @ 17.5% on (c)	25,351	14.9%	54.99				
TOTAL	170,214	100.00%	369.23				

Note

⁴ Although the system in Option B is essentially a loose system costs are given in the fixed furniture category to reflect the need for professional installation and reorganisation.

7.27 The furniture costs⁴ shown in these case studies include only furniture and equipment seen on the drawings ie: benches, shelving, coats and bag racks, filing cabinets, tray units, tables, chairs, chemical cupboards etc. The equipment costs include for: mobile re-circulatory fume cupboards, computer trolleys, (IT equipment is not included) overhead projectors, refrigerators and dishwashers. Two of the furnishing options in Case Study 1 allow for solid iroko bench worktop material, the third option is assumed to be finished in solid laminate, its standard finish. A range of materials, including solid laminate, is shown in Case Study 3.

second factor relates to the lower mechanical and electrical services costs of the loose serviced furniture system (Option B) reflecting the element of servicing included within the furniture itself.

7.29 Average building work costs per laboratory (including fees and VAT) are fairly similar in the three options at about £13,800, £11,000 and £14,400 respectively, average furniture costs are about £13,000, £15,000 and £13,000. The relatively higher furniture cost in Option B reflects the element of servicing included within the furniture itself. Average equipment costs per laboratory are broadly the same for each option at about £3,500.

**Adaptation Case Study 1:
Options A, B and C (Figure 7/3)**

7.28 The difference in building work costs between the options can be attributed to two main factors. Firstly, the need with the serviced bollard system (Option C) to take up and relay timber flooring to allow for underfloor servicing of the island bollards. This is unnecessary in the other two options where the services are fixed to the face of walls above floor level. In other adaptation schemes however the installation of underfloor services may be considerably more difficult, eg. with reinforced concrete floors etc, and the costs involved may make it an uneconomic solution. The

7.30 In terms of the distribution of costs, the analyses show that the furniture and equipment items make up by far the major element accounting for 57-67% of the total with unit costs ranging from about £210 to £242 per m². This compares with about £120 to £160 per m² for the building work elements of which about 60% relate to services.

7.31 Although there cost variations between the building and furniture and equipment elements of the three options, overall costs are broadly similar. The total costs expressed per laboratory are about £34,000, £33,000 and £34,000 for Options A to C respectively. These costs are about a third of those for new science accommodation.

Note: Gross floor area affected by adaptation work = 445m². Cost at first quarter 1999 prices.

Figure 7/4³
Case study 3: Tender cost analysis

ANALYSIS OF TOTAL COSTS				Furniture and Equipment costs		
	Cost £	%	Cost £ per m ²		Furniture £	Equipment £
Adaptations	32,725	13.1%	73.5	Laboratory 1	17,234	1,988
Finishes	13,296	5.3%	29.9	Laboratory 2	19,220	2,102
Mech. & Elec. services adaptations	29,281	11.7%	65.8	Laboratory 3	25,534	1,892
(a) Building works sub totals	75,302	30.1%	169.2	Laboratory 4	31,859	1,892
Furniture (from box opposite)	115,982	46.4%	260.6	Laboratory 5	22,135	2,200
Equipment (from box opposite)	10,074	4.0%	22.6	Total	115,982	10,074
(b) Sub total	201,358	880.6%	452.5			
Profession fees @ 15% on (a)	11,295	4.5%	25.4			
(c) Sub totals	212,653	85.1%	477.9			
VAT @ 17.5% on (c)	37,214	14.9%	83.6			
TOTAL	249,867	100.00%	561.5			

Adaptation Case Study 3. (Table 7/4)

7.32 This analysis, as with the previous one, shows the furniture item to be by far the major cost element accounting for 59% of the total. The total cost, again expressed as cost per laboratory, is higher than shown in the previous case study at about £50 ,000. This does not include any costs associated with the preparation rooms. The difference can be largely attributed to the use of more expensive worktops, particularly solid laminates, but also to more builder's work in adapting the existing structure and services, non-standard sized components and the boxing-in around services. This cost is about half of that of a new building of a similar size.

Case Studies Conclusions

7.33 The case studies show that adaptation and refurbishment of existing accommodation is a cost effective alternative to building new. These particular examples indicate how a relatively modest amount of building work in conjunction with new furniture and equipment can provide up-to-date laboratory accommodation at less than half of the cost of new. These examples allow for all-new furniture and equipment, but if it was feasible to re-use much of the existing provision then these costs could be reduced substantially and it may be possible to provide acceptable solutions at less than 10% of the cost of new.

7.34 These case studies suggest that the type of worktop material has a major impact on the overall cost of a laboratory, particularly in adaptation schemes as illustrated here where the furniture and equipment budget comprises a major element of the total cost. The type of furniture system and method of servicing appear, by comparison, to have less influence on costs. The relatively higher supply cost of systems which contain their own services may be offset by savings in the cost of services in the building work.

Appendix 1: Check List

Planning The Suite

Number and Size of Laboratories

When planning a new science block or adapting existing accommodation, the following information is needed in order to determine the number and size of laboratories required:

- the amount of science curriculum time at each key stage and in the sixth form;
- numbers of pupils taking science including those in sixth form;
- maximum group size expected;
- any particular teaching methods intended, eg. team teaching.

It is also worth considering:

- timetabling is more flexible if all laboratories are the same size;
- timetabling becomes more difficult if rooms are used more than 90% of the time.

Supplementary Teaching/ Non Teaching Spaces

Support spaces in addition to those for preparation and storage may include:

- staff base;
- display and resource area (preferably at the entrance to the suite);
- greenhouse (located to avoid vandalism);
- animal room (to be secure and well ventilated);
- a secure store.

Planning Principles

The following points are worth considering when planning a science department:

- it is advantageous to group as many laboratories together as possible, served by a central preparation room;

- any ancillary spaces should be easily accessible from the suite;
- circulation routes should allow for trolley movement.

Laboratories may be grouped in various ways, each has particular advantages:

- a **linear plan** may allow interdepartmental links but travel distances can be long;
- a **central preparation room** may reduce distances from preparation to laboratory but there may be no external view for technicians;
- a **central courtyard** can provide a sheltered external teaching space;
- a **linear plan on 2 floors** divides resources and equipment, a hoist may be needed.

The Laboratory

A Planning Strategy

When designing an individual laboratory consider the following:

- the range of activities that are likely to take place;
- the equipment that will be housed in the laboratory, including the level of storage.

A successful layout needs to take account of:

- the safe movement of pupils around furniture;
- the position of shared facilities, eg. computer workstation, wash up sink;
- space for storing pupils' coats and bags, near to laboratory entrance;
- the visibility of the whiteboard to all pupils;
- a serviced position from which the teacher can demonstrate;
- a fume cupboard position which ensures visibility and safety during class demonstration;
- the layout characteristics of the chosen furniture system.

Services Distribution

A decision will need to be made early on about the method of servicing the laboratory. Each method has different characteristics and will affect the choice of furniture system.

- **Overhead:** flexible; easy to maintain; droppers may look untidy.
- **Underfloor:** neat appearance; less easy to maintain; service coordination crucial.
- **Perimeter:** more difficult to service tables in the centre of the room; neat appearance; straightforward to install and maintain.

Servicing systems

The range of serviced furniture systems can be broadly divided into four generic types each with particular characteristics.

Serviced Spine:

- unit provides all services to tables, some of which are loose;
- serviced from perimeter, above or below;
- relocatable.

Serviced Bollard:

- serviced from perimeter, above or below;
- units generally fixed but tables can be rearranged.

Service Pod:

- a small unit carrying principally gas and electricity is clamped to loose tables;
- usually served from above;
- flexible, may look untidy.

Serviced Furniture:

- services carried within furniture;
- serviced from perimeter, below or above;
- some systems relocatable;
- central areas can be serviced from perimeter.

The Preparation Room

The preparation room can be divided into five zones of activity which should be organised to make the best use of the space:

- **main storage:** bulk storage may be kept in a rolling storage system which provides 30% extra volume per unit area;
- **preparation/ dispensing/ cleaning;**
- **the trolley park;**
- **the clean work area;**
- **the chemical store:** chemicals should ideally be kept in a separate ventilated store and organised according to COSHH regulations.

Furniture and Equipment

The range of furniture in a laboratory is partly dependent on the choice of servicing system but the following key points are generally applicable:

- all laboratory furniture should be designed and installed in accordance with BS 3202;
- 850mm is a suitable work surface height for secondary schools (surfaces should generally not be less than 600mm deep);
- work surfaces need to be able to withstand impact, heat and chemicals;
- storage systems should be compatible with those used in the preparation room;
- trolleys increase flexibility and the mobility of resources;
- top hung storage and display systems may also be considered.

The Environment/ Health and Safety

The following need to be taken into consideration:

- the laboratory must be adequately ventilated;
- fume cupboards must be designed and installed in accordance with BB88;
- fixed furniture must not impede air flow around heating outlets;
- lighting must be sufficient to safely perform practical work;
- all electrical installations must be in accordance with IEE regulations;
- all laboratories must have a manual gas shut-off valve and can have automatic shut off (ref IM25).

Cost Guidance

The following points are worth considering.

- Professional fees can add a further 10 - 15% to the cost of a new science building.
- The cost of procuring furniture and equipment need to be taken into account when setting the budget.
- Advice from the Local Customs & Excise Office on VAT should be obtained in relation to zero-rating parts of the work.

- Phasing a project can increase the overall cost.
- The total cost of a new science building can be £1,000 - £1,400 per m². Adaptation and refurbishment of existing spaces to provide equivalent accommodation can cost less than half of this.
- Temporary buildings can provide a cost effective solution to short term accommodation difficulties.
- Worktop material is the main determinant of laboratory furniture cost, whereas the type of serviced furniture system and the method of service supply appear to have little overall effect.
- The generally higher initial cost of furniture containing its own services is broadly balanced by savings in the services cost of the building contract.
- Savings can be made by re-using existing furniture.
- In adaptation projects, underfloor servicing may be uneconomic depending on the nature of the floor construction.
- Where ducting is a problem, mobile recirculatory fume cupboards can provide a cost effective alternative to fixed fume cupboards.

Appendix 2: Glossary

BESA: British Educational Supplies Association, London 0171-537 4997

BS: British Standard.

BUNDED: A sloping floor which leads to a drainage hole.

COSHH: Control of Substances Hazardous to Health.

CLEAPSS: Consortium of Local Education Authorities for the Provision of Science Services, or School Science Service.

CD ROM: Compact Disc Read Only Memory - computerised reference material.

FREQUENCY OF USE (%): The average amount of time that a space is used, expressed as a percentage of the total number of teaching periods available.

KEY STAGE (KS): The statutory school years are divided into four phases which mark stages of development. These approximate to age as follows.

- KS1: age 5 - 7
- KS2: age 7 - 11
- KS3: age 11 - 14
- KS4: age 14 - 16

LEA: Local Education Authority

MIDDLE SCHOOLS: Middle schools may be either 'middle deemed primary' with an age range of 8-12 or 'middle deemed secondary' with an age range of 9-13.

NATIONAL CURRICULUM CORE: There are three subjects that make up a statutory core in the National Curriculum. All pupils study Mathematics, Science and English through all key stages.

OHP: Overhead Projector.

PECT: Pneumatics, Electronics, Control Technology.

SERVICED LABORATORY: This refers to a space which provides pupils with one or more outlets for gas, water and electrical services.

SERVICING SYSTEMS: Methods for providing service outlets alongside work surface, eg. serviced bollard.

SUITE: In this publication a suite refers to an identifiable group of same-subject spaces.

TEACHING PERIOD: Schools divide up the week in different ways. For example, 40 periods of 35 minutes.

WARDIAN WINDOW: A unit of secondary glazing inside a window which provides a self-sustaining environment.

WORKPLACE: A place to work, ie. table space and seat, for one pupil.

YEARS 7 TO 11: Secondary school years are numbered from 7 (first year) to 11 (end of statutory schooling). The sixth form is sometimes referred to as years 12 and 13.

GENERAL REGULATIONS & GUIDANCE

The Education (School Premises) Regulations, 1999. (Statutory Instrument 1999 No. 2) London: The Stationery Office, 1999. ISBN: 0 11 08 0331 0.

HSE Workplace (Health Safety and Welfare) Regulation, 1992 (Statutory Instrument 1992/3004). London: HMSO, 1992. ISBN 0 11 02 5804 5.

The Construction (Health, Safety and Welfare) Regulations 1996. (Statutory Instrument 1996/1592). London: HMSO, 1996.

Department for Education and Employment. **Letter to Chief Education Officers etc. 19 September 1997.** Annex: The 1999 Constructional Standards.

Elliott Chris (ed). **Building for Science: a Laboratory Design Guide.** Hatfield: Association for Science Education, 1989. ISBN: 0 86 35 7119 0.

Department for Education and Employment. **Constructional Standards for New School Buildings.** London: DfEE, 1997.

Archenbold W F, Jenkins EW and Wood-Robinson C. **School Science Laboratories.** London: John Murray, 1989.

CLEAPSS. Laboratory Handbook. Uxbridge: School Science Service, 1989.

Adler D (ed). **Metric Handbook.** 2nd edition. Oxford: Butterworth-Heinemann, 1999. ISBN: 0 75 06 0899 4.

Dearing Ron. **The National Curriculum and its Assessment. Final Report.** London: School Curriculum and Assessment Authority, 1994.

Department for Education and Employment. **Area Guidelines for Schools (Building Bulletin 82).** London: HMSO, 1996. ISBN: 0 11 27 0921 4.

Department of Education and Science. **The Outdoor Classroom. (Building Bulletin 71.)** London: HMSO. 1990. ISBN: 0 11 27 0730 0.

SERVICES AND ENVIRONMENTAL DESIGN

Health And Safety Executive. **Electrical Safety in Schools. (Guidance Note GS 23.)** Health and Safety Executive, 1985.

Gas Safety (Installations and Use) Regulations, 1998. (Statutory Instrument 1998/2451). London: The Stationery Office, 1998. ISBN 0 11 07 9655 1.

Institution of Electrical Engineers. **Regulations for Electrical Installations: IEE Wiring Regulations.** Stevenage: Institution of Electrical Engineers, 1992. ISBN: 0 85 29 6557 5.

Department of Education and Science. **Maintenance of Mechanical Services. (Building Bulletin 70.)** London: HMSO, 1990. ISBN: 0 11 27 0717 3.

The Electricity at Work Regulations 1989 (Statutory Instrument 1989 No. 655). London: HMSO, 1989. ISBN: 0 11 09 663 5.

British Gas and Department of Education and Science. **Guidance Notes on Gas Safety in Educational Establishments. (IM 25).** London: British Gas, 1989.

Department for Education and Employment. **Guidelines for Environmental Design in Schools (Revision of Design Note 17). (Building Bulletin 87).** London: The Stationery Office, 1997. ISBN: 0 11 27 1013 1.

HEALTH AND SAFETY

Health and Safety Commission. **COSHH: Guidance for Schools.** London: HMSO, 1989. ISBN: 0 11 88 5511 5.

Health and Safety Executive. **A Step by Step Guide to COSHH Assessment.** London: HMSO, 1993. ISBN: 0 11 88 6379 7.

The Control of Substances Hazardous to Health Regulations 1999. (Statutory Instrument No. 1999/437). London: The Stationery Office, 1999. ISBN: 0 11 08 2087 8.

Department of Education and Science. **Safety in Science Laboratories. 3rd ed. (DES Safety Series No 2.)** London: HMSO, 1978. ISBN: 0 11 27 0473 5.

Wray J D and Gaitens J F. Animal Accommodation in Schools. Schools Council Educational Use of Living Organisms series. London: English Universities Press, 1974.

Animal (Scientific Procedures) Act 1986. London: HMSO, 1986. ISBN 0 10 54 1486 7.

Royal Society for the Prevention of Cruelty to Animals. Animals in Schools. Horsham: RSPCA, 1985.

Health and Safety Executive. Storage and Use of Highly Flammable Liquids in Educational Establishments. Leaflet. Code Number IAC(L) 15. HSE, 1986 (out of print).

Department of Education and Science. The Use of Ionising Radiations in Education Establishments in England and Wales. Administrative Memorandum 1/92. London: DES, 1992.

Association for Science Education. Topics in Safety 2nd edition. Hatfield: ASE, 1988. ISBN: 0 86 35 7104 2.

The Highly Flammable Liquids and Liquefied Petroleum Regulations. 1972, SI 1972 No. 917. The Stationery Office, priced hard copy or free internet version.

FURNITURE AND EQUIPMENT

British Standards Institution. BS 3202: Laboratory Furniture and Fittings. Milton Keynes: BSI, 1997. In 4 parts.

British Standards Institution. BS 4875: Strength and Stability of Furniture. Milton Keynes: BSI, 1985-1995. In 8 parts.

British Standards Institution. BS 5873: Educational Furniture. Milton Keynes: BSI, 1980-1998. In 5 parts.

Department for Education and Employment. Fume Cupboards in Schools (Revision of Design Note 29). (Building Bulletin 88.) London: The Stationery Office, 1998. ISBN: 0 11 27 1027 1.

British Standards Institution. BS 7258: Laboratory Fume Cupboards. Milton Keynes: BSI, 1994. In 4 parts.

British Standards Institution. BS 1363: Specification for 13A Fused Plugs and Switched and Unswitched Socket Outlets. Milton Keynes: BSI, 1984. ISBN: 0 58 01 355 6.

British Standards Institution. BS 1552: Specification for Open Bottomed Taper Plug Valves for 1st, 2nd and 3rd Family Gases up to 200 m bar. Milton Keynes: BSI, 1995. ISBN: 0 58 02 3726 5.

British Standards Institution. BS 5412: Specification for the Performance of Draw-off Taps with Metal Bodies of Water Services. Milton Keynes: BSI, 1976.











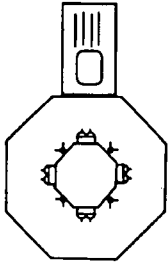
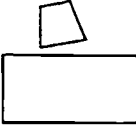
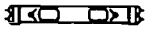

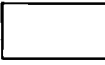

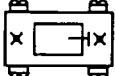





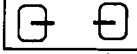























British Standards Institution. BS 5459: Specification for Performance Requirements and Tests for Office Furniture. Milton Keynes: BSI, 1977.

British Standards Institution. BS EN 60309-2: Dimensional Interchangeability Requirements for Pin and Contact Tube Accessories of Harmonised Configurations. Milton Keynes: BSI, 1992. ISBN: 0 58 02 1181 9.

British Standards Institution. BS 8313: Code of Practice for Accommodation of Building Services in Ducts. Milton Keynes: BSI, 1997. ISBN: 0 58 02 7363 6.

CLEAPSS. Bench Materials for School Laboratories. Uxbridge: School Science Service, 1991.

Key to symbols

	= OCTAGON AND SINK		=TEACHERS DESK AND CHAIR
	= OVERHEAD GANTRY SYSTEM		=COMPUTER TABLE
	= CONTROL BOX FOR OVERHEAD SYSTEM		=1200X600 TABLE
	= 600X600 BOLLARD		=1500X600 TABLE
	=1200X600 BOLLARD		=1200X1200 TABLE
	=1200X300 SERVICED SPINE		=1500X750 TABLE
	= TABLE-TOP SERVICE POD		=1500 DIA TABLE
	= 1500X600 SINK TABLE		=STOOL
	=1500X600 SINK TABLE		=TROLLEY
	= 750X750 SINK TABLE		=TRAY UNIT
	= TABLE TOP SERVICE POD (PYRAMID)		=TRAY UNIT UNDER BENCH
	= WALL SERVICING DUCT		=CUPBOARD UNIT
	=SS SINK		=CUPBOARD UNIT UNDER BENCH
	= WALL BENCHING SINK		= TALL CUPBOARD
	= FUME CUPBOARD		=GLASS FRONTED WALL CUPBOARD
	= FIXED FUME CUPBOARD		= LOCKER
	= STORAGE RACKING		= FILING CABINET
	= DISHWASHER		=COATS AND BAGS STORAGE
	= FRIDGE		=SHELF
	= FREEZER		=WHITEBOARD
	= DISTILLATION UNIT		=OHP ON TROLLEY
	= FIRE EXTINGUISHER AND BUCKET		=TELEVISION
	= GAS BOTTLES		=PHOTOCOPIER
			=LASER PRINTER
			=TELEPHONE



INVESTOR IN PEOPLE

**The
Stationery
Office**

Published by The Stationery Office and available from:

The Publications Centre

(mail, telephone and fax orders only)

PO Box 276, London SW8 5DT

Telephone orders / General enquiries 0870 600 5522

Fax orders 0870 600 5533

www.tso-online.co.uk

The Stationery Office Bookshops

123 Kingsway, London WC2B 6PQ

020 7242 6393 Fax 020 7242 6412

68-69 Bull Street, Birmingham B4 6AD

0121 236 9696 Fax 0121 236 9699

33 Wine Street, Bristol BS1 2BQ

0117 926 4306 Fax 0117 929 4515

9-21 Princess Street, Manchester M60 8AS

0161 834 7201 Fax 0161 833 0634

16 Arthur Street, Belfast BT1 4GD

028 9023 8451 Fax 028 9023 5401

The Stationery Office Ortel Bookshop

18-19 High Street, Cardiff CF1 2BZ

029 2039 5548 Fax 029 2038 4347

71 Lothian Road, Edinburgh EH3 9AZ

0870 606 5566 Fax 0870 606 5588

The Stationery Office's Accredited Agents

(see Yellow Pages)

and through good booksellers

66

BEST COPY AVAILABLE

ISBN 0-11271039-5



9 780112 710394



U.S. Department of Education
Office of Educational Research and Improvement (OERI)
National Library of Education (NLE)
Educational Resources Information Center (ERIC)



NOTICE

REPRODUCTION BASIS



This document is covered by a signed "Reproduction Release (Blanket) form (on file within the ERIC system), encompassing all or classes of documents from its source organization and, therefore, does not require a "Specific Document" Release form.



This document is Federally-funded, or carries its own permission to reproduce, or is otherwise in the public domain and, therefore, may be reproduced by ERIC without a signed Reproduction Release form (either "Specific Document" or "Blanket").

EFF-089 (9/97)