

## DOCUMENT RESUME

ED 450 808

IR 058 079

AUTHOR Barrett, Jaia, Ed.; Wetzell, Karen A., Ed.  
TITLE Preservation of Digital Information. Proceedings of the Membership Meeting of the Association of Research Libraries (131st, Washington, DC, October 15-17, 1997).  
INSTITUTION Association of Research Libraries, Washington, DC.  
ISSN ISSN-1075-0886  
PUB DATE 2001-00-00  
NOTE 191p.  
AVAILABLE FROM Association of Research Libraries, 21 Dupont Circle, Washington, DC 20036 (\$45 per year, \$25 per individual copy ARL members; \$70 per year, \$35 per individual copy nonmembers). Tel: 202-296-2296; Fax: 202-872-0884; e-mail: pubs@arl.org; Web site: <http://www.arl.org/arl/proceedings/index.html>.  
PUB TYPE Collected Works - Proceedings (021)  
EDRS PRICE MF01/PC08 Plus Postage.  
DESCRIPTORS \*Archives; \*Electronic Text; Information Management; Information Storage; Information Technology; \*Library Associations; \*Library Materials; Library Technical Processes; \*Preservation; Reference Materials; Research Libraries

## ABSTRACT

The 131st meeting of the Association of Research Libraries (ARL) focused on preservation of digital information. The ARL Preservation Committee convened three panels of experts to highlight major issues raised by the archiving of digital resources, and to encourage discussion about options for operating models and criteria for digital archives. Panelists were invited to address three questions: Who should be responsible for archiving digital materials? How should this be paid for? What are the characteristics of an effective operating model? The program began with an opening and welcome by Gloria Werner, ARL Presiding President, followed by a discussion of key issues associated with digital archiving and international strategies to create research and action agendas to guide digital library creators in furthering effective digital preservation. Another discussion included the role of software in ensuring the longevity of digital documents. Individuals with expertise in the preservation of digital information from different organizational perspectives reported on their experience and future plans. The final segment of this program session began with a brief report about the community response to the 1996 Commission on Preservation and Access and the Research Libraries Group CPA/RLG report and the follow-up steps that were recommended by the leadership of the sponsoring organizations. Strategies for research library engagement in an agenda of the preservation of digital information were then suggested. The program session concluded with a discussion among panelists and the audience on how the research library community should respond to challenges. The Federal Relations program was a presentation on Article 2B of the Uniform Commercial Code. Program Session II focused on the state of development of copyright management information systems, how these systems could influence the management of intellectual property, and their impact on research library operations. At the ARL Business Meeting, members voted on establishment of 1998 dues and elected three members to the ARL Board. This was followed by

Reproductions supplied by EDRS are the best that can be made  
from the original document.

reports and discussion of three programs of long-term strategic importance to the research library community: CLIR's National Digital Library Federation, the AAU/ARL Global Resources Program, and the ARL Leadership and Career Development Program. Appendices include reports from the Association Business Meeting, Report on Association Activities, May-September 1997, and an ARL attendance list. (AEF)

ED 450 808

IR058079

PERMISSION TO REPRODUCE AND  
DISSEMINATE THIS MATERIAL HAS  
BEEN GRANTED BY

**C.A. Mandel**

TO THE EDUCATIONAL RESOURCES  
INFORMATION CENTER (ERIC)

1

U.S. DEPARTMENT OF EDUCATION  
Office of Educational Research and Improvement  
EDUCATIONAL RESOURCES INFORMATION  
CENTER (ERIC)

 This document has been reproduced as  
received from the person or organization  
originating it.

Minor changes have been made to  
improve reproduction quality.

Points of view or opinions stated in this  
document do not necessarily represent  
official OERI position or policy.

2

PRESERVATION OF  
DIGITAL INFORMATION

ASSOCIATION OF RESEARCH LIBRARIES  
PROCEEDINGS OF THE 131ST MEETING

WASHINGTON, D.C.  
OCTOBER 15-17, 1997

GLORIA WERNER, PRESIDING

© COPYRIGHT 2001  
ASSOCIATION OF RESEARCH LIBRARIES  
ISSN 1075-0886

*Proceedings of the Membership Meeting* are published  
by the  
ASSOCIATION OF RESEARCH LIBRARIES  
21 Dupont Circle  
Washington, DC 20036  
(ph) 202-296-2296  
(fax) 202-872-0884  
email: <pubs@arl.org>  
<<http://www.arl.org/arl/proceedings/index.html>>

Edited by  
Jaia Barrett and Karen A. Wetzel

Price: ARL Members: \$45.00 per year — \$25.00 per individual copy  
Nonmembers: \$70.00 per year — \$35.00 per individual copy

Printed in USA

ISSN 1075-0886

© Copyright Notice

The papers in this compilation are copyrighted by their authors. The authors have granted permission to reproduce and distribute copies of these works for nonprofit educational or library purposes, provided that copies are distributed at or below cost, and that the author, source, and copyright notice are included on each copy. This permission is in addition to rights of reproduction granted under Sections 107, 108, and other provisions of the U.S. Copyright Act.



The paper used in this publication meets the minimum requirement of American National Standard for Information Sciences—Permanence of Paper for Printed Library Materials, ANSI Z39.48-1992.

## TABLE OF CONTENTS

FOREWORD.....	5
---------------	---

### OPENING AND WELCOME

Gloria Werner, Convener, ARL President .....	7
--	---

### PROGRAM SESSION I PRESERVATION OF DIGITAL INFORMATION: ISSUES, CHALLENGES, ACTION

INTRODUCTION .....	11
Meredith Butler, Convener, Chair, ARL Preservation Committee	
BUILDING RESEARCH & ACTION AGENDAS FOR DIGITAL ARCHIVING .....	13
Peter Graham, Associate University Librarian, Rutgers University	
PARTNERS IN PRESERVATION: THE ICPSR EXPERIENCE.....	19
Richard Rockwell, Executive Director, and Janet K. Vavra Inter-university Consortium for Political and Social Research (ICPSR)	
QUESTION AND ANSWER SESSION.....	25
THE ROLE OF SOFTWARE IN ENSURING THE LONGEVITY OF DIGITAL DOCUMENTS.....	27
Jeff Rothenberg, Senior Computer Scientist Rand Corporation	
AN ORGANIZATIONAL MODEL FOR PRESERVING DIGITAL USDA PUBLICATIONS .....	47
Jan Olsen, Associate University Librarian for Sciences and Director, Mann Library, Cornell University	
USDA DIGITAL PUBLICATIONS: CREATING A PRESERVATION ACTION PLAN .....	49
Evelyn Frangakis, Preservation Officer National Agricultural Library	
QUESTION AND ANSWER SESSION.....	59

### SESSION I, PART II

INTRODUCTION .....	61
Marianne Scott, ARL Preservation Committee	
RESPONSES TO THE RLG/CPA REPORT .....	63
Deanna Marcum, President Council on Library and Information Resources (CLIR)	
STEPS TOWARD A SYSTEM OF DIGITAL ARCHIVES: SOME TECHNOLOGICAL, POLITICAL, AND ECONOMIC CONSIDERATIONS THE REARRANGING EFFECT .....	65
Donald J. Waters, Director, Digital Library Federation, CLIR	
EXPERT PANEL DISCUSSION WITH THE AUDIENCE.....	75

LUNCHEON SESSION  
FEDERAL RELATIONS PROGRAM

UCC ARTICLE 2B:  
SOME PRELIMINARY COMMENTS ON A NEW ISSUE FOR THE LIBRARY COMMUNITY .....81  
    Robert L. Oakley, Professor, Georgetown University Law Center  
QUESTION AND ANSWER SESSION.....87

PROGRAM SESSION II  
COPYRIGHT MANAGEMENT INFORMATION SYSTEMS

INTRODUCTION .....93  
    James G. Neal, Chair, Working Group on Copyright Issues  
WHEN TECHNOLOGY LEADS POLICY.....95  
    Clifford Lynch, Executive Director, Coalition for Networked Information (CNI)  
THE LEGAL AND POLICY IMPLICATIONS OF CMI.....101  
    Julie E. Cohen, Assistant Professor of Law  
    University of Pittsburgh Law School  
THE INDUSTRY NEED FOR IDENTIFIERS AND A CMI SYSTEM.....105  
    John Connors, Director of Operations and Process Engineering  
    Harcourt Brace & Company  
QUESTION AND ANSWER SESSION.....111

PROGRAM UPDATES

CLIR'S DIGITAL LIBRARY FEDERATION .....117  
    Deanna Marcum, President, Council on Library and Information Resources (CLIR)  
    Donald J. Waters, Director, Digital Library Federation, CLIR  
AAU/ARL GLOBAL RESOURCES PROGRAM.....121  
    Betty Bengtson, Director of University Libraries, University of Washington  
    Deborah Jakubs, ARL Visiting Program Officer, Duke University  
LEADERSHIP & CAREER DEVELOPMENT PROGRAM.....125  
    Joan Giesecke, Dean of Libraries, University of Nebraska-Lincoln  
    DeEtta Jones, Program Officer for Diversity, ARL

APPENDICES

I. ASSOCIATION BUSINESS MEETING .....127  
    PRESIDENT'S REPORT, Gloria Werner, ARL President.....127  
    REPORT OF THE NOMINATIONS COMMITTEE, James G. Neal, ARL President Elect.....127  
    REPORT OF THE EXECUTIVE DIRECTOR, Duane E. Webster, ARL Executive Director.....134  
    SPARC PROPOSAL .....137  
II. REPORT ON ASSOCIATION ACTIVITIES, MAY-SEPTEMBER 1997.....143  
III. ATTENDANCE LIST .....193



## FOREWORD

### PRESERVATION OF DIGITAL INFORMATION

One of the distinguishing characteristics of a research library is its mission to identify and preserve research resources that are important for future users. Examining how research libraries could most effectively pursue this mission for information in electronic formats was the focus of a 1996 report sponsored by the Commission on Preservation and Access and the Research Libraries Group, Inc. In response to this report, the ARL Preservation Committee convened three panels of experts to highlight some of the major issues raised by the archiving of digital resources, and to encourage discussion about options for operating models and criteria for digital archives.

In the course of their remarks, panelists were invited to address three questions:

1. Who should be responsible for archiving digital materials?
2. How should this be paid for?
3. What are the characteristics of an effective operating model?

The program opened with remarks from Peter Graham, Associate University Librarian, Rutgers University, who identified the key issues associated with digital archiving and describe international strategies to create research and action agendas to guide digital library creators in furthering effective digital preservation. Jeff Rothenberg, a computer scientist at Rand Corporation, spoke on the role of software in ensuring the longevity of digital documents. Individuals with expertise in the preservation of digital information from different organizational perspectives—a membership-based archiving depository and a partnership between land grant university libraries and the National Agricultural Library—reported on their experience and future plans.

The final segment of this program session began with a brief report from Deanna Marcum, President of the Council on Library and Information Resources (CLIR), about the community response to the CPA/RLG report and the follow-up steps that were recommended by the leadership of the sponsoring organizations. Donald Waters, primary author of the CPA/RLG report and newly appointed Director of the National Digital Library Federation at CLIR, suggested strategies for research library engagement in an agenda of the preservation of digital information. The program concluded with a discussion among the panelists and the audience on how the research library community should respond to this set of challenges.

#### **Federal Relations Luncheon Program**

The Federal Relations program, sponsored by the Information Policies Committee, was a presentation on Article 2B of the Uniform Commercial Code by Robert Oakley, Georgetown University Law Center.

#### **Copyright Management Information Systems**

Also on Thursday, the Working Group on Copyright Issues presented a panel on the state of development of copyright management information systems, how these systems could influence the management of intellectual property, and their impact on research library operations.

#### **Business Meeting/Member Only Programs**

At the ARL Business Meeting, members voted on establishment of the 1998 dues and elected three members to the ARL Board. This was followed by reports and discussion of three programs of long-term strategic importance to the research library community: CLIR's National Digital Library Federation, the AAU/ARL Global Resources Program, and the ARL Leadership and Career Development Program.



## OPENING SESSION

Convened by Gloria Werner, ARL President

MS. WERNER: It is a pleasure to welcome you to the 131st ARL Membership Meeting. I'd like all of us to join in extending a special thank you to Dr. Billington, Winston Tabb, and the entire Library of Congress staff for the gorgeous reception in the Jefferson Building last night. That thanks further extends to Deanna Marcum and her colleagues at CLIR for the opportunity to see that very sobering film, *Into the Future*.

As you know, ARL has a longstanding tradition of introducing our newest members. Today we have the joyful privilege of welcoming eight new directors of institutional members of ARL. Let's begin by asking Jennifer Cargill to introduce to us Dale Cluff, who is from ARL's newest member library, Texas Tech.

MS. CARGILL (Louisiana State University): It is a privilege to introduce Dale Cluff, Dean of Libraries at Texas Tech. Dale has been at Texas Tech for 15 years, and before that he was at Southern Illinois and the University of Utah.

When he went to Texas Tech in 1982, Dale was absolutely determined to do several things. His track record is an example of being able to successfully sell your university administration on the needs of a library. He wanted the library to be more visible within the state and the region, and he has certainly accomplished that. Another of his goals was to make Tech the newest Texas member of ARL. He has successfully done that, as well.

Dale has also paid his dues in the State Library Association, as president and in serving on many committees, as well as chair of AMIGOS and serving on many AMIGOS committees. He has been successful in getting additional funding for the library, making very good connections around the state, and moving into some much needed facilities programs, first with the new special collections and now with a renovation.

I invite you to get to know him. He is a very nice person, and, for those of you looking for committee members, he's a hard worker. I know that from personal experience. I would like to welcome Dale Cluff.

MS. WERNER: Jim Williams will now introduce to us Camila Alire.

MR. WILLIAMS (University of Colorado): What is impressive is that Camila still loves being the Dean of Libraries at Colorado State University, having endured what, I think we will all agree, is the worst natural disaster in an ARL library in recent memory.

She came to her post at CSU from the University of Colorado at Denver, where she was also dean. Before her nine years at the University of Colorado at Denver, her career included administrative posts in the college library, the library school, and the public policy research arena.

Camila is also an ALA counselor. She was, until recently, Chair of the ALA Executive Directors Search Committee. She is the past president of Reforma and she is currently a member of the Board of the Colorado Endowment for the Humanities. Proudly, she is the 1997 recipient of the ALA Elizabeth Futas Catalyst for Change National Award and the 1997 Reforma Librarian of the Year National Award.

Please help me welcome my personal friend and our most beleaguered, fatigued, tested, yet determined, Camila Alire, Dean of Libraries.

MS. WERNER: Joe Boissé will next introduce to us Stella Bentley.

MR. BOISSÉ (University of California-Santa Barbara): Thank you. It is very much a personal pleasure to introduce Stella Bentley, the new Dean of Libraries at Auburn University.

Stella began her library career at Indiana University, where she received both her masters and her Ph.D. in Library Science, and then worked for approximately ten years in various positions in the Indiana University Library System, including as Assistant to the Dean of Libraries when Elaine Sloan was Dean of Libraries there, I believe. She finished her career there as Budget and Personnel Officer.

She then went to Case Western Reserve to serve as Assistant Director for Public Services and Collection, and, in 1988, I had the good fortune to back her for the position of Assistant University Librarian for Collections at Santa Barbara, a portfolio that was expanded shortly after she came to include services, as well.

Stella has been active professionally, especially in LAMA, and has written on a number of topics, most recently on the flattening phenomenon in academic libraries. Stella is a delightful colleague and I am sure that all of you will be very pleased to work with her in the coming years.

MS. WERNER: We have some other Californians who migrated. Don Bosseau, who has moved from the Southwest to the Southeast.

MR. WEBSTER (Executive Director, ARL): Don is a very special colleague to all of us. He has the distinguishing notoriety of having been the director of three ARL libraries. He is now the new director at the University of Miami Library. Welcome, Don Bosseau.

MS. WERNER: I would like Paul Mosher to introduce Nancy Gwinn to us.

MR. MOSHER (University of Pennsylvania): Librarianship gives one the opportunity to meet valued friends and colleagues at various times in their professional careers. Today we have such an opportunity as I welcome Nancy Gwinn to our ranks in ARL.

Many of you have known Nancy at various stages of her career. She was a Fulbright Scholar and is an alumna of the University of Michigan Library School. She also has the distinction of completing a mid-year Ph.D. in American Studies, a real accomplishment.

She began her professional career at the Library of Congress, working in the Congressional Reference Service for a time. Nancy went on then to the Council on Library Resources, where many of us knew her. She then moved on to the Research Library School in Collections and Preservation, where I had the great pleasure of collaborating with her on a prize-winning article on that dubious object, the Conspectus.

Since 1990, Nancy has been at the Smithsonian as Director of Collection Management and Development, where she has worked as Head of Research Services, prominent in the development of exhibitions, and in Development, in development fund raising.

We are delighted to have our paths cross again, and welcome her to our ranks, at last, as an ARL director.

MS. WERNER: I call on Jim Williams one more time, to introduce Bernard Margolis to us.

MR. WILLIAMS: For some reason, for most of my professional life I seem to have followed Bernie, at least geographically. I met him first in Michigan, during the early 1980s, when he was Director of the

Monroe County Library District, and he and I were in the throes of trying to reframe the Michigan Library Consortium to be more—and watch out Don—to be more than just an OCLC library network.

Bernie left Michigan for Colorado six months before I did. There he became Director of the Pike's Peak Library District, where he spent all of ten years building the public library of the future for the Colorado Springs metropolitan area.

And now he has been recently appointed as President of the Boston Public Library. I invite all of you to spend some time with Bernie and have him tell you about how he pinches himself daily as he carries on the very important work of our colleague, dear friend, and past ARL president, Arthur Curley.

Please help me give a rousing welcome to my friend, and our now colleague, President of the Boston Public Library, Bernie Margolis.

MS. WERNER: Sul Lee will be introducing to us Maureen Pastine.

MR. LEE (University of Oklahoma): Good morning. Maureen Pastine is an experienced ARL director. Maureen started her professional career at the University of Nebraska in Omaha and then Southern Methodist University in Dallas. From there, she became the University Librarian at San Jose State University, and then she moved on to Washington State University, where she was for eight years.

Maureen is now the new director at Temple University. Please join me in welcoming Maureen.

MS. WERNER: Bill Studer, would you come forward and introduce Jennifer Younger, University of Notre Dame?

MR. STUDER (Ohio State University): Jennifer is a native of Wisconsin and holds a B.A., M.A., and Ph.D. from the University of Wisconsin-Madison, where she still makes her permanent home. Her pre-OSU library work experience included positions at the U.S. Department of State, Northwestern, and U.W.-Madison.

I first met Jennifer in the 1980s at User's Council. We became good colleagues there. I was very pleased to have her follow Bill Crowe when he left OSU in 1990, and she became AD in 1991. Her learning experience in the role has been extensive and intensive, as we have been through seemingly endless budget retrenchments, downsizings, reengineering, technology upgrades, you name it. It's all been there for her to do.

Jennifer has been very engaged in our profession. She is a steady author of high quality. She is very frequently invited as a speaker. At all levels, she is nationally known for her expertise in technical services. She has earned her stripes, many times over, in the profession.

I know that Jennifer will thrive in her new environment. Notre Dame will love her, and ARL will, too. Jennifer, a hearty welcome.

MS. WERNER: I would also like to extend a welcome to just a few of our many guests here this morning.

Peter Givler is the newly appointed Executive Director of the Association of American University Presses. ARL has already had some very enjoyable times working with him and we look forward to many more.

Some of you will also have met our very special visitor from IFLA, Leo Voogt, IFLA Secretary General. Leo is on a month-long sabbatical from IFLA and is temporarily headquartered at ARL to learn

about associations and their management. I think the ARL folks are learning a lot, as well. It is turning out to be a very mutually satisfying collaboration.

Also joining us is Kate Wittenberg, Editor-in-Chief of the Columbia University Press and Chair of the AAUP Library University Press Relations Committee.

With us from the American Library Association is its president, Barbara Ford, and also here is Carla Funk, Executive Director of the Medical Library Association. As you all know, ALA, MLA, and several other of the library associations are partners with ARL in the Shared Legal Capability. It's a delight to see you both here.

Toni Carbo, President of ALISE, will be with us this morning, as will Lee Hisle, President of ACRL. Mary Jenkins, Executive Director of the American Library Association, is also here.

Finally, John Vaughn from AAU, and Laila Van Eyck from NASULGC need very little introduction to this group; they really are partners and old friends from the higher education community.

I want to thank our introducers. We are now ready to move on to Program Session I, focusing on how research libraries can most effectively develop strategies for preserving our digital heritage.

PROGRAM SESSION I  
PRESERVATION OF DIGITAL INFORMATION:  
ISSUES, CHALLENGES, ACTION

Convened by Meredith Butler, Chair  
*ARL Preservation Committee*

Good morning. I am Meredith Butler, Chair of ARL's Preservation Committee, and I am pleased to introduce this program on the critical issue of preserving digital information.

When we discuss this topic, we are confronting the very essence of what it will mean to be a research library in the 21st century. How will we ensure that resources that exist in digital form are available, over time, to the scholars who need them?

As we saw last evening, in the video *Into the Future*, there is an urgency to these discussions. Millions of bits of information that do not, or cannot, exist in alternative media, such as print or microfilm, are being lost. How can the research library community help address this significant global issue?

Preserving digital information is fraught with complex technical, economic, and organizational questions. While many of these will be explored during the program, we have invited each of our speakers this morning to address three particular questions: Who should be responsible for archiving digital materials? How should it be paid for? What are the characteristics of an effective operating model?

Long before we have solved all of the problems associated with the preservation and storage of print materials, we are faced with the challenges of preserving digital information. The problems seem overwhelming. Some of us have stepped up to the challenge. Others of us wait, concerned that the cost will far outstrip our ability to pay. We wait for others to step up: publishers, societies, utilities, new vendors in this area, our colleagues in the largest institutions. But it is increasingly clear that the survival of the digital culture will require a coordinated effort of research, development, and practice.

Before introducing our first speaker, I would like to take a moment to remind us of how this program came to be and, most importantly, why. In the summer of 1996, the ARL Preservation Committee held a meeting with Deanna Marcum to discuss the kinds of steps ARL could take to move forward the recommendations of the recently issued CPA/RLG Task Force Report.

Six steps were identified at that meeting, two of which are very much in evidence today. First, educating ourselves on the issues in archiving digital resources and, second, conducting a program at an ARL membership meeting, where the players engaged in the preservation of digital resources could be available to discuss these issues with us.

This morning's program is a direct result of the Committee's commitment to digital preservation as a top priority for the year. Last spring, the Committee met with Peter Graham and Richard Rockwell, from whom you will hear shortly, as well as with Deanna Marcum, who will speak this afternoon. Our purpose was to discuss how we, as a community, can work together to advance this important agenda. The program today is a direct outcome from these conversations.

In addition to today's program, you have seen another major step in our educational campaign. Prior of this meeting, ARL sent each of us the fine essay from *Transforming Libraries 5: "Issues and Innovations in the Preservation of Digital Information,"* prepared by OMS's Organizational Development Consultant,

George Soete (available at <<http://www.arl.org/transform/pdi/index.html>>). Today's speakers have all been asked to complement, rather than repeat the comments recorded in his report.

I would now like to introduce our first panelist. Peter Graham is an Associate University Librarian at Rutgers University. Since 1987, he has been in charge of acquisitions, cataloging, and network information services, and for the last three years he has also served as Associate Vice President for Information Services, with responsibility for the University's academic and administrative computing and networking operations.

Peter is a member of the governing bodies of ALA, the Bibliographic Society of America, and the Center for Electronic Text in the Humanities. He has published extensively on issues of scholarly preservation and digital library requirements. He will summarize the key issues associated with digital archiving and describe international programs that are underway to develop effective preservation plans. Please join me in welcoming Peter Graham.

Our second presenter, Dick Rockwell, is Executive Director for the Inter-university Consortium for Political and Social Research (ICPSR), and adjunct Professor of Sociology at the University of Michigan. Dick received a B.A. in Zoology and an M.A. and Ph.D. in Sociology from the University of Texas at Austin. He will speak to us today on addressing the issue of collaboration and cooperation in digital preservation, from the perspective of someone who has been in the business of preserving digital data for the past 20 years.

Our next two speakers this morning, Jan Olsen and Evelyn Frangakis, will share their expertise and experiences with the national cooperative, discipline-based National Preservation Program for Agriculture Literature, a partnership formed by the National Agricultural Library at Cornell University.

Jan Olsen will begin. Jan is known to many of us; she is currently the Associate University Librarian for Sciences and Director of Cornell's Albert Mann Library. At the end of this year she will be leaving Cornell to become the Vice-President for External Relations at Wells College in Aurora, New York.

Jan has conducted a number of research projects exploring the application of electronic technology to the use and storage of scholarly information. She received a Masters in Library Science at the University of Wisconsin, and an M.A. and Ph.D. in Education at Cornell.

Evelyn Frangakis is the National Agricultural Library (NAL) Preservation Officer. She is responsible for developing the NAL's new preservation program and spearheading efforts to safeguard the library's collections into the 21st Century.

Evelyn is the former head of the preservation program at the University of Maryland Libraries. Prior to joining Maryland, she was the Preservation Program Director for the Society of American Archivists. In this capacity, she led the Society's national preservation management training program, which assisted almost 50 institutions in preservation program development.

She is an active member of numerous library archival preservation and conservation organizations, and is published widely in the field. She holds degrees from Franklin & Marshall College, Rutgers University, and Columbia University.

Please join me in welcoming our speakers.



## BUILDING RESEARCH & ACTION AGENDAS FOR DIGITAL ARCHIVING

Peter Graham, Associate University Librarian  
*Rutgers University*

Good morning. It's a pleasure to be here.

There's a story my father-in-law likes very much about a pair of people who drive to a lumber yard. One person gets out of the car and asks the clerk for some lumber. And the clerk says, "Well, what size do you want?" The guy goes back to his car, sticks his head in the window, consults with his colleague, and comes back and says, "Two-by-fours." The clerk then asks, "All right, how long do you want them?" The guy goes back and sticks his head in the car, consults again, and then returns to the clerk and says, "For a long time; we're building a house."

This is, of course, what we're doing here today: building for a long time. As Meredith and Gloria suggested earlier, it's very appropriate for ARL to take on the topic of digital archiving. It is the distinctive role and mission of the research library to take on the challenge of making information available for a long time, complementing our colleagues in other important areas of librarianship who are making information currently available, as we do.

One of the questions we have been asked to deal with is whose responsibility it is to archive. I think it is ultimately the library's and, I would add, the archive community's responsibility to preserve information over the long haul. Other agencies, such as publishers or authors, basically don't have a track record on this. Nor do they have the social mandate that we do. If the archivists and librarians together don't do this, no one else will.

### Digital Archiving Challenges

I have been asked to review some of the challenges involved in digital preservation, talk about what is happening here and elsewhere, and then briefly allude to the research and action agendas.

The technical challenges are three, and there are two organizational challenges to be dealt with, as well.

None of the technical challenges are truly easy to deal with, but two of the them are relatively easy to deal with, while the third will be very difficult and very expensive. The first challenge, technically, is medium preservation. How do we preserve the actual medium on which information is recorded? One of the reasons that this is fairly simple is that most parties talking about digital preservation have decided that this is really not the issue.

There are mechanisms by which we can preserve information that is digitally recorded, but it's not typically to conserve the tape itself or to conserve the disk. Instead, it is achieved by copying the information. Michael Lesk, in a Commission on Preservation and Access document, has written very explicitly that preservation in the digital environment means copying or migrating information, not conserving the actual object on which that information is recorded. The present media—disks, tapes, CD-ROMs—are simply too volatile to depend on for any extended length of time.

"Migration" brings us to the second technological challenge, which is the extensive and difficult one: technology preservation. How are we to preserve information through the vicissitudes of technologies that

we have seen already so rapidly changing over the past couple of decades, and that we know will change even more rapidly over the long period of time that is before us?

The solution here is migration of information. Not simply copying it, but moving it from one technology to another, whether hardware technologies or software technologies, so that information is useable at a later date, even though the technology that created the information may have disappeared or be unavailable.

There are some obvious examples, e.g., eight-inch DisplayWrite disks from the early 1980's. Who can read them? Even if you have the hardware to do it, is the software still available? I have understood that WordPerfect, which is presently at Version 6.0, cannot read its own WordPerfect Version 1.0 files.

How do we migrate information forward? This presents us with a couple of major strategic decisions. If we want information to be available in the future, we have to think about the "just in case" and the "just in time" options.

Just in case: we could migrate everything. Take all information that's in digital form, everything that we choose to collect, and as each new technology comes along, move it from one technology to the next. This would assure broad availability of information, but it would also be very costly because of the massive task of moving information through the technologies.

Also, there is, of course, an uncertainty of what information will be used over time. We know very well that many books in our collections are not used, or will be used very little over time. That likelihood is certain to be true for many categories of digital information. So, "just in case" could be a very extensive proposition, for not much return.

On the other hand, we could migrate information just in time, that is, migrate it simply when it's needed. This presents problems in its own right, and many expenses, as well. We will still need to preserve the old applications in order to know what it is we will be migrating from and to, as well as preserving the documents themselves. Further, if we only migrate at the point of need, the point of use, then we're introducing a time delay that will necessarily discourage use of the information. The cost of analysis and the cost of conversion will still be very substantial.

There is likely to be a mix of both of these approaches. What really ought to be emphasized, is not only that there will be a mix in this respect, but there will also be a mix in many other respects. There will not be a single solution to any of the digital preservation problems. Documents and applications are varied. Preserving word processing will be different from preserving a digital image or an engineering document, for instance. Both the kind of solutions used and the technology of the solutions will be varied, so the likelihood of there being a single quick fix, or even a single slow fix, is very unlikely.

The third technological issue is intellectual preservation, the assurance of information authenticity and integrity. We must make sure that we know what we have in order to preserve the scholarly discourse that is important in our research environment, and to preserve public credibility in electronic documents of any kind.

A few years ago, at the University of Southern California, I heard Professor Harvey Wheeler speak on the virtues of the dynamic document. He enthusiastically described how one could put a document out electronically, and then a few months later change one's mind and go back and alter the document. The document thus keeps up with one's intellectual development. But, for many of us, in scholarly terms, this is an appalling idea. The need for what is sometimes called version control is essential. Does the footnote link that we're looking at refer to the document that was in place at the time the person first made the footnote, or to a version changed since then? Will we be looking at the same information when we conduct scholarly discourse?

There are three kinds of change that can happen to documents: unintended change, accidental loss, or modification. There are also two kinds of intended change.

There is the intended change that is well meant. Databases are constantly being developed and in flux, as are directories of various kinds. There are scholarly databases that need constant attention. These constantly change, but there may be snapshots that are needed at points in time, and that can be identified. There is also the intended change that is not well meant, this is to say, fraud. We have had examples of this in all areas of our life: public, government, business, even scholarly. We need protection against it.

There are solutions to all of these problems of intellectual preservation. They involve various uses of cryptographic techniques, which, however, will not require that information be hidden. Information can be public and available, but the cryptographic techniques can assure that a document is what it claims to be.

At this point, I want to note some comments that Cliff Lynch, Executive Director of the Coalition for Networked Information, has recently made on what the nature is of the document that we're trying to preserve, and what it is we're trying to save. Are we trying to preserve simply the content of the document, or the document's form? A printed document might have various forms of typography or of layout. If we are preserving an old recording, are we concerned about the sound characteristics of that recording as recorded: the snaps, the crackles, the pops of a 1920s recording? What about the Ted Turner approach to preserving movies using colorization?

Interestingly, the issues here are related to current literary critical theory, that is, the relationship of form and text. What is the distinction between content and form? Among the things the history of the book has taught us is that text cannot be simply abstracted from its appearance on the page. The way the text is presented to a public has an enormous effect on how the content is perceived and used.

This question of how form affects content is the right question to be asked when considering preservation. What is it we're really trying to preserve? If we are migrating information through various word processors, to take a simple case, do we need to worry about the boldface and italics, or do we just want to get the basic text (begging the question of what that really is)? The question gets even larger as you consider more complex forms of data. It is certainly a question that will have to be dealt with, in practice, by any preservation techniques we come up with.

There are two organizational challenges, as well, as we face digital preservation. The first, for libraries, is to restructure our personnel arrangements and organization within libraries, recognizing that electronic information crosses many present departmental lines.

How decisions are made to acquire electronic information is intimately tied up with systems issues, with public access issues, and with cataloging issues. The standard tri-partite division of libraries into technical services, public services, and collection development doesn't serve us too well when we look at how electronic information is acquired and made available. We will have to find ways to use people in organizational structures that will be different from what we tend to have now.

The second organizational challenge is for our institutions—for the university libraries, I mean our parent institutions as well as ourselves. We need to face the question of funding over time.

We are used to funding our library operations on a year-to-year basis. But one of the problems with electronic information is that it needs constant monitoring and tending. Broadly speaking, if you throw a book in a closet and shut the door, in 500 years, you can open the closet, pull out the book and use it. With electronic information, this simply isn't the case. If it is not cared for more or less carefully, over the course of a year or two that information will be very volatile and very difficult to deal with. The question of how to construct institutional arrangements that provide for funding over long periods of time is one that will call on some of our best management and leadership skills.

## National and International Activities

I want to talk briefly about what's happening, both in this country and abroad, as organizations and communities prepare for digital preservation. Let me start with what's happening in North America. There is a lot of isolated activity. But, in some ways, compared to what's going on in other countries, relatively little is happening here.

The NSF Digital Library projects, the six major digital library activities funded by the National Science Foundation that started several years ago, have hardly noticed the issue of preservation. The second round of NSF proposals, which is currently being prepared, only uses the word "preservation" once. But, again, the projects that are currently being touted as candidates don't, in fact, have much to do with preservation.

In the library community, there are several activities going on and we're hearing about more and more every day. In the past few years, for example, there has been the Research Libraries Group ARCHES project, which is an outgrowth of some activities that the MidDecade Planning Group within RLG proposed in 1994. The ARCHES project is intended to be a model for digital preservation. But, to an extent, it has been subordinated to the content emphases of the Studies in Scarlet projects and now to the immigration projects. ARCHES is a quiet project. We have heard a little bit about it, especially since May, when it was more publicly announced, but there's not a great deal available about what, in fact, is going on.

OCLC has committed to archiving electronic journals. Among the things it has said is that it is committing to the migration issue, one of the most significant issues about digital preservation. It is silent on the details of how it proposes to go about the migration, except that it is clear they recognize that there is a challenge. They recognize it when they say that, "at its discretion," OCLC will migrate information forward. That's not encouraging to those of us who don't think we have a lot of discretion about this.

The Digital Libraries Federation (DLF) has proposed archiving as one of its three main thrusts. When the DLF was formed a couple of years ago, it was very encouraging to many of us, and it preempted the field in some respects by raising our hopes and expectations about what would be happening. But, in fact, we haven't heard much from DLF about successes, accomplishments, or planning. I think, however, that will change. It's very encouraging that we're scheduled to hear more today about it today from Don Waters, Director of the DLF.

George Soete, in his document *Issues and Innovations in the Preservation of Digital Information*, has summarized many other efforts that are going on in a kind of partial mode (see <<http://www.arl.org/transform/pdi/index.html>>). LC and individual libraries are beginning to attack parts of the digital preservation problem.

In Canada, the Canadian Initiative in Digital Libraries has just been formed and announced. Programs are not evident in archiving. Their focus is primarily on the collections front, that is, on digitizing materials and on rights management. To some extent, they intend conscious emulation of the print environment.

What's really interesting is the progress in the United Kingdom and Australia. The contrast to North American activity is notable. There is a sustained focused attention from the national communities that has been in place for several years. These are communities that have long traditions of national planning and of doing things in concert.

In the United Kingdom, a libraries review at a national level was conducted in 1993. The Follett Commission, headed by Sir Brian Follett, resulted in the formation of the Joint Information Steering Committee (JISC). From 1994 until the present, JISC has overseen the distribution of £15 million of funding. The funding is likely to be renewed in two waves, supporting at least 63 projects in access, digitization,

document delivery, electronic journals, on-demand publication, electronic reserves, and other digital library components.

The mandate that JISC has given on preservation issues has been taken up by the British Library Research Initiatives Consortium. In 1996, the British Library (BL) conducted a major workshop on preservation, at which Margaret Hedstrom (University of Michigan) and myself were speakers. The BL has recently produced a paper entitled, "Digital Archives: Who Keeps Them and Who Pays?" This is just one example of the many reports that they have presented. Chris Rusbridge, who is Director of Electronic Library Activities for the U.K. Office of Library and Information Networking (UKOLN), has been a participant in digital library meetings in this country, as well.

In Australia, in 1993, after recommendations from some oversight committees, the Preserving Australian Digital Information agency, or PADI, was formed. It has developed vision statements, goals, and objectives, and now has a budget of \$150,000 a year. It is headed by Jan Lyall, of the National Library of Australia, who is the agency's Director of National Initiatives and Coordination.

The Australians have consciously built strong links between the library and archiving communities. They have developed reports on electronic records management, as well as a number of essays on their web pages that cover such matters as definitions, proposed propositions, and statements of principles on the preservation of Australian digital objects. A national consensus has apparently already been reached. The reports and essays that the Australians have produced include documents on responsibilities. Who is responsible for what kind of archiving? What must be done? How should the information be preserved? They have also begun grappling with what the costs are, and how they are to be paid.

After this survey of international activities, some contrasts and commonalities are evident. What's common among the efforts going on the English speaking world is consortial activity. Where activity is taking place, it is consortial: NDLF, OCLC, RLG, PADI, JISC, the CIDL. These are all group organizations, working together with the understanding that digital archiving is not a matter that can be solved individually. There are good collection development and technological reasons for reaching this conclusion.

In contrast with the U.S., however, the U.K. and Australian agencies have been very public with their concerns, intentions, and projects. They are very effective at communicating with each other internally and externally. In North America, it really is difficult to ascertain from the outside what thinking is going on among the many agencies that are working on digital archiving. These major players don't appear to be talking to each other, as well. An exception, of course, is the excellent CPA/RLG report of a year and a half ago (itself a joint project), which laid out many of the important issues. It has been a foundation document for the U.K. and Australian efforts, as well.

## Research and Action Agendas

One of the things that came out of the Preservation Committee meeting last May was that there was no clear research agenda for digital archiving. What is it that really needs to be done? Is there a consensus? We agreed that there was none. As a result, one outcome of our meeting was a proposition to the National Endowment for the Humanities for a series of preservation archiving workshops. ARL, CNI, and CLIR have all agreed to be sponsoring organizations for these workshops. We have asked for funding, which, if it comes, will be announced in April for a year-long series of about five workshops on specific topics, such as collection development: What are the redundancy issues? What are the collection development issues? Are they different now than in the print environment? Migration issues, authenticity issues, rescue and trusteeship and other intellectual property issues are other topic examples.

About 30 to 50 of the active archiving organizations in North America will be invited. There will be some overseas invited guests, as well—you can see why, from the kinds of international activities I have talked about. We will try to bring in people who are active in these issues from a variety of communities:



not only the libraries and archiving communities, but the computing community, museums, scholarly societies, vendors, publishers, and other organizations that are succeeding in this area, such as ICPSR. To my mind, one of the most important functions of this series of workshops will be to bring the players together who need to be brought together.

Our intent is to review the present state of understanding on these topics, and then gain consensus on what needs to be done and on who the proper players are to either volunteer or to be asked to take on a particular task. Of course, we will produce publications, both on the Web and in paper format, that report on the discussions. Research agendas are one thing, but action agendas are another. In my mind, the important thing to do at this point is get started. It's late, and this country is behind, relative to other countries, in actually planning and accomplishing digital preservation.

As an action agenda goes, we need to take a lead from the computing community. They may have a good deal to learn from the library community about user orientation and about careful planning, but we have a good deal to learn from the computing people about getting moving, trying things, making mistakes and moving on. The approach of the Internet Engineering Task Force (IETF) is not to create standards over a long period of time and then implement them, but to implement things first, and worry about the standards later. Their explicit motto is, "rough consensus and working code." It is a motto that we could well take on in the digital archiving environment, for it is an orientation toward action.

Another goal is communication between us all, which has been relatively lacking compared to what's been happening in the UK and Australia. Don Simpson this morning made an announcement about their intent at the Center for Research Libraries (CRL) to take on an archiving role. In conversation with him, he told me that he is concerned he may be duplicating some effort elsewhere, or that CRL may be taking on tasks that others have already tried. The mutual communication issue is one that is before us, and we need to get moving on that to make sure that we're not tripping over each other.

The sponsoring organizations met about a month ago, and we agreed that the first workshop will be held in June of 1998. Planning for that will begin in January. We are looking for comments and suggestions about the topics and the structure of these workshops. I will be glad to hear from you about that.

I look forward very much to hearing from Dick Rockwell, and from Don Waters and DLF, about what we can begin doing. I think that the iceberg is cracking and we will begin moving ahead. It is very important for us and for our future scholars and students.

Thank you very much.



PARTNERS IN PRESERVATION:  
THE ICPSR EXPERIENCE

Richard Rockwell, Executive Director

and

Janet K. Vavra

*Inter-university Consortium for Political and Social Research*

**Background**

Digital information has been a part of America's life, since the nation's infancy. Among the first producers of digital information were the country's founders, who mandated a decennial census in the Constitution, thereby initiating the collection of basic demographic and socioeconomic information about the population that continues to this day. In 1790, the year of the first census, population statistics were collected by assistants appointed by United States Marshals working under the direction of Thomas Jefferson. Jefferson summarized the information and had it transcribed onto parchment with quill pen in two colors (one for the actual count, and the other for what Jefferson thought was the correct count). [For a fascinating account of the census through the years, see *The American Census: A Social History*, by Margo J. Anderson, published by Yale University Press, 1988.]

The 1790 census data now reside in electronic form in the archives of the Inter-university Consortium for Political and Social Research (ICPSR). The ICPSR, headquartered at the University of Michigan, is a computer-readable archive of social science data that is accessible through the World Wide Web from anywhere in the world. The 1790 census data have been in the holdings of ICPSR for 30 years.

The 1790 census data are a perfect example of preservation of a data collection for over 200 years. More than two centuries after their collection, the data remain available to scholars throughout the world and in a format that makes them totally compatible with today's computerized information-handling environment. Since the first paper copies were created, the census data have been preserved, primarily by migrating the information from one medium to another as the times demanded. The data were put on microfilm by the Bureau of the Census (probably about 1890) and converted into machine-readable form by the ICPSR in the late 1960s. The data have since migrated through several different media, keeping pace with changing technology. They were initially entered onto keypunch cards by ICPSR and subsequently written onto 9-track tapes. Later, the data were moved to 3480 cartridge tapes, on which archival security copies are currently stored. They now also reside on magnetic disk so that users can download them directly from the Internet.

Today, college and universities libraries are finding themselves faced with the same set of circumstances that previously confronted organizations such as ICPSR in dealing with the ongoing changes and challenges resulting from the technical revolution in information gathering, storage, and dissemination. These challenges are illustrated by the 1790 census example, which applies to only one small collection of data but must be multiplied by the thousands of collections that now exist at ICPSR and elsewhere. These challenges, while exciting, also frequently produce sleepless nights for the directors and staffs of libraries (and other organizations) who must deal with the daily explosion of digital information sources. Further, setting aside the 1790 census data (where there is surely little

argument about the need for preservation), libraries must have serious questions about what to acquire, what to preserve, how to preserve it, and how to finance the activity. These questions will loom large for each collection in the archive. We have yet to de-accession a data set, although this has been considered from time to time for collections thought to be of inferior scientific quality.

Libraries are natural homes for the preservation of much of the digital information that is being generated and certainly are natural potential partners with other organizations involved in digital preservation. Libraries recognize this, as evidenced by this panel. Together we now find ourselves routinely struggling with issues such as what digital information to preserve, what media to use for preservation and distribution, what format to employ, how to retrain staff to continue to be productive and comfortable in this rapidly changing environment, how to keep abreast of new developments, and, finally, how to pay for it all. Using the ICPSR experience, we will report how ICPSR has faced many of these issues and suggest what we hope can be opportunities for cooperation in the future.

### The ICPSR Experience

ICPSR has been archiving digital data since 1962. Until a few years ago, nothing like ICPSR existed in the natural sciences. Founded on the premise that the data collected by research projects are valuable resources that can be mined by many, for both research and teaching, ICPSR was from its beginning charged with responsibility for archiving and preserving electronic social science data in perpetuity and making them available indefinitely. This has enabled the writing of thousands of research papers, books, dissertations, and student papers, and it has conserved scarce resources. The very existence of ICPSR has stimulated the collection of new information, resulting in at least half a century's accumulating observations on virtually every aspect of the society, and the emergence of standards for survey research, particularly regarding the continuity of survey questions. While the first data collections arrived on punch cards at what when then ICPR (The "Social" was added later) today scholars from around the world download data from ICPSR 24 hours a day.

Our website <<http://www.icpsr.umich.edu>> received 11,493 different visitors last week from 8,455 different computing sites, who "hit" our website 73,114 times, accessed 4,745 different data files, and downloaded at least 3.1 gigabytes of data (some of it went out other ways, including quarterly CD-ROMs, that contain all additions to the archive in the previous quarter).

That wasn't our busiest week at all, and the counts actually under-represent usage; for example, the 50 hits from AOL subscribers show up in our records as always being from the same user. Less than half the accesses to ICPSR came from the educational (.edu) domain. U.S. commercial users represent the single largest cluster of users outside academia. Users in 70 countries hit us, including the Faroe Islands. Only the continent of Africa was not among our users that week; Antarctica shows up as "U.S. government." People in the U.S. government itself came to us 437 times that week for data. We did not distribute data on this scale until a few years ago and then annually, rather than weekly. Today, we are a multi-terabyte operation each year. We service this clientele with a staff no larger than when our customer base was a fifth of today's size.

We have this enormous customer demand because, first, ICPSR currently has over 40,000 individual data files that represent nearly 3,500 discrete study titles, many of which are unique to ICPSR and were developed at ICPSR; second, because we provide excellent user support, including outstanding documentation and computer support; and third, because our Summer Training Program is world-renowned. Additionally, in recent years we have added a number of new services, including online interactive analytical and data extraction services, computer conferences, web bulletin boards, etc. And increasingly, we see ourselves as a "virtual" archive as well as a real archive: we provide links on our website to other data providers all over the world, and we offer to "really" archive their data for security reasons.

ICPSR is a membership-based organization that has been supported by members dues since its inception. It has grown from 21 research universities plus the University of Michigan to encompass more than 325 member colleges and universities in North America, and the national archives of most developed nations. Essentially, every research university is a member of ICPSR. Additional funding (which has now grown to over 60% of the organization's budget) comes from special grants and contracts from a variety of funding agencies. It is with this combination of funds that ICPSR pursues its mission of archiving and distributing social science computer-readable data sources. The key to ICPSR's stability and flexibility is our foundation of funding by the social science community itself, through member dues. Without that funding, we would have been tossed about far more by the changing winds of funding agencies. An endowment would be most welcome, of course; \$60 million would do nicely.

ICPSR has been archiving data since its founding, with many of the older files in the holdings moving from early electronic formats to the current formats in which they are stored and used by scholars. ICPSR's guiding principle is that preservation archiving must be the top priority for the organization. This dedication comes with a commitment of resources, including staff, equipment, media supplies, training, training and retraining, and climate-controlled storage facilities. From its beginning, ICPSR had as one of its central functions the preservation and security of all files for all collections in its holdings. We have not yet lost a data collection, although over the years we have had a few scares.

Today, ICPSR maintains an Archival Operations unit whose sole responsibility is the maintenance and security of copies of all files in the holdings. Staffed by full-time permanent employees with a dedication to the preservation and security of the organization's data holdings, the unit enjoys equal status with the five other functional units by ICPSR: Administration, Archival, Development, Computer and Network Services, Training Program, and User Support. Archival operation is thus administratively shielded from both external users and internal ICPSR staff, who do not interfere in its operations, and it maintains not only a separate archival collection that is inaccessible by anyone outside the unit, but also separate databases about that archival collection.

### **The Process of Ensuring Archival Integrity**

Archival Operations receives the original copies of all files coming into ICPSR. As soon as a new data collection arrives, it is promptly accessioned by being assigned a unique ICPSR study number. The files are then evaluated for contents and format. Virus-checking procedures are employed for any studies coming into the archive that might be vulnerable to viruses (such as studies arriving on diskettes, ftp, etc.). A non-networked virus-checking computer station is equipped with a variety of virus-hunter software, which is rigorously kept current. After the preliminary identification and evaluation steps are completed, the staff creates two copies of any files that have been supplied. Two copies are created to ensure that there is always a back-up copy for any file in the holdings, as a security precaution.

Currently files are stored either on IBM 3480 cartridge tape or on Digital Linear Tape (DLT), depending upon the format in which the files were submitted. Both media are rated to have expected lifetimes of 10-100 years by the National Media Laboratories. Straight ASCII or EBCDIC files can be stored on the cartridge tapes, but files that may contain information embedded in special formats are frequently best stored on DLT tapes. When the tapes are filled, they are physically stored in separate climate-controlled locations as a further security measure.

All materials are inventoried, and the inventory becomes part of the permanent record of the archive. All copies of the files created are checked as soon as they are made to assure that there has not been any corruption during the copying process. This checking is performed by comparing the original file to the files created, and, if no discrepancies exist, the copy is considered a duplicate of the original. In addition to creating two archival copies of each file and doing an inventory of the materials received, staff record identifying information about the collection and all of the electronic files and their characteristics in an electronic database.

The same procedures are followed for any data files processed by ICPSR staff (files to which ICPSR adds value). The processed files are treated essentially the same way as newly-accessioned material. An additional step with processed data is the creation of a servicing or distribution copy of the files and the entry of the information about each file in a collection into an Oracle database that we use to manage the electronic data distribution service of ICPSR. Additionally, when data are processed for release, the Archival Development staff who prepare the files for distribution prepare metadata for the collection. The metadata are then made available on our website when the data collection is released for distribution. Finally, the disk copy of the servicing collection is incrementally backed-up in an automated procedure each evening, and those back-ups are stored in a bank vault outside the building in which ICPSR is housed. But we're still a bit nervous, and for that reason we have agreed with Cornell University to create an incremental mirror archive there. Our partnership with the San Diego Supercomputer Center in the NSF NPACI award may also create a mirror archive there, this time on the San Andreas fault.

The distribution or servicing copy of the data is generated by the User Support staff, who are responsible for maintaining and providing user support for all data available from ICPSR. The process of preparing the distribution file includes making sure that the documentation for any data collection is available, whether in machine-readable form or in hard-copy. While ICPSR plans on eventually converting all hard-copy documentation into electronic text that can be browsed on the Internet, currently a significant proportion of the collection still has only hard-copy documentation. The hard-copy documentation is automatically supplied to users when they order the data.

As technology continues to change at an ever more rapid pace, ICPSR has had to migrate its data holdings from one medium to another just to keep the data viable. We spent about a quarter of a million dollars from our equity on the last migration. While in the past the medium on which the data files were stored remained constant for a significant number of years, each generation of new media has had roughly half the lifetime of its predecessor. Therefore, ICPSR now considers data migration to be more of an ongoing process than a project undertaken every five or even ten years, and data migration has replaced the "refresh" procedures that we followed for almost 30 years.

## Data Migration

Data migration involves more than simply copying files from one medium to another. In the past, when the storage medium remained constant for a number of years, preservation activities centered around ensuring that the medium remained readable—this was where "refreshing" copies came in. In recent years, significant changes in computing platforms has made many older data formats much more difficult to use. Therefore, migration now routinely includes an evaluation of the formats in which any data are presently stored and the viability of those formats with the current software and hardware. For example, ICPSR has been actively converting many of its older holdings that have been stored exclusively in OSIRIS format (OSIRIS is a statistical package developed at the University of Michigan in the 1960s) to data files with SAS and SPSS data definition statements. If this conversion were not started at this time, many of ICPSR's older holdings would be at risk of being very difficult if not impossible to use in the near future. This conversion is now a crucial and critical part of the preservation process for these collections. In general, we find that imbedding data into any software format, such as that of OSIRIS, is a bad idea; the SAS and SPSS data definition statements do not embed the data in a proprietary format.

Besides preserving data, migration fulfills another critical function: providing easy access to the data resources. Not only must the data be preserved, but they also must remain accessible and usable by the clientele. A critical component of this migration is assuring that the data continue to be compatible with the current computing environments. Just as staff responsible for the migration of the data must be knowledgeable about technical and substantive matters, so also must the staff who assist scholars in locating and using the data. Consequently, all staff in the archive must be trained and retrained on an



ongoing basis to keep pace with the changes in the software and hardware currently in use and to keep abreast of what principal investigators, researchers and users are doing.

Our experience with data migration leads us to a recommendation about standards for preservation archiving. The archiving/library profession has not yet agreed to standards for preservation archiving, but it might try to move in the direction it moved with preservation microfilming and acid-free paper. It would be entirely inappropriate, however, to apply that model to the preservation archiving of digital data. We do not need standards for which media to choose, which format to adopt, how to store the archive physically, etc. What we need, instead, is a standard for the functionality of any preservation archiving process: What must be achieved for what period of time, at what cost, for which kinds of digital archives?

### **Partnerships are the Future**

As the above surely communicates, preservation archiving of digital information is neither simple nor cheap. As the amount of digital data grows and the technological changes continue at an ever more rapid pace, other methods for reaching the goals of preservation and access will have to be identified. While ICPSR has functioned as a membership-based organization where membership dues and special grants have funded preservation distribution, the very high costs of these preservation activities and the need to pursue them within an ever shorter time frame calls for complementary approaches, most of which have yet to be developed. It is clear that further automation of all our procedures is essential. It is also clear that we do need that endowment to ensure that the nation's archive of social science data will remain viable into the next centuries.

Further, the growth and flexibility of the Internet challenges the way we did business in the past. This is especially true in an era when almost all organizations engaged in preservation activities face effectively shrinking budgets and growing costs relative to increased demands on them. At the same time, users continue to demand more access and services (such as our new analytical serves), and they demonstrate a low level of tolerance for fees associated with those services. Although an institutional membership in ICPSR is priced lower than many journal subscriptions that serve five scholars rather than all the social scientists at an institution, we constantly hear complaints about "high dues." There is still the folk culture of the Internet that holds that "everything should be free." We have heard our own version of Ross Perot's "great sucking sound" as vast portions of our archive flew off (but not away) to massive file servers at member institutions.

We know a lot about preservation archiving of digital information, but there is much more that we need to learn. We have not fully conquered the problem of extracting data from behind software interfaces, which have a life expectancy of a few years. We worry about version control and about authentication: How can the user be certain that the data set purporting to contain the 1790 Census data is really that data set? We are considering encryption of all our data with a public-key system so as to ensure authentication, but we worry about hiding the data behind such a proprietary shield. We do not know how to "archive the Web," but we are certain that the daily changing in our website will eventually come back to haunt us. We have further to go in developing comprehensive electronic documentation standards; in fact, on another front we are just finishing the development of SGML/XML Document Type Definition for "codebooks" that document social science data sets; you can find it on our website. We are doing this in partnership with individuals at member institutions and in federal statistical agencies.

### **Partnering in Preservation**

No one organization can any longer hope to keep pace with the information being generated or to be able to preserve all of it, even if that organization focuses only on the information available in a small field. The ease with which users can access information on the Internet may negate the need for each institution to possess the same materials. Much like many libraries today do not purchase all the

publications in every field, organizations involved in digital preservation will not be able to locally maintain all digital information in a given field, but they will want to retain access to them. Therefore, they should look toward developing partnerships in which preservation and access responsibilities are shared with other organizations. And ICPSR plays a critical and central role in making that feasible in the social sciences.

Partnerships appeal to us for many reasons, not the least of which is that none of us has enough resources or enough good ideas to attack the problem alone. The time has come for the organizations facing these challenges to come together to start to look for ways to cooperate. This cooperation is necessary so that valuable information resources now being generated are not lost forever because nobody knew they existed, or everybody thought someone else would do the work, or no one had the resources to archive the information. Accordingly, ICPSR now makes two concrete offers that would start "partnering in preservation."

First, we offer to organize a Laboratory for Social Science Data Archiving. This will be a place in which we can experiment on some of the unanswered questions mentioned above, in which we can provide training to data archivists from around the world, and in which we can develop new technologies, perhaps including new hardware. We would love to host interns from ARL libraries as soon as possible. We would hope to see similar organizations develop around other topics of digital information, and we offer our hand in partnership with those other efforts.

Second, we offer to host the first National Conference on Social Science Data Archiving Policy. The content would encompass issues of acquisition and processing policies, priorities for preservation, access conditions, funding, and the creation of a "virtual archive" with ICPSR as the solid center. We propose holding this conference in cooperation with ARL and other major archiving and library organizations, and we will allocate some of our funding to that conference. If it makes sense to expand the conference beyond the archiving of social science data, we would be willing to consider doing so. And again, we offer our hand in partnership.



## QUESTION AND ANSWER SESSION

MS. BUTLER: Well, I think that Dick gave us some concrete examples of how a membership organization has changed its operations and processes over time, and how they've faced the challenges of continually converting and migrating data to different media and new formats. Dick, before you leave the room, I have to say what we all really want to know is how have you done five times more work, with the same number of staff.

MR. ROCKWELL: There really is a simple answer to that. Automation can solve a lot.

MS. BUTLER: Thank you.

I would now like to open the floor to other questions.

MR. WEDGEWORTH (University of Illinois): Peter, you pointed to the NSF digital research projects and said that they had ignored preservation issues. That is accurate if you go into our websites and look for preservation, but I think the comments by Dick Rockwell make clear that the storage of both existing information and new information in electronic form still has some significant problems.

The focus of the digital project at Illinois for science and technology is addressing the problem from a functionality point of view. We know that we can archive electronic information in science and technology now. The difficulty is that much of that information could not be retrieved in the way that we would like to retrieve it in the long term. So the focus is currently on solving the retrieval problems that have to do with things like chemical formulas and equations. Many of the journals use a different format for those formulas than for the text; this presents a problem for retrieval.

For that reason, I think that we do have a lot of work to do in developing standards for how we store this information before we can address some of the more significant archiving questions.

MR. GRAHAM: There is a lot of potential for cooperation here. What I don't mean to say is that the NSF digital projects are not enormously valuable to what we want to do. We understand that one of the things that a library does is preserve information over time. The emphasis of the NSF projects has not been on that particular topic.

When you say we know how to archive digital information, I am glad you do, but I don't think we do. I don't think it's generally known how to archive digital information, which comes back to one of the question of how we will know if we are being effective in doing digital archiving.

This isn't very helpful or practical, but I think the end result will be the credibility of our user community—the ability of people to rely on an archive as safe and having integrity, and liable to be there 50, 100, 500 years from now. I don't think that credibility is widespread, or even exists at this point. The NSF project is doing wonderful things, but that's not the area on which they're working.

MR. BENNETT (Yale University): I want to thank the panel for bringing Dick Rockwell to speak with us and I urge us all to remember what he said the next time we're talking with a publisher who says it's going to cost 130 to 190 percent of print publication to get it in digital format—it may not be true.

MS. BUTLER: As there are no more questions, I would like to begin the second half of our program session.

We have heard this morning that, while decisions must be made about the best medium to use for preserving digital information, technology will not produce the silver bullet. Instead, it may be more

important to concentrate on the role of software in ensuring that we will be able to read and interpret digital information created today far in the future.

Our next speaker, Jeff Rothenberg, will explore with us the importance of emulation. Jeff's work is familiar to many of us. He wrote a seminal article in *Scientific American* in January 1995, alerting the scientific community to the urgency of addressing the long term survival of digital documents. In addition, Jeff was an active participant in the film, *Into The Future*, which we saw last evening.

Jeff is a senior computer scientist with Rand Corporation. His recent activities include the use of metadata to evaluate, record, and improve the quality of complex databases, and the development of methods to ensure the longevity of digital documents. Jeff has recently been hired by CLIR to undertake an analysis of organizational models for digital archiving.

Please join me in welcoming Jeff Rothenberg.

## THE ROLE OF SOFTWARE IN ENSURING THE LONGEVITY OF DIGITAL DOCUMENTS

Jeff Rothenberg, Senior Computer Scientist  
*Rand Corporation*

We were asked to address issues of organizational and economic models for archiving. However, my role here as a technologist, I believe, is to point out that all such models and approaches must first be based on some kind of technological foundation. Until we know what it is that we have to do in order to preserve documents, it is premature to talk in too much detail about who should do what and how it should be paid for.

Those of you who saw the documentary *Into the Future* know that in it I refer to the couplet of Shakespeare's 18th sonnet (see charts 1 and 2).

"So long as men can breathe or eyes can see, so long lives this, and this gives life to thee."

If we were to rewrite that in a digital version, it would be something like this:

So long as the magnetic flux on this disk has not been disturbed, and so long as we have disk drives that it will fit in, and we have hardware controllers and software drivers, and we know what the main codings are and the formats and we have the software, etc.

That is the essence of the problem.

There are, in fact, a number of modes of decay or loss for digital documents. Media decay is perhaps the most obvious. Media obsolescence is probably even more rapid than the media decay.

I will focus on what I think is a much harder problem, dependence on incompatible or obsolete software. The fact is that applications software runs in a software environment that consists of an operating systems, drivers and all of that, and it requires a hardware platform. Therefore, the dependence of documents on software really means that they're dependent on an entire hardware/software environment.

What does this mean? Documents really can only be seen by running a program, that is, if they are digital documents. This is becoming increasingly true. It is true for fairly simple kinds of things, like word processing, but it is all the more true for hypermedia and hypertext documents. The point is that the file you save for a document is not the document. It is a representation, but it is not understandable without the software that produced the document, and software dependence really means dependence on an entire platform.

Software dependence, unfortunately, is a difficult problem. Does it mean that we have to actually run the software that we used to create a document? Can we even do that in the far future? Could we run similar software? Can we translate the document into new forms as they come along? This is what is usually meant by "migration." There are some problems with all of those approaches.

What makes a document software-dependent? Well, essentially, it is dependent if it is meaningful only to its original software, without which it can't be understood or seen exactly as the author or the

reader saw it. This is true for historical or aesthetic purposes, but you can also imagine it to be true for legal or ethical accountability purposes.

For an example of how information can be lost, consider the periodic table of elements (charts 10-12). This can be represented in many ways, but this first particular representation is simply text, with spacing between the columns, a perfectly reasonable way to represent the periodic table of elements.

If you merely change the font, you lose the spacing. Merely change from a fixed width to a proportional width font, and all of the information, or most of the information, on the table is lost.

If you then go to a further extreme and take away the footnoting to the series below, and you shrink tabs and spaces, and you string the lines together, you get this. And if you compact out the spaces, you get complete gibberish. So, the point is, the text is not always all that you care about.

Next is a more serious example; it has to do with accountability. This is data about the failure of the O-ring seals in the solid fuel rocket boosters for the space shuttle, prior to the Challenger launch. The first figure (chart 15) shows, on a nonlinear scale, the experience that NASA had with O-ring seals at various temperatures. It plots, in a form that is rather difficult to interpret, information about prior experience with O-ring problems. This was the form in which the information was available prior to the Challenger incident.

If the data had been plotted this way (chart 16.1), Challenger would probably not have been launched. The information wasn't originally available this way, but if it had been, and someone had seen only the tabular form, the essential information would have been lost.

The final example, which I will come back to a little later, is an entity-relation diagram—which is a way of designing data models for relational databases—shown in a proprietary format by a program called ERWin (chart 16.2). It runs under Microsoft Windows. This is an example of a common way of graphically presenting data.

And my point here is that the file that gets saved doesn't look much like the original. This is a textual representation of the previous document (chart 18). But without the software, there is no way to know that this is supposed to produce that.

Now, the problem, of course, is that a bunch of bits, in the middle of a stream of bits, can be anything. The fact that we have some ideas about how to encode things now in no way implies that people in the future will be limited to those same encodings, or will even think that those encodings are natural or obvious. Furthermore, you cannot, in principle, make a stream of bits self-explanatory. You have to know what something refers to in order to read it. An obvious example is a string of English words where, if you don't know what the words signify, there's really no way of understanding the sentence. (See charts 18.1, 19, and 20 for illustrations.)

So, if you have a digital document of some sort, you either have to run the software that was used to create it, or run some other software that's very similar. But you need to somehow make each document self-explanatory in order to know what software to run. Then you have to store the software along with the document, and you have to be able to somehow run that software in the future. This is very difficult.

There have been two classes of solutions proposed. One is essentially to rely on standards, whereby new programs can read the data produced by old programs, the documents—stored in "enduring" standard forms. The key there, of course, is enduring. Or you can have a sequence of standards, and translate documents from one to the other. That's the migration approach.

The other class of approach is to save and run obsolete hardware and software. I am not sure anyone here takes that very seriously, but there are still people who talk about that as a solution in computer museums. Both of these approaches have serious problems.

For the standards approach, it is really premature to think that we can standardize programs, much less know what kinds of digital documents we are going to have. Computer science is still inventing itself—that's what it is all about. In 50 or 100 years it may plateau and we may know better what the standards ought to be, but it is premature to do that at the moment.

Further, the problem with translating from one form to another is similar to what happens in the parlor game where you whisper a phrase into someone's ear, and they whisper it into the next person's ear, and by around the seventh person the phrase is completely unintelligible. Imagine taking the Iliad and translating it from ancient Greek through every intermediate language in between. You might conceivably still have the story, but it would certainly not be the Iliad. Furthermore, there are paradigm shifts, when you go from flat databases to hierarchical ones, then hierarchical to relational, and now relational databases are giving way to object-oriented ones. Each time you make a change of that sort, it is meaningless to translate. What you do is redesign.

So, if we use this approach we will have old documents that eventually get abandoned, as we have no way of translating them. Evolving standards always lag behind state-of-the-art technologies, and that will continue until we stop evolving at the rate that we are now.

I won't talk much about saving obsolete hardware and software. It's really not much of a solution. Among other things, it ignores the media problems. You will have to refresh media one way or another. So, in 50 years, you might have a 50-year-old computer, but you won't have a 50-year-old eight-inch disk with the information that went on that computer. You will have some DVD or evolution of that that won't fit in the eight-inch disk drives of the 50-year-old computer. So, you will just have to build interfaces between every new form of medium and every old computer in your museum. That's not really thinkable.

The approach that I have proposed for a number of years now—though without funding I haven't been able to research it thoroughly—is to emulate the original software. What does that mean? What you really want to do is emulate the behavior of the document's original software. But there's a catch: we don't know how to describe the behavior of software. Computer science has not evolved to that point. Therefore, the only decent way of emulating the behavior of a piece of software is to run it. So, we have to run that original software somehow, in its original software environment, on some emulation of the original hardware platform. Is that possible? It is, because software is self-describing; it tells the system how it should behave when it runs.

Hardware has been described in detail. In fact, we couldn't have built the systems we have if they weren't described in tremendous detail. The environments and hardware/software specifications need only be saved once, logically, in an archive somewhere. And we know how to emulate hardware; in fact, every time Intel produces a new chip, before they even cut the silicon they produce an emulator for the new chip that runs on an older computer so that they can prove that the Pentium works correctly. They can then start writing software for it. An emulator is a program that makes one computer pretend to be a different computer; it is a very well worn technique. IBM used it for years to provide upward compatibility in their software for users.

So, we know how to do that. In the future, you might imagine a scholar coming into an office with a document, circa 1980, having his system do some research, find a specification for the original hardware platform, create an emulator, and then run the original software under that emulator. This does rely on one assumption about the future: that in the future, our computers will be even faster, more powerful, and cheaper than they are today. I think that's a fairly safe assumption.

What's involved in doing this? You have to encapsulate (chart 27). Exactly what that means is something of a research issue, but, in principle, you have to build a wall around the original document that is being saved, the software that you need to view that document, the software environment, and the description of the hardware on which it runs. There also needs to be some metadata at the surface of this encapsulation. Specifically, some explanation telling you how to open all this up and read the document. It would also be nice to have some indexing information so that the librarian, when filing these, doesn't have to open up the encapsulation and read the document every time.

Logically speaking, these pieces of the puzzle don't need to be saved with every single document. They could be applied to a collection at a particular archive; they could be saved in one place, for example at a national archive; or they could be saved with each document. There is a lot of flexibility here. But, logically speaking, this is what you need to encapsulate.

So the approach becomes: annotate, encapsulate, transmigrate, and emulate (chart 28). What does that mean? Well, annotate means you need the explanation of how to get at this stuff, and the explanations have to be more readable than the documents themselves. So, we need to have some work here to develop ways of making these explanations readable into the future, probably using simple textual standards. I refer to these as "bootstrap standards" because they get you going in this process. Those descriptions may need to be translated from time to time, but you don't translate the documents themselves. You encapsulate, as in the previous slide (chart 27), and then you do something I refer to as "transmigrate": you migrate the bitstreams. That is, you refresh the media, but you do not translate it (except for the explanations).

Ideally, you would prefer not to have to understand what each kind of document is, and the details of each document every time you copy it because of the huge volume of copying we go through every few years. So, question the statement that there should be, or will be, different approaches for things like word processing, CAD/CAM documents, or GIS documents. If that's the case, we're going to lose. We need to figure out a way of treating everything as bits, and copy those bits without regard to what they represent. Of course, the one exception is that we need these explanations to be readable. So, if the bootstrap standard that we used to encode those explanations changes, we need to either translate the explanation or at least store a translator along with the encapsulation so that we can read those explanations in the future.

Finally, just to show you that this isn't entirely fantasy, I will show you this figure again (chart 16.2). This is the entity-relation diagram, a proprietary form of ERWin, running under MS Windows 3.1.1. However, you will notice that it is actually running on my Macintosh Powerbook, under an emulator called SoftWindows, a commercially available program that makes a Macintosh pretend it's a Windows machine. So, this is a perfectly viable approach that, at least in this case, is in use.

That is, in essence, the approach that I have proposed and a little outline of why I think it's necessary. Thank you.

MS. BUTLER: Thank you for the thought-provoking talk. We have time for one or two questions.

MR. WATERS (Digital Library Federation): Jeff, could you speculate on why it is that you haven't been funded? What are the hurdles that this isn't opening up to computer science research?

MR. ROTHENBERG: It is partly due to the fact that the computer science profession, as a whole, has not yet gotten fired-up about this problem. I think it could, but not much has been done in that direction.

I have, however, written an article on this ("Ensuring the Longevity of Digital Documents," *Scientific American* 272.1 [Jan. 1995]: 24-29), and have promised myself to write something for the computer science literature, which I hope will help.



MS. BUTLER: Jeff, you seem to be one of the few computer scientists who are focused in this area, and thank you for that. But, also, any advice about what we might do to engage faculty on our own campuses in these discussions?

MR. ROTHENBERG: That's an interesting question. It occurred to me recently that it might be useful to either put together a conference specifically on this subject or to at least have a session on it at an existing conference in the computer science world. IEEE, for instance, is willing to put together special purpose conferences. It might also be useful to form some kind of joint effort between the computer science and library worlds.

Certainly, there's nothing to prevent you from contacting people on your own campuses in computer science or information science departments and trying to get them interested in this.

MS. BUTLER: I suppose the fastest way would be the availability of funding to explore topics.

MR. ROTHENBERG: Yes.

MS. BUTLER: Thank you very much.

[Editor's note: Attached are overhead slides from the presentation. See the author's chart 31.1 for references to additional reading on this topic.]

## Digital Information Lasts Forever— Or Five Years, Whichever Comes First

---

Jeff Rothenberg

*(jeff@rand.org; 310/393-0411 ext. 7703)*

October 16, 1997

### Shakespeare's Sonnet 18

---

**S**hall I compare thee to a Summers day?  
Thou art more lovely and more temperate:  
Rough windes do shake the darling buds of May,  
And Summers lease hath all too short a date:  
Sometime too hot the eye of heaven shines,  
And often is his gold complexion dimm'd,  
And every faire from faire some-time declines,  
By chance, or natures changing course untrim'd:  
But thy eternall Sommer shall not fade,  
Nor loose possession of that faire thou ow'st,  
Nor shall death brag thou wandr'st in his shade,  
When in eternall lines to time thou grow'st,  
So long as men can breath or eyes can see,  
So long lives this, and this gives life to thee,

Chart 1

## **“Digitized” version of Sonnet 18 couplet**

---

### **original:**

So long as men can breath or eyes can see,  
So long lives this, and this gives life to thee,

### **vs. modern version:**

So long as the magnetic flux on this disk has not been disturbed,  
and so long as humans retain the appropriate size and speed disk drives,  
and so long as they have hardware controllers and software device drivers  
capable of reading the bits from this disk,  
and so long as they have access to the software that encoded the file structure  
and character codes employed in the bit stream of this document,  
and so long as they can still find or recreate the computing environment  
necessary to run that software,  
*and* so long as they can still breathe or see,

So long lives this,...

Chart 2

## **Digital documents are vulnerable to loss in many ways**

---

- **Media decay or “evaporation” of bits**
  - Due to physical, chemical, magnetic effects, etc.
- **Media obsolescence**
  - Physical and logical format incompatibilities
  - Unavailability of suitable “drives” or “controllers”
- **Dependence on incompatible or obsolete software**
  - e.g., for word processing or hypermedia documents, DBs, etc.
- **Dependence on obsolete software environments**
  - Unavailability of OS, I/O drivers, etc. for required software
- **Dependence on obsolete hardware**
  - Unavailability of hardware required to run required software

Chart 3

## The best we can say (so far) is...

---

- “Digital documents last forever — or five years, whichever comes first”

$\min(\infty, 5)$

Chart 4

## Digital documents are software-dependent

---

- Documents that can only be seen by running a program
  - They are stored in encoded form, understood only by a program
  - They cannot be accessed, read, or printed without that program
  - Examples include documents created with:
    - word processors or electronic publishing programs;
    - spreadsheets;
    - database management systems (DMBSs);
    - geographic information systems (GISs);
    - hypertext/hypermedia programs
- The data file for a software-dependent document is *not* enough
  - The file can be properly interpreted only by its software
  - Without the software, the document is unusable (may not even really exist)
  - “Virtual documents” may consist of multiple (distributed) files
- Software-dependent documents are really *system*-dependent
  - They require a software environment (OS, drivers, etc.)
  - Which in turn requires a hardware environment (CPU, I/O devices, etc.)

Chart 5

## Software-dependence is a hard problem

---

- **Do we have to run the software that created a document?**
  - In order to “read” the document?
  - This might require running the entire obsolete software/hardware environment in which the document was created
  - Can we even do this?
- **Can we run “similar” software instead?**
  - If so, how similar does it have to be?
  - How much of the original document do we lose by doing this?
- **Can we translate the document into some new form instead?**
  - And run new software to read it?
  - How much of the original document do we lose this way?

Chart 6

## What makes a document software-dependent?

---

- **It is meaningful only to its original software**
  - Its structure & content can be understood only by the program that created it
  - We can make sense out of it *only* by running this software
- **Or we need to see exactly what its author or reader saw**
  - To understand the source of their insights or blind-spots (e.g., for research)
  - To hold them legally or ethically accountable for what they should have been able to infer from the document
  - To understand their appreciation of the document
  - To experience some subtle artistic effect
  - I.e., when a document must retain its original functionality

Chart 7

## Reformatting can make documents unrecognizable

SHALL I COMPARE THEE TO A  
SUMMERS DAY? THOU ART  
MORE LOVELY AND MORE TEM-  
PERATE: ROUGH WINDES DO  
SHAKE THE DARLING BUDS OF  
MAIE, AND SOMMERS LEASE  
HATH ALL TOO SHORT A DATE:  
SOMETIME TOO HOT THE EYE  
OF HEAVEN SHINES, AND OF-  
TEN IS HIS GOLD COMPLEXION  
DIMM'D, AND EVERY FAIRE  
FROM FAIRE SOME-TIME DE-  
CLINES, BY CHANCE, OR NA-  
TURES CHANGING COURSE UN-  
TRIM'D: BUT THY ETERNALL  
SOMMER SHALL NOT FADE,  
NOR LOOSE POSSESSION OF  
THAT FAIRE THOU OW'ST, NOR  
SHALL DEATH BRAG THOU  
WANDR'ST IN HIS SHADE,  
WHEN IN ETERNALL LINES TO  
TIME THOU GROW'ST, SO LONG  
AS MEN CAN BREATH OR EYES  
CAN SEE, SO LONG LIVES THIS,  
AND THIS GIVES LIFE TO THEE,

Chart 8

## Reformatting can destroy meaning

          this                                  take  
if      is      shall      really      to  
          flying I          never          it.

—Piglet getting bounced along by Kanga,  
*Winnie The Pooh*, A. A. Milne, p. 103

**Transcribed as linear text:**

this take  
if is shall really to  
flying I never it.

Chart 9



## Reformatting can lose information

---

### The Periodic Table of the Elements

```
H He
Li Be B C N O F Ne
Na Mg Al Si P S Cl Ar
K Ca Sc Ti V Cr Mn Fe Co Ni Cu Zn Ga Ge As Se Br Kr
Rb Sr Y Zr Nb Mo Tc Ru Rh Pd Ag Cd In Sn Sb Te I Xe
Cs Ba * Hf Ta W Re Os Ir Pt Au Hg Tl Pb Bi Po At Rn
Fr Ra ** Rf Ha Sg Ns Hs Mt
```

\* La Ce Pr Nd Pm Sm Eu Gd Tb Dy Ho Er Tm Yb Lu

\*\* Ac Th Pa U Np Pu Am Cm Bk Cf Es Fm Md No Lr

Chart 10

## Even simple reformatting can lose information

---

### Changed to variable-width font

```
H He
Li Be B C N O F Ne
Na Mg Al Si P S Cl Ar
K Ca Sc Ti V Cr Mn Fe Co Ni Cu Zn Ga Ge As Se Br Kr
Rb Sr Y Zr Nb Mo Tc Ru Rh Pd Ag Cd In Sn Sb Te I Xe
Cs Ba * Hf Ta W Re Os Ir Pt Au Hg Tl Pb Bi Po At Rn
Fr Ra ** Rf Ha Sg Ns Hs Mt
```

\* La Ce Pr Nd Pm Sm Eu Gd Tb Dy Ho Er Tm Yb Lu

\*\* Ac Th Pa U Np Pu Am Cm Bk Cf Es Fm Md No Lr

Chart 11

## Even simple reformatting can lose information

**Shrink tabs, append footnotes, remove end-of-lines**

H He Li Be B C N O F Ne Na Mg Al Si P S Cl Ar K Ca Sc Ti V Cr Mn Fe Co  
 Ni Cu Zn Ga Ge As Se Br Kr Rb Sr Y Zr Nb Mo Tc Ru Rh Pd Ag Cd In Sn  
 Sb Te I Xe Cs Ba Hf Ta W Re Os Ir Pt Au Hg Tl Pb Bi Po At Rn Fr Ra Rf Ha  
 Sg Ns Hs Mt La Ce Pr Nd Pm Sm Eu Gd Tb Dy Ho Er Tm Yb Lu Ac Th Pa U  
 Np Pu Am Cm Bk Cf Es Fm Md No Lr

**Ignore tabs, footnotes, end-of-lines, case**

hhelibebcnofnenamgalsipsclarkcasctivcrmnfeconicuzngageassebrkrrbsryzrnb  
 motcrurhpdagcdinsnsbteixecsbahftawreosirptaubgtlpbbipoatrnrfrarfnhasgnsh  
 smt

Chart 12

## A particular "view" of information may be crucial

**Example: Space Shuttle O-ring damage vs. temperature  
 Prior to Challenger**

<b>Levels of O-ring damage</b>	<b>3</b>	1																		
	<b>2</b>																			
	<b>1</b>		1	1	1						2									
	<b>0</b>					1	3	1	1	2	1	1	1	2	1	1	1	1	1	1
			53	57	58	63	66	67	68	69	70	72	73	75	76	78	79	80	81	
		<b>Temperature °F</b>																		

Chart 15

## Revealing View of Space Shuttle O-ring Data

Extrapolation of damage curve to the 31° F temperature forecast for Challenger's launch on January 28, 1986.

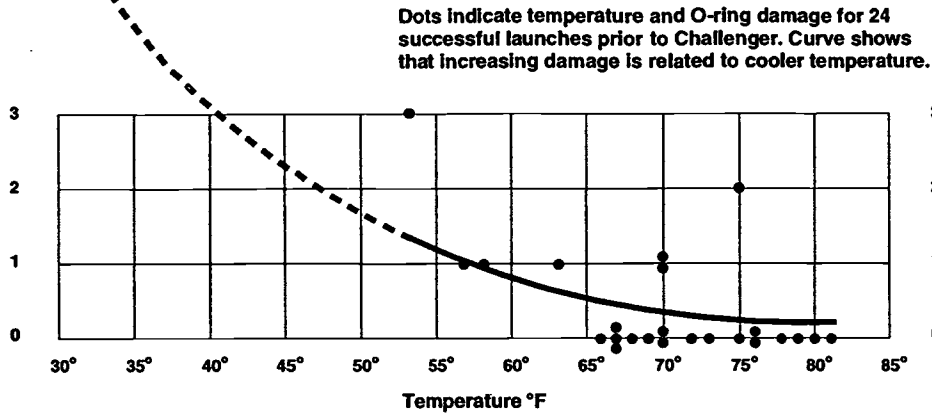

Chart 16.1

## What you see may *not* be what you get

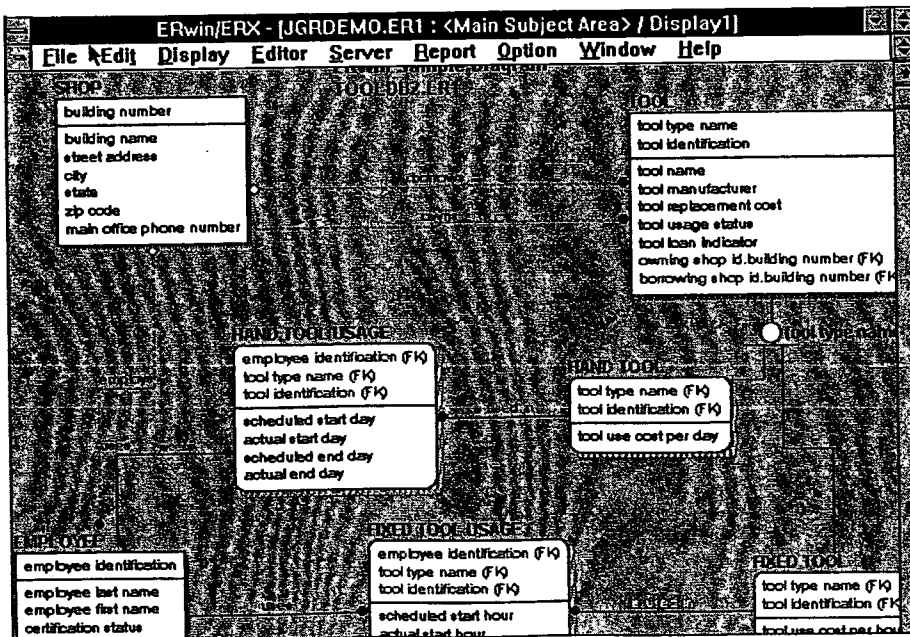

Chart 16.2

BEST COPY AVAILABLE

## Text may not tell the story at all

### V2.24 ERwin

```
if
  %JoinPKPK(oldrows,newrows," <> "," or ")
then
  select count(*) into numrows
  from %Child
  where
    %JoinFKPK(%Child,oldrows," = "," and");
  if (numrows > 0)
  then
    signal parent_updrstrct_err
  end if;
end if;
if
  %JoinPKPK(oldrows,newrows," <> "," or ")
then
  update %Child
  set
    %JoinFKPK(%Child,newrows," = "," ,")
  where
    %JoinFKPK(%Child,oldrows," = "," and");
end if;
```

Chart 18

## Deciphering a bit stream is hard

Consider typical entries from a checking account statement:

<u>date</u>	<u>chk/dep</u>	<u>amount</u>	<u>balance</u>
4/5/94	deposit	\$500.00	\$500.00
4/26/94	chk# 314	\$100.00	\$400.00
4/27/94	deposit	\$ 50.00	\$450.00
11/3/94	chk# 315	\$100.00	\$350.00

Removing all spaces and punctuation and translating dates into 6 digits (mmddyy), check numbers into 4 digits, deposits into 0000, and amounts into 11-digits, the above entries become:

```
040594000000000005000000000050000
042694031400000001000000000040000
042794000000000000500000000045000
110394031500000001000000000035000
```

Concatenating these entries produces the following decimal digit stream:

```
040594000000000005000000000050000042694031400000
0100000000004000004279400000000005000000000450
00110394031500000001000000000035000
```

Chart 18.1

41

## Bits in a bit stream can represent *anything*

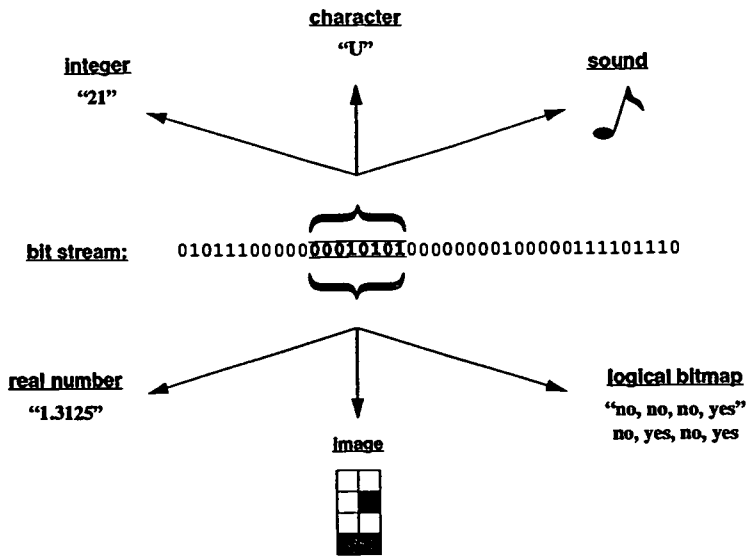

Chart 19

## A bit stream *cannot* be made self-explanatory

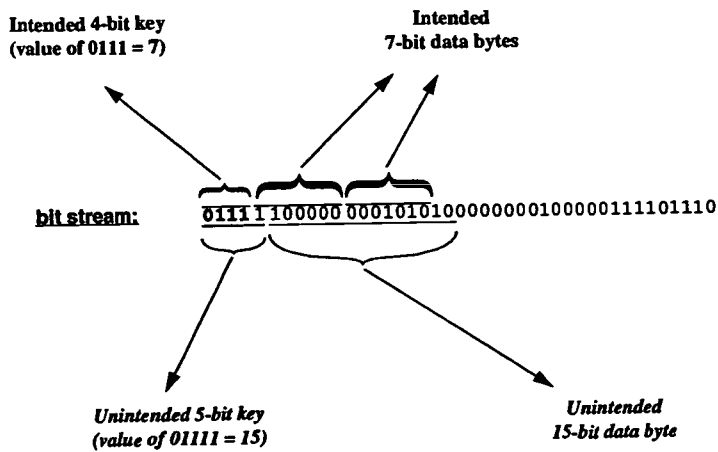

Chart 20

## **So we must run software to read a digital document**

---

- **Either the software that was used to create it**
  - Despite its being obsolete
  - And requiring an obsolete hardware/software environment to run
- **Or some other software that is *very* similar**
  - In both function *and* "look and feel"
- **Each digital document must be made self-explanatory**
  - Telling us what software to run to read it
- **We must store (or provide access to) the required software**
  - With each document
- **We must facilitate running this software in the future**
  - Using future computers, obsolete computers, or emulation

Chart 21

## **Proposed solutions fall into two classes**

---

- **Rely on standards**
  - To allow new programs to read old documents in enduring standard forms
  - OR translate documents from old standards to new ones as standards evolve
- **Save and run obsolete hardware and software**
  - In "computer museums"
  - To read documents by running the original programs that created them
- **Both of these approaches have serious shortcomings**
  - Though they may have a role to play in the ultimate solution

Chart 22



## Standards alone are inadequate

---

- **Ultimate standards are not realistic in the foreseeable future**
  - Information science is still inventing itself
  - Even the categories of kinds of information processing are not yet clear
  - So ultimate standardization is premature
- **Using successive, evolving standards would require translation**
  - But translation between standards is rarely reversible without loss
  - So this cannot reconstruct an original document
  - Translation forward across “paradigm shifts” may be impossible
  - So old documents may eventually be abandoned or corrupted
- **Evolving standards will always lag behind state-of-the-art use**
  - Until information science stops evolving
  - So state-of-the-art documents are likely to be “orphaned”
- **Can't force users to conform to constraining standards**
  - This asks them to forego the use of new capabilities
  - Which are the motivation for using information technology in the first place

Chart 23

## Saving obsolete hardware & software is inadequate

---

- **It sounds romantic but is not realistic**
  - As generations of hardware/software multiply, this becomes a nightmare
  - How long can we keep old hardware running cost-effectively?
- **It would greatly restrict access to old documents**
  - To a few “computer museums”
  - Losing the distributed aspect of digital information
- **It ignores storage media problems**
  - Neither old documents *nor old software* will last on their original media!
  - Once copied onto new media, they won't fit in their original machines
  - So would need to build and maintain a new hardware interface to each old machine for each new generation of storage media
- **This is best reserved for “heroic efforts”**
  - Retrieving information from old media that may still be readable
  - Verifying the behavior of emulators for old systems and environments

Chart 24

44

## The solution: use emulation

- **Ideally, emulate the *behavior* of a document's original software**
  - But we don't yet know how to describe the behavior of software...
  - The only adequate description is the software itself
- **So we must actually run the document's original software**
  - To recreate its behavior
  - This requires saving its software environment (operating system, etc.)
  - And emulating the hardware on which it originally ran
- **This is ambitious but not impossible**
  - Software environments (like any software) are "self-describing" when they run
  - Hardware could not be built if it were not specified in great detail
  - Hardware/software environments & specifications need only be saved once
- **Hardware emulation is well understood**
  - Most new machines are emulated before they are built
  - Computers often emulate their predecessors for "upward compatibility"
  - Generic emulators could be written for unknown future machines

Chart 25

## Encapsulated document and metadata

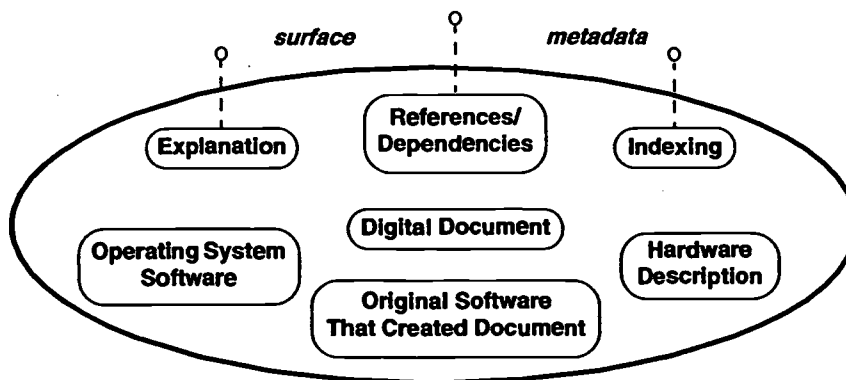

Chart 27

## Annotate, Encapsulate, Transmigrate, Emulate

---

- **Annotate**
  - Associate with each document an explanation of how to read it
  - Use "bootstrap standards" to make these explanations easily decipherable
  
- **Encapsulate**
  - Documents, software, and hardware specifications
  - Store with explanations in digital form, but resistant to corruption
  
- **Transmigrate**
  - Migrate (copy) bit streams verbatim to new media frequently to prevent loss
  - Ideally refresh storage media *without* having to know what they contain
  - Translate "bootstrap standard" explanations whenever necessary
  
- **Emulate**
  - Using saved explanations and hardware specifications
  - Run saved software to decipher saved documents

Chart 28

## References

---

- **Scientific American article**
  - Original "Ensuring the Longevity of Digital Documents," Jan 1995 (Vol. 272, Number 1), pp. 42-47.
  - Expanded version "Ensuring the Longevity of Digital Information," Jan 23, 1998,  
Online at <http://www.cilir.org/programs/otheractiv/ensuring.pdf>
  
- **"Avoiding Technological Quicksand:  
Finding a Viable Technical Foundation for Digital Preservation"**
  - Report to the Council on Library & Information Resources (CLIR)
  - View online at <http://www.cilir.org/pubs/reports/rothenberg/contents.html>
  - Download from <http://www.cilir.org/pubs/reports/rothenberg/pub77.pdf>
  
- **American Archivist paper**
  - "Scholarly Communication and Information Technology: Exploring the Impact of Changes in the Research Process on Archives" (Ara Michelson & Jeff Rothenberg), 55:2, 1992, pp. 236-315.
  - Reprinted as RAND RP-187, April 1993; Online : <http://www.cilir.org/programs/otheractiv/aapaper.html>
  
- **IEEE Metadata paper**
  - "Metadata to Support Data Quality and Longevity," First IEEE Metadata Conference, April 16-18, 1996
  - Online at [http://computer.org/conferen/meta96/rothenberg\\_paper/ieee.data-quality.html](http://computer.org/conferen/meta96/rothenberg_paper/ieee.data-quality.html)
  
- **PBS film**
  - "Into the Future," by Terry Sanders, 1997, available in 60 or 30 minute versions from American Film Foundation, 1333 Ocean Ave., Santa Monica 310/459-2116
  - Described online at <http://www.cilir.org/programs/otheractiv/intro.html>

Chart 31.1

## AN ORGANIZATIONAL MODEL FOR PRESERVING DIGITAL USDA PUBLICATIONS

Jan Olsen  
Associate University Librarian for Sciences  
and  
Director, Mann Library  
*Cornell University*

Good morning. We will be presenting a case study that I believe is an application of the concepts and ideas that you have heard presented this morning. I will give an introduction to set the stage and then Evelyn Frangakis, Preservation Officer at the National Agricultural Library, will follow up with greater detail.

Several years ago, the Mann Library at Cornell University and the United States Department of Agriculture formed a partnership to deliver to the nation digital information that the Department of Agriculture was producing. In particular, it involved three economic agencies within the Department: the Economic Research Service (ERS), the National Agricultural Statistics (NAS), and the World Agricultural Outlook Board (WOAB). These three provide the crux of the economics work done in the Department of Agriculture. They produce a great deal of information of tremendous vitality and use to the United States and whose native form is digital. However, when the information aged a little and when storage space was running out, it was dumped. Important public information was lost.

Rather than lose that information, Cornell has agreed to take that data as it is produced, and deliver it across the United States to anyone who wishes to use it, free of charge. We receive extremely time-sensitive data, re-format it, and within 30 minutes have it available on the Web, at <http://usda.mannlib.cornell.edu/usda/>.

Let me define what kind of data is involved. It is data that was produced for public use. A lot of the information is statistical, and much of it is textual. In the last calendar year, there were 2.1 million files of this data downloaded from the Mann Library site. It is popular and used heavily.

The USDA provides a grant that purchases storage space. Mann Library contributes the staff time, programming, and reference support for the data. In any given year, Mann receives about 150,000 information requests. The contract has just been renewed with the Department of Agriculture. In this coming year the system will be enlarged and improved so that it is a comprehensive economics information system.

Of particular concern with this system is the fact that the data is aging. As a library, we must not just dump the data. I mentioned that these are natively digital; there is no printed equivalent. So the question of archiving, maintaining, and sustaining this data is a very large and important one.

This problem is a national challenge. It is an example of government data to which this nation should have access, but it is government data in need of systematic preservation. While that is true for the USDA, it is also true for other government departments. We decided to treat this as a national issue. As a first step, we worked with the National Agricultural Library and planned a national, invitational conference. We invited approximately 70 people who had a vested interest in the need to preserve this data, and held a two-day conference at the Smithsonian Institution.

There was a good cross-section of participants. Attendees included USDA and other government people, those who had explored the issue of preserving digital information in the past, academics, and average users. The purpose of the conference was to encourage the USDA to acknowledge the need to preserve such data and to begin to work out a plan for preservation. I think it's fair to say that we achieved this objective. The National Agricultural Library accepted responsibility to get planning underway and to put in place strategies and policies, ultimately passed by the USDA, to archive digital data in a systematic fashion.

The final outcome of the conference was that the USDA recognized at the very highest level the need to work on this problem in a rigorous way, and subsequently issued a report with a plan for preserving digital data.

Evelyn will now describe to you the projected next steps.

USDA DIGITAL PUBLICATIONS:  
CREATING A PRESERVATION ACTION PLAN

Evelyn Frangakis, Preservation Officer  
*National Agricultural Library*

I'd like to refer back, momentarily, to Jeff Rothenberg's presentation, to the point of discussion about Shakespeare's sonnet. We have done something similar at NAL, but we have looked to the Bible for inspiration. We have taken a psalm and translated it to the psalm of the digital life. This psalm was born during a challenging digital moment, when a colleague came to me and said, "I don't think I want to hear the "D" word any more." I'd like to share the resulting creative energy output with you:

*Psalm of the Digital Life - 2*

*Digital imaging is my destiny.  
I will not print.  
It cleanseth the shelves of paper.  
It restoreth my access.  
It draggeth me into computer science,  
for the common good.*

*Yea, though I surf through the ether  
of bits and bytes,  
I will begrudge no computer sapient.  
They provideth me a necklace of perl scripts  
in the tapestry of information  
and grindeth my brain to bits.*

*Surely "file inaccessible" and memory overload  
Shall follow me all the days of my life  
and I shall dwell in the house of pixelated information  
forever.*

(by Evelyn Frangakis and Eileen McVey, September 1997, National Agricultural Library)

The National Agricultural Library (NAL) has a historical role in obtaining, maintaining, and making available for use print materials of the U. S. Department of Agriculture (USDA). NAL and Cornell have had a long-standing cooperative relationships, predating the report, *A National Preservation Program for Agricultural Literature*, produced by Nancy Gwinn in cooperation with the U. S. Agricultural Information Network (USAIN). The handout, "Status of the National Preservation Program for Agricultural Literature," (see attached) graphically depicts the relationships and responsibilities for areas of the agriculture literature that need to be preserved and lists who will participate in those efforts. This status report states that a great deal has been accomplished to date. In addition, Cornell has just applied for another round of NEH funding to continue the state and local literature component. Should funding be forthcoming, work will be underway toward systematic preservation of the relevant literature in fifteen of the fifty states. That represents thirty percent of the long-range goal of this component of the national plan. At the completion of all phases of this national project, approximately 9,000 titles and 15,000 volumes published between 1820 and 1945 will be preserved, from a diverse cross-section of fifteen states, representative of the history of American agricultural and rural life. That's just to give a perspective of where we're coming from and where we're moving toward.



Today the USDA is increasingly, and in some instances exclusively, publishing information in electronic form. USDA digital publications produced need to be systematically identified, prioritized, preserved, and archived. While important, sometimes these electronic publications are extremely transitory. For example, NAL's attempts to locate, catalog and provide access to the annual issues of USDA's *Agriculture Fact Book* in electronic form illustrate why it is important to develop a plan to ensure continued access to data representing earlier editions. When the 1995 edition of the *Agriculture Fact Book* was made available electronically, its preceding electronic edition was removed from its location on a remote computer to make space for the new edition. NAL had entered a record for the electronic editions but had no means to ensure continued access to the complete set of electronic versions. Solutions to the problems of maintaining the entire body of electronic publications and making them available for as long as needed call for cooperative efforts. NAL will need to partner with USDA agencies, related federal agencies and other stakeholders to capture and preserve these important electronic agricultural resources.

Given that a number of USDA agencies have begun publishing exclusively in electronic form, the NAL and other key stakeholders and responsible parties believe it is essential to develop a preservation plan for digital USDA publications as soon as possible. Such a plan will need to be developed together with the Department's Chief Information Officer and key representatives of all USDA agencies, other responsible Federal government entities, such as the Government Printing Office (GPO) and the National Archives and Records Administration (NARA), the land-grant university libraries, and other non-governmental institutions and groups in the agricultural community.

The NAL, with the Economic Research Service (ERS) of the USDA, GPO, Cornell University, and the Farm Foundation recently took the first step in a cooperative venture by convening a 2-day meeting, held March 3-4, 1997 in Washington, D.C., with representatives of many of the above groups to begin to identify the major elements and requirements of such a plan. Under the auspices of the NAL, the meeting was organized by Cornell University's Albert R. Mann Library. The meeting served as a call to action to develop a preservation strategy for USDA digital publications.

The first day set the stage for work ahead by providing models and perspectives of responsible parties and key stakeholders. The second day was devoted to action. Participants were assigned to one of four breakout groups, which met all morning, to address a range of questions on a given issue in order to work toward drafting a preservation action plan. The following elements of a plan were discussed:

- the management framework and related institutional roles and responsibilities, both inside the Department and externally, in the long-term preservation of digital USDA publications;
- the underlying technological infrastructure and technical document management requirements;
- the development of long-term retention criteria and processes for digital USDA publications; and
- the main issues in long-term user access to and retrieval of those digital publications.

The afternoon was devoted to breakout group report results and a plenary discussion of the elements of a national plan. The results of the Institutional Roles discussion were very influential in shaping the plan, as the organizational structure is being taken directly from the results of that group's discussion. Much of the discussion in the plan and annexes regarding retention and deselection criteria reflects the discussion of the long-term retention criteria breakout group. Similarly, many of the main points regarding User Access and Technical Requirements are represented in the guidelines set forth in the plan and the discussion contained in the annexes.

Based on the results of this meeting, an initial preservation plan has been developed for discussion within the Department over the next few months. This preliminary plan identifies the principal USDA agencies involved, resources required, and steps to be taken in the near term as well as over an extended

period of time. This plan will serve as a discussion draft for obtaining commitment and support to proceed with this important initiative.

Now I would like to refer you to the summary handout titled, *Framework For The Preservation of and Permanent Public Access to USDA Digital Publications*. In it you will find the proposed organizational model for preserving USDA digital publications. NAL has a central role in this effort and there are a great number of key stakeholders and responsible parties interacting in this proposed relationship. The plan calls for a steering committee to be organized to oversee the plan. The steering committee will have three task groups under it, the: Task Group on Inventory and Life-Cycle Management, Task Group on Technical Requirements and Task Group on User Access and Retrieval.

The remainder of the handout provides an executive summary of the plan that was produced as a result of the March meeting. It is recommended that the plan's implementation be based on a management model with the following attributes: a customer orientation; distributed responsibilities with minimized levels of bureaucracy and improved leveraging of resources; procedural and technical standardization; and cost minimization. Specific organizational actions refer to the steering committee and its responsibilities, including defining the management structure, recommending to the Secretary how preservation and public distribution of these digital publications should be funded on a permanent basis, identifying legislative or administrative actions or policies that will be required to implement the plan, and establishing any task groups or pilot projects that are necessary, and conducting periodic assessments.

In conclusion, the next steps in the preservation of USDA digital publications initiative will include:

- The NAL Director will present the *Framework For The Preservation of and Permanent Public Access to USDA Digital Publications* to the USDA Chief Information Officer for subsequent distribution and endorsement throughout the USDA.
- The *Framework* will be distributed to participants of the "National Conference on Creating an Action Plan for Preserving USDA Digital Publications."
- The *Framework* will be made widely available to external stakeholders for endorsement.
- A budget request to USDA will be developed to initiate key aspects of the plan.
- Funding will be requested for a pilot project to apply the *Framework* to a microcosm of USDA digital publications.
- Discussions will continue with key stakeholders such as GPO, NARA, and NSF to gather information on proceeding with a digital publications preservation pilot. As a result of initial discussions with these groups, several USDA agencies have already emerged as possible sites for implementation of the digital publications preservation pilot.

# NATIONAL PRESERVATION PLAN FOR AGRICULTURAL LITERATURE -- PRINT

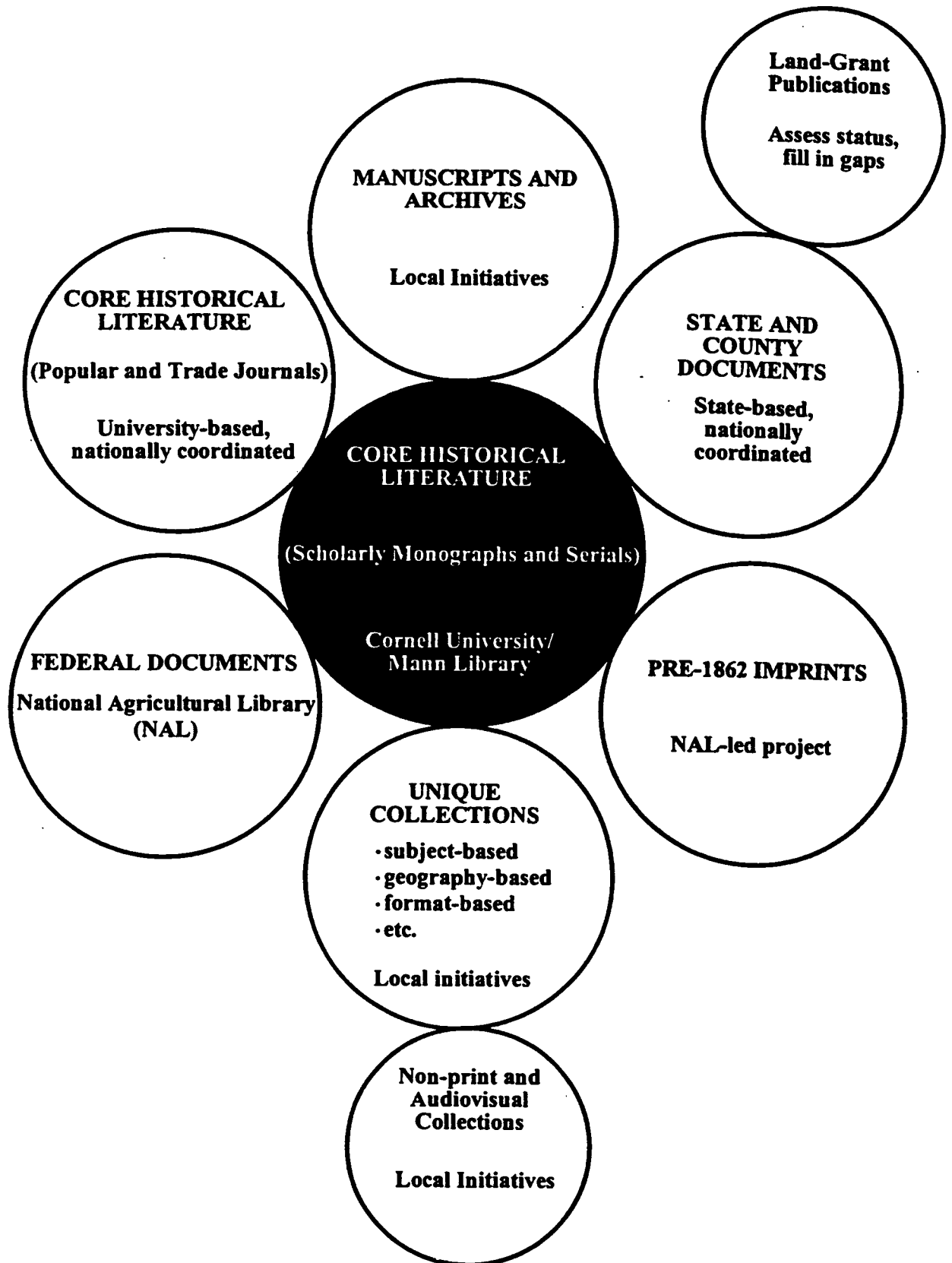

From: *A National Preservation Program for Agricultural Literature*, 1993  
By: Nancy E. Gwinn, Smithsonian Institution Libraries

# Status of the National Preservation Program for Agricultural Literature

## Overview

The National Preservation Program for Agricultural Literature (NPPAL), a discipline-based preservation plan, was adopted by the U.S. Agricultural Information Network (USAIN) in 1993. With leadership from its governing USAIN National Preservation Plan Steering Committee, substantial progress has been achieved. The NPPAL's defining characteristics are that it: 1) is a national cooperative plan, 2) is discipline based, looking beyond the preservation needs of individual collections to the needs of the discipline as a whole, 3) involves scholars in setting preservation priorities, and 4) has a national library that serves a central role as an archive for the literature of agriculture preserved through a series of cooperative projects.

The National Agricultural Library (NAL) received funding to implement a preservation program and appointed Evelyn Frangakis as NAL Preservation Officer in January 1997. The Mann Library at Cornell University has volunteered leadership in coordinating activities of the NPPAL, and both NAL and Cornell have provided staff and funds to assist the program's movement forward.

## State And Local Literature

Each state is responsible for preserving its agriculture and rural life literature. Under a USAIN cooperative preservation project funded by the National Endowment for the Humanities (NEH), nine states (AL, CA, CT, FL, NB, NY, PA, TX, & WI) have identified and set preservation priorities for their state's relevant publishing and four states are proceeding to film the top-ranked materials. With funding from USAIN and NAL, an NEH proposal was written for phase two of this project, which would extend this preservation activity for four continuing states and add seven new states (AK, AZ, HI, IA, KS, MN, & MT). If the phase two proposal is funded, fulfillment of this component of the plan will be underway in 33% of the states.

## Land Grant Publications

NAL has conducted an inventory and evaluation of microfilm produced from the land-grant publication cooperative microfilming project it led. A database is under creation. The few states which did not participate in the earlier project will be encouraged to preserve their land grant publications within the framework of the state and local literature component.

## Core Scholarly Journals And Monographs Of National Interest

Cornell University is responsible for scanning and making available to the nation the core historical monographs and journals of U.S. agriculture, identified by Wallace C. Olsen as part of the Core Literature Project. To date 2,340 volumes have been scanned. NAL has provided funding to Cornell to secure permission to make accessible those volumes in the core historical literature which are still under copyright and this project will be completed in 1998.

## Federal Documents

NAL has begun to establish overall and specific priorities for preservation of federal publications. Twenty USDA titles are included in the overall list of core historical monographs and journals of U.S. agriculture. NAL, with responsibility for preserving relevant federal documents, has begun to digitize several federal titles (two monographs as well as the *Journal of Agricultural Research (JAR)*) using preservation quality scanning. To date 15 volumes of *JAR* have been scanned and the remainder are scheduled for digital conversion. NAL will begin contributing a special collection to the National Digital Library in 1998.

## Pre-1862 Imprints

NAL, with responsibility for leading an effort to conserve early imprints in U.S. agriculture, conserves these publications as needed. NAL has begun to establish a special collections conservation plan as part of its overall preservation goals.

## Manuscripts And Archives

Cornell and NAL have allocated funding to plan for a published guide to manuscript and archival collections in agriculture and rural life. This guide will serve as a basis for setting priorities and coordinating national activity in this component part of the literature.

by Sam Demas, Cornell University and Evelyn Frangakis, National Agricultural Library, 10/97

**FRAMEWORK  
FOR THE  
PRESERVATION OF AND PERMANENT PUBLIC ACCESS TO  
USDA DIGITAL PUBLICATIONS**

**By  
Paul Uhler  
Project Consultant  
National Science Foundation**

**September 1997**

# Proposed Model for Preserving USDA Digital Publications

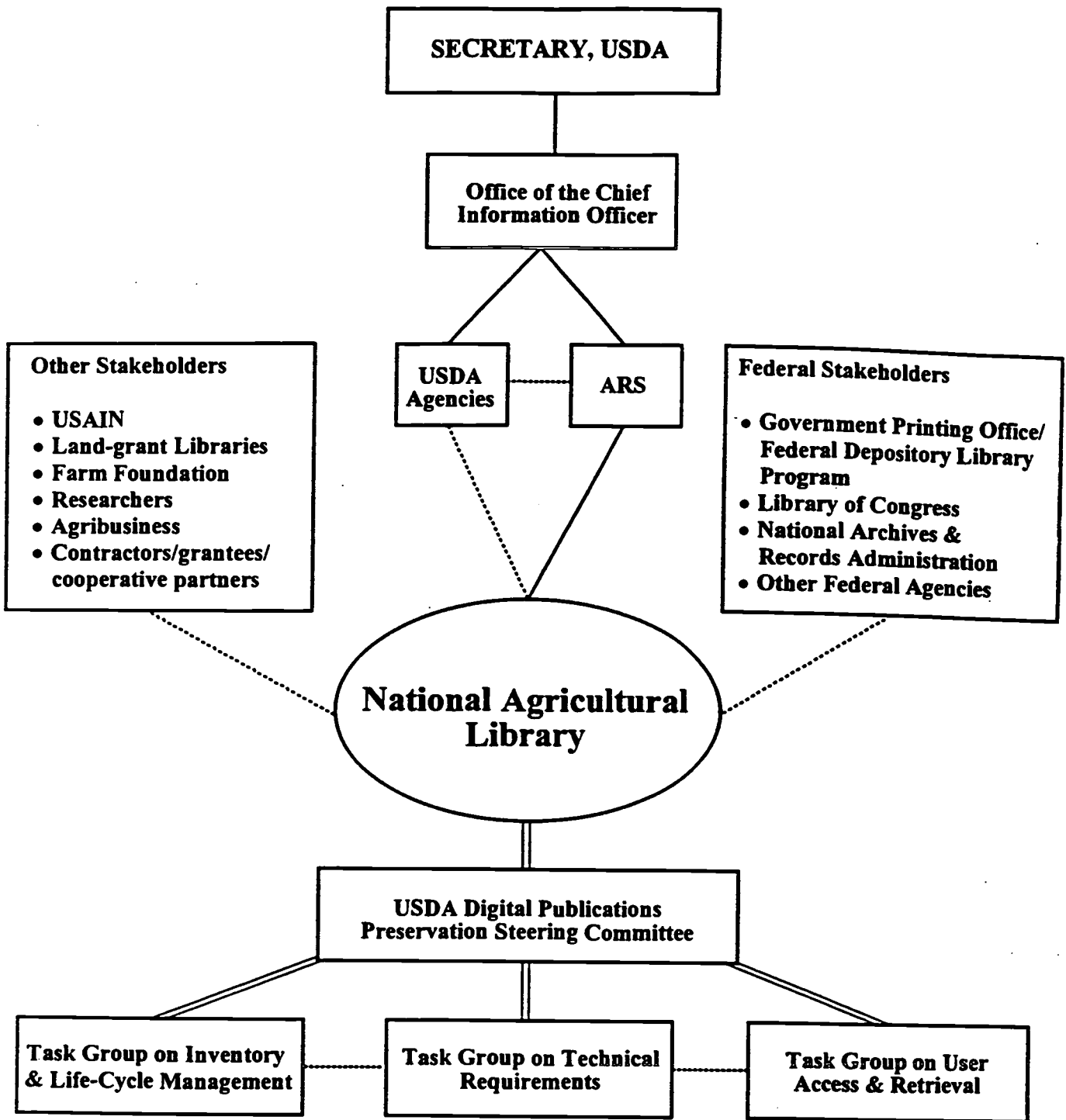

- Direct management or funding authority
- Formal cooperative relationship (current or prospective)
- ==== Proposed formal relationships

Abbreviations: ARS = Agricultural Research Service; USAIN = U.S. Agricultural Information Network



## EXECUTIVE SUMMARY

The National Agricultural Library (NAL) and other stakeholders within and outside the Department of Agriculture believe it is essential to develop, as quickly as possible, a comprehensive program for preserving the Department's digital publications. Failure to address this issue in the near term will result in the irrecoverable loss of substantial portions of the Department's rapidly growing volume of electronic data and information.

NAL will have primary responsibility for implementing and coordinating the key provisions of this plan. The plan's implementation should be based on a management model with the following attributes:

- a customer orientation;
- distributed responsibilities with minimized levels of bureaucracy and improved leveraging of resources;
- procedural and technical standardization; and
- cost minimization.

### Specific Organizational Actions

Several organizational actions need to be taken in the near term by the NAL in consultation with the other stakeholders and customers identified in the plan:

- a) Complete the formal review and adoption of the plan by all stakeholders within the Department and obtain the endorsement by representatives of key external constituent groups;
- b) Create a Steering Committee for the implementation of the plan, chaired by the NAL Director, and including representatives from the Office of the Chief Information Officer, other Departmental Agencies, and key external stakeholders. The purpose of the Steering Committee will be to:
  - (i) Fully define the management structure and organizational relationships and responsibilities, both within the Department and externally;
  - (ii) will recommend to the Secretary how the preservation and public distribution of all USDA digital publications should be funded on a permanent basis, taking into account the need to minimize the costs of access and retrieval to the users of that information;
  - (iii) Identify any legislative or administrative actions or policies required to implement the provisions of this plan;
  - (iv) Establish any task groups, pilot projects, and programs that may be required; and
  - (v) Conduct periodic assessments of the status of the implementation of this plan, and of the plan itself.

As soon as possible following the formal approval of this plan, the Steering Committee will establish three task groups: Task Group on Inventory and Life-Cycle Management, Task Group on Technical Requirements and the Task Group on User Access and Retrieval, all chaired by the NAL. Within a specified period established by the Steering Committee, each task group will develop a comprehensive plan for addressing the stated requirements, together with an estimate of resources necessary to fully implement those functions, and present it to the Steering Committee for approval. The activities of all task groups should be coordinated with the activities under the Information Systems Technology

Architecture (ISTA) process currently under development by the Office of the Chief Information Officer, as well as with each other.

### **Inventory and Life-Cycle Management**

This task group, to be created by the Steering Committee, will conduct a comprehensive inventory of all Departmental digital information products and how they are being managed. This task group, chaired by the National Agricultural Library and including representatives of the Office of the Chief Information Officer and all USDA Agencies, also will recommend a system for tracking the creation of each new USDA digital information product that is intended for public distribution.

Following the completion of the Department-wide inventory of digital publications, the task group should develop a comprehensive set of selection and retention criteria for all categories of publications to be covered under this plan. These criteria and the process for applying them should be established in consultation with representatives from the principal creators and users of these publications, including depositories.

### **Technical Requirements**

This plan is consistent with the Information Systems Technology Architecture (ISTA) currently under development by the Office of the Chief Information Officer. However, there are several technical functions specific to the preservation and distribution of digital publications that need to be explicitly addressed, consistent with the ISTA process currently underway:

- (a) Identification of acceptable document formats and media, and related standards, for long-term retention;
- (b) Development of processes for transferring all digital publications from old storage media to new media;
- (c) Establishment of one or more separate back-up facilities for all digital publications;
- (d) Review and establishment of system security protocols;
- (e) Review and establishment of system interoperability requirements; and
- (f) Identification and review of other permanent digital preservation and access initiatives.

### **User Access and Retrieval**

The following requirements for user access and retrieval of USDA digital publications should be followed consistent with the need to maintain a customer orientation:

- (a) Provide equitable access and retrieval services to all potential users;
- (b) Minimize technical, regulatory, and cost barriers to access and retrieval;
- (c) Assure the integrity of the information that is made publicly available;
- (d) Make the information as easy to find and use as possible, with directories and documentation (metadata), consistent with the Government Information Locator System, while protecting confidential or proprietary information; and
- (e) Establish a means for users to provide feedback and a mechanism for responding to user feedback.

\* \* \*

## QUESTION AND ANSWER SESSION

MS. BUTLER: I want to thank Jan and Evelyn for presenting us with what I believe is a quite viable organizational model. This is an issue that I know members of the preservation committee have been struggling with: how we can begin moving forward in the various arenas.

Jan, do you think that the model, as you have developed it in working with the National Agricultural Library, is scalable? You knew who the stakeholders were. There were many. Nevertheless, you could bring people together in this common effort. Do you think that a similar model is scalable when we're talking about the preservation of digital information in general?

MS. OLSEN: That's a crucial question. You could say that this works particularly well because it's a national library in the discipline area. That makes it a lot easier. The same would be true for medical data and so forth. However, for many years there has been the regional depository system, whereby, as you know, many of us are depository libraries for government-created information. It seems to me that this same kind of relationship can exist between libraries in other disciplines and the GPO, to ensure that the libraries understand their role and requirements in preserving information as it becomes increasingly digital as it emanates from the Government Printing Office.

So, yes, I think that not only is it scalable, it has to be scalable, because we have to have arrangements in place for dealing with the information coming to us through the depository program in increasingly digital form. What is happening to it, you might ask, as it ages? And so, it's not really a question of shall we scale it or shan't we, it's a matter of needing to work out the arrangements across the nation for that program, in addition, perhaps, to some specialized programs, the likes of which we just described to you.

MS. BUTLER: Are there other questions for any of our panelists in this session? Seeing none, I would like you to join me in thanking all of our program speakers. I also want to say a special word of thanks to Mary Case and Jaia Barrett for their fine staff work in helping us put together this program this morning and for the energy and wonderful ideas they have contributed to the ARL Preservation Committee.

Thank you. We are adjourned.

PROGRAM SESSION I  
PART II

Convened by Marianne Scott  
ARL Preservation Committee

Good afternoon, everyone. Welcome back to the concluding panel and discussion on the theme of Preservation of Digital Information. As you can tell from the program, the ARL Preservation Committee is engaged in an effort to determine how the research library community could best address the issues that we are confronting in our libraries as we determine how to allocate resources to preserve digital material. And complex issues they are, as we heard this morning.

Today's program and the discussions we will have later this afternoon will help contribute to a sharpening of the Committee's definition of future ARL strategies in the area of preservation of digital information. ARL's work in preservation is undertaken in collaboration with a number of other organizations, especially the Commission on Preservation and Access and its new host the Council on Library and Information Resources (CLIR).

We next hear from two key individuals from CLIR, Deanna Marcum and Don Waters. Deanna Marcum is President of CLIR and certainly, to this audience, needs no introduction. She has agreed to describe briefly the community response to the important CPA/RLG report, *Preserving Digital Information* (available at <http://www.rlg.org/ArchTF/>).

Our next speaker, Don Waters, is presently the Director of the Digital Library Federation of the Council of Library and Information Resources. Previously, he held several positions at Yale University, including Head of the Library Systems Office and, most recently, Associate University Librarian.

Don co-chaired the CPA/RLG task force on the archiving of digital information. He is also an anthropologist by training, with a masters and a Ph.D. degree from Yale.

We welcome both our speakers.

## RESPONSES TO THE RLG/CPA REPORT

Deanna Marcum, President  
*Council on Library and Information Resources*

Thank you. I have a very limited amount of time to talk to you today, so I am going to be, I hope, uncharacteristically blunt. I hope you will forgive me for that.

*Preserving Digital Information*, published jointly by the Research Libraries Group and the then Commission of Preservation and Access, received high praise when it was released in May 1996. The reviews were uniformly laudatory. In fact, the publication just won the Society of American Archivists' Preservation Publication of the Year Award. It is cited in virtually every article about digital preservation that has been published since the first draft of that paper appeared in 1995, and it is available on the Web at <<http://www.rlg.org/ArchTF/>>.

While everyone agrees that it is an eloquent presentation of the issues, I must ask: Does anyone agree with the fundamental assumptions that underlie all of the recommendations in that report? I have heard almost no discussion on two of those assumptions, listed at the beginning of the report. I would like to paraphrase them for you. I would like ARL to consider these assumptions.

The first of the two is that a process of certification for digital archives is needed to create an overall climate of trust about the prospects of preserving digital information. The second assumption is that certified digital archives must have the right and accept the duty to exercise an aggressive rescue function as a fail-safe mechanism for preserving valuable digital information that is in jeopardy of destruction, neglect, or abandonment by its current owner.

I revisit these assumptions with you this afternoon, for your reaction to them will determine how we should proceed as a community of research libraries, committed to preserving the intellectual record.

Is it possible, at a time when there are great pressures to make no distinctions among research libraries, to support a few of them as digital repositories for the common good? Now, the question that comes up always is, "Who will establish the criteria?" This seems to be the question that stops progress. How can we assure that, in addition to being a traditional research library, an institution also meets the criteria for being a digital archive? Can we organize ourselves to monitor information that is born digitally, to assure that it is available over time?

We can no doubt agree on one fundamental truth: That a primary role of research libraries is to preserve information that supports research and teaching for as far into the future as possible. We have not understood that truth to apply only to print on paper. And this is agreed upon, our greatest challenge is to figure out how we can meet our obligations.

The ARL Preservation Committee endorsed the RLG/CPA report, and this meeting did, in fact, grow out of a discussion of that report. However, ARL has not yet commented on the recommendations that were listed at the end of that report, and certainly not on those two fundamental assumptions. So, allow me to put the question to you very directly: Does ARL wish to become an organization that specifies the standards, criteria, and mechanisms needed to certify repositories of digital information as archives, as called for in recommendation number seven? Does ARL wish to take on the assignment of preparing a white paper on the legal and institutional foundations needed for the development of effective, fail-safe mechanisms to support the aggressive rescue function, to make sure that endangered digital information is protected?

To me, it seems essential that ARL answer these questions. What I have said to the Preservation Committee is, if the word "certification" is what is getting in the way, perhaps we can find another word. But, I would like very much to see ARL consider what role it will play in specifying just what we mean when we say that we are going to preserve digital information. And how will we know it is being done? As many speakers have pointed out, we can't see it, so we must have other means of assuring preservation over time.

I also want to let you know what CLIR is doing, as a result of this report.

We had a very good discussion with the CLIR board about the next steps we should take, and we decided that we could add to the information base about digital archiving. Perhaps that is the most important role we can play. We have done two things.

We convened our technical advisory committee, and asked them to look at the recommendations and let us know if they were technically feasible. They endorsed the report and urged us to raise money to support pilot projects. We have tried to do that, and we have already begun to fund a few of them. We will do as much of that as possible.

The CLIR board also concluded that we should take a closer look at the digital archiving models that are now in place, and from them try to make some assessment of what is working, what isn't, under what conditions, and for what kinds of materials.

As Meredith mentioned to you this morning, we have hired Jeff Rothenberg as a consultant to work with us in looking at the various models of digital archiving and to begin to describe the existing conditions of certain kinds of materials. We hope that from that project we will be able to develop a checklist of what any organization will want to consider when it is thinking of becoming a repository for digital information.

We have talked to the ARL Preservation Committee about serving as an informal advisory group for that project, and the Committee has agreed to do so. We are very pleased about it. And we will be talking with ARL, through the Preservation Committee, about the project as it develops.

Thank you very much.



STEPS TOWARD A SYSTEM OF DIGITAL ARCHIVES:  
SOME TECHNOLOGICAL, POLITICAL, AND ECONOMIC CONSIDERATIONS

THE REARRANGING EFFECT

Donald J. Waters, Director, Digital Library Federation  
*Council on Library and Information Resources*

The use of technologies, including the use of those that underlie emerging digital libraries, are subject to what historian Edward Tenner calls a rearranging effect. Malcolm Gladwell called attention to the phenomenon in a commentary earlier this year in the *New Yorker*. He observed that anyone standing on a city subway platform on a hot summer day experiences a rearranging effect.

Subway platforms seem as if they ought to be cool places, since they are underground and are shielded from the sun. Actually, they're anything but. Come summer, they can be as much as ten degrees hotter than the street above, in part because the air-conditioners inside subway cars pump out so much hot air that they turn the rest of the subway system into an oven. In other words, we need air-conditioners on subway cars because air-conditioners on subway cars have made stations so hot that subway cars need to be air-conditioned. It's a bit like the definition the Viennese writer Karl Kraus famously gave of psychoanalysis: "the disease of which it purports to be the cure."

Not all technological advances result in this kind of problem, of course. But it happens often enough so that when someone comes along making spectacular claims on behalf of a new technology, it's worth asking whether that technology really solves the problem or simply rearranges the hot air from the car to the platform (Gladwell 1997: 7).

And so it is with digital library technologies. Popular rhetoric attributes considerable transforming effects to them. Yet, digital information and the technologies on which they depend are extremely fragile. Their fragility makes it highly uncertain that digital libraries can endure over time and it makes one wonder about the durability of their supposed benefits. Does the emergence of digital libraries, rather than helping to transform research, learning, and other forms of scholarly communication, promise merely to rearrange the hot air from car to platform, shifting the balance of information services from enduring to immediate access? If such a rearranging effect is indeed at work, then systems of scholarly communication will have to pay dearly to compensate for the loss of the information that they generate and on which the quality of future scholarship depends. At a time when higher education is already under fire for, among other things, its soaring costs, we must avoid such a perilous outcome. But how?

We have heard this morning and, just now, from Deanna, a variety of steps that we need to take, can take, or are taking to preserve digital information and to avoid the rearranging effect in digital libraries. In the next few minutes, I want to focus your attention specifically on the argument of the Task Force on the Archiving of Digital Information that the problem of preserving digital information for the future is not only—or even primarily—a problem of fine-tuning a narrow set of technical variables. Rather, in the words of the Task Force report, it is a problem of organizing ourselves over time and as a society to maneuver effectively in a digital landscape. It is a problem of building—almost from scratch—the various systematic supports, or "deep infrastructure," that will enable us to tame our anxieties and move our cultural records naturally and confidently into the future (Task Force 1996: 6).

## The Challenge of Creating Deep Infrastructure

In thinking about the steps necessary to build a "deep infrastructure," or system for digital archiving, I suggest we start with a series of assumptions. First, I am assuming that the pressures to transform systems of scholarly communications do not arise solely, or even primarily, from technological imperatives. Rather, new digital technologies give us tools with which to respond to profound political and social impulses in the emerging knowledge economy. Peter Drucker (1993) and others have identified and analyzed these impulses. Our success in responding to them depends on how astute we are in identifying and understanding the key organizing principles of the knowledge economy and then in designing appropriate means of applying the technologies as part of its overall development.

Second, I assume that one of the key organizing principles of the knowledge economy is that libraries play an essential preservation role in the pursuit of knowledge. Libraries can, of course, take a variety of organizational forms, including those that individuals manage for their own personal use, as well as more elaborate entities such as public, corporate, academic, and research libraries. The timeframe over which libraries preserve works of knowledge can also vary from the relatively short span of an individual's personal library to the centuries covered by a large national or university research library. Regardless of their particular form or the timeframe of their preservation objective, what libraries preserve is the integrity of the works they contain so that these works are reliably and economically available to the individuals or communities whose pursuits of knowledge they support. Depending on their scale, libraries preserve the use and usability of works of knowledge through the more or less elaborate management of a set of operating features such as the selection of particular works for the collection, as well as their acquisition, cataloging, storage, and circulation.

As a new variant of the form, digital libraries manage collections of digital works. Like libraries of other kinds, digital libraries must organize themselves to preserve the integrity of the works they manage for use over time by the individuals or communities that they support in the overall knowledge economy. However, the fragile nature and other distinctive features of digital information give special shape to the essential preservation function of digital libraries and to the core features of their operations.

My third assumption is that preservation means different things to different people. A significant challenge of the digital environment is for communities of common interest to ensure that the information crucial to their pursuits of knowledge endures. One can make great sense of the apparent chaos of the World Wide Web by focusing on the various, and sometimes interlocked, communities of interest that have found a home there (see, for example, Hagel and Armstrong 1997, and Hof 1997). So, too, one can chart the building of the "deep infrastructure" needed to preserve the use and usability of digital information in the emerging knowledge economy by distinguishing and tracking the development of the various communities of interest in the pursuit of knowledge. These communities differ, of course, and are even changing in the nature and subjects of their common interests, in their uses of digital information, and in the corresponding development of their digital libraries. However, for our purposes here, let us focus on the uses of digital libraries in the communities we know best, namely those embraced by research universities.

Let us also remember the distinctive characteristics of digital information. One can readily copy digital information without changing the original and one can transmit it widely over networks. These and other features have a variety of implications, but among other things they mean that the use and preservation of digital information are subject to economies of scale and to organization in digital libraries that differ from those in libraries of paper-based materials. Many of the functional attributes—the need for circulation, cataloging, and reference, for example—are the same. However, the division of labor to realize digital economies of scale can and almost certainly will result in digital libraries that effectively manage their collections by allocating functional responsibilities for their operation largely outside their organization, in ways that are quite different from how we are presently accustomed to seeing them. Indeed, if we look closely at the research university, we can see that the political, economic, and other

conditions that shape the use of digital information in this community of our common interest are giving rise, before our eyes, to new and distinctive kinds of library organizations.

### Developing the Deep Infrastructure for Digital Archiving

To illustrate how the "deep infrastructure" for the enduring use of digital libraries is developing in and affecting the research university community—and our research libraries—I focus on three specific issues. First, I examine the distributed organization of repositories of digital information, which must be the locus of any digital preservation activity. Second, I turn to the dependence on contract, rather than copyright law, as the basis for using and preserving the information in these repositories. Third, I conclude by reviewing the evolution of integrated systems of discovery and retrieval, which must support the information that we aim to preserve.

### Distributed Repositories

Two years ago, when I last talked to you about these matters, I suggested that the problems in the scholarly communication process, which appear as a spiral of escalating prices and journal cancellations are, at least in large part, problems of ensuring the durability of the electronic record of knowledge (see Waters 1995). In increasing numbers, scholarly societies, such as those in high energy physics, astrophysics, engineering, and computing, are recognizing the dis-economies of the present system and have accepted responsibility for setting up and maintaining electronic channels of communication for their disciplines. Conventional publishers, such as Elsevier, Springer-Verlag, and Academic Press, are also opening electronic channels for disseminating their publications. Colleges and universities, usually through the agency of the library, or through consortiums of libraries acting as buying clubs, ensure that the information in these newly opened channels reach the researchers and students in their institutions.

The dynamics of this shift from conventional printed publication to the electronic medium raises a number of intriguing issues. Not only is the transition incomplete, but it is highly uneven across disciplines, meaning that the scholarly community is today experiencing significant transition costs (see Okerson 1995). Stakeholders maintain both print and electronic streams of publication as they decide when to shift permanently to the electronic medium. The unevenness of the transition, however, is also a positive signal, at least in this case, because there is tremendous competitive pressure to take advantage of the benefits of the electronic medium. The differences in skill and products among the scholarly societies and publishers provide an intense learning environment, which under substantial competitive pressure generates a highly productive "leap-frog" effect. Each new investment builds on known solutions, but also advances the field by offering competitive solutions to problems still remaining. The cumulative result is a rapid, sometimes disorienting, advance in the quality and reliability of the electronic systems.

Given the rapidity of the changes underway, the dust may not settle for some time on the transition from print-based to electronic scholarly communication. Still, the transition is far enough along in many disciplines to discern that there is demonstrably little economic benefit for libraries each to manage the costly logistics of disk storage, software compatibilities, and forward migration of scholarly works that publishers distribute to them in electronic form (see, for example, Task Force 1996: 29-35). Instead, economies of scale in the electronic medium favor a model for the management of the scholarly record over time that is network-based and centers the responsibility, at least initially, with creators, providers and publishers. Thus, scholarly societies and publishers are today creating and will presumably manage over time—either by themselves or via an outsourced repository management agent—their own electronic repositories of scholarly works. From these repositories, they distribute virtual copies to users over networks using standard browser software.

Organizing repositories in this way—closer to the point of the creation of electronic works than to the point of their use—vests long-term care of the works with those who, at least initially, care most about them. Such an organization also opens numerous possibilities for redesigning the scholarly publication process so that labor in tasks that are currently bundled in the process may be divided, the quality of work

in these tasks improved and the overall costs of the process reduced. As many of you know, Paul Ginsparg has, from his considerable experience in managing the pre-print archives in high energy physics, imagined a network of discipline-based repositories for which scholarly societies are responsible and into which scholars deposit their works as they complete them. The repositories could help simplify at least two separate components of the complex publication process. Editors could manage the certification of quality through peer review by simply pointing reviewers to works rather than physically distributing them. Similarly, they could simplify the publication process itself by compiling pointers to the network of repositories for the works that they wish to disseminate to the targeted audiences they serve, rather than repackaging those works (Ginsparg 1997). Further development of these processes might even suggest that certification of the quality of scholarly works would be more effectively and efficiently managed separately from, rather than as part of, the publication stream that leads to the dissemination of works to targeted audiences.

Organizing repositories close to the point of the creation of scholarly works has significant implications not only for the publication process but also for the preservation of digital information in digital archives. Some libraries might position themselves to serve as mirror sites for the electronic repositories of publishers. Others might contract with scholarly societies, as Stanford University's High Wire Press has done, to provide repository and other publication services. Still others might follow the lead of the Mellon Foundation's JSTOR and position themselves to serve as a fail-safe repository for back issue works that publishers themselves no longer wish to manage. Generally, however, economies of scale in the storage and accessibility of digital works mean that the challenge of collection management in digital libraries will be to preserve the use and usability of works that are stored not locally and under the direct control of the digital library, but remotely and under the control of various and widely distributed agents. In the community of research universities, libraries are meeting that challenge on two major fronts: by developing licenses for digital works and by redesigning systems of discovery and retrieval.

### Dependence on Contract

The common means today for libraries to acquire the rights to use scholarly works in digital form is to execute a detailed contract, or license. For owners and providers, the general protections that copyright law presently affords in the sale of intellectual property seem completely inadequate in the digital realm. There, copying is technically so easy that it seems to put at great risk of loss the rights that owners have in their property. Thus, in the application of contract law, they seek directly from users the greater protections they feel they need.

Libraries, on the other hand, have regarded the resort to licensing suspiciously. They have viewed it as an attempt to subvert or sidestep the general protections, such as fair use, which copyright law affords to users of intellectual property in the interest of promoting "the progress of science and the useful arts." Indeed, in the worst case, licensing may actually constrain the rights of users in substantial ways. For example, if libraries terminate a license and the provider withdraws previously licensed information, the prior investment becomes worthless and the user experiences a loss of the record of knowledge. Licenses may also extend the liability of users in the case of misuse, while limiting penalties for the provider if the information products fail to endure over time or otherwise to perform as advertised (see Okerson 1996a: 68-69).

Although licenses for the use of digital works appear to put libraries and their users at a disadvantage, growing experience of both providers and libraries in creating them suggests that contracts are not only appropriate to present circumstances in the digital arena, but can actually benefit both parties. Contracts provide the means for divergent interests to meet in times of uncertainty, high risk, and great promise. By engaging in the negotiation of content licenses, publishers and libraries are not just forging agreements, they are crafting the durable and trustworthy relationships that are so necessary to sustain the electronic information products they both need. In their contract-making, publishers and libraries are, as Ann Okerson has put it so well, "making [their] own peace, thoughtfully and responsibly, one step at a time" (Okerson 1996b).



When publishers and libraries are as unsure of one another as they are today in the digital environment, one way that licenses enable them to "make peace" is to define formally and legally who the parties to the agreement are. Licenses also enable the parties to specify their mutual responsibilities and provide for ways to settle disputes, should they arise. A growing trend in the creation of content licenses is for libraries joined by regional affiliation or other common features to define themselves as a consortium or buying club in relation to a publisher for the purpose of acquiring a license to use a digital work or set of works. Such an arrangement benefits publishers because it reduces the overhead of marketing products separately to each institution. For the libraries, the benefits include discounts on the purchase price, or inclusion in the purchase of more works for all the institutions than any institution acting separately could have afforded. Perhaps more importantly, licenses that define groups of libraries as buying clubs are beneficial because they serve to align library interests where previously there was disunity. Such an alignment is especially critical in an environment in which repositories of digital information are widely distributed and under external control. To assert any influence over the information products, libraries must be able to act in concert with themselves and the publishers. Buying clubs provide libraries an identity, defined by contract, for such concerted action.

Content licenses also provide a way for libraries and publishers to "make peace" with one another when the stakes are high. The retooling necessary to traffic in electronic, rather than print, publications is expensive for both parties. Publishers suddenly need to invest in systems engineering of processes that have been relatively stable for years and they have to provide annual budgets for research and development where previously they had little or none. Research libraries, who generally have had systems engineers on staff for years, regard with concern the relative naiveté of publishers. Libraries worry about the five to ten percent of their collection budgets that they currently have at risk in electronic information.

Publishers seek to limit their risk under contract by defining and limiting the community of users who can use the electronic information they provide to libraries. The categories of authorized users generally tend to exclude alumni and corporate partners in the research university community, the very categories to which these institutions are looking to extend their services. Libraries, however, focus in the development of content licenses on what authorized categories of users can do. Can they make copies? On what terms can they make copies for colleagues or readers who do not have a license to this particular resource? How can the resource be used in the rapidly evolving world of classroom access? Libraries are finding that, within the defined categories of users, the answers to these questions lead both parties back to the provisions of fair use and other rights generally afforded under copyright (*ibid.*).

Finally, content licenses afford a way, when the need and promise is as great as it is in the emerging knowledge economy, for libraries and publishers together to create and develop new markets and ways of conducting business. They provide a space to experiment and explore, affording a pragmatic way to achieve change and to build the necessary infrastructure for improving the quality, lowering the cost, and expanding the reach of education in research universities. One of the areas most in need of such attention is how new electronic information products integrate into the larger mix of resources that digital libraries provide their users. In the present jargon, the question is how do electronic systems of discovery and retrieval "inter-operate."

### **Systems of Discovery and Retrieval.**

The information that digital libraries in research universities are licensing for use from various and distributed repositories is composed of works that have diverse document and data structures and depend on various search engines and vocabularies for access. The heterogeneity of the information in structure and form significantly challenges users in their ability to identify, retrieve, and discern the quality of needed information. Designing and constructing systems that lower the barriers for discovery and retrieval of these heterogeneous materials is essential for the enduring use of digital libraries and is, as more and more materials become available to members of the research university communities, an increasingly urgent task.

To reliably stimulate the attention of users over time, information from a distributed set of repositories must integrate into the information space of a digital library. Such a space typically consists of four areas: a catalog of the works selected for the library or set of libraries; a series of index structures that describe works in greater detail than the catalog or in ways that the catalog does not permit; the works themselves; and tools with which to use or analyze the works.

The library catalog describes and organizes at either an item or collection level much of the material selected for a library and judged to be most pertinent to the community of users it serves. MARC is the standard interchange format in which catalog records are represented electronically. Concern about the complexity of the MARC record and its inability to represent complex hierarchical and certain other kinds of relationships among source works has led in recent years to the development of the so-called "core" record and the exploration of alternatives such as the Dublin Core and the use of SGML for tagging fields. MARC has proved remarkably durable, however. The development of the 856 field in the MARC record, which links to related objects in digital form, the Z39.50 protocol, and World Wide Web interfaces to the protocol, have made it possible for MARC-based library catalogs to integrate seamlessly into a networked environment.

Although crucial, library catalogs simply are not sufficient for digital libraries to provide intellectual access to the world of knowledge. Traditional abstract and index files have long been available electronically to provide detailed information about the contents of journals, and providers are moving quickly to place them in the networked environment. Significant work recently on the Encoded Archival Description (EAD) has produced a standard method for detailed, online descriptions of archival collections. Similarly, work is progressing under the auspices of the Inter-university Consortium for Political and Social Research (ICPSR) for a standard means of encoding the data dictionaries, or codebooks, for data files. Less advanced, but now moving rapidly, are efforts to organize the methods for describing and classifying visual resources, such as photographs and works of art. Finally, inverted indices for full-text documents and the means of searching them are also figuring prominently in the digital landscape.

As catalogs and index structures for various types of work—books, serials, archives, data files and visual resources—all appear on-line in a distributed networked environment, so, too, are the sources, or digitized surrogates of them, appearing there in greater quantities. In some cases, the library may have licensed the sources; in other cases, it may own and hold them locally. In addition, tools for on-line textual, data, and image analysis and manipulation also exist online and have become increasingly sophisticated in function.

Given the short span of time since the invention of the World Wide Web, it is almost miraculous that so many of these components—catalogs, index structures, sources, and tools—now live on the Web and that together they comprise a fully navigable information space for discovery, retrieval, and use. One can, for example, search a catalog, find a record, and link from it through the Web directly to the source book. One can also search, find a catalog record for an archival collection, link to the EAD for collection, traverse the finding aid and then link again to a surrogate of a photograph contained in the collection. Alternatively, one could skip the catalog search and start directly by searching an EAD or collection of them. Perhaps more complex is the example of student searching the catalog, finding a data file of survey results, linking to the relevant online codebook, and using it to extract a subset of data for analysis using a favorite statistics program.

Experiencing for the first time an integrated online information space for discovery, retrieval, and use in these ways can leave one breathless with excitement. However, it is mostly an excitement of anticipating a promising future rather than of having it realized. As publishers deploy their repositories into this online space, they are learning about weaknesses in design and how to correct them. For example, some publishers provide journal titles that are directly addressable from a catalog or other index structure. Many, however, do not, and this deficiency in effect cripples the navigation mechanism for the reader who cannot move from a catalog record or journal index directly to the title. Publishers, such as Academic Press,

in fact designed their system to force the reader upon entry to it to initiate another search to find the title, regardless of the information the reader brings to the repository from other searches elsewhere.

A design problem like this one clearly prevents a body of work from being well integrated into a prevailing information space, and the appropriate solutions are not always obvious. The development of supporting mechanisms, such as standard protocols for repository access and facilities for searching across a multitude of index structures, would facilitate such integration and is presently the subject of sustained research on agent architectures at the University of Michigan and at Stanford University under the auspices of the National Science Foundation's Digital Library Initiative. Another hot area of research and development is how to support dynamic links among citations in electronic works through standard document identifiers, such as the SICI, and other means. In the end, however, the success of such research and of its eventual implementation cannot be measured solely by how well or poorly it supports integrated systems of discovery and retrieval. Rather, the measure is against a higher standard: Does it lower, rather than raise, the barriers to effective use of digital libraries by those in the communities they serve? And does it thereby fulfill the essential library goal of preserving for future members of those communities the use and usability of the record of knowledge?

## Conclusion

Will Rogers is alleged once to have said that a revolution is like one cocktail—it just gets you organized for the next. The unfolding of the knowledge economy in what Peter Drucker calls post-capitalist society is not the first revolution in the organization of knowledge. How well did those earlier cocktails organize us for this one? Are we just drunk now with hype about the significance of current developments? To return to the question with which I opened: Are we simply moving hot air from car to platform?

The development of the digital library in all its aspects—technical, economic, political, and social—amounts to nothing if it does not generate literate citizens capable of engaging sensibly and productively in the discourse of the world in which they live. The literate citizen in the emerging knowledge economy is smart about how to use information and has it ready at hand or, in the current jargon, at one's desktop. Allow me now to close by offering a description of such a desktop.

*With this desk a man absolutely has no excuse for slovenly habits in the disposal of his numerous papers, and the man of method may here realize that pleasure and comfort which is only to be attained in the verification of the maxim: a place for everything and everything in its place. The operator having arranged and classified his books, papers, etc., seats himself for business at the writing table and realizes at once that he is master of the situation. Every portion of his desk is accessible without change of position and all immediately before the eye. Here he discovers that perfect system and order can be attained; confusion avoided; time saved and vexation spared; dispatch in the transaction of business facilitated and peace of mind promoted in the daily routine of business (quoted in Cooper 1983).*

Don't you want one of these? This advertisement appeared in 1880 and describes the Wooton Patent Desk. The desk is a lovely piece of furniture but, as Donald Norman points out in *Things That Make Us Smart*, it proved for a variety of reasons to be relatively useless (Norman 1993: 158-159). It did not spare vexations. It created more and worse ones.

As we aspire to the high purpose of preserving the use and usability of the record of knowledge in digital form, and as our technical, political, economic, and social strategies for doing so lead us to create and maintain digital libraries, let us resolve at least to learn from one past drunken mistake and avoid the fabrication of more Wooton Patent Desks.

## References

Bronson, Po. 1996. "George Gilder." *Wired* 4.03 (Mar.): 122-126, 186-195.



- Cooper, Deborah. 1983. "Evolution of Wooton Patent Desks." In *Wooton Patent Desks: A Place for Everything and Everything in its Place*, edited by J. Camille Showalter and Janice Driesbach. Indianapolis and Oakland: Indiana State Museum and the Oakland Museum.
- Gilder, George. 1995. "Angst and Awe on the Internet." *Forbes ASAP* (4 Dec.). Available at: <<http://homepage.seas.upenn.edu/~gajl/ggindex.html>>.
- Gladstone, Malcolm. 1997. "Chip Thrills." *New Yorker* (20 Jan.): 7-8.
- Drucker, Peter. 1993. *Post-Capitalist Society*. New York: HarperBusiness.
- Ginsparg, Paul. 1997. "Winners and Losers in the Global Research Village." Paper presented at the International Conference of the Academia Europaea on The Impact of Electronic Publishing on the Academic Community. Stockholm, Sweden, April 16-20.
- Graham, Peter. 1995. "Requirements for the Digital Research Library." *College and Research Libraries* 56(4): 331-339.
- Grauer, Neil. 1995. *Remember Laughter: A Life of James Thurber*. Lincoln: University of Nebraska Press.
- Hagel, John and Arthur Armstrong. 1997. *Net Gain: Expanding Markets Through Virtual Communities*. Cambridge: Harvard Business School Press.
- Hof, Robert. 1997. "Internet Communities." *Business Week* (5 May): 64-80.
- Lanham, Richard A. 1993. *The Electronic Word: Democracy, Technology and the Arts*. Chicago: The University of Chicago Press.
- Lehmann, Klaus-Dieter. 1996. "Making the Transitory Permanent: The Intellectual Heritage in a Digitized World of Knowledge." *Daedalus* 125(4): 307-329.
- Lynch, Clifford A. 1995. "The Technological Framework for Library Planning in the Next Decade." In "Information Technology and the Remaking of the University Library," edited by Beverly P. Lynch, *New Directions for Higher Education* 90 (Summer), 93-106. San Francisco: Jossey-Bass Publishers.
- National Research Council. 1995(a). *Preserving Scientific Data on Our Physical Universe: A New Strategy for Archiving the Nation's Scientific Information Resources*. Washington, D.C.: National Academy Press.
- National Research Council. 1995(b). *Study on the Long-Term Retention of Selected Scientific and Technical Records of the Federal Government: Working Papers*. Washington, D.C.: National Academy Press.
- Norman, Donald. 1988. *The Psychology of Everyday Things*. New York: Basic Books, Inc.
- Norman, Donald. 1993. *Things That Make Us Smart: Defending Human Attributes in the Age of the Machine*. Reading, MA: Addison-Wesley Publishing Co.
- Okerson, Ann. 1995. "Can We Afford Digital Information? Libraries? An Early Assessment of Economic Prospects for Digital Publications." In *The Prospect of Digital Library*, KIT International Roundtable for Library and Information Science, 9-10 Nov., 1995. The Japan Foundation: Library Center, Kanazawa Institute of Technology.

- Okerson, Ann. 1996(a). "Licensing Perspectives: The Library View." Paper presented at the ARL/CNI Licensing Symposium, San Francisco, 8 Dec. Available at <<http://www.library.yale.edu/~okerson/cni-license.html>>.
- Okerson, Ann. 1996(b). "Buy or Lease? Two Models for Scholarly Information at the End (or the Beginning) of an Era." *Daedalus* 125(4): 55-76. Also available at <<http://www.library.yale.edu/~okerson/daedalus.html>>.
- Pelikan, Jarislov. 1992. *The Idea of the University: A Reexamination*. New Haven: Yale University Press.
- Task Force on Archiving of Digital Information. 1996. *Preserving Digital Information*. Report of the Task Force on Archiving of Digital Information. Washington, D.C.: Commission on Preservation and Access. Also available at <<http://www.rlg.org/ArchTF>>.
- Waters, Donald J. 1996. *Realizing Benefits from Inter-Institutional Agreements: The Implications of the Draft Report of the Task Force on Archiving of Digital Information*. Washington, D.C.: The Commission on Preservation and Access. Also available at <<http://arl.cni.org/arl/proceedings/127/waters.html>>.

70

PRESERVATION OF DIGITAL INFORMATION  
EXPERT PANEL DISCUSSION

Facilitated by

George Soete, Organizational Development Consultant  
ARL/OMS

MS. SCOTT: Many of you know George from his work conducting OMS workshops or from his previous position as an AUL for Collections at the University of California-San Diego. From reading his background paper for this meeting [later published as Transforming Libraries 5/Spec Kit 228, *Issues and Innovations in Preserving Digital Information*, December 1997], we must now also know George as a reporter and as a skillful writer.

George interviewed 21 people in 14 organizations to produce what is labeled a preliminary report. Based on those interviews and the discussions yesterday in the Preservation Committee and in this morning's program, George has some questions for us and for the panelists to start off our discussion.

MR. SOETE: Thank you, Marianne.

As Marianne suggested, the Preservation Committee yesterday gave us our marching orders: to focus on actions, to focus on next steps. My first question, then, is, "What actions should ARL take?" What seems to be reasonable, doable, and imperative that ARL do now, as a result of the discussions that have been taking place during this day and also during the last few years? What actions might individual ARL libraries take; what might you do when you get back home? What are the potential opportunities and obstacles to moving into an action mode?

I would first like to hear some ideas about what ARL can do from people at the "expert" tables.

Also, remember that there are some questions hanging in front of the group, two that Deanna presented this afternoon, and one that Dick Rockwell brought up this morning about a conference. Would any of the experts like to comment on the first item?

MR. GRAHAM: What I know of ARL is that it's not an operational organization, so that the kind of leadership it could take would be to clearly support individual libraries at home by articulating that digital preservation use continues the natural mission of the research library.

MR. LYNCH: We need to be very careful about just talking about the sort of broad, undifferentiated, digital preservation problem. There are an awful lot of different kinds of digital information, each with different problems around it.

One of the leadership roles ARL could take is helping to facilitate a community taxonomy of the different kinds of digital preservation problems and identify what the priorities are in various areas. Then, perhaps, ARL could start dealing with specific strategies for some of those priority areas, rather than leaving it to grow into a monster we can't get our hands around.

MR. SOETE: During the last break, someone mentioned to me the need for a glossary defining the various terms. What, for instance, is the distinction between digital preservation and digital archiving—if there is a distinction? I think that's following up on your idea, Cliff.

MS. BUTLER: I would like to see ARL put together a task force of members from the Information Policies Committee, the Preservation Committee, and the Scholarly Communications Committee to address the recommendations in the CPA/RLG report.

MS. DRAKE (Georgia Tech): ARL needs to build on its practice of forming partnerships with appropriate organizations, such as with scholarly publishers, all the computing organizations, and others who are parties to this. I don't think we can do it alone.

MR. SOETE: One of the messages that I clearly heard when interviewing those 21 people was the need for partnerships and collaboration, and the insistence that this can't be done alone, as a person, certainly, and not even as an institution. So, those are real words of wisdom.

(From the Audience): This builds on what Mimi just said, only on the internal level. ARL could provide us with a kit or notebook, as they have in other areas, to provide guidelines that help us to discuss this issue with the key stakeholders on campus.

(From the Audience): I think ARL ought to pull together a description of the pilot projects and white papers that are going on in our libraries. Over the last two days I have heard a lot of discussion with some great ideas, but I also know of six or eight projects that nobody has mentioned. If I know of that many, there must be more. Bringing them together would help ensure that we're not all making the same mistakes.

MR. SOETE: That was one of my great anxieties when I was doing the interviews, the fact that there must have been a lot going on out there that I was simply missing.

MR. NEAL (Johns Hopkins University): I think ARL can help in the development of appropriate standards and, secondly, guarantee that there is a national or even international legal framework, particularly in the intellectual property arena, to allow for this to happen.

MR. SHAUGHNESSY (University of Minnesota): I found myself, after reading George's paper on the plane coming in and then listening to the program this morning, just overwhelmed by the problem. It's not only preserving digital content, but, as we heard this morning, it's issues related to the software and the encapsulation of software, instructions, and the kind of hardware that will be necessary to retrieve this information in the future.

A real service that ARL could provide would be to break this problem down for us so that it doesn't appear to be so enormous. One almost feels helpless in the face of what we've heard today. If ARL could help us break this thing down into manageable chunks, we may feel that, while we can't do much about the software or the hardware issue, the computer science community can help us with that piece. The Shared Legal Capability will have to help us with the copyright issue. Some other group might have to help us with another piece, and so on. But by looking at all of these sections, we may be able to identify one that individual libraries can work on. ARL could then somehow fit these pieces together for us. Maybe this is what Cliff was getting at when he mentioned the taxonomy. Nonetheless, the problem has to be broken down into more manageable parts.

MS. HITCHINGHAM (Virginia Tech): ARL is really each and all of us, and what I would like to see is an operational project that solves one digital preservation problem for many of us. It could be something like the project news publications that many of us take. Project news gives us the opportunity to digitally preserve those publications; I don't know if anybody has actually done that yet. Many of us are wondering how to preserve the ideal journals, a much tougher problem, because you would have to negotiate with the vendor.

There are over 100 of us here. We could pitch in the money, do one project, develop the taxonomy, and look at the whole operation that has to be done. And it is "us" as ARL doing this. I would like to see a practical project, I guess.

MS. WITTENBERG (Columbia University Press): Just a follow-up on that last comment. There are publishers, including Columbia, who right now every day are trying to figure out how to address these very issues as we develop our electronic products. We are trying to set technical standards and license agreements that can solve some of the problems you're having.

At Columbia we are very lucky to work with Elaine Sloan and the staff at the Columbia library very closely. That's not the case everywhere. If there were some way to have some sort of a working group that involved some of the publishers who are developing these products right now, you might have some sort of case study where you can actually work together to solve some of these issues before they get to be problems.

MR. BILLINGS (University of Texas): I hate to be iconoclastic, but, no, no, no. Please, let's not forget that when we talk about digital libraries, we're talking about what is still a very small proportion of the responsibility that we have in terms of managing our research libraries.

It bothers me that we're taking such a turn towards this focus on digital libraries and ignoring the traditional library part. We need to build some greater congruence with what is happening digitally. We also have to keep in mind that as we deal with digital library issues we're talking about distance information, and the delivery of electronic information is quite like the interlibrary lending of physical objects. We have to look at these in the larger frame of reference.

I had this brought home to me not too long ago by my head of collections and information services, who pointed out that, in terms of useful scholarly information that's available to us right now, our libraries already contain so many millions more bytes of useful information than what we are starting to get electronically. I don't doubt that we're going to get more, but, I think that in our discussions we simply have to maintain a proper relationship when we think about mixing digital library resources and practices in with our traditional ones.

It seems to me that each one of us, I suspect, probably has already embarked on some kind of preservation activities relating to digital information. I cannot believe that there are very many of us who are not already undertaking some kind of responsibility. I'm certainly digitizing and I am going to have resources that are on servers at home and, I suspect, most of us are similarly moving into this sort of thing.

So, there's no question but that we will have distributed responsibility. I have to disagree with the point that ARL is not programmatic. But ARL is certainly a lot more programmatic than it has been historically. There certainly are some programs like this that we can do within ARL to be informative. There are strategies that we're working on, in terms of our missions and goals, and ARL is where we can bring our committees together and accomplish these things.

This will all develop over time. There is, you know, very rapid evolution going on. But I just really don't want us to run off too far from thinking about the real role that we have, as research libraries, where we must mix traditional and digital practices.

MR. BENNETT (Yale University): It's a fool's task to disagree with Harold, but I am going to be a fool. We need to pay attention to this issue for the simple reason that we don't know how to do this. We know how to do what Harold called the traditional business of libraries, because we've been in that business a very long time. We are surrounded by very talented people, who know how to do that.

Digital preservation, most particularly, is what we don't know how to do. Let's pay very close attention to this.

MR. WEDGEWORTH (University of Illinois-Urbana): I would like to reinforce what Tom Shaughnessy was saying, because I think that there is a framework missing that would be extremely helpful to the people, whether they're sophisticated in terms of their involvement in the development of digital libraries, or whether they're looking at it at a very early stage.

This development represents what may be the best opportunity that our libraries have had in a long time to work closely with other elements on our campus. But we have to be able to articulate these problems in ways that, for example, sociologists understand, that here's a new testbed for them to look at group behavior. In such a way that computer scientists, who are not normally very interested in information storage and retrieval, might see the opportunities for new avenues of research as we look beyond what is now 30-year-old technology, in terms of storage and retrieval of information.

Unless there is a framework that allows the members of ARL to pick and choose how they might move into these areas, based on the local characteristics, it will be very difficult for us to do anything as a group.

I would also say, partially in defense of Harold, and quoting one of my own faculty members, that our problem is not digital libraries, but managing two libraries in one for a fairly extended period into the future.

MR. KOBULNICKY (University of Connecticut): ARL's role can be to remind us that the reason for doing this is not to preserve things long into the future for the sake of preserving them, but to preserve things for their effective use. By preserving things in a digital environment, we extend the use of information for very valid purposes. And not only in time, but across space and to areas of the globe that can't otherwise gain access to them. It's the beginning of a model for extreme access and for sharing the development of resources that can be used by societies everywhere.

MR. HEATH (Texas A&M University): I would like to ask you to indulge me for a moment while I tell you a story that I told the Information Policies Committee last week about Internet2.

I was privileged to attend an Internet2 meeting last week. I was struck by some comparisons: there are 110 Internet2 members with \$15,000 dues, like us. There was perhaps a feeling that there were some people who should have been there but weren't, and there were some members that shouldn't have been there. Sometimes I think we share those feelings.

There were some other interesting things. To my knowledge, I was the only librarian there, other than ARL's staff. Each campus had three liaisons appointed to attend that meeting: an executive liaison, a networking liaison, and an applications liaison. No librarians. The applications liaisons were generally PIs, pushing huge data sets in a digital library environment, without knowledge or care about general standards, without issues of preservation or access to those data sets, by anyone.

That's one of the things I learned. And yet, I was kind of intimidated being there in that capacity. As I was leaving, I was taken by the elbow by one of the liaisons of the Texas group that was there, and who said to me, "We need your help. What we would like to do when we get back to Texas is to get the librarians with us and talk about applications, access, and preservation issues." That's interesting; we were not there.

We have to, as an association, get to the Internet2 table. As individual librarians, we have a role on our own campuses to find out who those liaisons are and come to know those people very well.

MR. GHERMAN (Vanderbilt University): To follow on what Tom and Bob have said, I also think that we need to think about a framework or matrix that lays out the problem, defines it more clearly, and starts to assign areas of responsibility. I don't think we can take on this all.

As an example, are data owners responsible for preserving information? If so, who are the data owners? The publishers? They have never taken on that role before, but suddenly, from what I hear, they perceive that it is theirs. It's been our role in the past, but I am not so sure it will be in the digital world, or what our role will be. We need to define that.



I know there was a technical level problem, which we heard about this morning. Whose responsibility will it be to solve that issue? Will it be the information science community, rather than the library community? Can we define that and maybe hand off certain aspects to certain communities?

Are we talking about agencies such as OCLC evolving into some type of archival agency? Or, do we need to develop new agencies, like we did in the '70s, which we call the utilities today? This matrix needs to be developed so that we can understand what part of the problem is ours so we can work on that. It goes back to Tom's point about breaking the problem down to make it solvable.

MS. COLAIANNI (National Library of Medicine): To add to that agenda item, I would like to go back to what Dick Rockwell said this morning about functionality.

One of the problems we have is that much of the digital material we're using is not static. It's linked to other materials. And, since you have a very broad user base that would contribute to thinking about this, when a digital item is preserved, is it the item with its links and the ability to maneuver through all of that? Or is it the content material in the original or initial document?

I would be very interested in a discussion of those issues. It makes one's view of the preservation of digital material quite different, depending on the answer.

MR. SOETE: Yes, indeed. I would like to hear a bit now about what some of you have to say about what individual libraries might do and what might be some of the opportunities and hindrances there.

MR. GRAHAM: I wanted to pick up on what Paul Gherman was saying about building a matrix and the planning environment, and suggest that that's what we've always done well. We need to take the cue, as I said earlier this morning, from the computing community and just do it.

That is the next step for most libraries. There are all kinds of reasons not to do it, but the overwhelming reason to do it is that we *need* to. That may mean joining a local consortium, but it may also mean starting some kind of project locally to discover where the pitfalls are and to begin the process of having our own staffs communicating with the right people at other institutions.

I think Paul is right that some planning and matrix building is necessary. But, if we wait for that, it won't work properly.

MR. MOSHER (University of Pennsylvania) : The problem resembles, metaphorically, the thing itself, that is, for networked or digital information we use various tools like the Web to make it available, making it then three-dimensional. Within that three-dimensional matrix, it seems to me less useful to talk about what each point does than talking about the webs or nets of points.

There is a group of stakeholders, as we know, who are in this, all of whom have the same issues that we're addressing here. But I notice that consortia are left out. Utilities are left out. And publications producers are left out of this formula. But, to some extent, the conference idea that came up earlier would draw together the various major stakeholders, because otherwise we're dealing with only one tiny point or dimension of what is, in fact, a web of need.

MR. SOETE: Again, the idea of partnership and collaboration. Thank you.

Other comments? Tom.

MR. SHAUGHNESSY: I love Peter's comment. I am reminded of a discussion that we had on our campus years ago about closing the card catalog because we had the OPAC up and running. A faculty member said, "I think we should take a wait-and-see attitude." Another faculty member at this same meeting said, "It is much too early to take a wait-and-see attitude."



So, I think that what we should do as individual libraries is start doing this stuff. Make small investments. Get some staff involved in this kind of activity. We will make lots of mistakes, and we will waste some money. But, I think that's exactly what we need to do and we will learn from these experiments. Get something going.

MR. SOETE: Great. I asked this question of just about everyone I interviewed, and the responses varied from getting immediately involved in some project or other, to, what Martha suggested, having some framework or vehicle document to open up discussions. One person suggested that, even if you did a selected inventory of the digital resources on your campus, you would be way ahead of most people. That might be something to do. So, there are a number of options to work with.

Thank you very much. We have gotten some good ideas on how ARL can continue in this arena and what individual members can do.

LUNCHEON SESSION  
FEDERAL RELATIONS PROGRAM

UCC ARTICLE 2B:  
SOME PRELIMINARY COMMENTS ON A NEW ISSUE FOR THE LIBRARY COMMUNITY

Robert L. Oakley, Professor  
*Georgetown University Law Center*

Good afternoon. Prue has asked me to spend a few minutes with you this afternoon to alert you to a relatively new set of issues that has come to the fore in the last several months. Unfortunately, as I begin here today, this topic is going to sound like a lot of arcane lawyer-talk, since it deals with the obviously unintelligible subject of Article 2B of the Uniform Commercial Code. But I think you will see by the end that since the real topic is the state law governing licenses, it will be of critical importance to us as librarians as we rely more and more on licenses as a mechanism for the acquisition of information.

In order to make all of this make sense, I need to first give you a little background—about the Uniform Commercial Code in general and about the way in which Uniform state laws are created and adopted. Then, I will talk a little about Article 2B and where we are now in the debate to create this new body of state law. Finally, I will review with you five issues that concern me about Article 2B as it stands today.

Okay. First, some background. What are uniform laws anyway? And how are they created? And anyway, what is the UCC?

The need for state laws that are essentially the same across all 50 states is a by-product of our federal system of government. As you know, the U.S. Constitution enumerates certain powers for the federal government and leaves everything else to the states. Some examples of things that are left to the states include family law—marriage, divorce, adoption, child custody, and so on—most criminal law, the laws pertaining to wills, trusts, and estates, and most commercial law.

In the early years of the nation, these areas and others developed largely through the common law method of individual cases resolving individual disputes and, in some cases, by statutes adopted separately by the different states. With 50 different court systems and 50 different state legislatures each taking a different approach to these different topics, it eventually became very difficult understand the law, or transact business, or settle an estate, or deal with custody issues where more than one state was involved. In any single state, the law could seem settled and rational, but when a business transaction crossed state lines or a child custody dispute involved two states, the differences in the laws made everything difficult.

As a result of these concerns, it was decided that where possible it would be a good idea to unify the laws of the 50 states in certain key areas. Since commerce between and among the 50 states was so important to the future of the nation, among the most important areas needing attention were the laws affecting the way business is conducted. These laws included the laws related to contracts, the laws related to banks and banking, and the the debtor-creditor laws of secured transactions. To make a very long story very short indeed, we eventually wound up with the Uniform Commercial Code governing all of these different types of business transactions and some others. Article 2 of the Uniform Commercial Code deals specifically with contracts for the sales of goods. Remember that: Article 2 governs contracts for the sales of goods; I'll come back to that in a minute.

Okay. If that's what the uniform law is, how do we get one? The draft laws are major efforts to harmonize the existing laws of the 50 states. They are written as a joint effort by two different groups: The American Law Institute, which is a prestigious body, primarily of scholars and legal academics, and the National Conference of Commissioners on Uniform State Laws (sometimes known as NCCUSL), which is equally prestigious and has representatives from each of the 50 states. They go through an iterative process that usually takes years to arrive at a proposed law that can be accepted by as many states as possible. The drafting is done by a committee whose work is reviewed by each of the two parent groups in turn. When everyone is in relative harmony over the draft it is finally adopted by the Commissioners as a proposed Uniform Law and sent to the states for adoption.

As you might imagine, because of the length and complexity of the process, because of the care with which it is approached, and because of the inherent prestige of the parent organizations, most state legislatures approach such proposals with a good deal of deference. As a result, many of the proposals have, in fact, been widely adopted. The Uniform Commercial Code has been adopted in all 50 states.

That, then, is the general background about the Code and how it came to be. How does Article 2B fit into all of this and where does it stand right now?

As I said a minute ago, the existing Article 2 of the Uniform Commercial Code governs contracts for the sales of goods. During the centuries over which contract law developed, most contractual transactions were just that: a sale of crops from a farmer to a store owner, a sale of raw materials to a manufacturer, a sale of a car or a house to a consumer. And in that type of economy—based on the sale of tangible objects—common law contract and eventually the Uniform Commercial Code worked just fine. But a number of years ago it began to be recognized that our economy was no longer based simply on the sales of goods; the economy was rapidly evolving into one that was highly dependent on contracts for intangibles—the creation, production, or access to information. Issues of contract formation, performance, and warranties that worked for the sale of tangible products didn't work the same way when networks were involved or when the issue related to intangibles such as the development of software or the licensing of information.

As a result, it began to be felt that a new commercial law governing such transactions was needed if the information economy was going to flourish. A drafting committee was appointed with Professor Ray Nimmer as the Reporter. The Committee began its work four or five years ago, meeting several times a year to develop the proposal for a uniform state law on the licensing of information. Since article 2 dealt with contracts for the sales of goods, it was decided to insert contracts for the licensing of information right afterward—hence the designation Article 2B.

The Information Industry has been represented at the drafting meetings throughout the process, both through their trade association, the IIA, and through the presence of a number of individual member companies. Until the last few months, however, there has been little or no representation from consumer groups or the library community.

Having worked on this legislation for several years, the drafters now believe the process is nearing a conclusion. The draft was presented to the annual meeting of the American Law Institute last spring. At that meeting, one of the members raised the question about the interface between this proposal and copyright—in other words, can copyright owners use a contract mechanism to change the balance of rights they have under the Copyright Act? After some debate, the group passed a motion to the effect that in mass market licenses (more on that concept in a minute), a contract term that is inconsistent with the applicable copyright law is void. Such a provision would make it harder for libraries or individuals to contract away their fair use rights or other rights granted under the copyright act, and I supported the motion.

When that same matter was presented to the NCCUSL meeting in July, after some sustained lobbying by the industry, the Conference respectfully asked the ALI to reconsider its decision, based on a freedom of

contract notion, and asked the drafters to remain neutral on the issue of whether or not the Copyright Act should pre-empt such contracts.

Formally, that's where matters stand at the moment. There was another drafting committee meeting in Minneapolis at the end of the last month where some of these issues were discussed at length. On the pre-emption issue, the drafters remained neutral by simply inserting a section that said, in effect, "any section of this Act that is pre-empted by any applicable federal law, is pre-empted." That doesn't get us very far, frankly, and it leaves all the other issues unresolved.

Let me then highlight for you some of the issues that I have found in the draft as it stands now. Some of these have been debated and discussed; some of them haven't.

Before I go through the issues, there is one little bit more that you need to know about what the legislation covers. We haven't talked about that yet. Really the law, like its Article 2 counterpart, does two things. First it talks about the formation of a contract—what does it take to constitute a valid agreement between the parties? Second, it supplies some default terms in case the contract is silent or omits some key elements. Such default terms might include terms about warranties, what constitutes performance of the contract, and remedies in case one of the parties defaults. I have uncovered problems in the formation section, some of the default terms, and perhaps rather significantly, the overall scope of the law. Let me walk through those concerns with you now.

The heart of the controversy around these proposals is in the section on formation. This proposed state legislation endorses the creation of what the drafters call mass market licenses. You may be familiar with shrink-wrap licenses and the discussion and controversy that has surrounded those for the last several years. Shrink-wrap licenses are the licenses that typically accompany a piece of software and state that if you open the shrink-wrap or break the seal on the software envelope you are bound by the terms of the license whether or not you had a chance to read the whole agreement. Most of the courts that have reviewed such contracts have concluded that they are not valid because they do not reflect a true meeting of the minds between the parties since the license couldn't be reviewed and agreed to before the software was purchased. One court—the seventh circuit—has endorsed such licenses, essentially because once the box was opened the purchaser could have rejected the terms of the license and taken the software back for a refund.

The 2B drafting committee has endorsed shrink-wrap licenses. Further, they have broadened the concept in recognition of the need for clickable licenses for parties to be able to create valid contracts over the internet. Calling them by the more general term mass-market licenses, they have stated that a valid manifestation of assent to a license may be found with the click of a mouse on a button that says "I agree" or other words to that effect, so long as the party had an opportunity to review the terms and whether or not they actually ever had the terms on their screen.

Such validation of shrink-wrap and other mass-market licenses is obviously fairly controversial. But the larger issue for libraries comes up in the context of whether or not there are any limits to what may be agreed to. Most of the industry believes that so long as the terms are not unconscionable—that's a pretty high standard—they should be valid. But this is where the McMannis motion and the library community come in. We have been worried that individuals and libraries might inadvertently be signing away fair use rights, interlibrary lending rights, preservation rights, or other rights granted to them under the copyright act, without even knowing it.

In general, we have tended to think that although we weren't particularly comfortable with shrink-wrap licenses, we could understand the need for clickable licenses on the internet. On the other hand, we have thought that if such licenses are necessary for electronic commerce, then people ought not to be bound to terms that remove rights they have under copyright unless they at least know that's what they are doing and agree to it. As a result, we have tried to argue that if mass market licenses are going to be validated, when a licensee gives up rights granted to them under the Copyright Act at the very least it should be called to their attention that that is what they are doing, and they should have to separately

indicate their agreement to such a term. You might think of this idea as similar to the car rental contracts where you have to specifically indicate your intention to waive certain insurance coverage. On the other side, the industry is worried that such a requirement would make the creation of such a contract unduly cumbersome. We think that's a minimal requirement if someone is giving up rights they have come to expect under copyright.

Okay, that is the first issue—mass market licenses. It is of concern to us both because it will affect the rights of our users and also because the way “mass-market” is defined in the statute, it will also apply to some library transactions. We have felt that libraries should not lose their rights through this kind of mass market license unless they are clearly on notice that that is what they are doing.

The second issue is related. Another section of the statute covers “standard form contracts.” This is the more typical way in which libraries obtain licenses today—although the clickable license is clearly the way for the future. A standard form contract is what happens now when a vendor presents you with a form and says “that’s it.” Sign. Suppose you do and you later learn that the fine print precludes your users from making fair use copies of the information in the database. Or suppose, it says that under no circumstances may any part of the information contained in this database be shared with another library. You may well be willing to agree to such a term, but we have argued that such terms must be clearly brought to the attention of the licensee so that you are not later surprised by such limitations.

Those two issues are related to the creation of the contract in the first place. The next issue is the use of the statute to validate a potentially controversial contract term. Strictly speaking, it shouldn't be necessary to have such a provision in the law since an agreement between the parties is presumptively valid unless something is unconscionable. Presumably, then, the drafters have felt that someone might argue that such a term is unconscionable, and they want to remove that possibility by validating it legislatively ahead of time.

This issue is related to first sale, on which libraries are so dependent. As you know, under the Copyright Act, the First Sale doctrine allows libraries or other owners of a copy of a work to transfer ownership or possession of the copy. It permits libraries to lend copies of things they purchase, and it permits individuals to lend or give away or even sell copies of what they have purchased.

Section 503 of the draft is very difficult to parse, but it seems to say that a contract term that precludes a transfer is valid and enforceable. Moreover, such a term could be part of a mass market license and never have come to the attention of the purchaser. As a result, an individual user might download something, pay the price, test the program and decide they can't really use it. But they can't give it away either. If it were a book, they could pass it on to a friend. Under the terms of a license, however, they may be precluded from doing so. Similarly, a library might buy an item—say a CD-ROM directory—and replace it a year later with a newer edition. If it were a book, they could sell the old one in the library booksale. A license term authorized by Section 503 would preclude the library from doing that—or even from lending the item as part of the collection.

The next issue deals with one of the default terms that are supplied by the Act. Remember now, these are terms that you will be bound by under the terms of the Act, if the contract is simply silent on the issue. You might not even be aware of it unless you were familiar with the statute. A contrary contractual provision will override the statute, as always, but you need to be aware of what is in the Act in order to know that you might want a contrary provision.

Section 614 of the draft deals specifically with “Access Contracts.” These are types of contracts that will be of great interest to libraries, since they are defined as being “a contract for electronic access to a resource containing information, a resource for processing information, a data system, or other similar facility ...” (See sec. 2B-102 (1).) That is our bread and butter. Those are the kinds of contracts we deal with now on a very regular basis.



Section 614 says first that except as otherwise provided by the contract, information obtained is free of any use restrictions except restrictions already covered by the intellectual property rights of the licensor. It goes on to say, however, the licensee may make a transitory copy for purposes of viewing or other agreed use only but may make a permanent copy of the information accessed only if authorized by the agreement. I read that and I wonder whatever happened to fair use. I wonder about library preservation. This provision makes it clear that you can't take basic copyright rights for granted. If this legislation passes and you want the ability to allow your users to make copies, or you might want to make an archival copy for preservation, you need to be sure that you look for and put such rights in your contract.

Finally, the last issue that I have been concerned about concerns the overall scope of the legislation. It is very broad indeed, maybe broader than we are comfortable with. Section 103 says that the Article covers "licenses of information and software contracts." "Information" is defined to mean "data, text, images, sounds, and works of authorship, including computer programs, databases, literary, musical or audiovisual works, motion pictures, mask works, or the like, and any intellectual property or other rights in information."

That definition is broad enough to include everything that is now covered by copyright, including books and other more traditional tangible forms of information. Under this legislation we can easily envision the licensing and shrink-wrapping of books. In the market place, that is not a very likely scenario. But it is possible. More important, perhaps, is the inclusion in this definition of the word "databases." It is clear that this bill is yet another way for the industry to find a means to protect databases. By now, it is well known that databases enjoy only limited protection under copyright, and some may not be protected at all. It may yet be that some form of database protection bill will still pass Congress, but that is by no means certain. In the meantime, the industry is clearly looking to contract law to provide them with the protection they want.

Speaking very personally, now, I am not yet sure how I feel about that. We all opposed the database protection bill last year because it was over-inclusive and did not carve out any reasonable exceptions for libraries or education. On the other hand, I do understand that the industry is investing millions of dollars in the creation of databases that are valuable to us. I have some sympathy with the notion that even while I want to assure our users of the right to access and make fair use of the information in those databases, I can understand that the creator of such a database wouldn't want to see it ripped off and distributed over the internet without further compensation to the person whose work created the database in the first place. On this issue, I can see that database owners do have a point worth considering.

I hope that gives you some familiarity with the 2B issue. I've talked a bit about uniform laws in general, article 2B in particular and highlighted five issues for your consideration: mass market licenses, standard form contracts, the impact on first sale, the impact on fair use, and the overall scope of the proposal. I'd be happy to try to answer any questions.

Thank you.

## QUESTION AND ANSWER SESSION

MR. MOSHER (University of Pennsylvania): If I understand correctly, in some of these click licenses or shrink-wrap licenses libraries, in fact, do not only abrogate their own rights under law, they abrogate the potential rights of all of their users, which is a kind of wrinkle that proves it is worth pursuing.

MR. OAKLEY: What this law does is, in effect, set up the system by which you, as one party, can agree with the producer of the information, as another party, and validate certain terms that might be within that. And, yes, you could, under those mass-market licenses, agree to abrogate the rights of your users as well as of the library.

In other words, say that I, as the library, will not permit any form of copying to take place with this database. In effect, if I know that's what I'm doing, well, I guess freedom of contract permits that. But one of the things that we need to do is make sure that those kinds of terms are specifically brought to my attention and then we can negotiate over that once I'm aware of them, and I can then say, I can't accept those terms. Or, if I have to, I want a substantially reduced price, or something.

(From the Audience): Beyond the stage where you say we are now, where there is still debate going on, at what point might this become the law of the land?

MR. OAKLEY: That's a good question. What happens next—well, the debates are ongoing. It is still with the drafting committee. We are in this interesting procedural posture where ALI has passed on a request to the drafting committee and NCCUSL has said, no, no, no. So the drafting committee has to somehow figure out what to do with that.

The next step will be a next draft, they will go back to the next annual meetings for both the ALI, which will be in April, and NCCUSL, which will be in July. If it's matured to a point where people are comfortable with it, it will then be adopted and sent out to the 50 state legislatures for their adoption. The process will then be a legislative one in the 50 states.

What this suggests is that there's an interest in trying to get it right, because, at some point, it will go to 50 state legislatures. And if you weigh in in your state legislature your voice will have some weight. People know that. So, there is a substantial interest in trying to get this to a point where people are reasonably comfortable with it because, at some point, it gets out of this essentially academic process and moves into a more political process.

Usually when these go to the state legislatures they sail through, because they come with such authority, coming from NCCUSL and ALI. But if there is some substantial group that is troubled by it, and they weigh in on that, then there could be political problems with getting it through. And nobody wants that to happen.

(From the Audience): What's the impact to the home state of the company that owns this property? If they're based in Texas, for instance, and they pass this code in Texas, does that apply to the rest of the 50 states around the country?

MR. OAKLEY: Well, that's the whole point of having a uniform law in the first place—the expectation that the law will be adopted in virtually all of the jurisdictions. As of now, the existing Uniform Commercial Code, which does not include this, has been adopted in all 50 states.

The expectation would be that if they get this to a point where it's not too controversial, then it, too, would be adopted as part of the UCC in all 50 states. And then you avoid those potential conflicts of terms. If it doesn't happen, if it's adopted in 23 jurisdictions, for example, then you still have the same



kind of conflict. You have 23 jurisdictions that agree while the other 27 are still operating under their old law, whatever that was. And, in many cases, that was not to validate shrink-wrap licenses.

This isn't, by any means, the only set of issues, by the way. A long time at the drafting meeting was spent discussing viruses, warranties. There are a lot of very knotty, difficult problems to deal with, on which the industry, software developers and so on, have very strong feelings. This one is kind of our set of issues, but there are also many other difficult ones, and a lot of people need to be made happy.

MR. WEDGEWORTH (University of Illinois-Urbana): I first want to thank you for your presentation. I also want to comment on the fact that some of us have been around long enough to know that software manufacturers originally tried to be eligible under the copyright law provision in 1976. Now it looks as if they're going back in the other direction to the states, because of the exemptions that exist for educational uses of software.

Would that be a proper interpretation of their reaction, or is this just a completely new generation of attorneys taking on a case?

MR. OAKLEY: I hadn't thought about that particular—do you have any thoughts about that, Mike?

(From the Audience): (Away from microphone.) —recent cases; Feist, in particular.

MR. OAKLEY: Yeah. I think the reason this has come up, especially some of the need to protect database issues, as Mike suggests, the Feist case, and the fact that databases, the protectability of databases is now in serious question. And that, I think, is one of the major impetuses behind this. Software developers are certainly very active participants in this process. There's no doubt about that.

It's an interesting thing to think about. I don't really have a good answer on that one, Bob.

(From the Audience): My question is, will the rest of the library community hear from you on this? Are you going to publish this some place? This is serious stuff, and the whole community needs to benefit from your vigilance.

MR. OAKLEY: I think we are beginning to get the word out. I believe that that is one reason why Prue asked me to be here today.

The group that's known as the Shared Legal Capability, the five library associations, have been engaged on this issue. And over the last several months, the word is beginning to get out. I will be reporting on this, among other things, to the Executive Board of AALL in a couple of weeks. There was a program on UCC 2B at the AALL meeting last summer, and there will be another one at next summer's meeting. I don't know what's been done with MLA, but I think the word is beginning to get out. And certainly we, who work on policy issues, are clearly engaged. Adam Eisgrau, from ALA, was present at the last drafting meeting. I was there. Someone from SLA was there. So, there are people who are now actively engaged on this issue, and will continue to be so.

The next drafting meeting is in Memphis in November. I think everyone plans to be there.

(From the Audience): In spite of where this issue goes, isn't there an ultimate guarantee, one of being sure that in any contract we sign, that we will keep the rights that we're entitled to and any others we can think of?

MR. OAKLEY: I think the key here, and it's true today and it would be true under this, as well, is that if you're presented with a license agreement, don't accept, at face value, that you have to sign it. Look at what's in it, and if you don't like what you see in it, make sure you get the terms in it that you think

should be there. I have done that with more than one vendor, gone back and said I want to be able to do this, that, or the other thing.

We're in a situation right now, where there's enough uncertainty in the marketplace that people are willing to negotiate and discuss those kinds of things with you. But you need to be vigilant about that, both with standard form contracts, which you will see on a regular basis, and also with mass-market licenses.

MR. BILLINGS (University of Texas): Move in this direction.

MR. OAKLEY: Part of it may be a need for you to try to work with the University General Counsel Office office to educate them as to what some of the issues are from your perspective. If you're identifying a database that you want to acquire in your library to make available on your campus, I would imagine that they would not be dealing with that contract unless you had first made that acquisition decision, that you want that. So, presumably you would have had an opportunity to look at that contract and transmit it to them with your recommendation, as to whether it should or shouldn't be signed, or telling them, we should try to get this, that, or the other thing incorporated into the contract.

So, if you're in that position, it will mean that you may be called upon to deal with that office more closely than in the past, to make sure you get the provisions that you want.

MS. ADLER (ARL): Bob, could you briefly describe the relationship between the UCC effort and what it means to all the work that we're doing with preservation, how that relationship is susceptible to all that other work?

MR. OAKLEY: I have been a little bit worried about all of this, because in some ways it seems to me that it may make completely irrelevant the work that we're doing on copyright reform. In other words, we're working really hard on copyright reform to try to maintain the kind of balance people have always had in the copyright law.

But, if we begin to move to a world where information is acquired more by license, more over the Internet and less by sale, where it's governed more by licenses and less by the Copyright Act, you can see how broad that language was of the scope of inclusion of what was potentially included in this bill. I have been very concerned that we may move more to a world of contract, and less to a world of copyright, as this moves through. I think that the reason for that is because of the Internet and the potential it has for distributing information electronically. And people feel the need to protect those works by some mechanism. So, I have been really worried about these contracts completely undercutting the copyright balance we've worked so hard to create.

What I have been concerned about is that the licenses will completely trump copyright balance and that we will, in fact, begin to see much of the distributed information governed by licenses rather than by contract. That's why we have to work on both of these issues. They're both difficult. They're both interrelated.

MR. LOWRY (University of Maryland): Prue's question relates directly to mine. I'd like to start with an anecdote to set the groundwork. Some years ago in another state and another job, I was signing licenses primarily for films and video, which were extremely restrictive. And, in many cases, I ended up arguing with vendors and getting them to adapt the licenses. This got to be a tiresome process.

I asked for some legal advice from system lawyers, who told me that I could not, by signing a license, surrender any right that I had under federal law. And that, in fact, I could sign as many of these as I wanted, and still have the full right to use them in the ways that we know we want to use them; that is, lend them to individual borrowers and show them in classrooms.

My question to you relates to the relationship between UCC and federal law. If indeed we have a federal law that gives us the basic rights to media and to electronic information that we've made the case for in the print world, how does the UCC, passed by individual states, override our rights under the federal law?

MR. OAKLEY: That's a complicated question; it's been the subject of enormous discussion at the drafting meeting, as a result of Professor McMannis's motion.

Some people argue that it simply cannot. That's why that section on preemption is in there. They said, if any part of this state law is preempted by federal law—in this case, federal copyright law—then it's preempted.

But the problem with that, from my perspective, is that it's not the statute that is particularly in conflict with the copyright law. I don't think this gets to the question. What's in conflict with the copyright law is the terms of the contract, not the terms of the statute. And, generally speaking, the way the copyright law has been created is it establishes a baseline of respective rights between the parties and the people are free to vary those.

For example, you're a creator whenever you write something. You own the rights to that work. You can sell that work. How do you do it? You sell it by contract. And by means of that contract, you have transferred some of your rights to someone else. That's the way copyright works. There are very few things, as stated within the Copyright Act, that you can't transfer by means of copyright. There are a few, but there are only a very few. A lot of that balance you can change by contract even now. So, it's not clear to me that the preemption issue, while it's an interesting theoretical one, gets to the essential point of what you can do by means of contract.

MR. GRAHAM (Rutgers University): You sped over one point that was increasingly disturbing to me—the potential for retrospective application of the Code, as modified, to artifactual objects. The idea of a shrink-wrap license on a new journal issued from a large publisher occurs to me and, I suspect, might occur to others. Do you believe that that could happen? Do you have any sense that the publishers are not, in fact, interested in this? And can the first-sale right of material objects be abrogated in that way?

MR. OAKLEY: The retroactive applicability of such a thing. Somehow, I don't think that would be valid.

MR. GRAHAM: Perceptually, applying it to artifactual objects, not just shrink-wrapping a journal, as an example.

MR. OAKLEY: Yes, I think that could happen. But I don't think it could affect rights that you had acquired previously. You know, you go to a bookstore and buy a book that, theoretically, could be shrink-wrapped, as well, saying that you may not quote from this for review purposes or anything of the sort. But in the marketplace, that's not very likely to happen. So, I don't see it. But, in the world in the serials that you folks deal with, where the markets are very limited, we've seen other interesting kinds of things tried from some of the publishers, in terms of differential pricing and that kind of thing, so that I wouldn't be surprised to see that kind of thing happen with some of those serials.

The other point that I wanted to get to, and it's somewhat theoretical and a little bit abstract, but it is, perhaps, important, is the question of rights—whether or not the rights you have under the Copyright Act are really rights. There's a disagreement on this. We usually argue that these are rights we have. But, in fact, the way the copyright law is set up, they are not. The copyright law declares that they are defenses to an infringement claim and are not, therefore, affirmative rights to use X, Y or Z in terms of fair use. So, it's a little hard to think of that, fair use, as a right.

The library rights are a little bit clearer. Those, too, by the way, are exceptions to rights. So, the structure of it is not as clear as we might like it to be that these are affirmative rights that we have. And so, that little piece comes into play there when you think about you can't give up rights that are given to you under the federal law. It's not clear whether they're rights or merely defenses to an infringement action. We like to say they're rights, because that's a good way of thinking about them. But, it's not so clear that that's the case.

(From the Audience): Bob, a comment on the international implications of UCC revision—

MR. OAKLEY: That's a good question. I don't think there are any international implications of the UCC revision. I think there are no direct implications, because this would be statutory change that would be adopted in the 50 states and would become the pattern for contracting throughout the United States and Canada would be doing whatever it is doing today.

To the extent that what happens in one country gets picked up on and followed in another country, it could have an impact. But they presumably would have their own process to go through. If you begin to see this set of terms as being the default way in which contracts were developed within this country, there would be some pressure for some carryover, I would think, across the border. But because these are state laws, there are no direct implications.

MR. FRIEND (University College-London): I am not sure you're right about that. I mean, I think if I click onto a license, I would be bound—

MR. OAKLEY: Oh, that's true.

MR. FRIEND: I have another question about how, in practice, we object to terms that we don't like. With paper licenses, we cross out the terms that we don't like. For example, if they say no interlibrary loans, we cross it out. What, in practice, do we do when the license is on the screen and we have to click on to say that we accept it?

MR. OAKLEY: You don't click on "I accept."

MR. FRIEND: Well, we don't get the product then?

MR. OAKLEY: That's right. And that's the bind. Presumably, you would have to look elsewhere on the website to see if there's a phone number you can call or some other way you could reach them. But, it will become a much more complex transaction if you're sensitive to these issues.

Most people never get past the screen that has the button on it. There will be a subsidiary screen that has the text, but most people don't look at that text. I think it will be crucial for us to begin to look at that text, whether or not there's a specific thing that calls your attention to the things you're giving up.

(From the Audience): This is, in a sense, a follow-up to Paul Mosher's question. Assuming a library signs a license agreement that changes some of our normal practices, fair use copying and that sort of thing, if the users violate provisions of that license, what kind of potential liabilities does that present to the library?

MR. OAKLEY: It really depends on what the contract said. If the contract said that the library will exercise due diligence to assure that users do not make copies from this database, then you will need to figure out some way to exercise due diligence, whatever that might mean. Have no printer on the computer. Have no ability to download. Install some mechanism by which you've made some effort to make it harder for your users to make copies.

If it's a more absolute kind of thing, there shall be no copying, for instance, then you obviously have a much more difficult standard to meet. I think that it would be reasonable, assuming you showed that you had exercised due diligence, done everything you could, but copies were nonetheless being made somehow, I think that would, in all likelihood, be an adequate answer to the problem.

If someone came back and told you that you should have done something else, well, then you probably would need to take those additional steps. But it puts it all in a very different kind of environment, because what you're really operating under is the agreement between you and the other party. No longer are you operating under the more universal umbrella of federal law under which we've operated for so long.

I am told that's the last question. Thank you very much.

## PROGRAM SESSION II

### COPYRIGHT MANAGEMENT INFORMATION SYSTEMS

#### INTRODUCTION

James G. Neal, Chair  
*ARL Working Group on Copyright Issues*

I would like to welcome everyone to this final program session of today's membership meeting. My name is Jim Neal, and I am Chair of the ARL Working Group on Copyright Issues.

I would like to start with a thank you to the conveners and presenters from this morning and this afternoon's sessions, who so artfully covered the various issues and concerns of both the present and the future surrounding the preservation of digital information. As we would have predicted, the possibilities, as they say, are endless.

One certainly has to be amazed at the shifting vocabulary of our profession and the rampant growth in the use of acronyms. At lunch, UCC was suddenly thrust on our lips. Now, we have CMIs and DOIs, as we turn our attention to copyright management information systems and digital object identifiers and we talk about how they will influence the management of intellectual property and, in turn, how they will impact research library operations and the work of our students and our researchers.

We have assembled a very rich diversity of perspectives by bringing together our three speakers for this afternoon. Our first speaker is Clifford Lynch. As the newly appointed bi-coastal Director of the Coalition for Networked Information (CNI), Cliff develops an agenda for CNI's 200 organizational members concerned with the use of information technology and networked information to enhance scholarship and intellectual productivity.

Cliff holds a Ph.D. in Computer Science from UC-Berkeley and is an adjunct professor at Berkeley's School of Information, Management, and Systems. In his presentation this afternoon, Cliff will examine how technology and its inherent advantages and constraints impact policy development.

Our second speaker is Julie Cohen. Julie is Assistant Professor at the University of Pittsburgh School of Law, where she teaches and writes about intellectual property (IP), with particular focus on computer IP law and the intersection of copyright, privacy, and the First Amendment in cyberspace. She received an A.B. from Harvard-Radcliffe, and her J.D. from Harvard Law School. Ms. Cohen, in her presentation today, will address the legal and policy implications of copyright management information.

Our last presenter for this program session is John Connors. John is Director of Operations and Process Engineering for Harcourt Brace Publishing Company. He represents Harcourt Brace on the Association of American Publishers' Enabling the Technology Committee and on the committee that is responsible for the digital object identifier. He also works closely with the Academic Press division, which is prototyping the use of DOI in conjunction with their electronic journal publications.

Prior to joining Harcourt Brace, John worked in the magazine and newspaper publishing industries at Time and Knight-Ridder. John will speak about industry perspectives on CMIs and DOIs.

Please join me in welcoming our speakers.



## WHEN TECHNOLOGY LEADS POLICY

Clifford Lynch, Executive Director  
*Coalition for Networked Information*

I'd like to briefly cover two specific classes of technologies: identifier systems and rights management systems. I want to put these kinds of technologies in a context, and to discuss how technology choices can actually preempt policy decisions. One of my key illustrations follows naturally from some of the points Bob Oakley made at lunch today. I didn't know he would be joining us, and I was delighted when he laid a lot of the groundwork for what I want to say. Bob made the point that some of the important practices we have historically enjoyed and counted on, to the point that we now rather glibly talk about them as "rights"—such as the right to fair use—are really not legal rights at all. Legalistically speaking, fair use is a defense that is invoked after an action. For example, if you have copied something and someone charges you with infringement, you can appeal to fair use as a defense. If you can't do something in the first place, it doesn't matter what defense or justification you might have been able to cite in support of that action, had you been able to take it. Legal defenses are *not* traditionally arguments for why you should be capable of doing something; rather, they are arguments for why you should not suffer legal consequences for having done something. Specifically, the fair use defense does not, as I understand it, in any way imply that people must have the *ability* to make copies, but only that, if they can manage to do so, then in some cases they may be able to justify or defend that action through an appeal to fair use.

Historically, in our society we have had a great deal of freedom to act; we are held accountable for our actions. This accounting, when required, takes place within a broad framework of law and human judgment and considers a very broad context of purpose, intent, and consequence. As a society, we have also developed a wide range of commercial and social practices and expectations which go far beyond any legal guarantees. And, until today, there have been many activities that have simply been impractical to monitor, regulate, or prevent. However, we are now being presented with technology options that don't necessarily allow us to take actions and be accountable for them. They also create the possibility of restructuring our commercial and social practices in radical new ways. They make it possible to control and monitor activities that have historically been impractical to address.

We have developed certain expectations, certain practices that we have so internalized that many of us may believe they are rights. But I'm not at all confident that they really are rights, in the legal sense, within the current legal framework. To take another example besides the area of fair use, I think many of us expect that we should be able to browse or read materials, without necessarily identifying ourselves or the details of our reading to the author or the publisher of those materials. (Note that we may have to go to a library or a bookstore to do this, to borrow or purchase a copy of the work in question. I'm not suggesting there's a widespread view that authors or publishers are obligated to give copies of works to any anonymous reader that expresses an interest in them.) I will leave it to wiser people to discuss the legal specifics of reading anonymously, noting only that my colleague on this panel, Julie Cohen, has written a very interesting paper on this topic. But I think that these two examples—fair use and the anonymous/unmonitored reading—illustrate areas where it's not clear that legal defenses and social and commercial traditions of practice are going to guarantee that we can carry our expectations forward into the digital world. We need to be conscious of the dichotomy between after-the-fact justifications and protections (such as protections of privacy) that one might take within a legal system and actual affirmative rights. This dichotomy underlies all of this discussion.

Let me talk first a little bit about identifier systems. Certainly, identifier systems are the foundation for many activities, ranging from rights management to citation, and I, at least, view them as an essential construct for building our whole record of social and scholarly discourse. Without the ability to



cite, we would be in very bad straits. Citations and identifiers to facilitate citations are not new concepts to the library community. We have been using them for centuries in various forms. Identifier schemes have always been very powerful applications in a fundamental way. But now there's something new in the network environment. Identifiers and citations are actionable. Somehow they are not merely passive textual data—they are something that can actually, at least potentially, transport you directly to the material they describe or cite.

This actionable system may be the only path into the network environment. If any of your workspaces are like mine, they are full of stacks of paper. You may have forgotten or lost the exact citations. But searching through those stacks of paper often uncovers that very item that you now remember you need. But did you ever lose a URL to some material? You may remember what site it's on, but often there's no way to get to the specific document without knowing the URL. Unfortunately, there's no analogous concept to serial browsing yet in many of our electronic resources, and we rarely keep stacks of personal copies scattered around our desktops. So naming and citation become just enormously powerful activities. We will have to ask a lot of contextual questions about identifiers when we start evaluating when they make sense and what their purpose will be.

In the most recent ARL newsletter I've authored a discussion about some of the digital identifier schemes that are currently under consideration. I don't want to reiterate their specifics, but I do want to highlight a few characteristics that are common to all identifier schemes and suggest that we think about them in the context of what sort of world we want and what their implications are for the management of content and the ability to use and reuse that content. There are many questions to answer: Who gets to assign identifiers? Who can make decisions about naming and about when two things are the same or different (whether they get the same identifier)? Who can create objects in a world of identifiers so they can be referenced? Do identifiers last for ever? Are they resolvable forever, or do they go away after a while, like so many URLs? How are they resolved, and how is the resolution process managed and controlled? How do you find out what the identifiers are for digital objects?

All identifier schemes need to struggle with the difficult philosophical question of exactly what they are identifying. Sameness and difference are very subtle and contextual kinds of issues. One community will say two things are the same (or close enough): all instances get the same name. Other communities will draw fine distinctions between variant forms of a similar object, and develop complex ways of identifying the differences among these variations (naming the variations). We face those kind of problems in areas as simple as differentiating hardbacked and paperbound versions of the same work. Despite their identical intellectual content, some identifier schemes distinguish their binding because it's important for sales channels.

When we move into digital environments, we have some profound questions which interrelate in rich and subtle ways to some of the questions we were talking about in the preservation and reformatting context earlier. If I have a document in two different formats, are they assigned different identifiers? Or should they all be named the same, and should choice among formats be an artifact of the transaction that I perform in order to access the document (in other words, the system just asks me if I'd like it in ASCII or PostScript)? Jeff Rothenberg showed us one way we can answer the question: When is meaning altered in a fundamental way? These are imprecise, contextual, and ultimately philosophical issues, but they are fundamental to understanding and evaluating identifier systems.

There are two final considerations about identifier systems that are not talked about much. First of all, you want some method of resolving identifiers to the objects that they identify. In the print world we have various printed directories, for example, of ISSNs. These resources have evolved into electronic databases. Most of these databases are used by libraries, suppliers to libraries, and booksellers—today more as part of the business apparatus, than as an end-user access apparatus. As identifiers are used to create electronic interdocument links and references, however, they will become an ever-larger part of the basic access apparatus that every reader will need to navigate.

We need to recognize that, as soon as a print resource turns into a database, use of that database potentially leaves electronic trails. Therefore, it's always worth asking: Who gathers those trails and what do they do with the information? What are the privacy issues? What are the statistical aggregation issues? What are the market issues? We've seen, for example, the use of citation indexes in tenure and promotion in some institutions. Suppose you actually had counts of how often materials were being read. Is that really information you want public? And, if so, under what constraints and framing? Are we going to have scholars building software robots that do nothing but reference all their articles, as many times a second as their computer can do it, to run up those counts? We need to think about this collection of issues. As we start talking about identifiers that are user-oriented, we need to think very carefully about these privacy and control issues.

Finally, I want to discuss the issue of citation. Actionable, navigable citations are one of the most attractive aspects of the networked information environment. In talking with readers, one of the things that they are most excited about is the ability to move from citation to cited work at the click of a link. Yet, I believe we need to be very careful about the use of identifiers in citation. One of the most appalling prospects that I can imagine is the introduction of a citation system whereby one needs some form of permission to cite—for example, where the identifier value for the work to be cited can only be obtained from the rightsholder, or from a third party that has a monopoly control over identifiers and their resolution. I think that strikes at the heart of everything we've come to assume about the way we do scholarship, the way we do reviews and criticism and analysis of events, and the way we conduct our discourse. Any kind of identifier system that introduces that requirement is tremendously dangerous as an underpinning for citation.

Let's go on to rights management. First, I want to observe that if you can't identify material, you can't really talk about rights management. So there's a very direct connection there.

There are two basic classes of rights management systems—or, more precisely, things that are being generally referred to as rights management systems—with which I'm familiar. (Actually, for completeness, there is a third class of systems dealing with watermarks and unauthorized copy detection, which I won't discuss further today. I would also argue these are not appropriately termed rights management systems.)

One system is built on registries about rightsholders. At its most basic level, such a registry is a database which would be indexed by various kinds of identifiers that name who holds the rights to the material and where to contact them. It may also include other information, such as standard terms and conditions and royalty rights for common uses of the material. This is useful, particularly for people in the multimedia area who want to repurpose and incorporate content into composite multimedia works. These multimedia developers are often spending more money tracking down rightsholders and clearing rights (and not necessarily in actual royalty payments to rightsholders, but in legal and detective work so they can make the payments) than they are for any other component of building multimedia works. We desperately need databases like this.

(I can't resist a small aside here. One of the charming changes that has happened fairly recently is that copyright law now passes a work into the public domain as a function of when the author died, rather than when the work was published. Before this change, you could usually make some assumptions about when a work was likely to pass into the public domain. Now, you need to hire a detective agency. Registries that include such details as whether or not the author is deceased and, if so, when, are going to be very useful. Hopefully, everybody is doing something to preserve the obituaries from their local newspapers, because we're going to want them.)

That's your basic model of one fundamental type of rights management system. And you can extend this model a bit by enabling automated transactions of certain kinds of rights clearances. For example, if you are willing to accept a standard license agreement, you can submit a payment through the system and immediately obtain authorization for 50 copies of an article for a course reader. Systems like this are

already well along. They don't prevent anything: rather, they facilitate compliance with copyright and commerce in copyrighted materials. They reduce transaction costs.

The other kind of system that falls under the general rubric of copyright management goes by names such as envelopes, secure containers, lockboxes, or Cryptolopes. Some of these are really product trademarks or perhaps service marks. For such systems, content comes integrated with (often aggressive) rights management software. For example, the content is "wrapped" in a layer of software, so that you can only print it, view it, or duplicate it by going through the wrapper software; you can only utilize the content with the permission and cooperation of the wrapper. And the wrapper can keep track of who is reading what, and how often, and can potentially not only gather data but can also report to third parties. In most variations of this theme the content is encrypted so that you cannot bypass the mediating wrapper software. In some variations the encrypted content doesn't come with its own software, but rather requires that a general-purpose trusted "reader" software environment already be installed on your machine; this reader interprets the content and its accompanying rights management data. This kind of wrapper technology is troublesome for several reasons.

The first reason is technical, and I'll only go into these issues briefly because they are complicated, because the details vary greatly from scheme to scheme, and also because many of the details of specific schemes are highly proprietary. But these comments should offer some grounds for concern. The software that is needed to make use of this wrapped content effectively "colonizes" your machine on some other agency's behalf in the name of creating a safe haven for intellectual property. It creates a "trusted" environment on your machine—protected from you—in which the wrapped intellectual property can exist and be used "safely." The words here are interesting, and revealing: "trusted" means that a third party, like a rightsholder, will trust your machine to ensure that its constraints on the content take precedence over actions you may attempt on your own machine. "Safely" means that digital objects on your own machine are safe from your own ability to perform (and, presumably, when necessary, to justify or defend) actions upon them.

In computer science this is sometimes termed a distributed "trusted system" model, the idea being that your machine forms part of a larger system with behaviors that can be depended upon by third parties no matter what the owner of each individual machine may do, and that the owners of individual machines cannot subvert the trusted system's expected behavior. We have many examples of trusted systems (of varying degrees of robustness and incorruptibility) today: for example, taxi meters, which are installed and verified by third parties, supposedly cannot be altered by the taxi driver. They serve as a fair witness to the fare for both driver and passenger. Certified weigh scales are another example. Most of the trusted systems that we are familiar with and accept are relatively passive, and record and redistribute rather than constrained information. But I would suggest that a taxi meter with a video camera that recorded passengers, their behavior and conversations, and their points of embarkation and debarkation and broadcasted this information for access to any third party willing to pay to access it would meet with considerable resistance.

Now, there are reasons why you might want to go along with the installation of a trusted system that takes over part of your computer as a condition of being able to access digital content, but I don't think anyone has thought adequately about how to audit and vet such systems. Certainly computer scientists, particularly those who work in security, will agree with me when I say that nobody really knows how to guarantee that a trusted system doesn't open up all sorts of security and privacy problems—especially if it can interact with other machines over the Net—other than empirically, that is, the system has been widely studied and tested and used and nobody has noticed a problem yet. (Remember that many of the current trusted systems being proposed for managing intellectual property are highly proprietary.)

We have seen some examples that give us a taste of the issues. There was much concern over "registration wizards" (as one large company termed them, though I think that the idea is far from unique to that company) that were shipped along with various commercial software packages. Nominally, they were intended to "serve you better" by making sure that the software vendor had enough information about

your configuration to diagnose problems, until people realized they weren't sure what these wizards were doing—uploading a copy of your configuration and all the software that you had installed to a third party (Is all of this software legal? Do you really want every body to know what software you have?), or perhaps a list of all the names of your data files, or perhaps a copy of all your documents? Paranoia, rumors, and urban legends abounded, and it became clear that most users had no idea how to figure out what such a wizard was doing, or even whom to trust to figure this out. That's a good example of what happens when there's no audit or verification mechanism for trusted systems. This is a technical issue that we can not and should not overlook.

Personally, the security and privacy issues involved in trusted systems—particularly those deployed by potentially interested parties to facilitate commerce in a competitive marketplace—make me very nervous. I'm not at all enthusiastic about having these on my machine, even though I doubt I have anything very interesting to hide. Perhaps I'm old-fashioned and paranoid: I'm not very comfortable with programs that automatically download updates, install system files without telling me in advance, have web browsers that download executable code from remote sites, or lots of other things that seem to be growing more commonplace these days.

There is another problem with these trusted systems which isn't technical. To return to my first point in this talk, these systems constrain your actions rather than permit you to be accountable for them. These systems can prevent you from making fair use of content. Remember, you don't have a *right* to fair use today. If you can make a copy of something without permission, and if the rightsholder challenges your action, you can mount a defense based upon fair use. That these systems can prevent you from using content at all in some specific ways, or from using it without paying for that use, is troublesome. It makes the issue of fair use moot, or predicates your ability to make uses (and later argue that they fall under fair use) on your ability to circumvent the trusted system. I am not optimistic that we'll see software that puts up a payment menu and then offers a button that says "Click here to bypass payment if you believe you are making a use of the content covered under fair use." Similar questions arise around the ability of readers to read anonymously.

And I don't think these content guardians, if we accept them, are necessarily going to go away gracefully as material passes into the public domain. (It would be very hard for them to determine whether 75 years have elapsed since the author of the material has died—think of the problems involved in engineering software that reliably self-destructs based on such a criteria. Simply engineering it self-destruct or become inactive at some certain date is an enormously difficult problem.) There is no right or guarantee that we can make copies of public domain material, at least as I understand it, only protection from legal action charging copyright infringement for materials that are in the public domain. (An exception is that government agencies are required to provide people with copies of some materials that are in the public domain by virtue of being created by the government.) At the core of much of the work that libraries and other social institutions do to preserve materials is the belief that we are holding these materials in trust for future generations who will be able to use them when they ultimately enter the public domain. Putting protective mechanisms on content, and making content available only when coupled with these protective mechanisms, undermines that premise in a very basic way.

I titled this talk "When Technology Leads Policy," and I hope that I have at least illustrated a few areas in which technical developments—if they find acceptance in the marketplace and if the technologies themselves prove successful—threaten to radically shift well-established social practices and expectations. As I've tried to show, the legal framework that has developed to underpin and guarantee these practices and expectations is not likely to be equal to the challenge raised by these new technical developments. Knowing that actions are justifiable or defensible means little when those actions themselves become impossible in the new technical framework. It's important that we not simply capitulate to technological determinism in the digital environment; we need to think carefully about what limitations on our actions we will accept, and perhaps even whether some of our cherished practices and expectations need to be re-codified as affirmative rights, balanced with appropriate accountability for their exercise.



## THE LEGAL AND POLICY IMPLICATIONS OF CMI

Julie E. Cohen, Assistant Professor of Law  
*University of Pittsburgh Law School*

At the outset, I think it is useful to differentiate between two things: CMI, Copyright Management Information, which is information attached to a digital file that would tell you, for example, who the author is, who owns the copyright, and what the terms of access and use are; and CMS, Copyright Management Systems, which are technological protections that enforce the terms of use. CMS can be designed pretty much to measure, meter, and charge in whatever way one wants, and can also be designed to capture reader use information for billing and other purposes, such as direct marketing, perhaps.

You have already heard, and I think it was probably immediately obvious to most of you, that, if implemented in their full capability, these systems force us to really rethink Sections 107 and 108 of the Copyright Act, the fair use and library copying privileges provisions.

It is technically true that if you look to how fair use is defined in the Copyright Act, it is defined as a defense. And that makes some practical sense, if you think about how a fair use issue might arise. It wouldn't really arise until somebody is sued for alleged infringement, and then could be used an argument to establish why the suit is meritless. The advent of CMI and CMS forces us to think about that categorization of fair use as a defense, and whether that is all that it is or that we want it to be. If you look at the case law on fair use and the history of the fair use doctrine, there is real tension, at least in United States law, between two competing visions of what fair use is.

Under one vision, it is just a mechanism that we have developed to cure market failure caused by the fact that transaction costs become high in connection with particular kinds of uses, such as private or home copying, parodies, use in classroom settings, and so on. If that is how you see fair use, then the minute there is a fairly inexpensive mechanism, such as automated CMS, to take care of all these transactions cheaply and easily, the rationale for fair use disappears.

But it is not so simple, and if you look at the entire history of the doctrine and of copyright, there is as much support for quite a different vision of fair use, a vision which one might say starts to look like an affirmative right in some circumstances. There is a very strong argument to be made for the proposition that copyright wasn't ever intended to apply to things like private home copying and private home use in the first place.

Similarly, as to the Section 108 library privileges, obviously, if you have the possibility of charging fractional royalties so that the expense of using works that one wouldn't ordinarily purchase goes down, then, if you subscribe to the "market failure" notion of what copyright is all about, it is really not so important to give libraries the ability to make copies of works for their patrons. They can just serve as information facilitators, helping patrons find their way to various works and sources of information. But the reader's actual access to that information would occur in the context of a licensing transaction between the reader and the content owner. The role of the librarian really has changed very significantly in that vision.

If you look to other aspects of the history of copyright, you might note, for example, that we have always had a requirement that works be deposited with the Library of Congress. That requirement has been modified in some respects recently, to take into account things like computer source codes that contain trade secrets. Still, by and large, we do have a deposit requirement, and implicit in that requirement is that works become publicly accessible by means of that deposit.

We have also had, implicit in the structure of our information markets, a practice that libraries follow of buying works once they are commercialized, once they are made available on the market. And so, in practice, what that has meant is that once a work was made available for general readership, people could have access to it, if not through their local library, then via interlibrary loan, or, in a case of last resort, through the Library of Congress.

Thus, I think one could fairly argue that Section 108, like Section 107, reflects a principle of access that is also present in the copyright law, as developed by our courts over time and as reflected in some aspects of the legislative history of the copyright statute.

This may all become a moot point, as Cliff Lynch told you earlier. If there is a rights management system that prohibits you from exercising your right of fair use, or prohibits you, if you are a librarian, from making a copy that your patron has requested, it is really beside the point whether you have these rights—unless, because they are affirmative rights, that also means that content owners can't make it more difficult to exercise them. That's a difficult subject.

It has been my contention in my writings in this area that if fair use is an affirmative right, then it has to be expected and it has to be legal for readers to exercise technological self-help in instances in which they would like to make fair use of published materials. One might think that a market would develop, as it did a decade and a half ago for systems to defeat copy-protection technologies to enable people to make archival copies of their software. The market might provide, for example, software tools that would help people make fair use, private home use, of reading material.

That may be a somewhat Panglossian view of the way the world should be, because currently pending in Congress is a bill sponsored in the Senate by Senator Hatch and in the House by Representative Coble to protect rights management systems against so-called "circumvention" by users and other types of people who are generally not to be trusted.

Also pending is a different bill, sponsored by Senator Ashcroft, that would focus more specifically on the act of circumvention only in cases where it would defeat a right that the copyright owner actually has, as opposed to a right that the copyright owner is trying to aggrandize through a technological protection mechanism. It is vitally important for the future of fair use and the future of library copying privileges that the library community take an interest in those two bills, or if a compromise between the two is reached, take extra care to ensure that it looks more like Ashcroft's bill than Hatch's.

To throw another acronym into the mix, at lunch you heard about UCC 2B, and we also need to think about UCC 2B and how it relates to copyright. If content providers can contract around the rights that otherwise would be established by copyright, then copyright isn't terribly relevant. It is quite simple to set up a rights management system in such a way as to structure every transaction in terms of what you could call a "click-wrap" contract, where you click on little boxes to manifest your assent to various things, such as the surrender of your fair use rights if you're an individual, or surrender of your Section 108 rights if you are a librarian.

Traditionally, courts have said that contract is not preempted by copyright, because contract has a sort of extra element to it as a matter of law. Contract is a specific relationship that is established between the two parties, whereas copyright is a right against the world, and so it is okay if two parties want to bargain to particular terms, because the rest of the world will still have the rights that copyright gives pertaining to that work.

If you think about how this might apply to standard-form click-wrap contracts, to which one must agree in order to access digital material, you may think that contract will look a bit like a right against the world, the kind of sweeping right that, in essence, constitutes private legislation. If we are to pay more



than lip service to the idea of having a federal copyright system, you might conclude that such contracts should not be able to override federal copyright rights.

This is going to be an issue that will need to be confronted in the courts and probably also in Congress, particularly if the UCC 2B is enacted by the states in the form that it is in now. It is an issue that is raised by the Ashcroft and Coble bills about protecting rights management systems against circumvention. Again, I think it's something that the library community has a clear interest in, because it is really a choice of either copyright as a supreme federal law, or doing whatever you want as a matter of contract and it doesn't matter what the copyright law says.

Let me say a little bit about the privacy half of this problem, and then a bit about what sort of approach might be taken to address the problems that I'm raising.

As Cliff has told you, clear privacy violations are threatened by systems that capture, on a very fine-grained level, details of what individuals are reading, perhaps even down to the chapter or the pages of a book, how many times they have read it, and whether they wanted to excerpt it or not. You might think that there would be some privacy law that protects against this, but, in fact, in the United States there really isn't any comprehensive source of privacy protection concerning the collection of information like this, by private entities, although there is some protection against what government entities can do.

But, other than some very specific laws—for example, we got the "Bork Bill" after we heard about what movies Judge Bork liked to rent, and there is a privacy law that governs cable TV subscriber information—other than narrow provisions like those, there really isn't anything that applies to private entities. In addition, there is the Direct Marketing Association, a quite powerful lobbying organization that for years has been maintaining that its members actually have a First Amendment right to collect and share information about what their customers buy, what their customers like, and what their customers want.

It may not trouble you much if someone knows that you bought a Black & Decker hand-held vacuum cleaner or some Tropicana orange juice, but it might trouble you more if the stored information concerns what you like to read, what ideas you consider persuasive, and, perhaps, what medical information is important to you and your family, which you have been looking for on the Web.

I have argued, and I think it is quite a legitimate argument, that one can find elements of an affirmative right to read anonymously grounded in First Amendment principles. I will just briefly explain why. The First Amendment protects against compelled speech. You don't have to recite the pledge of allegiance if you don't want to. You don't have to subscribe to opinions that you don't hold. And you don't have to speak unless you want to. Information about what you are reading and whose ideas you find persuasive is a form of communication. It tells the person who is looking at that information something about who you are, and what you believe.

If this information were widely available, it would create the kind of chilling effect that the Supreme Court has found troubling in other contexts. It would, for example, chill the exercise of HIV positive people to go and read lots of material about HIV, if they thought that their employers could go and purchase databases of who is accessing this material. I am sure you could think of many other chilling effects that might arise.

The Association of American Publishers (AAP)—though I can stand to be corrected and I hope I would be when John speaks—the AAP has not been that sensitive to privacy issues thus far. Their European counterparts have been somewhat more sensitive. The library community, in contrast, has historically been very sensitive to reader privacy, and therefore it is a topic on which they can provide valuable input. It is a subject that really hasn't had enough attention paid to it thus far, and I would hope that there would be a lot more attention paid to it before we get any kind of law enacted, defining what kind of information people can or cannot collect and share.

In closing I would just like to say a word about the title of Cliff's presentation, "When Technology Leads Policy." It should be clear by now to everybody here that these systems can pose very real threats to various things that historically we have valued very deeply. On the other hand, I think it is false to think of rights management systems as things that can only be implemented in one way. It is false to think of rights management as something that can only be accomplished by dividing works into the smallest fractional unit that is still possible to bill, while keeping the most information that is possible to keep. Those things aren't necessary, and, I think, are in fact quite the opposite.

We should be focusing our efforts not on trying to identify what kinds of measurement and data aggregation are possible, but on what kinds of functions we would like to see these systems perform from the perspective of readers, librarians, and the academic community.

For example, would we want people physically present in libraries to have a right to browse? And can we design systems that permit people to browse for, say, no more than three hours and don't allow any printing or digital copying? Would that be something that would be satisfactory, given that there is a legitimate need to protect content owners against the wholesale making of hundreds of thousands of copies of their content. That's not something that we would like to see, either.

Maybe we want to preserve the right to—and I do think it is a right—to make some private home copying. We might want to disable any digital copying functions, but still allow printing to occur on a screen by screen basis to mimic the slowness and inconvenience of a photocopy machine, while still making it possible for people to engage in some copying.

You might say that, well, now that we have this wonderful capability in our hands, why do we want to mimic the inconveniences and the frustrations of older technology? Let me just give you one example of an area in which, in fact, that has been done.

You may remember that back in 1987 there was a big stock market drop that was traced to automatic computer programs that conducted program trading for large mutual funds. These funds have enormous stock holdings, and so an automatic decision to buy or sell could have enormous repercussions, sending the market into a tailspin, all just as a matter of the automated performance of computer systems.

As a response to that problem, it was decided to actually build some lag time into the program-trading computers in order to mimic, in some degree, the slower response one would get if the system were not automated, to thereby avoid crashing the entire stock market. This example is from a slightly different area, but it is a good illustration of why it might always not be such a bad thing to have real-world capabilities, rather than virtual capabilities, operative.

So, copyright management systems need not pose a stark tradeoff between efficiency on the one hand and access and total redistribution of intellectual property to the people on the other. (Though, if it were such a tradeoff, I would favor redistribution over efficiency hands down.) There is some middle ground that we can identify, and that is really the task that lies ahead for the library community. I hope that you will accept it, because you have a voice that a lot of people will pay attention to if you make it heard.

Thank you.

## THE INDUSTRY NEED FOR IDENTIFIERS AND A CMI SYSTEM

John Connors, Director of Operations and Process Engineering  
*Harcourt Brace & Company*

Let me just say what a pleasure it is to be at your meeting and to participate. This is my first opportunity to interact with the library community and I have found it very pleasurable and very educational. Thank you.

As Jim mentioned, I have been working very actively with the Enabling Technologies Committee in the course of the last year, on the Digital Object Identifier project. And my company, Harcourt Brace and Academic Press, in particular, has been very active in taking a leading role within our environment, prototyping the use of Digital Object Identifiers with their electronic journals project.

What I would like to do today is talk to you about the Digital Object Identifier (DOI) and exactly what it is, because I think there is room for lots of clarification relative to that particular issue. Here's my agenda.

I would like to give you some background on the Digital Object Identifier. I would like to describe its components and tell you how it works. I would like to give some examples of how publishers are using it and, perhaps, also talk about how publishers might use it in the future. And then answer questions you might have about the DOI. And, perhaps most importantly, listen to your feedback—listen to your concerns about the Digital Object Identifier and how it will be used.

It's important to realize how the DOI evolved. The Enabling Technologies Committee was responsible for an initiative begun around two and a half years ago. The early experience of that Committee addressed a very broad scope of applications.

Some of the things that we have heard about today were on the agenda of topics discussed by that Committee. There was talk about cryptolopes. There was talk about protection technology. There was talk about management systems, licensing, and licensing management systems. These discussions were conducted in a very diverse community of publishers.

And, quite frankly, the project was all over the map. I think that we perhaps panicked other communities about just what was going to emerge from the Enabling Technologies Committee.

Approximately a year ago, the Committee developed a new focus on a fundamental issue required before any copyrights management could occur. That requirement was to identify the entity to be managed. The entity to be offered. The entity to be licensed. This identification was something the Committee felt was missing.

The Digital Object Identifier accomplishes this basic function, along with the ability to permanently link an element of intellectual property with the current rights holder. And, as I show you the Digital Object Identifier, I can make it clear how that's supposed to happen.

The identifier was necessary because in an electronic environment the physical containers that used to house intellectual property—the bound books and the bound journals—would no longer exist. We were working at a different level, where it would be desirable to present information at a finer level, appropriate to the electronic environment.

Let me just address some of the concepts behind the Digital Object Identifier. We talked a number of times today about persistence. And one concept behind the DOI is that it is designed to provide a more persistent link between the intellectual material and the owner, or the current owner of that material. Persistence is an important characteristic.

Cliff made reference to the URN, or the Uniform Resource Name. We see the DOI fitting very well into the context of the URN. The URN provides resolution that accomplishes persistence, where that's not available with a uniform resource locator, and we feel that the DOI accomplishes that same persistence function.

Another important aspect of the DOI is that it is an actionable identifier. The DOI acts as a key to connect the user to the publisher. I will be able to show you how this is accomplished. But, the important point here is that the identifier is more than just a numbering system. The identifier is actually part of a system, a system involving computers, involving technology, that is intended to connect the user with the publisher.

The DOI Committee also felt it was necessary to look at other industries, to look in the international arena, to see what other groups were doing in terms of developing solutions to these problems. What was being done in the audio industry, in the film industry, and on an international basis? We looked at other numbering systems that the publishing industry uses, such as the SICI and the PII. We looked at the International Standard Work Code. We saw much of what was good in these systems, but felt that there was reason to move forward with the Digital Object Identifier. Not so much in contrast or in competition with these systems, but to complement these systems.

Now, I would like to define the DOI and its components.

I would like to refer to this diagram as we talk about the components of the Digital Object Identifier. The DOI, the number itself, would exist as a clickable entity on the screen that the user would see.

The other components are the directory and the publisher's system. The identifier can be thought of as a telephone number. It is a persistent number that is capable of connecting a user to the current holder of the rights for the intellectual property being referenced by the DOI.

The directory itself can be thought of as a communications switch, like that at your telephone company. When you place a call, it is channeled to the local office, and your call is redirected to the party you're calling. Likewise, the publisher's system represents the party receiving the call. The final interaction is the establishment of a dialogue between the user and the publisher.

Now, I would like to talk about the identifier itself. The identifier is a two-part entity, containing a prefix and a suffix. The prefix portion of the digital object identifier belongs to the DOI system. The prefix is assigned to a publisher by a director/manager. It represents the publisher, or the imprint belonging to the publisher. It is applied by the publisher, along with a suffix, to particular content that the publisher wishes to identify.

A question that I have heard raised many times in relation to the Digital Object Identifier is: Just what do you identify? Is every paragraph identified? Is every photograph identified? And, in discussing this conceptually with a diverse group of publishers, there is a lot of debate as to the answer in different environments.

The most reasonable explanation I have heard, relative to what will be assigned to DOI, is a piece of intellectual property that has standing value in and of itself. Now, that might be a product that can be sold and that has commercial value, or referenced and have value in the research community, or it might be an ancillary to another product. As we talk about some examples of how the publisher will use the DOI, that will become a little clearer.

The suffix portion of the DOI belongs to the publisher. Let me stress that one objective of the Digital Object Identifier is to give the publisher flexibility in choosing a suffix strategy. The publisher has an option of having that number be a completely proprietary number, relative to their own internal operation. But, basically, we're seeing very few applications moving in that direction.

A common use of that suffix is to incorporate existing numbering schemes, like the PII, or like the SICI code, so it will be of greater use to the existing community and the future community. I know that, for example, in the Academic Press application of the Digital Object Identifier we are using the SICI code as the suffix portion of the DOI.

Now, I would like to talk about the DOI directory.

The directory is the working portion of the DOI. The directory is the component that is actually a computer system. The computer systems will house the lookup tables that are used to resolve the DOIs referenced by the user, connect that user to the publisher's system and establish a dialogue.

The directory system has been developed by the Corporation for National Research Initiatives. They have existing hardware and software in place to support the distributed nature of that system. It is important that this function is scalable and that it can be distributed from the standpoint on avoiding a single point of failure, and for performance reasons.

CNRI has based the DOI system on previous work with their handle system, and has established these systems throughout the United States and in Europe. We feel at this point that they're well prepared to carry this project forward.

I would like to show you an interaction map. The steps in the interaction map are numbered here. A user is sitting at a workstation and finds in his browsing, or in his work, a DOI or reference to a DOI. The Digital Object Identifier would appear as a link on which to click. The DOI can also be manually entered, so that it's possible to pick up the DOI from printed material, for example, and enter that much as you would enter a URL in today's systems.

The Digital Object Identifier is routed to the directory, and the directory performs a look-up to determine the current rights holder for that information. That information is passed back to the user, with a redirect to the browser. The redirect is transparent to the user.

From there, it is sent to the publisher's gateway. The publisher, receiving the query, has two pieces of information to work with. They have the address of the person making the query, and they have the DOI that generated that query. At that point, it's up to the publisher to determine how to carry on that interaction.

The interaction may take many different forms. For example, it might be the straightforward delivery of the information represented by the DOI. It might be a response screen asking the user if, for example, he subscribed to a particular journal. It might be a screen asking the user what associations he has that, perhaps, have access to that journal.

There is almost no limit to the format that that dialogue can take. We feel this is an important concept behind the DOI; it provides this flexibility, and restrict transactions into any kind of set framework.

The last component of the Digital Object Identifier system is the publisher's database. The publisher's database can be distributed. It can be centralized and it's from the publisher's database that the dialogue is carried out with the user.

A question that has come up often in our DOI meetings is related to this component. A publisher's database makes sense for large scale publishers who have the ability to establish this technology and to conduct this dialogue. But does it close out any small publishers who would not be able to participate in this kind of dialogue?

One possibility regarding this issue is that there will be a business opportunity for organizations to provide this publisher's database service, that will be able to host websites for publishers who do not wish to establish their own sites and basically conduct that dialogue for that publisher.

I would like to conclude by referring you to a website containing some examples of how publishers will use DOIs, <<http://www.doi.org>>.

There is also reference to another site, <<http://www.doi.org.gallery/>>, where there are even more recent demonstrations of publishers' use of the DOI.

Thank you for having me participate and begin to share these ideas. The DOI is a very new project. Much hard work and thinking have gone into the project so far, but much remains to be done, and the Association of American Publishers and the DOI committee are very open to working with you, listening to your feedback, and moving together towards bringing this program along.

Thank you very much.

[Editor's note: Overhead slides attached.]



# DOIs in Action

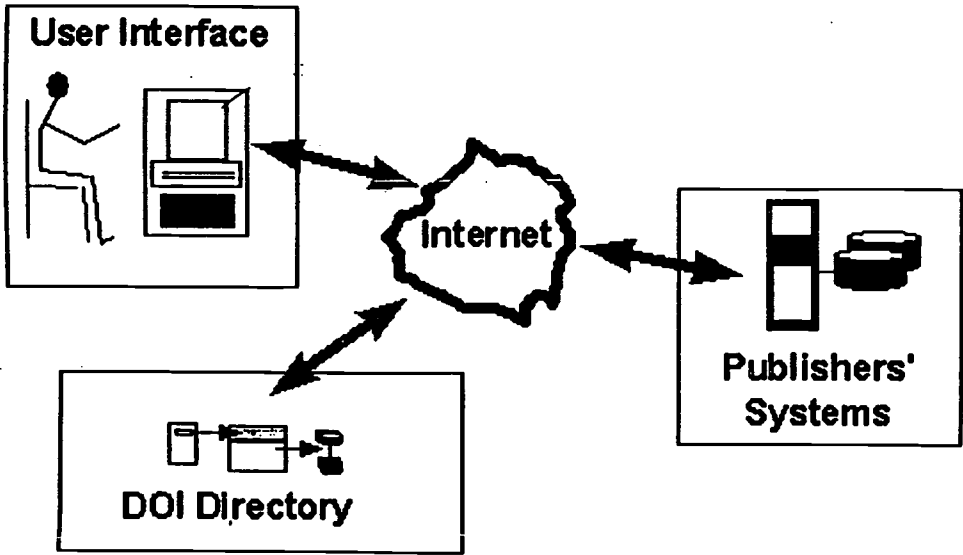

Slide 1

# Examples of DOIs

Publisher ID assigned by DOI Agency	Item ID assigned by Publisher
10.1048	/ 872
10.156	/ catalog-96
10.1532	/ PII
10.18698	/ SICI

Slide 2

BEST COPY AVAILABLE

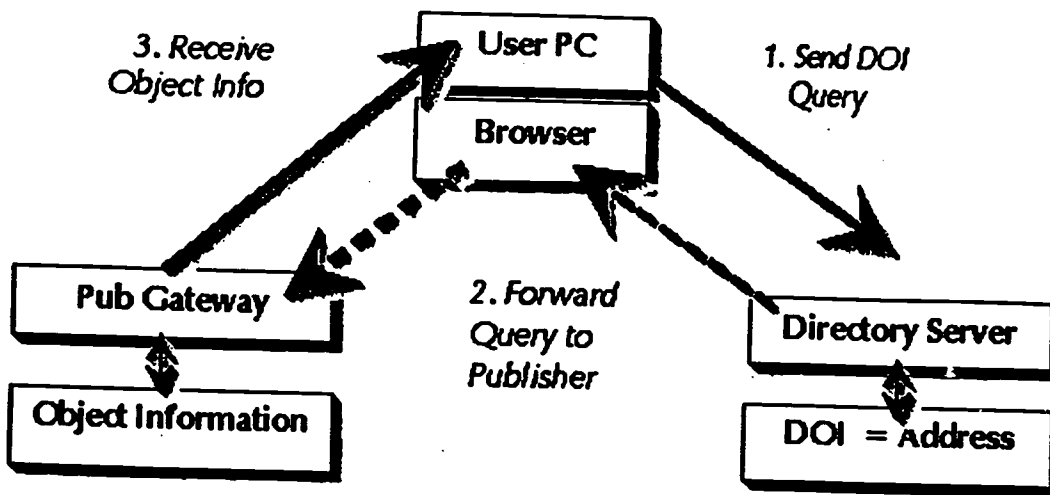

Slide 3

**Information about Digital Object Identifiers**

**WWW.DOI.ORG**

**Information about the Association of American Publishers**

**WWW.PUBLISHERS.ORG**

**Information about the Corporation for National Research Initiatives**

**WWW.CNRI.RESTON.VA.US**

Slide 4

## QUESTION AND ANSWER SESSION

MR. NEAL: We have listened to the policy, and we've listened to the legal and publishers' perspectives. I don't know about you, but I'm scared.

Would you please bring some questions and ideas to the attention of our speakers?

MR. FRAZIER (University of Wisconsin): I want to make a point about language that doesn't contradict any of the legal or technical points that Professor Cohen, Clifford Lynch, and Robert Oakley made today. First off, it seems to me that it cuts both ways. The exclusive rights of copyright owners aren't rights either. These are statutory monopolies, granted by government, for a limited period of time.

The question as to whether or not copyrights were natural rights was settled in 1774 in the case of *Donaldson v. Beckett*. I will trade you: I will stop talking about fair use rights, if the publishers will refer to exclusive rights as their monopolies. If we can have monopoly management, that will work for me.

Also, we all want to remind ourselves that there's no exclusive constitutional right to privacy. It's still excellent public rhetoric to speak of a right to privacy. I teach students that they have sweeping rights to use intellectual property for research and study; that's what I intend to continue to do. I will also teach students that they have no right to piracy.

I think it still makes a good deal of sense today to talk about a right to access information in the public domain, and a right to access the information created at public expense. We should continue to talk that way in public, because that's how we will end up with a just and democratic society.

I realize that the technical points are all pretty much on the nose.

MR. MOSHER (University of Pennsylvania): I would like to thank the speakers for a very interesting and provocative session. I would also like to reemphasize Ken's points on the fact that the U.S. has a Constitution, not merely a set of laws, or a common law principle. That Constitution should underlie everything we consider.

More specifically, though, I have a question to direct to our last speaker. We all have digital libraries, and we are a significant segment of the publishers' market, one which is very sympathetic to the needs and interests of these publishers, as well as of our users and readers, with which we often act in some role with regard to your publications. The implications of what you're designing in your identifiers have some importance to us in terms of what we do with our own infrastructural development. So, how are we going to link what we are developing with what you're providing?

MR. CONNORS: If I understand the question properly, you are asking how the dialogue that is conducted between users and publishers will also make room for the very important services provided by the library community?

MR. MOSHER: Well, let me clarify a little. I am not entirely sure what you mean by dialogue between publishers and users. I am also not entirely sure that the libraries are not major users.

MR. CONNORS: I agree that libraries are major users. The dialogue I am referring to is one that would perhaps take the place, in some cases that exist now, between users and libraries and libraries and publishers, if that makes sense. It's important that we determine a way not to remove or exclude the library from the services they provide to the user.

Additionally, to your point, libraries are very important users to the publishers, and the digital object identifier needs to be sensitive to that so that libraries are treated in a special way, perhaps, given the licenses and agreements that they have established with us publishers. We need to recognize libraries as partners in providing this information.

MR. LYNCH: Let me speak to that question, as well, in two ways. I recently spent the better part of the day with a number of members of the group working on the DOI. One of the things that they have asked the Coalition to do is to pull together a group of people from CNI's community to talk with them further about the DOI. Now, that's a very worthwhile discussion to have, but I need to stress that, in my view, the first thing we all really need to do is understand this thing thoroughly.

As I tried to suggest in my remarks, and I think you also heard this from the other two speakers, these are fairly complicated things with fairly complicated ramifications. One of the things that has happened is that the community inside the publisher world has had a very intense dialogue about these issues. Much of what has come from those just has never been formalized or stated. So, when I was in this meeting I was asking questions that, in some cases, received the response, "That's obvious." But it's not obvious to me. I didn't sit through all the discussions.

In other cases, looking at this from the outside, new issues began to surface. Having said that, I think it's important to understand this. The next step is to understand what uses this has for the library community. One of the things we need to be careful about is to not get carried away by the rhetoric of its name.

Certainly, if nothing else, it promises to be a useful tool in the same way other numbers are for communicating with publishers and jobbers when acquiring material. We will need those tools for digital material, just like anything else. Beyond that, I think we really need to understand what applicability it has. It's an open question, and a question that's useful for discussion among ourselves and with the developer community. Even if it turns out that it's primarily an acquisitions device that doesn't necessarily make it a bad thing. We just need to understand what it is.

MS. COHEN: I'd just like to speak to the point that we do have a Constitution in this country. It's not a trivial point. A lot of what's going on with respect to the implementation is largely being driven by international trade concerns. It hasn't been stressed as much as it needs to be that, at least here, intellectual property is a subject that has constitutional significance and that is now starting to surface in a more sustained way in connection with the hearings on the bills, now that Senator Ashcroft's bill is also in play. But it's not trivial and it needs to be repeated as often as humanly possible.

MS. COLAIANNI (National Library of Medicine): Through the DOI, will publishers be maintaining URLs?

MR. CONNORS: Yes. The DOI does not replace URLs.

MS. COLAIANNI: But libraries, at least ours, are having trouble with changing URLs. The question is, if the publishers standardize on a DOI, will they then take the responsibility of linking that to the URL?

For example, we run an interface to Medline. There's a hotlink through that interface to the actual article on the publisher's website, through the journals that have made those arrangements to have those hotlinks put in. It's my understanding, through the developers, that publishers have agreed to maintain the URLs so that all we carry is that link. Is the DOI equivalent to that link? That would be a very positive attribute to the library community.

agreed to maintain the URLs so that all we carry is that link. Is the DOI equivalent to that link? That would be a very positive attribute to the library community.

MR. CONNORS: I certainly recognize the problem. The problem is with the lack of persistence in the URL. The DOI is intended to solve that problem. Whether it will be used in that particular application, I can't say for sure. But, certainly, the objective of the DOI is to solve exactly the problem that you've described. I will make sure to take that back and call that to attention. I know that within the Academic Press that will also have particular import.

MR. BILLINGS (University of Texas): I would just like to remind us that we're living these days in a world of global commerce and global information. Unfortunately, we don't have an international Constitution.

MR. NEAL: Most of the libraries in this room, I think, have worked hard to create site license-type approaches to most of the electronic information that we access, not exclusively, but certainly heavily. Does the DOI phenomenon and technology move us down the path, perhaps, of moving from a site license to a pay-per-view kind of environment? Or is that a policy decision that still is to be made?

MR. CONNORS: If anything, it's a policy still to be made. I don't think that pay-per-view is a reasonable alternative to site licenses. As somebody mentioned this morning, site licensing has been extremely beneficial to the publisher, as well as to the institutional community. Pay-per-view could, in some respects, be facilitated by DOI, but by no means is it inevitable in that particular community.

I might point out, as I have said before, that the publisher community is a very broad and diverse community. Further, as Cliff mentioned, there are many areas where there is contention as to how something like the DOI will be used. So it doesn't absolutely preclude pay-per-view, but, certainly in the STM community, it is not something that has surfaced.

MS. MARTIN (Georgetown University): First of all, you said that defining an entity had been a topic of conversation and that it would be a significant piece of intellectual property. But when you look at the example of how publishers will assign or use DOIs, can I assume that, for example, for a book or an article, a DOI would be a bibliographic entity?

MR. CONNORS: Relative to a book or an article, it would be a bibliographic entity. But, beyond that, I had a further layer of granularity. The DOI might be a reference to a piece of animation that would obviously not be included in the book or the article. That will not be a bibliographic entity unless a case is made by both communities to make sure that it does happen. So, I don't think anything precludes it from being citable, but it does still need to be worked out.

MS. MARTIN: Okay. Then my next question is, you said that you would indicate how publishers would use DOIs, but I am afraid I just still don't understand. Partly, I don't understand in relation to the slide that you showed that indicated, I thought, that a great deal of this would be transparent to the user.

I would like to know to what extent this transparency will happen. I assume that you don't necessarily know the answer, but if you could take a guess. Will it be totally transparent to the user? Would it be a kind of a system, for instance, where a user would be told the charges for using a certain piece of information? Do you click yes or no? Will the user be also given the option of saying, oh, yeah, I want the text, but I don't want the photograph that goes with it. Those kinds of things. Will the user be given a choice?

MR. CONNORS: What would be transparent to the user would be the technology behind establishing a connection to the publisher. When you click on a DOI, what you'll next see is a response

screen from the publisher. That response screen will determine what that particular DOI was. But, specifically, what you won't see is any pass through the directory and that redirection back.

But now, to address your point. The response screen from the publisher, as I said before, will be in relation to the digital object. The publisher has complete flexibility to structure that dialogue. It's certainly in their interest to provide as much information as possible.

Speaking from the standpoint of Harcourt Brace's Academic Press, if we were to structure something where there would be a charge for accessing a particular pieces of information, we would certainly present you with the fact that there would be a charge.

MR. NEAL: It's my understanding that we're not only looking at what we call whole-book or whole-article level DOI capability. As I understand it, we will see a situation where objects, like maps, illustrations, film clips, datasets, or software programs, can be independently DOI'ed and, theoretically, independently charged.

MR. CONNORS: Yes. That's absolutely correct. It could be complex, but that's the importance of having it be a dialogue. For example, we talked at lunch about a wrapper contract, where simply by clicking, all of a sudden, you commit yourself. You give away rights, or you commit yourself to something you didn't intend.

We certainly would not want to do that, speaking for my publishing company. We would want to present you with information that basically gave you choice as to what you access and provided to you in the context of the prices, if there were prices, that were involved with that access.

MS. MERRILL-OLDHAM: Jan Merrill-Oldham, Consultant to the Preservation Committee from Harvard University.

Cliff, at the end of your remarks you cautioned libraries against shaping policy according to technological capability. I wonder if you have a vision for how libraries can contribute to making decisions and maintaining the kind of world that we believe in, vis-a-vis information access; what is the library's role in trying to shape that world? Given the role that economics plays in this whole thing.

MR. LYNCH: I don't know that there's a simple answer to that. But, in the context of the sort of things that we're discussing here, I would say that one of the things that is important is to think constructively, rather than reactively. It's a general principle we need to follow. We need to understand what the DOI does, but the right response to that may be to say, great, that does what it does, it serves a function that, for us in the library community, is kind of a niche. We need something else for other purposes and now we have kind of a functional definition of what that is.

I am sort of struck in another context of the same kind of principle. We have been through a number of flurries around copyright issues. Some of that initially was very reactive to legislation that we thought was flawed for one reason or another. It's very valuable to try and go past that and think about what affirmatively you do want to see recognized in these kinds of systems.

I guess I don't know how to succinctly answer any better than that.

MS. COHEN: I have one specific thing to add to that. In terms of reader privacy and reader identifying data, not only have libraries historically been quite sensitive to the need to maintain the privacy of reader data and, indeed, often because they're required to by state law, but libraries also collect data.

For example, at state schools, and probably very likely at any school, you will need to submit a



budget, presumably with some aggregate data on the use of the materials in your library. So, I would bet that libraries might have some very specific experience of how to balance, on the one hand, the need for privacy with, on the other hand, the need to gather certain types of data that are useful in aggregate. That's not a kind of balancing act that private commercial concerns have been very used to doing. That's a specific instance where I think that could be really valuable.

MR. ROTHENBERG (Rand Corporation): I have two comments. One, continuing a little of what Cliff just responded to, I agree heartily that one should not be a technological determinist, but the issue is that technology enables new things that we couldn't have imagined previously. I think the library community wants to reach out and think about the possibilities of what could be enabled in the future in a world that we would like to see and try to leap out ahead of what's going on and make that happen rather than waiting for, say, the publishers of the world to do something that you then feel is an infringement of what you'd like to see.

The second comment goes back to the discussion of DOI transparency. I am all for transparency, but I note that it has a dark side. In particular, the architecture that you put up on the screen allows for the collection of management and access information, such as who's reading and accessing what, at not one, but two places—at both the DOI directory and the publisher's location. Neither of which is required to be a trusted site. A different architecture, in which a trusted agent was interposed between the user and the rest of that picture, would make it a very different implementation in which user information could be protected fairly easily.

I don't know if that's been considered, but I just wanted to point out the two possible violations of privacy in the architecture.

MR. CONNORS: I recognize the issue. I don't know if I would deem them actual violations of privacy. However, just along those lines, one of the reasons we feel very strongly about CNRI operating that directory is because of what they bring, in terms of their reputation and their involvement to that.

By contrast, when we look at schemes or methods that publishers have used in the past, for example, ISBN, we feel that we've taken a step in the right direction to moving to a more detached party by having CNRI manage that directory.

MR. ROTHENBERG: Fair enough. I just point out that this is an occasion where there is a technological solution that would enable a very strong degree of privacy to be built into the system. Whether legislation then decides that you need to breach that or not in the future is another issue.

MS. COHEN: I'd like to address that quickly. Imprimatur, the European consortium that's been working on rights management issues, has members that are university libraries as well as members that have publishers. Their proposed architecture involves what they call "privacy enhancing technologies," where you do try to clarify your role, basically between anything that could identify specific attributes of the reader, payment, and so forth. It doesn't even preclude the kinds of privacy discrimination that John was talking about.

For example, you could be identified as an authorized educational user without being identified by your name and address. So, it might make sense to look to Europe and find out what they've been doing in that area.

MR. NEAL: Thank you very much. Please join me in thanking our panelists.

## PROGRAM UPDATES

### CLIR'S DIGITAL LIBRARY FEDERATION

Deanna Marcum, President  
*Council on Library and Information Resources*

and

Donald J. Waters, Director, Digital Library Federation  
*Council on Library and Information Resources*

MS. MARCUM: Good morning. I am happy to introduce Don Waters, the new Director of the Digital Library Federation (DLF). Many of you heard his presentation yesterday, but I believe this is the first time he has spoken to you as DLF's Director.

In June, we sent a press release to all the members of ARL indicating that we were opening participation in the Federation to all libraries with an active digital library program as well as to those willing to make the same financial commitment that the charter members had made. What we want to do today is give you a quick overview of where we are and the kinds of projects that are being planned.

MR. WATERS: Good morning.

I would like to start off with an announcement. This may not be widely known, but the Federation's name has changed from the National Digital Library Federation to the Digital Library Federation. At the Advisory Committee meeting in September, the Committee regarded the word "national" as implying that we were setting up some sort of national boundaries in the work. That's just not the case and it seemed unnecessary to keep that in the name.

I will report on some of the received work of the Federation that has been organizing itself over the last year and a half or so, as well as some elements of future work. I was just saying to Deanna how remarkable it is to see how much things have changed in just the one week since I prepared these remarks. Already I am rethinking some ideas and it's clear that this is already dated a bit. So, with that caveat, let me proceed.

I want to take time to review the premises on which the Federation was founded, some of the goals that we have, the framework in which we are working, and some of the current initiatives. Then I will mention how we are organizing ourselves to do this work.

DLF participants are committed to a shared investment in developing the infrastructure needed for libraries of digital works. This is a group of institutions who have come together to work and take the risks of that work collaboratively. What we mean by infrastructure is those things that will enable digital libraries to bring together, or federate the works that they manage, in a distributed way. We're not trying to build a central repository; the assumption is that there are many distributed repositories that need to work together to present a common front to a user.

The Federation's original charter sets forth a fairly wide-ranging set of objectives. Almost immediately after that charter was issued, a planning task force was set up. That group came back with a report that highlighted three program areas for initial focus: discovery and retrieval; intellectual property rights and economic models; and archiving.

The Federation is approaching these goals in a context of a number of key distinctions that I want to briefly review with you. First, the principal participating institutions really serve the purpose of grounding these goals in a particular way, that is, primarily in research and education institutions. The mission of the Federation is therefore really grounded in that arena.

Much of the work to date is focused on reformatting. This work is really valuable for a lot of reasons. It is mostly of value because it helps people learn about the digital arena. However, I think many of you will realize that this is a very costly way to build digital libraries. We have to recognize that fact, or we have to take action to dramatically lower conversion costs. It's possible that we might want to work on lowering the costs.

Attention, I believe, needs to be turned in a fairly substantial way to those digital works that are born in digital form, not converted to it. There is an awful lot out there to which we just simply aren't paying enough attention.

Another set of distinctions that has emerged is that the metadata needed to construct effective repositories is extremely complex. The word itself embraces a whole arena of areas, and one way to break that down is to talk about: 1) descriptive information about contents, 2) structural information that is needed to manipulate objects in the digital arena, and 3) administrative information.

Some of the work that is before me and members of the Federation are site visits, the development of what we have been calling "architecture." Basically, it is a framework for working on digital projects and then some investment in particular projects. My impression, right off the top, is that the DLF participants really do represent a useful cross-section of public and private institutions, large and small, academically and not so academically oriented. I will be visiting most of these institutions over the next three to four months in order to get an overview of the projects that each of those institutions are working on, and to identify how those projects are grounded in the missions of the institutions in which they are working. I then hope to provide a coordinated picture of what is successful and what the barriers to further success are. The results of these visits will dramatically inform the next phases of Federation work.

We have had an architecture group operating for some time under the leadership of Dale Flecker at Harvard. It has made some substantial progress, particularly on distinguishing these areas of metadata and how those distinctions are important for creating digital library systems. There was some concern yesterday about communication. We can always do better with communication. But Dale has made a point of reporting the work, both at CNI's spring conference and at the Digital Library Initiatives conference in June. We have met separately with RLG and CNRI on their various digital library initiatives, and there are more of those kinds of outreach plans in place. In addition, we have agreed to join with the Common Solutions Group and organize a fairly substantial session on digital library architecture at their meeting in January. Finally, there is a corporate interest in the work that we are doing. We will be reaching out to see how we can integrate some of that interest into the work that we are doing in our architecture group.

The Federation has mostly invested, so far, in what has been called the Making of America project. The original Making of America project was between Michigan and Cornell. The next round was a Berkeley-led project that made a proposal to NEH last June, and is focused on special collection materials. The Federation sponsored a lot of the planning work for that project, and will sponsor some of the preparatory work between now and early next year.

In addition to that, the Federation is looking for ways to help institutions that are now working on visual resource materials. It is a very hot topic on many campuses with a lot of work focused on it, and the Federation wants to help out with some of that work.

There is also a project that started last year and sort of died in the spring. I want to see if there is further interest in it. The project links social science data to the code books on documentation, in electronic form. This was a particular project that Mr. Rockwell identified yesterday in his talk.

Turning to organizational matters, the original charter in the Planning Task Force called for the development of a collaborative management structure. We have several components of that structure in place, and others are under development. Those things that are in place include the fact that we are operating under the umbrella of the Council as one of its programs. We have established an advisory committee that consists of the directors of the participating institutions. I report to the president of CLIR and work closely with the advisory committee.

The operations budget of the Federation does include resources for an assistant, another position that needs to be defined and recruited. Categories of participation need continued attention: the architecture group needs a little more foundation as a standing advisory group, and then there is the general question of how the Federation will invest in various projects.

As Deanna mentioned, participation as a principal member in the Federation is now widely open, but subject to the conditions of the original charter members, which are: an annual contribution; a capital contribution over three years; and a serious demonstrated commitment to digital libraries. This is all based on the concept that not only is there collaboration in solving problems, but there is also collaboration in taking risks.

RLG and OCLC now participate on the Advisory Committee with voice, but without vote. There is still the general question of what other groups and categories are desirable to bring needed expertise and resources to bear. All the resources that are needed to carry forward the Federation work aren't necessarily within the bounds of the participating members; we have to figure out ways to reach out and secure those.

The Architecture Group was originally formed as a part of the Making of America project. It was very clear that it was generating wider value than just to that project. It presently includes library NIT professionals in the participating institutions of the Making of America project. To date, it has largely viewed architecture from an implementer's point of view. There is room for additional and broader perspectives on that work, if we regard it as a standing advisory committee to the Federation.

The Planning Task Force, when it issued its strategic plan for the Federation, emphasized the importance of grounding project work in infrastructure. But, it has been very clear from the limited experience that we have had so far that the Federation can't manage those projects itself, nor can it fully sponsor them. So, we have to find ways to administer that capital fund so that they are leveraged against other sources and ways to make strategic investments that further the interests and goals of the Federation.

Briefly, that's where we are. If you have questions, I will be happy to take them.

MS. DRAKE (Georgia Institute of Technology): Don, I am looking over some of your program areas, particularly metadata, discovery and retrieval, intellectual property, etc. I see a big overlap with what CNI is doing. I was wondering if you could tell us how you view the relationship of the Federation with CNI and how that can be made productive?

MR. WATERS: Cliff Lynch and I had a fairly extensive conversation on Wednesday about the potential overlap in our agenda. It isn't a complete overlap, although there is a lot. It is the case, though, that members of the Federation are a proper subset of CNI. So, there is a lot of room to bring the resources of the Federation to bear on specific things that CNI has identified as agenda items.

Cliff and I also talked about a couple of projects that we can jointly sponsor, but it's too early to get into details about that.

One of the major advantages that CNI offers is a forum for articulating ideas and explaining the results that the Federation would generate. We took advantage of that during CNI's spring meeting, as I mentioned, but greater advantage of the forum and the wider audience that CNI provides could be taken. Finally, CNI provides critical thinking about Federation work.

There is a whole range of opportunity there. We will take advantage of that.

Thank you very much.

AAU/ARL GLOBAL RESOURCES PROGRAM

Betty Bengtson, Director of University Libraries  
*University of Washington*

and

Deborah Jakubs, ARL Visiting Program Officer  
*Duke University*

MS. BENGTSON: The purpose of the ARL Global Resources Program is to improve access to international research materials and resources. It is a fully functioning program of ARL, addressing one of the Association's 1997 program priorities.

Deborah Jakubs, an ARL Visiting Program Officer from Duke University, will begin by giving a brief status report on the various program project activities. I will then talk a bit about the first meeting of the Global Resources Program Advisory Board.

MS. JAKUBS: I will just give you an overview of some of the more recent highlights, since you have heard reports on these projects at various times.

The Global Resources Program really encompasses a set of regional projects, plus other activities that share the goal of enhancing access to international materials.

The Latin American Project has 37 members. It has developed a database of tables of contents of approximately 330 Argentine, Mexican, and now Brazilian journals—that's something new—that are generally not indexed. We have distributed responsibility for maintaining subscriptions and delivering articles through interlibrary loan, our document delivery. The database is housed at the University of Texas Latin American Network Information Center. There is also a component that focuses on non-governmental organizations. This has proven to be rather problematic, and so I won't go into detail here. But you will be seeing more about that in an evaluation of the project later this year.

We have a digitization component, which is now nearly complete, of all the presidential messages from Argentina and Mexico, which also complements the CRL Brazilian project of the same materials. There is also the monographic component, the most interesting new addition to this project, which asks participants to redirect seven percent of their Latin Americanist monograph budget toward an area of strength and therefore rely on other institutions for materials from other countries. Of the 37, about 22 members have signed on for this monographic part. I think it's one of the more creative and interesting aspects of our project.

There has been a recent shift from formal central coordination to a model of more shared responsibilities. This shift is most easily seen in the distributed input of tables of content. Institutions now do their own inputting through a web template, rather than sending these things to LANIC. The database currently contains over 27,000 articles and we have just received the interim report, which I know will interest all of you, from a University of Florida economist named Jennifer Cobb, with the title, "Is Cooperation Cost Effective?" There will be further evaluation of each component, and a survey will be sent to all of you this fall in order to accomplish that.



The Japan project has 28 members and is now working with the National Coordinating Committee on Japanese Library Resources to advance its goal of accessing resources in Japan. Progress has been made on three fronts.

Funded by the Center for Global Partnership and the Northeast Asia Council of the Association for Asian Studies, five Japanese studies librarians spent two weeks in Tokyo during the summer of '97, being trained to search Japanese bibliographic and text files. The five are now planning workshops for librarians and end users in the U.S.

Negotiations with ARL counterpart libraries in Japan are underway to work through the copyright and currency exchange barriers to easy interlibrary loan access with Japanese libraries. A web-based union list capacity is being tested at Ohio University.

The German project has 22 members and has been slowed down, as you probably know, by a lack of funding. An October 2 meeting of the advisory group determined the directions for the project in the coming year. Those are:

- to focus on digitizing government publications in German and sharing access to them;
- collaboration with German libraries and librarians to improve interlibrary loan possibilities; and
- the investigation of the potential of a Harrassowitz database of items not selected by U.S. libraries.

They also are looking into creating some links with IFLA. Leo Voogt (IFLA) was at our advisory group meeting and that was very helpful.

Of the new area projects under development, the most developed is the South Asia Project. ARL has developed a contractual agreement with the libraries at the University of Chicago and Columbia University for a two-year project called "The Digital South Asia Library." This project will develop the infrastructure for intercontinental document delivery to and from selected Indian libraries, create new electronic reference resources, and create electronic indexing records for some 38,000 articles in Tamil journals, 38,000 articles in Urdu journals, and about 5,000 English journal articles, all from the 19th and 20th centuries.

The Africa project continues to develop. We hope to soon complete a contractual agreement with the Africana Librarians Council of the African Studies Association and with CRL in order to create a newspaper union list, web-based and searchable, of African newspapers. That fits in nicely with CRL's global newspapers ICON. Further, we intend to expand preservation microfilming and explore digitization options in collaboration with Northwestern University library.

Last but not least, the Southeast Asia project is still under development, and will probably focus on a distributed system of periodical indexing, involving multiple institutions.

I will just mention a couple of other projects and initiatives. One thing we want to do is model a National Directory of Area Librarians on the Ohio project. Some of you may have heard of the Ohio project, which is a gathering the expertise of area librarians within international activities.

We have been working with the Future of Area Librarianship project at Indiana University. We are working on the possibility of meeting with the directors of the Library of Congress's overseas offices to explore their potential involvement in the Global Resources Program.

On October 8 we had the first meeting of the Advisory Board, on which Betty will elaborate some, but I just want to highlight a couple of things that came out of that. One is the very important role that faculty play in these projects. We don't want to just develop things that we think might be interesting or necessary. We really want faculty involvement. In that vein, we plan to hold a set of small meetings for

faculty play in these projects. We don't want to just develop things that we think might be interesting or necessary. We really want faculty involvement. In that vein, we plan to hold a set of small meetings for key faculty and for area librarians for each world area, to determine what the strategic needs regarding libraries and technology will be for each world area in the next five years or so.

My conclusions are that individuals and their initiative are critical in these projects. We couldn't have gotten where we are without the expertise and dedication of many of the individuals in your libraries. We have also discovered the importance of associations and their involvement—SALALM, WESS, CORMOSEA, the area librarian groups.

We recognize the need for institutional commitments to the implementation of the programs at the highest levels and a good awareness on their part of what we are trying to do. I particularly mean at the university administrator's level.

Finally, institution-wide communication and a team approach to implementation are vital. For example, bibliographers working with interlibrary loan staff and with catalogers to fulfill project commitments.

With this in mind, we think it would be useful to prepare a set of guidelines for directors and collection development officers that will help to implement these projects in your own libraries; a listing of what you need to know to make this work in your library.

With that, I will turn the podium over to Betty. Thank you.

MS. BENGTON: As Deb mentioned, the Advisory Committee had its first meeting last week. In addition to myself, there are three other ARL directors involved with the Committee: Hwa-Wei Lee, from Ohio University; Carol Moore, from the University of Toronto; and Suzanne Thorin, from Indiana University.

Representing university administrators we have President Myles Brand from Indiana University and Jonathan Cole, Provost of Columbia University. In addition, Stan Katz, who has just left ACLS and is now at Princeton University, serves on the Committee, as does David Wiley, from Michigan State University. David is Chair of the National Resource Center's Directors Group and represents faculty who are involved in world areas.

Also attending the meeting was Duane Webster and Richard Ekman, from the Mellon Foundation, which, as you know, has provided us a grant to support the program for a three-year period. Glen Zimmerman provided staff support for the meeting.

I was very pleased, particularly with the engagement of the non-library members of the Committee in the issues that we were discussing and their interest in pushing forward the program objectives. Deb has mentioned that we discussed the issue of involving faculty more in the program, and some actions, which we will be pursuing, were suggested for doing that. In addition, we discussed the need for strong institutional commitment at the presidential level in our universities. This will help with local needs, the desire to build local collections versus the thrust of the program towards cooperation, and building collections on a distributed model and sharing resources. Commitment at the presidential level would be very helpful on a campus in making those choices.

We also talked about how to establish a long-term self-sustaining financial base for the various projects and programs. We focused on a membership-type project that would involve a membership fee for participation. That way, a university library could choose to participate in the particular area programs that are of interest to their faculty and students. The AAU has endorsed, in principle, the idea of a membership contribution. We need more discussion within ARL, but Deb and others of us within the Association have agreed to try to put some structure to the idea.

We talked about the need to better define the responsibilities of an institution that made the commitment to take a lead in a program area. The success of the Global Resources Program will depend, in large part, on the efficiency and speed of document delivery and interlibrary loan. There is also the need within each of the participating institutions for better communication and cooperation between the area studies librarians and interlibrary loan, cataloging, and all of the other various areas of the library that support the delivery of information to users.

Evaluation is seen as critical. Therefore, the Advisory Board strongly urges evaluation of all of the programs and projects, which is, of course, underway.

As a last point, I just want to let you know that both the Mellon representative, Richard Ekman, and the university administrator representatives all are quite pleased with the Program's progress. As you know, there has been concern about keeping the AAU presidents engaged in the Global Resources Program and in some of our joint projects. So, it was reassuring to see that we seemed to be making satisfactory progress from their point of view.

Thank you.

## LEADERSHIP & CAREER DEVELOPMENT PROGRAM

Joan Giesecke, Dean of Libraries  
*University of Nebraska-Lincoln*

and

DeEtta Jones, Program Officer for Diversity  
*Association of Research Libraries*

MS. JONES: ARL has recently been funded to pilot a Leadership and Career Development Program over a one-year span, from July 1997 to July 1998. The Program's mission is to prepare minority librarians who have currently at least three to five years experience in the library community for top leadership positions in academic and research libraries.

The Program has three primary components. The first is to give two one-week institutes to spend critical time with participants, working with ARL and OMS faculty on leadership and skill development, and creating a community and network amongst themselves as librarians who are advancing in their profession.

The second component is project development. Participants will be asked to engage in research project development and design that will finalize in a project to be presented at the program's end and will be available for publication, as well, contributing to the field.

The third and final factor is a mentoring component. Participants will be paired with a director of an ARL institution in a mentor/protégé relationship, to enable participants to have access to current leaders in the library and information science community, to provide participants with a model of how to advance in their own career development, and to provide them with visibility within the profession, which we know is quite important.

That's the Program's overall scope. We have met with and selected participants, a process Joan will describe. We will definitely keep directors informed regarding the participants, so that you will have enough information by which to contact them.

MS. GIESECKE: As DeEtta said, we had a wonderful meeting on Tuesday. Forty-four incredibly talented people applied for this program. The committee worked very hard and very quickly to come to a consensus on the top 21 people whom we will invite to participate, as well as noting some alternates for a backup pool. The 21 participants are representative of the pool in terms of diversity. We did want to note two things. Sixteen of the applicants are from ARL libraries, and five are from non-ARL libraries. We also have a mix in terms of library experience: the group consists of both seasoned professionals as well as of people who are fairly new to the field. We hope that will bring a nice mentoring relationship to the group.

At this meeting, we were also able to make connections with the ALA Spectrum Program, a scholarship program for 50 minority students attending ALA-accredited graduate schools or school media specialist programs. The participants in the Leadership and Career Development Program will serve in ways as mentors to some of the Spectrum students.

We have also connected with ALISE, particularly in terms of the research projects. Toni Carbo has volunteered ALISE members to help us with that process. So, if you are considering advising someone on a

research project in an area where you would like to get some help and support, we do have our library school faculty to draw on, as well.

Our next step is to get the word out regarding this program and the participants, their areas of research interest, and the institutions they are from in order to recruit mentors to work with these participants. We call it a 20 percent solution: we need 20 percent of our membership to come forward and serve as mentors. I know a number of you have already expressed interest in that program. As indicated in the handout, the mentor relationship is one of maintaining good communication and giving help and advice on the research project, or getting them in touch with someone who can help them with their research project.

We also ask that mentors try to arrange a visit with the participant sometime during the program for some interaction to help build their relationship. In order to make fairly simple, at ALA's Midwinter Meeting we will have an opportunity for potential mentors to meet with participants. It's a very well planned program. We're very excited about it. It has potential to remain a permanent part of the ARL system.

We hope that you will step forward and work with these people. They're a dynamic group. Thank you.

## APPENDIX I

### ARL BUSINESS MEETING

#### President's Report

MS. WERNER (University of California-Los Angeles): Welcome, ladies and gentlemen. I am pleased to see so many of you here today.

I want to begin by giving you some updates, primarily relating to Board action. First on that list is that, when the Board met on Tuesday, we elected a new president-elect. I am thrilled to tell you that Betty Bengtson is our next president-elect.

(Applause)

We also nominated Susan Martin to the IFLA Ad Hoc Committee on Access and Freedom of Information, and Jim Neal to IFLA's Committee on Copyright and Other Legal Matters.

Speaking of Jim Neal, I would like to call on him for a report of the Nominations Committee.

#### Report of the Nominations Committee

MR. NEAL (Johns Hopkins University): The Nominations Committee members this year were Ann Wolpert, Graham Hill, and myself. We would now like to bring to the membership three nominees for the Board: Carla Stoffle, University of Arizona; Paula Kaufman, University of Tennessee; and Scott Bennett, Yale University. I move for adoption.

MS. WERNER: Are there additional nominations from the floor? Hearing none, may we adopt this slate by acclamation.

(Applause)

Welcome to our new Board members.

#### Establishment of Dues

I also want to put forward for a vote your Board's recommendation for next year's dues. We submitted to you some weeks ago an explanation of what these dues are and why we are recommending the level we are. As you will remember, at the Board's recommendation, dues for next year are \$15,100. That provides income that we feel is urgently needed, first of all, for merit-based salary increases for the ARL staff; an increase of dues support for our Diversity Program; and for routine increases in expenses, such as the office lease.

I ask at this time if there are any questions or items for discussion?

(No response)

Will all those who are in favor of this dues increase be so kind as to raise your hand? Any opposed? Seeing none, the ayes have it, and I want very much to thank you for all of your support.

#### Report of the Working Group on SPARC

We have had a productive meeting. We have had several lively discussions about the project that has the working name SPARC, an acronym for Scholarly Publishing and Academic Resources Coalition, and which has a lot of metaphors attached to it.



The ideas for this have been percolating for a number of years, but the concepts were really developed by an informal working group. The Board took action this week to endorse SPARC as an ARL project, and to move forward with the next steps.

I would like to now call on Ken Frazier, Chair of the working group, to summarize for us where we are with the SPARC project and what next steps look to be.

MR. FRAZIER (University of Wisconsin): One goal is to seriously focus on partners, including evaluating which of the potential partners would be able to go forward immediately in planning, exploring, and designing a publishing model that would reflect our values and stand a real prospect of success in the marketplace.

We have discussed who some of those partners might be. But, we also know of potential partners who we haven't yet sat down with to have a serious discussion. So, there is definitely work ahead of us before we could hope to identify a serious proposal.

We did agree, though, that we need to focus on action. We would like to have a new publishing product, a journal, on the street by January 1999. We feel the need for help, and the need to immediately extend the circle of discussion to include people with expertise who could move us along in a timely way.

We intend to speak directly with Peter Givler, President of the Association of American University Presses, to see if he would be willing to assist us in developing a plan of action. Peter, by the way, has experience in advising start-up publishing ventures, knows a good deal about what it takes to be successful in the marketplace and, of course, he represents the link to the university presses, which is certainly one of the best candidates we know of for sharing values and moving ideas along.

We all agree that message is crucial. It is as important to be able to explain SPARC as it is to move the agenda along. I have to tell you, though, there is a bit of a divide, even within the Steering Group, between a kind of populist, go-public position, and a position that would reflect more of the traditions of the ARL community and a style of communication that would maintain the largest possible coalition of interest around the idea of alternative publishing ventures.

I think we can resolve that. But we are really going to work hard to develop a list of talking points that reflect our public position on the issue of alternative publishing ventures.

We also spoke of identifying a particular discipline and bringing in faculty. The area we talked most about was chemistry. We feel confident that it would be possible to identify chemists who would be at least willing to talk about publishing in this field, and begin to explore for contributors and potential editors who might be able to help avoid what is, in our view, one of the most difficult obstacles to success: developing editorial boards and enrolling faculty leaders in order to move the publishing project along.

That pretty much covers the top list. I do want to forewarn you, though, that there was also a decision made last night to poll this community and ask you to tell us how much you spend on Elsevier journals, so that we can begin to develop a base of information, in order to communicate to the AAU and others a sense of the economic scale of the Elsevier-Kluwer investment that we make in aggregate.

This could be the beginning of information gathering that could help us assess the economics of alternative publications, and also perhaps begin to look ahead to develop a cost model to determine what kind of costs we might be facing.

I am fearful that I am leaving something out. So, if Mary Case or Paul, or any other members of the Steering Committee would care to fill in the blanks, I would appreciate it. We will be asking about not just Reed Elsevier, but Kluwer, North Holland—the conglomerates, yes, for journals.

MS. WERNER: Are there any other questions for our SPARC working group?

Yes. Bill Studer.

MR. STUDER (Ohio State University): If AAU pursues the issue of decoupling the certification process from the publication process, how does that fit with this and what is ARL's position on the AAU movement?

MR. FRAZIER: The SPARC document (see attachment on pp. 137-42) includes four approaches that we would be interested in supporting. The fourth one I described as visionary models, including academic institutionally-based servers and discipline-based servers. As I understand the AAU proposal, it would fit in that category. Also, as David Bishop commented at one of the table discussions yesterday, it should be one of our objectives not to interfere with a possibility that could have success and support that idea.

MR. WEBSTER (Executive Director, ARL): I might add, too, that the Pew Higher Education Roundtable is going to take place on November 12th and 13th. That discussion, which will involve AAU as a co-sponsor for the Roundtable, will look at a range of strategies. We hope that because of that discussion this effort, as well as the effort that you described, will be more carefully articulated and be agreed upon formally by the parties involved at the Pew Roundtable, to then be promoted and distributed to the community as a whole through the *Policy Perspectives* publication that will come out of that discussion.

So, we hope that the Pew Roundtable discussions will, in fact, lead to an agreement on a limited number of strategies on which we should focus as a higher education community addressing this set of issues. No one strategy will be seen as the silver bullet, but instead, there would be clarity on which strategies to focus on and how to advance those.

MR. FRAZIER: After the Pew Roundtable, we hope to go through the process of identifying new participants to expand the SPARC Steering Committee. I would very much like to know if there are members of the ARL community who are interested in being involved in moving this along. Please let me know.

MS. WERNER: Thank you for that report, Ken. The timing here is really interesting. We have had discussions about the SPARC proposal here at this meeting. The Pew Higher Education Roundtable is next month. We will be having a call, quite shortly, for statements of interest from all of you as to what committees and working groups within the Association you may want to be appointed to. Everything is lining up in terms of timing.

#### **Report on Colorado State University Flood Recovery Effort**

We thought it would be interesting for everyone here to have some brief updates that are not so much Board action related. I wanted to call on Camila Alire to give us an update on the status of the Colorado State University flood recovery effort.

MS. ALIRE (Colorado State University): Thank you very much, Gloria and Duane. I don't want to spend too much time on the information; only to say that we still are estimating that over 400,000—close to 500,000—volumes have been damaged, affecting all of our bound periodicals and half of the book collection that was in the library.

We had a 14-day pack-out, which was really a long time to pack-out the materials, longer than we expected. But, about midway through the pack-out, some folks on campus fired the first recovery processing firm and hired another one. Half of our materials went to freezers in Wyoming, with the first firm. The other half went to Fort Worth.

In packing out with the second group, they tried a new process. They had hired someone who does a lot of effects for movies, and so when they got all of the boxes into the trailers, he filled each trailer with liquid nitrogen until the nitrogen actually got the inside of the trailer to about 30 to 40 degrees below zero. That's how the second half of our damaged materials left campus.

Whenever I talk about this, I always say that this was no ordinary, run-of-the-mill library flood. What really had happened was that we had a flash flood in the library, in the basement, because a wall broke. There was a big hole in the wall, two million pounds of water with a flow of about 5,000 square feet. The flood literally knocked over a lot of the ranges of shelving.

We have literally been pioneers in this. Nobody in this country had really gone through what we have, though there have been smaller situations where maybe 20,000-26,000 books were damaged. We designed three major projects practically in the first week.

Our water damage was not from roof leakage, nor was it water coming up. The flash flood created a great mess for us because of the amount of our materials floating in the water. So, we had to make some major assumptions. Absolutely everything we did was based on assumptions. So far, we've been pretty close on those assumptions, but we have a lot more to go.

We concentrated on three areas for public services. We have set up six Ariel remote sites that are working exclusively for CSU. We selected four Alliance libraries, Colorado Association of Research Libraries, based on their collections. I want to publicly thank Cornell, because Sarah Thomas and her folks did agree to be the fifth site, based on their collection, particularly, veterinary medicine, forestry, agriculture, etc. I also want to thank Sherry Schmidt and Arizona State University, because we also went to them. Those are operating as of this week.

We knew that, in terms of bound periodicals, we circulated at least 22,000 times per month in previous years. So we anticipate that there will be at least 1,000 Ariel orders per day that will go to these six sites, as well as to our interlibrary loans sites that have agreed to give us extraordinary services.

We also enhanced our interlibrary loans program. We hired about five more FTE—I understand that's probably about 10 student workers. A couple of weeks ago, we got about 200 orders in one hour. That's considerable for us.

We enhanced our UnCover services. Since July 29th, the day after the flood, to date, we have expended \$206,000 just with UnCover. We had to do that because we knew that there would be a certain length of time between the day of the flood and the time that we got the Ariel workstations up that we would have to use document delivery for all of the journals that we could not provide to our students and faculty.

Then we also implemented the shuttle busses. I was not real happy about this one, though it was our idea. We knew we had to do it. It goes to four sites, again, chosen based on collection: University of Colorado at Boulder; University of Northern Colorado, because of their education collection; University of Denver, because they have the third largest collection in the state; and the Colorado School of Mines for engineering and technology.

The second area that we concentrated on was technical services. In this area, there were two major projects that we have started. The first is what we call the 6,000 Plus program. The President decided that he would like for us to purchase copies of the most-circulated monographs that had been damaged and packed out in the library. We came up with a figure of 6,136 items.

Unfortunately, the Vice-President for Administrative Services had said that this could be done in 30 days. We reported that we had at least a thousand that had already been purchased through BNA and that they were already on the shelves; that was not the 6,000 that he was expecting by the end of August.

The second project is the processing plant. This processing plant is as big, in terms of FTE, as is the entire staff at CSU libraries. We are outsourcing this particular center. They will be processing the damaged books coming in, the 6,000 plus replacements, and the aggressive gift materials from the campaign we have.

That center alone will cost \$16 million, and it will take from 18 months to two years to get everything processed. It's a major project. We anticipate that there are three parts to it on the processing side. The outsourcing part we've called "Earth." The library part, which includes the gifts and the 6,000-Plus Program is called "Venus." Finally, our gift program is called "Mars 1" and "Mars 2." That's the only way we can keep things straight.

The third area, our major gifts program, really had to be redesigned last week. We found out two things: first, the president was not happy; second, we had Disaster Recovery Services (DRS), the firm that packed out and shipped to Fort Worth, bring us a small truckload of about seven to eight randomly selected boxes of items that they had cleaned and processed. These boxes came from various stages of the packout: the first, third, fifth, seventh, ninth day, etc. Then, with the consultant, we came up with a sheet listing certain standards by which we could evaluate the materials.

We had insurance representatives, FEMA representatives, three different consultants, our preservation people, two library people, a couple of university administrators, and a teaching faculty member go through all the boxes and each, on their own, rate every book. We then entered that information in a database. The ratings were based on three categories of materials. The first was: it's acceptable, put it on the shelf right away. The second category is determined by the person who is unpacking the boxes and decides that an item doesn't look very good, but it doesn't look bad enough to throw away. Library staff will then consider whether those items will be kept or thrown away. The third category is the throw-aways. Based on those three categories we found that, out of all of those materials, only one volume was acceptable.

Because of that, we're now concentrating on journals for our gifts program. You have responded to our calls, and we ask you to be very patient. This is a massive program. We will be getting back to you.

What we heard from other folks who had gone through some kind of flood process was to control the gifts. However, to do so is very time consuming. In the redesign of the program last week, we put about another four or five FTE to work on this particular program.

We anticipate that we will probably take in more than 200,000 gifts. But, understand that we expect a lot of duplication, a lot of what we call non-exact titles, and a lot that we probably will not keep.

The insurance will only pay for us to process what they call "exact" titles. Any other titles cannot be processed through Earth or Venus.

The cost for this program so far, including bricks and mortar, is about \$40 million. The library, and that's why the president is really on top of this one, is the highest cost organization on campus, in terms of flood recovery.

Let me just share with you just a few challenges, and I will try to be as diplomatic as I possibly can. First of all, the bureaucracy is unbelievable. We are dealing with insurance reps, FEMA reps, and consultants. All of them have been very good, but each one of them has taken a different slant from the previous one, and that has affected our operations quite dramatically. We have had to make changes in terms of cost estimates and design based on the consultant *du jour*.

I would like to publicly thank Sarah Michalak, because Randy Silverman was the first consultant who came in and really steered us in the right way.

The second challenge is the administration. There has been a lot of what I would call micromanaging. These folks do not know libraries; they do not know library processing. They probably have learned more about libraries and library processing. They just assume you get a book and it's put on the shelf. They had no idea that this processing center (a) should have been a reality, and (b) would cost so much.

Funding. The issue here is that we have all these costs. We submit these operational plans, these cost estimates and then find out that we don't know if two, three, five, or ten years from now if each item, plan, or whatever it is, will be reimbursed either by insurance companies or by FEMA. That is very disconcerting. But, my position right now is, that's down the road and I'll deal with it when it happens.

Facilities. This processing center—believe it or not folks, it was a micromanagement decision—is going to be in the basement of the library. We have no landscaping mitigation that's completed yet. I keep reminding them about El Niño and we are quite concerned about a repeat flood. We got seven inches of water in four hours. All it took was four hours of rain for us to have this major flood damage.

The other issue in terms of facilities is storage. Right now, they don't want to pay to store all of the gifts coming in, but we have no shelves. So that continues to be a challenge.

Then there's one other area, in terms of challenge; I call it "personnel and personal." I have a stellar staff. That is what keeps me going. I have been blessed by folks in that library who not once have ever complained, who stay night and day. We have done overnights and people who come in on Sundays—they are just unbelievable. There are about 20 key people in the library who work with me.

The challenge, in terms of staff, is the workload. We have to operate the library, but we also work full-time in terms of flood recovery. It has taken a heavy toll on key staff, but we plug away.

Documentation is another challenge. We found out about six weeks after everything had started that we were supposed to be keeping time sheets on all our time spent on flood recovery. Then we found out last week that not only were we supposed to keep time sheets, but we were supposed to put down the particular activity and the length of time we were involved in it. I can't imagine what we're going to do about that.

The third thing I find very challenging is more personal, and I think you could identify with this: having to be positive all the time. If you're down for even a second, the staff picks up on it.

Let me leave you with the moral dilemma. We have found that within the next two weeks we have to decide on the fungicide. This material was not cleaned before it went out, because we didn't have the time to do that. It was cleaned and then they sprayed everything with what they call a slimicide and then they blocked it and then they refroze it and now they're going to freeze dryers and pallets.

We literally have to pick a fungicide, because the materials were contaminated. There was bacteria from sewage, etc., that's on every bit of the materials. The moral dilemma is that, as we check with the LC consultants and others, their experience has been with maybe 100 books, or perhaps as many as five thousand books.

The most effective fungicide is called OPP. We are talking about bringing potentially 400,000 items back to that library, with a fungicide residue, in a basement where there is no fresh air. We are losing sleep over that one.

That's my report. Wish us luck. Thank you.

MR. FRAZIER: Well, I know we're ready to ship you some books. I would assume, if we all ship books to you at once, it wouldn't be to your advantage. Is there a way you're managing that?



MS. ALIRE: Well, the good news is that you understand libraries and storage and shelving and are patient. You understand when we say that we will contact each one of your libraries and say, "Ship today," or "Ship this week." The bad news is that the President doesn't understand that.

We have redesigned the gift program so that by the end of March, to the President's satisfaction, we will have over 200,000 gift books. We don't know where we're going to store them. We are accepting about 2,500 gifts per day, in addition to the 7,000 items per week that we'll be getting back from the processing center.

We will contact you, and that's sort of where the bottleneck happens, because I only have so many people to do that. And if you can help with the shipping costs, fine. If not, we will find the funds.

MR. WEDGEWORTH (University of Illinois-Urbana): Why is your president so unhappy about the gifts program?

MS. ALIRE: Diplomacy. The gifts program and the 6,000 plus were his ideas. We had talked about doing this gifts program, and in the first meeting he said, "Well, I want at least 35 percent of the damaged material to be in gifts."

We did not originally design the program at the magnitude that we probably should have when we designed the processing center. So, when reporting to the President, I was very proud of what we have been able to do. We had, in fact, about 7,600 gifts already in a trailer that was donated to us to use.

He was very dissatisfied. He was expecting to have approximately 70,000 volumes worth of gifts in place by now. Again, though, we have no shelves; we have no storage. But, I have learned very quickly that you don't whine, you don't complain, and you don't make excuses. So, we cleared our calendars all last week and redesigned the program. We still don't have any place to put the volumes, though.

MS. BENGTON (University of Washington): Did you have to deal with the perception, especially at the administrative level, that you didn't need those books, that they could be accessed on a computer?

MS. ALIRE: Only at the beginning. One person came in and told the administration, don't recover the bound journals, get microfilm. We had 200,000 volumes of bound journals, so we did a quick study. We called UMI and randomly selected four titles across the disciplines, and got a cost estimate for only 20 years retrospective for each of those titles. One was as cheap as \$900 and another one was \$100,000. We took an average of those costs and I went back and asked, "Do you want to do that? It's \$283 million."

Then they came back with an idea for e-journals. I had just gone to a conference on the virtual library. So, I knew in the back of my mind that we didn't have a lot of e-titles, but I didn't have the data.

So, after some quick research, the next day I came forward and told them that the company with the most e-journals didn't have retrospective runs. That sort of finished that.

It also helped when I got the consultants on board. They have all been—except for two—library folks; so they understand libraries besides being experts on disasters. When I would prep them I could ask, "Would you please remind them," and they would help that way. Of course, once a consultant said it, then everything was fine.

MS. WERNER: Camila, many thanks.

MS. ALIRE: Thank you.

MS. WERNER: On behalf of all of us here, you can go home and tell your entire staff, including yourself, that we take off our hats to them.



### **Report on Paul Evan Peters Scholarship**

Now, we would love to have an update on the Paul Evan Peters scholarship. Chuck Henry.

MR. HENRY (Rice University): Thank you, Gloria. As most of you probably know, ARL and CNI have put together a Paul Evan Peters scholarship. The scholarship will be awarded annually to a student in a field related to information technology. The student chosen will evidence qualities that distinguished Paul Evan Peters, founding Director of the Coalition for Networked Information.

These qualities include: clarity of thought and analytical insight into the problems embodied in the emerging civics of networked information; a positive approach to bridging personal, technological, and bureaucratic issues to foster inclusiveness and advance the common good; and a commitment to democratic values and humor, vision, humanity, and imagination.

I have agreed to chair the fundraising efforts for this scholarship, and we hope, in the next couple of years, to raise an endowment that will generate about \$5,000 annually to perpetuate Paul's legacy. I will be working very closely, I hope, with some of you on this effort, and with Joan Lippincott in CNI. Joan and I will keep you posted on our activities and information relating to the scholarship.

Thank you.

MS. WERNER: Thank you very much.

Duane, I think it's time for the Executive Director's report.

### **Report of the Executive Director**

MR. WEBSTER: We were very pleased to welcome you to our offices last night for the reception. I hope you enjoyed your visit there. We continue to find ourselves in awe of the opportunity to work in such a wonderful facility, so well positioned and really put together in a way that allows us to work very effectively within the higher education community.

That location, on Dupont Circle, allows us to bring together a number of groups, particularly the presidential association groups, that find themselves realizing that, when they come to ARL, they are coming to a real place, with a presence in the Washington community.

I hope you feel welcome there. We would like to invite you, particularly the newer directors, to come by and meet with staff when you do come to D.C. We would love to spend time talking to you about what you are doing and how ARL relates to those activities.

I also just want to take a moment to acknowledge the ARL staff. You have a wonderful staff working on your behalf, and I would like you to join me in recognizing their hard work and their commitment to your institutions and the issues that we face. They are a joy to work with, an inspiration, and, believe me, they keep me running, trying to keep ahead of them.

We also had an orientation for directors new to ARL member libraries this year, an orientation that was intended to talk substantively about the nature of our agenda, how it changes, and what we are currently addressing.

I would urge those of you who have not looked at the Program Plan for 1997 to glance at it to see the range of issues presented therein. The agenda is dynamic and the discussions we have had the last couple of days will influence the 1988 program. It is dynamic, it does change, but it is focused. We do realize that we're a small organization. We have to limit and focus our efforts on a few things. Working with the Board and with the committees, you can see that we have been able to identify the handful of issues on which we need to focus our efforts.

In the orientation, we had the opportunity of having the staff talk about the programs they're operating, what those programs are doing, and how they're doing it. I thank Gloria for asking the senior staff to discuss the programs and activities at enough length and detail to give, at least, the new members a chance to understand and be aware of the character and nature of the priorities.

A couple of announcements. First of all, there is a new electronic address for the ARL. There's a new domain. We are now <<http://www.arl.org/>>. We are moving to the new address, so all of the individual email addresses for ARL staff will be <name@arl.org>.

Secondly, at the turn of the year, the Office of Management Services will change its name to the Office of Leadership and Management Services. That change will likely correspond with the appointment of a new OMS director. We are making good progress in the search for the OMS director. We have an excellent pool of candidates; it's small, but it's sterling.

I would invite any of you who would like to nominate additional people to do so. We expect to identify the handful of people whom we want to interview in the next several weeks. We expect to interview in November and hope to have closure on this position by the end of the year. We are working closely with the Leadership and Management Committee in this process. They've helped us define the job description and Paul, Sarah, and Sherry will be working with us in the interview stage.

I would just like to close by saying a thank you to Gloria. She is a delight to work with and we've had a wonderful year together. Thank you.

MS. WERNER: Thank you, Duane. It's been an absolute delight for me, as well.

#### **Tributes to Board Members and Transfer of Presidency**

Could three of my colleagues join me at this point in time? Nancy Cline, Nancy Eaton and Barbara von Wahlde have just concluded their terms on the ARL Board. I can't quite describe for you the relationships that have developed amongst the people who serve on this hard-working Board. I believe that more friends and a closer relationship are built here than in any other sector of association work in our profession. So, it is my great pleasure to give to the two Nancies and Barbara these certificates of appreciation for a fantastic job done on the Board of ARL.

I have a feeling that it's time for me to turn this gavel over to Mr. Jim Neal. I just am going to take two seconds to try to convey to you some of the thoughts that I have had about this. You know, I did not become an ARL director until about seven years ago. This is the end of my fifth year on the Board, and, I am pleased to say, I get to stay on one more year.

I truly mean it when I say this has been the most satisfying, the most instructive, really the best external professional kind of responsibility I have ever had happen to me. So, I asked myself this morning, why is that? Several things stand out my mind. First of all, this association is a relatively small one. It's very collegial. We have a great deal in common when we talk to our peers here, and we can really get to know almost every individual.

Probably more importantly, this Association, in my view, has come to focus on the few major issues that will really make a difference, not just now, but in the future for our libraries and for our institutions. I have taken a great deal of pleasure in watching the impact that a tiny little group like this can have. Just to give one example, consider our impact on federal legislation regarding intellectual property and copyright issues.

I think of our partnerships with higher education associations, our partnerships with learned societies. We have gotten really good at this over the last few years and I think it's critical that we continue in this same way. Obviously, we need to have partnerships with library associations.

Give a little bit of thought to how far we've come, in a very short time, with scholarly communication. We have a fantastic office. Actually, we have just fantastic people working in ARL overall. I shouldn't really just single any group out.

The potential of our Global Resources Program, which is something I think all of us need to devote a lot of thought to, is considerable. Within our own midst, we can either make these programs eminently successful or not. I think we all owe it to our successors to do as much as we can in those areas.

Duane, you are very fond of commending your superb staff here. Let me do the same. I have gotten to know them not by working with them here in Washington, but rather by communicating with them with great frequency from way out on the West Coast. I have not before had the occasion to work with such a small and superb group of professionals all across the board. That, in itself, is a really fantastic experience. So, let me ask all of you to join me in giving the ARL staff a big hand.

(Applause)

It is now my pleasure to hand over the gavel to Jim Neal.

MR. NEAL: Thank you, Gloria. You not only have been such an extraordinarily effective president, but you bring such class and dignity to your leadership. We thank you for that. As a token of our appreciation for all that you've done for the Association, we have the traditional paperweight. We thank you.

(Applause)

I look forward to serving you as president. I look very much forward to working with the Board and with membership over the coming year. Thank you.

# SPARC

## The Scholarly Publishing & Academic Resources Coalition

**Proposed Mission:** SPARC is conceived as a partnership project of the Association of Research Libraries (ARL) and other educational and research organizations. Its mission is to be a catalyst:

- To Create a more competitive marketplace for research information by providing opportunities for new publishing ventures; endorsing new publications and information products; and recruiting authors, editors, and advisory board members.
- To Promote academic values of access to information for research and teaching; the continuation of Fair Use and other library and educational uses in an electronic information environment; and the ethical use of scholarly information.
- To Encourage innovative uses of technology to improve scholarly communication by collaborating in the design and testing of new products; advancing new publishing models as appropriate applications of electronic networks, such as Internet 2; and developing systems and standards for the archiving and management of research findings.

**Background:** In 1988 the Association of Research Libraries (ARL) commissioned a report by Economic Consulting Services, Inc. (ECS) to review price data for four large commercial publishers as compared to estimated publisher costs for the years 1973 through 1987. The contractor's report concludes the Executive Summary with this sentence:

*If such estimated rates of growth are reasonably accurate, then the library community would benefit greatly from such measures as the encouragement of new entrants into the business of serials publishing, and the introduction of a program to stimulate greater competition among publishers . . .*

Similar findings and resolutions appear at regular intervals in the minutes of ARL meetings since the time period covered by the ECS report. During the last decade, the need for "new entrants" and "greater competition" in the serials marketplace has become increasingly urgent because of the growing concentration of the publishing industry and the limited effectiveness of local strategies to control costs. ARL statistics confirm that research libraries are spending ever increasing amounts of money to buy fewer titles, despite canceling hundreds of thousands of dollars worth of journal subscriptions. With prices continuing to increase by more than 10 percent annually in many disciplines, the cost of maintaining research collections has become unsustainable for many institutions. Although it has been slow in coming, transformative change in the scholarly communication system has been made possible by the convergence of four key factors:

- Alternative models of scholarly communication are now economically and technologically feasible.
- Capable partners are ready to join with research institutions to create new publishing alternatives.
- Libraries and universities are prepared to redirect budget resources to support new forms of scholarly publishing.
- Faculty and academic administrators will support initiatives that offer realistic alternatives for disseminating research findings and scholarship.

## **The Emerging Plan**

On June 30, 1997, representatives from 45 ARL institutions met to discuss a proposal to create an electronic publishing fund and to seek publishing partners interested in entering the serials market in areas in which prices are highest and there is the greatest need for alternative models of research communication. The meeting resulted in the formation of a small working group of library directors who volunteered to work with ARL staff in developing an action plan.

## **Potential Partners**

The working group identified potential partners that are actively considering opportunities to develop new approaches for disseminating research findings. The organizations that are interested in forming partnership relationships with libraries and educational institutions include:

- Professional societies and university presses interested in launching new publishing initiatives.
- Start-up electronic publishers that have already created publications in subject fields dominated by commercial publishers.
- For-profit enterprises that offer new strategies for controlling costs and improving access to research information.
- "Visionary" enterprises, including both discipline and institution-based server models, seeking to create entirely new economic models for scholarly communication.

## **Proposed Management Structure**

The Scholarly Publishing & Academic Resources Coalition will be established initially as a project of the Association of Research Libraries, closely linked to the Office of Scholarly Communication. Members of SPARC will include ARL libraries and their institutions. An ad hoc Working Group to be appointed by the ARL Board of Directors will guide the next phase of SPARC's development.

SPARC will develop a membership model that invites the participation of non-ARL institutions and other educational and research organizations in the effort to establish new models of scholarly communication.

## **First Efforts**

The Scholarly Publishing & Academic Resources Coalition Working Group will be charged with the responsibility to develop a business plan and action agenda to support at least five alternative publishing ventures during the next twelve months.

For further information contact: Mary Case, Director, Office of Scholarly Communication, Association of Research Libraries, 21 Dupont Circle, N.W., Suite 800, Washington, D.C. 20036 (202) 296-2296 x112 Fax: (202) 872-0884 Internet: marycase@arl.org

*Draft October 14, 1997*



## POTENTIAL PARTNERS

- Scholarly and Professional Societies
- University Presses
- Universities
- Consortia
- Publishers
- Libraries
- Technology Organizations
- Utilities
- Government Agencies
- Research Institutes

Association of Research Libraries SPARC



## TYPES OF PARTNERS

- a publishing organization with the technical infrastructure and resources in place to develop new products
- a publisher with current products that it wishes to publish under the name and the principles of SPARC
- a publisher (e.g., university press, society) that needs resources to finish building the infrastructure to develop new products
- an organization (e.g., utility, library, consortium) with the technology in place to support the publications of others

Association of Research Libraries SPARC



## CRITERIA FOR SELECTING PARTNERS

- Shared Values
- Readiness
- Credibility
- Leadership
- Technical Infrastructure
- Publishing Experience
- Commitment of Resources

Association of Research Libraries SPARC



## SHARED VALUES

- Fostering a competitive market for scholarly publishing by encouraging new participants in the publishing field.
- Developing policies for intellectual property management emphasizing broad and easy distribution and reuse of material.
- Encouraging innovative applications of available information technology to enrich and expand research and scholarship and the available means for distribution.
- Assuring that new channels of scholarly communication sustain quality requirements and contribute to promotion and tenure processes.
- Enabling the permanent archiving of research publication and scholarly communication in digital formats.

Association of Research Libraries SPARC



## SPARC

### ARL Statement of Principles *(June 1994)*

1. Promote scholarly publishing in the public interest
2. Preserve fair use & information user rights
3. Use technology to preserve & disseminate knowledge
4. Develop licensing models that serve research needs
5. Educate & inform scholars of new publishing models
6. Continue access to publicly funded research findings
7. Establish new economic models that preserve incentives

Association of Research Libraries SPARC



## ARL SERIALS PRICES PROJECT

### Report Recommendations:

- Communicate nature of the problem to constituencies
- Orchestrate actions to introduce greater competition
- Form partnership with scholarly groups to examine scholarly publishing and to manage information explosion

Report, 1989

Association of Research Libraries SPARC





**INSTITUTIONAL  
MANAGEMENT  
STRATEGIES**

- Journal cancellation/reduced acquisitions
- Improved document delivery service models
- Cooperative collection development
- Site licensing for electronic information resources
- Consortial licensing by groups of institutions

Association of Research Libraries

SPARC



**REED ELSEVIER 1995  
BUSINESS DATA**

In 1995, 15% of sales and 26% of operating profits came from scientific publications.

Elsevier Science accounted for 76% of the company's revenues from "Scientific" publications in 1995.

Lexis-Nexis accounted for 49% of the "Professional" publications revenues in 1995.

*Standard and Poor's Stock Reports (1/29/97), p.1907.*

Association of Research Libraries

SPARC



**ELSEVIER SCIENCE**

**Our Mission**  
Elsevier Science intends to be the preferred global scientific information provider.

**Toward a More Informed Future**  
Our size and experience give us a vital edge in dedicating human and financial resources to copyright issues. As information delivery methods are influenced by technology, we will continue to advance the interests of authors by protecting against improper and illegal use or reproduction.

*Elsevier Science Web site*

Association of Research Libraries

SPARC



**REED ELSEVIER &  
WOLTERS KLUWER  
MERGER**

**New Company**  
*Elsevier Wolters Kluwer*

The companies had combined 1996 sales of \$6.6 billion.

*"The main thing is that they can now together make the large investments needed for the change from print publishing to electronic publishing."*  
Rainer Westering, an analyst with Streeve Bank in Amsterdam.

*NY Times, 10/14/97, p. D6.*

Association of Research Libraries

SPARC



**REED ELSEVIER  
HOLDINGS**

- MDL Information Systems
- The Michle Co.
- National Register Publishing
- OAG (Official Airlines Guide)
- Reed Books
- Reed Elsevier Business Information
- Reed Elsevier Technology Group
- Reed Educational & Professional Publishing
- Reed Elsevier Legal Division
- Reed Exhibition Companies
- Reed Travel Publishing
- Reed Technology and Information Services
- K.G. Saur
- Shepard's
- Springhouse Corporation
- Utah International

Association of Research Libraries

SPARC



**REED ELSEVIER  
HOLDINGS**

- Bowker/Saur
- Butterworth/Heinemann
- Cahner's Publishing
- Chilton's
- Congressional Information Service
- Editions Du Juris-Classeur
- Editions Scientifiques et Medicales Elsevier
- Elsevier Opladingen
- Elsevier Science (imprints include Elsevier, Pergamon, North-Holland, Excerpta Medica)
- Greenwood Publishing Group
- IPC Magazines
- The Lancet
- LEXIS-NEXIS
- Marquis Who's Who
- Martindale Hubbell

Association of Research Libraries

SPARC

## Donaldson v. Beckett

### Ends the Booksellers' Monopoly

"They take all our learning and set what price their avarice chuses to demand, till the public become as much their slaves as their own hackney compilers are."

Lord Camden, c. 1774

"the booksellers of London have endeavoured of late to monopolize books of all kinds, to the hurt of all booksellers and to the prejudice of all his Majesty's subjects in the three Kingdoms as well as the British colonies."

Alexander Donaldson

"The booksellers, who, like all other men, have strong prejudices in their own favor, are enough inclined to think the practice of printing and selling books by any but themselves, an encroachment on the rights of their fraternity."

Samuel Johnson

"The London booksellers play me all manner of tricks. If I do not allow them ridiculous profits, they will do nothing to promote the sale."

Horace Walpole

## APPENDIX II

### ASSOCIATION OF RESEARCH LIBRARIES

#### REPORT ON ASSOCIATION ACTIVITIES MAY-SEPTEMBER 1997

##### TABLE OF CONTENTS

<b>Preface</b> .....	145
<b>ARL Mission Statement and Strategic Objectives</b> .....	147
<b>ARL Capabilities</b> .....	148
<b>1. Scholarly Communication and Information Policies (Objective 1)</b>	
1.1 Office of Scholarly Communication	
1.1.1 Scholarly Communication Committee	
1.1.2 Firm Subscription Prices Working Group	
1.2 Federal Relations and Information Policy Development	
1.2.1 Committee on Information Policy	
1.3 Intellectual Property and Copyright Issues	
1.3.1 Working Group on Copyright Issues	
1.4 AAU/ARL Research Libraries Project	
<b>2. Access and Technology (Objectives 2 and 5)</b>	
2.1 Access and Technology	
2.1.1 Committee on Access to Information Resources	
2.1.2 Working Group on Scientific and Technical Information	
2.1.3 ILL/DD Performance Measures Committee	
2.2 Coalition for Networked Information	
2.2.1 Steering Committee for the Coalition	
<b>3. Collection and Preservation (Objectives 3 and 4)</b>	
3.1 Collection Services	
3.1.1 Committee on Research Collections	
3.2 Preservation	
3.2.1 Committee on Preservation of Research Library Materials	
<b>4. Staffing and Management (Objectives 6 and 7)</b>	
4.1 Diversity	
4.1.1 Diversity Committee	
4.2 Office of Management Services	
4.2.1 Organizational Development and Consulting	
4.2.2 Information Services	
4.2.3 Training and Leadership Development	
4.2.4 Committee on the Research Library Leadership and Management	
<b>5. Performance Measures (Objective 8)</b>	
5.1 Statistics and Measurement	
5.1.1 Committee on Statistics and Measurements	

- 6. **Supporting Capabilities**
  - 6.1 Governance
    - 6.1.1 Standing Committees and Selected Advisory/Project Groups
  - 6.2 Communications and External Relations
    - 6.2.1 Publications
    - 6.2.2 Electronic Communications and Technology
  - 6.3 Membership Meetings
  - 6.4 International Relations
  - 6.5 General Administration
- 7. **Research and Development**
  - 7.1 Office of Research and Development
    - 7.1.1 Visiting Program Officer
    - Summary of Grant Funded Activities
- Glossary ..... 190

## PREFACE

ARL is unique in bringing together the chief officers of 121 major research libraries throughout North America. To pursue the association's mission "to shape and influence scholarly communication," member library representatives call for ARL to focus on a limited number of key issues with special attention given to matters that warrant collective or coordinated actions.

Eight strategic objectives articulate the scope of ARL's agenda; defining strategies to pursue these objectives is the result of ongoing communication between and among member library representatives and association program staff. Typically, the ARL Board or a standing committee discusses and shapes ARL's agenda for any particular matter; full membership discussion about committee findings and/or recommendations for ARL action takes place during the semi-annual membership meeting programs and business meetings.

ARL has eight standing committees and a smaller number of working groups and project advisory committees. The charge and scope of the standing committees tend to be defined broadly; committee members, with active involvement and assistance from association staff, develop targeted agendas based on the committee's sense of greatest needs and potential payoff for member libraries. Committee members also provide guidance to the Board and to program staff on the development of ARL program capabilities to advance ARL's objectives. As a result, committee agendas and program capabilities are in a perpetual cycle of renewal. From time to time, program developments may prompt the Board or a committee to request a review or clarification of a committee charge. Current committee agendas are summarized as part of each program capability report.

The Board's responsibility as the governing body for the association includes the endorsement of program priorities and an accompanying budget for allocating member dues and other ARL resources. In addition to reviewing the substance of ARL's annual agenda, the Board monitors the horizon issues facing research libraries to anticipate where ARL program strengths will be needed. In 1994, following adoption of the ARL mission and strategic objectives, the Board put in place a set of developmental priorities for ARL programs that link the budget setting process to ARL's planning priorities.

Five developmental priorities for ARL programs were identified to guide the Board's stewardship of ARL resources during the near term. These developmental priorities are:

- **Federal Relations:** undertake an accelerated legislative agenda (re-digitizing research resources, copyright, telecommunications).
- **Legal Counsel:** secure legal counsel on matters affecting rights and responsibilities associated with intellectual property.
- **Minority Recruitment:** develop ARL's newest program capability to build a pool of talented and culturally diverse research librarians.
- **Refreshing Management Programs:** provide leadership training, performance measurement, and organizational improvement programs that will assist libraries to make a successful transition to the electronic environment.
- **Access to Research Resources:** accelerate collaboration between libraries and a broad constituency of private sector players to extend access, contain costs, and strengthen the delivery of remotely-held resources and materials.

An additional, ongoing priority is the Board's commitment to build a member generated reserve fund for ARL.

In February 1997, the Board reviewed and endorsed a draft of the ARL Program Plan distributed to member libraries in the spring. As a result of that review, the Board identified the following activities



as 1997 priorities for ARL:

- Accelerate and broaden copyright advocacy and education within the research and educational communities and the general public;  
See Section 1.3
- Build partnerships to explore and promote cost effective strategies and models for managing global scholarly communication;  
See Section 1.1, 1.2, 2.1, 2.2, 3.1, and 3.2
- Develop programs and products to help research libraries move into a transformed environment;  
See Section 1.1, 2.1, 4.1, 4.2, and 5.1
- Influence the development of advanced networking applications and Internet2.  
See Sections 1.2 and 2.2

How the Association pursues each of the above is the challenge and the opportunity for ARL programs this year.

The following report is an overview of ARL activities for the current year. It is organized first into nine sections describing distinct program capabilities, two of which highlight activities around intellectual property and copyright issues (Section 1.3) and ARL's collaboration with the Association of American Universities (Section 1.4). This is followed by a series of reports on supporting capabilities including the Office of Research and Development. In each section, there is a summary of activities of the year and highlights of committee agendas—all presented in the context of one of ARL's eight strategic objectives.

## ARL MISSION STATEMENT AND STRATEGIC OBJECTIVES

The mission of the Association of Research Libraries is to shape and influence forces affecting the future of research libraries in the process of scholarly communication. ARL programs and services promote equitable access to, and effective use of recorded knowledge in support of teaching, research, scholarship and community service. The Association articulates the concerns of research libraries and their institutions, forges coalitions, influences information policy development, and supports innovation and improvement in research library operations. A not-for-profit membership organization comprising the libraries of North American research institutions, ARL operates as a forum for the exchange of ideas and as an agent for collective action.

**Objective 1. Scholarly Communication & Information Policies**

To understand, contribute to, and improve the system of scholarly communication and the information policies that affect the availability and usefulness of research resources.

**Objective 2. Access to Research Resources**

To make access to research resources more efficient and effective.

**Objective 3. Collection Development**

To support member libraries' efforts to develop and maintain research collections, both individually and in the aggregate.

**Objective 4. Preservation**

To support member libraries' efforts to preserve research collections, both individually and in the aggregate.

**Objective 5. Technology**

To assist member libraries to exploit technology in fulfillment of their mission and assess the impact of educational technologies on scholarly communication and on the role of research libraries.

**Objective 6. Staffing**

To identify on an ongoing basis the capabilities and characteristics required for research library personnel to best serve their constituencies, and to assist member libraries and educational programs in the recruitment, development, and effective use of staff.

**Objective 7. Management**

To assist member libraries in augmenting their management capabilities.

**Objective 8. Performance Measures**

To describe and measure the performance of research libraries and their contributions to teaching, research, scholarship, and community service.

## **Section 1: Scholarly Communication and Information Policies**

### **1.1 Office of Scholarly Communication**

The OSC undertakes activities to influence the forces affecting the production, dissemination, and use of scholarly and scientific information. The Office seeks to promote innovative, creative, and alternative ways of sharing scholarly findings, particularly through championing evolving electronic techniques for recording and disseminating academic and research scholarship. The Office also collaborates with others in the scholarly community to build common understanding of the challenges presented by electronic scholarly communication and to generate options for concerted action. OSC activities build on the results of the ARL Serials Prices Project as well as interest and research ongoing in the profession. The capability receives guidance from the ARL Committee on Scholarly Communication.

#### **Summary of 1997 Activities**

In seeking to understand, contribute to, and improve the system of scholarly communication, the OSC engages in a number of short and long-term strategies to transform the process of scholarly communication and assist the various constituents of the educational community to work in a transitional environment while planning for the future.

#### **Pew Roundtable on Managing Intellectual Property**

As a result of discussions with the Associate Director of the Pew Higher Education Roundtable, a speaker at the October 1996 membership meeting, Pew invited ARL to co-sponsor a national roundtable on the management of intellectual property in higher education. Co-sponsored by ARL and AAU, the Roundtable will bring together 25-30 key members of the higher education community in a meeting in Baltimore on November 13 and 14, 1997. The purpose of the Roundtable is to examine how the academy, in cooperation with not-for-profit publishers and scholarly societies, can take steps to manage its own intellectual property in more cost-effective ways while assuring sustained access to scholarly research. The discussions will result in the publication of an issue of *Policy Perspectives* and, it is hoped, a commitment to concerted action. ARL and AAU have received funding for this special event from the Gladys Krieble Delmas Foundation and the W. K. Kellogg Foundation.

#### **A Proposal for Participation in the Scholarly Publication Process**

At the ARL May Membership Meeting, Ken Frazier, University of Wisconsin, proposed that ARL libraries join together to create an electronic publishing fund and identify partners willing to publish Scientific, Technical, and Medical journals in order to develop a more cost-effective market. Forty-five ARL institutions sent representatives to a meeting in San Francisco during ALA to discuss this proposal. A small group of directors was charged with developing the concept and beginning discussions with potential partners. At its July meeting, the ARL Board encouraged the group to continue its work and to develop a business plan for consideration at the October meeting.

#### **AAU Committee on Digital Networks and Intellectual Property**

ARL continues to work closely with AAU through a variety of formal and informal mechanisms to address both policy and legislative issues. AAU, as a part of an internal restructuring, created a new committee on Digital Networks and Intellectual Property. This committee is chaired by Gerhard Casper (President, Stanford University), and members include presidents, chief academic officers, librarians, chief information officers, and law professors/legal staff. The librarians appointed to the committee are Peter Lyman (California, Berkeley) and James Neal (Johns Hopkins). The committee is in the process of defining its agenda. Several proposals, such as the electronic publishing fund and the separation of peer-review from publishing, have been presented to the committee. This group supplants the AAU/ARL Research Libraries Steering Committee.

#### **Conference on the Specialized Scholarly Monograph**

ARL, AAUP, and ACLS co-sponsored a program on the crisis in publishing the specialized scholarly monograph. Held on September 11 and 12 in Washington, D.C., the conference was attended by approximately 150 representatives of university presses, libraries, scholarly societies, faculty, and administrators. The program covered a broad array of issues involved with the scholarly monograph and explored alternatives offered by new technologies. The papers from the conference will be mounted on the ARL Web site and will be published. ARL was represented on the Program Planning Committee by Joe Hewitt (North Carolina, Chapel Hill), Carol Mandel (Columbia), and Karin Wittenborg (Virginia). Mary Case, OSC, coordinated the program planning.

#### **Endangered Monograph Proposal**

ARL is developing with the American Historical Association (AHA) a proposal to explore the feasibility of an electronic repository to support the dissemination and use of scholarly works. The proposal was reviewed by the ARL Scholarly Communication Committee and by the AHA Board. A meeting to develop the proposal further was held in conjunction with the Scholarly Monograph Conference. About 25 participants representing university presses, libraries, and scholarly societies attended. The discussion was extremely helpful, and as a result, a revised proposal will be developed.

### **NHA Principles for Managing Intellectual Property**

In early April, the National Humanities Alliance adopted a statement of Basic Principles for Managing Intellectual Property in the Digital Environment, developed by the NHA Committee on Libraries and Intellectual Property. The document is intended to help build consensus within the educational community on mutual expectations for publisher and user behavior regarding the use of intellectual property in the digital environment. The statement has been endorsed by 16 organizations thus far, including ARL, ALA, the American Council of Learned Societies, NINCH, Music Library Association, Modern Language Association, the American Historical Association, and others. Individual ARL member institutions are encouraged to use the Principles to foster local discussion and to seek institutional endorsement. The NHA Committee is chaired by Duane Webster and is supported by Mary Case, Prue Adler, and Mary Jackson. The Principles can be found at <[http://www.ninch.cni.org/ISSUES/COPYRIGHT/PRINCIPLES/NHA\\_Complete.html](http://www.ninch.cni.org/ISSUES/COPYRIGHT/PRINCIPLES/NHA_Complete.html)>.

### **Principles for Licensing Electronic Resources**

A set of principles for licensing electronic resources was drafted by a working group representing the American Association of Law Libraries, ALA, the Association of Academic Health Sciences Libraries, ARL, MLA, and SLA. The draft has now been endorsed by all six organizations and will be widely distributed in the library and publishing community. The Principles are intended to guide libraries in negotiating license agreements for access to electronic resources and to provide licensors a sense of the issues important to libraries and their user communities. SLA provided funding to support the development and distribution of the principles. Mary Case represented ARL on the working group and has coordinated the effort. Drafts of the Principles were reviewed by the ARL Working Group on Copyright Issues and the Scholarly Communication Committee. The ARL Board endorsed the July 15 Final Draft at its July meeting. The Principles are available on the Web at <<http://www.arl.org/scomm/licensing/principles.html>>.

### **Licensing Workshops**

ARL has developed a workshop for libraries on the review and negotiation of licenses for electronic information resources. Two workshops are planned for the fall, one was held in Boston (September 18-19) and one will be held in Chicago (November 20-21), with plans underway for California and North Carolina early in 1998. Visiting Program Officer Trisha Davis (Ohio State), was appointed to help design and present the workshops. Karen Hersey, MIT Intellectual Property Counsel, is also participating. A workshop with CARL for its October meeting is also being planned. A half-day session on licensing will be offered for ARL directors in conjunction with the October Membership Meeting. A one-day seminar is also being developed for the Association of American Health Sciences Libraries meeting in early November.

### **Licensing Electronic Resources: Strategic and Practical Considerations for Signing Electronic Information Delivery Agreements**

A booklet entitled Licensing Electronic Resources: Strategic and Practical Considerations for Signing Electronic Information Delivery Agreements was prepared by Patricia Brennan (ARL), Karen Hersey (MIT), and Georgia Harper (Texas). It was published by ARL in February 1997 and made available electronically at <<http://www.arl.org/scomm/licensing/licbooklet.html>>. It is also available from the ARL Publications department at <[pubs@arl.org](mailto:pubs@arl.org)>.

### **Electronic Scholarly Publication**

Electronic Scholarly Publication was the topic of Transforming Libraries #3, published in June. Written by George Soete with editorial advice from the Mary Case, Director of OSC, the publication reviews current activities in 14 institutions including libraries, publishers, and aggregators.

### **Directory of Electronic Journals, Newsletters, & Academic Discussion Lists**

This year's Directory, the seventh edition, will soon be available. The number of entries has again grown dramatically. The 1997 Directory will include over 3400 titles of electronic journals and newsletters as well as over 3800 electronic discussion groups. As in past editions, each entry includes a description and access information. In the e-journal section, readers will also find information as to whether a title is peer reviewed, whether back issues are available, and whether there is a fee for subscriptions. New to this edition is a subject index which will make locating Internet resources much easier. The 1997 Directory will be available in both print and on the WWW with full search capabilities. Research Assistants Ann Doty, Joy Booker, and Jennifer Dollar contributed to the project by locating titles, contacting editors, and verifying information. Research Associate Kim Maxwell developed the DEJ thesaurus and consultant Ed Fishwick assigned keywords to each e-journal entry. Dru Mogge serves as editor to the Directory.

See Section 6.2.2 for a discussion on the electronic communications agenda.

Mary Case, Director, OSC <[marycase@arl.org](mailto:marycase@arl.org)>

### 1.1.1 Scholarly Communication Committee

This committee was established in February 1991 by the ARL Board of Directors to help the Association understand, contribute to, and improve the system of scholarly communication. The committee is charged to monitor developments, determine critical issues requiring ARL attention, inform members, and design strategic responses that can serve to influence the future of scholarly communication. The Committee also advises and guides the ARL staff on matters regarding the plans and strategies of the Office of Scholarly Communication.

**Members:**

Scott Bennett	(1996-1998)
Susan Brynteson	(1996-1998)
David Ferriero	(1997-1999)
Paul Gherman	(1997-1999)
Eileen Hitchingham	(1996-1998)
Sharon Hogan	(1996-1998)
Margot Montgomery	(1995-1997)
Carole Moore	(1995-1997)
Margaret A. Otto	(1997-1999)
Carlton Rochell	(1995-1997)
Paul Wiens	(1997-1999)
Elaine Sloan, Chair	(1997-1998)

**Staff Liaison:** Mary Case, Director, OSC <marycase@arl.org>

### 1.1.2 ARL Firm Subscription Prices Working Group

To assist in efforts to obtain firm serial subscription prices in a timely fashion, the Board approved the formation of a working group under the aegis of the Scholarly Communication Committee. While actively sponsoring publisher and vendor meetings in its early years, the Working Group has been monitoring developments in a low-key mode for the past couple of years. The group consists of volunteers who offered their services to ARL to work on this issue.

Members of the Working Group were polled in October 1996 on the status of publishing pricing for 1997 and on the future of the Group. They reported some slippage in the timeliness of setting prices for 1997 and indicated an interest in continuing the Group's existence. The poll also sparked debate in the larger community over the effectiveness of the firm prices strategy.

**Members:**

- Tony Angiletta
- Scott Bennett
- Dale Canelas
- Lois Ann Colaianni
- Sheila Creth
- Fred Friend
- Paul Gherman
- Graham Hill

**Staff Liaison:** Mary Case, Director, OSC <marycase@arl.org>

## 1.2 Federal Relations and Information Policy Development

The Federal Relations and Information Policy Program is designed to: monitor activities resulting from legislative, regulatory, or operating practices of international and domestic government agencies and other relevant bodies on matters of concern to research libraries; prepare analysis of and response to federal information policies; influence federal action on issues related to research libraries; examine issues of importance to the development of research libraries; and develop ARL positions on issues that reflect the needs and interests of members.

Copyright and Intellectual Property issues are a major focus of this and other ARL programs. For an overview of activities in these areas and program plans for 1997, see Section 1.3.

### Summary of 1997 Activities

In 1997, ARL actively participated in information policy debates. ARL's focus has been to:

- respond to and shape national and international legislative initiatives that impact research libraries;
- influence agency programs such as the GPO Access Program;

- manage the ARL GIS Literacy Project;
- monitor and influence congressional appropriations; and
- provide regular updates on these selected national and international legislative activities via regular monthly federal relations e-news.

### Legislation and Legal Activities

Efforts to revamp federal information dissemination policies continued as ARL staff met with congressional and executive branch staff to discuss these proposals. ARL, with others in the library community, responded to numerous Government Printing Office proposals, including the GPO Transition Plan. ARL participated in numerous discussions with members of the executive and legislative branches regarding changes to Title 44, including the Inter Association Working Group on Government Information (IAWG), comprised of representatives of library associations. The IAWG submitted draft legislative language to members of Congress which will be considered in the debates regarding how to update Title 44 (printing and procurement) and the Depository Library Program. ARL with other members of the Working Group testified before the Senate Committee on Rules and Administration on proposed revisions to title 44. The Working Group testimony focused on the library community's comments on draft GPO-related legislation. Prue Adler is a representative to the Working Group.

### Influencing Agency Programs

ARL participated in a NASA program to evaluate user information needs for global change data (EOSDIS program). A key goal of the evaluation was to enhance public access to EOSDIS information. Prue Adler continues to participate in a USGS sponsored panel to examine issues relating to the National Land Remote Sensing Archive, specifically focusing on long-term access and preservation issues. ARL continues to collaborate with others in the public interest community and with agencies in implementing the Government Information Locator Service (GILS) proposal. GILS provides a framework and common approach for federal agencies to make their information resources publicly available.

Promoting the advancement of the NII continues to be a priority of the Clinton-Gore Administration. ARL's focus in this area has been to:

- influence specific legislative proposals, including those regarding networking and restructuring the telecommunications infrastructure;
- work with agencies to implement NII programs and respond to NII proposals;
- collaborate with others in the education, library, private sector, and public interest communities; and
- provide timely updates via the Federal Relations monthly e-news and related efforts.

### Legislation and Legal Activities

Restructuring the telecommunications infrastructure, due to the passage of the Telecommunications Act of 1996, resulted in a slight shift in ARL's agenda, summarized above. ARL reviewed and endorsed ALA filings before the Federal Communications Commission on discounted telecommunications rates for schools and libraries. These activities will continue on the federal and state levels for some time. Most recently, ARL joined with others in the library and education communities to request that the FCC clarify that, as noncommercial entities, libraries, colleges, and universities are not required to contribute to the universal services support mechanism.

### Communications Decency Act

ARL participated in challenging provisions included in the Telecommunications Act of 1996 that dealt with restrictive access to selected information resources. ARL actively opposed provisions included in Title V [the Communications Decency Act (CDA)] of the Telecommunications Act that sought to prohibit access to indecent or patently offensive materials via the Internet. These provisions would impose fines and criminal penalties for transmitting and/or providing access to these resources. ARL, as a member of the Citizens Internet Empowerment Coalition (CIEC), challenged the CDA in court. Several lower courts ruled that provisions in the CDA are unconstitutional and overly broad. The Supreme Court struck down the Communications Decency Act, a move seen by many in the public interest and civil liberties communities as a step toward establishing a "Bill of Rights for the 21st Century," and a clear victory for the First Amendment. The Court found that content-based regulations cannot be constitutionally applied to the Internet. In addition, the Court also found that the Internet is indeed a unique medium and deserves First Amendment protection at least as broad as that applied to the print environment. Finally, the Court noted that user-based filtering technologies are more effective than content regulations. Two related U.S. District Court cases in New York and Georgia were also struck down just prior to the Supreme Court decision on the CDA.

### Influencing Agency Programs

ARL staff worked with several government agencies in designing and proposing network applications programs, such as the NASA Information Infrastructure Technology and Applications Program (IITAP), the NSF/ARPA/NASA digital library initiative (DLI), and the NTIA IITAP program. This included working with staff of Appropriations Committees in support of these programs. Staff participated in the EOSDIS Users Report, an evaluation of user information needs for global change data; Project Alexandria, an NSF/ARPA/NASA Digital



Library Initiative; meetings of the High Performance Computing Coalition regarding continued support for HPCC programs and Next Generation Internet (NGI); and in NSF network related efforts. Prue Adler is a member of the Project Alexandria Design Review, an NSF/ARPA/NASA Digital Library Initiative.

ARL staff participate in the Internet2 initiative in addition to working with executive branch agencies involved in the related effort, Next Generation Internet (NGI). A number of ARL directors have been nominated to work with the members of I2 on applications issues.

ARL is a member of the Coalition for International Education, which supports funding for the Higher Education Act Title VI, International Programs. The Coalition has proposed revisions to the HEA Title VI programs in the upcoming reauthorization process. ARL, the National Humanities Alliance, and the Commission on Preservation and Access submitted a statement in support of the NEH FY98 budget request. ARL also provided testimony in support of the FY98 budget requests for the Government Printing Office and the Library of Congress before both the House and Senate Appropriations Committees. ARL staff and ARL directors actively supported funding for the GPO depository library program and for the NEH. In addition, ARL staff worked in support of the National Science Foundation FY97 budget request, including garnering support for the Social, Behavioral, and Economic Directorate and the Digital Library Initiative. ARL joined two science coalitions and COSSA to support NSF's budget requests. With others in the education, industry, and communications arena, ARL worked in support of the High Performance Computing and Communications Program and NGI. ARL staff and members actively supported the Department of Commerce TIIAP program in FY98 budget discussions and worked with a coalition of higher education groups and associations in support of HEA Title VI FY98 appropriations before the House and Senate.

ARL, with the American Library Association and the American Association of Law Libraries, testified before the House Subcommittee on [the] Legislative on FY98 appropriations for the Library of Congress and the Government Printing Office. Similar statements were submitted for the record before the Senate Appropriations Subcommittee on the Legislative Branch. Additional correspondence and Congressional visits continue as the House and Senate appropriations bills are considered in conference to resolve differences between the bills. In addition, ARL staff worked closely with staff of the House and Senate Appropriations Committees regarding approval of provisions for the Library of Congress to continue with the overseas program.

Finally, ARL continues to work with a coalition of over 800 non-profit groups to oppose language in appropriations bills that would severely restrict the ability of non-profits to work with others in the executive and congressional branches of government. These provisions continue to crop up in a number of appropriations and authorization bills. The ARL GIS Literacy Project continues to expand and evolve. The project seeks to educate librarians and users about GIS as well as to develop GIS capabilities in research libraries. Background materials related to this project, including a database of all project participants, are now available on the Web at <<http://arl.cni.org/info/gis/index.html>>.

ARL participates in numerous discussions and conferences related to the development of a national spatial data standard and issues relating to access to GIS resources. The increasing reliance upon GIS by multiple communities, including government agencies and members of the academic and research communities, indicate the need for research librarians to be well situated to provide access to the growing array of digital cartographic and spatial information. Prue Adler submitted a chapter and numerous articles on GIS and libraries to the leading GIS textbook, *Geographical Information Systems: Principles, Techniques, Management, and Applications*.

Under the auspices of ARL, a new effort to address GIS literacy for library and information science professionals will be undertaken during the next year. With additional funding from the Environmental Systems Research Institute and ALA, ARL, with librarians and geographers from University of Texas-Austin, ESRI, University of Dalhousie Library, and University of Maryland, will develop a web-based introduction to GIS for library and information science schools throughout North America.

The Federal Relations capability continues to publish the Federal Relations monthly e-notes. This service provides information electronically on topics of interest to members of the library and education communities. Ann Doty, Federal Relations Research Assistant, regularly updates the Federal Relations Notebook on the World Wide Web.

Prue Adler, Asst. Ex. Dir., Federal Relations & Info. Policy <[prue@arl.org](mailto:prue@arl.org)>

### 1.2.1 Committee on Information Policy

At the Committee's meeting in October 1996, members discussed FY 1997 priorities and requested that staff continue to focus on and respond to the following ongoing issues: copyright and intellectual property; telecommunications and networking issues with a particular focus on digital library applications, Internet2 initiatives and cost access issues; government information dissemination programs (with the understanding that an investment in maintaining more government information in the public domain will, in the long-term, have an impact on ARL's needed

investment in copyright and intellectual property); and support of agency programs that are of direct importance to research libraries.

<b>Members:</b>	Joe Boisse	(1997-1999)
	Jerry Campbell	(1996-1998)
	Nancy Cline	(1997-1998)
	Sheila Creth	(1996-1998)
	Kenneth Frazier	(1996-1998)
	Ernie Ingles	(1995-1997)
	Paula Kaufman	(1996-1998)
	Gerald Lowell	(1995-1997)
	Susan K. Martin	(1995-1997)
	Merrily Taylor	(1996-1998)
	Robert Wedgeworth	(1996-1998)
	James F. Williams	(1995-1997)
	Ann Wolpert	(1997-1999)
	Fred Heath, Chair	(1997-1998)

**Staff Liaison:** Prue Adler, Asst. Ex. Dir., Federal Relations & Info. Policy <prue@arl.org>

### 1.3 Intellectual Property and Copyright Issues

#### Summary of 1997 Activities

The ARL Board of Directors identified intellectual property and copyright as a defining set of issues for the future of scholarly communication. All programs were urged to identify ways to advance the ARL agenda in these critical areas. As a result, many programs contributed to the following 1997 activities:

- raise library and scholarly community awareness of issues associated with copyright and intellectual property management;
- review and respond to legislative revisions to the 1976 Copyright Act and related NII efforts;
- develop strategies in response to specific legislative proposals including the copyright term extension, PTO reform, sui generis database proposal, and the No Electronic Theft (NET) Act;
- develop strategies to respond to and participate in the UCC discussions concerning licensing in the electronic arena and, in particular, UCC 2b/mass market licenses;
- design strategies to respond to specific legal challenges when they arise;
- provide background information to the membership on new copyright and intellectual property proposals; and
- develop and distribute the copyright briefing packet and regular updates via the federal relations monthly e-news.

ARL continues to work closely with four other library associations on copyright issues through the Shared Legal Capability, with others in the public and private sectors through the Digital Future Coalition, and with those who share our common interests in the Database Proposal Coalition.

#### Shared Legal Capability

ARL is collaborating very closely with four other library associations on copyright and NII issues through the formation of the Shared Legal Capability (SLC). During 1997, SLC met with members of the Administration and congressional staff to discuss many proposed changes to the Copyright Act; participated in negotiations with other interested stakeholders on copyright term extension legislation; submitted statements to the House and Senate regarding the NII Copyright Protection Act of 1995; drafted alternative legislative proposals to the Act with others in the Digital Future Coalition; participated in congressional negotiations with online service providers and content owners on online service liability issues; and agreed to explore the development of "best practices" issue briefs (in lieu of "fair use guidelines") in selected areas such as e-reserves, ILL, and licensing; and joined four library associations (ALA, AALL, MLA, and SLA); four university presidential associations (AAU, AASCU, ACE, and NASULGC); and five organizations representing scholarly, educational, and cultural organizations (ACLS, NEA, NHA, NINCH, and NSBA) in the issuance of a press release that pledged to undertake a renewed effort to explore fair use in the digital environment in the aftermath of CONFU's last meeting. The signatories noted that no agreement was reached on proposals for fair use guidelines and their shared goal is to encourage the development, use, and sharing of fair use policies and practices that provide for the special needs and concerns of education and scholarship, while also providing as much clarity as possible about the boundaries of fair use as experience and good faith permit.

To help provide guidance in the evolving environment of licensing electronic resources, AALL, ALA, AAHSL, ARL, MLA, and SLA have combined to develop a statement of principles. The six associations represent an international membership of libraries of all types and sizes. The intent of the statement is two-fold: 1) to guide libraries in

negotiating license agreements for access to electronic resources, and 2) to provide licensors with a sense of the issues of importance to libraries and their user communities in such negotiations. SLA provided funding to support the development and distribution of the principles, which are available on the Web at <<http://arl.cni.org/scomm/licensing/principles.html>>. The process was coordinated at ARL by Mary Case.

#### **Digital Future Coalition**

With others in the public and private sectors, ARL formed the Digital Future Coalition (DFC). This Coalition is comprised of a diverse constituency of library, education, legal, scholarly, consumer, and public interest associations; hardware and software manufacturers; and telecommunications providers who share concerns with both the White Paper and pending legislation and who share the belief that any copyright legislation must strike a balance between owners, users, and creators of copyrighted works. Prue Adler is the ARL representative to DFC and is a member of the DFC steering committee.

The DFC submitted testimony to both the House and Senate on copyright-related bills; conducted numerous visits to meet with Members of Congress, their staff, and senior members of the Administration on copyright issues; sponsored a technology briefing for Senate staff; developed alternative proposals to those included in the legislation and submitted to the World Intellectual Property Organization (WIPO); launched a campaign focused on the international dimensions of the NII bills, particularly the activities of the WIPO; commenced a public awareness campaign regarding the critical importance of this legislation; and influenced the U.S. Administration's position submitted to WIPO, participated in the WIPO treaty deliberations, and successfully influenced the outcome of the WIPO deliberations. On September 17, Douglas Bennett, President of Earlham College, testified on behalf of the Digital Future Coalition on issues relating to W.I.P.O. implementing legislation. Dr. Bennett stressed the importance of achieving balance between the interests of owners, users, and creators of proprietary works.

He also spoke in favor of the treaties and in opposition to the implementing language as drafted. The DFC developed new legislative language that addresses a host of issues such as fair use, preservation, distance education, online service provider liability and more. Sen. Ashcroft (R-MO) introduced S. 1146, which included most of the DFC proposals. Rep. Boucher (D-VA) announced his intentions to introduce related legislation.

The Home Recording Rights Coalition (HRRC) and the Digital Future Coalition (DFC) launched an education effort regarding the upcoming congressional copyright debates. These Coalitions created bookmarks that state: "Protect Your Right To Read – Public access to information is being threatened," and "Fight for Your Right to Record – Learn about consumer products such as VCRs, computers, and DVDs." Both the HRRC and DFC websites are referenced for additional information. Several thousand bookmarks were distributed widely at the ALA Annual Conference, are being sent out by ARL with every publication order, and were distributed at the recent IFLA conference. The bookmarks are available in bulk from the HRRC at 800-282-8273.

#### **Ad Hoc Copyright Coalition**

ARL staff participated in another copyright-related collaboration, the Ad Hoc Copyright Coalition, comprised of private sector online service providers. This Coalition shares many of the same concerns as the SLC and the DFC and is primarily focused on network liability issues and the expansion of selected copyright owner's rights.

#### **Database Proposal Coalition**

ARL organized a new coalition to address issues relating to the database proposal and pending House legislation. ARL participated in numerous database forums, including presentations to the National and International Data Center Directors. In addition, there have been Congressional and Executive Branch visits and discussions.

#### **NII Copyright Issues**

ARL staff conducted numerous visits to House and Senate offices to discuss pending legislation on NII related bills, legislation seeking to extend copyright terms, and legislation seeking to extend new intellectual property protections to databases. In addition, Prue Adler and Mary Case prepared a paper on intellectual property rights issues for presentation at a workshop hosted by the National Research Council. The National Science Foundation asked the NRC to provide initial advice and recommendations on the construction of a digital National Library for undergraduate science, mathematics, and engineering education.

#### **Online Service Provider Liability**

On September 4, Robert Oakley, Professor of Law, Georgetown University Law Center and Director of the Law Library, testified before the Senate Judiciary Committee on behalf of 18 library and education organizations and associations concerning online service provider liability issues. On September 16, Professor Oakley testified on the same issue before the House Subcommittee on Courts and Intellectual Property, a division of the Committee on the Judiciary, on behalf of 23 library and education organizations.

#### **Copyright Term Extension**

Members of SLC participated in negotiations with other stakeholders on legislative proposals seeking to extend the copyright term from life of the author plus fifty years to life of the author plus seventy years. Prue Adler and Arnie

Lutzker, Fish & Richardson, represented ARL in these discussions, which were facilitated by the Register of Copyrights.

#### **CONFU**

CONFU participants met in May 1997 to determine whether the "proposals" for educational fair use for distance education, digital images, and multimedia have received sufficient endorsement to be included in a final report of CONFU. Mary Jackson represented ARL in the CONFU discussions. ARL did not endorse any of the proposed guidelines. It is anticipated that another meeting of CONFU participants will occur next spring. Three themes emerged from ARL member library comments on all of the draft guidelines concerning electronic reserves, digital images, distance learning, interlibrary loan, and multimedia:

- the quantitative limitations and restrictions included in the proposals unduly narrow the interpretation of fair use by moving away from the four factor analysis that is specified in Section 107 of the Copyright Act of 1976;
- guidelines as rigid and specific as those being proposed were premature given the rapid evolution of new technologies and the lack of experience in the areas in which proposals were being considered; and
- the proposals are technically and administratively burdensome to libraries and their institutions because they add new responsibilities and raise new liability issues.

#### **National Humanities Alliance**

At the Membership Meeting in May, the ARL Board endorsed the NHA *Basic Principles for Managing Intellectual Property in the Digital Environment*. Additional endorsements are being solicited from individual ARL members as well as other scholarly and educational organizations. See Section 1.1 for current status information.

#### **Presidential Associations**

The six major presidential associations—AACC, AASCU, AAU, ACE, NAICU, and NASULGC—are working collaboratively to identify key issues of importance for higher education in the national policy governing digital networks, intellectual property, and information technology to the benefit of the teaching, research, and service missions of colleges and universities. ARL and Educom have been asked to work with them in a close liaison capacity to identify issues, share intelligence, and coordinate activities.

#### **Pew Roundtable Discussion on Managing Intellectual Property**

ARL and AAU will co-sponsor a national Pew Roundtable Discussion on Managing Intellectual Property Rights. See Section 1.1.

#### **Consequences for Copyright**

The terms and conditions agreed to by libraries in the process of negotiating licenses for electronic resources may have consequences for both copyright legislation and the development of the Uniform Commercial Code. It is important, then, that libraries understand the complexities involved in licensing and the dangers in signing away rights. To help libraries negotiate the best licenses possible, ARL is working on a number of initiatives to educate our community on licensing issues. See Shared Legal Capability in Section 1.1 for a summary of the SLC Working Group developing licensing principles.

#### **Licensing Workshops**

A workshop, *License Review and Negotiation: Building A Team-Based Institutional Process*, was held in Boston, September 18-19 with a second one planned for November 20-21. These workshops provide an overview of the legal foundations of license agreements and an in-depth look at typical license terms and contract language for electronic information resource agreements. In addition, the workshops highlight the importance of and present strategies for developing an institutional process for license review, negotiation, and administration. Mary Case heads the workshop. See Section 1.1 for further details.

#### **Copyright Workshop**

ARL continues to sponsor copyright workshops, most recently at the ACRL National Conference in April. Entitled *Copyright in the Digital Age: A Leadership Workshop for Librarians*, it provided a foundation for understanding the current copyright law, guidelines, and key legal decisions. Mary Jackson led the workshop and faculty included Adam Eisgrau (ALA); Lolly Gasaway (UNC-Chapel Hill); Bill Robnett (Vanderbilt); and Karen Hersey (MIT).

#### **Special Copyright Issue of the ARL Newsletter**

The June 1997 issue of the *ARL Newsletter* (ARL#192) was a special issue devoted to copyright and fair use in digital environments. It includes reports about the fallout from the Conference on Fair Use (CONFU), ARL's specific concerns with the proposed fair use guidelines, ways the educational community can work toward consensus on copyright in the digital environment, a showcase of Northwestern's e-reserve policies, the NHA *Basic Principles for Managing Intellectual Property*, reports on the World Intellectual Property Organization (WIPO) process including the controversial proposal for database protection, and U.S. and Canadian legislation updates. The Newsletter is available on the web <<http://www.arl.org/newsletter/192/192toc.html>> or via the ARL Publications Department.



## Licensing Electronic Resources: Strategic and Practical Considerations for Signing Electronic Information Delivery Agreements

A booklet entitled *Licensing Electronic Resources: Strategic and Practical Considerations for Signing Electronic Information Delivery Agreements* was prepared by Patricia Brennan (ARL), Karen Hersey (MIT), and Georgia Harper (Texas). It was published by ARL in February 1997 and made available electronically at <<http://www.arl.org/scomm/licensing/licbooklet.html>>.

### ARL Copyright and Intellectual Property Web Site

ARL continues to add information to its website on copyright and intellectual property rights at <<http://www.arl.org/info/frn/copy/copytoc.html>>. Recent additions include testimony regarding online service provider liability issues and legislation introduced that includes many positive provisions of interest to the library and education communities.

### Compilation of Policy Documents

ARL issued a call for members to provide copies of local or consortial policies, practices, and experiences that would advance a community-wide understanding of fair use in digital environments. ARL plans to release a publication if enough information is received. Contact Patricia Brennan <[patricia@arl.org](mailto:patricia@arl.org)> for more information.

### ARL Copyright Team

Prue Adler, Asst. Ex. Dir., Federal Relations & Info. Policy <[prue@arl.org](mailto:prue@arl.org)>  
Jaia Barrett, Deputy Executive Director <[jaia@arl.org](mailto:jaia@arl.org)>  
Julia Blixrud, Senior Program Officer <[jblix@arl.org](mailto:jblix@arl.org)>  
Patricia Brennan, Program Officer <[patricia@arl.org](mailto:patricia@arl.org)>  
Mary Case, Director, OSC <[marycase@arl.org](mailto:marycase@arl.org)>  
Mary Jackson, Access & Delivery Services Consultant <[mary@arl.org](mailto:mary@arl.org)>  
Duane Webster, Executive Director <[duane@arl.org](mailto:duane@arl.org)>

### 1.3.1 Working Group on Copyright Issues

The Working Group on Copyright Issues was asked by the Board to continue to coordinate ARL activities on intellectual property and copyright issues. The Group is comprised of members from four standing committees of the ARL and the Executive Committee. Members of the Group serve as liaisons to their respective Committees on these issues.

<b>Members:</b>	Scott Bennett	(Scholarly Communication)
	Betty Bengtson	(Board)
	Nancy Cline	(Board, Information Policies)
	Ken Frazier	(Board, Information Policies)
	Ernie Ingles	(Information Policies)
	Paula Kaufman	(Information Policies)
	David Kohl	(Preservation)
	Peter Lyman	(At Large)
	Susan Nutter	(At Large)
	George Shipman	(Access)
	Elaine Sloan	(Scholarly Communication)
	Robert Wedgeworth	(Information Policies)
	Gloria Werner	(Board)
	Jim Neal, Chair	(Board)

**Staff Liaison:** Prue Adler, Asst. Ex. Dir., Federal Relations & Info. Policy <[prue@arl.org](mailto:prue@arl.org)>  
Mary Jackson, Access & Delivery Services Consultant <[mary@arl.org](mailto:mary@arl.org)>  
Duane Webster, Executive Director <[duane@arl.org](mailto:duane@arl.org)>

### 1.4 AAU/ARL Research Libraries Project

In 1994, the Association of American Universities (AAU) and ARL endorsed a common action agenda that had emerged from the AAU Research Libraries Project. The main points of the joint AAU/ARL action agenda were to:

- improve access to and delivery of global research resources;
- introduce more competition and cost-based pricing into the marketplace for scientific and technical information;

- ensure that electronic networks and policies are in place to take full advantage of the technologies at hand, accommodate the demands of distributed research collections, and support transformed methods of scholarly and scientific inquiry; and
- build academic/research community consensus and bring other organizations into discussions of intellectual property in an electronic environment.

To further this agenda, three related but distinct initiatives were addressed during 1995: an electronic scholarly publishing program; a comprehensive university license for the reproduction of copyrighted materials; and a program to build a distributed collection of global research resources to ensure North American access to foreign publications. Work in these areas led AAU and ARL to an agreement to move forward on developing the concept of an electronic scholarly publishing initiative and the development of a global resources plan.

During 1996, the AAU/ARL Research Libraries Steering Committee endorsed the Global Resources Program and recommended seeking financial support from AAU presidents and chancellors. In the area of electronic scholarly publishing, however, the Steering Committee decided to reconsider the collective action that it desired to support and to rethink the formal structure through which the two organizations work. A new AAU committee on Digital Networks and Intellectual Property supplants the Research Libraries Steering Committee. A summary of 1997 activities to advance the electronic scholarly publishing agenda is described in Section 1.1.

In December 1996, The Andrew W. Mellon Foundation awarded \$450,000 to ARL for the creation of the AAU/ARL Global Resources Program. While not requiring a contribution of funding from AAU, the Foundation nevertheless acknowledged the commitment of the AAU presidents to the program and encouraged their pro bono contributions of staff time, on-campus support for models of distributed collections and new electronic means of access to scholarly resources, and assistance with effecting a culture shift among faculty to accept a more interdependent collections structure among ARL libraries.

Information on the Global Resources Program, including updates on the individual projects, is summarized in Section 3.1, and can also be found at the program's website <<http://www.arl.org/collect/grp/index.html>>.

Duane Webster, Executive Director <[duane@arl.org](mailto:duane@arl.org)>  
 Mary Case, Director, OSC <[marycase@arl.org](mailto:marycase@arl.org)>  
 Deborah Jakubs, Dir. Global Resources Project <[jakubs@acpub.duke.edu](mailto:jakubs@acpub.duke.edu)>

## Section 2 Access and Technology

### 2.1 Access and Technology

Three groups contribute to ARL's Access and Technology objectives (objectives 2 and 5): ARL's Committee on Access to Information Resources, ARL's Working Group on Scientific and Technical Information, and the Steering Committee for the Coalition for Networked Information.

In addition, this capability draws upon a key cooperative program established among ARL, Educom, and CAUSE: the Coalition for Networked Information.

This summer, the governing boards of CAUSE and Educom announced their intent to join forces and create a new organization. They indicate that the missions and programs pursued individually by the two groups will be much stronger with the formation of a new association. Plans to begin operating under the aegis of a new corporation are expected to begin on or about January 1, 1998. Meanwhile, the boards of both organizations have formed a committee to guide the process of providing the current members with a prospectus of the new organization and to facilitate the comment period for member input. The new organization would be based in Boulder, CO, with a national advocacy office in Washington, DC. A new president will replace Jane Ryland and Bob Heterick, both of whom had already notified their Boards of their intent to retire in the near future. For more information, see <<http://www.cause.org/admin/neworg.html>>. The merger will not have an impact on CNI sponsorship or governance. The CNI program is described in Section 2.2.

#### Summary of 1997 Activities

The two-year, Mellon-funded, ILL/DD Performance Measures Study has moved its focus from data collection to data analysis. In the spring of 1997, preliminary reports were sent to each library participating in the study with a request for review and verification of data. A briefing on the study and the preliminary reports was held for all ARL directors at the May Membership Meeting. With some revisions, 119 final institutional reports were distributed in August. The seven-page report places institution-specific results on ILL/DD costs, turnaround time, fill rate, and user satisfaction in the context of either the 97 research libraries or 22 academic library participants.

BEST COPY AVAILABLE



The findings of the study indicate, for many of the research libraries participating in both studies, that borrowing and lending costs have decreased since the 1992 ARL/RLG ILL Cost Study. Turnaround time averages just over two weeks, fill rates are about 85% for borrowing and 60% for lending, and in general, users are satisfied with the service. The final report, to be published this fall by ARL, will analyze these findings against a set of data on general characteristics of the participating ILL operations and will describe the "best practices" of both participant groups. The report will also include a special section on the effectiveness of user-initiated ILL as measured by the performance of four ARL members of OhioLINK. Directors of the four ARL libraries that participated in the study agreed to share their results with the library community.

A Frequently Asked Questions (FAQ) report about the study and its findings was mailed to study participants with the final institutional report. The FAQ is also available on the ARL web site: <<http://arl.cni.org/access/illfaq.html>>. Mary Jackson, the Principle Investigator for the Study, chaired a session on ILL/DD performance measures at the 5th Interlending and Document Supply International Conference in Aarhus, Denmark in late August. In that session, she presented a paper on the ILL/DD Performance Measures Study.

Based on the results of the ILL/DD Performance Measures Study, the NAILDD Project is exploring options for holding a conference or series of workshops to showcase the "best practices" and explore how the findings of the study can be used to improve interlibrary loan and document delivery services in all institutions, including those that did participate in the study.

The NAILDD Project promotes three ILL/DD technical system enhancements with 50 private sector vendors through semi-annual meetings at ALA. The Directors Forum on Managing ILL/DD Operations is held on the Friday morning prior to ALA meetings, and the Developers/Implementors Group (DIG) meets in the afternoon.

#### **Directors Forum**

The February 1997 Directors Forum in Washington, DC focused on high volume lending operations and showcased several vendors implementing the ILL Protocol, an international ILL communications standard. The June Directors Forum in San Francisco focused on how to evaluate Protocol compliant systems and again showcased several vendors implementing the Protocol.

#### **DIG Meetings**

Discussions at both 1997 DIG meetings centered on the implementation of the ISO ILL Protocol as well as the proposed standardization of an interlibrary loan policies directory. Summaries of the Directors Forum and DIG meetings are available at <<http://arl.cni.org/access/forum.html>>.

The major focus of the NAILDD Project during the past nine months is the implementation of the ISO ILL Protocol. Use of protocol-compliant messaging systems would permit ILL staff to forward (without re-keying) unfilled ILL requests to other Protocol-compliant systems or update the status of ILL requests in Protocol-compliant systems when documents are sent via Ariel.

The ILL Protocol Implementors Group (IPIG) is meeting quarterly:

February:	One-day meeting at ARL
June:	Three-day meeting at the National Library of Canada
September:	Three-day meeting at the Research Libraries Group
December:	Meeting to be held at ARL

#### **ILL Protocol Tutorials**

To speed vendor implementation, the Project has organized and sponsored two tutorials on the ILL Protocol. The first tutorial was attended by nearly 40 participants representing 24 organizations from four countries; a second brought together 20 participants from 3 countries. The National Library of Canada plays a major role in the tutorial, providing staff resources and resource materials.

#### **Giving Visibility to the ILL Protocol Implementors**

To emphasize the significant progress in implementation of the Protocol, the NAILDD Project issued two press releases this year. The following highlights typify the progress made by IPIG members:

- the Library Corporation and CISTI have developed a "transponder" to convert either BER or EDIFACT encoding, thus eliminating a barrier to inter-system interoperability, especially between libraries in the U.S. and Canada;
- the Library Corporation announced the availability of an annual license for platform-independent software to run the complete Protocol;
- OCLC introduced the OCLC ILL Direct Request Service that accepts an ISO ILL Request from an external system and forwards it to the OCLC ILL system for processing by borrowing staff; and

- OCLC and The Library Corporation continue to support IPIG testbeds. Innovative Interfaces, DRA, TRLN, CISTI, Fretwell-Downing, and Ameritech have successfully tested two messages: the ILL Request and the Status-or-Error. The NAILDD Project home page includes a chart detailing the status of testing by IPIG members at <<http://www.arl.org/access/naildd/>>.

Mary Jackson worked with Fay Turner, NLC, on a presentation of the ISO ILL Protocol at the IFLA Annual Conference in Copenhagen in early September. A model presentation on the Protocol is being developed with a small grant from the IFLA Standing Committee on Document Delivery and Interlending. In addition, an article on the status of implementation was published in the October issue of the ARL Newsletter.

#### Other Technical Priorities

Recent developments relating to the Project's other technical priorities for comprehensive ILL management software and for financial management software follow.

- Sale of ISM, including the AVISO management software, to AGCanada. The future of the AVISO management software will continue to be monitored.
- Introduction of CLIO, management software package developed by Perkins Associates. This summer Perkins Associates confirmed their intent to enhance CLIO to become Protocol-compliant.
- Commitment by OCLC to develop a management component for the next version of the ILL MicroEnhancer. This version will incorporate some of the functionality of comprehensive management software defined by the NAILDD Project.
- Agreement by OCLC to explore how the IFLA voucher coupon can be accepted as payment within the OCLC ILL Fee Management System (IFM). IFLA will also investigate the feasibility of developing an electronic equivalent to the paper voucher coupon.

As a follow up to the Conference on Fair Use (CONFU) the Access capability agreed to lead the effort to draft a document that establishes "user community principles" and describes librarian-generated "best practices" for electronic reserves, distance education, digital images, and multimedia activities. ARL is working with others in the Shared Legal Capability and scholarly community represented by the National Humanities Alliance on this initiative.

The Access capability contributed to the June, 1997 ARL Newsletter, a special copyright issue, by soliciting an article from Brian Nielsen (Northwestern) on Northwestern's development of an electronic reserve policy. Mary Jackson gave two presentations on electronic reserves: in June 1997 for the ACRL Electronic Reserves Discussion Group at the ALA Annual Conference in San Francisco and in July at a workshop sponsored by the Western New York Library Resources Council.

Federal Express discontinued the discounted library program as of July 1, 1997. FedEx also discontinued similar agreements with RLG and AMIGOS. Members of the Big Twelve Plus consortium were also unable to reach an agreement on an extension of their separate, but similar, contract with FedEx. ARL participants' low volume of shipping coupled with a new distance-based pricing structure may have contributed to the Fed Ex decision. Monitoring of other potential carriers will continue on a low-key basis.

The Access capability also contributes to ARL's initiatives associated with copyright and intellectual property. In 1997, activities included:

- participation in the Conference on Fair Use (CONFU) to develop fair use guidelines for the NII; and
- organization of a Copyright & Libraries Leadership Workshops in April before the ACRL National Conference. The workshop featured copyright experts who discussed recent pressures on the copyright law and how the potential changes may impact institutional and library operations.

The Access capability and the NAILDD Project provide advice and support on access and delivery issues that emerge in theAAU/ARL Global Resources Program projects. In 1997, this included:

- advising the Japan Journals Project on a proposal for improving bi-national ILL/DD for the project;
- serving as a resource for developing a standards-based approach to streamline user initiated ILL requests and services from the UT-LANIC TOC database for the Latin Americanist Project, with support from OCLC; and
- exploring an OCLC Group Access Capability (GAC) for interested libraries in North and South America.

In May 1997, the Access Committee began a review of their agenda by examining the state of library infrastructure in support of resource sharing. The discussion considered Z39.50 application issues, trends in union catalogs, distributed searching, and cross-database linkages and weighed the impact of the resulting uneven accessibility of holdings information on resource sharing. The outcome was a request to revisit this set of issues again after the results of the ILL Performance Measures Study were available. The committee will next consider if there is a new agenda item that research libraries should pursue to improve the state of infrastructure for resource sharing.

Committee consensus in May was that the criteria for a new agenda item should be that it both maximize access and have a reasonable prospect to minimizing library costs in the short term.

The discussion used several articles as background including one prepared for the ARL Access Committee by the National Library of Canada (Issues Related to the Use of Z39.50) based on NLC experience using Z39.50 to build a virtual union catalog. The NLC paper is available on the Web <<http://www.nlc-bnc.ca/resources/vcuc/z395ap.htm>>.

Mary Jackson, Access & Delivery Services Consultant <[mary@arl.org](mailto:mary@arl.org)>  
Jaia Barrett, Deputy Executive Director <[jaia@arl.org](mailto:jaia@arl.org)>

### 2.1.1 Committee on Access to Information Resources

The ARL Committee on Access to Research Resources was established to help the Association make access to research information resources more effective. This committee is charged to monitor developments, determine critical issues requiring ARL attention, inform members, and design strategic responses to influence the access to research information resources. The Committee also advises and guides the ARL staff on matters regarding the plans and strategies of the ARL program capability on Access and Technology.

The current committee focuses on an agenda in support of resource sharing in an electronic environment. Issues identified as key to this agenda are a reconceptualization of ILL in an electronic environment and articulation of the principles and values that support resource sharing among research libraries. In May 1997, the committee began a review of their agenda by examining the state of library and network infrastructure in support of resource sharing. The agenda items addressed by the committee are:

- promote and support NAILDD to advance priority developments;
- review the committee agenda to identify horizon issues;
- monitor the progress and work of NINCH (National Initiative for a Networked Cultural Heritage) to seek opportunities for research library contributions and collaborations with museums and archives;
- contribute to AAU/ARL Global Resources Program to demonstrate and evaluate the concept of a distributed, multi-institutional research library collection that is linked together and made accessible to users via networked service; and
- continue to monitor and support the progress made at LC to implement copy cataloging, strengthen cooperative cataloging programs, and pursue other approaches to increase cataloging effectiveness and productivity.

**Members:**

Pam Andre	(1995-1997)
Ellen Hoffman	(1996-1998)
Charles Lowry	(1997-1999)
Paul Mosher	(1996-1998)
Michael Ridley	(1996-1998)
Thomas Shaughnessy	(1997-1999)
George Shipman	(1995-1997)
Sarah Thomas	(1997-1999)
Shirley Baker, Chair	(1997-1998)

Marianne Scott, National Library of Canada Liaison  
Winston Tabb, Library of Congress Liaison

**Staff Liaisons:** Mary Jackson, Access & Delivery Services Consultant <[mary@arl.org](mailto:mary@arl.org)>  
Jaia Barrett, Deputy Executive Director <[jaia@arl.org](mailto:jaia@arl.org)>

### 2.1.2 Work Group on Scientific and Technical Information

The Work Group was formed to follow up the report of the 1991 ARL Task Force on a National Plan for Science and Technology Information Needs. The Work Group monitors STI developments and functions as an advisor to the Board for shaping ARL activities in this area.

The Group met at the May 1997 Membership Meeting. There were reports from members about the STI projects planned or underway at Linda Hall, North Carolina State, the UC System, the National Agricultural Library, CISTI, and the University of Washington. The group also discussed potential organizations and individuals in the sciences who would be impacted by the proposed database protection legislation.

In October, the group will meet to discuss a proposed electronic publishing initiative that aims to establish affordable e-journals in the sciences.

**Members:** Pamela Andre  
Betty G. Bengtson  
Joe Boisse  
C. Lee Jones  
Margot Montgomery  
Susan K. Nutter  
Marilyn J. Sharrow, Chair

**Staff Liaison:** Jaia Barrett, Deputy Executive Director <jaia@arl.org>

### 2.1.3 ILL/DD Performance Measures Committee

The Advisory Committee for the ILL/DD Performance Measures Study, funded by the Mellon Foundation, is comprised of library directors representing ARL committees with an interest in the study, as well as a representative of the Oberlin Group libraries.

The Committee met for a day in July 1997 with other resource guests to advise on presentation of the study findings.

**Members:** Barbara Brown  
William Crowe  
Paul Kobulnicky  
William Studer  
Shirley Baker, Chair

**Staff Liaison:** Mary Jackson, Access & Delivery Services Consultant <mary@arl.org>

## 2.2 Coalition for Networked Information

CNI is an organization for institutions concerned with realizing the promise of high performance networks and computers for the advancement of scholarly communication and publishing and the enrichment of intellectual productivity. The Coalition was formed in 1990 by the Association of Research Libraries, CAUSE, and Educom. The Coalition pursues its mission with the guidance of a nine member steering committee and the aid of a 200-member task force made up of higher education institutions, publishers, network service providers, computer hardware, software, and systems companies, library networks and organizations, and public and state libraries.

### Summary of 1997 Activities

In early May 1997, CNI appointed Dr. Clifford A. Lynch to become the Coalition's new Executive Director. Dr. Lynch was the Director of Library Automation at the University of California Office of the President. Lynch was at the University of California since 1979 where he oversaw university-wide library automation and internetworking activities. Internationally known for his development of Melvyl, an information system that serves all of the campuses of the University of California, Lynch has played a key role in the development of information standards. Lynch began his position as CNI's Executive Director in July 1997.

From December 1996 to the present, CNI focused on its key initiatives for the year, divided into four areas:

- Information
- Individuals and Organizations
- Technology
- Task Force Meetings and Affiliated Conferences

CNI will be distributing its 1997-98 Program Plan at the Fall 1997 Task Force Meeting, October 26-27, in Minneapolis. The plan will also be available on the website at <<http://www.cni.org/>>.

Three initiatives that fall under the area of Information include Institution-Wide Information Strategies, Federal Information, and Cost Centers and Measures in the Networked Information Value Chain.

As part of its work on the Institution-Wide Information Strategies (IWIS) initiative, CNI worked with a number of research and education institutions that represent best practices in this field. At CNI's Spring Task Force Meeting a project briefing was held to inform interested parties about the project, its deliverables and the criteria to be used to

select participants. CNI held an initial project conference in August 1997. The following institutions participated: California State University System; Joint Information Systems Committee (UK); Indiana University; Lehigh University; Mt. Holyoke College; University of California - Davis; University of Memphis; University of Michigan; and Villanova University.

A draft of CNI's White Paper, Access to and Services for Federal Information in the Networked Environment, was posted to the CNI server.

Presentations were made at the Spring Task Force Meeting. Joan Lippincott gave testimony to the Senate Committee on Rules and Administration on May 22 on aspects of electronic federal information, based on the findings of the White Paper.

A draft report of the Cost Centers and Measures initiative was issued at the CNI Spring Task Force Meeting. At the meeting, a panel of publishers, intermediaries, and users reacted to the report.

Three initiatives that fall under the area of Individuals and Organizations are Assessment, Working Together and New Learning Communities.

To continue work on its Assessment initiative, CNI engaged several colleges and universities in a coordinated field-test of the assessment measures outlined in McClure and Lopata's *Assessing the Academic Networked Environment: Strategies and Options*. The following institutions were selected to participate in the project based on their responses to an open call for statements of interest and experience: Brown University; Dartmouth College; Gettysburg College; Johns Hopkins University; King's College, London; Mary Washington College; University of North Carolina, Chapel Hill; University of Washington; and Virginia Polytechnic Institute and State University. CNI held the first meeting of teams from these institutions on April 2 and 3 and the teams are currently developing their institutional assessment plans.

The Working Together initiative aims to provide information professionals (librarians, technologists) and others a structured workshop experience to help them improve their ability to collaborate and build partnerships with colleagues on campus. CNI hosted pre-conference workshops during both the Delaware and London regional conferences discussed below.

CNI and the University of Washington's UWired project held a successful New Learning Communities pre-conference of the ACRL National Conference in April. CNI, ACRL, AAHE, and Educom also co-sponsored a conference in August. The August event was part of CNI's New Learning Communities Program, which is supported by a grant from the U.S. Department of Education.

Strides were made in the Technology category that focuses on issues of application middleware, network authentication, metadata, and information discovery and retrieval. Through various project briefings held during the Spring Task Force Meeting and through its support of the Internet2 Project, CNI continues fostering collaboration between the expertise of its membership and the Internet2 Project. CNI installed the Internet2 server and is the server administrator. Specifically, CNI participated in the design and creation of the Internet2 website. CNI also participated in the Internet2 meeting held in Helsinki.

CNI's Spring Task Force Meeting was extremely successful. Three hundred and 27 attendees representing 180 institutions participated in the meeting held in Arlington, Virginia, April 1-2. Internet2 Content Issues was the theme of the spring meeting. CNI also participated in two regional conferences: *Delivering the Curriculum and Student Services in a Technologically Enriched Fashion*, held May 21-23 in Delaware; and *Beyond the Beginning—The Global Digital Library*, held June 16-17 in the UK. CNI also participated in a metadata workshop.

October 26-27, 1997                      CNI Fall Task Force Meeting  
    Minneapolis, Minnesota

April 14-15, 1998                      CNI Spring Task Force Meeting  
    Washington, DC

Clifford A. Lynch, Executive Director <clifford@cni.org>  
Joan K. Lippincott, Assistant Executive Director <joan@cni.org>  
Craig Summerhill, Systems Coordinator <craig@cni.org>  
Maurice-Angelo Cruz, Assistant Systems Coordinator <angelo@cni.org>  
Louise Ann Fisch, Coordinator of Communications <louise@cni.org>  
Jacqueline J. Eudell, Office Manager <jackie@cni.org>  
Sharon C. Royal, Administrative Assistant <sharon@cni.org>

Robert Heterick, President, Educom  
Jane Norman Ryland, President, CAUSE



Duane E. Webster, Executive Director, ARL

### 2.2.1 Steering Committee for the Coalition for Networked Information

As part of the governance structure of the Coalition for Networked Information, each of the three founding organizations (ARL, CAUSE, Educom) has three seats on the CNI Steering Committee. ARL representatives to the committee have been given staggered terms to achieve consistency with other ARL Committee assignments. The members of the committee meet with the ARL Board to review communication and advisory processes between ARL and CNI.

The ARL Board met in July with the newly appointed Executive Director of the Coalition to discuss the Coalition's program priorities.

**Members:** David Bishop (Northwestern University)  
Jacqueline D. Brown (Princeton University)  
Miriam A. Drake (Georgia Institute of Technology)  
Susan Foster (University of Delaware)  
William H. Graves (University of North Carolina at Chapel Hill)  
Sharon A. Hogan (University of Illinois at Chicago)  
Ken Klingenstein (University of Colorado-Boulder)  
M. Stuart Lynn (University of California)  
Richard Paul West, Chair (California State University)

**Staff Liaison:** Duane Webster, Executive Director <duane@arl.org>

## Section 3 Collections and Preservation

### 3.1 Collection Services

The Research Collections Committee provides oversight for a number of distinct but related initiatives to pursue this objective. Strategies include: promotion of government and foundation support for collections of national importance in the United States and Canada; efforts toward improving the structures and processes for effective cooperative collection development programs, including digital resources; and development and operation of collection management training programs.

#### Summary of 1997 Activities

In December 1996, ARL received a three-year grant from The Andrew W. Mellon Foundation in support of the AAU/ARL Global Resources Program. This initiative is the natural outgrowth of earlier activities, most notably the four-year, Mellon-funded project on the state of foreign acquisitions, which culminated in 1996 with the publication of *Scholarship, Research Libraries, and Global Publishing*. The principal goal of the Global Resources Program is to improve access to international research resources. To that end, the Program is sponsoring three ongoing projects (Japan, Germany, and Latin America) and is developing several new projects (Africa, South Asia, and Southeast Asia). Other Global Resources Program activities include a clearinghouse of web-based international resources, an inventory of linkages and agreements that North American research libraries maintain with libraries and research institutes abroad, participation in projects related to the future of area librarianship, and plans for symposia to inform faculty and librarians about network-based, distributed models of cooperative collection development for global resources. The Global Resources Program web site provides background information on projects underway as well as updated information on new activities related to this initiative <<http://www.arl.org/collect/grp/index.html>>.

ARL joined the Center for Research Libraries, the Council on Library and Information Resources, and the Library of Congress in sponsoring the *Symposium on Access to and Preservation of Global Newspapers*, held on May 27-28, 1997 at the Library of Congress. The event included an assessment of the state of collection management of foreign newspapers, including challenges to their access and preservation. Elements of a preliminary action agenda were identified at the meeting, and will be developed further by a working group to be named in the fall of 1997.

AAU and ARL have formed an Advisory Board for the Global Resources Program to facilitate the implementation of Program activities and assist in determining the direction of new cooperative initiatives designed to expand access to international research materials. Their initial meeting is scheduled for October 8, 1997.

**Board Members:** Betty Bengtson, Chair (University of Washington)  
Myles Brand (Indiana University)



Jonathan Cole (Columbia University)  
Joe Hewitt (University of North Carolina, and ex officio as Chair, ARL Research Collections Committee)  
Deborah Jakubs (ARL)  
Stanley Katz (Princeton University)  
Hwa-Wei Lee (Ohio University)  
Carole Moore (University of Toronto)  
Suzanne Thorin (Indiana University)  
John Vaughn (AAU and ex officio)  
David Wiley (Michigan State University and Co-Chair, Council of Title VI National National Resource Center Directors)

The original three demonstration projects form the first phase, providing models for a distributed program for the coordinated acquisition of and access to foreign materials. Each has evolved differently; all three are reviewed by the ARL Research Collections Committee as part of the overall testing and evaluation of new strategies for coordinating collection management. ARL's Access Committee provides advice on access and delivery issues that arise in the projects.

#### **Latin Americanist Research Resources Project**

The project seeks to expand the range of materials available to Latin Americanist students and scholars, to restructure access to these materials through distributed, cooperative collection development based on new uses of technology, and to assist libraries in containing costs through reallocation of collections funds. Start-up funding for the project was provided by two grants from The Andrew W. Mellon Foundation and the 37 participating ARL libraries. An Advisory Committee, chaired by Deborah Jakubs of Duke University <jakubs@acpub.duke.edu>, oversees project implementation. In fall 1996, project coordination activities related to the journals table of contents database were assumed by Grete Pasch, a research assistant at the University of Texas Latin American Network Information Center (UT-LANIC). Other coordination is provided by the six project working groups, each chaired by a bibliographer at an ARL member library. These focus on: serials; publications of non-governmental organizations; monographs; government publications; partnering; and project evaluation.

In 1997, the number of participating ARL libraries expanded to 37, and activities have included:

- the digitization and indexing of presidential messages from Argentina and Mexico;
- the expansion of the table of contents database of Argentine and Mexican journals to include back issues and titles from Brazil;
- a pilot interlibrary loan service designed by UT-LANIC and OCLC to facilitate requests for articles from the table of contents database;
- the development of various strategies to expand the availability of publications of Argentine and Mexican non-governmental organizations;
- a study conducted by an economist at the University of Florida, "Is Cooperation Cost-Effective?" that focuses on Florida's Caribbean collection and resource sharing;
- an agreement on the part of the participating libraries to cancel a project journal from among those that are widely held, and accept responsibility for a new title;
- the addition of a monographic component, in which participating libraries reallocate a percentage of their Latin American monographic budget to focus on an area of particular strength;
- building partnerships with Latin American libraries, research institutes, and book dealers; and
- a formal project evaluation, including reports from each working group and survey responses from all participating libraries.

#### **Japanese Journals Access Project**

Early in 1997, the Japan project issued a call for participation, to which 28 ARL libraries responded. In March 1997, representatives of 18 of the participating libraries met to further develop the project. Co-sponsored by the National Coordinating Committee on Japanese Library Resources (NCC), the Project is coordinated by Dorothy Gregor (OCLC) <dgregor@emf.net> and chaired by Don Simpson (CRL) <simpson@crlmail.uchicago.edu>.

Project activities fall into two categories: (1) improving access to Japanese journals available in North America, and (2) improving access to Japanese journals and journal articles in Japan. Recent developments in support of these activities include:

- contacts have been made with a Japanese library committee looking at procedures for international interlibrary loan, and with a university that may be interested in serving as a "gateway";
- websites of potential value for locating serials and enabling document delivery have been added to the Project's web page, hosted by the Ohio State University Library <<http://pears.lib.ohio-state.edu>>;
- tests are underway to consider the feasibility of loading records from participants' local systems into a web-based union list of serials, one of the primary goals of the Project;

- five librarians were trained at NACSIS in Tokyo in the use of electronic resources, with funding from the Center for Global Partnership, and are ready to offer workshops for other librarians and end users here in the United States (project participants interested in hosting a workshop on their campus should contact Dorothy Gregor <dgregor@emf.net>); and
- NACSIS is making available indefinitely and at no cost its Webcat, which contains both the Union List of Books and the Union List of Serials for all Japanese libraries (over 400) that catalog on the NACSIS system; Webcat is a major source of bibliographic information for Japanese titles.

The Project has identified an important issue that the Coordinator and participants seek to address with input from library directors. This issue, which has relevance for all of the Global Resources projects, has to do with the need to connect the activities and decisions of the Japanese studies librarians who represent participating ARL libraries to other library operations, particularly interlibrary loan. Support from the directors and collection development officers for all aspects of collaborative collection development, and especially for reallocating resources as a result of the project, is also a key element of these projects.

#### **German Demonstration Project**

The primary goals of the German Demonstration Project are: (1) to ensure effective and timely access to German language research materials through electronic resources sharing and improved interlibrary document delivery services; and (2) to test linking between North American and German libraries to expand access to specialized research resources.

This is anticipated to be a cooperative effort among research institutions in the United States, Canada and Germany with strong German library collections and an institutional commitment to research in German history and political science. The Project has 22 participating libraries and is coordinated by a Working Group chaired by Winston Tabb (Library of Congress) <wtabb@loc.gov> and Sarah Thomas (Cornell) <set9@cornell.edu>. A top priority for the Project has been to obtain funding to enable the participants to undertake cooperative activities. The Working Group will meet with a small number of guests on October 2 at ARL to identify those activities and to consider future directions for the project.

#### **The Digital South Asia Library: A Pilot Project**

The libraries of the University of Chicago and Columbia University, as lead institutions, have designed a two-year project to: (1) develop the infrastructure for inter-continental electronic document delivery to and from selected South Asia libraries, and (2) create new electronic reference resources. Partner institutions in India are the Raja Muthiah Research Library (Madras) and the Sundarayya Vignana Kendram (Hyderabad). The results of the Digital South Asia Library project will include:

- electronic indexing records for approximately 38,000 articles in Tamil journals, 38,000 articles in Urdu journals, and 4,750 English journal articles, published during the nineteenth and twentieth centuries;
- electronic full-text versions of three classic nineteenth-century South Asia reference books printed in roman characters;
- full-text electronic versions of five select titles from the Official Publications of India, one of which will be a statistical source structured as an electronic database;
- a website providing global access to the project's electronic resources;
- scanning capacity at research libraries in Madras, Hyderabad, and Chicago;
- delivery on demand via the Internet of page images of the Tamil and Urdu journal articles indexed under this project either directly to scholars or through libraries;
- planning of grant proposals to support a second phase of the project for expanded participation in North America and South Asia, contingent on favorable interim review at the end of the pilot project's first year;
- planning for a self-sustaining program of services beyond that second phase; and
- a formal evaluation and cost-benefit analysis of the project.

The project will create models for other area studies groups, especially those in the developing world. The pilot project involves building an electronic library infrastructure abroad while enabling delivery of valuable services in North America. For more information, contact Jim Nye <jnye@midway.uchicago.edu> or David Magier <magier@columbia.edu>.

#### **Southeast Asia Regional Periodical Index: A Consortial Approach**

The Committee on Research Materials on Southeast Asia (CORMOSEA) has developed a preliminary proposal to create a distributed system of periodical indexing with initial participation from libraries in the United States and Southeast Asia. A web-based, searchable database will be the product, and it will be updated and available via the Internet. The project seeks to develop a collaborative approach to indexing the region's periodical literature that will allow for data input to a web server by libraries from the two regions and eventually by libraries from Europe and Australia. Discussion of the details of the proposal and of plans for its implementation is underway. For the text of the proposal, see <<http://www.library.wisc.edu/guides/SEAsia/cormosea/ARL/intro.htm>>.

### African Newspaper Union List and Preservation Project

The Center for Research Libraries (CRL) will host a site for this project, a joint endeavor of the Africana Librarians Council of the African Studies Association (ALC/ASA) and the Cooperative Africana Microform Project. The Project will develop a web-based, searchable union list of African newspaper holdings, in all formats and languages, organized by country. A second step will be to expand preservation microfilming and explore digitization as a means of both preservation and access. The preservation effort will be led by Northwestern University Library.

The Project focuses on the newspapers of sub-Saharan Africa, including South Africa, regardless of date or language. It will begin with holdings in the United States and be expanded to include holdings in Africa and other countries, as time and funding allow. It will combine currently received titles, as compiled and updated by the ALC and Northwestern in *African Newspapers Currently Received by American Libraries* <<http://www.library.nwu.edu/africana/resources/96crlnews.html>> with holdings of newspapers that have ceased. CRL will host a part-time staff member to carry out this work.

Expanded preservation of African newspapers is an essential and complementary element to the access that will be provided through the electronic union list. Working cooperatively with CAMP and CRL, the staff of the Melville J. Herskovits Library of African Studies and the Preservation Department of Northwestern University will oversee the preservation microfilming of a number of African newspapers held there, and the digitization of a number to test both preservation and access issues related to digitization. As sub-Saharan African institutions gain access to the web, they will be able to take advantage of this union list. It will also enable ALC members who are visiting African institutions to collect newspapers holdings information in Africa and to identify runs of papers in need of preservation. For more information on the project, contact Helene Baumann <[baumann@acpub.duke.edu](mailto:baumann@acpub.duke.edu)>.

Deborah Jakubs, Research Collections Visiting Program Officer <[jakubs@acpub.duke.edu](mailto:jakubs@acpub.duke.edu)>

### 3.1.1 ARL Committee on Research Collections

This Committee is charged to: monitor advances in the collections arena and communicate such developments to the membership; contribute to the development of coordinated and comprehensive planning of North American collecting activities; encourage ARL libraries to recognize their responsibilities in building their own individual collections as part of the research resources of North America; advise in developing and assessing progress on the plans and strategies of the ARL Collections capability; identify issues requiring Association policy, inform members and recommend positions for the Board and membership to consider to further national collection planning or to support member libraries collecting activities; develop a research agenda for collection development concerns and help identify means for acting on this agenda; maintain liaison with appropriate groups outside of ARL; work with other ARL Committees and Task Forces to accomplish the goals of ARL pertaining to the development and use of research library collections.

The primary focus of the Committee on Research Collections in 1997 was implementing the AAU/ARL Global Resources Program. Throughout the year, the committee monitored the progress of the three demonstration projects to look for lessons learned that could be folded into steps to scale up the projects or to apply in new projects.

Discussions at the Committee meetings also highlighted concern about the implications of electronic information resources and the need to develop innovative approaches and structures aimed at facilitating electronic resource sharing. The Committee will further explore the implications of electronic information in developing research collections and plans to discuss the role of special collections in research libraries as well as:

- provide ARL guidance and oversight for the AAU/ARL Global Resources Program;
- address the findings of the International Newspapers Symposium in conjunction with the May and October ARL Membership Meetings; and
- consider the role of special collections in ARL libraries.

<b>Members:</b>	Betty Bengtson	(1996-1998)
	Claude Bonnelly	(1995-1997)
	Joseph Branin	(1997-1999)
	Francis Groen	(1997-1999)
	Hwa-Wei Lee	(1997-1999)
	George Terry	(1995-1997)
	Suzanne Thorin	(1997-1999)
	Barbara von Wahlde	(1996-1998)
	Karin Wittenborg	(1997-1999)
	Joe A. Hewitt, chair	(1997-1998)

Donald Simpson, Center for Research Libraries Liaison

Winston Tabb, Library of Congress Liaison

**Staff Liaison:** Deborah Jakubs, VPO for Research Collections <jakubs@acpub.duke.edu>

### 3.2 Preservation

The work of the Preservation of Research Library Materials Committee covers this capability. Strategies to accomplish ARL's preservation objective include: encouraging and strengthening broad-based participation in national preservation efforts in the U.S. and Canada; support for development of preservation programs within member libraries; advocacy for strengthening copyright legislation to support preservation activities in the electronic environment; support for effective bibliographic control of preservation-related processes; encouragement for developing preservation information resources; and monitoring technological developments that may have an impact on preservation goals.

ARL's Preservation agenda was reviewed and recast in 1995. The outcome identified six initiatives where ARL should pursue activities of importance to its members. See Section 3.2.1 for an overview of the Preservation Plan.

#### Summary of 1997 Activities

##### **ARL Membership Meeting Program on Preserving Digital Information**

Preserving digital information was identified by the Preservation Committee as a priority for 1997. In its response to the 1996 CPA/RLG Task Force Report on Preservation of Digital Information, the Committee proposed a series of actions including holding a special program at an ARL meeting that brings together a number of players engaged in preserving digital information. That program will take place at the October 1997 Membership Meeting.

##### **A Report on Current Projects to Preserve Digital Information**

George Soete is in the process of conducting interviews with libraries, vendors, publishers, archivists, and others to develop an overview of what is currently being done to preserve information in digital formats. A draft of his report will serve as a background piece for the October membership meeting with publication anticipated later in the fall as part of the *Transforming Libraries* series.

At its May meeting, the ARL Board supported a Preservation Committee proposal to amend the Preservation Microfilming Guidelines to accommodate digital technology. RLG has also endorsed this project and has agreed to support the work necessary to revise the guidelines. A task force co-chaired by Steve Chapman (Harvard) and Robin Dale (RLG) was created and includes representatives from Berkeley, University of Florida, Harvard, MIT, and the Library of Congress. Technical advisors include representatives from SunRise Imaging and Mekel. A first meeting is planned for September to identify the modifications to filming needed to accommodate digital scanning. Prototype filming and scanning projects will be conducted during fall and winter, with assessment of the results planned for early next spring. RLG has set up a Web site to monitor progress of the project <<http://www.rlg.org/digital/>>. Jan Merrill-Oldham (Harvard), consultant to the ARL Preservation Committee, represents ARL in this initiative.

ARL member leaders and staff contributed to a series of meetings with representatives of the Modern Language Association, American Historical Association, Society of American Archivists, CPA/CLR and others to consider issues involved in the preservation of the artifact/primary records. The group decided to commission a work that would describe, for a general campus readership, the evolution of research libraries in this country, the strategies libraries have employed in addressing preservation issues, and perspectives on preservation concerns from different segments of the scholarly community.

A separately funded initiative is the National Register of Microform Masters (NRMM) RECON projects funded by NEH. This multi-year effort has completed the conversion of over 22,000 serials and 500,000 monographic reports into machine-readable records. Additional details for recent and ongoing NRMM projects are described as part of the Research and Development capability.

Mary Case, Director, OSC <marycase@arl.org>

#### 3.2.1 ARL Committee on Preservation of Research Library Materials

The ARL Committee on Preservation of Research Library Materials is charged to plan for and monitor the implementation of ARL Objective 4. In particular, the committee: contributes to the development of coordinated and comprehensive planning of national preservation activities; encourages ARL libraries to recognize their responsibilities in preserving their own individual collections as part of research resources of North America; communicates issues and developments relevant to the management of preservation activities to the ARL Membership; recommends as appropriate, to the ARL Board of Directors, actions to be taken by the Association to



further national preservation planning or to support member libraries' preservation activities; and works with the ARL Committee on Access to Information Resources and the ARL Committee on Research Collections to accomplish the goals of ARL pertaining to the development and use of research library collections as outlined in Objectives 2 and 3. The Committee continues to monitor developments and advise ARL staff on copyright issues related to preservation through a liaison to the Copyright Working Group.

In considering ARL's preservation agenda, the Preservation Committee has focused on activities that complement ARL's capabilities, support the broader mission of member institutions, and acknowledge the work of the CPA and current trends and issues in North American research libraries. In its five-year preservation plan developed in 1995, the Committee lists an array of ongoing ARL preservation program strategies and identifies six new preservation initiatives. These center on strengthening copyright legislation to support preservation activities in the electronic environment, investigating the feasibility of establishing a national coordinated serials preservation project, developing cost models for preservation decision making, and promoting the results of preservation-related digitizing projects, standards, and science research. During 1996, the Committee directed its efforts to two major areas: digital archiving and preservation of the artifact.

The Preservation Committee has identified digital archiving and especially the long-term maintenance of university-generated digital archives as its priority for 1997. In addition to refining a plan of action in this arena, the Committee developed a program on digital archiving for a 1997 membership meeting.

**Members:** C. Lee Jones (1997-1999)  
David Kohl (1995-1997)  
Marianne Scott (1997-1999)  
Marilyn Sharrow (1997-1999)  
William Walker (1996-1998)  
Meredith Butler, Chair (1995-1997)

Diane Kresh, Library of Congress Liaison  
Jan Merrill-Oldham, Harvard University (Consultant)

**Staff Liaison:** Mary Case, Director, OSC <marycase@arl.org>

## Section 4 Staffing and Management

### 4.1 Diversity

The charge of the Diversity Program is twofold: defining and addressing diversity issues in ARL libraries and supporting activities that encourage broad participation in the field. To this end, the program focuses on issues surrounding work relationships in libraries, while considering the impact of diversity on library services, interactions with library users, and the development of collections. The primary concern is the development of workplace climates that embrace diversity.

The Program also seeks to encourage exploration of the rich gifts and talents diverse individuals bring to the library. Program staff work closely with a broad range of libraries, graduate library education programs, and other library associations to promote awareness of career opportunities in research libraries and support the academic success of students from groups currently under-represented in the profession.

To meet the program's goals, the Program Officer for Diversity provides staff development seminars, presentations, and on-site, email, and telephone consultation; facilitates staff discussions; conducts research via reviews of the literature and site visits to institutions; prepares articles and publications to share the findings from the program; seeks to identify strategies for adaptation by libraries and library schools; and identifies issues and strategies and promotes them within ARL, as well as other national library-affiliated groups; and fosters partnerships on behalf of ARL with natural allies in the profession.

#### Summary of 1997 Activities

January through August 1997 have been filled with Program Officer orientation, project completion, and new program development. The completion of the *ARL Partnerships Program* publication served as a transition point for program reflection, evaluation, and clarification. Among this year's developments: new workshops were designed and offered; a diversity contact electronic discussion list was created to disseminate information; the minority librarian mailing list was established to allow position descriptions to be shared directly with librarians from underrepresented racial and ethnic groups; and the Diversity Program web pages have been redesigned to provide more subject-specific information.

The Diversity Program was awarded full funding through an HEA Title IIB grant to support the creation of the ARL Leadership and Career Development Program (LCDP). The LCDP was designed by the Diversity Program, drawing upon the OMS for curriculum and other similar leadership development models, to encourage racial minority librarians to pursue leadership roles in academic and research libraries. The program consists of two components. The first component is an institute to provide advanced leadership skills to experienced and promising minority librarians; the second component is a support program, during which time a mentoring relationship is put in place and a practical project pursued.

Once designed and tested, the ARL Leadership and Career Development Program will be available to be replicated for all experienced and promising librarians. Its strength will draw from its initial emphasis on diversity issues and from the experience in conducting the program with a diverse group of minority individuals—comparable to the very work force that is the goal of the late 20th century research library.

The Diversity Program, in an effort to create and nurture alliances while developing useful resources for contribution to the field, invited Mark Winston, Assistant University Librarian and Assistant Professor at Valdosta University, to serve as Visiting Program Officer for Diversity. Mr. Winston is working with the Program Officer for Diversity to create an ongoing publication series that synthesizes current issues and trends in diversity, leadership, and career development.

The Program Officer for Diversity, in fulfilling a 1997 Developmental Priority, designated a significant amount of time to site-visits, and community outreach. The following reflects conferences, site-visits, consultations, public speaking engagements, and workshops attended.

- ALISE
- ALA Midwinter - Diversity Contact discussion group
- CNI
- NAFEO
- ACRL - Diversity Contact discussion group
- ALA - Diversity Contact discussion group
- BCALA
- Hispanic Leadership Institute
- ASTD
- AAUP - Speech on Diversity Issues in Higher Education
- University of Delaware
- Affirmative Actions: Implications in Higher Education Workshop
- Johns Hopkins University - MSEL Diversity Committee formation and retreat
- University of Kansas
- University of Maryland - CLIS minority mentoring program
- Penn State University - Diversity Committee strategic plan implementation and Diversity Conference Planning
- University of Pittsburgh - Libraries discussion group and School of Information Science site-visit
- Princeton University Libraries - Presentation on The Mosaic of Diversity
- Wright State University Libraries - Fostering a Climate for Diversity Workshop
- Trinity College - Cross-Cultural Communication Workshop
- University of Arizona Libraries - University Diversity Committee presentation and Library discussion group
- National Agricultural Library - Management Team meeting

The Diversity Program and the OMS, after conversations with representative committees and between capabilities, have agreed to formalize communication between the Diversity and Leadership Committees. Joan Giesecke (Nebraska) from the Leadership Committee and Nancy Baker (Washington State) from the Diversity Committee have volunteered to act in a liaison capacity.

The Program Officer for Diversity will begin working with the OMS Training design and delivery team on several different leadership development events during the year. This work will not be instead of, but in addition to, currently offered diversity training programs. Thus far, the two capabilities:

- co-facilitated a Leadership Institute for Johns Hopkins University;
- co-designed an Organizational Cultures workshop to be offered in November;
- co-designed the Leadership and Career Development Program for minority librarians to be offered in 1997-98;
- created complimentary links between the OMS and Diversity Program websites;
- will offer a Leading Change pre-conference workshop at the University of Arizona; and
- will assess and redesign OMS curriculum to include diversity as an integral component.



The ARL Partnerships Program: Breaking Down Walls and Building Bridges was published in June and is available through the ARL Publications Office. It provided a vehicle for institutions participating in the ARL Partnership Program to tell their stories and relate their experiences with diversity. The publication has been designed to facilitate use of the models described by contributors.

DeEtta Jones, Program Officer for Diversity <deetta@arl.org>

#### 4.1.1 Diversity Committee

The Committee seeks an ongoing relationship with ALISE as a means of collaboratively addressing diversity needs in the library profession. Toward this goal, ARL hosted a reception for ALISE in February 1997 when the educators met in Washington, DC. Discussions at the May meeting about joint initiatives with ALISE to identify strategies for achieving a diverse workforce led to invitations to representatives of ALISE, ALA, and ACRL to join the Committee meeting in October. Also in May, the committee discussed trends in Affirmative Action with Gloria DeSole, Vice President, SUNY-Albany. The Committee also planned a well-received plenary program for the ARL May Membership Meeting on "Building Community Through Diversity."

<b>Members:</b>	John Haak	(1996-1998)
	Edward Johnson	(1996-1998)
	Mod Mekkawi	(1997-1999)
	Michael Ridley	(1997-1999)
	Karin Trainer	(1997-1999)
	James Williams	(1996-1998)
	Nancy Baker, Chair	(1997-1998)

Joan Giesecke, Leadership Committee Liaison  
Toni Olshen, Consultant

**Staff Liaison:** DeEtta Jones, Program Officer for Diversity <deetta@arl.org>

#### 4.2 Office of Management Services

Established to help research and academic libraries develop better ways of managing their human and material resources, the OMS has assisted library leaders in finding more efficient and effective ways of meeting user needs for over 25 years. 1997 is a pivotal year for the OMS, with changes in personnel in both the past year and on the horizon. In 1997, Maureen Sullivan and George Soete, ARL/OMS Organizational Development Consultants, signed contracts for services to be rendered for 1997 through 1999. The Consulting and Organizational Development Program and the Training and Leadership Development Program rely greatly on these individuals to serve the memberships' organizational development needs. Laura Rounds, Program Officer for Information Services, resigned her position in July 1997. The appointment of a new OMS Director will determine how the Information Services program will be managed. Currently the Information Services Program is being guided by Julia Blixrud, Senior Program Officer, with the assistance of George Soete, Transforming Libraries editor, and Patricia Brennan, Program Officer.

The OMS Directorship has been open since former Director Susan Jurow resigned in May 1996. The Director position was reviewed by the Executive Office, the ARL Board, and the Research Libraries Leadership and Management Committee, the position description revised, and a national search for a replacement started in late summer 1997. A new Director is expected to be appointed by the end of 1997.

In the spring of 1997, the committee recommended and the ARL Board endorsed a name change for the Office. Effective with the arrival of a new Director, the OMS will be renamed the Office of Leadership and Management Services.

There are three performance centers operating under the OMS umbrella: the OMS Organizational Development and Consulting Program, the OMS Training and Leadership Development Program, and the OMS Information Services Program. Each contributes to the Board's 1997 priorities by developing products and services to help research libraries move into a transformed environment. Activities undertaken by these three performance centers are described in the sections that follow.

##### 4.2.1 OMS Organizational Development and Consulting

To assist libraries in making the transition from being a predominately archival entity to becoming an information gateway in a period of limited resources and digital transformation, the OMS Organizational Development and

Consulting Program provides a wide range of consulting services, incorporating new research on service delivery and marketing, as well as on organizational effectiveness. Using an assisted self-study approach, the Program provides academic and research libraries with programs to develop workable plans for improvement in such areas as public and technical services, planning, team building, and organizational review and design. The OMS provides on-site and telephone consultation, staff training, manuals, and other materials to aid participants in gathering information and analyzing situations.

#### **Summary of 1997 Activities**

Activities between January and October 1997 continue to focus primarily on support for strategic planning efforts and redesigning organizational structure and process.

OMS Strategic Planning facilitation is designed to help establish a clearer understanding of the future course a library should take, including priorities, strategies, management philosophy, and ways of meeting new challenges. Recent OMS facilitation was provided to:

- University of California at Santa Cruz
- University of Connecticut
- Emory University
- Harvard University Houghton Library
- University of Massachusetts at Amherst
- University of Missouri
- North Carolina State University
- University of Pittsburgh
- University of Southern California
- University of Texas at El Paso

Key to the success of organizational reorganization is facilitation and consultation for reliable and effective change. OMS provided this service to:

- Brown University
- Clark Art Institute
- Emory University
- Iowa State University
- Queen's University
- Rutgers University

The OMS assists the development of leadership and senior management teams through facilitation and consultation. Recent clients are:

- University of Arizona
- Harvard College Library
- Pennsylvania State University
- State University of New York at Buffalo

Skilled facilitators are available to work with short- and long-term committees, work groups, and library-wide community efforts to build a strong foundation for group effectiveness. Issues such as group development, conflict management, interpersonal relations, idea generation, and process planning are explored. Action planning that supports ongoing efforts is a key component of this program. OMS delivered such service to:

- Pennsylvania State University
- University of Washington

Kathryn Deiss, OMS Senior Program Officer for Training and Leadership Development <kathryn@arl.org>

#### **4.2.2 OMS Information Services Program**

The OMS Information Services Program maintains an active publications program with principal components of the Systems and Procedures Exchange Center (SPEC) and the OMS Occasional Paper Series. Through the OMS Collaborative Research Writing Program, librarians work with OMS staff in joint research and writing projects that are published by OMS. Participants and staff work together in all aspects of the publication process, from survey design, writing, and editing, to seeking management perspectives on current academic concerns.

### Summary of 1997 Activities

SPEC Kits organize and collect selected library documents concerning a specific area of library management. Kits are designed to illustrate alternatives and innovations used in dealing with particular issues. Documents describing both the administrative and operational aspects of the topic are included. While this program was established to exchange useful information for strengthening library operations and programs among ARL members, a number of academic, public, and special libraries are among the more than 500 SPEC subscribers. Approximately 4,000 SPEC Kits were distributed this year.

#### SPEC Kits produced in 1997

- #219 *Transforming Libraries: Issues and Innovations in Geographic Information Systems*  
George Soete; Prue Adler, editorial advisor
- #220 *Internet Training in ARL Libraries*  
Jon E. Cawthorne and Richard Bleiler
- #221 *Evolution and Status of Approval Plans*  
Susan Flood
- #222 *Electronic Resource Sharing*  
Donna R. Hogan and Barbara J. Dahlbach
- #223 *Transforming Libraries: Issues and Innovations in Electronic Scholarly Publication*  
George Soete; Mary Case, editorial advisor
- #224 *Staff Training and Development*  
Kostas Messas, et al.
- #225 *ARL Partnerships Program*  
Allyn Fitzgerald and DeEtta Jones

#### SPEC Kits currently in progress:

- Affirmative Action
- Network Security
- Digital Archiving
- Electronic Resources
- Customer Service Programs
- Library Homepages
- Outreach and Extension Services
- Organization of Government Documents
- Evaluation of Library Directors
- User Surveys
- Library Security
- Use of Teams
- Food and Drink Policies
- Gifts and Exchange Function

An *Occasional Paper* on video collections and multimedia in ARL libraries was published in April. Another on library network security and one on the educational backgrounds of systems librarians will be published before the end of the year.

*Transforming Libraries* is a new OMS publication series that focuses on how libraries are using technology to transform library services and operations. Each issue addresses how institutions and individuals are pioneering in a particular subject and report on that area. Issues released in 1997 focused on geographic information systems (February) and electronic scholarly publication (June). Two more issues are scheduled for release in the fall of 1997: Digital Preservation and User Surveys.

Julia Blixrud, Senior Program Officer <jblix@arl.org>  
Patricia Brennan, Program Officer <patricia@arl.org>

#### 4.2.3 OMS Training and Leadership Development

The OMS Training & Leadership Development Program provides support for libraries by delivering unique and dynamic learning events that actively and positively assist academic and research libraries to recognize, develop, optimize, and refine staff talents and skills.

##### Summary of 1997 Activities

Increased demand for sponsored Training Institutes and On-Site Learning Workshops and Programs has continued. Organizations experiencing tightened resources are finding it more cost-effective and more productive to bring OMS staff to their sites. Highlights of 1997 customized activities follow:

- contributed curriculum for two important grant proposals to support the leadership development of individuals from underrepresented groups. Both the ARL Diversity Program Leadership and Career Development Program, and the University of Minnesota Training Institute for Affirmative Action Library Science Interns were funded by the Department of Education;
- designed and delivered an expanded version of the Training Skills Institute for Implementing an Integrated Library System for Illinois Library Computer System Office (ILCSO), a consortium of 45 Illinois libraries. As part of the design for this event, the OMS created its first training web pages specifically for post-event support of the participants;
- designed and delivered a week-long, custom-designed Training Skills Institute for Implementing an Integrated Library System for the University of British Columbia (described in *ARL Newsletter #194*, October 1997);
- designed and delivered a special program, Leadership and the Nature of Change, for Directors of the ILCSO libraries, to engage the directors of the ILCSO consortium libraries in thinking about how they are leading change both within their own institutions and within the consortium;
- provided a specially designed version of the Library Management Skills Institute I for a group of Russian Library Directors (Thatcher Fellows) at the Library of Congress (LC) in November 1996 (this event was missed by the timing of the previous activities report and is recorded here due to its importance);
- developed and implemented a comprehensive Customer Services Training Program for all staff and managers in the Library of Congress Human Resources Services Department; and
- designed and delivered The Evolving Organization: An Exploration of Change retreat for university administrators and financial officers in the Montana University System.

##### Other Workshops and Institutes Offered January 1997 – October 1997

Focuses on skill development of in-house facilitators who can assume key roles in helping groups and teams produce better quality results.

Evanston, IL — June 11–13

Participants are introduced to the concepts and disciplines of a learning organization and begin practicing the application of these in the workplace.

North Suburban Library System

Practical approaches to team learning, personal mastery, and mental models (three of the five disciplines of learning organization) are offered.

ACRL Preconference - Nashville, TN — April 11

Examines the basics of organizational development; methods and strategies of facilitating and leading meaningful and successfully implemented change; dynamics of organizational change; and the importance of transitions.

Arizona State University — July 7–8

One of the OMS core programs, the LMSI is designed to assist participants in furthering their own growth as managers and leaders, and to allow them to address the critical issues they face. The focus of this public event is on the individual and his/her relationship to the library as a whole.

New York Public Library — January 6–9

Washington, D.C. — March 4–7

Harvard & MIT Universities — May 20–23

University of Southern California — October 6–9

Focuses on the manager's role as leader in the larger organization. Within the framework of the learning organization, participants explore such issues as organizational communication, shared visioning, strategic planning, and gaining staff commitment to organizational change.

Ontario Council of University Libraries — April 28 – May 1

New York Public Library — May 19–23

Clark Art Institute — April 16–17

Specifically designed to enhance the ability of team members to share leadership and to examine individual leadership behaviors and roles.

University of Arizona — August 19

Special week-long Institute designed for librarians from Eastern European libraries.

Library of Congress — March 24–28

Through exposure to and discussion of models and group learning, this workshop focuses on seeking common ground and enhancing communication in a learning organization.

Penn State Harrisburg — August 6

Kathryn Deiss, OMS Senior Program Officer for Training and Leadership Development <kathryn@arl.org>

#### 4.2.4 OMS Committee on Research Library Leadership and Management

In early 1997, the Committee proposed a new charge for itself that better reflects the focus that they see as useful for the Association. The new focus is also reflected in a renaming of the Committee. The new charge, endorsed by the ARL Board, reads as follows:

In keeping with the 1997 Board of Directors priority to "develop programs and products to help research libraries move into a transformed environment," the ARL Committee on Research Library Leadership and Management is established by the Board of Directors to provide a continuing focus on issues of leadership and management in research libraries as well as on issues of leadership and management in the broader information environment. These issues include planning, service assessment, organizational development, resource management, staff training and human resources development, the broad application of technology to library functions and services and the role of the library in the broader information services structures of the University. The work of the Committee on Research Library Leadership and Management should serve to inform and guide the membership by way of programs, publications and/or collegial discussion.

The Office of Leadership and Management Services (OLMS—formerly the OMS) exists to support the needs of each member library, as well as the membership in the aggregate, in advancing both the discourse and practice of shaping research library and information service organizations of the future. The Committee on Research Library Leadership and Management is also charged to serve as a general advisory body to the OLMS to ensure that the programs and services of the OLMS are consistent with the leadership and management issues identified by both the committee and the membership in such a dynamic and transformational environment. In turn, the staff of the OLMS work to support the agendas of the Committee on Research Library Leadership and Management as it undertakes its charge.

Among the Committee's strategies for serving the membership are:

- review research library issues, needs, and aspirations and identify those that should be addressed through broader discussion and/or experimentation within the membership;
- evaluate the applicability of research and best practice in areas of organizational and leadership interest to research libraries;
- make recommendations to the ARL Board on research library policies, programs, and positions related to management and leadership;
- develop leadership and management programs and activities for the benefit of the membership; and
- work with and through the Office of Leadership and Management Services to create and sustain partnership and linkages with other organizations to strengthen leadership and organizational capability.

Specific elements this charge are:

- identify critical management/leadership issues requiring testing and experimentation, and the initiation and revision of Association policy;
- assess new or changed approaches to management and leadership issues and communicate such approaches to the membership;
- through the offices of ARL/OMS, assist member libraries to continuously improve management practices and the capabilities of their staffs, and to share best practices;
- develop a research agenda for library management and human resource issues and propose ways to advance this agenda;
- serve in an advisory capacity to the Office of Leadership and Management Services; and
- initiate and maintain linkages as appropriate within and outside the Association.

The name change for the committee was effective immediately. Implementation of the name change for the OMS will be timed with the recruitment and arrival of a new director of the office.

**Members:**

Nancy Baker (Liaison from Diversity Committee)	
Nancy Eaton	(1996-1998)
Joan Giesecke	(1997-1999)
Charles Henry	(1997-1999)
Graham Hill	(1995-1997)
Sarah Michalak	(1996-1998)
Robert Migneault	(1996-1998)
Rush Miller	(1995-1997)
Charles Osburn	(1995-1997)
Sherrie Schmidt	(1996-1998)
Carolyn Snyder	(1996-1998)
Paul Kobulnicky, Chair	(1996-1998)

William Studer (ex officio as Chair, Statistics & Measurements Cte.)

**Staff Liaison:** Kathryn Deiss, OMS Senior Program Officer for Training and Leadership Development  
<kathryn@arl.org>

## Section 5 Performance Measures

### 5.1 Statistics and Measurement

The Statistics and Measurement Program describes and measures the performance of research libraries and their contribution to teaching, research, scholarship, and community service. The program includes support for the ARL Statistics and Measurement Committee and collaboration with other national and international library statistics programs.

#### Summary of 1997 Activities

Statistical compilations produced in 1997:

- *ARL Statistics 1995-96*
- *ARL Academic Law and Medical Libraries Statistics 1995-96*
- *Developing Indicators for Academic Library Performance: Ratios From the ARL Statistics 1994-95 and 1995-96*
- *ARL Annual Salary Survey 1996-97*
- *ARL Preservation Statistics 1995-96*

Apart from these formal publishing efforts, program staff are compiling two reports: the ARL Supplementary Statistics 1995-96 and the Library Expenditures as a Percent of Educational and General University Expenditures 1995-96.

In addition to these printed publications, the program continues its strong presence in electronic publishing activities. Of special interest is the interactive electronic publication of the ARL Statistics on the WWW, which is being completely revised by the Social Science Data Center at the University of Virginia. The Program's web site was also revised to reflect the publication of new editions of the Statistics publications.

This year, for the first time, ARL libraries will be able to submit their institutional statistical data using the WWW. ARL staff have developed a web version of the annual main, law, and medical statistics questionnaires and instructions. The data collection web site was developed under contract with the Library Research Center of the University of Illinois. For the near future, salary survey data will continue to be collected through disks or paper to ensure confidentiality.



### **Innovative Services**

This new survey gathers information about whether certain services are available at ARL libraries (e.g., patron-initiated circulation, email reference, digital imaging). The results were distributed electronically to survey coordinators in July and will be published this fall.

### **Electronic Investments Initiative**

The Council on Library Resources awarded a grant of \$11,800 to ARL to study the "Character and Nature of Research Library Investment in Electronic Resources." The project goal is to develop new definitions that support collection of information about the transformation of research library collections. Timothy Jewell, Head of the Electronic Information Program at the University of Washington Libraries, is Visiting Program Officer. He made presentations and gathered comments at two survey coordinator meetings and held an extensive discussion with Statistics and Measurement Committee members in May. Mr. Jewell has prepared two reports, one an interim report for the Council on Library Resources and a second report on a trend analysis of the data that will be published as part of the Supplementary Statistics report for 1995/96. In addition, a revised set of questions regarding research library investments in electronic resources will be distributed to ARL members as part of the 1996/97 Supplementary Statistics questionnaire to be tested this year.

Custom reports for peer institution comparisons for various ARL member libraries were prepared from the ARL Statistics, ARL Performance Indicators, and ARL Annual Salary Survey. Staff began working on a major contracting activity that includes oversight and analysis for the AALL Biennial Salary Survey 1997.

Two workshops on User Surveys in Academic Libraries were conducted in the spring. A workshop on Electronic Publishing of Datasets on the WWW is being planned for later this year on the West Coast.

### **Liaison with External Statistical Programs**

ARL cooperates with other library and higher education data gathering efforts, extending the influence of ARL perspectives and seeking experience to assist ARL in refining data gathering and measurement approaches. Specifically, the ARL Statistics and Measurement Program was represented in the following committees/activities in 1997:

*ALA/IPEDS Advisory Committee* advises NCES on the IPEDS Academic Libraries survey. This committee meets twice a year in conjunction with the ALA meetings, and participants also attend various IPEDS/ALS training meetings. Julia Blixrud attended two meetings in 1997.

### *NCES Library Cooperative Working Group*

ARL staff are participating in the development of the first Library Cooperatives Survey to be conducted by the National Center for Education Statistics. This survey is intended to be a benchmark of information about library organizations with formal arrangements, budgets, and paid staff that provide library and information services for the mutual benefit of participating members.

*NPEC Council on Postsecondary Education* is a voluntary partnership among governmental and non-governmental providers and users of education data "to produce and maintain with the cooperation of the states, comparable and uniform educational information and data that are useful for policy making at the Federal, state and local levels." ARL program staff are members of this council for information and coordination purposes. The next meeting is scheduled for November 1997.

### **Liaison with Survey Coordinators**

Communication activities with the ARL Survey Coordinators included management of the three electronic lists for the three annual statistical surveys (arl-statsurvey, arl-statsalary, and arl-statpresv) and hosting meetings for the ARL Survey Coordinators in conjunction with the ALA Midwinter and Annual meetings.

### **Relation to Other ARL Programs**

Statistics and Measurement works closely with other related ARL programs, including Access to Information Resources, Diversity, Office of Management Services, Preservation, and Research Collections. Members of the ARL Statistics and Measurement Committee serve as advisors to the ILL Performance Measures Study, which is funded by The Andrew W. Mellon Foundation. At the operational level, program staff participate in planning for ARL technologies through the Technology Team and coordination of publications and communications through the Communications Team.

Julia Blixrud, Senior Program Officer <jblix@arl.org>

### 5.1.1 ARL Committee on Statistics and Measurement

The Committee is placing increased emphasis on the measurement of service quality and expenditures for electronic resources. In February 1997, the ARL Board reiterated the importance of defining new measures for service quality while still retaining quantitative measures that identify trends. They also encouraged the Committee to address issues related to format neutrality as well as the impact of consortial activities on data collection. The Committee began these discussions in May 1997.

The program has developed workshops that have been well received and have increased the cost recovery component for the ARL Statistics and Measurement Program. The Committee has advised on the development of the content and "deliverables" coming out of these workshops. The Committee also advised on a strategy to review the collection of data on preservation activities with the goal of minimizing the burden on individual libraries while retaining the ability to follow trends. Jan Merrill-Oldham (Harvard), consultant to ARL, is coordinating a review of the Preservation Statistics instrument for ARL.

<b>Members:</b>	Martha Alexander	(1997-1999)
	Jennifer Cargill	(1995-1997)
	William Crowe	(1997)
	Ronald Dow	(1997-1999)
	Ray Metz	(1996-1998)
	William Potter	(1997-1999)
	Carolynne Presser	(1996-1998)
	Carla Stoffle	(1997-1999)
	Don Tolliver	(1995-1997)
	William Studer, Chair	(1997-1998)

Kendon Stubbs, Consultant

**Staff Liaison:** Julia Blixrud, Senior Program Officer <jblix@arl.org>

## Section 6 Supporting Capabilities

### 6.1 Governance of the Association

The capability for governance of the Association is intended to represent prudently the interests of ARL members in directing the business of the Association. The governing body is the ARL Board of Directors, whose functions include: to establish operating policies, budgets, and fiscal controls; to approve long-range plans; to modify or clarify the ARL mission and continuing objectives; to monitor performance and the succession of the Executive Director; and to represent ARL to the community. The staff role in this capability is to provide information to the Board adequate to fulfill its responsibilities in a knowledgeable and expeditious manner. The Board establishes several committees to help achieve effective governance of the Association.

#### Summary of 1997 Activities

ARL's planning process calls for annual Board review of each program to assess priorities for the year and their overall effectiveness in meeting the Association's strategic objectives. The ARL Program Plan reviews progress made in the past year, identifies priorities for the prospective year, and notes the allocation of resources to each capability. At its February meeting, the Board reviewed the *ARL Program Plan 1997* and the proposed 1997 resource allocations as developed by the Executive Director and staff to implement the program objectives and financial strategies. The February Board discussions led to the adoption of four major program priorities for ARL in 1997:

- accelerate and broaden copyright advocacy and education within the research and educational communities and to the general public;
- build partnerships to explore and promote cost-effective strategies and models for managing global scholarly communication;
- develop programs and products to help research libraries move into a transformed environment; and
- influence the development of advanced network applications and the Internet2.

The ARL Board recommended that all member libraries receive a copy of the *ARL Program Plan 1997* as a guide to association activities and to encourage active involvement in ARL's ongoing planning process. The distribution of the *Plan* served as the activity report for members in preparing for the Albuquerque meeting.

The ARL Board of Directors met for two days in February. In addition to the review and approval of the *ARL Program Plan for 1997*, the Board received a briefing on the recent World Intellectual Property Organization (WIPO) treaty discussions in Geneva, Switzerland.

The Board also met on July 28-29, 1997 in Washington, DC. Members conducted conversations with Diane Frankel, Director of the Institute of Museum and Library Services; Pat Schroeder, newly appointed President of the Association of American Publishers; and John Carlin, Archivist of the United States. They also met with Clifford Lynch, new Executive Director of the Coalition for Networked Information, who described possible new programs for CNI. It was during this July meeting that the Board reviewed ARL's financial status and made a recommendation for 1998 dues.

In February, with Educom and CAUSE, the Board endorsed joint sponsorship of an award in honor of Paul Peters. The Board sought a fuller role in shaping the operation of the award as it is implemented. Conversations with Educom and CAUSE have provided assurance that this will be the case. The ARL Executive Committee selected Marilyn Sharrow (UC-Davis) and Nancy Eaton (Penn State) to represent ARL on the steering committee for the award.

The ARL Board, at their meeting on July 28, presented Stanley N. Katz with an award for his distinguished contributions to research libraries and the scholarly community, specifically his leadership in influencing and shaping the future of scholarly communication. This summer, Dr. Katz resigned as President of the American Council of Learned Societies. He served eleven years as President of ACLS, during which time he established exceptionally effective working relationships with the leadership of research libraries. He is returning to full-time teaching at the Woodrow Wilson School at Princeton.

**1997 Board of Directors:**

- Gloria Werner - President
- Nancy Cline - Past President
- James Neal - Vice President/President Elect
- Shirley Baker
- Betty Bengtson
- William Crowe
- Nancy Eaton
- Kenneth Frazier
- Carole Moore
- William Potter
- Barbara von Wahlde

Three Board members conclude their terms in October: Nancy Cline (Harvard), Nancy Eaton (Penn State), and Barbara von Wahlde (SUNY Buffalo). The Nominating Committee, chaired by Jim Neal (Johns Hopkins) and including Graham Hill (McMaster) and Ann Wolpert (MIT), brought forth the nominations of Scott Bennett (Yale), Paula Kaufman (Tennessee), and Carla Stoffle (Arizona). The membership will vote on these nominations at the October 1997 Membership Meeting.

In 1997, almost 100 member library directors are participating in eight standing committees, and seven advisory committees and task forces. Virtually all interested library directors were involved in ARL groups during the course of the year. Recent changes in ARL committee appointments include:

- **Information Policies Committee**  
At her request, Nancy Cline (Harvard) relinquished the role of chair of this committee. Fred Heath (Texas A&M) was named the new chair to complete Nancy's term through 1998.
- **1997 Nominations Committee**  
See above for current membership.
- **Diversity and Leadership Committees**  
Co-liaisons between the Leadership and Diversity Committees were identified. Nancy Baker (Washington State) and Joan Giesecke (Nebraska) will serve in these roles.
- **Collections Committee**  
At his request, Don Simpson was designated Center for Research Libraries liaison to the Collections Committee, recognizing the special role and perspective of the CRL to the agenda of this committee.
- **Leadership Committee**  
The Executive Committee, following the October 1996 discussions with the Chair, developed a new charge for the Management Committee, with the assistance of the entire Committee. An added feature of these recent discussions is the recommendation for a new title for the committee. The new title is ARL Committee

on Research Library Leadership and Management. In May, the ARL Board endorsed the committee charge recommended by current members. See Section 4.2.4.

At the 1997 Spring Membership Meeting in Albuquerque, New Mexico, the ARL membership voted to invite Texas Tech University Library to join as its 121st member. Located in Lubbock, Texas, the University was elevated to the status of a Carnegie Research University II in 1994. E. Dale Cluff, Dean of Libraries, has overseen the library's development for the past 15 years. The membership vote followed an extensive multi-year review of qualitative and quantitative documentation and a site visit to Lubbock. The ad hoc visiting committee established to consider the eligibility of the Texas Tech University Library System was comprised of Charles B. Osburn (Alabama, Chair), Paula T. Kaufman (Tennessee), and Martin Runkle (Chicago).

Duane Webster, Executive Director <duane@arl.org>  
Jaia Barrett, Deputy Executive Director <jaiab@arl.org>

### 6.1.1 Standing Committees and Selected Advisory and Project Groups

Full descriptions of each of the following committees and their charges are provided in the ARL Program Plan, 1997. Committee rosters and updates to committee activities appear in the following sections indicated.

Board of Directors .....	Section 6.1
Executive Committee .....	Section 6.1
Nominating Committee .....	Section 6.1
Access to Information Resources Committee .....	Section 2.1.1
Diversity Committee .....	Section 4.1.1
Information Policies Committee .....	Section 1.2.1
Research Library Leadership and Management Committee .....	Section 4.2.4
Preservation of Research Library Materials Committee .....	Section 3.2.1
Research Collections Committee .....	Section 3.1.1
Scholarly Communication Committee .....	Section 1.1.1
Statistics and Measurement Committee .....	Section 5.1.1
Working Group on Copyright Issues .....	Section 1.3.1
Firm Subscription Prices Working Group .....	Section 1.1.2
Work Group on Scientific and Technical Information .....	Section 2.1.2
Advisory Committee on ILL Performance Measures .....	Section 2.1.3

### 6.2 Communication and External Relations

The capability for Communication and External Relations is designed to: acquaint ARL members with current, important developments of interest to research libraries; inform the library profession of ARL's position on these issues; influence policy and decision makers within higher education and other areas related to research and scholarship; and educate academic communities about issues related to research libraries.

Through print and electronic publications as well as direct outreach, members of the library, higher education, and scholarly communication communities are informed of important developments and ARL positions on issues that affect the research library community. External relations with relevant constituencies are also carried on through all ARL programs.

#### 6.2.1 ARL Publications Program

The ARL publications program offers a full range of timely, accurate, and informative resources to assist library and higher education communities in their efforts to improve information delivery through technology and education. Print and electronic publications are issued from all ARL programs on a regular basis. ARL now makes several of its titles available electronically via the World Wide Web; some are available in excerpted form for preview before purchase, and others are available in their entirety. The electronic publications catalog can be accessed via <<http://arl.cni.org/pubscat/index.html>>.

Development of a plan to enhance ARL's communications capability and maximize use of both print and electronic formats is in progress. An initial step toward this goal was to make more ARL publications available on the ARL server.

### Summary of 1997 Activities

The first formal publication ever from the ARL Diversity Program was released in June. The *ARL Partnerships Program: Breaking Down Walls and Building Bridges* is available through the Publications Office. It provided a vehicle for institutions participating in the ARL Partnership Program to tell their stories and relate their experiences with diversity. The publication was designed to facilitate use of the models described by contributors.

### Newsletter

Six issues of *ARL: A Bimonthly Newsletter of Research Library Issues and Actions* will be published in 1997, including a special issue on copyright. ARL newsletters are available on the ARL website at <<http://www.arl.org/newsltr/newsltr.html>>. A reader survey was distributed with the August issue; responses will guide the editor in planning for 1998.

### Conference on Scholarly Communication and Technology

ARL collaborated with The Andrew W. Mellon Foundation to make papers from the Conference on Scholarly Communication and Technology available via the ARL website: <<http://www.arl.org/scomm/scat/index.html>>.

### Proceedings of the ARL Annual Membership Meetings

A concentrated effort is being made to bring the Proceedings series up-to-date. The May 1995 meeting proceedings should be released in the fall.

### Directory of Key Staff in ARL Libraries

Planning is underway for production of a directory of key staff in ARL libraries. This directory will be available both in print and online to provide those interested in communicating with ARL member libraries with a convenient tool that provides general information about member institutions and identifies appropriate contacts within each institution.

Publications program staff assisted with the preparation, production, and promotion of publications issued by ARL programs, including:

- *ARL Partnerships Program: Building Bridges and Tearing Down Walls*
- *ARL Statistics 1995-96*
- *ARL Academic Law and Medical Libraries Statistics 95-96*
- *ARL Annual Salary Survey 1996-97*
- *ARL Preservation Statistics 1995-96*
- *Licensing Electronic Resources: Strategic and Practical Considerations for Signing Electronic Information Delivery Agreements*
- *NHA Basic Principles for Managing Intellectual Property in the Digital Environment*

See section 4.2.2 for a complete list of SPEC and other OMS titles.

The ARL-Announce service continues to be developed and strengthened to deliver timely information about ARL and, this year, news items about ARL member library activities. The subscriber base is over 700 and continues to grow. To subscribe, send email to <[listproc@cni.org](mailto:listproc@cni.org)> with the following message, "subscribe arl-announce [your name]". Directors of ARL member libraries are automatically subscribed.

ARL regularly receives information requests on a vast array of topics from a variety of sources, including students, educators, the press (scholarly and popular), and representatives of the information industry. To facilitate handling these requests, ARL Publications has developed Focus Flyers (newly redesigned) on particular topics and a standard ARL Information Packet that includes key resource documents about ARL programs and services, including: fact sheets, recent press releases, a publications catalog, OMS training schedule, and information about pertinent resources available on the ARL Server. Current flyers include information on economics issues, copyright, preservation, and interlibrary loan. An updated ARL publications catalog was produced in April.

1997 saw an increased focus on marketing ARL products and services with the appointment of the Marketing and Production Coordinator. In addition to creating pamphlets and brochures that advertise publications, workshops, and conferences, ARL actively sought opportunities to advertise in library journals, at trade shows, via no-cost electronic lists, and through direct mail campaigns. Advertisements have appeared in *Library Administration and Management*, *College & Research Libraries*, *College and Research Libraries News*, and *CHOICE*. The *Academic Law and Medical Library Statistics* was included in the EBSCO Sample Issue Program at the Medical Library Association Annual Meeting and the ARL 1997 Catalog was entered and received honorable mention in the ALA Best of Show Awards in the Services Available category. Also, a brochure developed for the 1996 Directory of Electronic Journals was included in the meeting packet for attendees of the Computers in Libraries annual conference in Washington, D.C. ARL also exhibited its products at the ACRL National Conference in Nashville.



In February, the Statistics and Measurement Program created a brochure that was mailed to 40,000 librarians and social science professionals to educate them about the kinds of products and services offered by the program and to entice them to purchase such products. This campaign followed on similar efforts for the OSC Directory of Electronic Journals and the OMS Systems and Procedures Exchange Center and Training and Leadership Development program, all undertaken in late 1996. To date, the response to these direct mail campaigns has been encouraging. Brochures were also developed for the Diversity Program and the Specialized Scholarly Monograph conference.

Collaboration on both a technical and policy level is documented under all individual capabilities. Activities at the executive level in the past six months include collaborations with, among others, the National Humanities Alliance, NASULGC, the Association of American Universities, the American Council of Learned Societies, The Andrew W. Mellon Foundation, CAUSE, and NINCH.

The six major presidential associations (AACC, AASCU, AAU, ACE, NAICU, and NASULGC) are exploring ways to work collaboratively to identify and address key issues related to digital networking, intellectual property, and information technology. ARL has been asked to provide advice and assistance in the work and discussions of this forum. Prue Adler and Duane Webster are the primary contacts.

#### **Association of American Universities**

AAU, as a part of internal restructuring, has created a new committee on Digital Networks and Intellectual Property. For more information, see Section 1.1.

#### **National Humanities Alliance**

NHA emerged this year in a new leadership role to promote the development of Principles for the Management of Intellectual Property in a Digital Environment. Working with individuals who represent a full range of views within the scholarly community, the NHA was successful in finding consensus around the articulation of some basic understanding. To date, 16 organizations have formally endorsed the principles. Duane Webster chairs the NHA Committee on Intellectual Property.

#### **NINCH-Networking Cultural Heritage**

ARL became a founding member of NINCH to ensure that research libraries were part of the early phases of this cultural community initiative and to influence the direction it took. Over the last 3 months, 27 ARL libraries have joined NINCH to participate in a short-term strategy that includes community building, advocacy, communication and education. Membership in NINCH gives a timely flow of information and easy access to the leaders in other sectors of the cultural community. As a result, the initiative has been invaluable for ARL to extend outreach to new sectors of the educational community. Duane Webster serves on the NHA Board.

Two topics have dominated ARL's agenda with NINCH during the last year: intellectual property in a networked environment, and collaboration among museums and between museums and libraries. NINCH Executive Director David Green has been generous in writing for the research library audience. In addition to NINCH e-announcements and a growing NINCH website, three articles were written for the ARL newsletter: about the initiative itself (ARL #190), fall-out from CONFU (ARL #192), and on museum collaboration to market digital images (ARL #193). The NINCH Web site <<http://www-ninch.cni.org>> is a rich resource, particularly as a site for news and papers on copyright related developments. NINCH also maintains an e-resource to track endorsements of the NHA Principles.

The Communications Team, formed in 1995, consists currently of the Electronic Services Coordinator, the Office and Personnel Manager, the Marketing and Production Coordinator, the Senior Program Officer, the Program Officer, and the Publications Assistant. The team works to ensure uniform, time efficient approaches to ARL's bulk external communications. Included in external communications are all ARL/OMS publications, promotional activities, and electronic services.

ARL continues to work with Professional Mailing and Distribution Services, Inc. (PMDS) for publications fulfillment. Efforts are ongoing to refine the procedures used, both at ARL and at PMDS, to fulfill orders in a timely and efficient manner.

Jaia Barrett, Deputy Executive Director <[jaia@arl.org](mailto:jaia@arl.org)>  
Julia Blixrud, Senior Program Officer <[jblix@arl.org](mailto:jblix@arl.org)>  
Patricia Brennan, Program Officer <[patricia@arl.org](mailto:patricia@arl.org)>  
Allyn Fitzgerald, Marketing and Production Coor. <[allyn@arl.org](mailto:allyn@arl.org)>  
Duane Webster, Executive Director <[duane@arl.org](mailto:duane@arl.org)>



## 6.2.2 Electronic Communications and Technology

### Summary of 1997 Activities

In late 1996, a decision was made to upgrade the ARL server. The Technology Team looked at several different options for hardware, software, and platforms. The choice was made to install a Windows NT server running Microsoft's Internet Information Server on a Pentium Pro processor. This upgrade will enable a search engine to be installed as well as more flexibility in the administration of the server. The ARL newsletter <<http://www.arl.org/newsltr/newsltr.html>> got a new look this spring and all issues will now be available on the Web as well as in print. The Federal Relations Notebook continues to be updated each month and offers the latest on information policy. The ARL/OMS Training Skills Support Site <<http://www.arl.org/training/ilcso/>> was added this summer and offers a range of resources on developing effective training programs. Online registration was successfully used for several ARL workshops in 1997.

ARL Web           <<http://www.arl.org/index.html>>  
ARL Gopher       <<gopher://arl.cni.org/>>

Public lists such ARL-EJOURNAL, ARL-ERESERVE and ARL-ANNOUNCE continue to be a popular service offered by ARL, and internal, private lists continue to offer the ARL community a way to communicate between meetings. In addition to the ARL-DIRECTORS list and those set up for ARL committees, several lists were created and used to communicate with registrants at ARL workshops, both before and after the scheduled events. With the recent migration of the ARL email system to a new CNI server and an upgrade in the ListProcessor software, list administration will be easier to maintain.

The acquisition of several new Power Macintosh computers in 1997 has allowed for another round of upgrades for ARL staff, although some of the purchases were made due to the failure of older machines. Macintosh continues to be the primary operating system in use by ARL and most computers are now running OS 7.5 or higher. With the integration of the Windows NT server for web hosting, ARL staff members using Windows 3.1 are encouraged to move to the NT environment. Thanks to the initiative of Craig Summerhill, CNI Systems Coordinator, ARL now has an automated back-up system for each personal computer on the 8th floor. While we have had the ability to back up our work on the CNI server in the past, this recent development offers a more timely and regular back-up regimen. Hardware and software upgrades continue to be made on an as-needed basis to accommodate the information technology requirements of ARL staff.

Starting this fall, ARL email addresses now use <arl.org> as the domain, although email services are still available to staff through the CNI server.

The old email addresses <user@cni.org> will continue to work indefinitely, but staff and others are encouraged to use the new address <user@arl.org> whenever possible. This change necessitated a move to a new email software (pine) from the software (elm) that most staff have used for several years. Although there was a rash of Microsoft Word Macro viruses infecting ARL computers, anti-virus software was installed before much damage was done. Staff are encouraged to scan all disks before opening them to prevent future infection. It was determined that the Macro virus came from disks outside the office. Technology support for ARL staff continues to be on an ad hoc basis and is supplied by the Electronic Services Coordinator.

In early 1996, the Technology Team updated the ARL Technology Strategic Plan, written in 1995. The composition of the team changed in 1996. The year began with Susan Jurow, Martha Kyrillidou, Kathryn Deiss, and Dru Mogge. The Team, now comprised of Kathryn Deiss, Mary Case, Julia Blixrud and Dru Mogge, meets about every month or more frequently when needed to review the technology needs of ARL. The most recent issue before the Tech Team was the purchase of a new server for ARL. The Electronic Services Coordinator profiled several configurations—staying with NeXTStep, moving to Macintosh, moving to a higher end unix system or moving to Windows NT. The Tech Team reviewed these configurations and chose the Windows NT system. Not only is the NT system significantly less expensive than unix, more flexible than NeXTStep and more powerful than Macintosh, it offers a community of users that was not available under NeXTStep. In addition, both searching and electronic commerce are readily available under NT.

Dru Mogge, Electronic Services Coordinator <dru@arl.org>

## 6.3 ARL Membership Meetings

The ARL membership meeting capability is designed to develop programs on topics of interest to the ARL membership, schedule and manage meetings and activities, coordinate local arrangements, and evaluate the success of these meetings. The May meeting emphasizes a topical program, coordinated by the ARL President-elect; the October meeting focuses on strategic planning.

### Summary of 1997 Activities

The spring 1997 Meeting was held in Albuquerque, New Mexico and hosted by the University of New Mexico. The program theme was "Consortial Leadership: Cooperation in a Competitive Environment." It was developed in collaboration with ARL President Gloria Werner (UCLA).

The fall Membership Meeting sessions were developed by the Preservation Committee around the theme "Preservation of Digital Information."

The site of the May 1998 meeting is Eugene, Oregon, to be hosted by the University of Oregon. The program theme is being developed by ARL President-elect Jim Neal (Johns Hopkins).

Mary Jane Brooks, Office and Personnel Manager <maryjane@arl.org>

## 6.4 International Relations

The International Relations capability is designed to monitor activities, maintain selected contacts, identify developments on issues of importance to North American research libraries, and share experiences of North American research libraries that may contribute to the development of research libraries internationally. This capability draws on staff and projects across several ARL programs.

### Summary of 1997 Activities

As with scholarly relations, international relations represents a capability that is manifested by activities in several separate program areas rather than through a consolidated office.

The NAILDD Project's ILL Protocol Implementors Group expanded to include projects and vendors beyond North America. Over 50 organizations from several countries now participate in this initiative to promote the use of international ILL communications standards. See Section 2.1.

Dorothy Gregor (OCLC) represents ARL to the National Coordinating Committee on Japanese Library Resources. The committee's mission is "to mobilize the resources of information providers, information users, and funding organizations toward the long-range goal of creating a comprehensive national system of cooperative collection, development, and ready access to Japanese information in as wide a range of fields as possible for all current and potential users in North America."

Prue Adler serves as the ARL representative on the Department of State Advisory Panel on International Copyright, Advisory Committee on International Intellectual Property, addressing GATT, the WIPO Copyright Program, and related issues.

Deborah Jakubs is involved with international analyses and collaborations, including projects on foreign publications, Latin American Studies, and the German and Japanese Research Resources Projects that are part of the AAU/ARL Global Resources Project. See Sections 1.4. and 3.1.

The 63rd IFLA General Conference was held in Copenhagen, Denmark on August 30, 1997, through September 5, 1997. University of Illinois Library Director Robert Wedgeworth convened the conference as the IFLA President and he was honored for his leadership of IFLA over the past six years. Three thousand delegates from 129 countries attended. The U.S. delegation of over 200 included 14 ARL Directors. The theme of the conference was "Libraries and Information for Human Development." Topics dealt with electronic technology and its impact on information flow. A statement on copyright was advanced by the conference, affirming that copyright protection should not hinder information flow.

IFLA reviews and updates their committee membership every two years. ARL belongs to 10 of the 38 sections of IFLA, including:

- national libraries
- university libraries and other general research libraries
- acquisition and collection development
- document delivery and interlending
- serial publications
- conservation
- library buildings and equipment
- information technology
- statistics
- education and training
- regional activities: Latin America and the Caribbean

ARL seconded the nomination of Marianne Scott (National Library of Canada) to stand for election as President of IFLA to succeed Robert Wedgeworth (Illinois at Urbana), whose term concluded in August at the Copenhagen meeting. ARL also seconded the nomination of Nancy John (AUL, Illinois-Chicago) to stand for election to the IFLA Executive Board. Nancy will serve as a consensual representative for all US Associations. This collective action is an important development for the US Associations as they work together to plan an IFLA conference in Boston in 2001.

An invitation extended by the U.S. Associations to the Steering Committee of IFLA to hold the General Conference of 2001 in the U.S. was accepted. A National Organizing Committee (NOC) was established to oversee the planning and operation of the IFLA Conference in Boston. The Committee is comprised of the Chief Executive Officer and a designated leader from each of the seven Associations comprising the American delegation to IFLA. James Neal (Johns Hopkins) and Duane Webster represent ARL. Gary Strong (Brooklyn Public Library) and Duane Webster serve as co-chairs of the NOC. The Committee has established an organizational structure for the effort and has organized 7 subcommittees charged with beginning work. A meeting of the NOC with Boston area librarians is scheduled for November 7 and 8. It is expected that the Committee will meet quarterly for the next five years.

Leo Voogt, Secretary General of IFLA, will spend a month long sabbatical in Washington at the ARL offices September 27 through October 27, 1997.

Duane Webster, Executive Director <duane@arl.org>

## 6.5 General Administration

General Administration encompasses overall coordination and management of the Association, staffing, financial planning and strategy, space planning, fiscal control, secretarial support, and office operations.

### Summary of 1997 Activities

A new auditing firm was selected late in December 1996 by the ARL Board of Directors. This firm, Gelman, Rosenberg, and Freedman, submitted their financial review and the Board accepted it at their July 1997 meeting. The Gelman report is consistent with the year-end report prepared by the ARL accounting firm of Whelan, Barsky & Graham and indicates an excess of revenue (\$2,134,700) over expenses (\$2,060,000) for the year. The General Operating Fund had a \$74,700 positive balance before the transfer of \$85,900 to the Board's permanent reserve. For the first time, in 1996 the General Operating Fund statement includes an unrealized loss of \$32,700 on investments. This is required to conform to the new accounting rule, FASB 124. The Office of Management Services (OMS) experienced a \$27,600 surplus on revenues of \$677,700. This surplus was applied to the OMS negative fund balance developed over the last several years, reducing it to a minus \$83,300. An annual contribution of \$60,000 was made to the Board Designated Reserve along with \$25,900 of interest earned on the Reserve during 1996. The Board Designated Reserve totaled \$486,400 at the end of 1996. The unrestricted fund balance (net assets) ended the year at \$277,600. This includes a cumulative unrealized loss on investments of \$81,500. The ARL unrestricted fund balance is \$12,760 less than the closing balance from 1995.

The 1997 ARL financial plan discussed by the ARL Board of Directors at its February 1997 meeting and subsequently adopted by the Executive Committee, projects a balanced budget for General Funds Combined embracing revenue of \$2,249,450 and expenditures of an equal amount. The August financial report indicates that the Executive Office is on target for budgeted expenses and well ahead of budget for revenue received since most member dues are received in the first quarter of the year. There are two potential problem areas: the August financial report indicates the OMS is working a deficit of \$32,000, with revenues lagging by 13%, and the Diversity Program is carrying a deficit of \$7,000, with its revenue about 9% less than expected. The OMS is expected to generate the revenue needed to balance its budget by the end of the year, but revenue for the Diversity Program is lagging and the shortfall may be as large as \$20,000.

The ARL Board of Directors proposes a steady state ARL budget and minimal membership dues increases as the 1998 financial strategy. The Board identified the following elements of the 1998 budget that warrant an incremental dues increase: 1) supplemental support for diversity related activities; 2) merit-based salary adjustments; and 3) increases in the costs of office operations. Thus, the ARL Board of Directors recommended for membership consideration at the October business meeting a dues increase for 1998 of \$650 to a level of \$15,100. The 1998 dues recommendation continues the pattern of incremental increases recommended by the 1989 Financial Strategy Task Force, whose work has formed the basis for major financial decisions over the last seven years. This financial strategy also calls for a continuing commitment to building a reserve fund to support innovative projects, and membership approval of any new programs that have dues implications.

Important changes took place with ARL staff in 1997:

- Each year, the Past President leads the Executive Committee and the Board in a review of the Executive Director's performance. As a result of this review, the Board renewed the employment for the ARL Executive Director for a continuing three-year period.
- Julia Blixrud was recruited in December 1996 as Senior Program Officer to assume some of the responsibilities of Martha Kyrillidou in the Statistics and Measurements Program and some of the responsibilities of Patricia Brennan in the Communications Program. Upon Patricia's return in June, she took up some of the activities previously pursued by Laura Rounds.
- Martha Kyrillidou returned to Greece in May for a two-year stay to fulfill her Fulbright obligations. She continues to work part-time with the Statistics and Measurement Program and she and Julia Blixrud look forward to documenting the experience of a truly off-site/telecommuting/job-sharing experience.
- Patricia Brennan returned from a six-month leave of absence to resume responsibilities in the ARL communications and publications program that was managed in her absence by Julia Blixrud. With the resignation of Laura Rounds from the OMS Information Services position, both Julia Blixrud and Patricia share publications responsibilities.
- Laura Rounds announced her resignation as ARL/OMS Program Officer for Information Services effective June 13. Over the last 2 years, Laura contributed to the advancement of the SPEC program and the introduction of a new publication series, *Transforming Libraries*. Her efforts served to provide the Association a sound base to plan future development of these services.
- Kathryn Deiss was promoted to ARL/OMS Senior Program Officer for Training & Leadership Development effective April 1. The promotion recognizes her accomplishments in the development and delivery of OMS training services over the last 2 years.
- Glen Zimmerman was recruited as a part-time consultant to support the AAU/ARL Global Resources Program and the Scholarly Communication Program.
- Prue Adler, ARL Assistant Executive Director, was named the 1997 recipient of the CIS/GODORT/ALA "Documents to the People" Award. The award, one of the highest honors bestowed by the Government Documents Round Table, is presented annually to the individual, group, or organization that most effectively encouraged the use of documents in library service. This award was accorded Prue in recognition of her significant role in the progress being made in access to government information, especially her leadership of the ARL Geographic Information Systems (GIS) Literacy Project.
- Recruitment for the position of Director of OMS began over the summer with the goal of filling the position by the end of the calendar year.

Duane Webster, Executive Director <duane@arl.org>

## Section 7 Research and Development

### 7.1 Research and Development

The ARL Office of Research and Development consolidates the administration of grants and grant-supported projects administered by ARL. The major goal within this capability is to identify and match ARL projects that support the research library community's mission with sources of external funding. The ARL Visiting Program Officer project is also a part of this capability.

#### Summary of 1997 Activities

Description of ongoing project activities:

- *The Endangered Monograph*
- Library Security
- Cost Models for Preservation Decision Making
- Measuring the Quality of Library Services
- Pew Roundtable Discussion on Intellectual Property Rights Management
- Copyright Education Initiative
- Shared Legal Capability (Copyright Legislation & Licensing Principles)
- National Initiative for a Networked Cultural Heritage
- AAU/ARL Global Resources Program
- Latin Americanist Research Resources Project

- Latin American Book Price Index
- Japanese Journals Project
- Streamlining Network ILL/DD Requests for Users & Libraries
- NRRM: Non-Roman Reports & Musical Scores
- ILL/DD Cost and Performance Measures
- Character and Nature of Research Library Investments in Electronic Resources
- Leadership and Career Development Program
- ARL GIS Literacy Project

Jaia Barrett, Deputy Executive Director <jaiab@arl.org>

### 7.1.1 ARL Visiting Program Officer Program

The ARL Visiting Program Officer (VPO) program provides an opportunity for a staff member in a member library to assume responsibility for carrying out part or all of a project for ARL. It provides a very visible staff development opportunity for an outstanding staff member and serves the membership as a whole by extending the capacity of ARL to undertake additional activities.

Typically, the member library supports the salary of the staff person, and ARL supports or seeks grant funding for travel or other project-related expenses. Depending on the nature of the project and the circumstances of the individual, a VPO may spend extended periods of time in Washington, DC, or may conduct most of their project from their home library. In either case, contact with ARL staff and a presence in the ARL offices is encouraged as this has proved to be mutually beneficial for the VPO and for ARL.

- Valdosta State University  
Mark Winston, to research and write on diversity issues in academic libraries.
- Ohio State University  
Trisha Davis, to collaborate with ARL's Office of Scholarly Communication to design a licensing workshop and produce supporting written materials.
- University of Washington  
Timothy Jewell, to study the character and nature of research library investments in electronic resources.
- Duke University  
Deborah Jakubs, to develop the AAU/ARL Global Resources Program, coordinate the work of the ongoing pilot projects (Latin America, Japan, Germany) and promote projects for other world areas (Africa, South Asia, and Southeast Asia).

The ARL website <<http://www.arl.org/>> reflects the scope of ARL's current agenda and suggests the range of issues where a Visiting Program Officer project could make a contribution. The following are examples of projects where VPO contributions would be particularly welcome. Individuals with expertise related to one of these issues should contact the ARL staff person identified and indicate an interest in a VPO assignment.

- Workshops on analytical, management, and electronic publishing of datasets (contact: Julia Blixrud, <jblix@arl.org>)
- A clearinghouse of research available or underway about the cost of research library operations (contact: Julia Blixrud, <jblix@arl.org>)
- Identification of cost models for preservation decision-making (contact: Mary Case, <marycase@arl.org>)
- An examination of the practices and policies for using digital images or multimedia in educational settings (contact: Mary Jackson, <mary@arl.org>)
- An examination of institutional copyright policies (related to either use or ownership of intellectual property) (contact: Patricia Brennan, <patricia@arl.org>)
- Development of web resources about issues pertaining to scholarly communication (contact: Mary Case, <marycase@arl.org>)
- Development of a self study to assess library security procedures (contact: Glen Zimmerman, <gzimmer@arl.org>)



- Development of a program to address training for technology skills for librarians (contact: Kathryn Deiss, <kathryn@arl.org>)
- Identification of innovative library uses of technology to improve access to scientific and technical information for research and for teaching, especially in areas of chemistry, engineering, or environmental studies (contact: Jaia Barrett, <jaiabarrett@arl.org>)

Individuals who wish to propose another project they could advance for ARL, or those who wish to nominate a librarian to serve as a VPO, may contact Jaia Barrett, ARL Deputy Executive Director <jaiabarrett@arl.org>. Each appointment has its own time frame and will be dependent on securing support from the potential VPO's home library and identifying the financial resources needed to undertake the assignment. A roster of individuals who have previously served as an ARL Visiting Program Officer, and the issue each addressed, is on the ARL website <<http://www.arl.org/arl/vpo.html>>.

#### **Summary of 1997 ARL Grant-Funded Activities**

The Office of R&D provides the Association with a point of coordination for grant seeking activity and idea management. This office provides a consolidated picture of ARL activities that are operated with "soft" funds. All ARL program officers play roles in the development of project concepts and funding contacts.

#### **Measuring the Quality of Library Services**

The Statistics & Measurements Program collaborated with Danuta Nitecki on a project to explore the applicability of the SERVQUAL instrument as a reliable diagnostic tool to measure customer criteria for service quality. A proposal submitted to the Council on Library Resources was not funded. However, the Committee on Statistics and Measurement has asked that other options for pursuing the project be developed. (Contact: Julia Blixrud)

#### **The Endangered Monograph**

ARL and the American Historical Association (AHA) are developing a project to design and test the functionality of an electronic database of monographic literature important for teaching and research in historical studies. The goal is to identify strategies to publish and disseminate monographic literature that are more cost effective than the traditional print model for readers, publishers, and libraries. Targeted material are books out-of-print but in-demand and new monographs that would be produced in short print runs. A project proposal was reviewed by the ARL Scholarly Communication Committee, by the AHA Board, and was the topic of growing community interest at the September 1997 ARL/AAUP/ACLS conference on the Endangered Monograph. (Contact: Mary Case)

#### **Library Security**

Because library security is an area of specialized knowledge, ARL is seeking support to hire a committed, experienced firm to assist in the development of assessment materials and to provide training in the area of security for ARL staff who will undertake the program development and implementation. The program will consist of an initial site visit by the project consultants, who will meet with a local project team to outline the process and tour the library's facilities. An audit to assess current security vulnerabilities, threats, capabilities and performance will be undertaken and analyzed by the consultants. Recommendations will be prepared and a plan of action will be jointly developed with the local project team. Site visits are planned for fall 1997. (Contacts: Glen Zimmerman and Duane Webster)

#### **Cost Models for Preservation Decision Making**

ARL's Preservation agenda calls for a cost model to compare the cost effectiveness of various strategies for preserving collections. Strategies to be embraced include all options, from conservation of the artifact to reformatting (including digitization) within the context of collection use, condition, and value. A proposal will be developed to engage a consultant to develop a feasible methodology. (Contact: Mary Case)

#### **Pew Roundtable Discussion on Intellectual Property Rights**

The Institute for Research in Higher Education proposed the topic of intellectual property rights as timely for a Pew Roundtable Discussion and invited ARL to seek co-sponsors for the discussion in the research community and to help organize the event. AAU will co-sponsor the Roundtable with ARL. The Gladys Kreible Delmas Foundation provided \$15,000 to support the costs of organizing a round table and publishing an issue of *Policy Perspectives* that will summarize the issues discussed. The Kellogg Foundation has pledged \$25,000. (Contacts: Duane Webster and Mary Case)

#### **Copyright Education Initiative**

The H.W. Wilson Foundation awarded ARL funding to develop an educational initiative on copyright compliance. The initiative includes development of training resources to assist library managers. The initiative supported the design of workshops for librarians who have a training or spokesperson role in copyright compliance. Four workshops for U.S. librarians have been held, most recently at the ACRL National Conference in Nashville, April 1997. In addition, in collaboration with CARL and the Association of Universities and Colleges of Canada, ARL developed a workshop for Canadian educational institutions held October 3-4, 1996 in Ottawa. To date, two



publications have resulted: a notebook used in the workshops and a booklet on licensing agreements. The fund has also been used to print additional copies of educational resources, such as the *NHA Basic Principles for Managing Intellectual Property* and a special copyright issue of the ARL newsletter. (Contact: Mary Jackson)

#### **Shared Legal Capability (Copyright Legislation & Licensing Principles)**

ARL organized and manages a fund for legal expertise on intellectual property and the NII. The American Library Association, the American Association of Law Libraries, the Medical Library Association, and the Special Libraries Association have each contributed or pledged \$25,000 toward this fund in 1997. In September 1996, SLA agreed to contribute \$10,000 to the SLC fund for development of a set of principles to guide non-profit and for-profit libraries in negotiating license agreements with vendors of digital information resources. (Contacts: Duane Webster, Prue Adler, and Mary Case)

#### **NINCH**

The Gladys Kreible Delmas Foundation awarded ARL \$10,000 to join the National Initiative for a Networked Cultural Heritage (NINCH). The initiative, launched in 1996, seeks to encourage the development of the NII as a means to preserve, access, and creatively build on our cultural legacy. The Delmas award supported ARL's role in NINCH through June 1997. Thereafter, ARL's financial contribution will be based on a combination of ARL member institutions' contributions. (Contact: Duane Webster)

#### **AAU/ARL Global Resources Program**

In December 1996, The Andrew W. Mellon Foundation awarded ARL \$450,000 in support of the AAU/ARL Global Resources Program. The award, which covers a three year period, will expand access to foreign-language research materials while containing costs for libraries by developing distributed collections and expanding electronic document delivery. See Section 3.1 for an overview of the project. (Contact: Deborah Jakubs)

#### **Latin American Research Resources Project**

The aim of the project is to make available a broader array of resources to Latin American students and scholars, to restructure access to these collections on a comprehensive scale, and to assist research libraries in containing costs. (See Section 3.1 of this report for project activities summary). The start-up Project funding was received from The Andrew W. Mellon Foundation and thirty-five participating ARL Libraries. For 1995 and 1996, Brigham Young University supported Mark Grover's role as VPO/Project Coordinator. For the first six months of 1997, the University of Texas supported Drew Racine to develop an evaluation process for the project. In October 1995, The Mellon Foundation awarded ARL a \$125,000 grant for the second phase of the project that is ongoing into 1997. (Contact: Deborah Jakubs)

#### **Latin American Book Price Index**

CLR awarded ARL \$7,100 to support a project to develop and test a methodology for a Latin American book price index. The work is being carried out under the direction of Dan Hazen, Librarian for Latin America, Spain, and Portugal in the Widener Library of Harvard College Library. (Contact: Deborah Jakubs)

#### **Japanese Journals Project**

In April 1995, OCLC agreed to provide support for Dorothy Gregor to serve ARL as consultant to the Japanese Journals Project. Ohio State University maintains project files as part of the East Asian Libraries Cooperative WWW site. The project also receives support from the National Coordinating Committee for Japanese Research Resources. See section 3.1 of this report for a summary of project activities. (Contact: Deborah Jakubs and Jaia Barrett)

#### **Streamlining Network ILL/DD Requests for Users & Libraries**

In November 1995, OCLC agreed to collaborate with the NAILDD Project to build a standards-based linkage between the AAU/ARL Table of Contents Database located at UT-LANIC, and the OCLC ILL messaging system. The linkage allows network users to initiate an ILL/DD request for an article cited in the database and have it forwarded into the online system of the holding library and, if desired, into the system of the user's home library for user authentication. Lessons from this application will be applied to other databases, other ILL messaging systems, and sets of libraries. As part of its contribution to scaling up the AAU/ARL demonstration projects, OCLC has agreed to supply the same kind of system linkages for up to a dozen additional databases. (Contacts: Deborah Jakubs and Mary Jackson)

#### **National Register of Microform Masters (NRMM) RECON Project: Non-Roman Reports and Musical Scores**

In May 1996, the National Endowment for the Humanities awarded ARL a grant of \$114,000 in support of the final phase of the NRMM RECON Project. In cooperation with the Library of Congress and New York Public Library, ARL is managing a cooperative project for creating more than 13,800 online records for non-Roman reports as well as for other remaining NRMM reports. ARL is using the OCLC Conversion Services to produce the records. Scheduled to end in the last quarter of 1997, this final NRMM project completes a complex, multi-year effort to provide online access to more than half a million bibliographic records for preservation microform masters. (Contact: Jutta Reed-Scott)

#### **ILL/DD Cost and Performance Measures**

In June 1995, The Andrew W. Mellon Foundation awarded ARL \$160,000 to conduct an ILL/DD Performance Measures Project. This cooperative project, developed with Martin Cummings of the Council on Library Resources, examines the cost and performance of interlibrary loan and document delivery services. A total of 119 libraries participated, including 97 ARL libraries and 22 Oberlin Group libraries. Final institutional reports were released in August; the project report will be released in fall 1997. (Contact: Mary Jackson)

#### **The Character and Nature of Research Library Investments in Electronic Resources**

In 1996, the Council on Library Resources provided \$11,800 to support a review and assessment of three years of ARL supplementary survey data about research library expenditures for electronic resources. The University of Washington is supporting Timothy Jewell, Head, Electronic Information Program, to work as a Visiting Program Officer to undertake this analysis for ARL. A preliminary report was released in March 1997 and presentations made to the ARL Statistics and Measurement Committee and at ALA. As a result, new questions are being included in ARL's 1996-97 Supplementary Statistics Survey. (Contacts: Martha Kyriallidou and Julia Blixrud)

#### **Leadership and Career Development Program**

In July 1997, the ARL Diversity Program received a grant of \$99,760 from the Higher Education Act Title II-B program to conduct a one-year ARL Leadership and Career Development program. The goal is to prepare racial minority librarians for top leadership positions in academic and research libraries. The program will be designed and delivered by the Diversity Program in collaboration with ARL's Office of Management Services. (Contacts: DeEtta Jones and Kathryn Deiss)

#### **ARL GIS Literacy Project**

With funding from the ALA Government Documents Round Table and the Environmental Systems Research Institute, ARL is launching a new phase of the GIS Project. In collaboration with libraries and geographers from UT-Austin, ESRI, Dalhousie University, and the University of Maryland, ARL will help develop a web-based introduction to GIS for library and information science schools throughout North America. (Contact: Prue Adler)

## GLOSSARY

AALL	American Association of Law Libraries
AAP	Association of American Publishers
AAU	Association of American Universities
AAUP	Association of American University Presses
ACLS	American Council of Learned Societies
ACRL	Association of College and Research Libraries
AHA	American Historical Association
ALA	American Library Association
ALS	Academic Library Survey
ALISE	Association of Library and Information Science Educators
ARL	Association of Research Libraries
ARPA	Advanced Research Projects Agency
ASCAP	American Society of Composers, Authors and Publishers
BMI	Broadcast Music, Inc.
CANCOPY	Canadian Copyright Licensing Agency
CARL	Canadian Association of Research Libraries
CCUMC	Consortium of College and University Media Centers
CDA	Communications Decency Act
CIC	Committee on Institutional Cooperation
CIS	Congressional Information Service
CIT	Commission on Information Technology (NASULGC)
CIEC	Citizens Internet Empowerment Coalition
CISTI	Canada Institute for Scientific and Technical Information
CLR	Council on Library Resources
CNI	Coalition for Networked Information
CNRI	Corporation for National Research Initiatives
CPA	Commission on Preservation and Access
CONFU	Conference on Fair Use
COSLA	Chief Officers of State Library Agencies
COSSA	Consortium of Social Science Associations
CRL	Center for Research Libraries
DFC	Digital Future Coalition
DIG	Developers/Implementors Group (NAILDD Project)
DLI	Digital Library Initiative
EI	Engineering Index
EOSDIS	Earth Observing System Data and Information System
ESAL	Electronic Services in Academic Libraries (ALA/Ameritech)
ESP	Electronic Scholarly Publishing
FARNET	Federation of American Research Networks
GATT	General Agreement on Tariffs and Trade
GIS	Geographic Information Systems
GILS	Government Information Locator Service
GPO	Government Printing Office
HEA	Higher Education Act
HEIRAlliance	Higher Education Information Resources Alliance
HPCC	High Performance Computing Coalition
H.R.	House Resolution
HTML	Hyper Text Mark-up Language
IAWG	Inter Association Working Group on Government Information
ILL/DD	Interlibrary Loan/Document Delivery
IFLA	International Federation of Library Associations
IITAP	Information Infrastructure Technology and Applications Program (NASA)
ILL	Interlibrary Loan
IPEDS	Integrated Postsecondary Education Data System (U.S. Dept. of Education)
IPIG	ILL Protocol Implementors Group (NAILDD Project)
IScAn	International Scholars Academic Network
ISO	International Standards Organization
JICST	Japanese Information Center for Science and Technology (Japan)
LAMA	Library Administration and Management Association (ALA)
LC	Library of Congress
LITA	Library and Information Technology Association (ALA)

MDS	Princeton University Press v. Michigan Document Services
Mellon	The Andrew W. Mellon Foundation
MLA	Medical Library Association
NACSIS	National Center for Science Information Systems (Japan)
NACUBO	National Association of College and University Business Officers
NAILDD	North American Interlibrary Loan and Document Delivery
NAL	National Agricultural Library
NASA	National Aeronautics and Space Administration
NASULGC	National Association of State Universities & Land Grant Colleges
NCC	National Coordinating Committee
NCES	National Center for Education Statistics
NCGIA	National Center for Geographic Information and Analysis
NCSU	North Carolina State University
NDL	National Diet Library (Japan)
NEH	National Endowment for the Humanities
NCAA	National Collegiate Athletics Association
NGI	Next Generation Internet
NGO	Non-governmental organization
NHA	National Humanities Alliance
NII	National Information Infrastructure
NINCH	National Initiative for a Networked Cultural Heritage
NLC	National League of Cities
NLM	National Library of Medicine
NPEC	National Postsecondary Education Council
NRMM	National Register of Microform Masters
NTIA	National Telecommunications and Information Administration
NSF	National Science Foundation
OCLC	OCLC Online Computer Library Center
OMS	Office of Management Services (ARL)
ORD	Office of Research and Development (ARL)
OSC	Office of Scholarly Communication (ARL)
OSU	Ohio State University
PMDS	Professional Mailing and Distribution Services
PTO	Patent and Trademark Office (U.S.)
READI	Rights for Electronic Access to and Dissemination of Information (CNI)
RLG	Research Libraries Group
S.	Senate Resolution
SERVQUAL	Service Quality (Assessment Instrument)
SFAS	Statement on Financial Accounting Standards
SLA	Special Libraries Association
SLC	Shared Legal Capability
SPA	Software Publishers Association
SPEC	ARL/OMS Systems and Procedures Exchange Center
STI	Science and Technology Information
SUNY	State University of New York
TIIAP	Telecommunications Information Infrastructure Assistance Program
TOC	Table of Contents
TRLN	Triangle Research Library Network
UC	University of California
UCLA	University of California-Los Angeles
USIS	United States Information Service
USGS	United States Geological Survey
UT-LANIC	University of Texas-Latin American Networked Information Center
VPO	Visiting Program Officer
WIPO	World Intellectual Property Organization
WLN	Western Libraries Network
WWW	World Wide Web

APPENDIX III

ARL Attendance List  
October 14-17, 1997

Member Institution

University of Alabama  
University of Alberta  
University of Arizona  
Arizona State University  
Auburn University  
Boston Public Library  
Boston University  
Brigham Young University  
University of British Columbia  
Brown University  
University of California-Berkeley  
University of California-Davis  
University of California-Irvine  
University of California-Los Angeles  
University of California-Riverside  
University of California-San Diego  
University of California-Santa Barbara  
Canada Institute for Scientific & Technical Info  
Case Western Reserve University  
Center for Research Libraries  
University of Chicago  
University of Cincinnati  
University of Colorado at Boulder  
Colorado State University  
Columbia University  
University of Connecticut  
Cornell University  
Dartmouth College  
University of Delaware  
Duke University  
Emory University  
University of Florida  
Florida State University  
Georgetown University  
University of Georgia  
Georgia Institute of Technology  
University of Guelph  
Harvard University  
University of Hawaii  
University of Houston  
Howard University  
University of Illinois at Chicago  
University of Illinois-Urbana  
Indiana University

Represented by

Charles Osburn  
Ernie Ingles  
Carla Stoffle  
Sherrie Schmidt  
Stella Bentley  
Bernard Margolis  
Robert Hudson  
Randy Olsen  
[not represented]  
[not represented]  
Susan Rosenblatt  
[not represented]  
Shirley Leung  
Gloria Werner  
[not represented]  
Gerald Lowell  
Joseph Boissé  
Brenda Hurst  
[not represented]  
Donald Simpson  
Martin Runkle  
David Kohl  
James Williams  
Camila Alire  
Elaine Sloan  
Paul Kobulnicky  
Sarah Thomas  
Margaret Otto  
Susan Brynteson  
David Ferriero  
Joan Gotwals  
Carolyn Henderson  
Charles Miller  
Sue Martin  
William Potter  
Miriam Drake  
Michael Ridley  
Nancy Cline  
John Haak  
Dana Rooks  
Mod Mekkawi  
Nancy John  
Robert Wedgeworth  
Suzanne Thorin

**Member Institution**

University of Iowa  
Iowa State University  
Johns Hopkins University  
University of Kansas  
Kent State University  
University of Kentucky  
Laval University  
Library of Congress  
Linda Hall Library  
Louisiana State University  
McGill University  
McMaster University  
University of Manitoba  
University of Maryland  
University of Massachusetts  
Massachusetts Institute of Technology  
University of Miami  
University of Michigan  
Michigan State University  
University of Minnesota  
University of Missouri  
National Agricultural Library  
National Library of Canada  
National Library of Medicine  
University of Nebraska-Lincoln  
University of New Mexico  
New York Public Library  
New York State Library  
New York University  
University of North Carolina-Chapel Hill  
North Carolina State University  
Northwestern University  
University of Notre Dame  
Ohio State University  
Ohio University  
University of Oklahoma  
Oklahoma State University  
University of Oregon  
University of Pennsylvania  
Pennsylvania State University  
University of Pittsburgh  
Princeton University  
Purdue University  
Queen's University  
Rice University  
University of Rochester  
Rutgers University  
University of Saskatchewan  
Smithsonian Institution Libraries  
University of South Carolina  
University of Southern California  
Southern Illinois University

**Represented by**

Sheila Creth  
Olivia Madison  
James Neal  
William Crowe  
Mark Weber  
[not represented]  
Claude Bonnelly  
Winston Tabb  
Lee Jones  
Jennifer Cargill  
Frances Groen  
Graham Hill  
Carolynne Presser  
Charles Lowry  
Margo Crist  
Ann Wolpert  
Don Bosseau  
William Gosling  
Clifford Haka  
Tom Shaughnessy  
Martha Alexander  
Pamela André  
Marianne Scott  
Lois Ann Colaianni  
Joan Giesecke  
[not represented]  
Heike Kordish  
Lee Stanton  
Carlton Rochell  
Joe Hewitt  
Susan Nutter  
David Bishop  
Jennifer Younger  
William Studer  
Gary Hunt  
Sul Lee  
Edward Johnson  
Andrew Bonamici  
Paul Mosher  
Nancy Eaton  
Rush Miller  
Karin Trainer  
Emily Mobley  
Paul Wiens  
Charles Henry  
Ronald Dow  
Marianne Gaunt  
Frank Winter  
Nancy Gwinn  
George Terry  
Chris Ferguson  
Carolyn Snyder



### Member Institution

Stanford University  
State University of New York-Albany  
State University of New York-Buffalo  
State University of New York-Stony Brook  
Syracuse University  
Temple University  
University of Tennessee  
University of Texas  
Texas A&M University  
Texas Tech University  
University of Toronto  
Tulane University  
University of Utah  
Vanderbilt University  
University of Virginia  
Virginia Polytechnic Inst. & State University  
University of Washington  
Washington State University  
Washington University  
University of Waterloo  
Wayne State University  
University of Western Ontario  
University of Wisconsin  
Yale University  
York University

### Represented by

Assunta Pisani  
Meredith Butler  
Barbara von Wahlde  
Joseph Branin  
David Stam  
Maureen Pastine  
Aubrey Mitchell  
Harold Billings  
Fred Heath  
Dale Cluff  
Carole Moore  
Phil Leinbach  
Sarah Michalak  
Paul Gherman  
[not represented]  
Eileen Hitchingham  
Betty Bengtson  
Nancy Baker  
Shirley Baker  
Murray Shepherd  
Carole McCollough  
[not represented]  
Kenneth Frazier  
Scott Bennett  
Ellen Hoffmann

### Guests/Speakers

Association of American Universities  
Association of American University Presses  
ACRL/Austin Community College  
American Institute of Physics  
ALA/Virginia Commonwealth University  
American Library Association  
American Library Association  
American Library Association  
ALISE/University of Pittsburgh  
Coalition for Networked Information  
Coalition for Networked Information  
University College London  
Columbia University Press  
Cornell University Library  
Council on Library and Information Resources  
Council on Library and Information Resources  
Council on Library and Information Resources  
Council on Library and Information Resources  
Covington and Burling  
Folger Shakespeare Library  
Georgetown University Law Library  
Harcourt Brace & Company

John Vaughn  
Peter Givler  
Lee Hisle  
Marc Brodsky  
Barbara Ford  
Mary Ghikas  
Carol Henderson  
Lillian Lewis  
Toni Carbo  
Clifford Lynch  
Joan Lippincott  
Fred Friend  
Kate Wittenberg  
Jan Olsen  
Deanna Marcum  
James Morris  
Abby Smith  
Don Waters  
Richard Meserve  
Werner Gundersheimer  
Robert Oakley  
John Connors

## Guests/Speakers

Harvard University	Jan Merrill-Oldham
IFLA	Leo Voogt
ICPSR	Richard Rockwell
ICPSR	Janet Varna
Institute of Museums and Library Services	Diane Frankel
Library of Congress	Diane Kresh
Louisiana State University	Alma Dawson
Medical Library Association	Carla Funk
National Agricultural Library	Evelyn Frangakis
National Endowment for the Humanities	George Farr
National Commission on Libraries & Info Science	Jane Williams
National Humanities Alliance	John Hammer
NASULGC	Laila Van Eyck
OCLC/ARL	Dorothy Gregor
OCLC, Inc.	Donald Muccino
University of Pittsburgh	Julie Cohen
The Rand Corporation	Jeff Rothenberg
The Research Libraries Group	James Michalko
Rutgers University Libraries	Peter Graham
Smithsonian Institution Libraries	Mary Augusta Thomas
Valdosta State University	Mark Winston
University of Virginia	Kendon Stubbs
University of Washington	Timothy Jewell
York University	Toni Olshen

## ARL Staff

Adler, Prudence	Asst. Executive Director-Federal Relations & Info. Policy
Barrett, Jaia	Deputy Executive Director
Blixrud, Julia	Senior Program Officer
Brennan, Patricia	Program Officer
Brooks, Mary Jane	Office and Personnel Manager
Case, Mary	Director, Office of Scholarly Communication
Deiss, Kathryn	OMS Senior Program Officer for Training & Leadership Development
Jackson, Mary	Access and Delivery Services Consultant
Jakubs, Deborah	Director, Global Resources Program, Duke University
Jones, DeEtta	Program Officer for Diversity
Mogge, Dru	Electronic Information Services Coordinator
Soete, George	OMS Organizational Development Consultant
Webster, Duane	Executive Director
Zimmerman, Glen	Senior Program Officer

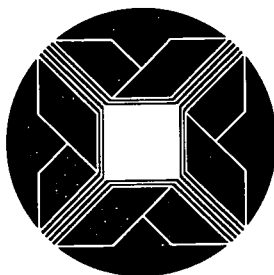

ASSOCIATION OF RESEARCH LIBRARIES  
21 Dupont Circle  
Washington, DC 20036



**U.S. Department of Education**  
Office of Educational Research and Improvement (OERI)  
National Library of Education (NLE)  
Educational Resources Information Center (ERIC)



## NOTICE

### REPRODUCTION BASIS



This document is covered by a signed "Reproduction Release (Blanket) form (on file within the ERIC system), encompassing all or classes of documents from its source organization and, therefore, does not require a "Specific Document" Release form.



This document is Federally-funded, or carries its own permission to reproduce, or is otherwise in the public domain and, therefore, may be reproduced by ERIC without a signed Reproduction Release form (either "Specific Document" or "Blanket").