

## DOCUMENT RESUME

ED 444 638

JC 000 590

AUTHOR Andres, Lesley; Carpenter, Susan  
TITLE Today's Higher Education Students: Issues of Admission, Retention, Transfer, and Attrition in Relation to Changing Student Demographics.  
INSTITUTION British Columbia Council on Admissions and Transfer, Vancouver.  
PUB DATE 1997-12-00  
NOTE 71p.  
AVAILABLE FROM For full text: <http://www.bccat.bc.ca>.  
PUB TYPE Reports - Descriptive (141)  
EDRS PRICE MF01/PC03 Plus Postage.  
DESCRIPTORS College Admission; College Transfer Students; Educational Research; Foreign Countries; Higher Education; \*Nontraditional Students; \*Postsecondary Education as a Field of Study; School Demography; \*School Holding Power; \*Student Attrition; Student Characteristics  
IDENTIFIERS \*British Columbia

## ABSTRACT

The paper discusses retention models for the nontraditional student population, including transfer students, older adult learners, commuters, part-time students, graduate students, women, students with disabilities, and ethnic minorities. Since 1975, leading research in the field of postsecondary student retention has been grounded on Tinto's (1975) argument that the student-institution "fit," or the students' social and academic integration into the institution, is a good predictor of dropout or persistence. Other models of student retention focus on student involvement and the institution's responsibility to promote student retention. In the 1980s, attrition models were modified to address some of the shortcomings of previous schema. Similar to traditional student models, most models that try to predict non-traditional student retention are concerned with student-institution "fit." Benjamin's "Quality of Student Life" model, however, focuses on conceptualizing satisfaction as a multidimensional construct involving the interaction among personal, interpersonal, social and contextual factors and/or processes. It attempts to grapple with the complex and dynamic nature of students within postsecondary systems, and recognizes that competing demands of parents, friends, romantic partners, employers, and others, as well as financial and health problems, can influence students' coping abilities and life decisions. Discussed are the challenges faced by particular groups of non-traditional students, and the factors that affect the attrition rates of these students. Contains 164 references and 18 figures. (JA)

Reproductions supplied by EDRS are the best that can be made  
from the original document.

***Today's Higher Education Students: Issues of Admission, Retention, Transfer, and Attrition in Relation to Changing Student Demographics***

*Prepared for:*

*The British Columbia Council on Admissions and Transfer*

*Prepared by:*

*Lesley Andres & Susan Carpenter*

*Centre for Policy Studies in Education  
University of British Columbia*

*December 1997*

PERMISSION TO REPRODUCE AND DISSEMINATE THIS MATERIAL HAS BEEN GRANTED BY

J. Karlinski

TO THE EDUCATIONAL RESOURCES INFORMATION CENTER (ERIC)

1

U.S. DEPARTMENT OF EDUCATION  
Office of Educational Research and Improvement  
EDUCATIONAL RESOURCES INFORMATION CENTER (ERIC)

This document has been reproduced as received from the person or organization originating it.

Minor changes have been made to improve reproduction quality.

• Points of view or opinions stated in this document do not necessarily represent official OERI position or policy.

AC 000 590

## TABLE OF CONTENTS

<b>1. INTRODUCTION.....</b>	<b>4</b>
<b>2. CONCEPTUAL BACKGROUND: THE EVOLUTION OF RETENTION MODELS.....</b>	<b>5</b>
<b>2.1 PSYCHOLOGICAL MODELS.....</b>	<b>6</b>
<b>2.2 MODELS OF STUDENT-INSTITUTION INTEGRATION.....</b>	<b>12</b>
2.2.1 Spady's model.....	12
2.2.2 Tinto's model.....	14
2.2.3 Traditional student models in the spirit of Tinto.....	14
2.2.4 Students as workers.....	19
2.2.5 Institutional involvement.....	21
<b>2.3 MODELS OF NON-TRADITIONAL INSTITUTIONS.....</b>	<b>25</b>
<b>2.4 CHANGING DEMOGRAPHICS OF HIGHER EDUCATION.....</b>	<b>25</b>
<b>2.5 NON-TRADITIONAL STUDENTS.....</b>	<b>27</b>
2.5.1 Benjamin's Quality of Student Life model.....	28
<b>3. NON-TRADITIONAL STUDENT EXPERIENCE.....</b>	<b>33</b>
<b>3.1 TRANSFER STUDENTS.....</b>	<b>33</b>
<b>3.2 OLDER ADULT LEARNERS.....</b>	<b>36</b>
3.2.2 Lifelong learning and recurrent education.....	40
<b>3.3 COMMUTER STUDENTS.....</b>	<b>41</b>
<b>3.4 PART-TIME STUDENTS.....</b>	<b>41</b>
<b>3.5 GRADUATE STUDENTS.....</b>	<b>41</b>
<b>3.6 WOMEN.....</b>	<b>42</b>
<b>3.7 STUDENTS WITH DISABILITIES.....</b>	<b>44</b>
<b>3.8 ETHNIC MINORITIES.....</b>	<b>45</b>
<b>4. CONCLUSION: IMPLICATIONS FOR INSTITUTIONAL CHANGE.....</b>	<b>45</b>
<b>REFERENCES.....</b>	<b>47</b>

## TABLE OF FIGURES

FIGURE 1. Schematic presentation of a conceptual framework for the prediction of specific intentions behaviors (Fishbein & Ajzen, 1975) .....	3
FIGURE 2. Dimensions of the “getting ready” categories (Attinai, 1986).....	5
FIGURE 3. General model of achievement behaviors (Eccles et al., 1983).....	6
FIGURE 4. Estimated model of student persistence (Ethington, 1980).....	7
FIGURE 5. Explanatory sociological model of the dropout process (Spady, 1975).....	9
FIGURE 6. Conceptual schema for dropout from college (Tinto, 1975).....	11
FIGURE 7. Conceptual model for research on student-faculty informal contact (Pascarella, 1980).....	13
FIGURE 8. A conceptual model of dropout syndrome (Bean, 1985).....	14
FIGURE 9. A causal model of student attrition (Bean, 1980).....	16
FIGURE 10. Student retention model (Billson & Brooks-Terry, 1987) .....	19
FIGURE 11. Conceptual model of nontraditional student attrition (Bean & Metzner, 1985; 1987) .....	25
FIGURE 12. Modified path model of quality of student life (Benjamin, 1984).....	26
FIGURE 13. Life domains and major subdomains among undergraduate students (Benjamin, 1994).....	28
FIGURE 14. Full-time and part-time enrolment in community colleges by sex, 1989-90 to 1993-94, British Columbia .....	34
FIGURE 15. Full-time and part-time enrolment in universities by sex, 1989-90 to 1993-94, British Columbia .....	34
FIGURE 16. Full-time and part-time graduate enrolment by sex, 1983-84 to 1993-94, British Columbia .....	38
FIGURE 17. Full-time university undergraduate enrolment by sex, 1920 to 1993, Canada.....	39
FIGURE 18. Full-time university undergraduate enrolment by sex, 1955 to 1993, British Columbia.....	39

**TABLE OF TABLES**

*TABLE 1. Full-time Post-secondary Enrolment by Age, 1993-94,  
British Columbia and Canada ..... 32*

*TABLE 2. Part-time Undergraduate and Graduate University Enrolment,  
1983-94 and 1993-94, British Columbia ..... 33*

*TABLE 3.a. Full-time University Enrolment, by Age Group and Sex as a Proportion  
of that Age Group, 1989-90 to 1993-94, Canada ..... 35*

*TABLE 3.b. Part-time University Enrolment, by Age Group and Sex as a  
Proportion of that Age Group, 1989-90 to 1993-94, Canada ..... 36*

## **1. INTRODUCTION**

Among the policy issues facing Canadian higher education, questions concerning access, admission, transfer, retention, and attrition remain central. Numerous studies have sought to develop, test, and modify models dealing with the participation patterns of “traditional students” – that is, full-time post-secondary students between the ages of 18 to 24 years. By contrast, relatively few studies have addressed the needs of “non-traditional students,” – those who do not fit this definition. This paper examines the nature of today’s post-secondary students in light of current Canadian and American research dealing with admission, transfer, retention, and attrition.

The paper begins with an overview of retention models. Early models, dealing with the retention and attrition of traditional students, provide some understanding that can be broadly transferred to non-traditional students, but alone they do not adequately explain all changes resulting from demographic shifts in the student population. After introducing emergent theories studying the attrition of non-traditional students, we will attempt to make the theories concrete in a discussion of non-traditional student populations, including transfer students, older adult learners, commuters, part-time students, graduate students, women, students with disabilities, and ethnic minorities. We will conclude with a summary discussion of the implications for change.

## **2. CONCEPTUAL BACKGROUND: THE EVOLUTION OF RETENTION MODELS**

Over the past 25 years, theoretical models of post-secondary student retention have examined student-institution “fit” by looking at student variables, institutional variables, and specific themes such as the integration of students into higher education institutions. This represents quite a leap in the development of theoretical constructs, for until the 1970s, research concerning college student attrition had been more descriptive than theory-based. As such, this early body of work failed to explain the variation in student attrition (Spady, 1970; Tinto, 1975; Pascarella & Terenzini, 1980) and, according to Ratcliff Whitaker, “consisted of single-variable studies that looked at a specific demographic variable” (1993 p. 24). Other models developed since the early 1970s have examined the psychological variables of students. Still others have compared student satisfaction to worker

satisfaction in an organization. And many more have discussed institutional responsibility for providing sufficient student support. These retention models, to be discussed below, all attempt to understand what factors affect post-secondary students' decisions to persist or withdraw.

## ***2.1 PSYCHOLOGICAL MODELS***

Models that focus on psychological variables are among the earliest attempts to build theories of retention. Fishbein and Ajzen's (1975) psychological model is based on the importance of student intentions (see Figure 1). The researchers make a distinction among beliefs, attitudes, intentions and behaviours, and are concerned with the relations among these variables. The model suggests that a person's intentions are a function of certain beliefs that influence attitudes toward a behaviour. A person's behavioural intention is a function of two factors: one's attitude toward the behaviour and one's subjective norm. Fishbein and Ajzen report that a student's decision to drop out is the result of past behaviour, attitudes and norms that drive behaviour through the formation of intent. Attrition, then, is seen as a result of weakened intentions. The variable of student intent has become so prominent in the literature that in 1987 Tinto, the most influential theorist of student retention and attrition, added it to his revised model.

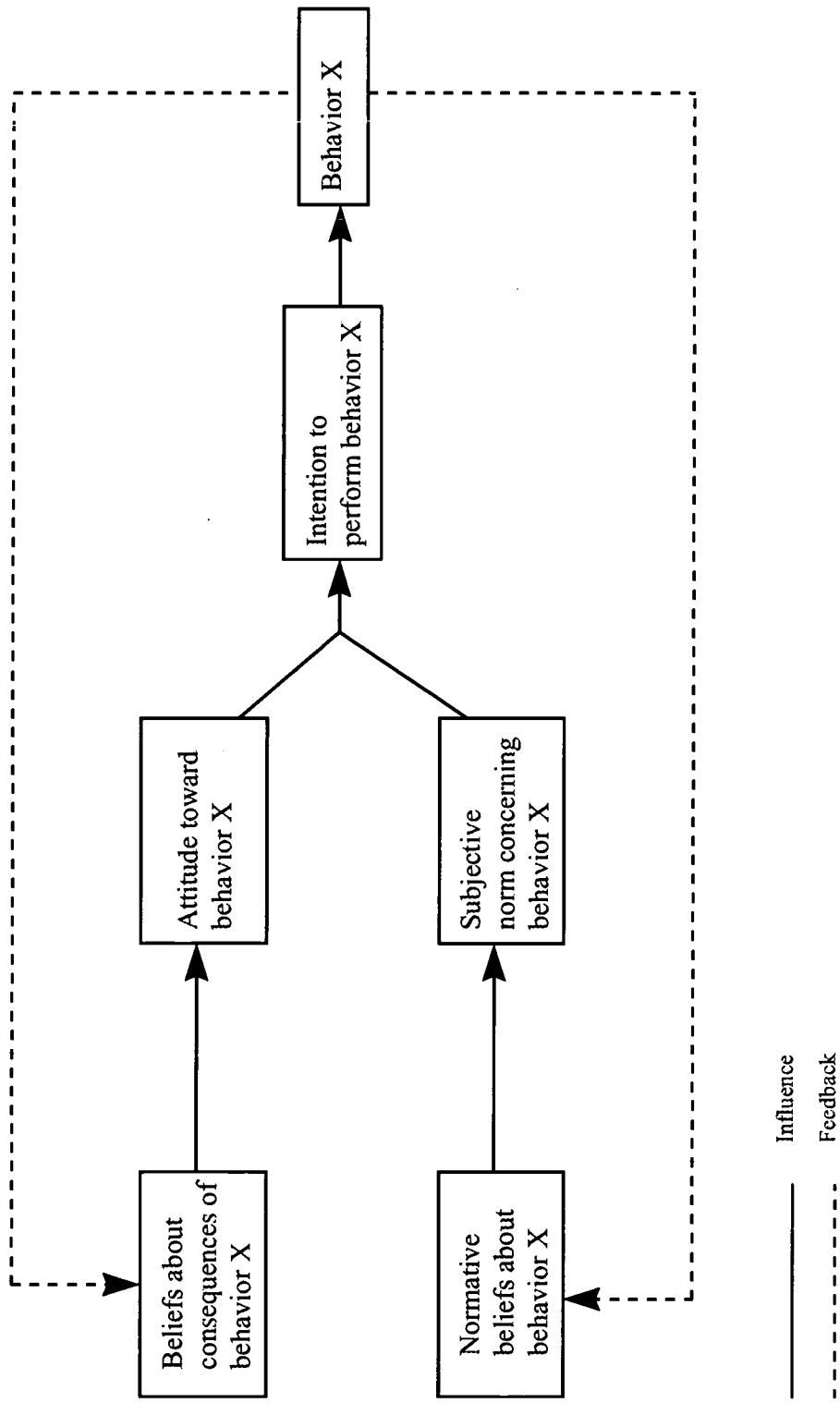

**Figure 1. Schematic presentation of a conceptual framework for the prediction of specific intentions behaviors (Fishbein & Ajzen, 1975)**



Fishbein and Ajzen's model is expanded in Attinasi's (1986) understanding of retention as being based on student perceptions of experiences and attitudes encountered before and during the college years. Douglas's (1980) research on the sociologies of everyday life influenced Attinasi's research. According to Attinasi, the student analyzes interactions with the everyday world and acts on perceived meanings. Attinasi used two sociological approaches in this model: symbolic interactionism and ethnomethodology. Symbolic interactionism contends that meanings result from the interaction of the individual with others: it is on the basis of socially-constructed meanings that the individual makes personal decisions. Ethnomethodology studies how people perceive, describe and explain the world in which they live. Attinasi's model suggests that persistence and attrition results from (1) the student's perceptions and analysis of various things in the everyday world, and (2) the student's acceptance or rejection of the idea that post-secondary education is significant to the student's life (see Figure 2).

Ethington (1990) constructed a more thorough psychological model that took into account Tinto's (1975) conceptual schema of student dropout by including student goals. Ethington's (1990) psychological model of student persistence examines the applicability of the Eccles *et al.* (1983) model of "achievement behaviours" (defined as persistence, choice and performance) to college students' persistence (see Figure 3). One of the main premises of the Eccles model is that prior achievement influences future achievement behaviours by influencing family encouragement, self-concept, the perception of the task's difficulty, student goals, values and expectations for success. Ethington found that values and expectations as well as level of degree aspirations had a direct influence on persistence (see Figure 4). And he concluded that student demographic makeup and personal influences directly affected student values, expectations and aspirations which ultimately influenced the decision to persist or withdraw.

<u>Category</u>	<u>Type of Activity</u>	<u>Other Participants</u>	<u>Message Converted</u>	<u>Outcome</u>
Initial Expectation Engendering	<ul style="list-style-type: none"> <li>• Oral Communication</li> </ul>	<ul style="list-style-type: none"> <li>• Parents</li> <li>• Friends</li> <li>• Classmates</li> </ul>	<ul style="list-style-type: none"> <li>• You are a future college-goer</li> </ul>	<ul style="list-style-type: none"> <li>• Expectation of being a college student.</li> </ul>
Fraternal Modeling	<ul style="list-style-type: none"> <li>• Observation</li> <li>• Oral Communication (a description)</li> </ul>	<ul style="list-style-type: none"> <li>• Siblings</li> <li>• Other relatives</li> </ul>	<ul style="list-style-type: none"> <li>• You are a future college-goer</li> <li>• This is what college is like for me, your brother</li> </ul>	<ul style="list-style-type: none"> <li>• Expectation of being a college student.</li> <li>• Expectation of what being a college student is like.</li> </ul>
Mentor Modeling	<ul style="list-style-type: none"> <li>• Oral Communication (a description)</li> </ul>	<ul style="list-style-type: none"> <li>• High School teachers (especially mentors)</li> </ul>	<ul style="list-style-type: none"> <li>• This is what college was like for me, your teacher.</li> </ul>	<ul style="list-style-type: none"> <li>• Expectation of what being a college student is like.</li> </ul>
Indirect Simulation	<ul style="list-style-type: none"> <li>• Oral Communication (a prescription or prediction)</li> </ul>	<ul style="list-style-type: none"> <li>• High school teachers (especially mentors)</li> </ul>	<ul style="list-style-type: none"> <li>• This is what you should do in college.</li> <li>• This is what college will be like for you.</li> </ul>	<ul style="list-style-type: none"> <li>• Exception of what being a college student is like</li> </ul>
Direct Simulation	<ul style="list-style-type: none"> <li>• Participant Observation</li> </ul>	<ul style="list-style-type: none"> <li>• Campus people</li> </ul>	<ul style="list-style-type: none"> <li>• Oh, so this is what college will be like for me the informant.</li> </ul>	<ul style="list-style-type: none"> <li>• Expectations/Experience of what being a college student is like.</li> </ul>

**Figure 2: Dimensions of the “Getting Ready Categories (Attinai, 1986)**

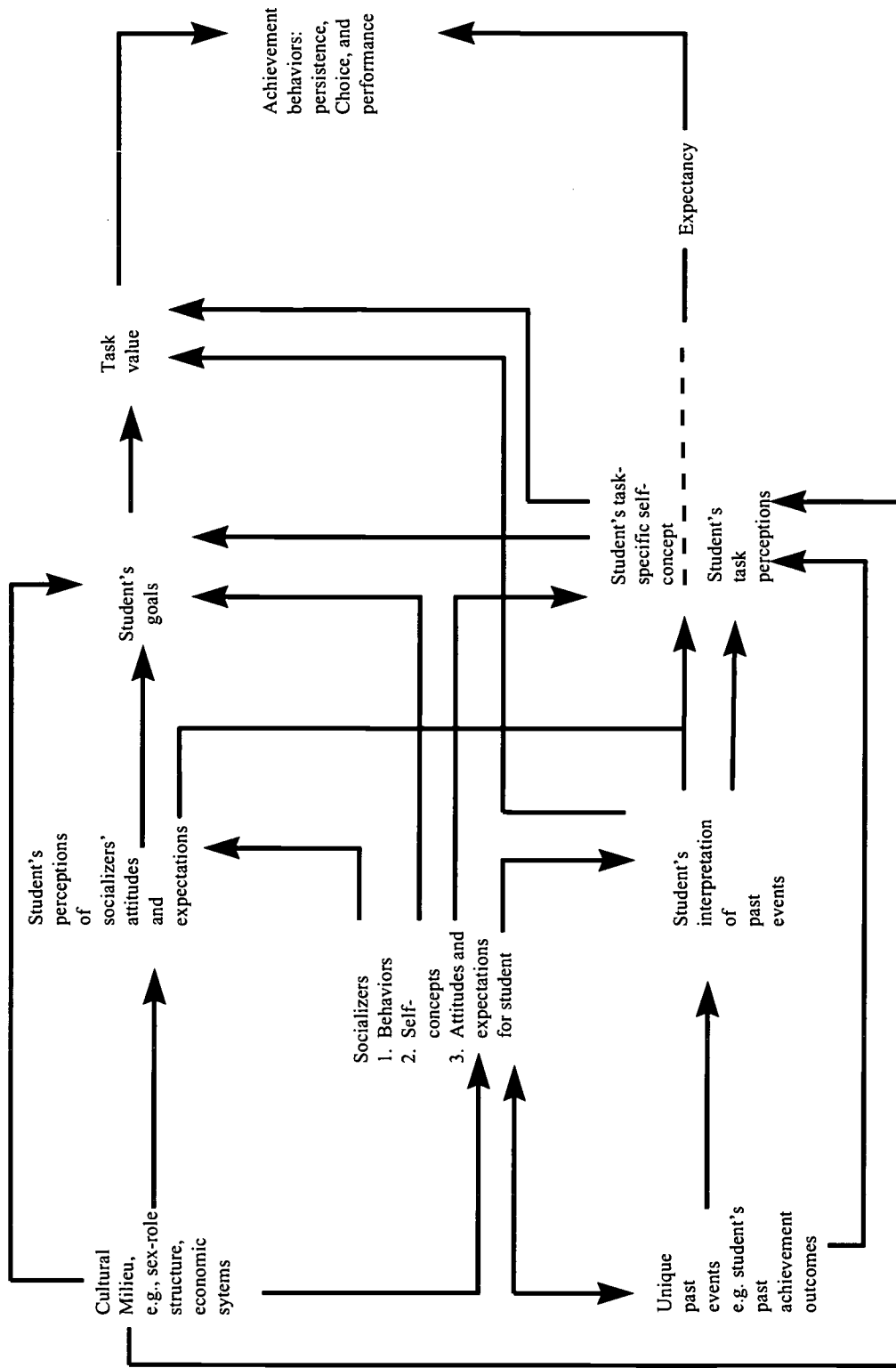

Figure 3: General Model of Achievement Behaviors (Eccles et al., 1983)

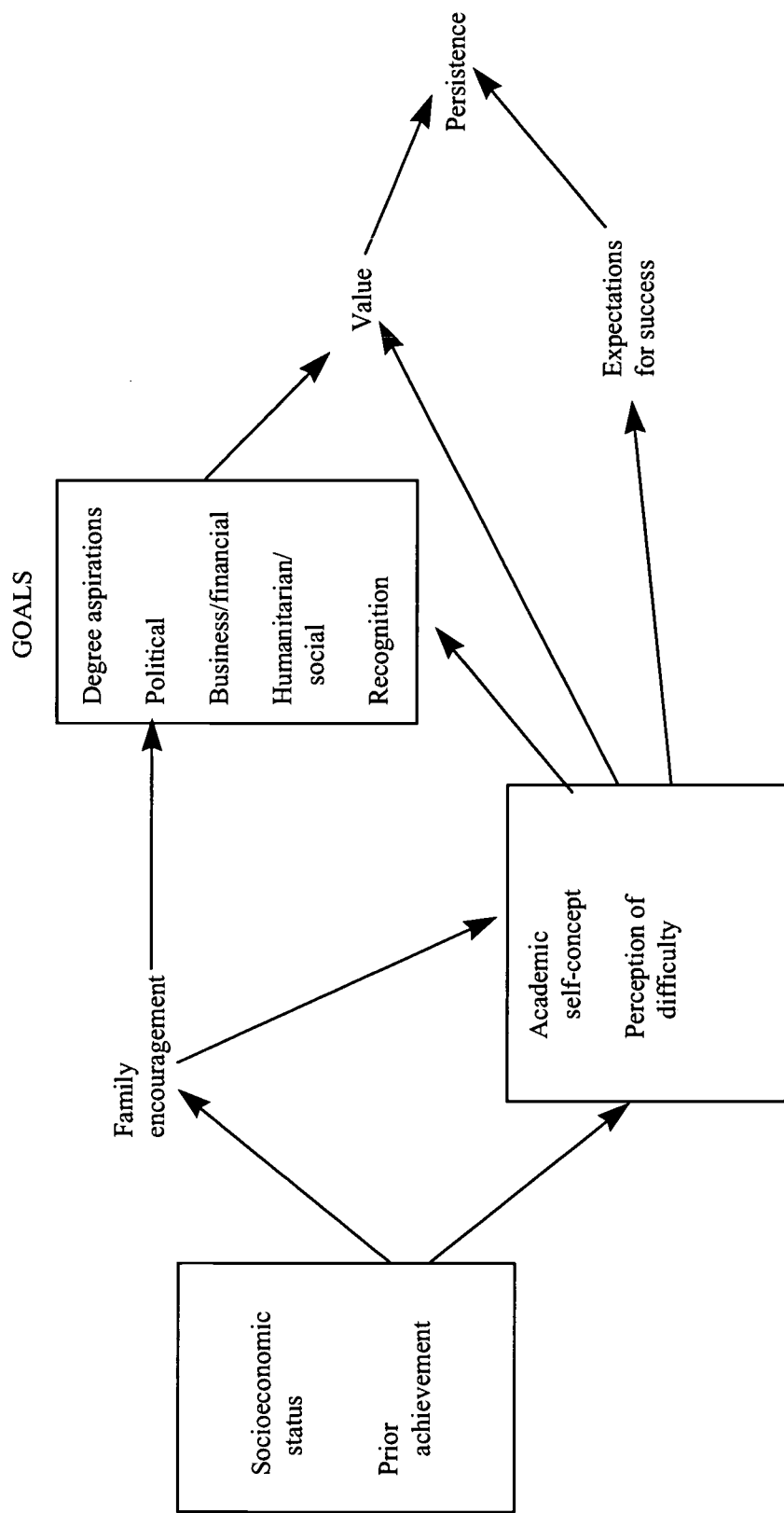

Figure 4: Estimated Model of Student Persistence (Ethington, 1980)

## ***2.2 MODELS OF STUDENT-INSTITUTION INTEGRATION***

Early models that attempted to understand student-institution “fit” focused on traditional students and their academic and social integration into the most prevalent higher education institution of the time – the university (Spady, 1970; Cope & Hewitt, 1971; Rootman, 1972; Tinto, 1975, 1987; Cope & Hannah, 1975, Pascarella, 1980). As the name indicates, models designed to understand student-institution “fit” set out to examine student and institutional variables that affect the compatibility of students and institutions. Seminal models which other models built upon and adapted were designed by Spady (1971) and Tinto (1975; 1987) to focus upon the academic and social integration of traditional students.

### ***2.2.1 Spady’s model***

Spady’s (1975) model of the undergraduate dropout process (See Figure 5) is based on his (1970) study of Durkheim’s (1897/1966) theory of suicide. Durkheim argued that suicide is a result of a person breaking ties with the social system because of a lack of integration into society. The likelihood of suicide increases when there is insufficient moral consciousness (low normative congruence) and insufficient collective affiliation (low friendship support). Spady claims that these same types of integration directly affect student persistence or withdrawal. He suggests that dropping out is a result of students not becoming integrated into the higher education environment. Spady argues that family background is one of many sources exposing students to influences, expectations and demands, which in turn affect the student’s level of integration. Full integration calls for meeting the demands of the college’s social and academic systems.

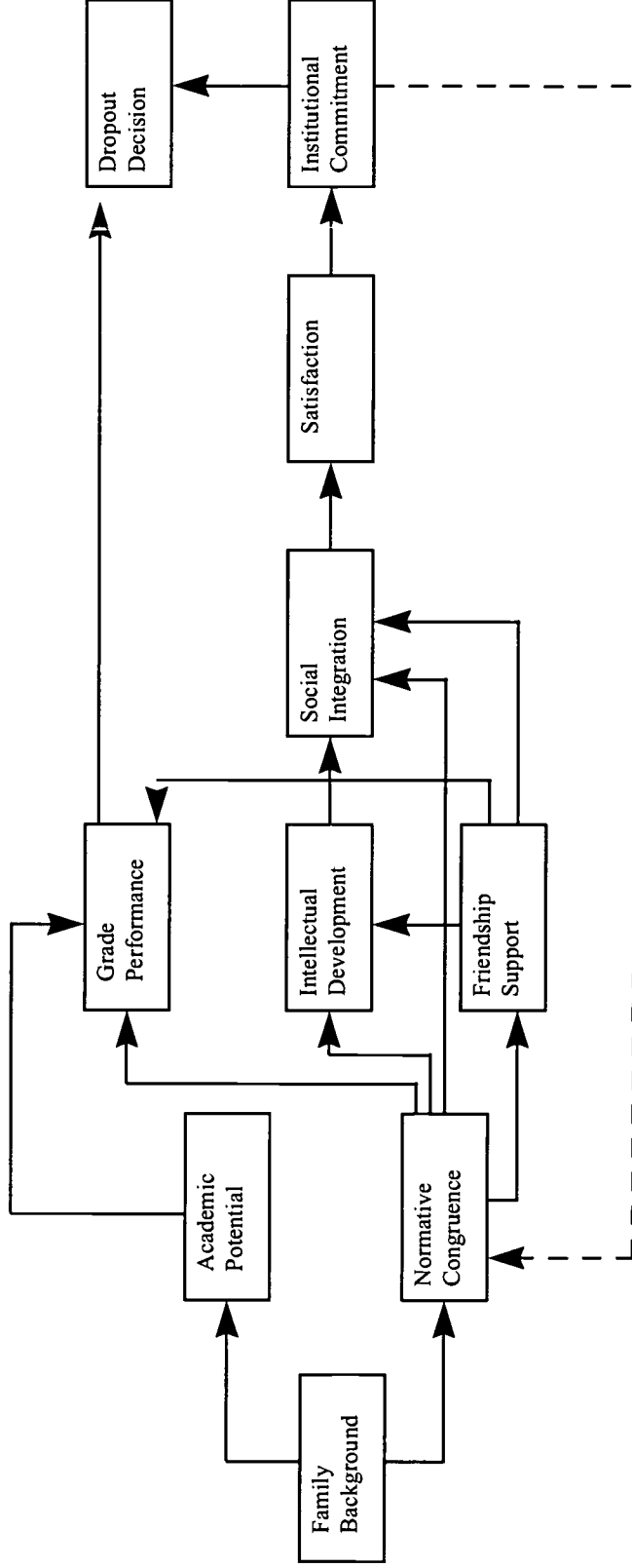

**FIGURE 5: Explanatory Sociological Model of the Dropout Process (Spady, 1970)**

### ***2.2.2 Tinto's model***

Tinto (1975) expanded on Spady's retention model by applying the exchange theory to Durkheim's theory of suicide (See Figure 6). The exchange theory is based on the understanding that humans avoid costly behaviour and seek rewarding statuses, relationships, interactions, and emotional states (Nye, 1979). According to Tinto, students apply the exchange theory in determining their academic and social integration, interpreted as goals and levels of institutional commitment. If the perceived benefits of college are higher than the costs, the student remains in school; if other activities are perceived as having higher rewards and less cost, the student will decide to drop out.

As the student proceeds through post-secondary education, several variables influence the strength of the student-institution match: students enter university with a set of background characteristics that influence their higher education experiences. These include family background (socio-economic status, parental values), individual attributes (race, gender) and pre-university schooling (secondary school grades, course of study). These characteristics combine to influence initial commitments to the institution and the goal of graduating. Tinto measures successful academic integration by grade performance and evaluates social integration by the development and frequency of positive interaction with peers and faculty and involvement in extracurricular activity. The stronger these commitments to the institution and the goal of completing, as well as the higher the levels of academic and social integration, the less likely the student will be to withdraw.

### ***2.2.3 Traditional student models in the spirit of Tinto***

Since 1975, leading research in the field of post-secondary student retention has been grounded on Tinto's (1975) explanatory model of the persistence/withdrawal process. The research has had ambiguous results. It has sometimes confirmed Tinto's argument that the fit between the individual and the institution is a good predictor of dropout or persistence (Grosset, 1991; Nora, 1987; Nora & Rendon, 1990; Pascarella & Terenzini, 1980).

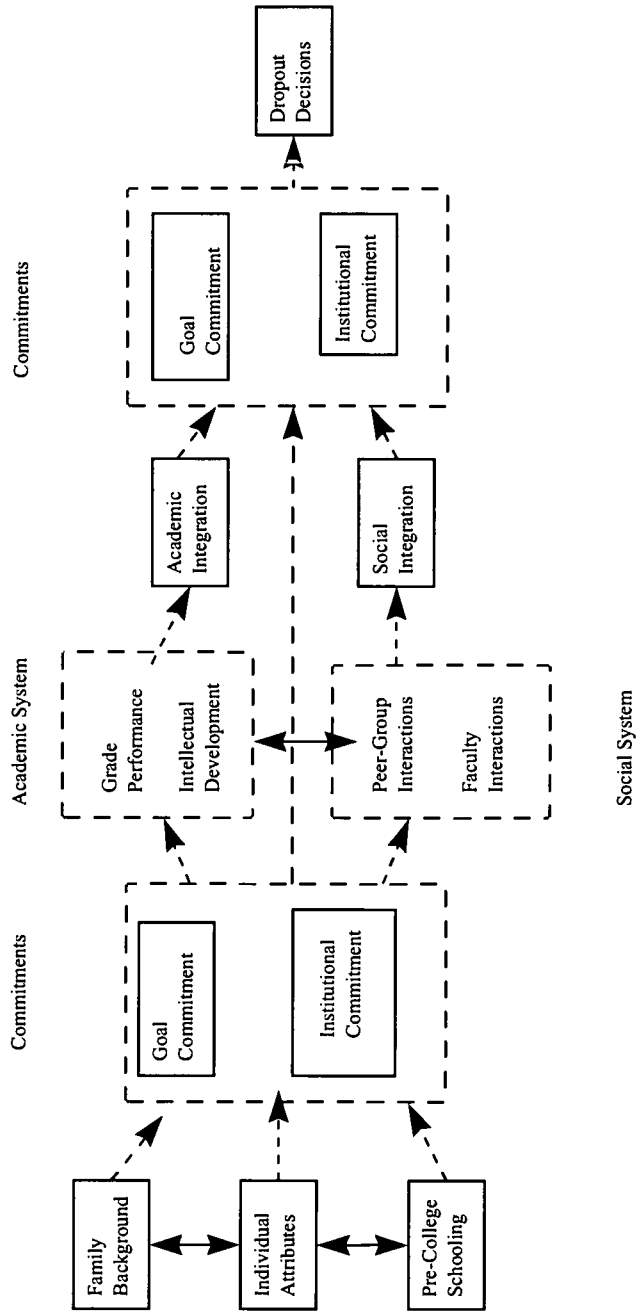

FIGURE 6: Conceptual Schema for Dropout from College (Tinto, 1975)



At other times social integration has been found to be negatively associated with persistence (Anderson, 1981; Pascarella & Chapman, 1983a, 1983b; Bean, 1980, 1985; Pascarella, Smart, & Ethington, 1986). Indeed, Pascarella, Smart and Ethington (1986) found that students with high affiliation needs dropped out at a higher rate than students with fewer faculty and peer contacts.

Two studies that provide conditional support for Tinto's thesis also contrast with one other (Pascarella 1980; Bean 1985). Pascarella's (1980) student-faculty informal contact model (see Figure 7) emphasizes the importance for students to have informal contact with faculty members. Based on Katz and Kahn's (1978) theory of social psychology involving organizational behaviour, the model suggests that effective social learning of normative attitudes and values is strongly influenced by informal interaction with the agents of socialization. Pascarella's model suggests that background characteristics interact with institutional factors (informal contact with faculty and other university experiences) to impact on satisfaction with university, educational aspirations, intellectual and personal development, academic achievement and first to second year persistence in university.

A model which both contrasts and compares with Pascarella's thesis is Bean's (1985) model of the factors affecting dropout. These factors emphasize academic, social and personal outcomes of institutional selection and socialization of students (see Figure 8), but Bean found that a student's peers are more important agents of socialization than informal faculty contacts. In the model, academic, social-psychological and environmental factors influence socialization and selection factors such as college grades, institutional fit, and institutional commitment. Environmental factors, such as finances, opportunity to transfer, and outside friends can lead to either dropout or institutional commitment. He also argues that students play a more active role in their socialization

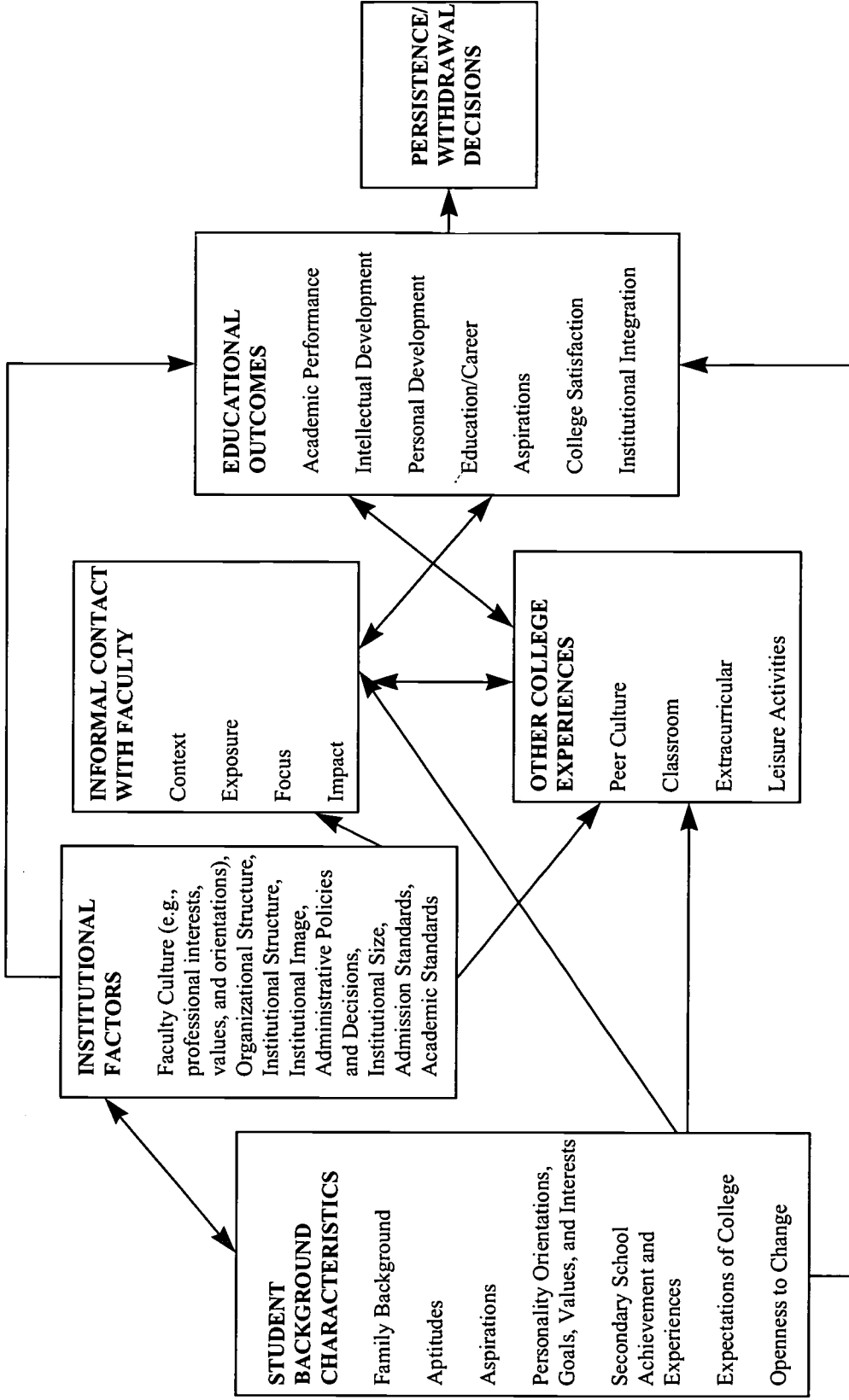

**FIGURE 7. Conceptual model for research on student-faculty informal contact (Pascarella, 1980)**

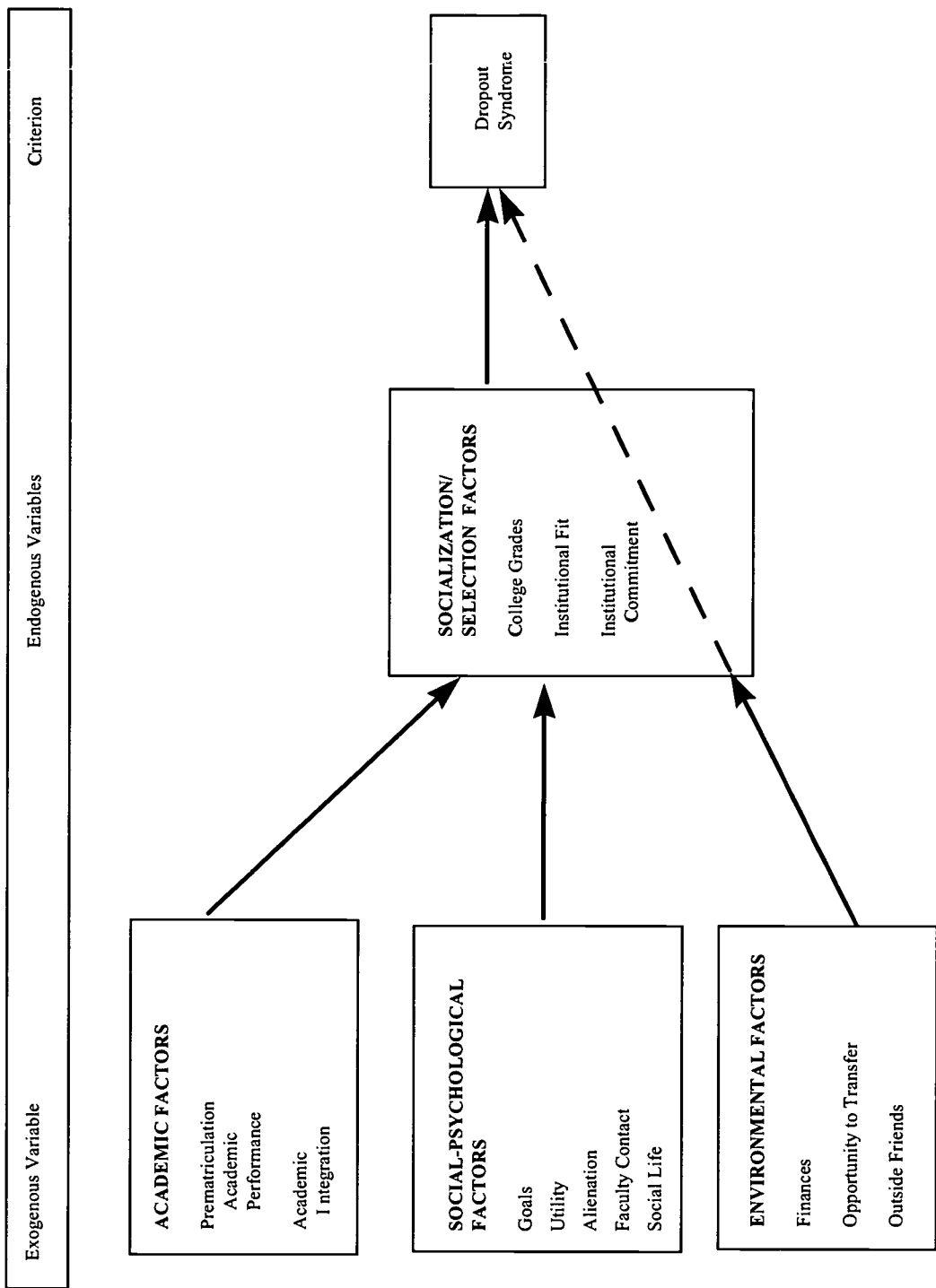

FIGURE 8. A conceptual model of dropout syndrome (Bean, 1985)

than previously thought, and that college grades appear to be more the product of selection than socialization.

#### ***2.2.4 Students as workers***

Other models based on Spady's and Tinto's theses of institutional commitment focus on institutional factors that promote student retention. The comparison of students to industrial workers has been made by various models of retention (Bean, 1980; Brown & Kayser, 1982). Bean's (1980) structural model adapted Price's (1977) model of employee turnover in industrial organizations to student attrition in higher education institutions. Price's (1977) model implies that organizational determinants affect employee satisfaction and the decision to stay or leave. Bean added background characteristics to this model in an effort to understand their influences on student-institutional fit, then tested and ranked the explanatory power of institutional characteristics on student attrition. Variables were ranked by their degree of influence on variations in student attrition, and included a dependent variable – dropout; intervening variables – satisfaction and institutional commitment; organizational determinants; and background variables (see Figure 9). Bean found a causal relationship between background characteristics and organizational determinants which led toward satisfaction or dissatisfaction and finally to institutional commitment or withdrawal.

Similar to Bean (1980), Brown and Kayser (1982) created a model of educational adjustment based on a theory of work development constructed by Dawis, England and Lofquist (1964), Dawis, Lofquist and Weiss (1968), and Lofquist and Dawis (1969). As a study of interactions between workers and their work environment, the theory suggests work adjustment is a condition resulting from worker's "satisfaction" with their work environments and employers' beliefs that employees are performing well on the job. The concept of work personality is central to this theory. Work personality is determined by the individual's work skills and psychological need for reinforcement. The model specifies three sets of variables thought to influence educational adjustment levels: (1) student background characteristics and demographics; (2) satisfaction variables; and (3) "satisfactoriness" or performance variables.

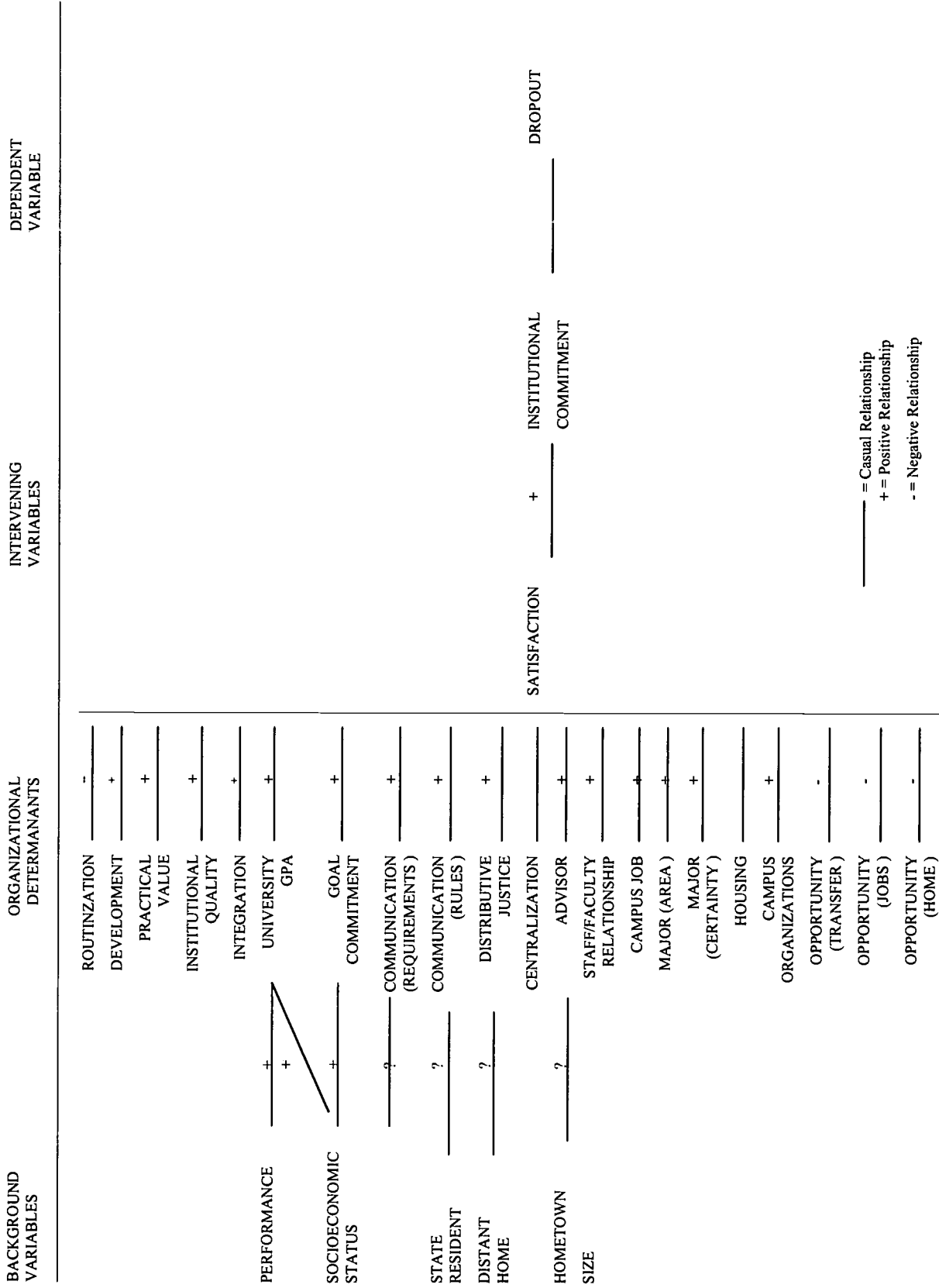

\_\_\_\_\_ = Casual Relationship  
 + = Positive Relationship  
 - = Negative Relationship

Figure 9: A Casual Model of Student Attrition (Bean, 1980)

### ***2.2.5 Institutional involvement***

Other models of student retention focus on student involvement and the institution's responsibility to promote student retention (Astin, 1984; Billson & Brooks-Terry, 1987). Student involvement is considered to be the amount of physical and psychological energy that the student devotes to the academic experience (Astin, 1984). Retention in these models is influenced by educational policies and practices that prompt student effort and investment of energy (Astin, 1984; Billson & Brooks-Terry, 1987).

*Astin's theory of involvement.* Astin's (1984) theory of involvement attempts to explain empirical knowledge concerning environmental influences on student development. He suggests that institutional policy can have a direct affect on student learning and development. For example, regulating class attendance can directly affect the amount of time and effort students commit to their classes. Astin ties three pedagogical theories together in order to fully explain possible student developmental outcomes: (1) subject-matter theory (also known as content theory), (2) resource theory, and (3) individualized (eclectic) theory. The subject-matter theory of pedagogy is based on the idea that student learning and development depend on exposure to the right subject matter. Students are perceived as passive agents who will experience a fixed set of course requirements involving lectures, reading assignments and library work. Avid readers, good listeners and highly motivated students tend to do best under this pedagogical process.

In contrast, the resource theory of pedagogy is based on the idea that the acquisition of resources is of utmost importance to student learning and development. Quantitative research support for this theory focuses on the merits of a low student-faculty ratio, while qualitative supporting research emphasizes that increasing the proportion of "high-quality" faculty and recruiting high-achieving students will strengthen the educational environment. The two main limitations to implementing this theory are that human resources are finite and the mere accumulation of resources with little attention to their use may turn out to be the greater waste.

A third theory, individualized (eclectic) theory, attempts to identify the curricular content and instructional methods that best meet the needs of the individual student. Although the subject-matter approach generally results in a fixed set of course requirements, the individualized approach

emphasizes electives. However, it goes far beyond the curriculum by stressing the importance of advising, counseling, independent study, and self-paced instruction. Its limitations are its expense, and the extreme difficulty of implementing an ambiguous process that knows virtually no bounds to variations in subject matter and pedagogical approach, in addition to having no current means for specifying what types of educational programs or teaching techniques would be most effective with different students.

Astin argues that all three pedagogical theories lack the element of student involvement. He suggests, instead, that greater attention needs to be paid to the passive or unprepared student -- the one most likely to drop out. He encourages teachers to focus less on content and teaching techniques and more on student behaviours as a means for understanding student motivation and the amount of time and energy students spend on the learning process. Counsellors and student personnel workers are encouraged to focus their energies on increasing student involvement. Peer interaction and quality learning teams have also been identified as useful.

*Billson and Brooks-Terry's construct of institutional support.* Similar to Astin (1984), Billson and Brooks-Terry (1987) constructed a student retention model based on the premise that increasing student involvement and improving institutional supports to the student will reduce attrition. The model includes eight phases of the student's path through post-secondary institutions, from outreach to recruitment/selection, assessment, preparation, orientation, integration, maintenance, and separation (see Figure 10). Billson and Brooks-Terry contend that it is the institution's responsibility to provide services and programs to support students through the system. Neglect to do so at any of the eight phases may result in increased attrition.

### STUDENT RETENTION MODEL

OUTREACH	RECRUITMENT SELECTION	ASSESSMENT	PREPARATION	ORIENTATIONS	INTEGRATION	MAINTENANCE	SEPARATION
Reciprocal high school/college visits.	Filtering: Income, H.S. grades, TSW/SAT scores Class rank + "X" factor	Placement testing for writing course/Summer Writing Program	Honor Program preparation	Orientation Program (residential) with integrative seminars on time management, prioritizing, goal setting, relationship between liberal arts and career choice, social interaction, involvement on campus, etc.	Develop pride, spirit, involvement via clubs, event, Greeks, honor societies	Sophomore year exit requirement in writing for community colleges	Planning for further education
Admissions contact with high school teachers re: competency levels and writing tests.	Early admissions decisions	Placement testing for math course/Summer Math Program	PEP Program	Parent Program	Honors program	Junior year Writing evaluation for 4-yr. colleges	Career planning
Early enrolment program for gifted high school students.	Early housing decisions		Summer Writing Program	Spouse/Children Program	General Education (liberal arts) core courses	Enrichment colloquia	Sessions with job recruiters
	Honors program recruitment/selection	Diagnostic testing of reading and study skills for referral to Reading Center	Summer Math Program	Continues identification of talented, gifted, and higher-risk students	Writing 100 (required of all students) University 101 (orientation course)	Follow-up on dismissals, absentees, etc. Three-semester grace policy	Building resumes, interview skills Alumni awareness alumni role model colloquia
	Financial aid planning	Vocational Interest Testing/SIGI			Tutorial Services	Financial Aid review and planning	
		Assessment of student values, attitudes, and knowledge base (ACE Freshman Survey, ACT Comp TEST, etc.)			Learning Centers Faculty Advisement Training Faculty Mentoring Program	Streamlined registration keyed to advisement	
		Professional and self-assessment of learning styles and intellectual development			Peer Counseling Program Support Group System	All-college pre-registration week for next semester Writing across the curriculum, and other workshops for faculty	
					Follow-up of higher risk students by Academic Advisement Center/New Student Programs		

Figure 10. Student Retention Model (Billson & Brooks-Terry, 1987)



*Issues of institutional involvement.* Many institutional characteristics affect student satisfaction and the decision to stay or leave. As Maguire and Lay (1981) indicate, “Every action (or inaction) by schools influences individuals by changing their perceptions and evaluations of the schools relative to one another” (p. 124). Relationships with faculty and campus resources and services are a few of the institutional characteristics that may lower the student’s level of stress and raise the student’s perception of personal control and social support (Andres, Andruske, & Hawkey, 1996; Bean & Metzner, 1985; Metzner, 1989). However, the importance of institutional supports should not be overstated. In their studies of traditional students, Franklin (1995), Grosset (1991) and Dietsche (1990) maintain that quality of student efforts in academic pursuits and interactions with faculty and peers were more influential on learning than the institution’s characteristics and environment.

All these models have followed Tinto’s (1975) model of student dropout/persistence, which was constructed at a time when the majority of students were white, able-bodied, middle-class males aged 18 to 24 attending university (see Figures 20 and 21, later in this document). Over the past 25 years student demographics have changed to include women, students from different ethnic backgrounds, physically disabled individuals and older students (Bean & Metzner, 1985, 1987; Guppy & Bednarski, 1993; Johnson, 1991; Stahl & Pavel, 1992). The higher education system has also evolved to include community colleges, university-colleges, and open learning agencies. Researchers have therefore begun to create models that may predict retention of non-traditional students as well as all students in the growing variety of higher education institutions (Pascarella & Chapman, 1983a). Although Tinto’s model is considered comprehensive (Guppy & Bednarski, 1993; Tierney, 1992; Pascarella & Terenzini, 1987), in that it provides a general theory of student participation, other models of student-institutional fit have been designed for particular student bodies and institutional types. In discussing these models, we first address the limited studies that focus on the impact that non-traditional institutions have had on student attrition and retention, then attend to the more prevalent literature dealing with non-traditional students.

Johnson (1994) developed a model of Canadian university undergraduate student withdrawal, comprehensive in scope and clearly distinguishing between student-initiated and institution-initiated university withdrawal. Two main factors are likely to precipitate the decision by undergraduate students to withdraw from their programs: academic performance and psychological state.

### ***2.3 MODELS OF NON-TRADITIONAL INSTITUTIONS***

Research that attempted to test the relevancy of Tinto's (1975) model in predicting retention of students in non-traditional higher education institutions include Pascarella and Chapman (1983) and Pascarella, Smart and Ethington (1986). Pascarella and Chapman (1983a) produced a multi-institutional, path analytic model of college withdrawal to test the validity of Tinto's model for different types of institutions: four-year residential institutions, four-year commuter institutions and two-year commuter institutions. They found interesting differences in the influence exerted by different institutional types on student persistence. Social integration appears to play a stronger role in influencing persistence at four-year residential institutions, while academic integration is more important at two- and four-year commuter institutions. This research has been extended by Pascarella, Smart and Ethington (1986) to test gender differences in persistence of students in two-year post-secondary institutions. The research supported the earlier contention that academic and social integration were the two core concepts accounting for the long-term post-secondary persistence of students initially enrolled in two-year institutions. For men, the quality and frequency of informal interaction with faculty is the most significant social integration variable; for women, involvement in leadership activities related to the educational institution has the greatest positive affect on persistence. In addition, secondary-school achievement is shown to have a positive direct effect on degree completion for men, while for women, both secondary school social involvement and socioeconomic status have a positive influence on degree completion.

### **3. CHANGING DEMOGRAPHICS OF HIGHER EDUCATION**

Higher education enrolments have increased dramatically since the 1960s. Moreover, although demographic forecasts predicted smaller cohorts of 18 to 24 year olds over the last decade, persistent increases in both full and part-time enrolments continued. Much of this growth has been the result of to increased participation by non-traditional students, including women, adults over the age of 25, and part-time students (Andres Bellamy & Guppy, 1991; Anisef, 1989; Gilbert & Guppy,

1988). According to the OECD (1988, p. 40), supply and demand of opportunities in higher education have increased for the following reasons:

- ◆ the prospect of well paid employment and promotion within career lines
- ◆ the need to update knowledge and skills in response to changes in knowledge-based technologies
- ◆ shifts in career opportunities in some fields: individuals enrol in programs that enable them to develop deeper or more varied job skills or to change jobs
- ◆ shorter working hours and more leisure time for retirees
- ◆ increased demand from adults who did not benefit from higher education opportunities on leaving secondary school: *e.g.*, women, minority groups, immigrants and other “disadvantaged” groups. (OECD, 1988, p.40)

Mounting pressure for increased accountability by institutions of higher education, together with the changing demographic composition of the student body, have stimulated the development of more detailed and sophisticated retention models – models that reflect the lives of today’s post-secondary students.

Improved access to higher education for students from a variety of backgrounds, with an emphasis on equality of opportunity, has been one of the most persistently recurring themes in Canadian educational research and policy over the past three decades (Guppy & Pendakur, 1989). This theme accounts for an increase in the number of traditional universities and community colleges and the emergence of new types of institutions (*e.g.*, university colleges). Federal government policy such as the Canada Student Loans Program and specific provincial incentives (*e.g.*, *the Access for All Initiative* in British Columbia) have also been implemented to enable geographically and economically disadvantaged students to pursue post-secondary studies.

### *3.1 NON-TRADITIONAL STUDENTS*

In higher education research, the concept of a non-traditional student is a recent phenomenon. In the 1980s, attrition models were modified to address some of the shortcomings of previous schema. Bean and Metzner (1987) provide a clear definition:

older than 24, does not live in a campus residence (e.g., is a commuter), or is a part time student, or some combination of these three factors; is not greatly influenced by the social environment of the institution; and is chiefly concerned with the institution's academic offerings (especially courses, certification and degrees). (p.489)

Despite such definitions, the concept remains rather nebulous, as attested by the variety of labels – such as re-entry, older, mature, adult and non-traditional – used to describe these students.

Similar to traditional student models, most models that try to predict non-traditional student retention are concerned with student-institution “fit” – the students’ social and academic integration into the institution (Bean & Metzner, 1985; Fox, 1986; Johnson, 1991; Stahl & Pavel, 1992). Numerous studies have cast doubt on whether Tinto’s model’s is relevant to all students and higher education institutions. Many studies indicate that although social and academic integration are important factors in predicting persistence, they are not equally important to every student. Anderson (1981), Braxton and Brier (1989), Pascarella and Chapman (1983a, 1983b) and Pascarella, Smart and Ethington (1986) report that academic integration had stronger affects on institutional commitment and therefore a stronger indirect effect on persistence than did social integration.

Similar research suggests that the majority of students, who now live off campus and are older than traditional students, do not value social integration as an important deciding factor of persistence or withdrawal (Andres, Hawkey, & Andruske, 1996; Bean & Metzner, 1985, 1987; Benjamin & Hollings, 1995; Ethington, 1990; Johnson, 1991; Stahl & Pavel, 1992; Voorhees, 1987). The Bean and Metzner (1985;1987) model of non-traditional undergraduate student attrition proposes that there are four sets of variables affecting dropout: (1) academic performance measured in terms of past and present GPA; (2) intent which is influenced by psychological outcomes and academic variables; (3) defining variables such as age, enrolment status and resident status as well as background variables such as educational goals, high school performance, ethnicity and gender; and (4) environmental variables -- those factors not controlled by the institution (see Figure 11). This research found that non-traditional student attrition is affected more by the external environment than

social interaction variables which tend to more strongly influence traditional student attrition. In later research Metzner and Bean (1987) found that while social integration variables were not significant for the non-traditional student group, grade point average and institutional commitment directly affected dropout through their impact on perceptions of a post-secondary education's usefulness in gaining employment, satisfaction and opportunity to transfer.

Other studies have found that social and academic integration, particularly in the form of faculty contact, may explain the retention of non-traditional students. After examining several studies, Pascarella (1989) concludes that academic integration, measured by grades, intellectual development and faculty interaction, is most influential for persistence and degree attainment for students with low social integration such as non-traditional students who do not spend much time on campus.

### ***3.1.1. Benjamin's Quality of Student Life model***

Benjamin (1994) criticizes "integration" models of higher education, such as that posited by Tinto (1987). Although parsimonious, these models are limited in scope, and hence do not adequately reflect the complex and multileveled lives of today's students.

Instead, Benjamin (1994) proposes a "Quality of Student Life" model. This ecological model of student satisfaction (see Figure 12) conceptualizes satisfaction as a multidimensional construct involving the interaction among personal, interpersonal, social and contextual factors and/or processes. Here, instead of viewing students in one of several unidimensional ways, a more complete view is gained in which the relationship between the student and the institutional environment is seen as both reciprocal and dynamic.

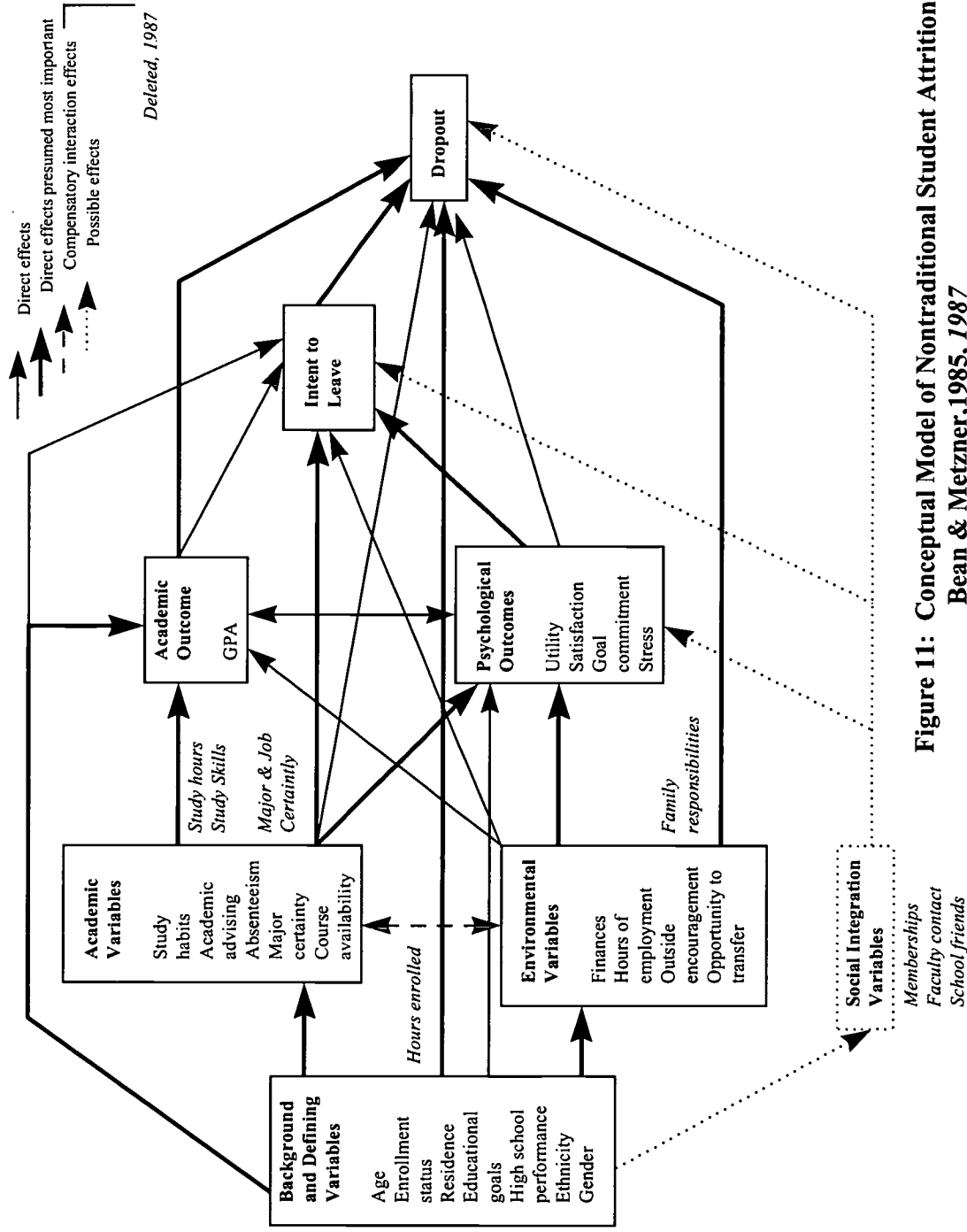

**Figure 11: Conceptual Model of Nontraditional Student Attrition**  
 Bean & Metzner, 1985, 1987

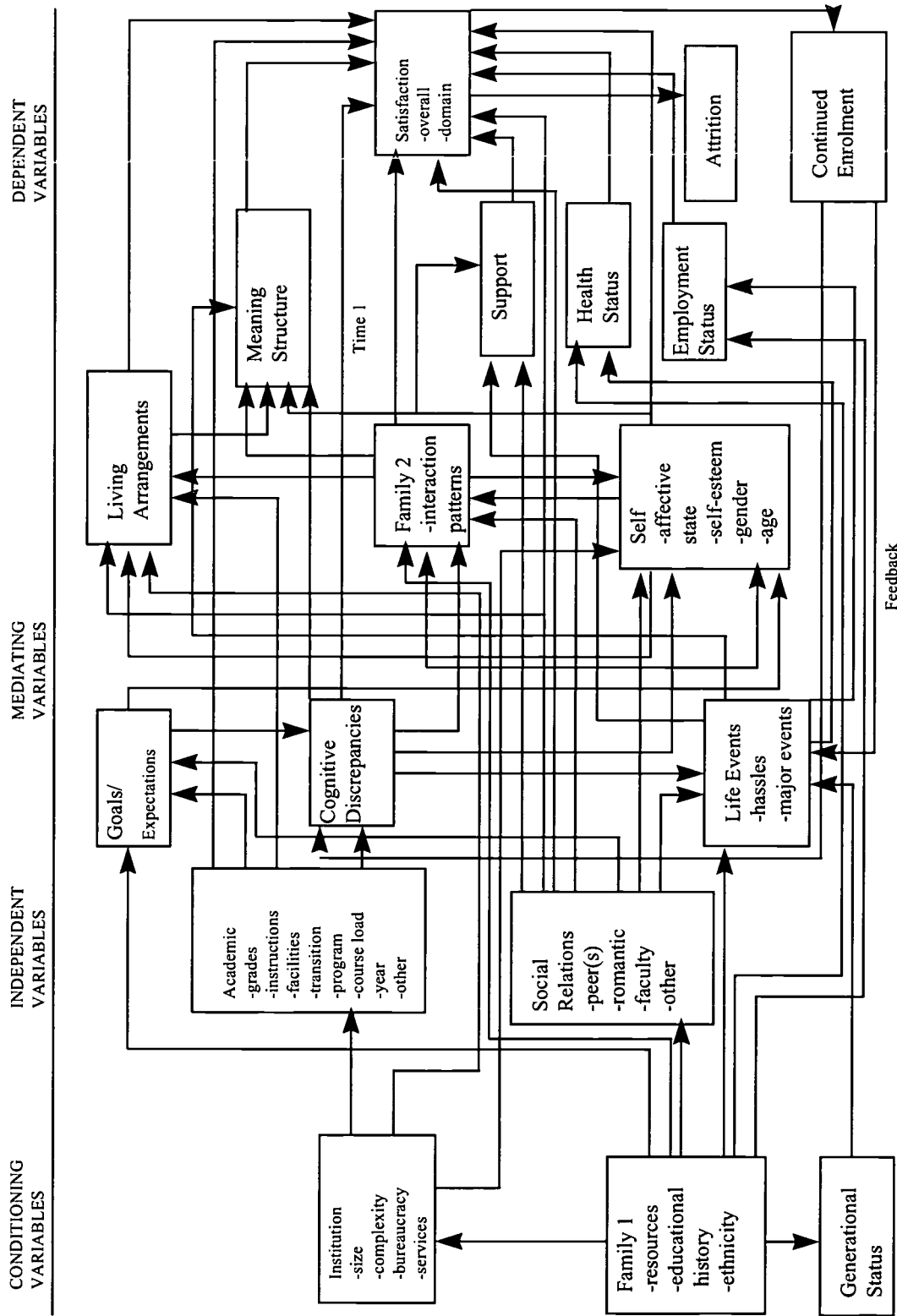

Figure 12. Modified Path Model of Quality of Student Life (Bejamin, 1994)

Benjamin defines Quality of Student Life as “student short-term perception of satisfaction and happiness with multiple life domains in light of salient psychosocial and contextual factors, and personal meaning structures” (p. 229). He outlines eight indicators that influence the student’s subjective well-being (p. 228):

- (1) satisfaction (cognitive)
- (2) happiness (affective)
- (3) multiple life domains (on and off campus)
- (4) short-term past (events occurring within two weeks)
- (5) objective circumstances
- (6) institutional circumstances
- (7) psychosocial factors
- (8) meaning structures.

The model stresses the need to consider the student’s on- and off-campus environments if efforts to assess student satisfaction and happiness are to be meaningful. His model includes eight multiple life domains (see Figure 13). Objective circumstances include demographic indicators such as age, gender, social class, ethnicity and current physical health. Institutional circumstances include individual indicators such as academic year, program and number of courses. Meaning structures are composed of prevailing family interaction patterns, goals, expectations and “identity” – self-defined by one’s personal esteem and perception of competence.

Using this model as a basis for a *Quality of Student Life* survey, Benjamin and Hollings (1995) found “involvement” by itself to be an inadequate concept that decontextualizes student experience. The researchers suggested that it is meaningful to think of students’ lives as complex and multi-levelled, with outcomes such as campus satisfaction being multi-determined. They found that competing demands of parents, friends, romantic partners, employers and others, as well as problems such as health, finances or life events, can influence students’ coping ability and their decisions to maintain, persist in, or change their life course. While acknowledging that students’ coping efforts vary, they suggest that the university must change in order to attract and retain students.



- |   |                                     |   |
|---|-------------------------------------|---|
| <p>1. Social</p> <ul style="list-style-type: none"> <li>- Parents/Family</li> <li>- Friends</li> <li>- Romantic Partner</li> <li>- Support/Acceptance</li> <li>- Demand/Conflict</li> <li>- Other</li> <li>- Links (*)</li> </ul>   | <p>2. Finances</p>                  | <ul style="list-style-type: none"> <li>- Employment</li> <li>- Options</li> <li>- Awards/Scholarship</li> <li>- Other</li> <li>- Link(*)</li> </ul>   |
| <p>3. Individual</p> <ul style="list-style-type: none"> <li>- Identity</li> <li>- Motivation/Aspiration</li> <li>- Values</li> <li>- Attitudes</li> <li>- Self-Esteem/Confidence</li> <li>- Stress/Pressure</li> <li>- Background/Experience</li> <li>- Vocational Goals</li> <li>- Other</li> <li>- Link (*)</li> </ul>  | <p>4. Living Arrangements</p>       | <ul style="list-style-type: none"> <li>- Advantages</li> <li>- Disadvantages</li> <li>- Structure</li> <li>- Gender Mix</li> <li>- Maturation</li> <li>- Location</li> <li>- Group Membership</li> <li>- Other</li> <li>- Line (*)</li> </ul> |
| <p>5. Academic</p> <ul style="list-style-type: none"> <li>- Workload</li> <li>- Faculty/TAs</li> <li>- Grades/Evaluation</li> <li>- Structure</li> <li>- Program</li> <li>- Level/Year</li> <li>- Facilities/Equipment</li> <li>- Affective Response/Time</li> <li>- Skill/Knowledge</li> <li>- Professional Schools (**)</li> <li>- Time Use/Management</li> <li>- Other</li> <li>- Line(*)</li> </ul> | <p>6. University Services</p>       | <ul style="list-style-type: none"> <li>- Access</li> <li>- Utility</li> <li>- Extracurricular</li> <li>- Other</li> <li>- Line (*)</li> </ul>   |
| <p>7. Gender</p> <ul style="list-style-type: none"> <li>- Safety/Security</li> <li>- Difference</li> <li>- Role Models</li> <li>- Other</li> <li>- Link(8)</li> </ul>   | <p>8. University Administration</p> | <ul style="list-style-type: none"> <li>- Courses</li> <li>- Bureaucracy</li> <li>- Complexity</li> <li>- Student Organizations</li> <li>- Scheduling</li> <li>- Other</li> <li>- Line(*)</li> </ul>   |
| <p>9. Other</p> <ul style="list-style-type: none"> <li>- Health</li> <li>- Situation</li> <li>- Adjustment/Entry/Exit</li> <li>- Other</li> <li>- Link(*)</li> </ul>  |                                     |   |

\* Identifies a like between two or more life domains/subdomains.  
 \*\* Refers to a range of differences between "regular" undergraduates and those in a Professional School.

**Figure 13. Life Domains and Major Subdomains among Undergraduate Students (Benjamin, 1994)**

### **3.2. NON-TRADITIONAL STUDENT EXPERIENCE**

Non-traditional students differ from “traditional” students both quantitatively and qualitatively. The term “non-traditional” attempts to capture an eclectic range of individual attributes that are used to distinguish these students from those considered “traditional” students.

The following section provides a discussion of the problems faced by non-traditional students, including transfer students, older adult learners, commuters, part-time students, graduate students, women, students with disabilities and ethnic minorities.

#### ***3.2.1 Transfer Students***

Transfer students share certain characteristics upon entering post-secondary studies (Small, Vaala, & Tyler 1989). They are more likely to be older and married, have weaker academic backgrounds, and are less confident about their prospects for program completion. It has been argued that they are a disadvantaged group (Alba & Lavin, 1981; Anderson, 1981) with a lower social and academic self-image, lower academic ability and motivation, and half as likely to aspire to education beyond the baccalaureate degree than students who begin their post-secondary studies at a university (Lunneborg & Lunneborg 1976; Sandeen & Goodale 1976).

Transfer students often start at a community college because of lower tuition costs, more relaxed admission requirements, or demographic convenience, and then attempt to transfer to a university after completing one or two years toward a degree. Numerous studies document that difficulties can arise at any stage of the transfer process (Alba & Lavin, 1981; Dougherty, 1987; Grubb, 1991; Lee & Frank, 1990; Lee, Mackie-Lewis & Marks, 1993; Nora & Rendon, 1990; Prager, 1993; Velez & Javalgi, 1987).

Those more likely to experience difficulties with transfer tend to belong to the following categories: women, minority students, students from lower socio-economic backgrounds, graduates from the general and vocational tracks, and low achievers in high school (Grubb, 1991; Lee & Frank, 1990; Lee, Mackie-Lewis & Marks, 1993; Nora & Rendon, 1990; Prager, 1993; Townsend, McNerney, & Arnorld, 1993; Velez & Javalgi, 1987). Being male increases a student’s chances of

transferring by about 18 percent (Velez & Javalgi 1987). Ease of transfer, however, does not predict graduation (Jones & Lee, 1992).

The transfer process has been found to hinder actual completion of a degree. Karabel (1986) contends that students who are comparable in socioeconomic background, academic ability, educational aspirations and other relevant individual characteristics are more likely to earn bachelor's degrees if they start post-secondary studies at a university. Numerous studies confirm that the probability of degree completion is generally superior when post-secondary education begins in a degree-granting institution (Alba & Lavin, 1981; Anderson, 1984; Astin, 1982; Elliott, 1972; Hatfield & Stewart, 1988; Medsker & Tillery, 1971; Velez, 1985; Meskill & Sheffield, 1970; Monroe, 1972; Newlon & Gaither, 1980; Tweddale, 1977). However, the situation in the U.S. is somewhat different. Warner Kearney, Townsend, and Kearney (1995) found that 33 percent of students receiving a diploma at a public urban university in the United States were originally matriculated elsewhere. But most of these successful transfer students were of high socio-economic origins, and, according to Warner *et al.*, may be categorized as "ultimate persisters." This is not the case for most transfer students.

Attrition after transfer may be influenced by loss of credits (Dennison & Jones, 1970; Dougherty, 1987; Small, Vaala, & Tyler, 1989; Swift, 1986) and declining academic performance (Johnson, 1987; Willingham, 1985). Most research on post-transfer student experiences has been a quantitative attempt to measure academic grade loss or "transfer shock" (Britton, 1969; Dennison & Jones, 1970; Diaz, 1992; Gold, 1972, 1979; Knoell & Medsker, 1965). Diaz's (1992) in-depth meta-analysis of 62 studies dealing with transfer shock reveals that 79 percent of community college transfer students experienced a drop in grades, indicating these students faced problems in adjusting to another institutional culture. Vaala and Holdaway (1989) report that transfer "students tended to perceive the major adjustments to university as including (a) larger classes, (b) heavier workloads, and (c) less personal professor-student interactions" (p.178). Numerous studies support these findings, showing that students experience "transfer shock" due to a lack of academic and social integration (Britton, 1969; Dennison & Jones, 1970; Diaz, 1992; Gold, 1972, 1979; Knoell & Medsker, 1965).

Other factors influencing attrition after transfer have been argued to include ethnicity, residence location, admissions policies and problems with conforming to a culture intended for

traditional students (Anglin, Davis & Mooradian 1995; Cohen & Brawer 1981; Cross 1968; Pascarella 1986; Rich 1979). Gender is also a factor: post-transfer attrition rates are higher among women than men, despite research indicating that on average women earn higher marks at university (Holahan, Green & Kelley 1983; Al-Sunbul 1987). Transfer students who start post-secondary studies at a community college may be disadvantaged socially, financially and academically upon entering university. Financial problems combine with other pressures to act as a major deterrent to staying in university. Students who start at a community college and later complete their degree at a university usually spend more money to stay in school longer, and face stronger demands to get higher marks in order to transfer (Dougherty, 1987).

The amount of transfer activity and student success at the university are two main indicators of the institutional effectiveness of a community college. As Grubb (1991) states, “the ability of students to transfer to four-year colleges and then compete as equals against students who begin in four-year colleges is one test of the acceptability of community colleges within higher education” (1991, p.195; see also Eaton 1991). However, not only are post-transfer attrition rates high, but several studies also reveal that transfer rates from community colleges to universities are low (Alba & Lavin, 1981; Anderson, 1984; Astin, 1982; Medsker & Tillery, 1971; Velez, 1985).

The subsequent success of transfer students at a university is not solely the responsibility of community colleges. Although the needs of transfer students have been frequently outlined (Barbour, Startzel, Kenny, Anderson, & Richards, 1977; Williams, 1973; Cejda, 1994; and Lunneborg and Lunneborg, 1976), the literature also suggests it is unlikely these needs will be addressed with urgency. For universities, there is a lack of incentive. In the first place, the transfer student is often not the preferred student (Sandeem & Goodale, 1976). Second, there is little reason to be more accommodating when quantitative research shows that previous college or high school GPA is a strong indicator of post-transfer student’s academic success in university (Britton, 1969; Dennison & Jones, 1970; Gold, 1972; Phlegan, Andrew, & McLaughlin, 1981, Nickens, 1972, 1975; Richardson & Doucette, 1980; Wray & Lewischuck, 1971). Third, the drop in GPA that the majority of students experience after transfer has been found to be only one half of a grade point or less for the majority, and 67 percent of the studies in Diaz’s (1992) meta-analysis indicated that students usually recover from the decline within a year after transferring.

### 3.2.2 Older Adult Learners

“Older” students, that is those beyond the age of 24, engage in post-secondary activities in ways quite different than their traditional counterparts learners (Ashar & Skenes 1993; Andres, Andruske, & Hawkey 1996; Andres, Hawkey, & Andruske, 1996). Hence, the notion of “social integration” must be reconsidered for these post-secondary participants.

Recent Statistics Canada data (1995) indicate that the majority of full-time students (92%) are between the ages of 18 and 22. Students 25 years and older account for only 6 percent of full-time enrolments in post-secondary education in British Columbia (Table 1). Canadian figures for the same group (over 24) are only marginally higher at 7 percent.

**Table 1.**  
**Full-time Post-secondary Enrolment by Age, 1993-94, British Columbia and Canada**

years	B.C. %	Canada %
17	2.5	9.8
18	20.3	23.4
19	22.2	35.8
20	19.0	34.1
21	17.7	29.8
22	13.0	22.5
23	9.7	15.3
24	7.3	10.6
25-29	3.7	4.5
30-34	1.6	1.9
35 and over	0.4	0.4

Source: Statistics Canada, Cat. 81-229-XPB, 1995

University enrolment statistics for British Columbia for the 1993-94 year reveal that 54 percent of part-time undergraduate students are aged 25 years and older (see Table 2).

**Table 2.**  
**Part-time Undergraduate and Graduate University Enrolment,**  
**1983-84 and 1993-94, British Columbia**

	1983-84 %	1993-94 %
<b>Undergraduate</b>		
19 years or less	5	6
20-24	28	40
25-29	22	18
30-39	28	19
40-49	10	13
50 or older	6	4
<b>Total</b>	<b>100</b>	<b>100</b>
<b>Graduate</b>		
19 years or less	-	-
20-24	3	2
25-29	21	18
30-39	53	38
40-49	17	34
50 or older	5	7
<b>Total</b>	<b>100</b>	<b>100</b>

Source: Statistics Canada, Cat. 81-229-XPB, 1995

However, as Table 2 indicates, between 1983-84 and 1993-94, the proportion of “older” part-time undergraduates has decreased from 66 percent to 54 percent. Slight increases are evident only in the 40-49 age cohort (from 10% in 1983-84 to 13% in 1993-94). Graduate student enrolments increased by 19 percent for those aged 40 and older (from 22 percent in 1983-84 to 41 percent in 1993-94).

This is further demonstrated in Canadian statistics for full-time and part-time university enrolments as a proportion of the relevant age group reveal that more women, older women and those studying part-time, participate in some instances at twice the rate of men (Table 3a & 3b). However, overall, when compared to younger women, older female students account for a small proportion of the total of student population.

**Figure 14: Full-time and Part-time Enrolment in Community Colleges by Sex, 1989-90 to 1993-94, British Columbia**

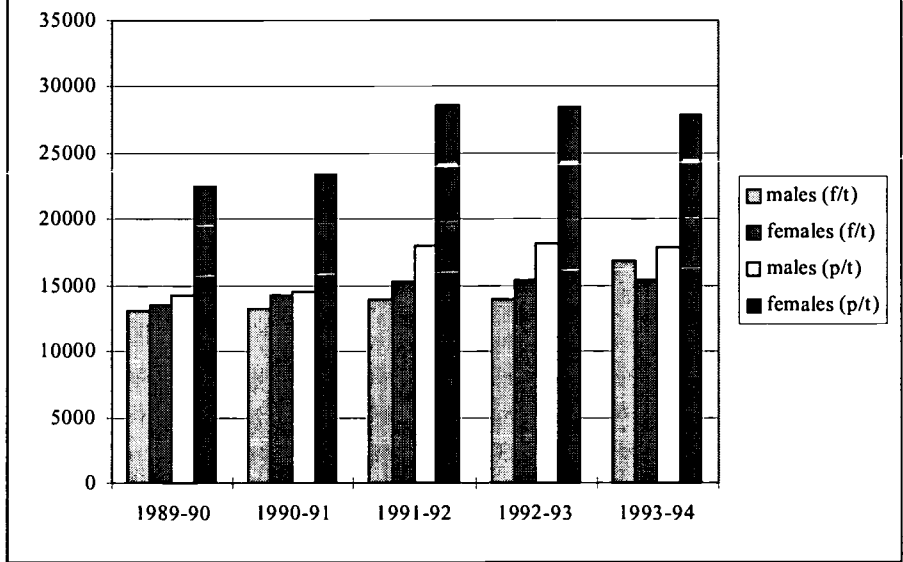

**Figure 16. Full-time and Part-time University Enrolment in B.C. by Sex, 1989-90 to 1993-94**

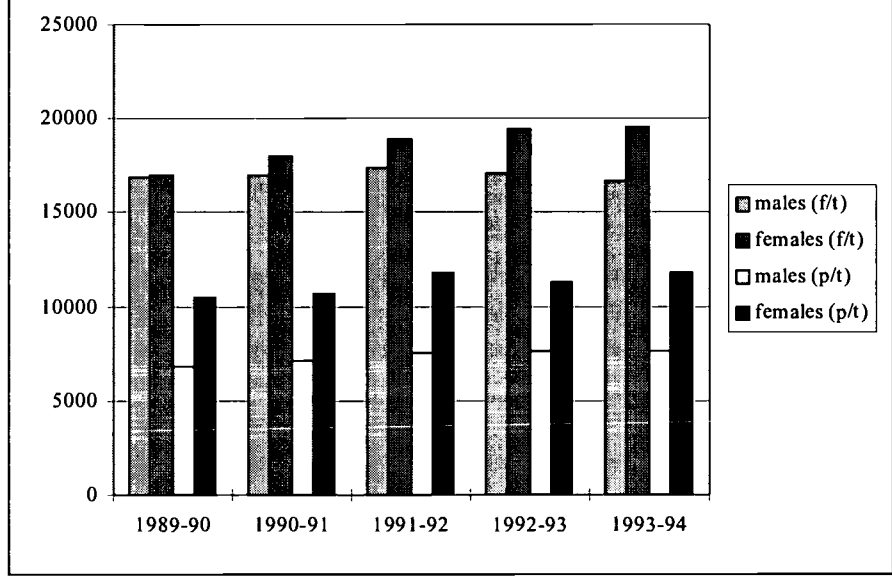

Source: Statistics Canada, Cat. 81-229-XPB, 1995

**Table 3.a.**  
**Full-time University Enrolment, by Age Group and Sex as a Proportion of that Age Group, 1989-90 to 1993-94, Canada**

		1989-90	1990-91	1991-92	1992-93	1993-94
18-21	male	13.9	14.2	14.5	14.6	14.4
	female	17.6	18.4	19.4	19.9	20.1
	total	15.7	16.3	16.9	17.2	17.2
22-24	male	8.7	9.3	10.1	10.6	10.6
	female	7.9	8.8	9.7	10.6	11.0
	total	8.3	9.0	10	10.6	10.8
25-29	male	1.9	1.9	2.0	2.1	2.2
	female	1.5	1.6	1.7	1.8	1.8
	total	1.7	1.7	1.9	2.0	2.0
30-34	male	0.5	0.5	0.6	0.6	0.6
	female	0.6	0.6	0.6	0.7	0.6
	total	0.6	0.6	0.6	0.6	0.6
35-39	male	0.3	0.3	0.3	0.3	0.3
	female	0.4	0.4	0.5	0.5	0.4
	total	0.4	0.4	0.4	0.4	0.4
40-49	male	0.1	0.1	0.1	0.1	0.1
	female	0.2	0.2	0.2	0.2	0.2
	total	0.2	0.2	0.2	0.2	0.2

Source: Statistics Canada, Cat. 81-229-XPB, 1995



**Table 3.b.**  
**Part-time University Enrolment, by Age Group and Sex as a Proportion of that Age Group, 1989-90 to 1993-94, Canada**

		1989-90	1990-91	1991-92	1992-93	1993-94
18-21	male	1.1	1.2	1.3	1.4	1.4
	female	1.6	1.7	1.8	1.9	1.9
	total	1.4	1.5	1.6	1.7	1.6
22-24	male	2.5	2.8	3.0	3.2	3.2
	female	3.5	3.6	3.9	4.1	4.2
	total	3.0	3.2	3.5	3.7	3.7
25-29	male	1.7	1.7	1.8	1.8	1.8
	female	2.5	2.5	2.7	2.7	2.5
	total	2.1	2.1	2.2	2.2	2.1
30-34	male	1.2	1.2	1.2	1.2	1.1
	female	2.1	2.1	2.1	2.0	1.8
	total	1.7	1.6	1.6	1.6	1.5
35-39	male	1.0	1.0	1.0	1.0	0.9
	female	2.3	2.2	2.2	2.1	1.8
	total	1.7	1.6	1.6	1.5	1.4
40-49	male	0.7	0.7	0.7	0.7	0.6
	female	2.0	2.0	2.0	1.9	1.6
	total	1.3	1.3	1.3	1.3	1.1

Source: Statistics Canada, Cat. 81-229-XPB, 1995

### ***3.2.3 Lifelong learning and recurrent education***

Duke describes the importance of lifelong learning and recurrent education as “reflecting a need to continue learning and to return periodically to education throughout life in order to cope with rapid technological and other changes” (1992, p.1055). In British Columbia, several reports suggest that lifelong learning and recurrent education should be a key component of our economic and social strategies (e.g., Day, 1992; Faris, 1992). Such an approach would help to ensure that educational opportunities are available for adult learners .

Distance education delivery, such as those offered through British Columbia’s Open Learning Agency, may also increase participation by non-traditional groups.

### ***3.2.4 Commuter Students***

Because commuter students spend less time on campus than their residential peers, they may be less likely to participate in extra-curricular activities designed to enhance their academic and social involvement. However, two Canadian studies suggest that such involvement may not be essential for commuters. Dietsche's (1990) study of 3,817 commuter students in a community college found that academic integration and educational commitment were more important in accounting for persistence than social integration and institutional commitment. And according to Grayson (1994), classroom experiences appeared to have a greater impact on students than contact with faculty outside the classroom at commuter institutions like York University in Ontario.

### ***3.2.5 Part-time Students***

Part-time participation in universities and community colleges has expanded considerably over the past decades in British Columbia (see Figures 14 and 15, earlier in this paper). However, despite provision of specific university programs for part-time students (Thompson & Devlin, 1992) many challenges in promoting participation and retention of part-time students remain (Anisef, 1989). One such challenge is limited resources which could be deemed better spent to ensure young high school graduates attend full-time study (OECD, 1988).

### ***3.2.6 Graduate Students***

In British Columbia, full-time graduate enrolments have risen at a steady rate (see Figure 16). However, since 1983-84, part-time graduate student enrolment by both women and men, has been either static or has declined. Limited access to part-time graduate programs may provide one explanation for this trend.

**Figure 16. Full-time and Part-time Graduate Enrolment, 1983-84 to 1993-94, British Columbia**

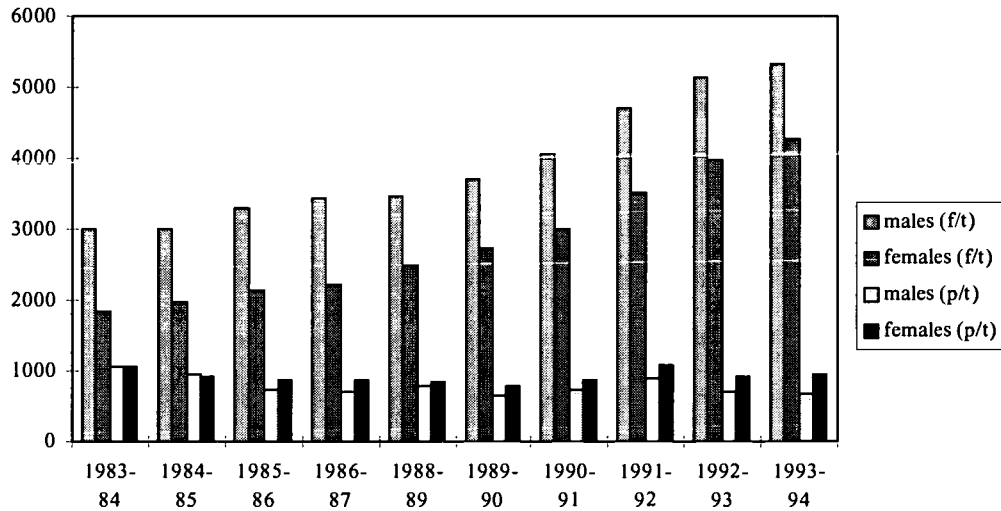

Source: Statistics Canada, Cat. 81-229-XPB, 1995

### 3.2.7 Women

Clearly, increased participation by women in institutions of post-secondary education has been phenomenal. Between 1960 and 1985 enrolments by women increased steadily. By 1988, women's enrolment had surpassed men's (Figure 17). Part-time enrolment of women has also increased dramatically. By 1993-94, more women were enrolled in both full-time and part-time undergraduate university programs than men (see Figure 15).

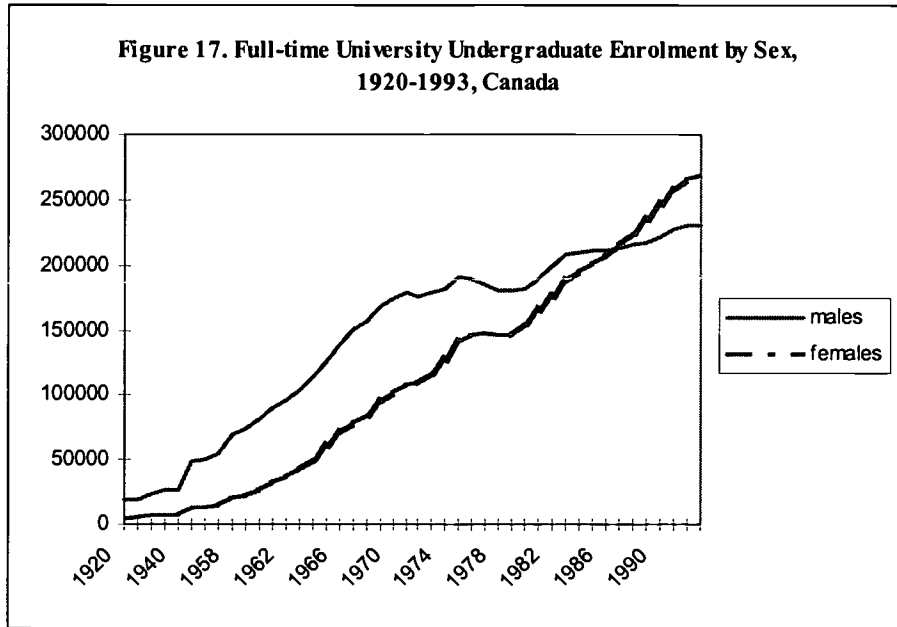
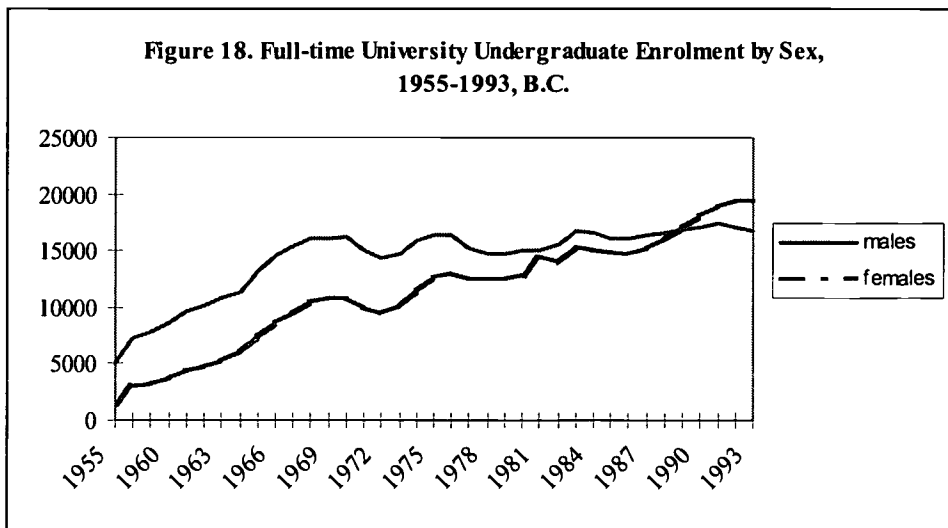

Figure 18 portrays a similar increase in full-time participation in undergraduate study by women in British Columbia universities.



Women are still more likely than men to enrol in and graduate from university programs (Andres Bellamy & Guppy, 1991). Although women are still underrepresented in graduate education, enrolments have gradually increased at both the master's and doctorate levels (see Figure 16).

In British Columbia, at the community college level, more men are enrolled full time at these institutions. However, part-time enrolment figures indicate that women study part-time in greater numbers than men (see Figure 14).

Despite these advances, challenges continue to exist for women. A study by Young (1992) illustrates the challenges faced by professional women. Four women holding doctorates in Educational Administration were interviewed to determine the nature of challenges facing women in higher education. Several "themes" emerged. Under the "Late Bloomers" category, career development and hence greater professional competence occurred later in life (around the mid-thirties). The "Competing Urgencies" theme was generated by interviewees' descriptions of the challenges associated with juggling a professional career and family.

### ***3.2.8 Students with Disabilities***

Very few studies have addressed the issue of enrolment of students with disabilities in Canadian post-secondary institutions. A document released by The Council of Ministers of Education entitled *Opportunities: Post-secondary Education and Training for Students with Special Needs* (1987) highlights access and retention issues pertaining to students with disabilities. According to this report, students with special needs remain under-represented in higher education, however, enrolments are increasing for this group.

One Canadian study examined the degree to which universities across Canada were addressing issues of access and retention for students with disabling conditions (Leigh-Hill, 1992). Leigh-Hill found that overall, universities have embraced this issue and are attempting to improve both facilities and resources.

### 3.2.9 *Ethnic Minorities*

Models of retention and attrition have been remiss in accounting for the effects of race and ethnicity. This is compounded with little available data to examine post-secondary participation and retention patterns by different racial and ethnic groups.

## 4. CONCLUSION: IMPLICATIONS FOR HIGHER EDUCATION

The demographic composition of students in the Canadian and British Columbia higher education systems has changed dramatically. Women on university and community college campuses can no longer be considered a “non-traditional” presence. Although those in the 17-24 age range continue to account for the majority of full-time university enrolments, large numbers of older students attend part-time. At B.C. community colleges, the large proportion of women attending part-time is noteworthy. Unfortunately, very little research has been conducted on participation patterns by students with disabilities and racial and ethnic minority students. Also, although institutional arrangements increasingly promote interinstitutional transfer, transfer patterns and rates are difficult to document with accuracy.

Despite these demographic shifts, for the most part, we continue to employ models that were designed to explain retention, admission, transfer, and attrition patterns of a very traditional student body. The constructs in these models have contributed greatly to our understanding of students’ experiences within institutions of higher education. However, research to date tells us very little about these constructs – including social and academic integration, expectations for success, institutional commitment, goal commitment, peer-group and faculty interactions the expectations and experiences of student populations – in relation to students who no longer conform to the “traditional” norm. Moreover, systems which include community colleges, university colleges, technical and vocational institutes, and private post-secondary systems add another level of complexity in terms of understanding that goes well beyond studying young, full-time undergraduate students attending university.

Schema such as Benjamin’s (1994) *Quality of Student Life Model* attempt to grapple with the complex and dynamic nature of students within post-secondary systems. The challenge for researchers, administrators and policy makers within the field of higher education is to continue to

develop and refine these models in relation to current and changing student demographics, to operationalize them in meaningful ways, and to use the results of theory and research to enhance the post-secondary experiences for today's higher education students.

## REFERENCES

- Al-Sunbul, A. (1987). The achievement of two-year transfer students in four-year institutions: A case study. Community/Junior College Quarterly of Research and Practice, 11(1), 1-9.
- Alba, R.D., Lavin, D.E. (1981). Community colleges and tracking in higher education. Sociology of Education, 54(4), 223-37.
- Anderson, K.L. (1981). Post-high school experiences and college attrition. Sociology of Education, 54(1), 1-15.
- Anderson, K.L. (1984). Institutional differences in college effects. Boca Raton: Florida Atlantic University. (ERIC No. ED 256 204).
- Andres, L. (*forthcoming*). Multiple life sphere participation of young adults. In W. Heinz (Ed.), From Education to Work: Cross National Perspectives. Cambridge: Cambridge University Press.
- Andres, L., Andruske, C., & Hawkey, C. (1996). Mapping the realities of first year post-secondary life: a study of students at three post-secondary institutions. Report prepared for the British Columbia Council on Admissions and Transfer.
- Andres [Bellamy], L., & Guppy, N. (1991). Opportunities and obstacles for women in Canadian higher education. In J. Gaskell and A McLaren (Eds.), Women and Education (pp. 163-192). Calgary: Detselig Enterprises Ltd.
- Andres, L., Hawkey, C., & Andruske, C. (1996). Activating voices within: Individual/institutional dynamics of the first year student experience. Paper prepared for the annual meeting of the American Educational Research Association, New York.
- Anglin, L.W., Davis, J.W., & Mooradian, P.W. (1995). Do transfer students graduate? A comparative study of transfer students and native university students. Community College Journal of Research and Practice, 19(4), 321-330.
- Anisef, P. (1989). Studying part-time in Canada's universities: a social change perspective. The Canadian Journal of Higher Education, 19(1), 11-28.
- Arthur, N. (1994). Coping stability: rearranging our bias. Paper presented at the annual conference of the Canadian Society for the Study of Higher Education, June 1994.
- Ashar, H. & Skenes, R. (1993). Can Tinto's student departure model be applied to nontraditional students? Adult Education Quarterly, 43(2), Winter, 90-100.
- Astin, A. (1975). Preventing students from dropping out. San Fransisco: Jossey Bass.



- Astin, A. (1982). Minorities in American higher education. San Francisco: Jossey Bass.
- Astin, A. W. (1993). What matters in college: four critical years revisited. San Francisco: Jossey Bass.
- Astin, A.W. (1984). Student involvement: A developmental theory for higher education. Journal of College Student Personnel, 25(4), 297-308.
- Attinasi, L.C. Jr. (1986). Getting in: Mexican American students' perceptions of their college-going behavior with implications for their freshman year persistence in the university. ASHE 1986 Annual Meeting Paper, San Antonio, TX. (ERIC No. ED 268 869).
- Barbour, JR. Jr., Startzel, J., Kenny, E., Anderson, E.F., & Richards, C. (1977). A look at graduates of four-year colleges to which they transferred. College and University, 52(4), 633-655.
- Bean, J.P. & Metzner, B.S. (1985). A conceptual model of nontraditional undergraduate student attrition. Review of Educational Research, 55(4), 485-540.
- Bean, J.P. (1980). Dropouts and turnover: The synthesis and test of a causal model of student attrition. Research in Higher Education, 12(2), 155-187.
- Bean, J.P. (1985). Interaction effects based on class level in an explanatory model of college student dropout syndrome. American Educational Research Journal, 22(1), 35-64.
- Bélanger, R., Lynd, D., & Mouelki, M. (1982). Part-time degree students: tomorrow's majority. Ottawa: Minister of Supply and Services Canada.
- Bélanger, R. & Omiecinski, T. (1987). Part-time university enrolment. Canadian Social Trends. Summer, 22-25.
- Benjamin, M. (1990). Freshman daily experience: Implications for policy, research and theory. Student-Environment Group. Student Development Monograph Series, Vol. 4 (ERIC No. ED 346 794).
- Benjamin, M. (1994). The quality of student life: Toward a coherent conceptualization. Social Indicators Research, 31(3), 205-264.
- Benjamin, M., & Hollings, A.E. (1995). Toward a theory of student satisfaction: An exploratory study of the "Quality of student life." Journal of College Student Development, 36(6), 574-586.
- Billson, J. M., & Brooks Terry, M. (1987). A student retention model for higher education. College and University, 62(4), 290 -305.

- Braxton, J. M., & Brier, E. M. (1989). Melding organizational and interactional theories of student attrition: A path analytic study. Review of Higher Education, 13(1), 47-61.
- Breese, J.R. & O'Toole, R. (1994). Adult women students: development of a transitional status. Journal of College Student Development, 35(1), 183-187.
- Britton, R. (1969). The first semester academic performance of urban junior college transfer students to Columbia vs. two urban campuses of the University of Missouri. Columbia MO: University of Missouri (ERIC No. ED 043 331).
- Brown, J. M., & Kayser, T.F. (1982). The transition of special needs learners into post-secondary vocational education. St. Paul: University of Minnesota, Minnesota: Research and Development Center for Vocational Education (ERIC No. ED 217 298).
- Campbell, D. (1984). The new majority: Adult learners and the university. Edmonton: The University of Alberta Press.
- Cejda, B.D. (1994). Reducing transfer shock through faculty collaboration: A case study. Community College Journal of Research and Practice, 18(2), 189-199.
- Cohen, A.M., & Brawer, F.B. (1981). The persistent issues. Community and Junior College Journal, 54(4), 17-21.
- Cope, R.G., & Hannah, W. (1975). Revolving college doors: The causes and consequences of dropping out, stopping out, and transferring. New York: John Wiley and Sons.
- Cope, R.G., & Hewitt, W. (1971). Types of college dropouts: an environmental press approach. College Student Journal, 5(2), 46-51.
- Cross, K.P. (1968). The junior college students: A research description. Princeton, NJ: Educational Testing Service.
- Dawis, R.V., England, S.W., & Lofquist, L. H. (1964). Minnesota studies in vocational rehabilitation XV: A theory of work adjustment. Minneapolis: University of Minnesota, Minneapolis Industrial Relations Center.
- Dawis, R.V., Lofquist, L.H., & Weiss, D.J. (1968). A theory of work adjustment (A revision). Minnesota Studies in Vocational Rehabilitation: XXIII (ERIC No. ED 031 740).
- Day, W. (1992). Continuing education in British Columbia's colleges and institutes: a foundation for lifelong learning. A report prepared for the Centre for Policy Studies in Education, the University of British Columbia.

- Dennison, J.D., & Jones, G. (1970). The community college transfer student at the University of British Columbia: A three year study. Vancouver: Vancouver City College.
- Dey, E.L. & Hurtado, S. (1995). College impact, student impact: A reconsideration of the role of students within American higher education. Higher Education, 30(2), 207-223.
- Diaz, P.E. (1992). Effects of transfer on academic performance of community college students at the four-year institution. Community/Junior College Quarterly of Research and Practice, 16(3), 279-291.
- Dietsche, P. (1990). Freshman attrition in a college of applied arts and technology of Ontario. The Canadian Journal of Higher Education, 20(3), 65-84.
- Dougherty, K.J. (1987). The effects of community colleges: Aid or hindrance to socio-economic attainment? Sociology of Education, 60(2), 86-103.
- Douglas, J.D. (1980). Introduction to the sociologies of everyday life. In J. D. Douglas (ed.), Introduction to the sociologies of everyday life. Boston: Allyn and Bacon.
- Duke, C. (1992). Adults returning to education. In B.R. Clark and G. Neave (Eds.), The Encyclopedia of Higher Education. vol. 2 (pp.1055-1068). Oxford: Pergamon Press.
- Durkheim, E. (1897/1966). Suicide, a study in sociology. Translated by J.A. Spaulding and G. Simpson (ed.). New York: Free Press.
- Eaton, J.S. (1991). Encouraging transfer: The impact on community colleges. Educational Record, 72(2), 34-38.
- Eccles, J., Adler, T.F., Futerrman, R., Goff, S.B., Kaczala, C.M., Meece, J.L., & Midgley, C. (1983). Expectancies, values, and academic behaviors. In J. T. Spence (Ed.), Achievement and Achievement Motives: Psychological and sociological approaches. San Francisco: W. H. Freeman and Co.
- Elliott, E.S. (1972). The academic achievement of transfer students and the college comprehensive tests. Journal of College Student Personnel, 13(3), 266-269.
- Ethington, C.A. (1990). A psychological model of student persistence. Research in Higher Education, 31(3), 279-293.
- Faris, R. (1992). Lifelong Learning for the 21st century. A report on the future development of adult/continuing education in British Columbia. A report prepared for the Ministry of Education and the Ministry of Advanced Education, Training, and Technology, and the Centre for Curriculum and Professional Development.

- Fichten, C.S. (1988). Students with physical disabilities in higher education: Attitudes and beliefs that affect integration. In H.E. Yunker (Ed.), Attitudes Toward Persons with Disabilities (pp. 171-186). New York: Springer.
- Fishbein, M., & Ajzen, I. (1975). Belief, attitude, intention and behavior: An introduction to theory and research. Reading, MA: Addison-Wesley.
- Fletcher, J., & Stern, R. (1992). Report on a survey of recent and current doctoral students at the University of Toronto. Paper presented at the Council of Ontario Universities/Ontario Council Graduation Studies Colloquium. Toronto, Ontario.
- Foot, D., & Stoffman, D. (1996). Boom, bust, and echo. How to profit from the coming demographic shift. Toronto: Macfarlane, Walter & Ross.
- Fortin, M. (1987). Accessibility to and participation in the post-secondary education system in Canada. Saskatoon: National Forum on Post-Secondary Education.
- Fox, R.N. (1986). Application of a conceptual model of college withdrawal to disadvantaged students. American Educational Research Journal, 23(3), 415-424.
- Franklin, M. (1995). The effects of differential college environments on academic learning and student perceptions of cognitive development. Research in Higher Education, 36(2), 127-153.
- Frei Raven, M. & Jimmerson, R.M. (1992). Perceptions of nontraditional students, teaching and learning held by faculty and students. Higher Education Review, 56(3), 137-154.
- Gilbert, S., & Auger, M. (1987). Admission and attrition: Preliminary results of the CEASE project on student attrition. Paper presented at the Canadian Society for the Study of Higher Education, McMaster University, Hamilton.
- Gilbert, S., & Guppy, N. (1988). Trends in participation in higher education by gender. J. Curtis *et al.* (Eds.), Social Inequality in Canada: Patterns, Problems, Policies. Toronto: Prentice Hall.
- Gilley, A., & Hawkes, R.T. (1989). Nontraditional students: a changing student body redefines community. Educational Record, Summer/Fall, 33-35.
- Gold, B.K. (1972). Academic performance of LACC transfers to UCLA through the special services program, 1971-1972 (ERIC No. ED 067 089).
- Gold, B.K. (1979). Academic performance of LACC transfers to California State University at Los Angeles, 1966-78 (ERIC No. ED 172 885).
- Gomme, I.M., & Gilbert, S.N. (1984). Paying the cost: Some observations on the problem of postsecondary student attrition. Canadian Journal of Higher Education, 14(3), pp. 95-100.

- Gomme, I.M., Hall, M.P., & Murphy, T.J. (1993). In the shadow of the tower: The view of the undergraduate experience. The Canadian Journal of Higher Education, 23(3), 19-35.
- Grayson, P.J. (1994). First year science in a commuter university: where to intervene. Canadian Journal of Higher Education, 24(2), 17-42.
- Grosset, J.M. (1991). Patterns of integration, commitment, and student characteristics and retention among younger and older students. Research in Higher Education, 32(2), 159-178.
- Grubb, W.N. (1991). The decline of community college transfer rates. Journal of Higher Education, 62(2), 196-221.
- Guppy, N., & Bednarski, V. (1993). Enhancing student retention in higher education: a literature review. Report for BC Council on Admission and Transfers: Anthropology and Sociology, University of British Columbia.
- Guppy, N., & Pendakur, K. (1989). The effects of gender and parental education on participation within post-secondary education in the 1970's and 1980's. Canadian Journal of Higher Education, 19(1), 49-62.
- Haggar-Guenette, C. (1992). Mature students. Canadian Social Trends, Autumn. pp.26-29.
- Hatfield, S., & Stewart, D. (1988). Stamping out the transfer run-around. Educational Record, 69(2), 50-53.
- Hoffman, A.M. & Julius, D.J. (1995). Total quality management: implications for higher education. Prescott Publishing.
- Holahan, C.K., Green, J.L., & Kelley, H.P. (1983). A 6-year longitudinal analysis of transfer student performance and retention. Journal of College Student Personnel, 24(4), 305-310.
- Hore, T. (1992). Nontraditional students: third-age and part-time. In: Clark, B. & Neave, G. (Eds), The Encyclopedia of Higher Education. Oxford: Pergamon Press (Vol 2) pp.1666-1674.
- Hybertson, D., Hulme, E., Smith, A.W., & Holton, M.A. (1992). Wellness in non-traditional-age students. Journal of College Student Development, 33(1), 50-55.
- Johnson, D.R. (1991). Formulating a conceptual model of nontraditional student attrition and persistence in post-secondary vocational education programs. Berkeley, CA: National Center for Research in Vocational Education (ERIC No. ED 332 012).
- Johnson, G.M. & Buck, G.H. (1995). Students' personal and academic attributions of university withdrawal. Canadian Journal of Higher Education, 25(2), 53-77.

- Johnson, G.M. (1994). Undergraduate student attrition: A comparison of students who withdraw and students who persist. Alberta Journal of Educational Research, 40(3), 337-353.
- Johnson, N.T. (1987). Academic factors that affect transfer student persistence. Journal of College Student Personnel, 28(4), 323-329.
- Jones, J.C., & Lee, B.S. (1992). Moving on: A cooperative study of student transfer. Research in Higher Education, 33(1), 125-140.
- Kallio, R.E. (1995). Factors influencing the college choice decision of graduate students. Research in Higher Education, 36(1), 109-125.
- Karabel, J. (1986). Community colleges and social stratification in the 1980s. In L.S. Zwerling (ed.), The community college and its critics. New Directions for Community Colleges, San Francisco: Jossey-Bass, 54(2), 13-30.
- Katz, D., & Kahn, R.L. (1978). The social psychology of organizations. NY: Wiley.
- Knoell, D., & Medsker, L.L. (1965). From junior to senior college: A national study of the transfer student. Washington, D.C.: American Council on Education.
- Lea Moore, M. & Piland, W.E. (1994). Impact of campus physical environment on older adult learner. Community College Journal of Research and Practice, 18(3), 307-317.
- Leacy, F.H. (1983). Historical statistics of Canada. 2nd edition. Statistics Canada.
- Lee, V.E., & Frank, K.A. (1990). Students' characteristics that facilitate the transfer from two-year to four-year colleges. Sociology of Education, 63(3), 178-193.
- Lee, V.E., Mackie-Lewis, C., & Marks, H.M. (1993). Persistence to the baccalaureate degree for students who transfer from community college. American Journal of Education, 102(1), 80-114.
- Leigh-Hill, J. (1992). Accessibility: students with disabilities in universities in Canada. Canadian Journal of Higher Education, 22(1), 48-83.
- Levin, J.S., & Dennison, J. (1989). Responsiveness and renewal in Canada's community colleges: a study of organizations. Canadian Journal of Higher Education, 19(2), 41-57.
- Levine, A. (1990). Defying demographics. Currents, 16(6), 26-30.
- Lofquist, L.H., & Dawis, R.V. (1969). Adjustment to work; a psychological view of man's problems in a work-oriented society. New York: Appleton-Century-Crofts.

- Lunneborg, A.E., & Lunneborg, P.W. (1976). Characteristics of university graduates who were community college transfers. Journal of College Student Personnel, 17(1), 61-65.
- Luzzo, D.A. (1993). Career decision-making differences between traditional and non-traditional college students. Journal of Career Development, 20(2), 113-120.
- Maquire, J., & Lay, R. (1981). Modeling the college choice process: Image and decision. College and University, 56(2), 123-139.
- Mayo, J.R.; Murguia, E. & Padilla, R.V. (1995) Social intergration and academic performance among minority university students. Journal of College Student Development, 36(6), 542-552.
- McEwen, J.I. (1995). Report in respect of the Political Science Department of the University of British Columbia. Vancouver. UBC.
- Medsker, L., & Tillery, D. (1971). Breaking the access barrier. New York: McGraw Hill.
- Meskill, V.P., & Sheffield, W. (1970). A new specialty: full-time academic counselors. Personnel and Guidance Journal, 49(1), 55-58.
- Metzner, B.S. & Bean, J.P. (1987). The estimation of a conceptual model of nontraditional undergraduate student attrition. Research in Higher Education, 27(1),15-38.
- Metzner, B.S. (1989) Perceived quality of academic advising: The effect on freshman attrition. American Educational Research Journal, 26(3), 422-442.
- Monroe, C.R. (1972). Profile of the community college. San Francisco: Jossey-Bass.
- Morgan, G. (1986). Images of organization. Sage. London.
- Neumann, Y. & Neumann, E.F. (1989) Predicting juniors' and seniors' persistence and attrition: a quality learning experience approach. Journal of Experimental Education, 57(2), 129-140.
- Newlon, L.L., & Gaither, G.A. (1979-1980). Factors contributing to attrition: An analysis of program impact on persistence patterns. College and University, 55(2), 237-251.
- Nickens, J.M. (1972). "Transfer shock" or "transfer ecstasy"? (ERIC No. ED 116 721).
- Nickens, J.M. (1975). Articulation. Gainesville, FL: Florida Community Junior Colleges. (ERIC No. ED 116 721).
- Nora, A., & Rendon, L. I. (1990). Determinants of predisposition to transfer among community college students: A structural model. Research in Higher Education, 31(3), 235-255.

- Nora, A. (1987). Determinants of retention among Chicano college students: A structural model. Research in Higher Education, 26(1), 31-59.
- Nora, A., & Rendon, L. I. (1990). Determinants of predisposition to transfer among community college students: A structural model. Research in Higher Education, 31(3), 235-255.
- Nye, F.I. (1979). Choice, exchange, and the family. In W. R. Burr, R. Hill, F. I., Nye, and I. L. Reiss (Eds.), Contemporary theories about the family (pp.102-236). New York: The Free Press.
- OECD. (1988). Universities under scrutiny. Paris: OECD.
- Pascarella, E. T., & Terenzini, P. T. (1987). The influence of college on self-concept: a consideration of race and gender differences. American Educational Research Journal, 24(1), 49-77.
- Pascarella, E.T. (1980). Student-faculty informal contact and college outcomes. Review of Educational Research, 50(4), 545-595.
- Pascarella, E.T. (1986). College environmental influences on learning and cognitive development: A critical review and synthesis. In J.C. Smart (Ed.), Higher education: Handbook of theory and research (pp. 1-62). New York: Agathon.
- Pascarella, E.T. (1989). "The development of critical thinking: does college make a difference?" Journal of College Student Development, 30(1), 19-26.
- Pascarella, E.T., & Chapman, D.W. (1983a). Validation of a theoretical model of college withdrawal: Interaction effects in a multi-institutional sample. Research in Higher Education, 19(1), 25-48.
- Pascarella, E.T., & Chapman, D.W. (1983b). A multi-institutional, path analytic validation of Tinto's model of college withdrawal. American Educational Research Journal, 20(1), 87-102.
- Pascarella, E.T., & Terenzini, P.T. (1980). Predicting freshman persistence and voluntary dropout decisions from a theoretical model. Journal of Higher Education, 51(1), 60-75.
- Pascarella, E.T., Duby, P.B., & Iverson, B.K. (1983). A test and reconceptualization of a theoretical model of college withdrawal in a commuter institution setting. Sociology of Education, 56(2), 88-100.
- Pascarella, E.T., Smart, J.C., & Ethington, C.A. (1986). Long-term persistence of two-year college students. Research in Higher Education, 24(1), 47-71.
- Phlegan, A.G., Andrew, L.D., & McLaughlin, G.W. (1981). Explaining the academic performance of community college students who transfer to a senior institution. Research in Higher Education, 15(2), 99-108.



- Polson, C.J. (1994). Developmental advising for nontraditional students. Adult Learning, 6(1), 21-28.
- Prager, C. (1993). Transfer and articulation within colleges and universities. Journal of Higher Education, 64(5), 539-554.
- Price, J.L. (1977). The study of turnover. Ames: Iowa State University Press.
- Pyke, S.W., & Sheridan, P.M. (1993). Logistic regression analysis of graduate student retention. Canadian Journal of Higher Education, 23(2), 44-64.
- Ratcliff Whitaker, B. (1993). Differentiation of self and retention in higher education of eastern Kentucky Appalachian students. Doctoral Dissertation. Lexington, Kentucky: University of Kentucky.
- Rich, I.A. (1979). Counseling the transfer student: myths and realities. Journal of College Student Personnel, 20(2), 175-176.
- Richardson, R., & Doucette, D.J. (1980). Persistence, performance, and degree achievement of Arizona's community college transfer in Arizona's public universities. (ERIC No. ED 197 785).
- Rootman, I. (1972). Voluntary withdrawal from a total adult socialization organization: A model. Sociology of Education, 45(3), 258-270.
- Sandeen, A., & Goodale, T. (1976). The transfer student: An action agenda for higher education. (ERIC No. ED 154 750).
- Secretary of State. (1989). Open Learning and distance education in Canada. Canadian resource guide. Open Learning Agency of B.C. Ottawa: Ministry of Supply and Services.
- Segal, B. (1990). Retrospective on the Forum. Canadian Journal of Higher Education, 20(1), 1-3.
- Small, J.M., Vaala, L.D., & Tyler, D. (1989). College-to-university transfer: status and issues in Alberta. Paper presented at the Annual Conference of the Canadian Society for the Study of Higher Education, June 3-5.
- Smith, K. (1995) Comparison of the college decisions of two-year and four-year college students. College and University, 65(2), 109-125.
- Smith, S, 1991. Report of the Commission of Inquiry on Canadian University Education. Ottawa: Association of Universities and Colleges in Canada.
- Spady, W.G. (1970). Dropouts from higher education: An interdisciplinary review and synthesis. Interchange, 1(1), 64-85.

- Spady, W.G. (1971). Dropouts from higher education: Toward an empirical model. Interchange, 2(3), 38-62.
- Stahl, V., & Pavel, M. (1992). Assessing the Bean and Metzner model with community college student data. Dissertation presented at the annual meeting of the American educational research association (ERIC No. ED 344 639).
- Statistics Canada. (1979). Education in Canada : A statistical review for 1978-1979. Ottawa: Minister of Supply and Services. (Catalogue No. 81-229).
- Statistics Canada. (1995). Education in Canada, 1995. Ottawa: Minister of Supply and Services. (Catalogue No. 81-229-XPB).
- Swift, J., Jr. (1986). The community college transfer and "plus two" programs: Access to a baccalaureate degree in four years? Community/Junior College Quarterly, 10(4), 307-316.
- Thompson, G., & Devlin, L. (1992). Access by part-time students: a question of openness in Canadian Universities. Canadian Journal of Higher Education, 22(3), 57-75.
- Tierney, W.G. (1992). An anthropological analysis of student participation in college. Journal of Higher Education, 63(6), 603-618.
- Tinto, V. (1975). Dropout from higher education: A theoretical synthesis of recent research. Review of Educational Research, 45(1), 89-125.
- Tinto, V. (1987). The principles of effective retention. Paper presented at the fall conference of the Maryland College Personnel Association, Largo, MD.
- Tousignant, J. (1989). Les personnes handicapées inscrites dans les universités Québécoises: Situation et perspectives. Québec: Ministère de l'Enseignement supérieur et de la Science, Direction générale de l'enseignement et de la recherche universitaire.
- Townsend, B.K., McNerney, N., & Arnold, A. (1993). Will this community college transfer student succeed? Factors affecting transfer student performance. Community College Journal of Research and Practice, 17(5), 433-443.
- Tweddale, R.B. (1977). Attendance behavior of new students entering GVSC fall, 1975, and fall, 1976. (ERIC No. ED 156 014).
- Ungar, S.B. (1980). The retention problem: An analysis of enrolment attrition at a Canadian college. Canadian Journal of Higher Education, 10(1), 57-74.
- Vaala, L.D., & Holdaway, E.A. (1989). The college to university experience: Satisfaction and success of students who transfer. Alberta Journal of Educational Research, 35(2), 171-186.

- Velez, W. (1985). Finishing college: The effects of college type. Sociology of Education, 58(3), 191-200.
- Velez, W., & Javalgi, R.G. (1987). Two-year to four-year college: The likelihood of transfer. American Journal of Education, 96(1), 81-94.
- Voorhees, R.A. (1987). Toward building models of community college persistence: A logit analysis. Research in Higher Education, 26(2), 115-129.
- Warner Kearney, G., Townsend, B., & Kearney, T.J. (1995). Multiple Transfer students in a Public Urban University. Research in Higher Education, 36(3), 320-342.
- Williams, R.J. (1973). Transfer shock as seen from the victim's point of view. College and University, 48(1), 320-321.
- Willingham, W.W. (1985). Success in college. New York: College Entrance Examination Board.
- Winchesky, M. (1986). Post-secondary programmes and services for exceptional persons: North American trends. Paper presented at the Canadian Symposium on Special Education Issues, Toronto, Ontario.
- Wray, F.E., & Lewischuck, G.S. (1971-72). Predicting academic success of junior college transfers. College and University, 47(1), 10-16.
- Young, B. (1992). On Careers: Themes from the Lives of Four Western Canadian Women Educators. Canadian Journal of Education, 17(2), 148-141.



*U.S. Department of Education  
Office of Educational Research and Improvement (OERI)  
National Library of Education (NLE)  
Educational Resources Information Center (ERIC)*



## **NOTICE**

### **Reproduction Basis**



This document is covered by a signed "Reproduction Release (Blanket)" form (on file within the ERIC system), encompassing all or classes of documents from its source organization and, therefore, does not require a "Specific Document" Release form.



This document is Federally-funded, or carries its own permission to reproduce, or is otherwise in the public domain and, therefore, may be reproduced by ERIC without a signed Reproduction Release form (either "Specific Document" or "Blanket").

EFF-089 (3/2000)