

## DOCUMENT RESUME

ED 441 395

IR 020 291

TITLE Girls & Technology: An Idea Book for Educators & Parents.  
INSTITUTION National Coalition of Girls' Schools, Concord, MA.  
SPONS AGENCY National Science Foundation, Arlington, VA.  
PUB DATE 2000-00-00  
NOTE 70p.  
AVAILABLE FROM National Coalition of Girls' Schools, 228 Main Street,  
Concord, MA 01742. Tel: 978-287-4485; Fax: 978-287-6014;  
e-mail: ncfgs@ncgs.org; Web site: <http://www.ncgs.org>.  
PUB TYPE Guides - Classroom - Teacher (052)  
EDRS PRICE MF01/PC03 Plus Postage.  
DESCRIPTORS Computer Literacy; \*Computer Uses in Education; Educational  
Resources; \*Educational Technology; Elementary Secondary  
Education; \*Females; Learning Activities; Lesson Plans  
IDENTIFIERS \*National Coalition of Girls Schools

## ABSTRACT

This booklet represents an effort to combine research findings, strategies, teaching and parenting tips, activities, career profiles, and print and online information that can help make technology more accessible to girls. Chapters include: "Why a Focus on Girls & Technology: New Priorities"; "Girls & Technology: Different Styles of Learning"; "Girls & Technology: Different Teaching Strategies"; "Technology Tips for Teachers & Parents"; "The Internet: An Incredible Resource!"; "Computer Games for Girls"; and "Girls, Work and the 21st Century." A final section, "Technology in the Classroom: A Sampling of Ideas from Teachers," presents over 40 pages of lesson plans, activities, assignments, and charts and diagrams to guide teachers in integrating technology into the curriculum. A selected bibliography and a list of additional selected organizational resources with contact information are also included. At the end of the booklet is a brief description of the National Coalition of Girls' Schools (NCGS). (AEF)

**Girls & Technology: An Idea Book for Educators & Parents**

By National Coalition of Girls' Schools

U.S. DEPARTMENT OF EDUCATION  
Office of Educational Research and Improvement  
EDUCATIONAL RESOURCES INFORMATION  
CENTER (ERIC)

This document has been reproduced as received from the person or organization originating it.

Minor changes have been made to improve reproduction quality.

• Points of view or opinions stated in this document do not necessarily represent official OERI position or policy.

# An Idea Book

## For Educators & Parents

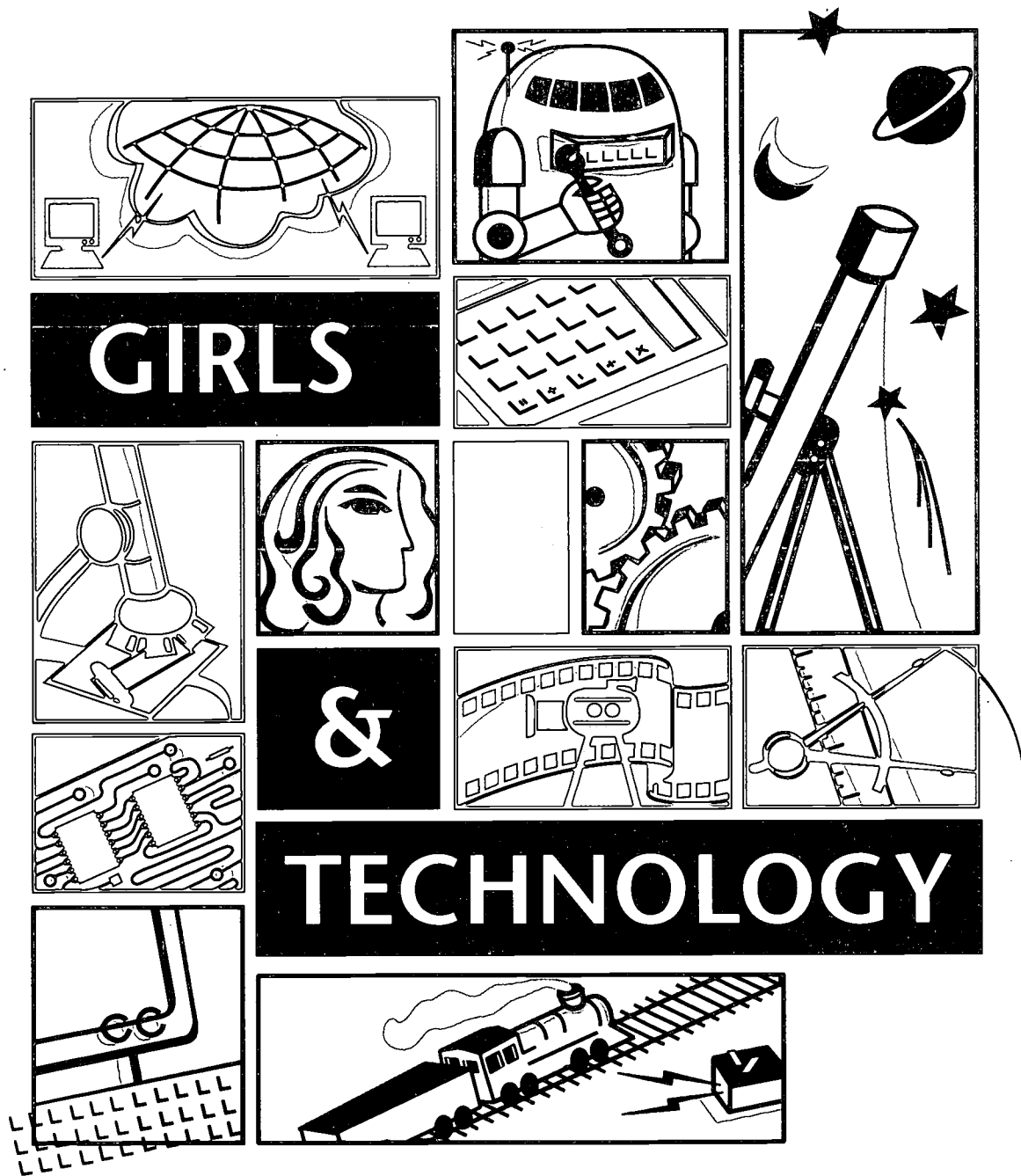

Tips for Parents & Teachers 🍏 Technology in the Classroom  
Girls on the Net 🍏 Girls and Computer Games  
Girls, Work and the 21st Century 🍏 Lesson Plans for Teachers  
Bibliography & Additional Resources

# Girls & Technology

## An Idea Book For Educators and Parents

### Inside:

Why a Focus on Girls & Technology: New Priorities .....	1
Girls & Technology: Different Styles of Learning .....	2
Girls & Technology: Different Teaching Strategies .....	5
Technology Tips for Teachers & Parents .....	6
The Internet: An Incredible Resource! .....	9
Computer Games for Girls .....	14
Girls, Work and the 21st Century .....	17
Technology in the Classroom: A Sampling of Ideas from Teachers .....	19
Bibliography & Additional Resources .....	61
NCGS: A Word About Our Organization .....	64

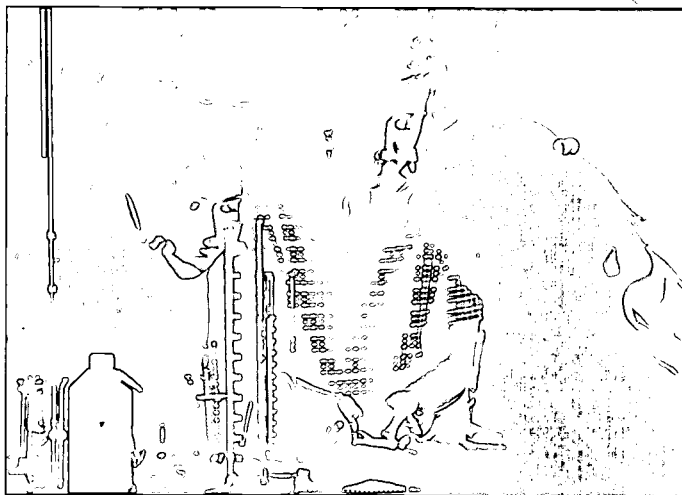

Prepared By The National Coalition of Girls' Schools

With Support From The National Science Foundation





## Why A Focus on Girls & Technology: New Priorities

ACCORDING TO THE U.S. DEPARTMENT OF LABOR, women will comprise fifty-five percent of the work force in the United States by the year 2000. The National Science Foundation estimates that by 2010, one quarter of all new jobs will be technologically oriented. A vast majority of jobs will require a sound grounding in math and science. During the early years of the new millennium, the number of computer programmers, engineers, and systems analysts is expected to grow by ninety percent; starting salaries for college graduates in those professions are expected to be between \$40,000 and \$50,000.

Yet, as recently as 1996, although women in the United States constituted 51 percent of the population and 46 percent of the labor force, they only accounted for 22 percent of scientists and engineers, according to a National Science Foundation report. All one has to do is pick up a newspaper practically any day of the week and read the help-wanted ads. It is clear that technology is the new frontier of work: women need to be there.

Within the last five years, research conducted by the American Association of University Women and other groups illustrates significant disparities between boys' and girls' attitudes, achievements, experiences, and self-esteem in the areas of math, science and technology. Unless the situation can be addressed, girls and women will face a technological employment gap which will have serious consequences for their professional and economic futures. This nation needs to use the talents of *all* its citizens as the world grows ever more technologically advanced. As Dr. Jo Sanders states in her book *The Neuter Computer*, "... Girls' tendency to reject the computer is costing them later in technological skills and jobs...". The ultimate goal must be to keep the "employment gateway" an open and equitable one.

In today's world, "technology" is a broadly defined term. It encompasses a variety of tools and problem-solving methods using computers, measuring devices, electronic equipment, simple machines, appliances, building and repair implements ... in other words, the full gamut of widgets, gadgets and machinery that affect our everyday life. People come into daily contact with a wide variety of simple and complex technologies—in the home, workplace, and in recreational activities. In so doing, they need to understand the

### Important Questions To Consider

—□—

- What is the culture that surrounds technology, and how does it impact girls?
- How can we draw on the ways girls learn as we integrate technology into their lives?
- What are girls' thoughts and feelings about technological objects and careers?
- How do girls describe themselves in relationship to technology?
- How can we provide opportunities for girls to tinker, take apart, and build with materials and tools that are not traditionally a part of their education or experiences?
- What strategies are successful in encouraging their use of technology to solve learning challenges and to explore subject matter?
- How can we show the relevance of technology to the lives and futures of girls?
- What are our attitudes and feelings about technology? How do they affect, positively and negatively, our interactions with girls?
- How should we rethink the way we teach or parent as we examine the use of technology across disciplines and in our daily lives?
- How can teachers and parents work together in support of girls using and learning technology?

diversity of technological applications and processes, and to recognize the human and environmental impact. Both boys and girls need to be equal participants in our increasingly technological society.

The National Coalition of Girls' Schools (NCGS), with support from the National Science Foundation, seeks to engage educators and parents to learn why girls continue to lag in the areas of math, science and technology while concurrently devising strategies to encourage girls' curiosity, confidence, and involvement in these fields. To that end, NCGS sponsored two conferences entitled **Girls & Technology**, produced a seventeen-minute video, and wrote a *Resource Guide* hoping to bridge the gap between the sexes.

This *Girls & Technology Idea Book* is an effort to combine research findings, strategies, teaching and parenting tips, activities, career profiles, print and online information that can help make technology more accessible to girls. The pages of this booklet offer ways girls can be encouraged to tinker, explore, take things apart, problem solve; in short, to learn how things work and why they sometimes don't. NCGS' ultimate goal is to send more girls to math, science and technology-related fields of study, and ultimately careers, thereby offering them more choices and richer lives.

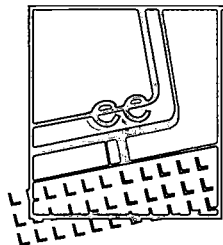
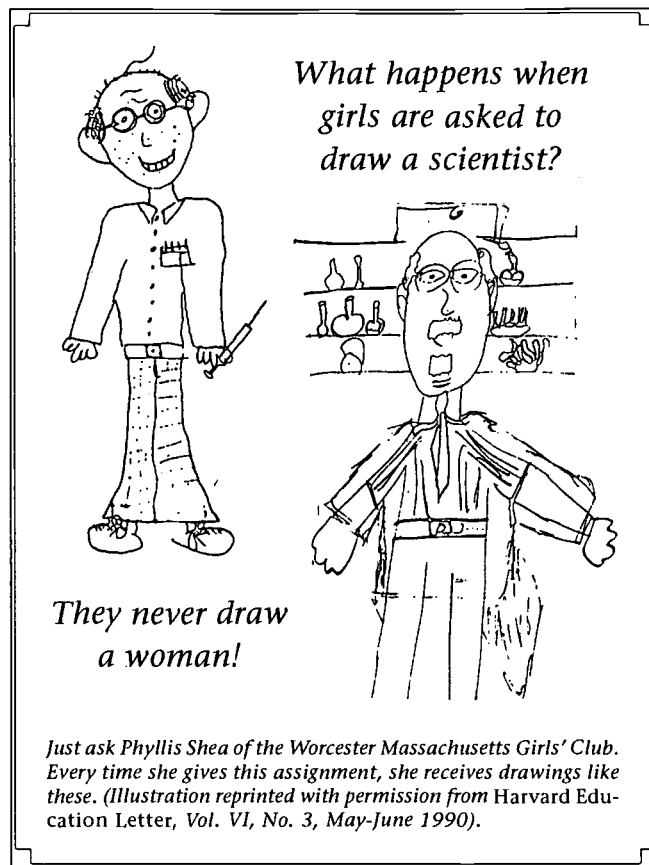

## Girls & Technology: Different Styles of Learning

**D**R. JANE BUTLER KAHLE, at a conference on girls, math and science, reported that the gains women have made in the last two decades in entrance and retention in scientific and technological fields are eroding. For a variety of reasons, gender issues in science in particular seem more complicated than those in math. Girls tend to stop doing science, especially physical science, in the middle and high school years.

The less than favorable climate for girls and women in math, science and technology is caused by a series of small, often unintentional discriminatory behaviors. Such behaviors communicate to some females that they are not as worthwhile and are not expected to participate in the classroom or elsewhere as much as males.

Research examples demonstrate that females tend to be ignored, singled out, or treated differently from males. Women tend to get more diffuse responses, are asked subtly less difficult questions, and are more frequently interrupted.

Men's success is typically attributed to talent; women's success to luck or hard work. The resulting lack of self-esteem in girls means that they are less likely to take risks and more likely to blame themselves when things go wrong. Boys having a hard time with science or technology are likely to say, "This is a rough course," or "The teacher was not good," or "The machine has a problem," or "I was so busy with sports and didn't have time to study." Girls are more likely to say "I'm just not smart enough," or "I can't do this."

Dr. Cornelia Brunner and Dr. Margaret Honey from the Center for Children and Technology have done studies on the attitudes of girls and boys, men and women toward technology. Boys/men tend to be excited about technology and to use it as an extension of their power over their physical universe. Girls/women tend to have more muted feelings and think of technology primarily as a means of enhancing their everyday activities, connecting with other people, or solving personal problems and dilemmas.

Participants in one of the Center's studies were asked to invent a machine. Boys tended to invent fantastic cars, toys, or vehicles for flight with names such as Lance 2000X with powerful propulsion devices, fuel injection, and turbo jets. Girls tended to create useful tools to help with everyday chores and challenges. They depicted luxury

features in their inventions (movable seats, sensor devices, switches that magically took care of the inner workings of a machine).

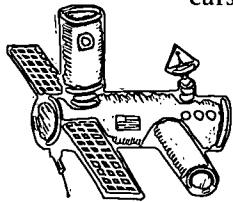

***"Technology is the science of applying knowledge for practical purposes."***

***Brunswick/MSAD#75 Beacon Center, 1995***

## Research Results by Kahle & Colleagues

—□—

- Nine-year-old boys, when compared with nine-year-old girls, are provided more opportunities to use scientific equipment, to perform science experiments, and to go on science-related field trips.
- At ages 9, 13, and 17, girls more often than boys select "I don't know" as a response to achievement test questions. Boys were willing to risk a guess; girls were unwilling to take the chance.
- Girls undervalue math and science activities. When asked to choose between advanced math and advanced English courses, significantly more high school girls than boys select English regardless of their academic grades in the two subjects.
- Kahle reported that research in England by Alison Kelly suggests that science as an intellectual domain is perceived as masculine because men are largely those who practice it; thus, curricular and instructional materials in science are largely masculine and the practice of science in schools, including student and teacher interactions, follows a masculine format.
- Intervention programs in math and science must aim to improve the achievement and retention levels for girls.
- "Target students" (those judged to be the brightest, who grab for and receive the most attention in a classroom) are 4:1 male to female in coed settings. Changes in teaching styles must take place to counteract this phenomenon.
- The 1987 study by Campbell and Connolly indicates that Caucasian girls avoid mathematics and science competitions and their parents support that decision, while this "over-protective behavior was not found among Asian-American parents."
- Girls' loss of self-confidence in science, as opposed to math, may be related to discrepancies in the amount and type of feedback provided in the two subjects by most teachers.

*Source: Dr. Jane Butler Kahle is Editor of Women In Science and the Condit Distinguished Professor of Science Education at Miami University of Ohio.*

# What's The Difference?

By Janese Swanson, Ed.D.



## VIDEO GAMES

- The video arcade provides many children with an introduction to the culture of computers. Video games tend to be designed by males for males. Female characters are rarely emphasized as having a leading role in video game scenarios. In a sample of 100 video arcade games, 92% did not include any female roles, and of the remaining 8%, six percent had females assuming "damsel in distress" roles and 2% active roles.
- Hard mastery is the gaining of control over a machine by using a plan (the way planners or engineers work). Soft mastery is a more interactive approach to work (the way artists or humanitarians function). Girls tend to be soft masters while the hard masters are overwhelmingly male.
- Characters in the games socialize females to be dependent and males to be dominant.
- In a comprehensive survey of close to two thousand students, from kindergarteners through college freshmen, both boys and girls viewed video games as more appropriate for boys.

## BOYS AND GIRLS



- Electronic games and boys' behavior while playing them contain elements of aggression, violence, competition, fast action, and speed.
- Of forty-seven top-rated video games made for Nintendo systems, forty of the games included violence as their major theme.
- While violent games are popular, many boys prefer games that challenge them mentally; many boy players also have interests in music, programming, reading, and school.
- Boys and girls generally like different types of video game play.
- Girls' interest in video games includes the social aspects of the games. In contrast to boys, girls can more often name the characters, describe story lines, and correctly indicate the relationships between characters. Girls often pretend they are the character, sometimes giving an androgynous character gender.
- Grouping girls around one computer did not result in a competition but improved the game.

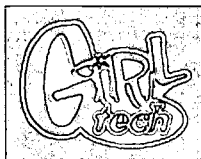

- Girls tend to choose games with familiar environments and have more desire than boys to solve puzzles, think, and draw.
- Girls tend to prefer games that have more than one way to win. Some girls dislike having characters die on screen.

- The play station environment affects girls' play patterns. When boys dominate a station, girls don't usually join in.
- Girls tend to work together, socialize in-between play, and enjoy the presence of others.
- Girls enjoy playing electronic games and the challenge they present.

## COMPUTERS & TECHNOLOGY



- Research shows that many girls think of technology as belonging to the "male" world (like football and tinkering with car engines).
- At home, three times as many girls as boys said they did not use their computers at all. Five times as many boys as girls used the technology more than anyone else in the family.
- Parents purchased technology twice as much for their sons as their daughters.
- At school, only a quarter of the students using computers during free time were girls.
- In 1995, a nine-month poll of 1,200 families revealed that before the fourth through seventh grade, young girls actually spend about one hour more per week on computers than young boys. After that, girls' usage dropped off.
- A study found that girls use computers more for learning and word processing, whereas boys use computers more for games.
- Girls are discouraged from computer use for the following reasons: 1) Teachers and parents assume that girls are not as interested as boys and encourage them less. 2) There are few adult and peer female role models. 3) Computers are associated with machines and math, both of which are thought of as male domains. 4) Software has not been developed with girls' interests in mind. 5) Computers are used less in language, arts, and humanities classrooms, which tend to be more female.

Source: *What's the Difference?* produced by GirlTech, copyright 1996, KidActive LLC, All Rights Reserved. Reprinted with permission. For more information: GirlTech, 851 Irwin Street, Suite 100, San Rafael, CA 94901. Phone: 415-256-1510 Fax: 415-256-1515 E-mail: grltek@aol.com Internet: <http://www.girltech.com>



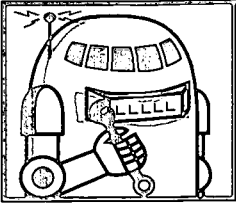

## Girls & Technology: Different Teaching Strategies

**G**IRLS AS WELL AS BOYS need to gain more of the hands-on experience with technology that they typically lack... taking apart and repairing bicycles, designing and building things, handling tools, learning about torque and engines, cruising the information highway, assembling and motorizing lego machines, experimenting with robotics, investigating the mechanics of household appliances.

Expecting girls to learn like boys and to be like boys is not the answer. Instead, teachers will need to consider some of the strategies listed below:

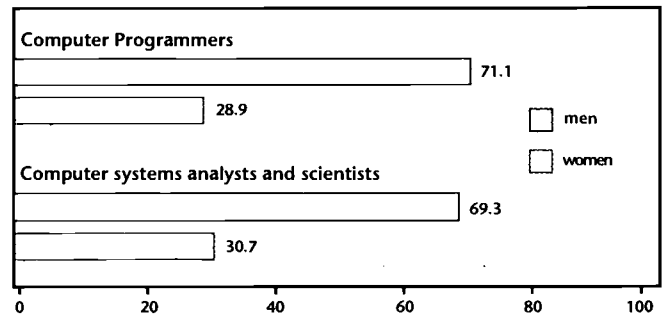

Percentage of Computer Specialists in 1994  
Source: Bureau of Labor Statistics, US Department of Labor

### Ideas for the Classroom

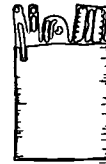

- Draw on collaborative and cooperative learning activities.
- Encourage female students by letting them know you expect them to succeed.
- Keep a teaching diary that documents participation and use it to encourage the silent students.
- Study the language used when talking about math, science and technology. Balance male metaphors with female ones—for every problem you tackle, have one you get your arms around; for every skill you master, have one you integrate.
- Keep journals so students can record how they feel along with what they are learning.
- Encourage cooperative learning, reaction papers, generalizing.
- Expect all students to participate and keep track of who does and doesn't.
- Allow more waiting time before calling on someone else.
- Call on all students by name.
- Make eye contact with female as well as male students.
- Share the contents of the waste paper basket showing twelve false starts to a problem.
- Show multiple ways of answering a problem and give more time to finding solutions.
- Illustrate the relativity of math, science and technology to students' lives; demonstrate the mystery, wonder, excitement and passion of these subject areas.
- Describe the variety of fields that require technology, such as graphic design, commercial illustration, architecture or landscape design.





# Technology Tips for Teachers

## IN GENERAL

- ☞ Expect and encourage girls to be interested in technological fields. Start each course with a description of the ways in which all students will need to participate.
- ☞ Portray how technology can help solve problems.
- ☞ Many girls use computers differently than do many boys. Few girls will play with a computer just because it is there: most often girls use it as a tool, not a toy. They need to see its relevance to their lives.
- ☞ Get to know the way your female students think about math, science and technology. Study how they learn and validate the characteristic approaches they bring to learning and scientific inquiry.
- ☞ Expand your view of "right" answers. The way girls form questions and approach problems can represent a new way of looking at a subject. They often introduce feelings and relationships into their view of these disciplines.

## IN THE CLASSROOM



- ☞ Connect mathematics, science and technology to the real world, real people, and their historical, philosophical, and functional context. Illustrate how these subjects contribute to the good of the world.
- ☞ Choose metaphors that reflect the experiences of both girls and boys. Balance words like master, command, or tackle, with ones like connect, choose, or embrace.
- ☞ Monitor which students are at the computer most often, have their hands on the equipment, are leading the experiments. Be sure the girls in your class are as active as the boys. Require equal time on the computer as part of your assignments. Don't let only the boys act as experts in the computer class.
- ☞ Brainstorm with students about the breadth of careers that use technology. Help them develop a more inclusive definition of who will need to be computer literate. Develop a list of the many occupations that use technology: architects, fashion designers, teachers, artists, musicians, choreographers, home design consultants, athletes, business people, librarians, etc.
- ☞ Foster an atmosphere of true collaboration. Many teachers insist that a true group project is one in which no single group member could complete the project without the group's help.
- ☞ Encourage girls to act as experts. When the teacher has all the answers, students rarely exhibit self-confidence. As students critique their own work and that of their peers, they begin to see themselves as scientists. The technique of the teacher refusing to act as an expert is a powerful learning prompt for students.
- ☞ Experiment with alternatives to note taking. Girls often get so absorbed in taking down every bit of information that they miss out on discussions. Set aside some classes where no note taking is allowed, hand out lecture notes ahead of time, or rotate the note taking responsibility, with notes shared afterward.

## AT SCHOOL

- ☞ Ask the school library to sponsor a display of female mathematicians, scientists, and computer specialists who have excelled in their fields.
- ☞ Use on-line bulletin boards, like the educational equity list (edequity@tristram.edc.org), for tips and information about gender and technology issues.
- ☞ Host a Family Technology Night for students and their families to learn more about multimedia and to ask any questions they wish. The program is cosponsored by Microsoft, Gateway 2000, and FamilyPC Magazine and is completely free of charge. For more information, call 1-800-203-5520.
- ☞ Organize a math, science and technology career day and bring back to campus recent female graduates of your school who are working in these fields. Encourage mentoring relationships and ongoing conversations.
- ☞ Consider starting a Take Apart/Put Together room or club where students can disassemble and reassemble old and broken appliances brought from home to discover how they work. Also include an introduction to the most commonly found household tools and how they are generally used. Items may include radios, hair dryers, vacuum cleaners, telephones, coffee makers, toaster ovens, food processors, lamps, juicers, etc.



## Technology Tips for Parents

### IN GENERAL

- ☞ Analyze your own attitudes toward technology. Are certain tasks in the home always handled along gender lines? Do both parents use a computer? Where? At home? At work? At the library? On what kind of projects? Is your daughter aware of how the computer effects your life?
- ☞ Your words make a difference. Parental encouragement is most frequently mentioned by women scientists and engineers as the primary element in their success. Point out the value of math and science in her life; avoid statements like, "I've always hated math," or "I never could do science."
- ☞ Identify role models and mentors for your daughter. Find out more about career opportunities and requirements and share these with your daughter. Don't assume the school will do it all for them.
- ☞ Talk about math and science. Children who are successful in school talk about their subjects outside the classroom. Ask girls specifically about their math and science classes. You don't have to be the expert; let them do the explaining.

### AT SCHOOL

- ☞ Ask your daughter's teachers about specific hands-on lessons in math, science and technology. Express interest in your daughter's participation in these activities. Find out what computer programs, materials, and equipment are available for her use and how often she uses them. If the teacher replies "not often" find out why not.



## AT SCHOOL, CONTINUED

- 🍏 Talk with your daughter as she plans her class schedule each year. Monitor her math, science, and computer course choices. Urge her to take more than the minimum requirements in these fields. They are often gateway subjects for future career choices. Encourage her to pursue physical as well as biological sciences. Talk to her teachers about which math and science courses will help prepare her for the widest variety of career choices.
- 🍏 Urge your daughter's school to plan special events with a focus on technology and women. Offer suggestions of local resources and other parents who might have experience in related fields.
- 🍏 Consult with your daughter's teachers. Make sure they are aware of the subtle messages that can steer girls away from computers.
- 🍏 Suggest to teachers that they set aside time in the computer room that is just for girls. Or be sure that teachers make computer use a mandatory activity for all students.



## AT HOME

- 🍏 Cultivate your daughter's interest in how things work by having her tinker, take things apart, and put things together. Keep expectations high. Children are natural scientists because of their inquisitiveness. Encourage her to learn how to repair the loose chain on her bicycle, program the VCR, take apart a broken appliance, fix the toaster, change a tire. Work with her as she does these things.
- 🍏 Engage her in projects that develop spatial reasoning and analytical skills. Older girls may enjoy tinkering with a chemistry set or building a robot from a kit. For younger ones, try some at-home science experiments—there are many books at your local library that have fun activities with step-by-step instructions. Better yet, have her do these things with her girlfriends.
- 🍏 Discover math and science together by playing math games, learning new software, or working on everyday math activities, such as budgeting household expenses, mapping out travel routes, designing a garden, or comparison shopping.
- 🍏 Create a computer area within your home that is as accessible to your daughter as it is to your son. If there is only one computer shared by the children, place it in a family area rather than one child's room.
- 🍏 Find examples of math and science in everyday life to discuss with your daughter.
- 🍏 Provide role models. If you have friends who are scientists or engineers, have them talk with you and your daughter about their work, preparation, and education.
- 🍏 Take your daughter to science fairs, museums, special exhibits. Find out about enrichment programs available on weekends or during the summer. Let her witness your own curiosity about subjects you don't know a lot about.
- 🍏 Get your daughter's peers involved. Find out which of her friends also like math and science. Organize a party around a science or building theme. Have the girls prepare a collage of famous women scientists and mathematicians. Have the girls guess who the various people are and what they contributed to their fields.

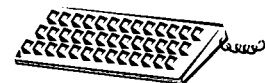

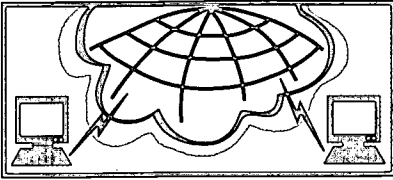

## The Internet: An Incredible Resource!

**W**HAT AN INCREDIBLE RESOURCE INDEED! NCGS has collected a variety of resources for use by girls, their parents and teachers. The list is just a beginning! As the adults in your childrens' lives, you must take responsibility in guiding its use. Parents have begun to teach children to be savvy about other media (movies, television, print advertising); they should focus attention on the Internet as well.

All children (girls and boys) should be taught about the Internet and given the tools to discern the informative, or simply entertaining, from the harmful. Nicholas Negroponte believes that the Internet provides a wealth of resources to guide, instruct, and entertain. How to identify and use helpful resources with a particular focus on girls and education is the purpose of this chapter.

***"Students who do not learn and work with technology today will be disadvantaged tomorrow. Our educational challenge is not to produce "knowers," but rather "information handlers."***

**Nicholas Negroponte, *Being Digital***

the bookstore might be useful and *The Internet for Dummies* (John R. Levine et al.) could prove a worthwhile purchase.

We have collected some Internet resources which might be useful to you as parents and teachers as well as to the girls in your lives. Our list is by no means complete, but it's a start. At the end of this chapter we have, courtesy of Girl Tech (<http://www.girltech.com>), included guidelines to help you to determine pro-girl, girl friendly, and gender neutral sites for girls.

The amount of information available on the Web is overwhelming. Where to start? What's worth viewing? Browsers, search tools, and indexes are useful pathfinders and information consolidators. To venture out onto the information highway for the first time, we suggest accessing Yahoo's K-12 Education Index. If you are unfamiliar with the Web, a trip to

### Some Facts



- In 1972 only 150,000 computers existed. In 1996, Intel alone shipped 100 million computers worldwide.
- 37 million people in the United States and Canada have access to the Internet (translates to 20% of North America) .
- Since 1988 the Internet has shown an average growth rate of 100% per year.
- Internet use is expected to grow 10% a month.
- 62% of the Internet users are male and 38% female.
- 42% of the Internet users are between the ages of 18 and 25.
- 25% of the Web users have an income of more than \$80,000 a year as compared to 10% of the general population.
- 40% of the households in America have computers; 11 million have access to the World Wide Web.
- 60% of children between the ages of 8 -12, according to a *New York Times* poll, expect to get their daily news as adults through the Internet.
- There are 19 million girls between the ages of 7 and 17 in the United States.
- An estimated 6 million households have girls between 8 and 18 years old and also own multimedia PCs (1996).



## Internet Sites with an Emphasis on Girls



### Internet Sites For Girls



**G.I.R.L.** ■ <http://www.worldkids.net/girl>

Girls internationally writing letters. A pen pal club for girls ages 8 - 14 around the world, which also has its own newsletter, *Caught in the Web*.

**Girl Tech** ■ <http://www.girltech.com>

A club for middle school girls. On the site are a chat room, game café, newsletters, opinion polls, news of girls and women, sports news, women in history, and book reviews.

**Cyber Sisters** ■ <http://worldkids.net/clubs/CSIS>

A network of girls on the Internet in a club that's "intelligent and fun"—a club for wired net girls.

**Girl InterWire** ■ [www.planetgirl.com/interwire](http://www.planetgirl.com/interwire)

A newsletter by and for girls.

**Girl Talk** ■ <http://cosmos.netgate.net>

Girl Talk is a forum for teenage girls (over 13). It's designed to be a place for girls to talk about things that matter to them — books, music, sports, friends, school.

**Soda Shop** ■ <http://cosmos.netgate.net>

A chat place for girls up to age 12 to hang out on the net. It's a place for them to meet new friends and chat about sports, siblings, school work.

**Gurl** ■ <http://www.tspa/mui/edigIR:/current>

A Web page used for older girls. The menu includes discussions in which girls share strategies, talk about body image, have fun with comics and animation.

**An Income of Her Own** ■ <http://www.anincomeofherown.com>

A place where teen girls can learn about starting a business, developing independence, and pursuing their dreams. This site contains a newsletter, information about Camp \$tart-Up, and links to other sites.

**New Moon** ■ [www.newmoon.org](http://www.newmoon.org)

A magazine for girls and their dreams.

**A Girls World** ■ <http://www.agirlsworld.com>

An on-line club house to educate and entertain girls. It presents girls with positive role models and activities to enhance their self-esteem.

**American Girl** ■ [www.americangirl.com](http://www.americangirl.com)

American Girl celebrates girls of yesterday, today, and tomorrow. This site contains an on-site chat room and a

sample of stories, crafts, games, puzzles, etc. that are available in the Pleasant Company's magazine, *American Girl*.

**CyberKids** ■ <http://www.cyberkids.com>

The site's goal is to promote youth community worldwide and give kids a voice and an interactive place to experience the "global village." This site contains educational resources that can be used by teachers and parents as well as teacher training and student mentor program with lessons.

**Cyberspace Middle School** ■ [www.scri.fsu.edu/~dennisl/CMS.html](http://www.scri.fsu.edu/~dennisl/CMS.html)

Designed for students in the 6<sup>th</sup>, 7<sup>th</sup>, 8<sup>th</sup>, 9<sup>th</sup> grades who are using the World Wide Web to get an education.

**Cognito Homework Helper** ■ <http://www.cognito.com>

Students can use this helpful information source to aid in their school work. It draws on a variety of databases.

**Crayola Crayons** ■ <http://www.crayola.com/crayola>

This is a fun site and contains an online tour of how crayons are made along with contests and product information.

**How a Book is Made** ■ [www.harperchildrens.com/howabook](http://www.harperchildrens.com/howabook)

Peek inside publishing on this site — learn how a book is made, make your own pop-up book, and learn how to write and illustrate a book.

**LEGO** ■ <http://www.lego.com>

Find out all about LEGOS and have fun on this site. Join the LEGO Surfer Club. Several Internet games are also available including: Build a Duck, Exploriens, and Treasure Hunt.

**The Exploratorium** ■ <http://www.exploratorium.edu>

Visit this site and participate in interesting exhibits ranging from how to build your own rotocopter to studying mutant fruit flies.

**Kids Space** ■ [www.kids-space.org](http://www.kids-space.org)

A site with fun things for children. An especially creative part is *Story Book*, which allows children to post and share their own stories.

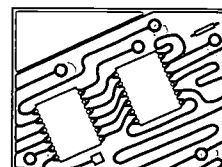

## Internet Sites For Parents

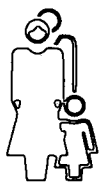

**Daughters (A Newsletter for Parents)** ▫ [www.webriver.com/daughter](http://www.webriver.com/daughter)

A newsletter for parents of girls ages 8–18.

**Girl Games** ▫ <http://www.girlgamesinc.com>

An interactive software company designing entertaining and educational CD-ROMs for girls of all ages. Their goal is to encourage girls to explore cutting edge technology and provide meaningful computer experience that will prepare them for the demands of a technologically advanced future. This site also has puzzles for girls to solve, ways to contribute to the community of girls, and helpful on-line resources for parents and mentors.

**Her Online** ▫ <http://www.her-online.com>

Sponsored by American Laser Games with a specific focus on “girls who are not afraid of a mouse” and games for girls that are highly interactive. The site contains reviews of ALG’s latest CD-ROMs including *McKenzie & Co.*, *Pippi Longstocking*, and *The Vampire Diaries*.

**Wombat** ▫ [www.batnet.com/wombat/children.html](http://www.batnet.com/wombat/children.html)

A list of children-oriented Web pages from the Museum of Paleontology at the University of California to the NASA Space Shuttle Mission to Time Magazine for Kids.

**Children’s Literature Web Guide** ▫

[www.acs.ucalgary.ca/~dkbrown/index.html](http://www.acs.ucalgary.ca/~dkbrown/index.html)

Fairy tales and fables, C.S. Lewis and Dr. Seuss, and a variety of other children’s stories can be enjoyed online. Full texts are accessible along with a comprehensive reading list, book reviews, and links to other sites.

**Girls Incorporated** ▫ <http://www.girlsinc.org>

Girls Incorporated is a national organization dedicated to “helping girls become strong, smart, and bold.” A variety of programs are listed on this site — each centered on preparing girls to “lead successful, independent, and complete lives.” Of particular note is the Girls Incorporated program Project SMART which helps to foster in girls an interest in technological careers.



**Girl Scouts of the USA** ▫ <http://www.gsusa.org>

Girl Scouts devotes its energies to helping girls realize their potential and prepare for their futures. This site contains organizational news and an index of available resources.

**Take Our Daughters to Work Day** ▫ <http://www.sherryart.com/daughters/toc>.

Each year in April parents are encouraged to take their daughters to work with them. This site explains the day, has questions girls might consider asking, and offers on-line events.

**Yahooligans** ▫ <http://www.yahooligans.com>

A Web guide for kids which includes games, news, sports, weather, science and other indexes and has its own Search capability.

**Net Nanny** ▫ <http://www.netnanny.com>

A software program that allows parents/educators to control children’s access to the Internet and restricted sites.

**National Geographic** ▫ <http://www.nationalgeographic.com>

An incredible resource for parents, students, educators alike. Highly visual and interactive. A true glimpse into the world around us.

**Dr. Math** ▫ <http://forum.swarthmore.edu/dr.math>

This site provides on-line help for students from kindergarten through graduate school. It is operated by the Math Forum of Swarthmore College and funded by the National Science Foundation.

**Family Education Network** ▫ <http://www.familyeducation.com>

This site is sponsored by Microsoft and offers several educationally-oriented Internet resources. This site contains a variety of search engines and an impressive list of sources for learning about everything from English to foreign languages to art and science.

**Camp T-Equity** ▫ <http://www.girltech.com>

A 4-week technology immersion day camp in Springfield, VA whose primary goal is to help increase girls’ participation in science and math through technology immersion in the earth and environmental sciences.

**National Coalition of Girls’ Schools** ▫ <http://www.ncgs.org>

The Coalition sponsors research, conducts symposia, and produces publications for educators and parents with an interest in helping young women achieve their academic and personal possibilities. Tips for parents and teachers, publications, teaching strategies in math, science, and technology are all housed on this site. Links exist to girls’ schools and other sites with a girl and education focus.

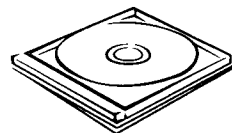



## Internet Sites For Educators

**GirlTECH** ▫ <http://www.crpc.rice.edu/CRPC/women/GirlTech>

A teacher training and student mentor program with lesson plans and on-line resources to explore gender differences in computer use and access, along with innovative teaching strategies that positively impact gender equity in the classroom.

**Center for Children & Technology** ▫ <http://www.edc.org/CCT/ccthome>

The Center creates and researches new ways to foster learning and improve teaching by developing and implementing thoughtful technologies. Reports, newsletters, on-going projects are listed on this site.

**Telementoring: Support for Girls in Science & Math** ▫ <http://www.edc.org/CCT/Telementoring>

This site contains information about the Center for Children and Technology's Telementoring project. This project involves giving girls access to advice and guidance through e-mail and on-line forums with mentors in science, math, engineering, computers.

**American Association of University Women (AAUW)** ▫ <http://www.academic.org>

The AAUW promotes equity for all women and girls through a variety of research projects and publications. This site lists resources for teachers K-12.

**WEEA Equity Resource Center** ▫ [www.edc.org/WomensEquity](http://www.edc.org/WomensEquity)

The center has a variety of resources for teachers and parents on topics related to gender equity. Of particular interest is the Center's equity forum on math, science, and technology.

**Women of NASA** ▫ <http://quest.arc.nasa.gov/women>

Women associated with NASA are featured on this site as are teaching tips, resources, and live Web chats with NASA women.

**Tomorrow's Women in Science & Technology** ▫ [www.sig.net/~scicomp/twist/twist.html](http://www.sig.net/~scicomp/twist/twist.html)

TWIST sponsors activities designed to encourage math and science education and career awareness for girls and women. Of particular note is a middle school girl math/science newsletter and a conference focusing on hands-on math/science opportunities.

**National Women's History Project** ▫ (<http://www.nwhp.org>)

This site highlights the different ways women have contributed to history and offers a variety of resources to teachers and parents alike.

**TERC** ▫ <http://www.terc.edu>

A non-profit research and development organization committed to improve math and science learning and teaching.

**LabNet** ▫ <http://labnet.terc.edu/labnet>

LabNet, sponsored by TERC, is an electronic community of math and science teachers. It provides a place where teachers can participate in discussions and on-line courses, get new ideas for curricula and projects, and access a library of software, articles, and teaching materials. It also provides a means to work collaboratively with classrooms across the country.

**Busy Teachers' Computer Technology Page** ▫ [www.ceismc.gatech.edu/busyT/TOC.html](http://www.ceismc.gatech.edu/busyT/TOC.html)

This is a "must do" stop for teachers. It contains a listing of references, teacher-to-teacher and student-to-student links, cites new developments in technology, and makes available technology downloads to equip teachers with the tools of the trade.

**EdWeb** ▫ <http://edweb.cnidr.org/K12.html>

EdWeb is a resource guide for K-12 use and focuses on the interconnectivity of educational reform and information technology. It offers an extensive collection of Internet and on-line resource information.

**International Society for Technology in Education** ▫ <http://www.iste.com>

A non-profit organization dedicated to improving education through computer-based technology. ISTE sponsors forums, offers lesson plans, extends links to other technology education sites.

**IBM K-12 Web Resource** ▫ [www.solutions.ibm.com/K12](http://www.solutions.ibm.com/K12)

Educators and parents have a wealth of links to sites that are educationally oriented. This site is well indexed.

**Frog Dissection** ▫ <http://teach.virginia.edu/go/frog>

Dissect a frog without even touching the real thing.





**Microsoft K-12 Resources** □ <http://www.microsoft.com/education>

This site lists company products and makes available its K-12 Technology Newsletter which comes complete with tips to help administrators, technology coordinators, parents, and students to use technology in the learning process.

**Franklin Institute Science Museum** □ <http://sin.fi.edu/tfi/welcome.html>

This site hosts an array of online exhibits with topics ranging from the human heart to Benjamin Franklin.

**Apple** □ [www.apple.com/education](http://www.apple.com/education)

This page is sponsored by Apple computers. K-12 educators, parents, and students will find resources and information including news and events, lesson plans, international education projects, educational products and promotions, and links to other education sites.

**Cyberspace Middle School** □ [www.scri.fsu.edu~dennisl/CMS.html](http://www.scri.fsu.edu~dennisl/CMS.html)

Contains helpful information and links to our educationally-oriented sites for teachers trying to make the World Wide Web a part of their classroom.

**Annenberg/CPB Math and Science Project** □ [www.learner.org/theguide](http://www.learner.org/theguide)

The Guide to Math and Science Reform (a database of over 1000 projects and organizations dedicated to improving K-12 math and science education) can be downloaded from this site.

**AskEric** □ <http://ericir.syr.edu>

The Educational Resource Information Center (ERIC) is a federally-funded national information resource system that provides a variety of services and products on a broad range of education-related issues.

**Library of Congress** □ <http://thomas.loc.gov>

A classroom resource for teachers and students alike.

**Quest** □ <http://quest.arc.nasa.gov>

Quest is the home of NASA's K-12 Internet Initiative. Its Web pages include online adventures and opportunities to communicate with the people working at NASA.

**AT&T Learning Network** □ [www.att.com/learningnetwork](http://www.att.com/learningnetwork)

AT&T Learning Network links a community of educators and students in elementary and secondary schools. The network is a curriculum-based program that provides teachers with a network of resources for learning how to use telecommunications as an instructional tool in the classroom.

**Bill Nye the Science Guy** □ <http://nyelabs.kct.org>

This science guy is fun for students of all ages. Visit his online laboratory.

**Le Web Louvre** □ <http://sunsite.unc.edu/louvre>  
Tour the Louvre in Paris and enjoy the galleries.

## How Girls' Schools Use the Internet

—□—

### Most Frequently Cited

E-Mail □ Research (Science, Social Studies) □ Reference □ Databases/Statistics □ Library Catalogs □ Foreign Language Exposure □ Entertainment

### Other Uses

Following Explorations □ Scientific Data Entry □ Surveying □ Conference Updates □ National Geographic Network □ Globe Project □ List Services for Teachers □ Math Forum □ Foreign Language Pen Pals □ On-Line Language Dictionaries □ Holocaust Project □ Designing Home Pages □ Academy One French Project □ Daily Stock Market Information □ Environmental Projects □ Weather Maps □ Weather Stations □ "Virtual Trips" to Museums □ Astronomy □ World Music □ Egyptian Artifacts Research □ Collaborative Projects with Other Schools □ 550 Nations by Microsoft □ Kids Pub □ Government Searches □ United Nations Proceedings □ Supreme Court Records □ Business Indicators □ CyberKids & CyberTeens □ Acid Rain Project (National Geographic) □ National Lab Data □ National Budget Simulations □ Vietnam Vets Project □ Daily Foreign Language Newspapers □ Kidnet Project □ Graphics and Sound Files □ Erie Canal Project □ Virtual Frog Dissection □ Model United Nations □ Genetic Diseases Research □ Earthquake Data □ Treasure Hunts □ Geometer's (Math) Forum □ International News □ NASA Photographs □ Scholastic Network □ Middle East Crisis Simulation □ Al Roger's Global School House □ E-mail Drawing Project □ Foreign Language Video Conferencing



## Computer Games For Girls

**I**NTERACTIVE SOFTWARE CAN HELP GIRLS TO incorporate technology into their lives. While having fun, girls become more familiar with how computers work. They learn to see computers as user-friendly tools and enjoyable toys.

Girls are drawn to games that involve them emotionally and offer them a creative outlet. Popular games for girls tend to be unstructured, interactive, and visual. They feature adventure (not violence) and include familiar aspects of every day life. Laura Groppe, President of **Girl Games**, an interactive software company, observes,

*"Girls want games that include emotional involvement with characters, advance the story line through decision making, offer a creative outlet, feature adventure without violence, and include familiar elements from everyday life."*

*Patricia Flannigan,  
Her Interactive*

and educators should consult the Children's Software Revue. This company reviews new children's titles both in print and online (<http://www2.childrenssoftware.com>) with an eye to gender neutrality and with a particular focus on titles for girls. The company specializes in the sciences, simulation and creativity.

ware company, observes, "Girls want an environment that is rewarding and stimulating and doesn't keep score. They are interested in activities that involve communication. They like to talk with their friends and think about relationships." Janese Swanson, founder of **GirlTech**, would agree. The goal of her company, she says, is to encourage young girls to retain their innate spirit of adventure and to discover that technology can be as easy as riding a bike.

This chapter offers software that is user-friendly for girls and suggestions for interactive game sites on the Net. In addition, parents



### Some Facts

*GirlTech, San Rafael, CA*

—□—

- Research shows that in television, video games, microcomputers, and other media technologies, representation of girls is generally absent.
- Girls are more likely than boys to choose "practice" play which fosters cooperative play.
- Girls are not using video games as much as boys.
- One study has found that girls used computers for learning and word processing while boys used computers for games.
- From a sample of 100 video arcade games, 92% of the games did not include any female roles. Of the remaining 8%, 6% had females assuming "damsel in distress" roles and only 2% had females in active roles.
- Over \$45 billion is spent by girls in retail purchases every year.
- According to a study by Mattel, for every four software programs parents buy for sons, they buy only one for daughters—even though girls and boys ages 6-10 spend the same amount of hours on computers.

*"Practical problem solving is the marriage of an investigative approach to learning with the manipulation and use of materials"*

*Peter Sellwood  
Technology Teacher, December, 1989*



## Computer Games with an Emphasis on Girls



### **Chop Suey** ■ (Magnet Interactive Studio, CD, ages 7 and up, around \$35)

Two female heroes overdose on chop suey and licorice and end up hallucinating a highly creative adventure complete with singing pickles and talking flowers. The meal leads to day dreaming, which takes girls to odd places like Aunt Vera's backyard and the town carnival. The loose storybook format allows players to move through whimsically drawn scenes at their own pace, exploring as they go.

### **Desktop Tool Kit** ■ (GirlTech)

This collection contains a custom home page builder (*My Home Page*), a pro-girl 3D Interactive Screen Saver and a weekly Electronic Calendar. This software is designed for girls new to the Internet and encourages girls to use computers.

### **Donkey Kong Country 2** ■ (Nintendo, \$70)

Dixie Kong, the main character, flies through the air by spinning her ponytail. She is appealing to young users.

### **Gex** ■ (Crystal Dynamics, about \$40)

Young girls will enjoy this interactive video that features a friendly lizard with suction-cup paws.

### **Julliard Music Adventure** ■ (Theatrix, CD, ages 9 and up, about \$35)

Introduces kids to music through puzzles they must solve in order to restore music to the Queen's castle. They learn rhythm by mimicking a blacksmith's hammer and melody by recreating the last half of a tune. Other scenes teach orchestration, pitch and form. Kids can create and save their own music as well, packaging it with background scenes that move with music.

### **Let's Talk About ME!** ■ (Simon & Schuster, Interactive, CD-ROM)

This game gives adolescent girls a variety of self-exploration tools like the diary, personality quizzes, and honest girlfriend advice on their changing bodies. It also has animated story books, interactive rooms, jigsaw puzzles and interactive games with many variations. Fitness and health are emphasized. The program contains a personalized interactive nutrition planner.

### **McKenzie & Co.** ■ (Her Interactive, American Laser Games, Inc., CD-ROM, \$60)

A light-hearted social adventure set at an all-American high school which incorporates live-action comedy, friends, dating, school, part-time jobs, family fun, mini games and shopping. A role-playing, multi-media game for teens.

### **The Babysitters Club Friendship Kit** ■ (Philips Media)

Builds on the popular book series, *The Baby Sitters Club*. Includes a calendar, stationery maker, address book and babysitter checklists.

### **The Magic School Bus** ■ (Scholastic, 6 and up, \$40)

Players follow the adventures of an elementary school science class as they get on a magic bus that takes them to explore the human body, the solar system, and the ocean floor. It's up to the player to avoid danger, collect clues, explore, and discover as she guides the bus to safety.

### **Earthbound** ■ (Nintendo, 8 and up, \$70)

A role-playing game about kids who save the earth.

### **Smartypants** ■ (CD-ROM, info call 1-888-4Smarty)

This CD-Rom presents a wonderland of math and Martians, spelling and spells, grammar and glamour for the elementary school girl.

### **Opening Night** ■ (MECC, CD-ROM, 8 and up, \$48)

Allows girls (and boys) ages 8 and up to write, direct, costume and perform their own computer play. Participants choose from 40 characters, 100 scenes, and more than 800 props. The realistic characters even speak. Designers/creators can add music and special lighting, control audience reaction, and even print up their own playbills.

### **Pippi Longstocking** ■

This interactive game is based on the book series, *Pippi Longstocking*. Pippi is brought to life through narrated, animated storybooks, interactive rooms full of surprises and amusing games, and puzzles. It is translated into 11 languages which gives the players the option to listen and learn a variety of languages. It helps girls 4 and up develop computer literacy, expand vocabulary, improve reading comprehension and hone decision making and puzzle solving skills.

### **The Vampire Diaries** ■ (Her Interactive, CD-ROM)

When children start falling ill and missing in Fells Church, Elena and her friends try to unravel the puzzle, but soon Elena finds herself in danger and discovers a secret.

### **Where in the World is Carmen Sandiego** ■

#### **Where in the USA is Carmen Sandiego** ■ (Borderbund Software: 1-800-548-1798)

Players can learn about the United States and countries around the world as they search for the elusive Carmen. Educational and fun. A winner with both girls and boys.

### **Zoop** ■ (Viacome New Media, ages 8 and up, \$30)

This video game sets the player up in the middle of a 3-D grid which fills up with game pieces that need to be cleared away with increasing speed. This game is somewhat akin to Tetris.

### **Barbie Fashion Designer** ■ (Mattell, ages 6 and up)

While Barbie isn't exactly everybody's ideal role model, this CD-ROM kit lets girls design outfits on screen and then print them at home.



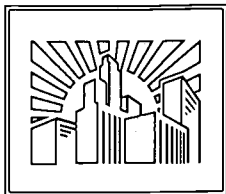

## Girls, Work and the 21st Century

**F**INDING REWARDING CAREERS while balancing personal and professional lives is all too often a far-off fantasy for today's girls. Differing career expectations for boys and girls are frequently left unchallenged by the many adults who influence their lives. No longer can girls assume that to work is a fall-back position or that income earned is an add-on for the extras in life. From an early age, girls need to know and understand much more about their career options. Too often they assume that the study of math, science, and technology doesn't really apply to the areas they think they will most likely pursue. At the very least parents and educators must help them appreciate how a solid grounding in these courses serves as a pathway to future opportunities, higher wages, and greater employability. Girls today need to realize the important connection between studying math, science, and technology and achieving successful, interesting careers.

Decisions that shape a girl's personal and professional path are sometimes made with an alarming lack of awareness about workplace realities. Many girls believe that they can "opt out" of career preparation because they will be "stay at home mothers" supported by their husbands. Today's girls can expect to spend more than 30 years in the work force, regardless of whether or not they marry and have children. The following statistics (*AAUW Outlook, Spring, 1997*) tell a sobering story:

- With a college degree a woman is lucky to earn what a man with a high school diploma earns. A woman can expect to earn \$.72 to a man's \$1.00.
- According to the Census Bureau if you are a woman of color you can expect to earn \$.61 to a man's \$1.00.
- In a lifetime, a man's earnings will exceed a woman's by \$200,000. But as women earn post graduate degrees, the gap in these ratios narrows.

Where are the women in the higher paying careers? There is no question that the more one learns the more one earns. And yet, women and girls continue to prepare for lower paying jobs in traditional occupations. They need more information and a broader

### Some Facts

—□—

- Nearly 75% of tomorrow's jobs will require use of computers; fewer than 33% of participants in computer courses and related activities are girls.
- Women comprise only 11% of today's technical work force.
- One third of this country's gains in national productivity has come from technology.
- The rate of growth in math-related occupations is about twice all other occupations.
- 8 out of 10 of the fastest growing jobs in the 90's will be in science-based occupations.
- Two of the fastest growing sectors in the business world are technology and women-owned businesses.

(Source: US Labor Statistics: JOBS 2000)

understanding of tomorrow's workplace so they can choose interesting, lucrative careers.

### Teaching Working-World Know-How

When girls ask "Why take more math and science courses?" the answer is really quite simple: "That's where the money is!" A wide variety of professional, technical and vocational fields, requiring and not requiring college degrees, expect adequate preparation in math and science. Teachers and parents can help build greater awareness by engaging girls in conversations and addressing some very important questions about their current studies and future plans.

Girls should ponder, discuss, and answer important questions about their lives and careers, such as:

- Imagine yourself working in 10-15 years. What do you hope to be doing?
- What preparation will you need for such work?
- What is the working environment like?
- Will there be much time for the personal side of your life?
- What other benefits does this kind of work offer? (travel, ability to work at home, continuing education, adventure, health benefits, retirement savings, vacations)

- Are there jobs that might combine what you love with what you could do?
- How much money might you be making?
- How important is making a lot of money to you?
- What jobs do you think pay the most money?
- What do you most love doing?

Discussions around these questions can help pave the way for more enlightened decision-making and preparation. The prospects for today's girls are limitless, yet they will need guidance and support as they first explore their myriad options and then embark upon the necessary education and training.



### Selected Fields of Study Requiring High School Preparation in Math and Science



- **Architecture:** Four years of high school college prep math.
- **Biology:** Four years of high school prep math; high school chemistry, biology and physics.
- **Business Administration:** Three years of high school college prep math; four years strongly recommended.
- **Computer Science:** Four years of high school college prep math; one year of high school physics.
- **Costume Studies:** Three years of high school college prep math; one year of chemistry recommended.
- **Dental Hygiene:** Four years of high school college prep math or equivalent; high school biology, chemistry and physics recommended.
- **Nursing:** Four years of high school college prep math, including math analysis, geometry and algebra II; one year of physics and chemistry recommended.
- **Occupational Therapy:** Four years of high school college prep math; high school biology, chemistry and physics recommended.
- **Oceanography:** Four years of high school college prep math; one year of biology, chemistry and physics recommended.
- **Pharmacy:** Three years of high school college prep math; one year of biology, chemistry and physics recommended.
- **Physical Therapy:** Three years of high school college prep math; one year of biology, chemistry and physics recommended.
- **Textile Sciences:** Three years of high school college prep math; one year of high school chemistry; four years of math recommended.



Adapted from a publication of the Office for Affirmative Action  
University of Washington, Seattle, WA



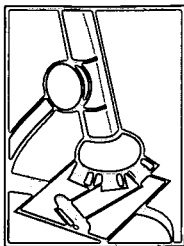

## Technology in the Classroom: A Sampling of Ideas from Teachers

**C**YBERSPACE IS A WORLD RULED by knowledge and driven by communication. Never before has there been the possibility of such a level playing field in such an immediate medium ... The root forces behind the medium—communication, community, and creativity are inherently feminine. These are things women innately excel at. Plainly put, we were built to do this."

*Kristen Spence,  
Senior Writer, Purple Moon*

Using technology in the classroom can stretch the thinking and reach of teachers worldwide. Limitless information is virtually at the fingertips of educators willing to explore the latest frontier. In many ways, faculty members are free to create their own curriculums in order to better engage girls in non-traditional experiences. Exploration, experimentation, risk taking, shifts in teaching methodologies and new pedagogies must be the norm if the opportunities and possibilities are to be realized.

The following section is a sampling of creative thinking by educators who teach technology as they experiment with new ideas and approaches. The lesson plans, activities, assignments, charts and diagrams should spark your imagination and get you talking with students and colleagues as you explore new ways to engage girls in thinking, learning, and using technology.



The teachers who have offered their ideas share the belief that: Successful technological activities should...

- make tasks, such as measuring, less tedious.
- be personalized.
- involve communicating and sharing information with others.
- provide opportunities for students to gain computer skills.
- highlight access to information that is not readily available elsewhere.
- include open-ended activities that allow students to use their own creativity.
- encourage students to apply their knowledge to a practical, hands-on problem and thereby demystify subjects (such as astronomy).
- involve trial and error.
- demonstrate the importance of integrating several different applications to produce a final result.
- be fun!!!

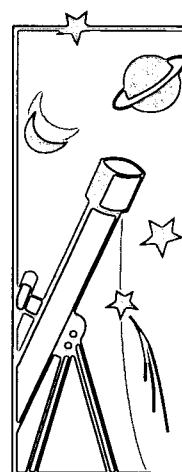
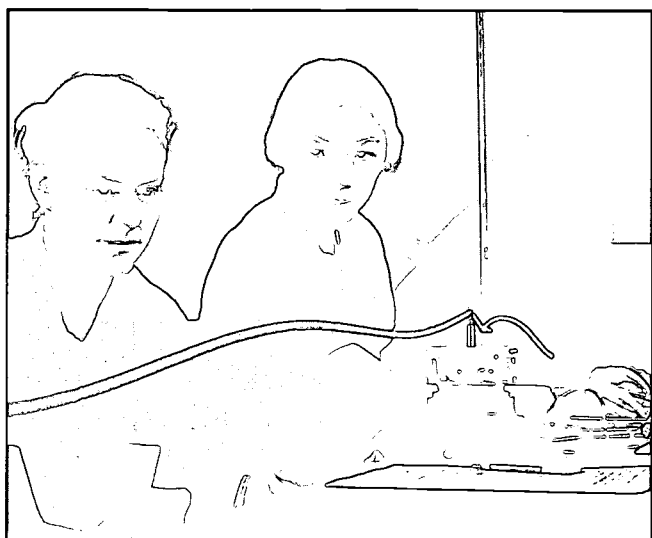

# Table of Contents, Classroom Ideas

## Section I: General Use

☞ <b>Life-Long Learning is the Goal!</b> .....	21
Martha Svateck, Science Teacher, Nashoba Brooks School, Concord, MA.	
☞ <b>Teaching Methods and Technology</b> .....	21
<i>From Technology Making A Difference: The Peakview Elementary School Study, 1994.</i>	
By Brent G. Wilson, Roger A. Hamilton, James L. Teslow, and Thomas A. Cyr. Syracuse, NY: ERIC Clearinghouse.	
☞ <b>Guidelines for Evaluating Science Books for Stereotyping and Bias</b> .....	22
Compiled by Marylyn A. Hulme, Rutgers University, Equity Assistance Center, New Brunswick, NJ.	
☞ <b>InGEAR: Gender and Science Inventory</b> .....	23
Molly Weinburgh, Ph.D., InGEAR Professional Development Strand Director, Georgia State University, Atlanta, GA.	

## Section II: Grades 1-8

☞ <b>The Wonder Box</b> .....	24
ToyWorks Projects, Museum of Science, Science Park, Boston, MA.	
☞ <b>The Mighty Mousetrap Investigation</b> .....	25
*Joreen Hendry, Educational Consultant, Heinemann Educational Books, Inc., Dunbarton, NH.	
☞ <b>Sebastian, the Humanoid Robot</b> .....	26
Robotics at Kilvington, Victoria, Australia.	
☞ <b>Doing "Real" Science with the NGS Kids Network</b> .....	27
*Judith Vesel, Curriculum Manager, TERC, Cambridge, MA.	
☞ <b>Making Graphs &amp; Letter Recognition</b> .....	32
*Elin Saltveit, Schools of the Sacred Heart, San Francisco, CA.	
☞ <b>Building Models</b> .....	35
Horrey County Schools, Playcard Environmental Center	
☞ <b>Design Technology Program Description</b> .....	37
*Linda Caleb, Faculty, The Holton-Arms School, Bethesda, MD.	
☞ <b>Creating a Design-Based Learning Environment</b> .....	40
From <i>News from Center for Children and Technology</i> , October 1991, New York, NY.	
☞ <b>Go On A Cyber Scavenger Hunt</b> .....	40
From <i>Tech Girls' Internet Adventures</i> by GirlTech, IDG Books, Foster City, CA.	

## Section III: Grades 9-12

☞ <b>So... You Want to Build A Model Solar Car</b> .....	41
*Pamela Akiri, Science Teacher, The Ethel Walker School, Simsbury, CT.	
☞ <b>Electricity and Trains</b> .....	47
*Karen Funkenstein and *Christine McCormack, Faculty, The Winsor School, Boston, MA.	
☞ <b>Guiding Science Fair Participants: Using the Dartmouth Problem-Solving Approach</b> .....	48
Jim Housley, Dartmouth College, Hanover, NH.	
☞ <b>Design Technology: Using Materials and Tools for Constructing</b> .....	50
*Francis Eberle, Maine Mathematics and Science Alliance, Augusta, ME.	
☞ <b>Suggested Classroom Strategies</b> .....	54
*Francis Eberle, Maine Mathematics and Science Alliance, Augusta, ME.	
☞ <b>Technology Patches</b> .....	50
GirlTech, IDG Books, Foster City, CA.	
☞ <b>Computing Licence</b> .....	55
*Graham Rixon, Principal, Penrhos College, Western Australia.	
☞ <b>Integrating Math, Science, and Technology: Problem Solving Through Group Dynamics</b> .....	56
Dan Bavelaar, Paul Hartley, Virgil Valente, High School Prism	
☞ <b>Practice Problems</b> .....	58
At Gordon, Straffordshire Technology Education Program	
☞ <b>Building Technology Confidence Through Hardware Installations and Setup</b> .....	60
Tracy Anne Sena, Convent of the Sacred Heart High School, San Francisco, CA	
* Presenter at one of the Girls & Technology Conferences sponsored by The National Coalition of Girls' Schools	





## Section I: General Use

### ☞ Life-Long Learning Is the Goal!

*Martha Svatek, Science Teacher,  
Nashoba Brooks School  
Concord, MA*

—□—

#### *Why Use Technology?*

- ★ Empowers the student
- ★ Invigorates learning
- ★ Strengthens subject area
- ★ Develops ways to solve problems
- ★ Promotes use of tools for locating, selecting, presenting and organizing information
- ★ Prepares students and teachers for the 21st century
- ★ Assists with collecting, manipulating and interpreting raw data
- ★ Allows authentic experimentation
- ★ Communicates via Internet with scientists, shares information world wide on global issues such as air pollution, endangered species, etc.
- ★ Allows students to work at own pace in a non-judgemental environment
- ★ Provides a way for students to easily replicate and change experiments
- ★ Enhances cooperative learning
- ★ Provides the transition to a student-centered classroom

### ☞ Teaching Methods & Technology

*By Brent G. Wilson, Roger A. Hamilton, James L. Teslow,  
Thomas A. Cyr. Syracuse, NY: ERIC Clearinghouse on  
Information & Technology*

**T**HE FIELD OF EDUCATION is being influenced by a new understanding of how we learn and new applications of technology to teaching and learning. Allan Collins, a noted cognitive psychologist, has identified the following eight shifts in teaching methodology supported by research in cognitive psychology. Each of these changes can be facilitated by technology.

- A shift from whole-class to small-group instruction. New research shows a dramatic decrease in teacher-led activities when computers are used, from 70 percent to less than 10 percent.
- A shift from lecture and recitation to coaching. New research also shows an increase in the class time teachers spend serving as facilitators (rather than directors of behavior) when using computers, from 90 percent to 50 percent.
- A shift from working with better students to working with weaker students. In traditional classrooms, teachers most often interact with brighter students who raise their hand; they frequently ignore slower students to avoid embarrassing them. With technology, that pattern is reversed; slower students receive two to four times more attention from the teacher.
- A shift toward more engaged students. A number of studies have demonstrated that students who work with computers become more involved in their studies, often to the point of fighting over computers between classes and after school.
- A shift from assessment based on test performance to assessment based on products, progress, and effort. Teachers have traditionally relied on end-of-unit tests for assessment. Technology shifts the focus of assessment from tests to progress on projects and to the final product of students' efforts.
- A shift from competitiveness to cooperation. A number of researchers have noted great mutual assistance among students when using technology.

▣ A shift from all students learning the same things to different students learning different things. A number of studies have shown how technology can support students as they tackle various parts of a complex project, each contributing to a larger final product. Technology helps students maintain focus and manage information as they work on separate aspects of a problem.

▣ A shift from the primacy of verbal thinking to the integration of visual and verbal thinking. Visual media—television, film, and computers—are beginning to compete with abstract text as the primary means of learning in our day. Lectures, multiple-choice tests, and recitation of knowledge becomes less relevant when technology-based alternatives are available.

In conclusion: Many teachers go through identifiable stages on their way to becoming experienced technology users. In the early stages, they use computers to support traditional methods of teaching such as drill-and-practice, text orientation, whole-group lectures, and seatwork. Later, as teachers gain confidence, they use technology as part of more innovative instruction, including team teaching, interdisciplinary, project-based instruction, and individually-paced projects. Finally, they enter an inventive stage in which they experiment and change, using technology to support active, creative, and collaborative learning.

*From Technology Making A Difference: The Peakview Elementary School Study (1994)*

## ▣ Guidelines for Evaluating Science Books for Stereotyping and Bias

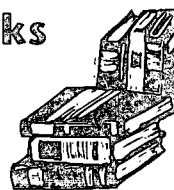

— ▣ —  
*Compiled, revised, updated and edited by Marilyn A. Hulme,  
 Rutgers University, Equity Assistance Center, New Brunswick, NJ.  
 with reference to "Non-Sexist Curricular Materials for Elementary Schools"  
 by Laurie Olson Johnson, The Feminist Press, 1974.*

### Check the Illustrations

- ▣ Compare the number of girls and boys pictured *doing* experiments.
- ▣ Compare the number of girls and boys pictured *watching* experiments.
- ▣ Compare the number of women and men pictured in the role of researcher (e.g. conducting experiments).
- ▣ Are members of diverse ethnic and cultural groups depicted as active in the illustrations? Are there women and men from such groups?
- ▣ What types of experiments are shown done by girls? What type of activities?
- ▣ What types of experiments are shown done by boys? What type of activities?
- ▣ Are girls and boys, women and men, shown working together in cooperative groups?

### Check the Text

- ▣ Are there examples of experiments or written problems using girls and boys? As investigators? As recorders? As observers? If so, how many are girls and how many are boys? Together?
- ▣ What language is used to address women and men? To refer to them?
- ▣ Is the text free of sexist/racist language?

- ▣ Are there inferences, however unintentional, that boys are more competent in science than girls? That science is more important to boys' future careers than to those of girls?
- ▣ If there is a career section, does it represent both women and men in a wide variety of scientific and technological jobs?
- ▣ Are trade jobs included as well as professional jobs? Are people from diverse ethnic and cultural groups represented?

### In Conclusion

- ▣ How is the "doing of science" depicted—involving teamwork, or as a solitary occupation?
- ▣ Do texts include the contributions to the field of science made by women as well as men, and by members of diverse ethnic and cultural groups?
- ▣ Do the references to boys and men in the illustrations and text greatly outnumber the references to girls and women?
- ▣ Does the historical information (if any) depend mostly upon the history of science in the West?
- ▣ Are there inferences overall, however unintentional and subtle, that give messages suggesting that females and students of color might not be welcome and may not have a place in science?
- ▣ Would you want your children to use this book?

# InGEAR: Gender & Science Inventory

Molly Weinburgh, Ph.D., INGEAR Professional Development Strand Director,  
Georgia State University, Atlanta, GA.

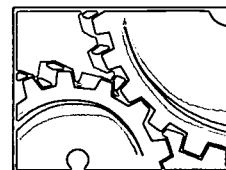

**R**ESearch concerning student achievement in and attitudes toward science, suggest that teachers' attitudes and corresponding actions may help to determine the level of participation by all students. In order to encourage females to participate in class activities, discussions, and peer interactions to the same degree as males, science teachers must become more sensitive to issues of gender and science. Teachers are often unaware of their own visions of both gender and science (Weinburgh, Franklin, & Franklin, 1994).

To explore your vision of males, females, and scientists, we invite you to take the segment from *Gender and Science Inventory* below. By taking the inventory, you may discover that you view males, females, and scientists in conflicting ways. There are no correct answers—simply by looking at your responses you will be able to tell if you are stereotyping any one of these categories.

Weinburgh, M. H., Franklin, B. & Franklin, C. (1994, Spring).  
*Gender Equity in Middle School Science Classrooms.*  
*Current Issues in Middle Level Education*, 2(1), 11-19.

## Inventory:

- 1. Read the following statements and insert the word "scientists" in the blank. Think about how you feel about the statement. Record your answers in the column marked with an "S" by putting an upward arrow in the blank if you think the statement is generally true or a downward arrow in the blank if you think the statement is generally false.
- 2. Cover the answers in the first column with a strip of paper and repeat the procedure reading the statements inserting the word "males" in the blank space. Think about how you feel. Record your response in the column marked with an "M" as you did for the "S" column.
- 3. Next, cover the answers in the first and second columns with a strip of paper and repeat the procedure reading the statements and inserting the word "females" in the blank. Think about how you feel. Record your answers in the column marked with an "F" as you did previously.

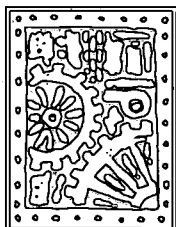

	S	M	F	
1.	_____	_____	_____	1. _____ daydream.
2.	_____	_____	_____	2. _____ are logical.
3.	_____	_____	_____	3. _____ play it safe.
4.	_____	_____	_____	4. _____ love danger.
5.	_____	_____	_____	5. _____ love to read.
6.	_____	_____	_____	6. _____ love tools.
7.	_____	_____	_____	7. _____ are cooperative.
8.	_____	_____	_____	8. _____ are competitive.
9.	_____	_____	_____	9. _____ follow the rules.
10.	_____	_____	_____	10. _____ challenge authority.
11.	_____	_____	_____	11. _____ are loners.
12.	_____	_____	_____	12. _____ think others are important.
13.	_____	_____	_____	13. _____ are smarter than most other people.
14.	_____	_____	_____	14. _____ are absent minded.
15.	_____	_____	_____	15. _____ are secretive.
16.	_____	_____	_____	16. _____ share information and ideas.
17.	_____	_____	_____	17. _____ are playful.
18.	_____	_____	_____	18. _____ are serious.
19.	_____	_____	_____	19. _____ are good at following directions.
20.	_____	_____	_____	20. _____ invent questions.
21.	_____	_____	_____	21. _____ are certain.
22.	_____	_____	_____	22. _____ ask questions.
23.	_____	_____	_____	23. _____ make nature yield its secrets.
24.	_____	_____	_____	24. _____ are in harmony with nature.
25.	_____	_____	_____	25. _____ are weird.

The National Science Foundation Grant, Integrating Gender Equity and Reform (InGEAR), is using this inventory in several awareness seminars that are a part of the professional development strand of this three year, higher education collaboration. For further information about the professional development component and other inventories, contact: Dr. Molly Weinburgh, Georgia State University. (404) 651-2584. E-mail: mweinburgh@panther.gsu.edu

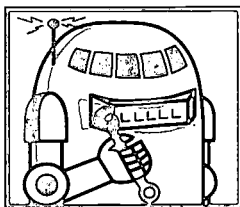

## Section II: Grade 1-8

### ☰ The Wonder Box

*ToyWorks Projects, Museum of Science, Boston, MA.*

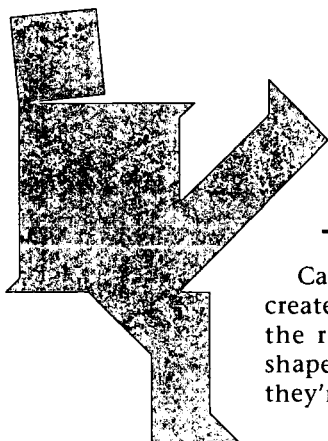

#### Tangram Challenge

Can you cut out these shapes and create the "little man" pictured to the right? (Suggestion: Make the shapes larger with a photocopier, so they're easier to work with.)

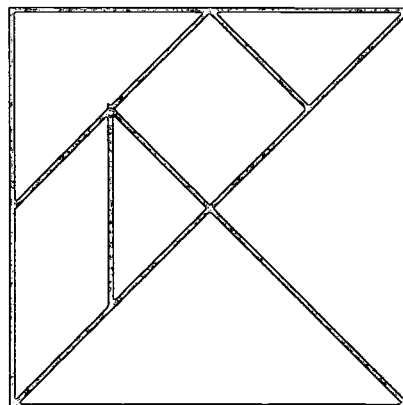

#### Going Further

What else can you create using all seven of these shapes? A house? A cat? A watering can? Tangrams are dissection puzzles that originated in China. They have been popular for almost 200 years.

### Did You Know?



Last year 2.24 million girls participated in high-school sports, up from 295,000 in 1972, according to the National Federation of State High School Associations. Still, the number of girls' programs nationwide lags behind that of male athletic programs. A 1994 survey by the National Federation of State High School Associations found that a typical high school has eight girls programs compared with ten for boys.

*Source: Educational Equity Report, American Association of University Women*

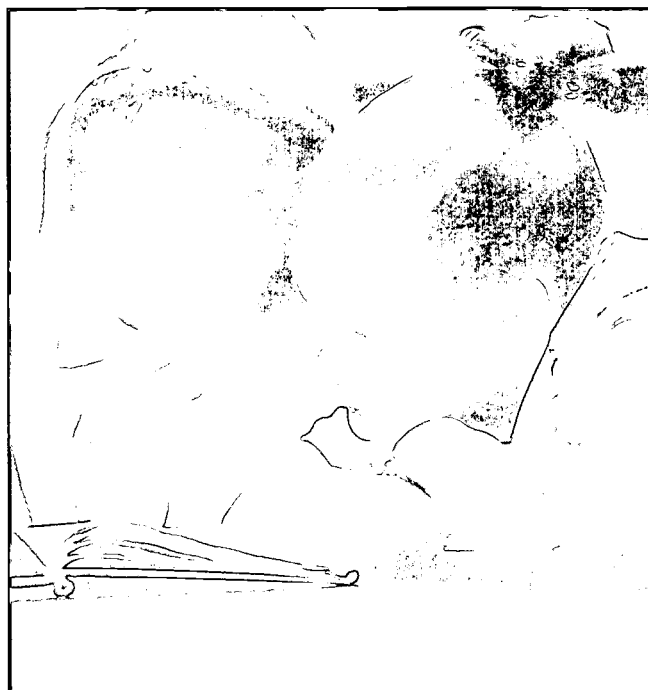

# ☞ The Mighty Mousetrap Investigation

Joreen Hendry, Educational Consultant  
Heinemann Educational Books, Inc., Dunbarton, NH.



## ✦ Purpose ✦

To demonstrate changes in mechanical energy (potential to kinetic) in a series of events. To use the energy stored in a set mousetrap spring to put out the flame of a candle located one meter from the mousetrap.

## ✦ Materials per Group ✦

one modified mousetrap (see below) ■ one lump of clay ■ one birthday candle ■ one pencil or chopstick to trip the trap ■ matches (teacher keeps until needed) ■ a meter stick ■ assorted recycled material = junk

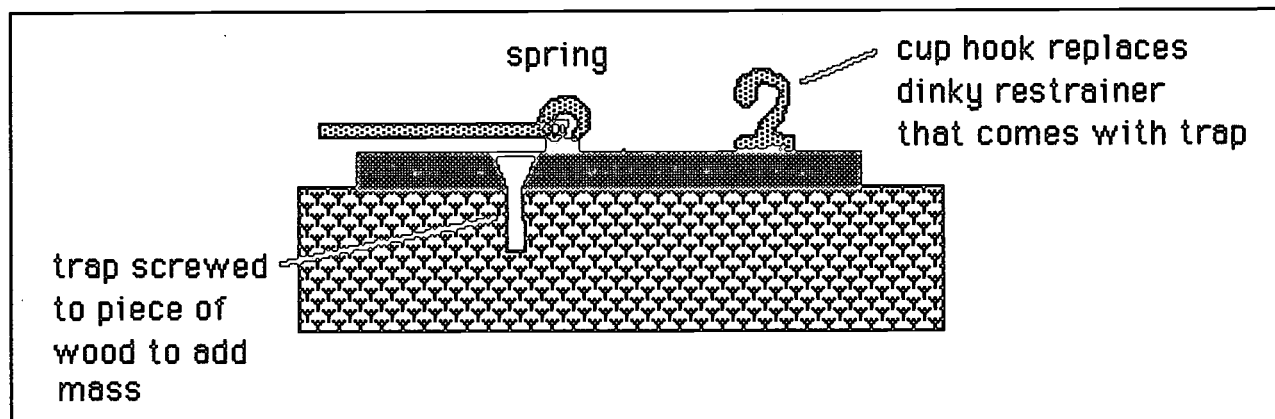

## ✦ Procedure ✦

1. Class does a concept map about energy.

If possible, bring out the following concepts: Energy is the ability to do work. Work is done when something has been moved. Energy can be potential (stored) or kinetic (moving). The potential energy stored in the set spring can do the work of moving something to accomplish the task of putting out the flame.

2. Teacher provides purpose of the investigation.
3. Students are divided into small groups and are given approximately 20 minutes to discuss possibilities and to select items from the junk pile. They are then given one night to think about it at home.
4. The next day, they are given approximately 45 minutes to set up the invention. Each group demonstrates to the rest of the class.
5. Assessment: There are many possibilities. I often do the following:
  - a. candle flame is put out on first demonstrated try
  - b. on second try
  - c. on third try
  - d. still doesn't work but group can explain why not
6. Wrap Up: Class discusses the energy transformations and what a candle flame needs to burn.

# Sebastian, The Humanoid Robot

Robotics at Kilvington, Victoria, Australia  
Dr. Gree Wilmoth  
(wilmoth~kilvineton.schnet.edu.au)

He talks, dances and performs a host of amazing feats. His name is Sebastian, a two metre fully remote robot that was the creation of eight, Year-eleven girls in the VCE Systems and Technology class.

**A**NIMATION IS CREATED by fifteen pneumatic cylinders and two electric drive motors. Sebastian also possesses a host of electronic special effects. His structure was fabricated by the girls from raw materials, mainly aluminium. He carries his own air and power supplies and his routines are coordinated by a Festo programmable logic controller.

Each student was responsible for the creation of a particular section of the robot, as well as for writing a computer program to control a routine of her own design.

The three-wheeled base provides excellent maneuverability. Each front wheel is driven by a 12 volt, 90 watt, geared electric wheelchair motor, enabling him to spin around on the spot.

## Control Technology:

An action under sensory control. These procedures form the basis to most modern automated domestic and industrial systems. Sensors deal with a multitude of tasks. They are able to control, monitor, switch, position, measure, count and regulate certain procedures.

## Robotics:

Robotics is a study of modern automated mechanisms with sensory input and computer control. A robot must be reprogrammable in order to perform different tasks and it must have a minimum of three axes of movement. This covers many applications of control technology.

## Course Sequence:

Students are introduced to Kilvington's robotics program in Years 5 and 7 as part of Technology studies. More advanced studies in a number of elective units enable students to further develop their interests in this area, culminating with sophisticated robotics projects in VCE Systems and Technology.

## An Introduction to Robotics Year 5 & 7

Using Lego, students study a number of mechanical principles by constructing models of their own design. Early projects include topics models such as hill-climbing vehicles (pictured), winches, ferris wheels, etc.

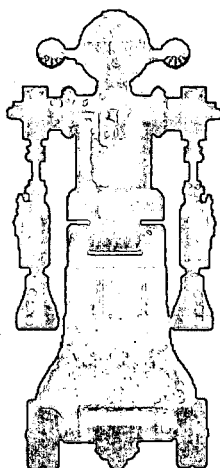

Simple sensory control is progressively introduced and concepts of computer programming are used to give students control over what they've constructed. Typical projects developed by the end of the unit include Lego vehicles that avoid obstacles, and automatic opening doors.

Each project is an exercise in design and development. Using examples of certain mechanical principles as a guide, students are required to develop working solutions to each particular problem. The emphasis in class is on learning by doing; as such, most class time is devoted to practical work. At least one formal programming test is given. Project reports are generally completed as homework exercises.

The lego winch pictured above is very highly geared (286,000 to 1.) It can easily lift 25kg. It has even pulled a motor car by one metre over one hour. It was developed by a student to demonstrate the force multiplying effect of gearing.

Lego Control Lab interfaces link sensory devices, motors and lights with the student's laptop computers. Programming is done using LOGO. Students study this unit for 5 periods per week for one third of the year.

## Robotics Elective Year 9

Lego is the main medium used; however, later in the unit some students may elect to study some basic pneumatic or electronic systems. The open-ended nature of the project work enables all students to be appropriately challenged and pursue areas of special interest to them.

Lego projects constructed in this unit are generally more complex than those developed in the Year 7 course. Again the emphasis is on student designed solutions to practical problems; however, topics tend to concentrate on 'state-of-the-art' applications, eg: bar code scanners, thermostats, pick and place machines, sorting mechanisms.

This is a single semester unit of 4 x 40 minute periods per week.

## Systems & Technology VCE Units 1 & 2

### An Introduction to Pneumatic Systems

Students are introduced to basic pneumatic systems and sensory control mechanisms which are incorporated into projects of their own design.

Pneumatics provides a clean, safe and simple means for creating movement. It can be switched electrically, so is ideal for control by computer. Students learn basic programming principles using the FST statement list programming language. Programs are written on the student's laptop computers and downloaded to Festo 202c programmable logic controllers (PLCs).

Each project generally requires fabrication of certain

materials using a variety of hand and power tools. A bench lathe in the laboratory enables construction of high precision components. All students learn to drill, cut, tap, thread and turn aluminium on the lathe.

Most projects are done in a small group situation; however, each girl also works as an individual on specific aspects. This enables complex tasks to be undertaken, but also develops cooperative group learning and project management skills which are important qualities in today's workplace.

An aluminium can crusher was designed and developed by a team of four students. It incorporates five pneumatic cylinders and it is able to sequentially crush a rack of aluminium cans. A series of magnetic and optical sensors report the progress of the operating cycle to the coordinating PLC, ensuring a smooth and efficient process. Each girl developed a particular section of the model and wrote a program to control the process.

Other projects attempted have included animated dinosaurs, a pneumatic cuckoo clock and pneumatic grippers. A pneumatic door opener has also been developed with smart card access, sound effects and electronic special effects.

Classes are at least 80% practical work; the focus is on learning by doing. There are 5 x 40 minute periods per week in the subject.

### ▽ Systems & Technology ▽ VCE Units 3 & 4

#### □ Advanced Programmable Electro-pneumatic Systems

Girls develop sophisticated electro-pneumatic projects in a group situation. Generally, a single project is the focus for the whole year, enabling a complex mechanism to be refined and to evolve into a high level of precision.

#### □ Some recently completed projects:

1. Sebastian, the humanoid robot
2. An automated production line
3. Triassic Park: Beyond 2000 Technology Challenge

Five 40 minutes periods per week are devoted to these elective studies.



## Doing "Real" Science With The NGS Kids Network

*Judith Vesel, Curriculum Manager  
TERC in Cambridge, MA.*



### Introduction

#### 1. Why is it important for girls to use the NGS Kids Network?

- Kids Network is good science.

*"Kids Network is good science. All good science fits into a curriculum. Kids Network allows students to explore a central concept in depth....Kids Network offers everything that's advocated by Project 2061 and the National Science Standards."*

*Susan Botts, Teacher  
Southwest Middle School  
Orlando, Florida*

- Kids discover that they can work with students in other areas to solve local environmental and social issues.

*"Kids Network brings the world to the classroom like nothing else."*

*Robert Kopicko, Teacher  
Abbott Middle School  
West Bloomfield, Michigan*

- Kids engage in dialogues with middle-grade students in other areas. And, let's face it, these dialogues are just plain fun.

*"This program [the National Geographic Society (NGS) Kids Network] with all the schools is cool because we get to talk to people we can't see!"*

*Dustin Carter & Logan Wade,  
Seventh Grade Students,  
Craigmont Junior High School,  
Memphis, Tennessee*

#### 2. What is Kids Network?

- The NGS Kids Network (for Grades 6-9) is a telecommunications-based science curriculum, which was developed by TERC, Inc. with funding from the National Science Foundation (NSF) and the National Geographic Society (NGS). Each of the units in the series—What Is Our Soil Good For?; Are We Getting Enough Oxygen?; How Loud Is Too Loud?; and Is Our Water at Risk?—is shaped by the following principles:

- Students address topics about aspects of the natural world and apply their ideas to important environmental and social issues.

- Students engage in activities similar to those undertaken by professional scientists.
- Students use a computer network to exchange their findings, ideas, and questions with colleagues in other classrooms.
- Students doing an NGS Kids Network unit work collaboratively to investigate a topic. The work begins as a class, then extends to a group of classes called a research team.

### 3. What are the design elements of each unit?

- Each Kids Network unit is divided into four parts. In Part I, students learn by observing. In Part II, they learn by measuring. In Part III, they exchange data on a network and analyze the larger data set. In Part IV, students return to a question raised by their studies and design their own investigation to answer that question.

## Doing 'Real' Science With "What is Our Soil Good For?"



### Data Collection

- Participants determine the textural class and color of a soil sample and decide on questions and ideas to share with other students doing the unit.
- Refer to attachments.

### Data Analysis

- During the following activities, participants explore NGS Works—an integrated software tool with features for telecommunications, wordprocessing, and data display and manipulation:
  - Writing letters to their research teammates
  - Entering their data on textural class and color into a data table
  - Analyzing maps and graphs to answer their questions
  - Using data displays to make predictions about the organic-matter content, water-holding capacity, or pH of their soil
  - Using references on diskette to find out about their questions

### Further Research

- Participants identify new questions for exploration and experience the ongoing nature of scientific research.

## ☆ NGS Kids Network ☆ Grades 6-9

### The Core Package

NGS Works

What Stories Do the Data Tell?

### Units

What Is Our Soil Good For?

Is Our Water at Risk?

Are We Getting Enough Oxygen?

How Loud Is Too Loud?

### Curriculum Principles

Students explore real-life problems

- They apply new ideas about the natural world to important environmental and social problems.

Students conduct research in their own classrooms

- They develop ideas by asking questions, making predictions, collecting, recording, and analyzing data, re-evaluating predictions, reasking old questions, and asking new questions.

Telecommunications enhances learning

- Students examine their ideas in a broader context by collaborating with other student researchers on a computer network.

Assessments are embedded in the curriculum

- Students consolidate and demonstrate their ideas by writing research reports and discussing their findings.

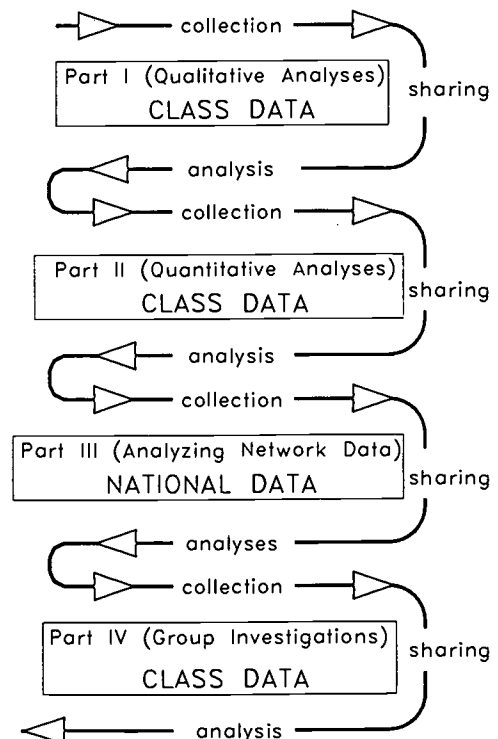



## ☆ How Large Are the Particles in Our Soil?

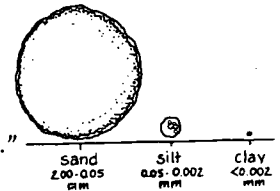

### Procedure for collecting data on particle size:

- Use two sheets of paper. Label one sheet "Leftover Material" and the other "Soil Particles."
- Hold a piece of screen or a wire-mesh strainer over the paper labeled "Soil Particles."
- Place a large handful of soil on the screen or in the strainer.
- Shake the screen or strainer from side to side for about 30 seconds, until as much soil as possible has fallen onto the paper.
- Pour the material that remains on the screen or in the strainer onto the sheet of paper labeled "Leftover Material."
- Put it aside for later analysis (if time permits).
- Use a hand lens or microscope to examine the contents on the paper labeled "Soil Particles." What are the shape, size and color of the particles you see? Record your observations on the chart below.

shape
size
color

Rub some of the soil particles between your thumb and forefinger. How do they feel?

Use an eyedropper to moisten the soil slightly. Rub some of the soil between your thumb and forefinger. How do the moistened particles feel?

## ☆ Procedure for Classifying the Particle Size and Textural Class of Our Soil

1. Which of the descriptions of particle size on the chart below sounds the most like your soil sample? Talk to the members of your group and agree on the best description. Draw a large square around that description and the particle size next to it.

Description	Particle Size
Visible to the naked eye. Feels gritty.	Large
Visible with an ordinary microscope. Feels like flour when dry; feels smooth (soapy, greasy, or slippery) when moist.	Intermediate
Visible only with a specialized microscope. Forms small clumps when dry; feels sticky when moist.	Small

What is the dominant particle size in your soil sample? Talk to the members of your group and agree on the dominant one. Draw a large square around that particle size, and around the main material next to it.

Particle Size	Main Material	Textural Class
Mostly large particles	Sand	Sandy
Mostly intermediate particles	Silt	Silty
Mostly small particles	Clay	Clayey
An almost even mix of large, intermediate, and small particles	Sand, silt, and clay	Loamy

## ☆ What Color Is Our Soil?



### Procedure for determining soil color:

- Put a handful of soil on a sheet of notebook or typing paper.
- Compare the color of your soil sample to the three groups of crayons that your teacher has assembled. Talk to the members of your group and decide which group of crayons most closely matches the color of your soil sample.
- Draw a box around that color group below.
  - Group 1 – black, brown, olive green;
  - Group 2 – tan, burnt sienna, goldenrod;
  - Group 3 – red, dandelion, bittersweet, yellow, gray, peach, white.
- Take one piece of crayon from each color in the group you selected. Hold each crayon next to the soil sample to see whether any of the crayon colors matches the color of your soil sample.
- If the color of your soil appears to look like a combination of the colors in the group, use scissors to shave off bits of some or all of the colors in that group. Try to match the color of your soil using a mixture of the bits.
- If you can't find a close color match, try another group of colors. When you find a color match, record the name of the color (or colors) on the line below:

- Use the information on the chart below to determine the color category of your soil sample. Draw a box around the soil color and color category.

Soil Color	Color Category	Amount of Organic Matter
Black, brown, olive green	Dark	High
Tan, burnt sienna, goldenrod	Medium	Medium
Red, dandelion, bittersweet, yellow, gray, peach, white	Light	Low

### Did You Know?



Women earn 50 percent of the bachelor's degrees in psychology and social sciences, 33 percent of bachelor's degrees in mathematics and physical sciences and only 16% of bachelor's degrees in engineering. Women are only 22 percent of the science and engineering labor force, and because of their relatively recent entry into these fields, far fewer women than men attain the rank of full professor in academia or management positions in industry.

Source: National Science Foundation Report (1996) "Women, Minorities, and the Disabled."



**If you would like to conduct a laboratory investigation,  
think about using one of these questions:**



- Do plants grow more rapidly in soil that is acidic, neutral, or alkaline?
- How can you change the pH of your soil sample?
- Does the pH of the surface layers in your soil pit differ from the pH of the subsoil layers? Does the amount of organic matter in the surface layers differ from the amount of organic matter in the subsoil layers?
- What are the soil characteristics of compost? (Consider particle size, textural class, color, water-holding capacity, organic content, pH.)
- How does the addition of fertilizer to your soil alter its characteristics?
- How can soil erosion be stopped? (Build a model to demonstrate your ideas.)
- How do different kinds of barriers stop wind erosion? (Build a model to demonstrate your ideas.)
- How does organic matter affect soil erosion? How does organic matter affect soil pH?
- What methods can you find to measure the amount of organic matter in your soil (other than the experiments already conducted)?
- How do the characteristics of soil from other sites in your area compare with the characteristics of the sample of soil you tested in class.
- What is the water-holding capacity of pure gravel, pure sand, pure clay, and potting soil?
- Does peat moss hold more water than clayey soil?
- What is the water-holding capacity of the soil in your local landfill?
- How do the organisms in your local soil compare with the organisms in soil from other sites in your area? How do they compare with the organisms in soil from distant places?
- What is the percentage of sand, silt, and clay in your soil sample?



**If you would like to work with the network data,  
think about using one of these questions:**

- How do the characteristics of soil in another area compare with the characteristics of your soil? How do the characteristics of soils in another country compare with the characteristics of your soil?
- Do soils in agricultural regions contain more organic matter than soils in cities?
- What do the network data tell you about the amount of organic matter in soils in different color categories?
- What do the network data tell you about the relationship between the amount of organic matter in soil and the textural class of soil?
- What is the pH of soils in agricultural areas? Are the pH readings close to the optimum pH range for plants?

**If you would like to conduct a survey or examine written  
material, think about using one of these questions:**



- Has any substance contaminated the soil near railroad tracks in your area? Near a power plant? Near a local factory? Near local agricultural land?
- How long would it take for the local landfill to overflow? How would the overflow affect nearby soil?
- How is soil affected when trees and other vegetation are removed?
- How do architects and engineers design buildings to minimize cracks that develop from settling and shifting of the foundation?
- How do highway engineers design roads that are appropriate to the characteristics of the soil?
- How have humans altered the soil in your area in the last 100 years?
- How do the characteristics of subsoil affect what the soil is good for?

# ☰ Making Graphs & Letter Recognition

Elin Saltveit, Teacher  
Schools of the Sacred Heart, San Francisco, CA.

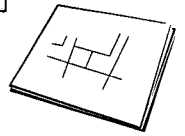

**B**EFORE USING GRAPHING SOFTWARE, kids should create their own graphs from scratch (using meaningful data collected beforehand). Otherwise, it is too easy for them to make graphs (automatically) without understanding them conceptually. So, have kids first graph in KidPix (or any drawing program), reinforcing concepts of labelling, amount, and equal increments. When finished, they can graph the same data using computer graphing software to compare.

**Grade Level:** 5-8

**Objectives:** Graphing Concepts, Statistics, Science

**Time:** 90 Minutes

## Step-By-Step Description:

1. Discuss what a graph is—basically just a picture of some numbers and how they relate to each other.
2. Review the basic drawing tools.
3. Graph from scratch, using stamps or small drawings.
4. Have a discussion on how graphs can be distorted or manipulated and how graphing programs distort them automatically by changing the scale!
5. If you have computer graphing software, use it to automatically graph the same data. Compare the two. This is a good time to explain the subjectivity of graphs and how they can distort or emphasize your point.

## For Pie Graphs:

1. Draw a circle.
2. Use the straight line tool to partition (estimated) percents.
3. Fill the parts with color or stamps.
4. Label parts last.
5. Create a legend, label and title.

**Variation:** Create 3-D Graphs!

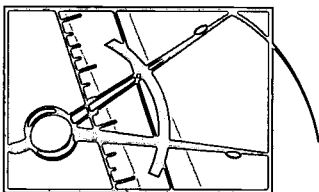

## ◇ Creating Graphs ◇

### ◇ Pie Graphs

*Examples of Pie Graphs:*

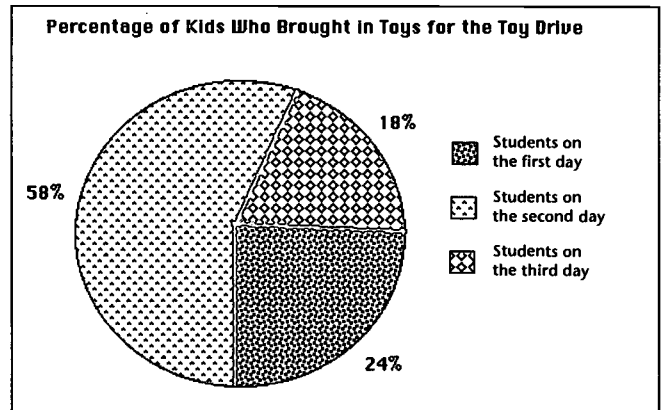
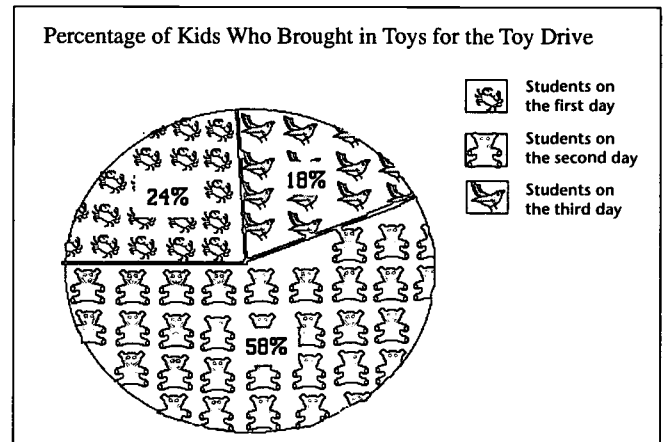

### ◇ Pictographs

*For Pictographs:*

1. Have students draw a horizontal line.
2. Label the categories (Hot, Medium Hot).
3. Create a legend (i.e. One fish = 2 fishes).
4. Stamp number of pictures for data. Or, if you don't have stamps, draw one small picture, then copy and paste the picture the number of times needed.
5. Add a title.

### Examples of a Pictograph:

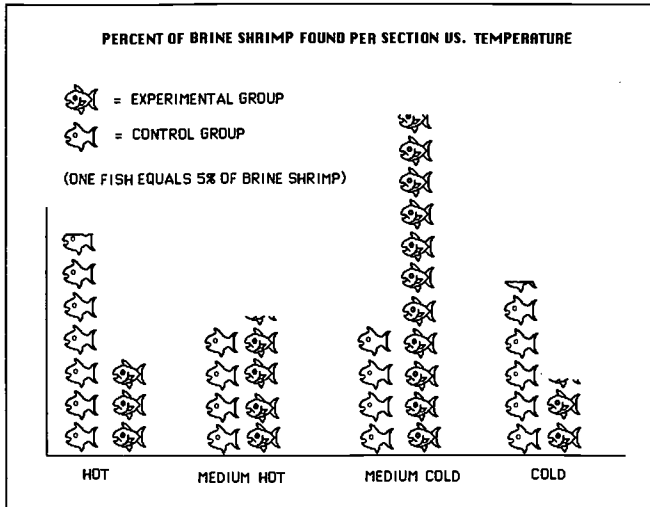

### ◇ Bar Graph

#### For Column or Bar Graphs:

1. Draw the x axis and y axis.
2. Label each axis.
3. Put ticks on each axis (0, 10, 20, 30, ... & 1, 2, 3, 4).
4. Draw rectangles for each amount of data. Fill the rectangles with a pattern.
5. Create a legend.
6. Add a title.

#### Example of a Bar Graph:

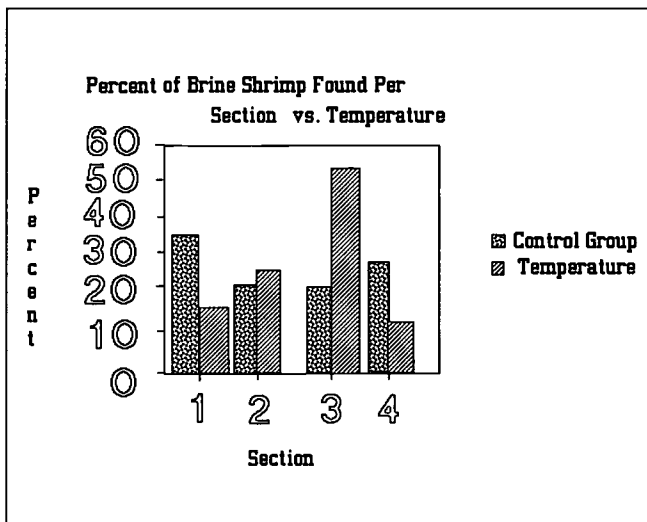

### ◇ Line Graphs

#### For Line Graphs:

1. Draw vertical and horizontal lines, and add tick marks.
2. Label the axes (add numbers and quantities).
3. Stamp pictures on graph. If you don't have stamps, you could just draw dots, or draw small pictures, copying and pasting one to get duplicates.
4. Connect the pictures using a straight line tool, or a pencil tool.
5. Add a title.

#### Example of a Line Graph:

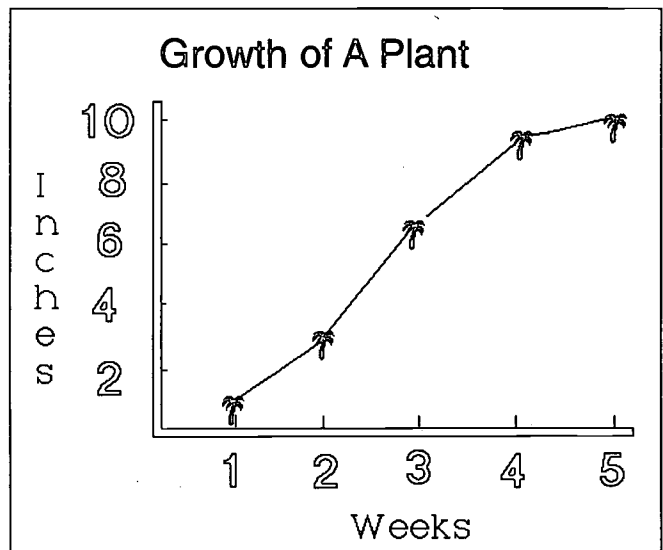

## ◇ Letter Recognition ◇

KidPix has many stamps (small clip art pictures). I find these stamps limit the students' creativity, and don't let the students use them in their illustrations. But, these stamps can be put to good use, as in the following examples:

**Grade Level:** K-4

**Educational Skills:** Alphabet Letters,  
Sounds that Letters Make

**Computer Skills:** Drawing Tools

**Time to Complete:** 30-60 Minutes

**Software:** Use any drawing program—programs, such as KidPix have pre-drawn pictures (stamps). If your software does not have clip art, have students draw the letters first, then draw small pictures below each letter. Microsoft Word has a Dingbats font and an Insert Symbol function which makes this possible, but not as easy as the other ways.

### What to Do:

1. Have each student type his or her name at the top of a KidPix screen.
2. Starting with the first letter (of their name), have the student look for all stamps that start with the same sound and insert that stamp once below the letter.

### Example:

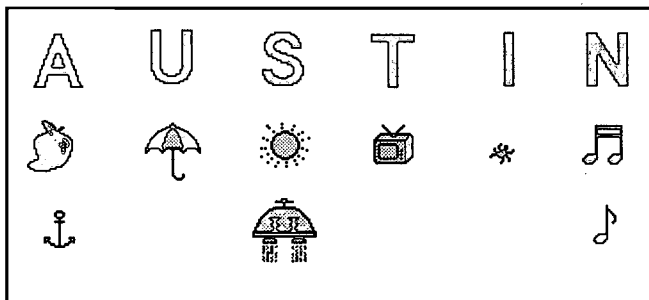

## ◇ Alphabet Variation

*Example of the Alphabet in English:*

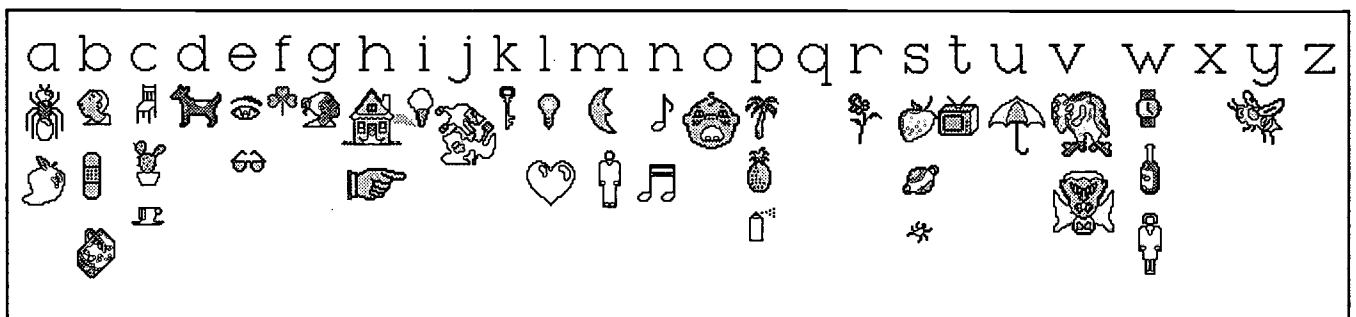

## ◇ Foreign Language Variation

I was reminded how difficult a task letter recognition can be for a 1st grader when I attempted to do the following in Spanish.

**Educational Objectives:** Grammar Skills, Ability to Recognize Words in the Target Language

### What to Do:

1. Have each student type his or her name at the top of a KidPix screen.
2. Starting with the first letter (of their name), have the student look for all stamps that start with the same sound (in Spanish, or whatever language is being studied) and insert that stamp once below the letter.

### Example in Spanish:

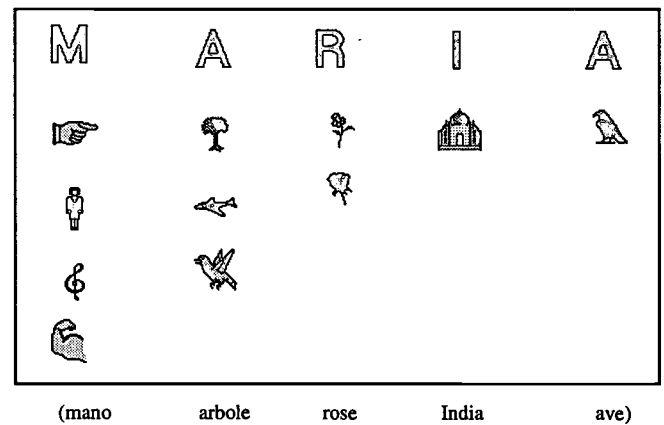

### Example in French:

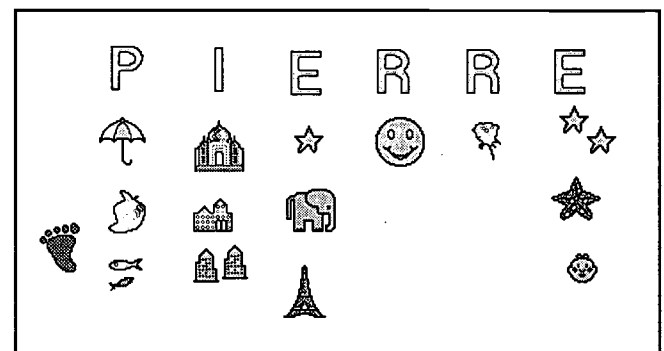



# Building Models

Horrey County Schools, Playcard Environmental Center

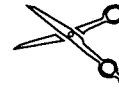

## ⇒ Third & Fourth Grade's Wind Powered Vehicle Challenge:

Design, draw, and construct the fastest wind powered rolling vehicle on a frame size no larger than 15 cm x 20 cm using light winds. The course will have a 1/2 meter sand section. It is to be timed over a distance of 2 meters.

### Testing:

Sail area =

Trial	Time	Distance	Speed
1			
2			
3			

## ⇒ Fifth Grade's Ping Pong Moving Challenge:

Design, draw, and construct a stationary device that will move a ping pong ball at least two meters into a 1 meter diameter target area.

### Testing:

How high can you make it go?

How far can you make it go?

How much force in your device is used?

## ⇒ Ninth Grade's Torque Vehicle Challenge:

Design, draw, and construct a vehicle that will go up the steepest angle slope using the materials provided.

### Testing:

What features are key to the success of your design?

What features did you change in your design?

Why?

## ⇒ Elastic-Powered Water Models

Can you make a 'boat' powered by a propeller to be used in a large bath or pool of water?

You are provided with wood, two plastic bottles, elastic bands and a bead (and anything else that may be available).

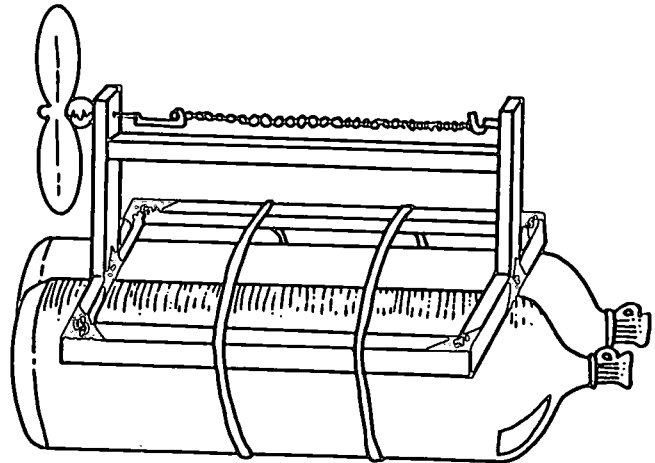

Power your models using a propeller and elastic band. How far can you make your boat go? Can you make it go any further?

Try redesigning your model. How else could you make a floating model?

Will ballast (heavy load) make any difference to speed or distance covered?

Will it make any difference if you wind the propeller clockwise or anti-clockwise?

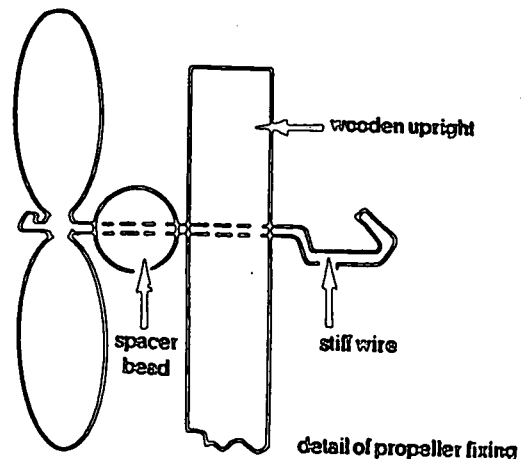

## ⇒ A Crane—3-D and Pulleys

Cranes are flimsy things yet they can lift heavy masses. Have a go at making a crane that can lift a mass (a load). Build the structure and add rods and pulleys—a string for the winching wire. Make sure that your crane is strong and stable.

How do you make a structure rigid?

Is this the best pulley arrangement?

Can you motorize it?

Could you design and build an arrangement of cogwheels to make your crane rotate?

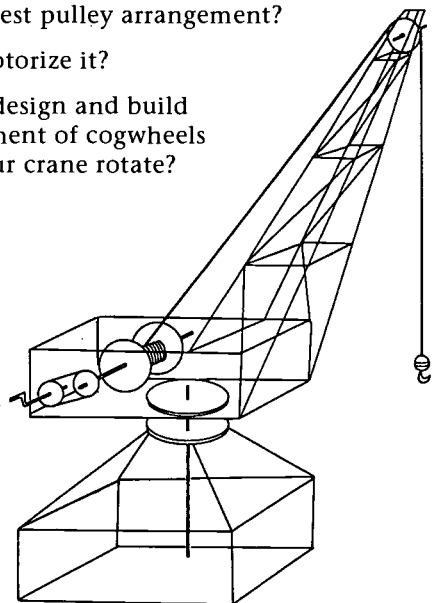

## ⇒ A House

Can you build a house?

Think about the dimensions of your house.

What will you make the height, the length and the breadth?

Will it be a bungalow?

Will it have two or three floors?

What sort of roof—flat or pointed?

Can you add a chimney?

Put on decorative walls of cardboard.

Try wiring up your house so that an electric light can be used inside.

How could you turn the light on and off?

Try making a scale model of your own house.

Draw a picture before you begin.

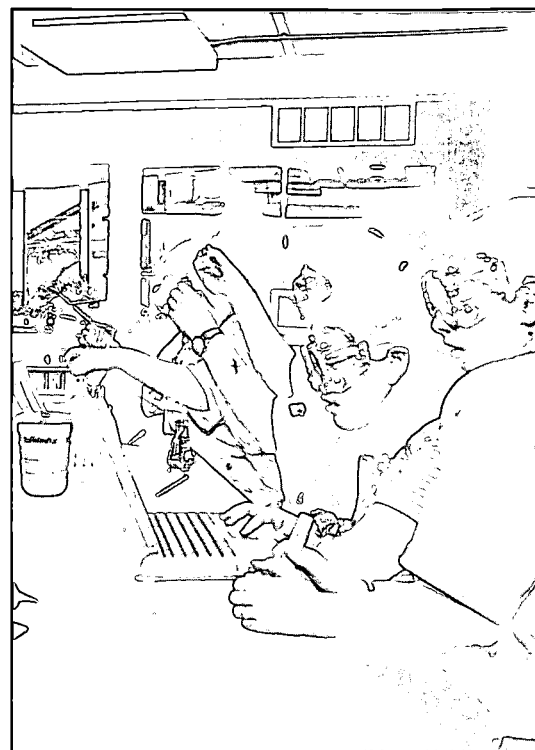
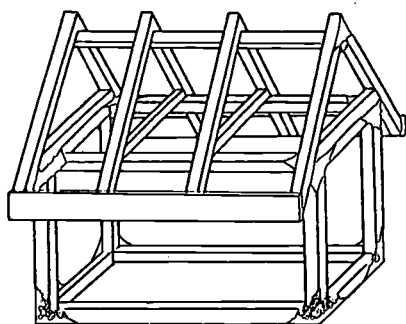

## ⇒ Teacher's Notes

**Materials** ▫ Let children look at lots of different houses and buildings. Make a cutting plan. How many pieces of each length?

**Construction** ▫ Assemble box to planned dimensions. Saw trusses with 45-degree angles at one end on mitre jig assemble. Measure and cut tie bar. Assemble with gusset triangles. Make sure that all roof frames are the same size!

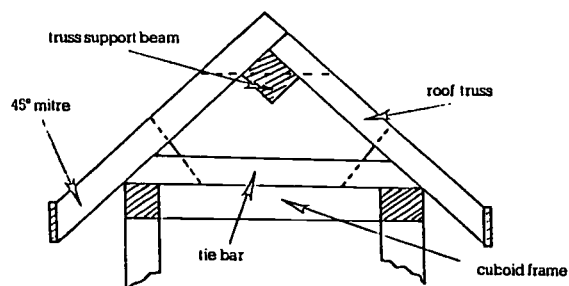

**Discussion Points** ▫ Is the structure strong?

Test using addition of masses.

Where and how to suspend masses?

Add a few at a time or all at once?

Measure—observe bending or to breaking point (model needs mending!)



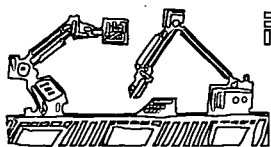

# Design Technology Program Description

Linda Caleb, Science Teacher  
The Holton-Arms School, Bethesda, MD.

**D**ESIGN TECHNOLOGY is a natural, intellectually and physically interactive process of design, realization and reflection. Through the consideration of ideas, aesthetics, implications, and available resources, children become imaginative engineers, exploring alternative solutions to contextualized challenges. Design Technology is based upon the premise that children are primarily “doers” who learn best when given the opportunity and space to use materials and tools to design and make things.

The Design Technology curriculum is offered as an extension of the school’s Mission Statement which states, “Our goals are to build the confidence, integrity, and love of learning that will prepare young women for a changing world...”. It is built upon the need to address three important areas regarding the education of young girls.

## *Learning and Gender Issues*

Recognizing the significance of those teaching strategies and learning environments which best support optimum learning for girls, Design Technology seeks to provide:

- Exposure and opportunities to explore alternative solutions to problem-solving challenges using a variety of materials and equipment which may not be a regular part of a young girl’s learning experience.
- An interdisciplinary approach to learning which permits girls to create in an holistic sense.
- Abundant opportunities for collaborative learning.
- A model that technology is accessible to all, regardless of perceived skills and abilities.

## *Learning and Technology*

Recognizing that technology will continue to shape our lifestyles into the next century, Design Technology seeks to:

- Introduce a different, but complimentary, aspect to the understanding of technology.
- Combine technological skill with interactive learning which engages the students in critical reflection and original thought.
- Combine technological skill with an awareness and concern for aesthetics and environmental impact.

## *Learning Styles*

Recognizing the developmental needs and individual learning styles of all students, Design Technology seeks to:

- Integrate meaning into an instructional experience which places the child at the center.

- Make the student an active investigator and the sole inventor of personal meaning.
- Provide an intensely hands-on, interactive, and kinesthetic type of learning.
- Maximize the strengths and abilities of each person by presenting a wide array of learning activities.
- Promote greater retention of scientific and mathematical concepts through the use of concrete examples and activities.

Historically, public access to science and technology has often been pursued through reductionistic avenues, breaking bodies of knowledge into fundamental parts. This approach tends to produce highly abstract pieces of information, rather than a knowledge of the essential interrelationships that exist.

Design Technology seeks to provide children with opportunities to explore understanding of their world through contexts based upon their needs, capabilities, and desires. Similar to technological innovations, expressed human need is central to change and progress.

## ❖ Description of Course ❖

As a curriculum, the primary goal of Design Technology is to provide a variety of enabling experiences which empower young girls to shape their environment, develop their own evaluation skills, and integrate concepts and skills from seemingly diverse curriculum areas. Through the process of Design Technology girls have the opportunity to use their minds and hands interactively, to work collaboratively with others, and to then reflect thoughtfully about the processes used as well as the resulting products. The activities associated with Design Technology draw on skills, knowledge, and understanding from other curriculum areas and are concerned with optimum rather than correct solutions.

Integral to Design Technology is a central process which incorporates numerous skills. The process itself can be described as falling into four broad categories, or steps, although oversimplification is not intended. The four major categories are: Investigation, Invention, Implementation, and Evaluation.

- **Investigation** includes the development of context, clarification of task, and inquiry into an array of options. The student poses a question, becomes aware of a need or problem, or accepts a challenge. She engages in questioning, as an individual or as part of a group, which helps her to locate parameters and gain clarity. Then ideas are expanded through design questions, information is gathered and ideas are generated which lead to a tentative selection. The suitability of materials and tools

is explored. She works with a variety of resources, notes detail, imposes judgments where discrepancies exist, and begins to develop the major aspects of workable solutions.

■ **Invention** encompasses continued inquiry, planning, and the realization of a design. Alternatives are weighed, eliminated, and combined, based on criteria which fits the purpose. The student plans her ideas in graphic and verbal form, detailing particular aspects of the engineering design. Materials, tools, and techniques are chosen and the response to the problem is often fashioned through the construction of a prototype.

■ **Implementation** of the design presents opportunities to realize, test, and modify the original design. The student examines her creation, experiments with other ideas, and makes modifications in light of her observations. She may also isolate and check variables in designing tests and interpreting the reliability of the results.

■ **Evaluation** of the process and the product is carried out in consideration of predetermined and emerging criteria. The student interprets the results, reflecting on her achievements. She determines the extent to which the design addresses the initial challenge or problem. At some point she may discover a need to make a modification. This review and critique of the process and product often fuel further investigation.

Because the curriculum focuses on skills, attitudes, processes, and ways of thinking it does not become tied to specific content areas. Rather the content remains fluid, thus permitting virtually all topics to become relevant for exploration.

During the first semester of school, the third and fourth grade has each participated in a seven week Design Technology unit. During those seven weeks, for 45 to 60 minutes each day, the third graders explored frames and structures and the fourth grade investigated wheels and how things move. Each unit consisted of a specific set of sequential, open-ended activities which culminated in a final project which drew on the accumulated learning and understanding of the previous weeks. Each grade level will experience two more Design Technology units before the end of the school year. All classes are taught by a team of three people: the Lower School Librarian, Lower School Art teacher, and Lower School Science teacher for grades 3 and 4.

### ❖ The Curriculum ❖

The interdisciplinary nature of Design Technology is evident in the unobtrusive yet obvious reflection of different curriculum areas:

□ **Math:** on a daily basis students measure, calculate, and explore mathematical relationships as they move from idea to drawing to prototype to full scale projects

■ **Literature:** "The Green Book", a piece of children's literature, provided the hypothetical environment necessary for the construction of full-scale structures as well as providing a context for the students which gave meaning to their work

□ **Art:** on a daily basis students are engaged in planning and constructing a variety of projects, which also demand attention to aesthetical as well as functional concerns

■ **Science:** on a daily basis students evaluate and modify their ideas and projects, a wide variety of physical science concepts are demonstrated through the various activities

### ❖ Methodology ❖

Problems in Design Technology are presented as learning situations which can be related to a real-life problem or which arise from an artificial challenge given with specific restraints. However, most of the elements of the students' work are non-prescriptive in nature so that each girl is encouraged to think for herself. The activities reward curiosity, persistence, and risk-taking as breakthroughs turn frustrated attempts into successes. This approach to learning envelops the notion that interest, curiosity, and a sense of adventure and discovery are the seeds that develop into meaningful learning.

In the process of investigating and understanding her world, a child considers complex interrelationships of perspective, experience, and meaning. Motivated by the need to know, she embraces and shapes opportunities to satisfy an intense urge to make sense of her surroundings. Each individual experience forms a base for future attitudes and understanding. This natural process of learning and resulting change, is not prescribed, but discovered.

The role of the teacher is to work alongside the students and to observe their initial questions and intuitive beginnings, to appreciate patterns of work and reflect on what is known and how it is applied. In creating experiences that foster intrinsic motivation, the teacher becomes a resource and reflector, as well as model and guide. Teaching and learning then become a process choreographed by inquisitive and dynamic minds.

### ❖ Methods of Evaluation ❖

This approach to learning requires assessment and evaluation which are developmentally appropriate and non-traditional in manner. To that end, assessment:

■ Is shared equally by students and teacher.

■ Is on-going, with specific checks and balances throughout the learning process.

■ Occurs constantly and within the immediacy of the learning moment.

- Stresses multiple and optimum solutions, rather than correct answers.
- Provides immediate feedback which can then be used by students to modify ideas or to advance to the next step.

Evaluation occurs as teachers continuously engage in observing, monitoring and evaluating, formally and informally. Information is gathered to establish baselines against which progress can be measured. Information is collected informally through child-watching and more formally through work appraisals and testing of solutions. Over time progress is gauged relative to individual criteria, which is based upon the teacher's knowledge of what is developmentally appropriate for each student.

**Evaluation information can be obtained through:**

- **Conferences** between student and teacher provide on-going opportunities to explore open-ended questions and to engage in self-reflection. By listening carefully and following the student's lead, questions are posed which probe intuitive hunches and illuminate intent. These discussions are critical for uncovering what each child understands and has attempted and for visualizing further development.
- **Worksheets** are valuable as a written format for capturing thoughts that have also been expressed verbally. As the worksheets are also correlated to the specific task at hand, they also provide access to the development of the project as well as to the development of the child. Examples of the type of information included in a typical worksheet include drawings, results of recent trials, and ideas for modifications. Early entries may also serve later purposes when projects take unexpected turns.
- **Drawings** are extremely valuable when it is difficult for a young child to respond to in writing. Often the student replicates a project in a current stage for the purpose of clarification of thought or critique of an idea.



❖ **Abstract** ❖

Design Technology is essentially a practical problem-solving process which involves the whole being, physical, intellectual, and spiritual. As a process it involves and provides purpose for other studies and, because it is concerned with real things, it provides a recognizable context for a variety of learning and thinking to take place. The practical nature of the activity creates an involvement in which disciplines are seen in context, immediate feedback increases understanding of limitations, evaluation is essential and acceptable, and within which confidence and competence can grow. Against this background it is possible to develop a range of skills, as children working in groups learn to cooperate, to compromise, to plan and construct, to make decisions and through the excitement and pleasure of creation to encourage self-fulfillment and a positive appreciation of the value of doing.

*(Curriculum Guidelines for CDT, Berkshire 1984)*

## Books & Materials



### *Professional Sources*

- Hands-On Technology*, Iris Katherine Idle, 1991
- Design and Make, Folios 1-9*, Joe Kellett, David Jinks, 1993
- Rainbow Technology*, Chris Gibson, Jean Harding, Janet Hutchings, John Mapstone, Brian Pengelly, 1991
- Design and Technology*, Pat Williams, David Jinks, 1985
- Design Technology-Children's Engineering*, Susan Dunn, Rob Larson, 1990
- Cooperative Learning, Science and Success*, Lynn Molyneux, 1992
- Problem Solving in School Science*, Robert Johnsey, 1986
- Design and Technology Through Problem Solving*, Robert Johnsey, 1990
- An Early Start to Technology from Science*, Roy Richards, 1990

### *Published Materials*

- Design Technology: The Linx System
- LEGO Dacta

### *Cost to School*

The estimated cost for Design Technology in lower school, grades 3 - 6, is \$1,000 per grade per year.

# Creating a Design-Based Learning Environment

News from Center for Children and Technology, October 1991, New York, NY.

IN A FINAL PHASE OF OUR RESEARCH on women and technology, we created a computer-based design tool: a program that enables girls to create machines starting from their own imaginative vantage points. *Imagine* lets them draw these machines, from scratch or composed of preexisting parts, and tell their stories. Then it lets them animate the parts of their machines to show how they work.

To test the use and effectiveness of this program for encouraging girls' technological imaginations, an elective course in design based on *Imagine* was offered in an alternative junior high school in New York City. The goal of the pilot research was to conduct a small-scale, qualitative investigation into the ways in which girls used *Imagine* in the context of a supportive but relatively unstructured classroom environment.

Based on the work that the girls in this study did during the course of a semester, it is clear that *Imagine* is effective in serving as a conceptual space where girls are encouraged to create and elaborate design ideas for technological devices. With minimal encouragement, the majority of these girls were able to develop imaginative devices that performed a range of creative functions. *Imagine* appeared to facilitate a process of mental and graphic tinkering. In the absence of a well-defined and rigorous design curriculum, *Imagine* appears capable of legitimating the psychological experience of thinking of oneself as an inventor—an important first step in legitimating and affirming girls' technological imaginations.

## Beth's Robot

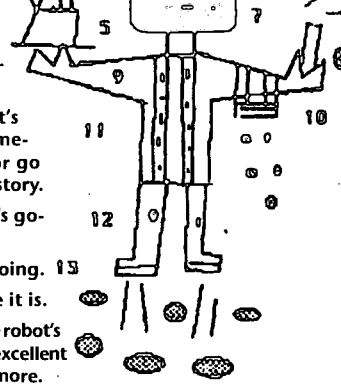
- 
1. This is one half of the robot's brain. It sends messages to the robot and he will understand everything you say.
  2. This is the other half of the robot's brain. It knows when you want something to eat, drink, or just to rest or go to sleep, so it can tell you a bedtime story.
  3. This helps the robot see where it's going, just like a human.
  4. This also helps it see where it is going.
  5. This helps the robot sense where it is.
  6. This is a piece of soap they used in the robot's land before he landed on Earth. It's excellent for your face and wakes you up even more.
  7. This is the mouth. It helps the robot talk just like humans do. It also helps you if you want to watch a movie. You tell it which movie you want and it comes out of its mouth. The best part of all is that it tells you the answers to your homework if you need help.
  8. This is a tray full of food for breakfast. It's brought to my bed every morning.
  9. This is an arm that clips on to things. Every morning it picks me up by my shirt and carries me into the bathroom.
  10. This is the towel that wakes me up every morning. But when it wakes me up, it's freezing cold!!!
  11. These are his suspenders from his old planet. They control all of his actions and sayings. Almost everything he does revolves around his suspenders.
  12. These are his legs. They help him walk. The little buttons in the middle help all of his leg actions.
  13. These are pumps. They help him jump to all my needs.

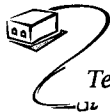

## Go On a Cyber Scavenger Hunt

Tech Girls' Internet Adventures ☆ GirlTech, IDG Books, Foster City, CA.

Here's an Adventure that gives you practice hunting through the Internet for important facts and fun tidbits of information. Besides all the fun stuff on the Net, there is a wealth of information for you to discover. Do an Internet scavenger hunt to find health tips. Find the correct answers by visiting the sites listed below each question. **Hint:** means this is a clue to the section within the site where you will find the information you need.

What fact do cigarette advertisements try to hide from people?

<http://www.health.org/kidsarea>

**Hint:** Be smart with the surgeon General.

What makes a diet good or bad?

<http://ificinfo.health.org/brochure/IOtipkid.htm>

**Hint:** Best is last!

How much of a healthy body is made of fat?

<http://kidshealth.org/kid/>

**Hint:** Ask SomeBody about eating disorders.

Can loud music cause deafness?

<http://kidshealth.org/kid/>

**Hint:** Kids wanted to know.

What is garlic good for?

<http://www.mistral.co.uk/garlic>

**Hint:** You don't have to look too far.

What do starchy foods such as bread, cereal, rice, and pasta give you?

<http://www.ganesa.com/food/index.html>

**Hint:** Breads and grains

For more information: GirlTech, 851 Irwin Street, Suite 100, San Rafael, CA 94901.

Phone: 415-256-1510 • Fax: 415-256-1515 • E-mail: [grltek@aol.com](mailto:grltek@aol.com) • Internet: <http://www.girltech.com>

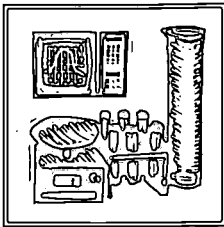

## Section III: Grades 9-12

### ☰ Rays of Sunshine: A Solar Car Project



By the Girls of The Ethel Walker School (EWS)  
and Dr. Pamela Jeanne Akiri, Science Teacher, Simsbury, CT.

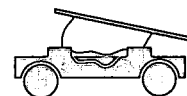

**H**OW DO YOU START A SOLAR CAR PROJECT? How do you fit it into the busy schedule of a private secondary school? How much does it cost? Where can you get money, expertise, help? How do you get the students fired up and maintain their drive to the completion of the project? And just how do you manage to get an all-girl high school team to design, build, and race a car in the Tour de Sol successfully? These are some of the questions that are addressed in the following pages.

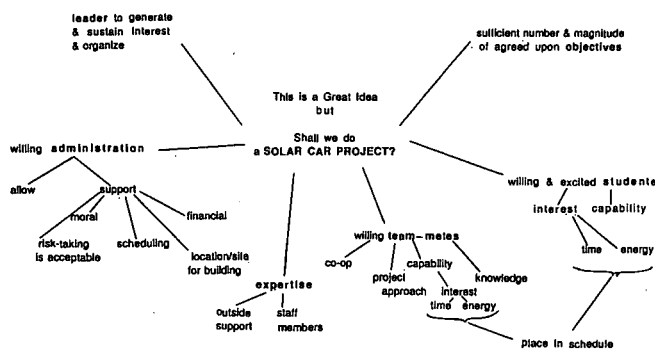

Concept map for starting a solar car

Building a solar powered model car is similar to building a real car. Young engineers must consider the effects of the following forces when they design their vehicles and select the materials to use for the chassis and wheels.

Friction	Inertia	Speed
Momentum	Gravity	Drag

Engineers must consider aerodynamics-the motion of air and the forces that act on a body in motion-when they design the vehicles.

In addition, the builders of solar cars must know how a solar cell works and how to transfer the sun's energy to the wheels of the vehicles. This unit includes information and activities that will demonstrate solar cells and gears.

#### Objectives and Benefits Of the EWS Solar Car Project

- ☆ Prove girls can-do it!
- ☆ Show individuals can make a difference about environmental problems
- ☆ Achieve visible results doing "real" research
- ☆ Improve girls' image of themselves as scientists and engineers
- ☆ Advance the project approach
- ☆ Provide an integrated approach to physics
- ☆ Interdisciplinary: planning, publicity, art, management, physics, math, English composition, computer work, oral communication, video technology, biology, ergonomics, engineering
- ☆ Teamwork, cooperative learning, responsibility: not only among students, but also between students and teachers, non-teaching staff, parents, businessmen, community residents
- ☆ Be the 1st all-girls contingent to enter the Tour de Sol; ConVal was the first high school, EWS was the second
- ☆ Finish the Tour de Sol!—proving that all of us together can achieve an "impossible" goal
- ☆ Galvanized the entire school; everyone was involved in some way
- ☆ Publicity for worthwhile achievement: to spotlight Walker's image as a school for science with local, state, and national coverage
- ☆ Fund-raising
- ☆ Admissions
- ☆ Research into girls' approach to science

# Solar Energy

## Teacher Background

Why do we experiment with and research alternative energy sources such as solar energy? Solar vehicles convert the sun's energy directly into electricity. Electric vehicles have their energy stored in a battery. Since electric and solar vehicles do not directly burn fuel, there are few harmful emissions produced. Replacing gasoline fueled vehicles with electric or solar cars would reduce CO<sub>2</sub> emissions by 43% to 54% per vehicle.

The basic building block of a solar-electric system is the Photovoltaic Cell. The amount of electrical power delivered by the cell depends on its size and efficiency. These cells are thin silicon wafers with a positively charged impurity, such as Boron, deposited on the surface. The parent silicon wafer is negatively charged. This "sandwich" forms a "p-n" junction where the "p" layer accepts electrons and the "n" layer gives them up to create a flow of current.

When exposed to light, a Photovoltaic panel experiences a flow of electrons from one layer to another; these electrons are driven by photons in the light striking them. By attaching conducting wires to the "p" and "n" layers, a source of power is formed that will power a radio, drive a motor, or charge a storage battery.

The electrical output of a photovoltaic panel or cell may be measured directly by using a voltmeter or milliammeter. Voltage represents the potential or pressure of electricity being produced while Amperes are a rate of flow for the electrical current. Power or wattage can be determined from a combination of volts and amps. A small multimeter works best for these experiments and can be connected directly to the positive and negative terminals of the solar cell.

The activities that follow give students an opportunity to explore the power generated by solar cells or panels. By trial and error, students can determine conditions that provide for optimal performance of a model using this system.

## Activity One

**Topic:** During what part of the day is the most power produced by the sun?

**Materials Needed:** Solar cell, motor with propeller or spinner, sunshine

**Procedure:**

1. Connect the solar cell to the motor.
2. Take cell and motor outside. Notice how fast it runs.
3. Count how many times per minute the fan turns.
4. Do it at different times of the day: 9 a.m., noon, 3 p.m.
5. Note the weather conditions at each trial.
6. Repeat above steps for several days.

**RECORD THE NUMBER OF TURNS OBSERVED AT DIFFERENT TIMES OF DAY:**

DATE	9 AM	12 noon	3 PM	WEATHER CONDITIONS
<b>AVERAGE</b>				

**Conclusions:**

- At what time of the day is more power produced?
- What weather conditions are most advantageous to the production of power?
- What weather conditions are the least advantageous?

**Expansion:**

Why are storage batteries used in the system?

## Activity Two

**Topic:** At what angle of inclination does the sun produce the most power ?

**Materials Needed:** Average Turns Data from Activity One, straw protractor, sunshine

**Procedure:**

1. Hold a straw so that is parallel to the sun's rays and casts no shadow (other than a ring).
2. Measure the angle using a protractor.
3. Do this at the times of day used in Activity One.

**RECORD THE ANGLE OF THE SUN AT DIFFERENT TIMES OF DAY:**

	9 AM.	12 noon	3 PM
<b>ANGLE OF THE SUN</b>			
<b>AVERAGE # TURNS</b>			

**Conclusion:**

What effect could the altitude of the sun have for the use of solar power?

What modifications must be made in the solar panel's placement in order to maximize the power at any time during the day?

**Expansion:**

Graph the angle of inclination and the number of turns observed in Activity One.

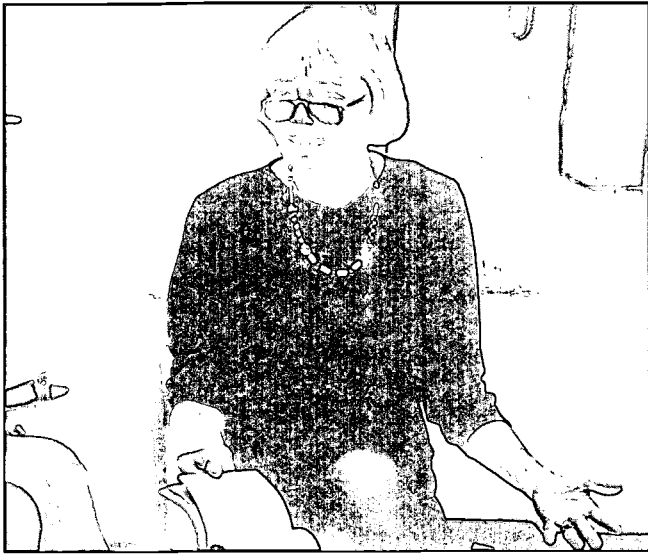

### ☀ Activity Three

**Topic:** Which delivers more power, 2 solar cells in a series or parallel?

**Materials Needed:** 2 photocells about 5V, 1 small motor (1.5V), 1 milliammeter, 1 voltmeter, soldering iron, black and red wire

**Procedure:**

(see diagrams at top of page)

1. Prepare the cells (if not already) by soldering the red wire to the back side or positive pole. Solder the black wire to the front or negative pole.
2. Wire the solar cells into a series.
3. Place in full sun and measure the milliamps and volts.
4. Wire the solar cells into a parallel circuit.
5. Place in full sun and measure the milliamps and volts.
6. Compute the Power in watts that was generated.

$$\text{Volts} \times \frac{\text{milliamps}}{1000} = \text{Watts}$$

	Milliamps	Volts	Power in watts
Series			
Parallel			

**Conclusion:**

Which circuit produced a higher voltage? Which circuit produced the greatest power in watts?

**Teacher Note:**

Cells wired in series produce a higher voltage (charge). Cells wired in parallel produce a stronger current. No more energy is produced in either wiring method. Just different voltage and current conditions occur.

### Gear Information

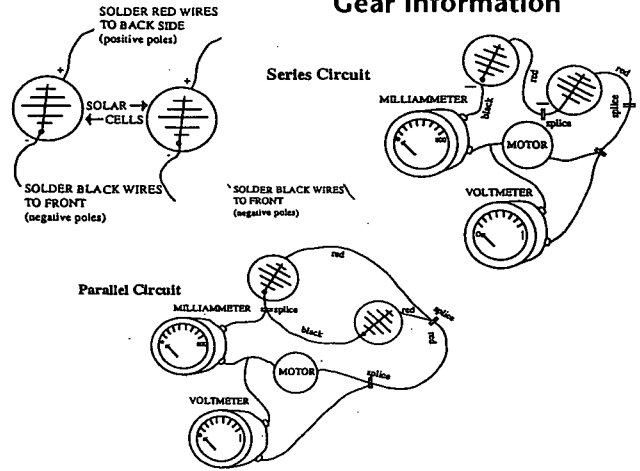

### ☀ Activity Four

**Topic Generalization:** Drive belts are a form of pulley system that can be used to turn wheels and gears.

**Materials Needed:** hammer, nails, board, rubberband large spool and small spool

**Procedure:**

1. Hammer two nails into a board far enough apart to lightly stretch the rubberband between them.
2. Place the small wooden spool over one nail and the larger spool over the other nail. The spools should turn freely.
3. Slip the rubber around both spools so when one spool is turned the other moves.
4. Place a mark on the top edge of each spool.
5. Beginning at the mark, turn the large spool through one complete turn.

**Conclusions:**

How many times did the small spool turn?

In which direction did the spools turn?

**Expansion:**

Does the length of the drivebelt make a difference?

### ☀ Activity Five

**Topic Generalization:** Gears can be used to transfer forces from one part of a machine to another part. With gears, the direction or speed of rotation of other objects can be changed.

**Materials Needed:** board and spools from Activity Four, hammer and nails, rubberband

**Procedure:**

1. Drive another nail farther away from the large spool and move the small spool onto it.
2. The rubberband will now stretch tighter around both spools.
3. Turn the large spool around once again to see if the smaller spool turns the same distance as before.
4. Twist the rubberband so that it forms a cross between the spools.
5. Turn the larger spool again.

**Conclusions:**

How many times did the smaller spool turn?

In what direction did it turn?

 **Activity Six**

**Topic Generalization:** The mechanical advantage in gears is determined by the ratio of the number of teeth on the gears.

**Materials Needed:** piece of heavy cardboard, compass, pencil, scissors, board, nails, hammer.

**Procedure:**

1. Cut a 3" gear with 8 teeth and a 6" gear with 16 teeth from heavy cardboard.
2. Mount the gears on the board with the nails so their teeth mesh and they turn freely.
3. Mark one tooth on each gear.
4. Turn the small gear to the right. On the chart, record how far the large gear turns.
5. Turn the large gear. Note how the small gear turns.
6. Now cut a 12" gear with 32 teeth and test it as you did the other two gears.

RECORD NUMBER OF TURNS OBSERVED

3" Gear	1	2	---	1	2	---
6" Gear				XXX	XXX	XXX
12" Gear	XXX	XXX	XXX			

RECORD NUMBER OF TURNS OBSERVED

3" Gear				XXX	XXX	XXX
6" Gear	1	2	---	1	2	---
12" Gear	XXX	XXX	XXX			

RECORD NUMBER OF TURNS OBSERVED

3" Gear				XXX	XXX	XXX
6" Gear	XXX	XXX	XXX			
12" Gear	1	2	---	1	2	---

**Conclusion:**

What is the ratio of the small gear to the middle-sized gear?

What is the ratio of the middle-sized gear to the largest gear?

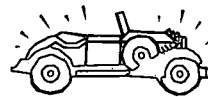

**So You're Building A Model Solar Car!**

Here are some tips on the construction process from teachers and engineers.

**Materials and Design**

Weight is crucial. Solar cells do not provide much power to move heavy vehicles. Choose materials that are light as well as easily formed. Examples: Balsa wood, construction insulation foam, and cellophane on a frame.

Aerodynamics are also important. Drag and crosswinds should be considered. The chassis should provide for stability and allow for the placement of the components (e.g., motor, solar panel, and eyelet).

The choice of material for the wheels and the wheel alignment can make a big difference on the amount of friction. There should be minimal rolling resistance.

**Mechanization**

The drivetrain, tire, and gear assembly can be collected from old toys or snap together car kits. On four-wheel-drive-kit vehicles it is best to disconnect the front wheel drive as it increases the amount of friction to be overcome.

A gear is a wheel with teeth on the outer edge. By itself a gear does not do much of anything. Gears must be teamed up with other gears in order to provide torque. Gears can change speed of rotation and direction.

In a car, the crankshaft revolves in line with the car's direction of travel. So the work done by the engine has to change direction in order to turn the driving wheels. The direction is changed by having two gears that are set at right angles. A good demonstration of this would be seen in a rotary egg whisk. The handle turned is connected to a gear on the spindle of a whisk. This changes vertical movements to horizontal movements for the whisk to beat an egg.

Imagine you have two gears that mesh together - one with ten teeth and the other with twenty teeth. If you turn the smaller gear, the driven gear, it will go around once while the twenty-toothed gear has made only half a revolution. With an arrangement like this you would be able to lift a heavy weight with a small amount of effort. Exactly one-half the force has been expended over twice the time. But if you turn the larger gear, it will go around once while the ten toothed gear has done two revolutions. You would use this arrangement for speed. See Fig.1



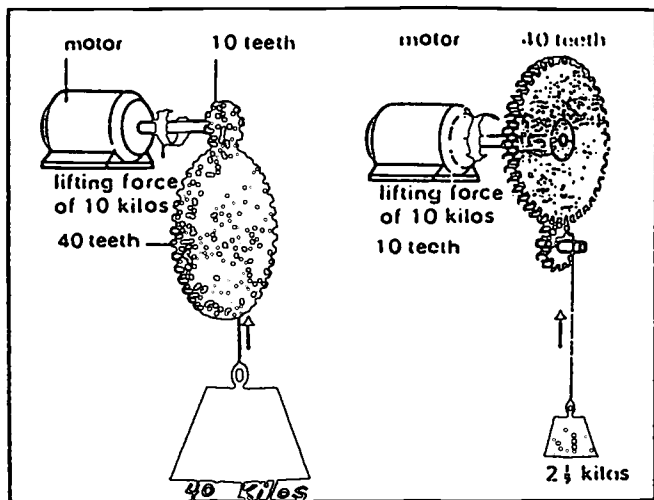
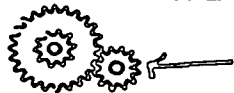

Fig. 1: In this machine, the smaller wheel, the pinion, has only a quarter as many teeth as the larger, so it will turn four times as fast. The left-hand machine will lift the heavier weight. When the positions are reversed, only a smaller weight can be lifted, but at a greater speed.

#### HIGH SPEED TYPE



Driving gear: the-gear in which power is being applied

#### HIGH TORQUE TYPE



Driving gear

### Bibliography

- *Bright Ideas* published by the Arizona Energy Office, 3800 North Central Ave. Suite 1200, Phoenix, AZ 85012
- Lowery, Thomas. *The Everyday Science Book*. Palo Alto, CA: Seymour Publications, 1985.
- *American Tour de Sol* pamphlet published by the Northeast Sustainable Energy Association, 23 Ames Street, Greenfield, MA 01301.
- Pollard, Michael. *How Things Work*. New York, NY: Larousse & Co., 1978.

### Helpful Hints for Transmission Design

1. *How should I design the transmission?*  
Be creative. There is no one solution to the problem.
2. *How should I get power from the motor to the wheels?*  
Experiment with several different ways such as gears, pulleys, or some other method of drive, to get the power to the wheels. Don't be discouraged -- your first try may not work.
3. *What should I know about gears?*  
The pitch of a gear describes the number of teeth that can be put on a 1-inch diameter gear. Gears with different pitches will not fit together well, so the same pitch must be used throughout the transmission. Gears in 48 and 64 pitch are the ones most often used in slot cars. You can buy gears for the 1/24 scale slot cars at slot car tracks in your local hobby shop.
4. *Where can I find parts?*

Cheap, motorized toys, old cassette/8 track tape players, old motorized can openers, recycled materials and small gear reduction boxes will have gears and pulleys that may work in your transmission. Look for them in secondhand stores, discount stores like Target and Walmart, the family's tool box.

5. *What else should I think about as I design the car?*

Think about the friction of the following components:

- Gears moving against each other
- The stretching or slipping of a belt
- The tires on the track
- All the other moving parts of the car

### Theoretical Calculations for a Solar Car

en·er·gy *n, pl -gies* [LL *energia*, fr. Gk *energeia* activity, fr. *energos* active, fr. *en* in + *ergon* work - more at work] 1: the capacity of acting or being active <intellectual> 2: natural power vigorously exerted <work with-> 3: the capacity for doing work.

A solar car takes electromagnetic radiation (light) from the sun and converts it into electrical energy with its solar panel. It then converts that electrical energy into mechanical energy using a motor. Finally, the motor converts mechanical energy into kinetic energy and the car moves forward. Energy can easily be converted from one form to another although there is usually a loss of energy with each conversion. For instance, if you connect your motor to a AA battery, it will run and slowly begin to heat up. This heat is lost energy! If the motor were converting the electrical energy into mechanical energy without any losses, the motor would not heat up at all. There are so many possible sources of lost energy in a real-world situation that we often simplify the problem by assuming that there are no losses at all.

**Problem:**

If we assume that there are no losses in the conversion of energy from the solar panel to the forward motion of the car, how long will it take our car to travel the 20 meter length of track?

What additional information do we need to make our calculations? Clearly if the car weighs more, we would expect it to travel slower. Therefore we would expect that the velocity of our car will depend upon its mass (m). We can measure the mass of our car by weighing it on a scale.

In addition, we need to be familiar with the concept of power. Power takes into account how quickly a given amount of energy is released. We could find a candle and a firecracker that have the same energy content, but the way in which that energy is released is quite different. In this case, the firecracker has considerably more power than the candle.

For the solar cell array, we can calculate the power output, *P*.

The panel is rated at 3 volts, 1.5 amps. How does this correspond to power? Electrical power is the product of voltage and current:

$$P(\text{watts}) = I(\text{amps}) \cdot V(\text{volts}) = \frac{\text{kilogram} \cdot \text{meter}}{\text{seconds}} = \frac{\text{kg} \cdot \text{m}^2}{\text{s}^3}$$

Electrical power is usually expressed in units of watts. A watt is volt x 1amp. Therefore our solar panel produces: 1.5amps · 3volts = 4.5 watts. Compare this to a 60 or 100 watt light bulb. Our solar panel produces very little power!

**Model Solar Cars**

Junior Solar Sprint - Boston Area  
BASEA  
1-617-49-solar

Science Source  
P.O.Box 727  
Waldoboro, ME  
1-800-295-5469  
Source of wood, gears, motors etc.

Midwestern Products  
School Division  
1-800-348-3497  
Source of wood

Lego Dacto  
1-800-527-8339  
555 Taylor Road, P.O. Box 1600  
Enfield, CT 06083-9803  
Source of individual lego parts

Radio Shack  
Source of electrical parts

**Miscellaneous information:**

Motors are rated at 1.5 to 4.5 volts  
solar panels output ~ 3 watts, 1.1 amps, 2.7 volts

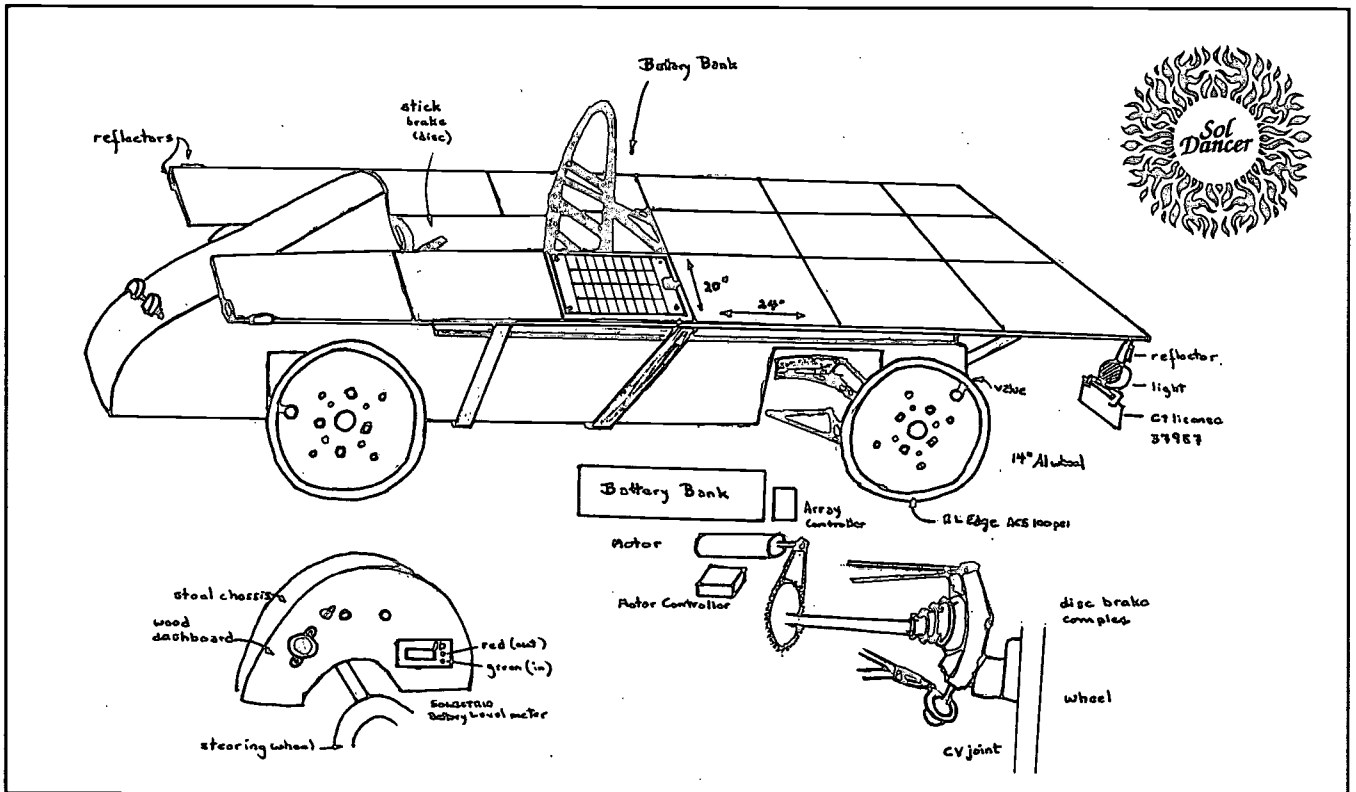

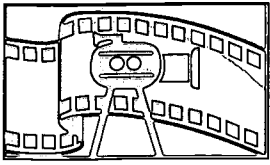

## Guiding Science Fair Participants Dartmouth Problem-Solving Approach

*Jim Housley, Dartmouth College, Hanover, NH*

**A** PROBLEM-SOLVING APPROACH promoted by the Thayer School of Engineering at Dartmouth College can be helpful in guiding students in all phases of science fair involvement, from finding an idea to completion. No previous scientific or engineering background is needed to apply the method, nor is it limited to engineering problems. The Dartmouth approach is outlined, and illustrated as applied to developing a science fair project.

□ **The Problem Statement.** A mentor's first contact with an aspiring science fair participant often begins one of two types of problem statement. The first is a very open-ended, almost plaintive, "I need an idea for the science fair." The second is highly specific, such as, "I need to find a dielectric mirror." Surprisingly, the first student may be closer to a successful project.

□ **Detecting Bias in Problem Statements.** Problem statements should not be accepted at face value. The student who wants a special mirror has started down a pathway, perhaps a blind alley, hoping for a solution. Questioning may reveal that the student plans to build a laser, and that a number of difficulties more serious than lack of a mirror await. The problem expressed to the mentor is likely a description of a perceived obstacle, and not the real problem.

□ **Redefining the Problem.** More questioning may reveal that the student actually would be satisfied to experiment with a laser, or wants to own one. Designing and building a device to use with a laser as an engineering project, or using a laser as part of a scientific investigation, may be more satisfying to the student, and result in a superior project. One or more steps backward may thus be needed to redefine the problem in terms that make it possible for the student to solve. The student who "needs an idea for the science fair" has truly expressed the problem in a way that is free of bias and preconceptions, and is ready to move forward.

□ **Developing Criteria.** A student needs not an idea,

but rather, many ideas. It's better, however, to first develop criteria by which these ideas can be judged. Some of these criteria are established by the rules of the science fair. The student's teacher may have additional criteria if the project is to be awarded credit in a science class. Additional criteria will be determined by the student's interests, skills, and other personal circumstances. These may be brought to light in one-to-one conversations or brainstorming sessions within groups.

For the student who had no ideas in the beginning, the criteria that emerge might be:

- a. Involves electronics (due to student interest),
- b. Involves study of marine environment (student wants to receive extra credit in Oceanography class),
- c. Can be completed within six months,
- d. Will involve low cost,
- e. Can be done in several hours per week,
- f. Involves research of local importance (student is competing for certain local scholarships; project would support candidacy),
- g. There is a high probability of at least modest success (this student, like many, is risk averse),
- h. Will comply with science fair and other regulations,
- i. Sounds fun! (If personal feelings aren't openly taken into account, they will likely be subconsciously considered in ways that will complicate the decision-making process.)

□ **Brainstorming Alternatives.** Now is the time for the students and mentors to suspend any judgmental attitude. Any idea for a science project should be recorded, no matter how difficult, impractical, trivial, or even silly it may appear at first glance. In the next step of the Dartmouth method, these unsatisfactory ideas will be eliminated. Therefore, any immediate criticism is unnecessary, and will tend to kill the spontaneity that helps generate good ideas.

Alternatives	-----Criteria-----									Item's Score
	a	b	c	d	e	f	g*	h*	i	
#1	-	+	+	+	+	+	+	+	o	6
#2	o	+	+	+	+	+	+	+	o	7
#3	+	-	+	-	+	-	+	+	+	3
#4	+	-	+	-	+	o	-	+	o	1*
#5	+	+	+	-	+	+	o	+	+	6

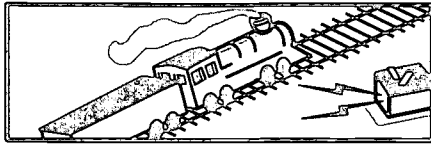

# Electricity and Trains

Karen Funkenstein & Christine McCormack  
The Winsor School, Boston, MA.

## What do you need to create an electric circuit?

### Action:

Using the diagram below, connect a battery to a switch and a bulb using wires with alligator clips.

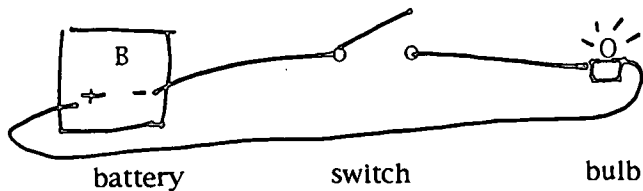

Notice the switch. Take your pencil and trace the path of electricity from the negative terminal of the battery around the wires to the positive end of the battery. You will notice a break in the path. Remember this break.

### Observations:

1. Where did you start and finish when you traced the path or electricity?
2. The path that you traced has a name. What is it called?
3. When tracing the path you were asked to remember any breaks or openings. Where did you notice any?
4. Knowing when a circuit is "open" or "closed" is another part of this activity. The up and down position of the switch or the connected or not connect position of the switch reveals the answer. If the switch is down or connected the circuit is \_\_\_\_\_. If the switch is up or unconnected the circuit is \_\_\_\_\_.
5. If the lamp is not lighted, is the circuit open or closed? \_\_\_\_\_. If the lamp is lighted. Is the circuit open or closed? \_\_\_\_\_.
6. How could the circuit be completed if the switch was removed?
7. Explain what you need for an electric circuit.

### Question:

You are stranded on a desert island. There is a city across the bay. No one knows where you are. You have with you, aluminum foil, a battery and a bulb. What can you do to be rescued? (There are shark infested waters surrounding the island and there are no trees or shrubs for raft building.)

## How to Make An Electronic Quiz Board

### What you need:

1. Bell wire or aluminum foil
2. Brass fasteners or paper clips (plain *not* rubber coated)
3. Questions and answers on electricity, chemistry, geology or nutrition
4. One piece of cardboard or poster board
5. Your homemade switch

### How to do it:

1. Write your questions and answers on either side of the front of the cardboard
2. Put one brass fastener or paper clip next to each question and answer.
3. On the back of the cardboard connect questions and answers with bell wire remembering to *strip* the wire before you wrap it around the brass fastener or paper clip.
4. Once the wire is wrapped around the brass fastener, separate the tongs of the fastener and press them against the cardboard to secure the wire. Once the wire is wrapped around the paper clip tape it to the card board to make it secure.
5. Use some cardboard to make a stand for your quiz board so that it stands up.
6. Set it up with a lantern battery, a light, your homemade switch and wires with stripped ends to use for choosing the questions and answers that go together (Hint: You can bend the stripped wires at the end into loops).

See the diagram below for the front and back of the quiz board

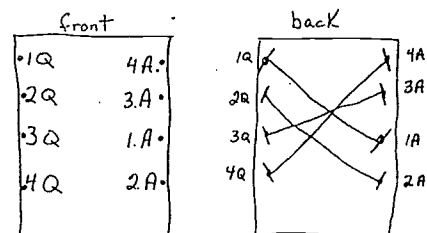

□ **First Cut of Alternatives.** Now the list of alternatives should be reduced to a more workable number, perhaps ten or fewer. This can be accomplished either by eliminating obviously less viable items, by combining related items, or both.

In the example of the student we are following, the following alternatives might survive the first cut:

1. Conduct a study at the Dipac salmon hatchery.
2. Conduct an environmental baseline study.
3. Build and make improvements to a stereo speaker system described in an electronics magazine.
4. Try to relate reception from local broadcasters to local weather conditions.
5. Design and use an instrument to remotely measure something at a depth in sea water.

□ **Selecting the Most Viable Alternative.** A matrix is now used to select the best idea for further development. In the matrix, each alternative is evaluated using the criteria developed earlier. In the professional world, this may be a highly involved process, involving developing numerical scoring systems for each criterion, together with weighting factors to express the relative importance of the various criteria. More useful at the beginning is a back-of-the-envelope approach such as shown below.

The scoring of the matrix shows Alternative #2, "Conduct an environmental baseline study," to be the most promising idea for further consideration. In the scoring, a "plus" was counted as a positive one, a "minus" as a negative one, and zeros ignored.

Two criteria, "g" and "h", are critical in the sense that any alternative that scores negative on either of these is completely unacceptable, regardless of the total numerical score. These criteria are noted with an asterisk. In this example, the one alternative, #4, that scored a negative on one of these would have been rejected even if its total score had been highest.

Besides helping the student in organizing the decision-making process, the matrix provides other benefits. It helps the student convey to science fair judges the idea that success was not just luck, but the result of original, systematic work. It also provides the security of fallback positions. If Alternative #2 proves unworkable, the matrix shows #1 and #5 to be the next to investigate.

### *Continuing The Cycle:*

□ **The Dartmouth method is a cycle.** The student has a new problem: find a suitable specific topic of study for an environmental baseline study. The same steps apply. Some of the previous criteria will apply, but some new criteria will be pertinent to the new problem. Brainstorming with local professionals should reveal a number of local baseline studies that are rich in possibilities, as well as being important to the scientific community. Again, a matrix can help select the most promising alternative.



□ **New problems will arise** What are the relevant factors to measure? How to measure them? What level of uncertainty can be tolerated? Each new problem is an opportunity to perform another iteration of the problem-solving cycle. It is impossible to predict the direction that the better projects will go.

□ **Additional thoughts** Truly individual work is becoming less common in science and in science education. The Dartmouth approach relies on group work. Although the organizers of the International Science Fair have recognized this trend by creating a group category, the bulk of the prizes are awarded in the numerous individual categories. Travel and other costs make local and regional fair organizers reluctant to send group projects on to the next level. These considerations and others make many students determined to do individual projects. A question naturally arises: How can the Dartmouth problem-solving approach be used by individuals?

My answer (which is not official) is that the individual student should be the common thread through the problem-solving path, asking advice from a large number of people, assembling a brainstorming group for one iteration of the process, and a different group for the next. The acts of contacting people, explaining the problem, and selecting among the disparate advice that any team of experts will offer should establish the project as individual work to the extent that any project of quality can be said to be the work of an individual.



# Design Technology

## Using Materials and Tools for Constructing Focusing on Using the LINX™ System

Francis Eberle, Maine Mathematics and Science Alliance, Augusta, ME.

### Science, Mathematics, and Technology (Design Technology)

Context Based ★ Connection to National Standards  
Collaborative Skills ★ Communication Skills  
Problem-Solving Skills

#### ► Context Based

1. Connected to the real world
  - a. Based on real world issues
  - b. Historical basis and work to examine
  - c. Solves a problem
2. Connected to how we think
  - a. Integrated
  - b. Process oriented rather than sequential
  - c. Ask questions and share ideas
3. Connected to national standards
  - a. AAAS Benchmarks - Nature of Science, Technology, The Physical Setting, The Designed World, Common Themes, Habits of Mind
  - b. National Science Education Standards - Science as Inquiry, Physical Science, Science and Technology
  - c. NCTM Standards - Mathematics as Communication, Problem-solving, Connections, Reasoning

#### ► Connections to National Standards National Science Education Standards (Draft November 1994)

#### Standard Topic (Characterized by):

##### Science as Inquiry

Understand and do scientific inquiry  
(Do an investigation for some purpose)

##### Physical Science

Properties of objects and materials  
Position and motion of objects  
(Use materials and see how they differ.  
Experience the motion of vehicles and what effects their motion)

##### Science and Technology

Understand technological design  
(Use problem-solving in designing a model)

##### History and Nature of Science

Science is a human endeavor  
(See their vehicles are similar to real ones, and that people design and test vehicles in life)

#### Unifying Concepts and Properties

See how evidence and models help explanations.  
(Make models. Observe performance of models.  
Change models and record what happens)

#### National Council of Teacher of Mathematics Standards (NCTM)

#### Standards (Characterized by):

- #2. **Communication**  
(Students write about and draw their design and the results of their testing with the design)
- #3. **Reasoning**  
(Changing variables such as ramp height and making predictions about the results)
- #4. **Connections**  
(Changing variables and predicting the results)
- #5. **Estimation**  
(Predicting behaviors by experimental conditions)
- #8. **Whole Number Computation**  
(Adding, measurement and figuring distances)
- #9. **Geometry and Spatial Sense**  
(Drawing vehicles in front and side views.  
Constructing from a two dimensional drawing)
- #10. **Measurement**  
(Designing, cutting, building and collecting)
- #11. **Statistics and Probability**  
(Collect, organize, describe and interpret data)

#### Benchmarks for Science Literacy (AAAS)

#### Benchmark (Characterized by):

##### The Nature of Science

Scientific Inquiry, Scientific Enterprise  
(Carrying out an experiment, collecting data and describing results, realizing team work is okay)

##### The Nature of Mathematics

Patterns and Relationships.  
(Discovering that shapes can be found in designs  
Vehicles can be made to move in certain ways and directions)

##### The Nature of Technology

Technology and Science, Design and Systems  
(Using tools to make things. Following directions and asking questions. Use a model to solve things.  
Learning not everything can be made accurately)

### The Physical Setting

Motion, Forces of Nature  
(Seeing that objects move in different ways, and that you can change motion by pushing or pulling)

### The Designed World

Materials and Manufacturing  
(Discovering that some materials are better than others, and some can be used again. Taking several steps to make something)

### The Mathematical World

Explain your ideas. Uncertainty, Reasoning  
(Learning that some things can be predicted and others can not. Seeing we don't always know why things happen)

### Common Themes

Systems, Models, Constancy and Scale  
(Using models with parts and that have a change, function. Seeing models are different from real life.)

### Habits of Mind

Values and attitudes, Manipulation, Observation, Communication skills, Critical-Response Skills  
(Learning to ask questions and seek answers. Construct a model to carry out a task. Describe and draw models)

#### ➤ Collaboration Skills

- Asking for other's opinions.
- Listening.
- Reflecting on what has been said.
- Being concise.
- Giving reasons for ideas.
- Allowing everyone to contribute.
- Pulling ideas together.
- Finding out if a group is ready to make decisions.

#### ➤ Communication Skills

- Planning for a project or idea.
- Drawing and designs for the projects.
- Planning the use of materials, tools, and resources.
- Makes drawings of ideas.
- Prepares steps for construction and assembly of project.
- Collect and communicate results from the performance of the project or model.
- Write about the project.
- Prepares final work as a collection of all previous work: drawings, writing, models, and final presentation of the idea.

### Concept Map for Design Technology

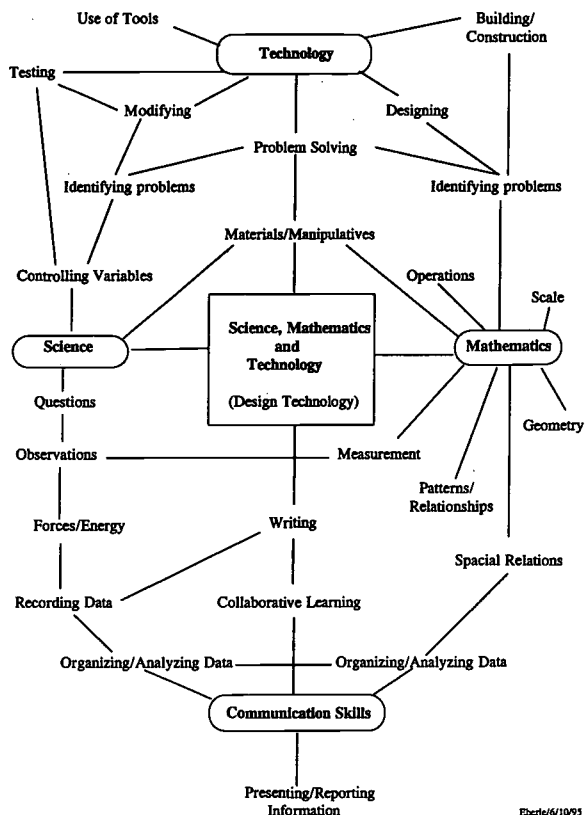

#### ➤ Problem Solving Skills What Do We Mean?

- **Open Ended:** Students are provided no questions to investigate, given no materials, and no plan of action. *(This is most like what a scientist does.)*
- **Guided:** Students are given questions to investigate, but no plan and no materials.
- **Directed:** Students given questions, plan or steps, and materials to complete the problem. *(Step by step—most like typical science activity.)*
- **Demonstration:** Give question, materials and plan, and students watch and comment.

#### ➤ Science, Mathematics and Technology Background

##### Science

The concepts that can be taught from LINX projects are the scientific inquiry process and many physical science ideas. The scientific inquiry process concepts are problem solving, questioning, exploring, experimenting and evaluating. The physical science concepts are the forces of gravity and friction, and the measurement of a vehicle's speed.

The forces students will be observing are gravity and friction. Gravity causes the vehicles to go down, i.e., fall to the floor, and roll down ramps. Other forces can act against gravity, such as the wind. This force is greater than gravity so it moves the vehicle ahead. Once it is moving it has gained inertia, a force related to the mass and speed of the vehicle. Inertia (another force working against gravity) can carry a vehicle against gravity until it is not as strong as gravity. The other force is friction. It is due to two surfaces being in contact. Friction in the students' vehicle will show up in many places, in the axles, between the wheels and the ramp, and wheels and floor. Friction will slow the vehicle because friction works against gravity or any other force exerted on a vehicle. Friction can be reduced in many ways: oil, graphite or silicone.

The measurement of the movement of the vehicles can be done using different units, but the reason to measure is to answer the questions, "How far did my car go?" or "How fast did my car go?" Distance can be measured with premeasurement units like paper clips, etc, or using feet, meters, or centimeters. Speed is the way we describe how fast something is going. It is defined as the distance a vehicle travels during a particular length of time. For example, inches per second, feet per minute, or meters per second are all measurements of speed. To calculate speed you need to divide the distance by the time it took to travel that distance:

$$\text{SPEED} = \text{Distance/Time}$$

The measurement of the results allows the children to look back and compare. It helps them then predict what might happen if a different variable was changed in the vehicle.

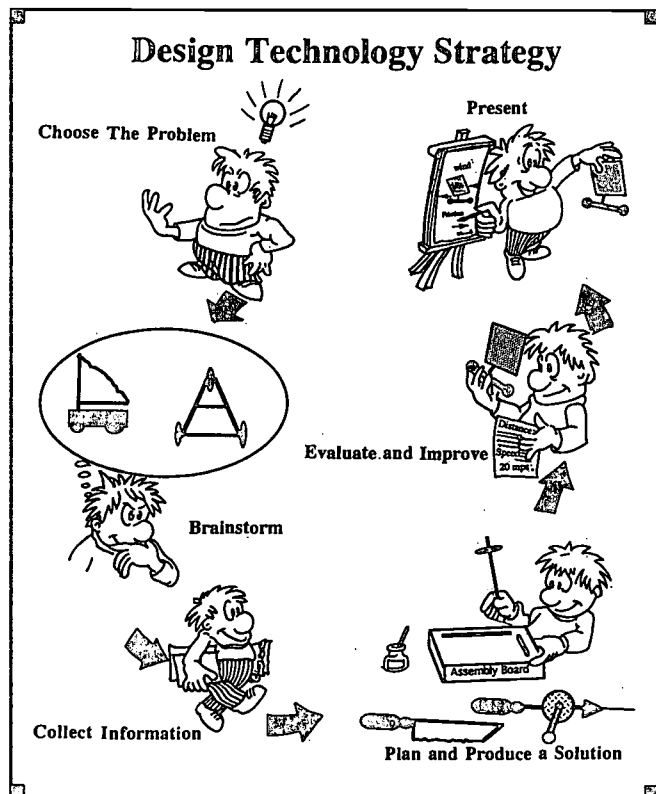

## Mathematics

The mathematics concepts are computation, geometry, data gathering, surface area, presentation of data, interpretation of data and estimation. Geometry can be used in the shape of the vehicles or sails. More subtle, however, is the practice students will have in developing spatial relationships. By having the students draw their vehicles, in the design part of the activities, they have to visualize three dimensions and convert to two dimensions. What do shapes look like from the other side or from a different angle? Having them draw their vehicle from a top and side view will do this. Data gathering and displaying data is a must when doing these activities. The data allows for children to look for patterns, make estimates and compare their results of the different vehicles. Make a bar graph of the distances traveled; another display could be the speed of the vehicles and size of sail.

More complex areas can be discussed: relationship between variables (algebra), and statistics by manipulating variables and then having students use prior data to make predictions. Students can use the statistics to make informed decisions about the performance of their vehicle.

## Technology

The technology concepts are problem-solving, design, materials identification and selection, construction, testing and assessing results. The process in technological problem-solving involves several steps:

1. Defining a problem
2. Proposing a solution
3. Experimenting
4. Analyzing the result
5. Evaluating the process

As a part of the problem-solving process, having children draw their vehicles is a good task. It builds many skills in children. This designing is a step often left out.

For children at this age, material exploration is exciting. They will want to look at everything and try most of it. Have ready what is needed for the task and other materials that they can use such as posterboard, cardboard, paper towel tubes, pipe insulation, paper fasteners, plastic, rug samples, sand paper, beads, etc. It will allow them to become familiar with those materials.

Always use tools safely and emphasize that with your students.

## Assessment: What Do You Look For?

Trying to determine what children learn is difficult, but it becomes more complex when they learn through completing tasks as in LINX™ projects. A Design Challenge usually contains several steps and therefore each step or activity of the challenge can be examined for assessment purposes, or the whole project can be assessed. A collection of the steps in a design challenge can be kept in a portfolio or project folder. It is most important to decide why and how you want to use the



information collected from the student. Will it be information for you to adjust instruction, or is it for establishing levels of a student's ability or skills? Once you decide, then selecting which pieces of work should not be and should not assessed will be easier.

Here is a chart using some examples of student work as a result of a Design Challenge. It provides examples of what information you might assess and how you might assess a student's progress.

<p><b>A Design Drawing</b> Accuracy of Measurement • Spatial Relationships • Completeness of Drawing • Units of Measurement</p> <p>You could select one or all of these things to examine: A rubric with a range of 1-5 (1=none and 5=uses well) might be another approach here. Check actual measurements: Is the drawing in perspective? • Is the drawing complete? • Did they use a unit of measurement? • How many perspectives did they use? • Did they write anything to describe the design?</p>
<p><b>A Complete Model</b> Constructed properly • Does it function as described in the challenge? • Aesthetically pleasing.</p> <p>You could test the model and look at how it is put together. Using a Rubric ranging from done to not-done could meet the objectives here. Roll it, How does it move? • Look at the joints, Are they solid? • Was there care taken for how looks? • Is there any unusual construction? • Any unusual use of materials? • What care was taken for appearance?</p>
<p><b>Data Display</b> Is it clear? • Is it accurate? • Is it a display taught in class? • Does it represent the results of the activity undertaken?</p> <p>Again, a Rubric looking for the features you want the students to be able to do could be used here to assess these characteristics: What information is displayed? • Does it help explain information? • Are the techniques used as taught? • Are patterns made clear?</p>
<p><b>Project Portfolio</b> For a project portfolio students would keep all the work completed during their work. You can then look at each piece of work and determine if they met the expectations you had for that work. Another method for assessing whether students understand the goals of the program is to give them a Design Challenge that incorporates the knowledge and skills you want them to learn. Then the design challenge becomes a performance task.</p>

## > Winding Away

Alternative power vehicles are becoming more important with the high cost of fossil fuels. Many different sources of energy have been studied and suggested. What other sorts of energy sources can be used to move vehicles?

### Design Challenge:

Design and make a vehicle that will move as far as possible using the power of a rubber band.

Use a piece of graph paper to sketch out your designs. When your model is complete, draw the vehicle in detail.

How far do you think it will go?

What supplies the energy for your vehicle?

Test your vehicle several times to see how it goes. Keep a record of your tests in the data chart. Note any special design features.

### DATA CHART

Name of Vehicle	Distance (d)	Time (t)	d/t = speed
Trial 1			d/t =
Trial 2			d/t =
Trial 3			d/t =
Average (Sum + 3 = Av.)			

### Questions:

What surprised you in how far your vehicle traveled?

Now that you know it goes, what might you change to see if it goes better?

Did changing the number of rubber band twists change the way your vehicle moves? How?

Discuss with your group an investigation you can do using your vehicle. Select something to change (wheels, surface, # of winds, etc.), and then test how it goes.

Make predictions then try them out.

Predicted Distance \_\_\_\_\_ (cm)

Predicted Speed \_\_\_\_\_ (cm/sec)

### DATA CHART

Name of Vehicle	Distance (d)	Time (t)	d/t = speed
Trial 1			d/t =
Trial 2			d/t =
Trial 3			d/t =
Average (Sum + 3 = Av.)			

How did this set of trial compare to your first set? Make a graph showing the relationship.

What would you now change to make your vehicle even better?

Write a paragraph about designing, making, changing and testing this vehicle. Was it difficult? What was fun? What would you do next?

## > LINX™

Create a grid on a sheet of paper, then draw what you want to build with LINX™. Show a top view and side view. Include a legend showing scale. Label important features of your design.



## ☰ Some Suggested Classroom Strategies

### For Gender Equity in Math, Science and Technology



- Create a positive learning environment that is organized, perceptually stimulating and well equipped. (It reduces the potential for less aggressive people to be left out because not enough equipment is available.)
- Create a positive learning environment that encourages skill building and communication by all rather than to weed out all but the top students. (A teacher's style has more influence on girls' future decisions than does the gender of the teacher.)
- Encourage cooperative learning in which students are equals. Girls can work in small groups. (Small group work means less opportunity for domination.)
- Look for books that emphasize practical application before introducing a technical concept.
- Introduce new concepts by using topics that are familiar to girls. (This doesn't mean sex stereotyped things like vacuum cleaners, but includes societal issues or people.)
- Use lessons that have more than one possible approach to solve a problem.
- Use lessons that have manipulatives or are "hands-on" in some way.
- Use lessons that have some relevance to the life of the student. (Historical connections or experiences of people with the field rather than a body of facts.)
- Use lessons that allow students the freedom to explore, try things out and make mistakes (and discoveries) without being evaluated.
- Use lessons that have an end product. This could include sketches and drawings of an experiment. (This helps the need for experimentation to be relevant.)

#### For more information:

Francis Eberle □ Maine Mathematics and Science Alliance □ P.O. Box 5259, Augusta, ME 04332  
phone: (207) 287-5881 □ E-mail: feberle@mmsa.agate.net



## ☰ Club GirlTech Technology Patches

([www.girltech.com](http://www.girltech.com))

Girl Tech has produced a technology curriculum to encourage girls to use and have fun with the Internet. Girls who complete the program will earn Technology Patches. They have also produced a wonderful book titled "Tech Girls' Internet Adventures" with basic information about the internet, chat rooms, bulletin boards, girl-centered sites to visit, e-mail, special subjects on-line, Internet scavenger hunts, etc. Also included is a CD ROM which offers one month free Internet access via The Microsoft Network along with instructions on how to build a home page.

#### For more information:

GirlTech, 851 Irwin Street, Suite 100, San Rafael, CA 94901  
phone: 415-256-1510 □ fax: 415-256-1515 □ E-mail: grltek@aol.com □ Internet: <http://www.girltech.com>

# Computing License Check List



Penrhos College Middle School  
Graham Rixon, Principal  
Penrhos College, Western Australia.

**I**N ORDER TO ACHIEVE a computing licence at our school, students must demonstrate that they can perform all of the following skills.

To give students the opportunity of making a good start in computing, we hold 4 sessions during Orientation Week followed by time in class to progress towards completing their licence. When they begin, they are given five booklets to complete:

### Booklets:

- Introduction to the laptop computers
- Word processing
- Spreadsheets
- Drawing
- Information Retrieval

### Instructions:

During Orientation Week your teacher will guide you through the Introduction booklet. Following this, you should work through the booklets carefully and at your own pace. Make sure you read all the instructions carefully. This is essential in completing all the exercises. When you have completed a booklet, review the check-lists below and check off items that you have mastered, as well as those that might need a little more work.

*After completing the Introductory Booklet, I feel confident that I can:*

- Use all the keys on the keyboard
- Use the mouse/trackball
- Format a floppy disk
- Save a document to a floppy disk
- Open a document from a floppy disk
- Print a document
- Open Works
- Quit Works

*After completing the Word Processing Booklet, I feel confident that I can:*

- Enter and edit text
- Format text by altering
  - font
  - size
  - style
  - line spacing

- Use the spell check feature
- Position text by using
  - paragraph alignment
  - indents
  - tabs
  - add headers and footers

*After completing the Spreadsheet Booklet, I feel confident that I can:*

- Identify rows and columns
- Enter data (text and numbers)
- Enter simple formula
- Draw and format charts

*After completing the Drawing Booklet, I feel confident that I can:*

- Use regular shaped drawing tools
- Duplicate objects
- Rotate objects
- Arrange objects
- Group objects



*After completing the Information Retrieval Booklet, I feel confident that I can:*

### Use Dynix Automated Library System to:

- Identify the right type of search
- Use search items
- Refine and revise a search
- Identify possible resources
- Evaluate resources

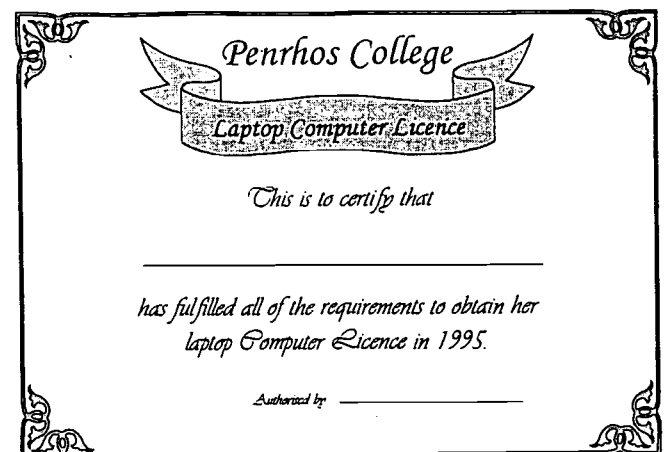

### Use the CD ROM applications to:

- Show basic skills in MS Windows
- Manipulate data
- See the right application for the task
- Save the data to a floppy disk
- Reference applications

# Integrating Math, Science, and Technology

## Problem Solving Through Group Dynamics

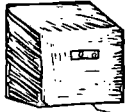

High School Prism, March 1993  
Dan Bavelaar • Paul Hartley • Virgil Valente



### Project Objectives

#### The student will:

- ◇ Have fun while applying the engineering process.
- ◇ Develop constructive group dynamics.
- ◇ Brainstorm without criticism.
- ◇ Suggest topics to investigate.
- ◇ Identify and develop specifications.
- ◇ Justify decisions.
- ◇ Effectively use a variety of library and data resources.
- ◇ Apply writing skills to maintain a journal.
- ◇ Use the scientific method to conduct appropriate experimentation and testing.
- ◇ Use appropriate connections between math and science to analyze results and draw conclusions.
- ◇ Present findings in a public forum.
- ◇ Learn problem solving techniques that can be applied in any situation.
- ◇ Have opportunity to observe application of CAD.
- ◇ Experience "hands-on" in construction of a project.

### The Problem

Build a device which will throw a standard eraser a distance of 5 meters.

#### Restrictions

1. The original motion must not be in the same direction as the target.
2. An accounting of the cost must be maintained and the \$10 given to each team must not be exceeded.
3. The size of the device must not exceed 1 meter in any direction.
4. The distance of 5 meters is to be measured from where the eraser is resting when the device is armed.

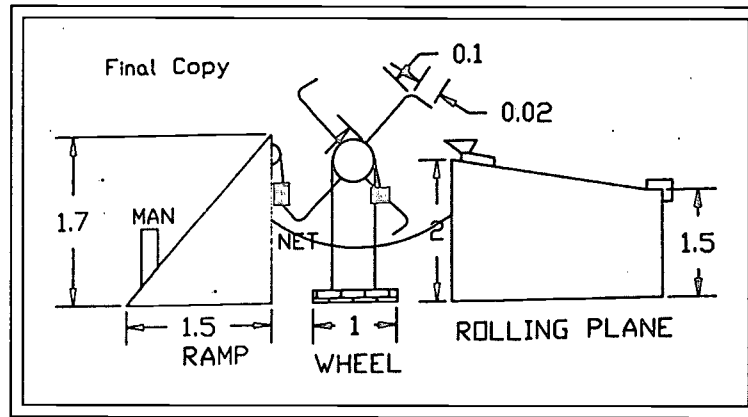

5. The materials used must be unassembled pieces before being used in the device.

6. Any common materials found around the home or garage may be used and need not be figured when determining the cost of the device.

7. Device cannot be a simple bow and arrow or sling shot.

### Time Table

9/30-10/7	Research of the problem
10/7-10/21	Designing the device
10/14	Progress report due
10/21	CAD design due
10/21-11/4	Construction of device
10/28	Report due
11/4-11/16	Testing of device
11/16	Final written reports due Competition in class during week

### Report Requirements

All groups will be required to keep a log book and record all group activities ( brainstorming, discussions, etc.)

#### 10/14 Report (20 pts)

1. Minutes of brainstorming sessions and an accounting of how responsibilities will be shared within group.
2. A listing of the math relationships or formulas which will be used in solving problem.
3. A statement of who has done what to date.
4. A rough sketch of all parts of the apparatus as planned at this point.
5. A list of possible sources of error and plans to overcome them.
6. A narrative describing how design evolved.

**10/21 Report (15 pts)**

Presentation of CAD drawing.

**10/28 Report (5 pts)**

- 1. A dated log of construction progress to date.
- 2. A statement as to nearness of completion.

**11/16 Final Report (20 pts)**

- 1. All previous reports.
- 2. Data from testing (tables and graphs would be nice).
- 3. A statement of expenditures.
- 4. A list of modifications to design made after testing.
- 5. An evaluation of exercise including:
  - a. Was it worthwhile for you?
  - b. What did you learn about group dynamics?
  - c. What parts did you enjoy?
  - d. What things should we change next time?
  - e. Any suggestions for another activity?
- 6. List the contributions of each member of the group.

**Week of 11/16: Presentation (25 pts)**

- 1. An oral presentation with a demonstration of the effectiveness of device to judges. See project evaluation sheet for criteria of oral presentation.

**Accuracy of device: (15 pts)**

within 25 cm of target	15 pts
within 50 cm of target	12 pts
within 75 cm of target	9 pts
eraser leaves device	6 pts

**Report Requirements**

**12/22 Report (25 pts)**

- 1. Minutes of brainstorming sessions and an accounting of how responsibilities will be shared within the group.
- 2. A rough drawing of all parts of apparatus.
- 3. A narrative showing how design evolved into final design.
- 4. A list of possible sources of error and plans to overcome them.
- 5. A listing of math relationships or formulas which will be used to determine how potential energy is converted to kinetic energy in each part of device.

**1/15 Assignment (10 pts)**

Complete CAD drawing due; requirements set by teacher.

**2/1-2/5 Final report (30 pts)**

- 1. Previous report.
- 2. Data from testing.
- 3. A statement of expenditures.
- 4. A list of modifications to design made after testing.
- 5. Determination of changes in potential and kinetic energy while device is operating.
- 6. An evaluation of exercise including:
  - a. Was it worthwhile to you?
  - b. What did you learn about working in groups?
  - c. What parts did you enjoy?
  - d. Did you find this project enjoyable? challenging?
  - e. What things should we change next time?

**2/1-2/5 Presentation (20 pts)**

- 1. Oral presentation should include first five sections of final report.
- 2. See separate sheet for criteria used in judging.

**Accuracy (15 pts)**

Marble makes the box	15 pts
Mechanisms work but not in box	13 pts
Malfunction	10 pts
Design problems caused failure	5 pts

**Project Evaluation Sheet**

Point values should be assigned for each category between zero and the maximum as listed in ( ).

- 1. **Appearance:** (10) Is there neatness of construction? Has an effort been made to create an aesthetically pleasing project?
- 2. **Design:** (15) Is there clear explanation as to how the group came to the final design? Is it evident that various designs were considered?
- 3. **Creativity:** (15) Is there evidence of ingenuity in design? Is the design attractive?
- 4. **Experimentation:** (20) Is there evidence that adequate experimentation was performed? Was data recorded and interpreted?
- 5. **Oral Presentation:** (25) Is project presented in a logical manner? Is it easy to follow chronologically?
- 6. **Analysis:** (15) Is it evident that appropriate mathematical analysis has been used to interpret data?



# Practice Problems

At Gordon, Staffordshire Technology Education Program



**T**HE TYPES AND NUMBERS of problems which can be worked on is limited only by our imagination. This section offers some suggestions for teams to use in practice.

These problems have various degrees of difficulty and involve principles in various disciplines. Most problems can be accomplished with very little material costs. Teachers and coaches should be ready to see the fun and humor in the solving of these problems. Divergent, or unusual solutions, should be encouraged at all times. When students present their solutions, a valuable and enjoyable experience can be had by all.

## • The Mousetrap Mobile

Design a method to transport a brick (weighing six pounds) a distance of 13 inches over a relatively smooth, level floor. The source of power to be used is a standard, regular, normal, everyday, no nonsense mousetrap.

## • The Egg Package

Design a package which will contain three medium size, natural, uncooked chicken eggs. The package must protect its contents when thrown or dropped from a height of eight feet onto a hard surface such as concrete or blacktop. The volume of the package may not exceed 100 cubic inches. Food stuffs, such as gelatin, may not be used.

A second part of the problem may be to design a device which will throw the package a minimum height of eight feet into the air. The throwing device may not exceed three pounds in weight. This second part of the problem may be omitted if the teacher allows the students to drop the egg from a second story window onto a hard surface.

## • The Firemouse

Design a device utilizing a mousetrap which will put out the flame of a typical birthday candle.

### Limitations

1. The only source of energy allowed is a typical mousetrap.
2. A maximum of \$2.00 may be spent including the mousetrap.
3. There will be no group projects.
4. The operator cannot put the mousetrap within 36" of the candle. The mousetrap can be  $\pm 6"$  from the base of the candle.
5. The operator will have one chance to put out the flame without penalty. Each additional attempt is penalized minus one point. If the candle flame is put out on the first try, 25 points are awarded. Team scores may be added together. If the candle burns itself out before being extinguished, no points are awarded.
6. The device has to put out the flame within the limit of the candle's normal life. If the flame goes out of its own accord, the student will not have met the problem requirements.

## • What Goes Down?

### Challenge

Design and construct a device for delivery of a payload, (4 small washers) to the ground, from 1.5 meters up, and land in exactly 2 seconds.

1. This challenge presents an interesting dilemma. Keep track of your process again, and record all important data collected for your device. For example; How many different materials did you try before settling on one? How much material did you use? How many trials did you have and what results did they present?
2. When you have accomplished this task, add to the capabilities of your device. For example:
  - a. Have it land in a specific, small as possible, area, 30cm diameter circle, whenever you want it to.
  - b. Make it fall as slowly as possible.
  - c. How much change in the amount of material is needed with a heavier payload to meet the same criteria? (4 large washers)

d. Is there a relationship to the amount of material and weight for this time limit to land on the ground? How do you know?

3. Other ideas to extend and experiment with are: a. Have the device land as far as possible from the launching point. b. Put an egg as the payload and launch from high up, like a roof top. c. Have the device launched from 3 meters up in the air. What sort of launching device is needed?

### o What Now, Its Dark?

You are driving home from work after dark and your car stops running. Your car has this problem and all you have to do is connect a wire that often comes loose and your car starts. Unfortunately you are on a very quiet road and if you wait for the next car to come by it might be several hours. You get out to fix the wire and the car headlights go out. Now what, you say?

Luckily, you remember you have some materials in your car that might help. You will need to:

#### **Challenge:**

Design and construct a flashlight, *with a switch*, from those materials. The flashlight must be able to be turned on and off so you don't drain the only batteries you have.

For reporting & displaying purposes the following is suggested:

1. What process did you undertake?
2. What is your data?
3. What conclusions did you make?
4. What AAAS Benchmarks were involved by doing this activity?
5. What materials and resources did you use?
6. What artifacts do you have to show your process and result?

### o Child's Wheeled Toy



#### **Context:**

As Christmas approaches, the local kindergarten wishes to provide each child with a small wooden wheeled toy that contains some moving or rotating parts which converts the rotating movement into reciprocating movement to encourage exploration.

The principal has asked your TSA chapter to provide the toys at the minimum cost.

#### **Need:**

To design and develop a low cost wooden toy that contains moving parts. The toy should be based upon an animal or cartoon figure and be safe and colorful.

#### **Additional Information:**

This activity could bring together the organization of a TSA chapter and the entrepreneurial activities to do with design, manufacture and marketing of a successful product.

### o Robotic Arm Technology

#### **Challenge:**

NASA needs your help. The astronauts have to catch and repair a tiny satellite on their next mission. They are filling every empty space on the shuttle with top secret science experiments, so they will not be able to take the MMU's with them. The large Canadian robotic arm will not work because this satellite is too small and delicate. The astronauts will have to catch the broken satellite with a new smaller robotic arm. Your assignment is to design a robotic arm for the next space shuttle mission. Your robotic arm will have to catch the satellite, bring it back to the shuttle, and after repairs release it.

#### **Design Specifications**

- ★ Every robotic arm **must** have at least two gears on it.
- ★ Every robotic arm **must** use pneumatics at least once.
- ★ To catch the satellite, your robotic arm will have to be able to **swing** in a 180 degree arc.
- ★ The satellite will have a small bar hanging from the bottom. The bar will have a small magnet on it.

**GOOD LUCK, DESIGNERS!**





## Building Technology Confidence Through Hardware Installations and Set-up



by Tracy Anne Sena  
Convent of the Sacred Heart High School, San Francisco, CA.

**R**ECEIVING A BUNDLE OF NEW COMPUTERS in the middle of the school year could have been disruptive to the smooth running of our computer lab as the new units needed not only to be unpacked, but have ethernet cards installed, loaded with software, and then configured to run on the school's network. Additionally, the set-up also included first harvesting ethernet cards from the computers which were being replaced before these older models were moved to un-networked study areas around the school. Rather than having one or two technology teachers spending days at repetitive tasks which they already very well knew how to do, we decided to have our students do the work in the space of two 80-minute class blocks. The focus here will be on the students who were involved in the actual hardware installations.

One section of the freshman Computer I class (which normally spends one grading period learning word processing and a second learning BASIC programming) was given the opportunity to harvest ethernet cards from LC Macintosh computers and install them in new PowerMacs. Hoover Chan, the school's network administrator, gave the students the basics in working with electrical components, instructing them on how to ground themselves and how to avoid picking up additional static electricity. The students then set about opening the CPU's.

Working in pairs, many of the young women found themselves holding a screwdriver for the first time; none had cracked a computer case before. Mr. Chan toured the students through the components of the motherboard, explaining where the basic functions which the students already knew the computer performed took place. After identifying the RAM SIMMS, co-processors and the disk drives, the students found the ethernet cards and positioned themselves to remove them. Most students were initially timid about pulling out the cards, but after exerting the final tug which released the cards from the boards, confidence in handling the computer components began to build. After setting the cards aside on mouse pads, the CPU's were quickly dusted with compressed air, reassembled, then put aside.

Opening the new computers and sliding out the motherboards gave the students a second perspective on the inner workings of the CPU. Following another brief instruction period, the pairs quickly removed the covers to the ethernet ports, inserted the cards, and re-seated the motherboards. With a final turn of Phillips screwdrivers, the power plugs were connected and all the computers resounded with the familiar Macintosh start-up chord. When the students were finally instructed to set the network control to utilize ethernet, it became obvious to each student that her team had indeed installed its card correctly.

The students' written reflections on this experience helped many of them to realize that they were competent to tackle a project which was intimidating just hours earlier. Their young women's responses are telling of the confidence which they gained in dealing with computer hardware by engaging in this short exercise:

*"[This] was a first for me. I had never even tried to look inside of my computer. I always wanted to, though. I learned a couple of new tips that day, like stand in one place and don't move around that much because there is a lot of static electricity circulating. Also, you should touch the ground prong on the plug so that you have the same voltage as the [computer] ...It was a once in a lifetime experience."*

♦ Melissa

*"I was apprehensive at first about even touching the inside of a computer for fear of somehow damaging it.... Over all, the experience taught me a lot about installing and led me to be more confident when working with computers. This hands-on learning opportunity really helped me to understand the whys and hows of installing."*

♦ Gillian

*"...Now that everything was done, I thought, "It wasn't so bad after all..."*

♦ Kimiko

*"When I went home I wanted to take apart my computer and look at the inside. In the beginning I was nervous about destroying the computer because I have had some problems with doing that before... But I lost this feeling... This experience made me look at computers in a whole different way."*

The students almost unanimously agreed that their confidence in handling computers and their components was increased from this hands-on session. Additionally, many students expressed that they had been curious about the computer components, but had never been given the opportunity to explore, or that they felt timid about initiating such investigations. Because of the students' enthusiastic responses, we have decided to rethink how we go about installing computers around our school and employ student help wherever possible. Not only do technology teachers and staff save time, but students take on a sense of pride and accomplishment when they are called upon to perform these tasks. A win-win situation. Imagine that.





## Selected Bibliography Additional Resources

- **A Hand Up: Women Mentoring Women in Science.** Washington, DC: Association for Women in Science, 1995.
- Appleton, Helen (Ed). **Do it Herself: Women and Technical Innovation.** London: Intermediate Technical Publisher, 1995.
- Ardley, Neil. **"How Things Work: 100 Ways Parents and Kids Can Share the Secrets of Technology."** Pleasantville, NY: Reader's Digest Association, Inc., 1995.
- "Beyond Equal Access: Gender Equity in Learning with Computers." *Women's Educational Equity Act Publishing Center Digest.* Newton, MA: Education Development Center Inc., June, 1992.
- Campbell, Patricia B. **Encouraging Girls in Math and Science.** Newton, MA: WEEA Publishing Center, 1992.
- Clayfield, Helen and Robyn Hyatt. **Designing Everyday Things: Integrated Projects for the Elementary Classroom.** Portsmouth, NH: Heinemann Press, 1994.
- Cobb, Kitty B. and Catherine R. Conwell, eds. **Science EQUALS Success.** Charlotte, NC: Charlotte EQUALS, 1988.
- Countryman, Joan. **Writing to Learn Mathematics: Strategies that Work, K-12.** Portsmouth, NH: Heinemann Press, 1992.
- Featherstone, Heather. **"Girls' Math Achievement: What We Do and Don't Know."** *Harvard Education Letter*, January, 1986.
- Girl Tech. **Tech Girl's Internet Adventures.** Foster City, CA: IDG Books Worldwide, 1997. (includes CD-ROM)
- "Girls and Math: Enough is Known for Action." *WEEA Publishing Center Digest.* Newton, MA: Education Development Center Inc., June, 1991.
- **Girls and the Physical Sciences: Symposium Highlights.** Concord, MA: National Coalition of Girls' Schools, 1993.
- Hanson, Katherine. **"Gender Discourse and Technology."** *Center for Equity and Diversity Working Paper 5.* Newton, MA: Education Development Center, 1997.
- Henderson, Charles. **Develop a Favorable Environment for Technology, Ten Ways to Cure Technophobia, Resources to Help Bring Your Faculty on Board for Technology.** Wilmington, DE: Independent School Management, May, 1995.
- Hendler, Marjorie R. **Studying Science, Math and Technology: A Parent's Guide to Programs, Places and Publications.** New York, NY: City University of New York, Center for Advanced Study in Education, 1990.
- Honey, Margaret, et al. **"Girls and Design: Exploring the Question of Technological Imagination."** *Center for Children and Technology Newsletter*, New York, NY: Educational Development Corporation, July 1991.
- Hulme, Marilyn A. **Equity Materials in Mathematics, Science & Technology: A Resource Guide.** Philadelphia, PA: Mid-Atlantic Eisenhower Consortium for Mathematics and Science Education, 1995.
- Hulme, Marylin A. **Family Tools and Technology.** New Brunswick, NJ: Rutgers Consortium of Educational Equity, 1996.
- Hulme, Marylin A. **Family Tools and Technology: A Selected Bibliography.** New Brunswick, NJ: Rutgers Consortium of Educational Equity, 1996.
- Kinkoph, S., et al. **Computers: A Visual Encyclopedia.** Indianapolis, IN: Alpha Books, 1994.
- Macaulay, David. **The Way Things Work.** Boston, MA: Houghton Mifflin Co, 1988.
- **Math and Science for Girls: The Complete Proceedings.** Concord, MA: National Coalition of Girls' Schools, 1992.
- **Math and Science for Girls: Executive Summary and Task Force Reports.** Concord, MA: National Coalition of Girl's Schools, 1992.
- Matyas, Combs, and Ehrenfield. **Girl Scouts, Science, and Mathematics Linkages for the Future: A Workshop Manual for Adult Leaders.** Washington, DC: American Association for the Advancement of Science (AAAS), 1991.
- McMurdy, Deirdre. **"Gender and Numbers: Women Still Shy Away from Math and Science."** *McLean's Special Report*, Nov. 9, 1992.
- Messenger, Mildred (Ed). **The House That Jill and Jack Built.** Berkeley, CA: Berkeley Unified School District, 1976.
- Miranker, Cathy and Alison Elliott (Eds). **Computer Museum Guide to the Best Software for Kids.** New York, NY: Harper Perennial, 1995.

- **NAIS List of Math/Science/Technology Resources for Educating Girls.** Washington, DC: National Association of Independent Schools.
  - National Association for Women in Education. *"Initiatives: Gender Equity in Math and Science, Parts 1 and 2."* Journal of NAWE, Vol. 55, no. 2 and 3. Washington, DC: Edpress, 1992.
  - Pollina, Ann. "Gender Balance: Lessons from Girls in Science and Mathematics." *Educational Leadership*, Vol. 53, No. 1, Sept. 1995.
  - Rayman, Paula and Belle Brett. *Pathways for Women in the Sciences.* Wellesley, MA: Wellesley Center for Research on Women, 1994.
  - Sanders, Jo. *Lifting the Barriers: 600 Strategies that REALLY WORK to Increase Girls' Participation in Science, Mathematics, and Computers.* New York, NY: Center for Advanced Study in Education, 1994.
  - Sanders, Jo and Starla Rocco. *Bibliography on Gender Equity in Mathematics, Science and Technology: Resources for Classroom Teachers.* New York, NY: Center for Advanced Study in Education, date?
  - *The Scientist Within You: Experiments and Biographies of Distinguished Women in Science.* Eugene, OR: ACI Publishing, 1996.
  - Stanley, Autumn. *Mothers and Daughters of Invention: Notes for a Revised History of Technology.* Metuchen, NJ: Scarecrow Press, 1993.
  - Thompson, Valerie and Judith Love Cohen. *You Can Be A Woman Zoologist.* Culver City, CA: Cascade Pass, 1992. Series also includes *You Can Be A Woman Engineer, You Can Be A Woman Architect, You Can Be A Woman Marine Biologist.*
  - Tobias, Sheila. *Overcoming Math Anxiety.* New York, NY: Norton, 1978.
  - Tobias, Sheila. *Succeed with Math.* New York, NY: College Entrance Examination Board, 1987.
  - Tobias, Sheila and Carl Tomizuka. *Breaking the Science Barrier.* New York, NY: College Entrance Examination Board, 1992.
  - Tunstall, Margaret (Ed). *Girls and Science: Link Up With the Future.* Washington, DC: AAAS, 1995.
  - Turkle, Sherry. "Computational Reticence: Why Women Fear the Intimate Machine." *Technology and Women's Voices*, Cheris Kramerac (Ed). New York, NY: Pergamon Press, 1986.
  - Turkle, Sherry. *Life on the Screen.* New York, NY: Simon & Schuster, 1995.
  - Vetter, Betty M. *The Status of Women Scientists and Engineers in the U.S.* Washington, DC: AAAS, 1995.
  - Warren, Rebecca Lowe and Mary H. Thompson. *The Scientist Within You.* Eugene, OR: ACI Publishing, 1995.
  - White, Patricia E. *Women and Minorities in Science and Engineering: An Update.* Washington, DC: National Science Foundation, 1992.
  - White, Ron. *How Computers Work.* Emeryville, CA: Ziff-Davis Press, 1993.
  - "Women in Science '93: Gender and Culture." *Science*, Vol 260, Washington, DC: AAAS, 1993.
- Magazines, Journals, etc:**
- It's A Living! Career News For Girls*
  - Electronic Learning*
  - Education Week*
  - Tech Directions*
  - Ed. Tech. News*
  - Independent School Magazine*
  - Teaching & Technology*
  - Wired*
- Selected Organizational Resources**
- American Association for the Advancement of Girls & Science  
1333 H Street NW  
Washington, DC 20005  
(202) 326-6674  
CONTACT: Gaynelle Bowden
  - Association for Women in Mathematics  
University of Maryland  
College Park, MD  
(301) 405-7892  
awm@math.umd.edu
  - Association for Women in Science  
1522 K Street NW, Suite 820  
Washington, DC 20005  
(202) 326-8940  
CONTACT: Kate Durocher  
awis@awis.org
  - Boston Computer Museum  
300 Congress Street  
Boston, MA 02210  
(617) 426-2800 ext. 345  
CONTACT: Marilyn Gardner: gardner@tcm.org.
  - Christa McAuliffe Planetarium  
3 Institute Drive  
Concord, NH 03301  
(603) 271-7831  
CONTACT: Judy Miner

■ **Consortium for Educational Equity**  
Rutgers University  
Livingston Campus  
Building 4090  
New Brunswick, NJ 08903  
(732) 445-2071  
CONTACT: Marylin A. Hulme

■ **Eisenhower National Clearinghouse for Mathematics and Science Education**  
Ohio State University  
1929 Keny Road  
Columbus, OH 43210-1079  
(800) 621-5785

■ **EQUALS**  
University of California at Berkeley  
Lawrence Hall of Science  
Berkeley, CA 94720  
(510) 642-1823

■ **Girls, Incorporated**  
Operation SMART  
National Resource Center  
441 W. Michigan St.  
Indianapolis, IN 46202  
(317) 634-7546  
CONTACT: Susan Houchin

■ **Junior Engineering Technical Society (JETS)**  
1420 King Street, Suite 405  
Alexandria, VA 22314  
(703) 548-5387  
CONTACT: Leann Yoder

■ **Math/Science Network**  
Mills College  
5000 MacArthur Blvd.  
Oakland, CA 94613  
(510) 430-2222  
CONTACT: Betty Levitin  
msneyh@mills.edu

■ **National Coalition of Girls' Schools**  
228 Main Street  
Concord, MA 01742  
(978) 287-4485  
CONTACT: Meg Milne Moulton or Whitney Ransome  
ncgs@ncgs.org  
<http://www.ncgs.org>

■ **National Council for Research on Women**  
530 Broadway at Spring Street  
10th Floor  
New York, NY 10012-3920  
(212) 274-0730  
CONTACT: Linda Basch



■ **National Council of Teachers of Mathematics**  
1906 Association Drive  
Reston, VA 22091  
(703) 620-9840

■ **Science by Mail**  
Museum of Science  
Science Park  
Boston, MA  
(800) 729-3300

■ **Society of Women Engineers**  
120 Wall Street  
New York, NY 10005  
(212) 509-9577  
CONTACT: Marisol Sanchez

■ **Women and Mathematics**  
Department of Mathematics and Computer Science  
Meredith College  
Raleigh, NC 27607  
(919) 829-8471  
CONTACT: Virginia Knight

■ **Women's College Coalition**  
125 Michigan Avenue, NE  
Washington, DC 20017  
(202) 234-0443  
CONTACT: Jadwiga Sebrechts  
<http://www.academic.org>

■ **Women's Educational Equity Resource Center**  
(Free catalog of publications)  
c/o Education Development Center  
55 Chapel Street  
Newton, MA 02160  
(800) 225-3088  
[www.edc.org/womensequity](http://www.edc.org/womensequity)

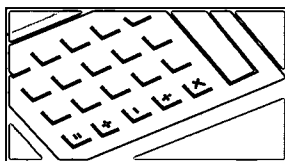



## The National Coalition of Girls' Schools

**T**HE NATIONAL COALITION OF GIRLS' SCHOOLS (NCGS) is a non-profit, eighty-four member association of private and public, day and boarding schools from across the United States with affiliates in Australia, Canada, and New Zealand. Member schools differ in their histories and philosophies and the number and type of students they serve. Yet each school is dedicated to guiding girls as they realize their personal and academic potential while providing them with the skills and self-confidence to participate equally and fully in their schools and communities.

Founded in 1991, the National Coalition of Girls' Schools continues to be guided by its founding purpose: to raise the visibility of schools for girls as valuable educational options and as national resources. To that end, the Coalition engages in the following:

- ▣ Supports research on the environments in which girls learn best
- ▣ Sponsors symposia that center on developing effective teaching and learning strategies that work well for girls
- ▣ Sustains a national/regional media campaign that validates and promotes the value and benefits of schools for girls
- ▣ Assumes an active public service role in the discussion of issues related to girls, schools, and growing up and makes available its publications to the public at large
- ▣ Provides member school support through its publications, workshops, marketing, and public relations counsel
- ▣ Builds links with other national organizations to further the well-being of girls and young women

### About Our Membership



- ▣ 84 private and public, day and boarding schools across the United States (with affiliates in Canada, Australia and New Zealand) belong to the Coalition.
- ▣ Over 37,000 students are enrolled in Coalition schools in the United States.
- ▣ Enrollment in member schools has increased by 15% since 1991.
- ▣ Schools range from 30 to 1,530 students.
- ▣ Student/faculty ratios average 7.9 to 1 at day schools, 6.4 to 1 at boarding schools.
- ▣ Over 80% of Coalition schools have women as heads or principals.
- ▣ Students of color represent 18% of the total enrollment; faculty of color 7%.
- ▣ Girls' schools awarded \$48 million this year in need-based financial aid. Almost 6,000 students receive financial aid with average day awards at \$7,578 and boarding at \$11,866.
- ▣ Almost 100% of graduating seniors go on to college.
- ▣ In 1996-97, endowment at girls' day schools grew by 37% and at girls' boarding schools by 28%.

### With Thanks!

Idea Book Contributors ▣ Whitney Ransome and Meg Milne Moulton, Editors ▣ Ann Parke and Sue Sauer, Assistant Editors ▣ Sara Lennon, Designer ▣ Goodman Research Group, Inc.

And the following NCGS member schools for the use of their photographs:  
The Brearley School ▣ The Bryn Mawr School ▣ Dana Hall School ▣ Foxcroft School ▣ Marlborough School ▣ Marymount School ▣ Miss Porter's School



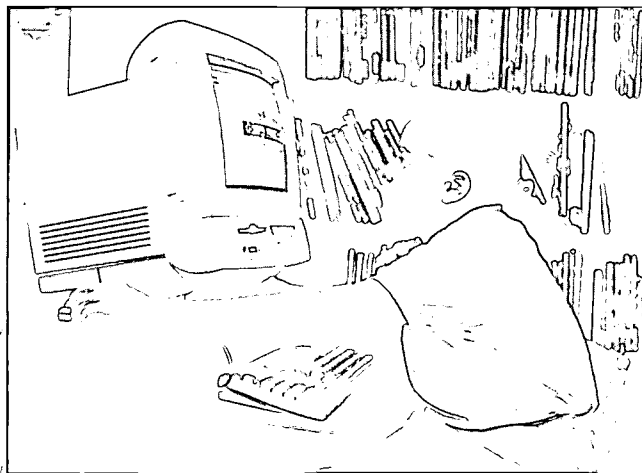

For More Information

**THE NATIONAL COALITION OF GIRLS' SCHOOLS**  
228 Main Street □ Concord, Massachusetts 01742

Phone: (978) 287-4485 □ Fax: (978) 287-6014

[ncgs@ncgs.org](mailto:ncgs@ncgs.org) □ <http://www.ncgs.org>

**THE NATIONAL COALITION OF GIRLS' SCHOOLS**

228 Main Street • Concord, Massachusetts • 01742

Phone: (978) 287-4485 • Fax: (978) 287-6014

World Wide Web: <http://www.ncgs.org>

E-mail: [ncgs@ncgs.org](mailto:ncgs@ncgs.org)





**U.S. Department of Education**  
Office of Educational Research and Improvement (OERI)  
National Library of Education (NLE)  
Educational Resources Information Center (ERIC)



## NOTICE

### Reproduction Basis



This document is covered by a signed "Reproduction Release (Blanket)" form (on file within the ERIC system), encompassing all or classes of documents from its source organization and, therefore, does not require a "Specific Document" Release form.



This document is Federally-funded, or carries its own permission to reproduce, or is otherwise in the public domain and, therefore, may be reproduced by ERIC without a signed Reproduction Release form (either "Specific Document" or "Blanket").

EFF-089 (3/2000)