

## DOCUMENT RESUME

ED 439 964

SE 063 488

AUTHOR Lee, Felicia  
TITLE Construct-a-Greenhouse. Science by Design Series.  
INSTITUTION National Science Teachers Association, Arlington, VA.  
SPONS AGENCY National Science Foundation, Arlington, VA.  
ISBN ISBN-0-87355-179-6  
PUB DATE 2000-03-00  
NOTE 105p.; For other books in the Science by Design Series, see SE 063 489-491.  
CONTRACT ESI-9252894; ESI-9550540  
AVAILABLE FROM NSTA Press, 1840 Wilson Blvd., Arlington, VA 22201-3000; Web site: <http://www.nsta.org>.  
PUB TYPE Books (010) -- Guides - Classroom - Teacher (052)  
EDRS PRICE MF01/PC05 Plus Postage.  
DESCRIPTORS \*Construction (Process); Energy; \*Greenhouses; High Schools; \*Plants (Botany); \*Problem Solving; Resource Materials; \*Science Activities; Science Education; Teaching Methods

## ABSTRACT

This book is one of four books in the Science-by-Design Series created by TERC and funded by the National Science Foundation (NSF). This series presents directed instruction on how to successfully formulate and carry out product design. Students learn and apply concepts in science and technology to design and build a pair of insulated gloves, a model boat, a greenhouse, and a catapult. This book engages high school students in a problem-solving challenge to design and build a physical system that provides an optimal environment for plant growth. In addition to learning and applying concepts in thermodynamics, light absorption, and plant biology, students must make a range of decisions as they encounter cost constraints, construction alternatives, and environmental changes. The activities have assessment suggestions and Internet extensions through the National Science Teachers Association's (NSTA) sciLINKS program. The activities are designed to meet the new International Technology Education Standards as well as the National Science Education Standards. Key ideas include: (1) "Transformation and Transfer of Energy"; (2) "Repurposing and Tradeoffs"; (3) "Plant Growth and Stages of Development"; and (4) "Inquiry and Design." Appendices contains inquiry and design processes, text reconstruction, law limiting factors, and species specifications to consider. (Contains a glossary and 25 references.) (CCM)

Reproductions supplied by EDRS are the best that can be made  
from the original document.

U.S. DEPARTMENT OF EDUCATION  
Office of Educational Research and Improvement  
EDUCATIONAL RESOURCES INFORMATION  
CENTER (ERIC)

This document has been reproduced as  
received from the person or organization  
originating it.

Minor changes have been made to  
improve reproduction quality.

• Points of view or opinions stated in this  
document do not necessarily represent  
official OERI position or policy.

by Design

ED 439 964

# greenhouse

**NTA**press  
NATIONAL SCIENCE TEACHERS ASSOCIATION

ERIC  
Full Text Provided by ERIC

BEST COPY AVAILABLE

---

# Construct-a-Greenhouse

Developed by TERC  
Lead author: Felicia Lee

*This curriculum was developed by  
TERC, Cambridge, Massachusetts.  
Funded in part by a grant from the  
National Science Foundation.*

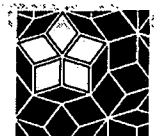

TERC

*National Science Teachers Association  
1840 Wilson Boulevard  
Arlington, VA 22201  
<http://www.nsta.org>*

**NSTA**press  
NATIONAL SCIENCE TEACHERS ASSOCIATION



Shirley Watt Ireton, Director  
Beth Daniels, Managing Editor  
Erin Miller, Associate Editor  
Jessica Green, Assistant Editor  
Anne Early, Editorial Assistant

**Art and Design**  
Kim Alberto, Director  
**NSTA Web**  
Tim Weber, Webmaster  
**Outreach**  
Michael Byrnes, Editor-at-Large  
**Periodicals Publishing**  
Shelley Carey, Director  
**Printing and Production**  
Catherine Lorrain-Hale, Director  
**Publications Operations**  
Erin Miller, Manager  
**sciLINKS**  
Tyson Brown, Manager

**National Science Teachers Association**  
Gerald F. Wheeler, Executive Director  
David Beacom, Publisher

NSTA Press, NSTA Journals, and the NSTA Web site deliver high-quality resources for science educators.

© 2000 by the National Science Teachers Association. The mission of the National Science Teachers Association is to promote excellence and innovation in science teaching and learning for all.

Permission is granted in advance for the reproduction of short portions of this book for the purpose of classroom or workshop instruction. To request permission for other uses, send specific use requests to:

NSTA Press  
1840 Wilson Boulevard  
Arlington, VA 22201-3000  
<http://www.nsta.org/>

*Science by Design: Construct-a-Greenhouse*  
Library of Congress Catalog Card Number 00-131681  
NSTA Stock Number: PB152X3  
ISBN 0-87355-179-6

Printed in the United States of America by Automated Graphic Systems, Inc.  
Printed on recycled paper

All rights reserved. No part of this publication may be reproduced, stored in a retrieval system, or transmitted, in any form or by any means, electronic, mechanical, photocopying, recording, or otherwise, without the prior written permission of the copyright owner.

This book was prepared with the support of the National Science Foundation under Grant Nos. ESI-9252894 and ESI-9550540. However, any opinions, findings, conclusions, and/or recommendations herein are those of the authors and do not necessarily reflect the views of the National Science Foundation.

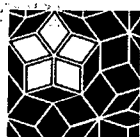

TERC



# CONSTRUCTCONSTRUCTCONSTRUCTCONSTRUCT

## Acknowledgments

The creation of the NSTA *Science by Design* series builds on five years of research and development at TERC. This work was funded by two National Science Foundation grants: ESI-9252894 and ESI-9550540 and was directed by John Foster, David Crismond, William Barowy, and Jack Lochhead.

We are especially grateful for the vision, guidance, and prodding of our program officer, Gerhard Salinger, who was our GPS in uncharted territory.

We were helped in innumerable ways by an especially insightful advisory board: Joan Baron, Goery Delacote, Andy DiSessa, Woodie Flowers, John Foster, Mike Hacker, Colleen Hill, Gretchen Kalonji, Robert McCormick, Jim Minstrell, Jim Neujahr, and David Perkins.

The members of the TERC team who contributed to the development and testing of the *Science by Design* units include:

Tim Barclay	Felicia Lee
William Barowy	Jack Lochhead
Cathy Call	Tasha Morris
Judith Collison	Tracy Noble
David Crismond	Alison Paddock
Brian Drayton	Meghan Pfister
Christine DiPietrantonio	Lee Pulis
Joni Falk	Jerry Touger
John Foster	Margaret Vickers
June Foster	Paul Wagoner
Riley Hart	Kelly Wedding
Nathan Kimball	Amy Weinberg

Special mention must be made of the enthusiasm, dedication, and long hours contributed by David Crismond and Earl Carlyon. The following hard-working consultants added greatly to our efforts: Hilton Abbott, Robert B. Angus, Carol Ascher, Warren R. Atkinson, Earl Carlyon, Michael Clarage, Jan Hawkins, Kathy Kittredge, Crispin Miller, James E. LaPorte, Kjell-Jan Rye, Rick Satchwell, Mike Stevens, and Ron Todd.

The authors of the final *Science by Design* units were William Barowy, Felicia Lee, Jack Lochhead, Alison Paddock, and Lee Pulis of TERC.

*Science by Design: Construct-a-Greenhouse* was produced by NSTA Press: Shirley Watt Ireton, director; Beth Daniels, managing editor; Erin Miller, associate editor; Jessica Green, assistant editor; Michelle Treistman, assistant editor; Anne Early, editorial assistant. Beth Daniels was project editor for the *Science by Design* series. The cover design and book design are by Camden Frost and Vicky Robinson of Graves Fowler Associates.

---

Field testing of the *Science by Design* series depended on the dedication of dozens of teachers and the helpful cooperation of their school systems:

Jerian Abel, Northwest Regional Education Laboratory	Walter Lewandowsler, Bartlett High School
Bruce Andersen, Buker Middle School	David R. Littlewood, Agawam Junior High School
Dave Armstrong, Lawrence Middle School	John Matthews, Southwick Tolland Regional High School
Henry Bachand, Mansfield High School	Eilen McCormack, South Jr. High Brockton
Hilda Bachrach, Dana Hall School	Scott McDonald, Needham High School
Ronald Bjorklund, Leicester High School	Brian McGee, Lexington Middle School
Marcella Boyd, Manchester Junior High School	Bob Meltz, Manchester Junior-Senior High School
Karen Bouffard, Governor Dummer Academy	Charles O'Reilly, Lexington High School
Althea Brown, Medford High School	Constance Patten, Lincoln-Sudbury High School
Lee Burgess, Lawrence Middle School	Fred Perrone, East Junior High School
David Corbett, Whittier Regional Vocational Technical High School	Joe Pignatiello, Somerville High School
Steve Cremer, Braintree High School	Doug Prime, Lancaster Middle School
Deborah Crough, Long Beach High School	Michael Rinaldi, Bedford High School
Ron Daddario, McCall Middle School	Thomas Rosa, Walsh Middle School
Raymond P. Gaynor, Reid Middle School	Eugene A. Santoro, Silver Lake Regional High School
Elizabeth George, Westborough High School	John Schott, Smith Academy
Pam Glass, Talbot Middle School	Bruce Seiger, Wellesley High School
Rick Harwood, Ware High School	Douglas Somerville, Woodward Middle School
Gary Herl, Tantasqua Regional Junior High School	John Stamp, Manchester High School
Kate Hibbitt, Lincoln School	Mike Stevens, Maynard High School
Patrick Keleher, Norwood Junior High School	Michael Sylvia, Charles E. Brown Middle School
Marty Kibby, Minetron Technology Education Office	Syd Taylor, Mahar Regional School
Matias Kvaternik, Chelmsford Public Charter School	Ted Vining, Monument Regional High School
Jeff Leonard, F.A. Day Middle School	Frank Viscardi, Framingham High School

This project would not have been possible without the help and critique of hundreds of students whom we regretfully cannot mention by name.

# CONSTRUCT CONSTRUCT CONSTRUCT **Table of Contents** CONSTRUCT CONSTRUCT

## INTRODUCTION

A Note from the Developers .....	1
Key Ideas .....	2
Assessment .....	3
Standards & Benchmarks Connections .....	4
sciLINKS .....	6
Course Outline .....	7

## ACTIVITY 1: Design Brief

**1 DAY**

Student Activity Pages	
Greenhouse Design Brief .....	9
Snapshot of Understanding .....	10
Teacher Pages	
Overview—Design Brief .....	13
Teaching Suggestions .....	13

## ACTIVITY 2: Quick-Build Greenhouse

**2 DAYS**

Student Activity Pages	
Overview—Quick-Build .....	16
Quick-Build Greenhouse Schematic .....	17
Qualitative Observations .....	18
Seed Starting .....	20
Teacher Pages	
Overview—Quick-Build .....	23
Teaching Suggestions .....	23
Miscellaneous Suggestions .....	24

## ACTIVITY 3: Research

**3 DAYS**

Student Activity Pages	
Overview—Research .....	26
Species Specifications .....	27
Tolerance and Limiting Factors .....	30
Identifying Variables and Making Measurements .....	32
Data Recording for Seed Germination Phase .....	33
What We Do with the Data .....	34
Rules of Thumb .....	36

Teacher Pages	
Overview—Research .....	38
Teaching Suggestions .....	38

**4 DAYS**

**ACTIVITY 4: Development**

Student Activity Pages	
Overview—Development .....	41
Criteria and Materials .....	42
Scaling and Costing .....	44
Design Drawing .....	45
Prototype Construction .....	46
Performance Tests .....	48
Proof-of-Design Performance Evaluation .....	49
Teacher Pages	
Overview—Development .....	50
Teaching Suggestions .....	50
Scale and Cost .....	52

**3 DAYS**

**ACTIVITY 5: Communication**

Student Activity Pages	
Overview—Communication .....	54
Presentation .....	55
FAQ Assessment .....	56
Reflection and Recommendations .....	58
Estimation: How Much Does Your Pumpkin Weigh? .....	60
Snapshot of Understanding .....	62
Teacher Pages	
Overview—Communication .....	64
Teaching Suggestions .....	64

**APPENDIX A: Side Roads**

Side Roads .....	68
Internet Information Search .....	69
Inquiry Process .....	71
Passive Thermal Control .....	73
Design Process .....	77



---

**APPENDIX B: Text Reconstruction**

Text Reconstruction ..... 80  
Key Ideas Explained ..... 81  
Energy Transfer Text Reconstruction Exercise ..... 82  
Repurposing Text Reconstruction Exercise ..... 84  
Plant Growth Text Reconstruction Exercise ..... 86  
Energy Transfer Text Reconstruction Key ..... 88  
Repurposing Text Reconstruction Key ..... 89  
Plant Growth Text Reconstruction Key ..... 90

**APPENDIX C: Sample Answers**

Species Specifications ..... 92  
The Law of Limiting Factors ..... 92  
Data Recording Plan for Seed Germination Phase ..... 93  
Rules of Thumb Worksheet ..... 93

**GLOSSARY ..... 94**

**REFERENCES ..... 96**

## A NOTE FROM THE DEVELOPERS

### *Integrating Science and Technology*

**C**onstruct-a-Greenhouse is aligned with the *National Science Education Standards* for process and content in physical science, biology, and technology. This alignment is illustrated in the Standards and Benchmarks table on pages four and five. Through a variety of hands-on design activities, students engage in the iterative processes of scientific inquiry and technological design to develop conceptual understanding of heat energy transfer, photosynthesis, plant metabolism, thermal regulation, and feedback control.

Compare these materials to a highway: if you rush straight through, your students will learn only a little about the territory they have crossed. We provide a number of interesting side roads that offer additional opportunities to investigate the linkage between inquiry and design. For your first trip, you may want to stay close to the highway, but as you gain experience, we hope you will drift further and further from the main path to explore other options.

### *Schedule and Cost*

The time needed to complete the core unit is between 13 and 19 days. If you have time, you may choose to cycle through the research and development phases several times, either for the purpose of exploring science concepts in greater detail or to produce a state-of-the-art greenhouse.

Students develop models of their designs, build the models, conduct further investigations, analyze their data, and redesign if necessary. This unit concludes with students' communicating their product and their scientific argument to their classmates (three to four days). Students are given the *Design Brief* and instructions for making a Quick-Build Greenhouse (two to three days). During the research and development phases (8–12 days), students identify relevant variables, design and conduct experiments, and generate possible solutions to their design obstacles. In this way, students come to think of research and development as a repeating cycle.

*Construct-a-Greenhouse* works particularly well in a multidisciplinary course, or taught as a team effort involving faculty in physics, technology, and biology. The biological demands of this project vary with geographic location, altitude, time of year, and available solar exposure. Students should research the time requirement for each

growth phase of the selected plant, and scale their prototype growth enclosure to fit with the calendar time allotted for the project.

Cost of consumables can be kept at about \$5.00 per student, if materials are carefully controlled. If you decide to undertake full-scale construction for the prototype-building phase, this will, of course, dramatically increase costs.

## **KEY IDEAS**

### ***Transformation and Transfer of Energy***

Energy can change from one form to another in a controlled physical environment just as it does in the living world. In *Construct-a-Greenhouse*, students build light trap systems, in which light is changed to heat. They then learn to use the principles of heat transfer to design and build a system for growing a plant of a particular species of vegetable.

### ***Repurposing and Tradeoffs***

The values of any technology may be different at different points in time. To start their seeds, students must engineer the growth enclosure such that it will convert light to heat. Once the seeds sprout, the design emphasis shifts toward maximizing light intensity. Students *repurpose* the physical system (the greenhouse) to provide an optimal environment for the biological system (the plant) as it grows through different stages. Also, students must make numerous decisions involving tradeoffs as they encounter cost constraints, construction alternatives, and other design factors.

### ***Plant Growth and Stages of Development***

The needs of a plant vary as it goes through different stages of its life cycle. These stages are: germination, seedling, leaf, stem, and root growth, and fruit development

Three important factors in the germination of nearly all seeds are water, oxygen, and temperature. After a seed germinates, the growing seedling requires carbon dioxide, water, and light to support photosynthesis. To produce new leaves, stems, roots, and fruit, plants must obtain additional essential nutrients from the soil in which they grow. Most weight gain comes from the process of photosynthesis, which converts carbon, oxygen, and hydrogen in air and water into plant mass. Deficient factors can limit growth, as can an excessive supply.

---

## ***Inquiry and Design***

Students undertake *inquiry* as an iterative process which includes designing and conducting investigations, recognizing and applying models, constructing explanations, making predictions, and using evidence to evaluate explanations and models. *Design* is practiced as an iterative multi-disciplinary process in which students develop abilities to identify, create, investigate, decide, build, test, and evaluate. These process cycles of inquiry and design are outlined as resource readings in *Side Roads* (Appendix A).

## **ASSESSMENT**

**S**tudent activity sheets may be used for formative or summative assessment. The first *Snapshot of Understanding* is intended as a pre-learning index of prior knowledge. Compare this initial *Snapshot* to similar answers on the final *Snapshot* given at the end of the last activity for student self-assessment. Because group work is stressed throughout the unit, group assessment may prove more appropriate than individual scores. However, depending upon your class objectives, homework assignments may provide the best measure of individual performance.

## ***Student Portfolios***

Portfolios can be useful tools for maintaining individual accountability in a teamwork setting.

### **Potential Portfolio Items**

The following set of items and products can be accumulated in portfolios for summative assessment (student activity sheets are in italics):

- ☞ Initial questions: *Design Brief*
- ☞ Individual information search
- ☞ Sketch of Quick-Build
- ☞ Brainstorming record
- ☞ List of variables
- ☞ Research and results
- ☞ Group process description: *The Inquiry Process*
- ☞ Group process description: *The Design Process*
- ☞ Prototype demonstration notes
- ☞ Group summary documentation
- ☞ *Snapshot of Understanding* (Post-test and self-assessment)

# CTC CONSTRUCT TO CONSTRUCT CONSTRUCT

TASK	SOURCE
------	--------

*Students identify and describe variables that affect functioning of a simple, passive solar collection system to store and convert radiant energy for specific purposes* AAAS 9–12, NSES 9–12

**Standard/Benchmark:** Energy Transformations; Motion; Flow of Matter and Energy; Physical Science Content Standard B; Earth and Space Science

*Students identify alternatives in system components and configuration, and develop experimental proposals to investigate them* AAAS 9–12

**Standard/Benchmark:** Design and Systems

*Students interpret scale drawings and interpret and draw three-dimensional objects* AAAS 9–12, NCTM 7

**Standard/Benchmark:** Communication Skills; Geometry from a Synthetic Perspective

*Students learn critical components of scientific inquiry by reflecting on concepts that guide the inquiry, and by establishing an adequate knowledge base to support their investigation* AAAS 9–12, NSES 9–12

**Standard/Benchmark:** Scientific Worldview; Science as Inquiry

*Students research and organize information about requirements for optimal growth of the Atlantic Giant Pumpkin, limiting factors, and tolerance* AAAS 9–12, ITEA II, NSES 9–12

**Standard/Benchmark:** Flow of Matter and Energy; Nature of Technology; Science as Inquiry

*Students research the scientific principles that support some "rules of thumb" for building a passive solar energy trap* AAAS 9–12, ITEA I & III, NSES 9–12

**Standard/Benchmark:** Energy Transformations; Nature of Technology; Science as Inquiry; Physical Science

*Students keep a laboratory notebook/design log to document their work and to reflect on their work* AAAS 9–12, ITEA III, NSES 9–12

**Standard/Benchmark:** Computation and Estimation; Science as Inquiry

*Students practice design process as an iterative cycle of multidisciplinary activities including research, choosing between alternatives, drawing, building, testing, and evaluating* AAAS 9–12, ITEA I

**Standard/Benchmark:** Design and Systems; Nature of Technology

*Students identify relevant materials properties and make choices based on constraints of cost, suitability to criteria, and availability* ITEA I

**Standard/Benchmark:** Nature of Technology

*Students use previously researched rules of thumb to mathematically scale aspects of their design* AAAS 9–12, NCTM 1

**Standard/Benchmark:** Scale; Mathematics as Problem Solving

TASK	SOURCE
------	--------

*Students identify alternatives in system components and configuration, and build a prototype for performance testing* AAAS 9–12, ITEA II & III, NSES 9–12

**Standard/Benchmark:** Energy Transformations; Nature of Technology; Science and Technology

*Students reflect and write recommendations based on their design tests* AAAS 9–12, ITEA II

**Standard/Benchmark:** Communication Skills; Nature of Technology

*Students give an oral presentation on their prototype design specifications, its operating procedures, and the quantitative and qualitative plant growth results obtained* AAAS 9–12, ITEA I

**Standard/Benchmark:** Communication Skills; Nature of Technology

*Students articulate principles of science employed in passive solar greenhouse operation* AAAS 9–12, ITEA VII, NSES 9–12

**Standard/Benchmark:** Critical-Response Skills; Technology and Society; Life Science

*Students self-assess their learning by comparing pre- and post-Snapshots of Understanding* AAAS 9–12, NCSS VIII

**Standard/Benchmark:** Issues in Technology; Science, Technology, and Society

**SOURCE KEY:**

- AAAS American Association for the Advancement of Science. 1993. *Project 2061: Benchmarks for Science Literacy*. New York: Oxford University Press.
- ITEA International Technology Education Association. 1996. *Technology for All Americans: A Rationale and Structure for the Study of Technology*.
- NCSS Task Force on Social Studies Teacher Education Standards. 1997. *National Standards for Social Studies Teachers*. Washington, DC: National Council for the Social Studies.
- NCTM National Council for Teachers of Mathematics. 1991. *Professional Standards for Teaching Mathematics*. Reston, VA: NCTM.
- NSES National Research Council. 1996. *National Science Education Standards*. Washington DC: National Academy Press.

BEST COPY AVAILABLE



Go to: [www.scilinks.org](http://www.scilinks.org)

Topic: conduction/  
convection  
Code: CAH01

Topic: radiation  
Code: CAH02

Topic: photosynthesis  
Code: CAH03

Topic: plant life span  
Code: CAH04

Topic: primary/secondary  
growth  
Code: CAH05

Topic: scientific inquiry  
Code: CAH06

Topic: vascular/non-  
vascular plants  
Code: CAH07

Topic: presenting data  
Code: CAH08

Topic: heat transfer  
Code: CAH09

*Science by Design: Construct-a-Greenhouse* brings you *sciLINKS*, a new project that blends the two main delivery systems for curriculum—books and telecommunications—into a dynamic new educational tool for all children, their parents, and their teachers. This effort, called *sciLINKS*, links specific science content with instructionally rich Internet resources. *sciLINKS* represents an enormous opportunity to create new pathways to learners, new opportunities for professional growth among teachers, and new modes of engagement for parents.

In this *sciLINKed* text, you will find an icon near several of the concepts you are studying. Under it, you will find the *sciLINKS* URL (<http://www.scilinks.org/>) and a code. Go to the *sciLINKS* Web site, sign in, type the code from your text, and you will receive a list of URLs that are selected by science educators. Sites are chosen for accurate and age-appropriate content and good pedagogy. The underlying database changes constantly, eliminating dead or revised sites or simply replacing them with better selections. The ink may dry on the page, but the science it describes will always be fresh. *sciLINKS* also ensures that the online content teachers count on remains available for the life of this text. The *sciLINKS* search team regularly reviews the materials to which this text points—revising the URLs as needed or replacing Web pages that have disappeared with new pages. When you send your students to *sciLINKS* to use a code from this text, you can always count on good content being available.

The selection process involves four review stages:

1. First, a cadre of undergraduate science education majors searches the World Wide Web for interesting science resources. The undergraduates submit about 500 sites a week for consideration.
2. Next, packets of these Web pages are organized and sent to teacher-Webwatchers with expertise in given fields and grade levels. The teacher-Webwatchers can also submit Web pages that they have found on their own. The teachers pick the jewels from this selection and correlate them to the National Science Education Standards. These pages are submitted to the *sciLINKS* database.
3. Then scientists review these correlated sites for accuracy.
4. Finally, NSTA staff approve the Web pages and edit the information provided for accuracy and consistent style.

### **Introduction**

- Read *Greenhouse Design Brief*
- Take *Snapshot of Understanding*

### **Quick Build**

- Read *Qualitative Observations*
- Make a Quick-Build greenhouse
- Work through *Seed Starting Materials; Starting the Seed*
- What you do in the next few days

### **Research**

- Read *Research Overview*
- Fill out *Species Specifications*
- Research *Growth Factors*
- Fill in *Tolerance and Limiting Factors*
- Brainstorm *Limiting Factors*
- Work through *Identifying Variables and Making Measurements*
- Complete *Rules of Thumb*
- Research *Passive Thermal Control* (optional)

### **Development**

- Read *Development Overview*
- Complete *Criteria and Materials*
- Team fills in *Scaling and Costing*
- Complete *Design Drawing*
- Build *Prototype Construction*
- Conduct *Performance Tests*
- Conduct *Performance Evaluation*

### **Communication**

- Read *Communication Overview*
- Outline presentation
- Prepare presentation
- Fill out *Reflection and Recommendations*
- Take *Snapshot of Understanding*



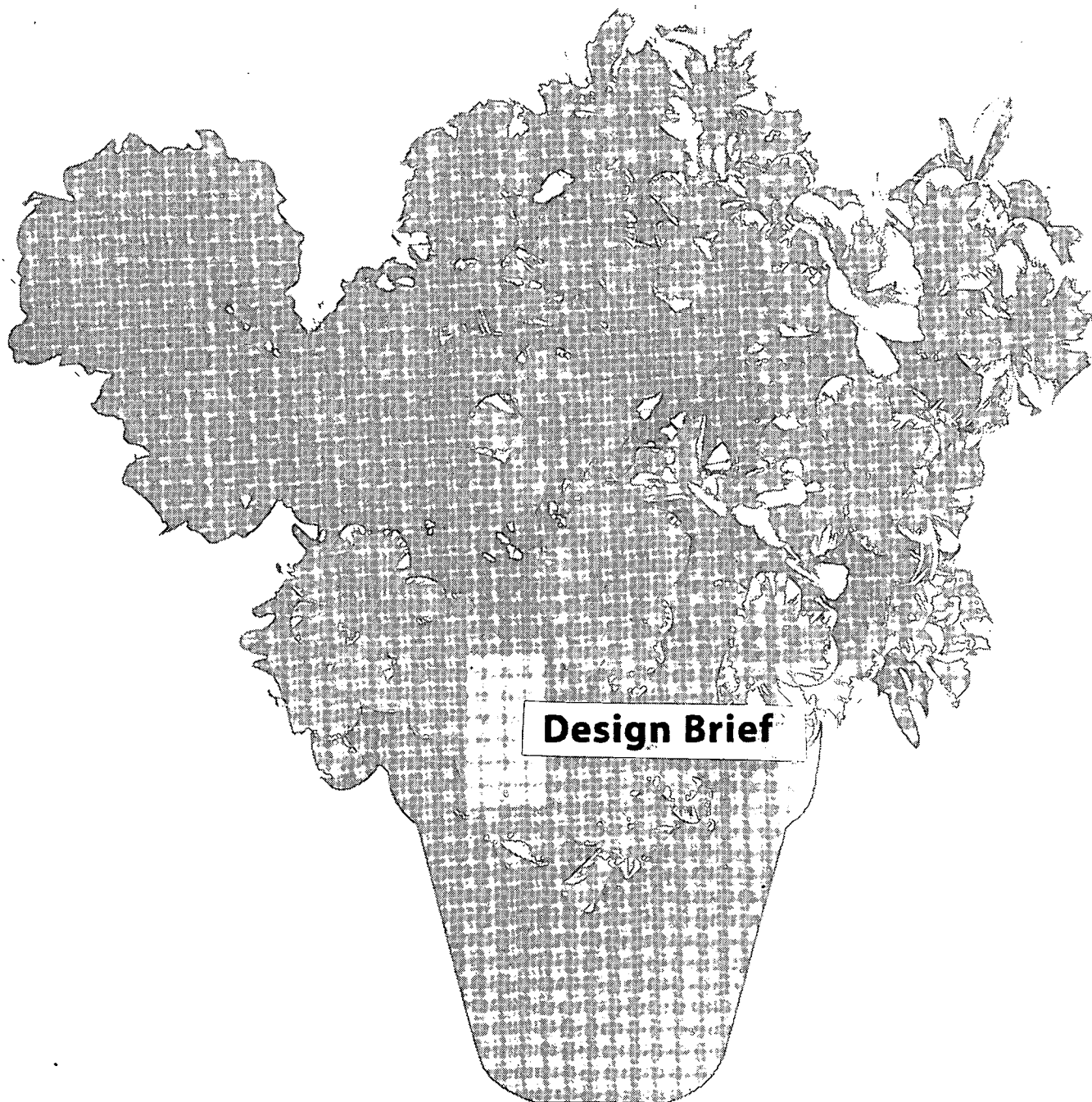

**Design Brief**

## GREENHOUSE DESIGN BRIEF

In this challenge module, you will be designing and building an engineered environment for growing a giant vegetable. You will need to do some research on what the optimal conditions are for seeds to sprout, for seedlings to thrive, and for the vegetable to grow to maximum size. You will also need to do research on desirable sizes, shapes, and materials for your greenhouse.



### **Construct-a-Greenhouse *Design Challenge***

As a member of a development team, design and build an environment adaptable to changing heat, light, humidity, and space requirements for the progressive growth stages of a giant pumpkin (or other specified vegetable).

#### ***Scope of Work***

- ☺ Quick-Build: Build a simple greenhouse according to specifications.
- ☺ Experimentation: Conduct experiments to collect, record, and communicate baseline data. Explore science concepts related to the functioning of the greenhouse.
- ☺ Redesign and Repurposing: Modify initial greenhouse or design anew to accommodate specific requirements of your plant at different growth stages.
- ☺ Report and Defense: Summarize orally the outcomes of your effort, respond to questions, and provide written advice to assist others in achieving success.

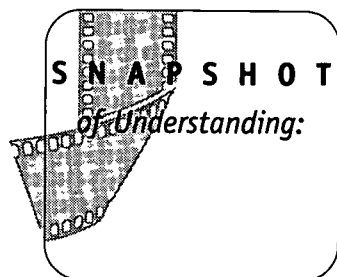

## What I Already Know about Light Absorption and Energy Conversion

This activity will help you review what you already know about the processes of absorption and conversion of light energy to heat. It will also help you think about certain features to consider in your design of a greenhouse that you can optimize for changing plant growth requirements. The activity involves a short experiment combined with several questions.

### ***A Quick Experiment***

For a quick experiment, assemble an “insta-build” greenhouse according to instructions. Measure temperature changes as an indication of energy absorption, conversion, and transfer over a brief time interval. Then answer the questions. You will revisit these questions at the end of the challenge module.

Part	Type	Size or Quantity
box	cardboard, foam, or wood	20 cm x 13 cm x 6 cm
clear cover	transparent plastic/film, glass, or Plexiglas	single sheet, minimum size 22 cm x 15 cm x 0.025 mm
thermal mass	aluminum soda can	1
spray paint	quick-dry, flat black, or matte finish	1 can
insulation	bubble wrap or newspaper	1 sheet
glue stick	quick bonding	1
thermometers	alcohol, 0–50 °C	2 (one small enough to fit in box)
light source	desk lamp, 60 W bulb	1
tape		

### ***Assembly Instructions***

1. Assemble your small greenhouse according to the perspective drawing shown below.
2. Crush soda can flat and paint it black.
3. Tape one thermometer to an inside wall and the other on an outside wall of the insta-build.
4. Glue or tape transparent film to box edges, sealing the edges against air leakage.

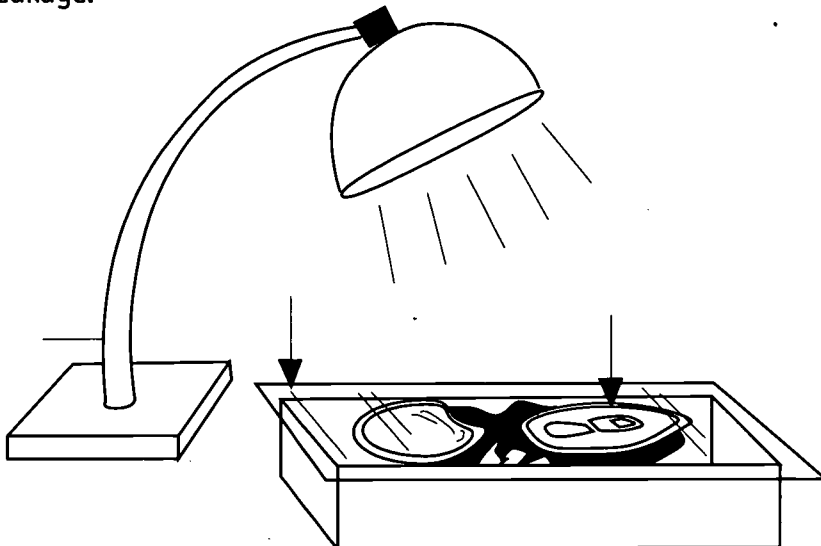

### ***Data Collection***

- Position your small greenhouse such that the absorber surface (flattened soda can) is  $90^\circ$  and 15–20 cm from the 60 W light bulb of a desk lamp.
- Read both thermometers just before you turn the light on, record your readings, and note the time.
- Answer questions 1–3 below (you have 20 minutes before taking a second thermometer reading).
- Take a second reading on each of the thermometers about 20 minutes after your first reading. Record your data in your portfolio notebook, then answer question 4.



Topic: conduction/  
convection

Go to: [www.scilinks.org](http://www.scilinks.org)  
Code: CAH01

Topic: radiation

Go to: [www.scilinks.org](http://www.scilinks.org)  
Code: CAH02

Topic: photosynthesis

Go to: [www.scilinks.org](http://www.scilinks.org)  
Code: CAH03

### Questions

1. When objects of different temperatures are in contact, heat flows from the warmer to the cooler, eventually reaching a common temperature. Describe in one or two sentences each of the listed key processes of temperature equalizing.

*Conduction:*

*Convection:*

*Radiation:*

2. Why does a good absorber of radiant energy appear black?
3. What does it mean to say that the “greenhouse effect” is like a one-way valve?

Read the thermometers and record your data.

4. In about five sentences, describe what you have learned from your observations and measurements about visible light absorption and its conversion to other forms of energy. [Remember—this is not a test; there are no right or wrong answers.]



**OVERVIEW—DESIGN BRIEF**

Give students the *Construct-A-Greenhouse* Design Challenge and the *Snapshot of Understanding*. The *Snapshot* includes a mini experiment called an “insta-build,” which is best done in small groups of two or more students, depending on the space available to set up. This *Snapshot* is a performance assessment of student understanding. It uses construction and measurement activities, combined with short, written questions.

**Design Brief**

Students read the following *Construct-a-Greenhouse* Design Challenge:

*As a member of a development team, design and build an environment adaptable to changing heat, light, humidity, and space requirements for the progressive growth stages of a giant pumpkin (or other specified vegetable).*

Advise students that they will use processes in both technological design and scientific inquiry to meet the design challenge. They will then collect data on an “insta-build” experimental greenhouse, design and test an im-

proved engineered environment, and finally present and defend their team’s activities as proof of meeting the challenge.

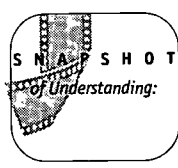

**Snapshot of Understanding**

In a single class session, students work

in pairs, following instructions and reading drawings to construct a very simple “insta-build” greenhouse. They expose the greenhouse to either solar or incandescent radiation and record temperature increases after 20 minutes. While waiting for 20 minutes to pass, they answer three of four *Snapshot* questions. After completing measurements, students write short answers to questions about their observations.

**TEACHING SUGGESTIONS**

Hand out the *Design Brief* student activity sheets. Ask students to keep these and future sheets together and to bring them to the classroom with other notes to serve as a record and reference for daily activity (and assessment) in the unit. Divide the class into pairs or teams of three. Advise students that they will use processes of technological design and scientific inquiry together; that other

**MATERIALS**

**FOR EACH STUDENT**

- Student Activity Sheets**
- Greenhouse Design Brief
  - Snapshot of Understanding
- Ring, Pocket, or Folio Binder**
- (student supplied) for keeping student activity sheets, notes, and drawings for reference and User’s Manual

**PREPARATION**

- Obtain “insta-build” construction and testing materials.
- Tailor instructions and assembly drawings to materials obtained.

## FOR EACH TEAM

### Insta-Build Materials

- shallow cardboard, foam, wood, or otherwise non-conductive box, open on one side—a bit larger in length and width than a crushed soft drink can
- clear transparent sheet, such as overhead transparency, glass, Plexiglas, etc. (Do not use plastic food wrap; it is too thin.)
- instant-bonding, dry glue stick
- scissors
- aluminum soft drink can, crushed flat
- instant drying black spray paint, flat or matte finish
- sheet insulation material, such as bubble wrap or newspaper
- thermometer (0–50 °C)
- light source: direct sunlight or 60 W lamp
- clock or watch
- tape
- pencil and paper
- recyclable flash camera (or digital or instant camera)

teams will critique their prototype with respect to the challenge criteria; and that they must each document their activity to contribute effectively to both the final team presentation, and their individual portfolio assessment. Be clear on your rubrics for assessing their work. Indicate which activities will be individually graded and which will be given a team score. Be prepared to justify team scoring if some students (or parents) are not used to the idea.

### **Snapshot of Understanding**

Hand out the *Snapshot of Understanding* emphasizing that students will not be graded on this activity. Its purpose is self-diagnostic: to find out what they know initially about the unit's key science and technology learning objectives.

At the end of *Construct-a-Greenhouse* students will be able to compare these to answers to similar questions given at the end of the unit. Allow about 35 minutes for students to complete the *Snapshot of Understanding*, then collect and retain.

### **Issuing the Construct-a-Greenhouse Challenge**

Refer the class to the *Greenhouse Design Brief* and discuss the challenge statement. Indicate how far you will be going with the challenge. Will the project stop in a few weeks when the seeds have sprouted or will you be following progress for several months through to harvest of giant pumpkins? If the former, you may want to donate the seedlings to the care of a class of younger students, day care center, or community garden. This will give the project a greater sense of purpose. To get ideas for expanding the Challenge, look through a greenhouse supply catalog, e.g. Charleys at [www.charleysgreenhouse.com](http://www.charleysgreenhouse.com) (current at time of publication).

This unit contains directions for growing Atlantic Giant Pumpkins. If you use another type of seed, adjust the instructions according to the seed package directions.

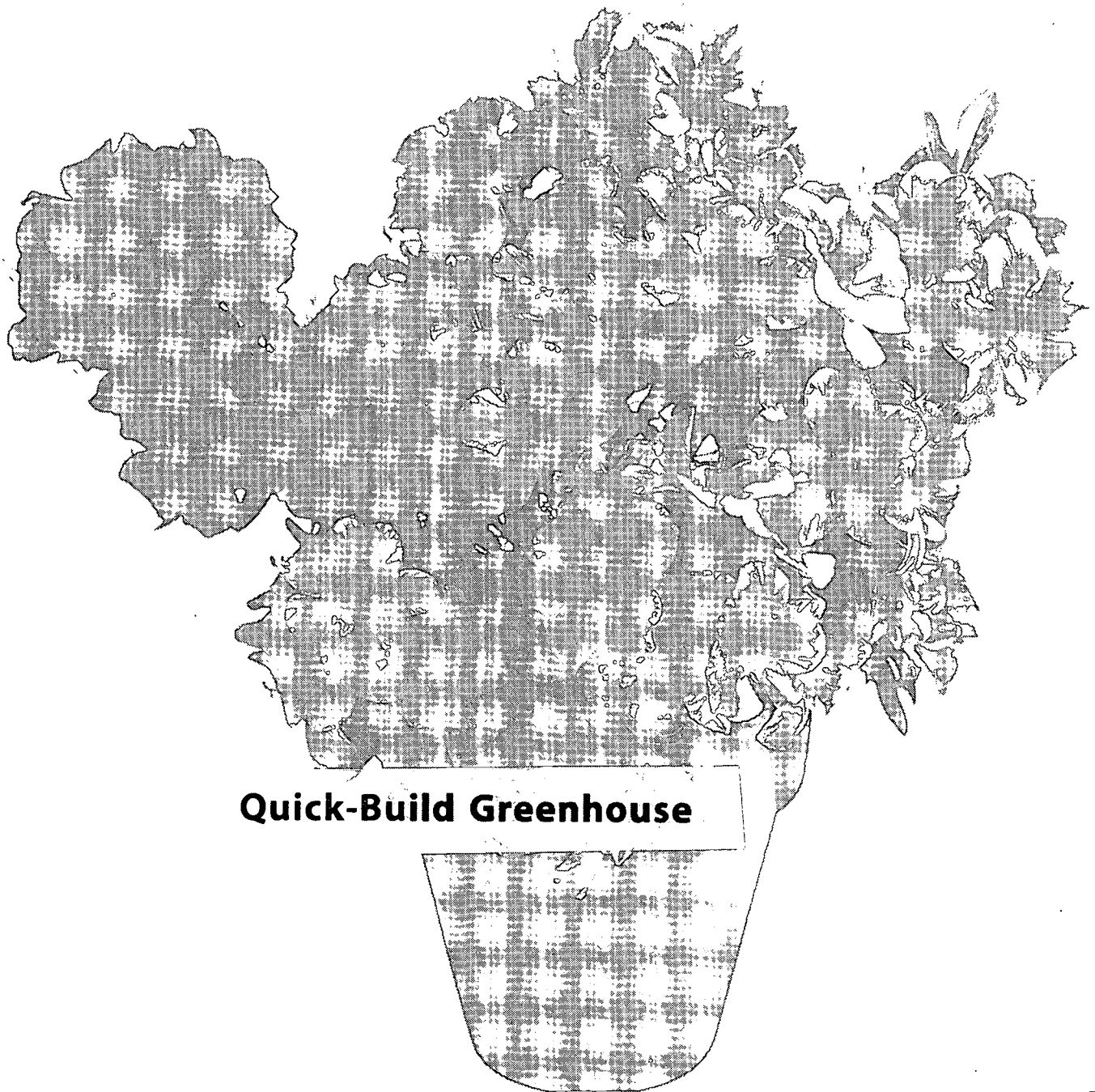

**Quick-Build Greenhouse**





## MATERIALS

### FOR EACH TEAM

- two black or white vinyl-clad 3" ring binders
- duct tape, 2" width
- clear plastic film, 30 cm x 40 cm, at least 0.05 mm thick
- alcohol thermometer (0–50 °C)
- 60 W adjustable desk lamp (goose neck, clamp or tension arm)
- scissors
- ruler
- two plastic planting pots, 4" square or equivalent size round pots
- two coffee filters, paper towels or other liner for the pots
- potting soil, sterile, light tilth mix, approximately one pint
- two to six seeds (provided by the teacher)
- water (approximately 250 ml per pot)

## OVERVIEW—QUICK-BUILD

The Quick-Build Greenhouse is a simple enclosure for absorbing, converting, and accumulating light energy as heat. You can build the greenhouse quickly, within one class period. You will use specified materials to build this enclosure, following technical instructions. You will then use the Quick-Build to make some baseline measurements to inform your research and development efforts in later activities.

The practice of building to specifications ensures that everyone starts in the same way, so it is important that you construct your Quick-Build according to the technical instructions and drawings provided. You will be assessed later on the improvements you can make to the Quick-Build's baseline performance.

## Instructions

1. Review the *Quick-Build Greenhouse Schematic*.
2. Cut one cover flap off each ring binder at its vinyl seam. Take care not to expose the cardboard edge; if exposed by mistake, seal the edge with moisture-proof (duct) tape.
3. Holding the parts in place (one binder spine with attached cover forming partial top and back, the other binder cover with attached spine forming partial front and bottom, the detached covers forming side walls), mark end points for folds where side walls meet; cut edges of top and front panels. Refer to schematic for visual aid.
4. Connect end point marks with straight edge and bend (or cut off) the corner of each separated cover flap to make side wall edge slant as shown.
5. Use duct tape to fasten all adjoining edges together in the configuration indicated on the diagram.
6. Clamp the thermometer in the binder rings at top of greenhouse.
7. Cut the clear plastic sheet to fit opening with ample overlap on all sides and tape it at top and bottom.

## QUICK-BUILD GREENHOUSE SCHEMATIC

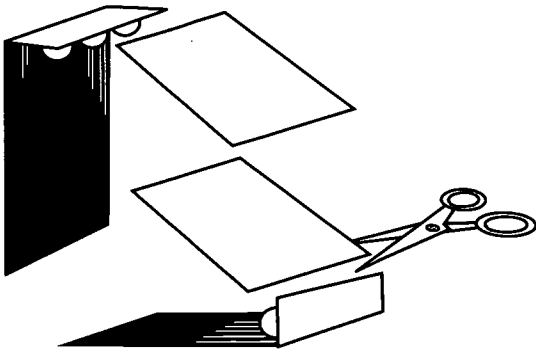

Cut one cover flap off each binder at the seam.

Hold parts together and mark end points of sidewall diagonal folds (shown by arrows).

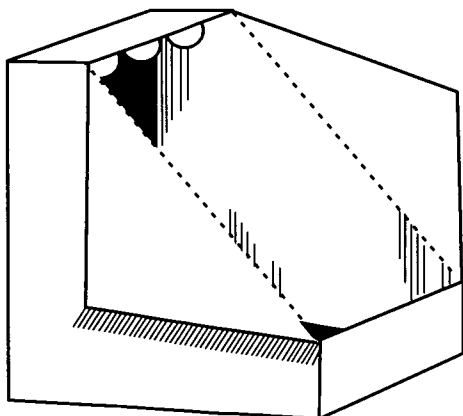
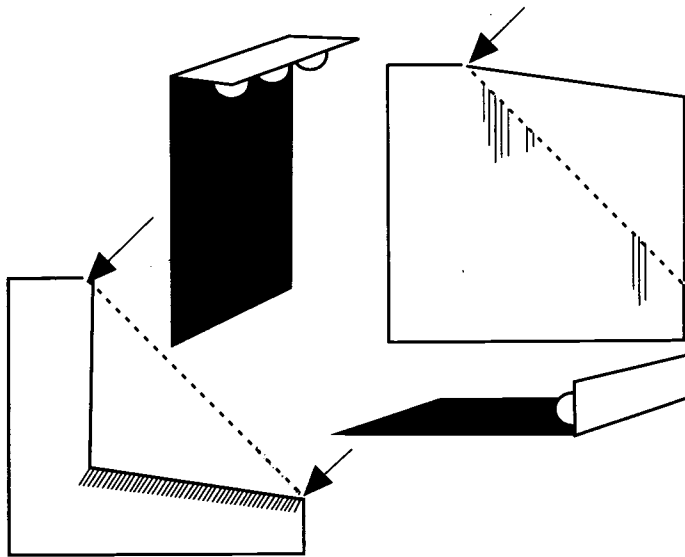

Tape all adjoining edges. Tape the thermometer inside the top rings positioned such that it can easily be read. Tape the clear plastic only at the top. It should cover the front slanted opening and swing up to give access to the inside.

*Laboratory notebooks or journals are often used in the patent process to establish the time during which certain results were achieved, for the purpose of protecting patent rights to processes or products.*

## QUALITATIVE OBSERVATIONS

### ***Keeping a Journal***

**N**ot only is a journal an important tool for inventors, it is particularly useful for biological research. Unlike many physical systems, a living, growing, biological system cannot be measured easily or evaluated quantitatively. Biological systems seldom provide the observer with simple correspondences among various components within a system. Growth occurs in stages, and takes varying amounts of time. One way to study a biological system is to keep careful descriptive records of procedures and observations over an extended period of time.

Keep a ***laboratory journal***. The purpose of keeping a journal is to record as much detail as is necessary, as concisely as possible, so that you or other researchers can repeat the experiment later. It is also important to put dates on your records. It is usually unnecessary to write flowery prose when you write in your notebook or journal.

### ***Observing the Biological System***

You will shortly begin preparing your greenhouse for sprouting seeds. Listed below are the kinds of information you will want to record in your journal as you are preparing the seed bed.

#### **Observing Seed Germination**

Start your journal entry on the day that you begin preparing an environment for starting your seeds. Enter your thoughts (including why you choose to do one thing and not another) and describe your procedure.

Record the following information:

- soil characteristics, including
  - mixture of organic and inorganic materials
  - soil texture when dry and soil texture when saturated with water
  - how well the soil holds moisture
- how far below the surface the seeds were planted

- soil temperature and how the temperature is to be maintained
- how watering is to be done, how often it is done, and the amount of water added
- number of days until seedling emerges

### Observing the Seedling

Note the day that you first see seed leaves emerge from the soil in your laboratory journal as Day One of the seedling stage. (Seed leaves are attached to the outer covering of the seed, so you will probably see the whole seed emerging.) Then, on each subsequent day, enter in your observation log all relevant information, such as:

- height of seedling
- number of seed leaves
- number of days until true leaf appears
- size of leaves (dimensions, leaf area, total leaf area)
- leaf surface reflectance (shiny or dull)
- height/diameter ratio
- general appearance (stoutness, texture, coloration, etc.)

### Recording the Physical Conditions

For each journal entry, note and record all pertinent conditions, such as the following:

- start and end times of light periods
- maximum and minimum air temperatures (internal and external)
- soil temperature
- relative humidity
- time of day of watering and amount of water (in ml)



Topic: plant life span  
Go to: [www.scilinks.org](http://www.scilinks.org)  
Code: CAH04

Topic: primary/secondary growth  
Go to: [www.scilinks.org](http://www.scilinks.org)  
Code: CAH05

## MATERIALS

- your team's Quick-Build Greenhouse
- two or three plastic planting pots, 4" square or equivalent size round pot (one used for control)
- pot saucers or dishes to hold drained water
- coffee filters, paper towels, or pot liners
- potting soil: sterile, light tilth mix, (approximately one pint)
- Atlantic Giant Pumpkin (or other) seeds (two to six)
- water (about 250 ml per pot)
- 60 W adjustable lamp (goose-neck, clamp, or tension arm)
- masking tape, sticks, pot labels, ruler

## SEED STARTING

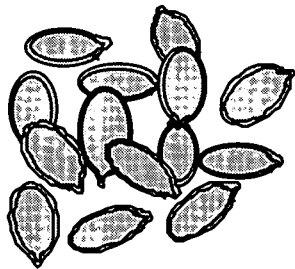

In order to provide optimum conditions for the process of germination, most growers start their seeds in small containers and later transplant the seedlings into the garden. This process is called *indirect seeding*—when seeds germinate in a location different from that of the final growing area.

At the peak of the fruit growth stage of the Atlantic Giant Pumpkin, for example, weight gain can be as much as 25 pounds per day. This means that every extra day added at the beginning of the growing season could mean a 25-pound difference at the time of harvest for contest weighing. To gain this advantage, the greenhouse you construct will be designed to optimize conditions for rapid germination.

### **Starting The Atlantic Giant Pumpkin Seed**

1. Fill and lightly pack the 4" pots with potting soil.
2. Saturate the planting mixture with water, and place the pots in drain dishes.
3. Plant one seed in each pot, 2–3 cm below the soil surface, with the pointed end of the seed down.
4. Put one or two seeded pots inside your Quick-Build Greenhouse.

How will you keep track of the seedlings later on?

5. Position your Quick-Build for exposure such that the absorber surface is 90° to the light source (desk lamp), and 15–20 cm from the 60 W light bulb.

- 
6. Position the remaining pot(s) outside the Quick-Build, about 30.5 cm from the light source, but well shielded from that source.
  7. Read both the inside and the outside thermometers just before you turn the light on, and record your readings in your laboratory journal.
  8. Note the starting time.

### **Over the next few days**

1. Leave the light on for the entire germination stage.
2. If you have not done so yet, start your laboratory journal *today*.
3. About three times a day, if possible during school hours, team members should observe the Quick-Build temperatures and the status of the pots. Record the following information in your observation log and consolidate individual readings daily into a team record sheet:
  - Date and time
  - Thermometer readings on both the inside and the outside
  - Is there any condensation in the system?
  - Are there any signs the seedlings will break out of the soil soon?
4. The ideal temperature range for germination is 24–27 °C.

What would you do if the temperature you observe is different from the ideal temperature range?

In your laboratory journal, note any steps taken to correct deviations from the ideal temperature.

5. Specifically note the amount and location of any condensation within the greenhouse.

---

If you notice condensation on an inside surface of the Quick-Build, what does it mean? Will it affect the optimal condition for germination? If so, how will you correct the situation? In your laboratory journal, note what corrective action, if any, is taken.

6. If you notice the soil bulging (a sign that the seedling will be breaking out within a few hours), let the rest of the team know, and keep a close watch for the appearance of the seedling. Record the date and time of the first indication of imminent or actual seedling emergence.

### OVERVIEW—QUICK-BUILD

In a single, fast-paced class session, students work in groups of three, following instructions to construct a Quick-Build Greenhouse. Following instructions in the *Seed Starting* activity sheet, student teams prepare and plant seedbeds. The activities that follow must be spread out over several days and can either be conducted during parts of Activity 3 or during some other activity of your own design. The total time needed depends on the kind of seed used and on greenhouse temperatures.

Because *Construct-a-Greenhouse* stresses scientific inquiry, much of the Quick-Build activity involves careful implementation of precise instructions. Following and writing precise instructions are important elements of inquiry; they are required to ensure a standard starting point from which progress is assessed. Students may need your help to understand when they are expected to follow instructions precisely and when they should innovate. In *Construct-a-Greenhouse*, the first two activities tend to be more formulaic than the remaining three, which require more independent thought.

### Time Requirement

Two Class sessions

- One class for completion of greenhouse and seedbed.
- One class period (or less) for completion of *Seed Starting*. Because students make observations of the germinating seed over several days, the exact number of days required for completion of this activity is difficult to predict.

### TEACHING SUGGESTIONS

#### *Building, Testing, and Sketching the Quick-Build*

The Quick-Build class needs to be fast paced.

Allow students one class session working in teams of three to build the Quick-Build Greenhouse and plant the seeds. Customize directions to the specific materials you provide.

Arrange the common tools and supplies, such as scissors, knives, staplers, adhesives, and tape, so that all students have easy access to them. Students may need reminders or demonstrations of safe and effective use. Be alert to safety during all tool and adhesive use sessions.



### PREPARATION

- Obtain Quick-Build construction and testing materials.
- Tailor Quick-Build instructions to materials obtained.
- Consider noise, safety, access to water and light in choice of worksites.
- Designate and arrange assembly and testing areas for the Quick-Build.
- Organize materials for easy access.
- Determine student team sizes and formation strategies.
- Contact related workplace representatives, such as nursery operators, for establishing context and relevance of lesson.
- Preview library and Internet resources.



## MATERIALS

### FOR EACH STUDENT

#### Student Activity Sheets

- Overview – Quick-Build
- Quick-Build Greenhouse Schematic
- Qualitative Observations
- Seed Starting

### FOR EACH TEAM

- *two black or white vinyl-clad 3" ring binders*
- *duct tape, 2" width*
- *clear plastic film, 30 cm x 40 cm, at least 0.05 mm thick*
- *alcohol thermometer (0–50 °C)*
- *60 W adjustable desk lamp (goose neck, clamp or tension arm)*
- *scissors*
- *ruler*
- *two plastic planting pots, 4" square or equivalent size round pots*
- *two coffee filters, paper towels or other liner for the pots*
- *potting soil, sterile, light tilth mix, approximately one pint*
- *two to six seeds (provided by the teacher)*
- *water (approximately 250 ml per pot)*

## MISCELLANEOUS SUGGESTIONS

**P**redicting the length of time needed to sprout seeds may be difficult until you have had some experience with the greenhouse lab. You will need to exercise careful and flexible planning to ensure that your students make productive use of the time between planting and seed sprouting.

Student journal writing should be an important part of this activity. Most students will need frequent and precise instructions from you to engage them in such writing. Remind them that the detailed notes they take now will prove very useful in later activities.

Before the end of class, each student should make a rough sketch of his/her group's Quick-Build, and for homework, fully label each part of that sketch. If appropriate for your class, you might recommend that manual drafting, Computer Aided Design (CAD), or other technical illustration processes be used for later inclusion in the team report and individual portfolios.

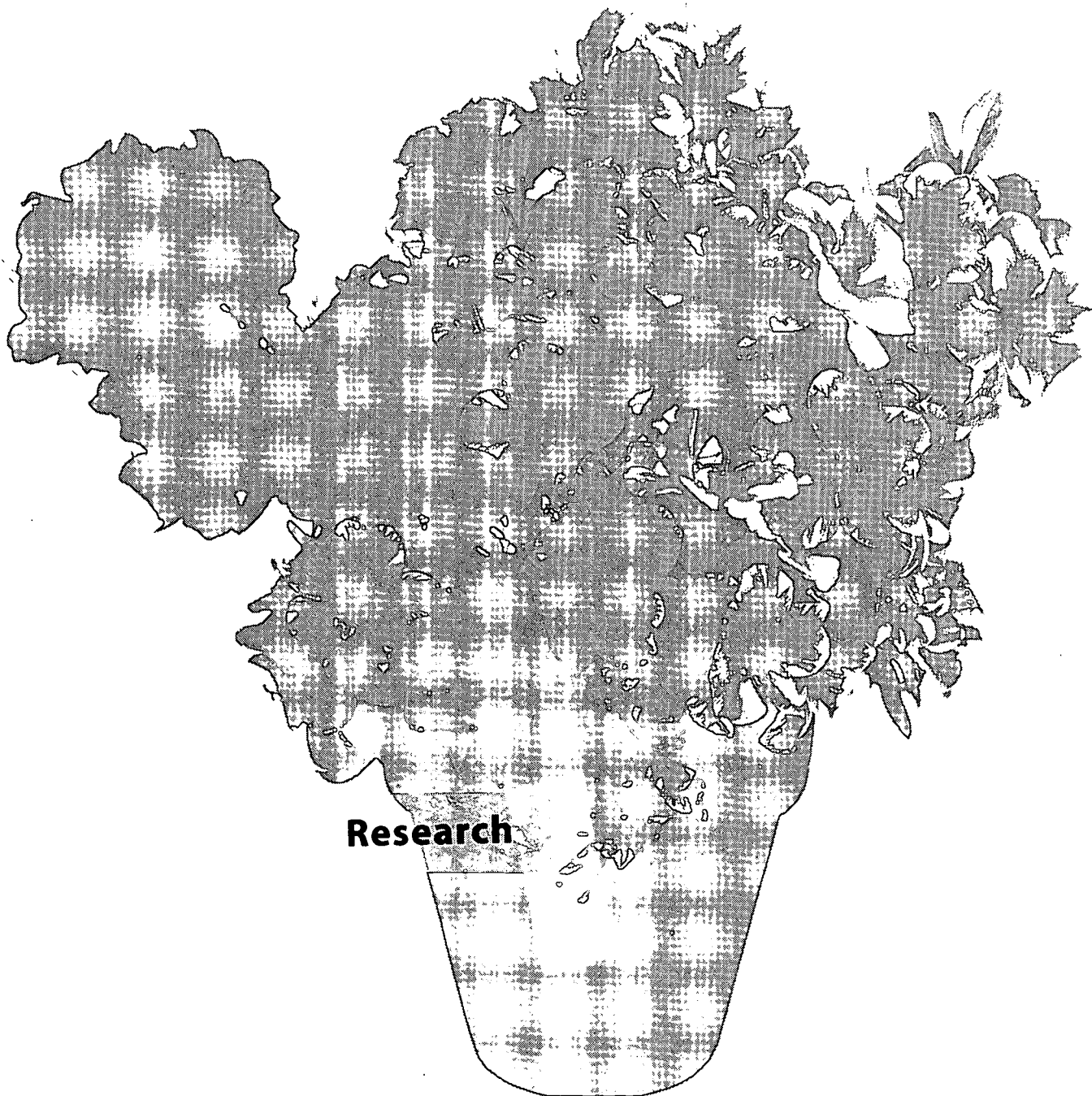

**Research**



## OVERVIEW—RESEARCH

You have completed the Quick-Build and observed conversion of light energy into heat. To successfully optimize this device, you will need to learn about both the physical and biological systems involved. You will also need to collect data on variables that are important to productive plant growth.

There are different ways to go about this. Trial-and-error is one way—fiddling around until something works; however, when you are limited in time, money, and available materials, the trial-and-error method is usually too costly to pursue.

A systematic approach to research involves careful planning and documentation and has several important strengths. Planning allows you to make reasonable cost estimates, devise a manageable time schedule, and establish a sensible division of labor. Estimates and schedules are essential if you want to finish a project on time and at a cost you can afford.

### *Scope of Work*

- ☺ Research the biology of plant growth.
- ☺ Experiment with your Quick-Build to determine baseline data.
- ☺ Research the science concepts related to the functioning of the Quick-Build Greenhouse.
- ☺ Study the physics of heat and light.
- ☺ Think critically about alternative ways to create an enclosure to provide optimum conditions for your plant.

You will probably revisit the Research activities several times, because as you work through the Development activities, you will find that you need information you had not previously thought of. No matter how carefully you plan, you may make mistakes; be alert to learn from them and adjust your plans accordingly.

---

## **SPECIES SPECIFICATIONS**

### ***Pumpkin Growth Stages***

#### **Growing Area**

Research the geographical position and climate of your growing area.

It takes 120–150 days to grow an Atlantic Giant Pumpkin. If you live in a region that barely experiences 120 frost-free days, you have a particular challenge to maximize the time to optimize the conditions for your plant. This means carefully planning and taking appropriate actions at specific times in the life of the pumpkin.

Answer the following questions on the geography and climate of your area:

What is the latitude? \_\_\_\_\_

What is the altitude? \_\_\_\_\_

What is the elevation? \_\_\_\_\_

How many frost-free days do you have, in an average year? \_\_\_\_\_

Approximately when does the first frost-free day occur? \_\_\_\_\_

When do you anticipate harvesting your pumpkin for weighing-in? \_\_\_\_\_

With the information you now have, what is your strategy for starting your Atlantic Giant Pumpkin seeds? Describe when and how you will start your seeds, and explain why you plan to do it that way.

### **Growth Stages**

The stages in the life cycle of a pumpkin can be defined by four distinct stages of growth, each with specific needs. These stages are: the seed germination stage, the seedling growth stage, the leaf and root growth stage, and the fruit growth stage. The table below identifies the features of your plant that indicate transition into the next phase of its growth.

<b>Growth Stages</b>	<b>Characteristics Marking the End of this Stage</b>
Seed germination	emergence of seed leaves, with the seed coating still adhering
Seedling growth	three fully developed leaves
Leaf and root growth	fruit on the vine for 2–3 weeks
Fruit growth	ends when pumpkin is harvested

Research the major needs of your pumpkin plant at each growth stage.

### **Tools**

- books and journals—suggested topics: agriculture, plants, gardening
- World Wide Web—suggested key words: pumpkin, giant pumpkin, vegetable garden, giant vegetable
- personal communication—local farmers, gardening clubs, prize-winning pumpkin growers in your area, county extension agents

### Research Questions

1. Working with your team, make a list of questions you will need to answer in order to raise your plant properly. Divide the responsibility for finding these answers. Use the *Growth Factors* chart to help identify key questions but do not restrict your questions to the entries given there.
2. Conduct your research to find answers to as many of your questions as possible. Indicate the resource where you found each answer.

### Growth Factors Chart

Growth Stage	Duration # of days	Ideal Conditions for Growth			
		Air Temperature	Soil Temperature	Moisture	Nutrients
Seed germination					
Seedling growth					
Leaf and root growth					
Fruit growth					

If you also found other important factors for optimal growth, specific or non-specific to the growth stage, list them in the space below and on additional pages. Remember to indicate the source for each entry; you may need to refer back to it later.

BEST COPY AVAILABLE

## TOLERANCE AND LIMITING FACTORS

### *The Law of Tolerance*

The *law of tolerance* states that the growth of an organism is limited by the environmental factor for which that organism has the narrowest range of tolerance. An organism grows and reproduces under varying environmental conditions, such as available sunlight and moisture. When growth and reproduction are vigorous, the conditions that enable this healthy development comprise the organism's *optimum range* for that variable. A plant should grow easily within this optimum range (unless some other unfavorable variable interferes).

Too much or too little of an environmental variable forces an organism to work a lot harder to maintain acceptable internal conditions. The regions on the tolerance scale just above or just below the optimum range are called *stress zones*. The greater the environmental stress on an organism, the more work it has to do to stay alive, and the less energy it has available for growth and reproduction. Still higher and lower on the scale are ranges beyond which the organism cannot survive. These are the *zones of intolerance*.

Research the range of environmental variables and the physiological response of the Atlantic Giant Pumpkin seedling in the different zones.

### *Results of Your Research*

For the seedling growth stage of the pumpkin plant, make a tolerance scale to show the range of each of the following environmental variables:

- sunlight
- temperature
- moisture

Here is an example of a tolerance scale:

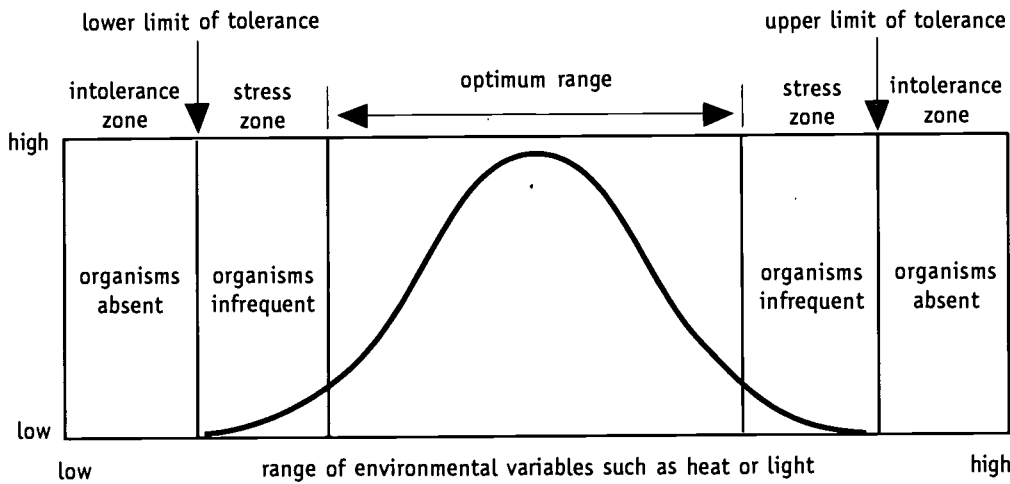

### ***The Law of Limiting Factors***

The *law of limiting factors* states that the growth of an organism will be limited if any essential growth factor is present in insufficient quantity relative to the other factors. While sunlight, temperature, and nutrients are the most important and most obvious, there are many other, less obvious, variables that may also limit growth. In an engineered environment—like your greenhouse—we can control these limiting variables to *optimize* growth conditions as the needs of the plant change from one stage to another.

Brainstorm to discover possible deficiencies and strategies to prevent, correct, or overcome them for each growth stage of the Atlantic Giant Pumpkin.

Record, organize, and summarize your team's ideas.

BEST COPY AVAILABLE





Topic: scientific inquiry  
Go to: [www.scilinks.org](http://www.scilinks.org)  
Code: CAH06

Topic: vascular/non-vascular plants  
Go to: [www.scilinks.org](http://www.scilinks.org)  
Code: CAH07

## IDENTIFYING VARIABLES AND MAKING MEASUREMENTS

### *What light are we trapping?*

Depending on what is available, you can choose to use sunlight or artificial light (like a 60 W light bulb). Think about what is best for control and consistency, as well as what is best your plant.

### *What are we measuring?*

Before answering this question, think about what the greenhouse will be used for. Reread the Greenhouse Design Brief if you are still unclear about the main challenge. Keep in mind that you will eventually need to provide an engineered environment for at least the first two of these growth phases:

1. seed germination
2. seedling growth
3. leaf and root growth
4. fruit growth

For *seed germination*, collect data on these variables:

- light/heat energy supplied over time
- external air temperature over time
- internal (greenhouse) air temperature over time
- soil temperature over time

For each of the variables above, think about what you have to measure, and how you would go about taking these measurements. Fill in the *Data Recording Plan for Seed Germination Phase* table.

## DATA RECORDING PLAN FOR SEED GERMINATION PHASE

Variable	What to Measure	Frequency of Measurements	How to Measure
<i>energy supplied over time</i>			
<i>external temperature over time</i>			
<i>internal temperature over time</i>			
<i>soil temperature over time</i>			

What other variables can you think of that are important for your design?  
Are these measurable, and if so, how would you measure them?

### ***Repurposing for the Next Growth Stage***

When your plant is at the second growth stage (seedling growth), will there be important variables to consider other than those you have just listed?

List the key differences in requirements for the first two growth stages.

BEST COPY AVAILABLE



Topic: presenting data  
Go to: [www.scilinks.org](http://www.scilinks.org)  
Code: CAH08

## WHAT WE DO WITH THE DATA

You have already designed your experiments—now you must be sure to keep good data. But “good data” does not mean “correct answers”; “good data,” means data that are carefully collected and recorded, with notes on unexpected occurrences (such as a light bulb that burns out during the course of measurement or a greenhouse that is blown over by the wind) and deviations from the intended procedure (such as taking a reading a few minutes late or having to cut short an experiment because of time constraints).

Organize your data so that you can make sense of them and use them later when you are designing your ultimate greenhouse. Two of the most common ways to organize and represent data are with tables and graphs.

### *Set Up Tables for Recording Raw and Calculated Data*

Here is an example of recording and calculating data for the change of internal air temperature over time.

9:05 a.m.			
9:15 a.m.			
9:25 a.m.			
9:38 a.m.			
9:45 a.m.			

What questions have the sample data raised for further investigations?

Set up similar tables for all variables that you have identified and measured.

### **Represent Your Data Using Graphs**

Here is an example for representing the change of internal air temperature over time.

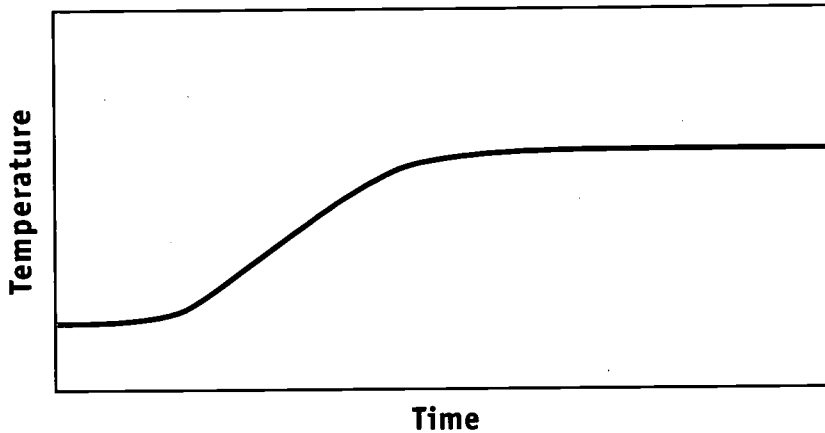

Making similar graphs for all variables that you have identified and measured will help others quickly visualize your results.

### **Are There Other Ways to Work with Data?**

If you have access to a computer and spreadsheet software, try making the tables and graphs electronically.

---

## **RULES OF THUMB**

### ***Introduction***

**A**rchitects, engineers, contractors, and builders design their buildings (or other products) based on “rules of thumb” that they or other people have developed through experience. These rules of thumb tell us how something should be built to fulfill certain requirements and to serve some specific purposes.

A useful rule of thumb should be specific but not overly restrictive. You can make calculations to verify and modify rules of thumb *after* the design has been done. This means that these rules should not be taken too literally. With research and more experience, you can always revise and refine these helpful guidelines. You may have information that is more accurate or relevant to your particular situation, than these generic advisory statements.

### ***Assignment***

Whether or not a rule of thumb works well within your design depends to a certain extent on how well you understand and apply that rule. Here are several rules of thumb for designing a full-sized greenhouse, taken from various sources that address a mix of horticultural as well as *sunspace* (you’ll learn about sunspace in the next activity) uses. Your assignment is to choose one rule of thumb, determine the science behind this rule, and explain how it can be applied to design your greenhouse, with or without modification. Consult the glossary for definitions of unfamiliar terms.

### ***Some Rules of Thumb for Designing Greenhouses***

#### **Glazing**

- Double-glazing is recommended for latitudes above 32°N.
- The total glazing area, including overhead and vertical glass, should equal 1.5 times the area of the base of the interior.

---

### **Thermal Mass**

- For storage material, it is recommended that 126–210 liters of water or 600–1000 kg of masonry be used for every square meter of south-facing glazing.
- If you can keep the soil warm, the plants will do fine, even when the temperatures are slightly below freezing.

### **Ventilation**

- Ventilation in the summer should achieve at least one air change per minute, with inlets positioned low and outlets positioned high.
- Ventilation openings to the exterior is approximately one-sixth of floor area.

### ***Your Work Sheet***

1. What is the rule of thumb you have chosen?
2. Are there other similar rules of thumb that you have encountered? What are they? Do they support or contradict the one you have chosen from the given list?
3. Explain the scientific basis for the rule of thumb you have chosen?
4. Can this rule of thumb be applied directly to the design of your greenhouse? Explain why and how you may have to refine or modify it to serve your needs.

### MATERIALS

#### FOR EACH STUDENT

##### Student Activity Sheets

- Overview—Research
- Species Specifications
- Law of Limiting Factors
- Identifying Variables and Making Measurements
- What We Do with the Data
- Rules of Thumb

#### FOR EACH TEAM

- *thermometers (two–three, scale 0–50 °C)*
- *hygrometer (one)*
- *metric rulers*
- *measuring cylinder (one)*

### PREPARATION

- *Provide resource lists, such as URLs, almanacs, yellow pages, names of local farmers (you have contacted in advance).*
- *Provide a timeline that students can use to plan their research accordingly. Be ready to assist students with research if their seedlings emerge before they have time to complete the research activity.*



### OVERVIEW—RESEARCH

Students search for information on the Atlantic Giant Pumpkin (or other plant you have selected) and on conditions for optimal growth. The *Species Specifications* worksheet provides guidance on the questions to be explored. If you are not growing the Atlantic Giant Pumpkin, use this section as a model to create a specification sheet for the plant you choose. Students will use as many different types of resources as possible, including personal communication with out-of-school personnel, and share research results among teams. They will investigate the *Growth Stages* of their plant and the *Tolerance and Limiting Factors* of the species, and brainstorm on how the *Law of Limiting Factors* affects their plans.

In *Identifying Variables and Making Measurements* students identify important and controllable variables for development of the Greenhouse and they design protocols for measuring these variables. Students consider how to represent their data in *What We Do with the Data* by making appropriate graphs and tables.

Students are given *Rules of Thumb* for building sunspaces and greenhouses. They examine the validity of these rules, choose one to research and study in detail, make recommendations, and suggest other rules. To review lessons on heat transfer, assign the *Passive Thermal Control* activity sheet in Appendix A.

### TEACHING SUGGESTIONS

#### DAY 1

Group students in product research and development (R & D) teams of three to five. Review their assignment to determine factors influencing the growth stages of their plant as per student activity sheets *Species Specifications*, *Tolerance and Limiting Factors*, and *The Law of Limiting Factors*. Have teams work separately for 15 to 20 minutes, then bring class together. Comparing findings across the class should reinforce appreciation of the numerous variables involved. List missing data and discuss where that data might be found. Have each group assign research responsibilities so that by next class all necessary data will be in hand.

## **DAY 2**

**B**egin with a short team-brainstorming session based on activity sheet *The Law of Limiting Factors*. After brainstorming, each team lists improvements that will be needed in their prototype greenhouse. Begin *Identifying Variables and Making Measurements* and move on to the *Data Recording Plan* and *What We Do with the Data*. Be sure teams are far enough along to complete all three sheets for homework.

## **DAY 3**

**C**over *Rules of Thumb* and any incomplete business needed for the next activity: Development. This would be a good day for having a visiting expert on greenhouses. Another option is to skip this day and assign the activity sheets as homework.

## **ASSESSMENT**

**A**ssessment may be based on whether students state testable hypotheses, follow through and document a controlled variable experiment, graph and write interpretations of results, record reflections on areas for improvement, and contribute to their team effectively.



**Activity 4**

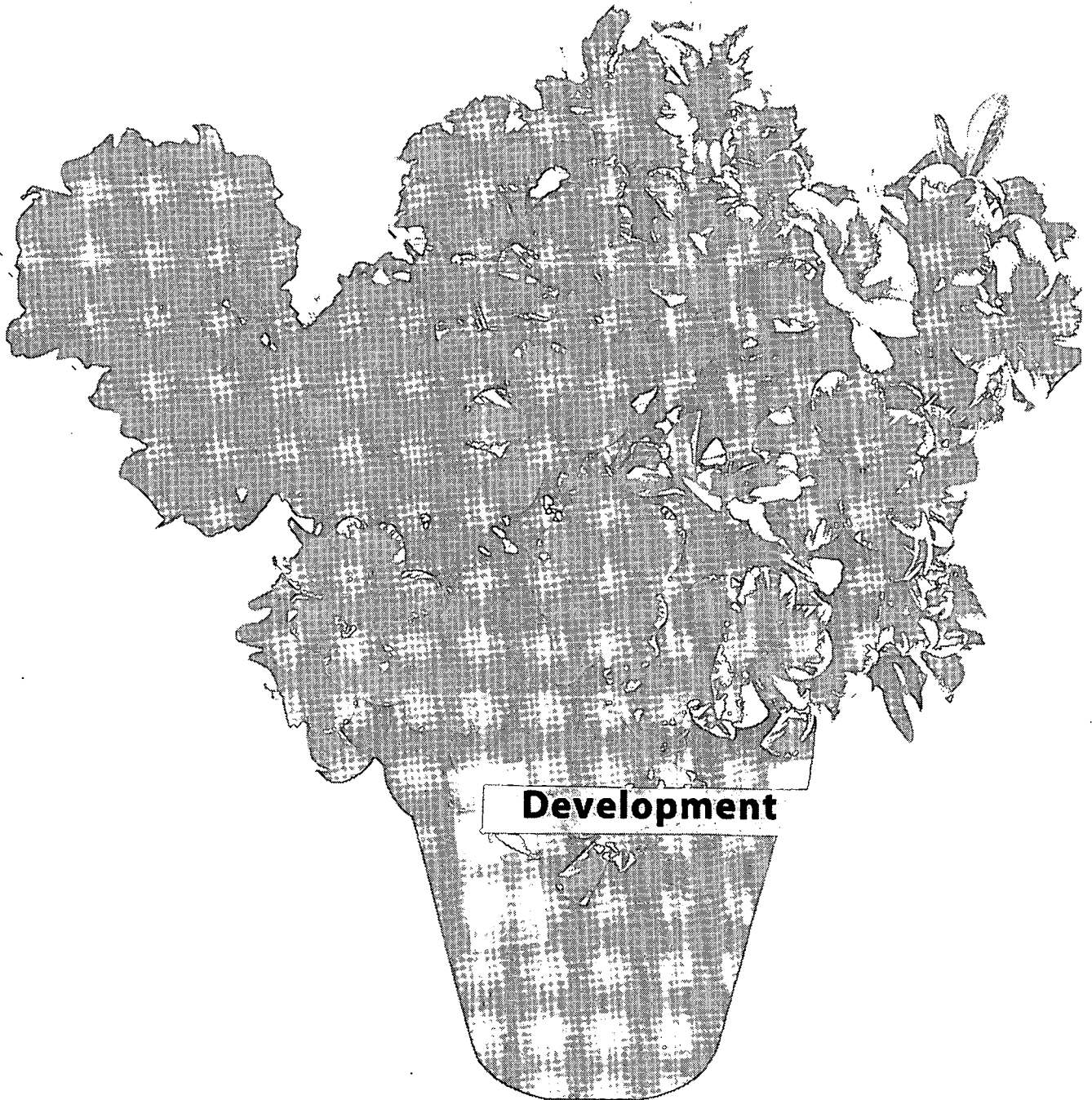

## OVERVIEW—DEVELOPMENT

You have completed activities investigating conversion of light energy to heat. You have also researched the light and temperature requirements for optimizing growth at various stages for your plant. To meet the *Construct-a-Greenhouse* Design Challenge, you will now develop a prototype that allows you to shift and control the balance between light absorption and light reflection, optimizing each for the changing needs of the growing plant.



### ***Scope of Work***

- ④ Redesign your greenhouse so that it can be repurposed as plant growth requirements change.
- ④ Build your prototype and test its performance.
- ④ Measure and record conditions inside the enclosed environment.
- ④ Compare growth of the enclosed plant to that of a control plant outside of the greenhouse.

Good planning is essential to good design. Take another look at the research activities for which you identified variables and wrote about the key differences in requirements for the first two growth stages. Think how to best combine design options with changing plant requirements. Be creative, but work within your objectives and constraints. Review the *Inquiry Process* and *Design Process* resource sheets for ideas. Evaluate your prototype critically and make modifications until you are satisfied with improved performance, or are simply out of time. Remember to reflect on your process, because how you go about your design—and what you learn—are key elements in the communication and assessment activities to follow.



Topic: heat transfer  
Go to: [www.scilinks.org](http://www.scilinks.org)  
Code: CAH09

## CRITERIA AND MATERIALS

One advantage of team product development is that many crucial tasks can be split up into a manageable division of work, yielding a shortened time period for completion. From the paired tradeoff factors listed below (or others you can think of) divide team assignments so that each member considers only two or three, but in considerable detail.

For each factor, determine how the configuration of design criteria and materials might differ for the seed germination growth stage and the seedling growth stage. A two-column table that might help you sort out the differences and tradeoffs. Make notes in your laboratory journal describing your objectives and whether modifying your design is necessary to accommodate the needs of the growing plants (repurposing). Use your notes and table to formulate conclusions on the design criteria and materials to address, and describe your factor-specific recommendations in a paragraph or two.

### *Example*

#### **Light vs. heat**

The first purpose of the greenhouse is to convert incoming light to heat in order to raise the temperature of the potted soil and speed up the biological process of seed germination. From the "Species Specs" information search, the soil temperature range recommended for seed germination is \_\_\_\_\_ to \_\_\_\_\_ °C.

Maintaining temperature in this range requires dark-colored, light-absorbing materials, and possibly insulation, thermal mass and/or double-glazing to prevent heat loss at night. The number of days gained in the growing season will optimize chances for overall maximum growth.

After the seed leaves break ground, light absorption for conversion to heat becomes less important, but you would want to increase interior light levels to maximize photosynthesis. This repurposing will require modification of the original design, and interior surfaces exposed to incoming light should be predominantly white or reflective rather than black.

---

### ***List of Considerations***

- Ventilation for temperature stability vs. gas exchange
- Nutrients required at different growth stages
- Interior vs. exterior weatherproofing
- Insulation vs. accessibility and ventilation
- Strength vs. cost and ease of construction
- Portability vs. permanence
- Size to maturity vs. material and space constraints
- Controlled vs. natural light
- Other factors

Accumulate and discuss the input from each team member, then prioritize, vote, or otherwise reach consensus to determine your approach and choose among alternatives. Next, generate a cost estimate of materials required for your prototype. See the *Scaling and Costing* activity sheet for additional guidance.

## SCALING AND COSTING

**W**hen you have decided your objectives and the criteria that your design must meet, combine those factors with your research on the growth of the plant species you are working with. Your goal is to arrive at a suitable size for your prototype growth-optimizing chamber. If your goal includes growing the specimen to maturity, you must plan for the appropriate time for transplanting.

Sketching or drawing drafts of your design will help your decision-making process. You can then label parts, get an idea how the patterns could be made from available materials, and revise to economize if necessary. Compile your specific bill of materials and use telephone inquiries, advertisements, or printed price lists to arrive at a total cost to construct. Be sure to list all your pricing sources and compare with other teams for mutual advantage.

The following partial list may help you get started; spreadsheet software (if available) could make price extensions, totaling, and revisions easier to manage.

Part	Material	Dimensions	Unit Price	Extended Price
Glazing				
Glazing frame				
Base				
Side walls				
Thermal absorber and storage				
Planting bed				
Reflecting surface				
Access opening				
Venting				
			<b>Total Cost</b>	

---

## DESIGN DRAWING

**W**hen you have decided your objectives and the criteria that your design will meet, you should make another sketch of the overall design and then detail the various parts, giving them names for ease of referral. On your drawing indicate with dimensions or notes the sizes of parts and how they are joined. Use the rest of this page for initial sketches and attach your prototype drawing as a separate sheet. Use of Computer-Assisted Drawing (CAD) software makes initial input somewhat slower, but makes revisions easier, which may pay off if you later think of design improvements.

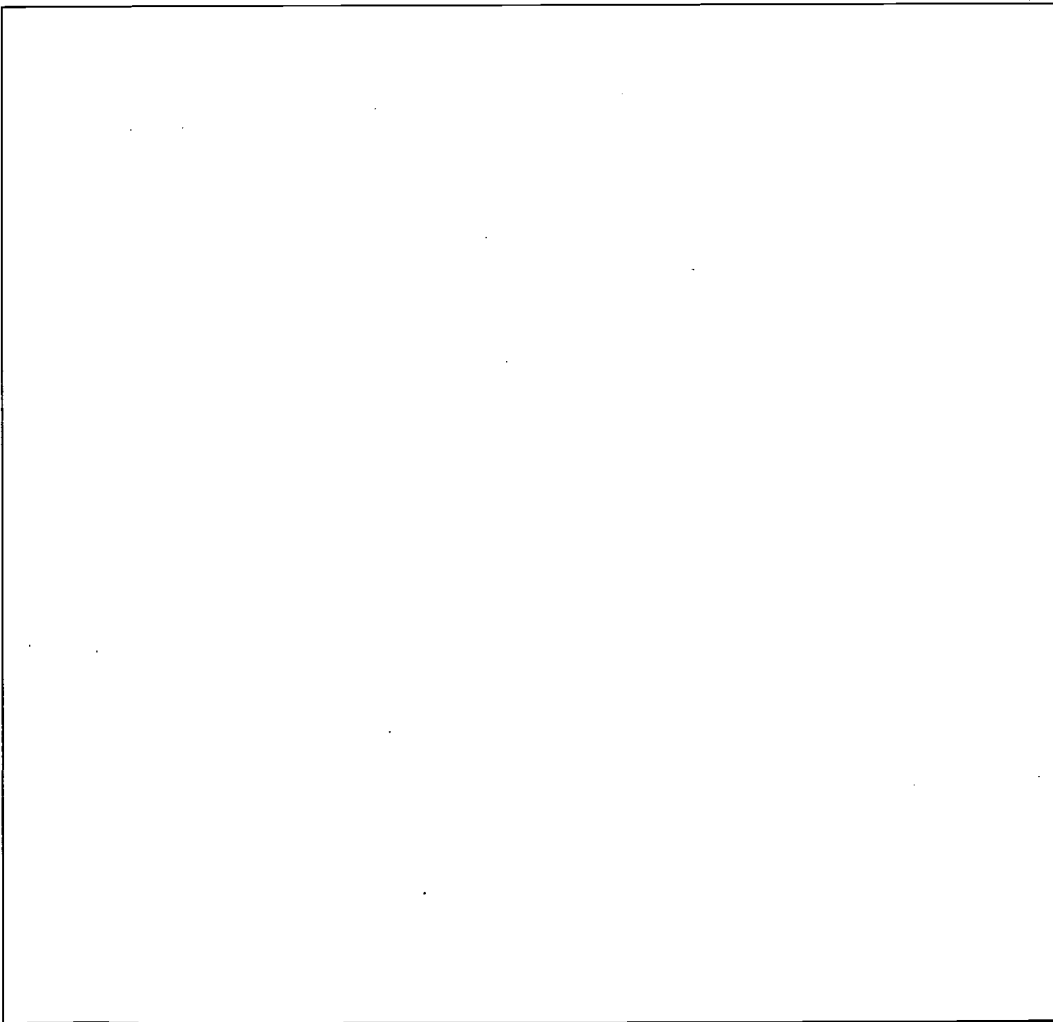

## PROTOTYPE CONSTRUCTION

### *Design Details*

**A**s you construct your prototype, make notes about the difficulties you encounter and your ideas for improvements, so that you can revise or make recommendations for others.

Some sample questions about design details are given below as a checklist for your thinking:

- Is there enough height in the structure for the growing seedling?
- What is the angle of the glazing with respect to the light source?
- Is there adequate ventilation for heat and humidity control and gas exchange (following what rule(s) of thumb)?
- Will parts of the structure shade the interior at any time?
- Is the interior able to withstand high humidity?
- Do the joints prevent air leakage?
- Are there provisions for removing the grown plant from the structure?
- Is there access for watering?
- If you are making an outdoor structure, can it withstand wind and weather?
- Is there provision for protection against pests?
- Is the insulation or thermal mass adequate for temperature stabilization?
- Is light absorption and conversion to heat optimized for the germination phase?
- Is light reflectance optimized within the enclosure for the seedling phase?
- Are there any semi-automatic maintenance plans, such as a wick for watering, or a passive vent opening and closing?
- Have parts been planned and laid out for cutting to produce the least material waste?
- Are the joints structurally sound for the level of use?
- Have costs been carefully calculated—are you within budget?
- How is the planting bed contained and drained?

---

### ***Additional Process Questions***

- Does each team member have a responsibility for specific tasks of construction? Will you employ second-party inspection and sign-offs for each aspect for *quality assurance*?
- How does your construction *schedule* coincide with the time of seed planting and sprouting?
- What kind of fertilizer *inputs* will you use and how and when will you add them?
- What kinds of *tool(s)* will you use?

### ***Design Improvement Notes***

In the space below and/or on additional pages, organize and record your notes for design improvements. Prioritize these changes with respect to importance and feasibility. Include sections for categories such as construction rationale, difficulties, and recommendations.



---

## PERFORMANCE TESTS

### *Pre-Operational Testing*

To minimize potential problems and gather input for last-minute design changes, it is a good idea to pilot test your prototype prior to placing the sensitive biological specimen inside. Depending on how different your team's prototype is from your previously tested Quick-Build, you may need to measure parameters like internal temperatures, and make qualitative observations on light levels, condensation, vent and access panel operation, etc.

Record here the parameters you will measure:

### *Operational Monitoring*

When the team is satisfied that conditions within the prototype environment will optimize growth conditions, place the specimen inside. Immediately record the starting conditions of the plant and the external as well as internal environment. These data should form the start of a periodic record of measurements and observations that will help you assess physical and biological status and make necessary adjustments.

Record here the parameters you will measure:

---

## PROOF-OF-DESIGN PERFORMANCE EVALUATION

As indicators of successfully meeting the *Construct-a-Greenhouse* Design Challenge, there will be both biological and physical factors to consider. Your data should show that the engineered environment met specifications over the extended period of seedling growth as you anticipated. In addition, you can make both quantitative and qualitative observations of plant vigor and compare your specimen to those grown by other teams who approached the optimization challenge differently. Possible parameters of plant vigor might include leaf color, number of leaves and buds, total leaf area, girth and height of main stem, etc. Several solutions may produce similar results, but differ in cost, appearance, ease of construction, etc. Perhaps some particular conclusions will emerge as universal or unique. There are many ways to achieve success.

Record below the parameters that your class agreed to use to measure success.



**MATERIALS**

**FOR EACH STUDENT**

**Student Activity Sheets**

- Greenhouse Design Brief (from Activity 1)
- The Design Process (from Side Roads, Appendix A)
- Overview—Development
- Criteria and Materials
- Scaling and Costing
- Design Drawing
- Prototype Construction
- Performance Tests
- Proof-of-Design Performance Evaluation

**FOR EACH TEAM**

- *paint: white and black*
- *foam board: plywood or other rigid sheet material to meet the interior or exterior conditions you specify*
- *thermometers (0–50 °C)*
- *light source: direct sunlight or 100 W lamp and electric outlet*
- *glazing: glass, Plexiglas, or clear sheet plastic*
- *clock or watch*
- *duct tape*
- *hammer and nail assortment*
- *screwdrivers and screw assortment*
- *waterproof glue(s)*
- *pencil and paper*
- *recyclable flash, digital, or instant camera (optional)*

**OVERVIEW—DEVELOPMENT**

**A**fter reviewing the design process and the Design Brief, students list elements of the engineered environment that are important for plant growth optimization, using the *Criteria and Materials* activity sheet. They compare differences and tradeoffs involved in repurposing the environment from one that is aimed at accelerating germination to one that enhances the growth of the sprouted seedling. Next, students consider *Scaling and Costing*. You will need to define the limits on size and cost and provide that to students ahead of time. Alternatively, you can define the materials available and provide a supply of them.

Students make initial sketches based on the criteria they have identified, name parts, note dimensions, and produce a *Design Drawing* of the prototype.

In the prototype construction phase, students reflect on interlinked variables and their complexity, consider tradeoffs, and make choices for design optimization to accommodate change. Depending on the scale and quality of construction feasible in your situation, this phase may take from one day to several weeks.

Students build, evaluate, and revise their greenhouse prototypes. They collect data and make quantitative and qualitative comparisons between growth of seedlings in the chamber and a control group using the *Proof-of-Design Performance Evaluation* activity sheet.

**Time Requirement**

This activity will take a minimum of four days.

Define a time scale that is tight but realistic for the size and complexity of the structures you expect students to build. A simple cold frame could take one day—a high-tech greenhouse with automatic controls might require weeks and cost a substantial amount.

**TEACHING SUGGESTIONS**

**Discussion of Homework**

Discuss the homework in *The Design Process* activity sheet. A good initial question to pose might be: *Does the diagram depicting the design process reflect your experience in designing and building?*

Other questions to ask are ones from their homework:

- Which elements of this process have you already experienced?

- Where in the process do you think you are now?

You may wish to make the criteria you will use to assess students' technological design capability available at this point and invite discussion.

Suggest to students that if they become stuck at any point they should refer again to their portfolio sheets for ideas about what to do next. Highlight, or elicit, examples of how students already used or might soon use the design process loop in non-linear progression. Students may wish to record scenes illustrating their group process with photographs or video.

### ***Starting to Redesign the Improved Greenhouse***

Students may choose to proceed with the redesign of their greenhouse either by improving upon their Quick-Builds, or by starting fresh. In either case, they should: (a) preserve or build upon modification conclusions reached working with the Quick-Build system in the Research phase, or (b) begin anew on a distinctly different system, in which case initial research must be inserted in the development process. Advise them also to keep the selected or specified purpose of their greenhouse constantly in mind to guide decisions.

### ***Resources for Redesigning***

Before students begin redesigning, they might individually review and then discuss as a team the *Criteria and Materials* resource sheet to define the team's design issues.

### ***Timely Feedback***

As students move beyond their Quick-Builds, it is essential that teams be allowed to grapple with the challenges of designing, building, testing, and revisiting these processes. It is important, however, that they receive input at critical times. One source of input is the team itself; encourage brainstorming as an official design process to be performed by the rules (see Side Roads).

Another important source is timely intervention from you. Very often, a suggestion about how to solve a problem, or a reference to a diagram or picture will stimulate action. Drawings or some sample student-built prototypes from previous classes may be helpful to stalled teams. But judgment must be exercised to avoid intervening too early.

### **PREPARATION**

- *Prepare the fabrication zone.*
- *Consider quantities of workspace, materials, tools, fasteners, and adhesives available and optimize spatial arrangements for safe, efficient access.*
- *Set up the performance testing arena. If this is outside your classroom or indoors, you may need to undergo careful negotiations with others in your school to ensure that the area remains undisturbed. Do not forget to include the custodian in these discussions.*
- *If space allows, give each group its own separate area to test the performance of its prototype.*
- *Consider which technological tools you might add., e.g., CAD.*
- *If your students are proficient with computerized temperature probes, spreadsheet software, or graphing calculators, the data they collect during performance testing can be entered, manipulated, and printed.*

## SCALE AND COST

**Y**ou will need to provide limits to the scale and cost of each greenhouse. Students who find that costs are too high should be encouraged to rescale the size of their design to fit the budget. This can provide important insights on differences in the ways in which volume and surface area are scaled.

### ***Collecting Data***

Wise students will pretest the temperature behavior of their greenhouses prior to planting.

### ***Deciding How Good Is "Good Enough"***

This decision can be left to the great pumpkin. If plants survive, the system is good enough. If plants grow robustly, the design is superior.

### ***Design Self-Assessment***

As a final Development activity, students reflect upon what they have done thus far in the *Proof-of-Design Performance Evaluation*.

### ***Assessing Students' Design and Build Capability***

There are several key elements of students' design and build capabilities you could assess throughout the Development phase:

- *How well students are able to develop solutions.* Developing ideas through to workable solutions is at the core of technological design. Look for evidence of students' ability to do this, both in your ongoing observations of students at work and in the responses they give to Development Activity sheets.
- *How well students are able to evaluate the processes they have used.*  
This includes the extent to which they are able to identify strengths and weaknesses of their prototypes. Look for evidence of students' ability to do this, both in your ongoing observations of students at work and in the responses they give on the activity sheet *Reflections on Your Design*.
- *To what extent do students exhibit ownership of the task? Did it change with time? How much initiative did they take?* Look for evidence of this in your ongoing observations of your students.

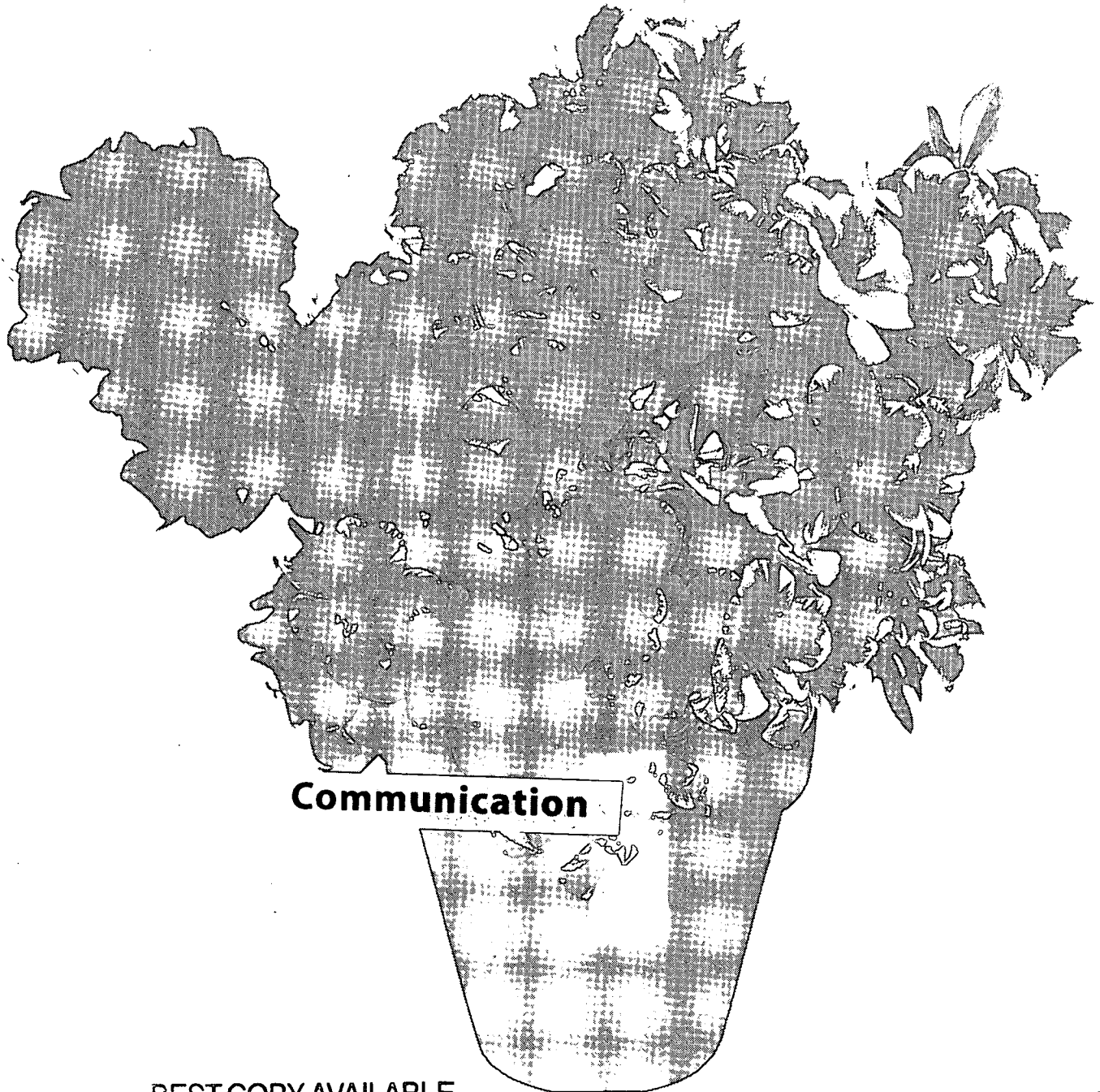

**Communication**

BEST COPY AVAILABLE



## OVERVIEW—COMMUNICATION

**Y**ou have met the challenge. You have redesigned, built, and tested a device for growing giant pumpkins. But you will not win any prizes if nobody knows about what you have done. Until you communicate the importance of your work to the people who matter, your efforts will have little meaning. Indeed, one of the most critical abilities today is to be able to communicate clearly, effectively, and persuasively.

As an engineer, scientist, and product developer, you are dependent on funding from private and public foundations. It is important to convince those with money why they should give support to the work you do. You may want to present your ideas to local officials or create a Web page that would make your work accessible to the entire world. There are agricultural fairs to show off farmers' best work, trade fairs to present new products to the market, and scientific journals to describe new discoveries. Publications are also important for communicating your findings to the greater scientific community.

Think about the discoveries you have made with the *Construct-a-Greenhouse* Design Challenge. Communicate the important parts of what you have done to several different audiences including: your classmates or a group of novice pumpkin growers. Think about the interests your audience might have in your work. Recognize that there are many possible formats to communicate with your audience. Select one or more formats to present your work.

### ***Scope of Work***

- ☉ Present your redesigned greenhouse, including the rationale, substance, and outcomes of your effort.
- ☉ Serve on the answer panel of a FAQ site.
- ☉ Write a set of instructions for others who might be interested in building their own greenhouses.
- ☉ Write a set of next-steps for someone to continue nurturing your plant to maturity.

---

## PRESENTATION

In *Construct-a-Greenhouse*, you designed and built an engineered environment for growing a giant vegetable. You have kept careful records (perhaps even photographs) and you have the prototype model as well as the growth-enhanced biological specimen for display. You are now asked to present orally the rationale, substance, and outcomes of your effort. You have limited time for your presentation, so you should do some careful planning and rehearsal. This should be a team effort, with each team member responsible for communicating a key part of the presentation. You should also expect to field questions from your teacher and your audience. You may find visual aids useful in presenting key data and in providing your audience with tools for quick and clear analyses.

Prepare an outline of key points to cover, focusing on capturing your audience's interest, but clearly identifying the strengths and distinguishing features of your design for comparison with those in other presentations. Present the evidence that the design accomplished its purpose by quantitative and qualitative comparisons to the class control plant specimen, using the criteria developed previously by the class.

List your preliminary presentation outline with team member assignments below. Consult with your teacher as a resource in your planning.

### Presentation Outline

### Team Member Assigned

TITLE:

I.

II.

III.

IV.



## **FAQ ASSESSMENT**

### ***Frequently-Asked-Questions Panel***

**Y**our team and other teams in your class rotate serving as answer panel for an actual or mock Frequently Asked Questions site, responding with concise answers by computer, telephone, or writing. This simulates challenges faced by master gardeners consulting to the community, cooperative extension agents, pumpkin growers, or gardening columnists. To prepare well for your role, you will have to study, as you are accountable for anything covered in this project, for a random question test. When you don't know an answer, you should be able to point the questioner to a proper source. On the World Wide Web, there are some FAQ links on giant pumpkin pages with ready-made questions. Some of the questions and topics are listed below.

#### ***General***

- How early should I start?
- How do I enter a contest?
- Are there any good books or other sources of information?
- Who holds the world record for largest pumpkin grown?
- Where can I buy good seeds?
- Which vine should I choose?
- Should I milk-feed my pumpkin?

#### ***Growing Tips***

- Watering
- Mounding

#### ***Bug Problems***

- Cucumber beetles
- Vine borers

#### ***Plant Problems***

- Split stems/Stem stress
- Yellow stem
- Deformed leaves
- Enormous seed leaves
- Plant stress
- Leaf wilt
- Light green leaves are OK
- Hail storm

---

### ***Propagation***

- Heating cables
- Ungerminated seeds
- Growing tips
- Seed pollination
- pH levels
- Starting seeds indoors

### ***Fertilizer***

- Fertilizer program
- Best times to fertilize the pumpkins

### ***Weight***

- Weighing process
- Weight table (over the top method)
- Weight of a pumpkin

### ***Estimation***

- How much does your growing pumpkin weigh?

---

## REFLECTION AND RECOMMENDATIONS

Set forth at least eight prioritized rules of thumb, factors to consider, design criteria or statements of general wisdom and advice you would offer to others designing a greenhouse. Make your recommendations based on the experience and knowledge you have gained through research, development, and testing of your own engineered environment and on comparing your results with those of other teams.

### *Optimizing Germination and Seedling Growth for Transplanting*

1. \_\_\_\_\_
2. \_\_\_\_\_
3. \_\_\_\_\_
4. \_\_\_\_\_
5. \_\_\_\_\_
6. \_\_\_\_\_
7. \_\_\_\_\_
8. \_\_\_\_\_

---

### *Growing a Seedling to Maturity*

1. \_\_\_\_\_
2. \_\_\_\_\_
3. \_\_\_\_\_
4. \_\_\_\_\_
5. \_\_\_\_\_
6. \_\_\_\_\_
7. \_\_\_\_\_
8. \_\_\_\_\_

## ESTIMATION: HOW MUCH DOES YOUR PUMPKIN WEIGH?

Even if you carefully place a developing pumpkin on a bathroom scale, the increasing size and weight will quickly outpace your measurement system, and the risks of damaging the vine, scarring the rind or injuring yourself rise accordingly. You may be inventive enough to devise an actual weighing system, but such a system would be more likely site-dedicated rather than portable, and the final weight will still be that determined at an official contest site.

Without some agreed upon measurement system, however, growers would not have much basis other than guesswork to compare the "fruits of their labor" prior to the end-of-season weigh-off date. Most growers do rely on experienced judgment, but combined with either of two estimation techniques copyrighted by the World Pumpkin Confederation. Leonard Stellflug (1989) and Howard Dill (1991) are the growers who originated the two very different estimation systems.

### *Stellflug's Circumference Equation*

$$\text{Weight} = 0.000213 \times \text{Circumference}^3 + 20$$

The largest circumference of the fruit is measured in inches, generally parallel to the ground at approximately stem height. A table of calculated weights (in pounds) for different circumferences makes the system quite convenient. The method incorporates consideration of fruit diameter and density including allowances for wall thickness and the seed cavity.

Starting and ending values for the actual system table are provided in the table below. Calculate and provide two other values for points of your choice in between.

Circumference in Inches	Weight Estimate in Pounds
70	93
169	1048

How would you suppose the decimal factor, cubic exponent, and addition of 20 units might have been derived?

Rewrite the equation for a system based on metric units of measure.

### ***Dill's Over-the-Top Method***

This method requires more measurements, but has also proven to be reliable.

1. Measure the distance over-the-top from ground to ground along the axis from stem to blossom end. (Allow the measuring tape to drape to the ground from the sides of the pumpkin; do not hug the undersides to the point of ground contact.)
2. Add the distance measured from ground level over-the-top to ground level on the opposite side at the widest portion of the pumpkin and perpendicular to the stem-blossom-end axis measured above. (Again, allow the measuring tape ends to drape.)
3. Add the circumference measured parallel to the ground from blossom end to stem.
4. Multiply the sum of the three measurements by 1.9, yielding an estimate of pumpkin weight.

Study Dill's method and explain why you think it works. It may be helpful to make a drawing and consider the pumpkin first as a geometric solid. Then consider appropriate correction factors for irregularities in shape and non-uniform density. *Respond in the space below:*

*Data and suggestions for refinement of these methods to help worldwide growers better determine pumpkin weights prior to contest weigh-offs may be sent to:*  
WPC, 14034  
Gowanda State  
Road, Collins, NY  
14034.

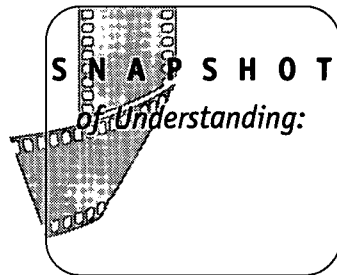

## What I Now Know about Light Absorption and Energy Conversion.

1. List four key physical and natural science topics relevant to the Greenhouse Design Challenge and demonstrate your knowledge of each in a brief paragraph.
2. Briefly describe the design process.
3. How is the design process similar to the process of scientific inquiry? How are they different?
4. Describe *quantitatively* two key parameters you controlled to achieve accelerated seed germination.

- 
5. Describe *qualitatively* two key factors you enhanced to optimize seedling growth.
  
  
  
  
  
  
  
  
  
  
  6. What do you recommend finding out about a rule of thumb before faithfully applying it in important design work?
  
  
  
  
  
  
  
  
  
  
  7. Is green a good absorber of radiant energy? Why or why not?
  
  
  
  
  
  
  
  
  
  
  8. Compare and distinguish between the horticultural “greenhouse effect” experienced in this challenge module and the global environmental greenhouse effect.



**MATERIALS**

**FOR EACH STUDENT**  
Student Activity Sheets

- Reflection and Recommendation
- Estimation: How Much Does Your Pumpkin Weigh?
- Snapshot of Understanding

**FOR EACH TEAM**

- *visual presentation system (marker board, overhead projector, etc.)*
- *audience*
- *oral presentation assessment rubric*

**PREPARATION**

- *Make evaluation rubric available to students for use in presentation planning (if you have not already done so).*
- *Provide highest technology visual presentation aids feasible for student use.*
- *Consider offering spectator invitations, competitive aspect, and focus on launching guides.*
- *Review student options for extracurricular continuation of growth optimization activity. Be prepared to suggest opportunities and sources of support for various requirements, such as growing location(s), mentors, tools, water supply, soil amendments, and mulch. Some research on area agricultural fair and contest weigh-in dates might offer inspiration.*



**OVERVIEW—COMMUNICATION**

Students, working in teams, prepare an oral presentation to communicate their research and development efforts and results to classmates and invited audience.

Students prepare written recommendations for next steps to support continued optimum growth of their plants. Beyond the end of the curriculum unit, you might encourage individual students to transfer their responsibility to other students (such as an elementary school science class), or continue as horticultural caregivers, following their own advice.

Students prepare for final assessment by assembling their portfolios according to the provided checklist, and responding to a set of Frequently Asked Questions (FAQ) compiled from classmates' and others' inquiries.

Students answer *Snapshot of Understanding* questions similar to those answered at the beginning of the unit and, by comparison, self-assess their learning.

**Time Requirement**

Three class sessions:

- One class for team formulation of reflections and recommendations and preparation of presentation. Additional time needed as homework.
- One and a half classes for team presentations and FAQ preparation.
- Half a class for final evaluation and self-assessment.

**TEACHING SUGGESTIONS**

**Reflection and Recommendations**

Students may wish to continue nurturing their specimen beyond the scope of the unit and the capacity of their prototype, by transplanting it outdoors to a home or school garden, competing in a fair or contest, or growing it for market, for decoration, or for further learning. Any such initiative and follow-through clearly merits encouragement and support for furthering student academic or hobby/sport enjoyment. In any case, written continuation recommendations and instructions are the assigned product from the reflection activity, and should be evaluated for its basis in research and realistic projection on the part of all team members.

## ***Presentations***

Teams are asked to divide presentation responsibilities among members so that effort and benefit of the work and learning are distributed equitably. The team should provide support, emotional and academic, where needed, with particular sensitivity to ensuring to the greatest extent possible that this assignment in public speaking be a positive experience for each member. An assessment rubric, tailored to fit your class learning and evaluation objectives, should be made available to teams well ahead (possibly at the beginning of the prototype development phase) to encourage maximum awareness, planning, and preparation.

## ***Completing the Snapshot of Understanding***

**Warning:** This *Snapshot* has an important catch! By using thin plastic wrap they lose the greenhouse effect. Contrary to expectations, students should not observe much temperature gain. You will learn a great deal about their understanding of the greenhouse effect by observing how they attempt to answer the questions in this *Snapshot* and relate them to the earlier *Snapshot*.

After students complete the final *Snapshot of Understanding* (allow about 35 minutes), provide a brief time for

them to compare their new answers with those on their prior-learning *Snapshot*. Seeing how much is learned in this brief, but intensive, experience can be informative.

## ***Sample Oral Presentation Assessment Rubric***

<b>Evaluation Criteria</b>	<b>Points</b>
Presenters/Participations	5
Date/Time/Length	5
Title/Topic/Communication of Objective	10
Methods Used/Style/Visual Aids	20
Interaction/Engagement with Audience	20
Delivery Factors	10
Goal Achievement	10
Strengths/Effectiveness	10
Areas to Improve—Self-Assessment	10
<b>Total</b>	<b>100</b>

## ***Overall checkpoints***

Is the information presented:

- Relevant?
- Purposeful?
- Organized?
- Accurate?
- Interactive?

## ***Did the Presenters Report***

- Science principles that explain observations?
- What they would do differently again and next?
- How they employed processes of inquiry and design to meet the challenge?

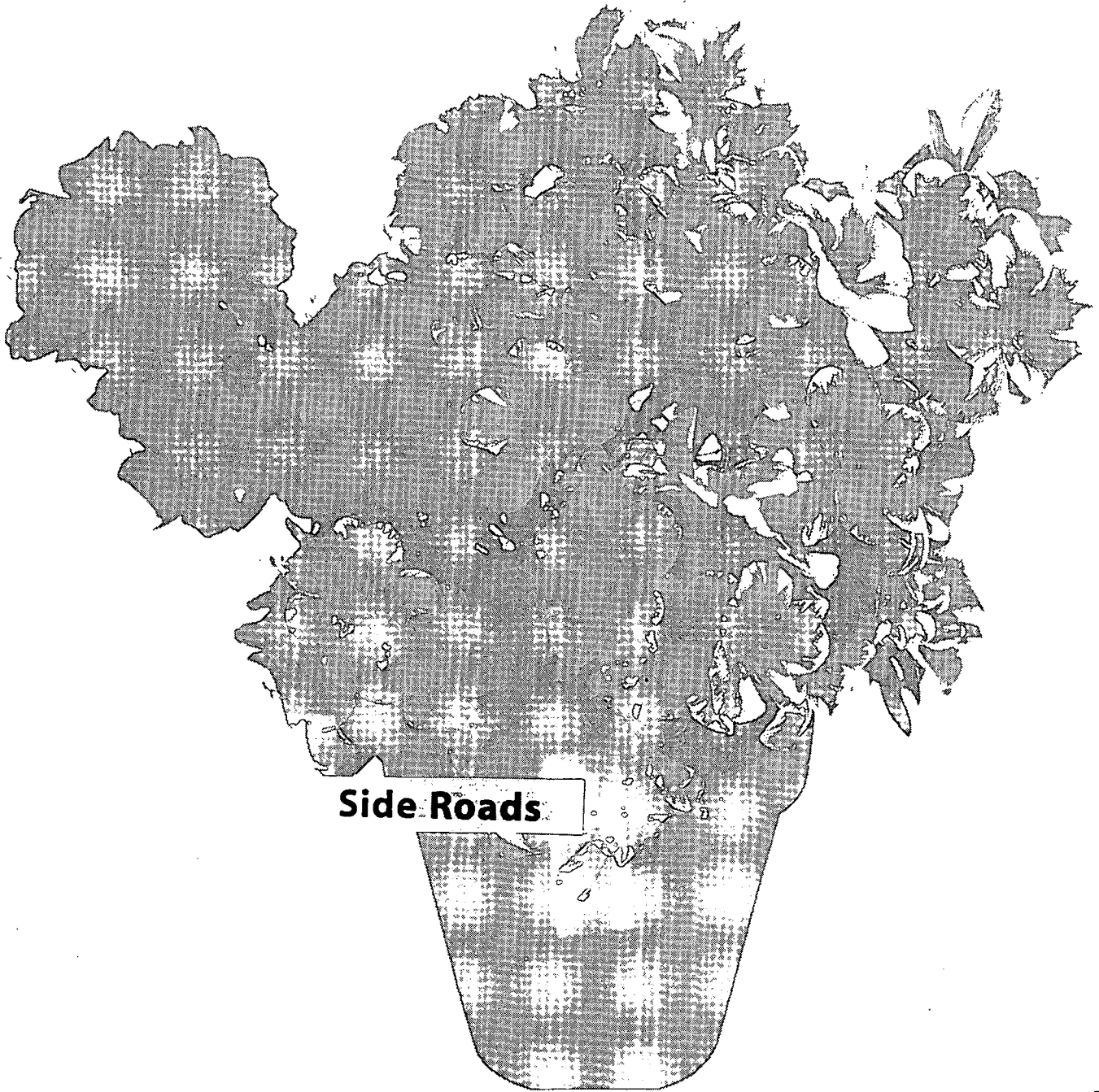

Side Roads

BEST COPY AVAILABLE

CONSTRUCT-A-GREENHOUSE

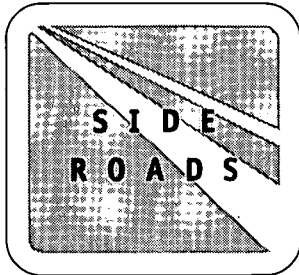

## **SIDE ROADS**

**T**he following pages correspond to the Side Road suggestions made in each activity. Many of these are key activities, but they have been placed in the Side Roads section because they can fit in several different places—exactly where they are used is a matter best decided by you in response to student questions and feedback.

Some activities may be profitably used more than once. An analysis of the design process, for example, will provide different insights in the Research activity section than those of the Design activities.

### ***In this section:***

- ☞ Internet Information Search
- ☞ The Inquiry Process
- ☞ Passive Thermal Control
- ☞ The Design Process

## INTERNET INFORMATION SEARCH

If at all possible, prepare for a quick demonstration showing students the steps and what to expect—either real-time or pre-taped via feed to large screen TV monitor in the classroom.

A few cautionary words about censorship, commercialism, and privacy issues should be included at the outset. Consult your school policy and lab director for assistance.

Set an objective, assignment, or contest that requires each student or pair of students to turn in a search path or research result printout at the end of the session. Inform students how the deliverable will be used for assessment.

Schedule enough time for the activity so that slow navigators will reach satisfying pre-determined destinations (with provisions for speedsters to move beyond).

Consider pairing students: inexperienced with familiar, confident with scared, leaders with followers, disciplinary problems with angels, etc., to create peer teaching opportunities and reduce individual distractions from allowing you to gain group attention.

Pairing will also decrease the network traffic in your lab that could otherwise decrease computer response times.

If your lab or media center administrator has not already done so, prepare a brief but precise list of sequential steps to start up, log on, connect to the Internet, and select and arrive at a search screen. Duplicate and provide as a handout to each pair of navigators. Some "Don'ts" may need to be listed, such as do not double click (or more) with easy-to-remember explanations, like machines hate to be told twice, or more technical reasons such as slowing the processor to sort through duplicate instructions and exceeding memory to open and display duplicate screens.

The structure of search commands will have to be covered, as well as how to limit a search by combining key words. You might want to prepare a list of key words you have tried and found productive for groups to pick from according to their interests or assigned objective. Having everyone achieve a common destination and then diverge will increase the class's overall depth of exploration if results are to be shared.

You may wish to show students how to create bookmarks and then print their lists of bookmark addresses so they can return to interesting sites later, outside of class. After the search, you may wish to provide a list of known web sites from your own reference and resource list and invite students to submit additions to it. Providing short-cut instructions on how to GO TO or OPEN a known URL as distinct from the search procedures just conducted will be helpful to avoid confusion.

The following URLs were active and helpful during the development of the curriculum:

*Hobby Greenhouse*

<http://www.orbitworld.net/hga>

*Technical Brief—Designing the Passive Sunspace*

<http://www.bamafolks.com/~rsggs/sunspace.htm>

*Insects Common to the Greenhouse*

<http://www.bamafolks.com/~rsggs/bug.htm>

*Greenhouses & Garden Structures*

A discussion forum for enthusiasts of greenhouses and other garden structures

<http://www.gardenweb.com/forums/strucs/>

*State of the Art Energy Efficient Greenhouses*

<http://www.gardenweb.com/forums/load.cgi/strucs/msg1201203816380.html?8>

*Greenhouse Heating*

<http://www.gardenweb.com/forums/load.cgi/strucs/msg0921362415131.html?22>

*Heating a Greenhouse in Winter*

<http://www.gardenweb.com/forums/load.cgi/strucs/msg0817574727514.html?4>

*Seed Germination Chamber*

<http://www.gardenweb.com/forums/load.cgi/strucs/msg0119191811081.html?2>

*Greenhouse Materials Preference*

<http://www.gardenweb.com/forums/load.cgi/strucs/msg1017333025843.html?5>

## INQUIRY PROCESS

The *inquiry process* is often viewed as a cycle of action that repeats until the investigators reach a satisfying solution. It can be described with seven basic elements:

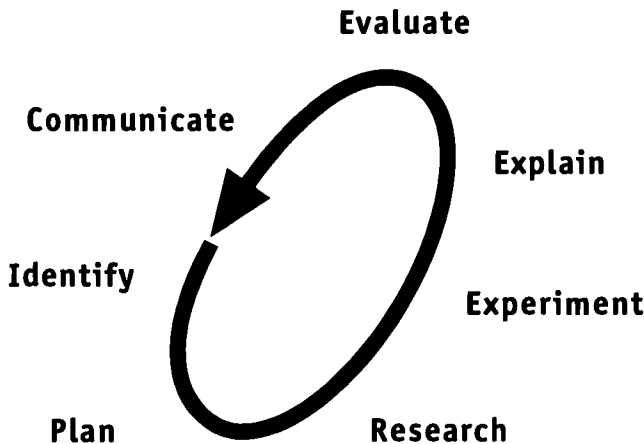

**Identify** and clarify questions. Understand the issue or problem, and make a testable hypothesis.

**Plan** appropriate procedures. Brainstorm, draw and write ideas, clarify their ideas, and suggest possible strategies or methods.

**Research** major concepts. Learn what is known about the situation from sources other than actual investigation, and obtain information from preliminary experiments. Decide what technology, approach, equipment, and safety precautions are useful. Document your experiments and log your data.

**Experiment.** Use tools and measuring devices to conduct experiments. Use calculators and computers to store and present data.

**Explain** logical connections. Analyze your data. Formulate explanations using logic and evidence, and possibly by constructing a physical, conceptual, or mathematical model.

**Evaluate** alternatives. Compare your explanations to current scientific understanding and other plausible models. Identify what needs to be revised, and find the preferred solution.

**Communicate** new knowledge and methods. Communicate results of your inquiry to your peers and others in the community. Construct a reasoned argument through writing, drawings, and oral presentations. Respond appropriately to critical comments.

---

### **Questions**

Read the following questions, but do not answer them until after your team has experienced working together on the design challenge research activities.

1. Make your own checklist of team activities that correspond to steps in the cycle described above:
2. Create your own version of the inquiry process using words and pathways that fit your team's activity.
3. What shape is your inquiry pathway diagram (circle, spiral, cascade, other)?
4. How and where do the seven steps described above fit within your process description?



## PASSIVE THERMAL CONTROL

### Review of Basics

#### Heat Transfer Processes

When solids, liquids, or gases of different temperature come into contact, without further disturbance, heat flows from warmer to cooler entities to reach a common temperature. Three basic heat transfer processes are summarized in Figures 1–5:

- conduction
- convection
- radiation

A material may achieve equilibrium with its surroundings through any or all of the processes.

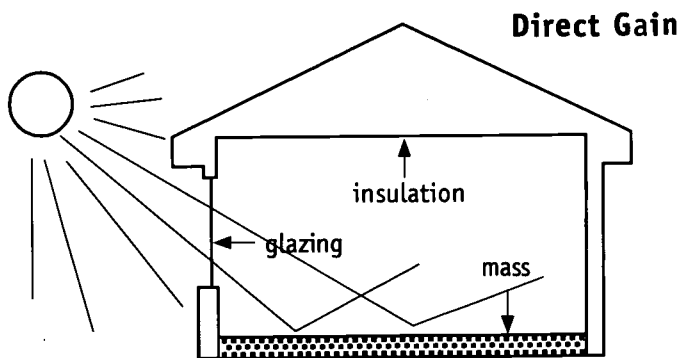

**Figure 1:** Sunlight enters a building directly through windows. Large amounts of solar heat can be absorbed and stored by heavy materials in the building for later use.

**SCILINKS.**  
THE WORLD'S A CLICK AWAY

Topic: heat transfer  
Go to: [www.scilinks.org](http://www.scilinks.org)  
Code: CAH09

Topic: conduction/  
convection  
Go to: [www.scilinks.org](http://www.scilinks.org)  
Code: CAH01

Topic: radiation  
Go to: [www.scilinks.org](http://www.scilinks.org)  
Code: CAH02

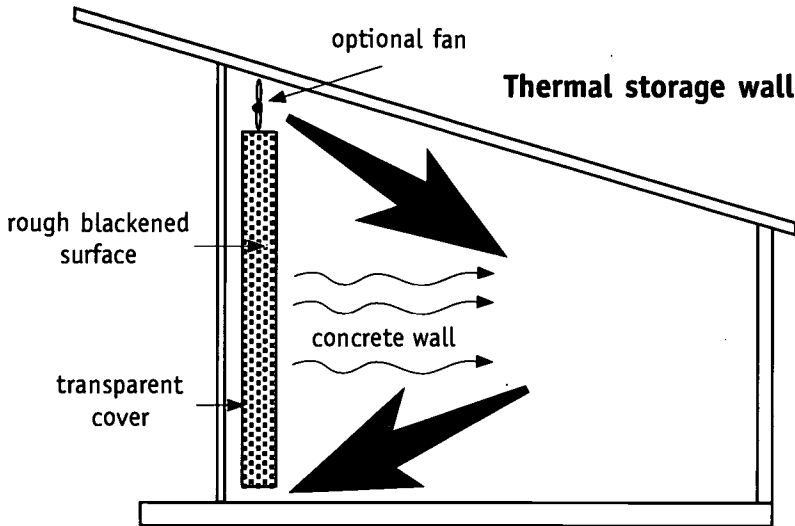

**Figure 2:** The thermal storage wall is made of heavy materials such as concrete, stone, or containers of water. Radiant energy that passes through the windows is stored in the wall. At night, the wall radiates warmth to the building. With vents at the top and bottom of the wall, some of the heat entering the building is circulated directly by natural convection.

**Figure 3:** Most thermal storage roofs consist of waterbed-like containers. The water absorbs the radiant energy from the sun, conducts the heat energy throughout the ceiling, and warms the building by radiation.

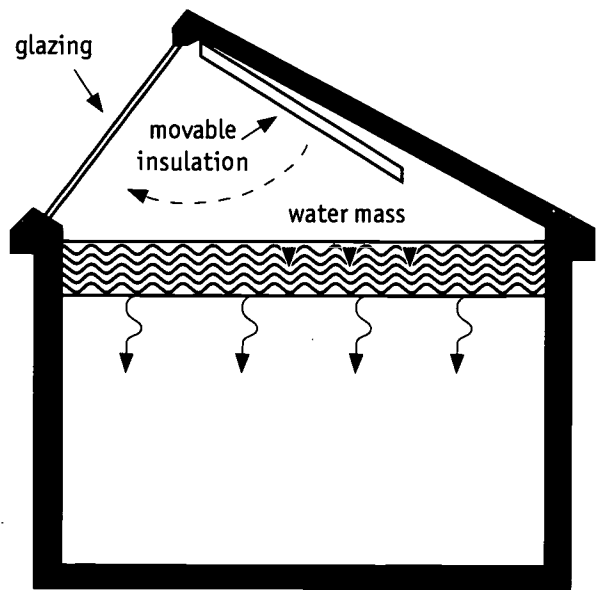

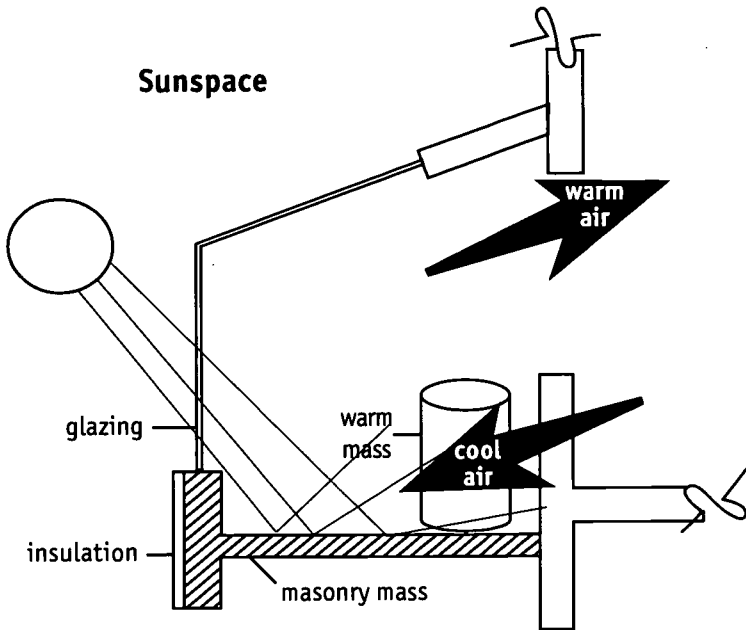

**Figure 4:** A sunspace, such as a greenhouse or an atrium, can provide considerable solar heat to a building and reduce heat loss. *Can you identify the features of a sunspace?*

**Figure 5:** A connective loop is formed when hot air rises and cool air moves in to replace it. *Can you describe what is happening in the building illustrated in this figure?*

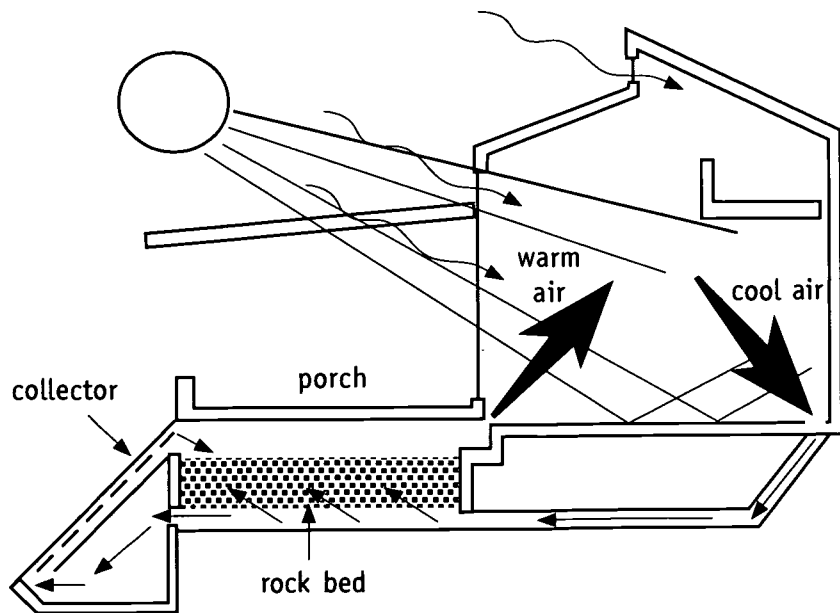

---

### ***Thermal Mass Materials***

Each material responds uniquely to thermal (and light) energy input. Several relevant properties of materials that have been described to characterize the differences are:

- density
- specific heat
- heat capacity
- surface finish
- emissivity
- conductivity
- reflectance
- R-factor

In addition there are properties related to the geometry of where materials are placed. These include:

- convection
- angle of incidence

### ***Assignment***

Divide up the parameters among your team members. Each team member should prepare a review of key concepts related to the parameters assigned to them. In addition, select those parameters that require further research and design and conduct a set of simple experiments to help your team make soundly based quantitative and qualitative choices among alternative materials, passive control strategies, and configurations for your prototype design. For example, Cheerios can make good thermal insulators but the R-factor is not printed on the box. If you plan to use Cheerios, you will need to determine the R-factor and compare it to that of other possible materials. Summarize the following for each experiment:

- objective
- approach
- materials
- observations and measurements
- data analysis
- conclusion(s)

The methods and results of your experiments will be reviewed in the Proof-of-Design performance test comparisons with other teams as well as referenced in your team's final report and recommendations.

## DESIGN PROCESS

The design process is often viewed as a cycle of action that repeats until the designers reach a satisfying solution. It can be described with seven basic elements:

**Identify** and clarify the situation. Understand the challenge or problem, including the criteria for success and constraints on the design.

**Create** solutions. Brainstorm, draw and write ideas, and suggest possible strategies or methods.

**Investigate** possibilities. Learn what is known about the situation, and what technology or approach could be useful. Conduct experiments to test your ideas.

**Choose** a solution. List the solutions most likely to be successful, and make decisions for how well each solution meets the design challenge or solves the problem.

**Implement** the design. Learn that a successful design often depends on good fabrication, whether it is a scaled or life-sized version of the product.

**Evaluate** the design. Perform tests to obtain the feedback that informs them about the parts of the design that worked or needed improvement.

**Communicate** the solution. Present your designs to your peers and others in the community, communicating your ideas through drawings, writing, formal presentations, informal discussions.

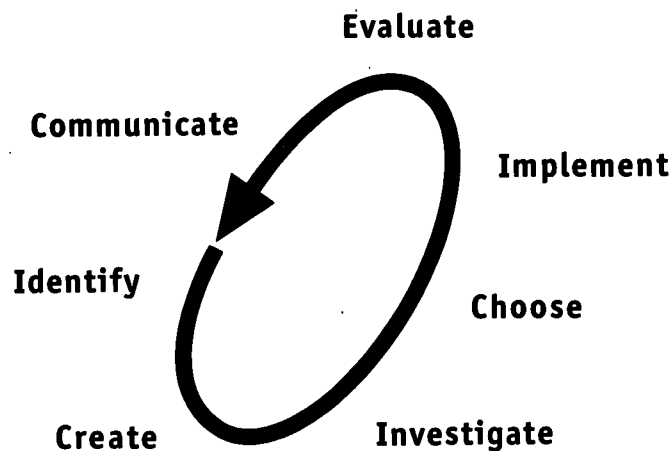

---

## ***Questions***

After reading about the design process, answer the following questions:

1. What elements of the process have you already experienced?
2. What elements have you not yet experienced?
3. Where in the process do you think you are now?
4. What will your next steps be?

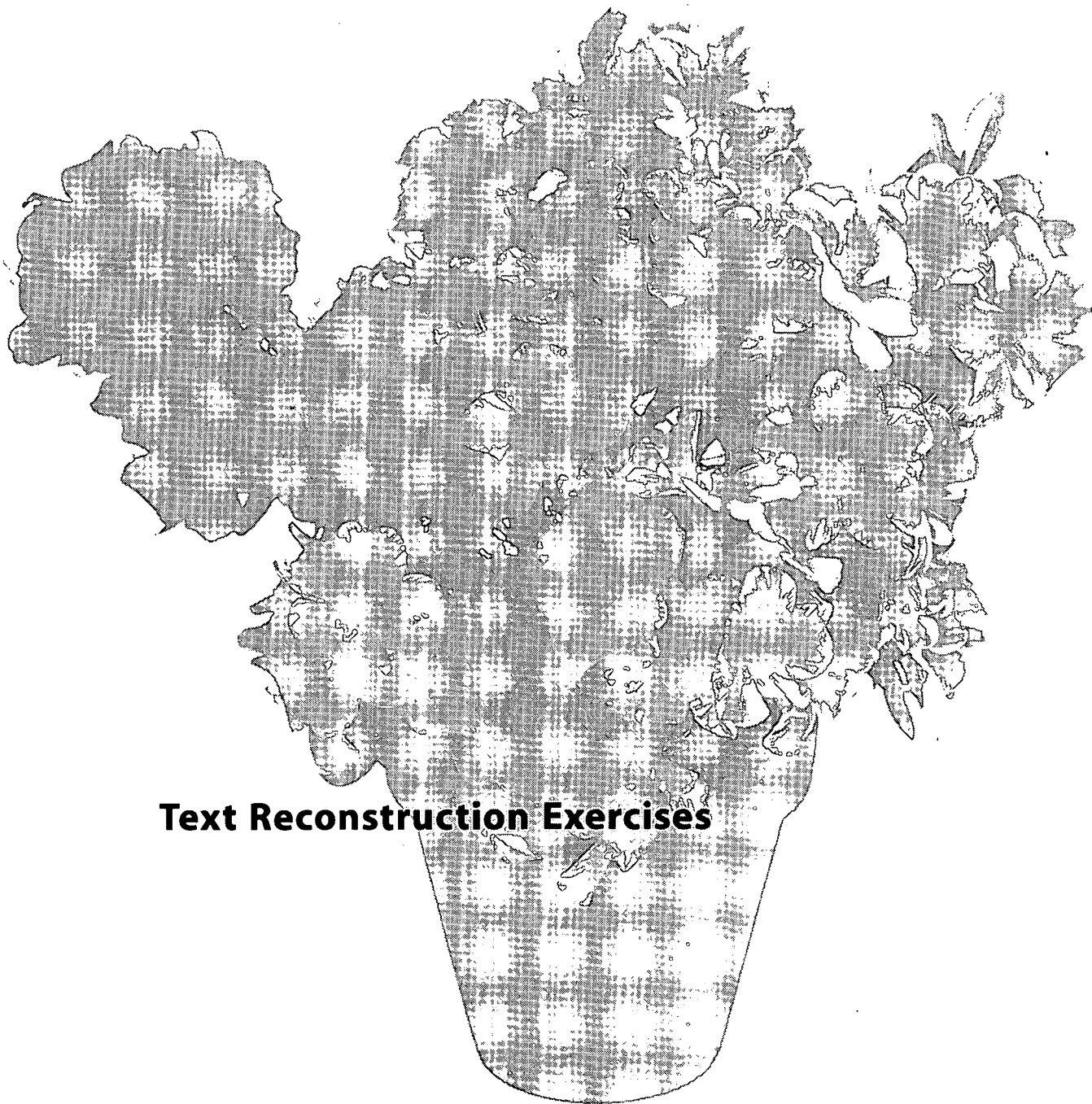

**Text Reconstruction Exercises**

## TEXT RECONSTRUCTION

The jumbled paragraphs in the following reading assignments are examples of Text Reconstruction (TR). This well-established technique for reading and writing improvement has roots going back to Benjamin Franklin as well as a number of famous authors. Many teachers find that including TR in a reading assignment highly motivates students and results in a much higher rate of homework completion. We suggest you read Chapter 5 of *Why Johnny Can't Write* for complete instructions on how to design your own exercises. Additional exercises can be found in *How to Analyze, Organize, & Write Effectively*.

An instructional process that uses design or inquiry places great demands on class time. It is impossible to cover all essential content within the few hours per week students spend in class. Science and technology courses must therefore insist that students learn from reading. This means they must also provide realistic opportunities for students to improve their ability to learn from reading.

Text Reconstruction works as a method of improving reading skills by focusing student attention on the most important elements of the reading task. First, it changes the reader's perception of his or her role from that of a passive

absorber of information to that of an active agent who must sort out a puzzle. This is probably the main reason TR exercises are popular with students. Secondly, TR forces students to pay attention to the logic of a paragraph. In science, it is not the separate ideas that are important, but rather the logic that ties them together. When passively reading a paragraph one can easily miss that logic, but in TR it is impossible to complete the task without thoroughly understanding these interconnections. A student who reconstructs a paragraph will understand its structure and meaning far more deeply than a student who memorizes every word but considers them only in their current order.

In the *Science by Design* series, we employ various techniques to encourage student reading and writing. These are not extras, but rather essential elements of the program. The exercises included assume that your students are relatively strong readers. If your students are weak readers or are not used to serious homework, then you will need to increase the amount of attention you pay to improving reading skills. Text Reconstruction can be used to convert any kind of reading assignment into a stimulating puzzle. The more use you make of TR, the more your students will read and the better they will understand.



## KEY IDEAS EXPLAINED

Each key idea Text Reconstruction sheet covers one key science idea that is used in *Construct-a-Greenhouse*. The TR employed in the first sheet, Energy Transfer, involves a very simple reconstruction and is intended as an introduction to TR. The later sheets involve much more difficult reconstructions.

*For more information on Text Reconstruction Across the Curriculum contact: The Institute for TRAC Research, P.O. Box 7336, Albuquerque NM. Tel. (505) 831-2654 or visit the New Intelligence Web site at <http://www.newintel.com>*

## ENERGY TRANSFER TEXT RECONSTRUCTION EXERCISE

The three paragraphs below describe important information about energy transfer. To keep this information confidential, some of the sentences within each paragraph have been reordered. Your task is to restore them to their proper order.

### Energy Transfer

Q1

- \_\_\_ Trust us, it will be.
- \_\_\_ The famous physicist Richard Feynman said that nobody really knows what energy is—all we know is that it is conserved.
- \_\_\_ If we keep track of all the places it goes, we note that there is always the same amount after as there was before.
- 2   Energy keeps getting transformed from one type to another.
- \_\_\_ Unfortunately, in most everyday situations, it is very difficult to keep track of all the transformations energy goes through and so it often seems some energy is getting lost.
- \_\_\_ This can make learning about energy difficult and confusing unless you are willing to accept on faith that it is always conserved.

Q2

- \_\_\_ Thus, we have three kinds of energy to consider: light, heat, and chemical.
- \_\_\_ If there are green plants in the greenhouse, then some of the light is converted by photosynthesis into the chemical energy which binds organic matter together.
- \_\_\_ Light is one form of energy and heat is another.
- 2   In the greenhouse, light is converted into heat.

---

— Because we will not be measuring, we will not need to make direct use of the principle of energy conservation.

93

— In the greenhouse design, you will be considering energy transfers among these three kinds of energy.

2 But we will not need to measure the amount of energy transferred.

— Still, it is useful to know that the only energy we have to work with is the light that comes through the window.

## REPURPOSING TEXT RECONSTRUCTION EXERCISE

The paragraphs below describe the concept of repurposing. Only in this case, the paragraphs have been repurposed into a puzzle. Some of the sentences in each paragraph have been reordered. Your task is to restore them to the original order.

### Repurposing

91

4 Think about how you might redesign a shirt so it could be both a shirt and a towel.

\_\_\_ Have you ever dried your hands on your shirt or dress?

2 This is an example of repurposing.

\_\_\_ Shirts and dresses are not designed to be towels, but since some shirts and dresses are designed to absorb sweat, they can make pretty good towels.

92

\_\_\_ This conflict between our two goals is known as a tradeoff.

\_\_\_ The problem with a device that has more than one purpose is that it may not be possible to accomplish both purposes well.

\_\_\_ Our shirt-towel probably has a long tail or other extension that makes an okay towel, but adds unnecessary bulk to the shirt.

4 To make a better shirt, we may have to make a worse towel.

---

\_\_\_\_\_ Tradeoffs are important in every design because we always have more than one consideration.

93

\_\_\_\_\_ Cost and style are two considerations that affect most designs, yet are almost never completely in line with the device's main objective.

\_\_\_\_\_ The process of making changes to these jelly jars to make them good drinking glasses is known as repurposing.

94

\_\_\_\_\_ Some objects are designed to serve one purpose for a while and then a second purpose later.

  2   Some jelly jars are designed to be used as drinking glasses after the jelly has been used up.

\_\_\_\_\_ We repurposed the shirt to make it a towel.

\_\_\_\_\_ In *Construct-a-Greenhouse*, you will repurpose a device designed to convert light into heat to make it a device that concentrates light on the leaves of plants.

## PLANT GROWTH TEXT RECONSTRUCTION EXERCISE

The paragraphs below describe stages of plant growth. Sentences within each paragraph have been reordered. Your task is to find the original order.

### Plant Growth

91

- \_\_\_\_\_ They begin life as a small seed that is self-contained and can survive on its own for a very long time (in some cases, thousands of years).
- \_\_\_\_\_ Plants are amazing.
- \_\_\_\_\_ All the time the seed is checking to see if conditions are ready for it to sprout.
- \_\_\_\_\_ Sprouting is determined by temperature and humidity.
- \_\_\_\_\_ As the seed sprouts, it uses its own stored energy source (food) to grow.
- \_\_\_\_\_ In order to burn this energy, the plant must take oxygen from the air.

92

- \_\_\_\_\_ The chemicals are carbon, oxygen, hydrogen, and nitrogen.
- \_\_\_\_\_ Once the seedling has developed leaves, it begins to generate its own food.
- 2   It makes this food by converting light energy into chemical bond energy through a process known as photosynthesis.
- \_\_\_\_\_ This process requires light and chemicals.
- \_\_\_\_\_ The plant finds all these chemicals except nitrogen in the air (not in the soil, as is often assumed).
- \_\_\_\_\_ During the day, the plant absorbs carbon dioxide from the air. It generates oxygen as a waste product.
- \_\_\_\_\_ At night, or when there is little light, the plant absorbs some oxygen from the air as it burns its food.

---

\_\_\_\_\_ As long as they have no leaves, they will not remove carbon dioxide from the air and they will not generate excess oxygen.



\_\_\_\_\_ Some plants take a rest in the winter.

\_\_\_\_\_ They lose their leaves or retreat down into their roots.

  3   These plants continue to burn a little oxygen as they "hibernate."

---

## ENERGY TRANSFER TEXT RECONSTRUCTION KEY

The paragraphs below show the correct order of sentences in the Energy Transfer Text Reconstruction exercise.

### Paragraph 1

1. The famous physicist Richard Feynman said that nobody really knows what energy is—all we know is that it is conserved.
2. Energy keeps getting transferred from one type to another.
3. If we keep track of all the places it goes, we note that there is always the same amount after as there was before.
4. Unfortunately, in most everyday situations, it is very difficult to keep track of all the transformations energy goes through and so it often seems some energy is getting lost.
5. This can make learning about energy difficult and confusing unless you are willing to accept on faith that it is always conserved.
6. Trust us, it will be.

### Paragraph 2

1. Light is one form of energy and heat is another.
2. In the greenhouse, light is converted into heat.
3. If there are green plants in the greenhouse, then some of the light is converted by photosynthesis into the chemical energy which binds organic matter together.
4. Thus we have three kinds of energy to consider: light, heat, and chemical.

### Paragraph 3

1. In the greenhouse design, you will be considering energy transfers among these three kinds of energy.
2. But we will not need to measure the amount of energy transferred.
3. Because we will not be measuring, we will not need to make direct use of the principle of energy conservation.
4. Still, it is useful to know that the only energy we have to work with is the light that comes through the window.



---

## REPURPOSING TEXT RECONSTRUCTION KEY

The paragraphs below show one correct way to order the sentences in the Repurposing Text Reconstruction exercise.

### Paragraph 1

1. Have you ever dried your hands on your shirt or dress?
2. This is an example of repurposing.
3. Shirts and dresses are not designed to be towels, but since some shirts and dresses are designed to absorb sweat, they can make pretty good towels.
4. Think about how you might redesign a shirt so it could be both a shirt and a towel.

### Paragraph 2

1. The problem with a device that has more than one purpose is that it may not be possible to accomplish both purposes well.
2. Our shirt-towel probably has a long tail or other extension that makes an okay towel, but adds unnecessary bulk to the shirt.
3. This conflict between our two goals is known as a tradeoff.
4. To make a better shirt, we may have to make a worse towel.

### Paragraph 3

1. Tradeoffs are important in every design because we always have more than one consideration.
2. Cost and style are two considerations that affect most designs, yet are almost never completely in line with the device's main objective.

### Paragraph 4

1. The process of making changes to these jelly jars to make them good drinking glasses is known as repurposing.
2. Some objects are designed to serve one purpose for a while and then a second purpose later.
3. Some jelly jars are designed to be used as drinking glasses after the jelly has been used up.
4. We repurposed the shirt to make it a towel.
5. In *Construct-a-Greenhouse*, you will repurpose a device designed to convert light into heat to make it a device that concentrates light on the leaves of plants.

## PLANT GROWTH TEXT RECONSTRUCTION KEY

The paragraphs below show one correct way to order the sentences in the Plant Growth Text Reconstruction exercise.

### Paragraph 1

1. Plants are amazing.
2. They begin life as a small seed that is self-contained and can survive on its own for a very long time (in some cases, thousands of years).
3. All the time the seed is checking to see if conditions are ready for it to sprout.
4. Sprouting is determined by temperature and humidity.
5. As the seed sprouts, it uses its own stored energy source (food) to grow.
6. In order to burn this energy, the plant must take oxygen from the air.

### Paragraph 2

1. Once the seedling has developed leaves, it begins to generate its own food.
2. It makes this food by converting light energy into chemical bond energy through a process known as photosynthesis.
3. This process requires light and chemicals.
4. The chemicals are carbon, oxygen, hydrogen, and nitrogen.
5. The plant finds all these chemical except nitrogen in the air (not in the soil, as is often assumed).
6. During the day, the plant absorbs carbon dioxide from the air. It generates oxygen as a waste product.
7. At night, or when there is little light, the plant absorbs some oxygen from the air as it burns its food.

### Paragraph 3

1. Some plants take a rest in the winter.
2. They lose their leaves or retreat down into their roots.
3. These plants continue to burn a little oxygen as they "hibernate."
4. As long as they have no leaves, they will not remove carbon dioxide from the air and they will not generate excess oxygen.

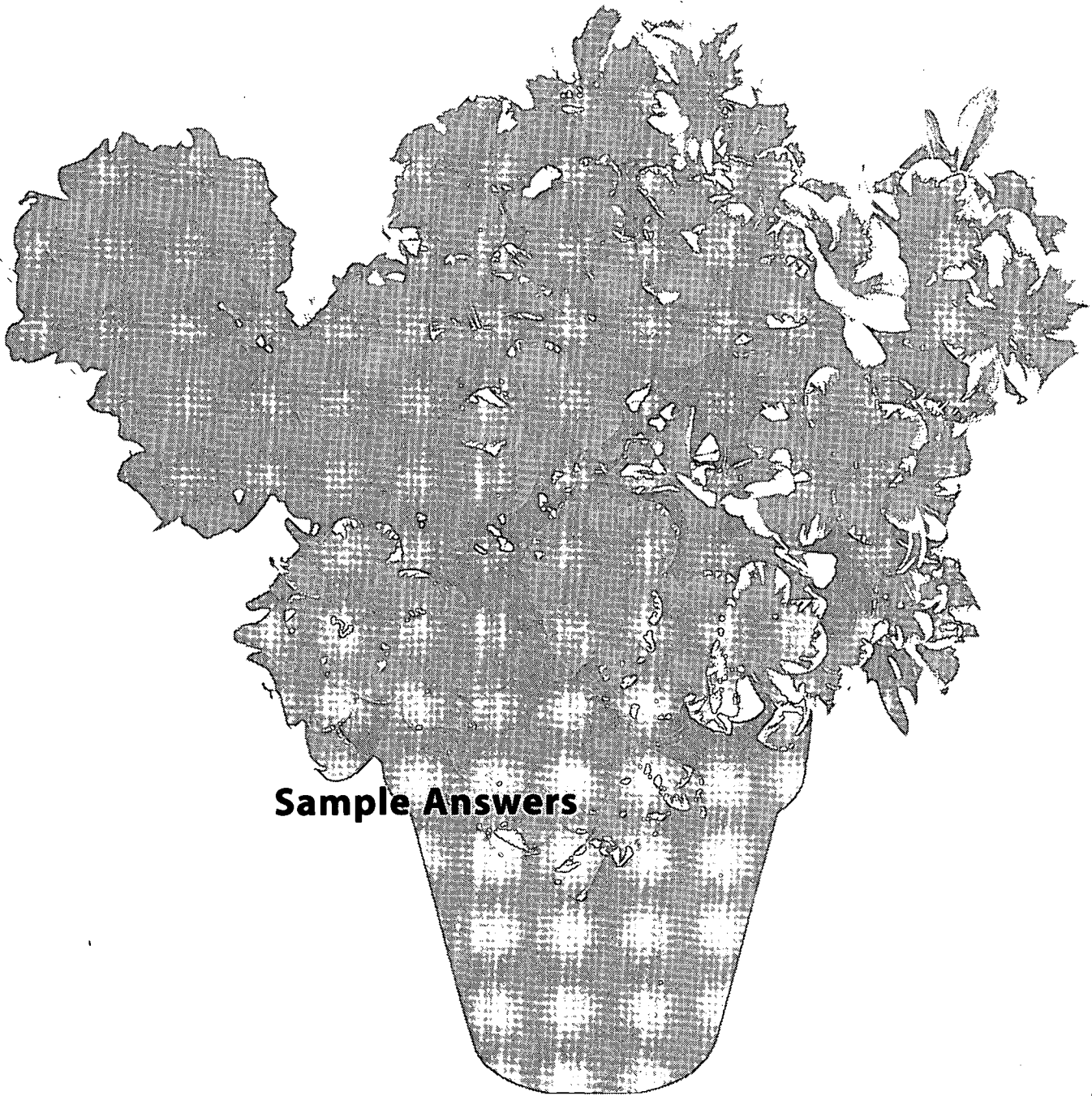

**Sample Answers**

Activity 3, p. 27

## SPECIES SPECIFICATIONS

### *Pumpkin Growth Stages*

Students are asked to research the geographical position and climate of their growing area. Here are some suggestions for where to find the answers to the geographical position and climate of the growing area.

What is the latitude? *local map, weather person*

What is the altitude? *local map, airport, weather station*

What is the elevation? *measure yourself*

How many frost-free days do you have, in an average year? *local farmers, weather station*

Approximately when does the first frost-free day occur? *local farmers, weather station*

When do you anticipate harvesting your pumpkin for weighing-in? *you decide*

Activity 3, p. 31

## THE LAW OF LIMITING FACTORS

Students brainstorm possible deficiencies and strategies to prevent, correct, or overcome these deficiencies, for each growth stage of the Atlantic Giant Pumpkin. As students record, organize, and summarize their team's ideas, make sure students include the following factors:

*Water, maximum sunlight, adequate fertilizer, and heat.*

Other protective factors might include:

*Protect the base of the pumpkin from rot*

*Protect the plant from pests—insects, birds, rodents*

*Protect the plant from theft*

## DATA RECORDING PLAN FOR SEED GERMINATION PHASE

Activity 3, p. 33

Sample answers to the data recording plan are given below:

Variable	What to Measure	Frequency of Measurement	How to Measure
energy supplied over time	sun light; temperature	several times a day	light meter; thermometer
external temperature over time	temperature in shade	several times a day	thermometer
internal temperature over time	temperature in standard place	once or twice a day	thermometer
soil temperature over time	temperature in soil	once or twice a day	thermometer

Activity 3, p. 36

## RULES OF THUMB

### Student Work Sheet—Examples

- What is the rule of thumb you have chosen?  
*total glazing = 1.5 times the area of the floor*
- Are there other similar rules of thumb that you have encountered? What are they? Do they support or contradict the one you have chosen from the given list?  
*Plant after Memorial Day*
- Explain the scientific basis for the rule of thumb you have chosen?  
*We need more glass than floor, because as the sun moves, the area lit will move. With more glass, we keep the floor fully lit for a longer time.*
- Can this rule of thumb be applied directly to the design of your greenhouse? Explain why and how you may have to refine or modify it to serve your needs.  
*Yes, it helps in designing the right amount of window. Insta-build and Quick-Build both have too little glass.*

BEST COPY AVAILABLE

101



**U.S. DEPARTMENT OF EDUCATION**  
*Office of Educational Research and Improvement (OERI)*  
*Educational Resources Information Center (ERIC)*



## NOTICE

### REPRODUCTION BASIS

This document is covered by a signed "Reproduction Release (Blanket)" form (on file within the ERIC system), encompassing all or classes of documents from its source organization and, therefore, does not require a "Specific Document" Release form.

This document is Federally-funded, or carries its own permission to reproduce, or is otherwise in the public domain and, therefore, may be reproduced by ERIC without a signed Reproduction Release form (either "Specific Document" or "Blanket").