

DOCUMENT RESUME

ED 432 472

SE 062 721

AUTHOR O'Sullivan, Christine Y.; Weiss, Andrew R.
TITLE Student Work and Teacher Practices in Science: A Report on What Students Know and Can Do.
INSTITUTION National Center for Education Statistics (ED), Washington, DC.
REPORT NO NCES-1999-455
ISBN ISBN-0-16-050036-2
PUB DATE 1999-07-00
NOTE 401p.
AVAILABLE FROM ED Pubs, P.O. Box 1398, Jessup, MD 20794-1398; Tel: 877-433-7827 (Toll Free); Web site: <http://www.ed.gov/pubs/edpubs.html> (online ordering); Web site: <http://nces.ed.gov/naep> (full-text); alternate formats available upon request.
PUB TYPE Information Analyses (070) -- Numerical/Quantitative Data (110) -- Reports - Research (143)
EDRS PRICE MF01/PC17 Plus Postage.
DESCRIPTORS *Academic Achievement; Classroom Techniques; Educational Environment; *Educational Practices; Elementary Secondary Education; National Competency Tests; *Science Education; *Science Process Skills; *Science Teachers; Scientific Concepts; Standardized Tests; Student Attitudes; Tables (Data); Teacher Characteristics; Teaching Methods
IDENTIFIERS *National Assessment of Educational Progress; *Science Achievement

ABSTRACT

In 1996, the National Assessment of Educational Progress (NAEP) assessed the knowledge and skills of students in the areas of earth science, life science, and physical science. It also collected information related to the background of students (grades 4, 8, and 12), their teachers (grades 4 and 8), and the schools they attended (grades 4, 8, and 12). This report is intended primarily for science teachers; hence, the results presented relate directly to student performance, classroom practices, and school climate. This report also discusses students' attitudes and beliefs about science. The report is divided into four parts. In the first part (chapter 1), an overview of the assessment is provided. This includes information about the framework used in the development of the assessment, a description of how the assessment was administered to students, and an explanation of how to interpret NAEP results. In the second part (chapters 2, 3, and 4), examples of questions and student responses are presented. These chapters are divided by grade. The third part (chapters 5 and 6) contains information collected from students, teachers, and school administrators about classroom practices, student motivation, and parental involvement in learning. Finally, the fourth part contains appendices offering a fuller description of the procedures used for the NAEP 1996 science assessment (appendix A), scoring guides for questions discussed in chapters 2, 3, and 4 (appendix B), and standard errors for the statistics presented in the report (appendix C). (WRM)

ED 432 472

STUDENT WORK AND TEACHER PRACTICES IN SCIENCE



U.S. DEPARTMENT OF EDUCATION
Office of Educational Research and Improvement
EDUCATIONAL RESOURCES INFORMATION
CENTER (ERIC)

This document has been reproduced as received from the person or organization originating it.

Minor changes have been made to improve reproduction quality.

Points of view or opinions stated in this document do not necessarily represent official OERI position or policy.



U.S. Department of Education
Office of Educational Research and Improvement

NCES 1999-455

What is The Nation's Report Card?

THE NATION'S REPORT CARD, the National Assessment of Educational Progress (NAEP), is the only nationally representative and continuing assessment of what America's students know and can do in various subject areas. Since 1969, assessments have been conducted periodically in reading, mathematics, science, writing, history, geography, and other fields. By making objective information on student performance available to policymakers at the national, state, and local levels, NAEP is an integral part of our nation's evaluation of the condition and progress of education. Only information related to academic achievement is collected under this program. NAEP guarantees the privacy of individual students and their families.

NAEP is a congressionally mandated project of the National Center for Education Statistics, the U.S. Department of Education. The Commissioner of Education Statistics is responsible, by law, for carrying out the NAEP project through competitive awards to qualified organizations. NAEP reports directly to the Commissioner, who is also responsible for providing continuing reviews, including validation studies and solicitation of public comment, on NAEP's conduct and usefulness.

In 1988, Congress established the National Assessment Governing Board (NAGB) to formulate policy guidelines for NAEP. The Board is responsible for selecting the subject areas to be assessed from among those included in the National Education Goals; for setting appropriate student performance levels; for developing assessment objectives and test specifications through a national consensus approach; for designing the assessment methodology; for developing guidelines for reporting and disseminating NAEP results; for developing standards and procedures for interstate, regional, and national comparisons; for determining the appropriateness of test items and ensuring they are free from bias; and for taking actions to improve the form and use of the National Assessment.

The National Assessment Governing Board

Mark D. Musick, Chair

President
Southern Regional Education Board
Atlanta, Georgia

Michael T. Nettles, Vice Chair

Professor of Education & Public Policy
University of Michigan
Ann Arbor, Michigan
and Director
Frederick D. Patterson Research Institute
United Negro College Fund

Moses Barnes

Secondary School Principal
Fort Lauderdale, Florida

Melanie A. Campbell

Fourth-Grade Teacher
Topeka, Kansas

Honorable Wilmer S. Cody

Commissioner of Education
State of Kentucky
Frankfort, Kentucky

Edward Donley

Former Chairman
Air Products & Chemicals, Inc.
Allentown, Pennsylvania

Honorable John M. Engler

Governor of Michigan
Lansing, Michigan

Thomas H. Fisher

Director, Student Assessment Services
Florida Department of Education
Tallahassee, Florida

Michael J. Guerra

Executive Director
National Catholic Education Association
Secondary School Department
Washington, DC

Edward H. Haertel

Professor, School of Education
Stanford University
Stanford, California

Juanita Haugen

Local School Board President
Pleasanton, California

Carole Kennedy

Elementary School Principal
Columbia, Missouri

Honorable Nancy Kopp

Maryland House of Delegates
Bethesda, Maryland

Honorable William J. Moloney

Commissioner of Education
State of Colorado
Denver, Colorado

Mitsugi Nakashima

First Vice-Chairperson
Hawaii State Board of Education
Honolulu, Hawaii

Debra Paulson

Eighth-Grade Mathematics Teacher
El Paso, Texas

Honorable Norma Paulus

Former Superintendent
of Public Instruction
Oregon State Department of Education
Salem, Oregon

Honorable Jo Ann Pottorff

Kansas House of Representatives
Wichita, Kansas

Diane Ravitch

Senior Research Scholar
New York University
New York, New York

Honorable Roy Romer

(Member Designate)
Former Governor of Colorado
Denver, Colorado

John H. Stevens

Executive Director
Texas Business and Education Coalition
Austin, Texas

Adam Urbanski

President
Rochester Teachers Association
Rochester, New York

Deborah Voltz

Assistant Professor
Department of Special Education
University of Louisville
Louisville, Kentucky

Marilyn A. Whirry

Twelfth-Grade English Teacher
Manhattan Beach, California

Dennie Palmer Wolf

Senior Research Associate
Harvard Graduate School of Education
Cambridge, Massachusetts

C. Kent McGuire (Ex-Officio)

Assistant Secretary of Education
Office of Educational Research
and Improvement
U.S. Department of Education
Washington, DC

Roy Truby

Executive Director, NAGB
Washington, DC

NATIONAL CENTER FOR EDUCATION STATISTICS

**Student Work and
Teacher Practices in Science**

A Report on What Students Know and Can Do

**Christine Y. O'Sullivan
Andrew R. Weiss**

July 1999

**U.S. Department of Education
Office of Educational Research and Improvement**

NCES 1999-455

U.S. Department of Education

Richard W. Riley
Secretary

Office of Educational Research and Improvement

C. Kent McGuire
Assistant Secretary

National Center for Education Statistics

Pascal D. Forgione, Jr.
Commissioner

Assessment Division

Peggy G. Carr
Associate Commissioner

July 1999

SUGGESTED CITATION

U.S. Department of Education. Office of Educational Research and Improvement. National Center for Education Statistics. *Student Work and Teacher Practices in Science*, NCES 1999-455, by C. Y. O'Sullivan, and A. R. Weiss. Washington, DC: 1999.

FOR MORE INFORMATION

Content contact:
Arnold Goldstein
202-219-1741

To obtain single copies of this report, while supplies last, or ordering information on other U.S. Department of Education products, call toll free 1-877-4ED Pubs (877-433-7827), or write:

Education Publications Center (Ed Pubs)
U.S. Department of Education
P.O. Box 1398
Jessup, MD 20794-1244

TTY/TDD 1-877-576-7734
FAX 301-470-1244

Online ordering via the Internet: <http://www.ed.gov/pubs/edpubs.html>

Copies also are available in alternate formats upon request.

This report also is available on the World Wide Web: <http://nces.ed.gov/naep>.

The work upon which this publication is based was performed for the National Center for Education Statistics, Office of Educational Research and Improvement, by Educational Testing Service.

Table of Contents

Highlights

Performance, Knowledge, and Skills	i
Classroom Practices	i
Attitudes, Motivation, and School Climate	ii

Chapter 1	1
Introduction	2
NAEP's Mission	2
The NAEP 1996 Science Framework	3
Figure 1.1 Descriptions of the Three Fields of Science	4
Figure 1.2 Descriptions of Knowing and Doing Science	5
Figure 1.3 Descriptions of Overarching Domains	6
Table 1.1 Distribution of Estimated Assessment Time by Field of Science	7
Table 1.2 Distribution of Estimated Assessment Time by Ways of Knowing and Doing Science	7
Table 1.3 Number of Questions by Grade Level and Type	9
The Assessment Design	10
Reporting NAEP Results	11
Table 1.4 Policy Definitions of NAEP Achievement Levels	13
Figure 1.4 Summary of the 1996 NAEP Science Achievement Level Descriptions	14
Table 1.5 Percentages of Students Within Each Science Achievement Level for the Nation	15
Figure 1.5 Map of Selected Questions on the NAEP Science Scale for Grade 4	17
Figure 1.6 Map of Selected Questions on the NAEP Science Scale for Grade 8	18
Figure 1.7 Map of Selected Questions on the NAEP Science Scale for Grade 12	19
Interpreting NAEP Results	20
Cautions in Interpretations	20
Additional NAEP Science Publications	21
Overview of Remaining Chapters	22

Chapter 2 Grade 4: Performance, Knowledge, and Skills	23
Introduction	23
Table 2.1 Distribution of Questions by Fields of Science and by Ways of Knowing and Doing Science, Grade 4: Public and Nonpublic Schools Combined	24
Grade 4 Science Teaching Content	25
Table 2.2 Teachers' Reports on How Much Time They Spent Teaching Life Science, Earth Science, and Physical Science, Grade 4: Public and Nonpublic Schools Combined	25
Average Question Score	26
Table 2.3 Average Question Score for Earth Science, Physical Science, and Life Science, Grade 4: Public and Nonpublic Schools Combined	26
Table 2.4 Average Question Score for Conceptual Understanding, Scientific Investigation, and Practical Reasoning, Grade 4: Public and Nonpublic Schools Combined	27
Sample Questions and Student Responses	28
Table 2.5 Sample Questions Categorized by Fields of Science and by Ways of Knowing and Doing Science, Grade 4: Public and Nonpublic Schools Combined	29
Conceptual Understanding	30
Table 2.6 Percentages Choosing Each Response: Grade 4 Major Source of Gasoline	31
Table 2.7 Percentages Correct within Each Achievement Level Interval: Grade 4 Major Source of Gasoline	31
Table 2.8 Percentages Choosing Each Response: Grade 4 Earth's Surface	33
Table 2.9 Percentages Correct within Each Achievement Level Interval: Grade 4 Earth's Surface	33
Table 2.10 Percentages Choosing Each Response: Grade 4 Visibility of Moon from Earth	35
Table 2.11 Percentages Correct within Each Achievement Level Interval: Grade 4 Visibility of Moon from Earth	35
Table 2.12 Percentages Choosing Each Response: Grade 4 Sources of Smog	37
Table 2.13 Percentages Correct within Each Achievement Level Interval: Grade 4 Sources of Smog	37

Table 2.14	Percentages at Different Score Levels: Grade 4 Natural Forces	43
Table 2.15	Percentages <i>Complete</i> or <i>Essential</i> within Each Achievement Level Interval: Grade 4 Natural Forces	43
Table 2.16	Percentages Choosing Each Response: Grade 4 Pattern of Ripples	45
Table 2.17	Percentages Correct within Each Achievement Level Interval: Grade 4 Pattern of Ripples	45
Table 2.18	Percentages Choosing Each Response: Grade 4 Mealworm Life Cycle	47
Table 2.19	Percentages Correct within Each Achievement Level Interval: Grade 4 Mealworm Life Cycle	47
Table 2.20	Percentages at Different Score Levels: Grade 4 Plants: Parts and Functions	51
Table 2.21	Percentages <i>Complete</i> or <i>Essential</i> within Each Achievement Level Interval: Grade 4 Plants: Parts and Functions	51
Scientific Investigation		52
Table 2.22	Percentages Choosing Each Response: Grade 4 Volume	53
Table 2.23	Percentages Correct within Each Achievement Level Interval: Grade 4 Volume	53
Table 2.24	Percentages Choosing Each Response: Grade 4 Bar Graph	55
Table 2.25	Percentages Correct within Each Achievement Level Interval: Grade 4 Bar Graph	55
Table 2.26	Percentages at Different Score Levels: Grade 4 Experimental Setup	59
Table 2.27	Percentages <i>Complete</i> within Each Achievement Level Interval: Grade 4 Experimental Setup	59
Practical Reasoning		60
Table 2.28	Percentages Choosing Each Response: Grade 4 Radio Malfunction	61
Table 2.29	Percentages Correct within Each Achievement Level Interval: Grade 4 Radio Malfunction	61
Table 2.30	Percentages at Different Score Levels: Grade 4 Properties of Metals	65
Table 2.31	Percentages <i>Complete</i> within Each Achievement Level Interval: Grade 4 Properties of Metals	65

Theme Block	66
Table 2.32 Percentages at Different Score Levels: Grade 4 Metamorphosis	69
Table 2.33 Percentages <i>Complete</i> within Each Achievement Level Interval: Grade 4 Metamorphosis	69
Table 2.34 Percentages at Different Score Levels: Grade 4 Grasshoppers and Butterflies	76
Table 2.35 Percentages <i>Complete</i> or <i>Essential</i> within Each Achievement Level Interval: Grade 4 Grasshoppers and Butterflies	76
Table 2.36 Percentages at Different Score Levels: Grade 4 Life Cycles	79
Table 2.37 Percentages <i>Complete</i> within Each Achievement Level Interval: Grade 4 Life Cycles	79
Hands on Task	80
Table 2.38 Percentages at Different Score Levels: Grade 4 Mystery Water	84
Table 2.39 Percentages <i>Complete</i> within Each Achievement Level Interval: Grade 4 Mystery Water	84
Table 2.40 Percentages at Different Score Levels: Grade 4 Ease of Floating	88
Table 2.41 Percentages <i>Complete</i> within Each Achievement Level Interval: Grade 4 Ease of Floating	88
Summary of Grade 4 Data	89
Chapter 3 Grade 8: Performance, Knowledge, and Skills	91
Introduction	91
Table 3.1 Distribution of Questions by Fields of Science and by Ways of Knowing and Doing Science, Grade 8: Public and Nonpublic Schools Combined	92
Grade 8 Science Teaching Content	93
Table 3.2 Teachers' Reports on How Much Time They Spent Teaching Life Science, Earth Science, and Physical Science, Grade 8: Public and Nonpublic Schools Combined	93
Average Question Score	94
Table 3.3 Average Question Score for Earth Science, Physical Science, and Life Science, Grade 8: Public and Nonpublic Schools Combined	94
Table 3.4 Average Question Score for Conceptual Understanding, Scientific Investigation, and Practical Reasoning, Grade 8: Public and Nonpublic Schools Combined	95
Sample Questions and Student Responses	96
Table 3.5 Sample Questions Categorized by Fields of Science and by Ways of Knowing and Doing Science, Grade 8: Public and Nonpublic Schools Combined	96

Conceptual Understanding	96
Table 3.6 Percentages Choosing Each Response: Grade 8	
Location of Earthquake	97
Table 3.7 Percentages Correct within Each Achievement Level Interval: Grade 8	
Location of Earthquake	97
Table 3.8 Percentages Choosing Each Response: Grade 8	
Windchill	99
Table 3.9 Percentages Correct within Each Achievement Level Interval: Grade 8	
Windchill	99
Table 3.10 Percentages Choosing Each Response: Grade 8	
Insulated Bottle	100
Table 3.11 Percentages Correct within Each Achievement Level Interval: Grade 8	
Insulated Bottle	100
Table 3.12 Percentages Choosing Each Response: Grade 8	
Nonrenewable Resource	101
Table 3.13 Percentages Correct within Each Achievement Level Interval: Grade 8	
Nonrenewable Resource	101
Table 3.14 Percentages at Different Score Levels: Grade 8	
Mirrors and Windows	103
Table 3.15 Percentages <i>Complete</i> within Each Achievement Level Interval: Grade 8	
Mirrors and Windows	104
Table 3.16 Percentages Choosing Each Response: Grade 8	
Mitochondria	105
Table 3.17 Percentages Correct within Each Achievement Level Interval: Grade 8	
Mitochondria	105
Table 3.18 Percentages Choosing Each Response: Grade 8	
Classification	106
Table 3.19 Percentages Correct within Each Achievement Level Interval: Grade 8	
Classification	107
Scientific Investigation	108
Table 3.20 Percentages at Different Score Levels: Grade 8	
Hydra	113
Table 3.21 Percentages <i>Complete</i> or <i>Essential</i> within Each	
Achievement Level Interval: Grade 8	
Hydra	113
Practical Reasoning	114
Table 3.22 Percentages at Different Score Levels: Grade 8	
Lightbulbs	117
Table 3.23 Percentages <i>Complete</i> within Each Achievement Level Interval: Grade 8	
Lightbulbs	117
Table 3.24 Percentages at Different Score Levels: Grade 8	
Heating Rate Prediction	124

Table 3.25	Percentages <i>Complete</i> or <i>Essential</i> within Each Achievement Level Interval: Grade 8 Heating Rate Prediction	124
Table 3.26	Percentages at Different Score Levels: Grade 8 Food Poisoning	129
Table 3.27	Percentages <i>Complete</i> within Each Achievement Level Interval: Grade 8 Food Poisoning	129
Table 3.28	Percentages at Different Score Levels: Grade 8 Inheritance	133
Table 3.29	Percentages <i>Complete</i> within Each Achievement Level Interval: Grade 8 Inheritance	133
Theme Block	134
Table 3.30	Percentages Choosing Each Response: Grade 8 Graph Reading	136
Table 3.31	Percentages Correct within Each Achievement Level Interval: Grade 8 Graph Reading	136
Table 3.32	Percentages at Different Score Levels: Grade 8 Seasons	140
Table 3.33	Percentages <i>Complete</i> within Each Achievement Level Interval: Grade 8 Seasons	140
Hands-on Task	140
Table 3.34	Percentages at Different Score Levels: Grade 8 Salt Solution: Measurement	150
Table 3.35	Percentages <i>Complete</i> or <i>Essential</i> within Each Achievement Level Interval: Grade 8 Salt Solution: Measurement	150
Table 3.36	Percentages at Different Score Levels: Grade 8 Salt Solution: Average	151
Table 3.37	Percentages <i>Complete</i> within Each Achievement Level Interval: Grade 8 Salt Solution: Average	151
Table 3.38	Percentages at Different Score Levels: Grade 8 Salt Solution: Graphing	152
Table 3.39	Percentages <i>Complete</i> within Each Achievement Level Interval: Grade 8 Salt Solution: Graphing	152
Table 3.40	Percentages at Different Score Levels: Grade 8 Salt Solution: Interpolating	153
Table 3.41	Percentages <i>Complete</i> or <i>Essential</i> within Each Achievement Level Interval: Grade 8 Salt Solution: Interpolating	153
Summary of Grade 8 Data	154

Chapter 4 Grade 12: Performance, Knowledge, and Skills	155
Introduction	155
Table 4.1 Distribution of Questions by Fields of Science and by Ways of Knowing and Doing Science, Grade 12: Public and Nonpublic Schools Combined	156
Average Question Score	157
Table 4.2 Average Question Score for Earth Science, Physical Science, and Life Science, Grade 12: Public and Nonpublic Schools Combined	157
Table 4.3 Average Question Score for Conceptual Understanding, Scientific Investigation, and Practical Reasoning, Grade 12: Public and Nonpublic Schools Combined	158
Sample Questions and Student Responses	159
Table 4.4 Sample Questions Categorized by Fields of Science and by Ways of Knowing and Doing Science, Grade 12: Public and Nonpublic Schools Combined	159
Conceptual Understanding	160
Table 4.5 Percentages Choosing Each Response: Grade 12 Solar Eclipse	161
Table 4.6 Percentages Correct within Each Achievement Level Interval: Grade 12 Solar Eclipse	161
Table 4.7 Percentages at Different Score Levels: Grade 12 Pacific Ring of Fire	165
Table 4.8 Percentages <i>Complete</i> or <i>Essential</i> within Each Achievement Level Interval: Grade 12 Pacific Ring of Fire	165
Table 4.9 Percentages Choosing Each Response: Grade 12 Path on Ice	167
Table 4.10 Percentages Correct within Each Achievement Level Interval: Grade 12 Path on Ice	167
Table 4.11 Percentages Choosing Each Response: Grade 12 Interpretation of Velocity/Time Graph	169
Table 4.12 Percentages Correct within Each Achievement Level Interval: Grade 12 Interpretation of Velocity/Time Graph	169
Table 4.13 Percentages at Different Score Levels: Grade 12 Genotype	173
Table 4.14 Percentages <i>Complete</i> or <i>Essential</i> within Each Achievement Level Interval: Grade 12 Genotype	174

Scientific Investigation	175
Table 4.15 Percentages Choosing Each Response: Grade 12 Concluding from Results	176
Table 4.16 Percentages Correct within Each Achievement Level Interval: Grade 12 Concluding from Results	176
Practical Reasoning	177
Table 4.17 Percentages at Different Score Levels: Grade 12 Flooding	179
Table 4.18 Percentages <i>Complete</i> within Each Achievement Level Interval: Grade 12 Flooding	179
Table 4.19 Percentages at Different Score Levels: Grade 12 Keeping Ice Cream Cold	182
Table 4.20 Percentages Correct within Each Achievement Level Interval: Grade 12 Keeping Ice Cream Cold	182
Table 4.21 Percentages at Different Score Levels: Grade 12 Heart Disease	185
Table 4.22 Percentages <i>Complete</i> within Each Achievement Level Interval: Grade 12 Heart Disease	185
Table 4.23 Percentages at Different Score Levels: Grade 12 Malaria	188
Table 4.24 Percentages <i>Complete</i> within Each Achievement Level Interval: Grade 12 Malaria	188
Theme Block	189
Table 4.25 Percentages Choosing Each Response: Grade 12 Temperature & Evaporation	191
Table 4.26 Percentages Correct within Each Achievement Level Interval: Grade 12 Temperature & Evaporation	191
Table 4.27 Percentages at Different Score Levels: Grade 12 Identification of Ocean and Lake Water	196
Table 4.28 Percentages <i>Complete</i> or <i>Essential</i> within Each Achievement Level Interval: Grade 12 Identification of Ocean and Lake Water	196
Table 4.29 Percentages at Different Score Levels: Grade 12 Cloud Formation	201
Table 4.30 Percentages <i>Complete</i> within Each Achievement Level Interval: Grade 12 Cloud Formation	201

Hands-on Task	202
Table 4.31 Percentages at Different Score Levels: Grade 12 Physical Properties	207
Table 4.32 Percentages <i>Complete</i> or <i>Essential</i> within Each Achievement Level Interval: Grade 12 Physical Properties	207
Table 4.33 Percentages at Different Score Levels: Grade 12 Separation of Materials	211
Table 4.34 Percentages <i>Complete</i> or <i>Essential</i> within Each Achievement Level Interval: Grade 12 Separation of Materials	211
Table 4.35 Percentages at Different Score Levels: Grade 12 Description of Method	217
Table 4.36 Percentages <i>Complete</i> or <i>Essential</i> within Each Achievement Level Interval: Grade 12 Description of Method	217
Summary of Grade 12 Data	218
Chapter 5 Classroom Practices	219
Introduction	219
Instructional Objectives	220
Table 5.1 Teachers' Reports on How Much Emphasis They Give to Student Objectives, Grades 4 and 8: Public and Nonpublic Schools Combined	221
Classroom Activities	223
Table 5.2 Teachers' Reports on How Often Students Do a Variety of Classroom Activities, Grades 4 and 8: Public and Nonpublic Schools Combined	225
Table 5.3 Reports from Students Currently Taking a Science Course on How Often They Do a Variety of Classroom Activities, Grade 12: Public and Nonpublic Schools Combined	227
Teacher Activities	228
Table 5.4 Teachers' Reports on Using Different Teaching Activities, Grades 4 and 8: Public and Nonpublic Schools Combined	229
Table 5.5 Students' Reports on How Often Their Teachers Use Different Teaching Activities, Grade 12: Public and Nonpublic Schools Combined	231
Hands-on Tasks	231
Table 5.6 Students' Reports on Doing Hands-on Tasks, Grades 4, 8, and 12: Public and Nonpublic Schools Combined	233
Investigations Taking a Week or More	234
Table 5.7 Students' Reports on Whether or Not They Conduct Science Projects or Investigations that Take a Week or More, Grades 4, 8, and 12: Public and Nonpublic Schools Combined	234

Computers and Science Instruction	235
Table 5.8 Teachers' Reports on How They Use Computers for Science Instruction, Grades 4 and 8: Public and Nonpublic Schools Combined	237
Homework	237
Table 5.9 Teachers' Reports on How Much Science Homework They Assign, Grades 4 and 8: Public and Nonpublic Schools Combined	238
Summary	239
Chapter 6 Attitudes, Motivation, and School Climate	241
Introduction	241
Student Attitudes and Beliefs about Science	242
All Students	243
Table 6.1 Students' Reports on Attitudes and Beliefs about Science, by Gender, Grade 4: Public and Nonpublic Schools Combined	245
Gender	248
Race/Ethnicity	249
Table 6.2 Students' Reports on Attitudes and Beliefs about Science, by Race/Ethnicity, Grade 4: Public and Nonpublic Schools Combined	250
Positive Attitudes	256
Table 6.3 Relationship Between Students' Average Scale Scores and Positive Attitudes and Beliefs about Science, Grades 4, 8, and 12: Public and Nonpublic Schools Combined	257
Students' Motivation on the NAEP Science Assessment	258
Table 6.4 Students' Reports About their Motivation and Performance on the NAEP Science Assessment, Grades 4 and 8: Public and Nonpublic Schools Combined	260
Table 6.5 Students' Reports About their Motivation and Performance on the NAEP Science Assessment, Grade 12: Public and Nonpublic Schools Combined	261
Parental Involvement in School	262
Table 6.6 Schools' Reports on Parental Involvement, Grades 4, 8 and 12: Public and Nonpublic Schools Combined	263
Perceived School Problems	264
Table 6.7 Schools' Reports on the Severity of Three Problems in the School, Grades 4 and 8: Public and Nonpublic Schools Combined	265
Summary	267
Appendix A Overview of Procedures Used for the NAEP 1996 Science Assessment .	269
Appendix B Scoring Guides	287
Appendix C Standard Errors	321
Acknowledgments	

Highlights

In 1996 the National Assessment of Educational Progress (NAEP) assessed the knowledge and skills of students in the areas of earth science, life science, and physical science. It also collected information relating to the background of students (grades 4, 8, and 12), their teachers (grades 4 and 8), and the schools they attended (grades 4, 8, and 12). This report is intended primarily for teachers; hence, the results presented relate directly to students' performance, classroom practices, and school climate. The report also discusses students' attitudes and beliefs about science.

Performance, Knowledge, and Skills

At grades 4 and 8, the amount of exposure to the different fields of science was not associated with differences in the composite, life science, earth science, or physical science average scale scores of students or the percentage of students at or above *Proficient*.

At grades 4 and 8, male students had a higher average question score than female students for questions that measured conceptual understanding. At grade 12, male students outperformed female students on questions that measured conceptual understanding and practical reasoning.

At grades 4, 8, and 12, White students had a higher average question score than Black and Hispanic students for questions that measured earth, physical, and life science and also for questions that measured conceptual understanding, scientific investigation, and practical reasoning.

Classroom Practices

Seventy-eight percent of fourth graders and 88 percent of eighth graders had teachers who reported placing heavy emphasis on understanding key science concepts. These students had higher average scale scores and were more likely to be at or above the *Proficient* level than students whose teachers placed less emphasis on this objective.

Forty-one percent of students in grade 8 had teachers who reported placing a heavy emphasis on developing laboratory skills; 15 percent of fourth graders had teachers who reported the same emphasis. The eighth-grade students had higher average scale scores and were more likely to perform at or above the *Proficient* level than eighth graders whose teachers reported placing less emphasis on laboratory skills. There

was no difference in performance among fourth graders that was associated with how much emphasis their teachers gave to developing laboratory skills.

Teachers of 56 percent of fourth graders and 80 percent of eighth graders reported students doing hands-on activities at least once or twice a week. At the eighth-grade level, students who did hands-on activities almost every day or once or twice a week had higher scale scores and were more likely to be at or above the *Proficient* level than students who did hands-on activities once or twice a month or never or hardly ever. A similar pattern was seen at grade 12, based on self-reporting by students. No differences were seen at the fourth-grade level.

Approximately half of the student population at grades 4 and 8 had teachers who reported not using computers for instruction in science.

Teachers of 42 percent and 87 percent of students in grades 4 and 8, respectively, reported that they expected their students to spend one hour or more on their homework each week.

Attitudes, Motivation, and School Climate

At the fourth-grade level, 67 percent of students said they liked science. The percentages were somewhat lower for eighth and twelfth graders: 50 and 52 percent, respectively. Those who said they liked science outperformed those who said they did not like science.

In general, the greater the number of positive attitudes towards science, the higher the performance of students at grades 4, 8, and 12.

The percentage of students who thought it was important to do well on the NAEP science assessment was highest at the fourth-grade level, 59 percent, and lowest at the twelfth-grade level, 9 percent. Students who thought it most important to do well did not necessarily perform better than students who thought it less important to do well.

Where the school problems of student absenteeism, teacher absenteeism, and lack of parental involvement were more severe, as reported by school administrators, student performance was lower.

Chapter 1

This is a report written primarily for science teachers. It has as its focus samples of questions and student responses taken from the National Assessment of Educational Progress (NAEP) science assessment that was administered in 1996 to students in grades 4, 8, and 12. The assessment was unique on two counts: first, each student who participated in the assessment was required to do a hands-on task; and second, slightly more than 60 percent of the questions were open-ended and thus required students to construct their own responses. For ease of reading, the report is divided into four parts. In the first part (chapter 1), an overview of the assessment is provided. This includes information about the framework used in the development of the assessment, a description of how the assessment was administered to students, and an explanation of how to interpret NAEP results. In the second part (chapters 2, 3, and 4), examples of questions and students' responses are presented. These chapters are divided by grade; that is, chapters 2, 3, and 4 discuss the performance, knowledge, and skills of students in grades 4, 8, and 12, respectively. The third part (chapters 5 and 6) contains information collected from students, teachers, and school administrators about classroom practices, student motivation, and parental involvement in learning. These chapters give teachers a snapshot of what is taking place in fourth-, eighth-, and twelfth-grade classrooms across the United States. Finally, the fourth part contains appendices offering a fuller description of the procedures used for the NAEP 1996 science assessment (appendix A), scoring guides for questions discussed in chapters 2, 3, and 4 (appendix B), and standard errors for the statistics presented in the report (appendix C).

Introduction

The teaching and learning of science in the nation's schools has been a primary educational concern for the last half of this century. Although a variety of approaches and methods have been explored and implemented during this time, recent reform efforts demonstrate a general consensus on basic principles for enhancing students' learning of science. Government agencies and professional organizations such as the National Science Board, the American Association for the Advancement of Science, the National Science Teachers Association, and the National Research Council have expressed agreement on several key goals for the teaching of science:

- Students should acquire a core of scientific understanding, including organized factual information.
- Students should acquire the ability to relate scientific concepts to each other and to problems they encounter in and out of school.
- Students should be able to apply science knowledge in practical ways.
- Students should be familiar with experimental design and have the ability to carry out scientific experiments that are developmentally appropriate.
- Students should acquire the science knowledge and understanding that will allow them the opportunity to pursue further study in scientific fields or enter science- or technology-related careers.¹

As the science curriculum evolves to account for these and other important educational goals, assessing students' achievement in science learning is essential for informing the curriculum development and policy planning that is ongoing. In 1996, NAEP conducted a national assessment of science achievement at grades 4, 8, and 12. The assessment was based on a framework that placed particular emphasis on conceptual understanding and the application of knowledge and skills, as well as the factual knowledge that is fundamental for science literacy.

NAEP's Mission

The National Assessment of Educational Progress (NAEP) is the only nationally representative and continuing assessment of what students in the United States know and can do in various academic subjects. NAEP is authorized by Congress and directed by the National Center for Education Statistics (NCES) of the U. S. Department of Education. The National Assessment Governing Board (NAGB), an independent body, provides policy guidance for NAEP.

Since its inception in 1969, NAEP's mission has been to collect, analyze, and produce valid and reliable information about the academic performance of students in the United States in various subject areas. In 1990, the mission of NAEP was expanded to include state-by-state

¹ National Assessment Governing Board. (1995). *Science framework for the 1996 National Assessment of Educational Progress*. Washington, DC: Author.

results. State participation in NAEP is voluntary and grew from 40 states and territories in 1990 to 47 in the 1996 science assessment. NAEP has also become a valuable tool in tracking progress toward the National Education Goals. The subjects assessed by NAEP are those highlighted at the 1989 Education Summit and in later legislation.²

The NAEP 1996 Science Framework

The science assessment was crafted to measure the content and skills specifications described in the science framework for the 1996 National Assessment of Educational Progress.³ The framework was developed in 1991 through a consensus process involving educators, policy makers, representatives of the business community, assessment and curriculum experts, and members of the public. The project was managed by the Council of Chief State School Officers (CCSSO) under the auspices of NAGB.

The NAEP science framework is based on the view that “scientific knowledge should be organized to provide a structure that connects and creates meaning for factual information, and this organization is influenced by the context in which the knowledge is presented.”⁴ Moreover, “science proficiency depends upon the ability to know and integrate facts into larger constructs and to use the tools, procedures, and reasoning processes of science for an increased understanding of the natural world.”⁵ Thus, the framework called for the NAEP 1996 science assessment to include the following:

- Multiple-choice questions that assess students’ knowledge of important facts and concepts and that probe their analytical reasoning skills;
- Constructed-response questions (questions that require students to create short or extended answers) that explore students’ abilities to explain, integrate, apply, reason about, plan, design, evaluate, and communicate science information; and
- Hands-on tasks that probe students’ abilities to use materials to make observations, perform investigations, evaluate experimental results, and apply problem-solving skills.

The core of the science framework is organized along two dimensions. The first dimension divides science into three major fields: earth, physical, and life. The second dimension defines characteristic ways of knowing and doing science: conceptual understanding, scientific investigation, and practical reasoning. Each question in the assessment is categorized as measuring one of the ways of knowing and doing science within one of the fields of science (e.g., scientific investigation in the context of earth science). Brief descriptions of the three major fields of science and the three ways of knowing and doing science are contained in figures 1.1 and 1.2.

² Executive Office of the President. (1990). *National goals for education*. Washington, DC: Government Printing Office. *Goals 2000: Educate America Act*, H.R. 1804, 103rd Cong., 2nd Sess. (1994).

³ National Assessment Governing Board. (1995). *Science framework for the 1996 National Assessment of Educational Progress*, p.31. Washington, DC: Author.

⁴ Ibid.

⁵ Ibid.

Earth Science

The earth science content assessment centers on objects and events that are relatively accessible or visible. The concepts and topics covered are solid Earth (lithosphere), water (hydrosphere), air (atmosphere), and Earth in space. The topics under "solid Earth" consist of: composition; forces that alter its surface; the formation, characteristics, and uses of rocks; the changes and uses of soil; natural resources used by humankind; and natural forces within Earth (not at grade 4). Concepts and topics related to water include the water cycle; the nature of oceans and their effects; and the location of water, its distribution and characteristics. The topic "air" is broken down into composition and structure of the atmosphere (including energy transfer); the nature of weather; climate (not at grade 4) and interactions of human society with atmosphere. "Earth in space" consists of: the setting of Earth in the solar system; the setting and evolution of the solar system in the universe (not at grade 4); tools and technology that are used to gather information about space; apparent daily motions of the Sun, the Moon, the planets, and the stars; rotation of Earth about its axis, and Earth's revolution around the Sun; the tilt of Earth's axis that produces seasonal variations in the climate; and Earth history.

Physical Science

The physical science component addresses basic knowledge and understanding of the structure of the universe as well as of the physical principles that operate within it. The major sub-topics probed are: matter and its transformations, energy and its transformations, and motion. "Matter and its transformations" are described by diversity of materials (classification and types and the particulate nature of matter); temperature and states of matter; properties and uses of material (modifying properties, synthesis of materials with new properties); and resource management (not at grades 4 and 8). "Energy and its transformations" involve different forms of energy; energy transformations in living systems, natural physical systems, and artificial systems constructed by humans; and energy sources and use, including distribution, energy conversion, and energy costs and depletion. "Motion" is broken down into an understanding of frames of reference; force and changes in position and motion; action and reaction (not at grade 4); vibrations and waves as motion; general wave behavior (not at grades 4 and 8); electromagnetic radiation; and the interactions of electromagnetic radiation with matter.

Life Science

The fundamental goal of life science is to attempt to understand and explain the nature and function of living things. The major concepts assessed in life science are change and evolution, cells and their functions (not at grade 4), organisms, and ecology. "Change and evolution" includes: diversity of life on Earth; genetic variation within a species; theories of adaptation and natural selection; and changes in diversity over time (not at grades 4 and 8). "Cells and their functions" consists of information transfer; energy transfer for the construction of proteins; and communication among cells. "Organisms" are described by reproduction, growth and development; life cycles; and functions and interactions of systems within organisms. The topic of "ecology" centers on the interdependence of life—populations, communities, and ecosystems.

SOURCE: National Assessment Governing Board, *Science Framework for the 1996 National Assessment of Educational Progress*, 1995.

FIGURE 1.2

***Descriptions of Knowing
and Doing Science***



Conceptual Understanding

Conceptual understanding includes the body of scientific knowledge that students draw upon when conducting a scientific investigation or engaging in practical reasoning. Essential scientific concepts involve a variety of information, including: facts and events the student learns from both science instruction and experiences with the natural environment; and scientific concepts, principles, laws, and theories that scientists use to explain and predict observations of the natural world.

Scientific Investigation

Scientific investigation probes students' abilities to use the tools of science, including both cognitive and laboratory tools. Students should be able to acquire new information, plan appropriate investigations, use a variety of scientific tools, and communicate the results of their investigations.

Practical Reasoning

Practical reasoning probes students' abilities to use and apply science understanding in new, real-world applications.

SOURCE: National Assessment Governing Board. *Science Framework for the 1996 National Assessment of Educational Progress*. 1995.

The framework also presents two overarching domains that describe science: the nature of science and the organizing themes of science (see figure 1.3). The **nature of science** encompasses the historical development of science and technology, the habits of mind that characterize science, and the methods of scientific inquiry and problem solving. It also includes the nature of technology — specifically, design issues involving the application of science to real-world problems and associated trade-offs or compromises. The **themes of science** include the notion of systems and their application in the scientific disciplines, models and their functioning in the development of scientific understanding, and patterns of change as they are exemplified in natural phenomena.

The Nature of Science

The nature of science incorporates the historical development of science and technology, the habits of mind that characterize these fields, and methods of inquiry and problem-solving. It also encompasses the nature of technology, including issues of design, application of science to real-world problems, and trade-offs or compromises that need to be made.

Themes

Themes are the "big ideas" of science that transcend the various scientific disciplines and enable students to consider problems with global implications. The NAEP science assessment focuses on three themes: systems, models, and patterns of change.

- Systems are complete, predictable cycles, structures, or processes occurring in natural phenomena. Students should understand that a system is an artificial construction created to represent or explain a natural occurrence. Students should be able to identify and define the system boundaries, identify the components and their interrelationships, and note the inputs and outputs of the system.
- Models of objects and events in nature are ways to understand complex or abstract phenomena. As such, they have limits and involve simplifying assumptions, but also possess generalizability and often predictive power. Students need to be able to distinguish the idealized model from the phenomenon itself and to understand the limitations and simplified assumptions that underlie scientific models.
- Patterns of change involve students' recognition of patterns of similarity and differences, and their ability to recognize how these patterns change over time. In addition, students should have a store of common types of patterns and be able to transfer their understanding of a familiar pattern of change to a new and unfamiliar one.

SOURCE: National Assessment Governing Board. *Science Framework for the 1996 National Assessment of Educational Progress*. 1995.

The percentage of assessment time devoted to each field of science and each way of knowing and doing science was clearly specified by the framework.⁶ Table 1.1 shows the distribution of estimated assessment time by field of science. At grades 4 and 12, the distribution of content across the three fields of science is approximately equal. For grade 8, the framework placed a somewhat heavier emphasis on life science (40 percent), with the remaining assessment time evenly divided between earth science and physical science. The distribution at grade 8 "reflects the importance for this age group of human biology, which is increasingly recognized both in curriculum and instruction."⁷

⁶ National Assessment Governing Board. (1995). *Science framework for the 1996 National Assessment of Educational Progress*. Washington, DC: Author.

⁷ Ibid.

TABLE 1.1

**Distribution of Estimated Assessment Time
by Field of Science**



	Grade 4	Grade 8	Grade 12
Earth	33%	30%	33%
Physical	34%	30%	33%
Life	33%	40%	34%

SOURCE: National Assessment Governing Board. *Science Framework for the 1996 National Assessment of Educational Progress*. 1995.

Table 1.2 shows the distribution of estimated assessment time by ways of knowing and doing science. At each grade level, approximately 45 percent of assessment time is devoted to the measurement of conceptual understanding. Scientific investigation is more heavily emphasized at grade 4 than at grades 8 and 12. This was thought desirable by the authors of the framework “because learning by doing plays a crucial role for younger students, and ways of knowing in science need to be introduced early.”⁸ The proportion of assessment time spent on the measurement of practical reasoning is lowest at grade 4 “because of developmental considerations and lack of opportunities at early ages.”⁹

TABLE 1.2

**Distribution of Estimated Assessment Time
by Ways of Knowing and Doing Science**



	Grade 4	Grade 8	Grade 12
Conceptual Understanding	45%	45%	44%
Scientific Investigation	38%	29%	28%
Practical Reasoning	17%	26%	28%

SOURCE: National Assessment Governing Board. *Science Framework for the 1996 National Assessment of Educational Progress*. 1995.

⁸ National Assessment Governing Board. (1995). *Science framework for the 1996 National Assessment of Educational Progress*. Washington, DC: Author.

⁹ Ibid.

The NAEP 1996 science assessment was made up of three types of questions: multiple choice, short constructed response, and extended constructed response. For the purposes of test construction, it was assumed that each multiple-choice question would take approximately one minute to complete, each short constructed-response question would take approximately two minutes to complete, and each extended constructed-response question would take approximately five minutes to complete. Short constructed-response questions required a few words or a sentence or two for an answer (e.g., briefly stating how nutrients move from the digestive system to the tissues). Extended constructed-response questions generally required a paragraph or more (e.g., outlining an experiment to test the effect of increasing the amount of available food on the rate of increase of a Hydra population). Some extended constructed-response questions also required diagrams, graphs, or calculations. Table 1.3 shows how many questions of each type were administered at grades 4, 8, and 12. For example, at grade 4, 51 of the questions administered were multiple-choice, 73 were short constructed-response, and 17 were extended constructed-response. Thus, 36 percent of the total number of questions administered at grade 4 were multiple choice. In addition, the table shows how many overlap questions were administered. An overlap question is one administered to students at two grades, either grades 4 and 8 or grades 8 and 12. For example, 9 multiple-choice, 16 short constructed-response, and 4 extended constructed-response questions were administered to students at grades 4 and 8. This “double” utilization of questions was done to ensure that there were enough questions to measure the higher-ability students at the lower grade levels and the lower-ability students at the higher grade levels. Table 1.3 also shows the percentages of time devoted to each question type for the assessment as a whole. Approximately 20 percent of students’ time was spent answering multiple-choice questions and approximately 80 percent answering short and extended constructed-response questions.

TABLE 1.3

Number of Questions, Percent of Questions, and Percent of Questions by Time, by Grade Level and Type



	Grade 4			Grade 8			Grade 12		
	MC ¹	SCR ²	ECR ³	MC	SCR	ECR	MC	SCR	ECR
Grade 4 Only	42	57	13						
Grades 4 and 8 Overlap	9	16	4	9	16	4			
Grade 8 Only				44	58	12			
Grades 8 and 12 Overlap				21	26	3	21	26	3
Grade 12 Only							49	63	28
TOTAL Number of Questions by Grade	51	73	17	74	100	20	70	89	31
TOTAL Percent of Questions by Grade	36%	52%	12%	38%	52%	10%	37%	47%	16%
TOTAL Percent by Time	18%	52%	30%	20%	53%	27%	17%	44%	38%

¹ Multiple-choice questions

² Short constructed-response questions

³ Extended constructed-response questions

NOTE: Numbers may not add to 100 due to rounding.

SOURCE: National Assessment Governing Board, National Assessment of Educational Progress, 1996 Science Assessment, 1996.

The Assessment Design

At each of grades 4, 8, and 12, there were 15 different sections or “blocks” of science questions, usually consisting of both multiple-choice and constructed-response questions. These questions assessed ways of knowing and doing science in the context of earth, physical, and life science. Hands-on tasks comprised 4 of the 15 blocks at each grade level. In these tasks, students were given sets of equipment and asked to conduct an investigation and answer questions related to the investigation. For example, students in grade 12 were given a mixture of five substances and asked to separate them.

Three of the 15 blocks assessed themes. One of these blocks addressed systems, a second addressed models, and a third addressed patterns of change. For example, students at grade 8 were shown a simplified model of part of the solar system, with a brief description, and were then asked a number of questions based on this information.

Each student in the assessment received a booklet that contained 3 of the 15 blocks of science questions. One of these blocks was always a hands-on task. At the fourth-grade level, students were allowed 20 minutes to complete each block of questions. At the eighth- and twelfth-grade levels, students were allowed 30 minutes to complete each block. Theme blocks were placed randomly in the student booklets. Not every booklet contained a theme block, but no booklet contained more than one theme block.

In addition to answering science questions, students also answered questions about their general backgrounds, their science experiences, and their motivation. Further information regarding the assessment design and background questionnaires can be found in the forthcoming *NAEP 1996 Technical Report*.¹⁰

It should be noted that not every student in grades 4, 8, and 12 took the assessment. However, since the assessment was administered to nationally representative samples, the results can be extrapolated to all fourth-, eighth- and twelfth-grade students in the United States. Appendix A gives an overview of the sampling process.

¹⁰ Allen, N. L., Carlson, J., & Zelenak, C.A. (in press) *The NAEP 1996 technical report*. Washington, DC: National Center for Education Statistics.

Reporting NAEP Results

The NAEP Science Scale

The NAEP 1996 science assessment spanned the broad field of science in each of the grades assessed. Because of the survey nature of the assessment and the breadth of the domain, each student participating could not be expected to answer all the questions in the assessment without imposing an unreasonable burden on students and their schools. Instead, each student was administered a portion of the assessment, and data were combined across students to report on the achievement of fourth, eighth, and twelfth graders and on the achievement of subgroups of students (e.g., subgroups defined by demographics such as gender or race/ethnicity).

Student responses to the assessment questions were analyzed to determine the percentages of students responding correctly to each multiple-choice question and the percentages of students achieving each of the score categories for constructed-response questions. A series of scales was then created to summarize student performance. The same methodology was used at each grade level. First, scales were created to correspond to earth science, physical science, and life science. Then, a composite scale was created, using a weighted average of the three fields of science scales. These weighted averages were proportional to the relative importance assigned to each field of science as specified by the framework. For example, at the eighth-grade level, a greater proportion of time was spent on questions measuring life science (40 percent) than on questions measuring earth science or physical science (30 percent each), and thus life science received a heavier weighting in the composite scale. Unless otherwise indicated, scale score results presented in this report are based on this overall composite scale.

The composite scale at each grade ranges from 0 to 300, with a mean of 150 and a standard deviation of 35. While the scale-score ranges are identical, the scale was derived independently at each grade. Also, scales were weighted differently at different grades in determining the overall scale. Therefore, average scale scores across grades cannot be compared. For example, equal scale scores on the grade 4 and grade 8 scales do not imply equal levels of science achievement. (Additional details of the scaling procedures can be found in appendix A of this report and in the forthcoming *NAEP 1996 Technical Report*.¹¹)

¹¹ Allen, N. L., Carlson, J., & Zelenak, C.A. (in press) *The NAEP 1996 technical report*. Washington, DC: National Center for Education Statistics.

Average Question Score

Average question score represents a different way to look at student performance than the scale scores customarily used in NAEP. For multiple-choice questions and constructed-response questions that are scored on a two-part scale (right or wrong), the question score is the percentage of students answering each question of this type correctly. For questions that are scored on either a three-level or a four-level scale, the question score represents the average of all student scores on that question, expressed as a percentage of the maximum possible score. For example, on a question using a three-level scoring guide, scores of *Complete*, *Partial*, and *Unsatisfactory* are converted to 1, 0.5, and 0, respectively. These converted scores are then multiplied by the percentage of students receiving each score and the sum found. In other words, if 10 percent of students received a score of *Unsatisfactory* (i.e., 0), 30 percent received a score of *Partial* (i.e., 0.5), and 60 percent received a score of *Complete* (i.e., 1), the question score would be $[(0 \times 0.1) + (0.5 \times 0.3) + (1 \times 0.6)] = 0.75$. The average question score is found by combining the question scores over the full set of questions within an area of interest (such as life science or conceptual understanding) and dividing by the number of questions in that area. For example, the average question score for the 47 life science questions administered at grade 4 is 0.44 out of a possible 1. Average question scores are used in chapters 2, 3, and 4 to discuss student performance in each of the fields of science and ways of knowing and doing science.¹²

Achievement Levels for Student Performance

Since 1988, NAGB has been required by law to set performance standards, called “achievement levels,” for NAEP. The achievement levels are developmental, and as such are continually under review. Table 1.4 presents the policy definitions of the three NAEP achievement levels — *Basic*, *Proficient*, and *Advanced* — that apply across grades and subject areas. The levels are cumulative; that is, students performing at the *Proficient* level should have all the knowledge and skills of students at the *Basic* level, and students performing at the *Advanced* level should have all the knowledge and skills of students performing at the *Proficient* level. Additional information about achievement levels can be found in the report, *1996 Science Performance Standards: Achievement Results for the Nation and the States*.¹³

¹² To make valid inferences from the student samples to the respective populations from which they were drawn, sampling weights were used in the analysis.

¹³ Bourque, M. L., Champagne, A. B., & Crissman, S. (1997). *1996 science performance standards: Achievement results for the nation and the states*. Washington, DC: National Assessment Governing Board.

TABLE 1.4**Policy Definitions of
NAEP Achievement Levels****Advanced**

Superior performance.

Proficient

Solid academic performance for each grade assessed. Students reaching this level have demonstrated competency over challenging subject matter, including subject-matter knowledge, application of such knowledge to realworld situations, and analytical skills appropriate to the subject matter.

Basic

Partial mastery of prerequisite knowledge and skills that are fundamental for proficient work at each grade.

The science achievement levels consist of specific content descriptions of what students know and can do at the three levels. Cut scores on the 0-to-300 NAEP science scale define the three achievement levels. The content descriptions were developed by a broadly representative group of scientists and science educators and were based on student achievement on the assessment questions. A summary of the science achievement level descriptions and the corresponding cut scores is found in figure 1.4.

Cut Score

Content Descriptions

Grade 4**BASIC**
138

Students performing at the *Basic* level demonstrate some of the knowledge and reasoning required for understanding of the earth, physical, and life sciences at a level appropriate to Grade 4. For example, they can carry out simple investigations and read uncomplicated graphs and diagrams. Students at this level also show a beginning understanding of classification, simple relationships, and energy.

PROFICIENT
170

Students performing at the *Proficient* level demonstrate the knowledge and reasoning required for understanding of the earth, physical, and life sciences at a level appropriate to Grade 4. For example, they understand concepts relating to the Earth's features, physical properties, and structure and function. In addition, students can formulate solutions to familiar problems as well as show a beginning awareness of issues associated with technology.

ADVANCED
204

Students performing at the *Advanced* level demonstrate a solid understanding of the earth, physical, and life sciences as well as the ability to apply their understanding to practical situations at a level appropriate to Grade 4. For example, they can perform and critique simple investigations, make connections from one or more of the sciences to predict or conclude, and apply fundamental concepts to practical applications.

Grade 8**BASIC**
143

Students performing at the *Basic* level demonstrate some of the knowledge and reasoning required for understanding of the earth, physical, and life sciences at a level appropriate to Grade 8. For example, they can carry out investigations and obtain information from graphs, diagrams, and tables. In addition, they demonstrate some understanding of concepts relating to the solar system and relative motion. Students at this level also have a beginning understanding of cause-and-effect relationships.

PROFICIENT
170

Students performing at the *Proficient* level demonstrate much of the knowledge and many of the reasoning abilities essential for understanding of the earth, physical, and life sciences at a level appropriate to Grade 8. For example, students can interpret graphic information, design simple investigations, and explain such scientific concepts as energy transfer. Students at this level also show an awareness of environmental issues, especially those addressing energy and pollution.

ADVANCED
207

Students performing at the *Advanced* level demonstrate a solid understanding of the earth, physical, and life sciences as well as the abilities required to apply their understanding in practical situations at a level appropriate to Grade 8. For example, students perform and critique the design of investigations, relate scientific concepts to each other, explain their reasoning, and discuss the impact of human activities on the environment.

Grade 12**BASIC**
145

Students performing at the *Basic* level demonstrate some knowledge and certain reasoning abilities required for understanding of the earth, physical, and life sciences at a level appropriate to Grade 12. In addition, they demonstrate knowledge of the themes of science (models, systems, patterns of change) required for understanding the most basic relationships among the earth, physical, and life sciences. They are able to conduct investigations, critique the design of investigations, and demonstrate a rudimentary understanding of scientific principles.

PROFICIENT
178

Students performing at the *Proficient* level demonstrate the knowledge and reasoning abilities required for understanding of the earth, physical, and life sciences at a level appropriate to Grade 12. In addition, they demonstrate knowledge of the themes of science (models, systems, patterns of change) required for understanding how these themes illustrate essential relationships among the earth, physical, and life sciences. They are able to analyze data and apply scientific principles to everyday situations.

ADVANCED
210

Students performing at the *Advanced* level demonstrate the knowledge and reasoning abilities required for a solid understanding of the earth, physical, and life sciences at a level appropriate to Grade 12. In addition, they demonstrate knowledge of the themes of science (models, systems, pattern of change) required for integrating knowledge and understanding of scientific principles from the earth, physical, and life sciences. Students can design investigations that answer questions about real-world situations and use their reasoning abilities to make predictions.

SOURCE: National Assessment Governing Board, National Assessment of Educational Progress, 1996 Science Assessment. 1996.

Table 1.5 shows the percentages of students within each science achievement level at grades 4, 8, and 12, as well as the percentages of students below the *Basic* achievement level. At grades 4, 8, and 12, three percent of students performed at the *Advanced* level for that specific grade. Twenty-six percent of students at grades 4 and 8 were at the *Proficient* level, whereas 18 percent of grade 12 students were at the *Proficient* level. At least one-third of students at each grade performed below the *Basic* level.

A complete description of the achievement levels can be found in appendix A. In this report, information pertaining to achievement levels is included with the sample student responses in chapters 2, 3, and 4. The percentages of students performing at or above the *Proficient* level are also presented in the tables in chapters 4 and 5, together with scale scores.

TABLE 1.5		Percentages of Students Within Each Science Achievement Level for the Nation			
		Below Basic	Basic	Proficient	Advanced
Grade 4		33	38	26	3
Grade 8		39	32	26	3
Grade 12		43	36	18	3



SOURCE: National Center for Education Statistics, National Assessment of Educational Progress (NAEP), 1996 Science Assessment.

Item Maps

Another way to illustrate the range of performance on the NAEP science scale is to map questions from the assessment onto the 0-to-300 scale at each grade level. The resulting item maps are visual representations that compare questions with ability. More specifically, they indicate which questions a student at a given performance level on the NAEP scale is likely to answer correctly.¹⁴ Figures 1.5 through 1.7 show item maps for grades 4, 8, and 12, respectively. The illustrative questions shown in these maps are the same as those discussed in chapters 2, 3, and 4 of this report. Multiple-choice questions are denoted by (mc), and each constructed-response question by its score value in parentheses after the short description of the question.¹⁵ All multiple-choice questions in this assessment had four options.

The following examples will help in interpreting these maps. In figure 1.5, which shows the mapping of assessment questions for grade 4, a four-option, multiple-choice question about reading the level of a liquid in a graduated cylinder maps at the 129 point on the scale. This means that fourth-grade students with science scale scores at or above 129 have at least a 74-percent chance of answering this question correctly.¹⁶ Put slightly differently, this question is answered correctly by at least 74 of every 100 students scoring at or above the 129 scale-score level. This does not mean that students at or above the 129 scale score always answer the question correctly or that students below the 129 scale score always answer it incorrectly. Rather, the percentage of students who can successfully answer the question depends on their overall ability as measured on the NAEP science scale. As another example, consider the constructed-response question that maps at a scale score of 252 on the grade 4 composite science scale. This question asks what forces impact Earth's surface and how they impact it. Scoring of responses to this question allows for partial credit by using a four-level scoring guide. Mapping the question at the 252 scale score indicates that at least 65 percent of the students performing at or above this point achieved a score of 4 (*Complete*) on the question.

¹⁴ Details on the procedures used to develop the item maps will be provided in the forthcoming *NAEP 1996 Technical Report*. The procedures are similar to those used in past NAEP assessments.

¹⁵ The placement of constructed-response questions is based on the mapping of 2 (*Complete*) on a 2-point scoring guide for short constructed-response questions scored as right or wrong, 3 (*Complete*) on a 3-point scoring guide for short constructed-response questions, and 4 (*Complete*) on a 4-point scoring guide for extended constructed-response questions.

¹⁶ For constructed-response questions, a criterion of 65 percent was used. For multiple-choice questions, the criterion was 74 percent. The use of a higher criterion for multiple-choice questions reflected students' ability to "guess" the correct answer from among the alternatives.

FIGURE 1.5

Map of Selected Questions on the
NAEP Science Scale for Grade 4

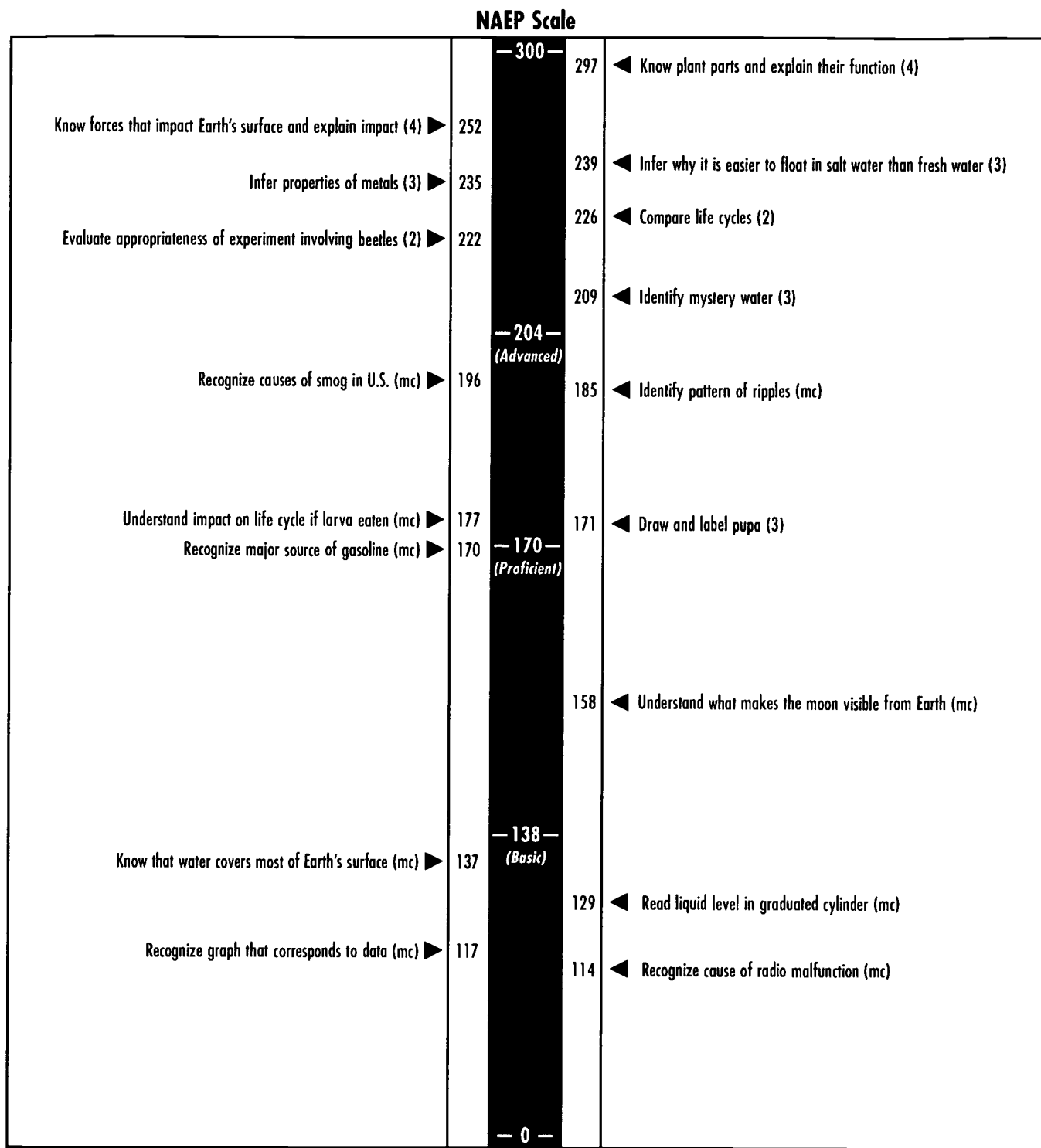

NOTE: Each grade 4 science question was mapped onto the NAEP 0-to-300 science scale. The position of the question on the scale represents the scale score attained by students who had a 65-percent probability of reaching a given score level on a constructed-response question or a 74-percent probability of correctly answering a 4-option multiple-choice question. Only selected questions are presented. Achievement level cut points are referenced on the map.

NOTE: "mc" indicates a multiple-choice question.

NOTE: The number in parentheses indicates the score level.

FIGURE 1.6

Map of Selected Questions on the
NAEP Science Scale for Grade 8



NAEP Scale

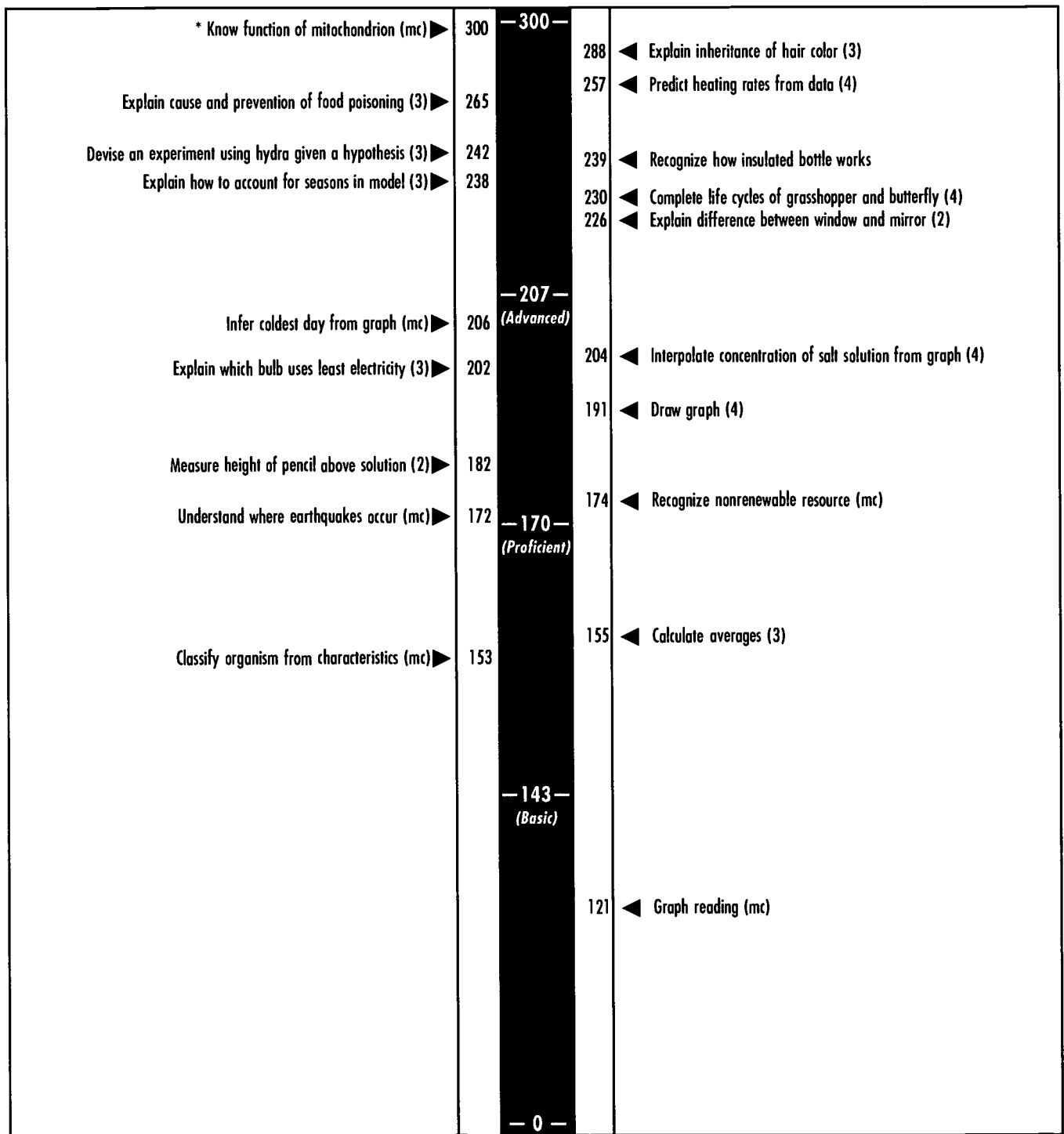

NOTE: Each grade 8 science question was mapped onto the NAEP 0-to-300 science scale. The position of the question on the scale represents the scale score attained by students who had a 65-percent probability of reaching a given score level on a constructed-response question or a 74-percent probability of correctly answering a 4-option multiple-choice question. Only selected questions are presented. Achievement level cut points are referenced on the map.

NOTE: "mc" indicates a multiple-choice question.

NOTE: * The characteristics of this item do not meet the mapping criteria at this value. However, in order for it to meet the criteria, the item would have to be assigned a value beyond the valid range of scores.

NOTE: The number in parentheses indicates the score level.

FIGURE 1.7

Map of Selected Questions on the
NAEP Science Scale for Grade 12

NAEP Scale

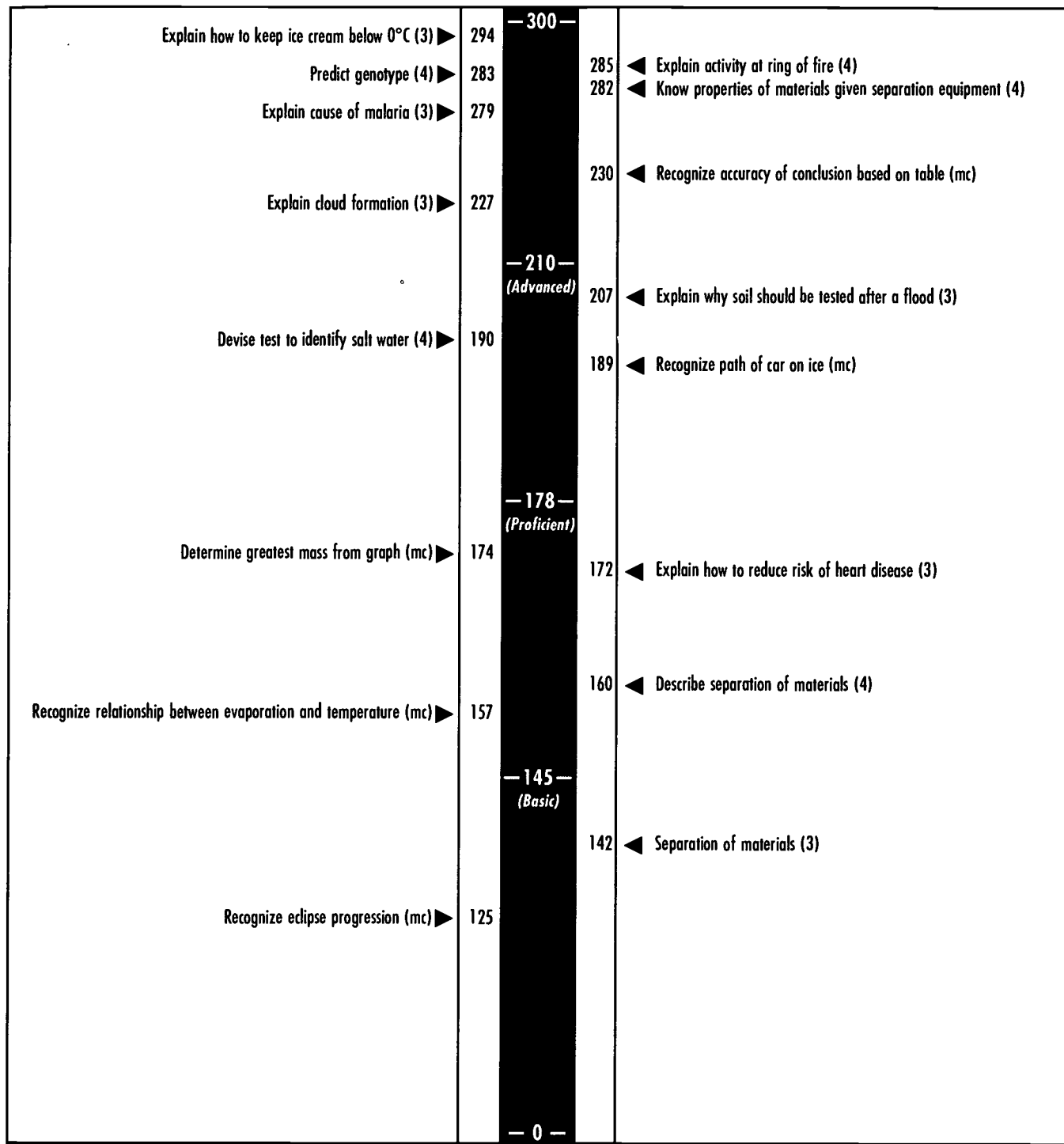

NOTE: Each grade 12 science question was mapped onto the NAEP 0-to-300 science scale. The position of the question on the scale represents the scale score attained by students who had a 65-percent probability of reaching a given score level on a constructed-response question or a 74-percent probability of correctly answering a 4-option multiple-choice question. Only selected questions are presented. Achievement level cut points are referenced on the map.

NOTE: "mc" indicates a multiple-choice question.

NOTE: The number in parentheses indicates the score level.

Interpreting NAEP Results

The results presented in this report are estimates because they are based on samples rather than on the entire population. As such, the results are subject to a measure of uncertainty that is reflected in the standard errors of the estimates. Standard errors provide a measure of how much survey results could vary if a different but equally valid sample of students were chosen. The standard errors are presented in appendix C.¹⁷

In this report, comparisons among question types or between subgroups of students are based on statistical tests that consider both the magnitude of the differences between the average percentages and their standard errors. Throughout the report, differences are discussed only when they are significant from a statistical perspective. This means that observed differences are unlikely to be due to chance factors associated with sampling variability. All differences are significant to the 0.05 level with appropriate adjustments made for multiple comparisons. The term “significant,” therefore, is not necessarily intended to imply judgment about the absolute magnitude or educational relevance of the differences.

Cautions in Interpretations

There are several cautions that readers of this report should bear in mind as they look at the data presented. The first caution relates to the information collected from responses to the NAEP background questions. This information was self-reported and, while the questions were written as unambiguously as possible, respondents’ interpretations of them may nonetheless have differed. The second caution relates to interpreting as causal the statistical relationships between student, teacher, or school variables and students’ performance. This report presents student performance data for individual background variables, and some readers understandably might be tempted to see the background variable as causing the level of performance. Readers must understand, however, that differences in science performance rarely have a single cause, but rather stem from multiple, interrelated educational and socioeconomic factors. Therefore, neither the existence nor absence of statistical correlations between student performance and any single variable should be taken as conclusive evidence regarding a causal relationship between the two. Conclusions about the relative effectiveness of different teaching approaches or the impact of various technologies on student performance, for example, are likely to be misleading if based solely on single-variable data. The final caution concerns the fact that although the data reported here are cross-sectional (based on student performance at one time), learning is cumulative. The classroom-based variables examined in this report reflect students’ experiences during half of the school year (because the assessment is given in January-March) and do not reflect either their experiences in three, seven, or eleven years of previous schooling or their experiences outside of school.

¹⁷ The standard errors in this report should be interpreted in the following fashion: There is a 95-percent probability that a statistic for a population of interest is within two standard errors of the mean reported. For example, if we report that 50 percent of female students answered a question correctly and the standard error is 0.5, then there is a 95-percent chance that the actual value of the statistic for the whole population of female students falls between 49 and 51 percent.

The above considerations notwithstanding, the data presented are quite useful. They are collected from a national sample and so can be generalized to the population of students in a specific grade. The percentage data indicate how commonly a variety of classroom practices are employed, the extent of parental involvement in school, and the range of student attitudes and beliefs about science. And despite the caution with which they must be approached, the performance data linked to background variables are suggestive of what students know and can do in science in an assortment of contexts. The data also are a place from which to begin additional investigations, in-depth research, and constructive conversations about educational practices and student work. It is unlikely that any other large-scale assessment design could yield data of greater breadth or depth without a far greater investment of time and money.

Additional NAEP Science Publications

This report is one of a series of reports designed to provide a comprehensive account of the results from the NAEP 1996 science assessment. Four reports are already completed: the *NAEP 1996 Science Report Card for the Nation and the States*, which examines and compares the science performance of groups of students defined by demographic characteristics or by responses to background questions (e.g., males compared to females); a companion report, *1996 Science Performance Standards: Achievement Results for the Nation and the States*, which presents the NAGB's achievement levels within the context of demographic variables; *What do Students Know?*, a summary of the NAEP 1996 science results; and *Students Learning Science: A Report on Policies and Practices in U.S. Schools*, which provides a "snapshot" of current teacher practices, school policies, and student achievement.¹⁸ This report — *Student Work & Teacher Practices in Science* — is directed at teachers and contains examples of questions, student responses, and data relating to classroom activities.

A final report will present results from a special study conducted in conjunction with the main NAEP 1996 science assessment that assessed students with advanced training in science. In addition, that final report will present a second study that identifies and describes the cognitive processes required to answer each question administered in the NAEP 1996 science assessment.

It should be noted that the NAEP 1996 science assessment provided a wealth of information, not all of which appears in reports. However, data from the assessment (referred to as Summary Data Tables) are available on the World Wide Web and can be accessed through <http://nces.ed.gov/naep>. NAGB reports and assessment frameworks can be found through <http://www.nagb.org>.

¹⁸ O'Sullivan, C. Y., Reese, C. M., & Mazzeo, J. (1997). *NAEP 1996 science report card for the nation and the states: Findings from the National Assessment of Educational Progress* (NCES Publication No. 97-499). Washington, DC: National Center for Education Statistics.

Bourque, M. L., Champagne, A. B., & Crissman, S. (1997). *1996 science performance standards: Achievement results for the nation and the states*. Washington, DC: National Assessment Governing Board.

National Assessment Governing Board. (1997). *What do students know?* Washington, DC: Author.

O'Sullivan, C.Y., Weiss, A. R., & Askew, J. M. (1998). *Students learning science: A report on policies and practices in U.S. schools*. (NCES Publication No. 98-493). Washington, DC: National Center for Education Statistics.

Overview of Remaining Chapters

Chapters 2, 3, and 4 of this report present analyses of student performance in three fields of science and three ways of knowing and doing science. In addition, chapters 2, 3, and 4 contain examples of questions and students' responses for grades 4, 8, and 12, respectively. Although students generally took sets of questions that covered all three fields of science, the questions discussed in these chapters are grouped into the three ways of knowing and doing science — conceptual understanding, scientific investigation, and practical reasoning. The two exceptions to this grouping relate to questions taken from the theme blocks and hands-on tasks. These questions are discussed separately. Two tables appear with each sample question in chapters 2, 3, and 4. These tables differ depending on whether the question is multiple-choice or constructed-response. For multiple-choice questions, the first table shows the percentage of students choosing each response option and the second table shows the percentage of students within each achievement level interval choosing the correct option. For constructed-response questions, the first table presents the percentage of students in each score category. The second table displays the percentage of students within each achievement-level interval that received a score of *Complete* in the case of short constructed-response questions and *Complete* or *Essential* in the case of extended constructed-response questions.

Chapters 5 and 6 contain information collected from students, teachers, and school administrators about classroom practices, student motivation, and parental involvement in learning. The averages and percentages presented in these chapters are estimates because they are based on samples rather than on all members of each population.

Finally, this report contains appendices that support or augment the results presented. Appendix A contains a detailed description of the science achievement levels, information on national samples, and information pertaining to the background questionnaires. Appendix B presents scoring guides for questions discussed in chapters 2, 3, and 4. Appendix C contains the standard errors for the statistics presented in this report. Detailed information about the measurement methodology and data analysis techniques used in this report is available in the two NAEP technical reports.¹⁹

¹⁹ Allen, N. L., Swinton, S. S., Isham, S. P., & Zelenak, C. A. (1997). *Technical report of the NAEP 1996 state assessment program in science* (NCES Publication No. 98-480). Washington, DC: National Center for Education Statistics.

Allen, N. L., Carlson, J., & Zelenak, C. A. (in press) *The NAEP 1996 technical report*. Washington, DC: National Center for Education Statistics.

Chapter 2

Grade 4: Performance, Knowledge, and Skills

Introduction

There are many questions about science learning that are of interest to educators. For example, how much class time is spent on earth science, physical science, and life science? Do male and female students perform differently on different types of science questions? How do students perform on multiple-choice and constructed-response questions? Data collected during the NAEP 1996 science assessment have been analyzed and provide some answers to these kinds of questions. This chapter discusses the results.

The grade 4 assessment was constructed according to specifications outlined in the *Science Framework for the 1996 National Assessment of Educational Progress*.¹ The specifications stated that, at the fourth-grade level, the distribution of assessment time across the three science fields should be approximately equal. In addition, 45 percent of assessment time should be directed toward conceptual understanding, 45 percent toward scientific investigation, and 10 percent toward practical reasoning. (A description of the fields of science and the ways of knowing and doing science is presented in chapter 1, and figures 1.1 and 1.2). Each question in the science assessment was classified as measuring one of the ways of knowing and doing science within one of the fields of science (for example, scientific investigation in the context of life science).

Table 2.1 shows the number of multiple-choice, short constructed-response, and extended constructed-response questions in each of the major fields of science and ways of knowing and doing science. The total number of each question type is also shown. There were 51 multiple-choice questions and 94 constructed-response questions in the grade 4 assessment. Each constructed-response question had its own unique scoring guide that defined the criteria used to evaluate students' responses.² Short constructed-response questions were usually scored

¹ National Assessment Governing Board. (1995). *Science framework for the 1996 National Assessment of Educational Progress*. Washington, DC: Author.

² Appendix B contains scoring guides for the sample questions that appear in this report.

according to three levels of performance: *Complete*, *Partial*, or *Unsatisfactory*; however, some of them were scored as either right or wrong (*Complete* or *Unsatisfactory*). Extended constructed-response questions were usually scored according to four levels: *Complete*, *Essential*, *Partial*, or *Unsatisfactory*. In a few instances, however, five- and six-level scoring guides were used. In total, 275,339 student responses were scored; this number included the 25 percent of student responses that were scored twice to monitor the reliability of the scoring process.³ (See appendix A for a more complete description of the scoring process.)

TABLE 2.1

Distribution of Questions by Fields of Science and by Ways of Knowing and Doing Science, Grade 4: Public and Nonpublic Schools Combined



	Multiple-Choice	Short Constructed-Response	Extended Constructed-Response	Total
Fields of Science				
Earth Science	22	27	4	53
Life Science	16	25	6	47
Physical Science	13	26	6	45
Total	51	78	16	145
Knowing and Doing				
Conceptual Understanding	36	36	9	81
Scientific Investigation	9	23	5	37
Practical Reasoning	6	19	2	27
Total	51	78	16	145

SOURCE: National Center for Education Statistics, National Assessment of Educational Progress (NAEP), 1996 Science Assessment.

³ For grade 4, the percentage agreement for the 1996 reliability sample was 94. This means that the scores given by first and second scorers agreed 94 percent of the time.

Grade 4 Science Teaching Content

As part of the NAEP science assessment, teachers of grade 4 students were asked to specify how much time they spent teaching life science, earth science, and physical science. Teachers were presented with the response options “A Lot,” “Some,” “Little,” and “None.” The results are shown in table 2.2.

Teachers of approximately 28, 19, and 16 percent of grade 4 students reported spending a lot of time covering life science, earth science, and physical science, respectively. It should be noted that although teachers were covering each of the major fields of science, no information was collected on the nature of that coverage. Thus, it is not known whether students had the opportunity to learn the material that was assessed on the NAEP survey. The amount of exposure to the three fields of science did not have an impact on the average scale scores of students or on the percentage of students that attained the *Proficient* level. No statistical differences were found. In addition, the amount of exposure to the different fields of science was not associated with differences in scale scores of students in the different fields. For example, students whose teachers reported that they spent little time on life science performed as well on life science questions as did students whose teachers reported that they spent a lot of time on life science.

TABLE 2.2

Teachers' Reports on How Much Time They Spent Teaching Life Science, Earth Science, and Physical Science, Grade 4: Public and Nonpublic Schools Combined



In this class, about how much time do you spend on each of the following areas in science?	Percentages of Students	Average Scale Score				Percentages At or Above Proficient
		Composite (all fields)	Life Science	Earth Science	Physical Science	
Life Science						
A Lot	28	150	151	150	150	29
Some	65	151	151	151	152	31
Little	6	150	151	151	150	26
None	1	—	—	—	—	—
Earth Science						
A Lot	19	151	152	151	151	31
Some	76	151	151	150	151	29
Little	5	153	148	153	153	29
None	0	—	—	—	—	—
Physical Science						
A Lot	16	154	155	154	154	34
Some	73	151	151	151	151	30
Little	9	145	145	146	146	25
None	2	134	136	139	134	16

— — Sample size is insufficient to permit a reliable estimate.

SOURCE: National Center for Education Statistics, National Assessment of Educational Progress (NAEP), 1996 Science Assessment.

Average Question Score

Table 2.3 shows the average question score of earth science, physical science, and life science questions for all students, male and female students, and White, Black, and Hispanic students. For all students the average question score for questions measuring earth science was 0.40. For questions measuring physical science and life science, the average question scores were the same, 0.44.⁴

Readers are cautioned not to make comparisons among the fields of science for any group of students. Variations may have been due, for example, to the particular make-up of the set of questions administered and could have differed if students were administered a different set of questions covering the same fields of science. Comparisons can be made, however, among the different reporting groups within each field of science. It was found that White students had a higher average question score than Black and Hispanic students for the earth science, physical science, and life science questions. In addition, male students had a higher average question score than female students for the earth science questions.

TABLE 2.3		Average Question Score for Earth Science, Physical Science, and Life Science, Grade 4: Public and Nonpublic Schools Combined		
		Earth Science	Physical Science	Life Science
All Students	0.40	0.44	0.44	0.44
Male	0.42	0.44	0.44	0.44
Female	0.39	0.44	0.44	0.44
White	0.44	0.48	0.48	0.48
Black	0.29	0.33	0.34	0.34
Hispanic	0.31	0.35	0.36	0.36



NOTE: There were insufficient sample sizes for the American Indian and Asian/Pacific Islander racial/ethnic subgroups to produce reliable results. Consequently, racial/ethnic subgroup information is provided only for White (not Hispanic), Black (not Hispanic), and Hispanic subgroups.

SOURCE: National Center for Education Statistics, National Assessment of Educational Progress (NAEP), 1996 Science Assessment.

⁴ See chapter 1 for a more complete description of the analysis.

Table 2.4 shows the average question score for questions classified as conceptual understanding, scientific investigation, or practical reasoning.⁵ For all students, the average question score was 0.44 for questions measuring conceptual understanding, 0.43 for questions measuring scientific investigation, and 0.38 for questions measuring practical reasoning.

Again, readers are cautioned not to compare performance among the ways of knowing and doing science, since student performance may have varied if different sets of questions had comprised these categories. When the data for the different reporting groups within each way of knowing and doing science are examined, however, several differences emerge. White students had a higher average question score than Black and Hispanic students for questions that measured conceptual understanding, scientific investigation, and practical reasoning. In addition, male students had a higher average question score than female students for the questions that measured conceptual understanding.

TABLE 2.4

Average Question Score for Conceptual Understanding, Scientific Investigation, and Practical Reasoning, Grade 4: Public and Nonpublic Schools Combined



	Conceptual Understanding	Scientific Investigation	Practical Reasoning
All Students	0.44	0.43	0.38
Male	0.45	0.43	0.38
Female	0.43	0.44	0.37
White	0.48	0.47	0.41
Black	0.33	0.32	0.27
Hispanic	0.35	0.34	0.29

NOTE: There were insufficient sample sizes for the American Indian and Asian/ Pacific Islander racial/ethnic subgroups to produce reliable results. Consequently, racial/ethnic subgroup information is provided only for White (not Hispanic), Black (not Hispanic), and Hispanic subgroups.

SOURCE: National Center for Education Statistics, National Assessment of Educational Progress (NAEP), 1996 Science Assessment.

⁵ See chapter 1 for a more complete description of the analysis.

Sample Questions and Student Responses

A more in-depth understanding of students' performance on the NAEP 1996 science assessment can be gained by examining individual test questions and how students responded. Table 2.5 summarizes the science questions that are discussed in this section of chapter 2. They are organized by ways of knowing and doing science and by fields of science. Since the discussion of sample questions must be limited to those questions that have been released to the public, no examples of scientific investigation in the context of earth science are available for discussion. The items that were not released to the public (approximately 73 percent of the assessment) will be reused next time NAEP administers the science assessment. This is planned for the year 2000. Some of the questions described could be classified in more than one field of science and more than one way of knowing and doing science. For the purposes of test construction and analysis, however, the classification had to be limited to one field of science and one way of knowing and doing science.

In this chapter, the questions are organized for discussion by the three ways of knowing and doing science — conceptual understanding, scientific investigation, and practical reasoning. The sample questions from the theme block and the hands-on task are discussed as a unit because this is how they were administered to the students. For example, one student may have been asked ten questions covering the three fields of science and the three ways of knowing and doing science, followed by a set of questions based on a theme, followed by a set of questions based on a hands-on task. The questions relating to a theme or hands-on task are indicated in table 2.5 by “Theme” and “Task.”

Two tables displaying data are included with each question. For multiple-choice questions, the first table shows the percentage of students choosing each response and the second table shows the percentages correct within each achievement-level interval. For constructed-response questions, the first table shows the percentages of students at different score levels and the second shows the percentages of students that received a score of *Complete* (or *Essential* or higher in the case of extended constructed-response questions) within each achievement-level interval. In this chapter, the tables showing percentages of students within each achievement-level interval do not contain data in the column labeled “*Advanced*” because the number of students classified as *Advanced* was too small to permit a reliable estimate.⁶

⁶ Allen, N. L., Carlson, J., & Zelenak, C. A. (in press) *The NAEP 1996 Technical Report*. Washington, DC: National Center for Education Statistics.

TABLE 2.5

**Sample Questions Categorized by Fields of Science and
by Ways of Knowing and Doing Science, Grade 4:
Public and Nonpublic Schools Combined**



	Earth Science	Physical Science	Life Science
Conceptual Understanding	Major source of gasoline (mc) Earth's surface (mc) Visibility of Moon from Earth (mc) Sources of smog (mc) Natural forces (ecr)	Pattern of ripples (mc)	Mealworm life cycle (mc) Plants: parts and functions (ecr) Theme: Pupa (scr) Theme: Grasshoppers and butterflies (ecr)
Scientific Investigation		Volume (mc) Task: Mystery water (scr)	Bar graph (mc) Experimental set-up (scr)
Practical Reasoning	Task: Ease of floating (scr)	Radio malfunction (mc) Properties of metals (scr)	Theme: Life cycles (scr)

NOTE: "mc" indicates a multiple choice question; "scr" indicates a short constructed-response question; and "ecr" indicates an extended constructed-response question.

Conceptual Understanding⁷

Eighty-one questions administered to fourth graders in the NAEP 1996 science assessment measured knowledge and understanding of basic facts and concepts across the three fields of science: earth, physical, and life. A selection of these questions follows.

Major Source of Gasoline

The multiple-choice question shown below measures students' knowledge of a "resource from Earth used by humankind." and is classified under the earth science topic "Solid Earth." In the question, students were told that cars and other machines use gasoline as an energy source and were then asked to recognize what substance gasoline is made from and where it is found.

2. Cars and many other machines use gasoline as an energy source. What is the major source of gasoline?
- Ⓐ Water from the Earth's oceans
 - Ⓑ Wood from large trees
 - Ⓒ Gases in the atmosphere
 - Ⓓ Oil from beneath the Earth's surface

The correct option is D.

⁷ See figure 1.2 for a description of conceptual understanding.

The percentage of fourth graders choosing each response is reported in table 2.6. Approximately two-thirds of students answered the question correctly. Twenty-eight percent thought that gasoline came from gases in the atmosphere. This choice may have been due to the presence of the word “gases” in the option and “gasoline” in the question. The remainder chose water or wood.

TABLE 2.6 **Percentages Choosing Each Response:**
Grade 4
Major Source of Gasoline



Response Options

A	B	C	D	Omit
5	2	28	64	1

The percentages of students within each of the achievement level intervals who successfully answered the question are shown in table 2.7. Sixty-six percent of students at the *Basic* level and 82 percent at the *Proficient* level answered the question correctly. Nearly half the students classified as below *Basic* knew the source of gasoline and where it was found.

TABLE 2.7 **Percentages Correct within Each Achievement Level Interval:**
Grade 4
Major Source of Gasoline



Below Basic (0-137)	Basic (138-169)	Proficient (170-203)	Advanced (204-300)
45	66	82	--

-- Sample size insufficient to permit a reliable estimate.

Earth's Surface

The following multiple-choice question measures recall of factual information. It is classified under the earth science topic “Water” and asks specifically whether or not students know that most of the Earth’s surface is covered by water.

7. Most of the Earth’s surface is covered by

- Ⓐ oceans
- Ⓑ lakes
- Ⓒ land
- Ⓓ ice caps

The correct option is A.

The question proved to be somewhat easy (table 2.8). Seventy-eight percent of fourth graders knew that most of Earth's surface is covered by oceans (water). The only other attractive option, perhaps not surprisingly, was land. A few students (four percent) thought that the correct response was lakes or ice caps.

TABLE 2.8 **Percentages Choosing Each Response:**
Grade 4
Earth's Surface



Response Options

A	B	C	D	Omit
78	3	18	1	1

NOTE: Numbers do not add to 100 due to rounding.

The percentages of students within each of the achievement levels that answered the question correctly is shown in table 2.9. The question proved easy for students classified as *Basic* and *Proficient*. Eighty-three percent and 94 percent of students, respectively, knew that most of Earth's surface is covered by oceans.

TABLE 2.9 **Percentages Correct within Each Achievement Level Interval:**
Grade 4
Earth's Surface



Below Basic (0-137)	Basic (138-169)	Proficient (170-203)	Advanced (204-300)
56	83	94	--

-- Sample size insufficient to permit a reliable estimate.

Visibility of Moon from Earth

The next sample multiple-choice question is classified under the earth science topic “Earth in Space.” This question required students to understand that the Moon is visible because it reflects light from the Sun.

7. We can see the Moon from Earth because the Moon
- Ⓐ is so hot that it glows like the Sun
 - Ⓑ reflects light from the Sun
 - Ⓒ has many volcanoes that give off a glowing gas
 - Ⓓ is made of rocks that give off their own light

The correct option is B.

Seventy percent of fourth graders answered the question correctly; however, 20 percent thought that the Moon was made of rocks that gave off their own light (table 2.10).

TABLE 2.10 **Percentages Choosing Each Response:**
Grade 4
Visibility of Moon from Earth 

Response Options

A	B	C	D	Omit
7	70	3	20	1

NOTE: Numbers do not add to 100 due to rounding.

Student performance data show that just over half of students classified as below *Basic*, 70 percent classified as *Basic*, and 87 percent classified as *Proficient* knew that the Moon is visible because it reflects light from the sun.

TABLE 2.11 **Percentages Correct within Each Achievement Level Interval:**
Grade 4
Visibility of Moon from Earth 

Below Basic (0-137)	Basic (138-169)	Proficient (170-203)	Advanced (204-300)
53	70	87	--

-- Sample size insufficient to permit a reliable estimate.

Sources of Smog

In the next multiple-choice question, students were asked to indicate the major sources of smog. The question was designed to measure knowledge relating to “interactions of human society with atmosphere” under the major earth science topic “Air.” Since smog may have been a term that was not familiar to fourth-grade students, several of its properties were mentioned.

8. In some parts of the United States, smog sometimes makes the air seem hazy, even on a sunny day. Smog also makes it hard for some people to breathe. Where does most of the smog in the air come from?

- Ⓐ Factories and automobiles
- Ⓑ Volcanoes and earthquakes
- Ⓒ Forests and farm fields
- Ⓓ Nuclear power plants

The correct option is A.

This question could have been answered by straight recall; however, it could also have been answered by deduction. Students may have known that there are few active volcanoes in the United States and that forests and farm fields are unlikely to give off noxious fumes. Many students would not know about the existence of nuclear power plants unless they lived near one. Some students, however, probably recognized that there are many cars and factories in the United States and deduced that these may be a source of smog.

Information on the percentages of students choosing each response is shown in table 2.12. Fifty-five percent of students knew that most of the smog in air comes from factories and automobiles. Option D proved very attractive to fourth graders, with 22 percent believing that nuclear power plants were the major source of smog.

TABLE 2.12 **Percentages Choosing Each Response:**
Grade 4
Sources of Smog



Response Options

A	B	C	D	Omit
55	10	11	22	2

Table 2.13 shows the achievement-level data. Thirty-nine percent of students classified as below *Basic* and 57 percent of students classified as *Basic* knew that the sources of smog were factories and automobiles.

TABLE 2.13 **Percentages Correct within Each Achievement Level Interval:**
Grade 4
Sources of Smog



Below Basic (0-137)	Basic (138-169)	Proficient (170-203)	Advanced (204-300)
39	57	70	--

-- Sample size insufficient to permit a reliable estimate.

Natural Forces

The following example is an extended constructed-response question that measured concepts relating to “Solid Earth.” It asked students to think about natural forces that change features of Earth’s surface, either quickly or slowly. “Quickly” was defined as a period of days and “slowly” was defined as hundreds of years. To make the question more accessible to students and to allow them to think and respond to each part, the question was formatted to allow each part to be answered in turn. The question was scored using a four-level scoring guide.⁸ To receive a score of *Complete*, a student had to name two natural forces and explain how each changed the Earth’s surface. A score of *Essential* was obtained if a student named two forces and explained how one of them changed Earth’s surface. A score of *Partial* could be obtained in several ways. A student could have named one or two forces or named a force and stated how it changed Earth’s surface. A score of *Unsatisfactory* was given to those student responses that attempted to answer the question but failed to name a correct natural force.

6. Natural forces are always changing features of the Earth’s surface. Some changes happen quickly and some changes happen slowly.

(a) Name one natural force that can change a part of the Earth’s surface over a period of days.

How is the Earth’s surface changed?

(b) Name one natural force that can change a part of the Earth’s surface over a period of hundreds of years.

How is the Earth’s surface changed?

⁸ Appendix B contains scoring guides for the sample questions that appear in this report.

Sample 1: Complete Response

A variety of answers were included in the credited responses for this question. For example, students could have identified volcanoes, earthquakes, storms, or fires for short-term forces and erosion, weathering, or glaciers for long-term forces. In the sample response shown below, the student correctly chose volcanoes as a natural force that can change Earth's surface over a period of days, and rivers as a natural force that can change a part of Earth's surface over hundreds of years. The student also explained how Earth's surface is changed by these forces, specifying ash and lava for volcanoes and the carving of a canyon by a river.

Sample 1: Natural Forces

6. Natural forces are always changing features of the Earth's surface. Some changes happen quickly and some changes happen slowly.

- (a) Name one natural force that can change a part of the Earth's surface over a period of days.

Volcanos make the
earth change by blowing
up.

How is the Earth's surface changed?

The earth's surface
changes by ash, lava.

- (b) Name one natural force that can change a part of the Earth's surface over a period of hundreds of years.

Rivers

How is the Earth's surface changed?

The river will carve
into the rock, just
like the grand canyon.

Sample 2: Essential Response

The next sample response received a score of *Essential*. To receive this score, students had to correctly name a short-term and a long-term force and explain how one of these forces changed Earth's surface. This student identified "earthquake" and "water freezes in cracks." There was, however, no explanation given for the earthquake. The student merely repeated that the "Earth's surface changes." The information given for part (b) was accepted since the student knew that water expands as it freezes and causes cracks to widen.

Sample 2: Natural Forces

5. Natural forces are always changing features of the Earth's surface. Some changes happen quickly and some changes happen slowly.

- (a) Name one natural force that can change a part of the Earth's surface over a period of days.

The ground shaking
alot to cause a
earthquake.

How is the Earth's surface changed?

The Earth's surface changes
sometimes be eathquakes,

- (b) Name one natural force that can change a part of the Earth's surface over a period of hundreds of years.

Up in the mountains
water freezes in cracks
of rock.

How is the Earth's surface changed?

When the water freezes
it expands making the
rock's crack bigger.

Sample 3: Partial Response

The student response shown below indicates one correct force with a satisfactory explanation. The student was given credit for “Earth shack” and “Because it would crack the soil of the Earth.” No credit was given to the second part of the response since the natural force indicated was too vague — “a moutan can.”

Sample 3: Natural Forces

6. Natural forces are always changing features of the Earth’s surface. Some changes happen quickly and some changes happen slowly.

- (a) Name one natural force that can change a part of the Earth’s surface over a period of days.

A Earth shack could.

How is the Earth’s surface changed?

Beacues it would crack the soil of the Earth

- (b) Name one natural force that can change a part of the Earth’s surface over a period of hundreds of years.

A moutan can.

How is the Earth’s surface changed?

The Moutan would grow high.

Sample 4: Unsatisfactory Response

The following response received a score of *Unsatisfactory*. Clearly the student did not understand what natural forces were and chose instead to write about trees.

Sample 4: Natural Forces

6. Natural forces are always changing features of the Earth's surface. Some changes happen quickly and some changes happen slowly.

- (a) Name one natural force that can change a part of the Earth's surface over a period of days.

The trees can get cut down by chain saws.

How is the Earth's surface changed?

All the tree would be cut down and there would be no more trees left.

- (b) Name one natural force that can change a part of the Earth's surface over a period of hundreds of years.

The trees would come back. And tree that have not got cut down would be bigger.

How is the Earth's surface changed?

Animals would be happier that trees wher

Information on student performance is presented in table 2.14. The question proved to be very challenging. Four percent of students were able to name two forces, one long-term and one short-term, and describe how the Earth's surface was changed by these forces. Two percent of students were able to identify two forces and explain how one of them could change Earth's surface. A third of the fourth-grade population were in the *Partial* category, either stating two correct forces or one force and a description. Nearly half the student population was unable to correctly answer any part of the question.

TABLE 2.14 **Percentages at Different Score Levels: Grade 4 Natural Forces** THE NATION'S REPORT CARD 

Complete	Essential	Partial	Unsatisfactory	Omit
4	2	34	49	10

NOTE: Numbers do not add to 100 due to rounding.

The percentage of students at each achievement level attaining a score of *Essential* or better is shown in table 2.15. Zero percent of students who were classified as below *Basic*, 4 percent who were classified as *Basic*, and 14 percent who were classified as *Proficient* were able to name two forces and explain at least one of these forces.

TABLE 2.15 **Percentages Complete or Essential within Each Achievement Level Interval: Grade 4 Natural Forces** THE NATION'S REPORT CARD 

Below Basic (0-137)	Basic (138-169)	Proficient (170-203)	Advanced (204-300)
0	4	14	--

-- Sample size insufficient to permit a reliable estimate.

Pattern of Ripples

The following multiple-choice question addressed vibrations and waves as motion and was classified under the physical science topic "Motion." The question asked students to recognize the pattern of ripples that formed after a small stone was dropped into water. This question proved to be somewhat difficult, as it required students either to remember this phenomenon from past experiences of playing with water or to visualize what would happen when a stone disturbs water.

3. You stand on the end of a boat dock and toss a small stone out into a pond of still water. Ripples form on the surface of the water. Which drawing shows what you will see when you look down at the water? (X marks where the stone enters the water.)

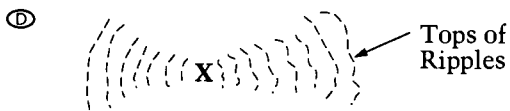
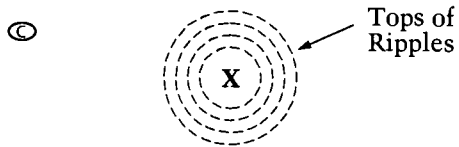
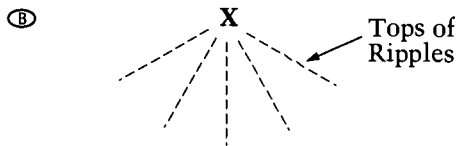
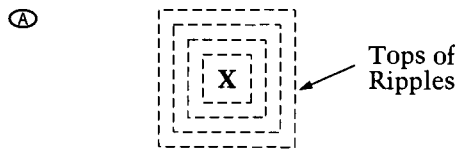

The correct option is C.

Information on student performance is presented in tables 2.16 and 2.17. Fifty-seven percent of fourth graders answered the question correctly. A third of the students knew that the ripples radiated out, but failed to realize that they did so in concentric circles. The 4 percent of students who chose option A understood that the ripples moved out from the stone, but thought that the pattern was in the form of a square. The item proved somewhat easy for students classified as *Proficient*. Seventy-eight percent of these students knew the correct pattern of ripples emanating from a disturbance of pond water.

TABLE 2.16 **Percentages Choosing Each Response:**
Grade 4
Pattern of Ripples THE NATION'S
REPORT
CARD 

Response Options

A	B	C	D	Omit
4	6	57	33	1

NOTE: Numbers do not add to 100 due to rounding.

TABLE 2.17 **Percentages Correct within Each Achievement Level Interval:**
Grade 4
Pattern of Ripples THE NATION'S
REPORT
CARD 

Below Basic (0-137)	Basic (138-169)	Proficient (170-203)	Advanced (204-300)
37	58	78	--

-- Sample size insufficient to permit a reliable estimate.

Mealworm Lifecycle

The following multiple-choice question presented students with a diagram of an insect life cycle and asked them to choose from a set of predictions of what would happen if the larva were eaten by a bird. It was classified under the life science topic “Organisms.”

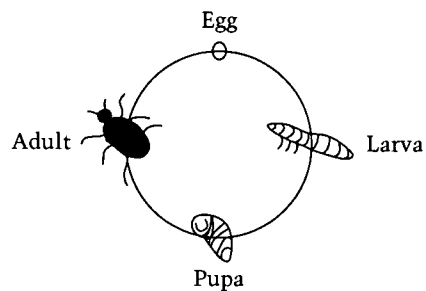

4. The life cycle of a mealworm is pictured above. What would happen if this larva were eaten by a bird?
- Ⓐ The larva would die before it could reproduce.
 - Ⓑ The bird would become sick.
 - Ⓒ The mealworm species would be wiped out.
 - Ⓓ The mealworm eggs would be spread by the bird.

The correct option is A.

Information on student performance is presented in table 2.18. The question was fairly challenging for students; 57 percent answered it correctly. Students found options B and D attractive. Eighteen percent thought that the bird would get sick and 16 percent thought that the mealworm eggs would be spread by the bird. A further eight percent may have thought that the diagram applied to all mealworms, since they believed that the mealworm species would be wiped out.

TABLE 2.18		Percentages Choosing Each Response: Grade 4 Mealworm Life Cycle			THE NATION'S REPORT CARD 
Response Options					
A	B	C	D	Omit	
57	18	8	16	1	

As shown in table 2.19, 57 percent of students classified as *Basic* and 81 percent classified as *Proficient* answered the question correctly.

TABLE 2.19		Percentages Correct within Each Achievement Level Interval: Grade 4 Mealworm Life Cycle			THE NATION'S REPORT CARD 
Below Basic (0-137)	Basic (138-169)	Proficient (170-203)	Advanced (204-300)		
39	57	81	--		

-- Sample size insufficient to permit a reliable estimate.

Plants: Parts and Functions

The extended constructed-response question shown below was designed to measure whether students could identify the major parts of a plant, and give a function for each identified part. The diagram showed a flowering plant, with numbers pointing to a flower, a leaf, and a root. In order to answer this question completely, students had to know the meaning of the word “function” in the context of this question. The question was scored using a four-level scoring guide.⁹ In order to receive a score of *Complete*, students had to name the three plant parts and state a function for each. There were several ways for a student to receive a score of *Essential*. The student could name two or three plant parts and give a function for two of them. A score of *Partial* was given to those responses that named as a minimum one part. A response that was scored as *Unsatisfactory* contained no correct information.

5. Name the parts of the plant below that are labeled 1, 2, and 3. Explain the function of each part.

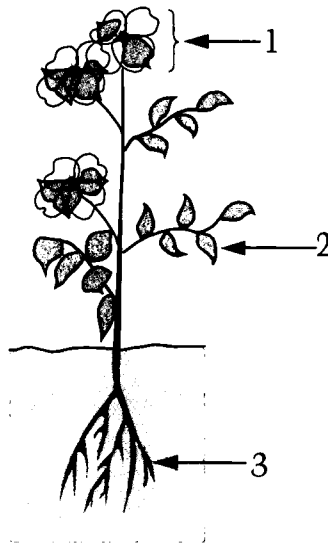

Name of Part

Function

1. _____

2. _____

3. _____

⁹ Appendix B contains scoring guides for the sample questions that appear in this report.

Sample 1: Complete Response

A number of different functions were acceptable for each plant part. For example, students could say that the roots take in water or minerals or that they hold the plant in the soil. Credited responses for the flower ranged from the specific “it has the pollen” to the more general “it makes more life.” In addition, students were given credit for writing “bud” for flower. This student was able to identify the parts of the plant and give a correct function for each.

Sample 1: Plants: Parts and Functions

Name of Part	Function
1. <u>flower</u>	<u>make the plant reproduce</u>
2. <u>leaves</u>	<u>leaves make the food</u>
3. <u>roots</u>	<u>suck up nutrients and water</u>

Sample 2: Essential Response

The next sample response received a score of *Essential*. This student identified the three parts correctly but was only able to give a correct function for the roots, that is, “to hold the plant in place.”

Sample 2: Plants: Parts and Functions

Name of Part	Function
1. <u>flower</u>	<u>It blooms out into a flower</u>
2. <u>leaves</u>	<u>they are grown on sticks</u>
3. <u>root</u>	<u>It is in the soil to perfect the flower to hold the plant in place.</u>

Sample 3: Partial Response

The sample response shown below received a score of *Partial*. It has two parts labeled correctly, “flower” and “ruts.” “Stim” was not credited since the arrow on the diagram is pointing to a leaf. The student did not attempt to state a function for the labeled parts.

Sample 3: Plants: Parts and Functions

	<u>Name of Part</u>	<u>Function</u>
1.	flower	_____
2.	stim	_____
3.	ruts	_____

Sample 4: Unsatisfactory Response

The next response received a score of *Unsatisfactory*. The student did not name any part and appeared to answer the question, “What does it (the flower) do?” with “It grows on it.”

Sample 4: Plants: Parts and Functions

	<u>Name of Part</u>	<u>Function</u>
1.		It grows on it. _____
2.		It stays on the plant. _____
3.		And it doesn't grow. _____

Table 2.20 shows the percentages of students at each score level. Two percent of students received a score of *Complete*. They were able to name the three plant parts and state a function for each. Twenty-seven percent of students received a score of *Essential*. This meant that they could name at least three parts and state one function or name two parts and state two functions. Sixty-five percent of fourth-grade students received a score of *Partial*. They could name at least one plant part or state one function. Three percent of students were unable to name any of the three major parts of a plant or give their function.

TABLE 2.20 **Percentages at Different Score Levels:**
Grade 4
Plants: Parts and Functions

THE NATION'S
REPORT CARD 

Complete	Essential	Partial	Unsatisfactory	Omit
2	27	65	3	4

NOTE: Numbers do not add to 100 due to rounding.

Table 2.21 shows the percentages of students within each of the achievement-level intervals who received a score of *Essential* or better. Twenty-six percent of students classified as *Basic* and 10 percent of students classified as below *Basic* were able to name at least two parts of a plant and state their functions correctly.

TABLE 2.21 **Percentages Complete or Essential within Each**
Achievement Level Interval: Grade 4
Plants: Parts and Functions

THE NATION'S
REPORT CARD 

<i>Below Basic</i> (0-137)	<i>Basic</i> (138-169)	<i>Proficient</i> (170-203)	<i>Advanced</i> (204-300)
10	26	56	--

-- Sample size insufficient to permit a reliable estimate.

Scientific Investigation¹⁰

Thirty-seven questions administered to fourth graders in the NAEP 1996 science assessment measured the knowledge and skills related to scientific investigation. These exercises ranged from testing for discrete skills such as indicating the volume of water in a graduated cylinder to asking students to plan an appropriate investigation. The following examples indicate some of the breadth of this skill area.

Volume

The first multiple-choice question asks students to read a graduated cylinder, a skill that is important when conducting investigations. While the question could have been classified in all three domains, it was classified under the physical science topic “Matter and its Transformations,” since the NAEP science framework specifically states, “Students can use metric devices to measure linear dimensions of objects, weight, volume, and temperature.”¹¹ To answer this question correctly, students had to understand the scale of the cylinder and what each graduation measured.

1. The pictures below show containers with water in them. Which container has 35 milliliters (mL) of water in it?

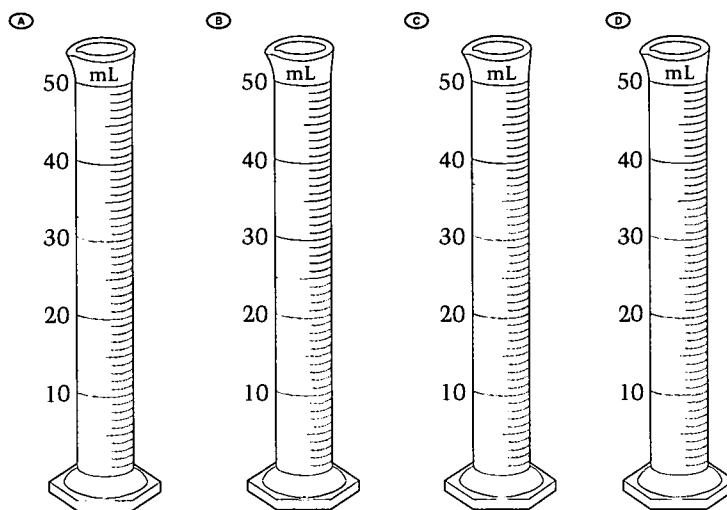

The correct option is D.

¹⁰ See figure 1.2 for a description of scientific investigation.

¹¹ National Assessment Governing Board. (1995). *Science framework for the 1996 National Assessment of Educational Progress*. Washington, DC: Author.

Just over three-quarters of the student population was able to measure the volume correctly (table 2.22). Five percent of students chose option A, and 3 percent chose option C. These students failed to read the graduations correctly. The two percent who chose option B — 25 ml — may have counted down from the 30 ml mark instead of up.

TABLE 2.22 **Percentages Choosing Each Response:**
Grade 4
Volume



Response Options				
A	B	C	D	Omit
5	2	3	76	15

NOTE: Numbers do not add to 100 due to rounding.

The percentage of students within each of the achievement levels that provided a correct response is shown in table 2.23. The question proved to be easy; 82 percent of students classified as *Basic* knew how to read a graduated cylinder. However, the omit rate for this question was high. Fifteen percent of grade 4 students did not attempt to answer the question even though it was the first question in the block.¹²

TABLE 2.23 **Percentages Correct within Each Achievement Level Interval:**
Grade 4
Volume



Below Basic (0-137)	Basic (138-169)	Proficient (170-203)	Advanced (204-300)
55	82	91	--

-- Sample size insufficient to permit a reliable estimate.

¹² A block of questions took 20 minutes to complete. Each student was presented with three blocks.

Bar Graphs

Displaying data in a variety of ways is an important skill in scientific investigation. The sample question below shows a multiple-choice question set in a life science context that asked students to recognize which bar graph represented data shown in a table. To answer this question correctly, students had to ascertain the height of the bar graphs in each option and choose the bar graph that represented the data in the table.

2. Data about the hair color of fifteen students are shown in the table below.

Hair Color			
Red	Black	Brown	Blond
1	5	6	3

Which of the following bar graphs represents the data shown in the table?

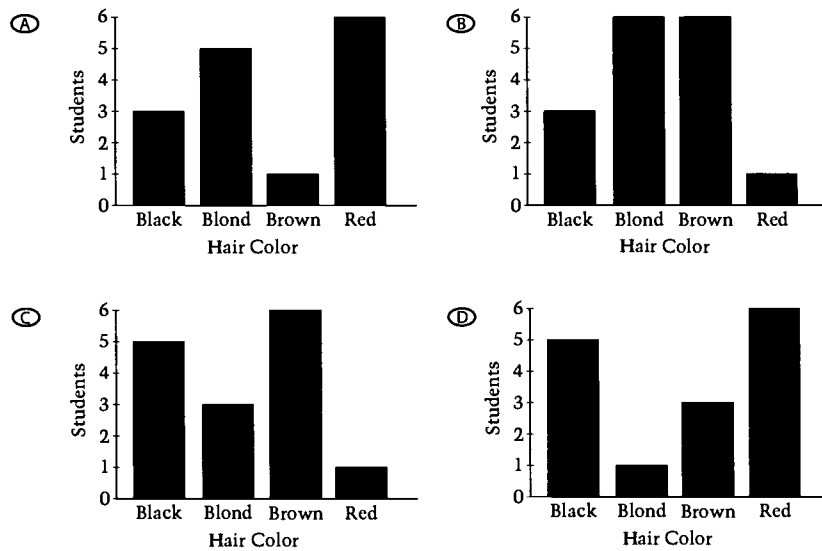

The correct option is C.

Information on student performance is presented in table 2.24, and the percentage of students at each achievement level that chose the correct response is shown in table 2.25. Fourth graders found this question very easy, with 84 percent choosing option C, the correct answer. Four percent chose option A. These students may have failed to look at the scale on the abscissa (the x-axis) and therefore chose the order strictly on the size of the bars, incorrectly viewing one as the highest and six as the lowest. Six percent and three percent of students chose options B and D, respectively. As indicated by the achievement-level data, 89 percent of students that were classified as *Basic* answered the question correctly.



TABLE 2.24		Percentages Choosing Each Response: Grade 4 Bar Graph			THE NATION'S REPORT CARD 
Response Options					
A	B	C	D	Omit	
4	6	84	3	3	

TABLE 2.25		Percentages Correct within Each Achievement Level Interval: Grade 4 Bar Graph			THE NATION'S REPORT CARD 
Below Basic (0-137)	Basic (138-169)	Proficient (170-203)	Advanced (204-300)		
69	89	98	--		

-- Sample size insufficient to permit a reliable estimate.

Experimental Setup

The purpose of this short constructed-response question was to find out whether fourth-grade students could recognize an experimental setup that would answer the question “Do beetles choose to live in bright light or in the shade?” To answer this question correctly, students had to understand that the variable was light versus dark, that the beetles had to be able to move freely from a light to a dark area or vice versa, and that certain other factors had to be controlled.

Three experimental setups were presented to the students, one of which is included here. The two that are not included showed a correct setup with a dish of water on the light and dark sides, and an incorrect setup where there were two separate boxes, one open to the light and the other covered with a lid. Each box in the incorrect setup contained a dish with water; however, there was no way for the beetles to transfer from box to box. Therefore, they could not choose where to live. The question shown below was scored using a three-level scoring guide.¹³ A response received a score of *Complete* if it stated that the experimental design was inappropriate and explained why. To receive a score of *Partial*, the response merely had to state that the experimental setup was inappropriate with an incorrect or no explanation. A score of *Unsatisfactory* was given to responses that contained no correct information.

Questions 9-11

Some fourth-grade students were doing a project for their science class. They were trying to find the answer to the question “Do beetles choose to live in bright light or in the shade?” The next three pictures show the ways that three different students set up an experiment to find out if beetles choose to live in bright light or in the shade.

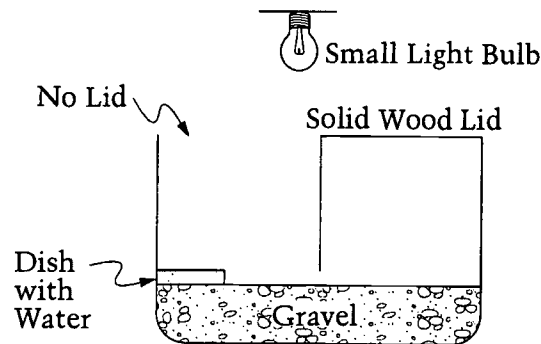

9. Is this a good way to set up this experiment? Tell why or why not.

¹³ Appendix B contains scoring guides for the sample questions that appear in this report.

Samples 1 and 2: Complete Response

Samples 1 and 2 both received full credit. The response indicated in the first sample clearly demonstrates that the student understood that water had to be present in both the light and the dark areas. The second sample response is somewhat different. The student starts by saying, "Yes cause of the wall that blocks the light," which is incorrect. However, the student then states, "But I would put a water dich in the shad to so the water can be on wich ever side he chocesz." The student has, therefore, understood that the conditions have to be identical on each side of the wall. This response was also given a score of *Complete*.

Sample 1: Experiment Setup

9. Is this a good way to set up this experiment? Tell why or why not.

No because it has its water bowl in the light and maybe the beetle likes to be in the shade. How will it get its water?

Sample 2: Experiment Setup

9. Is this a good way to set up this experiment? Tell why or why not.

Yes cause of the wall that blocks the light. But I would put a water dich in the shad to so the water can be on wich ever side he chocesz.

Sample 3: Partial Response

Students in this category answered “no” but were unable to articulate a correct reason for their dissatisfaction with the setup. The student in the sample response thought that the experimental setup was not good because “it just not good for this experiment.”

Sample 3: Experiment Setup

9. Is this a good way to set up this experiment? Tell why or why not.

No I don't think so because
it just not good for this
experiment

Sample 4: Unsatisfactory Response

A student response that received a score of *Unsatisfactory* is shown below. This response, while enthusiastic, simply states what is present in the diagram and makes a judgment about the experiment and not the experimental setup — “So yes I do think it is a good experiment.”

Sample 4: Experiment Setup

9. Is this a good way to set up this experiment? Tell why or why not.

Yes, I think it is a really good
idea because it has a small light
bulb. It has a dish of water
plus it has gravel. So yes I
do think it is a good experiment.

Information on student performance is presented in table 2.26. Twelve percent of students were able to recognize that the setup was incomplete and give a valid explanation. Twenty-seven percent of the student population recognized that the experimental setup was flawed but were unable to justify their decision adequately. Fifty-nine percent of fourth-grade students were unable to recognize that the experimental setup was flawed because it was not adequately controlled.

TABLE 2.26 **Percentages at Different Score Levels:
Grade 4
Experimental Setup** THE NATION'S
REPORT
CARD 

Complete	Partial	Unsatisfactory	Omit
12	27	59	3

NOTE: Numbers do not add to 100 due to rounding.

The percentages of students within each of the achievement levels who successfully answered the question are presented in table 2.27. The item was very difficult; six percent of students classified as *Basic* and one percent classified as below *Basic* were able to judge and explain adequately the correctness of an experimental setup.

TABLE 2.27 **Percentages Complete within Each
Achievement Level Interval: Grade 4
Experimental Setup** THE NATION'S
REPORT
CARD 

Below Basic (0-137)	Basic (138-169)	Proficient (170-203)	Advanced (204-300)
1	6	29	--

-- Sample size insufficient to permit a reliable estimate.

Practical Reasoning¹⁴

In order to do well on questions that measured practical reasoning, students need to remember scientific facts and concepts and apply them. Of the 145 questions that constituted the grade 4 NAEP science assessment, 27 were classified as measuring practical reasoning. A selection of these is shown below.

Radio Malfunction

The following multiple-choice question required students to recognize why a portable radio did not work after being left on all night. It was classified under the physical science topic “Energy and its Transformations.”

1. Kristen was listening to a portable radio one afternoon and forgot to turn it off. The next morning the radio would not work. What is the best explanation for why the radio would not work?
 - Ⓐ All the radio stations stopped broadcasting.
 - Ⓑ The energy stored in the batteries was all used up.
 - Ⓒ It was too cold the next morning for the radio to play.
 - Ⓓ The radio speaker broke because it was left on for so long.

The correct option is B.

¹⁴ See figure 1.2 for a description of practical reasoning.

Many students are familiar with batteries from everyday life, as evidenced by the fact that 85 percent of the grade 4 population answered this question correctly (table 2.28). Very few were attracted to options A and C. Option D, which referred to the radio breaking because it was left on too long, did prove to be attractive to 10 percent of the population. However, given the limited life of batteries, option B was clearly the best explanation. The achievement level data shown in table 2.29 indicate that 90 percent of students classified as *Basic* answered the question correctly.

TABLE 2.28 **Percentages Choosing Each Response:**
Grade 4
Radio Malfunction



Response Options

A	B	C	D	Omit
2	85	2	10	2

NOTE: Numbers do not add to 100 due to rounding.

TABLE 2.29 **Percentages Correct within Each Achievement Level Interval:**
Grade 4
Radio Malfunction



Below Basic (0-137)	Basic (138-169)	Proficient (170-203)	Advanced (204-300)
70	90	96	--

-- Sample size insufficient to permit a reliable estimate.

Properties of Metals

The following short constructed-response question was designed to find out whether fourth-grade students knew any properties of metals. It was classified under the physical science topic “Matter and its Transformations.” The question’s introductory sentence was included to help students focus on familiar metallic objects. They could then use the examples as a springboard for thinking about why metals are used to make different things. A three-level scoring guide was used to score the responses.¹⁵ Students had to record two properties of metals in order to receive a score of *Complete*, one property to receive a score of *Partial*, and no properties to receive a score of *Unsatisfactory*.

10. Many things are made of metal, such as pots, pans, tools, and wire.
Give two reasons why metals are used to make many different things.

¹⁵ Appendix B contains scoring guides for the sample questions that appear in this report.

Sample 1: Complete Response

The first sample response received a score of *Complete*. This student focused on the objects given in the question and indicated a number of properties. Thus the student indicated that “a pot gets warm...it heats the food,” implying conductivity. The student also noted that the tools were both hard and not easy to break and that the wire “easy lets electricity travel through it.”

Sample 1: Properties of Metal

10. Many things are made of metal, such as pots, pans, tools, and wire. Give two reasons why metals are used to make many different things.

Because when a pot gets warm on a stove it heats the food, The metal for a tool is hard, It doesn't break easy. And the wire easy lets electricity travel through it.

Sample 2: Partial Response

Students who achieved the score of *Partial* recorded one correct property. In the example, the student stated that “Metal is a good conductor.”

Sample 2: Properties of Metal

10. Many things are made of metal, such as pots, pans, tools, and wire. Give two reasons why metals are used to make many different things.

Metal is a good conductor

Sample 3: Unsatisfactory Response

The following response clearly demonstrates that the student did not understand what the question was asking. The reason the student gave is that if “they don do pots, pans, tools, wire, din we we’ll not have nothing.” In other words, if they don’t make them out of metal then we won’t have any.

Sample 3: Properties of Metal

10. Many things are made of metal, such as pots, pans, tools, and wire.
Give two reasons why metals are used to make many different things.

*It they don do pots, pans,
tools, wire din we we'll not
have nothing.*

Data for student performance are shown in tables 2.30 and 2.31. Nineteen percent of fourth graders were able to think of at least two properties. Thirty-four percent of students were able to think of one property. Forty percent of fourth graders were unable to think of any reason why metals are used to make many different things. A further six percent of students omitted the question. Approximately one-third of students classified as *Proficient* received a score of *Complete*. However, students classified as *Basic* and below *Basic* found the item challenging; 18 percent and 6 percent, respectively, answered the question fully.

TABLE 2.30 **Percentages at Different Score Levels:**
Grade 4
Properties of Metals THE NATION'S
REPORT
CARD 

Complete	Partial	Unsatisfactory	Omit
19	34	40	6

NOTE: Numbers do not add to 100 due to rounding.

TABLE 2.31 **Percentages Complete within Each**
Achievement Level Interval: Grade 4
Properties of Metals THE NATION'S
REPORT
CARD 

<i>Below Basic</i> (0-137)	<i>Basic</i> (138-169)	<i>Proficient</i> (170-203)	<i>Advanced</i> (204-300)
6	18	35	--

-- Sample size insufficient to permit a reliable estimate.

Theme Block

Three of the fifteen 20-minute blocks of questions at the fourth-grade level address each of the three themes — systems, models, and patterns of change — outlined in the *Science Framework for the 1996 National Assessment of Educational Progress*.¹⁶ Not every student in the assessment was administered one of these theme blocks and no student was administered more than one. These blocks of questions differed from others in the assessment in that they probed deeply into students' understanding of a given area of science — such as life cycles — whereas most blocks usually did not devote more than one or two questions to any given topic.

The eight questions based on the theme “patterns of change” have been released to the public and can be found on the Internet.¹⁷ Students were presented with information relating to Ms. Brown's fourth-grade class (see below). Ms. Brown told her class that she would put the pond water and frogs' eggs she had collected into a fish tank and then they could all watch as the eggs developed into tadpoles and frogs. The students were then asked two questions that related to the life cycles of frogs and a third that asked how tadpoles and frogs got oxygen into their bodies. The remaining five questions, of which three are presented here, addressed the life cycles of a number of other animals such as salamanders and butterflies.

Questions 1-8 refer to the life cycles of different animals.

One day Ms. Brown brought a bucket of pond water to her fourth-grade class. In the bucket were several clumps of frogs' eggs—and there were many eggs in each clump, as you can see in Picture 1. “We'll put these eggs and the pond water into the fish tank on the table in the back of the room,” said Ms. Brown, “and soon these eggs will hatch into tadpoles. Then we can watch as the tadpoles grow and change into frogs.”

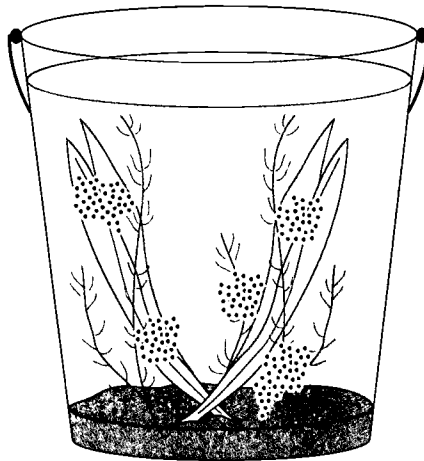

Picture 1

¹⁶ National Assessment Governing Board. (1995). *Science framework for the 1996 National Assessment of Educational Progress*. Washington, DC: Author.
See figure 1.3 for a description of themes.

¹⁷ National Center for Education Statistics: National Assessment of Educational Progress. (1997). *1996 science assessment public release, grade 4* [On-line]. Available: <http://nces.ed.gov/naep>.

Theme Block: Metamorphosis

The question depicted below asks students to recognize the missing stage of the life cycle of a butterfly. Since the pupal stage varies in appearance depending on the species, the diagram was scored somewhat leniently. In addition, three labels were accepted — pupa, chrysalis, and cocoon. The question was scored according to a three-level scoring guide.¹⁸ To receive a score of *Complete*, students had to both draw and label the missing part of the life cycle. A drawing or a diagram gave the student a score of *Partial*. Students who received a score of *Unsatisfactory* attempted the question but were unable to draw or label the missing part.

5. Insects also change as they grow. Look at the picture below. One part of the picture is missing. Draw and label the missing part of the picture.

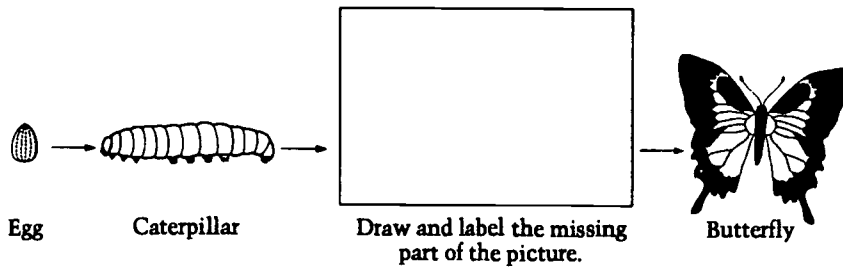

¹⁸ Appendix B contains scoring guides for the sample questions that appear in this report.

Sample 1: Complete Response

The following sample response received a score of *Complete*. This student was able to draw and label the missing part as “the cocoon.”

Sample 1: Metamorphosis

5. Insects also change as they grow. Look at the picture below. One part of the picture is missing. Draw and label the missing part of the picture.

The diagram illustrates the life cycle of a butterfly. It starts with an 'Egg', followed by a 'Caterpillar'. An arrow points to a box containing a hand-drawn cocoon, which is labeled 'the cocoon'. Below the box is the instruction 'Draw and label the missing part of the picture.' Another arrow points from the cocoon to a 'Butterfly'.

Sample 2: Partial Response

The next sample response received a score of *Partial*. This student was able to draw the missing part but did not label it. While the diagram does look somewhat like the caterpillar, the fact that it is hanging from what looks like a twig indicates that it is probably the pupal stage. Students could also receive a *Partial* score for a correct label with a missing or incorrect diagram. Most students, however, did attempt a diagram.

Sample 2: Metamorphosis

5. Insects also change as they grow. Look at the picture below. One part of the picture is missing. Draw and label the missing part of the picture.

The diagram illustrates the life cycle of a butterfly. It starts with an 'Egg', followed by a 'Caterpillar'. An arrow points to a box containing a hand-drawn pupa hanging from a twig. Below the box is the instruction 'Draw and label the missing part of the picture.' Another arrow points from the pupa to a 'Butterfly'.

Sample 3: Unsatisfactory Response

The following sample response received a score of *Unsatisfactory*. This student drew an “egg” and labeled it.

Sample 3: Metamorphosis

5. Insects also change as they grow. Look at the picture below. One part of the picture is missing. Draw and label the missing part of the picture.

The diagram shows a sequence of four stages in the butterfly life cycle, connected by arrows from left to right. The first stage is an oval labeled 'Egg'. The second stage is a segmented caterpillar labeled 'Caterpillar'. The third stage is a square box containing a drawing of an egg and the handwritten label 'egg'. Below the box is the text 'Draw and label the missing part of the picture.' The fourth stage is a butterfly labeled 'Butterfly'.

The question was of average difficulty; 51 percent of students received a score of *Complete* (table 2.32). Thirty-seven percent of students received a score of *Partial*. Nine percent of students were unable to draw or label the missing pupa.

TABLE 2.32 Percentages at Different Score Levels: Grade 4 Metamorphosis THE NATION'S REPORT CARD

Complete	Partial	Unsatisfactory	Omit
51	37	9	4

NOTE: Numbers do not add to 100 due to rounding.

Achievement level data shown in table 2.33 indicate that 74 percent of students classified as *Proficient* answered the question correctly. Twenty-four percent of students classified as below *Basic* were also able to draw and label the missing stage of the butterfly life cycle.

TABLE 2.33 Percentages Complete within Each Achievement Level Interval: Grade 4 Metamorphosis THE NATION'S REPORT CARD

Below Basic (0-137)	Basic (138-169)	Proficient (170-203)	Advanced (204-300)
24	56	74	--

-- Sample size insufficient to permit a reliable estimate.

Theme Block: Grasshoppers and Butterflies

The next question in the theme block showed students the life cycle of a grasshopper. They were asked to compare the life cycle of this organism to that of a butterfly. This question was scored using a four-level scoring guide.¹⁹ In order to receive a score of *Complete*, students had to indicate at least two differences and one similarity or one difference and two similarities between the life cycle of a grasshopper and the life cycle of a butterfly. A score of *Essential* was given to responses that included two differences or similarities or one difference and one similarity. A score of *Partial* was given to responses that contained just one correct difference or similarity. Responses receiving a score of *Unsatisfactory* provided no appropriate information.

The question was somewhat difficult to score since students tended to be repetitious and scorers had to decide when something new was being stated. Also, many students wrote about things that the organisms do such as flying and hopping. Such answers were not credited.

¹⁹ Appendix B contains scoring guides for the sample questions that appear in this report.

6. The picture below shows the life cycle of a grasshopper.

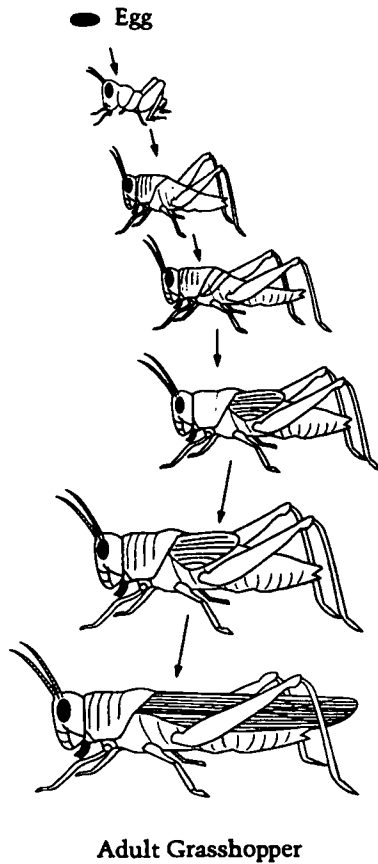

Tell one way that the grasshopper's life cycle is different from the butterfly's life cycle.

Tell one way that the grasshopper's life cycle is the same as the butterfly's life cycle.

Tell some other ways that the grasshopper's and the butterfly's life cycles are similar and different from each other.

Sample 1: Complete Response

The following student response indicated a number of differences and similarities. This student recognized that the grasshopper got bigger, whereas the butterfly changed in appearance. The student stated that “both of them are eggs first.” This was the most popular student response for describing a way that the grasshopper’s life cycle is the same as the butterfly’s life cycle. The student added that both go through “many stages” and that the grasshopper “has more stages to go through.”

Sample 1: Grasshoppers and Butterflies

Tell one way that the grasshopper’s life cycle is different from the butterfly’s life cycle.

Because all of its
it look the same but
it just gets bigger. Other
then the butterfly it changes
the way it looks.

Tell one way that the grasshopper’s life cycle is the same as the butterfly’s life cycle.

Both of them are
eggs first. They also
go through many
stages.

Tell some other ways that the grasshopper’s and the butterfly’s life cycles are similar and different from each other.

The way that they
are similar is that they
both turn to bigger things,
they are a egg first, and
both have antenns. They
are different by the grasshopp
has more stages to go throught
the butterfly is first a catapiller
then it turns into a cocannon

Sample 2: Essential Response

The student in the response shown below indicates that grasshoppers “do not wrap up there body,” presumably referring to the presence of a cocoon. In addition, the student stated that they “both hatched out of a egg.” The additional differences and similarities were discounted since these referred to actions of the organisms.

Sample 2: Grasshoppers and Butterflies

Tell one way that the grasshopper's life cycle is different from the butterfly's life cycle.

They do not wrap up
there body.

Tell one way that the grasshopper's life cycle is the same as the butterfly's life cycle.

They both hatched out of
a egg

Tell some other ways that the grasshopper's and the butterfly's life cycles are similar and different from each other.

They both can fly and
walk on two or four
legs.

Sample 3: Partial Response

The next response indicated one difference that was accepted. This student recognized that the grasshopper came from an egg, whereas the butterfly developed from something that looked different, that is “a warm.”

Sample 3: Grasshoppers and Butterflies

Tell one way that the grasshopper's life cycle is different from the butterfly's life cycle.

Because the butterfly comes from
a warm. The grasshopper comes from
egg.

Tell one way that the grasshopper's life cycle is the same as the butterfly's life cycle.

No because the grasshopper it doesn't
come from a warm the butterfly do
come from the warm.

Tell some other ways that the grasshopper's and the butterfly's life cycles are similar and different from each other.

Sample 4: Unsatisfactory Response

The student response shown below received a score of *Unsatisfactory*. Clearly the student did not understand what the question was asking.

Sample 4: Grasshoppers and Butterflies

Tell one way that the grasshopper's life cycle is different from the butterfly's life cycle.

The caterpillar took into a butterfly
then took in a grasshopper.

Tell one way that the grasshopper's life cycle is the same as the butterfly's life cycle.

The grasshopper hoppers and the
butterfly flies.

Tell some other ways that the grasshopper's and the butterfly's life cycles are similar and different from each other.

The butterfly can go near water
and can too.

Information relating to the percentages of students at different score levels is shown in table 2.34. Eighty percent of students were able to state at least one difference or one similarity between the life cycle of a grasshopper and the life cycle of a butterfly. Sixteen percent of students were able to describe at least two differences and one similarity or one difference and two similarities.

TABLE 2.34 **Percentages at Different Score Levels:**
Grade 4
Grasshoppers and Butterflies THE NATION'S
REPORT
CARD 

Complete	Essential	Partial	Unsatisfactory	Omit
16	34	30	19	0

NOTE: Numbers do not add to 100 due to rounding.

The percentages of students at each achievement level who received a score of *Complete* or *Essential* are shown in table 2.35. Students who were classified as below *Basic* found the question challenging, as evidenced by the four percent who were able to name at least two differences or two similarities or one difference and one similarity.

TABLE 2.35 **Percentages Complete or Essential within Each**
Achievement Level Interval: Grade 4
Grasshoppers and Butterflies THE NATION'S
REPORT
CARD 

Below Basic (0-137)	Basic (138-169)	Proficient (170-203)	Advanced (204-300)
4	17	30	--

-- Sample size insufficient to permit a reliable estimate.

Theme Block: Life Cycles

The question shown below was the last question in the theme block. It asked students to decide whether the human life cycle is more like a frog's life cycle or a grasshopper's life cycle. To answer the question successfully, students had to synthesize information that had been presented to them earlier in the block in the form of a diagram of the life cycle of a grasshopper and a number of questions relating to the frog's life cycle. Students were also given additional information to help clarify what constituted a human life cycle. Their responses were scored according to a two-level scoring guide as either *Complete* or *Unsatisfactory*.²⁰ Students who received a score of *Complete* were able to justify their choice of organisms satisfactorily.

8. Think about how humans grow and develop from newborn babies to adults. Is a human's life cycle more like a frog's life cycle or more like a grasshopper's life cycle? Explain your answer.

Sample 1: Complete Response

The student writing this sample response clearly understood the purpose of the question. The student stated "grasshoppers because they keep growing." Although the explanation was somewhat general, the student did add that the "frog changes into different things."

Sample 1: Life Cycles

8. Think about how humans grow and develop from newborn babies to adults. Is a human's life cycle more like a frog's life cycle or more like a grasshopper's life cycle? Explain your answer.

More like a grasshoppers
because they keep
growing. a frog changes
into different things.

²⁰ Appendix B contains scoring guides for the sample questions that appear in this report.

Samples 2 and 3: Unsatisfactory Response

In the first *Unsatisfactory* response sample, the student chose “frog” and explained this choice on the basis of the statement “when we are in are mothers stomak,” thus discounting the information concerning “newborn babies to adults.” In the second *Unsatisfactory* response sample, the student chose to describe the human life cycle, thus responding to the first sentence in the question. Since there was no *Partial* score for this question, a response that indicated the correct organism but gave an incorrect explanation was scored as *Unsatisfactory*.

Sample 2: Life Cycles

8. Think about how humans grow and develop from newborn babies to adults. Is a human's life cycle more like a frog's life cycle or more like a grasshopper's life cycle? Explain your answer.

We are more like a frog because the frog when it hatches it grows legs and arms the same as when we are in are mothers stomak.

Sample 3: Life Cycles

8. Think about how humans grow and develop from newborn babies to adults. Is a human's life cycle more like a frog's life cycle or more like a grasshopper's life cycle? Explain your answer.

Human cycle is when a baby is born and it grows up and is a kid then teenager. Next an adult and turns old, then dies.

Information relating to performance data is shown in tables 2.36 and 2.37. The question was challenging. Nineteen percent of fourth graders received a score of *Complete*. Achievement level data indicate that 38 percent of students classified as *Proficient* were able to explain how the human life cycle was more like a grasshopper life cycle than a frog life cycle.

TABLE 2.36 *Percentages at Different Score Levels: Grade 4 Life Cycles* THE NATION'S REPORT CARD 

Complete	Unsatisfactory	Omit
19	80	1

TABLE 2.37 *Percentages Complete within Each Achievement Level Interval: Grade 4 Life Cycles* THE NATION'S REPORT CARD 

Below Basic (0-137)	Basic (138-169)	Proficient (170-203)	Advanced (204-300)
4	13	38	--

-- Sample size insufficient to permit a reliable estimate.

Hands-on Task

Four hands-on tasks were administered in the NAEP fourth-grade science assessment. Each task asked students to use materials to perform an investigation, make observations, record and evaluate experimental results, and apply problem-solving skills.

The first page of one of the four tasks presented to students is shown below. An instrument constructed from a pencil and thumbtack served as a hydrometer in this task. Students were asked to observe, measure, and compare the lengths of a portion of pencil, marked with calibrations for ease of measurement, that floated above the water surface in fresh water and in salt water. The students then determined if the unknown sample was fresh water or salt water and predicted how the addition of more salt to the salt solution would affect the floating pencil.

The task assessed students' abilities to make simple observations, measure volume using a graduated cylinder, measure length using a ruler, apply observations and measurement to test an unknown, make generalized inferences from observations, and apply understanding to an everyday situation. The task, scoring guides for each question, and sample student responses can be found on the Internet.²¹

FLOATING PENCIL

Using a Pencil to Test Fresh and Salt Water

You have been given a bag with some things in it that you will work with during the next 20 minutes. Take all of the things out of the bag and put them on your desk. Now look at the picture below. Do you have everything that is shown in the picture? If you are missing anything, raise your hand and you will be given the things you need.



Pencil with
Thumb Tack
in Eraser



Bottle of
Fresh Water

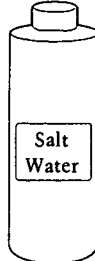

Bottle of
Salt Water



Bottle of
Mystery Water



Red
Marker

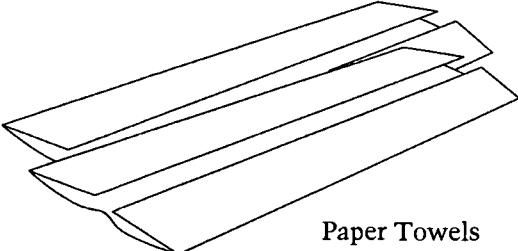

Paper Towels



Plastic Bowl

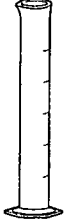

Graduated
Cylinder

²¹ National Center for Education Statistics. National Assessment of Educational Progress. (1997). *1996 science assessment public release, grade 4* [On-line]. Available: <http://nces.ed.gov/naep>.

Hands-on Task: Mystery Water

The short-constructed-response question shown below appeared toward the end of the task, after students had measured the height of the pencil above the surface of the fresh water, salt water, and mystery water. Students were then asked to identify the “mystery water” and justify their answers. The question was scored using a three-level scoring guide.²² Students received a score of *Complete* if they correctly identified the water and justified their choice. To receive a score of *Partial*, students had only to state the identity of the mystery water. A score of *Unsatisfactory* was given to responses that misidentified the mystery water.

10. **Is the mystery water fresh water or is it salt water?**

How can you tell what the mystery water is?

²² Appendix B contains scoring guides for the sample question that appear in this report.

Samples 1 and 2: Complete Response

The sample responses below both received a score of *Complete*. Both responses state that the mystery water was fresh water and correctly relate the answer to the height of the pencil above the solutions.

Sample 1: Mystery Water

10. Is the mystery water fresh water or is it salt water?

Fresh water

How can you tell what the mystery water is?

The pencil floated at the same level in the mystery water as the fresh water.

Sample 2: Mystery Water

10. Is the mystery water fresh water or is it salt water?

fresh

How can you tell what the mystery water is?

The pencil came as high as it did in fresh water.

Sample 3: Partial Response

In the example shown below, the student indicates fresh water and justifies this answer by stating “because it do not have salt and it.” This answer did not relate to the task and therefore received no credit.

Sample 3: Mystery Water

10. Is the mystery water fresh water or is it salt water?

fresh water

How can you tell what the mystery water is?

because it do not have salt and
it

Sample 4: Unsatisfactory Response

The following response received a score of *Unsatisfactory*. The student chose salt water, which was incorrect, and justified the answer without referring to the task.

Sample 4: Mystery Water

10. Is the mystery water fresh water or is it salt water?

salt water

How can you tell what the mystery water is?

slt is saltier then the
fresh water,

The percentages of students receiving various scores are shown in table 2.38. Twenty-eight percent of fourth graders were able to identify the mystery water as fresh water and correctly explain their choice. Forty-five percent of grade 4 students were able to identify the mystery water as fresh water but were not able to justify their selection adequately. Twenty-seven percent of students were unable to identify the water correctly.

TABLE 2.38 **Percentages at Different Score Levels: Grade 4 Mystery Water** 

Complete	Partial	Unsatisfactory	Omit
28	45	27	1

NOTE: Numbers do not add to 100 due to rounding.

When results are presented by achievement level (table 2.39), 21 percent of students classified at the *Basic* level and 49 percent classified at the *Proficient* level answered the question correctly.

TABLE 2.39 **Percentages Complete within Each Achievement Level Interval: Grade 4 Mystery Water** 

Below Basic (0-137)	Basic (138-169)	Proficient (170-203)	Advanced (204-300)
5	21	49	--

-- Sample size insufficient to permit a reliable estimate.

Hands-on Task: Ease of Floating

The question shown below was the last one in the task. Students were expected to relate the experiences encountered when doing the task to a practical situation. Thus, students were asked to consider whether it was easier to stay afloat in the ocean or in fresh water. They had already been told at the beginning of the task that “fresh water has very little salt in it and is quite different from salt water, which is found in oceans.” They did not have to bring into the assessment the knowledge that oceans are salty. The question was scored using a three-level scoring guide.²³ In order to receive a score of *Complete* on this question, students had to state “ocean” and present an explanation that referred back to the hands-on task. A response that merely stated “ocean water” received a score of *Partial*. Students who did not relate the concept of density to floating in salt water versus fresh water received a score of *Unsatisfactory*.

11. When people are swimming, is it easier for them to stay afloat in the ocean or in a freshwater lake?

Explain your answer.

Sample 1: Complete Response

The following response received a score of *Complete*. The student correctly indicates “ocean,” states that the ocean contains salt, and explains the choice in terms of the pencil floating higher in salt water than in fresh water.

Sample 1: Ease of Floating

11. When people are swimming, is it easier for them to stay afloat in the ocean or in a freshwater lake?

_____ ocean _____

Explain your answer.

The ocean has salt water and the pencil stayed higher a float in salt water than fresh water.

Sample 2: Partial Response

In the following sample response, the student stated “the ocen,” which is correct; however, the explanation was too general. Thus the response received a score of *Partial*.

Sample 2: Ease of Floating

11. When people are swimming, is it easier for them to stay afloat in the ocean or in a freshwater lake?

_____ the ocen _____

Explain your answer.

salt is in the ocean.
salt makes things float.

Sample 3: Unsatisfactory Response

Responses in the *Unsatisfactory* category identified the mystery water as fresh water and very often gave a justification that was related to experience. This student chose fresh water because “the water won’t burn the eyes as much,” thus answering the question, “which water do you prefer to swim in and why?”

Sample 3: Ease of Floating

11. When people are swimming, is it easier for them to stay afloat in the ocean or in a freshwater lake?

freshwater lake.

Explain your answer.

because the water won't burn the eyes as much.

Data relating to student performance are shown in tables 2.40 and 2.41. Fourteen percent of fourth graders were able to use the results from the experiment in a real-world situation. Twenty-nine percent of grade 4 students chose the correct answer but failed to explain it adequately. Thus they received a score of *Partial*. Fifty-six percent of grade 4 students were unable to answer the question.

TABLE 2.40 **Percentages at Different Score Levels:**
Grade 4
Ease of Floating THE NATION'S
REPORT CARD 

Complete	Partial	Unsatisfactory	Omit
14	29	56	1

Students found this item very difficult, as evidenced by the achievement level data (table 2.41). Ten percent of students classified as *Basic* and two percent classified as below *Basic* received a score of *Complete* for the question.

TABLE 2.41 **Percentages Complete within Each**
Achievement Level Interval: Grade 4
Ease of Floating THE NATION'S
REPORT CARD 

Below Basic (0-137)	Basic (138-169)	Proficient (170-203)	Advanced (204-300)
2	10	22	--

-- Sample size insufficient to permit a reliable estimate.

Summary of Grade 4 Data

The data presented in this chapter give an indication of how students in grade 4 perform on science questions that cover a range of topics and make use of a variety of question types. The questions presented had to be limited to those that were released to the public.²⁴ However, these are fairly representative and do give an indication of the understandings and skills surveyed in the assessment. Similarly, the data for the small group of questions discussed in this chapter represent the data seen for the questions as a whole. In general, students found questions that asked them to construct their own responses more difficult than questions that allowed them to choose the answer from a set of options.

- The amount of exposure to earth science, physical science, and life science was not associated with differences in the scale scores of students in these fields. For example, students whose teachers reported that they spent little time on life science performed as well on life science questions as did students whose teachers reported that they spent a lot of time on life science.
- Male students had a higher average question score than female students for the earth science questions.
- White students had a higher average question score than Black and Hispanic students for the earth, physical, and life science questions.
- Male students had a higher average question score than female students for questions that measured conceptual understanding.
- White students had a higher average question score than Black and Hispanic students for questions that measured conceptual understanding, scientific investigation, and practical reasoning.
- For the questions presented in this chapter, the percentage of students who gave correct responses to the multiple-choice questions ranged from 55 percent to 85 percent.
- For the questions presented in this chapter, the percentage of students who received a score of *Complete* on the constructed-response questions ranged from 2 percent to 51 percent.

²⁴ National Center for Education Statistics. National Assessment of Educational Progress. (1997). *1996 science assessment public release, grade*. [On-line]. Available; <http://nces.ed.gov/naep>.

Chapter 3

Grade 8: Performance, Knowledge, and Skills

Introduction

Science instruction in the early years in school tends to be general. However, as students enter middle school there is a tendency for science to be taught in the fields of earth, physical, or life. Evidence for this tendency can be found from data collected from students during the NAEP 1996 science assessment. These data indicated that approximately 63 percent of grade 8 students were taking a science course that was field specific. The remainder reported taking either general science or integrated science.¹

Since the types of science courses and the order in which students take them vary from district to district, the NAEP science assessment surveys grade-appropriate content from earth, physical, and life science. The data collected can then be analyzed to ascertain, for example, how students would perform if given only physical science questions or only life science questions. This chapter discusses the results of such analyses and also presents questions and student responses from the three fields of science — earth, physical, and life.

The NAEP science survey that was administered in 1996 to students in grade 8 was constructed according to specifications outlined in the *Science Framework for the 1996 National Assessment of Educational Progress*.² The specifications state that 40 percent of assessment time should cover life science, 30 percent earth science, and 30 percent physical science. The framework also specifies that 45 percent of assessment time should be spent on questions that measure conceptual understanding, 30 percent on scientific investigation questions, and 25 percent on practical reasoning questions. (A description of the various categories is presented in chapter 1.) Like questions in the fourth-grade assessment, every grade 8 question was classified as measuring one of the ways of knowing and doing science within one of the fields of science (for example, conceptual understanding in the context of earth science).

¹ O'Sullivan, C. Y., Weiss, A. R., & Askew, J. M. (1998). *Students learning science: A report on policies and practices in U.S. schools*. (NCES Publication No. 98-496). Washington, DC: National Center for Education Statistics.

² National Assessment Governing Board. (1995). *Science framework for the 1996 National Assessment of Educational Progress*. Washington, DC: Author.

The number of multiple-choice, short constructed-response, and extended constructed-response questions in each of the major areas is presented in table 3.1, as is the total number of questions. There were 74 multiple-choice questions and 120 constructed-response questions in the grade 8 assessment. Each constructed-response question had its own unique scoring guide that defined the criteria used to evaluate students' responses. Short constructed-response questions were usually scored according to three levels of performance: *Complete*, *Partial*, or *Unsatisfactory*; however, some of them were scored as either right or wrong (*Complete* or *Unsatisfactory*). Extended constructed-response questions were usually scored according to four levels of performance: *Complete*, *Essential*, *Partial*, or *Unsatisfactory*. In a few instances, however, five- and six-level scoring guides were used. In total, 322,261 student responses to constructed-response questions were scored. This included the responses that were scored twice to monitor the reliability of the scoring process — 25 percent of responses for national NAEP.³ Appendix A describes the scoring process in more detail.

TABLE 3.1 *Distribution of Questions by Fields of Science and by Ways of Knowing and Doing Science, Grade 8: Public and Nonpublic Schools Combined*



	Multiple-Choice	Short Constructed-Response	Extended Constructed-Response	Total
Fields of Science				
Earth Science	26	35	4	65
Life Science	24	36	6	66
Physical Science	24	29	10	63
Total	74	100	20	194
Knowing and Doing				
Conceptual Understanding	59	48	3	110
Scientific Investigation	8	19	11	38
Practical Reasoning	7	33	6	46
Total	74	100	20	194

SOURCE: National Center for Education Statistics, National Assessment of Educational Progress (NAEP), 1996 Science Assessment.

³ For grade 8, the percentage agreement for the 1996 reliability sample was 94. This means that scores given by the first and second scorers agreed 94 percent of the time.

Grade 8 Science Teaching Content

As part of the NAEP 1996 science assessment, teachers of eighth-grade students were asked to specify how much time they spent teaching earth, physical, and life science. Teachers were presented with the response options "A Lot," "Some," "Little," and "None." The results are shown in table 3.2.

Forty-one percent of eighth-grade students were taught by teachers who reported spending a lot of time teaching earth science and 49 percent were taught by teachers who reported spending a lot of time teaching physical science. Nine percent had teachers who indicated that they had not taught earth science and four percent had teachers who indicated they had not taught physical science. About the same percentage of students had teachers who said that they spent a lot of time teaching life science (19 percent) as who said they spent no time teaching it (18 percent). The amount of exposure to the different fields of science showed no relationship with the composite (all fields of science combined), life science, earth science, or physical science average scale scores of students or the percentage of students at or above *Proficient*.

TABLE 3.2

Teachers' Reports on How Much Time They Spent Teaching Life Science, Earth Science, and Physical Science, Grade 8: Public and Nonpublic Schools Combined



In this class, about how much time do you spend on each of the following areas in science?	Percentage of Students	Average Scale Score				Percentage At or Above Proficient
		Composite (all fields)	Life Science	Earth Science	Physical Science	
Life Science						
A Lot	19	149	148	149	150	28
Some	40	150	151	150	150	29
Little	23	156	155	157	155	34
None	18	157	159	156	155	35
Earth Science						
A Lot	41	151	151	152	150	30
Some	39	151	151	152	152	30
Little	11	155	157	152	155	36
None	9	157	161	155	155	34
Physical Science						
A Lot	49	153	153	152	153	32
Some	35	153	153	153	152	32
Little	12	154	153	156	152	32
None	4	144	149	143	139	21

SOURCE: National Center for Education Statistics, National Assessment of Educational Progress (NAEP), 1996 Science Assessment.

Average Question Score

The average question score for questions measuring earth science, physical science, and life science was 0.38, 0.42, and 0.35, respectively (Table 3.3). Readers are cautioned not to make comparisons among the fields of science for any group of students. Variations may, for example, be due to the particular make-up of the set of questions administered and could well not hold if students were administered a different set of questions covering the same fields of science. Comparisons can be made, however, among the different reporting groups within each field of science. Several significant differences were found. Male students outperformed female students on both the physical science questions and the earth science questions. On questions that measured physical science or earth science, White students and Asian/Pacific Islander students outperformed Black and Hispanic students, and Hispanic students outperformed Black students. In addition, on questions that measured physical science, White students outperformed Asian/Pacific Islander students. On the questions that measured life science, White and Asian/Pacific Islander students outperformed both Black and Hispanic students.

TABLE 3.3

**Average Question Score for Earth Science,
Physical Science, and Life Science, Grade 8:
Public and Nonpublic Schools Combined**



	Earth Science	Physical Science	Life Science
All Students	0.38	0.42	0.35
Male	0.39	0.44	0.35
Female	0.37	0.41	0.35
White	0.42	0.46	0.38
Black	0.24	0.30	0.27
Hispanic	0.28	0.34	0.28
Asian/Pacific Islander	0.39	0.42	0.36

NOTE: There were insufficient sample sizes for the American Indian racial/ethnic subgroup to produce reliable results.

NOTE: White refers to White (not Hispanic), Black refers to Black (not Hispanic).

SOURCE: National Center for Education Statistics, National Assessment of Educational Progress (NAEP), 1996 Science Assessment.

Table 3.4 shows the average question score for questions that measured conceptual understanding, scientific investigation, and practical reasoning. For all students, the average question score was 0.39 for questions that measured conceptual understanding, 0.46 for questions that measured scientific investigations, and 0.30 for questions that measured practical reasoning. Again, readers are cautioned not to compare performance among the ways of knowing and doing science, since student performance may have varied if different sets of questions had comprised these categories. When the data for the different groups of students within each way of knowing and doing science are examined, however, several differences emerge. Male students outperformed female students for questions that measured conceptual understanding. For questions that measured conceptual understanding and scientific investigation, White students and Asian/Pacific Islander students outperformed Black and Hispanic students, and Hispanic students outperformed Black students. For questions that measured practical reasoning, White students outperformed Black and Hispanic students and Hispanic students outperformed Black students.

TABLE 3.4

Average Question Score for Conceptual Understanding, Scientific Investigation, and Practical Reasoning, Grade 8: Public and Nonpublic Schools Combined



	Conceptual Understanding	Scientific Investigation	Practical Reasoning
All Students	0.39	0.46	0.30
Male	0.40	0.46	0.31
Female	0.38	0.46	0.30
White	0.43	0.50	0.34
Black	0.28	0.32	0.20
Hispanic	0.32	0.36	0.22
Asian/ Pacific Islander	0.40	0.48	--

-- Sample size is insufficient to permit a reliable estimate.

NOTE: White refers to White (not Hispanic), Black refers to Black (not Hispanic).

SOURCE: National Center for Education Statistics, National Assessment of Educational Progress (NAEP), 1996 Science Assessment.

Sample Questions and Student Responses

The following section contains sample questions for each of the major fields of science. Table 3.5 summarizes the classification of questions that are discussed. Since the discussion must be limited to test questions that have been released to the public, no examples of questions measuring scientific investigation in the area of physical science or of questions measuring practical reasoning in the area of earth science are available for discussion. Some of the questions described could be classified in more than one field of science or way of knowing and doing science. For the purposes of test construction and analysis, however, the classification had to be limited to one field of science and one way of knowing and doing science.

TABLE 3.5

Sample Questions Categorized by Fields of Science and by Ways of Knowing and Doing Science, Grade 8: Public and Nonpublic Schools Combined



	Earth Science	Physical Science	Life Science
Conceptual Understanding	Location of earthquakes (mc) Windchill (mc) Theme: Seasons (scr)	Insulated bottle (mc) Nonrenewable resources (mc) Mirrors and windows (scr)	Mitochondria (mc) Classification (scr)
Scientific Investigation	Theme: Graph reading (mc) Task: Measurement (scr) Task: Average (scr) Task: Graphing (scr) Task: Interpolating (scr)		Hydra (ecr)
Practical Reasoning		Light bulbs (scr) Heating rate prediction (ecr)	Food poisoning (scr) Inheritance (scr)

NOTE: "mc" indicates a multiple choice question; "scr" indicates a short constructed-response question; and "ecr" indicates an extended constructed-response question.

Conceptual Understanding⁴

One hundred and ten questions administered to eighth graders during the NAEP 1996 science assessment measured conceptual understanding. These included both multiple-choice and constructed-response questions in each of the three major content fields — earth science, physical science, and life science. A selection of these questions follows.

⁴ See figure 1.2 for a description of conceptual understanding.

Location of Earthquakes

The following multiple-choice question is classified under the earth science topic “Solid Earth.” In order to answer it correctly, students had to know the relationship between tectonic plate boundaries and occurrence of earthquakes.

2. If the locations of earthquakes over the past ten years were plotted on a world map, which of the following would be observed?
- Ⓐ Earthquakes occur with the same frequency everywhere on Earth.
 - Ⓑ Earthquakes generally occur along the edges of tectonic plates.
 - Ⓒ Earthquakes most frequently occur near the middle of continents.
 - Ⓓ Earthquakes do not seem to occur in any consistent pattern.

The correct option is B.

The percentages of students choosing each response are shown in table 3.6. Sixty percent knew that earthquakes were associated with tectonic plates. Twenty-four percent thought that they did not seem to occur with any consistent pattern. These students may have been thinking about the frequency of earthquakes rather than the location of earthquakes.

TABLE 3.6 Percentages Choosing Each Response: Grade 8 Location of Earthquake



Response Options				
A	B	C	D	Omit
6	60	10	24	1

The percentages of students within each of the achievement level intervals that successfully answered the question are shown in table 3.7. A fairly high percentage of students who were classified as below *Basic*, *Basic*, or *Proficient* were able to answer the question correctly.

TABLE 3.7 Percentages Correct within Each Achievement Level Interval: Grade 8 Location of Earthquake



Below Basic (0-142)	Basic (143-169)	Proficient (170-206)	Advanced (207-300)
41	61	83	--

-- Sample size insufficient to permit a reliable estimate.

Windchill

The following multiple-choice question is classified under the earth science topic “Air.” To answer this question correctly, students had to consider several pieces of information that were presented in the table, namely the high and low temperatures on any given day and the average wind speed. In addition, they had to understand the meaning of “average windchill temperature.”

The following question refers to the table below.

	Monday	Tuesday	Wednesday	Thursday	Friday
High Temperature (°F)	43	50	42	53	60
Low Temperature (°F)	28	38	28	39	45
Precipitation (inches)	0.0	1.0	1.5	0.0	1.6
Average Wind Speed (mph)	15	10	7	10	10

2. On which day was the average windchill temperature likely to be the lowest?
- Ⓐ Monday
 - Ⓑ Tuesday
 - Ⓒ Wednesday
 - Ⓓ Friday

The correct option is A.

Information relating to student performance is presented in Table 3.8. The question was somewhat difficult. There were two days on which the lowest temperature was 28 degrees F — Monday and Wednesday. The high temperature on these two days — 43 and 42, respectively — differed by 1 degree F. In addition, the average wind speed on these two days was 15 mph and 7 mph, respectively. Since the question asks about the average windchill temperature, students had to realize that the one degree difference in high temperature, is likely less important than the 8 mph difference in average wind speed. Thus, the correct response is Monday (option A). Although many students probably knew that they had to evaluate wind speed and temperature, 48 percent of the student population chose the day on which the lowest average wind speed occurred (7 mph), instead of the day with the highest average wind speed (15 mph). Thus, less than half the student population (41 percent) was able to evaluate the three pieces of information correctly — that is, high and low daily temperatures and average wind speed.

TABLE 3.8 **Percentages Choosing Each Response:**
Grade 8
Windchill



Response Options

A	B	C	D	Omit
41	3	48	8	0

The percentages of students within each achievement level interval who chose the correct answer are presented in table 3.9. The question proved to be somewhat difficult; 57 percent of students at the *Proficient* level answered the question correctly.

TABLE 3.9 **Percentages Correct within Each Achievement Level**
Interval: Grade 8
Windchill



Below Basic (0-142)	Basic (143-169)	Proficient (170-206)	Advanced (207-300)
27	39	57	--

-- Sample size insufficient to permit a reliable estimate.

Insulated Bottle

The following multiple-choice question was classified under the physical science topic “Energy and its Transformations.” It required students to understand how cold liquids are kept cold in an insulated bottle.

11. An insulated bottle keeps a cold liquid in a bottle cold by

- Ⓐ destroying any heat that enters the bottle
- Ⓑ keeping cold energy within the bottle
- Ⓒ trapping dissolved air in the liquid
- Ⓓ slowing the transfer of heat into the bottle

The correct option is D.

Information relating to students’ performance is presented in tables 3.10 and 3.11. As can be seen from the results, energy tends to be a very difficult concept for students to understand. Just over half of eighth graders (54 percent) thought that cold energy was kept within the bottle. Fifteen percent thought the bottle destroyed the heat entering it or that liquid was kept cold by trapping dissolved air. Thirty-one percent of students thought that the insulated bottle slowed the transfer of heat into the bottle. The question proved difficult for students at all achievement levels. Forty-five percent of students classified as *Proficient* chose the correct response.

TABLE 3.10 **Percentages Choosing Each Response:**
Grade 8
Insulated Bottle THE NATION'S REPORT CARD 

Response Options

A	B	C	D	Omit
5	54	10	31	1

NOTE: Numbers do not add to 100 due to rounding.

TABLE 3.11 **Percentages Correct within Each Achievement Level**
Interval: Grade 8
Insulated Bottle THE NATION'S REPORT CARD 

Below Basic (0-142)	Basic (143-169)	Proficient (170-206)	Advanced (207-300)
20	32	45	--

-- Sample size insufficient to permit a reliable estimate.

Nonrenewable Resource

The next multiple-choice question, also classified under “Energy and its Transformations,” asked students to choose the energy source that was nonrenewable from a list of four options.

3. Which of the following energy sources is the best example of a nonrenewable resource?

- Ⓐ Coal
- Ⓑ Wind
- Ⓒ Water
- Ⓓ Sunlight

The correct option is A.

Information on the percentages of students choosing each response is shown in table 3.12. Students had to know the meaning of the word “nonrenewable” to answer the question correctly. Sixty-one percent of students chose coal. Thirty-nine percent did not know the meaning of a “nonrenewable resource” and chose wind, water, or sunlight, all of them renewable resources.

TABLE 3.12 Percentages Choosing Each Response: Grade 8 Nonrenewable Resource



<i>Response Options</i>				
A	B	C	D	Omit
61	14	8	17	0

Information on the percentages of students classified within each achievement level interval is presented in table 3.13. Forty-four percent of students who were classified as below *Basic* were able to recognize a nonrenewable resource.

TABLE 3.13 Percentages Correct within Each Achievement Level Interval: Grade 8 Nonrenewable Resource



Below Basic (0-142)	Basic (143-169)	Proficient (170-206)	Advanced (207-300)
44	63	82	--

-- Sample size insufficient to permit a reliable estimate.

Mirrors and Windows

The following constructed-response question was classified under the physical science topic “Motion,” since it required students to know something about the behavior of light. It was designed to find out whether students could explain the difference between mirrors and windows. Instead of simply asking for differences between mirrors and windows, the question was placed in context — that is, Sarah asked her brother to explain why she could see herself in a mirror but could see through a window. The question was scored according to a three-level scoring guide.⁵ In order to achieve a score of *Complete*, students had to address both mirrors and windows. In order to receive a score of *Partial*, students could address either a mirror or a window. A response that received a score of *Unsatisfactory* showed no evidence of knowing the difference between a mirror and a window.

6. Raul’s little sister, Sarah, wants to know why she can see herself in a mirror, but she can see through a window. What should Raul tell his sister to explain the differences between mirrors and windows?

Sample 1: Complete Response

In the first sample response, the student addresses the subject of the mirror backing and states that, “This reflects light and any other object that can be seen.” The student also states that, “Glass doesn’t have anything on the back or front that reflects.” One can assume, therefore, that the student knows that light passes through the window. While a certain amount of light will reflect off the glass, the student was not penalized for omitting this information.

Sample 1: Mirrors and Windows

6. Raul’s little sister, Sarah, wants to know why she can see herself in a mirror, but she can see through a window. What should Raul tell his sister to explain the differences between mirrors and windows?

The back of mirrors are painted a dark color. This reflects light and any other object that can be seen. Glass doesn't have anything on the back or front that reflects.

⁵ Appendix B contains scoring guides for the sample questions that appear in this report.

Sample 2: Partial Response

The student in the next sample response states that there was something on the back of the mirror (and not on windows). No mention was made of the reflective properties of mirrors and windows. Students also received a score of *Partial* if they stated that light bounces off a mirror but goes through glass.

Sample 2: Mirrors and Windows

- 6. Raul's little sister, Sarah, wants to know why she can see herself in a mirror, but she can see through a window. What should Raul tell his sister to explain the differences between mirrors and windows?

Their something on the back of the
mirror.

Sample 3: Unsatisfactory Response

The next sample response received a score of *Unsatisfactory*. The student does not appear to understand what the question was asking, merely stating how mirrors and windows were used.

Sample 3: Mirrors and Windows

- 6. Raul's little sister, Sarah, wants to know why she can see herself in a mirror, but she can see through a window. What should Raul tell his sister to explain the differences between mirrors and windows?

He should tell her mirrors are made for
you to look at your self and windows are made to
keep air out your house, car, and other things.

Information on student performance is presented in table 3.14. The question proved to be very difficult, with just two percent of the eighth-grade population receiving a score of *Complete*. Twenty-eight percent received a score of *Partial*. Sixty-six percent of students were not able to tell any difference between a mirror and a window.

TABLE 3.14

**Percentages at Different Score Levels:
Grade 8
Mirrors and Windows**



Complete	Partial	Unsatisfactory	Omit
2	28	66	4

Table 3.15 shows the percentages of students within each achievement level interval. The question was very challenging. Zero percent of students classified as below Basic, one percent classified as Basic, and four percent classified as Proficient received a score of Complete.

TABLE 3.15 *Percentages Complete within Each Achievement Level Interval: Grade 8 Mirrors and Windows* 

Below Basic (0-142)	Basic (143-169)	Proficient (170-206)	Advanced (207-300)
0	1	4	--

-- Sample size insufficient to permit a reliable estimate.

Mitochondrion

At the middle school level, the structure and function of cells is an integral part of life science textbooks. The following question asks about the function of a mitochondrion and was classified under the life science topic "Cells," as specified by the framework.⁶

10. What does a mitochondrion do in a cell?
- Ⓐ It controls the transport of substances leaving and entering the cell.
 - Ⓑ It contains the information to control the cell.
 - Ⓒ It produces a form of energy that the cell can use.
 - Ⓓ It breaks down waste products in the cell.

The correct option is C.

⁶ National Assessment Governing Board. (1995). *Science framework for the 1996 National Assessment of Educational Progress*. Washington, DC: Author.

Student performance data are presented in table 3.16. This question proved to be very difficult for students and did not discriminate well among students of different ability levels, which might suggest that students were guessing. To answer this question correctly, students could either recognize that mitochondria produce cellular energy or choose the correct option through elimination. For example, they may have recognized that option A refers to the cell membranes, that option B refers to the cell nucleus, and that option D refers to lysosomes. Twenty-eight percent of students answered this question correctly by choosing C. However, choices A and D were also attractive. Choice B attracted only 15 percent of students, presumably because the description referred to the nucleus, the organelle that students are most likely to remember because of its link to genes.

TABLE 3.16 **Percentages Choosing Each Response:**
Grade 8
Mitochondria

THE NATION'S
REPORT CARD 

Response Options

A	B	C	D	Omit
27	15	28	30	1

NOTE: Numbers do not add to 100 due to rounding.

As shown in table 3.17, approximately equal percentages of students who were classified as below *Basic*, *Basic*, and *Proficient* answered the question correctly (26, 29, and 28 percent, respectively). Given that students had a 25 percent chance of getting this question correct by guessing and that the percentages of students within each achievement level interval were similar, few students knew the function of a mitochondrion.

TABLE 3.17 **Percentages Correct within Each Achievement Level**
Interval: Grade 8
Mitochondria

THE NATION'S
REPORT CARD 

Below Basic (0-142)	Basic (143-169)	Proficient (170-206)	Advanced (207-300)
26	29	28	--

-- Sample size insufficient to permit a reliable estimate.

Classification

The multiple-choice question shown below is classified in the life science topic “Change and Evolution.” It measures students’ ability to recognize an organism from its characteristics.

1. A certain organism has many cells, each containing a nucleus. If the organism makes its own food, it would be classified as

- Ⓐ a bacterium
- Ⓑ a fungus
- Ⓒ a plant
- Ⓓ an animal

The correct option is C.

Each choice represents one of the major classification groups, namely, bacteria, fungi, plants, and animals. To answer the question correctly, students had to know some of the characteristics of each of these groups. For example, they had to know that bacteria are usually unicellular and contain no nucleus and that fungi and animals do not make their own food. This leaves plants as the only possible answer. As shown in table 3.18, 72 percent of eighth graders were able to answer this question correctly.

TABLE 3.18 Percentages Choosing Each Response:
Grade 8
Classification

THE NATION'S
REPORT
CARD 

Response Options

A	B	C	D	Omit
14	12	72	2	0

The percentages of students in each of the achievement levels that answered the question correctly are shown in table 3.19. The question proved to be fairly easy; 74 percent of students classified as *Basic* knew the characteristics of a plant.

TABLE 3.19 **Percentages Correct within Each Achievement Level**
Interval: Grade 8
Classification



Below Basic (0-142)	Basic (143-169)	Proficient (170-206)	Advanced (207-300)
61	74	84	--

-- Sample size insufficient to permit a reliable estimate.

Scientific Investigation⁷

Thirty-eight of the 194 questions administered to eighth graders in the NAEP 1996 science assessment were classified as scientific investigation. The types of questions asked ranged from those requiring students to demonstrate skills such as measurement and graph drawing to those requiring students to devise experiments based on given hypotheses. A sample question is shown below. A selection of questions from a hands-on task that also measures scientific investigation is presented at the end of this chapter.

Hydra

The following extended constructed-response question was part of a set of three concerning a class project using an organism called *Hydra*. Students were told that the organism was an animal and given a diagram of its appearance as shown below.

Data were presented to the students and they were asked a series of three questions based on this data. The first question asked students to explain the changes in appearance and number of hydras and tested students' ability to relate reproduction — budding — to increase in population. The second question, shown below, asked students to design an experiment, with appropriate controls, to test the effect of increasing the amount of food on the rate of increase of the hydra population. The third question asked students if they thought that the hydra population could double in one day given unlimited food. Only student responses to the second question are shown here. The question was scored according to a four-level scoring guide.⁸ Students at the highest level, *Complete*, had to devise a valid experiment that included more than one hydra and an appropriate control. To achieve a score of *Essential*, the student response had to include an appropriate control but use only one hydra instead of a number of them. The responses that received a score of *Partial* had some fundamental problems, such as absence of a control and inappropriate amounts of food. A score of *Unsatisfactory* was given to responses that gave no indication of the ability to set up a controlled experiment.

⁷ See figure 1.2 for a description of scientific investigation.

⁸ Appendix B contains scoring guides for the sample questions that appear in this report.

Questions 14-16. Hydras are tiny (1-centimeter long) animals that live in streams and ponds. The picture below shows an adult hydra drawn larger than actual size.



Evita and Michael used 20 hydras for a class science project. They kept the hydras in a glass dish about 5 centimeters high, fed them regularly, and bubbled air into the water to make sure the hydras had enough oxygen.

Evita and Michael observed the hydras every day for 10 days. Each day they drew in their lab notebook the appearance of a typical hydra and recorded the total number of hydras. Their records for day 1, day 4, day 7, and day 10 are shown below.

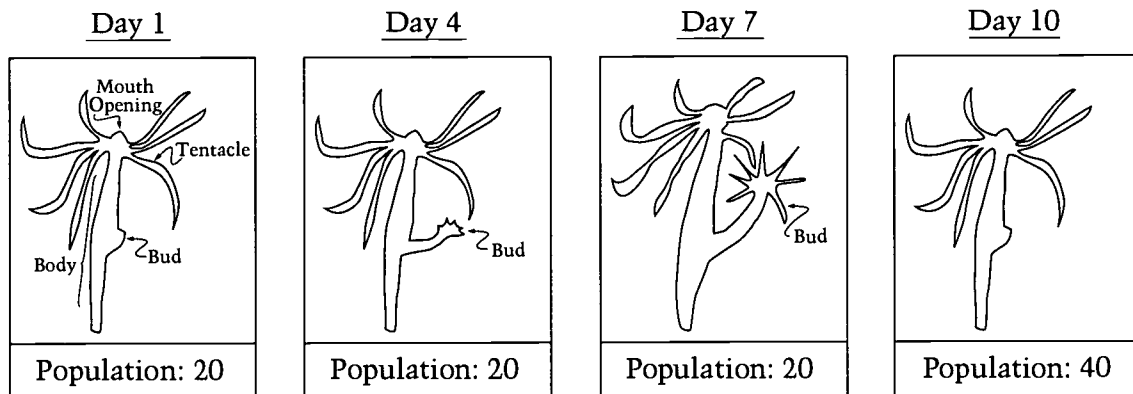

15. Evita and Michael predicted that if they fed the hydras twice as much food, the population of hydras would double their number in 5 days. Describe an experiment with appropriate controls that Evita and Michael could do to test this hypothesis.

Sample 1: Complete Response

The following sample response received a score of *Complete*. The student clearly identifies two sets of hydras, one of which is the control group. The food amounts are also correctly stated: “the normal amount” and “twice as much food.” The response then states “compare at the end of five days,” implying that the two sets of hydras should be examined to see whether the population can double in five days when twice the amount of food is fed to them.

Sample 1: Hydra

15. Evita and Michael predicted that if they fed the hydras twice as much food, the population of hydras would double their number in 5 days. Describe an experiment with appropriate controls that Evita and Michael could do to test this hypothesis.

Take two sets of hydras and one set give them the normal amount of food. The give the second set twice as much food. Then compare at the end of five days.

Sample 2: Essential Response

The second sample response received a score of *Essential*. Students who received this score described a correct experiment except they included only one organism in each group. The student who wrote sample response 2 recognizes that a control is needed but chooses to put only one hydra in each group: “Have two different hydras feed on of the hydras twice as much. And feed the other on the regular amount...”

Sample 2: Hydra

15. Evita and Michael predicted that if they fed the hydras twice as much food, the population of hydras would double their number in 5 days. Describe an experiment with appropriate controls that Evita and Michael could do to test this hypothesis.

Have two different hydras feed on of the hydras twice as much. And feed the other on the regular amount. Study them both for five days. then you'll get your conclusion.

Sample 3: Partial Response

The next sample response received a score of *Partial*. This student fails to mention a control group, but does understand that the hydras have to be fed twice as much for only five days. Students also received a score of *Partial* for mentioning two groups of hydras without specifically stating a food amount.

Sample 3: Hydra

15. Evita and Michael predicted that if they fed the hydras twice as much food, the population of hydras would double their number in 5 days. Describe an experiment with appropriate controls that Evita and Michael could do to test this hypothesis.

They would probably have to get a 10 cm high glass dish, they would feed them twice as much regularly, and leave them in there for only five days.

Sample 4: Unsatisfactory Response

The following student response received a score of *Unsatisfactory*. This student states “feed the hydras only a little bit each day and see how big they are after five days...” and then suggests increasing the amount a little bit more. This response clearly demonstrates that the student lacked the knowledge and skills necessary to construct a valid experiment since no attempt was made to feed the hydras twice the amount of food.

Sample 4: Hydra

15. Evita and Michael predicted that if they fed the hydras twice as much food, the population of hydras would double their number in 5 days. Describe an experiment with appropriate controls that Evita and Michael could do to test this hypothesis.

To test their hypothesis they can only feed the hydras only a little bit each day and see how big they are after five days then feed them a little bit more and see how big it is after five days, then keep on repeating the process then you can see how much food you give the hydras how big or small it would be.

Table 3.20 shows the percentage of students at different score levels. Twelve percent of students were able to answer this completely, suggesting those students understood the purpose of a control and also that more than one hydra was needed in each group. Six percent of students understood the need for a control but failed to realize that a number of hydras was needed in each group to make a valid comparison. Thirty percent of students received a score of *Partial*. Their answers contained some fundamental errors, such as the lack of a valid control. The 44 percent of eighth graders who were in the category *Unsatisfactory* were unable to set up a fairly simple experiment based on a hypothesis presented to them.

TABLE 3.20 **Percentages at Different Score Levels: Grade 8 Hydra** THE NATION'S REPORT CARD 

Complete	Essential	Partial	Unsatisfactory	Omit
12	6	30	44	10

NOTE: Numbers do not add to 100 due to rounding.

Table 3.21 shows the percentages of students within each achievement level interval that received a score of *Complete* or *Essential*. Overall, students found the question somewhat difficult. Six percent of students classified as below *Basic*, 15 percent classified as *Basic*, and 30 percent classified as *Proficient* were able to construct a valid experiment from a given hypothesis.

TABLE 3.21 **Percentages Complete or Essential within Each Achievement Level Interval: Grade 8 Hydra** THE NATION'S REPORT CARD 

<i>Below Basic</i> (0-142)	<i>Basic</i> (143-169)	<i>Proficient</i> (170-206)	<i>Advanced</i> (207-300)
6	15	30	--

-- Sample size insufficient to permit a reliable estimate.

Practical Reasoning⁹

The following sample questions give an indication of the types of questions that were thought to measure practical reasoning. They address subject matter from physical and life science only, since no practical reasoning questions addressing earth science topics were released to the public.

Lightbulbs

The following short constructed-response question measures whether students knew that heat requires energy for production. They were asked which of two types of lightbulbs — incandescent or fluorescent — would use the least amount of electricity and why. Students did not have to remember the properties of one type of lightbulb versus another; they were told that fluorescent lightbulbs produced much less heat when operating. The question was scored on a three-level scale.¹⁰ A response that received a score of *Complete* needed to indicate “fluorescent lightbulb” and link heat to energy consumption. To receive a score of *Partial*, students had merely to state the correct lightbulb with no explanation or an explanation that was faulty. A student response that received a score of *Unsatisfactory* indicated the incorrect lightbulb.

7. When operating, ordinary incandescent lightbulbs produce a lot of heat in addition to light. Fluorescent lightbulbs produce much less heat when operating. If you wanted to conserve electricity, which type of bulb should you use? Explain your answer.

⁹ See figure 1.2 for a description of practical reasoning.

¹⁰ Appendix B contains scoring guides for the sample questions that appear in this report.

Sample 1: Complete Response

The following response received a score of *Complete*. The student knows that electricity is needed to produce heat and that the incandescent lightbulb uses more electricity because it produces more heat.

Sample 1: Lightbulbs

7. When operating, ordinary incandescent lightbulbs produce a lot of heat in addition to light. Fluorescent lightbulbs produce much less heat when operating. If you wanted to conserve electricity, which type of bulb should you use? Explain your answer.

Fluorescent lightbulb

Explain your answer.

Because to produce heat you need more electricity and the incandescent lightbulb produces more heat which is more energy.

Sample 2: Partial Response

The next response received a score of *Partial*. This student chose fluorescent lightbulbs. However, the explanation has to do with safety and does not address conservation of electricity.

Sample 2: Lightbulbs

7. When operating, ordinary incandescent lightbulbs produce a lot of heat in addition to light. Fluorescent lightbulbs produce much less heat when operating. If you wanted to conserve electricity, which type of bulb should you use? Explain your answer.

Fluorescent lightbulbs.

Explain your answer.

because if you have to touch them they won't be as hot as the ordinary lightbulbs

Sample 3: Unsatisfactory Response

The following student response received a score of *Unsatisfactory*. The student's answer is based on previous experience. While it relates to saving money, it does not address the issue of energy conservation.

Sample 3: Lightbulbs

7. When operating, ordinary incandescent lightbulbs produce a lot of heat in addition to light. Fluorescent lightbulbs produce much less heat when operating. If you wanted to conserve electricity, which type of bulb should you use? Explain your answer.

A soft-white bulb is more useful

Explain your answer.

The reason for this is, soft-white bulbs last longer than any light bulb, according to an experiment that was done.

Information relating to student performance is shown in tables 3.22 and 3.23. One third of the eighth-grade population answered the question correctly; that is, they chose fluorescent lightbulbs and correctly linked heat to energy consumption. Thirty-nine percent of students chose the correct lightbulb but were unable to justify their answers satisfactorily. Twenty-four percent of eighth graders chose the incandescent lightbulb.

TABLE 3.22 **Percentages at Different Score Levels: Grade 8 Lightbulbs** THE NATION'S REPORT CARD 

Complete	Partial	Unsatisfactory	Omit
33	39	24	4

As shown in table 3.23, 15 percent of students classified as below *Basic*, 34 percent classified as *Basic*, and 53 percent classified as *Proficient* were able to choose the correct lightbulb and link heat and energy consumption.

TABLE 3.23 **Percentages Complete within Each Achievement Level Interval: Grade 8 Lightbulbs** THE NATION'S REPORT CARD 

Below Basic (0-142)	Basic (143-169)	Proficient (170-206)	Advanced (207-300)
15	34	53	--

-- Sample size insufficient to permit a reliable estimate.

Heating Rate Prediction

An experiment concerning the heating of soil and water was described to students. Students were then presented with two questions. In the first question, students were asked what variables needed to be controlled in the experiment. They were then presented with some data and asked to relate that data to another situation, namely a beach. The second question asked students to predict, explain their predictions, and then give reasons why their predictions might be faulty. The responses were scored according to a four-level scoring guide.¹¹ To receive a score of *Complete*, students had to predict correctly, explain their predictions, and then state why their predictions might be incorrect. For a student response to receive a score of *Essential*, it had to contain a correct prediction and either explain the prediction or explain why the prediction could be wrong. A response that contained a correct prediction only was given a score of *Partial*. Students who were unable to predict or explain were given a score of *Unsatisfactory*.

¹¹ Appendix B contains scoring guides for the sample questions that appear in this report.

Questions 15-16 refer to an experiment your teacher asks you to perform to compare the heating rate of soil with that of water. To do this, you are given the following materials.

- 2 heat lamps
- 2 bins
- 2 thermometers
- 1 sample of soil
- 1 sample of water
- 1 timer

You are instructed to heat a sample of soil and a sample of water with heat lamps, measuring the temperature of each sample once a minute for 8 minutes.

16. Suppose that the experiment yielded the results shown in the table below.

Time (min)	0	1	2	3	4	5	6	7	8
Soil temp (°C)	20	21	22.5	24	26	27.5	29.5	30.5	32
Water temp (°C)	20	21.5	23	23.5	24	25.5	26	27.5	28.5

At a beach that has white sand, you measure the temperature of the sand and the temperature of the seawater at 9:00 a.m. You find that both have a temperature of 16°C. If it is clear and sunny all morning, what do the data from the experiment predict about the temperature of the white sand compared to the temperature of the seawater at noon?

Explain your answer.

Explain why the prediction based on the data might be wrong.

Sample 1: Complete Response

The following sample received a score of *Complete*. The student predicts that the sand will be hotter, and refers clearly to the experimental data in the explanation. The student then gives a number of plausible explanations for why the prediction might be wrong, including a constantly moving ocean and the presence of salt in the ocean.

Sample 1: Heating Rate Prediction

16. At a beach that has white sand, you measure the temperature of the sand and the temperature of the seawater at 9:00 a.m. You find that both have a temperature of 16°C. If it is clear and sunny all morning, what do the data from the experiment predict about the temperature of the white sand compared to the temperature of the seawater at noon?

the sand will be hotter.

Explain your answer.

You can tell from the experiment that the soil is getting hotter faster than the water—so I believe the same thing will happen at the beach.

Explain why the prediction based on the data might be wrong.

because there are other factors to consider such as the ocean is constantly moving and the ocean has salt in it and the ocean is heated by the sun and not a lamp.

Sample 2: Essential Response

The next sample response received a score of *Essential*. This student is able to predict and explain the prediction. However, he or she is unable to come up with reasons why the prediction might be incorrect.

Sample 2: Heating Rate Prediction

16. At a beach that has white sand, you measure the temperature of the sand and the temperature of the seawater at 9:00 a.m. You find that both have a temperature of 16°C. If it is clear and sunny all morning, what do the data from the experiment predict about the temperature of the white sand compared to the temperature of the seawater at noon?

It will increase more than
that of the water

Explain your answer.

In the first experiment, the
soil heats up faster. (Also, water
has the highest specific heat of
any substance, which will take
longest to heat up and cool down)

Explain why the prediction based on the data might be wrong.

I don't see why it would
be wrong

Sample 3: Partial Response

The following sample response received a score of *Partial*. The student predicts that the sand would be warmer but does not use the data to explain the prediction. Since the prediction is based on experimental data, reasons why the prediction might be wrong should have referred to the experimental conditions that produced the data.

Sample 3: Heating Rate Prediction

16. At a beach that has white sand, you measure the temperature of the sand and the temperature of the seawater at 9:00 a.m. You find that both have a temperature of 16°C. If it is clear and sunny all morning, what do the data from the experiment predict about the temperature of the white sand compared to the temperature of the seawater at noon?

the sand will be warmer
than the water

Explain your answer.

water holds heat but it also
releases it and land holds
heat and dose not release
it.

Explain why the prediction based on the data might be wrong.

if there is alot of shade
on the beach it can cause
the sand to be cooler
because less sun like can
get to it.

Sample 4: Unsatisfactory Response

The next response received a score of *Unsatisfactory*. The student clearly does not relate any part of the response to the data and thinks that the water will be warmer. Judging from the explanation, the student has some knowledge of reflective properties but fails to link the answer to the data. The explanation for the prediction was not credited since the prediction is incorrect.

Sample 4: Heating Rate Prediction

16. At a beach that has white sand, you measure the temperature of the sand and the temperature of the seawater at 9:00 a.m. You find that both have a temperature of 16°C. If it is clear and sunny all morning, what do the data from the experiment predict about the temperature of the white sand compared to the temperature of the seawater at noon?

The water will be warmer.

Explain your answer.

The white sand is lighter color than the water and absorbs less heat.

Explain why the prediction based on the data might be wrong.

You never know, what if sea currents bring in cooler water from the outer sea?
Or, the sand might be constantly moved, resulting in different temp.

Table 3.24 presents the percentages of students at different score levels. The question proved to be very challenging. The percentage of eighth-grade students that received a score of *Complete* was six percent. Thirty-one percent of students were able to look at the data and transfer the information to a different scenario, but were unable to give a satisfactory explanation. Thus, they received a score of *Partial*. Fifty-four percent of students were unable to answer the question.

TABLE 3.24 **Percentages at Different Score Levels:**
Grade 8
Heating Rate Prediction

THE NATION'S
REPORT
CARD 

Complete	Essential	Partial	Unsatisfactory	Omit
6	6	31	54	4

NOTE: Numbers do not add to 100 due to rounding.

The percentages of students within each of the achievement levels that provided a *Complete* or *Essential* response are shown in table 3.25. The question was very challenging for students within each of the achievement level intervals. One percent of students classified as below *Basic*, eight percent classified as *Basic*, and 25 percent classified as *Proficient* were able to predict and present valid explanations.

TABLE 3.25 **Percentages Complete or Essential within Each**
Achievement Level Interval: Grade 8
Heating Rate Prediction

THE NATION'S
REPORT
CARD 

Below Basic (0-142)	Basic (143-169)	Proficient (170-206)	Advanced (207-300)
1	8	25	--

-- Sample size insufficient to permit a reliable estimate.

Food Poisoning

The purpose of this short constructed-response question was to find out whether eighth graders knew that organisms that cause food poisoning could grow in a potato salad on a hot day, and that a way of preventing this growth was to keep the salad cold. The question was classified under the life science topic “Organisms.” The students were given some information to help them. They were told that the picnic was held on a hot day. They were also told that the salad was made using mayonnaise. Some may have known that mayonnaise contains eggs as one of its ingredients — a fairly common source of bacteria. The question was scored using a three-level guide.¹² A response that received a score of *Complete* had to answer both parts of the question satisfactorily, whereas a response that received a score of *Partial* gave a correct explanation for only one of the parts. Responses that received a score of *Unsatisfactory* addressed neither part of the question correctly.

13. A group of students took potato salad made with mayonnaise to a picnic on a very hot day. Explain how eating the potato salad could cause food poisoning.

Describe something that could be done to the potato salad to prevent the people who eat it from getting food poisoning.

¹² Appendix B contains scoring guides for the sample questions that appear in this report.

Sample 1: Complete Response

The following student response received a score of *Complete*. The student recognizes that bacteria can grow in the mayonnaise when it gets hot. The student also knows that the salad should be kept in a cooler at all times.

Sample 1: Food Poisoning

13. A group of students took potato salad made with mayonnaise to a picnic on a very hot day. Explain how eating the potato salad could cause food poisoning.

When mayonnaise gets too hot it starts growing poisonous bacteria which can give you food poisoning.

Describe something that could be done to the potato salad to prevent the people who eat it from getting food poisoning.

It can be kept in a cooler and stay cool until they want to eat it, then they should put it back in the cooler.

Sample 2: Partial Response

The next student response received a score of *Partial*. This student recognizes that the mayonnaise can spoil but fails to state what causes the spoiling. The student does, however, recognize that the salad needs to be kept cold to prevent spoiling. Students also received a score of *Partial* if they satisfactorily explained how eating the potato salad could cause food poisoning with no explanation of how to prevent the food poisoning.

Sample 2: Food Poisoning

13. A group of students took potato salad made with mayonnaise to a picnic on a very hot day. Explain how eating the potato salad could cause food poisoning.

The mayonnaise could separate, and since mayonnaise is made out of egg the egg could spoil, causing food poisoning.

Describe something that could be done to the potato salad to prevent the people who eat it from getting food poisoning.

They could put it into a cooler so that the egg doesn't get hot and spoil.

Sample 3: Unsatisfactory Response

The student response shown below received a score of *Unsatisfactory*. The student states that the mayonnaise in the potato salad will get “old and shriveld up” — maybe meaning dried up — and “could cause food poisoning.” This is clearly incorrect. The student made a general statement for the second part of the question and said that the salad should not be exposed “to the sun.”

Sample 3: Food Poisoning

13. A group of students took potato salad made with mayonnaise to a picnic on a very hot day. Explain how eating the potato salad could cause food poisoning.

The mayonaise in the potato salad will get old and shriveld up in the hot sun which bleached the mayonaise and could cause food poisoning.

Describe something that could be done to the potato salad to prevent the people who eat it from getting food poisoning.

Do not expose the potato salad to the sun.

Student performance data are presented in table 3.26. Ten percent of students knew that the growth of pathogenic organisms caused food poisoning and that keeping the salad cold could prevent this. Sixty-one percent of students received a score of *Partial*. The majority of these received credit for the second part of the question; that is, they knew that the potato salad should be kept cold but did not know why. Twenty-six percent of the eighth-grade student population received a score of *Unsatisfactory*.

TABLE 3.26 **Percentages at Different Score Levels: Grade 8 Food Poisoning** THE NATION'S REPORT CARD 

Complete	Partial	Unsatisfactory	Omit
10	61	26	3

The percentages of students within each of the achievement levels that provided a response of *Complete* are shown in table 3.27. The question proved to be difficult, with just 2 percent of students classified as below *Basic*, 8 percent classified as *Basic*, and 18 percent classified as *Proficient* receiving a score of *Complete*.

TABLE 3.27 **Percentages Complete within Each Achievement Level Interval: Grade 8 Food Poisoning** THE NATION'S REPORT CARD 

<i>Below Basic</i> (0-142)	<i>Basic</i> (143-169)	<i>Proficient</i> (170-206)	<i>Advanced</i> (207-300)
2	8	18	--

-- Sample size insufficient to permit a reliable estimate.

Inheritance

The next question asks students to demonstrate an introductory knowledge of genetics in a practical setting. They were told that hair color in humans is an inherited trait, and were expected to know the difference between a dominant and recessive trait. They were also expected to know that in order for a recessive trait to be expressed, both parents must pass on the gene for that trait to their offspring. The question was scored using a three-level guide.¹³ To receive a score of *Complete*, students had to explain that the child inherited recessive genes from its parents. A student response that received a score of *Partial* had to mention that the trait for blond hair was passed from grandparents to parents to the child. A response that received a score of *Unsatisfactory* did not demonstrate any understanding of the concept of recessive genes.

7. Hair color in humans is an inherited trait. How is it possible for two people who had brown hair from birth to produce a child with blond hair?

¹³Appendix B contains scoring guides for the sample questions that appear in this report.

Sample 1: Complete Response

The first sample response received a score of *Complete*. This student provides a diagram to aid in the explanation. The parents are shown with genotypes Bb and Bb and a key indicates that B is brown and b is blond. The explanation states that the blond gene is recessive. The student also gives the possible genotypes resulting from this cross, one of which is bb, indicating the possibility that the parents could have a child with blond hair. This student obviously has a very good grasp of basic genetics.

Sample 1: Inheritance

7. Hair color in humans is an inherited trait. How is it possible for two people who had brown hair from birth to produce a child with blond hair?

if the people have had a recessive gene of blond it is possible if any dominant gene is present it takes that trait but if two recessive (Blond) genes are grouped it creates blond.

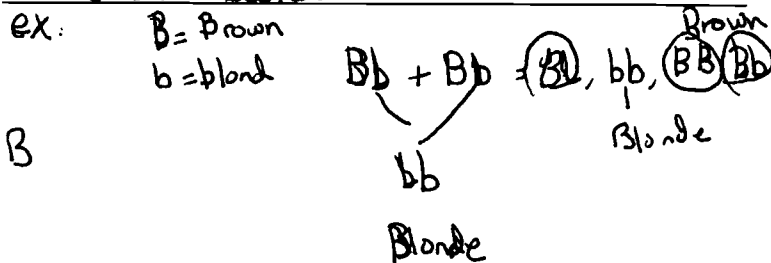

Sample 2: Partial Response

The following sample response received a score of *Partial*. This student answered the question in general terms, stating, “Mabee the mother or fathers, mother and fathers had blond hair.”

Sample 2: Inheritance

7. Hair color in humans is an inherited trait. How is it possible for two people who had brown hair from birth to produce a child with blond hair?

Mabee the mother or fathers,
mother and fathers had blond hair.

Sample 3: Unsatisfactory Response

The next sample response is an example of a student’s response that shows no understanding of inherited traits.

Sample 3: Inheritance

7. Hair color in humans is an inherited trait. How is it possible for two people who had brown hair from birth to produce a child with blond hair?

The brownness of the parents hair could have had light or dark hair. The two mixed could have shown the hair lighter just from the sun or the actual color of the parents hair.

Table 3.28 presents the percentages of students at each of the different score levels. Four percent of the grade 8 student population received a score of *Complete*, whereas 60 percent were unable to think of a valid reason why a child could have blond hair when each of its parents had brown hair.

TABLE 3.28 **Percentages at Different Score Levels: Grade 8 Inheritance** THE NATION'S REPORT CARD 

Complete	Partial	Unsatisfactory	Omit
4	30	60	6

Table 3.29 shows the percentages of students within each achievement level interval. The difficulty of the question is reflected in the data. Zero percent of students classified as below *Basic*, two percent classified as *Basic*, and eight percent classified as *Proficient* received a score of *Complete* on the question.

TABLE 3.29 **Percentages Complete within Each Achievement Level Interval: Grade 8 Inheritance** THE NATION'S REPORT CARD 

Below Basic (0-142)	Basic (143-169)	Proficient (170-206)	Advanced (207-300)
0	2	8	--

-- Sample size insufficient to permit a reliable estimate.

Theme Block

Three of the fifteen 30-minute blocks of questions at the eighth-grade level addressed each of the three themes — systems, models, and patterns of change — outlined in the *Science Framework for the 1996 National Assessment of Educational Progress*.¹⁴ Not every student in the assessment was administered one of these theme blocks and no student was administered more than one. These blocks of questions differed from other questions in the assessment in that they probed students' understanding of a given area of science such as the Solar System and afforded students the opportunity to display both breadth and depth of understanding. Other 30-minute blocks of questions covered material in earth, physical, and life science and usually not more than one or two questions were devoted to any topic.

The 12 questions based on the theme “models” have been released to the public and can be found on the Internet.¹⁵ Students were presented with a picture illustrating a simplified model of part of the Solar System (shown below). The four planets closest to the Sun were included and the orbit of Earth shown. Students were then asked a series of questions relating to this model. For example, they were asked to draw in the orbits of the other planets, explain the differences and similarities between the simplified model of the Solar System and the real Solar System, and explain the difficulties that they would encounter if they attempted to add the other planets to the diagram. In addition, several questions were asked that related to the graph shown on the next page, one of which is presented here. The final question asked students to explain why seasons occur. That question is also presented in this chapter.

The picture below illustrates a simplified model of part of the Solar System. The Sun and the four planets closest to the Sun are represented by the shaded figures. The Earth's orbit (the path that it takes as it moves around the Sun) is represented by the large circle and the arrow on this circle shows the direction in which the Earth moves.

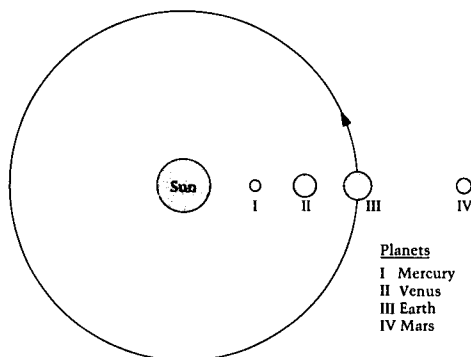

¹⁴ National Assessment Governing Board. (1995). *Science framework for the 1996 National Assessment of Educational Progress*. Washington, DC: Author

See figure 1.3 for a description of themes

¹⁵ National Center for Education Statistics: National Assessment of Educational Progress (1997). *Science assessment public release, grade 4* [On-line]. Available: <http://nces.ed.gov/naep>.

Theme: Graph Reading

The following question was presented to students halfway through the theme block and measured students' ability to read a graph. The graph showed the time it took planets to move around the Sun (in Earth days) versus the average distance of planets from the Sun. Students were asked to indicate which of the four options was a true statement based on the graph.

The planets move at different speeds and require different amounts of time to circle the Sun. The following graph shows the number of Earth days it takes for each of the four planets to move around the Sun once.

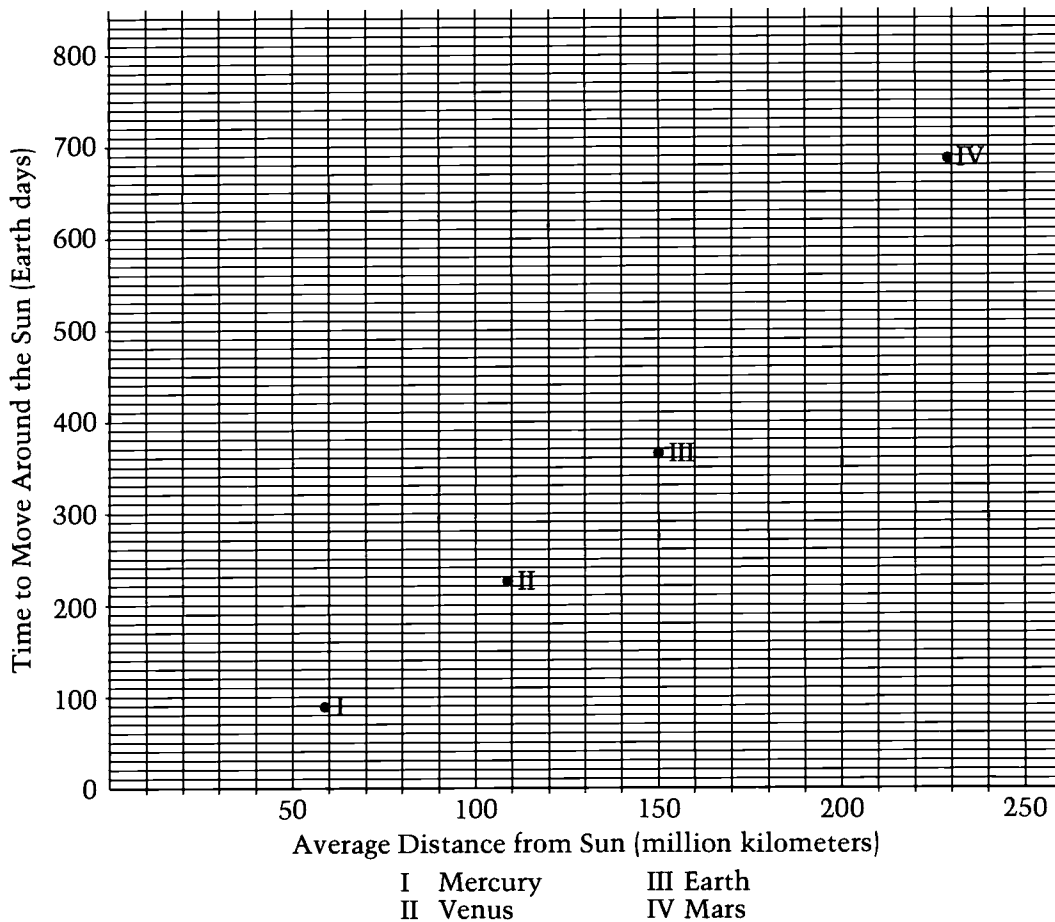

8. Based on the graph, which of the following is true?
- Ⓐ The farther a planet is from the Sun, the longer it takes for the planet to move around the Sun.
 - Ⓑ The closer a planet is to the Sun, the longer it takes for the planet to move around the Sun.
 - Ⓒ The smaller a planet is, the longer it takes for the planet to move around the Sun.
 - Ⓓ The larger a planet is, the longer it takes for the planet to move around the Sun.

The correct option is A.

Performance data are shown in table 3.30. Students found this multiple-choice question relatively easy, as indicated by the 85 percent who chose the correct option — A.

TABLE 3.30 Percentages Choosing Each Response: Grade 8 Graph Reading THE NATION'S REPORT CARD 

<i>Response Options</i>				
A	B	C	D	Omit
85	5	5	4	2

NOTE: Numbers do not add to 100 due to rounding.

The percentages of students in each of the achievement levels that chose the correct option are shown in table 3.31. The question proved to be easy; 95 percent of students at the *Basic* level were able to interpret the graph correctly.

TABLE 3.31 Percentages Correct within Each Achievement Level Interval: Grade 8 Graph Reading THE NATION'S REPORT CARD 

<i>Below Basic</i> (0-142)	<i>Basic</i> (143-169)	<i>Proficient</i> (170-206)	<i>Advanced</i> (207-300)
66	95	99	--

-- Sample size insufficient to permit a reliable estimate.

Theme: Seasons

The next question appeared in the last position in the theme block. It asked students to specify what changes had to be made to the model that was initially given to them, and to explain why January is colder than July in the Northern Hemisphere. Students could draw a picture as part of their answer. However, this was not mandatory. The question was scored according to a three-level scoring guide.¹⁶ A student response that received a score of *Complete* could draw and/or describe changes to the model. A response that received a score of *Partial* mentioned the Earth's tilt but did not elaborate further. A response that received a score of *Unsatisfactory* showed no understanding of the causes of seasons.

12. What additions or changes could be made to this model of the Solar System to best explain why the Northern Hemisphere of the Earth is colder in January than in July? You may draw a picture as part of your answer.

¹⁶ Appendix B contains scoring guides for the sample questions that appear in this report.

Sample 1: Complete Response

The first sample response received a score of *Complete*. This student correctly shows the Earth's tilt and labels the Earth in summer and winter. The student also includes a description that addresses direct rays. The response clearly demonstrates understanding of why the Earth is colder in January than in July.

Sample 1: Seasons

12. What additions or changes could be made to this model of the Solar System to best explain why the Northern Hemisphere of the Earth is colder in January than in July? You may draw a picture as part of your answer.

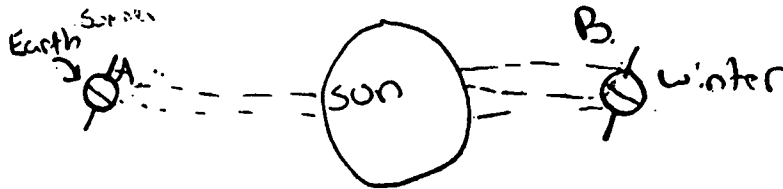

A. In the summer the earth's axis tilts towards the sun. With this the Northern Hemisphere receives more direct rays.

B. In the winter the southern hemisphere receives less direct rays because the earth's axis is tilted away from the sun.

Sample 2: Partial Response

The following response received a score of *Partial*. This student knows that the tilt of the Earth had something to do with the temperature differential between winter and summer, but fails to explain it adequately.

Sample 2: Seasons

12. What additions or changes could be made to this model of the Solar System to best explain why the Northern Hemisphere of the Earth is colder in January than in July? You may draw a picture as part of your answer.

It is because of the way the earth is tilted on it's axis at those times of the year.

Sample 3: Unsatisfactory Response

Sample response 3 received a score of *Unsatisfactory*. This particular response fails to show the angle of tilt. In addition, the student thinks that the Earth is closer to the Sun in July than in January, which is incorrect — the reverse is true.

Sample 3: Seasons

12. What additions or changes could be made to this model of the Solar System to best explain why the Northern Hemisphere of the Earth is colder in January than in July? You may draw a picture as part of your answer.

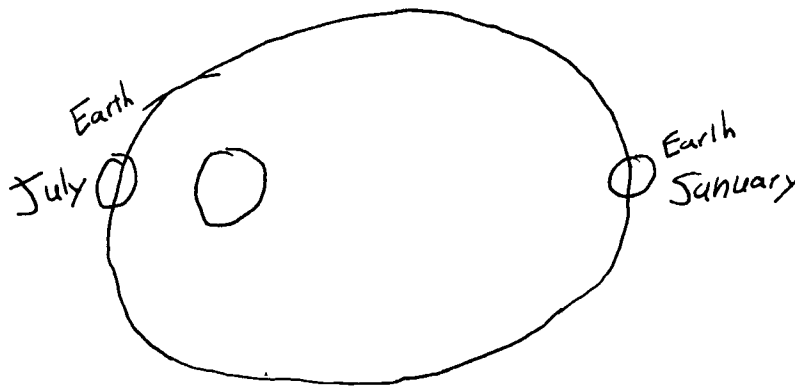

Because the earth is closer
to the Sun in July and
it is farther away from the
Sun in January. The reason
for that is because the earth
has an egg like orbit.

Performance data are shown in tables 3.32 and 3.33. Eighth graders found the question very challenging. Eight percent of students received a score of *Complete*, 12 percent a score of *Partial*, and 76 percent a score of *Unsatisfactory*. When results are presented by achievement level, 1 percent of students classified as below *Basic*, 6 percent classified as *Basic*, and 16 percent classified as *Proficient* were able to suggest additions or changes to the model to best explain why the Northern Hemisphere of the Earth is colder in January than in July.

TABLE 3.32 **Percentages at Different Score Levels:**
Grade 8
Seasons THE NATION'S
REPORT
CARD 

Complete	Partial	Unsatisfactory	Omit
8	12	76	3

NOTE: Numbers do not add to 100 due to rounding.

TABLE 3.33 **Percentages Complete within Each**
Achievement Level Interval: Grade 8
Seasons THE NATION'S
REPORT
CARD 

<i>Below Basic</i> (0-142)	<i>Basic</i> (143-169)	<i>Proficient</i> (170-206)	<i>Advanced</i> (207-300)
1	6	16	--

-- Sample size insufficient to permit a reliable estimate.

Hands-on Task

Each student who participated in the NAEP 1996 science assessment took one of four hands-on tasks. Each task was designed to use materials to perform an investigation, make observations, record and evaluate experimental results, and apply problem-solving skills. The first page of one of the four tasks presented to students is shown below. It is similar to the one administered to fourth graders, which is discussed in chapter 2; however, the questions asked were more difficult. For example, students were expected to be able to construct a graph and interpolate from that graph.

An instrument constructed from a pencil and thumbtack served as a hydrometer in this task. Students were asked to observe, measure, and compare the lengths of a portion of pencil, marked with calibrations for ease of measurement, that floated above the surface in distilled water and in a 25% salt solution. Based on these observations, the students were asked to

predict how the addition of more salt to the salt solution would affect the floating pencil. Students then measured the length of the pencil that floated above the surface of a solution of unknown salt concentration and used the results of their previous observations to estimate the salt concentration of the unknown solution.

The task assessed students' abilities to make simple observations, measure length using a ruler, apply observations to an unknown, draw a graph, interpolate from graphical data, and make a generalized inference from observations. The task also assessed students' understanding of the value of performing multiple trials of the same procedure. The complete task, scoring guides for each question, and sample student responses can be found on the Internet.¹⁷

SALT SOLUTIONS

Estimating the Salt Concentration of an Unknown Salt Solution Using the "Floating Pencil Test"

For this task, you have been given a kit that contains materials that you will use to perform an investigation during the next 30 minutes. Please open your kit now and use the following diagram to check that all of the materials in the diagram are included in your kit. If any materials are missing, raise your hand and the administrator will provide you with the materials that you need.

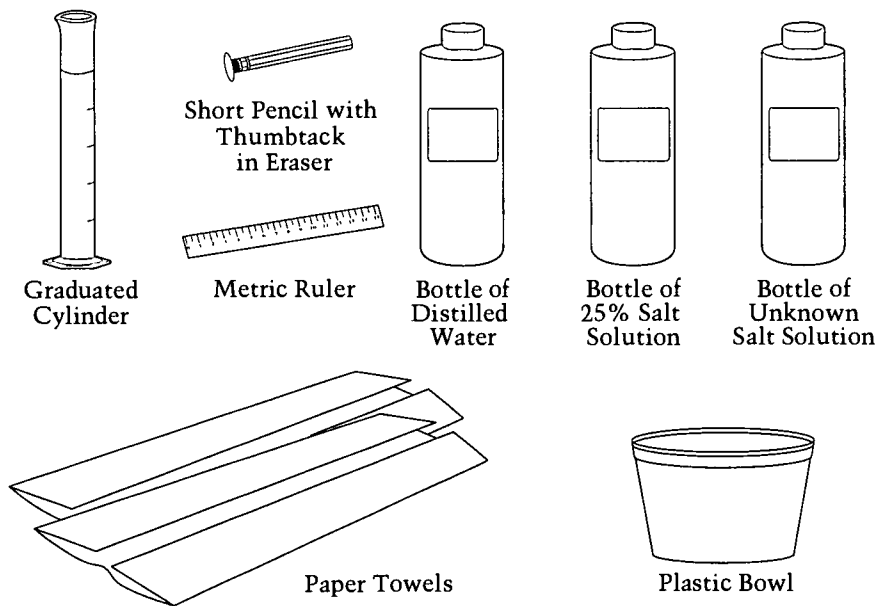

¹⁷ National Center for Education Statistics. National Assessment of Educational Progress. (1997). *1996 science assessment science public release, grade 8* [On-line]. Available: <http://nces.ed.gov/naep>.

The next diagram shows several questions taken from the task. The first three questions relate to measurement and averages. The last two (12 and 14) relate to graph drawing and interpolation. These are followed by student responses. Each set of student responses shown below belongs to one student. Thus, readers can judge the accuracy of each student's graphing and interpolation skills. The questions relating to measurement and interpolation were scored using four-level scoring guides and the questions relating to average and graphing were scored using three-level guides.¹⁸

To receive a score of *Complete* on the question that assessed measuring skills, students had to show three sets of measurements that agreed within ± 0.2 cm and the correct relative order of pencil heights above each solution had to be correct. (Since the pencils were not uniform in length, the height of different pencils above the same solution varied. Thus, students' responses were credited for the closeness exhibited between the two measurements taken for each solution and the relative order of pencil heights above each of the three solutions.) A score of *Essential* was given to responses that had each pair of measurements within ± 0.2 cm, but whose relative order was unexpected. A score of *Partial* was given to those responses that showed two sets of measurements that agreed within tolerance, and a score of *Unsatisfactory* was given to those responses that had one or no sets of measurements that agreed within tolerance.

The question that related to calculating averages was scored using a three-level guide. A score of *Complete* was given to responses that correctly calculated three averages; a response that correctly calculated one or two averages was given a score of *Partial*. A response that received a score of *Unsatisfactory* contained no correct averages.

The ability to graph was also measured using a three-level guide. A score of *Complete* meant that students could plot their own data correctly and draw a line between each point. A score of *Partial* was given for plotting one data point correctly or two data points correctly without connecting them. A score of *Unsatisfactory* was given to a graph that was incorrectly plotted.

The skill of interpolation was measured using a four-level guide. To receive a score of *Complete*, the student had to indicate a salt concentration that was consistent with the data and correctly explain how the answer was obtained. If the response showed a correct concentration but lacked a clear explanation, it received a score of *Essential*. A score of *Partial* was given to responses that calculated the salt concentration using proportional reasoning and not a graph. A response received a score of *Unsatisfactory* if the value for the salt concentration was not consistent with the graph.

¹⁸ Appendix B contains scoring guides for the sample questions that appears in this report.

3. Now take the pencil out of the water and dry it with a paper towel. Use the ruler to measure the length of the pencil that was above the water. Record the length in Table 1 below under Measurement 1.

TABLE 1

Type of Solution	Length of Pencil Above Water Surface (cm)		
	Measurement 1	Measurement 2	Average
Distilled Water			
Salt Solution			
Unknown Salt Solution			

4. Now place the pencil back in the distilled water and repeat steps 2 and 3. Record your measurement in Table 1 under Measurement 2.
5. Calculate the average of Measurements 1 and 2 and record the result in the data table.
(You can calculate the average by adding Measurement 1 and Measurement 2 and then dividing by two.)
12. On the graph below, plot the average values you obtained for the distilled water and the 25% salt solution. Draw a straight line between the two data points. Assume that this line represents the relationship between the length of pencil that is above the water surface and the concentration of salt in the water.

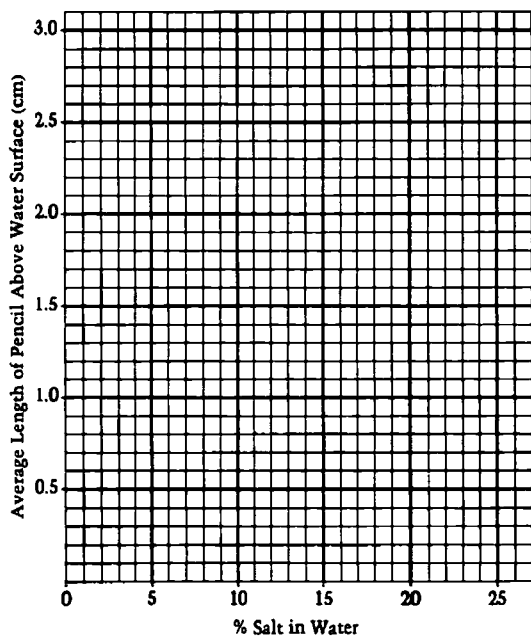

14. Based on the graph that you plotted, what is the salt concentration of the unknown solution? _____
Explain how you determined your answer.

Hands-on Task: Salt Solution, Sample Set 1

Sample set 1 shows responses that each received a score of *Complete*. This student is able to measure and calculate averages accurately. This latter task was somewhat easy because the two measurements for each solution were identical. The concentration of salt in the unknown is accurate (16 percent) and the student gives a good explanation of how to interpolate.

Sample Set 1: Salt Solution: Measurement and Average

TABLE 1

Type of Solution	Length of Pencil Above Water Surface (cm)		
	Measurement 1	Measurement 2	Average
Distilled Water	1 cm	1 cm	1 cm
Salt Solution	2 1/2 cm	2 1/2 cm	2 1/2 cm
Unknown Salt Solution	2 cm	2 cm	2 cm

12. On the graph below, plot the average values you obtained for the distilled water and the 25% salt solution. Draw a straight line between the two data points. Assume that this line represents the relationship between the length of pencil that is above the water surface and the concentration of salt in the water.

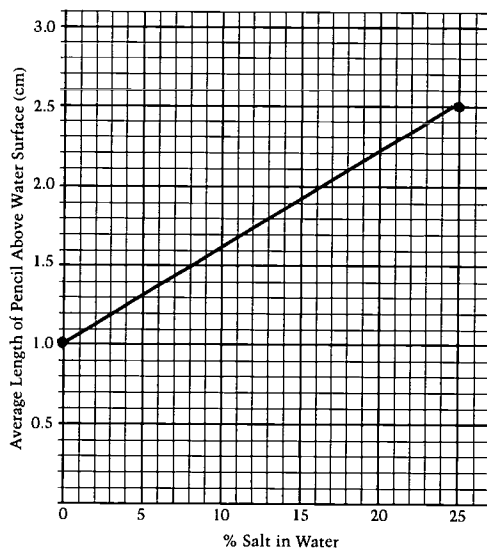

14. Based on the graph that you plotted, what is the salt concentration of unknown solution?

about 16%

Explain how you determined your answer.

with the line connecting the
distilled water and the salt solution
I measured 2 cm. The measurement
connects to the line at about 16%
so the unknown solution is about 16%

Hands-on Task: Salt Solution, Sample Set 2

Sample set 2 shows responses that demonstrate the skill of graphing only. Only one of the three sets of measurements (the one for distilled water) is within the range of tolerance (agreement between the two measurements within ± 0.2 cm). Therefore, the student received a score of *Unsatisfactory* for measuring. The same student is able to calculate one average but is not able to calculate averages that involve fractions. This response received a score of *Partial*. The student is then able to plot the data correctly, thus receiving a score of *Complete* for the graph, but is unable to interpolate and admits to guessing.

Sample Set 2: Salt Solution: Measurement and Average

TABLE 1

Type of Solution	Length of Pencil Above Water Surface (cm)		
	Measurement 1	Measurement 2	Average
Distilled Water	1cm	1 cm	1cm
Salt Solution	2½cm	2¼cm	2cm
Unknown Salt Solution	1½cm	2cm	1cm

12. On the graph below, plot the average values you obtained for the distilled water and the 25% salt solution. Draw a straight line between the two data points. Assume that this line represents the relationship between the length of pencil that is above the water surface and the concentration of salt in the water.

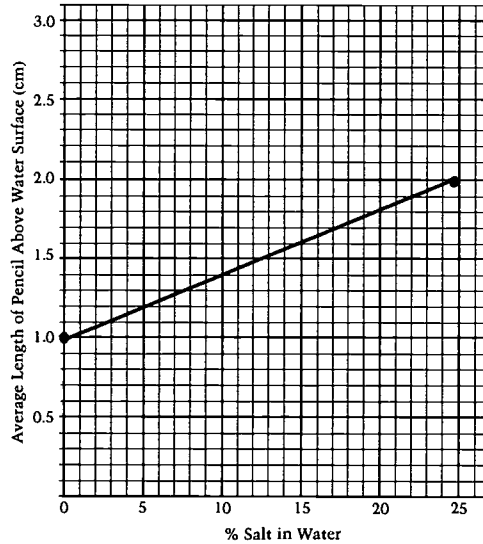

14. Based on the graph that you plotted, what is the salt concentration of unknown solution?

10%

Explain how you determined your answer.

I guessed

Hands-on Task: Salt Solution, Sample Set 3

Sample response 3 received a score of *Complete* on measurement and averaging. This student is unable to graph the data correctly and cannot interpolate, thus receiving a score of *Unsatisfactory* for both questions.

Sample Set 3: Salt Solution: Measurement and Average

TABLE 1

Type of Solution	Length of Pencil Above Water Surface (cm)		
	Measurement 1	Measurement 2	Average
Distilled Water	0.7	0.5	0.6
Salt Solution	2	1.9	1.9
Unknown Salt Solution	1.5	1.5	1.5

12. On the graph below, plot the average values you obtained for the distilled water and the 25% salt solution. Draw a straight line between the two data points. Assume that this line represents the relationship between the length of pencil that is above the water surface and the concentration of salt in the water.

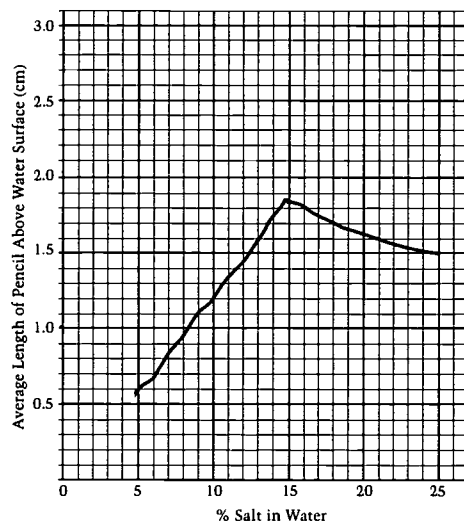

14. Based on the graph that you plotted, what is the salt concentration of unknown solution?

more salt

Explain how you determined your answer.

Because it was the highest
of all the waters.

Tables 3.34 and 3.35 present student data for the question relating to measurement. Forty-two percent of eighth-grade students were able to measure the height of the pencil above the surface of three solutions and thus received a score of *Complete*. Thirty-nine percent of students classified as below *Basic*, 61 percent of students classified as *Basic*, and 77 percent classified as *Proficient* were able to take duplicate measures that agreed within +/- 0.2 cm.

TABLE 3.34 **Percentages at Different Score Levels:**
Grade 8
Salt Solution: Measurement



Complete	Essential	Partial	Unsatisfactory	Omit
42	16	21	20	1

TABLE 3.35 **Percentages Complete or Essential within Each**
Achievement Level Interval: Grade 8
Salt Solution: Measurement



Below Basic (0-142)	Basic (143-169)	Proficient (170-206)	Advanced (207-300)
39	61	77	--

-- Sample size insufficient to permit a reliable estimate.

Tables 3.36 and 3.37 show the percentages of students at different score levels and the percentages of students within each achievement level interval for the question that asked students to calculate averages. Fifty-seven percent of eighth graders were able to average correctly. In addition, 65 percent of students classified as *Basic* and 91 percent classified as *Proficient* were able to calculate averages accurately.

TABLE 3.36 **Percentages at Different Score Levels:**
Grade 8
Salt Solution: Average



Complete	Partial	Unsatisfactory	Omit
57	22	18	3

TABLE 3.37 **Percentages Complete within Each**
Achievement Level Interval: Grade 8
Salt Solution: Average



Below Basic (0-142)	Basic (143-169)	Proficient (170-206)	Advanced (207-300)
23	65	91	--

-- Sample size insufficient to permit a reliable estimate.

Data relating to student performance on graphing are presented in tables 3.38 and 3.39. Twenty-eight percent of students were able to transfer their data to graphs. Forty-two percent of students were not able to perform this skill successfully. Students who were classified as *Below Basic* found graphing extremely challenging; two percent were able to graph correctly. By contrast, 61 percent of students classified as *Proficient* were able to graph correctly.

TABLE 3.38 **Percentages at Different Score Levels:**
Grade 8
Salt Solution: Graphing



Complete	Partial	Unsatisfactory	Omit
28	19	42	11

TABLE 3.39 **Percentages Complete within Each**
Achievement Level Interval: Grade 8
Salt Solution: Graphing



Below Basic (0-142)	Basic (143-169)	Proficient (170-206)	Advanced (207-300)
2	21	61	--

-- Sample size insufficient to permit a reliable estimate.

Tables 3.40 and 3.41 present performance data for the skill of interpolating. Twenty-eight percent of eighth graders were able to interpolate and received a score of *Complete* or *Essential*. The question proved very difficult for those students who were below the *Basic* level or at the *Basic* level. Three percent of students classified as below *Basic* and 19 percent classified as *Basic* were able to find the concentration of salt in the unknown solution using their own data.

TABLE 3.40 **Percentages at Different Score Levels:**
Grade 8
Salt Solution: Interpolating THE NATION'S
REPORT
CARD 

Complete	Essential	Partial	Unsatisfactory	Omit
20	8	16	53	3

TABLE 3.41 **Percentages Complete or Essential within Each**
Achievement Level Interval: Grade 8
Salt Solution: Interpolating THE NATION'S
REPORT
CARD 

Below Basic (0-142)	Basic (143-169)	Proficient (170-206)	Advanced (207-300)
3	19	54	--

-- Sample size insufficient to permit a reliable estimate.

Summary of Grade 8 Data

The data presented in this chapter give an indication of how students in grade 8 perform on science questions that cover a range of topics and make use of a variety of question types. The questions presented had to be limited to those that were released to the public.¹⁹ These are fairly representative and do give an indication of the understandings and skills surveyed in the assessment. Similarly, the data for the small group of questions discussed in this chapter represent the data seen for the questions as a whole. In general, the multiple-choice questions that required students to know facts, such as the function of a mitochondrion or the meaning of windchill, or concepts such as energy were more difficult than those that asked for skills such as simple graph reading. Constructed-response questions that required students to demonstrate their understanding of concepts such as seasons and behavior of light also proved very difficult, whereas skills such as measuring and simple averaging were somewhat less difficult.

- The amount of exposure to the different fields of science was not associated with differences in the composite, life science, earth science, or physical science average scale scores of students or the percentage of students at or above *Proficient*. For example, students whose teachers reported that they spent little time on physical science performed as well on physical science questions as did students whose teachers reported that they spent a lot of time on physical science.
- Male students had a higher average question score than female students for questions that measured physical science and earth science.
- White students and Asian/Pacific Islander students had a higher average question score than Black and Hispanic students for questions that measured earth science, physical science, and life science.
- Male students had a higher average question score than female students for questions that measured conceptual understanding.
- White students and Asian/Pacific Islander students had a higher average question score than Black and Hispanic students for questions that measured conceptual understanding and scientific investigation.
- The percentage of students who gave correct responses to the multiple-choice questions discussed in this chapter ranged from 28 percent to 85 percent.
- The percentage of students who received a score of *Complete* on the constructed-response questions discussed in this chapter ranged from 2 percent to 57 percent.

¹⁹ National Center for Education Statistics, National Assessment of Educational Progress. (1997). *1996 science assessment public release, grade 8*. [On-line]. Available; <http://nces.ed.gov/naep>.

Chapter 4

Grade 12: Performance, Knowledge, and Skills

Introduction

The NAEP 1996 science assessment was administered nationally to grade 12 students. The assessment was constructed according to specifications in the *Science Framework for the 1996 National Assessment of Educational Progress*.¹ Each question in the assessment was classified as either earth, physical, or life science. (A description of the fields of science can be found in Chapter 1) The amount of time specified for each field of science was approximately equal. For the ways of knowing and doing science, the specifications state that 45 percent of assessment time should be spent on conceptual understanding, 30 percent on scientific investigation, and 25 percent on practical reasoning. As with questions in the fourth- and eighth-grade assessments, each grade 12 question was classified as measuring one of the elements of knowing and doing science within one of the fields of science (for example, scientific investigation in the context of life science). The number of multiple-choice, short-constructed response, and extended constructed-response questions in each of the content and cognitive domains is presented in table 4.1. There were 70 multiple-choice questions and 120 constructed-response questions in the grade 12 NAEP science assessment.

Each constructed-response question had its own unique scoring guide that defined the criteria used to evaluate students' responses.² Short constructed-response questions were usually scored according to three levels of performance: *Complete*, *Partial*, and *Unsatisfactory*; however, some of them were scored as either right or wrong (*Complete* or *Unsatisfactory*). Extended constructed-response questions were usually scored according to four levels of performance: *Complete*, *Essential*, *Partial*, and *Unsatisfactory*. In a few instances, however, five- and six-level scoring guides were used. In total, 242,104 student responses were scored. This included the 25 percent of responses that were scored twice to monitor the reliability of the scoring process.³ The scoring process is described in more detail in appendix A.

¹ National Assessment Governing Board. (1995). *Science framework for the 1996 National Assessment of Educational Progress*. Washington, DC: Author.

² Appendix B contains scoring guides for the sample questions that appear in this report.

³ For grade 12, the percentage agreement for the 1996 reliability sample was 94 percent. This means that the scores of the first and second scorers agreed 94 percent of the time.

TABLE 4.1

Distribution of Questions by Fields of Science and by Ways of Knowing and Doing Science, Grade 12: Public and Nonpublic Schools Combined



	Multiple-Choice	Short Constructed-Response	Extended Constructed-Response	Total
Fields of Science				
Earth Science	22	33	9	64
Life Science	22	34	10	66
Physical Science	26	23	11	60
Total	70	90	30	190
Knowing and Doing				
Conceptual Understanding	62	43	9	114
Scientific Investigation	3	22	12	37
Practical Reasoning	5	25	9	39
Total	70	90	30	190

SOURCE: National Center for Education Statistics, National Assessment of Educational Progress (NAEP), 1996 Science Assessment.

As part of the NAEP 1996 science assessment, students and school administrators answered questions relating to science course work and graduation requirements. The results give an indication of the current status of science education in the United States and provide a context for understanding students' performance vis-à-vis the number and types of science courses taken. For example, analyses of data from the NAEP 1996 science assessment show that students who took courses in biology, chemistry, and physics outperformed students who did not take these three courses. In particular, physics appeared to be a critical course; students who took any combination of subjects that included physics outperformed their peers who did not take physics as one of their courses.⁴ However, data also show that 96 percent of students completed course work in biology, 74 percent in chemistry, and 41 percent in physics.⁵

The relatively low percentage of students taking physics can be explained in a number of ways. Although students may either choose or be advised not to take physics, graduation requirements and prerequisites also play a role. Sixty-three percent of students attended schools or districts having a two-year science requirement for graduation, and while many students took more science courses, 41 percent reported having taken two years or less of science. Since physics is generally not offered as a first- or second-year course, these students were unlikely to take physics as one of their two requirements for graduation.⁶ Furthermore, many students are not able to take physics because they have not fulfilled the mathematics

⁴ O'Sullivan, C. Y., Weiss, A. R., & Askew, J. M. (1998). *Students learning science: A report on policies and practices in U.S. schools*. (NCES Publication No. 98-493). Washington, DC: National Center for Education Statistics.

⁵ Ibid.

⁶ Ibid.

National Center for Education Statistics, National Assessment of Educational Progress. (1997). *1996 Science assessment summary data tables* [On-line]. Available: <http://nces.ed.gov/naep/tables96/index.html>.

requirements imposed by many schools for entry into the course. Students may, therefore, take more than two years of science, but will often take courses other than physics, such as advanced biology or science and technology.

Additional data collected during the 1996 assessment indicated that 32 percent of students in grade 12 had completed course work in biology, chemistry, and physics.⁷ The data also showed that 46 percent of students were no longer enrolled in a science course when they were administered the NAEP 1996 science assessment.

Average Question Score

The average question scores for earth science, physical science, and life science questions are presented in table 4.2. For all students 0.42 was the average question score for both earth science and physical science questions. The average question score for life science questions was 0.40. Readers are cautioned not to make comparisons among the fields of science for any group of student. Variations may, for example, be due to the particular make-up of the set of questions administered and could well not hold if students were administered a different set of questions covering the same fields of science. Comparisons can be made, however, among the different groups of students and several differences were found. Male students had a higher average question score than female students on earth science and physical science questions. The performance of White students on earth, physical, or life science questions was higher than the performance of Black and Hispanic students in these same fields of science. In addition, White students outperformed Asian/Pacific Islander students for the questions that measured physical science. Asian/Pacific Islander students had higher average question scores than Black and Hispanic students on questions that measured earth, physical, and life science and Hispanic students had a higher average question score than Black students on questions that measured earth science.

TABLE 4.2

Average Question Score for Earth Science, Physical Science, and Life Science, Grade 12: Public and Nonpublic Schools Combined



	Earth Science	Physical Science	Life Science
All Students	0.42	0.42	0.40
Male	0.44	0.44	0.40
Female	0.39	0.41	0.40
White	0.46	0.46	0.43
Black	0.28	0.30	0.30
Hispanic	0.33	0.33	0.32
Asian/Pacific Islander	0.41	0.42	0.39

NOTE: White refers to White (not Hispanic), and Black refers to Black (not Hispanic).

SOURCE: National Center for Education Statistics, National Assessment of Educational Progress (NAEP), 1996 Science Assessment.

⁷ O'Sullivan, C. Y., Weiss, A. R., & Askew, J. M. (1998). *Students learning science: A report on policies and practices in U.S. schools*. (NCES Publication No. 98-493). Washington, DC: National Center for Education Statistics.

Table 4.3 shows the average question score for questions that measured conceptual understanding, scientific investigation, and practical reasoning. For all students, the average question scores for questions measuring conceptual understanding, scientific investigation, and practical reasoning were 0.42, 0.45, and 0.35, respectively. Again readers are cautioned not to compare the performance among the ways of knowing and doing science since student performance may have varied if different sets of questions had comprised these categories. When the data for the different groups of students within each way of knowing and doing science are examined, however, several differences emerge. Male students had a higher average question score than female students for questions that measured conceptual understanding and practical reasoning. For questions that measured conceptual understanding and scientific investigations, White students outperformed Black, Hispanic, and Asian /Pacific Islander students, Hispanic and Asian/Pacific Islander students outperformed Black students, and Asian/Pacific Islander students outperformed Hispanic students. For questions that measured practical reasoning, White students outperformed Black, Hispanic, and Asian/Pacific Islander students, and Asian/Pacific Islander students outperformed Black and Hispanic students.

TABLE 4.3

Average Question Score for Conceptual Understanding, Scientific Investigation, and Practical Reasoning, Grade 12: Public and Nonpublic Schools Combined



	Conceptual Understanding	Scientific Investigation	Practical Reasoning
All Students	0.42	0.45	0.35
Male	0.44	0.46	0.36
Female	0.40	0.45	0.34
White	0.46	0.49	0.38
Black	0.31	0.32	0.25
Hispanic	0.34	0.36	0.26
Asian/ Pacific Islander	0.41	0.46	0.34

NOTE: White refers to White (not Hispanic) and Black refers to Black (not Hispanic).

SOURCE: National Center for Education Statistics, National Assessment of Educational Progress (NAEP), 1996 Science Assessment.

Sample Questions and Student Responses

The following section contains sample questions for each of the major fields of science (earth, physical, and life science). Table 4.4 summarizes the classification of these questions. Some questions can be classified in more than one field of science or way of knowing and doing science. For the purposes of test construction and analysis, however, the classification had to be limited to one field of science and one way of knowing and doing science. As in chapters 2 and 3, the questions are organized by ways of knowing and doing science. The theme block and hands-on task are discussed separately since each was administered to students as a unit.

Two tables displaying data are included with each question. For multiple-choice questions, the first table shows the percentage of students choosing each response and the second table shows the percentages correct within each achievement-level interval. For constructed-response questions, the first table shows the percentages of students at different score levels and the second shows the percentages of students that received a score of *Complete* (or *Essential* or higher in the case of extended constructed-response questions) within each achievement-level interval. In this chapter, the tables showing percentages of students within each achievement-level interval do not contain data in the column labeled “*Advanced*” because the number of students classified as *Advanced* was too small to permit a reliable estimate.⁸

TABLE 4.4

Sample Questions Categorized by Fields of Science and by Ways of Knowing and Doing Science, Grade 12: Public and Nonpublic Schools Combined



	Earth Science	Physical Science	Life Science
Conceptual Understanding	Solar eclipse (mc) Pacific ring of fire (ecr) Theme: Cloud formation (scr)	Path on ice (mc) Object with greatest mass (mc) Theme: Temperature and evaporation (mc)	Genotype (ecr)
Scientific Investigation	Theme: Identification of ocean and lake water (ecr)	Task: Properties of materials (ecr) Task: Separation (ecr) Task: Description of method (ecr)	Concluding from results (mc)
Practical Reasoning	Flooding (scr)	Keeping ice cream cold (scr)	Malaria (scr) Heart disease (scr)

NOTE: “mc” indicates a multiple choice question; “scr” indicates a short constructed-response question; and “ecr” indicates an extended constructed-response question.

⁸ Allen, N. L., Carlson, J., & Zelenak, C. A. (in press) *The NAEP 1996 Technical Report*. Washington, DC: National Center for Education Statistics.

Conceptual Understanding⁹

The NAEP 1996 science assessment administered at grade 12 contained 190 questions. One hundred and fourteen of these addressed conceptual understanding. A selection of questions follows. These questions measure understanding of basic facts and concepts taken from the fields of earth science, physical science, and life science.



Solar Eclipse

The first multiple-choice question is classified under the earth science topic “Earth in Space.” To answer this question correctly, students had to recognize the next stage in the progression of a solar eclipse. In addition, students had to recognize the direction the Moon takes as it passes directly between the Earth and the Sun.

1. Noon 12:30 p.m. 1:00 p.m. 1:30 p.m.

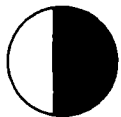

Four stages in the progression of a solar eclipse are shown above. How would the eclipse most likely look at 2:00 p.m.?

(A)  (B)  (C)  (D) 

The correct option is C.

⁹ See figure 1.2 for a description of conceptual understanding.

Student performance data for this question are shown in table 4.5. The question was fairly easy for twelfth-grade students. Eighty percent chose the correct option, C. A small percentage of students chose one of the three incorrect options, A, B, or D. The most attractive of these was D.

TABLE 4.5		Percentages Choosing Each Response:			THE NATION'S REPORT CARD	
		Grade 12				
		Solar Eclipse				
		Response Options				
A	B	C	D	Omit		
5	3	80	11	1		

The percentage of students within each of the achievement level intervals that successfully answered the question is shown in table 4.6. Sixty-nine percent of students classified as below *Basic* and 86 percent classified as *Proficient* answered the question correctly.

TABLE 4.6		Percentages Correct within Each Achievement Level Interval:			THE NATION'S REPORT CARD	
		Grade 12				
		Solar Eclipse				
Below Basic (0-144)	Basic (145-177)	Proficient (178-209)	Advanced (210-300)			
69	86	92	--			

-- Sample size insufficient to permit a reliable estimate.

Pacific Ring of Fire

The purpose of this extended constructed-response question was to find out whether students knew that volcanic activity and earthquakes usually occurred at the boundaries of tectonic plates. It was classified under the earth science topic “Solid Earth.” The question explained where the Ring of Fire is located and then asked students to link this area with volcanic activity and earthquakes. To answer this question satisfactorily, students had to have some knowledge of the tectonic plate theory. The responses were scored according to a four-level scoring guide.¹⁰ Students at the highest level, *Complete*, had to include in their responses the notion of volcanic activity and earthquakes being caused by the relative movement of tectonic plates diverging, converging, or sliding past each other. To achieve a score of *Essential*, a student had to mention the relative movement of plates or link the movement of plates to activity. A score of *Partial* was given to responses that merely stated “plates” or “movement” without adequate explanation. A response that received a score of *Unsatisfactory* demonstrated no knowledge of plate movement as a cause of volcanic activity or earthquakes.

6. The Pacific Ring of Fire is a belt-shaped region that roughly coincides with the seacoasts bordering the Pacific Ocean. Explain why volcanic activity and earthquakes occur frequently in this region.

¹⁰ Appendix B contains scoring guides for the sample questions that appear in this report.

Sample 1: Complete Response

The first sample response received a score of *Complete*. The student links the relative movement of plates to volcanic activity and earthquakes. Although the response does not use the technical language associated with movement, the response does imply that “divergent” movement is taking place and that this movement leaves an open area where lava builds up, “causing a volcano.”

Sample 1: Pacific Ring of Fire

6. The Pacific Ring of Fire is a belt-shaped region that roughly coincides with the seacoasts bordering the Pacific Ocean. Explain why volcanic activity and earthquakes occur frequently in this region.

Volcanic activity and earthquakes frequently occur where two plates, which make up the crust of the earth, coincide. The plates are constantly shifting. This causes pressure and friction between the plates. Sometimes the pressure is so great that earthquakes occur. The space between these plates leaves an open area to the mantle which is molten earth. When lava builds up in these crevasses it sometimes explodes, causing a volcano.

Sample 2: Essential Response

The second sample response received a score of *Essential*. This student clearly links movement of plates to volcanic activity and earthquakes — “Two large plates are running into each other” — but does not describe the movement in any detail.

Sample 2: Pacific Ring of Fire

6. The Pacific Ring of Fire is a belt-shaped region that roughly coincides with the seacoasts bordering the Pacific Ocean. Explain why volcanic activity and earthquakes occur frequently in this region.

Volcanic activity and earthquakes often occur here because of plate tectonics. Two large plates are running into each other.

Sample 3: Partial Response

The student in the next sample merely states that, “this is where two plates of the earth come together.” This explanation was considered to be too general because the student did not indicate that the plates were indeed moving in some way. Thus, it received a score of *Partial*.

Sample 3: Pacific Ring of Fire

6. The Pacific Ring of Fire is a belt-shaped region that roughly coincides with the seacoasts bordering the Pacific Ocean. Explain why volcanic activity and earthquakes occur frequently in this region.

This is where two plates of
the earth come together.

Sample 4: Unsatisfactory Response

The next sample shows a typical response that received a score of *Unsatisfactory*. This student thinks that water movement from the Pacific Ocean causes the level of the underground surface to shift, producing volcanic activity and earthquakes.

Sample 4: Pacific Ring of Fire

6. The Pacific Ring of Fire is a belt-shaped region that roughly coincides with the seacoasts bordering the Pacific Ocean. Explain why volcanic activity and earthquakes occur frequently in this region.

Volcanic activity and earthquakes
occur frequently in this
region because the level
of the underground surface
tends to shift as a result
of the water movement
from the Pacific Ocean

Table 4.7 presents the percentages of students at each of the score levels. The item proved to be difficult. Four percent of twelfth graders were able to give a fairly full explanation as to why volcanic activity and earthquakes frequently occur in a given region. Forty-eight percent of students knew that the activity had something to do with “plates.” The remaining 34 percent gave an incorrect answer to the question. In addition, the omit rate for this question was very high, 15 percent, suggesting that many students thought the question was too hard to attempt to answer.

TABLE 4.7 **Percentages at Different Score Levels:**
Grade 12
Pacific Ring of Fire 

Complete	Essential	Partial	Unsatisfactory	Omit
4	26	22	34	15

Note: Numbers do not add to 100 due to rounding.

Table 4.8 presents the percentages of students within each achievement level interval that received a score of *Complete* or *Essential*. Ten percent of students classified as below *Basic*, 32 percent classified as *Basic*, and 63 percent classified as *Proficient* were at least able to explain the relative movement of plates or link the movement of plates to activity. Insert Table 4.8

TABLE 4.8 **Percentages Complete or Essential within Each**
Achievement Level Interval: Grade 12
Pacific Ring of Fire 

Below Basic (0-144)	Basic (145-177)	Proficient (178-209)	Advanced (210-300)
10	32	63	--

-- Sample size insufficient to permit a reliable estimate.

Path on Ice

The next multiple-choice question was classified under the physical science topic “Motion.” The diagram depicts a car that is traveling around a curve onto ice. The question asks students to choose from four options which path the car is most likely to take on the ice. Students were told that the frictional force on the tires was reduced to zero. To answer this question correctly, students had to understand the meaning of the word “friction” and realize that the car’s tires would no longer grip and the car would, therefore, continue on the path it was taking when it encountered the ice.

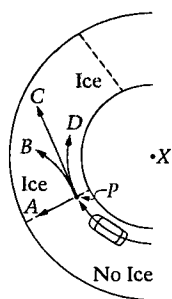

2. A car initially travels with constant speed around a tight, unbanked curve in a circular arc with center X , as shown in the diagram above. At position P , the car encounters a patch of ice, which reduces the frictional force on the tires to zero.

Which of the following best shows the path that the car takes while it is on the ice?

- Ⓐ A
- Ⓑ B
- Ⓒ C
- Ⓓ D

The correct option is C.

The percentages of students choosing each response are shown in table 4.9. Fifty-four percent of grade 12 students answered the question correctly. Options B and D were also attractive to students. Students who chose option B thought that the car would veer to the left; those who chose option D thought the car would continue in its circular path.

TABLE 4.9 **Percentages Choosing Each Response:**
Grade 12
Path on Ice



Response Options

A	B	C	D	Omit
5	26	54	15	0

The percentages of students within each of the achievement level intervals are presented in table 4.10. Thirty-eight percent of students classified as below *Basic* and 59 percent classified as *Basic* recognized the correct path a car took on ice.

TABLE 4.10 **Percentages Correct within Each Achievement Level Interval:**
Grade 12
Path on Ice



Below Basic (0-144)	Basic (145-177)	Proficient (178-209)	Advanced (210-300)
38	59	76	--

-- Sample size insufficient to permit a reliable estimate.

Interpretation of Velocity/Time Graph

The question shown below required students to infer from a graph of velocity as a function of time which object had the greatest mass. It was classified under the physical science topic "Motion." To answer this question correctly, students had to realize that the object with the greatest mass would have the least velocity because the same net force was applied to each object. They also had to understand the meaning of the word "velocity" and be able to recognize that as time increased so too did velocity.

10. A graph of velocity as a function of time when the same net force is applied to three different objects is shown below.

Which object has the greatest mass?

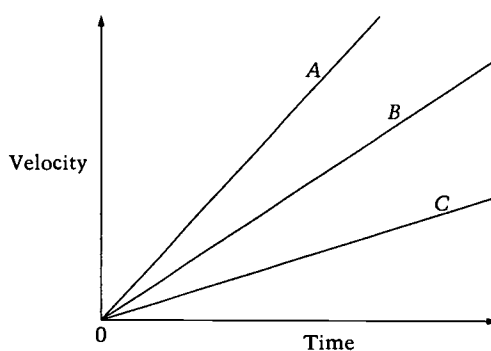

- Ⓐ A
- Ⓑ B
- Ⓒ C
- Ⓓ They all have the same mass.

The correct option is C.

Information relating to student performance is presented in tables 4.11 and 4.12. Fifty-three percent of students answered the question correctly. Twenty-two percent thought that all the objects had the same mass, despite the evidence that each object was accelerating at a different rate. The achievement level data show that 87 percent of students classified as *Proficient* answered the question correctly. Twenty-seven percent of students classified as below *Basic* were also able to answer the question correctly.

TABLE 4.11 Percentages Choosing Each Response:
Grade 12
Interpretation of Velocity/Time Graph



Response Options

A	B	C	D	Omit
15	9	53	22	1

TABLE 4.12 Percentages Correct within Each Achievement Level Interval:
Grade 12
Interpretation of Velocity/Time Graph



Below Basic (0-144)	Basic (145-177)	Proficient (178-209)	Advanced (210-300)
27	63	87	--

-- Sample size insufficient to permit a reliable estimate.

Genotype

In the example shown below, students were told the phenotype for earlobes of a mother, father, and their children. They were then asked to predict the genotype of the father and to supply additional information to support their prediction if they thought it was needed. This question required knowledge of a number of principles key to the understanding of genetics. Students had to understand the meaning of the terms “dominant,” “recessive,” and “genotype,” and also had to be able to perform a simple genetic cross based on information that was given to them. While the convention for representing genetic crosses is usually the Punnett square, students did not have to conform to this. The question deliberately did not ask for the Punnett square, but merely for a diagram to support students’ predictions. The question was scored using a four-level scoring guide.¹¹ To receive a score of *Complete* a student had to address the three parts of the question by providing a correct prediction, a supporting diagram, and some additional information that would help support the prediction. Students could have made one of several predictions. For example, they could have chosen the most likely situation (given the phenotypes of the 5 children) in which the trait for free earlobes is dominant. Thus, the genotype of the father could be FF or Ff. If the genotype were FF, then all the offspring would have free earlobes; if the genotype were Ff, the offspring would have a 50/50 chance of acquiring free earlobes. However, given the phenotypes of the children (all free earlobes), the genotype FF may be more likely. Students could also have decided that attached earlobes were dominant. In this situation, the father’s genotype would have to be ff and mother’s genotype Ff. In this case the children would also have a 50/50 chance of receiving the trait for free earlobes.

The question also asked what further information might be needed to support the prediction. Several student responses were accepted. For example, students could have stated that it would be helpful to know the genotype or phenotype of the father’s parents, or they could have talked about the need for a sixth child. If this child had attached earlobes, then the father’s genotype would have to be Ff. Also, they could have explained that the genes for types of earlobes could be mapped and the DNA sequence determined — thus giving a definitive answer to the prediction.

A score of *Essential* addressed two of the three parts of the question, and a score of *Partial* addressed one of the three parts. Students receiving a score of *Unsatisfactory* did not correctly answer any part of the question.

¹¹ Appendix B contains scoring guides for the sample questions that appear in this report.

16. A mother with attached earlobes and a father with free earlobes have 5 children — 4 boys and 1 girl. All of the children have the father's type of earlobes. What can be predicted about the genotype of the father? Construct a genetic diagram to support your prediction. What additional information, if any, would you need to determine the genotype of the father? Explain.

Sample 1: Complete Response

The first sample response received a score of *Complete*. Although the student uses an incorrect term — “homogeneous” instead of “homozygous” — it is clear from the diagram that free earlobes are dominant, since the student has used the typical convention of genetic crosses: a capped letter for dominant and an uncapped letter for recessive genes. The student also clearly states that the genotype of the father's parents would be needed to prove the genotype of the father.

Sample 1: Genotype

16. A mother with attached earlobes and a father with free earlobes have 5 children — 4 boys and 1 girl. All of the children have the father's type of earlobes. What can be predicted about the genotype of the father? Construct a genetic diagram to support your prediction. What additional information, if any, would you need to determine the genotype of the father? Explain.

The genotype of the father is homozygous.
 The genotypes of the parents of the father would be needed to prove this however, because the father inherits his traits from his parents

Ff Ff Ff Ff Ff

F = free earlobes
 f = attached earlobes.

Sample 2: Essential Response

Sample response 2 received a score of *Essential*. This student states “E” for the genotype but then makes it clear in the diagram that it is in fact “EE.” Thus, the father’s genotype is predicted and evidence for the prediction is given in a Punnett square. The student fails, however, to mention what further information might be needed to support the prediction.

Sample 2: Genotype

16. A mother with attached earlobes and a father with free earlobes have 5 children — 4 boys and 1 girl. All of the children have the father’s type of earlobes. What can be predicted about the genotype of the father? Construct a genetic diagram to support your prediction. What additional information, if any, would you need to determine the genotype of the father? Explain.

E. The father has the dominant trait for earlobes while the mother has the recessive gene.

	Father EE	Mother ee	
	E	e	
E	EE	Ee	therefore all the children would have both dominant and recessive genes for the attachment of the earlobes, but the dominant gene is the one that is shown.
e	Ee	Ee	

Sample 3: Partial Response

Sample response 3 received a score of *Partial*. Here the student predicts that the “father’s genes are more dominant over the mothers,” but gives no further details.

Sample 3: Genotype

16. A mother with attached earlobes and a father with free earlobes have 5 children — 4 boys and 1 girl. All of the children have the father’s type of earlobes. What can be predicted about the genotype of the father? Construct a genetic diagram to support your prediction. What additional information, if any, would you need to determine the genotype of the father? Explain.

The father's genes are more dominant over the mothers.

Sample 4: Unsatisfactory Response

The last example received a score of *Unsatisfactory*. The student clearly does not understand the concepts needed to answer the question and writes instead in general terms about bloodlines.

Sample 4: Genotype

16. A mother with attached earlobes and a father with free earlobes have 5 children — 4 boys and 1 girl. All of the children have the father's type of earlobes. What can be predicted about the genotype of the father? Construct a genetic diagram to support your prediction. What additional information, if any, would you need to determine the genotype of the father? Explain.

The blood line comes through the father so maybe in some way that is connected with why their earlobes are the same as the fathers.

Table 4.13 presents the percentages of twelfth graders at the different score levels. The question was very difficult. Nineteen percent of students had a solid understanding of basic genetics. Forty-three percent had a minimal understanding and received a score of *Partial*. Thirty-six percent of students received a score of *Unsatisfactory*.

TABLE 4.13 Percentages at Different Score Levels:
Grade 12
Genotype

THE NATION'S
REPORT
CARD



Complete	Essential	Partial	Unsatisfactory	Omit
3	16	43	36	2

The percentages of students within each achievement level that received a score of *Complete* or *Essential* are shown in table 4.14. The data show that despite the difficulty of the question, five percent of students classified as below *Basic* were able to answer the question fully. This can probably be explained by the fact that simple genetic crosses are usually a core component of any high school biology course and, according to data collected during the NAEP 1996 science assessment, 96 percent of all twelfth-grade students had taken a course in biology.¹²

TABLE 4.14 **Percentages Complete or Essential within Each Achievement Level Interval: Grade 12 Genotype** THE NATION'S REPORT CARD 

Below Basic (0-144)	Basic (145-177)	Proficient (178-209)	Advanced (210-300)
5	18	37	--

-- Sample size insufficient to permit a reliable estimate.

¹² O'Sullivan, C.Y., Weiss, A .R. and Askew, J.M. (1998). *Students learning science: A report on policies and practices in U.S. schools.* (NCES Publication No. 98-493) Washington, DC: National Center for Education Statistics.

Scientific Investigation¹³

Thirty-seven questions of the 190 that make up the NAEP 1996 science assessment for grade 12 measure the knowledge and skills that comprise scientific investigation. One of the questions classified as scientific investigation is shown below. Questions that measure scientific investigation can also be found in the section describing the hands-on task “Separation.”

Concluding from Results

One of the skills necessary for scientific investigation is the ability to draw valid conclusions from results. The sample below displays a table that shows what happens to red blood cells when they are placed in three different solutions. Based on the results, the technician concluded that the red blood cells could not function in any fluid except serum. Students were asked to choose from among four statements that related to the accuracy of this conclusion.

4. A laboratory technician places red blood cells into three different solutions. Observations are recorded each minute for five minutes.

Solution	Time				
	1 min.	2 min.	3 min.	4 min.	5 min.
Solution 1	No change	Cells are slightly larger.	Cells are much larger.	Cells are huge.	Cells are gone.
Solution 2	No change	No change	No change	No change	No change
Solution 3	No change	Cells are slightly smaller.	Cells are much smaller.	Cells look wilted.	Nothing that looks like a cell can be found.

The laboratory technician concludes that red blood cells cannot function in any fluid except serum. Which of the following best characterizes this conclusion?

- Ⓐ It is accurate on the basis of the information given.
- Ⓑ It is accurate because the cells changed in all the solutions but one.
- Ⓒ It is inaccurate because the cells were outside the body.
- Ⓓ It cannot be substantiated with the data provided.

The correct option is D.

¹³ See figure 1.2 for a description of scientific investigation.

Information on student performance is presented in table 4.15. This question proved to be somewhat difficult. To answer this question correctly, students had to examine each statement vis-à-vis the table. The only conclusion that could be drawn from the table was that the cells in solution 2 did not change, whereas those in solutions 1 and 3 did change, one set of red blood cells becoming larger and the other becoming smaller. The technician, however, extrapolated from the behavior of the cells in three solutions to the universe of solutions. Thus, options A and B are incorrect. However, they drew 13 percent and 32 percent of twelfth graders, respectively. Eleven percent of students chose option C. This statement questioned the conclusion on the grounds that the experiment was conducted outside the body. Forty-three percent chose the correct answer; the technician had made a conclusion that could not be substantiated with the data provided.

TABLE 4.15 **Percentages Choosing Each Response:**
Grade 12
Concluding from Results



<i>Response Options</i>				
A	B	C	D	Omit
13	32	11	43	1

The percentages of students within each of the achievement levels that answered the question correctly are shown in table 4.16. Thirty percent of students classified as below *Basic*, 49 percent classified as *Basic*, and 57 percent classified as *Proficient* were able to evaluate a conclusion based on a set of results.

TABLE 4.16 **Percentages Correct within Each Achievement Level Interval:**
Grade 12
Concluding from Results



Below Basic (0-144)	Basic (145-177)	Proficient (178-209)	Advanced (210-300)
30	49	57	--

-- Sample size insufficient to permit a reliable estimate.

Practical Reasoning¹⁴

The 1996 NAEP science assessment at grade 12 contained 39 questions that measured the ability of students to apply scientific understanding to everyday situations. A selection of these questions appears below. They are set in the context of earth science, physical science, or life science.

Flooding

The first short constructed-response question is set in the context of earth science. Students were asked to think of reasons why soil on a farm should be tested after a major flood. While the question did not require students to know fundamental scientific facts, they did have to recognize that factories and farms were sources of pollution. They also had to recognize that water washes away topsoil and leaches out nutrients necessary for plant growth. This question was scored according to a three-level scoring guide.¹⁵ A score of *Complete* was given for two flood-related reasons for testing the soil, and a score of *Partial* was given for one flood-related reason. Incorrect reasons were given a score of *Unsatisfactory*.

5. You live along a major river, and your farm was flooded this spring. There are many larger farms and a few factories upriver that were also flooded. Provide two flood-related reasons for testing your soil before planting this year.

¹⁴ See figure 1.2 for a description of practical reasoning.

¹⁵ Appendix B contains scoring guides for the sample questions that appear in this report.

Sample 1: Complete Response

The first sample received a score of *Complete*. This student clearly states, “to make sure there are no toxins in the soil from the factories” and also understands that it would be important to know “if the nutrients are still in the soil.” Thus the student has provided two flood-related reasons for testing the soil.

Sample 1: Flooding

5. You live along a major river, and your farm was flooded this spring. There are many larger farms and a few factories upriver that were also flooded. Provide two flood-related reasons for testing your soil before planting this year.

Test to make sure there are no toxins in the soil from the factories, and to make sure the nutrients are still in the soil.

Sample 2: Partial Response

Sample response 2 is a more general answer. However, the student does realize that because “the factories could have contaminated the water in the river,” the soil might also have become contaminated. The student, therefore, was credited with one valid reason and received a score of *Partial*.

Sample 2: Flooding

5. You live along a major river, and your farm was flooded this spring. There are many larger farms and a few factories upriver that were also flooded. Provide two flood-related reasons for testing your soil before planting this year.

For one the RIVER could have picked up about anything from going over its NORMAL Boundaries. For two the factories...could have contaminated the water in the RIVER.

Sample 3: Unsatisfactory Response

The following response received a score of *Unsatisfactory*. Although this student mentions “river” and “factories,” he or she failed to indicate why these might cause problems for crop growth.

Sample 3: Flooding

5. You live along a major river, and your farm was flooded this spring. There are many larger farms and a few factories upriver that were also flooded. Provide two flood-related reasons for testing your soil before planting this year.

The river and the factories are the two reasons for checking the soil

The percentages of students who attained the different score levels are presented in table 4.17. Seventy-two percent of students were able to think of a least one flood-related reason why soil should be tested before planting.

TABLE 4.17

**Percentages at Different Score Levels:
Grade 12
Flooding**



Complete	Partial	Unsatisfactory	Omit
32	40	20	8

Achievement level data (table 4.18) show that 55 percent of students classified as *Proficient* provided a complete response to the question. The question also proved accessible to students who were classified as below *Basic*: 13 percent of these students received a score of *Complete*.

TABLE 4.18

**Percentages Complete within Each
Achievement Level Interval: Grade 12
Flooding**



Below Basic (0-144)	Basic (145-177)	Proficient (178-209)	Advanced (210-300)
13	37	55	--

-- Sample size insufficient to permit a reliable estimate.

Keeping Ice Cream Cold

The next question asks students how they could keep ice cream below 0 degrees C for several hours. The question was classified under the physical science category “Matter and its Transformations.” To answer this question correctly, students had to realize that placing the ice cream in ice would not keep the ice cream colder than 0 degrees C for several hours. Substances that have temperatures lower than 0 degrees C, such as dry ice, would have to be utilized, or substances such as rock salt would have to be added to ice to lower the melting point of ice, thus increasing the cooling effect on the ice cream. Responses were scored using a three-level scoring guide.¹⁶ A student had to choose a correct method and explain how it worked to receive a score of *Complete*. A response that received a score of *Partial* mentioned a method that would work but had no adequate explanation. A score of *Unsatisfactory* was given to student responses that attempted the question but failed to answer any part of it correctly.

6. You are taking ice cream in a cooler to a picnic and want to keep the ice cream colder than 0°C for several hours. How could you do this?

Sample 1: Complete Response

Sample response 1 received a score of *Complete*. The student chooses to pack the ice cream in ice and then add rock salt. The student knows that this will keep the temperature lower than 0 degrees Celsius — “It makes the freezing point much lower.”

Sample 1: Keeping Ice Cream Cold

6. You are taking ice cream in a cooler to a picnic and want to keep the ice cream colder than 0°C for several hours. How could you do this?

Put ice all around it, then add
Rock salt to it

Explain how your method works.

It makes the freezing point
much lower.

¹⁶ Appendix B contains the scoring guides for the sample questions that appear in this report.

Sample 2: Partial Response

The next example received a score of *Partial*. This student knows that salt can be added to ice but does not state clearly that salt lowers the melting point of ice.

Sample 2: Keeping Ice Cream Cold

6. You are taking ice cream in a cooler to a picnic and want to keep the ice cream colder than 0°C for several hours. How could you do this?

You can keep it cooler
by adding salt pouring
the salt over the ice will
help preserve the ice

Explain how your method works.

Because of the Na present
in the salt and the different
temperatures.

Sample 3: Unsatisfactory response

The following sample response received a score of *Unsatisfactory*. The student adds ice only — a method that will fail to keep the ice cream colder than zero degrees for several hours. The addition of ice on its own was a common student response.

Sample 3: Keeping Ice Cream Cold

6. You are taking ice cream in a cooler to a picnic and want to keep the ice cream colder than 0°C for several hours. How could you do this?

I think you should put a little ice
on the bottom of the cooler than sit the
ice cream inside and fill the cooler with
a lot of ice.

Explain how your method works.

Having a lot of ice on the cooler
allows the ice cream to stay frozen

Performance data are presented in table 4.19. One quarter of the students were able to state a viable method for keeping ice cream colder than 0 degrees C, but were unable to explain why their methods worked. Sixty-two percent of the twelfth-grade students were unable to come up with a valid method.

TABLE 4.19 **Percentages at Different Score Levels:**
Grade 12
Keeping Ice Cream Cold

THE NATION'S
REPORT
CARD 

Complete	Partial	Unsatisfactory	Omit
10	25	62	4

NOTE: Numbers do not add to 100 due to rounding.

The percentages of students who received a score of *Complete* within each of the achievement level intervals are shown in table 4.20. The item was very difficult. Four percent of students classified as below *Basic*, 9 percent classified as *Basic*, and 20 percent classified as *Proficient* were able to provide a correct methodology for keeping ice cream colder than 0 degrees C together with a correct explanation of how their methodologies worked.

TABLE 4.20 **Percentages Correct within Each Achievement Level Interval:**
Grade 12
Keeping Ice Cream Cold

THE NATION'S
REPORT
CARD 

Below Basic (0-144)	Basic (145-177)	Proficient (178-209)	Advanced (210-300)
4	9	20	--

-- Sample size insufficient to permit a reliable estimate.

Heart Disease

The next sample shows a question that asks students to describe two ways a person can reduce his or her risk of heart disease. Since this is a topic commonly in the news, it might be expected that twelfth graders would find the question easy to answer. This was borne out by the results. Ninety-four percent of students could describe one or more ways to reduce the risk of heart disease. The question was scored using a three-level guide.¹⁷ A description of two ways a person can reduce the risk of heart disease received a score of *Complete*. A description of one way received a score of *Partial*.

7. Heart disease is a major cause of death in the United States. Describe two ways a person can reduce the risk of heart disease.

Sample 1: Complete Response

The first response received a score of *Complete*. The student talks about eating “healthful foods” and specifically mentions what these are. The response also indicates that exercise is important for reducing the risk of heart disease.

Sample 1: Heart Disease

7. Heart disease is a major cause of death in the United States. Describe two ways a person can reduce the risk of heart disease.

One can reduce the risk of heart disease by eating healthful foods such as: fish, poultry, fruits and vegetables high in fiber and avoiding foods high in saturated fats and cholesterol.
*Exercise at least 3 times a week for 30 min is very important as well.

¹⁷ Appendix B contains the scoring guides for the sample questions that appear in this report.

Sample 2: Partial Response

The next response received a score of *Partial*. In this response, the student mentions exercising every day (for which the student received credit) and then states that “A second way is to eat properly.” This was not credited since the statement is very broad and gives no indication that the student understands what “properly” entails. Many students received a score of *Partial* because one of their descriptions was too general.

Sample 2: Heart Disease

7. Heart disease is a major cause of death in the United States. Describe two ways a person can reduce the risk of heart disease.

One way is to exercise daily. A second way is to eat properly.

Sample 3: Unsatisfactory Response

The following response received a score of *Unsatisfactory*. This answer was typical of responses in this category. Students tended to know that they had to “eat right,” but did not describe what that meant. Four percent of students were in this category.

Sample 3: Heart Disease

7. Heart disease is a major cause of death in the United States. Describe two ways a person can reduce the risk of heart disease.

Take vitamins.
Eat adequate diet

Table 4.21 presents the percentages of students at each of the score levels. Fifty-seven percent of students received a score of *Complete* for this question.

TABLE 4.21 **Percentages at Different Score Levels:**
Grade 12
Heart Disease

THE NATION'S
REPORT
CARD 

Complete	Partial	Unsatisfactory	Omit
57	37	4	2

The percentages of students within each achievement level interval who provided a correct response indicates that the question was accessible on all levels (table 4.22). Forty-five percent of students who were classified as below *Basic* were able to describe two ways a person can reduce the risk of heart disease.

TABLE 4.22 **Percentages Complete within Each**
Achievement Level Interval: Grade 12
Heart Disease

THE NATION'S
REPORT
CARD 

Below Basic (0-144)	Basic (145-177)	Proficient (178-209)	Advanced (210-300)
45	61	72	--

-- Sample size insufficient to permit a reliable estimate.

Malaria

The purpose of the following constructed-response question was to find out whether twelfth graders knew what causes malaria and how it is transmitted. This question proved to be very difficult. To answer the question satisfactorily, students had to know that malaria is spread by mosquitoes. However, students were not expected to know that the organism (*Plasmodium*) is carried by a special type of mosquito that is prevalent mostly in the tropics. Thus, only the explanations were scored, using a three-level guide.¹⁸ To receive a score of *Complete*, a student had to specifically address cause and transmission. A score of *Partial* was given to a response that mentioned the cause and/or transmission of malaria in very general terms. A response received a score of *Unsatisfactory* when it displayed no understanding of the cause of malaria and its transmission.

8. A person has just returned to the United States from the tropics and is found to have malaria. What is the risk of other people catching the disease from this person?

Explain your answer.

Sample 1: Complete Response

The first sample response received a score of *Complete*. This student states that the risk is high if mosquitoes are plentiful. The student knows that the parasite is picked up by a mosquito from an infected person and can be transmitted to others — the implication being other people.

Sample 1: Malaria

8. A person has just returned to the United States from the tropics and is found to have malaria. What is the risk of other people catching the disease from this person?

if mosquitos are plentiful, the risk is high.

Explain your answer.

If a mosquito bites a malaria-infected person, the parasite enters the mosquito and can be transmitted to others

¹⁸ Appendix B contains scoring guides for the sample questions that appear in this report.

Sample 2: Partial Response

In the next response, the student knew that “insects and flies” were linked to malaria. However, the explanation dealt more with prevention — “If the person is kept away from other people then no insects or fly could infect another person” — than with why the risk was nonexistent. Thus the response received a score of *Partial*.

Sample 2: Malaria

8. A person has just returned to the United States from the tropics and is found to have malaria. What is the risk of other people catching the disease from this person?

none

Explain your answer.

Malaria is transported by
insects and flies. If the person
is kept away from other people
then no insects or fly could
infect another person.

Sample 3: Unsatisfactory Response

The next response received a score of *Unsatisfactory*. Many answers were based on a general knowledge of diseases and did not reflect malaria in particular. For example, some students thought the risk was low because of vaccines, whereas others thought that people with good immune systems would not catch it. Still others, as in sample 3, thought that the risk was high because “malaria is contagious.”

Sample 3: Malaria

8. A person has just returned to the United States from the tropics and is found to have malaria. What is the risk of other people catching the disease from this person?

Very good.

Explain your answer.

Malaria is contagious. Other
people could get it.

Table 4.23 presents information on the percentages of students at each score level. The question proved to be very challenging; 3 percent of twelfth graders received a score of *Complete*. Seventy-one percent of students who attempted the question received a score of *Unsatisfactory*. Ten percent of students omitted it.

TABLE 4.23 **Percentages at Different Score Levels:**
Grade 12
Malaria

THE NATION'S
REPORT
CARD 

Complete	Partial	Unsatisfactory	Omit
3	16	71	10

Table 4.24 presents the percentages of students within each achievement level interval that received a score of *Complete*. Students at all levels found the question very difficult. Five percent of those classified as *Proficient* knew what causes malaria and how it is transmitted.

TABLE 4.24 **Percentages Complete within Each**
Achievement Level Interval: Grade 12
Malaria

THE NATION'S
REPORT
CARD 

Below Basic (0-144)	Basic (145-177)	Proficient (178-209)	Advanced (210-300)
1	4	5	--

-- Sample size insufficient to permit a reliable estimate.

Theme Block

Three of the fifteen 30-minute blocks of questions at the twelfth-grade level addressed each of the three themes — systems, models, and patterns of change — outlined in the *Science Framework for the 1996 National Assessment of Educational Progress*.¹⁹ Not every student in the assessment was administered one of these theme blocks and no student was administered more than one. These sets of questions differed from others in the assessment in that they probed deeply into students' understanding of a given area in science — such as the Water Cycle — whereas most blocks usually did not devote more than one or two questions to any given topic.

The 15 questions based on the theme “systems” have been released to the public and can be found on the Internet.²⁰ Students were presented with a diagram (see below) showing aspects of the water cycle in a region near the coast of a large continent. They were then asked a series of questions relating to this system. For example, they were asked where in the system water existed as a gas or a solid, during which part of the cycle solid impurities separated from water, and what role trees played in the cycle. They were also asked several questions about climate in the region and the effects of acid rain on the system. Three questions are shown here, one relating to rate of evaporation, one asking students to come up with a methodology for distinguishing ocean water from land water, and one asking students to explain how clouds form.

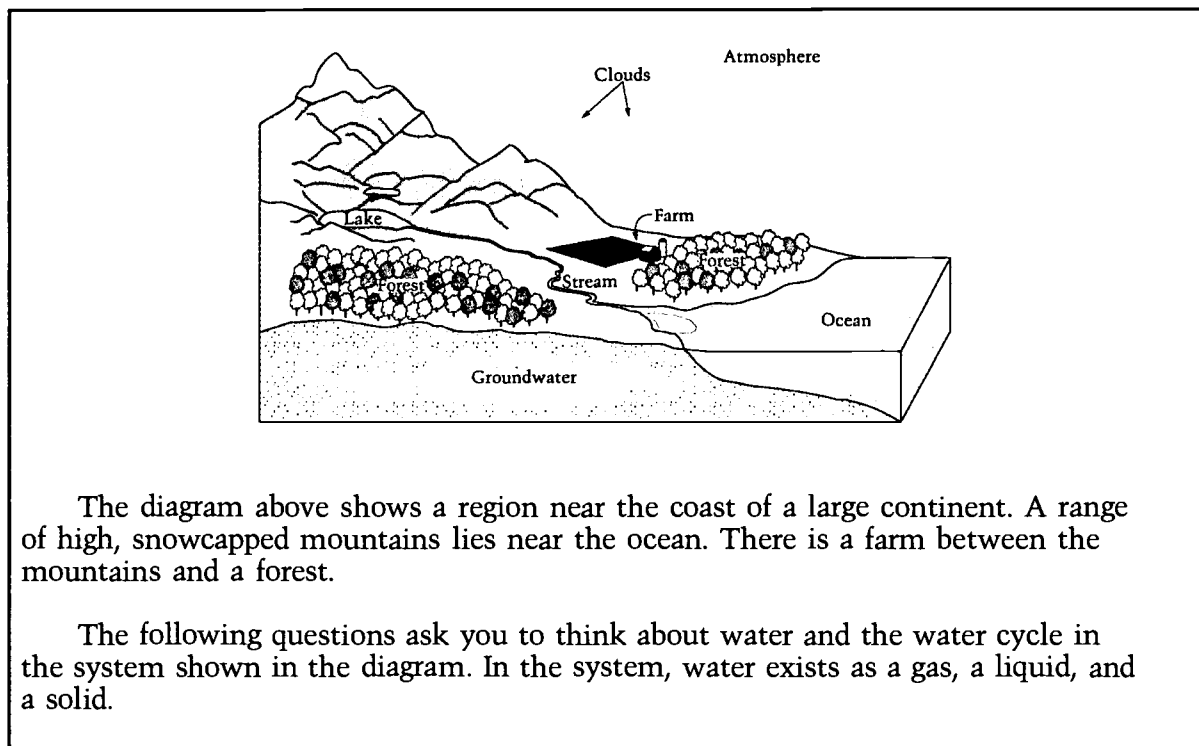

¹⁹ National Assessment Governing Board. (1995). *Science framework for the 1996 National Assessment of Educational Progress*. Washington, DC: Author.

²⁰ National Center for Education Statistics. National Assessment of Educational Progress. (1997). *NAEP 1996 science assessment public release, grade 12* [On-line]. Available: <http://nces.ed.gov/naep>

Theme Block: Temperature and Evaporation

The multiple-choice question shown below asks students to select a graph that shows how the rate of evaporation changes with changes in water temperature. To answer this question correctly, students had to be able to read the graphs and understand that the x -axis showed temperature increasing and that the y -axis showed rate of evaporation increasing. They then had to understand that evaporation is the transformation of liquid into a gas, and that this requires the input of energy — in this case, increasing temperature.

6. Which of the following graphs shows how the rate of evaporation changes with changes in water temperature?

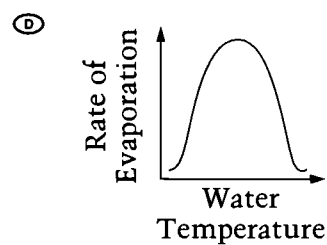
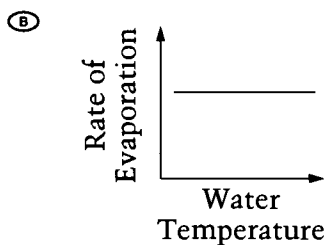
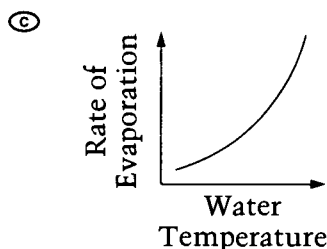
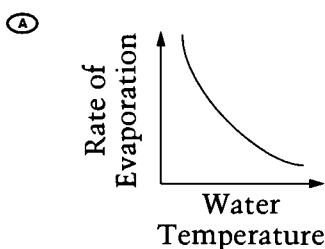

The correct option is C.

Information on the percentages of students choosing each response is shown in table 4.25. Students found this question fairly easy. Sixty-eight percent of twelfth graders could recognize which graph depicted how the rate of evaporation changes with changes in water temperature. Twelve percent of students chose option A. These students may have equated rate of evaporation with amount of water remaining; that is, they may have thought the graph depicted a large amount of water whose volume decreased as temperature increased. Very few students chose option B and 17 percent chose option D. Students who chose option D may have thought that the rate of evaporation is high initially and then steadily decreases as the water in the container diminishes.

TABLE 4.25 **Percentages Choosing Each Response:**
Grade 12
Temperature & Evaporation

THE NATION'S
REPORT
CARD 

Response Options

A	B	C	D	Omit
12	3	68	17	0

Table 4.26 presents achievement level data. The question proved to be fairly easy; 46 percent of students classified as below *Basic* answered it correctly.

TABLE 4.26 **Percentages Correct within Each Achievement Level Interval:**
Grade 12
Temperature & Evaporation

THE NATION'S
REPORT
CARD 

Below Basic (0-144)	Basic (145-177)	Proficient (178-209)	Advanced (210-300)
46	78	92	--

-- Sample size insufficient to permit a reliable estimate.

Theme Block: Identification of Ocean Water

A second question taken from the theme block asked students to determine which of two unlabeled jars contained ocean water and which contained lake water. To answer this question correctly, students had to understand that ocean water contains salt and then come up with a method to test this. A number of methodologies such as distillation, testing differences in density, and testing differences in freezing points were accepted. However, to achieve a score of *Complete* the student's methodology had to be clear and indicate how the test would differentiate the ocean water from the salt water. The question was scored using a four-level scoring guide.²¹ A score of *Complete* was given to a student response that clearly demonstrated a valid test and also stated how the test would work. Responses that received a score of *Essential* described a method and its results but provided minimal detail or the method was flawed in some way. A score of *Partial* was given to a response that described a valid method but omitted details on how the method would work. Students who received a score of *Unsatisfactory* demonstrated no knowledge of a correct methodology for determining which water was ocean water and which was lake water.

7. Some students were studying water in the environment. They filled one sample jar with ocean water and another sample jar with fresh water from the lake. The labels on the jars fell off, and the water in both jars looked the same. Describe a test, other than tasting or smelling the water, that the students could do to determine which jar held the ocean water and which jar held the lake water. Explain how the test could work.

²¹ Appendix B contains scoring guides for the sample questions that appear in this report.

Sample 1: Complete Response

The first sample received a score of *Complete*. The student describes a very thorough method and clearly states that the “salt water will leave a white residue of the bottom of the pot (which is salt particles).”

Sample 1: Identification of Ocean and Lake Water

7. Some students were studying water in the environment. They filled one sample jar with ocean water and another sample jar with fresh water from the lake. The labels on the jars fell off, and the water in both jars looked the same. Describe a test, other than tasting or smelling the water, that the students could do to determine which jar held the ocean water and which jar held the lake water. Explain how the test could work.

Get two metal pots (small) empty
one jar into one pot & the other
jar into the other pot. Set both
jar on a hot plate and let
them boiling. When all the
water is boiled off or evaporated
the salt water will leave a white
residue of the bottom of the pot
(which is salt particles); the fresh water
pot should boil clean and leave
no residue.

Sample 2: Essential Response

In the next response, which received a score of *Essential*, the student mentions distillation and expands on it a little: “in which you heat up the water.” However, the student fails to mention that the ocean water is the water that contains salt and does not make it clear that the water evaporates and leaves the salt behind.

Sample 2: Identification of Ocean and Lake Water

7. Some students were studying water in the environment. They filled one sample jar with ocean water and another sample jar with fresh water from the lake. The labels on the jars fell off, and the water in both jars looked the same. Describe a test, other than tasting or smelling the water, that the students could do to determine which jar held the ocean water and which jar held the lake water. Explain how the test could work.

Another test that could be done
would be distillation. In which
you heat up the water in both
jars and by heating the salt
separates from the water

Sample 3: Partial Response

Sample response 3, which received a score of *Partial*, is similar to the response that received a score of *Essential*. However, the student gives no description of a test, other than “letting the water dry up.”

Sample 3: Identification of Ocean and Lake Water

7. Some students were studying water in the environment. They filled one sample jar with ocean water and another sample jar with fresh water from the lake. The labels on the jars fell off, and the water in both jars looked the same. Describe a test, other than tasting or smelling the water, that the students could do to determine which jar held the ocean water and which jar held the lake water. Explain how the test could work.

They could test the waters
for salt. By letting the water dry
up.

Sample 4: Unsatisfactory Response

Sample 4 received a score of *Unsatisfactory*. Many students knew that the presence of salt should be investigated, but could not come up with a methodology. A number of students talked about tasting and smelling, which were specifically mentioned in the question. Others talked about viewing the samples directly under a microscope. In these instances, students were looking for differences such as sediment on the bottom of the jars or salt crystals and parasites visible under a microscope.

Sample 4: Identification of Ocean and Lake Water

7. Some students were studying water in the environment. They filled one sample jar with ocean water and another sample jar with fresh water from the lake. The labels on the jars fell off, and the water in both jars looked the same. Describe a test, other than tasting or smelling the water, that the students could do to determine which jar held the ocean water and which jar held the lake water. Explain how the test could work.

You could design a test or procedure that would detect salt. This test could tell you which jar contained the salt water and which jar held the fresh water.

Performance data are presented in tables 4.27 and 4.28. Thirty-nine percent of twelfth graders were able to explain a test in some detail and explain the results of the test. Forty percent of twelfth graders could not answer the question and thus received a score of *Unsatisfactory*. An examination of the achievement level results indicates that the question was accessible to students classified as below *Basic*, *Basic*, and *Proficient*.

TABLE 4.27 **Percentages at Different Score Levels:**
Grade 12
Identification of Ocean and Lake Water



Complete	Essential	Partial	Unsatisfactory	Omit
39	7	6	40	8

NOTE: Numbers do not add to 100 due to rounding.

TABLE 4.28 **Percentages Complete or Essential within Each**
Achievement Level Interval: Grade 12
Identification of Ocean and Lake Water



Below Basic (0-144)	Basic (145-177)	Proficient (178-209)	Advanced (210-300)
23	56	74	--

-- Sample size insufficient to permit a reliable estimate.

Theme Block: Cloud Formation

The next sample question asks students to explain how clouds form as air rises. To answer this question correctly, students had to explain both that water vapor condensed to form clouds and that condensation took place because the air cooled as it rose, causing the water vapor to turn from a gas to a liquid in the form of clouds. Many students chose to draw a diagram supplemented with explanatory material. The question was scored using a three-level scoring guide.²² A score of *Complete* was given to a response that mentioned cooling and condensation. A score of *Partial* was given to responses that mentioned that droplets of water in the air form clouds. A score of *Unsatisfactory* was given to those responses that demonstrated no understanding of cloud formation.

9. Explain how clouds can form as air rises. You may draw a diagram as part of your explanation.

²² Appendix B contains scoring guides for the sample questions that appear in this report.

Sample 1: Complete Response

The first sample received a score of *Complete*. This student clearly indicates an understanding of the process by stating that, "When the air cannot hold all of the evaporated water because it is too cold, the water vapor condenses on dust particles to form clouds."

Sample 1: Cloud Formation

9. Explain how clouds can form as air rises. You may draw a diagram as part of your explanation.

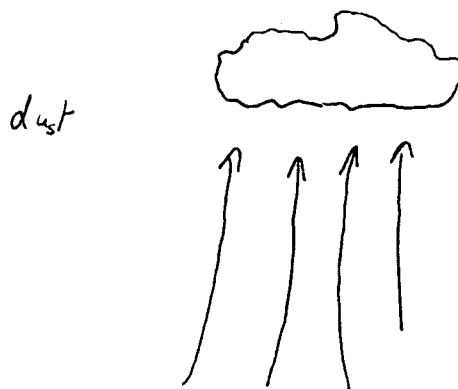

As air rises it is lifted and the vapor pressure of water is reduced. When the air cannot hold ^{all of} the evaporated water because it is too cold, the water vapor condenses on dust particles to form clouds.

Sample 2: Partial Response

The following student response received a score of *Partial*. This student states that condensation took place but fails to mention cooling.

Sample 2: Cloud Formation

9. Explain how clouds can form as air rises. You may draw a diagram as part of your explanation.

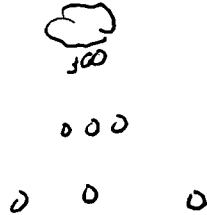

as water evaporate
it condenses in the
sky and forms clouds

Sample 3: Unsatisfactory Response

Sample response 3 received a score of *Unsatisfactory*. While the student talks about condensation, he or she relates it to air and not to water vapor. The “more dense air becomes condensed and clouds form.”

Sample 3: Cloud Formation

9. Explain how clouds can form as air rises. You may draw a diagram as part of your explanation.



As hotter air rises into a cooler air that is trying to drop pressure increase. The more dense air becomes condensed and clouds form.

Table 4.29 contains information relating to the percentages of students receiving various scores. This question proved to be very challenging. Eight percent of students were able to give an adequate explanation of how clouds form. Nineteen percent of students gave an explanation that did not fully explain the process. Fifty-seven percent of students were unable to answer the question satisfactorily.

TABLE 4.29 **Percentages at Different Score Levels:**
Grade 12
Cloud Formation

THE NATION'S
REPORT CARD 

Complete	Partial	Unsatisfactory	Omit
8	19	57	16

Information on the percentages of students classified within each achievement level interval is presented in table 4.30. Zero percent of students classified as below *Basic* were able to explain how clouds form as air rises.

TABLE 4.30 **Percentages Complete within Each**
Achievement Level Interval: Grade 12
Cloud Formation

THE NATION'S
REPORT CARD 

Below Basic (0-144)	Basic (145-177)	Proficient (178-209)	Advanced (210-300)
0	6	21	--

-- Sample size insufficient to permit a reliable estimate.

Hands-on Task

Each student who participated in the NAEP 1996 science assessment at grade 12 performed one of four hands-on tasks. Each task required students to use materials to perform an investigation, make observations, record and evaluate experimental results, and apply problem-solving skills. The diagram below shows the first page of one of the hands-on tasks as presented to students.

SEPARATION

Separating a Mixture of Solid Materials

For this task, you have been given a kit that contains materials that you will use to perform an investigation during the next 30 minutes. Please open your kit now and use the following diagram to check that all of the materials in the diagram are included in your kit. If any materials are missing, raise your hand and the administrator will provide you with the materials that you need.

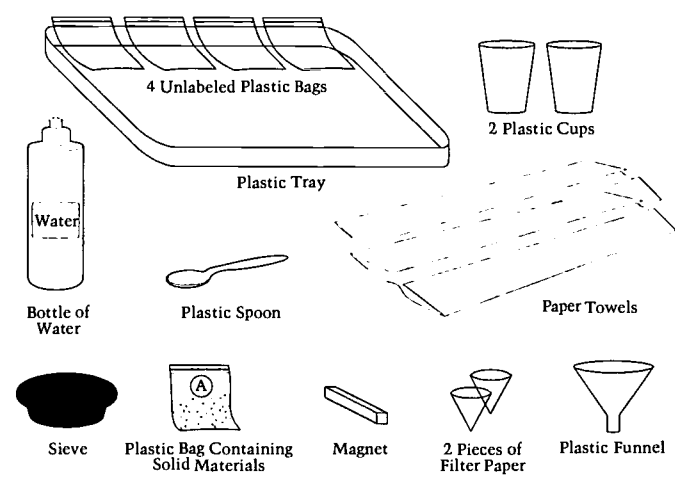

The diagram illustrates the materials provided for the separation task. It includes a plastic tray containing four unlabeled plastic bags, two plastic cups, a bottle of water, a plastic spoon, a stack of paper towels, a sieve, a plastic bag containing solid materials, a magnet, two pieces of filter paper, and a plastic funnel.

- 4 Unlabeled Plastic Bags
- Plastic Tray
- 2 Plastic Cups
- Bottle of Water
- Plastic Spoon
- Paper Towels
- Sieve
- Plastic Bag Containing Solid Materials
- Magnet
- 2 Pieces of Filter Paper
- Plastic Funnel

In the separation task, students were asked to apply their understanding of basic physical principles and the use of simple laboratory equipment to separate a mixture of five solid materials that have different properties (copper pellets, steel pellets, iron filings, sand, and salt). Students designed the procedures and used them to accomplish the task. This task assessed students' abilities to apply their conceptual knowledge of physical principles, to draw inferences from investigative results, and to evaluate and effectively communicate their investigative procedures. It also assessed students' understanding of one aspect of the nature of technology by asking students to apply their knowledge to the design of a practical separation procedure.

Three questions from this task are shown on the following page. Since students had to devise their own methodologies for this task, the first question was included to help them think about how the equipment could be used. The second question in the hands-on task directed students to use the equipment supplied to them to separate the components of the mixture. They were told to place each separated component into one of the plastic bags. Immediately after the students were assessed, the assessment administrator recorded how pure the components were on a grid. The third question in the hands-on task asked students to write step-by-step instructions that would allow someone else to separate the components from the mixture. The complete task, scoring guides for each question, and sample student responses can be found on the Internet.²³

²³ National Center for Education Statistics. National Assessment of Educational Progress. (1997). *1996 science assessment public release, grade 12* [On-line] Available: <http://nces.ed.gov/naep>.

The Investigation: The plastic bag (A) contains a mixture of five solid materials. Your job is to design a procedure for separating the materials in the mixture using the equipment in your kit.

It is known that the mixture contains five different substances:

Three different metals

Sand

Salt

You will be asked to write a complete plan of all of the steps in your separation procedure. You will also be asked to save samples of the separated materials in small plastic bags.

As you perform this task, follow the directions step-by-step and write your answers to the questions in the space provided in your booklet.

Important Note: If you need more of the mixture, raise your hand and the administrator will give you another bag.

1. Look at the contents of plastic bag (A) without opening it. What properties do the substances in the mixture have that would allow the following equipment to be used to separate the mixture?

Magnet:

Filter paper:

Sieve:

2. Now use this equipment to separate the five materials in the mixture. Each time you successfully separate a material from the mixture, place this separated material in one of the small unlabeled plastic bags. The materials that you separate do not have to be 100 percent pure, but they should be as pure as possible. Each separated material should be placed in its own plastic bag. The bags with the separated materials will be collected after you have completed the task.

[Notes: 1) If you have collected a material in the filter paper, you do not need to separate the material from the filter paper. Just put the filter paper in the plastic bag. 2) If you end up with one of the five materials dissolved in water, you can leave this material in the cup.]

3. Based on what you discovered as you worked to separate the materials in the mixture, write in the space below step-by-step instructions that would allow someone else to separate all five solids using the same set of equipment.

Hands-on Task: Physical Properties

The first question was scored using a four-level scoring guide.²⁴ Since three properties were sought, a student response that stated all three received a score of *Complete*. Two properties elicited a score of *Essential*, and one property received a score of *Partial*. A response that indicated no correct properties received a score of *Unsatisfactory*.

Sample 1: Complete Response

Sample response 1 received a score of *Complete*. The student clearly describes three properties — namely, magnetism, solubility, and size — that can be used to separate the components of the mixture.

Sample 1: Physical Properties

1. Look at the contents of plastic bag (A) without opening it. What properties do the substances in the mixture have that would allow the following equipment to be used to separate the mixture?

Magnet: Some of the material is magnetic, or iron.

Filter paper: Some of the mixture looks as though it doesn't dissolve in water.

Sieve: some of the mixture is much larger than other parts.

²⁴ Appendix B contains scoring guides for the sample questions that appear in this report.

Sample 2: Essential Response

Sample response 2 received a score of *Essential*. Here the student implies that all metals are magnetic, thus receiving no credit for this part of the question.

Sample 2: Physical Properties

1. Look at the contents of plastic bag (A) without opening it. What properties do the substances in the mixture have that would allow the following equipment to be used to separate the mixture?

Magnet: The magnet will attract all of the metal materials

Filter paper: This will allow all solid materials to be separated from dissolved ones

Sieve: This will separate the smaller ones from the larger ones

Sample 3: Partial Response

Sample response 3 received a score of *Partial*. Only the third part of the question was given credit.

Sample 3: Physical Properties

1. Look at the contents of plastic bag (A) without opening it. What properties do the substances in the mixture have that would allow the following equipment to be used to separate the mixture?

Magnet: Metal balls magnetic attraction

Filter paper: Allows filterous material go down into the cup

Sieve: Allow smaller particles to fall

Sample 4: Unsatisfactory Response

Sample response 4 received a score of *Unsatisfactory*. The question specifically asked for “properties”; however, many students did not identify properties but rather identified which of the substances in the mixture could be separated by the particular piece of equipment. Thus, sample 4 shows components of the mixtures — metal, dirt, and rocks — but not their properties.

Sample 4: Physical Properties

1. Look at the contents of plastic bag (A) without opening it. What properties do the substances in the mixture have that would allow the following equipment to be used to separate the mixture?

Magnet:
metal

Filter paper:
Dirt

Sieve:
rocks

Table 4.31 presents the percentages of students at different score levels. Grade 12 students found it difficult to articulate any properties of the materials as evidenced by the 52 percent who received a score of *Unsatisfactory*.

TABLE 4.31 Percentages at Different Score Levels: Grade 12 Physical Properties 

Complete	Essential	Partial	Unsatisfactory	Omit
2	10	29	52	8

Table 4.32 shows the percentages of students within each achievement level interval that received a score of *Complete* or *Essential*. Two percent of students classified as below *Basic*, 12 percent classified as *Basic*, and 26 percent classified as *Proficient* knew at least two properties of materials that would allow for their separation using specific equipment.

TABLE 4.32 Percentages Complete or Essential within Each Achievement Level Interval: Grade 12 Physical Properties 

Below Basic (0-144)	Basic (145-177)	Proficient (178-209)	Advanced (210-300)
2	12	26	--

-- Sample size insufficient to permit a reliable estimate.

Hands-on Task: Separation

The second question required students to separate the components of the mixture and place them in bags. Administrators then recorded the results on a grid (see below). The grid had two sets of labels. The labels at the top were for each component and the labels down the side were for each bag. Thus if one bag contained copper pellets (CP), the oval beside CP and 1 was filled in. The grids were subsequently scored according to a five-level guide.²⁵ If a student successfully separated all five components, a score of *Complete* was given. Separation of three components gave students a score of *Essential*. A score of *Adequate* was given for two separated components, and a score of *Partial* was given for one separated component. Students who were unable to separate any of the five components from the mixture received a score of *Unsatisfactory*.

Sample 1: Complete Response

The grid shown in the first sample received a score of *Complete*. This student had pure samples of copper pellets (CP) in bag 1, steel pellets (SP) in bag 2, iron filings (IF) in bag 3, sand (SD) in bag 4, and therefore, by default, salt (ST) in water.

Sample 1: Separation of Materials

	CP	SP	IF	SD	ST
1	●	○	○	○	○
2	○	●	○	○	○
3	○	○	●	○	○
4	○	○	○	●	○

²⁵ Appendix B contains scoring guides for the sample questions that appear in this report.

Sample 2: Essential Response

The next grid received a score of *Essential*. This student had pure samples of iron filings (IF), sand (SD), and therefore, by default, salt (ST) in water. Bag 1, however, contained two substances, copper pellets (CP) and steel pellets (SP). The student failed to realize that these could be separated based on the property of magnetism.

Sample 2: Separation of Materials

	CP	SP	IF	SD	ST
1	●	●	○	○	○
2	○	○	●	○	○
3	○	○	○	●	○
4	○	○	○	○	○

Sample 3: Adequate Response

The next grid received a score of *Adequate*. This student had pure samples of copper pellets (CP) in bag 2 and steel pellets (SP) in bag 4. Bag 1 contained iron filings, sand, and salt; thus, the student only separated two of the components.

Sample 3: Separation of Materials

	CP	SP	IF	SD	ST
1	○	○	●	●	●
2	●	○	○	○	○
3	○	○	○	○	○
4	○	●	○	○	○

Sample 4: Partial Response

The fourth grid received a score of *Partial*. This student had a pure sample of iron filings (IF) in bag 2 only. Bag 1 contained copper and steel pellets, bag 3 contained iron filings and sand, and bag 4 contained iron filings, sand, and salt. Iron filings were found in three of the five bags; however, since they appeared to be pure in one of the bags, the student was given a score of *Partial* for one separated component.

Sample 4: Separation of Materials

	CP	SP	IF	SD	ST
1	●	●	○	○	○
2	○	○	●	○	○
3	○	○	●	●	○
4	○	○	●	●	●

Sample 5: Unsatisfactory Response

The final grid received a score of *Unsatisfactory*. This student did not succeed in separating any of the components of the mixture. Bag 1 contained copper and steel pellets and bag 2 contained the remaining three components.

Sample 5: Separation of Materials

	CP	SP	IF	SD	ST
1	●	●	○	○	○
2	○	○	●	●	●
3	○	○	○	○	○
4	○	○	○	○	○

Table 4.33 presents the percentages of students at different score levels. Eighty-five percent of students received a score of *Complete*, *Essential*, *Adequate*, or *Partial*, indicating that they were able to separate out at least one component of the mixture. Thirty-four percent of students received a score of *Complete*, indicating they were able to separate out all five components.

TABLE 4.33 **Percentages at Different Score Levels:**
Grade 12
Separation of Materials

THE NATION'S
REPORT
CARD 

Complete	Essential	Adequate	Partial	Unsatisfactory	Omit
34	33	8	10	9	6

This task proved accessible to all students. As shown in table 4.34, 58 percent of those students classified as below *Basic* received a score of *Complete* or *Essential*.

TABLE 4.34 **Percentages Complete or Essential within Each**
Achievement Level Interval: Grade 12
Separation of Materials

THE NATION'S
REPORT
CARD 

Below Basic (0-144)	Basic (145-177)	Proficient (178-209)	Advanced (210-300)
58	72	75	--

-- Sample size insufficient to permit a reliable estimate.

Hands-on Task: Description of Method

The question that asked students to write step-by-step instructions on how to separate the mixture was scored using a five-level guide.²⁶ If a student described how to separate all five components, a score of *Complete* was given. A description that led to the separation of three components was given a score of *Essential*. A score of *Adequate* was given to a description that allowed for separation of two components, and a score of *Partial* was given to a description that allowed for the separation of one component. A score of *Unsatisfactory* was given to student responses that were too general, inaccurate, or hard to follow.

Sample 1: Complete Response

The first student response was given a score of *Complete*. This student has written a description that would enable someone else to separate the components of the mixture.

Sample 1: Description of Method

3. Based on what you discovered as you worked to separate the materials in the mixture, write in the space below step-by-step instructions that would allow someone else to separate all five solids using the same set of equipment.

Start by sifting the sand, salt, and metal shavings from the metal balls. Separate the balls using the magnet. Then use the magnet to separate the metal shavings from the sand and salt. Then take the sand and salt and place it in a cup along with water and stir until the salt dissolves. Then filter the salt water out of the sand by using the filter paper.

²⁶ Appendix B contains scoring guides for the sample questions that appear in this report.

Sample 2: Essential Response

The next response received a score of *Essential*. This student sifted out the metal balls, but did not realize that there were two types of balls present, one of which was magnetic.

Sample 2: Description of Method

3. Based on what you discovered as you worked to separate the materials in the mixture, write in the space below step-by-step instructions that would allow someone else to separate all five solids using the same set of equipment.

① Using the sieve, sift out the metal balls, ② pour the contents into the tray and pull the magnet through the contents to attract and separate another metal ③ pour the contents into the funnel with a filter in it, ④ pour water over the material to dissolve live salt ⑤ the sand is left

Sample 3: Adequate Response

The following sample response received a score of *Adequate*. This student separated out the two sets of balls (copper and steel pellets). The description then became very general: "With the remaining sediment, Filter it out using the Funnel Filter paper and water in some way or another." Thus, no credit was given for this part of the response.

Sample 3: Description of Method

3. Based on what you discovered as you worked to separate the materials in the mixture, write in the space below step-by-step instructions that would allow someone else to separate all five solids using the same set of equipment.

Dump all of the sediment into the sieve over the tray. After the smaller sediment runs through the sieve collect of of the metal balls with the magnet. Put them in a bag. The remaining balls put them into another bag. With the remaining sediment, Filter it out using the Funnel Filter paper and water in some way or another

Sample 4: Partial Response

The fourth response received a score of *Partial*. This student talked in general about the separation process. The only specific direction that would lead to the separation of one component was “I used the magnet to get the shaved metal out,” meaning the iron filings. This was credited. The statement “I got the little balls out w/the sieve” was not credited since there were two types of “balls,” copper and steel.

Sample 4: Description of Method

3. Based on what you discovered as you worked to separate the materials in the mixture, write in the space below step-by-step instructions that would allow someone else to separate all five solids using the same set of equipment.

The only two things that I actually separated was the little metal balls and another metal. The rest of it I had no idea how to separate because I have never done this before. To separate the metals, first I got the little balls out w/ the sieve. Then I used the magnet to get the shaved metal out.

Sample 5: Unsatisfactory Response

The final sample response received a score of *Unsatisfactory*. This student did not furnish any step-by-step instructions but merely stated that the materials should be put in a sieve and then put into the plastic bags.

Sample 5: Description of Method

3. Based on what you discovered as you worked to separate the materials in the mixture, write in the space below step-by-step instructions that would allow someone else to separate all five solids using the same set of equipment.

Frist, you would put them in
the sieve to separate the
materials in the mixture
Then, you would place them
in the plastic bags.

Student performance data are presented in tables 4.35 and 4.36. Twenty-six percent of students at grade 12 were able to give step-by-step instructions on how to separate out the components of the mixture. Achievement level data show that 33 percent of students classified as *Below Basic*, 69 percent classified as *Basic*, and 82 percent classified as *Proficient* received a score of *Complete* or *Essential*.

TABLE 4.35 **Percentages at Different Score Levels:**
Grade 12
Description of Method THE NATION'S
REPORT CARD 

Complete	Essential	Adequate	Partial	Unsatisfactory	Omit
26	32	4	21	16	1

TABLE 4.36 **Percentages Complete or Essential within Each**
Achievement Level Interval: Grade 12
Description of Method THE NATION'S
REPORT CARD 

Below Basic (0-144)	Basic (145-177)	Proficient (178-209)	Advanced (210-300)
33	69	82	--

-- Sample size insufficient to permit a reliable estimate.

Summary of Grade 12 Data

The data presented in this chapter give an indication of how students in grade 12 perform on science questions that cover a range of topics and make use of a variety of question types. The questions presented had to be limited to those that were released to the public.²⁷ These are fairly representative and do give an indication of the understandings and skills surveyed in the assessment. Similarly, the data for the small group of questions discussed in this chapter represent the data seen for the questions as a whole. In general, students found the constructed-response questions more challenging than the multiple-choice questions. Questions that required application of knowledge and understanding proved to be the most difficult.

- Male students had a higher average question score than female students for questions that measured earth science and physical science.
- White students had a higher average question score than Black and Hispanic students for questions that measured earth, physical, and life science.
- Male students had a higher average question score than female students for questions that measured conceptual understanding and practical reasoning.
- White students had a higher average question score than Black, Hispanic, and Asian/Pacific Islander students for questions that measured conceptual understanding, scientific investigation, and practical reasoning.
- The percentage of students who gave correct responses to the multiple-choice questions discussed in this chapter ranged from 43 percent to 80 percent.
- The percentage of students who received a score of *Complete* on the constructed-response questions described in this chapter ranged from 2 percent to 57 percent.

²⁷ National Center for Education Statistics, National Assessment of Educational Progress. (1997). *NAEP 1996 science assessment public release, grade 12* [On-line]. Available: <http://nces.ed.gov/naep>.

Chapter 5

Classroom Practices

Introduction

Over the past decade, leading science organizations have spearheaded efforts to reform science education in the United States. The National Research Council of the National Academy of Sciences, the American Association for the Advancement of Science, and the National Science Teachers Association have all proposed curriculum reforms designed to emphasize themes rather than traditional content divisions, concepts rather than facts, and active rather than passive learning.¹ Moreover, many states and districts have been revising their science curriculum, often using the national proposals as guidelines.² As part of the NAEP 1996 science assessment, students and their teachers were asked a number of questions related to instructional objectives and classroom activities. This chapter discusses the results of these questionnaires and thus sheds light on recent instructional practices as well as the extent to which schools and teachers have adopted these reforms.

The tables in this chapter present three sets of data: percentages of students who responded to or whose teachers responded to questions in the student and teacher questionnaires; the average scale scores of students; and the percentages of students at or above *Proficient*.³ The following example demonstrates how these data can be read. In the top left-hand box in table 5.1, there are three numbers with superscripts: 44^a, 151^b, and 30^c. The superscript 'a' denotes percentage of students, superscript 'b' denotes average scale score, and superscript 'c' denotes percentage at or above *Proficient*. Thus 44 percent of students had teachers who reported heavily emphasizing knowing science facts, these students had an average scale score of 151, and 30 percent of them were at or above the *Proficient* level. The order of the data is the same in each box of every table in this chapter.

¹ American Association for the Advancement of Science. (1993). *Benchmarks for science literacy*. Washington, DC: Author.
National Research Council of the National Academy of Sciences. (1995). *National science education standards*. Washington, DC: Author.

National Science Teachers Association. (1992). *Scope, sequence, and coordination of secondary school science*. Washington, DC: Author.

² Blank, R.K. & Pechman, E.M. (1995). *State curriculum frameworks in mathematics and science: How are they changing across the states?* Washington, DC: Council of Chief State School Officers.

O'Sullivan, C.Y., Weiss, A.R., & Askew, J.M. (1998). *Students learning science: A report on policies and practices in U.S. schools*. Washington, DC: National Center for Education Statistics.

³ Chapter 1 and appendix A both contain descriptions of scale scores and achievement levels.

The reader is cautioned against overinterpreting the results. If no statistically significant correlations exist, there may still be cause-and-effect relationships; however, these may be masked by other factors. Similarly, when statistically significant correlations do exist, it is also impossible to assign cause and effect to a single variable since many factors may impact student performance.

Instructional Objectives

The way teachers teach science and the knowledge and skills students take away from their science courses depend, in part, on the district and state requirements that determine the curriculum and, in part, on teachers' own understanding of how children learn and which teaching approach is most effective.⁴ As part of the NAEP 1996 science assessment, teachers of fourth- and eighth-grade students were asked how much emphasis they gave to nine different instructional objectives. Two of the objectives were related to content knowledge ("knowing science facts and terminology" and "understanding key science concepts"); five addressed the development of different skills (problem-solving, communicating ideas, laboratory, data analysis, and using technology); and two were about getting students to appreciate science ("developing students' interest in science" and "learning about the relevance of science to society and technology"). The results are shown in table 5.1.

At the fourth-grade level, 44 percent of students had teachers who gave heavy emphasis to knowing science facts and terminology, whereas 78 percent had teachers who heavily emphasized understanding key science concepts. Clearly, some teachers were giving heavy emphasis to both facts and concepts. The percentages of students whose teachers gave heavy emphasis to the five objectives that addressed the development of different skills ranged from 49 percent for science problem-solving skills to 12 percent for data analysis skills and using technology as a scientific tool. Teachers of nearly half of fourth graders (48 percent) gave little or no emphasis to using technology as a scientific tool. A relatively large number of students (70 percent) had teachers who reported placing a heavy emphasis on developing students' interest in science, whereas one percent of students had teachers who gave it little or no emphasis.

At the eighth-grade level, teachers of 88 percent of students placed a heavy emphasis on understanding key science concepts, with the remaining 12 percent of students' teachers giving conceptual understanding moderate emphasis. Fifty-five percent of students had teachers who placed moderate emphasis on knowing science facts and terminology, while 40 percent had teachers who gave knowing science facts and terminology heavy emphasis.

⁴ Tobin, K., Kahle, J. & Fraser, B. (1990). *Windows into science classrooms: Problems associated with higher-level cognitive learning*. London: Falmer Press.

Appleton, K. & Asoko, H. (1996). A case study of a teacher's progress toward using a constructivist view of learning to inform teaching in elementary science. *Science Education*, 80(2), 165-80.

Kadel, S. (1992). *Problem-centered learning in mathematics and science. Hot topics: Usable research*. Washington, DC: Office of Educational Research and Improvement.

Haury, D. L. (1993). *Teaching science through inquiry*. Washington, DC: Office of Educational Research and Improvement.

TABLE 5.1

Teachers' Reports on How Much Emphasis They Give to Student Objectives, Grades 4 and 8: Public and Nonpublic Schools Combined



About how much emphasis will you give to each of the following objectives for your students?	Grade 4			Grade 8		
	Heavy	Moderate	Little or None	Heavy	Moderate	Little or None
Knowing science facts and terminology	44 ^a 151 ^b 30 ^c	53 150 29	3 158 45	40 148 28	55 154 32	4 154 30
Understanding key science concepts	78 152 31	22 146 23	0 — —	88 153 31	12 145 23	0 — —
Learning about relevance of science to society and technology	32 149 27	55 151 30	12 156 34	46 152 31	49 150 29	5 164 45
Developing students' interest in science	70 152 31	29 149 26	1 162 43	69 152 31	28 150 30	3 148 25
Developing science problem-solving skills	49 152 31	45 149 27	6 157 35	67 153 31	30 150 30	3 140 20
Learning how to communicate ideas in science effectively	35 152 31	51 149 28	14 156 34	41 152 31	44 151 31	15 151 27
Developing lab skills and techniques	15 157 36	55 150 29	30 150 29	41 154 32	44 154 33	15 138 18
Developing data analysis skills	12 150 31	53 152 30	35 150 28	24 155 35	64 152 30	12 141 22
Using technology as a scientific tool	12 153 32	41 150 29	48 152 30	15 149 27	52 153 32	33 150 30

^a Percentage of Students

^b Average Scale Score

^c Percentage At or Above *Proficient*

— Sample size was insufficient to permit reliable estimates.

NOTE: Percentages may not add to 100 due to rounding.

SOURCE: National Center for Education Statistics. National Assessment of Educational Progress (NAEP), 1996 Science Assessment.

Teachers of eighth-grade students also placed emphasis on some areas of skill development. Sixty-seven percent of students had teachers who reported placing a heavy emphasis on developing problem-solving skills, 41 percent had teachers who put heavy emphasis on knowing how to communicate ideas in science effectively, and 41 percent had teachers who put heavy emphasis on developing laboratory skills and techniques. By contrast, fewer than one in four students (24 percent) were taught by teachers who placed a heavy emphasis on developing data analysis skills, and the teachers of 33 percent of students placed little or no emphasis on using technology as a scientific tool. As was the case in fourth grade, a large majority of eighth graders (69 percent) had teachers who placed heavy emphasis on developing students' interest in science.

There were a few instances in which varying degrees of emphasis on instructional objectives were statistically related to differences in performance. Among fourth graders, students had higher scale scores and were more likely to be at or above the *Proficient* level if their teachers placed a heavy, rather than a moderate, emphasis on understanding science concepts. Also, fourth graders whose teachers reported placing a heavy emphasis on learning about the relevance of science to society and technology had lower scale scores than those whose teachers gave little or no emphasis to this objective.

As with fourth graders, eighth graders had higher average scale scores and were more likely to be at or above the *Proficient* level if their teachers placed a heavy emphasis, rather than a moderate emphasis, on understanding science concepts. Further, grade 8 students had higher scale scores and a greater percentage of them reached the *Proficient* level if their teachers placed either a heavy or moderate emphasis on developing laboratory skills and techniques than if their teachers gave little or no emphasis to these skills. Finally, eighth-grade students whose teachers reported placing a heavy or moderate emphasis on developing data analysis skills had higher scale scores than those whose teachers gave these skills little or no emphasis. The percentage of students at or above the *Proficient* level was higher for those whose teachers placed a heavy emphasis on data analysis skills than those whose teachers placed little or no emphasis on data analysis skills.

Classroom Activities

From reading a textbook or writing a report to doing hands-on activities or working collaboratively on projects, teachers have available a wide variety of classroom activities to assign their students. The trend in science education for over a decade has been toward “doing science” and collaborative learning. Hands-on activities, active participation, the exchange of ideas through group projects and discussions, the use of innovative resources and technologies to engage students and enrich understanding — these activities are increasingly considered to be better suited to the way students actually learn than traditional ones such as textbook reading, teacher lectures, and individual deskwork.⁵ Data collected as part of the NAEP 1996 science assessment shed light on the frequency of various classroom activities.

Teachers of fourth- and eighth-grade students were asked how often their students did each of 10 different activities. Twelfth-grade students were asked how often they did each of 13 different activities (the 10 activities asked of the fourth- and eighth-grade teachers plus three additional age-appropriate activities). The results of the fourth- and eighth-grade teacher questionnaires are shown in table 5.2 and the results of the twelfth-grade student questionnaire are shown in table 5.3.

⁵ Siversten, M.L. (1993). *State of the art: Transforming ideas for teaching and learning science*. Washington, DC: U.S. Office of Educational Research and Improvement.

Suter, L.E. (Ed.). (1996). *The learning curve: What we are discovering about U.S. science and mathematics education*. Washington, DC: National Science Foundation.

As indicated in table 5.2, few students did any given activity almost every day. Reading a textbook was the most frequently assigned classroom activity at both grades 4 and 8, with 28 percent of fourth graders and 34 percent of eighth graders having teachers who reported that their students did this almost every day. These findings are consistent with those of other studies that have shown the persistence of textbook-centered instruction. Alternative teaching methods are most commonly used as supplements to, rather than as replacements for textbooks, even among teachers who believe in structuring learning around activities other than textbooks.⁶ On the other hand, no more than five percent of students at either grade read a book or magazine about science, did oral or written science reports, used computers, or took a science test or quiz almost every day. Of the activities assigned once or twice a week, hands-on activities appeared to be the most frequent; 47 percent of fourth graders and 62 percent of eighth graders had teachers who reported their students did hands-on activities once or twice a week. Further, teachers of 40 percent of fourth graders and 53 percent of eighth graders indicated that their students talked about measurements and results of those hands-on activities once or twice a week.

Among infrequently assigned activities, 69 percent of fourth graders never or hardly ever used computers, 56 percent never or hardly ever gave oral science reports, and 53 percent never or hardly ever prepared a written science report, according to their teachers. Fifty-two percent of eighth-grade students never or hardly ever gave oral science reports, and 62 percent never or hardly ever used computers for science, according to their teachers.

At grade 8, performance data show a few differences associated with the frequency with which classroom activities were performed. These differences suggest a positive relationship between frequency of certain activities and science performance. Students who did hands-on activities almost every day or once or twice a week outperformed those who did hands-on activities once or twice a month or never or hardly ever. Students who did hands-on activities or investigations in science monthly also outperformed those who never or hardly ever did them. Students who talked about the results of hands-on activities had higher scale scores and were more likely to be at or above the *Proficient* level than students who never or hardly ever talked about them, and students who talked about the results weekly had higher scale scores and percentages at or above *Proficient* than those who talked about them monthly.

⁶ Hynd, C.R., et. al. (1994). *Learning counterintuitive physics concepts: the effects of text and educational environment*. Athens, GA: National Reading Research Center.

Powell, R. (1991). Teaching alike: A cross-case analysis of first-career and second-career beginning teachers' instructional convergence. *Teaching and Teacher Education*, 13(3), 341-356.

Belcher, C. D. & Williams, W. (1995). *Middle school science teachers' perception of textbook congruency with classroom needs*. Paper presented at the Annual Meeting of the Missouri Unit of the Association of Teacher Educators, Osage Beach, MO.

Lee, O. (1995). Subject matter knowledge, classroom management, and instructional practices in middle school classrooms. *Journal of Research in Science Teaching*, 32(4), 23-40.

Mastropieri, M. N. & Scruggs, T.E. (1994). Text versus hands-on science curriculum: Implications for students with disabilities. *Remedial and Special Education*, 15(2), 72-85.

TABLE 5.2

**Teachers' Reports on How Often Students Do
a Variety of Classroom Activities, Grades 4 and 8:
Public and Nonpublic Schools Combined**

THE NATION'S
REPORT
CARD



About how often do your science students do each of the following?	Grade 4				Grade 8			
	Almost Every Day	Once or Twice a Week	Once or Twice a Month	Never or Hardly Ever	Almost Every Day	Once or Twice a Week	Once or Twice a Month	Never or Hardly Ever
Read a science textbook	28 ^a 151 ^b 29 ^c	36 149 28	14 151 28	21 154 34	34 152 32	42 153 30	14 153 31	10 149 28
Read a book or magazine about science	5 155 33	26 152 30	48 152 31	22 147 26	1 144 18	15 150 28	58 152 31	26 153 33
Discuss science in the news	4 144 27	29 150 28	48 152 31	19 150 29	15 154 32	33 151 30	44 151 30	8 155 35
Work with other students on a science activity or project	6 152 33	35 152 31	47 150 29	12 147 25	24 155 32	44 154 32	25 147 28	6 151 31
Give an oral science report	0 -- --	5 144 27	39 151 30	56 151 30	0 -- --	3 149 21	45 150 29	52 154 33
Prepare a written science report	0 -- --	4 153 36	43 151 29	53 150 29	1 -- --	9 151 29	58 151 29	32 155 35
Do hands-on activities or investigations in science	9 148 29	47 152 31	42 150 28	3 144 21	18 154 32	62 155 33	18 143 24	2 122 9
Talk about measurements and results from students' hands-on activities	6 148 29	40 153 33	44 149 27	10 148 27	12 154 30	53 155 34	31 149 27	4 127 11
Use computers for science	2 150 29	9 150 29	20 154 33	69 150 28	0 -- --	7 159 36	30 152 30	62 151 30
Take a science test or quiz	0 -- 26	13 144 24	76 152 31	10 148 27	2 148 24	43 152 32	51 152 30	3 148 27

^a Percentage of Students

^b Average Scale Score

^c Percentage At or Above Proficient

-- Sample size was insufficient to permit reliable estimates.

NOTE: Percentages may not add to 100 due to rounding.

SOURCE: National Center for Education Statistics. National Assessment of Educational Progress (NAEP), 1996 Science Assessment.

The data on grade 12 classroom activities are presented in table 5.3. Readers should note that the data are derived not from all students but rather from the 54 percent of students who indicated that they were taking a science course in twelfth grade.⁷ The percentages therefore tend to reflect the classroom experiences of a select subset of the student population — those taking more years of science, including more advanced classes.

For most of the activities, the grade 12 percentages are not unlike those seen at grades 4 and 8. Reading a science textbook was the most frequently used classroom activity. Twenty-eight percent of twelfth-grade students reported that they read a science textbook almost every day, and an additional 36 percent read a science textbook once or twice a week. Moreover, 42 percent of students reported doing hands-on activities or investigations in science once or twice a week, and 37 percent reported talking about the measurements and results from their hands-on activities or investigations once or twice a week. In results comparable to those for students at fourth and eighth grade, the majority of students at twelfth grade never or hardly ever gave oral science reports or used computers for science. Sixty-nine percent of twelfth graders reported never or hardly ever designing and carrying out their own experiments, and 62 percent reported never or hardly ever going outside to observe or measure things.

An analysis of scale score and proficiency data reveals many performance differences related to the frequency with which the classroom activities were done. None of the 13 variables examined at grade 12 was without at least some relationship to overall scale scores. Rather than mention each relationship found, it might be more useful to point to two patterns, one in which doing an activity less often corresponded to lower performance and one in which doing an activity more often corresponded to lower performance. Students who reported never or hardly ever doing the following activities had lower scale scores and a lower percentage at or above *Proficient* than students who did those activities more often: reading a science textbook, discussing science in the news, working with other students on a science activity or project, doing hands-on activities or investigations in science, talking about the measurements and results from their hands-on activities or investigations in science, or analyzing data and forming conclusions from their investigations. Students who reported that they prepared a written science report or went outside to observe or measure things almost every day had lower scale scores than those who reported doing them less often. In addition, students who reported going outside to observe or measure things almost every day were less likely to be at or above the *Proficient* level than students who reported doing this once or twice a month or never or hardly ever.

⁷ O'Sullivan, C. Y., Weiss, A. R., & Askew, J. M. (1998). *Students learning science: A report on policies and practices in U.S. schools*. (NCES Publication No. 98-496) Washington, DC: National Center for Education Statistics.

TABLE 5.3

**Reports from Students Currently Taking a Science Course
on How Often They Do a Variety of Classroom Activities,
Grade 12: Public and Nonpublic Schools Combined**



When you study science in school, how often do you do each of the following?	Grade 12			
	Almost Every Day	Once or Twice a Week	Once or Twice a Month	Never or Hardly Ever
Read a science textbook	28 ^a 163 ^b 34 ^c	36 165 37	14 160 32	22 149 20
Read a book or magazine about science	4 159 34	16 162 35	30 167 39	49 156 26
Discuss science in the news	8 162 33	23 169 41	29 167 39	40 151 22
Work with other students on a science activity or project	17 166 38	36 167 40	28 160 29	19 144 16
Give an oral science report	1 — —	3 136 14	23 158 29	73 163 34
Prepare a written science report	2 138 17	14 163 36	38 163 34	46 159 30
Do hands-on activities or investigations in science	16 164 35	42 168 40	30 160 29	12 133 9
Talk about measurements and results from students' hands-on activities	15 164 35	37 169 40	28 163 33	20 141 14
Use computers for science	4 162 36	13 164 39	23 167 38	61 158 28
Design and carry out your own science investigation	3 159 33	6 152 29	22 165 36	69 160 31
Analyze data and form conclusion from your investigations	9 163 35	32 170 43	30 163 33	29 148 18
Take a science test or quiz	7 150 23	58 161 31	30 167 39	5 133 10
Go outside and observe or measure things	2 134 11	7 149 23	28 166 37	62 161 32

^a Percentage of Students

^b Average Scale Score

^c Percentage At or Above *Proficient*

— — Sample size was insufficient to permit reliable estimates.

NOTE: Percentages may not add up to 100 due to rounding.

SOURCE: National Center for Education Statistics, National Assessment of Educational Progress (NAEP), 1996 Science Assessment.

Teacher Activities

New technologies are providing science teachers with an expanding range of instructional activities for their classrooms. In addition to traditional activities such as lecturing and performing demonstrations, teachers can now make use of computers and a variety of other technologies.⁸ But do teachers actually employ these various resources in their classrooms? Fourth- and eighth-grade teachers and twelfth-grade students were asked to report on how frequently five different activities for science instruction were used: talking to the class about science, doing a science demonstration, showing a science video or science television program, using computers for science, and using CD's or laser disks on science.

The results are shown in tables 5.4 and 5.5. The data provide a useful starting point for understanding the extent to which each of the activities is employed in science classrooms, but readers would do well to bear in mind some related issues which the data do not address. For example, how frequently teachers make use of the activities and technologies may depend not only on their preferences but on whether they have access to the necessary equipment and are trained in how to use it. Moreover, the degree to which activities contribute to higher student achievement depends on the effectiveness with which teachers match them to students' needs and integrate them into the learning process.⁹

Talking to the class about science, i.e., lecturing, was the primary instructional activity at all grades. The remaining activities were generally employed much less frequently, especially at the middle school and high school levels.

At grade 4, teachers of 59 percent of students reported that they talked to their classes about science almost every day. On the other hand, teachers of fewer than five percent of students said they did science demonstrations, showed videotapes or television programs, used computers, or used CD's or laser disks almost every day. After talking to the class, the most frequent activity was doing a science demonstration. Forty-six percent of fourth graders had teachers who indicated doing such demonstrations weekly.

At the eighth-grade level, 87 percent of students had teachers who reported talking about science almost every day. Teachers of 49 percent of students said they did a science demonstration once or twice a week. Data from teachers' reports also show that 21 percent of eighth graders had teachers who reported showing a science videotape or science television program one or more times a week. Few students had teachers who made frequent use of computers, CD's or laser disks for science.

⁸ Perkins, D. N. et al. (1995). *Software goes to school: Teaching for understanding with new technologies*. New York: Oxford University Press.

Hawkes, M. (1995). *Educational technology dissemination: Its impact on learning, instruction, and educational policy*. Paper presented at the Annual Meeting of the National Rural Education Association, Salt Lake City, Utah.

⁹ Rieber, L.P. (1993) A pragmatic view of instructional technology. In K. Tobin, (Ed.), *The practice of constructivism in science education* (pp. 193-212). Washington, DC: AAAS Press.

Scale scores and percentages of students at or above *Proficient* associated with the teachers' reports about the frequency of science activities show no significant differences at grade 4. At grade 8, students whose teachers reported talking to their class about science almost every day had higher scale scores than students at grade 8 whose teachers reported talking to their class once or twice a week. Students at grade 8 whose teachers said they did demonstrations weekly performed at a higher level than those students whose teachers said they did demonstrations almost every day. Finally, students at grade 8 whose teachers said they showed videotapes or television science programs monthly had higher scale scores than those whose teachers never or hardly ever showed those programs.

TABLE 5.4

Teachers' Reports on Using Different Teaching Activities, Grades 4 and 8: Public and Nonpublic Schools Combined



When you teach science, about how often do you do each of the following?	Grade 4				Grade 8			
	Almost Every Day	Once or Twice a Week	Once or Twice a Month	Never or Hardly Ever	Almost Every Day	Once or Twice a Week	Once or Twice a Month	Never or Hardly Ever
Talk to the class about science	59 ^a 152 ^b 31 ^c	35 149 28	6 148 25	0 — —	87 153 32	11 146 24	1 — —	0 — —
Do a science demonstration	4 156 39	46 151 30	43 149 28	7 154 30	10 146 21	49 154 34	39 151 29	3 148 32
Show a science videotape or TV science program	0 — —	12 150 30	61 152 30	26 148 27	1 — —	20 152 31	64 154 32	15 144 25
Use computers for science	2 151 28	6 147 25	20 155 34	72 150 29	1 — —	7 153 30	28 153 31	65 151 30
Use CDs or laser disks on science	1 — —	4 156 31	17 153 33	78 150 29	2 148 27	11 157 36	28 150 28	59 152 31

^a Percentage of Students

^b Average Scale Score

^c Percentage At or Above *Proficient*

— — Sample size was insufficient to permit reliable estimates.

NOTE: Percentages may not add to 100 due to rounding.

SOURCE: National Center for Education Statistics. National Assessment of Educational Progress (NAEP), 1996 Science Assessment.

At the twelfth-grade level, data were collected from students about how frequently their teachers did certain activities. The data are from all twelfth graders, not only those taking science in twelfth grade, and therefore reflect some students' experiences in earlier grades. The results are shown in table 5.5. Sixty-eight percent of students said their teachers talked to the class about science almost every day, and over half of students (55 percent) had a science demonstration at least once a week. Fewer than five percent of students said their teachers showed science videotapes or science television programs, used computers, or used CDs or laser disks almost every day, although 22 percent of students said their teachers showed science videotapes or science television programs once or twice a week. Two thirds of twelfth graders reported that their teachers never or hardly ever used a computer when teaching science.

Among twelfth graders, the greater the frequency with which teachers talked to their students about science, the higher the students' performance. Students whose teachers did demonstrations almost every day or weekly had higher scale scores than students whose teachers did demonstrations monthly or never or hardly ever. In addition, students whose teachers did monthly demonstrations had higher scale scores than those whose teachers never or hardly ever did them. The percentage of students at or above *Proficient* was lower for students whose teachers never or hardly ever did science demonstrations than for students whose teachers did demonstrations more frequently. Students whose teachers showed videotapes or television science programs weekly or monthly had higher scale scores than students who either saw these programs almost every day or never or hardly ever saw them; the pattern was identical for achievement level data.

Higher student performance was associated with moderate computer use. Students whose teachers used computers for science almost every day had lower scale scores than those whose teachers used them once or twice a month, and students whose teachers never or hardly ever used computers had lower scale scores than those whose teachers used them weekly or monthly. Achievement level data show that the percentage of twelfth graders performing at or above *Proficient* was greater for students whose teachers used computers for science weekly or monthly than for students whose teachers never or hardly ever used computers for science.

Students whose teachers used CDs or laser disks on science weekly or monthly had higher scale scores than students whose teachers used CDs or laser disks almost every day or never or hardly ever. The percentage of students at or above *Proficient* whose teachers never or hardly ever used CDs or laser disks on science or who used them almost every day was lower compared to those whose teachers used them once or twice a month.

TABLE 5.5

**Students' Reports on How Often Their Teachers
Use Different Teaching Activities, Grade 12:
Public and Nonpublic Schools Combined**



When you study science, how often does your teacher do each of the following?	Grade 12			
	Almost Every Day	Once or Twice a Week	Once or Twice a Month	Never or Hardly Ever
Talk to the class about science	68 ^a 160 ^b 28 ^c	7 143 17	5 136 9	20 129 6
Do a science demonstration	18 158 29	37 159 28	21 153 22	25 133 8
Show a science videotape or TV science program	4 139 13	22 154 24	44 157 26	30 142 16
Use computers for science	4 150 23	9 157 29	20 159 29	67 148 19
Use CDs or laser disks on science	3 144 17	8 157 30	16 162 32	73 149 19

^a Percentage of Students

^b Average Scale Score

^c Percentage At or Above *Proficient*

NOTE: Percentages may not add to 100 due to rounding.

SOURCE: National Center for Education Statistics. National Assessment of Educational Progress (NAEP), 1996 Science Assessment.

Hands-on Tasks

The importance of using hands-on activities in science instruction is widely accepted in both theory and practice. According to the American Association for the Advancement of Science, "construing habits of mind to include manipulation and observation skills raises no eyebrows in science. Scientists know that finding answers to questions about nature means using one's hands and senses as well as one's head."¹⁰ As seen in tables 5.2 and 5.3, almost all fourth- and eighth-grade teachers reported that their students did hands-on tasks at least once or twice a month, and 88 percent of twelfth-grade students who were studying science said that they, too, did hands-on activities at least once or twice a month. Some teachers do shy away from hands-on tasks, claiming that they lack the necessary content knowledge, do not have enough materials, or that the tasks require too much time and effort.¹¹ Nevertheless, hands-on activities appear to be widely used in regular science instruction.

¹⁰ American Association for the Advancement of Science. (1993). *Benchmarks for science literacy*. Washington, DC: Author.

¹¹ Sumrall, W. J. (1997). Why avoid hands-on science? *Science Scope*, 32(4), 16-19.

Haury, D. L. & Rillero, P. (1994). *Perspectives of hands-on science teaching*. Washington, DC: Office of Educational Research and Improvement.

Students in grades 4 and 8 were asked if they had ever done any hands-on activities or projects in school with living things, electricity, chemicals, rocks/minerals, a magnifying glass/microscope, a thermometer/barometer, or with simple machines. Grade 12 students were asked if they had ever done science investigations or projects in school using the same list of materials.¹² In addition, grade 12 students were asked if they had ever done science investigations or projects in school with instruments for measuring speed and velocity. Students at all three grade levels were also asked to indicate if they had done “none of the above” activities. To all of the questions, students could either respond in the affirmative or not respond at all; students not responding are assumed to have not done the activity. The results for grades 4, 8, and 12 are shown in table 5.6. Several patterns emerge from the data. First, in all three grades more students reported having done each activity than reported not having done that activity, with one exception: at grade 4, over half (57 percent) of students said they had not done a hands-on activity with simple machines. The percentages of students at grade 4 who had done hands-on activities ranged from 52 percent for activities involving thermometers or barometers to 63 percent for activities with living things. For eighth graders, the range was from 55 percent for activities with simple machines to 81 percent for activities with chemicals, and for twelfth graders from 64 percent for activities measuring speed or velocity to 88 percent for investigations or projects using either chemicals or magnifying glasses or microscopes. Eighteen percent of fourth graders, 6 percent of eighth graders, and 3 percent of twelfth graders indicated that they had used “none of the above” to do hands-on tasks.

For each variable, scale scores and achievement levels were tested for differences between those who indicated that they had used living things, electricity, chemicals, rocks/minerals, magnifying glass/microscope, thermometer/barometer, simple machines, or instruments for measuring speed and velocity (grade 12 only) and those who did not respond. At grade 4, students who said they had done hands-on activities or projects with a magnifying glass or microscope had higher scale scores than those not responding, and students who said they had done hands-on activities or projects with living things had lower scale scores than those not responding. In addition, the percentage of students at or above *Proficient* was higher for those who had done hands-on activities using a magnifying glass or microscope than for those who did not respond. Fourth graders who responded that they had done “None of the Above” hands-on tasks had lower scale scores and were less likely to be at or above the *Proficient* level than students not responding. At grades 8 and 12, for each activity or project, students who responded affirmatively had higher scale scores and were more likely to be at or above the *Proficient* level than students who did not respond. Students who indicated that they had done “None of the Above” had lower scale scores and were less likely to be at or above the *Proficient* level than those who did not respond. There was one exception to this pattern: at grade 12, the percentage of students at or above *Proficient* was the same for those who had done hands-on activities with rocks/minerals as for those who did not respond.

¹² Includes data from all grade 12 students, not only those taking science.

TABLE 5.6

**Students' Reports on Doing Hands-on Tasks,
Grades 4, 8, and 12:
Public and Nonpublic Schools Combined**



Have you ever done hands-on activities or projects in school with any of the following?	Grade 4		Grade 8		Grade 12	
	Yes	No	Yes	No	Yes	No
Living things (plants, animals, bacteria)	63 ^a 149 ^b 28 ^c	37 152 30	71 154 33	29 140 20	87 153 23	13 128 7
Electricity (batteries, flashlight)	54 149 27	46 151 31	69 153 32	31 143 22	74 155 25	26 136 11
Chemicals (mixing or dissolving)	56 151 30	44 149 28	81 154 32	19 134 15	88 154 23	12 121 5
Rocks/Minerals (identifying type)	53 151 29	47 149 28	64 153 31	36 145 25	69 152 21	31 145 21
Magnifying glass/microscope	57 152 30	43 148 27	80 154 32	20 134 15	88 153 23	12 124 7
Thermometer/barometer	52 150 29	48 150 29	69 155 33	31 139 19	80 155 25	20 128 7
Simple machines (pulleys and levers)	43 150 30	57 150 28	55 155 33	45 144 24	69 157 26	31 135 10
Instruments for measuring speed and velocity*					64 154 24	36 142 15
None of the Above	18 130 12	82 154 32	6 117 6	94 152 30	3 114 6	97 151 22

* Question not asked at grades 4 and 8

^a Percentage of Students

^b Average Scale Score

^c Percentage At or Above Proficient

NOTE: Questions only offered a "yes" option. Students not responding were assumed to have not done the activity and are included in the "no" category.

NOTE: Percentages may not add to 100 due to rounding.

SOURCE: National Center for Education Statistics. National Assessment of Educational Progress (NAEP), 1996 Science Assessment.

Investigations Taking a Week or More

Real-world questions in science are usually not answered quickly. Formulating hypotheses, developing and carrying out experiments, analyzing data, and drawing conclusions require time and persistence. As teachers attempt to expose their classes to the methods and thinking of science, it is useful for students to participate in investigations that progress over a period of time. Students at grades 4, 8, and 12 were asked if they had ever done science projects in school that took a week or more to complete. The results are presented in table 5.7.

Sixty percent of students at grade four, 64 percent at grade eight, and 68 percent at grade 12 reported having done a science project that took a week or more. At grades 8 and 12, this activity was positively associated with performance; students who indicated that they had engaged in long-term projects had higher scale scores and were more likely to be at or above the *Proficient* level than students who indicated that they had not.

TABLE 5.7

Students' Reports on Whether or Not They Conduct Science Projects or Investigations that Take a Week or More, Grades 4, 8, and 12: Public and Nonpublic Schools Combined



<i>Do you ever do science projects in school that take a week or more?</i>	Grade 4		Grade 8		Grade 12	
	Yes	No	Yes	No	Yes	No
Percentage of Students	60	40	64	37	68	32
Average Scale Score	150	151	152	147	155	142
Percentage At or Above <i>Proficient</i>	29	29	31	26	25	15

NOTE: Percentages may not add to 100 due to rounding.

SOURCE: National Center for Education Statistics. National Assessment of Educational Progress (NAEP), 1996 Science Assessment.

Computers and Science Instruction

A good deal of support exists nationally for the use of computers in schools. *America's Technology Literacy Challenge*, a 1996 White House initiative, called for all classrooms to be equipped with modern computers and connected to the Internet, and for teachers to be trained "to help students learn through computers."¹³ As of fall 1996, 65 percent of U.S. public schools had internet access, and most that did not planned to be connected by the end of the decade.¹⁴ Many educators, including science educators in the American Association for the Advancement of Science (AAAS) and the National Research Council of the American Academy of Sciences, also support the goal of integrating computers into the classroom. According to the AAAS, "students should start using calculators and computers early and use them in as many different contexts as possible. Properly used over time, calculators and computers can actually help students learn mathematics and acquire quantitative thinking skills" necessary for science achievement.¹⁵ The rush to technology has not gone unchallenged. Critics express concern that computers might be used in age-inappropriate ways, undermine the critical relationship between teacher and student, become a substitute for more important activities, and draw resources away from more critical areas.¹⁶

Reflecting the growing interest in computers in classrooms, students participating in the 1996 NAEP science assessment and their teachers were asked a number of questions regarding computer use. Teachers of 15 percent of fourth-grade students and 16 percent of eighth-grade students reported having no computers available for their science classes, whereas teachers of 53 percent of fourth graders and 38 percent of eighth graders said they had at least one computer in their classrooms.¹⁷ Teachers of the remaining 32 percent of fourth graders and 46 percent of eighth graders reported having computers available in computer laboratories, although the computers were not necessarily easy to access.¹⁸ Most teachers made infrequent use of computers in their science classes. Tables 5.2 and 5.3 of this chapter show that at grades 4, 8, and 12 approximately two thirds of students never or hardly ever used a computer for science, and tables 5.4 and 5.5 reveal that at all three grades about two thirds of students had teachers who never or hardly ever used a computer for teaching science.

¹³ Executive Office of the President. (1996). *National technology literacy goals*. Washington, DC: US Government Printing Office.

¹⁴ Heavyside, S., Riggins, T., & Farris, E. (1997). *Advanced telecommunications in U.S. public elementary and secondary schools, fall 1996*. Washington, DC: National Center for Education Statistics.

¹⁵ American Association for the Advancement of Science. (1993). *Benchmarks for science literacy*. Washington, DC: Author. National Research Council of the American Academy of Sciences. (1995). *National science education standards*. Washington, DC: Author.

¹⁶ Cordes, C. (1998, January 16). As educators rush to embrace technology, a coterie of skeptics seeks to be heard. *The Chronicle of Higher Education*, 44 (19), A25-26.

¹⁷ O'Sullivan, C. Y., Weiss, A. R., & Askew, J. M. (1998). *Students learning science: A report on policies and practices in U.S. schools*. (NCES Publication No. 98-496) Washington, DC: National Center for Education Statistics.

¹⁸ Ibid.

When teachers did use computers for science instruction, how did they use them? Teachers of students in grades 4 and 8 were asked if they used computers for any of five tasks or if they did not use computers for instruction. The results are shown in table 5.8. At the fourth-grade level, computers were used most frequently for playing science/learning games (30 percent of students) and least frequently for “drill and practice” and “data analysis and other applications” (5 percent and 6 percent of students, respectively). Teachers of 53 percent of grade 4 students reported they did not use computers for science instruction. An analysis of performance data shows that grade 4 students whose teachers did not use computers for instruction had lower scale scores and were less likely to reach the *Proficient* level than those students whose teachers did use computers. Students whose teachers used computers for playing science/learning games and for word processing had higher scale scores and were more often at or above *Proficient* than students whose teachers did not use computers for these purposes. Also, students whose teachers used computers for simulations and modeling had higher scale scores than those students whose teachers did not.

Teachers of grade 8 students who used computers tended to place a somewhat different emphasis on their use than teachers of grade 4 students, generally reflecting the more highly developed cognitive skills of the older children. Twenty-five percent, 19 percent, and 22 percent of students had teachers who used computers for simulations and modeling, data analysis, and word processing, respectively. Twenty-one percent of students had teachers who used computers for playing science/learning games. Forty-six percent of students had teachers who reported not using computers for science instruction. Among eighth graders, there were no differences in scale scores or percentages at or above *Proficient* that were associated with how computers were used.

TABLE 5.8

**Teachers' Reports on How They Use Computers
for Science Instruction, Grades 4 and 8:
Public and Nonpublic Schools Combined**



How do you use computers for instruction in science?	Grade 4		Grade 8	
	Yes	No	Yes	No
Drill and practice	5 ^a 149 ^b 28 ^c	95 151 30	8 156 36	92 151 30
Playing science/learning games	30 154 33	70 149 28	21 152 29	79 152 31
Simulations and modeling	18 155 34	82 150 29	25 155 32	75 151 30
Data analysis and other applications	6 149 29	94 151 30	19 152 30	81 152 31
Word processing	10 159 37	90 150 29	22 154 34	78 151 30
I do not use computers for science instruction.	53 148 27	47 154 32	46 150 29	54 153 32

^a Percentage of Students

^b Average Scale Score

^c Percentage At or Above Proficient

NOTE: Percentages may not add to 100 due to rounding.

SOURCE: National Center for Education Statistics. National Assessment of Educational Progress (NAEP), 1996 Science Assessment.

Homework

The effectiveness of homework — its contribution to student learning — depends on many factors, including the quality and appropriateness of the assignments, the amount of homework assigned, and the attention given to completed assignments by teachers. Studies indicate that, in general, homework is correlated with higher achievement among high school students, with somewhat higher achievement among middle school students, and with no difference in achievement among grade school students. Moreover, assignments of more than about one hour per night tend to raise achievement for high school students but not for elementary or junior high school students.¹⁹ Teachers of fourth- and eighth-grade students who participated in the

¹⁹ Black, S. (1996). The truth about homework. *American School Board Journal*, 183 (10), 48-51.

1996 NAEP science assessment were asked how much time they expected students in their classes to spend doing science homework each week. The results are shown in table 5.9. One in five grade 4 students was not expected to do any science homework, 38 percent were expected to do one-half hour of science homework each week, and 33 percent were expected to do one hour of science homework each week. There was no relationship between scale scores or the percentage of students at or above *Proficient* and teachers' reports of the amount of homework expected. More science homework was assigned in the eighth grade. Thirteen percent of students had teachers who expected them to spend one-half hour or less on science homework each week and 47 percent had teachers who expected them to spend two hours or more on science homework each week. Eighth-grade students whose teachers expected them not to do any science homework had lower scale scores than those whose teachers expected them to do an hour or more a week. Students whose teachers expected them to spend one-half hour a week on science homework had lower scale scores than those whose teachers expected them to spend two hours or more a week on science homework. The same differences were seen in the percentage of students at or above *Proficient*.

TABLE 5.9

Teachers' Reports on How Much Science Homework They Assign, Grades 4 and 8: Public and Nonpublic Schools Combined



About how much time do you expect a student in this class to spend doing science homework each week?	Grade 4				Grade 8			
	None	One Half Hour	One Hour	Two Hours or More	None	One Half Hour	One Hour	Two Hours or More
Percentage of Students	20	38	33	9	2	11	40	47
Average Scale Score	152	149	152	147	134	144	152	155
Percentage At or Above <i>Proficient</i>	30	29	31	28	15	21	31	35

NOTE: Percentages may not add to 100 due to rounding.

SOURCE: National Center for Education Statistics. National Assessment of Educational Progress (NAEP), 1996 Science Assessment.

Summary

As part of the NAEP 1996 science assessment, teachers of students in grades 4 and 8 and students in grades 4, 8, and 12 were afforded the opportunity to respond to questions directly related to classroom activities.

Grade 4

- Seventy-eight and 15 percent of students, respectively, were taught by teachers who reported placing heavy emphasis on understanding key science concepts and on developing laboratory skills and techniques.
- Students had higher average scale scores and were more likely to be at or above the *Proficient* level if their teachers placed a heavy emphasis on understanding key science concepts than if their teachers did not.
- Forty-seven percent of students were taught by teachers who reported assigning hands on activities or investigations to students once or twice a week.
- Sixty percent of students indicated that they had done science projects that took a week or more.
- Approximately half the student population had teachers who reported not using computers for instruction in science, whereas 30 percent of students had teachers who reported using the computer to play science/learning games during science instruction.
- One fifth of the student population had teachers who reported expecting no time to be spent on science homework each week.

Grade 8

- Eighty-eight and 41 percent of students, respectively, were taught by teachers who reported placing heavy emphasis on understanding key science concepts and on developing laboratory skills and techniques.
- Students had higher average scale scores and were more likely to be at or above the *Proficient* level if their teachers placed a heavy emphasis on understanding key science concepts or on developing laboratory skills and techniques than if their teachers did not.
- Sixty-two percent of students were taught by teachers who reported assigning hands-on activities or investigations to students once or twice a week. Students who did hands-on activities almost every day or once or twice a week had higher scale scores than students who did hands-on activities once or twice a month or never or hardly ever.
- Sixty-four percent of students indicated that they had done science projects that took a week or more.
- Forty-six percent of students had teachers who reported not using computers for instruction in science, whereas 25 percent of students had teachers who reported using computers for simulations and modeling during science instruction.
- Eighty-seven percent of students had teachers who reported expecting one or more hours to be spent on science homework each week.

Grade 12

- Forty-two percent of students currently taking science reported doing hands-on activities or investigations once or twice a week. Students who did hands-on activities almost every day or once or twice a week demonstrated higher performance than students who did hands-on activities once or twice a month or never or hardly ever.
- The greater the frequency with which teachers talked to their students about science, the higher the students' scale scores.
- Sixty-eight percent of students indicated that they had conducted science investigations that took a week or more.

Chapter 6

Attitudes, Motivation, and School Climate

Introduction

What students learn in school is influenced by many things beyond what teachers plan for their classes. Students' attitudes, the interest and involvement of parents, and school climate all can affect teaching and learning both positively and negatively, although it would be inadvisable to assume a causal connection between any single variable and a student's performance. As part of the NAEP 1996 science assessment, all students were asked questions concerning their attitudes and beliefs about science and their motivation and performance on the assessment. School administrators were asked questions about parental involvement in their schools and about school climate. Taken together, this information creates further context for understanding student performance in the science assessment.

The tables in this chapter present three sets of data: percentages of students who responded to or whose teachers responded to questions in the student and teacher questionnaires; the average scale scores of students; and the percentages of students at or above *Proficient*. The following example demonstrates how these data can be read. In the top left-hand box in table 6.1 there are three numbers with superscripts: 67^a, 153^b, and 32^c. The superscript 'a' denotes percentage of students, superscript 'b' denotes average scale score, and superscript 'c' denotes percentage at or above *Proficient*. Sixty-seven percent of students reported liking science. These students had an average scale score of 153, and 32 percent of them were at or above the *Proficient* level.

Student Attitudes and Beliefs about Science

It is well understood among educators that students learn best when they are motivated. As seen in the previous chapter, in addition to teaching content, teachers of nearly all fourth- and eighth-grade students placed a moderate or heavy emphasis on developing their students' interest in science (see Table 5.1). Science teachers try many ways to motivate their students, from simply exhibiting enthusiasm for the subject to stimulating interest by using hands-on tasks, technology, games, and other techniques.¹

Are teachers' efforts successful? What do students think about science? Students at grades 4, 8, and 12 were asked how much they agreed with eight statements regarding their attitudes and beliefs about science. The results are presented in Table 6.1 for all students and by gender, in Table 6.2 for all students and by race/ethnicity, and in Table 6.3 as a composite based on how many positive attitudes toward science students had. Throughout the discussion that follows, the terms "positive attitudes" and "negative attitudes" refer specifically to the way students responded to six of the eight statements. The positive attitudes consisted of the "agree" responses to three statements — "I like science," "I am good at science," and "Science is useful for solving everyday problems" — and the "disagree" responses to three statements — "Learning science is mostly memorizing," "If I had a choice I would not study any more science in school," and "Science is boring." Conversely, "disagree" responses to the first three questions and "agree" responses to the latter three questions were interpreted as negative attitudes. "Not sure" responses and all responses to the statements "Everyone can do well in science if they try" and "Science is a hard subject" were considered to be neither positive nor negative. Students' responses show that their attitudes toward science were, on average, neither very positive nor very negative. Fourth graders seemed to be the most favorably disposed to science, with eighth and twelfth graders being somewhat less so.

¹ Nolen, S. B. & Haladyna, T. M. (1990). Motivation and studying in high school science. *Journal of Research in Science Teaching*, 27(2), 115-26.

Swanson, C. B. (1995). How technology in the chemistry classroom affects students' attitudes and motivation. *Teaching and Change* 3(1), 63-75.

Nemerow, L.G. (1996). Do classroom games improve motivation and learning? *Teaching and Change* 3(4), 356-66.

The picture becomes more complex when women and minorities are considered separately. Women and minorities have historically been underrepresented in the fields of science and engineering. Two causes that have been identified as contributing to this underrepresentation are negative attitudes and perceptions of science and poor academic performance in science on the part of women and minorities. According to Clewell, Anderson, and Thorpe, “factors affecting females’ and minorities’ attitudes include a poor self-concept as a ‘doer’ of math or science; their negative perception of the utility of these subjects in ‘real life’; the stereotyping of math and science as White male activities; and the influence of significant others, such as parents, teachers, and peers, in discouraging participation in these subjects.” Moreover, research has suggested that the relatively poorer academic performance of females and minorities stems, in part, from their more negative attitudes and beliefs about science.²

All Students

Among fourth-grade students, 67 percent said they liked science and 64 percent said they would continue to study it even though less than half (45 percent) believed they were good at it. Eighty-four percent thought everyone can do well in science if they try. Forty percent thought science was mostly memorizing. A majority of students, 70 percent, did not agree that science is boring (see Table 6.1).

Half of eighth graders (50 percent) said they liked science and would continue to study it if it were their choice. Forty percent thought science is useful for solving everyday problems and 37 percent thought it is a hard subject. Forty-seven percent of eighth-grade students believed themselves to be good at science, although 67 percent believed everyone could do well if they tried.

As with eighth graders, about half of twelfth graders (52 percent) said they liked science. However, 43 percent thought they would continue to study it if given the choice (compared to 50 percent of eighth graders and 64 percent of fourth graders). Twelfth graders were more likely to recognize the relevance of science than were younger students; half agreed it was useful for solving everyday problems. Twelfth graders were also more likely than fourth and eighth graders to think that science was hard (50 percent), less likely to think that they were good at it (39 percent), and less likely to think that everyone can do well at it (49 percent).

² Clewell, B. C., Anderson, B. T., & Thorpe, M. E. (1992). *Breaking the barriers: Helping female and minority students succeed in mathematics and science*. San Francisco, CA: Jossey-Bass Publishers.

Skolnick, J., Langbort, C., & Day, L. (1982). *How to encourage girls in math & science*. Englewood Cliffs, NJ: Prentice-Hall, Inc.

In many cases, what could be considered positive attitudes toward science correlated with higher performance. For example, students who liked science outperformed those who did not. However, readers are again cautioned against drawing conclusions regarding causality; it is impossible to tell from the data presented whether students did better because they liked science, whether they liked science because they did well at it, or because of a combination of these and other variables.

At the fourth-grade level, students who said they liked science or were good at science had higher scale scores and were more likely to perform at or above the *Proficient* level than those who said they were not sure or did not like science. Students who indicated that they were not sure if they were good at science outperformed those who did not think they were good at it. Students who disagreed that learning science is mostly memorizing and students who were not sure of this outperformed students who agreed that it is mostly memorizing. Students who would study more science if given the choice and who did not think science was boring had higher scale scores and were more likely to reach the *Proficient* level than those who would not study any more or thought science was boring.

Eighth- and twelfth-grade students who agreed that they liked science, that they were good at science, or that science was useful for solving everyday problems had higher scale scores and were more likely to be at or above the *Proficient* level than their counterparts who were not sure or disagreed with these three statements. Students who answered that they were not sure outperformed those who disagreed with the three statements. Students who agreed that science was boring or that they would not study it if they had the choice had lower scale scores and were less likely to reach the *Proficient* level than students who were not sure or who disagreed, while students who were not sure were outperformed by those who disagreed. Eighth graders who thought science was a hard subject had lower scale scores and were less likely to reach the *Proficient* level than students who did not think science was hard. Finally, twelfth graders who disagreed that science was mostly memorizing outperformed those who were not sure or who agreed, while those who thought that everyone can do well in science if they try were outperformed by those who were not sure or disagreed with that statement.

TABLE 6.1

**Students' Reports on Attitudes and Beliefs
about Science, by Gender, Grade 4:
Public and Nonpublic Schools Combined**



How much do you agree with the following statements?	All Students			Males			Females		
	Agree	Not Sure	Disagree	Agree	Not Sure	Disagree	Agree	Not Sure	Disagree
I like science.	67 ^a 153 ^b 32 ^c	23 146 24	10 144 20	68 154 35	22 146 26	11 143 20	66 151 29	25 145 22	10 145 21
I'm good at science.	45 156 36	45 148 26	10 135 13	49 157 38	41 149 27	10 134 14	41 154 33	49 148 24	10 136 12
Learning science is mostly memorizing.	40 146 24	36 153 31	24 155 34	42 149 28	35 153 33	23 155 36	38 143 21	38 153 30	25 154 32
Science is useful for solving everyday problems.	35 152 32	34 151 30	32 149 26	36 152 34	33 153 34	31 149 26	33 151 29	35 148 26	32 149 25
If I had a choice, I would not study any more science in school.	17 140 19	19 144 24	64 155 33	19 143 22	18 144 26	62 156 36	14 137 16	19 144 23	66 154 30
Everyone can do well in science if they try.	84 151 29	10 152 34	5 139 22	83 153 32	11 151 34	6 138 22	86 150 26	10 153 35	4 142 23
Science is boring.	15 141 19	15 143 24	70 154 33	17 142 21	15 141 24	69 156 36	13 138 17	16 144 23	72 153 30
Science is a hard subject.	27 146 25	31 152 31	42 152 31	28 148 28	29 153 33	43 153 32	26 145 22	32 151 28	42 152 29

^a Percentage of Students

^b Average Scale Score

^c Percentage At or Above *Proficient*

NOTE: Percentages may not add to 100 due to rounding.

SOURCE: National Center for Education Statistics, National Assessment of Educational Progress (NAEP), 1996 Science Assessment.

TABLE 6.1
(continued)

**Students' Reports on Attitudes and Beliefs
about Science, by Gender, Grade 8:
Public and Nonpublic Schools Combined**



How much do you agree with the following statements?	All Students			Males			Females		
	Agree	Not Sure	Disagree	Agree	Not Sure	Disagree	Agree	Not Sure	Disagree
I like science.	50 ^a 157 ^b 37 ^c	28 146 24	21 141 18	54 158 39	26 145 24	20 140 19	47 155 34	30 147 24	23 141 17
I'm good at science.	.47 162 43	37 143 21	16 133 10	52 163 44	33 142 21	14 132 10	42 161 41	40 145 21	18 134 10
Learning science is mostly memorizing.	33 150 28	36 149 28	31 152 32	34 150 29	37 150 30	29 155 37	32 150 27	36 149 27	32 149 28
Science is useful for solving everyday problems.	40 156 37	34 151 29	25 141 18	42 157 38	33 152 31	25 141 19	39 155 35	36 150 26	25 140 18
If I had a choice, I would not study any more science in school.	23 141 18	27 148 27	50 156 36	22 141 18	27 149 29	52 157 38	24 141 17	28 147 25	48 155 34
Everyone can do well in science if they try.	67 148 26	22 157 37	11 151 31	67 149 29	21 158 39	12 151 32	67 147 24	22 157 36	11 151 30
Science is boring.	28 144 21	26 149 27	46 156 36	27 144 22	25 148 28	48 158 39	28 144 20	27 149 26	44 154 33
Science is a hard subject.	37 148 26	30 150 29	32 154 33	37 147 27	30 151 31	33 156 36	38 148 25	31 149 28	32 151 30

^a Percentage of Students

^b Average Scale Score

^c Percentage At or Above Proficient

NOTE: Percentages may not add to 100 due to rounding.

SOURCE: National Center for Education Statistics, National Assessment of Educational Progress (NAEP), 1996 Science Assessment.

TABLE 6.1
(continued)

**Students' Reports on Attitudes and Beliefs
about Science, by Gender, Grade 12:
Public and Nonpublic Schools Combined**



How much do you agree with the following statements?	All Students			Males			Females		
	Agree	Not Sure	Disagree	Agree	Not Sure	Disagree	Agree	Not Sure	Disagree
I like science.	52 ^a 161 ^b 32 ^c	22 142 12	26 136 9	56 164 37	22 141 13	22 137 11	48 158 27	23 142 11	29 136 7
I'm good at science.	39 166 39	37 146 14	24 132 5	45 169 43	36 145 15	19 130 6	33 164 34	38 146 13	29 134 5
Learning science is mostly memorizing.	34 147 17	27 146 17	39 157 29	34 149 20	30 148 19	37 161 36	34 145 14	25 144 14	41 153 23
Science is useful for solving everyday problems.	50 159 30	30 144 15	20 139 10	51 162 35	29 146 19	20 140 11	50 155 25	31 143 12	20 138 8
If I had a choice, I would not study any more science in school.	33 141 11	24 145 15	43 161 33	30 141 13	26 147 17	44 165 40	36 140 9	22 144 13	43 157 27
Everyone can do well in science if they try.	49 147 19	29 154 25	22 155 24	51 151 23	29 155 29	20 156 29	48 143 14	29 152 22	23 154 19
Science is boring.	25 137 9	25 146 17	50 159 30	23 139 12	26 148 19	50 163 36	26 136 7	23 144 14	51 156 24
Science is a hard subject.	50 150 19	26 150 21	23 154 28	44 151 23	29 151 23	27 159 34	56 149 16	24 148 19	20 147 20

^a Percentage of Students

^b Average Scale Score

^c Percentage At or Above *Proficient*

NOTE: Percentages may not add to 100 due to rounding.

SOURCE: National Center for Education Statistics, National Assessment of Educational Progress (NAEP), 1996 Science Assessment.

Gender

Results from the NAEP 1996 science assessment show that male and female performance was the same at both grades 4 and 8 but that males outperformed females at grade 12.³ Did the attitudes of male and female students toward science also start out the same and then diverge?

As shown in Table 6.1, among fourth graders, male and female attitudes toward science were generally similar; equal numbers of students indicated they liked science and did not think it was boring or mostly memorizing. Although males were as likely as females to think that science is a hard subject (28 percent vs. 26 percent), they were more likely to think that they were good at it (49 percent vs. 41 percent). At eighth grade, more males than females liked science (54 percent vs. 47 percent), and 10 percent more males than females thought they were good at it (52 percent vs. 42 percent). Answers to the other questions did not differ between males and females at grade 8. Attitudes diverged somewhat more at grade 12. As with eighth graders, more males than females liked science (56 percent vs. 48 percent) and thought they were good at it (45 percent vs. 33 percent). In addition, more females than males at grade 12 said they would not study more science if they had a choice (36 percent vs. 30 percent) and more females than males agreed that science was a hard subject (56 percent vs. 44 percent).

There were differences in performance between males and females at fourth and twelfth grade associated with some of the attitudes and beliefs presented in Table 6.1. There were no differences at eighth grade. In each instance where differences were found, males outperformed females. This took place regardless of whether the attitudes were positive, negative, or unclear. For example, at the fourth-grade level, males who liked science — a positive attitude — were more likely to be at or above *Proficient* than were females who liked science. Males who agreed that learning science was mostly memorizing — a negative attitude — had higher scale scores and were more likely to be at or above *Proficient* than females who felt the same way. Males who were not sure if science is useful for solving everyday problems — an unclear attitude — were more likely to have reached the *Proficient* level than females who were not sure if science is useful. Among twelfth graders, males who liked science outperformed females who liked science, males who believed they were good at science outperformed females who believed they were good at science, males who would study more science if given the choice outperformed females who would study more science, and males who did not think science is boring outperformed females who did not think science is boring. Males who thought learning science is mostly memorizing were more likely to be at or above the *Proficient* level than were females with the same attitude, but males who did not think learning science is mostly memorizing also outperformed females who did not think learning science is mostly memorizing. It should be noted that the comparisons above are between male and female students giving the same responses to the questions (i.e., males who agree compared to females who agree, males who disagree compared to females who disagree).

³ O'Sullivan, C. Y., Reese, C. M., & Mazzeo, J. (1997). *NAEP 1996 science report card for the nation and the states*. Washington, DC: National Center for Education Statistics.

Race/Ethnicity

Do members of different racial and ethnic groups have different attitudes toward science? Table 6.2 provides data on the attitudes and performance of White (not Hispanic), Black (not Hispanic), Hispanic, Asian/Pacific Islander, and American Indian students. NAEP creates these subgroups based on students' reports of their race/ethnicity. The discussion below highlights those areas in which student attitudes differed the most, usually by eight to ten percent or more. There were additional instances in which the differences in attitudes were found to be statistically significant but were not large enough to be considered noteworthy.

Among fourth graders, attitudes toward science differed somewhat, but not a great deal, among members of different racial/ethnic groups. Forty-seven percent of White students and 47 percent of Black students thought they were good at science, compared to 37 percent of Hispanic students and 35 percent of Asian/Pacific Islander students. Thirty-seven percent of White students believed learning science was mostly memorizing, compared to 48 percent of Black students and 45 percent of Hispanic students. More White students (32 percent) and Black students (35 percent) disagreed that science is useful for solving everyday problems than did Asian/Pacific Islander students (24 percent). Sixty-six percent of White students said they would not stop studying science if they had a choice, compared to 59 percent of their Black peers. Seventy-two percent of White students disagreed that science is boring, compared to 64 percent of Black students.

At the eighth-grade level, a greater percentage of White students (50 percent) thought they were good at science than did either Hispanic students (35 percent) or Asian/Pacific Islander students (39 percent). More Black students (46 percent) than Hispanic students also believed they were good at science. Fifteen percent of American Indian students disagreed with the statement "science is useful for solving everyday problems," a smaller percentage than for White (25 percent), Black (27 percent), or Hispanic (29 percent) students. White students were less likely to agree that everyone can do well in science if they try (63 percent) and more likely to disagree (13 percent) than were Black (77 percent and 8 percent), Hispanic (74 percent and 9 percent), or Asian/Pacific Islander (80 percent and 5 percent) students. Asian/Pacific Islander students were less likely to agree that science is boring (20 percent) than were White (29 percent) and American Indian (39 percent) students. Black students were more likely to disagree that science is a hard subject (41 percent) than White (31 percent), Hispanic (30 percent), Asian/Pacific Islander (26 percent), or American Indian (28 percent) students.

TABLE 6.2

**Students' Reports on Attitudes and Beliefs
about Science, by Race/Ethnicity, Grade 4:
Public and Nonpublic Schools Combined**



How much do you agree with the following statements?	All Students			White			Black		
	Agree	Not Sure	Disagree	Agree	Not Sure	Disagree	Agree	Not Sure	Disagree
I like science.	67 ^a 153 ^b 32 ^c	23 146 24	10 144 20	67 162 41	23 156 31	10 153 27	64 126 8	23 121 5	13 126 6
I'm good at science.	45 156 36	45 148 26	10 135 13	47 165 45	44 157 33	9 145 18	47 127 9	41 124 6	13 117 4
Learning science is mostly memorizing.	40 146 24	36 153 31	24 155 34	37 157 33	38 161 39	25 163 42	48 123 6	30 126 8	22 127 7
Science is useful for solving everyday problems.	35 152 32	34 151 30	32 149 26	35 161 41	33 160 38	32 158 33	35 125 8	30 123 6	35 125 7
If I had a choice, I would not study any more science in school.	17 140 19	19 144 24	64 155 33	16 152 27	18 156 33	66 163 41	21 116 3	20 117 6	59 130 9
Everyone can do well in science if they try.	84 151 29	10 152 34	5 139 22	84 160 37	11 162 43	5 152 31	86 126 7	8 120 8	6 116 3
Science is boring.	15 141 19	15 143 24	70 154 33	14 151 26	14 157 33	72 162 41	18 118 5	19 116 5	64 129 8
Science is a hard subject.	27 146 25	31 152 31	42 152 31	26 156 33	32 161 39	42 161 39	29 124 7	25 119 5	46 128 8

^a Percentage of Students

^b Average Scale Score

^c Percentage At or Above *Proficient*

NOTE: Percentages may not add to 100 due to rounding.

SOURCE: National Center for Education Statistics, National Assessment of Educational Progress (NAEP), 1996 Science Assessment.

TABLE 6.2
(continued)

**Students' Reports on Attitudes and Beliefs
about Science, by Race/Ethnicity, Grade 4:
Public and Nonpublic Schools Combined**

How much do you agree with the following statements?	Hispanic			Asian/Pacific Islander			American Indian		
	Agree	Not Sure	Disagree	Agree	Not Sure	Disagree	Agree	Not Sure	Disagree
I like science.	64 ^a 131 ^b 11 ^c	27 124 7	9 124 6	71 154 34	23 143 16	6 — —	70 149 30	20 — —	11 — —
I'm good at science.	37 133 12	52 129 9	11 114 3	35 158 41	57 149 23	8 — —	42 156 35	48 139 22	10 — —
Learning science is mostly memorizing.	45 126 8	34 130 9	21 134 14	42 149 25	38 150 27	21 159 38	49 144 27	31 144 26	20 — —
Science is useful for solving everyday problems.	33 129 10	37 128 9	30 130 8	36 153 31	40 152 29	24 147 24	31 143 20	34 146 31	35 144 27
If I had a choice, I would not study any more science in school.	18 119 5	21 119 7	61 135 11	10 — —	24 138 15	66 159 37	20 — —	16 — —	64 152 31
Everyone can do well in science if they try.	83 130 9	12 129 12	5 107 1	90 151 28	8 — —	2 — —	83 146 27	10 — —	6 — —
Science is boring.	16 122 7	17 115 6	67 134 11	9 — —	16 — —	75 156 33	17 — —	18 — —	65 151 31
Science is a hard subject.	30 124 7	31 130 11	40 131 10	23 142 16	40 153 28	36 155 37	30 132 14	20 — —	51 153 35

^a Percentage of Students

^b Average Scale Score

^c Percentage At or Above *Proficient*

— Sample size was insufficient to permit reliable estimates.

NOTE: Percentages may not add up to 100 due to rounding.

SOURCE: National Center for Education Statistics. National Assessment of Educational Progress (NAEP), 1996 Science Assessment.

TABLE 6.2
(continued)

**Students' Reports on Attitudes and Beliefs
about Science, by Race/Ethnicity, Grade 8:
Public and Nonpublic Schools Combined**



How much do you agree with the following statements?	All Students			White			Black		
	Agree	Not Sure	Disagree	Agree	Not Sure	Disagree	Agree	Not Sure	Disagree
I like science.	50 ^a 157 ^b 37 ^c	28 146 24	21 141 18	51 166 46	27 157 31	22 148 22	50 126 8	28 118 3	21 115 1
I'm good at science.	47 162 43	37 143 21	16 133 10	50 170 52	35 153 27	15 141 13	46 128 8	36 117 3	18 111 0
Learning science is mostly memorizing.	33 150 28	36 149 28	31 152 32	32 160 36	36 159 36	33 160 39	39 124 5	36 120 5	25 118 6
Science is useful for solving everyday problems.	40 156 37	34 151 29	25 141 18	41 166 47	35 159 36	25 150 24	41 125 6	32 124 6	27 112 3
If I had a choice, I would not study any more science in school.	23 141 18	27 148 27	50 156 36	22 150 23	27 158 34	51 165 45	24 114 2	27 119 3	49 126 7
Everyone can do well in science if they try.	67 148 26	22 157 37	11 151 31	63 158 35	24 164 44	13 158 36	77 120 4	15 126 9	8 119 4
Science is boring.	28 144 21	26 149 27	46 156 36	29 151 26	24 159 36	47 166 45	26 114 1	29 123 6	45 125 7
Science is a hard subject.	37 148 26	30 150 29	32 154 33	38 156 32	30 160 37	31 165 43	33 119 4	26 121 5	41 123 6

^a Percentage of Students

^b Average Scale Score

^c Percentage At or Above *Proficient*

NOTE: Percentages may not add to 100 due to rounding.

SOURCE: National Center for Education Statistics, National Assessment of Educational Progress (NAEP), 1996 Science Assessment.

TABLE 6.2
(continued)

**Students' Reports on Attitudes and Beliefs
about Science, by Race/Ethnicity, Grade 8:
Public and Nonpublic Schools Combined**



How much do you agree with the following statements?	Hispanic			Asian/Pacific Islander			American Indian		
	Agree	Not Sure	Disagree	Agree	Not Sure	Disagree	Agree	Not Sure	Disagree
I like science.	46 ^a 135 ^b 14 ^c	34 123 8	20 125 8	49 161 41	36 148 25	15 135 12	39 148 26	33 — —	27 — —
I'm good at science.	35 142 20	46 125 7	19 118 5	39 166 49	48 146 22	14 — —	39 — —	39 — —	22 — —
Learning science is mostly memorizing.	34 132 13	39 128 11	26 128 8	32 157 34	41 147 23	27 155 39	31 — —	33 — —	36 — —
Science is useful for solving everyday problems.	37 132 13	34 130 11	29 123 8	46 157 34	33 152 31	21 144 25	36 — —	49 — —	15 — —
If I had a choice, I would not study any more science in school.	23 123 8	29 127 10	48 134 13	16 141 21	31 144 23	53 161 40	37 — —	27 — —	36 151 33
Everyone can do well in science if they try.	74 129 10	17 134 13	9 126 13	80 150 28	15 — —	5 — —	72 151 29	16 — —	12 — —
Science is boring.	24 126 10	32 128 11	43 132 12	20 142 19	36 151 29	44 159 38	39 — —	26 — —	35 — —
Science is a hard subject.	36 127 9	33 127 8	30 134 16	39 145 23	35 154 31	26 161 42	38 — —	34 — —	28 — —

^a Percentage of Students

^b Average Scale Score

^c Percentage At or Above *Proficient*

— — Sample size was insufficient to permit reliable estimates.

NOTE: Percentages may not add to 100 due to rounding.

SOURCE: National Center for Education Statistics. National Assessment of Educational Progress (NAEP), 1996 Science Assessment.

TABLE 6.2
(continued)

**Students' Reports on Attitudes and Beliefs
about Science, by Race/Ethnicity, Grade 12:
Public and Nonpublic Schools Combined**

THE NATION'S
REPORT
CARD



How much do you agree with the following statements?	All Students			White			Black		
	Agree	Not Sure	Disagree	Agree	Not Sure	Disagree	Agree	Not Sure	Disagree
I like science.	52 ^a 161 ^b 32 ^c	22 142 12	26 136 9	54 169 39	21 151 16	25 144 12	47 134 7	22 116 1	32 116 2
I'm good at science.	39 166 39	37 146 14	24 132 5	42 174 47	36 155 18	23 140 7	38 135 7	36 121 3	25 113 0
Learning science is mostly memorizing.	34 147 17	27 146 17	39 157 29	32 155 22	27 155 21	41 165 36	42 126 3	25 119 3	32 126 5
Science is useful for solving everyday problems.	50 159 30	30 144 15	20 139 10	52 167 37	30 153 20	19 147 13	48 129 5	30 119 3	22 121 2
If I had a choice, I would not study any more science in school.	33 141 11	24 145 15	43 161 33	33 147 14	24 154 20	43 171 42	35 119 2	24 121 2	42 130 6
Everyone can do well in science if they try.	49 147 19	29 154 25	22 155 24	44 158 26	31 161 31	25 159 27	61 123 3	25 124 5	14 130 6
Science is boring.	25 137 9	25 146 17	50 159 33	24 145 13	24 155 21	51 168 37	29 114 0	24 122 3	46 132 6
Science is a hard subject.	50 150 19	26 150 21	23 154 28	53 156 23	26 159 27	21 168 40	38 125 5	25 121 3	37 126 4

^a Percentage of Students

^b Average Scale Score

^c Percentage At or Above Proficient

NOTE: Percentages may not add to 100 due to rounding.

SOURCE: National Center for Education Statistics, National Assessment of Educational Progress (NAEP), 1996 Science Assessment.

TABLE 6.2
(continued)

**Students' Reports on Attitudes and Beliefs
about Science, by Race/Ethnicity, Grade 12:
Public and Nonpublic Schools Combined**



How much do you agree with the following statements?	Hispanic			Asian/Pacific Islander			American Indian		
	Agree	Not Sure	Disagree	Agree	Not Sure	Disagree	Agree	Not Sure	Disagree
I like science.	47 ^a 140 ^b 12 ^c	28 121 3	26 123 3	56 162 32	29 139 14	15 128 5	44 — —	24 — —	32 — —
I'm good at science.	27 150 20	45 126 3	28 119 3	31 173 46	45 143 14	25 132 8	29 — —	41 — —	29 — —
Learning science is mostly memorizing.	34 132 8	29 126 5	37 133 9	38 148 18	26 143 17	36 157 31	32 — —	21 — —	47 — —
Science is useful for solving everyday problems.	40 139 14	35 124 2	25 125 4	57 157 28	31 143 18	12 — —	50 — —	22 — —	28 — —
If I had a choice, I would not study any more science in school.	32 126 4	27 123 4	41 139 12	21 137 8	26 146 19	53 157 30	28 — —	21 — —	51 — —
Everyone can do well in science if they try.	61 128 7	25 133 9	14 137 9	66 146 20	24 154 25	10 — —	44 — —	25 — —	— — —
Science is boring.	24 124 2	27 122 5	49 139 11	16 137 9	29 148 24	55 154 26	23 — —	19 — —	58 — —
Science is a hard subject.	48 132 8	28 128 7	24 131 7	56 149 20	27 149 23	17 153 29	52 — —	26 — —	22 — —

^a Percentage of Students

^b Average Scale Score

^c Percentage At or Above *Proficient*

— — Sample size was insufficient to permit reliable estimates.

NOTE: Percentages may not add up to 100 due to rounding.

SOURCE: National Center for Education Statistics, National Assessment of Educational Progress (NAEP), 1996 Science Assessment.

Attitudes at grade 12 followed a pattern closer to that at grade 8 than at grade 4. Among twelfth graders, a greater percentage of White (25 percent) and Black (32 percent) students disagreed with the statement “I like science” than did Asian/Pacific Islander students (15 percent). Moreover, fewer Black students (47 percent) agreed with the statement than did White students (54 percent). Forty-two percent of White students said they were good at science, compared to 27 percent of Hispanic students and 31 percent of Asian/Pacific Islander students. A greater percentage of Black students than Hispanic students said they were good at science (38 percent compared to 27 percent). Asian/Pacific Islander students were relatively likely to agree and unlikely to disagree that science is useful for solving everyday problems. Fifty-seven percent agreed, compared to 40 percent of Hispanic students, and 12 percent disagreed, compared to 19 percent of White, 22 percent of Black, 25 percent of Hispanic, and 28 percent of American Indian students. A higher percentage of White (33 percent), Black (35 percent), and Hispanic (32 percent) students agreed that if given the choice they would not study any more science in school than did Asian/Pacific Islander students (21 percent). As at eighth grade, White students were less likely to agree (44 percent) and more likely to disagree (25 percent) that everyone can do well in science if they try than were Black (61 percent and 14 percent), Hispanic (61 percent and 14 percent), or Asian/Pacific Islander (66 percent and 10 percent) students. Fewer Asian/Pacific Islander students (16 percent) agreed that science is boring than did White (24 percent), Black (29 percent), or Hispanic (24 percent) students. Black students were less likely to agree (38 percent) and more likely to disagree (37 percent) that science is a hard subject than were White (53 percent and 21 percent), Hispanic (48 percent and 24 percent), or Asian/Pacific Islander (56 percent and 17 percent) students.

Positive Attitudes

To develop a more complete picture of student attitudes, data from the questions about beliefs and attitudes were combined and compared to provide a sense of how favorably students felt about science. A positive attitude index was developed based on student responses to six of the background questions — the “agree” responses to three statements — “I like science”; “I am good at science”; and “Science is useful for solving everyday problems” — and the “disagree” responses to three statements — “Learning science is mostly memorizing”; “If I had a choice I would not study any more science in school”; and “Science is boring.” Table 6.3 presents the percentages of students, average scale score, and percentages at or above *Proficient* for the range of positive attitudes — from zero positive attitudes to six positive attitudes for each of grades 4, 8, and 12. The index gives composite values for attitudes; therefore, there is no way to know which of the positive attitudes students displayed, except when the number of positive attitudes is either zero or six.

At all three grades, students were dispersed across the range of positive attitudes, although the lowest percentage at each grade had all six positive attitudes. Among fourth

graders, 2 percent had six positive attitudes and 8 percent had zero positive attitudes, whereas 23 percent had three positive attitudes and 27 percent had four positive attitudes. At grades 8 and 12, fifty percent of students had 2 or fewer positive attitudes. Five percent of eighth graders and 9 percent of twelfth graders had six positive attitudes.

An examination of performance data at each grade shows a fairly consistent pattern in which the greater the number of positive attitudes over two or three, the higher the student performance (students with zero, one, or two positive attitudes performed similarly to each other). At grade 4, scale scores rose with each positive attitude over two, and the percentage of students at or above *Proficient* rose with each positive attitude over three. At grade 8, scale scores and the percentage of students at or above *Proficient* rose with each positive attitude over two, with one exception: The percentage of students at or above *Proficient* did not differ significantly between those with three positive attitudes and those with four positive attitudes. Among twelfth graders, scale scores increased with each positive attitude over two, and the percentage of students at or above *Proficient* also increased with each positive attitude over two, with one exception: There was no difference in the percentage at or above *Proficient* for students with three positive attitudes and students with four positive attitudes.

TABLE 6.3

Relationship Between Students' Average Scale Scores and Positive Attitudes and Beliefs about Science, Grades 4, 8, and 12: Public and Nonpublic Schools Combined



	Number of Positive Attitudes						
	0	1	2	3	4	5	6
Grade 4							
Percent of Students	8	12	15	23	27	13	2
Average Scale Score	141	141	141	148	155	163	180
Percentage At or Above <i>Proficient</i>	19	21	20	25	33	43	71
Grade 8							
Percent of Students	14	19	17	16	16	13	5
Average Scale Score	143	141	142	148	157	165	180
Percentage At or Above <i>Proficient</i>	19	19	19	27	35	47	68
Grade 12							
Percent of Students	16	19	15	14	14	13	9
Average Scale Score	137	136	139	149	157	168	185
Percentage At or Above <i>Proficient</i>	7	8	12	19	25	39	62

NOTE: The Positive Attitude Index is a composite score based on student responses to six questions in the Student Background Questionnaire. The Agree responses to three questions: ("I like science"; "I am good at science"; and "Science is useful for solving everyday problems") and the Disagree responses to three questions: ("learning science is mostly memorizing"; "if I had a choice I would not study any more science in school"; and "science is boring") were combined to form the index.

SOURCE: National Center for Education Statistics, National Assessment of Educational Progress (NAEP), 1996 Science Assessment.

Students' Motivation on the NAEP Science Assessment

Because students do not receive individual scores on NAEP assessments, there is some question as to how strongly they are motivated to try to do well.⁴ Students participating in the NAEP 1996 science assessment were asked four questions related to their experiences taking the assessment. Two of the questions were about how well students thought they performed and two questions were about how motivated students were to do well. A fifth question asked if students had been required to write long answers to questions on tests during the school year. It was designed to explore how well students might have been prepared for the type of constructed-response questions found on the assessment. The results are presented in Tables 6.4 and 6.5.

Among fourth graders, 40 percent thought they answered almost all of the questions on the assessment correctly and 6 percent thought they answered less than half correctly. At the eighth-grade level, 18 percent thought they answered almost all questions correctly and 11 percent thought they got less than half correct. At the twelfth-grade level, 13 percent said they got almost all the questions right, whereas 23 percent said they got less than half right.

According to their responses, older students were less motivated to do well on the assessment than were younger students. Forty-two percent of fourth graders said they tried much harder on the NAEP science assessment than on other science tests and 9 percent said they did not try as hard. Among eighth graders, 18 percent said they tried much harder and 16 percent said they did not try as hard. At twelfth grade, 6 percent said they tried much harder while 39 percent said they did not try as hard. Similarly, doing well appears not to have been as important to older students. Doing well was very important to 59 percent of fourth graders, 25 percent of eighth graders, and 9 percent of twelfth graders, whereas doing well was not very important to 5 percent of fourth graders, 15 percent of eighth graders, and 29 percent of twelfth graders.

An examination of student performance data reveals numerous differences among students based on their motivation and performance on the NAEP science assessment. For example, at the fourth-grade level, the more questions students thought they got right, the better their performance, although there was no difference between students who thought they got almost all the questions right and those who thought they got more than half right. Fourth graders who thought the assessment was harder than most science tests and those who thought it was about as hard as most science tests outperformed students who thought it was either easier or much harder than other science tests.

Trying hard on the test did not necessarily correlate with better performance at grade 4. Students who said they tried about as hard on the NAEP assessment as they did on other science tests outperformed students who said they tried much harder, harder, and not as hard. However, students who did not try as hard as on other science tests were outperformed by students in the other three categories.

⁴ Kiplinger, V. L. & Linn, R. L. (1993). *Raising the stakes of test administration: The impact on student performance on NAEP*. Washington, DC: National Center for Education Statistics.

Burke, P. (1991). *You can lead adolescents to a test but you can't make them try*. Final Report. Washington, DC: U.S. Office of Technology Assessment.

Similarly, there was not a consistent positive relationship between how important it was for fourth-grade students to do well and how well they did. Students for whom it was not as important to do well on NAEP as on other science tests had lower scale scores and were less likely to be at or above the *Proficient* level than were students for whom it was somewhat important, important, or very important. However, students for whom it was very important to do well had lower scale scores and were less likely to be at or above the *Proficient* level than were students for whom it was important to do well, and they were also less likely to be at or above the *Proficient* level than were students for whom it was somewhat important to do well.

Finally, students who indicated that they had been asked to write long answers on science tests and assignments once or twice a month outperformed students who had written long answers at least once a week, once or twice a year, or never. Students who said they were never asked to write long answers were outperformed by all other students.⁵

At the eighth-grade level, the more questions students thought they had answered correctly, the better they performed. Students who thought the NAEP assessment was much harder than other science tests were outperformed by students who thought it was harder, about as hard, or easier. As at the fourth-grade level, trying hard or thinking it important to do well did not necessarily relate to higher performance. Students who tried about as hard on the NAEP assessment as they did on other science tests outperformed students who tried much harder, harder, or not as hard as they did on other tests, and students who tried much harder on NAEP actually performed less well than all other students. Students who thought it was very important to do well had lower average scale scores than those who thought it was important or somewhat important to do well; there were no differences in the percentages at or above *Proficient*. As at fourth grade, eighth-grade students who indicated that they never were asked to write long answers to science questions did not perform as well as students who were asked to write them.

Twelfth graders, like eighth graders, had a good sense of how well they performed; the more questions they thought they got right, the better their scale scores and the more likely that they would be at or above the *Proficient* level. Twelfth graders also were good judges of how difficult the assessment was for them. The easier they thought it was, the better they performed. However, higher student motivation did not relate to better performance. In fact, students whose responses indicated that they were the most motivated to do well on the assessment did not do the best and those whose responses showed them to be the least motivated did not do the worst. Students who said they tried about as hard on NAEP as on other tests or not as hard as on other tests outperformed students who said either that they tried harder or much harder, and students who said it was very important for them to do well had lower scale scores than those who said it was important, somewhat important, or not very important.

Finally, the more often twelfth graders had been asked to write long answers to science questions, the better they performed, except there was no difference between those who said they were asked to write long answers at least once a week and those who said they were asked to write long answers once or twice a month.

⁵ Eighty percent of the assessment time in the NAEP 1996 science assessment was devoted to constructed-response questions.

TABLE 6.4

**Students' Reports About their Motivation and Performance
on the NAEP Science Assessment, Grades 4 and 8:
Public and Nonpublic Schools Combined**



	Grade 4			Grade 8		
	Percentage of Students	Average Scale Score	Percentage At or Above Proficient	Percentage of Students	Average Scale Score	Percentage At or Above Proficient
About how many questions do you think you got right. . . ?						
Almost All	40	153	34	18	165	50
More Than Half	37	154	32	42	157	36
About Half	17	144	18	29	141	16
Less Than Half	6	129	9	11	127	6
How hard was this test compared to most other tests. . . ?						
Much Harder	23	142	20	14	136	15
Harder	20	155	36	26	152	31
About as Hard	30	156	36	34	154	34
Easier	27	147	23	26	152	29
How hard did you try on this test compared to how hard you tried on most other science tests. . . ?						
Much Harder	42	148	24	18	135	14
Harder	19	151	31	21	147	25
About as Hard	30	159	39	45	159	38
Not as Hard	9	134	14	16	150	28
How important was it to do well. . . ?						
Very Important	59	149	27	25	146	26
Important	26	154	33	33	151	30
Somewhat Important	9	153	35	27	154	32
Not as Important	5	137	15	15	151	30
This year in school, how often have you been asked to write long answers to questions on tests. . . ?						
At Least Once a Week	40	150	28	39	152	31
Once or Twice a Month	29	156	37	35	155	34
Once or Twice a Year	15	150	30	15	148	26
Never	16	141	18	11	135	14

NOTE: Percentages may not add to 100 due to rounding.

SOURCE: National Center for Education Statistics, National Assessment of Educational Progress (NAEP), 1996 Science Assessment.

TABLE 6.5

**Students' Reports About their Motivation and Performance
on the NAEP Science Assessment, Grade 12:
Public and Nonpublic Schools Combined**

THE NATION'S
REPORT
CARD



	Grade 12		
	Percentage of Students	Average Scale Score	Percentage At or Above Proficient
About how many questions do you think you got right. . . ?			
Almost All	13	175	53
More Than Half	33	164	33
About Half	31	145	11
Less Than Half	23	126	2
How hard was this test compared to most other tests. . . ?			
Much Harder	12	128	5
Harder	21	143	13
About as Hard	34	150	18
Easier	33	166	38
How hard did you try on this test compared to how hard you tried on most other science tests. . . ?			
Much Harder	6	127	4
Harder	11	134	9
About as Hard	44	156	25
Not as Hard	39	154	24
How important was it to do well. . . ?			
Very Important	9	139	14
Important	25	152	23
Somewhat Important	36	153	22
Not as Important	29	152	23
This year in school, how often have you been asked to write long answers to questions on tests. . . ?			
At Least Once a Week	28	156	27
Once or Twice a Month	26	156	28
Once or Twice a Year	13	149	21
Never	33	143	13

NOTE: Percentages may not add to 100 due to rounding.

SOURCE: National Center for Education Statistics, National Assessment of Educational Progress (NAEP), 1996 Science Assessment.

Parental Involvement in School

When school personnel and parents develop an effective means of communication, they strengthen the learning environment for the students both at school and at home.⁶ One of the reasons cited most frequently by school personnel for contacting parents is to request parent volunteer time in school.⁷ As part of the NAEP 1996 science assessment, school administrators in grades 4, 8, and 12 were asked a number of questions about how frequently they tried to involve parents in the teaching and learning process. The administrators were asked to categorize this frequency as “Yes, routinely,” “Yes, occasionally,” or “No.” For the purposes of this report the second two categories — “Yes, occasionally” and “No” — were combined. The results are presented in Table 6.6.

As the data show, the higher the grade level, the less likely schools were to involve parents in the four activities described. For example, 39 percent of grade 4 students attended schools that reported regularly using parents as aides in classrooms. This number decreased to 13 percent in grade 8 and 4 percent in grade 12. The only parental activity that was sustained in any appreciable measure across all three grades was having a parent volunteer program. According to school administrators, 78 percent of grade 4 students, 55 percent of grade 8 students, and 41 percent of grade 12 students attended schools that routinely had parent volunteer programs. Performance data show no differences in average scale scores or the percentage of students at or above *Proficient* associated with parental involvement at any of the three grades.

⁶ Griffith, J. (1996). Relation of parental involvement, empowerment, and school traits to student academic performance. *Journal of Educational Research*, 90(1), 33-41.

Rutherford, B. et al. (1995). *Parent and community involvement in education. Vol. I: Findings and conclusions. Studies of education reform*. Washington, DC: Office of Educational Research and Improvement.

Illinois State Board of Education. (1993). *The relationship between parent involvement and student achievement: a review of the literature*. Springfield, IL: Author.

⁷ U.S. Department of Education. (1995). *The Condition of Education, 1995*. Washington, DC: National Center for Education Statistics.

TABLE 6.6

**Schools' Reports on Parental Involvement,
Grades 4, 8 and 12:
Public and Nonpublic Schools Combined**



<i>Does your school do any of the following to involve parents?</i>	Grade 4		Grade 8		Grade 12	
	Yes	No	Yes	No	Yes	No
<i>Use parents as aides in the classroom</i>						
Percentage of Students	39	61	13	87	4	96
Average Scale Score	151	150	155	150	144	151
Percentage At or Above Proficient	30	29	37	29	15	22
<i>Have parents review or sign students' homework</i>						
Percentage of Students	70	30	53	47	8	92
Average Scale Score	149	152	153	148	145	151
Percentage At or Above Proficient	28	30	31	28	17	22
<i>Assign homework for students to do with parents</i>						
Percentage of Students	33	67	24	76	3	97
Average Scale Score	149	151	151	151	151	151
Percentage At or Above Proficient	27	30	29	29	21	21
<i>Have a parent volunteer program</i>						
Percentage of Students	78	22	55	45	41	59
Average Scale Score	150	148	152	149	150	151
Percentage At or Above Proficient	30	26	31	27	21	21

SOURCE: National Center for Education Statistics, National Assessment of Educational Progress (NAEP), 1996 Science Assessment.

Perceived School Problems

Studies have shown that “teacher absenteeism appears highest in elementary schools, schools with lower student achievement, schools composed of economically disadvantaged and minority students, and urban school districts. Teachers holding temporary teaching certificates were absent more often and poorly achieving students had more temporary and absent teachers.”⁸ A number of questions included in the NAEP 1996 science assessment school questionnaire were designed to gather data about the types of challenges schools face as they strive to provide optimal learning environments for their students. Specifically, school administrators were asked to evaluate the seriousness of certain problems in their schools along a continuum that included “not a problem,” “minor problem,” “moderate problem,” and “serious problem.” Responses to three of the questions — covering student absenteeism, teacher absenteeism, and parental involvement — are found in Table 6.7.

The data indicate that although most students attended schools where these three problems were generally not thought to be serious, many students, and in some cases a majority, were exposed to them to some degree. Moreover, more students were exposed to worse degrees of the problems as grade level increased. For example, in all three grades a majority of students attended schools in which student absenteeism was considered to be at least a minor problem: 57 percent at the fourth-grade level, 67 percent at the eighth-grade level, and 85 percent at the twelfth-grade level. Fifteen percent of fourth graders, 20 percent of eighth graders, and 51 percent of twelfth graders attended schools where the problem was moderate or serious. No fourth- or eighth-grade students and one percent of twelfth-grade students attended schools where teacher absenteeism was considered to be a serious problem, but 41 percent of fourth graders, 45 percent of eighth graders, and 56 percent of twelfth graders attended schools where it was a minor or moderate problem. Lack of parental involvement was not a problem where 29 percent of fourth graders, 14 percent of eighth graders, and 15 percent of twelfth graders attended school, but it was a moderate or serious problem where 36 percent of fourth graders, 40 percent of eighth graders, and 46 percent of twelfth graders attended school.

An examination of scale score and achievement level data at the three grades reveals many differences in performance associated with different responses to the questions. Although there was not a difference in performance for each comparison, every difference that was measured fit the same pattern: the more severe the problem, as reported by school administrators, the lower the scale score and/or percentage of students at or above *Proficient*. For example, at the eighth-grade level, students attending schools where lack of parental involvement was a serious problem had lower scale scores than students attending schools where it was not a problem. Students in schools where lack of parental involvement was a moderate problem had lower scale scores and were less likely to be at or above the *Proficient* level than students in schools where lack of parental involvement was a minor problem or was not a problem.

⁸ Pitkiff, E. (1993). Teacher absenteeism: What administrators can do. *NASSP Bulletin*, 77(551), 39-45.

See also Ehrenberg, R. G., et al. (1991). School district leave policies, teacher absenteeism, and student achievement. *Journal of Human Resource*, 26(1), 72-105.

TABLE 6.7

**Schools' Reports on the Severity of Three Problems
in the School, Grades 4 and 8:
Public and Nonpublic Schools Combined**



<i>To what degree is each of the following a problem in your school?</i>	Not a Problem	Minor Problem	Moderate Problem	Serious Problem
Grade 4				
Student Absenteeism				
Percentage of Students	44	42	11	4
Average Scale Score	156	148	141	124
Percentage At or Above Proficient	35	27	20	7
Teacher Absenteeism				
Percentage of Students	58	34	7	0
Average Scale Score	155	146	134	--
Percentage At or Above Proficient	33	24	15	--
Lack of Parental Involvement				
Percentage of Students	29	35	29	7
Average Scale Score	157	153	143	135
Percentage At or Above Proficient	36	32	21	15
Grade 8				
Student Absenteeism				
Percentage of Students	33	47	18	2
Average Scale Score	158	150	142	--
Percentage At or Above Proficient	38	28	20	--
Teacher Absenteeism				
Percentage of Students	55	39	6	0
Average Scale Score	155	147	139	--
Percentage At or Above Proficient	34	26	18	--
Lack of Parental Involvement				
Percentage of Students	14	46	32	8
Average Scale Score	159	154	145	140
Percentage At or Above Proficient	40	32	22	22

-- Sample size was insufficient to permit reliable estimates.

NOTE: Percentages may not add to 100 due to rounding.

SOURCE: National Center for Education Statistics, National Assessment of Educational Progress (NAEP), 1996 Science Assessment.

TABLE 6.7
(continued)

**Schools' Reports on the Severity of Three Problems
in the School, Grade 12:
Public and Nonpublic Schools Combined**



<i>To what degree is each of the following a problem in your school?</i>	Not a Problem	Minor Problem	Moderate Problem	Serious Problem
Grade 12				
Student Absenteeism				
Percentage of Students	15	34	40	11
Average Scale Score	161	152	149	136
Percentage At or Above <i>Proficient</i>	28	22	20	12
Teacher Absenteeism				
Percentage of Students	43	46	10	1
Average Scale Score	153	150	140	--
Percentage At or Above <i>Proficient</i>	23	21	14	--
Lack of Parental Involvement				
Percentage of Students	15	39	38	8
Average Scale Score	161	156	145	132
Percentage At or Above <i>Proficient</i>	32	24	17	9

-- Sample size was insufficient to permit reliable estimates.

SOURCE: National Center for Education Statistics, National Assessment of Educational Progress (NAEP), 1996 Science Assessment.

Summary

As part of the NAEP 1996 science assessment, students were asked about their beliefs and attitudes vis-à-vis science, and school administrators were asked questions about parental involvement in their schools and also about school problems such as student and teacher absenteeism. The data show the following:

- Among fourth-grade students, 67 percent said they liked science. The percentages of students at grades 8 and 12 who said they liked science were somewhat lower — 50 and 52 percent, respectively.
- At all three grades, students who agreed with the statement “I like science” outperformed their counterparts who disagreed with the statement “I like science.”
- At the fourth-grade level, 47 percent of White students and 47 percent of Black students thought they were good at science compared to 37 percent of Hispanic students and 35 percent of Asian/Pacific Islander students.
- At the eighth-grade level, a greater percentage of White students (50 percent) thought they were good at science than did either Hispanic students (35 percent) or Asian/Pacific Island students (39 percent). More Black students (46 percent) than Hispanic students (35 percent) thought that they were good at science.
- At the twelfth-grade level, 42 percent of White students said they were good at science compared to 27 percent of Hispanic students and 31 percent of Asian/Pacific Islander students. A greater percentage of Black students (38 percent) than Hispanic students (27 percent) indicated the same thing.
- In general, the greater the number of positive attitudes towards science, the higher the performance of students at grades 4, 8, and 12.
- Forty percent, 18 percent, and 13 percent of students in grades 4, 8, and 12, respectively, thought they had answered almost all the questions on the assessment correctly.
- Fifty-nine percent, 25 percent, and 9 percent of students in grades 4, 8, and 12, respectively, thought it was very important to do well on the NAEP science assessment.
- According to school reports, 78 percent of grade 4 students, 55 percent of grade 8 students, and 41 percent of grade 12 students attended schools that had parent volunteer programs.
- The more severe a school problem (such as student absenteeism), as reported by school administrators, the lower the student performance.

Appendix A

Overview of Procedures Used for the NAEP 1996 Science Assessment

Conducting a large-scale assessment such as the National Assessment of Educational Progress (NAEP) entails the successful coordination of numerous projects, committees, procedures, and tasks. This appendix provides an overview of the NAEP 1996 science assessment's primary components: the framework, instrument development, administration, scoring, and analysis. A more extensive review of the procedures and methods used in the science assessment is included in two technical reports: the *Technical Report of the NAEP 1996 State Assessment Program in Science* and the *NAEP 1996 Technical Report*.¹

The Science Framework

The science framework for the 1996 National Assessment of Educational Progress was produced under the auspices of the National Assessment Governing Board (NAGB) through a consensus process managed by the Council of Chief State School Officers, which worked with the National Center for Improving Science Education and the American Institutes for Research.² The framework was developed over a 10-month period between October 1990 and August 1991. The following factors guided the process for developing consensus on the science framework:

- The active participation of individuals such as curriculum specialists, science teachers, science supervisors, state assessment developers, administrators, individuals from business and industry, government officials, and parents;

¹ Allen, N. L., Swinton, S. S., Isham, S. P. & Zelenak, C.A. (1997). *Technical report of the NAEP 1996 state assessment program in science* (Publication No. NCES 98-480). Washington, DC: National Center for Education Statistics.

Allen, N. L., Carlson, J., & Zelenak, C.A. (in press) *The NAEP 1996 technical report* (NCES Publication No. 98-479). Washington, DC: National Center for Education Statistics.

² National Assessment Governing Board. (1995). *Science framework for the 1996 National Assessment of Educational Progress*. Washington, DC: Author.

- The representation of what is considered essential learning in science, and the recommendation of innovative assessment techniques to probe the critical abilities and content areas; and
- The recognition of the lack of agreement on a common scope of instruction and sequence, components of scientific literacy, important outcomes of learning, and the nature of overarching themes in science.

While maintaining some conceptual continuity with the NAEP 1990 science assessment framework, the 1996 framework acknowledges some of the reforms currently taking place in science education as well as documents such as the science framework used for the 1991 International Assessment of Educational Progress. In addition, the Framework Steering Committee recommended that a variety of strategies be used for assessing students' performance. These included:

- Multiple-choice questions that assess students' knowledge of important facts and concepts and that probe their analytical reasoning skills;
- Constructed-response questions that explore students' abilities to explain, integrate, apply, reason about, plan, design, evaluate, and communicate science information; and
- Hands-on tasks that probe students' abilities to use materials to make observations, perform investigations, evaluate experimental results, and apply problem-solving skills.

The Assessment Design

Each student in the assessment received a booklet comprising six sections, or blocks. Three of these blocks consisted of cognitive questions that assessed the knowledge and skills outlined in the framework.³ The other three blocks were sets of background questions. Students at grades 8 and 12 were allowed 30 minutes to complete each cognitive block, while students at grade 4 were given cognitive blocks that required 20 minutes to complete. The background questions took students in each grade about ten minutes to answer. Thus students in grade 4 took approximately 70 minutes to answer the cognitive and background questions whereas students in grades 8 and 12 took approximately 100 minutes.

³ National Assessment Governing Board. (1995). *Science framework for the 1996 National Assessment of Educational Progress*. Washington, DC: Author.

At each grade level there were 15 different sections, or blocks, of cognitive questions, usually consisting of both multiple-choice and constructed-response questions. Four of the fifteen blocks at each grade level presented hands-on tasks. In these tasks, students were given sets of equipment and asked to conduct an investigation and answer questions related to the investigation. Every student conducted a hands-on task.

Three of the 15 blocks assessed themes. One of the three addressed systems, a second addressed models, and a third addressed patterns of change. For example, students were shown a simplified model of part of the solar system, with a brief description, and then were asked a number of questions based on that information. Theme blocks were placed randomly in the student booklets. Not every booklet contained a theme block, but no booklet contained more than one theme block.

The Background Questionnaires

As part of the national NAEP 1996 science assessment, approximately 2,500 teachers responsible for teaching science to students who participated in the fourth- and eighth-grade assessments responded to a questionnaire. The questionnaires were composed of two sections. One section contained questions about teachers' backgrounds, education, and resources. The other asked about teachers' science preparation and instructional practices. Teacher sampling for the teacher questionnaires was based on participating students, hence the responses do not necessarily represent all fourth- and eighth-grade teachers in the nation. Rather, they represent teachers of a representative sample of students in the assessment. Consequently, the findings portray the nature of students' instructional experiences and the backgrounds of their teachers. There was no background teacher questionnaire at grade 12 because approximately half the students that participated in the NAEP science assessment were not enrolled in a science course and thus could not be linked to any teacher.

Approximately 700 principals or other administrators of sampled schools at grades 4, 8, and 12 completed a school questionnaire for the main NAEP study. Each of the grade-specific questionnaires focused on five areas: instructional content, instructional practices and experiences, teacher characteristics, school conditions and contexts, and conditions outside the school (i.e., home support, out-of-school activities, and attitudes).

Approximately 23,000 students in grades 4, 8, and 12 in main NAEP responded to three sets of background questions in addition to science cognitive exercises. The background questions probed students' general backgrounds, their science experiences, and their motivations.

It is important to note that in this report, as in all NAEP reports, the student is the unit of analysis, even when information from teacher or school questionnaires is reported. This is because the sampling for the teacher and school questionnaires was based on participating students and does not represent all teachers or schools in the nation or in a state. For example, when discussing how much science homework teachers reported assigning to students, NAEP can report that 38 percent of fourth-grade students were expected to spend one-half hour on science homework each week.

National Samples

Results presented in this report are based on nationally representative probability samples of fourth-, eighth-, and twelfth-grade students. The samples were selected using a complex multistage sampling design that involved sampling students from selected schools within selected geographic areas across the country. The sample design had the following stages:

1. Selection of primary sampling units (geographic areas such as: a county, group of counties, or metropolitan statistical area)
2. Selection of schools (public and nonpublic) within the selected areas
3. Selection of students within the selected schools

Each selected school that participated in the assessment and each student assessed represents a portion of the population of interest. Sampling weights are needed to make valid inferences between the student samples and the respective populations from which they were drawn. In addition, NAEP oversamples nonpublic schools and schools in which more than 15 percent of the student population is non-White. Sampling weights adjust for disproportionate representation due to such oversampling.

Table A.1 provides a summary of the weighted and unweighted student sample sizes for the national NAEP 1996 science assessment. The numbers reported include public and nonpublic school students.

Table A.1		National School and Student Sample		<small>THE NATION'S REPORT CARD</small> 
	Number of Schools	Unweighted Student Sample Size	Weighted Student Sample Size	
Grade 4	237	7,305	3,621,677	
Grade 8	202	7,774	3,568,034	
Grade 12	232	7,537	2,907,065	

SOURCE: National Center for Education Statistics, National Assessment of Educational Progress (NAEP), 1996 Science Assessment.

Data Collection and Scoring

Data collection for the main NAEP assessment was conducted by trained field staff from Westat, the NAEP grantee for data collection. For the state component of the assessment, data were collected by local school personnel trained by Westat representatives. Materials from the assessment were shipped to National Computer Systems (NCS), where trained scorers evaluated the responses to the constructed-response questions using scoring rubrics or guides prepared by Educational Testing Service (ETS). Each constructed-response question had a unique scoring guide that defined the criteria used to evaluate students' responses. The extended constructed-response questions were evaluated with four- or five-level guides, while the short constructed-response questions were rated according to two- or three-level guides.

The constructed-response questions were scored using NCS's image technology. Scorers working at computer terminals (image stations) scored students' responses on-line. This tool allowed for several advantages. First, training could be conducted on one item at a time rather than a block of items. Second, responses that were to be scored twice as an indicator of reliability could be routed automatically to a second scorer. Information on adjacent and perfect agreement, score distribution, and quantity of responses scored was available on demand. Third, backreading of student responses could be accomplished in a timely manner, allowing for ongoing evaluation of the accuracy of scores assigned by the scorers.

The training for scoring constructed-response questions was conducted on an item-by-item basis. Each scoring team consisted of approximately 10 scorers, one table leader, and one trainer. A set procedure was employed for each training session that utilized anchor papers, practice papers, calibration papers, and, in addition, for the extended constructed-response questions, qualification sets. First, scorers were introduced to the question and scoring guide. Second, the trainer explained each anchor paper vis-à-vis the scoring guide. Third, each member of the team scored a set of practice papers, and then discussed the responses as a group. If the question required an extended response, scorers were given a set of qualification papers to score. Eighty percent exact agreement was required to qualify for scoring. When the trainer and table leader were confident that the scorers were ready, scoring commenced. During the beginning stages of scoring, responses that had previously not been encountered were discussed by the team to ensure that scoring decisions not addressed in training were handled in the same manner by all team members.

For the national science assessments, just over 1 million constructed responses were scored. This number includes rescoring to monitor interrater reliability. The overall percentages of agreement for the 1996 national reliability samples were 94 percent at grade 4, 94 percent at grade 8, and 93 percent at grade 12.

Data Analysis and IRT Scaling of Student Responses

Subsequent to the professional scoring, all information was transcribed to the NAEP database at ETS. Each processing activity was conducted with rigorous quality control. After the assessment information had been compiled in the database, the data were weighted according to the population structure. The weighting for the national and state samples reflected the probability of selection for each student as a result of the sampling design, adjusted for nonresponse. Through stratification, the weighting ensured that the representation of certain subpopulations corresponded to figures from the U.S. Census and the Current Population Survey.⁴

Analyses were then conducted to determine the percentages of students that gave various responses to each cognitive and background question.

Item Response Theory (IRT) was used to estimate average science scale scores for the nation, for various subgroups of interest within the nation, and for the jurisdictions. IRT models the probability of answering a question in a certain way as a mathematical function of proficiency or skill. The main purpose of IRT analysis is to provide a common scale on which performance can be compared across groups (for example, those defined by characteristics such as gender and race/ethnicity). The item mapping is also based on IRT.

Because of the complex way the blocks of items are placed in booklets, students do not receive enough questions about a specific topic to provide reliable information about individual performance. Traditional test scores for individual students, even those based on IRT, would lead to misleading estimates of population characteristics, such as subgroup means and percentages of students at or above a certain scale score level. Consequently, NAEP constructs sets of plausible values designed to represent the distribution of performance in the population. Plausible values for an individual are not scale scores for that individual but may be regarded as representative values from the distribution of potential scale scores for all students in the population with similar characteristics and identical patterns of item response. Statistics describing performance on the NAEP science scale are based on the plausible values. They estimate values that would have been obtained had individual scale scores been observed, that is, had each student responded to a sufficient number of cognitive questions so that his or her individual scores could be estimated precisely.⁵

⁴ For additional information about the use of weighting procedures in NAEP, see Johnson, E. G. (1989). Considerations and techniques for the analysis of NAEP data. *Journal of Educational Statistics*, 14, 303-334.

⁵ For theoretical and empirical justification of the procedures employed, see Mislevy, R. J. (1991). Randomization-based inferences about the latent variables from complex samples. *Psychometrika*, 56(2), 177-196.

For computational details, see E. G. Johnson & R. Zwick (Eds.), *Focusing the new design: The NAEP 1988 technical report* (pp. 267-296). Washington, DC: National Center for Education Statistics and Johnson, E. G., & Allen, N. L. (1992). *The NAEP 1990 technical report* (No.21-TR-20). Princeton, NJ: Educational Testing Service, National Assessment of Educational Progress.

At each grade, three distinct 0-to-300 scales were created to summarize students' abilities in the three defined fields of science: earth, physical, and life. The scales summarize student performance across all three question types in the assessment (multiple-choice, short constructed-response, and extended constructed-response). For each grade, the mean for each field of science was set at 150 and the standard deviation at 35. Constraining the mean and standard deviation of the scales to 150 and 35 also constrained, to some degree, the locations of the percentiles for the total group of students at each grade. However, within-grade comparisons of percentiles across subgroups still provide valuable comparative information. This reporting metric was developed using data from the national assessment program, and the results for the state assessment program were linked to these scales. Because the assessment was developed using a new framework, it was not appropriate to compare or link the results from the 1996 assessments to previous NAEP science assessments.

In addition to the plausible values for each scale, a composite of the three fields of science scales was created as a measure of overall science performance. This composite was a weighted average of the plausible values for the three science scales, in which the weights were proportional to the relative importance assigned to each field of science in the assessment framework. More detailed information about data analysis and items are presented in the *1996 NAEP Technical Report*.⁶

NAEP Reporting Groups

Findings from the NAEP 1996 science assessment are presented for groups of students defined by shared characteristics. Data are reported for subgroups only when sufficient numbers of students and adequate school representation are present. There must be at least 62 students in a particular subgroup from at least six different primary sampling units.⁷ Data for all students, regardless of whether their subgroups were reported separately, were included in computing overall national results. The reporting subgroups presented in this report are gender and race/ethnicity.

⁶ Allen, N. L., Carlson, J., & Zelenak, C.A. (in press) *The NAEP 1996 technical report* (Publication No. NCES 98-479). Washington, DC: National Center for Education Statistics.

⁷ For the national assessment, a primary sampling unit is a selected geographic region (a county, a group of counties, or metropolitan statistical areas).

Achievement Level Results

NAEP results are reported for student performance according to the newly defined achievement levels set by the NAGB. The results are expressed as percentages of students or percentages of selected subgroups who have reached *Basic*, *Proficient*, and *Advanced* levels. The three levels are at each grade and are cumulative in nature. That is, it is assumed that students at the *Proficient* level are likely to be successful at the *Basic* and *Proficient* levels, and that students at the *Advanced* level are likely to be successful at the *Basic*, *Proficient*, and *Advanced* levels. Results in this report are presented as percentages of students at or above the *Proficient* level. The achievement levels that NAGB develops usually specify what students should know and be able to do. The science achievement levels were developed somewhat differently because NAGB believed that some of the levels derived from the traditional achievement level setting process did not meet its criterion of reasonableness. Some levels were believed to be too high while others were too low based on comparisons to achievement levels for other NAEP subjects, Advanced Placement (AP) results, and Third International Mathematics and Science Study (TIMSS) data for eighth-grade students. The Board therefore chose to set new levels that satisfied their criterion of reasonableness. Science educators and scientists were then asked to develop descriptions of what students know and can do at each achievement level based on the actual performance of students on the assessment questions.⁸ Full descriptions of the achievement levels for each grade follow in table A.2.

⁸ Bourque, M.L., Champagne, A.B., & Crissman, S. (1997). *1996 science performance standards: Achievement results for the nation and the states*. Washington, DC: National Assessment Governing Board.

Table A.2

**1996 NAEP Science
Achievement Level Descriptions:
Grade 4**



Cut Score	Content Descriptions*
<p>BASIC</p> <p>138</p>	<p>Students performing at the <i>Basic</i> level demonstrate some of the knowledge and reasoning required for understanding of the earth, physical, and life sciences at a level appropriate to Grade 4. For example, they can carry out simple investigations and read uncomplicated graphs and diagrams. Students at this level also show a beginning understanding of classification, simple relationships, and energy.</p> <p>Fourth-grade students performing at the <i>Basic</i> level are able to follow simple procedures, manipulate simple materials, make observations, and record data. They are able to read simple graphs and diagrams and draw reasonable but limited conclusions based on data provided to them. These students can recognize appropriate experimental designs, although they are unable to justify their decisions.</p> <p>When presented with diagrams, students at this level can identify seasons; distinguish between day and night; and place the position of the Earth, sun, and planets. They are able to recognize major energy sources and simple energy changes. In addition, they show an understanding of the relationship between sound and vibrations. These students are able to identify organisms by physical characteristics and group organisms with similar physical features. They can also describe simple relationships among structure, function, habitat, life cycles, and different organisms.</p>
<p>PROFICIENT</p> <p>170</p>	<p>Students performing at the <i>Proficient</i> level demonstrate the knowledge and reasoning required for understanding of the earth, physical, and life sciences at a level appropriate to Grade 4. For example, they understand concepts relating to the Earth's features, physical properties, and structure and function. In addition, students can formulate solutions to familiar problems as well as show a beginning awareness of issues associated with technology.</p> <p>Fourth-grade students performing at the <i>Proficient</i> level are able to provide an explanation of day and night when given a diagram. They can recognize major features of the Earth's surface and the impact of natural forces. They are also able to recognize water in its various forms in the water cycle and can suggest ways to conserve it. These students recognize that various materials possess different properties that make them useful. Students at this level are able to explain how structure and function help living things survive. They have a beginning awareness of the benefits and challenges associated with technology and recognize some human effects on the environment. They can also make straightforward predictions and justify their position.</p>
<p>ADVANCED</p> <p>204</p>	<p>Students performing at the <i>Advanced</i> level demonstrate a solid understanding of the earth, physical, and life sciences as well as the ability to apply their understanding to practical situations at a level appropriate to Grade 4. For example, they can perform and critique simple investigations, make connections from one or more of the sciences to predict or conclude, and apply fundamental concepts to practical applications.</p> <p>Fourth-grade students performing at the <i>Advanced</i> level are able to combine information, data, and knowledge from one or more of the sciences to reach a conclusion or to make a valid prediction. They can also recognize, design, and explain simple experimental procedures.</p> <p>Students at this level recognize nonrenewable sources of energy. They also recognize that light and sound travel at different speeds. These students understand some principles of ecology and are able to compare and contrast life cycles of various common organisms. In addition, they have a developmental awareness of the benefits and challenges associated with technology.</p>

* Shaded areas indicate summary of content descriptions.

Table A.2
continued

1996 NAEP Science
Achievement Level Descriptions:
Grade 8



Cut Score	Content Descriptions*
<p>BASIC</p> <p>143</p>	<p>Students performing at the <i>Basic</i> level demonstrate some of the knowledge and reasoning required for understanding of the earth, physical, and life sciences at a level appropriate to Grade 8. For example, they can carry out investigations and obtain information from graphs, diagrams, and tables. In addition, they demonstrate some understanding of concepts relating to the solar system and relative motion. Students at this level also have a beginning understanding of cause-and-effect relationships.</p> <p>Eighth-grade students performing at the <i>Basic</i> level are able to observe, measure, collect, record, and compute data from investigations. They can read simple graphs and tables and are able to make simple data comparisons. These students are able to follow directions and use basic science equipment to perform simple experiments. In addition, they have an emerging ability to design experiments.</p> <p>Students at this level have some awareness of causal relationships. They recognize the position of planets and their movement around the sun and know basic weather-related phenomena. These students can explain changes in position and motion such as the movement of a truck in relation to that of a car. They also have an emerging understanding of the interrelationships among plants, animals, and the environment.</p>
<p>PROFICIENT</p> <p>170</p>	<p>Students performing at the <i>Proficient</i> level demonstrate much of the knowledge and many of the reasoning abilities essential for understanding of the earth, physical, and life sciences at a level appropriate to Grade 8. For example, students can interpret graphic information, design simple investigations, and explain such scientific concepts as energy transfer. Students at this level also show an awareness of environmental issues, especially those addressing energy and pollution.</p> <p>Eighth-grade students performing at the <i>Proficient</i> level are able to create, interpret, and make predictions from charts, diagrams, and graphs based on information provided to them or from their own investigations. They have the ability to design an experiment and have an emerging understanding of variables and controls. These students are able to read and interpret geographic and topographic maps. In addition, they have an emerging ability to use and understand models, can partially formulate explanations of their understanding of scientific phenomena, and can design plans to solve problems.</p> <p>Students at this level can begin to identify forms of energy and describe the role of energy transformations in living and nonliving systems. They have knowledge of organization, gravity, and motions within the solar system and can identify some factors that shape the surface of the Earth. These students have some understanding of properties of materials and have an emerging understanding of the particulate nature of matter, especially the effect of temperature on states of matter. They also know that light and sound travel at different speeds and can apply their knowledge of force, speed, and motion. These students demonstrate a developmental understanding of the flow of energy from the sun through living systems, especially plants. They know that organisms reproduce and that characteristics are inherited from previous generations. These students also understand that organisms are made up of cells and that cells have subcomponents with different functions. In addition, they are able to develop their own classification system based on physical characteristics. These students can list some effects of air and water pollution as well as demonstrate knowledge of the advantages and disadvantages of different energy sources in terms of how they affect the environment and the economy.</p>

* Shaded areas indicate summary of content descriptions.

Cut Score	Content Descriptions*
ADVANCED 207	<p>Students performing at the <i>Advanced</i> level demonstrate a solid understanding of the earth, physical, and life sciences as well as the abilities required to apply their understanding in practical situations at a level appropriate to Grade 8. For example, students perform and critique the design of investigations, relate scientific concepts to each other, explain their reasoning, and discuss the impact of human activities on the environment.</p> <p>Eighth-grade students performing at the <i>Advanced</i> level are able to provide an explanation for scientific results. They have a modest understanding of scale and are able to design a controlled experiment. These students have an understanding of models as representations of natural systems and can describe energy transfer in living and nonliving systems.</p> <p>Students at this level are able to understand that present physical clues, including fossils and geological formations, are indications that the Earth has not always been the same and that the present is a key to understanding the past. They have a solid knowledge of forces and motions within the solar system and an emerging understanding of atmospheric pressure. These students can recognize a wide range of physical and chemical properties of matter and some of their interactions and understand some of the properties of light and sound. Also, they can infer relationship between structure and function. These students know the differences between plant and animal cells and can apply their knowledge of food as a source of energy to a practical situation. In addition, they are able to explain the impact of human activities on the environment and the economy.</p>

* Shaded areas indicate summary of content descriptions.

Table A.2
continued

1996 NAEP Science
Achievement Level Descriptions:
Grade 12



Cut Score	Content Descriptions*
<p>BASIC</p> <p>145</p>	<p>Students performing at the <i>Basic</i> level demonstrate some knowledge and certain reasoning abilities required for understanding of the earth, physical, and life sciences at a level appropriate to Grade 12. In addition, they demonstrate knowledge of the themes of science (models, systems, patterns of change) required for understanding the most basic relationships among the earth, physical, and life sciences. They are able to conduct investigations, critique the design of investigations, and demonstrate a rudimentary understanding of scientific principles.</p> <p>Twelfth-grade students performing at the <i>Basic</i> level are able to select and use appropriate simple laboratory equipment and write down simple procedures that others can follow. They also have a developmental ability to design complex experiments. These students are able to make classifications based on definitions such as physical properties and characteristics.</p> <p>Students at this level demonstrate a rudimentary understanding of basic models and can identify some parts of physical and biological systems. They are also able to identify some patterns in nature and rates of change over time. These students have the ability to identify basic scientific facts and terminology and have a rudimentary understanding of the scientific principles underlying such phenomena as volcanic activity, disease transmission, and energy transformation. In addition, they have familiarity with the application of technology.</p>
<p>PROFICIENT</p> <p>178</p>	<p>Students performing at the <i>Proficient</i> level demonstrate the knowledge and reasoning abilities required for understanding of the earth, physical, and life sciences at a level appropriate to Grade 12. In addition, they demonstrate knowledge of the themes of science (models, systems, patterns of change) required for understanding how these themes illustrate essential relationships among the earth, physical, and life sciences. They are able to analyze data and apply scientific principles to everyday situations.</p> <p>Twelfth-grade students performing at the <i>Proficient</i> level are able to demonstrate a working ability to design and conduct scientific investigations. They are able to analyze data in various forms and utilize information to provide explanations and to draw reasonable conclusions.</p> <p>Students at this level have a developmental understanding of both physical and conceptual models and are able to compare various models. They recognize some inputs and outputs, causes and effects, and interactions of a system. In addition, they can correlate structure to function for the parts of a system that they can identify. These students also recognize that rate of change depends on initial conditions and other factors. They are able to apply scientific concepts and principles to practical applications and solutions for problems in the real world and show a developmental understanding of technology, its uses, and its applications.</p>

* Shaded areas indicate summary of content descriptions.

Cut Score	Content Descriptions*
<p>ADVANCED</p> <p>210</p>	<p>Students performing at the <i>Advanced</i> level demonstrate the knowledge and reasoning abilities required for a solid understanding of the earth, physical, and life sciences at a level appropriate to Grade 12. In addition, they demonstrate knowledge of the themes of science (models, systems, patterns of change) required for integrating knowledge and understanding of scientific principles from the earth, physical, and life sciences. Students can design investigations that answer questions about real-world situations and use their reasoning abilities to make predictions.</p> <p>Twelfth-grade students performing at the <i>Advanced</i> level are able to design scientific investigations to solve complex, real-world situations. They can integrate, interpolate, and extrapolate information embedded in data to draw well-formulated explanations and conclusions. They are also able to use complex reasoning skills to apply scientific knowledge to make predictions based on conditions, variables, and interactions.</p> <p>Students at this level recognize the inherent strengths and limitations of models and can revise models based on additional information. They are able to recognize cause-and-effect relationships within systems and can utilize this knowledge to make reasonable predictions of future events. These students are able to recognize that patterns can be constant, exponential, or irregular and can apply this recognition to make predictions. They can also design a technological solution for a given problem.</p>

* Shaded areas indicate summary of content descriptions.

Estimating Variability

Because the statistics presented in this report are estimates of group and subgroup performance based on samples of students rather than the values that could be calculated if every student in the nation had answered every question, the degree of uncertainty associated with the estimates should be taken into account. Two components of uncertainty are accounted for in the variability of statistics based on student ability: (1) the uncertainty due to sampling only a relatively small number of students; and (2) the uncertainty due to sampling only a relatively small number of cognitive questions. The first component accounts for the variability associated with the estimated percentages of students who had certain background characteristics or who answered a certain cognitive question correctly.

Because NAEP uses complex sampling procedures to select students for participation, conventional formulas for estimating sampling variability that assume simple random sampling are inappropriate. NAEP uses a jackknife replication procedure to estimate standard errors. The jackknife standard error provides a reasonable measure of uncertainty for any student information that can be observed without error. However, because each student typically responds to only a few questions within any content area, the scale score for any single student would be imprecise. In this case, plausible values technology can be used to describe the performance of groups and subgroups of students, but the underlying imprecision involved in this step adds another component of variability to statistics based on NAEP scale scores.⁹ Appendix C provides the standard errors accounting for both components of uncertainty for the results presented in this report.

When the standard error is based on a small number of students or when the group of students is enrolled in a small number of schools, the amount of uncertainty associated with the standard error may be quite large. This situation is identified in this report when it occurs.

The reader is reminded that, like findings from all surveys, NAEP results are subject to other kinds of error, including the effects of imperfect adjustment for student and school nonresponse and unknowable effects associated with the particular instrumentation and data collection methods. Nonsampling errors can be attributed to a number of sources: inability to obtain complete information about all selected schools in the sample (some students or schools refused to participate, or students participated but answered only certain questions); ambiguous definitions; differences in interpreting questions; inability or unwillingness to give correct information; mistakes in recording, coding, or scoring data; and other errors in data collecting, data processing, and sampling and in estimating missing data. The extent of nonsampling error is difficult to estimate and, because of their nature, the impact of such errors cannot be reflected in the data-based estimates of uncertainty provided in NAEP reports.

⁹ For further details, see Johnson, E. G. & Rust, K. F. (1992). Population inferences and variance estimation for NAEP data. *Journal of Educational Statistics*, 17, 175-190.

Drawing Inferences from the Results

The results from the sample, taking into account the uncertainty associated with them, are used to make inferences about the population. Using confidence intervals based on the standard errors provides a way to make inferences about the population averages and percentages in a manner that reflects the uncertainty associated with the sample estimates. An estimated sample average scale score ± 2 standard errors approximates a 95-percent confidence interval for the corresponding population quantity. This statement means that one can conclude at the 95-percent confidence level that the average performance of the entire population of interest (e.g., all fourth-grade students in public schools in a jurisdiction) is within ± 2 standard errors of the sample average.

As an example, suppose that the average science scale score of the students in a particular group was 156 with a standard error of 1.2. A 95-percent confidence interval for the population quantity would be as follows:

$$\begin{aligned} & \text{Average } \pm 2 \text{ standard errors} \\ & 156 \pm 2 \times 1.2 \\ & 156 \pm 2.4 \\ & 153.6, 158.4 \end{aligned}$$

Thus one can conclude at the 95 percent level of confidence that the average scale score for the entire population of students in that group is between 153.6 and 158.4.

Similar confidence intervals can be constructed for percentages, if the percentages are not extremely large or extremely small. For extreme percentages, confidence intervals constructed in the manner above may not be appropriate, and accurate confidence intervals can be constructed only by using procedures that are quite complicated.

Extreme percentages, defined by both the magnitude of the percentage and the size of the sample from which it was derived, should be interpreted with caution. (The forthcoming *NAEP 1996 Technical Report* contains a more complete discussion of extreme percentages.)¹⁰

¹⁰ Allen, N. L., Carlson, J., & Zelenak, C.A. (1999). *The NAEP 1996 technical report* (Publication No. NCES 98-479). Washington, DC: National Center for Education Statistics. Report in preparation.

Statistical Tests for Determining Group Differences in Performance

Statistical tests are used to determine whether the evidence, based on the data from the groups in the sample, is strong enough to indicate that the averages or percentages are actually different for those groups in the population. If the evidence is strong (i.e., the difference is statistically significant), the report describes the group averages or percentages as being different (e.g., one group performed higher or lower than another group), regardless of whether the sample averages or percentages appear to be approximately the same. If the evidence is not sufficiently strong (i.e., the difference is not statistically significant), the averages or percentages are described as being not significantly different, regardless of whether the sample averages or percentages appear to be approximately the same or widely discrepant.

The reader is cautioned to rely on the results of the statistical tests rather than on the apparent magnitude of the difference between sample averages or percentages when determining whether the sample differences are likely to represent actual differences among the groups in the population.

To determine whether a real difference exists between the average scale scores (or percentages of a certain attribute) for two independently sampled groups in the population, one needs to obtain an estimate of the degree of uncertainty associated with the difference between the averages (or percentages) of these groups for the sample. This estimate of the degree of uncertainty, called the standard error of the difference between the groups, is obtained by taking the square of each group's standard error, summing the squared standard errors, and taking the square root of that sum.

$$\text{Standard Error of the Difference for Independent Groups} = SE_{A-B} = \sqrt{\left(SE_A^2 + SE_B^2 \right)}$$

In a manner similar to that in which the standard error for an individual group average or percentage is used, the standard error of the difference can be used to help determine whether differences among groups in the population are real. The difference between the averages or percentages of the two groups plus or minus two standard errors of the difference represents an approximate 95-percent confidence interval. If the resulting interval includes zero, there is insufficient evidence to claim a real difference between the groups in the population. If the interval does not contain zero, the difference between the groups is statistically significant (different) at the .05 level. In this report, differences among groups that involve poorly defined variability estimates and extreme percentages are not discussed.

As an example, to determine whether the average science scale score of Group A is higher than that of Group B, suppose that the sample estimates of the average scale scores and standard errors were as follows:

Group	Average Scale Score	Standard Error
A	118	0.9
B	116	1.1

The difference between the estimates of the average scale scores of Groups A and B is two points (118 - 116). The standard error of this difference is

$$\sqrt{0.9^2 + 1.1^2} = 1.4$$

Thus, an approximate 95 percent confidence interval for this difference is

Difference \pm 2 standard errors of the difference

$$2 \pm 2 \times 1.4$$

$$2 \pm 2.8$$

$$-0.8, 4.8$$

The value zero is within the confidence interval; therefore, there is insufficient evidence to claim that Group A outperformed Group B.

The procedures described in this section and the certainty ascribed to intervals (e.g., a 95-percent confidence interval) are based on statistical theory that assumes that only one confidence interval or test of statistical significance is being performed. However, in chapters 2 to 6 of this report, many different groups are being compared (i.e., multiple sets of confidence intervals are being analyzed). In sets of confidence intervals, statistical theory indicates that the certainty associated with the entire set of intervals is less than that attributable to each individual comparison from the set. To hold the significance level for the set of comparisons at a particular level (e.g., 0.05), adjustments called multiple comparison procedures must be made to the methods described in the previous section. One such procedure, the Bonferroni method, was used in the analyses described in this report to adjust the confidence intervals for the differences among groups when sets of comparisons were considered.¹¹ Many of the confidence intervals discussed in the main body of this report were components of a set of multiple comparisons, and so included Bonferroni adjustments. Thus the confidence intervals for these comparisons are more conservative than the confidence interval (described above) for what a single comparison would be.

Derived Variables

A derived variable is a variable that is created by combining responses from two or more variables into one set of responses.

Table 6.3 and the corresponding standard error table in appendix C contain data involving students' positive attitudes toward science. The positive attitude index was a composite score based on student responses to six questions in the student background questionnaire. The "agree" responses to three questions — "I like science," "I am good at science," and "Science is useful in solving everyday problems" — and the disagree responses to three questions — "Learning science is mostly memorization," "If I had a choice I would not study any more science in school," and "Science is boring" — were combined to form the index.

¹¹ Miller, R. G. (1966). *Simultaneous statistical inference*. New York, NY: McGraw-Hill.

Appendix B

Scoring Guides

Grade 4 Scoring Guides

Natural Forces

6. Natural forces are always changing features of the Earth's surface. Some changes happen quickly and some changes happen slowly.

(a) Name one natural force that can change a part of the Earth's surface over a period of days.

How is the Earth's surface changed?

(b) Name one natural force that can change a part of the Earth's surface over a period of hundreds of years.

How is the Earth's surface changed?

TABLE B2.14

**Grade 4 Scoring Guide
Natural Forces**



(4) Complete	Student identifies two forces and describes how each force changed Earth's surface.
(3) Essential	Student identifies two forces and describes how one of the forces changed Earth's surface.
(2) Partial	Student identifies one force and describes how it changed Earth's surface or identifies one or two forces only.
(1) Unsatisfactory	Student does not identify forces that change Earth's surface.
Examples of Credited Responses	
Short Term:	<p>Volcanic eruption – can blow up part of a mountain top, cover earth with lava, create new rock</p> <p>Earthquakes – can uplift land, cover up land, create cracks in surface</p> <p>Storms – can change coastline, cause flooding or mudslides</p>
Long Term:	<p>Erosion and weathering – water causing rocks to crack because of freezing and thawing, wind shaping rocks over time, gradual wearing of rocks.</p> <p>Glaciers – movement of rocks, shaping of land forms.</p>

Plants: Parts and Functions

5. Name the parts of the plant below that are labeled 1, 2, and 3. Explain the function of each part.

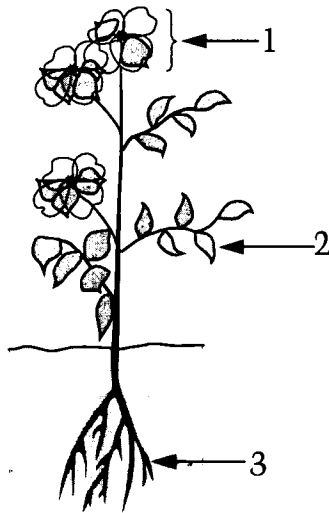

Name of Part

Function

1. _____
2. _____
3. _____

TABLE B2.20**Grade 4 Scoring Guide
Parts and Functions**THE NATION'S
REPORT
CARD

(4) Complete	Student identifies the three plant structures and gives a correct function for each structure (six response parts).
(3) Essential	Student names two or three structures and gives a function for two of them (four or five response parts).
(2) Partial	Student responds correctly to one to three parts of the question.
(1) Unsatisfactory	Student is unable to name any plant structure or state any function correctly.
Examples of Credited Responses Flower (blossom, petals, bud) – reproductive structure; produces pollen Leaves – part of plant where food is produced; carries out photosynthesis Roots – take in water; anchor plant	

Experiment Setup

Questions 9-11

Some fourth-grade students were doing a project for their science class. They were trying to find the answer to the question "Do beetles choose to live in bright light or in the shade?" The next three pictures show the ways that three different students set up an experiment to find out if beetles choose to live in bright light or in the shade.

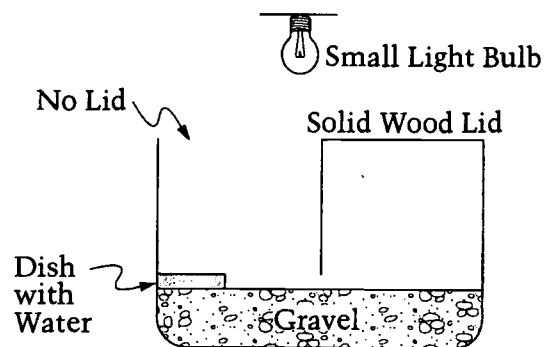

9. Is this a good way to set up this experiment? Tell why or why not.

TABLE B2.26

Grade 4 Scoring Guide Experimental Setup



(3) Complete	Student states that the experimental design is not appropriate and clearly explains that a dish of water should be provided on both the lighted side of the container and the shaded side.
(2) Partial	Student states that the experimental design is not appropriate and offers no explanation or an incorrect explanation.
(1) Unsatisfactory	Student states that the experimental design is appropriate and may or may not include an incorrect explanation.

Properties of Metal

10. Many things are made of metal, such as pots, pans, tools, and wire. Give two reasons why metals are used to make many different things.

TABLE B2.30

Grade 4 Scoring Guide Properties of Metals



(3) Complete	Student identifies two properties of metals.
(2) Partial	Student identifies one property of metals.
(1) Unsatisfactory	Student does not correctly identify any properties of metals.

Examples of Credited Responses

Generally hard and strong, some are magnetic, conduct heat and electricity, can be made into different shapes (malleable and ductile)

Metamorphosis

5. Insects also change as they grow. Look at the picture below. One part of the picture is missing. Draw and label the missing part of the picture.

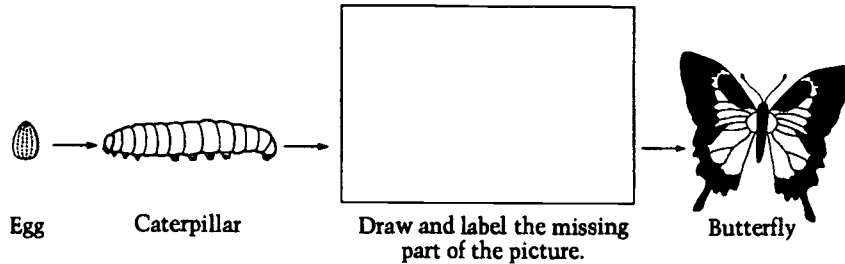

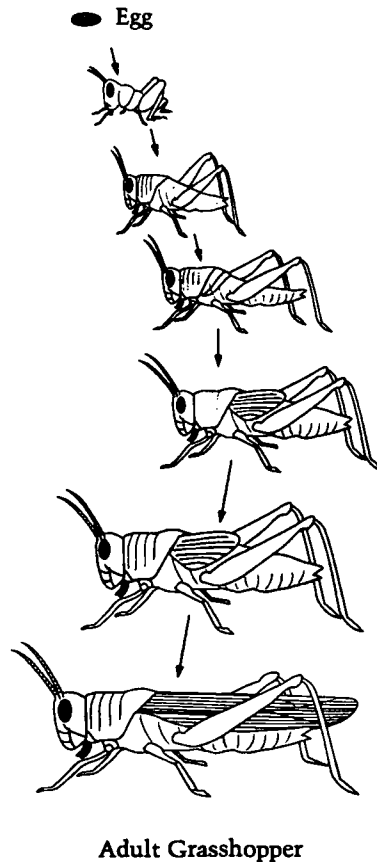

TABLE B2.32	<p>Grade 4 Scoring Guide</p> <p>Metamorphosis</p>	<p>THE NATION'S REPORT CARD</p> 
(3) Complete	Student draws and correctly labels the pupal stage of the butterfly life cycle. Acceptable labels include pupal, cocoon, or chrysalis.	
(2) Partial	Student is able either to draw the pupal stage or write the correct label.	
(1) Unsatisfactory	Student is unable to draw the pupal stage of a butterfly's life cycle or give a correct label.	

Grasshoppers and Butterflies

6. The picture below shows the life cycle of a grasshopper.



Tell one way that the grasshopper's life cycle is different from the butterfly's life cycle.

Tell one way that the grasshopper's life cycle is the same as the butterfly's life cycle.

Tell some other ways that the grasshopper's and the butterfly's life cycles are similar and different from each other.

TABLE B2.34

**Grade 4 Scoring Guide
Grasshoppers and Butterflies**



(4) Complete	<p>Student tells two ways the grasshopper's life cycle differs from the butterfly's life cycle and one way the life cycles are similar</p> <p>Or, one way the grasshopper's life cycle differs from the butterfly's life cycle and two ways the life cycles are similar.</p>
(3) Essential	<p>Student tells one way the grasshopper's life cycle differs from the butterfly's life cycle and one way the life cycles are similar</p> <p>Or, two ways the life cycles are different</p> <p>Or, two ways the life cycles are similar.</p>
(2) Partial	<p>Student tells one way the grasshopper's life cycle differs from the butterfly's life cycle</p> <p>Or, one way the life cycles are similar.</p>
(1) Unsatisfactory	<p>Student does not tell any differences or similarities.</p>
<p>Examples of Credited Responses</p> <p>Differences</p> <p>The grasshopper does not change much in form after it hatches from the egg but mainly increases in size, while the butterfly changes from a caterpillar to a pupa to a butterfly.</p> <p>The grasshopper eats the same food as it develops, the butterfly does not.</p> <p>The butterfly goes into a cocoon, the grasshopper does not.</p> <p>Similarities</p> <p>Both hatch from eggs</p> <p>Both undergo a great increase in size</p> <p>Both molt</p> <p>Neither born with wings</p>	

Life Cycles

8. Think about how humans grow and develop from newborn babies to adults. Is a human's life cycle more like a frog's life cycle or more like a grasshopper's life cycle? Explain your answer.

TABLE B2.36

Grade 4 Scoring Guide
Life Cycles



(3) Complete

Student is able to state a reasonable justification that includes a brief description of one correct similarity between the human life cycle and the grasshopper or frog life cycle.

(1) Unsatisfactory

Student is unable to describe a similarity between the human life cycle and the grasshopper or frog life cycle.

Examples of Credited Responses

Grasshopper — humans and grasshoppers do not undergo complete metamorphosis

Grasshopper — both have the same form all along

Mystery Water

10. Is the mystery water fresh water or is it salt water?

How can you tell what the mystery water is?

TABLE B2.38

Grade 4 Scoring Guide
Mystery Water



(3) Complete	Student states that the mystery water is fresh water and adequately justifies this conclusion by using a comparison.
(2) Partial	Student states that the mystery water is fresh water but does not give adequate justification.
(1) Unsatisfactory	Student does not correctly identify the mystery water.

Examples of Credited Response Explanations

The pencil floated to the same level as it did in the fresh water.
The water went up to the same place as in fresh water.
Because in the fresh water it went to A and it went to A again.

Examples of Partial Response Explanations

It looked like fresh water.
It works like fresh water.
It was the same as fresh water.

Ease of Floating

11. When people are swimming, is it easier for them to stay afloat in the ocean or in a freshwater lake?

Explain your answer.

TABLE B2.40

Grade 4 Scoring Guide
Ease of Floating



(3) Complete

Student demonstrates a beginning understanding of the concept of density by stating "ocean" and presenting an explanation that refers back to the hands-on task.

(2) Partial

Student demonstrates some understanding of floating and density by explaining that the ocean is salt water or relates answer to pencil but does not give a complete explanation.

(1) Unsatisfactory

Student does not relate swimming in salt water and fresh water to density.

Examples of Credited Responses

Ocean – the pencil floated the highest in the salt water.

Ocean – because the salt water pencil floated higher than the fresh water pencil.

Grade 8 Scoring Guides

Mirrors and Windows

6. Raul's little sister, Sarah, wants to know why she can see herself in a mirror, but she can see through a window. What should Raul tell his sister to explain the differences between mirrors and windows?

TABLE B3.14

Grade 8 Scoring Guide
Mirrors and Windows



(3) Complete	Student includes statements about the physical properties of mirrors and windows and the reflective properties of mirrors and windows (light must be mentioned). Student refers to both the backing of the mirror and the reflective properties.
(2) Partial	Student states that mirrors have a backing on them but windows do not, or student states that light bounces (reflects) off a mirror but travels through a window.
(1) Unsatisfactory	Student states that mirrors and windows differ but gives no reason for the differences, or student restates the question.

Hydra

15. Evita and Michael predicted that if they fed the hydras twice as much food, the population of hydras would double their number in 5 days. Describe an experiment with appropriate controls that Evita and Michael could do to test this hypothesis.

TABLE B3.20

Grade 8 Scoring Guide
Hydra



(4) Complete	Student describes an experiment that would test the hypothesis. This includes a control and more than one hydra in each group.
(3) Essential	Student describes an experiment that would test the hypothesis. This includes a control, but only one hydra in each group.
(2) Partial	Student describes an experiment that includes feeding hydras twice as much food but has no control group. (A statement about comparing it to the previous setup was not considered to be a control.) Or, student response incorporated two groups of hydras but did not specifically mention food amounts.
(1) Unsatisfactory	Student experiment does not test the hypothesis.

Lightbulbs

7. When operating, ordinary incandescent lightbulbs produce a lot of heat in addition to light. Fluorescent lightbulbs produce much less heat when operating. If you wanted to conserve electricity, which type of bulb should you use? Explain your answer.

TABLE B3.22

Grade 8 Scoring Guide
Lightbulbs



(3) Complete	Student chooses fluorescent lightbulbs and explains that heat comes from electrical energy and that the less heat produced the more light is obtained for a given amount of electrical energy or, the less heat is produced, the less electricity is used for a given amount of light. Some link between heat and energy consumption must be made.
(2) Partial	Student chooses fluorescent lightbulbs but an incorrect or no explanation is given.
(1) Unsatisfactory	Student chooses incandescent lightbulb or no lightbulb with no explanation or an incorrect explanation.

Heating Rate Prediction

At a beach that has white sand, you measure the temperature of the sand and the temperature of the seawater at 9:00 a.m. You find that both have a temperature of 16°C. If it is clear and sunny all morning, what do the data from the experiment predict about the temperature of the white sand compared to the temperature of the seawater at noon?

Explain your answer.

Explain why the prediction based on the data might be wrong.

TABLE B3.24

Grade 8 Scoring Guide
Heating Rate Prediction



(4) Complete	Student provides a reasonable prediction such as the sand will be hotter at noon than the water. The response also provides a reasonable explanation that relates to the data in the table. For example, the soil temperature was hotter than the water temperature after 8 minutes. Finally, the response must provide a reasonable explanation of why the prediction may be wrong. Credited responses include difference in length of time, sample size, color of samples, soil versus sand, and fresh water versus salt water.
(3) Essential	Student provides a reasonable prediction and either an explanation of the prediction or an explanation of why the prediction may be incorrect.
(2) Partial	Student provides a reasonable prediction.
(1) Unsatisfactory	Student provides no reasonable prediction or explanations.

Food Poisoning

13. A group of students took potato salad made with mayonnaise to a picnic on a very hot day. Explain how eating the potato salad could cause food poisoning.

Describe something that could be done to the potato salad to prevent the people who eat it from getting food poisoning.

TABLE B3.26

Grade 8 Scoring Guide
Food Poisoning



(3) Complete	Student explains that bacteria cause food poisoning and describes a method of prevention, such as putting the salad in a cooler.
(2) Partial	Student explains the cause of food poisoning or recognizes that the salad has to be kept cold.
(1) Unsatisfactory	Student does not understand that bacteria cause food poisoning and does not recognize that keeping the salad cold will help prevent this.

Inheritance

7. Hair color in humans is an inherited trait. How is it possible for two people who had brown hair from birth to produce a child with blond hair?

TABLE B3.28

Grade 8 Scoring Guide Inheritance

THE NATION'S
REPORT
CARD



(3) Complete	Student explains the inheritance of recessive genes by a child from the child's parents. Grandparents did not have to be mentioned.
(2) Partial	Student knows that the trait (gene) is passed from grandparents or ancestors to parents to child but does not explain recessive genes.
(1) Unsatisfactory	Student is unable to demonstrate any understanding of the concept of recessive genes.

Seasons

12. What additions or changes could be made to this model of the Solar System to best explain why the Northern Hemisphere of the Earth is colder in January than in July? You may draw a picture as part of your answer.

TABLE B3.32

Grade 8 Scoring Guide
Seasons



(3) Complete	Student describes or draws changes to the model such as adding the tilt of Earth. The responses may also refer to rotation or traveling in the orbit or a brief description of why it is colder in January than in July.
(2) Partial	Student does not make any additions to the model but mentions Earth's tilt or direct/indirect sunlight, or more/less sunlight. Student provides an incomplete diagram (no month and/or hemisphere labels) but makes an attempt at explaining why Earth is colder in January.
(1) Unsatisfactory	Student shows no understanding of the causes of the seasons. This includes responses that conflict with reality such as "the Earth is farther from the Sun in January."

Measurement, Average, Graphing, Interpolating

3. Now take the pencil out of the water and dry it with a paper towel. Use the ruler to measure the length of the pencil that was above the water. Record the length in Table 1 below under Measurement 1.

TABLE 1

Type of Solution	Length of Pencil Above Water Surface (cm)		
	Measurement 1	Measurement 2	Average
Distilled Water			
Salt Solution			
Unknown Salt Solution			

4. Now place the pencil back in the distilled water and repeat steps 2 and 3. Record your measurement in Table 1 under Measurement 2.
5. Calculate the average of Measurements 1 and 2 and record the result in the data table.
(You can calculate the average by adding Measurement 1 and Measurement 2 and then dividing by two.)
12. On the graph below, plot the average values you obtained for the distilled water and the 25% salt solution. Draw a straight line between the two data points. Assume that this line represents the relationship between the length of pencil that is above the water surface and the concentration of salt in the water.

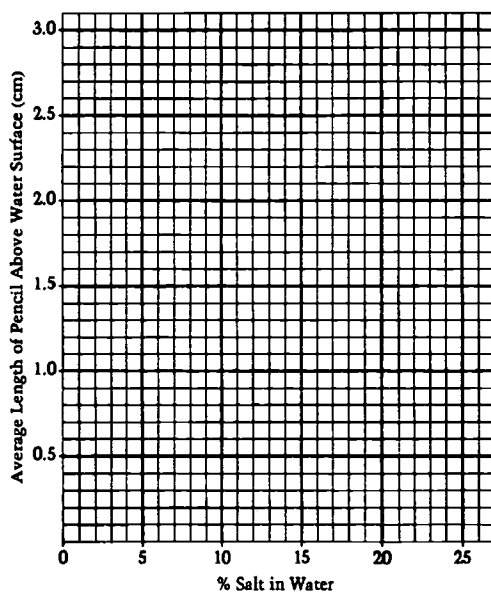

14. Based on the graph that you plotted, what is the salt concentration of the unknown solution? _____
Explain how you determined your answer.

TABLE B3.34**Grade 8 Scoring Guide
Measurement**

(4) Complete	Student shows three sets of measurements that agree within ± 0.2 cm, and the relative order of pencil heights above each solution is correct.
(3) Essential	Student shows three sets of measurements that agree within tolerance, but the relative order of pencil heights above each solution is incorrect.
(2) Partial	Student shows two sets of measurements that agree within tolerance.
(1) Unsatisfactory	Student shows one or no sets of measurements that agree within tolerance.

TABLE B3.36**Grade 8 Scoring Guide
Average**

(3) Complete	Student shows correct calculations of the average of the three sets of measurements to within ± 0.1 cm.
(2) Partial	Student shows correct calculation(s) of the average of one or two sets of averages within ± 0.1 cm.
(1) Unsatisfactory	Student shows no correct calculations.

TABLE B3.38**Grade 8 Scoring Guide
Graphing**THE NATION'S
REPORT
CARD

(3) Complete	Student draws a plot of two data points based on student's own data and draws a line between the two points.
(2) Partial	Student draws a graph of one data point based on student's own data or correctly plots two data points but fails to connect them.
(1) Unsatisfactory	Student fails to show any correct plotting of data.

TABLE B3.40**Grade 8 Scoring Guide
Interpolating**THE NATION'S
REPORT
CARD

(4) Complete	Student indicates a salt concentration that is consistent with the data and correctly explains how the answer was obtained.
(3) Essential	Student indicates a salt concentration that is consistent with the data but fails to explain adequately how the value is obtained, or a correct explanation of how to interpolate is given but an error is made with the value.
(2) Partial	Student shows how to use proportional reasoning in the explanation or gives an unclear explanation of how to use the graph but does not have a graph that can be used to interpolate.
(1) Unsatisfactory	Student does not show a value consistent with the graph or give an explanation.

Grade 12 Scoring Guides

Pacific Ring of Fire

6. The Pacific Ring of Fire is a belt-shaped region that roughly coincides with the seacoasts bordering the Pacific Ocean. Explain why volcanic activity and earthquakes occur frequently in this region.

TABLE B4.7

Grade 12 Scoring Guide
Pacific Ring of Fire



(4) Complete	Student demonstrates a thorough understanding of why volcanic activity and earthquakes occur in the region of the Pacific Rim. The response has to include volcanic activity and earthquakes being caused by the relative movement of two (tectonic) plates diverging, converging, or sliding past each other.
(3) Essential	Student mentions plates and the relative movement of them but does not link this to the activity that causes volcanic activity or earthquakes, or student's response links plates to activity but does not adequately describe the relative movement.
(2) Partial	Student mentions plates but does not link these to volcanic activity or earthquakes.
(1) Unsatisfactory	Student does not mention the movement of plates as the cause of volcanic activity or earthquakes.

Genotype

16. A mother with attached earlobes and a father with free earlobes have 5 children — 4 boys and 1 girl. All of the children have the father's type of earlobes. What can be predicted about the genotype of the father? Construct a genetic diagram to support your prediction. What additional information, if any, would you need to determine the genotype of the father? Explain.

TABLE B4.13

Grade 12 Scoring Guide
Genotype



(4) Complete	Student predicts the father's genotype, supports the prediction in diagrammatic form, and gives some additional information that will help determine the genotype.
(3) Essential	Student addresses two of the three elements described under Complete.
(2) Partial	Student addresses one of the three elements described under Complete, often in general terms.
(1) Unsatisfactory	Student addresses none of the elements described under Complete.

Flooding

5. You live along a major river, and your farm was flooded this spring. There are many larger farms and a few factories upriver that were also flooded. Provide two flood-related reasons for testing your soil before planting this year.

TABLE B4.17

Grade 12 Scoring Guide Flooding



(3) Complete	Student states two distinct reasons for testing the soil such as presence of toxins from factories or farms, erosion of topsoil, and leaching of essential minerals from the soil.
(2) Partial	Student states one reason for testing the soil.
(1) Unsatisfactory	Student states no correct reasons for testing the soil.

Keeping Ice Cream Cold

6. You are taking ice cream in a cooler to a picnic and want to keep the ice cream colder than 0°C for several hours. How could you do this?

TABLE B4.19

Grade 12 Scoring Guide
Keeping Ice Cream Cold



(3) Complete	Student indicates a correct method and satisfactorily explains how the method works. The student could give methods such as adding salt or packing in dry ice and explain that the salt lowers the freezing point of water or the melting point of ice, or that the temperature of the dry ice is well below zero.
(2) Partial	Student indicates a correct method but fails to explain it adequately.
(1) Unsatisfactory	Student fails to indicate a correct method.

Heart Disease

7. Heart disease is a major cause of death in the United States. Describe two ways a person can reduce the risk of heart disease.

TABLE B4.21

Grade 12 Scoring Guide
Heart Disease



(3) Complete	Student describes two ways to reduce the risk of heart disease such as eating less saturated fat and exercising more.
(2) Partial	Student describes one way to reduce the risk of heart disease.
(1) Unsatisfactory	Student is unable to describe correctly any way to reduce the risk of heart disease.

Malaria

8. A person has just returned to the United States from the tropics and is found to have malaria. What is the risk of other people catching the disease from this person?

Explain your answer.

TABLE B4.23

Grade 12 Scoring Guide
Malaria



(3) Complete	Student states that malaria is spread by mosquitoes and states that a mosquito must bite the infected person and then bite an uninfected person for the disease to be transmitted.
(2) Partial	Student states that malaria is spread by mosquitoes (insects) but does not connect it to the person in the question or student has a general sense of what causes malaria.
(1) Unsatisfactory	Student demonstrates no understanding of the cause and transmission of malaria.

Ocean and Lake Water

7. Some students were studying water in the environment. They filled one sample jar with ocean water and another sample jar with fresh water from the lake. The labels on the jars fell off, and the water in both jars looked the same. Describe a test, other than tasting or smelling the water, that the students could do to determine which jar held the ocean water and which jar held the lake water. Explain how the test could work.

TABLE B4.27

Grade 12 Scoring Guide ***Ocean and Lake Water***



(4) Complete	Student describes both a method and its results. For example, the student could say that the salt water would leave a residue of salt if boiled or allowed to evaporate.
(3) Essential	Student describes a method and its results but provides minimal detail, or provides a partial or flawed method.
(2) Partial	Student describes a method but does not indicate how it would work. For example, student advises measuring the density of water in each jar.
(1) Unsatisfactory	Student describes an inconclusive method.

Cloud Formation

9. Explain how clouds can form as air rises. You may draw a diagram as part of your explanation.

TABLE B4.29

**Grade 12 Scoring Guide
Cloud Formation**



(3) Complete	Student states that a change in temperature causes water to condense, thus forming clouds.
(2) Partial	Student states that as moist air rises, droplets of water form clouds.
(1) Unsatisfactory	Student may know that clouds are made up of water droplets and/or ice crystals, but no explanation is given for how a cloud forms.

Physical Properties

1. Look at the contents of plastic bag (A) without opening it. What properties do the substances in the mixture have that would allow the following equipment to be used to separate the mixture?

Magnet:

Filter paper:

Sieve:

TABLE B4.31

Grade 12 Scoring Guide Physical Properties

THE NATION'S
REPORT
CARD



(4) Complete	Student states the properties that may be useful for separating a mixture of substances using magnetism, solubility, and size.
(3) Essential	Student states two of the properties that would allow for separation.
(2) Partial	Student states one of the properties the would allow for separation.
(1) Unsatisfactory	Student is unable to give any properties that would allow for separation.

Separation of Materials

2. Now use this equipment to separate the five materials in the mixture. Each time you successfully separate a material from the mixture, place this separated material in one of the small unlabeled plastic bags. The materials that you separate do not have to be 100 percent pure, but they should be as pure as possible. Each separated material should be placed in its own plastic bag. The bags with the separated materials will be collected after you have completed the task.

[Notes: 1) If you have collected a material in the filter paper, you do not need to separate the material from the filter paper. Just put the filter paper in the plastic bag. 2) If you end up with one of the five materials dissolved in water, you can leave this material in the cup.]

TABLE B4.33

Grade 12 Scoring Guide Separation of Materials



(5) Complete	Student separates all of the solids in the mixture, except for the salt, which remains dissolved in water.
(4) Essential	Student separates three or four of the solids in the mixture.
(3) Adequate	Student separates two of the solids in the mixture.
(2) Partial	Student separates one of the solids in the mixture.
(1) Unsatisfactory	Student is unable to separate any of the solids in the mixture.

Description of Method

3. Based on what you discovered as you worked to separate the materials in the mixture, write in the space below step-by-step instructions that would allow someone else to separate all five solids using the same set of equipment.

TABLE B4.35	Grade 12 Scoring Guide Description of Method	THE NATION'S REPORT CARD 
(5) Complete	Student describes steps that lead to five separated components.	
(4) Essential	Student describes steps that lead to three separated components.	
(3) Adequate	Student describes steps that lead to two separated components.	
(2) Partial	Student describes steps that lead to one separated component.	
(1) Unsatisfactory	Student is unable to describe any of the separations.	

Note: There are a number of different steps that can be followed. All are valid provided that the components can be separated by following the student's directions.

Appendix C

Standard Errors

TABLE C2.2

Standard Errors for Teachers' Reports on How Much Time They Spent Teaching Life Science, Earth Science, and Physical Science, Grade 4: Public and Nonpublic Schools Combined



<i>In this class, about how much time do you spend on each of the following areas in science?</i>	Percentage of Students	Average Scale Score				Percentage At or Above Proficient
		Composite (all domains)	Life Science	Earth Science	Physical Science	
Life Science						
A Lot	2.7	1.5	1.8	1.8	2.0	1.7
Some	2.8	1.2	1.5	1.2	1.6	1.3
Little	1.4	3.8	4.0	3.5	5.2	5.1
None	0.4	--	--	--	--	--
Earth Science						
A Lot	2.1	2.3	2.6	2.9	2.5	2.6
Some	2.4	1.0	1.3	1.2	1.4	1.2
Little	1.0	4.1	4.1	4.5	5.3	4.4
None	0.3	--	--	--	--	--
Physical Science						
A Lot	2.3	2.3	2.8	2.6	2.8	2.3
Some	2.5	1.1	1.5	1.1	1.6	1.4
Little	1.5	3.5	4.0	3.8	4.0	3.5
None	0.5	7.4	7.5	8.6	7.4	5.9

-- Sample size was insufficient to permit a reliable estimate.

SOURCE: National Center for Education Statistics, National Assessment of Educational Progress (NAEP), 1996 Science Assessment.

TABLE C2.3

**Standard Errors for Average Question Score for
Earth Science, Physical Science, and Life Science, Grade 4:
Public and Nonpublic Schools Combined**



	Earth Science	Physical Science	Life Science
All Students	0.004	0.004	0.004
Male	0.005	0.005	0.005
Female	0.004	0.004	0.004
White	0.004	0.005	0.005
Black	0.007	0.009	0.007
Hispanic	0.008	0.007	0.008

NOTE: There were insufficient sample sizes for the American Indian and Asian/ Pacific Islander racial/ethnic subgroups to produce reliable results. Consequently, racial/ethnic subgroup information is provided only for White, Black, and Hispanic subgroups.

SOURCE: National Center for Education Statistics, National Assessment of Educational Progress (NAEP), 1996 Science Assessment.

TABLE C2.4

**Standard Errors for Average Question Score for
Conceptual Understanding, Scientific Investigation, and
Practical Reasoning, Grade 4: Public and
Nonpublic Schools Combined**



	Conceptual Understanding	Scientific Investigation	Practical Reasoning
All Students	0.004	0.004	0.004
Male	0.005	0.005	0.005
Female	0.004	0.005	0.005
White	0.004	0.005	0.004
Black	0.007	0.009	0.008
Hispanic	0.008	0.007	0.007

NOTE: There were insufficient sample sizes for the American Indian and Asian/ Pacific Islander racial/ethnic subgroups to produce reliable results. Consequently, racial/ethnic subgroup information is provided only for White, Black, and Hispanic subgroups.

SOURCE: National Center for Education Statistics, National Assessment of Educational Progress (NAEP), 1996 Science Assessment.

TABLE C2.6

**Standard Errors for Percentages Choosing
Each Response: Grade 4
Major Source of Gasoline**



Response Options

A	B	C	D	Omit
0.6	0.5	1.8	1.9	0.4

SOURCE: National Center for Education Statistics, National Assessment of Educational Progress (NAEP), 1996 Science Assessment.

TABLE C2.7

**Standard Errors for Percentages Correct within
Each Achievement Level Interval: Grade 4
Major Source of Gasoline**



Below Basic (0-137)	Basic (138-169)	Proficient (170-203)	Advanced (204-300)
3.4	4.1	3.2	---

--- Sample size insufficient to permit a reliable estimate.

SOURCE: National Center for Education Statistics, National Assessment of Educational Progress (NAEP), 1996 Science Assessment.

TABLE C2.8

**Standard Errors for Percentages Choosing
Each Response: Grade 4
Earth's Surface**



Response Options

A	B	C	D	Omit
1.4	0.6	1.2	0.3	0.2

SOURCE: National Center for Education Statistics, National Assessment of Educational Progress (NAEP), 1996 Science Assessment.

TABLE C2.9

**Standard Errors for Percentages Correct within
Each Achievement Level Interval: Grade 4
Earth's Surface**



Below Basic (0-137)	Basic (138-169)	Proficient (170-203)	Advanced (204-300)
3.8	2.3	1.8	--

-- Sample size was insufficient to permit a reliable estimate.

SOURCE: National Center for Education Statistics, National Assessment of Educational Progress (NAEP), 1996 Science Assessment.

TABLE C2.10

**Standard Errors for Percentages Choosing
Each Response: Grade 4
Visibility of Moon from Earth**



Response Options

A	B	C	D	Omit
1.0	2.0	0.5	1.7	0.3

SOURCE: National Center for Education Statistics, National Assessment of Educational Progress (NAEP), 1996 Science Assessment.

TABLE C2.11

**Standard Errors for Percentages Correct within
Each Achievement Level Interval: Grade 4
Visibility of Moon from Earth**



Below Basic (0-137)	Basic (138-169)	Proficient (170-203)	Advanced (204-300)
3.7	3.6	2.3	--

-- Sample size was insufficient to permit a reliable estimate.

SOURCE: National Center for Education Statistics, National Assessment of Educational Progress (NAEP), 1996 Science Assessment.

TABLE C2.12

**Standard Errors for Percentages Choosing
Each Response: Grade 4
Sources of Smog**



Response Options

A	B	C	D	Omit
1.9	1.0	1.0	1.4	0.5

SOURCE: National Center for Education Statistics, National Assessment of Educational Progress (NAEP), 1996 Science Assessment.

TABLE C2.13

**Standard Errors for Percentages Correct within
Each Achievement Level Interval: Grade 4
Sources of Smog**



Below Basic (0-137)	Basic (138-169)	Proficient (170-203)	Advanced (204-300)
3.6	4.2	3.8	--

-- Sample size was insufficient to permit a reliable estimate.

SOURCE: National Center for Education Statistics, National Assessment of Educational Progress (NAEP), 1996 Science Assessment.

TABLE C2.14

**Standard Errors for Percentages at
Different Score Levels: Grade 4
Natural Forces**



Complete	Essential	Partial	Unsatisfactory	Omit
0.9	0.5	1.6	1.9	0.8

SOURCE: National Center for Education Statistics, National Assessment of Educational Progress (NAEP), 1996 Science Assessment.

TABLE C2.15

Standard Errors for Percentages Complete or Essential within Each Achievement Level Interval: Grade 4 Natural Forces



Below Basic (0-137)	Basic (138-169)	Proficient (170-203)	Advanced (204-300)
--	1.9	3.0	--

--Sample size was insufficient to permit a reliable estimate.

SOURCE: National Center for Education Statistics, National Assessment of Educational Progress (NAEP), 1996 Science Assessment.

TABLE C2.16

Standard Errors for Percentages Choosing Each Response: Grade 4 Pattern of Ripples



Response Options

A	B	C	D	Omit
0.7	0.6	2.4	2.2	0.7

SOURCE: National Center for Education Statistics, National Assessment of Educational Progress (NAEP), 1996 Science Assessment.

TABLE C2.17

Standard Errors for Percentages Correct within Each Achievement Level Interval: Grade 4 Pattern of Ripples



Below Basic (0-137)	Basic (138-169)	Proficient (170-203)	Advanced (204-300)
3.0	4.0	3.6	--

--Sample size was insufficient to permit a reliable estimate.

SOURCE: National Center for Education Statistics, National Assessment of Educational Progress (NAEP), 1996 Science Assessment.

TABLE C2.18

**Standard Errors for Percentages Choosing
Each Response: Grade 4
Mealworm Life Cycle**



Response Options

A	B	C	D	Omit
1.7	1.3	0.9	1.2	0.2

SOURCE: National Center for Education Statistics, National Assessment of Educational Progress (NAEP), 1996 Science Assessment.

TABLE C2.19

**Standard Errors for Percentages Correct within
Each Achievement Level Interval: Grade 4
Mealworm Life Cycle**



Below Basic (0-137)	Basic (138-169)	Proficient (170-203)	Advanced (204-300)
3.0	3.0	3.2	---

--- Sample size was insufficient to permit a reliable estimate.

SOURCE: National Center for Education Statistics, National Assessment of Educational Progress (NAEP), 1996 Science Assessment.

TABLE C2.20

**Standard Errors for Percentages at Different
Score Levels: Grade 4
Plants: Parts and Functions**



Complete	Essential	Partial	Unsatisfactory	Omit
0.5	2.0	2.1	0.4	0.7

SOURCE: National Center for Education Statistics, National Assessment of Educational Progress (NAEP), 1996 Science Assessment.

TABLE C2.21

Standard Errors for Percentages Complete or Essential within Each Achievement Level Interval: Grade 4 Plants: Parts and Functions



Below Basic (0-137)	Basic (138-169)	Proficient (170-203)	Advanced (204-300)
3.6	4.2	3.8	--

--Sample size was insufficient to permit a reliable estimate.

SOURCE: National Center for Education Statistics, National Assessment of Educational Progress (NAEP), 1996 Science Assessment.

TABLE C2.22

Standard Errors for Percentages Choosing Each Response: Grade 4 Volume



Response Options

A	B	C	D	Omit
0.7	0.5	0.6	1.4	1.0

SOURCE: National Center for Education Statistics, National Assessment of Educational Progress (NAEP), 1996 Science Assessment.

TABLE C2.23

Standard Errors for Percentages Correct within Each Achievement Level Interval: Grade 4 Volume



Below Basic (0-137)	Basic (138-169)	Proficient (170-203)	Advanced (204-300)
3.2	2.4	2.5	--

--Sample size was insufficient to permit a reliable estimate.

SOURCE: National Center for Education Statistics, National Assessment of Educational Progress (NAEP), 1996 Science Assessment.

TABLE C2.24

**Standard Errors for Percentages Choosing
Each Response: Grade 4
Bar Graph**



Response Options

A	B	C	D	Omit
0.5	2.0	2.1	0.4	0.7

SOURCE: National Center for Education Statistics, National Assessment of Educational Progress (NAEP), 1996 Science Assessment.

TABLE C2.25

**Standard Errors for Percentages Correct within
Each Achievement Level Interval: Grade 4
Bar Graph**



Below Basic (0-137)	Basic (138-169)	Proficient (170-203)	Advanced (204-300)
3.6	4.2	3.8	--

-- Sample size was insufficient to permit a reliable estimate.

SOURCE: National Center for Education Statistics, National Assessment of Educational Progress (NAEP), 1996 Science Assessment.

TABLE C2.26

**Standard Errors for Percentages at
Different Score Levels: Grade 4
Experimental Setup**



Complete	Partial	Unsatisfactory	Omit
1.4	1.6	1.6	0.3

SOURCE: National Center for Education Statistics, National Assessment of Educational Progress (NAEP), 1996 Science Assessment.

TABLE C2.27

**Standard Errors for Percentages Complete within
Each Achievement Level Interval: Grade 4
Experimental Setup**



Below Basic (0-137)	Basic (138-169)	Proficient (170-203)	Advanced (204-300)
0.8	2.6	4.4	—

— Sample size was insufficient to permit a reliable estimate.

SOURCE: National Center for Education Statistics, National Assessment of Educational Progress (NAEP), 1996 Science Assessment.

TABLE C2.28

**Standard Errors for Percentages Choosing
Each Response: Grade 4
Radio Malfunction**



Response Options

A	B	C	D	Omit
0.5	1.4	0.4	1.0	0.4

SOURCE: National Center for Education Statistics, National Assessment of Educational Progress (NAEP), 1996 Science Assessment.

TABLE C2.29

**Standard Errors for Percentages Correct within
Each Achievement Level Interval: Grade 4
Radio Malfunction**



Below Basic (0-137)	Basic (138-169)	Proficient (170-203)	Advanced (204-300)
2.9	2.8	1.8	—

— Sample size was insufficient to permit a reliable estimate.

SOURCE: National Center for Education Statistics, National Assessment of Educational Progress (NAEP), 1996 Science Assessment.

TABLE C2.30

**Standard Errors for Percentages at
Different Score Levels: Grade 4
Properties of Metals**



Complete	Partial	Unsatisfactory	Omit
1.4	1.8	1.7	0.7

SOURCE: National Center for Education Statistics, National Assessment of Educational Progress (NAEP), 1996 Science Assessment.

TABLE C2.31

**Standard Errors for Percentages Complete within
Each Achievement Level Interval: Grade 4
Properties of Metals**



Below Basic (0-137)	Basic (138-169)	Proficient (170-203)	Advanced (204-300)
1.8	2.7	3.4	--

-- Sample size was insufficient to permit a reliable estimate.

SOURCE: National Center for Education Statistics, National Assessment of Educational Progress (NAEP), 1996 Science Assessment.

TABLE C2.32

**Standard Errors for Percentages at
Different Score Levels: Grade 4
Metamorphosis**



Complete	Partial	Unsatisfactory	Omit
1.7	1.3	0.8	0.5

SOURCE: National Center for Education Statistics, National Assessment of Educational Progress (NAEP), 1996 Science Assessment.

TABLE C2.33

Standard Errors for Percentages Complete within Each Achievement Level Interval: Grade 4 Metamorphosis



Below Basic (0-137)	Basic (138-169)	Proficient (170-203)	Advanced (204-300)
2.5	3.0	2.8	--

-- Sample size was insufficient to permit a reliable estimate.

SOURCE: National Center for Education Statistics, National Assessment of Educational Progress (NAEP), 1996 Science Assessment.

TABLE C2.34

Standard Errors for Percentages at Different Score Levels: Grade 4 Grasshoppers and Butterflies



Complete	Essential	Partial	Unsatisfactory	Omit
1.2	1.8	1.8	1.6	0.2

SOURCE: National Center for Education Statistics, National Assessment of Educational Progress (NAEP), 1996 Science Assessment.

TABLE C2.35

Standard Errors for Percentages Complete or Essential within Each Achievement Level Interval: Grade 4 Grasshoppers and Butterflies



Below Basic (0-137)	Basic (138-169)	Proficient (170-203)	Advanced (204-300)
1.3	2.1	3.7	--

-- Sample size was insufficient to permit a reliable estimate.

SOURCE: National Center for Education Statistics, National Assessment of Educational Progress (NAEP), 1996 Science Assessment.

TABLE C2.36

**Standard Errors for Percentages at
Different Score Levels: Grade 4
Life Cycles**



Complete	Unsatisfactory	Omit
1.4	1.4	0.3

SOURCE: National Center for Education Statistics, National Assessment of Educational Progress (NAEP), 1996 Science Assessment.

TABLE C2.37

**Standard Errors for Percentages Complete within
Each Achievement Level Interval: Grade 4
Life Cycles**



Below Basic (0-137)	Basic (138-169)	Proficient (170-203)	Advanced (204-300)
1.4	2.3	3.3	--

-- Sample size was insufficient to permit a reliable estimate.

SOURCE: National Center for Education Statistics, National Assessment of Educational Progress (NAEP), 1996 Science Assessment.

TABLE C2.38

**Standard Errors for Percentages at
Different Score Levels: Grade 4
Mystery Water**



Complete	Partial	Unsatisfactory	Omit
1.9	1.7	1.8	0.2

SOURCE: National Center for Education Statistics, National Assessment of Educational Progress (NAEP), 1996 Science Assessment.

TABLE C2.39

**Standard Errors for Percentages Complete within
Each Achievement Level Interval: Grade 4
Mystery Water**



Below Basic (0-137)	Basic (138-169)	Proficient (170-203)	Advanced (204-300)
1.8	2.9	3.4	—

— — Sample size was insufficient to permit a reliable estimate.

SOURCE: National Center for Education Statistics, National Assessment of Educational Progress (NAEP), 1996 Science Assessment.

TABLE C2.40

**Standard Errors for Percentages at
Different Score Levels: Grade 4
Ease of Floating**



Complete	Partial	Unsatisfactory	Omit
1.2	1.4	1.5	0

SOURCE: National Center for Education Statistics, National Assessment of Educational Progress (NAEP), 1996 Science Assessment.

TABLE C2.41

**Standard Errors for Percentages Complete within
Each Achievement Level Interval: Grade 4
Ease of Floating**



Below Basic (0-137)	Basic (138-169)	Proficient (170-203)	Advanced (204-300)
—	1.9	2.8	—

— — Sample size was insufficient to permit a reliable estimate.

SOURCE: National Center for Education Statistics, National Assessment of Educational Progress (NAEP), 1996 Science Assessment.

TABLE C3.2

Standard Errors for Teachers' Reports on How Much Time They Spent Teaching Life Science, Earth Science, and Physical Science, Grade 8: Public and Nonpublic Schools Combined



<i>In this class, about how much time do you spend on each of the following areas in science?</i>	Percentage of Students	Average Scale Score				Percentage At or Above Proficient
		Composite (all domains)	Life Science	Earth Science	Physical Science	
Life Science						
A Lot	4.1	2.5	2.8	2.9	2.8	3.4
Some	5.3	2.4	2.5	2.5	2.5	2.5
Little	3.6	2.7	2.5	3.1	2.8	3.5
None	4.5	4.0	4.7	4.4	3.2	5.9
Earth Science						
A Lot	5.0	2.5	2.6	2.8	2.5	3.0
Some	4.5	2.1	2.2	2.1	2.1	2.3
Little	2.7	4.7	4.7	5.5	4.2	6.7
None	1.9	3.5	4.4	3.8	3.2	5.2
Physical Science						
A Lot	4.3	1.7	2.1	1.8	1.6	2.4
Some	4.4	2.7	2.7	2.9	2.9	3.2
Little	3.2	3.3	3.4	4.4	2.9	3.5
None	1.2	6.4	6.9	7.0	6.2	5.3

SOURCE: National Center for Education Statistics, National Assessment of Educational Progress (NAEP), 1996 Science Assessment.

TABLE C3.3

**Standard Errors for Average Question Score for
Earth Science, Physical Science, and Life Science, Grade 8:
Public and Nonpublic Schools Combined**



	Earth Science	Physical Science	Life Science
All Students	0.005	0.004	0.004
Male	0.005	0.005	0.004
Female	0.006	0.004	0.005
White	0.006	0.005	0.004
Black	0.005	0.005	0.004
Hispanic	0.008	0.007	0.008
Asian/Pacific Islander	0.014	0.012	0.015

NOTE: There were insufficient sample sizes for the American Indian racial/ethnic subgroup to produce reliable results.

SOURCE: National Center for Education Statistics, National Assessment of Educational Progress (NAEP), 1996 Science Assessment.

TABLE C3.4

**Standard Errors for Average Question Score for Conceptual
Understanding, Scientific Investigation, and Practical Reason-
ing, Grade 8: Public and Nonpublic Schools Combined**



	Conceptual Understanding	Scientific Investigation	Practical Reasoning
All Students	0.004	0.004	0.004
Male	0.004	0.005	0.005
Female	0.004	0.005	0.005
White	0.004	0.005	0.005
Black	0.004	0.006	0.005
Hispanic	0.006	0.008	0.008
Asian/ Pacific Islander	0.013	0.017	--

-- Sample size is insufficient to permit a reliable estimate.

NOTE: There were insufficient sample sizes for the American Indian racial/ethnic subgroup to produce reliable results.

SOURCE: National Center for Education Statistics, National Assessment of Educational Progress (NAEP), 1996 Science Assessment.

TABLE C3.6

**Standard Errors for Percentages Choosing
Each Response: Grade 8
Location of Earthquake**



Response Options

A	B	C	D	Omit
0.6	1.8	0.8	1.7	0.2

SOURCE: National Center for Education Statistics, National Assessment of Educational Progress (NAEP), 1996 Science Assessment.

TABLE C3.7

**Standard Errors for Percentages Correct within
Each Achievement Level Interval: Grade 8
Location of Earthquake**



Below Basic (0-142)	Basic (143-169)	Proficient (170-206)	Advanced (207-300)
2.9	4.0	3.1	—

— Sample size was insufficient to permit a reliable estimate.

SOURCE: National Center for Education Statistics, National Assessment of Educational Progress (NAEP), 1996 Science Assessment.

TABLE C3.8

**Standard Errors for Percentages Choosing
Each Response: Grade 8
Windchill**



Response Options

A	B	C	D	Omit
2.2	0.5	2.1	0.9	0.1

SOURCE: National Center for Education Statistics, National Assessment of Educational Progress (NAEP), 1996 Science Assessment.

TABLE C3.9

Standard Errors for Percentages Correct within Each Achievement Level Interval: Grade 8 Windchill

THE NATION'S
REPORT
CARD



Below Basic (0-142)	Basic (143-169)	Proficient (170-206)	Advanced (207-300)
3.8	3.6	4.4	--

-- Sample size was insufficient to permit a reliable estimate.

SOURCE: National Center for Education Statistics, National Assessment of Educational Progress (NAEP), 1996 Science Assessment.

TABLE C3.10

Standard Errors for Percentages Choosing Each Response: Grade 8 Insulated Bottle

THE NATION'S
REPORT
CARD



Response Options

A	B	C	D	Omit
0.7	1.9	1.1	1.4	0.2

SOURCE: National Center for Education Statistics, National Assessment of Educational Progress (NAEP), 1996 Science Assessment.

TABLE C3.11

Standard Errors for Percentages Correct within Each Achievement Level Interval: Grade 8 Insulated Bottle

THE NATION'S
REPORT
CARD



Below Basic (0-142)	Basic (143-169)	Proficient (170-206)	Advanced (207-300)
2.3	3.4	6.6	--

-- Sample size was insufficient to permit a reliable estimate.

SOURCE: National Center for Education Statistics, National Assessment of Educational Progress (NAEP), 1996 Science Assessment.

TABLE C3.12

**Standard Errors for Percentages Choosing
Each Response: Grade 8
Nonrenewable Resource**



Response Options

A	B	C	D	Omit
2.4	1.6	1.0	1.4	0.2

SOURCE: National Center for Education Statistics, National Assessment of Educational Progress (NAEP), 1996 Science Assessment.

TABLE C3.13

**Standard Errors for Percentages Correct within
Each Achievement Level Interval: Grade 8
Nonrenewable Resource**



Below Basic (0-142)	Basic (143-169)	Proficient (170-206)	Advanced (207-300)
3.2	3.5	5.4	—

— Sample size was insufficient to permit a reliable estimate.

SOURCE: National Center for Education Statistics, National Assessment of Educational Progress (NAEP), 1996 Science Assessment.

TABLE C3.14

**Standard Errors for Percentages at
Different Score Levels: Grade 8
Mirrors and Windows**



Complete	Partial	Unsatisfactory	Omit
0.4	1.7	1.9	0.6

SOURCE: National Center for Education Statistics, National Assessment of Educational Progress (NAEP), 1996 Science Assessment.

TABLE C3.15

Standard Errors for Percentages Complete within Each Achievement Level Interval: Grade 8 Mirrors and Windows



Below Basic (0-142)	Basic (143-169)	Proficient (170-206)	Advanced (207-300)
--	0.8	1.3	--

-- Sample size was insufficient to permit a reliable estimate.

SOURCE: National Center for Education Statistics, National Assessment of Educational Progress (NAEP), 1996 Science Assessment.

TABLE C3.16

Standard Errors for Percentages Choosing Each Response: Grade 8 Mitochondria



Response Options

A	B	C	D	Omit
1.5	0.9	1.7	1.4	0.3

SOURCE: National Center for Education Statistics, National Assessment of Educational Progress (NAEP), 1996 Science Assessment.

TABLE C3.17

Standard Errors for Percentages Correct within Each Achievement Level Interval: Grade 8 Mitochondria



Below Basic (0-142)	Basic (143-169)	Proficient (170-206)	Advanced (207-300)
2.2	2.7	4.5	--

-- Sample size was insufficient to permit a reliable estimate.

SOURCE: National Center for Education Statistics, National Assessment of Educational Progress (NAEP), 1996 Science Assessment.

TABLE C3.18

**Standard Errors for Percentages Choosing
Each Response: Grade 8
Classification**



Response Options

A	B	C	D	Omit
1.1	1.4	1.9	0.5	0.1

SOURCE: National Center for Education Statistics, National Assessment of Educational Progress (NAEP), 1996 Science Assessment.

TABLE C3.19

**Standard Errors for Percentages Correct within
Each Achievement Level Interval: Grade 8
Classification**



Below Basic (0-142)	Basic (143-169)	Proficient (170-206)	Advanced (207-300)
3.2	2.7	3.1	--

-- Sample size was insufficient to permit a reliable estimate.

SOURCE: National Center for Education Statistics, National Assessment of Educational Progress (NAEP), 1996 Science Assessment.

TABLE C3.20

**Standard Errors for Percentages at
Different Score Levels: Grade 8
Hydra**



Complete	Essential	Partial	Unsatisfactory	Omit
2.4	0.8	1.7	2.6	0.8

SOURCE: National Center for Education Statistics, National Assessment of Educational Progress (NAEP), 1996 Science Assessment.

TABLE C3.21

**Standard Errors for Percentages Complete or Essential
within Each Achievement Level Interval: Grade 8
Hydra**



Below Basic (0-142)	Basic (143-169)	Proficient (170-206)	Advanced (207-300)
2.0	3.5	6.6	--

-- Sample size was insufficient to permit a reliable estimate.

SOURCE: National Center for Education Statistics, National Assessment of Educational Progress (NAEP), 1996 Science Assessment.

TABLE C3.22

**Standard Errors for Percentages at
Different Score Levels: Grade 8
Lightbulbs**



Complete	Partial	Unsatisfactory	Omit
2.0	1.5	1.3	0.7

SOURCE: National Center for Education Statistics, National Assessment of Educational Progress (NAEP), 1996 Science Assessment.

TABLE C3.23

**Standard Errors for Percentages Complete within
Each Achievement Level Interval: Grade 8
Lightbulbs**



Below Basic (0-142)	Basic (143-169)	Proficient (170-206)	Advanced (207-300)
2.8	4.6	4.4	--

-- Sample size was insufficient to permit a reliable estimate.

SOURCE: National Center for Education Statistics, National Assessment of Educational Progress (NAEP), 1996 Science Assessment.

TABLE C3.24

**Standard Errors for Percentages at
Different Score Levels: Grade 8
Heating Rate Prediction**



Complete	Essential	Partial	Unsatisfactory	Omit
0.8	1.0	1.9	1.8	0.7

SOURCE: National Center for Education Statistics, National Assessment of Educational Progress (NAEP), 1996 Science Assessment.

TABLE C3.25

**Standard Errors for Percentages Complete or Essential
within Each Achievement Level Interval: Grade 8
Heating Rate Prediction**



Below Basic (0-142)	Basic (143-169)	Proficient (170-206)	Advanced (207-300)
--	2.5	4.7	--

-- Sample size was insufficient to permit a reliable estimate.

SOURCE: National Center for Education Statistics, National Assessment of Educational Progress (NAEP), 1996 Science Assessment.

TABLE C3.26

**Standard Errors for Percentages at
Different Score Levels: Grade 8
Food Poisoning**



Complete	Partial	Unsatisfactory	Omit
1.5	1.8	1.5	0.6

SOURCE: National Center for Education Statistics, National Assessment of Educational Progress (NAEP), 1996 Science Assessment.

TABLE C3.27

Standard Errors for Percentages Complete within Each Achievement Level Interval: Grade 8 Food Poisoning



Below Basic (0-142)	Basic (143-169)	Proficient (170-206)	Advanced (207-300)
1.1	2.3	4.0	---

--- Sample size was insufficient to permit a reliable estimate.

SOURCE: National Center for Education Statistics, National Assessment of Educational Progress (NAEP), 1996 Science Assessment.

TABLE C3.28

Standard Errors for Percentages at Different Score Levels: Grade 8 Inheritance



Complete	Partial	Unsatisfactory	Omit
1.2	1.3	1.7	0.6

SOURCE: National Center for Education Statistics, National Assessment of Educational Progress (NAEP), 1996 Science Assessment.

TABLE C3.29

Standard Errors for Percentages Complete within Each Achievement Level Interval: Grade 8 Inheritance



Below Basic (0-142)	Basic (143-169)	Proficient (170-206)	Advanced (207-300)
---	1.0	1.9	---

--- Sample size was insufficient to permit a reliable estimate.

SOURCE: National Center for Education Statistics, National Assessment of Educational Progress (NAEP), 1996 Science Assessment.

TABLE C3.30

**Standard Errors for Percentages Choosing
Each Response: Grade 8
Graph Reading**



Response Options

A	B	C	D	Omit
1.4	0.7	0.7	0.4	0.5

SOURCE: National Center for Education Statistics, National Assessment of Educational Progress (NAEP), 1996 Science Assessment.

TABLE C3.31

**Standard Errors for Percentages Correct within
Each Achievement Level Interval: Grade 8
Graph Reading**



Below Basic (0-142)	Basic (143-169)	Proficient (170-206)	Advanced (207-300)
2.8	1.8	—	—

— — Sample size was insufficient to permit a reliable estimate.

SOURCE: National Center for Education Statistics, National Assessment of Educational Progress (NAEP), 1996 Science Assessment.

TABLE C3.32

**Standard Errors for Percentages at
Different Score Levels: Grade 8
Seasons**



Complete	Partial	Unsatisfactory	Omit
1.2	1.5	2.1	—

— — Sample size was insufficient to permit a reliable estimate.

SOURCE: National Center for Education Statistics, National Assessment of Educational Progress (NAEP), 1996 Science Assessment.

TABLE C3.33

Standard Errors for Percentages Complete within Each Achievement Level Interval: Grade 8 Seasons



Below Basic (0-142)	Basic (143-169)	Proficient (170-206)	Advanced (207-300)
--	1.4	3.0	--

-- Sample size was insufficient to permit a reliable estimate.

SOURCE: National Center for Education Statistics, National Assessment of Educational Progress (NAEP), 1996 Science Assessment.

TABLE C3.34

Standard Errors for Percentages at Different Score Levels: Grade 8 Salt Solution: Measurement



Complete	Essential	Partial	Unsatisfactory	Omit
1.7	1.3	1.4	1.3	0.2

SOURCE: National Center for Education Statistics, National Assessment of Educational Progress (NAEP), 1996 Science Assessment.

TABLE C3.35

Standard Errors for Percentages Complete or Essential within Each Achievement Level Interval: Grade 8 Salt Solution: Measurement



Below Basic (0-142)	Basic (143-169)	Proficient (170-206)	Advanced (207-300)
2.7	2.4	2.9	--

-- Sample size was insufficient to permit a reliable estimate.

SOURCE: National Center for Education Statistics, National Assessment of Educational Progress (NAEP), 1996 Science Assessment.

TABLE C3.36

**Standard Errors for Percentages at
Different Score Levels: Grade 8
Salt Solution: Average**



Complete	Partial	Unsatisfactory	Omit
1.3	1.0	1.0	0.4

SOURCE: National Center for Education Statistics, National Assessment of Educational Progress (NAEP), 1996 Science Assessment.

TABLE C3.37

**Standard Errors for Percentages Complete within
Each Achievement Level Interval: Grade 8
Salt Solution: Average**



Below Basic (0-142)	Basic (143-169)	Proficient (170-206)	Advanced (207-300)
2.0	2.1	1.7	—

— Sample size was insufficient to permit a reliable estimate.

SOURCE: National Center for Education Statistics, National Assessment of Educational Progress (NAEP), 1996 Science Assessment.

TABLE C3.38

**Standard Errors for Percentages at
Different Score Levels: Grade 8
Salt Solution: Graphing**



Complete	Partial	Unsatisfactory	Omit
1.6	1.2	1.4	0.8

SOURCE: National Center for Education Statistics, National Assessment of Educational Progress (NAEP), 1996 Science Assessment.

TABLE C3.39

**Standard Errors for Percentages Complete within Each Achievement Level Interval: Grade 8
Salt Solution: Graphing**



Below Basic (0-142)	Basic (143-169)	Proficient (170-206)	Advanced (207-300)
0.7	2.2	4.6	—

— Sample size was insufficient to permit a reliable estimate.

SOURCE: National Center for Education Statistics, National Assessment of Educational Progress (NAEP), 1996 Science Assessment.

TABLE C3.40

**Standard Errors for Percentages at Different Score Levels: Grade 8
Salt Solution: Interpolating**



Complete	Essential	Partial	Unsatisfactory	Omit
1.2	1.0	1.3	1.6	—

— Sample size was insufficient to permit a reliable estimate.

SOURCE: National Center for Education Statistics, National Assessment of Educational Progress (NAEP), 1996 Science Assessment.

TABLE C3.41

**Standard Errors for Percentages Complete or Essential within Each Achievement Level Interval: Grade 8
Salt Solution: Interpolating**



Below Basic (0-142)	Basic (143-169)	Proficient (170-206)	Advanced (207-300)
1.3	2.8	3.5	—

— Sample size was insufficient to permit a reliable estimate.

SOURCE: National Center for Education Statistics, National Assessment of Educational Progress (NAEP), 1996 Science Assessment.

TABLE C4.2

**Standard Errors for Average Question Score for
Earth Science, Physical Science, and Life Science, Grade 12:
Public and Nonpublic Schools Combined**



	Earth Science	Physical Science	Life Science
All Students	0.004	0.004	0.004
Male	0.007	0.006	0.005
Female	0.004	0.004	0.004
White	0.005	0.005	0.004
Black	0.009	0.006	0.005
Hispanic	0.011	0.009	0.009
Asian/Pacific Islander	0.019	0.012	0.013

SOURCE: National Center for Education Statistics, National Assessment of Educational Progress (NAEP), 1996 Science Assessment.

TABLE C4.3

**Standard Errors for Average Question Score for Conceptual
Understanding, Scientific Investigation, and Practical Reasoning,
Grade 12: Public and Nonpublic Schools Combined**



	Conceptual Understanding	Scientific Investigation	Practical Reasoning
All Students	0.004	0.004	0.004
Male	0.006	0.007	0.006
Female	0.004	0.004	0.004
White	0.005	0.005	0.005
Black	0.006	0.008	0.007
Hispanic	0.008	0.010	0.010
Asian/ Pacific Islander	0.015	0.014	0.015

SOURCE: National Center for Education Statistics, National Assessment of Educational Progress (NAEP), 1996 Science Assessment.

TABLE C4.5

**Standard Errors for Percentages Choosing
Each Response: Grade 12
Solar Eclipse**



Response Options

A	B	C	D	Omit
0.7	0.6	1.3	0.8	0.4

SOURCE: National Center for Education Statistics, National Assessment of Educational Progress (NAEP), 1996 Science Assessment.

TABLE C4.6

**Standard Errors for Percentages Correct within
Each Achievement Level Interval: Grade 12
Solar Eclipse**



Below Basic (0-144)	Basic (145-177)	Proficient (178-209)	Advanced (210-300)
2.6	2.2	2.2	—

—Sample size was insufficient to permit a reliable estimate.

SOURCE: National Center for Education Statistics, National Assessment of Educational Progress (NAEP), 1996 Science Assessment.

TABLE C4.7

**Standard Errors for Percentages at
Different Score Levels: Grade 12
Pacific Ring of Fire**



Complete	Essential	Partial	Unsatisfactory	Omit
0.7	2.1	1.3	1.7	1.1

SOURCE: National Center for Education Statistics, National Assessment of Educational Progress (NAEP), 1996 Science Assessment.

TABLE C4.8

**Standard Errors for Percentages Complete or Essential within
Each Achievement Level Interval: Grade 12
Pacific Ring of Fire**



Below Basic (0-144)	Basic (145-177)	Proficient (178-209)	Advanced (210-300)
1.9	3.0	3.9	—

— Sample size was insufficient to permit a reliable estimate.

SOURCE: National Center for Education Statistics, National Assessment of Educational Progress (NAEP), 1996 Science Assessment.

TABLE C4.9

**Standard Errors for Percentages Choosing
Each Response: Grade 12
Path on Ice**



Response Options

A	B	C	D	Omit
0.8	2.1	2.3	1.2	0.2

SOURCE: National Center for Education Statistics, National Assessment of Educational Progress (NAEP), 1996 Science Assessment.

TABLE C4.10

**Standard Errors for Percentages Correct within
Each Achievement Level Interval: Grade 12
Path on Ice**



Below Basic (0-144)	Basic (145-177)	Proficient (178-209)	Advanced (210-300)
2.8	3.0	6.1	—

— Sample size was insufficient to permit a reliable estimate.

SOURCE: National Center for Education Statistics, National Assessment of Educational Progress (NAEP), 1996 Science Assessment.

TABLE C4.11

**Standard Errors for Percentages Choosing
Each Response: Grade 12
Interpretation of Velocity/Time Graph**



Response Options

A	B	C	D	Omit
1.2	1.0	1.7	1.2	0.2

SOURCE: National Center for Education Statistics, National Assessment of Educational Progress (NAEP), 1996 Science Assessment.

TABLE C4.12

**Standard Errors for Percentages Correct within
Each Achievement Level Interval: Grade 12
Interpretation of Velocity/Time Graph**



Below Basic (0-144)	Basic (145-177)	Proficient (178-209)	Advanced (210-300)
2.6	3.6	4.5	—

— Sample size was insufficient to permit a reliable estimate.

SOURCE: National Center for Education Statistics, National Assessment of Educational Progress (NAEP), 1996 Science Assessment.

TABLE C4.13

**Standard Errors for Percentages at
Different Score Levels: Grade 12
Genotype**



Complete	Essential	Partial	Unsatisfactory	Omit
0.8	1.5	1.8	1.8	—

— Sample size was insufficient to permit a reliable estimate.

SOURCE: National Center for Education Statistics, National Assessment of Educational Progress (NAEP), 1996 Science Assessment.

TABLE C4.14

Standard Errors for Percentages Complete or Essential within Each Achievement Level Interval: Grade 12 Genotype



Below Basic (0-144)	Basic (145-177)	Proficient (178-209)	Advanced (210-300)
1.3	2.5	4.4	--

-- Sample size was insufficient to permit a reliable estimate.

SOURCE: National Center for Education Statistics, National Assessment of Educational Progress (NAEP), 1996 Science Assessment.

TABLE C4.15

Standard Errors for Percentages Choosing Each Response: Grade 12 Concluding from Results



Response Options

A	B	C	D	Omit
1.1	1.4	1.1	1.9	0.3

SOURCE: National Center for Education Statistics, National Assessment of Educational Progress (NAEP), 1996 Science Assessment.

TABLE C4.16

Standard Errors for Percentages Correct within Each Achievement Level Interval: Grade 12 Concluding from Results



Below Basic (0-144)	Basic (145-177)	Proficient (178-209)	Advanced (210-300)
2.4	3.1	4.1	--

-- Sample size was insufficient to permit a reliable estimate.

SOURCE: National Center for Education Statistics, National Assessment of Educational Progress (NAEP), 1996 Science Assessment.

TABLE C4.17

**Standard Errors for Percentages at
Different Score Levels: Grade 12
Flooding**



Complete	Partial	Unsatisfactory	Omit
1.7	1.6	1.2	0.7

SOURCE: National Center for Education Statistics, National Assessment of Educational Progress (NAEP), 1996 Science Assessment.

TABLE C4.18

**Standard Errors for Percentages Complete within
Each Achievement Level Interval: Grade 12
Flooding**



Below Basic (0-144)	Basic (145-177)	Proficient (178-209)	Advanced (210-300)
1.9	4.2	5.6	—

— — Sample size was insufficient to permit a reliable estimate.

SOURCE: National Center for Education Statistics, National Assessment of Educational Progress (NAEP), 1996 Science Assessment.

TABLE C4.19

**Standard Errors for Percentages at
Different Score Levels: Grade 12
Keeping Ice Cream Cold**



Complete	Partial	Unsatisfactory	Omit
1.3	1.5	1.8	0.7

SOURCE: National Center for Education Statistics, National Assessment of Educational Progress (NAEP), 1996 Science Assessment.

TABLE C4.20

**Standard Errors for Percentages Correct within
Each Achievement Level Interval: Grade 12
Keeping Ice Cream Cold**



Below Basic (0-144)	Basic (145-177)	Proficient (178-209)	Advanced (210-300)
1.4	2.0	3.4	—

— — Sample size was insufficient to permit a reliable estimate.

SOURCE: National Center for Education Statistics, National Assessment of Educational Progress (NAEP), 1996 Science Assessment.

TABLE C4.21

**Standard Errors for Percentages at
Different Score Levels: Grade 12
Heart Disease**



Complete	Partial	Unsatisfactory	Omit
2.1	2.1	0.7	0.5

SOURCE: National Center for Education Statistics, National Assessment of Educational Progress (NAEP), 1996 Science Assessment.

TABLE C4.22

**Standard Errors for Percentages Complete within
Each Achievement Level Interval: Grade 12
Heart Disease**



Below Basic (0-144)	Basic (145-177)	Proficient (178-209)	Advanced (210-300)
2.9	4.3	5.5	—

— — Sample size was insufficient to permit a reliable estimate.

SOURCE: National Center for Education Statistics, National Assessment of Educational Progress (NAEP), 1996 Science Assessment.

TABLE C4.23

**Standard Errors for Percentages at
Different Score Levels: Grade 12
Malaria**



Complete	Partial	Unsatisfactory	Omit
0.6	1.5	1.8	1.0

SOURCE: National Center for Education Statistics, National Assessment of Educational Progress (NAEP), 1996 Science Assessment.

TABLE C4.24

**Standard Errors for Percentages Complete within
Each Achievement-Level Interval: Grade 12
Malaria**



Below Basic (0-144)	Basic (145-177)	Proficient (178-209)	Advanced (210-300)
0.6	1.2	1.1	---

--- Sample size was insufficient to permit a reliable estimate.

SOURCE: National Center for Education Statistics, National Assessment of Educational Progress (NAEP), 1996 Science Assessment.

TABLE C4.25

**Standard Errors for Percentages Choosing
Each Response: Grade 12
Temperature & Evaporation**



Response Options

A	B	C	D	Omit
1.0	0.5	1.8	1.2	0.2

SOURCE: National Center for Education Statistics, National Assessment of Educational Progress (NAEP), 1996 Science Assessment.

TABLE C4.26

Standard Errors for Percentages Correct within Each Achievement Level Interval: Grade 12 Temperature & Evaporation



Below Basic (0-144)	Basic (145-177)	Proficient (178-209)	Advanced (210-300)
2.4	2.7	2.1	--

-- Sample size was insufficient to permit a reliable estimate.

SOURCE: National Center for Education Statistics, National Assessment of Educational Progress (NAEP), 1996 Science Assessment.

TABLE C4.27

Standard Errors for Percentages at Different Score Levels: Grade 12 Identification of Ocean and Lake Water



Complete	Essential	Partial	Unsatisfactory	Omit
1.3	1.0	0.6	1.6	0.7

SOURCE: National Center for Education Statistics, National Assessment of Educational Progress (NAEP), 1996 Science Assessment.

TABLE C4.28

Standard Errors for Percentages Complete or Essential within Each Achievement Level Interval: Grade 12 Identification of Ocean and Lake Water



Below Basic (0-144)	Basic (145-177)	Proficient (178-209)	Advanced (210-300)
2.0	2.5	4.2	--

-- Sample size was insufficient to permit a reliable estimate.

SOURCE: National Center for Education Statistics, National Assessment of Educational Progress (NAEP), 1996 Science Assessment.

TABLE C4.29

**Standard Errors for Percentages at
Different Score Levels: Grade 12
Cloud Formation**



Complete	Partial	Unsatisfactory	Omit
1.6	1.2	2.3	1.4

SOURCE: National Center for Education Statistics, National Assessment of Educational Progress (NAEP), 1996 Science Assessment.

TABLE C4.30

**Standard Errors for Percentages Complete within
Each Achievement Level Interval: Grade 12
Cloud Formation**



Below Basic (0-144)	Basic (145-177)	Proficient (178-209)	Advanced (210-300)
--	2.9	2.5	--

--Sample size was insufficient to permit a reliable estimate.

SOURCE: National Center for Education Statistics, National Assessment of Educational Progress (NAEP), 1996 Science Assessment.

TABLE C4.31

**Standard Errors for Percentages at
Different Score Levels: Grade 12
Physical Properties**



Complete	Essential	Partial	Unsatisfactory	Omit
0.8	0.9	1.4	1.6	0.7

SOURCE: National Center for Education Statistics, National Assessment of Educational Progress (NAEP), 1996 Science Assessment.

TABLE C4.32

Standard Errors for Percentages Complete or Essential within Each Achievement Level Interval: Grade 12 Physical Properties



Below Basic (0-144)	Basic (145-177)	Proficient (178-209)	Advanced (210-300)
0.7	1.7	3.9	--

-- Sample size was insufficient to permit a reliable estimate.

SOURCE: National Center for Education Statistics, National Assessment of Educational Progress (NAEP), 1996 Science Assessment.

TABLE C4.33

Standard Errors for Percentages at Different Score Levels: Grade 12 Separation of Materials



Complete	Essential	Adequate	Partial	Unsatisfactory	Omit
2.0	1.9	0.9	1.2	1.6	1.8

SOURCE: National Center for Education Statistics, National Assessment of Educational Progress (NAEP), 1996 Science Assessment.

TABLE C4.34

Standard Errors for Percentages Complete or Essential within Each Achievement Level Interval: Grade 12 Separation of Materials



Below Basic (0-144)	Basic (145-177)	Proficient (178-209)	Advanced (210-300)
3.0	3.9	5.5	--

-- Sample size was insufficient to permit a reliable estimate.

SOURCE: National Center for Education Statistics, National Assessment of Educational Progress (NAEP), 1996 Science Assessment.

TABLE C4.35

**Standard Errors for Percentages at
Different Score Levels: Grade 12
Description of Method**



Complete	Essential	Adequate	Partial	Unsatisfactory	Omit
1.2	1.6	0.6	1.5	1.3	0.2

SOURCE: National Center for Education Statistics, National Assessment of Educational Progress (NAEP), 1996 Science Assessment.

TABLE C4.36

**Standard Errors for Percentages Complete or Essential within
Each Achievement Level Interval: Grade 12
Description of Method**



Below Basic (0-144)	Basic (145-177)	Proficient (178-209)	Advanced (210-300)
2.5	3.2	3.1	—

— — Sample size was insufficient to permit a reliable estimate.

SOURCE: National Center for Education Statistics, National Assessment of Educational Progress (NAEP), 1996 Science Assessment.

TABLE C5.1

Standard Errors for Teachers' Reports on How Much Emphasis They Give to Student Objectives, Grades 4 and 8: Public and Nonpublic Schools Combined



About how much emphasis will you give to each of the following objectives for your students?	Grade 4			Grade 8		
	Heavy	Moderate	Little or None	Heavy	Moderate	Little or None
Knowing science facts and terminology	2.8 ^a	3.0	0.9	3.4	3.1	2.0
	1.5 ^b	1.3	6.7	2.1	1.3	4.0
	0.9 ^c	1.7	8.7	2.2	1.9	6.9
Understanding key science concepts	2.1	2.1	--	2.3	2.2	--
	0.9	1.9	--	1.1	2.2	--
	1.0	2.8	--	1.4	2.9	--
Learning about relevance of science to society and technology	2.6	2.7	1.9	4.5	3.7	2.3
	1.5	1.3	2.2	1.7	1.5	5.2
	2.1	1.7	3.0	2.0	2.0	8.8
Developing students' interest in science	2.8	2.9	0.4	4.3	4.3	1.6
	0.9	2.1	4.9	1.3	3.0	9.1
	1.2	2.6	7.8	1.6	3.8	8.6
Developing science problem-solving skills	3.0	2.8	1.5	3.9	3.4	1.4
	1.2	1.5	3.6	1.3	2.8	15.5
	1.5	1.6	5.8	2.0	3.5	11.5
Learning how to communicate ideas in science effectively	2.6	2.7	1.9	4.5	3.7	2.3
	1.5	1.3	2.2	1.7	1.5	5.2
	2.1	1.7	3.0	2.0	2.0	8.8
Developing lab skills and techniques	1.8	2.5	2.5	4.0	4.4	2.3
	2.5	1.2	1.6	1.9	1.9	2.8
	3.0	1.4	2.2	2.6	2.6	2.6
Developing data analysis skills	1.7	2.9	2.7	3.9	4.7	2.7
	3.6	1.3	1.2	2.4	1.5	1.2
	4.0	1.6	2.2	3.1	2.1	2.2
Using technology as a scientific tool	1.9	2.8	3.1	2.8	3.9	4.1
	2.6	1.3	1.6	2.3	1.5	2.5
	2.9	1.7	2.0	2.8	1.8	3.3

^a Percentage of Students

^b Average Scale Score

^c Percentage At or Above *Proficient*

-- Sample size was insufficient to permit reliable estimates.

SOURCE: National Center for Education Statistics, National Assessment of Educational Progress (NAEP), 1996 Science Assessment.

TABLE C5.2

Standard Errors for Teachers' Reports on How Often Students Do a Variety of Classroom Activities, Grades 4 and 8: Public and Nonpublic Schools Combined



About how often do your science students do each of the following?	Grade 4				Grade 8			
	Almost Every Day	Once or Twice a Week	Once or Twice a Month	Never or Hardly Ever	Almost Every Day	Once or Twice a Week	Once or Twice a Month	Never or Hardly Ever
Read a science textbook	2.9 ^a	2.6	2.3	3.0	3.5	3.4	2.7	2.5
	1.1 ^b	1.5	1.7	2.8	2.1	2.0	2.2	2.6
	2.2 ^c	1.7	3.1	3.8	2.5	2.8	2.8	3.6
Read a book or magazine about science	1.5	2.6	3.1	2.6	0.6	2.4	4.0	3.8
	4.1	1.9	1.3	1.9	4.5	2.6	1.4	2.5
	5.4	2.2	1.5	2.5	4.5	3.2	1.9	2.8
Discuss science in the news	1.4	2.6	3.2	2.5	4.3	2.7	4.5	2.3
	7.7	1.7	1.5	2.4	3.3	1.8	1.8	6.9
	6.1	2.2	1.7	2.8	5.0	2.3	2.1	10.0
Work with other students on a science activity or project	1.1	2.2	2.7	1.7	2.8	3.8	3.1	3.5
	4.8	1.7	1.1	2.4	1.6	1.8	3.0	13.9
	5.8	2.0	1.6	2.8	3.2	2.3	3.9	14.1
Give an oral science report	0.2	1.4	2.7	2.8	--	1.1	4.4	4.4
	--	6.3	1.5	1.5	--	3.4	1.8	1.9
	--	6.8	1.6	1.8	--	5.0	2.3	2.4
Prepare a written science report	--	1.0	2.8	3.1	0.4	2.0	4.0	3.6
	--	6.3	1.2	1.6	--	3.2	1.4	2.0
	--	8.2	1.2	2.2	--	3.2	1.8	2.5
Do hands-on activities or investigations in science	1.6	2.9	3.5	1.1	2.9	3.2	2.3	0.6
	3.2	1.3	1.6	4.5	2.1	1.5	2.5	3.8
	3.6	1.8	1.9	4.2	3.2	2.0	2.3	3.5
Talk about measurements and results from students' hands-on activities	1.4	2.4	2.8	1.7	2.6	3.9	3.7	1.0
	3.6	1.5	1.2	2.9	2.0	1.6	1.8	3.8
	4.2	1.9	1.6	3.3	4.0	2.1	2.0	3.1
Use computers for science	0.6	2.2	2.6	3.5	0.3	2.2	3.6	3.9
	8.6	2.7	1.7	1.4	--	4.0	2.1	1.6
	12.2	2.8	2.4	1.7	--	4.9	3.0	1.7
Take a science test or quiz	2.0	1.5	2.3	1.8	1.1	4.9	5.0	1.6
	--	3.0	1.2	3.9	3.5	1.8	2.0	6.6
	--	2.6	1.4	4.8	3.5	2.4	2.9	7.5

^a Percentage of Students

^b Average Scale Score

^c Percentage At or Above Proficient

-- Sample size was insufficient to permit reliable estimates.

SOURCE: National Center for Education Statistics, National Assessment of Educational Progress (NAEP), 1996 Science Assessment.

TABLE C5.3

Standard Errors for Reports from Students Currently Taking a Science Course on How Often They Do a Variety of Classroom Activities, Grade 12: Public and Nonpublic Schools Combined



When you study science in school, how often do you do each of the following?

	Grade 12			
	Almost Every Day	Once or Twice a Week	Once or Twice a Month	Never or Hardly Ever
Read a science textbook	1.3 ^a	1.0	0.9	1.0
	1.4 ^b	1.4	2.3	1.9
	2.4 ^c	2.4	2.9	2.0
Read a book or magazine about science	0.4	0.8	0.9	0.9
	3.8	2.0	1.5	1.4
	5.0	2.7	2.3	2.4
Discuss science in the news	0.5	1.1	0.9	1.2
	3.7	1.5	1.6	1.3
	1.1	2.3	2.8	1.8
Work with other students on a science activity or project	1.1	1.5	1.1	1.2
	2.0	1.5	1.4	1.8
	4.3	2.0	2.2	2.1
Give an oral science report	0.2	0.4	1.3	1.5
	7.6	4.6	1.7	1.2
	—	6.6	2.9	1.8
Prepare a written science report	0.3	1.2	1.1	1.7
	6.6	2.4	1.3	1.1
	9.6	3.9	2.4	2.0
Do hands-on activities or investigations in science	1.3	1.2	1.3	1.0
	2.4	1.3	1.6	2.3
	4.6	2.2	2.7	2.0
Talk about measurements and results from students' hands-on activities	1.1	1.2	1.1	1.1
	1.8	1.3	1.8	1.7
	3.6	2.2	3.0	1.9
Use computers for science	0.5	0.9	1.0	1.6
	4.5	1.7	1.6	1.4
	6.2	3.4	2.2	2.1
Design and carry out your own science investigation	0.3	0.6	1.1	1.4
	4.6	3.6	1.8	1.0
	6.5	4.6	3.4	1.4
Analyze data and form conclusion from your investigations	0.8	1.2	0.9	1.4
	2.8	1.5	1.5	1.4
	5.0	2.5	2.6	1.8
Take a science test or quiz	0.7	1.3	1.4	0.5
	2.4	1.2	1.9	4.6
	3.3	1.8	3.5	3.4
Go outside and observe or measure things	0.3	0.6	1.2	1.5
	5.3	3.6	1.8	1.1
	4.3	4.1	3.2	1.7

^a Percentage of Students

^b Average Scale Score

^c Percentage At or Above Proficient

— Sample size was insufficient to permit reliable estimates.

SOURCE: National Center for Education Statistics, National Assessment of Educational Progress (NAEP), 1996 Science Assessment.

TABLE C5.4

Standard Errors for Teachers' Reports on Using Different Teaching Activities, Grades 4 and 8: Public and Nonpublic Schools Combined



<i>When you teach science, about how often do you do each of the following?</i>	Grade 4				Grade 8			
	Almost Every Day	Once or Twice a Week	Once or Twice a Month	Never or Hardly Ever	Almost Every Day	Once or Twice a Week	Once or Twice a Month	Never or Hardly
Talk to the class about science	3.3 ^a	3.1	1.3	0.3	2.4	2.2	0.7	0.2
	1.2 ^b	2.6	5.0	—	1.1	2.8	—	—
	1.7 ^c	3.0	7.4	—	1.5	3.7	—	—
Do a science demonstration	1.0	3.7	3.7	1.4	2.1	3.1	3.7	0.8
	7.1	1.7	1.4	2.5	2.1	1.7	1.7	0.7
	7.0	1.9	1.4	3.6	2.4	2.4	2.4	8.7
Show a science videotape or TV science program	—	1.7	2.6	2.6	0.6	3.8	4.2	2.5
	—	2.9	1.2	2.3	—	3.7	1.1	3.2
	—	3.2	1.4	2.5	—	5.3	1.5	3.6
Use computers for science	1.2	1.2	2.8	3.4	0.3	2.2	4.2	4.7
	10.0	3.2	1.8	1.4	—	3.2	2.0	1.6
	11.3	3.7	2.4	1.7	—	4.9	2.9	1.8
Use CDs or laser disks on science	0.3	1.4	2.5	2.7	0.9	2.6	3.3	4.0
	—	3.6	2.3	1.2	4.6	3.7	1.9	1.5
	—	5.4	2.9	1.3	4.3	4.8	1.7	2.0

^a Percentage of Students

^b Average Scale Score

^c Percentage At or Above Proficient

— — Sample size was insufficient to permit reliable estimates.

SOURCE: National Center for Education Statistics, National Assessment of Educational Progress (NAEP), 1996 Science Assessment.

TABLE C5.5

**Standard Errors for Students' Reports on How Often
Their Teachers Use Different Teaching Activities, Grade 12:
Public and Nonpublic Schools Combined**



When you study science, how often does your teacher do each of the following?	Grade 12			
	Almost Every Day	Once or Twice a Week	Once or Twice a Month	Never or Hardly Ever
Talk to the class about science	0.9 ^a	0.4	0.3	0.7
	0.9 ^b	2.5	2.6	1.3
	1.7 ^c	2.8	2.0	1.0
Do a science demonstration	0.9	0.8	0.7	0.8
	1.5	1.1	1.3	1.1
	2.5	1.5	2.0	1.0
Show a science videotape or TV science program	0.4	1.0	1.4	1.1
	2.8	1.4	1.1	1.5
	3.0	2.7	1.4	1.2
Use computers for science	0.4	0.5	0.7	1.2
	2.5	1.9	1.5	1.0
	3.7	3.0	2.1	1.3
Use CDs or laser disks on science	0.3	0.7	1.0	1.6
	2.8	2.6	1.6	1.0
	3.2	4.1	2.6	1.2

^a Percentage of Students

^b Average Scale Score

^c Percentage At or Above *Proficient*

SOURCE: National Center for Education Statistics, National Assessment of Educational Progress (NAEP), 1996 Science Assessment.

TABLE C5.6

Standard Errors for Students' Reports on Doing Hands-on Tasks, Grades 4, 8, and 12: Public and Nonpublic Schools Combined



Have you ever done hands-on activities or projects in school with any of the following?	Grade 4		Grade 8		Grade 12	
	Yes	No	Yes	No	Yes	No
Living things (plants, animals, bacteria)	1.2 ^a	1.2	1.2	1.2	0.7	0.7
	0.8 ^b	1.1	1.0	1.2	0.9	0.9
	1.1 ^c	1.7	1.3	1.5	1.3	1.2
Electricity (batteries, flashlight)	1.6	1.6	1.3	1.3	0.8	0.8
	1.1	1.0	1.1	1.5	0.9	1.5
	1.2	1.4	1.4	1.9	1.3	1.4
Chemicals (mixing or dissolving)	1.2	1.2	1.3	1.3	0.6	0.6
	1.1	0.9	0.9	1.9	0.8	2.1
	1.3	1.3	1.3	1.9	1.2	1.2
Rocks/Minerals (identifying type)	1.8	1.8	1.6	1.6	1.1	1.1
	1.2	0.9	1.1	1.5	0.9	1.5
	1.3	1.3	1.4	1.8	1.2	1.8
Magnifying glass/microscope	1.3	1.3	1.3	1.3	0.7	0.7
	1.0	1.0	0.9	1.3	0.8	2.0
	1.3	1.3	1.3	1.5	1.3	1.3
Thermometer/barometer	1.0	1.0	1.3	1.3	0.9	0.9
	1.0	1.9	1.0	1.3	0.9	1.9
	1.2	1.3	1.5	1.4	1.3	1.2
Simple machines (pulleys and levers)	1.3	1.3	2.0	2.0	1.1	1.1
	1.1	0.8	1.2	1.4	1.0	1.1
	1.2	1.2	2.0	1.9	1.4	1.1
Instruments for measuring speed and velocity*					1.0	1.0
					1.0	1.1
					1.3	1.4
None of the Above	0.7	0.7	0.5	0.5	0.3	0.3
	1.6	0.7	1.9	1.8	3.3	0.8
	1.4	1.0	1.5	1.2	1.7	1.2

*Question not asked at grades 4 and 8

^a Percentage of Students

^b Average Scale Score

^c Percentage At or Above Proficient

SOURCE: National Center for Education Statistics, National Assessment of Educational Progress (NAEP), 1996 Science Assessment.

TABLE C5.7

Standard Errors for Students' Reports on Whether or Not They Conduct Science Projects or Investigations that Take a Week or More, Grades 4, 8, and 12: Public and Nonpublic Schools Combined



<i>Do you ever do science projects in school that take a week or more?</i>	Grade 4		Grade 8		Grade 12	
	Yes	No	Yes	No	Yes	No
Percentage of Students	1.4	1.4	2.5	2.5	0.9	0.9
Average Scale Score	0.9	1.1	1.2	1.6	0.9	1.1
Percentage At or Above <i>Proficient</i>	1.2	1.6	1.7	2.0	1.4	1.1

SOURCE: National Center for Education Statistics, National Assessment of Educational Progress (NAEP), 1996 Science Assessment.

TABLE C5.8

Standard Errors for Teachers' Reports on How They Use Computers for Science Instruction, Grades 4 and 8: Public and Nonpublic Schools Combined



<i>How do you use computers for instruction in science?</i>	Grade 4		Grade 8	
	Yes	No	Yes	No
Drill and practice	1.5 ^a	1.5	3.9	3.9
	5.3 ^b	1.0	5.8	1.2
	4.1 ^c	1.2	6.8	1.7
Playing science/learning games	2.6	2.6	3.5	3.5
	1.7	1.1	3.2	1.3
	2.0	1.2	4.5	1.6
Simulations and modeling	2.8	2.8	5.0	5.0
	1.8	1.1	2.2	1.5
	2.0	1.4	3.9	1.9
Data analysis and other applications	1.2	1.2	3.1	3.1
	4.9	1.0	1.6	1.3
	5.9	1.2	2.2	1.6
Word processing	1.7	1.7	3.1	3.1
	2.9	1.0	1.2	1.2
	3.8	1.3	2.4	1.4
I do not use computers for science instruction.	3.0	3.0	3.9	3.9
	1.3	1.1	1.9	1.3
	1.5	1.5	2.1	1.9

^a Percentage of Students

^b Average Scale Score

^c Percentage At or Above *Proficient*

SOURCE: National Center for Education Statistics, National Assessment of Educational Progress (NAEP), 1996 Science Assessment.

TABLE C5.9

Standard Errors for Teachers' Reports on How Much Science Homework They Assign, Grades 4 and 8: Public and Nonpublic Schools Combined



<i>About how much time do you expect a student in this class to spend doing science homework each week?</i>	Grade 4				Grade 8			
	None	One Half Hour	One Hour	Two Hours or More	None	One Half Hour	One Hour	Two Hours or More
Percentage of Students	2.3	3.2	3.1	1.4	0.7	2.1	3.7	3.9
Average Scale Score	2.6	1.8	1.8	4.7	4.5	3.0	2.0	1.5
Percentage At or Above <i>Proficient</i>	3.7	2.0	2.1	6.5	3.4	3.2	2.4	1.9

SOURCE: National Center for Education Statistics, National Assessment of Educational Progress (NAEP), 1996 Science Assessment.

TABLE C6.1

Standard Errors for Students' Reports on Attitudes and Beliefs about Science, by Gender, Grade 4: Public and Nonpublic Schools Combined



How much do you agree with the following statements?	All Students			Males			Females		
	Agree	Not Sure	Disagree	Agree	Not Sure	Disagree	Agree	Not Sure	Disagree
I like science.	1.1 ^a	0.7	0.6	1.3	0.9	0.7	1.4	1.0	0.6
	0.9 ^b	1.1	1.7	1.1	1.7	1.8	1.0	1.5	2.5
	1.1 ^c	1.5	2.1	1.4	2.7	2.6	1.4	2.4	3.2
I'm good at science.	1.0	0.9	0.5	1.3	1.3	0.7	1.2	1.1	0.6
	1.0	1.0	1.8	1.0	1.3	2.2	1.5	1.2	2.1
	1.3	1.1	2.0	1.4	1.5	3.2	2.2	1.6	2.3
Learning science is mostly memorizing.	0.7	0.8	0.6	1.0	1.0	0.7	0.9	1.2	1.0
	1.0	1.1	1.0	1.1	1.3	1.2	1.2	1.2	1.3
	1.6	2.0	1.5	2.1	2.0	2.1	1.6	2.9	1.9
Science is useful for solving everyday problems.	0.7	0.6	0.7	1.0	0.9	0.9	0.9	0.9	1.1
	1.1	1.0	1.1	1.4	1.4	1.4	1.2	1.4	1.2
	1.3	1.6	1.5	1.7	2.0	2.0	1.9	2.2	2.1
If I had a choice, I would not study any more science in school.	0.6	0.7	0.8	0.9	0.8	1.0	0.8	1.0	1.2
	1.3	1.6	0.8	1.5	2.1	0.9	1.8	1.8	1.0
	1.5	2.1	1.1	1.9	2.4	1.3	2.3	2.6	1.5
Everyone can do well in science if they try.	0.6	0.6	0.3	0.8	0.7	0.4	0.9	0.8	0.4
	0.7	2.0	2.6	0.9	2.1	2.8	0.8	2.9	3.8
	0.9	2.9	3.1	1.1	3.5	3.1	1.3	3.1	4.8
Science is boring.	0.8	0.5	0.9	0.9	0.7	1.1	1.0	0.6	1.2
	1.8	1.7	0.8	1.8	2.3	1.0	2.4	1.8	0.9
	2.0	2.0	1.0	2.5	2.7	1.3	2.4	2.6	1.3
Science is a hard subject.	0.8	0.7	0.8	0.9	1.0	1.1	0.9	0.9	1.1
	1.1	1.2	1.0	1.4	1.6	1.2	1.4	1.4	1.3
	1.6	2.0	1.2	2.0	2.3	1.7	2.0	2.6	1.8

^a Percentage of Students

^b Average Scale Score

^c Percentage At or Above Proficient

SOURCE: National Center for Education Statistics, National Assessment of Educational Progress (NAEP), 1996 Science Assessment.

TABLE C6.1
(continued)

Standard Errors for Students' Reports on Attitudes and Beliefs about Science, by Gender, Grade 8: Public and Nonpublic Schools Combined



How much do you agree with the following statements?	All Students			Males			Females		
	Agree	Not Sure	Disagree	Agree	Not Sure	Disagree	Agree	Not Sure	Disagree
I like science.	1.3 ^a	0.7	1.0	1.4	0.9	1.0	1.6	0.9	1.3
	1.0 ^b	1.3	1.5	1.1	1.6	1.8	1.4	1.9	1.8
	1.7 ^c	1.8	1.7	1.6	1.6	2.6	2.4	2.6	1.8
I'm good at science.	1.1	0.8	0.8	1.4	1.2	1.0	1.3	1.0	0.9
	0.9	1.2	1.6	0.9	1.3	2.1	1.3	1.4	1.6
	1.6	1.4	1.5	1.6	1.4	2.1	2.4	1.9	1.9
Learning science is mostly memorizing.	0.8	0.5	0.8	1.3	0.7	1.4	1.0	0.9	1.1
	1.0	1.0	1.2	1.4	1.3	1.4	1.0	1.4	1.8
	1.3	1.5	2.0	1.7	1.8	2.2	1.6	2.1	3.1
Science is useful for solving everyday problems.	1.0	0.7	1.0	1.1	0.9	1.1	1.4	0.8	1.2
	1.0	0.9	1.4	1.2	1.3	1.6	1.4	1.4	1.7
	1.7	1.6	1.5	1.7	2.2	2.1	2.5	2.4	1.9
If I had a choice, I would not study any more science in school.	0.8	0.7	0.9	0.9	0.9	1.2	1.1	1.0	1.3
	1.4	1.1	1.0	1.7	1.4	1.2	1.6	1.3	1.5
	1.5	1.9	1.6	2.5	2.3	1.6	1.8	2.5	2.4
Everyone can do well in science if they try.	0.8	0.6	0.5	1.0	1.1	1.4	1.2	0.9	0.6
	0.8	1.6	2.1	1.1	1.5	2.4	0.7	2.1	2.8
	1.1	2.2	3.3	1.5	2.5	3.8	1.5	3.0	4.6
Science is boring.	1.0	0.6	1.2	1.0	1.1	1.5	1.4	0.9	1.5
	1.6	1.2	1.0	1.6	1.4	1.2	2.2	1.4	1.3
	1.8	2.0	1.6	2.6	2.1	1.7	2.1	2.4	2.5
Science is a hard subject.	1.2	0.7	1.2	1.4	0.9	1.2	1.3	1.0	1.6
	1.1	1.1	1.2	1.4	1.4	1.2	1.5	1.6	1.8
	1.4	1.4	2.0	1.8	1.6	2.1	1.8	2.4	2.9

^a Percentage of Students

^b Average Scale Score

^c Percentage At or Above Proficient

SOURCE: National Center for Education Statistics, National Assessment of Educational Progress (NAEP), 1996 Science Assessment.

TABLE C6.1
(continued)

Standard Errors for Students' Reports on Attitudes and Beliefs about Science, by Gender, Grade 12: Public and Nonpublic Schools Combined



How much do you agree with the following statements?	All Students			Males			Females		
	Agree	Not Sure	Disagree	Agree	Not Sure	Disagree	Agree	Not Sure	Disagree
I like science.	0.8 ^a	0.6	0.8	1.2	0.9	0.9	1.0	1.0	1.1
	1.0 ^b	1.2	1.1	1.4	1.6	1.6	1.0	1.5	1.4
	1.6 ^c	1.5	1.1	2.2	1.5	2.0	1.8	2.1	1.1
I'm good at science.	0.7	0.9	0.9	0.9	1.1	0.9	1.0	1.1	1.2
	1.1	1.2	0.8	1.5	1.5	1.3	1.3	1.2	1.1
	1.9	1.3	0.8	2.6	1.8	1.2	2.4	1.4	1.1
Learning science is mostly memorizing.	0.8	0.5	0.7	1.2	1.1	1.1	1.0	0.8	0.9
	1.0	1.3	1.3	1.5	1.6	2.0	1.2	1.7	1.3
	1.1	1.9	1.7	1.6	2.8	2.6	1.4	2.4	1.8
Science is useful for solving everyday problems.	0.8	0.9	0.8	1.2	1.0	1.0	0.9	1.2	1.1
	1.1	1.2	1.1	1.3	1.9	1.6	1.2	1.3	1.5
	1.4	1.5	1.0	2.1	1.7	2.0	1.6	2.0	1.1
If I had a choice, I would not study any more science in school.	0.8	0.6	0.9	1.0	0.9	1.2	1.1	0.8	1.2
	1.0	1.3	1.0	1.6	1.7	1.5	1.0	1.5	1.2
	1.1	1.4	1.7	1.7	2.1	2.8	1.2	2.0	1.9
Everyone can do well in science if they try.	1.0	0.7	0.8	1.2	0.9	1.1	1.3	1.0	1.0
	1.0	1.2	1.3	1.3	1.8	2.3	1.2	1.3	1.3
	1.3	1.5	1.7	1.9	2.3	3.1	1.3	2.0	2.0
Science is boring.	0.8	0.6	0.9	0.8	0.8	1.0	1.1	0.9	1.1
	1.1	1.0	1.0	1.6	1.6	1.6	1.3	1.6	1.1
	1.0	1.5	1.7	1.6	2.0	2.6	1.4	2.0	1.9
Science is a hard subject.	0.9	0.6	0.6	1.1	0.9	1.0	1.0	0.7	0.7
	0.9	1.3	1.6	1.5	1.8	1.9	0.9	1.7	1.5
	1.3	1.7	1.9	1.9	2.3	2.2	1.4	1.9	2.4

^a Percentage of Students

^b Average Scale Score

^c Percentage At or Above Proficient

SOURCE: National Center for Education Statistics, National Assessment of Educational Progress (NAEP), 1996 Science Assessment.

TABLE C6.2

Standard Errors for Students' Reports on Attitudes and Beliefs about Science, by Race/Ethnicity, Grade 4: Public and Nonpublic Schools Combined



How much do you agree with the following statements?	All Students			White			Black		
	Agree	Not Sure	Disagree	Agree	Not Sure	Disagree	Agree	Not Sure	Disagree
I like science.	1.1 ^a	0.7	0.6	1.3	0.9	0.7	1.5	1.3	1.1
	0.9 ^b	1.1	1.7	1.0	1.4	1.8	2.0	3.6	3.7
	1.1 ^c	1.5	2.1	1.5	2.2	2.7	1.6	2.5	2.9
I'm good at science.	1.0	0.9	0.5	1.1	1.0	0.6	2.0	2.1	1.2
	1.0	1.0	1.8	1.1	1.1	1.9	2.2	2.2	4.0
	1.3	1.1	2.0	1.6	1.6	2.6	1.9	1.6	2.6
Learning science is mostly memorizing.	0.7	0.8	0.6	0.8	1.1	0.9	1.4	1.7	1.4
	1.0	1.1	1.0	1.1	1.4	1.2	1.8	2.5	3.5
	1.6	2.0	1.5	2.1	2.7	2.0	1.5	2.6	2.1
Science is useful for solving everyday problems.	0.7	0.6	0.7	0.9	0.9	0.9	1.3	1.3	1.5
	1.1	1.0	1.1	1.1	1.2	1.2	2.3	1.9	2.6
	1.3	1.6	1.5	1.8	2.2	1.8	1.6	1.8	2.0
If I had a choice, I would not study any more science in school.	0.6	0.7	0.8	0.9	0.9	1.0	1.4	1.1	1.6
	1.3	1.6	0.8	1.5	1.6	1.0	2.7	4.1	1.9
	1.5	2.1	1.1	2.2	2.8	1.5	1.7	3.1	2.0
Everyone can do well in science if they try.	0.6	0.6	0.3	0.8	0.8	0.4	1.3	0.8	0.9
	0.7	2.0	2.6	0.8	2.2	2.7	1.9	4.6	6.2
	0.9	2.9	3.1	1.3	3.9	4.1	1.5	4.2	3.2
Science is boring.	0.8	0.6	0.9	1.0	0.7	1.2	1.3	1.2	1.3
	1.8	1.7	0.8	1.8	1.9	0.9	3.6	4.6	1.7
	2.0	2.0	1.0	2.9	3.0	1.4	2.2	3.5	1.5
Science is a hard subject.	0.8	0.7	0.8	1.0	0.9	1.1	1.3	1.4	1.5
	1.1	1.2	1.0	1.4	1.3	1.2	1.8	3.0	2.4
	1.6	2.0	1.2	2.7	2.6	1.7	1.9	2.3	2.0

^a Percentage of Students

^b Average Scale Score

^c Percentage At or Above Proficient

SOURCE: National Center for Education Statistics, National Assessment of Educational Progress (NAEP), 1996 Science Assessment.

TABLE C6.2
(continued)

Standard Errors for Students' Reports on Attitudes and Beliefs about Science, by Race/Ethnicity, Grade 4: Public and Nonpublic Schools Combined



How much do you agree with the following statements?	Hispanic			Asian/Pacific Islander			American Indian		
	Agree	Not Sure	Disagree	Agree	Not Sure	Disagree	Agree	Not Sure	Disagree
I like science.	1.7 ^a	1.5	1.0	3.0	2.3	1.3	3.5	3.2	2.4
	1.9 ^b	2.6	4.1	4.1	4.6	—	4.4	—	—
	1.8 ^c	1.7	3.5	5.7	5.0	—	5.8	—	—
I'm good at science.	1.5	1.5	1.0	2.9	2.9	1.9	4.6	4.6	2.2
	2.2	2.1	3.2	5.0	3.5	—	5.6	4.3	—
	2.5	1.4	2.7	8.6	4.1	—	7.0	6.0	—
Learning science is mostly memorizing.	2.1	1.4	1.3	3.1	3.7	2.3	4.2	4.1	3.0
	1.8	2.2	2.7	4.3	4.0	6.1	6.2	5.0	—
	1.7	1.4	2.9	7.0	5.2	9.0	7.7	6.3	—
Science is useful for solving everyday problems.	1.6	1.5	1.6	2.1	2.7	2.2	3.6	3.7	4.2
	2.3	2.4	2.2	4.2	4.8	4.6	5.6	4.9	6.1
	2.1	1.9	2.0	6.5	5.8	6.2	6.7	8.6	6.8
If I had a choice, I would not study any more science in school.	1.2	1.2	1.7	2.4	3.3	4.9	2.9	2.5	3.4
	2.6	2.9	1.7	—	3.6	3.5	—	—	4.2
	1.7	1.9	1.5	—	4.8	5.5	—	—	5.9
Everyone can do well in science if they try.	1.2	1.1	0.6	1.8	1.7	0.7	2.9	2.5	1.8
	1.8	3.0	5.7	3.6	—	—	3.9	—	—
	1.3	3.0	1.4	5.0	—	—	4.7	—	—
Science is boring.	1.3	1.1	1.5	2.1	2.0	2.8	2.9	3.3	3.5
	3.4	3.4	1.6	—	—	4.0	—	—	3.9
	2.6	2.0	1.7	—	—	5.9	—	—	5.8
Science is a hard subject.	1.4	1.3	1.4	3.0	3.8	3.6	3.9	2.7	4.6
	2.7	2.0	2.2	4.6	4.7	4.8	6.4	—	5.3
	2.0	2.1	2.1	6.1	7.2	7.7	4.3	—	7.2

^a Percentage of Students

^b Average Scale Score

^c Percentage At or Above *Proficient*

— Sample size was insufficient to permit reliable estimates.

SOURCE: National Center for Education Statistics, National Assessment of Educational Progress (NAEP), 1996 Science Assessment.

TABLE C6.2
(continued)

Standard Errors for Students' Reports on Attitudes and Beliefs about Science, by Race/Ethnicity, Grade 8: Public and Nonpublic Schools Combined



How much do you agree with the following statements?	All Students			White			Black		
	Agree	Not Sure	Disagree	Agree	Not Sure	Disagree	Agree	Not Sure	Disagree
I like science.	1.1 ^a	0.7	0.6	1.6	1.0	1.3	2.1	1.4	1.6
	0.9 ^b	1.1	1.7	1.2	1.5	1.7	1.7	1.4	2.3
	1.1 ^c	1.5	2.1	2.3	2.5	2.2	1.5	1.0	0.8
I'm good at science.	1.0	0.9	0.5	1.3	0.9	1.0	1.7	1.3	1.5
	1.0	1.0	1.8	0.9	1.3	1.9	1.7	1.8	2.3
	1.3	1.1	2.0	1.9	2.0	2.3	1.6	1.1	0.4
Learning science is mostly memorizing.	0.7	0.8	0.6	1.0	0.7	1.1	1.3	1.3	1.0
	1.0	1.1	1.0	1.3	1.1	1.5	1.7	1.7	1.7
	1.6	2.0	1.5	2.0	2.0	2.5	1.3	1.5	1.4
Science is useful for solving everyday problems.	0.7	0.6	0.7	1.2	0.9	1.3	1.4	1.4	1.4
	1.1	1.0	1.1	1.3	1.1	1.5	1.6	1.6	2.0
	1.3	1.6	1.5	2.4	2.3	2.2	1.5	1.5	1.0
If I had a choice, I would not study any more science in school.	0.6	0.6	0.3	1.1	0.8	1.1	1.4	1.4	1.7
	1.3	1.6	0.8	1.5	1.3	1.2	2.0	1.9	1.5
	1.5	2.9	1.1	2.0	2.7	2.2	0.7	1.6	1.5
Everyone can do well in science if they try.	0.6	0.6	0.3	1.0	0.8	0.7	1.0	1.0	0.9
	0.7	2.0	2.6	1.0	1.8	1.9	1.2	2.1	4.0
	0.9	2.9	3.1	1.7	2.7	4.2	1.1	2.4	1.7
Science is boring.	0.8	0.5	0.9	1.3	0.8	1.5	1.4	1.0	2.0
	1.8	1.7	1.8	1.9	1.3	1.2	1.9	2.7	2.1
	2.0	2.0	1.0	2.5	3.0	2.3	0.6	1.6	1.4
Science is a hard subject.	0.8	0.7	0.8	1.6	0.8	1.5	1.7	0.9	1.9
	1.1	1.1	1.0	1.3	1.3	1.3	1.6	2.0	1.6
	1.6	2.0	1.2	2.0	1.8	2.8	1.4	1.6	1.1

^a Percentage of Students

^b Average Scale Score

^c Percentage At or Above Proficient

SOURCE: National Center for Education Statistics, National Assessment of Educational Progress (NAEP), 1996 Science Assessment.

TABLE C6.2
(continued)

Standard Errors for Students' Reports on Attitudes and Beliefs about Science, by Race/Ethnicity, Grade 8: Public and Nonpublic Schools Combined



How much do you agree with the following statements?	Hispanic			Asian/Pacific Islander			American Indian		
	Agree	Not Sure	Disagree	Agree	Not Sure	Disagree	Agree	Not Sure	Disagree
I like science.	1.9 ^a	1.5	1.2	3.7	3.0	2.3	6.0	5.1	6.9
	1.8 ^b	2.3	2.5	3.1	4.4	4.3	5.0	--	--
	1.5 ^c	1.8	2.7	5.5	5.6	6.6	7.0	--	--
I'm good at science.	2.8	2.5	1.2	3.0	2.8	2.1	4.0	5.2	5.1
	1.9	1.5	3.0	3.2	3.1	--	--	--	--
	2.8	1.9	1.6	6.3	4.6	--	--	--	--
Learning science is mostly memorizing.	1.3	1.5	1.3	2.5	3.1	3.1	5.1	4.0	3.6
	2.1	2.3	2.7	3.4	3.6	6.9	--	--	--
	2.4	1.8	1.9	4.9	6.4	8.9	--	--	--
Science is useful for solving everyday problems.	2.1	1.3	1.7	3.8	3.1	2.0	4.2	3.8	2.7
	2.5	2.0	3.1	4.7	4.5	4.1	--	--	--
	2.2	2.2	1.7	7.0	6.8	6.6	--	--	--
If I had a choice, I would not study any more science in school.	1.3	1.7	2.0	2.7	2.2	3.8	5.9	3.8	5.2
	3.0	2.4	1.5	5.3	3.9	3.3	--	--	6.2
	2.3	2.3	1.4	8.0	5.4	5.0	--	--	8.1
Everyone can do well in science if they try.	1.3	1.2	0.9	2.9	2.3	1.5	3.2	3.0	2.8
	1.4	3.3	5.9	3.2	--	--	5.3	--	--
	1.1	2.9	4.1	3.7	--	--	8.4	--	--
Science is boring.	1.4	1.8	1.8	2.4	2.5	2.8	5.0	4.2	3.8
	2.7	2.3	1.9	4.4	4.4	3.7	--	--	--
	2.4	2.2	1.5	6.2	6.0	6.2	--	--	--
Science is a hard subject.	1.3	1.8	1.8	3.0	2.4	2.0	4.2	4.5	3.8
	2.5	2.6	1.9	3.7	3.3	5.0	--	--	--
	1.6	2.1	2.1	5.7	4.4	8.1	--	--	--

^a Percentage of Students

^b Average Scale Score

^c Percentage At or Above Proficient

-- Sample size was insufficient to permit reliable estimates.

SOURCE: National Center for Education Statistics, National Assessment of Educational Progress (NAEP), 1996 Science Assessment.

TABLE C6.2
(continued)

Standard Errors for Students' Reports on Attitudes and Beliefs about Science, by Race/Ethnicity, Grade 12: Public and Nonpublic Schools Combined



How much do you agree with the following statements?	All Students			White			Black		
	Agree	Not Sure	Disagree	Agree	Not Sure	Disagree	Agree	Not Sure	Disagree
I like science.	1.1 ^a	0.7	0.6	1.0	0.7	0.9	2.0	1.4	1.8
	0.9 ^b	1.1	1.7	1.0	1.1	1.3	1.8	2.2	1.7
	1.1 ^c	1.5	2.1	2.0	2.1	1.7	1.5	0.8	0.8
I'm good at science.	1.0	0.9	0.5	0.9	1.1	1.1	2.3	1.6	1.8
	1.0	1.0	1.8	1.2	1.1	0.9	2.2	2.4	2.2
	1.3	1.1	2.0	2.4	1.7	1.1	1.6	1.2	0.6
Learning science is mostly memorizing.	0.7	0.8	0.6	1.0	0.8	0.9	2.3	1.4	1.9
	1.0	1.1	1.0	1.0	1.3	1.5	1.7	3.0	2.1
	1.6	2.0	1.5	1.6	2.3	2.2	1.1	1.8	1.7
Science is useful for solving everyday problems.	0.7	0.6	0.7	0.9	1.1	0.9	2.1	1.6	1.6
	1.1	1.0	1.1	1.1	1.4	1.2	2.2	2.1	2.3
	1.3	1.6	1.5	1.7	2.2	1.7	1.4	1.5	0.8
If I had a choice, I would not study any more science in school.	0.6	0.7	0.8	1.0	0.7	1.1	1.8	1.6	1.6
	1.3	1.6	0.8	1.3	1.3	1.0	1.5	2.5	2.3
	1.5	2.1	1.1	1.6	1.7	2.1	0.9	1.6	1.6
Everyone can do well in science if they try.	0.6	0.6	0.3	1.2	0.9	1.0	2.0	1.5	1.4
	0.7	2.0	2.6	1.2	1.4	1.4	1.4	2.4	3.7
	0.9	2.9	3.1	2.0	1.9	2.1	0.9	1.9	2.8
Science is boring.	0.8	0.5	0.9	1.0	0.6	1.0	1.9	1.6	1.6
	1.8	1.7	0.8	1.3	1.1	1.1	1.9	2.3	2.0
	2.0	2.0	1.0	1.5	2.1	2.2	0.6	1.7	1.4
Science is a hard subject.	0.8	0.7	0.8	1.1	0.7	0.7	1.7	1.1	1.9
	1.1	1.2	1.0	1.0	1.6	1.6	2.3	2.4	1.9
	1.6	2.0	1.2	1.7	2.3	2.8	1.6	1.3	1.3

^a Percentage of Students

^b Average Scale Score

^c Percentage At or Above Proficient

SOURCE: National Center for Education Statistics, National Assessment of Educational Progress (NAEP), 1996 Science Assessment.

TABLE C6.2
(continued)

Standard Errors for Students' Reports on Attitudes and Beliefs about Science, by Race/Ethnicity, Grade 12: Public and Nonpublic Schools Combined



How much do you agree with the following statements?	Hispanic			Asian/Pacific Islander			American Indian		
	Agree	Not Sure	Disagree	Agree	Not Sure	Disagree	Agree	Not Sure	Disagree
I like science.	2.4 ^a	2.0	2.6	2.7	2.3	2.2	5.8	3.9	6.2
	3.2 ^b	3.4	2.8	3.2	4.0	3.7	---	---	---
	2.3 ^c	1.1	1.6	4.7	4.4	2.4	---	---	---
I'm good at science.	1.4	2.1	1.8	3.2	3.0	1.9	6.2	5.7	6.0
	3.4	2.7	2.7	3.2	3.1	3.9	---	---	---
	3.8	1.0	1.2	5.8	3.7	2.9	---	---	---
Learning science is mostly memorizing.	2.1	1.9	1.7	2.9	1.8	2.7	12.0	8.5	7.8
	3.2	3.3	2.6	3.8	4.3	3.5	---	---	---
	2.7	2.6	1.8	4.1	5.0	5.6	---	---	---
Science is useful for solving everyday problems.	2.1	1.9	1.7	2.9	1.8	2.7	12.0	8.5	7.8
	3.2	3.3	2.6	3.8	4.3	3.5	---	---	---
	2.7	2.9	1.8	4.1	5.0	5.6	---	---	---
If I had a choice, I would not study any more science in school.	2.1	1.6	2.0	3.0	2.5	1.6	5.0	4.9	4.9
	2.9	2.5	2.8	3.0	5.1	---	---	---	---
	2.7	0.9	1.5	4.5	4.9	---	---	---	---
Everyone can do well in science if they try.	2.5	1.6	1.7	2.5	2.4	1.5	6.5	6.6	4.9
	2.1	4.1	4.5	3.2	5.3	---	---	---	---
	1.7	1.9	3.1	3.6	6.5	---	---	---	---
Science is boring.	1.9	1.8	2.3	1.4	3.2	3.2	5.1	7.0	8.2
	2.4	3.2	3.2	4.7	4.0	3.0	---	---	---
	1.8	1.5	2.6	4.8	4.3	4.7	---	---	---
Science is a hard subject.	2.0	1.5	2.1	2.4	2.1	1.9	9.3	10.6	5.2
	2.8	2.6	3.1	3.0	4.7	7.4	---	---	---
	1.8	1.8	2.9	3.8	5.9	9.6	---	---	---

^a Percentage of Students

^b Average Scale Score

^c Percentage At or Above Proficient

--- Sample size was insufficient to permit reliable estimates.

SOURCE: National Center for Education Statistics, National Assessment of Educational Progress (NAEP), 1996 Science Assessment.

TABLE C6.3

Standard Errors for Relationship Between Students' Average Scale Scores and Positive Attitudes and Beliefs about Science, Grades 4, 8, and 12: Public and Nonpublic Schools Combined



		Number of Positive Attitudes						
		0	1	2	3	4	5	6
Grade 4								
	Percent of Students	0.7	0.5	0.5	0.7	0.7	0.6	0.2
	Average Scale Score	1.9	1.7	1.5	1.2	1.2	1.0	2.3
	Percentage At or Above <i>Proficient</i>	2.2	2.1	1.7	1.6	1.6	1.9	4.5
Grade 8								
	Percent of Students	0.7	0.6	0.6	0.4	0.5	0.7	0.3
	Average Scale Score	2.0	1.1	1.3	1.4	1.4	1.2	2.4
	Percentage At or Above <i>Proficient</i>	2.1	1.2	1.4	2.5	2.3	2.4	4.4
Grade 12								
	Percent of Students	0.5	0.6	0.5	0.6	0.4	0.4	0.4
	Average Scale Score	1.4	1.0	1.3	1.5	1.3	1.2	1.2
	Percentage At or Above <i>Proficient</i>	1.3	1.0	1.7	2.3	2.1	2.4	2.8

NOTE: The Positive Attitude Index is a composite score based on student responses to six questions in the Student Background Questionnaire. The Agree responses to three questions: ("I like science"; "I am good at science"; and "Science is useful for solving everyday problems") and the Disagree responses to three questions: ("learning science is mostly memorizing"; "if I had a choice I would not study any more science in school"; and "science is boring") were combined to form the index.

SOURCE: National Center for Education Statistics, National Assessment of Educational Progress (NAEP), 1996 Science Assessment.

TABLE C6.4

Standard Errors for Students' Reports About their Motivation and Performance on the NAEP Science Assessment, Grades 4 and 8: Public and Nonpublic Schools Combined



	Grade 4			Grade 8		
	Percentage of Students	Average Scale Score	Percentage At or Above Proficient	Percentage of Students	Average Scale Score	Percentage At or Above Proficient
About how many questions do you think you got right. . . ?						
Almost All	0.8	1.0	1.3	0.6	1.2	2.4
More Than Half	0.6	0.8	1.4	0.8	1.1	1.6
About Half	0.6	1.2	2.0	0.5	1.2	1.6
Less Than Half	0.4	2.4	2.4	0.5	1.6	1.4
How hard was this test compared to most other tests. . . ?						
Much Harder	0.7	1.2	1.3	0.5	1.9	2.4
Harder	0.7	1.4	2.2	1.1	1.4	2.4
About as Hard	0.7	1.4	2.1	0.7	1.2	1.7
Easier	0.9	1.1	1.3	1.1	1.2	1.6
How hard did you try on this test compared to how hard you tried on most other science tests. . . ?						
Much Harder	0.7	1.0	1.1	0.7	1.6	2.0
Harder	0.6	1.3	1.7	0.7	1.2	1.4
About as Hard	0.8	1.1	1.6	0.9	1.0	1.8
Not as Hard	0.6	1.8	2.2	0.6	1.8	2.2
How important was it to do well. . . ?						
Very Important	0.8	0.8	1.0	1.0	1.4	1.9
Important	0.6	1.1	1.6	0.7	1.2	1.6
Somewhat Important	0.4	2.0	2.3	0.6	1.1	2.0
Not as Important	0.3	2.3	3.4	1.0	2.2	2.8
This year in school, how often have you been asked to write long answers to questions on tests. . . ?						
At Least Once a Week	1.2	0.8	1.1	1.0	1.1	1.4
Once or Twice a Month	0.6	1.2	1.7	0.8	1.1	1.6
Once or Twice a Year	0.5	1.5	2.1	0.5	1.3	2.3
Never	1.0	1.3	1.7	0.6	1.7	1.6

SOURCE: National Center for Education Statistics, National Assessment of Educational Progress (NAEP), 1996 Science Assessment.

TABLE C6.5

Standard Errors for Students' Reports About their Motivation and Performance on the NAEP Science Assessment, Grade 12: Public and Nonpublic Schools Combined



	Grade 12		
	Percentage of Students	Average Scale Score	Percentage At or Above Proficient
About how many questions do you think you got right. . . ?			
Almost All	0.5	1.7	3.6
More Than Half	0.6	0.9	1.7
About Half	0.6	1.0	1.3
Less Than Half	0.7	1.0	0.8
How hard was this test compared to most other tests. . . ?			
Much Harder	0.7	1.5	1.1
Harder	0.6	1.1	1.6
About as Hard	0.7	1.1	1.5
Easier	1.0	1.1	2.0
How hard did you try on this test compared to how hard you tried on most other science tests. . . ?			
Much Harder	0.4	2.2	1.0
Harder	0.5	2.0	2.1
About as Hard	0.9	1.2	1.8
Not as Hard	1.0	1.2	1.4
How important was it to do well. . . ?			
Very Important	0.5	2.4	2.1
Important	0.9	1.9	2.7
Somewhat Important	0.6	1.2	1.6
Not as Important	0.9	1.0	1.4
This year in school, how often have you been asked to write long answers to questions on tests. . . ?			
At Least Once a Week	1.0	1.4	1.9
Once or Twice a Month	0.6	1.3	1.9
Once or Twice a Year	0.6	1.4	1.5
Never	0.9	1.2	1.0

SOURCE: National Center for Education Statistics, National Assessment of Educational Progress (NAEP), 1996 Science Assessment.

TABLE C6.6

Standard Errors for Schools' Reports on Parental Involvement, Grades 4, 8 and 12: Public and Nonpublic Schools Combined



<i>Does your school do any of the following to involve parents?</i>	Grade 4		Grade 8		Grade 12	
	Yes	No	Yes	No	Yes	No
<i>Use parents as aides in the classroom</i>						
Percentage of Students	3.6	3.6	3.2	3.2	1.5	1.5
Average Scale Score	1.8	1.4	5.4	1.2	6.5	1.0
Percentage At or Above <i>Proficient</i>	2.0	1.3	5.3	1.5	5.6	1.4
<i>Have parents review or sign students' homework</i>						
Percentage of Students	4.0	4.0	5.8	5.8	2.2	2.2
Average Scale Score	1.3	2.1	1.6	2.4	3.3	1.1
Percentage At or Above <i>Proficient</i>	1.6	2.5	2.3	2.8	2.9	1.4
<i>Assign homework for students to do with parents</i>						
Percentage of Students	4.1	4.1	5.2	5.2	1.6	1.6
Average Scale Score	1.9	1.2	3.3	1.3	5.1	1.0
Percentage At or Above <i>Proficient</i>	2.3	1.3	4.2	1.6	4.4	1.3
<i>Have a parent volunteer program</i>						
Percentage of Students	2.8	2.8	5.7	5.7	4.6	4.6
Average Scale Score	1.0	3.1	1.7	1.9	1.8	1.8
Percentage At or Above <i>Proficient</i>	1.2	3.2	2.0	2.4	1.9	2.0

SOURCE: National Center for Education Statistics, National Assessment of Educational Progress (NAEP), 1996 Science Assessment.

TABLE C6.7

**Standard Errors for Schools' Reports on the Severity of
Three Problems in the School, Grades 4 and 8:
Public and Nonpublic Schools Combined**



<i>To what degree is each of the following a problem in your school?</i>	Not a Problem	Minor Problem	Moderate Problem	Serious Problem
Grade 4				
Student Absenteeism				
Percentage of Students	3.7	3.9	2.1	1.0
Average Scale Score	1.9	1.9	3.6	4.9
Percentage At or Above Proficient	2.1	1.8	3.8	2.8
Teacher Absenteeism				
Percentage of Students	4.0	4.3	2.1	—
Average Scale Score	1.4	2.2	5.7	—
Percentage At or Above Proficient	1.8	2.2	5.2	—
Lack of Parental Involvement				
Percentage of Students	4.0	3.3	4.2	1.8
Average Scale Score	2.4	1.9	2.2	6.0
Percentage At or Above Proficient	3.0	2.0	2.3	5.1
Grade 8				
Student Absenteeism				
Percentage of Students	4.3	4.4	3.4	3.4
Average Scale Score	2.4	1.5	3.2	3.2
Percentage At or Above Proficient	3.2	1.8	3.0	3.0
Teacher Absenteeism				
Percentage of Students	4.9	4.9	2.0	2.0
Average Scale Score	1.9	2.2	5.3	5.3
Percentage At or Above Proficient	2.4	2.1	5.3	5.3
Lack of Parental Involvement				
Percentage of Students	2.5	4.1	4.5	4.5
Average Scale Score	2.8	1.8	1.9	1.9
Percentage At or Above Proficient	3.8	2.1	2.4	2.4

— — Sample size was insufficient to permit reliable estimates.

SOURCE: National Center for Education Statistics, National Assessment of Educational Progress (NAEP), 1996 Science Assessment.

TABLE C6.7
(continued)

**Standard Errors for Schools' Reports on the
Severity of Three Problems in the School, Grade 12:
Public and Nonpublic Schools Combined**



<i>To what degree is each of the following a problem in your school?</i>	Not a Problem	Minor Problem	Moderate Problem	Serious Problem
Grade 12				
Student Absenteeism				
Percentage of Students	3.0	4.0	4.3	1.8
Average Scale Score	2.6	1.5	1.9	3.0
Percentage At or Above Proficient	3.7	1.9	2.1	2.3
Teacher Absenteeism				
Percentage of Students	3.9	4.1	2.6	0.7
Average Scale Score	1.6	2.0	3.5	--
Percentage At or Above Proficient	1.7	2.2	2.2	--
Lack of Parental Involvement				
Percentage of Students	3.0	4.1	4.3	1.8
Average Scale Score	2.4	2.0	1.8	2.8
Percentage At or Above Proficient	2.9	2.4	1.6	2.1

-- Sample size was insufficient to permit reliable estimates.

SOURCE: National Center for Education Statistics, National Assessment of Educational Progress (NAEP), 1996 Science Assessment.

Acknowledgments

This report is the culmination of the efforts of many individuals who contributed their considerable knowledge, experience, and creativity to the NAEP 1996 science assessment. The NAEP 1996 science assessment was a collaborative effort among staff from the National Center for Education Statistics (NCES), the National Assessment Governing Board (NAGB), Educational Testing Service (ETS), Westat, and National Computer Systems (NCS). In addition, the program benefited from the contributions of hundreds of individuals at the state and local levels — governors, chief state school officers, state and district test directors, state coordinators, and district administrators — who tirelessly provided their wisdom, experience, and hard work. Most importantly, NAEP is grateful to the thousands of students and hundreds of teachers and administrators who made the assessment possible.

The NAEP 1996 science assessment was funded through NCES, in the Office of Educational Research and Improvement of the U.S. Department of Education. The Commissioner of Education Statistics, Pascal D. Forgione Jr., and the NCES staff — Peggy Carr, Arnold Goldstein, Steven Gorman, Gary W. Phillips, and Larry Ogle — worked closely and collegially with the authors to produce this report. The authors were also provided invaluable advice and guidance by the members of the National Assessment Governing Board, NAGB staff, and the Science Standing Committee. In particular, the authors are indebted to Arnold Goldstein of NCES for his daily efforts to coordinate the activities of the many people who contributed to this report.

The NAEP project at ETS is directed by Steven Lazer and John Mazzeo. The NAEP 1996 assessments were directed by Stephen Lazer and John Mazzeo. Tom Corley, Lee Jones, Tim Ligget, Beth Nichols, Christine O'Sullivan, Amy Pearlmutter, Will Pfeiffenberger, Mario Yepes-Baraya, and Ann Marie Zolandz worked with the Science Instrument Development Committee to develop the assessment instrument. Sampling and data collection activities were conducted by Westat under the direction of Rene Slobasky, Nancy Caldwell, Keith Rust, and Dianne Walsh. Printing, distribution, scoring, and processing activities were conducted by NCS under the direction of Brad Thayer, Patrick Bourgeacq, Charles Brungardt, Mathilde Kennel, Linda Reynolds, and Brent Studer.

The statistical and psychometric activities for NAEP at ETS are directed by Nancy Allen, John Barone, James Carlson, John Donoghue, and David Freund. The analyses presented in this report were led by John Donoghue and Steven Isham.

The considerable production efforts were done by Loretta Casalaina, Sharon Davis-Johnson, Katonya Davis and Kelly Gibson. The production of the World Wide Web version of this report was led by Patricia O'Reilly with assistance from Kelly Gibson, Phillip Leung, Jim Rura, and Terry Schoeps.

Many thanks are due to the numerous reviewers, both internal and external to NCES and ETS. The comments and critical feedback of the following reviewers are reflected in this report: Mary Lyn Bourque, Audrey Champagne, Michael Cohen, Angelo Collins, Lawrence Feinberg, Andrew Kolstad, Michelle Leon, Laura Lippman, Marilyn McMillen, Wayne Martin, Thomas Sachse, Sylvia Ware, Arthur Williams, David Williams, and Shi-Chang Wu.

ISBN 0-16-050036-2



90000

9 780160 500367

3 400

United States
Department of Education
Washington, DC 20208-5653

Official Business
Penalty for Private Use,
\$300

Postage and Fees Paid
U.S. Department of Education
Permit No. G-17

Standard Mail (B)





U.S. Department of Education
Office of Educational Research and Improvement (OERI)
National Library of Education (NLE)
Educational Resources Information Center (ERIC)



NOTICE

REPRODUCTION BASIS



This document is covered by a signed “Reproduction Release (Blanket) form (on file within the ERIC system), encompassing all or classes of documents from its source organization and, therefore, does not require a “Specific Document” Release form.



This document is Federally-funded, or carries its own permission to reproduce, or is otherwise in the public domain and, therefore, may be reproduced by ERIC without a signed Reproduction Release form (either “Specific Document” or “Blanket”).