

DOCUMENT RESUME

ED 431 294

EF 005 388

AUTHOR Funnell, Keith; Alford, Valerie; Denegri, Don; Johns, Sally; Young, Bob; Lucas, Bill; Titman, Wendy; Wood, Joan

TITLE School Grounds: A Guide to Good Practice. Building Bulletin 85.

INSTITUTION Department for Education and Employment, London (England). Architects and Building Branch.

ISBN ISBN-0-11-270990-7

PUB DATE 1997-00-00

NOTE 140p.; Colored photographs may not reproduce clearly.

AVAILABLE FROM HMSO Publications Centre, P.O. Box 276, London, SW8 5DT England; Tel: 0171-873-9090; Fax: 0171-873-8200 (19.95 British pounds).

PUB TYPE Guides - Non-Classroom (055)

EDRS PRICE MF01/PC06 Plus Postage.

DESCRIPTORS British National Curriculum; *Educational Environment; *Educational Facilities Design; Elementary Schools; Elementary Secondary Education; Foreign Countries; Guidelines; *Outdoor Education; Recreational Activities; School Maintenance; Secondary Schools

IDENTIFIERS England; *Outdoor Recreation

ABSTRACT

Limited financial resources and increasing pressures of competing claims on school outdoor grounds have created the need for greater quality enhancement of these areas to ensure they are used efficiently. This document addresses the issues and principles affecting school grounds, provides an analysis of the benefits of using and developing these areas, and outlines the processes necessary for successful school ground management as advocated by Learning through Landscapes. Chapters examine why ground surveying is important; how the National Curriculum provides a framework for the need to teach in the outdoor classroom; and why schools should develop a clear justification for their management of breaks and lunch times, as well as the special nature of this experience and its connection with student behavior. Additionally explored are recent research on the hidden curriculum and how school ground design influences behavior, different options and their contractual arrangements for school ground maintenance, and resources for planning grounds changes. It discusses the importance of the process of developing school grounds and of student involvement. Concluding sections offer reference material that includes information for school site and zone development, sports facilities, maintenance scheduling, key staff responsibilities, and a list of informational sources. Contains an index. (GR)

 * Reproductions supplied by EDRS are the best that can be made *
 * from the original document. *

School Grounds

A Guide to Good Practice

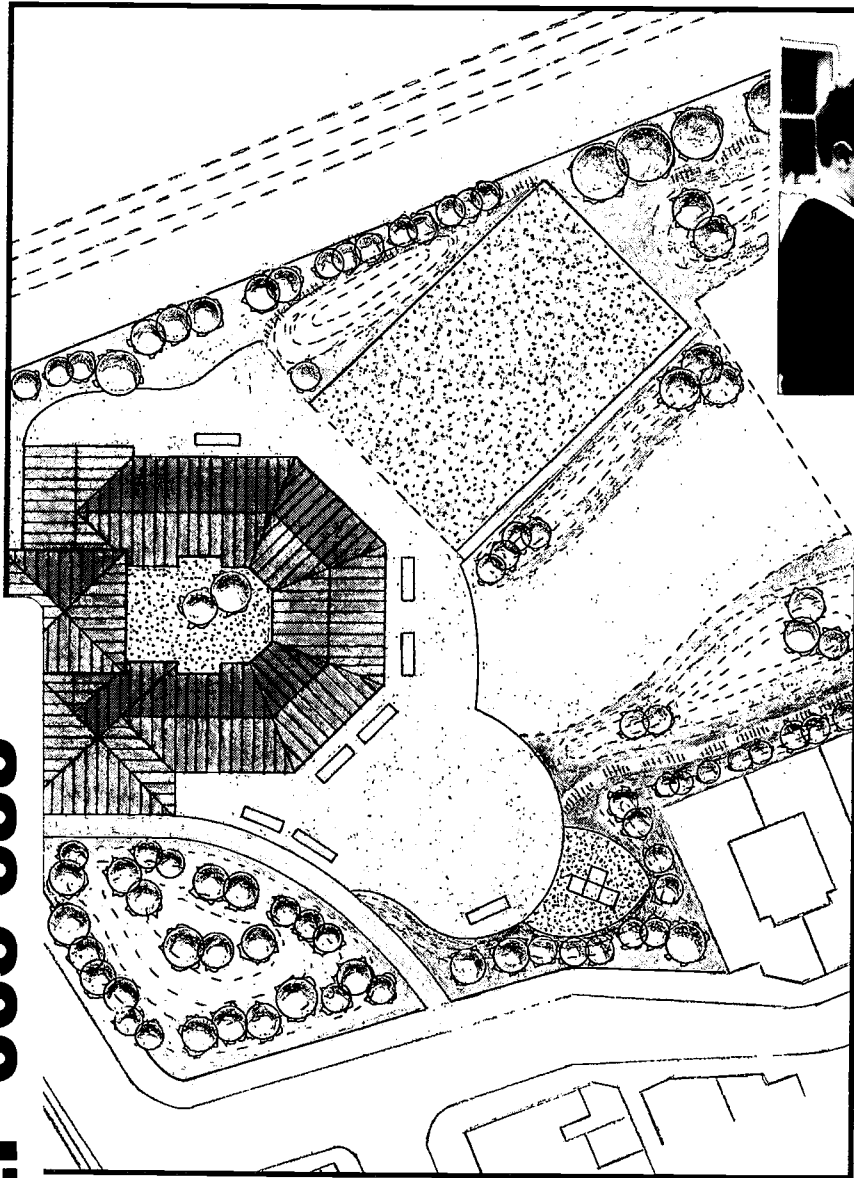

EF 005 388

U.S. DEPARTMENT OF EDUCATION
Office of Educational Research and Improvement
EDUCATIONAL RESOURCES INFORMATION
CENTER (ERIC)

- This document has been reproduced as received from the person or organization originating it.
- Minor changes have been made to improve reproduction quality.
- Points of view or opinions stated in this document do not necessarily represent official OERI position or policy.



Architects & Building Branch

PERMISSION TO REPRODUCE AND
DISSEMINATE THIS MATERIAL HAS
BEEN GRANTED BY

John Birch



Department for
Education and Employment

BEST COPY AVAILABLE

TO THE EDUCATIONAL RESOURCES
INFORMATION CENTER (ERIC)

SCHOOL GROUNDS

A guide to good practice

Architects and Building Branch
Department for Education and Employment

London: The Stationery Office

Acknowledgements

This guide is based on the work of a team of landscape and educational consultants led by Keith Funnell, and comprising Valerie Alford, Don Denegri, Sally Johns and Bob Young. There was also a substantial input by the Learning through Landscapes team of Bill Lucas, Wendy Titman and Joan Wood. DfEE would like to thank all of them and also the following organisations and individuals for their help and advice:

Organisations:

- Devon County Council
- Dudley Metropolitan Borough Council
- Kent County Council
- Learning through Landscapes
- National Playing Fields Association
- Oxfordshire County Council
- Royal Society for the Protection of Birds
- Sandwell Borough Council
- Sports Council
- Staffordshire County Council
- Tidy Britain Group

Individuals:

Ray Bullen, Edith Cave, Peter Dury, Pat Green, Kevin Harlock, Susan Humphries, Keith Loze, David Kirk, Jennifer Millest, David Oakley, Colin Parker, John Parker, Pam Payne, Judy Perkins, Madeleine Pickthorne, Trevor Smith, Tony Twigger, Jean Wenger, Colin Wilkes.

DfEE Project Team:

The Project was directed by John Brooke with support from:
Mukund Patel - Head of Architects & Building Branch
Jeremy Wilson - formerly Head of Architects & Building Branch
Andrew Thompson, Diane Holt, Tom Carden,
Kelvin English, Julia Ashford, Mike Bubb.

© Crown Copyright 1997. Published with the permission of the Department for Education and Employment on behalf of the Controller of Her Majesty's Stationery Office.

Applications for reproduction should be made in writing to
The Copyright Unit, Her Majesty's Stationery Office, St Clements House,
2-16 Colegate, Norwich NR3 1BQ

Preface

School grounds are a valuable resource. Their size and design, the features they contain, how they are used and the way they are managed can have a significant effect on the life and work of the school and on the quality of education its pupils receive.

The last decade has seen an upsurge of interest in school grounds. As horizons have been extended, however, the consequent pressures of competing claims on the grounds have intensified. The smaller the site, and the more limited the financial resources, the greater the need to enhance the quality of the existing grounds and ensure they are used to best advantage.

Recent changes in the management of schools and the role of Local Education Authorities (LEAs) have significantly shifted responsibility for school grounds, their use and management, from the LEA to the school's own governors and headteacher. This has focused attention on the need for efficient financial management and the strict ordering of priorities. At the same time it has given schools greater flexibility to deploy available resources as they choose and to involve parents in this process more closely.

One practical outcome of the growing interest in school grounds was the setting up, in 1990, of Learning through Landscapes (LTL), a national charity addressing all aspects of school grounds. This was a natural progression from a research project which had started four years earlier. One of the research recommendations was that official recognition should be given to the wider educational use of the grounds and making due allowance for a greater variety of outdoor resources to support the whole curriculum. It was further proposed that a comprehensive guidance document should show in more detail how this might be achieved.

In 1991, the Department commissioned a preliminary research programme into outdoor resources in school grounds. This enabled them to draw on the experience

of schools which had improved their grounds and on the advice of teachers, advisers, LEA officers, landscape architects and managers. This and other contributions, together with the detailed measurement and description of outdoor resources, have helped to frame the guidelines for the planning and design of existing and new school grounds which are contained within this document.

The changes made to The National Curriculum (1995), and to The Education (School Premises) Regulations in 1996, make it timely for the Department to publish guidance on good practice in the use, design, development and management of school grounds.

This is an advisory publication. Its purpose is to help all schools understand more about the range of issues affecting school grounds and to interpret them according to their own school's circumstances and priorities. It is particularly aimed at headteachers, governors and all those within schools and LEAs who have a management responsibility for school grounds. It is not a detailed guide to the process of school grounds development, although it has been possible to include some technical information, especially that relating to Building Bulletin 28, Playing Fields and Hard Surface Areas, HMSO 1982 (now superseded). This information is contained in a section called Understanding Technical Requirements and in a separate reference section. Outline guidance on the main issues in the choice and design of school sites and area guidance is separately given in Building Bulletin 82, Area Guidelines for Schools, HMSO 1996.

The advice contained in this publication takes account of The Education (School Premises) Regulations 1996. It amplifies messages contained in Building Bulletin 71, The Outdoor Classroom, HMSO 1990, and it provides advice in the context of the broad approach advocated by LTL.

1. Introduction	9
Interest in School Grounds - the broader context and role of Learning through Landscapes	
Previous Regulations - a summary	
Changing Emphasis - the growth of a concern for quality	
The Present Position - the latest regulations	
2. Understanding the Issues	12
Benefits and Principles - how schools can benefit if they develop their grounds in certain ways	
The Opportunities - introducing the formal, informal and 'hidden' dimensions of the school curriculum, the importance of the School Development Plan and the importance of involving pupils in the development process	
3. Managing School Grounds Development	17
Managing the Development Process - explaining the elements of the process, including understanding the issues, sharing the concept, setting up appropriate management structures, surveying the grounds, identifying needs, identifying solutions, planning and implementing changes and evaluation	
4. Surveying the Grounds	20
Carrying Out a Survey - why this is an important stage	
Desk Study - how maps, photographs and other data can help effective planning	
Site Investigations - looking carefully at existing use, soil, local climate, pollution, wildlife, trees and other site features	
Categorising the Elements - looking at the site in terms of the main areas, playing fields, hard surfaced games courts, informal and social areas, habitats and buildings and access and understanding the principle of multi-use of the grounds	
Use-zone Areas - advice on the sub-division of the site into specific areas	
5. Providing for the Formal Curriculum	28
A Rationale - how the National Curriculum provides a framework for the need to teach in the outdoor classroom	
Use, Design and Management Issues - understanding what the landscape implications are for teaching science, physical education, geography, English, mathematics, design and technology, history, art, environmental education, and for meeting special educational needs	
6. Providing for the Informal Curriculum	35
A Rationale - why it is important for schools to develop a clear justification for their management of breaks and lunchtimes, the special nature of this experience and connections with the behaviour of pupils	
Design Issues - looking at space, zoning, seating, shelter, the need for variety and diversity, and fixed play equipment	
Management Issues - exploring strategies, and looking at managing supervisory staff	
7. Understanding the Hidden Curriculum	39
A Rationale - understanding the hidden curriculum and exploring recent research	
Design Issues - understanding how design influences behaviour	
Management Issues - understanding the subtle ways in which management can affect behaviour and attitudes	

8. Understanding Technical Requirements	41
Planning and Creating Habitats - trees, woodlands, hedgerows, wild flower meadows, ponds, crops, animals and raised beds	
Layout and Construction of Pitches - playing fields, orienteering courses, gradient, the range of summer and winter games, possible pitch layouts, sports surfaces and drainage	
Other Design Issues - special schools, location of play and recreation areas, site furniture, shelter, surfaces, markings, walls, soft landscape, courtyards, earthworks, soil, microclimate, shelterbelts, shade, air and noise pollution, access, parking, pedestrians, supervision and safety	
9. Maintaining the Grounds	68
Key Issues - defining maintenance and its importance	
Organising Grounds Maintenance - exploring different maintenance options and their contractual arrangements	
A Management Plan - the need for a comprehensive plan and effective supervision, litter, vandalism, trespass and wear and tear	
10. Planning for Changes	75
Sources of Advice and Information - explaining the roles of local authorities, private consultants, the voluntary sector and community groups	
Material and Financial Support - grant schemes, business support, parental and community involvement, partnerships and the need for a fundraising strategy	
11. Conclusion	78
The importance of the process of developing school grounds and of involving pupils	

Reference Section

Page No

A. School Site and Zone Development	79
Exploring options for site development zones for a primary school; looking at layouts and zones for a nursery, infant and junior school, secondary school and special school; looking at two examples of restricted urban sites	
B. Sports Facilities	88
Multi-games areas; archery; association football; athletics; basketball; cricket; hockey; lacrosse; netball; rounders; rugby league; rugby union; softball and stoolball; tennis; volleyball	
C. Maintenance Schedule	106
Fine sports turf; winter sports pitches; games courts and hard porous surfaces; synthetic sports surfaces; sandfilled carpet; athletics facilities; amenity grass areas; rough grass and meadows; shrub borders; hedges and fences; newly planted trees; mature trees; wetland; ditches and drainage systems; hard landscape areas and site furniture; litter; typical schedule of rates for actual pricing	
D. A Description of Key Staff Responsibilities	111
For teachers with responsibility for the grounds	
E. Extract from DfEE Circular 10/96 - The 1996 School Premises Regulations	112
F. Recommended Site Areas, including Allocation of Area for Use-Zones	114
G. Looking to the Future: Capital Costs	122
H. Health and Safety	123
Legislation and guidance	
J. Sources of Information	127
Organisations; publications; videos and computer programmes	
K. Publications	130
L. Definitions of Zones	134
Index	135

000 8

List of Figures

No.	Title	
1.	Managing school grounds development	18
2.	Tree protection	24
3.	The range of habitats	41
4.	Trees valuable for wildlife	42
5.	Sizes of nursery stock	43
6.	Relative costs of nursery stock	43
7.	Different boundary details	44
8.	Pond and marsh construction	46
9.	Detail of a tree nursery	48
10.	Taking the garden up into the air	48
11.	Conversion of outdoor lavatory	50
12.	Junior games court	51
13.	Pitch orientation in relation to aspect	52
14.	Pitch orientation in relation to boundaries	53
15.	Possible pitch layouts	55
16.	Four types of turf construction	56
17.	Reinforcement materials for high wear areas	57
18.	Typical synthetic turf pitch construction (engineered)	57
19.	Typical synthetic turf pitch construction (dynamic)	58
20.	Shelterbelt design close to buildings	63
21.	Details of different shelterbelts	64
22.	A pollution screen	65
23.	Zoning of outdoor uses to improve security and safety	67
24.	Suggested model for ground maintenance	69
25.	A management plan	70
26.	Costs of maintaining soft landscape	71
27.	Looking at site development options	79
28.	Play provision for a nursery	81
29.	Infant and junior school provision	82
30.	Secondary school provision	83
31.	Special school plan (primary)	84
32.	A primary school example of use-zone areas on a restricted site	86
33.	A secondary school example of use-zone areas on a restricted site	87
34.	Multi-games area	88
35.	Target archery range	90
36.	Association football pitches	91

No.	Title	
37.	Athletics track	92
38.	Basketball courts	93
39.	Cricket square combined with winter games pitches	95
40.	Hockey pitches	96
41.	Lacrosse pitch (men's)	97
42.	Lacrosse pitch (women's and girls')	98
43.	Netball courts	99
44.	Rounders pitch	100
45.	Rugby League pitch	101
46.	Rugby Union pitch	102
47.	Tennis courts	104
48.	Padder tennis court	105
49.	Volleyball courts	105

List of Tables

1.	When to collect tree and shrub seeds	49
2.	Range of summer and winter games provision	54
3.	Association football: recommended pitch sizes	90
4.	Cricket pitch only: dimensions and areas	94
5.	Cricket pitch and winter games pitches	94
6.	Lengths of pitches and boundaries	94
7.	Hockey: recommended pitch sizes	96
8.	Lacrosse (men's): recommended pitch sizes	97
9.	Lacrosse (women's): recommended pitch sizes	98
10.	Rugby League: recommended pitch sizes	101
11.	Rugby Union: recommended pitch sizes	102
12.	Mini-rugby: recommended pitch sizes	102
13.	Tennis court sizes	103
14.	Typical schedule of rates for pricing by others	109
15.	Infant school: recommended areas	114
16.	Junior school: recommended areas	115
17.	Primary school: recommended areas	116
18.	Middle deemed primary school: recommended areas	117
19.	Middle deemed secondary school: recommended areas	118
20.	Any secondary school: recommended areas	119
21.	Special schools: recommended areas	121
22.	Some common items of capital cost	122

List of Photographs

No.	Title	No.	Title
1.	Wider environment can be investigated 9	14.	Outdoor games are important in the curriculum 29
2.	Strong messages are given out by the way a site is designed 10	15.	Outdoor games are important in the curriculum 29
3.	Keeping livestock promotes a sense of care 10	16.	Camping in grounds gives an introduction to adventurous activities 29
4.	Well designed woodland provides learning opportunities 13	17.	A maze affords mathematical possibilities 33
5.	Activities in grounds help children understand difficult concepts 13	18.	Murals provide opportunities for work in art 33
6.	Large scale demonstrations are possible outside 13	19.	Weather watching is made interesting by wind activated sculpture 33
7.	Surveying and mapping can be part of some studies 13	20.	Static electricity can be explored outside 34
8.	Play is important to children who have limited opportunity outside school 14	21.	Varied landscape is likely to better meet needs of pupils 37
9.	Trees as living things have ecological significance 15	22.	Shrubs can create natural dens 39
10.	Community involvement is important in grounds development 15	23.	Children love harvesting 47
11.	Pupils can play a useful part in grounds development 19	24.	Well-designed seating encourages appropriate pupil responses 60
12.	Maintenance and environmental education are mutually supporting 21	25.	Access for disabled pupils is important outdoors 66
13.	A pond provides opportunities for teaching science 28	26.	Even in winter it is possible to use grounds creatively 78

1. Introduction

Interest in School Grounds

- 1.1 Interest in the benefits to be gained from greater educational use of school grounds has grown rapidly in recent years. Their value has been underlined by the National Curriculum (NC), by reports produced by the Office for Standards in Education (OFSTED) and by research carried out by other organisations such as Learning through Landscapes (LTL).
- It is generally recognised that pupils of all ages learn best from first-hand experience, from seeing and hearing, handling, measuring and investigating the 'real world' for themselves. The school grounds can support such activities and often provide a useful compromise between the limitations of the classroom and the cost and inconvenience of going further afield.
 - The growth of interest in environmental issues has strengthened the cause of environmental education with its three interlocking strands of education *about* the environment, education *for* the environment and education *through* the environment. This has been enshrined in the most recent revisions to the National Curriculum (1995) which makes it clear that elements of a number of subjects in the National Curriculum can only be effectively taught outdoors.
 - School grounds have become increasingly important to children in today's society at a time when their access to external environments appears to be decreasing. The way in which school grounds are designed and managed influences children's attitudes and behaviour to a considerable extent.
 - LTL, since its inception in 1990, has been promoting the many benefits which schools developing their grounds can enjoy. Schools report on the development of an ethos of care and a sense of ownership by the whole community. They also describe reductions in the number of accidents and in the incidence of vandalism.
- 1.2 A school is a focal point for the community; its public image conveys messages about its aims, objectives and attitudes. With the increase in choice and diversity there is now a growing interest in the visual appeal of the school in its setting.

Previous Regulations

- 1.3 The recognition that school grounds are important is not new. As a result of the 1944 *Education Act*, minimum standards for the nature and extent of school grounds were established and set out in *The Education (School Premises) Regulations*. The size and layout of many of today's school grounds reflect these detailed provisions and their subsequent amendment.
- 1.4 During the period 1950 to 1955, the then Ministry of Education produced a series of Building Bulletins on the design of both primary and secondary schools. They saw '*children as the basis of design*' and recognised the need for the '*closest co-operation between the people who design the schools and the people who are to live in them and are responsible for their organisation*'. The desirability of retaining existing natural features '*...trees or hedgerows, irregularities of the ground in the form of hollows or banks, a stream or a pond...*' was identified, as were opportunities to enhance the local landscape and create sheltered environments.
- 1.5 The educational opportunities presented by the grounds were also emphasised: '*The learning process will continue outside the classroom if conditions are varied and attractive and inviting to both learners and teachers... Children need wider opportunities to read and write, to collect and to investigate, to contrive and to construct... Outside are yet more learning areas - sheltered courts where the children can build a model or act a play and pleasant places where they can stroll in the sun, converse and browse*'. The implication was that these activities can be facilitated by the design and management of the grounds.

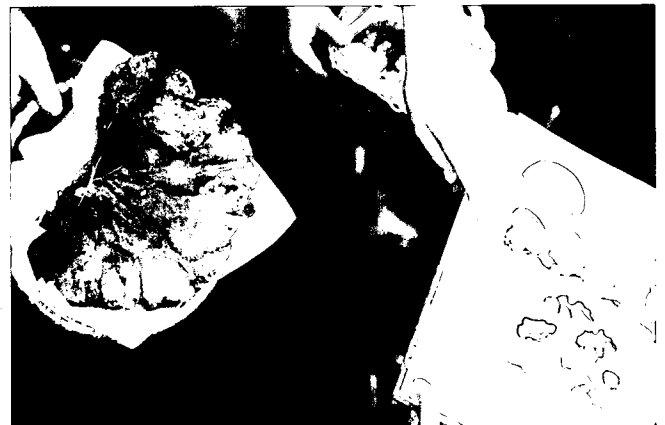

Photo 1 The wider environment can be investigated by observing and recording at first hand



Photo 2 Strong messages are given out by the way a site is designed



Photo 3 Keeping livestock on site helps to promote a sense of care. (Adult presence is needed when pupils are in contact with animals)

Changing Emphasis

1.6 The regulations governing school grounds have varied in emphasis over the years. In 1972, they defined separate minimum areas for the *playing fields* and for the *site*, which contained all other statutory facilities. The overall land requirement for any type or size of school was determined by adding the two figures together. The 1981 regulations marked an important step forward by introducing a quality, as well as an area, requirement for playing fields. They provided for:

- minimum recreation areas for all pupils, with a minimum proportion that must have a paved or hard porous surface;
- minimum areas of playing fields for pupils aged 8 or over that must be suitable for the playing of team games;
- grass playing fields to be capable of sustaining at least seven hours of play per week in term-time.

Many planners interpreted the regulations to mean that the principal functions of the grounds were to provide facilities for physical education and give pupils an opportunity to let off steam.

1.7 In reality there was a broader agenda. DES Broadsheet 9 issued in 1982, explained that: *'In addition to pupils' play and outdoor physical education there are many aspects of the school curriculum that need outdoor provision. Facilities are required to support creative play and exploration in the younger age ranges and in the older age groups for subject-related activities such as art, craft, science, rural science and geography. The 1981 Regulations were intended to ensure that sufficient land was provided to meet this wide range of requirements.'* There was recognition that physical education is not the only subject to which grounds could make a contribution, and work to demonstrate this was pioneered by the Learning through Landscapes Consortium.¹ As a result of that work, in 1990 the Department published Building Bulletin 71 *The Outdoor Classroom*.

The Present Position

1.8 In 1991, the Department commissioned research into the current educational demands on school grounds and the design, management and use of existing curriculum-related outdoor resources. The aspects explored included their size and design, functions, management and maintenance; how they were created; the number of pupils they could support; their educational value; and any discernible impact they might have on the public image of the school.

¹The Learning through Landscapes Consortium later became Learning through Landscapes (LTL).

Issues of vandalism, litter and site security were also considered.

1.9 As part of the preliminary research programme, teachers at a variety of schools were asked to rank a number of constraints affecting the educational use of the grounds. Safety and supervision were major considerations and trespass and vandalism were of particular concern (the latter especially at secondary level). At both primary and secondary schools, the design of the school grounds was felt to be very important. Noise pollution and climatic exposure were viewed as possible impediments to outdoor use.

1.10 The research identified a wide range of good practice in both primary and secondary schools and it highlighted a number of messages for those establishing or improving school grounds:

- **planning and design:** a preoccupation with surface treatments and the allocation of space can often result in a narrow focus on site planning as a two-dimensional exercise. The aim should be to achieve a comprehensive landscape design;
- **quantity and quality:** landscape quality, serviceability and the day-to-day usefulness of the outdoor environment as an educational resource are vital to the effective use of land;
- **funding arrangements:** financial provision needs to reflect a comprehensive view of all the functions that the school grounds can perform;
- **teamwork:** the greatest success is usually achieved where those responsible for the design and care of the grounds and those directly involved in their educational use work closely together;
- **sense of ownership:** the changes in the management and funding of schools enable teachers to assume a greater sense of ownership. This should make it easier for them to see the grounds as a natural extension of the classroom.

1.11 **Changes in legislation.** The Education (School Premises) Regulations 1996 introduced a number of changes. In recognition of the greater autonomy enjoyed by schools, the regulations governing outside areas were relaxed, retaining the previous area and quality requirements for school playing fields, but omitting minimum requirements for recreation areas. LEAs and governors, however, will need to ensure that provision of recreation area is adequate. This Building Bulletin, therefore, includes an indication of appropriate areas for various types of school. Area recommendations are given in Reference Section F. However, what was formerly known as 'recreation area' is now embraced in two zones; 'hard-surfaced

games court(s)' and 'informal and social areas'. The latter allows for both paved and soft areas for impromptu activities, leisure pursuits and, of course, the 'outdoor classroom'.

1.12 **Health and Safety considerations.** The grounds significantly contribute to the mental and physical growth of pupils and their needs, and consequently, safety must be a key consideration in planning, use and supervision. It should be remembered that employers are legally required to ensure that those in their care are as safe as is reasonably practicable. Employers should ensure that employees are made familiar with the school's health and safety policy. This should reflect the legal requirements, the school rules concerning the use of the grounds and the appropriate course of action to take in an emergency. In The Education (School Premises) Regulations 1996 the general health and safety requirement covering school buildings was extended to cover school land. References to health and safety and to legal requirements, alongside general guidance, are given in Reference Section H.

1.13 **Security in schools.** The school's attention is particularly drawn to the importance of security considerations on school premises. *Managing School Facilities, Guide 4 Improving Security in Schools* (HMSO 1996) includes advice on the management of security, and further design guidance is also planned.

1.14 **Purpose of the Bulletin.** This Building Bulletin contains guidance on what constitutes good practice in the use and development of school grounds. It is intended for use by headteachers, governors, others with responsibility for school grounds and LEAs, to help them ensure that schools make adequate provision for children in their grounds and to ensure that the process of developing school grounds is managed as effectively as possible.

2. Understanding the Issues

2.1 This section is concerned with understanding some of the issues about the ways in which the grounds can be used and developed as an educational resource.

Benefits and Principles

2.2 **The benefits.** Schools which have used and developed their grounds report a number of benefits in addition to the obvious ones relating to the ways in which they are used as an educational resource and improvement to the quality of the environment. These include:

- improved relationships between pupils and staff;
- improved relationships with parents;
- enhanced image and greater popularity with the local community;
- reductions in the incidents of bullying, accidents and vandalism;
- more effective teaching and learning;
- development of an ethos of care and a stronger sense of ownership;
- more efficient use of existing resources;
- a great deal of fun!

2.3 **The principles.** However, Learning through Landscapes has established through its research that these benefits are only likely to be enjoyed if the process of developing school grounds is undertaken in a certain way. The most successful school grounds developments are those which stress the importance of the process of change and where this process of change is:

- holistic - involving the whole site, the whole school community and all aspects of the curriculum;
- participative - involving children *with* adults in as many aspects as possible;
- sustainable - involving continuing consideration of the use, design, management and maintenance of school grounds as part of a school's ongoing development planning.

Sustainability has a special relevance when applied to landscape development which needs to be explored in schools. It raises questions of biological diversity - biodiversity. Without a wide variety of living things, life would be unsustainable. In the context of school grounds, this suggests opportunities for children to learn about this issue at first-hand. Schools may also want to take into account local and regional distinctiveness when considering the development of their grounds.

Understanding these principles and being aware of the full range of opportunities on a school site will enable schools to plan and implement changes more effectively.

The Opportunities

2.4 Schools can use their grounds in three main ways:

- through the formal curriculum - the outdoor classroom;
- through the informal curriculum - the experiences which are offered during break and lunch-times;
- through the 'hidden' curriculum - the messages and meanings which children 'read' from the ways in which their school's grounds are used, designed and managed.

In addition, there are extra-curricular and community opportunities, which most schools will want to consider.

2.5 **The formal curriculum.** An obvious use of the school grounds is to extend the teaching area beyond the confines of the classroom, and this is illustrated in photographs 4-7.

The grounds are a rich resource for learning right on a school's doorstep as has been shown in *The Outdoor Classroom*. There are many possibilities in science, English, mathematics, geography, history, design and technology, art and physical education and these are described in *The National Curriculum* (HMSO 1995) and in section 5 of this Bulletin. There are possibilities for the teaching of skills such as observation, communication, classification, estimation, surveying, analysis, comparison, design, investigation, mapping and recording. Broader issues related to environmental education and health can also be learned.

While undeveloped sites can be used for some teaching activities, a greater variety of opportunities for teaching will be presented on a more developed site. A pond may provide a resource for teaching about life processes and living things in science or about contrasting environments in geography, while at the same time providing a real context for using and applying mathematics. An understanding of the range of opportunities inherent in certain features will lead schools to consider those which meet their needs in a number of areas of the formal curriculum.



Photo 4 Well-designed woodland areas can provide a range of learning opportunities

School grounds give access to what has been termed the 'natural curriculum'. Plants, animals and soils can only be investigated thoroughly if pupils have direct experience of natural habitats. Changing weather conditions, the rotation of the seasons and the processes of growth and decay can provide a constantly changing context for learning. Indeed, the grounds can make a unique contribution to the development of an understanding of the natural world and the principles of biodiversity and sustainable development.



Photo 5 Activities in the school grounds help children to understand difficult concepts such as biodiversity and sustainability

One powerful aspect of the learning process for which the grounds are eminently suited is the provision of first-hand experience - letting pupils learn by seeing and experiencing for themselves rather than relying on textbooks, worksheets and the teacher's exposition. The grounds make available particular resources which cannot easily be reproduced in the classroom. Existing good practice in many schools and the non-statutory guidance provided by the School Curriculum and Assessment Authority (SCAA), especially *Teaching*

environmental matters through the curriculum, (SCAA 1996) both support this view.

Much of the process of involving pupils in surveying, analysing, designing and developing their grounds can be incorporated into the formal curriculum.

In understanding the issues it is important to consider the fullest possible range of teaching and learning possibilities, including those which fall outside the statutory elements of the National Curriculum, in order to provide broad and balanced curricular experiences.

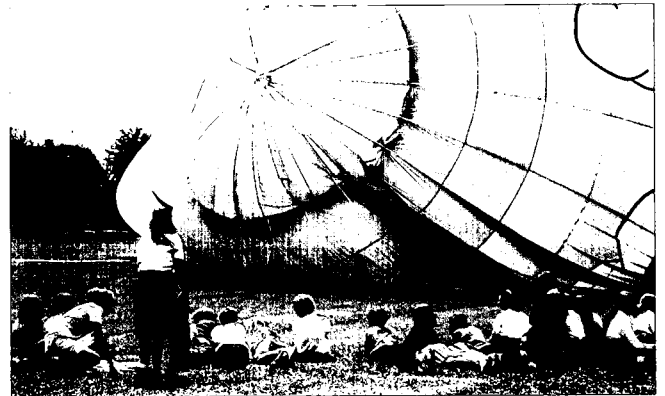

Photo 6 Large scale lessons about hot-air are best taught outside

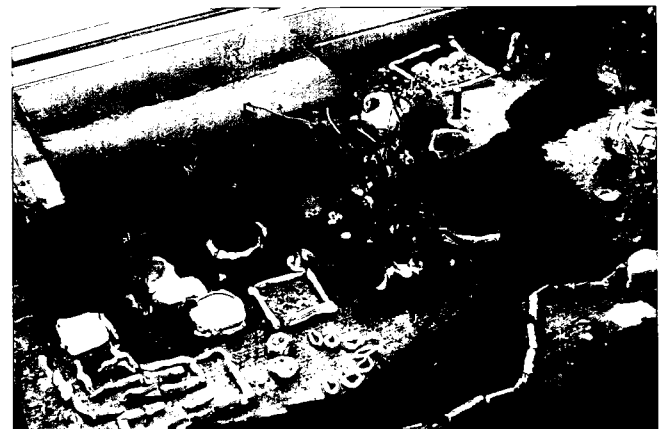

Photo 7 Pupils can undertake survey and mapping activities as part of design & technology or mathematics

2.6 **The informal curriculum.** At least a quarter of children's school day is taken up with break and lunch-time. The term 'informal curriculum' is now widely used to describe the times of day when children are in school but not involved in lessons, like lunch-time, as well as what they do at those times, for example play and recreation. Much of this time, weather permitting, is spent outside. This time is part of the school day and part of children's education. During this informal element much important learning takes place.

Play is a complex subject and its significance is not always understood. It is sometimes confused with amusement, diversion or simply 'letting off steam'. It involves learning about the self, about other people and about the environment. It is essential to healthy human development. It is a process of doing, of exploring, of discovering, of succeeding and, of course, at times of failing. These issues are explored further in section 6.

Play in school is different from play in a park because it is supervised and because of the environmental and educational context of the school in which it takes place.

What children can do at playtime is largely determined by the design and management of the school grounds. Even the most imaginative child will find it difficult to be creative and sociable in a bleak, sterile, largely tarmac place. The grounds need to provide diversity of places and habitats so that children have the maximum opportunity for interaction with other young people and other places.

It is important for schools to understand issues connected with the use of space - the degree to which football dominates some playgrounds is one obvious issue - and the ways in which it can be most effectively managed.

It is not just at primary school level that play is important; older pupils need opportunities for informal recreation which need to be addressed.

2.7 The hidden curriculum. Whether or not school grounds are well used, their very existence affects and influences pupils, staff, parents and the wider community. Research has shown that the messages conveyed by the nature of the school grounds, what may be called the hidden curriculum, are very important.

The hidden curriculum of school grounds is a concept which was introduced by the LTL Consortium in 1989 and developed in *Special Places; Special People* WWF/LTL 1994. The research suggested that a school's grounds are essentially signifiers of its ethos.

The main findings of this research will help schools to understand the complexity of the issues surrounding the use and development of school grounds. They are:

1. School grounds, as external environments, have become increasingly important to children in modern society.
2. School grounds, by their design and the way they are managed, convey messages and meanings about the ethos of schools to children which

influence their attitude and behaviour.

3. Children read these messages from a range of signifiers. These frame the cultural context of the environment and constitute the hidden curriculum.
4. The hidden curriculum has considerable influence, in a range of subtle but significant ways, on the operation of all schools.
5. It is within the power of those who manage schools to determine the nature of the hidden curriculum of their school grounds.

These issues are taken further in section 7.

The actual nature of school grounds developments - new features, new design or new management solutions are, of course, of immense benefit. It is the process of development, however, which causes the most wide ranging changes. This process can have considerable impact on the ethos of the school, changing the hidden curriculum of its grounds and providing a value-added factor which surprises many schools.



Photo 8 Play and recreation is very important to younger children who may have limited opportunities outside school



Photo 9 Children are keenly aware of trees as living things with great ecological significance



Photo 10 Community involvement is an important element of school grounds development

2.8 **Extra-curricular use.** Many schools run activities at the end of the school day, which may need to be taken into account when contemplating developments. After-school clubs can be a fruitful way of involving pupils, staff, parents and the wider community in using and developing the grounds.

2.9 **Serving the community.** Some schools have joint-use agreements with a local authority or with another outside organisation such as a local sports club. The implications of any possible changes will always need to be thought through very carefully with such bodies.

In many schools there could be more shared use of the outdoor facilities. One major concern has often been the quality of grass pitches, which have not always been adequate to meet the increase in wear and tear which out-of-school use, often by adults, can impose. The greatest potential for shared use may well lie in the hard games courts or a multi-games area, especially where floodlighting is provided. The creation of a new synthetic pitch may depend on shared use, either through a financial partnership to create it in the first place or through the generation of income to reimburse the school for its investment. Questions of time allocation seldom cause conflict between the school and the club or community, where these have been considered thoroughly beforehand.

The key issues are the quality, durability and viability of the facilities which need to be reflected in the design of both indoor and outdoor provision; this means good access, including parking, self-contained changing rooms and at least sufficient financial return to cover the marginal costs.

Further guidance about the issues schools need to consider in approaching questions of community use is given in *Our School - Your School*, published by the Department in 1995.

2.10 **School Development Plans.** Whatever their potential impact on the work of the school, the grounds will do little to enhance the learning environment of pupils unless their use and development is carefully planned and effectively managed. This needs to be considered within the context of the School Development Plan (SDP), which is a schedule for action, both organisational and curricular, drawn up by the headteacher and the governing body. Once established, the broad objectives require the firm support of the headteacher, and clearly defined day-to-day responsibilities need to be exercised by designated members of staff.

The resources in the school grounds will only be used effectively if teachers are convinced of their value and are motivated to use teaching approaches which, in the early stages at least, may seem complex and involve extra work. Some teachers may need to be persuaded of the benefits of first-hand observation and experience or to be shown how the school grounds can contribute to their pupils' knowledge, skills and understanding. Others may need to be assured about the practicalities: how to control pupils outside the classroom environment; what teaching styles and approaches are most effective in these conditions; how to cope with their own lack of expertise in unfamiliar territory. An unspoken assumption in some schools is that work outside the classroom is mainly for the academically less able pupils (who are assumed to need more first-hand experience than others and are unlikely to produce the highest grades in public examinations). Such assumptions and uncertainties need to be confronted openly. A suitable forum for their discussion and resolution may be found in the whole-school policy meetings which many schools now hold to discuss their SDP and as part of a regular programme of more general staff meetings.

2.11 **Responsibilities.** Responsibility for the production of the SDP, including whatever is proposed for the development and use of the site and the priority it should have, rests with the head in consultation with the governors. Subsequently it is the head's leadership which will determine how successfully the plans are translated into action. Styles of leadership differ. Some heads are, above all, entrepreneurs, adept at obtaining financial and material support for projects. Others are particularly skilled in using Local Management of Schools and the expertise of teachers to best advantage. Yet others excel as enablers, encouraging a leading member of staff, not always a teacher, to take responsibility for an initiative and giving that person practical and moral support. Whatever their individual strengths and styles, heads need to ensure that:

- the use of the grounds is clearly linked to the aims and objectives of the school as a whole;
- the school's management structures give status, authority and essential resources to those who take responsibility for the care of grounds and for their educational use;
- the schemes of work for each department, or area of the curriculum, take account of the grounds in their treatment of teaching approaches and the resources available;
- individual members of staff are actively encouraged to make good use of the opportunities which the grounds present;
- the policies for safe use and development of the grounds, like all other policies, are regularly evaluated to ensure that their impact on the pupils' learning and behaviour matches the original intention.

2.12 **Management structures.** Except in the smallest primary schools (and even here this may not be desirable), it is unlikely that the head can take personal charge of each aspect of the grounds and their use. Staff with the necessary expertise, enthusiasm and persuasiveness to exercise day-to-day responsibility need to be identified and a small management group established. In many schools it may be helpful to base a school grounds development group on an existing governors' sub-committee such as one dealing with the school premises. The roles of those with responsibility need to be made clear and they should be given all the support they need. Inevitably, teachers may take a leading role, but the involvement of other members of the school community is essential. In many cases it is possible to have more than one person, provided that their responsibilities are clearly identified. A governor or

parent or member of the local community may also be a useful addition to the management group. A list of the kinds of duties and responsibilities which need to be apportioned is contained in the Reference Section D. An outline of the management process which needs to be established for successful school grounds projects is contained in section 3.

2.13 **Involving pupils.** Pupils at both primary and secondary level, and also in special schools, have much to contribute to school grounds projects. The best results are achieved when the pupils, whatever their age, are involved in the planning from the earliest stages. Their exclusion may make things quicker and easier but it will dilute the educational benefits and reduce the opportunities for changing attitudes within the school. Schools with pupil councils report that this can be an effective means of involving pupils.

2.14 **Involving parents.** Most schools have a Parent Teacher Association (PTA) of some kind. A PTA is likely to be a good forum for raising issues to do with school grounds. It is also a useful channel through which plans can be shared, resources raised and involvement sought.

2.15 **Taking stock.** Whether the school is well endowed with outdoor facilities or has only a restricted area, the first challenge is to make the most of what exists. It is not a question of having particular features or types of space before anything can be done, indeed, adapting the grounds to create new features before the school or department has accumulated some expertise in the use of outdoor resources can be a recipe for failure. With flair and imagination, supported by sound planning and careful implementation, teachers of any subject can make profitable use of existing provision. In doing so they will acquire the experience and skills that enable them to identify priorities for change.

3. Managing School Grounds Development

- 3.1 This section describes the process of managing the development of school grounds. Development, as used here and throughout the rest of this Bulletin, includes changes to the physical design of a site *and* changes in the way it is managed.
- 3.2 The quality of the design and development of school grounds will largely be influenced by the way in which the process is managed. The temptation to undertake changes as rapidly as possible needs to be resisted. While it is important to maintain the interest and commitment of those involved, it is more important still to be sure that valuable resources are not wasted as a result of poor management.

Managing the Development Process

The development process involves the following key stages, summarised in Figure 1.

- 3.3 **Understanding the issues.** It is important that schools understand some key principles and recognise that developments affect all aspects of management and of the curriculum (see section 2). Unless this point is grasped, there is the danger that a grounds development scheme will not serve the needs of the whole school and will, therefore, become marginalised. This does not mean that developments have to proceed on all fronts at the same time. Clearly this would be undesirable and unmanageable. It does, however, mean that decisions need to be made about the respective priorities of conflicting needs and opportunities.
- 3.4 **Sharing the concept.** There is always a danger in any developmental activity in a school that it becomes the special concern of a small vested interest group. The best way of preventing this and of involving the widest possible group of relevant people is to ensure that lines of communication are effective. This is particularly important at the start of any school grounds project. Staff, pupils, parents, governors and the wider community need to be informed of the benefits of developing grounds and the ways in which such developments may, in very general terms at this stage, meet their needs. Well-structured meetings of various kinds will need to be held. Some of the benefits of developing school grounds have already been covered in 2.2. When developing ideas on the use and development of grounds, the materials produced by LTL, the British Trust for Conservation Volunteers (BTCV), the Royal Society for Nature Conservation (RSNC), the Royal Society for Prevention of Cruelty to Animals (RSPCA), the Tidy Britain Group and English Nature will be particularly helpful. At this stage, short videos are a useful way of selling the concept.

- 3.5 **Setting up a management structure.** One of the most common reasons given for school grounds developments which are less than satisfactory is that they have not been properly managed. There is sometimes a temptation to get started on practical work rather than thinking through the management implications of quite complicated tasks, often involving outside organisations and new areas of expertise for teachers and other school staff. The need to establish a small management group with clearly defined responsibilities has already been mentioned in 2.11-2.12.
- 3.6 **Surveying the existing site and the way it is used.** Unless schools have good data about their site, they run the risk of making inappropriate changes to their grounds. This is the part of the process when pupils and their teachers really begin to familiarise themselves with the grounds. It is here, too, that a strong sense of ownership of the project begins to emerge in parallel with a growing sense of excitement. There are two main elements to this work. The first and most obvious of these is the need to know what kind of features - trees, seats, ponds, sculptures, etc - currently exist. This must also extend to what is hidden from view, such as the services which run underground. The second and equally important element is a survey of the ways in which the grounds are used and managed. It may be that perceived problems, for example relating to the organisation of the lunch queue in a secondary school, can be overcome by a combination of design *and* management solutions. Much surveying can be undertaken by pupils as part of design and technology and science. However they are sought, their opinions about the way the grounds are used, especially at break and lunch-times, are essential. By the end of this stage it should be possible to produce a detailed site plan which indicates what features exist. This stage is covered in section 4.
- 3.7 **Establishing needs.** It is a frustrating fact that effective analysis of needs can only take place if there is a good degree of knowledge and understanding about the exciting ways in which the grounds can be used as an educational resource. While it is clear that schools need to provide for aspects of the delivery of physical education outside, they sometimes forget about those parts of science and geography, for example, which they can most effectively deliver in the grounds. Children have play needs, parents have needs, teachers have needs. It is important that *all* of these are carefully identified. This stage is dealt with in sections 5, 6 and 7, where the requirements of each element of the curriculum are examined.

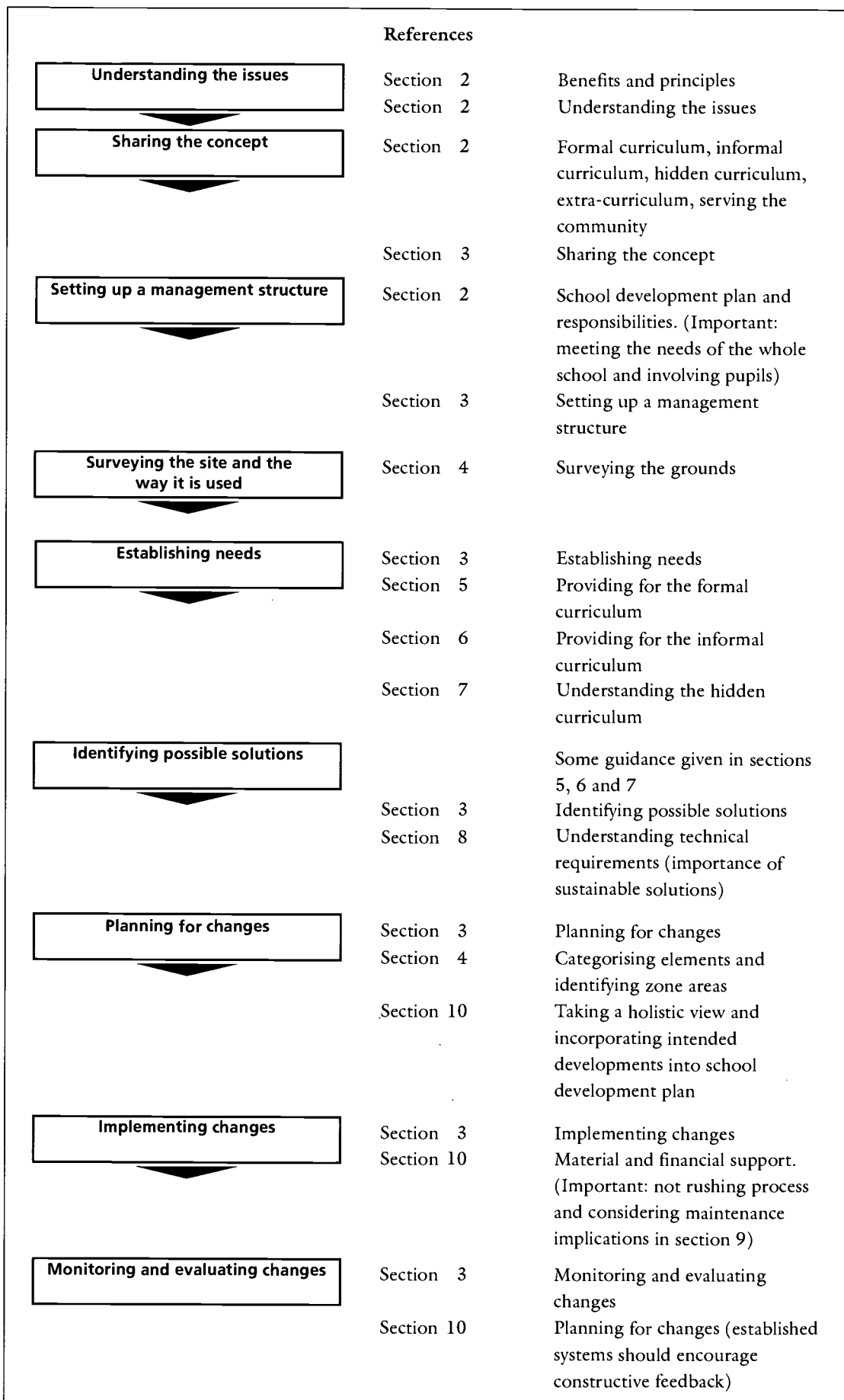

Fig. 1 Managing school grounds development - Flowchart

- 3.8 **Identifying possible solutions.** Projects which do not focus on solutions are unlikely to be sustainable. Once data from the survey has been gathered and needs have been clearly identified, it is important to come up with some possible answers. This is a complex part of the process because it involves prioritising and sometimes taking difficult decisions. For example, on an undeveloped primary school site it might be found that the creation of a wetland area with extensive seating meets the identified needs both for teaching science *and* for providing play and recreational opportunities. Solutions which meet more than one need will always be most useful. Those closely involved must then be consulted and consensus reached. There is not space in this publication to deal with this complex stage in depth, but some pointers are given at the end of sections 5, 6 and 7.
- 3.9 **Planning for changes.** If planned changes are not built into a school's SDP, then they are unlikely to attract the long-term support which they require. Once a clear sequence of development activities has been established, more detailed plans of action can be made. At this stage it may be that advice is required from a professional such as a landscape architect, artist or in-service trainer. Contracts may need to be

prepared, budgets monitored, publicity arranged and a high level of communication maintained throughout. It will increasingly be possible to predict costs and to develop a fund-raising strategy. Technical information contained in section 8 will be important here and during the 'Implementing changes' stage. At the same time it will be essential to consider maintenance implications, see section 9.

- 3.10 **Implementing changes.** For the implementation stage to be effective, meticulous planning and clear allocation of responsibilities is essential. Often this will involve coordinating work parties of pupils, school staff and outside individuals or agencies. This is the stage for which most people will really have been waiting and the one where the fun can really begin. Sections 8 and 9 contain information which is relevant to this practical implementation stage.
- 3.11 **Monitoring and evaluating changes.** It is important to establish systems which will encourage feedback from all the groups involved in a school grounds development project. This is covered in sections 10 and 11.

More detail on all aspects of the process of developing school grounds is contained in LTL School grounds toolkit (LTL 1997).



Photo 11 Pupils taking part in a survey of their grounds

4. Surveying the Grounds

- 4.1 This section examines the issues related to undertaking a survey of the grounds. It also contains guidance on the allocation of area within the site. Guidance on site area, and on statutory playing field areas as stated in The Education (School Premises) Regulations 1996, are given respectively in Building Bulletin 82 *Area guidelines for schools* and in an extract from DfEE Circular 10/96 in Reference Section E.

Carrying Out a Survey

- 4.2 Before any changes are made to the design or management of a site, it is essential that a thorough survey is carried out. Ideally this should be carried out by school staff and pupils with outside help only if necessary. A survey will enable a school to begin at first-hand the important process of familiarisation with its grounds. In particular, it will:

- identify features within the site already being used effectively as an outdoor resource;
- identify those aspects of a school site which are special and unique to it - its history, its flora and fauna, its geology, its culture;
- record those elements that may constrain future use, such as underground (and overground) services;
- provide the school with a number of reliable 'maps' of their site to use as a starting-point for discussions about possible changes.

Much of this work can be undertaken as part of the National Curriculum, for example, the science of plant identification, the history of the local area and the geographical skills involved in map work. Some of it involves desk study of historic or published information about the site and its surroundings, some involves site investigations.

Desk Study

- 4.3 A desk study of the grounds of an existing school always reveals fascinating new data, while on new sites, it gives a first indication of what to expect. Subsequent investigations on site are likely to be more successful when informed by a thorough grasp of the background data. Inconsistencies may arise, such as a service inspection cover which is evident on site but does not appear on plans of public service utilities, and it may bring about the necessity to check the accuracy of existing information. Even a full land survey should not be regarded as infallible, as mistakes can occur and such surveys become out of date.
- 4.4 **A base plan.** Even at the desk study stage, it is advisable to have a base plan for the recording of

information. Some or all of the following may be available:

- a current Ordnance Survey (OS) plan of the site at the largest possible scale;
- the original architect's site plan or an updated version, if available;
- the plan prepared for the school's landscape maintenance contract;
- a new land survey, which is the usual practice on new developments. This should record all existing landscape features within and around the site, such as drainage, levels, trees and other significant vegetation, any buildings or services and all the different types of ground surfaces.

- 4.5 **Ordnance Survey.** OS plans are available at a scale of 1:1250 for the major urban centres and 1:2500 elsewhere. It is important to keep the original as a master and make copies for immediate use. Enlargements may be produced by photocopier for more detailed design work. LEAs have copyright licences from OS that allow them to make copies or enable schools supported or maintained by the LEA to do so. Schools not covered by their LEA must obtain prior approval from OS. Old OS maps often contain fascinating data about earlier use of the site and can stimulate work in history lessons.

- 4.6 **Scale.** The scale of plan required for survey and subsequent design work varies greatly with the type and size of school and the nature of the information to be conveyed:

- a 1:1250 scale is usually adequate for large secondary schools in suburban or rural locations; for those within urban centres, a 1:500 scale might be more suitable;
- for primary schools, a scale of 1:500 may be preferred on large sites and in suburban or rural locations, with 1:200 for smaller or urban sites;
- even larger scales may be required for detailed proposals around buildings or for particular features.

The choice of scale may be influenced by the area the school would occupy on a standard 'A' size sheet of paper. Pupils, parents and other participants involved in any of the planning stages will probably require individual copies of the plans and A3 size is probably best for cost and convenience.

- 4.7 **Other plans and photographs.** Geological maps will give a good indication of the geology of the site and its surroundings. Such maps also show the soil conditions likely to be encountered. Most of England

and Northern Ireland and slightly smaller areas of Scotland and Wales are now covered at a scale of 1:63360 or 1:50000; maps at 1:25000 are limited to a few areas of special geological interest. The number of soils maps is still restricted and this aspect is usually best tackled by site investigation. Vertical or oblique aerial photographs can provide useful information, particularly about earthworks, vegetation and land use. Central agencies such as OS and the Ministry of Agriculture Fisheries and Food have aerial photographic coverage of much of the country, and county and district planning departments often commission similar surveys of their own areas.

4.8 Legal and planning issues. Besides the issue of land ownership, it is important to establish in as much detail as possible:

- the designations and policies in the current local plan for the area - these may affect any changes in the use of the site and information about them can be obtained from the local planning authority. The authority operates town planning control under the Town Planning Act 1990. Useful reference may be made to *Planning permission - a guide for Business*, published by the Department of the Environment;
- the existence of any Conservation Area or Tree Preservation Orders - these will affect the management of trees as well as their retention;
- any plans for future highway improvements - these may affect decisions on both access and design;
- the existence of any rights of way or access enjoyed by adjacent land users or public utilities;
- the presence of public rights of way - these are usually, though not always, shown on the 1:25000 OS Pathfinder maps, but the county or district public rights of way unit should be consulted to establish their exact nature and alignment.

Applications to stop, or simply to divert, public rights of way are often contested and it is important that this possibility is identified early on. The information about planning and highway issues can be obtained from the district or county council, although easements may only be included in legal documentation concerning the landholding. For all schools, there may be other valuable information in past reports or planning documents, including old site surveys.

4.9 Maintenance issues. As a result of Local Management of Schools (LMS) and Compulsory

Competitive Tendering (CCT), arrangements for maintaining school grounds have changed considerably in the recent past. At the survey stage, it is important to find out:

- which areas need maintenance and what they require;
- which member of staff deals with maintenance issues;
- whether the school has a maintenance contract with an outside body and if so, the nature of this contract. It will be important to examine any existing contract documentation;
- the annual costs of maintaining the grounds.

4.10 Services. Underground and overhead services, such as water, gas, electricity, telephone and drainage, may affect the design and use of the grounds, especially where any excavation or planting is planned. If the LEA cannot supply the information, a letter to all public utilities should explain that developments are proposed in the grounds and that these demand a prior knowledge of underground and overhead services on, and adjacent to the site.



Photo 12 Maintenance and environmental education can go hand in hand

4.11 **Meteorological data.** The nature of the local climatic conditions affects outdoor use of the grounds. A site survey and information from the school weather station may help in analysing the local climate and the micro-climate within different parts of the site. The local weather station, whose location may be obtained from the Meteorological Office, can give schools an indication of longer-term trends. A charge is made for the information which may include temperature ranges, relative humidity, rain, sunshine and wind. There are many opportunities for this to form part of geography lessons.

4.12 **Flora and historical records.** Maps of local or county flora will show the distribution of native and, in some cases, introduced species. By studying the distribution of particular plants and cross-checking with the local geology map, it may be possible to frame proposals which will reinforce or, if necessary, re-create the character of the local landscape. Such information might be published in book form or may be available at the local library or museum or county records centre. The latter may also hold historical records relating to the site and its surroundings. A sense of place and the continuation of a shared heritage can be achieved by responding to historical antecedents. An understanding of the classification of and variation between species is part of the science curriculum. Local distinctiveness is increasingly an issue in relation to biodiversity and sustainable development.

Site Investigations

4.13 **Setting.** Changing the use of any part of the school site may affect neighbouring residents. An important early stage in the survey of the site is therefore to record and appraise the immediate surroundings, including the proximity of neighbours and the wider pattern of access and circulation for both vehicles and pedestrians. The type, appearance and intensity of surrounding land uses should be noted, together with the nature and height of existing site boundaries. The task cannot be carried out entirely from within the grounds. To fully appreciate the site's setting, it is necessary to walk through the surrounding areas in order to establish how neighbours or residents perceive the grounds and to what extent they might be affected by any changes.

4.14 **Visual record.** Views into and out of the site should be recorded by photographs, video, sketches or written comments on plans. These provide a benchmark for 'before and after' comparisons with subsequent developments, and should always be dated. It is a good idea to select two or three crucial

vantage points from which to record and assess the views across the site itself. A plan can be made to show the different spaces created by landscape features or buildings; whether they are contained or relatively open; and where there are valuable landscape features or possible eyesores. There is much scope for work in art lessons here.

4.15 **Existing use.** Information about the features on a school site is only really meaningful if it can be set in the context of the way in which the site is used. Areas which need to be explored include:

- which subjects are currently taught outside, by whom and where;
- what variety of sporting and recreational activities are specifically catered for and how;
- whether there are currently any gardening or cultivation areas;
- whether livestock are kept on site, and if so, where;
- what happens during break and lunch-times - where pupils can and cannot go, what pupils like doing and where, how the informal aspects of the school day are managed, whether there is any play equipment and if so, what kind, where and what condition;
- how the site is used for extra-curricular activities;
- how the site is used by the wider community;
- whether there is any recent history of abuse of the site - vandalism - which needs to be noted at this stage. It is important to distinguish between vandalism and wear and tear or neglect or patterns of use which can be attributed to poor design rather than negative behaviour.

It is important to obtain pupil as well as staff and other user perspectives.

4.16 **Landform and soils.** The planning of new earthworks and the choice of plants and seeds will be influenced by existing landform and the type of soil. Significant topographical features such as changes of level, local ridges or valleys and high or low points should be noted, and the direction and degree of slopes measured or estimated.

Clues to the nature of the underlying soils may be given by the pattern of existing vegetation and further information, covering soil colour, texture and structure, can be gleaned from samples taken at selected points in the grounds. Schools can purchase soil testing kits and do the work themselves. Where more detailed laboratory analysis is considered

necessary, it can be undertaken, for a small charge, by such bodies as the Ministry of Agriculture Fisheries and Food, the county analyst, private firms or local agricultural colleges. If trial holes are being dug for new building works, it may be possible to extend them to include the grounds; otherwise a soil auger or spade is necessary for a detailed study of soil layers.

4.17 **Local climate.** Since weather conditions are not constant, the amount of survey data that can be obtained from a single site inspection is limited, but:

- the prevailing wind is often indicated by the direction and pattern of growth of existing vegetation such as isolated trees or hedgerows and the degree of shelter may be shown by the relative height and form of vegetation;
- other factors may be deduced, such as the nature of the aspect, sunny and sheltered areas, air drainage, possible frost pockets, damp hollows, severely shaded or exposed areas and wind funnels.

Existing schools have the advantage of being able to monitor the climatic conditions over time which could form part of a geographical project.

4.18 **Pollution.** Noise, fumes and visual disturbance caused by traffic and industry affect the educational value of many school sites. On a new school site it is possible to base the development of the whole area on an agreed pattern in which the various uses are carefully zoned to minimise the impact of pollution. With an existing school the creation of earth modelling and dense shelterbelts may help to combat the intrusion.

Sight, sound and smell can assist in the detection of some of the more obvious forms of pollution during a site survey.

The exact levels of air, water and noise pollution may require measuring instruments and laboratory analysis. It is only after accurate measurement, often as part of a sustained monitoring programme, that arguments for a change in site planning or ameliorative measures are likely to succeed.

The district council's environmental health officer may be able to advise on, or even assist in, the measurement of different forms of pollution.

4.19 **Wildlife.** It is valuable in any site survey to identify the various tree, shrub, herbaceous and wetland species and the type and extent of different habitats which may include hedgerows, ditches, wetlands, grasslands and woodland areas. At the same time, the numbers and types of fauna living on the site should be established, as their presence may affect future

development. Certain species now have legal protection and existing habitats may need to be preserved. In any ecological study of new or old sites, an officer from a county wildlife trust or English Nature or in some cases, a local authority, may be able to help by explaining how this aspect of the survey can be tackled.

4.20 **Tree surveys.** The presence of trees may affect patterns of development on both new and established sites. Construction work can affect trees and, conversely, trees - poplar, willow and oak in particular - can cause damage to buildings where the soil is shrinkable clay. It is unwise to retain a large tree as a focal point if it is over-mature or inherently unsafe. A survey which takes account of tree preservation orders needs to take place before any changes are discussed or design work commenced. Survey plans tend to depict all tree canopies as round, whereas in practice this is often not the case. When a survey plan showing individual trees is not available, the exact location has to be measured from fixed points, such as the corner of a building, and recorded on the plan. Where there are many trees, even if they form a single large group, each one should be numbered separately on the plan. Much of the measurement can be undertaken by pupils, who may also want to tell you about the relative merits of various trees for climbing. In many schools this is the moment when for the first time pupils and staff realise just what kind of trees they have on their site. Linked to exploratory work in science, history and art there are many opportunities for acquiring a greater understanding of the culture and history of the trees on the school site.

Any school site containing trees needs to have a clear policy concerning their management. For young trees this needs to include control of weeds until trees are established, removal of any branches likely to injure pupils and an awareness of any poisonous berries or flowers. For larger trees, the following issues need to be considered:

- loss of stability due to disease or root-damage;
- damaged limbs likely to fall to the ground;
- the possibility of disease being spread to healthy trees nearby;
- root loosening due to severe weather.

It is important that members of the school community have the opportunity to put their views concerning the retention or removal of any tree suspected as being unsafe during the survey stage. It is also important that the school is aware of any Tree Preservation Orders which cover trees on their site.

Where building works are proposed close to trees, the location and extent of protective fencing needs to be decided at the outset, as it will affect how work is organised on the site. As a guide, it is important to protect the ground beneath the tree's canopy or within a radius equal to half its height, whichever is the greater (Figure 2).

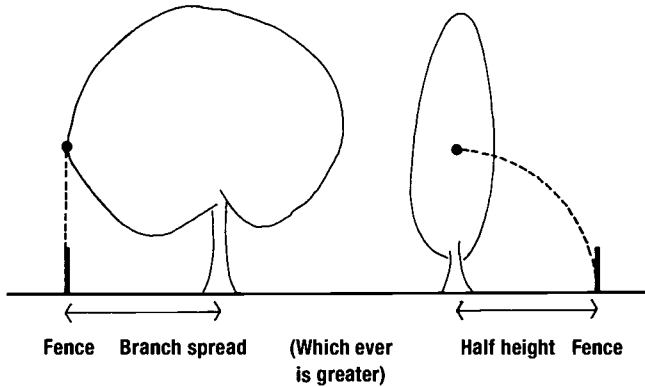

(a) Alternative location for protective fencing around trees to be retained

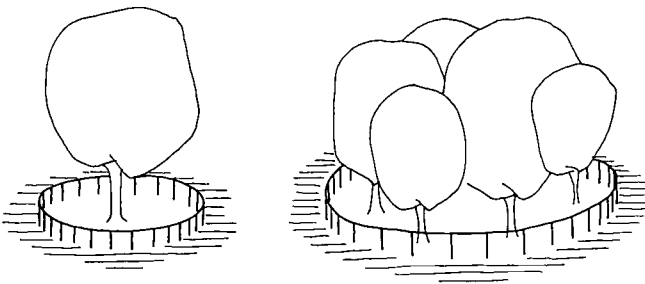

(b) All of the area, as defined in a) should be protected by fencing throughout the course of new works

Fig. 2 Tree protection

As part of the survey stage, schools need to identify their local tree warden and local tree or arboricultural officer, who may be able to give them advice and support.

4.21 Other site features. The site survey should also encompass:

- fences, walls and gates in and around the site, and changes of level such as steps, ramps and retaining walls;
- the type and condition of hard surfaces on roads, paths and any paved areas, since this may be relevant to future use;
- the line of overhead cables and the location of all service inspection covers and markers (even when public utilities have provided information about

them, the position of service inspection covers and markers should be recorded to ensure that they correspond with the plans supplied);

- the size and water quality of any streams, ditches, ponds, springs, wet spots and badly drained or marshy land;
- any features of the surface water drainage system such as outfalls, culverts or drainage falls on hard surfaces where there are already buildings on the site;
- any access routes around existing buildings for fire appliances and for maintenance;
- highway requirements for clear sight lines, either within the site or where vehicular or pedestrian accesses meet public highways.

Categorising the Elements (Zones)

4.22 Schools need to provide as much variety as possible in their grounds in order to meet the needs of all those who use them. The survey stage will produce a mass of useful data which will create an overview of the site and how it is used, but which is not always easy to organise. It may be helpful to stand back from this data and analyse it in terms of the main elements or zones likely to be found on any site. These have been listed below. General guidance on recommended areas for these elements is contained in 4.24. It is most important to retain a sense of the overall picture of the site. Where site size is restricted the overall site area recommended for the particular type and size of school may not be achieved. In these cases, the buildings and play areas are likely to require a greater proportion, and playing fields (assuming that the alternative options in School Premises Regulations are taken up) and habitats a lesser proportion of the recommended areas referred to in 4.24.

- **Playing fields.** As well as the playing fields themselves, these areas contain marginal land which cannot be used for games pitches. Such land can include surrounding boundary areas. Smaller and more intimate spaces extend the range of recreational and social opportunities. A mix of hard and soft landscape areas is desirable, with the emphasis not just on convenience and robustness of use, but also on shade, shelter, site furniture and a landscape of high quality suited to its purpose. To cater for good practice, the specific demands of the NC, and the requirements of the 1996 School Premises Regulations, a grass area for games use should be available to all pupils aged eight or over (see

Reference Section E) and preferably for younger pupils as well. Its area need not be defined solely in terms of a particular number of full-sized pitches. On small sites a combination of grass and all-weather or synthetic turf pitches may be appropriate to allow for time-tabled and extra-curricular games activities.

- **Hard surfaced games court(s):** All schools need some hard surfaces, but many need to review the balance between the amount of hard surfaced areas and the amount of softer, planted areas. In primary schools it is an advantage if the design provides for more than a rectangular tarmac playground and includes niches for less boisterous pursuits. For infants, this area is likely to be informally laid out for skill learning and small games, but for juniors there is a positive need for a court for organised games. This development is taken further at secondary level which requires a range of multi-games courts with ball retaining fencing for such games as tennis, netball and five-a-side football. At the secondary level there is benefit in providing and retaining certain hard surfaces solely for physical education. This would preclude their functioning as additional car parking space or informal play areas, when damage to both the surfaces and the surrounding fencing may occur.
- **Informal and social area.** Pupils' needs will vary greatly according to their age. This category contains a combination of hard and soft areas for play and for social purposes, but of course, such areas may have uses in teaching the NC. In infant schools the hard and soft areas and grass play areas can merge to provide a continuous surface for organised small games where necessary. Secondary schools may find it more appropriate to provide opportunities for boisterous activities without impinging upon the organised games area.
- **Habitat areas.** There is a demand in all sizes and types of school for a proportion of the grounds to be developed for a wide range of activities, including outdoor theatres, wildlife habitats, garden areas, livestock enclosures, etc. Equally, different habitats can support particular subjects, for example a biblical garden or an orienteering trail. They can also enhance play or recreational time, for example, imaginatively placed seating located in a garden area can enhance the aesthetic appeal of a site, as can a sculpture or mural. Increasingly these areas are being given a central and accessible location, rather than being seen as optional extras.

- **Buildings and access.** This includes access roads, service yards, car parks and other outdoor storage areas in addition to the building itself. Some soft landscape will fall within this zone where areas around and between these facilities cannot safely perform any of the functions listed. The proportion of the total site occupied by the buildings and access is likely to be higher in a small school than in a larger one of the same type.

Consideration of these five main features will help schools to establish an overview. The categories are not in themselves significant, but may help schools to determine their current provision in helpful ways, for example, by becoming aware that they do not have an adequate variety of habitat areas, while at the same time having too many hard-surfaced areas in relation to curricular demand.

- 4.23 **Multi-use of the grounds.** Land areas and landscape features need to satisfy a number of different demands. A shelterbelt of trees that improves climatic conditions on a playing field can also serve as a woodland habitat, and the meadow, pond or butterfly garden may form part of a social area near the buildings. The most successful solutions do not compartmentalise the grounds to create a separate nature or environmental area; they treat the grounds as a whole within which a variety of uses can be integrated.

The term 'multi-use of grounds' can apply also to situations where due to restricted sites hard surfaced areas double as games courts and recreation areas (Reference Section A (iii) gives two examples).

Use-Zone Areas

- 4.24 This section gives advice on the sub-division of the overall site into specific use-zones. It is to assist those wishing to review their existing sites and for those who are intending to do advance planning of new sites to be developed whilst taking account of the unique opportunities that exist on a site by utilising its landscape features to advantage. For advice on new sites, their recommended areas, their selection and their overall development, the listed publications may be consulted:

- for site areas for all schools and site selection - Building Bulletin 82 *Area Guidelines for Schools*;
- for site development in support of the curriculum - Building Bulletin 71 *The Outdoor Classroom*;

- for statutory playing field area - The Education (School Premises) Regulations 1996 - for an extract of the DfEE Circular No. 10/96 refer to Reference Section E;
- for hard surfaced games court(s) and informal and social areas. These will be touched on, and area recommendations given in Reference Section F. It includes infant schools, junior schools, primary schools, middle deemed primary schools, middle deemed secondary schools, any secondary schools, and special schools. For nurseries (units and schools) see 4.29.

4.25 **Use-Zones.** Before site survey data is used for more detailed planning, it may be helpful if the total site area is considered in terms of its use-zones. The site then may be sensibly divided on the basis of a proportion of the site being devoted to each zone as in tables 15 to 20 for the schools listed in 4.24. For illustrated examples of an area allocation for a primary school and a secondary school site refer to Building Bulletin 82.

To underline the need for flexibility in interpretation, the tables take the form of a range band with an upper and lower recommended area figure consistent with the overall site area, hard surfaced games courts, and informal and social areas recommended in Building Bulletin 82. The range would not apply to restricted sites which need to be dealt with on their merits - see 4.26 below.

4.26 **Restricted sites.** Where land is scarce the drawbacks of a confined site may need to be balanced against the advantages of a good location. Where the site is below the recommended area range or band, the shortage of space can be offset to an extent by an increase in landscape quality to allow multi-use (see 4.23). In practice, it is likely that a hard surfaced area such as hard porous or synthetic surface may be needed for multi-use for PE and recreation. In some instances, there may have to be greater reliance on off-site PE facilities including playing fields with reference to options in the 1996 School Premises Regulations. For illustrated worked area examples of a primary school and a secondary school site refer to Reference Section A (iii).

4.27 **Layout of use-zones.** In re-planning an existing site or planning a new school site, a flexible approach is essential if the objectives of the brief are to be achieved. This calls for the preliminary consideration of a wide range of options before the most likely

solutions are more fully investigated. The buildings, access and playing field layout are major factors in determining the size and qualities of the residual spaces or zones, which can vary considerably in the different options which are explored in Reference Section A(i), Exploring options for site development of zones for a primary school.

4.28 **Sites and boundaries between zones.**

Considerations of safety will often dictate the separation of areas accessible to pupils from busy access or service areas. On large school sites there is often no clear definition between zones as one blends into another, but on small sites there is frequently the need for definition, for example by a change of level or by providing a fence, wall, or hedge to separate boisterous activities from quiet ones, for the separation of pupils by age, or to protect carefully nurtured plants or areas for scientific study. Illustrated general advice on the layout of use-zones is given for a number of school types in Reference Section A(ii) nursery provision, infant and junior school provision, secondary school provision, and special school provision (a primary school).

4.29 **Nursery provision.** Nursery schools and nursery classes have not been included in these guidelines for overall site area. The site area should be taken as 15m² to 18m² per pupil, but design issues can be found in section 6. Reference Section A(ii) includes an example of a nursery garden, and additional information is given in Building Bulletin 82. Further guidance is being prepared.

4.30 **Special schools.** Recommended outdoor areas are given in Table 21. This provides an all inclusive hard surfaced area for games, with an informal social area, and a separate area for informal activities on grass, and for creating habitats. The area guidance is intended to be considered against the particular needs of individual special schools. Overall site areas are not given as these will vary in relation to the type of special school and the need for playing fields, but where the size and age range of pupils is comparable to other schools, the following factors should be borne in mind:

- the building area will occupy far more space than in other schools with the same pupil numbers on account of the larger teaching area per pupil and the greater range of support spaces required;
- more extensive provision for vehicular access will be needed to cater for waiting and for a one-way traffic flow to avoid reversing when pupils are set down at the main entrance;

- many schools cover a wide age range and some additional space in the grounds is needed to provide for a degree of age separation and for a protected environment for certain pupils;
- the design may need to preclude pupils gaining immediate outdoor access to service areas or public roads, for example by including self-closing gates;
- a canopy at the main entrance can give shelter to physically disabled pupils who may take longer to get into or out of vehicles.

- More detailed consideration of the site requirements for special schools and of how these vary between schools for different needs is contained in Building Bulletin 77 *Designing for Pupils with Special Needs: Special Schools* (HMSO 1992) and in *Grounds for sharing: a guide to developing special school grounds* (LTL 1996).

5. Providing for the Formal Curriculum

5.1 This section outlines some of the ways in which the school grounds can provide for the National Curriculum. **It needs to be read in parallel with section 6, which explores the informal curriculum, and section 7, which deals with the hidden curriculum.** After reading these three sections it will be easier to identify the range of needs which a school might have. Each of these three sections offers:

- a rationale;
- some comments on possible use, and on design and management issues.

Having read them, schools can look objectively at their survey data and at the analysis of needs for their site and so begin to identify possible design and management solutions.

A Rationale

5.2 **The National Curriculum.** The rationale for teaching in the school grounds has been provided by *The National Curriculum* (HMSO 1995). It is also evident in *The Outdoor Classroom* (HMSO 1990) and publications produced by Learning through Landscapes that there are opportunities for teaching outdoors at school in nearly every core and foundation subject within the National Curriculum. Aspects of some subjects can only be effectively taught outdoors. These include:

- science;
- geography;
- physical education.

In other subjects there are elements which schools report can best be taught outdoors. These include:

- English;
- mathematics;
- design and technology;
- history;
- art.

It is possible, with a little imagination, to teach any subject outdoors. The outdoor classroom of a school's grounds can provide a rich educational resource for teaching the formal curriculum right on a school's doorstep. The more school grounds are developed, the greater the opportunities for children to learn there. The fact that schools, especially at primary level, now have discretion to go beyond the NC, means that there are even more opportunities outdoors at school.

Use, Design and Management Issues

5.3 **Science.** Science is one of the three core subjects. It offers many opportunities in the school grounds. Scientific competence in the areas of classification, data-collection, data-analysis, experimentation, observation, analysis of evidence and environmental understanding can effectively be taught outside. The subject is divided into life processes and living things, materials and their properties, and physical processes, and all have obvious applications outside. It is difficult to see how understanding and classifying plants and animals in their environment, carrying out large-scale experiments with forces and working with materials like water can effectively be taught unless the lesson takes place outside. Science has much more potential including:

- understanding waste management and recycling;
- working with mini-beasts;
- exploring trees and plants;
- understanding the ecology of ponds and wetland areas;
- finding out more about grassed areas and learning about wild flowers;
- understanding the built environment.

Features such as ponds, vegetable plots, orchards, copses, herb gardens, wild flower meadows, animal enclosures, compost heaps and bird-tables provide opportunities for teaching science outdoors. More detail about habitat creation is contained in section 8.

In developing the grounds it will be important to take into account the specific demands of the NC at each Key Stage. All school grounds have the potential to become exciting outdoor laboratories. As always, solutions which provide resources for a range of activities may well be the most useful.



Photo 13 A pond provides rich opportunities for teaching science outdoors

5.4 **Physical education.** Physical education is a foundation subject which must be taught partly outdoors in the school grounds. Many secondary schools go beyond the minimum requirements to cater for GCSE and 'A' level examinations. Physical competence can be developed through participation in a range of activities, many of which rely on facilities within the school grounds. Such provision is all the more important where children have few opportunities to engage in physical activities near to where they live. It can extend beyond the necessary demands of team games into the provision of opportunities for outdoor and adventurous activities. The design of outdoor physical education facilities needs to begin with a clear understanding of:

- the Key Stage requirements of the NC and their implied demands for provision;
- organisational factors specific to the particular type of school - the ages of the pupils, the number and size of teaching groups and the estimated number of teaching hours per week for which outdoor facilities will be required;
- the extent of extra-curricular use such as team practices, school clubs, inter-school competition and community involvement and the standard of play and competition use - regional, county or district;
- the indoor facilities available for physical education including sports halls and dance studios, gymnasias and swimming pools and those facilities for indoor instruction in outdoor sports in accommodation provided to meet the shortfall in playing field area due to restricted sites;
- the feasibility of using off-site playing fields to alleviate a shortage of them, especially in urban areas. Whilst the quality of such provision may often be good, there is expenditure of time and money on travel, and pupils may lose the opportunity to practise skills and play team games in extra-curricular time. The potential for community use might also be reduced.

5.5 **PE in primary schools.** The outdoor provision for physical education in primary schools should not be regarded as a scaled-down version of facilities normally found at secondary level. It has to take account not only of the physical needs of all the children, including those with disabilities, but also of their broader social and personal needs. It is necessary for primary schools to provide for the NC programmes of study for physical education. For Key Stages 1 and 2, provision must be made for games,

gymnastic activities and dance. In addition, for Key Stage 2, provision must also be made for athletic activities, outdoor and adventurous activities and swimming. Schools may, however, provide for swimming in Key Stage 1 if they prefer. Schools may choose to extend their physical education curriculum further as well as organising extra-curricular sports activities for their pupils.



Photo 14

Photo 15 Outdoor games on playing fields and on games courts are important in the curriculum. Junior through to secondary aged pupils will be involved in full-sided games, whilst younger pupils will benefit from small-sided games and skills practice



Photo 16 Camping in the school grounds is a good introduction to outdoor and adventurous activities

Some young children will have limited opportunities outside school to play outdoors and to develop physical skills, because they live in built-up areas with heavy traffic or their parents are reluctant to let them out of doors unsupervised. The same outdoor facilities will often serve for both 'lessons' and 'play', particularly in primary schools. This mix of physical education activities with more informal recreational activities presents a challenge for anyone designing school grounds. There must be explicit provision for the former during lesson time, but it should not be at the expense of a wide range of opportunities for play and recreation at other times.

A stimulating environment at primary level for both curriculum work and play demands more than a flat expanse of tarmac. For the youngest children in particular, outdoor and adventurous activities can include scrambling and climbing and can beneficially extend to orienteering courses. Certain types of play equipment demand safety surfaces. The hard surfaced and grass areas need to be sufficiently spacious to allow vigorous activities, as well as the freedom to run, jump and chase. By the time they reach junior school age, children need suitable spaces for a variety of small-sided games, including simplified versions of recognised games. Athletic activities afford opportunities for improving the basic skills of running, jumping and throwing. Outdoor provision might include courts and pitches for mini-games and practice areas. Flexibility of use and layout enables the school to accommodate a changing pattern of demands through the seasons. More technical information about games courts is contained in section 8.

- 5.6 **PE in secondary schools.** A broad and balanced physical education curriculum is desirable for all secondary school pupils. Programmes of study are drawn up for six areas of activity; games, gymnastic activities, dance, athletic activities, outdoor and adventurous activities, and swimming. Pupils in Key Stage 3 (ages 11-14) must pursue games, at least one other full area of activity and at least two additional half areas of activity. At least one half area of activity must be either gymnastics or dance. Games should be taught in each year of the Key Stage. The breadth and balance offered by these requirements should extend beyond year 9 to cater for the continuing interests and needs of older pupils. In Key Stage 4 (ages 14-16), programmes of study for the same six areas of activity are drawn up. Pupils should be taught a minimum of two different activities, at least one of which should be a game.

- 5.7 **Special schools.** For some special school populations, appropriate outdoor provision will be similar to that for pupils of the same age in mainstream schools, for example where there are pupils with moderate and emotional and/or behavioural difficulties or hearing impairment without more complex disabilities. Relatively few special schools have playing fields suitable for large team games and few are big enough to make full use of such facilities. Where a special school lacks suitable playing fields of its own, those pupils able to participate in team games will need guaranteed timetabled access to provision elsewhere, such as that at a neighbouring mainstream school. Where playing fields are available, there will still be the usual need for paved and grassed areas for other activities. Where the school lacks playing fields of its own, this provision assumes even greater importance. All special schools require such facilities, including those for pupils with severe and profound and multiple learning difficulties and for those with physical disabilities. Most pupils will be able to participate in small-team games, and space is needed for races and boisterous games, whether on foot or in wheelchairs. For some pupils, alternative sports, such as archery, may be appropriate.

For pupils with special educational needs, the potential of the school grounds for supporting and enhancing other aspects of the curriculum besides physical education can be particularly important. As well as the activities mentioned elsewhere in this section, the site can offer a stimulating environment suited to practical activities, including for example horticulture, from which many pupils with special educational needs can benefit. Sensory gardens and opportunities for mobility and independence training can also be useful.

- 5.8 **Pupils with special educational needs in mainstream schools.** Mainstream schools are increasingly including pupils with a wide variety of special educational needs. They are expected to pursue, so far as it is possible for them to do so, the same curriculum as other pupils, but some of the additional considerations referred to in 5.7 and in greater detail in Building Bulletin 77 may also apply.
- 5.9 **Geography.** Geography is a foundation subject. Geographical skills, such as undertaking fieldwork activities, giving and following directions and mapping, are particularly suited to work outside. It is an essence of the subject that pupils should develop an understanding of their locality and their immediate environment. Indeed, as they must study the locality of their school, it is essential that they know and

understand the grounds and the land nearby. Pupils also have to be taught to investigate the quality of the environment and to express their views on its attractive and unattractive features. The school grounds provide one of the best and most real contexts for this aspect of study. Geography has potential for developing a wide range of skills when studying:

- weather and climate;
- water and landforms on the school site;
- people and settlements - the school community;
- the environmental quality of the grounds and how it could be improved;
- the development of a sense of place and local distinctiveness.

Features such as maps marked on the ground or walls, signposts, orienteering courses, toposcopes, weather-stations, ponds, streams, earth mounds, wildlife gardens, soil profiles, rock gardens, heathland and trees provide opportunities for the grounds to be used for the teaching of geography. Design and management issues like the pedestrian circulation, access for bicycles, car parking, traffic flows, litter-management, the choice of place names etc, are worthy of study in geography.

More detailed information can be found in *Geography in the school grounds* (LTL/Southgate 1996).

- 5.10 **English.** English is a core subject. The development of language is an essential part of education and this can be effectively learned outside. Something about the power of working with the natural world means that new words come tumbling out of children when they are faced with real experiences outdoors. Work in the school grounds can make a special contribution to the development of oral skills, to the stimulation of the imagination and to the encouragement of reading and writing for pleasure and for a variety of other useful purposes.

There are opportunities to study:

- story. Children construct the world through story and if this is recognised then much which takes place outside can become useful stimulus material, from stories about mini-beasts, to what happened at play time;
- poetry. It is possible to explore the senses, to respond to the natural world, to write about climate and the seasons, even to enact poems like the cautionary tale 'Matilda' by Hilare Belloc;

- drama. Drama which began outdoors in Ancient Greece can enrich life outdoors at school, as part of both the formal and the informal curriculum;
- writing. Constructing questionnaires, making a guide to the school grounds and recording play ground games are useful in English lessons.

The provision of seating arranged so that it facilitates discussion will promote language development. Some schools have gone further and developed an amphitheatre in the grounds. Natural slopes and banking with additional earth modelling where necessary can form semi-circular and circular arenas 10-20 metres in diameter. Imaginative signage around the site can be a constant source of interest in the written word.

More detailed information can be found in *English in the school grounds* (LTL/Southgate 1993).

- 5.11 **Mathematics.** Mathematics is a core subject. Mathematical skills such as problem-solving, reasoning, estimating, calculating, understanding patterns, classifying, comparing, using charts and diagrams, and understanding scale can be developed very effectively outdoors. The concepts of number, shape, space and measurement are particularly important. The school grounds give a real context for using and applying mathematics. Almost all constructional tasks in the grounds involve mathematics. For example, a school making a pond will need to calculate the size of the pond, how much liner or clay will be needed, the volume of water which will be required and how long it might take to fill it up. Collecting and analysing data as part of a school grounds survey can largely be taught as part of mathematics lessons. The mathematics of space, shape and scale is of obvious relevance, especially at the stage when maps and models are being used in the planning process. Mathematics has the potential for developing necessary skills and for studying:

- number, for example, at primary level, by counting bricks, windows, mini-beasts, potatoes grown in the school garden. There are real opportunities for multiplication - working out the amount of glass needed for six windows each with four panes of glass, and division, by working out whether a sum of money will be enough to buy animal food for a ten-week term;
- measurement, for example, establishing the girth of a tree, using standard and non-standard units from metres to the length of a child's arm;
- the space and shape of the grounds, learning how space and shape can affect use and quality;

- data, especially developing an understanding of what needs to be known, how the information can best be acquired, how it should be presented and what it can tell.

At primary level, playground games can encourage the development of mathematical skills as part of the informal curriculum. The presence of some playground markings can act as a constant stimulus to mathematical activities.

More detailed information can be found in *Mathematics in the school grounds* (LTL/Southgate 1993).

5.12 Design and Technology. Design and Technology is a foundation subject. Much of the school grounds design and development process can be taught as part of this subject. Design and Technology involves identifying problems, designing solutions, making the solutions happen and then evaluating the results. Many schools have developed extended projects which are based in the school grounds. In particular there are opportunities to:

- develop a design capability through assignments outdoors, for example looking at why some areas of grass become worn down, looking at the effective storage of bicycles, and examining pedestrian circulation;
- work with a range of materials, including wood, water, concrete, bricks and recycled materials;
- generate and communicate ideas, considering their strengths and weaknesses, especially as part of the stage of the development of school grounds when consultation is necessary;
- making different structures outside, from living willow sculptures to mazes, trails to bird-feeders.

This subject offers particular scope for children and teachers to work alongside landscape architects, architects, artists and designers in the school grounds.

5.13 History. History is a foundation subject. It offers a number of opportunities in the school grounds, especially those related to the local history of the school's area and the development of a sense of place. A carefully planned mixture of indoor and outdoor experiences can be particularly effective in bringing local history alive. A study of history develops an understanding of chronology and enquiry which can be nurtured outside. Before any school grounds developments are undertaken, it is vitally important that children, staff, parents and the local community have a clear sense of the history of the site.

There are opportunities to:

- learn about aspects of the school's past, especially locally interesting stories, the development of local place names, including the name of the school itself and significant local activities in the past;
- find out how information such as old maps and photographs can give clues about the earlier use of the site;
- learn about the ways in which evidence can be destroyed and can survive, for example by seeing what emerges from deep digging or from the careful burning in a bonfire and subsequent examination of a number of common everyday objects;
- communicate aspects of the school's past in a mural or pageant outside.

Some schools have constructed a time-line in their grounds depicting key moments of international, national and local history in a memorable way.

5.14 Art. Art is a foundation subject. The grounds offer a number of opportunities for pupils to explore and develop their artistic potential on a scale and with materials which cannot be found indoors. Art offers a particularly exciting way of surveying the grounds in a visual way and of creating images and pictures which can be used as part of the design and development process.

There are opportunities to:

- record outdoor experiences and features in a variety of media;
- find images and artefacts in the grounds to act as a stimulus for creative work;
- experiment with techniques outdoors, such as ephemeral art using items found in the grounds, chalking on the playground, making large-scale murals and sculptures.

There are obvious opportunities for pupils and teachers to work with artists and designers in the grounds. Some schools have created locally distinctive signs to celebrate their work outside. Others have created outdoor galleries with regularly exhibited items of sculpture, but this would only be possible where there was confidence that such works could be safely kept on site.

More detailed information can be found in *Arts in the school grounds* (LTL/Southgate 1996).

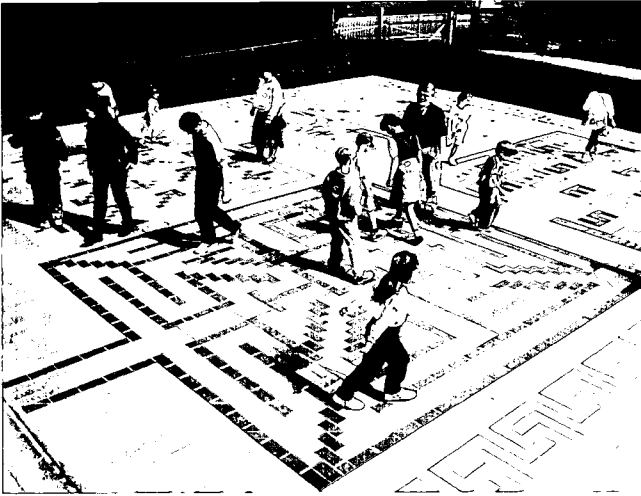

Photo 17 A maze affords endless attractive mathematical possibilities



Photo 18 Murals provide opportunities for work in art

5.15 **Environmental education.** Almost all of what has been described so far in this section could be studied as part of the cross-curricular theme of environmental education. Although in *Teaching environmental matters through the National Curriculum* (SCAA 1996) greater emphasis has been laid on the contribution of individual subjects to environmental education, all that was said in *Curriculum Guidance 7* (National Curriculum Council 1990) remains valid. In particular, the description of this area as having three distinct elements is helpful:

- education *about* the environment (knowledge);
- education *for* the environment (values, attitudes, positive action);
- education *in or through* the environment (a resource).

The school grounds can contribute powerfully to the development of a range of environmental competences in pupils. They can learn, at first hand,

lessons on sustainable development, biodiversity and environmental design and management. When considering changes to the physical design of the grounds, it will be helpful to remember that some features, for example, ponds, mazes and trees can serve the needs of a number of different subjects and a number of different aspects of environmental education. Indeed, especially at primary level, it is often possible to manage lessons so that more than one subject is being taught at the same time.



Photo 19 Weather watching in geography is made more interesting by this unusual wind sculpture

5.16 **Experiential learning.** The value of first-hand experience has already been described in section 2. Most work in the school grounds is of this kind. Much work outdoors is very different from work inside the classroom and teachers often need support in order to be able to deliver it effectively and with confidence. Whether a school decides to use its existing site resources for teaching or develop new ones there will be management implications for the in-service training of teachers and other staff. Well-planned, and more active approaches to teaching and learning will often be more memorable and, therefore, effective.



Photo 20 The science of static electricity can easily be explored outside

- 5.17 **Extra-curricular use.** It is worth considering the range of extra-curricular activities which a school would like to offer before planning any changes in the grounds. Many schools offer activities including sports, science and gardening clubs.

6. Providing for the Informal Curriculum

6.1 This section outlines some of the ways in which the school grounds can provide for the informal curriculum. **It needs to be read in parallel with section 5, which explores the formal curriculum, and section 7, which deals with the hidden curriculum.**

A Rationale

6.2 **The informal curriculum.** The term 'informal curriculum' is now widely used to describe both the times of the day when children are in school but not being taught ie, play and break times, and what they do at those times. Although the activities of pupils vary according to their age, the informal curriculum serves as a generic term across the nursery, primary and secondary age range. While there is much that has been written about this aspect of school life, there is not the same statutory requirement for it as for the formal curriculum. It is important, therefore, that schools consider this issue and develop their own rationale for dealing with the kind of issues raised in this section.

6.3 **Allocation of time.** While individual schools may vary slightly, there is generally a correlation between the age of pupils and the percentage of the day allocated to the informal curriculum. Thus, it is common to find that, for nursery and infants, it may account for one third of each day, for juniors a quarter and for secondary pupils, one fifth. It is also usual for children to be required to spend the greater amount of this time, weather permitting, in the school grounds or that part identified as 'the playground'. The informal curriculum, therefore, accounts for a substantial part of each pupil's education at school. However, the existence of the informal curriculum is often merely traditional or driven by organisational and administrative considerations such as the need for 'breaks' of various kinds.

6.4 **The process of developing a rationale.** Considerations about the amount of time spent by pupils are clearly an important element of any justification for such a substantial proportion of each school day. Often they serve to obscure the need to ensure that pupils gain real educational benefit from the time and the opportunity provided in the grounds. Such benefits are only likely to be realised where a clear rationale for the informal curriculum has been developed by the school. This should identify its purpose, value, aims and objectives, consider implications in terms of management practice and decisions relating to the design of the school grounds. The process of developing a rationale for the informal

curriculum requires consultation, investigation and consideration, ideally involving the whole school community. Whether or not this results in physical changes to the school grounds will depend upon the circumstances and needs of individual schools. However, the exercise will have inherent value if it achieves a greater understanding and clarity of purpose for this aspect of school life.

6.5 **Use of school grounds for the informal curriculum.** While the informal curriculum serves as a useful generic term for play or break times, there is no single word or simple definition which adequately describes the range of uses, activities, opportunities or experiences which are or should be provided for pupils during this time. Although the needs of pupils will differ according to their age, it is possible to identify a number of factors which have a bearing on the informal curriculum for all pupils.

- School grounds form a significant part of pupils' experience of the informal curriculum.
- Research has shown that children today have less freedom and independent mobility than previous generations. School grounds are the one external environment to which all children have regular access. For some, the informal curriculum may constitute the majority of their experience of being out of doors.
- Research has also shown that, especially to younger children, school grounds are important and different from any other type of external environment. They can represent a 'safe haven' in what is increasingly perceived as a dangerous world. They can offer a range of opportunities, experiences and activities unavailable anywhere else outdoors.

Clearly, pupils require more than the simple presence of outdoor space in order to benefit from and enjoy the opportunities presented by the informal curriculum.

6.6 **Special schools.** The grounds of special schools need to provide for similar activities to those of mainstream schools. Additional considerations have been mentioned under the formal curriculum such as the need for some pupils to practise mobility and independence skills. There may also be an additional need to allow for separation of the more vulnerable from those pursuing boisterous activities. Electric wheelchairs can be a particular hazard, especially where the pupil concerned is not yet very adept at manoeuvring. A space the size of a hard surfaced games court will usually be suitable, with adjacent

protected sitting areas. In all-age schools, the areas for primary and secondary age pupils should normally be separate. Security is important for all schools but it assumes even greater significance for pupils with special needs and there will often be a need to contain those spaces to which pupils have access at break times to avoid pupils straying, as well as to provide protection from vehicles and unauthorised visitors. This containment needs to be designed sensitively to avoid it appearing oppressive.

6.7 Pupils with special educational needs in mainstream schools. References to protected areas and containment in 6.6 may apply to some pupils with special educational needs in mainstream schools, particularly where there are those with severe and profound and multiple learning difficulties.

6.8 Learning opportunities. The informal curriculum provides a range of learning experiences and opportunities which are equally important as those provided by the formal curriculum. The main characteristic of the informal curriculum is that children are in school but not being taught. While they are supervised, pupils are expected to engage in self-directed and self-motivated activities. The nature of specific activities will differ according to the age of the pupils, but the absence of adult direction and organisation means that it constitutes a different form of learning experience. It provides opportunities for testing concepts, practising skills, confronting challenges, calculating risks, recognising capabilities and limitations and generally developing a sense of self-worth and self-confidence. The informal curriculum, therefore, provides for an essential element of every child's education and healthy development, especially if other opportunities are limited. In this regard, it is important to recognise that the quality of experience enjoyed by pupils is largely determined by the design and management of the school environment.

6.9 The nature of the experience. The informal curriculum requires a pupil to spend time amongst large numbers of others. There can be few other situations where they are required to co-exist in such large numbers. While this can be a valuable experience, helping them to understand people who are both similar to and different from themselves in size, age, background, culture, likes and dislikes, it can also prove a daunting and difficult experience. Problems are exacerbated where resources, space and equipment are inadequate. This is also the case where it is not possible to engage in an activity without inconveniencing others or to find any personal space for solitude and reflection.

6.10 Behaviour. In recent years much attention has focused on the informal curriculum because of a perceived increase in inappropriate behaviour and because of incidents and accidents across all age ranges. Schools expend considerable effort in devising strategies to modify unacceptable behaviour, in an attempt to reduce teasing, fighting and other forms of verbal and physical violence. Some of these strategies may prove effective in dealing with the manifestation of problems but they rarely address the underlying cause. Substantial evidence now exists to show that hostile school environments breed hostile behaviour. Many of the behavioural problems schools experience are, in short, caused or exacerbated by the way school grounds are designed and managed for the informal curriculum.

Design Issues

6.11 Design. There is no single solution to the design of schools for the informal curriculum since each school has different needs and particular opportunities and should use and develop its provision accordingly. Before embarking upon design changes, it is essential to undertake a survey of the site, to consult pupils, to consider the views of other sectors of the school community, especially supervisory staff and parents, and to develop a rationale for the informal curriculum. In this way, schools can be sure that they have identified the full range of their needs and opportunities.

As a general rule, the type and range of activities undertaken by children and young people will be determined to a considerable extent by the design of school grounds. Whilst it is not possible to examine all the options and possibilities, a number of common problems and possible solutions are discussed.

6.12 Space. The amount of space available for the informal curriculum is, in itself, a key factor. Schools may not be in a position to increase the amount of land they have, so it is important to consider how best to use available space. Frequently schools cite problems of over-crowding caused by too many pupils using a small area of tarmac. It is also common to find that additional space exists but, being grass, it is out of use for much of the year. It may be appropriate to consider extending the use of playing fields and sports pitches, when the weather allows, during informal curriculum time. This will obviously have implications for the wear and tear of such spaces. However, if the problem relates to children bringing mud into the school, consideration can be given to improving drainage, providing paths or changing the nature of the surface. It is also possible that restrictions are

borne of concerns related to the inadequacy of supervision. Faced with this kind of problem, some schools have employed additional supervisors, others benefit from a parents' rota and some have introduced a pool of wellington boots available for those using grassed areas.

6.13 **Zoning.** Another means of increasing the range of activities and opportunities available to pupils is to segregate or zone the space. In primary schools it is common to find that pupils are segregated by age out of concern for the safety of younger children. However this may actually increase the levels of boisterous activity among older children. It also prevents children from playing with siblings and those younger and older than themselves which many enjoy doing. An alternative approach involves zoning by activity, though this requires the appropriate development of areas to support the intended activities. Schools have devised ingenious ways of defining and separating the areas, including markings on tarmac and positioning of planters or other features such as cones in place of walls or fences.

6.14 **Seating.** The lack of places to sit, to read, to eat lunch and generally to socialise with friends is a major omission in many school grounds. Research has shown that the provision of places in which to sit is critically important and that due account needs to be taken of the environment, location and aspect as well as the design and quantity of seats. Children rarely use picnic benches as intended, while straight, linear seats positively inhibit social interaction. Seating should be positioned in sheltered rather than exposed places, on a scale relevant to the age and size of pupils. It should be formed so as to enable both small and large groupings. Attention also needs to be paid to the nature of the surface on which the seating is provided. This is to take account of the fact that it may be difficult to cut grass around uprights. Puddles will also form in areas prone to wear.

6.15 **Shelter.** The provision of structures which provide shade and shelter can greatly enhance the quality of school grounds for both informal and formal curriculum use. The range of sizes, shapes and designs developed by schools varies from small houses for nursery age children, some even going up to two storeys, to purpose-designed gazebos and pavilions. Some schools have provided a range of smaller units in preference to a single large structure. Others have converted bicycle stores and outdoor lavatories or renovated old, often dilapidated, outdoor shelters.

6.16 **Variety and diversity.** Whether provided by fixed elements, loose equipment, planting, sculpture or murals, it is essential that the environment offers as much variety and diversity as possible. Children and young people need, deserve and appreciate environments which engender a sense of joy and wonder. Their imagination and curiosity needs to be fed, as do their senses, in addition to providing opportunities to test and develop skills and talents. Having due regard to health and safety considerations, schools are continually discovering new and creative design solutions to the needs of the informal curriculum. Examples include musical play structures, planting to provide refuges and dens, mazes and puzzles incorporated into paving or painted on tarmac, seats designed as climbers and even the provision of 'personal planters' for those who like gardening.



Photo 21 A varied school landscape is most likely to better meet the different needs of pupils

6.17 **Fixed play equipment.** The provision of fixed play equipment in school grounds is now common and can, if carefully selected, make a useful contribution to meeting the needs of some aspects of the informal curriculum, especially for younger children. It is imperative that schools considering the installation of fixed play equipment are fully conversant with health and safety legislation and with British Standards. Local authorities will be able to provide advice and guidance. While fixed play equipment can provide for a range of specific physical activities, its location within school grounds requires careful consideration. Issues related to cost, quantity, age, relevance, space, surfacing, supervision and maintenance requirements will need to be balanced against the opportunities which the equipment may afford.

Management Issues

6.18 **Different strategies.** The allocation of time to the informal curriculum, as described in 6.3, can be considerable, even though, in recent years, there has been a trend towards reducing the time and number of breaks schools provide. This is often the result of concern over levels of inappropriate behaviour. It may also follow from difficulties arising during and after break or lunch-times. Some of the causes of such problems have already been mentioned. In many cases they can be solved by introducing new management strategies. For example, where space is very limited, staggering morning and afternoon break times can relieve pressure which results from the whole school using the grounds at the same time. Schools which encounter such problems often report that they occur only or mainly in the midday break where the environment, in failing to meet the needs of the pupils is the root cause of the problem. It follows that these will increase with time.

6.19 **Supervisory staff.** In primary schools, the management of midday breaks is usually undertaken by non-teaching staff and this will be a significant factor in the management of these times. Supervisory staff may be expected to supervise large numbers of pupils, be relatively unfamiliar with their charges and have little or no real authority. Equally, they may have received no training. Often, for reasons of expediency or incomplete understanding of the health and safety issues, this potentially very significant role is reduced to the level of policing the site. Some schools have

derived considerable benefits from a variety of approaches, including:

- increasing the number of staff;
- redefining job descriptions better to reflect the aims and objectives of the informal curriculum, and, possibly, making it closer to that of a playworker, emphasising participation as opposed to supervision;
- providing training to improve skills and confidence;
- organising regular meetings between teaching and non-teaching staff to improve communication and ensure a consistency of approach.

It is essential that all supervisory staff are familiar with the school's health and safety policy and the procedures which must be followed in an emergency. *All* staff involved in supervisory duties should be given training so that they can fulfil the requirements of their job description. Local circumstances will need to be considered when determining appropriate levels and styles of supervision (see health and safety check list for governors and teachers in Reference Section H).

6.20 **Loose equipment.** There is considerable value to be derived from providing loose equipment at break and lunch-time at primary level. Its success depends upon the quality, quantity and variety of equipment. Ideally, pupils should be involved in its selection, organisation and care.

7. Understanding the Hidden Curriculum

- 7.1 This section outlines some of the ways in which the school grounds can provide for the hidden curriculum. **It needs to be read in parallel with section 5, which explores the formal curriculum, and section 6, which deals with the informal curriculum.**

A Rationale

- 7.2 **The hidden curriculum.** The full significance of the hidden curriculum of school grounds was identified by research undertaken for the Worldwide Fund for Nature (WWF) and LTL and is explained in *Special Places; Special People - the hidden curriculum of school grounds* (WWF/LTL 1994). It has long been accepted that people make judgements about places based on appearance, and that design is a language which communicates. However, this research produced new knowledge because it found that school grounds, by their design and by the way they are managed, communicate messages and meanings which influence children's behaviour and attitude in a variety of ways. The fact that the environment exerts such influence and the way in which it communicates this, is now increasingly described as the hidden curriculum of school grounds.
- 7.3 **The importance of school grounds.** To children, school grounds are unlike any other kind of external environment because they are part of school. This creates expectations that the provision will reflect and support the aims, purpose and ethos of their school. School grounds are often the most visible part of schools. It is important to recognise that parents and other adults may also be influenced by the hidden curriculum of school grounds and may form judgements about its ethos, values and attitudes based on the messages and meanings conveyed by the grounds.

Design Issues

- 7.4 School grounds, like any spaces, are made up of a number of different elements, trees, tarmac, signs, etc. At its simplest level, if a school playground has no seats, children conclude that the school does not intend them to sit down outside. This example may convey other messages to children, the most obvious one being that the school disregards even the most basic needs of its pupils. Thus the absence of an element such as seats influences behaviour. In a practical sense, pupils do not sit down or, if they do,

they sit on other items which may not have been intended for that purpose. More profoundly, pupils' attitude to the school is potentially influenced negatively by the school's perceived lack of care.

Essentially, the design of school grounds determines the kinds of activities which are possible, but also it conveys messages about the intentions of those who manage the school. Where the only space provided for the informal curriculum is a rectangle of tarmac with some painted lines, some children will play football, others will 'rush around'. Pupils in this situation may be doing this because they like football or because the design prohibits other kinds of activities. Not unreasonably, they may also simply conclude that this is what they are intended to do.

Management Issues

- 7.6 The way school grounds are used, developed, maintained and managed has considerable significance.



Photo 22 Shrubs can create natural dens for pupils to enjoy

- 7.7 **The formal curriculum.** Where school grounds are used for teaching, as a resource to deliver some element of the National Curriculum, the status of the grounds is changed. This means that teachers will use the grounds and that parts of them will be used for work in lesson time, which most children believe adults view as more important than 'play' time. Alternatively, the use of school grounds for teaching may bring about a range of interesting changes and improvements to the grounds.
- 7.8 **The informal curriculum.** Another important aspect of the hidden curriculum relates to the way school grounds are managed for the informal curriculum. While there may be good reason for designating playing fields and pitches 'out of bounds' during this time, pupils may draw harsh conclusions about the school's priorities if, as a result, lunch and break times have to be spent on cramped areas of barren, windswept tarmac.
- 7.9 **Maintenance.** Finally it is important to recognise that the way in which school grounds are maintained and cared for constitutes an important part of the hidden curriculum. The presence of litter, broken fences, damaged equipment and graffiti in school grounds, may lead pupils to conclude that the school cares little for the environment or for those who use it. It may encourage some to make a bad situation worse. The extent to which school grounds are valued and cared for needs to be evident if pupils are to collaborate in the development of the kind of responsible caring ethos which all schools would want to see developed.

8. Understanding Technical Requirements

8.1 This section provides technical information about planting and habitat creation, the layout and construction of pitches and other relevant design issues which will be of use to schools.

Planting and Creating Habitats

8.2 Creating new habitats is one way of providing for the school's needs. As always, habitats which meet the needs of more than one area will tend to be successful solutions to identified needs. For example, a map of the world painted on the tarmac could facilitate the teaching of geography, the extension of play opportunities and, at the same time, be making a statement about the ethos of the school as a multi-cultural community.

It will also be important to consider how any new habitat will affect the school's sense of place, its aesthetic appeal and its implications for maintenance, see section 9. The siting of any new development is also an important design consideration.

8.3 **Existing habitats.** It is easy to overlook, or even to destroy, existing features in the pursuit of something new. Moreover, the choice of habitats within the school grounds should be considered alongside the range of readily accessible habitats within the immediate vicinity of the school. One secondary school in the Midlands became involved in a conservation project along a natural valley and a stretch of canal, both of which passed immediately outside the school boundary. As the habitats were already available, and did not need to be established, this was an advantage. A number of schools have successfully taken on the tenure of adjacent allotments and have developed strong links with the local gardening community. Provided that the school has undertaken a thorough survey, it should be possible to avoid unnecessary duplication and be able to select habitats which are most likely to meet the needs of the school community.

8.4 **Priorities.** The unique characteristics of every school site means that, as for all aspects of grounds development, each school should set its own priorities for habitats to be included.

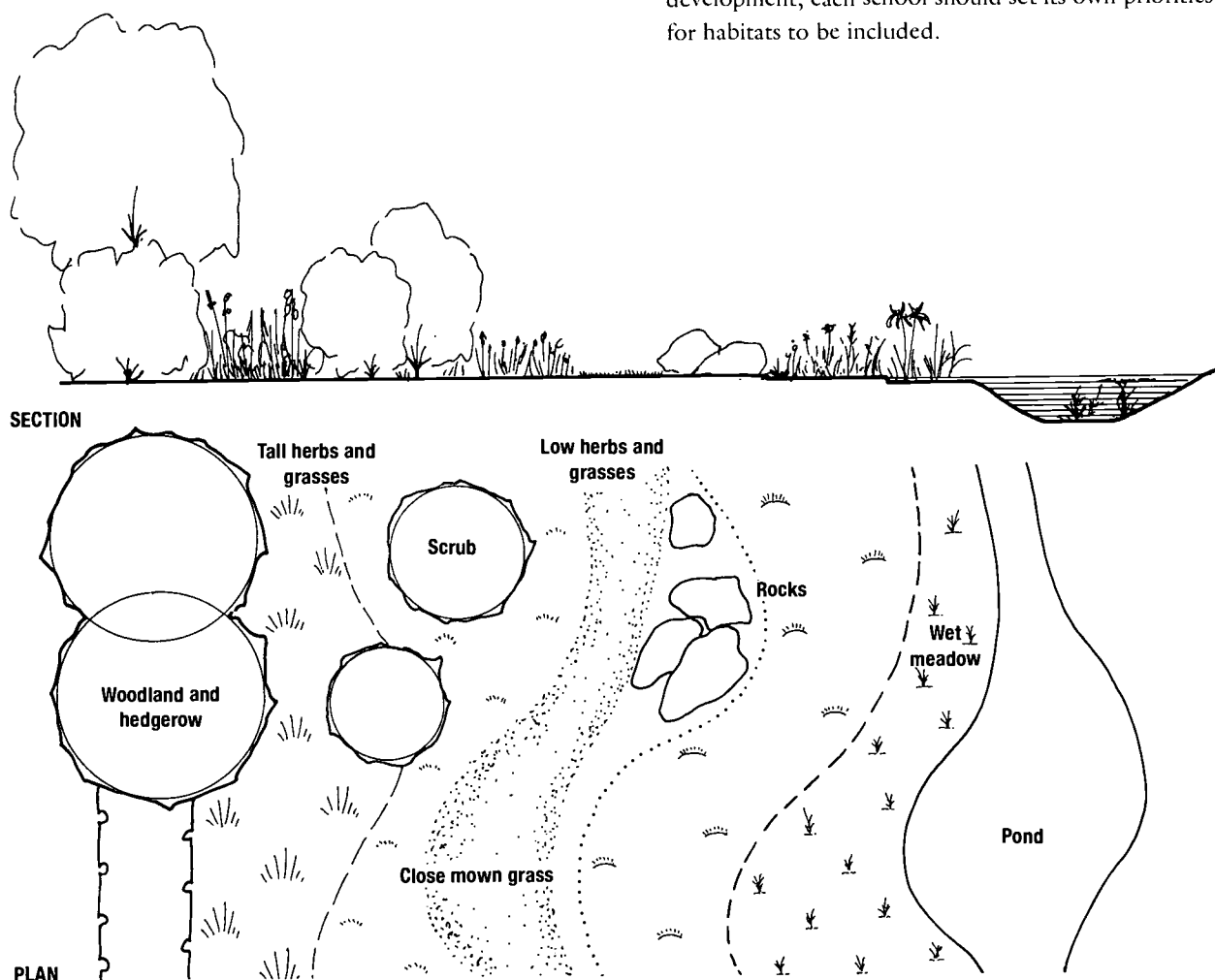

Fig. 3 The range of habitats can be extended by arranging them in tiers, and in linear bands of varying width

8.5 **Approaches.** It is worth stressing the need to take an overall, holistic approach to the development of the grounds. In the past, schools have often, sometimes unwittingly, adopted very different approaches on the same site, with highly ornamental planting at the entrance and a wildlife garden tucked away at the bottom of the playing fields. Schools have sometimes been unaware that they have been advocating management according to conservation principles in one area, while in another, they have been making heavy use of chemical pesticides. In addition to taking an holistic view of the whole site and its potential for use by all aspects of the curriculum, another useful approach is, as has been stressed throughout this Bulletin, the notion that any developments need to have many uses and functions. For example, plants can be attractive and at the same time, be beneficial to wildlife. It is also worth remembering that the view of the grounds from the classroom is important. Designing habitats in tiers is a useful technique in this respect. Such a linear arrangement allows great variety of habitats over a relatively small area (Figure 3) and so has merit on sites where space is constrained.

8.6 **Trees, woodlands and hedgerows.** The role of trees as umbrellas, windbreaks, air filters and definers of space has already been highlighted. They have many other functions: to act as a resource for the curriculum, to provide opportunities for play and recreation and to enhance the appearance of the grounds.

8.7 **Why trees?** Trees provide contrast with buildings in form, colour and texture; they can be used to screen obtrusive elements, disguise abrupt changes of level, enhance landform features or define boundaries and routes. They may be used as individual specimens, in avenues, in informal groups, within hedgerows or in small woodlands. Their features - shape, foliage, flowers, fruit, bark and the tracery of branches - have a variety of educational uses. Leaves can be used for collage, bark for rubbing, tree products such as osier or hazel sticks for crafts, twigs for cuttings and seeds for sowing, blossom for insect attraction or simply the tree's stature or form to inspire an artistic or literary response. They can be sat under, climbed up and leaned on. In short, they can be enjoyed in a number of different ways.

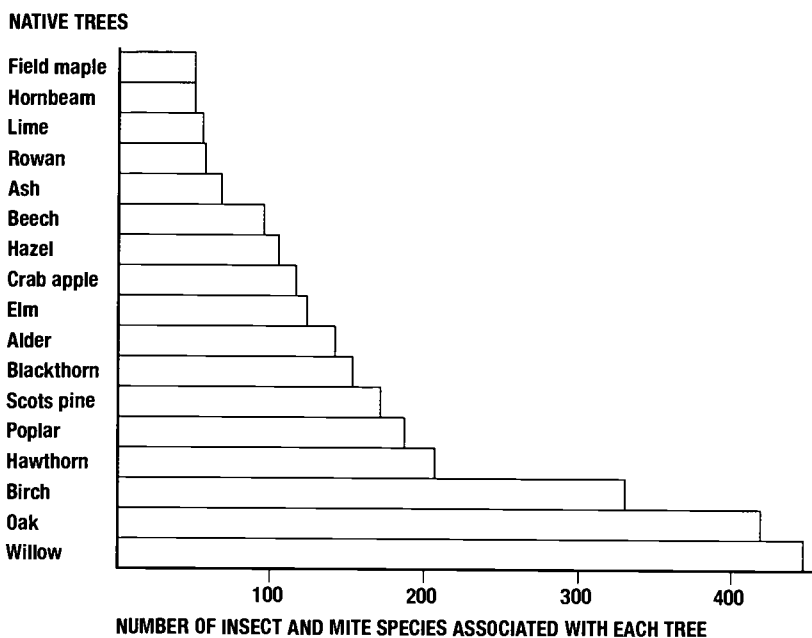

Fig. 4 Trees valuable for wildlife
C Kennedy & T Southwood. *Journal of Animal Ecology* 1984

8.8 **Choice of species.** School grounds are among the few places in urban areas where there may be room to plant large trees such as oak, lime, hornbeam or larch that will ultimately grow beyond the height of buildings and provide a strong vertical feature. The opportunities may range from one specimen tree in a tarmac yard to a small woodland in extensive grounds. Where choice is limited by the size and nature of the site, great care needs to be exercised in the choice of species. It is important that the trees selected have something to offer through the year, in terms of amenity and ecological value and of the opportunities for study. Aside from oak, which on good soils and with careful maintenance displays faster growth than it is given credit for, poplar, willow, birch, alder and cherry are all fast-growing pioneers that are good for wildlife over the short term. Native trees support a wide range of wildlife through their attraction to insects low down in the food chain (Figure 4). It may also be educationally important to explore the multicultural connections which exist with non-native species, making links with the family background of pupils wherever possible.

8.9 **Where to plant trees.** There are many books on tree planting and it is only possible to set out the briefest of design guidelines below:

- natural factors such as soil and microclimate must influence the choice of both native and ornamental trees;
- the intended use of trees to be planted must be taken into consideration;

- while a formal or geometric approach should only be used where there is good reason for it, the use of a bold statement such as an avenue is worth considering;
- care should be exercised in planting close to the boundaries with neighbouring properties as the eventual spread of the canopy may require regular pruning;
- a 'one-of-each' approach can create a 'spotty' effect as trees of distinctive colour or form compete for attention;
- some species, such as poplar, willow, oak and ash, should not be used close to buildings or underground services, especially on certain clay soils, and all trees must be kept clear of highway sightlines, lighting columns and overhead services;
- trees are seldom successful in pairs; groups of three, five or seven are more attractive and have a greater chance of survival;
- some species, such as birch, are far better in a large group, even ten or more, and more attractive in their natural 'feathered' form where the lower side branches have not been removed in the nursery;
- secretions by large leaves or fruits mean that certain trees, such as lime and horse chestnut, are less suited to car parks and pedestrian areas.

Schools may wish to use the more ornamental varieties in formal areas and the native trees as forestry transplants in the wider grounds. With good aftercare, the latter grow quickly, are cheap and can be planted by pupils. It is essentially a forestry rather than a horticultural approach to planting that needs to be adopted (Figures 5 and 6).

METRES

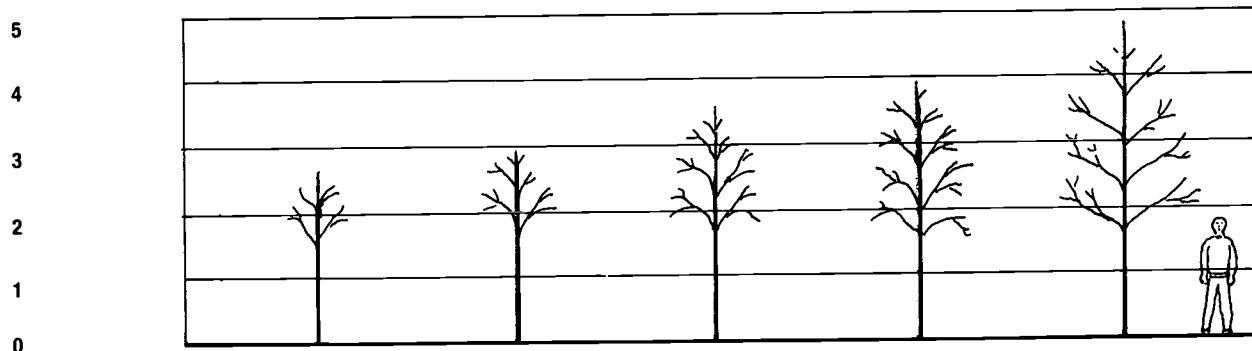

TYPES	Light Standard	Standard	Selected Standard	Heavy Standard	Ex. Heavy Standard
HEIGHT m	2.5 - 2.75	2.75 - 3.0	3.0 - 3.5	3.5 - 4.0	4.0 - 5.0
MIN. STEM HEIGHT m	1.5 - 1.8	1.8	1.8	1.8	1.8
GIRTH cm	6 - 8	8 - 10	10 - 12	12 - 14	12 - 14

Fig. 5 Sizes of nursery stock (in accordance with B.S.3936: Pt 1. 1980)

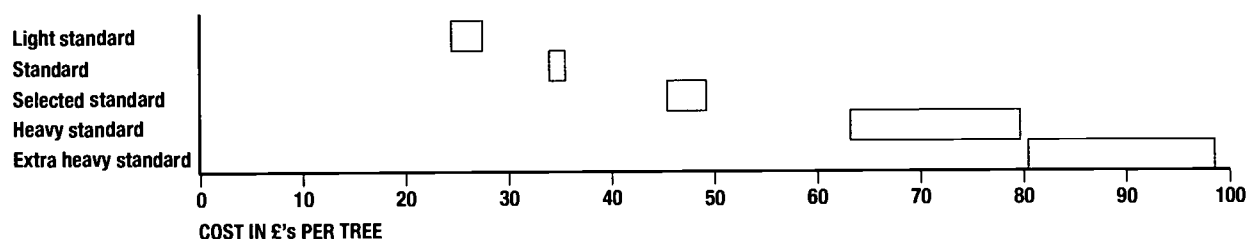

Note: These are typical price ranges for tree sizes related to B.S.3936: Pt 1. 1980. Costs include planting, a stake, tree ties and watering tube in the pit, but exclude VAT. The costs, however are only indicative and in practice they can vary considerably depending on factors such as location, site accessibility, and distance from the nursery.

For more detailed information on capital costs refer to E & FN Spon's Landscaping and External Works Price Book 1997. (ISBN 0 419 22220 0).

Fig. 6 Relative costs of nursery stock (1997)

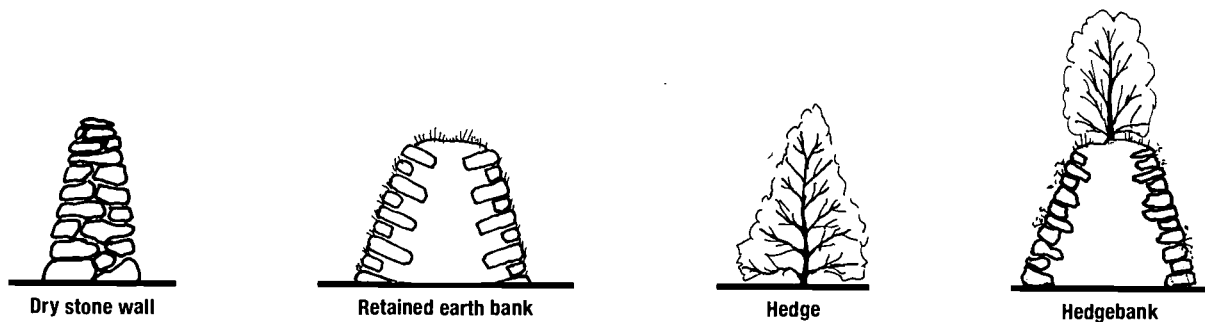

Fig. 7 Different boundary details

8.10 **Woodlands.** With more extensive tree planting, it is important to have a clear understanding of the type of woodland that is to be created and the kind of management it will receive. There are two main types:

- **Coppice.** This is cut on a regular cycle varying from 8 to 30 years depending on the species. Hazel, ash, sweet chestnut, alder, hornbeam and other species are grown for small diameter poles, the stumps or stools shooting up after cutting to produce a fresh crop. Sometimes forest trees, particularly oak, are included in the mixture to provide larger timber; this is called coppice-with-standards. Some schools may also want to show children the effect of pollarding some trees, especially if livestock is kept on site.
- **High forest.** All the trees are derived from seed, either self-sown or raised in a nursery. The woodland may vary from a plantation of trees, all of the same age, to a wide range of ages from seedlings to mature trees.

A study of woodlands in the locality of the school can assist the selection of trees to be planted and the proportions of the different species. If recent disturbance has resulted in an uncharacteristic mixture, reference to the county wildlife trust, or to books on the local vegetation, may assist in achieving the appropriate mix of species.

8.11 **Hedgerows.** Good, thick and regularly maintained hedgerows are valuable as a specific habitat type, as well as forming a boundary enclosure or low-level shelter. A dense thorn hedge can be as effective as chainlink fencing and far more attractive. Hedges do, however, need the initial protection of a fence to become established over a period of at least five years. The choice and mix of species depends on their intended function. A boundary hedge demands a different approach from one where the intention is to create an outdoor classroom. In the first case, hawthorn and blackthorn could form the major species, with more occasional hazel, dogwood, holly or field maple, depending on what is common in local

hedgerows. In the second, a single-species hedge of beech, hornbeam or a suitable conifer could be used. Hedging plants can be planted in a single row or in two rows, 250-500mm apart, with a total of between two and eight plants per linear metre.

8.12 **Hedgebanks.** These are a valuable variant of the hedge, offering more immediate containment and a taller screen. In certain regions, the hedgebank is a common landscape feature and its inclusion on school sites reflects and reinforces the local character. In other locations, such as against a busy road, a hedgebank can give immediate and effective screening. The greater exposure and potentially drier conditions for the young hedging plants on the bank are offset by increased protection from damage, especially trampling. In order to achieve a steep face, the bank may require a stone facing or the use of a geotextile material as a retaining structure. The latter follows the principle of sand bags, with earth-filled geotextile bags being used as building blocks. The bank inside the facing structure should contain a good growing medium with plenty of humus in the soil for water retention (Figure 7). It is important to take account of locally distinctive species and patterns of planting when introducing these features.

8.13 **Wild flower meadows and heathland.** A meadow need not be confined to one area, but could occupy a variety of locations displaying a range of sun and shade, aspect, soil moisture and fertility. The soil conditions in the grounds should be studied and analysed, as they are fundamental to the choice of plants and mixtures. Some meadow areas, and other wildlife habitats near classrooms and popular outdoor spaces, encourage incidental observation and are immediately available for study. The suitability of local soils and climate, the ability to thrive in a competitive sward, and the likelihood of flowering during term-time are all important considerations in the choice of wild flower species.

8.14 **Establishment.** The close-mown sward on most existing school grounds is an extremely fertile and

competitive environment. The most successful wild flower meadows are usually on sites of low fertility. Such an area creates valuable contrasts in colour and texture but often only a limited range of plants, predominantly the more aggressive grasses, do well. Whilst major earthworks on new sites can be used to leave subsoil at the surface, this is seldom an option for existing schools. The 'do-nothing-and-let-grow' option is useful as a control, for purposes of comparison, and it offers some prospect of success on less fertile soils. One danger is colonisation by less welcome species such as dock, thistle and nettle, which may take over an area and soon render it inaccessible. There are two main options.

- Create bare soil. Ideally, the turf is stripped and the topsoil removed to reduce soil fertility but where this is not possible, the sward can simply be rotovated and loose grass on the surface raked off. The choice is then between sowing a wild flower seed mix or spreading late-cut hay from a species-rich meadow. In the first case, the mix can either be a proprietary mixture or a non-competitive grass seed mixture with a number of wild flower seeds, anything from 6 to 10 species, purchased separately but sown with the grass mixture. In the latter case, hay bales are opened up and spread over the surface by hand after it has been cultivated. This causes much of the seed to settle in or on the tilth, with the stalks acting as a valuable mulch.
- Diversify the existing sward. It is possible to rotovate strips in the existing sward and sow wild flower seed in the same operation, whilst leaving the area otherwise undisturbed. An alternative is to purchase wild flower seed in single species packs, germinate and grow on the young seedlings in pots and plant them in random drifts in the close-mown sward which can then be allowed to grow on. The aim is that these pioneer plants will then spread more widely over the meadow in succeeding seasons.

The first option has greater application to new schools and the second to existing grounds. The purchase of packets of individual seeds and their germination and growing on for planting out offers both cost and educational benefits. Where a wild flower seed mix is to be used, autumn sowing is often more successful than spring sowing, especially in the drier parts of the country. The use of different techniques side by side will enable records to be kept of their respective development and comparisons to be made. Further opportunities are presented by sowing areas of bulbs

in the spring meadow, or creating an annual wild flower sward of cornfield species on a vegetable plot or a piece of bare soil.

- 8.15 **Mowing.** There is not one particular cutting regime, but rather a range from a lawn with wild flowers to a one-cut-a-year meadow. Conversion of gang-mown areas to wild flower meadows may not present significant cost benefits. Gang-mowing is very cheap compared to pedestrian mowing of smaller areas with difficult shapes or slopes. It is these more difficult areas that are often better locations for meadows. Whether the 'untidy' appearance of the meadow matters depends largely on the context and presentation of the area. If the boundaries of meadows adjacent to hard surfaces are regularly cut to a single mower width, the area appears better planned and cared for. The width of a gang-mower may also be necessary against boundaries where there could be complaints from neighbours about long grass and weeds. Similarly, mown pathways across larger meadows allow better access throughout the year, limit the need for wellington boots and afford a greater length of edge for study. They also create an interesting pattern of shapes that may offer more learning and play opportunities.
- 8.16 **Wear and tear.** With relatively free access, meadows may be subject to wear and tear from sitting, rolling, hiding and picking. If such use threatens the development of the meadow, it may need to be restricted, otherwise it should be permitted. Zoning could be used to identify quiet and active areas to accommodate various demands.
- 8.17 **Heathland.** Most, but not all, heathlands require an acidic soil; they can be dry or moist, with lowland and upland variants. Relatively few schools will have conditions that meet these criteria. Heathland habitats have, however, been lost over the last century and where impoverished and predominantly acidic conditions exist, or can be created, an area of heathland may be viable within the grounds. Some of the most successful heathland creation has used imported heathland topsoil which has been rotovated to a depth of 75-100mm before planting strippings from road schemes, mineral workings or similar developments, which would otherwise be lost. Other techniques include harvesting heathland seed or cutting turf. Often these result from 'rescue' operations prior to a building development, and a first reference point is the county wildlife trust. Heathland can be lost over time to scrub invasion and sustained management is necessary to prevent this.

8.18 **Ponds and wetlands.** There are many booklets about the school pond which are a rich source of information on the different means of constructing and stocking them. The aim here is to highlight wider design issues and extend the options to other wetlands.

8.19 **Position and design.** A location close to the building makes the pond more available for study; it could also be safer, as it is easier to supervise. A courtyard site makes vandalism less of a problem. Above all, the pond should be near a source of water as it will seldom have sufficient catchment to balance the loss through evaporation. Tapping roof water from a downpipe is one means of reducing reliance on the mains supply and thereby contributing to water conservation. A raised pond can improve accessibility, especially for the disabled. If it is built into a slope, it will facilitate movement by amphibians and give a more natural appearance. Pupils will benefit if one part is edged with timber decking or paving slabs; this enables them to make a close study of the aquatic life in relative safety (Figure 8).

8.20 **Safety.** A major dilemma is whether to fence around a pond. The range of practice extends from the open plan approach, where there is good supervision, to tight enclosure by a fence. Fencing of a fairly light construction - post and plain wire - can be valuable in defining the area for supervision purposes. The enclosed area needs to be large enough to allow groups to study and may include other habitats. The decision about fencing depends on the unique features of the initial site, its management and its ease of supervision. Careful thought should be given to a location where buildings or walls already afford some containment. If additional demarcation is considered necessary, it can be less intrusive if accompanied by planting of shrubs or low hedging.

8.21 **Other wetlands.** In the wider agricultural landscape, marshland, open ditches and wet meadows have declined in area and are still very much at risk. Their inclusion within school grounds demands a more imaginative approach to surface water drainage. Open ditches can be used to channel water in, and an area of impeded drainage can be formed to encourage marsh and wet meadow. A wet meadow can be created in a low-lying area of heavy soil. Marsh usually requires an artificial liner to retain sufficient water but this can be a cheaper polythene product rather than the butyl sheet commonly used for ponds. Where concerns about safety or vandalism discourage installation of a pond, marsh and wet meadow are alternatives well worth considering. They benefit from a board-walk

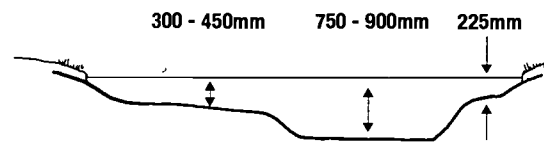

POND SECTION A-A

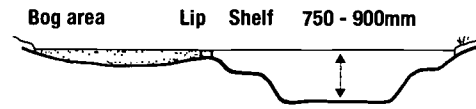

POND SECTION B-B

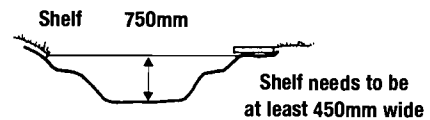

POND SECTION C-C

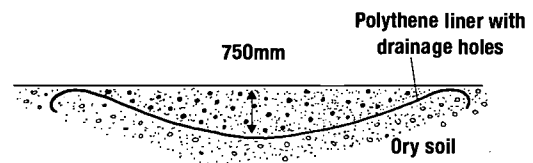

BOG AREA SECTION IN DETAIL

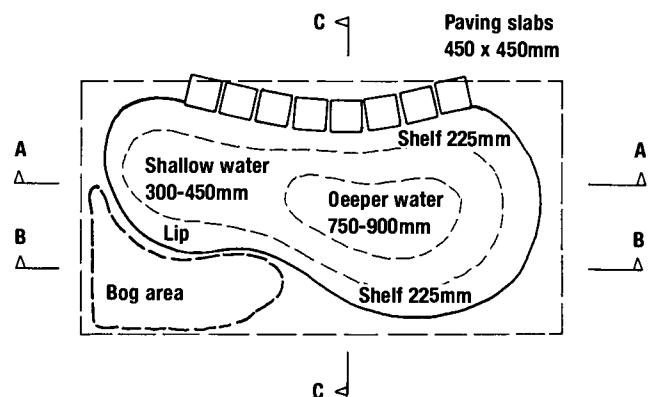

POND PLAN

Fig. 8 Pond and marsh construction

across them to assist access and provide more intimate contact with the fauna and flora.

8.22 Other habitats. With the exception of hedgerows, the habitats described above - even if they have been deliberately constructed - are still essentially 'natural' in the sense that they function as ecosystems. Other habitats may be more obviously artificial, their prime aim being to attract specific wildlife or to provide homes or shelter. There are almost limitless possibilities to be creative in this area, from mazes to model landscapes, brushwood piles to earth mounds, iron-age huts to soil profiles. Gardens may be created for insects generally, for butterflies and bees in particular, and for birds. They can also be 'themed' in a number of different ways, for example, from the Bible, by smell, shape, colour, country of origin, etc. A dry stone wall, either free-standing or better still as a retaining structure, affords a habitat for mosses and lichens, and niches for fauna. Its inclusion where it is a regional feature or where it can be constructed with local stone, will enhance the link with the surrounding landscape character. Piles of logs that are allowed to rot and drainage pipes that provide homes or shelters, are both simple but effective options that can provide for the needs of small mammals, reptiles or insects.

8.23 Crops and animals. Gardens for growing food crops and paddocks for keeping animals may also claim a share of the 'habitat' zone. It rests with the individual school to strike its own balance between competing uses and to decide whether the considerable demands of grazing stock can be accommodated.

8.24 Growing crops. Resources for gardening vary from a tiny chequer-board garden to a smallholding. Important considerations include the soil conditions, the location relative to the school, site security and access for machinery. On new sites, teachers and pupils should not strive vainly to turn subsoil into productive gardens, when good soil management (with importation of quality topsoil in the worst situations) is the right answer. Pupils like to see their plants grow and to tend them outside lesson time. A location, near the school, that can be supervised is desirable. Long narrow plots allow for rotovators to work more easily and for pupils to gain access from the side. Even if it cannot be provided initially, a site for a tool store is important, ideally with vehicular access. An emphasis on recycling is likely to increase the demand for compost bins nearby.

8.25 Using shrub borders. Where space is limited, some existing schools take over poorly stocked shrub borders and convert them to vegetable and flower gardens. Runner beans can be attractive climbers

against the school wall. If too many shrub and rose borders, which are expensive to maintain, have been placed around the building, the school may be better served by converting certain of these convenient and visible plots to more productive use. The herb border is a partnership between the aesthetic and the culinary and can lead to difficulties over location. For example, one LEA decided that a herb garden should be sited close to the kitchen, but also required that the kitchen be sited on the north side of the building wherever possible. This arrangement condemned many herbs to a slow death in the shade.

8.26 Orchards and nutteries. A small orchard with vigorous and dwarf rootstocks offers shade and a setting for recreation. It also provides a resource for the study of contrasts in history and science, and has the potential to stimulate work in art and English. Where there is not the room or the need for a wood, orchard trees can create some of the same spatial qualities, the canopy of branches and leaves contributing to a feeling of containment and shelter. The establishment of a diverse grassland with wild flowers beneath the trees helps to recreate the historically and ecologically valuable orchards, in which species-rich grassland beneath the trees is grazed by sheep.



Photo 23 Children love picking apples and other fruit or nuts

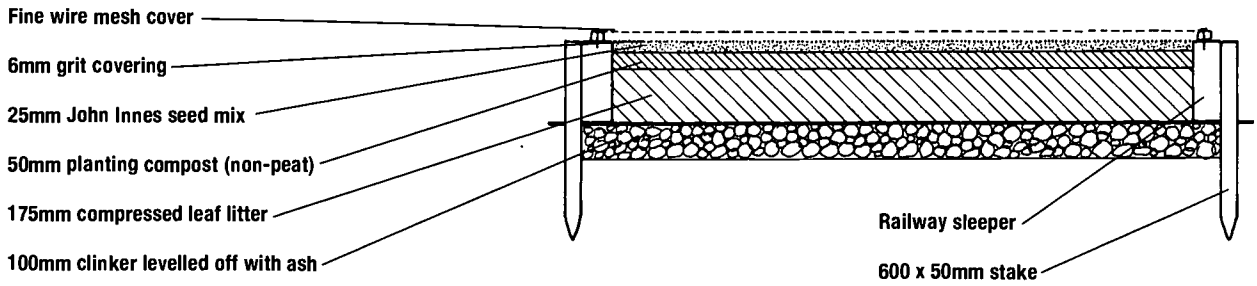

Fig. 9 Detail of a tree nursery bed

8.27 **Tree nurseries.** Confined space, even on the colder north side of a building, can be put to good use as tree nursery beds. The best location is often adjacent to, or as part of, a school garden. At least two beds are needed so that they can be cleared and re-sown in alternate years. Timber sleepers make ideal surrounds and the width can vary between 1.0m and 1.5m, with extension to any length required. Suitable mature tree species are needed as sources for seeds and cuttings. Oak, hazel, ash and hornbeam are good native trees, and horse chestnut and sycamore are successfully introduced species. Birch, alder and willow may set seed after only 5-8 years but these are more difficult to germinate. Poplar and willow are excellent for cuttings, especially the common osier, which can be used for basket-making (Figure 9 and Table 1).

8.28 **Keeping animals.** Over recent years, a number of schools have chosen to keep animals within their grounds, because of the beneficial experiences they can bring to children. Schools are well advised to examine the educational arguments and the demands of animal husbandry before going ahead¹. When they are kept in the school grounds, pets are suitably housed in hutches and small stabling, often as part of the garden area close to the school and main recreation areas. Keeping farm animals requires three or four small paddocks linked to indoor housing for effective management and security. In some cases, where crop and livestock husbandry is central to the school, the interest has extended beyond school hours and has spread into the community. This allows for deliveries to be made and livestock cared for at weekends and over holidays but a controlled independent access is necessary. The challenge is to make the enterprise an integrated part of school life, whilst at the same time ensuring strong links exist with the local community. Where animals are not present permanently, it can be useful to have a small corner for visiting pets or a paddock for visiting farm livestock. Such visits afford some experience of animals without the long-term commitments.

8.29 **Historical reconstructions and outdoor displays.** A further use of the habitat area is as a site to

reconstruct historical features, such as hedgebanks or wood banks, wattle fencing or walls made from local stone. There may be links with the surrounding landscape which can be integrated into the design of the grounds. A more ambitious approach, that demands detailed planning and considerable application of time and resources, is to re-construct pre-historic dwellings, or former industrial or agricultural enterprises or small Third World village settlements. These can be integrated with other activities and may afford further habitats for wildlife. Outdoor displays often centre on sculptural works because of their durability; they may be the result of a specific initiative in art and design or form part of a longer-term programme. Some of the best initiatives in this area arise from collaboration between the school pupils and a professional artist. The relative permanency of such features and the threat from vandalism both need to be fully assessed.

8.30 **Restricted sites.** Where space is restricted, there is scope for mini-versions of a number of the habitats described earlier. Size is an important issue but not an overriding one, because miniature habitats can enrich the most austere tarmac yard. Multi-use may well be a prerequisite since the garden created for use within the curriculum is likely to serve also as a social area if carefully planned.

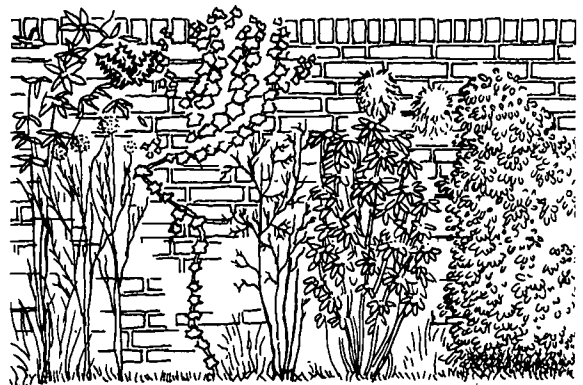

Fig. 10 Taking the garden up into the air

¹The RSPCA provides free: *Animals in Education - making your school animal friendly, which deals with all aspects of animal welfare.* Department of Education and Science Administrative Memorandum No3/90: *Animals and plants in schools; Legal aspects.*

- 8.31 **Design of small habitats.** The pressure of use often necessitates a change in level, if not a fence, to allow some soft landscape to thrive. Where access by pupils can be restricted, which means an area detached from the main play facilities, a mini-meadow as small as a few square metres is possible. A path of stepping stones will limit wear and assist the study of plants and wildlife. Further opportunities exist to elevate the garden by using walls, fences and trellises for climbing plants (Figure 10).
- 8.32 **Raised beds.** To limit the cost of beds, tarmac areas can sometimes be broken up with only the surface layer removed. Holes can be punched through the surface for drainage and a 600mm container wall and seat can be used to retain a depth of soil. This achieves a good growing medium. For those pupils with special needs, the cultivation of plants which require frequent

handling is easier when plants are grown in a raised bed. The width should be restricted to 600mm where access is from one side only and 1200mm when from both sides. Suitable heights can vary between 400mm and 700mm depending on the age of pupils; a height of 450 - 600mm is required for the wheelchair gardener. Features such as former outdoor toilets may be simply converted to meet these requirements (Figure 11). Troughs can be constructed from upright paving slabs or precast concrete fencing panels or they can be purpose-built in brick or timber as long as they are strong enough to retain the weight of the soil. Small gardens can also be made in plant containers, sinks, tyres or barrels. Such raised or artificial planters do, however, require more care, especially with regular watering and in the use of fertilisers.

TREES	Jan	Feb	Mar	Apr	May	Jun	Jul	Aug	Sep	Oct	Nov	Dec
Ash									■ ■ ■ ■ ■	■ ■ ■ ■ ■	■ ■ ■ ■ ■	■ ■ ■ ■ ■
Alder	■ ■ ■ ■ ■	■ ■ ■ ■ ■										
Birch								■ ■ ■ ■ ■	■ ■ ■ ■ ■	■ ■ ■ ■ ■	■ ■ ■ ■ ■	■ ■ ■ ■ ■
Beech									■ ■ ■ ■ ■	■ ■ ■ ■ ■	■ ■ ■ ■ ■	■ ■ ■ ■ ■
Field Maple										■ ■ ■ ■ ■	■ ■ ■ ■ ■	■ ■ ■ ■ ■
Lime										■ ■ ■ ■ ■	■ ■ ■ ■ ■	■ ■ ■ ■ ■
Hornbeam										■ ■ ■ ■ ■	■ ■ ■ ■ ■	■ ■ ■ ■ ■
Holly	■ ■ ■ ■ ■	■ ■ ■ ■ ■										
Oak									■ ■ ■ ■ ■	■ ■ ■ ■ ■	■ ■ ■ ■ ■	■ ■ ■ ■ ■
Rowan								■ ■ ■ ■ ■	■ ■ ■ ■ ■	■ ■ ■ ■ ■	■ ■ ■ ■ ■	
Scots Pine		■ ■ ■ ■ ■	■ ■ ■ ■ ■									
Service Tree									■ ■ ■ ■ ■	■ ■ ■ ■ ■		
Sweet Chestnut										■ ■ ■ ■ ■	■ ■ ■ ■ ■	
Whitebeam									■ ■ ■ ■ ■	■ ■ ■ ■ ■		
Wild Cherry							■ ■ ■ ■ ■	■ ■ ■ ■ ■				
SHRUBS												
Blackthorn							■ ■ ■ ■ ■	■ ■ ■ ■ ■	■ ■ ■ ■ ■	■ ■ ■ ■ ■		
Dog Rose								■ ■ ■ ■ ■	■ ■ ■ ■ ■	■ ■ ■ ■ ■	■ ■ ■ ■ ■	
Dogwood								■ ■ ■ ■ ■	■ ■ ■ ■ ■	■ ■ ■ ■ ■	■ ■ ■ ■ ■	
Elder							■ ■ ■ ■ ■	■ ■ ■ ■ ■				
Guelder Rose								■ ■ ■ ■ ■	■ ■ ■ ■ ■	■ ■ ■ ■ ■	■ ■ ■ ■ ■	
Hawthorn								■ ■ ■ ■ ■	■ ■ ■ ■ ■	■ ■ ■ ■ ■	■ ■ ■ ■ ■	■ ■ ■ ■ ■
Hazel									■ ■ ■ ■ ■	■ ■ ■ ■ ■	■ ■ ■ ■ ■	
Privet								■ ■ ■ ■ ■	■ ■ ■ ■ ■	■ ■ ■ ■ ■	■ ■ ■ ■ ■	
Purging Blackthorn								■ ■ ■ ■ ■	■ ■ ■ ■ ■	■ ■ ■ ■ ■	■ ■ ■ ■ ■	
Spindle Tree								■ ■ ■ ■ ■	■ ■ ■ ■ ■	■ ■ ■ ■ ■	■ ■ ■ ■ ■	
Wayfaring Tree							■ ■ ■ ■ ■	■ ■ ■ ■ ■	■ ■ ■ ■ ■	■ ■ ■ ■ ■		
CUTTINGS												
Poplar	■ ■ ■ ■ ■	■ ■ ■ ■ ■	■ ■ ■ ■ ■								■ ■ ■ ■ ■	■ ■ ■ ■ ■
Willow	■ ■ ■ ■ ■	■ ■ ■ ■ ■	■ ■ ■ ■ ■								■ ■ ■ ■ ■	■ ■ ■ ■ ■

Table 1 When to collect tree and shrub seeds and take cuttings

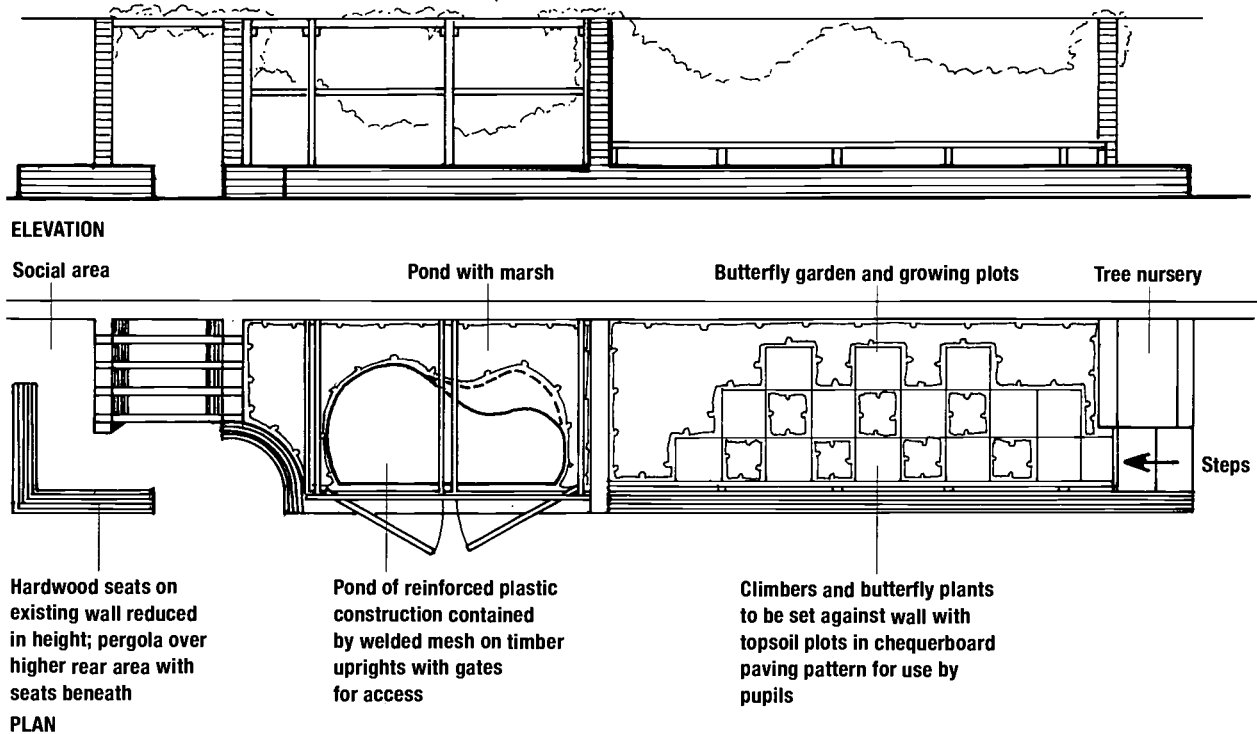

Note: The conversion shown involved reducing the outer walls to 450mm in height to provide dwarf walls for sitting and to form planters for a butterfly garden and plots for growing plants. A tank pond and marsh were created in a rigid plastic pond liner and for reasons of safety welded mesh doors were included.

Fig. 11 Conversion of outside lavatories provides a range of opportunities

Layout and Construction of Pitches

8.33 Games courts for primary schools. Useful reference can be made to 5.5 on physical education when reading these paragraphs and area guidelines for hard surfaced games courts given in Reference Section F. Outdoor games need plenty of space. The first requirement is for a hard surfaced drained area with a near level and even surface that is free of obstructions, such as drain covers or protruding sockets or service covers. The traditional netball court remains popular because the 'grids' formed by the markings can also be used for mini-games such as short tennis; it also provides a basic minimum area for class games activities when extended as in Figure 12. A margin of at least 1.0m should be provided between court boundaries and walls, but this margin should be increased where there are changes of level. Ball-retaining fencing might be required in order to protect buildings, nature resources, and neighbouring property.

At least one tarmac full-size senior netball court, 32.0 x 16.75m, including minimum overall margins might be appropriate at all but the smallest primary school. Where space is limited netball can be played on a slightly smaller court by scaling down the

dimensions. In 1993 the netball governing body introduced 'First Step Netball', a junior version of the game for younger pupils. It can be played across a third of the senior court or be marked out in its own right.

Any other hard surfaced areas need to be close to the court to enable the teacher to maintain effective supervision.

8.34 Playing fields for primary schools (1996 School Premises Regulations apply). The National Curriculum, which makes games compulsory for all primary year groups, reinforces the need for suitable grass areas in every primary school. For junior pupils, marked pitches will be needed. The maximum size of a grass pitch is usually 80 x 50m; smaller versions, such as 70 x 40m, or 65 x 37m, can be provided where space is limited or as a second pitch. On smaller pitches the centre line can be used to divide them into two for mini-games, while on larger pitches a division into quarters can be beneficial. It should be possible to mark out a straight running track with six to eight lanes with a length of 60-80m for summer use.

8.35 Games courts for secondary schools. It is now recommended that, in order to provide for the needs of the physical education curriculum at secondary

level, a minimum of four tennis courts is desirable on new sites. This is to allow for effective class or group games tuition, and allows the four courts to be combined as a multi-games area. This clearly has implications for any secondary school redesigning its site or facilities; useful reference can be made to area guidelines for hard surfaced games courts given in Reference Section F.

If games courts are to be used effectively, ballstop fencing is essential and kickboards or rebound walls are highly desirable. Wherever possible, the courts should be combined to form a multi-games area.

The area guidelines for informal and social areas given in Reference Section F allow space for a separate paved area that can be used for kick-about and other boisterous games during breaktimes, so that they need not therefore take place on the hard surfaced games courts.

8.36 Playing fields for secondary schools (1996 School Premises Regulations apply). The playing field area at secondary level should ideally provide a 400m running track and games pitches for other sports

chosen by the school. It is possible to alternate these sports on a termly basis, although this involves greater cost in moving goal posts and marking pitches. As a result, however, of changing types of games on pitches termly, for example rugby to soccer and hockey may have the consequence of not being able to prepare pitches to the necessary standard for the particular type of game to be played safely due to surface roughness making ball play hazardous with reference to hockey. Table 2 in this section shows the respective range of provision that can normally be accommodated within a minimum statutory area. Some possible pitch layouts for summer and winter games for schools of 600, 900 and 1,200 pupils are shown in Figure 15. In addition to games, the grounds can support preparation for outdoor and adventurous activities, such as orienteering, adventure training and camping. For these activities, it is an advantage to have varied terrain and some cover with limited visibility.

For area recommendations, Reference Section F can be consulted.

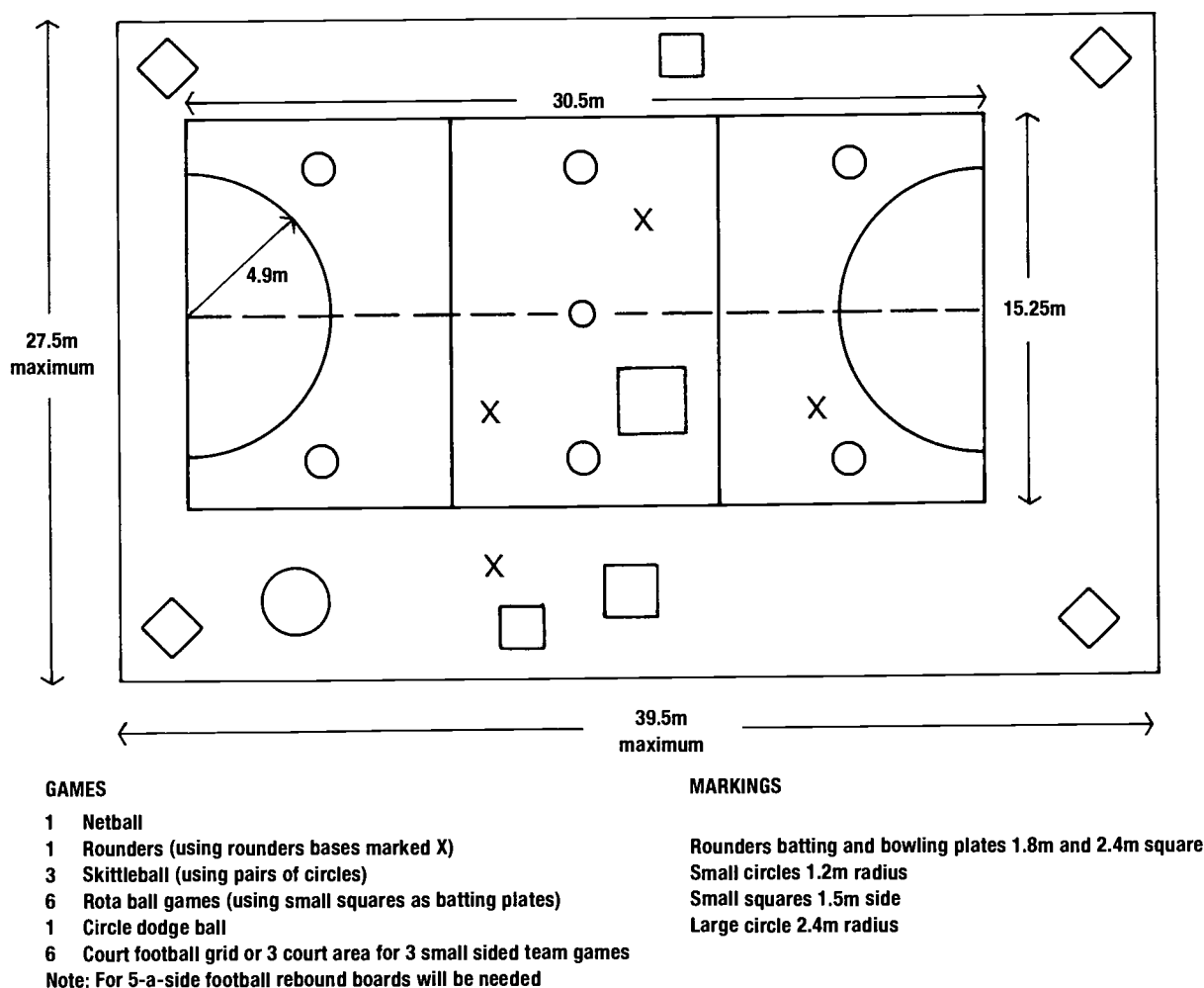

Fig. 12 Junior games court for 8-11 year olds

8.37 **Orienteering courses, trim trails and fitness circuits.** These facilities can be a useful resource for both physical education and geography.

Orienteering courses can have uses in many subjects which demand physical activity and direction-finding or observation skills.

Trim trails can offer a very useful extension to physical education activities, especially when other facilities are out of use. They give scope for individual challenge and achievement, which may prove attractive to some pupils, as well as for team events. They need to be as well designed and efficiently managed as any other sports facility.

Where they are to be used predominantly by parents and the wider community, they are better suited to a sports centre or public open space, since access to them at the weekends or evenings can present difficulties.

8.38 **School and community.** To meet the needs of the physical education curriculum, any accessible public and private sports and recreation facilities in the neighbourhood deserve to be considered. It is better for the school and the community if what is already available can be supplemented rather than replicated. When new facilities are being planned, local community and sports associations should be consulted about both indoor and outdoor provision. The Sports Council has stressed the importance of careful planning and assessment of needs, for the school's own pupils, and for the local community and local sports bodies.

8.39 **Layout of pitches.** Careful attention should be given to the layout of pitches, courts and practice areas; their location, size and shape; the margins required around them; their orientation and gradient; and the possibilities of shared school and community use. Practical considerations include the flexibility of the facilities regarding summer and winter activities, accessibility for maintenance equipment and the availability of a water source if irrigation is needed. Safety considerations may well influence the direction of play and the proximity of different activities.

8.40 **Sizes.** Pitch markings and court sizes for the major sports are given in Reference Section B. For many sports activities, the full-size pitches or courts should be scaled down progressively to suit younger pupils. Some national sports

have devised smaller and simpler layouts for mini-games, with consequent reductions in team-size and duration of play. These encourage fuller involvement of all pupils and provide for a greater range of activity within a given area. They also reduce the risk of skeletal and muscular stress injuries in younger pupils. The smaller team-sizes can be a particular advantage in schools where pupil numbers are small.

8.41 **Margins.** For effective use and safety, pitch layouts should include adequate margins around the playing area, often a distance of at least 6.0m at the ends and 4.5m at the sides will be needed and, a further 9.0m to one side allows winter games pitches to be moved in alternate years. In some layouts it is possible to undertake more radical re-planning, especially where mini-pitches are included in the layout.

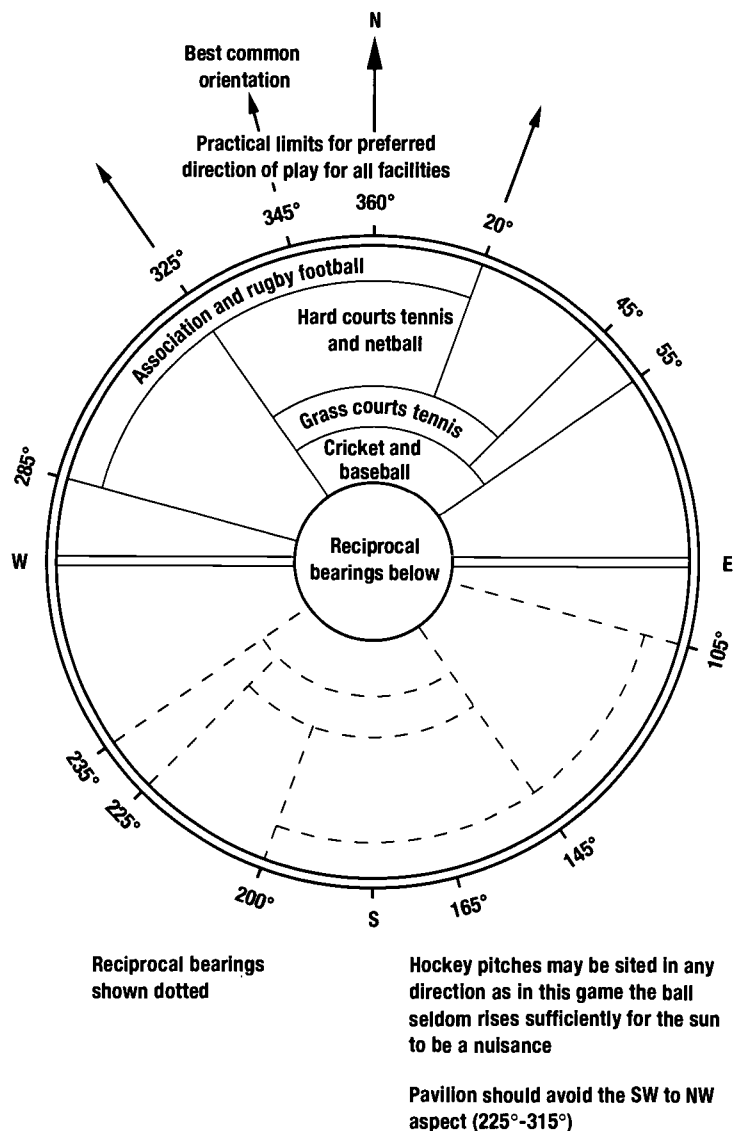

Fig. 13 Pitch orientation in relation to aspect
National Playing Fields Association

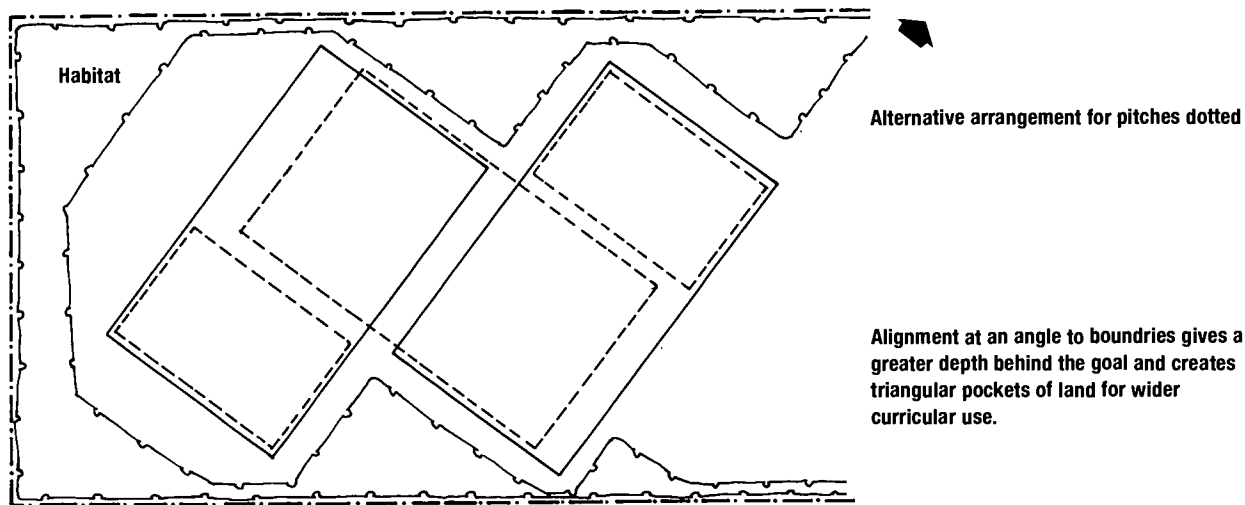

Fig. 14 Pitch orientation in relation to boundaries

8.42 **Orientation.** The orientation of courts and pitches raises two issues.

- The most familiar is the alignment of pitches and courts in relation to the position of the sun. This is less critical for games such as hockey, where the ball is on or close to the ground, but for soccer, rugby, netball, tennis and cricket it is an important consideration. Problems are caused not only by the early morning and evening sun in summer, but also by the low angle of the winter sun throughout much of the day. The general preference is for a north-south orientation for pitches so that players are faced with the sun at its highest and least troublesome (Figure 13).
- Where pitches are parallel to boundaries or buildings, there is often a narrow margin which is of little use for other activities and balls may continually have to be retrieved from neighbouring land. Orientation at an angle to boundaries can reduce this problem by creating a greater depth behind the goal area and at the same time these pockets of land can be used for the wider curriculum (Figure 14).

8.43 **Gradients.** A slight gradient rather than a level plateau is advisable, even where the soil is exceptionally free draining or where there is a 'permeable' synthetic surface that allows water to percolate. A gradient will assist surface water drainage and it may become more important when soils become compacted as a result of use. Existing topography may sometimes conflict with the preferred orientation of pitches and in such cases, the cost and convenience of constructing pitches to a suitable gradient may take precedence. The recommended

gradients for the different facilities are as follows:

- winter games and cricket outfield surfaces should have a gradient of between 1 in 60 and 1 in 80 on average, preferably across rather than along the line of play. It may be increased to a maximum of 1 in 40 where existing levels present problems;
- cricket tables should preferably be level between stumps with 1 in 100 as a maximum slope, and there should be a slight crossfall of 1 in 80, with 1 in 60 as the maximum;
- tennis, netball and basketball courts should have a crossfall of between 1 in 80 and 1 in 100, with courts level in the direction of play.

A change of level from the building to a lower plateau can often afford a terraced viewing area for spectators.

8.44 **Seasonal changes.** Summer and winter games facilities share the use of the playing field area. The more efficient the layout is, the less space is required. Winter pitches usually form a substantial part of the cricket outfield and the 400m running track. Because of their greater overall dimensions and lesser flexibility in terms of size, summer facilities are often crucial in determining the design and layout of playing fields. The extension of the season in some sports has made multi-use of areas more difficult. Hockey is a game where there are changing attitudes to turf due to the difficulty in achieving the surface quality required for safe play. There is now an increasing preference for synthetic turf with its high quality and reliable surface but its use may reduce opportunities of overlapping pitches with the cricket outfield owing to surface differences. The choice will depend on the popularity of individual sports within the school and the standards to which they are played.

8.45 **Deciding on location.** Choices for playing field layout can be drawn on plans and compared, and templates of the main facilities made to an appropriate scale will assist the process. If winter and summer layouts are printed on acetate they can be superimposed. Such an exercise helps not just to decide on the best layout, but it will also show how much flexibility exists to overcome severe wear and tear by a different arrangement of pitches. The location of both athletics field events and cricket nets should reflect the need for effective supervision and group teaching. Spreading them about the playing fields in left-over corners can frustrate educational use and may impede movement of winter pitches from season to season. The relationship of the pitches to the buildings in general, and to the changing rooms in particular, is fundamental to good planning. To prevent mud being deposited over other sports areas or in buildings, the routes to grass pitches should avoid other games or play areas and allow direct access to changing facilities. A number of possible layouts have been illustrated to highlight how to provide for winter and summer games (Figure 15).

8.46 **Sports surfaces.** The familiar combination of grass pitches and tarmac courts has been extended over recent years with the introduction of a variety of synthetic sports surfaces. Each has its advantages and disadvantages and the final choice of surface will depend on which of the criteria below are regarded as most compelling. A number of factors can influence the choice of sports surfaces.

- Space and availability. One of the reasons for the increasing use of synthetic surfaces has been their ability to accommodate a greater intensity and

variety of use. This has made them particularly attractive on confined urban sites, where use by the school may exceed 20 hours per week, as opposed to the 3 to 15 hours that may be possible on grass. They can ensure that at least one area is available for physical activities soon after heavy rainfall. At the primary level, synthetic surfaces can also function as the main playground on restricted sites.

- Capital costs. The high capital outlay for most synthetic surfaces, approximately £300,000 at 1997 prices for a football pitch, depending on soil type and excluding fencing and floodlighting, has meant that they have been used where restrictions on playing field area justify abnormal costs. Their installation in school grounds may depend on some form of joint venture with a local authority or sports club.
- Running costs. In addition to capital costs for the initial installation, there is considerable variability in the maintenance and replacement costs for different surfaces. This is particularly relevant at a time when schools are increasingly responsible for maintenance.
- Suitability for different sports. The choice of surface is also dependent on the major sporting activities within the individual school. Synthetic turf is unsuited to rugby, yet it is increasingly preferred for hockey. For some sports it is ideal for practice but it should be accompanied by natural grass for major team events. The age groups involved, the standard of play and the type of footwear necessary may influence the final choice.

Number of pupils in school	Statutory area Minimum total in m ²	Possible team games and sports provision on statutory area									
		Grass pitches			Cricket facilities			Athletics facilities			
		Small	Medium	Large	Cricket Square	Cricket Pitch (non-turf)	Cricket Nets	400m 6 lane track	High Jump	Long Jump	Pole Vault
401 to 500	25,000	1	1	1	1	-	3	1	1	1	1
501 to 600	30,000	2	1	1	1	1	3	1	1	1	1
601 to 750	35,000	2	2	1	1	1	3	1	1	1	1
751 to 900	40,000	3	2	1	1	1	3	1	1	1	1
901 to 1,050	45,000	3	3	1	1	1	3	1	1	1	1
1,051 to 1,200	50,000	3	3	2	1	2	3	1	1	1	1
1,201 to 1,350	55,000	4	3	2	1	2	4	1	1	1	1
1,351 to 1,500	60,000	4	4	2	1	2	4	1	1	1	1

Table 2 Range of summer and winter games provision for secondary schools that can be accommodated within statutory playing field area (refer to Figure 15 for pitch layouts for a number of sizes of schools)

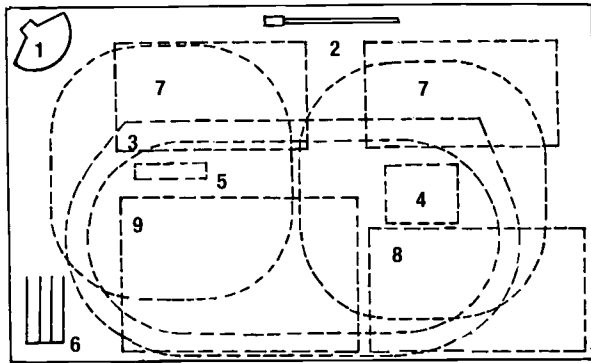

Four form entry mixed secondary school for 600 pupils aged 11-16 years 30,000m² all grass

KEY

Summer games facilities

- 1 High jump
- 2 Long jump
- 3 400m 6 lane track marked out in summer

Note: Pole Vault is not shown

Cricket

- 4 Grass square and out-field
- 5 Artificial wicket and out-field
- 6 Cricket nets

Winter games facilities based on association football pitch sizes

- 7 Small
 - 8 Medium
 - 9 Large
- For sizes refer to Association Football Table 3

For further information on games facilities refer to Reference Section 8

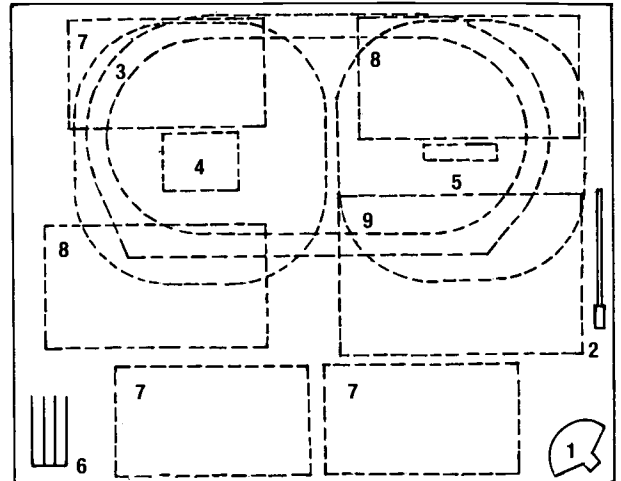

Six form entry mixed secondary school for 900 pupils aged 11-16 years 40,000m² all grass

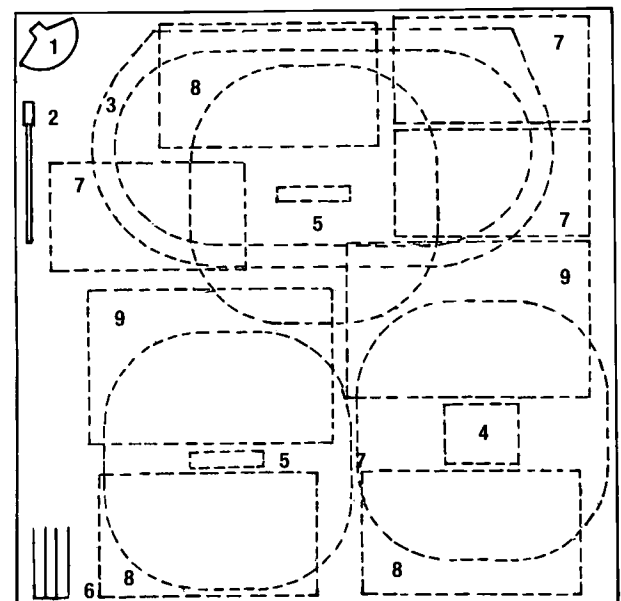

Eight form entry mixed secondary school for 1200 pupils aged 11-16 years 50,000m² all grass

Fig. 15 Some possible pitch layouts for summer and winter games for different sizes of secondary schools.

- Prevailing soil conditions and climate. Poor soil conditions and severe local climatic factors can be as significant as space limitation in determining choice of surface. It might in these circumstances be better to invest in higher quality provision over a smaller area than to provide extensive grass playing fields that may be unusable in winter.
- Possibility of shared use. Adult use will increase the rate of wear of grass pitches. Where the additional wear becomes significant, the individual school may wish to invest in a better quality natural turf or a synthetic surface, possibly a mini-pitch or the refurbishment of an existing hard surface, and to achieve some remuneration through lettings to local clubs or groups. If a large market demand is expected from the

catchment area surrounding the school, then a synthetic surface might become a cost-effective option.

- Indoor facilities. The range of indoor facilities such as sports halls, especially in urban schools, can influence priorities for outdoor sports provision where space is limited.

8.47 **Natural grass.** Grass is still the preferred surface for many sports, but it is vulnerable to wear if over-used, a situation that will be exacerbated by poor or inadequate initial construction. Grass is particularly susceptible to bad weather when pitches may be out of use for long periods in winter. Recent research shows that pipe drainage on its own offers little improvement to playability on poorly draining soils; it is only with the addition of 'slit' drainage that

significantly greater hours of use can be achieved. The stripping, storage and placement of topsoil and subsoil during playing field construction are crucial to the formation of a high-quality grass playing surface. Topsoil and subsoil depths vary considerably and this should be taken into account when specifying soil stripping. Such strippings should be stored quite separately during earthwork operations. To achieve the best possible natural turf surface it is essential to use machinery with low ground bearing capacity to avoid tracking over topsoiled areas, and to use a subsoiler to relieve ground compaction. Additionally, good supervision is necessary and only working when ground conditions are suitable will help to improve the end result.

8.48 **Drainage.** There are four main categories of natural grass pitch construction that deserve a mention.

- **Undrained.** Normally only considered where the prevalent soil conditions are unusually free-draining, as may be the case with sand or chalk.
- **Piped drainage.** A drainage system is installed, usually on a grid or herringbone pattern; it is only effective where sound construction techniques and soil type ensure adequate movement of surface water down through the soil.
- **'Slit' drainage.** In addition to the pipe drainage system, sand slits are cut across the slope in the overlying soil layers, normally across the main slope or at least at such an angle that the surface water will shed quickly to the slit drains.
- **Sand carpet.** Whilst the 'slit' drainage system can itself incorporate a sand dressing of 25mm, in this case the depth of sand is increased to as much as 100mm or more to form a carpet over the soil. An irrigation system is essential in many parts of the country to ensure a good quality grass playing surface is established and sustained.

The most cost-effective solution on heavier or poorer draining soils is the 'slit' drainage system which offers worthwhile benefits by extending the hours of play that a pitch can sustain. Catchwater drains may also be necessary around pitches of any type to stop water from getting on to the playing surface from surrounding higher ground (Figure 16). However it must be remembered that such systems require regular maintenance.

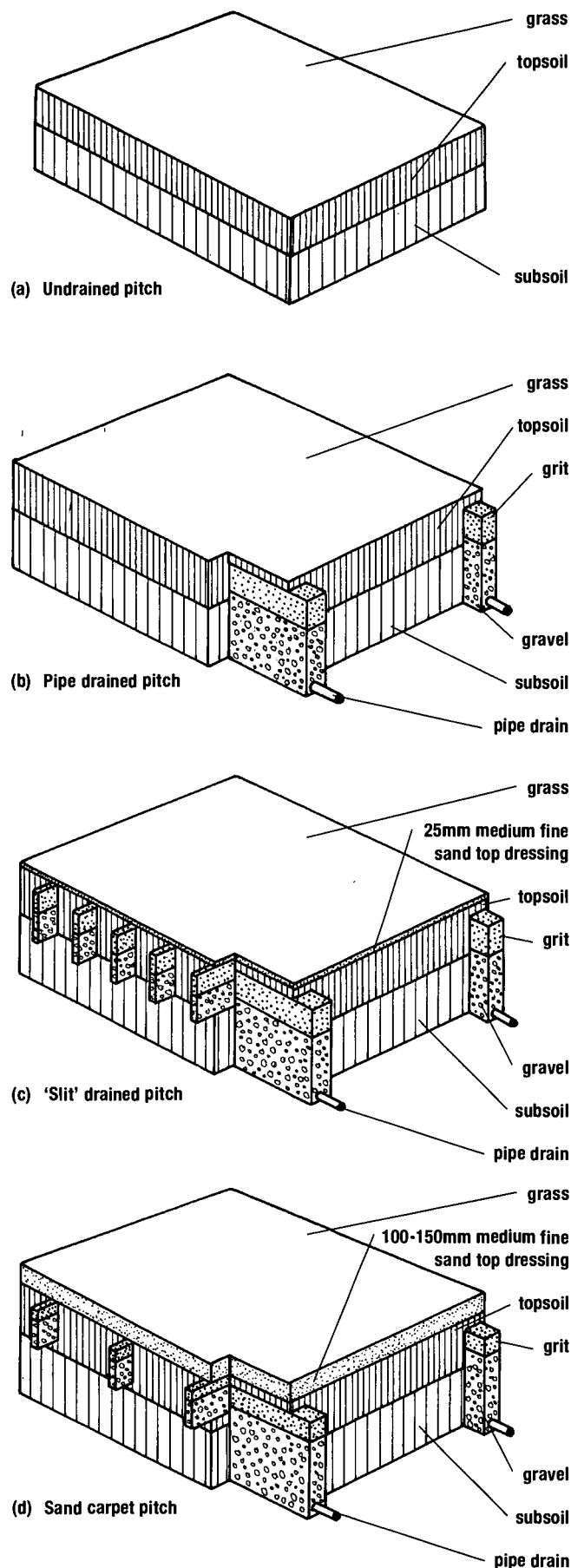
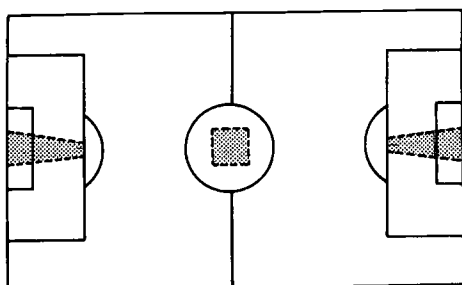

Fig. 16 Four types of natural turf construction
Sports Council, Natural Turf Pitches Prototypes Advisory Panel Report No 3 - 1989

8.49 **Reinforcement materials.** Synthetic reinforcement materials can be used to protect the grass and the soil on playing field surfaces. They offer greater advantages on topsoil pitches than on those of sand construction and are most effective in high-wear areas such as goalmouths and centre circles (Figure 17). The cost tends to preclude their use over the whole pitch. If problems of wear are widespread, it is better to install 'slit' drainage with a sand dressing or a sand carpet. Certain products have displayed poor traction or caused problems with grass establishment. Semi-rigid geotextile membranes need to be installed below stud depth and their anchorage should be regularly checked. Reinforcement materials can have beneficial effects on ground cover, surface ponding, ball rebound and ball roll, although the effect varies between the different products available. It is possible to spike through most reinforcement materials, although the long-term consequences of spiking have yet to be evaluated.



High wear areas where reinforcement materials might be considered, centre circle and goal mouths

Fig. 17 Location of reinforcement materials for high wear areas on games pitches

8.50 **Synthetic turf surfaces.** The original synthetic turf consisted of an open pile made of ribbons or blades intended to simulate the appearance of natural grass. More recently a different system incorporating a sand-filling between the pile has been introduced. Since 1981, when the first such pitches were established in the UK, this alternative form of construction has become the more popular, primarily because of its lower cost. Most proprietary systems consist of a carpet with a shockpad beneath which is laid on a prepared base.

- Sand-filled carpet. The pile is longer (20-28mm) and less dense than the original type and is tufted rather than knitted or woven. Sand is dressed into the pile to the top of the ribbons. The carpets are installed as strips which are seamed together on-site by adhesive bonding; line markings can be installed similarly. The carpet should be regularly topped up with sand to avoid wear and stress to seams.
- Shockpad. Both types (Figs 18 and 19) of synthetic turf are laid on a resilient underlay or shockpad which was developed from the original thin foam base. The thickness ranges from 6-40mm; thinner pads, particularly, may incorporate complex irregular shapes to enhance shock absorption.
- Base construction. The base below the shockpad started out by copying the techniques used in road building and it is generally known as 'engineered'. Unbound 'dynamic' and static constructions were introduced subsequently and some suppliers have now completely replaced the bound macadam layers with a blinding of small stones with bituminous spray. The thinner and

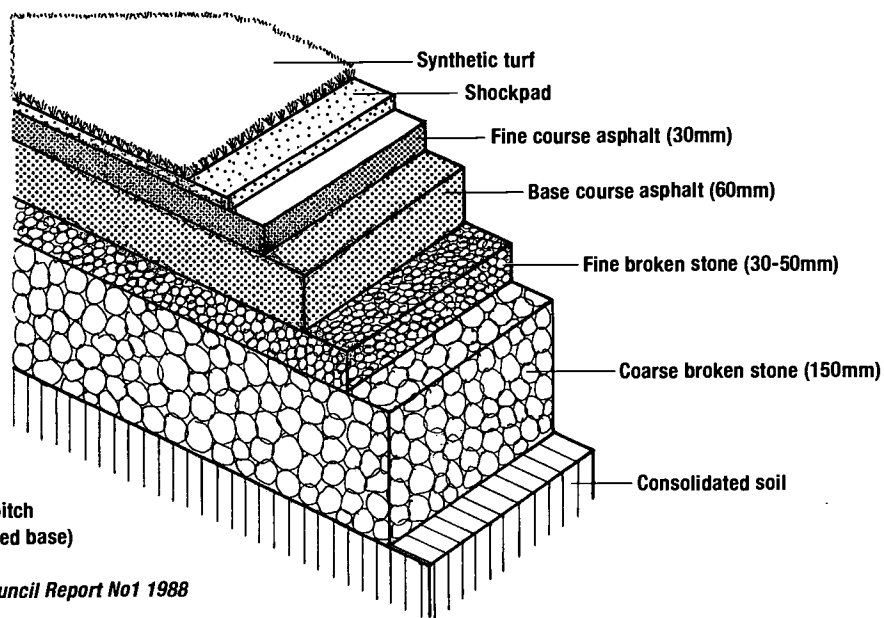

Note: Material thickness is only given to provide a general idea of the construction. Actual thickness would depend on site conditions.

Fig. 18 Typical synthetic turf pitch construction (Engineered base)
G Tipp & V Watson
National Turf Grass Council Report No1 1988

Note: Material thickness is only given to provide a general idea of the construction. Actual thickness would depend on site conditions.

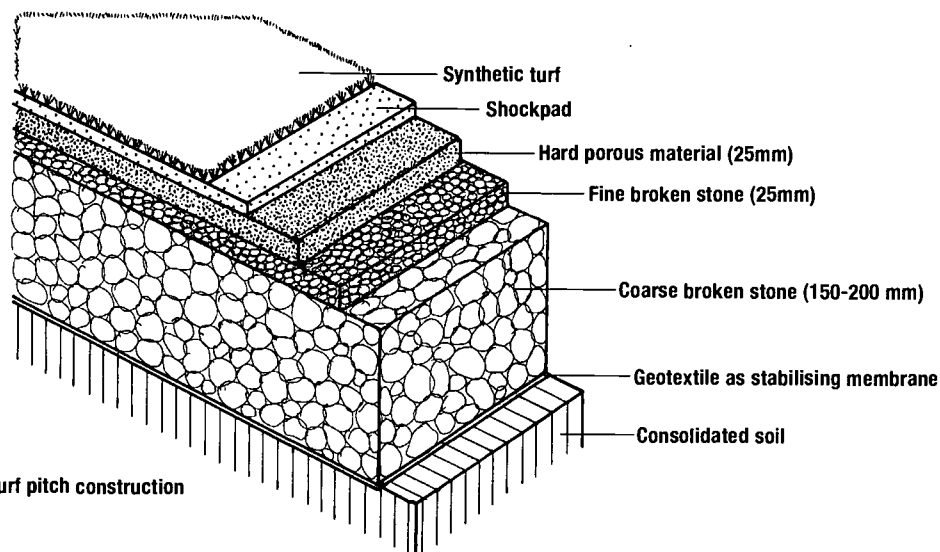

Fig. 19 Typical synthetic turf pitch construction (Dynamic base)
G Tipp & V Watson
National Turf Grass Council Report No 1 1988

less robust the construction, the lower the cost but the greater the risk of damage from frost and the lower the life expectancy. Dynamic bases are intended to be more yielding and may not require such an elaborate shockpad to produce the required performance characteristics. By their nature, however, they may not maintain the evenness of the engineered version (Figure 18).

8.51 **Applications.** The development of synthetic surfaces has led to a reduction in the area of fine sports turf, especially for hockey and cricket. This trend has been encouraged by the high maintenance costs of fine sports turf and the difficulty of sustaining standards which has led to concerns about safety. Non-turf cricket pitches and surfaces within cricket practice nets can be set semi-permanently on a hard porous surface, with the synthetic turf anchored at the edges. In larger secondary schools the combination of a synthetic cricket pitch and a grass cricket pitch with separate outfields is a useful mix. For smaller schools, a synthetic cricket pitch is a cost-effective choice. Another valuable application of synthetic materials is as a multi-games surface, and a number of schools that have found the cost of a full-sized pitch beyond their reach have installed a mini-pitch version for small games and practices.

8.52 **Polyurethane bonded rubber.** There are a number of forms and purposes for polyurethane (PU) resin used as a binder in combination with granular rubber. It can be laid in-situ using a wet-pour system on prepared concrete or tarmacadam bases set to precise tolerances and gradients. It can be laid on similar bases either in sheet or tile form as athletics tracks or in small areas, or as shockpads for synthetic turf

surface constructions as shown in figures 18 and 19. The material thickness ranges from 10-20mm according to its use, its colour can vary but usually red or green is chosen either as a total body colour or as an applied finish. The disadvantages in use of the material are in its cost, its impermeability (which demands accurate engineering), and its tendency to become slippery in wet weather. Efforts have been made to reduce this disadvantage by introducing rubber or mineral granules into the surface. Generally these surfaces support a narrower range of sports, though they have proved useful for multi-games courts, and where games courts serve for both play and sport activities. The material can also function as a safety surface when used in appropriate thickness. Refer to Broad Sheet (BS) 7108: Method of test for impact absorbing playground surfaces, and BS 5750: Quality systems; and for the material generally BS 7044: Artificial sports surfaces Part 4 BSI London (1990).

8.53 **Hard porous (waterbound) surfaces.** These were developed more than 50 years ago as multi-sports surfaces which, because of their permeable properties, could be used in most weather conditions. They consist of finely crushed or graded stone, 40-50mm thick, which is laid over a pipe-drained coarse stone base 150mm thick. The main drawback is that the surface can be unplayable during a thaw after frost or after prolonged heavy rain. The maintenance requirements entail frequent raking, brushing, rolling, spiking and watering, which are expensive and demanding. Hard porous surfaces can nevertheless accommodate intensive use and have been particularly popular for hockey until the recent growth in synthetic turf pitches.

- 8.54 **Hard games courts.** Coated macadam and asphalt remain the most popular choices on school sites for tennis and netball courts. They can also be used for 5-a-side football and basketball. Although the macadam can be laid as an open textured permeable surface, the pores tend to get blocked with grit and dust over time. Gradients of up to 1 in 80 may be required to ensure adequate surface drainage. A surface coating can be used to reduce abrasion and to provide alternative colours to black. Netball is the only sport for which these surfaces are the preferred choice of the governing body. The use of hockey or shinty sticks is not encouraged because of the risk of damage to the surface and wear to the sticks.
- 8.55 **Upgrading existing surfaces with a synthetic surface.** This is usually done to improve the surface for play, to extend the hours of use, and to reduce the cycle of regular maintenance of hard porous pitches. Generally, synthetic turf surfaces are beyond the financial reach of most schools but they might wish to consider organising a joint venture, with major funding from a partner, as part of a shared use arrangement. However before any decisions can be reached it is essential to take professional advice as much will depend on the quality of the surface as to whether it is suitable for upgrading.

Other Design Issues

- 8.56 **Designing for children.** Adult perceptions of play and recreation provision can easily be out of tune with those of the pupils. Young children have a capacity for vivid sensory experience which becomes weaker as they grow older. Contrasts in scale and minor changes in level can seem more prominent. A wide open space may seem intimidating and objects are perceived differently, a table may be a shelter and large shrubs can be trees. Sensitive watching and listening to children can help to bridge this contrast in perception. Ideally, the pupils should be involved in all stages of the grounds development process, so that their needs and ideas can be accommodated. In the case of a new school, it is important to ensure that a proportion of the budget for external works is withheld so that the new school's pupils can take part in the design process.
- 8.57 **Special schools.** Those special schools with pupils who are able to participate in team games and other outdoor activities pursued at mainstream schools should have, either on site or readily accessible, suitable provision as described elsewhere in the section. At schools with pupils who would be unable to make use of these facilities, there should be at least

a netball-sized hard surfaced games court plus a grassed area, in total equal to the recommended figure set out in Reference Section F table 21. More extensive use of safety surfaces may be necessary than at other schools. Careful consideration should be given to the design of, equipment within, and access to, areas for use in both the formal and informal curriculum. Particular aspects to consider are the height of equipment and garden boxes, the textures of different areas, spaces between equipment, and opportunities for several members of staff to work at the same time. Providers should create surfaces and spaces that allow for varying degrees of activity and vulnerability. Different special needs make a range of demands, for example:

- sensory impairment requires greater reliance on the senses that are unaffected. For visually impaired pupils colour, texture, smell and sound have an increased importance as they move about the school environment;
- physical disabilities demand considerate design to ensure access to all areas to encourage the development of greater independence, and to provide safe simulations of hazards pupils might meet outside school.

Detailed information about designing school grounds for children with special needs is contained in *Grounds for sharing: a guide to developing school sites* (LTL 1996). The same considerations will apply when pupils with special needs are integrated into mainstream schools.

- 8.58 **Location of play and recreation areas.** The location of play and recreation areas presents the designer with a number of potentially conflicting requirements. A position near to the building is generally desirable for ease of access and supervision. At the same time, care has to be exercised over the proximity of ball games to windows. One answer is to have a patio close to the building, acting principally as a social or teaching area, and put the active play areas just beyond it. To promote a choice of facilities and encourage pupils to engage in a variety of activities during break times, it is better if the areas for different types of play are clearly indicated. Quiet bays beside the larger spaces used for boisterous play enable separate activities to take place without isolation.
- 8.59 **Social areas.** Some schools already have spaces around the building which could serve admirably as social areas if site furniture were provided. The school garden, the outdoor classroom, the amphitheatre or the wildlife area could all accommodate such use.

Small social areas are especially valuable for the peace and solitude they afford. Bays situated off the games court area are a popular option, but there is still a need for other, more self-contained, separate spaces. Terraces in hard surfaced materials or even wide steps beside hard surfaced play areas may encourage social groups as well as provide for spectators. Such social areas can be used for story telling or discussion groups during lesson time and be made available to parents waiting for pupils at the end of the school day.

- 8.60 **Site furniture and shelter.** A common complaint from teachers and pupils concerns the lack of site furniture, especially for use in breaks and lunch hours. How the grounds are used at these times depends to a considerable extent on what seating is available, how it is designed and where it is located. For example, a line of wooden benches along the edge of the playground may well be ignored by pupils, as has already been pointed out in section 6. If this is all that is provided, many pupils prefer to gather in doorways or on steps. Groups of seats in circles, squares or triangles facing inwards are often more attractive.



Photo 24 Well-designed seating encourages a range of appropriate responses

A number of schools have successfully included picnic tables, as well as seats, in sheltered surroundings. Where vandalism is severe or where sufficient seating cannot be provided in other ways, low walls integrated into the design of outdoor spaces can increase the opportunities for pupils to sit down. The inclusion of covered areas and shelters with good hard surfaced access can extend use through the seasons.

- 8.61 **Impact absorbing surfaces.** These should be installed where the fall height from the equipment is greater than 600mm. They should extend 1.75m beyond static equipment and the same distance beyond the maximum travel of moving equipment. Although loose-fill safety surfaces such as bark, pea

shingle or sand are natural materials and initially less expensive, problems are often encountered in their use. These include more difficult access for pupils with special needs, the problem of keeping the area clean and safe from hazards, such as broken glass, and the scattering of the material over adjacent areas. Regular raking and topping up are necessary to ensure a depth of at least 300mm is sustained. The alternative safety surfaces are moulded rubber tiles or wet-pour rubber crumb, the quality of which can vary greatly between different manufacturers. Where fixed play equipment has been installed recently in schools, it has been over a limited and confined area. There is an increasing preference for high specification rubber crumb safety surfaces, although the capital cost is far greater than for loose-fill surfacing, but when the capital and maintenance costs are taken together over ten years they become more economic.

- 8.62 **Other safety issues.** In Europe, the two standards which are accepted as the most comprehensive and are most widely used, are the German DIN 7926 standard and the British Standard (BS) 5696. Part 3, the latter gives recommendations on siting and layout, surfacing materials, equipment, etc. The dangers from swings and the positioning and relationship between equipment, fixings and fastenings, steps of the wrong height or width and steep gradients are examples of potential problems. The movement patterns around and between equipment should be allowed for in the design to limit head-to-head and other collisions. Fixed play equipment should not frustrate access to and around the buildings by emergency or maintenance vehicles, impede surface water drainage or services, or interfere with other activities. Three categories of inspection, to be carried out on a daily, a 1-3 month and a 6-12 month cycle are set out in BS 5696. These inspections should cover the whole play area and not just the equipment. Safety is of the highest importance, but it does not mean that school grounds cannot be made more interesting and more challenging places.

- 8.63 **Playground markings.** The more complex playground markings are, the greater the time and the cost involved in applying them. Paint suppliers now guarantee their products over a one or even a two year period. The pupils themselves are sometimes put off by the limited choice of playground markings available to them, and this is a salutary reminder that selection by adults alone can be ill-advised. Beyond the more familiar shapes and games, some schools have developed their own markings, often as a response to curricular needs or as a result of games or activities

conceived by the pupils. Where there are only games court markings, pupils often invent their own games within the framework or markings provided. The drawback is that this can bring them into conflict with more boisterous activities taking place on the court. They would respond better to a greater variety of choice in a location set apart from the main games court. Having too many markings, with a great variety of colours, can itself prove distracting and confusing. Where a school has two playgrounds, one can be designated for active pursuits, the other reserved for more passive pursuits, and appropriate markings provided for each function. A large playground might be divided up to achieve the same ends. The markings which work most effectively in schools tend to be those in which pupils have been most closely involved in designing and, therefore, which meet their needs most effectively. Information about playground markings can be obtained from The National Playing Fields Association (NPFPA).

- 8.64 **Rebound walls.** The use of specially constructed walls for rebound ball games should be considered for both skill coaching and casual play. The marking of walls is not recommended unless the walls are in good condition, structurally sound and do not form part of a building as there may be noise transmission problems. The NPFPA multi-games wall provides good opportunities for training and play.
- 8.65 **Hard surface treatments.** Much of the hard surfaced area will inevitably be tarmac, for reasons of cost or use for games. There are different specifications, colours and textures which allow the hard games courts to be distinguished from pedestrian, and vehicular areas. Different hard surfaces can reflect particular uses, such as arrival and congregation points near entrances, sitting areas and routes. The edges and trim to surfaces such as tarmac can make use of local materials. The patterns, textures and sizes of hard surfaces are a significant teaching resource. Where surfaces have to be relaid, any changes in use need to be reflected in new proposals.
- 8.66 **Integrating hard and soft landscape.** Wet ground conditions often prevent pupils gaining access to areas of grass, shrubs and woodlands for more than a few weeks each summer. Pathways into soft areas can open up far greater access. Such integration may also create better cohesion in the design of outdoor spaces and avoid problems of wear on the margin where hard and soft surfaces meet. Conversely, wide expanses of tarmac can be broken up with planters or planting. Close to the building at least two-thirds of the surface treatment may need to be hard, whereas further away, the proportions may well be reversed.

8.67 **Soft landscape.** The treatment of soft landscape areas around the buildings may be at odds with the pattern and intensity of use. Shrub borders perform the helpful, if passive role of filling left-over spaces or reducing hazards where windows open outwards. There are design considerations when planting under windows, for example, rain shadow from the eaves, underground services, the need for access to clean windows and building security. Schools should consider the wider range of functions of soft landscape areas; attracting wildlife, creating visual stimuli for writing or drawing, and supplying materials for display, crafts and cooking. These are all sound reasons for soft landscapes provided the plants will thrive in their location. The use of grass is not recommended wherever there is heavy foot traffic, such as close to entrances where it is likely to be reduced to mud that will then be carried into the building.

8.68 **Planting around activity areas.** While sustained aftercare is fundamental to the establishment of trees and shrubs, the initial design is often the key to success. In developing ideas for planting around and within play areas, it is worth remembering that:

- plants with thorns or prickles should never be used to direct or prevent movement as there is risk of injury, especially to eyes;
- plants are seldom capable of restricting movement where there is an existing footpath problem as, without a change of level, they are trodden down before becoming established;
- poisonous plants should not be used;
- robust native plants, such as shrubby willow or dogwood can respond to damage by sending out new shoots;
- a sense of smell is important and it is good to include a range of scented plants and flowers;
- a proportion of evergreens will ensure that any necessary shelter or screening around activity areas is continued through the winter months;
- large shrubs or small trees with a spreading form, such as hazel or elder, can provide dens underneath;
- new planting in activity areas needs to be protected by fencing until it becomes established;
- trees with dense foliage such as maple or lime are useful because they cast shade throughout the day in summer and allow more light penetration in winter after leaf-fall.

8.69 The relationship between indoors and outdoors. The location, configuration, layout and servicing of the school buildings fundamentally affect the creation and effective use of external space. When the indoor and outdoor spaces are planned together, the effect that different building locations and orientations have on the design of the remainder of the site should be appraised before a final decision is reached. If later extension of the building is envisaged, it is better to identify from the start where this could be sited (see Reference Section A (i) Exploring options for site development of zones).

8.70 Courtyards. These can make an important contribution to outdoor use by providing unique spatial and protective qualities.

A small courtyard of under 20m² can be used as a viewing area from within the building for sculpture, other outdoor displays or beehives. In the last case, pupils can survey activity from indoors without the need for protective suits, providing the windows are sealed.

Larger courtyards, (150-700m² or more) may be used for informal recreation and for habitats such as butterfly borders or for vegetable gardens. Outdoor furniture, greenhouses, cloches or experimental plots are less likely to be damaged by vandals in a fully enclosed courtyard than elsewhere in the grounds. Access to water and electricity may be required.

Where an existing school has a space contained by the building on three sides, it is sometimes possible to create many of the advantages of a courtyard, especially an improved microclimate, by enclosing the space with a fence, wall, hedge or even a temporary building.

Buildings higher than a single storey will produce more shade, so courtyards need to be large if sunlight is important.

When considering courtyards, it is important to be clear about priorities of use to avoid conflict with social and other needs.

8.71 Earthworks and levels. Building construction always involves some earthworks and further modelling of the land around the building is often required to achieve a suitable fit with the surrounding topography. In addition, the creation of nearly level surfaces is necessary for playing fields. The design of landform should be approached on a comprehensive, whole-site basis.

Earthworks afford an opportunity to re-shape the landform to accommodate new uses. A school having

a building extension or digging a pond may be able to use any resultant spoil to advantage elsewhere on the site, and save the cost of having it carried away.

Gradients in the new landform are critical not just to subsequent aftercare but to the use itself. Where the slope on a tarmac playground is inadequate (less than 1:80), puddles result and the consequence is wet shoes and socks after a rain shower. Where it is too steep, ball games may be inhibited.

Often it is beneficial to divide the earthworks for a new school into two stages. As playing fields take 18 to 24 months to establish, their construction, together with related habitats and grass recreation areas, should ideally take place in tandem with, or even before, building works. They can usually form an initial contract and the landscape surrounds to the building itself can be completed later as part of the main building contract.

8.72 Soil. Good topsoil is a valuable and, in terms of the unique characteristics of the site, an irreplaceable resource. Its depth may vary from under 150mm to beyond 300mm and will have to be established by site investigation for every project. Excavated soils need to be handled with care, a pick and drop method using a backactor attached to a tractor or a dumper truck being preferred to a scraper box or a bulldozer which can cause excessive compaction of the subsoil. Storage should be for the shortest possible time, in stockpiles no higher than 2m for topsoil and 4m for subsoil. Re-soiling should reflect new uses, with 300mm depth of topsoil over shrub borders, 150mm over lawns and the poorest soil over wild flower meadows. It is rarely possible to rectify inherent problems of soil structure or drainage after completion, because of the excessive cost and disturbance. The additional time involved in careful stripping, soil replacement and cultivation is a wise investment.

8.73 Microclimate and design. The effects of the microclimate within the site should be taken into account in the location, orientation and juxtaposition of new buildings, in patterns of access and circulation and in the uses of the grounds themselves.

The first aim is to achieve the best match of new uses to the existing microclimatic conditions. This avoids having to rely on new landscape features designed to modify the climate, which will need time to establish.

The second aim is to modify the school grounds over a period of time so as to improve the more extreme conditions. Action may include the planting of trees and shrubs to provide wind shelter, shade or pollution control. Fences and walls, earth modelling, ground

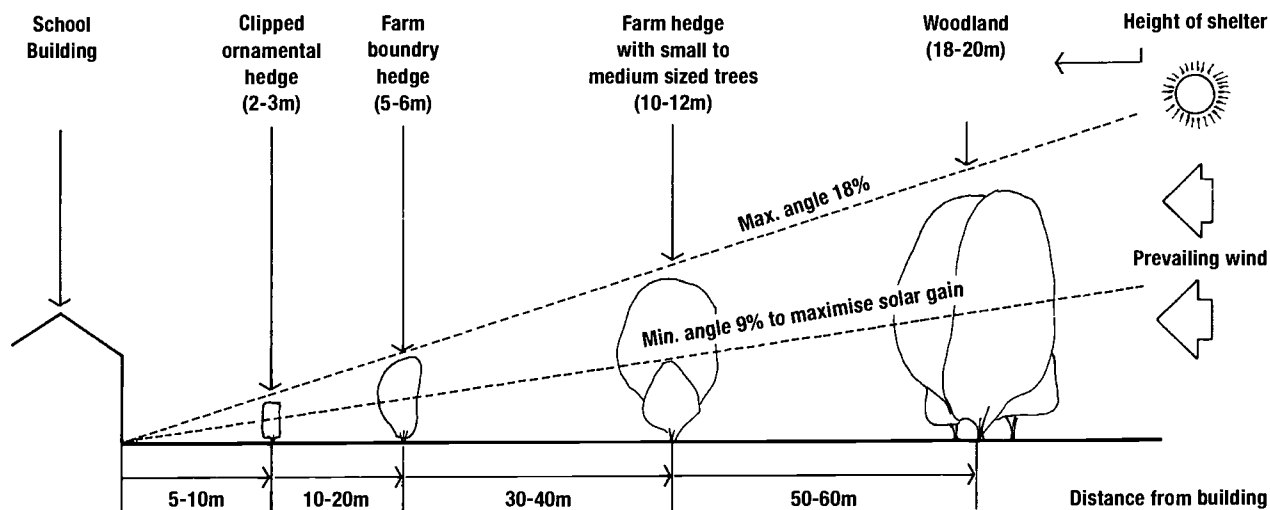

SECTION

Fig. 20 Shelterbelt design close to buildings

surface treatment and drainage all influence the microclimate in varying degrees. Some provide not merely shelter, but also habitats and amenities as extra benefits.

- 8.74 **Shelter and energy conservation.** Where they minimise heat loss through exposure and yet still allow good solar penetration, shelterbelts can reduce energy use in the building by between 5% and 20%. They also serve to make the grounds themselves more attractive and extend the outdoor uses through a greater part of the year. For maximum benefit, shelterbelts should take account of local exposure conditions and normally form an arc from west through north to east, with more distant shelter to the south-west.

A predominantly evergreen screen can hold warmer air around the building where there are cold winds. For maximum effect, the distance between windbreak and building should not exceed twice the height of the shelterbelt.

To avoid excessive shading to the south, the distance between shelterbelt and building should be at least five to six times the height of the shelterbelt. To reduce this, it is also possible to tier down the shelter towards the building with hedges or shrubs, to accommodate the low winter angle of the sun and afford shelter close to ground level.

To ensure warm air is held in a courtyard it should not be wider than about three times the height of the surrounding buildings.

- 8.75 **Design of shelterbelts.** Any obstacle which impedes windflow creates a zone of shelter, mainly on the leeward side and to a lesser degree on the windward. The effect can extend to a distance of 40 times the

height of the shelterbelt, of which about 25% is towards the windward direction and 75% to leeward.

The optimum density of foliage is one which allows about 40-50% of the wind to filter through. Where the type of use - for example, a sitting area or outdoor classroom - demands the maximum degree of shelter, a greater density of foliage with more evergreen species can be used.

While even a single row of trees can be beneficial, the use of three or more rows allows individual trees to be removed when necessary, without a temporary loss of shelter, while their replacements become established. Planting distances vary between 1.5m and 3m, with an average of about 2m.

Shelterbelts may restrict visibility and raise problems of site supervision and security; these need to be addressed at the design stage (Figures 20 and 21).

- 8.76 **Providing shade.** A roof or tree canopy can provide a valuable umbrella against the heat and brightness of high-summer sun. Few schools have sufficient outdoor shade, partly because the establishment of trees close to play and social areas, where it is most desirable, is fraught with problems but they are not insurmountable. However:

- the use of large standard trees is an expensive, yet robust answer that will afford some shade in the short term and can form an immediate focus for imaginative play. Careful location and the use of tree grilles or circular seating can reduce damage around the trees and stop undue soil compaction;
- a larger group of trees will cast shade over a wider area and may avoid the concentration of wear that can occur with individual trees;

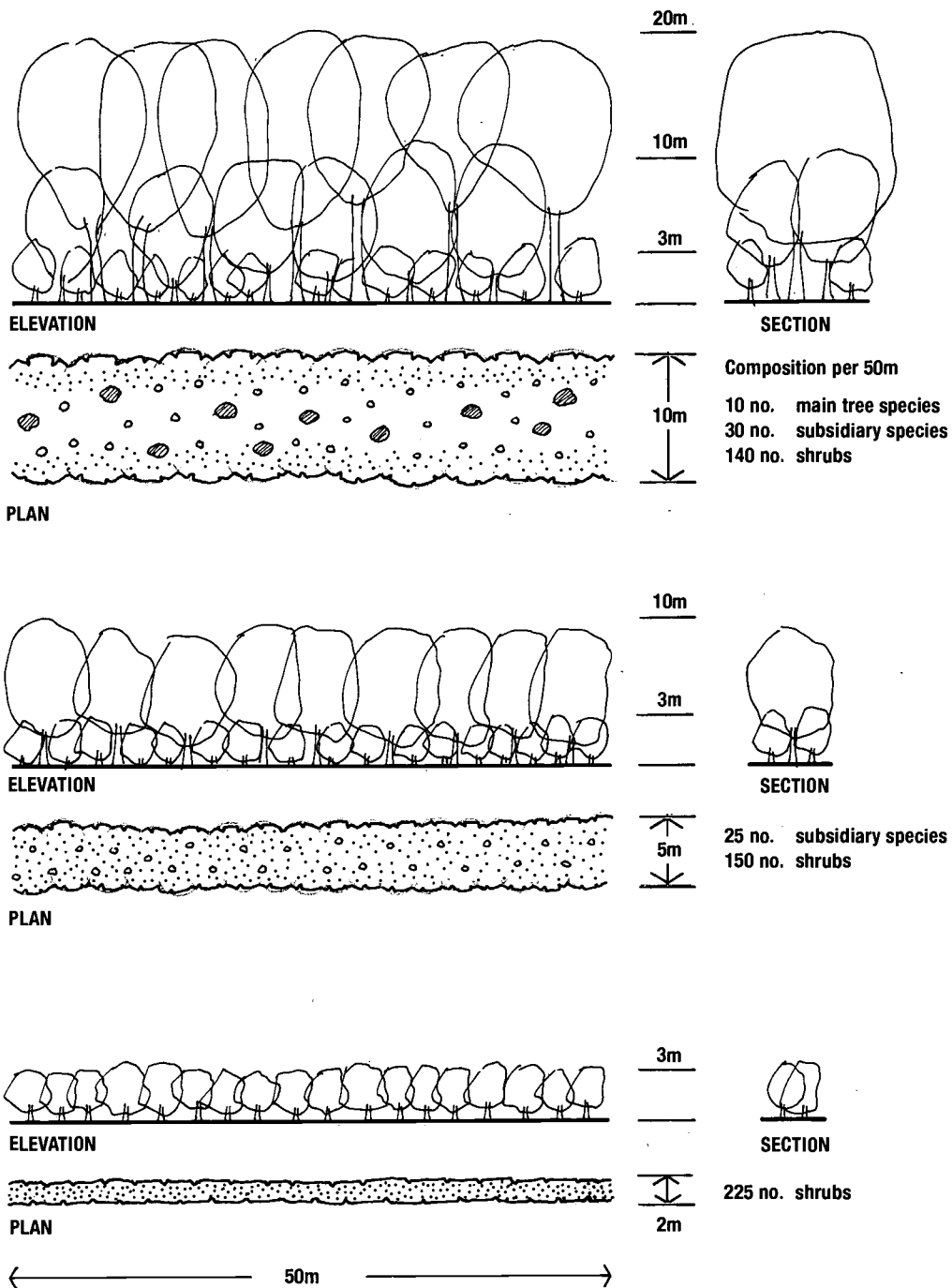

Fig. 21 Details of different shelterbelts
Shelterbelts and Windbreaks J M Caborn. Faber & Faber 1965

- some tree species provide a heavy shade which is cooler, others a lighter, more dappled, and thus 'warmer' shade. The foliage periods of deciduous trees also need to be taken into account.

8.77 **Air pollution.** Tree and shrub screens can be highly effective in combating air pollution. For maximum alleviation, they should be as close as possible to the area requiring protection. Thought should be given to the following:

- a band 30m in depth of planting will achieve almost complete dust removal. In most schools this depth would not be possible, yet even one row of trees can make a difference: tree-lined streets in cities have been found to have 25% lower concentration of dust (Figure 22);
- spaces within the shelterbelt allow settlement of particles by gravity and a rough canopy outline discourages aerodynamic sliding of air over the top;

- leaf surfaces which are fine and fibrous in structure are the most effective. Larch, which grows rapidly in poor soils, is a good choice, being deciduous, it is more tolerant of air pollution than pine, although pine is a more effective filter as it acts all the year round;
- broadleaved trees with narrow, small or pinnate leaves such as willow, hawthorn or rowan are better than those with larger, entire leaves such as maple or lime. Ash has the advantage of a high surface area, while oak and hornbeam often retain their leaves well into winter.

8.78 **Noise pollution.** Trees and shrubs can screen views of busy roads or other sources of noise but they do little to lower the actual noise levels. A solid barrier is more effective; the options are earth modelling, walls and fences, or a combination of the three. Modelling requires steep slopes as close as possible to, and facing, the noise source. A hedgebank with a stone facing, or geotextile bags filled with soil, can be used to form a low screen that affords another habitat and does not occupy too much space. If fences are to achieve significant noise reduction, they must be to a high specification and designed for the purpose, although even a simple close-boarded fence will bring some reduction. A combination of a mound with fencing on top can achieve greater height and effectiveness, but the stability and appearance of the fence needs careful consideration. If the noise barrier itself is visually intrusive, planting adjacent to it will benefit from the wind shelter and eventually improve screening.

8.79 **Access and security.** Access roads, service roads and car parks all fall within that proportion of the gross site area classified as buildings and access - anything from 3% in a large secondary school to 7% in a primary school may be taken up by such features. (These percentages exclude the building which also forms part of the 'buildings and access zone'.) The temptation is to regard such features as purely functional necessities. They do, however, affect the quality and use of the grounds as a whole and need proper consideration.

8.80 **Entrances and boundaries.** First impressions are important and lasting.

The route through the grounds and the area around the entrance to the building make an impact on visitors, parents and pupils. At their best, they convey favourable messages about the ethos of the school, its approach to learning, and its regard for its members as individuals.

The same is true of site boundaries - the most immediate statement the school makes to the wider community. Here, however, public impressions have to be weighed against the realities of site management. Nevertheless, where the prime requirement is for an effective barrier, careful design and additional planting may be able to soften its impact.

Useful reference may be made to 2.7 The hidden curriculum and, 7 Understanding the hidden curriculum.

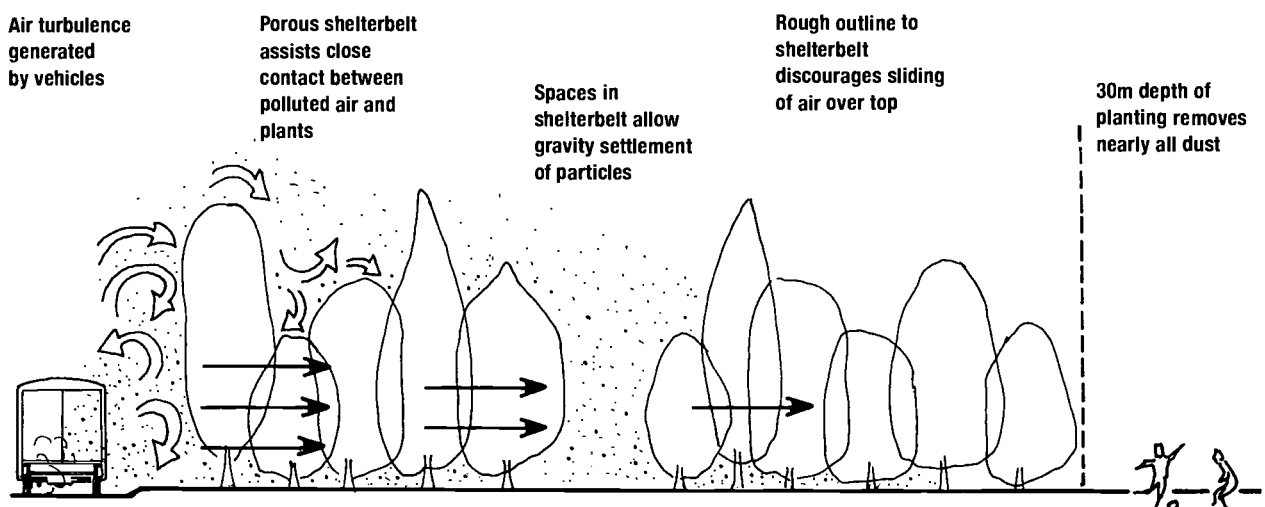

Fig. 22 **A pollution screen**
M. Madders & M. Lawrence *Landscape Design* August 1981

8.81 **Vehicular access and parking.** Children's freedom of movement in the wider community is already restricted by heavy traffic, and this pattern should not be repeated within the school grounds. Thought should be given to the following:

- vehicles should not dominate the spaces around the building or the grounds in general. The aim should be to keep vehicular movement within the grounds to a minimum and to segregate vehicles and pedestrians;
- parking design should be as economical of space as possible; this usually demands right-angled parking bays. Overflow car parking on games areas should be avoided because of the risk of damage to the surface itself, including spillage of oil, and to the surrounding fencing;
- provision for parents' cars at the beginning and end of the school day can be a major issue and there is no universal answer. Where appropriate, a drop-off facility can be included within the site, using a one-way system, but collection frequently involves parking on the public highway. In certain circumstances, traffic calming measures may be permissible to alert motorists and reduce speeds.

Whatever the provision, subsequent traffic management within the site and at all access points needs to be reinforced by clear signs and regular supervision.

8.82 **Pedestrian routes.** Separate access for pedestrians and vehicles is both more pleasant for the walker and safer for everyone. Additional pedestrian access points may also avoid damage to boundary fencing. Within the grounds, it is as well to acknowledge the realities: that pupils are gregarious and rarely walk in single file; that parents collecting young children often bring prams; and that most people will choose the shortest route between two points.

For well-used paths within the grounds, widths of 3m or more may be necessary.

Pedestrian routes should avoid abrupt changes of angle and follow direct lines which are integrated into the overall design. Where sharp corners are unavoidable they should be taken off at a 45° angle or a quarter circle.

A particular need is for areas around important access points to the building where pupils may congregate. Better than a path linking to classroom entrances is a hard-surface area, 4m or even 6m wide, which can also function as a usable space. It might vary in form, with bays for local meeting places, patios or simply small niches with seats. During lesson time it can form

a valuable and visible extension to the classroom.

8.83 **Access for the physically disabled.** Access to outdoor facilities has often lagged behind the provision within the building. While it may not be possible for the disabled to have access to every niche in the grounds, their opportunities for recreation and learning should not be compromised. Disabled children and adults should be able to engage in all group activities in the grounds.

Ramps should conform to the Department's recommendations in DN 18, *Access for disabled people to educational buildings* or its replacement. Surfaces should be firm, smooth but non-slip; suitable materials are tarmac, in-situ concrete with a non-slip finish and non-slip paving slabs. Smooth paving slabs and brick surfaces which become slippery should not be used.

Routes for the physically disabled need not be seen as extra provision. The paths provided for their use will also improve access for other pupils to parts of the grounds, which, in the winter months, or whenever there are wet conditions underfoot, might otherwise be unused.

Detailed information about special schools is contained in Building Bulletin 77 and in *Grounds for sharing: a guide to developing school sites* (LTL 1996).



Photo 25 Access for the physically disabled pupils to move safely round the grounds and to share equally in the facilities is important.

8.84 **Supervision and safety.** The design of outdoor spaces must allow for effective supervision, often over more than one activity at a time. This does not mean that the teacher should be able to see all pupils all the time.

- A key issue is the zoning of outdoor facilities; the concept of an inner 'core' of play and social areas surrounded by playing fields and habitat areas has much to recommend it (Figure 23).

- Safety considerations include not just the question of suitable sports and play surfaces and equipment but also the relationship of facilities one to another, pitch margins, surrounding enclosure, and site furniture.
- Safety is closely linked to security and management, for example to ensure the youngest pupils cannot wander off site or be abducted. Reference DfEE Managing School Facilities Guide 4 Improving Security in Schools (HMSO 1996).

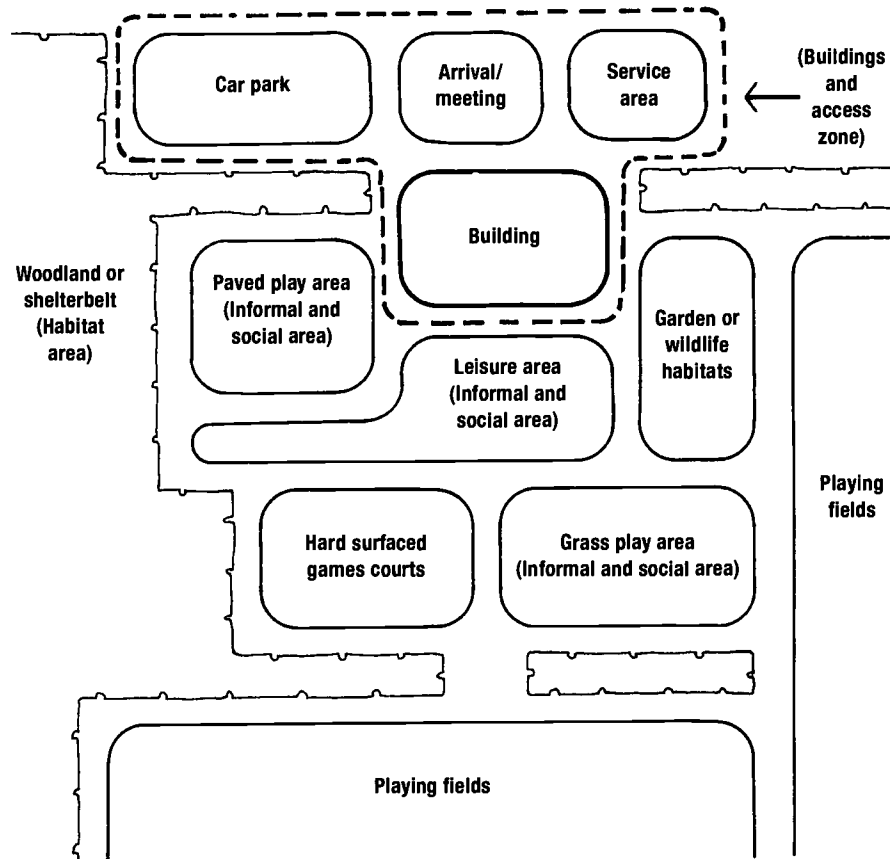

Fig. 23 Zoning of outdoor uses to improve security and safety (similar activities are grouped for better supervision)

9. Maintaining the Grounds

- 9.1 This section deals with some key issues relating to maintenance and outlines some options for organising grounds maintenance.

Key Issues

- 9.2 Traditionally the local authority was responsible for the overall management and maintenance of school grounds. The introduction of Local Management of Schools (LMS)¹ and Compulsory Competitive Tendering (CCT) have led to widespread changes in the ways in which maintenance is carried out in schools and placed the prime responsibility for care of the grounds on the school itself.

Under the Local Government Act 1988, maintenance is defined as:

1. the cutting and tending of grass (including turfing and reseeding but not initial turfing);
2. the planting and tending of trees, hedges, shrubs, flowers and other plants (but excluding new landscape works);
3. the control of weeds.

Clearly this is a very restricted definition and any school which is considering using and developing its grounds will need to carry out a much more complex range of management and maintenance tasks. While there has been very considerable progress in the use and development of school sites, grounds maintenance practices have not always been completely in harmony with this. Schools need to recognise the importance of nurturing and maintaining their investment in school grounds by setting up appropriate maintenance regimes.

Organising Grounds Maintenance

There are four main groups which schools may choose to involve in their maintenance, and these are described below. For more detail, refer to *A guide to management and maintenance of school grounds* (LTL/English Nature 1996).

- 9.3 **Private contractors and local authority Direct Service Organisations (DSOs).** LEAs now offer different levels of landscape advice with a range of professional fees. This allows the school to take on as much of the supervision as it wishes. There are also a number of commercial contractors to which schools can turn for services. Grant Maintained (GM) schools may choose the services of their former LEA or other LEAs which offer professional advice, or use private

consultants. The advice can cover both specifying and organising the work on the school's behalf and it may also extend to implementing it. Work which is particularly suitable for this option includes specialist sports maintenance, large-scale grass-cutting and routine garden maintenance works. Dealing with any contractor will involve a member of the school's staff in areas where an understanding of technical matters will be important.

- 9.4 **Directly employed ground staff.** Some schools have returned to employing full-time or part-time ground staff directly as it gives them greater control over their work. In some cases, a site ranger has been appointed whose job remit includes involving pupils, school staff and parents in maintenance where appropriate. Such a person may also have a role in helping staff to make greater use of the grounds as a teaching resource. This kind of arrangement is particularly suitable for small areas of grass cutting, general and specialist routine garden work, line marking for sports, wildlife habitat work, litter control and minor repairs. This may be of particular interest to independent and CCT exempt schools (see 9.7).
- 9.5 **Community-based organisations.** Organisations such as local wildlife trusts, groundwork trusts, British Trust for Conservation Volunteers groups and other local environmental groups are, in some cases, undertaking maintenance work with schools. Some can provide training and also advise on the creation and use of habitat areas. Some groups may do work for no charge; others will require payment. This kind of arrangement is especially suited to wildlife habitat and garden work, painting of murals or outdoor structures and infrequent tasks such as shrub pruning.
- 9.6 **Volunteers.** These may be drawn from a school's parent group or from the wider community, and may also include pupils. While it is unwise to rely on volunteers for large scale and extensive maintenance tasks, this kind of arrangement can be an extremely useful way of involving people in the maintenance and care of school grounds. Typical tasks appropriate for volunteers include wildlife and habitat maintenance, gardening, planting, work with animals, work in greenhouses, and small area grass cutting.
- 9.7 **Implementation.** The Local Government Act 1988 requires that school grounds in the state sector, along with parks and other open spaces, be subject to CCT for maintenance. Subsequently it has been confirmed that schools can be exempt from CCT for cleaning the buildings and grounds maintenance where three or

¹ Within the Governor's school budget under LMS or the annual maintenance grant in the case of Grant Maintained Schools, schools have considerable flexibility to determine their own spending priorities. They can decide what proportion of their budget to designate to school grounds use.

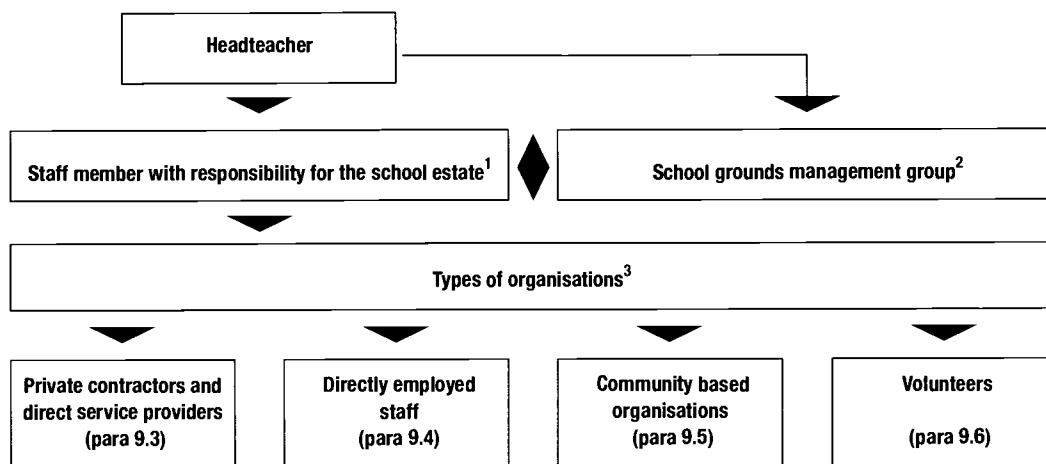

Note:

1. It is important that at least one member of school staff has day to day responsibility for management of the grounds. (Reference Section D has a description of the key duties.) The staff member is likely to be the point of contact for the grounds maintenance contractor.
2. The group is likely to include the governor's committee for school grounds and premises, staff, parents and pupils involved in grounds management and development.
3. The organisation or combination of organisations chosen will depend upon the extent and type of maintenance work to be undertaken.

Fig. 24 Suggested model for organising grounds maintenance

fewer full-time equivalent staff are employed on the two activities together. This means that primary schools, most middle schools and a few small secondary schools can either employ ground staff or a DSO directly.

9.8 Types of grounds maintenance agreement. Just as every school has a unique character, so there are a variety of grounds maintenance agreements. The type of agreement chosen will depend on a number of factors. Schools should ensure that:

- the type and content of the agreement meets the school's needs and takes into account site features, site use, soil and climatic conditions and the budget available;
- all parties are aware of their particular role where more than one agreement is in place for grounds maintenance;
- pupil and staff safety has been taken into account, including checking staff or individuals who will be working on site;
- insurance provision has been made, where necessary;
- arrangements for authorising payments for work done will stand up to scrutiny by auditors.

9.9 Types of agreement. There are four main types of agreement appropriate to the carrying out of maintenance tasks. Each of these has its strengths and weaknesses: it is important to choose the appropriate one for the way in which grounds maintenance is organised.

- **Contract.** This is the simplest form of agreement between two parties to discharge certain obligations, see 9.15-9.20.
- **Service-level.** This specifies the service to be provided, the costs involved and the timescale. It is often used by local authority DSOs.
- **Informal.** This varies from a verbal agreement to an exchange of letters. It is often used by local conservation groups. However, even a verbal agreement can constitute a legally binding contract.
- **Direct labour.** This involves the direct employment of a grounds person or other individual.

9.10 Using direct labour. Direct labour appears on the surface to offer the greatest degree of control. Employees directly engaged by the school can be more thoroughly and directly checked to test their suitability for working in the school environment. Their ability to undertake extra tasks can also be a

1. Planting on frontage of site is designed to screen out traffic on adjacent road and reduce pollution. A 50/50 mix of evergreen and deciduous species should be sustained with an overall height of 4-6m. Regular formative pruning will be required with some thinning after 3-7 years and gradual replacement of shrub species after 10-15 years.
2. Close mown fine lawn area for occasional small team or ball games and for outdoor teaching groups. Important to retain and maintain fence separating area from car park and to cylinder mow lawn on a regular basis with cuttings boxed off.

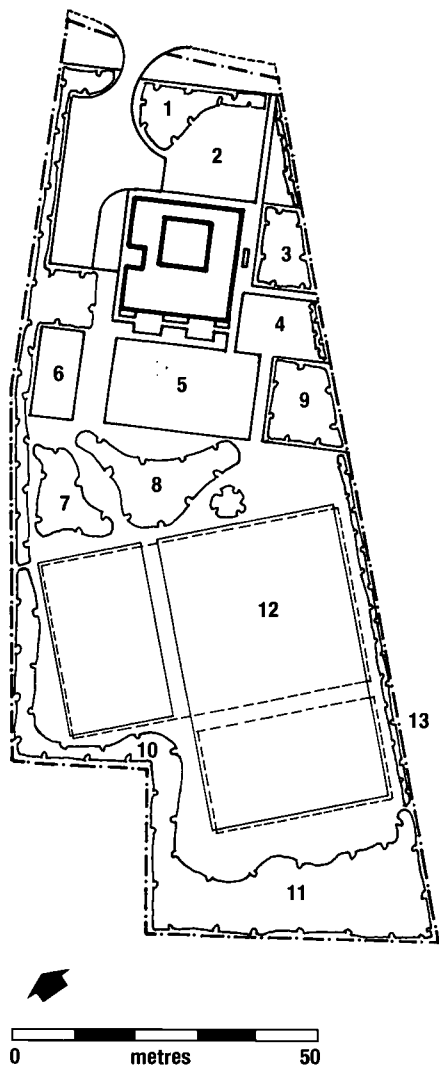

4. Small open space for informal recreation and social gathering with mix of hard and soft areas. Litter needs to be picked up as it arises and hard surfaces checked regularly for surface quality and level; site furniture should be inspected weekly. Grass needs to be cylinder mown on a regular basis.
5. Patio areas immediately outside classrooms are intended as overflow space in fine weather, for small group work and to attract wildlife. Shrubs have been selected to encourage insects and birds and require regular formative pruning and gradual replacement as necessary after 10-15 years.
6. A mixed coppice woodland area with hazel and sweet chestnut cut on a 7-10 and 15-18 year cycle respectively. Cycle to be arranged so that 1-3 coppice stools of each species are cut annually.
7. Summer meadow area to be cut in April and again in October with cuttings removed for animal feed or composting. Species to be regularly monitored and recorded, and greater diversity encouraged with gradual introduction of individual wild flower plants after first cut.
8. Area of standard trees to create open, shady areas beneath. Trees to be thinned by 30-50% after 10 years and as necessary thereafter and to be inspected at least annually for any signs of defects. Bulbs on periphery and within parts of area require grass cutting to be delayed until 7 weeks after flowering has ceased and thereafter at monthly intervals.
9. Spring meadow area with some areas of bulbs. Paths and gathering areas within area to be close mown and meadow to be cut in July and again in September. Wild flower plants to be set in sward as necessary after second cut to increase diversity.
10. Mixed shelterbelt of shrubs and small to medium-sized trees with 30% evergreens. 1m weed-free ring to be sustained for at least 5 years with fertiliser in years 2 and 4 and regular watering as necessary, especially in year 1.
11. Area of oak/ash/hazel high forest with subsidiary species and mixed understorey. Maintenance during establishment as for 10 and woodland wild flowers to be gradually introduced after woodland has started to form closed canopy in 7-10 years. Thinning to take place as necessary after year 5.
12. Playing field area to be close mown to a height of 20-50mm during growing season with pitches alternated annually as shown on plan to spread wear. Sports markings to be sustained throughout season of use and any excessive wear to be rectified immediately after term ends.
13. Eastern boundary hedge to be watered and fertilised as 10 during establishment phase and thereafter to be laid on 7-10 year cycle in such a manner as to allow an equal portion to be completed each year once the hedge has established.

3. A wildlife area close to the school with a pond and marsh area, butterfly plants and log piles. Post and rail fence defines area where pupils are only allowed under supervision. Paths and gathering area around pond to be close mown, meadow areas to be cut in July and September and pond to be cleared of any litter on a weekly basis and excessive vegetative growth on an annual basis (in the autumn to minimise disturbance to wildlife).

Fig. 25 Part of a grounds management plan - see 9.12

great bonus. Direct labour demands a high degree of day-to-day supervision on the part of the school and it can rarely offer the range of skills or the variety of tools and machinery available to the landscape contractor. For example, gang-mowers allow very competitive rates for large areas of close mown turf, but the high cost of the machinery makes them an unwise investment for a single school. Where schools have purchased machinery this is frequently under-utilised and the small size of the workforce means there is little cover for sickness and holidays. As with most appointments, much depends on assessment of character, aptitude and attitude to the work. A verbal reference from a former employer is valuable and initial appointment on a temporary basis for 6 months is advisable. An independent landscape assessor at the interview can help and his or her subsequent advice on job performance by means of quarterly visits could be combined with technical guidance on the enhancement of outdoor resources.

A Management Plan

9.11 Just as it is difficult to develop the grounds successfully without an overall development plan, so it is hard to organise annual maintenance without a landscape management plan. This is true whatever means are used to implement the work. Such a plan is of most value if it records both the design objectives and the type of management that is required to sustain them. It needs to allow for changing demands on the grounds and for the variability of plant growth. Recent legislation concerning health and safety, environmental protection, pesticides and tendering procedures has a direct bearing on how the grounds are managed. Measures for monitoring, updating and revising proposals, supervision, inspections and annual review need to be addressed.

9.12 **Aims and objectives.** In the first place, the key objectives for the grounds as a whole should be identified. A useful approach is to plan up to five years ahead. Anything less is too short to be meaningful and anything more invariably means increased uncertainty about the issues involved, which may include:

- aims and objectives for the school grounds;
- existing site features (data obtained after carrying out tasks described in section 4);
- constraints and relevant regulations affecting the site (data obtained after carrying out tasks described in section 4);
- planned site developments (data obtained after carrying out tasks described in sections 5, 6 and 7);
- current and intended educational use of the site (data obtained after carrying out tasks described in sections 5, 6 and 7);
- grounds maintenance work;
- community use;
- overall landscape character and quality;
- the skills and available time of teachers and pupils;
- the financial resources available.

Once these issues have been resolved, it is possible to look in more detail at individual resources and areas. This should be done before maintenance schedules are drawn up. An example of part of a management plan is included in Figure 25.

9.13 **Costs.** The various landscape areas within the school grounds differ widely in the demands they make on materials, manpower, and the annual costs of their upkeep (Figure 26). These continuing costs need to be assessed as part of the management plan and are

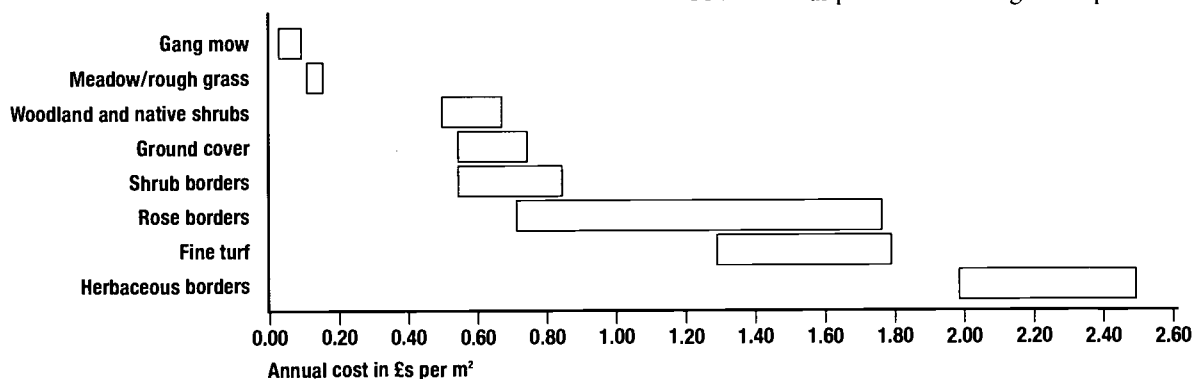

Note:

These are typical price ranges for various types of soft landscape maintenance. They are, however, only indicative, and, in practice, they can vary considerably depending on factors such as location, site, accessibility and scale of work.

For more detailed information on landscape maintenance costs, refer to *E & F Spon's Landscape and External Works Price Book 1997* ISBN 0 419 22220 0.

Fig. 26 Costs of maintaining soft landscape areas (1997 prices)

also a factor in the long-term development or adaptation of the grounds. Hard surfaced areas are relatively cheap to maintain until it comes to the time for refurbishment or replacement. Regular financial provision for this inevitability is advisable. Shrub borders and fine sports turf are expensive to maintain properly when compared to the maintenance of extensive grass areas. In many schools, the option of reducing the frequency of mowing has already been pursued. It is often possible to change the pattern of maintenance by increasing the proportion of woodland, meadow or rough grass. This requires investment of capital to facilitate change and may have to be phased over a number of years. If it is undertaken, the prime motivation should be specific educational advantages rather than simply cost savings.

9.14 Organising maintenance work. Detailed specifications of all maintenance works can reduce the time spent on day-to-day supervision, supply a common basis for competitive tendering, and permit the establishment of performance targets for direct labour. A distinction needs to be made between performance and operations criteria. The former focuses on what is to be achieved (such as height of grass cut) and the latter on how the work is to be implemented (such as the number of cuts per year). Concentrating on the operations themselves can obscure exactly what has to be achieved; the means become more important than the ends. An alternative is to set clearly defined performance targets for each type of maintenance by laying stress on fitness for purpose. The two approaches can be used together but they must not contradict each other, otherwise there will be confusion about which standard prevails.

9.15 Contract arrangements. Where a contract for landscape maintenance is used, it should state the exact responsibilities of both employer and contractor. These are usually in the form of 'General Conditions' and may be prepared by an LEA or by professional bodies. They define the responsibilities of the parties and set out the requirements and procedures governing insurance, payments, claims and termination in the event of default and for compliance with legal provisions. The contract also needs to address the issue of deduction of monies for defective work and, if this persists, for the termination of the contract. Penalty points are a means of dealing with poor workmanship or non-completion. When the number of points reaches a particular figure over a defined period it results in non-payment for an item or area. Such a system can be unduly punitive, if

money is withheld for other areas that were completed satisfactorily.

9.16 Specification and bills. So that contractors know exactly what they have to allow for in their tender, they will need to be supplied with:

- a comprehensive and precise specification of what is required, with all the relevant materials and dimensions, for every type of maintenance so that each item can be priced;
- a detailed site plan at a sufficiently large scale to define clearly the different types of maintenance required. This is often coloured to show the various categories and, if each individual area is given a code number, subsequent reference is much easier;
- a bill of quantities at the end of the documentation which sets out the dimensions for all the various items of work. Relevant sizes or numbers are usually measured from the plans and may have to be checked on site before quantities are finalised.

9.17 Timescale and payment. Preparing new contract documents demands expenditure of time and money and these outlays have to be weighed against the need to test the market at regular intervals by competitive tendering. A three-year term is about the minimum desirable; one or two year terms are generally too short but a four year contract gives more scope (four years is the maximum permitted under CCT legislation). Even though GM schools are exempt from this requirement, a term in excess of five years might mean annual costs becoming less representative of current market rates. It is unusual to seek a fixed price for a contract extending beyond one or two years; many provide for fluctuations of price after the first year on the basis of a nationally recognised index. Monthly payments are often a proportion of the annual lump sum for landscape maintenance; they can allow for the summer peak of work by setting a higher than average proportion for the months of April to September and a lower one for October to March. This prevents payment in excess for work completed during the slacker months of the year.

9.18 Variations. Payment on the basis of the annual lump sum demands that maintenance remains as originally specified through the year, although it can be varied from one year to another. Changes within the year are often better dealt with by means of separate instructions. This highlights the need for both a management plan to set out the objectives over the term of the contract and an annual planning meeting

to determine the maintenance for the coming year. A contract start date of 1 January allows the contractor time to get organised in advance of the main growing period. It is wise to include within the contract a schedule of rates for additional work (see Reference Section C for unpriced example). These rates are not to be totalled, but they do mean that such prices are set competitively rather than quoted subsequently. Finally, the school's budget may vary year on year and it is important to allow an element of flexibility in the landscape maintenance contract. This can be done by including provision for an annual increase or decrease of 10-20% of the total value of the works.

9.19 **Tendering.** If too few contractors are invited to tender, prices may not be representative of current market rates. If there are too many, it places a heavy burden on whoever is organising the work. It is also unfair on contractors who are required to do a great deal of preparatory work with a smaller prospect of success. The most appropriate number is between three and six, although the number will vary with the size and complexity of the work. It is unwise and inappropriate to rely solely on personal contact or recommendation in selecting tenderers. References must be sought and insurance provision checked. The willingness of contractors to tender should be established beforehand to avoid invitations being declined. Pre-tender meetings with contractors allow schools to ensure that the contractors are familiar with both the work and the site. They also provide contractors with an opportunity to raise any concerns or queries they may have. Such meetings are more feasible for the individual site than for a combined contract for a group of schools. Points raised at these meetings can then be clarified before the closing date for receipt of tenders.

9.20 **Supervision.** The maxim that a job is only as good as the supervision it receives certainly holds true with grounds maintenance, since the length of the contract means that standards can fall over time and attitudes become more lax. Contract compliance must be sustained through effective supervision to ensure value for money. Schools have always been involved in the supervision of works and their role has increased with greater autonomy.

- A contractor's performance cannot be judged from the classroom window. At least a weekly inspection of the grounds should be undertaken during term time. The division of responsibility for this lies between the school and its advisers and this needs to be made clear.

- Contract staff should be required to report or sign in on arriving at and leaving the grounds, so that contact may be established at each visit.
- The contractor should have one point of reference for all queries, either a member of staff or a landscape manager, who should be responsible for issuing all instructions.
- Some contracts require a formal monthly site meeting with the contractor's supervisor; this is useful because it sets a regular progress check for the contractor.

9.21 **Clarifying the objectives.** Sports facilities are one of the most difficult areas in which to achieve and sustain an acceptable standard. School grounds are like some parks in having a mix of recreation and sports facilities. The more relaxed attitude towards amenity turf can lead to a dilution of standards for sports turf. At the other extreme, ground staff versed in maintaining fine turf to a high standard find the move to managing a variety of grasslands hard to accept. Often good housekeeping has become ingrained and is difficult to dislodge. The style of maintenance is determined by the desired uses and it helps if these are made clear to everyone involved in the care of the grounds. The maintenance schedule in Reference Section C highlights the basic requirements for different outdoor facilities and features.

9.22 **Litter.** The Environmental Protection Act 1990 places a duty on schools to ensure that their grounds are kept free of litter as far as is practicable. The code of practice accompanying the legislation (the Code of Practice on Litter and Refuse, HMSO 1991) stresses the role of environmental education in schools in shaping positive attitudes towards environmental protection. On the basis that prevention is better than cure, the establishment of a caring and responsible attitude amongst pupils is a key to success. This can be supported by providing sufficient litter bins with lids, especially near areas where packaged food or refreshments are sold. As a last resort task forces have been used to clear accumulated litter. An emphasis on recycling and the implementation of an environmental audit of the grounds can also enhance caring attitudes. Evidence suggests that once the grounds are cleaned, and then diligently maintained free of litter, the problem declines as general respect for the condition of the site increases.

9.23 **Vandalism.** Whilst vandalism to the grounds is often less financially damaging than vandalism to the buildings, it is nonetheless extremely disheartening and can become an excuse for not using, let alone

improving, outdoor resources. The example of new tree planting has been adopted to show some of the ways in which vandalism can be combated:

- plant very large or very small nursery stock that are respectively difficult to snap, or easy and cheap to replace;
- involve youngsters from the local community, not just the pupils, in design, planting and aftercare;
- appoint tree wardens and undertake regular inspections;
- do not advertise the presence of a small transplant with a cane and a rabbit guard, since in urban areas the risk from rabbits may be far outweighed by that from vandals;
- choose a good proportion of bushy and thorny species, such as blackthorn or wild rose, and those that respond to damage by sending out new shoots, such as willow, alder or poplar;
- avoid planting trees that have a long single stem, such as whips of ash or standard trees that can be snapped by hand pressure;
- immediately rectify any damage and remember that as most trees can shoot from the base it is worth cutting back larger nursery stock if the stem has been broken;
- make young nursery stock less visible by cutting back all shrubby species after planting to a height of no more than 300mm above ground level;
- do not mow the grass outside of the weed-free ring; merely tread tall grass down around the young trees in June and September;
- replant all uprooted stock in the next planting season;
- consider the sowing of tree seeds, such as acorns, as an alternative to young plants.

9.24 **Trespass.** Many head teachers regard trespass as a major issue in the management of the grounds. In the worst cases, the health and safety hazards created can deter all use of the grounds other than the hard play surfaces which can be regularly swept. Dog mess can be a particular hazard. Problems arise from the fact that LEA schools in particular are regarded as 'council land' where residents assume a right of access. It is, therefore, as important to change public perceptions by educating neighbours as it is to take direct action.

Possible initiatives include:

- clear signs indicating private land and forbidding trespassing;
- good boundary fencing, which in the most difficult cases should be welded mesh, as chainlink is insufficient; wrought iron railings are once again increasing in popularity though costs are high;
- a good thorn hedge, though this needs the protection of a fence while it becomes established;
- an education programme involving pupils, parents and neighbours to emphasise the problems and ask for their support;
- a leaflet or visit to residents who overlook the site to ask for co-operation and assistance on a neighbourhood watch basis;
- regular liaison with the local police force;
- legal action in cases of persistent abuse.

Some LEAs have used the provisions covering nuisance under Section 40 of the Local Government (Miscellaneous Provisions) Act to prosecute trespassers on school land under their control.

Indirect approaches by the school and persuasion are more effective and less costly, and the appearance of the site can also be a deterrent to the trespasser, as it is to the vandal.

9.25 **Wear and tear.** All landscape designs have some raw edges, none more so than school grounds where the nature and intensity of use do not match original expectations. Whilst experience reduces errors, it cannot eliminate them, and the essential criterion is to respond to wear and tear quickly. Often there is no point in resowing or replanting a soft landscape feature when its vulnerability or location means that damage will be repeated. It is better to adjust the layout to suit the actual pattern of use. This situation provides a good opportunity to discuss issues and options with pupils and, where appropriate, for them to instigate change. A positive design solution is preferable to an immediate palliative, such as an area of tarmac or concrete.

10. Planning for Changes

- 10.1 This section outlines the need to turn possible solutions into a clear, long-term plan for the development of school grounds.
- 10.2 **Taking a holistic view.** It is likely that, as a result of the work which has been undertaken in understanding the issues, surveying the site, identifying needs and possible solutions, most schools will have collected a huge amount of data and ideas. That is the moment to produce clear plans in the light of available resources. It is vital that schools gain a strong sense of the overall purpose of their grounds and that they are confident that any proposals meet the needs of the school community. It is important to ensure that pupils are consulted at this stage. There is the danger that, as the project moves into the realm of school management, children's voices are heard less often.

Most schools have inherited their grounds, layout, and landscape. In this context, and following the guidance given in the publication, they may wish to make the best of what they have. There may be opportunities to review the existing estate, or to plan an extension to the grounds, or to plan a new site. This could involve consolidating the site to a better configuration by means of land swaps and/or disposals where receipts can be directed to the enhancement of facilities. Unusable land, surplus land and awkward parcels of land could be used positively in this way.

- 10.3 **Incorporating intended developments into the School Development Plan (SDP).** All schools are required to produce an SDP and most already contain an element devoted to the school premises. If the school's SDP does not, or if it is not fully developed, this is the moment to incorporate plans for the grounds.

Sources of Advice and Information

- 10.4 Even before the Education Reform Act 1988, the sources of advice and support to help schools at this stage were extending beyond the LEA. Since then, more powers have been devolved to schools, and the responsibilities of governors have been further extended. It is important that schools know just what assistance is available, where and when to buy in expert advice, and how best to implement both day-to-day maintenance and any new development proposals. The danger in seeking any form of outside help is that the educational objectives may be overshadowed by those of the outside agent. On the other hand, most schools will want to benefit from any relevant source of help, especially in areas where

they feel unqualified. Some of the options are described in 10.5-10.8.

- 10.5 **Local authorities.** Before the plans for the grounds have been finally incorporated into the SDP, the school should prepare at least a broad outline of its needs and priorities, and the district and county councils should always be consulted about a school's plans. Expert advice on their viability can also be sought from the best placed and most cost-effective source at any stage in the planning process, although as has been stated earlier, it is important for schools to retain control of their needs and proposed solutions. In most local authorities there are a large number of people who may be able to help with school ground developments. Schools should in particular contact the Education and Planning Departments, although, in some cases, it may be necessary to consult other departments.

- 10.6 **Private consultants.** After the initial stages, it may be that professional advice will be useful to schools. In this case, it is important to use landscape, educational and design consultants who are sensitive to the needs of pupils and teachers. The first steps are to establish that the prospective adviser has the necessary skills by asking about his or her work with other schools, and determining what the cost of such advice will be. It is always important to take up references from other schools with which they have worked.

One way is to agree a ceiling figure, on a 'not to be exceeded' basis, against a detailed brief or description of the work to be undertaken. Up to four separate fee proposals may be advisable on large schemes. Interviews with the consultants offering the two lowest tenders can assist in making a more effective judgement of their suitability and of the comparative value for money before awarding the work.

An alternative, for projects such as providing a synthetic sports surface, is to seek tenders from private contractors on a 'design and build' basis. In this case, the drawback is that the advice may not be totally impartial and comparison between tenders can be more difficult.

LTL maintains a data-base of active contacts in local authority areas.

- 10.7 **The voluntary sector.** LTL, county wildlife trusts and some BTCV groups give advice about developing school grounds. Many county wildlife trusts have an education officer and their details can be obtained from the Royal Society for Nature Conservation (RSNC). In addition, a number of towns and cities have urban wildlife groups that are involved in habitat

creation and direct action to promote nature conservation in their area. Other organisations such as the Royal Society for the Protection of Birds (RSPB) and the Royal Society for the Prevention of Cruelty to Animals (RSPCA) have regional or local officers, or networks of members' groups. The Regional Sports Council and the governing bodies of the individual sports may similarly be able to assist with advice on facilities for physical education.

- 10.8 **Community design.** There is an increasing number of community landscape design practices in major cities, with funding from government grant or sponsorship. They may be in a position to give low-cost or free advice to schools. In addition, many landscape design and management courses in higher education stress the importance of community involvement and are keen to collaborate with schools on 'live' projects, not just in preparing proposals but in some cases in implementing them as well. While such schemes can be extremely beneficial to all involved, it is very important that schools establish exactly what is involved before committing themselves to a project. A number of voluntary organisations have also established local or regional initiatives for schools.

Material and Financial Support

- 10.9 Even when advice can be obtained without cost, many projects to develop the grounds will need machinery, tools and materials as loans or gifts, or the funds to buy them. In addition to direct fundraising by the school itself, potential sources of funds include grant-aiding bodies, business and commercial sponsors, parents and the local community. Useful advice is given in the Department's publication *Our School - Your School*. Limited capital cost advice is provided in Reference Section G, *Looking to the future - capital costs*.
- 10.10 **Grants.** At any time, there is a bewilderingly large number of national and local grant schemes. LTL keeps information about these.
- 10.11 **Business and commerce.** Support for environmental initiatives by schools enables business and commerce to create a tangible and beneficial public reminder of their commitment to the local community.

Awards and competitions are generally run by national or international businesses such as oil companies, banks and the public utilities. Thorough planning and research by the school are essential since a successful application often depends on the quality and presentation of the arguments. Some schemes reward what the school has already achieved. They

may not be appropriate for the funding of new initiatives but can provide support for further phases of existing projects.

Local businesses usually provide support in kind, such as the loan of machinery, the gift of tools or the supply of trees and shrubs. Some form of public recognition of the firm's contribution is usually all that is necessary, and the related publicity is often as important for the school as for the benefactor.

- 10.12 **Parents and the local community.** These groups are potential sources of valuable help. While they can, of course, be a source of direct labour, they may also have a variety of valuable skills that will need to be carefully and tactfully supervised.

Parents, where they are willing to help, not only bring a direct commitment to the school but often assist with the participation of pupils by working alongside them.

Local groups may include the armed forces and their cadet corps, the scouts and guides, the BTCV and community service groups.

Whatever the available labour it is more readily directed towards new works of some magnitude than to long-term maintenance.

- 10.13 **Forming a partnership.** Some projects such as the creation of sports facilities could best be delivered through a partnership; perhaps a joint venture with a local sports club, local authority, or a private sector partner. The use, and possibly the funding, would be shared between the partners, with the school having priority during school hours. This approach may be more suited to the secondary sector because of the type and scale of the provision. A number of projects to provide all-weather outdoor facilities and sports halls have been successfully completed under the Private Finance Initiative. For example, a project at a secondary school in partnership with an enterprise company, the North West Regional Sports Council, and the Foundation for Sports and Arts, provided a new sports facility for the school's use during the day at no cost to the school or LEA. Partnership projects will need to take account of the attractiveness of a potential project to the private sector and the effect of the new facilities on the wider community.

- 10.14 **Creating a fundraising strategy.** There are many individuals and organisations which will provide help for development in school grounds. The only effective way to realise these resources is to plan a programme of applications and fundraising initiatives very carefully. Some schools have set up a separate charitable trust to deal with this aspect of their affairs.

- 10.15 **Reference organisations.** Details of those organisations giving advice or material assistance to schools are to be found in Reference Section J. Information on other local groups may be held by the public library, by Citizens' Advice Bureaux, and by LTL.
- 10.16 **The importance of not rushing.** Schools which have carried out the early stages of planning, those outlined in sections 2-9 of this bulletin, and who have turned these into costed, long-term plans are much more likely to reap many exciting benefits from this investment of their time, than schools which have moved too quickly and ignored key stages of the process.

11. Conclusion

11.1 **The importance of school grounds.** School grounds are increasingly important childhood environments. Over the last ten years, there has been a considerable growth of interest in their use, design, development and management.

11.2 **Meeting the needs of the whole school.** All schools have needs in:

- the formal curriculum;
- the informal curriculum;
- the hidden curriculum.

Many schools have a programme of extra-curricular and community use.

11.3 **The process determines the outcome.** How the process of using and developing the school grounds is managed is at least as important as what is actually developed. An expensive scheme, carried out at great speed to an outside agency's agenda will certainly change the environment, but it is unlikely to meet pupils' or staff needs and, therefore, will not be successful. In the case of new schools, much can be achieved by the intelligent anticipation of needs, by the involvement of school staff at the earliest possible time and by withholding the budget for some external works until the school is opened, and can make educationally useful adjustments.

11.4 **Involving pupils.** It is critically important to involve pupils at every stage of the process; the benefits in terms of behaviour, attitude, performance, and developing a genuine sense of ownership are very real.

11.5 **The process of managing school grounds development.** While it may seem that it takes a long time to consider carefully the options, the benefits of doing so are very great. Many schools are now enjoying their grounds as a rich educational resource, and all the more so on account of their hard work and persistence. Such developments are likely to endure. In total, it is considered this bulletin will be a stimulating and valuable resource for grounds development and will encourage and facilitate schools to open exciting opportunities for pupils, staff and the community.



Photo 26 Even in winter it is possible to use school grounds creatively

A(i). Layout of Use-Zones

Exploring options for site development of zones (Reference 4.27)

In re-planning or planning a school site a flexible approach is essential if the objectives of the brief are to be achieved. This study explores some of the planning options which need to be considered in relation to the main zones on any site when major development is being undertaken.

Effective planning of the major zones on site (the location and relationships of building(s), access and service areas, parking; playing fields; hard surfaced games courts; informal and social areas; and habitat areas) is vital to the successful development of school grounds. All the most useful options need to be considered. The preferred option should be the one which meets most needs within the space and cost constraints. The main consideration is the overall site layout and achieving a sensible and practical relationship between zones, and allowing for the location of essential features rather than any detailed preconceived landscape design. To avoid the loss of useful existing features it is essential that any substantial work on site is not undertaken until the preferred option has been agreed. Figure 27 explores some of the options for the expansion of a primary school.

An existing infant school on a shared site is to be replaced with a new building. The existing junior school building is to be retained. The urban site is fairly flat, with a busy distributor road to the north presenting potential problems of noise and air pollution. There are existing habitat areas and tarmac playgrounds around the junior school building that merit retention. The accompanying diagrams consider four options for the position of the new building.

In each case, varying the location of the main elements produces a different arrangement of outdoor resources, and different relationships between them. Option C is possibly the closest to the past provision with a sharp distinction between the buildings, playgrounds and playing fields; it lacks variety in the size and type of spaces and is in many ways the least attractive.

KEY

-  Playing fields
-  Hard surfaced games courts
-  Informal and social area (hard)
-  Informal and social area (soft)
-  Habitat areas
-  Buildings and access
-  Existing building outline
-  Proposed building

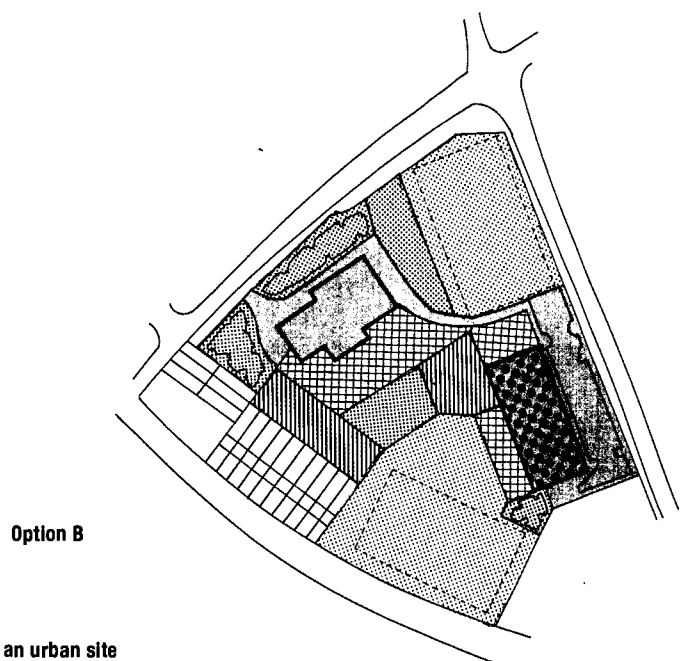
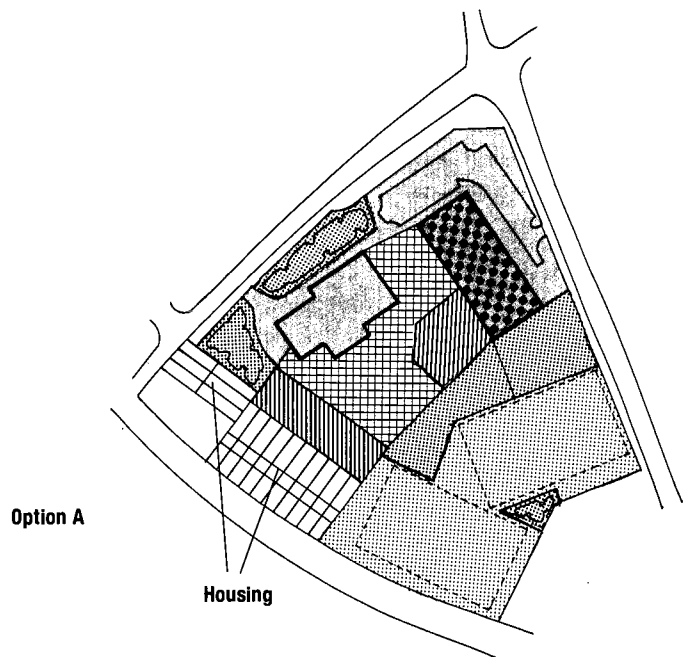
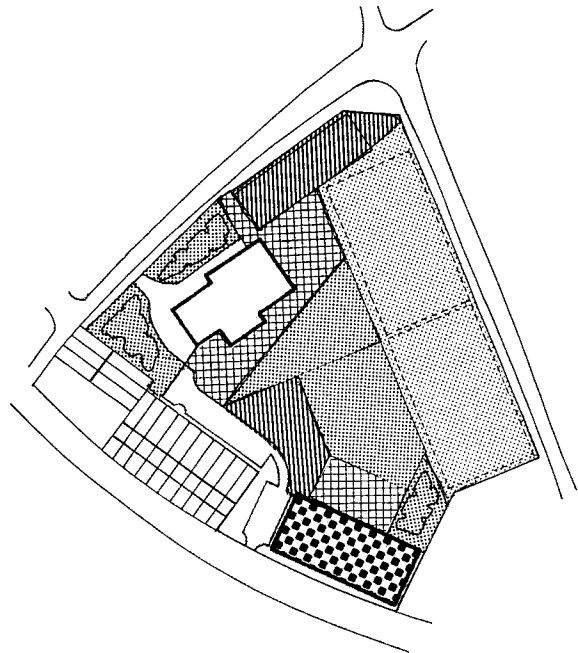

Fig. 27 Exploring options for site development zones.
Example: school for 270 Infants and 360 Juniors on an urban site

Options B and D both achieve a sunny and secure core area of play and recreation facilities contained by buildings and playing fields. The need to provide parking for the existing junior building does however extend vehicular access well into the site in these options.

In contrast Option A segregates all parking and service access, retains a core area for play and recreation, but is not so attractive in terms of the spaces created by the playing fields. By locating parking areas next to the main road and then using the building to separate them from the most important outdoor spaces the environmental impact of urban traffic is restricted. There are often options within options, and the best points can be selected from each; in this case, a layout derived from a combination of options A and D was finally adopted.



Option C

KEY

-  Playing fields
-  Hard surfaced games courts
-  Informal and social area (hard)
-  Informal and social area (soft)
-  Habitat areas
-  Buildings and access
-  Existing building outline
-  Proposed building

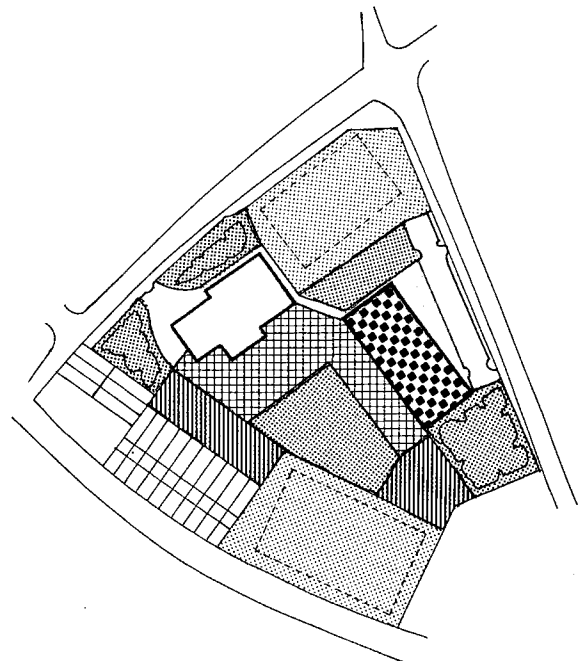

Option D

Fig. 27 Exploring options for site development zones.
Example: school for 270 infants and 360 juniors on an urban site.

A(ii). Site and Boundaries Between Zones

(Reference 4.28)

As well as looking at options and zones for site development, it is helpful to look in more detail at the boundaries between zones. A number of illustrated examples are given in this section for those undertaking major re-organisation of their grounds and seeking further guidance (see 4.27 and 4.28).

1. Nursery provision (under 5 years) (Reference 4.29)

Over a quarter of children aged under five are being taught in maintained nursery schools or nursery classes in maintained primary schools. A similar number are being taught in infant classes, including reception classes, in maintained primary schools. They arrive at school with different levels of competence, confidence, knowledge and experience. A well-planned range of equipment in a stimulating outdoor environment provides valuable opportunities for assessing their development and identifying problems. Usually the nursery forms an integral part of a school and uses its car park and services.

The example Figure 28 illustrates a typical nursery garden which shows most of the essential features.

- The outdoor play facilities extend the indoor play area to provide a different range of experiences, especially in the areas of physical, observational, investigative and imaginative play. The siting of the toy and equipment store gives convenient access for use of equipment inside and outside.
- The garden consists of a sitting area for story telling, informal gatherings and picnics, a climbing and play feature with safety surface, sandpit with removable cover to keep it clean and free from animals, a construction area with play kits, circuit for wheeled toys and tricycles, and a planted area where children can hide, get away, and build dens.
- To meet the demands of this age range the garden needs to be lively, imaginative, challenging, easy to supervise and above all safe and secure.

Although the example shows only the garden, it is highly desirable to have a gate between the nursery entrance door and the street for safety and security reasons. The site boundary (not shown) is secure from intruders, and the low fence round the play area prevents the children straying.

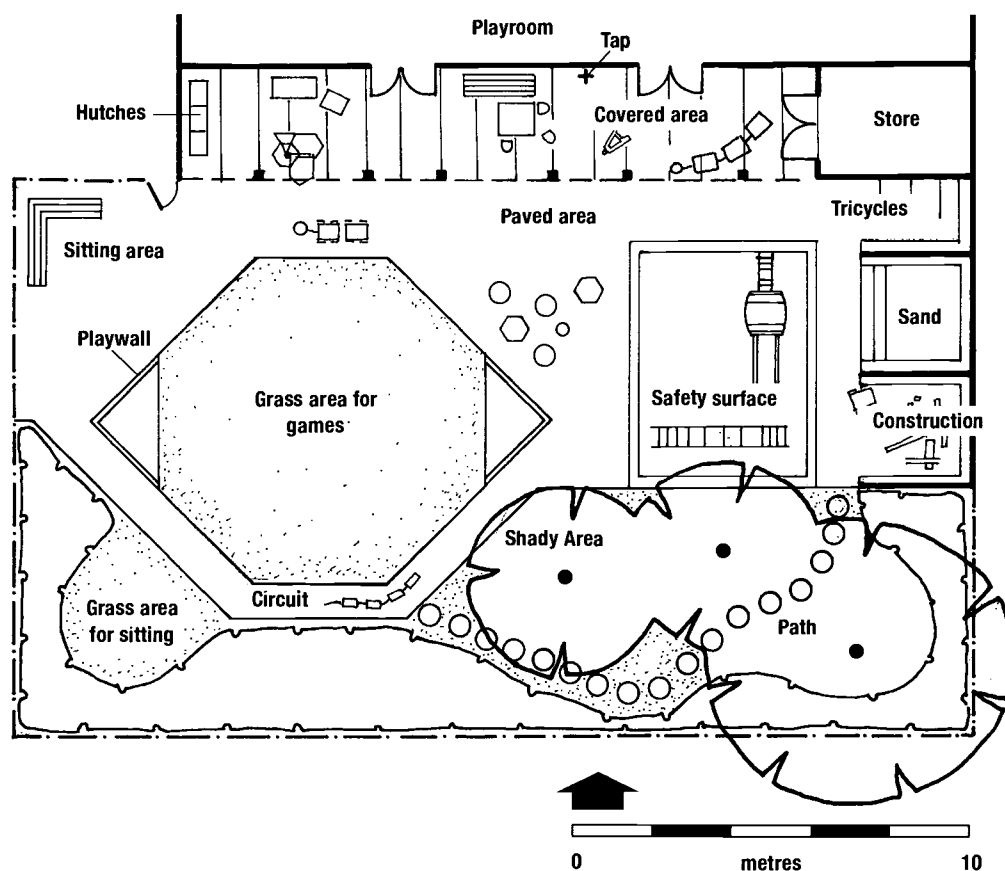

Fig. 28 Play provision for a Nursery for 39 (provided: 380m² outdoor area of which 205m² is paved)

2. Infant and junior school provision (Reference 4.28)

These schools need both hard and soft surfaces and varied opportunities for noisy and quiet, active and sedentary, lone and social play. Figure 29 shows how integrated provision can be arranged for these age groups.

The figure shows a primary school site bounded by the town's roads and a railway, which has a short drive to the building making economic use of the site and releasing as much land as possible to outdoor educational, recreational and leisure use.

Priority was given to the separation of infant play from boisterous junior play areas. The infant accommodation opens immediately on to their outdoor hard play area for organised and informal group and individual activities. It contains a sitting enclosure for small groups, play features, and playground games markings for formal and informal group and individual play during breaks. Leading off this area an alcove provides a climbing play feature with safety surface. Also off the hard play area lies their grass play area for small games, skills practices, and informal activities.

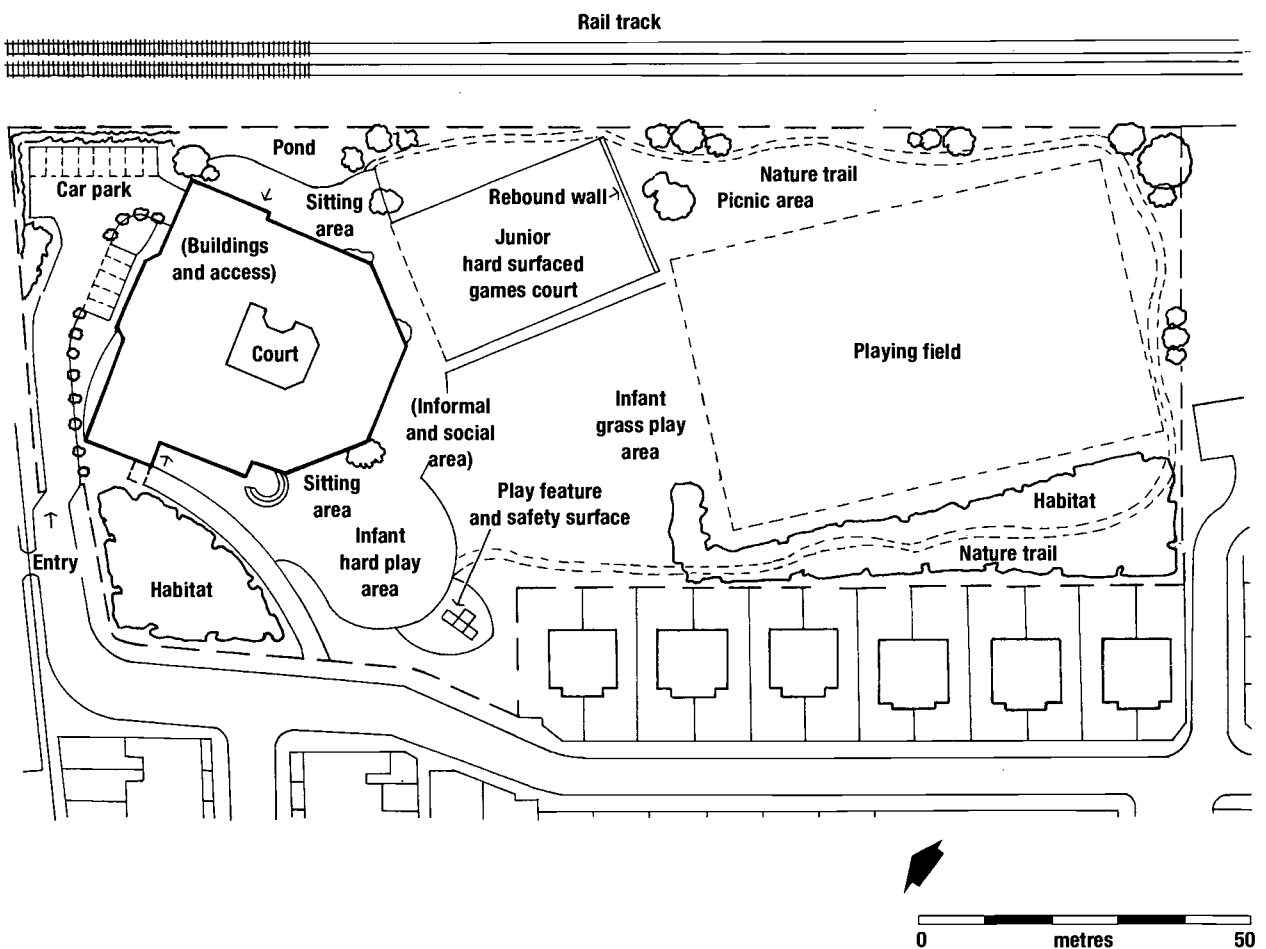

Fig. 29 Infant and Junior play provision for 210 pupils (provided: playing fields 2500m², hard surface games court 630m² and informal and social area 1890m²)

The junior play facilities, as infants, adjoins directly their teaching accommodation. Again, an informal recreation area for sitting and for socialising is available for small groups and quiet activities, and further away lies a hard surfaced area for team games; a ball rebound wall having goal posts and targets is incorporated into the ballstop fencing. Beyond the infants grass play area is the junior grass pitch area which allows for summer and winter games and informal group activities.

All these features are encircled by a continuous planting feature which includes a nature trail for study and quiet strolls through mixed woodland. It includes an orchard and nuttery giving opportunity for study and enjoyment of harvest. Separately provided are a wild flower meadow, herb gardens, pond and wetland, and a shaded group picnic area.

The example shows how with careful planning, imagination and knowledge of educational need, a relatively small site can immeasurably increase opportunity and give immense pleasure to pupils, staff, parents, and be a benefit to the community.

3. Secondary school provision (Reference 4.28)

These schools, unlike primary schools have to cater for the varied demands of developing teenagers so consequently what is needed to cope with the age range has more in common with a higher education campus. Attitudes to play and recreation differ widely through the age range, younger pupils appreciate boisterous games during breaks, some continue to do so through the school years, but increasingly teenagers seek more social and sedentary activities. The example shows how educational, recreational and leisure demands were met.

Although the site is not shown in total, the school buildings are located immediately off the town's road, pedestrian access is segregated from the two vehicular accesses catering for car parking for school and community use of facilities and for service needs.

The teaching blocks form two protected quadrangles and whilst facilitating access between curriculum areas, create a focus for educational and social outdoor activities for groups and individuals. One quadrangle provides for quiet study and an amphitheatre with seating for 60 pupils. Paths are arranged to take account of desire lines between buildings, steps were avoided to give free circulation for the disabled. The other quadrangle allows for more robust activities whilst still having a shaded seating area.

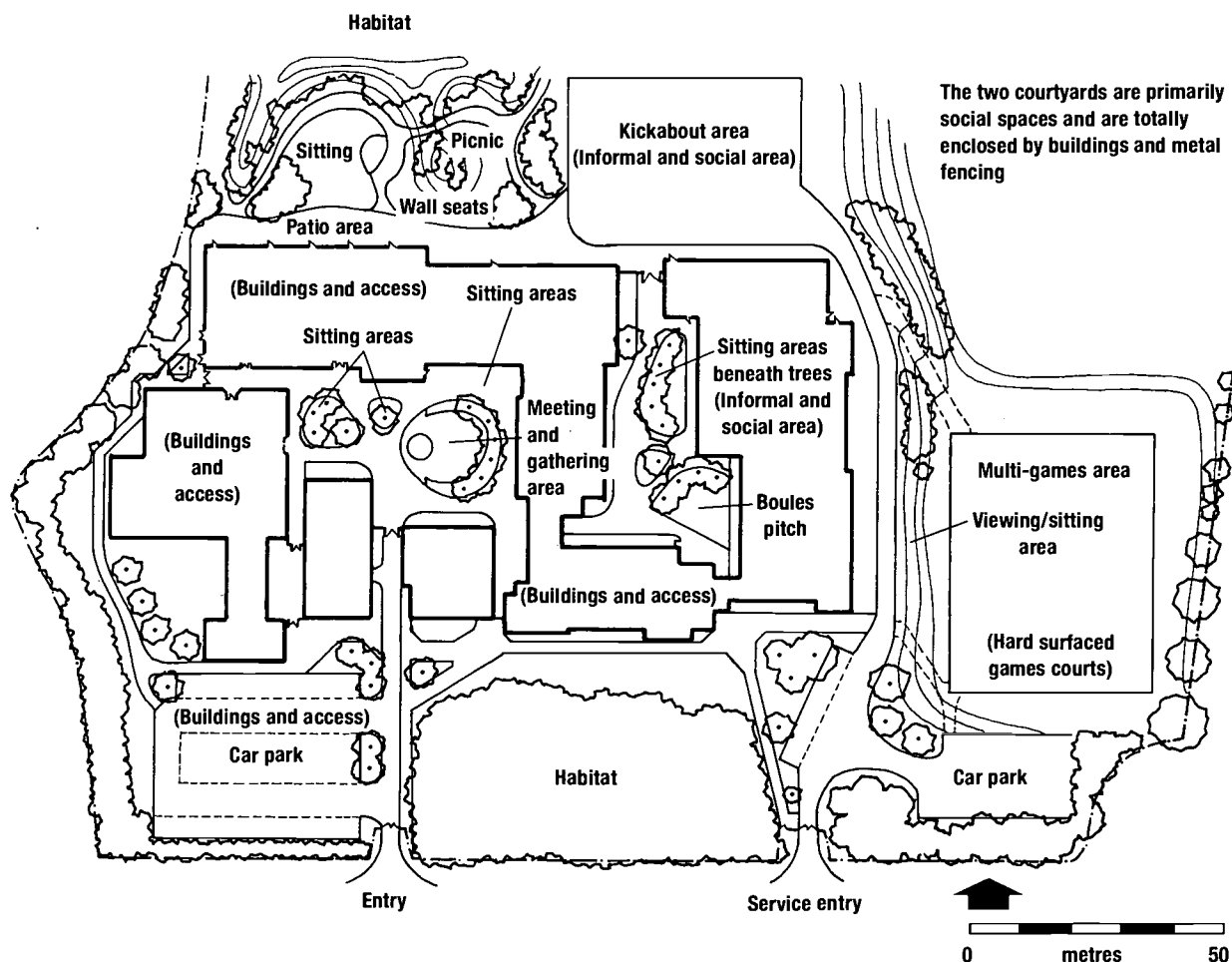

Fig. 30 Secondary provision for games play and recreation for 1600 pupils (provided: playing fields 6500m² (not shown), hard surfaced games courts 3500m² and informal and social area 6400m²)

Close to the buildings and quadrangles lie a range of educational facilities, a floodlit multi-games area with its close link to the sports hall, a paved kickabout area marked for court games, and a quiet shady area for outdoor classroom, sitting and picnicking. Beyond the immediate buildings the grounds contain a mixed woodland shelter belt protecting playing fields, the belt doubling as a nature trail which also creates opportunity for cross-country running. Linked with the mixed woodland area a pond and wetland support science, and additionally give opportunities for sketching and painting.

The setting has taken account of the need for the safety and security of pupils and staff and the need for good supervision. The surface treatment and site furniture are robust, and overall the landscape quality allows pupils to feel they are valued, bringing in turn their respect and caring for the created green and pleasant environment.

4. Special schools provision (References 4.30, 5.7, 6.6 and 8.57)

Figure 31 illustrates a layout suitable for a primary school with a nursery, for pupils with severe learning difficulties or physical disabilities. The building area would be appropriate for about 60 pupils, following the guidelines given in Building Bulletin 77. The grounds available for the formal and informal curriculum are generous and in excess of the recommended areas set out in Reference Section F table 21.

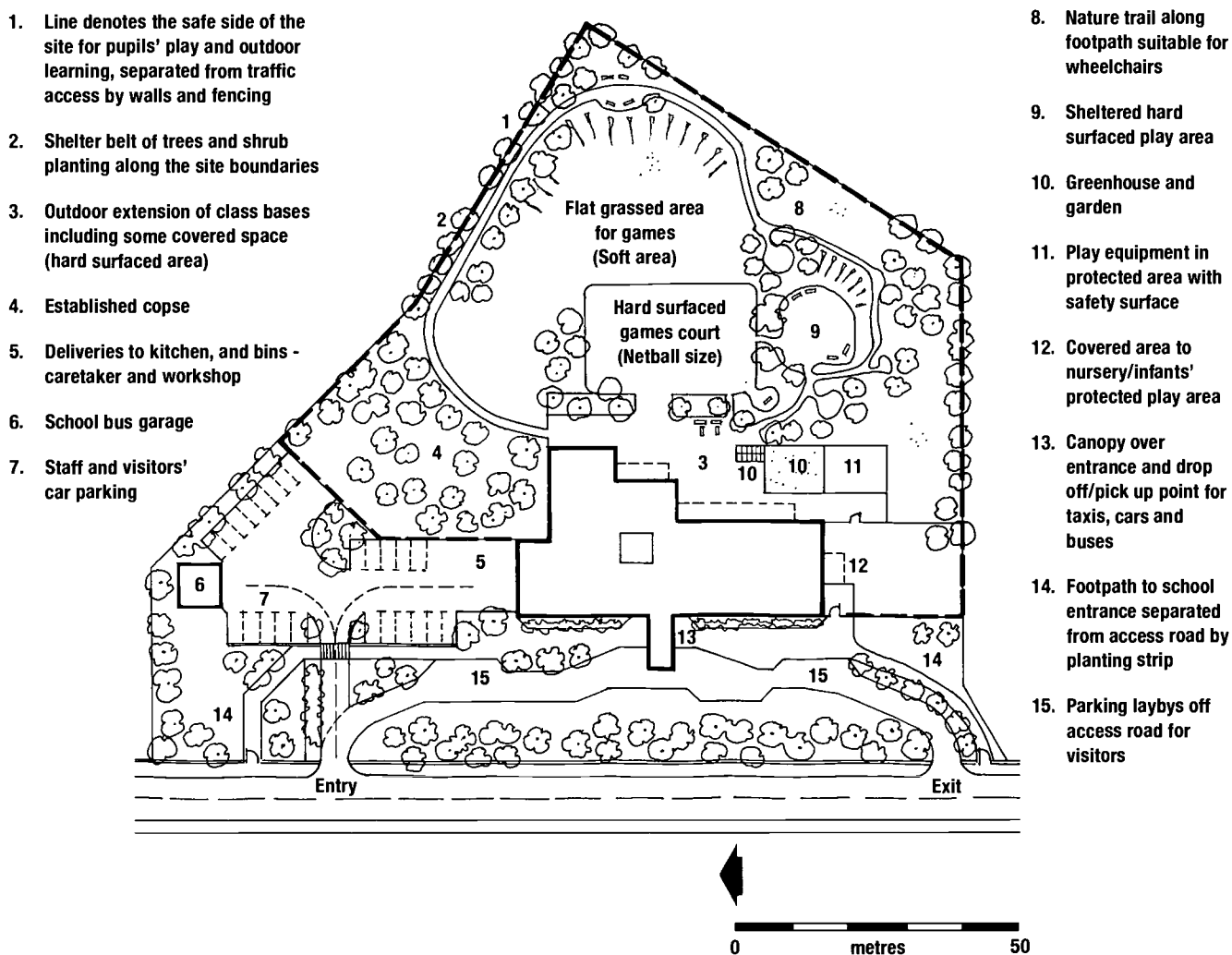

Fig. 31 Special school plan suitable for a primary school for about 60 pupils (provided: hard surfaces for games and informal and social area 1200 m², and soft area (grass), and generous habitat as site contains a copse)

Those areas accessible to pupils throughout the school day are enclosed and separate from pedestrian and vehicular access to the school, and from the parking area. The latter allows for the high staff to pupil ratio and the greater number of visitors to be expected at a special school. Provision for vehicular access to the main entrance takes account of the large number of cars, taxis and mini-buses which will need to queue at the beginning and end of the school day. It illustrates the one-way traffic flow recommended to avoid congestion and the need to reverse where pupils are embarking/disembarking.

Area guidance for hard surfaces for games and informal and social areas, and soft area (grass and planted) is given in Reference Section F table 21.

A(iii). Restricted School Sites

A Primary School and a Secondary School

Two examples, a primary school and a secondary school, are provided to demonstrate what is possible on restricted sites (reference 4.26). The area percentages in the two examples shown are given for information but are not comparable with sites whose area lies within the recommended area range.

A primary school example (Figure 32)

This example illustrates a 5-11 primary school for 315 pupils. The total site area of 7860 m² is below the recommended range (12922 - 14725m²). The statutory playing field area for 135 pupils over the age of eight years is 5000m². However, the regulations offer flexibility where synthetic surfaces are provided, and in this example a synthetic surfaced pitch provides a multi-games area which can additionally be used for the informal curriculum. As sufficient PE and games can take place on site, off-site playing fields would not normally be needed, except where the use of grass pitches is required. Although all the grounds are available to pupils, separate informal and social areas (hard and soft) are designated for infant pupil use.

Zone	Actual area	Percentage of total area	Recommended area from Table 17
1. Playing fields (synthetic surfaced multi-games area).	2100m ²	27	5000m ² (statutory)
2. Hard surfaced games courts, also used instead of grass for infants' play (synthetic surfaced area also provides games courts for juniors).	1200m ²	15	867-1199m ²
3. Informal and social areas. 1250m ² is paved, part of which provides an all-purpose infants' area with 'street' games, play features, activities space and leisure area. The rest is grass providing for an 80m running track and informal games practice and a leisure area for juniors.	2500m ²	32	1757-2033m ²
4. Habitat area. Owing to the very restricted site, habitat area is confined to limited but highly developed areas on the boundaries to support the curriculum; incidental habitat would be possible in the form of isolated groups of trees and shrubs.	260m ²	3	What can be provided
5. Buildings and access. A single entrance leads to a car park and a compact service area. The pedestrian site entry is separate from vehicular access.	1800m ²	23	Will depend on each individual case

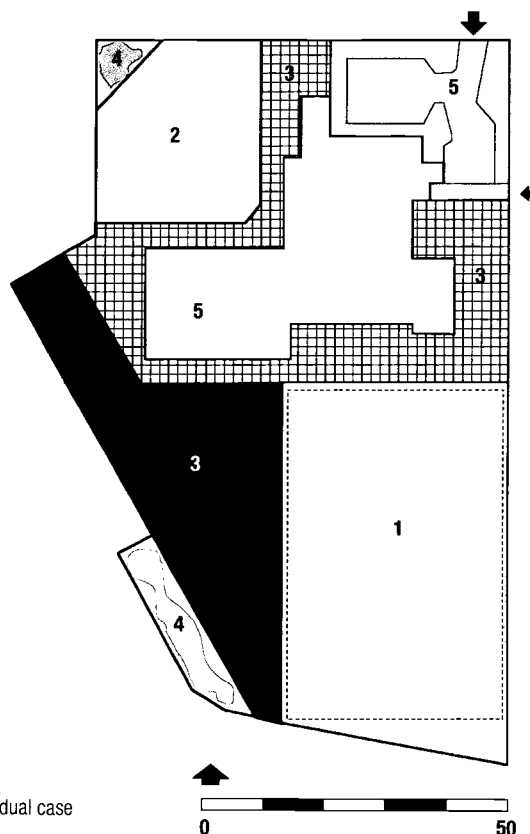

Fig. 32 Example of an urban site for a 315 place primary school

For an example of a site layout for a similar sized primary school developed by using the recommended guideline areas refer to Building Bulletin 82, Section 5.

A secondary school example (Figure 33)

This example illustrates a secondary school for 1000 pupils. The total site area of 24300m² is well below the recommended range (70000 - 76000m²). The statutory playing field area for 1000 pupils is 45000m². A synthetic surfaced pitch and games practice area are provided on site, and there is also access to sufficient off-site playing fields.

Zone	Actual area	Percentage of total area	Recommended area from Table 20
1. Playing fields Synthetic surfaced pitch 6700m ² (full size football pitch) plus a practice area 570m ² .	7700m ²	32	45000m ² (statutory)
2. Hard surfaced games courts. Multi-games area providing four tennis courts or three netball courts or small-sided games.	2600m ²	11	2100 -2500m ²
3. Informal and social area. All the paved areas, with the exception of service areas, are used for recreation and leisure. Planted internal courtyards with seats and external terracing lead onto grass and planted areas for informal activities. Boisterous breaktime activities are confined to the games courts and the games practice area.	6000m ²	24	4600-5000m ²
4. Habitat area. As in the previous example, habitat areas are confined to highly developed areas on the boundaries. Incidental habitat would be possible in isolated groups of trees and shrubs.	1200m ²	5	What can be provided
5. Buildings and access. A single entrance leads to a car park and a compact service area. The pedestrian site entry is separate from vehicular access.	6800m ²	28	Will depend on each individual case

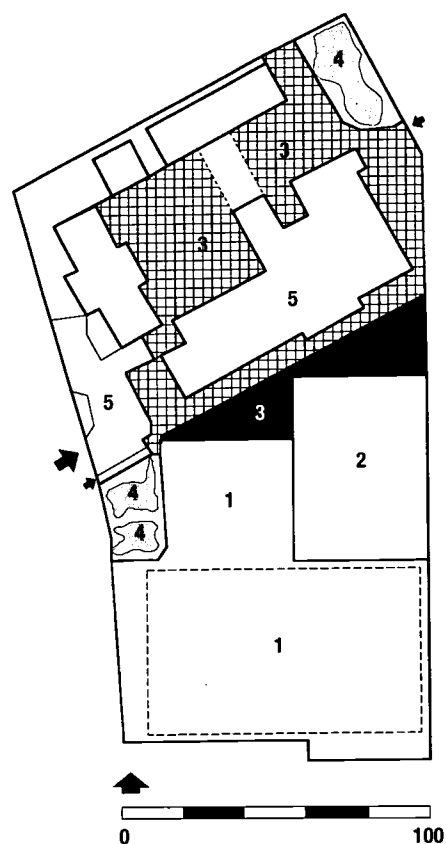

Fig. 33 Example of an urban site layout for a 1000 place secondary school

For an example of a site layout for a similar sized secondary school developed by using the recommended guideline areas refer to Building Bulletin 82, Section 5.

B. Sports Facilities

Multi-games Areas

Multi-games areas can be used more flexibly, economically, and can be better supervised if they are laid out in multiples of netball sized courts, allowing additionally for tennis and 5-a-side football as well as other games. Most major sports have 'mini' versions, and these can also use multi-games areas; these are described later. Such areas can reduce the pressure on indoor physical education facilities and fulfil the on-going demand for practice and skills training that do not need to occupy or wear out full-sized pitches. In the past, the most common solution for multi-games areas has been a tarmac surface marked out for three or four tennis, netball courts and a mini-pitch for 5-a-side football. Whilst this is still an extremely versatile facility, both synthetic turf and in-situ polyurethane bonded rubber are now attractive alternatives, depending on the financial resources available. As well as the choice of surface, other considerations include the variety of potential uses, and the number of pupils that can be accommodated at any one time.

Size. A multi-games area can range in size from a netball court 32 x 17m to a full-size pitch 90 x 60m; the consequent range of area, from 544-5400m², has considerable cost implications. A common solution in secondary schools is to opt for an area approaching a half-sized pitch, 1925-2600m², where three or four tennis and netball courts and 5, 6 or 7-a-side pitches can be included. These are shown in Figure 34.

Ball walls, fencing and gates. The blank wall of a sports hall can form one side of the multi-games area and function as a ball wall. It should be at least 5.5m, and preferably 8m long, with a height of at least 3m. A perimeter fence, minimum 2.4m high (welded mesh in preference to chainlink) is essential and a full 3m is desirable where the courts abut a main transport route. Maximum mesh of fencing for tennis should be 45mm x 45mm. Timber or masonry rebound walls, 1-1.5m high, will increase both the potential use and the durability of the facility. Access gates should be fixed in a corner position wherever possible and internally lined with timber in cases where they are included in a rebound wall. Gate handles and latches should be recessed.

Floodlighting, line marking and equipment. Full utilisation outside school hours can only be achieved with the installation of floodlights. They can, however, be a contentious planning issue in a residential area and considerable forethought should be given to the initial siting of the multi-games area and the relationship to neighbouring properties. At least two lighting columns, and on larger facilities four, are necessary to avoid one-sided illumination and dark shadows. Line markings should be a minimum of 50mm wide and conventionally colour-coded for the various games. Specialist suppliers provide a range of mobile and portable equipment, which avoids anchor holes in surfaces and allows larger areas to be divided up.

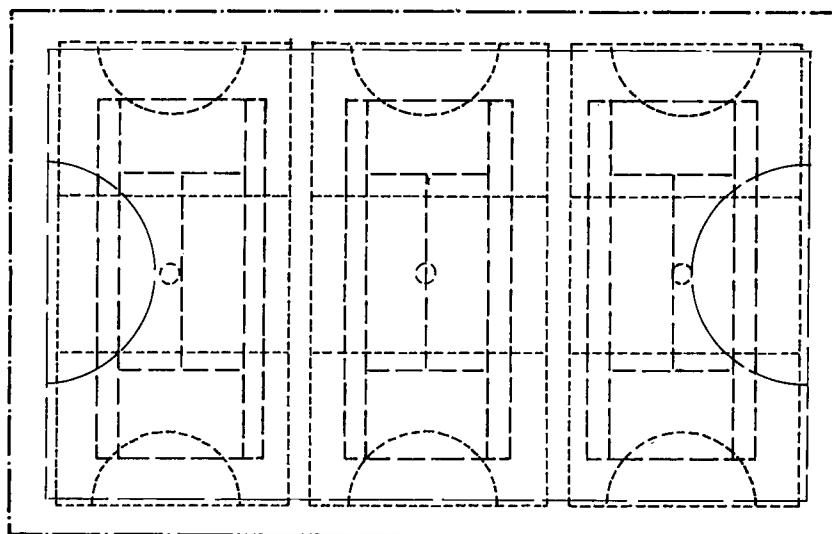

a) 3 tennis courts, 3 netball courts, 1 pitch area 50 x 30m - 1500m²
(overall 55 x 35m - 1925m²)

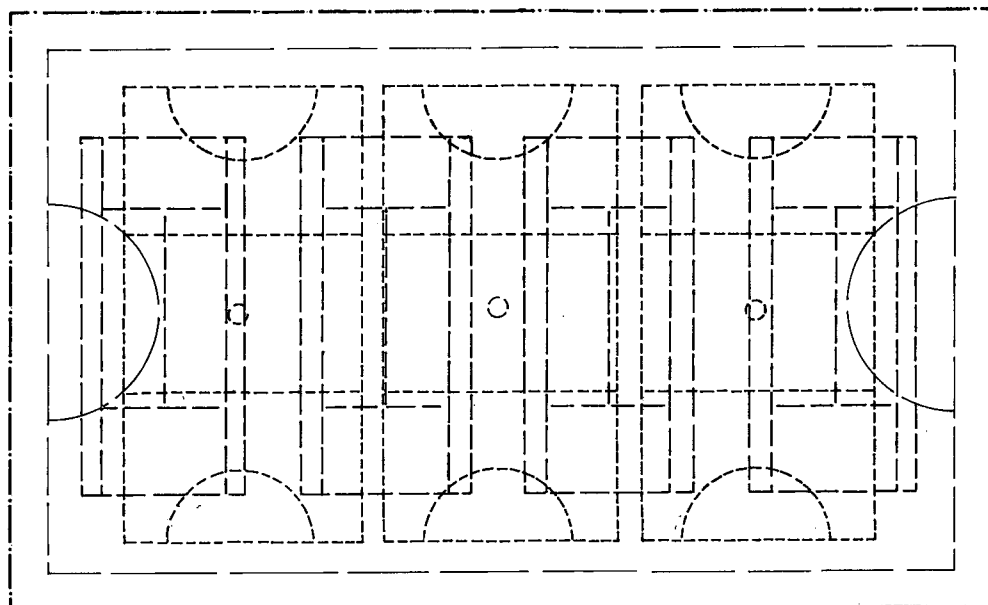

- b) 4 tennis courts, 3 netball courts, 1 pitch area 60 x 35m - 2100m²
(overall 65 x 40m - 2600m²)

Fig. 34 Multi-games areas

Archery

This should be sited in a secluded corner of the playing fields away from other activities. Strict safety precautions must be observed and the area roped off. A responsible adult must be present at all times and in control during shooting. The shooting range should be an area of flat, close-mown grass away from the overhang of trees. It should preferably be orientated in a northerly direction for shooting, but if this cannot be achieved the layout should avoid archers having to shoot into the sun, ie towards the south or south-west as school archery might take place after midday. The shooting line is permanent, the targets being moved up and down between the limits given. Ranges shorter than 90m are possible, but the targets must never be moved into the safety overshoot zone of 46m beyond the longest distance. Space for five to six targets is usually ample for school use.

Governing body. The Grand National Archery Society, Seventh Street, National Agricultural Centre, Stoneleigh, Kenilworth, Warwickshire CV8 2LG (Tel. 01203 696631).

Association for Archery in Schools, Bloxham School, Banbury, Oxfordshire OX15 4PE (Tel. 01295 721463).

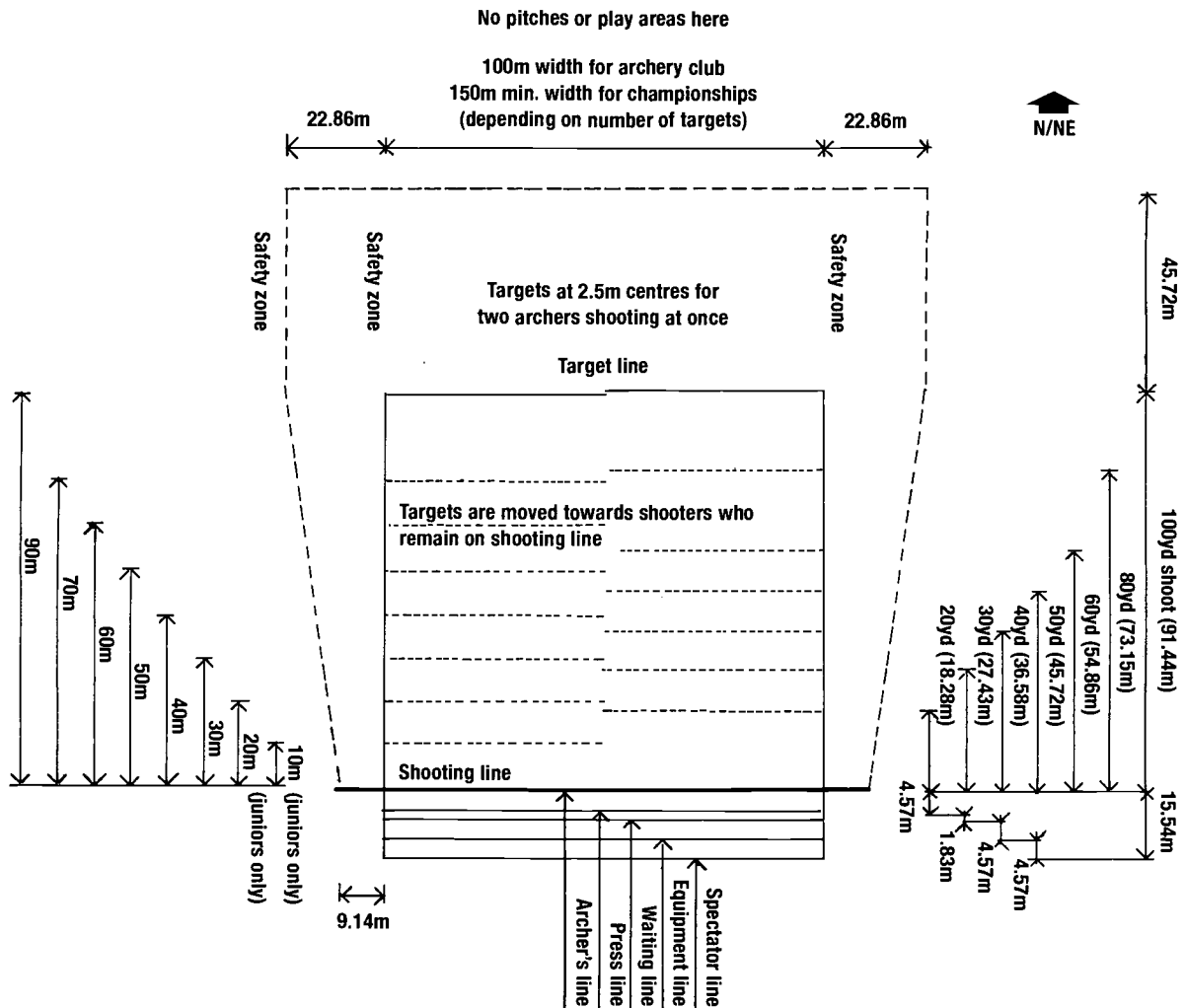

Fig. 35 Target archery range

Association Football

Full-size pitch. The game is played by teams of 11 players. The field of play should be level and rectangular, and for a senior pitch, the length should not be more than 100m nor less than 96m and its breadth not more than 64m nor less than 60m. The size is reduced for younger age groups and the penalty area for primary school pitches is two-thirds normal size with the penalty spot 9m from the goal line and the goal 6.4 x 2m.

Table 3: Recommended age related pitch sizes

Age group	Type of pitch	Length	Width	End Margins	Side Margins
8-13 years	Small	70-80m	40-50m	6.0m	4.5m
13-15 years	Medium	75-82m	45-55m	6.0m	4.5m
15-17 years	Large	91-96m	50-59m	6.0m	4.5m
Senior (18 years and over)		96-100m	60-64m	9.0m	6.0m
Adult		100-110m	64-75m	9.0m	6.0m

It is considered that primary aged pupils should play small-sided games on 5-a-side sized pitches.

Five-a-Side. Age Group 8-14 years. The game is played by teams of five players on a pitch of 30-40m in length and 18.5-28m in width. The markings differ from the full-size pitch by having semi-circular penalty areas based on a radius of 7.5m and a centre circle radius 1m. Four 5-a-side pitches can be fitted on to a full-size football pitch, or even a rugby pitch.

Governing body. The Football Association, 16 Lancaster Gate, London W2 3LW (Tel. 0171 402 7151/0171 262 4542).

For Football in Schools: English Schools' Football Association, Chief Executive, 1/2 Eastgate Street, Stafford ST16 2NO (Tel. 01785 251142).

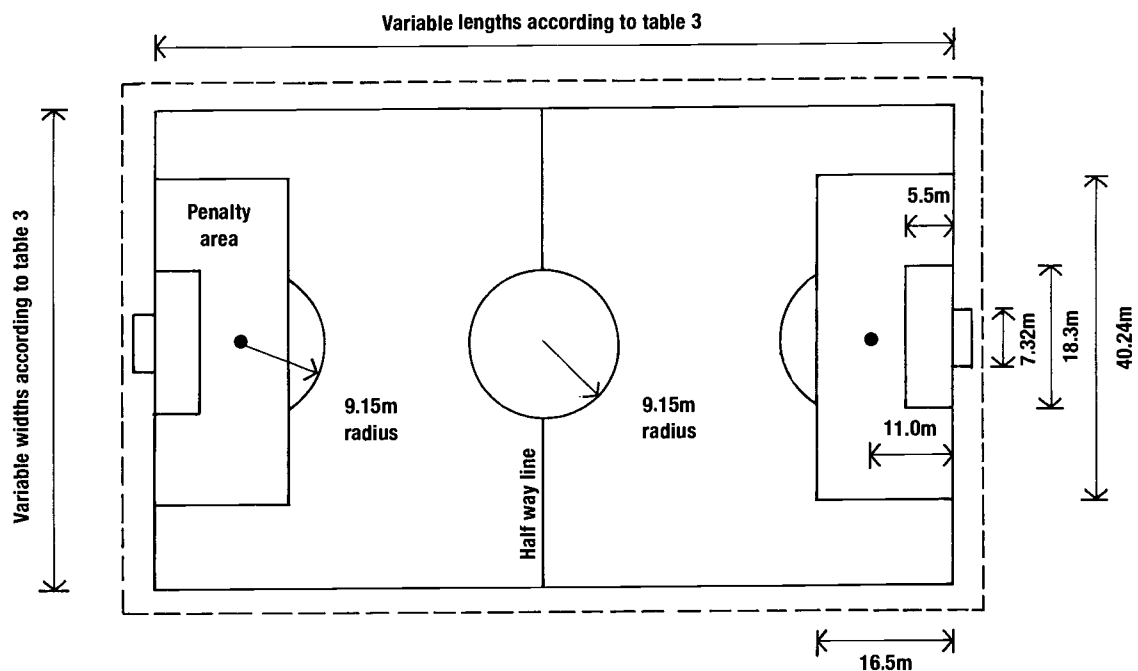

a) Full-size pitch

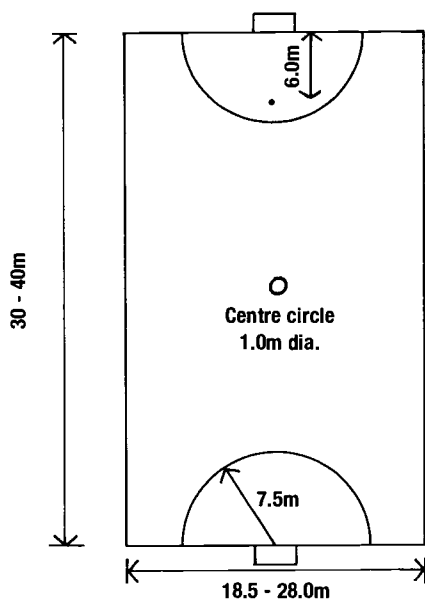

b) 5-a-side pitch

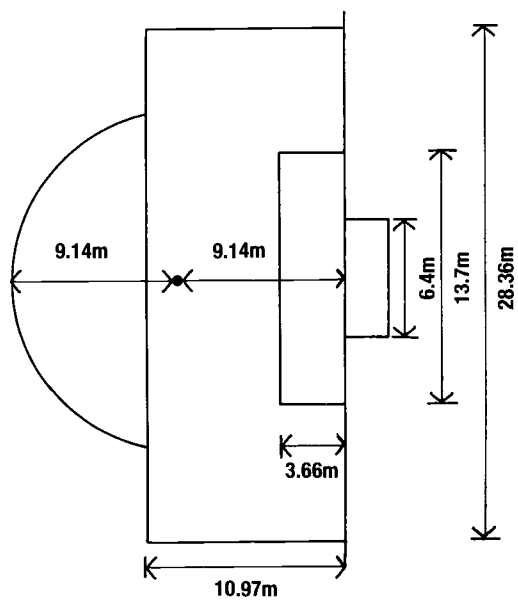

c) Penalty area for 8-13 year olds

Fig. 36 Association football pitches

Athletics

Track events. A 400m six or eight lane running track requires a minimum area of about two hectares, which is roughly equivalent to three winter games pitches. The layout should permit as many other activities as possible to be carried out safely within the track. The radius of semicircles should be between 32 and 42m for a 400m track, although where playing field space is not sufficient for a standard layout, alternative radii are possible, or a 300m track could be provided but this would be less satisfactory for running events. For pupils up to Year 6, straight tracks of 80-100m should be provided, with a minimum of six 1.2m wide lanes; as many as 20 lanes or more may be required depending on the needs of the individual school and the space available.

Field events. There are advantages in combining high jump, long jump, triple jump and pole vaulting in teaching areas which are capable of conversion to competitive use when necessary. Consideration might also be given to accommodating some field events on a multi-games area.

Throwing events may take place within the central space formed by the athletics track or elsewhere on the playing field, provided such areas are safely cordoned off from those not involved in the event. Safety cages should be provided for hammer throwing in competition and are strongly recommended for hammer and discus practice.

Setting out. Athletics facilities should be marked out in accordance with the current BAF handbook, normally prior to the commencement of the summer term.

Governing body. British Athletic Federation, 222A Bristol Road, Edgbaston, Birmingham B5 7UB (Tel. 0121 440 5000).

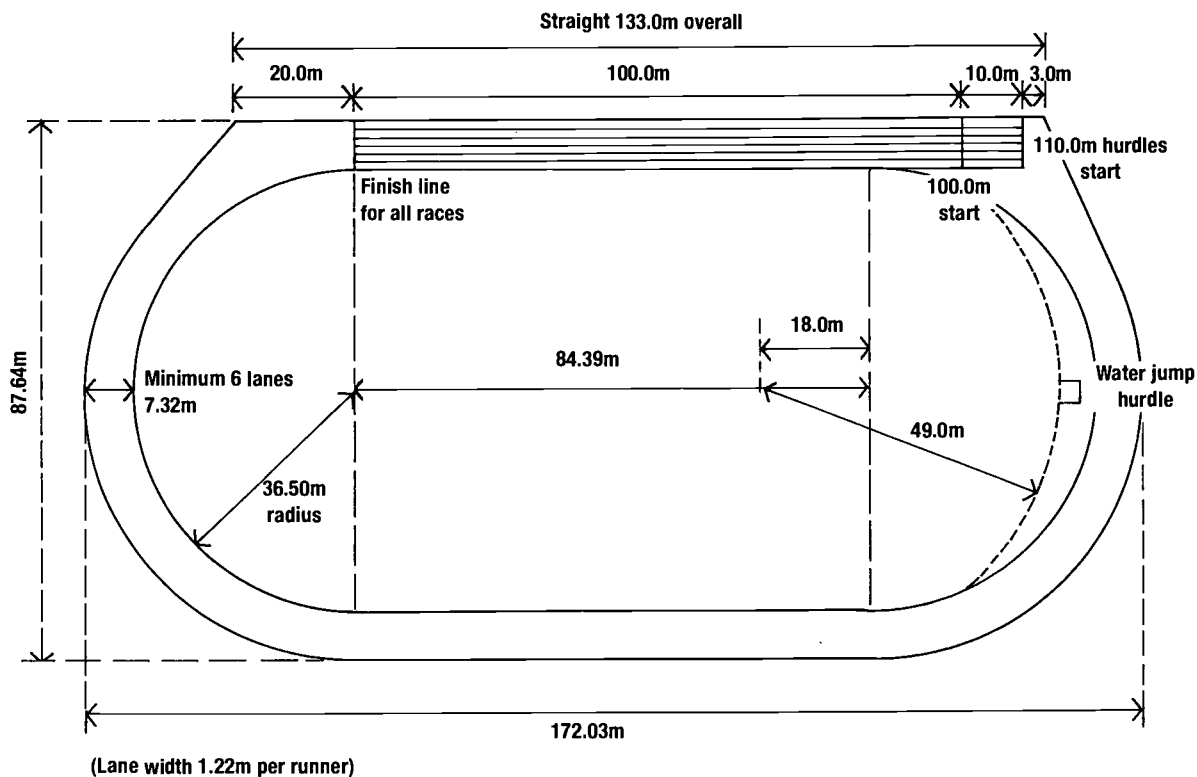

Fig. 37 Athletics track
 For further information on athletics refer to *Facilities for Athletics (track and field) 2nd Edition*.
 National Playing Fields Association 1980.

Basketball

Full-size court. The game is played by two teams of five players. The English Basketball Association encourages the development of the game as an outdoor activity; the court layout is similar to the indoor game. Where the facility shares a hard paved surface such as for tennis, it is suggested that court dimensions should be 28.0 x 15.0m but there can be variations on these up to minus 4.0m on the length and 2.0m on the width, such variations being in proportion to each other.

Mini-basketball is a recreational activity for boys and girls under the age of 12 years in teams of ten players, but only five players can be on the court at any time. It is designed to encourage children to discover the game as an enjoyable pastime and to develop the basic skills. The court markings are similar to the full-size game and the dimensions should be 28.0 x 15.0m. Other dimensions are possible providing the variations are proportional to each other such as: 26.0 x 14.0m; 24.0 x 13.0m; 22.0 x 12.0m and 20.0 x 11.0m. The baskets are set 2.6m above the floor.

Governing body. English Basketball Association, 48 Bradford Road, Stanningley, Leeds, West Yorkshire LS28 6DF (Tel. 01132 361166).

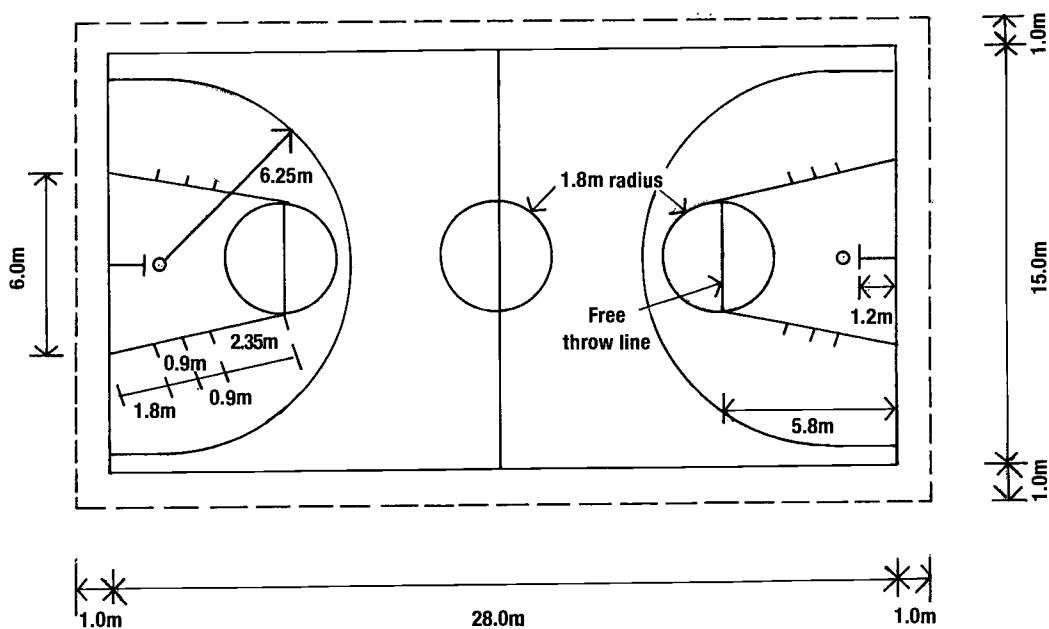

a) Full-size basketball court

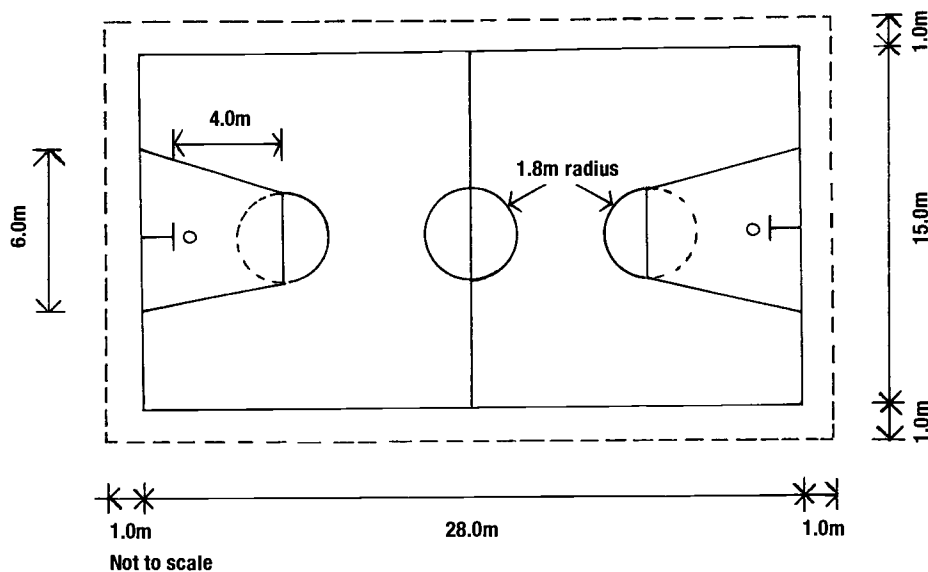

b) Mini-basketball court

1.0m 28.0m 1.0m
Not to scale

Fig. 38 Basketball courts

Cricket

A cricket table is usually combined for economy of land use with winter games pitches, often football or hockey pitches, and is constructed approximately 27m square to accommodate the 22 yd (20.12m) long full-sized pitch. The total width is determined by the number of games to be played and the need to rest pitches to avoid excessive wear. For example, to allow for a rotation of 18 positions for a pitch 20.12 x 3.05m, plus a spare pitch for practice and wet weather, a table of 10 pitch widths would be needed covering 27 x 30.5m. The minimum gross area required for a combination of a cricket square plus a large sized and medium sized football pitch is approximately 1.5 hectares. The overall cricket table dimensions and those of the outfield are presented in Figure 39 and tables 4 and 5.

Table 4 Cricket pitch only: Dimensions and Areas

No. of Pitches	Rotation	Width A	Width 1	Length	Approx. area
Junior with 37m boundary					
6	11	18.29m	98m	99m	1.0ha (2.4 acres)
9	17	27.44m	107m	99m	1.1ha (2.7 acres)
Senior with 46m boundary					
6	11	18.29m	116m	119m	1.4ha (3.4 acres)
9	17	27.44m	125m	119m	1.5ha (3.7 acres)

Table 5 Cricket and Winter Games Pitches: Dimensions and Areas

Cricket Square	Football	Football	Width 2	Length	Approx. area
27.44 x 18.29m	96 x 60m	82 x 46m	142m	114m	1.6ha (4 acres)
27.44 x 27.44m	100 x 64m	90 x 55m	164m	118m	2.0ha (5 acres)

Table 6 Lengths of pitches and boundaries

For senior and junior games of cricket the lengths of pitches and the boundaries of play may be reduced as recommended by the National Cricket Council.

Age Group	Pitch Length	Radius of Outfield
Under 7 years	14.63m	
Under 9 years	15.54m	30m or to fit available space
Under 10 years	16.46m	
Under 11 years	17.37m	
Under 12 years	18.29m	35-37m Junior
Under 13 years	19.20m	
Under 14 years	20.12m	
Under 15 years	20.12m	40-46m Senior
Adult	20.12m	

Non-turf cricket pitch. In recent years it has not always been possible to maintain grass cricket squares, this led to the growth of non-turf cricket pitches of 27-30m long and 2-2.75m wide laid between winter games pitches. These are usually synthetic turf carpets laid on various types of substructures to simulate normal ball bounce.

Cricket practice nets. An area of 31 x 15m can provide for four practice nets and their run-ups. The surface formation is similar to that of non-turf pitches. Their location might be on the field boundary to avoid interference with other activities, and they might usefully be sited near to games courts to keep practice areas together for reasons of supervision and safety.

Governing body: National Cricket Council, Lords Cricket Ground, London NW8 8QZ (Tel. 0171 286 4405).

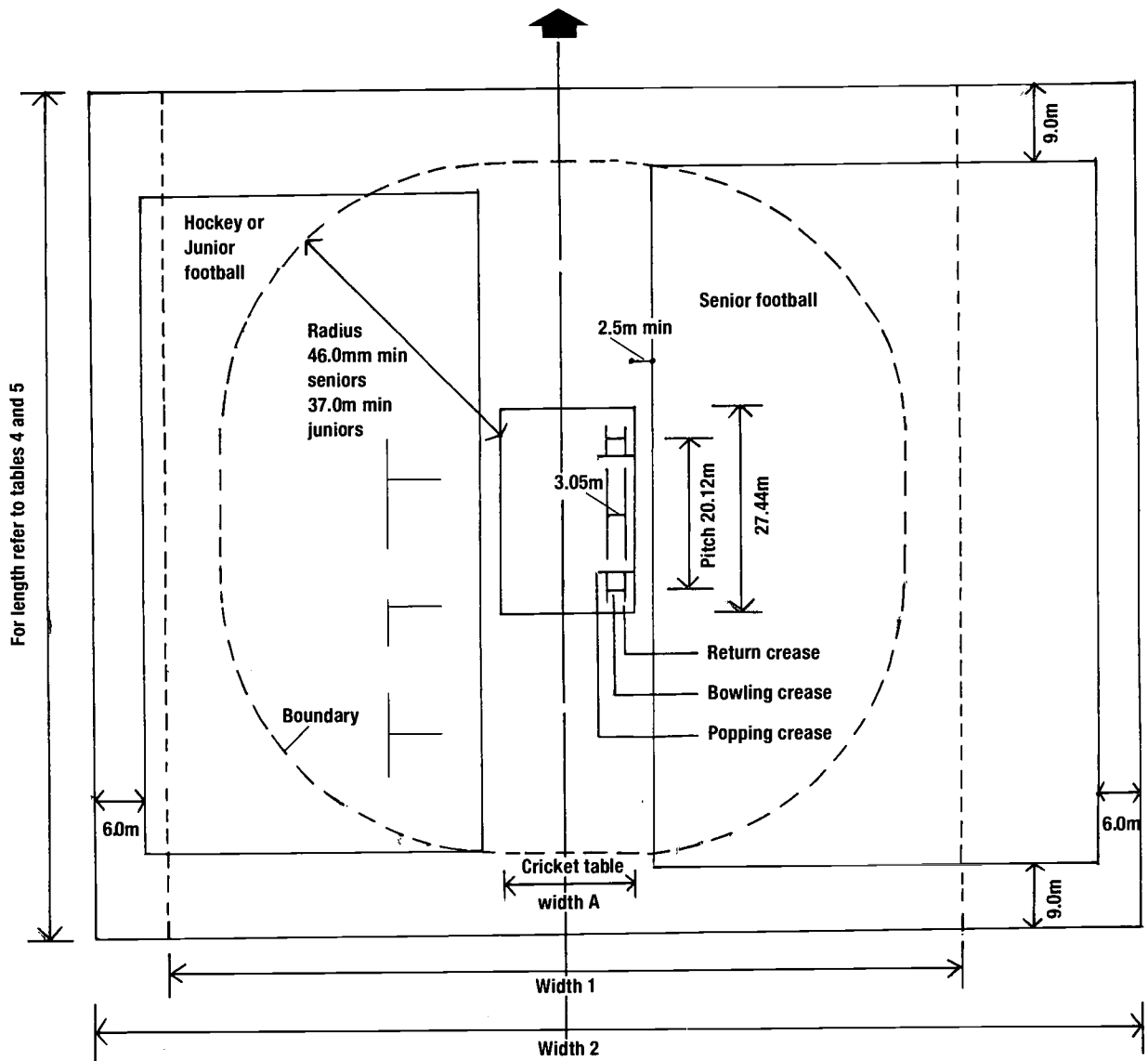

Fig. 39 Cricket square and field combined with winter games pitches

Hockey

Full-size pitch. Hockey is played by teams of 11 players on grass or on non-turf pitches, but the full-size pitch is scaled down for pupils aged 14 and under. A smooth and level pitch with adequate margins is essential for safe play, and usually to avoid playing on a damaged surface a pitch is permanently reserved for the game.

Table 7 Recommended age related pitch sizes

Age group	Type of pitch	Length	Width	End Margins	Side Margins
11-13 years	Small	73.2m	45.7m	4.55m	2.75m
13-15 years	Medium	82.3m	50.3m	4.55m	2.75m
15-16 years	Large	91.4m	50.3m	4.55m	2.75m
16 and over		91.4m	55.0m	4.55m	3.0m
Adult club					

Mini-hockey and 6 or 7-a-side hockey

Mini-hockey and 7-a-side hockey are played on half-sized pitches by teams of seven players, but the games are played to different rules. 7-a-side hockey is similar to true hockey, but it is scaled down and is intended for under 14 year olds. Mini-hockey is restricted to players aged ten years but under 12 years, and the pitch markings are different from true hockey or 7-a-side hockey. 6-a-side hockey is a scaled down version of 7-a-side hockey.

Governing Body. The Hockey Association, The Stadium, Silbury Boulevard, Milton Keynes MK9 1NR (Tel. 01908 241100).

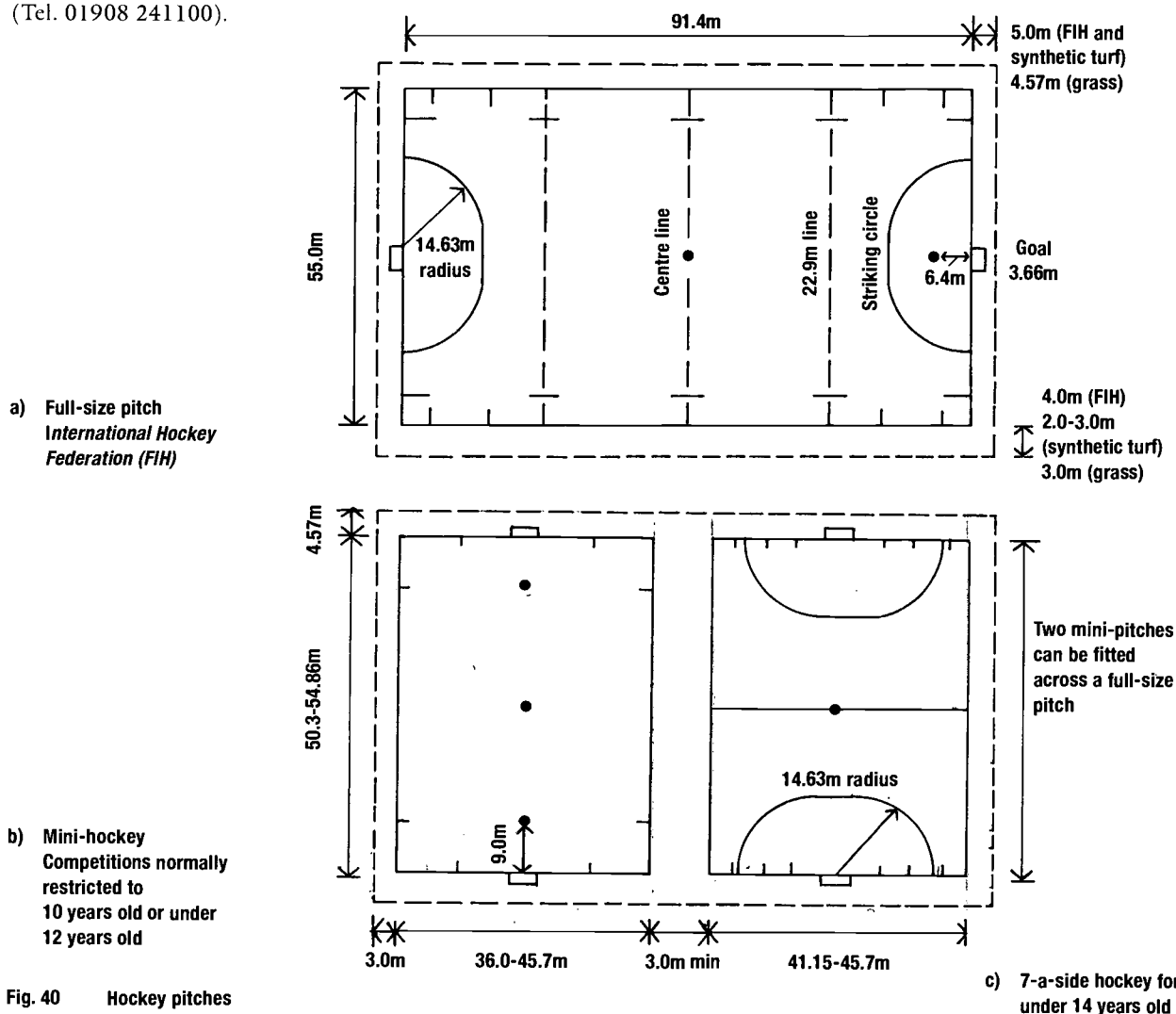

Fig. 40 Hockey pitches

Lacrosse: Men's

Full-size pitch. Lacrosse has a squad of 13 players, 10 on the pitch at any time. It is normally played on grass but synthetic surfaces are also used. Unlike women's lacrosse the pitch dimensions are prescribed.

Table 8 Recommended age related pitch sizes

Boys

Age group	Length	Width	In goal	End Margins	Side Margins
8-11 years	33.0m	15.0m	9.0m	(play to court boundary fencing)	
11-13 years	64.0m	45.0m	11.0m	3.0m	4.5m
13-15 years					
15-16 years	72.0m	55.0m	13.75m	3.0m	4.5m
Adults (max)	100.6m	55.0m	14.0m	3.0m	4.5m

Governing body. English Lacrosse Association, 4 Western Court, Bromley Street, Birmingham B9 4AN (Tel. 0121 7734422).

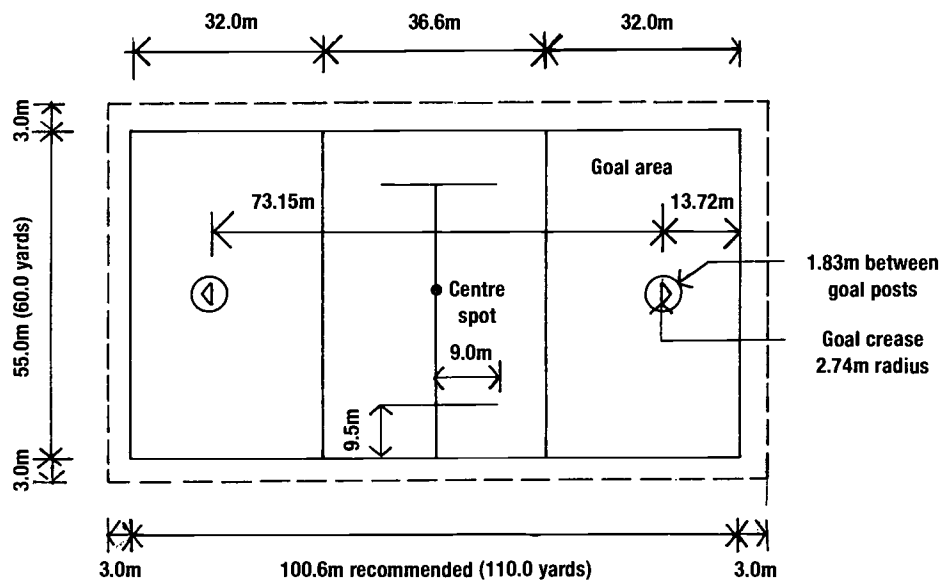

Fig. 41 Full-size men's lacrosse pitch

Lacrosse: Women's and Girls'

Full-size pitch. Lacrosse has a squad of 16 players, 12 on the pitch at any time, and is normally played on grass but synthetic surfaces are also used.

Table 9 Recommended pitch size

Women's & Girls'	Length	Width	In goal	End Margins Side Margins
All ages	110m recommended 100m minimum	60m	9.0m	Boundary lines are not defined but trees and other objects are not permitted within field of play, provide 4.0m clearance.

Note:

A smaller pitch may be used for non-ELA events by mutual agreement of captains

Mixed lacrosse. This is aimed at 11-16 year olds. The pitch dimensions will be the same as the women's game.

Pop lacrosse. This is the mini version of the game aimed at 7-11 year olds. There are eight players in a squad, five on the pitch. Teams can be mixed or single sex. Playing area - approximately four badminton court size (28.5 x 17.5m) indoor/outdoor, on hard surface or grass.

Governing body. English Lacrosse Association - see Lacrosse: Men's for address.

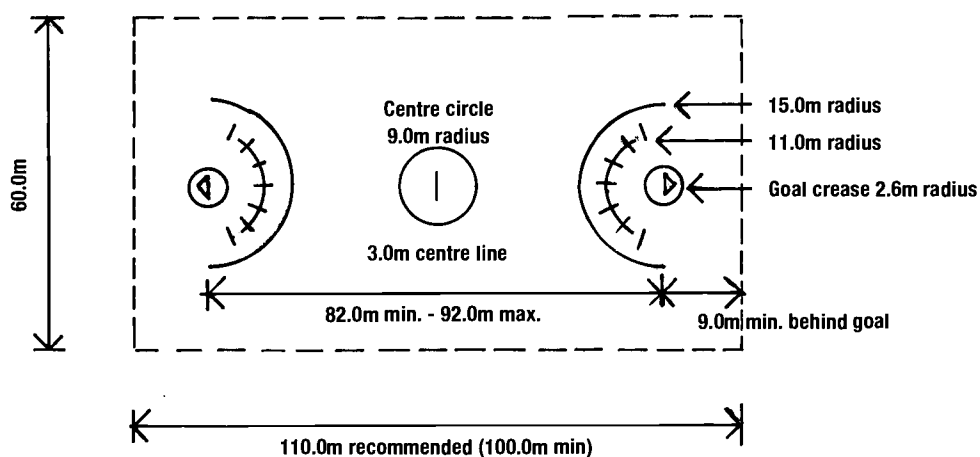

Fig. 42 Full-size women's and girls' lacrosse pitch

Netball

Full-size court. Age group 12 and over. Netball is played by 7-a-side teams of women and girls. The preferred surface for this sport is tarmacadam, although other surfaces can be used including concrete, hard porous, synthetic turf and polymeric construction. Netball courts should be marked out at least 1.22m clear of fence supports and, even with ball-stop fencing, the court location should allow for recovering stray balls. Where space is limited netball can be played on a slightly smaller court area by scaling down the dimensions.

'First step' Netball. Age group 8-11 years. This is a junior version of the senior game which was launched in 1993. It is designed for boys and girls; teams consist of 4 players and it can be played conveniently across a third of a full-sized netball court.

Governing body. All England Netball Association, Netball House, 9 Paynes Park, Hitchin, Hertfordshire SG5 1EH (Tel. 01462 442344).

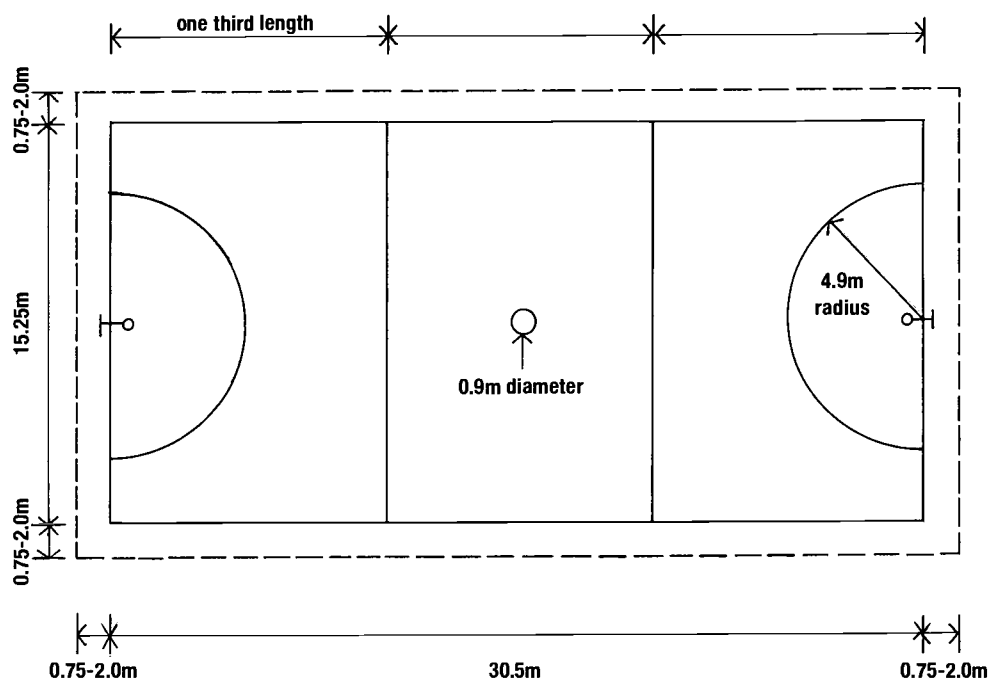

a) Full-size Netball court (senior)

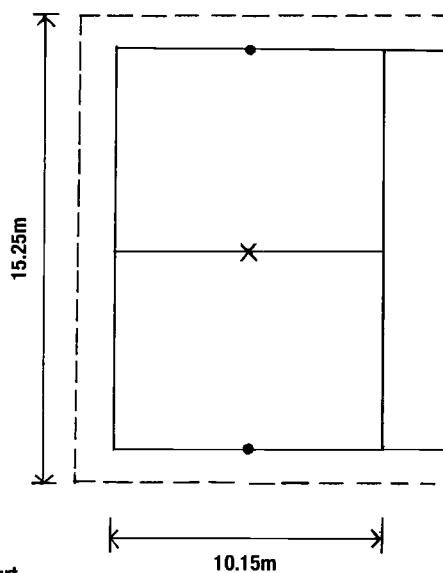

b) 'First Step' Netball court

- Markings** Centre line with a cross indicating the middle of the court
- Dot in the middle of each backline indicates position of the post.
- Equipment** Posts placed on centre point of each backline should be adjusted down from 3.05m (senior) to 2.44m (junior) and be fitted with a net.
- Margins** Same as for the senior game.

Fig. 43 Netball Courts

Rounders

Full-size pitch. Age group 11 and over. Rounders are played by teams of between six and nine. The game requires a relatively flat grass or hard surface area which can vary widely in size according to the age and strength of the players. If space allows, pitches can be laid out on any part of the playing fields not being used for other sports activities.

Mini-Rounders. The game is designed for primary aged pupils and is played on a reduced size pitch to suit small playgrounds; the dimensions are shown in brackets in Figure 44. Such a playground is shown in Figure 12 junior games court. If a netball court is used the pitch should be marked out centrally to allow for a suitable hitting area.

Governing body. National Rounders Association, 3 Denehurst Avenue, Nottingham NG8 5DA (Tel. 0115 9785514).

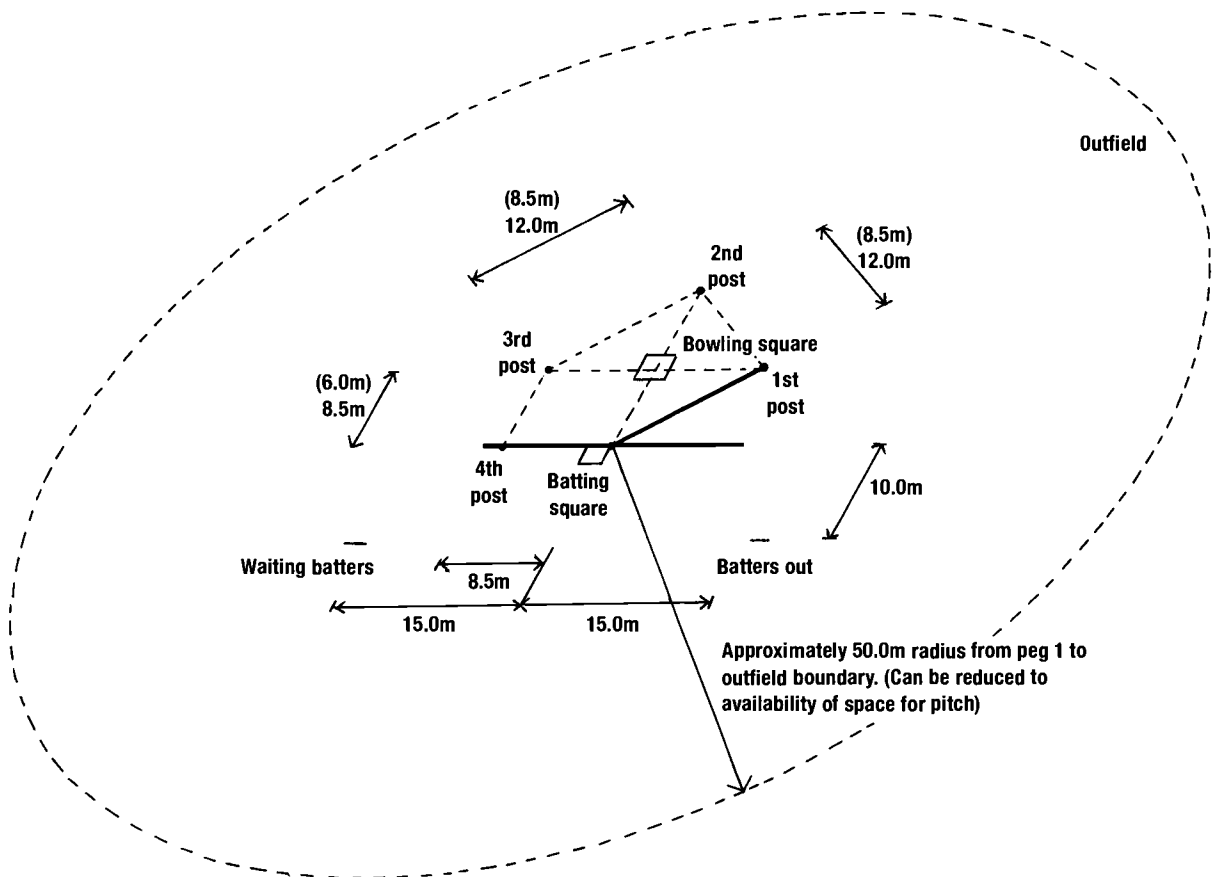

Note:

Dark lines are compulsory markings.

Pitches should not be marked out in corners of fields as this restricts the hitting area. Pitches should be marked parallel to boundaries and at least 15m from them.

Bowling squares are 2.5m square and batting squares 2.0m square.

Fig. 44 Rounders pitch (for primary aged pupils dimensions are in brackets)

Rugby League Football

Full-size pitch. The game is played by teams of 13 on a level pitch. The minimum playing area is 88 x 55m and the maximum is 100 x 68m. The side and end margins are 6m. Goal post uprights must exceed 4m and height from ground to crossbar is 3m.

Table 10 Recommended age related pitch sizes

Age Group	Type of pitch	Length	Width	In goal	End Margins	Side Margins
Under 9 years	Mini-league	60m	40m	dimensions not fixed as goals are set outside play area	5.0m	2.0-5.0m
Under 11 years	Mod-league Rugby league	50-80m	35-60m	as above	5.0m	2.0-5.0m
11 -13 years	Small	60-80m	35-50m	6.0-8.0m	5.0m	2.0-5.0m
13 -15 years	Medium	70-90m	40-60m	6.0-8.0m	5.0m	2.0-5.0m
15 and over (Adult)	Large	80-100m	55-68m	6.0-11.0m	6.0m	2.0-6.0m

Governing body. The Rugby Football League, Red Hall, Red Hall Lane, Leeds LS17 8NB (Tel. 01132 624637).

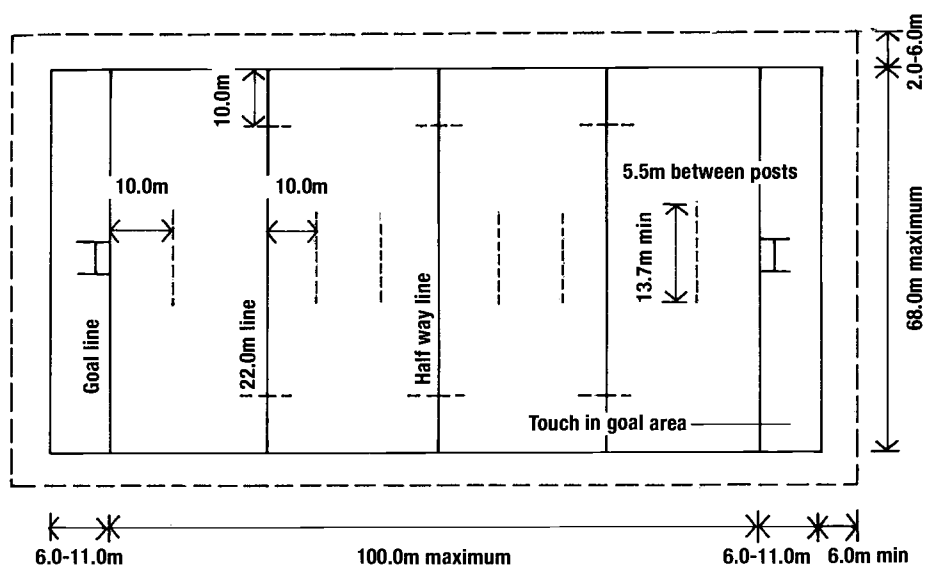

Fig. 45 Rugby League football pitch

Rugby Union Football

Full-size pitch. The game is played by teams of 15 on a level pitch. It should be remembered the pitch suffers from heavy wear and ideally should not form part of a cricket outfield. The maximum size of pitch is 100 x 69m with smaller recommended sizes for junior teams dependent on their age. Goal post uprights must exceed 3.4m and the height from the ground to the crossbar must be at least 3.0m.

Table 11 Recommended age related pitch sizes

Age group	Type of pitch	Length	Width	In goal	End Margins	Side Margins
11-13 years	Small	75m	46m	6.5m	3.0m	4.5m
13-15 years	Medium	82m	50m	6.5m	3.0m	4.5m
15-16 years	Large	91-96m	55-59m	9.0m	3.0m	4.5m
Adults (max)		100m	69m	22m (10m min)	3.0m	5.0m

Mini-Rugby. The game was created as a means of coaching and encouraging pupils with the aim of their playing 15-a-side rugby at the age of 13 years.

Table 12 Recommended age related pitch sizes

Under 7s (5 players) and under 8s (7 players)	-	30 x 20m plus 2.0m for each in-goal area.
Under 9s (9 players) and under 10s (9 players)	-	59 x 35m plus 5.0m for each in-goal area.
Under 11s (9 players)	-	59 x 38m plus 5.0m for each in-goal area.
Under 12s (12 players)	-	59 x 43m plus 5.0m for each in-goal area.

All pitches can be laid out across the width of a full-size pitch.

For further information contact the RFU.

Governing body. The Rugby Football Union, Rugby Road, Twickenham, Middlesex TW1 1DZ (Tel. 0181 892 8161).

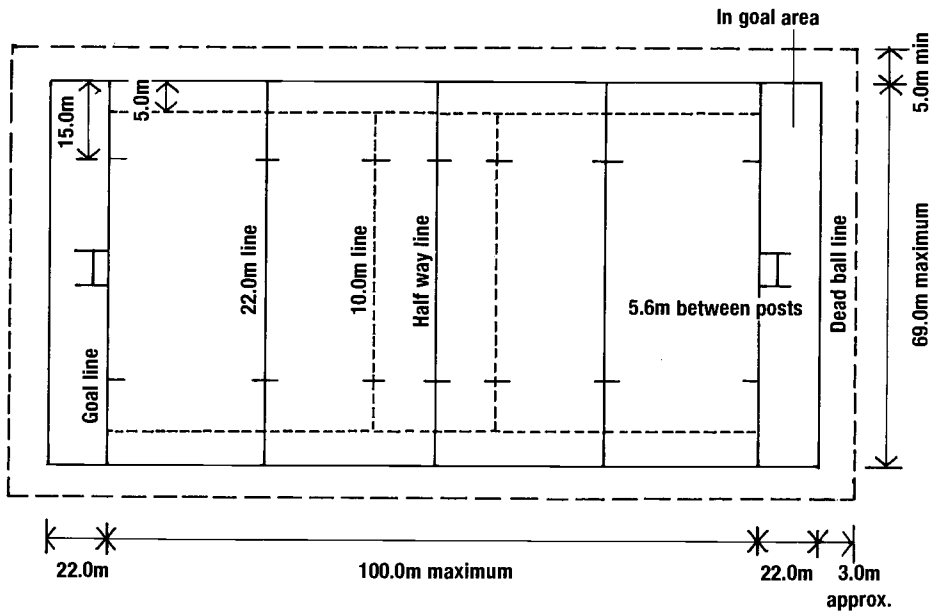

Fig. 46 Rugby Union football pitch

Softball

Softball is a member of the baseball family of games which is rather less played than other summer games in schools. It can be played by both primary and secondary aged pupils, pitch sizes vary according to the age. However, for those who wish to mark it out it is suggested the Sports Council's Outdoor Sports Handbook Vol 1 1993 or the governing body is consulted.

Governing body. British Softball Federation; National Development Officer, Mr R Fromer, Birchwood Hall, Storridge, Malvern, Worcestershire WR13 5EZ (Tel. 01886 884204).

Stoolball

This 11-a-side game is played largely in junior schools in southern England. The scoring and rules are similar to cricket but simpler. The 'wicket' is a faceboard 300mm square and mounted on a stake 1.1m above ground level, giving an overall height of 1.4m. For those who wish to mark it out it is suggested the Sports Council's Outdoor Sports Handbook Vol VI 1993 is consulted.

Governing body. National Stoolball Association, 3 Bramber Way, Burgess Hill, West Sussex RH15 8JU

Tennis

Courts. A major consideration in any court layout is a preference for a north-south axis and a slight gradient for drainage. A maximum fall of 150mm should be provided across the court width wherever possible for all-weather surfaces; synthetic, hard porous or tarmacadam. The LTA have recommended court dimensions according to the standard of play needed and these are shown in Table 13. For schools the minimum standard (c) would be appropriate. The runback should be at least 5.49m especially where there is dual use by adults, although a reduction to 4.57m may be unavoidable on restricted sites.

Multiple courts. There is a saving in playing surface by adopting multiple courts which share a common enclosure. Such facilities should be grouped side by side and in combinations of two, three or more courts according to curriculum need and for ease of supervision. This arrangement of space use also allows for multi-games use by netball, basketball, and 5-a-side football; the last would need fence reinforcement or rebound walls. However, care is needed in setting out clear and colour-coded court markings to avoid line confusion. Care should be taken in selecting games court sizes related to the standards of play required. It should be remembered that netball courts will need a slightly greater width than tennis courts and this should be taken into account.

Table 13 Tennis court sizes related to standards of play

	(A)	(B)	(C)
	International and National official Championships Full size	LTA Recommended Full size (club)	LTA Recommended Minimum (Recreational)
Marked out playing area			
Length	23.77m	23.77m	23.77m
Width	10.97m	10.97m	10.97m
Length of net (doubles)	12.80m	12.80m	12.80m
Width of lines (white) included with above court size	50mm	50mm	50mm
Runback (ie clearance behind baseline)	6.40m	6.40m	5.49m
Side-run (ie clearance beside sideline)	3.66m	3.66m	3.05m
Side-run between courts not separately enclosed	—	4.27m	3.66m
Overall size of enclosure			
Length	36.58m	36.58m	34.75m
Width for one enclosed court	18.29m	18.29m	17.07m
Width for two courts in one enclosure	—	33.53m	31.70m
Width added for each additional court	—	15.24m	14.63m

BEST COPY AVAILABLE

Short tennis. This is a miniature version of tennis created in Sweden especially for children of the age of five years or more. The scale of the game and equipment enables children to master hand-eye coordination skills and a repertoire of forehand and backhand strokes, including serving and volleying thus providing an introduction to the full-size game. It is played with a small racket and soft foam ball. A tennis court can accommodate four games, and a netball court the same number.

Governing body. Lawn Tennis Association, Queens Club, Barons Court, West Kensington, London W14 9EG
(Tel. 0171 381 7000).

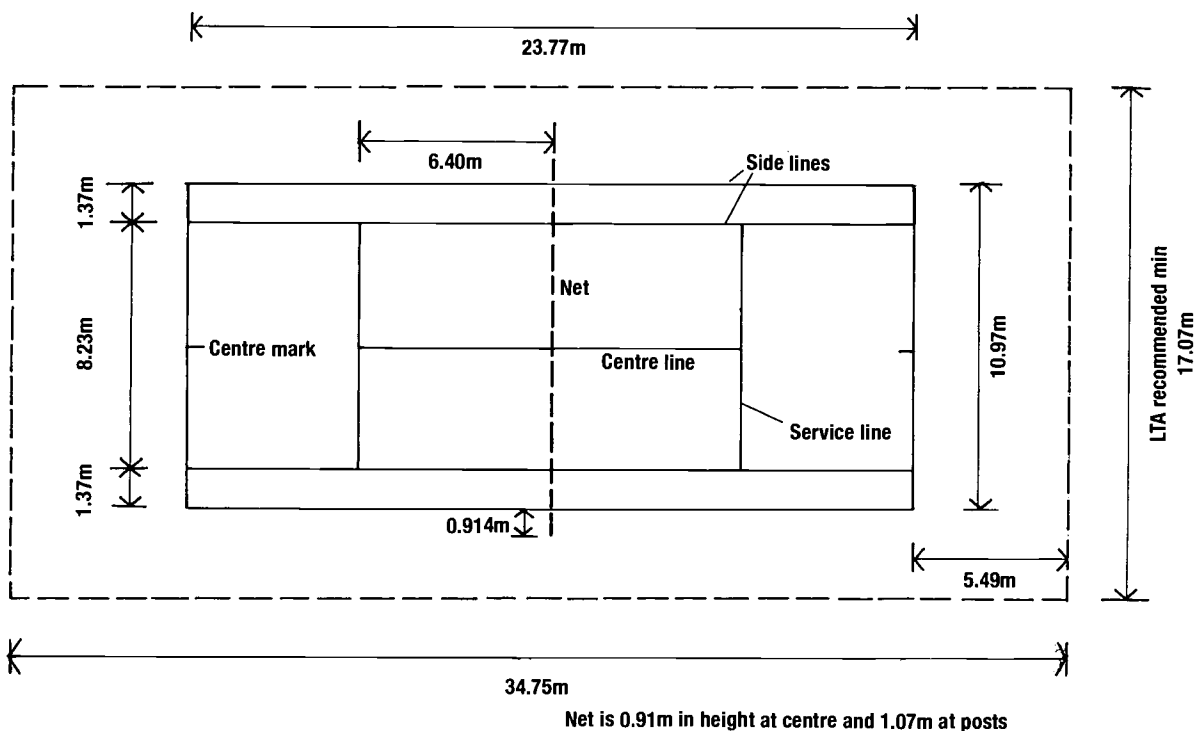

a) Full-size court (LTA recommended minimum size - recreational)

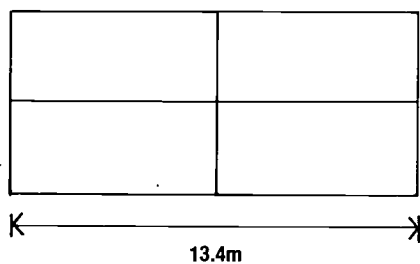

Dimensions to court run-off boundaries

	general play	competition
minimum run back	1.8m	2.6m
minimum side run	1.5m	2.1m
minimum side run between courts	1.8m	2.7m
minimum unobstructed height over court	4.0m	5.2m

Net is 0.80m in height at centre and 0.85m at posts

b) Short tennis court

Fig 47. Tennis court (full-size) and short tennis court

Padder tennis. This is a small form of tennis played with a wooden bat and a standard tennis ball. The game is appropriate to primary and junior schools for the learning of basic coordination skills.

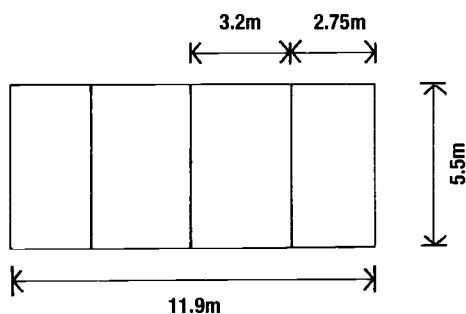

Fig. 48 Padder tennis court
(Four games can be accommodated on a full-size tennis court)

Volleyball

Full-size court. Volleyball is played by two teams of six players plus six substitutes; the preferred surface for this net game is grass or sand and particularly so for match play as paved or hard porous surfaces are too abrasive for players, although with care those surfaces might be played on for recreational purposes.

Mini-volleyball. The Association has especially introduced this mini game for 9-13 year olds; teams consist of three players plus three substitutes who play over a 2.10m high net. The game can occupy one third of the full-sized court. Six games can be accommodated on a netball court, and four games on a tennis court.

Governing body. English Volleyball Association, 27 South Road, West Bridgford, Nottingham NG2 7AG (Tel. 01159 816324).

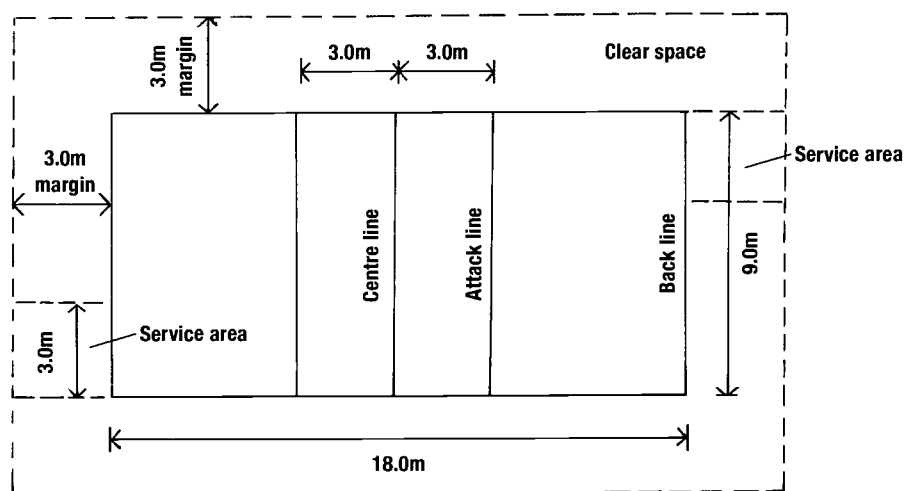

a) Full-size court

b) Mini-volleyball

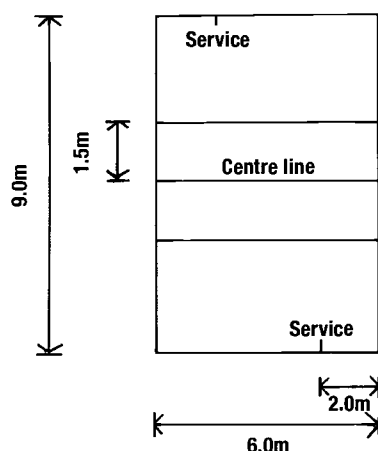

Fig. 49 Volleyball and mini-volleyball courts

C. Maintenance Schedule

The following schedule sets out the basic requirements for the different types of maintenance in school grounds. It is not intended as a definitive specification, since circumstances, and thus requirements, will vary between schools, but rather as a list of the different categories and what may need to be included.

Fine sports turf. The move towards contract systems, combined with pressure on revenue budgets, has contributed to a fall in the quality of maintenance and as a consequence the amount of fine turf in school grounds. The main point about fine sports turf is that it requires much more than mere cutting. There is variously a need for weed and fungal control, fertiliser and watering programmes and brushing, dragmatting and spiking, together with remedial works such as overseeding; these are fundamental to maintaining a good and safe playing surface. Grass cricket squares, tennis courts, and hockey pitches demand a smooth, flat and true surface with no undulations or holes that could lead to unpredictability of bounce. During the playing season the turf is maintained by cylinder mower with all clippings boxed off, within a height range of 6-10mm for cricket squares, 10-15mm for tennis, and 15-25mm for hockey.

Winter sports pitches. The necessary maintenance for football, rugby and lacrosse pitches includes similar provisions for fertiliser application, harrowing, rolling and spiking. The exact mix of techniques depends on the quality of the pitch and the intensity of use. On rugby pitches, grass should be cut by gang-mower to a height of 50-100mm during the playing season, and 20-50mm at other times where summer sports use is required. Lengths where lines occur may be defined by cutting with a rotary mower to a height of 20-50mm. Football pitches should be cut by gang-mower to a height of 20-50mm. It is essential to rectify wear and tear to pitches, especially goalmouths and central areas as soon as the season is over. Interim measures, such as replacement of divots, sanding and regular spiking of goalmouths should take place at least weekly through the season. Any depressions should be filled with good quality topsoil and/or sand dressing, as appropriate, and re-seeded or re-turfed. Re-seeded areas must be protected and watered through the summer to ensure good establishment. Winter goal posts should be removed at the end of the playing season and goal boxes made safe. Some schools choose to leave rugby posts up through the year to save on cost, but this can reduce the flexibility for summer use. Posts should be stored safely and painted during the close season and any damaged goal boxes should be replaced. Marking should maintain a clear white line at all times. Pitches should be moved at least once a year wherever space permits to change the pattern of wear from season to season.

Games courts and hard porous surfaces. All games courts should be kept weed-free, usually by the application of a non-selective herbicide outside of term time. Regular sweeping should take place to remove any accumulation of surface dust, grit or leaves. Gullies should be inspected at least monthly and any necessary clearance completed. Hard porous pitches and smaller facilities, such as run-up areas, should be well consolidated, true and level with a light covering of coarse particles on the surface. Many sites will require daily attention but this depends on the frequency of use. Marking needs to be carried out regularly to sustain clear lines for pitches and courts. Where an irrigation system is installed, a porous pitch should be watered frequently during dry weather with an annual application of salt to increase the hygroscopic properties. Drainage outlets should be checked at least twice a year.

Synthetic sports surfaces. No synthetic surface is maintenance-free and a diligent approach to the care of the pitch can significantly prolong its life. Access should be controlled by means of a totally fenced enclosure with washable boot wipers and litter bins at gates. Control of litter, debris and mud from adjacent areas will reduce the potential for their deposit on the synthetic surface. Food and drink, and smoking during community use sessions, should be prohibited. It is important to repair minor damage or vandalism quickly. Maintenance to line markings depends on whether they are built in or have been painted on. The former reduces maintenance costs but there may be distortion through material stretching. The life of paint lines is improving and re-marking frequency is moving towards an annual operation. However, maintenance should be on the basis of need rather than a time schedule. Build-up of paint should be avoided as this distorts levels and may make the surface slippery.

Sand-filled carpet. Litter and leaves should be regularly picked up, at least weekly where usage is above 30 hours a week, by hand or machine brushing or suction. Any excessive staining should be removed by warm water and detergent or grease spot remover, after checking use of specific products with the manufacturer. Any weed growth should always be treated by herbicide application and never hand-pulled. The nature and level of the sand in carpets have the greatest impact on the playing characteristics of the

surface. Sand will need re-dressing several months after installation. Larger, rounder sands may reduce compaction more successfully than smaller sieved grades and it is always essential to check use of types with the supplier of the surface. The major cause of problems in pitches is seam failure, though this has declined with the improvement in adhesives. This is often difficult to rectify due to tension in the carpet and an unsightly filler piece may be required. Pitch levels should not distort through settlement, heavy use or frost unless the initial construction, particularly the depth, was inadequate. Most suppliers offer surety for a 10 year life for the carpet.

Athletics facilities. Running tracks should be level and free from excessive undulations. The landing areas for javelin, discus and hammer throwing must be clear of other facilities. Cages, where erected, should be maintained in a good condition and removed at the end of the summer term. Grass perimeters around jump facilities should be maintained as an amenity lawn at a height of 20-25mm and edges should be cut annually. Fresh, soft, blown sand should be used to top up each jump pit as necessary at the start of the season to give a smooth surface level with the run-up. Any weeds or debris should be removed from the jump pit area on a regular basis and the sand raked to leave a level surface throughout the season. Take-off boards should be turned or renewed, annually if necessary, when the run-up is reinstated. They must be flush with the run-up and painted with white undercoat at the beginning of the summer term and as required through the season.

Amenity grass areas. Prior to mowing any area, it is important that litter and debris are removed. Areas of bulbs should not be mown until seven weeks after the bulbs have flowered and on finer lawn areas cuttings need to be collected and removed. Lawns should be cylinder mown to a height of 25-50mm depending on their use and desired appearance. At the completion of mowing, clippings should be left evenly spread over the surface without undue accumulations that might cause damage to the underlying sward. Cuttings that fall on to paved surfaces should be removed and marked accumulations of leaves cleared off lawns in the autumn. All the boundaries of grass areas need to be kept tidy, and maintenance should extend right up to any building line, fence, service marker, manhole cover or other obstruction. To avoid widespread and regular hand trimming, a herbicide can be used to sustain a weed-free strip, no wider than 250mm around such obstacles and against walls. Where schools do not wish herbicides to be used, a suitable hard surface material - not loose gravel - may be installed along this strip to reduce hand work. The fringe around shrub borders should be regularly clipped so that the grass never exceeds 50mm in height and recut once a year where necessary with a half moon edging iron. Lawn edges against kerbs or hard areas should be recut twice a year leaving no gap between turf and adjoining hard surface.

Rough grass and meadows. Rough grass areas can be cut with a rotary or flail mower to maintain the length of vegetation at 50-100mm, cylinder mowers should be used within 30m of the windows of buildings or cars during the school day as other types can throw up stones. Within young tree plantations and over meadows, grass can be cut once or twice a year dependent on the season or the specific demands of the habitat. Spring meadows are usually cut after the end of the summer term and a finishing cut may be necessary in October. Summer meadows can be cut in the spring and again in October. To prevent the build up of nutrients in the soil, cuttings should be removed from meadow areas wherever possible, either by machine over large areas or by hand raking over smaller ones. Grass around tree plantations only needs to be cut in the early years where there is a danger of long vegetation falling over the young transplants.

Shrub borders. All borders should be kept clear of litter and maintained weed-free. The latter can be assisted in the early years by a 75mm depth of bark mulch, and when the occasional weeds come through they are more easily pulled by hand. Bark mulch can however be undesirable around school buildings where shrub borders abut hard surfaces. If borders are at the same level and the mulch has not been feathered down to the edge, it can be kicked over the hard surface areas. This is often the result of poor landscape design. Shrubs should be regularly pruned to prevent undue obstruction to pathways and windows, to avoid overcrowding and to promote an acceptable shape for the species. It is essential that those responsible have the necessary skills to undertake this work. Restrictions on the use of certain chemicals and the increasing resistance to their use by schools, points to the need for a wider adoption of artificial or organic mulches, combined with careful choice of species, to create a closed canopy and to limit the amount of bare soil available for weed colonisation.

Hedges and fences. Cutting frequency and height are dependent on the species, but generally hedges around playing fields should be cut once a year. Around the buildings two or even more cuts may be necessary, especially where hedges abut footpaths. Once the hedge has reached its preferred height, it should be cut back to the previous year's growth and the hedge base cleared out at the time of clipping. All clippings should be raked into heaps and taken to a convenient disposal point on site for composting or, where this is not possible, carted off site to a tip. Any gaps which do arise due to death or damage should be filled in the following autumn and the young plants protected during establishment by temporary fencing. Minor day-to-day repairs to fencing should be undertaken as soon as they are noticed and in areas with more regular maintenance, fence-lines should be kept clear by herbicide application or the installation of a hard surface mowing strip. Where fences are persistently broken down by pupils taking short cuts, access arrangements should be reviewed and additional gates provided where it is convenient and safe to do so.

Newly planted trees. In the first year after planting, the prime requirement for establishment is water and the creation of a 1m diameter weed-free ring around the tree by herbicide application would be effective. Laying a mulch will restrict competition for nutrients as well as for water. This should be sustained for at least three, and ideally five, years. Even uncut grass is preferable to close mown grass which is fiercely competitive and brings the added danger of mower damage to the base of the tree. The latter can often affect over half the trees in grounds where they are set in close mown grass without protection. Impact damage and bark removal can severely affect the health and thus the safety of the tree in later life. Other maintenance considerations are as follows.

- **Re-firming and vertical position.** In the first year and possibly in the next two, wind-rocking and frost may have caused the tree to be loose in the ground and to bend over at an angle. Treading the soil around the stem should aim to place the tree in an upright position and firm in the ground without damaging it in any way.
- **Fertiliser.** An application in April of the second and fourth years can promote more active growth, especially on poor sites. It should have a nitrogen:potassium:phosphorus ratio of 15:10:10 and be applied at a rate of 15g/m² to forestry transplants and hedging plants, and 60g/m² to feathered trees.
- **Watering.** This may be necessary through the summer term, particularly in the south and east of the country. Guide quantities are 10 litres per transplant and hedging plant, and 20 litres per feathered tree per occasion. Where permissible, the frequency of watering in drought conditions needs to be weekly.
- **Pruning.** Annual pruning in the autumn should remove dead wood and encourage balanced growth; trees should have a clear leading shoot and branches should not rub against each other. Formative pruning may be necessary to reduce the density, and thus the weight of the branches, especially where there has been substantial annual growth that may make the plant top heavy.
- **Rabbit protection.** Where guards or fencing have been used (and they will be necessary on all but inner-city sites), regular monthly inspections should ensure they are effective and any damage to them is repaired.
- **Stakes and ties.** Stakes should be firm and upright and supporting the tree, rather than the other way around, and ties should be secure and prevent the tree rubbing against the stake. Short stakes, no more than 1m above ground and with a single tie near the top, encourage the tree to buttress at the base and become more wind-firm.

Mature trees. Regular inspection of mature trees should be undertaken by an arboriculturalist. The frequency will depend on the number, size and location of the trees. Inspections should never be more than two years apart and may need to be annually on sites with many mature trees. Interim inspections by the member of staff responsible for the grounds, on the basis of the earlier tree survey format, can assist in early recognition of problems. Timing of these is important since a survey in late summer will show any signs of crown dieback, in the early autumn it will pick up any fungal growth, and in winter it will reveal damage to the trunk or branches of deciduous trees. The aim should be to have a healthy population of

trees in all age ranges and some felling of older specimens may be necessary to allow re-planting to take place. Re-planting close to, let alone within, the canopy of existing mature trees results in distorted and often slow growth due to limited light, water and nutrients.

Wetlands, ditches and drainage systems. Where ponds do not have a direct supply of water, such as that from a roof, and sometimes even where they do, regular topping up will be required in summer to compensate for evaporation loss. Excessive growth of aquatic plants may need to be removed in the autumn of each year, especially where a soil layer has been placed over the artificial liner; it may be necessary to remove as much as 50% to allow sufficient area of open water. To prevent leaks great care should be taken to avoid damage to an artificial liner during this operation. Litter needs to be picked from the pond on a weekly or monthly basis depending on the severity of the problem. All ditches, silt traps and entrance grids to underground culverts should be cleared of excess silt and rubbish in the autumn of each year. All manhole inspection covers should be lifted at least once during wet weather in the winter months to check that the drains are running freely and any blockages should be removed.

Hard landscape areas and site furniture. All hard surface areas should be thoroughly inspected at least annually to check for any early breaking up of tarmac surfaces or for differential settlement over paved areas which has resulted in cracked slabs or a difference in level between them. Surfaces will need to be swept at regular intervals to remove excess grit, dust and accumulations of leaves in autumn. Site furniture should be checked at the beginning of each term to ensure stability in the ground, the effectiveness of all fasteners and the sound condition of all timber and metal work. More regular inspections of any fixed play equipment will be necessary and these have been set out in 8.62.

Litter. Whilst a good deal of litter collection may be undertaken directly by the pupils, the maintenance contract should allow for certain litter clearance, for example on grass areas before mowing. The aim should be to achieve grade A standard as specified in the Environmental Protection Act 1990 by removing all litter and refuse. As a minimum standard during school terms grade B, defined as predominantly free of litter and refuse apart from small items should be achieved after litter picking. If the standard falls to grade C, widespread distribution of litter with minor accumulations, it should be restored to at least grade B within 24 hours, excluding weekends and holidays. In the event of non-compliance a private individual can give five days' written notice to the school and if the situation is not rectified a complaint can be made to a magistrates' court. If the complaint is upheld a Litter Abatement Order will be issued requiring clearance and leading to a fine of up to £1000 in the event of continued non-compliance.

Additional work. So that more competitive prices can be set for any additional or unforeseen work, many maintenance contracts include a schedule requiring tenderers to provide prices on an area and operations basis before the contract is let. Table 14 shows a typical schedule of rates.

Table 14 Typical schedule of rates for actual pricing by others (not to be totalled)

Operation	daily rate £	hourly rate £
1. Operative with hand tools		
2. Operative with cylinder mower		
3. Operative with rotary mower		
4. Operative with strimmer		
5. Operative with knapsack sprayer		
6. Tractor mounted sprayer		
7. Tractor mounted harrow		
8. Tractor mounted 5+ gang-mower		
9. Ride-on triple grass cutter		
10. Tractor mounted roller		
11. JCB 3C or equivalent		
12. 4x4 wheeled dumper (4m ³ capacity)		

BEST COPY AVAILABLE

Table 14 continued

Area costs	Unit	£
1. 5+ gang-mower	1000 m ²	
2. Cylinder mower	100 m ²	
3. Pedestrian rotary mower	100 m ²	
4. Hover mower	100 m ²	
5. Pedestrian flail mower	100 m ²	
6. Knapsack sprayer	100 m ²	
7. Pedestrian fertiliser application	100 m ²	
8. Tractor mounted fertiliser spreader	1000 m ²	
9. Tractor mounted sprayer	1000 m ²	
10. Overseed by hand inc. scarification	100 m ²	
11. As 10 but with tractor mounted scarification	1000 m ²	
12. Turf (inc. materials)	100 m ²	
13. Plant forestry transplants	100 no	
14. Imported topsoil in feathered tree pits	10 no	

Spraying/fertiliser/soiling costs should exclude materials.

Note:

Grounds maintenance performance quality standards.

Performance quality standards for sports pitches, amenity turf and shrub borders are being developed by the Association of Landscape Managers. These standards are not established to indicate how a task should be performed, they are pre-determined levels of quality to which the finished product should conform at specific times. Once existing quality levels have been determined through assessment or measurement, realistic performance targets can be established which can be monitored to ensure facilities are maintained to acceptable levels. For information contact the Association of Landscape Managers, Mr Matthew J. Smith, Secretary, c/o WDS, Brook House, Bythesea Road, Trowbridge, Wiltshire BA14 8JH (Tel. 01225 771670).

111 111 111 111 111

D. Description of Key Staff Duties

For staff with responsibility for the grounds.

Whether or not the grounds are the responsibility of one or more persons, there are a number of duties which will need to be undertaken. These duties fall into two categories, those which need to be undertaken by the school grounds management group and those which may be delegated.

School grounds management group:

- develop a long-term policy for the school grounds and incorporate it into the School Development Plan;
- identify long-term and short-term curricular needs so that the grounds can be adapted to match changing requirements and staff training needs met;
- encourage those responsible for play (at primary level) and personal and social education (secondary level) to develop a rationale and policy for the informal curriculum;
- identify needs and provide training for those responsible for supervision at lunchtime;
- intervene, where necessary, to correct under-use and avoid over-use;
- oversee new developments;
- raise funds and keep financial records;
- co-ordinate publicity;
- oversee volunteer involvement;
- determine the overall management and maintenance of the grounds;
- oversee health and safety issues, see Reference Section H.

Ongoing duties include:

- co-ordinating planning to make each department or, in the case of primary schools, each teacher aware of what is being done by others;
- encouraging those responsible for subjects or areas of the curriculum to include specific references to the use of the school grounds in their guidelines and schemes of work;
- assisting individual teachers in their planning of lessons or programmes of work which are intended to make use of the grounds;
- organising ongoing maintenance and acting as the staff point of contact for contractors or outside agencies involved in the grounds;
- organising volunteer working parties in the grounds;
- co-ordinating involvement of pupils in grounds use and development;
- advising the headteacher on health and safety matters;
- co-ordinating community use of the site.

BEST COPY AVAILABLE

E. Extract from DfEE Circular No 10/96

The 1996 School Premises Regulations

Part V - Playing Fields and other sports facilities

72. The Regulations about school playing fields or equivalent sporting facilities apply to any school where there are pupils aged eight years or above. They do not apply to pupil referral units. 'Playing fields' are defined strictly in the Regulations. To qualify, an outdoor, grassed area provided for physical education must be:
- suitable for the playing of team games; and
 - laid out for that purpose; and
 - capable of sustaining team games for seven hours a week during term time.
73. The minimum area of playing fields which schools should have is set out in Schedule 2 to the Regulations. This minimum area - see Table 2 below - depends on the number of pupils at the school and their ages.

Table 2: Minimum total playing field areas in m² - figures from Schedule 2 to the Regulations.

Total number of pupils aged 8 years or older (Y4 and above)	Schools with pupils aged under 11 years (Y6 and below)	Schools with NO pupils aged under 11 years (below Y7)	All special schools
100 or fewer	2500	5000	The Regulations do not set out specific areas for special school playing fields.
101 to 200	5000	10000	
201 to 300	10000	15000	
301 to 400	15000	20000	
401 to 500	20000	25000	However, they do require that a special school with pupils who receive outdoor physical education should have an area of playing field sufficient to take account of pupils' needs.
501 to 600	25000	30000	
601 to 750	30000	35000	
751 to 900	35000	40000	
901 to 1050	40000	45000	
1051 to 1200	45000	50000	For special schools only, playing fields are required to be adjacent to, or in the immediate vicinity of the school buildings.
1201 to 1350	50000	55000	
1351 to 1500	55000	60000	
1501 to 1650	60000	65000	
1651 to 1800	65000	70000	
1801 to 1950	70000	75000	

74. For schools with more than 1950 pupils:
- choose the column above which is appropriate to the ages of the pupils;
 - select the largest figure in it; and
 - add an extra 5000m² for each complete 150 by which the number of pupils exceeds 1801.

For example, a secondary school with 2000 pupils would need 75000m² + 5000m² = 80000m² of playing fields.

Quality of playing fields

75. For a playing field to count towards the minimum requirement, it should be able to sustain the playing of team sports for at least 7 hours a week during term time.

Other sports facilities

76. Types of provision other than traditional grass playing fields may also be suitable for physical education. Therefore, for the purposes of the minimum area requirements, a playing field with a hard porous surface, which is large enough for the playing of team games, may be treated as if it were twice its actual area.
77. Synthetic surfaces of various types are also suitable for playing some team sports. Different types of synthetic surface have very different properties, and will not necessarily be an adequate substitute for grass, so the Regulations do not include a simple ratio for discounting synthetic surfaces against the requirement for grass playing fields.

78. But the Regulations do say that the area of grass playing field required is reduced 'so far as is reasonable' if a school enjoys the benefit of the following facilities:
- regular instruction in swimming (either at the school or elsewhere);
 - indoor instruction in team games (either at the school or elsewhere);
 - instruction in team games on synthetic surfaces (at the school); or
 - outdoor instruction in team games (not at the school).
79. When considering what constitutes a 'reasonable' reduction in the minimum area, LEAs and governors should take account of:
- the quality of any alternative facilities;
 - the ease of access to such facilities; and
 - the number of hours of use that would be available to the school.

F. Grounds Area Guidelines

(Recommended tables for site areas, and allocation of area for use-zones - Reference 4.25)

The area guidance tables provided below draw on the area guidance given in DfEE Building Bulletin 82 Area Guidelines for Schools. The site areas given in the tables incorporate minimum statutory playing field areas, recommended hard surfaced games court(s), and informal and social areas. The area allocated to habitat, buildings and access, and playing fields above the minimum statutory playing field area has been calculated by deducting the sum of the minimum statutory playing field area, the recommended hard surfaced games court(s), and the informal and social areas from the total recommended site area.

For convenience the area figures (m²) created by this process have been tabulated for the most commonly found mainstream schools in Tables 15 - 20 for infant, junior, primary, middle deemed primary, middle deemed secondary, and any secondary school.

Special schools (including nursery, primary, secondary, and all age special schools) have been treated separately due to the range and variety of special schools. Reference should be made to Table 21 for recommended pupil numbers related to outdoor areas for hard surfaced area for games and informal and social area, and soft area for informal activities and habitat area. (Site areas have not been included as these will vary in relation to the type of special school and the need for additional outdoor space for vehicle access and parking needed for pupil safety measures.)

Area Tables

To develop the area tables for the mainstream schools mentioned above, the recommended area formulae given in BB82 were used to generate site areas (hard surfaced games court(s), and informal and social areas). The formulae produced an upper and lower area range to provide a degree of flexibility. For area advice on schools with different age ranges from those given in the tables, BB82 Area Guidelines for Schools should be consulted.

Examples of a site layout for a primary school and a secondary school developed by using the recommended area guidelines and tables are provided in the same publication.

**Table 15 Infant school (5-7 years):
Recommended site and zone areas (m²)**

Number on roll	statutory minimum playing field area	grassed space for skills practice and small games	informal and social area	habitat areas, buildings and access, playing field area above stat. minimum	total site area
90	0	771	795	3824	5390
		462	609	3304	4375
120	0	828	960	4232	6020
		516	762	3622	4900
150	0	885	1125	4640	6650
		570	915	3940	5425
180	0	942	1290	5048	7280
		624	1068	4258	5950
210	0	999	1455	5456	7910
		678	1221	4576	6475
240	0	1056	1620	5864	8540
		732	1374	4894	7000
270	0	1113	1785	6272	9170
		786	1527	5212	7525
300	0	1170	1950	6680	9800
		840	1680	5530	8050
330	0	1227	2115	7088	10430
		894	1833	5848	8575
360	0	1284	2280	7496	11060
		948	1986	6166	9100
390	0	1341	2445	7904	11690
		1002	2139	6484	9625

116

**Table 16 Junior school (7-11 Years):
Recommended site and zone areas (m²)**

Number on roll	statutory minimum playing field area	hard surfaced games courts	informal and social area	habitat areas, buildings and access, playing field area above stat. minimum	total site area
90	2500	771	795	3879	7945
		462	609	3359	6930
120	2500	828	960	5022	9310
		516	762	4412	8190
150	5000	885	1125	3665	10675
		570	915	2965	9450
180	5000	942	1290	4808	12040
		624	1068	4018	10710
210	5000	999	1455	5951	13405
		678	1221	5071	11970
240	5000	1056	1620	7094	14770
		732	1374	6124	13230
270	10000	1113	1785	3237	16135
		786	1527	2177	14490
300	10000	1170	1950	4380	17500
		840	1680	3230	15750
330	10000	1227	2115	5523	18865
		894	1833	4283	17010
360	10000	1284	2280	6666	20230
		948	1986	5336	18270
390	10000	1341	2445	7809	21595
		1002	2139	6389	19530
420	15000	1398	2610	3952	22960
		1056	2292	2442	20790
450	15000	1455	2775	5095	24325
		1110	2445	3495	22050
480	15000	1512	2940	6238	25690
		1164	2598	4548	23310

**Table 17 Primary school (5-11 years):
Recommended site and zone areas (m²)**

Number on roll	statutory minimum playing field area	hard surfaced games courts	informal and social area	habitat areas, buildings and access, playing field area above stat. minimum	total site area
90	2500	771	795	2784	6850
		462	609	2264	5835
120	2500	828	960	3612	7900
		516	762	3002	6780
150	2500	885	1125	4440	8950
		570	915	3740	7725
180	2500	942	1290	5268	10000
		624	1068	4478	8670
210	2500	999	1455	6096	11050
		678	1221	5216	9615
240	5000	1056	1620	4424	12100
		732	1374	3454	10560
270	5000	1113	1785	5252	13150
		786	1527	4192	11505
300	5000	1170	1950	6080	14200
		840	1680	4930	12450
330	5000	1227	2115	6908	15250
		894	1833	5668	13395
360	5000	1284	2280	7736	16300
		948	1986	6406	14340
390	5000	1341	2445	8564	17350
		1002	2139	7144	15285
420	5000	1398	2610	9392	18400
		1056	2292	7882	16230
450	5000	1455	2775	10220	19450
		1110	2445	8620	17175
480	10000	1512	2940	6048	20500
		1164	2598	4358	18120
510	10000	1569	3105	6876	21550
		1218	2751	5096	19065
540	10000	1626	3270	7704	22600
		1272	2904	5834	20010
570	10000	1683	3435	8532	23650
		1326	3057	6572	20955
600	10000	1740	3600	9360	24700
		1380	3210	7310	21900
630	10000	1797	3765	10188	25750
		1434	3363	8048	22845

**Table 18 Middle deemed primary school (8-12 years):
Recommended site and zone areas (m²)**

Number on roll	statutory minimum playing field area	hard surfaced games courts	informal and social area	habitat areas, buildings and access, playing field area above stat. minimum	total site area
120	5000	828	960	4295	11083
		516	762	3345	9623
150	5000	885	1125	5621	12631
		570	915	4578	11063
180	5000	942	1290	6948	14180
		624	1068	5811	12503
210	10000	999	1455	3275	15729
		678	1221	2044	13943
240	10000	1056	1620	4602	17278
		732	1374	3277	15383
270	10000	1113	1785	5928	18826
		786	1527	4510	16823
300	10000	1170	1950	7255	20375
		840	1680	5743	18263
330	15000	1227	2115	3582	21924
		894	1833	1976	19703
360	15000	1284	2280	4909	23473
		948	1986	3209	21143
390	15000	1341	2445	6235	25021
		1002	2139	4442	22583
420	20000	1398	2610	2562	26570
		1056	2292	675	24023
450	20000	1455	2775	3889	28110
		1110	2445	1908	25463
480	20000	1512	2940	5216	29668
		1164	2598	3141	26903

Note: Due to the stepped change in minimum playing field area requirement a greater total site area may be desirable above 400 on roll

**Table 19 Middle deemed secondary schools (9-13 years):
Recommended site and zone areas (m²)**

Number on roll	statutory minimum playing field area	hard surfaced games courts	informal and social area	habitat areas, buildings and access, playing field area above stat. minimum	total site area
120	5000	828	960	6067	12855
		516	762	4777	11055
150	5000	885	1125	7578	14588
		570	915	6190	12675
180	5000	942	1290	9088	16320
		624	1068	7603	14295
210	10000	999	1455	5599	18053
		678	1221	4016	15915
240	10000	1056	1620	7109	19785
		732	1374	5429	17535
270	10000	1113	1785	8620	21518
		786	1527	6842	19155
300	10000	1170	1950	10130	23250
		840	1680	8255	20775
330	15000	1227	2115	6641	24983
		894	1833	4668	22395
360	15000	1284	2280	8151	26715
		948	1986	6081	24015
390	15000	1341	2445	9662	28448
		1002	2139	7494	25635
420	20000	1398	2610	6172	30180
		1056	2292	3907	27255
450	20000	1455	2775	7683	31913
		1110	2445	5320	28875
480	20000	1512	2940	9193	33645
		1164	2598	6733	30495

**Table 20 Any secondary school (11-16 + years):
Recommended site and zone areas (m²)**

Number on roll	statutory minimum playing field area	hard surfaced games courts	informal and social area	habitat areas, buildings and access, playing field area above stat. minimum	total site area
450	25000	1455	3350	13195	43000
		1110	3060	10030	39200
495	25000	1541	3485	15675	45700
		1191	3186	12343	41720
540	30000	1626	3620	13154	48400
		1272	3312	9656	44240
585	30000	1712	3755	15634	51100
		1353	3438	11969	46760
630	35000	1797	3890	13113	53800
		1434	3564	9282	49280
675	35000	1883	4025	15593	56500
		1515	3690	11595	51800
720	35000	1968	4160	18072	59200
		1596	3816	13908	54320
765	40000	2054	4295	15552	61900
		1677	3942	11221	56840
810	40000	2139	4430	18031	64600
		1758	4068	13534	59360
855	40000	2225	4565	20511	67300
		1839	4194	15847	61880
900	40000	2310	4700	22990	70000
		1920	4320	18160	64400
945	45000	2396	4835	20470	72700
		2001	4446	15473	66920
990	45000	2481	4970	22949	75400
		2082	4572	17786	69440
1035	45000	2567	5105	25429	78100
		2163	4698	20099	71960
1080	50000	2652	5240	22908	80800
		2244	4824	17412	74480
1125	50000	2738	5375	25388	83500
		2325	4950	19725	77000
1170	50000	2823	5510	27867	86200
		2406	5076	22038	79520
1215	55000	2909	5645	25347	88900
		2487	5202	19351	82040
1260	55000	2994	5780	27826	91600
		2568	5328	21664	84560
1305	55000	3080	5915	30306	94300
		2649	5454	23977	87080
1350	55000	3165	6050	32785	97000
		2730	5580	26290	89600
1395	60000	3251	6185	30265	99700
		2811	5706	23603	92120

Continued on page 120

Table 20 Continued
Recommended site and zone areas (m²)

Number on roll	statutory minimum playing field area	hard surfaced games courts	informal and social area	habitat areas, buildings and access, playing field area above stat. minimum	total site area
1440	60000	3336	6320	32744	102400
		2892	5832	25916	94640
1485	60000	3422	6455	35224	105100
		2973	5958	28229	97160
1530	65000	3507	6590	32703	107800
		3054	6084	25542	99680
1575	65000	3593	6725	35183	110500
		3135	6210	27855	102200
1620	65000	3678	6860	37662	113200
		3216	6336	30168	104720
1665	70000	3764	6995	35142	115900
		3297	6462	27481	107240
1710	70000	3849	7130	37621	118600
		3378	6588	29794	109760
1755	70000	3935	7265	40101	121300
		3459	6714	32107	112280
1800	70000	4020	7400	42580	124000
		3540	6840	34420	114800

Table 21 Special schools: nursery, primary, secondary, and all-age schools

Recommended outdoor areas related to pupil numbers: all inclusive hard surfaced area for games and informal and social activities, and a separate soft area (grass and planting) for informal activities and habitat.

Age Range	Number of Pupils	Hard surfaced area in m ² (includes area for games courts and hard informal and social area to give flexibility to cover the range of need for hard paving in different types of special school)	Soft area in m ² (grass and planting for informal activities and habitats)	Total area in m ²	Notes
Primary 5 - 11 years	Less than 100	600	350	950	Where there are pupils able to participate in team games there should also be access to playing fields, either within the school site or nearby. See paragraphs 5.7 and 8.57.
	100 or more	900	450	1350	
Secondary 11 - 16+ years	Less than 50	900	450	1350	In all cases there should be at least a netball-sized hard surfaced court on site. Appropriate provision will otherwise vary according to the special needs concerned. See paragraphs 5.7, 6.6 and 8.57.
	50 to 120	1100	600	1700	
	Over 120	1800	900	2700	
All ages 5 - 16+ years	Interpolate from the above according to primary and secondary numbers				It is usually advisable to provide separate games and informal and social areas for primary and secondary-aged pupils. See paragraph 6.6.
Nursery	Total area = Full time equivalent number of pupils x 9m ² Amount of hard surfaced area variable according to particular SEN but likely to be about 2/3rds of total area.				Nursery garden should open directly off the nursery and be separate from outdoor areas for older pupils.

G. Looking to the Future - Capital Costs

Developing the grounds is a form of investment (see Section 10 and following). It requires a long term view, not only of the potential benefits, but also of continuing costs of changing needs and circumstances.

Any financial analysis should include the capital costs of supply and installation, as well as the on-going costs of maintenance and replacement.

Change can be gradual and it is often better and easier to phase the work over a number of years, especially if there is a clear holistic vision, constantly being updated in line with changing formal and informal curriculum demands.

Trees and woodlands take time to become established. It therefore makes sense to make tree and woodland planting a priority so that they are maturing while other initiatives are taking shape. Even tree planting itself may need to be phased over a number of seasons, starting with the most prominent or important locations.

In the case of new school sites, advanced planting of some areas will hasten establishment. If the site is already the freehold property of the provider and the money can be found, trees can be planted five or even ten years before building takes place.

For a school grounds capital project to go ahead, its objectives have to be established, otherwise it will not be possible to cost proposals in detail. During the early stages of the project it is possible to begin to find out about costs in more general terms to enable prioritising to take place effectively. An indication of some common costs is shown in Table 22.

Table 22 Costs of some common items.

Source: A guide to fundraising for school grounds (LTL 1995)

These rough guide prices are exclusive of delivery, labour costs for planting or installation and ongoing maintenance. There may be regional variations, allowance should be made for availability and inflation from 1995.

Bark mulch (to be spread for weed control to a thickness of 100mm)	£15-18 per cubic metre
Chestnut paling fence	£3 per metre
Cycle sheds (simple, 10 free standing cycles)	from £400
Flagpole (eg 6 m)	from £400
Football goal posts (tubular steel)	from £320
Goal nets	from £65
Hockey goal posts (steel frames)	from £250
Paving slabs (pre-cast concrete)	£1.50 each
Pergola (depends on size)	from £1,500
Pond (depends on size)	from £200
Seats and benches	from £75 each
Shrubs and climbing plants - pot grown	from £2 each
Top soil	£6 - 8 per cubic metre
Trees (depending on size of tree and number ordered)	
Transplants	from 50p each
Whips	from £1 each
Wattle fencing panels (1.8x1.2m)	£40 each
Wild flowers	from 75p each
Wild flower meadow seed (likely sowing rate of 4g per square metre)	£5 - 10 per 100g

H. Legislation and Guidance

(Reference to the health and safety considerations 1.12)

The Department's role is to promote good health and safety practice in schools. The main requirements under Common Law Statute are set out below.

Common Law

There are long established and important Common Law requirements for those acting 'in loco parentis' to exercise the same care as would a reasonably prudent parent.

Statute

Health and Safety at Work etc Act 1974

Under the Act, employers are legally required to do all that is reasonably practicable to ensure the health, safety and welfare at work of employees, and the health and safety of non-employees such as pupils and visitors affected by their duties. Employers vary according to the type of schools: in county schools the employer is the LEA, in GM and voluntary aided schools the governing body is the employer, in city technology colleges it is the proprietor, and in independent schools it is the employing trust governing body or proprietor. This Act also places duties on those in control of the premises to take reasonable measures to ensure that they are safe.

Management of Health and Safety at Work Regulations 1992

These regulations require that employers introduce arrangements for planning, organising, controlling, monitoring and reviewing their management of health and safety measures. Employers need to identify hazards, assess risks, assign priority to risks and decide whether they are properly controlled or if action is needed. If there are five or more employees, the significant findings of these assessments must be recorded. Employees must be provided with information on these measures and effective health and safety training.

Construction (Design and Management) Regulations 1994

These regulations place duties on clients, designers and contractors of construction projects. They apply to all demolition and most construction works in schools ('construction' includes redecoration, roof work, rewiring etc). They apply to construction work of more than 30 days duration, or involving more than four people on site or lasting more than 500 person-days.

Control of Substances Hazardous to Health (COSHH) Regulations 1994

These regulations place a duty on employers to make an assessment of risks for work involving exposure to substances hazardous to health. Steps must be taken to prevent or control adequately the exposure of employers and others to these substances.

First Aid

Although pupils are not covered by the Health and Safety (First Aid) Regulations 1981, which relate to employees, those acting 'in loco parentis' have a duty of care. Pupils' first aid needs should be governed by the school's health and safety policy, which should ensure that the school has an appropriate number of qualified first aiders amongst the staff.

It is recommended that schools maintain an independent record of all incidents and accidents, however minor, in accordance with their authorities' instructions or, in the case of GM and independent schools, along similar lines to the Social Services record of accidents to employees (Form B1 510). Information from the accident book provides a valuable source of data to be considered in the assessment of risks in accordance with the Management of Health and Safety at Work Regulations.

The Environmental Protection Act 1990

The Act requires governing bodies to keep land under their control free, as far as possible, from litter, dog excrement and refuse. The standard of cleanliness is set out in the code of practice, copies of which were issued to the Chairmen of all school governing bodies in March 1991. It is important that the above legal requirements are clearly borne in mind when considering health and safety aspects of the design, use and management of playgrounds either as separate issues or in relation to the formulation of the school's health and safety policy.

Food and Environment Protection Act 1985

This was introduced to limit the variety of pesticides used so that only approved substances could be used for specified purposes and applied in specified ways. Pesticides users are now obliged to safeguard the environment, including all living animals, plants and water courses. Individuals who apply pesticides can be certified as competent and trained in this area of work.

Occupier's Liability Acts

The Acts define the duties of care owed by occupiers towards those who come onto their premises. The 1957 Act places a duty on the occupier to take reasonable care to make sure that any visitor will be safe on the premises for the purposes for which they have been invited or permitted by the occupier to be there. The 1984 Act extends the duty of care to trespassers (and anyone entering the premises without permission but with lawful authority) to make sure that they are not injured by some potential danger known to the occupier. In certain cases these duties can be met by giving warning of the dangers concerned. Schools should therefore take account of pupils and other children who might be using the school grounds as an unofficial play area after school hours or during weekends and holidays.

Reporting of Injuries, Diseases and Dangerous Occurrences Regulations 1995

These regulations came into effect on 1 April 1996. In addition to reporting fatal and major injuries on the premises, injuries arising out of or in connection with work requiring hospital treatment and any injury to employees caused by violence at work must now be reported.

Safety Signs (Signs and Signals) Regulations 1996

The above regulations, which came into force on 1 April 1996, require employers to display an appropriate safety sign and instruction wherever a significant risk to harm cannot be avoided or reduced by other means. Safety signs may be required to mark traffic routes.

British Standards

The British Standards Institution is the independent body responsible for preparing British Standards. Although compliance with a British Standard does not of itself confer immunity from legal obligations, some grounds maintenance documents now refer to these standards which represent good practice and may be referred to in a court case following an incident. Compliance with the relevant standards can be taken as evidence of the school's responsible approach to safety.

With respect to school grounds, the following are relevant:

BS 5696. Play equipment intended for permanent installation outdoors;

BS 7188. Methods of test for impact absorbing playground surfaces;

BS 7370. Grounds maintenance - managing, design related to maintenance, hard surfaces (not sports), turf (not sports) and soft landscape.

BEST COPY AVAILABLE

A Health and Safety Check List for Governors and Teachers

At a more detailed level, careful regard should be taken of:

- organisation of the use of grounds generally, and play recreation areas in particular;
- suitability, safety and maintenance of grounds, equipment and buildings;
- security of the site;
- routes for delivery vehicles (especially whilst construction work is taking place);
- dangerous obstacles.

In considering the level of supervision the following should be considered:

- age and physical and mental ability of the pupils;
- number of pupils using the area at any given time;
- type of activities;
- the need to avoid excessive exposure to ultra violet radiation.

All the points mentioned have a direct impact on health and safety in school. To achieve health and safety management, employers and staff should work together to produce a sound health and safety policy.

Additional information

The following includes DfEE publications and other relevant guidance:

Guide to the Reporting of Injuries, Diseases, and Dangerous Occurrences, Regulations 1995, ISBN 0 71 761012 8 available from HSE Books price £6.95.

The Management of Health and Safety at Work Regulations 1992 Statutory Instrument 1992 No 2051, ISBN 0 11 025051 6 obtainable from The Stationery Office price £2.30.

Managing Health and Safety in Schools ISBN 0 71 760770 4, HSE Books price £5.95.

5 Steps to Risk Assessment Leaflet IND(G)163L free from HSE Books.

Management of Health and Safety at Work Approved Code of Practice ISBN 0 71 760412 8, HSE Books price £5.00.

The Responsibilities of School Governors for Health and Safety ISBN 0 71 760436 5, HSE Books price £3.50. A revised edition was published in 1996 by HSE Books.

First Aid at Work: The Health and Safety (first aid) Regulations 1981: Approved Code of Practice and Guidance ISBN 0 71 761050 0, HSE Books 1997 price £6.75.

1996 edition of the British Association of Advisers and Lecturers in Physical Education guidance: **Safe Practice in Physical Education** ISBN 1 87 28093 price £20.00 plus £5.50 P&P. Available from Saltwells Education Development Centre, Bowling Green Road, Netherton, Dudley DY2 9LY.

Playgrounds Safety Guidelines. Available free of charge from the Department of National Heritage, 24 Cockspur Street, London SW1 5DH.

Schools: A List of HSE and Other Relevant Publications and Films - from HSE Information Centre, Broad Lane, Sheffield S3 7HQ. Free booklet containing details of publications from Government and other sources, in addition to the HSE area office addresses.

DfEE series **School Governors: A guide to the Law**. Separate editions are available for county, controlled and special agreement schools, aided schools, self-governing (grant-maintained) schools and special schools. Copies may be obtained free from Department for Education and Employment Publications, PO Box 5000, Sudbury, Suffolk, CO10 6YJ.

Guide to Playground Safety. Free leaflet SE 271 and list of information sheets on children's playgrounds are available from RoSPA, 3 Earning Street, Godmanchester, Cambridge PE18 8JD.

Contractors in schools, Leaflet IAC (L) 98, free from HSE Books.

Signpost to the Health and Safety (Safety Signs and Signals) Regulations 1996 Leaflet IN(G)184L free from HSE Books.

Guidance to help schools develop policies for protecting pupils from excessive exposure to the sun is available from Sun Know How Campaign, Health Education Authority, Hamilton House, Mabledon Place, London WC1H 9TX.

HSE publications can be ordered direct from: HSE Books, PO Box 1999, Sudbury, Suffolk CO10 6FS or any bookseller.

HMSO publications are available from 49 High Holborn, London WC1V 6HB

For full details see inside back cover.

Note: HMSO is now The Stationery Office (TSO)

J. Sources of Information

Organisation	Address	Role/Function
British Trust for Conservation Volunteers	36 St Mary's Street, Wallingford, Oxfordshire OX10 0EU (01491 839766)	national network helping to promote participation in practical conservation
Centre for Alternative Technology Canolfan y Dechnoleg Amgen	Machynlleth, Powys SY20 9AZ (01654 702400)	information on energy conservation and technology
Centre for Environmental Interpretation	Manchester Metropolitan University, St Augustine's, Lower Chatham Street, Manchester M15 6BY (0161 247 1067)	promotion of environmental interpretation in both rural and urban areas
Common Ground	Seven Dials Warehouse, 44 Earlham Street, London WC2H 9LA (0171 379 3109)	concerned with conservation and enhancement of local landscape character
Community Service Volunteers	237 Pentonville Road, London N1 9NJ (0171 278 6601)	co-ordinates community involvement schemes for all ages, from youngsters to retired people
Conservation Foundation	1 Kensington Gore, London SW7 2AR (0171 591 3111)	provides a link between conservation, business and industry and organises awards
Council for Environmental Education	University of Reading, London Road, Reading RG1 5AQ (01734 756061)	provides a forum for the exchange of ideas and information
Countryside Commission	John Dower House, Crescent Place, Cheltenham, Gloucestershire GL50 3RA (01242 521381)	advice and grants covering many aspects of countryside and landscape conservation
English Nature	Northminster House, Northminster Road, Peterborough, Cambridgeshire PE1 1UA (01733 455000)	advises government on nature conservation
Environment Council	21 Elizabeth Street, London SW1W 9RP (0171 824 8411)	a forum and information centre for environmental issues
Forestry Commission	231 Corstorphine Road, Edinburgh EH12 7AT (0131 334 0303)	publications on trees and forests and gives grants for larger areas of woodland
Friends of the Earth	26-28 Underwood Street, London N1 7JQ (0171 490 1555)	environmental campaigning organisation with range of publications
Groundwork Foundation	85-87 Cornwall Street, Birmingham B3 3BY (0121 236 8565)	some local trusts work with schools

Institute of Groundsmanship	19-23 Church Street, The Agora, Wolverton, Milton Keynes MK12 5LG (01908 312511)	professional organisation for groundsmen and greenkeepers
Institute of Leisure & Amenity Management	ILAM House, Lower Basildon, Reading RG8 9NE (01491 874222)	professional organisation for landscape managers
Landlife	The Old Police Station, Lark Lane, Liverpool L17 8UU (0151 728 7011)	wildlife charity producing both publications and wild flower seeds
Landscape Institute	6-7 Barnard Mews, London SW11 1QU (0171 738 9166)	professional body for landscape designers, managers and scientists
Learning through Landscapes (LTL)	3rd Floor, Southside Offices, The Law Courts, Winchester, Hampshire SO23 9DL (01962 846258)	national organisation dealing with all aspects of use, design and management of school grounds, including advice and membership
National Association for Environmental Education (UK)	c/o University of Wolverhampton, Walsall Campus, Gorway Road, Walsall, West Midlands WS1 3BD (01922 31200)	association of teachers and others concerned with education and the environment
National Council for Voluntary Organisations	Regents Wharf, 8 All Saints Street, London N1 9RL (0171 713 6161)	major source of information on voluntary organisations and environmental groups
National Federation of City Farms	The Greenhouse, Hereford Street, Bedminster, Bristol BS3 4NA (0117 9231800)	development organisation for gardening and caring for farm animals on urban community sites
National Play Information Centre	199 Knightsbridge, London SW7 1DE (0171 584 6464)	provides information on children's play
National Playing Fields Association	25 Ovington Square, London SW3 1LQ (0171 584 6445)	concerned with all matters related to play, sport and recreation environment
National Society for Clean Air	136 North Street, Brighton BN1 1RG (01273 326313)	information sheets on reducing noise, air and other pollutants
Royal Institute of British Architects	66 Portland Place, London W1N 4AD (0171 580 5533)	independent non-profit making practices for design of community projects; architects' workshops

Royal Society for Nature Conservation	The Green, Witham Park, Waterside South, Lincoln LN5 7JR (01522 544400)	partnership organisation that has addresses of all county wildlife and nature conservation trusts
Royal Society for the Prevention of Cruelty to Animals (Education Department)	The Causeway, Horsham, West Sussex RH12 1HG (01403 264181)	raising awareness of animal welfare in schools
Royal Society for the Protection of Birds	The Lodge, Sandy, Bedfordshire SG19 2DL (01767 680551)	education department with information, videos and publications
Shell Better Britain Campaign	Victoria Works, 21A Graham Street, Hockley, Birmingham B1 3JR (0121 212 9221)	supports practical action by voluntary groups and advises on sources of funds and advice
Sports Council	16 Upper Woburn Place, London WC1H 0QP (0171 273 1500)	gives advice on all aspects of sport and recreation, and grant aids facilities
Sports Turf Research Institute	St Ive's Research Station, Bingley, West Yorkshire BD16 1AU (01274 565131)	advice and information on all aspects of sports turf
Tidy Britain Group	The Pier, Wigan, WN3 4EX (01942 824620)	agency for litter abatement and environmental protection with education section giving advice and information
Tree Council	51 Catherine Place, London SW1E 6DY (0171 828 9928)	advises on planting and aftercare and organises National Tree Week
Urban Wildlife Trust	Unit 310, Jubilee Trade Centre, 130 Pershore Street, Birmingham B5 6ND (0121 666 7474)	ideas and strategies to give nature a place in the urban environment
Wildlife Watch	The Green, Witham Park, Waterside South, Lincoln LN5 7JR (01522 544400)	a club for young people who care for wildlife and the environment
Wild Fowl and Wetlands Trust	Slimbridge, Gloucester GL2 7BT (01453 890333)	range of information from education officer that is useful for school sites
World Wide Fund for Nature UK (WWF)	Panda House, Wayside Park, Godalming, Surrey GU7 1XR (01483 426444)	international nature conservation organisation with education section
Young Ornithologists Club (YOC)	YOC Project Officer, The Lodge, Sandy, Bedfordshire SG19 2DL (01767 680551)	encourages children to take an interest in birds and conservation

K. Publications

Publications relating to each section are listed for guidance.

Section 2

Council for Environmental Education **Rescue Mission Planet Earth** (a children's edition of Agenda 21) 1994. ISBN 1 85 697175 9

Department of Education and Science **Building Bulletin 71: The Outdoor Classroom** HMSO 1991. ISBN 0 11 270730 0

Learning through Landscapes **Challenge of the Urban School Site** 1996. ISBN 1 87 286516 X

Learning through Landscapes/English Nature **School Grounds Resource Directory** 1994. ISBN 1 87 286515 1

The National Curriculum HMSO 1995. ISBN 0 11 270894 3

World Wildlife Fund **Working in Neighbourhoods** 1995. ISBN 1 85 850084 2

World Wildlife Fund/Learning through Landscapes **Special Places; Special People: the Hidden Curriculum of School Grounds** 1994. ISBN 0 94 761348 X

Section 3

Learning through Landscapes **School Grounds Toolkit** 1997

Section 4

British Geological Survey **Catalogue of Printed Maps** published annually. Tel: 0171 589 4090

Common Ground **Holding your Ground: An Action Guide to Local Conservation** 1988. ISBN 0 70 453091 0

Department for Education **Building Bulletin 77: Designing for Pupils with Special Educational Needs: Special Schools** HMSO 1992. ISBN 0 11 270796 3

Department for Education and Employment **Building Bulletin 83: Schools' Environmental Assessment Method (SEAM)** HMSO 1996. ISBN 0 11 270920 6

Learning through Landscapes **Esso School Watch** 1992. ISBN 1 87 286522 4

Learning through Landscapes **Grounds for Sharing: A Guide to Developing Special School Sites** 1996. ISBN 1 87 286523 2

Meteorological Office **Met Office Information File**. Tel: 0171 242 3663

National Association for Environmental Education **Environment Audit - Towards a School Policy for Environmental Education** 1992. ISBN 0 90 790827 1

Ordnance Survey Maps, Atlases, Guides, Special Products and Services. Tel: 01703 792 763

Tidy Britain Group **Inside Out** 1988. ISBN 0 95 167399 8

Section 5

Learning through Landscapes **A Guide to Fund Raising for School Grounds** 1995. ISBN 1 87 286525 9

Learning through Landscapes **Beekeeping - A Practical Guide**. ISBN 1 87 2865038

Learning through Landscapes **Butterflies - A Practical Guide to their Study in School Grounds** 1989. ISBN 1 87 286500 3

Learning through Landscapes **Ecology in School Grounds** 1990. ISBN 1 87 286502 X

Learning through Landscapes Exploring Woodlands 1991. ISBN 0 08 040451 0

Learning through Landscapes Recycling - A Practical Guide for the School Environment 1992. ISBN 1 87 286506 2

Learning through Landscapes Slugs, Snails and Earthworms ISBN 1 87 286508 9

Learning through Landscapes School Grounds and Buildings: Understanding the Built Environment. ISBN 1 87 286513 5

Learning through Landscapes The Seasons in the School Grounds 1991. ISBN 1 87 286508 9

Learning through Landscapes/English Nature School Grounds Resource Directory 1994. ISBN 1 87 286515 1

Learning through Landscapes/Scholastic Arts in the School Grounds 1996. ISBN 1 85 741036 X

Learning through Landscapes/Scholastic Bright Ideas - The Outdoor Classroom 1990. ISBN 0 59 053034 8

Learning through Landscapes/Southgate English in the School Grounds 1992. ISBN 1 85 741031 9

Learning through Landscapes/Southgate Geography in the School Grounds 1996. ISBN 1 85 741023 8

Learning through Landscapes/Southgate Mathematics in the School Grounds 1993. ISBN 1 85 741021 1

Learning through Landscapes/Southgate Science in the School Grounds 1992. ISBN 1 87 286505 4

Learning through Landscapes/Southgate Trees in the School Grounds 1992. ISBN 1 85 741095 5

Royal Society for Nature Conservation/The Wildlife Trusts Partnership Watchword published three times a year by Watch

Royal Society for the Protection of Birds/Learning through Landscapes Wildlife and the School Environment 1992. ISBN 0 90 313851 4

Section 6

British Trust for Conservation Volunteers Footpaths ISBN 0 45 01699

Learning through Landscapes Grounds for Sharing: A Guide to Developing Special School Grounds 1996. ISBN 1 87 286523 2

Learning through Landscapes Play, Playtime and Playgrounds 1992. ISBN 1 87 286510 0

National Play Information Centre Children's Outdoor Play in the Built Environment. ISBN 1 87 175800 9

National Play Information Centre Playground Safety Guidelines 1992. ISBN 0 85 52240 5

NFER - Nelson Playtime in Primary School. ISBN 0 70 051238 110

The Urban Wildlife Trust I Know Someone Who's Afraid of Sunflowers. Tel: 0121 666 7474

Section 7

World Wildlife Fund/Learning through Landscapes Special Places: Special People 1994. ISBN 0 94 761348 X

Section 8

British Trust for Conservation Volunteers Practical Conservation Pack: Conservation in School Grounds 1986. ISBN 0 13 028595 222

British Trust for Conservation Volunteers Hedging 1975. ISBN 0 94 675202 8

British Trust for Conservation Volunteers Woodlands. ISBN 0 95 016437 2

British Trust for Ornithology Nestboxes Guide. ISBN 0 09 379329 6

Common Ground Orchards - a Guide to Local Conservation. ISBN 1 87 036408 2

Fauna and Flora Preservation Society Bat Boxes 1985. ISBN 0 94 790200 7

Football Association Mini Soccer 1991. Handbook. Tel: 0171 402 7151

Football Association/Sports Council Artificial Grass Surfaces for Association Football 1995. ISBN 0 90 09719

Heinemann Educational Books Mini sport - A Handbook for Teachers and Parents 1981. ISBN 0 43 586591 9

Johnsons Seeds, Boston, Lincs Wild Flower Manual 1991. Tel: 01205 365051

Learning through Landscapes Pond Design for Schools. ISBN 1 87 065122 7

Learning through Landscapes/Southgate People, Plants and Places 1995. ISBN 1 85 741017 3

London Ecology Unit A Guide to Habitat Creation 1991. ISBN 0 31 418534 1

Malcolm Emery Croom Helm Promoting Nature in Cities and Towns 1986. ISBN 0 70 990966 7

National Playing Fields Association Facilities for Athletics 1980. ISBN 0 90 085895 8

National Playing Fields Association Gradients for Sports Facilities 1993. (Republished as TAN 23 1996)

National Playing Fields Association Hard Surfaces for Games and Play Areas 1989. ISBN 0 94 608521 8

National Playing Fields Association Kick About Areas 1985. ISBN 0 94 608505 6

Ralph Cobham Spon Amenity Landscape Management 1990. ISBN 0 41 911570 6

Royal Society for Nature Conservation/The Wildlife Trusts Partnership Green it Yourself 1990

Royal Society for Nature Conservation/the Prevention of Cruelty to Animals, Education Department Small Mammals in Schools 1989

Royal Society for Nature Conservation/the Protection of Birds Feeder Handbook

School Garden Company Starting a Butterfly Garden 1987. Tel: 01775 769518

School Garden Company Starting a Wildlife Pond 1989

Sports Council Artificial Turf Pitches for Hockey 1990

Sports Council Trim Trails 1978

Sports Council/Butterworth Handbook of Sport and Recreational Building Design: Vol 1 Outdoor Sports (Second Edition) 1993. ISBN 0 75 061293 2

Sports Turf Research Institute Sands for Sports Turf Construction and Maintenance 1990

The Environment Centre Sharing Nature with Children 1989. ISBN 0 91 612414 2

The Tidy Britain Group Beating Litter 1989. ISBN 0 19 428246 20

Wastewatch Community Recycling 1995. Tel: 0171 248 1818

Wildfowl and Wetlands Trust Pondwatch Pack. Tel: 01453 890333

Section 9

British Trust for Conservation Volunteers Trees and Aftercare 1992. ISBN 0 94 675207 9

Learning through Landscapes Guide to the Management and Maintenance of School Grounds 1996.
ISBN 1 87 286512 7

National Playing Fields Association Sports Ground Maintenance - An Elementary Guide 1989.
ISBN 0 94 608507 2

Section 10

Charities Aid Foundation Directory of Grant-Making Trusts Published biennially. ISBN 1 85 93402
Tel: 01732 520 000

David Brown Goldmine - Resources for Teachers Published biennially. ISBN 1 85 742137 4
Tel: 01252 317 707

*Department for Education and Employment Our School - Your School, Community use
of schools* 1995. ISBN 0 85522 473 8

Learning through Landscapes/Southgate Guide to Fundraising for School Grounds 1995.
ISBN 1 87 286525 9

*Neighbourhood Initiatives Foundation/Joseph Rowntree Foundation Making it Happen - A User's Guide
to the Neighbourhood Action Packs* 1991. Tel: 01904 629241

Shell Better Britain Campaign Getting Help for Community Environmental Projects.
Tel: 0121 212 9221

Videos

Learning through Landscapes Grounds for Celebration. ISBN 1 87 286518 6

Learning through Landscapes Grounds for Examination. ISBN 1 87 286519 4

Learning through Landscapes Making the Best of Your School Grounds. ISBN 1 87 286521 6

*Learning through Landscapes/Hampshire County Council Maintaining and Managing
Your School Grounds* 1996. ISBN 1 85 975099 0

Royal Society for the Protection of Birds Gardening Strictly for the Birds

Royal Society for the Protection of Birds Wake up to Birds - Training for Primary Teachers

Sports Council Developing Community Use of Your School 1991

Computer Programs

Learning through Landscapes Thinking about Seating in Your School Grounds 1997.
ISBN 1 87 286526 7

BEST COPY AVAILABLE

L. Definition of Zones

The following terms for zones are used in this document:

1. Playing fields As described in DfEE Circular 10/96.
2. Hard surfaced games court(s) Paved area laid out for team games. It also includes extensions to such areas for small games and skills practice.
3. Informal and social areas Paved and soft areas, planted and seated as appropriate, for impromptu games, protected leisure and outdoor classroom areas.
4. Habitat areas Planted or specially developed areas for use in the formal and informal curriculum.
5. Buildings and access Areas for building, access to separate pedestrians and vehicles, car parking and service delivery areas.

Notes:

- a) 2 & 3 previously known as recreation areas.
- b) 3 includes nursery outdoor play space.

Access	
Access for disabled	66
Access and security	11, 65
Entrances and boundaries	65
Pedestrian access	66
Site supervision and safety	66
Vehicular access and parking	66
Ampitheatre - see English	
Archery	89
Area Guidelines Tables	114-121
Art	32
Artificial surfaces - see sports surfaces	
Asphalt surfaces - see sports surfaces	
Association football	90
Athletics	92
Basketball	93
Business and commerce supporting initiatives	76
Categories of grounds elements	
Areas of Zones - see Area Guidelines Tables	
Buildings and access	25
Habitat areas	25, 41-50
Hard surfaced games court(s)	25
Informal social areas	25
Playing fields	24, 50-59
Community sharing	15, 52
Capital costs - some common items	122
Nursery stock	43
Cost of Maintenance	
Contract arrangements	72
Soft landscape	71
Specification and bills	72
Supervision	73
Tendering	73
Courtyards	62
Cricket	94
Crops and animals	47
Animal keeping	48
Curriculum	
Formal	28-34
Informal	35-38
'Hidden'	39-40
Definitions of zones	134
Design & Technology	32
Disabled people - see access	
Drainage, pipe, 'slit', sand carpet	56
English	31
Environmental education	33
Examples of school sites and use-zones	81-85
Forming Partnerships	76
Fund raising	76
Furniture (site)	60
Games courts	30, 50, 88
Geography	30
Grants	76
Grass pitches - see pitches	
Hard porous - see sports surfaces	
Health and Safety considerations	11
Historic reconstruction and outdoor display	48
History	32
Hockey, mini-hockey, 7-a-side	96
Impact absorption surfaces - see safety	
Lacrosse	
Men	97
Women	98
Land forms and soils	22
Landscape - wear and tear	74
Layout of use-zones and exploring options	79-80
Laws and Regulations	
Education (School Premises)	112
Supervisory staff	38
Legal and planning issues	21
Legislation and guidance	11, 123-126
Litter	73
Macadam Surfaces - see sports surfaces	
Maintaining grounds	
Costs of maintaining soft landscape	71
Direct Service Organisations	68
Description of staff duties	111
Key issues	68
Maintenance issues	21
Management plans	70, 71
Schedule	106-110
Staff directly employed	68
Types of agreement	69

Managing grounds development		School and community sports facilities	52
Issues	17	Science	28
Management structure	17	Seating - see furniture	
Mathematics	31	Security - see access	
Microclimate	62	Shelter and energy	63
Multi-games areas	88, 89	Shade	63
Multi-use of grounds	25	Shelter belts	63
		Softball	102
Natural grass	55	Soft landscape and planting	61
Netball, 'First Step'	99	Sources of information	127-129
		Sports surfaces	
Outdoor classrooms - see social areas		Coated macadam and asphalt	59, 61
Outdoor play space - see play facilities		Hard Porous	58
		Polyurethane bonded rubber	58
Paths		Synthetic surface	57
Hard surface treatments	61	Upgrading surfaces	59
Paths in soft landscape	61	Standards relevant to school grounds, maintenance, play equipment and safety surfaces	
Pitches		BS 5696	60, 124
Grass pitch gradients	53	BS 7044	58
Layouts	55	BS 7188	124
Pitch orientation	52	Stoolball	103
Pitch sizes - see Reference Section B		Supervision and Safety	11, 38, 66
Reinforcement materials	57	Surveying existing sites	20-24
Physical education	29		
Planning for change	75-77	Tennis	103
Planning guidance, Department of the Environment	21	Padder tennis	105
Planting and creating habitats	41	Short tennis	104
Planting beds (raised)	49	Trees	
Play facilities - design issues	36, 37, 59	Hedgebanks	44
Playground marking	60	Orchards and nuttries	47
Playing field minimum areas	112	Surveys	23
Pollution (Air & Noise)	64, 65	Trees supporting insects	42
Ponds		Trees, woodland & hedgerows	44
Location, design and safety	46	Where to plant trees	42
Pupils with Special Needs	26, 30, 35, 59	Trespass	74
		Trim Trail	52
Rebound walls	61	Turf - see pitches	
Regulations - see Laws and Regulations		Vandalism	73
Relationships between indoors and outdoors	62	Volleyball and mini-volleyball	105
Restricted sites	26, 86, 87	Weather-protection and wind - see microclimate	
Rounders	100	Wild flower meadows and heathlands	44
Rugby League	101	Woodlands - see trees	
Rugby Union	102		
Safety		Zones	24-26
Impact absorbing surfaces	60		
Safety issues	60		

The Stationery
Office

Published by The Stationery Office
and available from:

The Publications Centre
(Mail, telephone and fax orders only)

PO Box 276, London SW8 5DT

General enquiries 0171 873 0011

Telephone orders 0171 873 9090

Fax orders 0171 873 8200

The Stationery Office Bookshops

49 High Holborn, London WC1V 6HB

(counter service and fax orders only)

Fax 0171 831 1326

68-69 Bull Street, Birmingham B4 6AD

0121 236 9696 Fax 0121 236 9699

33 Wine Street, Bristol BS1 2BQ

01179 264306 Fax 01179 294515

9-21 Princess Street, Manchester M60 8AS

0161 834 7201 Fax 0161 833 0634

16 Arthur Street, Belfast BT1 4GD

0123 223 8451 Fax 0123 223 5401

The Stationery Office Oriel Bookshop

The Friary, Cardiff CF1 4AA

01222 395548 Fax 01222 384347

71 Lothian Road, Edinburgh EH3 9AZ

(counter service only)

In addition customers in Scotland may mail,
telephone or fax their orders to:

Scottish Publication Sales,

South Gyle Crescent, Edinburgh EH12 9EB

0131 479 3141 Fax 0131 479 3142

Accredited Agents

(see Yellow Pages)

and through good booksellers

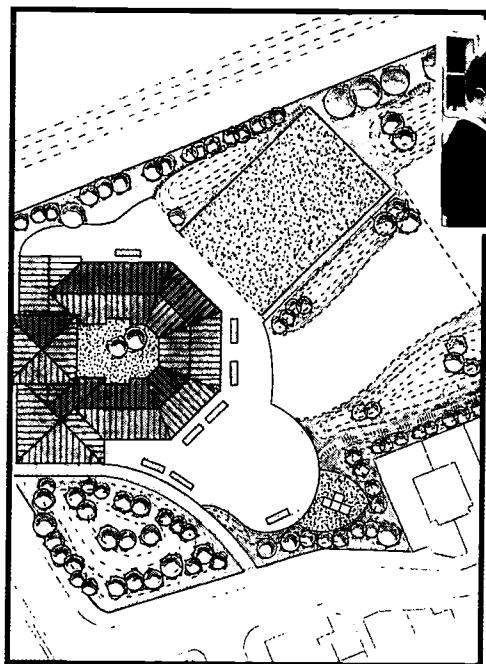

The purpose of this guide is to help schools of all kinds to benefit more effectively from their outdoor facilities. Major decisions about the care of the grounds now rest increasingly with the individual school and those wishing to improve their grounds may not have sustained access to professional advisers. The guide is principally intended for headteachers and governors, those with a responsibility for school grounds, whether in schools or in local authorities and those with a professional interest in their design and management.

Starting with some important principles and an analysis of the benefits of using and developing school grounds, the guide goes on to outline the processes necessary for the successful management of the development of existing school grounds as advocated by Learning through Landscapes. It offers a rationale for the widest possible educational use of grounds and it contains technical and reference sections to help those involved.

£19.95





U.S. Department of Education
Office of Educational Research and Improvement (OERI)
National Library of Education (NLE)
Educational Resources Information Center (ERIC)



NOTICE

REPRODUCTION BASIS



This document is covered by a signed "Reproduction Release (Blanket) form (on file within the ERIC system), encompassing all or classes of documents from its source organization and, therefore, does not require a "Specific Document" Release form.



This document is Federally-funded, or carries its own permission to reproduce, or is otherwise in the public domain and, therefore, may be reproduced by ERIC without a signed Reproduction Release form (either "Specific Document" or "Blanket").