

DOCUMENT RESUME

ED 430 382

EF 005 399

AUTHOR Poulton, Prue; Symons, Gillian
TITLE Eco School.
INSTITUTION World Wide Fund for Nature - UK, Surrey (England).
PUB DATE 1999-00-00
NOTE 73p.
AVAILABLE FROM Green Brick Road, 429 Danforth Ave., Ste. #408, Toronto, Ontario, Canada M4K 1P1; Tel: 800-473-3638 (Toll Free).
PUB TYPE Guides - Classroom - Teacher (052)
EDRS PRICE MF01/PC03 Plus Postage.
DESCRIPTORS Class Activities; *Educational Facilities Design; *Educational Facilities Improvement; Elementary Secondary Education; Energy Conservation; Foreign Countries; Public Schools; *Student Participation; Student Research
IDENTIFIERS United Kingdom

ABSTRACT

The Eco School information pack contains 10 sections outlining specific school areas that can be assessed by students for meeting the needs of all its users, the extent to which these areas use and abuse environmental resources, and the aesthetic contribution they make to the locality. Using this initial research, the document helps students design a school which is user-friendly, conservation conscious, and aesthetically pleasing. Student classroom activities used for each section's analysis are described, such as group brainstorming sessions; surveys, questionnaires, and interviews; and tips for model making and area planning and designing. Each section addresses specific aims and issues and contains comprehensive teachers' notes and activities for students. Additional resources are also listed in each section. Specific sections examine the following areas: overall school design; the school's entrance, grounds, classrooms, performing arts areas, indoor sports facilities, library, and dining room; waste and recycling; and energy conservation and lift design. Additionally covered are issues common to all school areas, such as access for people with disabilities and energy conservation. (GR)

* Reproductions supplied by EDRS are the best that can be made *
* from the original document. *

ED 430 382

ECO SCHOOL

PRUE POULTON & GILLIAN SYMONS

U.S. DEPARTMENT OF EDUCATION
Office of Educational Research and Improvement
EDUCATIONAL RESOURCES INFORMATION
CENTER (ERIC)

This document has been reproduced as received from the person or organization originating it.

Minor changes have been made to improve reproduction quality.

• Points of view or opinions stated in this document do not necessarily represent official OERI position or policy.

PERMISSION TO REPRODUCE AND DISSEMINATE THIS MATERIAL HAS BEEN GRANTED BY

Angela Royal _____

TO THE EDUCATIONAL RESOURCES INFORMATION CENTER (ERIC)

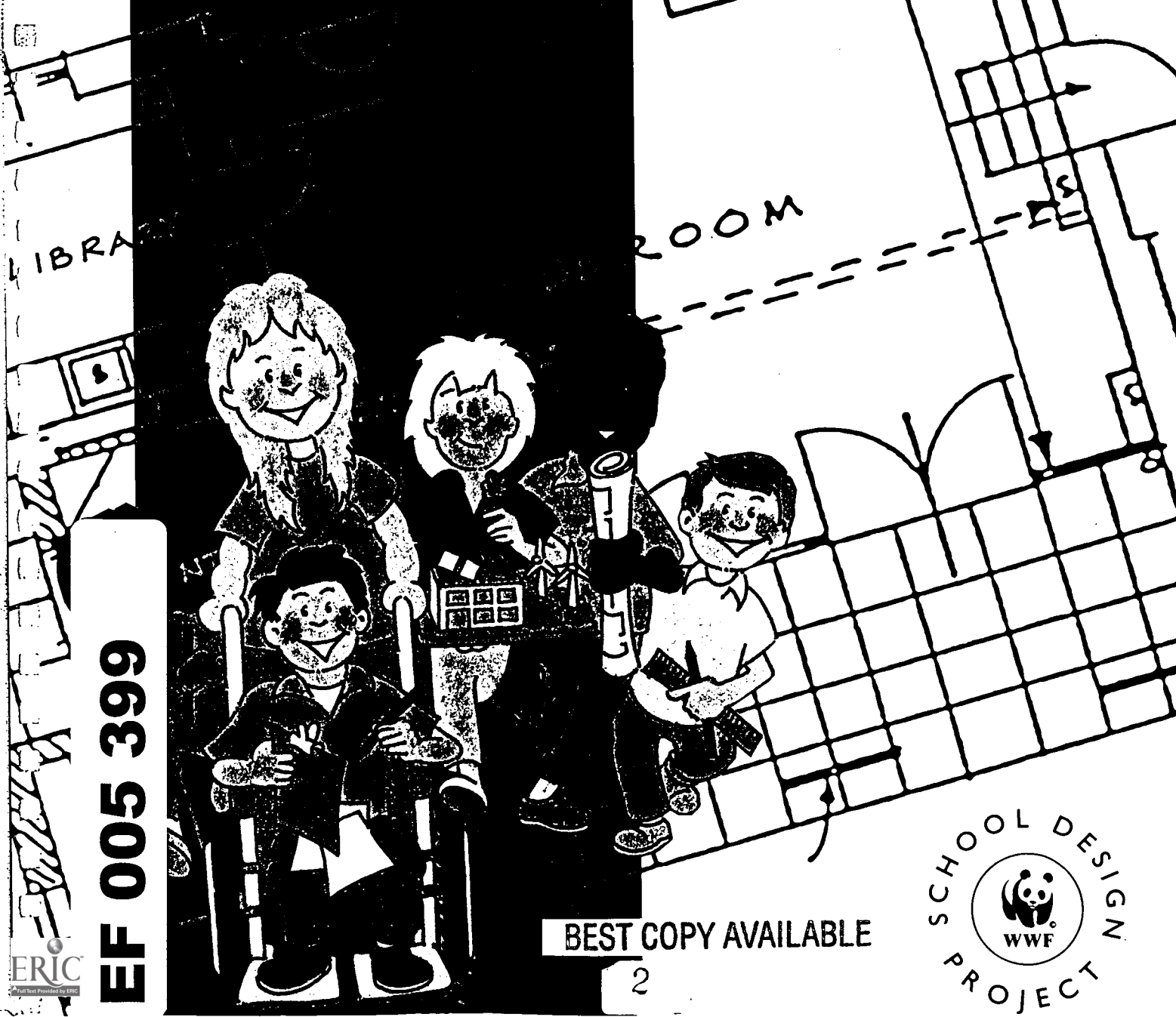

EF 005 399

BEST COPY AVAILABLE



ERIC
Full Text Provided by ERIC

E C O S C H O O L

PRUE POULTON &
GILLIAN SYMONS

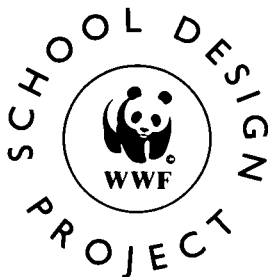



© World Wide Fund for Nature (WWF) UK

The pages in this book may be photocopied for use within the purchasing school only. All rights reserved.

Thanks to:

Stephen Endelman of Wind and Water Productions from whose opera, 'A Safe Place', came the inspiration for this work.

The students and teachers in Hackney schools with whom the ideas in the pack were trialled and whose co-operation contributed so much to the project.

Michael Hoeschen, freelance designer, who worked with us in schools on the model making and who took the model photographs featured throughout this book.

Geraldine Cater from Stoke Newington School who devised the 'Looking at Buildings' worksheet.

E C O S C H O O L

CONTENTS

INTRODUCTION

USING THE PACK	1
ATTAINMENT TARGETS	2

ACTIVITIES COMMON TO ALL SECTIONS

GROUP SHARING OF IDEAS	3
SURVEYS, QUESTIONNAIRES AND INTERVIEWS	3
SOURCES OF INFORMATION	4
MODEL MAKING	4
PLANS/SCALE DRAWINGS/ELEVATION DRAWINGS	5
EVALUATION	5
RESOURCES – GENERAL	6

ISSUES COMMON TO ALL SECTIONS

ACCESS FOR PEOPLE WITH DISABILITIES	7
RESOURCES – DISABILITY	7
ENERGY CONSERVATION	8
RESOURCES – ENERGY	9

ECOLOGY IN THE SCHOOL

ECOLOGY IN THE SCHOOL / RESOURCES	10
---	----

THE SECTIONS

1 OVERALL DESIGN		6 PERFORMING ARTS	
TEACHERS' NOTES	11	TEACHERS' NOTES	43
STUDENT ACTIVITIES	13	STUDENT ACTIVITIES	45
2 ENTRANCE		7 INDOOR SPORTS FACILITIES	
TEACHERS' NOTES	17	TEACHERS' NOTES	49
STUDENT ACTIVITIES	19	STUDENT ACTIVITIES	51
3 SCHOOL GROUNDS		8 SCHOOL LIBRARY	
TEACHERS' NOTES	23	TEACHERS' NOTES	53
STUDENT ACTIVITIES	26	STUDENT ACTIVITIES	55
4 CLASSROOM		9 ENERGY CONSERVATION AND LIFT DESIGN	
TEACHERS' NOTES	29	TEACHERS' NOTES	57
STUDENT ACTIVITIES	32	STUDENT ACTIVITIES	59
5 WASTE AND RECYCLING		10 DINING ROOM	
TEACHERS' NOTES	37	TEACHERS' NOTES	63
STUDENT ACTIVITIES	40	STUDENT ACTIVITIES	67

ABOUT WWF	70
-----------------	----

I N T R O D U C T I O N

USING THE PACK

This pack contains ten sections, each one relating to a specific area of a school. Students are asked to look critically at their own school and assess whether it meets the needs of all its users, the extent to which it uses and abuses environmental resources and the aesthetic contribution it makes to the locality. This initial research is then used to design a school which is user-friendly, conservation conscious and aesthetically pleasing.

STUDENT ACTIVITIES

The Student Activity sheets can be photocopied and given directly to pupils to work from and also to provide them with an overview of the project's development. Alternatively, activities could be made into workcards individually tailored to the age and ability of students.

TEACHERS' NOTES

The Teachers' Notes outline the aims and issues of each section and detail all the necessary stages to be undertaken in the course of the project. Where there is a directly complementary Student Activity or Worksheet, the appropriate reference is given.

Extension Activities are suggested which could be carried out in class or as homework. They are not essential for the logical progression of the project's aims but would provide opportunities for exploring certain sections further. This work is most appropriate for Key Stages 2 and 3 although ideas from the pack have been used successfully with students up to GCSE and CPVE level. It can also be carried out through a variety of subject areas ranging from English and Humanities to Art and Technology. A chart of the main Attainment Targets covered in each section is given on the following page to help teachers to plan project work appropriate to their pupils' requirements.

Students must understand that they are designing for 'ideal' conditions and that many of their ideas would not be logistically possible in their own school due to financial constraints, existing conditions, staffing etc. However, it is important that ideas which they do have about design or organisation, which could be viable in their own school, are respected and discussed.

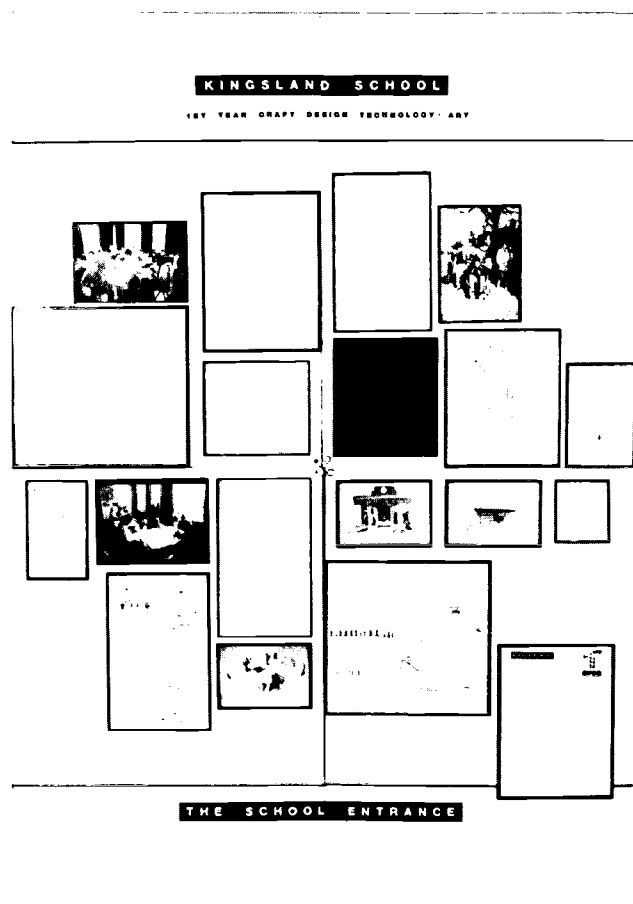

The project will have more credibility if it leads to action within the school, eg. rules developed in the School Grounds section for dealing with playground conflict could be implemented, a recycling scheme could be set up or posters reminding others to close doors could be displayed in appropriate places.

ATTAINMENT TARGETS

Attainment Targets for Each Section of the Pack

	SCIENCE	MATHS	GEOGRAPHY	ENGLISH	TECHNOLOGY
OVERALL DESIGN	6, 13, 15	1, 8, 9, 12, 13	1, 2, 7	↑ ↓ 1, 2, 3, 4/5	↑ ↓ 1, 2, 3, 4
ENTRANCE	6	1, 8	1, 2, 7		
SCHOOL GROUNDS	2, 3, 16	1, 8, 9, 12, 13	1, 2, 5, 7		
CLASSROOM	15	1, 8	1, 2, 7		
WASTE & RECYCLING	5, 13	1, 8, 9, 12, 13	1, 7		
PERFORMING ARTS	14	1, 8, 9, 12, 13	1, 2, 7		
INDOOR SPORTS	3	1, 8, 9, 12, 13	1, 2, 7		
LIBRARY		1, 8, 9, 12, 13	1, 7		
ENERGY / LIFT	10, 11, 13	1, 8	1, 7		
DINING ROOM	2, 3	1, 8, 9, 12, 13	1, 4, 7		

ACTIVITIES COMMON TO ALL SECTIONS

GROUP SHARING OF IDEAS

1. Brainstorming

This is an excellent way for groups to express a wide variety of ideas which are written down without comment. The resulting list can then be categorised to organise ideas into areas for further development.



2. Discussions

These can involve everyone: begin with discussion between pairs, then work in larger groups, feeding back to the whole class via a spokesperson. Minute taking is a useful way of recording the content of the discussion for future reference.

3. Collaborative practical group work

A large element of co-operation is required to produce ground plans and models in small groups. A group size of four students is recommended. Skills of negotiation and compromise are necessary to incorporate the suggestions of a group and to make co-operative decisions. Co-operation is also necessary to divide the tasks required to see ideas through to completion.

SURVEYS, QUESTIONNAIRES AND INTERVIEWS

As an integral part of each design, emphasis is placed on satisfying the needs of the future users. It is therefore necessary to assess the suitability for their intended purposes of existing facilities familiar to the students. By devising questions for users, levels of satisfaction with existing provision can be ascertained and suggestions for improvement sought.

Questions worked out by individuals or small groups should be brought together and made into a standard questionnaire. The results of the survey can be collated by all the class and statistics presented in a graphic form.

Students should then incorporate interview findings, as well as their own creative ideas, in order to produce designs which fulfil the varied requirements of users and succeed in being aesthetically pleasing.

BEST COPY AVAILABLE

SOURCES OF INFORMATION

First hand observation and experience offers a valuable complement to reference books and extracts from printed materials. Examples include:

1. Visits to buildings and facilities which provide stimulus for design ideas, eg. city centres, recycling centres, daycare centres for people with disabilities;
2. Visiting representatives of organisations can present an overview of particular needs or problems concerning design features of public facilities, eg. environmental health officers, planners, architects;
3. Surveys, questionnaires and interviews with users of a facility (see previous section);
4. Photographs, videos and slides with content relevant to design work.

MODEL MAKING

The models can range from the simple to the sophisticated, depending on the time and materials available and the curriculum areas involved. The wider the range of materials available, in particular interestingly shaped and textured bits and pieces, the more the students' imagination will flow.

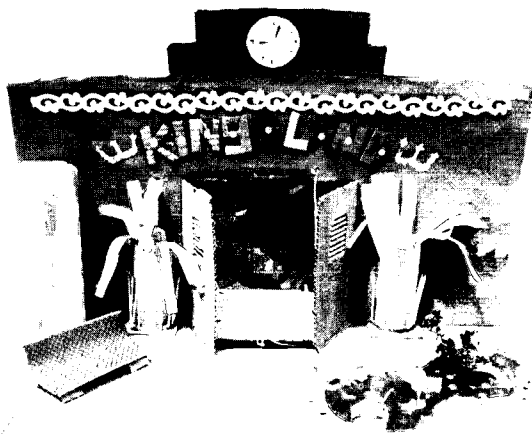

GLASS

EVERY TONNE OF GLASS RECYCLED SAVES THE ENERGY EQUIVALENT OF 30 GALLONS OF OIL. 12,000 TONNES OF GLASS ARE WASTED EACH YEAR IN CAMDEN.

RECYCLING HELPS TO —
* CONSERVE FINITE RESOURCES OF ENERGY AND RAW MATERIALS.
* REDUCE POLLUTION & PROTECT THE ENVIRONMENT.



Double sided corrugated card, of the sort used for cardboard boxes, is a useful, cheap, basic material as it is thick enough to be rigid for large areas and to stick well, but it warps when painted, so it is advisable to paint on paper first and to stick this to the card.

Essential equipment includes cutting boards, sharp scalpels (to be used under supervision) and metal safety rulers.

This section of the project necessitates thorough preparation and all necessary materials and tools should be readily available to the students at the beginning of sessions.

PLANS/SCALE DRAWINGS/ELEVATION DRAWINGS

The two dimensions to be considered in the design of a structure are the ground plan and the appearance of the vertical faces.

Simple bird's eye view sketches of the ground plan sketches should be developed into scale drawings involving careful measurements and calculations. Different scales are recommended for each design section, working towards ground plans and models that fit an A2 base.

For younger children however, it might be necessary to begin with a 1cm: 1m scale, transferring measurements of lengths and areas of rooms or spaces known to them onto large block graph paper.

Elevation drawings of structures are familiar to younger students. At all ages, they should be encouraged to make close observation drawings of elevations in the preliminary activities, paying attention to design features and essential proportions. Review of design proposals should take place throughout to identify areas for improvement and to enable refinements to take place.

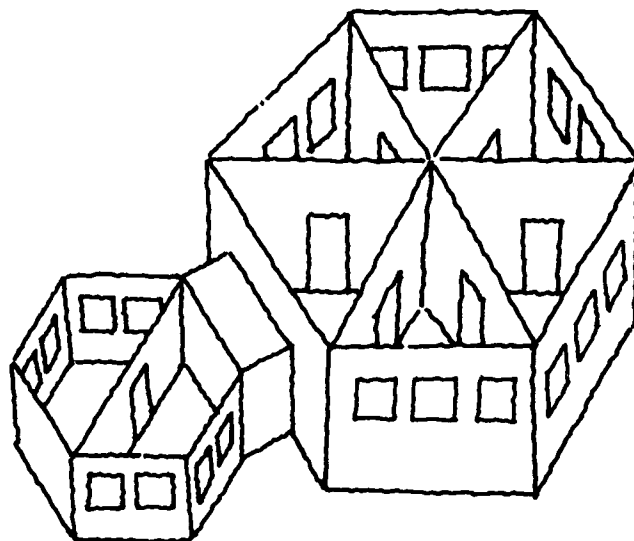
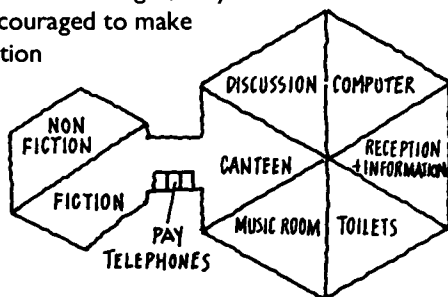

EVALUATION

Each school will no doubt have its own methods for evaluating project work and homework arising from it.

The following questions are suggested for inclusion:

1. Why my design would be good for the people who use it;
2. Why my design would be good for the environment;
3. Why my design would look good;
4. What I liked best about the project;
5. What I learned from the project;
6. What difficulties I had;
7. The changes I would make to my design;
8. Which skills have I improved through this project eg. scale drawing, using tools, working co-operatively, close observation, drawing, etc.?

RESOURCES

Theme Work

Development Education Centre,
Selly Oak Colleges,
Bristol Road, Birmingham, B29 6LE.
Suggestions for ways of developing group work skills and organising participatory learning.

World Studies 8-13 -

Simon Fisher and David Hicks
Oliver and Boyd
Suggestions for ways of developing group work skills and organising participatory learning, role play, etc.
Also sections on World Trade, Recycling, 'What is a Classroom Made of?'

What is Development?

ILEA Learning Resources Branch
Available from Television and Publishing Centre,
Thackeray Road, London SW8 3TB.
Section on 'Will Development Suit Everyone?' based around a group of teenagers' desire for a football pitch, and the effects, good and bad, that it will have on the rest of the community. Particularly relevant to the 'Safe Place' sections about community use of facilities.

The Built Environment - Structure - P. Manton
Stevenage Urban Studies Centre
Booklet considering the problem of how to make a building stand up and how different materials and developing techniques have affected the kinds of buildings it is possible to make.

Structure and Forces -
Schools Council Science 5-13
Macdonald Educational
Section on buildings contains lots of ideas and experiments about how buildings are made.

Design and Planning Games -
Jeff Bishop and Graham Russell
Resources for Learning Development Unit,
Bishop Road,
Bishopston, Bristol, BS7 8LS.
Games that give insight into the processes involved in design and planning.

The Young Green Consumer Guide -

John Elkington and Julia Hailes
Gollancz
Explains environmental issues, eg. the Greenhouse Effect, acid rain, etc. and has a section on 'The Green School', with ideas on how to investigate the current status of the students' own schools.

Blueprint for a Green Planet -

John Seymour and Herbert Girardet
Dorling Kindersley
As well as discussing the principle pollutants, contains sections on healthy eating and food production, waste disposal and recycling, 'green' building materials, organic gardening, and low energy buildings.

Your Health Series - Health and Food -

Dorothy Baldwin
Wayland.

Look Around Series - Look Around the School
Wayland.

As many as possible from the wide range of architectural design books and pictures of buildings from magazines, etc. should be available to students to stimulate ideas.

Slides:

- Entrances: different styles of entrances to public buildings
- Tutor Rooms: rooms for different subject areas, that are also used as tutor rooms
- Lifts: lift interiors, gates, lobbies, and control panels
- Public Buildings: building facades of varying ages and styles from Hackney and the City of London.

All available for hire from Hackney Environmental Education Project, 6-8 Lower Clapton Road, London, E5 0PD. Tel: 071 533 4567.

ISSUES COMMON TO ALL SECTIONS

ACCESS FOR PEOPLE WITH DISABILITIES

It is now becoming more widely accepted that, as far as possible, students with physical disabilities should go to the same schools as able-bodied students.

In 1985, it became a legal requirement for many classes of new buildings open to the public to provide access and facilities for physically disabled people.

However for many students, this right is not available to them because of insensitive design. There are also disabled teachers who have limitations put on their careers and parents for whom a visit to their children's classroom is fraught with difficulties, either because of disabilities, or because they are accompanied by younger children in baby buggies.

In a number of sections of this pack, it is suggested that students use borrowed wheelchairs to increase their awareness of the unnecessary obstacles and hazards that wheelchair users have to face. Wheelchairs can often be borrowed from local daycare centres for people with disabilities or for the elderly. Where this proves difficult, a journey with a weighted baby buggy can make the same point.



RESOURCES

Play for All - Workbook - ed: Robin Moore
National Playingfields Association
Guidelines on provision for disabled children.

Designing for the Disabled - Selwyn Goldsmith
Royal Institute of British Architects.

Disability Equality in the Classroom: A Human Rights Issue - Richard Rieser and Micheline Mason
ILEA

Comprehensive reference book for teachers, with a section on classroom activities for primary children matched to National Curriculum Attainment Targets.

Access for Disabled People and Designing for People with Sensory Impairments - Stephen Thorpe
Centre on Environment for the Handicapped for the Access Committee for England.
Notes for planners, architects and developers containing clear diagrams about design issues.

Access for Disabled People to Educational Buildings
Department of Education and Science
Identifies the minimum facilities required to enable disabled people to get into and move around an educational building.

How to - and how not to - develop projects with Schools
Fitch O'Connell
CSV Advisory Service
A handbook encouraging people with disabilities and school students to work together on design projects.

Centre on Environment for the Handicapped
35 Great Smith Street, London SW1P 3BJ.
Tel: 071 222 7980
Information and advice service on designing buildings for disabled people. Publishes design and access guides.

ENERGY CONSERVATION

Energy conservation should be a consideration in all the design areas because:

- fossil fuels are finite and create pollution, causing acid rain and global warming;
- nuclear power produces indestructible radioactive waste. An accident would cause irreversible environmental damage;
- other renewable energy sources (wind, active solar, water) have not yet been developed to a level where they can provide for more than a small proportion of the world's energy needs;
- all forms of energy are expensive to produce and use many other resources in the process;
- energy conservation is the cheapest, most practical and safest way to begin to deal with the problems created by the world's energy needs.

Passive solar principles can be used to reduce energy consumption for lighting and heating.

Natural light:

- displaces high cost, polluting energy sources;
- has psychological benefits (people are intolerant of unchanging light, which reduces concentration);
- minimises glare;
- has aesthetic benefits, showing architecture to its greatest advantage.

Use of artificial light can be reduced by:

- putting the window head as high as possible to increase light penetration;
- setting the sill height at the same level as working surfaces;
- using light colours for walls and ceilings to reflect natural light;
- using light coloured paving outside windows to reflect light into rooms;
- not planting trees close to buildings where they will obstruct daylight;
- installing rooflights (4 rooflights in a classroom can

lead to a 70% reduction in lighting energy use. Source: Building 2000);

- using new energy efficient light bulbs;
- wiring lighting in rows parallel to windows to enable darker areas to be lit independently.

Efficient temperature control:

- displaces high cost, polluting energy sources;
- increases comfort (air movement, caused by draughts and differences in temperature between one side of the body and another, affect comfort more than actual temperature does);
- affects efficiency (if internal temperatures rise above 27°C human efficiency falls by 40%, while Health and Safety rules state that below 15°C workers must have breaks at least once an hour).

Efficient temperature control can be achieved by:

- having temperature controls in every room;
- draught-stripping all windows and external doors;
- double glazing windows (halves heat loss of single glazing);
- closing doors;
- having draught lobbies, but these are only effective if at least one door stays closed at all times, and the minimum space between doors is 3 metres;
- keeping glazing between 25% and 40% of wall area (too much glazing is hot in summer, cold in winter);
- not having glazing below the level of working surfaces (it has no effect on lighting, while causing heat loss);
- providing blinds, shades or overhangs on south facing windows to prevent summer overheating;
- providing double or triple glazed, opening rooflights to reduce summer overheating by cross-ventilation;
- having circulation areas, where temperature is not so important, on the outside of the building to create a buffer zone between the classroom and the air temperature.

ENERGY CONSERVATION

The following figures illustrate the major impact of energy conservation:

- In system built schools in Kent which were refurbished according to energy conservation principles, it was found that heating energy use could be reduced by 30% - 50% and lighting energy use could be reduced by 70%.
(Source: Building 2000)
- Estimated annual electricity costs for a 2 bedroom terraced house with basic insulation: £358, with good insulation: £262.
(Source: London Electricity Board)
- £1 spent on energy saving is as effective as £7 spent on nuclear power. (Source: ECD Partnership)
- Energy efficient light bulbs cost more to buy but use less than 1/5 of the electricity needed by ordinary bulbs and last 8 times as long. If every household in Britain changed one 100W bulb to an energy efficient bulb, the reduction in energy demand would be equivalent to the output of 1 1/2 large power stations. (Source: Friends of the Earth)
- If everyone stopped watching 'Neighbours', there would be a daily electricity saving of £60,000. (Source: Green Magazine)

RESOURCES

Blueprint for a Green Planet - John Seymour and Herbert Girardet
Dorling Kindersley
Contains a chapter on energy and buildings.

Energy and Power - Richard Spurgeon and Mike Flood
Usborne
Lots of information on all forms of energy and ideas for practical experiments.

Energy: Economic Awareness and Environmental Education
Ken Webster
WWF/Oxford University Press
This pack consists of teachers' notes and student resources for photocopying, to encourage investigative, process-led approaches to environmental issues, integrated into the National Curriculum 'core' subjects. Aimed at 11-16 year olds.

Solar Power - Ed Catherall
Wayland
Information and suggested science experiments.

Junior Education December 1985
Topic Pack 'Energy'.

Using Energy from the Sun
Department of Energy
Clear information on passive solar principles, plus examples of buildings from the Department's Renewable Energy Research and Development Programmes.

Energy Resource Pack
Devon Educational Television Service
Information and statistics on alternative power sources.

Useful addresses for further information:

Centre for Alternative Technology, Machynlleth,
Powys, SY20 9AZ

Bristol Energy Centre, 101-109 Bedminster Parade,
Bristol, BS3 4DR

Milton Keynes Energy Park, Saxon Court, 502
Avebury Boulevard, Milton Keynes, MK9 3HS

Regional Gas and Electricity Boards.

ECOLOGY IN THE SCHOOL

There are plant and animal habitats to be found everywhere in school grounds. Students should study and compare what they find in different places, e.g. walls, corners, under stones, in green areas, in ponds, around trees, etc.

Questions to raise:

- a. Which habitats encourage which kinds of wildlife?
- b. Do weather conditions affect your findings?
- c. What do particular animals like mostly to eat?
- d. What conditions do particular plants seem to prefer?

Students can then decide which habitats offer the best conditions for variety of plants and animals to survive and decide how best to organise an area to encourage wildlife.

Minibeasts

For all the habitats, close observation of minibeasts is essential. After catching animals using pitfall traps, sweepnets or pond-dipping equipment, they should be collected using pipettes, paintbrushes or pooters (to avoid damaging them) into pots with lids. After closer examination in class with magnifiers, finds can then be identified using books. Students should be encouraged whenever possible to return live specimens to their place of origin.

More precise assessment of the numbers of animals (or plants) in an area can be done using a $\frac{1}{2}$ m quadrat and counting the numbers of particular plants/grasses/minibeasts inside it.

Birds

Bird watching is often better carried out from inside the school buildings, identifying the species and observing the most commonly visited areas and marking them on a map of the grounds. Bird tables or bird feeders hung in strategic positions will attract birds so that they can be studied more closely.

Larger Animals

These can be best studied by looking for clues such as footprints, signs of feeding, holes and tunnels with disturbed earth or droppings, hair or fur on fencing, etc.

RESOURCES

There are numerous excellent species identification books. A particularly useful section on setting up an environmental study area in school grounds is to be found in :

Bird Studies - Using the School Grounds
pub. R.S.P.B., The Lodge, Sandy, Beds. SG19 2 DL.

OVERALL DESIGN

TEACHERS' NOTES

AIMS To develop:

- an aesthetic awareness of the impact of buildings on the overall environment;
- an empathy with the needs of different users, including people with disabilities;
- an awareness of the environmental impact of materials;
- a critical approach to looking at architecture;
- an understanding of the relationship between the built and natural environment.

ISSUES

- How can a building be designed to be visually in sympathy with existing features of the environment?
- How can a building design make best practical use of existing environmental features?
- How should a building be designed to best fit the needs of all its users?
- What makes a building attractive (materials and design)?
- Which environmentally sound materials should be used?

Suggested scale: 1 cm : 5 m

ACTIVITIES

A ACTIVITY 1

An essential starting point is to examine the layout and design of the school with which the students are familiar. This is best introduced by small group discussions about the school, which can be fed back to the rest of the class.

Extension Activities

Following on from the discussion, students could write about good and bad design points in their school, giving reasons for their opinions.

Commonly used routes around the school could be timed. Students could also attempt to negotiate the routes in groups with one member in a wheelchair or blindfolded.

Plans of the school could be traced or photocopied and cut up and different arrangements of existing facilities could be experimented with.

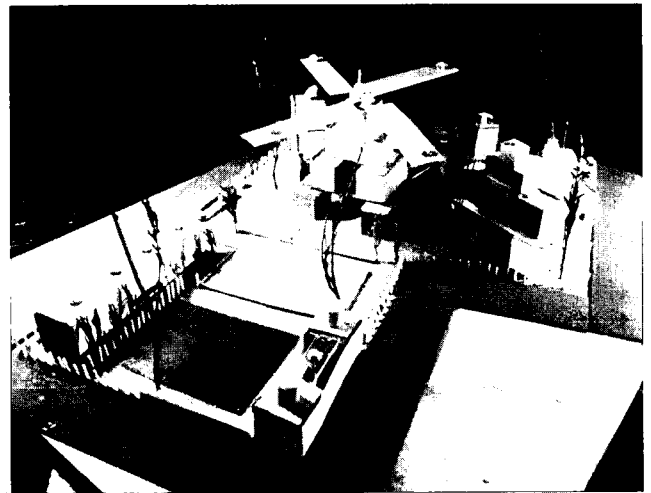

B ACTIVITIES 2 & 3

A survey should be devised to discover the opinions of students, teachers and support staff about existing facilities.

OVERALL DESIGN

TEACHERS' NOTES

ACTIVITIES

C BUILDINGS WORKSHEET

Research needs to be done into the design and materials used in different public buildings built in different periods.

A visit to the centre of most towns will present a range of building styles, ancient and modern. Cameras and sketch pads should be taken and a worksheet on which students can analyse the success or otherwise of building designs is useful.

Extension Activity

Magazine pictures of buildings can be analysed using the same worksheet. Further work can be done from photographs taken on the visit or from slides or photos of local buildings. A slide set showing a range of public building facades is available from Hackney Environmental Education Project (see General Resources List).

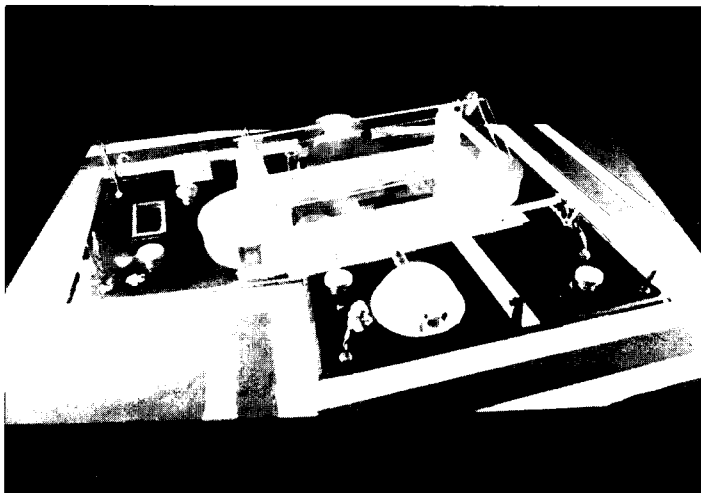

D ACTIVITY 4

Students should now organise themselves into working groups in which they will carry through their design brief. (See introductory notes on practical group work.) In their groups, they should discuss the information gained in their research and list which qualities, features and materials they think should be included in a school which would best suit the needs of all its users.

E ACTIVITY 5

Site plans with roads, existing trees, changes of level, scale and orientation marked on should be given to the groups. The attached site plan could be scaled up if required.

Using the list of decisions made in (D), the students should work together to make plan and elevation drawings of their proposed school design. (See introductory notes on plans, and scale and elevation drawings.)

Some students may find it helpful to start with blocks of various shapes and sizes that they can move around to design the basic layout.

Scale plans can be developed on squared paper. (See introductory notes on scale drawings.)

Extension Activity

Orientation is very important in building design to ensure light access and avoid glare. An anglepoise lamp with a simple model can be used to investigate the effects on light penetration into a building of sun movement throughout the day, and the difference in the sun's angle in summer and winter.

F ACTIVITY 6

A model of the planned building can now be constructed. (See introductory notes on model making.) Each member of the group should take responsibility for different sections of the model, eg specific classrooms or areas, entrance facade, site boundaries, window details, etc. Detailed elevation drawings are valuable to support the information given by the model.

Extension Activity

Groups could research different aspects and develop ideas for specific features, eg. energy conservation, materials, services, disabled access, etc.

G Evaluation.
(See introductory notes on evaluation.)

OVERALL DESIGN

S T U D E N T A C T I V I T I E S

ACTIVITY 1

1 Organise yourselves into groups of four.

As a group, discuss the design of your school. Choose one of the group as scribe to make notes on important points in the discussion to feed back to the rest of the class.

Think about the following:

a. *Does your school look good?*

Do you like the materials it is made of?
Has it got any interesting features?

b. *Does it work well?*

Is there enough space for all the things that need to happen in it:

Are there enough classrooms/
cloakroom facilities/toilets/halls?

Is it easy to move around:

Are the corridors and stairs wide enough and in the right places?

Would it be accessible to someone in a wheelchair?

Is it easy for visitors to find their way around?

c. *What are your favourite places in the school?*

What parts of the school don't you like?

Are there any changes you would like to make to make it look better?

Are there any changes you would like to make to make it work better?

ACTIVITY 2

2 Make a list of questions which you could ask other students and members of staff about what is good and bad about your school design and whether there are any changes which they feel could improve it.

Remember to ask students of all ages.

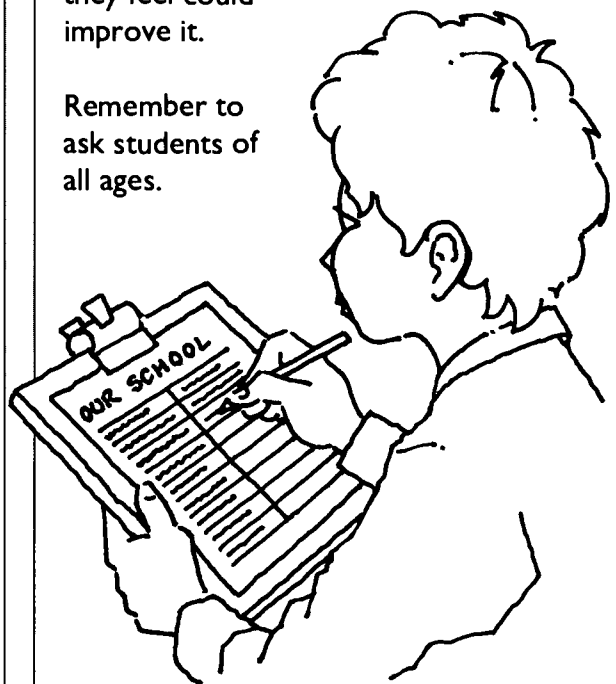

ACTIVITY 3

3 Your surveys will produce many different answers. Put together the answers found out by everyone in the class. Make a graph or chart to show the collated results. Write down what you have learnt from this survey.

OVERALL DESIGN

STUDENT ACTIVITIES

ACTIVITY 4

4 In your groups, you are going to design a building which you think would be good for a school. Remember all the information you have researched and what you have discovered from your surveys.

As a group, make a list of:

- a. the qualities you would like your building to possess;
- b. special features you would like it to have;
- c. the materials you think it should be made from;
- d. how many students the school will be for.

ACTIVITY 5

5 Sketch a ground plan or do a drawing of how you would like a school to look, using the list your group has produced. You can do this as a group, or do it individually and combine your ideas afterwards. Make sure that you have included enough facilities for the number of students your school is being planned for.

ACTIVITY 6

6 Using your drawings, make a model of your school building. Make sure that everyone in your group has a job to do.

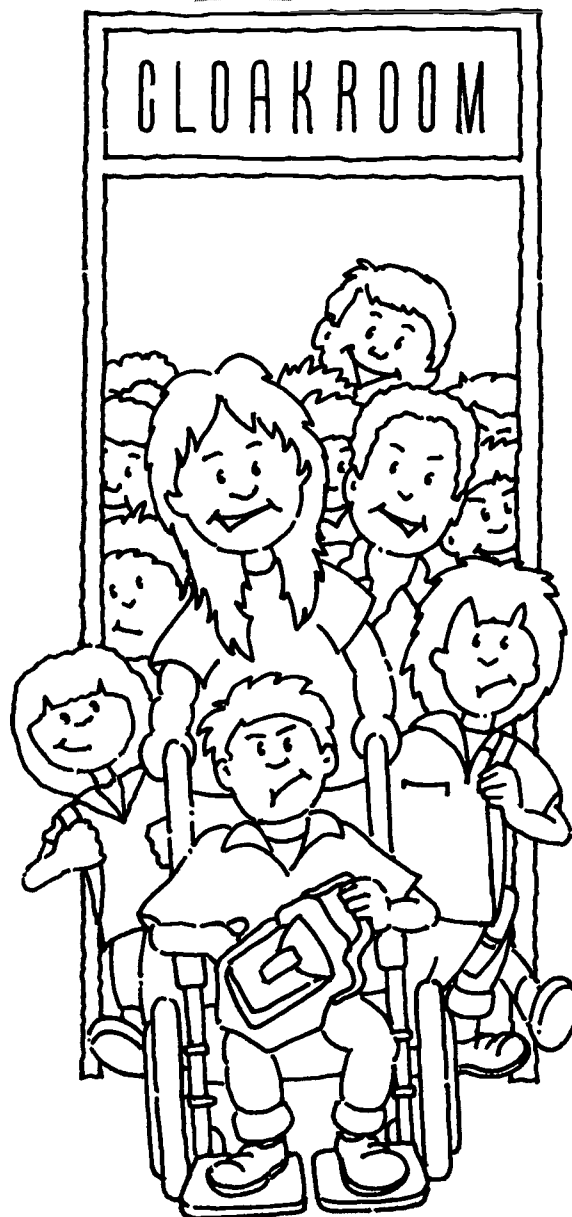

OVERALL DESIGN

S T U D E N T A C T I V I T I E S

Looking At Buildings – Fieldwork

NAME OF BUILDING _____

ADDRESS _____

1. What materials are used in the building?

2. Describe the building eg. how high it is, estimated number of floors, shape, estimated number of rooms, type of doorways, windows, roof shape etc.

3. Give your opinion. Is the building a suitable one for the area it is in? Does the building match well with the area or does it look out of place?

4. What do you think the building is (or was, or will be) used for? Give some reasons for your choice.

5. Imagine that YOU are using the building. How easy and comfortable do you think the building would be to use?

6. Can you see any facilities provided for people with disabilities? What facilities do you think are provided inside the building for people with disabilities?

PLAN OF SITE FOR SCHOOL BUILDING

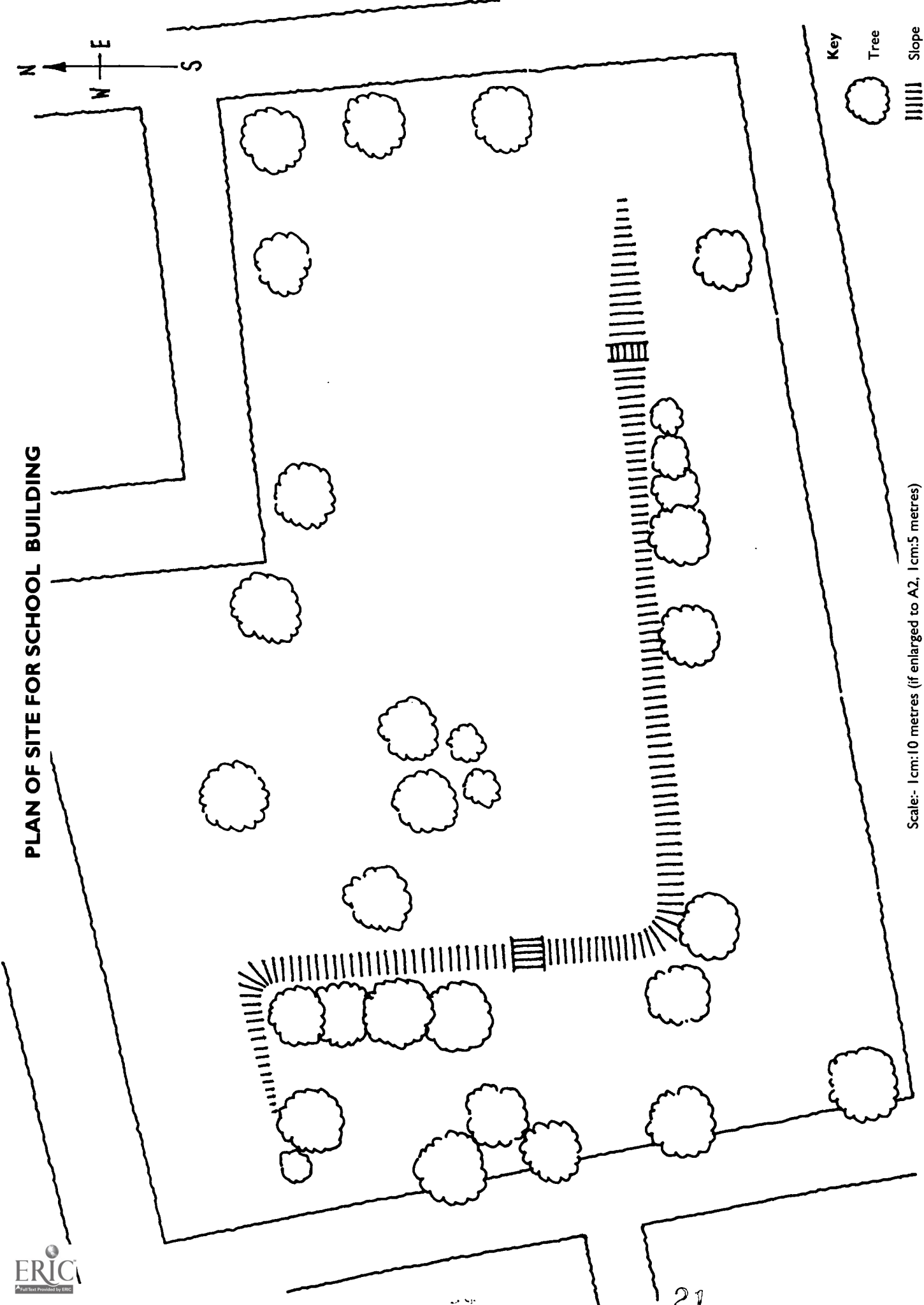
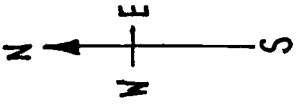

Key

- Tree
- Slope

Scale:- 1cm:10 metres (if enlarged to A2, 1cm:5 metres)

ENTRANCE

T E A C H E R S ' N O T E S

AIMS To develop:

- an awareness of the needs of all users;
- an awareness of the statement made by the way a building addresses the street;
- a critical approach to looking at buildings.

ISSUES

- How is a school ethos expressed by its reception area?
- How do entrances to buildings make us feel?
- How does colour affect ambience?

ACTIVITIES

A ACTIVITY 1

An excellent way to begin to examine the functions of the entrance to a public building such as a school is to focus on familiar entranceways. Students should examine the structure, design features and the materials used in the construction of their own school entrances in order to make detailed drawings and notes.

A large plan of the school and its grounds could be used to display the drawings and provide a stimulus for group discussion of the qualities and facilities their school entranceway should possess. (See introductory notes on group discussion.)

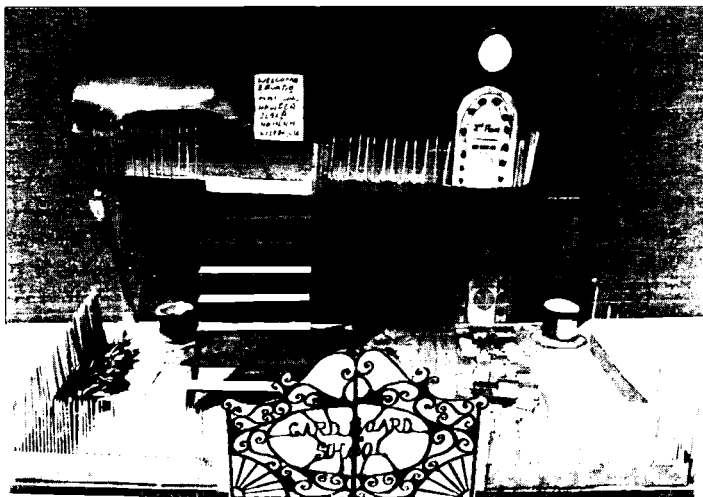

B ACTIVITY 2

Mapping the route from entranceway to office is intended to increase awareness of difficulties experienced by visitors to an unfamiliar building. As a starting point, students could be given an outline plan of the school site.

Mapping skills including symbols, keys and relative distances can be covered. Standard and non-standard measurements could be included. Accurate plans could be drawn to scale using squared paper. (See introductory notes on scale drawings.)

Extension Activity

ACTIVITY 3

Students can be reminded of the feelings and difficulties associated with approaching the entrance of an unfamiliar building by thinking back to their own first day at the school.

C ACTIVITIES 4 & 5

Using the map, small groups travel the route with a wheelchair. All hazards for the wheelchair should be marked on using a special symbol. Videoing, photographing or taping this exercise provides a permanent record for use in further discussion. (See (F).)



ENTRANCE

T E A C H E R S ' N O T E S

ACTIVITIES

D Within reach of every school there are public buildings such as libraries, places of worship, banks, hospitals, etc. Visiting them provides the opportunity to investigate ease of access and the efficiency and appropriateness of signs. If a wheelchair is available, it would be a valuable extension of this exercise which could then be related back to the similar experience in school. Again, a video, tape or photographic record would be useful for further work and written accounts of the experience would serve to focus attention on relevant design features.

E ENTRANCE WORKSHEET

Using videos, photographs, slides or magazine pictures, students can analyse entrances to public buildings according to a set of criteria ranging from the practical to the psychological. A slide set showing different styles of entrances is available from Hackney Environmental Education Project. (See General Resources Sheet.)

Extension Activity

ACTIVITY 6

Students can design signs for a school entrance. They should be reminded of signs they have seen in earlier work (Sections B, D and E) and pictures of signs can be displayed as examples. It is important to draw attention to the need to cater for all users by including symbols. It would also be useful to suggest the possibility of devising information signs which produce sounds eg push buttons which could give directions to key parts of the school such as the secretary's office. Also important is the awareness that the ethos of a school is expressed very clearly through first impressions (eg. 'Welcome' signs).

F ACTIVITY 7

Students should organise themselves into working groups in which they will carry through the design brief. (See introductory notes on collaborative practical group work.) In their groups they should discuss the experiences gained in their research (see introductory notes on group discussion) and list the qualities, features and materials they have decided would be suitable and desirable for a school entrance.

G ACTIVITY 8

Either individually or in groups the students should now make a plan or elevation drawings of entrance designs based on the list their group has produced.

H ACTIVITY 9

Using the group's drawings and ideas, the model of the entrance can now be constructed. (See introductory notes on model making.) Each member of the group can take responsibility for different sections of the model eg. gates, fences, signs, main doors, sculptures, natural features, planted areas, benches, litter bins, etc.

I Evaluation.
(See introductory notes on evaluation.)

ENTRANCE

S T U D E N T A C T I V I T I E S

ACTIVITY 1

1 Look closely at one of your school gates or entranceways.

Make detailed drawings and notes showing its design and the materials it is made from.

ACTIVITY 2

2 Draw a map of the route from the school gate to the office. Use a symbol or colour to show steps, doors and signs, and make a key for your map.

Imagine you were visiting the school for the first time. Mark on your map any other places where you think a sign would be useful.

ACTIVITY 3

3 Think about the very first time you came through the entrance of your school. Write a poem or description or draw a sequence of pictures about how you felt.

ACTIVITY 4

4 With one of your group in a wheelchair, repeat the route from the gate to the office.

Choose a new symbol and mark on your map any places which are difficult for the wheelchair to pass.









ACTIVITY 5

5 Write a description of your experiences of the journey with the wheelchair.

ACTIVITY 6

6 Think about all the signs you have seen (traffic signs, advertising signs, information signs etc). Some use words, some use symbols, some use sounds, some use a mixture of these.

Design some signs which you think would be suitable for a school entrance.

		Office	
		Main Hall	
		Canteen	
			

ENTRANCE

S T U D E N T A C T I V I T I E S

ACTIVITY 7

7 You are going to design an entrance which you think would be good for a school. Remember all the entrances you have looked at.

In your groups make a list of:

- a. the qualities you would like your entrance to possess;
- b. all the things you think should be in your entrance (eg. bins, gates, trees, etc);
- c. the materials you think should be used.

ACTIVITY 8

8 Sketch a ground plan or do a drawing of how you would like your entrance to be arranged, using the list your group has produced. You can do this as a group, or do it individually and combine your ideas afterwards.

ACTIVITY 9

9 Using your drawings, make a model of your entrance. Make sure that everyone in your group has a job to do.

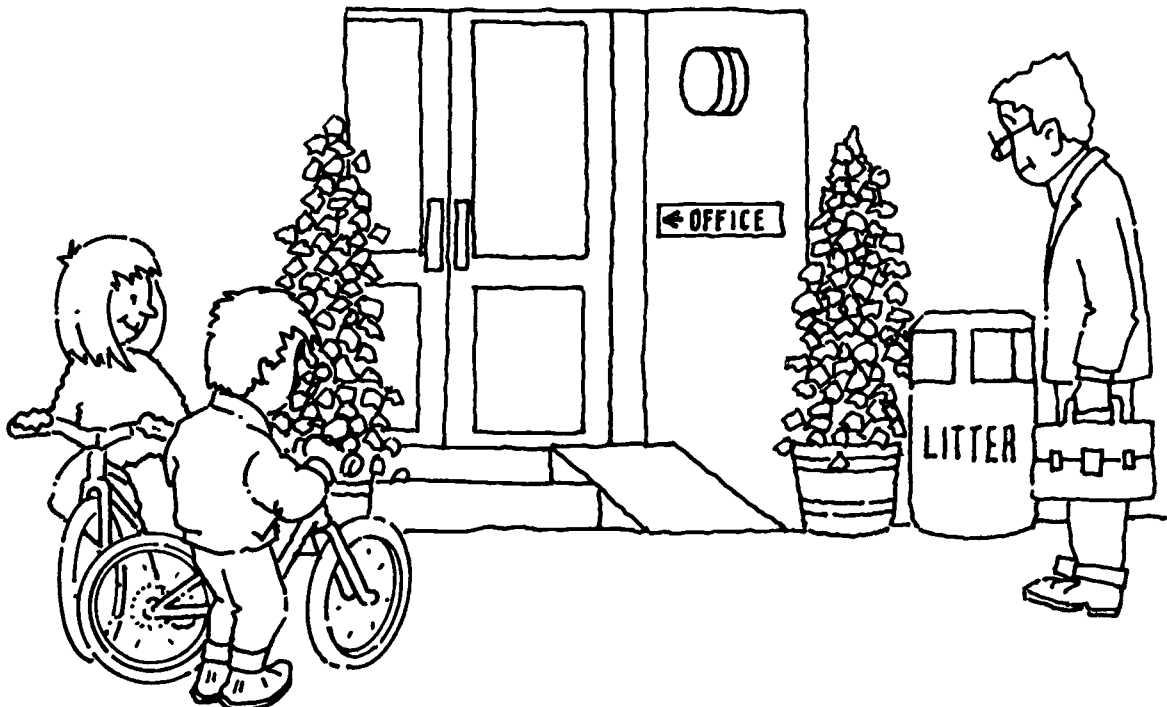

ENTRANCE

S T U D E N T A C T I V I T I E S

Entrances and Doorways – Fieldwork

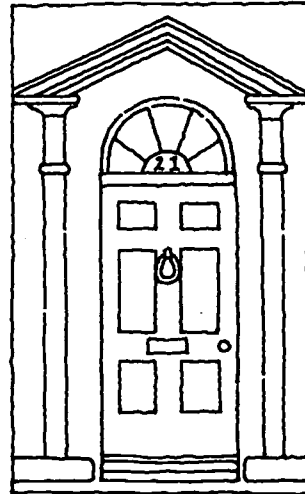
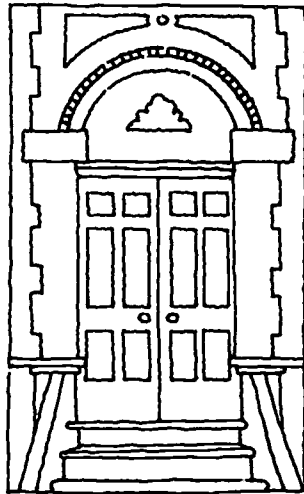

How does each one make you feel?

Look carefully at each example. Put a tick under the words you think are true for each entrance you look at.

Name of Building	Welcoming	Interesting	Accessible	Frightening	Grand

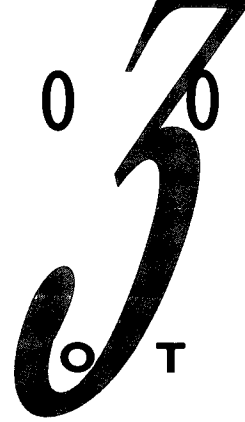

SCHOOL GROUNDS

T E A C H E R S ' N O T E S

ACTIVITIES

D Layout and design features of other open spaces should be looked at. Visits to local parks, open spaces and other school playgrounds with sketch pads and cameras would be useful. A slide set showing a range of open space features is available from HEEP (see General Resources list).

Included in the research should be different types of play equipment, styles of seating, bins, walls and fencing, ecological areas and decorative features such as mosaics, murals, sculptures etc.

E **ACTIVITY 4**

Attention should be drawn to the place of the school grounds as part of the wider community. Using a map of the local area, existing green spaces, outdoor sports facilities and schools should be marked to see if schools could be in important sites for wildlife habitats or if they have the only sports provision in their immediate locality.



Extension Activity

If your own school has limited outdoor space, the students could discuss ways of making better use of it and ways of attracting more wildlife by provision of raised flowerbeds, window boxes, hanging baskets, benches, murals etc. They could then approach the school PTA or local businesses and grant giving bodies requesting donations to carry out such improvements. If you are also working on the Waste and Recycling section of this project, litter bins designed by students could possibly be installed as well.

F The possibility of community use of school grounds out of school hours should be discussed in groups, focusing on advantages/disadvantages and management/organisation. (See introductory notes on group discussion.) The main arguments for and against community use should be written up.

Extension Activity

Wildlife surveys could be compared from different parts of the school grounds and a wild area to show the importance of ecological areas for wildlife. (See notes on Ecology.)

G **ACTIVITY 5**

Students should now organise themselves into working groups in which they will carry through their design brief. (See introductory notes on group work.) In their groups, they should discuss the information gained in their research and list which facilities they think should be included in school grounds which would best suit the needs of all users.

H **ACTIVITY 6**

Site plans showing the layout of a school building, existing trees, scale, orientation and changes of level should be given to each group. The attached site plan could be scaled up if required.

Trees - stress the importance of preserving existing mature trees as far as possible.

Orientation - draw attention to areas of sunlight and shade and their effect on people and wildlife. The students should also be given the measurements of fixed-size courts and pitches and make scale templates of any which they wish to include in their design. Using the list of decisions made in (G), students should work together to make a plan of their proposed design, beginning with a basic layout sketch.

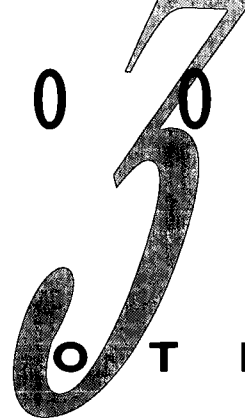

SCHOOL GROUNDS

T E A C H E R S ' N O T E S

ACTIVITIES

I ACTIVITY 7

A model of the planned space can now be constructed. (See introductory notes on model making.) Each member of the group should take responsibility for different sections of the model, eg. seating, play equipment, wildlife area etc.

ACTIVITY 8

Larger scale drawings and models of particular features can be developed.

J Evaluation.
(See introductory notes on evaluation.)

RESOURCES

Children Need Recreation - Wendy Davies
Wayland

This book looks at the importance of different kinds of play in children's lives, and explores some of the many forms of recreation enjoyed by children from different parts of the World.

How to Make a Wildlife Garden - Chris Baines
Elm Tree Books

Useful advice on planning and planting a garden to encourage wildlife.

It's Not All Swings and Roundabouts -
Rosy Martin

Women's Design Service

Aimed at making better play spaces for younger children, but includes lots of useful information and references about everything from suitable play surfaces for play spaces to anti-sexist, anti-racist play.

Making Playgrounds - Lin Simonon
Community Service Volunteers

A pack designed 'to help schools transform their playgrounds'. Everything from the history of play to practical advice on playground design. Useful for all ages, but worksheets aimed at secondary students.

Monitoring the Playground - Carol Ross
Isledon Teachers' Centre

A case study of a project at Tufnell Park School with ideas for surveys, role play etc.

Bird Studies: Using the School Grounds
RSPB

Useful section on creating and managing an environmental study area in school grounds.

Pond Design Guide for Schools - Graham Flatt
Hampshire Books.

School Nature Area Action File
Nature Conservancy Council.

Useful addresses for further info:

Playboard, Britannia House, 50 Great Charles
Street, Queensway, Birmingham, B3 2LP.
Tel: 021 233 3399

National Playing Fields Association, 25 Ovington
Square, London, SW3 1LQ.
Tel: 071 584 6445

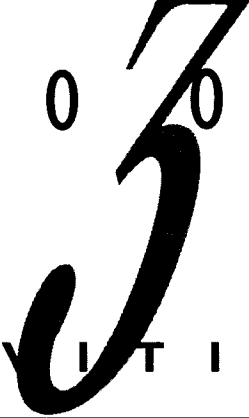

SCHOOL GROUNDS

S T U D E N T A C T I V I T I E S

ACTIVITY 1

1 On a plan of your school grounds, use a symbol or colour to show everything that is there (eg. courts, bins, seats, etc). Remember to show what happens in any areas you don't usually go into. Make a key for your plan.

ACTIVITY 2

2 Make a list of questions which you could ask other students and members of staff about what they like most about the school grounds, what they don't like and what other facilities they would like to be provided. Remember to ask students of all ages.

ACTIVITY 3

3 Your surveys will produce many different answers. Put together the answers found out by everyone in the class. Design a graph or chart to show the collated results. Write down what you have learnt from this survey.

ACTIVITY 4

4 On a map of your local area, mark in all the green spaces, outdoor sports facilities and schools. This information can be found in street atlases, Thompson's Local Directories and Telephone Directory Yellow Pages or from your local council or library.

Write down a list of which schools you think would be good sites to provide needed outdoor sports facilities or green spaces for public use.

ACTIVITY 5

5 Organise yourselves into groups of four.

You are going to design grounds which you think would be good for a school. Remember all the information you have researched and what you have discovered from your surveys. As a group, make a list of all the things you think should be included in your design.

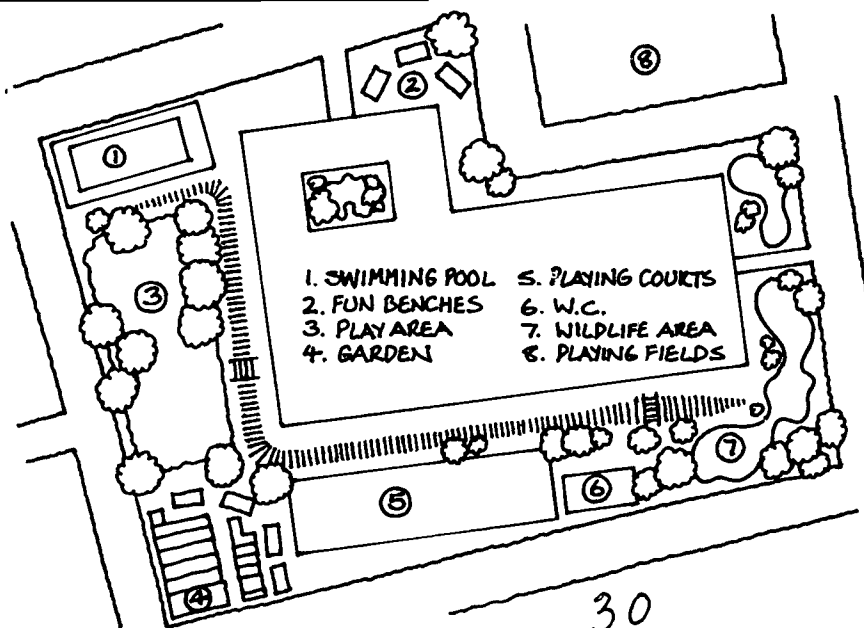



SCHOOL GROUNDS

S T U D E N T A C T I V I T I E S

ACTIVITY 6

6 On the site plan you have been given, your group now has to decide how to arrange the things from your list. Remember to keep to the scale of your site plan. You only have a limited space to work within and may have to leave some things out.

Some sports facilities are a fixed size:

- tennis courts 17m x 10m
- netball courts 30.5m x 15.2m
- football pitches 75m x 55m
- cricket fields 99m x 98m
- basketball courts 26m x 14m
- running tracks 80m x 40m
- volleyball court 18m x 9m
- hockey field 100m x 61m
- five-a-side football pitches 36m x 28m
- parking space for one car (minimum) 4.6m x 2.4m
- parking space for disabled drivers (minimum) 4.6m x 3.2m

Remember that some sports areas can be multi-purpose (eg tennis/netball/volleyball).

Make scale templates of the main facilities you wish to include, to help you with your design. Think also about appropriate places for things to be, eg. it might not be a good idea to put a pond next to the netball courts.

ACTIVITY 7

7 Using your ground plans, make a model of your school grounds. Make sure that everyone in your group has a job to do.

ACTIVITY 8

8 Draw or make anything in your playground which you think should be shown in greater detail, eg. a seat for a particular area, a bin, a corner of an ecological area, a piece of play equipment, a special tree or plant, a sculpture, a mural or mosaic.



PLAN OF SCHOOL GROUNDS

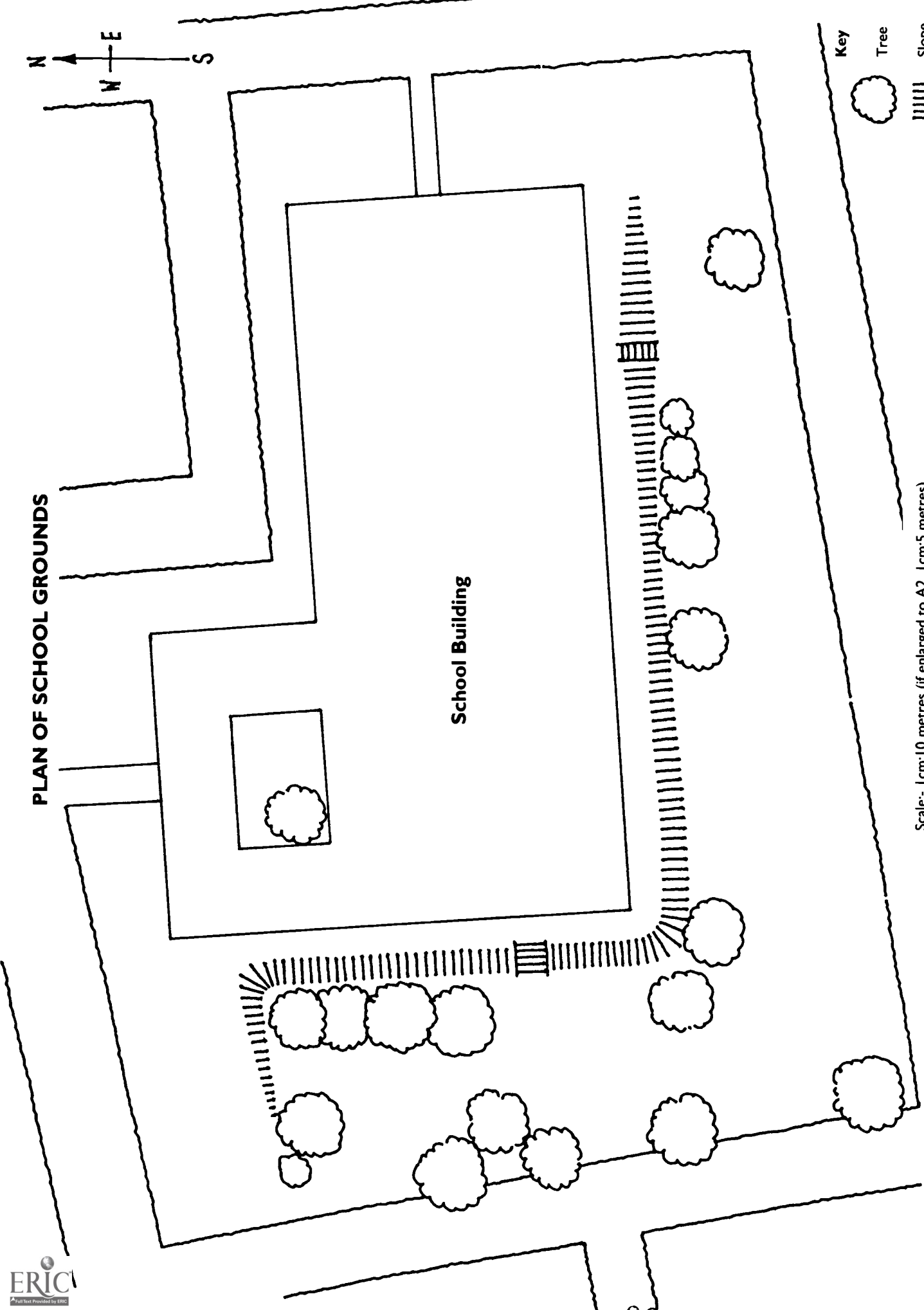
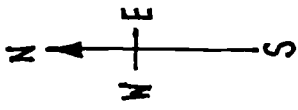

Key

- Tree (represented by a cloud-like shape)
- Slope (represented by vertical hatching)

Scale:- 1 cm:10 metres (if enlarged to A2, 1 cm:5 metres)

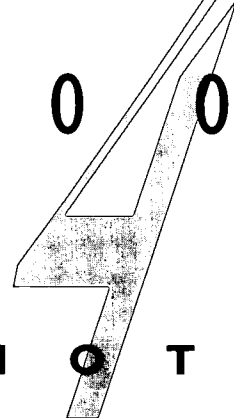

CLASSROOM

T E A C H E R S ' N O T E S

AIMS To develop:

- an empathy for the needs of other people;
- the co-operation of the class as a social group;
- the potential of registration time as a productive start to the day.

ISSUES

- What should the function of the classroom be?
- Should students have a secure personal space in school?
- What kind of atmosphere should classrooms create by their decor?
- How should classroom equipment best be organised?

Suggested scale: 5 cm : 1 m

ACTIVITIES

A A useful starting point is to think of all the different things that happen in the students' own classroom or tutor room. A good way to achieve this is to brainstorm with the whole group. (See introductory notes on brainstorming.)

B ACTIVITY 1

This can be developed in group discussion, which can then be fed back to the rest of the class. (See introductory notes on group discussion.)

C ACTIVITY 2

The group discussions will raise areas of conflict over use of the space, eg. 'We can't put the things we want on the walls because they're used for displaying geography work', or 'We're not allowed to practise dance there at break times because Miss won't let us move the tables', or 'We can't make models because they always get smashed'. Quotes from the discussion can be given as role play situations which can be shown to the class and then re-played trying out different responses and solutions. (See 'Theme Work' or 'World Studies 8-13' – listed in General Resources – for more on role play.) This exercise will be even more meaningful if some of the solutions discovered in the role play can be used to negotiate the real-life conflict areas.



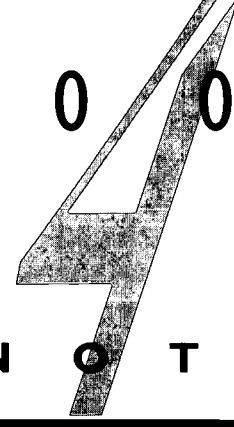

CLASSROOM

TEACHERS' NOTES

ACTIVITIES

D Of necessity, most tutor rooms are also subject rooms, while primary classrooms must suit the complete range of curriculum areas, both of which dictate the organisation of the space. Students should be encouraged to think about all the classrooms they have been in, both primary and secondary. Bearing in mind layout, decor, window areas, etc discussion can take place about likes and dislikes and how different effects are achieved.

As an aid to this discussion, students could be sent in pairs to research different classrooms around the school. A slide set showing a range of classrooms is available from Hackney Environmental Education Project. (See General Resources.)

Extension Activity

ROOM WORKSHEET

In order to start the students thinking about how the design of a room affects its function and ambience, pictures of nonspecific spaces can be presented and students' responses recorded.

Work on colour and mood can be developed through poems, written descriptions, alliterative words, discussion, etc. These will produce thoughts and ideas for use in later planning.

E ACTIVITY 3

Using shoe boxes (readily available on request from shoe shops) 'atmosphere' boxes can be created, using colour, texture, amount and position of light access, etc. The group can discuss which of these atmospheres would be conducive to the activities of a classroom.

F ACTIVITY 4

Students should now organise themselves into working groups in which they will carry through their design brief. (See introductory notes on practical group work.)

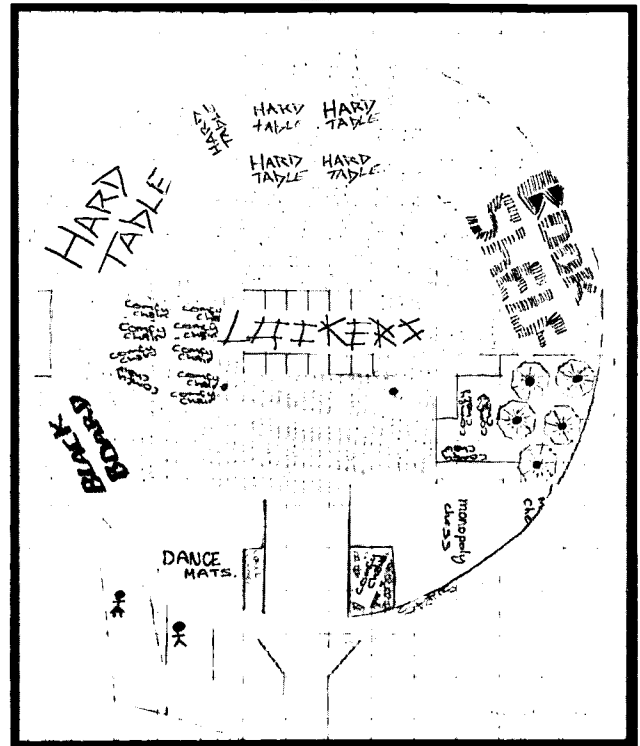

We chose to make our room round because it's more interesting. Most of the rooms we see around us are oblongs, squares or rectangles. Lots of children like to practise dancing and there isn't enough room so we decided to put dance mats in and the radio. There's a room which is sound proofed, so if anyone's doing quiet reading, they wouldn't have to listen to the music.

Sobe Dufeal

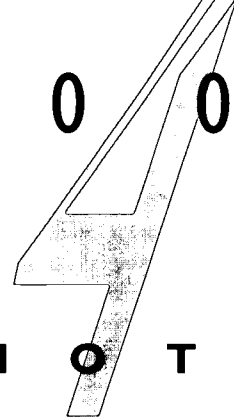

CLASSROOM

T E A C H E R S ' N O T E S

ACTIVITIES

ACTIVITY 5

Existing facilities should be measured and numbers and size of existing furniture should be recorded so that students will have information on which to base their own provision for a specified number of people.

G ACTIVITY 6

In their groups, students should discuss the experiences gained in their research and list which qualities, features and furniture they think should be included in a tutor room or classroom which would best suit the needs of all its users.

H ACTIVITY 7

Using the list of decisions made in (G), students should work together to make a plan of their design, beginning with a basic layout sketch. This can be developed on squared paper as a scale plan. (See introductory notes on scale drawing.) Elevation drawings with accompanying notes could also be made to develop ideas for furnishings, colour schemes, etc.

Extension Activity

ACTIVITY 8

The plan can be produced as a 'word drawing'. If large quantities of one item are needed, words can be photocopied.

I ACTIVITY 9

A model of the planned classroom can now be constructed. (See introductory notes on model making.) Each member of the group should take responsibility for different sections of the model eg. furniture, wall coverings, reading area, etc.

ACTIVITY 10

Larger scale models and designs of particular features can be developed.

- J** Evaluation.
(See introductory notes on evaluation.)

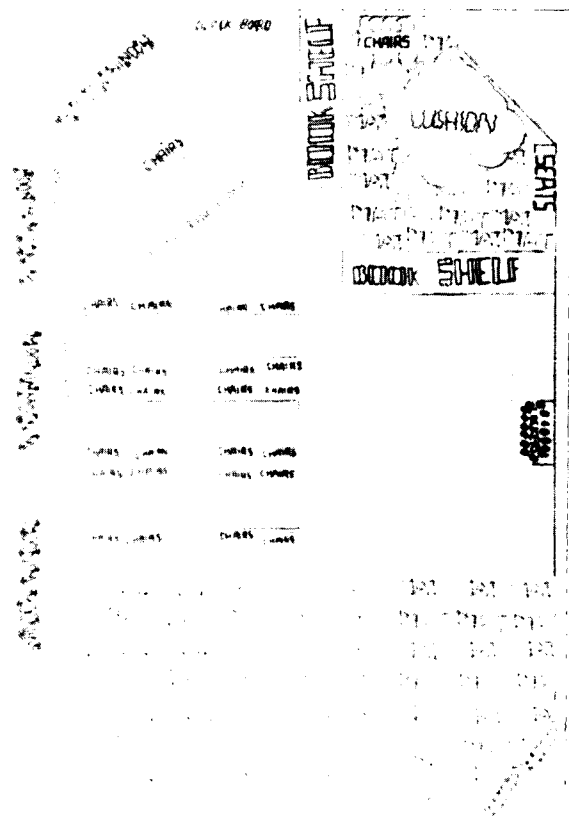

CLASSROOM

S T U D E N T A C T I V I T I E S

ACTIVITY 1

1 You have thought about all the things that currently happen in your classroom. In your group, discuss:

- a. what else you would like to be able to do in your classroom;
- b. if there is anything that stops you from doing the things you would like to do there;
- c. what other people need to do there.

Choose one of your group as scribe to make notes on important points in the discussion to feed back to the rest of the class.

ACTIVITY 2

2 You have been given a quotation about a conflict of needs in your classroom. In your group, each take the role of one of the people involved and try to think about that person's point of view.

How is that person feeling?

Try swapping roles. If people respond in different ways, are there different solutions to the problem?

Could you try any of these in real life?

ACTIVITY 3

3 Choose a feeling (eg. fear, fun, calm, etc.) and use materials whose colour, texture and shape express the mood, to create a shoebox 'room'.

Think about how much light you want in your 'room' and cut suitable size and shape holes in the box. You may want to cover them with coloured tissue or cellophane paper to add to the atmosphere. Remember to leave one hole uncovered to look through.

ACTIVITY 4

4 Organise yourselves into groups of four. How many people use your classroom at any one time? Measure the room and show the results on a plan. Decide whether you think the room is a good shape and size for the number of people using it.

ACTIVITY 5

5 Make a list of the number of tables and chairs and other necessary furniture in the room. Measure how big the tables are. Decide whether you think they are a good size for the number of people using them.



CLASSROOM

S T U D E N T A C T I V I T I E S

ACTIVITY 6

6 You are going to design a classroom which you think would be good for a school. Remember all the information you have researched about your own classroom.

As a group, make a list of:

- a. *the qualities you would like your classroom to possess;*
- b. *all the things you think should be in your classroom;*
- c. *the materials you think the furniture, floor coverings, etc should be made from;*
- d. *the size and shape you would like the room to be.*

ACTIVITY 7

7 Sketch a ground plan of how you would like your classroom to be arranged, using the list your group has produced. You can do this as a group, or do it individually and combine your ideas afterwards.

ACTIVITY 8

8 Make a 'word picture' from your ground plan. Choose suitable adjectives to describe each object in your room, eg. soft, thick carpet; strong, hardwearing mat; green, leafy plant, etc and write them out in a form of lettering (spiky, rounded etc.) that you think also expresses what the object is like. Stick them in the right places on your ground plan.

ACTIVITY 9

9 Using your ground plans, make a model of your classroom. Make sure that everyone in your group has a job to do.

ACTIVITY 10

10 Draw or make anything in your classroom that you think should be shown in greater detail, eg. a large scale model of one table and chair, a large scale model of a locker, a detailed sketch of a reading area, design and print a fabric for curtains, cushion covers, etc.

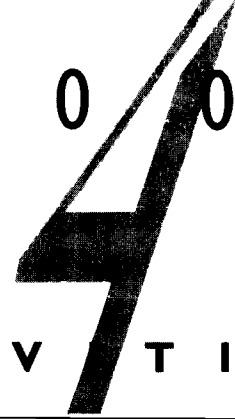

CLASSROOM

S T U D E N T A C T I V I T I E S

ROOM DESIGN

What do you think these rooms are used for?

- 1. _____
- 2. _____
- 3. _____

How would each room make you feel?

- 1. _____
- 2. _____
- 3. _____

What changes would you like to make to each room and why?

- 1. _____
- 2. _____
- 3. _____

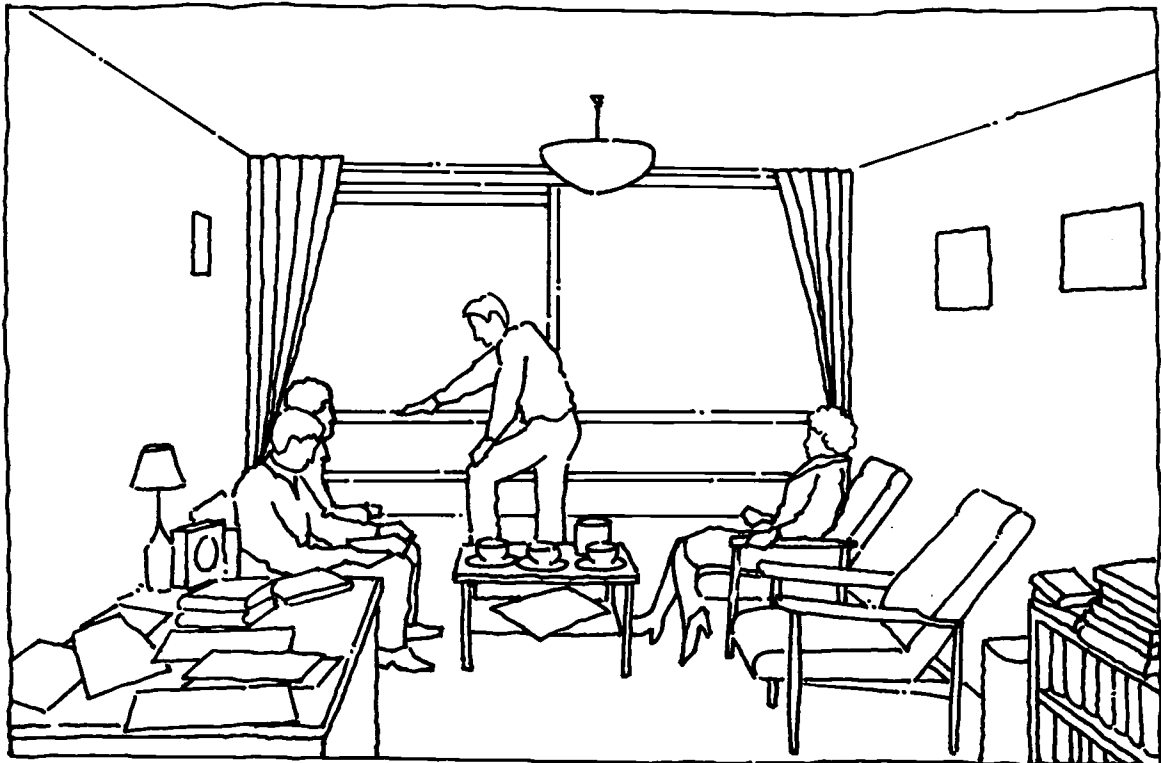

1.

CLASSROOM

S T U D E N T A C T I V I T I E S

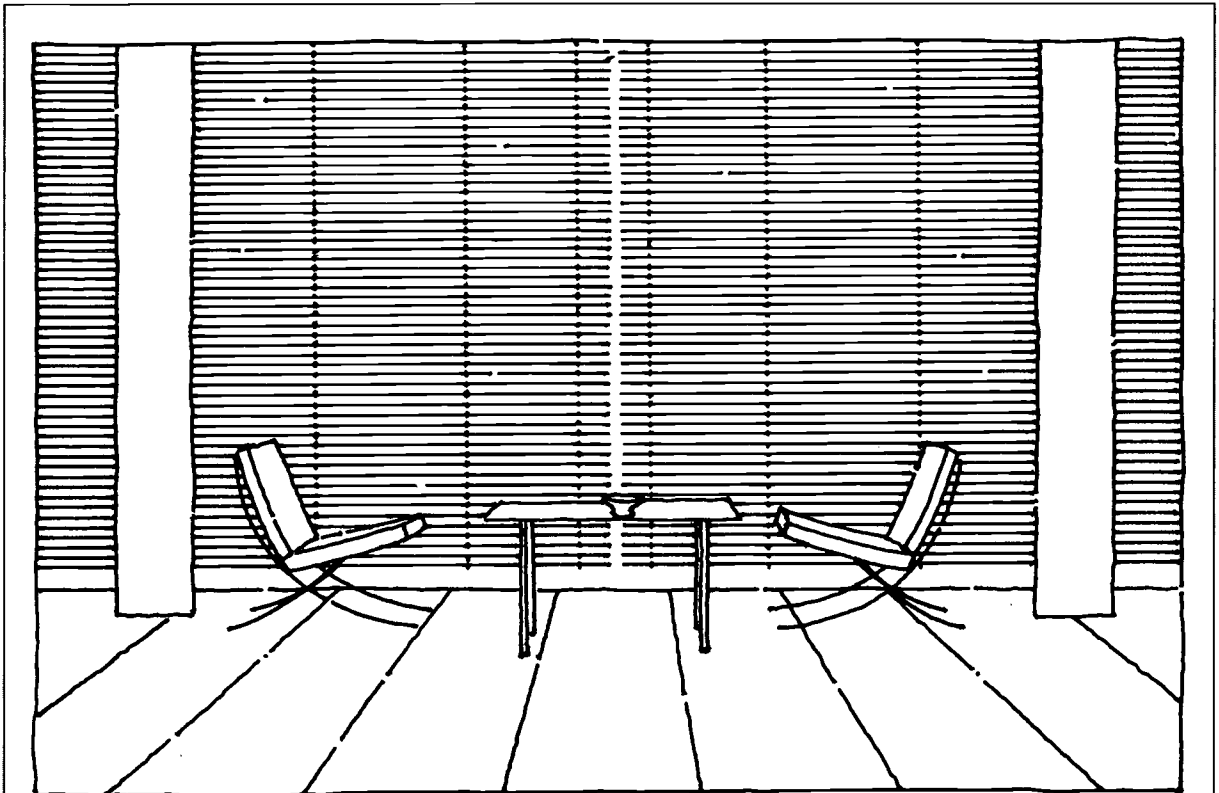

2.

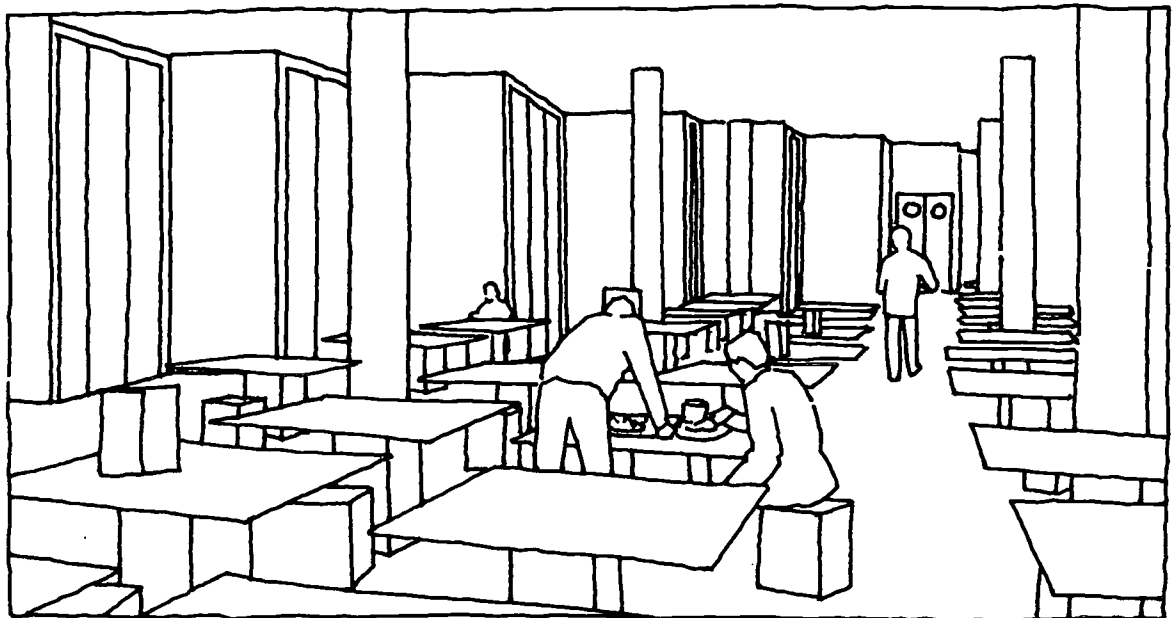

3.

WASTE AND RECYCLING

TEACHERS' NOTES

AIMS To develop:

- an understanding of the Earth's limited resources;
- an awareness of the pollution caused by waste disposal;
- an understanding of the potential of recycling.

ISSUES

- Is the school producing waste that could be recycled?
- Is the school producing unnecessary waste?
- How can recycling be organised efficiently?

Suggested scale: 5 cm : 1 m

ACTIVITIES

A ACTIVITY 1

Brainstorming is a good way to start the students thinking about all the types of waste that there are. (See introductory notes on brainstorming.) The brainstorm can be categorised by the students according to biodegradability, recyclability, materials, etc.

B WASTE WORKSHEET

The contents of dustbins in 1890, 1953 and 1982 can be compared to show the change in relative weights of each material over 100 years. Attention can be focused on the ways in which modern mass production generates packaging and the significant contribution made by the development of plastics.

C ACTIVITY 2

Using video or other resource material the journey of waste to a landfill site should be studied. The information can be recorded in writing or as a sequence of pictures/cartoons.

D ACTIVITY 3

A survey should be devised to investigate quantities, types and recycling potential of waste produced by different departments in school, eg. office, science department, kitchen, etc. (See

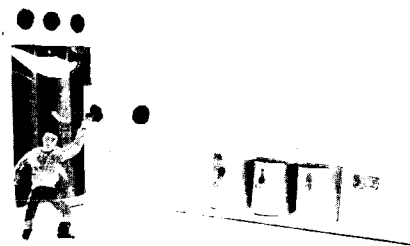

introductory notes on surveys.) The results of the surveys should be discussed and conclusions drawn.

E ACTIVITY 4

A useful method of recording the quantity and types of waste around the school is for groups to carry out surveys of specific areas, marking their results on a map of the school and its grounds, using colour codes and a key. Numbers and locations of bins can also be recorded and findings discussed.

Extension Activity

ACTIVITY 5

Students could design a bin which would encourage people to use it.

WASTE AND RECYCLING

T E A C H E R S ' N O T E S

ACTIVITIES

F The potential and responsibility for recycling certain wastes can be studied in several ways. Ideally a visit to a Recycling Centre should be arranged. If that is not possible, video materials can be used or a visitor from a voluntary recycling scheme, a council Recycling Officer or a local Friends of the Earth speaker could be invited into school where students could ask prepared questions.

The feasibility of creating a school compost heap should also be investigated.

Extension Activity

ACTIVITY 6

Letters could be written to Waste Management organisations, Friends of the Earth and other environmental organisations to obtain further information on recycling (see resource list).

ACTIVITY 7

Students could design an anti-litter or pro-recycling poster.

G ACTIVITY 8

Students should now organise themselves into working groups in which they will carry through their design brief. (See introductory notes on practical group work.)

As a group, students should discuss the experiences gained in their research and list which facilities they think should be included in a recycling centre which would be most suitable for a school. (See introductory notes on group discussion.) They should consider the possibility of such a centre also being available for community use.

H ACTIVITY 9

Using the list of decisions made in (G), students should work together to make plan and elevation drawings of their proposed sketch of the site with areas for various recyclable materials and access routes for collection vehicles. This can be developed on squared paper as a scale plan. (See introductory notes on scale drawing.)

Elevation drawings with accompanying notes could also be made to develop ideas for aesthetic screening of the site, to show logos and other signs denoting the contents of each container, etc.

I ACTIVITY 10

A model of the planned recycling site can now be constructed. (See introductory notes on model making.) Each member of the group should take responsibility for different sections of the model, eg. the various skips, bins, screening, access, etc.

ACTIVITY 11

Larger scale models and designs of particular skips or bins, which would encourage people to use them, can be developed.

J Evaluation.
(See introductory notes on evaluation.)

WASTE AND RECYCLING

T E A C H E R S ' N O T E S

RESOURCES

Spring Clean Your Planet - Ralph Levinson
Beaver Books
Interesting facts and practical experiments with waste.

Stefi Looks at Rubbish - Grazia Nidasio
Michael Benn and Associates
Comic strip book for children containing a lot of information in an accessible way.

Waste Not
Charities Aid Foundation
Directory of charities who welcome 'waste' for recycling.

The Dustbin Pack - Rob Stephenson and Harriet Blanchard
Waste Watch
Worksheets for primary schools with teachers' notes on all aspects of waste and recycling.
Available free from: Department of Trade and Industry, Business and the Environment Unit, Room 1016, Ashdown House, 123 Victoria Street, London, SW1E 6RB. Tel: 071 215 6082

Friends of the Earth Handbook -
Ed. Jonathon Porritt
Optima
Chapter on 'Wealth and Waste' gives information on recycling of many materials.

Blueprint for a Green Planet - John Seymour and Herbert Girardet
Dorling Kindersley
Chapter on 'Dismantling the Rubbish Mountain'.

Making Global Connections - Ed. David Hicks and Miriam Steiner
Oliver and Boyd
Chapter on 'Wasted Wealth'.

Waste
World Wide Fund for Nature
Double sided chart on treatment of waste around the world.

Waste
Junior Education Topic Pack July 1990
Full of useful ideas and resources.

Recycled Paper Making
P N L Press, Holloway Road, London, N7 8DB.

Organisations which supply materials and information:

Tidy Britain Group, The Pier, Wigan, WN3 4EX.
Friends of the Earth, 26-28 Underwood Street, London, N1 7JQ.

Greenpeace, Greenpeace House, Canonbury Villas, London, N1 2PN.

Recycling organisations:

Berryman Glass, Cullett Merchant, Monkhill Goods Yard, Ferrybridge, Pontefract, Yorkshire, WF8 2NX.

Waste Watch, NCVO, 26 Bedford Square, London, WC1B 3HU.

Aluminium Can Recycling Association,
I-Mex House, 52 Blucher Street, Birmingham, B1 1QU.

Cheshire Recycling, Bridgewater Mill, North Road, Ellesmere Port, South Wirral, L65 1AF.

Plastic Omnium, Haiesford 7, Telford, Shropshire, TF7 4RQ.

Make plastic containers for recyclable goods.

British glass, Northumberland Road, Sheffield, S10 2UA.

PD Rotomouldings, Rotation House, Thornton Heath, Surrey, CR7 7HL.

British Plastics Federation, 5 Belgrave Square, London, SW1X 8PD.

SWAP (Save Waste and Prosper), Jonathon Ayres, Environmental Promotion Officer, Dept of Housing and Environmental Health, Leeds City Council, Selectapost 12, Dugby House, 133 Albion Street, Leeds, LS2 8PP.

WASTE AND RECYCLING

S T U D E N T A C T I V I T I E S

ACTIVITY 1

1 Sort all the types of waste you have listed in your brainstorm. You may want to decide whether items of waste are recyclable or not, whether they will rot (are they biodegradable), or simply put them into groups of different materials.

ACTIVITY 2

2 Describe the journey of a piece of waste from when it is first produced until it reaches the place where it is finally disposed of by the refuse company. Your description can be done as a piece of writing or as a series of pictures.

ACTIVITY 3

3 Make a list of questions which you could ask staff in different departments in your school to find out how much and what types of waste they produce each week and whether they think some of it could be recycled.

ACTIVITY 4

4 Some parts of your school are probably messier and more littered than others. On a map of your school and its grounds, use different colours to mark all the types of rubbish you find. You could also mark on litter bins. Make a key for your map.

ACTIVITY 5

5 Design a bin which you think would encourage people to use it. It could be musical or talk to people or have an interesting mechanical action, or it could simply be a good attractive design.

ACTIVITY 6

6 Choose an organisation which is responsible for recycling or which manufactures equipment for recycling, such as bottle banks or paper skips. Write a letter asking for more information about that organisation and its products.

ACTIVITY 7

7 Design a poster aimed at encouraging people in your school to use the bins.

Or:

Design a poster which would encourage people to use a can or bottle bank.



WASTE AND RECYCLING

S T U D E N T A C T I V I T I E S

ACTIVITY 8

8 Organise yourselves into groups of four. You are going to design a recycling centre which you think would be good for the school. Remember all the information you have researched and what you discovered from your surveys.

As a group, make a list, or roughly sketch ideas for:

- a. *all the different types of materials you want to recycle;*
- b. *the different shapes containers for different materials should be;*
- c. *the materials you want to make your containers out of;*
- d. *ways of screening your site from general view, eg. trees, fencing, etc;*
- e. *logos or signs to show which waste materials should go into which container.*

ACTIVITY 9

9 Sketch a ground plan or do a drawing of how you would like your recycling site to be arranged using the list your group has produced. You can do this as a group, or do it individually and combine your ideas afterwards.

ACTIVITY 10

10 Using your plans and drawings, make a model of your recycling area. Make sure everyone in your group has a job to do.

ACTIVITY 11

11 Draw or make anything in your recycling centre which you think should be shown in greater detail, eg. a can bank which would encourage students to use it.

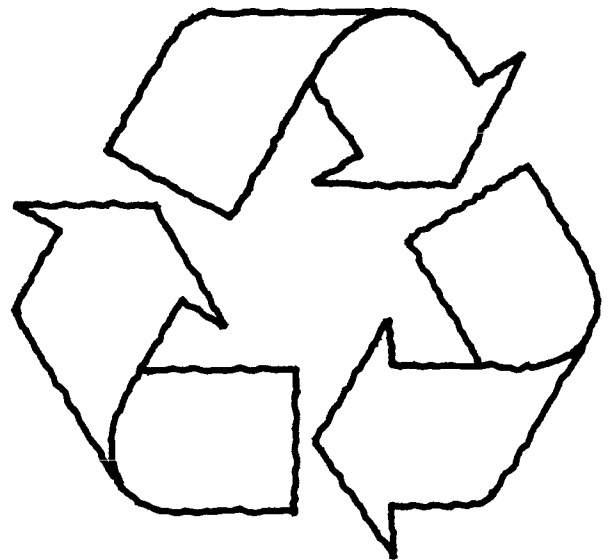

WASTE AND RECYCLING

S T U D E N T A C T I V I T I E S

Household Waste

The average contents of dustbins has changed considerably over 100 years.

All figures shown are % by weight.

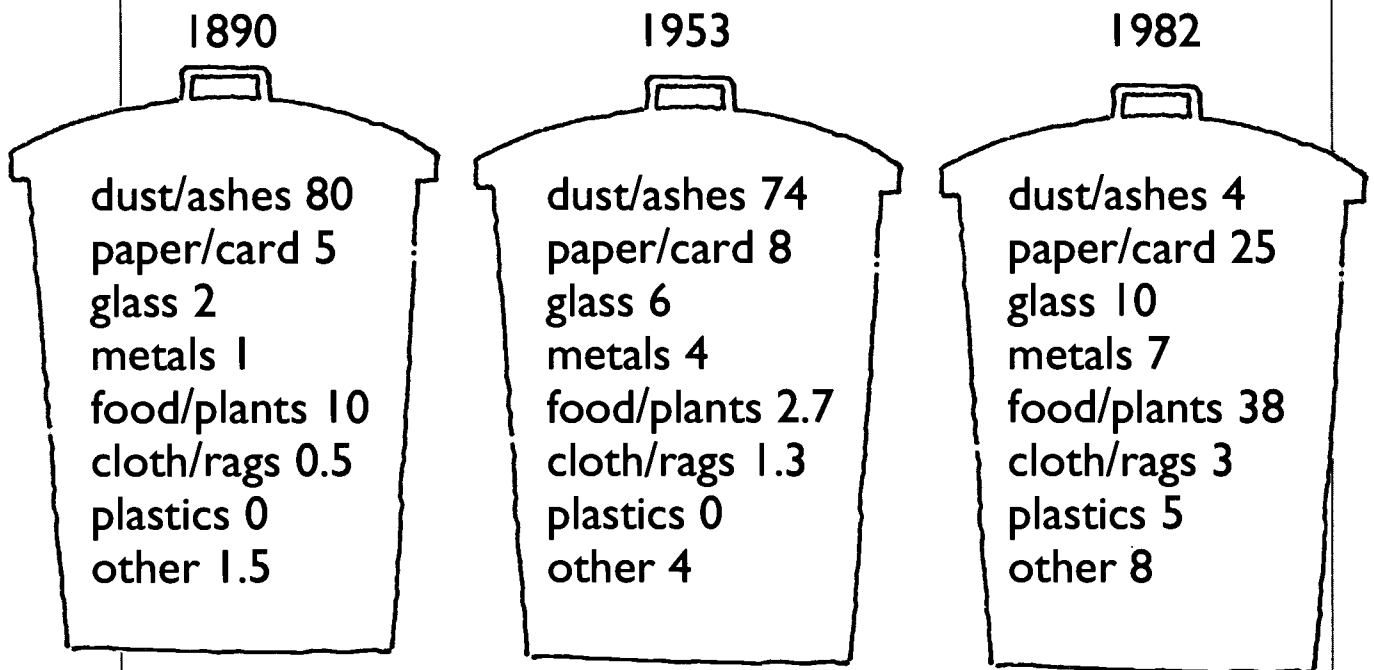

Which item of rubbish has decreased the most between 1890 and 1982?

Which item of rubbish has increased the most between 1890 and 1982?

Why is there so much more waste paper in 1982?

Why was there no plastic waste in 1890 and 1953?

Why is there more waste glass in 1953 and 1982?

Which of the items of rubbish could be recycled?

Can you think of reasons why the figures for food and garden waste have changed over the years?

What are the other sorts of rubbish which would be called 'other'?



PERFORMING ARTS

T E A C H E R S ' N O T E S

AIMS To develop:

- an awareness of the needs of different users;
- an awareness of the value of performing arts;
- the possibility of providing a resource for the community.

ISSUES

- Which performing arts activities should be provided for in schools?
- Do different aspects of the performing arts curriculum have conflicting needs?
- Should facilities be available to the community outside school hours?
- What design offers the most flexible space for performances/group practice/workshops?

Suggested scale: 1 cm : 5 m

ACTIVITIES

A **ACTIVITY 1**

Brainstorming is a good way to start the students thinking about all the possible activities that might take place in a performing arts space. (See introductory notes on brainstorming.) The brainstorm can be categorised by the students working in groups according to the kinds of facilities they would need.

B The value of participating in and watching performing arts should be discussed with the class.

C **ACTIVITIES 2 & 3**

A survey should be devised to discover the opinions of students, teachers and support staff about existing facilities and which performing arts they would like to see provided for in schools. (See introductory notes on surveys.)

D **ACTIVITY 4**

Attention should be drawn to the place of school performing arts facilities as part of the wider community. Using a map of the local area, existing performing arts facilities and schools should be located and marked, to see if schools could be providing performing arts facilities unduplicated in their immediate locality.

E The possibilities of community use of schools' performing arts facilities out of school hours should be discussed in groups, drawing attention to the advantages and disadvantages, management and organisation, etc. (See introductory notes on group discussion.) The main arguments presented for and against community use should be written up.

F A visit to a local arts centre should be organised to assess the range of facilities and to investigate some of the problems and solutions regarding mixed use.

Extension Activities

Letters to arts centres and theatres (eg. National Theatre), requesting ground plans of their performance spaces can provide further useful research information for the students' own designs.

Plays already studied in the school curriculum can be analysed for the most suitable type of staging and audience layout, linked to the ground plans of performance spaces.

G **SOUND WORKSHEET**

An experiment to investigate sound insulation should be carried out to raise students' awareness of the problems associated with noisy activities and to suggest possible solutions.

PERFORMING ARTS**T E A C H E R S ' N O T E S****ACTIVITIES****H** **ACTIVITY 5**

Students should now organise themselves into working groups in which they will carry through their design brief. (See introductory notes on practical group work.) The school's own performing arts facilities should be measured so that students have an idea of the room sizes suitable for different activities.

Extension Activity

The students could organise seating plans for an assembly or performance in the school hall, considering how they would cater for a large audience, including students, staff and parents and where the best position for staging, scenery and lighting would be.

I **ACTIVITY 6**

As a group, the students should discuss the experiences gained in their research and list what they think should be included in a school performing arts facility which would best suit the needs of all its users.

J **ACTIVITY 7**

Working to a given scale, the students should cut out templates of the rooms they would like to include from the list made in (I). They should then experiment with different layouts until a group decision is reached on the most practical arrangement. The templates should then be stuck down to make a working ground plan.

K **ACTIVITY 8**

A model of the performing arts space can now be constructed. (See introductory notes on model making.) Each member of the group should take responsibility for different sections of the model.

ACTIVITY 9

Larger scale drawings and models can be made of particular features.

L **Evaluation.**
(See introductory notes on evaluation.)

PERFORMING ARTS

S T U D E N T A C T I V I T I E S

ACTIVITY 1

1 In your groups, sort the performing arts activities listed in your brainstorm according to which ones could take place in the same spaces.

Think about:

- a. the size of room they would need;
- b. any special facilities or equipment they would require (eg. floor surface, sound proofing, stage blocks, etc.).

ACTIVITY 2

2 Make a list of questions which you could ask other students and members of staff about what they think of the performing arts facilities in your school and which performing arts they would like to see provided for in a school. Remember to ask students of all ages.

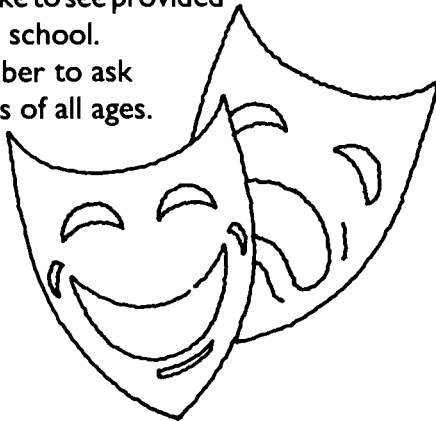

ACTIVITY 3

3 Your surveys will produce many different answers. Put together the answers found out by everyone in the class. Design a graph or chart to show the collated results. Write down what you have learnt from this survey.

ACTIVITY 4

4 On a map of your local area, mark in all the existing performing arts facilities and schools. This information can be found in Thompson's Local Directories, Yellow Pages and from your local library or council offices. Write a list of which schools you think would be in good sites to provide needed performing arts facilities.

ACTIVITY 5

5 Organise yourselves into groups of four. Between you, measure your school's performing arts space (halls, musical instrument teaching rooms, etc.) and write a list of the length, width and height of each room. Decide whether you think they are a good shape and size for their purpose.

ACTIVITY 6

6 You are going to design performing arts facilities which you think would be good for a school. Remember all the information you have researched and what you have discovered from your surveys.

As a group, make a list of:

- a. the performing arts activities you think should be provided for in a school;
- b. the facilities you think should be provided (number and sizes of rooms);
- c. the materials you think should be used (for walls, floors, screens, etc).



PERFORMING ARTS

S T U D E N T A C T I V I T I E S

ACTIVITY 7

7 Using the list your group has produced, make templates of the rooms you wish to include in your design. As a group, work out the best arrangement for them. Think about noise disturbance between rooms, public access for performances, whether

or not the room needs natural light, etc. If necessary, your facilities could be arranged on more than one floor. When you have reached a decision, stick your templates down. You now have a ground plan of your design.

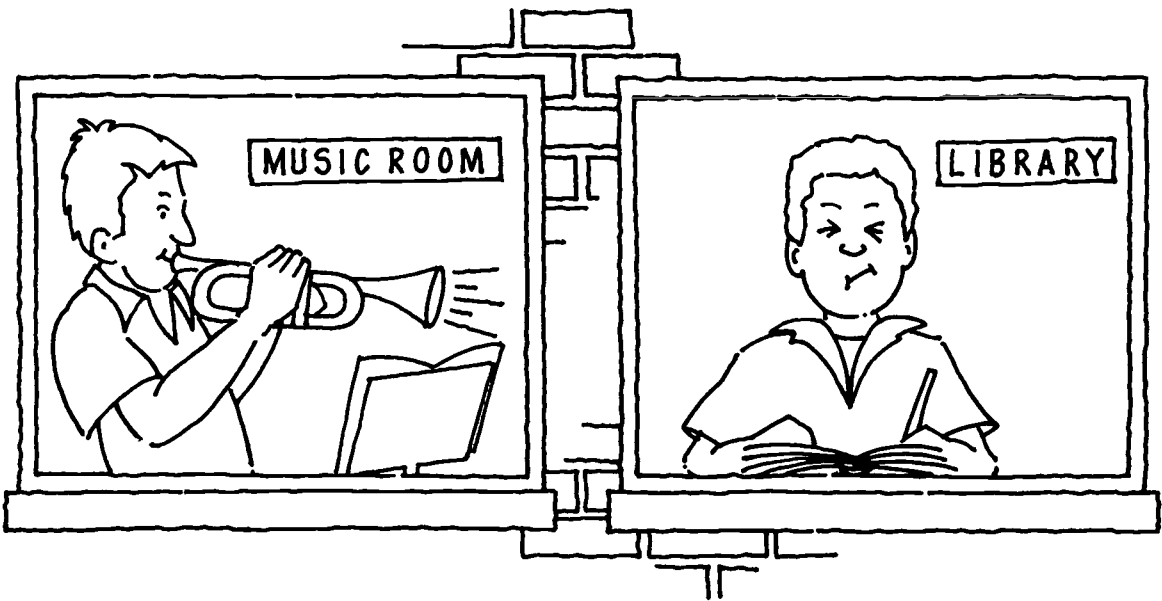

ACTIVITY 8

8 From the ground plan, make a model of your performing arts facility. Remember that the size and purpose of the room will affect the ceiling height (eg. a large hall that sometimes has performances will need a higher ceiling than a small practice room). You may need to adjust your ground plan accordingly. Make sure that everyone in your group has a job to do.

ACTIVITY 9

9 Draw or make anything in your performing arts facility that you think should be shown in greater detail, eg. flexible seating, sketches of possible performance layouts, a working light rig.

PERFORMING ARTS

S T U D E N T A C T I V I T I E S

WHICH MATERIALS SOFTEN SOUND?

You will need this apparatus:

a box with a lid; a stop clock with a loud tick; a metre rule; materials to put round the clock eg. cotton wool, rockwool, cloth, polystyrene. (It is advisable that plastic gloves are worn when handling rockwool.)

1. Start the clock and put it in the box. Close the box.
2. Move away until you can no longer hear the tick.
3. Use the metre rule to measure how far away you are from the box.
4. Repeat the exercise wrapping the clock in a different material each time.

Record the distances you moved away in this table:

MATERIAL	DISTANCE
EMPTY BOX	
COTTON WOOL	
ROCKWOOL	
CLOTH	
POLYSTYRENE	

Which material was best at softening sound?

What have you found out about the different materials and the way they act as soundproofing?

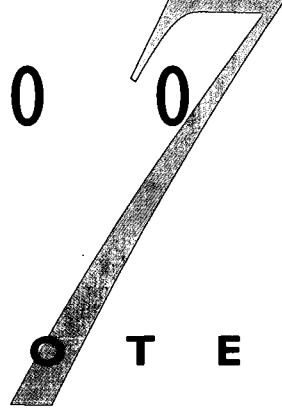

INDOOR SPORTS FACILITIES

T E A C H E R S ' N O T E S

AIMS To develop:

- an understanding of the need for exercise;
- an increased awareness of the possible range of sports activities at school and outside;
- the possibility of providing a resource for the community.

ISSUES

- What sports activities need to be provided for?
- Are all sports accessible to people with disabilities?
- Should facilities be available to the community which include provision extra to the school's needs eg. cafe, paydesk?

Suggested scale: 1 cm : 1 m

ACTIVITIES

A A useful starting point is for students to understand through class discussion the importance of exercise and sports for health and enjoyment as well as for developing co-operation and social networks. (See introductory notes on group discussion.) A visit from a local authority Sports Development worker could be arranged to stimulate the discussion.

B **ACTIVITY 1**

Brainstorming is a good way to start the students thinking about all the possible sports activities. (See introductory notes on brainstorming.) The brainstorm can be categorised into outdoor and indoor activities, marking the indoor ones students feel are suitable for school provision.

C **ACTIVITIES 2 & 3**

A survey should be devised to discover the activities which would be most popular with students of all ages. (See introductory notes on surveys.)

D **ACTIVITY 4**

Attention should be drawn to the place of school sports facilities as part of the wider community. Using a map of the local area, existing indoor

sports facilities and schools should be located and marked to see if schools could be providing sports facilities unduplicated in their immediate locality.

E The possibilities of the community use of indoor sports facilities out of school hours should be discussed in groups, drawing attention to the advantages and disadvantages, management and organisation, need to provide paydesks, a cafe, etc. The main arguments presented for and against community use should be written up.

F A visit to a local sports facility should be organised to assess the range of facilities, investigate the management and timetabling of various activities and to consider the dimensions of the spaces.

G **ACTIVITY 5**

Students should now organise themselves into working groups in which they will carry through their design brief. (See introductory notes on practical group work.) In their groups, they should discuss the experiences gained in their research and list which facilities, features and organisational methods they think should be provided in a school indoor sports facility which would best suit the needs of all its users.

INDOOR SPORTS FACILITIES

T E A C H E R S ' N O T E S

ACTIVITIES

H **ACTIVITY 6**

The groups are provided with a list of standard measurements for specific sports. Working to a given scale, the students should cut out templates of the rooms/halls/spaces they would like to include from the lists made in (G).

They should then experiment with different layouts until a group decision is reached on the most practical arrangement. The templates should then be stuck down to make a working ground plan.

I **ACTIVITY 7**

A model of the planned sports facility can now be constructed paying particular attention to the necessary heights of some areas, particularly if the proposed facilities are designed for a building with more than one floor. Each member of the group should take responsibility for particular sections of the model.

Extension Activity

If the facilities are intended for community use, students could design a poster advertising it, or write a newspaper article about its opening.

J Evaluation.
(See introductory notes on evaluation.)

Should school sports facilities be open to the public?

I would allow most of the community to use the sports area once I was sure they would not vandalise and damage property. It would be a good addition to the community because it would increase people's enjoyment of activities during their spare time . . .

. . . it is more important to think of people's physical well-being and enjoyment than worrying about vandalism.

*Kevin Flaberty, Aaron Fontaine, Nigel Hunt,
Karim Miah, John Abad*

INDOOR SPORTS FACILITIES

S T U D E N T A C T I V I T I E S

ACTIVITY 1

1 Sort your class' ideas into two lists of indoor and outdoor sports activities. Mark the indoor sports activities you think should be provided for in a school.

ACTIVITY 2

2 Make a list of questions which you could ask other students about which sports facilities they would like to see provided for in a school. Remember to ask students of all ages.

ACTIVITY 3

3 Your surveys will provide many different answers. Put together the answers found out by everyone in the class. Design a graph or chart to show the collated results. Write down what you have learnt from this survey.

ACTIVITY 4

4 On a map of your local area, mark all the indoor sports facilities and schools. This information can be found in street atlases, Thompson's Local Directories, Yellow Pages, or from your local council or library. Write a list of which schools you think would be in good sites to provide needed indoor sports facilities.

ACTIVITY 5

5 Organise yourselves into groups of four. You are going to design an indoor sports facility which you think would be good for a school. Remember all the information you have researched and what you have discovered from your surveys.

As a group, make a list of:

- a. the different sports you will include;
- b. the extra facilities you will provide if it is going to be used by the community;
- c. the changing facilities/showers etc you will need to provide;
- d. the activities which could share the same space (eg. a gym could be marked out with badminton, basketball and volleyball courts for use at different times).

ACTIVITY 6

6 Using the list your group has produced and the provided list of standard measurements, make templates of the spaces you would like to include in your design. As a group, work out the best arrangement for them. Remember that changing rooms need to be provided near to certain sports, eg. swimming, and that it is essential to provide a place to store sports equipment safely which is in easy reach of the facilities. If necessary, your facilities could be arranged on more than one floor. When you have reached a decision, stick your templates down. You now have a ground plan of your sports facilities.

INDOOR SPORTS FACILITIES

STUDENT ACTIVITIES

ACTIVITY 7

7 Using your ground plan, make a model of your sports facility. Remember that some sports need high rooms (eg. trampolining) while others do not need to be more than average height (4 metres). Make sure everyone in your group has a job to do.

Some fixed size facilities:

squash court 10 m x 7 m

badminton court 13 m x 6 m

volleyball court 18 m x 9 m

netball court 30.5 m x 15 m

archery/rifle room 25 m x 6 m

basketball court 26 m x 14 m

tennis court 17 m x 10 m

swimming pool 25 m x 10 m or 50 m x 25 m

table tennis: 1 table 1.5 m x 2.7 m room for 4 tables 13 m x 13 m

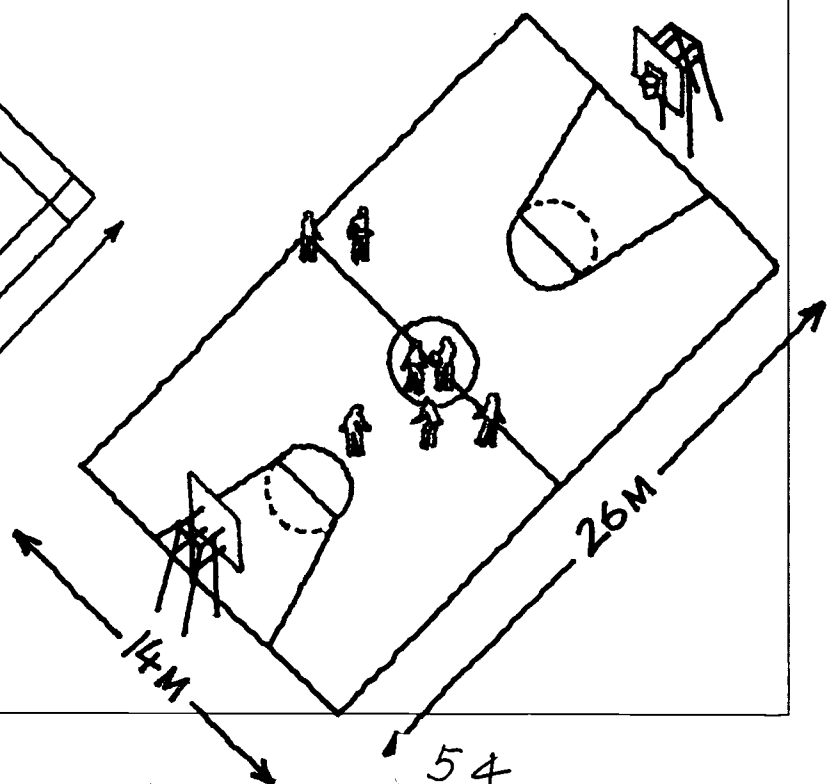
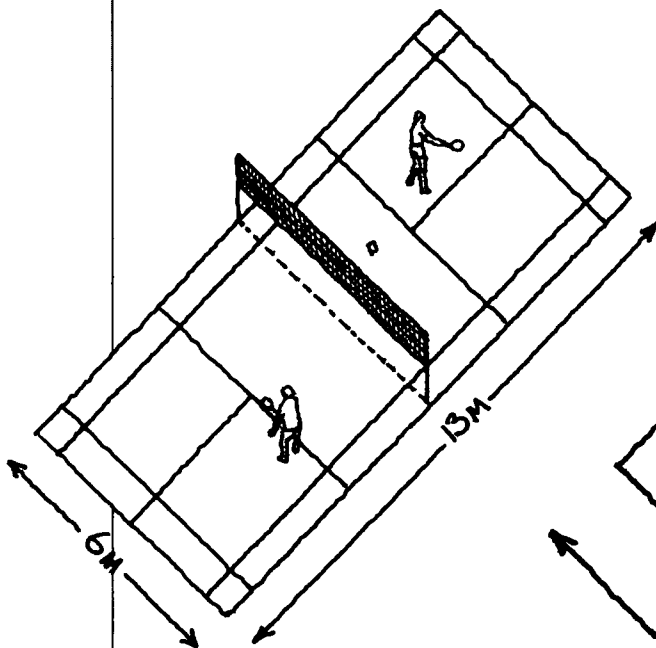
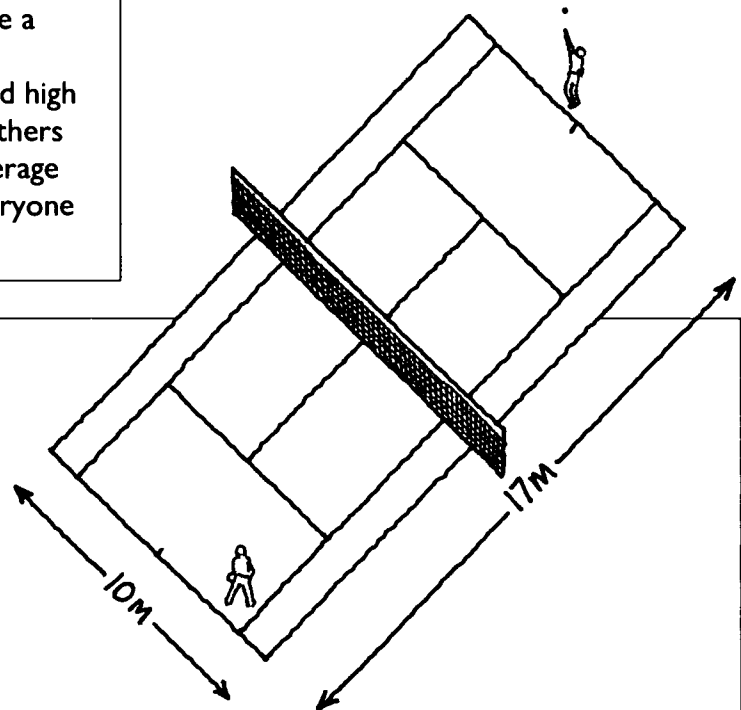

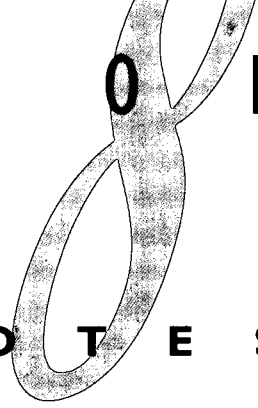

SCHOOL LIBRARY

T E A C H E R S ' N O T E S

AIMS To develop

- an awareness of the possibility of using a library for leisure, information and private study.

ISSUES

- Is the library designed so that people can use it?
- For what purposes can a library be used?
- What is the job of a school librarian?

Suggested scale: 2 cm : 1 m

ACTIVITIES

A ACTIVITY 1

A useful starting point is to examine the layout of the school's own library.

ACTIVITY 2

Dimensions and existing facilities should be measured and the number of tables, bookcases/shelves etc. listed. Also specific areas for study, reference and quiet reading should be noted. The information can then be used to make a basic layout sketch. This can be developed on squared paper as a scale plan. (See introductory notes on scale drawing.)

LIBRARY DESIGN.



B ACTIVITY 3

The person with responsibility for managing the library could be interviewed to ascertain the details of library management and organisation, such as opening times, what the job entails, how the facilities might be improved or changed, whether the library fulfils the needs of its users, etc.

C ACTIVITIES 4 & 5

A survey should be devised to discover the opinions of students and members of staff about existing facilities. (See introductory notes on surveys.)

D ACTIVITY 6

Students should now organise themselves into working groups in which they will carry through their design brief. (See introductory notes on group work.) In their groups, students should discuss the information gained in their research and list which qualities, features and organisational methods they think should be included in a school library which would best suit the needs of all its users. (See introductory notes on group discussion.)

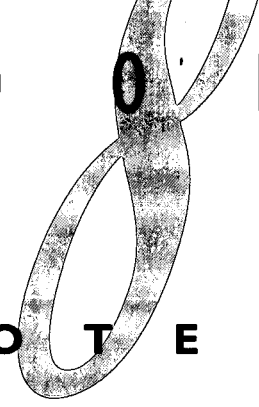

SCHOOL LIBRARY

TEACHERS' NOTES

ACTIVITIES

E ACTIVITY 7

Using the list of decisions made in (D), students should work together to make a plan of their proposed design, beginning with a basic layout sketch. This can be developed on squared paper as a scale plan. (See introductory notes on scale drawing.) Elevation drawings with accompanying notes could also be made to develop ideas for textiles, murals, colour schemes, book/newspaper/magazine display stands, etc.

We chose the design of the roof from a picture we found in the Architectural Source Book of a restaurant in Mexico. It's a bit like the Sydney Opera House in Australia.

We did a star shape because of the number of rooms we needed, a section for toilets, a section for homework, computers etc.

The outsides of the rooms are going to be covered in glass and alternate ones will be sitting areas and alternate areas will be flower beds but the public won't be allowed in. They'll just look pretty from the outside.

Nurcan

F ACTIVITY 8

A model of the planned library can now be constructed. (See introductory notes on model making.) Each member of the group should take responsibility for different sections of the model.

ACTIVITY 9

Larger scale models and designs of particular features can be developed.

G Evaluation.

(See introductory notes on evaluation.)

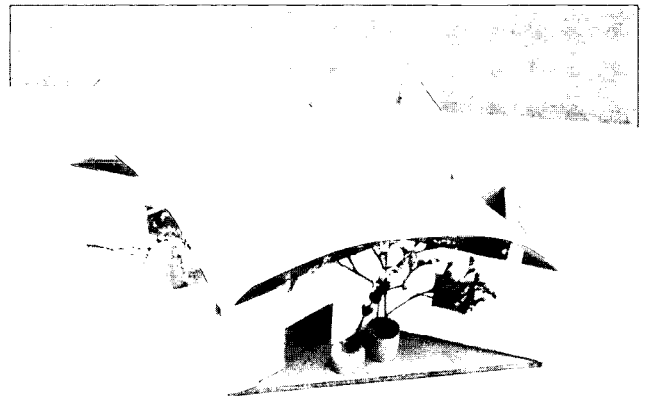

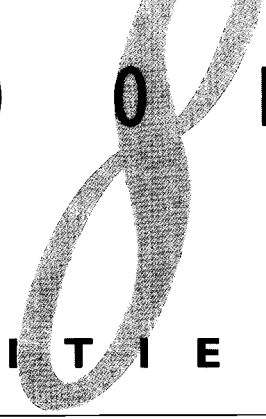

SCHOOL LIBRARY

S T U D E N T A C T I V I T I E S

ACTIVITY 1

1 Measure your school library and show the results on a plan.

ACTIVITY 2

2 Make a list of the number of bookcases, shelves, worktables, etc. of various sizes, in the library.

ACTIVITY 3

3 Make a list of questions for the person responsible for managing your school library to find out about their work, any problems they might have and any changes they would like to see made.

ACTIVITY 4

4 Make a list of questions which you could ask other students and members of staff who use the library about what is good and bad about its design, whether they think it could be improved and how they feel when they are there. Remember to ask students of all ages.

ACTIVITY 5

5 Your surveys will produce many different answers. Put together the answers found out by everyone in the class. Design a graph or chart to show the collated results. Write down what you have learnt from this survey.



SCHOOL LIBRARY**S T U D E N T A C T I V I T I E S****ACTIVITY 6**

6 Organise yourselves into groups of four. You are going to design a library which you think would be good for a school. Remember all the information you have researched about your own school library and what you have discovered from your surveys.

As a group, make a list of:

- a. *the qualities you would like your library to possess;*
- b. *all the things you think should be in your library;*
- c. *the materials you think the bookshelves, tables, chairs, floor coverings, etc. should be made from;*
- d. *the size and shape you would like the room to be.*

ACTIVITY 7

7 Sketch a ground plan of how you would like your library to be arranged, using the list your group has produced. You can do this as a group, or do it individually and combine your ideas afterwards.

ACTIVITY 8

8 Using your ground plans, make a model of your library. Make sure everyone in your group has a job to do.

ACTIVITY 9

9 Draw or make anything in your library which you think should be shown in greater detail, eg. a large scale model of a comfortable reading chair, a stand for newspapers/magazines, paperbacks or new library books, reading lights for study areas, design and print of a fabric for blinds, cushions, etc.

ENERGY CONSERVATION AND LIFT DESIGN

TEACHERS' NOTES

AIMS To develop:

- an awareness of the importance of energy conservation;
- an awareness of alternative energy sources;
- an awareness of the needs of disabled users.

ISSUES

- Why is a lift necessary?
- Should school buildings be accessible to disabled students and teachers?
- Is the most efficient use being made of alternative energy sources and energy conservation?

ACTIVITIES

A WORKSHEET 1

By asking the schoolkeeper about the amount of electricity used per year in school and comparing it to the amount used in their home and other buildings, students can begin to understand the energy needs of a large institution, eg. to power a lift, for lighting, computers, etc.

B WORKSHEET 2

They can then begin to think about ways of conserving energy, eg. by lowering room temperatures. A survey of the school building should be made to look for places where energy is being wasted or conserved (see energy conservation information under Issues Common to all Sections).

Extension Activities

WORKSHEET 3

Insulation Experiments.

ACTIVITY 1

Make a poster encouraging students to switch off unnecessary lights and close outside doors. Posters should be displayed in appropriate places around the school.

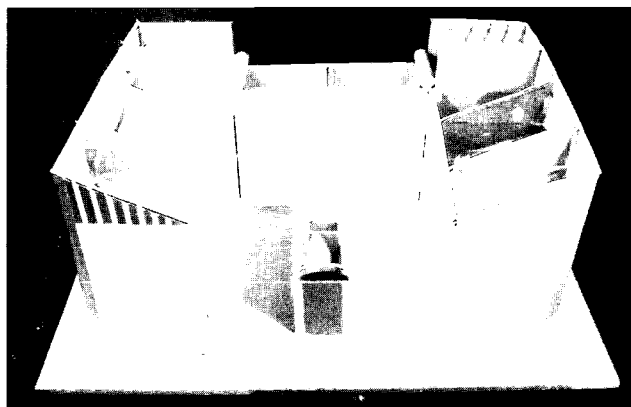

C A study of renewable energy sources such as solar and wind power can be made using video and written materials; solar cells and models of windmills could be introduced. Students could also write letters requesting information to organisations concerned with energy conservation.

D Students should attempt to make a working mechanism for a lift and devise ways of powering it. Possible approaches:

- investigate gears and pulley systems;
- operation of motors;
- counterweight systems;
- using Technic Lego or other construction kits;
- use of alternative power sources to charge batteries.

These approaches depend very much on age of students and availability of equipment.

ENERGY CONSERVATION AND LIFT DESIGN

TEACHERS' NOTES

ACTIVITIES

E ACTIVITY 2

To introduce the design brief, a useful starting point is for groups to take a wheelchair around the school to investigate accessibility to various areas of the building.

ACTIVITY 3

Students could either use an existing map/plan of the school or make one of the route they take and mark on the hazards they encounter.

- F** If there are enough buildings with lifts in the area (eg. tower blocks, large stores, museums etc.), it would be useful to visit them and study the different designs, dimensions, aesthetic qualities and features such as speed between floors, details of operating buttons and information panels. Alternatively, a collection of slides could be shown (available from Hackney Environmental Education Project - see resources).

ACTIVITY 4

Students could write letters to lift companies to obtain further information.

G ACTIVITY 5

Students should now organise themselves into working groups in which they will carry through their design brief. (See introductory notes on practical group work.) In their groups, students should list the experiences gained in their research and list which qualities, features, power source and materials they think should be included in a school lift which would best suit the needs of all its users. (See introductory notes on group discussion.)

H ACTIVITY 6

Using the list of decisions made in (G), students should work together to make a plan and elevation drawings of their proposed lift design.

I ACTIVITY 7

A model of the planned lift can now be constructed. (See introductory notes on model-making.) Each member of the group should take responsibility for different aspects of the model, eg. decor, button design, power source, overall dimensions, etc.

- J** Evaluation.
(See introductory notes on evaluation.)

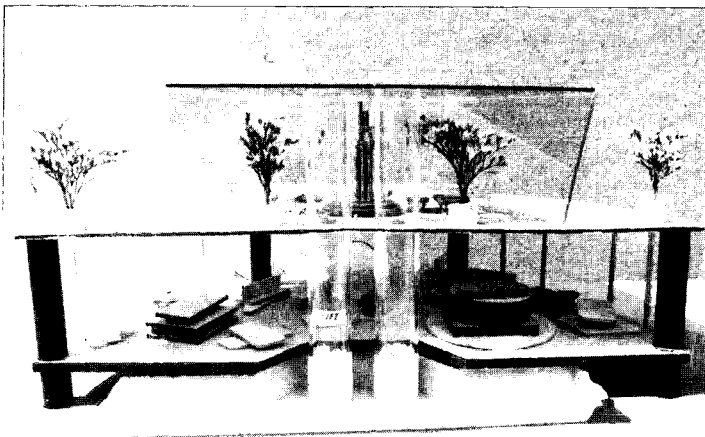

ENERGY CONSERVATION AND LIFT DESIGN

STUDENT ACTIVITIES

ACTIVITY 1

1 Design a poster or a sign which would either:

- remind people to switch off unnecessary lights; or
- remind people to close doors and prevent heat from the school escaping outdoors.

ACTIVITY 2

2 With one of your group in a wheelchair, try to take a route from one place to another in school. Draw a map of your route or use one provided by your teacher and mark onto it any places which are difficult for the wheelchair to pass.

ACTIVITY 3

3 Write a description of your experiences of the journey with the wheelchair. Decide how your school might be better designed to accommodate disabled students and staff.

ACTIVITY 4

4 Write a letter to a lift company asking for information about their lift designs, the sizes of their lifts, the mechanisms they use to operate their lifts and the materials they use in lift manufacture.

ACTIVITY 5

5 Organise yourselves into groups. You are going to design a lift which you think would be good for a school. Remember all the information you have researched.

As a group make a list of:

- a. *all the things you think should be in your lift, eg. decoration, control buttons, a bin etc;*
- b. *the materials you think should be used;*
- c. *the power source which you think would be the most practical and energy efficient.*

ACTIVITY 6

6 Sketch a plan or make drawings of how you would like your lift to be, using the list your group has produced. You can do this in a group, or do it individually and combine your ideas afterwards.

ACTIVITY 7

7 Using your plans and drawings, make a model of your lift. Make sure everyone in your group has a job to do.

ENERGY CONSERVATION AND LIFT DESIGN

STUDENT ACTIVITIES

WORKSHEET 1

How much electricity do people use?

By looking at the last 4 bills received for electricity use, you can discover how many units were used altogether in one year and their cost. This table shows the number of units of electricity used in different buildings in one year for lighting and electrical appliances such as computers, televisions, Hoovers, etc.

TYPE OF BUILDING	UNITS	COST (£)
2 room flat	760	50
2 bedroom house	3576	221
Office building	10793	720
Your home		
Your school		

Can you find out how many units of electricity you use in:

- a. your home in one year?
- b. your school in one year?

Which energy source is used to heat your school?

What is electricity used for in your home?

ENERGY CONSERVATION AND LIFT DESIGN**S T U D E N T A C T I V I T I E S****WORKSHEET 2**

Choose one area or room of your school building. Use this check list to look for places where energy is being wasted or saved:

1. Which direction does the room/area face?
Is it facing the right direction to benefit from the sun's light during school hours?
2. Is someone in charge of turning off lights in the room/area when everyone leaves, eg. at breaktimes?
3. What colour are the walls painted?
Why might light colours be useful for saving energy?
4. How many windows does the room/area have?
What size are the windows?
Are they double-glazed?
5. Windows in the roof are called roof-lights. Could the room/area have roof-lights?
6. Is it possible to turn the lights on only for the area of the room/area furthest away from the windows?
7. Are the work surfaces higher or lower than the bottoms of the windows?
8. Do the doors in and out of the room/area close automatically or does someone have to close them?
9. Is the room/area too hot, too cold or just right?
10. Can you turn the heating up or down in this room only?

ENERGY CONSERVATION AND LIFT DESIGN

STUDENT ACTIVITIES

WORKSHEET 3

Which materials conserve heat?

You will need the following apparatus:

6 milk bottles, thermometer, hot (not boiling) water in a measuring jug, materials to cover 5 of the bottles, eg. fibreglass, rockwool, cloth, polystyrene, fur/cottonwool. (It is advisable that plastic gloves are worn when handling rockwool and fibreglass.)

1. Wrap a different material around each bottle.
Leave one bottle uncovered.
2. Put the same amount of water in each bottle.
3. Test the temperature of the water every 5 minutes.

Record the temperature of each bottle in this table:

MATERIAL	Start Temp	After 5 min	After 10 min	After 15 min	After 20 min	After 25 min	After 30 min	After 35 min
rockwool								
fibreglass								
cloth								
polystyrene								
fur								
unwrapped								

Which bottle loses heat more quickly?

Which bottle stays hot for the longest time?

What have you found out about the way the different materials conserve heat?

DINING ROOM

T E A C H E R S ' N O T E S

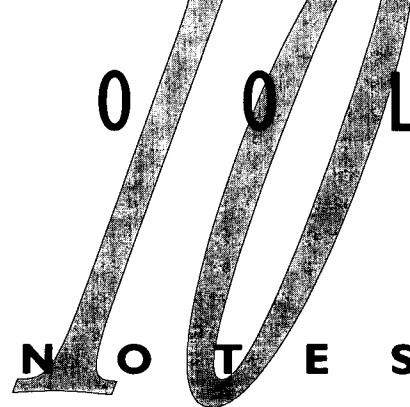

AIMS To develop:

- an awareness of global interdependence in food production;
- an appreciation of meal times as a social activity;
- an understanding of the necessity for good nutrition.

ISSUES

- Should a large institution be responsible for ensuring that its users have balanced meals available?
- How should school meals be organised?
- Where does our food come from?

Suggested scale: 2 cm : 1 m

ACTIVITIES

A ACTIVITY 1

A useful starting point is to make a detailed diary of all the food and drink eaten in one day or even for a week.

This diary can be used to analyse nutritional content and to stress the importance of a balanced diet and regular meals for good health (maybe relating also to dental hygiene).

B ACTIVITY 2

A collection of packaging provides information on a variety of ingredients in any prepared foods. This information can be extended by the use of nutrition tables to classify the ingredients simply as meat/fish, vegetables, cereals/grains, sugars, etc. or more precisely as carbohydrates, proteins, vitamins, etc.

A visit from a School Meals Supervisor or Health Authority nutritionist could be arranged to provide further information.

Extension Activity

ACTIVITY 3

Devising and costing nutritional menus for all tastes and cultural requirements, reflecting the needs of the school population.

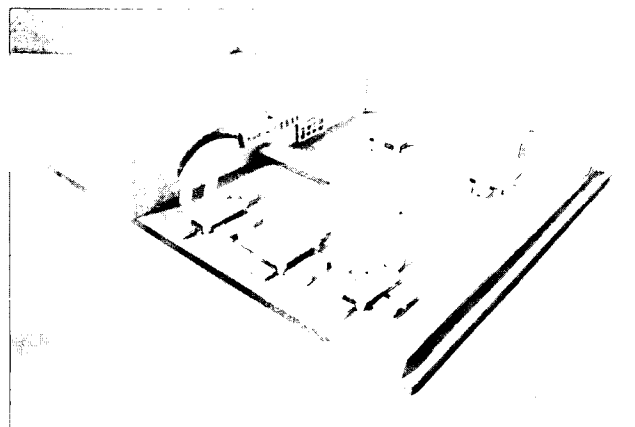

The plate unit moves along to different dinner halls where one class is. The plates move along and then they come back round and go back into the kitchen and then fall into the sink.

Wesley Lewis, George Talukder

DINING ROOM

T E A C H E R S ' N O T E S

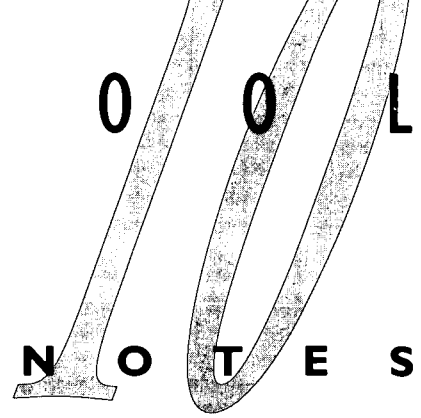
**ACTIVITIES****C** WORLD STUDIES RESOURCES

Food packaging also gives details of country of origin and price. This can be developed with the aim of showing interdependence between countries for food supplies, eg. 'World in a Supermarket Bag' - which requires students to 'unpack' a bag of groceries and list each item, its country of origin and its price. Origins are then located on a world map.

Extension Activity

Making a flow chart of the process of producing and distributing a food such as bananas, coffee, etc.

- D** Current school meal arrangements should be analysed for their efficiency and pleasantness. Making a video of a school mealtime is a very useful way of focusing on the management of the service. The video should then be shown to the class and used as a stimulus for discussion of organisation, lighting, decor, timing, supervision, noise levels, design and layout.

Extension Activities**ACTIVITY 4**

Write a description of school meal arrangements.

ACTIVITY 5

Devise a dream meal, describing the menu, table settings, people who would be present and the place where the meal would be eaten.

ACTIVITY 6

Gather information about meal arrangements for students in other countries. Survey questions could be devised for pupils and teachers who have lived in other countries and could also be sent to relatives and friends abroad. (See introductory notes on surveys). Information from the surveys could then be used to discuss reasons for and against providing school meals and the viability of alternative arrangements. (See introductory notes on group discussion.)

E ACTIVITIES 7, 8 & 9

A survey should be devised to discover the opinions of students, teachers and kitchen staff about existing facilities. (See introductory notes on surveys).

F ACTIVITIES 10 & 11

Students should now organise themselves into working groups in which they will carry through their design brief. (See introductory notes on practical collaborative group work). Existing facilities should be measured and the number of tables, cookers, sinks, etc should be listed so that students will have information on which to base their own provision for a specific number of people.

DINING ROOM

T E A C H E R S ' N O T E S

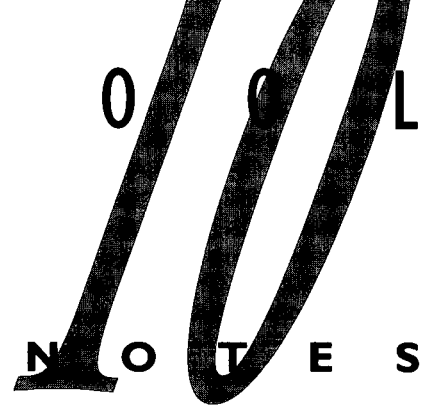

ACTIVITIES

G **ACTIVITY 12**

In their groups, students should discuss the experiences gained in their research and decide which qualities, features and organisational methods should be included in designing a dining room for a school which would best suit the needs of all its users. (See introductory notes on group discussion.)

H **ACTIVITY 13**

Using the list of decisions made in (G), students should work together to make a plan of their design, beginning with a basic layout sketch. This can be developed on squared paper as a scale plan. (See introductory notes on scale drawing.) Elevation drawings with accompanying notes could also be made to develop ideas for textiles, murals, colour schemes, etc.

I **ACTIVITY 14**

A model of the planned dining room can then be constructed. (See introductory notes on model making.) Each member of the group should take responsibility for different sections of the model eg kitchen fittings, dining tables and chairs, wall and floor coverings, serving facilities, etc.

ACTIVITY 15

Larger scale models and designs of particular features can be developed.

Extension Activity

ACTIVITY 16

Select school kitchen equipment from a catalogue within a given budget.

J Evaluation.
(See introductory notes on evaluation.)

The dining hall must be a place where people can eat and relax . . . By the window of the serving kitchen or around it there must be some live decorations like flowers that are rather smelly and freshing.

On the menu, which must be changed every day, there must be food for everyone's taste . . .

This kind of dining room would be suitable for everyone to eat in, not just for those who have school dinners. Some space should be provided for those who have packed lunches or home lunches.

Fulya Yalezan

DINING ROOM

T E A C H E R S ' N O T E S

RESOURCES

World in a Supermarket Bag - Ange Grunsell and Theresa Stearn

Oxfam

Activity sheet designed to arouse interest in the way our food links us to the rest of the world, with ideas for developing a food topic.

World Studies 8-13 - Simon Fisher and David Hicks Oliver and Boyd

A teachers' handbook giving classroom activities and resources concerning issues relevant to living in a multi-cultural society and an interdependent world. Useful section on world trade.

Meatballs and Molecules - Lesley Newson
A & C Black

The science behind food.

Exploring Food in Britain Series: Caribbean, Chinese, Indian, Greek Foods

Mantra Publishing Ltd

An introduction to foods of different communities in Britain.

Threads Series: Rice, Milk, Bread, Beans
A & C Black

A series aimed at juniors, which explains how the product is made and used and encourages children to find out more through investigation and activities across the curriculum.

Other sources of information:

District Health Authorities Health Education Units produce useful books on nutrition which they will supply free of charge.

Supermarkets - most of the large chains produce free leaflets on nutrition.

Food manufacturers - many have education departments which provide free materials. Addresses to be found on packaging.

British Gas and furniture centres (eg. MFI) supply free leaflets on kitchen planning - information on layout, surface heights, equipment, etc.

Video:

Banana Split - Christian Aid

Looks at banana growing in Dominica, highlighting the difficulties developing countries face when all food distribution is in the hands of multinationals. Useful stimulus for discussion for top juniors and secondary students. Can be borrowed free of charge.

DINING ROOM

S T U D E N T A C T I V I T I E S

ACTIVITY 1

Write a food diary for yesterday.
List everything you ate or drank and the time you had it.

Don't forget things like butter, sugar, etc.

On Monday I ate:

8 am	Tea, Milk, Sugar Cornflakes Toast, butter, jam
10.30 am	Biscuit Orange drink

ACTIVITY 2

Look at the labels of any packaged foods you ate. You may find that there are more ingredients than you had expected. List these next to the name of the food.

ACTIVITY 3

Different people like different kinds of foods, as you will see from looking at other people's food diaries. Some people's religious beliefs mean that they prefer not to eat certain foods. Some people have medical reasons for not eating some foods. Other people just don't like certain things and most people like what they are used to. But everyone needs something from all the different groups of foods each day to be healthy.

Plan a healthy menu for someone with particular food needs, eg. a vegetarian, a diabetic, a Moslem, an overweight person.

ACTIVITY 4

Write a description of the school meal arrangements at your school.

Include:

- a. What is the room like?
How is it decorated?
How is the furniture arranged?
- b. How are lunchtimes organised?
Who supervises them?
How is the food served?
How much choice do you have?
Who decides where you sit?
- c. What do you like about the eating arrangements?
What don't you like?

DINING ROOM

S T U D E N T A C T I V I T I E S

ACTIVITY 5

5 Write about your 'dream' meal. Think about what you would eat, who you would share it with and where you would like to be when you ate it.

ACTIVITY 9

9 Make a list of questions for the kitchen staff about the facilities they use to prepare and serve the meals, any problems they might have and any changes they would like to see made.

ACTIVITY 6

6 See what you can find out about school dinners in other countries. Do they have them? How are they organised?

Write down some questions you could ask other pupils or teachers who have lived in another country.

If you have friends or relatives living in another country, write to them and ask them the same questions.

ACTIVITY 10

10 How many people eat in your school dining room each day? Measure your school dining hall and show the results on a plan. Decide whether you think it is a good size and shape for the number of people using it each day.

ACTIVITY 7

7 Make a list of questions which you could ask other students and teachers who eat in the school dining room about what is good and bad about its design, whether they think it could be better and how they feel when they are there.

ACTIVITY 8

8 Your surveys will produce many different answers.

Put together the answers found out by everyone in the class.

Design a graph or chart to show the collated results.

Write down what you have learnt from this survey.

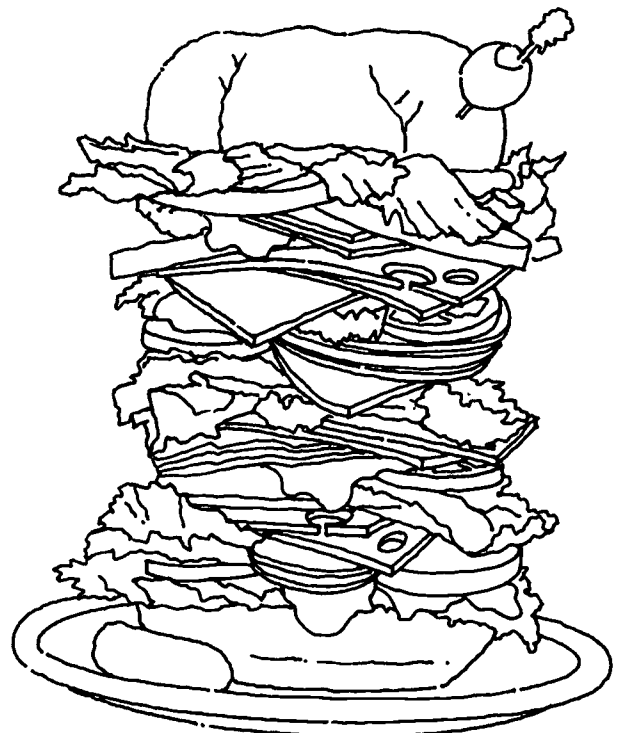

DINING ROOM

S T U D E N T A C T I V I T I E S

ACTIVITY 11

11 Make a list of the number of tables, cookers, sinks and cupboards in the dining room and kitchen.

ACTIVITY 14

14 Using your ground plans, make a model of your dining room and kitchen. Make sure everyone in your group has a job to do.

ACTIVITY 12

12 You are going to design a dining room and kitchen which you think would be good for a school. Remember all the information you have researched about your own school dining room and what you discovered from your surveys.

In your groups, make a list of:

- a. the qualities you think it should possess;
- b. all the things you think should be in your dining room;
- c. the materials you think the tables, chairs, floors, serving counters, etc. should be made of;
- d. the size and shape you would like the room to be.

ACTIVITY 15

15 Draw or make anything in your dining room which you think should be shown in greater detail, eg. make a large scale model of one table and chair, design a mural for the dining room wall, design a menu board, design and print wallpaper, design and print a fabric for curtains or blinds.

ACTIVITY 16

16 Using equipment catalogues, select the equipment you think would be needed for the kitchen you are designing. How much would it cost to equip?

ACTIVITY 13

13 Sketch a ground plan of how you would like your dining room to be arranged, using the list your group has produced. You can do this as a group or do it individually and combine your ideas afterwards.

About WWF . . .

WWF is an international environmental organisation with national groups around the world. Launched in 1961 to raise money for the conservation of nature and natural resources, it has so far channelled over one hundred million pounds into projects in 135 different countries.

WWF United Kingdom is committed to an education programme that aims to produce resource materials that enable teachers to bring environmental issues into everyday classroom teaching at all levels of education. The materials are designed to give young people knowledge and experience that allows them to make informed personal judgements about environmental issues. Resources are being developed for most subjects of the school curriculum, making use of the inherent qualities of each subject to develop specific aspects of environmental understanding and sensitivity. In addition, WWF has in progress projects designed to help teachers plan, implement and evaluate effective cross-curricular environmental education.

If you would like details about WWF's education programme, please write to: WWF UK, Education Department, Weyside Park, Godalming, Surrey GU7 1XR.





IS YOUR SCHOOL AN ECO SCHOOL?

This pack explores the principles and practice of good design by asking students to think about whether a building meets the needs of all its users as well as making a positive contribution to the environment, both aesthetically and practically.

By asking questions ranging from:

'How would a stranger feel on entering the building?', to

'Is the school producing unnecessary waste?', and

'Where does the food served in the dining room come from?'

Eco School encourages students to make a study of their own school and other public buildings and to use this research to develop plans, drawings and models of a school which would be good for all its users as well as the environment.

Eco School is divided into 10 sections, corresponding to different parts of the school building, each of which can be studied independently. Each section addresses specific aims and issues and contains comprehensive teachers' notes and activities for students.

The pack can be used successfully to develop National Curriculum work in subject areas ranging from English and Humanities to Art and Technology. It is intended primarily for use with upper junior and lower secondary students but the ideas have been adapted successfully for all ages.

Eco School will be of interest to all members of a school's community – staff, governors, parents and children – all those who have exciting opportunities for developing the full potential of the school and its grounds.

ABOUT THE AUTHORS

Prue Poulton and Gillian Symons work for Hackney Environmental Education Project, which was founded in 1984 to develop urban environmental education in Hackney's schools.

The aims of HEEP are to increase understanding of the environment, to encourage teachers to see the environment as a learning resource and to foster links between schools and the wider community.

The authors work directly with teachers and children both in school and out in the locality. They also provide INSET, either offering a general introduction to ways in which environmental work can fulfil National Curriculum requirements or responding to requests on specific environmental themes.

Distributed in North America By:

The Green Brick Road
429 Danforth Ave., Ste.#408
Toronto, ON, Canada M4K 1P1
1-800-473-3638

73

9 780947 613273



U.S. Department of Education
Office of Educational Research and Improvement (OERI)
National Library of Education (NLE)
Educational Resources Information Center (ERIC)



NOTICE

REPRODUCTION BASIS



This document is covered by a signed “Reproduction Release (Blanket) form (on file within the ERIC system), encompassing all or classes of documents from its source organization and, therefore, does not require a “Specific Document” Release form.



This document is Federally-funded, or carries its own permission to reproduce, or is otherwise in the public domain and, therefore, may be reproduced by ERIC without a signed Reproduction Release form (either “Specific Document” or “Blanket”).