

DOCUMENT RESUME

ED 428 964

SE 062 345

TITLE Newton's Apple Teachers Guides. Seasons 9-10-11-12: A Collection of Lessons and Activities.

INSTITUTION Twin Cities Public Television, St. Paul, MN.

SPONS AGENCY 3M, St. Paul, MN.

PUB DATE 1995-00-00

NOTE 293p.; For season 13, see ED 412 068.

AVAILABLE FROM Newton's Apple, 172 E. 4th Street, St. Paul, MN 55101; Tel: 800-588-6398 (Toll Free); e-mail: newtons.apple@umn.edu

PUB TYPE Guides - Classroom - Teacher (052)

EDRS PRICE MF01/PC12 Plus Postage.

DESCRIPTORS Architecture; Athletics; *Biological Sciences; Biology; Chemistry; Elementary Secondary Education; Geology; Hands on Science; Medicine; *Physical Sciences; Physics; *Problem Solving; *Science and Society; *Science Education; Space Sciences; Technology

ABSTRACT

Newton's Apple is a PBS family science program that explores basic science through high-energy, hands-on demonstrations. This volume is a collection of the teacher's guides from four seasons of Newton's Apple which were originally broadcast from 1991 through 1994. Each of the four seasons in the volume contains 26 lessons and a combination of supplementary materials, including family guides, transparencies, and indexes. Topics covered in Season 900 include Olympic sports, solar-powered cars, steroids, forensic science, cancer causes and treatments, Frisbee physics, sewer science, dinosaurs, domed stadium architecture, photosynthesis, tears, slinky physics, the Soviet space program, the color of the sky, acid rain, biomechanics of high jumping, medical quackery, microwave ovens, telecommunications, solar eclipses, hip replacement, and airbags and collisions. Topics featured in Season 1000 include how television works, satellite technology, Hollywood stunts, household chemistry, election polls and surveys, electric cars, creating monster masks, ozone, oil spills, diet and nutrition, Antarctica, AIDS, glass recycling, cockroaches, broken bones, Omnimax movie technology, archery, the Aurora Borealis, air pressure, traffic control, cryogenics, locks and dams, blood typing, diabetes, and galaxy mapping. Topics discussed in Season 1100 include rock climbing, taste and smell, emergency rescue, black holes, memory, in vitro fertilization, newspaper production, explosions, jumbo jets, meteors, windsurfing, permafrost, spotted owls and old growth forests, carpal tunnel syndrome, archeology, mazes and puzzle-solving, firefighting, dairy farming, North American bison, heart attacks, underwater diving and the bends, compact discs, garbage, infrared light, Mount Rushmore, and virtual reality. Season 1200 explores hang gliding, karate, Arctic survival and nutrition, aircraft carriers, brain science, garlic, dinosaurs in the movies, bread chemistry, movie sound effects, the sun, dinosaur extinction, floods, the Internet, antibiotics, ethnobotany, the Hubble Telescope, a raptor hospital, photography, redwood trees, electricity, printing money, gravity, bridges, and earthquakes. (WRM)

ED 428 964

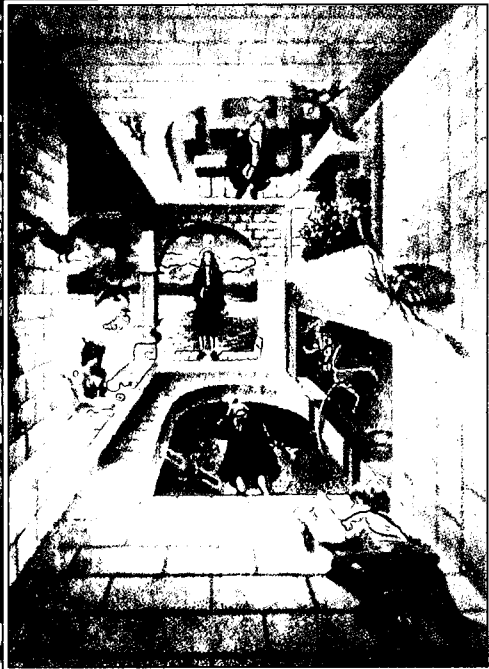

Newton's Apple Teachers Guides

Seasons 9 • 10 • 11 • 12

A COLLECTION OF LESSONS AND ACTIVITIES

PERMISSION TO REPRODUCE AND DISSEMINATE THIS MATERIAL HAS BEEN GRANTED BY

M. Sawyer

TO THE EDUCATIONAL RESOURCES INFORMATION CENTER (ERIC)

BEST COPY AVAILABLE

NEWTON'S APPLE

U.S. DEPARTMENT OF EDUCATION
Office of Educational Research and Improvement
EDUCATIONAL RESOURCES INFORMATION CENTER (ERIC)

- This document has been reproduced as received from the person or organization originating it.
- Minor changes have been made to improve reproduction quality.

• Points of view or opinions stated in this document do not necessarily represent official OERI position or policy.

00345
ERIC
Full Text Provided by ERIC

Newton's Apple Teachers Guides

Seasons 9 • 10 • 11 • 12

A Collection of Lessons and Activities

NEWTON'S APPLE is a production of **KTCA Twin Cities Public Television**.

Made possible by a grant from **3M**.

Educational materials developed with the **National Science Teachers Association**.

These materials can be duplicated for educational purposes only.

© 1995 Twin Cities Public Television

Welcome to Newton's Apple

Newton's Apple is the popular PBS family science program, broadcast on public television stations nationwide since 1983. Each program explores basic science through high-energy, hands-on demonstrations, featuring host David Heil, field reporter Peggy Knapp, and naturalist Nancy Gibson. Newton's Apple has answered thousands of science questions, ranging from "Why is the sky blue?" to "Why are flamingoes pink?" Comprehensive teachers guides have always accompanied the broadcasts of Newton's Apple, bringing the show's vivid demonstrations into classrooms at the elementary, middle and high school levels.

The teacher's guides are designed to accompany the Newton's Apple television program segments, but are also a rich stand-alone resource in the classroom. With over 100 subjects covered, they offer many ways to help students discover the wonders of science.

This volume collects the teachers guides from four seasons of Newton's Apple (seasons 9-12), which were originally broadcast in 1991 through 1994. Each of the four seasons in this volume has 26 lessons and a combination of ancillary materials (Street Smarts™, Science Try Its™, Family Guides, Animals, Transparencies, Season Indexes, Subject Indexes).

The programs featured in these guides are still being broadcast on many PBS stations. Call your local PBS station to find out when Newton's Apple airs in your area and refer to the subject by the show number in the subject index in the back of this book. Educators are free to videotape the programs and use those tapes in their classrooms for three years from the broadcast date. If you miss taping a segment, you can also order tapes of selected Newton's Apple shows (see below).

You can receive teachers guides for future Newton's Apple seasons for **FREE** by writing to:

NSTA - Marketing Division
1840 Wilson Blvd.
Arlington, VA 22201

For more information on how to order other Newton's Apple educational materials, including

- videotapes of selected programs,
- CD-ROM series "What's The Secret",
- Newton's Apple Multimedia Collection (interactive videodiscs),
- science kits,

call or write:

Toll Free:
1.800.LUV.NEWT
1.800.588.6398

E-mail:
newtons.apple@umn.edu

Address:
Newton's Apple
172 E. 4th St.
St. Paul, MN 55101

Special Note:

Because these are reprints of previous teachers guides, we are not able to include special inserts included in the original packets (e.g. the posters, videotape labels and stickers). So while the copy in the different sections of the materials refer to these added materials, they are not part of this book.

TABLE OF CONTENTS

	SHOW* NUMBER	PAGE		SHOW* NUMBER	PAGE
Season 9		9.1	Satellite Technology	1001	10.9
Welcome		9.2	Hollywood Stunts	1002	10.11
9th Season Index		9.3	Household Chemistry	1002	10.13
Past Seasons Index		9.4	Election Polls and Surveys	1003	10.15
Olympic Training Center	901	9.5	Electric Cars	1003	10.17
Luge	901	9.7	Monster Makeup	1004	10.19
Solar Powered Cars	902	9.9	Ozone	1004	10.21
Steroids	902	9.11	Oil Spills	1005	10.23
Murder Mystery	903	9.13	Diet and Nutrition	1005	10.25
Cancer Causes	904	9.15	Antarctica I	1006	10.27
Frisbee Physics	904	9.17	Antarctica II	1006	10.29
Sewer Science	905	9.19	AIDS	1007	10.31
Cancer Treatments	905	9.21	Glass Recycling	1007	10.33
Dinosaurs I	906	9.23	Cockroaches	1008	10.35
Dinosaurs II	906	9.25	Broken Bones	1008	10.37
Domed Stadium	907	9.27	Omnimax	1009	10.39
Photosynthesis	907	9.29	Archery	1009	10.41
Tears	908	9.31	Aurora Borealis	1010	10.43
Slinky Physics	908	9.33	Air Pressure	1010	10.45
Soviet Space	909	9.35	Traffic Control	1011	10.47
Sky Blue	909	9.37	Cryogenics	1011	10.49
Acid Rain	910	9.39	Locks and Dams	1012	10.51
High Jump	910	9.41	Blood Typing	1012	10.53
Medical Quakeries	911	9.43	Diabetes	1013	10.55
Microwave Ovens	911	9.45	Galaxy Mapping	1013	10.57
Telecommunications	912	9.47	10th Season Animals		10.59
Solar Eclipse	912	9.49	Science Try Its		10.61
Hip Replacement	913	9.51	Street Smart		10.63
Air Bags & Collisions	913	9.53	Transparency Master		10.65
9th Season Animals		9.55	Family Guide		10.67
Science Try Its		9.57	3M and Science Education		10.69
Family Guide		9.59	Credits		10.70
3M and Science Education		9.61			
Credits		9.62	Season 11		11.1
			Welcome		11.2
Season 10		10.1	Suggestions		11.3
Welcome		10.2	Newton's Apple Team		11.4
Suggestions		10.3	11th Season Index		11.5
Newton's Apple Team		10.4	Past Seasons Index		11.6
10th Season Index		10.5	Science Subject Index		11.7
Past Seasons Index		10.6	Rock Climbing	1101	11.9
How TV Works	1001	10.7	Taste and Smell	1101	11.11

* The show number corresponds to the season and the program. For example, 905 is the fifth program in the ninth season. Use this number to order a show or when asking your PBS station when they are going to rebroadcast it.

	SHOW* NUMBER	PAGE		SHOW* NUMBER	PAGE
Emergency Rescue	1102	11.13	Brain Mapping	1204	12.21
Black Holes	1102	11.15	Garlic	1204	12.23
Memory	1103	11.17	Movie Dinosaurs	1205	12.25
<i>In Vitro</i> Fertilization	1103	11.19	Bread Chemistry	1205	12.27
Newspaper	1104	11.21	Movie Sound Effects	1206	12.29
Bomb Squad	1104	11.23	Sun	1206	12.31
Jumbo Jets	1105	11.25	Dinosaur Extinction	1207	12.33
Meteors	1105	11.27	Floods	1207	12.35
Windsurfing	1106	11.29	Internet	1208	12.37
Permafrost	1106	11.31	Antibiotics	1208	12.39
Spotted Owl/ Old-Growth Forests	1107	11.33	Ethnobotany	1209	12.41
Carpal Tunnel Syndrome	1107	11.35	Hubble Telescope	1209	12.43
Archeology	1108	11.37	Raptor Hospital	1210	12.45
Mazes	1108	11.39	Photography	1210	12.47
Firefighting	1109	11.41	Redwoods	1211	12.49
Dairy Farm	1109	11.43	Electricity	1211	12.51
Bison Roundup	1110	11.45	Printing Money	1212	12.53
Heart Attack	1110	11.47	Gravity	1212	12.55
The Bends	1111	11.49	Bridges	1213	12.57
Compact Discs	1111	11.51	Earthquakes	1213	12.59
Garbage	1112	11.53	12th Season Animals		12.61
Infrared Light	1112	11.55	Science Try Its		12.63
Mount Rushmore	1113	11.57	Street Smart		12.65
Virtual Reality	1113	11.59	Transparency Master		12.67
11th Season Animals		11.61	Family Guide		12.69
Science Try Its		11.63	3M and Science Education		12.71
Street Smart		11.65	Credits		12.72
Transparency Master		11.67			
3M and Science Education		11.69			
Credits		11.70			
Season 12		12.1			
Welcome		12.2			
Suggestions		12.3			
Newton's Apple Team		12.4			
12th Season Index		12.5			
Past Seasons Index		12.6			
Science Subject Index		12.7			
Hang Gliding	1201	12.9			
Karate	1201	12.11			
Arctic Survival	1202	12.13			
Arctic Nutrition	1202	12.15			
Aircraft Carrier	1203	12.17			
Brain	1203	12.19			

* The show number corresponds to the season and the program. For example, 905 is the fifth program in the ninth season. Use this number to order a show or when asking your PBS station when they are going to rebroadcast it.

Seasons 9 • 10 • 11 • 12 Index

SUBJECT INDEX

SUBJECT	SHOW NUMBER	PAGE(S)
Acid Rain	910	9.39 - 9.40
African Elephants	1201	12.61
AIDS	1007	10.31 - 10.32
Air Bags	913	9.53 - 9.54
Air Pressure	1010	10.45 - 10.46
Aircraft Carrier	1203	12.17 - 12.18
Antarctica I	1006	10.27 - 10.28
Antarctica II	1006	10.29 - 10.30
Antibiotics	1208	12.39 - 12.40
Archeology	1108	11.37 - 11.38
Archery	1009	10.41 - 10.42
Arctic Survival	1202	12.13 - 12.14
Arctic Nutrition	1202	12.15 - 12.16
Aurora Borealis	1010	10.43 - 10.44
Bats	903	9.55
Bears	912	9.56
Polar	1112	11.62
Bends	1111	11.49 - 11.50
Bison Roundup	1110	11.45 - 11.46
Black Holes	1102	11.15 - 11.16
Blood Typing	1012	10.53 - 10.54
Bomb Squad	1104	11.23 - 11.24
Brain	1203	12.19 - 12.20
Brain Mapping	1204	12.21 - 12.22
Bread Chemistry	1205	12.27 - 12.28
Bridges	1213	12.57 - 12.58
Broken Bones	1008	10.37 - 10.38
Camels	908	9.55
Cancer Causes	904	9.15 - 9.16
Cancer Treatments	905	9.21 - 9.22
Caribou	1005	10.59
Carpal Tunnel Syndrome	1107	11.35 - 11.36
Chimpanzees	1113	11.61
Cockroaches	1008	10.35 - 10.36
Collisions	913	9.53 - 9.54
Compact Discs	1111	11.51 - 11.52

SUBJECT INDEX

SUBJECT	SHOW NUMBER	PAGE(S)
Condors	1009	10.60
Cougars	1003	10.59
Cryogenics	1011	10.49 - 10.50
Dairy Farm	1109	11.43 - 11.44
Dams	1012	10.51 - 10.52
Diabetes	1013	10.55 - 10.56
Diet	1005	10.25 - 10.26
Dinosaur Extinction	1207	12.33 - 12.34
Dinosaurs I	906	9.23 - 9.24
Dinosaurs II	906	9.25 - 9.26
Dolphins	1108	11.61
Domed Stadium	907	9.27 - 9.28
Eagles	911	9.56
Earthquakes	1213	12.59 - 12.60
Election Polls	1003	10.15 - 10.16
Electric Cars	1003	10.17 - 10.18
Electricity	1211	12.51 - 12.52
Elephants, African	1201	12.61
Emergency Rescue	1102	11.13 - 11.14
Ethnobotany	1209	12.41 - 12.42
Family Guide (season 9)		9.59 - 9.60
Family Guide (season 10)		10.67 - 10.68
Family Guide (season 12)		12.69 - 12.70
Firefighting	1109	11.41 - 11.42
Floods	1207	12.35 - 12.36
Forests, Old-growth	1107	11.33 - 11.34
Fox, Red	1211	12.61
Frisbee Physics	904	9.17 - 9.18
Galaxy Mapping	1013	10.57 - 10.58
Garbage	1112	11.53 - 11.54
Garlic	1204	12.23 - 12.24
Glass Recycling	1007	10.33 - 10.34
Gravity	1212	12.55 - 12.56
Hang Gliding	1201	12.9 - 12.10
Heart Attack	1110	11.47 - 11.48

SUBJECT INDEX

SUBJECT	SHOW NUMBER	PAGE(S)
Hedgehog	1206	12.61
High Jump	910	9.41 - 9.42
Hip Replacement	913	9.51 - 9.52
Hollywood Stunts	1002	10.11 - 10.12
Horses, Miniature	902	9.55
Household Chemistry	1002	10.13 - 10.14
Hubble Telescope	1209	12.43 - 12.44
Hummingbirds	1103	11.61
<i>In Vitro</i> Fertilization	1103	11.19 - 11.20
Infrared Light	1112	11.55 - 11.56
Internet	1208	12.37 - 12.38
Jumbo Jets	1105	11.25 - 11.26
Karate	1201	12.11 - 12.12
Komodo Dragon	1209	12.61
Lizards	1107	11.61
Llamas	909	9.56
Locks and Dams	1012	10.51 - 10.52
Luge	901	9.7 - 9.8
Mazes	1108	11.39 - 11.40
Medical Quakeries	911	9.43 - 9.44
Memory	1103	11.17 - 11.18
Meteors	1105	11.27 - 11.28
Microwave Ovens	911	9.45 - 9.46
Monster Makeup	1004	10.19 - 10.20
Money, Printing	1212	12.53 - 12.54
Mount Rushmore	1113	11.57 - 11.58
Movie Dinosaurs	1205	12.25 - 12.26
Movie Sound Effects	1206	12.29 - 12.30
Mosquitoes	1104	12.62
Murder Mystery	903	9.13 - 9.14
Musk Ox	1002	10.59
Newspaper	1104	11.21 - 11.22
Nutrition	1005	10.25 - 10.26

SUBJECT INDEX

SUBJECT	SHOW NUMBER	PAGE(S)
Oil Spills	1005	10.23 - 10.24
Olympic Training Center	901	9.5 - 9.6
Omnimax	1009	10.39 - 10.40
Ostrich	1013	10.60
Otters, River	1109	11.62
Ox, Musk	1002	10.59
Owl, Spotted	1107	11.33 - 11.34
Ozone	1004	10.21 - 10.22
Penguins	1006/1012	10.59
Permafrost	1106	11.31 - 11.32
Photography	1210	12.47 - 12.48
Photosynthesis	907	9.29 - 9.30
Pigs, Pot belly	913	9.56
Piranhas	1010	10.60
Printing Money	1212	12.53 - 12.54
Polar Bears	1112	11.62
Porcupines	905	9.55
Raptor Hospital	1210	12.45 - 12.46
Red Fox	1211	12.61
Redwoods	1211	12.49 - 12.50
Reindeer	1102	11.62
Rhinoceros	1008	10.60
River Otters	1109	11.62
Rock Climbing	1101	11.9 - 11.10
Satellite Technology	1001	10.9 - 10.10
Science Subject Index (season 11)		11.7 - 11.8
Science Subject Index (season 12)		12.7 - 12.8
Science Try Its (season 9)		9.57 - 9.58
Science Try Its (season 10)		10.61 - 10.62
Science Try Its (season 11)		11.63 - 11.64
Science Try Its (season 12)		12.63 - 12.64
Season Index (season 9)		9.3
Season Index (season 10)		10.5
Season Index (season 11)		11.5
Season Index (season 12)		12.5
Sewer Science	905	9.19 - 9.20
Siberian Tiger	1207	12.62

SUBJECT INDEX

SUBJECT	SHOW NUMBER	PAGE(S)
Sky Blue	909	9.37 - 9.38
Slinky Physics	908	9.33 - 9.34
Snakes	1210	12.64
Solar Eclipse	912	9.49 - 9.50
Solar Powered Cars	902	9.9 - 9.10
Soviet Space	909	9.35 - 9.36
Smell	1101	11.11 - 11.12
Steroids	902	9.11 - 9.12
Street Smart (season 10)		10.63 - 10.64
Street Smart (season 11)		11.65 - 11.66
Street Smart (season 12)		12.65 - 12.66
Sun	1206	12.31 - 12.32
Surveys	1003	10.15 - 10.16
Taste	1101	11.11 - 11.12
Tasmanian Devil	1204	12.62
Tears	908	9.31 - 9.32
Telecommunications	912	9.47 - 9.48
Television	1001	10.7 - 10.8
Tiger, Siberian	1207	12.62
Traffic Control	1011	10.47 - 10.48
Transparency Master (season 10)		10.65 - 10.66
Transparency Master (season 11)		11.67 - 11.68
Transparency Master (season 12)		12.67 - 12.68
Virtual Reality	1113	11.59 - 11.60
Wallabies	1205	12.62
Wolverines	1007	10.59
Wolves	1111	11.62
Windsurfing	1106	11.29 - 11.30

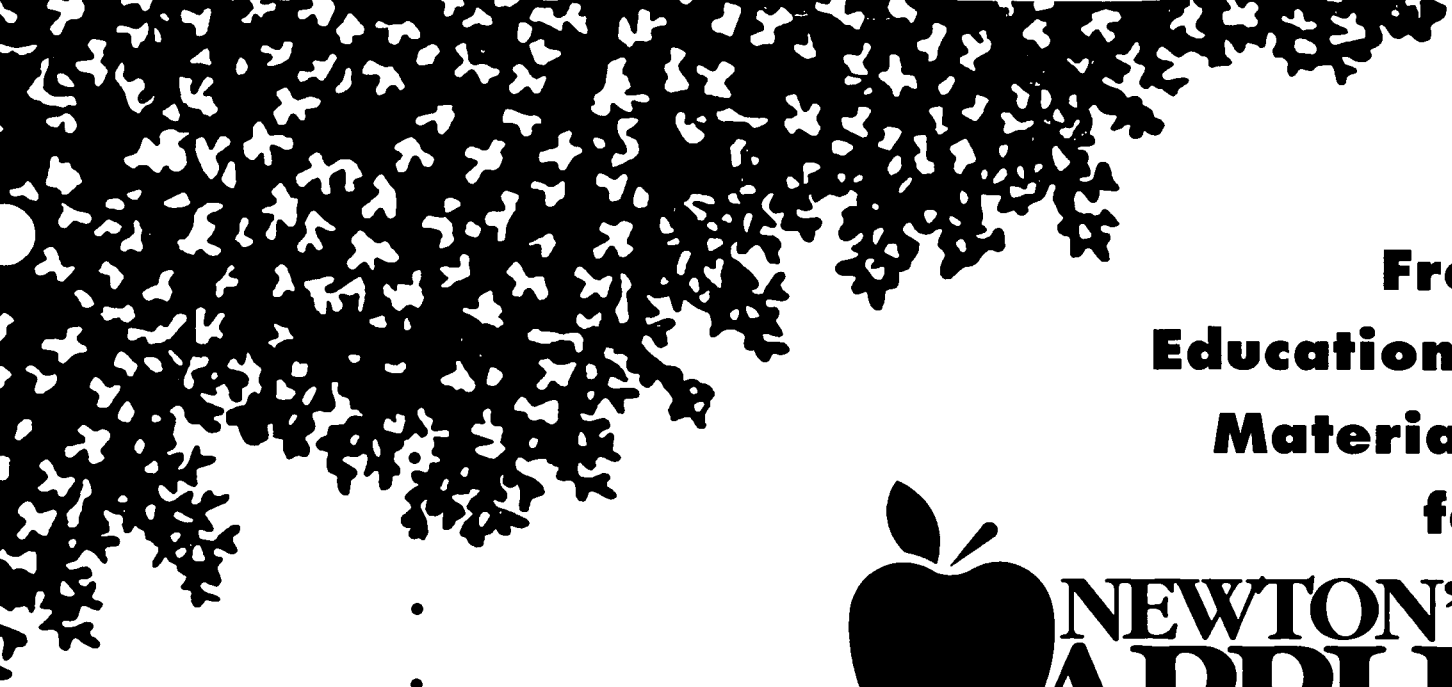

**Free
Educational
Materials
for**



**The Ninth Season of
NEWTON'S APPLE
Premieres
October 1991
on PBS.**

Educational Materials
Developed by the National
Science Teachers
Association—
Space, Science, and
Technology Division.

Newton's Apple is a
production of Twin Cities
Public Television—
St. Paul/Minneapolis and is
made possible by a grant
from 3M.

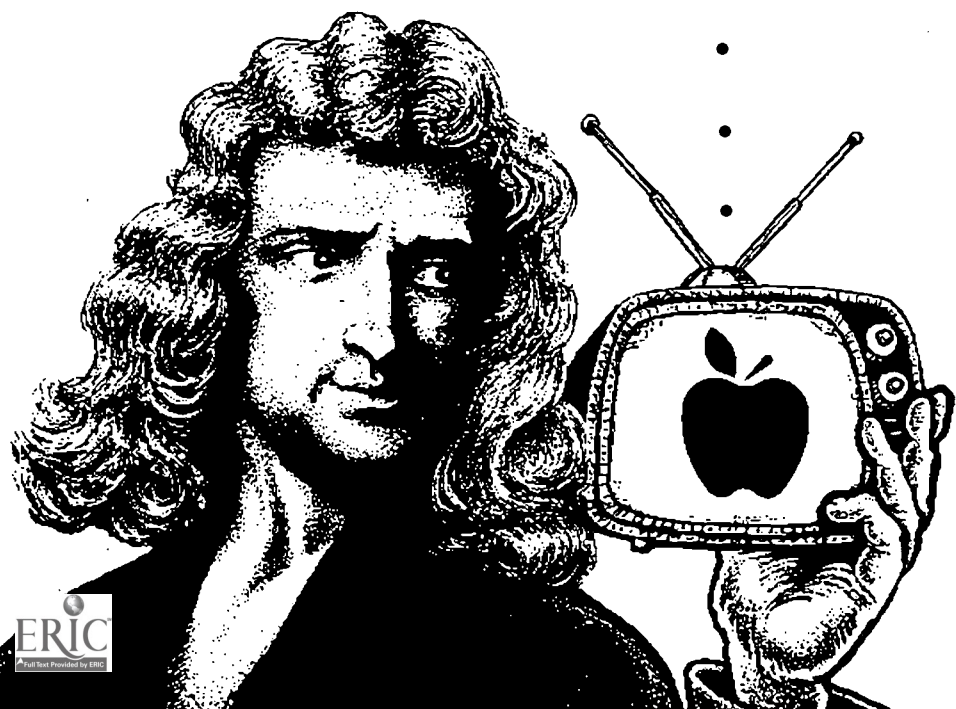

WELCOME TO THE NEWTON'S APPLE SEASON 900 EDUCATOR'S GUIDE!



The *Newton's Apple* poster features Isaac Newton in his orchard and highlights major 9th Season segments.

We hope the first thing you will do upon opening these materials is to hang up the *Newton's Apple* poster included at the end of this packet! This poster captures the philosophy of the series and previews several major segments featured in the 9th season of *Newton's Apple*. It was designed especially to promote discussion in the classroom. The *Newton's Apple* series, and these educational materials, are based on the elemental process of discovery: Asking questions about the world around us will lead us to new understanding. Ask your students if they know what each of the background illustrations in the poster are. Revisit the poster when you discuss the various lessons dealing with each illustration.

Although this guide was created to be useful to you even if you aren't able to view *each Newton's Apple* segment, we encourage you to assign your students to watch *Newton's Apple* when it airs in your area or videotape the program for classroom use—or do both. In fact, we urge you to videotape the entire 9th season for future use in your classroom!

The first page of the Guide is an index of the lesson pages, which are organized according to the corresponding Season 900 *Newton's Apple* program in which each topic appears (e.g., “Dinosaurs: Finding and Dating” appears in *Newton's Apple* program #906).

Each lesson page includes a general discussion about a major topic we're exploring on the series itself. We've also included related things to talk about in your classroom, a resource section and vocabulary. The back of each lesson page has a main activity along with several extended activities for you to do in the classroom or that your students can do at home.

You will notice that there are two special pages at the end of the lesson pages. One of these is about the menagerie of animals that will appear this season on *Newton's Apple*. The other page is a sampling of “Science Try Its,” an exciting new segment premiering this season! “Try Its” are simple and proven scientific experiments your students can try at home with their parents, using common household products.

The shorter segments that you will see in the *Newton's Apple* series (e.g., “Chats,” “Science of the Rich and Famous,” and David and Peggy “On the Spot”) are not discussed in these teaching materials. However, we believe that viewing these lively and entertaining segments on *Newton's Apple* will encourage even further discussion in your classroom!

The final piece of the Educator's Guide is our take-home viewer's guide, “Catch It At Home.” This page was written with your students and their families in mind. We hope you will photocopy this page and send copies home with your students. *Newton's Apple* is extremely proud of its record as a family show, and we want to continue encouraging parental and family involvement in the education of every young person.

We hope you find these materials useful *and* fun! If you have any questions or comments, please let us know—we welcome your feedback! Also, please remember to fill out and return one of the reply cards you will find inserted after segment #904. This will ensure that your name will remain on the list to receive next year's Educator's Guide (*Newton's Apple's* 10th Anniversary!!).



SEASON 900 SEGMENT INDEX

Following is an index of your *Newton's Apple* Educator's Guide. For your convenience, the lessons in this guide are organized numerically according to the *Newton's Apple* program in which the corresponding segment appears. Just look in the upper right hand corner of each lesson page for the show number (i.e. #901, #902, etc.).

On the reverse side of this page is a listing of the previous three seasons of *Newton's Apple*. These episodes will be rebroadcast throughout the year, and we hope you will continue to use them in your classroom.

Please check with your local PBS station for exact airdate and time. You can ask for a program by its show number. If season 900 of *Newton's Apple* doesn't appear in the Fall 1991 schedule of your local PBS station, call them to find out when they plan to run it.

Show #901
Olympic Training
Center
Luge

Show #902
Solar Powered Cars
Steroids

Show #903
Murder Mystery

Show #904
Cancer Causes
Frisbee Physics

Show #905
Sewer Science
Cancer Treatments

Show #906
Dinosaur I
Dinosaur II

Show #907
Domed Stadium
Photosynthesis

Show #908
Tears
Slinky Physics

Show #909
Soviet Space
Sky Blue

Show #910
Acid Rain
High Jump

Show #911
Medical Quackeries
Microwave Ovens

Show #912
Telecommunications
Solar Eclipse

Show #913
Hip Replacement
Airbags & Collisions

Newton's Apple is a production of KTCA Twin Cities Public Television. Made possible by a grant from 3M.

Educational materials developed by the National Science Teachers Association—Space, Science, and Technology Division.

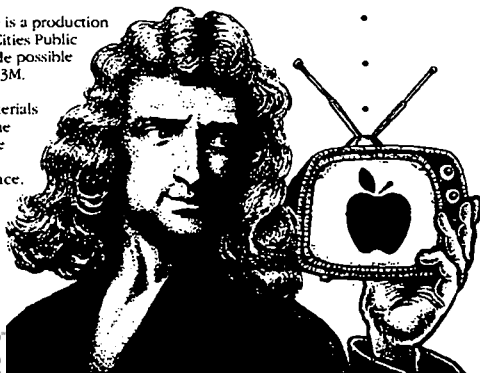

NEWTON'S APPLE SEASON 600 SEGMENT INDEX**SHOW 601**

Skydiving
Facial Symmetry
Baby Orangutans

SHOW 602

ILM Movie Creatures
Cholesterol
Suntan Lotion
Vulture

SHOW 603

Microsurgery
Strobes
Coordination Chat
Aardvark

SHOW 604

Air Traffic Control
Feet
Bell Curves
Tracking Bears

SHOW 605

Clouds
Rube Goldberg
Skin Itch Chat
Home Runs
Cold Remedies

SHOW 606

Marine Biological
Research at
Woods Hole, MA

SHOW 607

Rockets
CPR Chat
Inventor's Fair
Aerosols

SHOW 608

Fireworks
Papermaking
Gas Chat
Slow Loris

SHOW 609

Insomnia
Electron Microscope
Exponentials
Giraffe

SHOW 610

Liquid Nitrogen
Dolphins
Superconductivity
Insects

SHOW 611

Synthesizers
Maple Syruping
Wind Chill
Non-Stick Pans
Serval

SHOW 612

Magnets
Forest Fires
Night Blindness
Lynx

SHOW 613

Horse Jumping
Toys in Space
Dust Bunnies
Toucan
Carnivorous Plants

NEWTON'S APPLE SEASON 700 SEGMENT INDEX**SHOW 701**

Roller Coasters
Quicksand
Jelly Side Down
Tiger

SHOW 702

Bee Stings
Bowling
High-Speed Elevator
Boa

SHOW 703

Race Cars
Spider Webs
Tropical Fish

SHOW 704

Rain Forest
Buoyancy
Pouring Catsup
Cold Remedies

SHOW 705

Caffeine
Monarch Butterflies
Autumn Leaves Chat
Doppler Effect
Sloth

SHOW 706

Hawaii Special
Surfing
Volcanoes
Luau Chat
Sugar Processing
Hawaiian Language
Eel

SHOW 707

Whale Watch
Sunspots
Skunk

SHOW 708

Milky Way
Epilepsy
Inventor's Fair
Cuttlefish

SHOW 709

DNA
Rube Goldberg Contest
Parrot Chat
Chewing Tin Foil
Seahorse

SHOW 710

Marathons
Celestial Navigation
Cataracts Chat
Echidna

SHOW 711

Spinal Cord
Glue
Dog Behavior

SHOW 712

Cheese
Aging
Appendix Chat
Wolves

SHOW 713

Supercomputers
Greenhouse Effect
House Creaking
Owl

NEWTON'S APPLE SEASON 800 SEGMENT INDEX**SHOW 801**

Cartoons
Skateboards
Yo Yo's
Turtles

SHOW 802

Juggling
Greenwich Mean Time
Echoes
Flies

SHOW 803

Everglades
Tomorrow's World
Recycling Chat
Field Trip

SHOW 804

Demolition Derby
Stress
Topology Chat
Eagles

SHOW 805

Kidney Transplants
Music & Emotion
Swans

SHOW 806

Blood
Physics Circus
Fax Machine
Pronghorn

SHOW 807

Helicopter
Newton
Koalas

SHOW 808

Dyes
Pool & Billiards
Cheerios in Milk
Cheetah

SHOW 809

Desert Animals
Judo
Salt & Ice
Pigs

SHOW 810

Hydro Power
Whitewater Rafting
Mold
Weather Proverbs

SHOW 811

Wildlife Census
Eggs
Inventor's Fair

SHOW 812

Violins
Voyager
Rube Goldberg
Kinkajou

SHOW 813

Glaciers
Termites
Alligators



David and Peggy travel to the Olympic Training Center.

OLYMPIC TRAINING CENTER

How can biomechanics help an athlete?

What does it take to be an Olympic athlete? How important is training and practice for good performance? Do different sports require special training programs? How can science help Olympic athletes?

RESOURCES

Greenwood-Robinson, Maggie. "Touching Base With the New Push-Button Machines." *Women's Sports & Fitness*, May 1989.

Hilgers, Laura. "Cool School Days." *Sports Illustrated for Kids*, February 1991, pp. 40-45.

Milton, Joyce. *Greg Louganis: Diving for Gold*. New York: Random House, 1989.

Roessing, Walter. "Tommy Moe: Downhill to the Olympics." *Boys Life*, January 1991, pp. 29.

Vandeweghe, Ernest M. and Flynn, George L. *Growing with Sports*. Englewood Cliffs, NJ: Prentice-Hall, 1979.

Weintraub, Pamela and Teich, Mark. "Body and Seoul." *Omni*, September 1988.

DISCUSSION

- Scientists have developed many devices to analyze every detail of an athlete's performance.
- Advanced sports technology employs high-speed cinematography, force and torque measurement equipment, *ergometers*, electromyography, wind tunnels, mathematical modeling and many other devices.
- Athletes also employ *biomechanics* in their training. Biomechanics is the study of how the laws of physics can be applied to the human body.
- The biomechanics of swimming were ignored for years because it was very hard to quantify results in an open pool. But with the *flume*, a kind of treadmill for swimmers, scientists can now bring high-tech measurement and analysis to the Olympic swimmer.
- To understand how the flume helps the swimmer improve the "streamlining" of a stroke, involves a basic understanding

of *hydrodynamics*. Swimming differs from land sports in that energy must be expended to overcome drag forces which oppose forward movement of an object through a fluid.

The swimmer pushes down into the water with the hand. The water resists this motion, and this force, called *drag*, is transmitted through the swimmer's arm to propel the swimmer through the water. If the swimmer curves the hand and arm, an additional force comes into play: *lift*. The flow of water over the hand creates the same kind of lift force generated when air flows over an airplane wing. The goal of a winning swimmer is to maximize both the drag and the lift forces. This can be achieved with the assistance of the scientific measurements and analysis made possible by the flume.

Even non-Olympic exercisers now have access to much new technology: weekend joggers or bikers can have a videotape of their performance analyzed for biomechanical advice. Fitness clubs have stationary exercise equipment that offers instant feedback on current and average speeds, distance traveled and calories expended.

Things to Talk About

1. Why would athletes want to see videos of how they perform?
2. What other applications does this technology have? Could it be used in physical therapy?
3. Would you want to see movies of your performance in gym class?

VOCABULARY

Cinematography – The art or science of motion-picture photography. Advanced sports technology employs high-speed cinematography to assist athletes in their pursuit of better performance.

Kinesiology – The study of the principles of mechanics and anatomy in relation to human movement.

Drag – The retarding force acting on a body moving through a fluid, parallel and opposite to the direction of motion.

Lift – An upward force resulting from decreasing the pressure on the top of an object by increasing the velocity of the air flowing over the top of it.

Newton's Apple is a production of KTCA Twin Cities Public Television. Made possible by a grant from 3M.

Educational materials developed by the National Science Teachers Association—Space, Science, and Technology Division.

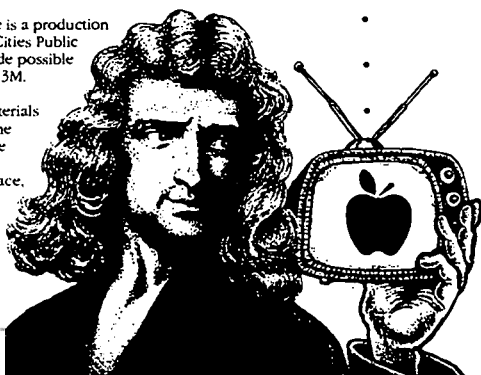

LIGHTS, CAMERA, ACTION!

Capture your athletic prowess on film!

TRY THIS...

Look into the future and try to predict the kinds of technology sports may be using then. Will there be new technologies or new sporting events? Can you create a new sport that uses both physics and biomechanics? Write the rules for the event and invite your friends to compete. What recent events have been added to the Olympic games?

MAIN ACTIVITY

You can learn more about your musculoskeletal system and improve your athletic performance by watching yourself participate in sporting activities.

Materials

- Video camera
- Blank videocassettes
- Television
- Videocassette Recorder (VCR)
- White Paper and Pencil

1. Decide on an activity like running, swimming or skating for your performance analysis.
2. Have friends or family members videotape you as you exercise.
3. Use the still frame on your VCR to look at specific points in the action. Diagram the motion by tracing a

sequence of these still-frames on a single sheet of paper.

4. Invite your gym teacher or coach to view the tape and help you analyze the biomechanics of your performance.

5. Compare your tapes to your classmates'.

Questions

1. After watching your performance, think of ways to improve your techniques. How else could videotaping activities be useful?
2. What would you watch for in an opponents tape? What might you learn about your own winning strategies?
3. What other Olympic biomechanical equipment would you like to try?

TRY THIS...

Invite a marathon runner or long-distance biker or swimmer to come talk to your class. Ask them about the issues of pacing, fluid replacement, mileage, speedwork and motivation. What is the longest distance you've ever gone in any of these sports? How did you prepare for competition? How did you feel after the activity? What damage do you think you could do without adequate preparation?

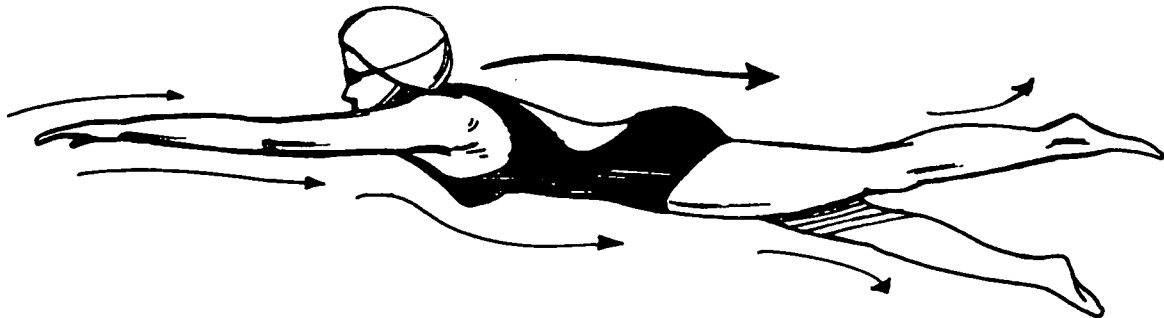

TRY THIS...

Find out about the sports curriculum at your local university. See if they offer any classes or programs on kinesiology, exercise physiology, sports medicine, biomechanics or the physics of sports. Ask them for course descriptions or typical assignments. Discuss these programs and try to do a few assignments with your friends. Could these programs help you improve your performance?

TRY THIS...

Sometimes other people can put a lot of pressure on an athlete to compete and win. Think about the following information attributed to the father of an Olympic swimmer: "The greatest motivating factor in my son's life has been his mother and myself. ... There was a point when I pushed him. ... Swimming isn't everything; winning is." How does this compare to De Coubertin's philosophy of the Olympics? Did this father really motivate the Olympian or did he have to motivate himself? What effects can parental or peer pressure have on athletes?



Peggy learns how gravity, friction and wind resistance all play a role in the sport of luge.

LUGE

How do engineering and technology play a role in the Olympics?

Would you like to take a ride on the luge? Why would athletes want to analyze their movements? How important is the start of the race? What kind and amount of strength does running a luge require?

RESOURCES

Freier, G.D. and Anderson, F.J. *A Demonstration Handbook for Physics Teaching*. College Park, MD: American Association of Physics Teachers, 1983.

Henry, Sara J. "The Need for Speed." *Women's Sport and Fitness*, Jan./Feb. 1991, pp. 58-59.

Milgrom, Harry. *First Experiments with Gravity*. E. P. Dutton & Co., New York: 1966.

Sklarwitz, Norman. "80 M. P. H. on Ice", *Boys Life*, Dec. 1990, pp. 36-37.

Wallechinsky, David. *The Complete Book of the Olympics*. Crawfordsville, Indiana: R. R. Donneley & Sons Co., 1985.

Additional Sources of Information

U. S. Luge Association
Box 651
Lake Placid, NY 12946
(518) 523-2071

DISCUSSION

- The Olympic luge event was introduced in 1964 at Innsbruck-Igis, Austria. The word *luge* is French for "racing sled." Lugers careen down the course feet first while lying on their backs. The luge sled was originally controlled by a hand-held strap which guided the front of the runner. Now luges are steered by the lugers exerting pressure on the sides of the car with their feet and shoulders.
- Sliders have limited visibility because of their body position combined with speeds of up to 80 miles per hour. Hairpin turns in the course and rules requiring one of the four runs to be run at night make this event one of the most dangerous in the Olympics. It is so dangerous, in fact, that in 1964 a Polish-born British slider named Kazimierz Kay-Skrzypeski was killed in a luge

accident, and later, two other German lugers were severely injured.

Several physical forces are demonstrated by a luge event. One is *friction*, the force that slows down moving objects when two surfaces rub together. Of course, the ice on the luge course minimizes the potential for friction on the surface. Lugers attempt to further reduce the force of friction by using the most slippery materials possible to construct the luge itself. The weight of the luger places pressure on the ice, melting it and creating a slippery layer of water that further reduces friction. But there are rules about overcoming friction. In 1968, the German Women's Olympic Team was disqualified for heating the runners on their sleds!

Another physical force involved with luge is *gravity*. Gravity causes acceleration and helps the luge move. The forward

motion is balanced by the friction of air pushing against the luge. Because of this air friction, designers must use *aerodynamic* principles to reduce the *wind drag* to a bare minimum. Often they use tight rubberized suits, special helmets with rounded face shields or smooth sleds designed with a low center of gravity.

Things to Talk About

Oftentimes, lugers are filmed on high speed video that is then converted to computer graphics to analyze performance. The use of this technology is a trend in modern sports and in the Olympics. By knowing more about physics and how it affects their performance, athletes can modify their training and practice sessions to improve their performance. What would you expect computer analysis to tell you about your favorite sport?

VOCABULARY

Friction – The force that acts to resist the relative motion (or attempted motion) of objects or materials that are in contact.

Air Resistance – The force that acts on something moving through the air.

Weight – The force on a body of matter due to the gravitational attraction of another body (commonly the earth).

Velocity – Speed together with the direction of motion.

Acceleration – The rate at which velocity is changing. The change may be in magnitude, direction or both.

Newton's Apple is a production of KTCA Twin Cities Public Television. Made possible by a grant from 3M.

Educational materials developed by the National Science Teachers Association-Space, Science, and Technology Division.

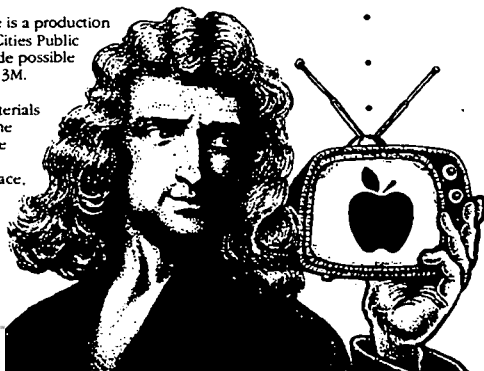

CONSTRUCT A LUGE

You can design your own luge and luge course. Try and find ways to make your luge car travel faster and then start racing!

MAIN ACTIVITY

By applying the physical forces of friction, the force that slows objects down when they rub together, and gravity, which helps the luge accelerate, you can design super fast luges and exciting luge courses.

Materials

- Graph paper
- Card board
- Rubber bands
- Waxed paper
- Butcher paper
- Aluminum foil
- Several toy cars of different shapes and sizes (Or, try to make your own luge with popsicle sticks, tongue depressors and glue)
- Stop watch

1. Have the class discuss what kind of course to build for your cars or luge. Choose what kinds of *variables* you want in your course, like the number of curves, angle of turns, *elevation* or length of the course. You may want to add a drop hole so the car or luge could drop through to another chute below.
2. Once your class has chosen a plan, divide into two teams. One team will design and build the course, the other will select the best cars or build a miniature luge.
3. Once the chute is constructed and the cars are ready, begin timing how long it takes the cars or luges to complete the course. Run several time trials and record your observations. Graph the results.

4. Try to modify the cars or luges to make them go faster. Record and graph the times of these modified trials.

5. Discuss your modifications, observations, and graphs. Select one car or luge for the course and invite other classes to enter a luge contest.

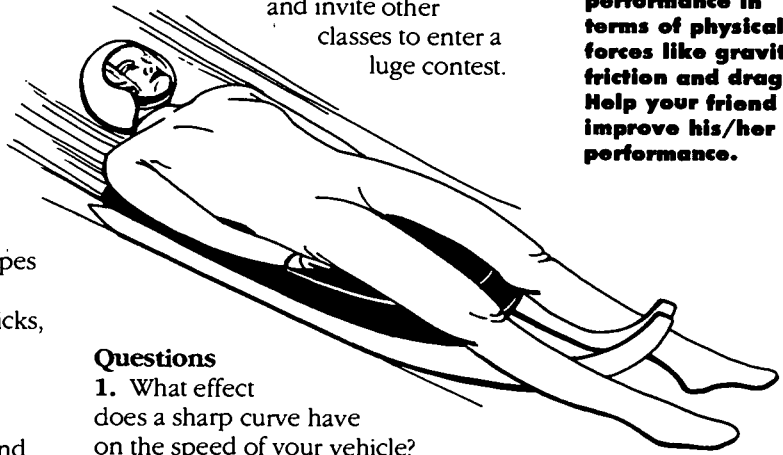

Questions

1. What effect does a sharp curve have on the speed of your vehicle?
2. Should a luge course be designed so that the car's speed increases continuously? Should there be parts of the course that level the luge out? Why or why not?
3. What factors increase or diminish speed?
4. Find out what *drag* means. Is there drag in water? What effect might it have on aquatic animals?
5. What affects your speed when you are sledding? How could you find ways to go faster? Could you find better ways to control the turns?

TRY THIS...

Videotape a friend playing a sport or performing an activity. Using freeze frame or slow motion, analyze the performance in terms of physical forces like gravity, friction and drag. Help your friend improve his/her performance.

TRY THIS...

Split up into several groups and discuss how friction helps us and how it hinders us in the things we do. See if you can find pictures that illustrate the effects friction has on our daily lives.

TRY THIS...

You can demonstrate the effects of air resistance when it interacts with gravity. Construct a paper parachute and attach it to a large iron washer. Hold another iron washer in your other hand. Drop the parachute with the washer and the solitary washer at the same time. Which washer reaches the floor last? Why?

TRY THIS...

Sports like tobogganing and bobsledding are similar to the luge. Split the class into teams and have them investigate the similarities and the differences between each sport. Pay particular attention to how each sport allows for physical forces like gravity, friction and air resistance. Go sledding if there is snow in your area. Each team should prepare a report to present to the class.



Peggy learns how a solar car is made and follows the General Motors Solar Car Sunrayce.

SOLAR POWERED CARS

How can the Sun help power a car?

- What are the benefits and drawbacks of solar powered cars?
- Would people save money and energy if more were on the road?
- Would you want to take a trip across the country in one?

RESOURCES

Asimov, Isaac. *How Did We Find Out About Solar Power?* New York: Walker and Company, 1981.

Catherall, Ed. *Solar Power.* New Jersey: Silver Burdett Company, 1982.

Gadler, Steve and Adamson, Wendy W. *Sun Power Facts About Solar Energy.* Minneapolis: Lerner Publications, 1980

Additional Sources of Information

Sunrayce
c/o General Motors
Attn: Bruce McCristal
GM Building
Detroit, MI 48202
(313) 556-2025

Electric Power Research Institute
Transportation Program Office
P.O. Box 10412
Palo Alto, CA 94303

U.S. Department of Energy
Conservation and Renewable Energy
1000 Independence Avenue, S.W.
Washington, DC 20585

DISCUSSION

- *Solar power* comes from the energy of our Sun, a yellow dwarf star located 93 million miles from the Earth. It is a middle-aged, mid-size star compared to the billions of other stars in the universe.
- The interior of the Sun is a region very high in temperature and filled with dense gases.
- The Sun's core is estimated to be approximately 27 million degrees Fahrenheit. Heat and light from the Sun are produced through a process called *nuclear fusion*.
- Sunlight is an excellent energy source and the future of using solar power is very exciting.
- The Sun's energy can be used to heat and cool buildings, generate electricity, operate communication and navigation systems and even power *solar cars*, like the ones in the General Motors Solar Car Sunrayce featured in the *Newton's Apple* segment!

Solar-powered cars all get their fuel from the same place—the Sun. The cars use hundreds of *photovoltaic cells* to convert sunlight into electricity. Each cell produces about one-half volt of electricity.

When the Sunrayce teams design their electrical systems they have to allow for variations in sunlight. The Sun's energy powers the car's motor and charges a battery for use when the Sun is hidden by a cloud. If a car is designed to put all of its energy toward driving and keeps nothing in reserve, it will stop completely in cloudy weather. If too much energy is diverted to the battery, the engine runs too slowly to keep up in the race.

Engineers and scientists still have many questions and problems to tackle before solar power becomes an efficient and economical way to fuel vehicles. But as the demand on *fossil fuel* resources increases,

research will continue to search for alternative energy sources, including harnessing the Sun's energy to drive a vehicle. The most exciting part of using solar power as an energy source is that it is pollution free and inexhaustible. If research continues, one day solar energy may replace today's combustion engine cars!

Things to Talk About

1. How did the team approach to designing and building the Northern Light car in the *Newton's Apple* segment work? What was the biggest challenge in the race?
2. What other things already use solar power for energy?
3. What other sources of energy are as pollution free as solar energy? What are these energy sources used for?

VOCABULARY

Solar – Referring to the Sun.

Solar Collector – An object that gathers the Sun's energy.

Nuclear Fusion – The process by which the Sun produces heat and light.

Fossil Fuels – Coal, oil and natural gas. Substances that have been formed by the decay of the remains of ancient plants and animals—in a sense they are a form of "buried sunshine."

Solar Panel – A device that captures the Sun's energy so it can be used for heating and other purposes.

Newton's Apple is a production of KTCA Twin Cities Public Television. Made possible by a grant from 3M.

Educational materials developed by the National Science Teachers Association—Space, Science, and Technology Division.

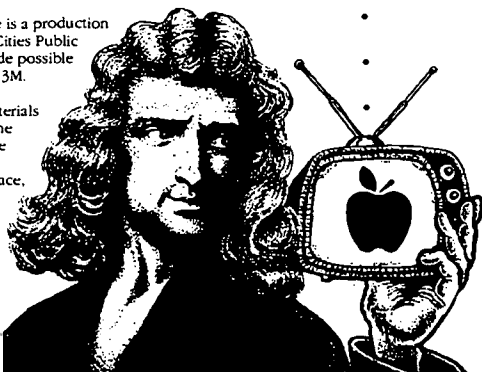

START YOUR ENGINES!

You can build your own solar powered cars and race them just like in the GM Solar Car Sunrayce!

TRY THIS...

Investigate other uses of solar power. Contact your local utility company and ask them about solar heating and cooling systems. Compare the costs of using solar power to natural gas and electricity. Prepare an annual budget and see which energy source is the most economical.

MAIN ACTIVITY

Build a custom-designed vehicle propelled by photovoltaic cells.

Materials

- 4 small solar cells
- Small 1 1/2 volt motor
- propeller

1. Place the solar cells side by side.
2. Connect them in a series by twisting the negative and the positive wire of one cell to the next cell.
3. Attach the motor to the remaining positive and negative wires.
4. Attach the propeller to the motor. Observe how fast it turns.
5. Design a custom body for the car. Compare your's with your classmates'.

6. Try a few time trials to see who's car is fastest. How can you modify your car to make it go faster?

Questions

1. What would happen if you used more cells? Does placement of the cells affect the power of the motor?
2. Does the arrangement of the cells affect the design of your car? How could you arrange the cells to make the car more efficient?
3. Do you have any solar-powered items at home? Where else could solar cells be used at home? At school?

*Adapted with permission from materials of the *Science Weekly*.

TRY THIS...

Discover how light and heat can be used as energy. Try filling one pie pan half full with white sand and another half full with dark soil. Insert a thermometer in each pan with the bulb just below the surface. Record the temperatures for both pans. Place pans at an equal distance under a lamp with a 150-watt light bulb. Turn the light on and wait for five minutes. Test the temperature in both pans and record your findings. Are the pans the same temperature? What would happen if the pans were further away from the light? How could scientists use this energy?

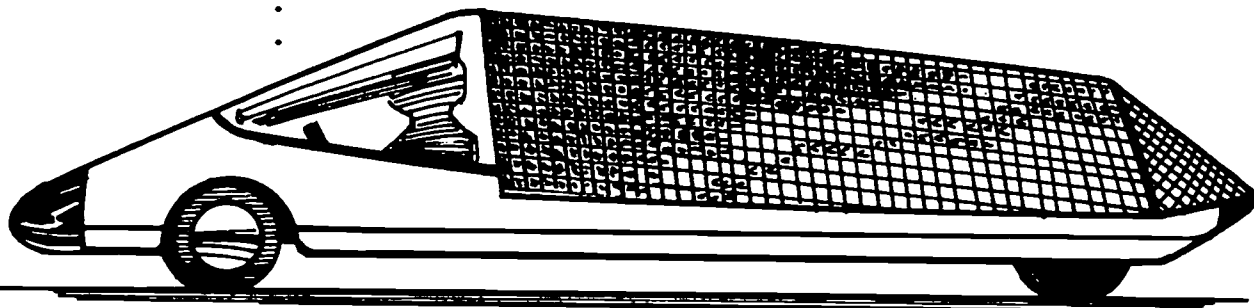

TRY THIS...

A radiometer is an instrument that measures radiant energy. See if your school has one you can use to study light. What happens if it is put in front of a light source? If you block the light with your hand, what happens? What kind of energy do the moving vanes have? Why are the vanes black and white? What powers the radiometer?

TRY THIS...

Color can change the amount of light and heat that are absorbed. Find out which colors are the most receptive. Paint a few tin cans different colors. Make sure you use matt paints or ones that aren't too shiny. Fill each can with equal amounts of water. Using a thermometer, record the temperature in each can. Allow them to sit in the sun for a few minutes. Test the temperatures in the cans and then arrange them in a rainbow from coolest to hottest. Now that you know which colors are coolest, what colors will you wear in the summer from now on? What about the winter? What color would you pick to paint your house to save energy?

Newton's Apple is a production of KTCA Twin Cities Public Television. Made possible by a grant from 3M.

Materials developed by National Science Teachers Association, Space, Science, and Technology Division.

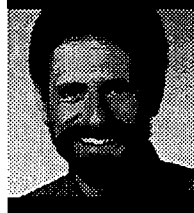

David learns how steroids are produced naturally in the body.

STERIODS

Do athletes need to take synthetic steroids?

What effects do steroids have on the body? Are there differences between natural steroids and manufactured steroids? Would you risk your health to look better or be stronger?

RESOURCES

Brancazio, Peter J., *Sports Science: Physical Laws and Optimum Performance*. New York: Simon and Schuster, 1986.

Goldman, Bob, *Death in the Locker Room: Steroids, Cocaine and Sports*. Tuscon: The Body Press, 1987.

Meer, Jeff. *Drugs & Sports*. New York: Chelsea House Publishers, 1987.

Additional Sources of Information

President's Council on Physical Fitness and Sports
Department of Health and Human Services
450 5th Street, N.W.
Washington, D.C. 20001
(202) 272-3420

Alzado, Lyle. "I Lied.", *Sports Illustrated*, July 8, 1991. pp. 20-25.

American College of Sports Medicine
(317) 637-9200

DISCUSSION

Anabolic steroids are male sex hormones, or androgens, that promote muscle growth. Your body produces them naturally, but they can also be produced *synthetically* in a laboratory. Both men and women produce these steroids. Men produce more steroids than women which tends to make men's muscles larger and stronger. Synthetic steroids are very similar to natural ones.

Physicians can use anabolic steroids as a treatment for a variety of conditions. In very small and controlled doses, steroids can, among other things, encourage people with muscle-wasting conditions to gain weight, control certain breast cancers, treat blood disorders, heal severe burns and relieve bone pain for people who have *osteoporosis*.

Not all steroids are made from hormones, nor are all hormones made of steroids. Physicians use another steroid called *corticosteroid*, also known as *cortisone*. This *catabolic* steroid helps reduce swellings in the body.

Some people use anabolic steroids to build their muscles and increase their endurance and speed. Since the 1950s, some athletes have used anabolic steroids to enhance their performance in competitions. But using steroids like this can cause side effects that are very serious.

Steroids can cause liver disorders, stunted growth in children and teenagers, personality changes, ulcerous acne and high *cholesterol* levels. Because steroids are made from synthetically-produced testosterone, which imitates

human sex hormones, they can also cause wasting of the testicles, impotence and negative changes in sexuality. Sometimes, when steroids are used illegally, they are injected with needles. Sharing these needles can also pass on the Human Immunodeficiency Virus, HIV, that causes the deadly disease AIDS.

Things to Talk About

1. Have any athletes gotten in trouble for using steroids? What do they think about steroids now?
2. Are other illegal drugs used in sports?
3. What other kinds of hormones are there? How important are these in the natural functions of the body?

VOCABULARY

Muscle – A tissue consisting of cells which have the power to contract. The contraction of muscles causes movement of joints.

Cortisone – A steroid hormone made by the cortex of the adrenal gland. It functions in cell metabolism, diminishes local inflammation and helps the healing of wounds.

Hormone – In animals, an organic substance produced by endocrine glands which help coordinate body functions. Hormones may be cholesterol derivatives, e.g., steroid hormones; amino acid derivatives e.g., thyroxin; or polypeptides, e.g., insulin. They are secreted directly into the vascular system and carried by blood to the site(s) of their activity.

Anabolic – Insofar as steroids are concerned, those effects involving the synthesis of protein for muscle growth and reparation.

Newton's Apple is a production of KTCA Twin Cities Public Television. Made possible by a grant from 3M.

Educational materials developed by the National Science Teachers Association-Space, Science, and Technology Division.

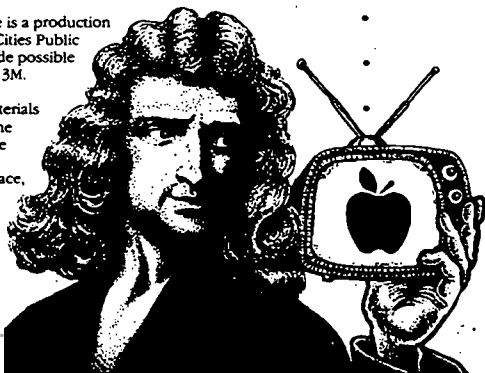

FOR THE RECORD

What's your opinion? Ask yourself and your friends and family what they think about the drug controversies surrounding sports today!

TRY THIS...

Interview several people who are active in sports, have arthritis or suffer from other joint injuries. Find out if they have been treated with steroids for inflammation. What kind of steroids were they given? Did the steroids help their conditions improve? Were there any side effects?

MAIN ACTIVITY

Before people can make rules and laws about certain activities, they collect scientific data, evidence and opinions. Here's your chance to state your opinion and compare it to other opinions at school, in the community, or at home.

Materials

- Paper
- Pencil

1. Use the statements below to collect the opinions of five friends or family members.
2. Read each statement aloud. Do you agree or disagree? Record your answers and your friends' answers next to the statements.

SPORTS OPINION POLL

1. All high schools should have drug information programs for their athletes.
2. Major league sports teams must take a firmer stand against anabolic steroid use by athletes.

3. Competitive sports in elementary school create performance pressure for young students that may later lead them to use anabolic steroids.

4. All junior and senior high school athletes should be tested regularly for anabolic steroid use.

5. Governments should encourage athletes to use anabolic steroids in Olympic competition so they have a better chance of winning medals.

6. A portion of the money made from sporting events should be used to treat athletes who have become dependent on anabolic steroids or other drugs.

7. Physicians and athletic trainers who provide anabolic steroids to athletes should lose their licenses to practice and have to pay large fines.

Questions

1. Are there any statements on which everyone agrees? Disagrees?
2. Can you make a graph out of the responses? What does this show you?
3. Who would benefit from knowing the results of your poll? How can you make a difference?

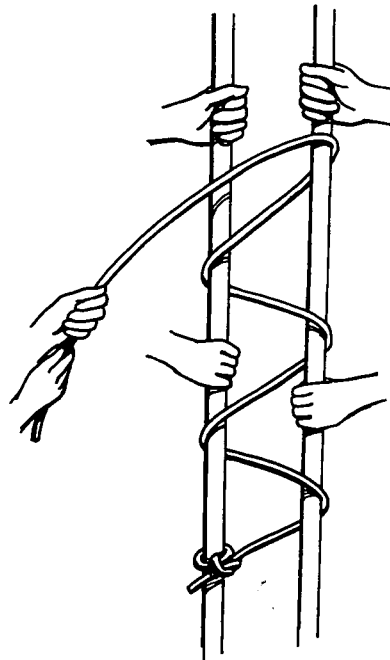

TRY THIS...

Just like smoking, overeating or using drugs, steroids can be habit-forming. Are you "hooked" on anything like chocolate, soda, or television? Whatever it is, try to stop doing it for one week. What does it feel like going without it? Do you act differently? Have you replaced one habit with another?

TRY THIS...

Exercise and training is still the best way to be physically fit. Learn ways you can improve your performance through practice. Exercise, practice, and then take the President's Council on Physical Fitness and Sports test.

TRY THIS...

How strong are you? Some people who do not have large or strong muscles can out perform people who do by using a little technology. Have two people with brooms stand about 60 cm apart with the brooms held upright in front of their bodies. Grab the two brooms and try to pull them together. The two people holding the brooms can easily keep them apart. Now tie a rope securely to one broom and wind the rope around both brooms three or four times. Be sure the rope does not cross itself. Ask the broom holders to try to keep the broom apart while you pull on the rope. What happens? Were the broom holders surprised? Where else have you seen technology like this in use?



Peggy and David investigate the "murder" of a loyal Newton's Apple viewer.

MURDER MYSTERY

How do forensic scientists help solve murders?

What is the first thing the police do when they arrive at a murder scene? What kind of evidence are they looking for? How is evidence gathered and stored? How important can crime scene material be in court?

DISCUSSION

- Whenever a person is murdered, the police initiate a thorough investigation into the crime, crime scene and friends and family of the victim. Each aspect of the *investigation* is important, but often it is the *physical evidence* of the crime that catches and convicts the criminal.
- Criminal investigations involve a variety of scientific fields and complex instrumentation. Chemistry, physics and biology are used in combination when detectives and laboratory technicians investigate a murder. Special tests include determining *blood alcohol* levels, using chemicals to make almost invisible blood stains very visible and typing blood to identify possible suspects. Geometry and trigonometry

help the investigators evaluate critical evidence like the angles of lethal blows and the *trajectory* of bullets. The tools of criminal investigations include computers, sophisticated photographic equipment, lasers, microscopes and other scientific equipment.

The study of both *forensics* and *criminology* require excellent observation skills and objectivity. The first official who arrives at the crime scene works quickly to seal off the area and preserve the scene as much as possible. Usually no one enters until the field investigator has had a chance to look about and collect every piece of evidence like hair and fiber samples, pieces of clothing or other personal belongings. Only then do other police officers or medical personnel enter the area.

When a piece of evidence is found at the scene of the crime, investigators are always careful to keep it in a labeled and sealed package until it can be safely stored in the police vault. It is only opened again when the case goes to court. This kind of evidence care-taking is especially important in drug-related cases when drugs are seized. Regardless, it is against the law to tamper with any kind of evidence.

Things to Talk About

1. What examples of forensic science have you seen in television mysteries or movies?
2. Would you like to be a forensic scientist? Why or why not?
3. Is there such a thing as a perfect crime?

VOCABULARY

Criminology – The scientific study of crime as a social phenomenon.

Forensic – A science that deals with the relation and application of facts to legal problems.

Plaster of Paris – A white powdery substance that swells when mixed with water and sets rapidly; used in making casts and molds.

Serology – The scientific study of the properties and action of the chemistry of the blood.

Trajectory – The path of a flying object (or substance), which can be analyzed using basic laws of physics.

RESOURCES

Brown, Robert J.
333 Science Tricks and Experiments.
Pennsylvania:
Tab Books, Inc., 1984.

Sobol, Donald J.
Encyclopedia Brown's Book of Wacky Crimes.
New York: Lodestar
Books, 1982.

Additional Sources of Information

State Bureaus of Investigation

Police investigative officers

Medical examiners

Local and state crime labs

Newton's Apple is a production of KTCA Twin Cities Public Television. Made possible by a grant from 3M.

Educational materials developed by the National Science Teachers Association—Space, Science, and Technology Division.

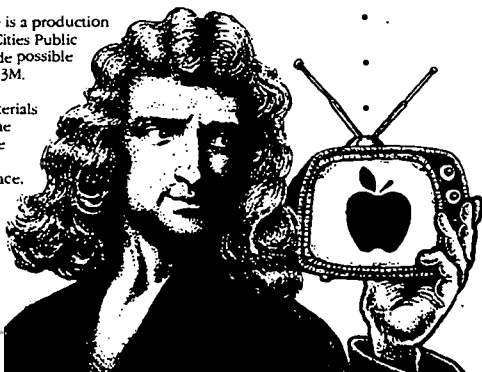



STEP RIGHT IN!

Learn how you can capture foot prints and simulate your own criminal investigation.

TRY THIS...

The orientation and placement of objects can be very important in criminal investigations. Learn about drawing to scale to make your own representative drawings. Measure your class room and any large pieces of furniture in the room. If one foot equals one half inch, how could you draw the room on graph paper. Ask someone to lay down in the room. Using their height and location can you draw them into your paper crime scene?

TRY THIS...

Collect a couple of pine cones or sea shells. Have several other people select one and study it for two minutes. Collect the pine cones or sea shells. Have everyone try to draw their particular object. Look at the group of items. Can you identify yours? After looking at someone else's drawing can you identify their item?

MAIN ACTIVITY

Scene investigators are always on the lookout for finger and foot prints. These clues can be essential in identifying or eliminating murder suspects.

Materials

- Plaster of Paris
- Water
- Hair spray

1. Divide your class into investigation and criminal teams. Have the "criminals" go outside and make footprints in some soft soil. Have some people wear their shoes and have others take them off.
2. While the "criminal" team is outside, the "investigation" team should mix the Plaster of Paris with water. Try to keep the consistency thick so that the impressions can retain small details.
3. The "investigators" should then locate the "criminals" footprints and spray each with the hair spray. This will keep the soil in place when you begin to make your mold.

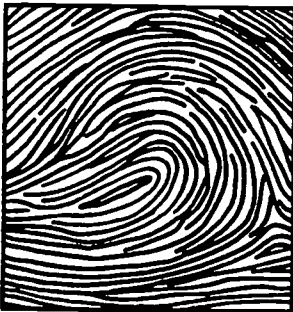
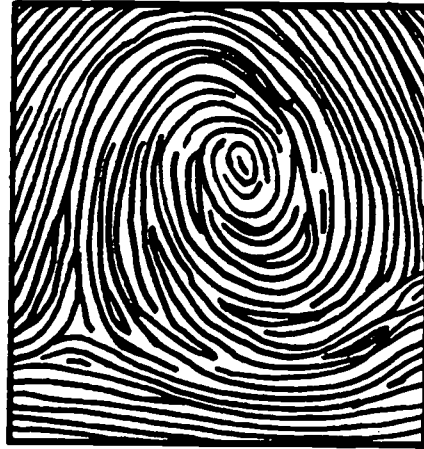

TRY THIS...

Have a person very quickly run into the classroom unexpectedly for about 10 seconds. They should be dressed in an unusual way. Write down everything you remember about the person including his/her size, hair color, clothing, or other details. Compare your list with other classmates. How many clues could you list? How could you improve your observation skills?

4. Pour the Plaster of Paris into the prepared footprints. Pour slowly from the sides and be careful not to disturb the area.
5. Allow the mold to set.
6. Have the investigation team try to match the footprints to the correct member of the "criminal" team.

Questions

1. What types of soil would tend to make better prints?
2. Would an actual footprint or a print from a shoe or boot be more distinctive? Why?
3. What conditions could keep the footprints from showing up very well? What properties does hair spray have that makes it useful for shoe printing?

TRY THIS...

Practice fingerprinting by using an ink pad and white pieces of paper. Each finger should be rolled from side to side to make a good print. Be careful with the ink and your clothing. (If some of your friends do not want to take their fingerprints, be sure that you respect their privacy.) Compare everyone's fingerprints. What kind of differences do you see? Are there differences between your fingers' fingerprints?



David learns what cancer is and how it develops.

CANCER CAUSES

Why do people get cancer?

Do a lot of people have cancer? What does a cancer cell look like? Can cancer be prevented? Who is at risk of getting cancer?

RESOURCES

Goldfarb, Ronald H. *Cancer Growth and Progression - Fundamental Aspects of Cancer*. Norwell, MA: Kluwer Academic Publishers, 1989.

Lafond, Richard. *Cancer: The Outlaw Cell*. Washington, D.C.: American Chemical Society, 1988.

Oppenheimer, Steven B. "Advances in Cancer Biology." *The American Biology Teacher*, January, 1987, pp. 11-15.

Oppenheimer, Steven B. "Tumor Suppressor Genes: A Key to the Cancer Puzzle?" *The American Biology Teacher*, January, 1991, pp. 22-24.

Additional Sources of Information

American Cancer Society
1599 Clifton Road, N.E.
Atlanta, GA 30329

National Cancer Institute
National Institutes of Health
Bethesda, MD 20892

Your school nurse

Your family doctor

DISCUSSION

- Ninety percent of cancers develop because of complex interactions between our bodies, our lifestyles, our *genetic makeup* and our environment. Scientists have discovered different factors that cause cancer. Research shows that tobacco is estimated to cause 30 percent of all cancer deaths, poor diet 35 percent, reproductive and sexual behavior seven percent, work-related causes four percent and the environment itself causes three percent.
- Scientists believe that genetic changes, whether inherited or acquired, are the basic cause of cancer. Some scientific theories do suggest that cancer may be a *hereditary* disease because each individual's make-up may make them more susceptible to certain cancers. About 50 of the more than 120 different types of cancer occasionally run in families.
- Most of the current scientific evidence indicates that a normal

AGENT	OCCUPATION	SITE OF CANCER
Ultraviolet Light	<i>Farmers, Sailors, Lifeguards, Everyone</i>	Skin
Radon (example- uranium)	<i>Underground Miners</i>	Lung
Asbestos	<i>Asbestos workers, Insulation workers</i>	Lung
Benzene	<i>Workers who use glue, varnishes, etc.</i>	Marrow (Leukemia)
X-rays, Radium	<i>Radiologists</i>	Skin

cell can become transformed into a cancer cell when certain genes become activated. Recent work in cancer biology concerns the study of *oncogenes*, a specific gene that participates in changing a normal cell into a cancer cell. It is thought that an oncogene might be present in an inactive form in normal cells and is some way activated to create cancer cells.

As mentioned, the nature of a person's work or the working environment can also be a factor in developing cancer.

The chart above identifies several cancer-causing agents, occupations where this exposure occurs and the types of cancers that can develop.

Things to Talk About

1. Can you develop cancer at any age?
2. Are some cancers more deadly than others?
3. What substances are carcinogens? What different types of cancer may they cause?

VOCABULARY

Carcinogen – A substance or agent that encourages the growth of cancer cells.

Carcinoma – A cancer which is a malignant growth of *epithelial* tissue or the tissue that forms the skin or blood vessels in an organism (e.g., the surface cells of the skin and the inside of the blood vessels).

Sarcoma – A cancer which is the malignant growth of connective tissue.

Leukemia – Cancer of the blood-forming tissues.

Newton's Apple is a production of KTCA Twin Cities Public Television. Made possible by a grant from 3M.

Educational materials developed by the National Science Teachers Association—Space, Science, and Technology Division.

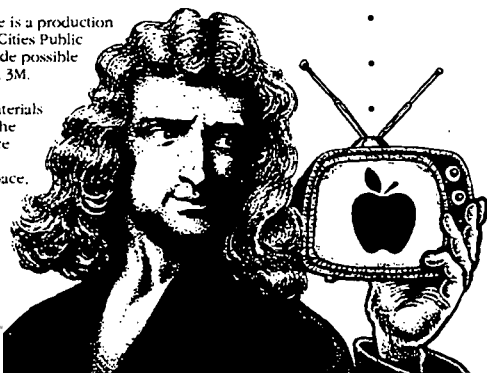

TAKE A CLOSE-UP!

Learn about human cells by taking a close look at your own.

TRY THIS...

Countries frequently have very different rates of cancer incidence. Try to determine which countries have high rates of rare cancers or high rates of one specific kind of cancer. Develop a data table which includes the country, type of cancer and cause.

TRY THIS...

Find out how the invention of the microscope helped scientists better understand the structure of the cell and how that structure is altered by carcinogens. How is an electron microscope different from the kind of microscopes you have in your science laboratory?

MAIN ACTIVITY

You will take a small sample of the epithelial cells that line the inside of your mouth. You'll get a glimpse of how scientists investigate inside cells.

Materials

- Microscope
- Slide and cover slip
- Flat toothpicks
- Charts and models of cells
- Medicine dropper
- Jar
- Iodine stain or methylene blue stain

1. Place a drop of stain on a microscope slide.
2. Gently scrape the inside of your cheek with the flat edge of a toothpick.
3. Dip this edge of the toothpick in the drop of stain on the slide.
4. Take another toothpick and once again scrape the inside of your cheek with the flat edge, and dip the second toothpick into the stain.
5. Spread the stain and cheek cells around in a small area with the toothpick and cover the slide with a cover slip.
6. First look at the slide under the low-power lens of the microscope. Focus carefully and record your observations. Now observe the slide under the high-power lens.

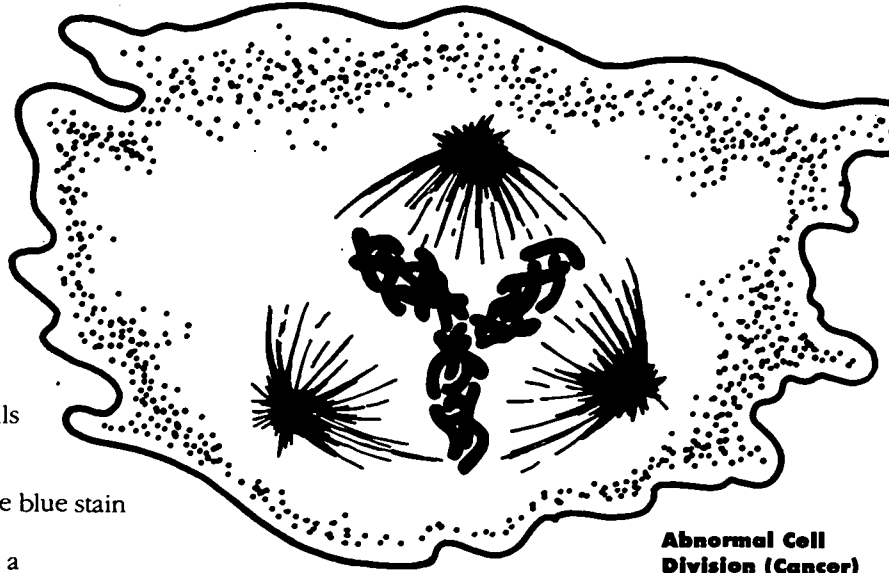

Abnormal Cell Division (Cancer)

Questions

1. How do the cells appear under low-power and high-power lenses? Outline the characteristics and highlight the similarities and differences.
2. Why was the iodine stain necessary for this activity?
3. Compare your cheek cells with your classmates. Are everyone's cells the same?
4. How long can cells live? What are examples of different types of cells and their life spans?
5. If cells live for different lengths of time, how are new cells added? Are all cells that die replaced?

TRY THIS...

Find out how scientists, biologists and chemists determine if materials are carcinogens. Why are scientists concerned about asbestos and radon? Find out if your school has been inspected for asbestos. What kinds of precautions do people take when it is removed?

TRY THIS...

Do some research on different environmental and lifestyle factors that cause cancer. Find out how pollution, tobacco and eating habits can increase the risk of cancer. Make a list of things you can do that might prevent cancer.



David learns the many different ways that Frisbees fly and the mysteries of disc physics.

FRISBEE PHYSICS

How does physics play a role in Frisbee flying?

- How does a Frisbee fly? Why is a Frisbee shaped the way it is?
- What would it be like to compete in a world championship Frisbee competition? How fast and how far can a Frisbee go?

RESOURCES

Horowitz, Judy and Bloom, Billy. *Frisbee, More Than Just A Game of Catch*. Champagne, Illinois: Leisure Press, 1983.

Johnson, Dr. Stencil E.D. *Frisbee. A Practioners Manual and Definitive Treatise*. New York: Workman Publishing Company, 1975.

Tips, Charles. *Frisbee by the Masters*, Millbrae, CA: Celestial Arts, 1977

Additional Sources of Information

Wham-O Sports Promotion Department
P.O. Box 4
San Gabriel, CA
91778-0004
(818) 287-9681

International Frisbee Disc Association
P.O. Box 970-P
San Gabriel, CA 91776

DISCUSSION

In the late 1940s Fred Morrison performed some experiments with flying discs. Some of the discs he experimented with were made out of metal while others were formed out of a new material called *plastic*. In 1955 the Wham-O Company purchased the rights and molds from Morrison. It wasn't until the early 1960s when Frisbees became the rage. Whamo-O's former General Manager Ed Headrick provided the organization and groundwork for the growth of the Frisbee craze. Today organized competitions take place each year around the world culminating in the World Frisbee Competition in California.

Two factors influence the flight of a Frisbee, *gravity* and *air*. Gravity acts on all objects the same way, accelerating their

mass towards the center of the Earth at 10 meters/second. Once in the air, *lift* and *angular momentum* act on the Frisbee giving it a ballet-type performance. Lift is generated by the Frisbee's shaped surfaces as it passes through the air. Maintaining a positive angle of attack, the air moving over the top of the Frisbee flows faster than the air moving underneath it. Under the *Bernoulli Principle*, there is then a lower air pressure on top of the Frisbee than beneath it. The difference in pressure causes the Frisbee to rise or lift. This is the same principle that allows planes to take off, fly and land. Another significant factor in the Frisbee's lift is *Newton's Third Law* which states that for every action there is an equal and opposite reaction. The Frisbee forces air down (action) and the air forces the Frisbee upward (reaction). The air is deflected

downward by the Frisbee's tilt, or angle of attack.

Spinning the Frisbee when it is thrown, or giving it angular momentum, provides it with stability. Angular momentum is a property of any spinning mass. Throwing a Frisbee without any spin allows it to tumble to the ground. The momentum of the spin also gives it *orientational stability*, allowing the Frisbee to receive a steady lift from the air as it passes through it. The faster the Frisbee spins, the greater its stability.

Things to Talk About

1. Does the thick rim of the Frisbee affect its flight?
2. What happens when you throw a Frisbee straight up? How do you aim a Frisbee?
3. What other sports use spin for better performance?

VOCABULARY

Gravity – The force that makes objects move or tend to move toward each other.

Lift – An upward force resulting from decreasing the pressure on the top of an object by increasing the velocity of the air flowing over the top of it.

Angular Momentum – A rotating body's resistance to change in its orientation and rate of rotation.

Angle of Attack – The angle formed by the tilt of the flying disk and the line parallel to the ground.

Newton's Apple is a production of KTCA Twin Cities Public Television. Made possible by a grant from 3M.

Educational materials developed by the National Science Teachers Association-Space, Science, and Technology Division.

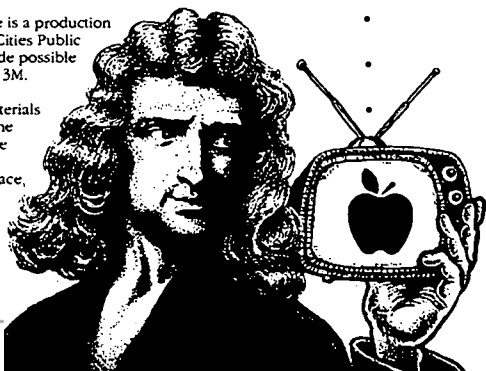



FLYING ON PAPER

Discover the best conditions for Frisbee distance flying!

TRY THIS...

Learn more about the three axes of motion. Stand with your arms extended straight out from your sides like the wings of a plane. Bend over at the waist and then bend backwards to imitate pitch. Lean your body from side to side to simulate a roll. Now rotate or twist your body at the waist to do a yaw. What other moves can you imitate? Which ones are the hardest to do?

MAIN ACTIVITY

By graphing the results of various tosses you will be able to calculate the average distance you can make a Frisbee fly and discover the best conditions for distance flying.

Materials

- Frisbee
- Tape measure
- Paper
- Pencil

1. Divide your class into equal teams. Take turns throwing the Frisbee.
2. Measure the distance from where you began to toss the Frisbee to where it hits the ground. Record your distances in a log.
3. After everyone has recorded the distances of a few tries, calculate the average distance of your team's throws.
4. Compare your average to the

other teams. Record the averages in your log and create a graph to represent your data.

Questions

1. What caused the Frisbee to fly the farthest? The shortest?
2. What could be done to improve the flight of the Frisbee? Experiment with your ideas to see if you can make it fly farther.
3. What would the best weather conditions be for distance flying? How might strong winds affect the distance a Frisbee could fly? Why?

TRY THIS...

What would it be like if you were a Frisbee? Would you like to live on a Frisbee or travel around the world on one? Write a story about the kinds of experiences you might have. What would you do if there was a strong storm coming? How would you navigate?

TRY THIS...

Find out about the similarities and differences between a Frisbee and an airplane. What makes heavier than air devices like helicopters, jets, single engine planes and rockets lift? Build a paper airplane and fly it. What physical forces affect its flight?

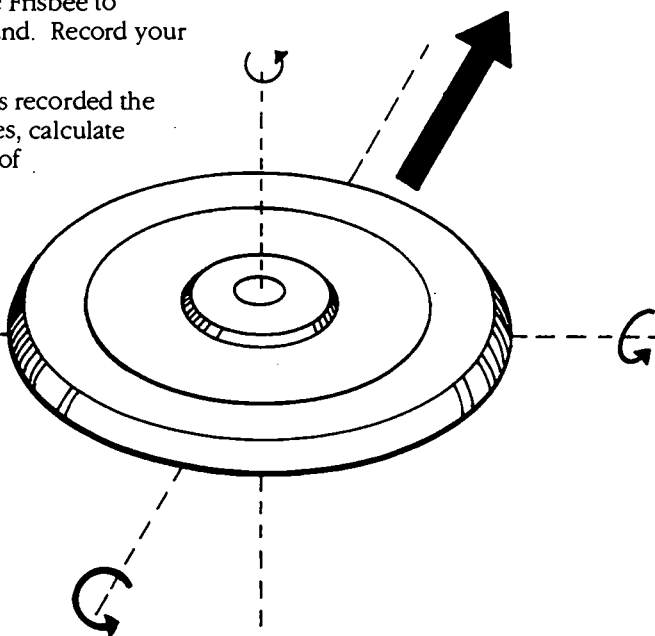

TRY THIS...

Invite a couple friends to help you calculate the velocity and acceleration of a Frisbee toss. Take turns acting as the time keeper, data recorder and tosser. Use a stop watch to time how long the Frisbee is in the air and a tape measure to determine the distance it travels. Record the data from each toss. Try calculating different kinds of throws like ones into the wind, with the wind and across the wind. Which direction works best? Does a fast flying Frisbee travel farther than a slower one?



Peggy takes a journey down her kitchen drain to explore the sewer system.

SEWER SCIENCE

Where does sewage go?

Where does our drinking water come from? What happens to waste water and sewage after it goes down the drain? Why is it important to treat wastewater before it returns to the environment? Does all sludge need to be destroyed, or can it serve a purpose?

RESOURCES

"Water, Water Everywhere," Filmstrip from the National Geographic Educational Services (800) 624-8301.

Water Quality Curriculums, American Waterworks Association, 6666 W. Quincy Avenue, Denver, Co 80235

Additional Sources of Information:

Environmental Protection Agency
Office of Water Programs
Washington, DC 20460
(202) 382-5700

Adopt A Stream
Izaak Walton League of America, Inc.
1701 North Fort Meyer Drive, Suite 1100
Arlington, VA 22209
(703) 528-1616

DISCUSSION

Clean water is one of our most precious natural resources. Yet every time we flush a toilet, pour oil down the drain or clean with strong household chemicals, we contaminate our supply. Before wastewater can be released into our waterways, it must go through a process called *sewage treatment* to be decontaminated.

A network of underground pipes collects the millions of gallons of waste material created by a community. When the waste and water arrive at the sewage treatment plant, large objects are filtered out with screening devices. The flow of the wastewater is then slowed to allow the *sludge* to settle. Oils and grease are skimmed off the surface of the *effluent* sewage. The effluent is then treated with chlorine to kill specific microorganisms that cause disease before the water is returned to the waterways. This process is called primary treatment. Unfortunately, this

treatment only removes about 50 percent of the pollutants found in wastewater and most sewage treatment plants must use a second stage of treatment.

In secondary treatment, effluent and sludge are exposed to oxygen in an *aeration* tank. Here, valuable microorganisms consume the organic matter and even some of the poisonous or toxic materials. Then chlorine is added before the water is released into the waterways.

Sludge from both primary and secondary treatments is pumped into oxygen-free digestion tanks and then dried. This processed sludge is often used as a fertilizer or as fuel. Sludge contaminated with toxic material must be incinerated or buried in a landfill.

One way or the other, water returns to the environment. That is why sewage treatment is so important.

Things to Talk About

1. What are the potential dangers if waste water and sewage are not properly treated?
2. Did you know that by turning off the tap while you brush your teeth, you can save one to two gallons of water? How else can you conserve water at home, school, or work?
3. During the making of the *Newton's Apple* segment on sewers, we learned that a small car engine was once found in the water in a waste treatment plant. How do you think the engine got there?
4. Where does your drinking water come from? What do you now put down the drain, that you might think twice about, knowing you may have to drink that water after treatment?

VOCABULARY

Sewer – A subterranean *conduit* to carry off sewage and sometimes surface water, like rain.

Sludge – Precipitated solid matter produced by water and sewage treatment processes.

Microorganisms – An organism of microscopic or ultramicroscopic size. While some promote disease and must be killed by chlorine in sewage treatment, others are necessary in removing organic matter and some toxic materials from liquid sewage.

Effluent – Waste material, such as liquid industrial refuse or sewage, discharged into the environment.

Newton's Apple is a production of KTCA Twin Cities Public Television. Made possible by a grant from 3M.

Educational materials developed by the National Science Teachers Association—Space, Science, and Technology Division.

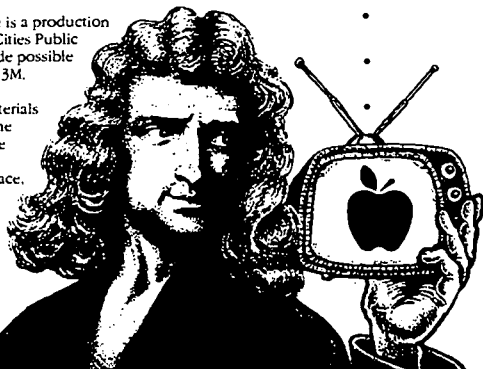

SETTLE DOWN!

Find out how sediment forms and deposits.

MAIN ACTIVITY

You will observe what happens when different sized particles are settled in water. You can create a model sedimentation tank to see how sludge and effluent are separated.

Materials:

- 3 cups of dirt
- 1 cup of sand
- 1 cup of pebbles
- 2-5 small rocks (1 inch in diameter)
- 1 gallon of tap water
- Salad oil
- Turkey baster
- Eye dropper
- 4 clear plastic cups numbered #1 to #4
- Small aquarium
- Bucket

1. Mix the dirt and water in a bucket. Fill the baster with the mixture from the bucket and put it into cup #1. Record your observations.
2. Put the sand, pebbles and rocks into the bucket. Fill the cup marked #2 from the bucket and record your observations.
3. Pour salad oil into the bucket. Fill the baster from the middle of the mixture in the bucket and place its contents into cup #3. Take a baster full from the top of the bucket and put it in cup #4. Observe cups #3 and #4.
4. Without mixing the contents of the bucket, pour the remainder of the mixture into the aquarium. What happens after an hour? Five hours? One day? One week?

Questions

1. What was different about each sample taken?
2. What did you notice about the samples in each cup? How would you remove the oil from the mixtures in #3 or #4?
3. Can you remove the dirt from the bottom of the aquarium without mixing it with the liquid on top?
4. How are your observations similar to what happens in ponds and streams in nature?

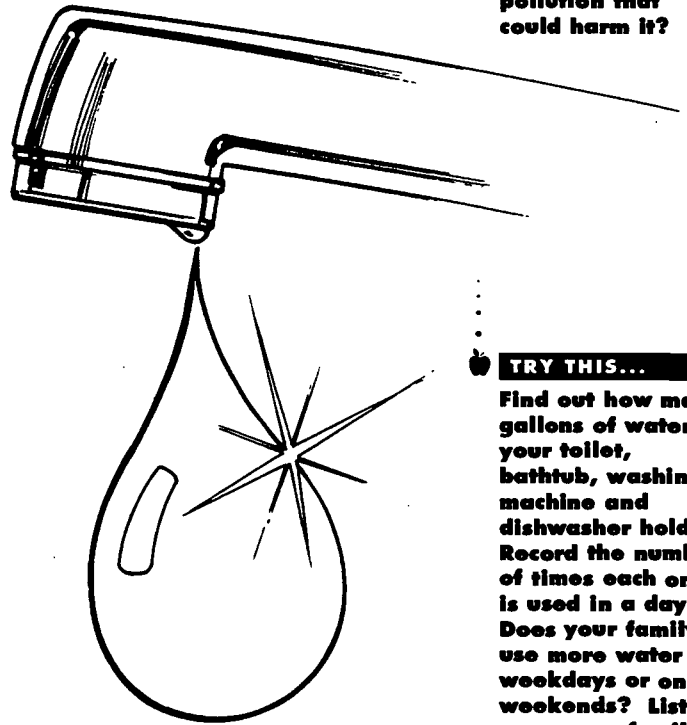

TRY THIS...

Adopt a stream in your community (see the Izaak Walton League in the Resources section). Learn about the chemicals used on lawns or farms in your neighborhood. Determine how these fertilizers affect your stream. Are there any other sources of pollution that could harm it?

TRY THIS...

Take an inventory of the products in your home. Which ones are poisonous or toxic to plants and animals? Contact a sewage treatment plant to find out how these products affect the waste streams at the plant. Try to find some alternative products that are not harmful to the environment.

TRY THIS...

Find out how many gallons of water your toilet, bathtub, washing machine and dishwasher hold. Record the number of times each one is used in a day. Does your family use more water on weekdays or on weekends? List ways your family could safely conserve water.

TRY THIS...

Take a field trip to your local waste treatment plant. Investigate how sludge from waste treatment is stored or recycled. Is it put in a landfill, used for fertilizer or incinerated? Find out if and why these ways are controversial.



David explores some of the most common methods for treating cancer.

CANCER TREATMENTS

Is cancer curable?

- What different kinds of treatments are available for cancer?
- What are the dangers or side effects of these therapies? How often do patients get treated? Are these treatments expensive?

RESOURCES

Hyde, Margaret O. and Hyde, Lawrence E. *Cancer in the Young: A Sense of Hope.* Philadelphia: Westminster, 1985.

Additional Sources of Information:

Students With Cancer: A Resource for the Educator. US Department of Health and Human Services, National Cancer Institute, Bethesda, MD.

National Cancer Institute Office of Cancer Communication 9000 Rockville Pike Bethesda, MD 20892

Cancer Information Services 1-800-4-CANCER

CANDLELIGHTERS FOUNDATION 2025 Eye Street, NW, Suite 1011 Washington, D.C. 20006

DISCUSSION

- The effectiveness of any kind of cancer treatment depends on a number of factors including the type of cancer, or *malignancy*, the location of the disease and the extent that the cancer has spread to other areas of the body.
- Most cancers are usually treated with a combination approach.
- The main cancer treatments include *surgery* to remove the cancerous cells, *radiotherapy*, *chemotherapy* and *immunotherapy*.
- Surgery and radiotherapy are local treatments. Both are used early in the treatment of cancer or in combination later with other treatments. They work best when the cancer cells have not spread too much within the body. Surgery may even be used after the cancer has advanced to relieve some of the symptoms and reduce the mass of malignant cells.
- Radiotherapy uses X-rays and radium to kill cancer cells.

Accelerator and betatron machines beam these rays at the patients.

Chemotherapy and immunotherapy are called *systemic* treatments because they can act on cancer cells throughout the body. Chemotherapy uses a variety of anti-cancer drugs that keep the malignant cells from multiplying. Effective treatments involve finding the best combination of drugs to treat the patient. Immunotherapy, also called biologic therapy, involves different types of treatments that rely on manipulating a patient's *immune system*. A relatively new approach to cancer treatment, immunotherapy procedures increase the body's natural ability to destroy malignant cells.

Prevention and early diagnosis, however, will probably continue to be the most effective ways to control cancer. There are a few strategies you can use to lower your risk of cancer. Eat a diet low in fat and high in fruit and grains, refrain from tobacco products and avoid too much exposure to the ultraviolet rays of the sun.

Things to Talk About

In the *Newton's Apple* segment there are several people who have or have had various forms of cancer. Some people may not know exactly how to treat someone who has cancer, especially at school. Talk about how you would want to be treated if you were diagnosed with cancer or some other illness. Would you want to talk about your illness and share your feelings with your friends?

VOCABULARY

Chemotherapy – Treatment of a disease by use of a chemical compound that will affect the particular *pathogen* involved, either by causing its destruction or by preventing its multiplication.

Malignant – Describes an abnormal growth which can often spread to other areas and may eventually cause death, e.g. a cancer.

Tumor – A lump in the body, without inflammation, it is caused by an abnormal growth of cells. It may be due to the presence of an infectious organism or it may occur spontaneously. In the latter case it can be *benign* or *malignant*.

Benign – Describes an abnormal growth which does not spread.

Cancer – The growth of abnormal cells in *epithelial*, or in connective tissue. The growth increases with time and eventually may cause death.

Newton's Apple is a production of KTCA Twin Cities Public Television. Made possible by a grant from 3M.

Educational materials developed by the National Science Teachers Association—Space, Science, and Technology Division.

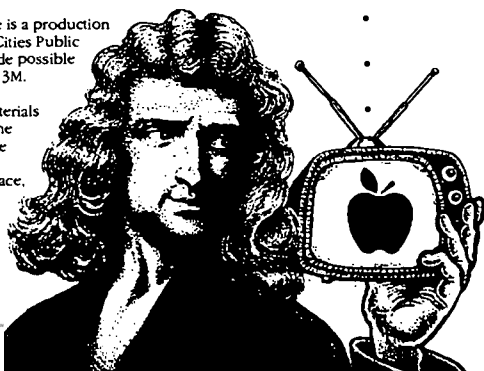

GROW! STOP GROWING!

With just the right combination you can control the growth of a foreign substance.

TRY THIS...

Find out how a patient's state of mind has an effect on the progress of the disease and the success of the treatment. Contact your local hospital to see if you can visit an oncology ward. Learn about support groups and activities for people with cancer. What is the purpose of these programs? Are they part of the medical treatments of cancer?

TRY THIS...

Discover how the study of genetics and the discovery of DNA made significant contributions to the early detection of cancer and helped to develop treatments for malignant cells. What other diseases and treatment have been discovered as a result of these scientific advances?

MAIN ACTIVITY

You can simulate how cancer develops by growing molds and then finding ways to control their growth like cancer researchers do when they develop new treatments for cancer.

Materials

- Several slices of white bread
- Orange sections
- Strawberries
- Jack or cheddar cheese
- Cantaloupe pieces
- 10 small glass jars
- Penicillium
- Eye dropper

1. Separate the jars into two groups of five each. One set will be used for the control group of samples which will not receive any special treatment. The other group will be used for the experimental group. Label each group's jars as "control" or "experimental".

2. Put a piece of each of the five foods into the five control jars and then into the five experimental jars.

Label each jar with the name of the food that is in it.

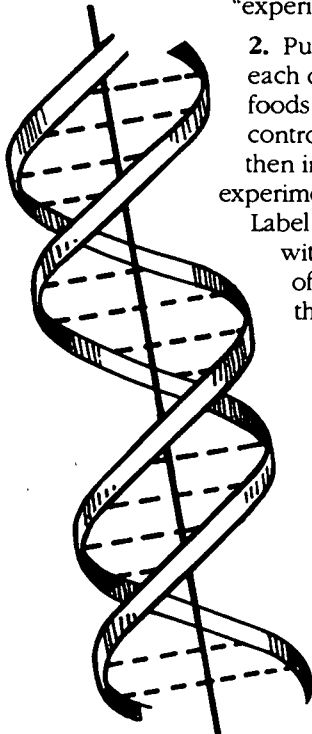

3. Make sure the experimental group of foods are kept under the same conditions as the control group both before and during the activity. Treat the food in each of the five experimental jars with ten drops of penicillium. The jars should be left open.

4. Observe what happens to the food over a period of several weeks. Check the jars each day for changes and record your observations. What effects does the penicillium have on the mold growth on each food?

5. Analyze both the experimental and control groups. Prepare a report summarizing your findings.

Questions

1. How does your experiment with growing mold compare to how scientists try and control cancer growth? What medications can be used for controlling cancer growth?
2. What type of foods contain molds that are not harmful? Are other moldy foods harmful and cancer-producing?
4. What types of experimental conditions are necessary to find cancer cures?
5. What branches of science are involved in the search for cancer cures?

TRY THIS...

Conduct a classroom panel discussion of different points of view concerning effective and ineffective cancer treatments. Find out if other countries have different cancer treatments than the United States. Why might U.S. physicians choose not to use these other treatments?

TRY THIS...

Invite an oncologist or cancer specialist from your community to come to your class for a discussion of cancer treatments. Find out which kind of cells are affected by chemotherapy. When might radiotherapy be chosen as a treatment? Learn how early detection of cancer is important to successful treatment. Ask the doctor about steps you can take to prevent cancer.



Peggy helps unearth a *Diplodocus* dinosaur skeleton; David finds out how the bones are dated.

DINOSAURS I

Finding and Dating

When you find something old, how do you know what it is or what it was used for? How long did dinosaurs live on the earth? How does that compare to how long man has been around? How do scientists excavate fossils?

RESOURCES

Arnold, Caroline. *Dinosaur Mountain*. Clarion, 1989.

Norman, David. *Dinosaur*. Knopf, 1989.

Parker, Steve. *How the Dinosaurs Lived*. Plaza Joven-Circulo, 1987.

"*The Dinosaur Hunters*." Film from BBCTV.

"*How Big Were the Dinosaurs*." Film/Video from the Wonder World of Science Series

Museums to Visit:

The Science Museum of Minnesota
St. Paul, MN

Denver Museum of Natural History
Denver, CO

National Museum of Natural History
Washington, DC

Dinosaur National Monument
Jensen, UT

DISCUSSION

Paleontology is the science of discovering and analyzing fossils to decipher the history of life on earth. Most often a *fossil* is the hard part of an animal like its bones, teeth or shell. Sometimes, the fossil is just the hard parts and sometimes it is the hard or soft parts hardened by minerals.

Paleontologists invented a special calendar called a geological time chart to outline the history of the Earth. During most of the Mesozoic era—between 200 million and 60 million years ago—great animals called dinosaurs were the dominant land animals.

Dinosaur fossils are often found when rock is mined, when nature exposes them by land movements and erosion, during scientific excavations and by amateur fossil-hunters, who stumble onto something curious. Skulls and teeth are more frequently found than other parts because of their

solid and hard characteristics. Sometimes softer parts, such as ribs, bones or skin can be found if they have been protected from rapid decay and mineralization.

To excavate a fossil, scientists establish coordinates over an *excavation* site. Using a variety of techniques from dynamiting and digging, covering the entire area in a plaster cast for transport to laboratories and cleaning with small picks and brushes, they preserve the dinosaur's fossils.

Dating the fossils is an important aspect of the scientist's work. There are three ways paleontologists determine the age of a fossil. One is studying how deeply the fossil was buried. Another is using *chronometric* techniques

(*chrono*=time, *metric*=measurement) which include Carbon-14 and Potassium-Argon dating. The third dating method looks at the Earth's magnetic field and its patterns in history. When these fields are preserved in rock, they leave a pattern that is unique for each span of geologic time.

Things to Talk About

1. In the *Newton's Apple* segment, a group of students discovered the complete skeleton of a *Diplodocus* dinosaur in Wyoming. Were they surprised?
2. What kind of rock preserved the fossils?
3. What "accidental" discoveries have you made? How important do you think "accidents" are in science?

VOCABULARY

Element – A substance made of identical atoms, which cannot be made into simpler units by a chemical process, but can spontaneously change through radioactive processes.

Excavation – To remove soil by digging.

Fossil – The evidence of the past existence of an organism. Fossilization can occur as actual remains; petrifications, where the original organic matter is replaced by minerals like quartz, calcite and pyrite; molds or casts of organisms; carbonized traces of plants found in rock or tracks, trails and burrows.

Diplodocus – A giant herbivorous dinosaur which lived 213 to 144 million years ago.

Sedimentary Rock – Formed of fragments transported over time from their source and deposited by water.

Newton's Apple is a production of KTCA Twin Cities Public Television. Made possible by a grant from 3M.

Educational materials developed by the National Science Teachers Association—Space, Science, and Technology Division.

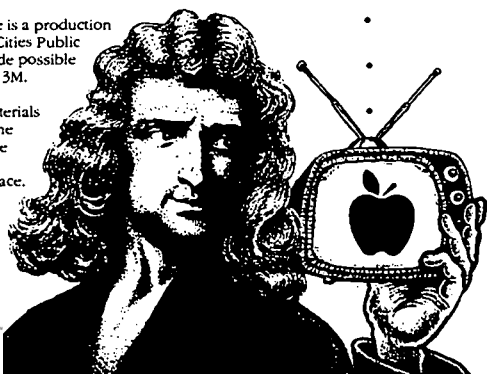



DIG IT!

Investigate ways paleontologists discover and analyze fossils to decipher the history of life on Earth.

TRY THIS...

Imagine that you are in a time machine and can visit the time dinosaurs lived. Write a story that describes what you see, hear, feel and do. You may also want to illustrate your work.

TRY THIS...

Investigate sedimentation. Shake water, soil, small pebbles and rocks inside of a closed jar that you can see through. Allow the jar to stand for a day, then observe the layers that form. What is the bottom layer? What is the top layer? Why is there a difference between the two layers?

MAIN ACTIVITY

You and your fellow students will work cooperatively as "paleontologists" to investigate and excavate "fossil" bones in a miniature classroom dig site. Prepare several boxes as dig sites (approximately five students per box) by compacting successive layers of soil and placing bones within soil layers. Exchange dig site boxes so each group is working on a different box than they prepared.

Materials:

- Bones and/or pieces of bones (or you could use pieces of a puzzle)
- Pencil and paper
- Magnifying lens
- Small cardboard or wooden box (minimum of two feet long by two feet wide by one foot deep).
- Small hand shovels
- Paint brushes
- Soil
- String
- Thumb tacks

1. Prepare the boxes for the dig sites.
2. Attach string over the top of the box containing your group's dig site at six inch intervals with thumb tacks to represent your coordinates. Letter or number string locations (see Figure A).
3. Dig and brush carefully to locate and remove any "fossils." Record the locations of where you found the bones on a paper diagram that has the same coordinates as your box. You also should record the depth of the find.

Questions

1. How is the classroom dig similar to and different from a scientific dig?
2. Why are coordinates important to a dig site?
3. Why do you think fossils are more often found in sedimentary rock formations?

TRY THIS...

Imagine that you are a reporter writing an article at a fossil dig site. Describe what the paleontologist would do first, second, third, etc., at the excavation site and the procedure that the scientist might follow when the fossils are assembled at the laboratory.

TRY THIS...

Draw different dinosaurs and identify their approximate size and weight. List the dinosaurs on a chart and compare physical characteristics like feet, mouths or heads.

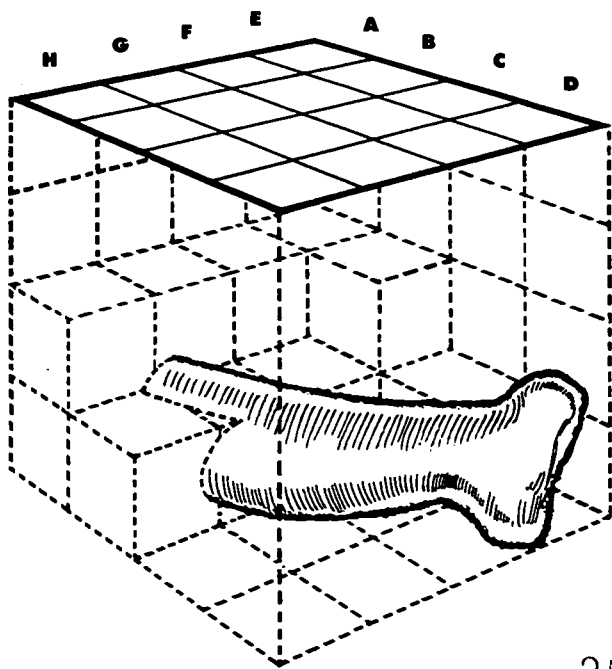

	A	B	C	D
E				
F				
G				
H				

Figure A



David and Peggy follow the process of assembling a *Diplodocus* dinosaur skeleton.

DINOSAURS II

Assembling a Dinosaur

Where do scientists find dinosaur bones? Why would someone want to rebuild a dinosaur? Why are people so interested in dinosaurs?

DISCUSSION

- The rocks where fossils are found can be soft and crumbly or very hard. Often both the rocks and the fossilized bones contain *minerals* that help protect the bones from weathering. Exposed bone, however, is sometimes very fragile. To prevent the bones from breaking, *paleontologists*, the scientists who study dinosaurs, use certain procedures to protect a fossil during its excavation and shipment to the laboratory.
- Once a specimen has been carefully exposed and examined for minerals, it is prepared for removal. First, the fossil is brushed with a type of glue or plastic and then covered with strips of wet paper and burlap dipped in Plaster of Paris for protection and support. The most critical part of this preparation is when the fossil has to be carefully turned over

and the underside is also covered and protected. After the plaster sets, the fossil is numbered and examined to determine what structural part of the animal has been recovered.

Back in the laboratory, each bone is cleaned and strengthened. Knowledge of today's animals' skeletons can help the scientists investigate the dinosaur's remains. By comparing features of bones, a paleontologist may be able to identify the fossil and its function. Bones along the back, from the skull or in the jaw are very distinctive and often used to identify the fossil's remains.

Most or all of the skeleton can then be pieced together if enough bones have been found. Paleontologists may have to estimate the size and shape of missing bones to complete a full skeleton. Once

all the pieces are identified, a model of the animal is built to assist the scientist in rebuilding the entire skeleton. Then a large metal framework is welded together to support the fossilized bones. The bones are then *free mounted* to the framework. If a simpler mount is desired, scientists will fasten the fossils to a slab and use a *bas-relief* mounting. Bas-relief mountings display the fossil as it was buried. Either method preserves the dinosaur's structure for further observation and research.

Things to Talk About

1. What kinds of rock preserve fossils the best?
2. What do we learn about the dinosaurs when we assemble their skeletons?
3. What other tests might a paleontologist want to perform on fossil remains?

VOCABULARY

Paleontologist – A scientist who analyzes fossils to decipher the history of life on earth.

Dinosaur – An extinct animal from a group, mostly terrestrial, of carnivorous or herbivorous reptiles. They appeared about 230 million years ago, and flourished 40 times longer than the time elapsed since our own ancestors emerged.

Mesozoic Era – The age of dinosaurs. Broken down into three periods: the Triassic Period (248-213 million years ago) marked the dawning of the age of dinosaurs; the Jurassic Period (213-144 million years ago) formed the middle of the age of dinosaurs; and the Cretaceous Period (144-65 million years ago), marked the last and longest part of the Age of Dinosaurs.

RESOURCES

Videos:

"The Dinosaur Age,"
FA PHENIX.

"Dinosaurs - Puzzles
from the Past," NGS

"Dinosaurs: The Terrible
Lizards," AIMS.

"The Dinosaur Hunters,"
BBC TV.

Museums to Visit:

Denver Museum of
Natural History,
Denver, CO

Field Museum of Natural
History
Chicago, IL

L.A. County Museum of
Natural History
Los Angeles, CA

National Museum of
Natural History
Washington, DC

Newton's Apple is a production
of KTCA Twin Cities Public
Television. Made possible
by a grant from 3M.

Educational materials
developed by the
National Science
Teachers
Association-Space,
Science, and
Technology
Division.

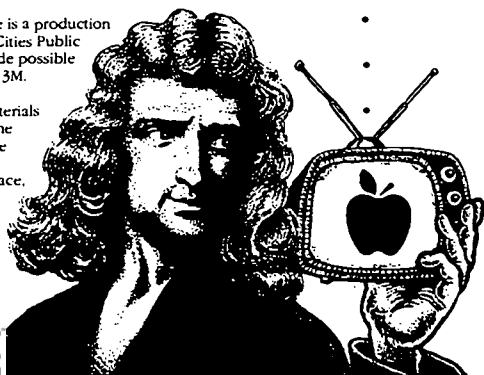

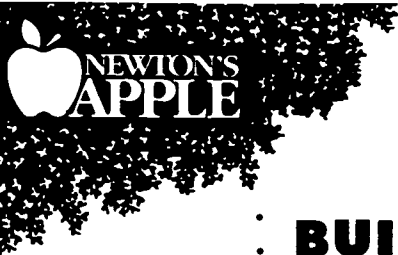

BUILD YOUR OWN DINOSAUR

You can create the same kind of models scientists use in their study of fossils!

TRY THIS...

Create a dinosaur's world. Investigate how their structure, function and behavior were adapted to their environment.

Make a chart that highlights their name, type, style of locomotion, choice of food, habitat and methods of protection. Does fossil evidence show what dinosaurs needed to survive? What are the theories about what may have happened to the dinosaurs?

MAIN ACTIVITY

Using similar techniques of mounting that paleontologists use, you will create a scale model of your favorite dinosaur. Make sure you know as much as you can about the dinosaur you choose to assemble.

Materials

- Various lengths of 3 cm and 6 cm-wide lumber
- Saw
- Hammer
- Nails
- Light wire or plastic mesh
- Newspaper
- Plaster of Paris
- Trowels
- Paint

1. After gathering information and pictures, select your favorite dinosaur.
2. Begin building a framework for your dinosaur model out of the wood, hammer, and nails.
3. Now cover your framework with mesh to begin creating the dinosaur's structure.

4. Dip newspaper in the plaster of Paris and begin wrapping it around your framework. If you want to add details like feathers, scales or other features, try carving them into the structure while the plaster is drying.

5. Once the plaster is completely dried, paint your dinosaur to make it look as realistic as possible.

6. Start a "dinosaur zoo" for the class's models.

Questions

1. How does your model compare to the actual height, size and weight of a real dinosaur? Calculate ratios of your comparisons.
2. How did your procedure for assembling a dinosaur compare to the work of a paleontologist? What things did you do that was your own idea?
3. What kind of environment did your dinosaur live in? What did it eat? Find out who its enemies were. You may want to build a diorama of its environment as a place to put your model.

TRY THIS...

Write a dinosaur riddle and see if your classmates can solve it. Here's just one example: I was the biggest dinosaur that ever lived. I was over 240 meters long and weighed as much as 50,000 kilograms. I had a long tail, long neck and nostrils on the top of my head. I also had very small eyes and legs like tree trunks to support my body. I spent most of my time eating plants. What am I? (The answer to this riddle is *Brachiosaurus*)

TRY THIS...

You can build a real animal skeleton. Save the bones from a chicken dinner. Carefully boil and bleach the bones and analyze which parts belong together. Using a framework, begin rebuilding the chicken by gluing its bones together. You may want to look at drawings of chickens and their skeletons to help you.

TRY THIS...

Learn more about paleontologists and their discoveries. One of the first major fossil finds was discovered by Mary Ann Mantell in 1822. Discover how this find revolutionized the study of fossils.

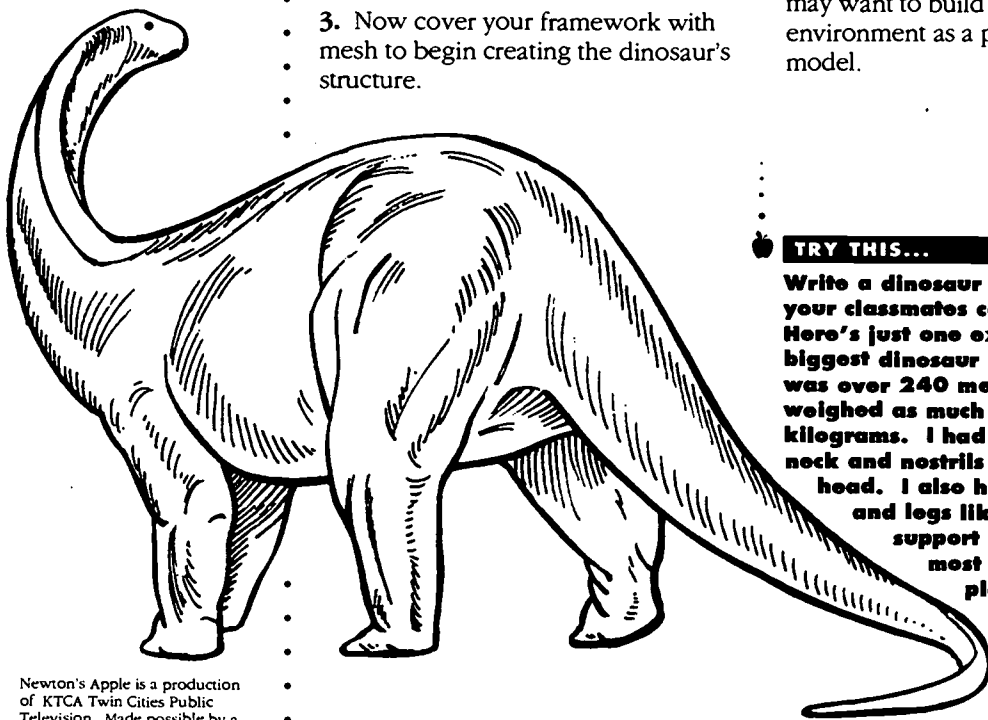

Newton's Apple is a production of KTCA Twin Cities Public Television. Made possible by a grant from 3M.



Peggy explores the physics and engineering necessary to keep a domed stadium from collapsing.

DOMED STADIUM

What keeps inflated stadiums up?

What is so unique about the Metrodome? How does it remain standing? Was it easier and more economical to build than a standard stadium? What other similar structures could an architect design? Are there other stadiums like the Metrodome?

RESOURCES

Berry, Donna A.
A Potpourri of Physics Teaching Ideas.
College Park, Maryland:
American Association of
Physics Teachers, 1987.

Additional Sources of Information

Air Supported Structure
Committee

IFAI
345 Cedar Street
Suite 800
St. Paul, MN 55101
(612) 222-2508

Foundation for Architecture

Attn: Rolaine Copeland
One Penn Center at
Suburban Station
Philadelphia, PA 19103
(215) 569-3187

Metrodome Stadium

Attn: Steve Macki
900 South 5th Street
Minneapolis, MN 55415
(612) 332-0386

Thermo-Flex Hazardous Waste Structures

Attn: Jim Roesner
P.O. Box 1184
Salinas, KS 67402
(913) 827-7201

DISCUSSION

- If you have ever bounced around on a "moon jump" at the fair or slept on an air mattress, then you know that fabric filled with air can support hundreds of kilograms of weight. This same principle is used at the Hubert H. Humphrey Stadium, also called the *Metrodome*, in Minneapolis, Minnesota.
- The stadium is an *air-supported* structure. The structure is covered with 10 acres of *teflon-coated* fabric. This flame-retardant coating on the outside is strong enough to protect the fabric from *ultraviolet radiation* from the Sun, air pollution, acid rain and other sources of physical damage.
- The stadium has 20 electric air fans to maintain a positive air pressure inside the structure,

although only three usually operate at one time. A computerized *pneumatic* system continually monitors the air pressure and engages extra 100-horsepower fans when the air pressure drops. These fans can blow air into the structure at about 100,000 cubic feet per minute. While positive air pressure keeps the Metrodome up, 26 cables are connected to the fabric to keep the entire structure in place.

Full-sized, air-supported sports stadiums are no longer being built in the United States. Too many problems with wet snow conditions and inadequate heating systems have had architects reconsider the design of large fabric-enclosed structures. Cable-supported or *tensile* structures are currently the preferred design for stadiums.

But designers have found other extremely practical uses for air-supported structures. They are used for temporary buildings and small sports facilities. The most exciting design is for hazardous waste clean-up sites. The air-supported covers prevent the sites from emitting toxic material into the environment.

Things to Talk About

1. What kind of structures would lend themselves to inflated support?
2. How would you make an air-supported structure?
3. Have you visited an inflated structure? Are there any where you live?

VOCABULARY

Pneumatic – Moved or worked by air pressure. Adapted for holding or inflated with compressed air.

Tensile Strength – The greatest longitudinal stress a substance can tolerate without separating.

Teflon – A modern polymer or plastic containing resins used especially for molding articles and for coatings to prevent sticking.

Ultraviolet Radiation – Electromagnetic radiation situated beyond the visible spectrum (light) at its violet end; abbreviated as UV radiation, it can damage materials exposed to direct sunlight for extended periods.

Newton's Apple is a production of KTCA Twin Cities Public Television. Made possible by a grant from 3M.

Educational materials developed by the National Science Teachers Association-Space, Science, and Technology Division.

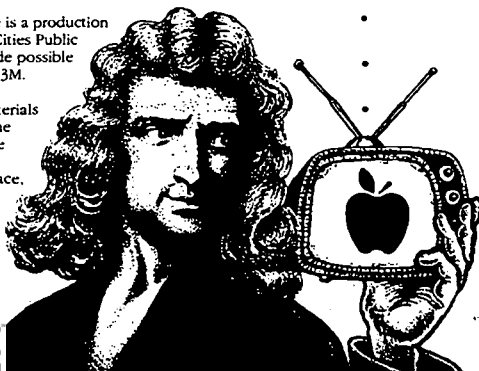

BLOW IT UP!

Find out how moving air can support weight in different conditions.

MAIN ACTIVITY

You can observe the effect that moving air has on inflatable materials. Discover how important changing conditions are on an inflated structure and how moving air can support it.

Materials

- Small fan with high and low settings and a protective covering
- 5 five-gallon plastic trash bags
- Masking tape
- Cloth tape measure
- Thumb tacks
- Pencil
- Paper

1. Tape the open end of the trash bag around the front of the fan.
2. Turn the fan on low. After the bag inflates, measure its widest part. Record your observations.
3. Turn the fan on high and measure the bag again. Record the new measurements.
4. Now turn the fan off and remove the bag. Using the thumb tack, poke a number of holes in the bag. Record the number of holes you made. Retape the bag to the fan in the same manner as before.

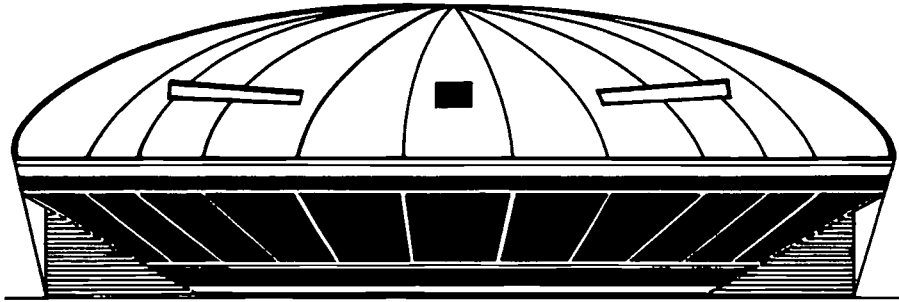

5. Turn the fan on low and measure the bag again. Turn the fan on high and measure once again. Record both observations.
6. Try adding more holes or larger holes to the bag.

ALWAYS REMEMBER TO TURN THE FAN OFF COMPLETELY EACH TIME YOU REMOVE AND REPLACE THE BAG. DO NOT PUT YOUR FACE OR HEAD IN THE PLASTIC BAGS!

Questions

1. How did the bag feel when it was inflated at the lowest setting? When the fan was on high?
2. How did the holes change the way the bag inflated?
3. Which holes affected the bag the most, the large ones or the small ones?

TRY THIS...

Draw a line on a balloon and then blow it up as much as you can. See what happens to the balloon if you change its environment. Try putting it in the freezer for an hour and then in the Sun or another warm place for an hour. How do these different conditions affect the balloon? Besides temperature, what other conditions might have an effect?

TRY THIS...

Contact a local car dealership and ask them about air bags. (Or watch *Newton's Apple's* show #913!) How do the same principles apply? Investigate the effectiveness of both air bags and seat belts. Would you want air bags in your car?

TRY THIS...

Conduct a "rip test" on a variety of everyday materials. Try tearing nylon, mylar, cardboard, and paper towels. Which ones are easiest to tear? Which ones are the hardest to tear? How are each of these materials used? Why would they need to be tear-resistant?

TRY THIS...

Have some fun with your hair dryer. See if you can keep different kinds of balls floating in the air! Try using cotton balls, Nerf balls and super balls. Or make your own light-weight balls out of tissue paper and aluminum foil. Which materials float the best? Why? Are the balls difficult to control? What other objects could you use with the hair dryer?

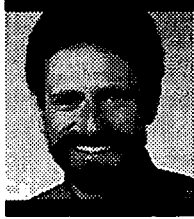

David learns why plants are green and how water is transported in plants.

PHOTOSYNTHESIS

How do plants make food?

What happens inside plants when the sun is shining or when it is raining? How do plants in the desert survive? How important are plants to our environment? What might happen if there were none?

RESOURCES

Bonnet, Robert L. & Keen, Daniel G. *Botany: 49 Science Fair Projects*. Blue Ridge Summit, PA, Tab Books, 1989.

"How Green Plants Make and Use Foods." Minneapolis, MN: University of Minnesota Films, 1984.

Education/Research Systems, Inc. *Project Learning Tree: Supplementary Activity Guide for Grades K-6*, The American Forest Council, Washington, DC, 1988.

Additional Sources of Information

Local foresters
Greenhouse managers
Garden shops
Conservatories
Nurseries

DISCUSSION

Of all the organisms in the natural world, green plants are the only ones that manufacture their own food. This process is called *photosynthesis* and begins when light strikes the plant's leaves (both sunlight and artificial light can power this process). Cells in the plant's leaves, called *chloroplasts*, contain a green pigment called *chlorophyll* which interacts with sunlight to split the water in the plant into its basic components.

Carbon dioxide enters the leaf through holes called *stomata* and combines with the stored energy in the chloroplasts through a chemical reaction to produce a simple sugar.

The sugar is then transported through tubes in the leaf to the roots, stems and fruits of the plants. Some of the sugar is used immediately by the plant

for energy; some is stored as starch; and some is built into a more complex substance, like plant tissue or *cellulose*.

Fortunately for us, plants often produce more food than they need, which they store in stems, roots, seeds or fruit. We can obtain this energy directly by eating the plant itself or its products, like carrots, rice or potatoes. Photosynthesis is the first step in the food chain which connects all living things. Every creature on earth depends to some degree on green plants.

The oxygen that is released by the process of photosynthesis is an essential exchange for all living things. Forests have been called the "lungs of the earth" because animals inhale oxygen and exhale carbon dioxide in the process of breathing, and plants take in carbon dioxide and give off oxygen in the process of photosynthesis.

But every year, over 28 million acres of tropical forest are cut and then burned to clear land for farming. Deforestation is also blamed for the "greenhouse effect" (global warming) which results from the build-up of carbon dioxide and other gases.

Things to Talk About

1. The *Newton's Apple* segment on photosynthesis talks about a few of the implications of rain forest destruction for people around the world. What are other possible implications? What do you think should be done?
2. How is the carbon-oxygen cycle between animals and plants like a battery that powers our biosphere?
3. Why is the term "food chain" a good metaphor? Would the metaphor "food web" work as well?

VOCABULARY

Chlorophyll – A green substance which gives leaves their color. Chlorophyll absorbs energy from sunlight which a plant uses to make food.

Chloroplast – A *plastid* that contains chlorophyll and is the site where photosynthesis and starch formation occur.

Photosynthesis – The formation of *carbohydrates* in the chlorophyll-containing tissues of plants exposed to light.

Stomata – A very small hole in the surface of a leaf. Oxygen and carbon dioxide from the air enter through the stomata; oxygen, carbon dioxide and water vapor leave through the stomata.

Newton's Apple is a production of KTCA Twin Cities Public Television. Made possible by a grant from 3M.

Educational materials developed by the National Science Teachers Association—Space, Science, and Technology Division.

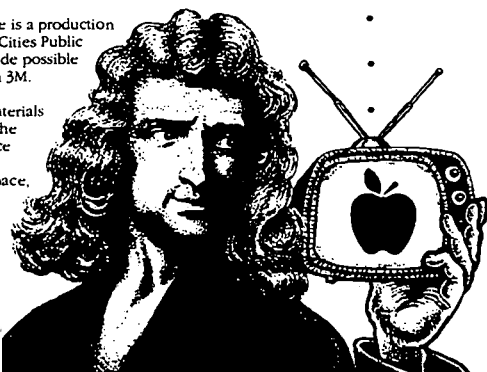

LIGHTS OUT!

Discover what happens if you change the patterns of a plant's light source.

TRY THIS...

It is the year 2040 and you are a research scientist. The amount of sunlight that reaches the earth has been reduced because of some major event like pollution, volcanoes or global fires. Farmers are asking you for help to save their failing crops. Figure out ways that you might help.

TRY THIS...

Design a way that you can make grass grow faster. Mark off two 10 cm x 10 cm boxes of grass and vary the amount of light each square gets. How did light affect the grass? What other changes could you make that would help grass grow faster?

MAIN ACTIVITY

Without enough sunlight, plants cannot use the process of photosynthesis to produce food.

Materials

- Small shrub, tree or house plant
- Cardboard or aluminum foil
- Scissors
- Paper clips

1. Pick a shrub, tree or houseplant that you can use for an experiment.
2. Using the cardboard or aluminum foil, cut out some geometrical shapes like a circle, square or triangle. Make sure your shapes are big enough to make a patch that will cover nearly half of the plant leaf.
3. Paperclip each shape on a different leaf.
4. If you use a house plant, place it near a south, west or east window where it will get plenty of sunlight. Make notes about the weather each day and add them to your observations.
5. After four days, remove the shapes from the leaves and observe each of the leaves that had a shape covering it.
6. Compare the areas on the leaf that were covered with the shape to other parts of the leaf.

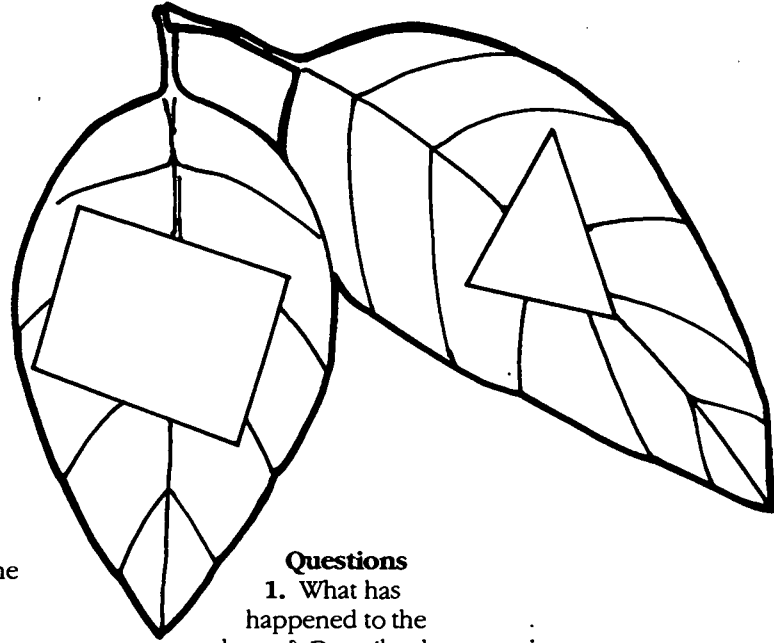

Questions

1. What has happened to the leaves? Describe the effects that the lack of sunshine has on leaves. What has or hasn't happened in the different parts of the leaf?
2. What is the best environment for a house plant? Why?
3. Where have you seen effects like these in nature?
4. Where would you expect to find fewer plants outside because of a lack of sunlight?

TRY THIS...

Discover if plants need soil for photosynthesis. Try growing a sweet potato just in water. Put the bottom third of the potato in a glass or jar of water. If you need help keeping the rest of the potato out of the water, you may want to insert toothpicks in the potato so that they rest on the rim of the glass. Add water every two to three days to keep the water level the same. Make sure the potato receives a lot of light, and watch it closely. Do roots start to grow in the water? Will the potato be able to sprout leaves or produce potatoes?

TRY THIS...

Take a trip to a local greenhouse to observe how they raise plants. Find out how they use light, water or other elements to increase growth and productivity.

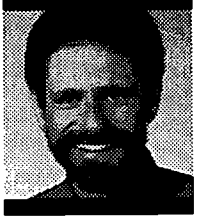

David explores the reasons we cry and talks with someone whose tear ducts don't function.

TEARS

Why Do We Cry?

What does it feel like after you've been crying? Are the tears we cry when chopping onions different from the tears we shed while watching a sad movie? Do we produce tears when we're asleep?

DISCUSSION

Tears flow from tear glands into your eyes through tiny tear ducts. The tear glands are located under your upper lids, and when stimulated, produce tears to form a thin film over your eyeballs. Every time you blink the film spreads over your eyes to keep them moist and free of dust and other irritants. Whether you are awake or asleep, happy or sad, this salty fluid is always flowing from the tear glands.

Besides protecting your eyes, the tear glands produce more fluid when your eyes are irritated. These extra tears are called *reflex* or *irritant tears*. And, when something makes you happy or sad, your tear glands will produce *emotional tears*. Used tears then drain down into two tiny openings on the brim of your upper and lower eyelids at the inner edge of your eyes, which lead to the

nasolacrimal tear ducts next to the bridge of your nose. From there, they are channeled into your nasal cavity where they are swallowed or blown out with other nasal fluids. If there are too many tears, they will overflow your lower lid and run down your cheeks.

Some people have to help stimulate the production of natural tears. This disease is called Dry Eye Syndrome or Sjogren's Syndrome. People who have diseases like rheumatoid arthritis or lupus often have this condition. They must use artificial tears up to every 10 to 15 minutes, and apply other medications to their eyes before going to bed as part of the treatment to improve the condition of their eyes.

Things to Talk About

1. In the *Newton's Apple* segment on tears, a woman talked about having Dry Eye

Syndrome. During the daytime, she must put special eye drops (artificial tears) in her eyes about every hour. Think about the things you do and the places you go where your eyes need protection. How would they change if you had Dry Eye Syndrome and had to use eye drops that often? What would it feel like to do something very often that other people don't even have to think about?

2. If Dry Eye Syndrome goes untreated it can cause blindness. What other *seemingly* insignificant things, such as not being able to cry, could result in such dramatic results?

3. Humans are the only animals that cry emotional tears. Do you think these tears have any other biological purpose? What might this purpose be?

4. What does someone who's been crying look like?

VOCABULARY

Lacrimal Gland – The glands which produce tears.

Reflex Tears – Also called irritant tears, these are extra tears which the tear glands produce when your eyes are irritated.

Emotional Tears – Extra tears that the tear glands produce in response to an emotional reaction.

Sjogren's Syndrome – Also called Dry Eye Syndrome is caused when the tear glands are damaged and produce an inadequate amount of tears. This also affects saliva glands.

RESOURCES

Frey, William H. and Lanseth, Muriel. *Crying, the Mystery of Tears*. Minneapolis: Winston Press, 1985.

Kapit, Wynn and Elson, Lawrence M. *The Anatomy Coloring Book*. NY: Harper and Row, 1977.

Additional Information Sources:

Frey, William H., M.D. Tear Research Expert
St. Paul-Ramsey Medical Center
640 Jackson Street
St. Paul, MN 55101

Sjorgen's Syndrome Foundation, Inc.
29 Gateway Drive
Great Neck, NY 11021
(enclose self-addressed stamped #10 envelope)

- A local ophthalmologist
- Contact lens maker or wearer
- Human physiology laboratory, university or medical center

Newton's Apple is a production of KTCA Twin Cities Public Television. Made possible by a grant from 3M.

Educational materials developed by the National Science Teachers Association-Space, Science, and Technology Division.

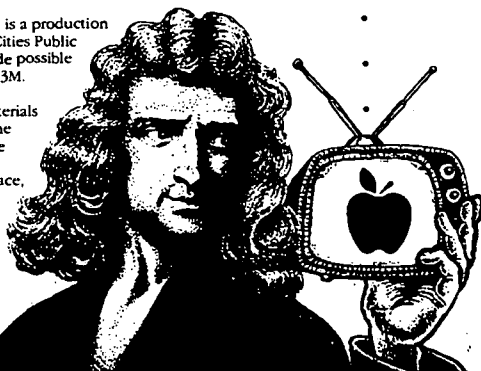

TEARS AND BLINKING

Find out how much your eyes work in a minute of blinking!

MAIN ACTIVITY

In this activity, you will determine the average number of times humans blink in one minute and the range of how the number of blinks per minute varies from one person to another.

Materials:

- Stopwatch or clock with a second hand
- Pencil/paper
- Chart for data collection

1. Ask at least 10 people to help you gather information (data) on blinking. You will want to observe everyone under the same conditions. This is called controlling the variables. You should control for time, temperature and location.
2. Count how many times each person blinks in a minute. Enter your data in a chart (see Figure A).
3. Add the number of blinks from all the people you observed. Divide the sum by the total number of people observed to determine the average number of blinks.
4. To find the range, look for the person with the lowest number of blinks and the person with the most blinks per minute. The difference between the fewest and the most is called the range. For example, if George had five blinks and Juanita

had 13, than the range is from 5 to 13.

Name of Subject	Length of Observation	Total Blinks	Blinks per Minute	Additional Observations

Figure A

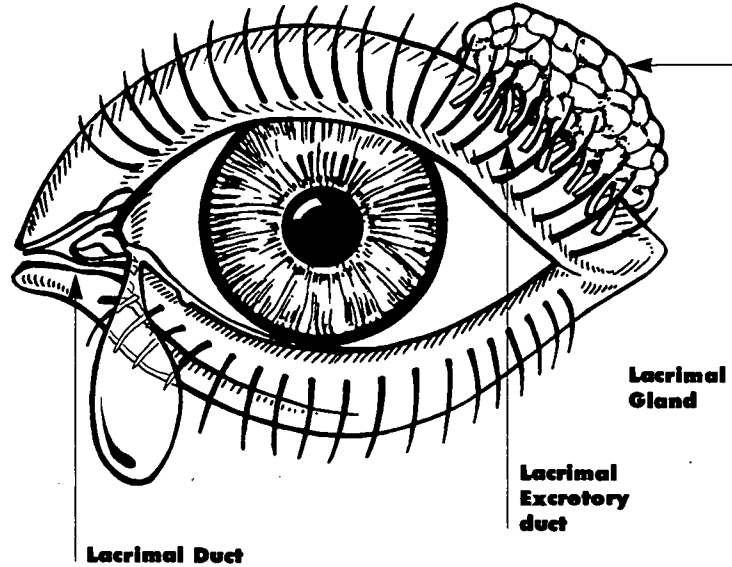

Questions

1. How does your data compare to other studies done by your class?
2. What might happen if people blink twice as much as the average? If they can't blink at all?
3. Why do you blink? What might cause you to blink more often? Are these the same reasons your classmates or family have? How are their reasons different?

TRY THIS...

Most animals that live in air produce tears to keep their eyes moist. Many have eyelids and lashes that also help protect their eyes. Read about different animals like turtles, owls and snakes and find at least three that do not have eyelids. How do they protect their eyes?

TRY THIS...

The act of shedding tears is referred to as "weeping" or "crying."

a. What do the following phrases or tears mean?

- Weeping Willow
- A Weeping Wound
- The Weeping Wall
- To Have a Good Cry
- Crocodile Tears

- Read it and Weep
- Brought Tears to His/Her Eyes
- Cry Baby
- Crying Your Heart Out

b. Write a poem about, or draw a picture of, a weeping sky.

Newton's Apple is a production of KTCA Twin Cities Public Television. Made possible by a grant from 3M.

ERIC materials developed by National Science Teachers Association - Space, Science, and Technology Division.

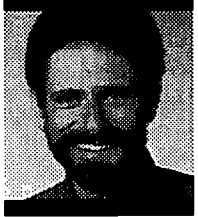

David discovers that the slinky and many other toys aren't as simple as they may look.

SLINKY PHYSICS

How do toys work?

Who invented the Slinky? How does it walk down stairs? Is it as simple as it looks? What other kinds of tricks can a Slinky perform? Are there other toys that work the same way?

RESOURCES

Ardley, Neil. *Muscles to Machine*. New York: Gloucester Press, 1990.

Hewitt, Paul. *Conceptual Physics*, 2nd Edition. New York: Addison-Wesley, 1991.

Milgrom, Harry. *First Experiments with Gravity*. New York: E.P. Dutton & Co., 1966.

Panati, Charles. *Extraordinary Origins of Everyday Things*. New York: Harper & Row, 1987.

Additional Sources of Information

Toys in Space Program
NASA CORE
Lorain County Joint
Vocational School
15181 Route 58 South
Oberlin, OH 44074

DISCUSSION

When the Slinky's inventor Richard James, a naval engineer, and his wife decided to demonstrate their new toy at Gimbel's Department Store in Philadelphia in the early 1940s, they feared that no one would buy it because it was so simple. They were so worried they gave a close friend a dollar to buy one. An hour and a half after the first demonstration, they had sold a total of 400 Slinkys!

The Slinky, whose design has been modified only once to crimp the ends for safety, remains the same today as it did at Gimbel's. Not only is the Slinky an excellent toy, its action also demonstrates a variety of physical forces and principles.

The Slinky, like all objects, tends to resist change in its motion. Because of this *inertia*, if it were placed at the top of the stairs it would stay at rest without moving at all. At this point it has *potential* or *stored* energy.

But once it is started down the stairs and *gravity* affects it, the potential energy is converted to the energy of motion or *kinetic* energy and the Slinky gracefully tumbles coil by coil down the stairs.

The physical properties of the slinky determine how quickly it moves under the influence of gravity. Although its movement may look simple, from a scientific point of view the motion is quite complex. As the slinky moves down the steps, energy is transferred along its length in a *longitudinal* or *compressional wave*, which resembles a sound wave that travels through a substance by transferring a pulse of energy to the next molecule. How quickly the wave moves depends on the *spring constant* and the *mass* of the metal. Other factors, such as the length of the slinky, the

diameter of the coils and the height of the step must be considered to completely understand why a slinky moves as it does.

James originally developed the Slinky for the Navy as an anti-vibration device for ship instruments. When the Slinky failed to work for the Navy, it became one of the most successful toys of all time!

Things to Talk About

1. Why can't a Slinky go upstairs? Would it work on a circular staircase? Is there any difference between plastic and metal Slinkys?
2. What are all the factors that might make one slinky move faster than another? Which factors are the most important? How would you test your answers?

VOCABULARY

Longitudinal Wave – A wave in which the vibration is in the same direction as that in which the wave is traveling, rather than at right angles to it. Sound waves are longitudinal waves.

Transverse Wave – A wave in which the vibration is at right angles to the direction in which the wave is traveling. Waves in the stretched strings of musical instruments, upon the surfaces of liquids, and the electromagnetic waves which make up radio waves and light are transverse.

Inertia – A property, or quality, that tends to keep objects in motion in a straight line, or to keep objects at rest motionless, unless either one is acted upon by an outside force.

Friction – The force that acts when two surfaces rub against each other. Friction always acts to slow movement and if no other force is applied, it will bring motion to a stop.

Newton's Apple is a production of KTCA Twin Cities Public Television. Made possible by a grant from 3M.

Educational materials developed by the National Science Teachers Association—Space, Science, and Technology Division.

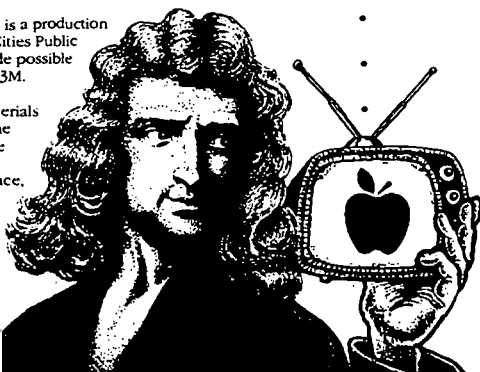

LET 'EM ROLL

Find out how you can convert potential energy into kinetic energy!

TRY THIS...

Collect as many dominoes as you can. Line them up in some creative patterns. Push the first domino to start a chain reaction of falling dominoes. How is the energy transfer similar to the operation of a Slinky? Can you find information about domino competitions? Draw some examples of the elaborate designs used in these competitions.

TRY THIS...

Select five of your favorite toys. These might include yoyos, hula hoops, roller skates, tops, marbles or any toy balls. The Slinky is an example of energy moving along a spring, but other toys transfer momentum from one object to another. Experiment with the motion of each and examine how potential energy is converted into kinetic energy.

MAIN ACTIVITY

You can overcome an object's inertia and watch physical forces act on it as it moves. You will also be able to create energy transfers.

Materials

- Empty spool of thread
- Small rubber band about the same length as the spool
- Metal washer
- Tack or pin
- Match stick
- Paper
- Pencil

1. Slip the rubber band through the hole of the empty spool.
2. Attach the end of the rubber band to the end of the spool with the tack or pin.
3. Pull the loose end of the rubber band through the metal washer.
4. Slip the match stick through the open end of the rubber band. Wind the rubber band around the match stick several times until there is no slack left in the rubber band.
5. Let go of the match stick and watch what happens!

Questions

1. Does the number of twists in the rubber band affect how far the model goes? What would happen if you used a longer rubber band?
2. Can you modify the design of your toy so that it can travel faster? Could you design it to go around corners?
3. What happens if you run the toy on a sloped surface? Does this affect the speed of the toy?

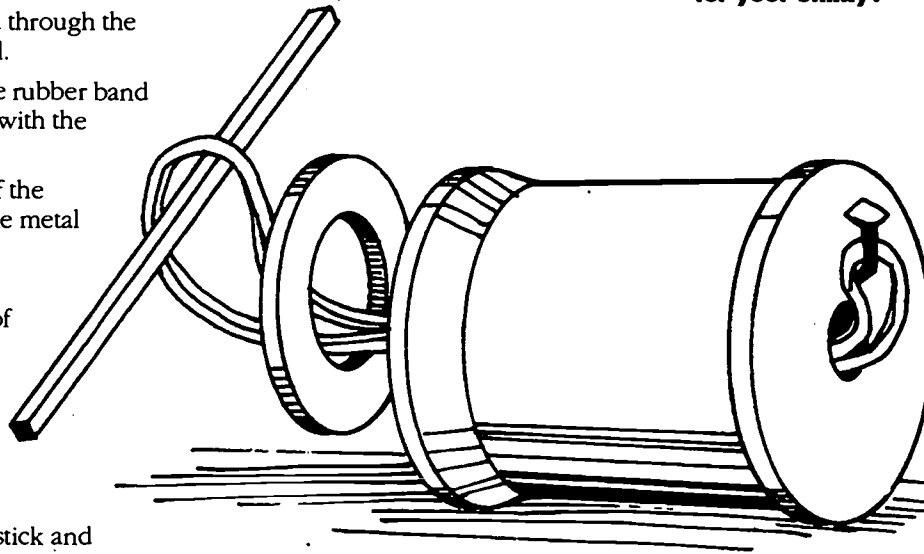

TRY THIS...

With your hands held horizontally, hold each end of the Slinky so that it forms an arch. Move one of your hands up. What happens to the coils of the Slinky? If you repeat that action but quickly return your hand to its original position the coils move very quickly. How do the connections from one coil to another affect the speed a Slinky moves?

TRY THIS...

United States soldiers who used radios during combat in Vietnam tossed the Slinky into trees to act as a makeshift antenna. Pecan harvesters used the Slinky to help collect the pecans and increase production. How do you think they did it? Find other ways Slinkys have been used by industry. What uses can you find for your Slinky?



Newton's Apple cameras follow a group of American high school students on a tour of the Soviet space program.

SOVIET SPACE

How does the Soviet space program differ from ours?

What is the history of the Soviet space program? Why do their space vehicles look identical to NASA's? How many different solutions to scientific challenges are there? What might the next space missions explore?

DISCUSSION

Achievements in space exploration have had an impact on science and technology around the world. The study and exploration of space is a quest for excellence and adventure, as well as a thirst for unlocking the secrets of the unknown.

The first decade of space exploration was marked by many Soviet and American firsts. In October 1957, the Soviets launched Sputnik I, the first artificial satellite to circle the Earth. A month later, Sputnik II rocketed spaceward carrying a dog, Laika, the first space traveller to orbit our planet. In following years, dozens of American and Soviet satellites were launched, with several probes exploring even more distant regions of space.

The real challenge of space exploration was to rocket people into space, and then toward the Moon. The first

human to orbit the Earth was Soviet *cosmonaut*, Yuri Gagarin. He flew in the Vostok I spaceship for one circuit of the globe in April 1961. During the 1960s, many Soviet cosmonauts and American *astronauts* mastered space flight. Only U.S. astronauts achieved the goal of landing on the faraway Moon.

In 1975, The Soviet Union and the United States worked together to link their respective spaceships above Earth – the U.S. Apollo and the Soviet Soyuz 19 – a historic first in space cooperation.

Today, U.S. space shuttles routinely take astronauts on voyages in Earth's orbit to experiment in *microgravity*. The Soviet Union uses their Space Station Mir to study the effects of long durations of weightlessness on the cosmonaut space travellers. Built of many modules, the Mir was first launched in 1986. On

one expedition aboard the Mir, the cosmonaut team of Musa Manarov and Vladimir Titov spent a total of 366 days, 18 hours and seven minutes in space – the current world's record.

In recent times, the Soviets have opened up their space program to more and more cooperation with other nations. They also want to commercialize their space program to help reduce its cost. In upcoming years, U.S. astronauts and Soviet cosmonauts are expected to once again fly together in space, forging friendships that could lead to a joint mission to the distant dunes of Mars.

Things to Talk About

1. How would your body change if you were to spend a year in microgravity? Would you be able to balance and run as well?
2. What other activities might be affected by microgravity?

VOCABULARY

Kaliningrad – The Soviet space mission control center.

Cosmonaut – A Soviet space traveller.

Microgravity – a state where the effects of gravity are barely noticeable, also known as *weightlessness*, found in orbit.

"Fat Face" – The effect of fluids shifting in a body due to a weightless environment.

Star City – The Soviet cosmonaut training compound.

RESOURCES

National Science Teachers Association–Space, Science and Technology Division.
Future Voyagers, 1742 Connecticut Ave., N.W. Washington, DC 20003-2140

Additional Information Sources

NASA CORE
Lorain County Joint Vocational School
15181 Route 58
South Oberlin, OH 44074

Challenger Center for Space Science Education
1101 King Street, Suite 190
Alexandria, VA 22314

Visions of Exploration Past, Present, Future
USA Today
(800) USA-0001

Newton's Apple is a production of KTCA Twin Cities Public Television. Made possible by a grant from 3M.

Educational materials developed by the National Science Teachers Association–Space, Science, and Technology Division.

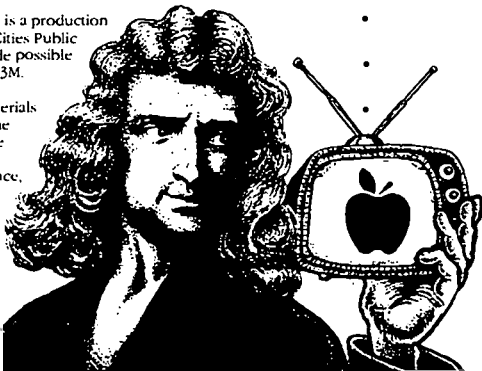

TOYS IN SPACE

How does gravity affect the operation of toys?

TRY THIS...

Compare the United States' Space Program with the Soviet Union's. Find out about both programs from 1957, when the Soviets launched Sputnik, and 1958, when NASA was formed, (including joint ventures) to the present. Create posters or pictorial time lines of space history to share with the class.

MAIN ACTIVITY

You will observe the physics of selected toys on Earth, and predict the physics of the same toys in a microgravity environment like that of the space shuttle. Space travellers have to learn to live, work and play in a weightless environment. In April 1985, the Space Shuttle Discovery transported 11 familiar toys into the weightlessness of space for the Toys In Space Project. This project was known simply as TOYS (Testing Of Youth Science). The TOYS Program included a selection of toys like those below. Find as many of these toys as possible.

Materials

- *Toys In Space* video (available from NASA CORE, see resource section.)
- Paper airplane
- Yoyo
- Set of ball and jacks
- Slinky
- Magnetic marbles
- Wheelo
- Wind-up car
- Paddleball
- Metal top
- Gyroscope
- Flipping mouse ("Rat Stuff")

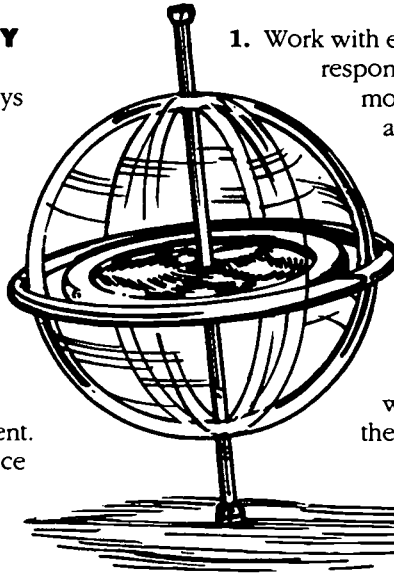

1. Work with each toy to see how it responds to gravity and motion. Try different actions with each toy like flying the plane or pushing the car backward and forward.

2. Write down your predictions of what you think would happen if you played with these toys aboard the Space Shuttle Discovery.

3. Match your predictions with what

happened on the "Toys In Space" video.

4. Talk about the reasons these activities might be valuable to space exploration.

Questions

1. How might you change each toy to work better in space?
2. Will a toy car go backward in space? If so, why?
3. What might happen if someone blew on the paper airplane in space?

TRY THIS...

Design your own spacesuit for a lunar mission. First, find out about the space suits of both the Americans and the Soviets. Then split up into small groups to work on your own design. Create drawings and write a proposal of what you team's suit should look like. Compare your design with the other teams and discuss the differences. What materials would build the best spacesuit? What would make a good visor? What are important human characteristics to keep in mind while designing the suit? You may want to try to construct part of your suit, like a glove, visor or boot. Or, you might want to construct the entire suit in miniature.

TRY THIS...

The U.S. space program uses a lot of acronyms, or initials, to describe various parts of the space program. Do you know what these acronyms stand for? How can you find out?

ESA
MMU
SRB
EVA
NASA
UV

Now make a list of more acronyms and their meanings. Try to stump your friends with your new list.



David finds out how the atmosphere makes different colors.

SKY BLUE

Why is the sky blue?

Where does color come from? Why isn't the sky blue at night? Is the sky always the same shade of blue? What does the sky look like on the Moon?

RESOURCES

Asimov, Isaac.
How Did We Find Out About Sunshine?
New York: Walker and Company, 1987.

Bohren, Craig F.
Clouds in a Glass of Beer: Simple Experiments in Atmospheric Physics.
John Wiley and Sons, 1987.

Gallant, Roy A.
Rainbows, Mirages and Sundogs: The Sky as a Source. New York: MacMillan, 1987.

Additional Sources of Information

NASA Goddard Spaceflight Center, Laboratory for Atmospheres
Room 16 Code 10
Building 21
Greenbelt Road
Greenbelt, MD 20771
(301) 286-5002

Weatherwise Magazine
Heldref Magazine
Good Apple, Inc.
P.O. Box 299
Carthage, IL 62321
(217) 357-3981

Edmund Scientific Co.
101 E. Gloucester Pike
Barrington, NJ
(609) 573-6250

DISCUSSION

- Why is the sky blue? People have been asking this question for centuries. The generally accepted scientific explanation for blue sky was first proposed by Lord Rayleigh, a British physicist and mathematician of the late 1800's.
- Rayleigh's theory was unique. He agreed with other scientists of the time that dust and other large particles in the atmosphere could scatter light, and that when this occurred, the *spectral* colors red and blue were revealed. Rayleigh also agreed that no light was absorbed by large particles, but he took this concept of scattering in the atmosphere one step further.
- Rayleigh concluded that as light traveled from the Sun to an observer, it encountered molecules, mostly of nitrogen and oxygen, in the atmosphere. Rayleigh then calculated a mathematical formula that demonstrated that, even in an atmosphere without smoke and

dust, gas molecules like oxygen could redirect sunlight and scatter it in many directions.

Sunlight is a form of visible light that contains all of the colors. When it is scattered, it is perceived by the human eye as having a specific color. When sunlight encounters gas molecules in the atmosphere, *high frequency* blue light is scattered out first. The most intense blues are usually seen between 10:00 a.m. and 3:00 p.m. on cloudless days, if we look at the sky about 45 degrees above the horizon with our backs to the Sun.

As the Sun begins to set, the sky at the horizon often appears to be red. Sunlight entering at the

horizon level travels through more atmosphere than sunlight entering overhead. Most of the shorter *wavelength* light has been scattered out, allowing longer wavelengths of light to reach our eyes. When particles of dust provide additional opportunities for scattering, sunsets have a red glow. The brilliance is often enhanced in the sky by clouds.

Things to Talk About

1. What kind of color do you see at night? What does the sky look like when the Moon is full?
2. What happens to light and the color of the sky during an eclipse?

VOCABULARY

Wavelength – The distance from the top of a crest of a wave to the top of the following crest. This measurement applies to waves of all kind. The length of a wave is inversely proportional to the frequency of the wave.

Frequency – The number of wavelengths which pass a point during one second.

Spectrum – For sunlight and other white light, the spread of colors seen when the light is passed through a prism: red, orange, yellow, green, blue and violet. (Some definitions also list the color indigo between blue and violet).

Blue – A color whose hue is that of the clear sky or that of the portion of the color spectrum lying between green and violet.

White – Light, such as sunlight, that is a combination of all the colors.

Hue – A graduation of color; the attribute of colors that permits them to be classed as red, yellow, green, blue or an intermediate between any pair of these colors.

Newton's Apple is a production of KTCA Twin Cities Public Television. Made possible by a grant from 3M.

Educational materials developed by the National Science Teachers Association-Space, Science, and Technology Division.

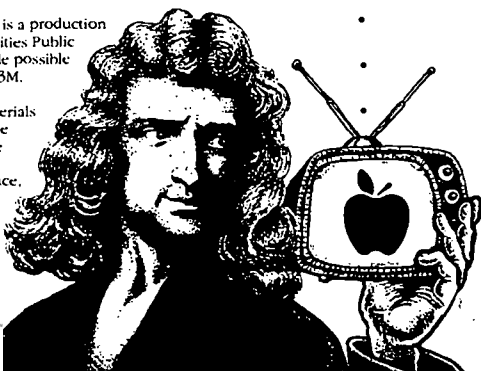

WEATHER OR NOT?

How does a change in weather affect the color of the sky?

TRY THIS...

Over the course of a month, look for examples of sunlight that has been scattered. Note the conditions that might have caused the sunlight to be redirected. Examples might include dew on a spider's web, oil on the ground after a rainstorm or light through a chandelier or glass ornament.

TRY THIS...

Make a variety of liquid suspensions. Add equal amounts of flour, baking soda, sugar and salt to 100 milliliters of water. Put a penny in several plastic cups and then pour equal amounts of the mixture into each cup. Shine a flashlight into the cup. What do you see? What happens if you vary the amount of the dry ingredients?

MAIN ACTIVITY

By keeping daily records of weather conditions, you will be able to study how particles in the atmosphere scatter light and change the color of the sky.

Materials

- Log book
 - Weather news or reports
1. Begin a two to four week log to record your daily observations of the sky where you live.
 2. Choose two times per day that you will record your observations in the log. Always look at the sky with the sun behind you, and choose two areas of the sky to monitor. Your observation points should be at a 45 degree angle above the horizon. **Never look directly into the sun!**
 3. Decide what words you will use to describe the different hues you may see. Pick a number to correspond to the intensity of the various hues. Include descriptions of the clouds and their brightness.
 4. Write a brief description of what you see at both observation points each time you observe the sky. Include your notes about the weather at the bottom of each day's entry.

Questions

1. How did the sun's angle in relation to the horizon affect what you saw at each viewing point? How was it different on sunny and rainy days?
2. What did you notice about the brightness of the thick and thin clouds?
3. When and where did you see the most intense colors? How might the cloud cover have contributed to what you observed?
4. Did the hue and the intensity compare to what you expected at the time you begin the activity?

NEVER LOOK DIRECTLY INTO THE SUN WHEN YOU ARE EXPLORING THE SECRETS OF LIGHT!

TRY THIS...

Build your own spectroscope to study the colors of the spectrum. You will need a covered shoebox or oatmeal box and a piece of diffraction grating (available through Edmund Scientific Company listed in the Resource section) that measures five centimeters by five centimeters. Cut a two and a half by two and a half centimeter square in one end of the box. Tape the diffraction grating over the hole. In the other end of the box, make a vertical slit about three centimeters long and no more than one centimeter wide. Look through the slit at the light of a lamp. Continue looking through the slit while rotating the box 90 degrees. Look through the slit at other light sources like florescent bulbs, halogen street lights, or at the sky **AWAY FROM THE SUN**. Compare your observations.

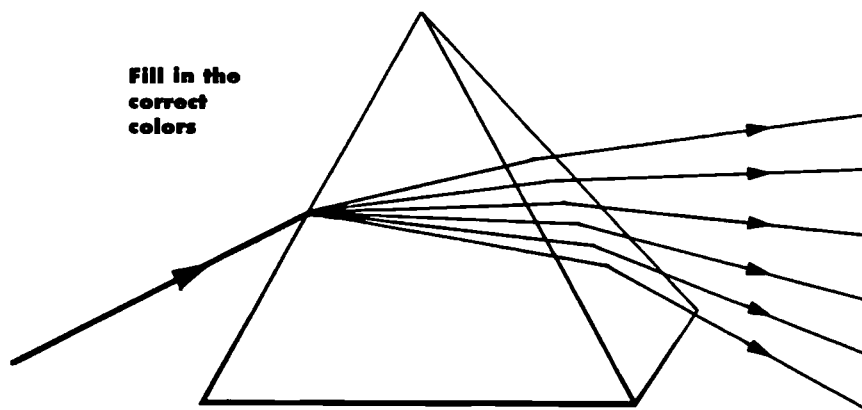



Peggy travels to the Wolf Ridge Environmental Learning Center to learn about acid rain.

ACID RAIN

What causes acid rain?

How does acid rain damage the environment? Is acid rain harmful to people? How does the acid get in the rain? Is there any way to stop the damage it causes?

RESOURCES

Gay, Kathleen. *Acid Rain*. New York: Franklin Watts Co., 1983.

McCormick, John. *Acid Rain*. New York: Gloucester Press, 1986.

Miller, Christian C. and Berry, Lousie A. *Acid Rain: A Sourcebook for Young People*. New York: Simon and Schuster, 1986.

USA Today, Earth Today, Volume 5. Number 1. Washington, DC: Gannett, 1990.

DISCUSSION

- Acid rain is considered by many people to be one of the most serious environmental problems of our time. It is a global problem that is gradually affecting our world. The term acid rain was coined by Angus Smith when he wrote about industrial pollution in England.
- Some rain is naturally acidic because of the *carbon dioxide* (CO_2) in air that dissolves with rain water and forms a weak acid. This kind of acid in rain is actually beneficial because it helps dissolve minerals in the soil that both plants and animals need.
- Recently there has been some concern that the acidity of rain caused by man has increased over the last several decades. Acid rain attacks wildlife, crops and lakes. It can cause the

death of forests and damage buildings and monuments. It is even harmful for human beings.

Acid rain is caused by *pollution*. Pollutants like *sulphur dioxide* and *nitrogen oxide* stay in the atmosphere and eventually react with the moisture in the air. When this polluted moisture falls to the ground, it is called acid rain. The source of these pollutants is not only from burning *fossil fuels*, but from both motor vehicle and chemical manufacturing *exhaust*.

Sulphur dioxide is unlike other kinds of acid pollution because it does not react with moisture until it has been taken long distances by the wind. Even worse is that rain and snow are not the only ways the environment can be damaged by air pollution. Dry fallout

from sulphur dioxide can still affect the environment.

Although places like the Adirondacks in New York have been seriously damaged because the lime in their soil is so easily dissolved by acid rain, there are ways to bring it under control. When both the United States and Canada began reducing the amount of sulphur dioxide released into the air, fresh water lakes and ponds in parts of Canada showed some improvement.

Things to Talk About

1. Have you seen examples of acid rain damage in your area? What other parts of the world have been affected by it? Are any other governments dealing with the problem?
2. How could you help stop acid rain?

VOCABULARY

Acid – A substance that has a *pH* less than 7.0.

Acid Rain – The popular term used for wet and dry acid deposition.

Base – A substance with a *pH* of more than 7.0.

Ecology – The study of the relationships of living things to one another and to their environment.

Environment – The aggregate of surrounding things, conditions or influences.

Indicator – A substance such as litmus that shows whether a solution is an acid or a base.

Snert – Acid snow.

pH Scale – A logarithmic scale (ranging from 0-14) that measures acidity.

Newton's Apple is a production of KTCA Twin Cities Public Television. Made possible by a grant from 3M.

Educational materials developed by the National Science Teachers Association-Space, Science, and Technology Division.

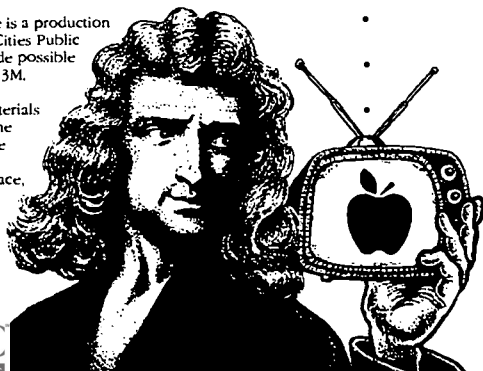

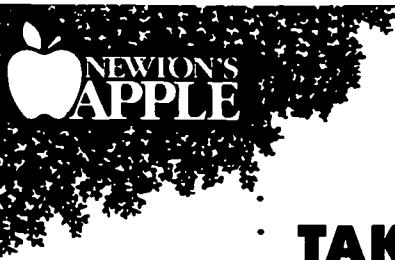

TAKE THE LITMUS TEST

With a simple test you can discover what acids you use everyday.

TRY THIS...

Compare the ingredients on the labels of various antacids. Do they have any common ingredients? Are these products acids or bases? When do you use these products? What other acids and bases are found in medicine?

MAIN ACTIVITY

Using a special kind of paper called *litmus paper*, you will test some common solutions. Litmus or *pH paper* is an indicator paper that turns different colors depending how acidic or basic a solution is.

Materials

- Measuring cups
- Water
- 4 glasses or jars
- Lemon juice
- Ammonia
- Baking Soda
- Cola soft drink
- Litmus paper

1. Put 250 ml of water in each glass or jar. Label the jars A, B, C and D.

2. Add 10 ml of lemon juice in A; 10 ml of ammonia in B; one gram of baking soda to C, and 10 ml of cola to D.

3. Dip a separate piece of litmus paper into each container. Compare your results to the color chart included with your litmus paper.

Questions

1. Were you surprised by the pH level of the cola? What about the ammonia?

2. Can you name other acidic solutions? What about base or alkali solutions?

3. What happens if you mix an acid and a base together? What does the litmus paper look like?

TRY THIS...

Watch the newspapers for two weeks and clip out any articles on air, water or land pollution. What are people doing about these environmental problems? If this is a global issue, how can everyone work together to help the environment? What can you do?

TRY THIS...

Put a piece of chalk into a jar of vinegar. Observe what happens to the chalk. Put a piece of limestone into another jar of vinegar. What happens to the liquid? Are any gasses being released? Could acid rain have the same effect on buildings and roadways?

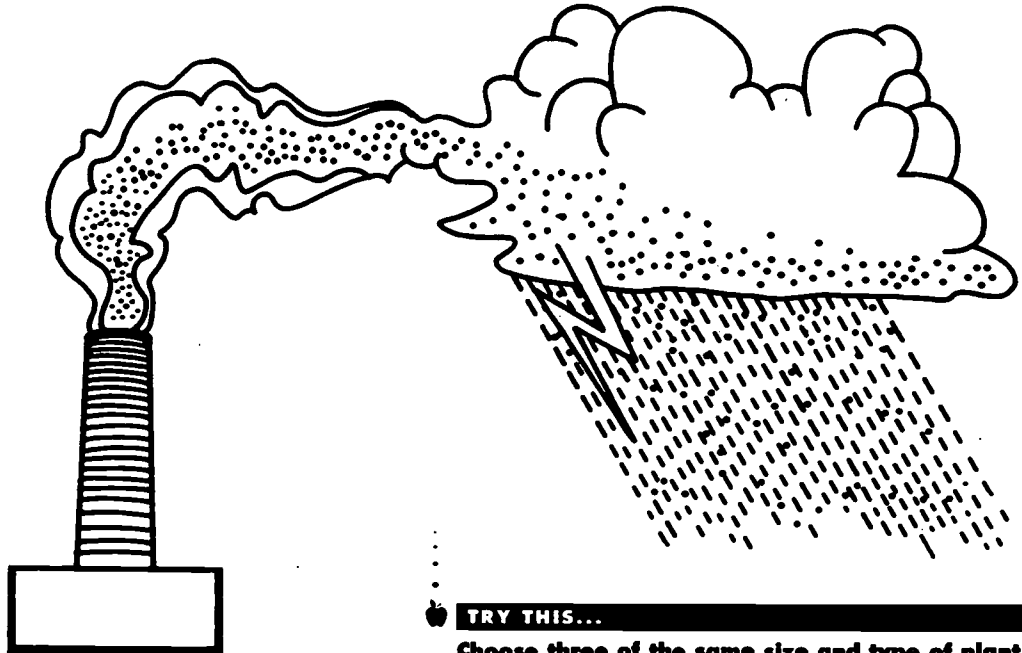

TRY THIS...

Choose three of the same size and type of plant for an experiment. Make sure that they are in the same size pots and have equal amounts of sunshine and liquid. Over a one to two week period, water plant A with just water, plant B with water and lemon juice and plant C with water and baking soda. Record your observations. Which plant looks the healthiest? Is there any damage to the plant that received baking soda?

Newton's Apple is a production of KTCA Twin Cities Public Television. Made possible by a grant from 3M.



David learns how physics helps high jumpers break records.

HIGH JUMP

How do high jumpers set new records?

• **Would you like to be able to jump higher? How do you feel when you figure out ways to improve your performance? What are the benefits of combining science with sports?**

DISCUSSION

• The jump style called the "Fosbury Flop" dramatically revolutionized the high jump. Dick Fosbury's movement technique involves racing toward the bar in a curved approach, lifting off with the left foot, pivoting the right leg backwards and sailing over the bar backwards, stretching the back and flipping the legs upward. In 1968, Fosbury set a personal and Olympic record of seven feet and four inches - a full two and a half inches higher than the 1964 Olympic record. By 1980, 13 of the 16 Olympic high jump finalists used the Fosbury Flop.

• All three phases of the high jump require allowing for and using different physical forces. The *approach* involves accelerating the body along a

curved path that leads up to the bar. At that point, the jumper is actually leaning away from the bar, allowing for the centrifugal force that will pull him or her into a vertical position for the jump.

The *lift-off* requires the jumper to overcome gravity by launching directly upwards while pushing against the ground. The greater the force applied to the ground, the greater the force that returns to the jumper.

Bar clearance requires careful management of the human center of gravity. The *center of gravity* is that point where an object balances perfectly. The force of gravity pulls down vertically and is concentrated at each object's center of gravity. For an object to remain balanced, the center of gravity

must be on a vertical line with the point of suspension, above or below it.

The ideal high jump position involves draping the body over the height of the crossbar at the peak of the jump.

Things to Talk About

1. How would you practice balancing your center of gravity? Why do you need to go over the bar backwards? How does the center of gravity affect different animals when they are jumping?

2. In the *Newton's Apple* segment on the high jump, Tom Ecker said that the high jumper's center of gravity always follows a *parabola*. Is it the same for a ball, a pen or a shoe? Why or why not?

VOCABULARY

Gravity – The force that tends to pull any two objects together. The force of gravity is usually large enough to be noticed only when one of the objects is massive, such as the earth.

Center of Gravity – The point at the center of an object's weight distribution where the force of gravity acts.

Balance – Stability produced by even distribution of weight on each side of the vertical axis.

Mass – The amount of matter an object has.

Weight – The force of gravity pulling on an object's mass.

Parabola – The mathematical curve that describes the flight of any thrown or tossed object (e.g., a jumper, a cannonball, or a ball).

RESOURCES

Chase, Sara B. *Moving to Win: The Physics of Sports*. New York: Julian Messner, 1977.

Ecker, Thomas. *Basic Track and Field Biomechanics*. Mt. View, California: Tasnews Press, 1985.

Laws, Kenneth. *The Physics of Dance*. New York: Schirmer Books, 1984.

Additional Sources of Information

Trainers from Local Fitness Centers

School Coaches

Sports Clinics or Doctors

Newton's Apple is a production of KTCA Twin Cities Public Television. Made possible by a grant from 3M.

Educational materials developed by the National Science Teachers Association—Space, Science, and Technology Division.

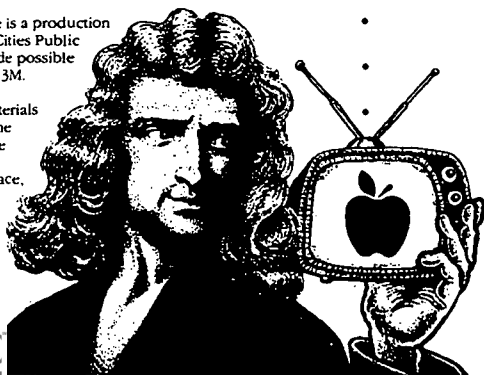



GET PUSHY!

Experiment with biomechanics to improve the height of your jump.

TRY THIS...

Go to a basketball game and watch how the players lift-off and use their center of gravity for balance. Talk with the coach and ask how players can improve their styles by consolidating physical forces in one direction. What happens if the players are blocked by the other team when jumping up with the ball? How are forces used during free shots?

TRY THIS...

Bend over and pick up something from the floor. Describe how your center of gravity changes. Stand against the wall. Without letting your feet or buttocks move away from the wall, try to pick something up. What happens?

TRY THIS...

Observe other sports that use physical forces. Look at pictures or films of sporting events. Can you find the athlete's center of gravity in the pictures or in the freeze frame shots of the film? Invite a karate instructor to your class and ask him to discuss the "physics of karate". How do karate experts combine their centers of gravity with momentum?

MAIN ACTIVITY

You can jump higher, too.

Experiment with different positions, styles and techniques to find ways to jump higher.

Materials

- 2-3 feet of butcher paper
- Colored chalk
- Tape

1. Tape the paper up on the wall so it is about two feet above the jumper's head.
2. Take turns standing with the right shoulder *perpendicular* to the sheets of paper. Hold a piece of chalk in your hand.
3. Jump from a standing position and mark the paper with the chalk at the high point of your jump.

4. Experiment with different jumping styles to see if you can jump higher. Suggestions:

- Start your jump from a squat position, with your arms above your head.
 - Start your jump from a squat position, using your arms to pump.
 - Start your jump from a standing position, then squat, then jump.
 - Take a running start then jump.
 - Try your own style, using combinations of the above suggestions, or using your own jumping techniques.
5. Record the success of the different styles you tried.

Questions

1. What ways can athletes combine their knowledge of physical forces to improve their performances? What ways can technology be used in this kind of research?
2. Why is the curved approach used in high jumping? Are there any other track events that use it?
3. How can high jumpers get the best use of their leg muscles? How could they add more power to the lift-off?
4. Find out what the "stretch reflex mechanism" is. How is this helpful to jumpers? Is it helpful in any other sports?

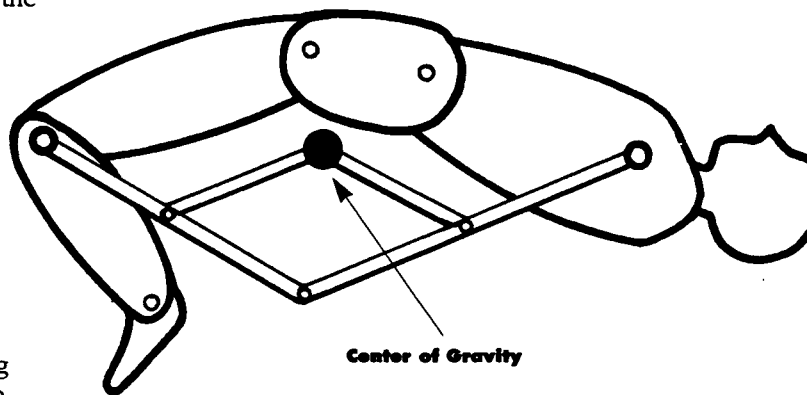

TRY THIS...

Try some experiments with the balance beam in the gym. Take some friends and try balancing on the beam. Discuss what is involved during a balancing act. Try balancing by holding a pole horizontally in front of you. Does this affect how you stay on the beam? What happens if you use a shorter pole? A longer pole? How do tightrope walkers use their center of gravity when performing feats on the wire?

Newton's Apple is a production of KTCA Twin Cities Public Television. Made possible by a grant from 3M.



David explores numerous medical quackery gadgets.

MEDICAL QUACKERIES

Can this machine cure me?

Have medical quackeries always been around? How can a consumer know if they are buying a good product? What do doctors think about these "treatments"? Can these products cause harm?

RESOURCES

Consumer Reports Books. *Health Quackery: Consumers Union Report on False Health Claims, Worthless Remedies and Unproved Therapies.* New York: Holt, Rinehart & Winston, 1980.

"Quackery: It's Alive and Well but Threatening Your Health and Pocketbook." *Mayo Clinic Health Letter*, 1988, pp. 1-8.

"Dangerous Doctors and Phony Cures." *Redbook Magazine*, October 1990, pp. 54-59.

"Health Fraud Racket". University Film & Video. Minneapolis: University of Minnesota.

Additional Sources of Information

Federal Trade Commission

Health Care Fraud Bureau of Consumer Protection Washington, DC 20580 (202) 326-222

DISCUSSION

The word *quackery* usually brings to mind old-time fast-talking medicine peddlers who conned their listeners into buying cure-all bottled syrup. It reminds people of flowery and curious advertisements promising miracles like "Certain cure for all contagious diseases without drugging the system!" But as Abraham Lincoln said, "It is true that you may fool all of the people some of the time, you can even fool some of the people all of the time, but you can't fool all people all of the time."

Have these alternative treatments gone the way of horse-drawn wagons, put out to pasture by medical advances and the regulations of the

government? Most medical and advertising experts say no. In fact, today's medical quacks, fraudulently earning millions of dollars, would be the envy of early practitioners. As fast as medical research debunks the quack claims, con artists invent profitable new packaging that simply draw on the latest words in medicine, like *electronic* and *hormonal*, or with references to new discoveries of wonder drugs. There is also an explosion of less threatening, yet still fraudulent, methods of self-medication from diet and cold remedies to hair restorers and wrinkle removers.

Quack medicine refers to any worthless treatments while medical *fraud* implies an intent to deceive the consumer. False or misleading health claims for

a food, drug, device or cosmetic are all forms of medical quackery. These products use human hope, fears and ignorance to make a profit. Only critical examination and careful consideration by consumers can limit the success of practitioners of these quack alternative therapies.

Things to Talk About

1. Have you ever bought something only to find it doesn't live up to its advertised claims? How did you feel when you realized you had been taken?
2. How should producers of medical quackeries be punished for misleading people?

VOCABULARY

Fraud – Intentional deception in order to induce another to part with something of value or to surrender a legal right.

Quack – Someone who pretends to have medical skill or resource.

Mountebank – To beguile or transform by trickery.

Alternative Treatment – A substance or technique used in treating something or someone that is other than the normal course of treatment.

Placebo – A medication prescribed for the mental relief of the patient rather than for its actual effect on a disorder or an inert or innocuous substance used especially in controlled experiments testing the ability of another substance.

Newton's Apple is a production of KTCA Twin Cities Public Television. Made possible by a grant from 3M.

Educational materials developed by the National Science Teachers Association—Space, Science, and Technology Division.

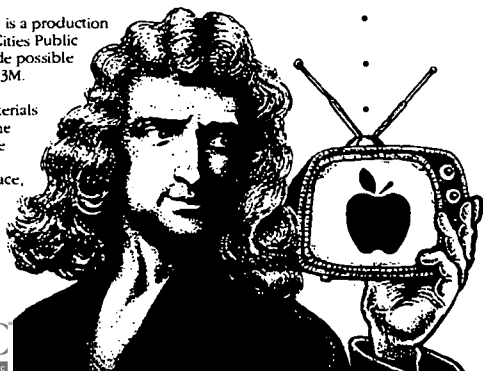

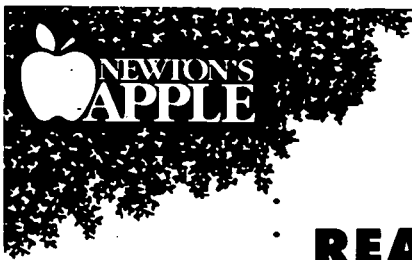

READING BETWEEN THE LINES

Discover ways you can evaluate the medical products and treatments you see advertised on TV and radio and in magazines and catalogs.

TRY THIS...

Contact your local consumer protection agency and ask if any quack remedies or devices are popular in your area. Survey your friends and families to see if any of the products they use are actually quack remedies. Where do they find these products? Do they know they may not be legitimate medical treatments? If so, why do they keep using them?

TRY THIS...

Sometimes medical quackery seems to work by relying on the placebo effect. Gain a better understanding of how this effect works. Which of the following would you call placebos: a pill made of sugar; penicillin to cure pneumonia; chicken soup; a warm bath; and a Teen Age Mutant Ninja Turtle bandage. Can you find other examples of placebos?

MAIN ACTIVITY

Some promoters sincerely believe in their quack products while others deliberately deceive consumers for profit or fame. Learn how to protect yourself and your family from these worthless products.

Materials

- Tabloid newspapers
- Magazines
- Mail order medicine catalogs
- Natural health magazines
- Health-related mail offers

1. Look through the materials you have collected. Pay particular attention to ads for aspirins, cold remedies, vitamins, weight-loss and weight-gain products, hair restorers and cosmetics.

2. Create a check list of questions to use in evaluating each advertised product. Try to determine if each claim about the product or treatment is believable or if it sounds suspicious. Does the advertisement contain words like secret, revolutionary, ancient, overnight, miracle or breakthrough? Has the promoter promised never to reveal the secret of their product? Does the advertisement claim there is a conspiracy among doctors to keep the product off the market? Does the advertisement claim that it can cure a long

list of problems with no side effects? Does the promoter claim to be the only person who can help?

3. Make a list of all the suspicious claims you find. Analyze each statement to see if there are any real facts in it. Describe what you think makes the product sound legitimate and what makes it appear misleading.

4. See if you can find several different types of products or treatments. Post your advertisements and analyses in the classroom. Compare yours with your classmates'.

Questions

1. What kinds of problems can quack medical products and treatments create? Could they delay someone from seeking legitimate medical help?

2. Look at a few advertisements for legitimate medicines. Do these ads use any of the same selling techniques? What are the best ways to tell which are real medicines and quack ones?

3. Some medical quacks have legitimate credentials and others have self-proclaimed or mail order education degrees. How could you investigate someone's credentials? If you found them to be illegitimate, what would you do?

TRY THIS...

The next time you have the hiccups, try some of these folk cures. Place your two little fingers in your ears and hold your breath. Or, hold both of your ears tightly closed and have someone else give you a drink of water. You also could try wearing some nutmeg around your neck. Have you heard of other ways that you can cure the hiccups? Make a list of folk medicine cures for other common ailments like warts, baldness and nosebleeds. Can you find information on the origins of these folk techniques?

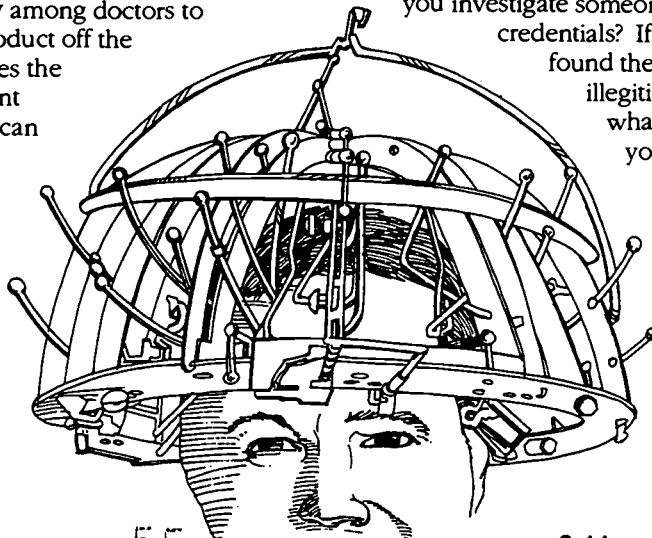

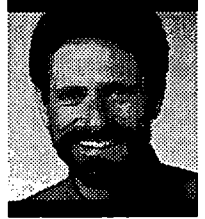

David explores how microwave ovens work, and how they interact with foods and packaging materials.

MICROWAVE OVENS

What is the science behind microwave cooking?

How does a microwave oven cook food? Why doesn't the oven get hot? How does special packaging speed up the cooking times? Why shouldn't you put metal objects in a microwave oven?

DISCUSSION

- Microwaves are a form of electromagnetic energy, like light waves or radio waves, and occupy a part of the *electromagnetic spectrum*.
- Microwaves are used to relay long-distance telephone signals, television programs and computer information across the earth or to a satellite in space. They are even used for a type of medical treatment called diathermy.
- The microwave is most familiar as the energy source for cooking food. Every microwave oven contains a magnetron, which generates microwaves at just the right frequency to interact with the molecules in food and heat it directly.
- All wave energy changes polarity from positive to negative with each cycle of the wave. In microwaves, these polarity changes happen millions of times every second.
- Food molecules—especially

the molecules of water—have a positive and negative end, in the same way a bar magnet has a north and a south pole. When microwaves at the right frequency bombard food, they cause the polar molecules to rotate at the same frequency, millions of times a second. All this agitation on the molecular level creates friction, which heats up the food. Because microwaves don't interact with molecules of glass, plastic or paper, only the food is heated.

Metal containers can produce dangerous *arcing* in a microwave oven. However, many food packages actually contain thin films of metal that speed the cooking process. For example, new packaging techniques use metalized *polyethylene terephthalate* (PET) film laminated to

paperboard as a heat susceptor. This surface absorbs microwaves, and becomes a miniature "frying pan" to brown or fry the foods in the package.

Things to Talk About

1. Have you eaten microwaved food in the last 24 hours? Listened to the radio? Made a long distance telephone call? What do all these activities have in common?
2. Why might you want to rotate foods cooking in a microwave oven? What foods would cook best in a microwave? What foods might not cook well at all? What kinds of containers would you not want to use in a microwave? Why?
3. How long are microwaves? How long are light waves? Radio waves?

VOCABULARY

Radiation – The spreading of energy by electromagnetic waves.

Conduction – The transfer of heat by molecular motion from a source of high temperature to a region of lower temperature, tending toward a result of equalized temperatures.

Convection – The mechanical transfer of heated molecules of a gas or liquid from a source to another area, as when a room is warmed by the movement of air molecules heated by as radiator.

Molecules – The smallest particle of any compound that has the chemical properties of that compound. Materials are considered to be made of molecules held together by *attractive* forces.

Susceptor – A material, usually a thin, metalized film inside the packaging of microwave foods, which converts microwave energy into heat energy and promotes the browning of foods.

RESOURCES

Asimov, Isaac. *How Did We Find Out About Microwaves?* New York: Walker, 1989.

Farley, Dixie. "Keeping Up with the Microwave Revolution." *FDA Consumer*, March 1990. pp. 24:17.

Hibler, Michelle. "The Perils of Plastics." *Canadian Consumer*, March, 1991. pp. 20-24.

"Microwave Popcorn." *Canadian Consumer*, 1989. pp. 30-35.

Klenck, Thomas. "How it Works: Microwave Oven." *Popular Mechanics*, September, 1989. pp. 7-8.

"Safe for Food?" *Canadian Consumer*, March, 1991 pp.19-20

Other Resources:

Food Safety Hot Line

United States Department of Agriculture
1-800-535-4555

Home Economics Teacher

Newton's Apple is a production of KTCA Twin Cities Public Television. Made possible by a grant from 3M.

Educational materials developed by the National Science Teachers Association—Space, Science, and Technology Division.

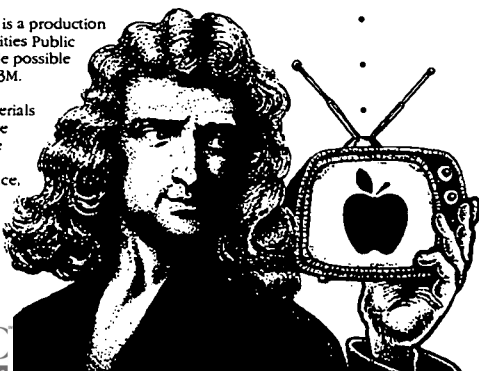

COOKING BY THE NUMBERS !

See the differences in how microwave ovens and conventional ovens heat different substances.

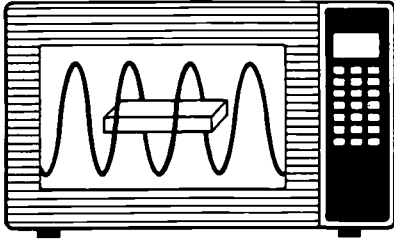

MAIN ACTIVITY

Although both microwaves and conventional ovens ultimately use thermal energy to cook food, the molecules in the food respond differently when exposed to an energy source.

Materials

- Microwave oven
 - Conventional oven
 - 500 milliliters of water
 - 500 milliliters of sterile sand
 - 2 microwaveable containers
 - 2 oven-safe containers
 - Thermometer
- *Use safety measures with the ovens.*

1. Pour 250 milliliters of water into one of the microwaveable containers. Measure and record the temperature of the water.
2. Pour 250 milliliters of sand into a similar container. Measure and record the temperature of the sand.
3. Place the container of water in the microwave oven and run the oven at its highest power setting for two minutes. Remove the container of water. Measure and record the new water temperature.
4. Place the container of sand in the microwave oven and run the oven at its highest power setting for two minutes. Remove the container of sand. Measure and record the new temperature of the sand.
5. Preheat the conventional oven to about 100 degrees Celsius or 200 degrees Fahrenheit.

6. Pour 250 milliliters water into one of the oven-safe containers. Measure and record the temperature of the water. Make sure that the temperature of this water is the same temperature that you recorded for the water that you put in the microwave oven.

7. Pour 250 milliliters of sand into one of the conventional oven containers. Measure and record the temperature of the sand. The sand, too, should be the same temperature as the sand used in the microwave oven.

8. Place both containers in the preheated oven. Heat the two pans for about 10 minutes. Remove both containers from the oven. Quickly measure and record the temperature of both the water and the sand.

9. Develop a table that lists your results.

Questions

1. What was the temperature change of the water and the temperature change of the sand in each oven? Which material had the greatest increase in temperature for each type of oven? Why do you think these results happened?
2. How would your results change if the water was left in the conventional longer? Try it!
3. What kinds of food cook best in a microwave oven? In a conventional oven? What are you basing your choices on?

TRY THIS...

Different waves affect the human body. Ask your school nurse about waves used in the study of human physiology. Invite a radiologist to your class. Ask him/her about brain waves and X-rays. Investigate biorhythms. How are they measured?

TRY THIS...

Many terms are used in describing electromagnetic waves. Investigate the following terms: wavelength, amplitude, cycle and frequency. How can these terms be used when describing a stone dropped into a tray of water?

TRY THIS...

Purchase several microwaveable products and dismantle the packaging. Compare the packages. How have theories of energy absorption been combined with cooking? Do any packages look like they might release adhesives into the product at high temperatures? Do any use heat susceptors?



David goes to AT&T's Bell Laboratories to learn about the ever-changing world of telecommunications.

TELECOMMUNICATIONS

New frontiers in electronic communications.

- How does a telephone work? How fast do sound and light travel?
- How could fiber optics improve our telecommunications? Are any fiber optics in use today?

DISCUSSION

- Alexander Graham Bell invented a talking machine that used pulses of electricity to carry sound through copper wires and called it the *telephone*. Soon after, he tested the *photophone*, another talking machine that used a beam of sunlight to carry voices from one place to another. Although he had high hopes for the future of his photophone, it depended on a constant source of sunlight and proved to be impractical.
- Not until the invention of *lasers* and *optical fibers* did Bell's dream come true. In the mid-1970s, researchers began pumping pulses of laser light through thin glass fibers to move information. Light is actually a sequence of vibrations. Scientists discovered how to vary these patterns of vibrations and convey information. When a conversation occurs over a telephone system that uses optical fibers, the vibrations of your voice are converted to the pattern of the laser. At the

other end, these variations are turned back into sound.

Because lasers can be modulated with highly complex patterns much greater quantities of information can be transmitted.

Stringing electrical cables or optical fiber cables from place to place is very expensive. Because the new optical fibers can handle so much more information than traditional telephone wires, it has become more economical to replace conventional wires with the new technology.

And, fiber-optic communications are not limited to telephone conversations. They can even be used to transmit complex information, like television or data between computers. As fiber-optic cables interconnect our area, it will be possible to see and purchase items from distant stores, participate in classes or meetings happening across the world, see people you're talking

to on the telephone and have instant access to the latest information stored in libraries, all without leaving your home!

Other industries benefit from fiber optics. Physicians use them to examine areas of the body instead of performing surgery. In industry, fiber optics aid workers in repairing jet engines, nuclear reactors and other complicated machinery. In the future, fiber optics will be used to control lighting, heating, air conditioning, security systems and other types of machinery. The most interesting uses of fiber optics are yet dreamed about!

Things to Talk About

1. What are the differences between sunlight and laser light?
2. Would you want a "videophone"?
3. What would Bell think about fiber optics? What new uses for fiber optic technology can you think of?

VOCABULARY

Laser – Light Amplification by Stimulated Emission of Radiation. A device which produces a light which is highly directional and travels in a narrow beam.

Optical Fibers – Strands of material through which light can travel; analogous to the way water travels through a hose.

Fiber Optics – A branch of physics based on transmission of light through fibers of glass or plastic.

Modulate – To vary the amplitude, frequency or phase of a carrier wave or signal in telephony, telegraphy, radio or television.

RESOURCES

Billings, Charlene W. *Fiber Optics: Bright New Way to Communicate*. New York: Dodd Mead & Company, 1986.

Burkig, Valerie. *Photonics, The New Science of Light*. Hillside, New Jersey: Enslow Publications, 1986

Whyman, Kathryn. *Light and Lasers*. New York: Glouchester Press, 1986.

Additional Sources of Information

AT&T Bell Laboratories
Media Relations
Room 11422
101 JFK Parkway
Shorthills, NJ 07078

Optical Fiber Source:
Edmund Scientific
Company
101 East Glouchester Pike
Barrington, NJ 08007

A local cellular telephone company

Audiologists

Newton's Apple is a production of KTCA Twin Cities Public Television. Made possible by a grant from 3M.

Educational materials developed by the National Science Teachers Association-Space, Science, and Technology Division.

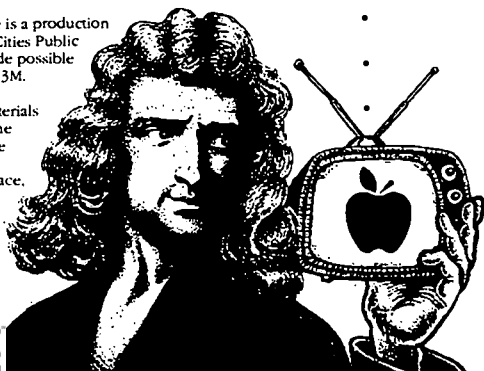

AMAZING LIQUID LIGHT

Light always travels in a straight line, doesn't it?

MAIN ACTIVITY

Light does travel in a straight line but there are times when it doesn't. Light can be inside a curving stream of water because the path of the light changes direction as it is reflected internally by the water. Discover how fiber optics use this principle.

Materials

- Tall, clear and slim jar with a lid
- Newspaper
- Flashlight
- Hammer
- Large nail
- Large container

1. Make two holes in the jar lid with the hammer and the nail. Make a large hole near one edge and a smaller hole near the opposite edge.
2. Fill the jar three quarters full with water.
3. Turn on the flashlight and hold it to the bottom of the jar so the light shines into the jar.
4. Wrap the jar and the flashlight together in the newspaper. Leave the lid

of the jar uncovered. Be careful not to spill the water. If needed, place tape over the holes until the pieces are wrapped together.

5. Now get ready to "pour" light. Turn the lights off and tilt the jar so the water flows out the largest hole into a large container.

Questions

1. What happens if you stick your finger in the water stream near the jar? Down further on the stream?
2. Was the light contained in the stream or did it shine out like a lamp?
3. What would the light look like if you used colored water?
4. How is the curved flow of the water similar to light pulses in fiber optics? What are the differences?
5. What does total internal reflection mean?

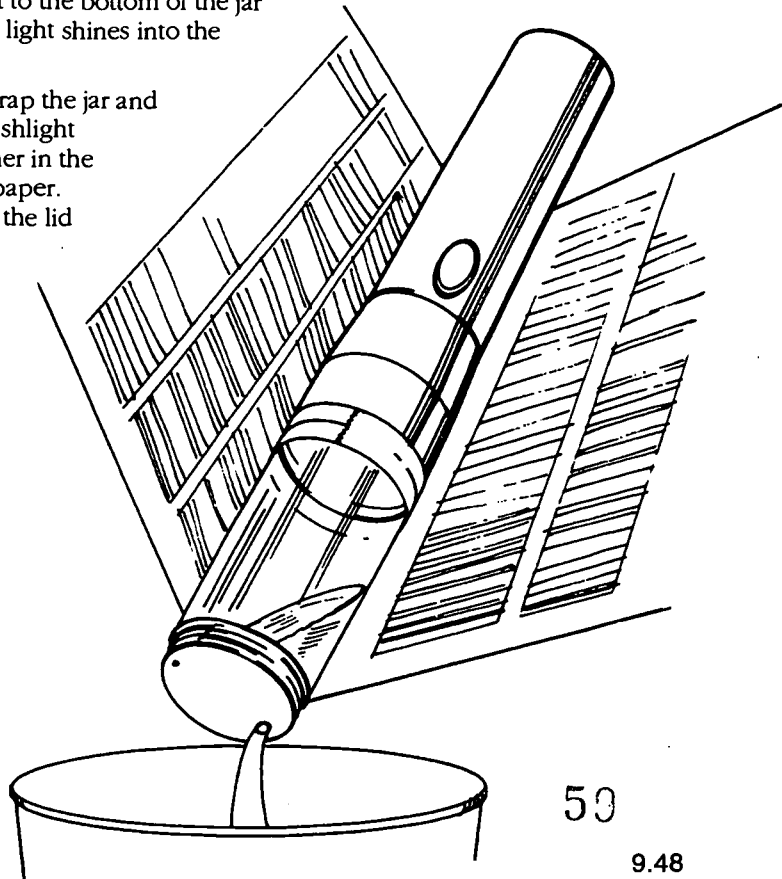

50

9.48

TRY THIS...

Lasers are used all around us. Find as many of their uses as you can. Where are lasers used in the supermarket? Ask your doctor about laser surgery. How is it different than standard surgery? Try to attend a laser light show to see energy waves become art.

TRY THIS...

Laser light is contained in an optical fiber because of internal reflection. A periscope uses the same principle but with mirrors instead of optic fibers. How could you use two mirrors to look around a corner?

TRY THIS...

Investigate ways light is used in communication. Learn more about Morse code and see if you and your friends can send messages to each other in the dark with a flashlight. How are holograms created?

TRY THIS...

Energy moves from one place to another in waves. Tie a long piece of rope to a tree or a pole. Make your own waves by shaking the rope up and down. What energy moves when you shake the rope? What other materials could you use to make waves? (See the Newton's Apple "Slinky Physics" for extra hints!) Light waves are the fastest waves we know about. How fast do light waves from the Sun travel to the Earth?



David learns how the orbits of the Moon and the Earth can produce an eclipse.

SOLAR ECLIPSE

Why don't eclipses happen more often?

Have you ever seen a solar eclipse? Why did early man fear them so much? How often do solar eclipses happen? When is the next one? What would you see if you were on the Moon during an eclipse?

DISCUSSION

- Eclipses have frightened, mystified and puzzled man since antiquity. The Chinese believed that an eclipse was caused by the celestial dragon eating the Sun.
- Tablets found in northwestern Mexico show that the Mayan Indians began making eclipse predictions and keeping records 2000 year ago. Even today, people travel great distances to witness this celestial alignment that brings awe and wonderment to all who see it.
- A *solar eclipse* occurs on Earth when the Moon blocks the Sun's light due to the relative positions of the Earth, Moon and Sun.
- The Sun is 400 times larger than the Moon and the Moon is 400 times closer to the Earth than

the Sun. The Sun and the Moon cover approximately the same area of the sky so that they appear to be the same size in the sky.

During a "new Moon" phase, the Moon is positioned between the Sun and the Earth. However, not every new Moon produces a solar eclipse, because the orbit of the Moon is slightly tilted with respect to the orbit of the Earth around the Sun. Only when the Moon's orbit brings it into direct alignment between the Sun and the Earth will the Moon's shadow fall on the Earth. The shadow is called the *umbra*, and during a solar eclipse sweeps darkness in a band 300 kilometers wide across the Earth at 1700 kilometers per hour! People inside the *umbra* will see the Sun completely

blocked by the Moon. People outside this path, in an area known as the *penumbra*, will see a partial eclipse, where the Moon only hides a portion of the Sun.

Things to Talk About

- If you didn't know anything about eclipses, and, in the middle of the day, the sky suddenly grew dark enough to see the stars, what might you think had happened?
- What happens when the Earth lines up between the Sun and the Moon? Would other planets in our solar system have eclipses too?
- How would the Earth look to an astronaut in Earth's orbit during an eclipse of the Sun? Of the Moon?

VOCABULARY

Shadow – The dark area formed by an object which blocks light. A shadow is formed because light travels in straight lines.

Eclipse – The darkening of a heavenly body when it moves into the shadow of another heavenly body. An eclipse of the Moon is seen when the shadow of the Earth falls on the Moon; an eclipse of the Sun is seen when the shadow of the Moon falls on the Earth.

Umbra – The area in a shadow from which light is completely cut off.

Penumbra – A lighter area between the umbra and the edge of a shadow; some light reaches it because the source is not small. A very small light source forms an umbra only; a large source form an umbra and a penumbra.

RESOURCES

Aveni, Anthony. *Skywatchers of Ancient Mexico*. University of Texas Press, Dallas, 1980.

Dyer, A. "When Worlds Align." *Astronomy*, Vol. 19, No. 7, pp. 62-73, July 1991.

Gingerich, O. "The Making of a Prize Eclipse." *Sky & Telescope*, July 1991, pp. 15-17.

Littmann, Mark and Wilcox, Ken. *Totality: Eclipses of the Sun*. University Press, 1991.

Additional Sources of Information

American Astronomical Society
2000 Florida Avenue, NW
Suite 300
Washington, DC 20009
(202) 328-2010

Astronomical Society of the Pacific
390 Ashton Avenue
San Francisco, CA 94112
(415) 337-1100

Astronomy Magazine
21027 Crossroads Circle
Waukesha, WI 53187

Newton's Apple is a production of KTCA Twin Cities Public Television. Made possible by a grant from 3M.

Educational materials developed by the National Science Teachers Association-Space, Science, and Technology Division.

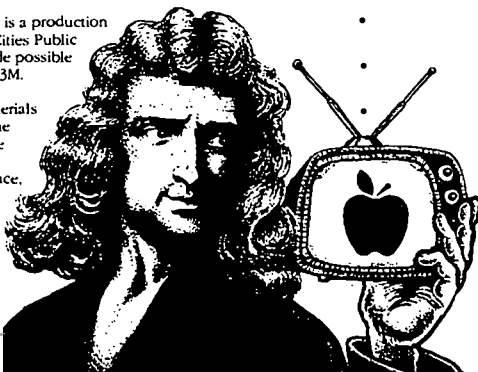

SEE IT FOR YOURSELF!

Build a projection camera so you can safely observe the next solar eclipse. You can also use this camera to study the Sun when there's not an eclipse!

MAIN ACTIVITY

Because of the intensity of the Sun's light, it isn't safe to look directly at the Sun during an eclipse. That's why you'll need to build a projection camera to protect your eyes. Once you've built the camera in this activity, you will be able to observe the *contacts* of an eclipse.

Materials

- Two, five-gallon ice cream containers
- Aluminum foil
- White paper
- Tape
- Pin

1. Cut a three cm hole in one end of the ice cream container.
2. Tape the piece of aluminum foil over the hole. Put a small pinhole in the center of the foil. This is where the sunlight will enter. **DO NOT LOOK DIRECTLY AT THE SUN THROUGH THE PINHOLE!**
3. Cut a larger viewing hole far enough below the pinhole to allow observation without blocking the Sun.
4. Tape a piece of white paper at one end of the other ice cream container. Then tape the two open ends of the container together.
5. Hold the projector so that the Sun is behind you and over your shoulder. The sunlight that comes through the pinhole should fall on the viewing screen at the opposite end of the container.
6. **DO NOT LOOK DIRECTLY AT THE SUN THROUGH THE PINHOLE!**

7. If you can't find the right size ice cream container, use two sheets of white cardboard. Put a small pinhole in one. Stand with you back to the sun and hold the sheets about 60-80 cm apart, with one in each hand. Project the Sun's image through the pinhole on the other piece of cardboard.

Questions

1. What causes the image to appear on the projection surface?
2. What happens when you move the projection surface closer to you? Further away from you?
3. Why is it unsafe to view the Sun directly?

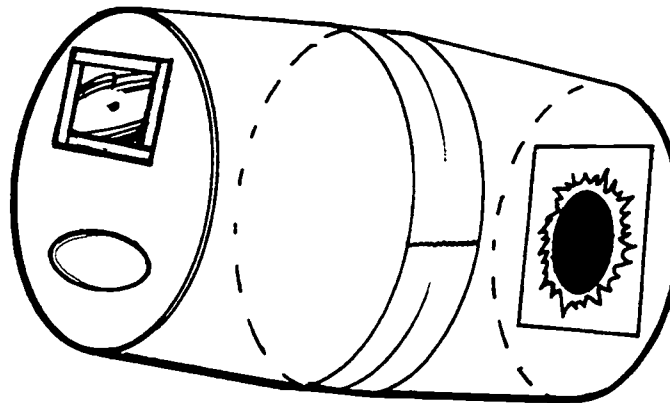

TRY THIS...

See how much you can tell about an object from its shadow. Shine the light of an overhead or slide projector on a wall. Turn your back to the light and have a friend hold an object up in front of the light. Can you guess what it is? How much of your ideas about an object are based on size? How can you make an apple as big as a beach ball?

TRY THIS...

Turn the beauty of an eclipse into words. Imagine that you are on the Space Shuttle Discovery. Write a poem that describes what you see. For inspiration, look for pictures, slides and films of recent missions. Share your poems and discover the different ways people interpret the beauty of a solar eclipse.

TRY THIS...

Become a human eclipse. Team up into groups of four or five people. Have one person play the Sun, one the Moon and one the Earth. Simulate how an eclipse occurs. Have the other team members stand in the umbra and penumbra. Try a lunar eclipse too!

TRY THIS...

Have some fun with shadows and silhouettes. Using a bright light source like an overhead or slide projector, shine the light against the wall. Tape a piece of construction paper on the wall. Stand between the wall and the light until your shadow covers two-thirds of the construction paper. Have a friend trace your silhouette on the paper. Decorate a bulletin board with everyone's profile drawings. How are shadows formed? Do the same principles of an eclipse work in your classroom?



David learns how orthopedic surgeons are replacing diseased joints.

HIP REPLACEMENT

How do artificial implants work in the body?

How important is the hip for walking? Why would someone need their hip replaced? Would an artificial hip interfere with any normal activities? How long will a new hip last?

RESOURCES

Parker, Steve. *Skeleton*. New York: Knopf Publishers, 1988.

"Guide to Making Model Joints." *Journal of Biological Education*, Reston, VA: National Association of Biology Teachers, Winter, 1985.

Additional Sources of Information

American Academy of Orthopedic Surgeons
Parkridge, IL 60068
(800) 346-2267

Arthritis Foundation
Information Line
P.O. Box 19000
Atlanta, GA 30336
(800) 283-7800

Evergreen Publications
"Total Hip Replacement"
Brochure
P.O. Box 996
Aberdeen, SD 57402
(800) 237-9646

DISCUSSION

The hip joint is located where the upper leg bone or femur meets the pelvis. At the tip of the femur is a femoral head which is ball-shaped to fit into an opening in the pelvis called the *acetabulum*. This ball and socket mechanism at the hip must be stable enough to bear the weight of the upper body and rotate freely enough to give the femur a free range of motion. The bones of the acetabulum and the femoral head are separated by both cartilage and a syrup-like lubricant called *synovial fluid* which surrounds it to cushion the bones and keep them from rubbing together.

When walking and other simple movement requiring rotation of the hip become painful, or when a hip joint is traumatized or dislocated, an orthopedic

surgeon will examine the patient and take X-rays of the hip joint. A common cause of joint pain in middle or old age is *osteoarthritis* which causes deterioration of the cartilage and the growth of bone spurs. When cartilage can no longer cushion the joint and is combined with the additional bone material, the grinding of bone against bone becomes very painful.

The practice of orthopedic surgery has evolved through the centuries from just physical manipulation of the *musculoskeletal system* to actual replacement of muscles, bones and cartilage with synthetic materials. Total hip replacement has been used in the United States since 1971. Today, hip replacement has become a routine operation with artificial hips designed and manufactured by computer.

During the hip replacement procedure, the head of the femur is removed and replaced with a *titanium prosthesis* or small metal ball. The new metal femoral head is made stable by attaching it to a metal stem which is inserted into the thigh bone. The acetabulum is then replaced by a metal cup. While the range of motion after recovery from the surgery does not match that of the original hip, the constant pain of bone-to-bone contact is permanently relieved.

Things to Talk About

1. Why do doctors use titanium for replacements?
2. What other joints can orthopedic surgeons replace?
3. Do you anyone who's had a joint replaced?
4. Would you want this procedure? Why or why not?

VOCABULARY

Acetabulum – An opening in the pelvis in which the femoral head fits into to create a joint.

Cartilage – A hard, but flexible tissue in the skeleton.

Synovial Fluid – A thick fluid found in movable joints. It nourishes and lubricates the cartilage covering the joints.

Orthopedics – The correction or prevention of skeletal deformities.

Prosthesis – An artificial device to replace a missing part of the body.

Newton's Apple is a production of KTCA Twin Cities Public Television. Made possible by a grant from 3M.

Educational materials developed by the National Science Teachers Association—Space, Science, and Technology Division.

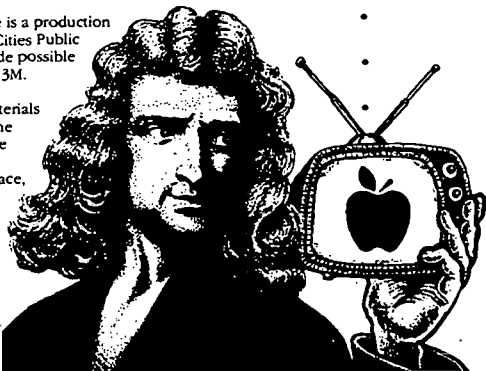

HIP AND SEEK

By taking a close look at animals' skeletons you will see how your pelvis and femur work together for movement.

MAIN ACTIVITY

Other animals' joints work similarly to ours. By investigating their skeletons we learn about the placement and functions of our own bodies.

Materials

- Owl pellets (available from science supply stores)
- Tweezers
- Paper towels
- Vegetable oil
- Sand paper

1. Place the owl pellet on a paper towel. Gently pull it apart with the tweezers and your fingers.
2. Separate the bones and sort them by size and shape. Look for the ball joints of the hind legs and the sockets of the hip bones. Compare the size of the femur of your pellet with your classmates'.
3. Fit the femur into the socket. Move the leg around in the socket. Add a few drops of vegetable oil and move the ball and socket again. Use the sand paper to sand down the ball end of the femur and try it in the socket again.
4. Look for other joints that connect to form the skeleton.

Questions

1. What happened when you added the oil? How did sanding the ball joint change the motion of the femur? What do you think happened to the cartilage?
2. What other joints did you find? Was the movement the same?
3. Could you rebuild the whole skeleton? How could you display it? (See *Newton's Apple's* "Dinosaurs: Assembly" for extra hints!)

TRY THIS...

Find out how much we rely on joints to move. Try walking without bending your knees, eating without bending your wrists and writing with only one bent finger. Can you think of other joint challenges?

TRY THIS...

Interview a physical therapist about orthopedic surgery. How do they help hip replacement patients recover? Are there special techniques used to build muscle tone or recover motion?

TRY THIS...

Look for evidence of man-made joints in common objects. Make a list of all you find. Does the joint restrict or enhance their movements? What human joints are similar to a door hinge?

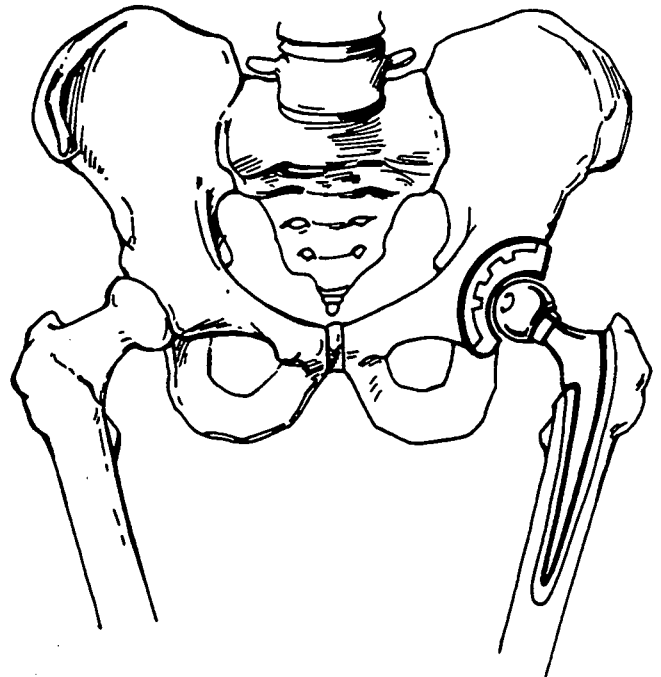

TRY THIS...

Explore the hip's range of movement with a friend. Lie down on the floor face up and bend one of your knees to your chest. Have your friend measure and record the distance from the middle of your kneecap to the end of your nose. Now rotate your knee toward the middle of the body and measure the distance to the other kneecap. Finally, rotate your knee away from your body and measure back to the other kneecap. Repeat these procedures again but this time lift your leg of the floor and stretch it out to the side. Measure from the ends of both big toes. Switch places with your friend so you can compare your measurements.



SHOW NUMBER:

913



David learns how car safety belts and air bags can save your life.

AIR BAGS & COLLISIONS

How do airbags prevent automobile injuries?

Do you always buckle your seat belt when you are in the car? Why do cars have headrests? Would you want to have air bags in your car? What other safety equipment is built into cars?

RESOURCES

Keller, Maryann N. "Better Safe Than Sorry." *Motor Trend*, January 1990, p 122.

Knepper, Mike. "Proper Restraint." *Home Mechanix*, September 1989, pp. 72-77.

Spencer, Peter L. "The Trouble With Air Bags." *Consumers' Research*, January, 1991, pp. 10-13.

Additional Sources of Information

National Highway Traffic Safety Administration (800) 424-9393

Local Department of Motor Vehicles

Local automobile dealers

Driver's Education Instructors

DISCUSSION

- Moving objects have *momentum*. Newton's First Law of Motion says that unless an outside *force* acts on an object, the object will continue to move at its present speed and direction. Automobiles consist of several objects, including the vehicle itself, the passengers inside and any other loose objects in the vehicle. Unless the objects inside the car are restrained they will continue moving at whatever speed the car is travelling even if the car is stopped by a crash.
- Changing or stopping an object's momentum requires a force acting over a period of time. If momentum changes instantly, as in a car crash, the force is very, very great! If the momentum can be changed over a period of time, even a fraction of a second, much less force needs to be applied with less damage or injury.
- In a head-on collision, if a passenger flies into the dashboard of a car, their momentum is instantly

stopped, and serious injury is often the result. If the passenger is restrained by a seatbelt, their momentum is reduced more gradually by the constant and smaller force of the belt acting over a longer period of time. Seatbelts can reduce the impact of a passenger to one-fifth of the impact suffered by the body of the car.

Passive restraint laws, combined with an interest in *air bags* have made vehicle safety a selling feature on automobiles. An air bag is made of a coated fabric and is stored in a module mounted on the steering wheel. Crash sensors, which activate upon impact at speeds of 10-15 miles per hour, are mounted in several locations on the car chassis.

In a crash, the sensors ignite a chemical, *sodium azide*, which releases harmless nitrogen gas to instantly inflate the bag.

As the driver or passenger is thrown into the bag, it applies a restraining force. Even though this entire process happens in only 1/25th of a second, the added time is enough to prevent serious injury.

Air bags are not intended to replace seat belts. They are part of a *supplemental restraint system*. Seat belts are still necessary because air bags only work in front-end collisions of more than 10 miles per hour. Only a seat belt can help in side impacts, rear-end collisions, side swipes and secondary impacts.

Things to Talk About

1. How does an air bag resemble a parachute? How is it different?
2. Is it possible to invent a springy car that would absorb the impact of accidents by itself? Why can't air bags help when a car is rear ended?

VOCABULARY

Momentum – The product of the mass and the velocity of an object.

Velocity – Speed in a certain direction (e.g., a car travelling along a straight road with a speed of 70 km/hour also has a velocity of 70 km/hour. A car traveling at 70 km/hour round a bend in a road has a velocity that is continuously changing as the road is not in a straight line.

Force – A push or pull which causes acceleration, or a change in the shape of an object, or a reaction. A force is measured by the change in momentum produced in one second. A force cannot be seen, only its effects can be seen.

Newton's Apple is a production of KTCA Twin Cities Public Television. Made possible by a grant from 3M.

Educational materials developed by the National Science Teachers Association-Space, Science, and Technology Division.

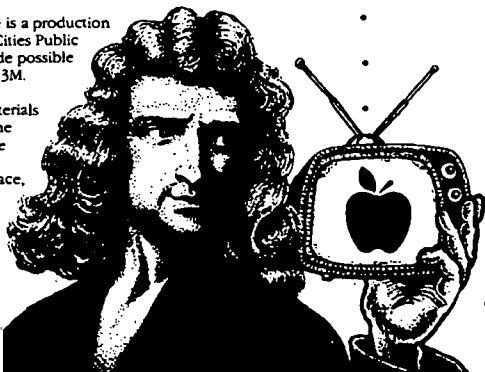

EGG PITCHING

You can find ways to throw eggs at high speed and not have them break!

TRY THIS...

See if you can find other examples of impact protection devices. Where are they most common? Why do you use pads for gymnastics? What about helmets and knee pads? Do they transfer momentum?

TRY THIS...

Toss a balloon filled with water into the air. Stop and analyze what happens when you successfully catch the balloon. What ways have you helped transfer the momentum?

MAIN ACTIVITY

Design ways to cushion an egg that is thrown through the air. Using the theories behind air bags in automobiles, find the best way to protect it from impact so you can throw it faster and further.

Materials

- Four-six raw eggs
- Flat bed sheet (twin size works best!)
- Two broom stick handles or dowels
- Needle
- Thread

1. Turn under the bottom edge of the sheet about 10 cm. Sew the flap up and insert the broom stick handles into the top cuff and the one you have just sewn.
2. Have four classmates hold the corners of the sheet out horizontally to the ground.
3. Have a fifth student take aim, wind up and pitch the egg up and over onto the sheet.

4. Experiment with different speeds and distances to see how far and how fast you can throw the egg without breaking it.

Questions

1. What happens to the egg's momentum? What would happen if you were dropping the egg on a concrete floor?
2. How could you cushion the egg itself? Would that transfer the momentum of the egg?
3. Would a parachute attached to the egg provide enough cushion to keep it from breaking? How high could you drop an egg attached to a parachute?
4. Does the size of the sheet make a difference in your experiments? What if you pulled the sheet taut?

TRY THIS...

Design a few posters that promote seat belt use. Hang them up around the school to promote automobile safety. Why would parents want to put small children in safety seats in the back seat of a car?

TRY THIS...

People have different opinions about mandatory seat-belt and air-bag use. In fact, this discussion often includes bicycle and motorcycle helmets for safety, too. Divide your class into two debating teams and discuss the following question: Can a society that believes in individual decisions regarding safety issues require individuals to use devices that may save their lives in an accident?

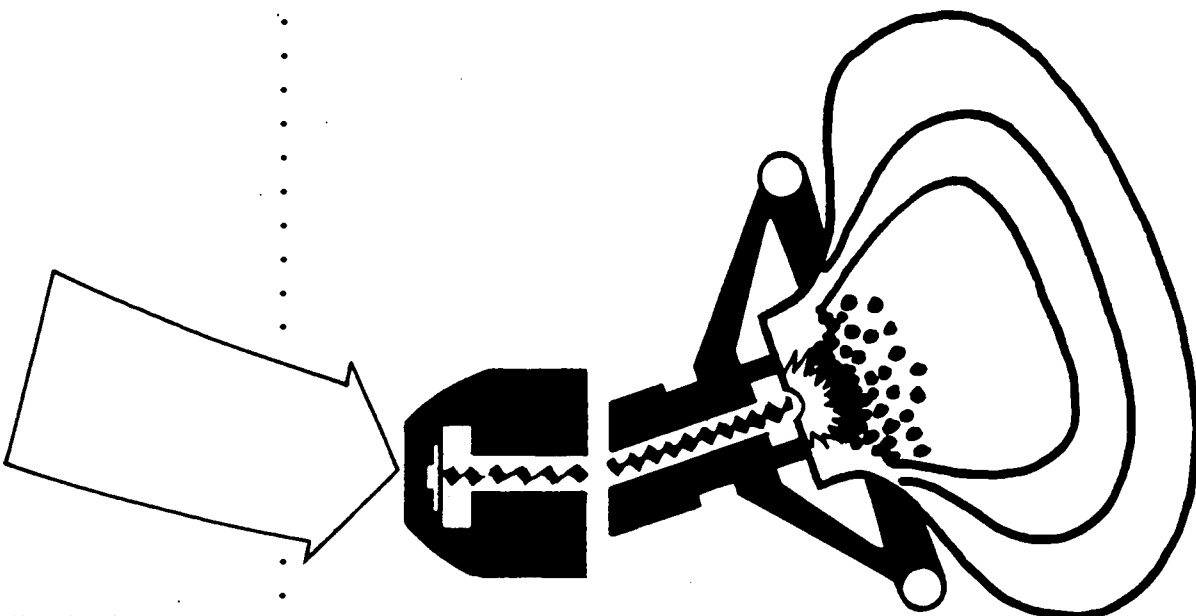

ANIMALS

The Newton's Apple Menagerie



Naturalist Nancy Gibson is back in season nine with more weird and wonderful animals.

MINIATURE HORSES SHOW #902

Just A Little

People have been able to breed certain species of plants and animals to create completely new twists on the original. From miniature poodles to miniature goats, chickens and horses, people are fascinated by smaller versions of animals. Visit a local horse farm or petting zoo to observe both miniature and standard sizes of animals. Why would people want to breed certain characteristics into animals? What about plants? Look into bonsai trees. Visit a florist or botanical garden to see how these trees are grown.

BATS SHOW #903

Bat Artistry

Think of what a pear-nosed bat, mouse-eared bat, long-eared bat, horse-faced bat, horseshoe bat, dog-faced bat, funnel-eared bat, sucker-footed bat, tomb bat or leaf-shinned bat might look like. Try to draw a few. Compare your drawings to pictures of these bats. How close did you come? Pick your favorite bat and investigate how it lives, what it eats and list its enemies. Would a bat make a good pet? Why or why not?

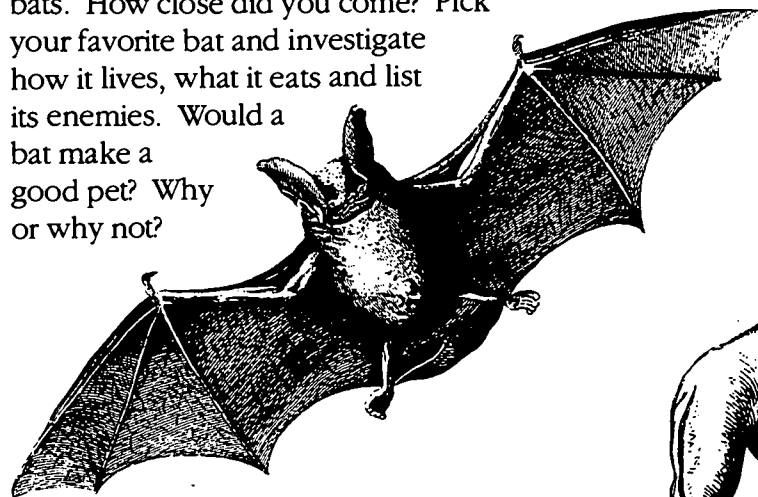

PORCUPINES SHOW #905

Fabled Feats

Many people believe the myth that porcupines can throw their quills. A porcupine will raise its quills when threatened but it cannot throw them. Because the quills are loosely attached to their skin, they come off easily when their enemies brush up next to them. How do you think this belief started? Find out what animals prey on porcupines. How do they conquer the quills?

CAMELS SHOW #908

Super Shoes

Camels have soft fleshy pads on the bottoms of their feet that keep them from sinking into the soft sand when they walk. Their large feet spread their weight over a larger area, which also makes it easier to walk in desert areas. The next time you are at the beach or in the snow, try walking on snowshoes. If you can't find any snowshoes, try making your own out of tennis rackets or cardboard. Get a feel for how a camel walks. Is it easy or hard to do? Would having four legs make it any easier?

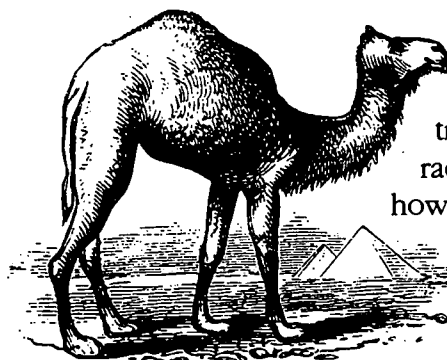

LLAMAS SHOW #909

Spit In Your Eye!

Most llamas spend their days feeding on shrubs, mosses, lichens and grasses. Although they are usually docile, watch out when they get upset! They will spit or actually vomit on an intruder. Camels, vultures and



other animals do the same thing. What other ways do animals use to warn you to stay out of their way?

Draw pictures of other interesting ways animals get their points across.

BEARS SHOW #912

A Frightful Sight

When you are out in the woods alone, coming up on a bear can be pretty scary. What lures bears to camp sights? Contact a state park authority to see if there have been any bear sightings. What do they suggest you do if you are surprised by a bear? Learn more about the lifestyles of bears. Do they like to come into the open? How long do they hibernate in the winter? Where do they like to live? Which wild bears are a threat to people? Which ones are not?



EAGLES SHOW #911

Eagle Eyes

When you look at an object, both of your eyes focus on it at the same time. This way of viewing is called binocular vision and helps you judge distances. Although some birds, like owls, also have *binocular* vision, an eagle's eyes are located on either side of its head. Positioned in this manner, each eye focuses independently so that the eagle can see two images at the same time. This kind of vision, or *monocular* vision, gives the eagle a wider field of vision. See if you can change your visual perspective. Make a patch and cover one of your eyes. Now try playing catch with a friend. How do your perceptions of distance change? What happens when you try to throw the ball?



POT BELLY PIGS SHOW #913

Hit The Road!

Pot belly pigs make excellent pets because they are domesticated and bred to live with people. Other kinds of pigs do not adapt well as pets. Wild or farm pigs kept as pets may become aggressive or grow sick and die. Take a trip to a local pig farm. Observe how the pigs live. Are they clean animals? What kinds of food do they eat? What are the differences between pigs, shoats, gilts, sows and boars?



Now you can do
Newton's Apple
at home!

SCIENCE TRY ITS

Try these experiments and see what happens. Then try to guess *why* it happens. Compare your results to the results on the back of this page.

TRY IT!! Float a Paperclip

How? Bend a paperclip into an "L" shape. Use this clip to gently lay another paperclip on the top of the water in a glass. What happens? Why?

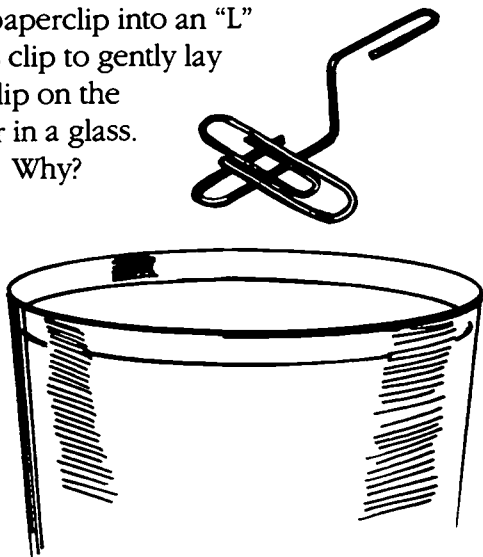

TRY IT!! Pop a Penny

How? Place an empty soda pop bottle in the freezer for at least an hour. Remove the bottle from the freezer and wet the top. Place a penny on the top. Grasp the sides of the bottle, and wait. What happens? Why?

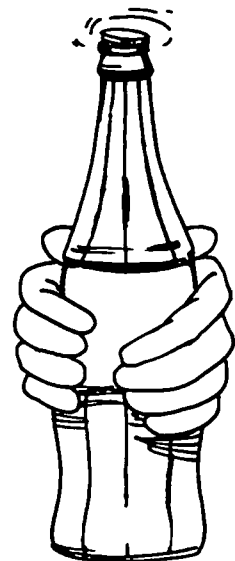

TRY IT!! Inflate a Balloon in a Bottle

How? Fill a bottle with hot water and a bowl with cold water. Let them sit for one minute, then empty the bottle. Stretch a balloon over the open end of the bottle and immerse the bottle in the cold water. What happens? Why?

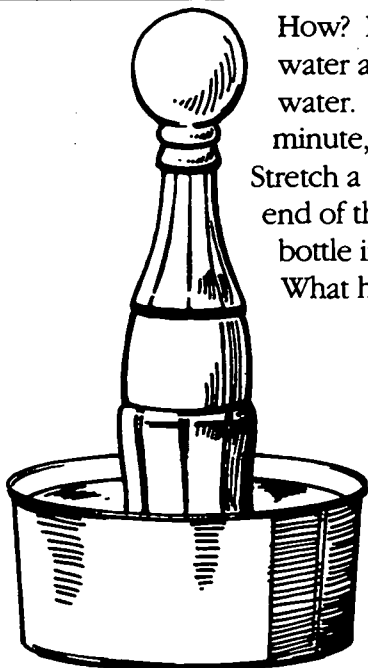

TRY IT!! Balance the Hammer

How? Tie a string in a loop and slip it over a ruler. The other end should twist into a loop and slide over the handle of a hammer resting at the end of its rubber grip. Place the ruler's edge with the hammer head underneath on the edge of a table. The hammer handle should rest against the other end of the ruler. What happens? Why?

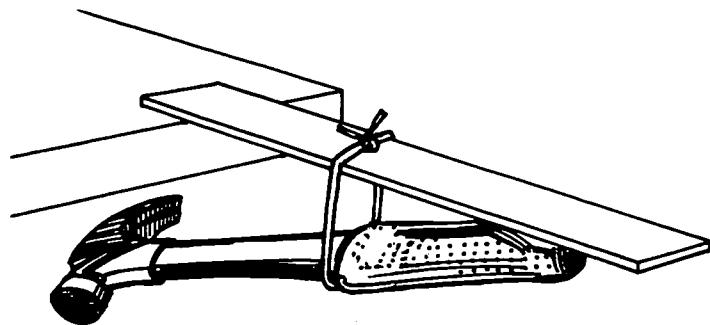

TRY IT!! Pick up a Jar of Rice with a Knife

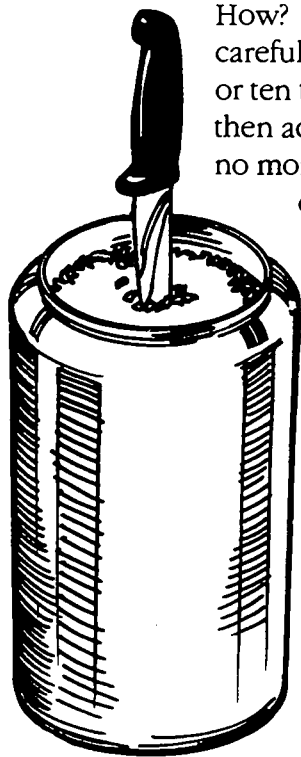

How? Fill a plastic jar with rice, carefully jab a knife into the rice five or ten times. The rice will settle a bit, then add more rice. Continue until no more rice can be added. Then quickly jab the knife into the rice and lift.

What happens? Why?

TRY IT!! Boil Water without Heat

How? Fill a glass three-quarters full with water. Place a handkerchief over the top of the glass and hold it on with a rubberband placed around the rim of the glass. Push down on the center of the handkerchief until it touches the water (the experiment works best if the handkerchief is slightly wet). Keep your fingers pressed on the handkerchief and turn the glass upside down. The water will

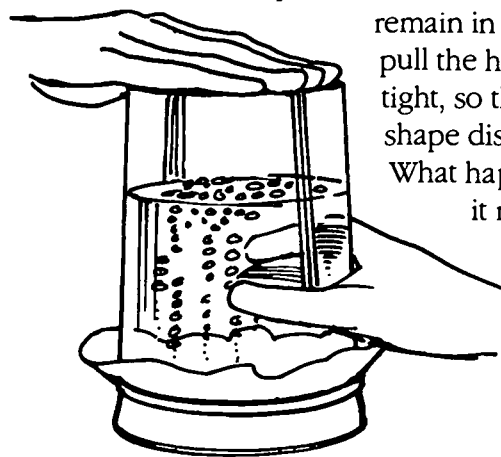

remain in the glass. Now, pull the handkerchief tight, so that the concave shape disappears.

What happens? Why? Is it really "boiling"?

The Science behind "SCIENCE TRY ITS"

Why Does the Paperclip Float?

The surface of the water bends around the weight of the paperclip like stretched rubber. This is because water has *surface tension*.

Why Does the Penny Pop?

Your hands warm the air inside the bottle which then expands. It can only escape by moving the penny and cracking the ice around the rim. The build up and release of air causes the popping, as long as ice remains between the penny and bottle.

Why Does the Balloon Inflate in the Bottle?

The warm water heats the bottle which, in turn, heats the air inside the bottle after the water is poured out. When the bottle is placed in the cold water, the air inside cools and contracts, causing outside air to be drawn in, pulling the balloon in and inflating it inside the bottle.

Why Does the Hammer Balance on the Edge of the Table?

All objects have a center of gravity that acts as if all the weight of the object were balanced there. The center of gravity of the ruler is in the middle, but the hammer moves the center of gravity of the system to under the table's edge which keeps it from falling.

Why Does the Water *Appear* to Boil Without Heat?

Surface tension prevents the water from seeping through the handkerchief. When you straighten out the handkerchief, the water drops down to a new level, reducing the pressure in the air space at the "bottom" of the glass. The higher air pressure outside the glass forces air to penetrate the handkerchief and bubble through the water. But it's not really boiling!

Why Are You Able Pick Up The Jar of Rice With the Knife?

The rice gets more and more packed down by repeated stabs from the knife until the rice is so compact that it presses against the blade of the knife with enough force to overcome the pull of gravity on the jar.



CATCH IT AT HOME!

Newton's Apple is proud of its record as an educational show, but the series is also fun and exciting family viewing! We developed this special guide to the major 9th season segments so you can "catch *Newton's Apple* at home" with your family and friends.* Of course, in addition to the segments listed here, you'll also see our short features, like David and Peggy "On the Spot," "Science Trivia," "Science of the Rich and Famous" and much more! Also, don't miss our newest feature, "Science Try Its" — simple, but surprising, experiments you can do at home!



Host David Hell, Field Reporter Peggy Knapp, and Naturalist Nancy Gibson return in Season 900 to answer your science questions.

SHOW 901

Olympic Science Special

- Physiology
- Biomechanics
- Luge
- Psychology

SHOW 902

Solar Cars
Steroids
Miniature Horses

SHOW 903

Murder Mystery
Bats

SHOW 904

Cancer Causes
Frisbee Physics

SHOW 905

Sewers
Cancer Treatments
Porcupines

SHOW 906

Dinosaur Special
•Mapping the Dig Site
•Dating the Bones
•Assembling a Diplodocus

Continued on next page...

* Please check with your local PBS station for exact airdate and time. If season nine of *Newton's Apple* doesn't appear in the Fall 1991 schedule of your local PBS station, call them to find out when they plan to run it. If you call to ask for a particular show, refer to it by the show number listed above (i.e., #901 for the "Olympic Science Special").

We've also listed some fun and interesting activities built around the segments that you can do with your family and friends. Have fun!!!

SEWERS

Show #905

Take an inventory of the products in your home. Which ones are poisonous or toxic to plants and animals? Contact a sewage treatment plant to find out how these products affect the waste streams at the plant. Try to find some alternative products that are not harmful to the environment.

Newton's Apple is a production of KTCA Twin Cities Public Television. Made possible by a grant from 3M.

Educational materials developed by the National Science Teachers Association—Space, Science, and Technology Division.

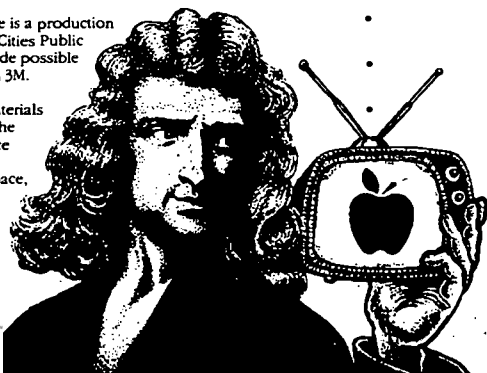

Continued from previous page...

FRISBEE PHYSICS

Show #904
Invite a couple of family members or friends to help you calculate the velocity and acceleration of a Frisbee toss. Take turns acting as the time keeper, data recorder and tosser. Use a stopwatch to time how long the Frisbee is in the air and a tape measure to determine the distance it travels. Record the data from each toss. Try calculating different kinds of throws like ones into the wind, with the wind and across the wind. Which direction works best? Does a fast flying Frisbee travel farther than a slower one?

SHOW 907
Domed Stadium
Photosynthesis

SHOW 908
Tears
Slinky Physics
Camels

SHOW 909
Soviet Space Special
Why is the Sky Blue?
Llamas

SHOW 910
Acid Rain
High Jump
Goats

SHOW 911
Medical Quackeries
Microwave Ovens
Golden Eagles

SHOW 912
Telecommunications
Solar Eclipse
Bear Cubs

SHOW 913
Hip Replacement
Airbags
Potbelly Pigs

TEARS

Show #908
Should people try not to cry over onions? Interview friends, family and neighbors to see what methods they use to keep from crying when they peel or slice onions. Experiment with other vegetables and fruits to determine if pooling, slicing or chopping any of them makes you cry.

DINOSAUR SPECIAL

Show #906
You and your family can build a real animal skeleton. Save the bones from a chicken dinner. Carefully boil and bleach the bones and analyze which parts belong together. Using a framework, begin rebuilding the chicken by gluing its bones together. You may want to look at drawings of chickens and their skeletons to help you.

MEDICAL QUACKS

Show #911
The next time you or a family member have the hiccups, try some of these folk cures. Place your two little fingers in your ears and hold your breath. Or, hold both of your ears tightly closed and have someone else give you a drink of water. Have you heard of other ways that you can cure the hiccups? Ask your parents or grandparents about folk-medicine cures they may have heard of, or used, for other common ailments like colds, warts, baldness and nosebleeds.

SOLAR CARS

Show #902
Color can change the amount of light and heat that are absorbed. Find out which colors are the most receptive. Paint a few tin cans different colors. Make sure you use matt paints or ones that aren't too shiny. Fill each can with equal amounts of water. Using a thermometer, record the temperature in each can. Allow them to sit in the sun for a few minutes. Test the temperatures in the cans and then arrange them in a rainbow from coolest to hottest. Now that you know which colors are coolest, what colors will you wear in the summer from now on? What about the winter? What color would you pick to paint your house to save energy?

3M AND SCIENCE EDUCATION

Scientists and engineers at 3M have developed innovative school outreach programs designed to interest elementary, junior, and senior high students in science, and to encourage them to pursue careers in science.

The 3M Technical Teams Encouraging Career Horizons (TECH) program provides

opportunities for students to meet and interact with 3M scientists and engineers. Volunteer 3M technical employees visit, by invitation, the classroom carrying the message to students that significant career opportunities await them if they keep their options open by studying math and science.

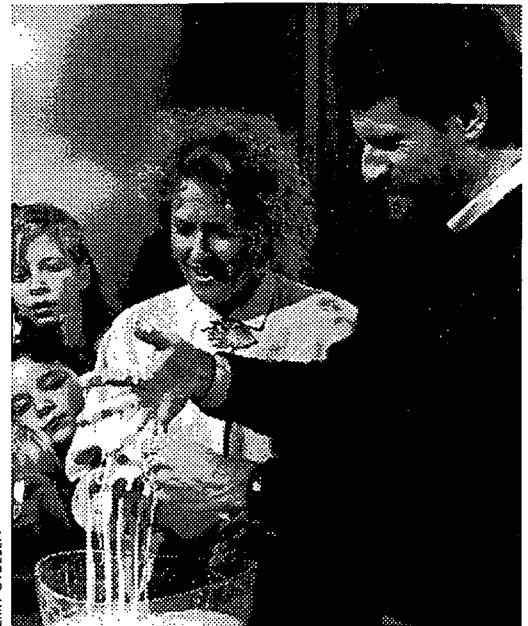

PHOTOS BY TERRY GYDESEN



The 3M Visiting Wizards program trains 3M employees and provides them with hands-on science activities to take into their own children's classroom. "Science is fun. Wouldn't you like to be a scientist, too?"

Would you like to set up your own school outreach programs? For more information about the 3M TECH and 3M Visiting Wizards programs, call 3M at 612/733-8936.

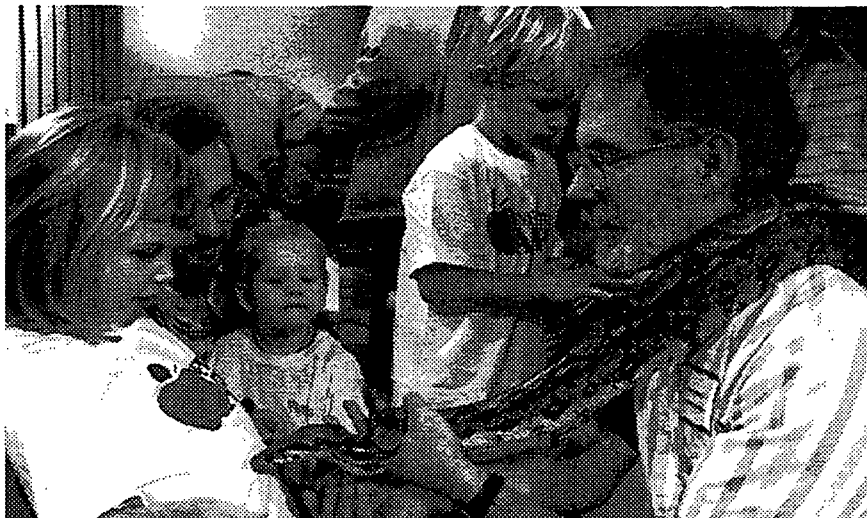

PHOTO BY TERRY GYDESEN



National Science Teachers Association-Space, Science, and Technology Division

Helenmaric Hofman, Ph.D., Director
Caroline R. Benson, Associate Director
Robin K. Lewis, Editor

Writing Team

Jane Benesch, Consultant, MD
Judy Braus, Consultant, VA
Elizabeth Frick, Ph.D.,
President, Educational Systems, MN
Melody Hall, Middle School Educator, GA
Kathleen A. Lundgren,
Science Museum of Minnesota
David Parisian, Science Educator, NY
Sidney Sitkoff, Ph.D., Science Educator, CA

Content Review Panel

Don Aldrich, Engineer, CA
F.G. Ashburn, Ph.D., Western Maryland College, MD
Judy Braus, Environmental Educator, VA
Leonard David, Space Data Resources, DC
Peggy Dixon, Ph.D., Physics Educator, MD
Martin Dukes, MD, Medical Consultant, DC
Richard King, U.S. Department of Energy, DC
Judy Patt, National Institute of Health, MD
Willa Ramsey, Ph.D., Physics Educator, CA
Marvin Russell, Ph.D., Science Educator, KY
Raymond Rye,
Smithsonian Museum of Natural History, DC
Judy White, National Zoo, DC

Advisory Board

Council of State Science Supervisors
International Technology Educators Association
National Council of Teachers of Mathematics
National Middle School Association
National Science Teachers Association
National Association of Elementary School Principals

3M

Don Larson
Barbara Kaufmann
Bruce Gengnagel
Liz McMahon
Judy Parker
Will Shapira

3M / Newton's Apple Education Committee

Bob Barton
Harvey Berwin
Sue Butzer
Yvonne Cadwallader
Mary Chilinski
Peggy Dingman
John Huizinga
Mary Hurlocker
Patty Konsti
Gary Kwong
Walt Lager
Gene Steele, Chair

KTCA/Newton's Apple

David Heil, Host
Peggy Knapp, Field Reporter
Nancy Gibson, Naturalist
Richard Hudson, Executive Producer
Kathryn Scott, Series Producer
Kristian Berg, Segment Producer
Marie Domingo, Segment Producer
Leslie Kratz, Segment Producer
Carrie Maloney, Segment Producer
Lynne Reeck, Segment Producer
Kathy Kraemer, Associate Producer
Gary Leatherman, Associate Producer
Jeff Nielsen, Associate Producer
Amy Kenefick, Production Assistant
Meighan Maloney, Production Office Coordinator
Leola Daniels, Researcher
Joel Dossi, Production Manager
Lynae Berge, Promotion and Outreach Coordinator
Georgia Gould,
Director of National Promotion, KTCA

KTCA/Design Group

Bob Hoffmann, Design Director
Tom Fisher, Designer

FREE EDUCATIONAL
MATERIALS



**The 10th
Anniversary
Season of
NEWTON'S APPLE
Premieres
October 1992
on PBS.**

Educational materials developed
with the National Science Teachers
Association - Space, Science,
and Technology Division.

Newton's Apple is a production of
KTCA Twin Cities Public Television
St. Paul/Minneapolis and is made
possible by a grant from 3M.

ERIC
Full Text Provided by ERIC

3M

Innovation working for you™

Dear Educators:

As national sponsors of *Newton's Apple*, we at 3M are pleased to make available these classroom materials for the series. *Newton's Apple* is designed to give students not just a collection of scientific facts, but a fascination with science itself. We hope these materials will enrich the classroom during the coming year —for your students and for yourself.

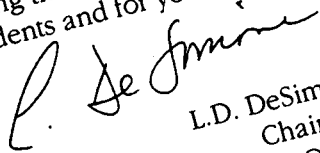

L.D. DeSimone
Chairman
and Chief Executive Officer

3M
Innovation working for you

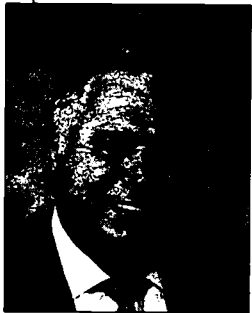

Dear Teachers:

The National Science Teachers Association, through the *Newton's Apple* project staff, is again pleased to be a partner with KTCA-TV, St. Paul/Minneapolis and 3M in association with this innovative television series. The creation of the interest in science is what draws learners and teachers of all ages to this series in order to find out the whys, hows, and whats of the workings of the world. *Newton's Apple* successfully meets the goals put forth by the association in its education goals of science education and informal life long learning.

Supporting learners and teachers through the *Newton's Apple* television series is a privilege.

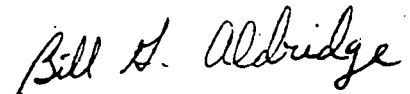

Bill G. Aldridge
Executive Director

NSTA National
Science
Teachers
Association

Greetings from the *Newton's Apple* Team!

This season we offer you and your students a chance to explore the earth from pole to pole with segments on the Alaska Oil Spill, Northern Lights, and a full half-hour special on the Antarctic. From our studio, we tackle the importance of ozone and the threat of AIDS. Some pretty dramatic science for your classroom!

As you've grown to expect over the years, we invite you and your students to join us in these explorations. In addition, since this season is our Tenth Anniversary, we would like to extend a special invitation for you to join us in celebrating ten years of making science fun!

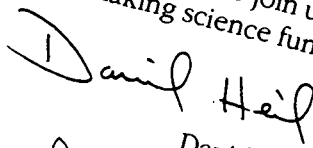

David Heil
Host

 **NEWTON'S
APPLE.**



SUGGESTIONS FOR USING THE NEWTON'S APPLE EDUCATOR'S GUIDE

Welcome to the Newton's Apple Educator's Guide. To assist you in using Newton's Apple in your classroom, we've developed detailed lessons around 26 major topics we explore on the 10th Anniversary season of the series. Each lesson includes **INSIGHTS** about the topic, **CONNECTIONS** to encourage classroom discussion, **RESOURCES** and **VOCABULARY**. There is also a **MAIN ACTIVITY** and several **TRY THIS...** activities related to each topic.

FOLLOWING THE LESSON PAGES, YOU WILL FIND FOUR SPECIAL PAGES.



First, a page devoted to the intriguing animals featured in the 10th season.

Second, a page with fun "Science Try It" experiments your students can do at home.



Third, try to stump your students with our "Street Smart" quiz.

Fourth, get your students' families interested in science by sending home with them the Newton's Apple at-home viewer's guide.



CELEBRATE WITH US AT HOME!!!

THESE FOUR PAGES WERE DEVELOPED ESPECIALLY FOR YOU TO PHOTOCOPY AND SHARE WITH YOUR STUDENTS.



Our guide is designed to accompany the 10th anniversary season of *Newton's Apple*, which will air in the Fall of 1992 on your local PBS station. Each lesson page is numbered in the upper right-hand corner according to the *Newton's Apple* show number in which that topic appears (i.e., Show #1001 for the "Behind the Scenes Special").



Please check with your local PBS station for the exact airdates and times in your viewing area. If the 10th season doesn't appear in your PBS station's Fall 1992 schedule, please **call** them to find out when they plan to run it. (You can ask when they are airing a specific program by its show number).



We are pleased to announce that we've extended our off-air record rights for educational purposes to **three years**. We encourage you to record *Newton's Apple* off the air to use in your classroom.



Please duplicate these materials to share with your colleagues and students!



The last item you'll find in the packet is our special edition 10th-anniversary poster. We hope you'll help us celebrate by hanging this up in your classroom.

P.S. Don't forget to send (and share with your colleagues) the mail-in reply card included in the materials so you'll continue to receive our free materials for future seasons!

MEET THE NEWTON'S APPLE TEAM:

Host David Heil, Field Reporter Peggy Knapp, and Naturalist Nancy Gibson.
They're all dressed up and ready to celebrate *Newton's Apple's* 10th anniversary
(and Sir Isaac's 350th birthday)!



DAVID HEIL returns for his fifth season as host of *Newton's Apple*. An avid outdoorsman and naturalist, David brings to the series an adventurous spirit to match his rich background in the professional fields of science and education. Formally trained in biology, chemistry, mathematics, and physics, David has conducted both laboratory and field research and has taught science to learners of all ages. He is recognized nationally as a creative conference planner and presenter, as well as a published author and public speaker on popular science and the joy of learning.

In addition to hosting *Newton's Apple*, David is the associate director of the Oregon Museum of Science and Industry in Portland. There he directs the National Science Outreach Network, an innovative program that develops and circulates small interactive science exhibits for museums, schools, and public libraries nationwide.

A native of the Northwest, David grew up in a small town with a city park that was perfect for a curious kid with a bent for exploration. Winding trails, dense natural areas, and a creek full of crawdads provided David with a terrific playground

for discovery. Since his youth, he has continued to regard the natural and technological worlds we live in as a rich resource for learning, inviting millions of viewers each week to join him in his favorite pastime of playful exploration.

PEGGY KNAPP (pictured at left) is now in her seventh season as field reporter for *Newton's Apple*. Peggy has diverse experience in television. In January of 1991, during the Persian Gulf crisis, she hosted *Kids Ask About War*, a national award-winning PBS special examining children's fears and concerns about the war. She is also a reporter/producer for *Network Earth* for Turner Broadcasting System.

Peggy was born and raised in Washington state. She was active in sports as a child, but when an injury sidelined her, her attention turned to theater and acting. She attended Evergreen State College, majoring in theater, and developed her improvisational skills at the Brave New Workshop in Minneapolis. Peggy's ebullience, wit, and inquisitive mind communicate science in a way everyone can understand.

NANCY GIBSON (pictured at right) has been *Newton's Apple's* resident naturalist since the series' inception in 1982. Her interest in and dedication to wildlife and the environment, however, goes far beyond her duties on the show.

Since 1987, Nancy has worked as a freelance public relations consultant to environmental causes, working with such groups as the Freshwater Foundation, the International Wolf Center, the U.S. Forest Service, and many others. Prior to 1987, Nancy was the public relations manager at the Minnesota Zoological Gardens. In addition to her current freelance work, Nancy is involved in numerous environmental civic and volunteer activities.

Nancy's love for animals started when she was growing up in rural Ohio. As a child she brought home all kinds of animals, from foxes and raccoons to snakes and skunks. In a way, she has been able to continue this practice—by bringing unique and fascinating animals into viewers' homes and explaining how these animals are an important part of the world around us.

Newton's Apple is a production of KTCA Twin Cities Public Television. Made possible by a grant from 3M.

ERIC
Full Text Provided by ERIC
Full materials developed with the National Science Education Association—Space, Science, and Technology Division.

WE ENCOURAGE
DUPLICATION FOR
EDUCATIONAL USE!

77

BEST COPY AVAILABLE

10.4

3M
Innovation working for you



SEASON 1000 SEGMENT INDEX

Following is an index for your *Newton's Apple* Educator's Guide. For your convenience, the lessons in this guide are organized numerically according to the *Newton's Apple* program in which the segment appears. Just look in the upper right hand corner of each lesson page for the show number (i.e., #1001, #1002, etc.).

On the reverse side of this page is a listing of the previous three seasons of *Newton's Apple*. These episodes may be rebroadcast on your local PBS station throughout the year, and we hope you will continue to use them in your classroom.

Please check with your local PBS station for exact airdate and time. You can ask for a specific program by its show number. If season 1000 of *Newton's Apple* doesn't appear in the Fall 1992 schedule of your local PBS station, call them to find out when they plan to run it.

Show 1001

How TV Works
Satellite
Technology

Show 1002

Hollywood Stunts
Household
Chemistry

Show 1003

Election Polls and
Surveys
Electric Cars

Show 1004

Monster Makeup
Ozone

Show 1005

Oil Spills
Diet and Nutrition

Show 1006

Antarctica I
Antarctica II

Show 1007

AIDS
Glass Recycling

Show 1008

Cockroaches
Broken Bones

Show 1009

Omnimax
Archery

Show 1010

Aurora Borealis
Air Pressure

Show 1011

Traffic Control
Cryogenics

Show 1012

Locks and Dams
Blood Typing

Show 1013

Diabetes
Galaxy Mapping

HOW TV WORKS

What's involved in making TV programs?

How does *Newton's Apple* get from the studio to my television? How does my television set receive sound and light energy?



David, Peggy, and Nancy conduct a "formal" investigation of how television works.

Segment length: 27:00

RESOURCES

Corbett, S. (1965) *What makes TV work?* Boston: Little Brown.

Macaulay, D. (1988) *The way things work.* Boston: Houghton Mifflin.

Potter, T. (1990) *How television works.* Great Britain: Times Four Publishing LTD.

VanCleave, J. (1991) *Physics for every kid.* New York: John Wiley and Sons.

The visual dictionary of everyday things. (1991) New York: Dorling Kindersley.

Additional source of information:
Edmund Scientific
101 E. Gloucester Pike
Barrington, NJ 08007
(609) 573-6250
(science kit:
Adventures in science: Color and light)

Community resources:
Television stations
Broadcast engineers
Vocational colleges

INSIGHTS

Behind-the-scenes at *Newton's Apple*, a team of performers, producers, directors, engineers, and editors work feverishly to produce a 30-minute, award-winning program. But how do the scenes that are shot in the studio and on location get converted from live action to videotaped entertainment?

To understand how television works, you need to know about light, sound, and *electromagnetic waves*. Simply put, a television camera turns the light and sound of live action into pulses of electricity that are transmitted from the television station in waves, and are then received by your television. Your TV reverses the process by turning electromagnetic waves back into light and sound, allowing you to see the images.

Using *Newton's Apple* as an example of this process, light bounces off of David and enters the television camera. The camera changes the light into electronic video signals. Simultaneously, the microphone picks up the sound of David's voice and changes it to electronic audio signals. To produce the electronic color signals, the camera separates David's image into the three primary colors of light: red, blue, and green.

When the program is broadcast, the electronic signals are sent to the station's *transmitter*. Here, the signals are converted to electromagnetic waves. This transmitter first produces a powerful carrier wave onto which both the video and audio signals are placed. The carrier wave is at a specific *frequency*, which you tune in on your TV dial. These waves are emitted by the station's *antenna* and are received by the antenna at your home.

When you turn to your PBS *channel*, you select the frequency on which the *Newton's Apple* transmitter is broadcasting. The television receiver sorts out that frequency from among the others, allowing only the signals specific to that channel to come through.

The receiver also separates the audio from the video signal,

sending the audio to the speaker and the video to the picture tube. The video signal is then separated into signals for each primary color. Each color signal has its own electron gun that sweeps across the inside of the picture tube and excites the more than 300,000 *phosphor* dots coated on the television tube. The picture emerges as the guns quickly scan the entire screen to create an image of David in lifelike color.

CONNECTIONS

1. Eighty-nine million homes in the U.S. have televisions for entertainment. List all the possible uses of TV.
2. How long has television been around? Who invented it? How are television and radio technology similar?

VOCABULARY

antenna conducting metal used to receive or send electromagnetic signals

channel a group or band of frequencies that carries a television transmission

electromagnetic waves that have electrical and magnetic properties (i.e., visible light, X-rays)

frequency the number of cycles or complete waves transmitted in one second

phosphor a substance that emits light when struck by electrons

transmitter a device that broadcasts electrical impulses in the form of waves

COLOR MY WORLD

Discover how a television creates multi-colored images by using only three primary colors.



MAIN ACTIVITY

Turn on a color television set and the screen lights up with tiny red, blue, and green dots. Because the dots are close together and change quickly, our brain mixes these colors together to produce an incredible assortment of colors. Mix colored lights together and see what happens.

Materials

- red, blue, and green 100-watt floodlamp lightbulbs OR red, blue, and green cellophane gels (available at art supply stores) to place over white or clear bulbs
- 3 clamp-on photo floodlamp or spotlight receptacles OR 3 standard flashlights
- standard projection screen OR a large sheet of white paper or fabric taped to a wall

1. Set up the different-colored spotlights so that they are all aimed at a central spot on your screen. (Try clamping them on the backs of three chairs or a table top, positioned about six feet back from the screen.)
2. Make the room as dark as possible and turn on the spotlights, adjusting them so that the combination of their light produces a whitish color on the screen.
3. Turn off the red spotlight. What color is evident now? Repeat by turning off the blue and green spots while leaving the others on: How

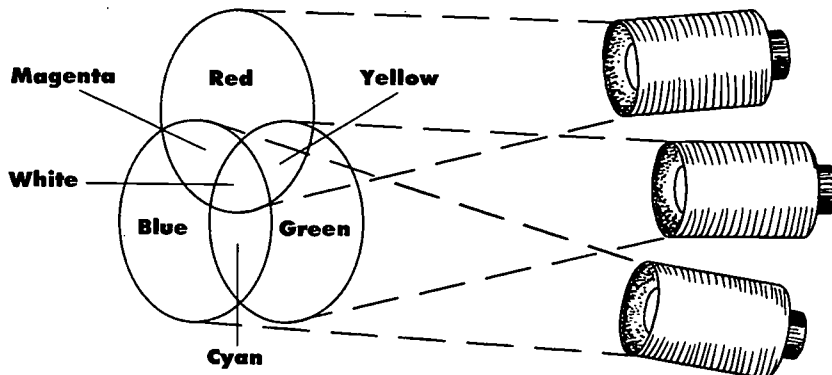

TRY THIS...

Videotape your own version of *Newton's Apple*. Divide the class into "production teams" and have each team select a science question to explore. Individuals can be assigned the specific responsibilities that go into making a television show: researcher, producer, director, performer, and videotape technician. Combine all the segments into one program and invite another class in for the official viewing.

many different colors can you get from only three colored lights?

4. Stand about halfway between the screen and the spots and wave your hands back and forth. What happens to the colors on the screen?

Note: The same procedure can be done with students holding flashlights and aiming the beams at a central point on the screen. However, it may be harder to create the colored shadows using this method.

Questions

1. Why do the colors on the projection screen change when you move your body in front of them? How might this relate to electron guns in a television set turning on and off?
2. Television isn't the only medium that uses color-blending to create full-color images. How does this same principle relate to the printing of color pictures in newspapers, or the processing of satellite images of the earth?

TRY THIS...

Take a magnifying glass and look closely at a show playing on your television set. Do you see the phosphor dots? Where else might you find the concept of tiny dots forming images? Which of your example uses the colors of light and which uses the colors of pigment?

TRY THIS...

Invite a television-repair person to visit your class and bring along a broken television set. Talk about and label the various parts of the television set and learn more about how your own television works.

TRY THIS...

Television flashes a series of images so fast that your eye sees them as one moving image. Make a flickerbook to help understand this idea. Take a small pad of paper stapled together at one end. Draw a series of simple images, such as a seed growing. Working from the last page to the first, draw the images with incremental differences. When done, flip through your book from the last page to the first.



Peggy gets an explanation of satellite technology from Isaac Newton himself.

Segment length: 4:37

SATELLITE TECHNOLOGY

How are satellites used to transmit TV shows?

What are satellites used for? How do satellites get into space and how do they stay there? What will future satellite technology bring?

RESOURCES

Baylin, F. (1986)
Satellites today: The complete guide to satellite television.
Indianapolis, IN:
Howard W. Sams.

Damon, T. (1989)
Introduction to space: The science of space flight. Malabar, FL:
Orbit Books.

Additional sources of information:
Estes Industries
1295 H Street
Penrose, CO 81240
(educational materials, including computer software for Apple IIe systems)

NASA
Education Division
Mail Code F
Washington, DC 20546

U.S. Printing Office
Superintendent of Documents
Washington, DC 20402
(request Subject Bibliography Index #297: Space, Rockets, and Satellites)

Smithsonian Museum's
Air & Space
P.O. Box 53261
Boulder, CO 80301
(periodical)

INSIGHTS

The post-World War II era ushered in the development of satellites and their launch systems, and with it, the communications revolution. In 1958, the "space race" began when the Soviets launched Sputnik. The first American communications satellite, Telstar 1, was launched in 1962. It could handle 600 telephone conversations simultaneously. Today, over 200 international communications satellites, similar to the Intelstat VI family, can carry 33,000 telephone calls at once. This capability will again be exceeded with the development of future satellites.

Isaac Newton first discovered how gravity keeps satellites in orbit when he observed how the moon orbits the earth. Any object, be it the moon or a communications satellite, is pulled toward the earth by the force of *gravity*. But, if it is moving fast enough and is moving perpendicular to the pull of gravity, it falls in a curved path and circles the earth. Although it's always falling, it stays in orbit. (It's similar to a ball on a string: if you swing it fast enough, it will travel in a circle around your hand.) If a satellite does not move fast enough, it eventually spirals closer and closer to the earth and burns up in the earth's atmosphere.

Satellites are sent into space and placed in orbit in one of two ways. The first way is with an expendable rocket that launches the satellite out of the earth's atmosphere. A smaller rocket attached to the satellite then places the satellite into the proper orbit. The second way of getting a satellite into space is on board a space shuttle. After the shuttle reaches a low earth orbit, astronauts release the satellite. The shuttle backs away and a transfer engine on the satellite places it in its proper orbit.

Satellites orbit the earth primarily in four ways: polar orbits, geosynchronous orbits, low earth orbits, and molniya orbits.

In a polar orbit, a satellite orbits the earth from pole to pole. It covers different parts of the earth as the earth turns beneath it. This orbit is used for observing the weather and mapping earth resources.

Most communications satellites are put into a geosynchronous orbit. This kind of orbit positions a satellite over the

equator; the satellite orbits the earth at the same speed as the earth is turning, giving the satellite the appearance of being stationary.

Low earth orbits vary with the type of satellites and their primary purposes. The uses of satellites in low earth orbit may range from scientific research to surveillance.

Molniya orbits are highly *elliptical* and are used primarily by Soviet communications satellites.

Satellites will continue to grow in popularity, complexity, and uses, limited only by the imaginations of those involved in the technology.

CONNECTIONS

1. What do satellites allow you to see "live" on TV that you would not see otherwise? What are some current events that you have seen on TV either as they happened or shortly after?
2. Why do communications-satellite orbits need to be so far from the earth?

VOCABULARY

digital describes a system or device in which information is transferred by electrical "on-off," "high-low," or "1/0" pulses

elliptical having the form of a closed oval-shaped curve

gravity the force that tends to pull any two objects together

orbit a closed path followed by a satellite

DIGITAL ART

Combine art and science in this communications experiment.

◆ MAIN ACTIVITY

You will learn how *digital* images are made, and how signals are sent and received.

Materials

- graph paper, 5 squares to the inch
- OR plain paper on which you have drawn lines vertically and horizontally, creating 5 squares to the inch
- pencils

1. Pair your students; one will be the "sender," the other the "receiver."
2. Distribute graph paper to each student, and have each student draw a 10" x 10" square on the paper.
3. Within this 10" square, have the sender draw a simple picture. The receiver should not be able to see what the sender has drawn.
4. Direct the sender to "read" her picture to the receiver, using a digital code: If a square is blank, the sender says, "Zero"; if the square is filled in, the sender says, "One." Using this code, start with the top row and read from left to right.
5. The receiver, upon hearing this code, transfers the information to his 10" square on his graph paper.
6. At the end of the first row, the sender says, "End row 1," and repeats this at the end of each row.
7. At the end of the 10th row, look at the picture on the receiver's paper. Check the results to see how accurate the transfer was.
8. Change roles and repeat steps 1 through 7. Try this activity using larger or more complex drawings.

► TRY THIS...

Find out about the parts of an electromagnetic wave: wavelength, height/amplitude, frequency, cycle, nodes, etc. Use a piece of rope (15- to 20-feet long) to demonstrate how electromagnetic waves are generated. Lay the rope out on the floor and have two people hold each end. Have one person move the rope side to side in quick motions; you have generated "waves," specifically, transverse waves. Stop the motion and the waves will stop in their form along the floor. Measure the wavelength, amplitude, and frequency. Sketch what you see.

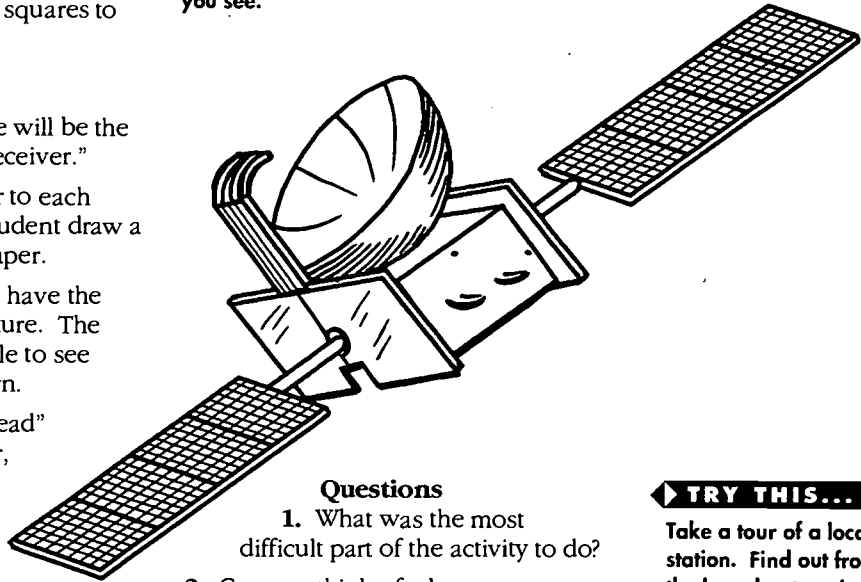

Questions

1. What was the most difficult part of the activity to do?
2. Can you think of a better way to transmit and receive information?
3. Describe how a digital image is formed based on your experiment.
4. Can you figure out how the information is coded electronically? (Hint: Using a light switch on the wall, assign a number to the switch when it is on. Assign a different number when the switch is off.)
5. What are some other devices or systems that communicate this way using 1s and 0s?

► TRY THIS...

Take a tour of a local station. Find out from the broadcast engineers how they receive television programs and transfer them to cable. This field trip will help you understand how *Newton's Apple* gets to your local PBS station, and ultimately, to your television at home or school.

- Newton's Apple is a production of KTCA Twin Cities Public Television. Made possible by a grant from 3M.
- Educational materials developed with the National Science Teachers Association—Space, Science, and Technology Division.

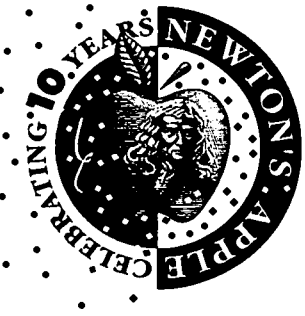

► TRY THIS...

Find out about space laws, specifically those governing geosynchronous orbits. (This kind of orbit is highly preferred, and for that reason, a branch of the United Nations governs the placement of satellites in this area of space.) How is geosynchronous space divided up? How is it determined who gets what? What if two sponsors wanted the same area in space? How could a conflict be resolved?

HOLLYWOOD STUNTS

What is the physics behind movie stunts?

How do scientific principles “protect” stunt performers as they perform dangerous feats? What kinds of protective gear do stunt people use? Why is timing so important in stunts?



David “goes Hollywood” as he applies the principles of science to learning about movie stunts.

Segment length: 11:30

RESOURCES

Baur, T. (1989)
Special effects and stunt guide. Beverly Hills, CA: Lone Eagle.

Dittman, R., and G. Schmiege. (1979)
Physics in everyday life. New York: McGraw-Hill.

Ehrlich, R. (1990)
Turning the world inside out. Princeton, NJ: Princeton University Press.

Grant, C. (1990)
Stunts. New York: Tor Books.

Hewitt, P. (1991)
Conceptual physics, 2d ed. New York: Addison-Wesley.

Additional sources of information:

Universal Studios Hollywood
100 Universal City Pl.
Universal City, CA 91608
(818) 777-3801

Hollywood's Stuntman's Hall of Fame and Museum
P.O. Box 277
Moab, UT 84532
(801) 259-6100

INSIGHTS

Hardly a movie made today is without some kind of amazing stunt work. We all are held breathless when a person falls out of a 20-story building or when a heart-stopping car chase ends in a spectacular crash. While these may seem to be spontaneous events, every moment of every stunt is carefully planned and controlled by the scene directors, who have an understanding of the basic scientific principles at work.

In falls, bodies obtain their speed because of the net *acceleration* due to the *forces* of *gravity* and air *drag*. On the earth, the acceleration rate of a free-falling body is 32 feet per second per second of fall (9.8 meters per second squared). This means that for each second the body is falling, its *velocity* increases 32 feet per second, up to a limiting velocity of approximately 125 miles per hour.

As the velocity of a falling body increases, so does its momentum. Momentum is calculated by taking the *mass* of a body and multiplying that number by its velocity. When two things crash, it's the rate of change of momentum that determines the forces (or “wallop”) and does the damage.

To reduce the chances of damage or injury, stunt

designers use devices that stretch out the time it takes to stop a body's momentum. These devices “soften the blow,” so to speak, both figuratively and literally. The longer the period of time used in changing the momentum, the less force will be released upon impact. Air bags are one of the devices used because they slow down the impact of the falling body by allowing the body to displace a large volume of air. The greater the displacement, the slower the final impact, and the less chance of injury. For very long falls of several hundred feet, stunt people often use decelerators: long elastic ropes that serve as a brake to limit the maximum velocity.

In addition to having the proper equipment, stunt people must know about human anatomy;

they must practice a lot; and they must wear the right protective gear. Even with all this knowledge and training, however, stunt people can get injured—the scientific principles they use to their advantage can be just as effective against them.

CONNECTIONS

1. What are some of the ways that the human body naturally absorbs energy during exercise?
2. Why is it important that stunt people fall on their backs instead of face down?
3. What properties should a material have in order to reduce impact or to prevent a stunt person from being injured by fire?

VOCABULARY

acceleration the rate at which the velocity of a moving object changes over time

drag the retarding force acting on a body moving through a fluid, parallel and opposite to the direction of motion

force a push or pull that causes a body to accelerate or change shape

gravity the force that makes objects tend to move toward each other

insulator a material that blocks the flow of heat energy from one region to another

mass the amount of matter a body or object contains; a measure of the inertia of a body or object

velocity the speed of a body moving in a certain direction.

CHILL OUT!

Find out how insulation can keep heat in and out.

◆ MAIN ACTIVITY

Test several different materials to see which are the best *insulators* of heat energy. Find the material that will take the longest amount of time to heat up and the least amount of time to cool down.

Materials

- 3 cups polystyrene-foam packing peanuts
- 2 wool socks
- 3 cups sand
- empty 1-lb. coffee can with lid
- long Celsius lab thermometer
- watch with a second hand OR a stopwatch
- paper and pencil
- scissors
- portable 1000-watt hair dryer

1. Set up a log sheet as suggested here:

Material	Starting Temp	Time up 10°	Time down 10°	Maximum Temp
Wool				
Polystyrene foam				
Sand				

2. Stuff the woolen socks inside the can. Put the lid back on the can.
3. Using scissors, poke a small hole in the lid. Slip the thermometer through the hole until it is about half-way into the can.
4. Allow the can to sit for five minutes. Then read the temperature on the thermometer and record this as your "starting temperature."
5. Begin heating the outside of the can by moving the hair dryer slowly around all sides of the can. Using a watch or stopwatch, start timing the experiment now. See how many

▶ TRY THIS...

Experiment with how different types of bungee cords and springs could be used as decelerators. Attach a large weight (e.g., a pail full of sand with a lid on) to one end of a cord or spring and let it freefall. Try to quantify your experiments by attaching a spring scale to the upper end and measuring the maximum force. What properties make for the best results?

seconds it takes for the thermometer to go up 10 degrees. Record this on your chart as "time up."

6. When you hit the 10-degree mark, turn off the hair dryer and time how many seconds it takes for the temperature to go back down to the starting point. Record this on your chart as "time down." (The temperature may continue to rise after removing the heat source. Record this on your chart as the "maximum temperature.")

7. Repeat the experiment again using the sand and foam peanuts in place of the wool socks.

Questions

1. Based on your experiments, which materials would make the most effective liner to protect a stunt person from heat? Why is it necessary for the material to heat up slowly and cool down quickly?
2. Did any of the materials get significantly hotter after you turned off the heat? What would cause this to happen?
3. What other materials could you test?

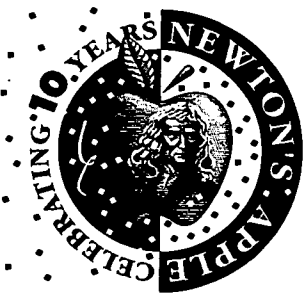
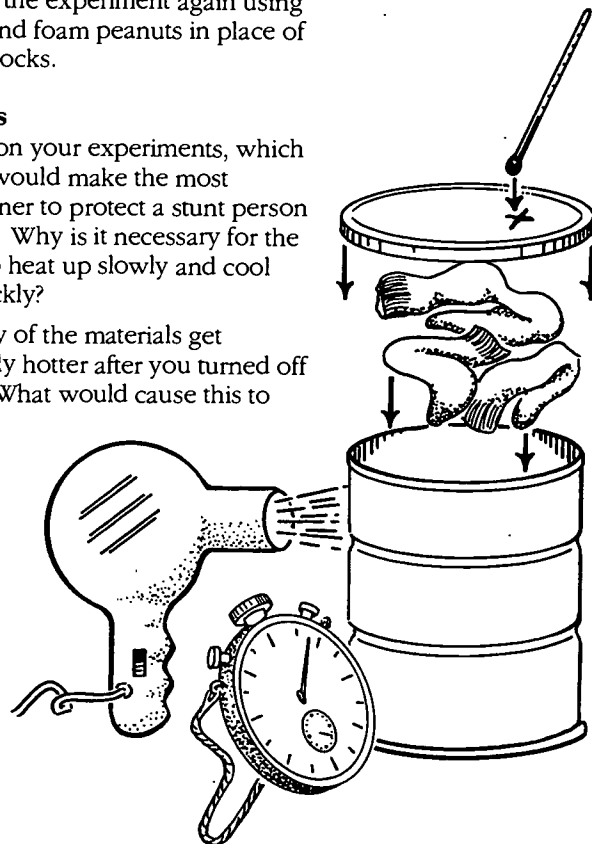

▶ TRY THIS...

What types of protective gear developed for stunt people have been incorporated into our daily lives? Which types of protective sports gear use the same principles as air bags and decelerators? How might you modify this equipment so that it is even better at reducing the force of impact?



David learns about chemistry from some household items and some uninvited guests.

Segment length: 7:15

HOUSEHOLD CHEMISTRY

How can common items found at home be used in chemistry experiments?

What is a chemical reaction? How can I do chemistry experiments at home? What is pH? How can I tell if something is an acid or a base?

RESOURCES

Farber, E. (1990) *The Nobel Prize winners: Chemistry*. New York: Salem Press.

Mullin, V. (1968) *Chemistry experiments for children*. New York: Dover.

Orii, E., and M. Orii. (1989) *Simple science experiments with water*. Milwaukee, WI: Gareth Stevens Children's Books.

Penrose, G. (1990) *Sensational science activities*. New York: Simon and Schuster.

VanCleave, J. (1989) *Chemistry for every kid*. New York: John Wiley and Sons.

Wyler, R. (1987) *Science fun with a homemade chemistry set*. New York: Simon and Schuster.

INSIGHTS

Chemistry is the study of the ways various substances are put together and their reactions under different conditions. It is a science that involves all of one's senses: seeing, hearing, tasting, feeling, and smelling.

Chemistry is the study of *matter*. Matter can be found in three basic "states" or forms: liquid, such as water, oil, and saliva; solid, such as wood, bone, and stone; or, gaseous, such as oxygen, helium, and methane.

The basic building blocks of matter are the *elements*. Elements cannot be broken down into simpler matter. Whether in nature or in the laboratory, two or more elements combine chemically to form a *compound*. The combined form may have different properties from the original elements. For example, when the element oxygen, a gas, combines chemically in one way with the element hydrogen, also a gas, one compound that can be formed is water. As a liquid, it looks and behaves differently from the gaseous forms of hydrogen and oxygen. A chemical change has caused this difference.

Two large and important groups of chemical compounds are acids and bases. Water

(H_2O or H^+OH) is both an acid and a base. As its chemical *formula* indicates, pure water has equal concentrations of H^+ (hydrogen *ions*) and OH^- (hydroxide ions). When the concentrations of those two ions are equal, a substance is called neutral. When there are more hydrogen ions than hydroxide ions, that substance is an acid. The opposite condition (more hydroxide ions) makes a material a base.

Whether a compound is an acid or a base is indicated by its pH or "power of hydrogen," which represents the amounts of acid or base in a solution. Pure water is neutral, and so registers 7 on the pH scale. The lower the reading below 7, the more acidic a solution is. The higher the reading above 7, the more basic a solution is. The pH of lemon juice is about 2.3—acidic; the pH of seawater is about 8.3—basic.

The cabbage-juice mixture used in the *Newton's Apple* segment contains compounds that change color as the pH changes. Therefore, it can be used as an indicator to show different levels of the pH scale. Litmus paper, which turns red for acidic solutions and blue for basic solutions, or the pH kits used to test aquariums, can also be used as indicators.

CONNECTIONS

1. Be a chemist at home. What are acids used for in your home? How are bases used in household items?
2. What are some of the signs of a chemical reaction occurring? What kinds of chemical reactions happen when you cook?

VOCABULARY

compound a substance made up of atoms of more than one element

element a substance composed of only one kind of atom

formula a combination of chemical symbols and numbers that represents the different atoms in a molecule, and that shows which elements are contained in a compound and their relative amounts

ion an atom or group of atoms carrying an electrical charge

matter what things are made or composed of; can be solids, liquids, gases, or plasma

ACID OR BASE?

Use indicator paper to find out what's acidic, what's basic.



◆ MAIN ACTIVITY

You can identify some everyday substances as being acidic, basic, or neutral. You will learn how to test for pH levels.

Materials

- universal indicator paper
- small paper cups
- wooden sticks
- labels
- newspaper or paper towels
- substances to be tested: water from your school; water from home; lemon, orange, and grapefruit juices; acetic acid (vinegar); apple juice; catsup (diluted); ammonia (diluted 1 part ammonia to 10 parts water); borax; soft drinks; milk of magnesia; sodium bicarbonate (baking soda)

1. Put some of each substance into a small cup and label the cups according to their contents.
2. Group the students and provide each group with some of the testing substances.
3. Direct the groups to test each substance with small 1" strips of indicator paper. (Place the end of a different indicator paper strip in each cup and observe the color changes.) Have the groups record their findings on a chart.
4. After the findings are recorded, arrange the substances according to their pH levels, from the strongest acid to the strongest base.
5. Students can compare the color changes seen in the segment to their own results from the activity.

- Note: Many foods with high sugar content indicate an acid reaction on indicator paper. The yeast cells functioning in a sugar solution cause this response.
-
-

- Newton's Apple is a production of KTCA Twin Cities Public Television. Made possible by a grant from 3M.
- Educational materials developed with the National Science Teachers Association—Space, Science, and Technology Division.

▶ TRY THIS...

The juices of certain plants, such as red cabbage, can be used as a pH indicator. Chop some red cabbage in a blender (keep the lid on and your fingers out while the blades are moving). Place the chopped cabbage in water and heat until the water turns a deep purple. Pour off and save the liquid. Saturate paper towels with the purple liquid solution and allow to dry. Cut the dried towels into strips to use as indicator paper. (If you don't plan to use the paper strips immediately after they dry, place them in plastic bags and put in your freezer to avoid odor.)

Questions

1. Which substances were acidic and which were basic?
2. Why did the indicator paper change color?
3. Test some soil samples mixed with water. Is your soil acidic or basic?
4. Dissolve dish soap in water and test it. Test again using laundry detergent.
5. What effect do you think stomach acid has on some of the germs that enter our digestive tract?



ACID OR BASE?

Substance	indicator paper change	acidic/basic?
School water		
Lemon juice		
Vinegar		
Sodas		
Etc.		

▶ TRY THIS...

Investigate the effect that oxygen has on the darkening of fruit. Cut an apple in half. Sprinkle a crushed vitamin C tablet over the cut surface of one of the halves. After one hour, observe, compare, and contrast the color of the untreated apple half with the color of the half that was treated with vitamin C. What gas do you think is reacting to the apple? (Hint: vitamin C is an anti-oxidant.)

▶ TRY THIS...

Observe the effect that salt has on the temperature of water by adding one cup of water and three tablespoons of salt to a can that is filled with crushed ice. Why does the outside of the can first become covered with water droplets? Why does the water on the outside of the can eventually freeze? Discuss the three states of water.



David learns the science and math of conducting polls and surveys.

Segment length: 9:30

ELECTION POLLS AND SURVEYS

What is the validity of polls?

What factors affect the accuracy of a survey? What effect does random sampling have on predicting the outcome of an election? How does sample size affect the margin of error of polls?

RESOURCES

Converse, P., and M. Traugott. (1986) Assessing the accuracy of polls and surveys. *Science* (Nov): 1094-97.

Lipset, S. (1980) Different polls, different results. *Public Opinion* (Aug/Sept): 19-20.

Mitofsky, W., and M. Plissner. (1980) Reporters guide to published polls. *Public Opinion* (June/July): 16-18.

Spence, J., et al. (1983) *Elementary statistics*. Englewood Cliffs, NJ: Prentice-Hall.

Additional source of information:

The Gallup Organization
P.O. Box 628
Princeton, NJ 08542
(609) 924-9600

Community resources:
Market research firm

Political parties

INSIGHTS

Reading or hearing about the results of a public opinion poll has become a common everyday experience for many. Everyone from political candidates to toy manufacturers seems to be trying to find out what people are thinking by polling the general population. The question is, can any of these surveys be trusted?

While many people don't think of surveys as being scientific, the implementation and interpretation of surveys belongs to a branch of mathematics called *statistics*. Professional statisticians use very strict rules in designing and evaluating these surveys, much like a physicist uses specific techniques to collect data from an experiment.

The two most important aspects of conducting an accurate survey involve *random sampling* and bias. Random sampling is a technique used to ensure that each member of a specific target population has an equal chance of being selected. There are a number of ways to get a random sample. A simple method would be to put into a hat many pieces of paper on which are written the names of the people in the target population. From this sampling, a certain number of names are literally "pulled out of a hat." This is the same

technique used in lottery drawings in which numbered balls are randomly selected. The drawback is obvious: If the population is large, the mechanics of taking the sample become unwieldy. Today, computers can be used to generate a table of random numbers—an electronic version of "shaking up the balls."

The second important factor in surveys is bias, which can creep into the selection process of the person who is to answer the questions, or into the design of the questions that are to be asked. *Selection bias* usually occurs when a part of the target population is inadvertently excluded. One example would be selecting individuals from a town by drivers' licenses. Since some people don't drive, they would be automatically excluded from the target population.

Bias also becomes a factor by the way in which the questions are written and presented. The wording of the questions and the choices of the answers must be structured so that all questions and answers are of equal value.

CONNECTIONS

1. What is the relationship between the size of a sample and the *margin of error* in a survey? Why does increasing the sample size give better results?
2. Most political opinion polls are conducted through telephone surveys of likely voters. Discuss if this kind of selection results in a biased survey. What criteria would you use to select individuals from your town for a survey that didn't have any selection bias?

VOCABULARY

margin of error the plus or minus range of variation that the survey answers will have with respect to the true answers, if the entire population were asked the same questions

random sampling the process of selecting individuals from a population so that each member of the population has an equal chance of being included in the survey

selection bias the exclusion, often unintentional, of certain members of a target population because of the way the selection process has been established or conducted

statistics a branch of mathematics dealing with the collection, interpretation, and presentation of numerical data

Newton's Apple is a production of KTCA Twin Cities Public Television. Made possible by a grant from 3M.

Educational materials developed with the National Science Teachers Association—Space, Science, and Technology Division.



POLL POSITION

Learn the ins and outs of being a pollster.



▶ TRY THIS...

Gather together a number of survey questions from magazines and journals. Analyze each of the questions for bias. Try rewriting the questions so that they have little or no bias in them.

▶ TRY THIS...

Put yourself in the position of a corporate market-research specialist. Your company has just come up with a new fast-food idea but before you spend millions of dollars promoting it, you want to get some idea as to whether or not people are going to eat it. Develop a market research poll that not only describes the product, but targets specific parts of the population.

◆ MAIN ACTIVITY

You will discover how bias in questioning affects the outcome of a poll. By asking two sets of questions, you might get two different conclusions.

Materials

- pencil
- plain paper
- graph paper

1. Prepare two questionnaires that will poll your schoolmates about their favorite foods to have in the school lunchroom. Design one set of questions with a minimal amount of bias (e.g., "On Mondays, which would you rather have: pizza, hamburgers, or fried chicken?"). Design the second set of questions so that they place substantial bias (e.g., "Wouldn't you rather have pizza for lunch instead of a boring hamburger?").
2. Select one grade level to be polled and get permission to poll two classrooms, one with the bias survey and the other with the unbiased one.

Conduct the polling so that the two groups of students don't know that they are getting separate questionnaires.

3. Compile the results of the two polls and graph the results.

Questions

1. How did the results of the two surveys differ? In which survey were the answers more predictable?
2. What elements of bias may have entered into the selection of the students in this survey?
3. When professional research firms conduct surveys, they often ask for the same information two or three times, each time worded differently, during the course of the survey. Why might they do this?

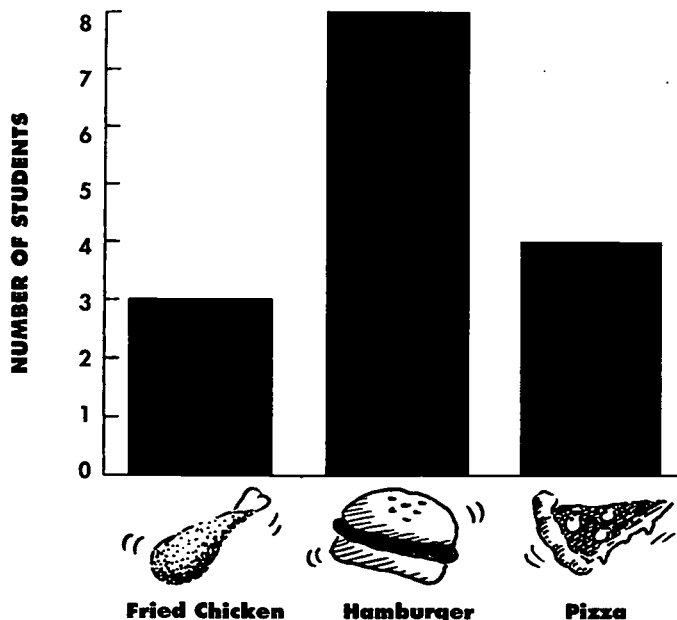

▶ TRY THIS...

Recently, there has been a debate on whether news organizations should release the results of election exit polls from the East Coast of the United States while residents of the West Coast have yet to vote. Some people say this influences the election outcome, while others say there is no harm. What's your opinion?

▶ TRY THIS...

How is probability related to polls and surveys? Place 50 pennies in a shoebox with a lid and shake them up. In theory, 25 of the coins should come up "heads." Count them and see if the numbers are close. Repeat the experiment four times and average the results. Compare the average values to the predicted values. How is the number of trials related to population size in surveys?

BEST COPY AVAILABLE



Peggy goes around in circles trying to find out what fuels an electric car.

Segment length: 5:50

ELECTRIC CARS

How can a car run on electricity alone?

What ever happened to the decades-old idea of an electric car? What are the newest designs for electric cars? What powers an electric car? What are the advantages and disadvantages of an electric car?

RESOURCES

Colvin, R.L. (1991)
"Electric-car buffs shift efforts into higher gear." In *Los Angeles Times* (February 11): Section B, pg. 3.

deLucenay, L.G. (1983)
The electricity story.
New York: Arco Publishing.

Traister, R.J. (1982)
All about electric and hybrid cars, 1st ed.
Blue Ridge Summit, PA: Tab Books.

Additional sources of information:

General Motors
Electric Vehicle Group
30200 Mound Rd.
Warren, MI 48090
(313) 556-5000

Solar & Electric Car
Racing Association
11811 N. Tatum Blvd.
Suite #3031
Phoenix, AZ 85028

INSIGHTS

Electric cars offer many advantages when compared to gasoline-powered cars. Electric cars run without burning gasoline, and therefore, produce no exhaust pollution. They are relatively quiet during normal operation and nearly silent when idling; therefore, they produce much less noise pollution than gasoline-powered cars.

Electric cars don't have many of the parts that gasoline-powered cars do—parts that need continual upkeep at best, and that often fail (e.g., fuel injectors, carburetors, mufflers, distributors, water pumps, etc.). There are no tune-ups or oil changes for electric cars. Required *battery* maintenance is minimal. There is no emission-control system, which is one of the most complex and expensive parts of a car that uses gasoline. Most of the components in an electric car are electrical or solid-state, with no moving parts. The overall costs for maintaining an electric car average about 30% of that for gas-powered cars.

So, if electric vehicles are so great, why don't we see many around? There are several reasons for this, the primary one being the relative efficiency of gasoline as a fuel. Gasoline is fairly inexpensive to produce; because it's a liquid, it's cheap

to store and transport; and it has a very high energy content per unit of weight. Batteries, by comparison, have a low energy content per unit of weight. Several hundred pounds of batteries are needed for some electric cars. These batteries store as much energy as a single gallon of gasoline, which weighs only about five or six pounds. In addition, an electric vehicle gets only about 100 miles to a charge and can take hours to fully *recharge*.

There are developments in electric cars that might eliminate some of the disadvantages. One example was seen in the *Newton's Apple* segment. This style of car is fueled by electrical metal strips laid within the roadbed. Electrical energy is provided from a central source through the metal strip. These electric cars do not require a battery source, only an *electric motor*.

The electric-vehicle industry continues to grow. By the year 2000, any manufacturer who wants to sell gas-powered cars in the state of California must also have electric cars available. The cost of an electric car is approximately \$17,000. Many "do-it-yourselfers" are converting their gas-powered cars to electric cars, thus saving money.

Our dependence on the internal combustion engine is costing us in many ways, including monetarily and environmentally. Electric vehicles can bring us cleaner air and greater energy independence.

CONNECTIONS

New technologies can have far-reaching impacts on our society. What are the consequences of a wider-use of electric cars in the U.S.? Environmental? Economic? Political? Safety?

VOCABULARY

battery an electric cell or a group of connected cells that furnishes an electric current for the transfer of energy

electricity a form of energy that can be transferred by the movement of electrons and protons

electric motor a machine for converting electrical energy into mechanical energy

photovoltaic a solar cell that changes light energy into electric energy

recharge to supply with chemical energy again, as a battery for conversion to electrical energy

MAKING THE CONNECTION

Investigate how different materials can produce electrical energy.



MAIN ACTIVITY

Test different substances to determine whether they can produce an electrical current.

PART I

Materials

- #6 dry cell
 - knife switch OR push button
 - compass
 - 15 feet of 28-gauge (or finer) insulated wire
1. Wind the insulated wire about 10 times around the compass at the north- and south-pole markings. The compass should be rotated so that the compass needle is also aligned in a north-south direction.
 2. Connect the wires in a complete circuit.
 3. Use the knife switch or push button to close the circuit *only* for a moment at a time.
 - **CAUTION: Leaving the circuit closed will result in a short circuit with the wires becoming very hot!**
 4. Now make your own batteries using household items and test them in the next investigation. Use the "compass" galvanometer to detect an electric current after constructing it in steps 1 through 4.

Questions

1. What happened to the compass needle when the circuit was closed?
2. How do you know that the deflection of the compass indicates a current flow? Try showing that a straight wire can also cause the compass to deflect when near a current-carrying wire.

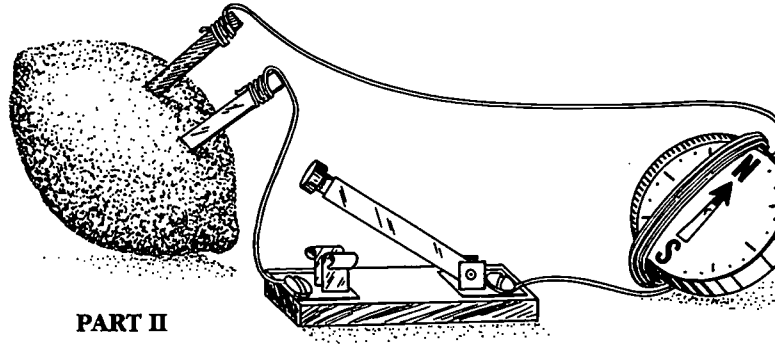

PART II

Materials

- lemon
- vinegar
- orange juice
- wire from Part I
- compass from Part I
- copper strip approximately 3/4" wide and 5" long
- zinc strip approximately 3/4" wide and 5" long
- wide-mouth glass jar

1. Carefully squeeze or roll on a hard surface the unpeeled lemon until it feels very soft. Be careful not to break or puncture the skin. Push the copper and zinc strips into the lemon.
2. Wrap the ends of the wires from the compass galvanometer around the metal strips as illustrated. What happened to the compass needle when the circuit was closed? Was the compass needle deflected? What does that indicate?
3. Now repeat the procedure using a jar of vinegar and then a jar of orange juice. Be sure to wash the metal strips with water before testing a new substance.

Questions

1. What would happen if you used a non-conducting liquid, such as milk? What needs to be present to cause a current to flow?
2. Look at and identify the parts of a battery. What components in your circuit correspond to these parts?

TRY THIS...

Investigate the various solar-electric-car races that have been held over the last few years. Compare the differences and similarities of a solar-electric car with a battery-electric car. Write a report on your findings.

TRY THIS...

Imagine you are a member of a debate team and you need to convince your audience that electric cars are better than gasoline-powered cars. Do research and present issues such as pollution, reliability, maintenance, operating costs, etc., to support your arguments.

TRY THIS...

Search literature about the history of science and technology for information about scientists who discovered ways of making and improving batteries. Develop a chart that includes the inventor and the contribution. Include such scientists as Alessandro Volta, Gaston Plante, Georges Leclanché, and Thomas Edison.



It's movie-magic time as Peggy gets a make-over!

Segment length: 6:00

MONSTER MAKEUP

How is an actor transformed into a monster using makeup?

What special materials and mixtures are used to create monster masks for the movies? How are the masks made to appear so lifelike? What's the secret to making a monster face so scary?

INSIGHTS

Since the earliest days of Hollywood, movie fans have been enthralled by the transformations made by actors when they don makeup to become out-of-this-world characters. In those early days, a makeup artist had to be as much a scientist as an actor, experimenting with materials not nearly as sophisticated as we have today.

The first true makeup magician was Lon Chaney Sr., often called the "man of a thousand faces." Doing all his own work, Chaney used materials such as fish skin, mortician's wax, and grease paint to accent his facial features for different parts. At one point, he even cut off the tips of cigar holders and inserted them into his nose to appear more authentic for a character role.

One of the most important makeup artists, Max Factor, was also a *chemist*. He developed makeup that would not melt under the hot lights. In 1914 he invented "Supreme Grease Paint" that helped reduce the glare of the makeup under the harsh lighting on the set. In 1937 he developed *Pancake makeup*, which not only became the industry standard for use in color films, but revolutionized the entire cosmetics industry.

Jack Pierce and Maurice Seiderman were two famous makeup artists who worked in the 1930s and revolutionized the movie business. Both men studied human anatomy in an effort to make their non-human characters more lifelike. In *Frankenstein*, Pierce transformed Boris Karloff into the mummy and the monster, and he turned Bela Legosi into the gruesome Count Dracula. Seiderman perfected the human-aging process so well that he successfully created 37 distinct looks for Orson Wells in *Citizen Kane*. Whereas their predecessors used wax as their primary makeup ingredient, both Pierce and Seiderman had the advantage of working with *latex* rubber, invented in 1929. Latex had many advantages over wax because it didn't crack and could be applied in thin coats to make the skin more lifelike.

Even though things have come a long way since the days of

Lon Chaney Sr., the one constant that all makeup artists use is time. To create the most lifelike characters, layer after layer of makeup is applied; each layer must be allowed to dry before applying the next. During the filming of *Elephant Man*, actor John Hurt needed 13 different appliances and eight hours in the makeup room to prepare for each day's shoot.

CONNECTIONS

1. Why is it important that makeup artists study and understand human anatomy? How could knowledge of geometry help a makeup artist?
2. How is color used to highlight certain features to make the characters look more realistic?
3. In what ways have advances in movie makeup been applied for use by the general public?

VOCABULARY

appliance a device most commonly made of latex rubber that is applied to the body or face to build up a specific feature

chemist one trained in the science of dealing with the compositions, structures, and properties of substances

latex a type of rubber that dries quickly and stays flexible; a material often used to simulate skin

Pancake makeup a Max Factor trade name for a cosmetic in the semimoist cake form

RESOURCES

Baygan, L. (1988) *Techniques in three-dimensional makeup*. New York: Watson-Guptill.

Everson, W. (1974) *Classics of the horror film*. New York: Carol Publishing.

Jans, M. (1986) *Stage makeup techniques*. Amsterdam: van Dobbenburgh.

Smith, D. (1985) *Dick Smith's do-it-yourself monster makeup handbook*. Chicago: Morris Costumes.

Additional sources of information:

Alcone Company Inc.
Paramount Theatrical Supplies
5-49 49th Ave.
Long Island City, NY
11101

American Museum of the Moving Image
36-01 35th Ave.
Astoria, NY 11106

Morris Costumes, Inc.
4300 Monroe Road
Charlotte, NC 28205

YOU'VE GOT THE LOOK!

Use science, math, and creativity to transform your face.



▶ TRY THIS...

You can create authentic-looking scars by using unflavored powdered gelatin. Mix about one teaspoon of gelatin with one teaspoon of hot water. Stir until gooey and apply to the body quickly to prevent hardening. Try to make the scar as irregular as possible. To make a bloody scar, add some red food coloring, and touch up with face powder when dry.

▶ TRY THIS...

Find a makeup book that describes what was done in the movie *Little Big Man* to age the title character, played by Dustin Hoffman. For example, foggy contact lenses were used to make the actor's eyes lose their bright, youthful appearance. What changes occur on a person's face as he or she ages from 20 years old to 80 years old?

◆ MAIN ACTIVITY

Create your own "creature feature" using makeup. To get a realistic yet fearsome look, you must employ some geometry, build on your anatomy, and design the proper color contrast.

Materials

- assorted makeup items including mascara, lipstick, powder, rouge, and pancake foundation
 - assorted *appliances*, such as artificial fingernails and teeth, wigs, etc., available at costume shops
 - sketch pad
 - drawing pencils and pastels
 - tape measure
 - camera and film
1. Start your creation by making a life-size drawing of your face, carefully measuring the placement of your eyes, nose, mouth, etc.
 2. Sketch the type of look you want by drawing in angles, hair, teeth, and color contrast. Write down the steps that you will follow to build your face.
 3. After you have drawn the type of features your monster face will have and have written down the procedures you will follow, begin applying makeup and appliances on your own face or the face of a friend. Modify your steps if things don't go as planned so that you will have a formula for recreating the face in the future. Once you have finished your creation, take a photograph of your creature.

▶ TRY THIS...

Movie-make-up artists do more than just work on monster faces. They are often responsible for making actors appear as though they have just been through a horrible accident. Experiment with making fake blood by using a variety of household items like catsup, powdered-drink mixes, and cornstarch. One recipe combines one ounce of red food coloring with one pint of clear corn syrup. To this, add one or two teaspoons of yellow food coloring and about an ounce of water (recipe from D. Smith book—see RESOURCES).

Questions

1. How can you modify the expression on your face by changing some of the angles of the nose, eyebrows, and mouth?
2. How did you build on your own anatomy to create a new feature or look?
3. How does lighting affect your new look? Is there a big difference in dim light as compared to bright light?
4. How can you modify the color contrast in your makeup to highlight your features?

▶ TRY THIS...

Poll your friends on what their favorite movie monsters are. What aspects of their makeup made them particularly scary, gross, gruesome, or funny? Collect still photos or videotapes of movie monsters and assemble a "rogues gallery." What techniques did the makeup artists use to create their creatures?



BEST COPY AVAILABLE



David climbs up through the layers of the atmosphere to explore an environmental concern.

Segment length: 8:00

OZONE

How do CFCs destroy ozone in the earth's atmosphere?

What is ozone? Is it harmful or beneficial? Is there really an "ozone hole" in the atmosphere? Can it be repaired?

RESOURCES

Aeronomy
Laboratory/NOAA
325 Broadway
Boulder, CO 80303
(303) 497-5785

Climate Protection
Institute
5833 Balmoral Drive
Oakland, CA 94619
(newsletter)

NASA
Education Division
Mail Code F
Washington, DC 20546
(Atlas 1 Teacher's
Guide: *Earth's
Mysterious
Atmosphere*)

NASA CORE
Larain County, JVS
15181 Route 58 S
Oberlin, OH 44074
(216) 774-1051 Ext. 293
(videotapes from
shuttle missions during
which *Blue Planet* was
filmed)

National Air and Space
Museum
Office of Education
Washington, DC 20560
(202) 357-3133
(*Blue Planet*
educational booklet)

PBS Environmental
Resource Compendium
1320 Braddock Place
Alexandria, VA 22314
(703) 739-5402

INSIGHTS

Ozone is a gas, a form of oxygen, that is found in the layers of the atmosphere, most predominantly in the *stratosphere*. Here, 90% of the atmosphere's ozone is distributed in a ratio of five ozone molecules to every million molecules of other gases. This minute distribution serves as a shield that helps screen the sun's rays by absorbing some of the *ultraviolet (UV-B) radiation*.

Depletion of the ozone in the atmosphere can have severe consequences on earth. Plants, animals, and humans all suffer when exposed to higher levels of ultraviolet rays. Food crops have stunted growth; marine phytoplankton can die off; and humans are more vulnerable to skin cancer.

Atmospheric research in the mid-1980s indicated a serious thinning of the ozone shield, upsetting a natural balance between oxygen and ozone in the stratosphere. This thinning was evident from satellite pictures and showed up as a dark area; thus the term "ozone hole" was coined. It was apparent to scientists studying the ozone depletion that chemicals called *chloroflourocarbons (CFCs)*, used in spray cans, refrigerators and air conditioners, foam, plastics, and cleaning solvents,

might be contributing to the problem. After being released, either during the manufacturing process or from consumer use, CFCs reach the stratosphere. There, chemical reactions break apart the CFCs. The *chlorine* then breaks down the ozone. A single chlorine atom can destroy 100 thousand molecules of ozone.

The degree of ozone depletion has followed an annual cycle that corresponds to the amount of sunlight that reaches the Antarctic. The cycle begins every year around June when the vortex winds develop in the Antarctic. Cold temperatures produced by these winds create polar stratospheric clouds that capture the floating CFCs. For the next two months, a reaction occurs on the cloud surface that frees the chlorine in the CFCs but keeps the chlorine contained within the vortex

area. In September, sunlight returns to the Antarctic and triggers a chemical reaction, causing chlorine to convert ozone to normal oxygen.

Measured ozone levels usually are lowest in October. November brings a breakdown in the vortex that allows the ozone-rich air to combine with the thinning ozone. Wind currents carry this mixture over the southern hemisphere and carry the "hole" over other areas of the earth.

CONNECTIONS

1. What can we do to help "close" the ozone hole?
2. In 1992, representatives of countries from around the world gathered in Rio de Janeiro for what was called the Earth Summit. What resolutions concerning ozone depletion came out of this meeting?

VOCABULARY

chlorine a chemical element important in the destruction of ozone

chlorofluorocarbons (CFCs) chemical compounds made up of carbon, fluorine, and chlorine

ozone a molecule made up of three atoms of oxygen

stratosphere the layer of the earth's atmosphere just above the troposphere; extends from 15km to about 50km above the earth

total ozone mapping spectrometer (TOMS) an instrument flown aboard the NIMBUS-7 spacecraft that provides high-resolution mapping information about atmospheric ozone content

ultraviolet radiation (UV-B) high energy electromagnetic waves that lie beyond the purple end of the visible spectrum





TAKE A LOOK!

Analyze and interpret the same ozone TOMS images as those used by NASA.

▶ TRY THIS...

Invite a dermatologist to speak to your class. Ask for information about the effects of exposure to ultraviolet radiation. What is the meaning of SPF on sunlotion packaging? Is there a time when exposure to ultraviolet radiation is helpful? What about tanning salons?

▶ TRY THIS...

Contact Goddard Space Flight Center in Greenbelt, Maryland and the Aeronomy Laboratory in Boulder, Colorado. Find out about the different methods of gathering data for ozone research. What types of spacecraft are used? What types of airplanes? How often are expeditions sent to the pole? How do they gather data? What are plans for future expeditions?

◆ MAIN ACTIVITY

Before information about ozone is released to the general public, scientists spend many hours analyzing ozone data from earth and space. Here's your chance to be an ozone-research analyst.

Materials

- NIMBUS-7 TOMS Images: The Twelve Octobers. Order one for each two students by lithograph name and number (HqL-308) from: NASA Goddard Space Flight Center Greenbelt, MD 20771 (301) 286-8955
- paper
- pencil

Note: Instructor may wish to make photocopies of the TOMS lithographs so that the information on the back is not available until students have interpreted the data.

1. Divide students into research-analyst pairs.
2. Discuss why the Dobson Unit key will be important and note the range of the value for each color. (If paper copies have been made, allow time for the students to color in the key.)
3. Use the questions below to analyze this data and to formulate predictions.

Questions

1. Which year had the lowest ozone concentration? Which had the highest? Did the level always drop from year to year? Explain possible reasons for this.
2. What is the geographic location of the thinnest concentration? The thickest? Why might this be? Have maps or globes available to aid in answering these questions, or superimpose lines of longitude and latitude on the TOMS maps.
3. Why were the images taken in October? What differences would you

▶ TRY THIS...

Create an videotape or audiotape a "news program" about the ozone situation. Be as factual as possible. Include information about what the ozone layer is, its importance, materials and actions that are believed to contribute to ozone depletion, and actions students could take to help improve the situation. Share this with your science class or ask permission to air it as a public service on school-wide television.

expect in images taken during November, December, and January?

4. How important is the use of color in these images?

5. Based on the October images, what predictions can you make for ozone levels in 1995? Justify your predictions.

6. What information might appear in a news article reporting this data? How could it be presented to help the general public understand its importance?

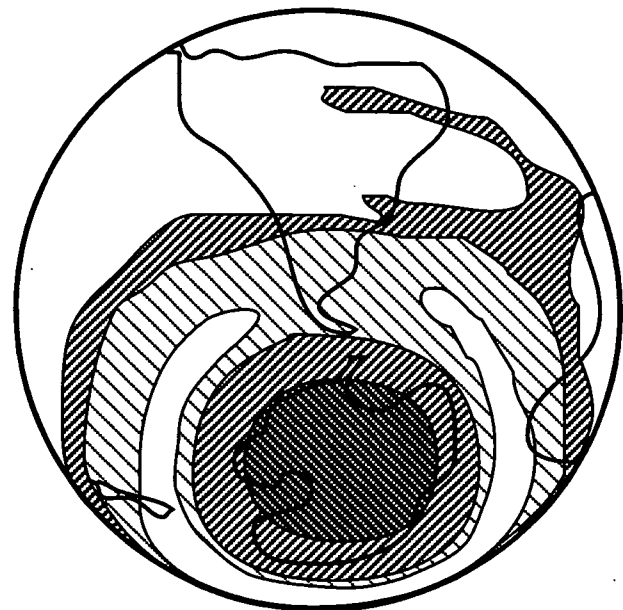

Highest
ozone
density



Lowest
ozone
density

OIL SPILLS

How do you clean up an oil spill?

What parts of the environment are affected by an oil spill? How does the ecosystem work to help clean up an oil spill? What technology is available to help clean up an oil spill? What can humans do to prevent oil spills?



Peggy gets a progress report on the clean up of one of the most well-known oil spills, the Exxon Valdez.

Segment length: 9:30

RESOURCES

Clarke, L. (1990) Oil-spill fantasies. *The Atlantic Monthly* (Nov): 65-77.

Hodgson, B. (1990) Alaska's big spill: Can the wilderness heal? *National Geographic Magazine* (Jan): 5-42.

Winslow, R. (1978) *Hard aground: The story of the Argo Merchant*. New York: Norton.

Additional sources of information:

Exxon Corporation
Valdez Publication Requests
P.O. Box 1280
Houston, TX 77252
(educational materials, videotapes)

Marine Spill Response Corp.
1350 I Street NW
Suite #300
Washington, DC 20005
(202) 408-5700

Community resources:
Environmental-organization chapters

State office of the Environmental Protection Agency

U.S. Fish and Wildlife Services

U.S. Coast Guard

INSIGHTS

When an oil spill occurs, often due to a ruptured oil tanker or leaking oil rig, people around the world are awed by the damage to the environment. Many oil spills are caused by human error, but there also are naturally-occurring oil spills, such as seepages from oil deposits beneath the ocean floor. Regardless of their origins, oil spills have an impact on the environment.

The initial impact of an oil spill on the environment is familiar to those who hear about the event and see its effects on the evening news: a film of oil spreading across the surface of the body of water; oil-stained beaches and shorelines; waterfowl and marine mammals coated with oil, struggling to survive; and the carcasses of wildlife littering the shoreline.

The environment sustains some of its most visible damage within the first few days or months of the spill. But what are the long-term effects of a large spill? Some evidence suggests that the oil from the Exxon Valdez spill may have entered the food chain, and that the crude oil itself could continue to wreck havoc with the environment. Since oil floats and crude sinks, both the surface and the bottom of the ocean ecosystem could be affected for a long time.

Cleaning up an oil spill is no small task. Exxon to date has spent over two billion dollars on the Valdez cleanup operations. There are many methods used to clean up the oil, including *cold- and warm-water washing*, *storm-berm relocation*, and manual removal.

Nature is sometimes capable of handling the oil on her own terms. The spreading out of the oil slick increases its surface area, allowing many natural processes to begin. Low- to medium-weight crude will start to *evaporate*. Solution *emulsification* and *photochemical oxidation* also assist in the cleanup. All of these processes, however, require much time.

Acts of nature and acts of humans contribute to the likelihood of oil spills. Nature's fury may twist a ship, rupture a storage tank, or prevent cleanup operations. Human factors such as poor judgment, lack of organization, and quest for fossil fuels can lead to decisions that trigger accidents.

CONNECTIONS

1. Automobiles are an obvious connection to our dependence on petroleum products. What other things do you use or come in contact with that are related to fossil fuels?
2. What are some of the things that could be done to reduce the risks of oil spills?

VOCABULARY

cold-water washing the pumping of seawater through a hose to remove the oil that is then flushed down to the waterline, trapped by booms, and recovered by skimmers

emulsification the process of dispersing one liquid in a second immiscible liquid

evaporate to change from a liquid to a vapor

oxidation the act or process of combining with oxygen

photochemical a change occurring because of exposure to light

storm berm the material deposited above the high-tide line during storms

storm-berm relocation the mechanical exposure and relocation of oiled storm berms into the tidal zone to allow natural tidal flushing and to enhance biodegradation

warm-water washing the application of heated seawater at moderate pressure to move oil

OIL SLICK

Use a small-scale model of an oil spill to observe its effects on the environment.

◆ MAIN ACTIVITY

You will create an oil-spill simulation, and observe the characteristics and effects of an oil spill. Record your observations by keeping track of how the oil spill changes in size and appearance.

Materials

- large shallow pan
 - water
 - dirty automotive oil
 - drinking straw OR electric fan
 - string
1. Pour water into the pan so that it is 2/3 filled. Gently pour a small amount of oil into the pan.
 2. Loop the string around the "oil spill."
 3. Mark the length of the string, measure it, and record the length on a data table.
 4. Wait five minutes, repeat the string measurements, and make any observations.
 5. Repeat steps 2 through 4 for a total of six readings.

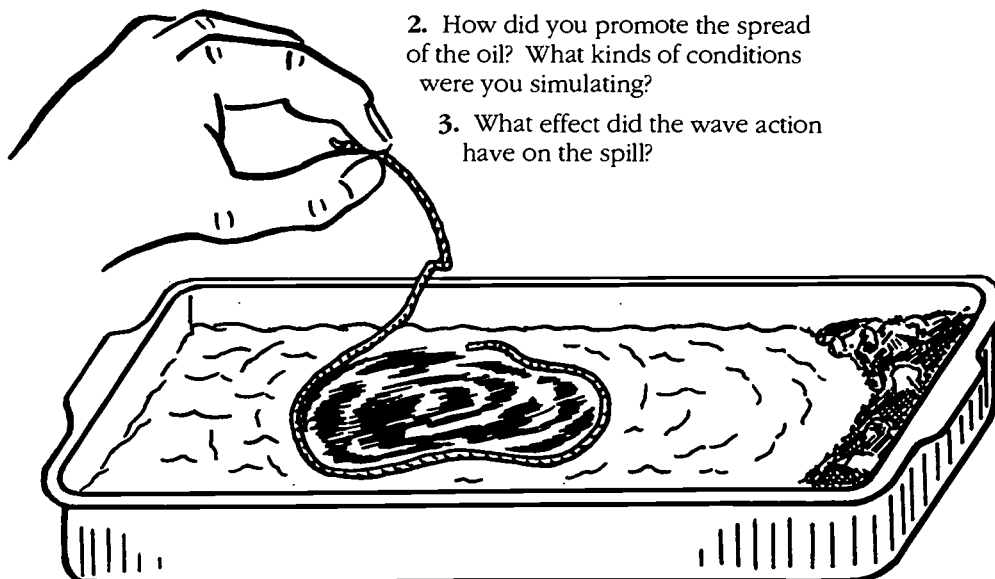

◆ TRY THIS...

Conduct a debate that represents the concerns of the people or organizations that are affected by an oil spill like the Exxon Valdez. Interests may include government, oil companies, the shipping industry, citizens living in the area, fishing industries, the tourism board, and environmentalists. Divide into teams to research and prepare the various sides of the issue. Focus on specific questions, such as: "Should the government relax environmental restrictions and encourage off-shore oil exploration in U.S. coastal waters?" Find actual position statements from organizations to use in your arguments.

6. Using the straw, lightly blow on the spill to spread it out; record observations and repeat every five minutes. If your spill covers the entire pan, start over. (If you use an electric fan for this step, exercise caution.)

7. Now, shake or vibrate the pan to create light wave action; record your observations.

Additional observations could be made by making a "shoreline" of sand and rocks. Note the effects of oil on these materials.

Questions

1. Left alone, did the oil spread out in an organized way? How did the oil spread?
2. How did you promote the spread of the oil? What kinds of conditions were you simulating?
3. What effect did the wave action have on the spill?

◆ TRY THIS...

Bring in a few stuffed animals, ones that won't shrink. Put some salad oil on them to simulate what happens when wildlife gets covered with oil from a spill. Try different ways of cleaning the animals. Use dish detergent, laundry soap, carpet cleaner, water, hair dryers, towels, and other devices to assist in the clean up. Devise the most efficient way to clean them.

◆ TRY THIS...

Fill your room with confetti, polystyrene-foam packing peanuts, or popcorn. Develop an ingenious way (or use a fan) to distribute the material all over the room to illustrate how haphazard and uncontrolled a spill can be. How can the "spill" be cleaned up quickly and efficiently? What kind of organization or chain of command is needed? Have vacuum cleaners, brooms, and bags available for the cleanup. Now that the mess is cleaned up, what do you do with the material?

BEST COPY AVAILABLE



David gets some nutritional advice to help answer every mother's question, "Are you eating right, Honey?"

Segment length: 6:50

DIET AND NUTRITION

What is the nutritional value of different foods?

What are proteins, fats, and carbohydrates? What is a calorie? How is good nutrition like a balancing act?

INSIGHTS

"You are what you eat." There's a lot of truth to this old cliché. What we eat and how much plays a big role in how healthy we feel. Culture also plays a role in how we feel about our bodies. Although healthy bodies come in a variety of shapes, many Americans hold ideal body images few can match. Teenagers are particularly susceptible to the myth of the perfect body, e.g., a thin body, or a muscle-bound physique.

For many teenagers, this is the time of rapid growth, yet the rate of eating disorders such as *anorexia nervosa* and *bulimia* for this age group have increased at alarming rates. Understanding basic nutrition and accepting our individual bodies are critical steps to good health.

Carbohydrates, fats, proteins, vitamins, and minerals are the basic nutritional building blocks that provide the fuel our bodies need to function and perform. Carbohydrates, such as breads, cereals, and sugar, are our main source of quick energy. Fats, whether solid or liquid, are our primary slow-burning energy sources. Proteins, both complete and incomplete, are the body's chief building materials. Essential vitamins and minerals are also found in many of the foods we eat.

Obtaining the right proportion of nutrients is critical to our health. Eating the right number of *calories* is just as important. Ideally, our caloric intake should equal the total amount of energy our bodies need for growth and repair. Using a *calorimeter*, nutritionists have calculated the caloric energy of particular foods. This information, and the product's ingredients, are listed on most food packages.

Keeping your body healthy is a personal balancing act. The goal is to get the essential

nutrients you need, while eating no more calories than your body expends.

CONNECTIONS

1. What influences you the most in what you eat? Friends? Television? Family patterns? Societal ideals?
2. How might the diets of your grandparents or great-grandparents differ from yours? Whose diet do you think is/was healthier?

VOCABULARY

anorexia nervosa an eating disorder involving a psychological loss of appetite, often resulting in self-starvation

bulimia an eating disorder involving bingeing and purging of food

calorie the amount of heat needed to raise the temperature of a kilogram of water 1°C

calorimeter an instrument that measures the energy found in food; a closed box containing a kilogram of water, an instrument to burn food, and a thermometer

carbohydrates sugars and starches made mostly by plants and used by the body as primary sources of quick-energy food

fats a group of nutrients found in solid and liquid form that is used as food or stored in the body as a slow-burning energy source

minerals 20 known nutrients that are found in trace amounts; include magnesium, phosphorus, potassium, sodium, and sulfur

proteins chief building material of the body, manufacturing muscles, bones, hair, and more; comprised of a variety of amino acids, all of which contain carbon, nitrogen, oxygen, and hydrogen

vitamins essential nutrients that are needed to sustain life; 13 vitamins have been identified: A, C, D, E, K, and eight parts of vitamin B

RESOURCES

Franz, M.J. (1990) *Fast food facts: Nutritive and exchange values for fast-food restaurants*. Wayzata, MN: DCI Publishing.

Kane, J.K. (1990) *Coping with sad diets*. New York: Rosen Publishing.

Natow, A.B., and J. Heslin. (1985) *Nonsense nutrition for kids*. New York: McGraw-Hill.

Additional sources of information:
Health Education Services
P.O. Box 7126
Albany, NY 12224
(printed materials and audio tapes: *Nutrition for Life*)

U.S. Department of Agriculture
Human Nutrition Information Service
Room 360
6505 Belcrest Road,
Hyattsville, MD 20782
(materials about the food pyramid)

Community resources:
Public-health nutritionist

University department of food and nutrition

Family-practice doctor

LUNCH AT FAST-FOOD FREDDY'S

Find out the nutritional value of fast-food.

▶ TRY THIS...

Does advertising influence your choices of foods? Record on audio tape or videotape a food commercial. As a class, listen to or watch the tape, and then discuss the commercial's effectiveness. Buy the advertised food and study the nutritional label on the package. Is it really as good as the commercial says it is?

▶ TRY THIS...

Compare the nutritional value of meals from various cultures. Calculate the total calories and nutritional content of a typical American meal. Look through ethnic cookbooks and create dinner menus that reflect Chinese, Mexican, and Italian meals. Tally the total calories and nutritional content of these dinners. Which meal might be the healthiest?

◆ MAIN ACTIVITY

One fast-food meal, heavy in calories and fat, can be balanced by eating other nutritious meals during the day. But, too many fast-food meals can throw your body out of balance. You will figure out the nutritional values of foods to understand the nature of a healthy diet.

Materials

- nutrition-information pamphlets from national fast-food restaurants
- graphic of Fast-Food Freddy's cash register
- calculator (optional)
- description or illustration of the food pyramid
- calorie-count information for males and females by age group

1. Select some students to collect nutrition information from their favorite fast-food restaurants. Or, refer to the Resources section for books that contain this information.
2. Share the cash-register graphic with your students and ask them to order their favorite lunch from Fast-Food Freddy's. Make a list of each order.
3. Using the fast-food restaurant's nutrition information, have students determine the approximate number of calories, fat, protein, and carbohydrates from their imaginary lunches.
4. Review the food pyramid. Which foods should eat the most of on a daily basis? Which foods the least?
5. Referring to the fast-food nutrition pamphlets, ask students to reorder their lunch from Freddy's, substituting foods with fewer calories and fats.
6. Divide students into groups. Assign each group a popular fast-food restaurant and determine a nutritional meal using the actual nutrition information from that

Fast Food Freddy's

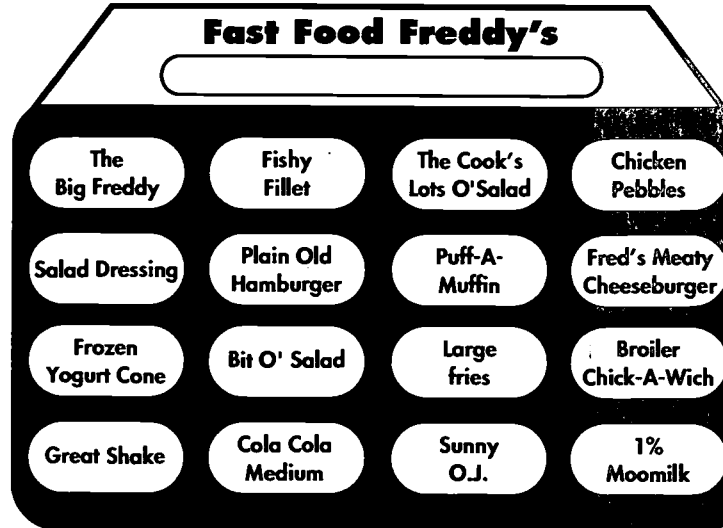

restaurant. Remind students to pay particular attention to the amount of fat and calories for each food item. Have students present their menus to the class and explain their choices.

Questions

1. What fast foods do you eat regularly? What are the calorie and fat contents of these foods? What satisfying substitutes might you choose that have less fat and fewer calories?
2. If you ate a fast-food lunch everyday, what would you have for breakfast and dinner to make your entire daily-food intake well-balanced and nutritional?

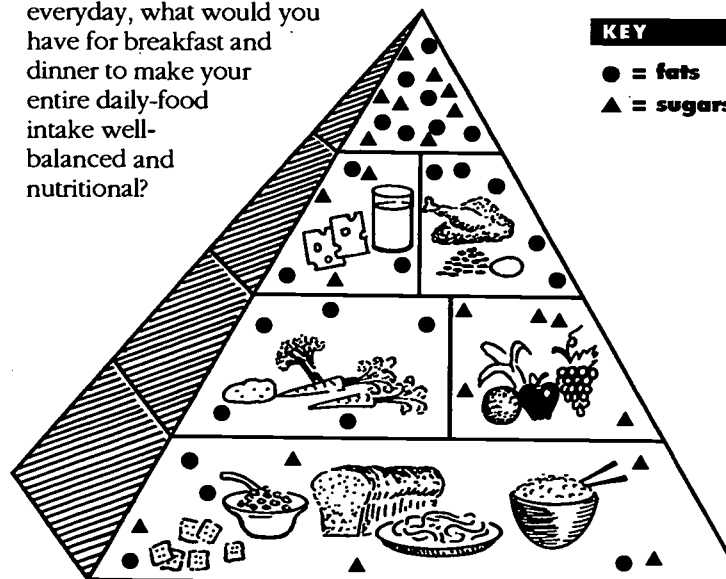



David goes south to learn about the place where everything is north.

Segment length: 27:47

ANTARCTICA I

Why do scientists go to Antarctica?

What is it like to explore a new frontier? How do you get to Antarctica? What kinds of organisms inhabit Antarctica? What is it like to live in Antarctica?

RESOURCES

Brown, M. (1969) *Shackleton's epic voyage*. New York: Coward-McCann.

Byrd, R.E. (1938) *Alone*. Covelo, CA: Island Press.

Dewey, J. (1989) *Birds of Antarctica: The Adelle penguin*. Boston: Little Brown.

Huxley, E. (1978) *Scott of the Antarctic*. New York: Atheneum.

International Polar Expeditions. (1989) *Trans-Antarctica: 1990 international expedition*. Des Moines, IA: Meredith.

Mear, R., and R. Swan. (1987) *A walk to the Pole*. New York: Crown.

INSIGHTS

Exploration of new or rarely-explored frontiers often requires remarkable courage, determination, and endurance. These characteristics, as well as others, were needed by the early explorers of the coldest and most desolate continent on earth—*Antarctica*.

Robert F. Scott of Great Britain, the second explorer to reach the South Pole, described a bleak and uninhabitable region in his journal. He wrote, "... One knows there is neither tree nor shrub, nor any living thing, nor even inanimate rocks—nothing but this terrible limitless expanse of snow." Scott was in a race with Roald Amundsen of Norway to become the first person to reach the South Pole. Amundsen reached the Pole in December 1911. Scott arrived there one month later to find a black flag tied to a part of a sledge—proof that Amundsen had reached the South Pole first. Scott and his companions died on the vast continent trying to return to their home base.

Scientists now know, after much further exploration, that Antarctica is much more than the bleakness described by Scott. Its topography includes mountains and mineral deposits. There are algae, moss, lichens, a few kinds of grasses, and even some microscopic animals and insect-like creatures. The seas

surrounding Antarctica support thriving plant and animal life. Almost 14 times the number of *plankton* grow in *Antarctic* waters as compared to tropical waters. Animals inhabit the coastal areas in great numbers, including sea birds, fishes, penguins, seals, whales, and *krill*.

Scientists who arrive on the Antarctic continent aboard C-14s are the explorers of today. Their areas of research are varied: the ozone "hole" in the atmosphere over the continent; the glacier dynamics on it; the minerals under it; or the life forms around it. Regardless of their areas of expertise, they all must prepare for the challenges of Antarctica, not the least of which is getting there—nine hours from New Zealand in planes without enough fuel to make a return trip, or crossing Drake Passage from Chile, some of the most dangerous waters in

the world. And, once there, they must endure a "roughing-it" lifestyle: living in darkness during the months of May through August, and in almost continuous light from November through February; dressing for subzero temperatures; protecting equipment and instruments from cold weather; and living in close quarters.

CONNECTIONS

1. Read the journals or diaries of Antarctic explorers, both past and present. Will Steger and Ann Bancroft are two modern-day explorers whose names are connected to Antarctica. Find out more about their adventures.
2. Imagine you were Robert F. Scott seeing Amundsen's flag. What would you write in your journal? What would you want to explore in the Antarctic now?

VOCABULARY

Antarctic pertains to the region of, at, or near the South Pole

Antarctica the continent that surrounds the South Pole

krill a type of shrimp-like animal belonging to the class *Crustacean*; a Norwegian word meaning "whale food"

McMurdo Sound the destination of Captain Scott's ship, the "Discovery"; located on the western side of Antarctica, now the site of the U.S. base, McMurdo Station

Palmer Station U.S. base on the Antarctic peninsula

plankton microscopic plants and animals found in the upper layer of marine and fresh-water habitats

LET'S EXPLORE!

Explore an "unknown" place and experience the excitement of an expedition.

◆ MAIN ACTIVITY

- Expeditions are part of our daily lives.
- Most likely, our expeditions are more "routine" than traveling to the South Pole, but regardless of their simplicity, daily expeditions help us discover "new" information. In this activity, you will learn how to successfully design, develop, and execute an expedition.
- A minimum of two or three days will be necessary to develop this activity.

◆ Materials

- white cotton material
- felt markers
- paper
- pens/pencils
- decorations such as fringe, etc.
- rope
- first aid kit
- hats, gloves
- sunglasses, suntan lotion

▶ TRY THIS...

Invite an explorer to visit your class. (Your definition of "explorer" can be quite broad, including those who challenge their environments by mountain climbing, scuba diving, hang gliding, etc.) Have the explorer bring equipment, artifacts, and pictures of her or his adventures.

PLANNING GUIDE FOR EXPEDITIONS

- I. Expedition destination
 - A. Establish a point of departure and expected point of arrival.
 - B. Generate a planned route, complete with a map.
 - C. Estimate a time frame and create a timeline.
- II. Expedition protocol
 - A. Outline the objectives of the expedition.
 - B. Determine what data will be collected and how it will be recorded
 - C. List items that will be included in the final report.
 - D. Discuss how to minimize anticipated risks.
 - E. Before traveling to your destination, get permission from appropriate authorities.
- III. Expedition organization
 - A. Select a "chief scientist" for the expedition.
 - B. Assign expedition duties to all members.
 - C. Design an expedition flag.
 - D. Draw an expedition map.
 - E. Compile an equipment list; gather the equipment.
- IV. Optional planning phase
 - A. Solicit financial support or arrange for donations of supplies and/or equipment.
 - B. Plan budget.
 - C. Arrange for publicity.
 - D. Obtain sponsors.



PART I

1. Divide students into small "expedition groups." Have them draft a Planning Guide for Expeditions, using the one shown here as a model.

2. Brainstorm, as a class, possible destinations for the expeditions (e.g., the boiler room, the kitchen of the cafeteria, the chemistry-supply room, the athletic-equipment room, etc., or, a destination outside the immediate school area).

3. Establish how much time each expedition team will have and let them plan their own expedition by following the Planning Guide for Expeditions.

PART II

1. Before or on the selected expedition day, have each team share with the class where they are going and what they hope to find. Let the expedition begin! (Make sure the proper individuals on the school staff and community have been alerted that your explorers will be entering their territory.)

2. Have each team report back to the class about their expeditions, using written, oral, or videotaped presentations.

Questions

1. Was the expedition a successful one? What makes an expedition successful?
2. Review the general planning guide for expeditions. Does it need to be modified? How did this help make the expedition run smoothly?
3. What types of people become explorers? What characteristics must they have?

▶ TRY THIS...

To simulate the cold of the Antarctic, turn the heat off in your classroom during the coldest part of the winter. Dress appropriately for this change in weather! If you live in a warmer climate, reverse these conditions and pretend your expedition takes you to the desert.



David learns about the importance of Antarctica and the scientific research being done there.

Segment length: 27:47

ANTARCTICA II

Why is Antarctica so important to our planet?

What kinds of resources are unique to Antarctica? What scientific considerations go into writing the treaties that govern Antarctica? Why is it important that countries work together to preserve the continent of Antarctica?

RESOURCES

Atkins, E.G., and L. Engel. (1989)

Antarctica. New York: Children's Television Workshop. Videotape.

Gorman, J. (1990) *The total penguin*. New York: Prentice Hall.

Osborne, B. (1989) *Antarctica wildlife*. New York: Mallard Press.

Stone, L.M. (1985) *Antarctica: A new true book*. Chicago: Children's Press.

Wood, J. (1990) *Icebergs*. New York: Puffin Books.

Additional source of information:

Los Angeles Unified School District
Office of Instruction
450 N. Grand Ave.
Los Angeles, CA 90012
(curriculum: *Project Polar Regions*)

INSIGHTS

Antarctica is a six million square-mile area locked in an ice age. Its waters team with more life than a tropical rain forest, and its coast plays host to some of the most magnificent animals in the world. Icebergs the size of Connecticut break loose from floating ice shelves that are larger than France, and chill the ocean waters for thousands of miles.

The continent has become an international science laboratory where scientists study its weather and climate, *oceanology*, and *geology*. From this frozen world, people may one day obtain food, water, and living space. We are only now beginning to realize the profound effects that Antarctica has on our environment and way of life. This continent holds 75% of the earth's fresh water, a possible resource given the depletion and pollution of fresh water elsewhere on earth. Antarctica may hold the key to understanding *food chains*, and the role of plankton in those chains. It is possible that these small organisms form the base of the *ecosystems* that support all living things.

One of the first joint efforts at studying Antarctica dates back to 1957 when scientists from 12 countries took part in a one-year, wide-scale program as

part of the International Geographical Year (IGY). The scientists concentrated their studies on such fields as meteorology, oceanography, earth magnetism, gravity, auroras, cosmic radiation, glaciology, seismology, and sunspot activity. Continued research included geology, biology, and mapping.

Since the close of the IGY, it is apparent from the influx of scientists, support personnel, visitors, and tourists that the Antarctic continent no longer enjoys the protection of isolation. Concern about the possible effects of the human presence on Antarctic ecosystems, the need for protecting birds and marine mammals, and the peaceful use of the continent has resulted in several treaties, signed by countries concerned about the future of this fragile continent.

CONNECTIONS

1. Antarctica has physical characteristics much like the moon and Mars, and may be the site of pre-space-exploration preparations. How could the exploration of Antarctica be a model for space exploration?

2. "From space, I saw Earth—indescribably beautiful with the scars of national boundaries gone." (Muhammad Ahmad Faris, Sryia) "The first day or so we all pointed to our countries. The third or fourth day we were pointing to our continents. By the fifth day we were aware of only one Earth." (Sultan Bin Salman al-Saud, The Kingdom of Saudi Arabia) These comments are those of astronauts (quotes taken from *The Home Planet*, edited by Kevin W. Kelley). How might they relate to Antarctica?

VOCABULARY

ecosystem a large group of plants and animals (biotic community), plus its non-living (abiotic) environments (temperature, moisture, rock, water, etc.)

food chain an arrangement of organisms showing how each organism feeds on the one before it

geology the science that studies the physical history of the earth, especially as it is found in rocks

oceanology the science that studies marine resources and technology



WHO'S IN CHARGE HERE?

Write your own treaty of governance for Antarctica.

▶ TRY THIS...

Some different steps or parts of a food chain includes producers, primary consumers, secondary consumers, and decomposers. For example, green plants are considered producers. Krill, which eat the green plants, are considered primary consumers. Baleen whales and large fish, which eat the krill, are secondary consumers. What are the decomposers? Can you identify other food chains?

▶ TRY THIS...

What is the life cycle of the penguin? How are penguins adapted to the harsh Antarctic climate? Are their feathers, beaks, and wings of any value for their survival? (Refer to the ANIMALS section of this packet for more information about penguins.)

◆ MAIN ACTIVITY

Ideas about who is in charge, who owns or governs, and how laws are enforced in Antarctica will be discussed by teams of students. What do you think should happen in Antarctica?

Materials

- paper
- pencils
- a copy of the United Nations Moon Treaty OR the Antarctic Treaty of 1956 OR the new Antarctic treaties on the use of living and non-living resources OR other treaties found in your library

1. Read the treaties you have selected with your students.
2. Divide into groups. Have each group make a list of and discuss the issues involved in developing or settling the Antarctic. Should we ever use the Antarctic and its resources, or should we keep it as a world park? Will people be allowed to settle there? If it is settled, who will own the continent, its animals, and its minerals? What will the laws be? How will problems be handled thousands of miles from most other countries? How might a treaty help answer these questions?
3. Divide the list of concerns among members of each team and have each member collect information about that concern and how it might be addressed in a treaty.
4. Now, have each team write their "Treaty for the Development, Use, or Settlement of Antarctica."
5. Have each team present their treaty proposals to the class, as if the class were the United Nations. The class may debate the points of each treaty by questioning the presenting team.

Questions

1. What were some of the common characteristics of the old treaties you looked up?
2. What do you think is the most important element of any treaty? Can a treaty work if there is no enforcing body?

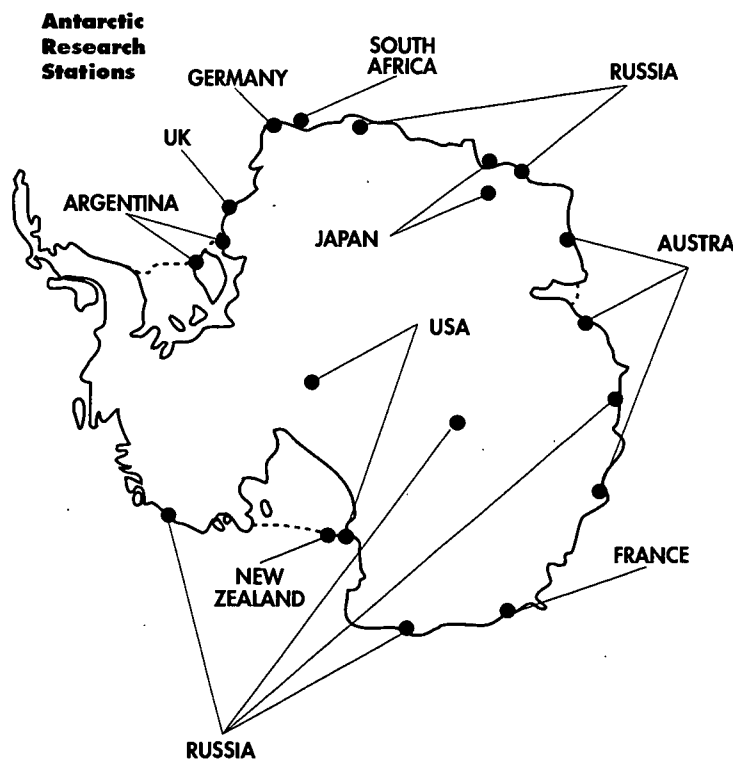

▶ TRY THIS...

Within 50 years, the ground-water stations in Saudi Arabia may be dry. Some people are promoting a novel idea for getting fresh water to this region: Tow an iceberg from the Antarctic to the Middle East. Does this sound crazy? Think about the feasibility of this idea. How would you get an iceberg to the Middle East? Take ice cubes and float them in a tub of room-temperature water. How fast do they melt? Now, work in pairs to figure out a way to protect your ice cube from melting. See which pair can prevent an ice cube from melting for the longest period of time. (Remember, the closer to the equator you and your iceberg would get, the faster it would melt.)

103



David takes a journey into the human body to learn about the immune system.

Segment length: 9:35

AIDS

What is acquired immune deficiency syndrome?

Why is it so difficult to find a cure for the AIDS virus? How does the human immune system work? How is AIDS transmitted?

INSIGHTS

The world has now entered the second decade of dealing with acquired immune deficiency syndrome (AIDS). According to the Centers for Disease Control, the AIDS virus was first named in 1982, and the human immunodeficiency virus (HIV) was identified in 1984. It is important to make the distinction between the two acronyms, AIDS and HIV: Once infected by the HIV virus, a person may not develop the disease AIDS for years. The incubation period for developing AIDS varies from one year to 10, though experts disagree on this.

The segment shows what happens in a normal immune system versus an immune system infected with HIV. Under normal conditions, disease-causing agents (*pathogens*) attempt to invade the body, inducing an immune response from *T-cells*, *B-cells*, and *macrophages*. T-cells process the foreign body so that it can be recognized by the B-cells, which in turn produce antibodies that grab the pathogens, pin them down, and mark them for destruction by the macrophages. More and more defenders descend upon the attacking virus until the invasion is neutralized.

HIV acts differently than most pathogens: It seeks out the

T-cells and incorporates itself into them. Then HIV either reproduces so quickly that it destroys the host cell, or it causes the genetic machinery to reproduce copies of itself, so that it can send out more virus particles to attack other T-cells. HIV doesn't always act quickly; it can hide out in the body and not reproduce immediately. But once in the body, HIV stays there forever, using the host cell as an HIV "factory."

Eventually, the body's supply of T-cells becomes depleted until the immune-defense system is severely weakened and susceptible to infection by "opportunistic" pathogens, such as *Pneumocystis carinii*, a serious respiratory infection, and malignant growths like *Kaposi's sarcoma*, a vascular-type cancer.

HIV is transmitted from an infected person to a healthy person in three basic ways: through sexual intercourse,

through the blood system by sharing needles, and perinatally from mother to child. In the United States, the first decade of HIV infection occurred primarily among intravenous-drug abusers, people who had received blood transfusions, homosexual men, bisexual men, and all of their sexual partners. In this second decade, "heterosexual transmission will become the predominant mode of HIV transmission throughout the world," according to the World Health Organization.

CONNECTIONS

What do people fear most about AIDS? Why is there such confusion about AIDS? Does the AIDS epidemic resemble others in our past (e.g., Hansen's disease, tuberculosis, polio)? Have other diseases generated as much fear and loathing?

VOCABULARY

B-cells a group of lymphocytes (white blood cells) that helps the body manufacture antibodies, or actually manufactures the antibodies themselves

macrophages "scavenger" cells in the immune system that engulf and destroy an invading virus

pathogens specific organisms (that may be cellular) with biological, chemical, or thermal agents that cause disease

T-cells a group of lymphocytes (white blood cells) that control and regulate the immune-defense system

RESOURCES

Collier, D.M. (1992) "AIDS." In *The new book of popular science* 5: 417-420 New York: Grolier.

Cox, F.D. (1992) *The AIDS booklet*. New York: William C. Brown.

Nourse, A.E. (1990) *Teen guide to AIDS prevention*. New York: Franklin Watts.

Saving a generation. (1991) Washington, DC: State of the Art. Videotape.

Additional sources of information:

American Red Cross AIDS Education Office
2025 E Street NW
Washington, DC 20006
(202) 728-6554 or 6531

Centers for Disease Control (CDC)
1600 Clifton Road NE
Atlanta, GA 30333

CDC National AIDS hotline
(800) 342-AIDS

CDC Spanish hotline
(800) 344-SIDA

CDC Hearing-impaired hotline
(800) AIDS-TTY

LET'S PLAY CARDS

Find out how HIV is transmitted, and perhaps more importantly, how it is not transmitted.

◆ MAIN ACTIVITY

A great deal of myth and mistaken information surrounds the subject of how people become infected with HIV. To clarify the specific ways that HIV is transmitted and to dispel some of the myths, create a card game.

Materials

- 3" x 5" cards
- box

1. On one card, print an actual or plausible risk factor associated with the transmission of HIV. On the next card, print an unlikely or implausible risk factor. Continue until you have as many cards as you wish. Put the cards in the box.
 2. Have each student pick a card from the box, read it aloud, and place it in one of two piles or mount it on a bulletin board using these two headings: *Risk factor* and *Not a risk factor*.
- ◆ **Examples of risk factors:** sharing needles with anyone; mixing of blood between persons (as in some rituals of scraping the skin to mingle blood); sexual intercourse; medical situations involving blood when no barrier precautions have been taken; being born to a mother who has HIV/AIDS; tattoo shops (if needles are reused); acupuncture (if needles are reused)
- ◆ **Examples of activities that are not likely to be risk factors:** cat bites; sharing food with a person infected with HIV/AIDS; eating food handled, prepared, or served by someone infected with HIV/AIDS; being coughed on; mosquito bites; bites from lice, flies, and other insects; swimming pools; toilet seats; wet towels; sweat; saliva or tears (Saliva and tears have the virus present, but it appears to break down and there have been no known cases.); urine;

- ◆ Newton's Apple is a production of KTCA Twin Cities Public Television. Made possible by a grant from 3M.
- ◆ Educational materials developed with the National Science Teachers Association—Space, Science, and Technology Division.

▶ TRY THIS...

The Centers for Disease Control (CDC) has published a list of recommended precautions to be used by health-care professionals with their patients. Invite a health-care professional who understands and uses the precautions on the job to demonstrate and discuss them in your classroom. Ask the health-care provider what he or she feels is the greatest risk when dealing with any patient. Is he frightened about catching the virus? Has she ever treated someone with the virus? Stress that the precautions work both ways—protecting both patient and health-care professional alike.

crowded elevators; hugging; shaking hands; laundromats; clothing; telephones; drinking glasses; eating utensils; giving blood; receiving a blood transfusion (Current screening procedures make blood transfusions almost risk-free.)

Questions

1. Have any of these issues regarding the transmission of HIV/AIDS appeared in the news?
2. How do misconceptions about the contagiousness of AIDS or any other disease get started? Is fear about contagion in general necessarily negative? What problems could be caused by misunderstanding the contagion factor of AIDS?

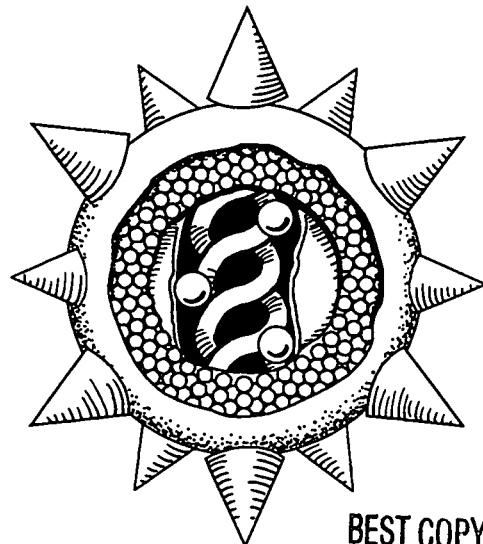

human immunodeficiency virus (HIV)

▶ TRY THIS...

Create an advertising campaign aimed at persuading young people to protect themselves against infection by HIV. Divide the class into groups and have each group aim its advertising at one of these target audiences: grades kindergarten through 3rd, 4th through 8th, and 9th through 12th. Plan radio and television spots, as well as print materials, including posters, articles in the school newspapers, and public service announcements. Work with a language arts teacher on the finer points of persuasion.

▶ TRY THIS...

Work with a language arts or social studies teacher in your school to stage a debate about AIDS and education. Some possible topics include: Should communities provide free needles and condoms to high-risk populations? Should doctors and dentists be required to be tested for HIV/AIDS? Could there ever be a reason at your school to have students screened for the virus? Do condoms make sex safe, or safer?

▶ TRY THIS...

There currently are several HIV vaccines being tested. The most common vaccines available today consist of doses of the pathogen so mild they cannot cause the disease itself, but strong enough to bring on an immune reaction in the body. Study some of the diseases for which vaccines have been developed: smallpox; yellow fever; rabies; influenza; polio; malaria; measles; mumps; rubella; diphtheria; and tetanus.

BEST COPY AVAILABLE



David finds out how his soft-drink bottle ends up on the grocery-store shelf again.

Segment length: 5:13

GLASS RECYCLING

What happens to my glass bottles after I put them in a recycling bin?

What is the step-by-step process of recycling glass? Can a brown bottle become a green bottle after recycling? Does recycling save money? How is it better for the environment?

RESOURCES

Chertow, M. (1989)
Garbage solutions: U.S. conference of mayors policy manual.
Washington, DC:
National Resources
Recovery Association.

MacEachern, D. (1990)
Save our planet: 750 everyday ways you can help clean up the earth. New York: Dell.

The Earthworks Group
(1989) *Fifty simple things you can do to save the earth.*
Berkeley, CA:
Earthworks.

Russell, H. (1973)
Earth: The great recycler. Nashville, TN: Thomas Nelson.

Additional sources of information:
Environmental
Protection Agency
Office of Water and
Waste Management
Washington, DC 20460
(EPA Booklet SW-801:
Let's Recycle)

Glass Packaging
Institute
1801 K St. NW
Washington, DC 20006
(202) 887-4850

Community resources:
Environmental
specialist

Recycling companies

INSIGHTS

Given the overcrowding of our landfills and the impact they have on the environment, fewer and fewer landfills are being built. Of the ones that are, very tight regulations are imposed. Communities across the country are reacting to this by developing and encouraging the use of recycling programs. The goal is to preserve our natural resources and save precious space in our landfills.

Jars, bottles, and other containers are some of the everyday objects made from glass that can be recycled. Not all glass is recyclable. Glass found in light bulbs, cookware, and window panes is made by incorporating ceramics with the glass. This type of glass is not recyclable because doing so would introduce impurities into the recycling process.

Once the glass is picked up by a recycling truck, it is separated by colors. Amber and green glass is made by adding a coloring agent during the original glass-manufacturing process; this color cannot be removed. Therefore, brown bottles can only make other brown bottles.

When the glass is taken to a manufacturing or recycling plant, it is broken up into smaller pieces called *cullet*. The

broken pieces are crushed, sorted, cleaned, and prepared to be mixed with other *raw materials* in the glass-making process. The cost savings of recycling is in the use of energy. When glass is made from scratch, high temperatures are needed to melt and combine all the ingredients. Since cullet melts at a lower temperature, the more of it you add to a batch of raw materials, the less energy you will need to melt it.

Recycling glass is not only cost-efficient; it benefits the environment in several ways. Glass produced from recycled glass instead of raw materials reduces related air pollution by 20% and related water pollution by 50%. Throwaway bottles consume three times as much energy as reusable, returnable containers. And, recycling glass reduces the space in landfills that would otherwise be taken up by used bottles and jars.

Ten to twelve percent of the glass used in the United States is recycled. Much of the glass used is not recycled. According to the Earthworks Group, about 28 billion bottles and jars are thrown away every year. That's enough to fill both towers of New York's World Trade Center every two weeks.

CONNECTIONS

1. What kind of recycling program do you have at your school or home?
2. Some recycling doesn't include destroying the old product to make a new product, rather, it involves reusing the old product in a new way. What kinds of things are good candidates for reuse? (e.g., milk cartons, detergent bottles and boxes, clothing, toys)

VOCABULARY

cullet pieces of glass, ordinarily discarded, that are added to new material to assist in the melting and making of new glass

raw materials crude or processed materials that can be converted by manufacture, processing, or combination into a new and useful product

sand fine-grain, loose, granular quartz used in making glass

soda ash commercial sodium carbonate used as a raw material for making glass

LESS VOLUME = MORE SPACE

See how compacting a container affects how much space it takes up.



▶ TRY THIS...

Develop a glass-recycling project for your classroom, school, or home. Discuss what procedures need to be established, what products you want to recycle, how they will be collected and recycled, and how the project will be organized. Determine what your community already does for recycling. Start a new community project or add to the existing one.

▶ TRY THIS...

Track for one week the type of glass you throw away or put into the recycling bin. Track the total number of pieces and the color of the glass. Develop a chart to record this information. Learn how to calculate the percentage of brown, green, and clear glass that you throw away. Expand this activity by counting other garbage you throw away or recycle.

◆ MAIN ACTIVITY

You will find out how the volume of a container can be measured. Using your calculations, you will see the significance of compaction as it relates to landfills.

Materials

- glass, aluminum, and plastic soft-drink containers (with tops or lids) of various volumes, shapes, and sizes
 - large pail
 - pan or tray
 - water
 - graduated cylinders (250 ml or larger)
 - sand
 - tape measure
 - calculators (optional)
 - paper and pencils
1. Divide your students into three groups. Each group will have the task of figuring out how to get the most containers into a 2-foot square area (your "landfill").
 2. Have each group select one type of container to conduct its tests on.
 3. Each group can use any method it can think of to find out how much volume its container has, i.e., how much space the container would take up in a landfill. Using the materials provided, have the students calculate the volume of the containers and record their findings on a data sheet. (Some ideas for calculating volume include immersing the container into a bucket of water and measuring the "overflow"; filling the container with sand and measuring that amount; or using a measuring tape and calculating the container's dimensions.)
 4. Next, have each group compact its container to its smallest form and repeat step 3.

▶ TRY THIS...

Stores used to sell soft drinks in returnable glass bottles. Some states currently require that a deposit be paid on beverage containers; this five- to ten-cent charge is reimbursed when the container is returned to the store. Other states have programs that encourage consumers to recycle the containers. Discuss or debate these practices. Which one do you think is most effective for encouraging people not to throw away recyclable materials?

Questions

1. Which type of container had the least volume for a given size? The greatest?
2. Which compacted container had the greatest volume? The least?
3. Which type of compacted container could you fit more of in a landfill?
4. Which type of container was the easiest to compact? Why?

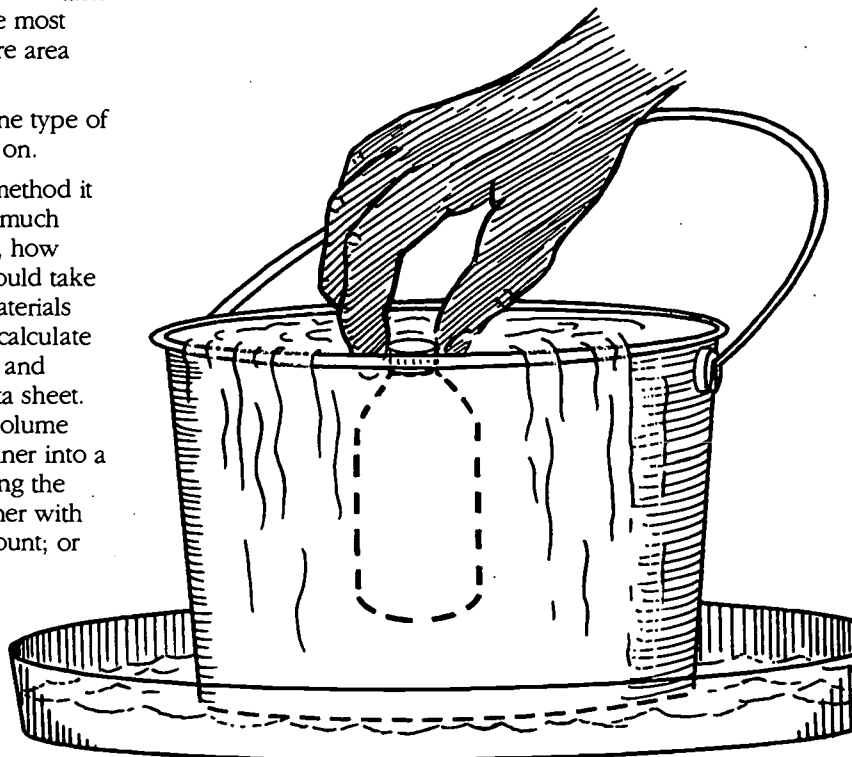



David goes to new depths to explore the life of a cockroach.

Segment length: 7:36

COCKROACHES

How do they get into our houses and how can we get them out?

What makes our homes such inviting places for cockroaches? How do they survive? What makes them so adaptable? How can we prevent a cockroach invasion, and if we have been invaded, how can we get rid of them?



RESOURCES

Insects. (1986)
Washington, DC:
National Geographic
Society. Videotape.

Souza, D.M. (1991)
*Insects around the
house.* Minneapolis,
MN: Carolrhoda
Books.

Wenner, A.M., and H.D.
Klein. (1991) *Tiny-
game hunting:
Environmentally
healthy ways to trap
and kill the pests in
your house and
garden.* New York:
Bantam.

*Additional sources of
information:*
Carolina Biological
Supply Co.
2700 York Road
Burlington, NC 27215
(800) 334-5551

Connecticut Valley
Biological
82 Valley Road
P.O. Box 326
South Hampton, MA
01073
(800) 628-7748

Community resources:
Pest exterminators

University entomology
extension services

INSIGHTS

Cockroaches. We humans consider them the "rats of the insect world," yet cockroaches could be considered one of the most successful creatures on earth. *Entomologists* have found fossilized cockroaches that are more than 300 million years old. Amazingly enough, these fossilized cockroaches look very similar to the ones scurrying around in our yards and homes today.

There are over 4,000 species of cockroaches. As one of nature's recyclers, they are often found eating natural forest debris. A few find their way into our kitchens, basements, and bathrooms, coming up through the drains, sneaking in through cracks, or carried in on grocery bags. These cockroaches are usually looking for warm, moist, dark places to call home.

Cockroaches, by design, are survivors. They are *nocturnal*, making them hard to spot. If they are discovered, their flat bodies make it easy for them to escape into small crevices. Their *antennae* and *cerci* help them detect changes in vibrations and air pressure, making it difficult to even step on them. Cockroaches are *omnivorous*. They eat anything from dog food to plaster. Internal *bacteria* help cockroaches digest these unusual meals. If necessary,

cockroaches can live for three months without food and one month without water.

Although cockroaches preen regularly, they are still suspected of transmitting diseases such as salmonella, dysentery, and typhus. They are also suspected of causing allergic reactions in half of the 17 million people afflicted with asthma.

Have cockroaches appeared in your home? Implement an Integrated Pest Management (IPM) program. First, start by making the site less attractive to cockroaches by storing food in tight containers and maintaining high sanitary standards. Then, if you must use pesticides, read the warning labels carefully. Traps and *boric acid* can be

used instead of highly-toxic sprays. Although an IPM is a safer approach for the environment, following it probably won't enable you to get rid of cockroaches completely. Remember, cockroaches have been around for 300 million years. They are sure to be around for a long time to come.

CONNECTIONS

1. Most cockroaches originated in Africa. Now they are found in all parts of the world. How might this spread of cockroaches have occurred?
2. You have just found cockroaches in your home. What will you do?

VOCABULARY

antennae a pair of sensory feelers on the head of an insect

bacteria microscopic organisms that, in this case, aid in a cockroach's digestion

boric acid a medical antiseptic; a powder that acts as an insecticide for cockroaches

cerci small nerve endings on the back of a cockroach that can detect changes in air pressure and movement

entomologists scientists who study insects

nocturnal active at night

omnivorous eating both animals and plants; in the case of cockroaches, eating almost anything

palpi sensitive appendages attached to the oral part of a cockroach enabling it to pre-taste food

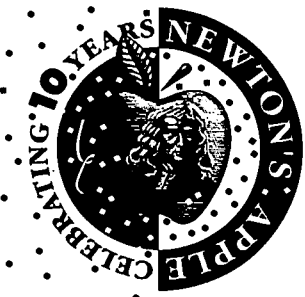

CAUGHT ONE!

Design a cockroach trap. See if you can catch one.

◆ MAIN ACTIVITY

Are cockroaches your invisible neighbors? Make a guess as to where you might find them. Design your own cockroach trap, or team up with your classmates. Then set out on an expedition to trap a cockroach.

Materials

- ◆ • wide-mouth container
- ◆ • container lid with holes
- ◆ • masking tape OR black paint OR black construction paper
- ◆ • petroleum jelly
- ◆ • cardboard strip OR wooden tongue depressor
- ◆ • food for cockroach bait

- ◆ 1. Coat the outside of your container with masking tape, black paint, or construction paper to make the inside of your container dark and inviting to a cockroach.
- ◆ 2. Smear a wide band of petroleum jelly around the inside of the container just below the neck.
- ◆ 3. Add bits of food to the container for cockroach bait.

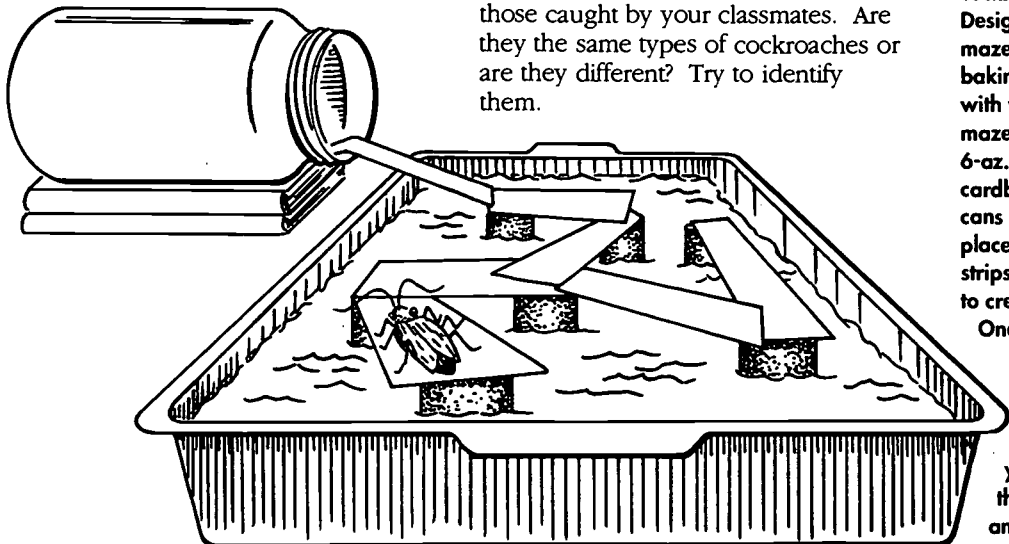

▶ TRY THIS...

Get out the calculators. A female German cockroach reproduces four to eight times in its life cycle, laying seven to eight egg cases, each case containing 35 to 40 eggs. About how many offspring might one female German cockroach have? Divide students into groups to solve the problem. Give each group a package of kidney beans to predict how many cockroaches their female would produce. Put all the beans together to see the effects of cockroach reproduction.

4. Where in your school, home, or community might cockroaches be hiding? Select a site, get permission, then go and set up your trap. Place the trap on its side. Create a miniature ramp using the cardboard strip or tongue depressor, extending the ramp from the floor to the container.

5. If you catch a few cockroaches, quickly screw the lid on tightly. You don't want any cockroaches to escape. Notify the building authorities of your discovery.

Questions

1. What plan would you suggest to help get rid of the cockroaches at your specific site? What experiments can you devise to see how well your plan works?
2. Compare your cockroaches with those caught by your classmates. Are they the same types of cockroaches or are they different? Try to identify them.

▶ TRY THIS...

Find out how smart a cockroach can be. Design a cockroach maze. Start with a baking pan half-filled with water. Build a maze using several 6-oz. cans and strips of cardboard. Arrange the cans in the pan and place the cardboard strips on top of the cans to create two pathways. One pathway leads to the cockroach's home, the other leads to a dead-end. Put your cockroach at the start of the maze and observe.

▶ TRY THIS...

What repels a cockroach? Experiment by putting a piece of bread in one end of a box and adding a cockroach. How long does it take for the cockroach to start eating the bread? Then, place a piece of peeled garlic into the box. Observe. Is the cockroach attracted to the garlic or repelled by it? Try bay leaves or cucumbers. Does your cockroach say "Na thanks!" to these? Experiment with other foods.

- ◆ Newton's Apple is a production of KTCA Twin Cities Public Television. Made possible by a grant from 3M.
- ◆ Educational materials developed with the National Science Teachers Association—Space, Science, and Technology Division.



David gets wrapped up in a cast to learn about broken bones.

Segment length: 7:30

BROKEN BONES

What can cause a bone to break?

What function does bone play in the human body? What are the different parts of a bone? What happens when a bone breaks? How does a splint protect a fracture? How does a cast aid in bone repair?

RESOURCES

American Red Cross standard first aid workbook. (1988) Washington, DC: American Red Cross.

Gray, H. (1901, 1977) *Gray's anatomy.* New York: Bounty Books.

Kapit, W., and L. Elson. (1977) *The anatomy coloring book.* New York: Harper Collins.

Community resources: American Red Cross chapter

School nurse

Emergency-response units

Hospitals or emergency-treatment centers

INSIGHTS

The human skeletal system is designed to support the human body, offer it protection, and provide a means of locomotion. Bone is the essential framework to which muscles are attached.

Bone is constructed in layers. The outside layer is known as the periosteum. This is where blood vessels and nerve cells are located. The next layer is the compact bone. This area has *collagen* and crystals of calcium and phosphorus. The next layer is of spongy bone, with shock-absorber qualities. Then the medullary cavity, filled with *marrow*, forms the inside of the bone. This layered-tube architecture allows the bone its *compressional strength*, while keeping it very light.

However, forces on bones are not always compressional. Lateral forces, twisting stresses, and powerful impacts may cause the bone to break, or fracture. There are two types of fractures: closed and open. A closed fracture occurs when the skin is not broken. An open fracture is when the skin has been broken and involves an open wound. This type of fracture is more serious because of the increased risk of infection and shock caused by blood loss and damaged tissue.

Keeping the broken body part stationary—immobilizing it—

will stabilize the injured area and prevent the bones from shifting until further treatment is available. Splints are used to immobilize an area. They can be made from cardboard, newspapers, sticks, or any other rigid material.

When a *cast* is needed, the doctor first checks that the bones are in correct alignment to promote proper healing. A cast is then placed over the fractured area to immobilize it, allowing the bones to grow back and heal in the desired configuration.

Although fractures are an unfortunate occurrence, most of us can take precautions to avoid them. There are certain diseases, however, that make some people more susceptible to fractures. Diseases of the

bone, including *osteoporosis*, *rickets*, and *osteoarthritis* can cause bone deterioration or fragility. This can increase the likelihood or severity of a bone fracture.

CONNECTIONS

1. What are the effects of nutrition on bones?
2. Invite an orthopedic surgeon to your classroom to discuss some of these topics: high-technology materials used in joint replacements; the effects of aging on bones; and the healing process of bones.
3. Have you ever broken a bone? What did it feel like? What was it like to wear a cast?

VOCABULARY

cast a device used to immobilize an area or fracture for an extended period of time

collagen protein found in skin, tendons, bones and teeth

compressional strength describes the resistance of a material to compressive stress—a compressing or crushing force

marrow the soft tissue found inside bones

osteoarthritis a degenerative joint disease of unknown origin causing pain and decreased joint motion

osteoporosis a general progressive loss of bone tissue resulting in weak skeletal strength

rickets a childhood disease characterized by soft, deformed bones caused by a failure to absorb calcium due to inadequate vitamin D or sunlight

TAKE A BREAK!

Why is it important to immobilize a fractured bone?

◆ MAIN ACTIVITY

Observe how to splint a fractured limb, and learn the importance of immobilization in the treatment of broken bones. You will also experience the sensation of limited movement created by a splint or a cast.

◆ Materials

- ◆ Red Cross First Aid Workbook OR another guide on splinting broken bones
- ◆ cardboard for splints
- ◆ triangular bandages made from torn sheets or fabric scraps
- ◆ newspapers
- ◆ padding for splinting
- ◆ any other type of material that can be used for splinting

1. Review the first-aid resources for information and diagrams on how to splint arms, legs, and fingers.
2. Demonstrate the proper procedures for splinting an arm.
3. Pair up and practice splinting each other. Try using different materials to splint the arm.
4. When the arm splint is completed, repeat steps 2 and 3 for the leg splint and the finger splint.

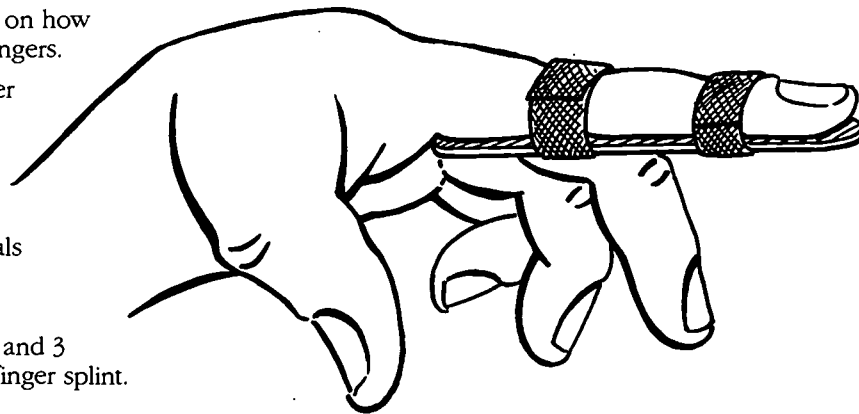

▶ TRY THIS...

Go to a butcher shop and ask for some bones with the joints attached. Use these as a visual aid to learn about the construction of the bone, joints, tendons, and ligaments. Draw pictures or write summaries about the structure of bones. (Bones can spoil, so make sure you refrigerate them!)

▶ TRY THIS...

Obtain two different X-rays of a broken bone: one of the bone before the cast was applied and one of the healed bone. Study each X-ray. Is the break visible in the X-ray? Does the bone change in size or appearance after it has healed? (It may appear thicker in the area of the break.) Arrange for a trip to the X-ray department of an area hospital, or invite an orthopedic surgeon to visit your classroom to help in this study of X-rays.

▶ TRY THIS...

Not all broken bones are treated in the same way. New medical techniques have improved the outcomes for those with broken bones, including better healing and increased mobility. Research the different methods for treating injured bones, such as the uses of different types of casts, the application of electronic equipment to relieve pain, or the use of artificial materials to create replacement bones and joints.

Questions

1. List other types of materials that can be used for splinting.
2. Discuss possible ways people may break a bone.
3. Which is easier to splint, the arm or the leg?

▶ TRY THIS...

Have a chicken dinner and save the bones. Wash them and clean off any remaining meat. Let them dry thoroughly. Place half of the bones in a jar of vinegar and store the other half in a dry area until needed. The bones in vinegar should sit for three to four days. At the end of this time drain the vinegar. The bones that were submerged in the vinegar should be flexible compared to the bones that have been left to dry. Compare the two different sets of bones, making sure you have an ample supply of each type. What is the difference between the two sets of bones? Find out what causes a bone to be hard. Why isn't one bone hard? What important mineral does the vinegar deplete? What other parts of your body are made of this type of material?



David gets a wide-angle view of filmmaking when he visits a large-screen projection facility.

Segment length: 5:40

OMNIMAX

How is a giant-screen movie made and projected?

What makes giant movie film so different? How does the film stock differ from the film used in a conventional movie? What technology has been developed to accommodate this large-scale film?

RESOURCES

Culhane, J. (1981) *Special effects in the movies: How they do it*. New York: Ballantine Books.

Elmer-DeWitt, P. (1990) Grab your goggles, 3-D is back! *Time* (Apr 16): 77-78.

Park, E. (1990) Around the mall and beyond. *Smithsonian* (Nov): 25-28.

Walt Disney's moving picture flip book. (1986) New York: B. Shackman & Co.

Additional source of information:

IMAX Corporation
Communications
Department
38 Isabella Street
Toronto, Ontario,
Canada M4Y 1N1
(416) 960-8509

Community resources:
Television stations

Movie theaters

Video or film
production houses

INSIGHTS

IMAX® and OMNIMAX® are counterpart motion picture systems using state-of-the-art technology to project huge images of tremendous clarity. The projected picture, which is up to 10 times the size of a conventional screen, extends beyond the human *peripheral* vision on all sides and puts the viewer in the middle of the scenes as it zooms between microcosmic and macrocosmic views. It tends to have *subliminal* effects on the viewers as well, often giving them the feeling of motion sickness, as if they were actually taking part in the event they are watching.

The first giant-screen IMAX showing premiered at EXPO '70 in Osaka, Japan. The IMAX image is projected on a vertical flat screen that is eight stories high and 70 feet wide. The sister OMNIMAX system premiered in 1973. This system projects images to fill 86% of a surrounding dome screen. The OMNIMAX screen is four stories high and 76 feet in diameter, with views of 180 degrees that wrap around a tilted tier of seats. The projected images fill the entire field of vision, creating a three-dimensional (3-D) illusion of being transported through any environment. Eighty-four speakers project music and sound. The movie reel for an

average feature of 34 to 45 minutes is 48 inches in diameter and weighs 150 pounds, so heavy that two people must load it into the projector.

The secret to creating the clear, big-screen imagery of the IMAX and OMNIMAX theaters begins with the film itself. The specially-designed IMAX and OMNIMAX cameras photograph the largest frames ever used in motion pictures: 70mm wide and 15 perforations per frame compared to a standard 35mm, 4-perforation motion-picture frame. The large film size is necessary because the image is projected over such a large area.

The projection process also requires special adaptations. The high performance and reliability of IMAX and OMNIMAX projectors come from the unique way the film loops, or "caterpillars," through them. This "Rolling Loop" projector advances the film horizontally, instead of vertically as does a regular film projector. This gives the super

high-speed film flexibility and helps prevent shredding. To keep the projected image steady during projection, each frame is positioned on fixed registration pins, and the film is held firmly against the rear element of the lens by a vacuum. The resulting picture and focus are steady and clear.

The future of IMAX and OMNIMAX rests in the development of computer animation and 3-D technology, already underway.

CONNECTIONS

1. Modern planetariums use domed theaters for projecting astronomy multimedia illusions. To what other uses could planetariums and their special light, sound, and motion effects be put?
2. Ask your students if any of them has been to a giant-screen movie. What were their experiences?

VOCABULARY

animation a motion picture made by photographing successive positions of inanimate objects to create the illusion of apparently spontaneous lifelike movements

mm a metric measure that is .001 of a meter, or approximately .039 inches

peripheral lying at the outside or away from the center part

subliminal below the threshold of consciousness

Newton's Apple is a production of KTCA Twin Cities Public Television. Made possible by a grant from 3M.

Educational materials developed with the National Science Teachers Association—Space, Science, and Technology Division.

MAKE A FLICKERBOOK

Create your own version of an animated movie.



▶ TRY THIS...

Explore the differences between animal and human eyes. Is there any connection between the "fish-eye view" that some animals have and the damed images in an OMNIMAX theater?

▶ TRY THIS...

Arrange a visit to a local motion-picture theater or an IMAX theater to tour the projection booth, or ask a theater owner or manager to visit your classroom to answer some questions about theater projection. How many rolls of film are there in a two-hour film? Why are so many films about two hours in length? How do movie theaters avoid a "break" in projection when they switch projectors? What changes have occurred in the technology in the last five years? What changes do they predict? How does standard projection differ from what the students saw in the segment?

◆ MAIN ACTIVITY

Animation is made possible because

- our eyes perceive two slightly different pictures, one after the other, as a moving image. It is a physiological fact that an image is registered onto our retina, remaining there for a bit even though the source of the image is out of view. The eye can register 12 pictures per second as separate images, so if the pictures appear more quickly than this, the eye perceives them as moving pictures.
- Motion pictures appear at the rate of 24 photographs (frames) every second.

Films today consist of a strip of

- transparent acetate with a series of small, sequenced frames, each representing a visual record of a moment in time. When the series of pictures is projected rapidly onto a screen, the illusion of continuous action is created.
- Before motion pictures were invented, people created the illusion of moving pictures by drawing a slightly different image on each page of a book, and then flipping through the book with a thumb. The pictures appeared so quickly that the eyes "saw" a steady movement. The first "flickerbook" appeared around 1890.

Invite your students to create a small flickerbook.

◆ Materials

- pencil, pen, or markers
- paper, needle and thread, and staples OR a small bound notebook OR a pad of removable sticky notes
- 1. If you are making your small books from scratch, use the paper, needle and thread, or staples to create some books of your design. If you are using a notebook or a pad of sticky notes, these can be your "books."

2. Have each student think of a simple story he or she would like to illustrate.

3. On the back side only of each page, draw a picture (close to the cut edge of the paper) in which the action is slightly different than the action in the previous picture. When the picture story is finished, hold the book in the one hand and flip the pages from front to back with the thumb of the other hand.

Questions

1. Are there certain actions or pictures that are particularly well-suited to this technology? Are there certain actions not well-suited to this device?
2. What happens if you flip through the pictures too quickly? Too slowly?

▶ TRY THIS...

Find out about planetariums, then visit one. What technology is used to create realistic otherworlds, landscapes, and skylscapes? How are planetariums similar to OMNIMAX theaters? How are they different?



Standard film frame: 35mm

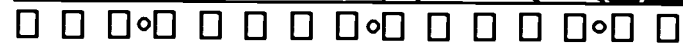
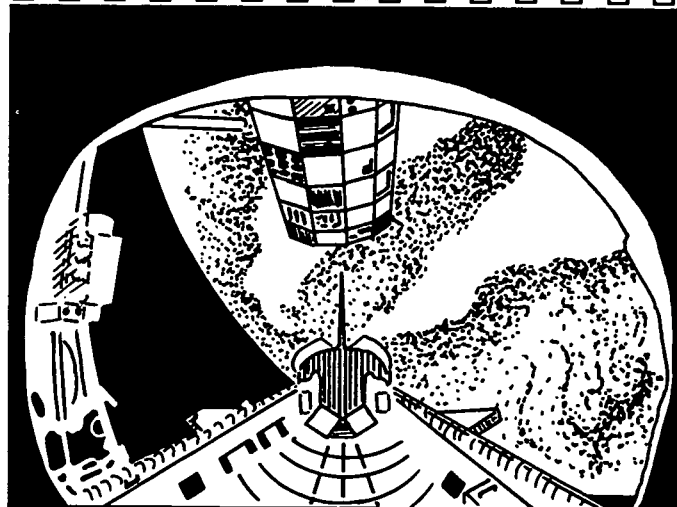

Giant-screen film frame: 70mm



David explores the physics and technology of shooting a straight arrow.

Segment length: 8:07

ARCHERY

How has technology changed the bow and arrow through the centuries?

What kinds of advances have been made in the design of the bow and arrow? What are the different parts of a bow and arrow? What is the human element of being a master archer?

RESOURCES

Elliot, C. (1982)
Archer's digest.
Northfield, IL: DBI
Books.

Hamm, J., ed. (1992)
*The traditional
bowyers bible*, vol. 1.
Azle, TX: Bois d'Arc
Press.

McEwen, E., R. Miller,
and C. Bergman.
(1991) Early bow
design and
construction.
Scientific American
(June): 76-82.

*Additional sources of
information:*

National Archery
Association
1750 E. Boulder St.
Colorado Springs, CO
80909
(719) 578-4576

National Field Archery
Association
Rt. #2 Box 514
Redlands, CA 92373
(714) 794-2133

*Traditional Bowhunter
Magazine*
P.O. Box 15583
Boise, ID 83715

Community resources:
Archery clubs

University archery
team

INSIGHTS

The use of the bow can be traced back to the earliest civilizations, as witnessed in writings and drawings from all over the world. Drawings, biblical writings, and ancient cultures make references to this tool and weapon. The bow and arrow have shaped history, whether it be on the plains of the ancient Roman and Greek battlefields, the defeat of the French army at Crecy in 1346, or the expansion of the American West. And, the sport of archery is considered one of the oldest traditions.

Today, archery is classified into two areas: target and field. Target archery requires archers to shoot a specific number of arrows at different distances, with set targets that have established values. Field archery includes an open-field target range where archers shoot different arrows at different targets or different distances around a course. This simulates the type of shooting experienced while hunting. Other field-archery sports include archery golf, roving, and bowhunting.

The bow is a simple *machine*, a two-arm spring. The archer stores energy by bending the bow. This *potential energy* is transferred to the arrow in the form of *kinetic energy* when the arrow is released.

Bows initially were made from one material, usually wood, and were called self-bows. These bows had difficulty handling the forces and stresses placed on them when they were drawn. The stresses would cause the bows to break. Early hunters developed the use of wood, horn, and *sineu*, glued together in layers to increase the bow's *tensile strength*. These bows were called composite, because they were made of two or more different materials. Today's bows are a combination of wood, fiberglass, lightweight metals, and high-technology materials. The evolution of the bow continues with the *recurve* design, the use of pulleys, and the latest in engineering research that makes the bow more efficient and easier to use.

Arrows have undergone an evolution of their own. Early arrows were made of wood and were *fletched* primarily with the feathers of such birds as eagle, crow, goose, and turkey. Most of today's arrows are still made of wood, but some are made from aluminum, fiberglass, and graphite. They are often fletched with feathers, although some have more modern spinwings or plastic veins.

CONNECTIONS

1. What other kinds of sporting equipment have changed with the introduction of modern materials? Are all the changes for the better?
2. A bow is a simple machine. What other sports incorporate the use of machines?

VOCABULARY

fletch to modify an arrow in a way that assists in the stability of flight (e.g., adding feathers to the tail)

kinetic energy the energy of motion, equal to half an object's mass multiplied by the square of its speed ($1/2mv^2$)

machine a device for multiplying forces or changing the direction of forces

potential energy energy that is stored and held in readiness by an object by virtue of its position

recurve the bending of the ends of the bow away from the archer; acts as a lever to help distribute the forces on the bow

sineu tendons and other animal parts that have a high tensile strength and a large spring constant

tensile strength the ability to withstand the forces that produce stretching

ARROWS R US!

Find out which design factors contribute to the best bow and arrow.

◆ MAIN ACTIVITY

You will learn the differences between self-bows and composite bows. Explore which types of arrows fly best, and identify and describe the parts of the bow and arrow.

- ◆ **CAUTION:** Safety precautions should be followed when using any kinds of bows and arrows. Adult supervision is recommended.

Materials

- ◆ various-size rubber bands
- ◆ 6" plastic drinking straws
- ◆ removable sticky notes
- ◆ scissors

PART I

- ◆ Make a bow following these directions:
 1. Notch a small "v" in each end of a straw.
 2. Place a rubber band over the ends of the straw, as in stringing a bow.
 3. Hold the straw and draw back on the rubber band as an archer would.
 4. What happened if you drew too far back? Record your observations.
 5. Diagonally roll a sticky note from the plain side to the glue side. Insert it down the middle of the straw.
 6. Draw back on the rubber band again and record your observations.

PART II

- ◆ Make an arrow following these directions:
 1. Use 6" straws for arrows; fletch with paper and cardboard.
 2. Create several different arrows, paying attention to tail-feather construction, weighting, and notching.

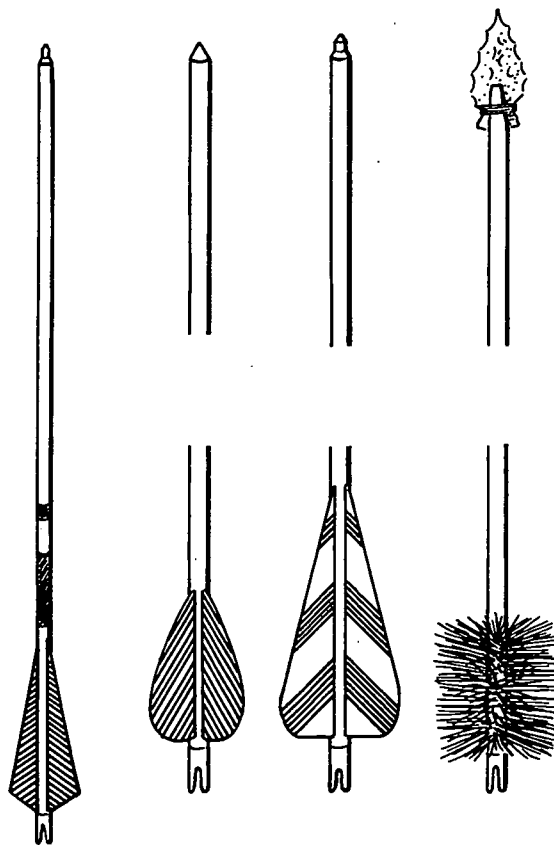

▶ TRY THIS...

Invite a member of the local archery club or archery team to speak about archery equipment and safety. Ask your guest to bring in bows and arrows to allow students to get a first-hand look. How do archers prepare for competition? What are the human components of shooting a bow and arrow? Purchase a toy bow and arrow made of soft foam and hold your own competition.

▶ TRY THIS...

Construct your own arrows! Use a piece of dowel stick (12" long) for the shaft. Use cardboard to design and shape tail feathers or other methods of fletching. Personalize it with a crest. Have a competition, awarding the most artistic efforts, the most aerodynamic arrow, the arrow with longest flight, and the arrow that best represents the information given in the segment and the lesson, to name a few. Don't forget to display them.

3. Record all the information that went into designing your arrows.

Test your arrows by holding the angle constant and measuring which one flies the farthest. The use of different rubber bands is likely to give different results, so try large ones and small ones, thick ones and thin ones.

Questions

1. What types of bows did you make Part I? Which one had greater strength?
2. What kinds of materials used on actual archery equipment was the rolled paper simulating?
3. What type of rubber bands worked best?

▶ TRY THIS...

Research the history of archery and the development of the bow and arrow. Divide into teams or groups and focus on particular regions of the world or particular time periods in which the bow and arrow played an important role. Present the results of your research to the class.

- ◆ Newton's Apple is a production of KTCA Twin Cities Public Television. Made possible by a grant from 3M.
- ◆ Educational materials developed with the National Science Teachers Association—Space, Science, and Technology Division.



Peggy travels to Alaska to learn about the science and beauty of the northern lights.

Segment length: 9:35

AURORA BOREALIS

What creates these shimmering celestial lights?

What causes the northern lights? When are they most visible? What creates the different colors? What do the auroras look like from space?

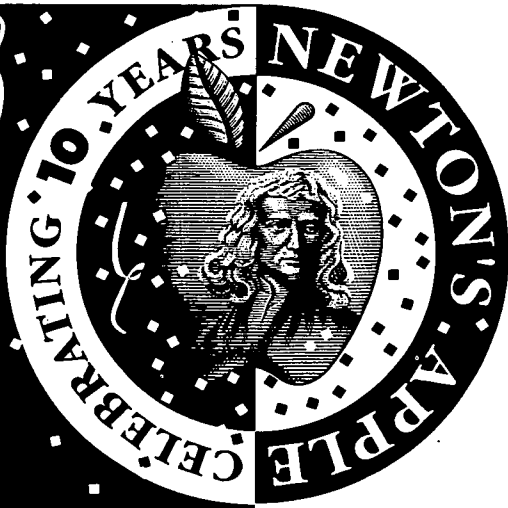

RESOURCES

Akasofu, S.I. (1982) *The aurora: New light on an old subject. Sky and Telescope* (Dec): 534.

Akasofu, S.I. (1989) *The dynamic aurora. Scientific American* (May): 90.

Maran, S.P., ed. (1992) *The astronomy and astrophysics encyclopedia*. New York: Van Nostrand Reinhold.

Additional sources of information:

NASA
Education Division
Mail Code F
Washington, DC 20546

NASA
Johnson Space Center
Media Services
Houston, TX 77058
(auroral photographs)

NOAA, E/GCI, Dept. 883
National Geophysical
Data Center
325 Broadway
Boulder, CO 80303
(303) 497-3000
(print materials, slides,
satellite images)

Community resources:
University astronomy
department

Meteorologists

INSIGHTS

Folklore is rich with explanations for the stunning night-sky lights, the aurora borealis. Various cultures have explained them as dancing spirits or blood raining from the clouds. Aurora was the Roman goddess of the dawn. *Boreal* is a Latin word, meaning "north." Thus, the northern lights. In the Antarctic, the lights are called the aurora australis, or southern lights.

The source of the *auroras* is the sun. The sun gives off high-energy charged particles (also called *ions*) that travel out into space at speeds of 200 to 440 miles per second. A "cloud" or gas of such ions and electrons is called a *plasma*. The stream of plasma coming from the sun is known as the *solar wind*.

As the solar wind interacts with the fringes of the earth's *magnetic field*, the particles are "shocked" into flowing around the earth. Some of the particles are trapped by the earth's magnetic field. They follow the magnetic lines of force down to the *ionosphere*. The particles strike the gases in the ionosphere, causing them to glow, the same way electrons passing through the gases in a neon tube make a neon sign light up. The colors correspond to the different gases in the ionosphere. Oxygen atoms

give off red and green light, depending on how high they are in the ionosphere. Nitrogen molecules give off blue and violet light.

The northern lights are always moving, like giant curtains of light weaving and swaying across the sky. This is caused by the constantly changing interaction between the solar wind and the earth's magnetic field. It is not unusual for the solar wind to generate 100,000 megawatts of electricity in a three-hour auroral display. This can cause temporary interference with power lines, radio and television broadcasts, and satellite-to-earth

communications. By studying the auroras, scientists can learn more about the solar wind and how it affects the earth's atmosphere.

CONNECTIONS

1. What are some examples of how we have used the sun's power? How might we use plasma power in the future?
2. Artificial auroras were created on a recent NASA shuttle mission. How did they do this? What might this lead to later that could be used on earth?

VOCABULARY

aurora rapid and irregular displays of colorful lights in the night sky, created when the solar wind causes beams of electrons from the magnetosphere to strike the upper atmosphere, causing atoms and molecules to glow

electromagnetic spectrum arrangement of electromagnetic waves according to wavelength

ion an atom or group of atoms carrying an electrical charge

ionosphere part of the earth's atmosphere containing electrically-charged particles that reflect radio waves.

magnetic field a region of space wherein a detectable magnetic force exists at every point

plasma a state of matter in which all of the particles are electrically charged

solar corona the sun's upper atmosphere where the solar wind is created

solar wind charged particles, mainly protons and electrons, that flow out from the sun and sweep out into space.

Newton's Apple is a production of KTCA Twin Cities Public Television. Made possible by a grant from 3M.

Educational materials developed with the National Science Teachers Association—Space, Science, and Technology Division.

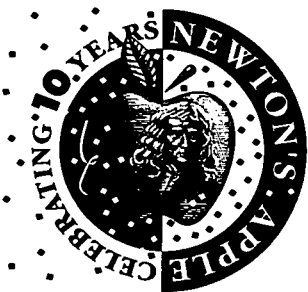

ALL CHARGED UP!

Find out how to turn on the light.

▶ TRY THIS...

Mythology and folklore are used to explain many natural geographical features and/or events of nature. Create a time-travel story, play, or dance, which reveals the "ancient" belief about a natural phenomenon, along with the related scientific theory or principle. Some ideas for natural events include lightning, solar and lunar eclipses, and rainbows.

▶ TRY THIS...

Make a miniature earth and its magnetic field by covering a bar magnet with some modeling clay, and then forming the clay into a sphere. Keeping the magnet upright, place the clay-earth model on a table. Cut a strip of cardboard to represent the equator, wrap it around the model, and tape the ends. Sprinkle iron powder or filings on the model. At what point do the lines build up? Is there a pattern? How do you think the filings would continue toward the southern pole?

◆ MAIN ACTIVITY

Use some common materials to discover if ions conduct electricity.

Materials

- beaker
- 1 meter of insulated bell wire
- distilled water
- 2-1.5-volt dry cells
- 3-volt flashlight bulb (microlamp)
- paper towels
- 1/2 cup sugar
- 1/2 cup salt
- wire cutters to strip insulation from wires

1. Cut the bell wire into three pieces and strip 1 cm of insulation from the end of each piece.
2. Connect the two batteries with one wire.
3. Connect one end of the remaining wire to a battery; connect the other end to the flashlight bulb. Attach the third piece of wire to the second battery and to the bulb.
4. Cut one wire in the circuit between the bulb and battery; remove 1 cm of insulation.
5. Place two bare ends of the wire into a beaker filled halfway with distilled water. How does the light react?
6. Dry off the ends of the wire; pour 1/4 cup of the salt on a paper towel. Put the wire ends into the salt. How does the light react?
7. Clean and dry the ends of wire again, sprinkle a few grams of sugar into the water, and place the ends of the wire into the water/sugar mixture. What happens to the bulb?
8. Replace the sugar water with plain distilled water. Add the salt. Does the light react?

▶ TRY THIS...

Invite your friends to a "northern lights" party. Give each person a pack of wintergreen-flavored round candies. (Do not use the sugar-free kind.) Go into a very dark room or outside at night. Ask each person to bite down on two or three pieces of candy. (Keep your mouth open as much as possible during this experiment.) Does the candy appear to sparkle and glitter as you bite down on it? Stress in sugar crystals is creating an electric field! These fields are taking outer electrons from molecules, recombining them with electrons, and giving off light. What colors can you see? Does having braces on your teeth make a difference in the result?

▶ TRY THIS...

The solar wind is always blowing. Solar storms that make sun spots also give the solar wind more energy. A stronger solar wind shifts the auroras from the Arctic to positions at lower latitudes, such as where most people in the United States live. Watch for possible auroras where you live. Do a library search of old newspapers to see if the aurora has ever been visible in your town. When? How often?

Questions

1. Ions conduct electricity. What was it that freed the ions? How do you know?
2. Which solutions or mixtures did not produce ions?
3. How is this similar to the process that creates the northern lights? To the process that creates fireworks?

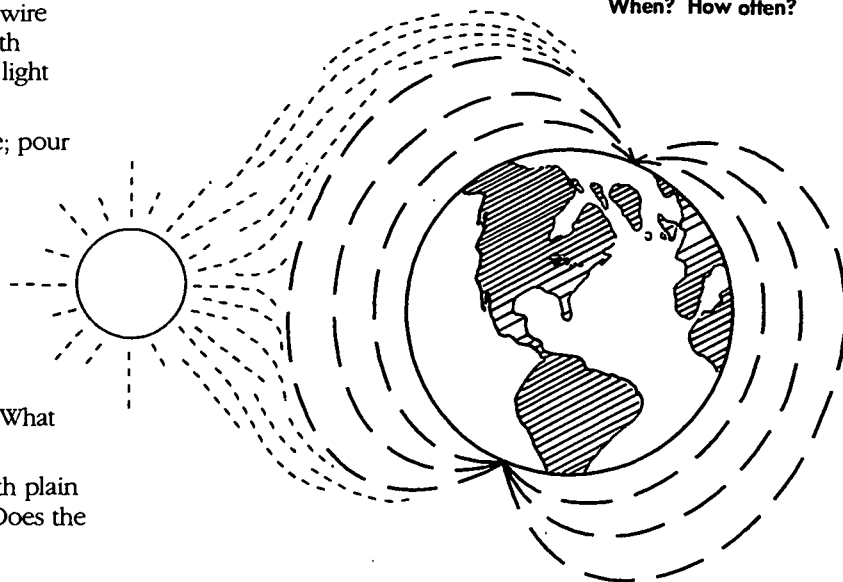

AIR PRESSURE

What is air pressure and how can its force be measured?

Can we measure the force with which the air is pressing on the earth? What does a drinking straw have to do with air pressure? How does a barometer work? What would happen to us in a vacuum?



A football team, a giant drinking straw, and a collapsed tank of water help David understand air pressure.

Segment length: 7:00

RESOURCES

3-2-1 Classroom

Contact: *Air is matter, air is there.* (1991)
New York: Children's Television Workshop.
Videotape.

Ehrlich, R. (1990)
Turning the world inside out. Princeton, NJ: Princeton University Press.

Gardner, M. (1981)
Entertaining science experiments with everyday objects. New York: Dover.

Hewitt, P. (1991)
Conceptual physics, 2d ed. New York: Addison-Wesley.

Additional sources of information:

National Weather Service
Division of NOAA
RAS/DC 472
Rockville, MD 20852
(301) 443-8910

Community resources:
Television or radio meteorologist
Airplane pilot

INSIGHTS

Even though we can't feel it, air is constantly pressing down on us with a tremendous *force*—14.7 lbs. per square inch (100,000 newtons per square meters), to be exact! This was graphically demonstrated in 1654 when Otto von Gueicke, Burgmeister of the town of Magdeburg, Germany used a *vacuum* pump to remove almost all of the air from the space between two half-meter diameter hemispheres. The air pressure holding them together was so strong that two teams of horses couldn't pull them apart; when air was let back in, the hemispheres fell apart easily.

Air pressure is created by the weight of the earth's atmosphere. Although we can't see air, the gas molecules still have *mass*, and *gravity* acts upon it.

The air pressure changes daily due to the heating and cooling of the earth's surface. When air gets warm, it expands, becoming less dense, and therefore pushes with less pressure. We can measure changes in *atmospheric pressure* by using a barometer. Some barometers use long glass tubes filled with mercury inverted in a dish. Air pressing down on the surface of the dish forces the

mercury up the tube. Normal air pressure can support a column of mercury about 760 mm high. When atmospheric pressure drops, the force of the air pushing on the dish isn't as great, so the column of liquid falls and we have a "falling barometer." When the atmospheric pressure increases, the mercury rises, thus a "rising barometer."

We use air pressure all the time when we breathe. When our diaphragm moves down, air is pushed into our lungs from the outside, expanding the volume of the chest cavity. The diaphragm doesn't "pull" air in; it expands the volume of our lungs, and the air pressure fills the volume.

VOCABULARY

aneroid barometer a device for measuring air pressure which uses an air-tight box instead of a tube of liquid

atmospheric pressure the force per unit area exerted by the atmosphere at any point within the gaseous envelope surrounding the earth

force a push or pull that causes a body to accelerate or change shape

gravity the force that makes objects tend to move toward each other

mass the amount of matter a body or object contains; a measure of the inertia of a body or object

vacuum a space from which all of the air has been removed

BEST COPY AVAILABLE

118

10.45

3M

Innovation working for you™

INHALE! EXHALE!

Find out about the connections between air pressure and breathing.



▶ TRY THIS...

Put a straw in a bottle of soda or juice and seal the top of the bottle around the straw with modeling clay so that no air can get in or out. Now try to take a drink through the straw. How does this experiment relate to the design of a mercury barometer?

▶ TRY THIS...

Fill a plastic tumbler with water and place a plastic coffee-can lid over the top. Holding the lid on tightly with your fingers, invert the tumbler, and then let go of the lid while holding on to the bottom of the glass. (Do this over a sink or dish pan!) Observe what happens and repeat the experiment with different-size glasses. How can you explain the results?

◆ MAIN ACTIVITY

You will construct a model of the human lung and identify the processes and mechanisms involved in breathing. You will explore the relationship of changes in air pressure and the ability of the "lung" to "breathe."

Materials

- large glass or clear plastic funnel
- 9" round balloon
- 6" round balloon
- 3 large rubber bands
- duct tape
- scissors

1. Carefully insert the wide end of the 6" balloon into the neck of the funnel and pull the lip of the balloon over the edge so that the balloon is securely fastened inside the funnel. This is the "inner balloon."

2. Cut the neck off the 9" balloon and stretch it completely over the wide end of the funnel. Wrap two or three rubber bands around the edge to hold it firmly in place. Reinforce with duct tape. This is the "diaphragm balloon."

3. Pull down on the diaphragm balloon and observe what happens to the inner balloon. Can you predict what will happen when you push up on the diaphragm balloon?

4. Rest the bottom of the funnel on a table top and try to inflate the inner balloon. What happens? Try inflating the inner balloon when the lower part of the funnel is under water. Does it still work?

Questions

1. How do the parts of the model relate to the human respiratory system? (The inner balloon is the lung, the funnel is the chest cavity, and the lower balloon is the diaphragm.)

2. What is the maximum amount the inner balloon can be inflated? Can you explain how differences in air pressure allow the balloon to inflate?

3. What would happen to the ability of your model lung to be inflated if you were to poke a small hole in either the funnel or in the lower balloon?

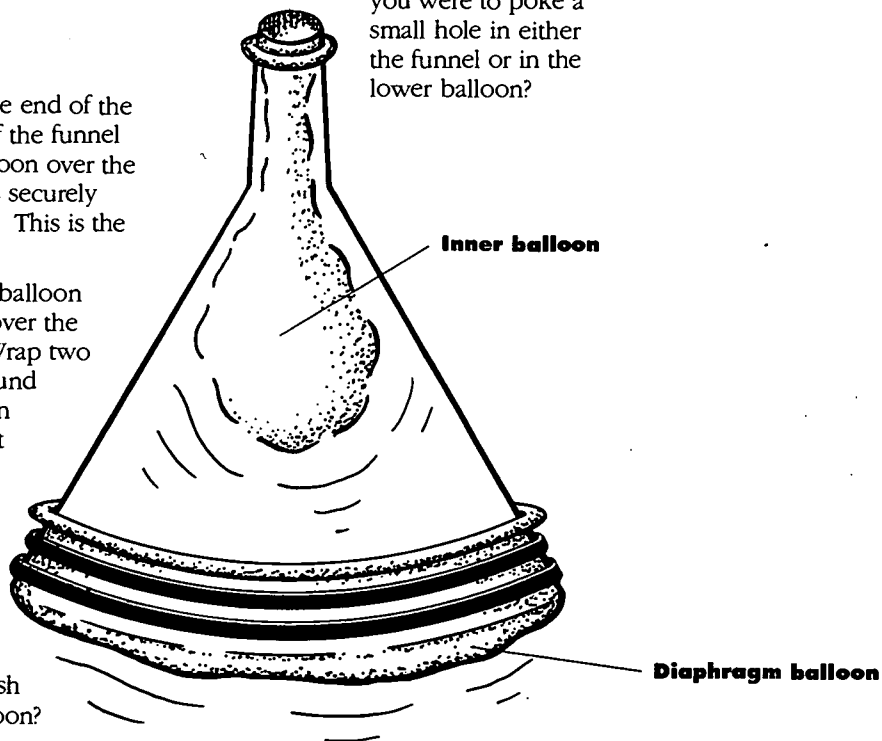

▶ TRY THIS...

Build a pair of Magdeburg hemispheres by placing two same-size toilet plungers "face to face" and squeezing out as much air as possible. (Or, get some pressure disks used to carry sheets of glass, available at hardware stores.) How much force is holding them together if the air presses down at 14.7 lbs. per square inch? (Hint: Find the surface area of one plunger in square inches; multiply by 2, and then by 14.7. Don't be surprised if your answer is as much as 600 lbs.!)

▶ TRY THIS...

Take an unopened can of your favorite soft drink or juice and punch only one hole in the top. Try to pour some of the beverage into a glass and observe what happens. Why do you need to punch two holes in the top of a can to get a decent flow?

TRAFFIC CONTROL

How can technology help alleviate traffic jams?

What causes a traffic jam? How can traffic-management systems ease traffic congestion? What will future systems for managing traffic be like?



When Peggy gets stuck in bumper-to-bumper traffic, she goes looking for some answers about traffic management.

Segment length: 7:00

RESOURCES

Freeman, D.W. (1991) Street smarts. *Popular Mechanics* (Nov): 33-36.

Lambert, M. (1986) *Transportation in the future*. New York: Bookwright Press.

O'Malley, C. (1991) Electronics as your copilot. *Popular Science* (Sept): 66-69.

Therrien, L. (1990) A gridlock-buster for the 21st century? *Business Week* (Aug 27): 84.

Zygmunt, J. (1992). Intelligent highways. *Omni* (Jan): 18.

Additional source of information:

3M Traffic Control Systems
Safety and Security
Systems Division
Bldg. 225-4N-14
St. Paul, MN 55144
(800) 328-7098

Community resources:
Traffic engineer

State Department of
Transportation

Regional traffic-
engineering council

INSIGHTS

The popularity of the automobile in the United States is reflected in some incredible statistics: From 1950 to 1986, the U.S. population increased by 60%, while the number of automobiles grew by 257%. During this same time period, new *highway* construction declined. The result? *Gridlock!*

One example is the Hollywood Freeway, built to handle 120,000 cars a day by 1970; in 1965, it was handling nearly twice that amount. In Los Angeles, *rush-hour* traffic crawls along at 35 mph; if nothing is done to improve conditions, by 2010, traffic will be moving at 11 mph. This kind of congestion was the subject of a Federal Highway Administration study, which found that recurring congestion (e.g., daily rush hours) along urban *freeways* during 1987 caused 700 million vehicle hours of delay. Non-recurring congestion (e.g., accidents or road work) resulted in over 1.2 million vehicle hours of delay. The costs of national traffic congestion are estimated at \$100 billion annually, including lost productivity and accidents.

Traffic management can significantly reduce some of these vehicle hours of delay by detecting and responding promptly to incidents and accidents, and rerouting traffic

where necessary. A section of Interstate 394 in Minneapolis is about to become the largest live traffic laboratory in the world, using 38 cameras atop poles every 1,000 feet to collect data that is fed to a monitor. This information will be monitored by a computer that can interpret traffic conditions and, ideally, implement a plan to alleviate the tie-ups.

Congress has recently appropriated federal funds to, in part, promote a new family of technologies for traffic management, known as Intelligent Vehicle/Highway Systems (IVHS). Several innovative systems are being studied; some, like an automobile navigation system, are already on the market. These navigation systems use compact discs (CDs) to store maps of all U.S. interstate highways and several

metropolitan areas. The rest of the system uses speed sensors, an electronic compass, and a small computer. When the driver punches in an address or destination, the computer responds by showing the map on a visual screen, and providing information about the distance in miles and the direction to be traveled.

CONNECTIONS

1. Why are we so dependent on the automobile? Do other industrial countries have similar traffic problems?
2. Our society places a great deal of emphasis on individualism and freedom of movement. Sometimes, individual rights may conflict with community goals of smooth traffic flow and minimal congestion. How can the two be reconciled?

VOCABULARY

Dates indicate when the word was first recorded in the English language.

freeways expressways with fully-controlled access (1930)

gridlock a traffic jam in which a grid of intersecting streets is so completely congested that no movement is possible (1980)

highway a main direct road (before the 12th century)

ramp metering a method of controlling the flow of traffic onto a freeway by requiring motorists to wait on the ramp until a green light allows them to proceed

rush hour an ironic phrase defining that period of the day when demands of traffic or business are at a peak (1898)

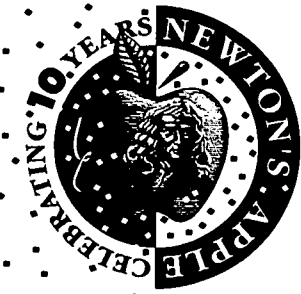

TRAFFIC WATCH

Predict, count, and project traffic patterns in your community.

▶ TRY THIS...

Traffic engineers study many of the issues concerning traffic management: peak periods and recurring congestion; accidents and other incidents; special events; construction and maintenance-work zones; inclement weather; and catastrophic events. Invite a traffic engineer to your class to discuss traffic in your community. How does your community "encourage" traffic to space itself more evenly during the day?

◆ **MAIN ACTIVITY**

By studying traffic flow on a local freeway or highway, you will learn how to control variables, formulate a model, hypothesize, measure, predict, and interpret data about traffic.

Materials

- one or more safe spots to view freeways or highways
- paper
- pencils
- chart for data collection
- stop watch
- device to measure the speed of a moving car, e.g., a radar gun (optional)

CAUTION: View traffic from safe locations. An adult should be present at all times when students are observing traffic. You may want to coordinate this activity with your local Department of Transportation.

1. Ask students to think about the issues and variables in designing a study of traffic patterns. Brainstorm as a class, or divide up into groups.
2. From your master list of ideas, design the parameters of the study (e.g., At what times will traffic be counted? Why those times? For how many minutes will it be counted?).
3. As the study is being designed, plan a chart on which to record your data.

4. Divide the students into pairs or groups. Have them write their predictions about what kind of traffic they will encounter before setting out. Then, go count traffic!

5. When the data have been collected, fill in the master chart with the appropriate information. What did each group observe? How does the information from each group vary?

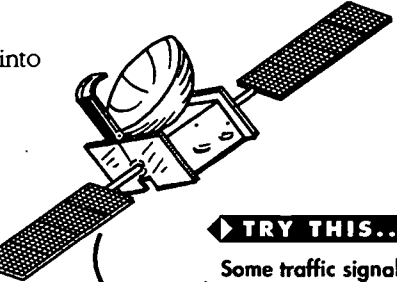

▶ TRY THIS...

Some traffic signals are timed to help clear congestion and keep the arteries moving at a regular pace. Ask someone you know who has a driver's license to drive you down a street in your community that might have timed signals. Can you figure out the optimum speed for traveling with all green lights? Some streets have signals timed so that cars don't always get a green light. Why would traffic engineers want to time the lights this way?

Questions

1. If your students were providing data to a highway engineering department, how often would they have to repeat their counts? Is there a way to automate this process? How might such a system work?
2. How would you project today's traffic count to future traffic flows?

▶ TRY THIS...

Statistics abound when looking into traffic issues. For example, in 1900 there were 8,000 autos and trucks in the United States; in 1929, there were 23,000,000 vehicles; and in 1981, there were 160,000,000 passenger cars, trucks and buses. Work with your librarian to find more statistics. How many miles of roads are there in the United States? How many additional miles are added each year? How many accidents were there 10 years ago in your metro community? How many were there last year? How many cars per person are there in China? How does this compare with the ratio in the U.S.? In your family? Design several graphs to present your information.

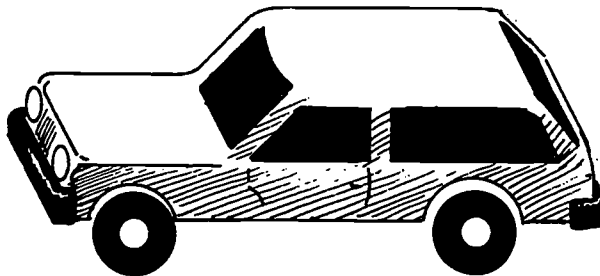

121 BEST COPY AVAILABLE



David finds out how some creatures can survive a deep-freeze.

Segment length: 7:00

CRYOGENICS

Is cryogenics science-fact or science fiction?

Can the human body be totally frozen for a long time and then resuscitated? Can any animals survive subfreezing temperatures? What is the future of cryogenics?

RESOURCES

Karow, A.M., and D.E. Peggy, eds. (1988) *The biophysics of organ cryopreservation*. New York: Plenum Press.

Marchand, P. (1987) *Life in the cold*. Hanover, NH: University Press of New England.

McClintock, P.V.E. (1984) *Matter at low temperature*. New York: Wiley and Sons.

Storey, J.M., and K.B. Storey. (1990) Frozen and alive. *Scientific American* (Dec): 92-97.

Storey, K.B. (1990) Life in a frozen state: Adaptive strategies for natural freeze tolerance in amphibians and reptiles. *The American Journal of Physiology*: 559-568.

INSIGHTS

Cryogenics is a branch of physics concerned with very low temperatures: how to produce the lowest temperatures possible (below minus 30°C), and what effects these low temperatures have on organisms or materials. The prefix *cryo* is derived from the Greek word *kryos*, meaning "cold."

The person considered by most to be the originator of modern experimental science, Francis Bacon, died as a result of a spontaneous experiment he was conducting on the effects of low temperatures. In 1623, while traveling on a cold and snowy day, Bacon decided to "experiment" to see whether snow would delay the putrefaction of flesh. He stuffed a fowl with snow to observe the effects. In the process, he caught a sudden chill. Over the years, this turned into acute bronchitis, which contributed to his death in 1626.

Although some animals are able to lower their body temperatures during *hibernation*, most animals, like people, cannot tolerate freezing temperatures within their body tissues. Normally, when an organism is exposed to below-freezing temperatures, ice forms in smaller blood vessels and either bursts the blood vessels or stretches them beyond the

point where they can function normally. In addition, ice in the blood vessels "captures" the water content, making it impossible for the blood cells to survive. Other types of cells are also damaged during freezing. Frostbite is a common malady caused by cold temperatures; frozen skin and blood cells are damaged from the dehydration due to freezing.

Scientists have discovered, however, that some varieties of frogs and turtles can actually survive being frozen. When these animals sense ice on the outsides of their bodies, their livers produce extra glucose (blood sugar), which floods into their cells to protect the cell from freezing and from damage. This also holds the cell's shape so it doesn't collapse upon itself. Nucleating proteins "guide" water out of the cells, allowing the water to go in between the cells and the organs. This allows the water to freeze, but in small pieces, without "spears" that could puncture the cell membrane.

Scientists know of only one mammal, the Arctic ground squirrel, that seems to be able to tolerate ice crystals in its bloodstream during a physiological state that falls somewhere between hibernation and freezing.

Scientists are studying the "cryoprotectants" of these animals to see whether they have application for the freezing of human organs for transplants. So far they have been successful in freezing only single cells (e.g., sperm cells) and corneas for transplants.

CONNECTIONS

1. Look up information about scientists finding a frozen mastodon that still had some meat and skin intact.
2. Discuss the pros and cons of using cryogenics to preserve a human for some future time.

VOCABULARY

cryobiology the science of the effects of low temperatures on biological systems

cryosurgery surgery using cryogenic techniques, as in wart removal and corneal transplants

hibernation inactive state of some animals in winter

liquification the conversion of a solid into a liquid by heat



FLIES CAN SURVIVE!

Discover that the common housefly can survive temperatures below freezing.

▶ TRY THIS...

An alkaline battery will retain its stored energy longer when kept at a low temperature. Why will it last longer? How is the preservation of a battery's stored energy similar to the preservation of food products?

◆ MAIN ACTIVITY

- You can experiment with common houseflies to discover that they are adapted to survive freezing temperatures. Fruit flies or mosquitoes can also be used to provide comparisons.

Materials

- a net for catching flies
 - a small gauze-sided container for housing the flies
1. Using a net or a large piece of nylon stocking or gauze, catch several houseflies alive.
 2. Carefully transfer the flies into a container that has gauze or fine cloth mesh sides.
 3. Place the box containing the live flies into a freezer (or the freezer compartment of a refrigerator) and keep them there overnight.
 4. The next day remove the box and observe the flies. Record your findings. Are they active? Does their level of activity change?
 5. Capture some live fruit flies that often congregate around pieces of ripe fruit. (Or, catch some mosquitoes.) Experiment to determine whether these insects can be frozen and still survive.
- CAUTION:** Several states do not permit vertebrates to be harmed in any way. For example, frogs are vertebrates and may not be experimented with if harmful or lethal results occur. It is recommended that you use only insects for this activity.

▶ TRY THIS...

Freeze a thin film of water on a microscope slide. Examine the ice crystals under a microscope. Describe the shape of the ice crystals. How do you think an ice crystal would affect a cell membrane, which is like the flexible skin of a balloon?

Questions

1. How did the activities of the flies change after being in the freezer? How long did it take for them to resume their "normal" activities?
2. Compare the changes in the houseflies with those of the fruit flies or mosquitoes.
3. Could other insects survive in the same way? Do a literature search to find out.
4. Visit a local Museum of Natural History or biology department of a local university. Interview the scientific staff to find some answers!

▶ TRY THIS...

Conduct an experiment to compare frozen plant tissue to fresh plant tissue. Select a variety of plant tissue: roots, stems, and/or leaves. Can you observe any differences between the cell structure of the frozen and fresh tissue?

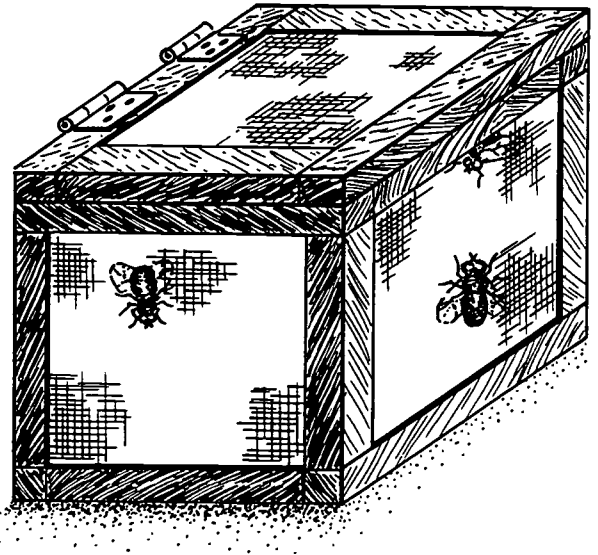

ACTIVITY LEVELS OF HOUSEFLIES AFTER FREEZING

ELAPSED TIME	OBSERVATIONS
After 5 min.	
After 10 min.	
Etc.	



Peggy finds out how the flow of the mighty Mississippi can be altered with the push of a button.

Segment length: 8:00

LOCKS AND DAMS

How does a lock and dam make an unnavigable part of a waterway navigable?

Why are dams sometimes necessary? How do locks and dams work? What are some of the effects of a lock and dam system on the river's environment?

INSIGHTS

Much of our folklore has explored the possibility of "escaping" on the river. Before the advent of the car, many a youth dreamed of traveling cross-country by water. Today there are 25,500 miles of navigable inland waterways in the United States; the Mississippi River, featured in the segment, accounts for approximately 9,000 miles of this system.

Equally appealing to youth is building a pint-size version of a dam by piling up sticks and debris to alter the flow of rainwater that is running down street-side curbs toward sewer drains. Dams are fascinating and useful; ruins of the world's oldest dam in Egypt along the Nile date to 2,700 B.C. (It was 37 feet high and 348 feet long.) More recently, the United States has built more than 5,000 dams, Japan has built about 2,000, and India has more than 1,000.

Universally, humans need water, but nature delivers water in imperfect amounts due to climate and weather. (Humans also contribute to problems of water availability; for example, deforestation can create desert-like climates in places where water was once abundant.) Some areas have too much water, some not enough, and some have both conditions at different times. Because of this irregularity, dams can be built to

make water supplies more useful. Dams have many functions: diversion dams control the supply of water to prevent floods; storage dams reserve water for use during dry periods; power dams generate electricity; and navigation dams provide navigable waters.

Some river areas may be unnavigable by commercial boats and barges because of shoals, rapids, waterfalls, or low water. The riverbed itself may change in elevation, which may prohibit reliable and economical navigation. Finally, some rivers have been dammed. A *lock* can help make navigation possible in each of these situations.

The technology of locks looks complex, but the principle is simple: The river is an inclined plane whose water moves in and out of locks by *gravity*. Think of locks as a flight of "water stairs" going up and down a hill. Water is drained

from the first lock (using gravity) until the water level is even with second one. The downstream gate is opened to allow the vessel into the lower lock, and the process is repeated. The lifting and lowering of vessels, some weighing up to 60 tons, is done without a great use of energy.

CONNECTIONS

1. Dams and the resulting reservoirs change wildlife habitats. Are all the environmental changes negative?
2. How important is commercial navigation by water in the U.S.? How does it compare to trucking and railroad transportation? Are some products not suited to waterway navigation?
3. If a dam were to be built in your area, how would your economy be affected? What kinds of jobs would be available?

VOCABULARY

floodplain the relatively broad, flat valley floor built up by an active river and periodically submerged with floodwater

gravity the force that tends to pull any two objects together

lock a short channel or a waterway divided into steps by watertight gates at either end

Pascal's law a law stating that a confined fluid transmits externally-applied pressure uniformly in all directions, without change in magnitude

watershed the area drained by a river or stream into the place where a dam will be built

RESOURCES

Adler, J. (1990) Troubled waters. *Newsweek* (Apr 16): 66-80.

Ardley, N. (1990) *How we build dams*. Ada, OK: Garrett Educational Corp.

Nelson, S.B. (1983) "Water engineering." In *Standard handbook for civil engineers*, ed. F.S. Merritt. New York: McGraw-Hill.

Old man river. (1988) St. Paul, MN: U.S. Army Corps of Engineers.

Skorupa, J. (1991) The problem with dams. *Popular Mechanics* (Dec): 106-107.

Additional sources of information:

Iowa Department of Transportation
River Transportation Division
5268 NW 2nd Ave.
Des Moines, IA 50313
(515) 281-4292

U.S. Army Corps of Engineers
1421 U.S. Post Office & Custom House
St. Paul, MN 55101

Community resources:
State Department of Natural Resources

Civil engineer



UNDER PRESSURE

Pascal's law is demonstrated in this water-pressure demonstration.

▶ TRY THIS...

Map the largest river near your school. Are there locks and dams on the river? Report on the geography and geology of the river, paying specific attention to the location of the locks and dams. How far could you go on an inland-water journey?

▶ TRY THIS...

A cubic foot of fresh water weighs 62.4 pounds (1 kilogram per liter). To understand the concept of how dense water is, calculate the weight of a waterbed. Call a waterbed store to find out the amount of water contained in a super-single-size waterbed, a queen-size waterbed, and a king-size waterbed.

◆ MAIN ACTIVITY

A cubic foot of fresh water weighs 62.4 pounds. Water weighs more than a heavy wood such as oak, but half as much as bricks. The point is, of course, that as the elevation of water behind a dam is increased, the height and density of it causes high pressure at the bottom of the dam. In this activity, you will observe what happens to the flow of water when it is under pressure.

Materials

- 2 tall empty juice cans
- nails
- adhesive tape

1. Punch three holes horizontally at the bottom of one can, about 1/2" to 3/4" apart. Cover the holes with adhesive tape. Ask your students to predict what will happen when you fill the can with water and remove the tape: Will any of the streams be longer than the others?
2. Punch three holes diagonally in the side of another can. Cover the holes with adhesive tape. Ask your students to predict what will happen when you fill the can with water and remove the tape: Will any of the streams be longer than the others?

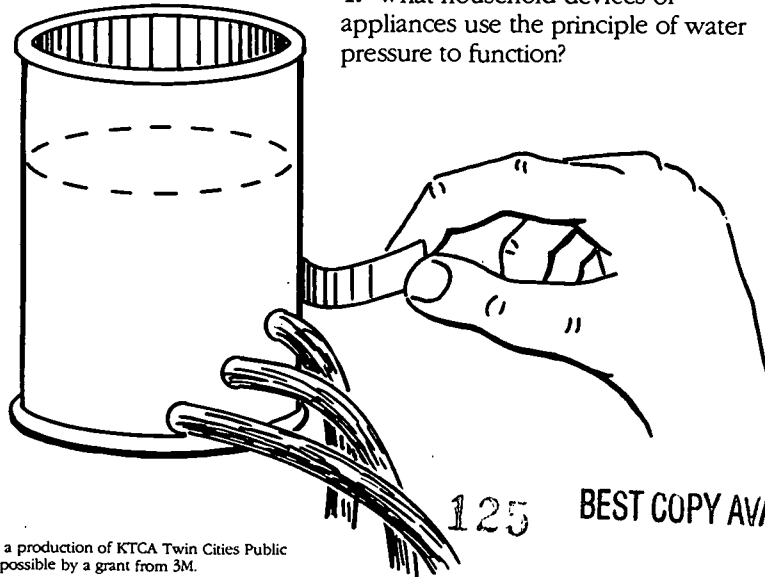

▶ TRY THIS...

Do some research about some of the world records for subjects pertaining to locks and dams: the dam with the greatest volume; the largest dam; the highest dam; the longest dam; the largest reservoir; the earliest-known reservoir; the most domoging dam disasters; the greatest number of locks on any one waterway; the largest set of locks; the deepest locks

3. Fill both cans with water, and then tear off the tape on the can with the horizontal holes. Observe what happens.
4. Now, remove the tape from the can with the diagonal holes. Observe what happens.

Questions

1. What happened when the tape was removed from the can with the horizontal holes? (All the streams are the same length because, according to *Pascal's law*, water pressure at a given depth is the same in every direction.)
2. What happened when the tape was removed from the can with the diagonal holes? (The longest stream of water shoots from the bottom hole because the deeper the water, the greater the pressure.)
3. Would this same principle of water pressure work with a balloon? Try it!
4. What household devices or appliances use the principle of water pressure to function?

▶ TRY THIS...

Visit a beaver dam. What similarities are there to dams constructed by humans? Why do beavers construct dams? What materials do beavers use?

- Newton's Apple is a production of KTCA Twin Cities Public Television. Made possible by a grant from 3M.
- Educational materials developed with the National Science Teachers Association—Space, Science, and Technology Division.

125 BEST COPY AVAILABLE

10.52



David gives a pint of blood and finds out about blood typing.

Segment length: 7:45

BLOOD TYPING

What makes different blood types different?

Is all blood the same? How can you tell what your blood type is? What are the different substances that make up your blood and what functions do they fill?

RESOURCES

Asimov, I. (1986) *How did we find out about blood?* New York: Walker & Co.

Merz, B. (1992) Blood count: What is your doctor looking for? *Good Housekeeping* (Mar): 136-140.

Villee, C., et al. (1989) *Biology*. Philadelphia: Saunders College Publishing.

Additional source of information:

American Red Cross National Headquarters
17th and D Street NW
Washington, DC
20006

Community resources:
American Red Cross chapter

Blood banks

Hospitals

INSIGHTS

By simply looking at a sample of human blood, it wouldn't seem like anything more than a red liquid. The truth is that blood is a complex fluid made up of many different components, each with a specific job. The first analysis of blood was carried out by Marcello Malpighi in 1661, who discovered that much of blood is composed of large red cells that have no nucleus. These cells are called erythrocytes, and we now know that they are responsible for gas exchange within the tissues of our body.

Almost 200 years later, Joseph Davaire discovered that blood also has large white cells that move about like amoebas. Outnumbered by red cells by a ratio of 650:1, these white cells—leukocytes—help protect our bodies from foreign agents, such as bacteria and viruses. In addition to red and white cells, most human blood contains *platelets* and *proteins* that help clot the blood. All three of these components can be separated from the blood after donation and used for different purposes.

The first successful human blood *transfusion* was accomplished in 1818 by James Blundell. In 1900, Karl Lanstreimer observed that the

blood of one individual, when mixed with the blood of another, might cause hemolysis, the visible clumping of red cells. This observation resulted in the establishment of blood typing: the distinction of four blood groups—A, B, AB, and O.

These different blood types are caused by the presence of a chemical marker—an *antigen*—on the surface of the type-A and type-B red blood cells. When mixed with the wrong blood type, these antigens are picked up by *antibodies* that cause the cells to clump. Someone with type-AB blood can receive any type blood with no ill effects, while people with type-O blood can only take their own type. People with type-A blood can receive A or O, and people with

type-B blood can take B or O. This makes type-O blood the universal donor. Blood donors and recipients must be typed and matched very carefully before transfusions are given.

CONNECTIONS

1. Why is it important for hospitals to have a ready supply of many different blood types? What kinds of tests are done on blood donations before they are used in transfusions?
2. Why is it important to know your own blood type?
3. For how long can different blood components be stored? What use does each of the components have?

VOCABULARY

agglutination the clumping together of blood cells in response to a specific antibody

antigen any substance that will trigger an immune response by a host organism

antibodies compounds produced by plasma cells that react with specific antigens invading a body

plasma the fluid portion of blood that contains proteins and salts, and in which blood cells and platelets are suspended

platelets cell fragments in blood that cause clotting

proteins essential constituents of all living things that are either made by the body or assimilated from food

transfusion the process of giving blood from one individual to another

WHAT'S YOUR TYPE?

Find out how your blood type fits in with that of the general population.

◆ MAIN ACTIVITY

By classifying blood types, you can find out what type of blood is most common among your students, and whether this information is similar to national statistics.

◆ Materials

- removable sticky notes
 - graph paper
 - pencils
1. Have each student find out his or her blood type by asking at home, consulting a birth certificate, or reviewing a recent blood test.
 2. Pass around the note paper and have each person record his or her blood type on a separate sheet.
 3. Collect the notes and post them on a wall, sorting them by groups to form a simple bar graph.
 4. Record the number of individuals in each group.
 5. Based on the class population and the information in the segment, calculate how many potential donors are present for each blood group. (For example, those with type-A blood can receive blood from either type-As or type-Os.)

BLOOD-TYPE FREQUENCY IN THE UNITED STATES:

Type	Percentage of Population
A	40%
B	10%
AB	4%
O	46%

- ◆ Newton's Apple is a production of KTCA Twin Cities Public Television. Made possible by a grant from 3M.
- ◆ Educational materials developed with the National Science Teachers Association—Space, Science, and Technology Division.

▶ TRY THIS...

Obtain prepared microscope slides of blood from at least five different organisms, such as a frog, a pig, a cat, a cow, and a human (available from most large science-supply houses). Make detailed drawings of what you observe on each of the slides and compare how the structure of blood cells varies from one animal to another.

▶ TRY THIS...

Take a field trip to a local blood center or medical laboratory where blood work-ups are done. Arrange for the technicians to demonstrate how blood is typed and centrifuged into its various components.

Questions

1. Are the blood types evenly distributed throughout the group or does one type dominate? Expand the population to include other classes or the whole school and see if the distribution changes. From your data, can you predict the general blood group distribution for your region?
2. Which blood type has the most potential donors in your group? Which blood type is most limited when it comes to donors?
3. Does the blood-group distribution for your class/area match the national distribution? What factors might influence the local patterns of blood types?

▶ TRY THIS...

You can get an idea of how blood is separated into its various components by using centrifugal force to separate chocolate milk. Try to relate the different components of chocolate milk to the different components of blood. Use powdered chocolate-milk mix to make about a cup of chocolate milk. Punch or drill two holes on either side of a clean, plastic, one-liter soda bottle about two inches down from the top and pass a wire or rope through the holes; securely tie the ends of the wire or rope together.

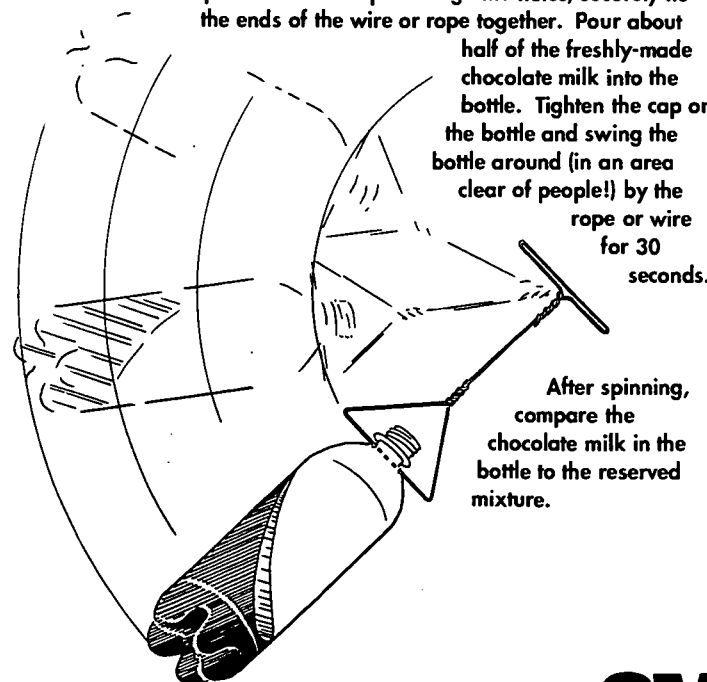

DIABETES

What is type I diabetes?

What are your chances of knowing someone with diabetes? What is happening in the body of someone with type I diabetes? What are the symptoms of diabetes?



Peggy travels to the Mayo Clinic to learn about diabetes.

Segment length: 6:08

RESOURCES

Almonte, P. and T. Desmond. (1991) *The facts about diabetes*. New York: Crestwood House.

American Diabetes Association. (1987) *Diabetes in the family*. New York: Prentice Hall.

Moynihan, P.M., B. Balik, S. Eliason, and B. Haig. (1988) *Diabetes youth curriculum*. Wayzata, MN: Diabetes Center.

Olsen, M.E. (1992) *Diabetes management: The balancing act*. Mayo (Spring): 3-14.

Additional sources of information:

American Association of Diabetes Educators
500 N. Michigan Ave.
Suite 1400
Chicago, IL 60611
(312) 661-1700

American Diabetes Association
Information Service
Center
P.O. Box 25757
1660 Duke Street
Alexandria, VA 22314
(703) 549-1500
(800) 232-3472

INSIGHTS

Diabetes mellitus and its complications affect over 12 million people in this country—that's one in 20 Americans—and five million adults don't even know they have the disease.

The segment shows Dane, who has type I diabetes, the kind of diabetes in which the *pancreas* secretes little or no *insulin*. Dane's body breaks down *carbohydrates* into *glucose*, but because he doesn't have enough insulin, the glucose can't leave the bloodstream and get into his body's cells. The blood carrying this excess sugar passes through the kidneys and causes an increased loss of body fluids. This need for replacement fluids leaves Dane feeling excessively thirsty. To feel good and live an active life, Dane injects insulin twice a day, tests his blood sugars, and balances his diet and exercise.

The cause of type I diabetes is not known for certain. The greatest evidence points to an autoimmune process that destroys the insulin-producing *beta cells* in the pancreas. It is unclear whether diabetes is inherited, but it is believed that some individuals may be genetically susceptible to getting diabetes. In these susceptible individuals, an environmental factor such as a viral infection may trigger the autoimmune process that leads

to type I diabetes. Type II diabetes, in which the body makes insulin but not enough, is associated with advancing age and obesity.

Almost all cases of type I diabetes occur before the age of 40, with a peak incidence of around age 14. However, of all the people who have diabetes, only about 10% are type I; the rest are type II. Many people with type II diabetes don't have to inject insulin, but can control it by eating properly or taking medications that stimulate insulin production. Both types of diabetes, however, require balancing acts: Diet must be varied; food intake must be scheduled; and sugar consumption must be moderate.

Promising medical advancements may make life for those with diabetes easier and less restrictive. Pancreatic transplants and *Islets of Langerhans* transplants might eliminate the need for insulin injections for some patients; computer-controlled blood-sugar monitoring and insulin administration may improve the day-to-day lives of many people who have diabetes.

CONNECTIONS

Consider this statement from *Diabetes Management: The Balancing Act* (see RESOURCES): "Diabetes, in the end, plays no larger a part in the lives of . . . people than they have chosen to give it. They choose instead to live their lives in balance."

VOCABULARY

- beta cells** the cells in the Islets of Langerhans that make insulin
- carbohydrates** any of a group of compounds that share a general biochemical structure containing carbon, hydrogen, and oxygen; includes sugars and starches
- glucose** the sugar derived from the breakdown of carbohydrates and starches that the body uses for fuel
- diabetes mellitus** a disorder characterized by the inadequate production or utilization of insulin
- insulin** a hormone produced by the beta cells of the pancreatic islets that enables sugar in the blood to enter the body cells
- Islets of Langerhans** clusters of cells that compose the endocrine portion of the pancreas and secrete insulin
- pancreas** a large elongated gland situated behind the stomach; secretes pancreatic juices, insulin, and glucagon for the regulation of carbohydrate metabolism

IT'S NOT MY FAULT!

Find out more about the causes of diabetes.

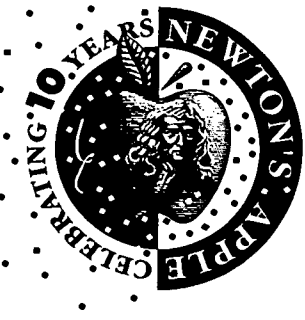

◆ MAIN ACTIVITY

This card game will help students understand the cause-and-effect relationships of diabetes, that those with type I diabetes are not responsible for having diabetes, and that there is treatment.

Materials

- ◆ • 3" x 5" notecards OR a pad of removable sticky notes
- ◆ • pencils or pens
- ◆ • 1. On separate cards, list plausible causes of diabetes, symptoms, statements for understanding it, and treatments, along with some inaccurate ideas about the causes of diabetes. Use the INSIGHTS and VOCABULARY sections as resources for your listings. Here are some examples:
 - ◆ • I ate too much sugar.
 - ◆ • White blood cells didn't attack a germ that got into my body, so the germ was able to attack my pancreas.
 - ◆ • I didn't behave in class.
 - ◆ • My stomach stopped making insulin.
 - ◆ • I am overweight.
 - ◆ • I caught it from another diabetic.
 - ◆ • Islets of Langerhans are clusters of cells found in the pancreas that secrete insulin
- ◆ • 2. Make enough cards so that there is one for each student. You may duplicate information on more than one card, but do not make more than three cards with one fact.
- ◆ • 3. Divide the class into four teams. Have each student chose a card and take it back to his or her team. The objective is for each team to gather a set of cards that correctly explains how diabetes comes about, its symptoms, and treatment.

▶ TRY THIS...

Many people who have any kind of permanent disease or ailment don't like to be labeled with the name of the disease. They may prefer to say, "I have diabetes," rather than, "I am a diabetic." Why is this semantic difference important to consider? How might this be extended to "epileptics," "paraplegics," or "asthmatics"?

▶ TRY THIS...

Invite some people who have diabetes into your classroom to view the segment with the class. If possible, your guests might be willing to show how they inject insulin and test for blood-sugar levels.

▶ TRY THIS...

List on the board the following famous people who have or had diabetes

- ◆ • Bret Michaels, rock vocalist
- ◆ • Jackie Robinson, major-league baseball player
- ◆ • Ernest Hemingway, writer
- ◆ • Mary Tyler Moore, actress
- ◆ • Wade Wilson, professional football player

Are there more? Are there famous people with epilepsy? Arthritis? Learning differences? Does this information matter?

4. RULES: Any member may trade a card with a member of another team. There can be only one member per team on his or her feet at any one time. Set a time limit, or play until one team gets a complete set of cards and wins. The winning team must explain the statements on its set of cards.

Questions

1. Why is it important to realize that type I diabetes is not caused by a person's actions or by "catching it"? What health problems *are* a direct result of individual behaviors and choices?
2. If you had diabetes, what would you have to do differently? What if you had just taken your shot of insulin and had eaten your dinner, and then you were invited out for pizza? What if you were so tired, you wanted to sleep until noon on Saturdays?

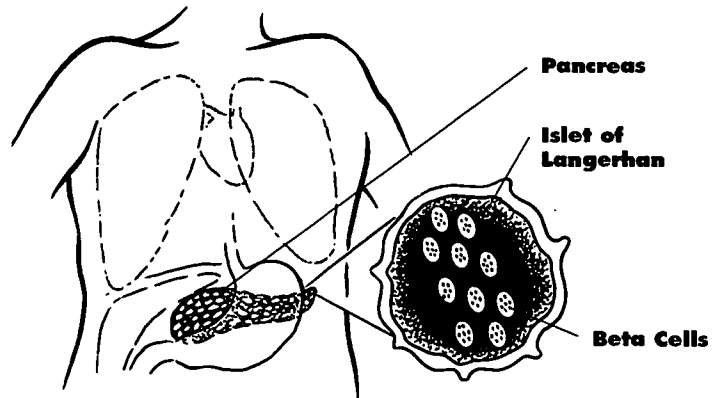



David finds out how scientists make maps of the cosmos.

Segment length: 8:35

GALAXY MAPPING

Why make maps of the galaxies?

What new technologies are being used to map the galaxies? Is there a pattern to where galaxies are located? Why would we want to map the galaxies?

INSIGHTS

Edwin Hubble's proof that the universe is dynamic and that our Milky Way is not the lone *galaxy* provoked a renewal of questions and theories. Understanding the positions, distances, and distribution patterns of other galaxies not only provides mapping information; it gives perspective on what the earth's relationship is to the overall universal plan; it provides clues about the earth's origin; and it gives a type of structure to an indistinct concept.

The *Doppler effect* can explain the *red shifts* found in the light from galaxies. According to the Doppler effect, the more that light is shifted to longer wavelengths (meaning toward the red end of the spectrum), the faster the source of the light is moving away from the observer. Edwin Hubble found that the farther away the galaxy, the more its light is red-shifted. This means that the farther the galaxy, the faster it is moving away from us. In other words, the universe is expanding.

Consider the universe as a huge ball of bread dough, speckled throughout with raisins, each raisin denoting a galaxy. There is no definite boundary or edge, however.

As this model universe is baking in the oven, yeast is making the dough expand. The expanding

dough carries the raisins farther and farther apart from each other, but the size of each raisin does not increase. In the same way, space expands the distance between galaxies in the universe, but the galaxies themselves do not get larger.

We are on the threshold of new discoveries about the galaxies. Using the latest technology, Margaret Geller and John Huchra are able to analyze "slices" of the universe. If the ball of raisin-bread dough represents the universe, Geller and Huchra so far have mapped only four very thin slices of bread slices that don't even go all the way through the loaf.

Their mapping illustrates a definite pattern to galaxy distribution. Galaxies appear to be positioned in a network of

thin, curved walls that surround huge, nearly empty voids. How empty the voids are and how they arose, no one yet knows.

The "Great Wall" of the universe is the largest structure known to humans, yet its size, 500 million *light years* by 200 million light years, poses a challenge to cosmological theories. No one can explain how, if only known forms of matter and known forces were at work, such a large structure was formed in the time since the *Big Bang*. Newer technologies and continued research promise to introduce new insights into the universe.

CONNECTIONS

What is your vision of a galaxy? Of space? Of the universe?

VOCABULARY

Big Bang a theory of the origin and evolution of the universe (This theory holds that approximately 2×10^{10} years ago, all matter in the universe was packed into a small agglomeration of extremely high density and temperature. It exploded, sending matter in all directions and giving rise to the expanding universe.)

Doppler effect a change in the frequency and wavelength of sound, light, or radio waves as perceived by an observer, caused by the relative motion of the source of the waves or the observer

galaxy a closed gravitational system of stars, their satellites, nebulae, and dust, that is spinning and traveling through space

light year the distance that light, traveling at 186,000 miles per second in a vacuum, travels in one year, or about 5.9 trillion miles

red shift a shift toward longer (redder) wavelengths in the spectrum of light from an object

RESOURCES

NASA
Education Division
Mail Code F
Washington, DC 20546
(booklets: *The Great Observatories for Space Astrophysics*, NP-128; *The Gamma-Ray Observatory*, NP-124)

Space Telescope Science Institute
3700 San Martin Dr.
Baltimore, MD 21218
(301) 338-4707
(slides, posters, videos, hands-on activities, brochures)

Astronomical Society of the Pacific
390 Ashton Ave.
San Francisco, CA 94112
(*Universe in the Classroom* newsletter)

Community resources:
Astronomy club

University departments of physics and astronomy



A NEW VIEW

See for yourself what a difference a 3-D map can make.

▶ TRY THIS...

Do you have a manually-adjustable camera? Begin a collection of your own constellation photos. A camera shutter held open for 10 to 15 seconds will record most of the brightest stars in a constellation. An exposure of longer than 15 seconds will record the stars as streaks and trails. Why? What is happening to the earth? Point the camera both north and south and take some pictures. What will be the pattern of the trails?

▶ TRY THIS...

Use a large balloon to represent our universe. Randomly place adhesive stars on the deflated balloon. Slowly inflate the balloon. What do you notice about the distances between the stars as the universe expands? Do the sizes of the stars change? Is there an edge to this universe? A center? Is the expansion infinite?

◆ MAIN ACTIVITY

You will observe models of constellations and galaxies from different vantage points to see how things look different when viewed from different locations.

Materials

- constellation and galaxy maps
- drawing paper 18" x 24"
- pieces of cardboard 18" x 24"
- black paint OR construction paper
- string
- tagboard
- markers
- aluminum foil
- scissors

PART I

1. Divide the class into teams of four.
2. Have each team choose a favorite constellation or galaxy and make a paper map of it, using the acquired constellation maps as guides.

PART II

1. Make a three-dimensional (3-D) model of your chosen constellation or galaxy. Start by transforming the cardboard into the unknown "dark matter" of space by painting or covering it with construction paper.
2. Determine the location on the cardboard and size of stars needed to create a 3-D model of the chosen constellation.
3. Use foil, tag board, string, and markers to create 3-D star models. Attach hanging stars to the cardboard by using varying lengths and thicknesses of string.
4. Suspend the completed 3-D maps from the classroom ceiling.

Note: Your finished project will illustrate only an approximation of the placement of the stars. It would be impossible, using these materials, to make something to scale.

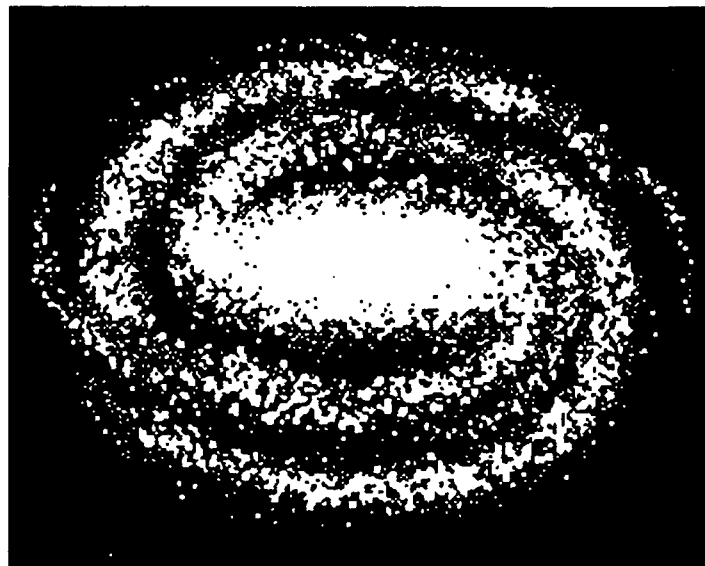

Questions

1. Lie on the floor and look up at your "night skies." Stand up and observe your creations from different locations in the room. Stand on a ladder and look "down" into your constellation. Which vantage point compares with the paper map? Would your conclusions change depending on your vantage point? Would you recognize the constellation from the different vantage points?
2. What types of technology still need to be invented to help us "see" more of the universe?

▶ TRY THIS...

Find a book that describes the common constellations. Try to find them in the night sky. Consider how the patterns of stars reflect the mythological names given to them.

▶ TRY THIS...

Demonstrate the Doppler effect by placing a battery-operated buzzer inside a hollow whiffle ball. Attach a 4- to 5-foot-long cord to the ball. Carefully swing the ball around in a circle above your head. Your classmates should be able to note an apparent change in the pitch of the buzzer. Take turns being in the center so that everyone can hear that the pitch does not change. In what part of the circle do you hear different sounds/pitches?

ANIMALS

The Newton's Apple Menagerie



Naturalist Nancy Gibson, Host David Heil, and Field Reporter Peggy Knapp meet some fascinating animals in season ten.

MUSK OX SHOW 1002

The bearded one

Eskimos called the musk ox *omingmak*, which means "the bearded one." A survivor of the ice age, this animal of the Arctic steppe and tundra provides people with a source of meat, warm clothing, and horn used for weapons and implements. The coat of the musk ox allows it to face Arctic blizzards without shelter. It has coarse, long guard hairs and a thick inner coat of soft, fine wool called quiviut. The quiviut completely covers the animal except on the lips and nostrils. It is prized for its softness, light weight, and ability to protect against cold and frost. Musk oxen have keen sight, hearing, and smell. How do all these adaptations—its thick coat, its keen senses, its horns—help the musk ox survive?

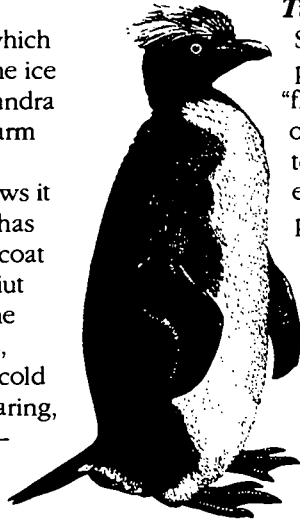

PENGUINS SHOWS 1006 AND 1012

Tuxedo birds

Sometimes mistaken for small porpoises, penguins are actually birds that appear to "fly" through the ocean. They weave in and out of the water, swimming at speeds of up to fifteen miles per hour. Describe an ocean environment. List some of the dangers penguins may encounter. Discuss how the following adaptations might contribute to the success of penguins living in and near the ocean: short stiff flippers instead of wings; small, hard, densely-packed feathers with shiny slightly-bent tips; a black back; a white belly; feet that radiate excess heat from the soles; a salt gland that excretes excess salt; solid bones; and a pointed tail.

COUGARS SHOW 1003

Super sleuth

Long muscular legs, a flexible backbone, powerful neck muscles, a long tail for balance, large eyes that allow as much light as possible to enter, and sharp retractable claws make the cougar an effective predator. Cougars are at the top of the food chain. Their efficient hunting skills help keep the populations of other animals stable.

Observe a cat hunting for prey or playing with a toy. Look carefully at the tail, paws, head, ears, and legs. What position do cats hold before pouncing on prey? What do cats do to the prey after they have caught it?

WOLVERINE SHOW 1007

Devil bear

Wolverines are members of the weasel family, which includes otters, mink, and fishers. The Eskimo called the wolverine the "evil one"; early European settlers in North America nicknamed it "glutton" or "devil bear." Wolverines are able to travel far. In the winter, their large, wide feet become overgrown with frost-free hair, making perfect "snowshoes." Studies have shown that males generally stay within a 164-mile radius, but from time to time, travel greater distances.

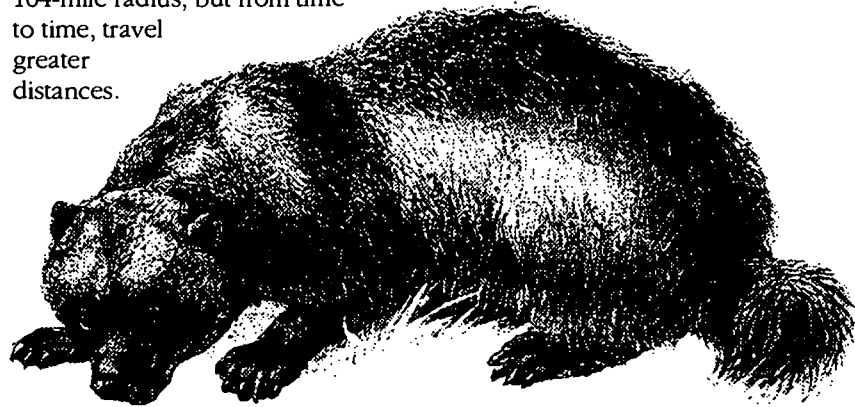

Look at a map that includes your home or school. What could a wolverine come across if it hunted for food within a 150-mile radius of your school or home?

CARIBOU SHOW 1005

Antlers, antlers everywhere

Caribou are the only deer in which both males and females have antlers. Antlers are the fastest form of bone growth known. It is actual living tissue. The blood-rich covering on the antlers is called velvet. Velvet is the only regenerating skin found among mammals. If an antler is injured while growing, it will heal, but will grow back deformed. Every year when a new antler is grown, the deformity is repeated. Why do animals have antlers or horns? What happens to male and female antlers in the fall and winter?

132

RHINOCEROS SHOW 1008

Hunted for its horn

The rhino has become the symbol of the plight of vanishing animals. Fewer than 11,500 are left in the world today, down from 73,000 in 1970. Despite its massive size, its thick "coat of armor," and a horn up to four feet in length, it is defenseless from poachers and habitat destruction. Hunters often kill a rhino only for its horn—a prized possession in the Far East where one horn could bring fifteen hundred dollars. The horn is considered by many to have medicinal value, and is also used for carving

jewelry and other objects.

Learn about the people who live in the African and Asian nations with rhino populations. Why

would a village allow poaching? What benefits might there be? How might poaching be stopped? What can you do to stop poaching?



CONDORS SHOW 1009

On the brink of extinction

The California condor is an American vulture. It is the largest living flying bird. Its body structure lacks the dash and strength

of typical birds of prey. And, its

beak is so weak, it is unable to tear flesh until it has partly rotted. This is one of the reasons it eats carrion.

What other adaptations do condors have for eating dead animals? Eating poison-contaminated carcasses, loss of habitat, and slow rate of

reproduction have led to their rapid decline. Only with captive breeding has the condor survived. It costs about one million dollars annually to operate the condor-breeding project. Is this money well spent?



PIRANHAS SHOW 1010

Fang!

Would you swim with piranhas? Children in South America do. Although doing this is rarely dangerous, the children know not to swim in a river when water levels are low and food is in short supply for the piranha. Natives of the

Amazon Basin use piranhas in a variety of ways. They remove their teeth and jaws before cooking them for food; they use the fish in cultural rituals; and they make tools from the teeth.

Design a tool that could use piranha teeth.

In North America, some people keep piranhas as pets, although this is illegal in many of the United States. Predict what would happen if a piranha were released into a body of water near your home.

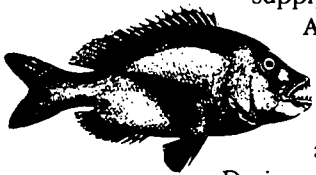

OSTRICH SHOW 1013

Megabird

The ostrich is the largest living bird. The female, on alternate days, can lay up to a dozen eggs. Each egg is six to nine inches long, five to six inches in diameter, and weighs up to 3.3 lbs. The shell is a quarter of an inch thick. It would take up to forty minutes to hard boil an ostrich egg! However, as large as the egg is, it's actually small in relation to the ostrich's size.

Complete the following math problem. If an adult ostrich weighs 260 lbs and lays a 3.3 lb egg, what percent of the adult's weight is the weight of the egg? Of the adult kiwi, who weighs 3.75 lbs and lays a 1-lb egg? Of the adult hummingbird, who weighs .05 ounces and lays a .01-oz egg? Which one lays the largest egg in proportion to its size? (A kiwi, a small relative of the ostrich, lays the largest egg in proportion to its size. The egg is 25% of the weight of the adult bird. The hummingbird egg weighs about 20% of the adult's weight. The ostrich egg weighs about 1% of the adult's weight.)

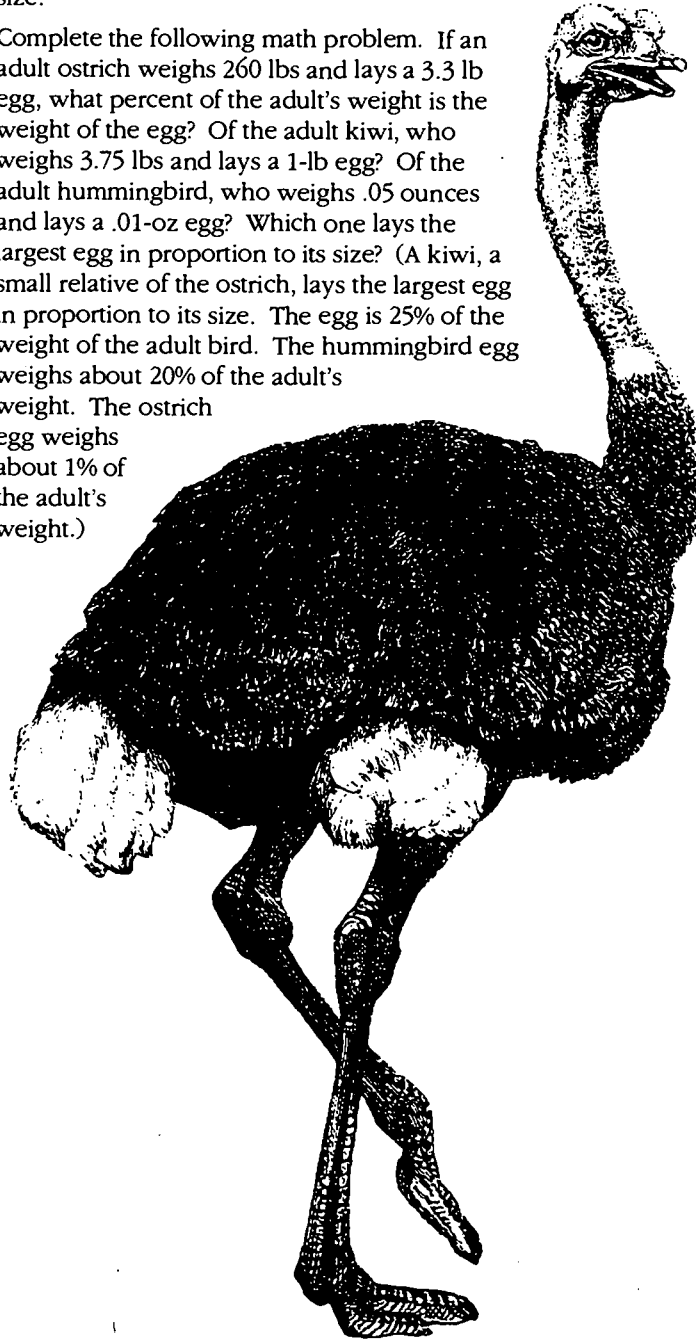

RESOURCES:

Wildlife Conservation, New York Zoological Society, Bronx, NY 10460

ZooLife, Ingle Publishing Co., 11661 San Vicente Blvd., Suite 402, Los Angeles, CA 90049

The Endangered Species Update, The School of Natural Resources, University of Michigan, Ann Arbor, MI 48109-1115.

BEST COPY AVAILABLE

Newton's Apple is a production of KTCA Twin Cities Public Made possible by a grant from 3M.

ERIC Full Text Provided by ERIC
Materials developed with the National Science Association—Space, Science, and Technology Division.

WE ENCOURAGE
DUPLICATION FOR
EDUCATIONAL USE!

133
10.60

3M
Innovation working for you

SCIENCE TRY ITS™

Try these experiments and observe what happens. Then try to guess why it happens. Compare your results to the results on the back of this page.



Now you can do
Newton's Apple
at home!

TRY IT! Oobleckh

How? Mix one and one half cups of cornstarch with one cup of water in a bowl. Slowly dip your finger into the gooey mixture; then try slapping it hard with your hand or a heavy spoon. What happens? Why?

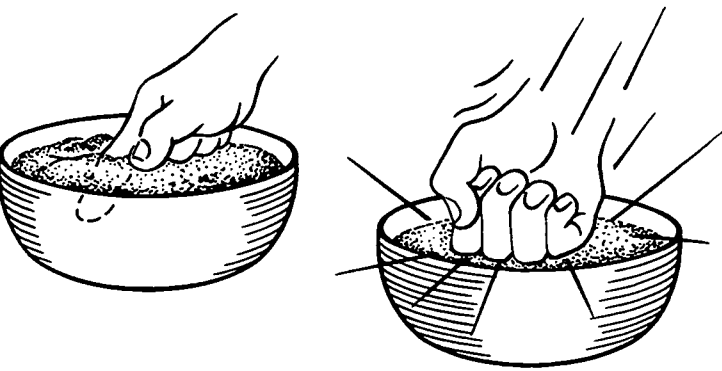

TRY IT! Density Stacker

How? Pour one-third cup of syrup into a glass jar followed by one-third cup of cooking oil. Then pour in one-third cup of water. Drop in a piece of plastic, followed by a grape, followed by a small cork. What happens? Why?

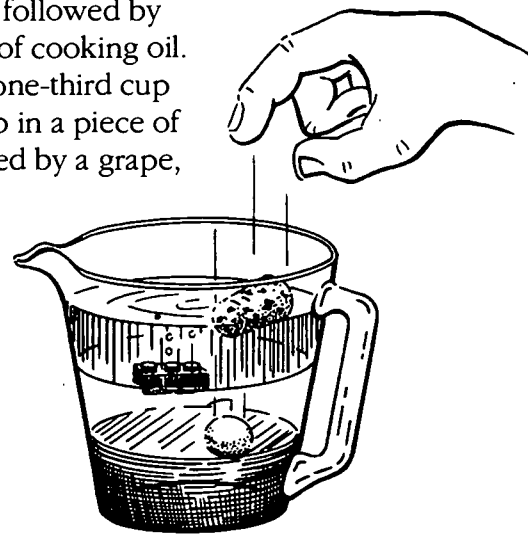

TRY IT! Fire Extinguisher

How? Place a short candle, a slightly taller candle, and a small dish or small glass filled with baking soda in the bottom of a large bowl. Light both candles. Then pour vinegar into the dish of baking soda. Observe the foaming reaction. What happens to the candles? Why?

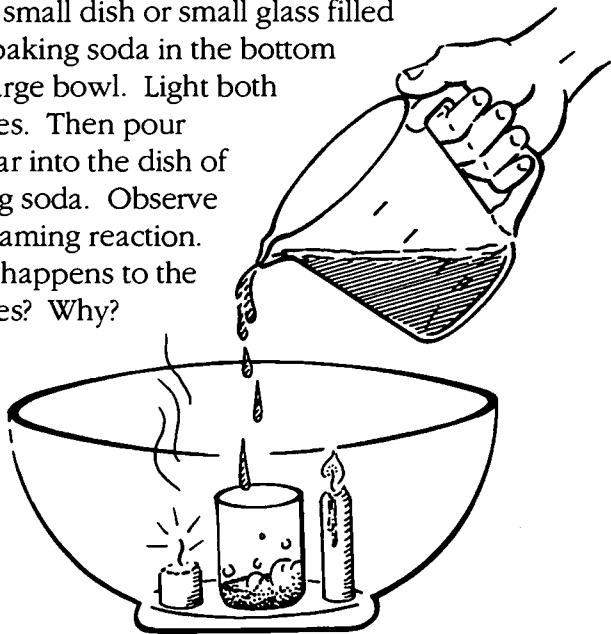

TRY IT! Dancin' Raisins

How? Fill a glass or bottle half full with carbonated water. Drop three to four raisins into the water. Wait. What happens? Why?

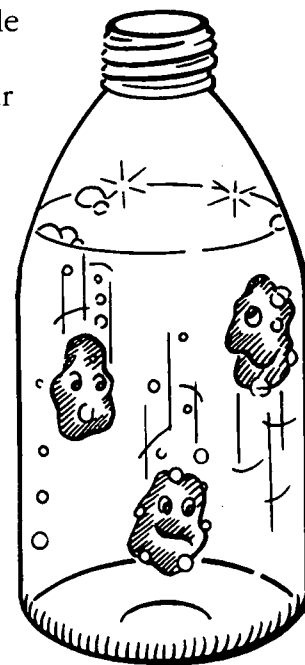

TRY IT! The Submariner

How? Fill a plastic bottle with water. Attach a small piece of clay on the arm of a plastic pen cap. Place the cap in the bottle so it floats and seal the bottle tightly. Squeeze the sides of the bottle. What happens? Why?

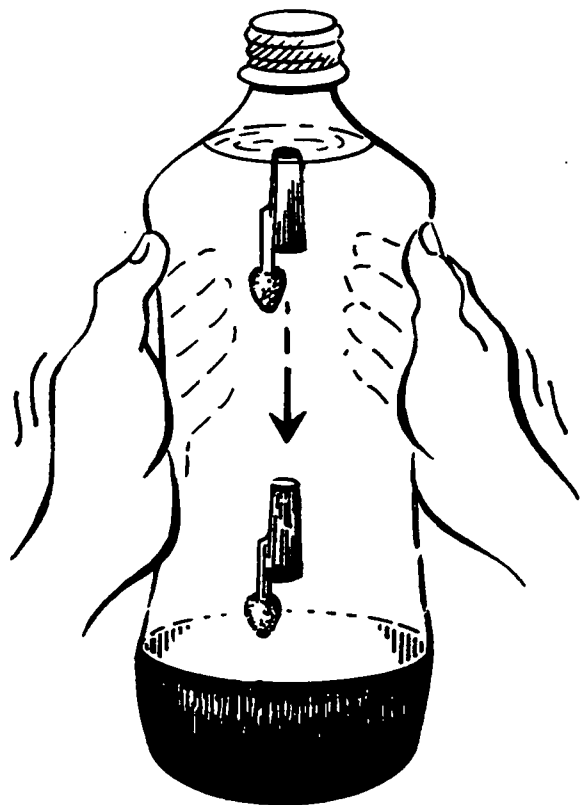

TRY IT! Egg in a Bottle

How? Drop three lit matches into a glass bottle that has a narrow neck (an apple cider jug works well). Quickly place a peeled, hard-boiled egg on the mouth of the bottle. What happens? Why?

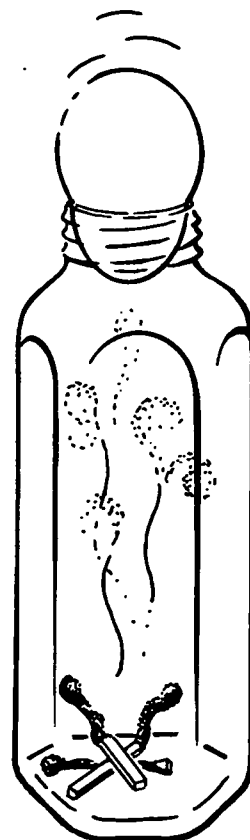

The Science behind "SCIENCE TRY ITS"

What prevents the ooblekh from splattering?

The molecules in ooblekh are very large compared to, for instance, molecules of water. When slapped quickly, they entangle themselves preventing any splattering. In this way the mixture behaves more like a solid.

Why do the different liquids stack in layers?

The liquids have different densities. The most dense (syrup) will be at the bottom, the least dense (oil) will be at the top, with the water in between. Each object will sink to the level of the liquid that has a greater density than the object. The object will then float on that layer.

What extinguishes the candles?

When vinegar reacts with baking soda, carbon dioxide gas is produced. This gas is heavier than air so it sinks to the bottom of the bowl and slowly begins to fill up the bowl as though it were water. When the level of carbon dioxide has risen to the level of the flame, the flame will go out from lack of air.

Why do the raisins bob to the surface?

Carbonated water contains dissolved carbon dioxide gas that collects on the irregular surfaces on the raisins. Once enough gas has collected, it will actually lift the raisins to the surface where the gas is released into the air, causing the raisins to sink once again.

Why does the pen cap sink when you squeeze the sides of the bottle?

By squeezing the bottle, you increase the pressure inside, thus forcing more water up into the pen cap. The added water in the cap increases its weight and causes the cap to sink.

Why does the egg go into the bottle?

The flames heat the air in the bottle. As the heated air expands, some of it escapes out the bottle. When the matches go out, the air inside the bottle cools and contracts, thus creating a lower pressure inside the bottle than outside. The greater pressure outside the bottle forces the egg into the bottle.



Now you can do
Newton's Apple
at home!

WHY DON'T SLEEPING BIRDS FALL OFF THEIR PERCHES?

- A. They have a good sense of balance.
- B. They have special brains.
- C. Clenching the branch is a relaxed state.
- D. They have a drill-like appendage that anchors them to the perch.

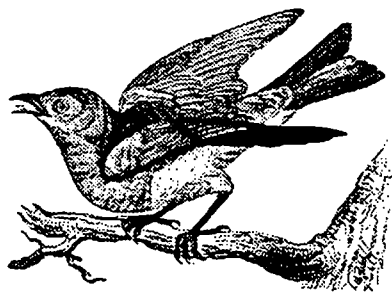

WHAT IS THE FASTEST ANIMAL ON EARTH?

- A. the gazelle
- B. the cheetah
- C. the zebra
- D. the porpoise



WHAT MAKES A JUMPING BEAN JUMP?

- A. a tiny creature in the bean
- B. little legs—little, tiny legs
- C. the soul of the bean
- D. something like popcorn

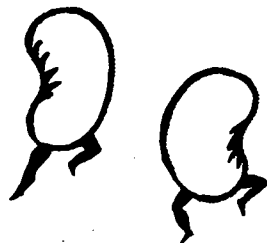

HOW MUCH DUST DOES AN AVERAGE HOME COLLECT IN A YEAR?

- A. 3 pounds
- B. 10 pounds
- C. 40 pounds
- D. 127 pounds



HOW MANY VOLTS CAN AN ELECTRIC EEL DISH OUT?

- A. 20 volts
- B. 120 volts
- C. 650 volts
- D. no volts, they produce watts

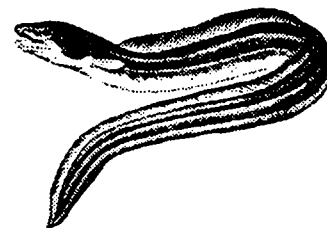

HOW MANY MUSCLES DO WE USE WHEN WE STAND?

- A. 4
- B. 2
- C. none, it's so easy
- D. 300





ANSWERS

Sleeping Birds?

For birds, clenching is a relaxed position. They have flexor tendons in their talons that respond to the pressure of a branch by automatically gripping. Unlike birds, humans would have to continuously concentrate on flexing their muscles in order to hang on, and it just doesn't seem worth it to sleep on a stick.

Fastest Animal?

The cheetah can catch both the gazelle and the zebra. The sure-footed cheetah is able to achieve an incredible 60 miles per hour, accelerating at the rate of a sports car. However, it cannot maintain that speed for long. It's simply too fast to last.

Jumping Bean?

Inside each bean is a tiny moth larva. The bean, which is really a seed from a weed originally found in Mexico, is a temporary home to the moth larva. Warmth stimulates the larva to jump and jiggle. It's great at parties, a real crowd pleaser.

Dust?

The average home collects about 40 pounds of dust per year. The dust material is composed of many kinds of solids carried in the air. Although it's annoying in the home, dust particles do help raindrops to fall and contribute to the beautiful colors seen at twilight—something to think about when you're dusting for the hundredth time.

Electric Eel?

This six-foot-long South American beast can deliver up to 650 volts and can stun a horse at 20 feet. Yes, it came as a shock to us, too.

Muscles?

We use an incredible 300 muscles in the simple act of standing. And we have more than twice that many (639 muscles have been named) in our entire body. Furthermore, there are more than six billion muscle cells, each thinner than a human hair but capable of supporting a thousand times its own weight—truly pumped up!

TRANSPARENCY MASTER



Show 1001
How TV Works

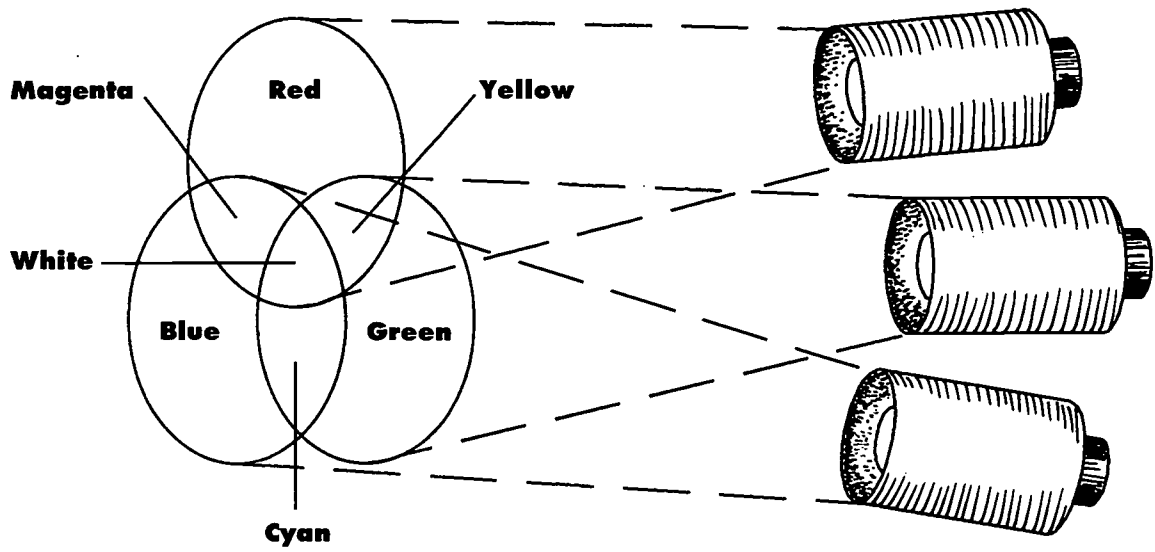

Show 1006
Antarctica II

Antarctic Research Stations

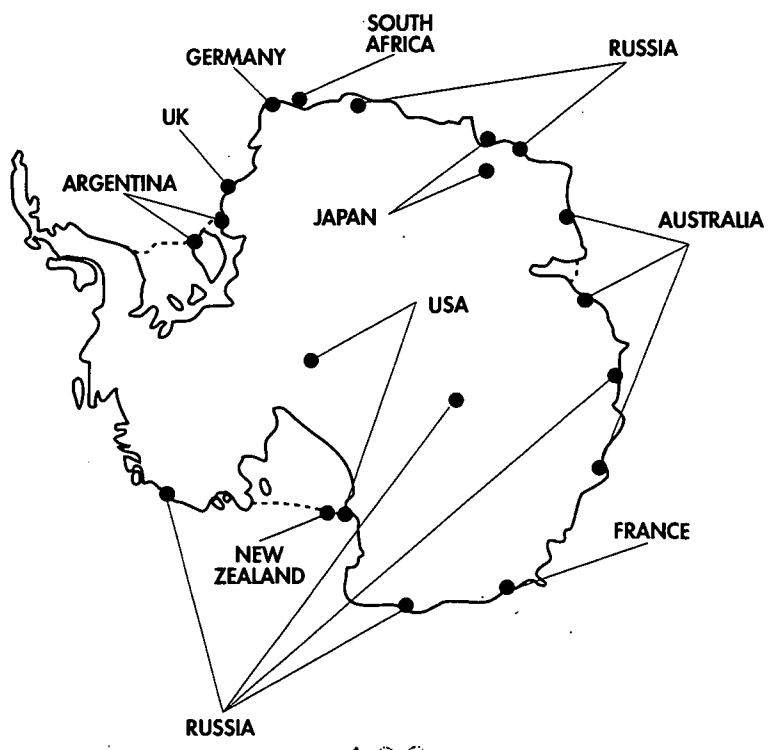

- Hints:**
- Make a copy of the original.
 - Use a thermofax or a copier to make the transparency.
 - Use a marker or with a marker, color film, etc.



TRANSPARENCY MASTER

Show 1010 Aurora Borealis

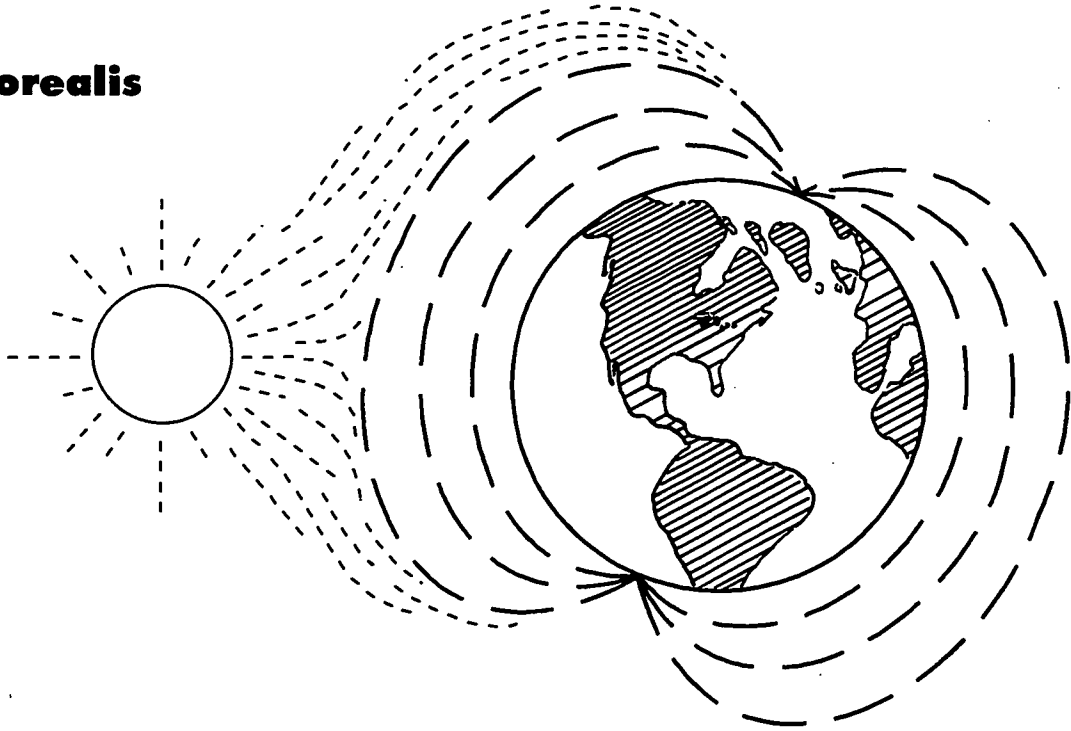

Show 1013 Diabetes

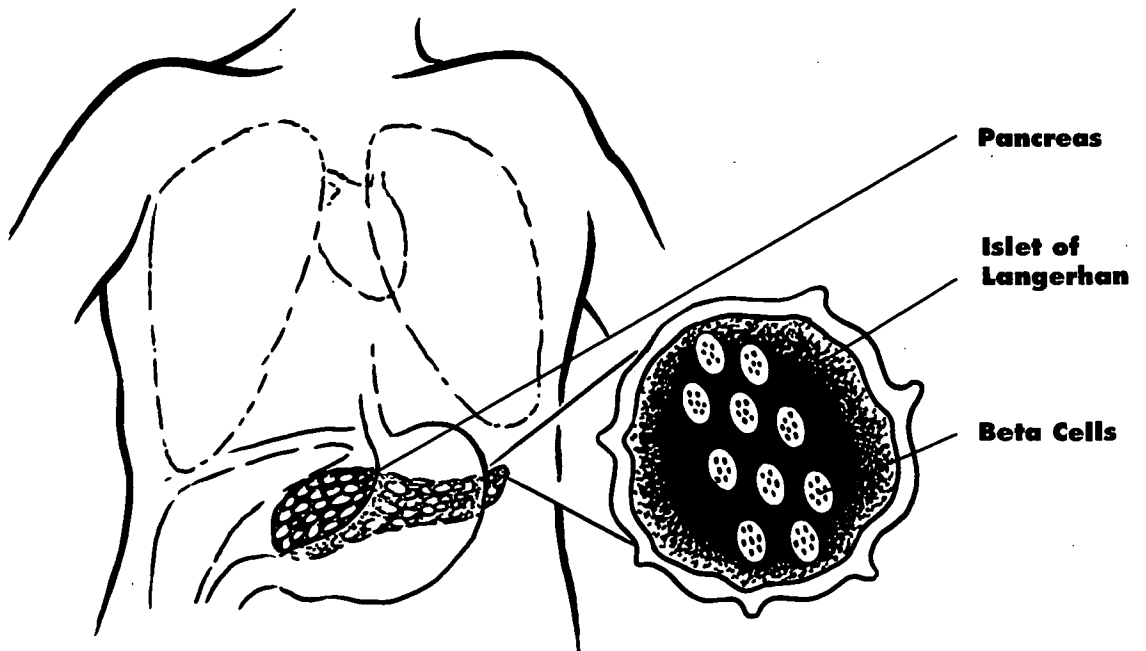

139

More Hints:

- Use a unique pointer to draw attention.
- Attract the audience's attention by turning the projector on and off.
- Use a piece of paper to hide what's to come.



CELEBRATE WITH US AT HOME!

Join our celebration of *Newton's Apple's* 10th anniversary by tuning in at home! This take-home page is a guide to the major segments explored in our 10th Anniversary Season and our special animal segments.* You and your family will enjoy learning about science through *Newton's Apple's* unique and entertaining style. In addition to the segments listed below, you'll also see our short features, like Peggy "On the Spot," "Science of the Rich and Famous," "Street Smart," and "Science Try Its"—simple yet surprising experiments you can do at home – and much, much more!



Host David Heil, Field Reporter Peggy Knapp, and Naturalist Nancy Gibson return in season ten to answer your science questions.

SHOW 1001

Behind-the-Scenes
Anniversary Special

- How TV Works
- *Newton's Apple* Studio Tour
- Control Room/Editing
- Satellite Technology

SHOW 1002

Hollywood Stunts
Household Chemistry
Musk Ox

SHOW 1003

Election Polls and Surveys
Electric Car
Cougar

SHOW 1004

Monster Makeup
Ozone

SHOW 1005

Oil Spills
Diet and Nutrition
Caribou

Continued on next page...

- * Please check with your local PBS station for exact airdate and time. If season ten of *Newton's Apple* doesn't appear in the fall 1992 schedule of your local PBS station, call them to find out when they plan to run it. If you call to ask for a particular show, refer to it by the show number listed above (i.e., #1001 for "Behind-the-Scenes Anniversary Special").

We've also listed some fun and interesting activities based on the segments that you can do at home with your family and friends. Have fun!

TRY THIS...

How TV Works

Shaw 1001

Television flashes a series of images so fast that your eye sees them as one moving image. Make a flickerbook to help understand this idea. Take a small pad of paper stapled together at one end. Draw a series of simple images, such as a seed growing. Working from the last page to the first, draw the images with incremental differences. When done, flip through your book from the last page to the first.



CELEBRATE WITH US AT HOME

Continued from previous page...

◆ SHOW 1006

Antarctic Special

- • The Journey to the Antarctic
- • Penguins
- • Palmer Station
- • Krill
- • Seals

◆ SHOW 1007

AIDS

- Glass Recycling
- Wolverine

◆ SHOW 1008

- Cockroaches
- Broken Bones
- Rhinoceros

◆ SHOW 1009

- OMNIMAX® Technology
- Archery
- Condor

◆ SHOW 1010

- Aurora Borealis
- Air Pressure
- Piranha

◆ SHOW 1011

- Traffic Control
- Cryogenics

▶ TRY THIS...

Glass Recycling Show 1007

Develop a glass recycling project for your home. Discuss what procedures need to be established, what products you want to recycle, how they will be collected and recycled, and how the project will be organized. Determine what your community already does for recycling. Start a new community project or add to the existing one.

▶ TRY THIS...

Air Pressure Show 1010

Fill up a plastic tumbler with water and place a plastic coffee-can lid over the top. Holding the lid on tightly with your fingers, invert the tumbler and then let go of the lid while holding on to the bottom of the glass. (Do this over a sink or dish pan!) Observe what happens and repeat the experiment with different-size glasses. How can you explain the results?

▶ TRY THIS...

Blood Typing

Show 1012

You can get an idea of how blood is separated into its various components by using centrifugal force to separate chocolate milk. Try relate the different components of chocolate milk to the different components of blood. Use powdered chocolate milk mix to make about a cup of chocolate milk. Punch or drill two holes on either side of a clean, plastic, one-liter soda bottle about two inches down from the top and pass a wire or rope through the holes; securely tie the ends of the wire or rope together. Pour about half of the freshly-made chocolate milk into the bottle. Tighten the cap on the bottle and swing the bottle around (in an area clear of people!) by the rope for 30 seconds. After spinning, compare the chocolate milk in the bottle to the reserved mixture.

SHOW 1012

- Locks and Dams
- Blood Typing
- Penguin

SHOW 1013

- Diabetes
- Galaxy Mapping
- Ostrich

▶ TRY THIS...

Galaxy Mapping

Show 1013

Find a book that describes the common constellations. Try to find them in the night sky. Consider how the patterns of stars reflect the mythological names given to them.

▶ TRY THIS...

Aurora Borealis

Show 1010

Invite your friends to a "northern lights" party. Give each person a pack of wintergreen flavored round candies. (Do not use the sugar-free kind.) Go into a very dark room or outside at night. Ask each person to bite down on two or three pieces of candy. (Keep your mouth open as much as possible during this experiment.) Does the candy appear to sparkle and glitter as you bite down on it? Stress in sugar crystals creates an electric field! These fields are taking outer electrons from molecules, recombining them with electrons, and giving off light. What colors can you see? Does having braces on your teeth make a difference in the result?

141

BEST COPY AVAILABLE **3M**

3M AND SCIENCE EDUCATION

For over 40 years, scientists and engineers at 3M have organized technical employees in volunteer outreach programs to encourage students at elementary, junior, and senior high levels to consider careers in science and engineering.

The 3M Technical Teams Encouraging Career Horizons (TECH) program provides opportunities for students to meet and interact with 3M scientists and engineers. Volunteer 3M technical employees visit the classrooms carrying the message to students that significant career opportunities await them if they keep their options open by studying math and science.

The 3M Visiting Wizards program involves 3M employee volunteers who visit schools with demonstrations designed to create an interest in science. Wizard classroom activities are creative, fun, hands-on approaches to science education.

For more information on TECH and Visiting Wizards contact 3M at (612) 733-9258.

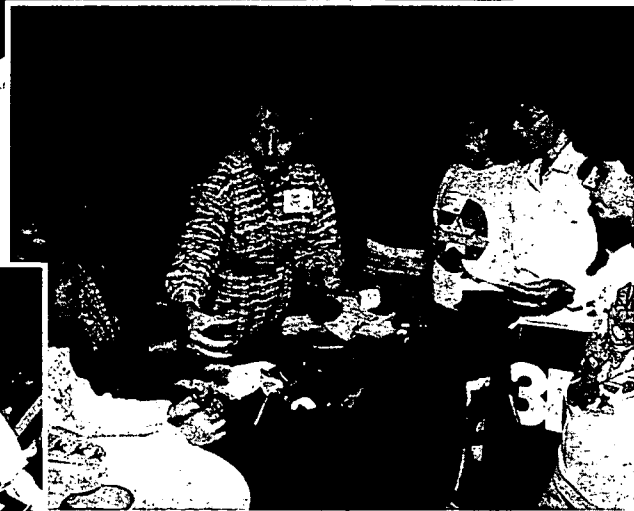

Writing Team

Lee Carey, Editor
Elizabeth Frick, Ph.D., Educational Systems, MN
Bonnie J. McClain, Mt. Pleasant Township Community School Corp., IN
Pamela O'Brien, Minnesota Zoo, MN
David P. Parisian, Oswego City School District, NY
Sidney Sitkoff, Ph.D., California State University-Dominguez Hills, CA
Caren Barzelay Stelson, Caren B. Stelson Associates, MN
Stephen M. Tomecek, Science Plus Inc., NY

National Science Teachers Association

Bill G. Aldridge, Executive Director
Helenmarie Hofman, Ph.D., Project Director
Stephanie Greene, Project Assistant

Content Review Panel

David Almgren, Ph.D., Q-Metrics, MA
Jane M. Benesch, Educational Consultant, MD
David Brandt, National Space Society, DC
Neal B. Brown, Geophysical Institute, University of Alaska-Fairbanks, AK
Shirlee S. Cavaliere, Biologist and Gettysburg High School, PA
Eric Flescher, Children's Museum of Kansas City and Univ. of Kansas, KS
Melody Hall, Middle School Educator, GA
John R. Kalloz, M.D., Gettysburg Internal Medicine Associates, Inc., PA
Stephen P. Maran, Ph.D., American Astronomical Society, MD
Martha G. McLaren, Gettysburg Junior High School, PA
Magdalena Mondejar, M.D., Gettysburg Hospital, PA
John Pottinger, Ph.D., Univ. of Alabama in Huntsville, AL
Marvin Russell, Ph.D., Univ. of Kentucky, KY
Tracy Schoolcraft, Ph.D., Gettysburg College, PA
Stephen M. Tomecek, Science Plus Inc., NY
Maxine C. Willis, Gettysburg Area Senior High School, PA
Paul J. Zeshonski, M.D., PA

Advisory Board

Council of State Science Supervisors
International Technology Educators Association
National Council of Teachers of Mathematics
National Middle School Association
National Science Teachers Association
National Association of Elementary School Principals

3M

Dick Hanson
Barbara Kaufmann
Bruce Gengnagel
Vic Girling
Dave Ginkel

3M/Newton's Apple Education Committee

Gene Steele, Chair
Bob Barton
Harvey Berwin
Sue Butzer
Yvonne Cadwallader
Mary Chilinski
Peggy Dingman
John Huizinga
Mary Hurlocker
Patty Konsi
Gary Kwong
Walt Lager
Judy Parker

KTCA/Newton's Apple

David Heil, Host
Peggy Knapp, Field Reporter
Nancy Gibson, Naturalist
Richard Hudson, Executive Producer
Kathryn Scott, Series Producer
Leslie Kratz, Segment Producer
Kristian Berg, Segment Producer
Dan Fiorucci, Segment Producer
Kathy Kraemer, Associate Producer
Gary Leatherman, Associate Producer
Jeff Nielsen, Associate Producer
Amy Kenefick, Production Assistant
Meighan Maloney, Production Office Coordinator
Leola Daniels, Researcher
Sandy Schonning, Production Manager
Lynae Berge, Promotion and Outreach Coordinator
Chris Velasco, Outreach Assistant
Georgia Gould, Director of National Promotion, KTCA

KTCA/Design Group

Bob Hoffmann, Design Director
Tom Fisher, Designer
John Thompson, Illustrator/Apple Engraving
Corbert Gauthier, Illustrator/Newton's Apple 10th Anniversary Poster
Bill Dobbs, Illustrator/Educator's Guide Lesson Pages

143

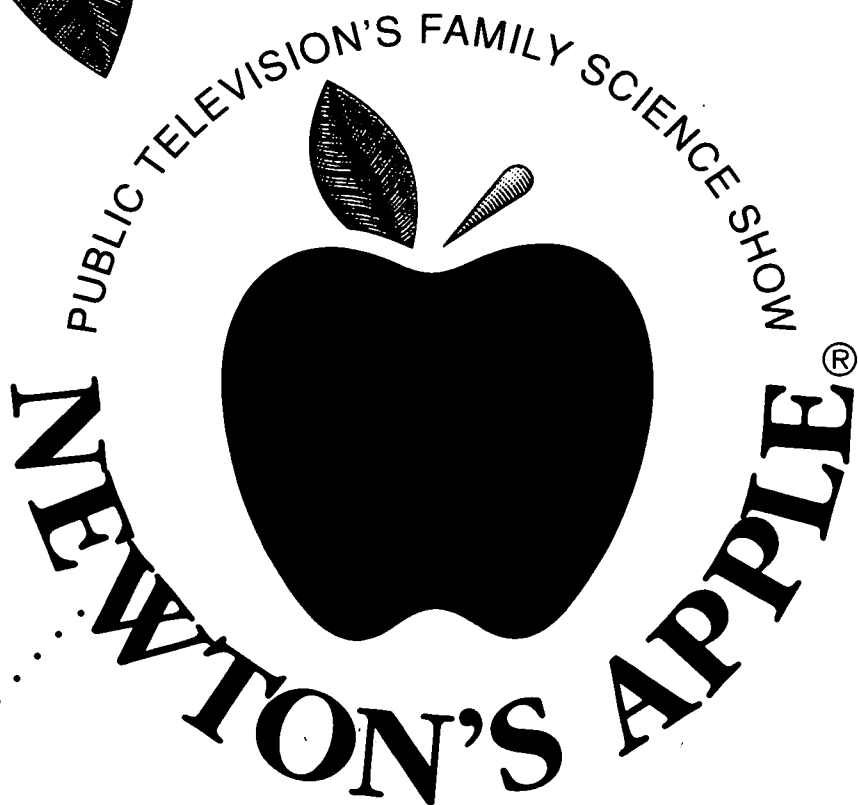

**The 11th Season of
Newton's Apple
Premieres October 1993
on PBS**

**FREE
EDUCATIONAL
MATERIALS**

Educational materials developed with the National Science Teachers Association.

Newton's Apple is a production of KTCA Twin Cities Public Television Saint Paul/Minneapolis and is made possible by a grant from 3M.

3M *Innovation*

Dear Educators:

Newton's Apple provides an astonishing discovery for many students: Science is more than facts—it's exciting and fun. That's why it's such a pleasure for 3M to sponsor the television program nationally. These companion materials for the series have been designed for classroom use. We hope they help you explore with your students the fascination with science that can enrich their outlooks and their futures.



L. D. DeSimone
Chairman
and Chief Executive Officer

3M Innovation



Dear Teachers:

The National Science Teachers Association is proud to serve in partnership with 3M and KTCATV, Saint Paul/Minneapolis. *Newton's Apple*—now in its 11th season—continues to attract learners of all ages. The hands-on activities in the *Newton's Apple* classroom packets provide the teacher with high-quality, stimulating science materials to motivate students to observe and question the world around them.

NSTA and *Newton's Apple* are dedicated to the student, the teacher, and scientific inquiry. It is a pleasure to participate in this project.

Bill G. Aldridge
Executive Director



Greetings from the *Newton's Apple* team!

Have you ever wondered why mosquito bites itch, what makes chili peppers hot, or what a trip through a black hole would *really* be like? If so, you're in luck! The eleventh season of *Newton's Apple* answers all these questions and more.

You and your students can join the *Newton's Apple* team exploring the physics and physiology of rock climbing, windsurfing and other outdoor adventures. And with these hands-on classroom materials you can do more than just watch... you can actually explore the science and technology right along with us!

That's what *Newton's Apple* is all about: exploration, discovery, and adventure! A great way to teach... and to learn science. Join us!

David Heil
Host



SUGGESTIONS ON USING THIS PACKET

Welcome to the Newton's Apple Educational Materials packet! These materials were developed to help you use the 11th season of Newton's Apple in your classroom.

BEFORE YOU DO ANYTHING ELSE... Take a look at the last two items in the packet. You will find our 11th season poster and a page of Newton's Apple VHS tape labels.

FIRST—after admiring our new poster, of course—turn it over to find a list of all the PBS stations in the U.S. The 11th season of Newton's Apple will be airing on most PBS stations beginning in October 1993. If you don't find it listed in your local TV guide or PBS viewer's guide, use this list to contact your PBS station to find out when it will be airing in your area. Be sure to let them know that you use Newton's Apple in your classroom!



SECOND—we've provided 13 Newton's Apple VHS tape labels—one for each show in the 11th season. Newton's Apple offers three-year off-air record rights for educational purposes. These tape labels will help remind you to tape Newton's Apple (or assign one of your students to tape it!) and assist you in keeping a library of shows for your classroom.

NOW, TAKE A LOOK AT THE REST OF THE PACKET...

Immediately following this page you will find four mail-in reply cards. Please fill out and return a card so you'll continue to receive the materials for future seasons. Share the remaining cards with your colleagues.

Next, you will find an index to the 11th season lesson pages (with a guide to three seasons of reruns on the back).

The next page is an "at-a-glance" curriculum grid which gives you a

quick overview of the science concepts in each lesson.

Twenty-six lesson pages on the major topics explored in the 11th season follow the grid. Each lesson includes

INSIGHTS about the topics, **CONNECTIONS** to encourage classroom discussion, **RESOURCES** and **VOCABULARY**. Lessons also include a **MAIN ACTIVITY** and several **TRY THIS** activities related to each topic.

Four special pages follow the lesson pages:

1. A feature on the interesting animals in the 11th season;
2. Hands-on "Science Try Its" experiments;
3. A "Street Smart" quiz;
4. A transparency master of several illustrations from the lesson pages.



MEET THE NEWTON'S APPLE TEAM:

Host David Heil, Field Reporter Peggy Knapp, and Naturalist Nancy Gibson are pictured here in our brand new studio, a giant brick warehouse where no question is too big or too small for *Newton's Apple* to handle!



DAVID HEIL returns for his sixth season as host of *Newton's Apple*. An avid outdoorsman and naturalist, David brings to the series an adventurous spirit to match his rich background in the professional fields of science and education. Formally trained in biology, chemistry, mathematics, and physics, David has conducted both laboratory and field research and has taught science to learners of all ages. He is recognized nationally as a creative conference planner and presenter, as well as a published author and public speaker on popular science and the joy of learning.

A native to the Northwest, David grew up in a small town with a city park that was perfect for a curious kid with a bent for exploration. Since his youth, he has continued to regard the natural and technological worlds we live in as a rich resource for learning, inviting millions of viewers each week to join him in his favorite pastime of playful exploration.

In addition to hosting *Newton's Apple*, David is the associate director of the Oregon Museum of Science and Industry in Portland.

PEGGY KNAPP (center) is now in her eighth season as field reporter for *Newton's Apple*. Peggy has diverse experience in television. In January 1991, during the Persian Gulf crisis, Peggy hosted *Kids Ask About War*, a national award-winning PBS special examining children's fears and concerns about the war. She is also a reporter/producer for *Network Earth* for Turner Broadcasting System.

Peggy was born and raised in Washington state and became interested in acting as a child. She attended Evergreen State College, majoring in theater, and developed her improvisational skills at the Brave New Workshop in Minneapolis. Peggy's ebullience, wit, and inquisitive mind communicate science in a way everyone can understand.

NANCY GIBSON

(left) has been *Newton's Apple's* resident naturalist since the series' inception in 1982. Her interest in and dedication to wildlife and the environment, however, go far beyond her duties on the show.

Since 1987, Nancy has worked as a freelance public relations consultant for environmental causes. Prior to 1987, Nancy was the public relations manager at the Minnesota Zoological Gardens.

Nancy's love for animals started when she was growing up in rural Ohio. As a child, she brought home all kinds of animals, from foxes and raccoons to snakes and skunks. In a way, she has been able to continue this practice—by bringing many unique and wonderful animals into viewers' homes and explaining how these animals are an important part of the world around us.

117

NEWTON'S APPLE SEASON 800 SEGMENT INDEX**SHOW 801**

Cartoons
Skateboards
Yo Yos
Turtles

SHOW 802

Juggling
Greenwich Mean
Time
Echoes
Flies

SHOW 803

Everglades
Tomorrow's World
Recycling Chat
Field Trip

SHOW 804

Demolition Derby
Stress
Topology Chat
Eagles

SHOW 805

Kidney Transplants
Music & Emotion
Swans

SHOW 806

Blood
Physics Circus
Fax Machine
Pronghorn

SHOW 807

Helicopter
Newton
Koalas

SHOW 808

Dyes
Pool & Billiards
Cheerios in Milk
Cheetahs

SHOW 809

Desert Animals
Judo
Salt & Ice
Pigs

SHOW 810

Hydro Power
Whitewater Rafting
Mold
Weather Proverbs

SHOW 811

Wildlife Census
Eggs
Inventor's Fair
Stone Crabs

SHOW 812

Violins
Voyager
Rube Goldberg
Contest
Kinkajou

SHOW 813

Glaciers
Termites
Alligators

NEWTON'S APPLE SEASON 900 SEGMENT INDEX**SHOW 901**

Olympic Sports
Science Special
• Physiology
• Biomechanics
• Luge
• Psychology

SHOW 902

Solar Cars
Steroids
Amazing Kreskin
Miniature Horses
Foot Asleep

SHOW 903

Murder Mystery
Ted Nugent
Bats

SHOW 904

Cancer Causes
Frisbee Physics
Computer Virus
Potato Chip

SHOW 905

Sewers
Cancer Treatments
Dick Cavett
Porcupines

SHOW 906

Dinosaur Special
• Mapping the Dig
Site
• Dating the Bones
• Assembling a
Diplodocus

SHOW 907

Domed Stadium
Photosynthesis
Polarized Sunglasses
Amusement Park

SHOW 908

Tears
Slinky Physics
Camels
Barcodes
Aspirin

SHOW 909

Soviet Space
Sky Blue
Inventor's Fair
Llamas

SHOW 910

Acid Rain
High Jump
Potholes
Goats

SHOW 911

Medical Quackeries
Microwave Ovens
Dollar Changer
Golden Eagles

SHOW 912

Telecommunication
Solar Eclipse
Blimp
Bear Cubs

SHOW 913

Hip Replacement
Airbags
Paper Cuts
Potbelly Pigs

NEWTON'S APPLE SEASON 1000 SEGMENT INDEX**SHOW 1001**

Behind the Scenes
Special
• How TV Works
• Studio Tour
• Control
Room/Editing
• Satellite
Technology

SHOW 1002

Hollywood Stunts
Household
Chemistry
Coffee/Cream
Musk Ox

SHOW 1003

Election Polls and
Surveys
Electric Cars
Ceramics Chat
Cougar

SHOW 1004

Monster Makeup
Ozone
Car Mirror
Artificial Sweeteners

SHOW 1005

Oil Spills
Diet and Nutrition
Crystal Gayle
Caribou

SHOW 1006

Antarctic Special
• Journey
• Penguins
• Palmer Station
• Krill
• Seals

SHOW 1007

AIDS
Glass Recycling
Cement On The Spot
Science Challenge
Wolverine

SHOW 1008

Cockroaches
Broken Bones
Dentist Chair
Rhinceros

SHOW 1009

Omnimax
Technology
Archery
Lightbulb Chat
Condor

SHOW 1010

Aurora Borealis
Air Pressure
Albert Gore
Piranha

SHOW 1011

Traffic Control
Cryogenics
Static Electricity Ch.
Russian Kids

SHOW 1012

Locks and Dams
Blood Typing
Moles Chat
Penguin

SHOW 1013

Diabetes
Galaxy Mapping
Dweezil Zappa
Ostrich

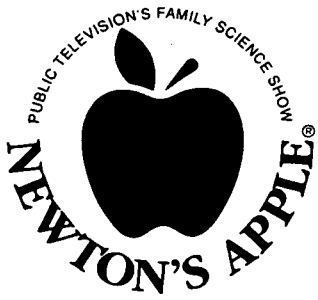

AN "AT-A-GLANCE" SCIENCE SUBJECT INDEX

Following is an at-a-glance index of the science disciplines dealt with in the *Newton's Apple* lesson pages. The index incorporates the National Science Teachers Association's Scope, Sequence, and Coordination of Secondary School Science model. We've listed some extended applications as well.

SEGMENT	BIOLOGY	CHEMISTRY	EARTH/SPACE	PHYSICS	TECHNOLOGY	MATH	ADDITIONAL APPLICATIONS
Rock Climbing	🍏			🍏	🍏		Physical Education
Taste and Smell	🍏	🍏				🍏	Home Economics
Emergency Rescue	🍏				🍏		Health
Black Holes			🍏	🍏	🍏	🍏	Astronomy
Memory	🍏					🍏	Psychology
<i>In vitro</i> Fertilization	🍏				🍏	🍏	Health Psychology
Newspaper		🍏			🍏	🍏	Journalism
Bomb Squad		🍏		🍏	🍏	🍏	Social Studies
Jumbo Jets				🍏	🍏	🍏	Aviation
Meteors			🍏	🍏		🍏	Astronomy
Windsurfing				🍏	🍏		Physical Education
Permafrost	🍏		🍏				Geology
Spotted Owl/ Old Growth Forests	🍏		🍏				Ecology Economics

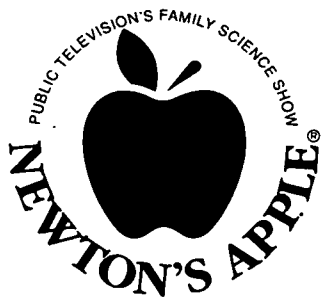

AN "AT-A-GLANCE" SCIENCE SUBJECT INDEX

SEGMENT	BIOLOGY	CHEMISTRY	EARTH/SPACE	PHYSICS	TECHNOLOGY	MATH	ADDITIONAL APPLICATIONS
Carpal Tunnel	🍏				🍏		Health
Archeology			🍏		🍏	🍏	History Ecology Computer Science Engineering
Mazes			🍏		🍏	🍏	Logic
Firefighting		🍏		🍏	🍏	🍏	Safety
Dairy Farm	🍏	🍏			🍏	🍏	Agriculture
Bison Roundup	🍏		🍏			🍏	History Ecology
Heart Attack	🍏				🍏	🍏	Health
The Bends	🍏			🍏	🍏		Physical Education
Compact Discs					🍏	🍏	Music
Garbage	🍏	🍏	🍏		🍏	🍏	Ecology
Infrared Light			🍏	🍏	🍏	🍏	Safety
Mt. Rushmore		🍏	🍏			🍏	Engineering History Geology Computer Science
Virtual Reality					🍏	🍏	Computer Science



David travels to Oregon to learn about the physics and biomechanics of rock climbing.

Segment Length – 8:36

ROCK CLIMBING

How can the human body stick to a sheer cliff?

What techniques do climbers use to help them get up a cliff face? What forces are at work in rock climbing?

RESOURCES

Bankson, R. (1992, June) Pushing the limit. *National Geographic World*, pp. 2–7.

Loughman, M. (1981) *Learning to rock climb*. San Francisco: Sierra Club Books.

Potterfield, P. (1991, Jan) Trapped on Chimney Rock. *Reader's Digest*, pp. 169–204.

Robbins, R. (1985) *Advanced rockcraft and basic rockcraft*. Glendale, CA: La Siesta.

Silva, R. (Ed.) (1992) *Leading out: Women climbers reaching for the top*. Seattle: Seal Press.

Walker, J. (1989, June) The mechanics of rock climbing, or surviving the ultimate physics exam. *Scientific American*, pp. 118–121.

Additional sources of information

American Mountain Guides Association
PO Box 2128
Estes Park, CO 80517
(303) 586-0571

American Sports Climbers Federation (ASCF)
125 W. 96th St., #1D
New York, NY 10025
(212) 865-4383

Climbing magazine
PO Box 339
502 Main St.
Carbondale, CO 81623
(303) 963-9449

Outward Bound USA
384 Field Pt. Road
Greenwich, CT 06830
(203) 661-0797

INSIGHTS

- Although rock climbing does not draw large crowds, it claims an annual growth rate of 50%, with women accounting for one-quarter of all climbers.
- Before beginning, however, climbers should get professional instruction so they understand how to use ropes to protect themselves against the forces of gravity.

- Climbers choose nylon ropes because they stretch and absorb the shock of a fall. Good climbing ropes will stretch to double their original length before breaking and have a breaking strength of over three tons of force. Ropes are used in two ways. In “top roping” (the safest method), climbers fix webbing to an immovable object at the top of a cliff—usually a tree or a rock. They attach the webbing to a *carabiner*. Then they pass a rope through the carabiner, letting the two ends dangle down the side of the cliff. One end is tied to the climber. The other is tied to and held by a person at the bottom, who keeps the rope taut to stop a fall.

- Sometimes top roping is impossible because the climb is longer than one-half a rope length or because the climbers don't have access to the top of the cliff to fix the webbing. In that case, someone must “lead climb” and place *protection* in

the cracks in the rock. The rope is clipped into the protection. The second climber *belays* the lead climber.

Biomechanics are crucial to climbing. Bones, joints, and muscles combine to provide wedges and levers—all the simple tools necessary to make it to the top. The most sophisticated climbing “gadget” is the human hand. Hand jams allow climbers to grab holds in seemingly impossible places. Climbers also manipulate their *center of mass* by working their bodies away from the rock face. This puts more force onto their feet. High-tech climbing shoes make good use of that force. Their rubber soles conform to the surface of the rock and create enough friction (or stickiness) to hold on to steep angles.

Climbing techniques put a variety of forces to work. In “face climbing,” the most common technique, climbers

pull down on handholds and push up on footholds to advance up the rock. By keeping their weight balanced over their feet, the climbers remain stable. In “stemming,” climbers push their legs outward against the two opposing rock faces. Their outward push forces their shoes into the walls and the shoes generate an upward frictional force which opposes gravity and allows the climbers to ascend.

Climbing is basically applied physics. Grace, rhythm, balance, concentration, and flexibility count more than strength. Although incorrect techniques, bad weather, and misuse of equipment can produce some dangerous situations, climbing is a safe sport when proper procedures are followed.

CONNECTIONS

1. Name other sports that utilize friction.
2. Explore other techniques that climbers use.

VOCABULARY

belay to secure a climber's rope so that a large amount of friction is produced to stop a fall. Also refers to the method or device used to secure the rope.

carabiner an aluminum alloy ring with a snap-link gate that permits insertion of the climbing rope. Used mainly to attach rope to anchors.

center of mass the single point associated with a body where all its mass can be considered to be concentrated

gravity the force that every mass (such as the earth) exerts on every other mass (such as a person)

protection device or anchor into which a climbing rope is clipped (e.g., wired stoppers for small cracks, cams for bigger cracks)

- Newton's Apple is a production of KTCA Twin Cities Public Television. Made possible by a grant from 3M.
- Educational materials developed with the National Science Teachers Association.

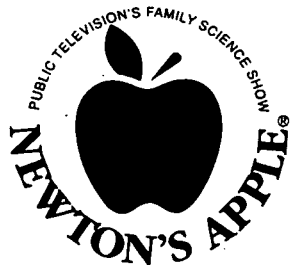

THE FORCE THAT BINDS

Create some friction by moving one object against another.

▶ TRY THIS...

Climbers climb on different types of rock: quartzite, limestone, sandstone, granite. How do these rock formations differ? How might that affect climbing techniques? Find some exposed bedrock near your house. Examine the rocks and holes.

▶ TRY THIS...

To help you understand a belay, wrap a medium thick rope (over 1/4" thick) two times around a flagpole and have a one-way tug of war. One person should try to pull the rope with both hands while the other person holds the rope with one finger. The friction of the cord wrapped around the flagpole acts as a belay. The belay increases the force exerted by one finger so much that the person pulling on the rope with both hands is unlikely to be able to pull much rope at all. This is how a belayer can counteract the large forces generated in a rock climbing fall.

• MAIN ACTIVITY

- Friction is the force that causes resistance when we try to slide one surface over another. Friction helps us walk, run, and jump. Without it, a climber would have a very difficult time going up a steep slope.

• Materials

- a few bricks
- a board or piece of plywood
- two sheets of sandpaper of different grade
- blocks of wood
- gym shoes

1. Pull a brick across the board three times, turning the brick each time to use a different face. Is the friction the same for each face?

2. Now put one brick on top of another and pull them both across the board. What happens? When you pull the two bricks, you will need to exert twice the effort you needed to pull one brick. Try this with wooden blocks or other materials. You'll find that the ratio of friction to load is the same for identical bodies. It varies, depending on the mass and the surface characteristics of the material.

3. Place an object on the board and raise one end of the board. Eventually the object will slide off the board. The higher you can raise the board before the object slides off it, the greater the friction force is between the object and the board.

4. Glue sandpaper to a board. Place shoes and other objects on the sandpaper. Raise one end of the board and notice how high you can raise it before the shoes slide off the board. The higher you can raise the board, the greater the friction. Find out whose shoes have the highest friction.

5. Place the sole of one of the gym shoes in water and then try to pull each shoe across the inclined board. How does the water affect the movement?

Questions

1. Look at the soles of several types of gym shoes. What sort of friction devices have been built in?
2. Friction creates heat. A rope running through the hands of a climber creates heat. What other examples can you think of where friction creates heat?

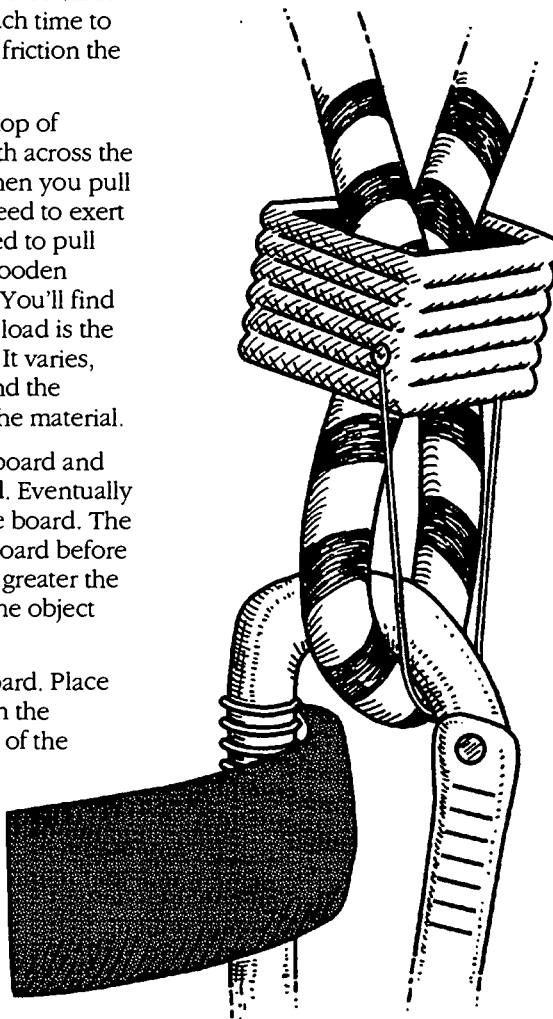

153

▶ TRY THIS...

Climbers are constantly exposed to the elements and must devise their own protection. What does this involve? Focus on different types of adaptation, such as clothing, bedding, and sun protection.

▶ TRY THIS...

Some mountaineering or outdoor stores have rock walls and many cities are acquiring rock gyms. Find out whether there are any climbing areas near you and take a field trip to learn more about rock climbing principles.

▶ TRY THIS...

The human hand is our prime manipulative tool. It has an opposable thumb, which gives us a great deal of dexterity. Think of the ways you use your hands as tools. Tape one of your thumbs to the side of your hand to immobilize it. You'll soon understand why the thumb makes your hand such an effective tool.



Peggy and David seek out a connection between our senses of taste and smell.

Segment Length – 7:35

TASTE AND SMELL

Why does food seem tasteless when you have a cold?

How do we perceive tastes and smells? How are taste and smell connected to communication?

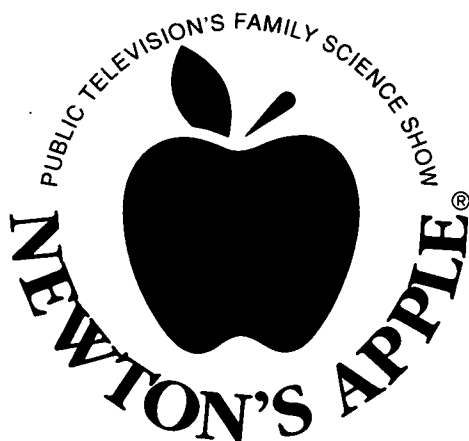

RESOURCES

Aldrey, N. (1992) *The science book of the senses*. San Diego: Harcourt Brace Jovanovich.

Gibbons, B. (1986, Sept) The intimate sense of smell. *National Geographic*, pp. 324–360.

Additional sources of information
Chemical Sources Association
1620 First St. NW, Suite 925
Washington, DC 20006
(202) 293-5800

Fragrance Foundation
145 E. 32nd St.
New York, NY 10016
(212) 725-2755
(request publication: *Living well with your sense of smell*)

Monell Chemical Senses Center
3500 Market St.
Philadelphia, PA 19104-3308
(215) 898-4236

National Geographic Educational Services
PO Box 98019
Washington, DC 20090
(800) 368-2728
(videotapes from the 1982 Human Senses series: *A Matter of Taste*, #51124, and *On the Nose*, #51161)

Community resources
Physician specializing in ear, nose, & throat
Psychologist or psychotherapist who practices aroma therapy

Physician specializing in ear, nose, & throat
Psychologist or psychotherapist who practices aroma therapy

Physician specializing in ear, nose, & throat
Psychologist or psychotherapist who practices aroma therapy

INSIGHTS

- Have you ever wondered why food loses its flavor when you have a cold? It's not your taste buds' fault. Blame your stuffed-up nose. Seventy to seventy-five percent of what we perceive as taste actually comes from our sense of smell. Taste buds allow us to perceive only bitter, salty, sweet, and sour flavors. It's the *odor molecules* from food that give us most of our taste sensation.

- When you put food in your mouth, odor molecules from that food travel through the passage between your nose and mouth to *olfactory receptor* cells at the top of your nasal cavity, just beneath the brain and behind the bridge of the nose. If mucus in your *nasal passages* becomes too thick, air and odor molecules can't reach your olfactory receptor cells. Thus, your brain receives no signal identifying the odor, and everything you eat tastes much the same. You can feel the texture and temperature of the food, but no messengers can tell your brain, "This cool, milky substance is chocolate ice cream." The odor molecules remain trapped in your mouth. The pathway has been blocked off to those powerful perceivers of smell—the olfactory bulbs.

- Of all our senses, smell is our most primal. Animals need the sense of smell to survive.

Although a blind rat might survive, a rat without its sense of smell can't mate or find food. For humans, the sense of smell communicates many of the pleasures in life—the aroma of a pot roast in the oven, fresh-cut hay, a rose garden. Smells can also signal danger, fear, or dread.

Although our sense of smell is our most primal, it is also very complex. To identify the smell of a rose, the brain analyzes over 300 odor molecules. The average person can discriminate between 4,000 to 10,000 different odor molecules. Much is unknown about exactly how we detect and discriminate between various odors. But researchers have discovered that an odor can only be detected in liquid form. We breathe in airborne *molecules* that travel to and combine with receptors in nasal cells. The cilia, hairlike receptors that extend from cells inside the nose, are covered with a thin, clear mucus that dissolves odor molecules not already in vapor form. When the mucus becomes too thick, it

can no longer dissolve the molecules.

Animals depend on odors secreted from their bodies to communicate. For humans, odors communicate a variety of messages, depending on the odor and the person receiving it. The aroma of a baking apple pie sends one message when someone is hungry and quite another when that person has just finished a six-course meal!

CONNECTIONS

1. You cannot smell food very well when you have a cold, but why is taste bland or even absent?
2. Think of some smells you like. When might those smells be unpleasant to you?
3. Have you ever smelled natural gas? Why do you think gas utility companies give it an unpleasant odor?
4. In what ways are odors like language?

VOCABULARY

molecule the smallest particle into which a substance can be divided without chemical change

nasal passages pathways between the nose and mouth which carry odor molecules to olfactory cells

odor molecules comprise specific smells; stimulate smell receptors

olfactory pertaining to or contributing to the sense of smell

receptor a nerve ending that senses or receives stimuli

Newton's Apple is a production of KTCA Twin Cities Public Television. Made possible by a grant from 3M.
Educational materials developed with the National Science Teachers Association.

15.4

11.11

3M Innovation

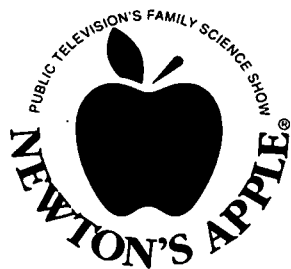

WHERE'S THE FLAVOR?

Challenge your taste buds and nose to a flavor competition.

▶ TRY THIS...

Recapture a "smell" memory. Put a number of different, fragrant items in separate paper bags—a pine bough, broken cinnamon sticks, mothballs, a cloth sprinkled with baby powder, lemons. Sniff each bag until one brings a strong memory to mind. Write about this memory.

▶ TRY THIS...

Create a survey to identify the favorite smells and tastes of your friends. Conduct your survey and display the results on a graph. Which smells and tastes were most popular? Now place your results in a Venn diagram. Do you see any overlap between favorite smells and favorite tastes?

▶ TRY THIS...

Can you tell the difference between an apple and a potato by using only the sense of taste? Cut an apple and a potato into the same size pieces. Close your eyes, plug your nose, and lick one of the pieces. Can you tell what it is? Next, unplug your nose and eat the piece. Can you identify it now?

• MAIN ACTIVITY

- Test your classmates' senses of taste and smell to find out which sends the clearest message to the brain.

• Materials

- 6 small paper bags
 - 6 small scoops of mini jelly beans in three different flavors (lemon, grape, cherry)
 - marking pen
1. With the marking pen, identify the bags as either taste or smell bags. Write "taste #1," "taste #2," and "taste #3" on three of the sacks and "smell #1," "smell #2," and "smell #3" on the other three sacks.
 2. Divide jelly beans among the bags so that you have a "taste" bag and a "smell" bag for each of the three flavors. Taste #1 and smell #1 jelly beans should be the same, taste #2 and smell #2 should be the same, and so on. Crush a few of the "smell" jelly beans so the odor molecules can escape into the bag. Close the bags by folding down the top.
 3. Before Testing: Choose three of your classmates as testers and give them each a sheet of paper. Instruct them to draw a data table with three columns and three rows. The columns should read: "smell only"; "taste only"; and "taste and smell." The three rows should read: "flavor 1"; "flavor 2"; and "flavor 3."
 4. Taste Test: Instruct the testers to close their eyes and plug their noses. Choose one of the taste bags and instruct each tester to chew on a sample from this bag. In five seconds, ask them to record on their data table what flavor they believe the sample to be. Repeat the procedure for the remaining taste bags. A small sip of water between samples will help clear away the previous flavor and provide a more accurate test. If they cannot tell the flavor, have them record "unknown."

5. Smell Test: Choose one of the "smell" sample bags. Have testers close their eyes, open the bag, and inhale the aroma for 10 seconds. Remove the bag and close the top tightly. Have your testers record the flavor of the sample on the data table. Make sure each of them repeats this procedure for the other two samples.

6. Smell and Taste Test: Use the "taste" bags again. Repeat the procedure as in step #4, "Taste Test," but do not have your testers hold their noses shut. Be sure, however, that they have their eyes closed. Ask them to record their guesses in the appropriate column on their data table.

Questions

1. Which sense, taste or smell, identified the correct flavor most often?
2. How were the "taste" messages your brain received different from the "smell" messages?
3. How do you think candy makers simulate fruit flavors?
4. Why do you taste more flavor when you chew a jelly bean than when you suck on it?
5. If you took the Smell and Taste Test with your eyes open, do you think you could recognize the flavor of a purple jelly bean that has an orange flavor? What data from your tests support your conclusion?

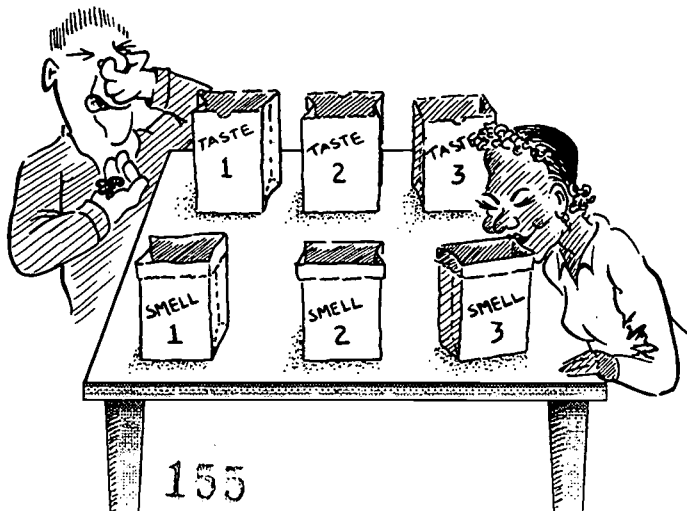

▶ TRY THIS...

Animals and insects use smells to send messages. Cats and dogs, for example, put their own personal smell stamp on objects to communicate the message "no trespassing." Ants lay down odor trails to mark the pathway to food. The monarch butterfly and ladybug produce odors that say, "I don't taste as good as I look." Research an animal by reading and thinking about how it uses smell to communicate.



Peggy learns about emergency medicine when she accompanies paramedics on a rescue mission.

Segment Length – 7:47

EMERGENCY RESCUE

What happens when there's an emergency call?

What is trauma? How do experts in emergency medicine treat trauma?



RESOURCES

- Beck, M. (1991, Oct 14) State of emergency. *Newsweek*, p. 52–53.
- Doelp, A. (1991, Mar) Race against death. *Reader's Digest*, p. 173.
- Goldfarb, B. (1992, Apr) Uncompensated care pushes trauma centers out of business. *Medical World News*, p. 32.
- Skolnick, A.A. (1992, June 10) Congress acts to resuscitate nation's financially ailing trauma care systems. *The Journal of the American Medical Association*, p. 2994.
- Additional sources of information**
- American Trauma Society
8903 Presidential Parkway,
Suite 512
Upper Marlboro, MD
20772
(800) 556-7890
- Emergency Medicine
Foundation
PO Box 61991
Dallas, TX 75261
(214) 550-0911
- Quantum Chemical Corp.
99 Park Ave.
New York, NY 10016
(212) 949-5000
(videotape on EMTs: *The critical difference*)
- San Diego County
Department of Public
Health
Division of EMS
6255 Mission Gorge Road
San Diego, CA 92120
(619) 285-6429
(brochure: *911 guidelines for schools*)

INSIGHTS

- Medical personnel call it *trauma*. Lay people call it injury. Regardless of the term used, it represents the leading cause of death for people under the age of 44.
- Every six minutes, an American dies from an injury. Automobile accidents are the leading cause, with alcohol a frequent contributing factor. Other major causes include guns, fire, falls, and drowning.
- The medical response to trauma often begins with a call to 911, the emergency response phone system.
- When a caller reports an accident to 911 dispatchers, specially trained *paramedics* or mobile emergency medical technicians (EMTs) rush to the scene of the injury.
- Paramedics stabilize and transport the victim to the hospital as quickly and safely as possible. Because the brain cannot be deprived of oxygen or blood flow for even a couple minutes, the EMT first attends to the ABCs (airway, breathing, and circulation). Blood, secretions, false teeth, food, vomit, or other obstructions in the victim's airway must be cleared first. If the patient is not breathing adequately,

technicians perform artificial respiration. They then check pulse and blood pressure to see if circulation is adequate. Because many trauma victims suffer blood loss, technicians usually put an intravenous (IV) line into the patient's vein and infuse it with a solution of salt water to help prevent shock.

To avoid additional injury on the way to the hospital, paramedics splint or immobilize broken or potentially broken bones. Victims who remain alert can help them by telling them if something hurts. The unconscious victim—who likely has suffered a head injury—requires special care so the neck and spine are protected from irreversible injury.

In regions well prepared to handle accident victims, the police, paramedics, and hospital personnel work in close cooperation. Often a helicopter speeds the victim

to the *trauma center*.

At the hospital, a trauma team of *emergency medicine* physicians, anesthesiologists, surgeons, and nurses takes over. They evaluate the patient, do another check of the ABCs, and then proceed with the necessary diagnostic and treatment measures.

Studies show that with good trauma systems in place, a city's trauma death rate tends to drop dramatically.

CONNECTIONS

1. Trauma systems vary. Some communities have no systems at all. Describe the problems this kind of scattered access creates.
2. Emergency technicians and physicians never know what kind of illness or injury the next patient will have. What can they do to be prepared for this?
3. Have you ever called a rescue service? What happened?

VOCABULARY

- emergency medicine** a branch of medicine concerned with diagnosing and treating acute or suddenly arising conditions
- cardiopulmonary resuscitation (CPR)** a basic emergency procedure for life support that consists of artificial respiration and manual external cardiac massage
- paramedic** a person trained in emergency medical procedures who acts as an assistant to a physician or in place of a physician
- trauma** injury
- trauma center** a specialized hospital, staffed 24 hours a day by physicians trained in the care of injured persons

- Newton's Apple is a production of KTCA Twin Cities Public Television. Made possible by a grant from 3M.
- Educational materials developed with the National Science Teachers Association.



LIGHTS, CAMERA, ACTION!

Create a documentary on emergency services in your community.

▶ TRY THIS...

Invite a local paramedic to your class to talk about training, everyday routines, and unforgettable experiences.

▶ TRY THIS...

Many trauma situations start as automobile accidents. Identify and discuss the risk factors that may contribute to the accident and the safety measures that might prevent severe injury if a car accident happens.

▶ TRY THIS...

Invite a CPR teacher in and learn all the basics of this lifesaving technique. Take the test and become certified in CPR.

• MAIN ACTIVITY

- Produce a video about emergency services available in your area.
- Learn about the roles that various emergency personnel play in trauma response, and share the information you have gained with other students. (You can modify this activity to do oral reports and skits if no video equipment is available.)

• Materials

- home video camera
 - colored paper
 - markers
1. Pair off into four teams, each with a home video camera to record different parts of the story of emergency services.
 2. The first team will research the availability of a 911 emergency response phone number in this area and write a script detailing when or when not to use it. Videotape a brief skit based on that script.
 3. The second team will contact some local paramedics and arrange to do a video interview either at the firehouse or the school. Don't forget to ask questions about training and other requirements for becoming a paramedic.
 4. The third team will set up a tour of your local hospital's emergency room. With the help of an emergency room nurse or physician, show

the important ER equipment and describe each item's function.

5. The fourth team will put all of the elements of the video together and show it to the class.

Questions

1. If one part of the emergency response system was missing, what would happen to the rest of the system?
2. Should this country have a national emergency response system? Why? What would it change?

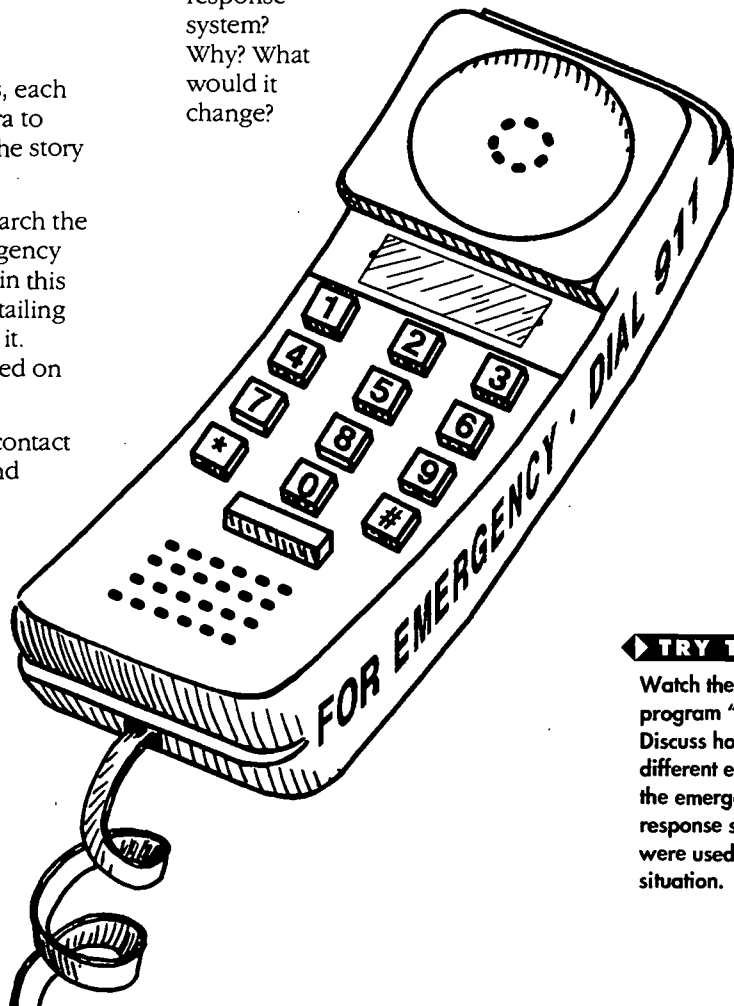

▶ TRY THIS...

Experts say one of the biggest problems with the 911 number is that people who have no real emergency misuse it. Come up with ten instances when you should call 911 and ten instances when you should not.

▶ TRY THIS...

Watch the television program "911." Discuss how different elements of the emergency response system were used in each situation.

157

- Newton's Apple is a production of KTCA Twin Cities Public Television. Made possible by a grant from 3M.
- Educational materials developed with the National Science Teachers Association.



David embarks on a dangerous and exciting journey to explore a black hole.

Segment Length - 7:39

BLACK HOLES

What is a black hole?

Why can't light escape from a black hole? How could a star become a black hole? Does this have anything to do with ordinary, everyday gravity?



RESOURCES

Asimov, I. (1978) *How did we find out about black holes?* New York: Walker and Company.

Asimov, I. (1988) *Quasars, pulsars, and black holes.* New York: Gareth Stevens.

Boslough, J. (1989) *Stephen Hawking's universe: An introduction to the most remarkable scientist of our time.* New York: Avon Books.

Folger, T. (1993, Jan) In the black. *Discover*, pp. 29-30.

Powell, C. S., & Horgan, J. (1991, July). Live from off-center: Astronomers follow the energetic trail of the Great Annihilator. *Scientific American*, pp. 29-30.

KCET/LA videotape: "Searching for black holes." *The Astronomers*, part 2. PBS Video: (800) 328-7271.

Community resources

Local astronomical societies or astronomy clubs. To find one near you, call the Astronomical Society of the Pacific at (415) 337-1100.

Astronomers or physicists from local colleges or universities

INSIGHTS

- Suppose you go outside and throw an apple straight up into the air. The Earth's *gravity* slows the upward speed of the apple until it finally stops—and then starts falling back down.

- But suppose you could throw the apple so fast that Earth's gravity could never quite make it stop and fall back down. That speed is called *escape velocity*—for Earth, the escape velocity is 25,000 miles per hour. On planets or stars with more gravity, the escape velocity would be even higher. Some planets and stars have the same mass but different sizes. In that case, the smallest one will have the greatest gravity at its surface.

- Stars can change size (and gravity) very dramatically. A star's gravity works not only on objects outside the star but also among the particles that make up the star. These particles attract one another and the star would collapse if it weren't for the nuclear energy pushing outward. When the nuclear fuel runs out, there is no more energy to keep the star from collapsing into a very small and dense sphere.

- The ultimate size of this sphere depends on the original mass of the star. Oddly, the largest stars result in the smallest spheres. If a star has a mass less than 1.4 times the sun's, gravity among its particles will not be able to

overcome the tendency of the electrons, protons, and neutrons to remain separate. The forces will balance when the star has become a white dwarf the size of a small planet. If a star has between 1.4 and 3.6 solar masses, the gravitational force is so great that electrons combine with protons to form neutrons. The resulting neutron star will be only a few miles in radius.

For stars with more than 3.6 solar masses, even the forces that hold elementary particles apart cannot overcome gravity and the entire star shrinks until its radius is essentially zero. In the region very near this pinpoint of matter, gravity becomes almost infinite. Even four or five miles from this *singularity*, gravity is so great that the escape velocity equals the speed of light. Einstein's general *theory of relativity* showed that light, though it does not react to gravity in the same way as ordinary matter, is nevertheless affected by strong gravitational fields. In fact, light

itself cannot escape from inside this region. The imaginary surface at this radius is known as the "event horizon."

From outside, the event horizon would appear perfectly dark (since no light can escape) and hence would appear to be a *black hole* in space. How do astronomers observe black holes?

When charged particles accelerate, they emit electromagnetic radiation (like visible light or X rays). Astronomers look for regions in the sky with radiation consistent with charged particles accelerating toward a black hole. Researchers attempt to rule out other possible causes of this radiation to prove that black holes really do exist.

CONNECTIONS

1. How do we know about black holes when we can't see them?
2. What would it be like if a black hole came near Earth?

VOCABULARY

black hole an object whose gravitational field is so strong that even light cannot escape it

escape velocity the speed you have to go to overcome a gravitational field completely

gravity a force of attraction between any two objects

singularity a position at which at least one quantity is infinite

theory of relativity Einstein's theory of space, time, mass, and motion. It has two parts: the special theory, which predicts (among other things) that time will pass more slowly as you approach the speed of light; and the general theory, which explains gravitation as the consequence of the distortion of space by all matter.



FIND A BLACK HOLE

Pretend you are an astronomer and shoot a light beam into space to locate a black hole.

▶ TRY THIS...

Stretch a piece of cloth over a round garbage can. Use rubber bands to hold the cloth in place, like a drum head. Have a partner depress the center of the cloth with the eraser end of a pencil to make a gravitational "well." Shoot marbles or Ping-Pong balls around the well. If they don't fly off, they'll "orbit" as they fall in. How many times can you get them to go around before they hit the pencil? (Wear goggles to do this activity.)

▶ TRY THIS...

Invite an astronomy teacher or student from a local college or university to talk about black holes. Ask your guest to bring slides or other visual aids. Ask him or her to describe how they think about complex subjects such as black holes.

▶ TRY THIS...

In a group, develop a skit about a black hole. Try to make it interesting and also scientifically accurate. For example, if you fell in, you really would get stretched. What else should you take into account? Make a video of your skit or perform it live.

• MAIN ACTIVITY

- Much of science involves making inferences about things that you cannot see. If there is nothing falling into a black hole, there is no way to see the black hole. Could we still find it? In this activity you will simulate trying to find a black hole by shooting "light beams" through a region of space and inferring the position of the black hole from the deflections of the beams.

• Materials

- graph paper
- protractor
- ruler
- pencil

1. Find a partner. One player operates the "black hole"; the other is an astronomer.

2. Each player draws a large square 20 cm (about 8") on a side. The black hole player secretly marks the hole's position in her/his square.

3. Using a ruler, the astronomer draws a light beam through her/his square.

4. The black hole player uses the protractor to deflect each beam. Here's how:

- Copy the beam from the astronomer's paper to your own.
- Measure how close the beam comes to the black hole.
- From the point of closest approach, bend the beam according to the following table:

0–1 cm	The beam is absorbed by the black hole. It doesn't come out.
1–2 cm	Deflect 60°
2–3 cm	Deflect 30°
3–4 cm	Deflect 15°
4–5 cm	Deflect 5°
>5 cm	No deflection

- On the astronomer's paper, mark where the beam comes out (not how

close the beam came). Repeat steps 3 and 4.

5. When the astronomer knows where the black hole is, that player marks the place (or the region) where it must be and gives it to the black hole player to check. Take turns hiding the black hole.

Extensions

1. Use coordinates to give your hypothesis and receive your result: "My beam goes in at (0, 7) and is heading for (18, 20)." "Well, it actually comes out at (11, 20)."
2. A teacher can draw the "astronomer's map" on the blackboard for all to see.

Questions

1. What do you know after one move of this game?
2. What strategies can you use to find the black hole?
3. This activity is really "science fiction" since this method couldn't really be used to find black holes. An authentic search would require an array of astronomers to cover a large part of the galaxy (or many galaxies) on the other side of the black hole from the origin of the light beam. Second, given the finite speed of light, even if such an array could be put in place, the experiment would require hundreds, if not thousands of years to complete. Given this information, if we were really doing this in space, what would be needed? What light beams could be used?

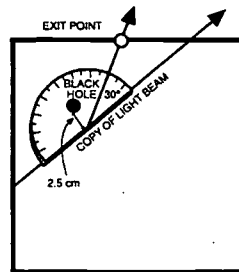

BLACK HOLE SPACE MAP
After one move

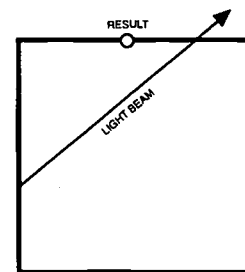

ASTRONOMER'S SPACE MAP
After one move

▶ TRY THIS...

On a flat plane, the sum of the angles of a triangle is 180°. But what if space is curved? Make some large triangles on a basketball with masking tape, and then use a protractor to measure the angles. What do you find? Why do you suppose that happens?



Peggy sharpens her memory when she figures out why she forgets.

Segment Length – 10:24



MEMORY

How do we remember things?

Is “memory loss” simply a failure to pay enough attention? Can you really “forget” something if you didn’t “get” it in the first place? Does information literally go in one ear and out the other?

RESOURCES

Baddeley, A. (1992, Jan 31) Working memory. *Science*, pp. 556–558.

Blackman, A. (1991, Oct 28) When can memories be trusted? *Time*, pp. 86–88.

Carey, B., Griffin, K., & Hossfeld, M. (1990, July/Aug) Remembrance of things placed: What’s up, what’s down. *In Health*, p. 11.

Crook, T. (1992) *How to remember names*. New York: Harper Collins.

Jaret, P. (1992, Aug) Brain-power boosters. *Family Circle*, pp. 52–57.

Lapp, D. (1992) (*Nearly*) total recall. Stanford, CA: Stanford Alumni Association.

Sangiorgio, M., Gutfeld, G., & Rao, L. (1992, Feb) Aerobic memory. *Prevention*, pp. 14–15.

The talking cure (speech rate related to short-term memory span). (1992, Sept/Oct) *Psychology Today*, p. 14.

Weintraub, P. (1992, Mar) Total recall: Ways to improve your memory. *American Health*, pp. 77–78.

Additional sources of information

Alzheimer’s Association
919 N. Michigan, Suite 1000
Chicago, IL 60611-1671
(800) 272-3900
TDD (312) 335-8882

INSIGHTS

- *Memory* is such a complicated process that no universally accepted theory exists to explain how it works. Scientists don’t even agree on where individual memories are stored.

- However, they do agree on some general information about memory. The brain’s cerebral cortex receives nerve messages from eyes, ears, and touch sensors. This sensory stimulus is held for a fraction of a second in the sensory memory. Unless an individual pays attention to the image for about eight uninterrupted seconds to encode the stimulus into short-term memory, it will be lost. The slightest interference at this stage can displace newly acquired information from our consciousness.

- *Short-term memory* (STM) is the brain’s system for remembering information “in use.” But as indicated above, STM doesn’t reliably hold on to information. It also has limited storage capacity—seven items, plus or minus two. If STM tries to acquire more items than it can handle, the middle items will often be displaced. Storage seems to increase if we pronounce the names of the items out loud—especially if they are grouped rhythmically. Grouping items into threes or fours also seems to aid recall.

Chunking also expands STM. A “chunk” is a unit of information that corresponds to some familiar pattern. Try reading this sequence and then recall it:

i g d b f d n o n u c a

Next, try the same exercise on these letters:

c o u n f b a d d i n g

Chunking it into a word you can pronounce made the difference.

Try the same process with this list of numbers:

2 8 3 4 9 6

Next, try remembering this:

28 34 96

Instead of six numbers, you only need to recall three.

To understand its function in the brain, think of STM as a circular tape loop. Once a complete loop is made, three things can happen: (1) the information can be “rehearsed” (repeated) silently or aloud, which will provide auditory cues; (2) the information goes into *long-term*

memory (LTM); or (3) the information will be lost.

Certain foods, aerobic exercise, and stress reduction can improve STM. On the other hand, marijuana users experience subtle STM deficits that continue for at least six weeks after their last usage. Stress or accidental trauma to the head can also affect STM.

The trick to improving memory is to plant information in STM and then transfer it into LTM. Many books, classes, and tapes offer suggestions for training STM. If you could just remember where you left that flyer...

CONNECTIONS

1. Describe the relationship between Alzheimer’s disease and memory issues.
2. How can a computer serve as a metaphor for the brain?

VOCABULARY

chunking a type of organization in which letters, digits, or words are grouped into some psychologically meaningful or familiar sequence

long-term memory (LTM) a memory storage system that has unlimited capacity to retain information over an extended time

memory a complex mental function of recalling things learned or experienced

mnemonic aids “remembering” systems or memory aids. Unusual tricks or clues work best.

short-term memory (STM) a memory storage system that lasts long enough to allow you to do activities like dial a phone number you have just looked up. If a memory is lost at this stage, it does not make it to the long-term storage area of the brain.



DON'T FORGET TO REMEMBER!

Apply your observation skills in this test of memory.

▶ TRY THIS...

Your local library probably has several books on improving memory. Some common techniques include using rhymes, acronyms, repetition, linking, story creation, or creation of bizarre or unusual mental pictures. Research a particular mnemonic system. Find some material to remember and devise a mnemonic device for the list.

▶ TRY THIS...

Memory is a function, but it is also a skill you can develop. Natural mnemonic devices can help you do that. Research some popular mnemonic devices, such as these two phrases for remembering the colors of the rainbow (red, orange, yellow, green, blue, indigo, violet): "Roy G. Biv" or "Richard of York Gains Battles in Vain."

• MAIN ACTIVITY

- Memory depends so much on observation. This activity will exercise both memory and observation skills!

• Materials

- As many age-appropriate clothing accessories as you can gather.
- 1. Divide into two groups ("A" and "B"). Each person will then pair with a member from the other group.
- 2. "A" group members will take two to three minutes to observe "B" group members carefully, noting all their accessories and how they are dressed.
- 3. After "A" members seem sure they know what "B" members are wearing, "B" members will go into an area where they can't be seen by "A" members.
- 4. "B" members will change five things about their clothing, including trading accessories with other "B" members and using the additional accessories provided. For example, transfer a watch to the other hand. Untie a shoelace. Remove or add a belt.
- 5. Return to the original observation place. Does the "A" member of the pair remember what the "B" member originally was wearing and notice all the changes?
- 6. Switch roles.
- 7. Try this activity again, but allow several hours to elapse between the original observation and the second observation after the change.

• Questions

- 1. Was there a difference in what observers noticed? Did minor changes go unnoticed and major changes stand out?
- 2. How can understanding this attention to detail help you in your other school work, such as writing?

▶ TRY THIS...

7 ± 2—the magic memory number! The human mind can remember seven (give or take 2) "chunks" of information, whether single digits or pieces of data. Pair up with a partner. Create a list of ten grocery items and read them slowly to your partner. How many can your partner remember? Take turns with different lists and record the results on a graph. Try your experiment with different age groups.

▶ TRY THIS...

We often learn skills slowly, by repetition, until they become a habit. "Unlearning" habits can be hard, as this exercise will show. In a group, have one person dictate a paragraph of very short sentences as fast as possible. The rest of the group should write down the sentences as fast as they can, without using capital letters or periods. Were the writers able to break the habit of punctuating? Try this experiment on young people and on adults. Do you notice a difference in their ability to break these habits?





David learns about technological advances that help infertile couples increase their odds for conception.

Segment Length - 7:19

IN VITRO FERTILIZATION

What are "test-tube babies" and how are they made?

What is *in vitro* fertilization? Why is it necessary?
How did the phrase "test-tube baby" come about?



RESOURCES

Nilsson, L., & Hamberger, L. (1990) *A child is born*. NY: Delacorte Press/Seymour Lawrence.

Hamson, M. (1990, Oct 24) The baby with two mothers. *The Wall Street Journal*.

Mikler, A. (1992, June 29) Baby makers inc. *Newsweek*, p. 38.

Hopkins, E. (1992, Mar 15) Tales from the baby factory. *The New York Times Magazine*, p. 40.

Cecchin, A. (1992, Nov) IVF babies: The next generation. *Medical World News*, pp. 15-17.

Handyside, A.H., et al. (1992, Sept 24) Birth of a normal girl after *in vitro* fertilization. *New England Journal of Medicine*, pp. 905-909.

Ezzell, C. (1992, Sept 12) *In vitro* fertilization: The pluses add up. *Science News*, p. 165.

Randal, J.V. (1991, May) Trying to outsmart infertility. *FDA Consumer*, p. 22.

Additional sources of information

Resolve
1310 Broadway
Somerville, MA 02144
(617) 623-0744
(support group for infertile persons)

The American Fertility Society
1209 Montgomery Highway
Birmingham, AL 35216
(205) 978-5000

INSIGHTS

- Ever hear the phrase "test-tube baby"? Then you may know that it is a misleading way of referring to a baby conceived through *in vitro* fertilization.

- All babies develop from two different cells that join together—the *sperm* and the *ovum*. Women are born with about a million reproductive ova that are produced and developed in the ovaries, organs which are located within the abdominal cavity. Men produce millions of sperm each day in organs called the testes. Knowing this, it seems that couples who want to become parents should have no problem doing so. But one of every 12 American couples who want to have a baby cannot.

- Infertility can be caused by any number of medical problems. Low sperm counts or poor-quality sperm sometimes cause infertility in men. Problems that affect *ovulation* or the ability of the ovum to enter the *fallopian tube* and move to the proper place for *fertilization* can cause infertility in women.

- A couple is considered infertile if they do not conceive a baby after one year of sexual intercourse using no birth control. At that point, one of the options open to them is *in vitro* fertilization (IVF). Normally, conception takes place inside a woman's body, in the fallopian

tube. However, when a couple has difficulty conceiving in the traditional manner, *in vitro* fertilization allows for conception outside the body.

During IVF, a physician collects ova from the woman at the time of her ovulation, using a high-tech procedure called laparoscopy. The ova are put in a petri dish (or test tube) and sperm, provided by the man, are added to them. Because ova and sperm are so tiny, the physician handles them through a process called micro-manipulation, using microscopic tools. The sperm and ovum remain in the dish or test tube for a few hours to fuse together. (This is how the misnomer "test-tube baby" came about. It is misleading because babies cannot grow in test tubes.)

The next step is for the fertilized ovum to be transferred into the woman's *uterus*. If the fertilized ovum becomes implanted

inside the uterus, the woman becomes pregnant.

While the very early stages of an *in vitro* conception take place in an unusual manner, the rest of the pregnancy, including the delivery of the baby, can be expected to take place normally. Even though conceived differently than most, the baby doesn't look any different and, in fact, is no different from other babies. The very first IVF baby was born in 1978. Since then, IVF has become a quickly growing field of medicine, showing how medicine and technology join together to overcome an obstacle of nature.

CONNECTIONS

1. Before *in vitro* fertilization can take place, what do doctors have to determine about the female and male?
2. Why is IVF considered a medical advancement?

VOCABULARY

fallopian tubes a pair of narrow tubes inside the female that carry the ovum from the ovary to the uterus

fertilization the process of joining together an ovum from a female and a sperm from a male

ovulation the discharge of a ripened ovum at about the midpoint of the female menstrual cycle

ovum the female reproductive cell produced each month by the ovary

sperm the male reproductive cell, which is produced in great numbers in the testes

uterus the hollow organ in the female, designed to lodge and nourish the developing fetus until the time of birth



STEADY HANDS AND SHARP EYES

Try your hand at a microscopic "operation"!

▶ TRY THIS...

For frogs, toads, and fish, external fertilization is natural. Buy a frog fertilization kit from a nature store. Follow instructions to learn the basics of fertilization. Remember, frog eggs are much larger than human ova.

▶ TRY THIS...

Learn about *in vitro* fertilization firsthand from a medical specialist in your area. Call a local medical center involved with IVF. Ask for a member of the center to come out and speak to your class. When that person arrives, ask for human interest stories about how IVF changed the lives of some infertile couples.

▶ TRY THIS...

What should parents tell children conceived by *in vitro* fertilization? Write a booklet explaining IVF to a child through words and pictures.

• MAIN ACTIVITY

- Find out what micro-manipulation is like by trying to move tiny "cells" in a drop of water.

• Materials

- microscope
- toothpicks
- strand of hair
- pepper flakes

1. Put a single drop of water under a microscope. Add some pepper flakes.

2. Using two toothpicks, try to move one flake of pepper around.

3. Take a single strand of hair and compare its size to that of one flake of pepper.

▶ TRY THIS...

In 1978 the first baby conceived using IVF was born. In the 1980s more than 25,000 couples successfully used IVF. Using your math skills, estimate how many more cases can be expected by the year 2000. Make a graph, starting with the first case in 1978 and going through the '80s and '90s up to the year 2000.

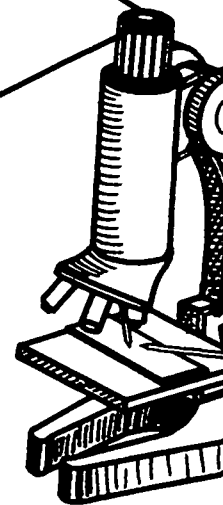
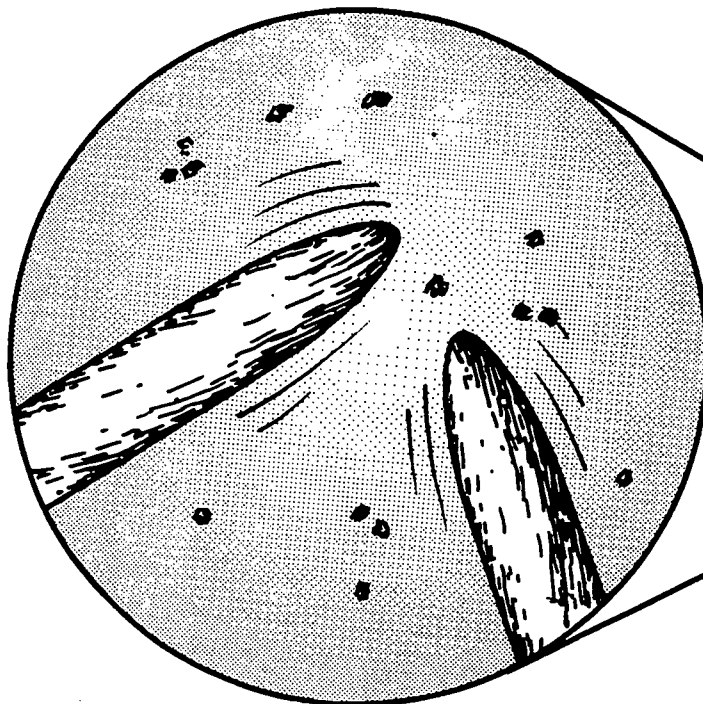

• Questions

1. The size of a single ovum is about one micron (one millionth of a meter) or about the same size as the diameter of a single hair. Estimate the diameter of your water drop and of the pepper flakes. How many times larger than a human ovum are they?

2. What kinds of tools would make this micro-manipulation easier?
3. Can you think of other examples of micro-manipulation? What about macro-manipulation? What are the differences between working on a "macro" scale versus working on a "micro" scale?

163

BEST COPY AVAILABLE



Peggy investigates the science behind newspaper production.

Segment Length – 7:12

NEWSPAPER

What technologies go into producing a modern newspaper?

How are newspaper stories readied for printing?

What printing process is used for newspapers?

How are pictures and color graphics printed?

RESOURCES

Evans, H. (1973) *Newspaper design: An illustrated guide to layout*. New York: Holt, Rinehart and Winston.

Gars, R., & Berstein, T. (1968) *Headlines and deadlines: A manual for copy editors*. New York: Columbia University Press.

Lent, H. (1952) *From trees to paper: The story of newsprint*. New York: Macmillan.

Macaulay, D. (1988) *The way things work*. Boston: Houghton Mifflin Co.

Science and Technology Illustrated (Vol. 18). (1984) Chicago: Encyclopedia Britannica, Inc.

Williams, T. (1987) *The triumph of invention*. London: Macdonald Orbis.

Additional sources of information

Newspaper Association of America Foundation
11600 Sunrise Valley Drive
Reston, VA 22091
(703) 648-1000

Garden State Paper Company
950 River Drive
Garfield, NJ 07026
(201) 772-8700

Community resources

Local newspaper

Commercial printer

INSIGHTS

- When we step outside each morning to pick up our newspaper, most of us don't consider the technology needed to produce it. From the moment a reporter starts on a story to the point when you read the headlines, anywhere from several dozen to several hundred people have applied the latest technology to put the news in your hands. Gone are typewriters and mechanical typesetting machines. Modern newspaper staffs depend on computers, digital imaging, satellite technology, and even robots to get the job done.

- Reporters write their stories on computer terminals tied into a central computer network. From it, editors can access the stories, edit them, and electronically format them for layout on a page. The final edited story is then photo-printed and passed to a designer, who creates a full-page layout on a *composing sheet*. At large national papers and wire services, a story may be *digitized* and sent via satellite to another location for typesetting.

- To reproduce color photographs and illustrations in print, technicians scan the image with a laser sensor that separates it into four process colors—yellow, magenta, cyan, and black. Each *color separation* consists of a series of

closely spaced dots of varying sizes. The larger the dot, the more dense that color ink will appear on the final printing.

This information goes into a computer and is later retrieved to produce proofs and negatives. The production department combines the color separation negatives with the typeset story to make the *printing plates*.

At most newspapers, printers make plates from negative film by coating thin aluminum sheets with chemicals sensitive to ultraviolet light. They then place the negatives against the sheets and expose them to ultraviolet light. The chemicals react and burn an image onto the plate. Before printing, the plates receive additional chemical treatment so that the ink only sticks to places where letters and pictures appear.

The press operator mounts the plates onto the press. Rotating

drums are used for each color to do the actual printing. The first, onto which the plates are mounted, is coated by rollers with ink and water. This action passes the negative image onto a rubber-coated *blanket* drum. The blanket then presses the image onto the paper to create a new positive image. Since the metal plate offsets the image onto the blanket first, this printing device has become known as an *offset press*.

CONNECTIONS

1. What effect will technology like lasers and digital image processing have on the future of newspapers? What other new processes might speed up newspaper production?
2. How has publishing technology impacted the advertising, communications, and graphics industries?

VOCABULARY

blanket a rubber roller for taking a negative image from a printing plate

color separation the process of breaking a color image into the four colors of yellow, magenta, cyan, and black

composing sheet mechanical pasteup of what the actual printed paper will look like

digitize to translate into a binary code that a computer can read

offset press a device where the printed paper never touches the printing plate directly

printing plate a thin metal plate which contains the positive image of the material to be printed

web a continuous sheet of printing paper before it is cut and folded

• Newton's Apple is a production of KTCA Twin Cities Public Television. Made possible by a grant from 3M.
• Educational materials developed with the National Science Teachers Association.

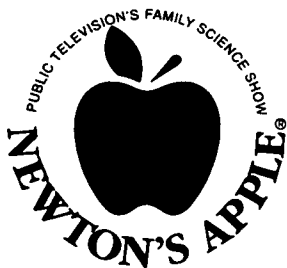

IN LIVING COLORS

Discover how only four colors of ink can produce an entire spectrum of colors on a printed page.

▶ TRY THIS...

Predict which section of your newspaper has the largest percentage of advertisements. Then take each section of the newspaper (world news, style, sports, and so on) and calculate the area of each newspaper page. What percentage of each section is advertising? Was your prediction correct? What do the percentages of advertisements and types of advertisements tell you about the readers of that newspaper section? Next, calculate the area devoted to advertisements.

▶ TRY THIS...

Contact a local newspaper to arrange a trip to see the different departments in action. Most large dailies offer organized tours for school classes, groups, and organizations.

• MAIN ACTIVITY

- Anyone who has ever mixed paints
- knows that a few primary colors in
- combination can produce a whole
- rainbow. When newspapers and
- magazines reproduce color images,
- they pass a prepared image over four
- different presses, each one adding a
- different color ink. If the proportions
- of ink and the preparation of the
- images are just right, the final picture
- will appear in full color. In printing,
- the four colors used are yellow,
- magenta, cyan, and black. In this
- activity, you will blend colors to
- produce your own full-color images.

• Materials

- several sheets of white bond paper
- red, blue, and yellow water-based,
- fine-point markers
- good-quality magnifying glass
- color picture from a newspaper or
- magazine

1. Look at a color picture in a newspaper under the magnifying glass. You'll see that the picture is really made up of many dots of different colors. With high enough magnification, you'll see that the dots are actually only four colors: yellow, magenta (red), cyan (blue), and black. These small dots are closely spaced and occasionally overlap each other. From a distance, they appear to blend together into continuous colors.

2. Begin your drawing by using the red marker to make a random pattern of closely spaced dots on the paper. Make sure that you leave some space between the dots and make the dots as small as possible.

3. Take the blue marker and fill in about one-half of the spaces between the red dots. Continue off to the other side of the red dots to make a pattern of blue dots on the white paper. Again, remember to keep the dots as small as possible.

4. Examining the pattern closely, you should see only red and blue dots. Take the paper and hold it at arm's length from your face. The greater the distance from your eye, the more you should start to see purple in the area where the dots overlap. That's because your eyes blend the dots and interpret them as a new color.

5. Add some more red dots to the white background and then fill in one-half of the spaces with yellow dots. What color do you expect to appear? If you said orange, you'd be right. Experiment by blending all three colors in different concentrations, and soon you'll be creating full-color images.

▶ TRY THIS...

One picture is worth a thousand words. To see how effectively pictures can tell stories, take several photos of people, places, and events. Write a short caption for each, describing the situation. Give the photos to friends to see how much information they can gather from just looking at the photos. Compare their answers to your captions to see if every picture does indeed tell a story!

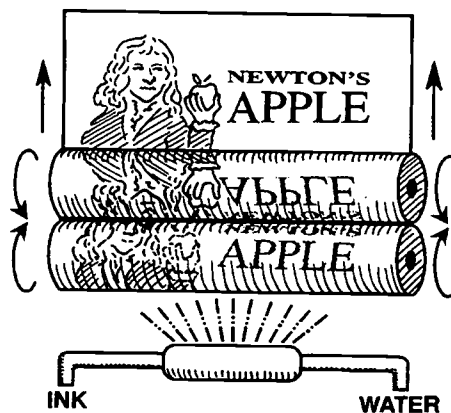

Questions

1. Newspapers aren't the only things that blend color by using tiny dots. Can you find other objects in your house that work in a similar way? Hint: You'll need a magnifier and an electron beam to see them!
2. When the dots on your picture created other colors, they did so using the optical receptors in your brain. How does this compare to mixing paints to get different colors? Your eyes can only see red, blue, and green, yet the primary pigments are red, blue, and yellow. How can you explain this?

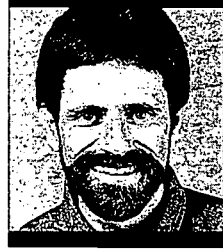

David confronts the dangers of explosives when he discovers a ticking bomb in the Newton's Apple studio!

Segment Length - 8:25

BOMB SQUAD

What is an explosion?

What types of explosives do people use? How do explosions take place? How can explosions be beneficial?

RESOURCES

Bahrani, A. (1986, July 10) Engineering with a bang. *New Scientist*, pp. 44-47.

WGBH-TV *Frontline* videotape: *Tracking the PanAm Bombers*. PBS Video: (800) 328-7271.

Watson, R. (1989, Jan 2) An explosion in the sky. *Newsweek*, pp. 28-30.

Watson, R. (1989, Jan 9) A trail of terror. *Newsweek*, pp. 16-19.

Additional sources of information

Bureau of Mines
2401 E St. NW
Washington, DC 20006
Publications: (202) 634-4882

Institute for Makers of Explosives
1120 19th St. NW, Suite 310
Washington, DC 20036-3605
(202) 429-9280
(Safety education materials in different media)

Community resources
Construction or explosive company

Fire department
Police department

INSIGHTS

- We often see the negative side of explosives on the news—images of twisted metal on damaged buildings or debris and rubble in a war zone. But explosives also help us construct tunnels, mine underground, remove obstacles during road construction, extinguish oil well fires, inflate automobile air bags, and destroy hazardous wastes.
- An explosive is a stable material that, upon stimulation, very rapidly changes from a solid or liquid into a hot, expanding gas.
- The sudden release of energy and the accompanying pressure exerted on the surrounding materials by the expanding gas constitute an *explosion*. If you confined an explosive, you would increase the likelihood of the *detonation* by increasing the speed of the reaction. For example, when gunpowder is confined within the paper wrapping of a firecracker, it explodes when ignited. However, the same powder sprinkled in the open simply burns when ignited. In the confined state, the heat generated at the point of ignition will immediately ignite a large amount of surrounding material. The expanding gases from all the "burning" gun powder will act together, resulting in an explosion.
- Explosives fall into two categories: detonating and

propellant. Detonating explosives are further classified as initiating (primary) or secondary. *Initiating explosives*, the more sensitive of the two, must be handled with extreme care. They require only a low energy stimulus, such as being touched with a hot wire or tapped with a hammer, to explode. For that reason, they are put into *blasting caps*.

Secondary explosives are less sensitive and can burn without producing an explosion. They only detonate by means of a severe shock, delivered by another explosive (usually a blasting cap) placed in or near them. Since they are relatively stable, large amounts can be moved and handled safely.

The velocity at which explosives detonate determines their function. Explosives of low detonating velocity supply a slow push or heave. Explosives with a high detonating velocity have a bursting or shattering effect.

Propellant explosives are used

for firearms, rockets, general engineering, and demolition work. They differ from detonating explosions in that an avenue of escape is provided for the expanding gases. For example, when the explosive propellant in the space shuttle solid rocket boosters is ignited, all the gases from the resulting continuous explosion escape out the bottom, providing upward thrust. Unlike a detonating explosive, not all the explosive material is burned at once in a propellant explosive.

Industries rely on small explosive charges for a number of purposes. In metallurgy, for example, metals can be pressed into dies, extruded, or welded together by means of such explosions. New metal alloys have been created that way.

CONNECTIONS

1. How has the use of explosives changed over the last 100 years. What does the future hold?
2. What regulations restrict the use of explosives?

VOCABULARY

- blasting cap** a capsule containing a small amount of easily explosive material used to explode more stable high explosives
- detonation** an explosion usually accompanied by a shock wave
- explosion** primarily the rapid conversion by chemical reaction of a solid or liquid to a hot, expanding gas, resulting in a release of energy and accompanying pressure
- initiating explosives** used to explode more stable secondary explosives. Also called primary explosive.
- propellant** the type of explosive used to move an object such as a bullet

• Newton's Apple is a production of KTCA Twin Cities Public Television. Made possible by a grant from 3M.
• Educational materials developed with the National Science Teachers Association.

BLAST RANGE

Measure the amount of space you can soak with a water balloon.

▶ TRY THIS...

How are explosives used for constructive purposes? In small groups, brainstorm the ways society benefits from explosives.

▶ TRY THIS...

An explosion is considered anything that combusts with a spread of over 3,000 feet per second. Convert this rate to miles per hour. What other events occur at this speed?

▶ TRY THIS...

Explosives have been around for a long time. Construct a time line to show the history of explosives from their invention to the present.

• MAIN ACTIVITY

- Explosives have different detonation velocities. Some shatter and others push. With water balloons, you will simulate the range of a blast.

• Materials

- meter stick
- stepladder
- 3 water balloons
- thumb tack

1. Fill three balloons with water so they are all about the same size.
2. Move outside into a large parking lot or paved playground.

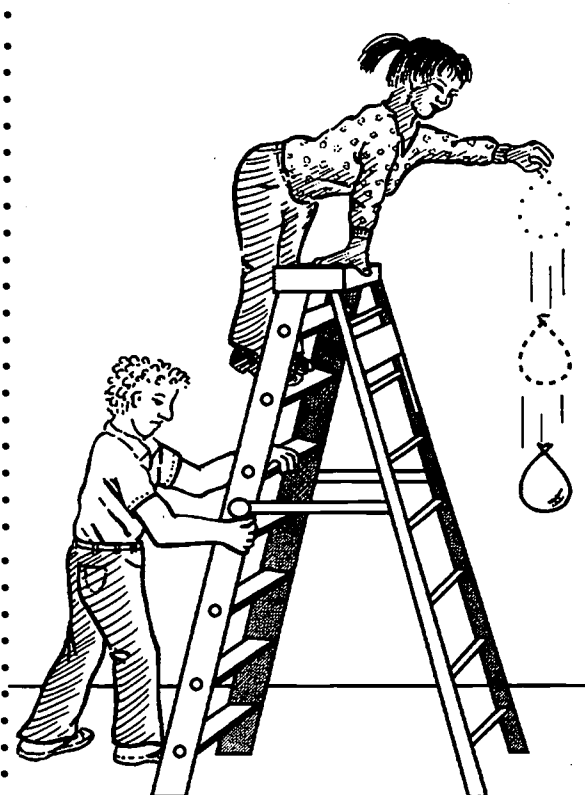

• Questions

1. How does the bursting of a water balloon illustrate the processes taking place in an explosion?
2. What was the relationship between the blast diameter and the height from which the balloon was dropped?

3. Place the thumb tack on the ground so that the point is facing up.

4. Place the meter stick next to the thumb tack and measure a height of one meter from the ground.

5. Position your balloon at arm's length over the tack at that height.

6. Drop the balloon and measure the diameter of the water blast range from the two farthest points.

7. Using the same procedure, climb the stepladder and drop your second balloon from a height of three meters. (Be careful on the stepladder. Make sure someone holds it steady and another person spots you.)

8. With the third balloon, move into a clear area and throw the balloon up as high as you can. Then watch out!

9. Record the distances dropped and the diameters of the wet areas for all three balloons.

10. Construct a graph showing the results of the investigation.

▶ TRY THIS...

View some videos dealing with explosives. They could be World War II documentaries, footage of a shuttle launching, or motion pictures such as *Hellfighters* (about Red Adair's life). Write on account of the role of explosives in these videos.

▶ TRY THIS...

From time to time, you will hear news of hydrogen gas, coal dust, grain dust, and even gasoline vapors that have exploded. What causes them to behave like an explosive? Research one of the above materials to determine its explosive characteristics and the conditions needed for explosions to occur.

3. What factors might control the blast range?
4. What factors besides the height could you change to increase the range of the splashing water?



Peggy discovers that jumbo jets, which can weigh up to 870,000 lbs., are just as safe as smaller planes.

Segment Length – 9:50

JUMBO JETS

How does a jumbo jet get off the ground?

How can an airplane as heavy as three blue whales get off the ground? How does the wing design of a 747 allow a plane longer than the Statue of Liberty to fly?



RESOURCES

Anderson, J.D., Jr. (1985)
Introduction to flight. New York: McGraw-Hill.

Additional sources of information

Smithsonian Museum's
Air and Space magazine
PO Box 53261
Boulder, CO 80301
(800) 766-2149

Aircraft Owners and Pilots
Association
421 Aviation Way
Frederick, MD 21701
(301) 695-2000
(free packet: *A teacher's guide to aviation*)

Federal Aviation Administration
800 Independence Ave. SW
Washington, DC 20591
(202) 366-4000

NASA
Education Division
Mail Code F
Washington, DC 20546
(402) 358-1110

Society of Automotive Engineers
Education Program Coordinator
400 Commonwealth Drive
Warrendale, PA 15096-0001
(412) 276-4841

Community resources

Local airport authority
Pilot or flight instructor

INSIGHTS

- People have always wanted to fly. Leonardo da Vinci, who often dreamed about flight, drew intricate designs for several different flying machines. Among the many scientists whose discoveries made human flight a reality are Sir Isaac Newton (1642–1727) and Daniel Bernoulli (1700–1782). Both are credited with developing the scientific principles that explain how an airplane flies. However, it was not until many years later, on December 17, 1903, that Orville and Wilbur Wright actually applied these principles to successful airplane flight. Their first flight lasted only 12 seconds, and they traveled only 120 feet. The entire trip could have taken place inside of a 747.
- Whether a single-seat propeller plane or a giant 747, there are four fundamental forces at work in airplanes. Thrust is the forward movement of the airplane, provided by the propellers or jet engines. Drag is the opposing force of the displaced air, the same force you feel walking into a strong wind. Gravity acts on the airplane, pulling it down toward the earth, and *lift* counteracts the force of gravity, keeping the airplane up in the air. The lift force is equal to the force of gravity when an airplane is in level flight.

Bernoulli's principle helps to explain lift. Bernoulli demonstrated that the faster a fluid moves, the less pressure it exerts. An airplane wing is shaped so that air (which is a fluid) moves faster over the top of the wing than it moves under the bottom of the wing. As a result, there is greater pressure underneath the wing than there is on the top of the wing, resulting in a net force which "lifts" the wing.

The angle at which the wing meets the air (the angle of attack) also contributes to lift. You can easily demonstrate this when you hold your hand out the window of a moving vehicle and change the angle at which your palm meets the oncoming air. If the surface of an airplane wing meets the air at an angle, the wing exerts a force on the air and the air exerts an equal force on the wing—an effect which Newton described in his third law of motion. There are many other factors that

influence lift: the shape and area of the wing, the *velocity* of the airplane, and even the density of the air.

Pilots and aeronautical engineers use the forces involved in lift to help them design and fly planes of all sizes and shapes. With the right lift, even a 870,000-pound jumbo jet can head for the sky.

CONNECTIONS

1. When you turn on the water to take a shower, why does the shower curtain move?
2. What different shapes of airplane wings can you think of? Why are they different?
3. How are the wings of birds like the wings of airplanes?

VOCABULARY

aerodynamics the study of the motion of air and the effect of moving air on obstructions

Bernoulli's principle The pressure in a fluid decreases as the speed of the fluid increases.

fluid a substance tending to flow and conform to the outline of its container

lift the force that allows for upward motion on a flying object

pressure the force exerted over a surface divided by its area

wind tunnel an enclosure in which a steady current of air can be maintained for the purpose of testing lift and friction

velocity the rate of change of displacement of a moving body with time

- Newton's Apple is a production of KTCA Twin Cities Public Television. Made possible by a grant from 3M.
- Educational materials developed with the National Science Teachers Association.



PLAYING BERNOULLI BALL

With a stream of air and Bernoulli's principle, you will hold a ball in midair before hitting it into a target.

▶ TRY THIS...

With the fingers of both hands, hold a single sheet of paper just below your lower lip. Allow the paper to bend and hang downward. Blow across the top surface of the paper. What happens? Explain, using Bernoulli's principle.

• MAIN ACTIVITY

• (also see the activity for *Windsurfing: Show 1106*)

• Challenge your friends to a game of Bernoulli Ball. The game looks easy, but you will quickly see that there are subtle forces at work which require shrewd analysis and manipulation for accurate shooting.

• Materials

- hair dryer with a cylindrical nozzle
- Styrofoam ball, 4-5 cm in diameter (1½" - 2")
- a couple of cardboard boxes of different sizes

1. The player sits in a chair or on a stool with the hair dryer "gun" about 1 meter (1.1 yds) away from the target box.

2. Place the smaller cardboard box inside a larger cardboard box to serve as the target. (Or cut and shape cardboard into curved sections and place in box, as illustrated below.) If you position the back of the box against a wall, you won't have to chase as many stray balls.

3. Scores for each part of the target are:

inner box	3
outer box	1
outside of boxes	0

4. Use the hair dryer on the cold-air setting. If there are low- and high-speed settings, use the low speed.

5. Each player is allowed five practice shots and five shots for official score.

6. To start the game, turn the dryer on and point the nozzle straight up. Place the Styrofoam ball in the airstream about 30 cm (1') above the nozzle.

7. The player shoots the ball by smoothly tilting the dryer so that the ball falls out of the airstream and continues on a curved path toward the target.

8. If the ball hits the dryer, the player gets to try again.

Questions

1. Why does the ball stay in the airstream when the dryer is pointed straight up?
2. Does the ball fall out of the airstream as soon as you start to tilt the gun?
3. Why does the ball leave the airstream when you continue to tilt the hair dryer?
4. After playing the game, do you have any suggestions for someone who has never played it?

▶ TRY THIS...

Make an atomizer out of a soda straw. With a knife, slit the straw one-third of its length from one end. Bend the straw at the slit and place the short section into a glass of water. Make sure that the slit is no more than one centimeter above the surface of the water. Blow hard through the other end of the long section of the straw. What happens? Explain using Bernoulli's principle.

▶ TRY THIS...

Find a Styrofoam ball about the size of a baseball. Play catch with a friend. Throw the ball in such a way that it spins. Try both a "top to bottom" spin and a "sideways" spin. What happens to the ball? Explain, using Bernoulli's principle.

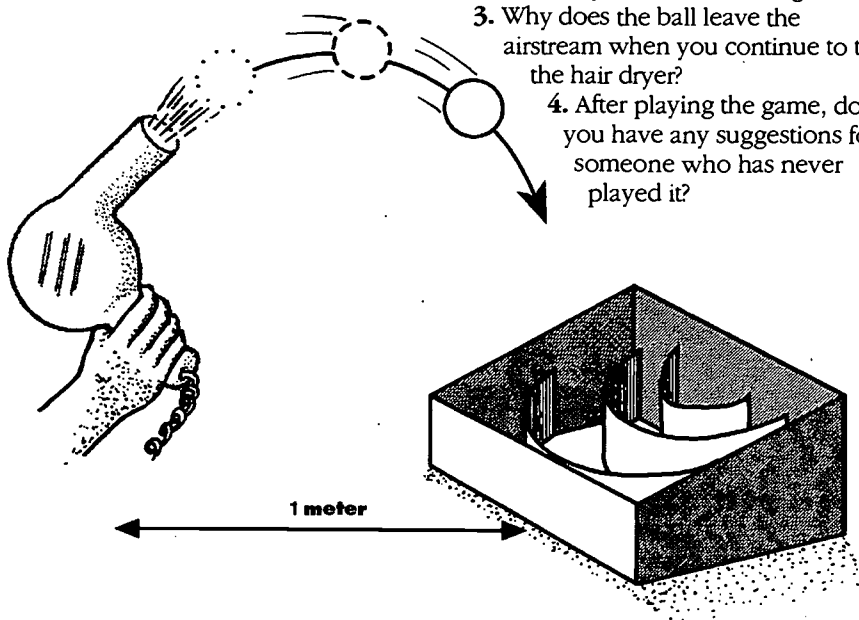

▶ TRY THIS...

Tape a table-tennis ball to a string and allow the ball to swing into a stream of water running smoothly from a spigot. Lightly tug on the string by pulling it to the side. What happens to the ball? Explain, using Bernoulli's principle.



David wants to learn more about meteors after a large one crashes through his roof!

Segment Length - 6:05

METEORS

What are meteors and where do they come from?

What is a meteor? When are you most likely to see meteors? Is there any way to predict them?



RESOURCES

Begley, S. (1992, Nov 23) The Science of Doom. *Newsweek*, pp. 56-60.

Berger, M. (1981) *Comets, meteors, and asteroids*. New York: G. P. Putnam's Sons.

Darling, D. J. (1984) *Comets, meteors, and asteroids: Rocks in space*. New York: Dillon.

Fichter, G. S. (1982) *Comets and meteors*. New York: Franklin Watts.

Hecht, J. (1993, Jan 16) Stony asteroid devastated Siberia. *New Scientist*, p. 16.

Langreth, R. (1992, Sept) Asteroid Watchers. *Popular Science*, pp. 76-81.

Additional sources of information

Center for Meteorite Studies
Arizona State University
Tempe, AZ 85281

Astronomy magazine
(800) 446-5489.

Community resources

Local astronomical societies or astronomy clubs. To find one near you, call the Astronomical Society of the Pacific at (415) 337-1100.

Astronomy or physics departments at local colleges or universities

Local museums and rock shops



INSIGHTS

- Most of us see *meteors* by chance. You're out with a friend on a dark night, and suddenly you see a bright object streak across the sky. You shout, "Look at the *shooting star*," but by the time your friend looks, it's gone.
- If you're lucky, you see it together.

- But can you *try* to see a meteor? You bet. Simply go out at night and watch and wait. Lie on your back, and look up at the sky. If you don't get too cold and you don't fall asleep, you'll probably see about five meteors an hour, though you can't predict exactly where or when they'll appear.
- These *sporadic meteors* are just chance collisions between a bit of space dirt and Earth's atmosphere.

- A typical meteor has a mass that is only a fraction of a gram.
- When it hits the atmosphere, it is probably going 10-40 kilometers per second (20,000-90,000 miles per hour). When it enters Earth's atmosphere, its surface heats up because of friction. Bits of matter fall away, and atoms evaporate from the surface to form a hot, gaseous envelope around the tiny particle. This hot envelope, which may be a foot or more in diameter, hurtles through the atmosphere, making a streak of light in the sky. The meteor usually burns up in the atmosphere—and the envelope dissipates—by the time it's

within 60 kilometers (200,000 feet) off the ground.

If you're really lucky, you'll see a much larger meteor. The bigger the piece of dirt, the longer and brighter the streak in the sky. Fewer than one in a thousand visible meteors are fireballs or *bolides*, which are especially bright and can make explosive or hissing noises.

If the meteor slows down enough, it will stop evaporating before it has been completely obliterated. These *meteorites* actually will fall to the ground.

If you don't like waiting around for a chance encounter with a sporadic meteor, you should go out on a night when astronomers are expecting a *meteor shower*. Several times a year, Earth passes through a known cloud of space dirt, usually debris from a comet. In these clouds, the *meteoroids*—the bits of matter in space—are about 50 kilometers (30 miles) apart.

Because meteor showers occur as Earth moves through a particular region of space, they happen at the same time every year. Here are a few of the most reliable meteor shower dates:

Quadrantids	January 1-3
Perseids	August 11
Orionids	October 20
Geminids	December 13

CONNECTIONS

1. Where do meteors come from? How old are most meteors?
2. How often do meteors hit Earth? How likely is it that a meteorite will hit you?
3. Why do meteors have different colors, such as red and blue?
4. How can meteoroids affect spacecraft?
5. Are humans made of meteor atoms?
6. Can you see meteors during the daytime? Why or why not?

VOCABULARY

bolide a fireball; a large, bright meteor

meteor material from interplanetary space falling through Earth's atmosphere

meteor showers times when you might see many meteors, usually when Earth passes through a cloud of meteoroids

meteorite a meteor that strikes Earth

meteoroid a piece of interplanetary material out in space—the kind of stuff that would be a meteor if it hit Earth's atmosphere

shooting star another name for a meteor

sporadic meteors meteors that appear by chance and are not associated with a meteor shower

Newton's Apple is a production of KTCA Twin Cities Public Television. Made possible by a grant from 3M.
Educational materials developed with the National Science Teachers Association.

170

11.27

BEST COPY AVAILABLE

3M Innovation



CRATER CREATION

Find out what the size of a crater can tell us about the meteorite that made it.

▶ TRY THIS...

Go out with a friend to a dark place at night—during a meteor shower if you can—and try to see some meteors. Bring a flashlight so you can find your way safely. While you watch, see if you can identify the path the meteors take.

▶ TRY THIS...

Get a topographic map of Meteor Crater, Arizona. How do they indicate the depression on the map? Find where Meteor Crater is on a map of the United States. Using the topographic map, make a model of Meteor Crater with clay or plaster of paris.

▶ TRY THIS...

Thousands of meteorites fall on our planet each year. They are small and usually harmless. Read "The Science of Doom" in *Newsweek* (Nov 23, 1992) to learn about the probability of a much larger meteorite making contact with Earth. When was our last "big hit"? Stage a debate regarding the use of tactics to divert an approaching meteor.

• MAIN ACTIVITY

- Make craters like David did in the *Newton's Apple* segment. Measure what factors make a difference in how big a crater is.

• Materials

- a sandbox (the finer the sand, the better)
- various objects: a marble, a large ball bearing, rocks of different sizes
- a ruler
- paper and pencil for recording data
- a scale, such as a kitchen scale, for weighing the objects (optional)
- a ladder (optional)

1. Make a recording sheet with two columns—one for recording information about your "meteorite" and another for information about the craters it produces.

2. Prepare a smooth, flat surface in the sandbox at least 30 cm (1') on a side. Be sure the sand is loose and dry beneath it.

3. Pick an object to act as your meteorite. Measure and record its length and, if you have a scale, weigh your meteorite and record that figure, too.

4. Make sure no one is in the way!

5. Throw the meteor down into the middle of the sand as hard and as fast as you can.

6. Look at the crater you made. Measure its diameter (to the nearest millimeter, if you can) and its depth.

7. Repeat steps 4 through 6 at least two more times to get three or more measurements from your meteorite.

8. Repeat steps 3 through 7 using different objects as meteorites.

9. (Optional) Repeat the steps, substituting flour for sand and

dropping the objects instead of throwing them. This will remove the added variable of velocity. Observe how your results differ when you drop the object into flour instead of throwing it into sand.

Questions

1. What problems did you encounter as you tried to measure the craters? How did you deal with those problems?
2. How did your craters vary? Did the same meteor always produce a crater of the same size? How did changing the meteor change the crater you made? Did you see any patterns?
3. How could you change this investigation? Can you think of other materials that would make good craters? Can you think of other things you might measure?
4. How does making craters in a sandbox help us understand real meteorite craters?
5. Based on the final pattern, can you tell which craters were made first? How can astronomers estimate the age of meteor craters on other planets?

▶ TRY THIS...

Find out about meteorite craters on other planets. Get photographs of the surfaces of the moon, Mars, and Mercury. How are they similar? How can you tell them apart? How can astronomers tell the age of meteor craters just from looking at their pictures?

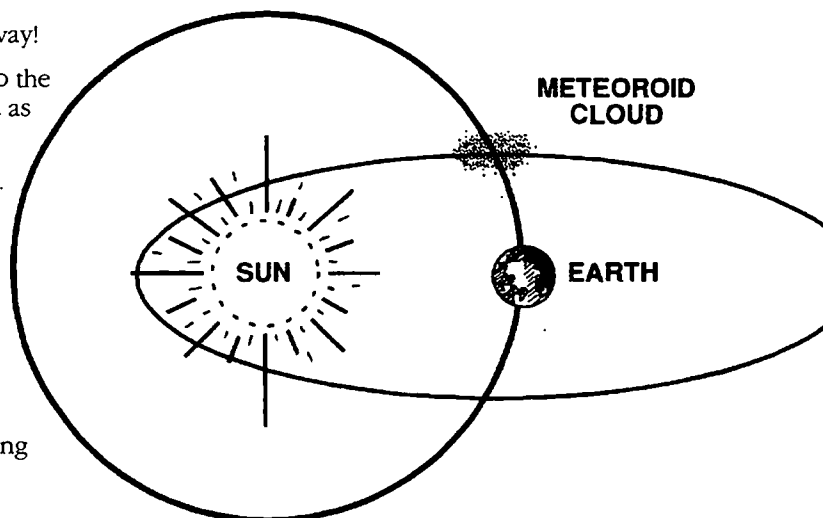

171

- Newton's Apple is a production of KTCA Twin Cities Public Television. Made possible by a grant from 3M.
- Educational materials developed with the National Science Teachers Association.

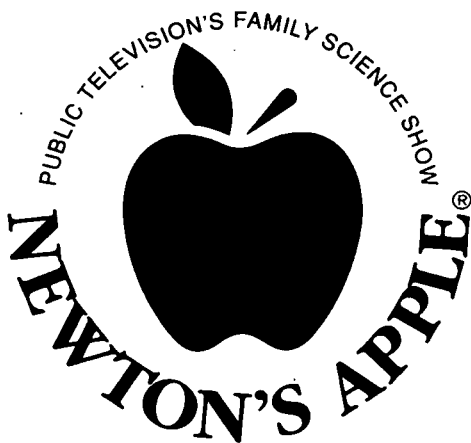

David experiences the powerful force of the wind firsthand as he windsurfs across the Hood River.

Segment Length – 8:35

WINDSURFING

How can windsurfers reach speeds faster than the wind that powers them?

**How does a windsurfing board use the wind to move
How does the windsurfer steer with the mast and sail**

RESOURCES

Beauchamp, M. (1989, Sept 18) In search of nuclear winds. *Forbes*, pp. 214–215.

Coombs, C. (1982) *Be a winner in windsurfing*. New York: William Morrow & Co.

Evans, J. (1992) *Windsurfing*. New York: Crestwood House Inc.

Jones, R. (1985) *Windsurfing basic and funboard techniques*. New York: Harper & Row Publishers.

Mason, C., & Rabinowitz, N. (1988, June) Jumping for joy in the gorge. *Sail*, pp. 82–86.

Olney, R. (1982) *Windsurfing—A complete guide*. New York: Walker & Co.

Prade, E. (1986) *Perfect windsurfing: Intermediate to advanced*. New York: Barrons.

Additional sources of information

U.S. Sailing Association
PO Box 209
Newport, RI 02840
(401) 849-5200

U.S. Windsurfing Association
PO Box 978
Hood River, OR 97031
(503) 386-8708

Community resources

Windsurfing retail store
Windsurfing club

INSIGHTS

- You skim across the surface of the water at incredible speeds, drive towards a whitecapped wave, and then take flight like a skateboarder in a half-pipe, each muscle straining against the force of the wind. Then you smash into the trough of the wave, spring up from near disaster, and look quickly for the next wave so you can do it all over again. This is the exciting sport of windsurfing.

- Windsurfing has its roots in the '60s when it began to take shape from conversations between an aeronautical engineer and a scientist. In 1969, the engineer presented a symposium paper entitled "Wind Surfing: A New Concept in Sailing." This new concept entailed releasing the mast from its traditional fixed vertical position and allowing it to pivot around its base. The sailor then can both steer and balance the board through appropriate movements of the mast and sail. From these beginnings, windsurfing has grown to become a popular sport attracting 100,000 newcomers a year.

- How does a windsurfer manage to move the sailboard across the water? The force that moves a sailboard (or any sailboat) is not produced simply by the wind pushing on the sail. The process is closely related to the *lift* on an

airplane caused by the air moving over a specially-shaped wing. Bernoulli's principle tells us that in a fluid (such as air), regions of higher velocity have lower *pressure* than surrounding regions.

A sail may be thought of as a vertical wing. The wind moves faster (in order to travel the greater distance) over the *convex* curve of the forward part of the sail than it does when it goes straight over the back part of the sail.

According to Bernoulli's principle, there is lower pressure on the forward part of the sail (shaded region in the figure at right) and thus a net force perpendicular to the sail. This is the force that propels the windsurfer, but you may have noticed that part of this force is to the side of the sailboard. What keeps the board from moving sideways? The answer is the "daggerboard" which extends from the sailboard down into the water.

This daggerboard not only keeps the board from drifting sideways, but it also acts as a

fulcrum about which the sailor pivots the board for steering.

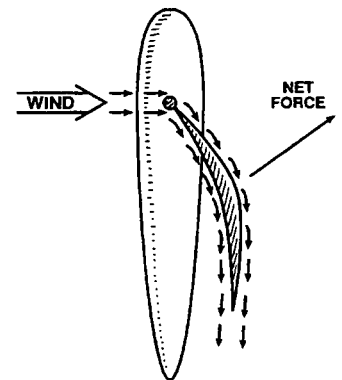

CONNECTIONS

1. What advanced technologies does windsurfing apply? Can you name other sports where these technologies also play a part?
2. What advanced materials go into the construction of sailboards? What other sports use these materials?
3. What other means of transportation could be developed that would harness wind power?

VOCABULARY

- airfoil** a surface, such as a wing, designed to aid in lifting or controlling an aircraft or pulling a sailboard
- convex** having a surface that is curved or rounded outwards
- fulcrum** the point of rest about which a lever turns
- lift** the net force caused by different pressures on opposite surfaces of a wing or sail
- pressure** force exerted over a surface divided by its area



WHAT IS LIFT?

Build a model wing and find out what happens when you move it through the air.

▶ TRY THIS...

What creates wind? How can you design a method to show how wind forms? In small groups, develop answers to these questions and share your results with the rest of your class.

▶ TRY THIS...

How do we use wind today? In the future, what types of transportation might rely on wind? Develop an idea for a transportation system that employs wind power. Locate regions of the world that would have enough wind for it to work.

• MAIN ACTIVITY

- The lift on the sail of a sailboard is similar to that on a wing of an airplane.
- What forces and pressures generate lift? Construct a model to demonstrate the force of lift.

• Materials

- two 8 1/2" x 11" sheets of paper
 - ruler
 - transparent tape
 - sharpened pencil
 - 60-cm (24") piece of monofilament fishing line
 - one 15-cm (6") straw
 - two 7.5-cm (3") straws
1. Fold one sheet of paper in half, but do not crease the fold.
 2. Tape the long opened edge of paper with three small pieces of tape to keep it closed. This taped side will be known as your "trailing edge," while the folded side will be known as the "leading edge."
 3. With the pencil, mark an "X" on the center line of the paper about one inch from the leading edge.
 4. Punch a hole through both the top and bottom of the paper at the "X."
 - (Be careful not to crease the paper at the fold.)
 5. Place the 15-cm straw through the hole you just punched. Use tape, if necessary, to hold the straw in place.
 6. Tie one end of the fishing line to the middle of a 7.5-cm straw.

7. Pass the other end of the fishing line through the 15-cm straw which is attached to the paper.

8. Pull the fishing line through and tie this end to the other 7.5-cm straw. The 7.5-cm straws will be your handles.

9. On the other piece of paper, trace two copies of the airfoil shape below and cut out the shapes. Tape the shapes to the open ends of the "wing." The flat edge of the shapes should be on the bottom of the wing (see illustration).

10. Taking the 7.5-cm straw handles, one in each hand, draw the fishing line tight and position it so the line is perpendicular to the floor. Make sure the flatter surface of the wing faces down.

11. With your arms out in front of you, make a quick sweeping motion through the air. Be certain that the leading edge of the wing is in front.

Questions

1. What did your piece of paper do?
2. What caused the wing to move upward?
3. Explain how this demonstration relates to a sail.
4. Explain the forces that move the paper upward.

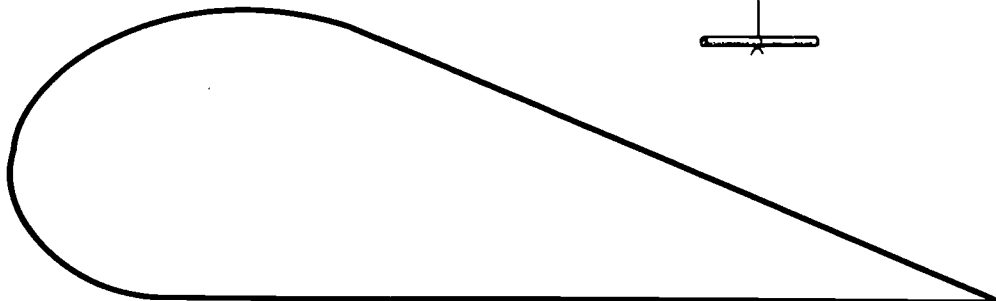
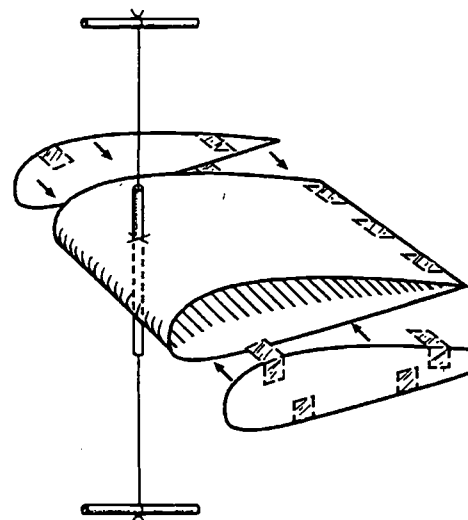



Peggy discovers treasures hidden for 30,000 years when she visits a permafrost tunnel in Alaska.

Segment Length – 5:57

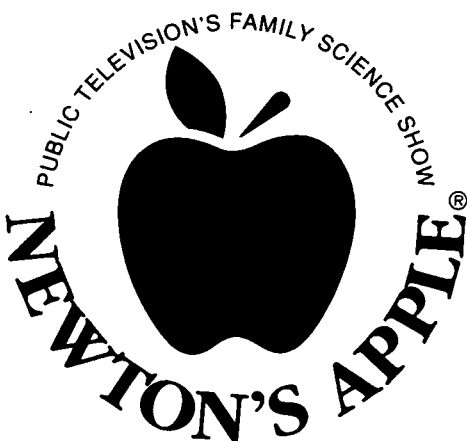

PERMAFROST

What is permafrost?

How can something be preserved for 30,000 years? How can humans adapt to permafrost? What can permafrost tell us about our past and future climate?

RESOURCES

Bruemmer, F. (1987, Apr) Life upon the permafrost. *Natural History*, pp. 31-38.

Fodor, R.V. (1981) *Frozen earth: Explaining the ice ages*. Hillside, NJ: Enslow Publishers.

Johnston, G.H. (1981) *Permafrost engineering design and construction*. New York: Wiley and Sons.

Kurten, B. (1986) *How to deep-freeze a mammoth*, (chapter 9). New York: Columbia University Press.

Sutcliffe, A.J. (1985) *On the track of ice age mammals*. Cambridge, MA: Harvard University Press.

Additional sources of information

Geophysical Institute
University of Alaska/Fairbanks
Fairbanks, AK 99775-0800
(907) 474-7558

International Permafrost Association
Troy Pêwé, President
Arizona State University
Box 871404
Tempe, AZ 85286-1404

INSIGHTS

- The *permafrost* tunnel 10 miles north of Fairbanks, Alaska, is called a “chilly, smelly time machine” because it exposes permafrost layers dating from 11,000 to more than 30,000 years ago. These layers contain plant and animal remains whose decay creates the smell.

- Permafrost underlies an estimated 20%–25% of the world’s land surface; it occurs in more than 50% of Russia and Canada, 82% of Alaska, 20% of China, and probably all of Antarctica. Permafrost in northern Siberia is 1,600 meters, (5,250 feet) thick and it is 650 meters (2,100 feet) thick in northern Alaska.

- The active surface layer of permafrost is a thin slice of tundra vegetation that thaws every summer and freezes in winter. A frozen sublayer keeps the water on the surface. The active layer is vulnerable to environmental damage. For example, tracks from a passing vehicle will tear up the fragile insulating tundra, allowing the soil to thaw into scars that may remain for hundreds of years.

- Underground, permafrost consists of frozen soils ranging from gravel to silt. Silty soil is made of fine, powdery sedimentary particles. They possess great “wicking” capacities, enabling water to migrate and accumulate in large

bodies of ice in the permanently frozen silt. If the ice melts, the resulting silt mixture resembles soup!

Construction disasters can be caused by such a thaw and the resulting subsidence, or settling, of surface features. Entire megaprojects—such as the Jenpeg dam diversion in Canada—have also been affected by the unpredictable behavior of permafrost.

Thermosiphons offered one solution to permafrost on the Alaska pipeline. Other options exist. To avoid settling, engineers try to build on bedrock or coarse, well-drained soil with a low ice content. Builders can also maintain stable soil by insulating structures to prevent permafrost thawing. Small, lightweight structures may need only an airspace between floor and soil surface, created by raising the building on stilts. Larger structures require the support of

insulated pilings driven deep into the permafrost. This technique allowed the Russians to build entire cities on permafrost in Siberia.

Permafrost’s capacity to preserve plants and animals for centuries gives scientists a window into the past to help them assess how rapidly greenhouse pollutants may be warming the Earth. Ground temperatures indicate past climatic conditions and current changes in world ambient temperatures, providing an understanding of the complex interactions of human-induced global warming, ice melting, and potential sea level changes.

CONNECTIONS

1. How do life-forms preserved in permafrost differ from fossils?
2. How do animals adapt to harsh permafrost environments?
3. How do thermosiphons work?

VOCABULARY

continuous permafrost permafrost that occurs throughout an entire region

discontinuous permafrost permafrost that occurs occasionally and in specific locations in a region

ice age a span of geologic time during which “permanent” ice covers a substantial portion of the Earth’s surface. There have been seven recorded major ice ages; the last one reached its peak about 18,000 years ago.

permafrost permanently frozen subsoil that maintains a temperature below 0° C continuously for two years or longer

thermosiphon a device that uses temperature changes in the environment to remove heat from the ground

Newton’s Apple is a production of KTCA Twin Cities Public Television. Made possible by a grant from 3M.
Educational materials developed with the National Science Teachers Association.



FREEZE AND THAW

Predict what factors will prevent damage to structures built on permafrost.

▶ TRY THIS...

If you must build on permafrost, you have three ways of dealing with it—keep it frozen, thaw it out, or let the building move. Devise a plan to keep the ground frozen, create a thawing program, and design a structure that can move with ground subsidence. Display the plans and structure.

▶ TRY THIS...

The Alyeska Pipeline Service Company was concerned about permafrost underlying three-quarters of the 800-mile, trans-Alaska pipeline. It drilled 12,000 holes to test for permafrost. You can "drill" a test sample of your playground. (Be sure to obtain permission.) Drill a vertical hole to create a core, using tools like copper tubing, plastic tubing, or gardening tools for digging bulbs. Call a local soil-testing firm for literature to share with your class.

• MAIN ACTIVITY

- The speed with which ice melts in permafrost depends on how much heat and pressure are applied to it.
- You can demonstrate these principles with coffee cups, water, and ice.

• Materials

- large, flat cake pan filled with water
- 5 identical ceramic coffee cups with bottom rims that would make an indentation
- hot water
- ice water
- sponge for insulation
- a freezer

1. Fill the pan with about 1" (2.5 cm) of water. Place it in a freezer, along with one of the empty cups.
2. When the water is frozen, remove the pan and cup from the freezer.
3. Place the empty cup on the ice.
4. Fill another cup with ice water and place it on the ice.
5. Fill a third cup with very hot tap water and place it on the ice. (Be sure to place all cups so that they do not touch each other.)
6. Fill a fourth cup with heavy rocks and place it on the ice.
7. Fill the last cup with hot tap water. Put the sponge on the ice and place the cup on top of the sponge.
8. If possible, place the pan with the five cups back into the freezer.
9. Every five minutes, remove the cups that

originally had hot water and refill them with hot water.

10. After 15 minutes, remove the pan from the freezer. Remove all five cups from the pan. Feel the surface of the ice. Can you tell where the empty cup sat? Can you tell which ring was created by the cup with hot water that sat directly on the ice? How does the ice look under the insulating sponge? What about the cup containing the rocks and the cup containing the ice water?

Questions

1. What construction techniques could minimize heat transfer from a building to the permafrost?
2. What construction techniques could minimize damage to a structure if permafrost melted and the surface level collapsed?
3. Do construction techniques for permafrost environments resemble those in earthquake zones?

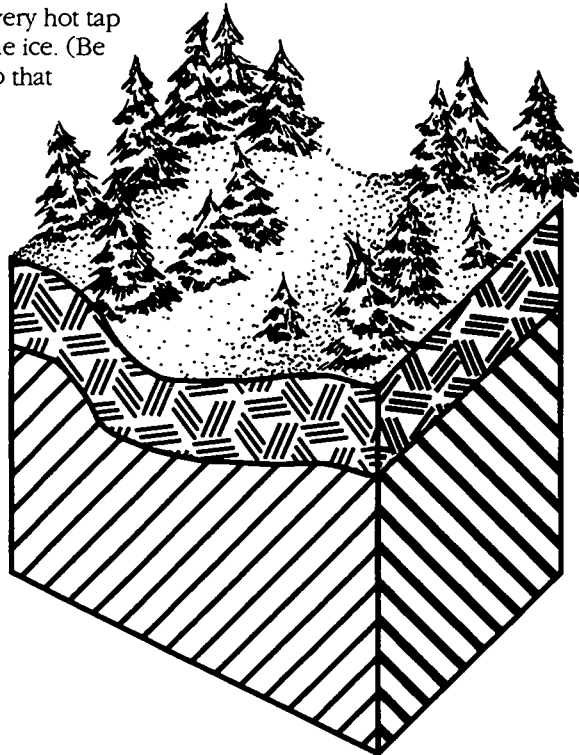

▶ TRY THIS...

Ice wedges form in the permafrost tunnel when water seeps into a crack in the frozen ground. The water freezes and ice expands, pushing out in all directions. The wedge partially melts during its formation, allowing more water to fill the void and expand the size of the wedge upon refreezing. Simulate the ice wedging by packing a shoe box with dirt (preferably some fairly impermeable soil, such as clay). Make a small crack and line it with plastic so it will hold water. Place water in the lined crack. Freeze the box. Did the soil move? Melt the ice, add more water to fill the plastic lining, and then refreeze the water. The size of the space will increase, as it does in the case of an ice wedge. Is this what happens between your house foundation and yard in winter if you live in a cold climate?



Peggy explores the complex ecosystem of an old-growth forest.

Segment Length – 8:18

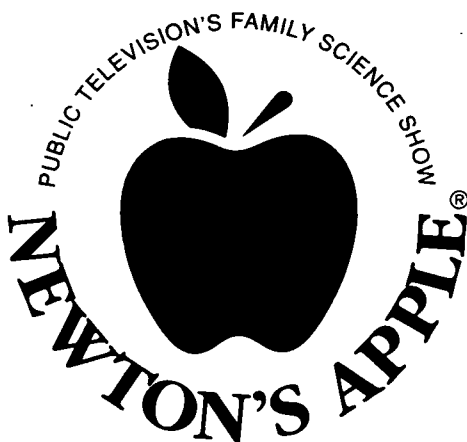

SPOTTED OWL/ OLD-GROWTH FORESTS

Why should we save the spotted owl?

Can we learn about managing our forests intelligently by listening to both industry and environmentalists?

RESOURCES

Facklam, M. (1990) *And then there was one*. San Francisco: Sierra Club Books.

Future of forests. (1991, June 22) *The Economist*, pp. 19–23.

Gup, T. (1990, June 25) Owl vs. man. *Time*, pp. 56–63.

Kelly, D., & Braasch, G. (1988) *Secrets of the old forest*. Salt Lake City: Peregrine Smith Books.

Lovett, S. (1992) *Extremely weird endangered species*. Santa Fe, NM: John Muir Publications.

McDonald, T.B. (1990, Dec) End of an era. *Architectural Record*, pp. 40–41.

Satchell, M. (1990, June 25) The endangered logger. *US News and World Report*, pp. 27–29.

Additional sources of information

American Forest Council
1250 Connecticut Ave. NW,
Suite 320
Washington, DC 20036
(202) 463-2455

National Audubon Society
801 Pennsylvania Ave. SE
Washington, DC 20003
(202) 547-9009

Wilderness Society
1400 I St. NW, Suite 550
Washington, DC 20005
(202) 828-6600

INSIGHTS

- The case of the northern spotted owl points out why we need forest management focused more on *ecosystem* values than we've had in the past. Studies in Oregon show that this owl's population declined by a third between 1976 and 1987. The U.S. Forest Service estimates only 3,000 to 6,000 northern spotted owl pairs remain in North America.

- Each pair requires a range of 4,000 to 9,000 acres for hunting and foraging and can nest only in the broken tops of dead "old-growth" firs. Because the spotted owl was declared an endangered species, a court injunction halted most timber sales in national forests where old-growth firs are found.

- But the importance of the complex ecosystem of an old-growth forest extends far beyond the preservation of the spotted owl. Old-growth forests in the Pacific Northwest are full of ancient standing trees, fallen trees, *snags*, and decaying vegetation (fungi, lichen, and moss) which provide shelter and food to plants and animals that cannot live elsewhere.

- At least 118 known vertebrate species live primarily in old-growth forests; 41 of these species cannot nest, breed, or forage anywhere else. New-growth forests are managed *monocultures*—containing only

a few species of trees that were planted at the same time. These areas do not offer the same *habitat* diversity for plants and animals. For example, only nine mammal species make their home in *second-growth* forests of young firs and hemlocks, compared to 25 in old-growth forests.

The classic old-growth forests contain redwoods, cedars, Douglas fir, hemlock, or spruce. These forests have at least eight big trees per acre that are older than 300 years or more than a meter (40 inches) in diameter at breast height.

Only 4.3 million acres of our old-growth forests remain, about one-third of it protected in designated national wilderness areas in parks. The loss of the old-growth Douglas fir is similar to the loss of the giant redwoods, originally the greatest old-growth forest on earth. Less than 4% of the giant

redwoods still stand, mostly in roadside parks.

Loggers, environmentalists, and scientists have started to hammer out a new form of forest management that protects the environment but attempts to endanger fewer jobs. A better understanding of the value of forests will help them arrive at a solution.

CONNECTIONS

1. Is there a connection between the struggle to protect the northern spotted owl and its habitat and what happened to bison in the 19th century?
2. How are our continent's old-growth forests like the rain forests of South America and Africa?

VOCABULARY

biodiversity the number of different species present in a given area. As forests disappear, the number of different kinds of plants and animals decreases also.

ecosystem community of plants and animals interconnected with the soil, air, and water in an environment

habitat the place or location that provides everything a plant or animal needs to survive

monoculture a forest composed of same-age trees and minimal genetic diversity of species

second-growth timber that has grown up after the original growth of forest was cleared by fire or logging

snag a stump or stub remaining on a tree after a branch has been broken off; a standing dead tree from which parts have fallen

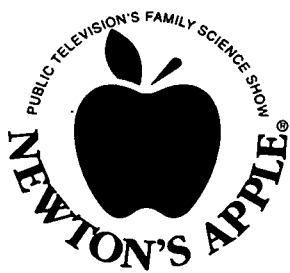

RING AROUND THE TREE

Count the rings on a tree's trunk to estimate its age.

▶ TRY THIS...

Exposing the hidden world under a log can be a revealing experience! The damp, rotting underside of a log can provide a home to a whole community of creatures—caterpillars, mites, snails, slugs, spiders, termites, beetles, ants, wood lice, and millipedes. If you find a dead tree, peel away some bark to look for tunnels underneath it. (Never remove bark from a living tree!) Do any insects, worms, or grubs live under the bark? Find some dead logs and sketch the variety of life you find under them. What is the largest creature you found? The smallest? How do these creatures return nutrients to the soil to feed the plants and trees? What animals rely on dead matter to survive? How can we protect these small creatures?

• MAIN ACTIVITY

- Trees grow both in height and in girth.
- The rings on the stump of a tree indicate how many years have passed in the tree's life. Spring wood can be recognized as light rings; summer wood as dark. One set of light and dark rings represents one year.
- Paleoclimatologists trace climatic changes and other disturbances by studying the ring patterns in old trees.

• Materials

- Obtain a variety of cut round sections from large tree trunks. A local tree service might provide pieces from different types of trees.

1. Make a sketch of the flat cut face of each trunk, showing all the rings that appear.
2. Count the number of rings across the surface of the trunk. (Count from the center out; do not count the bark.) This corresponds to the tree's age. Label each drawing.
3. Post the sketches next to each other.
4. Label the rings in your sketch to show several important historical events as well as major occasions in your life. Is the tree as old as you are?
5. Measure each trunk's diameter.

6. Research why some rings are farther apart than others. Remember that wide rings show periods of strong growth and narrow rings indicate adverse conditions.

• Questions

1. Does the diameter of the tree always correspond with its age? Why or why not?
2. What are the oldest trees in the world? In the United States?
3. What environmental factors might have encouraged growth? What might have hampered the growth of the tree?

▶ TRY THIS...

You can make a terrarium out of a big jar with a lid. Place the jar on its side in a small rack with slots to keep the terrarium from rolling sideways. Place a layer of small stones on top of a layer of sand in the jar and then lay down a layer of forest soil or potting soil. Collect some specimens from the forest. (Be sure to obtain permission first.) For example, a fresh acorn will sprout into a small oak. Wrap specimens in newspaper until you can plant them in the terrarium. After you've planted them, spray two or three squirts of water over them. Replace the lid after punching several holes in it. Why shouldn't you water the terrarium very often?

▶ TRY THIS...

You'll find biodiversity in many environments. Collect a leaf from each type of tree in a small, natural setting (your neighborhood or a local park). Make a leaf print of each to record texture, contour, and detail. To do this, place each hard, thick-veined leaf between two pieces of strong, thin paper. Rub one piece of paper with a thick pencil or graphite stick, or even a crayon. You can also make rubbings of tree bark to record variations in bark patterns. Tie lightweight paper around the tree with a string and rub over the paper with a dark wax crayon, from which you've peeled the paper wrapping. Rub steadily in one direction. (Smooth barks produce the best rubbings.) Don't strip bark from trees—this will injure or kill the tree.

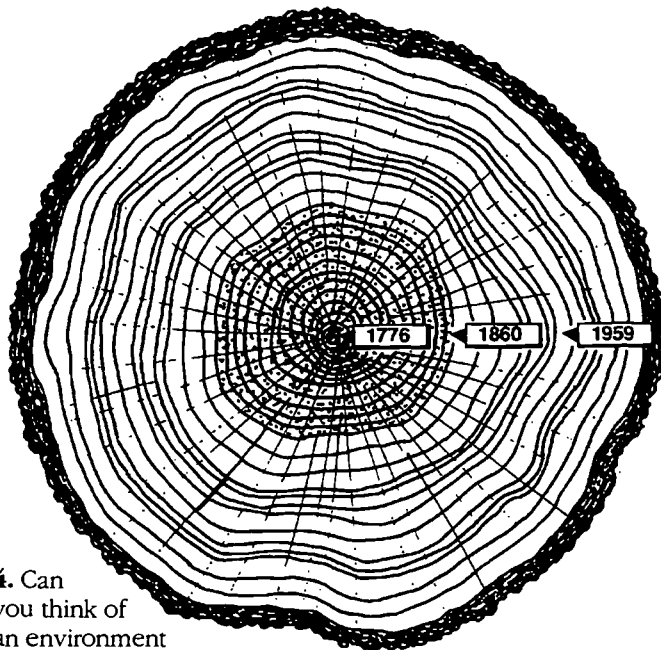

4. Can you think of an environment where it would be difficult to determine the age of a tree because there were no growth rings?

177



David seeks a medical opinion about his sore wrists.

Segment Length - 6:55

CARPAL TUNNEL SYNDROME

What is carpal tunnel syndrome?

**What is the carpal tunnel and how does it work?
How can you prevent CTS? What role does ergonomics play in CTS?**

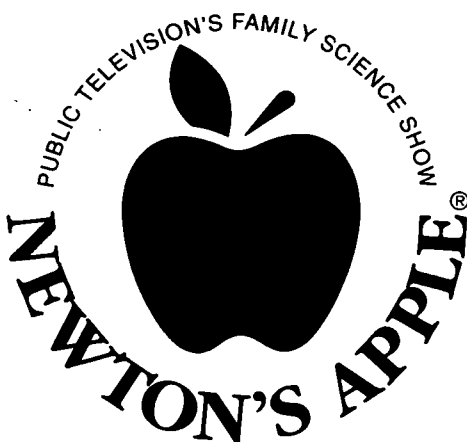

RESOURCES

Goldoftas, B. (1991, Jan) Hands that hurt: Repetitive motion injuries on the job. *Technology Review*, pp. 42-50.

Greer, B. G., Jenkins, W. M., & Roberts, R. (1992, Apr-June) Carpal tunnel syndrome: A challenge for rehabilitation. *The Journal of Rehabilitation*, p. 43.

McCormick, E., & Sanders, M. (1992) *Human factors in engineering design*. NY: McGraw-Hill.

Meyer, A. (1991, June) Carpal tunnel pain: Surprise! You may be at risk. Here's help. *Better Homes & Gardens*, pp. 38-40.

O'Malley, C. (1992, Mar) Don't get all bent out of shape by your computer. *PC Computing*, pp. 268-269.

Additional sources of information

National Institute for Occupational Safety and Health
200 Independence Ave. SW
HHH Building, Room 714B
Washington, DC 20201

The National Safety Council
444 North Michigan Avenue
Chicago, IL 60611

US Department of Labor
OSHA Publication Office
200 Constitution Avenue
Room N-3101
Washington, DC 20210
(publication # OSHA 3123:
Ergonomics: The study of work)

Community resources

Local physicians who specialize in orthopedics, neurology, or neurosurgery

INSIGHTS

The *carpal tunnel* is a very crowded, narrow passageway on the inside of your wrist, filled with *nerves, tendons*, and blood vessels. When you engage in quick, repetitive actions with your hands and wrists hour after hour, day after day, you can irritate and *traumatize* that narrow area. Inflammation and swelling might result, producing tingling, numbness, and pain in the hand. When that happens, you may have carpal tunnel syndrome (CTS).

Imagine a water hose with a kink in it. Even when you turn the water on full force, the flow coming out of the nozzle will not be full strength. This resembles what happens with CTS. When the *median nerve* in the carpal tunnel is squeezed, the result can be pain, numbness, some weakness, and eventually the inability to properly use the hand. The index finger, the middle finger, and thumb are most severely affected.

If you've ever fallen asleep on your arm or hand, the sensation of "pins and needles" that you experience upon waking is similar to what people with CTS experience. To test for CTS, doctors tap a patient's wrist area. If the patient feels a tingling in the fingertips, it could indicate CTS.

Although medical experts have known about this problem for over a hundred years, recent changes in the workplace have made CTS more common. People who work as typists, grocery checkers, and postal workers are among those most at risk for acquiring it.

For people who already have CTS, medical treatment includes splinting the wrist, medication, and sometimes surgery.

But something can be done to reduce the chances of acquiring CTS. Medical personnel suggest that workers keep their wrists in a neutral position, cut down on repetitive wrist motions or take frequent breaks from them, and practice various exercises.

Experts estimate that by the year 2000, repetitive motion injuries (including CTS) will make up half of all occupational-related illnesses. Some people are studying work environments

and trying to make them more comfortable and physically less stressful. They might suggest wrist rests for people who type a lot, anti-glare filters on computer terminals, and chairs with firm back support. This new area of study is called *ergonomics*, and it is a growing field.

As schools, homes, and workplaces become more computerized, more people may develop CTS. Everyone needs to be aware of this problem, since prevention is so important.

CONNECTIONS

1. Why is it especially important to know about CTS today?
2. What simple steps can office workers take to prevent CTS?
3. What jobs or activities make you prone to CTS?

VOCABULARY

carpal tunnel the narrow channel formed by bones, ligaments, and bands of connective tissue at the wrist through which nerves, tendons, and blood vessels must pass on their way to the fingers

ergonomics a new scientific field designed to alter the workplace so that it will more safely accommodate workers

median nerve a very important sensory and motor nerve that passes through the carpal tunnel

nerves the specialized cells that connect the brain and spinal cord to sensory organs, muscles, glands, and other body parts. They conduct impulses that are responsible for our ability to feel and do motor functions.

tendon a band of tough, fibrous tissue that connects a muscle to a bone or skeletal structure

traumatize harm by physical injury

Newton's Apple is a production of KTCA Twin Cities Public Television. Made possible by a grant from 3M.
Educational materials developed with the National Science Teachers Association.

WORKPLACE WISDOM

Modify a work space to cut down the risk of CTS.

▶ TRY THIS...

Divide into teams. Each team tries to list as many occupations with workers at risk for developing CTS as possible. The team with the longest list wins. Remember, repetitive action in the workplace is the key.

▶ TRY THIS...

Imagine that you have carpal tunnel syndrome. Keep your dominant hand (the hand that you use the most) immobile for an entire afternoon at school. How difficult is eating lunch, taking notes, and packing up your backpack? What sports or activities would be most difficult?

• MAIN ACTIVITY

- Learn how to alter a work space to
- lower the risk of acquiring carpal
- tunnel syndrome. Take this activity
- one step further by working on the
- ergonomics of the entire workplace.

• Materials

- • foam (firm but pliable)
 - • covering of your choice
 - • pillow
 - • light fixture
 - • cardboard to create a nonglare
 - • computer screen
1. Choose a workplace with a computer. It could be the computer area in your classroom or the school library.

2. Use the area and talk to other students who have used it for long periods of time. Find out what they think is uncomfortable about it. List these things.

3. First deal with the computer keyboard. Decide if the user's wrists are straight or at an uncomfortable angle when typing. If the wrists are bent, make a wrist rest to raise the hands to a more natural level. Do this by measuring the distance between the user's wrists and whatever they might comfortably rest on. Cut your piece of foam to this height. Place it on the rest area. Try it out. You may

need to make adjustments. Now cover the wrist rest with a nonirritating covering material.

4. Check out the chair and the lighting in this area. Make necessary adjustments to improve them.

5. Check the position of the computer monitor. Try raising or lowering it or tilting it. What position is most comfortable?

6. Decide if too much glare shows on the computer screen. If so, use cardboard to cut down the glare. You may also reduce glare by simply repositioning the screen.

Questions

You can take some simple and effective steps to help prevent carpal tunnel syndrome when you work in an office. But what if you are a musician or a beautician? What could you do to prevent CTS if you worked in these professions?

▶ TRY THIS...

Plan a class trip to your local medical center with an orthopedic department or invite a therapist who deals with CTS to speak to your class. Ask the therapist to bring a night splint or wrist rest to show you and to demonstrate the stretches and exercises you can do to prevent CTS.

▶ TRY THIS...

Name 15 at-home activities that a person with CTS would have difficulty doing.

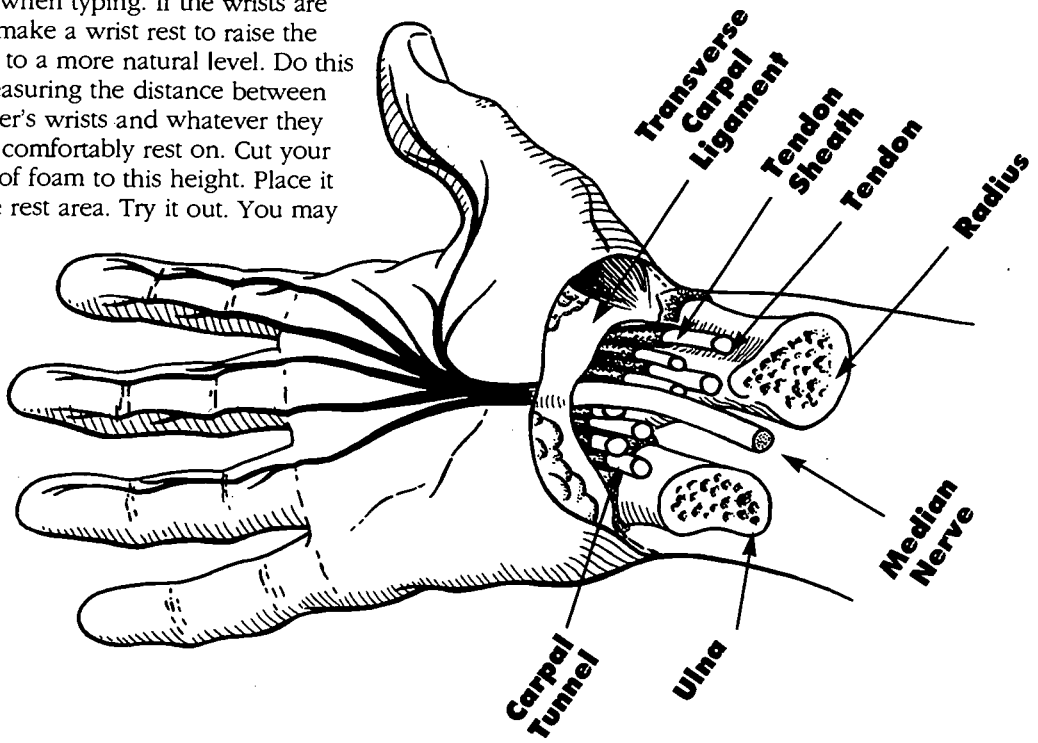



Peggy joins with archeologists to excavate a Hohokam village near Tucson.

Segment Length – 10:26

ARCHEOLOGY

How do archeologists know where to dig?

How do archeologists learn about people of the past? How can they turn bits and pieces of evidence into a big picture of the past?

RESOURCES

Brain, J. (Ed.) (1976) *Clues to America's past*. Washington, DC: The National Geographic Society.

Corbishley, M. (1990) *Detecting the past*. New York: Glouster Press.

Coville, B. (1990) *Prehistoric people*. New York: Doubleday.

Fagan, B. M. (1992) *People of the Earth: An introduction to world prehistory*. New York: Harper Collins.

Freeman, M. (1967) *Finding out about the past*. New York: Random House.

Scott, A. (1993, Summer) Ancient tech. *Invention and technology*, pp. 34-44.

Wiley, G., & Sabloff, J. (1974) *A history of American archaeology*. San Francisco: W.H. Freeman.

Community resources

Local historical society

College anthropology department

State historic preservation office

INSIGHTS

- Being an *archeologist* is a lot like being a detective. You spend most of your time trying to find clues, collecting information, and putting pieces together to solve a mystery.
- Both professions require a variety of tools and draw information from many different scientific disciplines. In fact, the only major difference is that detectives usually can question a witness while archeologists are lucky to find the witness's home! In the hands of a skilled archeologist, however, even a pile of trash can speak volumes.

- Archeologists must first know where to look for a *site*. The passage of time and the forces of nature often erase even the sturdiest buildings. Walking an area, archeologists look for special clues that tip them off to human occupation. Some broken pieces of pottery, an old arrowhead, or even a pile of stones can lead them to a site. Before digging, however, they map the surface in detail and sometimes attempt to "see" below the ground with the help of *remote sensing* techniques like *radar*.

- Once digging begins, workers scrape off each level in neat horizontal layers, a painstakingly slow process. Archeologists carefully observe rules of three important concepts: stratigraphy,

superposition, and context. Stratigraphy means that the material covering the site was placed there in layers—or *strata*. Superposition means that the deeper you dig, the older the material gets. While these rules don't give exact ages, they allow scientists to calculate relative time, which is almost as important. Context is also a critical concept, since *artifacts* only tell a story through the context in which they're found—where they are found and with what they are found.

After uncovering artifacts, an archeologist relies on techniques like X rays and chemical and microscopic analysis to determine what materials were used to make the artifacts, how they were made, their age, and their purpose. If enough artifacts are found, the archeologist puts them together into common groups called assemblages. By studying assemblages, the archeologist can then determine what people

did in different parts of the site at different times.

CONNECTIONS

1. Contrary to popular belief, archeologists do very little digging at a site, preferring to leave most of the artifacts buried. Why don't they dig up the whole area? What advantages could that have in protecting the site? How do they know what is buried at the site without digging it up?
2. How do the techniques used by archeologists compare to those used by geologists? State similarities and differences.
3. In forests, people often encounter lines of large rocks, long rows of old trees, and several ponds clustered in a small area. While all these features appear natural, could they be a result of human activity? Explain.

VOCABULARY

archeologist a scientist who studies past cultures or people by analyzing the things they left behind (sites and artifacts)

artifact any object made or used by people

radar a device that images an object from a distance by reflecting radio waves off of it and analyzing the signals

remote sensing a mapping technique that scientists use to analyze materials and landscapes from a distance, without making direct physical contact

site a geographic area once occupied by people

strata horizontal layers of soil or rock

survey examination of Earth's surface to discover archeological sites

Newton's Apple is a production of KTCA Twin Cities Public Television. Made possible by a grant from 3M.

Educational materials developed with the National Science Teachers Association.



RECORDING A SITE

Test your skills as an archeologist.

▶ TRY THIS...

Artifacts don't have to be thousands of years old to be interesting. Your family may have some tools, games, or toys at home that no one knows how to use. Check out your grandparents' home to find some really old stuff and invite your friends to collect some of their own "blasts from the past." Hold a "What is it?" day to see how many different uses you can come up with for each artifact. Have your grandparents show you the correct use.

▶ TRY THIS...

Visit a local historical society or museum to learn about people who lived in your area before the turn of the century. Find out who settled the area and identify the oldest known structure. Are there any archeological excavations nearby? If so, check them out!

• MAIN ACTIVITY

- Even before digging a single hole, archeologists develop a working model of what took place in an area.
- To do this, they conduct a *survey* to discover all the sites on the surface of the land and to describe what they can see at each site. Pieces of broken pottery, rocks arranged in patterns, and even trees growing in straight rows suggest that people once occupied an area. Using a local park or vacant lot, test your own ability to unravel past events.

• Materials

- notebook and pencil
 - ruler
 - magnetic compass
 - protractor
 - large sheet of drawing paper
1. Select a site for your survey. A wooded park, a campground, or even a vacant lot will do fine. Before starting, ask for permission to enter the property if it is privately owned!
 2. Using your compass to establish north, measure the site boundaries by pacing off the distance in feet in each direction. Log the direction and distance of your site boundaries in your notebook. To calculate your pace size, do the following:
 - With a long tape measure, mark off two points exactly 100 feet (30m) apart. Starting at one point, walk in a direct line toward the other point, counting the number of steps you take to get there. Your steps should be your normal pace. Divide 100 feet (30m) by the number of steps you took. This number is your normal pace size. For example, if you took 25 steps, your pace would be $100 \text{ feet} \div 25 = 4 \text{ feet/step}$ ($30 \div 25 = 1.2 \text{ meters/step}$). For more accuracy, you should repeat the measurement four times and average your results.

3. Starting at one corner of the site, walk slowly across the site in a systematic pattern. The best way is to cross back and forth at a regular interval of spacing. Look for anything that appears out of the ordinary—a broken bottle, an old can, a ring of rocks with some burnt material on the inside. Each time you encounter an artifact, describe it fully in the notebook and measure its distance and direction from one of the site corners.

4. Once you have completed your survey, plot your data on a scale map of the site. With your protractor, measure the compass direction from north and, with your ruler, measure off a scale distance. When all the data is plotted, see if you can find any patterns suggesting how people used the site.

Questions

1. When conducting site surveys, why walk back and forth in a regular pattern across the site rather than randomly?
2. What artifacts suggest that your site might be old? Which artifacts suggest your site has been recently used?

▶ TRY THIS...

Set up an excavation in a box. Get a 50-pound (22.5 kg) bag of topsoil. Starting at the bottom of the box and moving upward layer by layer, bury a number of different items associated with different tasks, such as cooking, cleaning, sewing, etc. Each group of associated items is called an *assemblage*, and they must be buried together on the same level. Invite some friends to help excavate and see if they can work out the context of events. (Example of a cooking assemblage: spoon, egg shells, milk carton, can opener.)

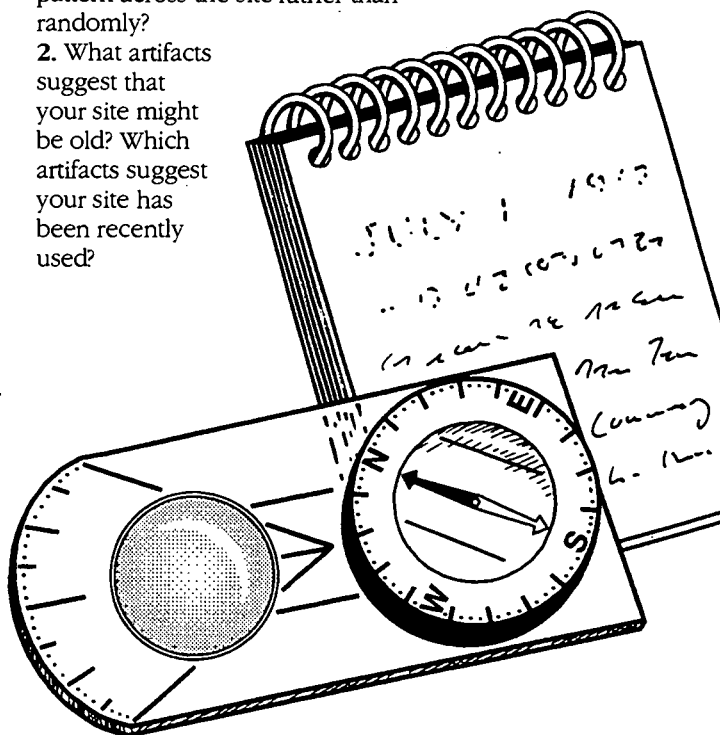



David solves a maze by applying the principles of mathematics.

Segment Length - 8:11

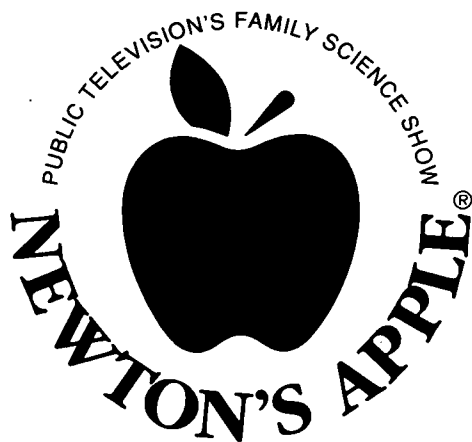

MAZES

How can we best solve these puzzles?

What does mathematics have to do with mazes? What is the history behind mazes? Are there different kind of mazes? What is topology?

RESOURCES

Fisher, A. (1990)
Labyrinth. New York: Harmony Books.

Kenner, H. (1986, Feb) The amazing world of mazes. *Discover*, pp. 33-39.

Matthews, W.H. (1970)
Mazes and labyrinths: Their history and development. New York: Dover Publications, Inc.

Pappas, T. (1989) *The joy of mathematics*. San Carlos, CA: Wide World Publishing/Tetra.

Reimer, L., & Reimer, W. (1990) *Mathematicians are people, too*. Palo Alto: Dale Seymour Publications.

Schattschneider, D. (1990)
Visions of symmetry: Notebooks, periodic drawings, and related work of M.C. Escher. New York: W.H. Freeman & Company.

Additional sources of information

Oriental Trading Company
(800) 228-2269
(maze puzzle assortment No. 25/13)

Minotaur Amusements, Inc.
8027 Sunnyside Ave. N.
Seattle, WA 98103
(206) 525-7552

Community resources

Computer engineer

Power company

Office computer analyst

Telephone company

Public works department

INSIGHTS

- Beware the Minotaur! This fearsome mythical creature, half man and half bull, lurked in the dark corners of the Cretan labyrinth, waiting to devour young people sent by King Minos. But Theseus conquered the Minotaur and, guided by a golden thread, emerged from the labyrinth a victor!

- Like the legend of the Minotaur, mazes and labyrinths have long fascinated us. Ancient civilizations left stories of enormous labyrinthian buildings with up to 3,000 rooms. Hedge mazes have decorated gardens for centuries, providing entertainment and secret meeting places. Psychologists use mazes to study how animals learn.

- What is the difference between a maze and a labyrinth? Actually, the two names are synonymous. However, maze is used more often, perhaps because of the popular hedge mazes. Labyrinthian describes something that has maze-like qualities—your thumbprint or a house with many rooms to wander through.

- What should you do if you become lost in a maze? That depends on the maze. A unicursal maze has only one path to follow, and while it may feel like you are getting lost as you twist and turn, you will eventually reach the goal. A

multicursal maze has branches and forks that require you to guess the best path. If lost, you apply the “right-hand rule”—keep your right hand against the maze wall as you walk. You are guaranteed an out—although it may be the entrance instead of the exit!

With a diagram of a maze, you can apply *topology*, a branch of mathematics created by the Swiss mathematician Leonhard Euler (1707–1783) as he solved the Königsberg bridge problem (see illustration on back). Located on the Preger River, Königsberg contained two islands connected by seven bridges. The citizens wanted to know if they could walk through their city while crossing each bridge only once.

Euler drew a diagram—or *network*—of the problem and, as a topologist, studied the *arcs* and *vertices*. He discovered that for a network to be *traceable*, it can only have two odd vertices.

A vertex is considered odd or even depending on the number of arcs that intersect it. In the Königsberg network, there are four odd vertices, making it impossible to cross each bridge only once. By examining arcs and vertices, you can determine the most efficient path through your maze.

Networks are commonplace in our world—from electricity and phone lines to computer systems and computers themselves. When you think about it, the impact that labyrinths and their study have on our lives is truly “a-maze-ing”!

CONNECTIONS

1. Why do you find mazes fascinating?
2. What will a maze of the future look like?
3. Where does the name “topology” come from? What are some uses for topology?

VOCABULARY

- arc** in a network, the path between two vertices
- even vertex** an intersection where an even number of paths meet
- goal** the place you are trying to reach after entering a maze
- maze** a path or series of paths that leads to a goal
- network** a diagram of the arcs and vertices of a problem
- topology** the branch of mathematics that deals with networks and surfaces
- traceable** describes a network in which every arc can be traveled only once in one sweep while vertices may be passed through more than once.
- vertex in a network** the intersection where arcs meet

• Newton's Apple is a production of KTCA Twin Cities Public Television. Made possible by a grant from 3M.

• Educational materials developed with the National Science Teachers Association.

THAT'S A-MAZE-ING!

Now it's your turn to design a maze.

▶ TRY THIS...

A Möbius strip is an unusual object studied by topologists. To make a Möbius strip, take a long strip of paper and twist it once, then tape the ends together. Place your pencil in the center of the strip and draw a line down the center. Now carefully cut along the center line. Try these same activities with a strip of paper connected at the ends without the twist. Try with two or three twists.

▶ TRY THIS...

M. C. Escher was an artist who employed mathematics to create unusual pictures. Many of Escher's drawings of buildings have labyrinthian qualities. Find some examples of Escher's drawings. What do you think makes them so unusual?

• MAIN ACTIVITY

- Using blueprints, you will create and build a maze. Is designing a maze easier or harder than solving one?
- Let's find out!

• Materials

- poster board measuring 56 cm x 71 cm (22" x 28")
- marbles
- scissors
- rulers
- glue and/or tape
- graph paper
- pencils
- paper
- crayons or markers

1. Divide into groups of four. Each group will need one sheet of poster board and one marble, as well as the other materials.
2. Create a blueprint of your maze on graph paper. The maze should have a:
 - name
 - entrance
 - goal
 - theme (optional)
3. Important: Each group only gets one piece of poster board to use for the floor and walls of the maze so plan before you cut! When cutting

strips to serve as the walls of the maze, leave 1 cm (1/2") to bend and serve as support. Paths should be wide enough to allow a marble to roll through.

4. Demonstrate your maze to the entire group. Explain how you designed it. Try the other groups' mazes.

Questions

1. Which mazes are unicursal? Multicursal?
2. Which maze is the most complicated? Why?
3. In which maze does the marble travel farthest from entrance to goal?
4. On your blueprints, identify the arcs and vertices in your maze. What is the most efficient path through your maze?
5. If you designed your maze again, what changes would you make? If you increased your maze in size to accommodate people, what design modifications would you make?
6. How would the right-hand rule work in your maze?
7. Is designing a maze easier or harder than solving one? Why?

▶ TRY THIS...

Try the right-hand rule at home. From your bedroom door, let the fingers of your right hand guide you around your home. Where do you end up? Will this method take you to any room that you want? What happens if you use your left hand?

▶ TRY THIS...

Learn more about networks and their applications. Invite computer engineers to your class to learn how they work with networks in their careers. Visit the local telephone company or electric company to see how networks connect their services. What classes or training prepared these technicians to work with networks?

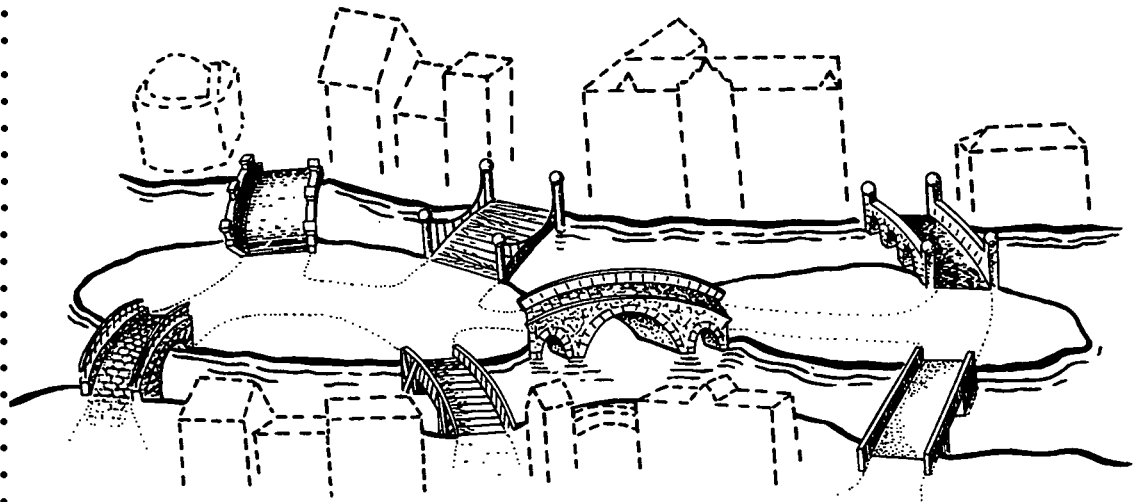



How does fire combust? David seeks an answer to this burning question.

Segment Length -10:07

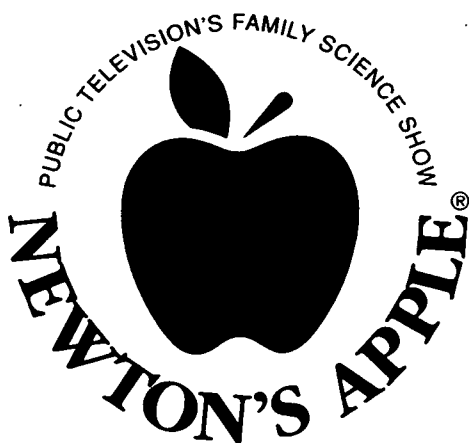

FIREFIGHTING

How do fires start and why can they spread so quickly?

What are the scientific principles involved in the transfer of heat energy? How does fire burn? How can you protect yourself in case of a fire?

RESOURCES

O'Donnell, J. (1980) *Fire: Its many faces and moods*. Englewood Cliffs, NJ: Silver Burdett.

Reuter, M. (1977) *Careers in a fire department*. Austin, TX: Raintree/Steck Vaughn.

Smith, B. (1981) *A day in the life of a firefighter*. Mahwah, NJ: Troll Associates.

Additional sources of information

Fire Protection Through Films
PO Box 11
Newton Highlands, MA 02161

National Fire Protection Association
Public Education
Batterymarch Park
Quincy, MA 02269
(607) 770-3000
(books on safety education)

United States Fire Administration
Office of Planning and Education
Federal Emergency Management Agency
Washington, DC 20472

Community resources

Local fire department

INSIGHTS

- Would you know what to do if a fire suddenly broke out in your home? You need to understand how fire burns, how heat energy is transferred in a fire, and how to protect yourself and others from it.

- Imagine a *fire triangle*—one side is *oxygen*, one side is *fuel*, and one side is *energy*. Fire needs a source of oxygen (air, ozone, etc.) which chemically combines with fuel at a high enough *temperature* to maintain the fire's *combustion* process. If one of these three factors is missing, fire cannot exist. Fire fighters extinguish fires by removing one or more of the sides of the triangle.

- Burning releases chemical energy, resulting in increased molecular motion and emission of electromagnetic waves. This increased molecular motion is detected as a rise in temperature. The energy is removed as heat by conduction, convection, and radiation. To occur, chemical reactions like burning often require a high molecular agitation—that is, a high temperature.

- Conduction is the transport of heat through solids by direct contact. This transfer goes from molecule to molecule down the chain, like a row of dominos.
- You feel the effect of conduction whenever you touch a hot object.

Convection is the transfer of heat in fluids. The process begins by heating a fluid. As the fluid warms, it becomes less dense and rises. Colder, denser fluid then sinks down and takes the place of the warmer fluid, creating a *convection cell*.

Radiation is the transfer of energy through empty space or transparent materials. The energy travels in waves from the source, such as the energy that travels from the sun to Earth or the heat you feel coming from a stove. Radiation causes the temperature of materials around a fire to rise. If the temperature increases, the material may reach its ignition temperature and burst into flames, adding more fuel to the fire.

Almost 70% of fatal house fires occur at night. Smoke is the most frequent cause of death, since it displaces the oxygen we breathe and fills the air with poisonous toxins. After only a few seconds in a smoke-filled room, you can become

disorientated and experience distorted judgment.

You should know what to do in the event of a fire. Plan escape routes from your apartment or home and practice using them. Install smoke alarms and maintain them by cleaning and testing them monthly. Learn fire prevention and safety procedures so you know what to do if a fire breaks out.

CONNECTIONS

1. How do fire fighters extinguish different kinds of fires, such as chemical, electrical, and wood?
2. What do fire fighters try to eliminate when they fight fires?
3. How do you use the three forms of energy transfer in your daily lives?
4. What can you do to make your home safer from fire?

VOCABULARY

combustion a chemical, physical, oxidation-reduction reaction that causes light and heat to evolve

convection cell a circulatory flow of energy set in motion by unequal heating of a fluid

flame retardant material that has been treated chemically to reduce its ability to ignite and spread the flame

fire triangle three factors that make up a fire—fuel, oxygen, and energy (high temperature)

oxygen found in air and the sole component of ozone, this gas is needed for fuel to burn at a high temperature

temperature a measure of the average kinetic energy of molecules

• Newton's Apple is a production of KTCA Twin Cities Public Television. Made possible by a grant from 3M.
• Educational materials developed with the National Science Teachers Association.



SMOKE-A-RISIN'

Create a convection cell to show why smoke travels upward.

▶ TRY THIS...

Demonstrate what sets off a smoke detector and how it operates. Discuss where smoke detectors should be placed and how they should be tested to make sure they work.

▶ TRY THIS...

Draw a floor plan of your house or apartment. Ask your parents to help you locate and diagram escape routes in case of fire, and then practice using them. Locate areas of potential danger and the best locations for smoke alarms. Complete the fire safety checklist available from your local fire department.

▶ TRY THIS...

Every year, fire destroys many acres of forests. Exactly how big is an acre? Calculate how many times your classroom would fit in an acre. Contact your local park authority for the number of acres of forests destroyed by fire in the United States last year. With your school as the center point, shade in the same number of acres on a map of your state.

• MAIN ACTIVITY

- The greatest threat to individuals in a fire is the smoke and toxic fumes generated from burning materials within a structure. Smoke quickly and easily moves upward through passages and openings, such as stairs and heating ducts. To understand why smoke rises so quickly, you must first understand the heat transfer process known as convection.

• Materials

- incense stick
- matches
- a tall, 1-quart, large-mouth canning jar or mayonnaise or spaghetti sauce jar with screw-top cap
- three small blocks of wood or other suitable replacements
- cup of sand

• **Caution: This activity involves an open flame. All participants must use safety glasses and follow safety procedures. This should be done with adult supervision.**

1. Form into a group of four and gather your materials.
2. Arrange the wood on a flat stable surface so that a triangle forms in the center of the three pieces. Allow a slight opening at one corner of the triangle.
3. Remove the cap from the jar and place the jar upside down on the wood, making sure air can flow into it.
4. Practice placing the unlit incense stick through the opening between the wood blocks. Hold it under the mouth of the jar.

5. Have your instructor light the incense stick. Place the lit incense under the middle of the jar's opening.

6. Allow the incense to burn under the jar for two minutes. Observe how the smoke behaves.

7. Next, screw the cap on the jar and place the lit end of the incense in the cup of sand.

8. Draw a diagram of the convection cell.

Questions

1. What causes the smoke to move around in the jar?
2. Explain why the smoke moved upward as the incense burned.
3. Explain how this model is similar to smoke in a fire.
4. What happened when the smoke reached the top of the jar?
5. If you want to avoid smoke, where should you go? Explain why.

▶ TRY THIS...

As an ongoing activity, watch for newspaper stories about local fires. Discuss causes of each fire, whether smoke alarms were present and operational, whether injuries or deaths resulted, and steps that might have prevented the fire or casualties.

▶ TRY THIS...

Research and discuss the major causes of fire. Divide into groups and brainstorm ways to reduce the danger or risk of fire.

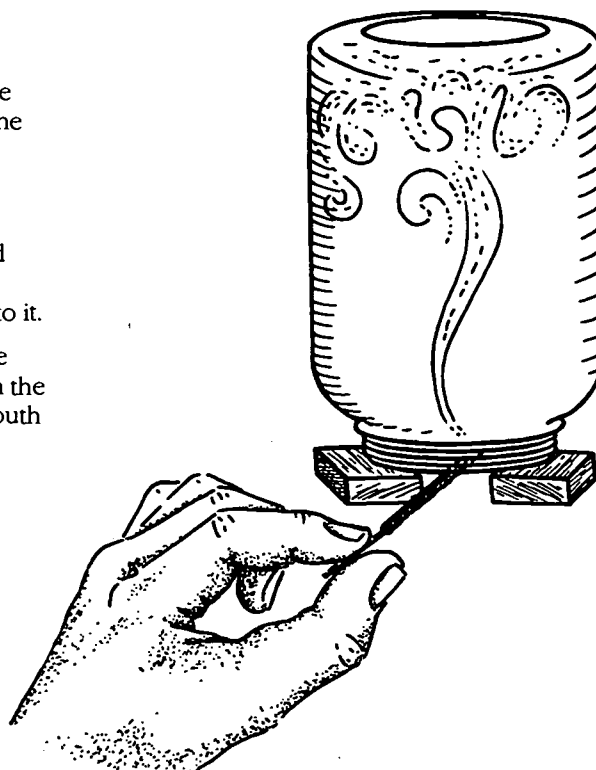

• Newton's Apple is a production of KTCA Twin Cities Public Television. Made possible by a grant from 3M.
• Educational materials developed with the National Science Teachers Association.

18511.42

3M Innovation



Peggy visits a dairy farm and a milk processing plant to learn how milk gets from a cow to the store.

Segment Length – 6:45

DAIRY FARM

Where does milk come from?

How does a cow produce milk? How does milk get from the cow to the store?



RESOURCES

Borcherding, J.R. (1986, Apr 5) Barnyard biotech. *Science News*, p. 213.

Borcherding, J.R. (1991, Aug) High-tech dairy cows. *Successful Farming*, p. 50.

Borcherding, J.R., & Peterson, C., Jr. (1990, Apr) More milk, less cost. *Successful Farming*, p. 32.

Dineen, J. (1988) *Food from dairy and farmyard*. World's Harvest Series. Hillside, NJ: Enslow Publishing.

Scuro, V. (1986) *Wonders of dairy cattle*. New York: Putnam Publishing Group.

Additional sources of information

Holstein Association
1 Holstein Place
Brattleboro, VT 05301
(802) 254-4551
(film: *From an art to a science*)

National Dairy Council
6300 N. River Road
Rosemont, IL 60018
(708) 803-2000

Community resources

Local 4H chapter
Dairy council
Dairy farmer
Veterinarian

INSIGHTS

- You may have heard milk described as “nature’s most perfect food.” That’s because it contains three main nutrients—protein, calcium, and riboflavin—essential for bones and teeth to grow, body tissues to repair themselves, and antibodies to form.
- Milking techniques and *milk processing* have changed a lot since Christopher Columbus brought the first cattle to the Western Hemisphere in 1493.
- Advancements such as automatic milking machines and computers have improved milk production, safety, and availability.
- Milk production begins with the cow. A mature cow eats, on average, 50 pounds of silage and drinks 25 to 50 gallons of water a day. A cow initially chews just enough to swallow. The food goes into the first chamber (called the rumen) of its four-part stomach. Later, the cow burps up small amounts of food and chews it again. The food then goes into the next chamber (reticulum) before passing through the final two chambers (abomasum and omasum), where bacteria and stomach acids work on it. Food provides cows with protein, energy, vitamins, minerals, and bulk. It is also the raw material that makes milk. However, to begin producing milk, a cow must first

give birth. The hormones released at birth and the sucking of the calf stimulate the cow to lactate (produce milk) for her calf. Cows produce the greatest amount of milk right after they give birth. If a cow is not milked, she will stop producing milk.

Milk is made and stored in the cow’s udder, which is divided into four separate quarters, each having its own milk supply. When laden with milk, each section can be drained through one *teat*. First the farmer spray-washes the cow’s udder with a warm iodine solution to control diseases. The milking machine cups are then attached and draw the milk from the udder into a system of pipes that transports the warm milk to a large storage tank for cooling. This milk is known as *raw milk*.

A trucker comes to the farm to collect and transport the raw milk to a processing plant. At the plant, milk is tested for acceptable levels of bacteria, and *pasteurized* by heating it to

77°C (170°F), then cooling it. This kills any harmful bacteria that may be in the milk.

During processing, *butterfat* is skimmed from the milk. The butterfat is then forced through small holes. This breaks it up into very tiny globules which will stay mixed evenly with the milk. Butterfat is then added back into the milk in proper proportions to produce skim, 2%, whole, and other types of milk. This process is called *homogenization*.

Once homogenization is completed, the milk goes into big storage tanks where it is cooled. It is agitated and then put into bottles or cartons for delivery. The total time from cow to shelf is 48 to 96 hours!

CONNECTIONS

1. How have dairy farms changed over the last 25 years?
2. How does the dairy industry apply biotechnology to milk production? What applications might it have in the future?

VOCABULARY

- butterfat** fat molecules present in milk. Also known as milk fat.
- homogenization** the reduction in size of fat molecules in milk so they stay mixed evenly throughout
- milk processing** techniques, including pasteurization and homogenization, used to prepare milk for consumption
- pasteurization** the method of killing disease-causing bacteria in milk by rapidly heating and then cooling it
- raw milk** milk that is fresh from the cow and has not been pasteurized or homogenized
- teat** the projection through which milk is drawn from an udder

Newton's Apple is a production of KTCA Twin Cities Public Television. Made possible by a grant from 3M.
Educational materials developed with the National Science Teachers Association.



MooooMath

Calculate the amount of food one cow can produce.

▶ TRY THIS...

Visit a dairy farm. What did you enjoy most? What did you like least? Would you like to live on a dairy farm?

• MAIN ACTIVITY

- The amount of milk needed to create different products varies. With the following information, organize and construct a data table to show how much milk is needed to produce some of these foods. Clue: One quart of milk weighs 2.15 pounds.

• Materials

- paper
- pencil
- 1. Assume that an average cow produces 14,000 pounds of milk in one year. Calculate how many pounds that animal would produce in a day, week, and month.
- 2. Calculate how many gallons of milk that would be in a day, week, month, and year.
- 3. One kilogram is equal to 2.2 pounds. Calculate how many kilograms it would be in a day, week, month, and year.
- 4. Use the information above and the following conversions to answer the following questions. Calculate your answers in both pounds and kilograms.

<u>To make one pound of</u>	<u>you need</u>
cheese	10.0 lbs of milk
ice cream (1 gal)	12.0 lbs of milk
milk powder	7.4 lbs of milk
butter	21.2 lbs of milk

▶ TRY THIS...

Interview a veterinarian or dairy farmer. Develop a series of questions to ask your interviewee. For example, what kinds of illnesses do cows get? What is a cow's normal temperature? What does he or she do when a cow gets sick? How much do cows sleep?

Questions

1. How much cheese could you make with the milk one cow produces each day?
2. How much ice cream could you make with one cow in a week?
3. How much milk powder could you make with one cow in a month?
4. How much butter could you make with one cow in a year?
5. If each person ate one pint of ice cream per day, how many people could you feed from one cow in a week?
6. If a family of four could live on 10 pounds of milk powder a week, how many weeks would your monthly supply last them?
7. If the average daily food ration for a cow is 50 pounds, how much would that cow eat in a year? If you had 120 dairy cows, how much would they eat in a year?

Adapted from USDA activity.

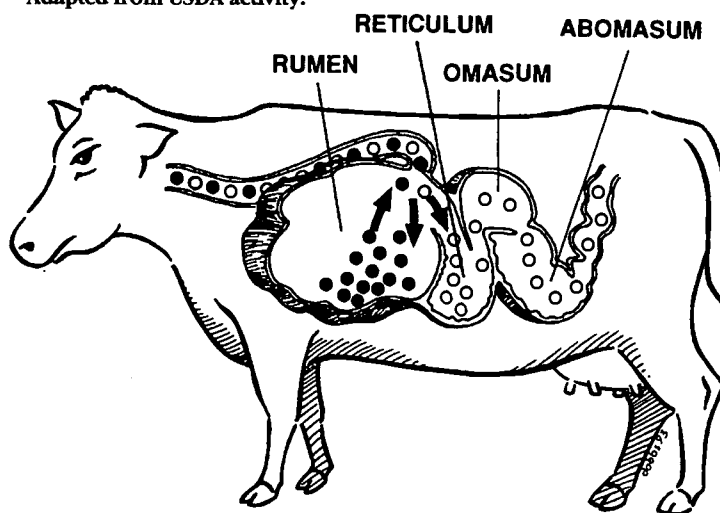

▶ TRY THIS...

Make ice cream with an ice cream maker. Show how the ice cream forms. Explain the chemical and physical principles behind it.

▶ TRY THIS...

Research one of the following men and women to find out their contribution to milk production: Louis Pasteur, Harvey D. Thatcher, Henry L. Coit, S. M. Babcock, Gail Borden, and Dolly Madison.

▶ TRY THIS...

Compare the nutritional value of soft drinks and milk. How do other food products compare nutritionally to milk? Develop a chart to show these values.



Peggy and Nancy hit the road in search of adventure and discover a stampede of bison!

Segment Length – 8:23

BISON ROUNDUP

How did wild North American bison come back from near extinction?

What role did bison play in North America's history? What factors contributed to their near extinction? What has been done to ensure their place in North America's future?

RESOURCES

Dary, D.A. (1974) *The buffalo book*. Chicago: Sage Books.

Lott, D.F. (1991) *American bison socioecology*. Amsterdam: Elsevier Science Publishers.

Luoma, J.R. (1993, Mar/Apr) Back home on the range? *Audubon*, pp. 46–52.

Macdonald, D. (Ed.) (1985) *Encyclopedia of mammals*. New York: Facts on File.

McHugh, T. (1972) *The time of the buffalo*. New York: Alfred Knopf.

Mitchell, J. (1993, Jan/Feb) The way we shuffled off the buffalo. *Wildlife Conservation*, pp. 44–50.

Neary, J. (1977) *Wild birds*. New York: Time-Life Films.

Palmer, A.L., & Fowler, H.S. (1977) *Fieldbook of natural history*. New York: McGraw-Hill.

Rifkin, J. (1992) *Beyond beef: The rise and fall of the cattle culture*. New York: Penguin Books.

Community resources
National parks

Zoo

INSIGHTS

- For thousands of years, bison (the North American buffalo) traveled widely over the western plains of North America, grazing on prairie grasses and finding drinking water with their acute sense of smell. These enormous animals can stand as tall as six feet and weigh up to 2,200 pounds.
- Plains Indians hunted bison, using almost every part of the animal in some way. They ate the meat, fashioned weapons from bones, ground hoofs into glue, and made hides into ropes, blankets, clothing, and shelters. Even bison droppings served as a source of fuel. The Native Americans adapted their way of life to follow the bison herd as it randomly moved across its large home range.
- Less than 200 years ago, over 60 million bison roamed the western grasslands. Settlers described herds so dense and covering such a large area that the ground shook and the prairie appeared to move as they ranged the grasslands. By the late 1800s, however, less than 1,000 bison survived.
- Experts link the decline directly to the movement of cattle onto the plains. Cattlemen recognized the uniqueness of the plains country. Unlike eastern grasses, wild western grasses of the plains resisted drought and dried out on the

open ground, providing nourishment for cattle even during winter. The cattlemen felt they faced one problem, however. Buffalo and Native Americans already occupied the grasslands. As long as they remained, the land couldn't be converted to pasture for cattle.

Because people thought the bison population was limitless, few laws protected the animals. Their size and *gregarious* (social) behavior made bison easy targets. From 1872 to 1874 alone, over three million were killed. Railroads and the army contracted with hunters like Buffalo Bill to supply buffalo meat for employees and soldiers. Professional *hides men* moved into the area, hoping to make big profits off the valuable hides, and homesteaders came to settle the new land. By the late 1800s, the animal was virtually eliminated from the western plains.

This dramatically affected Native Americans. Robbed of their livelihood, entire nations surrendered to the U.S. government. Most were driven onto reservations where they became totally dependent on the government.

Luckily, bison were never completely eradicated. Today, about 120,000 survive. Gone are the days when huge herds roamed the prairie. Instead, constrained by boundaries and surrounded by people, bison live a life quite different from that of earlier days.

CONNECTIONS

1. Bison meat compares favorably with other meats. It is higher in protein, yet lower in fat, cholesterol, and total calories. How could we make bison meat more marketable?
2. Today most bison range on private lands or in parks. What problems do landowners and park officials face when dealing with these fenced-in herds?

VOCABULARY

- endangered species** a species that is in immediate danger of becoming extinct
- exterminate** to get rid of by destroying completely
- extinction** the death of all members of a species
- gregarious** tending to move in or form a group with others of the same kind
- herd** a number of animals of one species that keep together as a group
- hides men** hunters who pursue animals for their hides
- natural selection** the principle that organisms with traits best adapted for an environment will survive to pass on those traits to their offspring



A SAMPLE LESSON

Use sampling to determine a bison population.

▶ TRY THIS...

Many Native American stories focus on the relationship between humans and nature. Read some examples of these stories that center around bison. What lessons do these stories teach? What can we learn about the people who shared them?

▶ TRY THIS...

During a stampede or flight, bison will walk, trot, bound, and gallop. Watch the Newton's Apple video, closely observing the bison movement. Analyze the gait of different individuals. Each gait is determined by the sequence in which the bison lifts and lowers its hoof.

• MAIN ACTIVITY

- Often we cannot determine the exact number in an animal population;
- instead, an estimate will do. How do scientists estimate animal populations?
- One method is by tagging a sample.
- Imagine that in a region, scientists can capture 90 bison and tag them to identify them later. The next year, in the same region, scientists capture 60 bison and find that 45 are tagged.
- Thus, three out of every four bison captured were tagged. Scientists then use a proportion to estimate the entire bison population for the region:

• 1st count		• 2nd count
• number of		• number of
• <u>bison tagged</u>	$=$	<u>bison tagged</u>
• population	$\frac{90}{y}$	• population
	$=$	
	$\frac{45}{60}$	

- To solve for y:
- $60 \times 90 = 45y$ [Cross multiply]
- $5400 = 45y$
- $\frac{5400}{45} = \frac{45y}{45}$ [Divide both sides by 45]
- $120 = y$
- Scientists could estimate that the area's bison population is 120.

Now, it's your turn to predict a bison population!

• Materials

- pencils
- crayons/markers
- polystyrene packing pieces ("peanuts" or "macaroni")
- calculators
- paper
- large paper grocery bags (1 per group)

1. Divide into groups. Ask a person not in the groups to choose (and not tell!) a number over 100 to represent the size of the bison population. Then have that person place this same

number of polystyrene pieces into each group's grocery bag.

2. Each group will tag the sample using the following method to predict the size of the population. (No fair counting the entire bag!)

(a) Scoop out some polystyrene pieces and mark them with one color. Count them and place this number in the proportion.

(b) Place these tagged pieces back into the grocery bag and shake it. Scoop out some polystyrene pieces again and count the tagged and untagged pieces. Place these numbers in the proportion.

$$\frac{\text{total number tagged}}{\text{predicted number of population (y)}} = \frac{\text{number tagged in 2nd sample}}{\text{total number in 2nd sample}}$$

(c) Cross multiply and divide to find the predicted size of the population. Record this prediction.

(d) Try tagging and sampling several times, using a different color each time you tag. Record the results.

3. Each group shares the predictions. What was the actual number?

Questions

1. How did the predictions compare with the actual number of bison (polystyrene pieces)? What was the result of tagging more than once?
2. What are the pros and cons of the tagging method?
3. In what other situations could you use this method?
4. What are other ways to estimate a population?

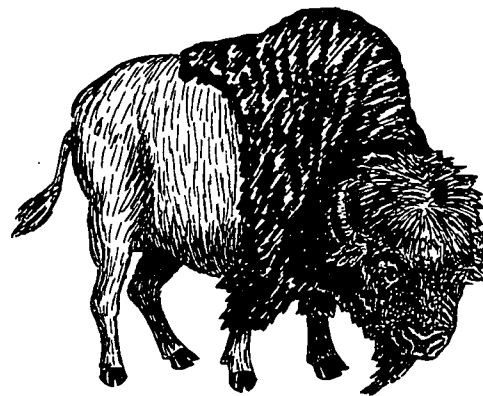

▶ TRY THIS...

Select an area in a state to begin a herd of bison. Determine the range quality—its carrying capacity and limiting factors. How many bison can be supported? What kind of vegetation will they need?



David learns about heart attacks and the ways in which they are treated.

Segment Length – 8:23

HEART ATTACK

What happens when you have a heart attack?

What is a heart attack and why does it happen? What goes on inside a person's body during a heart attack? How can people prevent heart attacks?

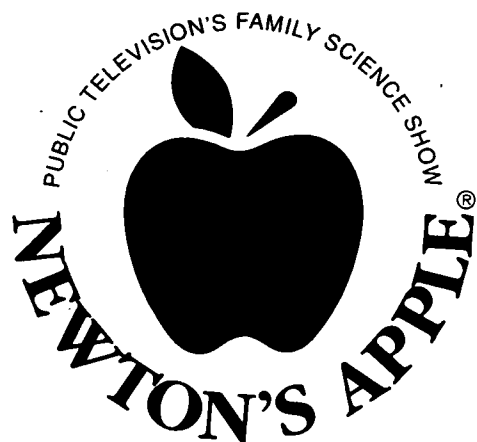

RESOURCES

Brody, J.E. (1992, July 22) Understanding and controlling risks can help lower chance of heart attack. *The New York Times*.

Catford, J.C. (1991, Nov/Dec) Heartbeat Wales. *World Health*, p. 10.

Padus, E. (1992, Feb) The cholesterol plunge. *Prevention*, p. 34.

Perlmutter, C., & McVeigh, G. (1991, July) Women and heart disease: How to develop a personal protection plan. *Prevention*, p. 42.

Politzer, B. (1991, Dec) Counter attack: Winning ways to protect your heart. *American Health*, p. 38.

Rees, A. M., & Hoffman, C. (1990) Cardiology. In *The Consumer Health Information Source Book* (3rd ed.). Phoenix, AZ: Oryx Press.

Spilner, M. (1993, Feb) The walking Rx for healing hearts. *Prevention*, p. 12.

Additional sources of information

American Heart Association
7272 Greenville Ave.
Dallas, TX 75231-4596
(214) 373-6300
(Check for a local chapter)

Mended Hearts
7320 Greenville Ave.
Dallas, TX 75231
(214) 706-1442
(Organization of people with heart disease. Check for a local chapter.)

INSIGHTS

- We all value the muscles in our legs and arms. But the *heart* is the most important muscle that keeps our bodies functioning. It pumps blood to the brain and the rest of the body. And since blood transports the food and oxygen our body cells need to survive, it's extremely important to keep it flowing.

- The average heart is about the size of an adult fist and weighs 250–350 grams (9 ounces). It normally beats about 70 times per minute. Each beat represents a coordinated muscular contraction conducted through a complicated nerve network. To beat properly, the muscles of the heart must get an adequate blood flow through the *coronary arteries*.

- Like soot in a chimney, *atheromatous plaque* can build up in the coronary arteries, narrowing them and reducing their blood flow. The heart then becomes "thirsty" for more oxygen and nutrients, particularly when under demand for increased output. The earliest symptom of this problem is mild chest pain, or *angina*. When the blood supply to the heart becomes critically deficient or blocked, a person suffers a *heart attack*.

- Symptoms of a heart attack include severe, prolonged chest pain or pain that travels to the shoulders, arms, neck, or jaw;

shortness of breath; perspiration; nausea; light-headedness; and irregular pulse. Immediate medical care can greatly increase a patient's chances of surviving a severe heart attack. Every second is crucial when a heart attack strikes.

If a person's heart stops, cardiopulmonary resuscitation (CPR) may keep the victim alive until emergency care arrives. At the hospital the victim receives medicine to dissolve the clot that is blocking blood flow to the heart muscle. Other medicines can relieve the chest pain and strengthen the pumping force of the weakened heart. If the heart stops or begins beating erratically, physicians often restart it with an electrical shock called defibrillation.

A diseased heart can be treated surgically or medically. Common surgical methods include coronary angioplasty, coronary bypass grafts, and

pacemakers. Physicians do these surgeries to improve blood flow and stabilize the heartbeat.

With medical management of coronary artery disease, physicians try to prevent the development of atheromatous degenerative trouble. They might put patients on a diet to lower their cholesterol level or to lose weight. They may recommend exercise and stress reduction programs. Doctors often prescribe medicines as well to control the pain of angina, prevent irregular heartbeats, and strengthen a weakened heart muscle.

CONNECTIONS

1. Do you think heart attacks and heart disease will ever be eradicated? How important is heredity?
2. Should medical experts concentrate on preventing coronary artery disease or treating it once it develops?

VOCABULARY

angina chest pain caused by insufficient blood flow to the heart
atheromatous plaque the deposit of cholesterol in the walls of arteries, which leads to their narrowing
coronary arteries the blood vessels that carry blood to the heart to provide it with oxygen and nutrients
heart muscular, cone-shaped organ that pumps blood throughout the body and normally beats about 70 times a minute
heart attack the consequence of an acute, critical reduction in blood flow to the heart muscle
heart rate pulse, calculated by counting the number of contractions of the heart muscle per minute

Newton's Apple is a production of KTCA Twin Cities Public Television. Made possible by a grant from 3M.
 Educational materials developed with the National Science Teachers Association.



PUMPING BLOOD!

Feel evidence that your heart is working—in your wrist!

▶ TRY THIS...

Obtain a cow's heart from a butcher or slaughterhouse. It is virtually identical to a human heart. Use an anatomy book to identify and label the important parts. These should include the aorta, pulmonary artery, left and right atrio, left and right ventricles, left and right coronary arteries, and the four heart valves. Explain what happens during a heart attack.

▶ TRY THIS...

High blood pressure (hypertension) contributes to more than a million heart attacks every year. Invite your school nurse to come in and speak about the dangers of high blood pressure. Ask that person to take the blood pressure of some students and explain how blood pressure is measured.

▶ TRY THIS...

Stress can cause heart disease. In a class discussion, define stress, identify some stressful situations, and come up with some possible ways to avoid them.

• MAIN ACTIVITY

- Take your pulse before and after exercise. See what a workout does to your pulse rate. Graph the results.
- (The normal resting pulse range for 15-year-olds is 50 to 98.) If possible, do the same experiment with an adult.

• Materials

- stopwatch
- paper
- ballpoint pen
- graph paper or grid drawn on blackboard

1. Sit on a chair. Turn one hand palm side up. Put the three middle fingers of the other hand on the side of the wrist nearest the thumb. Feel around until you detect the pulse beneath your fingers. Mark the spot with a ballpoint pen.

2. Start the stopwatch and count the number of beats under your fingers for one minute. Record this pulse rate.

3. Now stand and do 25 jumping jacks. Take your pulse again for one minute. Record that pulse rate.

4. On the graph paper, chart the results of the change in pulse rate with exercise for each member of the class. Set up a graph with heart rates recorded on the y-axis, and two x-axis columns labeled "rest" and "exercise." Plot the results for each class member.

Questions

1. What general conclusions can you make about the effect of exercise on your pulse rate? Why is this important to know?
2. Why shouldn't you take your pulse with your thumb?
3. What other places on your body can you find a pulse?
4. Why will regular exercise benefit your heart?

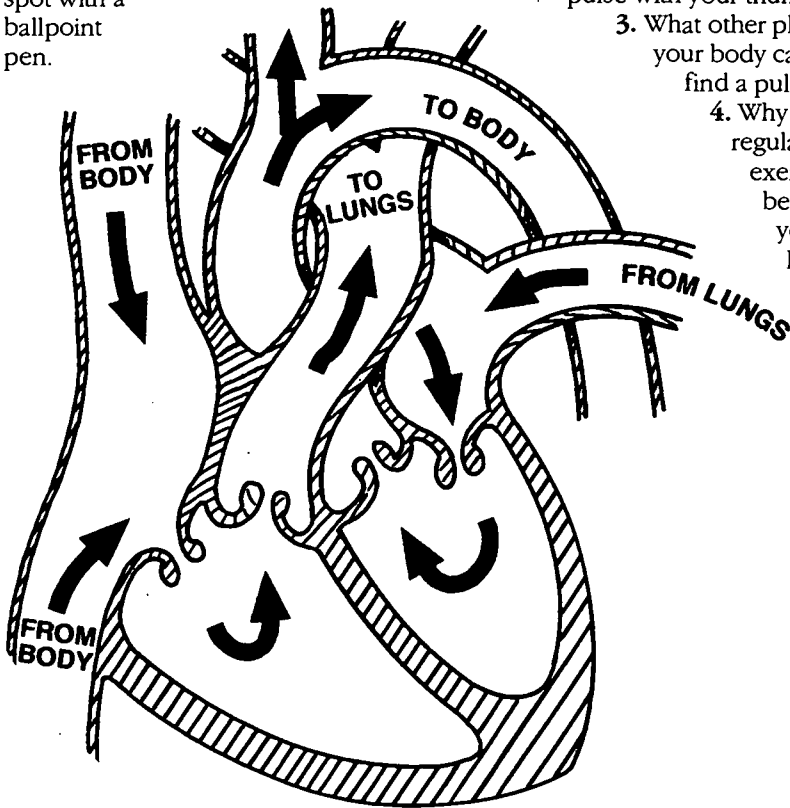

▶ TRY THIS...

Measure your heart rate per minute. Using figures from your classmates, calculate the class average. At home, find the heart rates of young siblings, parents, and grandparents. Share these with your classmates to find an average in each category. As a class, calculate the total number of heartbeats during a person's lifetime. Graph your results.

▶ TRY THIS...

According to the Department of Agriculture, heart disease can be linked to the consumption of partially hydrogenated oils in margarine and vegetable shortening. Discuss alternatives to these foods. Look at the ingredient labels on the containers of cooking oils, margarine, or butter used in your home. Read the labels for ingredients and analyze the fat content, calories, and sodium level in these food products.



Peggy is sent underwater to "get to the bottom" of dive injuries.

Segment Length – 7:20

THE BENDS

How do divers get the bends?

What happens when you get "the bends"? What are the effects of water pressure when you dive? What is an air embolism? What affects how much air you need underwater?

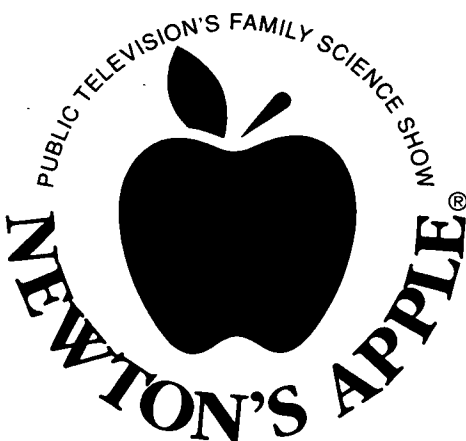

RESOURCES

Briggs, C.S. (1985) *Skin diving is for me*. Minneapolis: Lerner.

Griffiths, T. (1989) *Sport scuba diving in depth: An introduction to basic scuba instruction and beyond*. Princeton, NJ: Princeton Book Co.

Open water sport diver manual (4th ed.). (1989) Englewood, CO: Jeppesen Sanderson Inc.

McGovern, A. (1989) *Down under, down under: Diving adventures on the Great Barrier Reef*. New York: Macmillan.

Additional sources of information

National Association of Underwater Instructors
PO Box 14650
Mountain View, CA 91763
(909) 621-5801

The Cousteau Society
777 United Nations Plaza,
5th Floor
New York, NY 10017
(212) 949-6290

Community resources

The YMCA is the oldest dive certification organization.

INSIGHTS

- If you want a sport that puts you under a lot of pressure, try underwater diving. You can even feel some of the effects of pressure in a swimming pool.
- Down just a few feet underwater, your ears begin to hurt. That's caused by pressure on your eardrums.

- Where does that pressure come from? It's the weight of all the water—and air—above you. At the surface of the water, a column of air—stretching hundreds of miles out into space—weighs 14.7 pounds per square inch. Scientists call this amount of pressure "one atmosphere."

- When you go underwater, however, you add the weight of the water to the atmospheric pressure. A 10-meter (33-foot) column of water weighs 14.7 pounds per square inch, so at a depth of 10 meters, the pressure is two atmospheres: half from the water and half from the air above it.

- Pressure also influences how divers use air. At ten meters, for example, the increased pressure means your lungs hold twice as much air as they do at the surface—and you'll breathe all the air in your tank twice as fast. The deeper you dive, the more quickly you use up the air in your tank.

When you breathe compressed air through a *regulator* underwater, you ensure that the air spaces in your body are at the same pressure as the surrounding water. But if you breathe compressed air underwater and then ascend, holding your breath, the pressure around you decreases, so your lungs expand. Air sacs in your lungs could rupture, causing an *air embolism*, which means that bubbles of air enter your blood stream and block circulation to your brain.

"The bends," or *decompression sickness*, is another health hazard associated with pressure changes. The longer you stay down and the deeper you go, the more nitrogen dissolves into your body tissues. If you ascend too rapidly, the dissolved nitrogen comes out of solution too quickly and forms bubbles in your tissues. You could experience severe pain

(particularly in joints), dizziness, blindness, paralysis, and convulsions.

Although decompression sickness is rare, divers learn they must ascend slowly and, under certain circumstances, take "decompression stops" on the way up. This allows the dissolved nitrogen to come out of the body safely.

CONNECTIONS

1. Why is it important for people to learn to dive and to spend time underwater?
2. What are some precautions people should take as they dive underwater?

VOCABULARY

air embolism a dangerous condition in which air sacs in your lungs burst. This can create air bubbles in your bloodstream.

decompression sickness a serious condition (also known as "the bends") resulting from nitrogen coming out of solution and forming bubbles in body tissues. It happens when divers have been breathing compressed air at depth and then ascend too rapidly.

neutral buoyancy neither sinking nor floating; having the same average density as water

regulator a device which delivers air for breathing at the pressure of the surrounding water

wet suit a neoprene foam suit that will keep you warm in cold water by trapping a layer of water next to your body

• Newton's Apple is a production of KTCA Twin Cities Public Television. Made possible by a grant from 3M.
• Educational materials developed with the National Science Teachers Association.



BATTLE WITH BUOYANCY!

Find out what it takes to sink a floating object.

▶ TRY THIS...

Invite a diver to come and talk to your class about diving. Ask the diver to bring a regulator and a tank so you can see what it's like to breathe through a regulator on dry land. What do you think it will be like?

▶ TRY THIS...

In cold water, divers wear wet suits. These neoprene foam rubber suits trap a layer of water next to your skin. When you jump in, you feel the cold water seep into the suit, but your body warms up the water right away. Since this water isn't instantly replaced by the cold water around you, the heat—and the warm water—stay with your body. Wet suits look cold and clammy, but they're not! Visit a scuba dive shop and examine the equipment used.

▶ TRY THIS...

Can you hold a plastic cup over your mouth and chin by sucking some of the air out of it? The air pressure outside the cup is greater than the pressure inside; that difference in pressure holds the cup onto your face. If you equalize the pressure, the cup falls off.

• MAIN ACTIVITY

- It's important for divers to be of *neutral buoyancy*. That means they tend to stay at the depth they are—
- they neither sink nor float. You can explore buoyancy in a sink or bathtub.

• Materials

- several dozen washers, in a few different sizes if possible
 - some objects that float, such as wooden "kindergarten" blocks, Tinkertoys, or plastic film canisters
 - paper clips
 - duct tape
 - an inflated and tied balloon
1. Fill a bathtub (or any other deep container, such as a sink or a waterproof wastepaper basket) with as much water as is practical.
 2. Select an object. Verify that it floats.
 3. Find a way to attach the washers to the object as weights. For a wooden block, make a hook out of a paper clip and tape it to the block with duct tape; put the washers on the hook. For a Tinkertoy structure, put the dowel through the washer's hole. For a film canister, put the washers inside.

4. Add washers until the object just sinks. Record how many washers it takes to sink it.

5. If you have different-size washers, try to adjust the weight on the object so that the object is of neutral buoyancy.

6. If you have different-size objects (for example, wooden blocks or Tinkertoys in different sizes), see how the amount of weight it takes to sink them depends on their sizes.

7. Look around your home for objects that float which you can sink with washers. Try some. Were you surprised by any of them?

8. Try to sink the balloon. Tie a paper-clip hook to the neck of the balloon and add washers. What happens?

Questions

1. What did you notice about the number of washers and the size of the object? Is this what you expected?
2. Can you predict how many washers you'd need to sink a balloon?
3. Divers use balloons to lift heavy things from the bottom. How do you suppose they fill them?

▶ TRY THIS...

Imagine you are underwater and your face mask fills with water. You don't have to go to the surface. Just hold the bottom of the mask away from your face and exhale through your nose. The air will rise to the top of your mask and push the water out the bottom! This is how scuba divers clear their masks when they're underwater.

▶ TRY THIS...

If you wear a face mask in the water and swim down a few feet, you'll feel the water pressure pushing the mask harder and harder onto your face. To relieve that discomfort, make the pressure more equal by blowing air into the mask through your nose.

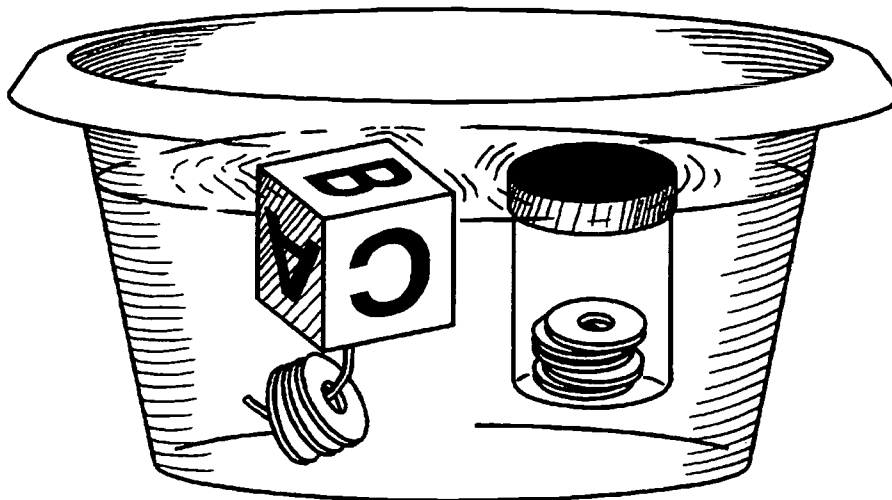



Peggy and David
"sound out" the
technologies used
to produce CDs
and LPs.

Segment Length — 8:40

COMPACT DISCS

Which sounds better—an LP or a CD?

What are the processes behind CD and LP technology? How do CDs and LPs encode and play back sounds? What are some of the advantages and problems associated with each technology?

RESOURCES

Berger, M. (1987) *Lights, lenses and lasers*. New York: G.P. Putnam's Sons.

Birchall, S. (1985, Jan) The CD: It's the pits that make the music. *Digital Audio*, pp. 26–30.

Hewitt, P. (1992) *Conceptual physics* (2d ed.). New York: Addison-Wesley.

Klein, L. (1989, Nov) The sound of CD. *Radio-Electronics*, pp. 74–75.

Macaulay, D. (1988) *The way things work*. Boston: Houghton Mifflin.

Community resources
High-end audio dealer

Record store

Sound studio

INSIGHTS

- A hot debate rages today around the question of which has better sound, compact discs (CDs) or long-playing records (LPs). Both do a good job of reproducing sound. They differ, however, in the way they encode sound and retrieve it for transmission back to our ears.

- LPs use *analog* technology. They capture and reproduce sound in a way similar—or analogous—to how it was originally created. All sounds begin with vibrations. In music, for example, the instruments vibrate—the strings of a guitar, the reed of a clarinet, the head of a drum. These vibrations create disturbances in the air, which we hear as sound.

- To make an LP, air vibrations are changed into electrical signals by a microphone. These then activate a tool that carves the pattern of the vibrations into the LP as tiny notches in the side of a groove. Etched in the same pattern in which they moved through the air, they are analogous to the original sound wave.

- To play back an LP, the phonograph stylus sits in the groove of the rotating LP, bouncing off the notches as it moves along. This causes the stylus to vibrate, and those vibrations are then electronically amplified and sent out through the speaker,

making a sound wave in the air. Because the stylus constantly rubs in the record groove, LPs can wear out, and if they get scratched, they are all but ruined. In addition, when the stylus hits a piece of dust in the groove, it reads it like a notch, so we hear a noise that shouldn't be there.

CDs avoid this problem by using *digital* technology, which eliminates the contact and the vibrations. To make a CD, incoming sound waves are captured electronically, as with an LP. But instead of keeping them intact, special electronics take them apart and turn them into a code, using technology called *signal sampling*. As the electric signal comes in, its *amplitude* is read or sampled at regular intervals, and assigned numerical values between 0 and 65,000. The greater the number of samples per second, the greater the resolution and the more accurate the sound. Most CDs use around 44,000 samples

per second, creating extremely accurate reproductions.

After sampling, circuitry encodes the sound and stores it on the CD as a series of reflective points and nonreflective pits. As the laser beam scans the surface of the CD, it either reflects off the disc's mirror-like surface, or it fails to reflect when it strikes the nonreflective pits. The pattern of reflections creates a sequence of ones and zeros—a binary code. The computer translates this binary code as a series of instructions. Using the code, the computer reassembles the samples, feeds the signal to the amplifier and speaker, and recreates the original sound wave recorded.

CONNECTIONS

1. What are some other ways digital processing is being used, and what advantages does it offer over the "old technology"?
2. Are CDs perfect or do they have some problems?

VOCABULARY

amplitude the maximum deviation (for example, of the pressure) from the average in a simple wave of one frequency. In a sound wave, it is directly related to the loudness.

analog technology which records a sound wave continuously, in the same way it was created. Used on an LP record.

digital technology which records sound by converting it into a binary code. Used on a CD.

frequency number of oscillations per second, such as in a vibrating object or in a wave

signal sampling a technique for taking segments of a sound wave and assigning them a binary code based on their deviation from the average



DOTS A LOT

See how increasing the number of samples improves the resolution of an image.

▶ TRY THIS...

The most expensive violin in the world would sound terrible if it didn't have a sound box to increase the amplitude of the wave of the violin string's vibration. You can make a simple one-string violin by punching a hole in the bottom of a large paper or plastic cup, tying a knot in one end of a string, and threading it through the hole. If you pull the string tight and pluck it, the sound will be greatly amplified.

▶ TRY THIS...

If you have a tape deck that has an LED (light-emitting diode) readout to show the volume of the music, you have a good model for how a sampler works. Play a tape and watch the lights. During loud sections they will jump up, and during soft sections they will just barely move. If you could count the number of lights on each time and turn it into a binary code, you would have a digital record of the song volume.

• MAIN ACTIVITY

- CD technology works because an extremely large number of samples (44,000 per second) is used to encode individual sound waves. In this activity, you will discover how increasing the number of samples changes the resolution of an image.

• Materials

- 3 pieces of 8 1/2" x 11" unlined tracing paper
- metric ruler
- pencil
- 1. Using the ruler, construct a 7 cm x 7 cm (2.8" x 2.8") square in the middle of the first sheet of tracing paper. Mark off points 10 mm (.4") apart from each other around the edge of the square and connect the dots across the square so that you have a grid with 10 mm (.4") boxes.
- 2. Lay the grid over the picture below or a picture of your choice. With the pencil, color in each box that contains a line of the drawing. Leave the other boxes empty. Make sure you color the entire box. Once you have finished coloring the boxes, label the drawing "grid A" and put it off to the side.
- 3. On a fresh piece of tracing paper, construct another 7 cm x 7 cm (2.8" x 2.8") grid, only this time make the

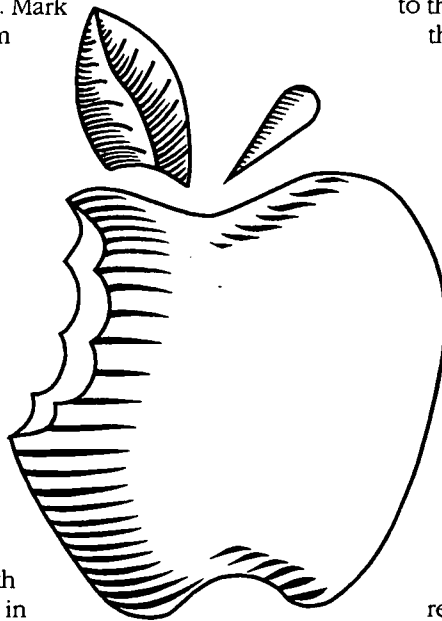

individual boxes 5 mm (.2") on each side. You should have twice as many boxes in each direction as the first grid. Using the same procedure as in step 2, color in all the boxes that a line from the drawing enters. Label this "grid B."

4. On the last piece of tracing paper, construct a third 7 cm x 7 cm (2.8" x 2.8") grid. This time make the individual boxes 2 mm (.08") on a side. (You may have to sharpen your pencil for this one!) Place it over the picture and fill in the boxes as before. Label this "grid C."

5. Compare the three drawings to the original. Drawing A is the standard. Drawing B has double the sampling points, and drawing C has five times the sampling points.

Questions

1. Which of the three drawings more closely resembles the original? Why?
2. How does increasing the number of sample points affect the accuracy of the drawing?
3. How might this relate to CD technology in terms of digitizing a signal?
4. On grid C, you used five times the number of sample points in each direction as on grid A. What would happen if you used ten times the number of samples? Is there a limit to the number of sample points you can use?

▶ TRY THIS...

The original Edison phonograph had no electronics. The device produced sound acoustically, by a vibrating needle attached to a large cone. To duplicate Edison's device roll up a piece of paper into the shape of a cone and stick a sewing needle through the body near the narrow end. Get an LP that you never plan to use again. (You will ruin it with this experiment.) Stick a pencil through the center hole and spin it like a top or lay the record on a turntable or lazy Susan. If you place the needle in the groove, you should hear the music come out the cone.

▶ TRY THIS...

Using a good magnifying glass or a dissecting microscope, compare the surface of a CD to that of an LP. What differences do you see? What similarities?

195



Peggy wades through piles of trash in the name of scientific inquiry.

Segment Length – 6:47

GARBAGE

What can we learn from our garbage?

How much garbage do Americans throw away? What can we learn about individual life-styles from studying solid waste? What are some future solid waste disposal alternatives?

RESOURCES

Dickson, N. (1991) *Composting to reduce the waste stream*. Ithaca, NY: Northeast Regional Agricultural Engineering Service.

Earth Works. (1989) *Fifty simple things you can do to save the planet*. Berkeley, CA: Earthworks Press.

Rathje, W. (1991, May) Once and future landfills. *National Geographic*, pp. 117–134.

Rathje, W., & Murphy, C. (1992) *Rubbish! The archaeology of garbage*. New York: Harper Collins Publishers, Inc.

3-2-1 Contact Extra videotape: *The Rotten Truth*. GPN: (800) 228-4630.

Additional sources of information

The Arizona Garbage Project
Department of Anthropology
University of Arizona
Tucson, AZ 85721
(602) 621-6290

Environmental Protection Agency
Office of Solid Waste
400 M St. SW
Washington, DC 20460
(EPA booklet 530-K-92-003: *The consumer's handbook for reducing solid waste*. Booklet 530-SW-90-005: *Let's reduce and recycle*)

Community resources

Public works department
Secondary materials dealer

INSIGHTS

- It's hard to imagine scientists having much to do with garbage. But as the solid waste crisis grows, simple garbage disposal will require some high-tech solutions.

- While getting rid of garbage has always been a problem, it only recently has hit epidemic proportions. For almost 7,000 years, people disposed of solid waste by gathering it up, carting it out, and dumping or burying it in an isolated place. Crude as it was, this system worked because most of the solid waste consisted of biodegradable organic compounds that easily decomposed. In addition, the volume of trash was much lower than now because there were fewer people and less packaging waste.

- Over the last 50 years new synthetic materials have been introduced into the waste stream, complicating the problem. These materials are not biodegradable and some produce toxic residue. This has led to tighter environmental controls on landfills. With open space in short supply, many communities are literally drowning in *municipal solid waste*.

- Before a community can decide how to safely and efficiently dispose of solid waste, it needs to define exactly what solid waste is. It may sound funny,

but all garbage is *not* created equally. Waste from industrial centers is very different from the waste generated on farms. Urban apartment garbage bears little resemblance to the household waste from suburbs.

Before composting, *recycling*, or waste-to-energy systems can be considered, scientists must analyze the waste stream in detail. First, investigators calculate how much of the waste from many different samples falls into basic categories, such as glass, plastics, metals, paper, and food waste. They can then predict the *BTU* value of the garbage, the volume of recyclable material, and how much of the waste is biodegradable.

Scientists also evaluate the effectiveness of different disposal techniques. If you add up the amount of food, yard, and paper waste generated by a typical American family, landfills appear an ideal option. After all,

these materials—which are biodegradable—make up almost 70% of the garbage. Unfortunately, little oxygen or water exists inside a landfill to help the decomposition process. Scientists have found that even after 50 years, much waste in landfills is still quite fresh. By monitoring decomposition rates and end products from other disposal techniques, they can create disposal systems that are safe, efficient, and economically viable.

CONNECTIONS

1. More than 60% of municipal solid waste is recyclable, yet only about 13% of it gets recycled. Why isn't more recycled? How can we improve this situation?
2. Excess packaging is one reason we have so much solid waste in the United States. How can you eliminate excess packaging before it gets into your house?

VOCABULARY

- anaerobic** an environment without oxygen
- BTU (British thermal unit)** energy unit that represents the amount of heat needed to increase the temperature of a pound of water 1°F.
- municipal solid waste** residential and commercial trash from a city or town
- recycled** products made from solid waste material
- recycling** the act of using the same materials again, though not necessarily in the same product
- sanitary landfill** a waste disposal system where trash is spread and covered with a layer of soil each day
- source reduction** the elimination of solid waste before it enters the waste stream by careful packaging and purchasing techniques

Newton's Apple is a production of KTCA Twin Cities Public Television. Made possible by a grant from 3M.
Educational materials developed with the National Science Teachers Association.

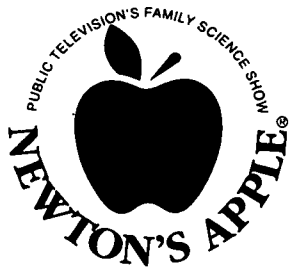

GARBOLOGY

Discover if your garbage is "typically American" by conducting your own waste stream analysis.

▶ TRY THIS...

One reason the United States leads the world in solid waste production is because we overpackage consumer goods. Become a waste watcher! Next time you buy a product, weigh the packaging and then weigh the product itself. List ways to cut down on wasteful packaging.

▶ TRY THIS...

Where does your garbage go? If you are like most of us, you probably don't know, once it's loaded on the garbage truck. Contact your local public works department and see if you can arrange a tour of a waste disposal facility. Find out if your community is considering other disposal methods.

• MAIN ACTIVITY

- According to 1988 figures from the Environmental Protection Agency, the typical American throws away about five pounds of trash each day. Of that amount, 40% is paper, 17.5% is yard waste, 8.5% is metals, 7.0% is glass, 8.0% is plastic, 7.5% is food waste, and 11.5% is miscellaneous materials. By analyzing your own household waste stream, you can see how you compare.

• Materials

- kitchen scale
- bathroom scale
- large plastic bucket
- rubber gloves

1. Set up a data chart with the categories listed in the solid waste breakdown above. To be accurate, you must weigh your waste every day for a month. (Note: Adapt time frame to fit your schedule.) For even greater precision, place cardboard, magazines, and newspapers into a separate category from other paper. If you currently recycle or compost any household waste, include the material in the weight analysis, and then keep a separate column for items recycled. This line will serve as a credit on your final garbage balance (so subtract this weight from your total garbage weight).

2. Each day, separate your garbage into the various components to be weighed. Wear plastic or rubber gloves. To minimize mess, store and weigh organic food waste in a plastic bucket. Make sure you subtract the weight of the bucket each time you weigh the materials in it and wash it out each night. Weigh other materials like cans, bottles, and plastic containers when they are empty and dry. You can use a box to weigh them, but make sure you subtract the box's weight. For yard waste and larger bulk items, use the

bathroom scale and record the weight to the nearest kilogram or pound.

3. After recording the data for a month, add up the total weight for each category. Then add up all of the category subtotals to get the number of pounds of solid waste generated by your family in one month. Divide this number by the number of people in your household. Remember, babies count as a whole person!

4. Divide each category subtotal by the total weight of garbage produced to get the weight percent for each category. If you do recycle or compost, divide that amount by the total amount produced to determine how much you are saving. Make a chart or graph of each category.

Questions

1. How do your numbers compare with the national averages? What factors might account for the differences?
2. How would your numbers compare if you kept track of your garbage for a whole year? Are there any seasonal variations in waste generation?
3. How much could you effectively reduce your household waste by using a source-management program, such as composting yard waste and recycling newspapers, bottles, and cans?

▶ TRY THIS...

Arrange to visit a local recycling program in action. It can be a municipally-run operation or a private scrap dealer. Discuss the types of materials which the program accepts and see what processing must be done before the final product is sold to a manufacturer.

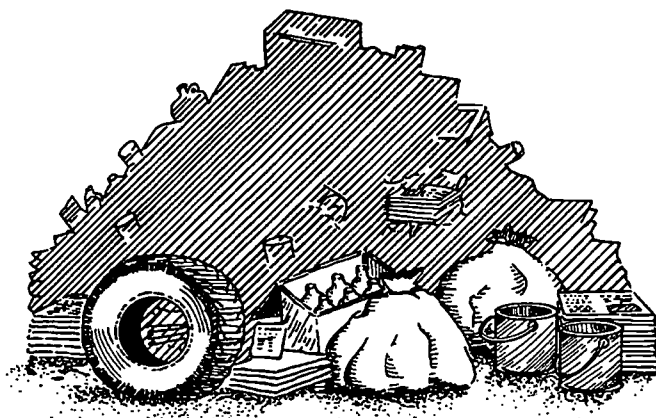

197



David uncovers exciting technological advances that use infrared light.

Segment Length - 6:35

INFRARED LIGHT

What is infrared light and how does it work?

How do we detect infrared light? How is it produced and how does it compare with visible light? What are some of the technologies that take advantage of infrared radiation?



RESOURCES

Hewitt, P. (1993) *Conceptual physics* (2d ed.). New York: Addison-Wesley.

Kohn, B. (1967) *Light you cannot see*. Englewood Cliffs, NJ: Prentice-Hall.

Newton's Apple Classic Video: Show #209—*Thermography*. GPN: (800) 228-4630.

Silverman, J., Moonet, J., & Shepard, F. (1992, Mar) Infrared video cameras. *Scientific American*, pp. 78-83.

3-2-1 Classroom Contact videotape: *Animal Vision*. GPN: (800) 228-4630.

Additional sources of information

NASA Education Division
Mail Code F
Washington, DC 20546
(LANDSAT and EROS photos)

Eastman Kodak
Consumer information hotline:
(800) 242-2424
(for sources that sell and develop infrared film)

Edmund Scientific Company
101 E. Gloucester Pike
Barrington, NJ 08007
(609) 573-6250
(radiometer and diffraction gratings)

Community resources

Contact your local utility about a thermographic home energy audit.

INSIGHTS

- When we talk about *infrared radiation*, we're really talking about a particular kind of light.
- If you combine infrared radiation with radio waves, microwaves, *visible light*, ultraviolet radiation, X rays, and gamma rays, you'll end up with a broad band of radiation frequencies called the

- *electromagnetic spectrum*. All of these types of *electromagnetic radiation* transfer energy through space via waves of oscillating electromagnetic fields. What distinguishes them from each other are the frequency of the oscillation and, consequently, the *wavelength*.

- An object's molecules and electrons are always in motion, vibrating and radiating electromagnetic waves. When the object heats up and its temperature increases, the motion will increase and so will the

- average *wave frequency* and the intensity of the radiation. You can see this at work in a toaster oven.

- When you turn the toaster on, you can feel some heat, but you see no light. As more electric energy is supplied and the wires get hotter, they begin to glow red.
- If you could really turn up the power so that the temperature reached about 3,000°C, the wires, like the filament in a light bulb, would glow white. The only problem is that they would probably burn up before they reached that temperature.

British astronomer Sir William Herschel discovered infrared radiation around 1800. He used a prism and a sensitive thermometer to detect "invisible" light found just below the red portion of the spectrum. The term infrared (meaning "below red") came into use because it describes where you find it on the electromagnetic frequency spectrum.

Any warm object gives off infrared radiation. But remember, warm is a relative term. An ice cube in a cooler is warmer than a flask of liquid nitrogen, so it gives off more infrared radiation. Using special infrared scanners, a *thermographic* scanner takes these differences in radiation intensity, codes them by color, and maps them out so that "hot spots" can be detected. With this technology, engineers can find heat leaks in buildings, doctors can find hidden tumors in the

body, and biologists can even find diseased vegetation in a forest.

Infrared imaging can even have applications in space. Astronomers use infrared imaging to detect warm dust around new stars not "hot" enough to give off visible light. This gives them a more complete picture of the whole universe, seeing where no one has seen before!

CONNECTIONS

1. Rattlesnakes and other reptiles can perceive infrared radiation. Does that mean they can see in the dark?
2. If you could only see in the infrared range, which would "light up" your life more—an electric iron or a fluorescent light?

VOCABULARY

electromagnetic radiation the transfer of energy by means of oscillating electromagnetic fields

electromagnetic spectrum the wide band of different types of electromagnetic radiation ranging from radio waves to gamma rays

infrared radiation or "light" invisible electromagnetic radiation that has a longer wavelength than visible light and is detected most often by its heating effect

thermograph a picture showing the differences in surface temperatures of an object

visible light the part of the electromagnetic spectrum that can be seen by humans

wave frequency the number of times a wave crest passes a point in a second

wavelength the distance between two successive wave crests

Newton's Apple is a production of KTCA Twin Cities Public Television. Made possible by a grant from 3M.
Educational materials developed with the National Science Teachers Association.

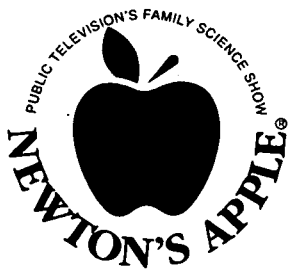

REMOTE CONTROLLING

You will discover how infrared radiation behaves compared to visible light.

▶ TRY THIS...

Kodak has developed infrared film that works in a standard 35-mm camera. This type of film can often be purchased at a well-stocked photography supply store. You can set up a test experiment by selecting several different targets and photographing them in both infrared and visible light. You'll be amazed at what develops!

▶ TRY THIS...

Go into a dark room that has an incandescent light bulb controlled by a dimmer switch. Observe the spectrum it produces through a diffraction grating when the light is fully turned on. (See resources for diffraction gratings.) Slowly turn the dimmer switch down while observing through the grating. What happens to the spectrum? What connection does this have to infrared radiation?

• MAIN ACTIVITY

- Most television remote control units work by means of infrared radiation rather than visible light. That's why you can't see the beam go on when you change channels. Because infrared radiation has a longer wavelength than visible light, it behaves differently when it encounters objects that get in its way.
- Using your television's remote control as a source of infrared radiation, you will compare the behavior of a beam of infrared radiation to that of a beam of visible light. You will see how each reacts when different materials are placed in its path.

• Materials

- television set and remote control unit
 - flashlight
 - cornstarch baby powder
 - clear glass of water
1. Clear all obstructions between you and the television set. Darken the room as much as possible. Stand about 3 meters (10') away from the set and test your remote control unit to make sure it is functioning properly. Test your flashlight by shining it against the dark television screen.
 2. Have a friend stand about halfway between you and the television, directly in front of the screen. Try turning on the television using the

remote control. Then try shining the flashlight onto the television screen. Observe what happens in each trial. Have your friend move around and notice how both "light" beams behave.

3. Have your friend blow some cornstarch baby powder in the air between you and the television and attempt to turn on the television through the dust. Repeat, using the flashlight, and observe what happens when you aim it at the screen.

4. Place the glass of water directly in front of the remote control unit and try to turn on the television. Now shine the flashlight through it. Note what happens in each case.

5. Hold the remote control in your right hand and place your left hand at several distances and angles relative to the remote control. Determine the conditions under which your hand motion prevents the signal from reaching the television.

Questions

1. Which of the objects interfered with the flashlight beam? Which stopped the infrared beam?
2. Why do you think infrared sensors are good at detecting hot spots in forest fires, yet have problems detecting warm bodies in the fog?
3. How does the longer wavelength of infrared radiation help to explain your observations?

▶ TRY THIS...

For over 10 years, NASA has photographed Earth in the infrared range from satellites to measure long-term environmental changes. Contact NASA (see resources) to obtain LANDSAT infrared images of your community and see how the different "heat" colors show the commercial and residential developmental pattern.

▶ TRY THIS...

Radiometers—those things that look like light bulbs with a weather vane inside—not only measure the intensity of visible light but react to infrared as well. Conduct an infrared survey by placing the radiometer near a variety of warm objects to see which has the most effect. The faster the "weather vane" spins, the more intense the radiation. (See resources for radiometers.)

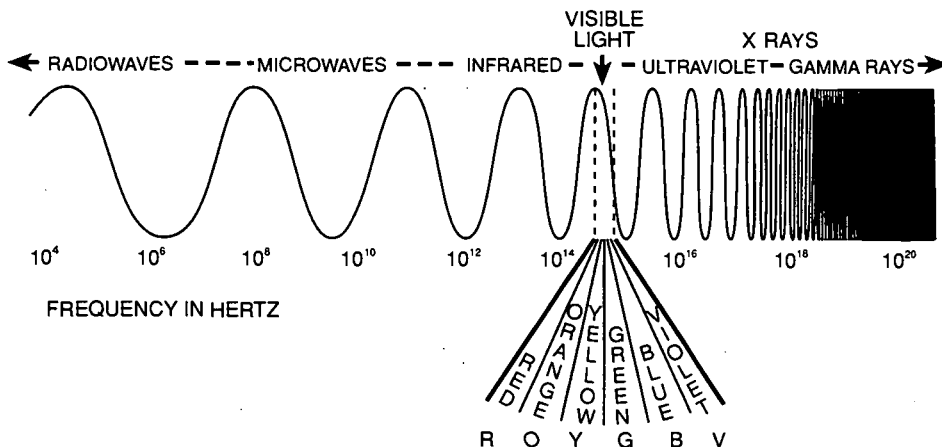



Peggy takes a hard-nosed look at how erosion is making it difficult to "save face" on Mount Rushmore.

Segment Length - 7:52

MOUNT RUSHMORE

What is the world's largest sculpture?

Can you break a rock you can't even lift? Can you carve a rock? Can rocks crumble?

RESOURCES

Chu, D. (1991, July 22) About faces: Sioux editor Tim Giago sees Mount Rushmore as a symbol of dishonor. *People Weekly*, pp. 68-69.

Fodor, R.V. (1983) Disappearing rocks: Weathering. In *Chiseling the earth: How erosion shapes the land*. Hillside, NJ: Enslow Publishers.

Geologist Badge. In *Webelos scout book* (1986), pp. 177-193. Irving, TX: Boy Scouts of America.

Heard, A. (1991, July 15 & 22) Mount Rushmore: The real story. *The New Republic*, pp. 16-18.

Shaff, H., & Shaff, A. K. (1985) *Six wars at a time: The life and times of Gutzon Borglum*. Sioux Falls, SD: Augustana College Center for Western Studies.

Sklarewitz, N. (1991, June) Mt. Rushmore turns 50. *Boys Life*, pp. 40-41.

Smith, R.A. (1991, July/Aug) Shrine of democracy. *American History Illustrated*, pp. 26-41.

Additional sources of information

Mt. Rushmore National Memorial Society
825 St. Joseph Street, Suite 217
PO Box 1066
Rapid City, SD 57709
(605) 341-8883

South Dakota Tourism
Capitol Lake Plaza
Pierre, SD 57501
(800) 952-2217

Community resources

State highway department

State geologist

INSIGHTS

- Over 2.5 million people a year visit Mount Rushmore in the Black Hills of South Dakota, where the world's largest presidential statues gaze at them through eyes 11 feet across. The sculpted heads of Washington, Jefferson, Lincoln, and Theodore Roosevelt measure 60 feet from chin to hairline. Noses are 20 feet long, and mouths stretch 18 feet. Had the presidents been carved full-body, they would stand 465 feet tall. (The Statue of Liberty stands 151 feet tall; the statue of President Lincoln in the Lincoln Memorial is 20 feet tall.)

- In 1927, South Dakota commissioned sculptor Gutzon Borglum to create a massive tourist attraction, "...colossal art, in a scale with the people whose life it expresses."
- Borglum chose to create his work from Mount Rushmore, knowing that it was a solid mass of granite.

- Granite is a tough, hard rock because it consists of interlocking crystals of the minerals quartz, feldspar, and mica. This granite formed at great depth, about 13 kilometers (7.8 miles), when a body of molten rock (magma) rose and cooled slowly, pushing up a dome-shaped structure now known as the Black Hills. This dome measures about 200 kilometers

(120 miles) long and 95 kilometers (57 miles) wide.

Weathering breaks rock down into smaller pieces. Granite resists weathering more than layered and bedded sedimentary rocks do. Rock outcrops are constantly subjected to the elements, which gradually cause chemical changes in the rock's minerals. Oxygen and carbon dioxide in runoff waters produce *chemical weathering*. *Physical weathering* occurs when water, lodged in *fractures* in the rock, freezes and expands in all directions, forcing the sides of the fractures apart. Tree roots have the same effect. Rocks exposed to long periods of alternating heat and freezing disintegrate into sand and clay.

To preserve the Mount Rushmore sculpture, experts needed to predict which of the granite blocks would shift. They conducted a \$250,000 high-tech checkup, which included *photogrammetry* and 3-D,

AutoCAD imaging. First, they shot a series of 300 overlapping photographs of the monument from precision cameras mounted on an airplane and a helicopter. From data provided by these photographs, a computer created 3-D projections of the internal fracture system.

With these images, preservationists can estimate the potential for damage to the monument. They can determine which fractures are stable, which will need to be filled with *silicone*, and which will eventually have to be held together with steel pins to prevent movement.

CONNECTIONS

Water and wind, the two most powerful agents of erosion, can destroy the grandest human-created structures. What other examples of the erosive powers of these agents can you think of? What role does time play in this process?

VOCABULARY

chemical weathering progressive breakdown of minerals by chemical reactions

fracture a crack or split in rock

photogrammetry the use of photographic records for precise measurement of distances or dimensions (e.g., aerial photography for surveying)

physical (mechanical) weathering the breakdown of rocks into smaller pieces without changing the composition of their minerals

rock mixture of minerals, each retaining its own characteristic

silicone silicon-containing polymer that has wide use in industry because of its great stability when subjected to heat, cold, or oxidation

Newton's Apple is a production of KTCA, Twin Cities Public Television. Made possible by a grant from 3M.

Educational materials developed with the National Science Teachers Association.

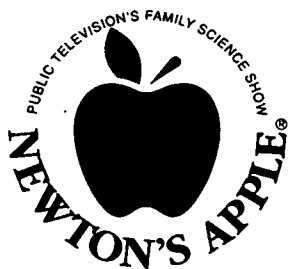

FROST WEDGING

Simulate the physical weathering that water can cause when it freezes in cracks in rocks.

▶ TRY THIS...

Examine physical and chemical weathering in your environment. What examples do you find in your school yard? Observe such things as slabs of sidewalks that have been uplifted by roots of trees, plants growing between cracks, moss on rocks, and areas that are rusting. Look particularly for cliffs or rocky walls that have small rocks at their base. What about your roads and streets? What causes cracks and pot holes in them?

▶ TRY THIS...

The ratio of Borglum's models to the actual figures is 1:12. If you grew 12 times as big as you are now, how tall would you be? Photocopy a small picture of yourself and on it draw a grid of 1-cm (.4") squares. On a large piece of paper, draw a similar grid of squares 12 cm (4.8") on a side. Using your picture as a guide, copy the details of each small square into the corresponding large square. Arrange drawings of your family or classmates on the wall for your own Mount Rushmore!

• MAIN ACTIVITY

- When substances change from liquid to solid, they usually decrease in volume. Water, however, increases in volume when it becomes a solid. To demonstrate what happens when water turns to ice, you'll need access to a freezer.

• Materials

- water
- glass and plastic containers with lids
- plastic containers without lids
- clear plastic wrap
- rubber bands
- trays large enough to hold containers spaced far apart

1. Divide into three groups. Each group will conduct this demonstration using a different form of container.
2. Two groups will use containers with lids: one group will use plastic, one glass. Fill the containers with water until they overflow, then secure the lid tightly without spilling. Wrap each glass container in aluminum foil or plastic wrap in case it shatters. Place the containers on the trays with several inches between them, and place the trays in the freezer.
3. The third group will use water to fill plastic containers nearly full and place them on trays. Then place the trays in the freezer, add water to fill the containers to the top, and cover the containers with clear wrap secured by a rubber band.

4. Leave the containers in the freezer overnight and bring them back to the classroom for observation and comparison. When water freezes it increases in volume by 10% and exerts a great amount of pressure. Spring thawing and freezing results in repeated melting of ice and freezing of water trapped in rock fractures. This "frost wedging" promotes mechanical (physical) weathering.

Questions

1. How does water change when it goes from liquid to solid?
2. Does water change in density when it goes from liquid to solid and back? How would you conduct an experiment to determine this?
3. How could you measure the exact volume of the expansion of water in a frozen state?
4. Why are docks removed from northern lakes every winter? Why do people insulate hot water pipes in winter?

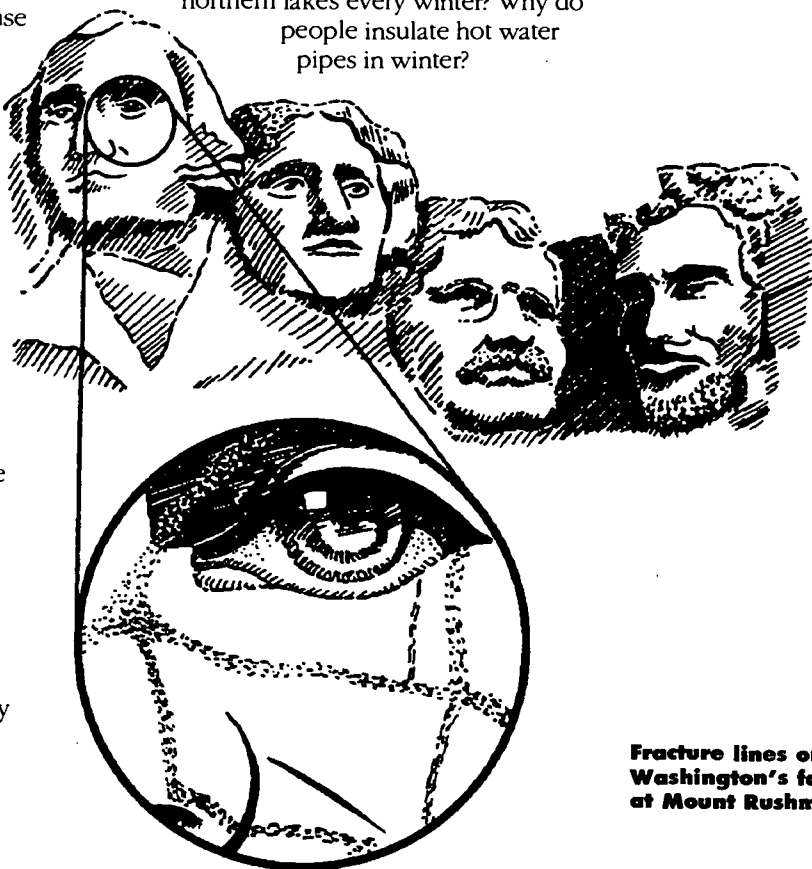

Fracture lines on Washington's face at Mount Rushmore

- Newton's Apple is a production of KTCA Twin Cities Public Television. Made possible by a grant from 3M.
- Educational materials developed with the National Science Teachers Association.

201

11.58

BEST COPY AVAILABLE

3M Innovation



David takes a wild ride on a *Cybertron*, a high-tech virtual reality game.

Segment Length – 7:53

VIRTUAL REALITY

What is virtual reality?

How is a virtual reality world created? What are some of the promising aspects of a virtual reality world? What are some of the problems of today's virtual reality worlds?

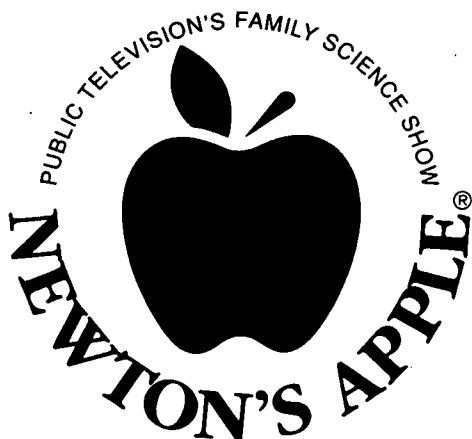

RESOURCES

Dede, C.J. (1992, May) The future of multimedia: Bridging to virtual worlds. *Educational Technology*, pp. 54–60.

Ferrington, G., & Loge, K. (1992, Apr) Virtual reality: A new learning environment. *Computing Teacher*, pp. 16–19.

Hamilton, J.O. (1992, Oct 5) Going where no minds have gone before. *Business Week*, p. 104.

Hamilton, J.O., et al. (1992, Oct 5) Virtual reality: How a computer-generated world could change the real world. *Business Week*, pp. 96–105.

Helsel, S. (1992, May) Virtual reality and education. *Educational Technology*, pp. 38–42.

Wilson, D.L. (1992, Apr 22) Researchers hope to lead students into virtual reality. *The Chronicle of Higher Education*, pp. A 23–25.

Community resources

Computer stores

Science museum

Stores that carry sophisticated electronic games

Theme park

Video arcade

INSIGHTS

- Virtual *reality* can transport you into a world of computer-generated sights, sounds, and tactile (touch) sensations. The more your senses are fooled, the more you believe the experience is *real*.

- If you want to enter a virtual reality world, you can choose a couple different approaches. In one, you would go into a booth containing a computer monitor. The booth might represent a cockpit and the monitor a windshield. With the keyboard or joystick, you change the three-dimensional perspective of what you see on the screen—and take the airplane you're piloting into a rapid nosedive or a steep climb.

- Another, more expensive approach to virtual reality involves "the helmet and gloves." When you place one of these helmets on your head, your head movements allow you to see and hear the *virtual* world. The gloves can replace real touch with virtual touch.

- In this approach, two televisions cameras (or computer-graphic images) generate the virtual world. One camera or image is placed in front of each of your eyes, slightly offset in *perspective*. This creates the *illusion* of depth of view, or "stereoscopic vision." As your head turns to

view different objects, a computer adjusts both the scene's perspective and associated sounds (coming through the headphones) to convince you that you are moving through the environment.

As your gloved hand touches a surface in the virtual world, *sensors* in the glove tell the computer where the hand is in space. With some gloves, the computer can send signals back to you through pressure vibrations to indicate when you've touched an object in the virtual world.

Virtual reality is more than just entertainment. For people with disabilities, it offers a way to interact with other people and to enter an artificial universe created by computer imaging, bypassing any physical limitations they may have. In industry, workers can draw upon this technology to design

parts without expensive physical *mock-ups*, conduct chemistry experiments without risk, and learn how to operate new equipment with little loss in productivity.

CONNECTIONS

1. Look through a View-Master or antique stereoscope. How does it create a three-dimensional image? Close one eye. Do you still get the same three-dimensional effect?

2. Make a list of your favorite video games. What aspects of the games fooled you into thinking that they were three-dimensional, that things in the game were moving, or that you were moving within the game? Design a video game on paper, using some of the techniques you have observed in your favorite game.

VOCABULARY

Cybertron a high-tech virtual reality arcade game that delivers a total-body experience

illusion a misleading image presented to the senses of sight, sound, touch, smell, and taste

mock-up a full-size structural model built accurately to scale. Used chiefly for study, testing, or display.

perspective the art or technique of creating a scene so that objects in it have apparent depth and distance

real not artificial, fraudulent, illusory, or apparent

reality the characteristic of being true to life—of being real

sensor a device that responds to a physical stimulus and transmits a resulting impulse

virtual being in essence or effect, but not in fact or name

DROWNING A CANDLE FLAME

Fool your friends into believing that water will not put out a candle flame.

▶ TRY THIS...

Visit a video arcade. How does the equipment employ virtual reality to get you involved in the game? Did you ever wonder whether it was the real world or a virtual reality world?

▶ TRY THIS...

Name some movies that have made you feel like you were actually in the scene. Watching a movie, have you every felt like you were riding on a roller coaster or flying low over a landscape in an airplane? Suggest ways that movie makers achieve this feeling of virtual reality through special effects, camera angles, and other strategies. Have you ever been to an Omnimax or Imax theater? How do you think they produce such realistic effects?

• MAIN ACTIVITY

- You will create a virtual reality with
- simple household materials and show
- your audience the amazing image of a candle burning underwater.

• Materials

- two identical birthday candles
- one piece of window glass, any size larger than the candles. Tape around the sides with masking tape.
- supports (such as books) that will firmly hold the glass upright
- modeling clay to hold the candles upright
- matches
- clear water glass taller than the candles

1. Use a couple of books to support the glass upright. (Always use care when handling glass!)
2. Place the candles in modeling clay equal distances from the glass, one in the front and one behind the glass. You can use the reflection of the front candle to position the back candle.

3. Light the front candle. When you look through the glass, the back candle looks as though it is lit. Part of the light from the flame on the front candle is reflected off the glass back to your eye.

4. Now place the back candle in the water glass. Again, adjust the equipment so that

the candle flame appears to be in the glass when viewed from the front.

5. Invite a friend to view from the front as you fill the water glass to a level above the candle flame.

Questions

1. What was your reaction the first time you saw this effect?
2. Look into a flat mirror, such as one in a bathroom. Where do you appear to be? Move toward the mirror, then back from it. How does the distance between you and the mirror compare with the distance your image is behind the mirror?
3. Look out a window. Does window glass seem to reflect some light? Have you ever seen yourself in the window at night?

▶ TRY THIS...

With masking tape, make a straight line that's 1 meter (3.3') away from and parallel to a wall. Mark a point in the center of this line. Stand on the point, facing the wall, and have a friend walk up from behind to your immediate left. Without moving your head, announce when you can see your friend and have that person mark that point on the floor. Now try it on your right. Connect the point you are standing on to the points on your left and right. Given that there are 360 degrees in a circle, what is the measure of your field of vision?

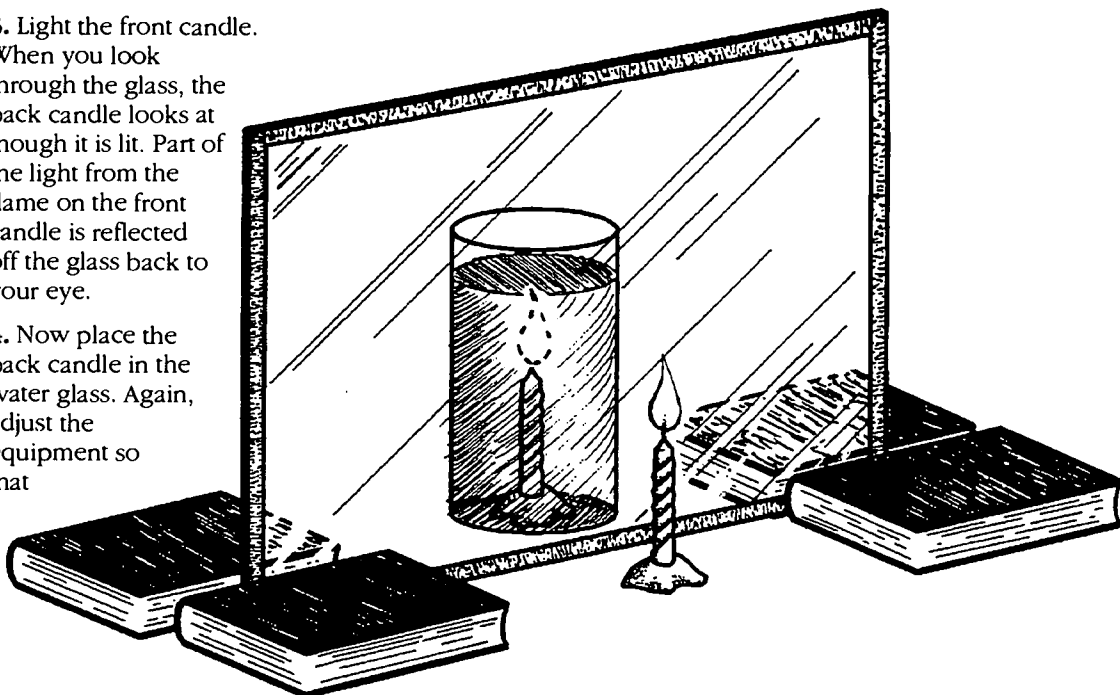

Newton's Apple ANIMALS



Naturalist Nancy Gibson, Host David Heil, and Field Reporter Peggy Knapp meet some fascinating animals in season 11.

CHIMPANZEES SHOW 1113

Primate parallels

What sets us apart from other primates? What does it mean to be human? Scientists who observe chimpanzees note similarities between the two species, including tool-making skills, similar sensory abilities, cooperative hunting, and the ability to learn and use words. Some scientists claim that chimpanzees actually select and consume certain medicinal herbs to feel better. Design a study of chimpanzees that a researcher could do in the field to verify or negate that claim.

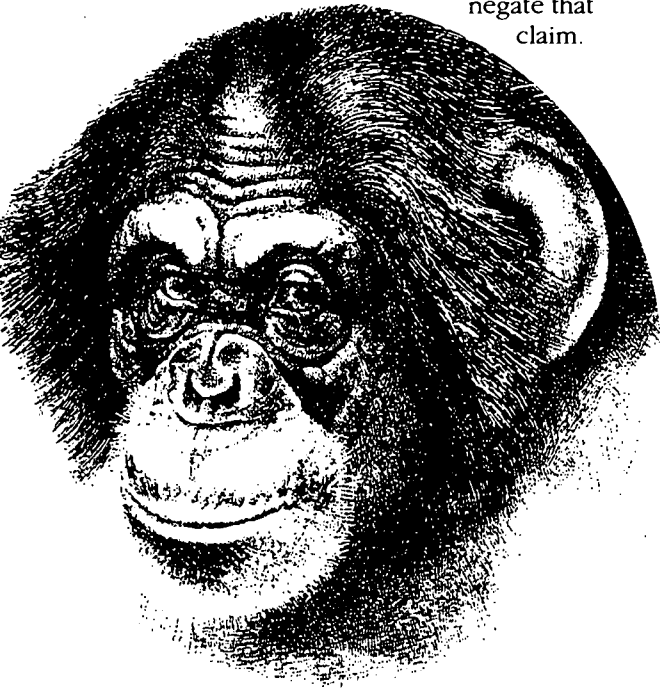

LIZARDS SHOW 1107

Tail droppers

Many lizards can shed their tails by contracting the tail muscles to create a break. When the break occurs, the surrounding muscles separate between the segmented muscle blocks. The discarded tail keeps wiggling for a time, distracting the predator while the lizard escapes. Some lizards can then regenerate at least part of a new tail. Draw a cartoon lizard creatively using this adaptation. List the advantages of this adaptation.

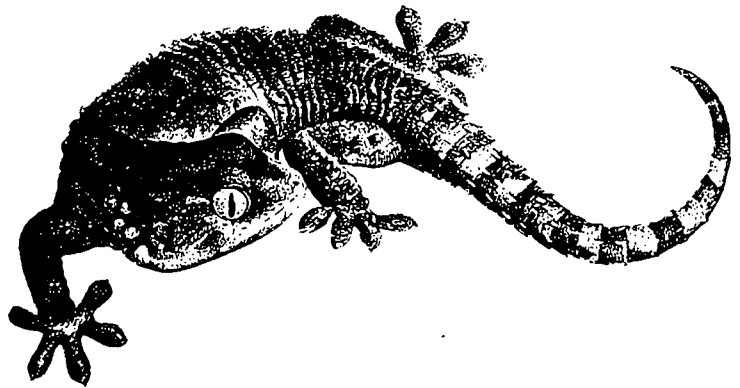

HUMMINGBIRDS SHOW 1103

Nature's helicopters

Hummingbirds move upward, downward, and sideways in a virtuoso performance of aerial acrobatics. These tiny birds can even fly backward. By rotating their wings forward and back in a figure eight, they can hover in midair, feeding on nectar and insects. The whole wing rotates (like a human wrist does) and can beat 22 to 79 times per second. Try to flap your arms in a figure eight. How long can you continue flapping before you get tired? Time yourself. Look up the wing speeds of other

birds. What factors should you take into consideration when comparing wing speeds?

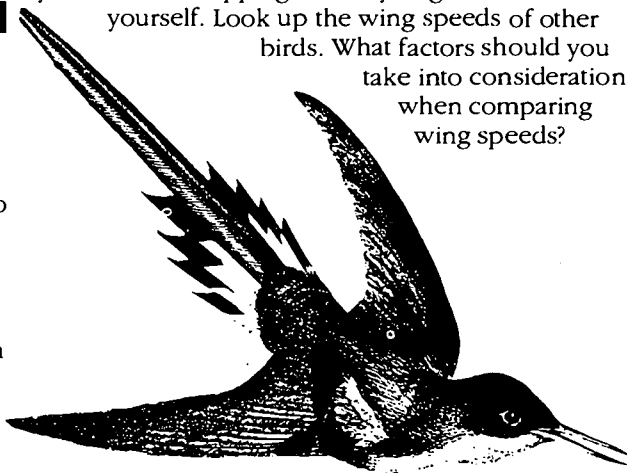

DOLPHINS SHOW 1108

Smart students

Trainers teach dolphins by reinforcing desired behaviors with food, rubdowns, verbal praise, splashes of water, and toys. This technique is called operant conditioning. List other things you think would positively reinforce behaviors in dolphins. To let the dolphins know when to perform a specific behavior, trainers cue the animal with a visual, tactile, or auditory signal. Dolphins learn to discriminate between different signals. Have your teachers conditioned you to behave a certain way in school? Does your teacher signal you in some way before you complete a behavior?

POLAR BEARS SHOW 1112

Arctic adaptations

The polar bear's coat serves a variety of purposes. It provides excellent camouflage for the bear in its Arctic habitat. Although the glossy fur looks white, it actually is made of transparent, hollow guard hairs. These act as solar collectors, conducting ultraviolet radiation to the black skin beneath. Woolly underhair and two to four inches of fat beneath the skin supply additional insulation. Along with the hollow guard hairs, the bear's fat increases its buoyancy, allowing it to swim more easily through the bitterly cold Arctic waters. Scientists first discovered the fur's unusual characteristics when they were having difficulty taking aerial photos of the polar bears because the animals blended in so well with their surroundings. Suggest why infrared photography was also difficult. How do you think scientists finally solved this problem?

RIVER OTTERS SHOW 1109

Aquatic predators

Otters usually eat fish. As aquatic predators at the top of the food chain, however, they also eat other things, depending on the time of year and the place. What do you think the American river otter eats? Fish dominates its diet but it also



consumes crayfish, amphibians (frogs and salamanders), and birds (ducks, grebes, and rails). Create an "otter menu." Include creative descriptions of appetizers, main course, and dessert—muskrat mud pie, for example.

REINDEER SHOW 1102

Disposable headgear

Reindeer are a part of the caribou family therefore both the males and females grow antlers. These antlers, which have a main shaft and one or more branches, do not stay permanently attached to the skull. During the reindeer's seasonal growth, the furry skin on the antlers (called velvet) protects the growing antler while carrying blood vessels and nerves throughout it. The velvet eventually dries and falls off when the antler growth is completed. Antlers fall off after the mating season. What other animals grow antlers? What animals grow horns? Compare and contrast horns and antlers.

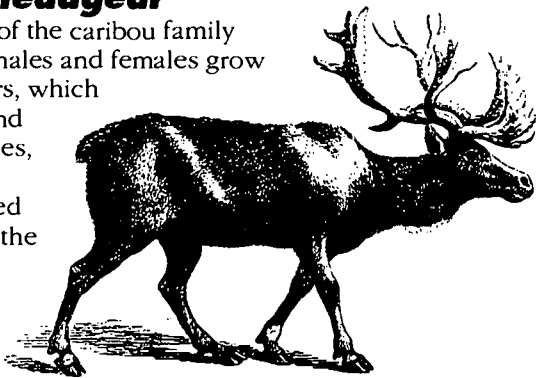

WOLVES SHOW 1111

Miscast villain

Many writers have portrayed the wolf as a villain, but the wolf has not always had such an evil reputation. In Cheyenne society, the wolf held a place of honor—it was considered a skillful hunter with courage and endurance. Native American tales commonly refer to the wolf as a teacher to whom humans should pay close attention. List stories that depict wolves as cunning, relentless, or savage. What other animals have storytellers portrayed in a negative way? Rewrite a common fable or fairy tale to portray wolves in a heroic way. Create a mask of the wolf portrayed in your fable.

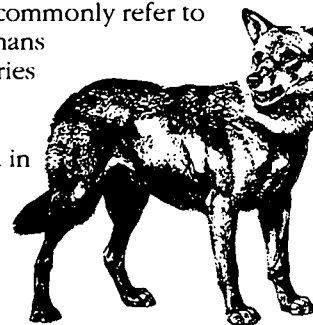

MOSQUITOES SHOW 1104

Lay eggs in standing water

Mosquito breeding sites can be found just about any place where water stands for a week or more after a rain. Females search for a moist vegetated depression that contains standing water in which they lay their eggs. Mosquitoes do not develop in moving water or in most lakes. Most common mosquitoes spend their whole lives within 1.6 kilometers (1 mile) of where they hatched but some can fly 32 kilometers (20 miles), depending on weather conditions. What areas

around you would be attractive to mosquitoes for laying eggs? Obtain topographic maps of your area. Determine if the land near you is conducive to mosquito production and locate potential mosquito breeding sites on the maps. Find out what your city or town does to control the mosquito population.

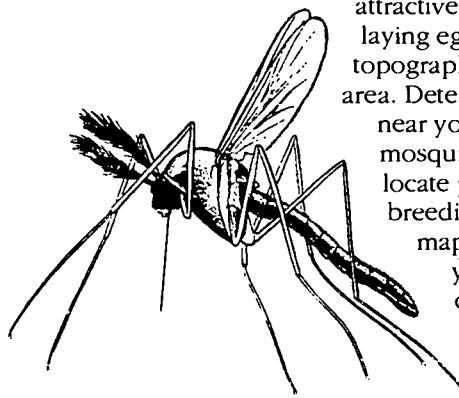

RESOURCES

Macdonald, D., (Ed.) (1984) *Encyclopedia of mammals*. New York: Facts on File.
Gibbons, A. (1991, Mar) Déjà vu all over again: Chimp language wars. *Science*, pp. 1561-1562.
Caduto, M., & Bruchac, J. (1991) *Keepers of the animals*. Golden, CO: Fulcrum Publishing.

International Wolf magazine, International Wolf Center, Ely, MN 55731.
Mobbs, A.J. (1982) *Hummingbirds*. Surrey, England: Triplegate LTD.
Wild Bird magazine, PO Box 6050, Mission Viejo, CA 92718.
Chanin, P. (1985) *The natural history of otters*. New York: Facts on File.
Renolds, J. (1992) *Far north vanishing cultures*. San Diego: Harcourt Brace Jovanovich.

BEST COPY AVAILABLE

SCIENCE TRY ITS™

Try these experiments and observe what happens. Guess why it happens and compare your results to those on the back of the page.



Now you can try Newton's Apple experiments at home!

TRY IT! Cut the Cube

Find a small-necked, corked bottle and balance an ice cube on top of it. Cut a 15-inch piece of thin, strong wire and tie a hammer to each end. Balance the wire across the middle of the ice cube. What do you think will happen? Try it!

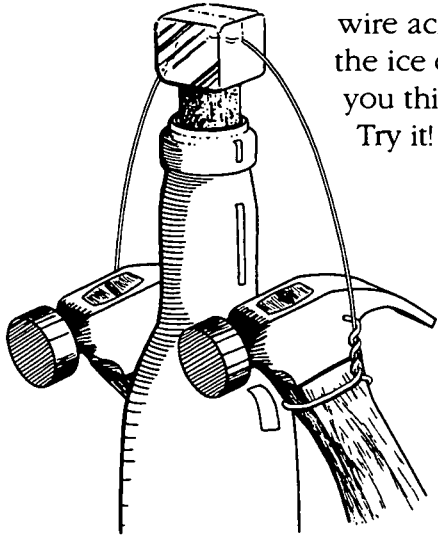

TRY IT! Spin the Carton

Poke a hole in the bottom left hand corner of each of the four faces of a half-gallon, paper milk carton. Poke an additional hole in the top flap of the carton and tie a string through it. Suspend the carton from the string. Cover the holes with your fingers and pour water into the carton. What will happen when you remove your fingers from the holes? Try it!

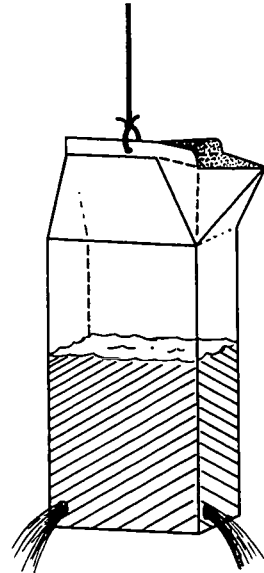

TRY IT! Swing the Record

Tie one end of a long piece of string to the middle of a matchstick. Pull the other end of the string up through the hole in the center of an LP record (so the matchstick is centered underneath the hole). Try to swing the record back and forth like a pendulum in smooth, even movements.

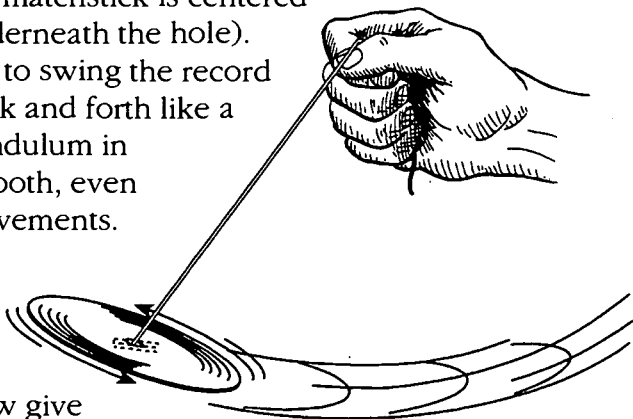

Now give the record a spin. What will happen when you try to swing the record again? Try it!

TRY IT! Eggs Supporting Books

Carefully break off the small end of four eggs and pour out the insides. Wind a piece of cellophane tape around the center of each eggshell. Cut through the center of the tape to make four dome-shaped shells (discard the broken end of each shell). Lay the four domes on a table with the cut sides down arranged in the shape of a rectangle. Next, guess how many telephone books you can lay on top of the shells before they break. Try it!

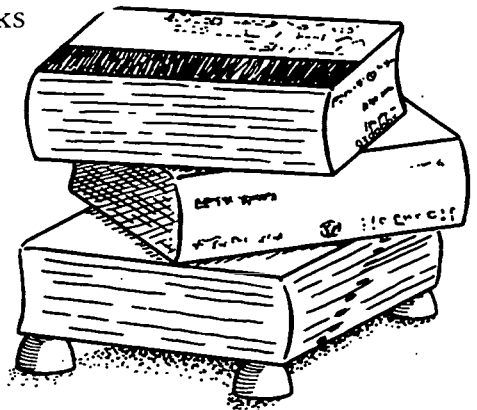

206

WE ENCOURAGE
DUPLICATION FOR
EDUCATIONAL USE!

11.63

3M Innovation

TRY IT! Blow Out the Candle

Light a candle and hold a cylindrical container in front of it (e.g. small oatmeal or salt package). Take a deep breath and blow against the other side of the container, keeping your mouth even with the flame of the candle. Can you blow out the candle? Try it!

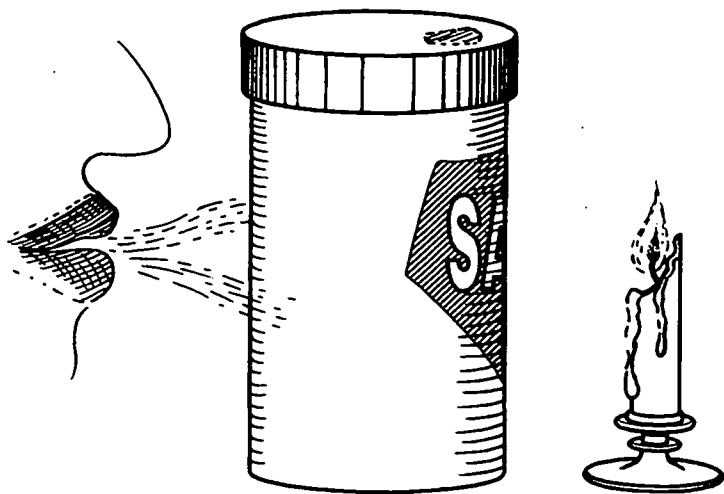

TRY IT! Knot the Water

Using a nail, make five holes in the side of an aluminum can. The holes should be made close to the base of the can and should be spaced 1/4" apart. Hold the can under a kitchen faucet or hose and fill it with water. Pinch the streams of water together with your thumb and forefinger. What happens?

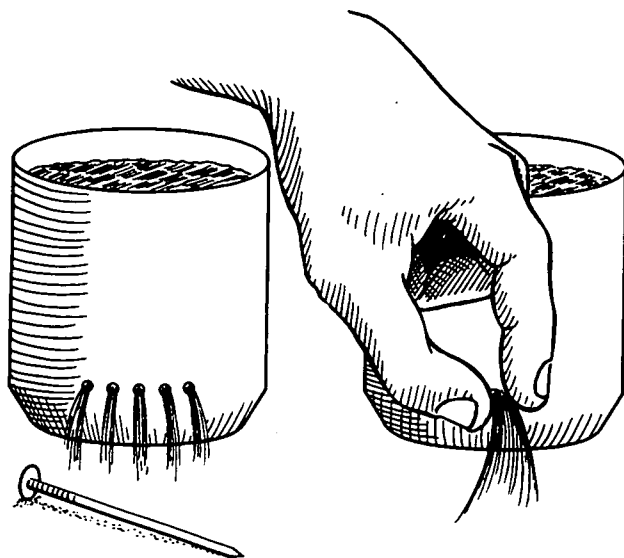

The Science Behind "SCIENCE TRY ITS"

How can the wire cut right through the ice cube without breaking it into two pieces?

The pressure of the wire causes the ice to melt beneath it. The wire sinks easily through the melted ice, while the ice above the wire, which is no longer subjected to pressure, refreezes. This scientific principle also applies to ice skating. The pressure that your skates exert on ice causes a layer of water to form under the blades, creating a slick and slippery surface for sliding.

What happens to the carton?

Newton's Third Law states that every action has an equal and opposite reaction. Water shoots out the holes, and pushes back on the carton with equal force. A turbine is formed as the energy of the moving liquid is converted into rotational energy.

What makes the record swing smoothly?

Gyroscopic inertia is the property of a rotating object to resist any force which would change its axis of rotation. Once the record is set spinning at an angle perpendicular to the string, it will resist any forces (such as gravity) that try to change that angle.

How can fragile egg shells support heavy books?

Arches—even those made of eggshells—are strong because they exert horizontal as well as vertical forces to resist the pressure of heavy loads. The crown of an eggshell can support heavy books because the weight is distributed evenly along the structure of the egg.

Why are you able to blow the candle out?

The Coanda Effect is the tendency of a fluid to follow the wall contour of a curved surface. In this case, air acts like a fluid and follows the contour of the round container. When the streams meet on the other side, they combine to blow out the candle.

Why do the streams knot together?

The streams of water are held together by the water's "stickiness," or surface tension. Surface tension is the tendency of the surface of a liquid to behave as though covered with a skin. This is due to the cohesive forces between the molecules at and near the surface.

207

Are you Street Smart?



Now you can do
Newton's Apple
at home!

What makes your stomach growl?

- A. digestive enzymes
- B. air
- C. a little hungry person in your stomach
- D. gastric juices



How long can humans go without sleep?

- A. 48 hours
- B. 10 days
- C. 3 months
- D. 100 days



What are cooties?

- A. a type of body lice
- B. germs
- C. tiny insects that burrow under your skin
- D. cooties are imaginary creatures



How long does it take to count to a billion?

- A. 11 hours
- B. 8 days
- C. 384 months
- D. 32 years

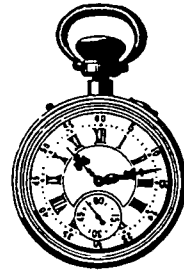

What is that sound we hear when we put a sea shell to our ear?

- A. an echo of the sea
- B. air bouncing around inside the shell
- C. an animal who lives in the shell
- D. blood circulating through your body



If you were lost without food, what article of clothing could you eat to survive?

- A. your denim jeans
- B. your leather shoes
- C. your cotton t-shirt
- D. you can't eat clothes





ANSWERS

Stomach Growls?

Air in your stomach moves around and bumps against the contents of your stomach. The sound resonates through your tissues and comes out sounding like a growl. When you're hungry, the resulting muscle contractions in your stomach increase the growling. It's not like a dog's growl, but a hot dog or two would probably quiet it down.

Sleep?

Humans can go longer without food than without sleep. After several days without z's, insanity will set in. More than 10 days without sleep can be fatal. So get a good night's sleep!

Cooties?

Cooties are real organisms. They are a small, parasitic type of body louse similar to bird lice. They may even carry diseases like typhus. Thinking about cooties may give you the willies... but don't worry, willies *aren't* real.

Counting to a Billion?

If you could count at the rate of one number each second, without stopping to eat or sleep, it would take nearly 32 years (or 384 months) to count to a billion. So you'd better get started!

Sea Shell Sounds?

It *is* the sound of the sea—your own internal sea. It's actually the sound of your own blood coursing through your body that you hear.

Edible Clothing?

Your leather shoes. Shoe leather can actually provide enough nutrients to keep you alive for a short time. Talk about putting your foot in your mouth!





TRANSPARENCY MASTER

We've enlarged four activities from the lesson pages to assist you in making transparencies for your classroom. Some helpful hints on making and using transparencies in your classroom are included at the bottom of each page.

Show 1108 Mazes

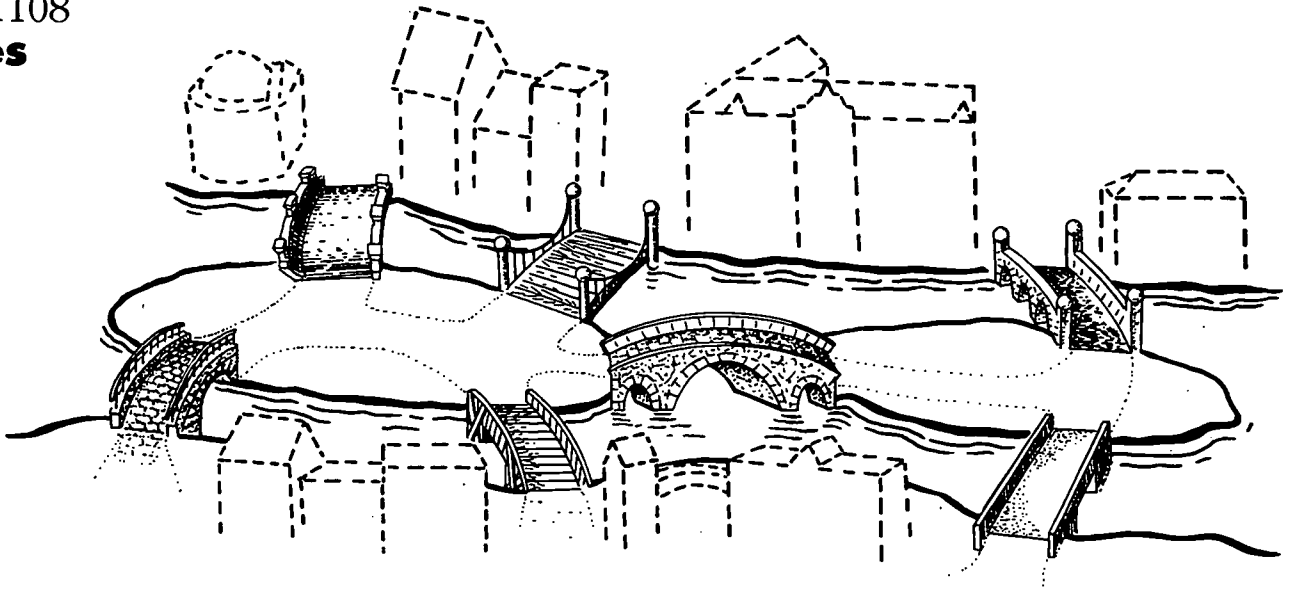

Show 1109 Dairy Farm

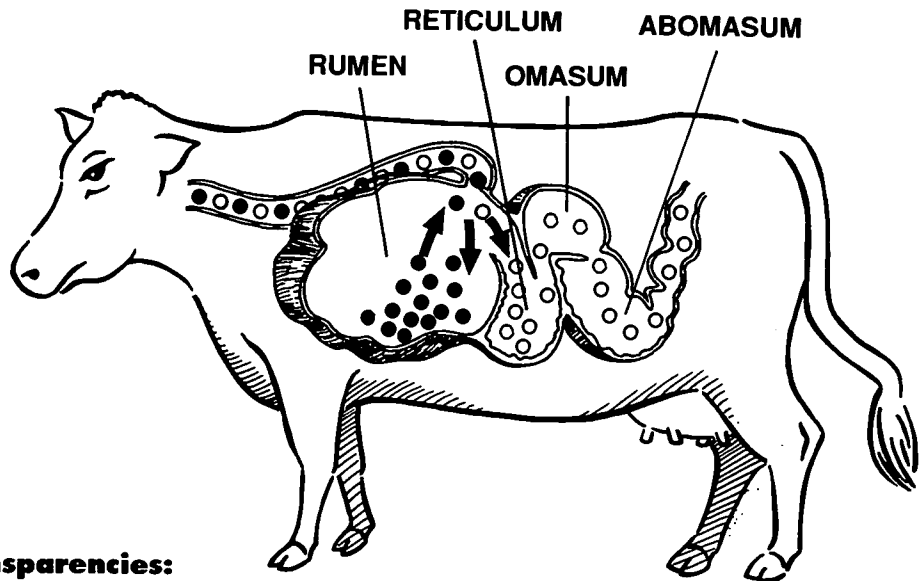

Hints for making clear transparencies:

- Make a copy of the original to work from. Enlarge if necessary.
- Use a thermofax or copier to make the transparency.
- Add color with a marker or color transparency film.

210



Newton's Apple is a production of KTCA Twin Cities Public Television. Made possible by a grant from 3M.

Materials developed with the assistance of the National Science Teachers Association.



11.67

3M Innovation



Show 1110
Heart Attack

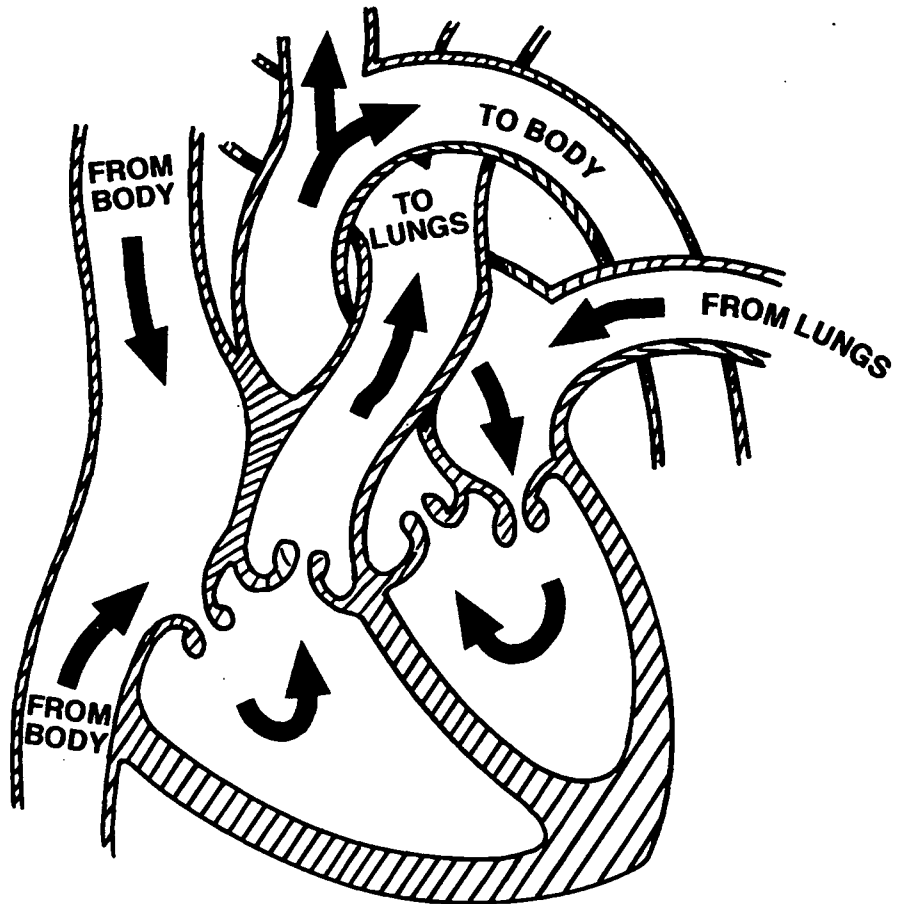

Show 1112
Infrared Light

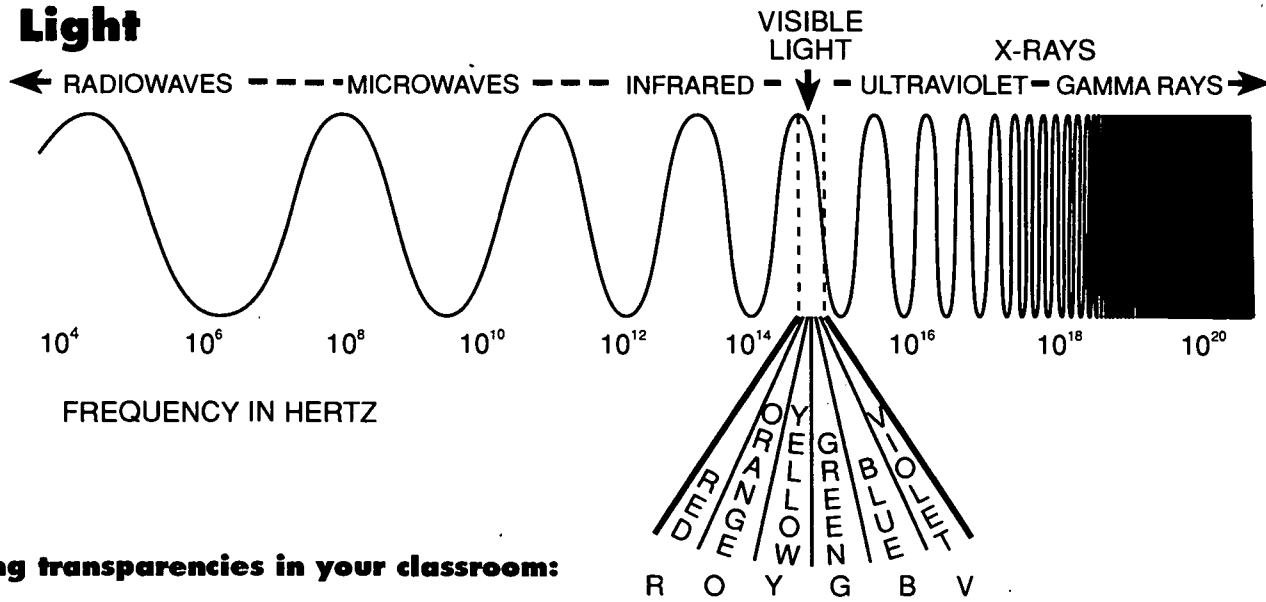

Hints for using transparencies in your classroom:

- Keep it simple.
- Make it interactive by leaving out some information and soliciting ideas from the class to fill in the blanks.
- Keep the attention of the class by providing handouts only after you've finished your presentation.

211

3M AND SCIENCE EDUCATION

3M's support of *Newton's Apple* is only one example of its commitment to science education.

For over 40 years, scientists and engineers at 3M have organized technical employees in volunteer outreach programs to encourage students at elementary, junior, and senior high levels to consider careers in science and engineering.

The Science Student Recognition Day and the Richard Drew Creativity Award programs invite high school science teachers within driving distance of St. Paul, Minnesota to select their best and most creative students and visit 3M laboratories with them for a day.

3M employees who have been trained as visiting Wizards visit schools with demonstrations designed to create an interest in science.

As part of the TECH (formerly Visiting Technical Women) program, 3M scientists and engineers visit schools as role models to students, with the message that career opportunities await them if they keep their options open by studying math and science and that technical careers are open to students regardless of gender or race.

Other programs include the STEP program for local high schools with high minority enrollment, the elementary teacher workshop, and a summer teacher program for local school districts.

While many of these programs are based at 3M headquarters in St. Paul, Minnesota, some 3M plants and other research locations have similar programs. For more information on 3M's Science Encouragement Programs, contact 3M at (612) 733-5687.



Newton's Apple Educational Materials Production Team

Lynae Berge, Outreach Coordinator
Janae Haaland, Outreach Assistant
Sue Wichmann, Editor

Writing Team

Tim Erickson, Epistemological Engineering, CA
Julie A. Fisher, Fairfax County Public Schools, VA
Elizabeth Frick, Ph.D., Educational Systems, MN
Bonnie B. Graves, MN
Chuck Lang, Ph.D., Omaha Westside High School/
University of Nebraska Lincoln, NE
Carol Morton, CA
Pamela O'Brien, Minnesota Zoo, MN
David P. Parisian, Enhance Technologies, NY
Stephen M. Tomecek, Science Plus Inc., NY

3M/Newton's Apple Education Committee

Richard Hanson
Barbara Kaufmann
Bob Barton
Harvey Berwin
Sue Butzer
Yvonne Cadwallader
Mary Chilinski
Peggy Dingman
John Huizinga
Mary Hurlocker
Patty Konsti
Gary Kwong
Walt Lager
Mike Lovejoy
Judy Parker

KTCA/Newton's Apple

David Heil, Host
Peggy Knapp, Field Reporter
Nancy Gibson, Naturalist
Richard Hudson, Executive Producer
Kathryn Scott, Series Producer
Kristian Berg, Senior Producer
Dan Fiorucci, Producer
Jeff Nielsen, Producer
Leslie Kratz, Producer
Gary Leatherman, Producer
Amy Kenefick, Associate Producer
Kathy Kraemer, Associate Producer
Kim MacDonald, Associate Producer
Chris Velasco, Production Assistant
Meighan Maloney, Assignment Manager
Dara Sanders, Production Office Coordinator
Sandy Schonning, Production Manager

Design Group

Bob Hoffmann, Design Director
David Schrimpf, Designer
Corbert Gauthier, Illustrator, 11th Season Poster
Bill Dobbs, Illustrator, Lesson Pages

National Science Teachers Association

Bill G. Aldridge, Executive Director
Karen Baker, Project Coordinator
Jennifer Laughlin, Program Assistant
Brian Aldridge, Program Manager

Content Review Panel

Joan Armistead, Editorial Coordinator, National Council of
Teachers of Mathematics, VA
Alan Baker, M.D., Surgical Oncologist, MD
Jeffrey C. Callister, Earth Science Teacher, Newburgh Free Academy, NY
Gerard F. Consuegra, Ph.D., Elementary Science Coordinator,
Montgomery Public Schools, MD
Robert S. Donaldson, Science Teacher, Blair High School, MD
Brenda S. Evans, Middle/Elementary Science Consultant,
North Carolina Department of Public Instruction, NC
Linda M. Gojak, Math Teacher, Hawken School, OH
Mario Iona, Professor Emeritus, Department of Physics,
University of Denver, CO
Michael Jay, Manager, Math and Science, Apple Computer, Inc., CA
Jim Kubichek, Science Teacher, Parkview Middle School, IA
Phyllis Marcuccio, Assistant Executive Director, National Science
Teachers Association, DC
M. Sheila Marshall, Project Coordinator, National Science
Teachers Association, VA
Joan Braunagel McShane, Elementary/Middle School Teacher,
Davenport Community Schools, IA
Patricia McWethy, Executive Director, National Association of
Biology Teachers, VA
Jonathan Merrill, M.D., Director, Interactive Media,
High Techsplanations, MD
Melinda Mills, Life Science Teacher, Space Center Intermediate School, TX
Mike Mogil, Certified Consulting Meteorologist, MD
John Morack, Department Head and Professor of Physics, University of
Alaska-Fairbanks, AK
Laurie A. Rudman, NSF Fellow in Psychology, University of Minnesota, MN
Judi Scioli, Director of Information for Montgomery County, MD
Solomon Snyder, M.D., Director, Department of Neuroscience,
Johns Hopkins University School of Medicine, MD
Mary Tisdale, Special Projects Manager, Bureau of Land Management, DC
Stephen M. Tomecek, Science Plus Inc., NY

Advisory Board

Council of State Science Supervisors
International Technology Educators Association
National Council of Teachers of Mathematics
National Middle School Association
National Parent Teachers Association
National Science Teachers Association
National Association of Elementary School Principals



213

11.70

3M Innovation



NEWTON'S APPLE®

Reproducible Guide
to Family Viewing
Enclosed

12th Season
Free
Educational
Materials

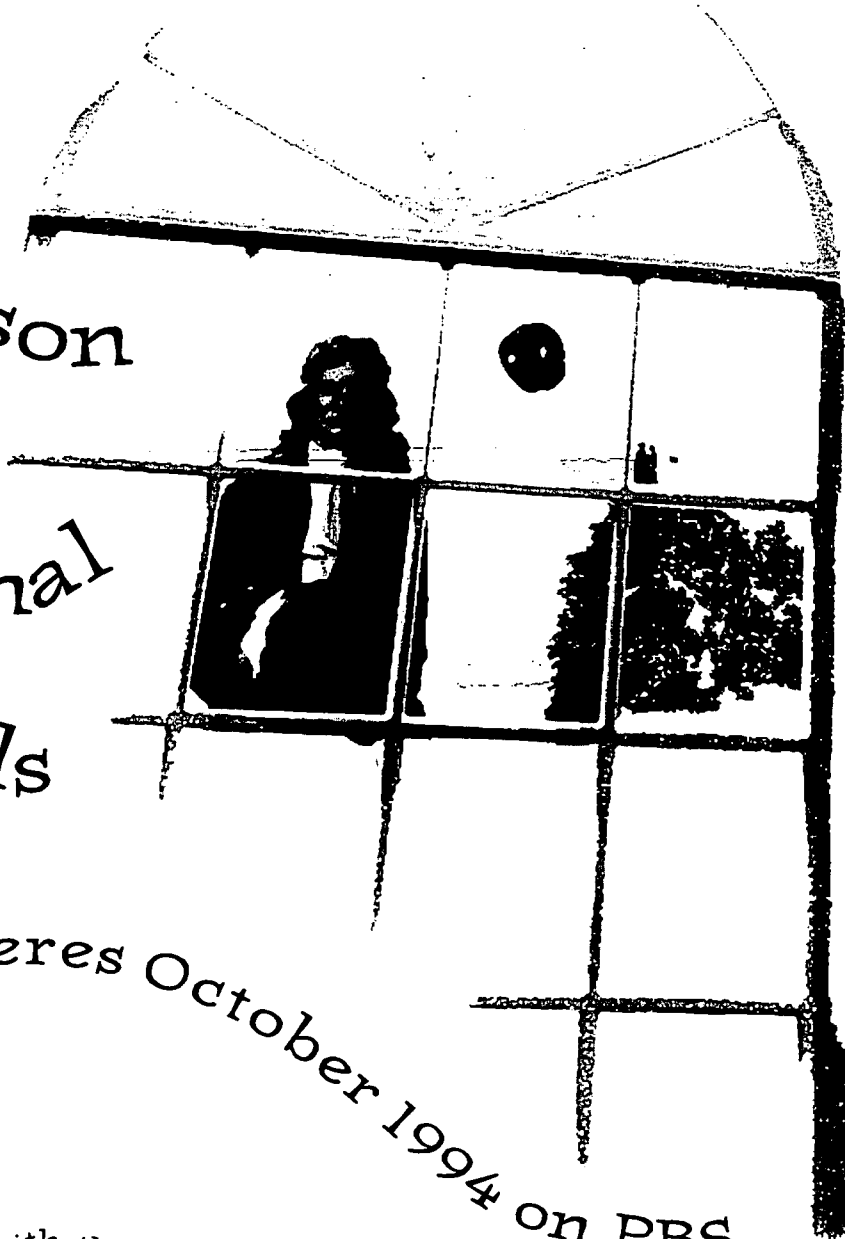

Premieres October 1994 on PBS

Developed
in partnership
with the

National Science Teachers Association

NEWTON'S APPLE is a production of
KTCA Twin Cities Public Television Saint Paul/Minneapolis
and is made possible by a grant from 3M.

3M Innovation

Greetings from the NEWTON'S APPLE team!

As a teacher, you know how hard it can be to keep up with the latest advances in science and technology. This year on NEWTON'S APPLE we help you and your students do just that, with topics like the Internet, antibiotics, the human brain, earthquakes, fixing the Hubble Telescope, and more.



In addition, we continue our long-standing tradition of discovery and high adventure by joining renowned Arctic explorer Will Steger as he prepares to cross the Arctic with a new international team. We'll also demonstrate the physics,

fear, and fun of hang gliding and take you behind the scenes of the hit movie *Jurassic Park*.

With these hands-on classroom materials, you and your students can do more than just watch. You can actually explore the science and technology right along with us! That's what NEWTON'S APPLE is all about, exploration and the thrill of discovery. Join us!

A handwritten signature in cursive that reads "David Heil".

David Heil



Dear Educators:

NEWTON'S APPLE provides an astonishing discovery for many students: Science is more than facts—it's exciting and fun. That's why it's such a pleasure for 3M to sponsor the television program nationally. These companion materials for the series have been designed for classroom use. We hope they help you explore with your students the fascination with science that can enrich their outlooks and their futures.



A handwritten signature in cursive that reads "L. D. DeSimone".

L. D. DeSimone
Chairman
and Chief Executive Officer

3M Innovation

Dear Teachers:

The National Science Teachers Association is proud to serve in partnership with 3M and KTCA-TV, Saint Paul/Minneapolis. NEWTON'S APPLE—now in its 12th season—continues to attract learners of all ages.

The hands-on activities in the NEWTON'S APPLE classroom packets provide the teacher with high-quality, stimulating science materials that motivate students to observe and question the world around them.

NSTA and NEWTON'S APPLE are dedicated to the student, the teacher, and scientific inquiry. It is a pleasure to participate in this project.

A handwritten signature in cursive that reads "Bill G. Aldridge".

Bill G. Aldridge
Executive Director



NSTA National
Science
Teachers
Association



Welcome to the **NEWTON'S APPLE**

Educational Materials packet! These materials were developed to help you use the **12th season** of

NEWTON'S APPLE in your classroom.

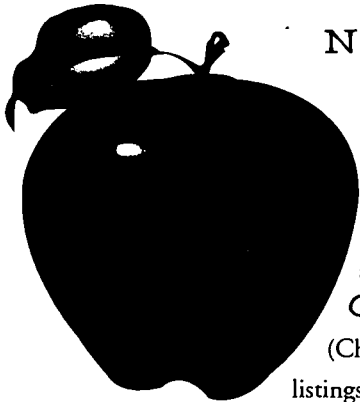

The 12th season of **NEWTON'S APPLE** will air on most PBS stations beginning in **October 1994**.

(Check your local PBS

listings for exact airdates and

times.) If you don't find **NEWTON'S APPLE** listed in your local TV guide or PBS viewers guide, contact your local PBS station to find out when the 12th season will be airing in your area. For your convenience, we've included a list of all the PBS stations in the United States (with their addresses and phone numbers) on the back of the classroom poster that you'll find in this packet.

Look what we have for you

Immediately following this page you will find an index to the 12th season lesson pages (with a guide to three seasons of reruns on the back).

The next page is an "at-a-glance" curriculum grid which gives you a quick overview of the science concepts in each lesson.

Following the grid are 26 lesson pages on the major topics explored in the 12th season.

Each lesson includes **Insights** about the topic, **Connections** to encourage classroom discussion, **Resources**, and **Vocabulary**. Lessons also include a **Main Activity** and several **Try This** activities related to each topic.

Five special pages follow the lesson pages: a feature on the interesting animals in the 12th season; hands-on "Science Try It" experiments; a "Street Smart" quiz; a transparency master of four illustrations from the lesson pages; and an at-home viewers guide that you can duplicate and send home with your students to help encourage family participation in science education. At the end of the packet, you will find our 12th season poster.

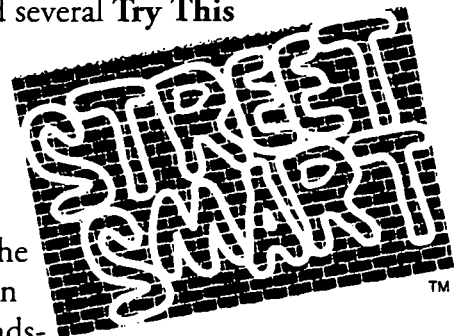

Don't forget **NEWTON'S APPLE** allows three-year off-air record rights for educational purposes.

If you have any comments or a change of address, please write to us at:

NEWTON'S APPLE
c/o Twin Cities Public Television
172 Fourth Street
St. Paul, MN 55101



Meet the NEWTON'S APPLE Team!

Naturalist Nancy Gibson, field reporter

Peggy Knapp, and host David Heil are

pictured here in the NEWTON'S APPLE

warehouse where no question is

too big or too small to handle!



David Heil returns for his seventh season as host of NEWTON'S APPLE. An avid outdoorsman and naturalist, David brings to the series an adventurous spirit to match his rich background in the professional fields of science and education. Formally trained in biology, chemistry, mathematics, and physics, David has conducted both laboratory and field research and has taught science to learners of all ages. He is recognized nationally as a creative curriculum and exhibit developer, teacher trainer, and conference presenter, as well as a published author and public speaker on popular science and the joys of learning.

A native to the Northwest, David grew up in a small town with a city park that was perfect for a curious kid with a bent for exploration. Winding trails, dense natural areas, and a creek full of crawdads and trout provided David with a terrific playground for discovery. Since his youth, he has continued to regard the natural and technological world we live in as a rich resource for learning, inviting millions of viewers each week to join him in his favorite pastime of playful exploration.

In addition to hosting NEWTON'S APPLE, David is the associate director of the Oregon Museum of Science and Industry in Portland.

Peggy Knapp (pictured in the center) is now in her ninth season as field reporter for NEWTON'S APPLE. Peggy has been a working actor and television reporter for 12 years. She has hosted such diverse productions as *Hometime*, a national PBS home improvement series; *Kids Ask About War*, an award-winning PBS special examining

children's fears and concerns about the Persian Gulf war; and *PM Magazine*, the long-running nightly entertainment magazine. Peggy can also be seen on the Turner Broadcasting System's award-winning environmental newsmagazine, *Network Earth*.

Peggy was born and raised in Washington state. When she wasn't exploring the Cascade mountain foothills that surrounded her home, she was on stage. From the age of seven, Peggy has worked as an actor. She graduated from The Evergreen State College in Olympia. Armed with a BA in theater, she moved to Minneapolis where she honed her improvisational and writing skills at *Dudley Rigg's Brave New Workshop*. Peggy's wit, wry curiosity, and sense of humor help her to communicate science in a way that everyone can understand.

Nancy Gibson (pictured on the left) has been the NEWTON'S APPLE resident naturalist since the series' inception in 1982. Her interest in and dedication to wildlife and the environment, however, go far beyond her duties on the show.

Nancy worked at the Minnesota Zoo from 1980 to 1987. She has traveled extensively to many remote regions of the world to study wildlife—from mountain gorillas in Africa to Arctic wolves near the North Pole. She gives presentations for many radio and television shows, schools, and other groups about wildlife and environmental issues.

Nancy's love for animals started when she was growing up in Ohio. As a child, she brought home all kinds of animals, from foxes and raccoons to snakes and skunks. In a way she has been able to continue this practice—by bringing many unique and wonderful animals into viewers' homes and explaining how these animals are an important part of the world around us.

217

Index to the 12th Season Lesson Pages

Below is an index to the following 26 lesson pages. We've organized the lessons numerically to indicate in which NEWTON'S APPLE show the topic appears. Just look in the upper right-hand corner of each lesson page for the NEWTON'S APPLE show number (e.g., #1201, #1202, #1203). In the same corner, we've also included the approximate segment running time.



On the back of this page you will find an index to the past three seasons of NEWTON'S APPLE. These episodes may be rebroadcast on your local PBS station throughout the year, and we hope you will continue to use them in your classroom.

Show 1201 Hang Gliding Karate	Show 1205 Movie Dinosaurs Bread Chemistry	Show 1209 Ethnobotany Hubble Telescope	Show 1212 Printing Money Gravity
Show 1202 Arctic Survival Arctic Nutrition	Show 1206 Movie Sound Effects Sun	Show 1210 Raptor Hospital Photography	Show 1213 Bridges Earthquakes
Show 1203 Aircraft Carrier Brain	Show 1207 Dinosaur Extinction Floods	Show 1211 Redwoods Electricity	
Show 1204 Brain Mapping Garlic	Show 1208 Internet Antibiotics		

Remember... If you have any questions about when NEWTON'S APPLE airs in your area, just check your local TV schedule or PBS viewers guide. You can also call or write your local PBS station and ask. Check the back of the poster included in this packet for a quick reference guide to the PBS stations across the country.

Index of Past Seasons

NEWTON'S APPLE 9th Season

Show 901 Olympic Sport Science Special

- Physiology
- Biomechanics
- Luge
- Psychology

Show 902 Solar Cars Steroids Amazing Kreskin Miniature Horse Foot Asleep

Show 903 Murder Mystery Ted Nugent Bat

Show 904 Cancer Causes Frisbee Physics Computer Virus Potato Chips

Show 905 Sewers Cancer Treatments Dick Cavett Porcupine

- ### *Show 906* Dinosaur Special
- Mapping the Dig Site
 - Dating the Bones
 - Assembling a Diplodocus

Show 907 Domed Stadium Photosynthesis Polarized Sunglasses Amusement Park

Show 908 Tears Slinky Physics Camel Bar Codes Aspirin

Show 909 Soviet Space Sky Blue Inventor's Fair Llama

Show 910 Acid Rain High Jump Potholes Goat

Show 911 Medical Quackeries Microwave Ovens Dollar Changer Golden Eagle

Show 912 Telecommunications Solar Eclipse Blimp Bear Cub

Show 913 Hip Replacement Airbags Paper Cuts Potbelly Pig

NEWTON'S APPLE 10th Season

- ### *Show 1001* Behind-the-Scenes Special
- How TV Works
 - Studio Tour
 - Control Room/
Editing
 - Satellite Technology

Show 1002 Hollywood Stunts Household Chemistry Cream in Coffee Musk Ox

Show 1003 Election Polls and Surveys Electric Car Ceramics Chat Cougar

Show 1004 Monster Makeup Ozone Car Mirror Artificial Sweeteners

Show 1005 Oil Spills Diet and Nutrition Crystal Gayle Caribou

- ### *Show 1006* Antarctic Special
- Journey
 - Penguins
 - Palmer Station
 - Krill
 - Seals

Show 1007 AIDS Glass Recycling Cement Science Challenge Wolverine

Show 1008 Cockroaches Broken Bones Dentist Chair Rhinoceros

Show 1009 Omnimax Technology Archery Lightbulbs Condor

Show 1010 Aurora Borealis Air Pressure Albert Gore Piranha

Show 1011 Traffic Control Cryogenics Static Electricity Russian Kids Visit

Show 1012 Locks and Dams Blood Typing Moles Penguin

Show 1013 Diabetes Galaxy Mapping Dweezil Zappa Ostrich

NEWTON'S APPLE 11th Season

Show 1101 Rock Climbing Taste Test Monty Hall Baby Bobcat

Show 1102 Emergency Rescue Black Holes Pizza Reindeer

Show 1103 Memory *In vitro* Fertilization Goose Bumps Hummingbird

Show 1104 Newspaper Bomb Squad Echoes Mosquito

Show 1105 Jumbo Jets Meteors Knuckle Crack Paper Recycling

Show 1106 Windsurfing Permafrost Tumbleweeds Zebra

Show 1107 Spotted Owl Carpal Tunnel Foggy Mirrors Lizards

Show 1108 Archaeology Mazes Dolphin

Show 1109 Firefighting Dairy Farm Inventor's Fair Otter

Show 1110 Bison Roundup Heart Attack Dead Fingernails Chile Peppers

Show 1111 The Bends Compact Discs Michael York Wolf

Show 1112 Garbage Infrared Shelley Duvall Polar Bear

Show 1113 Mt. Rushmore Virtual Reality Candles Chimpanzee



An "AT-A-GLANCE" Science Subject Index

Following is an at-a-glance index of the science disciplines dealt with in the NEWTON'S APPLE lesson pages incorporating the National Science Teachers Association's Scope, Sequence, and Coordination of Secondary School Science model.

We've also listed additional subjects where the segments may be used.

	Biology	Chemistry	Physics	Earth/Space	Math	Technology	Additional Applications
Hang Gliding							Physical Education
Karate							Physical Education
Arctic Survival							Health Physical Education
Arctic Nutrition							Health Food/Nutrition
Aircraft Carrier							Sociology Psychology Health
Brain							Health
Brain Mapping							Health
Garlic							Food/Nutrition
Movie Dinosaurs							Computer Science History Paleontology
Bread Chemistry							Food/Nutrition
Movie Sound Effects							Computer Science Music
Sun							Astronomy Environment
Dinosaur Extinction							Geology History

An "AT-A-GLANCE" Science Subject Index



	Biology	Chemistry	Physics	Earth/Space	Math	Technology	Additional Applications
Floods							Ecology Engineering Environment Geology Government
Internet							Computer Science Language
Antibiotics							Health
Ethnobotany							History Language Sociology
Hubble Telescope							Astronomy Government
Raptor Hospital							Ecology Environment
Photography							Journalism Photography
Redwoods							Ecology Economics Environment Government
Electricity							Engineering
Printing Money							Economics Government History
Gravity							History
Bridges							Government History
Earthquakes							Government History

How can hang gliders stay aloft for hours without motorized propulsion?
How does a pilot steer a hang glider?
Why must pilots know about geography and meteorology?

SHOW NUMBER

1201



Peggy learns the basics of hang gliding, then goes for a ride.

Segment length: 9:20

Hang Gliding

How does a hang glider work?

Insights & Connections

Usually, when somebody tells you to “take a flying leap,” they don’t really expect you to fly. But you can if you know what you’re doing and have a hang glider strapped on. Hang gliders work on the same principle as any winged aircraft. As the wings move forward, air is deflected above and below. The air traveling over the curved wing must travel farther—and faster—than the air below. When air speeds up, it drops in pressure, creating a low-pressure zone above the wing. This in turn gives the air traveling below greater relative pressure and the strength to push up the wing.

To become airborne, a hang glider’s *airspeed* must equal about 20 mph. Airspeed is a combination of the pilot’s running speed and the speed of the wind coming toward the pilot. Many different combinations are possible. If a pilot is running at 20 mph, no wind is necessary. (But this is unlikely, since the world’s fastest sprinters run only about 23 mph—without carrying hang gliders.) If the wind is blowing at 15 mph, the pilot need only run at 5 mph. A combination of a 10-mph wind with a 10-mph run is considered ideal.

As a wing lifts a glider up, gravity pulls it down. The two forces combine to create the gliding action, which is measured by the lift-to-drag (L/D) ratio. For instance, the average glider L/D ratio of 13:1 means that for every foot of drop, the glider sails 13 feet forward. However, pilots need to find constant upward forces to stay in the air for longer periods.

Thermals, huge masses of rising warm air, are what hang gliders ride to stay aloft. These thermals are formed near Earth’s surface and depend on warmth from the ground. Flat fields, dark pavement, and low-lying towns create heat early in the day, while wooded areas heat up more slowly and stay warm longer. Ridge lift is another power source. When a ridge or a hill deflects wind upward, gliders can “catch the wave!”

While suspended in the harness system, the pilot steers a hang glider by shifting his or her center of balance. Leaning forward and backward causes the glider to dive or climb. This motion changes the *angle of attack* and is used to take off and land, as well as to control speed during the flight. Shifting from side to side causes the glider to bank into turns. Pilots use a control bar to move their weight in relation to the wings. Other recommended equipment includes a helmet, parachute, *variometer*, and *altimeter*.

Breaking gliding records is difficult, but designers are always trying to glide farther, faster, and higher. The new boomerang-shaped SWIFT (swept wing with inboard flap) is capable of an incredible L/D ratio of 25:1 and has a top airspeed of 80 mph.

- ❏ How would the altitude of your launching point affect your flight and the equipment you would need?
- ❏ What sort of research could a pilot do before a flight to identify possible thermal locations?

Vocabulary

airspeed the speed at which a glider is passing through the air

altimeter instrument which measures altitude

angle of attack the angle at which a glider meets the air flowing over it. Decrease the angle of attack, and the glider dives and speeds up. Increasing the angle of attack slows the glider.

flare raising the nose of the glider sharply to stall forward motion and land

ground speed the speed at which the glider is passing over the ground. Ground speed is a result of airspeed and wind speed.

pitch movement which increases or decreases the angle of attack, controlled by shifting the pilot’s weight forward and backward

roll side-to-side control movements to make the glider bank and turn

unstable air when air temperature drops rapidly at higher altitudes. This makes thermals rise more rapidly, offering more lift for gliders.

variometer instrument which measures altitude gains and losses

wind speed the speed at which the wind is passing over Earth

Resources

Cheney, P. (1990) *Hang gliding for beginner pilots*. Rising Fawn, GA: Matt Taber.

Coleman, C. (1993, May 3) Flying with Pasipo. *Sports Illustrated*, pp. 91–95.

Fair, E. (1993, Mar 21) Zing time! *Los Angeles Times*, p. 6.

Gannon, R. (1992, Mar) Winging it. *Popular Science*, pp. 60–65.

MacLachlan, S.L. (1991, Sept 27) Ride the wind. *The Christian Science Monitor*, p. 10.

On the wing. (1993, Mar 20) *The Economist*, p. 100.

Plimpton, G. (1991, Dec) Four thousand feet over Africa. *Esquire*, pp. 87–89.

Skow, J. (1993, July 19) Sailing seas of air. *Time*, pp. 56–57.

Additional sources of information
General Aviation News & Flyer
8415 Steilacoom Boulevard
Tacoma, WA 98498
(800) 426-8538

Soaring Society of America, Inc.
PO Box E
Hobbs, NM 88241-1308
(505) 392-1177
(publishes *Soaring* magazine, *Technical Soaring* quarterly, and a directory of soaring sites)

U.S. Hang Gliding Association
PO Box 8300
Colorado Springs, CO
80933-8300
(719) 632-8300
(publishes *Hang Gliding* magazine. Can help you locate a hang gliding school or club in your area.)

Just Blowing Through

Launch your own glider into an air current with thermals and turbulence.



SHOW NUMBER

1201

Main Activity

In this activity, you'll make a model of the countryside and a simple glider. Then, using a blow dryer as a wind source, you'll recreate the air currents and thermals that a hang glider would encounter.

Materials

- pieces of paper about 20 cm x 25 cm (about 8" x 10"). Get a few different thicknesses.
- a room with open floor space
- blow dryer with extension cord
- measuring tape
- items to create different structures and landmarks. Be creative! You can use books standing on end to be buildings or lying propped open for cliffs. Cereal boxes, milk cartons, and teapots can be city skyscrapers. Pillows can be mountains, and so on.

1. Drop the pieces of paper just as they are to the floor from a height even with your chest. What happens? The air pressure below the paper is being released in random spurts. Now fold the pieces of paper in half to be 20 cm x 12.5 cm (8" x 5") and spread them open again. What happens now when you drop them, with the fold crease down? The fold is dividing air pressure equally on either side of it.

2. Open the creased pieces of paper on a table and fold a long edge back about 2 cm (3/4"), creating a sort of lip. What happens when you drop the paper again? Keep folding this edge

over onto itself, 2 cm at a time, and keep dropping it until you get a smooth gliding action. Why does this cause a forward motion? Can you figure out a way to calculate the lift-to-drag ratio, using the measuring tape? (Remember the *L/D* definition—as the glider drops, how far does it move forward?) What thickness of paper has the best *L/D* ratio? Why?

3. Using the blow dryer on a low, cool setting, turn your floor into a hang glider's paradise. Have a friend sit on the floor and hold the blow dryer even with a structure, while you fly your gliders over, around, and through your buildings and mountains. Create turbulence by shaking the blow dryer. Does a warmer setting cause different flight patterns? Create the ultimate thermal by pointing the blow dryer straight at the ceiling. Experiment using two blow dryers at once. Have fun!

(Hint: If you have trouble keeping the paper gliders aloft long enough to see the flight effects caused by your classroom countryside, try using air-filled balloons instead.)

Try This

Hang gliding pilots learn to "see" the air while they are flying. Stand outside on a breezy day. How many different ways can you determine what the air is doing? Pay attention to things such as how sound travels, how sun and shadows look on the ground, dust and blowing objects, plants and trees, etc. As you do this, can you anticipate what the wind will do next, even before you feel a shift in the breeze?

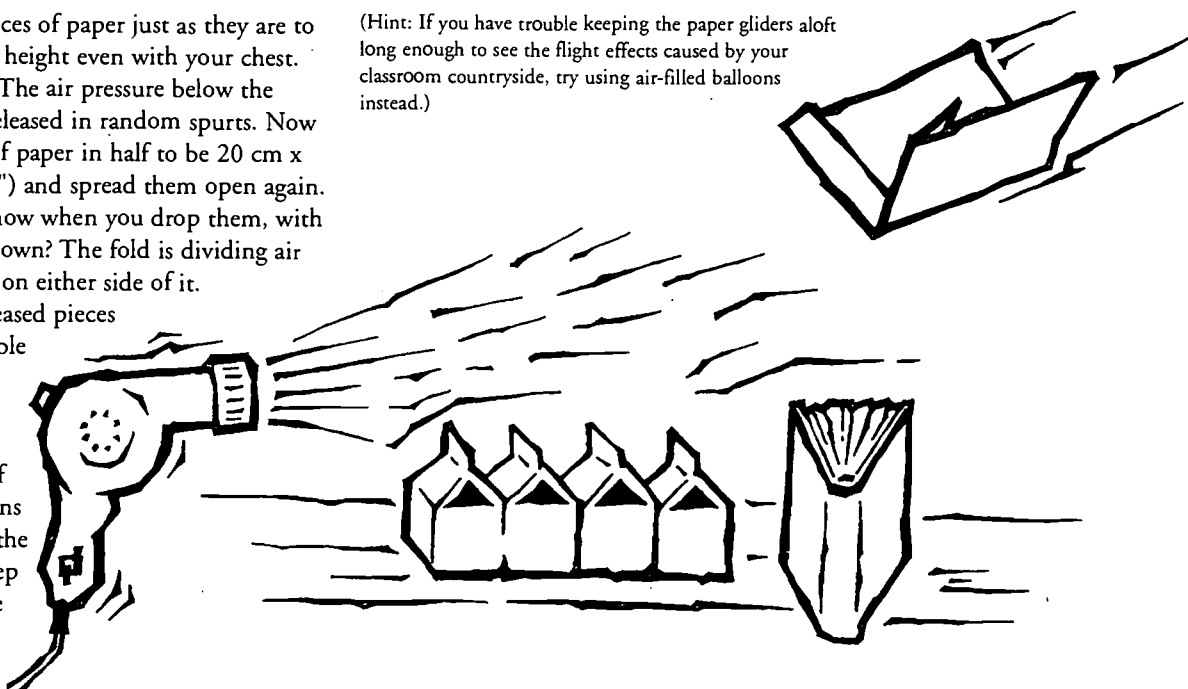

Try This

The world records for distance in hang gliding are 488.49 km for men set by Larry Tudor in 1990, and 335.96 km for women set by Kari Castle in 1991. Matching these distances, where could you go if you were able to travel by hang glider from your school?

Try This

Get a topographical map of your city, as well as an aerial photograph. Plan a flight over the city in a hang glider. Can you identify which parts of the city will have thermals rising from them and which will be cooler? What areas would you want to fly over at 8 a.m.? Noon? 6 p.m.?

223

Are your bones stronger than concrete?
Why does it take training
to learn to break a wooden board
without hurting your hand?

SHOW NUMBER

1201



David finds out how to break a board with the force of his hand.

Segment length: 7:12

Karate

How can karate experts break boards with their hands without injury?

Ron McNair raises his hand and brings it quickly down onto a pile of concrete bricks. As he pulls back his left hand, his right hand smashes through the concrete, sending it crumbling to the ground. An exciting picture, but what is it doing in *Scientific American* magazine?

That powerful *karate* chop might remind you of the superhuman feats found in Hollywood action movies. But the ability of karate experts to break bricks has an easy explanation in the principles of physics and physiology. In fact, karate experts view breaking bricks and boards as a demonstration of form and concentration. The true nature of karate involves a complete mental and physical discipline that goes far beyond simple hand strikes.

One key to understanding brick breaking is a basic principle of motion: The more *momentum* an object has, the more *force* it can generate. When it hit the brick, McNair's hand had reached a speed of 11 meters per second (24 miles per hour). At this speed, his hand exerted a whopping force of 3,000 *newtons*—or 675 pounds—on the concrete. A slab of concrete could likely support the weight of a few people weighing a total of 675 pounds (306 kilograms). But apply that amount of force concentrated into an area as small as a fist and the concrete slab will break.

Another key to brick breaking lies literally in the palm of your hand. Feel the bone on the edge of your hand, directly below your little finger. This bone (known as the fifth *metacarpal*) bears the brunt of McNair's hand strike. Human bones can actually resist 40 times more *stress* than concrete. (Picture a piece of concrete the size of a bone, and imagine how easily it would break.) The natural engineering of the human hand also lessens the severity of the impact. The muscle, *tendons*, *ligaments*, and other soft tissue in the hand provide a natural cushion, dispersing the impact energy up through the arm.

If you attempt brick breaking without proper training, you'll end up with an injured hand and possibly serious nerve damage! You must be instructed by an expert in proper technique. Proper training protects your hand because regularly striking a striking pad or post causes your skin to develop calluses, your muscles to strengthen, and your bones to thicken. Extensive training is also necessary to train your brain and muscles to bring your hand down just right—exactly as it reaches its full speed and right smack in the center, at the brick's weakest point.

Insights & Connections

??
??
??

- Have you ever broken a bone? What caused it to break?
- Why do you think karate practitioners yell "*kiai*" when they are carrying out a strike?
- Why do karate practitioners put their hands down several times on the board or brick before attempting to go through it? Why do they pull their other hand back when they strike?

Vocabulary

acceleration the time rate at which something speeds up or slows down or changes direction
force a push or pull on an object
karate literally, "empty hand" in Japanese. A martial art developed in Okinawa and brought to Japan in the early 1900s.
kiai Japanese word for the shout used in martial arts. Its literal meaning is "energy meeting."
ligaments strips of connective tissue in the body that hold bones together
metacarpals bones in the human hand that connect the wrist to the fingers and thumb

momentum the mass of an object times its velocity. An object's "bashing power."
newton unit of measurement for force. Approximately equal to the force exerted by the weight of an apple.
strain relative deformation of a brick, bone, or piece of wood when it is stressed
stress amount of force placed on an object that tends to bend or break it
tendon strips of connective tissue that attach bones and muscles to one another

Resources

Amann, G.A. & Holt, F.T. (1985, Jan) Karate demonstration. *The Physics Teacher*, p. 40.

Feld, M., McNair, R. & Wilk, S. (1979, Apr) The physics of karate. *Scientific American*, pp. 150–158.

Finn, M. (1988) *Martial arts: A complete illustrated history*. Woodstock, NY: Overlook Press.

Funikoshi, G. (1973) *Karate-do kyohan*. Tokyo/New York: Kodansha International.

Funikoshi, G. (1975) *Karate-do: My way of life*. Tokyo/New York: Kodansha International.

Gartrell, J.E., Jr. (1992) *Methods of motion*. Washington, DC: National Science Teachers Association.

Gordon, J.E. (1984) *The new science of strong materials* (2d ed.). Princeton, NJ: Princeton University.

Microcomputer-based lab experiments in motion. Grades 6 and up. Apple IIs, 64K. Queue, Inc.: (800) 232-2224.

Miller, D.E. (1987, Apr) Brick breakers. *Atlantic Monthly*, pp. 79–82.

Stein, S. (1992) *The body book*. New York: Workman Publishing.

Community resources
 Mechanical engineer
 Orthopedist
 Martial arts master instructor

What Gives?

Experiment with momentum and stress by testing pretzel sticks.



SHOW NUMBER

1201

Main Activity

Use pretzel sticks as a testing ground to understand better what causes materials to break. Eat the leftovers!

Materials

- pretzel sticks of varying thicknesses
- several pieces of uncooked spaghetti
- paper cup
- 2 rolls of 50 pennies each, plus 50 loose pennies
- empty plastic film container or small squeeze bottle with top removed
- thick string or wire approximately 6 cm (2.5") long
- craft knife or scissors with points
- pair of tweezers or chopsticks
- pencil and piece of paper

1. Build a pretzel strength-testing machine. Start by cutting a large hole out of the bottom of the paper cup. Set the cup on a table, bottom

side up. Rest a pretzel stick across the center of the cup.

2. Now create a weight bucket to hang on the pretzel. Take the empty plastic container and make two holes approximately 1 cm (0.4") from the top rim and directly across from each other. Thread the string or wire through the holes and tie the end at each hole. You'll want to make sure the bucket will hang on the pretzel without touching the table.

3. Start testing: With the bucket hanging on the pretzel stick, begin adding pennies. See how many pennies the pretzel can hold without breaking. Find the average number of pennies one type of pretzel stick can hold.

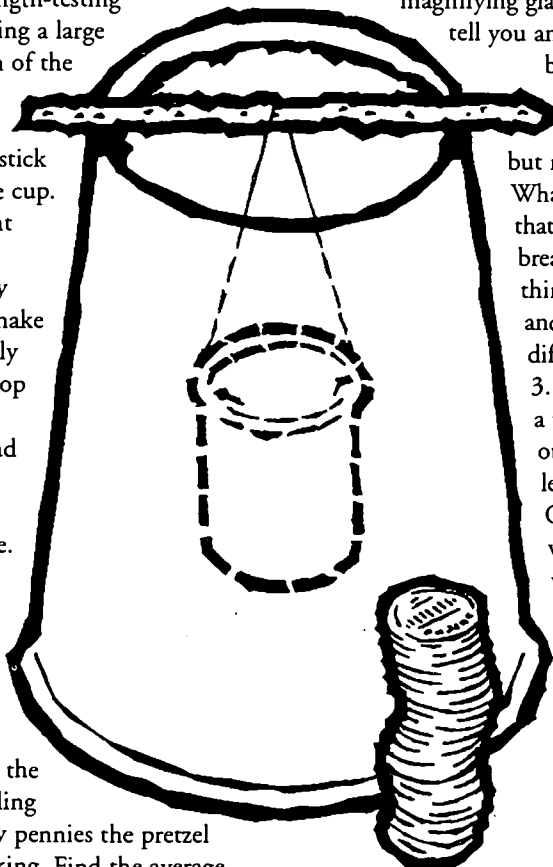

4. Gaining momentum: Test to see if it makes a difference if you drop the pennies in the bucket or if you place them in gently, using the tweezers or chopsticks. Record your results.

5. Breaking point: Test to see if the weakest point of the pretzel is really at the center.

6. Length and width test: Try pretzels of various lengths and widths to see what size and length hold the most and least pennies.

7. Compare with other materials: Do you think a pretzel or an uncooked piece of spaghetti is stronger when bent? Try testing uncooked spaghetti to see how it holds up in comparison to the pretzel sticks.

Questions

1. Look at the ends of a broken pretzel with a magnifying glass. Does its structure

tell you anything about its bending strength?

2. What foods break by stretching but not by bending?

What foods crush easily that would be hard to break apart? Do you think bending, crushing, and stretching involve different forces?

3. Can you figure out a way to spread weight out across the entire length of the pretzel? Can it hold more weight when the weight is distributed over a larger area?

Activity designed by Jane Copes, Science Museum of Minnesota.

Try This

If you have a friend who studies karate, ask that person to explain to you what the classes are like. How much repetitive training is involved? Does the sensei (instructor) expect the students to practice often on their own? Call a local karate or other martial arts school and ask if you can observe a class. Can you see how karate practice trains both mind and body?

Try This

Think of some skill that has taken you a long time to learn. How did you learn it? Were you training your mind or your body or both? Do you still need to practice it to keep up your skill? Write down your answers and compare results with those of your classmates. Which types of skills require frequent practice?

Try This

Karate practitioners develop thickened skin, or calluses, on their hands from practicing strikes on pads and straw-covered posts called makiwara. Notice which areas on your body have calluses. Do you know how you got them? Figure out what purpose they serve at each spot.

225

Do fabrics differ in their ability to keep the wearer warm and dry? Which is more important in frigid temperatures—keeping dry or staying warm?



David learns how to keep warm and dry in the Arctic with explorer Will Steger.

Segment length: 26:40

Arctic Survival

How do explorers keep warm in Arctic climates?

Blustery winds whirl around the explorers as they pitch their tents. They've just finished ten hours of sweat-producing activity—skiing and dog sledding in frigid Arctic conditions. But these people stay warm and dry, thanks to specially designed clothing and high-tech fibers.

To decide which *synthetic fabrics* to wear, explorers need to decide what they want their protective clothing to do. If they want it to repel water but still “breathe,” they might choose fibers such as nylon or polyester or waterproof, breathable laminates and coatings. Many fabrics contain a combination of fibers. For example, if your jacket has hydrophilic (water-loving) fibers on the outside and hydrophobic (water-fearing) fibers near your skin, the inner fibers will push moisture away from your skin while the next layer of fibers will pull the moisture outward.

Keeping dry is as important as keeping warm when it comes to survival and comfort in the Arctic. An adult normally loses about one liter of water a day through evaporation from the skin and lungs. During a day of strenuous activity, a person can lose ten liters of water. As the body burns energy during physical exertion, it creates heat. It then produces sweat, which provides a cooling effect as it evaporates. A sweaty person in wet clothes can lose heat rapidly if inactive in frigid temperatures.

Each member of Will Steger's team will wear five layers of clothing that provide *insulation*. Explorers can peel off or put on layers as weather conditions and activity levels change. The first layer consists of long underwear made of a lightweight, synthetic material that allows perspiration to move away from the skin to the second layer, a synthetic fleece shirt and pants. As it *wicks* moisture away, the quick-drying fleece helps the underwear layer provide warmth.

Next, a jacket covers the first two layers, offering insulation. Made of a heavier fleece designed for use in extreme cold, the jacket has two-way underarm zippers (as do garments in the top two layers) to help the explorer regulate body temperature. The fourth layer, a lightweight second jacket made of very fine, tightly woven *microfibers*, slows the rate of *moisture loss*. The final layer—a durable storm shell that is waterproof and breathable—protects against wind, rain, and snow. The shell is laminated with a film containing microscopic pores that allow water vapor (sweat) to escape while keeping moisture out.

Team members also wear mukluks, flexible boots designed by the Inuit people and made of animal hides and canvas. Sled dogs, too, wear booties as protection from rough ice and snow.

- ❓ What fabrics do you normally wear? Which are the warmest and which keep you cool? Do some fabrics allow more air movement than others?
- ❓ What difference does a hat make in regulating body temperature? Do you notice a difference when you take off a hat you've worn for several minutes?
- ❓ Which parts of the body make up its “heating core”?

insulation a material or fabric that helps a person retain heat

layering a system of wearing clothes in layers to provide maximum warmth and dryness. An effective system allows a person to adjust for a wide range of climatic conditions.

microfibers very thin fibers tightly woven. They trap warm air in clothing and cut heat loss.

moisture loss moisture lost through pores in our skin and through our noses and mouths as we breathe

synthetic fabric material made from fibers that do not occur naturally. Nylon is an example.

wicking the act of absorbing moisture and moving it away. A fabric that wicks perspiration absorbs sweat on the skin and moves it to an outside layer of material, leaving the fabric next to the skin relatively dry and helping the person stay warm.

Resources

Brody, H. (1987) *Living Arctic: Hunters of the Canadian North*. Seattle: University of Washington Press.

Forgey, W.W. (1985) *Hypothermia*. Merrillville, IN: ICS Books, Inc.

Getchell, D., et. al. (1993, Sept) Wild clothes: 1993 guide to functional outdoor apparel. *Backpacker*, pp. 61–80.

Randall, G. (1994) *The modern backpacker's handbook*. New York: Lyons & Burford.

Sierra Club, San Diego Chapter. (1993) *Wilderness basics: The complete handbook for hikers and backpackers* (2d ed.). Seattle: The Mountaineers.

Townsend, C. (1994) *Wilderness skiing and winter camping*. Camden, ME: Ragged Mountain Press.

Wilkinson, E. (1992) *Snow caves for fun and survival* (rev. ed.). Boulder, CO: Johnson Books.

Additional sources of information
American Textile Manufacturers Institute
1801 K Street NW, Suite 900
Washington, DC 20006
(202) 862-0500

Institute of Textile Technology
2551 Ivy Road
Charlottesville, VA 22903-4614
(804) 296-5511

Community resources
Specialist at an outfitter company

Fabric store

Store that sells camping gear and outdoor clothing

Perspiration Inspiration

Measure how much moisture you lose from your forearm during a workout.



SHOW NUMBER

1202

Main Activity

People lose moisture through evaporation from pores in the skin. When you're hot and begin to sweat, your rate of respiration speeds up in an effort to cool your body. Skin moisture can evaporate rapidly in a dry climate, even when you're not sweating. On average, an adult loses about one liter of water a day. When working hard and burning energy that produces heat, that person's water loss quickens proportionately. Create a lab that demonstrates aspects of water loss from your body.

Materials

- one plastic bag per student, or plastic wrap
- scissors
- masking tape
- paper and pencil

1. Cut the plastic bag into a single-layered square large enough to fit comfortably around your forearm. Place the piece of plastic around your forearm and tape it securely (but not too tightly) at top and bottom.
2. Wear the plastic over your forearm for at least ten minutes. Meanwhile, in teams of four people, take and record your pulse and respiration rates. Then walk up and down a

- flight of stairs five times. Record your new pulse and respiration rates. Next, run up and down the stairs five times and then record pulse and respiration. (If your school has no stairs, use a hallway or a walkway outside.)
3. After the exercise, note whether the plastic contains any water condensation released by your skin as it performed respiration and perspiration.
4. Take the bag off and feel the moisture on your skin where the plastic had been. Note the moisture level of the skin that was under the plastic as compared to skin exposed to air during the ten minutes.

Questions

1. What is the effect of moisture evaporating on your skin?
2. How much fluid does a person need to consume each day to replace regular moisture loss?
3. Do we lose only water, or do we lose other essential elements through evaporation as well?

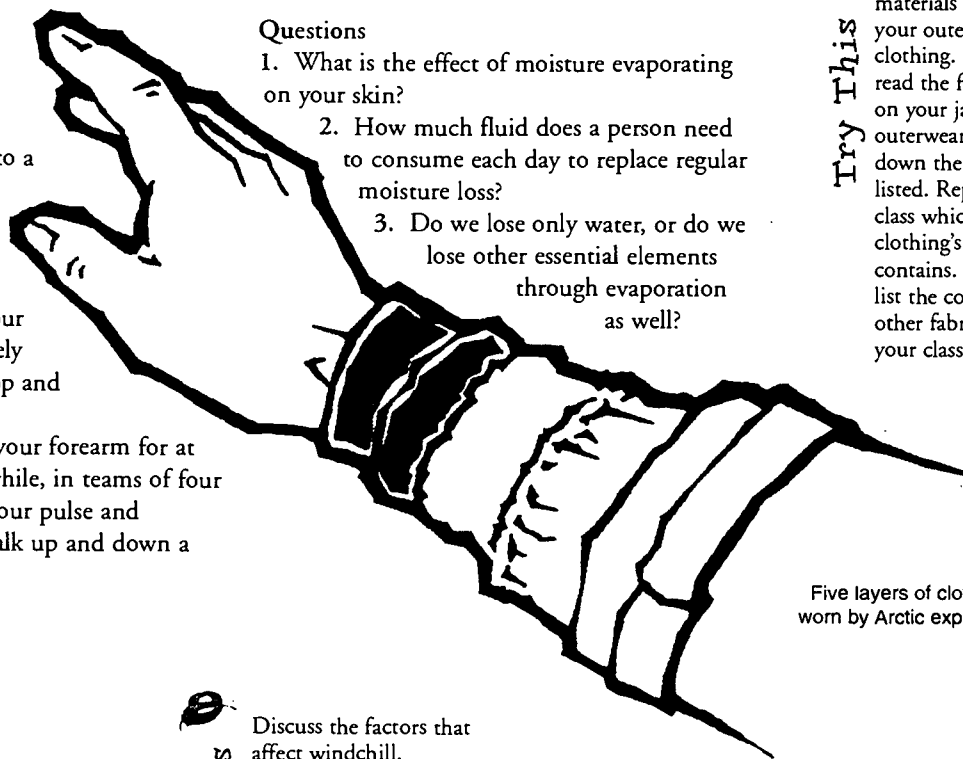

Five layers of clothing worn by Arctic explorers

Try This

Look through camping books, catalogs, and magazines to find references about materials used in boots, sleeping bags, packs, and other outdoor equipment. List the materials named in these articles and advertisements. What characteristics were cited as the most valuable?

Try This

Discuss the factors that affect windchill. Identify how windchill is created. What effect does it have on your body's ability to stay warm in cold weather?

Try This

Invite a representative from an outfitters or outdoor equipment store to discuss characteristics in fabrics that make the materials lightweight, provide warmth and insulation, and wick moisture. Examine clothing samples that demonstrate these characteristics.

Try This

Investigate the materials used to make your outer jackets and clothing. At home, read the fabric labels on your jackets and outerwear, and write down the materials listed. Report to the class which fibers your clothing's fabric contains. Add to your list the contents of any other fabrics worn by your classmates.

227

To receive the entire 12th season NEWTON'S APPLE Educational Materials packet please write:

NEWTON'S APPLE
c/o NSTA—Marketing Division
1840 Wilson Blvd.
Arlington, VA 22201

How do Arctic explorers get the energy they need to complete an expedition? Do some foods supply more energy than others?

SHOW NUMBER

1202



David trains for an Arctic expedition with explorer Will Steger.

Segment length: 26:40

Arctic Nutrition

What do Arctic explorers eat?

Day in, day out, Arctic explorers and their sled dogs perform fantastic feats of endurance and strength. They maneuver sleds that can weigh more than 500 kilograms (1,100 pounds) each across harsh, unforgiving terrain. On the move almost constantly—as much as 12 hours a day—the human explorers can burn up as much energy every day as someone running a marathon.

Will Steger and members of his team will each burn 4,000 to 6,000 *calories* daily—the amount found in 70 slices of bread! To maintain their energy they must eat more than two pounds of food a day. However, what these explorers eat is as important as how much they eat. Their ability to perform and think clearly depends on proper diet. If nutrition and energy needs are not met, an explorer can suffer *fatigue syndrome*, a condition that causes dizziness and violent mood swings. Expedition members plan carefully to make sure they have enough of the right food to last the entire trip—for both people and dogs.

Explorers also need water for drinking and food preparation. Dehydration is a danger during their long hours of physical exertion. Although snow is the most abundant source of water, it must be melted—a process that takes time and burns valuable fuel.

An *endurance diet* can provide the energy and nutrients necessary for peak performance in the Arctic. In the past, such diets contained 35% of calories from *fat*. That's because fat is a concentrated energy source that supplies nine calories per gram. *Carbohydrates* and *protein*, on the other hand, provide four calories per gram each.

But consuming fat does not allow the body quick access to calories. Current thinking favors a diet low in fat and high in carbohydrates. Carbohydrates supply large amounts of the sugar glucose. They can be stored in muscles and in the liver as a compound called *glycogen*, which quickly converts to sugar when needed, providing ready energy for exerting muscles. The Steger team will consume a diet in which 61% of calories come from carbohydrates and 26% from fat. They'll eat rice, pasta, and many grains and supplement those foods with products specifically designed for muscle recovery after strenuous exercise. On days of rest, the explorers will stock up on carbohydrates to replenish their muscle reserves of glycogen.

A carbohydrate-rich diet does have drawbacks. Because it takes about twice the amount of carbohydrates to provide the same number of calories found in fat, the sleds must carry heavier loads. The explorers also must prepare more food and eat more often to refuel their bodies, requiring additional time and cooking fuel.

- ? How do an explorer's energy needs compare with those of an average person going about normal day-to-day activities in your area?
- ? Do the sled dogs have the same nutritional needs as the explorers?

calorie a unit of heat that is also used as a measurement of energy in food
carbohydrates three classes of components that include sugars, starches, and cellulose found in such foods as fruit, vegetables, milk, and grains
endurance diet a diet with concentrated amounts of nutrients and calories that fuel an athlete's muscles and brain during rigorous exercise
fat a more concentrated source of energy than carbohydrates. The body can store unlimited amounts of fat, but it takes more time to turn it into energy than to access energy in glycogen stored in muscles.

fatigue syndrome a condition in which the body can't meet the energy needs of its muscles and brain
glycogen a carbohydrate stored in muscles and liver which converts to the sugar glucose as muscles work, providing quick energy
protein a class of components found in foods and made of amino acids. Protein helps muscles grow and repair and it provides energy and heat.

Coleman, E. (1988) *Eating for endurance*. Palo Alto, CA: Bull Publishing Company.

McManners, H. (1994) *The complete wilderness training book*. New York: Dorling Kindersley.

Rafoth, R. (1993) *Bicycling fuel: Nutrition for bicycle riders* (3d ed.). Mill Valley, CA: Bicycle Books, Inc.

Smith, L. (1993, July 13) Breakfast of champions. *The Baltimore Sun*, p. 1D.

Tilton, B. (1993, June) Hike farther, faster. *Backpacker*, pp. 28–29.

Tinley, S. & McAlpine, K. (1994) *Scott Tinley's winning guide to sports endurance*. Emmaus, PA: Rodale Press.

Wardlaw, G.M. & Insel, P.M. (1993) *Perspectives in nutrition* (2nd ed.). St. Louis: Mosby.

Additional sources of information
 Arctic Institute of North America
 The University of Calgary
 2500 University Drive NW
 Calgary, AB Canada T2N 1N4
 (403) 220-7515

International Federation of Sled Dog Sports
 Glenda Walling, President
 7118 N. Beehive Road
 Pocatello, ID 83201
 (208) 232-5130

Community resources
 Nutritionist or dietitian

Specialist at a sports medicine clinic

Marathon runner

Food for Thought

See if you're eating a balanced diet by checking nutrition labels on foods.



SHOW NUMBER

1202

Main Activity

Maybe you've heard the saying "You are what you eat." Each food you eat provides its own set of nutrients and calories. Every day you need to restock certain nutrients that your body uses as it moves, digests, thinks, grows, and repairs itself. By reading nutrition labels on food packages, you can learn more about what you're eating and what you need to help your body do its work.

Materials

- nutrition labels from a wide variety of foods

1. For one week, collect nutrition labels from different foods you eat. (Look on packages of cereal, yogurt, snacks, and frozen vegetables, for example.) Cut out the labels and bring them to school to share with others.
2. Read and discuss the labels. Include in the discussion what the foods contribute in calories and nutrients. How much does the food weigh in the amount you normally eat at one meal? What foods provide a wide combination of nutrients?
3. Figure out how much of the different foods would be required to make up the 4,000 to 6,000 calories an explorer needs each day. Compare the percentages of a person's daily nutrients that are supplied by each food.

4. New requirements for food label information went into effect in May 1994, adding details in terms of "percent daily values" (%DV). Calculations are based on a 2,000-calorie diet, determining what percentage of your body's daily needs are provided by the food. Some labels also provide additional information on these values. Discuss how you can use this information to improve your food choices.
5. Make a list of foods an explorer could take along for a seven-day trip. Consider the practicality of taking each food on a skiing or camping trip.

Questions

1. Explorers need up to 6,000 calories a day, or 42,000 calories a week. How much would 42,000 calories worth of food weigh?
2. How would you handle foods that need refrigeration on a camping trip? What kinds of food would simply be too heavy to take?

Try This

Discuss what happens when someone experiences fatigue syndrome and what can cause it. Identify ways to prevent fatigue syndrome.

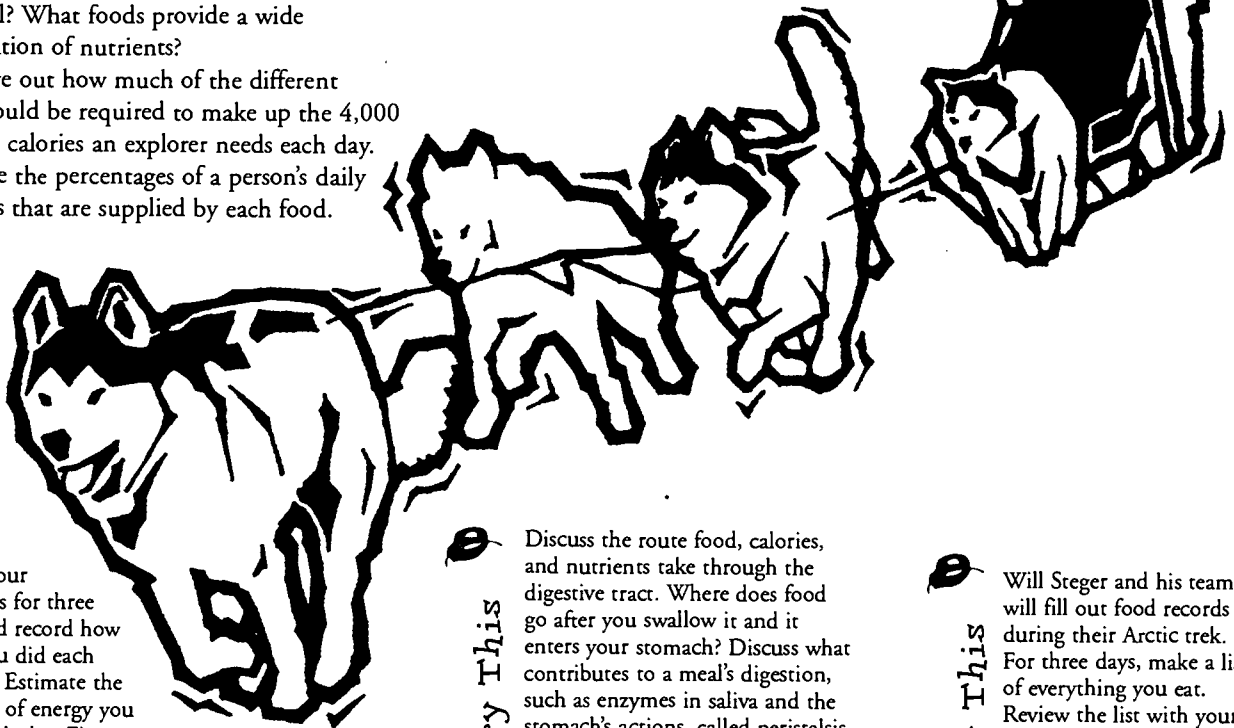

Try This

Track your activities for three days and record how long you did each activity. Estimate the amount of energy you used each day. Figure your base caloric needs first and then add the calories needed for each activity to calculate the total calories expended. Compare this number with your caloric intake.

Try This

Discuss the route food, calories, and nutrients take through the digestive tract. Where does food go after you swallow it and it enters your stomach? Discuss what contributes to a meal's digestion, such as enzymes in saliva and the stomach's actions, called peristalsis. Analyze a meal to learn what nutrients the foods supply.

Try This

Will Steger and his team will fill out food records during their Arctic trek. For three days, make a list of everything you eat. Review the list with your classmates. Did you get enough calories and nutrition? Which did you eat most—fat, protein, or carbohydrates?

To receive the entire 12th season NEWTON'S APPLE Educational Materials packet please write:

NEWTON'S APPLE
c/o NSTA—Marketing Division
1840 Wilson Blvd.
Arlington, VA 22201

220

How do pilots get up to over 150 mph in less than three seconds after takeoff? What types of supplies and energy are needed to run an aircraft carrier?

SHOW NUMBER

1203



Peggy makes a quick stop on an aircraft carrier.

Segment length: 8:00

Aircraft Carrier

How do aircraft traveling at 140 mph manage to land on a carrier runway?

Insights & Connections

You're cruising along at 140 mph, enjoying the incredible view of endless blue sky and sea from the cockpit of your lean, mean flying machine. Suddenly you hear the voice of the carrier's flight controller crackle over the radio: "Bring it in now!"

You must land your carrier onboard delivery (COD) aircraft on a 1,000-foot-long landing strip that looks more like a *postage stamp* in the middle of the ocean. Once you determine the ship's exact coordinates, you listen for instructions from the *landing signal officer (LSO)*. You monitor the *meatball* and see that you're coming in right on target. You've practiced for hours in a *flight simulator*, performed real landings on the 10,000-foot runway at the naval base, and then managed to land on the naval base's 700-foot practice runway, equipped with *arresting cables*. But this first landing on a carrier at sea is nerve-racking!

You must depend on physics to land on the "postage stamp." Your COD weighs about 50,000 pounds and you'll be flying at about 95 mph relative to the carrier deck when you land. Your aircraft has about twice the *momentum* of a 50,000-pound truck speeding down the highway at 50 mph. The 1,000-foot runway doesn't give you enough room to use brakes to slow down, so you'll use the set of four arresting cables stretched across the deck.

Your COD's *tailhook* misses latching onto the first cable, and then misses the next one. Don't put on your brakes, though. If you miss the next two cables and you're not flying at least 120 mph, you'll fall into the ocean! You hook onto the third cable, so you reduce your power and within two seconds you've come to a complete stop. Whew!

Aircraft carriers have served as warships since the early 1900s, but it was not until World War II that they played an integral role. Technology has led to an evolution in carrier design and features, and there are now four major classes of carriers, each named for the "star" ship in its class. Nimitz class carriers, such as the *Dwight D. Eisenhower*, cost several billion dollars to build. These "floating cities" carry up to 6,000 sailors and 100 pilots and normally stay at sea for up to six months, and even longer during wartime. The ships weigh about 80,000 tons, carry 500,000 gallons of fuel, generate power in a nuclear power plant, and make 400,000 gallons of water daily in a *desalination* plant. About 18,000 meals are prepared daily in the galley.

You've delivered your passengers and spare parts, and now it's time to fly the COD back to the naval base for supplies. The steam catapult, powered by the carrier's nuclear power plant, jettisons you from zero to 150 mph in a little more than two seconds, at a force three times that of gravity. In no time at all, you're off into the wild blue yonder.

- ? Today's aircraft carriers have more fire power than anything imaginable during WWII. How can we ensure that aircraft carrier weaponry is used appropriately by countries that operate carriers?
- ? Aircraft carriers now are said to help "maintain the peace." What does that mean?

Vocabulary

arresting cables set of four metal cables stretched across a carrier's deck to stop planes
COD acronym for carrier onboard delivery. Name used for the 29-seat C-2 transport plane that takes crews, cargo, and mail on and off a naval ship.
desalination removal of salt from sea water by boiling it and recondensing it into fresh water
flight simulator computer program that allows students to experience flight without leaving land
LSO acronym for landing signal officer. The LSO's job is to help pilots land safely.

meatball central light display on the deck of the aircraft carrier, used to guide pilots as they land
momentum a measure of the motion of a moving object, which equals the product of its mass (its size, not weight) and velocity (its speed in a particular direction, not just how fast it's going)
postage stamp pilots' nickname for aircraft carriers
tailhook hook on bottom of aircraft that attaches to the arresting cables on deck during landing

Resources

Bonds, R. (1988) *Modern carriers*. New York: Prentice Hall.

Bonanni, P. (1991) *Flight simulator companion*. New York: Bantam.

Norman, C.J. (1986) *Aircraft carriers*. New York: Franklin Watts, Inc.

Rawlinson, J. (1989) *Cruisers and Nuclear Carriers*. Vero Beach, FL: Rourke Publications.

Schultz, R. (1992) *Looking inside sports aerodynamics*. Santa Fe: John Muir Publications.

Terzibaschitsch, S. (1989) *Aircraft carriers of the U.S. Navy*. Annapolis, MD: Naval Institute Press.

Computer Resources
 Pacific strike. (1994) Austin: Origin Systems, Inc. (CD-ROM for MS-DOS)

SimCity. (1989) Orinda, CA: Maxis. (Macintosh and MS-DOS)

SimTown. (1994) Orinda, CA: Maxis. (CD-ROM for Macintosh, Windows, and MS-DOS)

TFX: Tactical fighter experiment. (1993) San Jose, CA: Ocean of America. (interactive computer flight simulator on CD-ROM for Windows and MS-DOS)

Additional sources of information
 Public Inquiries, Office of Information
 Department of the Navy
 The Pentagon, Room 2E 335
 Washington, DC 20350-1200

230

NEWTON'S APPLE is a production of KTCA Twin Cities Public Television. Made possible by a grant from 3M.
 Educational materials developed with the National Science Teachers Association.

12.17

3M Innovation

Floating City

Design an aircraft carrier that can take 5,000 sailors to sea for one month.

Main Activity

An aircraft carrier is a complex and self-contained city, and the largest carriers can stay at sea for six months or more. There are many questions to answer before you can design one of your own. For this activity, you'll need a lot of imagination and good teamwork skills. Your goal is to work in teams and as a group to design an aircraft carrier for 5,000 people who will be at sea for one month.

Materials

- lined writing paper
- drawing paper
- pencils
- markers
- model building supplies (recycled stuff is great)
- reference books about aircraft carriers
- computer programs that allow you to design a city (optional, but very helpful and lots of fun)
- one page per team that lists the main topics team members must think about:

Team 1: Goals, organization, and management

Team 2: Basic needs—energy, food, water, sleep

Team 3: Aircraft carrier design and maintenance

Team 4: Communications and navigation

Team 5: Everything else you need—medical services, exercise, entertainment, etc.

1. Form five teams with at least two people per team.
2. Assign each team to a subject area.
3. Brainstorm to get ideas and specific questions that each team can work on.
4. Work as teams to come up with as many ideas as you can while you consider each question. Write or draw your answers and ideas.
5. Meet as a group so that each team can present its ideas. Other teams should ask questions or make suggestions in areas where there are overlapping concerns. For example, the design is directly related to how much food and water needs to be prepared and stored.
6. Go back to your teams and rework your ideas based on input from the other teams.
7. Create a three-dimensional model and write a summary of each team's ideas.

Questions

1. What kinds of scientists and other specialists would you need to design a real aircraft carrier? Why?
2. What was the most difficult thing for your team to decide? What were the hardest things for the whole group to decide? What topics had the most in common with others? Did this make it harder or easier to make decisions?

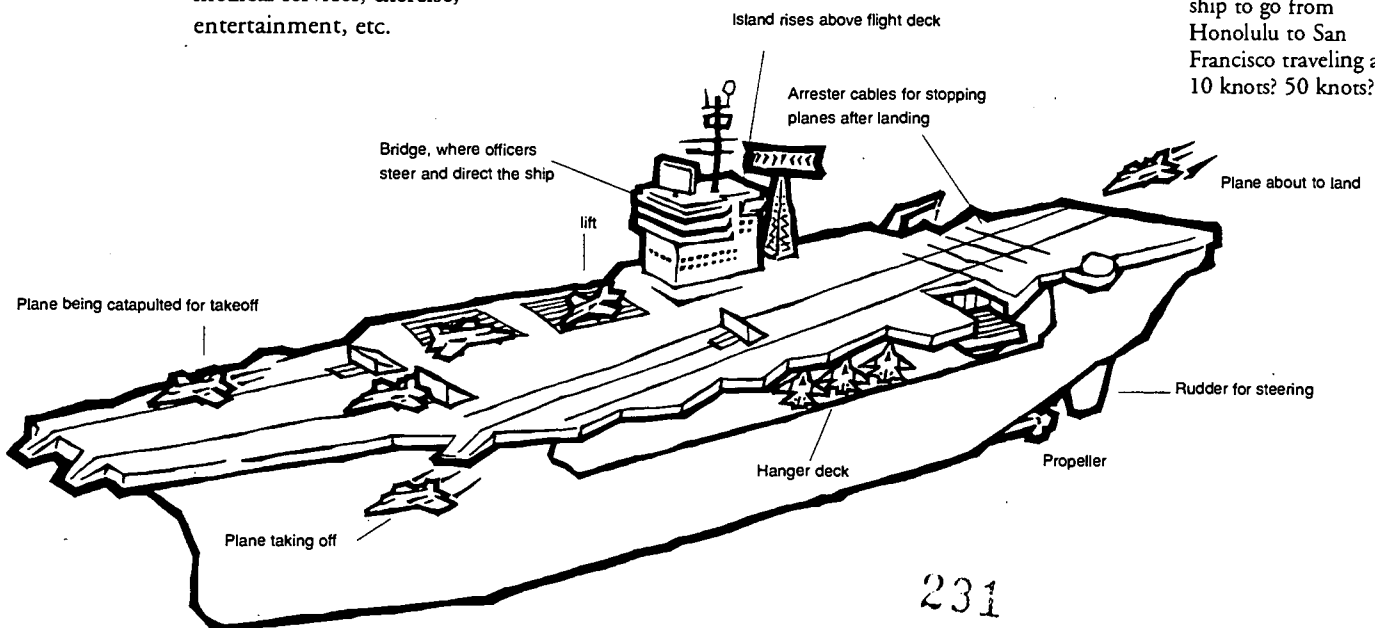

SHOW NUMBER

1203

Try This

An aircraft carrier can use as much as 1.5 million liters (400,000 gallons) of water daily. How much is that? Calculate how many Olympic-size swimming pools this amount could fill, or how many linear feet of shelf space it would take to store it in one-liter containers.

Try This

Distances at sea are measured in nautical miles. One nautical mile equals 1.85 km. Speed is measured by knots, or how many nautical miles are covered per hour. On a map, find the distance between Honolulu and San Francisco, and then calculate the distance in nautical miles. How long would it take a ship to go from Honolulu to San Francisco traveling at 10 knots? 50 knots?

What's going on in our heads? What are neurons and how do they send messages to one another? Do our brains actually change when we learn something new?

SHOW NUMBER

1203



David takes a look inside the brain.

Segment length: 8:45

Brain

What do our brains contain?

Imagine what your own brain looks like inside your head. It is pinkish gray on the outside, yellowish white on the inside, and covered with ripples or convolutions. The brain has a delicate consistency, like soft ice cream, and requires the shell-like skull to protect it from injury.

Although it may not seem like it, you have just performed an amazing feat. You have used your brain to think about itself. As far as we know, human beings are the only animals on Earth who can contemplate their own brains.

If you take a close look at a human brain, you'll find it has three main parts. By far, the largest is the *cerebrum* on top. The intricate surface of the cerebrum is called the *cerebral cortex*.

Although only 0.3 centimeters ($\frac{1}{8}$ " thick, the cerebral cortex is critical to your ability to move as you please, to understand what you see and hear, and to do the complex process called thinking—making decisions, learning, analyzing, remembering, planning, and contemplating.

Your cerebrum is divided into two halves. Each has specialized functions. An "electric highway" of nerve fibers, the corpus callosum, connects the two, allowing information to pass between.

At the back of your brain and beneath the cerebral cortex is the *cerebellum*. It coordinates skilled movement, giving you the ability to juggle, dance, type, walk without stumbling, and drink without slobbering. Located at the base of the brain is the brain stem, a stalklike structure that connects it to the spinal cord. The brain stem takes care of basic, involuntary functions, such as breathing, blinking, and keeping your intestines churning.

Every part of the human brain is made of billions of nerve cells called neurons. Each neuron has connections to thousands of other neurons. For you to read this (or even to daydream), millions of your neurons must communicate with one another.

A neuron accepts signals from other neurons through branchlike structures called *dendrites*. Whenever enough messages arrive from neighboring neurons to excite it, a neuron sends an electrical impulse down its trunklike *axon*. When the impulse arrives at the end of the axon, it causes little sacs to release chemical messengers. These chemicals, called *neurotransmitters*, then travel across tiny gaps called *synapses* to arrive at and excite other neurons.

When you learn something new, your neurons actually grow more dendrites to reach other neurons. The more you practice, the stronger these connections become. With 100 trillion possible connections, your brain is one of the most complex regions in the universe.

- ? When are you most aware of your brain in action? Which parts of your brain do you think are active when you sleep?
- ? What does information overload feel like? When, if ever, has it happened to you?
- ? Do you think your brain is similar to a computer? Why do some researchers compare a single neuron in the brain to a computer?

axon the long tail at the end of each neuron along which messages to other neurons are transmitted
cerebellum "small brain." The part of the brain that coordinates movements.
cerebral cortex the rippled or convoluted surface of the cerebrum
cerebrum the largest part of the human brain, primarily responsible for voluntary movement, thought, and language

dendrites branchlike endings on each neuron that receive incoming messages from other neurons
neurotransmitters chemicals that convey messages from one neuron to another
synapse tiny space across which one neuron communicates to another neuron

232

Dennett, D. (1991) *Consciousness explained*. Boston: Little, Brown and Company.

Diamond, M. *Within the human brain*. (videotape). University of California Extension Center for Media. Available through Lawrence Hall of Science store, Berkeley: (510) 642-1929.

Experiments in human physiology. Grades 7 and up. Apple IIs with a minimum of 48K. Queue, Inc.: (800) 232-2224.

Mind and brain. (1993) Alexandria, VA: Time-Life Books.

The mystifying mind. (1991) Morristown, NJ: Time-Life Books.

Restak, R.M. (1994) *Receptors*. New York: Bantam Books.

Stein, S. (1992) *The body book*. New York: Workman Publishing.

Willensky, D. (1993, Dec) The brain. *American Health*, p. 78.

Stark, F. (1991) *Gray's anatomy: A fact-filled coloring book*. Philadelphia: Running Press.

Additional sources of information
 National Foundation for Brain Research
 1250 24th St. NW, Suite 300
 Washington, DC 20037

Community resources
 Local MRI laboratory

University medical school

Neurologist

Psychiatrist

Show Some Nerve

Combine art and science to create a model of a neuron.



SHOW NUMBER

1203

Main Activity

Santiago Ramón y Cajal, a Spanish artist and neuroscientist, was the first person to figure out what a neuron looks like. Using a cell-staining substance called silver salts, he was able to observe and draw the intricate patterns of neurons in the brain and spinal cord. Through his research, he concluded that synapses provide the means for communication between nerve cells. In 1906 he won the Nobel Prize for his work. Use artistic and research skills to create your own model of a neuron.

Materials

An assortment of construction or modeling materials, such as:

- dominoes
- felt-tip markers
- paper cups and plates
- Ping-Pong balls
- plastic tubes
- plastic wrap
- sculpting clay
- small squeeze bottles
- wire

1. Research: Working alone or with a partner, investigate what a neuron looks like and what it does. What aspect of the neuron interests you the most?

Find the images and descriptions that you think illustrate it best.

2. Initial plans: Decide what form you want your model to take. As you design your model, emphasize the features that you

find most interesting or important. If you are collaborating with someone else, discuss your ideas with one another. Sketch out what you want your neuron model to look like.

3. Building: Use the materials you find most appropriate and begin building. If you get frustrated, take a break to look around at what others are doing, and then come back to your work in progress. If a certain material doesn't do what you would like, try another. Work with your model until you feel it represents

the basic structure and ideas you want it to represent.

4. Extending the model: If you haven't already, try

extending your model to include

neurotransmitters, both those that excite and those that inhibit another neuron from firing. Have several students "connect" their models together to show how neurons communicate as a neural network. How would you represent the stimulating effect of caffeine?

Questions

1. Do you think your model might help someone understand a neuron better? What aspects does it illustrate well? Is it more concerned with how the neuron looks or with how it works?

2. How does your model differ from other models or drawings?

3. What might you do to improve your model?

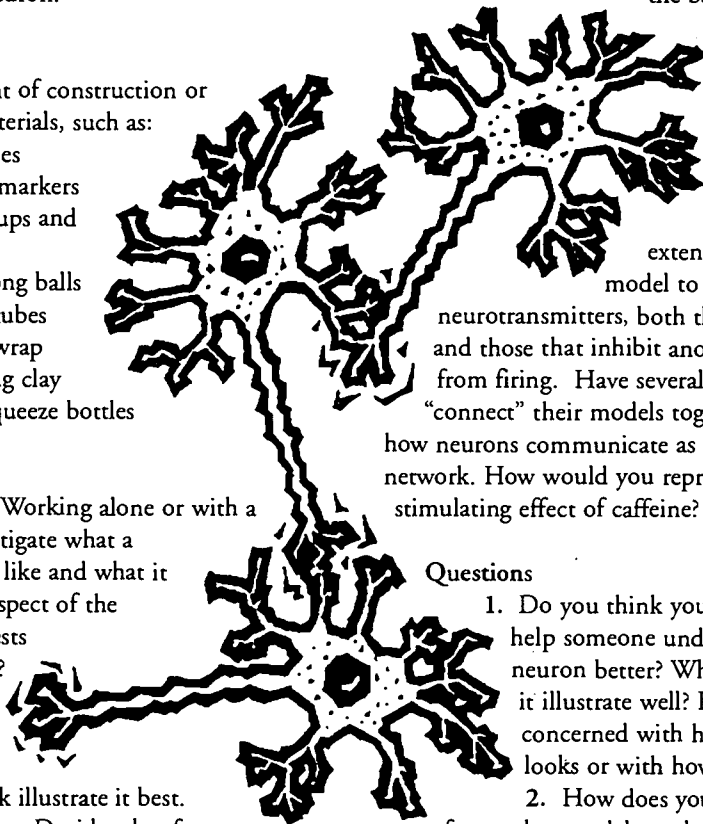

Try This

For a day, try doing as much as possible with the opposite hand that you normally use. Which tasks are particularly difficult? Do you think this is similar to the challenge young children have learning new actions, such as how to tie their shoes or pour juice into a glass?

Try This

Research a disease or injury that affects brain function, such as epilepsy, Alzheimer's, or Parkinson's. How does it affect the brain? What symptoms does a person with this problem display? Are there treatments for it? What causes it? What does this disease reveal about how the human brain works?

Try This

Hold your hand as far as you can above your head and drop a piece of paper. Try to catch it as it flutters to the grounds. Now try dropping a ball from the same height. Why is the piece of paper harder to catch? (Adapted from *Blood and Guts* by L. Allison [Boston: Little, Brown and Company, 1976], p. 117.)

Try This

As you learn, new connections are made between neurons. Choose something new you would like to learn, such as juggling, memorizing a poem, or speaking another language. Keep a journal in which you describe your learning process. What challenges do you encounter? When do you notice progress? How much time does it take to learn something so that you don't forget it?

233



We encourage duplication for educational use!

NEWTON'S APPLE is a production of KTCA Twin Cities Public Television. Made possible by a grant from 3M. Educational materials developed with the National Science Teachers Association.

12.20

3M Innovation

What technology is necessary to take a picture of the mind? How can we map the brain when we don't completely understand how it works?

SHOW NUMBER

1204



Peggy finds out about the progress being made in mapping the human brain.

Segment length: 8:44

Brain Mapping

Do any maps of the brain exist?

Insights & Connections

When Lewis and Clark set out to map America, they had to find ways to observe and chart the land around them. Today's surveyors also depend on creative ways of studying and mapping what many consider the final frontier—the human brain. While anatomical blueprints have existed for centuries, the new challenge lies in creating a functional map—a chart which shows where in our brain we hear music, get a joke, or even think about our brain.

Early scientists would secretly dissect cadavers to ponder over the three-pound mass of gelatinous tissue that forms our brain. A better way to understand the brain is positron emission tomography (PET). This technique relies on X-ray photography to track cerebral blood flow. Before the test, the patient is given an injection of a radioactive *glucose analogue*. Since the brain uses glucose as fuel, *neurologists* can identify neural hot spots by seeing which areas of the brain use more glucose and are therefore more active than other areas.

Some early functional maps were made by exposing a large area of the brain during surgery, stimulating its surface, and simply watching what happened. A technique using that same principle, called magnetoencephalography (you can call it MEG, unless you're really into tongue-twisters), gives *neuroscientists* a less-invasive look. Small sensors are placed all over the patient's head to detect electromagnetic changes caused by *neurons*. By monitoring this energy, scientists can measure levels of brain activity. This information is updated every millisecond, matching a patient's active thinking speed.

Scientists sometimes collect data on a subject in a roundabout manner. For instance, the brain uses one-quarter of all the oxygen you breathe. Neurologists can identify the active sections of the brain by tracking oxygen-rich blood. Magnetic resonance imaging, or MRI, is the first *noninvasive*, nonradioactive way to observe brain activity. An MRI machine relies on very large magnets to track the flow of blood cells in the brain and identify where the brain processes our thoughts, motor activities, and sensations. This system has such good terminal resolution that it can record changes in the brain which occur even just 50 milliseconds apart.

No single mapping technique provides complete information. Scientists combine a number of technologies to create more comprehensive maps of the human brain. These maps provide critical information to help neurosurgeons perform safer robotic microneurosurgery or even help scientists identify the brain sections that hear different musical tones. As technology advances, it's just a matter of time before a map of the human mind will be as detailed and comprehensive as a road map.

- ? Why do scientists need a functional as well as an anatomical map of the brain? How would a functional map aid in brain surgery, psychology, or sports?
- ? How are traditional mapping techniques used in brain mapping?

Vocabulary

glucose analogue a compound the body treats as glucose which has on its structure a substituted radioactive atom permitting it to be monitored

neurologist a doctor who specializes in the brain, the nerves, and the nervous system, as well as the diseases affecting them

neuron the basic cellular unit of the nervous systems

neuroscientist a scientist focusing study on some aspect of neural or nervous system function

noninvasive a medical procedure for which it is not necessary to enter the body to obtain diagnostic information

stimulus anything that causes a reaction. The plural of stimulus is stimuli.

the brain vs. the mind Your brain is the physical, anatomical part of your central nervous system. Your mind is your consciousness, where you feel emotions and think.

tracer a substance, usually radioactive, which is followed through a physical system to study it

Resources

Armstrong, L., et al. (1993, July 19) Watching the brain at work. *Business Week*, pp. 50–51.

Asimov, I. (1987) *How did we find out about the brain?* New York: Walker and Company.

Begley, S., et al. (1992, Apr 20) Mapping the brain. *Newsweek*, pp. 66–70.

Davidoff, J. (1993, Apr 10) Brain cells made for seeing. *New Scientist*, pp. 32–36.

Goldsmith, J. (1994, May) This is your brain on Tetris. *Wired*, pp. 72–73.

Harding, G. (1993, Dec 11) How surgeons could navigate the brain. *New Scientist*, pp. 28–31.

Posner, M.I. (1993, Oct 29) Seeing the mind. *Science*, pp. 673–674.

Additional sources of information
American Academy of
Neurology
2221 University Ave. SE,
Suite 335
Minneapolis, MN 55414
(612) 623-8115

Brain Information Service
BRI Publications Office
43-367 CHS/UCLA School of
Medicine
Los Angeles, CA 90024-1746
(310) 825-3417
(information on general brain
sciences)

Society of Neurological Surgeons
750 Washington St., Box 178
Boston, MA 02111
(617) 956-5858
(call to find members in your
city available for speaking)

234

We encourage duplication for educational use!

NEWTON'S APPLE is a production of KTCA Twin Cities Public Television. Made possible by a grant from 3M.

Educational materials developed with the National Science Teachers Association.

12.21

3M Innovation

Attention, Fellow Syymonians

Land your spaceship on planet Earth and chart the territory you observe.



SHOW NUMBER

1204

Main Activity

Neurologists continue to map the brain, even though they don't know exactly how it works. In this activity, you will map an area and then use your map as well as collected observational data to deduce the function of structures within the area.

Your name

Zotar from the planet GX-911, Galaxy Syymonia

Your mission

Map, identify, and explain one Earth block.

Your tools

- compass
- large measuring tape
- pencils
- large sheets of paper for map
- smaller sheets for observations
- a team of fellow Syymonians

Remember, this is your first visit to Earth from the galaxy Syymonia. Earth signs, symbols, and languages mean nothing to you. In all your observations, you must assume that you have *no previous knowledge* of the block and the humans you are studying.

Your orders

1. Select a fairly busy block. Make sure the block includes several types of buildings and lots of humans walking around.
2. Map the block and the streets adjacent to it. With the compass, find north and mark it with an arrow in an upper corner on your map. Using a scale of 1 cm = 2 meters, chart the buildings around

the block, measuring accurately to represent sidewalks, vegetation, and structures.

3. Establish observation posts. For approximately a half hour (in Earth time), study and take notes that will help you answer the following questions:

- Which buildings do humans enter and exit from most often?
 - Does only a particular type of human use a certain building? Identify them by characteristics such as age, sex, apparel, etc.
 - What items do the humans carry in and out of these buildings?
 - Observe individual human behavior. Does it differ depending on which buildings they enter?
 - Does the structure of the building itself seem to be a factor in its function?
4. Formulate theories on the uses of the various buildings on your block.

Questions

1. What data was most helpful? What technology would have made this mission easier?
2. Which were the easiest and hardest buildings to identify? Why?
3. If you, as an alien, had to choose a single symbol to identify a building, what would it be? (And as a real-life human, did you catch yourself cheating? How?)

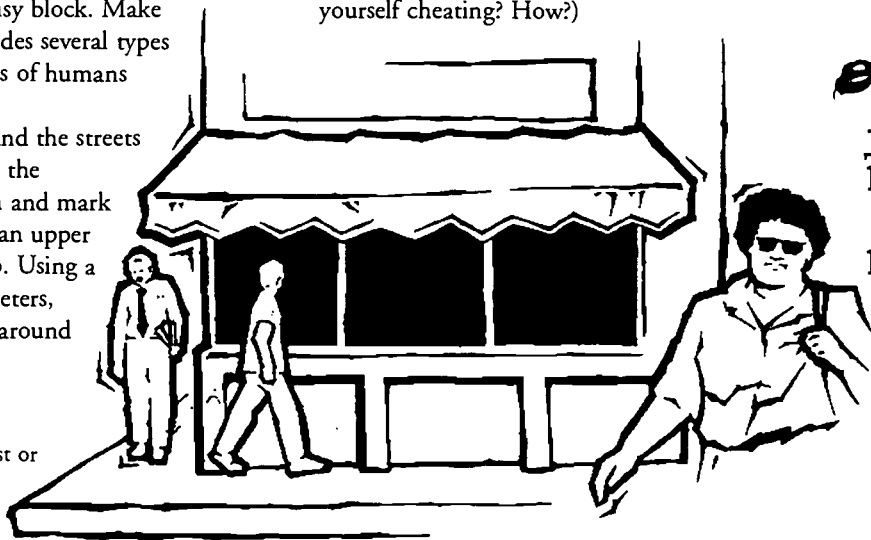

Try This

Invite a neurologist or neurosurgeon to visit your class to explain brain structure and mapping. Have that person describe problems such as tumors, strokes, and injuries and the functional trouble they produce.

Try This

Visit a radiology department at a local hospital and ask a radiologist to demonstrate the CAT, MRI, and PET scanners. Learn how tests are performed with these machines and what kinds of study results they produce.

Try This

Bring a variety of articles (games, books, kitchen utensils, etc.) to class and place them in a drawer. To see what kinds of problems result when a person loses one of the brain's important functions, blindfold a class member and have that student select an article from the drawer. Without looking at it or showing it to the class, that person should try to identify and describe it to the other students.

Try This

The brain houses and integrates dissimilar functions in much the same way that the rooms in a house and its yard do for different daily activities. Draw a house with a room plan and yard. Draw lines to connect rooms and areas with integrated functions. (For example, food prepared in the kitchen is eaten in the dining room; fatigue from playing in the yard is relieved by sleeping in the bedroom.) Imagine one of the rooms being destroyed. Discuss the impact this might have on an individual or on the family.

235



David sniffs out the chemistry of garlic.

Segment length: 7:37

What happens when you crush a garlic clove? What molecules are responsible for garlic breath?

Garlic

What chemical forces are at work in garlic?

Garlic is often called "the stinking rose." That's because it contains *molecules* composed of the same *atoms* that lurk in burnt matches and rotten eggs.

But if you put a whole clove of garlic right up to your nose, you won't smell much. The molecules that create the garlic smell are not actually present in natural garlic. They are synthesized in a reaction that occurs when garlic is cut or crushed. When a knife slices through garlic, cell membranes rupture, releasing an *enzyme* called allinase. Allinase can chemically change a tiny, odorless molecule called alliin into allicin. Allicin is the *pungent*, sulfur-containing molecule that can alienate friends who get too close and add zest to bland food.

During any chemical reaction, atoms rearrange themselves into new substances. But all chemical reactions do not proceed in the same way. Some transformations occur spontaneously and explosively while others are hard to initiate and proceed as slowly as a rusting fence. The ease and speed with which molecules change or undergo chemical reaction depend on how often they collide and the energy needed to get the reaction started.

Molecules are surrounded by negatively charged *electrons* which repel the electrons in other molecules. For each reaction, molecules must move fast enough to overcome these repulsive forces. This energy barrier is like crossing a mountain. Just as an ocean wave may have enough energy to knock you off your feet, a molecular collision must have enough energy to break chemical bonds. If the *reactant* molecules have enough energy, they can climb the energy mountain, react, and fall down the other side as *products*.

Usually you can give molecules extra energy and make them collide more often by heating them up. But alliin and allinase only need to meet at room temperature to create allicin.

The secret is in the structure of the allinase enzyme. One section of the molecule is called the *active site*. In a typical enzyme, the active site looks like a dent or crevice in the side of the molecule. The shape of the crevice in allinase exactly matches the molecular shape of alliin. The enzyme and *substrate* fit together like a key fits a lock. At the active site, alliin is stretched and twisted until chemical bonds holding it together snap and allicin is formed. Allicin, which no longer fits the enzyme, drifts away, leaving allinase unchanged and the whole process starts again. The enzyme facilitates the reaction by reducing the energy needed to break chemical bonds. Alliin and allinase have found a low-energy tunnel through the energy mountain.

After ingestion, the *odoriferous* sulfur molecules circulate in the bloodstream and escape from your body through exhaled air and perspiration—as any nose will tell you.

- ? Why don't some people like the smell of garlic? What smells are unpleasant to you?
 ? How does garlic get into your breath? What steps can you take to minimize garlic breath?

active site the location on the enzyme at which substances attach
atom smallest particle of a chemical element
electron a subatomic particle that carries a negative charge
enzyme a huge protein that facilitates and accelerates chemical reactions but itself remains unchanged
molecule group of atoms held together by sharing pairs of electrons

odoriferous having or giving off an odor
product a new substance produced in a chemical change
pungent a sharp, acrid taste or smell
reactant a starting material in a chemical change
substrate a substance that reacts with an enzyme to give a new substance

- Block, E. (1985, Mar) The chemistry of garlic and onions. *Scientific American*, pp. 114–119.
- Bonar, A. (1985) *The Macmillan treasury of herbs*. New York: Macmillan.
- Doolittle, R. (1985, Oct) Proteins. *Scientific American*, pp. 88–99.
- Grosser, A. (1981) *The cookbook decoder*. New York: Beaufort Books.
- Harris, L. (1975) *The book of garlic*. New York: Holt Rinehart and Winston.
- Hausman, P. (1989) *The healing foods*. Emmaus, PA: Rodale Press.
- Kowalchik, C. (1987) *Rodale's illustrated encyclopedia of herbs*. Emmaus, PA: Rodale Press.
- Scott, D. (1994, Apr) Designer catalysts. *ChemMatters*, pp. 13–15.
- Tocci, S. (1987) *Biology projects for young scientists*. New York: Grolier.
- VanCleave, J. (1990) *Biology for every kid*. New York: John Wiley & Sons.
- VanCleave, J. (1989) *Chemistry for every kid*. New York: John Wiley & Sons.

Community resources
 Nutritionist

Chemist or biochemist

County extension office

Enzymologist

Agents of Change

Test the ability of an enzyme to cause a chemical reaction in different foods.



SHOW NUMBER

1204

Main Activity

Enzymes are special proteins that help speed up the chemical reactions occurring in living cells. Enzymes are found in plants and animals. The enzyme catalase splits ordinary hydrogen peroxide molecules into water and oxygen gas. Can catalase break down other molecules? Do all plant or animal products contain catalase? Let's find out.

Materials

- several plastic cups
- 3% hydrogen peroxide
- potato, bread, apple, turnip, cheese, vinegar, and milk

1. Cut off the end of a small potato to expose the inner surface. Do not peel off the potato skin. Put the end piece of potato into a cup and cover it completely with hydrogen peroxide. What happens? When you cut the potato, cells are disrupted, releasing catalase. The enzyme immediately begins reacting with hydrogen peroxide, producing water and bubbles of oxygen gas. Does catalytic activity occur at both the peeled and unpeeled areas of the potato? Explain.
2. Cut another slice of potato and remove the skin. Cut this slice of potato into four pieces of equal size. Place each piece in a separate cup. Now pour hydrogen peroxide into the first cup. Pour vinegar into the second cup.

Pour water into the third cup. Pour milk into the fourth cup. What happens? You'll find that catalase is highly specific for the hydrogen peroxide molecule. Other molecules do not have the correct shape to react with this particular enzyme. You can try this with other liquids.

3. Now pour hydrogen peroxide into four cups. Add a small piece of bread to the first cup. Add a small piece of apple to the second. Add a small piece of cheese to the third. Add a small piece of turnip to the fourth cup. What did you observe? Try this activity with other foods.

Questions

1. Do all foods contain catalase? What other foods do you think contain catalase?
2. What evidence did you see that a reaction was taking place?
3. Does catalase decompose all of the liquids used in step 2?



Try This

Usually an increase in temperature will increase the rate of a chemical reaction. You can demonstrate this effect with two Alka Seltzer tablets. Alka Seltzer tablets contain dry chemicals that react in water to release bubbles of carbon dioxide gas. Pour cold water into one jar and hot water into a second jar. Now drop a seltzer tablet into each jar. What happens?



Try This

Garlic odor can be controlled by cutting. In a group, separate a garlic bulb into individual cloves. Now peel three of the cloves. Place one of the cloves on a paper plate. On a second plate, cut a clove into four sections. On a third plate, crush or mush a complete clove. Invite the members of your group to smell each sample and compare observations of odor intensity.



Try This

Researchers are looking at garlic and other foods for help in treating a range of illnesses. Find out about the healthful benefits of garlic. Make a chart to display a variety of foods and the illnesses they may prevent.

237

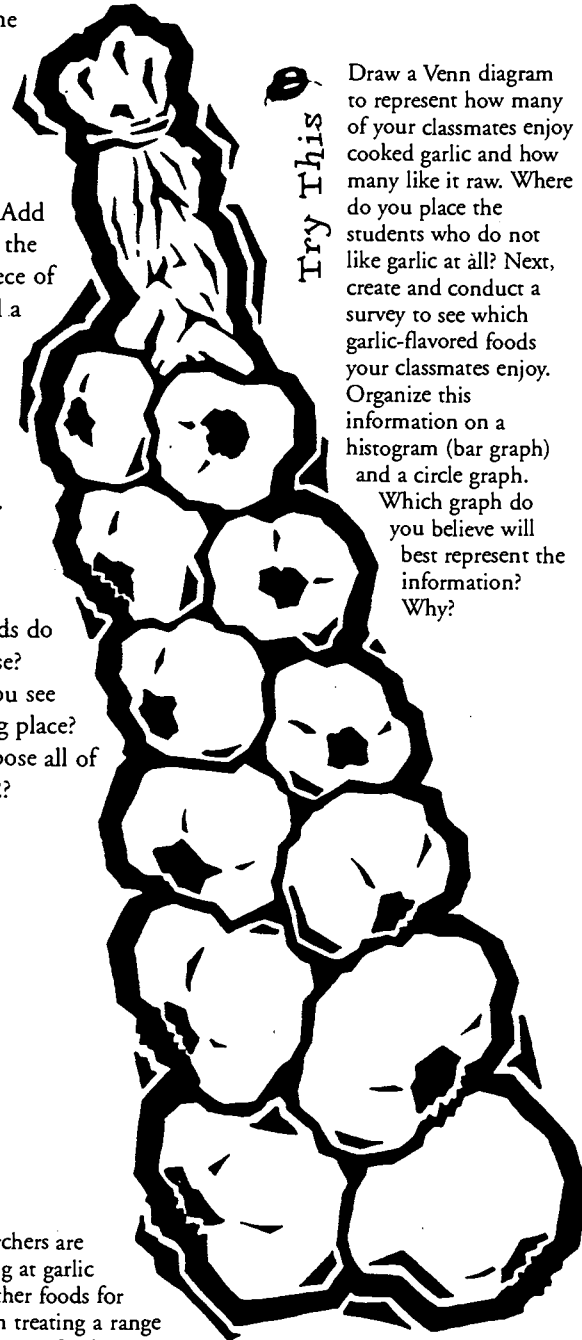

Why did the creators of *Jurassic Park* visit animal parks and study pantomime? Why is it difficult to make realistic-looking creatures on a computer?

SHOW NUMBER

1205



Peggy visits Industrial Light and Magic (ILM) to find out how they make computer-generated dinosaurs.

Segment length: 9:16

Movie Dinosaurs

How did they make the *Jurassic Park* dinosaurs?

Insights & Connections

It is a dark and stormy night. A *Tyrannosaurus rex* wildly rips through an electrified fence, then roars. The dinosaurs in the megahit movie *Jurassic Park* made history as the most realistic-looking movie stars ever created on a computer. Dozens of animators, artists, software programmers, and technicians collaborated on the project.

They developed a galloping herd of ostrich-like *Gallimimuses* entirely on computers. But most dinosaur scenes blended footage of robotic models, puppets, and cutting-edge computer graphics. For example, a full-body view of a computer-generated, gentle *Brachiosaurus* switched seamlessly to a shot of a hand-controlled, puppet dinosaur head.

To bring the *Tyrannosaurus* to life on a computer screen, animators first built a 3-D *wire-frame* skeleton on their computers, based on photographs of dinosaur bones. But how did a T-rex run and how fast could it go? To find out, the moviemakers consulted *paleontologists* and examined fossilized footprints and other dinosaur remains. They also observed wild animals, studying how giraffes eat and how elephants shift their weight as they walk.

The animation team practiced pantomime so they could understand how to create more compelling performances from their dinosaur stars. To help, technicians invented the Dinosaur Input Device, a T-rex puppet connected to a computer. *Stop-motion* animators—experts in animal movement—manipulated the robotic T-rex puppet with their skilled hands. Every time they moved it, the image on the computer screen moved too. When they opened the puppet's mouth to roar, the T-rex on the screen mirrored the movement, and the computer recorded it.

The animators used a special *scanner* made by Cyberware to capture the surface dimensions for the computer-generated dinosaurs. The scanner moved a laser beam around a sculpture model of the T-rex, capturing its form as a 3-D computer model.

One of the most difficult jobs was adding the skin. Computers are good at making shiny, smooth surfaces. But real animals are covered in varied wrinkles with shadows. The animators spent weeks determining how the skin of the T-rex should look as it moved.

Two years of painstaking work resulted in a total of six minutes of computer-generated dinosaur footage in the final film. The crew made great strides, improving computer animation technology and technique. Before long, expect to see computer-generated human actors appearing at a theater near you. Now, *that's* really frightening!

- ❓ The creators of *Jurassic Park* referred to dinosaurs model as "actors" and discussed each dinosaur's "performance." Were they really acting or were they programmed?
- ❓ The animators gave the dinosaurs wrinkles and other "imperfections" to make them look more believable. Have you ever seen something look so perfect that you didn't believe it was real?

Vocabulary

armature mechanical model of a movie character that is controlled by computer
CGI computer-generated images
claymation stop-animation in which the characters are formed out of clay
digitizer machine that "captures" real-world information and converts it into computer form
FX movie lingo for "special effects"
go-motion an animation technique designed by Industrial Light and Magic that allows stop-motion animators to record the way they move puppet models with their hands onto a computer

paleontologist scientist who studies past animal life-forms
scanner a machine that captures an image from the real world and turns it into digital form on a computer
stop-motion an animation technique that involves filming an object one frame at a time, moving it a short distance between each frame
wire-frame the basic line drawing of the shape of an object drawn in three-dimensions

Resources

Britton, P. (1993, Nov) The WOW factor. *Popular Science*, pp. 86-91.

Carmichael, K. (1994, Mar) Beyond *Jurassic Park*. *Popular Mechanics*, pp. 35-38.

Corliss, R. (1993, Apr 26) Behind the magic of *Jurassic Park*. *Time*, pp. 49-50.

Jenkins, P. (1991) *Animation: How to draw your own flipbooks, and other fun ways to make cartoons move*. Reading, MA: Addison-Wesley.

Schultz, R. (1992) *Looking inside cartoon animation*. Santa Fe, NM: John Muir Publications.

Shay, D. & Duncan, J. (1993) *The making of Jurassic Park*. New York: Ballantine Books.

3-2-1 Classroom Contact videotape: *How do you know? Make a model*. GNP: (800) 228-4630.

Computer resources
 Computer animation programs such as Animation studio, Animation works, Hanna-Barbera, Lifeforms, Macromind director, and Microworlds.

Additional sources of information
 SIGGRAPH (Special Interest Group on Graphics) Association of Computing Machinery (ACM) (312) 321-6830 (Ask for SIGKIDS information. For those with Internet access, log on to the ACM Gopher server at: siggraph.org)

Community resources
 Computer animator

Art school

Body Language Charades

Try to convey an attitude without using facial expressions.



SHOW NUMBER

1205

Main Activity

To develop an understanding of how its dinosaurs could give expressive performances, the *Jurassic Park* computer animation team took lessons in pantomime. They hid their faces behind Balinese masks and tried to express a variety of emotions, using only their bodies. Try this technique in the following variation on the game charades.

Materials

- 8 index cards
- two full-face masks (or 8 1/2" x 11" pieces of paper)

1. Set-up: On the front of each index card, write down an emotion or attitude. You can use the words from the following list, or come up with your own. Leave the reverse side of each card blank.

aggressive
playful
bewildered
depressed
annoyed
excited
peaceful
nervous

Select one person to be the referee and give the referee the cards. Divide the remaining players into two teams, with two to ten players on each team. Each team should have the same number of players. Number the players on each team, from one on up.

2. Playing the game: The referee picks a card from the stack and calls out a number corresponding to one of the player numbers. The players with that number on each team approach the referee.

Both players get a chance to look at the card, then each takes a mask to cover her or his face. On a signal from the referee, the two players then return to their respective teams and begin acting out the attitude written on the card, using body language only (no symbols or sign language allowed).

3. Scoring: The first team to correctly guess each attitude scores a point. A one-point penalty is subtracted if players acting out an attitude reveal their faces. The game continues until one team scores five points or until the cards are used up.

Questions

1. Did you find it difficult to convey an attitude without using facial expressions? Which attitudes were hardest to convey?
2. Why do you think that the *Jurassic Park* computer animation team spent time behind masks and behaving like dinosaurs?

Try This

There are 24 frames in each second of a motion picture film. Find the length in hours and minutes of your favorite movie. Estimate how many frames this movie contains. Compare your method of solution with that of other people in your group. Use a calculator to find the actual number of frames. How close was your estimate?

Try This

Compare an artificial flower to a real one of the same variety, if possible. In what ways does the artificial flower look different from the real one? Why do you think it is difficult to make something artificial look real?

Try This

The animators for *Jurassic Park* used both 2-D (flatbed) and 3-D scanners to capture images for the computer. Use a photocopier to scan your hand. What details of the hand does it capture? What does it miss? Do you recognize your own hand as distinguished from someone else's hand? If possible, compare the image of your hand to one captured using a computer flatbed scanner or a video camera attached to a computer. How might a 3-D scanner differ from these 2-D input devices?

Try This

The movie *Godzilla* was one of Steven Spielberg's inspirations for *Jurassic Park*. Rent a *Godzilla* video to watch. Do the monsters look convincing to you? Some people think that *Jurassic Park* will look like this to young people 20 years from now.

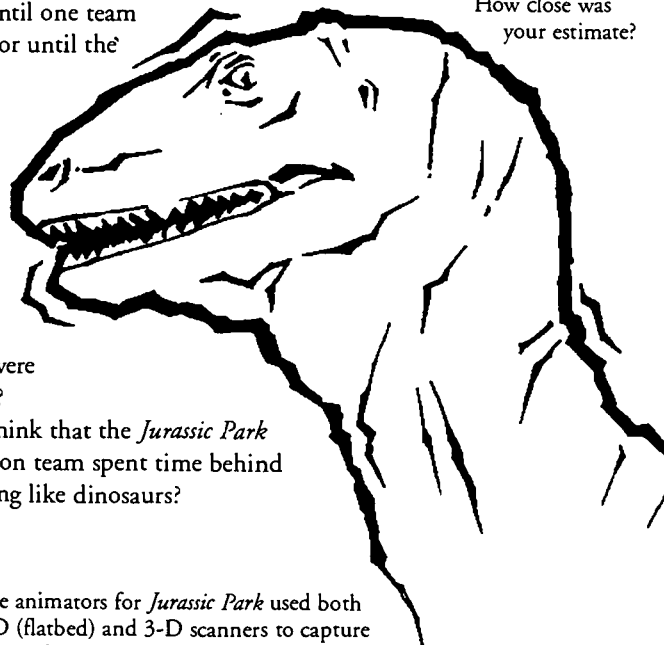
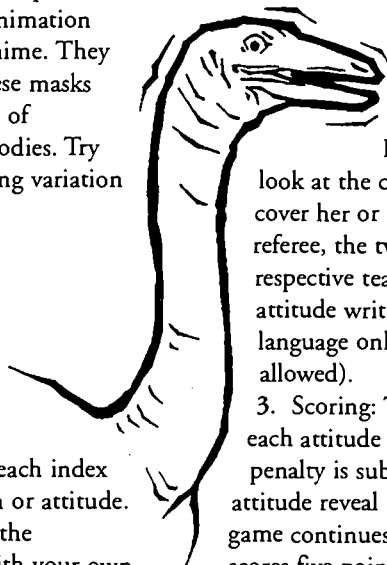

230

What's in a loaf of bread? What role do yeast and enzymes play in making bread? Why add salt?

SHOW NUMBER

1205



David explores the science behind baking bread.

Segment length: 5:46

Bread Chemistry

What makes bread rise?

Insights & Connections

Bread baking transforms an ordinary kitchen into a laboratory of earthy sights, smells, and tastes. A recipe, after all, reads like a scientific experiment. The baker combines flour, yeast, liquid, and salt in a bowl, shapes it all into a dough, lets the dough rise, and bakes it in a hot oven.

Flour, which gives bread its structure, is made by milling cereal grains such as wheat, barley, or rye. In this process, the grain seeds are crushed, releasing starch and proteins.

Starch molecules are long, gangly *polymers* of simple sugars linked head to tail by *chemical bonds*. Proteins are more complex—a single protein may contain hundreds of *amino acids* strung together like beads on a necklace.

What gives bread its light, fluffy texture? The answer is gliadin and glutenin, two proteins found in flour. When flour is added to water and kneaded, these proteins swell up like sponges and form a tough elastic substance called gluten. Gluten can stretch and trap the bubbles of gas that make dough rise.

That gas comes from the *leavening* action of tiny one-celled fungi called yeast. When you combine yeast with flour and water, you'll end up with a sticky white dough. Inside the dough, *fermentation* is occurring and molecules are on the move. *Enzymes* from the yeast cells attack starch, breaking it down into glucose. Other enzymes transform glucose molecules into carbon dioxide and ethanol. The carbon dioxide (CO₂) gas then bubbles up through the mixture, causing the dough to rise.

Breads which are leavened by baking powder instead of yeast lack the tasty molecules of fermented bread. That's because when baking powder gets wet, a *chemical reaction* occurs that releases only carbon dioxide, salt, and water.

In breads leavened with yeast, however, the yeast cells grow under *anaerobic* conditions and cannot convert glucose molecules completely to gas. Some sugar molecules get sidetracked and are converted into alcohols, acids, and esters—substances which add to bread's flavor.

Salt strengthens gluten by slowing down the enzymes which *catalyze* the breakdown of proteins. If you add too little salt, the dough is tough and sticky. If you add too much, water flows out of yeast cells by osmosis. Then nutrients are lost and production of carbon dioxide slows down.

After dough rises a couple of hours in a warm place, it's ready to go into the oven. There, heat causes pockets of gas in the dough to expand. Eventually the crust becomes toasty brown—and soon you're enjoying a slice of warm, home-baked bread.

??

Is bread a healthy food? In which food group does bread belong?

??

How many different kinds of bread do you like? Why are some breads white and some dark?

Vocabulary

amino acids organic acids that are the building blocks of proteins
anaerobic a process which takes place in the absence of oxygen
catalyze to speed up a chemical reaction
chemical bond the forces of attraction that bind atoms together in a molecule
chemical reaction a process where substances are changed into new substances

enzyme special protein molecules that speed up chemical reactions in living cells. Enzymes are biological catalysts.
fermentation a process where sugars are transformed into carbon dioxide and alcohol by the action of yeast enzymes
leavening substances that cause fermentation
polymer large molecules formed by linking together many small molecules. Proteins are polymers of amino acids.

Resources

- Amendola, J. (1992) *Understanding baking*. New York: Van Nostrand Reinhold.
- Bittman, M. (1993, Oct) Make your own bread. *American Health*, pp. 82–87.
- Dworkin, F. & Dworkin, S. (1987) *Bake your own bread*. New York: New American Library.
- Grosser, A. (1981) *The cookbook decoder*. New York: Beaufort Books.
- Moore, M. (1987) *The wooden spoon bread book*. New York: Atlantic Monthly Press.
- VanCleave, J. (1989) *Chemistry for every kid*. New York: John Wiley & Sons.
- Williams, R. (1991, Jan) Microbe phobia and kitchen microbiology. *American Biology Teacher*, pp. 10–11.
- Additional sources of information*
 General Mills
 Number 1 General Mills Blvd.
 Minneapolis, MN 55426
 (612) 540-7768
- American Institute of Baking
 1213 Bakers Way
 Manhattan, KS 66502
 (913) 537-4750

Community resources
 County extension office

Local bakery

Home economics teacher

Local milling company

Microscopic Art

Observe and sketch yeast cells by looking at them under a microscope.



SHOW NUMBER

1205

Main Activity

Yeast cells are tiny one-celled plants. Baker's yeast contains billions of cells in a single package. Each egg-shaped cell is, on average, five micrometers wide (1/10,000 of an inch). In this activity you will grow some yeast cells and study them with a microscope.

Materials

- plastic cup
- table sugar
- yeast
- microscope slides and cover slips
- microscope

1. On a sheet of blank unruled paper, draw two 7.5-cm circles (3"). Label one "low power" and the other "high power."
2. Pour one cup of warm water into the plastic cup. Add a package of yeast and one tablespoon of sugar. Mix and let stand for 45 minutes.
3. Place a drop of yeast solution onto a microscope slide and cover with a cover slip.

4. Look at the yeast with a microscope and a low-power eyepiece. Sketch what you see in the appropriate circle.
5. Next, look at the sample with a microscope and a high-power eyepiece. Sketch what you see in the appropriate circle.

Questions

1. What color are yeast cells under the microscope?
2. What was your first reaction to seeing yeast cells?
3. Describe what you saw.
4. How does increasing the magnification change the appearance of the yeast cells?

Try This

Baking powder is a chemical leavening agent. Read the label on a baking powder product to learn what ingredients are present. Place a tablespoon of baking powder in your left hand. Now pour a tablespoon of water over the powder. What did you see, hear, and feel? Repeat this activity with baking soda and vinegar and compare the results.

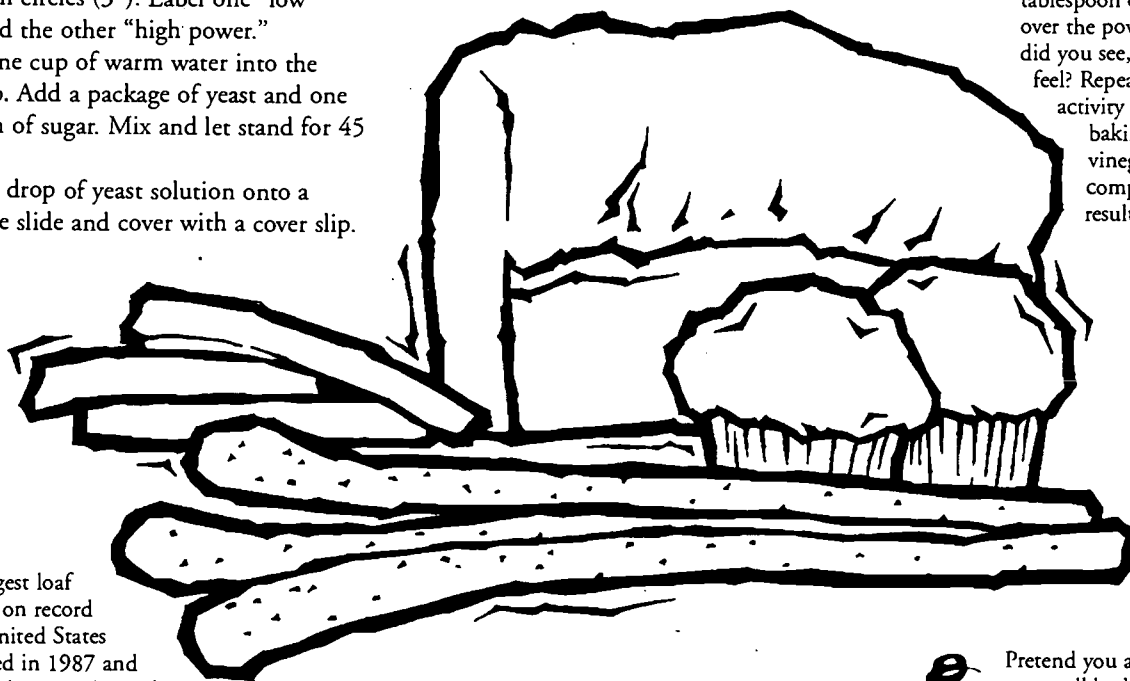

Try This

The longest loaf of bread on record in the United States was baked in 1987 and was 718.4 meters (2,357' 10") long. Using a grocery store loaf as a model, estimate how many slices you could cut from this large loaf. How many sandwiches could you make? Compare how you arrived at your estimate with the methods used by other people in your group. With a calculator, find the actual number of sandwiches. How close was your estimate?

Try This

Chemical leavening depends on the neutralization between an acid and a base to make carbon dioxide gas, water, and a salt.

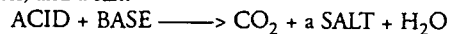

Add a scoop of baking soda to a plastic cup and begin adding vinegar drop by drop until the solid has disappeared and bubble formation has stopped. Decide when the neutralization (end point when the acid and base are equal) is complete. How many drops did it take to neutralize the acid? Try other acids (lemon juice, soda, buttermilk) and compare. What does the number of drops say about acid concentration? Repeat the activity using milk instead of vinegar. What happens? What do the results say about the nature of milk?

Try This

Pretend you are a yeast cell looking for a job making bread. Write a résumé describing yourself, your background, and why you feel qualified for the job.



How much sound in a movie is actually recorded while the actors are in front of the camera? What sort of technology is used to create the incidental sounds in film?



Peggy reveals some of the secrets behind movie sound effects at Skywalker Ranch.

Segment length 7:35

Movie Sound Effects

What is a foley studio?

Insights & Connections

As you go through an average day, how many sounds around you do you actually hear? Every time you close a door, do you listen for the click of the lock? Do you hear the clink of a glass as you set it down? Although you may not actively hear these sounds, if they weren't there you'd wonder what was missing. Foley, the process of creating incidental sounds, is the art that completes a film—all by adding sounds for which you never really listen.

Whether they're tearing heads of cabbage for a paper shredder in *The Temp* or "smooshing" gelatin in T-shirts for E.T.'s wobble, foley artists add sounds that make the experience more real for the audience. The process is named for radio and movie sound pioneer Jack Foley, a technician at Universal Studios in the 1950s who became famous for synchronized sound effects.

Foley artists begin their work by watching the film to determine which sounds need to be replaced, which need to be enhanced, and which just simply need to be added. At this time, the sound on the film includes all of the *dialogue* and sound effects created during the actual production of the film. These sounds are recorded on a production track or guide track.

Later, technicians may add crowd noises (also called *walla*), the musical *score*, rerecorded dialogue or ADR (automated dialogue replacement), sound effects, and sound-designed effects. It's not unusual to have 80% of a movie's sound track added and altered in some way after the movie is shot.

Some sound effects are common and can be pulled from prerecorded audio libraries. But many are unique to each movie—footsteps, for instance. As they watch the film, the artists identify which sounds they need to create and start thinking of ways to make them. In addition to the noises themselves, the foley artists must consider other factors, such as who makes the sound and in what environment. Some sounds are too complex for one take, so the foley artists carefully combine different noises to fully represent a single sound. In some cases, foley editors can digitally alter recorded sounds to fit a scene exactly.

In a foley studio, you'll find different surfaces for walking on, a *splash tank*, *echo chambers*, and a mixing booth where the sound engineers record and mix everything. Foley artists spend hours huddled around a microphone, reading *cue sheets* and watching a huge screen as they meticulously synchronize their noises to the action.

So the next time you see a movie, listen very carefully. If you don't notice a thing, you've got a foley artist to thank.

- 2. How would you create a sound for something that has never been heard by humans, such as sounds on a distant planet or a dinosaur egg hatching?
- 2. How can foley artists affect the mood or meaning of a film through sound effects?

Vocabulary

cue sheet a list of all the necessary sound effects, along with their "cues"—time code and/or film footage signals that indicate when the sound begins and ends

dialogue conversation or verbalizations in a film

echo chamber a box or container used to create the illusion of distance and reverberation

incidental casual, everyday sounds. Special sound effects that aren't necessarily "special."

mixing console a machine capable of taking in several different sounds, then mixing them at different levels to create a single, unified sound

reverberation a reechoed sound which fades until it becomes inaudible

rough cut the "first draft" of a film

score the background music throughout a film

splash tank a container filled with water for wet sound effects

walla the film industry term for background crowd noises in a movie

Resources

Belton, J. & Weis, E. (1985) *Film sound: Theory and practice.* New York: Columbia University Press.

Harris, R.J., Jr. (1992, Dec 21) The foley artists are a noisy bunch in moviemaking. *The Wall Street Journal*, pp. A1 & A5.

Mooser, S. (1983) *Lights! Camera! Scream! How to make your own monster movies.* New York: Simon and Schuster, Inc.

Mott, R.L. (1993) *Radio sound effects. Who did it, and how, in the era of live broadcasting.* Jefferson, NC: McFarland & Company, Inc.

Mantell, H. (1983) *The complete guide to the creation and use of sound effects for films, TV and dramatic productions.* Princeton, NJ: Films for the Humanities.

Smith, T.G. (1986) *Industrial Light and Magic: The art of special effects.* New York: Ballantine Books.

Community resources
Contact your state's film board to find out who does foley or sound work in your area.

Tour a local TV or film production company.

Contact a local radio station to find out if any DJs use sound effects.

Check your local library for LPs, tapes, and CDs containing sound effects libraries.

Contact the theater department of a local university for a speaker on theater sound effects.

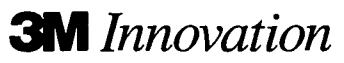

Sound Off!

Test your skills as a foley artist by creating sounds from ten easy-to-find objects.

Main Activity

How many different sounds can you create with just ten items and your tape recorder? For starters, you'll experiment with each individual material and see how many sounds you can make. Then start combining them. As you become more familiar with the properties of different materials, think about other sounds you can create with them.

Materials

- ball bearings
- balloons (uninflated)
- bottle of carbonated water
- bottle of noncarbonated water
- cellophane
- cylindrical oatmeal carton
- Popsicle sticks
- rubber bands
- sandpaper
- stiff pieces of cardboard
- tape recorder

1. Experiment with each of the above items to create different noises. Try creating new sounds by manipulating two or more items in combination or

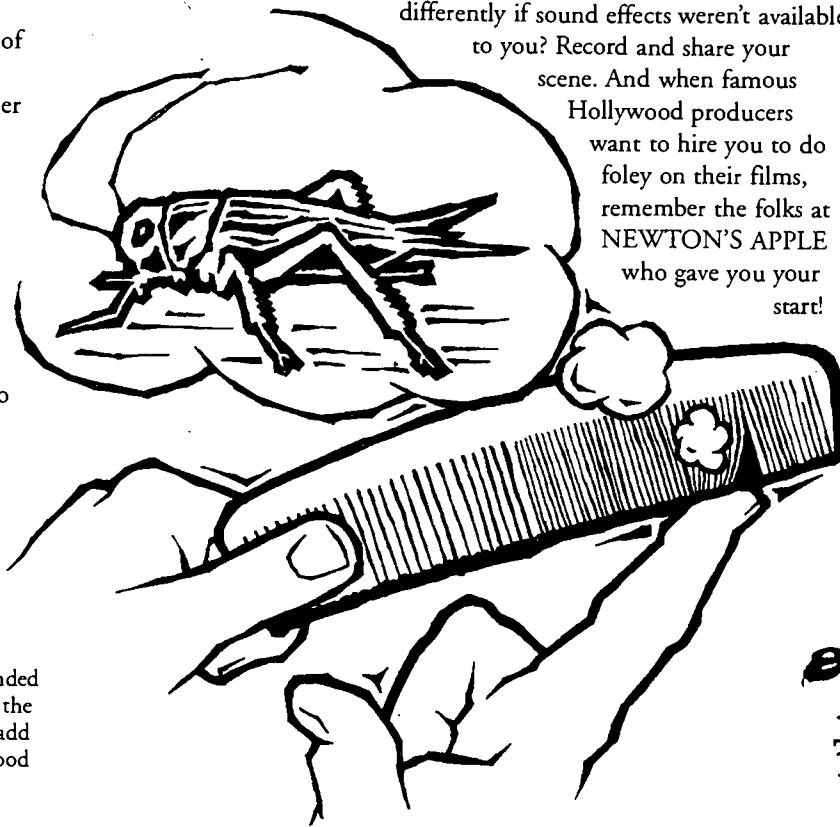

changing the environment you are in. Feel free to cut things apart, glue them together, or do whatever else inspires you. Decide what actual sounds your sound effects could represent. Tape-record your sounds. When you finish, write out a list of what each sound on the recording represents, as well as how you created it.

2. Now, your debut as a foley artist! Play the sounds for a few friends. Do they recognize what you intended the sound to be? If you like, draw pictures or add dialogue to the sound effects to make the noises more recognizable.

3. Using your new sound effects as inspiration, write a short scene for the radio. See how many different sound effects you can incorporate. How would you write this scene differently if sound effects weren't available to you? Record and share your scene. And when famous

Hollywood producers want to hire you to do foley on their films, remember the folks at NEWTON'S APPLE who gave you your start!

Try This

In the NEWTON'S APPLE foley segment, Peggy learns that there are several different sound elements in the dinosaur egg hatch—the cracking egg, the sticky membrane, and the motion of the baby dinosaur. Can you identify the different elements of other sounds? For instance, listen to a watermelon being cut open. Or a box of cereal being opened. How would you categorize the different types of sounds?

Try This

Silent films depended on an organist in the movie theater to add the music and mood to make a movie complete. Rent a silent Charlie Chaplin film. Treat it as a rough cut. Watch the entire film with the sound turned off. What sound effects would you add? How would you do them?

Try This

Take a tape recorder on a walk with you. Really listen to the sounds around you and record sounds that you hear every day, but typically ignore. Choose your top ten favorites and play them for friends. How many do they recognize? How many stump them? You can make it tougher by editing out part of longer sounds. (Here are two to get you started—a parking meter and a light bulb being screwed in.)

213

Try This

In the early days of live radio, John Dennis invented a way to create the sound of thunder. His method of rattling a large piece of thin copper sheeting suspended by wires became so popular with others in the field that an irate Dennis accused another producer of "stealing my thunder!" Dig through your kitchen. How many ways can you steal some thunder? (Hint: Don't do this before 10 a.m.)



SHOW NUMBER

1206

How big is the sun, and how far away is it from Earth? What is the sun made of, why is it hot, and will it ever burn up?

SHOW NUMBER

1206



David learns that the sun is so large a million Earths could fit inside it.

Segment length: 7:39

Sun

What keeps the sun on fire?

You step outside on a crisp, clear night and gaze up at a sky full of sparkling stars. You wonder which one to wish upon—they're all beautiful, but so far away.

Why not try wishing upon the star that's closest to our own planet Earth, the one we see almost every day, the one that provides the light and heat we need to survive?

Our sun is just one of the 100 billion or so stars in our *galaxy*, and there are billions of other galaxies in the universe. It may seem like the sun is close to us, but it's about 150 million kilometers (93 million miles) away. It's bigger than anything we can imagine—about 1.4 million kilometers (870,000 miles) in diameter. A million Earths could fit inside it!

The sun may be only one among billions of other stars in the universe, but it's the one that makes our life on Earth possible. How? By providing energy in many forms—solar power, fossil fuels, *wave power*, wind power. Without heat and light from the sun, Earth would be just another dark, cold place in space where life as we know it couldn't exist.

Where does the sun get all this energy? The sun's *mass* is approximately 300,000 times more than Earth's, and the greater an object's mass, the greater the pressure at its center. *Charles's law* tells us that when you squeeze—or compress—a gas, it gets hot. Most of the sun's mass is composed of *hydrogen* gas atoms, and about 100 years ago, physicists came up with the hypothesis that the sun's tremendous mass squeezed the hydrogen atoms until they ignited, releasing heat and light energy that eventually made it through space to us. Based on calculations of the mass of the sun, they figured that the sun would burn itself out in 6,000 years.

Evolutionary biologists and geologists knew from their own studies that life on Earth had been around much longer than 6,000 years, so the research continued. Decades later, a new hypothesis arose. Think about the hottest oven you can imagine, then turn up the temperature to about 25,000,000°F. That's how hot it gets in the center of the sun. At that temperature the hydrogen nuclei are moving so fast that when they crash into each other they stick together to form *helium* nuclei.

The "fallout" from this crash is a tremendous amount of energy, released mainly in the form of heat and light. This reaction at the nuclear level is called *nuclear fusion*. Scientists calculate that there is enough hydrogen in the sun to continue the fusion reaction and provide heat and energy for at least another five or six billion years.

2. What is the range of temperatures on Earth? Compare this with temperatures on other planets in our solar system. Do any other planets have a similar range that would allow for human survival?
2. What kinds of energy resources do we have on Earth? How are they related to the sun? Are any of our energy resources in danger of being used up? How can we conserve our energy resources?

Vocabulary

Charles's law When you squeeze a gas, it heats up.

evolutionary biologists scientists who study the development of organisms or species from their initial form to their present state

galaxy group of stars

helium light, colorless inert gas that places second on the periodic chart. It's often used to inflate party balloons and blimps.

hydrogen the lightest of all known substances, it comes in first on the periodic chart

mass measurement of how much matter there is (not how much that matter weighs)

nuclear fusion fusing, or joining, the smallest of nuclei to release tremendous amounts of energy

nuclear reaction reaction that takes place at the core of an atom. It converts mass into energy.

wave power energy generated by waves in the sea or in rivers and lakes

Resources

Asimov, I. (1987) *How did we find out about sunshine?* New York: Walker & Co.

Darling, D. (1984) *The sun: Our neighborhood star.* Minneapolis: Dillon Press.

Discover space. (1993) Novato, CA: Broderbund (MS-DOS).

Fowler, A. (1991) *The sun is always shining somewhere.* Chicago: The Children's Press.

Pecker, J.C. (1992) *The future of the sun.* New York: McGraw-Hill.

Rathbun, E. (1989) *Exploring your solar system.* Washington, DC: National Geographic Society.

The sun. (1990) Alexandria, VA: Time-Life Books.

Taylor, P. (1991) *Observing the sun.* Cambridge & New York: Cambridge University Press.

Where in space is Carmen Sandiego? (1993) Novato, CA: Broderbund (Macintosh, MS-DOS, Windows).

The view from Earth. (1992) Burbank, CA: Warner New Media (CD-ROM for Macintosh).

Additional sources of information

Teacher Resource Center

Jet Propulsion Laboratory

M.S. C-S 530

4800 Oak Grove Drive

Pasadena, CA 91109

Community resources

Observatory or planetarium

Local amateur astronomical society

A Sunny Perspective

Compare the relative sizes of the sun and Earth.



SHOW NUMBER

1206

Main Activity

Just how much bigger is the sun than Earth? And how far away is it? If you can't get a reservation on the next space shuttle flight, you'll have to go out to a field with a few friends and a few supplies to find the answers. You'll be amazed at what you observe when you compare the size of Earth with that of the sun and see how far you'd have to travel to get from one to the other.

Materials

- heavy butcher paper or 4 large sheets of poster board
- scissors
- tape or glue
- meter stick
- long-distance measuring tape
- marble, about 2 cm ($\frac{3}{4}$ " in diameter, to represent Earth
- athletic field or large open area, at least 250 meters (820') long
- stones or bricks to use as markers
- at least three people

1. Make a paper circle to represent the sun. It should be 2.3 meters (7.5') in diameter.

2. Next, go outside and measure a length of 246 meters (807') on an athletic field or other large area. Use bricks or stones to mark each end.
3. You'll need at least two people to stand next to one marker, holding the paper sun.
4. The third person holds the marble, representing Earth, and walks from the sun over to the other marker.

Questions

1. How could you represent the differences in the distances between Earth and the sun at various times of the year?
2. How far from the sun are other planets in our solar system? On a large sheet of paper position each planet at its appropriate distance from the sun and represent its size to scale.
3. Discuss the difficulties involved in representing relative diameter and distance in the same model.

Try This

When we talk about the sun, we must use extremely large numbers. When working with very large or very small numbers, we use scientific notation, which means rewriting a number as the product of a number between 1 and 10 and a power of 10. For example, the sun's diameter, approximately 1,391,000 km, would be written as 1.391×10^6 km. Write some other large numbers in scientific notation.

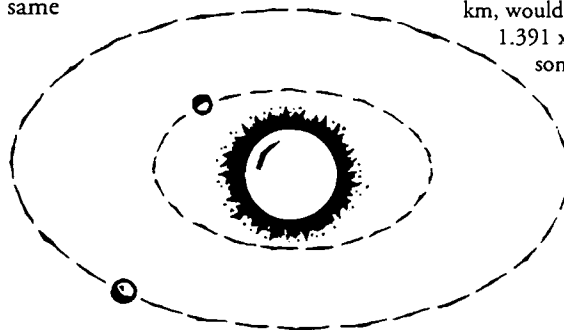

Try This

Simulate the transfer of energy that takes place in a nuclear reaction and recycle sheets of paper at the same time! Get a group of at least six people to form a circle, each wearing safety glasses. Give each person two sheets of used paper (everyone should have the same size and weight of paper) and ask them to crumple the sheets to make two paper balls. Each person in the circle should hold a paper ball in each hand, and be ready to toss them in the air. The leader tosses (don't throw) a ball at one person. Whoever is hit by the ball quickly tosses the two balls she or he is holding at the group. The two people that person hits in turn toss their paper balls at the group. This continues until everyone has tossed their paper balls. The process should only take a few seconds. Observe how the tossing action speeds up as more people get involved!



Try This

Sunlight looks colorless until it is refracted (bent) by water molecules in the air (raindrops), and displayed in the sky as a rainbow. There are many ways to capture white sunlight and create your own rainbow. Cut a slit that is 1 cm ($\frac{3}{8}$ " wide and 20 cm (8") long out of the middle of a sheet of opaque white paper or cardboard. Tape this sheet to the side of a clear glass of water so the sheet is standing vertically next to the glass. Place an 8 $\frac{1}{2}$ " x 11" sheet of white paper on a table next to a sunlit window. Position the glass of water and the slit paper on top of the other sheet so that the paper with the slit is between the glass and the window. The room must be darkened except for a small beam of sunlight. As sunlight passes through the slit, it will be refracted by the water, creating a spectrum of colors that you'll see on the plain sheet of paper.

245

What are mass extinctions and how do they occur? What evidence suggests an asteroid hit Earth 65 million years ago? Where is the crater and how can we confirm it?

SHOW NUMBER

1207



Peggy travels to Mexico to look for evidence that an asteroid may have caused the dinosaurs' extinction.

Segment length: 9:27

Dinosaur Extinction

Where did the dinosaurs go?

Insights & Connections

Trying to understand why the dinosaurs became extinct has become one of the great geological detective stories. Some recent findings from the small Mexican village of Chicxulub have given scientists new hope that the answer may soon be known.

The story starts a little over 15 years ago in the town of Gubbio, Italy, where geologist Walter Alvarez was collecting sediment from a layer of rock which marked the boundary between the Cretaceous and Tertiary time periods. Geologists had long known that this boundary was important because it marked a period in the Earth's history, some 65 million years ago, when almost half of all known species suddenly disappeared, including the dinosaurs.

Walter brought some of his sample back to the United States and his father, Nobel prize-winning physicist Luis Alvarez, analyzed it for any unusual chemicals. To their surprise, the sample showed a high concentration of the element iridium, a substance rare on Earth but common in *meteorites*. To make sure there was nothing unusual about the Gubbio sample, they analyzed other K-T boundary *strata* from around the world. They found extra iridium in these samples as well. Using the average thickness of the clay as a guide, they calculated a meteorite would require a diameter of about 10 kilometers (6 miles) to produce this much iridium.

If a meteorite that size had hit Earth, the results could explain the extinction of dinosaurs. The dust thrown up in the air would have caused major climatic changes to which many animals could not rapidly adapt. A major problem with this theory, however, was that a 10-kilometer meteorite would leave a very large *crater*, between 150 and 200 kilometers (93–124 miles) in diameter. While Earth has many impact craters on the surface, few are even close to this size.

Because 65 million years had passed since the hypothetical impact, scientists decided to shift the search underground. A crater that old would almost certainly have been filled in. Just by chance, a Mexican oil company drilling off the coast of Yucatan discovered what appeared to be a crater about one kilometer (0.6 miles) under the surface near the village of Chicxulub. When *core samples* were analyzed, they showed the crater to be about 180 kilometers (112 miles) in diameter and 65 million years old. Was this the cause of the dinosaurs' extinction? The jury is still out, but evidence strongly suggests that the case of the disappearing dinosaurs may finally be solved.

- ?? Suppose a ten-kilometer meteorite hit Earth today. What effect would it have on humans?
- ?? Massive meteorite impacts are only one possible cause of climatic change. Volcanoes, forest fires, and industrial pollutants can also affect weather. Many scientists feel that human activities may cause climatic change. What do you think?
- ?? How have meteor impacts affected our moon, Mars, and other solar system members?
- ?? What did astronomers learn when they watched fragments of the Shoemaker-Levy comet hit Jupiter in July 1994?

Vocabulary

core sample a section of a cylindrical soil or rock sample taken from below the ground by using a hollow drill
crater a large circular depression on the surface of a solid celestial object caused either by meteorite impact or volcanic eruptions
gravity anomaly the difference in the amount of gravity measured on Earth's surface compared with the theoretical value for that location

meteorite a small, rocky body from space that strikes Earth
strata distinct layers of sediment or rock
tektite a small, round- or oval-shaped, glassy object formed when ejecta is melted and rapidly cooled in the atmosphere as it lands back on Earth's surface

Resources

Asimov, I. (1988) *Did comets kill the dinosaurs?* Milwaukee: Gareth Stevens Publishing.

Bakker, R. (1986) *The dinosaur heresies*. New York: William Morrow and Company.

Bond, P. (1994, May) Assessing Earth impact hazards. *Astronomy*, pp. 18–20.

Gore, R. (1989, June) Extinctions. *National Geographic*, pp. 662–699.

Gore, R. (1993, Jan) Dinosaurs. *National Geographic*, pp. 2–53.

Hecht, J. (1993) *Vanishing life: The mystery of mass extinctions*. New York: Charles Scribner's Sons.

Kerr, R.A. (1993, Mar 12) Second crater points to killer comets. *Science*, p. 1543.

Lemonick, M.D. (1993, Apr 26) Rewriting the book on dinosaurs. *Time*, pp. 42–49.

NEWTON'S APPLE Show #1105—meteors segment. KTCA Video Services: (612) 229-1253. Or call your local PBS station to find out when it will be rerun.

Seyfert, C. & and Sirkin, L. (1979) *Earth history and plate tectonics*. New York: Harper and Row.

Community resources
 Contact a local astronomy club to go comet and asteroid hunting

Geology department at local college

Core Box Analysis

Drill down into clay to analyze what's beneath the surface.



SHOW NUMBER

1207

Main Activity

Because many geological features like craters are buried, geologists must find ways of probing beneath Earth's surface to understand what's there. Since it would be too expensive to simply dig one big hole, geologists do the next best thing—they drill long, slim holes and correlate the sections. In this activity, you can try your hand at unmasking a hidden geological structure.

Materials

- a cardboard shoe box
- 4 or 5 colors of plastic modeling clay, about 1 lb of each
- 25 wide plastic straws
- small, sharp scissors
- a metric ruler
- 2 blank pieces of paper and a pencil

1. Before starting this exercise, someone must create a geological structure in the shoe box. Begin by placing layers of clay, each a different color, one on top of each other in the box. Vary the thicknesses of the layers. In the middle of the box, either create a crater by cutting out a circular depression or make a dome by burying a big ball of one clay color in the different layers.

Once the structure has been completed, give it to the students doing the drilling.

2. To "drill" the structure, slowly insert one plastic straw into the top and push it down all the way to the bottom of the box. Before removing the straw, measure the exact location of the core relative to two sides of the box and mark that

point on the blank paper. Label it "core 1."

3. After marking the core location, slowly remove the straw. The clay should stay inside. With the scissors, carefully cut the straw lengthwise, starting at the bottom. Try not to disturb the clay inside. Using the ruler, start at the bottom of the straw and measure the thickness of each color of clay. Draw this on the second piece of paper and label it "core 1."

4. After marking the first core, take a second straw and repeat steps 2 and 3 in a second location. Continue until you have drilled, located, and measured 20 cores. Based on the location of the cores and the clay layers in each one, see if you can reconstruct a three-dimensional model of the geology in the shoe box. When you think you have done it, peel away the sides of the box and see how close you came.

Questions

1. Based on this exercise, how might increasing or decreasing the number of straws you use change the accuracy of your coring model?
2. When you are cutting open your straws, what error factors must you consider?
3. Besides coring, what other methods might geologists use to "look inside" Earth?
4. What hazards might a drill team encounter if they were drilling rock instead of clay?

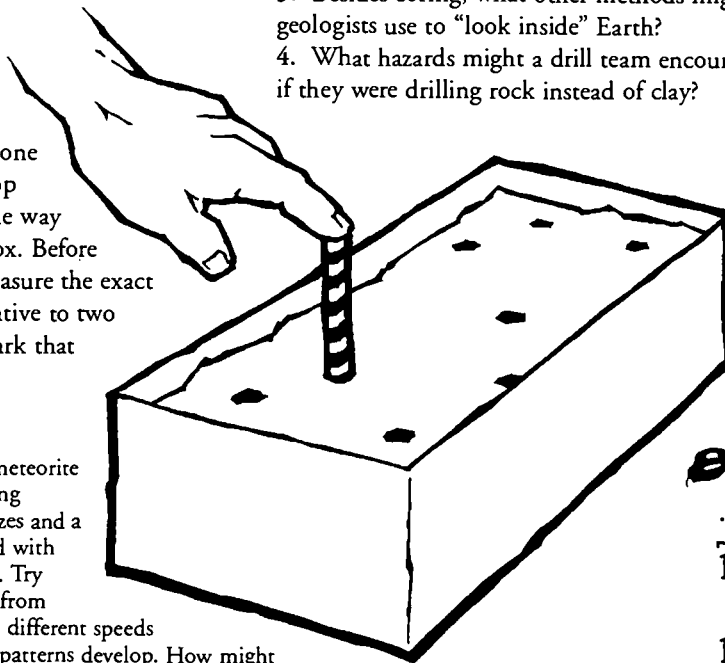

Try This

Try making a model meteorite bombing range by using marbles of different sizes and a large baking dish filled with about an inch of flour. Try dropping the marbles from different angles and at different speeds and see what types of patterns develop. How might this activity be used to tell the age of craters on the moon?

Try This

While the Chicxulub crater is a large one, it's not the only impact site on Earth. Research other impact sites in the United States and the world. Are any of these possible candidates for a dino crater as well? Do any of them support the idea of a multiple meteorite impact?

Try This

Go to a local museum or planetarium and check out some meteorite exhibits. How do the meteorites differ? What's the largest one researchers have found and where is it located?

Try This

Meteorite impact is only one theory used to explain the extinction of the dinosaurs. Do a little research and see what other extinction theories are being offered. Are any of them valid? Hold a debate with your friends and discuss these theories.

How do people control the flooding of rivers? Do these methods of control sometimes make matters worse?

SHOW NUMBER

1207



David experiences the powerful force behind a flooding river.

Segment length: 7:19

Floods

How can water be powerful enough to move a house?

It's hard to believe that a small, slow-running stream could cause harm. During a flood, however, even the calmest brook can become a torrent and cause unforeseen misery and damage.

Many people like to live near a body of running fresh water. Rivers and streams provide recreation, food, and, of course, drinking water. But when rain or melting snow produces large amounts of water, rivers and streams may flood, causing problems for those who live nearby. Although we describe floods as disasters, they are, in fact, natural phenomena.

Floods occur when a *watershed* receives so much water that its waterways cannot drain it off properly. A watershed is an area of land (usually quite large) that drains into a river or stream. A small river will drain several thousand or hundreds of thousands of *acres* of land. Within any one watershed, excess rain will cause increased water levels downstream. What occurs at any point along a river can affect not only that point but also the entire watershed.

To minimize the effects of a flood, engineers build *levees* to constrict the overflow of rivers. As more communities build levees, the water in a river is forced to run at a higher level because it cannot spread out. As the water runs at a higher level, it deposits sediment and raises the *riverbed*. The situation worsens as the water rushes downstream. The water level can only continue to rise, eventually spilling over the levees. During prolonged periods of flooding, many levees give way because they are under pressure from the swollen river and are being undercut by water seepage.

Floods in *undeveloped areas* are not as damaging as the floods in *developed areas*. First of all, many natural areas have thousands of acres of *wetlands* which act as giant sponges to soak up excess water. Second, many rivers overflow into the *floodplain*—a low, flat area on either side of the river.

If a river is allowed to spread out onto its floodplain, the flow downstream is slowed. A river's floodplain can accommodate huge amounts of water which are *diverted* from the main channel and held back. Allowed to flood in this way, the river creates less damage downstream. If humans do not interfere with it, a stream or river produces its own flood control system.

- Is there a problem with flooding in your area? What plan could you develop to improve the situation? Who would need to be involved?
- Can you design a levee that could withstand most floods? What would such a levee cost? Who would pay for it? How would it affect people living downstream from it?

acre an area of land equal to 4,047 square meters (4,840 square miles)

developed areas places with roads, levees, houses, factories, and other human-made structures

divert to channel something to another location

floodplain flat area on either side of a river which is under water during a flood

levee a bermlike structure that acts as a barrier to flood waters

riverbed the bottom of a river

undeveloped areas natural, wild areas that are untouched by human development

vegetation generic name for all the plants in a particular area

watershed an area of land that drains into a stream or river

wetlands marshy, wet areas which contain wildlife species and have the capacity to hold large amounts of water

Allen, W.H. (1993, Dec) The great flood of '93. *BioScience*, pp. 732-737.

Brownell, B. (1993, Oct) The great flood of '93. *National Geographic World*, pp. 23-25.

Mairson, A. (1994, Jan) The great flood of '93. *National Geographic Magazine*, pp. 42-81.

National Geographic videotape: *The Power of Water*. Check local PBS listings or call (800) 343-6610 for more information.

Snyder, G. (1992, May/June) The watershed. *Sierra*, pp. 24-26.

Additional sources of information
American Water Resources Assn.
5410 Grosvenor Lane, Suite 220
Bethesda, MD 20814-2192

America's Clean Water
Foundation
750 First St. NE, Suite 911
Washington, DC 20002-4241

Freshwater Foundation
725 Country Road 6
Wayzata, MN 55391-9611

National Water Information
Clearinghouse
U.S. Geological Survey
423 National Center
Reston, VA 22092-0001

Water Education Foundation
717 K St., Suite 517
Sacramento, CA 95814-3408

Community resources
Local Army Corps of Engineers

Soil Conservation Service field
office for your area

Water Bowl

Find out why forcing water to stay within a small area puts it under pressure.



SHOW NUMBER

1207

Main Activity

The presence of a natural floodplain is crucial to the management of floods. When water is allowed to spread out away from the main channel of a river, the river can accommodate more water. If, on the other hand, a river's flow is prevented from spreading, the only place for the water to go is up. An increase in water height means higher water pressure and an increase in damage. How does the spreading out of river water make a difference? How does it decrease water pressure? Try the following activity to get the "feel" of water at different depths.

Materials

- roll of clear plastic (poly), 6 mil or thicker, wide enough to produce at least two 3.7 meter x 3.7 meter (12' x 12') sheets
- garden hose
- supply of water

Number of people: Eight or more. If you have fewer, cut down on the size of the plastic sheet.

1. Find a level, soft surface outdoors that is close to an outdoor water spigot. Lay the plastic sheet flat on the ground. Depending on the thickness of your plastic, you may want to use two sheets to increase strength.
2. Organize participants around the perimeter of the sheet so that everybody is at equal distances from each other.
3. Each participant should firmly grab the plastic sheet with both hands.
4. All participants should come together towards the center to form a large "bowl"

5. Begin filling the plastic with water from the hose.
6. From here on, the goal is to put as much water as possible into the plastic without letting any escape. You can move about in any way you want to increase the capacity for water. See what you learn about the force of water. How much water can you hold?

Questions

1. How does this activity compare to actual watershed problems? What are the similarities and differences?
2. What is the best arrangement to hold the greatest amount of water? What arrangement requires the least effort? How deep a pool of water can you create? Can you devise a way to estimate the total number of gallons you can hold?
3. What would it take to create a better structure for holding more water?

 **Try This** Does a river run through the city where you live? Look on a map and see whether you can find any large cities that do not have rivers. List them. Where would their sewage go? Where would their water supply be?

 **Try This** Do you know your watershed? If a drop of rain falls on your rooftop, where does it eventually go? Trace its path. Map out the major streams and rivers that make up your watershed.

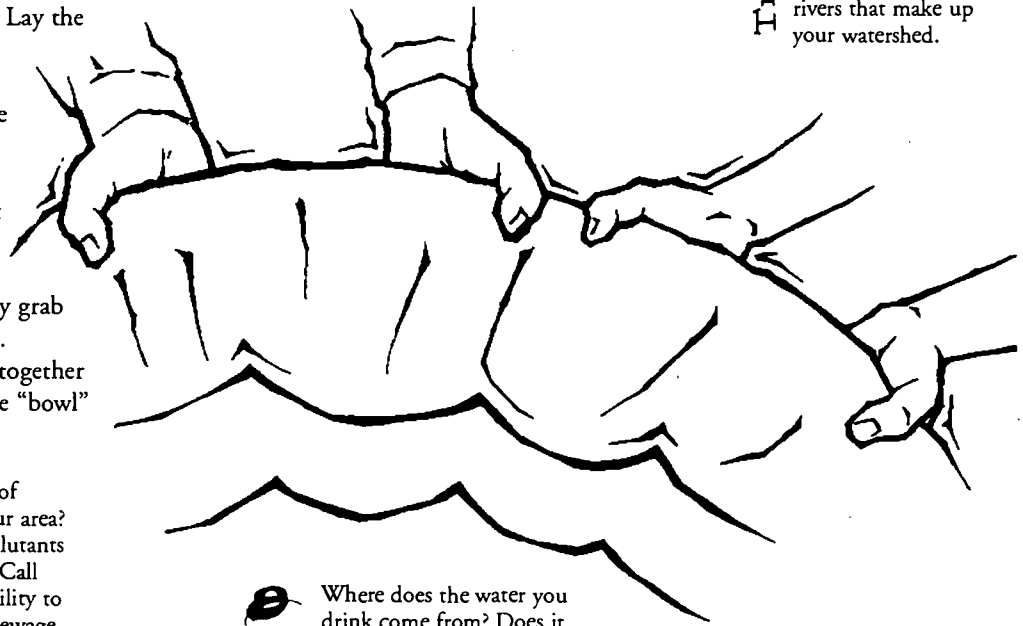

 **Try This** What are the sources of water pollution in your area? One of the largest pollutants could be city sewage. Call the local sanitation utility to find what is done to sewage before it is dumped back into the stream or river. Visit a sewage treatment plant.

 **Try This** Where does the water you drink come from? Does it come from a river? A lake? Underground? Call the city water department to find out. Ask to visit the water treatment plant.

219

Why is the Internet sometimes called the information superhighway? Why is it growing and changing so rapidly?

Internet

What is the Internet?

Insights & Connections

You hear about a new, world-class biology research laboratory and decide to visit it. You look around the lobby, then find your way into the chemistry lab where you pick up a carbon atom. After you change the number of protons and adjust the number of electrons and neutrons, the atom informs you it's become oxygen. Suddenly, you notice that two biochemists have entered the room and are discussing an article from the latest issue of *Science* magazine. You greet them, then change the atom further so it becomes nitrogen before you head toward the library.

The lab you have just visited is called the BioMOO biology center—and it only exists on a computer. You reach the lab through the *Internet*, an electronic network that connects computers around the world. Scientists (and anyone else who is interested) can meet at the BioMOO labs without leaving their desks, simply by guiding their computers to make a connection through the “information superhighway.”

The Internet is sometimes called the information superhighway because it provides electronic pathways for transporting vast quantities of information from place to place all over the world. There is so much information available on the computers connected to the Internet that you could never look at it all. Students, researchers, hobbyists, business executives, and other “net surfers” are constantly adding to it.

The Internet is actually a rapidly growing network of networks. Thousands of universities, businesses, and other organizations have their own computer networks. These networks are connected to each other over high-speed data lines. Together, the computer networks form an information and communication web known as the global Internet. More than 15 million people worldwide have logged onto the Internet, and approximately two million new people log on every month!

Besides visiting world-class “virtual” biology labs, you can also get information on almost any subject area, from how to make recycled paper to what the President is scheduled to do that day. You can communicate by exchanging electronic messages (called *e-mail*) delivered within minutes to people in almost any place in the world. You can meet enthusiasts interested in the same things you are—whether it's rap music or chess—and join them in a conversation or a cross-continent computer game. You can join in collaborative experiments and share results with other students and teachers throughout the world. You can gather pictures, sounds, and software from space shuttle missions, science museums, or amusement parks. The possibilities increase daily.

- ? Why is access to information valuable? What role does information play in our society?
- ? The Internet lets people around the world discuss issues without ever leaving their offices, schools, or homes. Will this have a negative or positive impact on our society and others?
- ? Anyone can post almost any information on the Internet. What are the pros and cons of this?

Vocabulary

baud rate the speed at which a modem sends information. The higher the baud rate number, the faster the information can be sent.

chat immediate interactive conversation between two or more people via text transmitted across the network

cyberspace the “place” you feel you are in when you enter, communicate through, and travel over computer networks

e-mail messages sent from one computer to another through a network. An e-mail message can be sent to just one person or to many people at a time, reaching almost any area in the world.

Internet a loosely-knit, international network of computers (*Inter* from international, *net* from network)

modem an electronic device that allows a computer to communicate with other computers or fax machines over a phone line

on-line connected to a computer network.

250

SHOW NUMBER

1208



Peggy investigates the Internet computer network.

Segment length: 7:39

Resources

Birkerts, S. & Kelly, K. (1994, May) The electronic hive: Two views. *Harper's Magazine*, pp. 17–24.

Corcoran, E. (1993, Sept 20) Why kids love computer nets. *Fortune*, pp. 103–106.

Eddings, J. (1994) *How the Internet works*. Emeryville, CA: Ziff-Davis.

Hahn, H. & Stout, R. (1994) *The Internet Yellow Pages*. Berkeley, CA: Osborne McGraw-Hill.

Harris, J. (1994, Mar) Information collecting activities. *The Computing Teacher*, pp. 32–36.

Wallich, P. (1994, Mar) Wire pirates. *Scientific American*, pp. 90–101.

Weiss, J., Jr. (1993, Mar) Real-world science in today's world. *Technology & Learning*, pp. 20–23.

Additional sources of information
Electronic Frontier Foundation
666 Pennsylvania Ave. SE,
Suite 303
Washington, DC 20003
(202) 544-9237
(Addresses social and legal issues related to the use of computer networks. Send e-mail to eff-request@eff.org and ask to be added to the mailing list.)

Community resources
Local business offices of multinational corporations

Local computer user group

Commercial on-line services that offer Internet access

Start an Information Service

Create an interactive bulletin board to understand how the Internet works.



SHOW NUMBER

1208

Main Activity

Newsgroups are electronic forums for discussing a topic. Through newsgroups, people with common interests can share information and ideas over the Internet. Thousands of Internet newsgroup topics exist, ranging from dance to artificial intelligence, from comic books to Brazilian culture. Anyone with a computer connected to the network can read or post messages to a newsgroup.

In this activity, you will start and maintain a bulletin board to get a sense of the potential and pitfalls of on-line newsgroups.

Materials

- a bulletin board
- pens and paper (recycled, if available)
- pushpins or thumb tacks

1. Choose a topic for your bulletin board, such as football, music, gymnastics, book club, comic books, horseback riding, etc. Choose one that you find interesting or important and that you feel others would like to discuss. Give your board a name and label it so that others can see what the topic is.

2. Begin your bulletin board by posting a message that you think will get people talking about the topic. Decide whether to moderate your board or leave it unmoderated. If you moderate it, anyone who wants

to post a message needs to submit the message first to you. You then decide to post it, keep it, or give it back to the sender. If you decide on an unmoderated board, anyone can post a message directly onto the board.

3. Now, hang your board in an accessible place and invite others to add to it.

4. As your bulletin board progresses, develop a list of frequently asked questions (FAQs) on your topic. Write up brief, straightforward answers for each question and post the list on your board.

5. Find out what it takes to keep people reading and contributing to an interactive bulletin board.

Questions

1. How did your bulletin board evolve? Did it meet your expectations?
2. What problems did you encounter in running your bulletin board? Do you think the same types of problems might develop in Internet newsgroups?
3. How might your bulletin board benefit from being on the Internet and allowing participation from anyone in the world? What difficulties might develop?
4. How might the way people participate in a bulletin board be different if it's electronic rather than on a wall with cards?

Try This

Emoticons are smiley and other faces (such as :-) and -8^ \) made from letters and other symbols typed on a keyboard. You usually have to look at them sideways to see the face. Someone writing an e-mail message may add emoticons to express emotion or to find a creative way to sign a name. Invent your own emoticon that looks like your favorite musician, actor, or yourself and make up the signature that you would like to use to sign e-mail messages.

Try This

Is there a question you have always wondered about? People "post" questions on Internet newsgroups or other discussion groups to ask about topics such as raising children, video games, and bicycle repair. Think of three questions. Find out where you might post or send your questions by looking in an Internet manual or directory. If you have access to the Internet, send out your questions. If not, find out how else you might get your questions answered.

251

How do antibiotics kill bacteria?
What could cause an antibiotic to lose
its effectiveness in curing a disease?



David discovers the importance of using antibiotics correctly.

Segment length: 7:45

Antibiotics

How do antibiotics work?

Insights & Connections

Chances are you or somebody you know had a sore throat recently. Most sore throats are caused by viral infections. But some are caused by *bacteria* like streptococci. On occasion, sore throats caused by streptococci can lead to rheumatic fever, an illness which can cause pain in the joints and severe damage to heart valves.

When examining a patient with a sore throat, a doctor does a throat culture to see if streptococcus is the responsible germ. This is done by wiping a cotton swab on the patient's throat and sending the sample to a laboratory. With the lab test results, the doctor can identify the causative germ and, if it is a bacterium, decide which *antibiotic* should be prescribed to help kill it.

Antibiotics, once considered miracle drugs, have sadly been losing ground in the fight against the same disease-causing bacteria that they routinely vanquished in the past. Because bacteria grow rapidly, a single cell can potentially produce millions of new cells each day. As they divide and reproduce, these cells have a natural tendency to change or mutate. Since the 1950s, due in part to the improper use of antibiotics, mutations have led to bacteria developing traits that make them more resistant to antibiotics and thus more of a threat to public health.

Through a complex process that involves the exchange of genetic information, some bacteria can even pass *resistance* along to unrelated strains of bacteria. As people travel around the world they can spread resistant bacteria to other areas, further magnifying the extent of the problem.

Antibiotics kill bacteria or arrest bacterial growth in a number of ways. Some, such as the quinolones and Rifampin, attack bacteria by interfering with their ability to divide. Others, such as the tetracyclines or aminoglycosides, prevent the manufacture of certain proteins essential to the bacteria. Penicillin antibiotics attack the ability of the bacterium to construct its cell wall. Through mutation, however, certain bacteria have acquired the ability to make a protein called penicillinase that destroys penicillin. Fortunately, scientists have been able to synthesize or make new antibiotics that penicillinase cannot destroy.

Antibiotics frequently are viewed as a sure cure for whatever ails us and may be requested when they aren't necessary. For example, antibiotics don't work against diseases like the flu or sore throats caused by *viruses*. Inappropriate use contributes to the resistance problem. To stop this trend, you should take antibiotics only when needed. The proper antibiotic should be chosen and used exactly as directed. Even though you may feel better after taking the antibiotic for only a few days (since most of the bacteria causing the infection are killed), you should complete the entire recommended course for the medication to insure that all the germs are eliminated.

- ? ? How do microbiologists determine which antibiotics are capable of killing particular bacteria?
- ? ? What is the difference between prescription drugs and over-the-counter (OTC) medications?
- ? ? Which bacteria are "good" bacteria, and what importance do they play in our lives?

Vocabulary

antibiotic a medication made of a natural or synthetic chemical that kills or arrests a microorganism, primarily bacteria. It is not effective against viruses.

bacteria one-cell microorganisms too small to see with the naked eye but visible when stained and viewed through a microscope

genetic mutation a process by which a cell's genetic makeup is altered, changing the cell and those cells it produces. Such mutation can produce an organism resistant to antibiotics.

resistance the natural or acquired ability of a bacterium to escape the harmful effect of an antibiotic

virus a subcellular particle, far smaller than most bacteria, that is parasitic and depends on living cells for growth and reproduction

Resources

Beardsley, T. (1992, Nov) Paradise lost? *Scientific American*, pp. 18-20.

Begley, S. (1994, Mar 28) Antibiotics: The end of miracle drugs? *Newsweek*, pp. 46-51.

Gibbons, A. (1992, Aug 21) Exploring new strategies to fight drug-resistant microbes. *Science*, pp. 1036-1038.

Levy, S.B. (1992) *The antibiotic paradox: How miracle drugs are destroying the miracle*. New York: DaCapo Press Inc.

Levy, S.B. (1993, Apr 14) Confronting multidrug resistance: A role for each of us. *Journal of American Medical Association*, pp. 1840-1842.

Schmidt, K.F. (1992, Oct 26) The troubling ghosts of scourges past. *U.S. News & World Report*, pp. 70-71.

Additional sources of information
Centers for Disease Control and Prevention
Center for Infectious Diseases
Office of Public Affairs
1600 Clifton Road NE
Atlanta, GA 30333
(404) 639-3401

American Society of Microbiology
1325 Massachusetts Ave.
Washington, DC 20005
(202) 737-3600

Community resources
Microbiology laboratory at hospital or clinic

Pharmacist

Bacteria Busters

Find out how some bacteria can become antibiotic-resistant.



SHOW NUMBER

1208

Main Activity

Antibiotics are medications that can kill bacteria, but they are not bulletproof. The type of bacteria they destroy can vary and bacteria may develop resistance to antibiotics. Bacteria might undergo genetic changes that prevent the antibiotic from doing its job. If a bacterial cell is genetically changed it may continue to thrive, even when treated with an antibiotic.

The following activity demonstrates how antibiotics work and how antibiotic-resistant bacteria can survive a medication's actions.

Materials

- pieces of paper 7.5 cm x 15 cm (3" x 6"), one per person
- straight pins, one per person
- four different color markers—red, yellow, blue, and green

1. On three of the pieces of paper, write the word "green" with the green marker to represent a trait that stops an antibiotic from working.
2. On the remaining pieces of paper, write about an equal number of the words "red," "yellow," and "blue" in their corresponding ink, one per paper. The colors depict ways that an antibiotic can destroy a bacterial cell. Blue

stands for the destruction of the cell's genetic material, red for breakdown of the cell wall, and yellow for an interruption in protein production critical to the cell's life.

3. Combine the papers

in a container. The participants should pick one paper each, to represent a specific trait of a bacterial cell, and

pin their individual papers onto their clothes. Once done, each participant should stand next to her or his desk or chair.

4. Explain what the blue, red, and yellow colors depict, omitting an explanation for the green resistance trait. After each color is explained, those "cells" wearing that color should sit down to indicate they've been destroyed by an effective antibiotic.

5. Note that three people are still standing, each wearing a green tag. Explain that these cells represent antibiotic-resistant bacteria that contain a specific trait (the green tag) which protects them from the antibiotic and leaves them unharmed. In real life, these cells would survive, living in an environment with fewer bacteria to compete for food and space than before.

6. If a bacterium can divide and produce 2 bacteria every 20 minutes, how soon will these three surviving resistant germs reach a total of one million organisms? 10 million? 100 million? One billion bacteria? Populations of this size, if pathogenic, are more than adequate to cause great harm.

Questions

1. What can happen to bacterial growth when there is little competition for food and space?
2. How can a doctor know for sure that the prescribed antibiotic works against the bacteria causing a person's sickness?
3. How many antibiotics do doctors have at their disposal? Which are the most common ones prescribed?

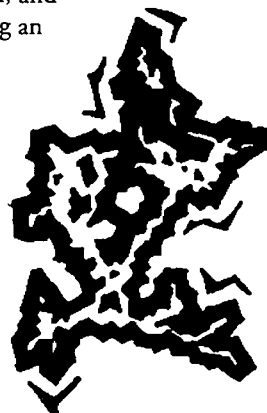

Try This

Some bacteria do not cause disease. Within our own bodies, bacteria help us digest the food we eat and gain access to its nutrients. Research how microorganisms can be helpful, such as decomposing leaves and wood, helping make yogurt, and producing insulin.

Try This

Find out how new drugs are developed, where new drugs might come from in the future, and what a company must do to receive approval from the U.S. Food and Drug Administration before a new drug can become available to the public.



Try This

Invite a microbiologist or physician with an interest in infectious disease to explain what antibiotics are and how they work. Discuss tests a lab might run to identify a bacterial strain and to learn which antibiotics effectively destroy it. Examine equipment from a lab and discuss the wide variation in types of bacteria.

Try This

Bacteria are all around us. Discuss how they can gain a foothold in our bodies—through a break in the skin, a depressed or immature immune system, or in food. List ways we can prevent this from happening, including good hygiene; proper food refrigeration, preparation, and thorough cooking; getting enough sleep and eating a balanced diet; proper cleaning and care of wounds; and getting vaccinated. What common household products have the capability to fight bacteria? Are we wise to use these products?

253

We encourage duplication for educational use!

NEWTON'S APPLE is a production of KTCA Twin Cities Public Television. Made possible by a grant from 3M. Educational materials developed with the National Science Teachers Association.

12.40

3M Innovation

How do ethnobotanists discover which types of plants were growing thousands of years ago and how people used them?

SHOW NUMBER

1209



Peggy explores how the ancient Maya culture used corn.

Segment length: 8:39

Ethnobotany

What is the science of *ethnobotany*?

Insights & Connections

Corn has always played an important role in the lives and culture of the Maya people. In fact, the Maya creation story states that the flesh of humans came from sacred ears of *maiz*. According to this story, the Creators saw people as a milpa, or cornfield, ready to serve them.

But apart from information we can gather through Maya legends and traditions, how do we know that corn was indeed an integral part of this culture and made up 80% of the Maya diet thousands of years ago? To answer questions like this, many scientists, including anthropologists, archaeologists, chemists, biologists, botanists, and ethnobotanists, must work together.

Ethnobotanists are scientists who study the role of plants in a society. To better understand how a particular culture interacted with plants in the past, ethnobotanists look for clues in many places. They can learn a lot by finding out how an area's current society uses plants.

When you visit the areas of Mexico and Central America populated by five million Maya descendants, it's easy to see that corn continues to be the most important food in the Maya diet. Maya cooks soak kernels of dried field corn in water and lime and then grind the mixture with a *mano* and *metate* to make the thick *zacan*, just as their ancestors have done for thousands of years. They pat the *zacan* into *tortillas* or fill it with meat, fruit, or chiles, and then wrap it with corn husks or banana leaves and steam it to make *tamales*. They even use ground corn to thicken atole, a drink often sweetened with fruit or *chocolate*.

But ethnobotanists need to examine information from sources other than present-day society. Paintings, carvings, figurines, and other art discovered at ancient Maya temple ruins reveal that corn played an important role in religion as well as diet, confirming that the Maya revered the maize god.

Since plants exposed to the elements decompose quickly, ethnobotanists also analyze soil samples taken from archaeological sites. They look for pollen, charred seeds, or food remains stuck in the bottom of broken pots. Then they study these fragile remains to analyze the plant's DNA and to compare it with that of the plant's contemporary descendants.

Ethnobotanists contribute much to our understanding of how the Maya have interacted with the plants in their environment for thousands of years. These scientists can show us how ancient customs translate into modern life and suggest methods to conserve the traditional ways of a proud culture such as the Maya.

- ? What other peoples in the world rely on corn as a dietary staple? How important is corn in your own diet?
- ? Popped kernels of corn several hundred years old were discovered with mummies buried in the ruins of a community in Paracas, Peru. What foods other than corn have been around that long? Ask grandparents or friends how their diets have changed over the past 50 years.

Vocabulary

chocolate a Mexican discovery, made from ground roasted cacao beans. Originally used to make religious ritual drink offerings and as money.
ethnobotany study of human relationship to plants, often involving study of ancient plant remains, oral history, written records, and myths
maiz Spanish word for maize, or corn
mano small, hand-held cylinder carved out of basaltic rock, used to grind corn in a metate

metate container carved out of basaltic rock, used with a mano to grind corn for dough
tamale ground corn dough filled with meat, fruit, or chiles, then wrapped in corn husks or banana leaves and cooked by steaming
tortilla flat, pancakelike food made from ground corn and baked on a griddle over an open fire or on a stove
zacan thick dough used to make tortillas and tamales

Resources

Amlin, P. (1994) *Popul Vuh: The creation myth of the Maya* (film). Washington, DC: NEH.

Coe, M. (1987) *The Maya* (4th ed., rev.). New York: Thames and Hudson.

Hernández, X., Ballonga, J. & Escofet, J. (1992) *San Rafael: A Central American city through the ages*. Boston: Houghton Mifflin.

Palazuelos, S., Tausend, M. & Urquiza, I. (1991) *Mexico, the beautiful cookbook: Authentic recipes from the regions of Mexico*. San Francisco: Collins Publishers.

Schele, L. & Miller, M.E. (1986) *The blood of kings: Dynasty and ritual in Maya art*. Fort Worth: Kimball Art Museum.

Stuart, G. & Stuart, G. (1983) *The mysterious Maya*. Washington, DC: National Geographic Society.

Tom Snyder Productions videodisc: *The Maya: Ancient Skywatchers. The Great Solar System Rescue* (side 2, frames 36132-41383). Check for it in your video library.

Trout, L.H. (1991) *The Maya*. New York: Chelsea House Publishers.

Community resources
 Local natural history museum
 Local Maya studies group
 Mexican restaurants

254

Separate Your Solutions

Borrow the techniques of an ethnobotanist to determine the contents of a mixture.



SHOW NUMBER

1209

Main Activity

Ethnobotanists make many discoveries by studying soil samples. As you work through several rounds of soil and water separation, try to imagine that you are working at an archaeological site and that your findings could reveal the way people lived and ate thousands of years ago.

Materials

- notebook for observations
- pencil
- clear plastic 2-cup containers with lids
- water
- bag of soil—allow about 1 kg (2.2 lbs) per person
- 1 paint tray per person (the kind used with roller brushes)
- about 1 cup each of dried corn, dried green and yellow peas, lentils, rice, and beans
- flower seeds
- grass seeds
- pepper
- sand
- glitter
- paper towels, coffee filters, cheesecloth, or screen material

1. Work in teams to create at least six different mixtures to analyze. They might include combinations of soil and grains, sand and glitter, pepper and grains, grass seeds and soil, etc. Try to include different weights.

2. Place each mixture in a different container and secure the lid. Label each mixture with a letter or number that doesn't reveal the contents. Keep track of the contents of each mixture in your notebook.

3. Trade mixtures with another team. Your goal will be to determine the contents of the mixture in each jar.

4. Shake each container well. Remove the lid and check the mixture. Has anything moved to the bottom or top of container? Record your observations.

5. Add enough water to make a soup the consistency of broth. Secure the lid and shake well.

6. Pour each mixture into a paint pan. Heavier matter in the mixture should filter out of the liquid and remain at the higher level in the pan. Liquids should flow to the deeper end of the pan and lighter matter should float on top of the liquid. Use paper towels, cheesecloth, or a screen to filter the liquid into another container. What's left in the filter? What's left in the liquid? Record your observations.

7. After you have repeated this process of separation for each mixture prepared by the other team, draw conclusions about the contents of each mixture. Ask the other team to check your findings.

8. Now that you've tried this activity indoors with mixtures you created, take your ethnobotany skills outside and collect real soil samples. Determine what methods of soil separation to use and record your findings.

Questions

1. How does soil and water separation work? Can you think of substances that could not be separated using water?
2. Ethnobotanists use soil separation in their research. What other scientists use this process as well?

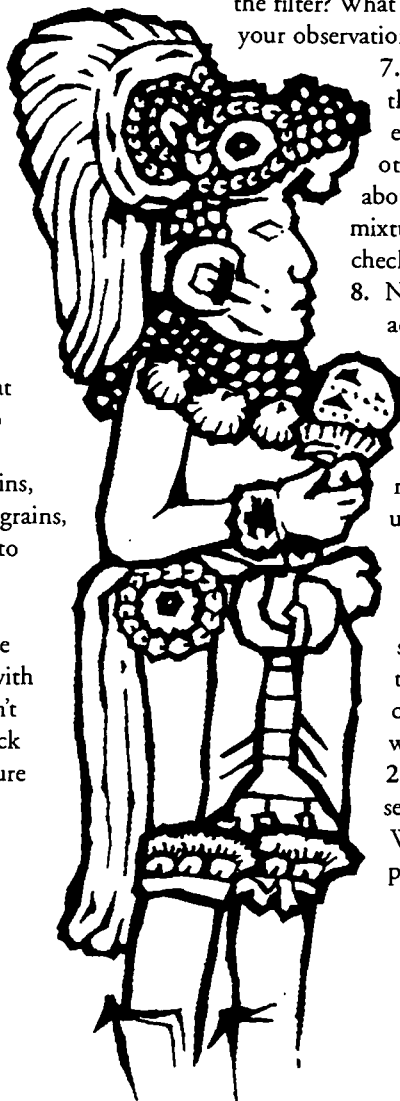

Try This

Look at pictures of Maya art. Look for representations of corn and other plants. Create a clay figure or a drawing that represents foods most important in your own culture.

Try This

How much do you know about the ethnic groups that live in your community? Visit a large grocery store and list as many products as possible that come from other countries. Visit local ethnic markets and note which plant foods seem to be most prevalent. Talk to the store owner about how the foods are prepared. You may need to ask someone in the store to translate the labels for you.

Try This

The ancient Maya numeration system used base 20, unlike the Hindu-Arabic system which uses base 10. Research the Maya numeration system, as well as other systems, and compare them with the system you use. Two good references are *Multicultural Math Posters* from Kay Curriculum Press [(800) 338-7638] and *Multicultural Mathematics Posters and Activities* from the National Council of Teachers of Mathematics [(800) 235-7566].

255

We encourage duplication for educational use!

NEWTON'S APPLE is a production of KTCA Twin Cities Public Television. Made possible by a grant from 3M. Educational materials developed with the National Science Teachers Association.

12.42

3M Innovation



Why is an orbiting telescope better than one on the ground? What was wrong with the Hubble Space Telescope and how did the astronauts fix it?

SHOW NUMBER

1209



David joins astronaut Jeff Hoffman for a close look at space.

Segment length: 7:47

Hubble Telescope

What is the Hubble Space Telescope and how does it work?

Is there anybody out there? Just as ancient explorers ventured out onto uncharted seas, astronomers have devised clever ways to explore space. Up until the early 1600s, the only tools people had for observing the night sky were their eyes and navigational instruments like sextants, astrolabes, and cross staffs. A major breakthrough came in 1609 when Galileo borrowed an idea from a Dutch lens maker and created the astronomical telescope.

With it, Galileo determined that Venus went through phases like our moon, that Jupiter had moons orbiting it, and that Saturn had protuberances of some kind. Based on these discoveries, he challenged Aristotle's Earth-centered model of the universe and the science of astronomy took a quantum leap forward.

Over the next hundred years, telescope-making became a well-established art. Late in the 1600s, Isaac Newton discovered that *refracting* lenses weren't the only way to bring distant objects close. By placing a *concave mirror* at the base of a hollow tube, he could concentrate more light with much less distortion. Using these new *reflecting telescopes*, astronomers like Caroline Herschel, George Hale, and Edwin Hubble pushed the limits of the visible universe even farther.

By the early twentieth century, reflecting telescopes grew to mammoth proportions. Because Earth is blanketed by a layer of air over 100 kilometers (62 miles) thick, ground-based telescopes must "see" through a soup of air currents, water vapor, and dust in the atmosphere. This distorts the light passing through the atmosphere and ultimately the image collected by the telescope.

The only way to get rid of distortion caused by the atmosphere is to place a telescope in orbit above it. In 1990, NASA used the space shuttle to place the Hubble Space Telescope (HST) in orbit around Earth at an altitude of about 613 kilometers (380 miles). HST is actually a combination of both optical and spectrographic instruments which capture light that is collected by HST's primary mirror. These instruments use computers to digitize images and send them back to Earth via radio transmissions. The digitized images are reassembled into pictures by computers on the ground. The primary mirror of HST is only 2.4 meters (8 feet) in diameter, which is small compared to many ground-based scopes. But because it's above the atmosphere, it can capture light from a volume of space almost 300 times greater than Earth-bound scopes.

Unfortunately, soon after its launch, project scientists found that the HST primary mirror had a slight imperfection which impaired its focusing power. In optical terms, this imperfection is called *spherical aberration*. Shuttle astronauts repaired the problem and gave HST better focus. By having HST in orbit above Earth's atmosphere, astronomers have now seen further than anyone has seen before.

- ? Many critics argue that the money for government-funded space projects could be better spent here on Earth. Do the spin-offs and scientific knowledge gained from space programs justify their expense, or are they a waste of resources?
- ? Do you think there is life on other planets? If so, how might we go about contacting it?

concave a curved surface that is bent inward
convex a curved surface that is bent outward
focus the point at which all the individual light rays are concentrated
focal length the distance between the mirror and the focal point
lens a device used for bending and concentrating light

mirror a device used for reflecting light
reflecting telescope a telescope that uses mirrors to concentrate light from a distant source
refracting telescope a telescope that uses a lens to concentrate light from a distant source
spherical aberration an imperfection in a lens that causes light to be focused at more than one point, distorting the image

Bunge, R. (1993, Aug) Big scopes: Dawn of a new era. *Astronomy*, pp. 48-53.

Bruning, D. (1994, Apr) Hubble better than new. *Astronomy*, pp. 44-49.

Bruning, D. (1994, Jan) Fixing Hubble. *Astronomy*, pp. 36-39.

Chaisson, E. (1994) *The Hubble wars*. New York: Harper Collins.

Davidson, G. (1993, Feb) How we'll fix Hubble. *Astronomy*, pp. 42-49.

Macauley, D. (1988) *The way things work*. Boston: Houghton Mifflin.

Smith, B. (1994, Jan) New eyes on the universe. *National Geographic*, pp. 2-41.

Additional sources of information
NASA CORE
 Lorain County Joint Vocational School
 15181 Route 58 S.
 Oberlin, OH 44074
 (216) 774-1051, ext. 293 or 294
 (catalog of A/V material available by request on school letterhead)

NASA Spacelink
 Attn: Spacelink Administrator
 Mail Code CA 21
 NASA Marshall Space Flight Center
 Huntsville, AL 35812
 (Computer information service supplies news about current NASA programs, activities, lesson plans, etc.)

Edmund Scientific
 101 E. Gloucester Pike
 Barrington, NJ 08071
 (609) 573-6250
 (catalog for optics)

Focusing in on Mirrors

Show why reflecting telescopes give us a clearer picture of space.



SHOW NUMBER

1209

Main Activity

Have you ever wondered why the side mirror on your car says "objects in mirror are closer than they appear" or why your reflection always looks strange in fun house mirrors? This activity gives you the opportunity to experiment with several different types of mirrors to shed light on how they focus.

Materials

- flashlight
- comb
- small, flat mirror
- three 8 1/2" x 11" sheets of plain white paper
- darkened room
- pencil
- large, shiny spoon

1. Lay the flashlight flat on a table on top of a piece of white paper. Make the room as dark as possible and turn on the light so that the beam spreads out across the sheet of paper. Take the comb and place it in front of the light so that the beam shines through the teeth. You should see a series of light rays spreading out from behind the comb.
2. Take the flat mirror and hold it up on edge so that it is facing the light rays coming from the flashlight. Use your pencil to trace the pattern of light rays as they strike and reflect off the flat mirror.
3. After tracing the pattern, label the page "flat" and put it off to the side. Put a new sheet of paper under the light and place the spoon in front of the light rays so that the back of the spoon is facing the flashlight. Trace this reflection

pattern on the second sheet and label it "convex." (Note: To be able to draw the light rays reflected from the spoon, you must place the paper and spoon at the edge of the table so that the rays are reflected from the center—not the edge—of the spoon.)

4. Place the third piece of paper under the light and this time, have the light rays shine into the bowl of the spoon. Trace this pattern on the paper and label it "concave." Turn on the lights and compare the three reflection patterns.

Questions

1. Compare the convex pattern with the flat pattern. How are they different? How might this explain why convex mirrors spread out the light from an object?
2. Compare the concave pattern with the flat pattern. How does this pattern explain why concave mirrors concentrate the light from an object? Can you identify the focal point?
3. Based on your experiment, why do you think wider-diameter concave mirrors are used to gather light from very distant astronomical objects?

Try This

Organize a star party for you and your friends. It's easy to do! All you need is a current star map available monthly in magazines like *Sky and Telescope*, *Astronomy*, or *Natural History* and a relatively dark place to view the night sky. You may want to contact a local amateur astronomy group to find out if they have regularly planned events. Or start your own club at school!

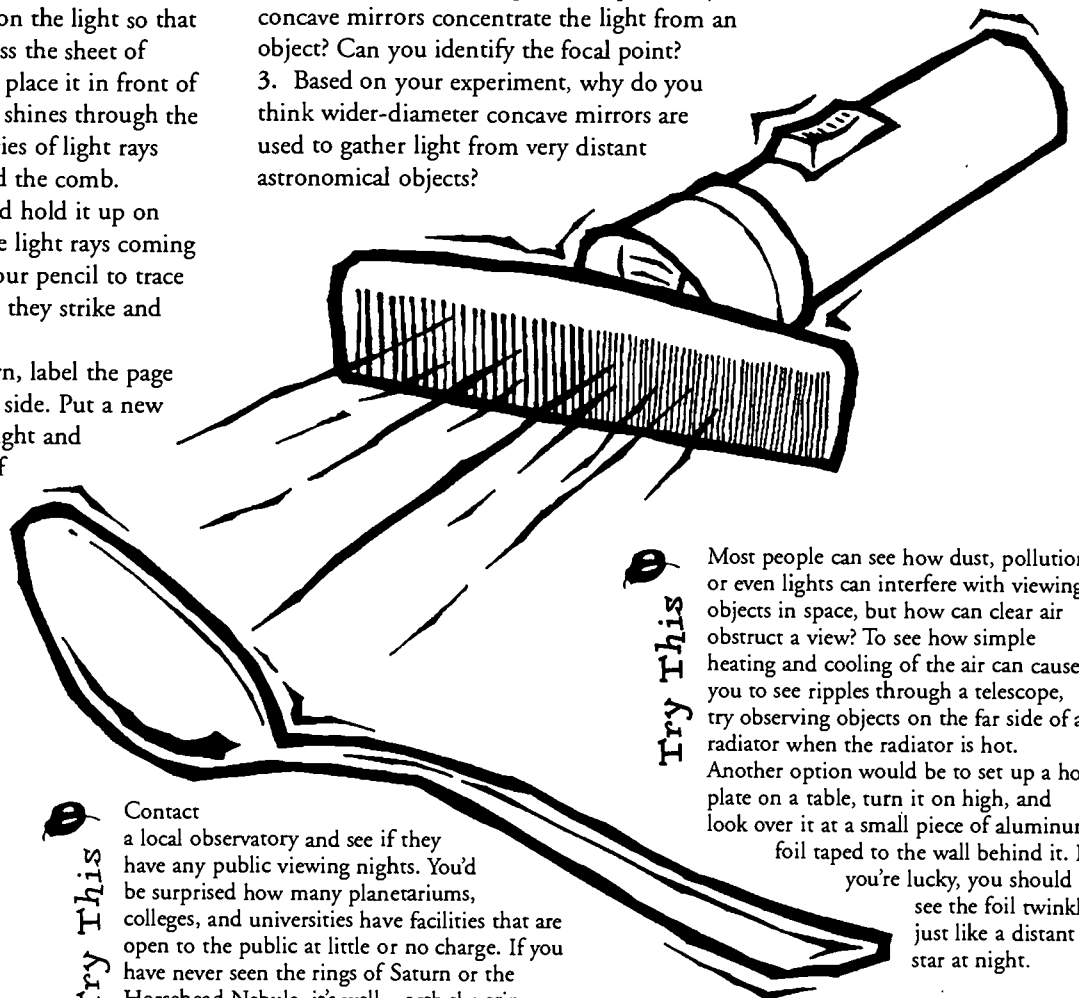

Try This

Most people can see how dust, pollution, or even lights can interfere with viewing objects in space, but how can clear air obstruct a view? To see how simple heating and cooling of the air can cause you to see ripples through a telescope, try observing objects on the far side of a radiator when the radiator is hot. Another option would be to set up a hot plate on a table, turn it on high, and look over it at a small piece of aluminum foil taped to the wall behind it. If you're lucky, you should see the foil twinkle just like a distant star at night.

Try This

Contact a local observatory and see if they have any public viewing nights. You'd be surprised how many planetariums, colleges, and universities have facilities that are open to the public at little or no charge. If you have never seen the rings of Saturn or the Horsehead Nebula, it's well worth the trip.

Try This

Try your hand at building a simple reflecting telescope. Simple, inexpensive plans are available in various science project books found in most libraries. Many basic parts can be obtained from local hardware stores or from a source like Edmund Scientific (see resources).

257

12.44



We encourage duplication for educational use!

NEWTON'S APPLE is a production of KTCA Twin Cities Public Television. Made possible by a grant from 3M.

Educational materials developed with the National Science Teachers Association.

3M Innovation

How can a raptor center or veterinary clinic rehabilitate a bird of prey so it can return to its natural environment? What should you do if you find an injured raptor?

SHOW NUMBER

1210



Peggy visits a raptor center that specializes in treating wounded birds of prey.

Segment length: 7:19

Raptor Hospital

How can we help injured raptors?

Raptors are majestic birds that can vary greatly in size and *habitat*. But they have one thing in common—they feed on *carion* or meat taken by hunting.

Although a large raptor like a bald eagle can have a wingspan up to 8 feet long and body length up to 3½ feet, it and other raptors are nevertheless vulnerable animals. Birds of prey may encounter many things in their environment that could harm them—often because of their proximity to humans. The birds may be poisoned by eating prey that has consumed poison. They may get hit by a car or caught in a leg-hold trap. They could become ill from disease or parasites.

When people find an injured bird of prey, they often contact a veterinarian, a raptor center, or their local conservation department. Commonly, raptors that come to a veterinary center have injuries to bone or flesh. Through expert care, many of them can be nursed back to health and returned to the wild.

A veterinarian thoroughly examines the injured raptor to assess its illness or injury. The examination might include blood tests and radiographs, pictures taken with X rays that show the bird's bones and internal organs. Depending on what the doctor finds, the raptor may need to be kept in captivity and treated with medication, surgery, and bandages. To repair a broken bone, the veterinarian may fix the break surgically, applying a pin, a plate and screws, or an external splint. A cast or bandage prevents the broken bone from moving. The injured bird is confined and fed its natural diet. Meanwhile, caretakers monitor its health and recovery.

While it is recovering, the bird loses some muscle strength due to its limited activity. Once it is healthy again, its *rehabilitation* takes a new course, shifting to a program that prepares it for reentry into its natural habitat. At the raptor center, the bird receives physical therapy appropriate to its specific injury. For a broken wing, for example, the program would help restore the bird's range of motion and coordination and prepare its muscles, heart, and airways for the physical exertion critical to its survival in the wild.

Controlled practice flights are an important part of rehabilitation. Outdoor flights lengthen as the raptor's strength improves. Once the bird has gained endurance, the center's staff releases it into its natural habitat. From there, it reestablishes itself in its environment, hunting and soaring overhead. Hopefully, it will reproduce, ensuring its species' place in the ecosystem.

- ? How does the anatomy of raptors compare to that of birds in your yard and at your bird feeder?
- ? How are the diets of yard birds such as robins, jays, and blackbirds similar to those of raptors? How do they differ?
- ? What position do raptors occupy in the *food chain*? Where do other wild creatures fit in?

carion dead and decaying flesh
food chain a natural order that starts with a simple organism being consumed by a higher-order organism which, in turn, is eaten by yet a higher organism
habitat environment in which a species thrives and is normally found
hawk More than 200 species of birds are classified as hawks, including eagles. Hawks are active during daylight and form three main categories: *buteos*, *accipiters*, and *falcons*.

ornithology branch of zoology that studies birds
pellet a bolus of waste material that owls and hawks spit up or regurgitate after consuming prey. It contains parts of the prey the bird can't digest.
raptor bird of prey, such as hawks, osprey, falcons, owls, and vultures
rehabilitation a program to bring an injured or weakened creature back to health so it can perform its natural activities in the wild
talons nails on a bird's foot that are sharp, curved, and long

- Baldwin, F.D. (1991, Jan/Feb) How to identify birds of prey. *Country Journal*, pp. 20–22.
- Clark, W.S. & Wheeler, B.K. (1987) *A field guide to hawks of North America*. Boston: Houghton Mifflin Co.
- Davenport, L. (1991/92, Dec/Jan) Sauk Prairie, Wisconsin: Where eagles soar. *Mother Earth News*, pp. 78–79, 90–91.
- Johnsgaard, P.A. (1990) *Hawks, eagles, & falcons of North America*. Washington, DC: Smithsonian Institution.
- Rowell, G. (1991, Apr) Falcon rescue. *National Geographic*, pp. 106–114.
- Savage, C. (1992) *Peregrine falcons*. San Francisco: Sierra Club Books.
- Sutton, C. & Walton, R.K. (1994) *North American birds of prey*. National Audubon Society Pocket Guide. New York: Alfred A. Knopf, Inc.

Additional sources of information
 Hawk Mountain Sanctuary Assn.
 RR 2, Box 191
 Kempton, PA 19529-9449
 (215) 756-6961

National Audubon Society
 700 Broadway
 New York, NY 10003
 (212) 979-3000

Raptor Education Foundation
 21901 E. Hampden Ave.
 Aurora, CO 80013
 (303) 680-8500

The Rap on Raptors

You can identify various raptors as they fly through the sky.



SHOW NUMBER

1210

Main Activity

We often see raptors only as they are flying through the sky. By studying raptor silhouettes, you can learn to identify different species from the ground. Although raptors may have different outward appearances, they share many features that help them catch their prey. Discuss which features various species of raptors share and learn about the food chain leading up to a bird of prey.

Materials

- transparencies of various raptor silhouettes. (Several are included as illustrations on this page. You can also find more silhouettes from books listed in the resource section.)
- transparencies of drawings showing details of the anatomy of different raptors. (You'll find these in reference books listed in the resources.)
- overhead projector
- paper
- pencil

1. Enlarge and make transparencies out of the three silhouettes on this page. Project the silhouettes on the overhead projector.

2. Study each silhouette and try to identify each type of raptor. (The three pictured are identified at the bottom of the page.)

3. Project the detailed drawings of various types of raptors on the overhead projector. Observe the different parts of the bird's anatomy. Take note of the similarities among various raptor species.

4. Sketch a bird of prey's food chain. Start with a raptor at the top of the food chain and work down. Where does each "layer" in the food chain get its food?

Questions

1. Discuss the parts of a raptor's anatomy that are crucial for it to catch prey. How do these parts differ from nonraptor bird species?
2. What factors in a raptor's food chain could contribute to the decline or health of a raptor species? Have these factors changed over time?

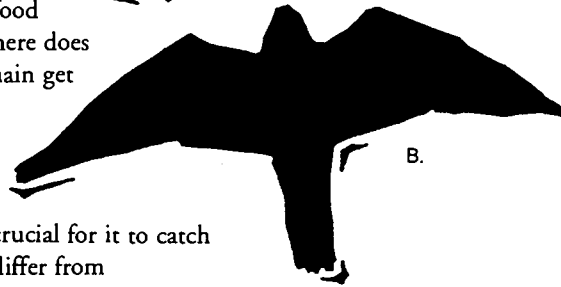
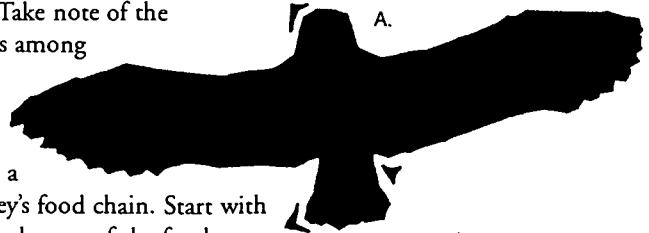

Try This

Plan a trip to a zoo to visit the raptors. Schedule a period with the zoo's raptor specialist to learn why the birds are in captivity, what foods they eat, and what role they serve as examples of raptors in the wild.

Try This

If you have a raptor center nearby, schedule a tour of its facilities. Or ask a specialist to bring a raptor to class for close inspection. Have the tour guide or specialist explain what people should do when they find an injured raptor, and what steps the center takes when a bird is brought to the facility.

Try This

Invite a wildlife specialist from your state conservation department to discuss the types of nests in which various raptors hatch and care for their young. What are the nests made of and where are they located? Will nesting raptors adopt young birds that are not their own?

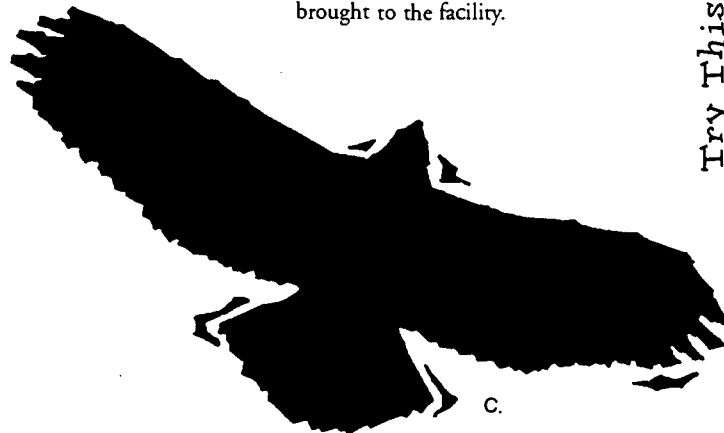

Answers
A. Owl
B. Falcon
C. Eagle

250

How do atoms in photographic film change when exposed to light? What happens when the film is developed? Is color film different from black-and-white?

SHOW NUMBER

1210



David finds out firsthand what happens when film is developed.

Segment Length – 8:03

Photography

How does a piece of photographic film form a picture?

Insights & Connections

You may have heard that photography is a “snap.” That’s because every picture begins with the snap of a shutter. When the shutter opens, light is captured and recorded on photographic film. It doesn’t matter if the film you’re shooting is black-and-white or color—the same chemical processes are at work.

Black-and-white film is made by suspending billions of tiny silver halide crystals in *gelatin* and coating a clear sheet of plastic with the gelatin. Each tabular-shaped crystal contains silver and bromide *ions* held together by strong *electrostatic forces*. *Photons* of light with the right amount of energy can change these crystals, producing silver ions, bromine atoms, and free *electrons*. An electron wanders through the crystal until it is captured by a silver ion. In the process, silver ions are changed into black metallic silver.

The number of silver atoms formed depends on the amount of light each crystal receives. In an exposed crystal, as few as four silver atoms may form. These atoms usually clump together in tiny dark specks too small to be seen even with the most powerful microscopes. Although the silver specks remain invisible to the naked eye, they form a pattern that depicts the photographed subject. This is called a latent image.

In a darkroom, you immerse the film in *developer* to make the latent image visible. The developer acts by pushing electrons into the film. The silver specks channel electrons into the exposed crystals, where more silver ions are changed to black metallic silver. Unexposed crystals react slowly or not at all with the developer. In this way, film exposed to light becomes darker than unexposed areas of the *emulsion*. This produces a negative.

Then you put the negative into a stop bath, where silver ions stop changing into silver atoms. That’s because the stop bath contains a weak *acid* that shuts off the supply of electrons from the developer. Next, the negative goes into the fixer. The fixer contains a solution (*hypo*) that dissolves silver bromide salts from the negative, leaving behind a dark silver image. After a final rinse in water to remove chemicals, the negative is ready to dry and print.

Color film is made by stacking three layers of black-and-white emulsion. Each layer is sensitive to one of the three primary colors of emitted light (red, blue, and green). When exposed to light, color film forms a latent image just as black-and-white film does. But during development, the developer reacts with other chemicals to form colored dyes. The dyes form in the emulsion at the exact location of the exposed crystals. Later, the exposed and unexposed silver is bleached out, leaving dye molecules that reproduce the color of the photographed object.

- 2. What causes photographic film to fog?
- 2. Why does some photographic film appear grainy?
- 2. Why can’t you develop film in the daylight?

Vocabulary

acids substances that release hydrogen ions in water and taste sour
developer a substance that changes silver bromide crystals into black metallic silver
electron a subatomic particle that carries a single negative charge
electrostatic force an attraction or repulsion between electrical charges at rest

emulsion silver bromide crystals floating in gelatin. Photographic film.
gelatin a water-soluble protein made by boiling animal skin and bones
hypo a water solution of sodium thiosulfate
ions charged particles formed when neutral atoms gain or lose electrons
photon a particle of light

Resources

Bustillo, I.J. (1989, Feb) How to. *Modern Photography*, pp. 54–55.

Cyr, D. (1977) *Teaching your children photography*. New York: American Photographic Book Publishing.

Keller, E. (1970, Dec) Images in color. *Chemistry*, pp. 8–11.

Keller, E. (1970, Oct) Images in silver. *Chemistry*, pp. 6–12.

Klavan, G. (1991, Mar) Color from a closet. *Popular Photography*, pp. 42–43.

Kolonia, P. (1993, Feb) Films of choice. *Popular Photography*, pp. 30–37.

Langford, M. (1981) *The darkroom handbook* (1st ed.). New York: Random House.

Neblette, C.B. (1970) *Fundamentals of photography*. New York: Van Nostrand Reinhold.

Willson, M. (1988, Mar) Make your own black-and-white prints. *Astronomy*, pp. 70–75.

Additional sources of information
 Eastman Kodak Company
 343 State St.
 Rochester, NY 14650
 (800) 242-2424

Community resources
 Local photographer or photo shop

School photography darkroom

Newspaper photojournalist

Pinhole Photography

Build and operate a simple camera.



SHOW NUMBER

1210

Main Activity

Make a photograph using a shoe box and some aluminum foil. Learn how a camera focuses and controls light. Develop the latent image into a negative.

Materials

- shoe box
- black construction paper
- glue stick
- aluminum foil
- tape
- scissors
- pin
- photo-enlarging paper
- 3 glass baking dishes
- common paper developer and fixer solutions

1. Cut a 2.5-cm (1") square in the top of a shoe box. Line the inside of the shoe box and its cover with black construction paper attached with glue stick to help cut down on stray light reflections. Next, cut a 5-cm (2") square of aluminum foil and press it smooth on a flat surface. Use a straight pin to prick a small hole at the center of the aluminum foil.

2. Now tape the aluminum foil over the cutout opening in the shoe box. Then cut a 7.5-cm (3") square of black construction paper.

3. You must load your camera in a darkened room. With the room darkened, cut a sheet of photo-enlarging paper to fit the bottom of the shoe box. Secure the paper, emulsion (or shiny) side up, by taping the four corners to the bottom of the box. Replace the cover on the box and use two rubber bands to hold it in place. Insert the 7.5-cm square of black construction paper under the rubber bands and over the pinhole to act as the shutter. Now you are ready to take a picture.

4. Take your pinhole camera out on a sunny day and make a picture by sliding the shutter (black paper) to one side of the pinhole. A good exposure time is 10 minutes but you may need to try other exposure times to get the best results with your camera. Don't bump or move your camera while the shutter is open. Do not hand-hold the camera—instead, support it on an object such as a rock or chair. After the exposure, close the shutter and remove the exposed paper in a darkened room. To reveal the latent image, the paper must be developed.

5. In a room that is either totally dark or illuminated by red light, slide the paper into a tray of paper developer and agitate the solution for two minutes. Remove the paper and allow it to drain. Next, slide the paper into a tray of fixer to make the image permanent. Agitate the fixer solution for four minutes, then remove the paper. Finally, wash your negative in a tray under running water for five minutes. Blot (do not rub) the negative dry with a paper towel and leave it to dry overnight.

Questions

1. How could you modify the pinhole camera? Can you think of other camera designs?
2. How does making a pinhole camera help us understand the workings of commercial cameras?
3. How would changing the size of the pinhole affect the image? Does the distance between the photographic paper and the pinhole make any difference? Why?
4. What did the enlarging paper do in the developer solution? What happened when the paper went into the fixer? What kinds of tools or resources would make developing easier?

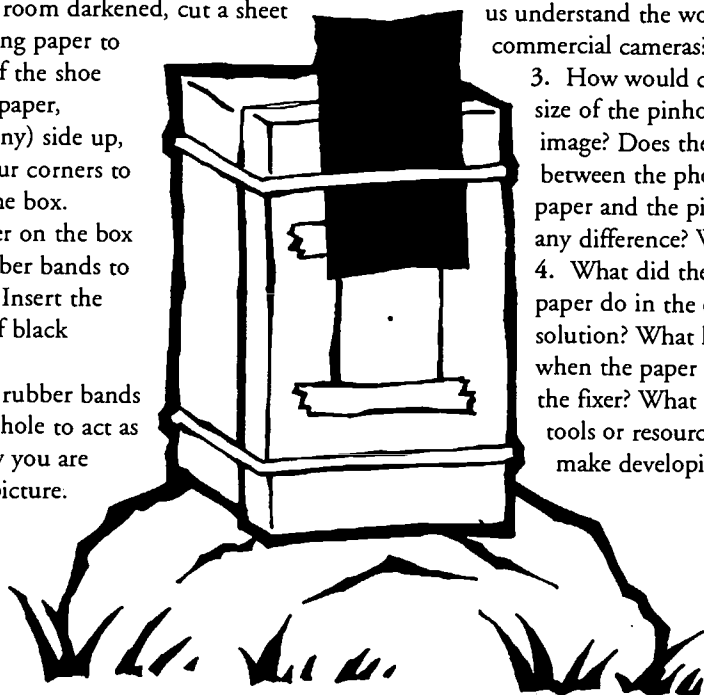

Try This

Why are different film speeds available? The size of the silver-nitrate grains on the film determines the speed—the larger the grains, the faster the film. Research why the speeds on a film box represent. Which speeds are better for which light conditions? Then read *What You See?* by B. M. Bolotovskiy in *Quantum* magazine (Mar/Apr 1993, pp. 4-8). This article explains why shutter speed and film speed are part of the reason we can't always believe our eyes.



Try This

Invite a photographer to come and talk to your class about photography. Ask the photographer to bring a camera and accessories to demonstrate the equipment and methods needed for good picture-taking.



Try This

Who made the first photograph? Construct a time line to show inventors of photography from the camera obscura to the present.



Try This

Discuss the settings on a 35mm, adjustable camera. How does the camera operate? Take pictures using different camera settings (shutter speed, aperture) to learn how to produce the best exposures.

261

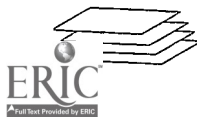

We encourage duplication for educational use!

NEWTON'S APPLE is a production of KTCA Twin Cities Public Television. Made possible by a grant from 3M.

Educational materials developed with the National Science Teachers Association.

12.48

3M Innovation



Peggy learns the amazing history of the redwoods.

Segment length: 8:29

Redwoods

Why do redwoods grow so tall?

Insights & Connections

They are the giants of the earth, bigger than dinosaurs or whales. They tower over 67 meters (220 feet) high, outlive most other forms of life, and have inspired pioneers, poets, and presidents alike. They are the redwoods of California.

Actually, the term "redwood" refers to several species. For example, the towering coast redwoods (*Sequoia sempervirens*) grow in the mild, misty climate along the Pacific coast of California and southern Oregon. The oldest among them is 2,200 years; the tallest measures 113 meters (370 feet). Their cousins, the giant sequoias (*Sequoiadendron giganteum*), live in the harsher climate of the Sierra Nevada mountains. These trees are more massive and live even longer. Although all redwoods are valuable natural resources, the coast redwoods are the focus of this NEWTON'S APPLE segment.

Like all trees, the coast redwoods have developed a highly successful root, trunk, and leaf system using air, water, and sunlight to live and reproduce. The shallow roots of the redwood can spread laterally over 75 meters (250 feet) as they collect and send water and minerals to the leaves. The leaves, in turn, create food through *photosynthesis* and send the nutrients back down through the trunk to the roots.

The unusual characteristics of the redwood's trunk have enabled it to survive the centuries. The outer layer of a tree's trunk, or bark, is made up of dead cells. In redwoods, the bark is fibrous and thick, often measuring 30.5 centimeters (one foot). The thickness of the bark and its lack of *resin* help redwoods resist damage from forest fires. *Tannic acid* in the bark helps the trees resist disease and insect infestation. The layers under the bark sustain the life of the tree. The *phloem*, *cambium*, *sapwood*, and *heartwood* each plays a role in the healthy growth of the redwood tree.

Because of the high demand for their wood, coast redwoods have long been a target of the lumber industry. Ecologically, forests have felt this impact. Without the trees' roots in place, *erosion* plays havoc by clogging up streams with silt and destroying the *watershed*.

Conservationist John Muir may have spoken for everyone working to save the redwoods when he wrote, "The clearest way into the Universe is through a forest wilderness."

- ? Conservationists and the logging industry have long been at odds. How would you explain the issues? What do you think our national policy should be toward logging the forests?
- ? Can you identify areas near your home or school that suffer from ecological stress? What might be the problem? What are some solutions?

Vocabulary

cambium layer of the trunk that produces new wood cells for the tree. The cambium is only one cell thick and lies just beneath the phloem.
conifer a tree that produces seeds in cones
erosion removal of surface soil by the forces of rain and wind
heartwood innermost layer of a tree's trunk consisting of dead, tightly packed cells that provide the strength of the tree
phloem a layer of the bark of a tree's trunk that carries food downward from the leaves to the rest of the tree and roots

photosynthesis the chemical process by which green plants convert sunlight and carbon dioxide into food
resin a substance produced by some plants and trees, often used to make varnish
sapwood layer of the trunk beneath the bark that carries water and soil nutrients upward and throughout the tree
tannic acid a yellowish substance produced by redwoods and other trees, often used in tanning, dyeing, and making medicines
watershed the tributary streams of a major creek or river and its surrounding land

Resources

Burnie, D. (1988) *Eyewitness books: Trees*. New York: Alfred A. Knopf.

Caduto, M.J. & Bruchac, J. (1989) *Keepers of the Earth: Native American stories and environmental activities for children*. Golden, CO: Fulcrum, Inc.

Earth Works (1990) *50 simple things kids can do to save the earth*. Kansas City and New York: Andrews and McMeel Books.

Hewes, J.J. (1992) *Redwoods: The world's largest trees*. New York: Smithmark Publishers.

National Audubon Society videotape: *Rage over trees*. PBS Video: (800) 344-3337.

Teale, E.W. (1954) *The wilderness world of John Muir*. Boston: Houghton Mifflin.

Additional sources of information
 Arbor Day Foundation
 211 N. 12th St.
 Lincoln, NE 68508
 (402) 474-5655
 (membership and services)

Save the Redwood League
 114 Sansome St., Room 605
 San Francisco, CA 94104
 (415) 362-2352

National Office of Project Learning Tree
 1111 19th St. NW, Suite 780
 Washington, DC 20036
 (202) 463-2462

Community resources
 Local Soil Conservation Service

Local university forestry department

How Tall Is It?

Measure the height of your favorite tree. Compare it to a California redwood.



SHOW NUMBER

1211

Main Activity

How does the height of a tree in your backyard compare to that of a 65-meter (214') redwood?

Materials

- a tree
- ruler
- tape measure
- graph paper and pencil
- twine measuring at least 100 meters (328')
- several friends

1. Select a tree to measure.
2. Standing near your tree, press the ruler horizontally against the bridge of your nose, holding the ruler at its end.
3. Flip the ruler vertically, making sure to keep it at a distance of one ruler's length from your face.
4. Walk backward until the top of the ruler lines up with the top of the tree.
5. Using the tape measure, calculate the distance between the tree and where you are standing. Add the measurement of your height to this calculation to find the approximate height of your tree.
6. Make a graph of the redwood tree, your tree, and your friends' trees.

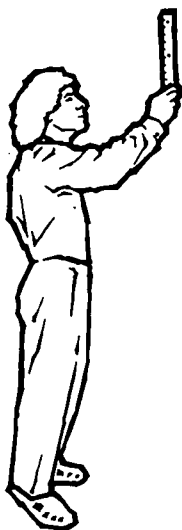

7. To visualize your graph, try this. Find an open area outside. Using twine, measure the length of the 65-meter redwood. First measure the length of your stride. Have a friend hold the ball of twine. Holding the other end of the twine, count your strides to measure the length for the redwood. Once you reach 65 meters, have a friend stand in that spot. Follow the same directions to measure the length of your tree. Imagine your tree next to a giant redwood as you compare the two lengths of twine.

Questions

1. Using your knowledge of right triangles, can you explain why this technique of measuring trees works?
2. Identify the trees you have graphed. Can you make any generalizations about the height and type of trees you have measured?

Try This

Trees send water through their trunks and out their leaves. Fill two cups with the same amount of water, mark the water levels, and tape paper covers over the cups' tops. Take two twigs, removing the leaves from one. Place one twig in each cup, poking the stems through the covers. Wrap a plastic bag around a few leaves to catch the moisture. Which cup loses the most water?



Try This

Water comes up through the tree's trunk and out to the leaves. Does moisture evaporate through a conifer's needles as it does through leaves of a broadleaf tree? Find out. Tie a small plastic bag over the needles of a conifer. Do the same for a broadleaf tree. Check the bags after a few hours and observe the amount of moisture in each bag.

Try This

Take a trip to a lumberyard. Collect various wood samples, including a piece of redwood. Interview a lumberyard employee about the desirability and availability of redwood. Finally, identify the woods and compare their characteristics. Try driving a nail through each wood sample and compare and contrast the densities of each sample.

203

What is electricity? How does electricity get from one place to another? What makes electricity so dangerous?

SHOW NUMBER

1211



David conducts a study of electrical circuits.

Segment length: 9:01

Electricity

Why don't birds get electrocuted when they sit on power lines?

Insights & Connections

When it comes to understanding electricity, to get to the heart of the matter you must literally get to the heart of matter—the atom. Atoms are the building blocks of matter and they are composed of three particle types. The central core of the atom is called the nucleus and it contains positively charged particles called protons and neutral particles called neutrons. The movement of many charged particles in the same direction is called an electric *current*.

Charged particles flow most easily through *conductors*, such as metals, or through some liquids, such as salt water. Electrons in metals are loosely attached to the atoms, so they can move easily. The human body (which is mostly salt water) is also a good conductor, which is why electric shocks can be so dangerous. *Insulators*, on the other hand, do not conduct electricity well. Their electrons are tightly bound to their atoms and do not move easily. Typical insulators include rubber, wood, glass, and most plastics.

Electricity will only flow when a power source, such as a battery or a *generator*, sets the electrons in motion and when the electrons can complete a full circle. Consider this example—electrons flow from a battery down a wire to a light bulb, through the filament of the bulb, and then back up another wire to the battery. This closed loop is called a *circuit*. No electrical device, whether it's a simple flashlight or a complex computer, will work unless the circuit that delivers the electric current is a complete loop.

Electricity becomes dangerous to you when you become part of the electrical loop—when the electrons have enough energy and make adequate contact to pass through your body. You can touch both ends of a flashlight battery and feel nothing, but if you're wet and in contact with household electricity, water can make a very good path through your skin and your body, making you part of the electrical circuit!

Electrical energy always seeks the shortest route around the circuit back to the source, which in the above example is the battery. If the wires both touch a conductor, such as a metal tabletop, the electrons will take that shorter route back to the battery, rather than travel to the light bulb. (Conveniently, scientists call this a "short circuit.")

So why don't birds get electrocuted when they sit on power lines? The power lines that are suspended in pairs between power poles are analogous to the wires that run between the battery and the light bulb. As long as birds sit on only one, they offer no "shortcut" to complete the circuit. But if their wings accidentally touch both adjacent power lines, the electrons take a new path and complete the circuit through the unfortunate bird's body!

- ? Imagine a world without electrical power. How would you cook, clean, and entertain yourself?
- ? Even though electrical energy is useful, its production often causes environmental problems. Acid precipitation from burning coal and disposal of nuclear waste are just two of them. What are some alternative power sources and how can conservation help minimize the damage?

Vocabulary

circuit a closed loop of conductors through which charges can flow

conductor a substance through which electrical charges can easily flow

current a flow of electrical charges

generator a device for producing electrical current by moving a coil of wire in a magnetic field

insulator a material through which electric charges cannot move

ion an atom that has gained or lost one or more electrons and is thus a charged particle

switch a device that closes or opens a circuit, thereby allowing or preventing current flow

voltage the pressure behind the flow of electrons in a circuit

Resources

Catherall, E. (1981) *Electrical power*. London: Wayland Publishers.

Cooper, A. (1983) *Visual science electricity*. Morristown, NJ: Silver Burdett Ginn.

Hewitt, P. (1992) *Conceptual physics* (2d ed.). New York: Addison-Wesley.

Kluger-Bell, B. (1990, Fall) Pickle power: My search for the perfect homemade battery. *Exploratorium Quarterly*, pp. 25-29.

Math, I. (1981) *Wires and watts*. New York: Charles Scribner's Sons.

Nye, B. (1993) *Big blast of science*. New York: Addison-Wesley.

Stanley, L. (1980) *Easy-to-make electric gadgets*. New York: Harvey House.

3-2-1 Classroom Contact videotape: *Generating Electricity*. GPN: (800) 228-4630.

VanCleave, J. (1991) *Physics for every kid*. New York: John Wiley Publishers.

Vogt, G. (1986) *Generating electricity*. New York: Franklin Watts Publishing.

Williams, J. (1992) *Projects with electricity*. Milwaukee: Gareth Stevens Children's Books.

Community resources
Local power utility

Build a Conductivity Tester

Check different materials to see if they conduct electricity.



SHOW NUMBER

1211

Main Activity

Which common objects are insulators and which are conductors? To test it for yourself, you can build a simple, battery-powered conductivity tester.

Materials

- flashlight with one fresh D cell
- 3 pieces of insulated wire, each approximately 15 cm (6") long with the ends stripped
- roll of masking or duct tape
- penny
- comb
- several pieces of fabric
- metal fork or spoon
- several different rocks
- various objects for testing

1. To build your tester, unscrew the top of the flashlight which has the bulb assembly in it. Take one wire and tape it to the metal tip of the light bulb and tape a second wire to the metal ring that touches the side of the bulb.
2. Tape the other end of the wire connected to the tip of the light bulb to the (+) end of a D cell and touch the free end of the

second wire to the (-) end of the cell. The light should go on because you have completed a circuit. If it doesn't, make sure all the connections are taped tightly and make good contact.

3. Tape one end of the third wire to the (-) end of the cell and touch its free end to the free end of the wire coming from the bulb holder. Again, the light should go on. Try touching the two free ends of the wires to the penny at the same time. The bulb should light because the penny is made of copper, a good conductor.

4. Collect your objects to be tested and predict if they are insulators or conductors. Then try them out with your tester.

Questions

1. In general, what types of materials make the best conductors?
2. Look inside the body of the flashlight.

How does the switch control make the light go on and off?

Try This

Examine your family's electric bill. What is a kilowatt? How much does the electric company charge for one kilowatt hour? Is that a constant rate? Make a list of the appliances that you think use the most electricity. Contact the electric company to see if you are correct. Does your family use the same amount of electricity each month? Why or why not?

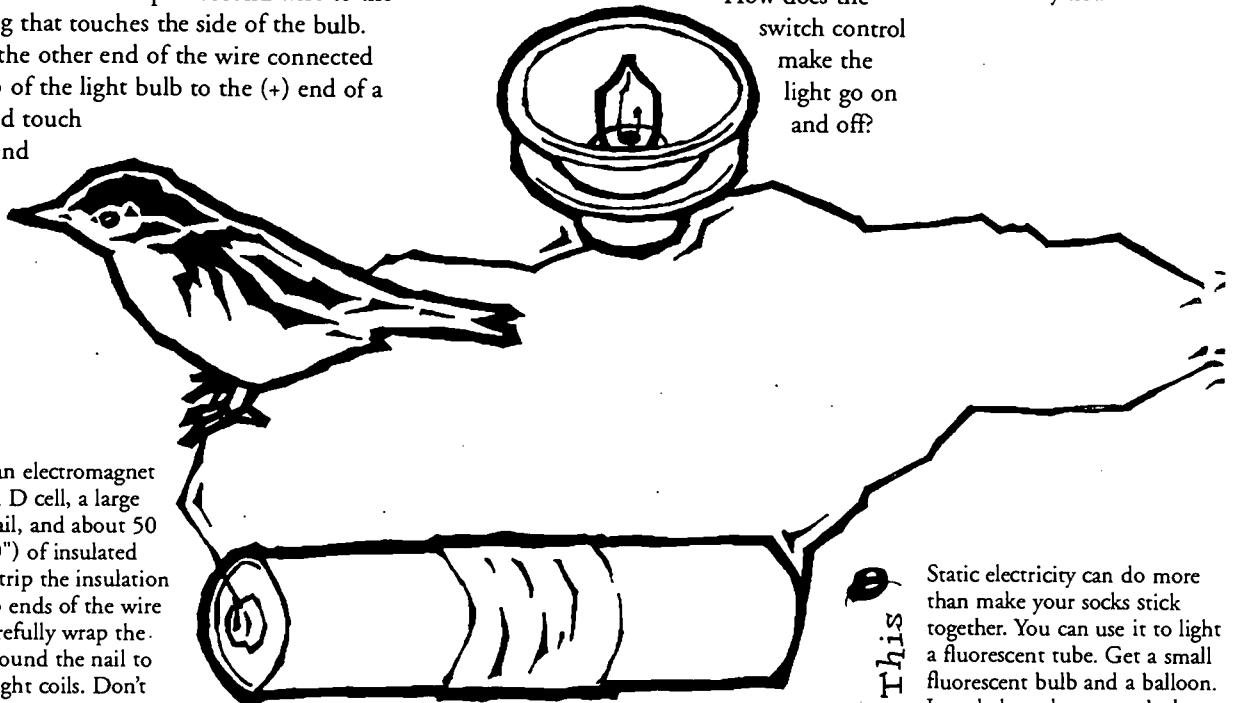

Try This

Build an electromagnet using a D cell, a large steel nail, and about 50 cm (20") of insulated wire. Strip the insulation off two ends of the wire and carefully wrap the wire around the nail to form tight coils. Don't overlap the coils and make sure that you leave at least 6 cm (2.4") of wire free at each end. Connect the two ends of the wire to the two ends of the D cell and bring the tip of the nail very near some metal paper clips. The magnet will only attract if the circuit is complete.

Try This

Static electricity can do more than make your socks stick together. You can use it to light a fluorescent tube. Get a small fluorescent bulb and a balloon. In a darkened room, rub the balloon on your hair a few times. Bring the charged balloon near one end of the bulb and you should see some light flashes.

265

How is money made? How long has paper money been around?

SHOW NUMBER

1212



Peggy follows the paper money trail to Washington, DC.

Segment length: 8:39

Printing Money

How does the Bureau of Engraving and Printing produce U.S. dollar bills?

You've heard the expression "Money doesn't grow on trees." So where does it come from?

Got a dollar bill in your pocket? Take a look at it. Notice the intricate artwork, the color of the ink, the texture. Take a minute and think about where and how your dollar bill was made.

Today your U.S. dollar bill, or *bank note*, is the most recognized and sought-after money in the world. But the United States did not invent paper money. Most *notaphilists* and *numismatists* credit the Chinese with the idea. From China, the concept of paper money to replace heavy coins spread to the rest of the world.

Paper notes have circulated in the United States since Colonial days. By 1836, at least 7,000 varieties of paper currency were in circulation, issued by state banks. But in 1862, the United States found itself in need of issuing government paper money to finance the Civil War. To accomplish this, it created the *Bureau of Engraving and Printing* in Washington, DC.

The design of the current dollar bill is a process of 65 complicated and distinct steps. It begins with highly skilled engravers who hand-cut portraits, lettering, and ornamentation into soft steel to make the original *die masters*.

Look at your dollar bill again. Notice that the images are a series of fine lines, dots, and dashes. This process of engraving is the first step of *intaglio printing*. Next, the images of the die master are transferred to a *printing plate*. Printing plates are then chromium-coated and readied for the high-speed presses.

Sheets of paper made of a special cotton-linen blend speed through the presses under 14 tons of pressure per square inch. This pressure forces the paper into the recessed lines of the plate where it picks up the ink. First the backs of the bills are printed with green ink, and then the faces are printed with black ink. Serial numbers and the Treasury and the Federal Reserve District seals and numbers are *overprinted* onto the notes.

The sheets are cut into smaller units, packaged into *bricks*, and distributed to the Federal Reserve Bank Districts. They, in turn, distribute them to individual banks. Eventually, the dollar bills wind up in our pockets. Right where you found yours!

Why is it important for a country to have standardized currency?

What are some of the features of U.S. paper money? What are the advantages of having intricately designed paper currency?

bank notes paper money issued by a bank
bricks 40 units of 100 bank notes packaged together

Bureau of Engraving and Printing a government office where U.S. paper money is made. It has two locations—Washington, DC, and Fort Worth, Texas.

die master metal sheet on which the original design of the bank note is engraved. Used to make the printing plates.

Federal Reserve System the U.S. monetary organization, created in 1913, that issues and regulates U.S. currency

intaglio printing lined-engraved, recess printing process

notaphilists collectors of paper money
numismatists collectors of paper money, coins, tokens, and related objects

overprint official printing completed on a bank note after the initial printing has taken place
printing plate copies of the original engraved die master. These plates are made of plastic.

Resources

Hessler, G. (1992) *The comprehensive catalog of U.S. paper money*. Port Clinton, OH: BNR Press.

Krause, B. (1992) *Collecting paper money for pleasure and profit*. Cincinnati, OH: Betterway Books.

Cantwell, L. (1984) *Money and banking*. New York: Franklin Watts.

Additional sources of information
Department of the Treasury
Bureau of Engraving and Printing
14th & C Street
Washington, DC 20228
(202) 874-3186

U.S. Mint
633 Third St. NW, 7th floor
Washington, DC 20226
(202) 874-5924

American Numismatic Assn.
Education Department
818 N. Cascade Ave.
Colorado Springs, CO 80903
(719) 632-2646

Public Information Office
Federal Reserve Bank
of St. Louis
PO Box 442
St. Louis, MO 63166-0442
(314) 444-8421
(cost of "The Money Tree" package is \$25)

Community resources
Local bank manager

Enthusiastic numismatist

District Federal Reserve Bank
closest to you

Making Money

Design your own intaglio-printed paper money.



SHOW NUMBER

1212

Main Activity

If you could design your own paper money, what would it look like? What images and symbols would you incorporate into your design? What security features would you provide to prevent counterfeiting? What paper would you use? Give this project a try and see how inventive you can be.

Materials

- acetate or plastic sheet at least 1/8" thick
- sharp scissors
- rubber roller or wood burnisher
- damp paper of various types
- cheesecloth
- plate ink

1. Discuss the distinguishing features and symbols of U.S. bank notes and bank notes from other countries. Design your own bank note on paper before engraving your plastic.
2. Cut the plastic to the size of your bank note. Using pieces of wire or a straightened pin, engrave your sheet. This approach roughly simulates the intaglio printing process used at the Bureau of Engraving and Printing.
3. Next, coat the surface of the sheet with ink, making sure that the engraved lines are

filled. Wipe the ink off the surface with the cheesecloth without wiping the filled engraved lines.

4. When you are ready, lay damp paper over the sheet and roll the rubber roller over the paper to pick up the images. The most effective method is to rub a wood burnisher over the area where the design is located. *Do not use a wooden roller.* Cut your printed "bank notes."
5. Repeat the process for the backside of the "bank note."

Extend the activity. Have committees design denominations of bank notes for class currency. Discuss the worth of each set of bills. Use the currency for payment of "goods and services" in the class to simulate the role of money in society.

Questions

1. What are common symbols and features of paper money?
2. What must a society do to assure its paper money has value?
3. What are the pros and cons of becoming a "cashless" society?



Try This

Research the symbolism of "The Great Seal of the United States" as displayed on the back of the one-dollar bill. What is the meaning of "E Pluribus Unum"? What is the eagle holding and how many stars are above its head? What is the date in Roman numerals at the base of the pyramid, and what does the eye signify at its top?



Try This

Plan an imaginary trip to a foreign country. Look at the "foreign exchange" chart in the business section of the local newspaper. How much money should you bring along in U.S. dollars? Convert that amount of money into the currency of the country you have chosen to visit.



Try This

Invite a local numismatist or notaphilist to show his or her collection to your class. Discuss the process of collecting money and determining the quality of individual pieces. Start a class penny collection to incorporate some of the concepts discussed.



Try This

How does U.S. paper money compare to the paper money of other countries? Start a class collection. Invite your classmates to share money from around the world that they may have at home. Compare and contrast the sizes, designs, counterfeiting prevention techniques, and qualities of the material. Make enlarged copies of this paper money and put them on display.

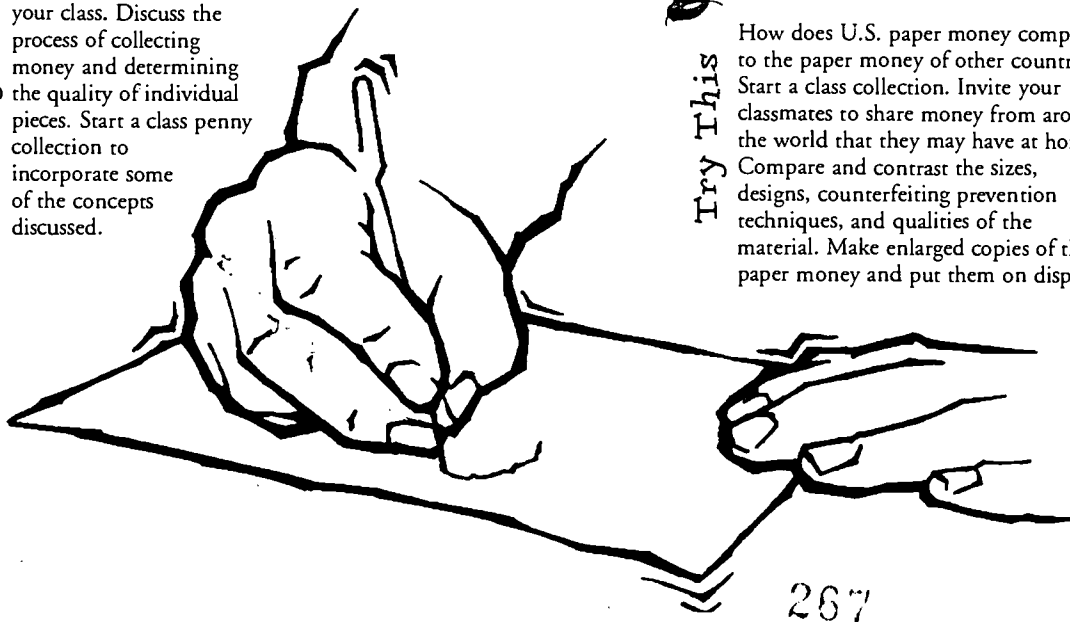

Are all objects equally affected by gravity? Does a bullet that's been shot actually fall? Does anything get in the way of gravity?

SHOW NUMBER

1212



David drops in on an experiment to test weightlessness.

Segment length: 9:30

Gravity

What causes weightlessness in a space shuttle?

Insights & Connections

Your fuel gauge is below empty. Both engines of the cargo plane you're piloting have just sputtered and gone silent. The nose of the plane points down and you begin a terrifying dive toward Earth. In a panic, you make your way out of the cockpit and into the back of the plane where your parachute is stored. But a 2,000-kilogram crate is blocking your path. What do you do?

No problem! Since the weight of the crate on the plane's floor is actually zero, you would not have to lift it in opposition to *gravity* or slide it in opposition to its friction with the floor. The *force* required to overcome the inertia of the crate would be small enough to allow you to move it by pushing hard with your feet braced against a wall. How is this so?

Let's look at the crate under normal flight conditions. The weight of the crate pushes down against the floor of the plane. What you might not realize is that the floor, which is supported by the airplane's wings and the forces that keep the airplane aloft, also pushes up against the crate. It pushes up with a force equal to the weight of the crate, so inside the plane, you're aware of how heavy the crate is.

When your plane goes into free-fall, the crate is still pulled by gravity just as during a normal flight. But the floor is no longer pushing up on the crate, since it and the crate are now falling freely toward the earth. Gravity is still acting on both the crate and the plane, but inside the airplane, without the upward push from the floor, the crate now seems to be weightless. Both the crate and the pilot will float freely inside the airplane until something—like Earth—stops them.

Astronauts in *orbit* experience *weightlessness* just like objects in the falling aircraft. A space shuttle in orbit is actually in a state of free-fall as it travels around Earth.

Hard to imagine? Picture yourself in a small spaceship a few meters above the ground. Now face the setting sun and go in a straight line for about 100 kilometers (62 miles). If you go in a perfectly straight line, you should notice that Earth is curving away from you.

A shuttle in orbit goes so fast that Earth curves "away" just as much as the shuttle falls. The shuttle falls, but never hits the ground!

- ? Falling appears to be different for different objects. For instance, which falls faster, a pen or a piece of paper? Why might one fall faster than the other?
- ? In real life, when do you experience something like free-fall? For how long?
- ? Which falls faster, a one-ton plane or a ten-ton plane?

Vocabulary

acceleration change in speed during a certain period of time

ascent going up

descent going down

force that which, when acting alone on an object, causes a change in the motion of the object

gravity force on Earth which pulls all objects toward its center

orbit falling around and around Earth

resistance a force opposing the motion of an object or opposing the forces trying to set an object in motion

weightlessness feeling or being observed as having no weight

Resources

Ardley, N. (1992) *The science book of gravity*. Chicago: Harcourt Brace.

Boslough, J. (1989, May) Searching for the secrets of gravity. *National Geographic*, pp. 563-583.

Covault, C. (1991, June) Columbia crew launched to gather unique zero-g life sciences data. *Aviation Week and Space Technology*, pp. 68-69.

Epstein, L. (1989) *Thinking physics*. San Francisco: Insight Press.

Lafferty, P. (1992) *Eyewitness science: Force and motion*. New York: Dorling Kindersley.

March, R. (1992) *Physics for poets* (3rd ed.). New York: McGraw-Hill.

Zee, A. (1989) *An old man's toy: Gravity at work and play in Einstein's universe*. New York: Macmillan.

Additional sources of information
American Institute of Physics
One Physics Ellipse
College Park, MD 20740-3843
(301) 209-3000
(Ask about Operation Physics)

NASA Education Division
Mail Code F
Washington, DC 20546
(202) 453-1000

Community resources
Physics department at a local college or university

Elevator Magic

Find out who has the hottest elevator in town.



SHOW NUMBER

1212

Main Activity

You have probably noticed an empty feeling in your stomach when an elevator starts its descent. That feeling is a result of a decrease of pressure against your feet and a corresponding change in the tightness of the muscles in your abdomen. Your feet feel less pressure, because the floor of the elevator is going out from under you momentarily. Find out how you could measure this feeling in more concrete terms, and learn which elevator has the fastest acceleration.

Materials

- bathroom scale (not digital)
- notebook paper
- pencil

1. Divide into small groups of two or three. Choose some elevators located nearby.
2. Create a data table like the one below for each of the elevators you are going to test.
3. Record each of your weights standing still.

4. Take the scale into the first elevator. Then one student at a time should get the maximum reading on the scale when the elevator starts its ascent and the minimum reading when the elevator starts its descent. You must have a quick eye and should be prepared for approximate results.
5. Have each student record his or her own data for each elevator tried.
6. Follow steps 2 through 5 for each elevator.

Questions

1. What happens to your weight when you begin your ascent? How long does the change last?
2. What happens to your weight when you begin your descent? How long does the change last?
3. Does a person's initial weight have anything to do with the amount of change recorded?
4. What kind of change would occur if the elevator cable were to snap? This, by the way, could never happen.

	<u>Standing Still</u>	<u>Ascent</u>	<u>Descent</u>
weight of (student name) _____	_____	_____	_____
weight of (student name) _____	_____	_____	_____
weight of (student name) _____	_____	_____	_____

Try This

You know that water falls downhill. What if the whole waterfall falls? Place a half-gallon plastic milk jug upright and punch a small hole 2.5 cm (1") up from the bottom. Place your finger over the hole and fill the jug with water. Go outside and remove your finger to watch the water flow. Now, gently toss the jug up and down without completely letting go. What happens?

Try This

Does the weight of objects affect how fast they fall? Take 14 pennies. Make two piles of seven. Tape one pile together. Hold one pile in your right hand and the other in your left. Reach both hands up high and cleanly drop the two piles at the same time. The taped pile is at least seven times the weight of each penny in the other pile. Any conclusions?

Try This

Place a half-gallon plastic milk jug upright and punch a small hole 2.5 cm (1") up from the bottom. Placing your finger over the hole, fill the jug with water. Go to a playground with a friend as an observer. Find a high place and make sure nobody is standing directly below. Take your finger off the hole and drop the jug. What does the observer see happening to the flow of water during the drop?

Try This

Sky divers are in a state of free-fall only at the beginning of the jump. Think of ways in which a sky diver could speed up or slow down the descent. Which body positions would be best for speed? Which would be best for hanging in the air?

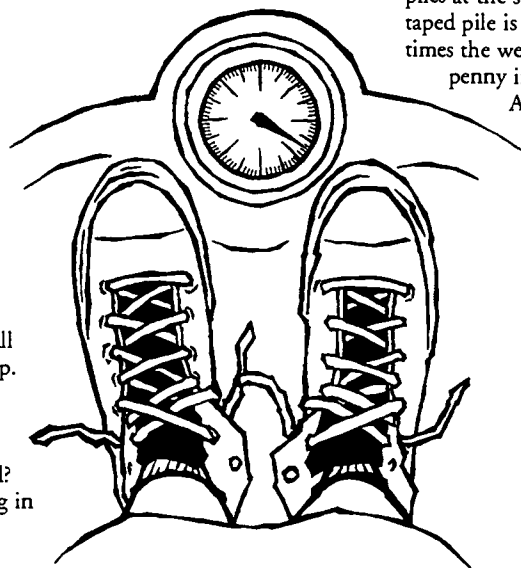

200



We encourage duplication for educational use!

NEWTON'S APPLE is a production of KTCA Twin Cities Public Television. Made possible by a grant from 3M. Educational materials developed with the National Science Teachers Association.

12.56

3M Innovation

Why would you choose one bridge design over another? How do bridges stay up? What different kinds of bridges are built? What is a truss?

SHOW NUMBER

1213



David finds out that a properly designed bridge made from dry pasta can actually support his weight.

Segment length: 8:19

Bridges

How do different bridge designs work?

"London Bridge is falling down, falling down, falling down." We all know the first verse to that nursery rhyme. But have you ever heard this one: "Set a man to watch all night, watch all night, watch all night"? People once felt that a bridge required a human spirit. They sometimes buried a human sacrifice in the bridge's foundation, so that the spirit could "watch all night." Fortunately, we no longer sacrifice a night watchman when we build these structures. But there is still more to bridges than meets the eye.

Bridge builders choose from one of several types of bridges or combine two or more. Three basic types are the arch, span, and suspension. The structural elements in a bridge are subjected to various *compression* and *tension* forces. Something bearing weight or being pushed together is under compression while something being pulled apart is under tension.

In an arch bridge, compression pushes the weight away from the arch and against the side walls and the stones of the arch itself. The Romans were first to build arch bridges, and some of their bridges and aqueducts still stand today.

Span bridges consist of beams and/or trusses resting on supports or piers. When the *span* length would require a very large or heavy beam to support the loads, a *truss* system is often used. Since a truss is composed of triangles (the strongest polygons because their shapes cannot be distorted), a truss bridge can support heavy loads with its relatively small weight.

A suspension bridge hangs from cables firmly anchored at each of its ends. Towers positioned at regular intervals along the span also support it. The main elements of suspension bridges, the cables, are in tension. The trusses hang from the cables and the trusses, in turn, support the deck. Trusses in these bridges provide stiffness to their *decks*. Suspension bridges are generally used for long spans.

Engineers need to accommodate *torsion* in their bridge designs. What causes a bridge to twist? Wind. An example of torsion was the Tacoma Narrows Bridge in the state of Washington. A suspension bridge without open trusses, this bridge twisted in the breeze. One day, the bridge twisted so violently in the wind that its center span collapsed. Since then, engineers test bridge models in wind tunnels prior to construction and build their decks more stiffly.

When determining what type of bridge to build, engineers evaluate terrain and length of span. In addition, bridges change as our needs and resources change. Engineers constantly look for ways to improve bridge designs and materials. During the recent earthquakes in California, for example, engineers analyzed highway overpasses to find ways to make them stronger.

Insights & Connections

- ? Why is it important to know whether parts of a bridge will be subjected to tension or compression?
- ? Why is a triangle the strongest polygon?

Vocabulary

compression the act of pressing or pushing
deck platform extending horizontally that often carries the roadway
engineer person who uses mathematical and scientific principles to design and construct efficient structures and machines
girder a horizontal beam used for support

span portion of a bridge between two supports
stress the force acting on a body divided by the body's cross-sectional area. Force per unit area.
tension the act of stretching or pulling
torsion the act of twisting
truss a rigid triangular framework

Resources

Burns, M. (1982) *Math for smarty pants*. Boston: Little, Brown and Company.

Clarke, D. (Ed.) (1979) *The encyclopedia of how it's built*. New York: A & W Publishers, Inc.

Corbett, S. (1978) *Bridges*. New York: Four Winds Press.

Spangenburg, R. (1991) *The story of America's bridges*. New York: Facts on File.

Stephens, J. (1976) *Towers, bridges, and other structures*. New York: Sterling Publishing Company.

Stix, G. (1993, Apr) Concrete solutions. *Scientific American*, pp. 102-112.

TV Ontario videotape: Trussworthy. *Landscape of Geometry* series. TV Ontario: (800) 331-9566.

Whitney, C. (1983) *Bridges*. New York: Greenwich House.

Wollomir, R. (1994, Jan) Inside the lab and out, concrete is more than it's cracked up to be. *Smithsonian*, pp. 22-31.

Additional sources of information
 Design kits such as Structures or The Structures Kit (found in teacher resource catalogs)

Roebbling Chapter of the Society for Industrial Archaeology
 c/o Bierce Riley
 19 Budd Street
 Morristown, NJ 07961

Community resources
 Architect

Civil engineer

Bridging the Future

Hold your own contest to design, build, and test a bridge.



SHOW NUMBER

1213

Main Activity

Engineers first create a blueprint and model of a bridge before they begin construction. Models enable them to test the design of their bridges. Often, engineering companies must compete to win a contract. For their presentations, they explain features of their designs with blueprints and models.

Materials

- graph paper
- pencils
- poster board (2' x 3')—one sheet per group
- scissors
- glue
- tape
- string

1. Each group will design and build a freestanding bridge for a transportation system of the future. First decide what type of transportation will cross the bridge and what type of bridge you will build. Create a blueprint of the bridge on graph paper.

2. Using your blueprint, create a model of your bridge from the poster board. Each group is only allowed one sheet of poster board, so measure carefully before you cut. The only other materials you can use in the construction of your bridge are tape, glue, and string.

3. Present your bridge to the large group. Explain the rationale behind your design.
4. With all the groups together, test the bridges for length, height, and strength.

Questions

For the individual groups:

1. How did you come up with the initial design for your bridge?
2. Did your design change as you built your bridge?
3. Which geometric shapes did you use in your bridge? Why?
4. How does the strength of the bridge compare to the weight of the bridge?
5. Would you make any changes in the design of your bridge?

For the large group:

1. Which bridge was the longest? Tallest? Strongest? Heaviest? Why?
2. What materials do you envision being used in future bridges?
3. How can computers help design bridges?

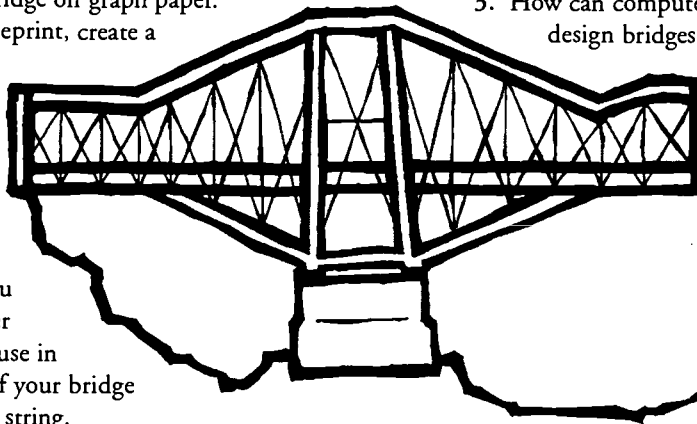

Try This

Concrete supports many of our bridges and overpasses. How is it holding up? Ice and road salt affect concrete bridges. Read "Concrete Solutions" by Gary Stix (*Scientific American*, April 1993) and "Inside the lab and out, concrete is more than it's cracked up to be" by Richard Wollomir (*Smithsonian*, January 1994). What are the pros and cons of building bridges with concrete? What is it better than steel? What is reinforced concrete?

Try This

Invite a civil engineer to talk to your class about bridges. What types of bridges exist in your area? Which mathematics and science courses did the engineer take to prepare for a career in engineering? What tools do engineers use to design bridges and other structures?

Try This

The longest cable suspension bridge is 1,410 meters (4,626'). Because its towers stand exactly perpendicular to Earth's surface, they are 3.49 cm (1 3/8") out of parallel to allow for the Earth's curvature. In a plane, two lines perpendicular to the same line are parallel. Why does this change when you work with a curved surface? By the way, the Akashi-Kaikyo bridge in Japan, which will open in 1998, will be 1,990 meters (6,528') long!

Try This

Test compression, tension, and torsion on different materials. First, take a strip of Styrofoam 10 cm x 38 cm (4" x 15"). Ask someone to hold the ends so you can press down gently on top to test compression. Hold each end and pull it apart to test tension. Hold the two ends and twist to test torsion. What were the results of your tests? Find materials that are strong in tension, weak in compression, and vice versa.



271

What is an earthquake? Where do most earthquakes occur in the world? How do you measure earthquakes and what determines how much damage they will cause?

SHOW NUMBER

1213



David probes the causes of earthquakes.

Segment Length – 7:59

Earthquakes

Why do earthquakes happen?

Insights & Connections

Picture it. You're sitting on the sofa watching another fun-packed episode of NEWTON'S APPLE when out of nowhere, you hear a dull roar. The room starts to shake, pictures fall off the wall, and for a few seconds it seems you've lost your sense of balance. Suddenly, all is quiet. Was it an explosion? Did a truck crash into your house? Finally, the announcement comes over the television—you have just survived an earthquake.

Could this really happen to you? If you live in California, it happens fairly often. But what if you live in places like North Dakota, Florida, or New York? Are you safe?

Well, don't get too comfortable. Earthquakes can happen in many places, although they are concentrated in certain areas.

An earthquake occurs when two parts of Earth's *lithosphere* slide past, away from, or into each other. According to current theory, Earth's surface is made up of many large slabs of crust called plates, which ride like giant rafts on semifluid rock below. Geologists believe that the plates are driven by large *convection currents* created by heat generated deep within Earth by the radioactive decay of certain elements. While most earthquakes happen at plate boundaries, some occur in the middle of a plate.

Just as the continents have moved, plate boundaries have also changed. Over the years, Earth's lithosphere has been split up and put together many times, leaving millions of scars or *faults*. Many of these old faults are static, but every so often stresses build up because of rock movement in the *mantle*, causing a fault to rupture and an earthquake to occur.

Today, geologists use two different scales to measure how strong an earthquake is. The Richter scale measures the actual size (or amplitude) of the wave generated by a particular earthquake on a *seismograph*. This is an indirect measure of the amount of energy released by the earthquake. A one-point increase on the Richter scale equals a tenfold amplitude of wave increase, which equals approximately 32 times more earthquake energy.

A second type of scale, the modified Mercalli intensity scale, measures the amount and type of damage that earthquakes do to buildings and other structures, and their effects on humans. Because of these differences in measurements, an earthquake with a low Richter magnitude reading that occurs in a densely populated area like Los Angeles can actually have a higher Mercalli value or intensity than a high-magnitude quake in a desolate region like Antarctica.

- ❓ What do you think would happen to your community if it were hit by a Richter magnitude-8 earthquake? What structures would be damaged? What evacuation plans could you make?
- ❓ How could you earthquake-proof your classroom?
- ❓ What are the pros and cons of releasing earthquake predictions to the public?

Vocabulary

convection current very slow movement of rock within Earth's mantle caused by heating and cooling
epicenter the point on Earth's surface directly above the focus of an earthquake
fault a crack in rock or soil along which there has been movement caused by stress
focus the point inside Earth which is the source of the earthquake

lithosphere outer solid portion of Earth including the crust and uppermost mantle
mantle the zone inside Earth between the solid outer crust and the inner core
seismograph a device for measuring and recording vibrations from earthquakes
subduction zone an area where one tectonic plate (usually part of the ocean) is going down under a second plate

Resources

Beatley, T. & Berke, P. (1992/93, Winter) Time to shake up earthquake planning. *Science & Technology*, pp. 82–89.

Bolt, B. (1993) *Earthquakes* (3d. ed.). New York: W. H. Freeman.

Coch, N. & Ludman, A. (1991) *Physical geology*. New York: Macmillan.

Davidson, K. (1994, May) Predicting earthquakes. *Earth Magazine*, pp. 56–63.

Earthquakes. (1989) Educational materials produced by NSTA and FEMA. To order, phone (800) 722-NSTA.

Robinson, A. (1993) *Earth shock*. London: Thames & Hudson.

Ross, K. (1992, Fall) Shake tables in the classroom. *Science Teachers Bulletin*, pp. 20–25.

3-2-1 Classroom Contact videotape: *Earth is change*. GPN: (800) 228-4630.

Additional sources of information
 National Earthquake Information Service
 U.S. Geological Survey
 Box 25046–MS 967
 Denver Federal Center
 Denver, CO 80225
 (800) 525-7848

Community resources
 College geology professor

State geologic survey for geological maps

All Shook Up

Design and build an earthquake-proof structure.



SHOW NUMBER

1213

Main Activity

One of the main causes of damage in an earthquake is the collapse of buildings not strong enough to withstand the shaking. Engineers and architects try to design buildings rigid enough to withstand the shock, but flexible enough to give a little under the stress. By building and testing different models, they can "shake down" their ideas and see which one "stands" the test of time.

Materials

- 40 coffee stirrers or cocktail straws
- 40 mini marshmallows
- a metric ruler
- 2 shallow cardboard boxes (the trays used for cases of soda cans work well)
- a pair of scissors
- 10–20 marbles
- 4 short rubber bands
- stapler

1. Before building your models, you must first build a shake tray. Place one cardboard box on a table and, with the scissors, cut the bottom out of the second box so that it fits inside the first box with a 2-cm clearance around each side. Place the marbles in the first box and rest the cut piece of cardboard on top of them. Use the stapler to attach one rubber band to each inside corner of the first box and then to the corners of the cardboard insert. The rubber bands should be taut, but not overstretched. To start the tray shaking, pull the insert toward one side of the box and let it go.

2. Using the marshmallows and straws (or stirrers) as building elements, assemble a structure that measures at least 50 cm high.

3. Place the structure on the middle of the shake tray and see how it stands up to your quake. Try building several different designs to see if one particular shape stands up better than the rest.

4. Hold a design competition with your friends. See who can build an earthquake-proof structure using the least amount of material.

5. Try varying the amount of time and the strength of the shaking by how hard you pull on the insert and how tight you stretch the rubber bands.

Questions

1. What structural shapes seem to survive quakes best? Can you think of any existing buildings that use this type of design?
2. What type of earthquake motion was your shake tray simulating? Are there other motions in a quake? How might you duplicate them?
3. Do you think that it is possible to build an earthquake-proof structure? Why or why not?
4. How does the amount of shaking time affect building damage?
5. How does the strength of the shaking affect building damage?

Adapted with permission from activity by Katharyn Ross, National Center for Earthquake Engineering Research, State University of New York at Buffalo.

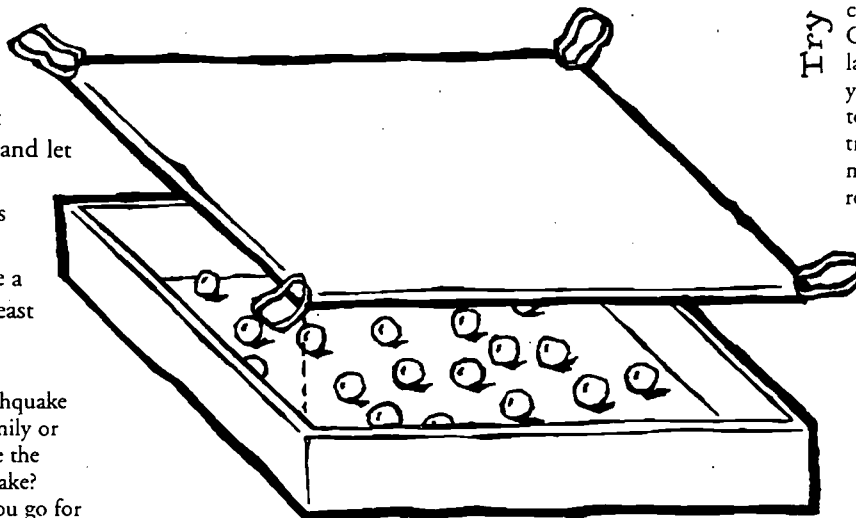

Try This Conduct an earthquake drill for your family or school. What are the proper steps to take? Where should you go for cover? What materials should you store in advance?

Try This Make a model of Earth's insides to see how plate tectonics work. The next time you cook oatmeal for breakfast, try placing some crackers on top of it while it simmers. Scatter them around and watch how they move. Is there any pattern to your continental cracker collisions?

Try This Make a plate tectonic model of Earth by tracing the present-day outlines of continents from a map onto a piece of heavy construction paper. Cut out the different land masses and see if you can put them back together again. If you try really hard, you might be able to reunite Gondwanaland.

273

NEWTON'S APPLE

Animals



Naturalist Nancy Gibson, host David Heil, and field reporter Peggy Knapp, meet some fascinating animals in season 12.

Hedgehog Show 1206

Fact or fiction?

The first thing you notice about a hedgehog is its pincushion of quills. To protect itself, the hedgehog erects its quills by using its strong skin muscles.



These muscles also help the hedgehog draw its body into a ball, like pulling a drawstring tight around the opening of a bag. In this curled-up position, the spine-covered skin on the back and sides protect the animal's vulnerable underparts. What predator would want to bother this prickly character! Hedgehogs and other small mammals have inspired writers and artists over the centuries. Authors Beatrix Potter and Lewis Carroll made hedgehogs famous in their children's books. Now you create a story for young children about hedgehogs.

African Elephants Show 1201

Trunks on the move

Next to its great size, the elephant's most remarkable feature is its trunk. This extended, muscular upper lip (sometimes as wide as three feet at its base) serves as a combination nose, hand, arm, tool, and food and water gatherer. In addition, the trunk greets, caresses, threatens, amplifies vocalization, and works as a snorkel. With it, an elephant can pick up a single leaf or suck up as much as 72-90 liters (19-24 gallons) of water each day. Design an elephant without a trunk, and show how it could perform all the work normally done with a trunk. How many new features did it take to replace the trunk?

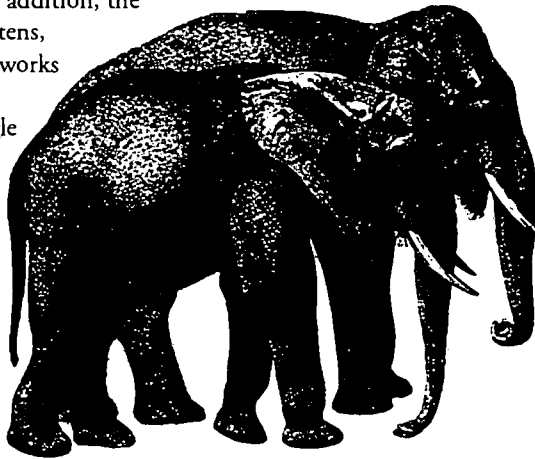

Red Fox Show 1211

Cunning and wily

What terms come to mind when describing foxes? Wily? Clever? Quick? As the most widespread member of the dog family, the red fox deserves its reputation as a resourceful, opportunistic forager. Surprisingly, the red fox compares with smaller cats in its hunting behavior and certain body features.

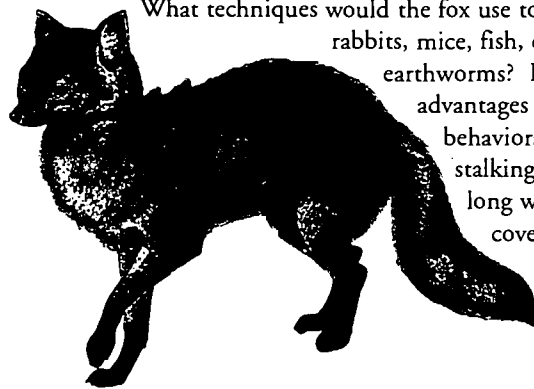

What techniques would the fox use to hunt rodents, rabbits, mice, fish, or even earthworms? Discuss the advantages of these fox behaviors or characteristics: stalking, surprise attacks, long whiskers, catlike fur-covered paws, semi-retractile claws, and vertical-slit pupils.

Komodo Dragon Show 1209

Heating up

The largest of all living lizards, the Komodo dragon grows to 300 centimeters (10 feet) long and weighs up to 135 kilograms (300 pounds). It's well equipped for surviving as the top predator on the small island of Komodo. Because it is a reptile, however, it must thermoregulate its body during the day, increasing or decreasing its temperature to function properly. The critical temperature of 41.7°C (107°F) is the highest temperature the dragon can tolerate. Locate the island of Komodo (see Indonesia) on a map. What techniques could this lizard use to stay within a "preferred temperature range"? A Komodo dragon must travel in search of prey and can eat an entire boar in a quick meal. Predict how it might spend the rest of the day.

Snakes Show 1210

Mimicry

Various arrangements of colors, patterns, or shapes mark many snakes' bodies. For some snakes, the color scheme sends a warning: "Poisonous—stay away from me." Other nonpoisonous snakes mimic the appearance of the poisonous snakes by using the same markings to scare away predators. For example, the poisonous coral snake and the docile, nonpoisonous scarlet king snake have similarly marked bodies. Obtain an identification book on snakes. List the differences between poisonous and nonpoisonous snakes in your state. Are some of these snakes considered mimics? Why?

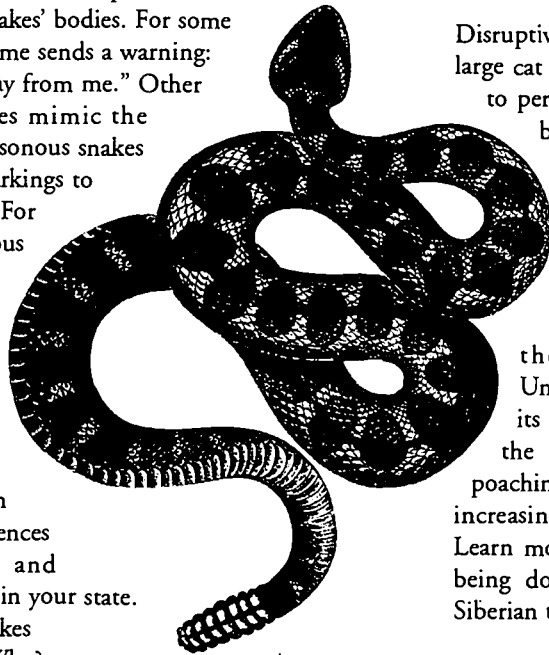

Siberian Tiger Show 1207

Vanishing before our eyes

Disruptive coloration, a form of camouflage, helps conceal this large cat within its habitat. The stripes reduce the prey's ability to perceive the outline of the tiger's body. To illustrate this basic principal of coloration, conduct this experiment. Draw a simple animal figure, using three colors. Note that on a white background all three colors are visible. Cut the drawing out and place it against a background that matches any one of its colors. See how the silhouette is altered. Unfortunately, the advantage of its cryptic coat cannot help the endangered tiger survive poaching, loss of habitat, and an increasing human population. Learn more about what is being done to save the Siberian tiger.

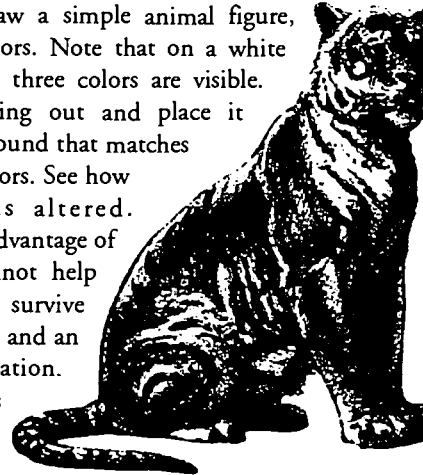

Tasmanian Devil Show 1204

Ferocious marsupial

As a carnivore and scavenger, the Tasmanian devil has a fierce reputation. Its powerful teeth crush and chew all parts of its prey with ease, even the

bones! With gusto it devours carrion or almost any living creature, including sheep and poultry.

What other animals have reputations as fierce? List the

reasons for your choices. Does the fact that an animal is a predator influence your decision? Why are these "fierce predators" important to the ecosystem and what will determine how well they survive?

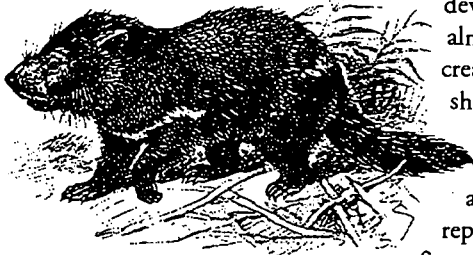

Wallabies Show 1205

Leaping locomotion

With its "spring-loaded" method of locomotion, the wallaby is one of a menagerie of incredible animals living in Australia. The wallaby—and its larger relative, the kangaroo—survive so well on this continent because they have an ample food supply of grasses and leaves, can go long periods of time without water, and have few natural predators. And, of course, their strong, powerful thighs and disproportionately long hind feet allow them to cover a lot of ground. Describe Australia's location, climate, and landscape. Why is it the home of the largest assortment of marsupials in the world?



Resources

Buron, M. (1969) *The hedgehog*. London: Deutsch.

Cajacob, T. & Burton, T. (1986) *Close to the wild: Siberian tigers in a zoo*. Minneapolis: Carolrhoda Books, Inc.

Guiler, E.R. (1992) *The Tasmanian devil*. Australia: St. David's Park Publishing.

Linden, E. (1994, Mar 28) Tigers on the brink. *Time*, pp. 44-51.

Lutz, D. & Lutz, J.M. (1991) *Komodo: The living dragon*. Salem, OR: Dimi Press.

Macdonald, D. (Ed.) (1984) *Encyclopedia of mammals*. New York: Facts on File.

Nowak, R. (Ed.) (1991) *Walker's mammals of the world*. Baltimore: Johns Hopkins University Press.

Weidensaul, S. (1992, Nov/Dec) Red shadows. *Country Journal*, pp. 35-36.

Science Try Its™

Try these experiments and observe what happens. Guess why it happens and compare your results to those on the back of the page.



Now you can try
NEWTON'S APPLE
experiments at home.

TRY IT! Make a Barometer

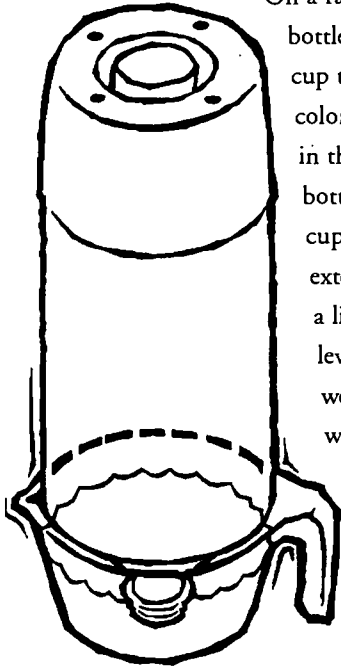

On a rainy or stormy day, flip an empty soda bottle upside down into a glass measuring cup that has a spout and contains some colored water. The bottle must fit snugly in the measuring cup so that the lip of the bottle will not touch the bottom of the cup. Make sure that the water in the cup extends into the neck of the bottle. Mark a line on the cup to indicate the water level within the bottle. When the weather turns sunny, reexamine the water level within the bottle. Did it change? Why?

TRY IT! Motorize a Paper Fish

Trace the following fish shape on a piece of paper and cut it out. Set the paper fish in a pan of water. Drop a tiny amount of vegetable oil or detergent into the hole in the fish.

What happens?



TRY IT! Listen to Vibrations

Use a rubber band to secure a metal spoon to the midpoint of a 2' string. Wrap the ends of the string around your index fingers. Rest your index fingers in your ears. Rock your body so that the spoon taps against the side of a table. What do you hear?

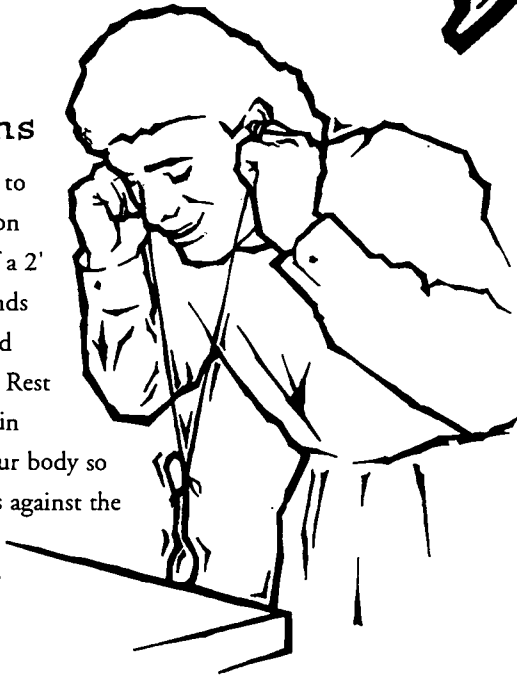

TRY IT! Taking Both Sides

Cut a 5-cm (2") strip lengthwise from an old newspaper. Holding the strip out straight, give it a half twist (180 degrees) and attach the two ends together. Take a pen and carefully draw a line along the center of the strip. Where do you end up? Is the line drawn on the inside or outside of the paper? Now cut the strip along the line you drew. How many chains do you get?

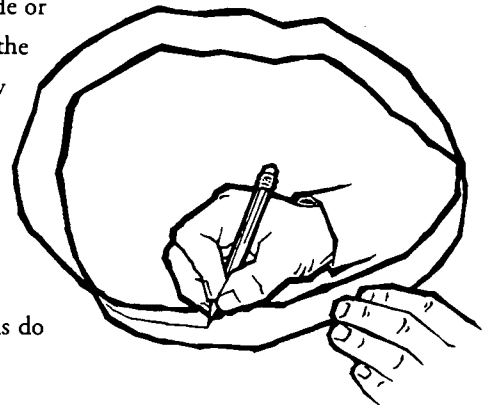

TRY IT!
Soak Some Spuds

Slice a small potato lengthwise into several pieces that each have two flat sides. Place some of the pieces in one dish and the rest in another. Fill both dishes with water. Add

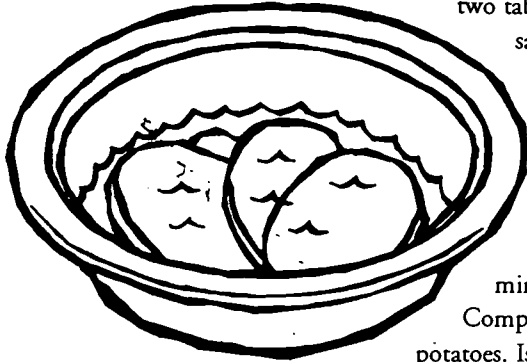

two tablespoons of salt to one of the dishes, and label it "salt water." Let the potatoes soak for 15 minutes.

Compare the potatoes. Is there a difference in firmness? Why?

TRY IT!
Catch a Bird

Draw a picture of your favorite bird on a small index card. On another card the same size, draw a cage. Now tape the two cards, drawing sides out, on opposite sides of a pen. Spin the pen between your hands or fingers. Is your

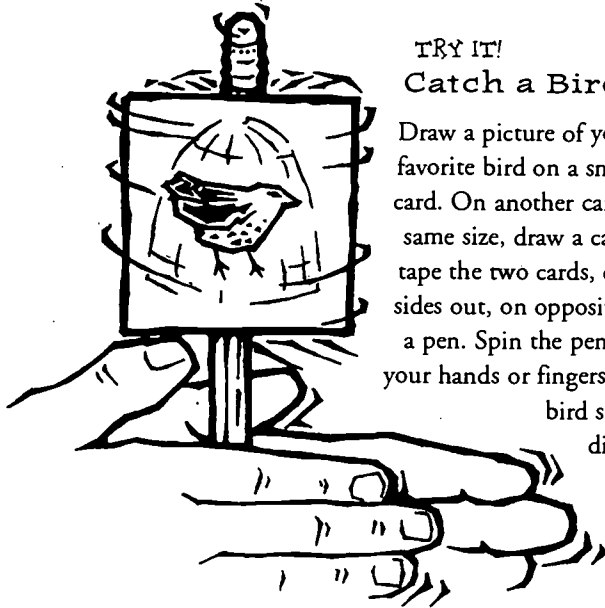

bird still free or did you catch it and put it in the cage?

The Science Behind "Science Try Its"

Why do plugged ears hear noises?

When the metal spoon taps against the table, it sends a vibration up the string, through your fingers, and into your ears. Your eardrums pick up the vibrations and send them to your brain where they are translated into sound.

Why does the fish move across the water?

All liquids have a certain amount of surface tension, a property that causes a liquid surface to behave like an elastic skin. The vegetable oil or detergent decreases the water's surface tension. If different parts of the fish have contact with different surface tensions, the fish will be propelled.

Why does the water level change?

The amount of air within the bottle is fixed at whatever the atmospheric pressure was on the day you turned the bottle upside down. The pressure on the surface of the water depends on the current air pressure. As the weather becomes drier, the air pressure increases, forcing the water to rise in the bottle.

Why does a potato become limp in salt water?

Through osmosis, water moves from areas of low salt concentrations to areas of high salt concentrations. Adding salt to the water creates a higher salt concentration in the dish than in the potato. Consequently, water in a potato that is soaking in salt water migrates out, leaving behind a limp spud!

Why do you have a strip with only one side?

Your chain is called a Mobius strip, which is a shape described by a science called topology. When you twisted your strip, the inside and outside became one continuous surface. And when you cut the strip, it became one longer chain but still had only one continuous surface. (Try the experiment again and give the paper a full twist. You'll be surprised by the results.)

Why does the bird appear to be in the cage?

It appears to be caged because of how your eyes and brain work. When you see the image of the bird, your brain holds onto the image for a short time—even though the image appears and disappears quickly. The same thing happens with the image of the cage. The two images actually overlap in your brain so the bird appears to be in the cage.

To receive the entire 12th season NEWTON'S APPLE Educational Materials packet please write:
NEWTON'S APPLE
c/o NSTA—Marketing Division
1840 Wilson Blvd.
Arlington, VA 22201

277



NEWTON'S APPLE®



Now you can do
NEWTON'S APPLE
at home!

1. What food contains the same chemical that the brain produces when people fall in love?



- A. Oysters
- B. Grapes
- C. Chocolate
- D. Roast beef

2. What part of your body acts as a compass?

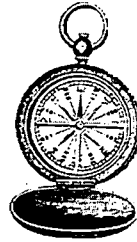

- A. Big toe
- B. Eyes
- C. Nose
- D. Pointer finger

3. How many bees does it take to make a jar of honey?

- A. 5,300
- B. 12
- C. 1,000
- D. 53,000



6. How many bones does the average adult have?

- A. 87
- B. 156
- C. 206
- D. 931



4. What is the largest human organ?

- A. Brain
- B. Heart
- C. Stomach
- D. Skin

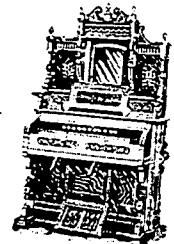

5. How much blood does your heart pump in an average day?

- A. 100 gallons
- B. 500 gallons
- C. 1,500 gallons
- D. 2,500 gallons

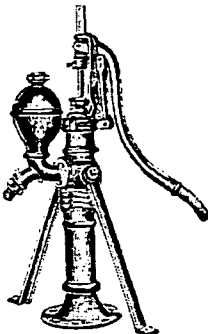



1. Love food?

Chocolate contains the same chemical—phenylethylamine—that the brain produces when people fall in love. By stepping up the heart beat and the body's energy levels, the chemical causes a happy, slightly dreamy feeling. Woo! Woo!

3. Bees and Honey?

It takes about 5,300 bees to gather enough nectar to make a pound of honey. The average busy bee will only produce about $\frac{1}{12}$ teaspoon (or .013 ounces) of honey in its lifetime. No wonder they always look and sound as busy as . . . BEES!!

5. Blood pumped?

Each day your heart pumps, on average, 1,500 gallons of blood. In a lifetime, the heart pumps enough blood to fill 13 super tankers, each holding one million barrels. Blood takes about 16 seconds to be pumped from the heart to the toes and back again.

2. Compass?

All humans have a trace amount of iron in their *noses*; this helps them "sense" the earth's magnetic field. Many people have the ability to use these magnetic deposits to orient themselves—even when blindfolded—to within a few degrees of the North Pole, exactly as a compass does. Now if we can find something that points to where the pizza is . . .

4. Largest organ?

The *skin* is the largest organ. Measured as a whole, the skin weighs 6 pounds and covers about 20 square feet on an average adult male. All of us completely change our outer skin about every 27 days. This adds up to almost 1,000 new outer skins in a lifetime. By the time we are 70 years old, we've shed an average of 40 pounds. This beats some diet programs.

6. Bones?

Babies are born with 350 bones, many of which fuse during growth, so upon reaching adulthood the number of bones drops to only 206. There is a strange exception: one out of every 100 people has an extra rib (most commonly found in men). Obviously, they must be able to take a good ribbing.

Answers



To receive the entire 12th season NEWTON'S APPLE Educational Materials packet please write:

NEWTON'S APPLE
c/o NSTA - Marketing Division
1840 Wilson Blvd.
Arlington, VA 22201

279

Transparency Master

We've enlarged four illustrations from our lesson pages to assist you in making transparencies for your classroom. Some helpful hints on making and using transparencies are included at the bottom of each page.

Show 1203

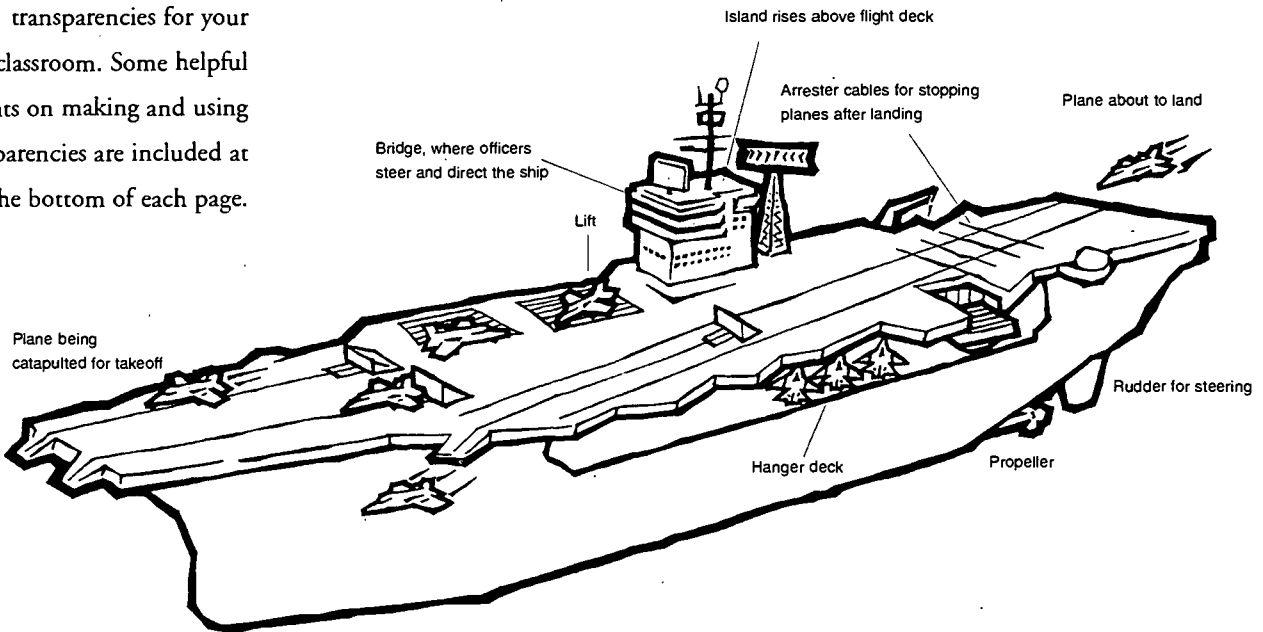

Show 1210

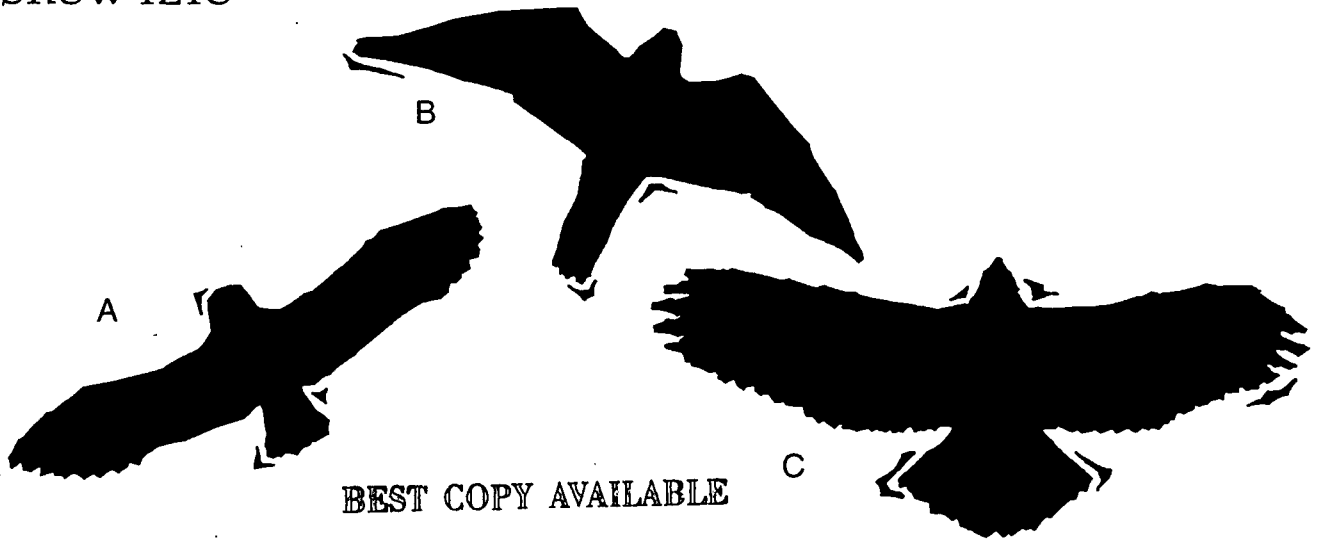

Hints for making clear transparencies.

Make a copy of the original to work from (enlarge, if necessary).

Use a thermofax or copier to make the transparency.

Add color with a marker or color transparency film.

280

NEWTON'S APPLE is a production of KTCA Twin Cities Public Television. Made possible by a grant from 3M.

Educational materials developed with the National Science Teachers Association.

12.67 **3M** Innovation

We encourage duplication for educational use!



	<u>Standing Still</u>	<u>Ascent</u>	<u>Descent</u>
weight of (student name)	_____	_____	_____
weight of (student name)	_____	_____	_____
weight of (student name)	_____	_____	_____

Transparency Master

Show 1213

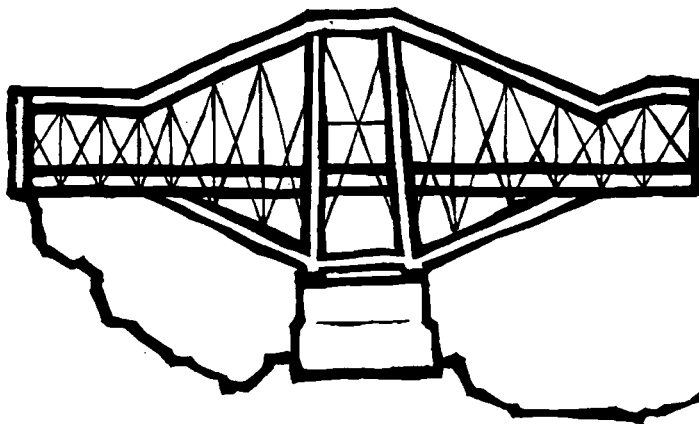

Hints for using transparencies in your classroom.

Keep it simple.

Make it interactive by leaving out some information and soliciting ideas from the class to fill in the blanks.

Keep your students' attention by providing handouts only after you've finished your presentation.

281

NEWTON'S APPLE 12th Season

- Show 1201**
Hang Gliding
Karate
Robin Leach
Science of the Rich 'n' Famous
Elephant
- Show 1202**
Arctic Project Special
• Sled Dogs
• Arctic Travel
• Life in Camp
• Arctic Weather
- Show 1203**
Aircraft Carrier
Brain
Carrier Life
- Show 1204**
Brain Mapping
Garlic
Sunscreens
Tasmanian Devil
- Show 1205**
Movie Dinosaurs
Bread Chemistry
Scott Hamilton
Science of the Rich 'n' Famous
Wallaby
- Show 1206**
Movie Sound Effects
Sun
Globetrotters
Science of the Rich 'n' Famous
Hedgehog
- Show 1207**
Dinosaur Extinction
Floods
Blue Seas
Siberian Tiger
- Show 1208**
Internet
Antibiotics
Panning for Gold
Taxidermy
- Show 1209**
Ethnobotany
Hubble Telescope
Inventor's Fair
Komodo Dragons
- Show 1210**
Raptor Hospital
Photography
Skipping Stones
Snakes
- Show 1211**
Redwoods
Electricity
Monuments
Red Fox
- Show 1212**
Printing Money
Gravity
Nature Labs
- Show 1213**
Bridges
Earthquakes
Chromakey
Grizzly Bear

fold here

Do you have a question about the world around you? Write us at:

NEWTON'S APPLE
c/o Twin Cities Public Television
P.O. Box 1200
172 Fourth Street
St. Paul, MN 55101

We'll send you a guide to our reruns and may answer your question on the show!

fold here

A Guide to Enjoying NEWTON'S APPLE at Home

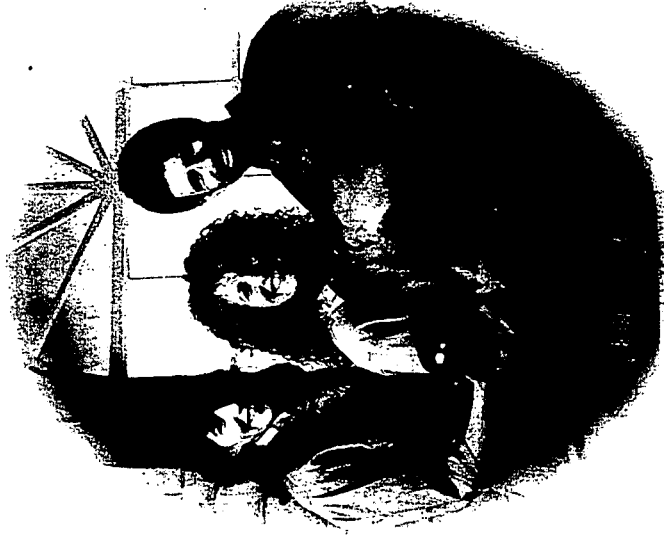

Naturalist Nancy Gibson, field reporter Peggy Knapp, and host David Heil answer your science questions in Season 12 of NEWTON'S APPLE!

NEWTON'S APPLE is proud that many of our viewers watch our show as a family. We've created this special guide to our 12th season to help you remember to tune in at home and to let you know what to expect each week. (Although with NEWTON'S APPLE, you'll learn to expect the unexpected.)

We've also developed some fun science activities that you can do with your family and friends. You can also try the "Science Try It" activities that appear on the show. (You may want to keep a paper and pencil handy while you're watching and write down the directions.) We'd love to hear how your experiments turned out!

Please check with your local PBS station for the exact dates and times that NEWTON'S APPLE airs in your area. If Season 12 doesn't appear in the Fall 1994 schedule of your local PBS station, call them to find out when they plan to run it. If you call to ask for a particular show, refer to it by the show number listed (e.g., 1201 for "Hang Gliding").

Try these activities with your family and friends!

at
Try This Home...

Taking Both Sides

Science Try It!

Cut a 5-cm (2") strip lengthwise from an old newspaper. Holding the strip out straight, give it a half twist (180 degrees) and attach the two ends together. Take a pen and carefully draw a line along the center of the strip. Where do you end up? Is the line drawn on the inside or outside of the paper? Now cut the strip along the line you drew. How many chains do you get?

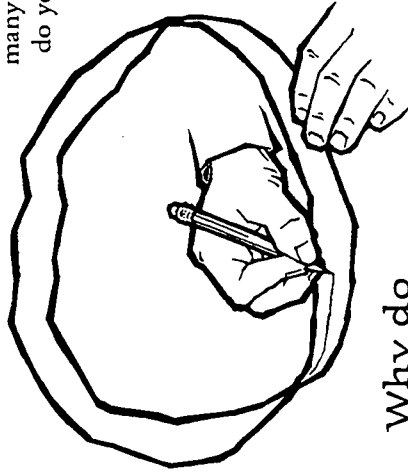

Why do you have a strip with only one side?

Your chain is called a Mobius strip, which is a shape described by a science called topology. When you twisted your strip, the inside and outside became one continuous surface. And when you cut the strip, it became one longer chain but still had only one continuous surface. (Try the experiment again and give the paper a full twist. You'll be surprised by the results.)

Earthquakes

Show 1213

Make a model of the inside of Earth and see how plate tectonics work. Next time you cook oatmeal, warm it to a slow simmer and scatter some crackers on top. Watch how they move. Is there any pattern to your continental cracker collisions?

Bread Chemistry

Show 1205

Baking powder is a chemical leavening agent. Read the label on a baking powder product to learn what ingredients it contains. Put a tablespoon of baking powder one of your hands. Now pour a tablespoon of water over the powder. What did you see, hear, and feel? Repeat this activity with baking soda and vinegar. Compare the results.

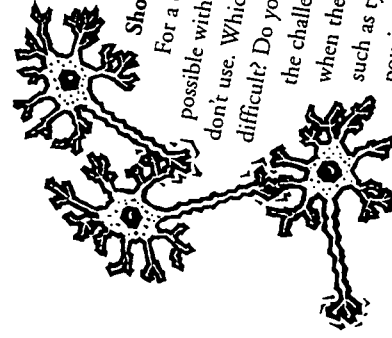

Brain

Show 1203

For a day, try doing as much as possible with the hand you normally don't use. Which tasks are particularly difficult? Do you think this is similar to the challenge young children face when they learn new actions, such as tying their shoes or pouring juice into a glass?

at
Try This at Home...

3M and Science Education

3M recognizes its responsibilities as a corporate citizen by supporting educational, cultural, community, health, and human services activities in communities where 3M has a major presence. Support of NEWTON'S APPLE is only one example of its commitment to science education.

For over 40 years, the 3M Technical Forum organization has guided employees in volunteer outreach programs designed to encourage students from kindergarten through college to consider careers in science and engineering. Today, the 3M Technical Forum Science Encouragement Programs cover a broad scope.

Through the award-winning 3M Visiting Wizard program, more than 250,000 elementary and secondary school children have been shown the fun of science through hands-on, high-quality, educationally-sound, science enrichment demonstrations. Every year, the Wizards also sponsor a science sharing resource fair for elementary teachers in Minnesota and western Wisconsin.



The Technical Teams Encouraging Career Horizons (TECH) program encourages students to explore technical careers by bringing 3M scientist and engineering role models into the middle and junior high school classroom. TECH is recognized

nationally for emphasis on encouraging young women in scientific careers.

STEP (Science Training Encouragement Program) is a partnership between 3M and the St. Paul School District, providing classroom instruction and summer jobs to minority and disadvantaged students. Through STEP, students earn credit toward graduation and are introduced to culturally diverse, modern-day heroes.

Science Student Recognition Day invites two outstanding high school seniors and teachers from local schools to a shadow program with 3M scientists and engineers.

Through TWIST (Teachers Working in Science and Technology), teachers from selected local school districts spend six weeks working on a challenging and active technical project in an industrial setting.

While many of these programs are based at 3M headquarters in St. Paul, some 3M plants at other locations around the world have similar programs. For information about 3M Technical Forum Science Encouragement Programs, call (612) 733-2508.



Richard G. Drew Creativity Award Day is named after Dick Drew, scientist and inventor. High school juniors are nominated by their science or math teachers

for their creative flair and

persistence in technical or scientific pursuits. They spend the day touring 3M labs, participating in a career panel, and listening to an expert speaker on creativity.

NEWTON'S APPLE Educational Materials Production Team

Lynae Berge, Outreach Coordinator
Paddy Faustino, Outreach Assistant
Sue Wichmann, Freelance Editor

Writing Team

Julie A. Fisher, Ann Arbor, MI
Thomas A. Frei, Fargo, ND
Maria L. M. Hidalgo, St. Paul, MN
Cheryl Lani Juarez, Educational Technology Specialist, Miami Museum of Science, Miami, FL
Mike McClure, Associate Professor of Chemistry, Hopkinsville Community College, Hopkinsville, KY
Pamela O'Brien, Minnesota Zoo, Apple Valley, MN
Natalie Rusk, Science Museum of Minnesota, St. Paul, MN
Colleen M. Sauber, Freelance Writer, St. Paul, MN
Caren Barzelay Stelson, Freelance Writer and Designer of Educational Curriculum, Edina, MN
Stephen M. Tomecek, Director, Science Plus Inc., Queens Village, NY

Content Review Panel

Richard Aldridge, Aerospace Consultant, Fredericksburg, VA
Joan Armistead, National Council of Teachers of Mathematics, Reston, VA
Louise Ashmun, Wasilla, AK
Alan R. Baker, M.D., Rockville, MD
Margaret Barker, Cornell Lab of Ornithology, Ithaca, NY
Clinton H. Brown, Montgomery County Public Schools, Rockville, MD
Jeffrey C. Callister, Newburgh Free Academy, Newburgh City Schools, Newburgh, NY
Rick Constant, Recreational Equipment Incorporated, Laurel, MD
Robert S. Donaldson, Ellicott City, MD
Janet Gerking, Larimie High School, Laramie, WY
Gregg M. Gochnour, Rockville, MD
Linda Gojak, Hawken School, Lyndhurst, OH
Heidi Hughes, Wild Bird Company, Rockville, MD
Mario Iona, Professor Emeritus, Department of Physics, University of Denver, CO
Michael Jay, Chancery Software Inc., Bellingham, WA
Fred Kaplan, Germantown, MD
Steven Kostant, Girard Video, Washington, DC
M. Sheila Marshall, National Science Teachers Association, Arlington, VA
Joan Braunagel McShane, Davenport Community Schools, Davenport, IA
Melinda B. Mills, Science Department Head, Space Center Intermediate School, Houston, TX
John Padalino, Pocono Environmental Education Center, Dingmans Ferry, PA
James Proctor, Department of the Treasury, Washington, DC
Don Scopel, Lt., U.S. Coast Guard Academy, New London, CT
C. Thomas Settlemire, Ph.D., Biology and Chemistry Depts., Bowdoin College, Brunswick, ME
Karen Simon, U.S. Hang Gliding Association, Colorado Springs, CO
Irwin L. Slesnick, Biology Department, Western Washington University, Bellingham, WA
Dale Syphers, Professor, Physics Department, Bowdoin College, Brunswick, ME
Dennie Thorpe, Denmarc Productions, Fairfax, CA
Stephen M. Tomecek, Director, Science Plus Inc., Queens Village, NY
Michael L. Weiss, NASA/Goddard Space Flight Center, Greenbelt, MD
John Wilczak, HSC Software, Inc., Santa Monica, CA

National Science Teachers Association

Bill G. Aldridge, Executive Director
Karen Baker, Project Coordinator
Brian Aldridge, Program Manager
Jennifer Laughlin, Program Assistant

Advisory Panel

Jerry Bell, American Academy for the Advancement of Science
Joan Dykstra, National Parent Teacher Association
Louise Hicks, Fairfax County Public Schools
Dale Marcellini, Washington Zoological Park
Phyllis Marcuccio, National Science Teachers Association
William McDonald, Montgomery County Public Schools
Oakie Russell, Public Broadcasting Service
Russell Wright, Montgomery County Public Schools

3M/NEWTON'S APPLE Education Committee

Richard Hanson	John Huizinga
Barbara Kaufmann, Chair	Mary Hurlocker
Bob Barton	Patty Konsti
Harvey Berwin	Gary Kwong
Sue Butzer	Walt Lager
Yvonne Cadwallader	Mike Lovejoy
Mary Chilinski	Marlyce Paulson
Peggy Dingman	

NEWTON'S APPLE Staff

David Heil, Host
Peggy Knapp, Field Reporter
Nancy Gibson, Naturalist
Richard Hudson, Executive Producer
Doug Bolin, Series Producer
Kristian Berg, Senior Producer
Dan Fiorucci, Segment Producer
Jeff Nielsen, Segment Producer
Gary Leatherman, Segment Producer
Amy Kenefick, Associate Producer
Kim MacDonald, Associate Producer
Darren Howelton, Production Assistant
Kevin Williams, Production Assistant
Tom Adair, Freelance Segment Producer
Linda Flynn, Freelance Segment Producer
Leslie Kratz, Freelance Segment Producer
Lynne Reeck, Freelance Segment Producer
Christine Maloney, Production Manager
Meighan Maloney, Production Manager
Melissa Butts, Assignment Manager
Candice Coleman, Production Office Coordinator
Lynae Berge, Outreach Coordinator

Design Group

Steve Weil, Project Design Director
Katie Osborn, Project Designer
Jeff Brice, Illustrator, NEWTON'S APPLE 12th Season Poster
J. Michael Gatlin, Illustrator, Lesson Pages

287



We encourage duplication for educational use!

NEWTON'S APPLE is a production of KTCA Twin Cities Public Television. Made possible by a grant from 3M.

Educational materials developed with the National Science Teachers Association.

3M Innovation

Seasons 9 • 10 • 11 • 12 Index

SUBJECT INDEX

SUBJECT	SHOW NUMBER	PAGE(S)
Acid Rain	910	9.39 - 9.40
African Elephants	1201	12.61
AIDS	1007	10.31 - 10.32
Air Bags	913	9.53 - 9.54
Air Pressure	1010	10.45 - 10.46
Aircraft Carrier	1203	12.17 - 12.18
Antarctica I	1006	10.27 - 10.28
Antarctica II	1006	10.29 - 10.30
Antibiotics	1208	12.39 - 12.40
Archeology	1108	11.37 - 11.38
Archery	1009	10.41 - 10.42
Arctic Survival	1202	12.13 - 12.14
Arctic Nutrition	1202	12.15 - 12.16
Aurora Borealis	1010	10.43 - 10.44
Bats	903	9.55
Bears	912	9.56
Polar	1112	11.62
Bends	1111	11.49 - 11.50
Bison Roundup	1110	11.45 - 11.46
Black Holes	1102	11.15 - 11.16
Blood Typing	1012	10.53 - 10.54
Bomb Squad	1104	11.23 - 11.24
Brain	1203	12.19 - 12.20
Brain Mapping	1204	12.21 - 12.22
Bread Chemistry	1205	12.27 - 12.28
Bridges	1213	12.57 - 12.58
Broken Bones	1008	10.37 - 10.38
Camels	908	9.55
Cancer Causes	904	9.15 - 9.16
Cancer Treatments	905	9.21 - 9.22
Caribou	1005	10.59
Carpal Tunnel Syndrome	1107	11.35 - 11.36
Chimpanzees	1113	11.61
Cockroaches	1008	10.35 - 10.36
Collisions	913	9.53 - 9.54
Compact Discs	1111	11.51 - 11.52

SUBJECT INDEX

SUBJECT	SHOW NUMBER	PAGE(S)
Condors	1009	10.60
Cougars	1003	10.59
Cryogenics	1011	10.49 - 10.50
Dairy Farm	1109	11.43 - 11.44
Dams	1012	10.51 - 10.52
Diabetes	1013	10.55 - 10.56
Diet	1005	10.25 - 10.26
Dinosaur Extinction	1207	12.33 - 12.34
Dinosaurs I	906	9.23 - 9.24
Dinosaurs II	906	9.25 - 9.26
Dolphins	1108	11.61
Domed Stadium	907	9.27 - 9.28
Eagles	911	9.56
Earthquakes	1213	12.59 - 12.60
Election Polls	1003	10.15 - 10.16
Electric Cars	1003	10.17 - 10.18
Electricity	1211	12.51 - 12.52
Elephants, African	1201	12.61
Emergency Rescue	1102	11.13 - 11.14
Ethnobotany	1209	12.41 - 12.42
Family Guide (season 9)		9.59 - 9.60
Family Guide (season 10)		10.67 - 10.68
Family Guide (season 12)		12.69 - 12.70
Firefighting	1109	11.41 - 11.42
Floods	1207	12.35 - 12.36
Forests, Old-growth	1107	11.33 - 11.34
Fox, Red	1211	12.61
Frisbee Physics	904	9.17 - 9.18
Galaxy Mapping	1013	10.57 - 10.58
Garbage	1112	11.53 - 11.54
Garlic	1204	12.23 - 12.24
Glass Recycling	1007	10.33 - 10.34
Gravity	1212	12.55 - 12.56
Hang Gliding	1201	12.9 - 12.10
Heart Attack	1110	11.47 - 11.48

SUBJECT INDEX

SUBJECT	SHOW NUMBER	PAGE(S)
Hedgehog	1206	12.61
High Jump	910	9.41 - 9.42
Hip Replacement	913	9.51 - 9.52
Hollywood Stunts	1002	10.11 - 10.12
Horses, Miniature	902	9.55
Household Chemistry	1002	10.13 - 10.14
Hubble Telescope	1209	12.43 - 12.44
Hummingbirds	1103	11.61
<i>In Vitro</i> Fertilization	1103	11.19 - 11.20
Infrared Light	1112	11.55 - 11.56
Internet	1208	12.37 - 12.38
Jumbo Jets	1105	11.25 - 11.26
Karate	1201	12.11 - 12.12
Komodo Dragon	1209	12.61
Lizards	1107	11.61
Llamas	909	9.56
Locks and Dams	1012	10.51 - 10.52
Luge	901	9.7 - 9.8
Mazes	1108	11.39 - 11.40
Medical Quakeries	911	9.43 - 9.44
Memory	1103	11.17 - 11.18
Meteors	1105	11.27 - 11.28
Microwave Ovens	911	9.45 - 9.46
Monster Makeup	1004	10.19 - 10.20
Money, Printing	1212	12.53 - 12.54
Mount Rushmore	1113	11.57 - 11.58
Movie Dinosaurs	1205	12.25 - 12.26
Movie Sound Effects	1206	12.29 - 12.30
Mosquitoes	1104	12.62
Murder Mystery	903	9.13 - 9.14
Musk Ox	1002	10.59
Newspaper	1104	11.21 - 11.22
Nutrition	1005	10.25 - 10.26

SUBJECT INDEX

SUBJECT	SHOW NUMBER	PAGE(S)
Oil Spills	1005	10.23 - 10.24
Olympic Training Center	901	9.5 - 9.6
Omnimax	1009	10.39 - 10.40
Ostrich	1013	10.60
Otters, River	1109	11.62
Ox, Musk	1002	10.59
Owl, Spotted	1107	11.33 - 11.34
Ozone	1004	10.21 - 10.22
Penguins	1006/1012	10.59
Permafrost	1106	11.31 - 11.32
Photography	1210	12.47 - 12.48
Photosynthesis	907	9.29 - 9.30
Pigs, Pot belly	913	9.56
Piranhas	1010	10.60
Printing Money	1212	12.53 - 12.54
Polar Bears	1112	11.62
Porcupines	905	9.55
Raptor Hospital	1210	12.45 - 12.46
Red Fox	1211	12.61
Redwoods	1211	12.49 - 12.50
Reindeer	1102	11.62
Rhinoceros	1008	10.60
River Otters	1109	11.62
Rock Climbing	1101	11.9 - 11.10
Satellite Technology	1001	10.9 - 10.10
Science Subject Index (season 11)		11.7 - 11.8
Science Subject Index (season 12)		12.7 - 12.8
Science Try Its (season 9)		9.57 - 9.58
Science Try Its (season 10)		10.61 - 10.62
Science Try Its (season 11)		11.63. - 11.64
Science Try Its (season 12)		12.63 - 12.64
Season Index (season 9)		9.3
Season Index (season 10)		10.5
Season Index (season 11)		11.5
Season Index (season 12)		12.5
Sewer Science	905	9.19 - 9.20
Siberian Tiger	1207	12.62

SUBJECT INDEX

SUBJECT	SHOW NUMBER	PAGE(S)
Sky Blue	909	9.37 - 9.38
Slinky Physics	908	9.33 - 9.34
Snakes	1210	12.64
Solar Eclipse	912	9.49 - 9.50
Solar Powered Cars	902	9.9 - 9.10
Soviet Space	909	9.35 - 9.36
Smell	1101	11.11 - 11.12
Steroids	902	9.11 - 9.12
Street Smart (season 10)		10.63 - 10.64
Street Smart (season 11)		11.65 - 11.66
Street Smart (season 12)		12.65 - 12.66
Sun	1206	12.31 - 12.32
Surveys	1003	10.15 - 10.16
Taste	1101	11.11 - 11.12
Tasmanian Devil	1204	12.62
Tears	908	9.31 - 9.32
Telecommunications	912	9.47 - 9.48
Television	1001	10.7 - 10.8
Tiger, Siberian	1207	12.62
Traffic Control	1011	10.47 - 10.48
Transparency Master (season 10)		10.65 - 10.66
Transparency Master (season 11)		11.67 - 11.68
Transparency Master (season 12)		12.67 - 12.68
Virtual Reality	1113	11.59 - 11.60
Wallabies	1205	12.62
Wolverines	1007	10.59
Wolves	1111	11.62
Windsurfing	1106	11.29 - 11.30

What Teachers Are Saying About Newton's Apple Teachers Guides:

"The Newton's Apple materials engage students at a level not achieved by worksheets, videos or reading alone. Learning can't help but happen."

"Excellent! Keep up the good job of bringing ideas and resources to teachers!"

"Very helpful and fun materials. Thank you!"

"Very useful to develop lessons and direct student-teacher discussion, written exercises easy to implement."

"We really enjoy Newton's Apple! We have gotten some good ideas for science fair projects from your activities."

"I am always happy to receive Newton's Apple and my students thank you too! Newton's Apple is a great teaching tool!"



U.S. Department of Education
Office of Educational Research and Improvement (OERI)
National Library of Education (NLE)
Educational Resources Information Center (ERIC)



REPRODUCTION RELEASE
(Specific Document)

DOCUMENT IDENTIFICATION:

Form with fields for Title, Author(s), Corporate Source, and Publication Date.

REPRODUCTION RELEASE:

In order to disseminate as widely as possible timely and significant materials of interest to the educational community, documents announced in the monthly abstract journal of the ERIC system, Resources in Education (RIE), are usually made available to users in microfiche, reproduced paper copy, and electronic media, and sold through the ERIC Document Reproduction Service (EDRS). Credit is given to the source of each document, and, if reproduction release is granted, one of the following notices is affixed to the document.

If permission is granted to reproduce and disseminate the identified document, please CHECK ONE of the following three options and sign at the bottom of the page.

The sample sticker shown below will be affixed to all Level 1 documents

The sample sticker shown below will be affixed to all Level 2A documents

The sample sticker shown below will be affixed to all Level 2B documents

PERMISSION TO REPRODUCE AND DISSEMINATE THIS MATERIAL HAS BEEN GRANTED BY

Sample

TO THE EDUCATIONAL RESOURCES INFORMATION CENTER (ERIC)

Level 1 checkbox with checkmark

PERMISSION TO REPRODUCE AND DISSEMINATE THIS MATERIAL IN MICROFICHE, AND IN ELECTRONIC MEDIA FOR ERIC COLLECTION SUBSCRIBERS ONLY, HAS BEEN GRANTED BY

Sample

TO THE EDUCATIONAL RESOURCES INFORMATION CENTER (ERIC)

2A

Level 2A checkbox

PERMISSION TO REPRODUCE AND DISSEMINATE THIS MATERIAL IN MICROFICHE ONLY HAS BEEN GRANTED BY

Sample

TO THE EDUCATIONAL RESOURCES INFORMATION CENTER (ERIC)

2B

Level 2B checkbox

Check here for Level 1 release, permitting reproduction and dissemination in microfiche or other ERIC archival media (e.g., electronic) and paper copy.

Check here for Level 2A release, permitting reproduction and dissemination in microfiche and in electronic media for ERIC archival collection subscribers only

Check here for Level 2B release, permitting reproduction and dissemination in microfiche only

Documents will be processed as indicated provided reproduction quality permits. If permission to reproduce is granted, but no box is checked, documents will be processed at Level 1.

I hereby grant to the Educational Resources Information Center (ERIC) nonexclusive as indicated above. Reproduction from the ERIC microfiche or electronic media by third party contractors requires permission from the copyright holder. Exception is made for to satisfy information needs of educators in response to discrete inquiries.

Sign here, please

Signature and organization address fields with handwritten entries: Melva B. Sayre, Newton's Apple, Twin Cities Public TV



KTCA
Twin Cities Public Television
172 E. 4th Street
St. Paul, MN 55101
612.222.1717

Melva B. Sayre
Outreach & Station Relations

tel: 612.229.1329
fax: 612.229.1570
e-mail: msayre@ktca.org

