

DOCUMENT RESUME

ED 427 699

IR 019 250

AUTHOR Dorner, Ralph; Schafer, Arno; Elcacho, Colette; Luckas, Volker
TITLE Using VRML for Teaching and Training in Industry.
PUB DATE 1998-11-00
NOTE 8p.; In: WebNet 98 World Conference of the WWW, Internet, and Intranet Proceedings (3rd, Orlando, FL, November 7-12, 1998); see IR 019 231. Figures may not reproduce clearly.
PUB TYPE Reports - Descriptive (141) -- Speeches/Meeting Papers (150)
EDRS PRICE MF01/PC01 Plus Postage.
DESCRIPTORS Animation; *Authoring Aids (Programming); *Computer Assisted Instruction; Computer Oriented Programs; Computer System Design; *Industrial Training; Information Technology; Lifelong Learning; Material Development; *Programming Languages; Three Dimensional Aids; *Virtual Reality; Visualization; World Wide Web
IDENTIFIERS Computer Animation

ABSTRACT

This paper shows how World Wide Web-based technology using VRML (Virtual Reality Modeling Language) can be applied in an industrial education and training context. Following an introduction to the importance of lifelong learning and training in industry, the state of the art of VRML is discussed, including its features and integration into the Web environment. Possible scenarios for the application of three-dimensional (3D) animation and virtual reality for industrial training are summarized. The following VRML tools are then described: (1) the CASUS (Computer Animation of Simulation Traces) System, an object-oriented approach to linking a 3D visualization to an event-oriented simulator; (2) the VRML authoring tool, consisting of scene composing, structure, and animation editors; and (3) the VRML application builder, including relation, annotation relation, and composing editors. Four figures present the CASUS System architecture, visualizations of production and logistics scenarios, a VRML-based plant manual, and an overview of the applications structure. (Contains 11 references.) (AEF)

* Reproductions supplied by EDRS are the best that can be made *
* from the original document. *

Using VRML for Teaching and Training in Industry

U.S. DEPARTMENT OF EDUCATION
Office of Educational Research and Improvement
EDUCATIONAL RESOURCES INFORMATION
CENTER (ERIC)

- This document has been reproduced as received from the person or organization originating it.
- Minor changes have been made to improve reproduction quality.
- Points of view or opinions stated in this document do not necessarily represent official OERI position or policy.

Ralph Dörner, Arno Schäfer, Colette Elcacho, Volker Luckas
Fraunhofer Institute for Computer Graphics
Dept. Animation and Image Communication
Rundeturmstr. 6, D-64283 Darmstadt, GERMANY
{doerner, aschaefer, elcacho, luckas}@igd.fhg.de

"PERMISSION TO REPRODUCE THIS
MATERIAL HAS BEEN GRANTED BY

G.H. Marks

TO THE EDUCATIONAL RESOURCES
INFORMATION CENTER (ERIC)."

Abstract: Lifelong learning and training has become an important issue in industry, because keeping track of innovations and adopting new developments is necessary for maintaining competitiveness in the market. In this paper we want to show how VRML can be generally used for teaching and training in an industrial context. We will discuss some aspects of learning and training in industry and sketch several application scenarios for VRML based training. Moreover we give an overview of tools that are suitable for designing teaching and training applications, and present authoring tools we have developed in this context.

1 Introduction

In industry, lifelong learning and training on an individual, team and organizational basis in all hierarchy levels from top management down to the work force is becoming increasingly important due to ever faster changing market dynamics, the rapidly evolving labor market and the constantly changing employment culture. Internal training of personnel, initial training and preparatory training for new tasks, the continuation of employee education, and also training on the job are the key forms of individual training. Team training often consists in special training courses on group dynamics and psychological aspects, but also includes the use of communication supporting software solutions that provide some assistance for efficient team communication. For instance the use of WWW technology as a basis for sharing information and documents, or the use of visualization techniques, aiming to provide a common understanding, can be classified into this category. Organizational learning and training often comprises the problem of knowledge representation and collection, especially in internationally operating companies and in companies that have historically evolved from mergers and buy-outs of different enterprises. For such organizational learning and training, well defined and globally accessible information systems are often a favored concept, for propagating factually transmissible information. Apart from internal training, external training of suppliers and sales agents on new products are other frequently occurring training situations. For global organizations it is an increasingly complex and difficult task to maintain an overview of the "strategic knowledge" the company and its affiliations and subsidiaries own. In the course of globalization of markets, an increasing number of companies rely on global communication networks such as the WWW for communicating internal information and for building up company wide information systems. Due to recent technological developments in the IT sector, the quest for more compelling visualization and information access is increasing and the demand for 3D graphics is rising. Innovative technologies such as *VRML (Virtual Reality Modeling Language)* [VRML97] enable the web based use of interactive 3D environments. VRML is applicable in different training scenarios, such as virtual training environments, both real time interactive 3D and immersive VR or hypermedia environments. In this paper we first describe the state of the art of VRML. After that, we present tools that are suitable for creating teaching and training applications using VRML, and show some application examples.

2 VRML State of the Art

The Virtual Reality Modeling Language (VRML) is a language and file format specification for exchanging 3D data, especially across the Internet. Since its inception in 1994, VRML, as an open and platform independent

ED 427 699

format, has gained widespread acceptance and support in both industry and academia. With its ISO standardization, finished in record time in November 1997, it has taken the step from de facto to de jure standard. By now, there exist numerous VRML browsers and plugins on many platforms, typically free of charge. Several dedicated VRML authoring tools are available. Most industry standard modeling and animation tools support VRML format, at least through export filters, and even more are supported through converters. VRML offers among others the following features:

- description of 3D geometry, including material properties and textures
- fog and light effects
- linear key frame animation
- user interaction with the 3D scene (e.g. through mouse clicks or drags)
- 3D sound
- animated (i.e. video) textures
- HTTP hyper links
- programming APIs for the Java and ECMAScript programming languages

The further development of VRML is coordinated by the VRML consortium [Consortium] and is carried out in working groups, such as the Humanoid Animation WG or the MPEG-4 Integration Task Group.

VRML is supported by the common WWW browsers Netscape Navigator and Microsoft Internet Explorer by means of "plugins" or "ActiveX controls". This means that VRML data can be integrated into WWW pages much like other multimedia file formats such as MPEG video or Macromedia Shockwave files. Moreover, HTTP hyper links and multimedia files such as sound (WAV, MIDI) or MPEG video can be integrated into the 3D scene, so that VRML is tightly integrated into the WWW hypermedia structure. This can be used to advantage by applications such as product information systems, which can be set up to provide 3D presentations of products, where additional information can be obtained by clicking on different parts of the 3D object.

An even more powerful way of integrating VRML into the WWW browser environment is the *VRML External Authoring Interface (EAI)* [Marrin 97], which makes it possible to access and modify a VRML scene from within a Java applet running on the WWW page. Many applications such as 2D user interfaces for manipulation of the 3D world, database access, or simulator linkage, are thus feasible.

Despite the increasing availability of authoring systems and supporting tools, VRML content creation is still a very labor intensive and time consuming process. The manual tasks such as editing of the VRML scene file and especially Java programming are often unavoidable even with today's tools, and require special knowledge, such as programming skills. They are therefore often not done by the same people creating the 3D models, which makes VRML content creation even more expensive.

3 Applications

3D animation and Virtual Reality can be applied in industry as a medium for vocational training and for continuing education in the context of lifelong learning. For instance, in order to train technicians, engineers, but also users on a newly launched product or on special tasks to be performed with that product, such as installation or maintenance, manuals and courses are usually provided.

The use of VRML for such training manuals allows to take advantage of features such as a true 3D representation of the product, the display of animations showing special actions to be performed, the definition of interaction and behavior, the integration of links to additional information, or the addition of sound, such as spoken instructions.

In repair instructions for technicians, 3D animation and annotated, interactive 3D exploded views of the product model can be of great help to intuitive understanding. The same technology can also be used in 3D installation manuals and user manuals. 3D exploded views of product models are of great help to intuition and are already widely used for intra-organizational communication, marketing and management presentations of all kinds. However, the generation of such views is still expensive and thus reserved to a small number of special areas. Efficient methods and tools for generating interactive exploded views will enable their routine use in a larger context, such as 3D interfaces to product information systems.

In the same way VRML, as a web-based technology, is well suited for distributed information access and offers the option to use 3D interfaces. To access technical information on a product or on its parts, a 3D interface that shows an exploded 3D view of the product is a very compact and intuitive interaction metaphor. Because programmed code can be easily integrated into VRML scenes and objects, the VRML representation of the product and its parts can be dynamically related to additional information, such as a part list or bill of materials, where each entry in the list can be dynamically related to the parts in the VRML model.

3D navigation interfaces, representing a product or production plant, are well suited for training applications due to the intuitively and immediately understandable metaphor. They can be equally used for training of new personnel, anticipant training on new products and on new production facilities. VRML applications are also suitable for mobile environments [Raposo 97]. VRML can be used to share one model with other employees via WWW. For instance, in construction, several engineers can work together on the same object. The same technology may also be used to communicate shared mental models [Stout 96]. VRML can be used for surveillance of production processes. Here sensor data can be used to automatically generate to a time-variant 3D visualization. Presenting the sensor data in a 3D model makes it easier to locate a malfunction in the real machine. Additionally, the 3D model can also be used in a training scenario.

Providing technology and tools, however, is not sufficient. In industry, cost effectiveness is usually a major concern. The authoring of 3D environments has to be done in an efficient manner. Animation, for example, is not considered as central as in traditional application fields of computer animation such as film and entertainment. This implies for instance that in the industrial application context a dedicated animation or network expert may not be available. Thus, easy to use authoring tools and support for automated generation is of special importance. At the economical level one main argument for using 3D/VR training environments is that they are often less expensive than real life training environments, while providing similar training quality, and offering the option of distributed access—the trainee does not have to be present in one specific place in order to participate in the training. Furthermore, instruction material may be collected and offered at a central point in the company.

In some industrial areas, the timely training of personnel on the distribution, installation and maintenance of new products is mission critical. For these time critical applications, it is essential that the training material be provided in time, i.e. prior to the launch of the product. In order to ensure this, the process of generating a training application must be parallel to product design.

4 VRML Authoring and Application Building Tools

We have developed enhanced VRML authoring and application building tools, suitable for creating interactive, annotated and animated VRML based applications such as training environments and information systems. One example is the CASUS system, which offers a linkage between industrial simulations and VRML. Other examples are authoring tools that support the automated generation of 3D exploded views of complex models and allow to embed the VRML application in different contexts using different interaction metaphors. These tools include a scene composing editor, a VRML structure editor, an animation editor, and an application builder.

The VRML authoring tools described in this section are realized in Java and work in conjunction with any VRML97 compliant browser supporting the VRML External Authoring Interface.

4.1 CASUS System

CASUS System [Luckas 97], an acronym for Computer Animation of Simulation Traces, is an object oriented approach to linking a three-dimensional visualization to an event-oriented simulator. The goal is a realistic visualization, which is, therefore, well suited for learner-oriented presentations. This is achieved by using computer-generated, three-dimensional animation. In realizing this approach, a modular concept is provided which allows—apart from offering easy adaptation to a variety of simulators—a highly automated animation generation.

CASUS System as a whole was designed to remedy the lack of visualization capabilities of many event-oriented industrial simulators. Since nowadays the presentation is primarily done with numeric tables or abstract symbolic visualization learners are very often unable to evaluate the results and develop own strategies or interpretations. Moreover the learner is forced to get involved with abstract simulation models and presentation tech-

niques. CASUS System solves this problem by establishing a link between the abstract simulation and the real world. Based upon event-oriented data, an automatic translation into dynamic animation sequences is established, making use of animation elements [Dörner 97], clipart-like predefined 3D objects with integrated behavior. Both the simulation expert and the trainee receive an adequate and meaningful presentation of the simulated problems and solutions individually adapted to their specific knowledge.

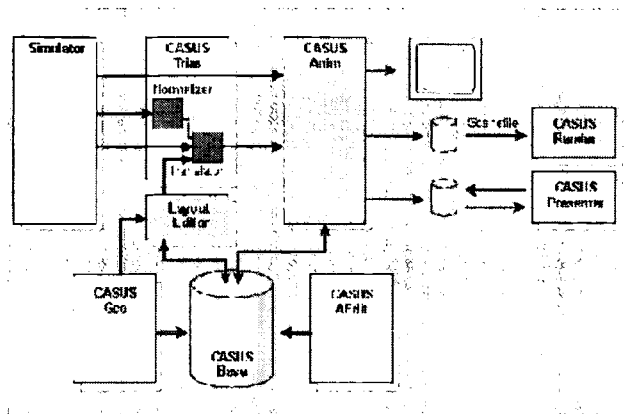

Figure 1: System Architecture of CASUS System

The architecture of CASUS System is based upon a pipeline that consists of an arbitrary simulator, the translator (CASUS Trias), the animation system (CASUS Anim) and different visualization systems, such as CASUS Presenter or CASUS Render [Figure 1]. At first the output of any event-oriented simulator is processed by the Translator CASUS Trias. Since there is no standard format for storing simulation traces a normalization tool is used. Referring to the normalized trace, this tool translates the simulation events into unified animation sequence descriptions. All animation sequence descriptions together form the animation script that is then processed by the animation system CASUS Anim. CASUS Anim allows the author to modify presentation parameters such as camera position, lighting, visualization time or frame rate, as well as the output format used, e.g. VRML. Therefore CASUS Anim offers a user interface that only provides the functionality that is essential for the user profile described earlier. The animation generation process is completely hidden from the user. Internal features, such as routing of events inside the VRML scene or reducing scene complexity, are maintained automatically by CASUS System.



Figure 2: Visualization of Production and Logistics Scenarios

BEST COPY AVAILABLE

4.2 VRML Authoring

The VRML scene composing editor provides the functionality of a general scene editor, and allows to build all kinds of VRML scenes regardless of the application context. The standard scene composing functionality is supported, such as to add new objects to the scene, to place objects, to group and ungroup objects and to define new objects. The scene composing editor uses a 3D graphical user interface, where the VRML objects can be directly manipulated. While building the scene, the user is monitored, and information on how objects have been grouped or joined is retained by the system. This information is used for animation computation.

The structure editor allows to modify the structure of the VRML scene, i.e. the hierarchy of VRML objects in the scene graph. The VRML structure editor provides both a 3D and a 2D graphical user interface, where the object hierarchy can be modified by drag and drop mechanism. The objects selected in the 2D view are also marked as selected in the 3D view of the scene. This has the advantage, that the user gets an immediate visual feedback of the selected VRML part.

The semantics of the scene graph hierarchy depends on the application, the user wishes to create. Imagine for example a scene that consists of different rooms or areas inside a building, such as a factory layout with different production areas. The user could thus decide to interpret a hierarchy level as a room or a production area. For an other application example imagine for instance a scene that consists of a highly complex 3D model, such as a motor or other machinery. In this case the user can decide to interpret a hierarchy level as a part group of the motor or of the machinery. The part hierarchy is used for the automated computation of explosion and disassembly animation.

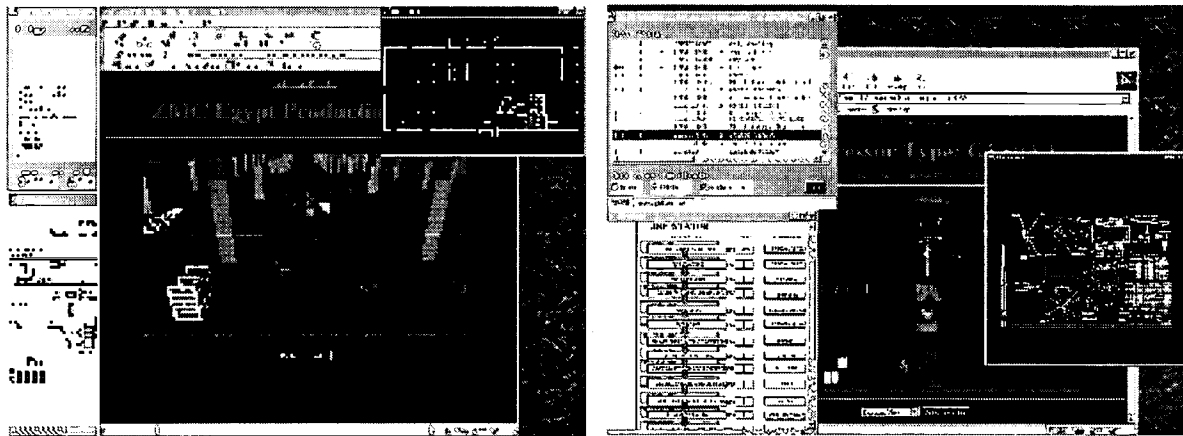

Figure 3: VRML Based Plant Manual, Drilling Machine Park and Product View

The animation editor offers support for the creation of general key frame animation. An explosion editor supports the automated generation of explosion animations. The automated generation of the explosion is based on the information tracked while the user has build the model. This includes information on the connectivity of parts and on surface normals. Based on this information an explosion animation is computed, that can be adjusted to the individual needs of an application.

BEST COPY AVAILABLE

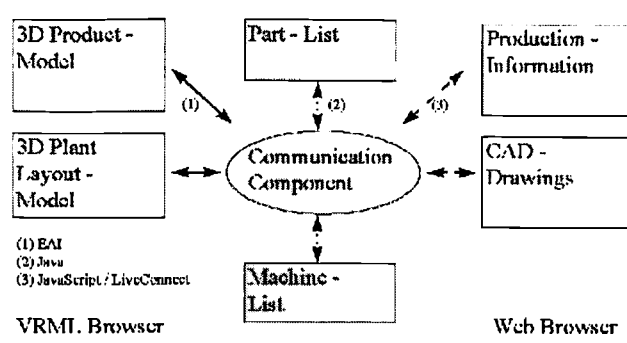

Figure 4: Overview of the Application Structure

4.3 Application Builder

The application building tool allows to embed the VRML application in a hypermedia context. The linking of parts of a VRML model to entries in an HTML based list or table is supported as well as the access to additional information. The examples depicted in [Figure 3] have been created with the tools described here and in the previous section. An overview of the technical structure of the applications described here is presented in [Figure 4]. The application builder consists of a relation editor, an annotation relation editor, and a composing editor.

The **relation editor** supports the definition of a relation between an object of the VRML file and an entry in a HTML page (table). When the default relation mode is applied, the relation editor will automatically create a relation for each object of the VRML file to a corresponding entry in the table on a sequential basis. The relation editor provides a 3D view of the VRML file, where objects can be connected to table entries by a double selection mechanism.

The **annotation relation editor** allows to define a set of information files to be related to both the VRML objects and the entries in a table or list. In the application depicted in [Figure 3], the additional information related to the parts in the VRML files consist in CAD drawings of the respective parts.

The **composition editor** composes the application, i.e. joins the relation information and the relation selectors (buttons) and creates an applet, and an embedding HTML page, from which the training application can be started.

The conjunction of both tools provides both automated support for the creation of 3D animation and automated support for integration in a hypermedia context.

5 Conclusion

In this paper we have shown how web-based technology using the Virtual Reality Modeling Language (VRML) can be applied in an industrial education and training context. Using VRML is not only a matter of providing technology but also of adapting technology to the specific application field. In the industrial application field automated VRML generation, cost-efficiency, industrial simulator linkage and integration in the established workflow are stressed. We presented examples of tools that show solutions how these application requirements can be met. As a result VRML in connection with the WWW opens new application fields of web technology in industrial companies.

6 References

- [Consortium] *The VRML Consortium*, <http://www.vrml.org/>
- [Dörner 97] R. Dörner, V. Luckas, and U. Spierling: *Ubiquitous Animation - An Element-Based Concept to Make 3D Animations Commonplace*, in Visual Proceedings, The Art and Interdisciplinary Programs of ACM SIGGRAPH '97, p.210, Computer Graphics Annual Conference Series 1997, ACM Press, Los Angeles, 1997
- [Lea 97] R. Lea, Y. Honda, K. Matsuda, and S. Matsuda, *Community Place: Architecture and Performance*, Proceedings of VRML 97 Second Symposium on the Virtual Reality Modeling Language, Monterey, 1997

- [Luckas 97] V. Luckas, T. Broll: *CASUS - An Object-oriented Threedimensional Animation System for Event-Oriented Simulators*, in N. Magnenat-Thalmann and D. Thalmann (Eds.), *Proceedings of Computer Animation 1997*, IEEE Computer Society Press, Geneva, 1997
- [Marrin 97] C. Marrin, *Proposal for a VRML 2.0 Informative Annex: External Authoring Interface Reference*, <http://www.vrml.org/WorkingGroups/vrml-eai/ExternalInterface.html>, November 1997
- [Raposo 97] A.B. Raposo, L. Neumann, L.P. Magalhaes, and I.L.M. Ricarte: *Visualization in a Mobile WWW Environment*, *Proceedings of WebNet 1997*, Toronto, Canada.
- [Repository] *The VRML Repository List of VRML Browsers And Authoring Tools*, <http://www.sdsc.edu/vrml/>
- [Rockwell 98] B. Rockwell, *From Chat to Civilization: The Evolution of Online Communities*, <http://www.blaxxun.de/company/vision/cmnty.html>, 1998
- [Schäfer 97] A. Schäfer, W. Müller, and V. Luckas: *A Java-based VRML 2.0 Browser: CASUS Presenter*, *Proceedings of 6th International World Wide Web Conference*, POS 734, Poster Presentation, Santa Clara, 1997
- [Stout 96] R.J. Stout, J.A. Cannon-Bowers, and E. Salas, *The Role of Shared Mental Models in Developing Team Situational Awareness: Implications for Training*, *Training Research Journal*, Vol. 2, 1996/1997, pp. 85-116
- [VRML97] ISO/IEC 14772-1, *The Virtual Reality Modeling Language*, <http://www.vrml.org/Specifications/VRML97/>, 1997



U.S. Department of Education
Office of Educational Research and Improvement (OERI)
National Library of Education (NLE)
Educational Resources Information Center (ERIC)



NOTICE

REPRODUCTION BASIS



This document is covered by a signed “Reproduction Release (Blanket) form (on file within the ERIC system), encompassing all or classes of documents from its source organization and, therefore, does not require a “Specific Document” Release form.



This document is Federally-funded, or carries its own permission to reproduce, or is otherwise in the public domain and, therefore, may be reproduced by ERIC without a signed Reproduction Release form (either “Specific Document” or “Blanket”).