

DOCUMENT RESUME

ED 425 076

SE 061 894

TITLE SUPERSTARS III: 6-8.
INSTITUTION North Carolina State Dept. of Public Education, Raleigh.
PUB DATE 1998-03-00
NOTE 299p.; For related documents, see SE 061 892-893.
AVAILABLE FROM Public Schools of North Carolina, 301 N. Wilmington Street, Room 540, Raleigh, NC 27601-2825.
PUB TYPE Guides - Classroom - Learner (051) -- Guides - Classroom - Teacher (052)
EDRS PRICE MF01/PC12 Plus Postage.
DESCRIPTORS Curriculum Enrichment; *Elementary School Mathematics; Enrichment Activities; Intermediate Grades; Junior High Schools; *Mathematical Enrichment; *Mathematics Education; *Mathematics Materials; Parent Participation; *Problem Solving; *Self Motivation; State Curriculum Guides; Student Motivation; Volunteers
IDENTIFIERS North Carolina

ABSTRACT

SUPERSTARS III is a K-8 program designed as an enrichment opportunity for self-directed learners in mathematics. The basic purpose of SUPERSTARS III is to provide the extra challenge that self-motivated students need in mathematics and to do so in a structured, long-term program that does not impinge on the normal classroom routine or the instructor's time. The program involves teachers, administrators, assisting adult volunteers, and parents in the learning process. Assisting adults devote a few hours each week to operate the system effectively in the school while an administrator provides visible support through coordinating the program in the schools. The levels of the program are named for the planets in the solar system. This packet contains materials for sixth grade (Uranus), seventh grade (Neptune), and eighth grade (Pluto). Materials within each grade are organized into two sections. Section I contains general information about the program and variations on the basic model, information/checklist for principals, information checklist for assisting adults, information for teachers, and letters to participating students and their parents. Section II is comprised of the student worksheets and adult volunteer commentary for student worksheets. (PVD)

* Reproductions supplied by EDRS are the best that can be made *
* from the original document. *

SE

ED 425 076

SUPERSTARS III

6 - 8

PERMISSION TO REPRODUCE AND
DISSEMINATE THIS MATERIAL HAS
BEEN GRANTED BY

E. Brumbaugh

TO THE EDUCATIONAL RESOURCES
INFORMATION CENTER (ERIC)

1

U.S. DEPARTMENT OF EDUCATION
Office of Educational Research and Improvement
EDUCATIONAL RESOURCES INFORMATION
CENTER (ERIC)

This document has been reproduced as
received from the person or organization
originating it.

Minor changes have been made to
improve reproduction quality.

• Points of view or opinions stated in this
document do not necessarily represent
official OERI position or policy.

BEST COPY AVAILABLE

2

SE041094

Super Stars

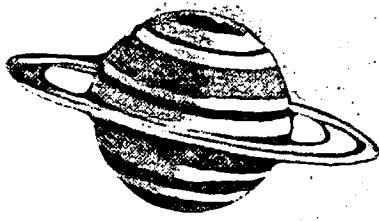
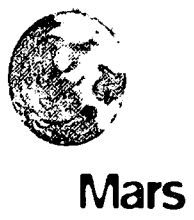
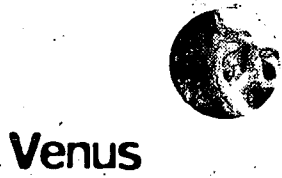

BEST COPY AVAILABLE

★ ACKNOWLEDGMENTS ★

This project, originally designated *Sunshine Math*, is the third in a series of problem solving programs. It was conceived, coordinated and developed through the Florida Department of Education with input from the mathematics staff members of the North Carolina Department of Public Instruction and the South Carolina Department of Education. In addition, it was supported financially through a grant to the School Board of Polk County, Florida. The rich history of these materials and the predecessor programs, **SUPERSTARS** and **SUPERSTARS II** goes back to the early 1980's. Many Florida teachers have been involved in developing and using these materials over the years. The original **SUPERSTARS** programs were adopted and adapted by North Carolina and South Carolina with their teachers contributing to revisions and personalizations for use in their states. Florida educators were primarily responsible for developing, field testing, and publishing *Sunshine Math*. Educators from the Carolinas developed the **MathStars Newsletter** to accompany and enhance this program.

School districts in North Carolina have permission to reproduce this document for use in their schools for non-profit educational purposes. Copies of each grade level are available from the publications unit of the North Carolina Department of Public Instruction. The contact for **SUPERSTARS III** and the **MathStars Newsletter** is Linda Patch, 301 North Wilmington Street, Raleigh, NC 27601-2825 : (919-715-2225).

Michael E. Ward
State Superintendent
North Carolina Department of Public Instruction

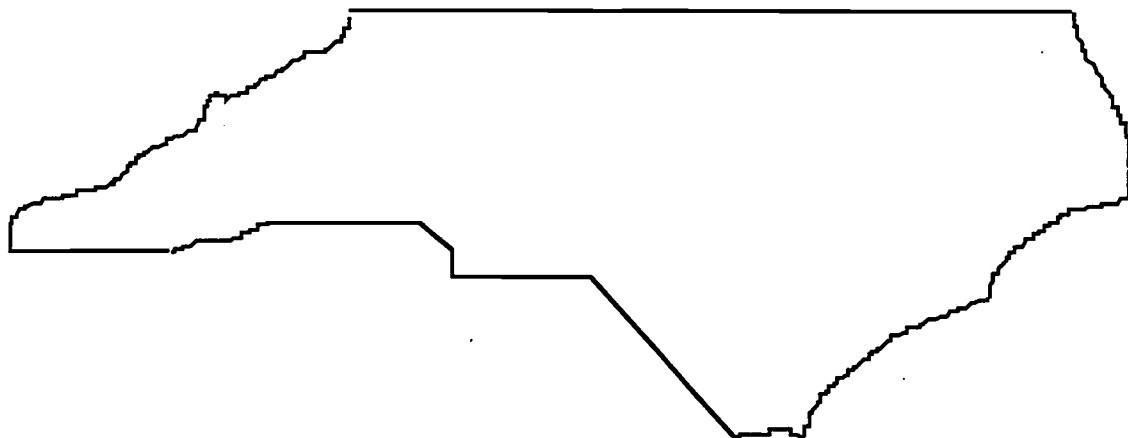

☆ *Preface* ☆

SUPERSTARS III encourages and enhances the positive aspects of students, parents, teachers and administrators working together. This program assumes that students, even young children, are capable of and interested in learning; that teachers want to help them learn to think for themselves; that administrators see their jobs as clearing the path so that quality education is delivered effectively in their schools; and that parents care about their child's learning and are willing to work with the school system toward that goal. Each of these four groups has a vital role to play in implementing **SUPERSTARS III**.

The designer of this program has a long history of working with elementary children. He believes that they are capable of much more than we ask of them, and that many children are on the path to becoming independent learners. A number of children in any classroom are bright, energetic and willing to accept extra challenges.

The basic purpose of **SUPERSTARS III** is to provide the extra challenge that self-motivated students need in mathematics, and to do so in a structured, long-term program that does not impinge on the normal classroom routine or the time of the teacher. The system is not meant to replace any aspect of the school curriculum -- it is offered as a peripheral opportunity for students who identify with challenges and who want to be rewarded for their extra effort. Participation in the program is always optional -- only those students who voluntarily choose to participate will, in the long run, benefit from **SUPERSTARS III**. Any student, regardless of prior academic performance, should be encouraged to participate as long as interest is maintained.

The predecessor program for **SUPERSTARS III** -- the **SUPERSTARS II** program -- has demonstrated that this concept can be extremely useful. What is required are several dedicated adults who devote a few hours each week to operate the system effectively in the school; an administrator who provides highly visible support; teachers who welcome a supplementary experience for their students to engage in higher-order thinking; and a typical classroom of students. If all of those ingredients are present **SUPERSTARS III** will become an integral part of the school fabric.

ORGANIZATION OF THESE MATERIALS

Section I Description of the SUPERSTARS III Program

1. General Information
2. Information/checklist for principals
3. Information/checklist for assisting adults
4. Information for teachers
5. Letter to participating students and their parents.

Section II Student worksheets for SUPERSTARS III

SUPERSTARS III
Jupiter, XXII

Name: _____
(This shows my own thinking.)

**1. If the 24th day of the month falls on Saturday, on what day did the 6th fall?

Answer: _____

**2. There are 4 six-packs of soda in a case. Chris bought 12 of a case and gave 13 of what he had to Dana. How many cans of soda does Chris have left?

Answer: _____ cans

**3. Together, 6 boys and 12 girls weigh 1050 pounds. The boys all weigh the same -- pounds. Each girl weighs 55 pounds. What is the weight of one boy?

bbbbbb sssssssssss

Answer: $x =$ _____ pounds

**4. The sum of 3 consecutive numbers is 276. What are the numbers?
(Consecutive numbers differ by one; example: 8, 9, and 10)

Answer: _____ and _____

**5. If a family of 12 spiders were shoes, how many pairs of shoes would they need?

 Answer: _____ pairs.

**6. A tropical storm passed through the town. It began to rain Monday morning at 8:45 AM and did not stop until the next day at 2:30 PM. How long did it rain?

Answer: _____ hours and _____ minutes



**7. There are 3 cars, 4 bicycles, 2 tricycles, and 1 unicycle in the neighbor's garage. How many wheels are there in all? Forget about any "spare tires"!

Answer: _____ wheels

**8. Rosemary bought a sweater on sale for \$6.98. She also bought a skirt for \$9.99. She paid an additional \$1.19 for sales tax. Rosemary gave the sales person a \$20 bill. How much change should she receive?

Answer: _____



**9. Study this pattern. 25 and also 32 would be in column E, if the pattern continued.

a. In which column would 100 appear?
b. In which column would 500 appear?
c. In which column would 1000 appear?

21	22						
14	15	16	17	18	19	20	
7	8	9	10	11	12	13	
0	1	2	3	4	5	6	
A	B	C	D	E	F	G	

Section III Commentary for student worksheets for SUPERSTARS III

Commentary
Jupiter, XXII

1. (Tuesday) Students can use a calendar or make a chart with "Su, M, T, W, Th, F, Sa" at the top and begin numbering backward putting 24 under Saturday. They may also realize that the 17th and 10th fall on Saturdays and count back from the 10th.

2. (6) Students can solve this problem by drawing a diagram or by visualizing 24 cans. 1/2 of 24 is 12, and 1/3 of 12 is 4. Therefore Chris gave away 4 of the 12 sodas, leaving 8.

3. (65) Students will probably solve this by first finding the total weight of the 12 girls: $12 \times 55 = 660$ pounds. Then they will compute $1050 - 660 = 390$ pounds, the weight of the 6 boys. Then $390 \div 6 = 65$ pounds per boy.

4. (91, 94, 93) Students may use the *guess-check-revise* method. Some students might know that the numbers they seek are about 1/3 of the total, and approximate the numbers by dividing 276 by 3. This gives 92, which is the middle number.

5. (48) Students may want to draw a picture to help solve this problem. Spiders have 8 legs, which would be 4 pairs of shoes per spider.

6. (29 hours and 45 minutes) Most students will realize that from 8:45 AM to 8:45 AM the next day, is 24 hours. They will then "add on" 5 additional hours to get to 9:45, 10:45, 11:45, 12:45, and 1:45, and then 45 minutes to get to 2:30 PM.

7. (27) There would be 12 wheels on the 3 cars, 8 on the 4 bicycles, 6 on the 2 tricycles, and 1 on the unicycle.

8. (\$18.6) Students will probably add \$6.98 and \$9.99 to get \$16.97; then add the tax of \$1.19 to get \$18.16. They will subtract this amount from \$20.

9. (a, c) b, D; e, G) Hopefully, students will notice that the multiples of 7 are in column A and use this fact to get "close to" the numbers 100, 500, and 1,000. Ninety-eight (14×7) is the closest multiple of 7 less than 100, so 98 would be in column A, forcing 100 to be in column C. Likewise, 497 or 71×7 is in column A, putting 500 in column D. Finally, 994 or 142×7 is in A, indicating that 1000 is in column G.

SUPERSTARS III: General Information

SUPERSTARS III is a K-8 program designed as an enrichment opportunity for self-directed learners in mathematics. The levels of the program are named for the planets in our solar system:

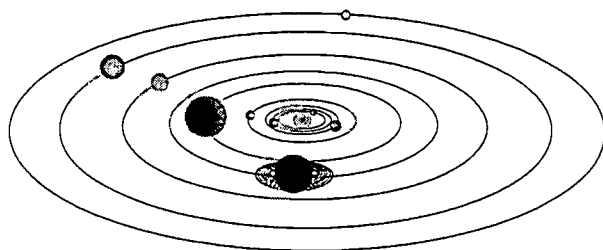

Kindergarten	Mercury	Fourth Grade	Jupiter
First Grade	Venus	Fifth Grade	Saturn
Second Grade	Earth	Sixth Grade	Uranus
Third Grade	Mars	Seventh Grade	Neptune
	Eighth Grade	Pluto	

Students of all ability levels choose on their own to participate in **SUPERSTARS III**. Seeing their names displayed in a prominent place in the school, with a string of stars indicating their success, is one reward students receive for their extra work. In some cases the school may decide to enhance this basic system by awarding certificates of achievement or some other form of recognition to highlight certain levels of success or participation in the **SUPERSTARS III** program.

SUPERSTARS III can function in a school in a number of different ways. A “tried and true” way is for assisting adults (volunteers, aides, etc.) to manage the program for the entire school, with support provided by school administrators and classroom teachers. This system has been adopted at the school level, with varying degrees of success, over the years. The basic model for conducting **SUPERSTARS III** is discussed below, with variations described on the next page.

The basic model

The basic model for **SUPERSTARS III** is for a school to establish a weekly cycle at the beginning of the academic year according to the following guidelines:

On Monday of each week student worksheets are distributed by the assisting adults to students in the program. Students have until Friday to complete the problems working entirely on their own. On Friday the classroom teacher holds a brief problem-solving session for the students in the program. The more difficult problems on the worksheet are discussed with students describing their thinking about strategies to solve the problems. They do not share solutions, only strategies.

Students receive double credit for those problems they have successfully completed prior to the problem-solving session, and regular credit for those they complete successfully over the week-end. On Monday all papers are handed in, checked by the assisting adult, and stars are posted for problems successfully completed. This completes one cycle of the **SUPERSTARS III** program.

SUPERSTARS III is not for every child -- it is only for those who are self-motivated and who are not easily frustrated by challenging situations. This does not diminish the value of the program, but rather makes us realize that there are children of all ability and socio-economic levels who are self-directed learners and who need challenges beyond those of the regular school day. These children will shine in **SUPERSTARS III**.

Variations of the basic model

The first variation that has been used successfully retains the weekly cycle and assisting adult role from the basic model. The teacher however, involves the entire class in the problem-solving discussions. For example, the teacher might select the four most difficult problems on the worksheet (indicated by three or four stars) and work a "parallel" problem with the entire class to open the mathematics lesson on Tuesday through Friday. Using this variation, all students are exposed to the problem-solving strategies, but only those who have chosen to participate in **SUPERSTARS III** will complete and turn in the worksheet on Monday.

A second variation has the assisting adult manage the entire program, including the Friday problem-solving session. This method has been used in situations where teachers lacked commitment to the program and thus implemented it inconsistently. In such cases, the assisting adult must have a progressive view of what constitutes problem solving in elementary mathematics. They should also receive extra assistance from the administration to ensure that students are released from class and that the cycles proceed smoothly.

Yet another variation is for a parent to manage **SUPERSTARS III** at home for his or her own child. The basic rules are the same -- a child gets the worksheet once a week and time to work the problems alone. The parent sets a night to listen to the way the child thought about each problem, offering suggestions or strategies only when the child is unable to proceed. The reward system is basically the same, stars on a chart, but can be enhanced by doing something special with the child, such as a trip to the museum or to a sporting event when the child reaches certain levels of success. If this method is adopted, the parent must not try to teach the child, but rather to stimulate discussion of problem-solving strategies. **SUPERSTARS III** is not a program for adults to teach children how to think.

Other variations exist. The basic model as stated is the best, all other factors being equal, for reaching more children in a consistent fashion than any of the other methods. However, we encourage individual schools, teachers, or parents to get some version started; some starlight is better than none.

SUPERSTARS III: Information for Principals

SUPERSTARS III is a K-8 enrichment package for mathematics designed to be managed by volunteer assisting adults with coordinated support from the classroom teacher and school administrators. The purpose of the program is to give self-motivated students of all ability levels a chance to extend themselves beyond the standard mathematics curriculum. The complete set of materials comes in nine packages, one for each grade K-8. The grade levels are identified by the names of the nine planets in our solar system and their order from the sun:

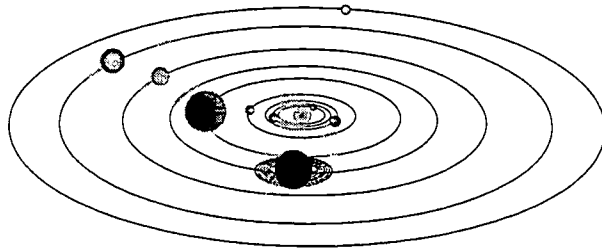

Mercury - Kindergarten
Earth - Second Grade
Jupiter - Fourth Grade
Uranus - Sixth Grade

Venus - First Grade
Mars - Third Grade
Saturn - Fifth Grade
Neptune - Seventh Grade

Pluto - Eighth Grade.

Your support is vital if this program is to succeed. As the school administrator, you need to stay in close contact with the **SUPERSTARS III** program. A “checklist for success” follows:

- Become familiar with the philosophy and component parts of the program.
- Introduce **SUPERSTARS III** to the faculty early in the school year. Ensure that teachers understand the philosophy of the program and have copies of the student worksheets and commentaries appropriate for their grade levels.
- Speak to parents at your school’s first open house of the year, explaining the purpose of **SUPERSTARS III** and the long term value of children working independently on challenging problems.
- Recruit several assisting adults (PTA members, aides, senior citizens, business partners, church members, etc.) who are enthusiastic, dependable people who are willing to manage the program. Early in the academic year, meet with these assisting adults to plan such details as:
 - ✓ A prominent place and format for the STAR CHART.

- ✓ A designated time and place each Monday and Friday for the assisting adults to be in school to meet with students, distribute and collect worksheets, and post stars.
- ✓ A system for the activity sheets to be duplicated each week.
- ✓ A plan for extra incentives for accumulating stars. (“World records” to be kept from year-to-year, a celebration day planned for the end of school, prizes earned by students for attaining certain levels of success -- see the diagram below for examples.)
- ✓ A schedule for the initiation of the program and a decision as to a “start over” point later in the academic year. Review the school calendar and only use weeks that are at least four days long. If there is not enough time in the year to complete all the activity sheets, decide which to eliminate or on a plan to “double up.”
- ✓ A **SUPERSTARS III** cap, name badge, tee-shirt, or other distinction for volunteers, if possible.
- Monitor the program every two weeks to get ahead of unforeseen difficulties. Administrators need to be highly visible and supportive for **SUPERSTARS** to succeed.

SUPERSTARS III is an optional program for students. It should be available to any student who wants to participate, regardless of prior success in mathematics. Typically, a large number of students will begin the program, but a majority will lose interest. A significant number however, will continue their efforts over the life of the program. This is normal and simply means that **SUPERSTARS III** is successfully addressing the needs of the self-directed learner.

Visual reminders help children see this mathematics program is challenging and rewarding. Some ideas are presented here:

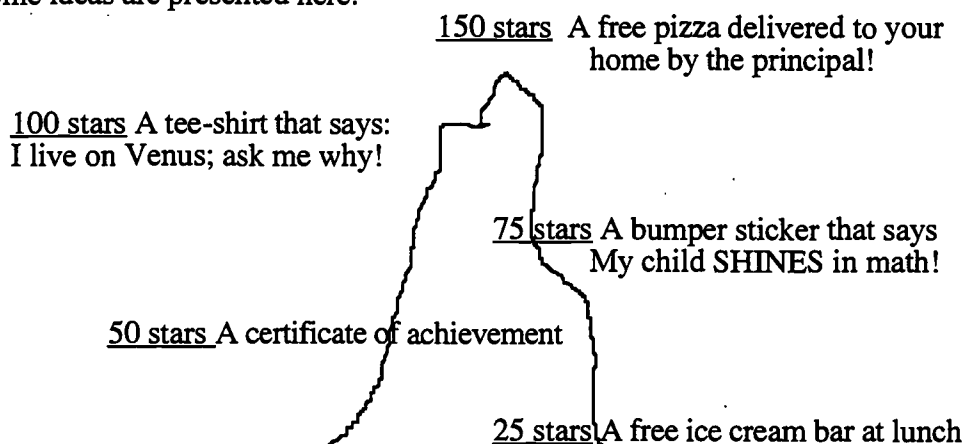

Climb the Mountain this Year!! Join the **SUPERSTARS III** Club

SUPERSTARS III: Information for Assisting Adults

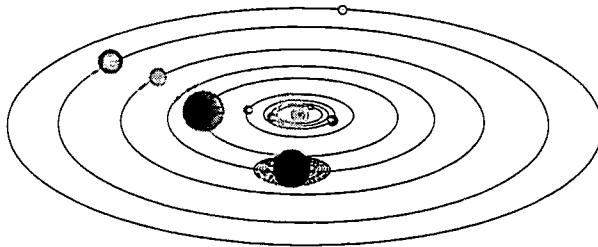

SUPERSTARS III is designed to give assisting adults a well-defined role to play in the school's mathematics program. The success of **SUPERSTARS III** depends upon a team effort among teachers, administrators, parents and you. Reliability and punctuality are important - students will quickly come to depend upon you to be there as scheduled, to check their papers and post their stars, and to listen to alternate strategies and interpretations of problems to help them arrive at solutions. If possible, wear an outfit or badge that fits with the **SUPERSTARS III** theme or logo; students will soon identify you as an important person in their school.



SUPERSTARS III works on a weekly cycle. Each Monday you will collect the worksheets from the previous week and distribute new worksheets to the participating students, all from your **SUPERSTARS III** area of the school. Allow students to see the answers to the problems, discuss any for which their answers differ and allow them credit if their interpretation and reasoning are sound. After checking all the work, you will post the stars earned by students on the STAR CHART.



Participating students have from Monday until Friday to work the problems entirely on their own -- the only help they should receive during that time is for someone to read the problems to them. On Friday the teacher will host a problem-solving session in the classroom where students will describe the strategies they used to approach the more difficult problems. Students who have successfully completed problems before this session will receive double points for their efforts. The teacher's initials on the worksheet will help you identify those problems. The students then have the week-end to complete or correct their problems and turn them in on Monday. All the correct problems thus completed will receive the indicated number of stars.



Be creative when designing your STAR CHART. The basic method of posting stars individually is a good way to begin but eventually you will want a more efficient system. Color coding by grade level, or posting just one star each week with a number in its center are ideas to consider. You may wish to personalize the chart and the entire **SUPERSTARS III** center with student pictures, "smiling faces", a logo, seasonal theme or some other feature that has a mathematical flavor. Occasionally feature a reward for each child such as a cookie or a hand stamp in the shape of a star just for turning in the worksheet. You are helping enthusiastic students develop high-level thinking skills -- be creative and enjoy your role!

Checklist for assisting adults:

- Plan the following with the principal:
- ✓ A prominent place and format for the

★ STAR CHART ★

- ✓ The time and place for you to collect, check, and distribute worksheets.
- ✓ A system for duplicating worksheets each week which ensures legible copies. Also a secure storage area for masters and other materials.
- ✓ Any additional incentives ("world records," stickers, coupons, pencils, tee-shirts, etc.) that will be part of the system for rewarding levels of achievement in **SUPERSTARS III**.



- Make the **SUPERSTARS III** center a happy place. Use bright colors, smiles, and cheerful expressions. Show confidence, friendliness, and encouragement to students.



- Collect the letters that are sent home prior to the first worksheet. These need to be signed by each student and a parent. If, in the future, you have evidence that the work submitted does not represent the thinking of the student, discuss the situation with the classroom teacher. These situations are best handled individually, confidentially and in a firm, consistent manner.



- Check the worksheets from the previous week uniformly. If you give partial credit for a problem with several parts do so in a fair way that can be understood by the students. Do not award partial credit for problems with only one answer.



- Have answer sheets available and encourage students to look at the solutions when they submit their worksheets. Allow them to explain their strategy or interpretation if they have arrived at a different answer. Award full credit if they show a unique and plausible interpretation of a problem and follow sound logic in arriving at their response.



- Leave extra worksheets with the classroom teacher for participating students who were absent on Monday. Accept a late-arriving worksheet only if the student was absent on Monday. If a student's name is missing or in the wrong place on the worksheet, check the paper but award stars to "No Name" on the STAR CHART. Adhering strictly to these rules will rapidly teach responsibility to the students and keep your work manageable.



- Keep all returned worksheets. As the same problems are used year after year, and many students have siblings who may later participate in **SUPERSTARS III**, it is important that worksheets do not circulate.



- On weeks when **SUPERSTARS III** is not available post a notice such as "No star problems this week, but please come back after vacation for more!"

SUPERSTARS III: Information for Teachers

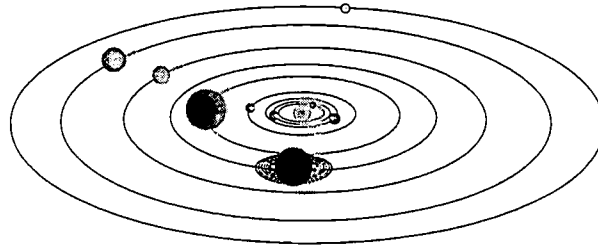

SUPERSTARS III is a program designed to complement your regular classroom mathematics curriculum. It offers a supplemental opportunity for students to practice mathematics skills appropriate for their grade level and at the same time to engage in challenging problem-solving activities. It is an additional challenge to those students who are self-directed learners providing them with an academic extracurricular activity.



Your involvement is essentially as a teacher. **SUPERSTARS III** will remain special to students if it is managed by someone outside of the classroom and if the teacher is viewed as a facilitator in the system, rather than as the authority figure. Your primary role is to monitor the system in your own classroom and to host a brief problem-solving session for **SUPERSTARS III** students on Friday of each week. You will also need to release the participating students from your class at a set time on Mondays to enable them to turn in completed work and receive new problem sets. You might make a special pin or banner for Mondays and Fridays to remind students that those days are special.

SUPERSTARS III
Jupiter, XXII

Name: _____
(This shows my own thinking.)

**#1. If the 24th day of the month falls on Saturday, on what day did the 6th fall?

Answer: _____

**#2. There are 4 six-packs of soda in a case. Chris bought 12 of a case and gave 13 of what he had to Dana. How many cans of soda does Chris have left?

Answer: _____ cans

**#3. Together, 6 boys and 12 girls weigh 1050 pounds. The boys all weigh the same → pounds. Each girl weighs 55 pounds. What is the weight of one boy?

bbbbbb eeeeeeeeeeee

Answer: s = _____ pounds

**#4. The sum of 3 consecutive numbers is 276. What are the numbers?
(Consecutive numbers differ by one: example: 8, 9, and 10)

Answer: _____ and _____

**#5. If a family of 12 spiders were shoes, how many pairs of shoes would they need?

🕷️

Answer: _____ pairs.

Commentary
Jupiter, XXII

1. (Tuesday) Students can use a calendar or make a chart with "Su, M, T, W, Th, F, Sa" at the top and begin numbering backward starting 24 under Saturday. They may also realize that the 17th and 10th fall on Saturdays and count back from the 10th.

2. (8) Students can solve this problem by drawing a diagram or by visualizing 24 cans. 1/2 of 24 is 12, and 1/3 of 12 is 4. Therefore Chris gave away 4 of the 12 sodas, leaving 8.

3. (65) Students will probably solve this by first finding the total weight of the 12 girls: $12 \times 55 = 660$ pounds. Then they will compute $1050 - 660 = 390$ pounds, the weight of the 6 boys. Then $390 \div 6 = 65$ pounds per boy.

4. (91, 92, 93) Students may use the guess-check-revise method. Some students might know that the numbers they seek are about 1/3 of the total, and approximate the numbers by dividing 276 by 3. This gives 92, which is the middle number.

5. (48) Students may want to draw a picture to help solve this problem. Spiders have 8 legs, which would be 4 pairs of shoes per spider.

6. (29 hours and 45 minutes) Most students will realize that from 8:45 AM to 8:45 AM the next day, is 24 hours. They will then "add on" 3 additional hours to get to 9:45, 10:45, 11:45, 12:45, and 1:45, and then 45 minutes to get to 2:30 PM.

7. (27) There would be 12 wheels on the 3 cars, 8 on the 4 bicycles, 6 on the 2 tricycles, and 1 on the unicycle.

8. (\$184) Students will probably add \$6.98 and \$9.99 to get \$16.97, then add the tax of \$1.19 to get \$18.16. They will subtract this amount from \$20.

9. (a, C; b, D; e, G) Hopefully, students will notice that the multiples of 7 are in column A and use this fact to get "close to" the numbers 100, 500, and 1,000. Ninety-eight (14×7) is the closest multiple of 7 less than 100, so 98 would be in column A, forcing 100 to be in column C. Likewise, 497 or 71×7 is in column A, putting 500 in column D. Finally, 994 or 142×7 is in A, indicating the 1000 is in column G.

Each student worksheet has an accompanying commentary page. This sheet provides hints on parallel problems which you might use in the Friday problem-solving session. It is important that students participate actively in this session, and that you

solicit from them their unique and varied approaches to the problems discussed. Only after students have presented their ideas should you provide guidance on the problems and then only if they are having difficulty. Even though there is a commentary provided for each problem, you will have to decide which two to four problems you will cover during this brief session. Concentrate on those which provide a new or unfamiliar strategy. The problem-solving session should last no more than 15 minutes.



Do not be disappointed if a large number of your students begin **SUPERSTARS III** and then significant numbers drop out after a few weeks. This is normal; problem solving requires a great deal of effort and not every student is ready for this challenge. On the other hand, you will notice that some students will choose to stay with **SUPERSTARS III** week after week even though they are not as successful as other students at earning stars. Their participation should be encouraged as they are certainly learning from the experience. Under no circumstances should **SUPERSTARS III** be reserved only for the advanced students in your class.



As a purely practical consideration, students are not to discuss the problems among themselves or with their families prior to the Friday cooperative group session. This allows the "think time" necessary for students to develop into independent thinkers; it also prevents students from earning stars for work that is basically someone else's -- the surest way to disrupt the entire **SUPERSTARS III** program. As the teacher you must monitor this in your classroom and ensure that students abide by the established rule.



It is important that you understand and support the overall philosophy of **SUPERSTARS III**. Do not worry if students encounter problems for which they have not been prepared in class -- such is the nature of true problem solving. Do not provide remedial instruction to ensure that students master certain types of problems. They will meet these same problem types repeatedly in the program. They will likely learn them on their own and from listening to other students at the problem-solving sessions. Enjoy what the students can do and don't worry about what they can't do. Read the general information and philosophy of the program to see how your role fits into the complete system.

Here are some thoughts you might find useful in your support for **SUPERSTARS III**:



Allow your students to leave the classroom at the designated time on Mondays to turn in their worksheets and pick up new ones.



Read each week's worksheet and feel free to structure classroom activities that parallel those in the **SUPERSTARS III** problems.



During the school week students may be allowed to work on their **SUPERSTARS III** problems during their free time, but the only help they may receive is for someone to read the problems to them. Give the students one warning if you find them discussing the worksheets, and take away their papers for the next violation. If it happens another time, suspend them from the program for a month.



At the Friday problem-solving sessions remember these points:

- Students come to this session with their worksheets, but without pencils.
- The session should be brief -- 15 minutes at most. Discuss only the two to four most difficult problems.
- Help students summarize their own approaches to the problems in a non-judgmental fashion. Offer your own approach last, and only if it is different from the students' strategies. Do not allow answers to be given to the problems.
- End the session by encouraging students to complete the problems over the weekend. Put your initials beside any problem discussed in class which a student has already successfully completed. The assisting adult will award double stars for these.



Remember that part of the **SUPERSTARS III** philosophy is that students learn responsibility by following the rules of the system. If participation is important to them they will adhere to the rules about where their names go on each paper, no credit awarded if they forget their paper on Monday, and no talking about problems prior to the problem-solving session.



Enjoy **SUPERSTARS III**. Students will impress you with their ability to think and their creative ways to solve problems that appear to be above their level or beyond their experience.



Dear Student,

Welcome to **SUPERSTARS III**, a program designed to enhance your journey through mathematics. Be prepared to face challenging problems which require *thinking*! As you work through the system you will experience many types of problems, stretching and expanding your brainpower in many exciting ways!

Expect to receive one worksheet at the beginning of each week. You will have the rest of the week to think about the problems and come up with strategies for their solutions. The thinking and solutions must be **YOUR VERY OWN!!!** Once a week you will attend a help session to discuss the most challenging problems for the week.

Your journey will be recorded by charting the stars you earn. Each problem is ranked according to its level of difficulty. The more stars you see beside a problem, the higher its level of difficulty and, of course, the more stars you can earn for solving it. You can earn double stars for solving a problem before the weekly sessions.

Your signature is just the beginning.

Good luck as you embark upon this mathematical adventure! The rewards will last a lifetime!



I am ready to begin the **SUPERSTARS III** program. All of the answers I submit will represent my own thinking.

Name: _____





Dear Parents,

Welcome to **SUPERSTARS III**, a program designed to enhance your child's journey through mathematics. By expressing an interest in challenging problem solving experiences, your student has taken the first step toward becoming an independent learner who is willing to address many types of problems.

On Mondays a **SUPERSTARS III** worksheet will be distributed to each child in the program. Each problem in the set is ranked according to its level of difficulty. As the number of stars increases, so does the level of difficulty and the earned stars to be awarded.

Each Friday a help session will be conducted to discuss the most challenging problems of the week. Any problem solved prior to the session will be given double stars. After the session, problems may be reworked before they are submitted the following Monday.

Your role in **SUPERSTARS III** is to encourage and facilitate problem solving. Feel free to offer guidance toward certain strategies, to read the problems to your child, but please, do not give them the answers. In order for this program to be effective, the students must work independently. The thinking must be their own!

It is normal for a student not to be able to complete every problem on every worksheet. The process of interpreting, understanding, and trying different strategies is valuable in the attainment of mathematical power. Remember, no student is expected to know the answer to every problem.

Thank you for allowing your child to embark upon this mathematical adventure; the rewards should last a lifetime!

_____ signature

Parent/Guardian of _____



After you have had a chance to review and use these materials, please take a moment to let us know if the **SUPERSTARS III** material has been useful to you. Your evaluation and feedback is important to us as we continue to work on additional curriculum materials. Please respond to:

Linda Patch
 Mathematics & Science Section
 NC Department of Public Instruction
 301 N. Wilmington Street
 Raleigh, NC 27601-2825

Indicate the extent to which you agree with statements 1-4.

	Strongly Disagree		Neither Agree nor Disagree		Strongly Agree
1. The materials will be helpful in teaching the mathematics goals and objectives set forth in the NC Standard Course of Study.	1	2	3	4	5
2. The materials are appropriate for the grade level indicated.	1	2	3	4	5
3. The problems are interesting and engaging for the students I teach.	1	2	3	4	5
4. The commentaries will encourage use of this material.	1	2	3	4	5
5. I plan to use these materials with my students in grade_____.					
6. Have you ever used earlier versions of the SUPERSTARS material?	YES		NO		

7. How was this program implemented with your students?

8. Additional comments:

SUPERSTARS III

Uranus, I

Name: _____

(This shows my own thinking.)

- ★★ 1. The map below shows the four time zones in the contiguous United States. Use the map to help you answer the following questions.

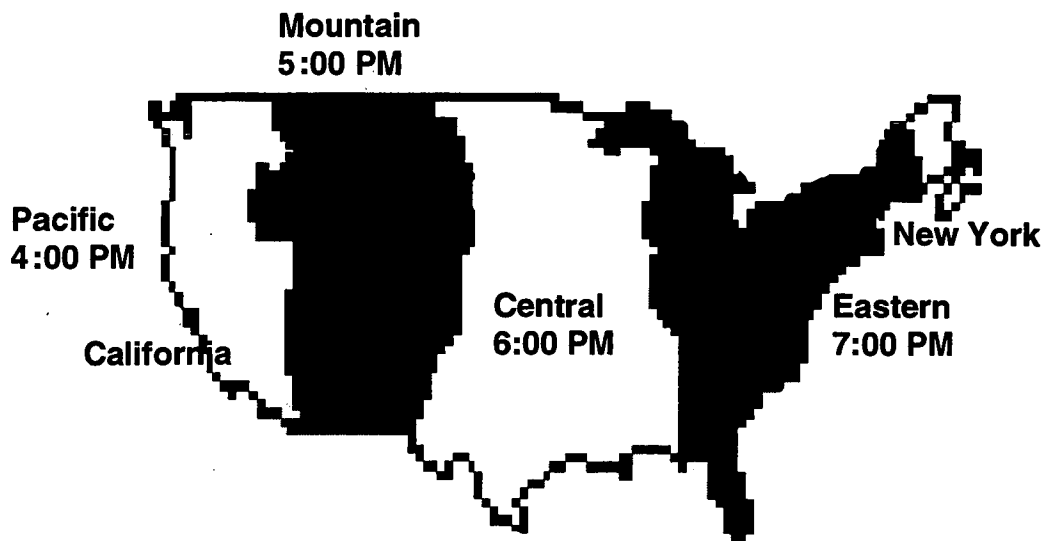

- a. If it is 11:00 A.M. in California, what time is it in New York?

Answer: _____

- b. If you left San Francisco, California, at 10:30 P.M. on a six hour flight to Miami, what time would it be in Miami when you landed?

Answer: _____

- ★ 2. Rusty can cut a log into 3 pieces in 20 minutes. At that rate, how long will it take him to cut another such log into 6 pieces?

Answer: _____

- ★★★ 3. Find three prime numbers, all less than 30, whose product is 1955.

Answer: _____, _____, and _____

- ★★ 4. One way to write 99 using four nines is $(9 \times 9) + (9 + 9)$; another way is $99 \div (9 \div 9)$. Write 100 using four nines.

Answer: _____

★★ 5. Put the numbers 1, 2, 3, 4, 5, and 6 in the circles below so that the sum "along a line" is 11 in figure A, and 12 in figure B.

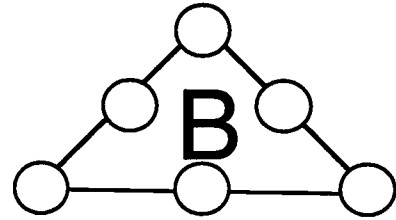
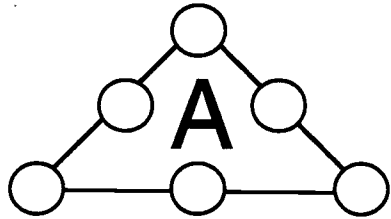

★★★★ 6. A train that is 1 mile long starts through a tunnel that is also 1 mile long. The train is traveling 15 miles per hour. How long does it take for the train to get completely out of the tunnel?

Answer: _____

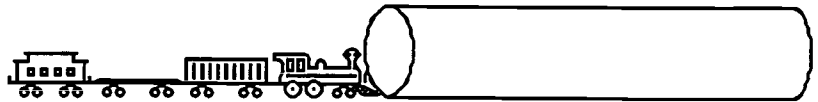

★★★ 7. Find the area of each polygon.

a.

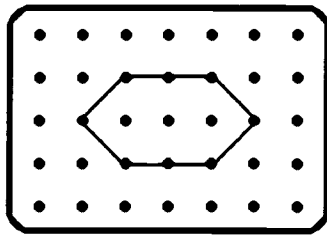

Answer: _____ square units

b.

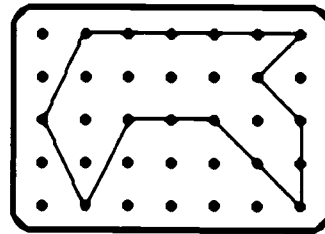

Answer: _____ square units

★★ 8. An equation for the situation to the right is:

$$2D + 25 + 5 + 1 = 61.$$

Solve the equation by finding how much one duck weighs.

Answer: $D =$ _____

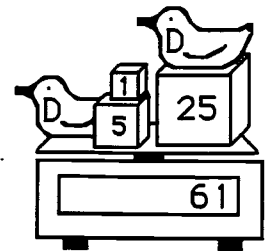

Commentary

Uranus, I

- (2:00 P.M.)** P.M. must be included.
 - (7:30 A.M.)** A.M. must be included. The time of flight as well as the time differential between time zones is considered in solving the problem.
- (50 minutes)** Drawing a picture helps in solving this problem. Students then see that only 2 cuts are needed to cut the log into 3 pieces, so it takes 10 minutes to saw through the log. It always takes one less cut than the number of pieces needed. To get 6 pieces you will make 5 cuts at 10 minutes each.
- (5, 17, 23)** *Guess, check, and revise* is a suggested strategy. Students should recognize that the number is divisible by 5 since 1955 ends in 5. $5 \times 391 = 1955$. They can then choose prime factors to multiply that might equal 391.
- ($99\frac{9}{9}$; $99 + (9 \div 9)$; other answers possible)** Students will probably realize that they can put two nines together to get 99 which is 1 away from the goal of 100. Therefore they need to find a way to put the other two nines together to get 1; $9 \div 9$ works.
- (The triangles can be turned to suggest other solutions.)

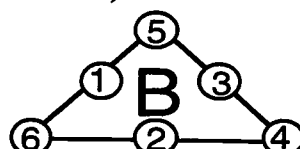
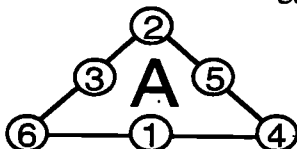

- (8 minutes)** Drawing a diagram helps students see that the train will have to travel 2 miles from where the engine is just entering the tunnel to where its caboose is out of the tunnel. 15 mph means the train is going $\frac{1}{4}$ mile per minute. So it would take 8 minutes to travel 2 miles. This problem may also be solved with a proportion: $\frac{2}{x} = \frac{15}{60}$

- (a. 6; b. 14)** It is helpful to draw in the lines connecting the dots and count the squares and half-squares for part a. For part b, draw in rectangles whose diagonals are the sides of the figure on the left end -- the area of the end triangles is then half of the surrounding rectangle.

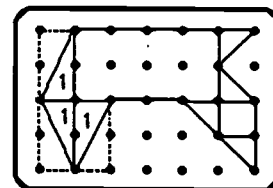

- (15)** This problem is a concrete example related to algebraic thinking. Students intuitively know that they can find the weight of 2 ducks by taking the known weights off the scale, and the display will show $61 - 31$, or 30; so they divide that result by 2 to obtain the weight of one duck. These steps give concrete meaning to solving this sort of linear equation.

SUPERSTARS III

Uranus, II

Name: _____

(This shows my own thinking.)

- ★★★ 1. Make an X on each of four toothpicks you could remove so that exactly 7 squares, all the same size, would be left.

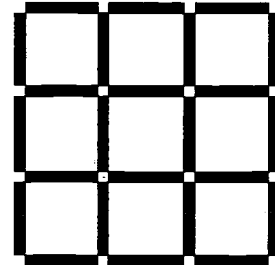

- ★★ 2. Joe keeps all his socks in one drawer. He has 7 blue socks and 9 brown socks. If he reaches in the drawer without looking, what is the least number of socks he can take out to be sure of getting a pair of the same color?

Answer: _____ socks

- ★★★ 3. The total price of a dictionary and an almanac is \$32. The total price of 2 dictionaries and 3 almanacs is \$86. What is the price of each book?



↔ \$32

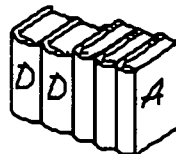

↔ \$86

Answer: The cost of a dictionary is _____. The cost of an almanac is _____.

- ★ 4. How many squares are there in the circle?

Answer: _____ squares

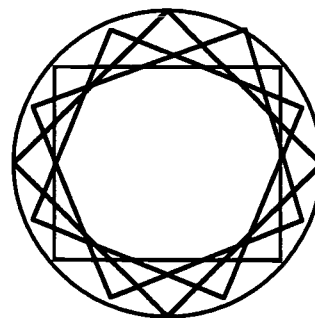

- ★★ 5. 5 years, 21 days, 4 hours, 32 minutes, 17 seconds
- 2 years, 93 days, 7 hours, 47 minutes, 24 seconds

- ★★★ 6. If a brick weighs exactly as much as a 9-pound rock plus half a brick, what does one and a half brick weigh?

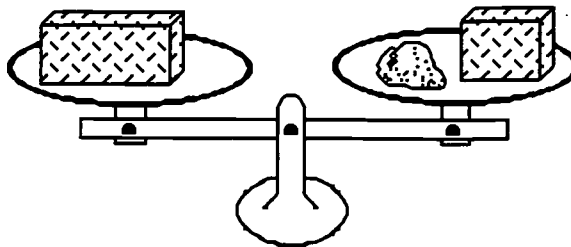

Answer: _____ pounds

- ★★ 7. Write a number in the \triangle that will give the answer 39.

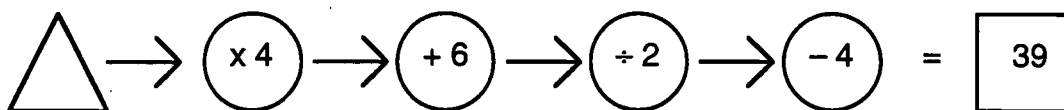

- ★ 8. How many of the 28 students in Andy's class are boys, if $\frac{4}{7}$ are girls?

Answer: _____ boys

- ★★★★ 9. If you made a spinner out of the circle below for a game you invented, what is the probability that the arrow would land on:

- a) zero? _____ c) a number greater than 9? _____
 b) an odd number? _____ d) either an odd number or 0? _____

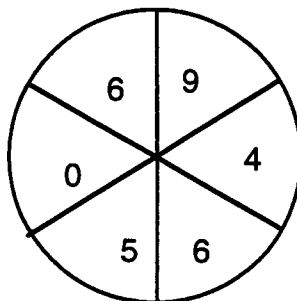

Commentary

Uranus, II

1. Mark out any two of the 4 corners and you will leave 7 squares. Two such cases are shown:

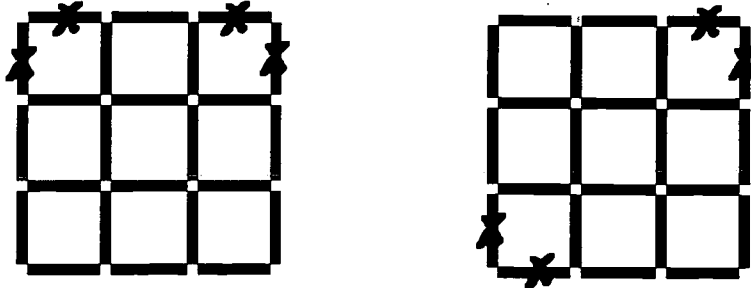

2. **(3 socks)** If the first two socks he draws are a brown and a blue, the next sock drawn has to match one of those.
3. **(dictionary: \$10; almanac: \$22)** The problem involves the same sort of thinking that students can later use to solve a system of equations in two unknowns in algebra. In this case, students might reason that since a dictionary and almanac together cost \$32, then twice that amount would cost twice as much -- i.e., 2 dictionaries and 2 almanacs would cost \$64. But we know 2 dictionaries and 3 almanacs cost \$86, so the difference of 1 almanac must be $\$86 - \64 or \$22. Then going back to the first situation, if an almanac costs \$22, and a dictionary and almanac cost \$32, a dictionary must cost \$10. There are other ways to arrive at this same conclusion.
4. **(4)** Students can see that, if they continued adding squares inside the circle, the inner figure would approach becoming a circle itself. This is well known in string designs.
5. **(2 years, 292 days, 20 hours, 44 minutes, 53 seconds)** Students will need to "borrow" in this problem, differently from what they have done in base-ten work. The time on the top line can be rewritten as 4 years, 385 days, 27 hours, 91 minutes, 77 seconds so that the bottom number can be subtracted, one term at a time.
6. **(27 pounds)** The 9-pound weight must be the same weight as $\frac{1}{2}$ of a brick, so we know that a whole brick weighs 18 pounds. Therefore a brick and a half weighs $18 + 9$ or 27 pounds.
7. **(20)** Work backwards is a possible approach. The number must have been 43 prior to subtracting 4 and getting 39. Prior to the next step, it must have been 86; prior to that, 80, and prior to that, 20.
8. **(12)** If $\frac{4}{7}$ of the students are girls, then $\frac{3}{7}$ are boys. $\frac{1}{7}$ of 28 is 4, so $\frac{3}{7}$ of 28 is 12.
9. **(a. $\frac{1}{6}$; b. $\frac{2}{6}$ or $\frac{1}{3}$; c. 0; d. $\frac{3}{6}$ or $\frac{1}{2}$)** For (a) since 0 is one of the six equal sections of the circle, the chances are 1 in 6 or $\frac{1}{6}$. For (b) the odd numbers are 5 and 9 and represent 2 of the 6 sections, so the chance is $\frac{2}{6}$ or $\frac{1}{3}$. For (c) there is no section labeled with a number larger than 9, so there is no chance the spinner will give this result. For (d) there are 2 sections with odd numbers and one section labeled with 0, giving three sections of the six. The chances are therefore 3 out of six or $\frac{3}{6}$, or $\frac{1}{2}$.

SUPERSTARS III

Uranus, III

Name: _____
(This shows my own thinking.)

- ★ 1. The Adrians were going to grandmother's house for Thanksgiving. They traveled 283 miles in 6 hours. Did they average more or less than 50 miles per hour?

Answer: _____

- ★★★★ 2. Martha bought a \$60 skirt at 40% off and a \$40 blouse at 20% off. What percent discount did she receive on the total purchase?

Answer: _____

- ★ 3. Count the dots.

Answer: _____ dots

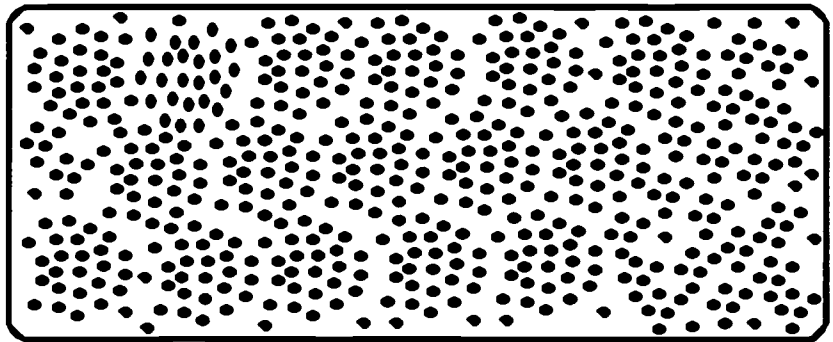

- ★★★ 4. When 3 times a certain number n is added to 6, the sum is 20 more than the original number. What is the number n ?

Answer: $n =$ _____

- ★★ 5. On February 19, the temperature in Orlando was 78° Fahrenheit. In Fairbanks, Alaska, the temperature was -49° F. What was the difference in these temperature readings?

Answer: _____ ° F

- ★★★ 6. Mrs. Gonzales has three children whose names are Javier, Juan, and Rosa. Their mean age is 11. Their median age is 10. Rosa is 15 years old. What is the age of the youngest child?

Answer: _____

★★★ 7. These values were used to find the total score for the figures in the examples below:

Triangle = 3 points
 Quadrilateral = 4 points
 Pentagon = 5 points
 Hexagon = 6 points

Examples:

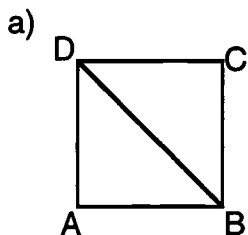

2 triangles
 1 quadrilateral

Score = 10

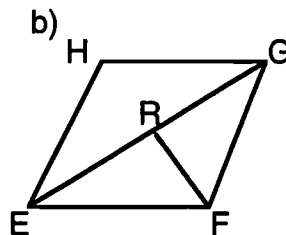

4 triangles
 1 quadrilateral
 2 pentagons

Score = 26

Total Score = 36

Now you do these. Find the scores for figures c and d. Add the scores for c and d and give the total score.

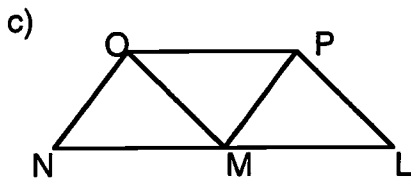

Score _____

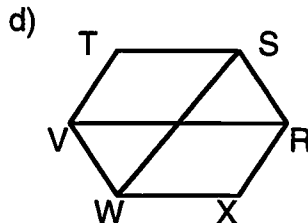

Score _____

Total Score: _____

★ 8. Write what goes in the if $a = 4$.

$$3 + a + 7 - 5 + 10 + a - a = \boxed{}$$

★★★ 9. If two prime numbers differ by 2, they are called TWIN PRIMES. List all the twin primes less than 50.

Answer: 3 & 5, _____

Commentary

Uranus, III

1. (**less than 50**) 283 is less than 300, and 300 miles is how far they would have gone in six hours at 50 miles per hour.
2. (**32%**) The skirt costs \$36 and the blouse costs \$32 for a total of \$68. The original cost was \$100. The discount was 32%. Another way to think of the problem is to look at the total saved -- \$24 for the skirt and \$8 for the blouse. Therefore \$32 was saved, out of the original price of \$100.
3. (**531**) Students might organize their work by sectioning off parts and counting each part, and total the parts. Some students might make a long "chain" and count; others will count the dots in groups of 25 or 50.
4. (**7**) One approach is simply to *guess-check-revise* until you find a number that works for n . Another is to solve an equation such as $3n + 6 = n + 20$.
5. (**127°**) $78 - (-49) = 127$. Students might want to make a sketch of a number line, to convince them that the absolute values of the numbers must be added, to find the difference.
6. (**8**) Since the mean age is 11, the total of their three ages is 33. Since the middle child is 10 (the median), the sum of the remaining ages is 23. Rosa is 15, so the age of the youngest is $23 - 15 = 8$.
7. (**c = 21, d = 48, total = 69**) Figure C has three triangles -- MNO, MPL, and OMP. It also has 3 quadrilaterals -- OPLN, OPMN, and OPLM. This totals $9 + 12$ or 21 points. Figure D has two triangles (let O be the center point) -- VOW and SOR. It has 6 quadrilaterals -- TSOV, TSWV, XROW, XRSW, TSRV, and WXRV. It also has 3 hexagons -- TSRXWV, TSROWV, and XRSOVW. This totals $6 + 24 + 18$ or 48 points. The grand total is then $21 + 48$ or 69 points. Note -- there are also 2 seven-sided figures. Some students might extend the scoring system, awarding 7 points for these two also, giving a total of 76 for figure D, and a grand total of 97.
8. (**19**) Students can substitute 4 in for a , and compute $3 + 4 + 7 - 5 + 10 + 4 - 4 = 19$.
9. (**3 & 5; 5 & 7; 11 & 13; 17 & 19; 29 & 31; 41 & 43**) Students might be encouraged to use a calculator to check and see if certain numbers are primes or not.

SUPERSTARS III

Uranus, IV

Name: _____

(This shows my own thinking.)

- ★ 1. In one 7-day week, how often does a clock show 3 o'clock?

Answer: _____

- ★★★ 2. Here is a triangle made of discs. Move only 3 discs and turn the triangle upside down. Draw arrows to show how you would move them. Practice with pennies if it will help you.

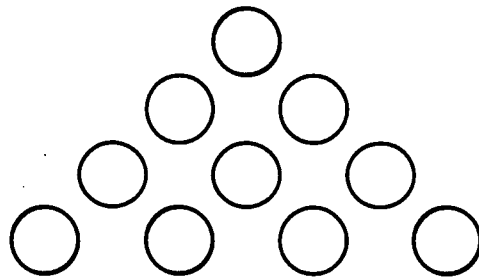

- ★★ 3. A furniture shop makes only tables and stools. Each table has four legs and each stool has three legs. The legs for both the tables and stools are the same. How many tables and how many stools can be made from 32 legs if some of each are made?

Answer: _____ tables and _____ stools

- ★ 4. If a regular octahedron has a surface area of 48 square inches, what is the surface area of each face?

Answer: _____

- ★★ 5. The thousands digit of a 4-digit number is 4 greater than the hundreds digit. The tens digit is 2 times the thousands digit. The ones digit is one-half the thousands digit. What is the number?

Answer: _____

- ★★ 6. If you put a million sheets of 30-cm long paper end-to-end, how many kilometers long would the paper be from beginning to end?

Answer: _____

- ★★★★ 7. Amy, Betty, David and Ed have last names of Gonzales, Jackson, Keller, and Perez, though not in that order. They recently participated in a 1500-meter race and they all finished the race in a different position. From the clues below match the first and last names and determine in what order they finished the race.

- a) Jackson said she would have finished higher if she had not slipped at the start of the race.
- b) Ed finished ahead of Perez, but behind Betty.
- c) Amy finished directly behind Gonzales.
- d) Neither David nor Ed finished third.

Answer: Amy _____ finished ____; Betty _____ finished ____;
David _____ finished ____; Ed _____ finished ____.

- ★★ 8. The newspaper used rounded off numbers to report that about 70,000 people attended the University of Florida vs. Florida State University football game last year. What is the greatest number of people that could have attended that game?

Answer: _____

- ★★★ 9. A farmer has three roosters. She keeps them in three pens like the ones shown below. She sold a cow and bought another rooster, but did not have enough money to build another pen. How can she rearrange the three pens she has to make a fourth pen? All the pens should be the same size and shape. Draw a picture below to show your solution.

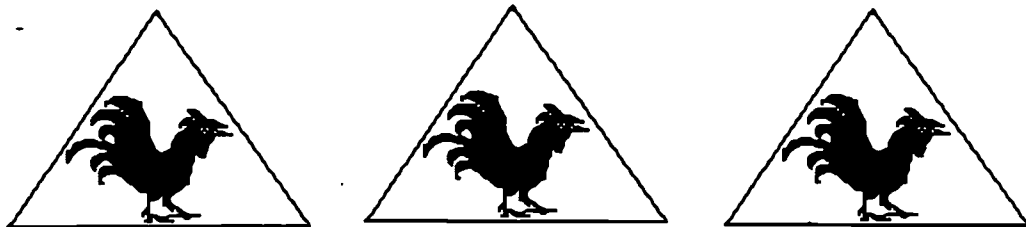

Commentary

Uranus, IV

- (14 times)** The clock shows 3:00 twice daily. So in 7 days this would occur 2×7 or 14 times.
- The seven discs in the center stay where they are. The 3 corner discs move so that 2 are on the top and the other becomes the bottom of the triangle.

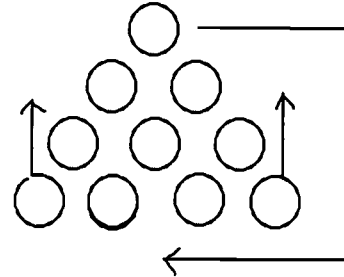

- (2 tables, 8 stools OR 5 tables, 4 stools)** *Guess, check and revise* is a possible strategy along with a table to help organize information. Students can begin to guess a number for either the tables or stools, and see if, using that number of legs required, it's possible to make some of the other piece of furniture, using up all the legs.
- (6 in²)** $48 \text{ in}^2 + 8 \text{ faces} = 6 \text{ in}^2$ per face. Some students might need help remembering that an octahedron has eight faces, or they might look it up in a dictionary.
- (4082)** Since the clues all mention the thousands digit, start guessing what that number might be. It has to be an even number because the ones digit is half of it. It can't be more than 4 because the tens digit is twice that number, and twice an even number more than four would be a 2-digit number. Therefore the first guess might be either 2 or 4.
- (300 km)** $1,000,000 \times 30 \text{ cm} = 30,000,000 \text{ cm}$, and dividing by 100 gives 300,000 meters. Dividing again by 1000 gives 300 km.
- (Amy Jackson-3rd; Betty Keller-1st; David Perez-4th; Ed Gonzales-2nd)** Students might begin by making a chart like the one below, and proceed by eliminating possibilities. From the first clue, David and Ed can't be Jackson. The chart shows these last names eliminated from consideration beside their names. One proceeds in this fashion until the process of elimination shows who has which last name, and where they finish.

FIRST NAME	LAST NAME	POSITION
AMY	G J K P	1 2 3 4
BETTY	G J K P	1 2 3 4
DAVID	G X K P	1 2 3 4
ED	G X K P	1 2 3 4

- (74,999)** This is the greatest number that can be rounded to 70,000.
- The pens are placed together to give another triangle shape in the center:



SUPERSTARS III

Uranus, V

Name: _____

(This shows my own thinking.)

- ★★★★ 1. Assign values to each letter so that the message becomes a meaningful addition example. Write your answer as an addition example beside the one below.

$$\begin{array}{r} \text{CROSS} \\ + \text{ROADS} \\ \hline \text{DANGER} \end{array}$$

Answer:

- ★★★★ 2. Every hour, on the hour, a train leaves Tallahassee for Jacksonville, while another train leaves Jacksonville for Tallahassee. The trip between the two cities takes exactly two hours. How many of the trains going in the opposite direction will a Tallahassee train to Jacksonville meet?

Answer: _____ trains

- ★★ 3. James purchased 3 hamburgers, 1 hot dog, 4 orders of French fries, and 4 soft drinks. The sales tax is 6%. How much change will he get from his \$20?

MENU			
Hamburger	95 ¢	Milk	65 ¢
Hot dog	85 ¢	Soft drink	79 ¢
Grilled cheese	75 ¢	Milk shake	99 ¢
French fries	89 ¢	Ice cream	69 ¢

Answer: _____ as change

- ★★ 4. At the beginning of a game of checkers, what percent of the squares are not covered by checker pieces?

Answer: _____ %

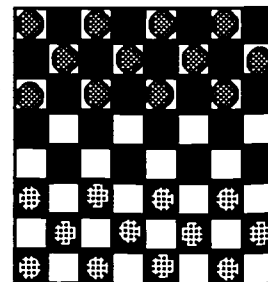

- ★ 5. On his way to school, Skip counted 17 trees on the right side of the street. On the way home he counted 17 trees on the left side of the street. How many different trees did he count in all?

Answer: _____ trees

- ★★ 6. Look at this figure:

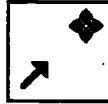

What is the correct order for these three figures to show the one above being turned 90°, another 90° and another 90°, all in the clockwise direction?

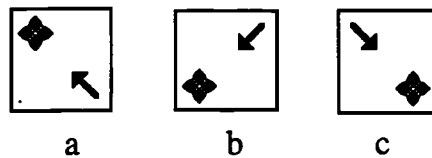

Answer: The order is _____, _____, and _____.

- ★★ 7. Pluto is about 5,900,000,000 kilometers from the sun. Scientists use a shortcut for recording large numbers called *scientific notation*. Write the distance from Pluto to the sun using this shortcut.

Answer: _____ km

- ★★★ 8. Two of the great baseball players of this century are Willie Mays and Mickey Mantle. The graph below shows their end of year batting averages over the years from 1954 to 1964.

- a. In which year did they both have the same average? _____
- b. In which year did they both average more than 1 hit in every 3 at bats? _____
- c. Which hitter had the smallest range between his best year and his worst year, batting-wise? _____

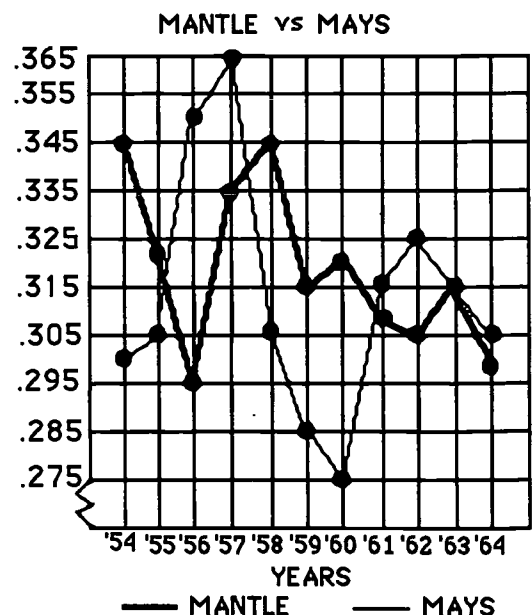

Commentary

Uranus, V

1.

96233
+62513
158746

Students might begin this problem by noting that $D = 1$, and that there are 3 S's and 3 R's. They might make boxes for all the digits, and fill in the 1 for D and then begin to guess the numbers that S and R might be. Start with a small number for S, perhaps 2, and then $R = 4$, and proceed to guess the other digits. This doesn't work, so try $S = 3$ and $R = 6$. This will work.

2. (5) Suppose a train leaves Tallahassee at 10 a.m. That train would pass the train that left Jacksonville at 8:00 at the Tallahassee station -- it would pass the 9:00 train $1/4$ of the way to Jacksonville. It would pass the train that leaves on the same hour at the half-way mark, and the train that leaves Jacksonville at 11:00 at the $3/4$ point. It would also pass the train that leaves Jacksonville at 12:00, at the Jacksonville station.

3. (**\$8.95**) Three hamburgers cost \$2.85; a hot dog cost \$0.85; 4 orders of fries cost \$3.56; and 4 soft drinks cost \$3.16. This totals \$10.42. Multiplying by 1.06 to add the tax gives \$11.05 when rounded up. $\$20.00 - \$11.05 = \$8.95$.

4. (**62.5% or 63%**) 24 out of 64 squares are covered, so $40/64$ are not covered. On a calculator, $40 \div 64$ gives 0.625. Students might also reason that $40/64 = 5/8$ in lowest terms, and $5/8 = 62.5\%$.

5. (17) Skip sees the same trees both times. Since he's going in the opposite direction going home, the trees appear on the other side of the street.

6. (C, B, A) Students might want to draw the design on a sheet of paper, and actually turn the paper to see if they are correct.

7. (**5.9×10^9**) *Scientific Notation* means that the number is written with one digit to the left of the decimal point, and the corresponding power of ten is used as the multiplier.

8. (a. **1963**; b. **1957**; c. **Mantle**) For (a) there is only one year in which the dots for the batting averages are the same, although the lines cross "between years" in several places. For (b) 1957 is the year in which both hit more than 0.333. For (c) Mantle's range is from 0.345 to 0.295 while Mays' range is from 0.365 to 0.275. Mantle's range of 50 points is less than Mays' range of 90 points.

SUPERSTARS III

Uranus, VI

Name: _____
(This shows my own thinking.)

- ★★ 1. The world record for limbo dancing under a flaming bar is $6\frac{1}{8}$ inches. The record for roller skating under a limbo bar is $5\frac{1}{4}$ inches. How much lower is the record on roller skates, than without roller skates?

Answer: _____ inches

- ★★ 2. Fill in the squares using non-zero digits.

Also, place the decimal point correctly

in the answer.

$$\begin{array}{r}
 .25 \\
 \times 3.\square \\
 \hline
 17\square \\
 \square 50 \\
 \hline
 \square 25
 \end{array}$$

- ★★★ 3. The edge of each of the cubes in the picture below has a measure of 1 inch. What is the total surface area of the figure, including the bottom?

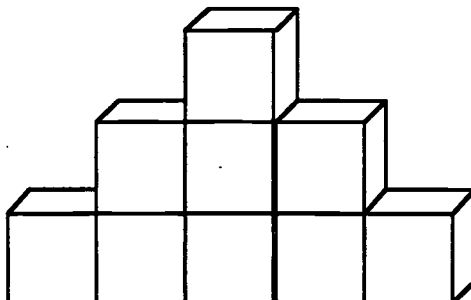

Answer: _____ square inches

- ★★ 4. If the moon takes an average of $27\frac{1}{3}$ days to revolve around the Earth, which is the closest estimate for the number of hours it will take? Circle your answer.

a) 400 hours b) 650 hours c) 1025 hours d) 900 hours

- ★★ 5. Find the number of letters in America's first President's last name. Multiply it by the number of letters that differ between the last names of America's second President and sixth President. What is your answer?

Answer: _____

- ★ 6. Scientists predict that by the year 2080, the Earth and its manned space stations will be inhabited by 4,327,650,189,012 people. Round this number to the nearest billion.

Answer: _____

- ★★ 7. Solve the following problem using Roman numerals. Be sure to give your answer as a Roman numeral.

$$(XL \div X) + XVI - XIX = \underline{\hspace{2cm}}$$

- ★★★★ 8. The picture below represents a spinner. Find the probability of hitting each of the following colors. Give your answers as fractions in lowest terms.

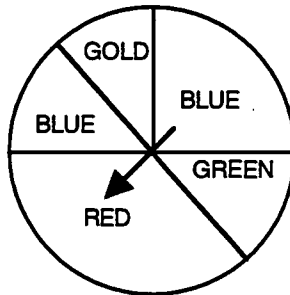

a) red: _____ b) blue: _____ c) gold or green: _____ d) orange: _____

- ★★ 9. A sandwich shop sells hamburgers and hot dogs. They offer French fries, chips and pretzels as side orders. They also have soda, milk or juice to drink. How many different combinations of a sandwich, a side order, and a drink are possible from their menu?

Answer: _____ combinations

- ★★ 10. There are 24 students in Mrs. Perimeter's class. If $87\frac{1}{2}\%$ of them passed their mathematics test, how many students did not pass?

Answer: _____ students did not pass

Commentary

Uranus, VI

- (7/8)** The difference can be found by subtracting $5 \frac{1}{4}$ from $6 \frac{1}{8}$, or by “counting up” from $5 \frac{1}{4}$ to $6 \frac{1}{8}$. To do the latter, it's $\frac{3}{4}$ of an inch from $5 \frac{1}{4}$ inches to 6 inches, and another $\frac{1}{8}$ to $6 \frac{1}{8}$ inches. So the sum of $\frac{3}{4}$ and $\frac{1}{8}$, which is $\frac{6}{8} + \frac{1}{8}$ or $\frac{7}{8}$, is the difference.
- .25**
$$\begin{array}{r} \times 3.7 \\ 175 \\ \underline{75} \\ 0.925 \end{array}$$
- (34 in²)** There are 9 faces “facing you,” and another 9 on the other side. There are 11 faces that make up the “stair steps” portion, and another 5 on the bottom. This totals 34.
- (650 hr)** Multiplying 27 days times 24 hours/day gives 648 hours. Add on 8 hours for the final $\frac{1}{3}$ day, and you have 656 hours. As a rounded number, this is closest to 650 hours.
- (0)** Washington has 10 letters. The second and sixth Presidents were both named Adams so $5 - 5 = 0$ and $10 \times 0 = 0$.
- (4,328,000,000,000)**
- (I)** $(40 \div 10) + 16 - 19 = 1$; 1 is written as I in Roman numerals.
- (a. $\frac{3}{8}$; b. $\frac{3}{8}$; c. $\frac{1}{4}$; d. 0)** The red portion is $\frac{1}{4}$ plus $\frac{1}{2}$ of $\frac{1}{4}$ or $\frac{1}{8}$, which is $\frac{2}{8} + \frac{1}{8}$ or $\frac{3}{8}$. Blue is the same area as red, although it's made up of two pieces. Gold and green together would be $\frac{1}{8} + \frac{1}{8}$, or $\frac{1}{4}$. Orange isn't pictured, so the chance of getting orange is 0.
- (18)** There are two types of sandwiches, three types of side orders, and three types of drinks; therefore $2 \times 3 \times 3 = 18$ gives the number of choices. For students who need a concrete experience to solve this problem, they might try labeling each choice, and combining the labels. For example, let A and B be the sandwich types, C, D, and E the side orders, and F, G, and H the drinks. Then ACF, ACG, ACH, ADF, ADG, ADH, AEF, AEG, and AEH are the combinations with the first type sandwich. There is the same number for the second type of sandwich.
- (3)** $100\% - 87.5\% = 12.5\%$ that did not pass, and $12.5\% \times 24 = 3$.

SUPERSTARS III

Uranus, VII

Name: _____

(This shows my own thinking)

- ★★ 1. A winning basketball team earned 336 points in the first 4 games last season. One-eighth of their points were made on 3-point shots. How many 3-point baskets had they made after four games?

Answer: _____ baskets

- ★★★ 2. Each large block below weighs the same amount. Each small block weighs the same amount. From looking at the pictures, find the weight of both the small and large blocks.

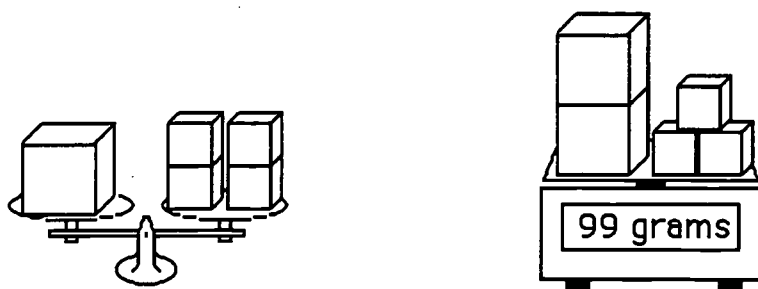

Answer: A small block weighs _____ grams.

A large block weighs _____ grams.

- ★★★ 3. What is the probability that you will roll a sum of 7 on one roll of a standard pair of number cubes (sides numbered 1 through 6 on each cube)?

Answer: _____

- ★★ 4. In lowest terms, what fraction of the large square is shaded?

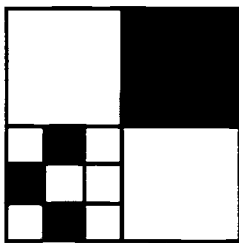

Answer: _____

- ★★ 5. Circle the shapes below that can be folded to form a closed box with no overlapping sides.

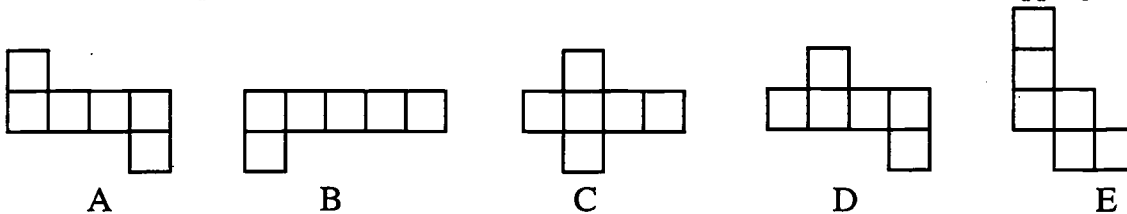

- ★ 6. Alfonso took a 40 question test. How many can he miss and still make an 85%?

Answer: _____ questions can be missed.

- ★★★ 7. A function machine is set up so that when an *input number* is dropped into the machine, a predictable *output number* comes out. When 1 is dropped in, for example, 2 comes out. Study the pattern of input and output numbers in the chart below, and fill in the missing numbers.

INPUT	OUTPUT
1	2
2	5
3	10
4	17
5	
6	
7	

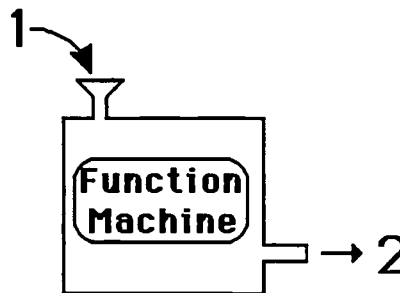

- ★★★ 8. a. For the function machine in problem 7, what number was the *input* number for the *output* number 101? _____

b. If the input number is called n , what would the *output* number be? _____

- ★ 9. Beth, Michael, Gale, Maria, and Dot are all different ages. Gale is older than Beth and younger than Michael. Maria is older than Michael. Dot is older than Beth and younger than Gale. List the names of the 5 people from the oldest to the youngest.

Answer: _____

Commentary

Uranus, VII

1. (14) $\frac{1}{8}$ of 336 is 42 points, and 42 points \div 3 points/basket is 14 baskets.
2. (9 and 36) Students can think of each larger block on the right-hand scale as composed of 4 small blocks. Therefore the right-hand scale shows that 4 + 4 + 3 or 11 small blocks weigh 99 grams. Or, each small block weighs 9 grams. Then a large block is 4×9 grams, or 36 grams.
3. (6/36 or 1/6) There are 6 ways to have a sum of 7 on a pair of number cubes: (1,6), (6,1), (2,5), (5,2), (3,4) and (4,3). There are 36 possible ways that two number cubes can land. Therefore the chance of getting a sum of 7 is 6/36 or 1/6.
4. (1/3) There are a number of ways for students to get this answer. One way is to add the large $\frac{1}{4}$ of a square to the smaller pieces, which are $\frac{3}{36}$ of the square, getting $\frac{9}{36} + \frac{3}{36} = \frac{12}{36}$ or $\frac{1}{3}$.
5. (Shapes A, C, and D should be circled.) Students with good visualization skills can do this problem without any physical representations. For other students, they might want to trace the figures, cut them out, and try to fold them along the lines given.
6. (6) 85% of 40 is 34, so Alfonso must correctly answer at least 34 questions. This means he can miss up to 6 questions:
7. (5 \rightarrow 26; 6 \rightarrow 37; 7 \rightarrow 50) The input number is squared and 1 is added.
8. (a. 10; b. $n^2 + 1$, or $n \times n + 1$) The problem encourages students to turn around their thinking from the previous problem. If a number that is squared and then increased by 1 gives 101, subtracting 1 from 101 gives the square of the number, 100. Therefore 10 must be the input number. Part (b) involves writing the function using a variable, if it can be generalized.
9. (Maria, Michael, Gale, Dot, Beth) Students might want to simply make a vertical list of the students' names, according to the clues given. Gale would go above Beth but below Michael from the first clue. Maria also goes above Michael, from the second clue. Dot goes above Beth but below Gale. Therefore the order is:

Maria
Michael
Gale
Dot
Beth

SUPERSTARS III

Uranus, VIII

Name: _____

(This shows my own thinking.)

- ★ 1. What fraction is equivalent to $\frac{4}{5}$ and has a denominator that is 4 more than its numerator?

Answer: _____

- ★★★★ 2. A man weighing 80 kg and his two children, each weighing 40 kg, want to cross a river. Each can row the boat they must use. The boat can carry only 80 kg. What is the least number of crossings that can be made to get from one side of the river to the other? (A crossing means going from one side of the river to the other side -- not a round trip.)

Answer: _____ crossings

- ★★★ 3. A hexagonal prism looks like the picture to the right. What is the total number of:

a. *faces* on the shape? _____

b. *edges* on the shape? _____

c. *vertices* on the shape? _____

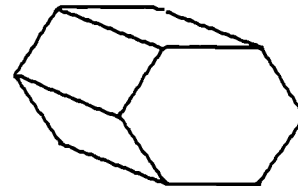

- ★★★ 4. Sarah's age is three times Anthony's age. Four years from now, Sarah will be twice as old as Anthony. How old is Sarah now?

Answer: _____

- ★★★ 5. Diane counted 28 geese and horses on the farm. Altogether, there were 78 legs on all of the animals. How many were geese?

Answer: _____ geese

- ★ 6. In the space below, show how to combine six 1's so that their sum is 123.

- ★★ 7. Maria likes to weigh her toy animals. She found that the animals below balanced the gram weights in her science kit. Three elephants and 2 donkeys balanced 28 grams; two elephants and 1 donkey balanced 17 grams. Maria says she can now tell how much both animals weigh. Are you as clever as Maria?

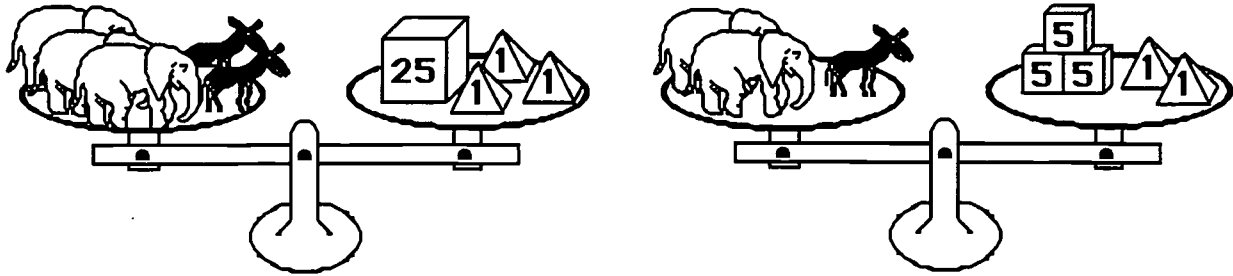

Answer: An elephant is _____ grams; a donkey is _____ grams.

- ★★★★ 8. A checkerboard is made from a number of small squares. Four of the small squares are grouped so that a larger square is formed. Nine of the small squares can be grouped so that even larger squares are formed. This process can be continued, up to all 64 small squares making one huge square. How many squares altogether can be formed on a checkerboard?

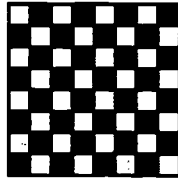

Answer: _____ squares

- ★★★ 9. Thomas works for his dad. He was given the choice of:
 (a) working for 25 days at \$15.00 per day
 or
 (b) working for 25 days and doubling his wages every day, beginning with 1¢ the first day, 2¢ the second day, 4¢ the third day, 8¢ the fourth day, etc.

Which choice, (a) or (b), will give Thomas the greater pay and how much more pay than the other choice?

Answer: Choice _____ will give him \$_____ more.

Commentary

Uranus, VIII

1. (16/20) Students might start listing fractions equivalent to $\frac{4}{5}$, as $\frac{4}{5}$, $\frac{8}{10}$, $\frac{12}{15}$, $\frac{16}{20}$, and so on, until they find one in which the denominator is 4 more than the numerator.

2. (5) Students would benefit greatly by drawing a diagram to solve this classic problem. One is shown to the right.

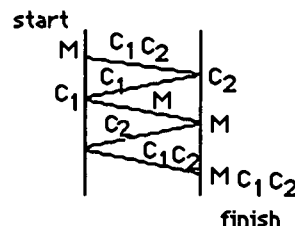

3. (a. 8; b. 18; c. 12) Students will have to imagine the parts of the figure they cannot see. This polyhedra and others like it follow Euler's rule that connects vertices, edges, and faces: $F + V - 2 = E$.

4. (12) Students might start by guessing ages for Anthony since he's the youngest, multiply that by 3 to get Sarah's age, and then add 4 to both ages and see if Sarah will be twice as old as Anthony in 4 years. Doing so yields Anthony as 4 years old and Sarah as 12.

5. (17) One approach is to notice that giving all 28 animals two legs uses up 56 of the legs. The remaining 22 legs must then be apportioned, in pairs, to make the 4-legged animals. Hence there must be 11 horses. Then $28 - 11 = 17$ is the number of geese.

6. (111 + 11 + 1) This can be found by trial and error.

7. (6 and 5) The problem can be approached in a concrete manner that will later be replicated when students begin to solve systems of equations. Notice that doubling what is on both sides of the right-hand scale will give that 4 elephants and 2 donkeys weigh 34 grams. Compared with the left-hand scale which has the same number of donkeys and one less elephant balancing 28 grams, we know that one elephant accounts for the difference between 34 and 28, or one elephant is 6 grams. Then we can use this amount to substitute for the elephant's weight in any of the given scales, and determine that the donkey weighs 5 grams.

8. (204) There are 64 small squares, 49 two-by-two squares, 36 three-by-three squares, 25 four-by-four squares, 16 five-by-five squares, 9 six-by-six squares, 4 seven-by-seven squares, and 1 eight-by-eight square. This totals 204 squares.

9. (b gives \$335169.31 more) This problem is exhausting to do with paper and pencil, but is quite easy with a calculator that has a repeating multiplier concept and a memory key. For such a calculator, pushing either 2×0.01 or 0.01×2 , followed by a sequence of [=] 's, gives the amount he made each of the 25 days. If you also use the [M+] key to add each new day's pay to what he made previously, at the end of 25 days (or 24 [=] 's being pushed), you should have 335544.31 when you push [MR]. You can then subtract $\$15 \times 25$, what he would make at \$15 per day for 25 days, to get the answer above.

SUPERSTARS III

Uranus, IX

Name: _____

(This shows my own thinking.)

- ★ 1. Look at the pattern. Fill in the next two numbers.

1, 1, 2, 3, 5, 8, 13, _____, _____

- ★★★★ 2. The 17-inch-by-9-inch piece of cardboard below has two holes that were cut from it. What is the area, in square inches, of the remaining cardboard?

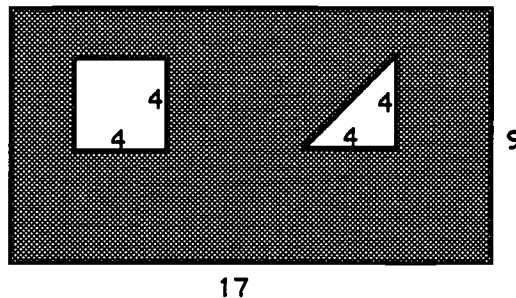

Answer: _____ square units

- ★★ 3. Susan challenged a friend with this problem:

Multiply the square root of 49 by 10 and subtract 50.
Then multiply that number by 7.
Now find $\frac{1}{5}$ of the product.

What is the answer to Susan's problem? _____

- ★★★ 4. Here's a number trick:

*Chose a number from 1 to 9.
Double it.
Add 5.
Multiply your result by 5.
Subtract 25.
Remove the ones digit.
Viola! You have your original number back.*

Does this number trick always work? Answer: _____ (yes or no)

- ★★★ 5. A high school track record that remained unbroken for over thirty years is Jim Ryun's 1965 mile run of 3 minutes, 58.3 seconds. Essentially he ran 1 mile in 4 minutes. What was his average speed, to the nearest whole number, in miles per hour?

Answer: _____ miles per hour



- ★★ 6. If Andy's average pulse rate is 72 beats per minute, about how many times will his heart beat in a day? Give your answer rounded to the nearest thousand beats.

Answer: _____ beats

- ★★★ 7. Jim's Sport Shop sells four pairs of roller blades for every three skateboards. Last week Jim sold sixteen pairs of roller blades. How many more pairs of roller blades did Jim sell than skateboards?

Answer: _____

- ★★ 8. Tamika took five math tests. Her teacher reported she had an average score of 91, but had lost one of Tamika's tests. The four the teacher had showed scores of 86, 92, 88, and 96. What was her score on the lost test?

Answer: _____

- ★★ 9. A real estate broker sold a house for \$120,000. Her commission was 8% of the selling price.

a. How much money did she earn in commission?

answer: _____

b. If she had to pay 28% of her commission in income tax, how much did she have left to spend?

answer: _____



Commentary

Uranus, IX

1. **(21, 34)** This pattern is the famous Fibonacci sequence in which you start with 1, 1, and from there on each term is the sum of the two preceding terms.
2. **(129)** Students will likely multiply 17×9 and get 153, and then subtract the area of the two holes from that. The rectangle has an area of 4×4 or 16, and the triangle is half of that, or 8. Therefore 24 must be subtracted from 153, leaving 129.
3. **(28)** The square root of 49 is 7, and $7 \times 10 = 70$. Subtracting 50 leaves 20, and 20×7 is 140. One-fifth of 140 is 28.
4. **(yes)** Most students will take several numbers and try them out, and since they all work, will conclude the number trick works. If one takes a 1-digit number x , and doubles it to get $2x$, adds 5 to get $2x + 5$, multiplies by 5 to get $10x + 25$, subtracts 25 to get $10x$, then one has the single digit again, but this time in the tens place. Removing the last digit, which is always a zero, gives the original number.
5. **(15)** One mile in four minutes means that every four minutes he could run a mile at that pace. Since there are 15 groups of four minutes each in 60 minutes or an hour, he could run 15 miles in an hour at that pace. He was therefore running 15 miles per hour.
6. **(104,000)** Using a calculator, multiply $72 \times 60 \times 24$ to get 103,680. Rounded to the nearest thousand, this number is 104,000.
7. **(4)** Four pairs of roller blades for every three skateboards is the ratio 4:3. This is the same ratio as 8:6, 12:9, 16:12, and so on. The ratio 16:12 is the one we're after, as that means 16 roller blades were sold. Then 12 skateboards were sold, and $16 - 12 = 4$.
8. **(93)** Students can think of the problem in this way: $(86 + 92 + 88 + 96 + x) \div 5 = 91$. This means that $(86 + 92 + 88 + 96 + x) = 91 \times 5$ or 455. This also means that $x = 455 - (86 + 92 + 88 + 96)$, or $x = 93$. Other students might know that since the average is 91, and the differences between the given scores and 91 are, respectively, -5, +1, -3, and +5, which sums to -2, the remaining test must compensate by scoring +2 over the average, and $91 + 2$ is 93.
9. **(a. \$9600; b. \$6912)** On a calculator, students can multiply \$120,000 by 8% or by 0.08. They can then multiply the result by 72%, which is the percent she would have left, after 28% in taxes is removed.

SUPERSTARS III

Uranus X

Name: _____

(This shows my own thinking.)

- ★ 1. Multiply 37 by 3. Now multiply 37 by 6. What would you have to multiply 37 by to get all fives?

Answer: _____

- ★★★★ 2. Solve each problem.

a. A 12-pack of colas cost \$4.48, including tax of \$0.28. How much would each cola cost, without tax? _____

b. Maria put 5 pups in a cage to send them on an airplane. The total weight was ninety pounds. The cage by itself was 25 pounds. On the average, how much did each pup weigh? _____

c. Garth gets to watch 15 hours of TV each week. There are only 5 hour-long shows he watches each week. How many half-hour shows can he watch? _____

d. The scale shows grams. How much does one egg weigh?
_____ grams

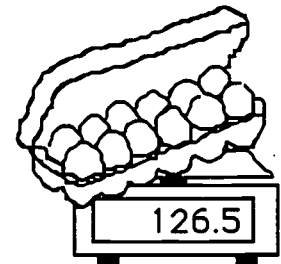
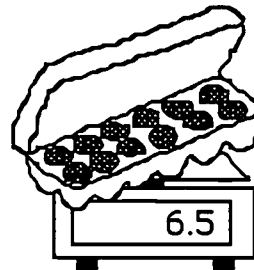

- ★★★ 3. Place the numbers 1 to 16 in the grid so that each row, column and diagonal will have a sum of 34. Some numbers have been placed for you.

		3	
	11	10	
9			12
		15	1

- ★★ 4. If a 27 in.^3 jar of peanut butter holds 16 ounces, how much peanut butter is in a jar that is 67.5 in.^3 in volume?

Answer: _____ ounces

- ★★★ 5. Molly and Meg are good friends who like to visit each other often. The map below shows the location of the two girls' houses. Molly decided to find all the different ways to get to Meg's house from hers. She can move only in the direction of east and north. How many different routes are there for Molly to use?

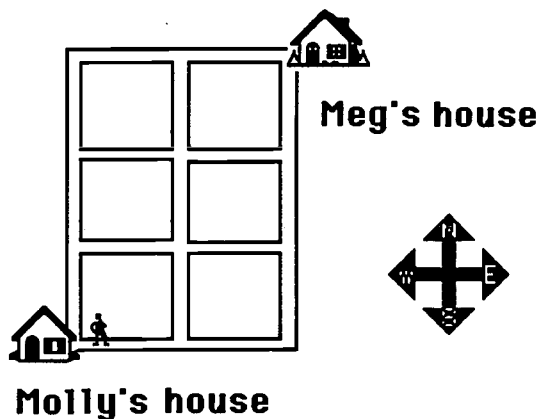

Answer: _____ routes

- ★★ 6. The function machine below shows what happens to a number dropped in the input place. Fill in the two missing output numbers, when 49 and 81 are dropped in.

INPUT	OUTPUT
64	8
36	6
4	2
100	10
49	
81	

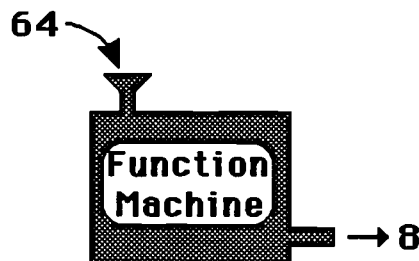

- ★★★ 7. In sixteen more minutes it will be as many minutes before 3 P.M. as it was after 2 P.M. ten minutes ago. What time is it?

Answer: _____

- ★ 8. Estimate the percent of the figure that is shaded.



Answer: _____

Commentary

Uranus, X

1. (15) Multiply 37 by 3 and you get 111, and by 6 and you get 222. The pattern seems to be that multiplying 37 by 3×1 gives all ones, and by 3×2 gives all twos. So you might guess that multiplying 37 by 3×5 would give all fives. Checking it on a calculator proves this is true.

2. (a. 35¢; b. 13 pounds; c. 20; d. 10) Each of these problems is set up in the form of what will later be a linear equation to solve. For (a), you can solve $12x + \$0.28 = \4.48 . For (b) you can solve $5x + 25 = 90$. For (c), $\frac{1}{2}x + 5 = 15$. For (d), $12x + 6.5 = 126.5$. At this point, students will not use equations to solve the problems -- they will simply subtract first, and then divide.

3.
$$\begin{array}{cccc} 16 & 2 & 3 & 13 \\ 5 & 11 & 10 & 8 \\ 9 & 7 & 6 & 12 \\ 4 & 14 & 15 & 1 \end{array}$$

The key to solving this problem easily is to start in a column in which you already know three of the four numbers necessary to total 34. You can put 6 under the 10, and then you know the number to the left of 6 must be 7. You also know that 16 must be in the upper left corner. From that point, *guess-check-revise* will enable students to solve the problem.

4. (40) Use a proportion to solve. $\frac{16}{27} = \frac{x}{67.5} \quad x = 40$

5. (10) Students will be helped by placing letters of the alphabet at the corners, and describing each path using these letters. Using the letters placed as below, the ten trips are completely determined by this list:

ABCE; ADCE; ADFE; ADFJ; GDCE; GDFE; GDFJ; GHFE; GHFJ; GHJI

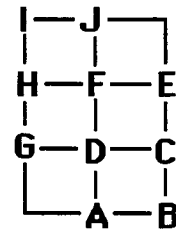

6. (7, 9) The function machine takes the square root of the number dropped in.

7. (2:27 P.M.) *Guess, check, and revise* may be the way students approach the problem. For example, guess 2:30 as the time -- in 16 more minutes, it is 2:46, which is 14 minutes before 3:00. But 10 minutes before 2:30 would be 2:20, which is 20 minutes after 2:00. So 2:30 doesn't work -- revise the guess down a little, and check as above. Eventually 2:27 works as 16 minutes later it is 2:43, which is 17 minutes before 3:00; and 10 minutes before 2:27 was 2:17, which is 17 minutes after 2:00.

8. (25%) Students could fill in the grid to see that there are 2 shaded squares of the 8 small squares. $\frac{2}{8} = \frac{1}{4} = 25\%$.

SUPERSTARS III

Uranus, XI

Name: _____

(This shows my own thinking.)

- ★★★★ 1. Harry the Hog is a disgrace to butchers everywhere! He's known for keeping his thumb on the scale for a little extra weight and therefore money. The T-bone sells for \$2.99 a pound, but Harry's thumb has added 0.3 lb. to the scale.

a. What will you pay for the steak if you don't notice his thumb? _____

b. What will you pay for the steak if you make him remove his thumb? _____

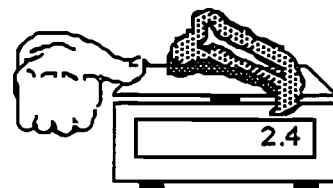

- ★★ 2. A notebook costs \$1 more than a pencil. Together they cost \$1.50. How much does each item cost?

Answer: a) The notebook costs _____.

b) The pencil costs _____.

- ★★★ 3. One of the classrooms at the middle school is shaped like the picture to the right. What is the area of the entire room?

Answer: _____

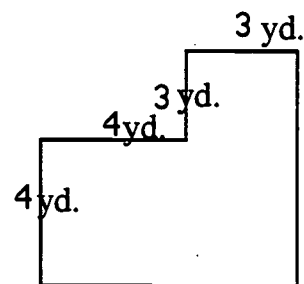

- ★ 4. Arrange the fractions $\frac{2}{3}$, $\frac{1}{2}$, $\frac{5}{6}$, $\frac{7}{12}$, and $\frac{3}{4}$ in order from smallest to largest.

Answer: _____

- ★★ 5. Johnny had a raise in pay that moved him from \$4.00 an hour to \$4.60 an hour. What was his percentage of increase in pay for one hour?

Answer: The percentage raise was _____% per hour.

- ★★★★ 6. In the array below, the middle entry in each *odd* row is the square of the row number itself. So in the third row the middle entry is nine, and $3 \times 3 = 9$.

- a) What is the middle entry of the 23rd row going to be?

Answer: _____

		1			→ row 1	
	3		5		→ row 2	
	7	9	11		→ row 3	
	13	15	17	19	→ row 4	
	21	23	25	27	29	→ row 5

- b) What will be the sum of the numbers in the 10th row?

Answer: _____

- ★ 7. A digit in the fifth place to the left of the decimal point has what place value?

Answer: _____

- ★★ 8. Complete the pyramid by adding adjacent fractions and placing the sum above the two numbers being added. Put your answers in lowest terms in the three squares.

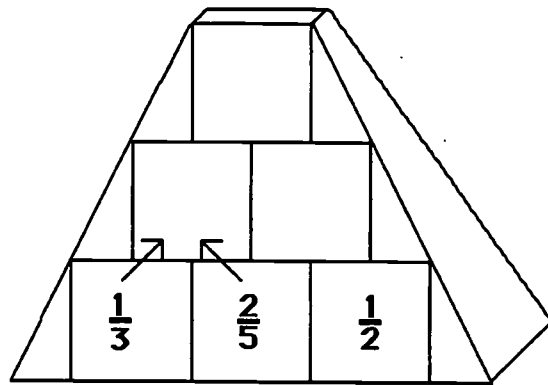

- ★★ 9. When making four servings of cream of wheat, bring to a boil 4 cups of water. Add $\frac{2}{3}$ of a cup of cream of wheat and stir. A family of three doesn't want to make four servings.

a. How much water would be required for three servings of cream of wheat? _____

b. How much cream of wheat would be required for three servings? _____

Commentary

Uranus, XI

1. (a. \$7.18; b. \$6.28) For (a), students can multiply \$2.99 times 2.4; for part (b), they can multiply \$2.99 times 2.1. In each case, they would round their answer up to the next cent.
2. (notebook costs \$1.25; pencil costs \$0.25) Students can solve this by *guess-check-revise*. They can guess the cost of the notebook first, determine the cost of the pencil as the difference between what is chosen for the notebook and \$1.50, and see if the difference in the two items is \$1. If not, revise the guess.
3. (37 yd² or 37 sq. yd.) Divide the shape into two rectangles and find the area of each. One rectangle is 3 yds. by 3 yds. or 9 square yards. The second is 4 yds. by 7 yds. or 28 square yards. $28 \text{ yd}^2 + 9 \text{ yd}^2 = 37 \text{ square yards}$. The shape could also be divided into rectangles that are 3 by 7 and 4 by 4. For full credit, students must have the correct label.
4. ($\frac{1}{2}$, $\frac{7}{12}$, $\frac{2}{3}$, $\frac{3}{4}$, $\frac{5}{6}$) Changing all of the fractions so they have the denominator 12 allows one to order them by looking at the numerators.
5. (15%) The increase is \$0.60. $\$0.60 \div \$4 = 0.15 = 15\%$. Another way to see this result is to take $60/400$, reduce it to lowest terms, $3/20$, and rename this fraction as $15/100$, which is 15%.
6. (a. 529 or 23^2 ; b. 1000 or 10^3) Square the row number to get the middle entry. The sum of the numbers in the row is the cube of the number of the row. $10^3 = 1000$
7. (ten thousands)
- 8.

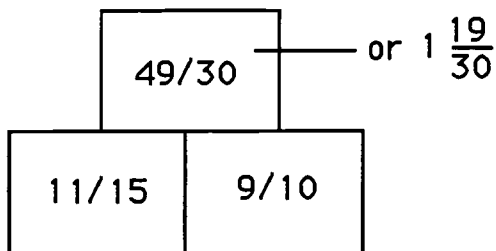

9. (a. 3 cups; b. $1/2$ cup) Part (a) involves simple realizing that $3/4$ of 4 is 3. Part (b) involves finding $3/4$ of $2/3$. This can be done by drawing a figure, or by computing $3/4 \times 2/3$ or $1/2$.

SUPERSTARS III

Uranus, XII

Name: _____
(This shows my own thinking.)

- ★★ 1. Goldbach, a Russian mathematician, conjectured that every even counting number greater than 2 can be written as the sum of two different prime numbers. For example, $10 = 3 + 7$.

Write each of these as a sum of two different primes:

a) $26 =$ _____

b) $82 =$ _____

- ★ 2. How many diagonals does a hexagon have?

Answer: _____

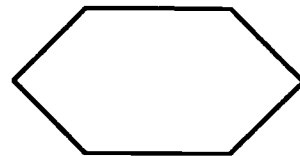

- ★★ 3. Mrs. Searcy's class is entering a riddle writing contest sponsored by *MATH WIZZ* magazine. Leila wrote this riddle:

Find 3 integers whose product is -36 and whose sum is 5.

What is the answer to Leila's riddle?

Answer: _____

- ★★ 4. Compute the following: $24 + 33 + 40$

Answer: _____

- ★★★ 5. Mark had to hit the same area of the spinner twice in a row to win his girlfriend a bracelet at the fair. What are his chances of hitting the same area two times in only two spins?

Answer: _____

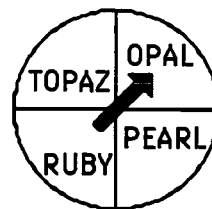

- ★ 6. Circle the greatest decimal number below.

2.05

2.5

2.005

★★ 7. Use the Egyptian Symbol Chart below to write the Egyptian numeral as a decimal numeral.

Egyptian Symbol		Decimal Numeral
	(stroke)	1
∩	(ox yoke)	10
9	(coil of rope)	100
⊗	(lotus plant)	1000
└	(bent finger)	10,000
🐸	(tadpole)	100,000
🧑	(astonished man)	1,000,000

└ ⊗ 999 = _____

★★★ 8. How can you make change for a dollar using exactly 50 coins and only the coins listed below?

_____ dimes _____ nickels _____ pennies

★★★★ 9. The picture shows a peek at a honeycomb. The queen's nest is shown in the center.

a. How many nests touch the queen's nest?

answer: _____

b. How many nests touch a nest that touches the queen's nest? _____

c. The two sets of nests above could be called neighborhoods 1 and 2. How many nests in neighborhood 3? _____

Neighborhood 4? _____

Neighborhood 5? _____

d. What is an expression for the number of nests in Neighborhood n ? _____

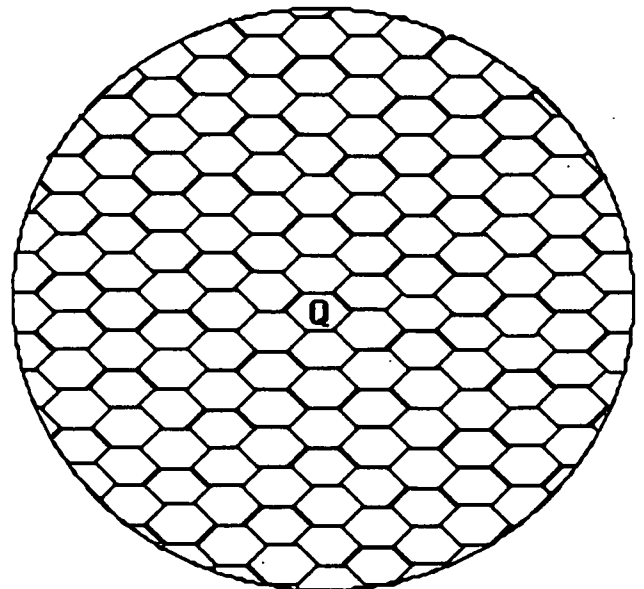

Commentary

Uranus, XII

1. (a. $26 = 23 + 3$; b. $82 = 23 + 59$) There may be other solutions.
2. (9) Three diagonals can be drawn from each of the vertices of a hexagon. There are 6 vertices. $6 \times 3 = 18$. However, the diagonals will have been counted twice, once at each vertex. So the total is half of 18.
3. (2,6,-3) Students will probably have to take the factors of 36, and try them in groups of three until they find a group in which the product is -36 and the sum is 5. They will be helped by remembering that a negative product and positive sum means that one number is negative.
 $2 \times 6 \times -3 = -36$ and $2 + 6 + -3 = 5$
4. (44) $2^4 = 16$; $3^3 = 27$; $4^0 = 1$; The sum is 44.
5. (1/4 or 25% or 0.25) It doesn't matter what the first spin is. The chance that the second spin will match it is 1/4.
6. (2.5) Many students will select one of the other choices because of the number of digits they have.
7. (21,300) $10,000 + 10,000 + 1,000 + 100 + 100 + 100 = 21,300$
8. (2 dimes, 8 nickels, 40 pennies) Students will likely guess-check-revise to solve this problem. A good place to start is with the number of pennies, which has to be most of the 50 coins due to the size of the other coins. There can't be 50 pennies, so try 45. That turns out to be impossible, so drop back to 40. There is a possibility with 40 pennies.
9. (a. 6; b. 12; c. 18, 24, 30; d. $6n$) The first two neighborhoods have dotted lines through them. The next three are marked by ✓, X, and ●. After counting the nests in the first five neighborhoods, students will notice that the neighborhood number times 6 gives the number of nests.

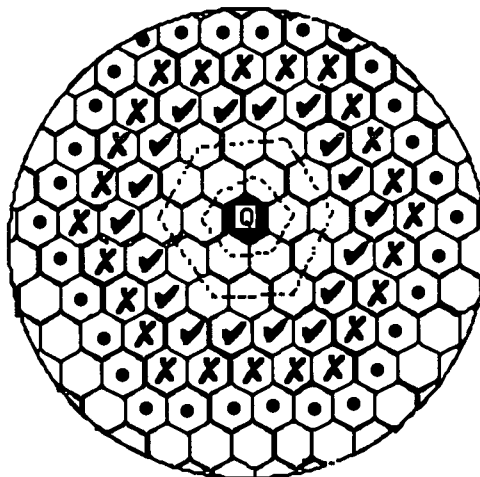

SUPERSTARS III

Uranus, XIII

Name: _____

(This shows my own thinking.)

- ★★★★ 1. Below you can see the side view and top view of three buildings in a pattern of buildings made from sugar cubes. Study the pattern until you can visualize how Building 5 would look.

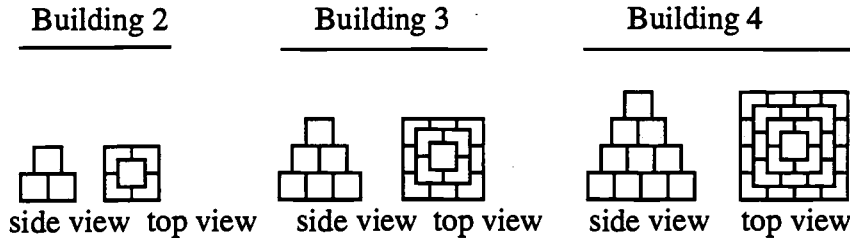

- a. Draw the side view and top view of building 5 below.

side view top view

- b. How many cubes would it take to make Building 5? _____
- c. How many cubes would it take to make Building 10 in the pattern? _____

- ★★ 2. A friend tells you she made 96, 83, and 87 on the past three math tests. What must she make on the next test to attain an average of 90?

Answer: _____

- ★★ 3. Compute:

a) $3.7 + 4.78 + 9\frac{3}{5} - 4.09 + 6 = \underline{\hspace{2cm}}$

b) $\frac{5}{12} + \frac{7}{8} - \frac{2}{3} + 1\frac{1}{2} - 2\frac{3}{24} = \underline{\hspace{2cm}}$

- ★ 4. A patch of water lilies doubles itself in size each day. From the time the first leaf appeared to the time when the pond was completely covered took 40 days. How long did it take for the pond to be half covered in lily pads?

Answer: _____

- ★★ 5. Look at the graph below. The point (5, 12) has a circle around it, and the point (12, 12) has a box around it. The first number in parenthesis shows how far to go horizontally to find the point, and the second number shows how far to go vertically to find the point. Follow these directions exactly and you should have a word spelled out. Make your lines very heavy, or use a different color, so the lines will stand out against the grid.

Put a big dot at (3, 3).

Connect (16, 7) to (16, 3).

Connect (14, 7) to (14, 3).

Connect (16, 5) to (14, 5).

Connect (7, 3) to (7, 7) to (5, 7) to (5, 5) to (7, 5).

Connect (3, 7) to (3, 4).

Connect (8, 3) to (10, 3) to (10, 7).

Connect (11, 7) to (13, 7) to (13, 3) to (11, 3).

Connect (12, 5) to (13, 5).

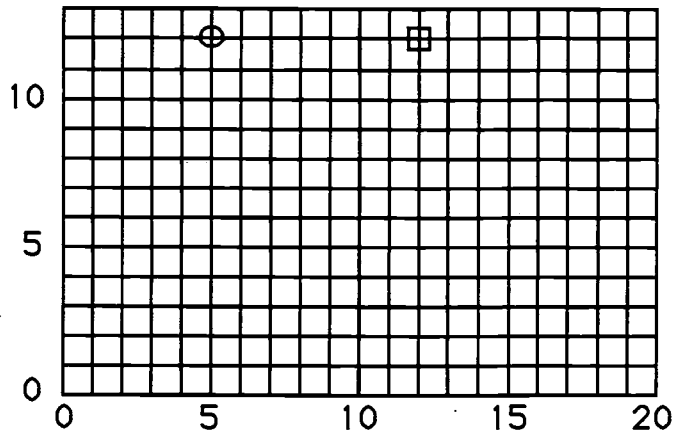

What word is spelled out? _____

- ★★ 6. Bob and Alex live in Pensacola, and they want to visit their aunt who lives in Miami. On the way, they want to stop and visit their cousins in Jacksonville. They need to calculate the distance they will travel from Pensacola to Miami, stopping in Jacksonville. On a map, the scale of miles shows that 1 cm represents 50 miles. Pensacola to Jacksonville is 7 cm, and Jacksonville to Miami is 6.5 cm. How many miles will they travel?

Answer: _____ miles

- ★★★★ 7. Name a ten-digit number such that:

The first digit on the left tells how many *zeros* are in the number.
 The second digit from the left tells how many *ones* are in the number.
 The third digit from the left tells how many *twos* are in the number.
 The fourth digit from the left tells how many *threes* are in the number.
 The fifth digit from the left tells how many *fours* are in the number.
 The sixth digit from the left tells how many *fives* are in the number.
 The seventh digit from the left tells how many *sixes* are in the number.
 The eighth digit from the left tells how many *sevens* are in the number.
 The ninth digit from the left tells how many *eights* are in the number.
 The tenth digit from the left tells how many *nines* are in the number.

Answer: _____

Commentary

Uranus, XIII

1. (a. see below; b. 55; c. 385) Each building in the pattern adds on the square of the "building number" of cubes. The 5th building would add 25 more cubes, the 6th would add 36, and so on. The cubes needed for Building 10 would therefore be $10^2 + 9^2 + \dots + 1^2 = 385$.

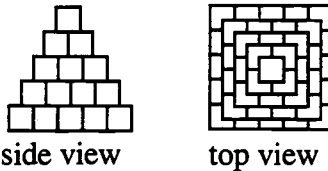

2. (94) An average of 90 on 4 tests means the sum of the four was $4(90)$ or 360. Subtracting the three known tests from 360 leaves 94, the score for the fourth test.
3. (a. 19.99; b. 0) For (a), think of $9 \frac{3}{5}$ as 9.6 and compute on a calculator. For (b), change all of the fractions to denominator 24, and the numerators will sum to zero.
4. (39 days) Students are tempted to take half of 40 days, and report 20 days. However, if the pond was half-covered on day 20, on day 21 it would be completely covered because the water lilies double in size each day.
5. (HELP! is spelled out backwards.)

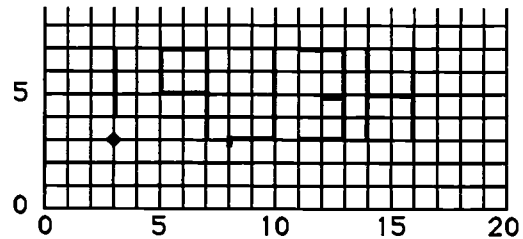

6. (675) The trip from Pensacola to Jacksonville is 7 cm or 7×50 miles which is 350 miles. The trip from Jacksonville to Miami is 6.5 cm or 6.5×50 miles which is 325 miles. The sum of the two is 675 miles.
8. (6,210,001,000) The way students will solve this problem is to guess-check-revise, likely starting at the left end with the guess 9,000,000,000. But this isn't quite right because it doesn't indicate there's 1 nine. So you alter the number to 8,000,000,001. But this has no 9 now, but it does have an 8, so you adjust again to 8,000,000,010. But, now there's a 1 in the number, which isn't accounted for. You continue to adjust the number in this fashion, working on both the right and left-hand ends, toward the middle. After much erasing, you get the answer above. Students will do much better if they make 10 blanks in ink, and write in numbers they can erase in pencil. It also helps to place below each blank what the digit represents, as below:

0's	1's	2's	3's	4's	5's	6's	7's	8's	9's

SUPERSTARS III

Uranus, XIV

Name: _____

(This shows my own thinking.)

- ★★★ 1. Carla sold lemonade at the school fair. She had only two sizes of cups: 5 oz. and 8 oz. Her friend Josie wanted to buy exactly 2 oz. How did Carla measure out 2 oz. of lemonade?

For the correct answer, arrange these steps in proper order by writing 1st, 2nd, 3rd, 4th, or 5th in the blanks beside the statements.

- _____ Pour its contents into the 8 oz. cup.
_____ 2 oz. will remain in the 5 oz. cup.
_____ Fill the 5 oz. cup.
_____ Pour its contents into the 8 oz. cup until the large cup is filled.
_____ Re-fill the 5 oz. cup.

- ★★ 2. Alison needs to add a liquid vitamin to her horse Bobo's food. The directions on the bottle say to add 7 mL per 25 pounds of the animal's body weight. If Bobo weighs 750 pounds, how much vitamin supplement should she add?

Answer: _____ mL



- ★★★ 3. Rounded to the nearest whole percent, what percent of the hexagon is each of the lettered parts?

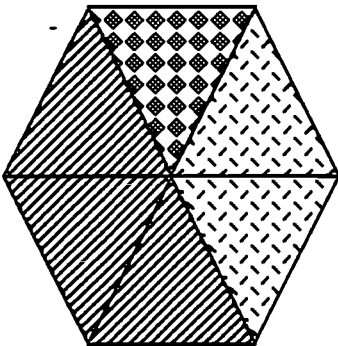

Answer: A = _____

B = _____

C = _____

- ★★ 4. Eight girls are sitting at a table. Five are wearing sweaters, three are wearing coats, and two are wearing both sweaters and coats. How many girls are not wearing a coat or a sweater?

Answer: _____

- ★★★ 5. Three squares have been made from 12 pencils below. Show how to move only three of the pencils, and make four squares this same size.

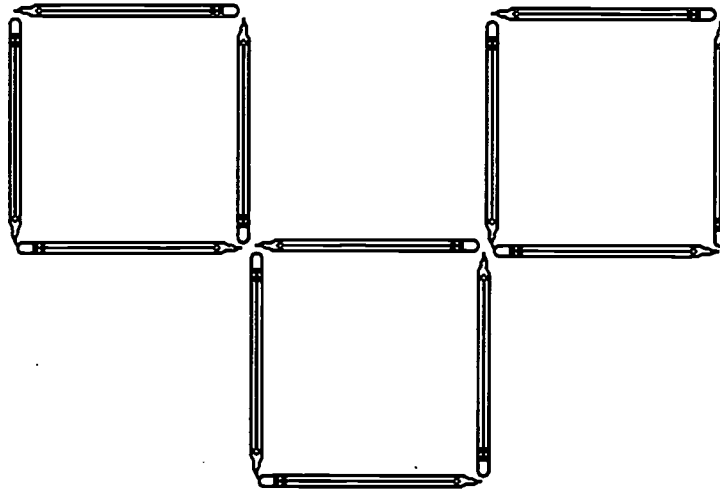

- ★★★★ 6. The scale below shows three helium balloons attached to a scale with two cans of unknown weight x . The helium balloons pull *up* on the scale, and so have a negative weight which has previously been measured as -5 because each one exactly balances a 5-gram weight. The cans push *down* on the scale and so have a positive unknown weight. Use your ingenuity to find the weight of one can.

Answer: $x =$ _____ grams

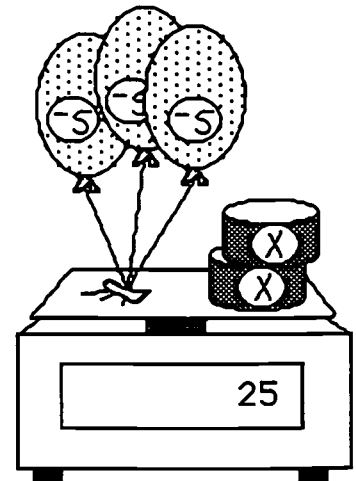

- ★★ 7. One gum ball costs 2 cents. The gum balls come in six different colors. What is the most money you would need to spend to ensure you get 3 gum balls of the same color? _____

Commentary

Uranus, XIV

1. (a. 2nd b. 5th c. 1st d. 4th e. 3rd) Students can draw a picture to help them think through this problem.
2. (210) $750 \div 25 = 30$, meaning that Bobo weighs 30 times as much as 25 pounds, and so needs 30 times 7 mL of vitamin.
3. (A = 50%; B = 17%; C = 33%) Three of the six equal-size regions are shaded like A, giving half or 50%. One region is shaded like B, and $1/6 = 1 \div 6 = 0.17$ when rounded, or 17%. Two out of six are shaded as C, so $1/3$ of the figure is like C -- this is 33 1/3 %, but this is 33% when rounded.
4. (2) A Venn diagram helps students see the situation. It's usually helpful to work from the overlap area toward the outside.

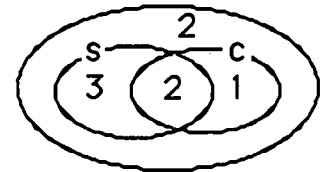

5. (See below.) Move three of the pencils on either of two ends.

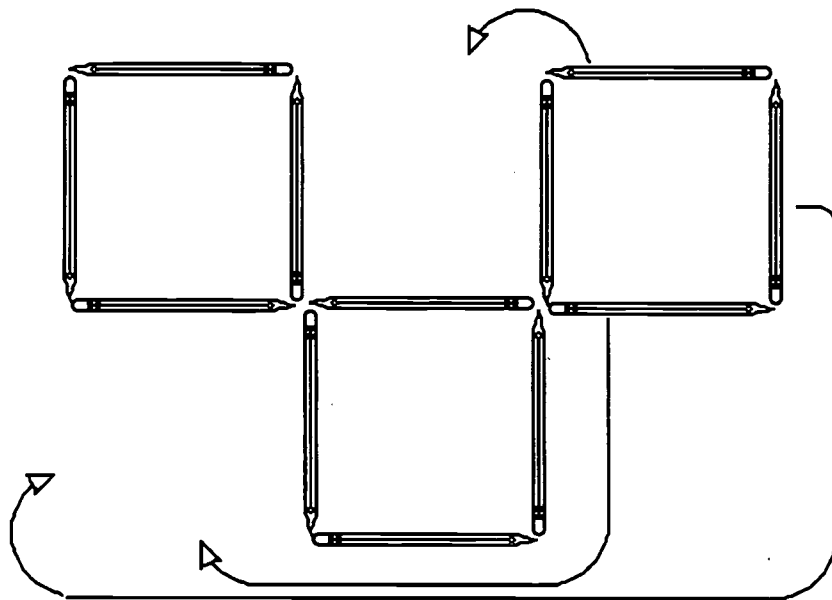

6. (20) If the helium balloons are removed from the scale, it will read 15 grams more than it does at present. Therefore the two cans by themselves would have a reading of $25 + 15$ or 40 grams. Then each can would weigh half of that amount or 20 grams. An equation for this situation is $2x + -15 = 25$.
7. (26¢) It's possible that the first 12 gum balls you get will result in two gum balls of each of the six colors; however, the next time you must get a gum ball that matches two others.

SUPERSTARS III

Uranus, XV

Name: _____

(This shows my own thinking.)

★★★ 1. Answer these questions about the graph.

a. How much does it cost for a 5-year old to go to a movie? _____

b. How much does it cost a 15-year old to go to a movie?

c. How much does it cost a senior citizen to go to a movie? _____

d. How much would it cost for a father and his 8-year old twins to go to a movie? _____

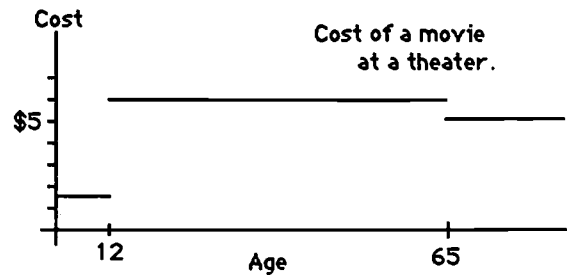

★★ 2. Karen has 20 coins worth \$1.35. The coins are all nickels and dimes. How many of each coin does she have?

Answer: _____ nickels

_____ dimes

★★★ 3. Five campers agreed to "share the lookout" one night. They divided the time between bedtime (9:00 PM) and sunrise (5:30 AM) into five equal time intervals. Give the resulting times below.

1st watch: 9:00 PM until _____

4th watch: _____ until _____

2nd watch: _____ until _____

5th watch: _____ until _____

3rd watch: _____ until _____

★ 4. The students at Harry's school are going to take a field trip. There are 487 students and 45 can ride on each bus. How many buses are needed for the field trip? Circle your answer.

a) 12 buses

b) 10 buses

c) 11 buses

- ★★★★ 5. A rectangle and a regular octagon share a common side. If the length of the rectangle is twice its width and the perimeter is 36 cm, what is the perimeter of the octagon?

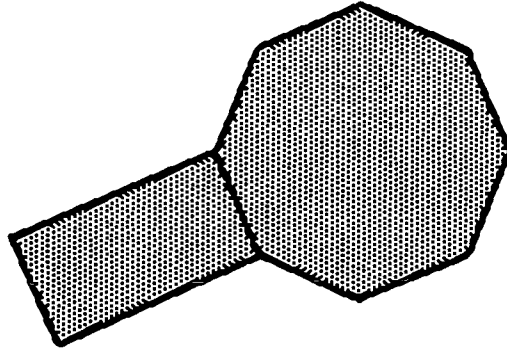

Answer: _____ cm

- ★★ 6. Marcus has 3 red marbles, 9 white marbles, and 4 green marbles. He wants to divide all the marbles evenly into two jars, but he only wants two colors in each jar. How can they be divided?

Answer: _____

- ★★★★ 7. The graph below shows the balance in Jeremy's savings account for 1995.

a. What was happening to Jeremy's account during the spring months?

answer: _____

b. What are two months when the savings dropped by \$10 at the end of the month?

answer: _____ and _____

c. Between what two months did the biggest change occur?

answer: _____ and _____

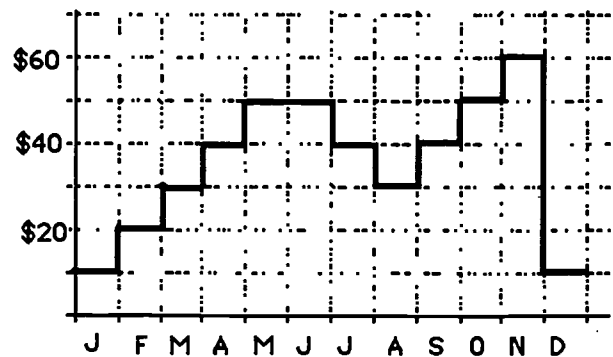

- ★★ 8. Larry's ice cream shop has chocolate macadamia nut ice cream, rocky road ice cream, and strawberry cheesecake ice cream. They also have sugar cones and waffle cones. How many different double-dip ice cream cones can they make from these selections?

Answer: _____

Commentary

Uranus, XV

1. **(a. \$1.50; b. \$6.00; c. \$5.00; d. \$9.00)** The problem involves reading the graph for the different age groups. For (d), note that a father would have to be in the middle group to have 8-year old twins. The cost would therefore be $\$6.00 + \$1.50 + \$1.50$.
2. **(13 nickels and 7 dimes)** Students might make an organized list of the possible number of dimes and nickels to have 20 altogether, and check out which combination totals \$1.35. Other students might simply guess-check-revise, perhaps starting with ten of each coin, and revise the guess since the total value would be \$1.50 which is too much. More nickels and fewer dimes are called for.
3. **(10:42; 12:24; 2:06; 3:48; 5:30)** Most students will count up to see that there is 8 1/2 hours to be divided, and convert that into 510 minutes. This means each camper will have 102 minutes to stay awake, which is 1 hour, 42 minutes. Students will then add 1:42 to 9:00, then again to the result, and so on.
4. **(11)** Students who divide 487 by 45 will get 10 buses with 37 students left over. Eleven buses will be needed to transport all the students.
5. **(48 cm)** The perimeter of the rectangle would be given by $w + 2w + w + 2w$. This means that $6w = 36$ cm, implying $w = 6$ cm. If $w = 6$ cm, then the perimeter of the octagon would be 8 times 6 cm or 48 cm.
6. **(3 red and 5 white in one jar; 4 white and 4 green in the other)**
7. **(a. His savings was increasing. b. June and July; c. November and December)** The problem involves reading the graph carefully at its critical points where the values change. This is called a "step graph".
8. **(12)** Students might want to label the ice cream A, B, and C, and the cones 1 and 2. Then assuming the order of the ice cream matters (i.e., A on top of B is different from B on top of A), there are six ways to combine A, B, and C two at a time: AB, AC, BA, CA, BC, CB. These six ways can go with either cone 1 or 2, giving 12 choices altogether.
(18) If a double dip of the same flavor can be considered, then students would add AA, BB and CC times two to the above solution.

SUPERSTARS III

Uranus, XVI

Name: _____

(This shows my own thinking.)

- ★ 1. The number described by these clues can be found in the grid below. Circle the number.

- a) It is greater than $588 \div 3$.
b) It is odd.
c) It has a ones digit and tens digit whose sum is 6.

144	324	214
304	233	323
151	342	123

- ★★★ 2. Mrs. Circle has a class of 30 students. For every three girls in the class there are 2 boys. How many boys are in the class?

Answer: _____ boys

- ★★ 3. The picture shows a pattern for making a polyhedron. If you could cut this out and fold it up, what is the name of the polyhedron you would make?

Answer: _____

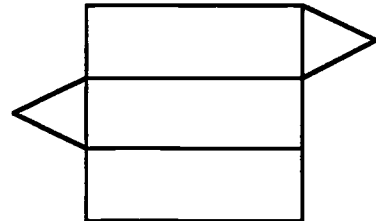

- ★★ 4. The cheerleaders are making lapel ribbons to sell at the Friday night football game. Each lapel ribbon requires $\frac{1}{4}$ yard of ribbon. They have 60 yards of ribbon with which to make new lapel ribbons. In addition they have 10 ribbons left from last week's game that they did not sell. All together how many ribbons will they have to sell at this Friday's game?

Answer: _____

- ★★ 5. In how many different ways can 4 books be arranged on a shelf?

Answer: _____ ways



- ★ 6. Examine this set of numbers to see what they have in common. Then write the next 3 numbers in the set.

2, 3, 5, 7, 11, 13, 17, _____, _____, _____,

- ★★★ 7. Dorothy, Jake, Vicky, Otis, and Nick wore red, blue, yellow, purple, and green jackets. They collected spiders, marbles, hammers, fish, and watches. No two people wore the same color or had the same collection. Use these clues to match the people to the color of their jackets and their collections.

- a) The boy in the green jacket collects spiders.
- b) A girl who collects marbles has a yellow jacket.
- c) Nick's favorite color is red and he always knows what time it is.
- d) Jake's mother is always picking up rocks and putting them in fish bowls.
- e) Dorothy collects hammers and hates the color blue.

NAME	JACKET	COLLECTION
DOROTHY		
JAKE		
VICKY		
OTIS		
NICK		

- ★★ 8. The letters S, T, and U have been left out of the sequence of letters below. Write each in its correct place above or below the line.

A
EF
HI
KLMN
VWXYZ

BCD
G
J
OPQR

- ★★★★ 9. You have three bottles -- a 10-liter, a 4-liter and a 3-liter. All of the bottles are unmarked and there is no other supply of water available. The 10-liter bottle is full. You want to divide the water in such a way as to have one liter of water in the 3-liter bottle, four liters in the 4-liter bottle and five liters in the 10-liter bottle. You can do this by pouring the water from one bottle to another. What is the fewest number of pourings that will achieve this division of the water?

Answer: _____ pourings

Commentary

Uranus, XVI

1. (233) As you read each clue, mark out those that do not fit the clue. $588 \div 3 = 196$, so mark out 144, 151, and 123. Mark out the even numbers 324, 214, 304, and 342. Now 233 and 323 remain. In 233 the tens digit and ones digit have a sum of 6.
2. (12) Girls and boys are in the class in a ratio of 3:2. So 2 out of every 5 students in the class are boys. $\frac{2}{5}$ of 30 = 12.
3. (triangular prism) Some students might want to trace over the figure, and cut it out and fold it up to see the triangular prism.
4. (250) $60 \div \frac{1}{4} = 60 \times \frac{4}{1} = 240$; $240 + 10 = 250$.
5. (24) $4! = 4 \times 3 \times 2 \times 1$. Another approach is to make an organized list. Label the books A, B, C, and D, and list the combinations.

ABCD	BACD	CABD	DABC
ABDC	BADC	CADB	DACB
ACBD	BCAD	CBAD	DBAC
ACDB	BCDA	CBDA	DBCA
ADBC	BDAC	CDAB	DCAB
ADCB	BDCA	CDBA	DCBA

6. (19, 23, 29) This is the set of prime numbers.
7. (Dorothy -- purple, hammers; Jake -- blue, fish; Vicky -- yellow, marbles; Otis -- green, spiders; Nick -- red, watches) Students may wish to make a logic chart to help them organize information. They could use the given chart, add in letters to represent the colors and collections, as shown below, and proceed by marking out impossibilities indicated by the clues and circling things they know. Process of elimination usually comes into play in these problems in that once you know a given fact, such as Nick's jacket being red from clue (c), you can cross out red everywhere else.

	Jacket	Collection
Dorothy	r b y p g	s m h f w

8. (T) All letters above the line are made of straight lines. Those below the
 S U lines have some curved lines.

9. (5)

10 L	4 L	3 L	
10	0	0	start
6	4	0	after filling the 4-liter from the 10-liter
6	1	3	after filling the 3-liter, from the 4-liter
9	1	0	after pouring what's in the 3-liter into the 10-liter
9	0	1	after pouring what's in the 4-liter into the 3-liter
5	4	1	after refilling the 4-liter from the 10-liter

SUPERSTARS III

Uranus, XVII

Name: _____

(This shows my own thinking.)

- ★ 1. The star at the right is a "magic star."
All fractions in each straight line have the same sum. What is the magic sum?

Answer: _____

- ★ 2. Add the fractions at the corners of the two large triangles. First, add the fractions $\frac{1}{2} + \frac{13}{16} + \frac{9}{16}$. Next, add $\frac{11}{16} + \frac{7}{16} + \frac{3}{4}$.

What is the magic sum?

Answer: _____

- ★ 3. Finally, add the fractions at the corners of small triangle A: $\frac{1}{2} + \frac{5}{16} + \frac{1}{4}$. Then add the fractions at the corners of each of the triangles marked B, C, D, E, and F. What is the sum?

Answer: _____

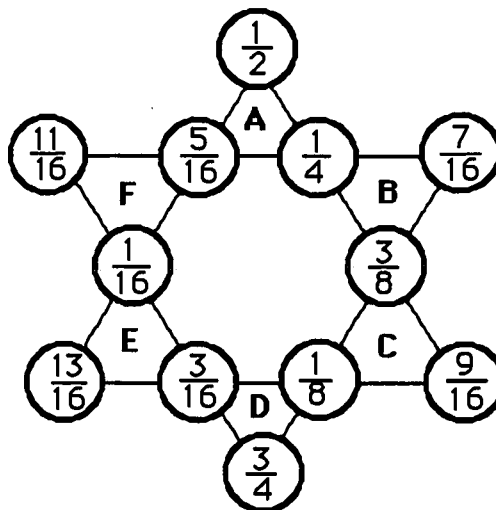

- ★★★★ 4. Replace the letters $a - j$ with the digits 0 - 9 to make each of these equations true. You may use each digit only one time.

a) $a \div 2 + 5 = 8$

b) $6(b - 8) = 6$

c) $8 \div (c + 4) = d$

d) $6 + e \times f = 30$

e) $2(g - h) = 10$

f) $3i + j = 15$

$a = \underline{\quad}$; $b = \underline{\quad}$; $c = \underline{\quad}$; $d = \underline{\quad}$; $e = \underline{\quad}$; $f = \underline{\quad}$;

$g = \underline{\quad}$; $h = \underline{\quad}$; $i = \underline{\quad}$; $j = \underline{\quad}$

- ★★★ 5. Rhonda went to a party where they were drawing marbles out of a box for prizes. The player wins if she draws out a black marble on the first draw. Circle the box below that would give Rhonda the best chance of winning.

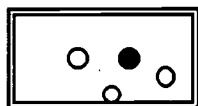

A

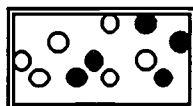

B

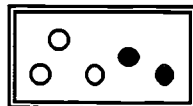

C

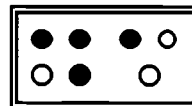

D

- ★ 6. Mrs. Walker bought a board 30 inches long for a class project. She needs to cut it into 1-inch pieces so that each student in her class will have a piece. How many cuts are required?

Answer: _____ cuts

- ★ 7. Joaquin made the figure below by stacking up centimeter cubes. The figure looks this same way when viewed from the back side. What is the volume of the figure?

Answer: ____ cubic centimeters

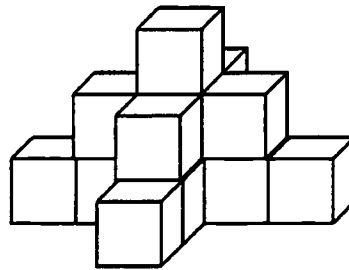

- ★ 8. Fill in the blanks in the numbers below with the largest digit possible to make each statement true.

a) 4, __ 2 3 is divisible by 3. b) 2 __, 9 3 6 is divisible by 9.

- ★★★ 9. The "unit fractions" are those whose numerator is 1, such as $\frac{1}{2}$, $\frac{1}{3}$, $\frac{1}{4}$, $\frac{1}{5}$, $\frac{1}{6}$ and so on. Find three different unit fractions whose sum is a whole number.

Answer: _____

- ★ 10. Jessie's total score after 3 games of bowling was 456. If she scored 132 in the fourth and final game, what was her average score per game?

Answer: _____

Commentary

Uranus, XVII

1. ($\frac{27}{16}$ or $1\frac{11}{16}$) Students can choose any line and add the four fractions found there.
2. ($\frac{15}{8}$ or $1\frac{7}{8}$) Accept alternate answers from students which are not in lowest terms: $\frac{30}{16}$ or $1\frac{14}{16}$
3. ($\frac{17}{16}$ or $1\frac{1}{16}$) The sum should be the same for each of the six triangles.
4. (a = 6; b = 9; c = 4; d = 1; e = 3; f = 8; g = 7; h = 2; i = 5; j = 0) Note that e and f may be switched.
5. (D) The probability of getting a black marble in the boxes is:
a) $\frac{1}{4}$ b) $\frac{5}{11}$ (c) $\frac{2}{5}$ d) $\frac{4}{7}$
Box D would be the best choice since $\frac{4}{7}$ is greater than any of the other fractions. Students can decide this by placing them all over a common denominator, or by using a calculator and dividing the numerator by the denominator. Another easy way is to note that $\frac{4}{7}$ is the only fraction greater than $\frac{1}{2}$, and therefore has to be the largest.
6. (29) Drawing a picture helps to solve problems such as this. The last cut produces 2 pieces.
7. (15) Students can find this volume by counting, but must realize that there are 3 cubes on the "back side" which are not fully visible. The clue in the problem says that the figure looks the same from the back.
8. (a. 9; b. 7) For part (a) to be divisible by three, the sum of the digits must be a multiple of three. For part (b) to be divisible by nine, the sum of the digits must be a multiple of nine. Another easy way to approach both problems, without using the rules of divisibility, is to use a calculator and begin by inserting 9 into the blank space for (a), and see if you get a whole number answer when dividing by 3. If not, try 8 in the blank. Proceed in this fashion until you have the largest digit that can be substituted, which results in a whole number answer. The same process works for (b) except you divide by 9.
9. ($\frac{1}{2}$, $\frac{1}{3}$, $\frac{1}{6}$) Other answers are possible.
10. (147) Adding 132 to 456 gives the total number of points, 588. Divide 588 by four to get the average, 147.

SUPERSTARS III

Uranus, XVIII

Name: _____

(This shows my own thinking.)

- ★★ 1. Hickory, dickory, dock
The mouse ran up the clock.
The clock struck four
The mouse ran down.
Hickory, dickory, dock.



If the clock strikes only on the hour, how many times will the clock strike before it strikes only four times again?

Answer: _____

- ★ 2. What is the prime factorization of the number 30?

Answer: _____

- ★★ 3. How many blocks are in the picture if each block sits on another and there are no hidden spaces?

Answer: _____ blocks

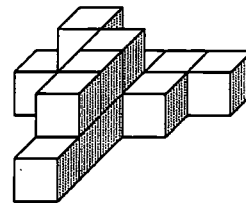

- ★★ 4. Dan is painting letters on the side of a model truck. The letters on the real truck are 40 inches high. The model is $\frac{1}{20}$ the size of the truck. How high should Dan make the letters on the model?

Answer: _____

- ★★ 5. According to the *Guinness Book of World Records*, Michel Lotito is the world champion eater of metal and glass. Since 1966, he has eaten 10 bicycles, 7 TV sets, a Cessna airplane, and a metal coffin, among other things.

His doctors say he can eat up to 2 pounds of metal a day. At this rate, how long would it take him to eat a small car which weighs about 1 ton?

Answer: _____ years and _____ days

Commentary

Uranus, XVIII

1. (74) $5 + 6 + 7 + 8 + 9 + 10 + 11 + 12 + 1 + 2 + 3 = 74$
2. ($2 \times 3 \times 5$) Students may draw a factor tree to determine the prime factorization. Such a tree is not unique, but gives a unique answer.
3. (14) 10 blocks are in the bottom layer and 4 are in the top layer.
4. (2 inches) Since the model is $1/20$ the size of the truck, the letters should be $1/20$ the size of the original letters. Computing $1/20$ of 40 gives 2.
5. (2 years, 270 days) One ton is 2000 pounds, so eating 2 pounds a day means it takes $2000 \div 2$ or 1000 days. At 365 days a year, 2 years would be 730 days. $1000 \text{ days} - 730 \text{ days} = 270 \text{ days}$.
6. (♥) The pattern involves a club and a heart. The club appears in this fashion: 1, 2, 3, 4, while the heart appears as 2, 2, 2, 2, and separates the clubs. The pattern then becomes one of: $1 + 2 + 2 + 2 + 3 + 2 + 4 + 2 + 5 + 2 + \dots$ until you get to or past 100. With a calculator, you get exactly to 100 when you add 12 from the preceding pattern; the 12 indicates you are in the club part of the pattern. Therefore the 101st term is a heart.
7. (20,736) $12 \times 12 = 144$; $144 \times 12 = 1728$; $1728 \times 12 = 20,736$ or $12^4 = 20,736$
8. (a=28.92604 b=3.85) For (a), round off the numbers mentally to 7 and 4 and multiply. For (b), 0.98 is almost 1. Any number divided by 1 is the same number.
9. (55) The helium balloon on the left scale must be "pulling up" with the power of a 15-gram pull, since it and 25 grams balances 10 grams. Therefore we can consider its weight as -15 grams. On the right-hand scale the two balloons would have a weight of -30 grams; the bag of groceries must then have a weight of 55 grams, so that the groceries and balloons together cancel out 25 grams. These situations are expressed mathematically as:
$$-15 + 25 = 10 \quad \text{and} \quad -15 + -15 + x = 25, \text{ so } x = 55.$$

Note: it's easy for students to see that, when you have a helium balloon that "pulls up" on a scale as -15 grams, the balloons can be replaced on the other side of the scale by a positive weight of that amount. (i.e., -15 can be "moved over" to +15 on the other side of the scale.)
10. (KX) Line up letters of the alphabet and divide them in half. A starts off the first half and N starts off the second half. B and O are next in the two sets; skip 1 letter to get D and Q; skip 2 letters for G and T; skip 3 letters to get K and X. The terms also alternate from upper case pairs to lower case pairs.

SUPERSTARS III

Uranus, XIX

Name: _____

(This shows my own thinking.)

- ★ 1. A football player ran from his own 38-yard line to the other team's 40 yard line. How long was his run?

Answer: _____ yards

- ★★ 2. Ryan can walk to school in $\frac{6}{15}$ of an hour. When he rides his bike, he can get there in 8 minutes. Can Ryan get to school quicker by walking or by riding his bike? How many times faster?

Answer: a) Ryan can get to school faster by _____.

b) _____ times faster.

- ★★★★ 3. Look at the equations to the right:

A, B, C, and D are whole numbers.

$$A \times B = 24$$

$$A + B = 14$$

$$C \times D = 48$$

$$A \times D = 192$$

$$B \times C = 6$$

What number is A? _____ What number is B? _____

What number is C? _____ What number is D? _____

- ★★★ 4. Start as shown. Draw only 4 straight lines to connect all 9 dots. Do not lift your pencil until all the dots are covered.

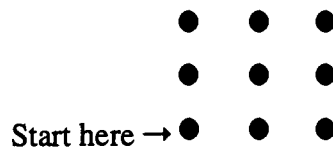

- ★★★ 5. Maria and Sarah are cutting strips of fabric for streamers to use in the P.E. show. Each strip needs to be $2\frac{1}{4}$ inches wide. How many strips can they cut from 6 feet of fabric if they cut from selvage to selvage?

Answer: _____ strips can be cut.

- ★★ 6. Write the missing digits in the problem:

$$\begin{array}{r}
 \square \square \\
 19 \overline{) \square 3 \square} \\
 \underline{\square \square} \\
 \square \square \\
 \underline{\square \square} \\
 \square \square \\
 \underline{\square \square} \\
 0
 \end{array}$$

- ★★★★ 7. Assume the area of the big square is 36 cm^2 . Name the areas of the parts described.

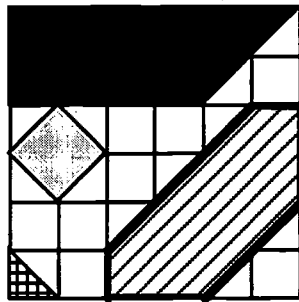

Black region: _____ cm^2
 Dotted region: _____ cm^2
 Striped region: _____ cm^2
 Crossed region: _____ cm^2

- ★★ 8. If you shot 3 arrows at this target and all 3 arrows hit the bull's eye, you would score 15 points.

If exactly 3 arrows hit this target, how many different total scores are possible?

Answer: _____

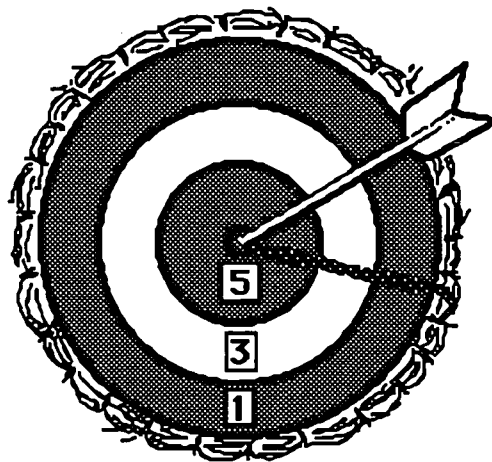

Commentary

Uranus, XIX

1. **(22 yards)** From the 38 to the 50-yard line is 12 yards, and from the 50 to the 40-yard line is another 10, and $10 + 12 = 22$.
2. **(a. bike; b. three times faster)** The $\frac{6}{15}$ of an hour Ryan spends walking is $\frac{6}{15} \times 60$ minutes, or 24 minutes. Riding his bike takes 8 minutes.
3. **(A = 12; B = 2; C = 3; D = 16)** Students can solve for A, B, C, and D by *guess-check-revise*. They would look at factors of 24, 48, 6 and 192 that “work out” in the equations, when used together. The first and second equations together tell you that A and B should be 12 and 2.
4. **(See right.)** Many students will miss this problem because they fail to go outside the “invisible boundary lines” that the brain places on the figure because of the dots arranged in a square.

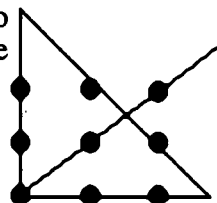

5. **(32)** Six feet is 12×6 inches, or 72 inches. This amount divided by $2\frac{1}{4}$ inches can be done using fractions ($72 \div 2\frac{1}{4} = 72 \div \frac{9}{4} = 72 \times \frac{4}{9} = 8 \times \frac{4}{1} = 32$). It can also be done by converting $2\frac{1}{4}$ inches to 2.25 inches and dividing using decimals or using a calculator.

6. **(See right.)** Successful students will probably start at the end of the problem, multiplying 19×3 to get 57, and working up the problem, bottom to top.

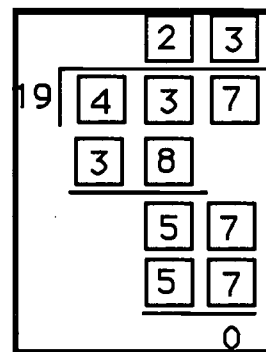

7. **(Black: 10; Dotted: 2; Striped: $9\frac{1}{2}$; Crossed: $\frac{1}{2}$)** Students might be more successful if they draw in the grid lines and count squares and half-squares.
8. **(7 scores)** There are 10 possible ways the arrows could land: (1,1,1); (1,1,3); (1,1,5); (1,3,5); (1,3,3); (1,5,5); (3,3,3); (3,3,5); (3,5,5); and (5,5,5). However, these only produce these seven scores: 3, 5, 7, 9, 11, 13, and 15.

SUPERSTARS III

Uranus, XX

Name: _____

(This shows my own thinking.)

- ★★ 1. I am a four-digit number.
All of my digits are *odd* numbers.
Each of my digits is different.
My *thousands* digit is the smallest counting number.
My *tens* digit is less than my units or hundreds digit.
The sum of my first and last digits is the same as the sum of my two middle digits.
What number am I?



- ★★★ 2. Karen's company needed to reduce its expenses. Her salary was cut by 10%. Later her company decided to give her a raise. By what percent must her salary then be raised to bring it back to the original amount?

Answer : _____ percent

- ★ 3. What math symbol can be placed between the 2 and the 3 in "23" to make a number greater than 2 but less than 3?

Answer: _____

- ★★ 4. A spaceship launched from Earth was in orbit for $29\frac{1}{2}$ days. What is the closest estimate for the number of hours it was in orbit? Circle your answer.

a) 700 hours b) 750 hours c) 650 hours

- ★ 5. The sixth grade math club gave this problem to its members to solve:

$$\boxed{13.6} + \boxed{2.7} - \boxed{4.8} \times \boxed{1.7} + \boxed{0.11} \Rightarrow \boxed{}$$

Solve the problem for them by writing the correct answer in the box. But don't forget "My Dear Aunt Sally" or you'll miss it!

- ★★ 6. Number each of the eight corners on the cube from 1 to 8 so that the sum of the four numbers at the corners of each face is 18.

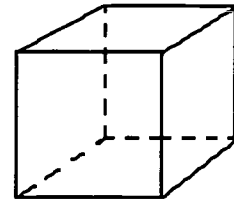

- ★★★ 7. The telephone company has 16 computer-controlled switching systems. Each system handles 650,000 calls *an hour*. The systems work with 98% accuracy. How many calls would not be accurately answered in *a day*?

Answer: _____ calls

- ★★ 8. There are two ways you can make change for a dollar bill using exactly 50 coins. How many of each coin would you use for each way? Write your answers in the chart below.

	pennies	nickels	dimes	quarters	half dollars
first way:					
second way:					

- ★★★ 9. The designs below are called *one-drawable*. This means you can draw them with one continuous line without lifting your pencil or retracing a line, if you start in the right place.

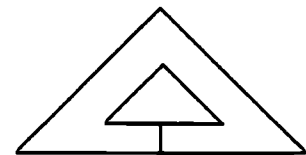
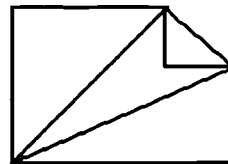
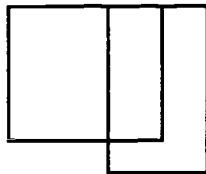

Which of the designs below are *one-drawable*? Circle your answers.

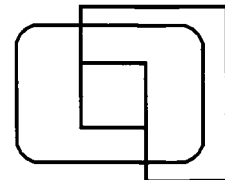
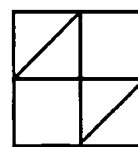
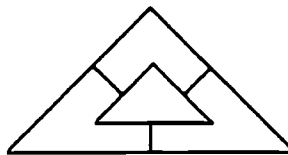
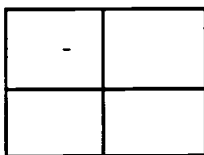

Commentary

Uranus, XX

1. **(1537 and 1739)** Start by placing a 1 in the thousands place. They can then *guess-check-revise* to find that the other digits are 5, 3, and 7 or 7, 3, and 9.
2. **(11.1%)** Accept 11% also. To solve this problem, students might suppose the original salary was \$100. Then after the decrease of 10%, she's making \$90. To get back to \$100, the salary must increase by \$10 -- the question is -- what percent of \$90 is \$10? $\$10 \div \$90 = 0.111\dots$, which is 11.1%.
3. **(a decimal point)** A decimal point changes "23" into "2.3" which is between 2 and 3.
4. **(700 hours)** Students might use a calculator to multiply 29.5×24 .
5. **(8.25)** Students can again use a calculator. "My Dear Aunt Sally" is a way to remember the order of operations in mathematics -- first perform all multiplications and/or divisions in order from left to right; then do all additions and/or subtractions in order from left to right. This means that, for this problem, students must compute 4.8×1.7 before subtracting this amount, 8.16, from the sum of 13.6 and 2.7.

6. **(See one solution to the right.)** Students can guess-check-revise to place the numbers at the corners. They might start by placing 8 and 7 on opposite corners and 1 and 2 on the same face with 7 and 8, but also on opposite corners. In that way they have the two largest numbers balanced off by the two smallest numbers.

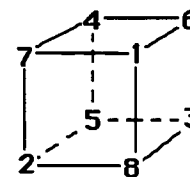

7. **(4,992,000)** The company would incorrectly answer 13,000 calls per hour per system, or 208,000 calls for all 16 systems per hour. Multiply that by 24 hours and the number of incorrectly answered calls in a day is 4,992,000.
8. **(40 pennies, 8 nickels, 2 dimes or 45 pennies, 2 nickels, 2 dimes, 1 quarter)** One key to solving this problem is to realize that most of the coins must be pennies, so start with large numbers of pennies and see if you can make the other coins "fit." Fifty pennies won't work, obviously, so drop back to 45 pennies. After some manipulation, you can see that 2 nickels, 2 dimes, and a quarter give 55¢, which when added to 45¢ gives \$1, and it consists of 50 coins. Try 40 pennies and again you can gain a solution.
9. **(The two figures to the far right should be circled.)** A network is *one-drawable* if it has 2 *odd vertices* or no *odd vertices*. A vertex is odd if it has an odd number of paths going in or coming out. To trace a network with no odd vertices, start anywhere and you'll finish tracing it back at the same point where you started. If it has 2 odd vertices, you can trace it if you start at one of the odd vertices and you'll finish up at the other odd vertex.

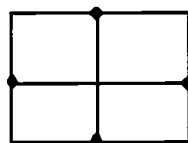

4 odd vertices

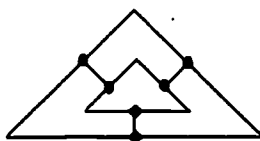

6 odd vertices

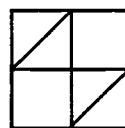

no odd vertices

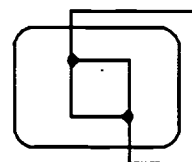

2 odd vertices

SUPERSTARS III

Uranus, XXI

Name: _____

(This shows my own thinking.)

- ★★★ 1. How much change will you get back from a \$5 bill if you order a cheeseburger platter? Sales tax is 5% and is always rounded up to the next penny if necessary.

Answer: _____

Hamburger	\$2.00	fries	.89¢
Cheeseburger	\$2.15	cola	.99¢
Tuna melt	\$2.45	shake	\$1.39
Platter (includes sandwich, fries and cola): add \$1.45 to sandwich price			

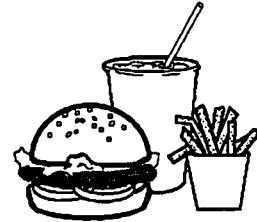

- ★ 2. Iris looked at the sign above, asked for a cola, and gave the clerk a penny and told him to "keep the change." Why was she justified for doing this, mathematically speaking?

Answer: _____

- ★★ 3. Josie's hobby is learning everything about the Presidents of the United States. Her friend Jacque loves math. Jacque posed the following situation to Josie: Find the number of letters in the last name of the third President of the United States. Add the total number of letters in the last name of the President elected in 1796. Now find the prime factors of this number. What is the correct answer?

Answer: _____

- ★★★ 4. The softball team won 70% of its games and won 4 more than it lost. How many games did the team lose?

Answer: _____ games

- ★ 5. What happens to the *area* of the piece of cardboard to the right if its length and width are both doubled? Circle the best answer.

- a. The area doubles. c. The area gets smaller.
b. The area stays the same. d. The area is 4 times as great.

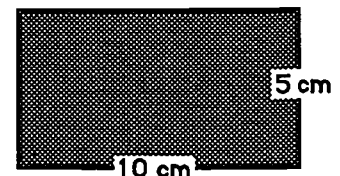

- ★★ 6. Dirk trained his water babies to have tug of war contests. He found that 3 turtles could tug the same as 5 goldfish, and 4 turtles could tug the same as 2 baby ducks. Which team would win between a baby duck and a turtle matched against 4 goldfish? Circle the winners below.

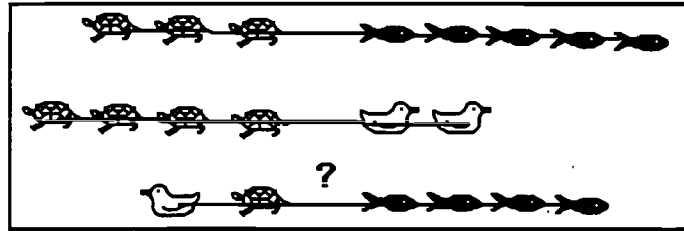

- ★★★ 7. In a gymnastics competition, five judges award scores on a 10-point scale for each event. The high and low scores are discarded before an average score is determined. The judges' scores for Terri's vault at a recent competition were 8.3, 9.0, 8.8, 7.5 and 8.4. What was Terri's score for the vault?

Answer: _____

- ★★★★ 8. Hannah kept track of the new baby elephant at the zoo. At one month the baby weighed 2 kg. At 2 months, he weighed 5 kg. At 3 months, he weighed 14 kg, and at 4 months he weighed 41 kg. Hannah noticed a pattern -- what was her prediction for his weight at 7 months?



Answer: _____ kg

- ★★ 9. Andy weighed his dog, then attached two identical helium balloons to his collar and weighed him again. If he attached a third identical balloon to the dog, what would the scale read? Write the correct answer in the scale.

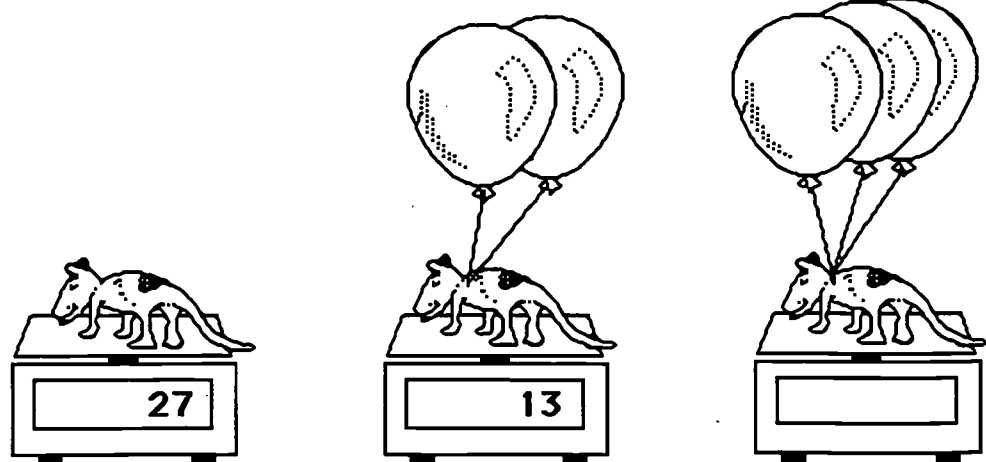

Commentary

Uranus, XXI

1. (**\$1.22**) $\$2.15 + \$1.45 = \$3.60$, and $\$3.60 \times 1.05 = \3.78 gives the price plus tax. This amount subtracted from $\$5.00$ is $\$1.22$.
2. (**The decimal point and ¢ sign together mean the sign implied the price was 99 hundredths of a penny, which is less than a penny.**) This mistake is a very common one in society. Students might want to begin looking for such mistakes by store owners and ask them for their change from a penny. They should keep a sense of humor, however, as most store clerks won't know what they're talking about when they try to explain it.
3. (**3 and 5**) Jefferson has 9 letters and Carter has 6 letters, giving 15 in all. The prime factors of 15 are 3 and 5.
4. (**3**) Students might guess-check-revise on the total number of games played in which they win 70%. A good place to start is with 10 games since it's easy to find 70% of 10. In this case, this guess is correct as they would win 7 games -- 70% of 10 is 7 -- meaning they lose 3 games, and they won 4 more than they lost.
5. (**d**) Students might calculate both areas. The given area is 5×10 or 50 cm^2 ; after the length and width are doubled, the area is 10×20 or 200 cm^2 . Two hundred is 4 times as much as 50. Many students who don't calculate both areas will immediately think the area is doubled.
6. (**duck and turtle**) Students can reason from the second tug-of-war that 1 duck equals 2 turtles in pulling power. So in the first tug-of-war, they can substitute a duck for two turtles and know that a duck and a turtle pull as hard as 5 fish. Then in the bottom tug-of-war, the duck and turtle could outpull 4 fish.
7. (**8.5**) After 7.5 and 9.0 are thrown out, students can find the average of 8.3, 8.8, and 8.4. Some students will add these three numbers and divide by 5 since there were 5 scores at the beginning. But this gives an unreasonable answer of 5.1.
8. (**1094**) The pattern she noticed is to triple the given weight then subtract 1 to get the next month's weight. If you triple 41 and subtract 1, you get 122. Triple that and subtract 1, and you get 365. Triple that and subtract 1, and you get 1094.
9. (**6**) Since the dog alone weighs 27 and the dog with two balloons weighs 13, the two balloons must remove 14 from the dog's weight. This means one balloon would remove half of that, or 7. So three balloons would remove 21, leaving 6. This problem can be thought of as using negative numbers in a real-world situation.

SUPERSTARS III

Uranus, XXII

Name: _____

(This shows my own thinking.)

- ★ 1. What is the difference between twice 50 and twice 7, and twice 57?

Answer: _____

- ★★★ 2. It costs \$1 per cm^2 to add gold plating to a surface. What will it cost to gold plate the shaded region below which is a rectangle with a hole cut in it?

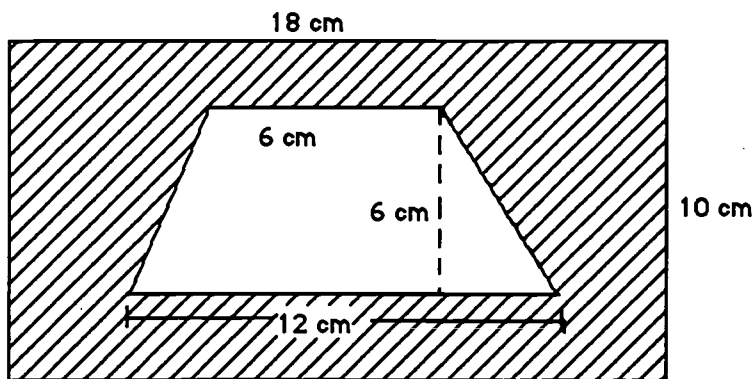

Answer: \$ _____

- ★ 3. A friend tells you that she is thinking of two 2-digit numbers and gives you the following clues. Find the numbers your friend is thinking of.

- The numbers have the same digits, only reversed in position.
- The sum of the digits is 8 in each number.
- The difference between the two numbers is 36.

Answer: _____ and _____

- ★★★ 4. A cube has a volume of 64 cubic inches. If you had to attach "string ribbon" to all of the edges of this cube, how many inches of ribbon would you need?

Answer: _____

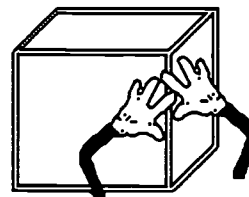

- ★ 5. Try adding these numbers mentally. Look for numbers that go together naturally to give 100, and add them first.

$$45 + 25 + 15 + 55 + 75 =$$

Answer: _____

- ★★★ 6. Consider the pattern of buildings below made from blocks.

- How many blocks would the 4th building require? _____
- How many blocks would the 5th building require? _____
- How many blocks would the 25th building require? _____

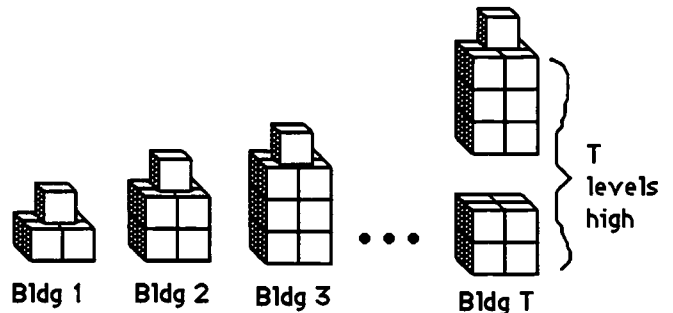

- ★ 7. How many blocks would it take to make building T in the pattern above, where T can be any whole number?

Answer: To make building T , I need this many blocks: _____

- ★★★ 8. In the *Stamps are Beautiful* stamp collecting club, 21 members have stamps from England, 19 members have stamps from Germany, and 11 members have stamps from Australia. Some of these same members have stamps from more than one country. Six have stamps from England and Germany, 4 have stamps from Germany and Australia, and 2 have stamps from England and Australia. No member has stamps from all three countries. How many members are in the *Stamps are Beautiful* stamp club? (HINT: Use the Venn diagram below.)

Answer: _____

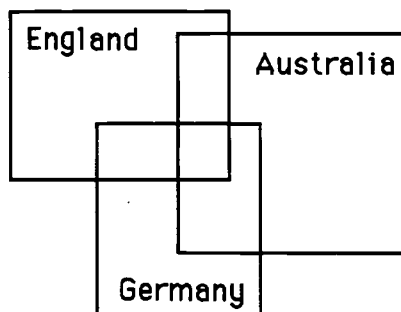

Commentary

Uranus, XXII

1. (0) Twice 50 and twice 7 is $100 + 14 = 114$. Twice 57 is $57 + 57 = 114$ also.
2. (\$126) a) The area of the large rectangle is 18×10 , or 180 cm^2 . The area of the trapezoid is $\frac{1}{2} \times (6 + 12) \times 6$, or 54 cm^2 . The area of the shaded part is then $180 - 54$, or 126 cm^2 .
3. (26 and 62) Students might simply list the 2-digit numbers in which the digits have a sum of 8 and the digits are reversed, and see which of them have a difference of 36. They would try $80 - 08 = 72$; $71 - 17 = 54$; $62 - 26 = 36$; $53 - 35 = 18$; $44 - 44 = 0$.
4. (48) Each edge of a 64 cubic inch cube is 4 inches long. A cube has 12 edges. $12 \times 4 = 48$.
5. (215) $45 + 55 = 100$ $25 + 75 = 100$ $100 + 100 + 15 = 215$
6. (a. 17; b. 21; c. 101) Students can make the first few buildings out of cubes, and they will notice that they have to add four more cubes to get each one in order from the previous building. Parts (b) and (c) almost force them to generalize beyond the "next term" approach to find a formula that does not depend on adding four to the previous building.
7. ($4 \times T + 1$ or $4T + 1$ or $T + T + T + T + 1$) Hopefully students will notice the relationship between the building number and the number of blocks required to make it. Accept any equivalent ways to express this number of blocks using the variable T .
8. (39) In working with Venn diagrams, it is often helpful to work from the inside out. That is, first fill in the number in the overlap area of all the sets, then move to the overlap area of each pair of sets. Finally, determine the number in each set which does not overlap another set.

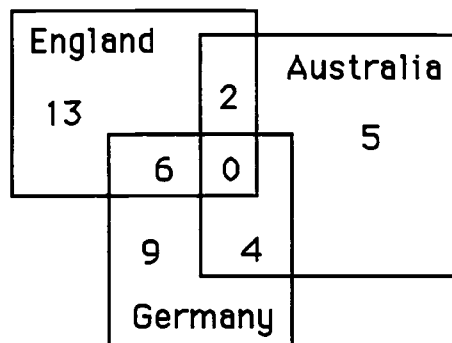

SUPERSTARS III

Uranus, XXIII

Name: _____
(This shows my own thinking.)

- ★★★ 1. You've heard of π and so has the mathematician who designed this new speed limit sign. To the nearest whole number, what is the speed limit here? Circle the best choice below.

- a. 25 mph b. 40 mph
c. 55 mph d. 60 mph
e. 65 mph f. 75 mph

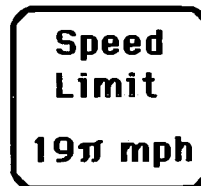

- ★★ 2. A steering wheel is shown below. How many degrees clockwise would you have to rotate this steering wheel before it looks like it's in its original position?

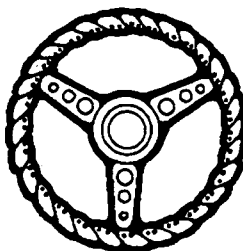

Answer: _____ degrees

- ★★★ 3. Try this number trick on several friends. What is the answer they always get, if they do it correctly?

Answer: _____

Number Trick:

*Take the number of brothers and sisters you have.
Double this number.
Add 4.
Multiply by 5.
Add one.
Subtract 10 times the number of brothers and sisters.*

What is your answer?

- ★★★ 4. If you started counting on April Fool's day at 8:00 AM and counted 1 number a second non-stop 24 hours a day, on what day would you get to 1 million?

Answer: _____

★★ 5. Wayne wrote the months of the year on twelve identical cards and put them in a bag. He told his younger brother to pull one out without looking. If the brother drew out his birthday month, Wayne would do his chores for that month for his present. If his brother pulled out a summer month, Wayne promised to take him along whenever he went to the pool as his present.

a. What is the brother's chance of drawing out his birthday month? _____

b. What is his chance of drawing out a summer month of June, July, or August? _____

★★★ 6. Arrange the digits 1 through 9 in the boxes below so that each row across and each column down has the same total.

□	□	□
□	□	□
□	□	□

★★ 7. There's only one thing wrong with the problem to the right. What is incorrect?

Answer: _____

$$\begin{array}{r}
 3.71 \\
 \times 4.05 \\
 \hline
 405 \\
 2835 \\
 + 1215 \\
 \hline
 1502.55
 \end{array}$$

★★★ 8. Mario wanted to get a tune-up for his bike before an upcoming road trip with his scout troop. The bike shop charges 25¢ to check and tighten each spoke, \$5.00 to tighten and oil the chain, \$8.00 to adjust the gears, and \$1.50 to inflate the tires properly. How much would this tune-up cost him?

Answer: _____

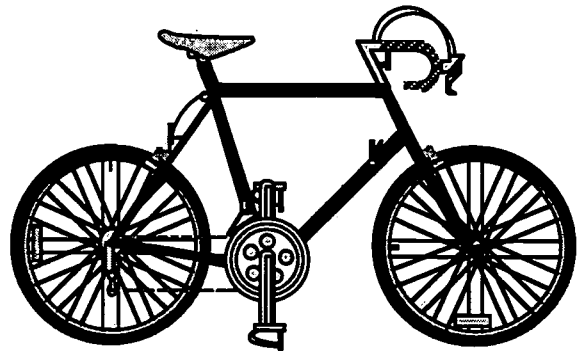

Commentary

Uranus, XXIII

1. **(d. 60 mph)** Pi is 3.14, rounded to two decimal places, and 19π means $19 \times \pi$ or 19×3.14 which is 59.66 or approximately 60.
2. **(120°)** The steering wheel has *rotational symmetry*, which means that it can be rotated and will line up with itself. The spokes of the steering wheel partition the circle into 3 congruent parts, so the angle through which it must be rotated to align itself is $360^\circ \div 3 = 120^\circ$
3. **(21)** Students might be curious as to why this trick works. Let x be the number of brothers and sisters. Doubling x means you have $2x$. Adding 4 gives $2x + 4$. Multiplying by 5 gives $10x + 20$. Adding 1 gives $10x + 21$. Subtracting 10 times the number of brothers and sisters means subtracting $10x$, which gives 21.
4. **(12 April)** It might be helpful to start with how many seconds there are in a 24-hour day which can be computed as $60 \times 60 \times 24 = 86,400$. Then $1,000,000 \div 86,400 = 11.57$. Therefore, in 11.57 days from 1 April, the counting should be over. This would be 12 April, at around 3:00 PM.
5. **(a. 1/12; b. 3/12 or 1/4)** These chances might also be written as percents or decimals.
6. **(One solution is shown below.)** Other arrangements are possible.

4	9	2
8	1	6
3	5	7

7. **(The decimal point should be between "5" and "0" in the answer.)** The only thing incorrect is that the decimal point is in the wrong place in the answer. Some students will say that the person multiplied incorrectly in that the partial products, 405, 2835, and 1215, are wrong. However, this is a legitimate way to multiply as can be seen by reversing the positions of 4.05 and 3.71 and multiplying using the normal algorithm. This should point out to students that there are a number of ways to multiply; however all should produce a reasonable answer, and an answer close to 1,502 isn't reasonable when you multiply two numbers that are each close to four.
8. **(\$30.50)** Every four spokes would cost \$1.00 so the tires on the bicycle shown have 8 groups of 4 spokes on each tire which would cost \$8. For two tires, the spokes would run \$16. Add to that \$5.00, \$8.00, and \$1.50 and you'll get \$30.50.

SUPERSTARS III

Uranus, XXIV

Name: _____

(This shows my own thinking.)

★★★ 1. Solve each problem below. The data comes from the *Guinness Book of World Records*. Round your answers to the nearest whole number.

a. The longest distance travelled by a go-kart in a 24-hour race is 1,018 miles. What was its average speed in miles per hour?

Answer: _____

b. The longest distance travelled by a truck riding on 2 side wheels is 2,864 miles. How far did the other two wheels travel on the trip?

Answer: _____

c. The fastest long-distance drive *backwards* in a car went 501 miles in 17.6 hours. What was the average speed for the car?

Answer: _____

★★★ 2. Tamara forgot to buy candles for her older brother's birthday cake, so she used the ones she had left from a previous birthday. She told him "Two candles stand for 6 years." How old was her older brother?



Answer: _____

★★★★ 3. Try this number trick on three people, except for the final step of telling their age and amount of change. Write down the answers each person gives you, together with their age and the amount of pocket change they have. Then decide how you can say how old they are and how much change they have *just from looking at the final answer they give you*.

Age and Pocket Change

by Dr. Wonderful

Step 1. Take your age (years).

Step 4. Subtract the number of days in 1 year

Step 2. Double it, then add 5.

Step 5. Add your pocket change (e.g., 49¢).

Step 3. Multiply by 50.

Step 6. Add 115. What's your answer?

Aha: You are _____ years old and have _____¢ in your pocket.

Answer: When I hear their final answer, _____ tells me how old they are, and _____ tells me their change.

★★ 4. Find 40% of $(13.5 - 2.08 + 8\frac{58}{100})$:

Answer: _____

★★★ 5. If you can read this message, then perhaps you are clever enough to solve this problem:

ot bad bad ytiq d td erew zrig z bad z yod z fi
 ed teum zgnob tnerffib ydm won ,gnob
 scheduled as that boy danced with each girl?
 _____ :Answer

★★ 6. Find the weight of a pencil. The scale is set to measure grams.

Answer: _____ grams

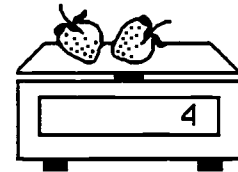
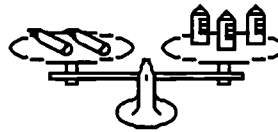
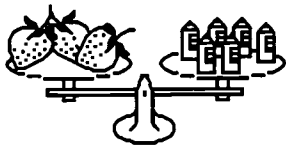

★ 7. The collection of gears below has seven gears in all. If you turn the one with the handle in a clockwise direction, in which direction will the seventh gear turn?

Answer: _____

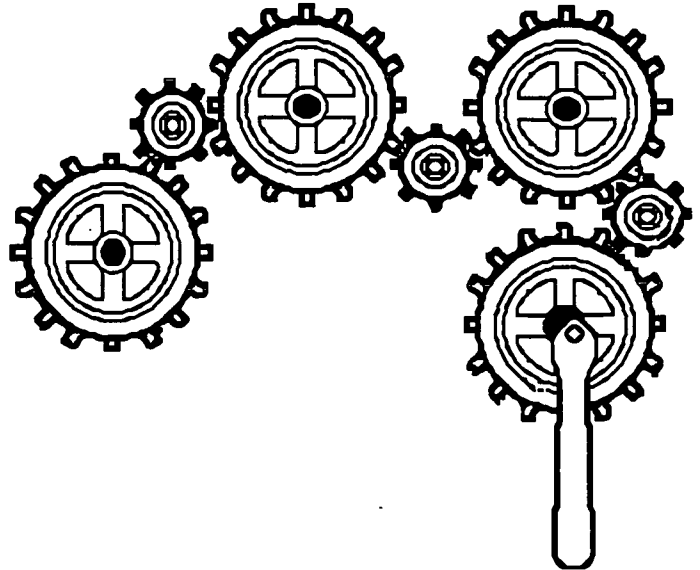

Commentary

Uranus, XXIV

1. (a. 42; b. 2,864 miles; c. 28 mph) Students are often quite interested in such strange records as those found in the *Guinness Book of World Records*. For (a), $1018 \div 24 = 42.4$, which is 42 when rounded to the nearest whole number. For (b), the other two wheels also travelled 2864 miles, as passengers. If students answer "0", give them credit also as they are interpreting "travel" to mean something different for a tire than a passenger. For (c), $501 \div 17.6 = 28.46$ which is 28 mph when rounded. Some students will incorrectly round 28.46 to 28.5 first and then 28.5 up to 29 mph.
2. (27) If two candles stand for 6 years, then each candle is 3 years. 9 candles times 3 is 27 years.
3. (The first two digits tell me how old they are, and the last two tell me how much change they have.) The above description works, except that if the person is a single-digit age, then it's the first digit, not the first two, that give the age. This problem also requires that the change be less than \$1.00.
4. (8) $13.5 - 2.08 = 11.42$. Adding 8.58, written as a decimal rather than a mixed number, gives 20. $40\% \times 20 = 8$.
5. (5) First, students will need to figure out that the problem is written with a reversed image which can be reversed again by holding it up in front of a mirror. They might be interested in knowing that Leonardo de Vinci wrote many of his manuscripts in this fashion to protect them from prying eyes. Students might be fooled into thinking that they add or multiply the two fives in the problem. It is easy to see, however, that if they think of the boys and girls lined up in two concentric circles, it only takes 5 turns of one of the wheels, while the other stays stationery, to match each boy with each girl.

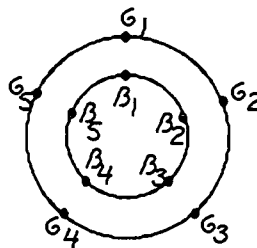

6. (1.5) From the right-hand scale, we know that a strawberry weighs 2 grams. Then on the left-most scale, 3 strawberries or 6 grams balancing 6 cans means each can is 1 gram. In the middle scale, 3 cans weighing 3 grams balance 2 pencils, so each pencil must be half of 3 grams, or 1.5 grams.
7. (clockwise) Gears that are connected in this fashion alternate in direction. If the first goes clockwise as it turns, it forces the next to go counterclockwise, which forces the next to go clockwise, and so forth. Every odd numbered gear will go in the same direction as wheel number 1; every even numbered wheel will go the opposite way.

SUPERSTARS III

Uranus, XXV

Name: _____

(This shows my own thinking.)

★★ 1. A person your age is usually awake about fourteen hours each day. Your eyes blink about 25 times a minute when you're awake.

a. About how many times each day do your eyes blink?

Answer: _____ times

b. About how many times per year do your eyes blink?

Answer: _____ times

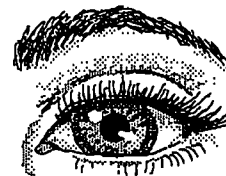

★★ 2. Sue and Sally were building their own bowling alley. There would be 15 lanes each needing ten pins. However, due to damage, they needed to keep on hand 20% more pins than were in use at any given time. How many pins did they need to purchase?

Answer: _____ pins

★★★ 3. Put the numbers 10 through 18 in the diagram below in such a way that the sum of the three numbers along any line totals 42.

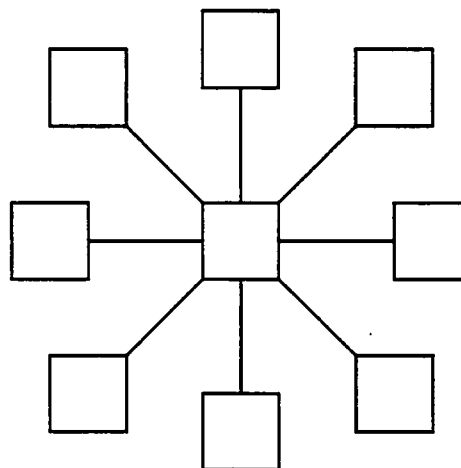

★★★ 4. A *perfect number* is one that is the sum of its proper divisors. Six is a *perfect number* because $6 = 1 + 2 + 3$. In the set of whole numbers, six is the first *perfect number*. What is the second *perfect number*? (Hint: It is less than 30.)

Answer: _____

- ★ 5. Rebecca bought 3 new cassette tapes on sale. She went into the music store with \$27 and came out with \$6. What was the average cost for the tapes?

Answer: _____

- ★★★★ 6. Sam keeps track of several stocks on the stock market. He watched one stock for five consecutive days and recorded the activity. On Monday morning, his favorite stock opened at $12\frac{1}{2}$ and gained $\frac{3}{4}$ points that day. On Tuesday there was a gain of $1\frac{3}{4}$ points. Wednesday the stock lost $5\frac{1}{2}$ points. On Thursday there was a change of $+2\frac{5}{8}$ points. On Friday afternoon the stock closed at $14\frac{1}{4}$. What was the change for Friday over Thursday's standing?

Answer: _____

- ★ 7. How many times does a symbol or word name for the number *one* appear on the dollar bill below?

Answer: _____ times

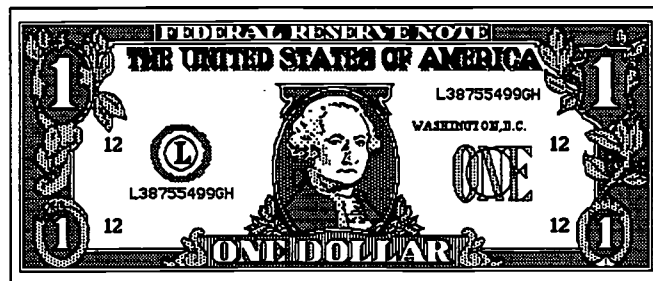

- ★ 8. Consider the watch face to the right. Turn it 180° , then flip it over to the left. Circle the figure below that shows what it would look like.

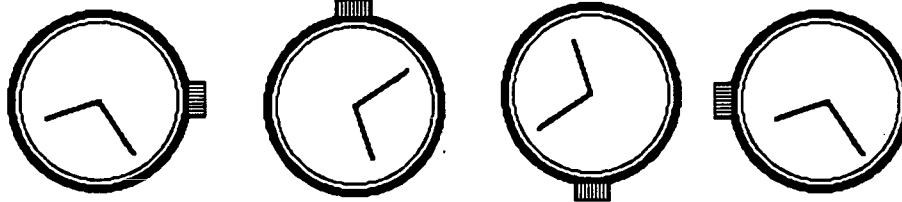

Commentary

Uranus, XXV

1. **(a. 21,000; b. 7,655,000)** The problem involves multiplication. For (a), $25 \times 60 \times 14 = 21,000$; for (b) $21,000 \times 365 = 7,665,000$.
2. **(180)** Ten pins in each of 15 lanes is 150 pins. Multiplying 150 by 1.2 gives the extra 20% in one step, and $150 \times 1.2 = 180$. There are many other ways students will find the extra 20% -- one common way is to realize that 10% of 150 is 15 pins, so 20% would be twice that or 30 extra pins.
3. **(One solution is shown to the right.)** Students who start with 14 in the middle square, because it's in the middle of the numbers from one through 18, will have an advantage. From that point, they can work in toward the center of the line of numbers making pairs that have the same sum.

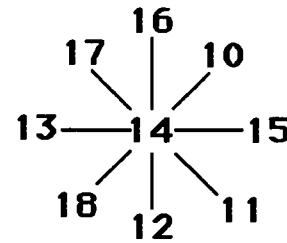

4. **(28)** $1 + 2 + 4 + 7 + 14 = 28$.
5. **(\$7)** If she went in with \$27 and came out with \$6, she spent \$21. Therefore each tape cost, on the average, $\$21 \div 3 = \7 .
6. **($+2\frac{1}{8}$)** The sum of the positive and negative amounts can be combined to determine the value of the stock on Thursday. This can then be compared with its closing price on Friday to find how much it gained or lost on Thursday.

$12\frac{1}{2} + \frac{3}{4} + 1\frac{3}{4} - 5\frac{1}{2} + 2\frac{5}{8}$ would give the closing price on Thursday.

$$12\frac{4}{8} + \frac{6}{8} + 1\frac{3}{4} - 5\frac{4}{8} + 2\frac{5}{8} = 15\frac{21}{8} - 5\frac{4}{8} = 17\frac{5}{8} - 5\frac{4}{8} = 12\frac{1}{8}$$

This closing price of $12\frac{1}{8}$ is then compared with $14\frac{1}{4} = 14\frac{2}{8}$, and you realize that the stock gained $2\frac{1}{8}$ on Friday.

7. **(10)** There are four 1's in the corners, four more 1's that are part of the 12's that are close to the four corners, and two "ones" printed on the bill.
8. **(Far-left figure should be circled.)** Students might trace the figure using a dark pencil or pen on a sheet of paper or an overhead transparency and go through the motions described.

SUPERSTARS III

Uranus, XXVI

Name: _____
(This shows my own thinking.)

- ★★ 1. For every new car made, 5 tires and 2 headlights must be made also. If the car manufacturer purchased 400 tires for its new cars one week, how many headlights did they need to purchase for those cars?



Answer: _____ headlights

- ★★★ 2. The drawing below shows triangles made from toothpicks, in a pattern. Figure 1 requires 3 toothpicks; figure 2 requires 9.

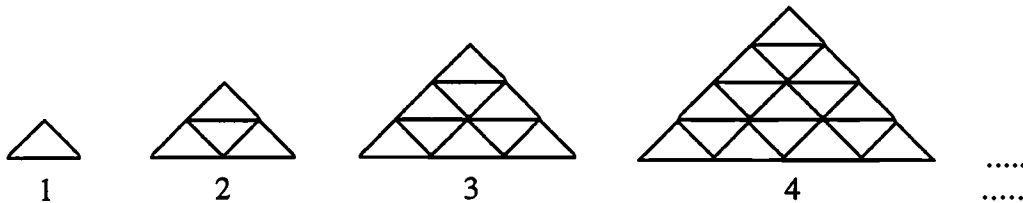

- a. How many toothpicks would be required for the 5th figure? _____
b. How many toothpicks would be required for the 6th figure? _____
c. How many toothpicks would be required for the 10th figure? _____

- ★ 3. Ashley is reading her favorite novel a second time and has read $\frac{2}{5}$ of it. The book is 495 pages long. How many more pages does she have to read to finish the book?

Answer: _____ pages



- ★★ 4. Daniel is using masking tape to hang pictures around the classroom. Each picture uses 1 ft. 2 in. of tape. How many pictures can he hang if he has a 20-foot roll of tape?

Answer: _____ pictures

- ★★★★ 5. Your teacher caught you chewing gum and took away the rest of the pack—9 sticks. He removed the wrapping from one stick and replaced the gum with a piece of cardboard the same size and shape but which weighed less. He then re-wrapped it. Now the lighter-weight stick looks and feels like the rest.

You can avoid going to the principal. You must tell him how to find the fake piece by using the balance scale only two times. Explain your reasoning, or go ahead on down the hall.

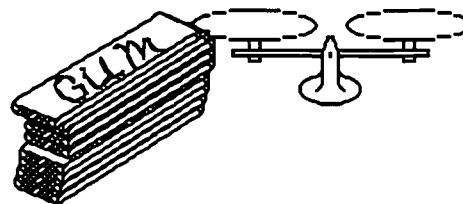

Answer: Attach a sheet of paper with your explanation that starts like this:

For the first weighing, I would:

For the second weighing, I would:

- ★ 6. A deep-sea fishing boat is tied to a dock in the harbor. Over its side hangs a rope ladder with its bottom rung almost touching the water. Rungs of the ladder are 1 foot apart. The tide begins rising at the rate of 8 inches per hour. At the end of six hours, how many rungs will be covered by water?

Answer: _____

- ★★ 7. A traffic court judge imposed a fine for speeding. The fine was \$80, plus \$1.75 for every mile per hour the speed limit was exceeded. What was the fine the judge imposed for traveling 57 mph in a 45 mph zone?

Answer: _____

- ★ 8. A square garden has five fence posts on each side. How many fence posts are there around the garden?

Answer: _____

- ★★★ 9. If you and four of your friends can stand on a square yard of carpet, how many of you can stand in a classroom that is 27 feet by 36 feet?

Answer: _____ people

Commentary

Uranus, XXVI

1. (160) $400 \div 5 = 80$ cars made. If 2 headlights are needed for each car, then 160 headlights are needed.
2. (a. 45; b. 63; c. 165) Most students will draw the next few figures and count the toothpicks. They will likely extend figure 4 down several times, to get each new figure, and just count the new toothpicks added on. A pattern emerges which some students might notice, although they might not be able to express it clearly:

Figure number:	1	2	3	4	5	n
Toothpicks required:	3	9	18	30	45	$\frac{(3)(n)(n+1)}{2}$

3. (297) Since $\frac{2}{5}$ of 495 is 198, Ashley has already read 198 pages, leaving 297 pages.
4. (17) A 20-foot roll of tape is 240" long. A 1 ft. 2 in. section of tape is 14" long. $240" \div 14" = 17.14$. There is not enough tape for the 18th picture.
5. (1st: Weigh three pieces of gum against another three pieces. If the scale balances, you know the light piece is one of the three in your hand. If the scale doesn't balance, you know which group of 3 pieces has the lighter one. 2nd: Weigh two of the three pieces from the lighter group. If the scale balances, the light piece is in your hand. If it doesn't balance, you know which piece is lighter.)
6. (0) The boat also rises as the tide comes in!
7. (\$101) The speed limit was exceeded by 12 mph. $\$80 + 12(\$1.75) = \$101$
8. (16) The students need to remember not to count the corner posts more than once. A drawing will help them see the situation.
9. (540) There are $27 \times 36 = 972$ square feet in the classroom. Since 9 square feet is 1 square yard, $972 \text{ square feet} \div 9$ gives 108 square yards. $108 \times 5 \text{ people} = 540 \text{ people}$.

SUPERSTARS III
Uranus, XXVII

Name: _____
 (This shows my own thinking.)

- ★★★★ 1. Mark claims the lump of clay weighs 25 grams but only has a 1-gram, a 3-gram, a 9-gram, and a 27-gram weight to use for the balance scale. Show where he can place the weights to prove the clay weighs 25 grams.

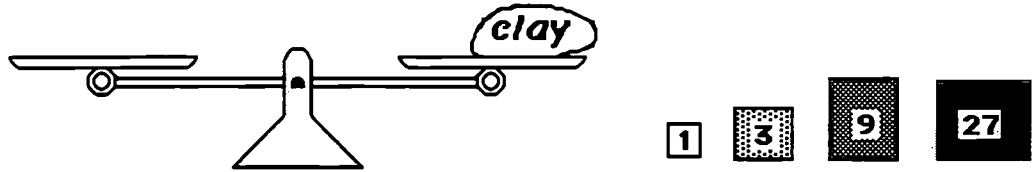

- ★★ 2. If your math scores were 76, 76, 83, 85, and 90, which statistic would give you the best final grade -- the *mean*, the *median*, the *mode*, or the *range* of these scores?

Answer: _____

- ★★★ 3. How can you arrange 4 pennies, 4 nickels, 4 dimes, and 4 quarters in this grid so that each row, each column, and each diagonal contain exactly one of each type of coin? Write P, N, D, or Q in each square to show your solution.

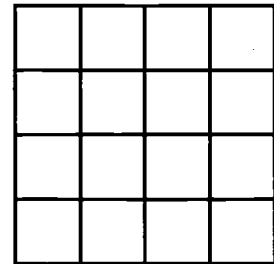

- ★★ 4. Diana and Felicia want to can 12 quarts of tomatoes from their family's garden. They already have 7 quart jars and 6 pint jars. If only quart and pint jars are available, what is the fewest number of jars they can buy to have enough?

Answer: _____ jars

- ★ 5. What is the probability of being born in a month with more than 30 days?

Answer: _____

- ★★★★ 6. The diagram below shows a new swimming pool at the city park. The pool contractor wants to border the pool with ceramic tiles that are 6" squares. If each tile costs \$2.75, what is the total cost of the tiles?

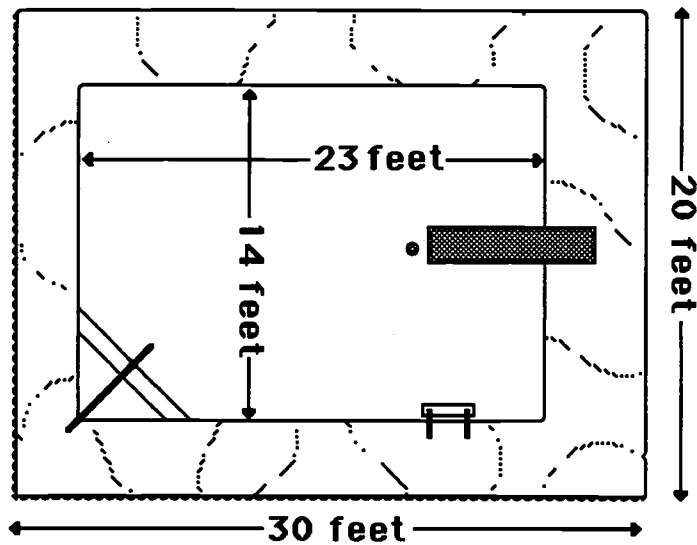

Answer: _____

- ★★ 7. Timothy received three \$20 bills for his birthday. He wants to buy a tennis racquet for \$29.95 and two cans of tennis balls for \$2.49 each. He also wants to buy a new tennis shirt for \$14.95. About how much money should he have left, if his mom agrees to pay the tax? Circle the correct answer.

a) \$10 b) \$5 c) \$15

- ★★ 8. Tim earned some extra money and bought some new CDs. 50% were rock, 25% were country-western, and the rest were classical. He bought 3 classical CDs. How many CDs did he buy?

Answer: _____

- ★ 9. Cleopatra was 39 years old when she died in 30 BC. In what year was she born?

Answer: _____

Commentary

Uranus, XXVII

1. (See below.) If the scale balances, the clay weighs 25 grams.

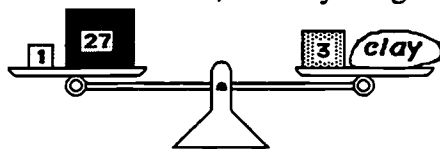

2. (**median**) The mean is $(76 + 76 + 83 + 85 + 90) \div 5 = 82$. The median is the middle number when all are lined up in order and is 83. The mode is the most frequently occurring number which is 76. The range is the difference in the highest and lowest scores which is 14.
3. (See chart to the right.) This is only one solution. Others are possible:
- | | | | |
|---|---|---|---|
| P | N | D | Q |
| Q | D | N | P |
| N | P | Q | D |
| D | Q | P | N |
4. (2) There are 2 pints in a quart. So the six pints would give 3 more quarts, 10 altogether with the jars they already have. They could buy two more quart jars to give them 12 quarts.
5. (7/12) The months with more than 30 days are January, March, May, July, August, October, and December. This is 7 months out of 12.
6. (\$3,058) The area to be covered can be found by taking the area of the large rectangle and removing the pool area. The area of the 20-by-30 rectangle is 600 square feet; the area of the 23-by-14 pool is 322 square feet. The difference is $600 - 322 = 278$ square feet. Each square foot would take 4 of the tiles; therefore, $4 \times 278 = 1112$ tiles needed. $1112 \text{ tiles} \times \$2.75 = \$3,058$.
7. (\$10) The racquet was about \$30, the tennis balls about \$5, and the shirt about \$15. He therefore spent about \$50, without counting tax. If his mom pays the tax for him, he should have about \$10 left.
8. (12) The 3 classical CDs must have been 25% of the total also, as that's all that is left from 100% when 50% and 25% are removed. If 25% or $1/4 = 3$, then 100% is 4 times 3 or 12.
9. (69 BC) The numbers that represent BC years can be thought of as negative numbers on the number line. The problem becomes finding the number that comes 39 units prior to -30 which would be -69 BC. As a check mathematically, notice that $-69 + +39 = -30$.

Super Stars

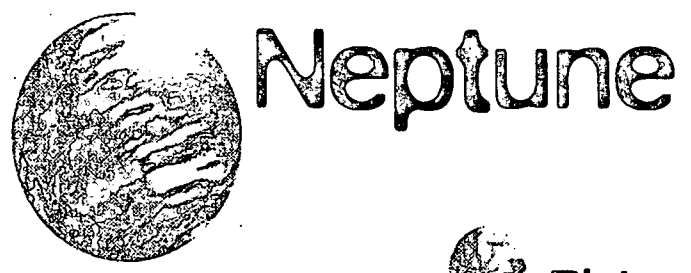
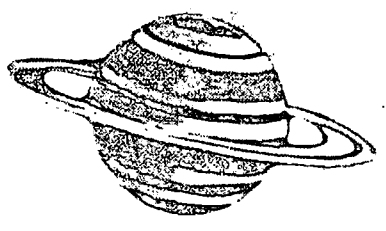
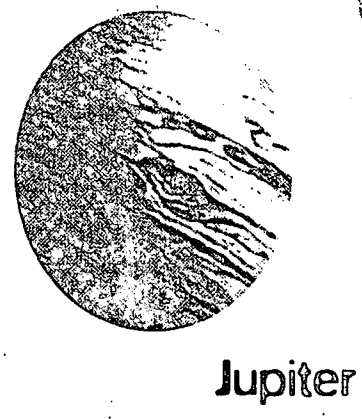
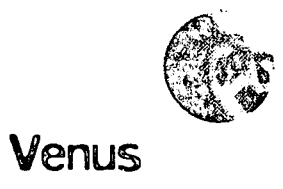

★ ACKNOWLEDGMENTS ★

This project, originally designated *Sunshine Math*, is the third in a series of problem solving programs. It was conceived, coordinated and developed through the Florida Department of Education with input from the mathematics staff members of the North Carolina Department of Public Instruction and the South Carolina Department of Education. In addition, it was supported financially through a grant to the School Board of Polk County, Florida. The rich history of these materials and the predecessor programs, **SUPERSTARS** and **SUPERSTARS II** goes back to the early 1980's. Many Florida teachers have been involved in developing and using these materials over the years. The original **SUPERSTARS** programs were adopted and adapted by North Carolina and South Carolina with their teachers contributing to revisions and personalizations for use in their states. Florida educators were primarily responsible for developing, field testing, and publishing *Sunshine Math*. Educators from the Carolinas developed the **MathStars Newsletter** to accompany and enhance this program.

School districts in North Carolina have permission to reproduce this document for use in their schools for non-profit educational purposes. Copies of each grade level are available from the publications unit of the North Carolina Department of Public Instruction. The contact for **SUPERSTARS III** and the **MathStars Newsletter** is Linda Patch, 301 North Wilmington Street, Raleigh, NC 27601-2825 : (919-715-2225).

Michael E. Ward
State Superintendent
North Carolina Department of Public Instruction

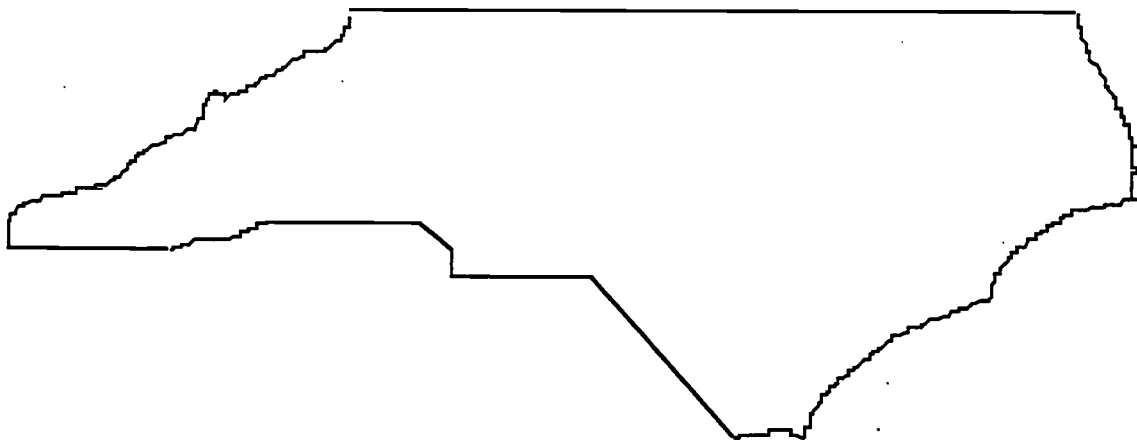

☆ *Preface* ☆

SUPERSTARS III encourages and enhances the positive aspects of students, parents, teachers and administrators working together. This program assumes that students, even young children, are capable of and interested in learning; that teachers want to help them learn to think for themselves; that administrators see their jobs as clearing the path so that quality education is delivered effectively in their schools; and that parents care about their child's learning and are willing to work with the school system toward that goal. Each of these four groups has a vital role to play in implementing **SUPERSTARS III**.

The designer of this program has a long history of working with elementary children. He believes that they are capable of much more than we ask of them, and that many children are on the path to becoming independent learners. A number of children in any classroom are bright, energetic and willing to accept extra challenges.

The basic purpose of **SUPERSTARS III** is to provide the extra challenge that self-motivated students need in mathematics, and to do so in a structured, long-term program that does not impinge on the normal classroom routine or the time of the teacher. The system is not meant to replace any aspect of the school curriculum -- it is offered as a peripheral opportunity for students who identify with challenges and who want to be rewarded for their extra effort. Participation in the program is always optional -- only those students who voluntarily choose to participate will, in the long run, benefit from **SUPERSTARS III**. Any student, regardless of prior academic performance, should be encouraged to participate as long as interest is maintained.

The predecessor program for **SUPERSTARS III** -- the **SUPERSTARS II** program -- has demonstrated that this concept can be extremely useful. What is required are several dedicated adults who devote a few hours each week to operate the system effectively in the school; an administrator who provides highly visible support; teachers who welcome a supplementary experience for their students to engage in higher-order thinking; and a typical classroom of students. If all of those ingredients are present **SUPERSTARS III** will become an integral part of the school fabric.

ORGANIZATION OF THESE MATERIALS

Section I Description of the SUPERSTARS III Program

1. General Information
2. Information/checklist for principals
3. Information/checklist for assisting adults
4. Information for teachers
5. Letter to participating students and their parents.

Section II Student worksheets for SUPERSTARS III

SUPERSTARS III
Jupiter, XXII

Name: _____
(This shows my own thinking.)

***1. If the 24th day of the month falls on Saturday, on what day did the 6th fall?

Answer: _____

***2. There are 4 six-packs of soda in a case. Chris bought 12 of a case and gave 13 of what he had to Dan. How many cans of soda does Chris have left?

Answer: _____ cans

***3. Together, 6 boys and 12 girls weigh 1050 pounds. The boys all weigh the same -- or pounds. Each girl weighs 55 pounds. What is the weight of one boy?

bbbbbb gggggggggggg
Answer: $x =$ _____ pounds

***4. The sum of 3 consecutive numbers is 276. What are the numbers?
(Consecutive numbers differ by one; example: 8, 9, and 10)

Answer: _____ and _____

***5. If a family of 12 spiders were shoes, how many pairs of shoes would they need?

 Answer: _____ pairs.

***6. A tropical storm passed through the town. It began to rain Monday morning at 8:45 AM and did not stop until the next day at 2:30 PM. How long did it rain?

Answer: _____ hours and _____ minutes

***7. There are 3 cars, 4 bicycles, 2 tricycles, and 1 unicycle in the neighbor's garage. How many wheels are there in all? Forget about any "spare tires!"

Answer: _____ wheels

***8. Rosemary bought a sweater on sale for \$6.98. She also bought a shirt for \$9.99. She paid an additional \$1.19 for sales tax. Rosemary gave the sales person a \$20 bill. How much change should she receive?

Answer: _____

***9. Study this pattern. 25 and also 32 would be in column E, if the pattern continued.
a. In which column would 100 appear?
b. In which column would 500 appear?
c. In which column would 1000 appear?

21	22
14	15
16	17
18	19
20	
7	8
9	10
11	12
13	
0	1
2	3
4	5
6	
A	B
C	D
E	F
G	

Section III Commentary for student worksheets for SUPERSTARS III

Commentary
Jupiter, XXII

1. (Necessary) Students can use a calendar or make a chart with "Su, M, T, W, Th, F, Sa" at the top and begin numbering backward putting 24 under Saturday. They may also realize that the 17th and 10th fall on Saturdays and count back from the 10th.
2. (8) Students can solve this problem by drawing a diagram or by visualizing 24 cans. $1/2$ of 24 is 12, and $1/3$ of 12 is 4. Therefore Chris gave away 4 of the 12 sodas, leaving 8.
3. (65) Students will probably solve this by first finding the total weight of the 12 girls: $12 \times 55 = 660$ pounds. Then they will compute $1050 - 660 = 390$ pounds, the weight of the 6 boys. Then $390 \div 6 = 65$ pounds per boy.
4. (91, 92, 93) Students may use the guess-check-revise method. Some students might know that the numbers they seek are about $1/3$ of the total, and approximate the numbers by dividing 276 by 3. This gives 92, which is the middle number.
5. (48) Students may want to draw a picture to help solve this problem. Spiders have 8 legs, which would be 4 pairs of shoes per spider.
6. (29 hours and 45 minutes) Most students will realize that from 8:45 AM to 8:45 AM the next day, is 24 hours. They will then "add on" 5 additional hours to get to 9:45, 10:45, 11:45, 12:45, and 1:45, and then 45 minutes to get to 2:30 PM.
7. (27) There would be 12 wheels on the 3 cars, 8 on the 4 bicycles, 6 on the 2 tricycles, and 1 on the unicycle.
8. (\$1.84) Students will probably add \$6.98 and \$9.99 to get \$16.97, then add the tax of \$1.19 to get \$18.16. They will subtract this amount from \$20.
9. (a, C) (b, D) (c, G) Hopefully, students will notice that the multiples of 7 are in column A and use this fact to get "close to" the numbers 100, 500, and 1,000. Ninety-eight (14×7) is the closest multiple of 7 less than 100, so 98 would be in column A, forcing 100 to be in column C. Likewise, 497 or 71×7 is in column A, putting 500 in column D. Finally, 994 or 142×7 is in A, indicating that 1000 is in column G.

SUPERSTARS III: General Information

SUPERSTARS III is a K-8 program designed as an enrichment opportunity for self-directed learners in mathematics. The levels of the program are named for the planets in our solar system:

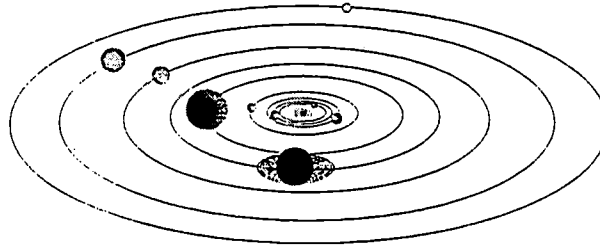

Kindergarten	Mercury	Fourth Grade	Jupiter
First Grade	Venus	Fifth Grade	Saturn
Second Grade	Earth	Sixth Grade	Uranus
Third Grade	Mars	Seventh Grade	Neptune
	Eighth Grade	Pluto	

Students of all ability levels choose on their own to participate in **SUPERSTARS III**. Seeing their names displayed in a prominent place in the school, with a string of stars indicating their success, is one reward students receive for their extra work. In some cases the school may decide to enhance this basic system by awarding certificates of achievement or some other form of recognition to highlight certain levels of success or participation in the **SUPERSTARS III** program.

SUPERSTARS III can function in a school in a number of different ways. A “tried and true” way is for assisting adults (volunteers, aides, etc.) to manage the program for the entire school, with support provided by school administrators and classroom teachers. This system has been adopted at the school level, with varying degrees of success, over the years. The basic model for conducting **SUPERSTARS III** is discussed below, with variations described on the next page.

The basic model

The basic model for **SUPERSTARS III** is for a school to establish a weekly cycle at the beginning of the academic year according to the following guidelines:

On Monday of each week student worksheets are distributed by the assisting adults to students in the program. Students have until Friday to complete the problems working entirely on their own. On Friday the classroom teacher holds a brief problem-solving session for the students in the program. The more difficult problems on the worksheet are discussed with students describing their thinking about strategies to solve the problems. They do not share solutions, only strategies.

Students receive double credit for those problems they have successfully completed prior to the problem-solving session, and regular credit for those they complete successfully over the week-end. On Monday all papers are handed in, checked by the assisting adult, and stars are posted for problems successfully completed. This completes one cycle of the **SUPERSTARS III** program.

SUPERSTARS III is not for every child -- it is only for those who are self-motivated and who are not easily frustrated by challenging situations. This does not diminish the value of the program, but rather makes us realize that there are children of all ability and socio-economic levels who are self-directed learners and who need challenges beyond those of the regular school day. These children will shine in **SUPERSTARS III**.

Variations of the basic model

The first variation that has been used successfully retains the weekly cycle and assisting adult role from the basic model. The teacher however, involves the entire class in the problem-solving discussions. For example, the teacher might select the four most difficult problems on the worksheet (indicated by three or four stars) and work a "parallel" problem with the entire class to open the mathematics lesson on Tuesday through Friday. Using this variation, all students are exposed to the problem-solving strategies, but only those who have chosen to participate in **SUPERSTARS III** will complete and turn in the worksheet on Monday.

A second variation has the assisting adult manage the entire program, including the Friday problem-solving session. This method has been used in situations where teachers lacked commitment to the program and thus implemented it inconsistently. In such cases, the assisting adult must have a progressive view of what constitutes problem solving in elementary mathematics. They should also receive extra assistance from the administration to ensure that students are released from class and that the cycles proceed smoothly.

Yet another variation is for a parent to manage **SUPERSTARS III** at home for his or her own child. The basic rules are the same -- a child gets the worksheet once a week and time to work the problems alone. The parent sets a night to listen to the way the child thought about each problem, offering suggestions or strategies only when the child is unable to proceed. The reward system is basically the same, stars on a chart, but can be enhanced by doing something special with the child, such as a trip to the museum or to a sporting event when the child reaches certain levels of success. If this method is adopted, the parent must not try to teach the child, but rather to stimulate discussion of problem-solving strategies. **SUPERSTARS III** is not a program for adults to teach children how to think.

Other variations exist. The basic model as stated is the best, all other factors being equal, for reaching more children in a consistent fashion than any of the other methods. However, we encourage individual schools, teachers, or parents to get some version started; some starlight is better than none.

SUPERSTARS III: Information for Principals

SUPERSTARS III is a K-8 enrichment package for mathematics designed to be managed by volunteer assisting adults with coordinated support from the classroom teacher and school administrators. The purpose of the program is to give self-motivated students of all ability levels a chance to extend themselves beyond the standard mathematics curriculum. The complete set of materials comes in nine packages, one for each grade K-8. The grade levels are identified by the names of the nine planets in our solar system and their order from the sun:

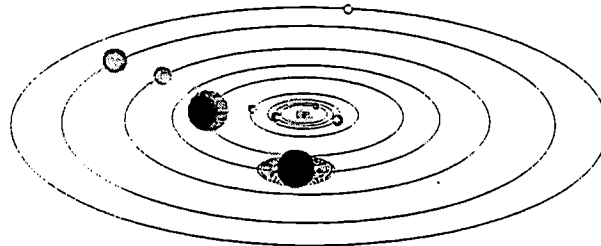

Mercury - Kindergarten

Earth - Second Grade

Jupiter - Fourth Grade

Uranus - Sixth Grade

Venus - First Grade

Mars - Third Grade

Saturn - Fifth Grade

Neptune - Seventh Grade

Pluto - Eighth Grade.

Your support is vital if this program is to succeed. As the school administrator, you need to stay in close contact with the **SUPERSTARS III** program. A “checklist for success” follows:

- Become familiar with the philosophy and component parts of the program.
- Introduce **SUPERSTARS III** to the faculty early in the school year. Ensure that teachers understand the philosophy of the program and have copies of the student worksheets and commentaries appropriate for their grade levels.
- Speak to parents at your school’s first open house of the year, explaining the purpose of **SUPERSTARS III** and the long term value of children working independently on challenging problems.
- Recruit several assisting adults (PTA members, aides, senior citizens, business partners, church members, etc.) who are enthusiastic, dependable people who are willing to manage the program. Early in the academic year, meet with these assisting adults to plan such details as:
 - ✓ A prominent place and format for the STAR CHART.

- ✓ A designated time and place each Monday and Friday for the assisting adults to be in school to meet with students, distribute and collect worksheets, and post stars.
- ✓ A system for the activity sheets to be duplicated each week.
- ✓ A plan for extra incentives for accumulating stars. (“World records” to be kept from year-to-year, a celebration day planned for the end of school, prizes earned by students for attaining certain levels of success -- see the diagram below for examples.)
- ✓ A schedule for the initiation of the program and a decision as to a “start over” point later in the academic year. Review the school calendar and only use weeks that are at least four days long. If there is not enough time in the year to complete all the activity sheets, decide which to eliminate or on a plan to “double up.”
- ✓ A **SUPERSTARS III** cap, name badge, tee-shirt, or other distinction for volunteers, if possible.
- Monitor the program every two weeks to get ahead of unforeseen difficulties. Administrators need to be highly visible and supportive for **SUPERSTARS** to succeed.

SUPERSTARS III is an optional program for students. It should be available to any student who wants to participate, regardless of prior success in mathematics. Typically, a large number of students will begin the program, but a majority will lose interest. A significant number however, will continue their efforts over the life of the program. This is normal and simply means that **SUPERSTARS III** is successfully addressing the needs of the self-directed learner.

Visual reminders help children see this mathematics program is challenging and rewarding. Some ideas are presented here:

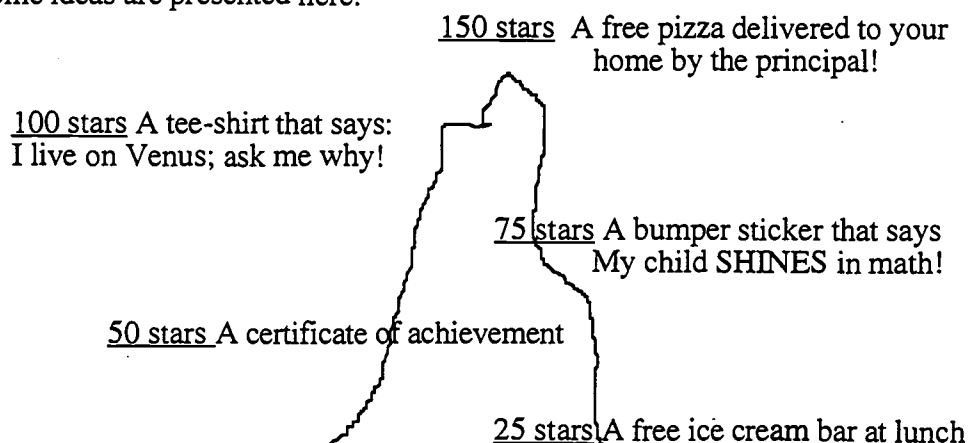

Climb the Mountain this Year!! Join the **SUPERSTARS III** Club

SUPERSTARS III: Information for Assisting Adults

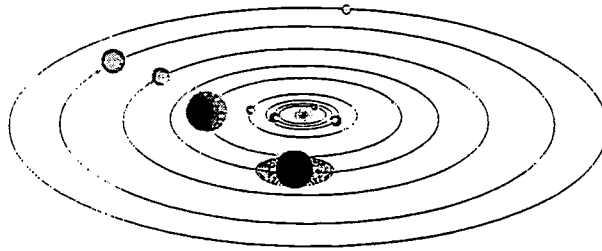

SUPERSTARS III is designed to give assisting adults a well-defined role to play in the school's mathematics program. The success of **SUPERSTARS III** depends upon a team effort among teachers, administrators, parents and you. Reliability and punctuality are important - students will quickly come to depend upon you to be there as scheduled, to check their papers and post their stars, and to listen to alternate strategies and interpretations of problems to help them arrive at solutions. If possible, wear an outfit or badge that fits with the **SUPERSTARS III** theme or logo; students will soon identify you as an important person in their school.



SUPERSTARS III works on a weekly cycle. Each Monday you will collect the worksheets from the previous week and distribute new worksheets to the participating students, all from your **SUPERSTARS III** area of the school. Allow students to see the answers to the problems, discuss any for which their answers differ and allow them credit if their interpretation and reasoning are sound. After checking all the work, you will post the stars earned by students on the STAR CHART.



Participating students have from Monday until Friday to work the problems entirely on their own -- the only help they should receive during that time is for someone to read the problems to them. On Friday the teacher will host a problem-solving session in the classroom where students will describe the strategies they used to approach the more difficult problems. Students who have successfully completed problems before this session will receive double points for their efforts. The teacher's initials on the worksheet will help you identify those problems. The students then have the week-end to complete or correct their problems and turn them in on Monday. All the correct problems thus completed will receive the indicated number of stars.



Be creative when designing your STAR CHART. The basic method of posting stars individually is a good way to begin but eventually you will want a more efficient system. Color coding by grade level, or posting just one star each week with a number in its center are ideas to consider. You may wish to personalize the chart and the entire **SUPERSTARS III** center with student pictures, "smiling faces", a logo, seasonal theme or some other feature that has a mathematical flavor. Occasionally feature a reward for each child such as a cookie or a hand stamp in the shape of a star just for turning in the worksheet. You are helping enthusiastic students develop high-level thinking skills -- be creative and enjoy your role!

Checklist for assisting adults:

- Plan the following with the principal:
- ✓ A prominent place and format for the

STAR CHART

- ✓ The time and place for you to collect, check, and distribute worksheets.
- ✓ A system for duplicating worksheets each week which ensures legible copies. Also a secure storage area for masters and other materials.
- ✓ Any additional incentives ("world records," stickers, coupons, pencils, tee-shirts, etc.) that will be part of the system for rewarding levels of achievement in **SUPERSTARS III**.



- Make the **SUPERSTARS III** center a happy place. Use bright colors, smiles, and cheerful expressions. Show confidence, friendliness, and encouragement to students.



- Collect the letters that are sent home prior to the first worksheet. These need to be signed by each student and a parent. If, in the future, you have evidence that the work submitted does not represent the thinking of the student, discuss the situation with the classroom teacher. These situations are best handled individually, confidentially and in a firm, consistent manner.



Check the worksheets from the previous week uniformly. If you give partial credit for a problem with several parts do so in a fair way that can be understood by the students. Do not award partial credit for problems with only one answer.



Have answer sheets available and encourage students to look at the solutions when they submit their worksheets. Allow them to explain their strategy or interpretation if they have arrived at a different answer. Award full credit if they show a unique and plausible interpretation of a problem and follow sound logic in arriving at their response.



Leave extra worksheets with the classroom teacher for participating students who were absent on Monday. Accept a late-arriving worksheet only if the student was absent on Monday. If a student's name is missing or in the wrong place on the worksheet, check the paper but award stars to "No Name" on the STAR CHART. Adhering strictly to these rules will rapidly teach responsibility to the students and keep your work manageable.



Keep all returned worksheets. As the same problems are used year after year, and many students have siblings who may later participate in **SUPERSTARS III**, it is important that worksheets do not circulate.



On weeks when **SUPERSTARS III** is not available post a notice such as "No star problems this week, but please come back after vacation for more!"

SUPERSTARS III: Information for Teachers

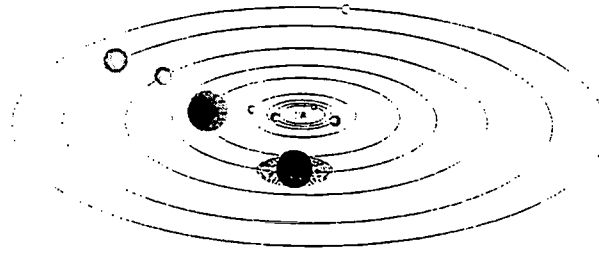

SUPERSTARS III is a program designed to complement your regular classroom mathematics curriculum. It offers a supplemental opportunity for students to practice mathematics skills appropriate for their grade level and at the same time to engage in challenging problem-solving activities. It is an additional challenge to those students who are self-directed learners providing them with an academic extracurricular activity.



Your involvement is essentially as a teacher. **SUPERSTARS III** will remain special to students if it is managed by someone outside of the classroom and if the teacher is viewed as a facilitator in the system, rather than as the authority figure. Your primary role is to monitor the system in your own classroom and to host a brief problem-solving session for **SUPERSTARS III** students on Friday of each week. You will also need to release the participating students from your class at a set time on Mondays to enable them to turn in completed work and receive new problem sets. You might make a special pin or banner for Mondays and Fridays to remind students that those days are special.

SUPERSTARS III
Jupiter, XXI

Name: _____
(This shows my new thinking.)

**1. If the 24th day of the month falls on Saturday, on what day did the 6th fall?
 Answer: _____

***2. There are 4 six-packs of soda in a case. Chris bought 12 of a case and gave 13 of what he had to Dana. How many cans of soda does Chris have left?
 Answer: _____ cans

**3. Together, 6 boys and 12 girls weigh 1050 pounds. The boys all weigh the same -- pounds. Each girl weighs 55 pounds. What is the weight of one boy?
 bbbbbb gggggggggggg
 Answer: _____ pounds

**4. The sum of 3 consecutive numbers is 276. What are the numbers?
(Consecutive numbers differ by one; example: 8, 9, and 10)
 Answer: _____ and _____

**5. If a family of 12 spiders wore shoes, how many pairs of shoes would they need?

 Answer: _____ pairs.

Commentary
Jupiter, XXI

1. (Tuesday) Students can use a calendar or make a chart with "Su, M, T, W, Th, F, Sa" at the top and begin numbering backward putting 24 under Saturday. They may also realize that the 17th and 10th fall on Saturdays and count back from the 10th.

2. (8) Students can solve this problem by drawing a diagram or by visualizing 24 sodas. 1/2 of 24 is 12, and 1/3 of 12 is 4. Therefore Chris gave away 4 of the 12 sodas, leaving 8.

3. (65) Students will probably solve this by first finding the total weight of the 12 girls: $12 \times 55 = 660$ pounds. Then they will compute $1050 - 660 = 390$ pounds, the weight of the 6 boys. Then $390 \div 6 = 65$ pounds per boy.

4. (91, 92, 93) Students may use the guess-check-revise method. Some students might know that the numbers they seek are about 1/3 of the total, and approximate the numbers by dividing 276 by 3. This gives 92, which is the middle number.

5. (48) Students may want to draw a picture to help solve this problem. Spiders have 8 legs, which would be 4 pairs of shoes per spider.

6. (29 hours and 45 minutes) Most students will realize that from 8:45 AM to 8:45 AM the next day, is 24 hours. They will then "add on" 5 additional hours to get to 9:45, 10:45, 11:45, 12:45, and 1:45, and then 45 minutes to get to 2:30 PM.

7. (27) There would be 12 wheels on the 3 cars, 8 on the 4 bicycles, 6 on the 2 tricycles, and 1 on the unicycle.

8. (\$184) Students will probably add \$6.98 and \$9.99 to get \$16.97, then add the tax of \$1.19 to get \$18.16. They will subtract this amount from \$20.

9. (a, C; b, D; c, G) Hopefully, students will realize that the multiples of 7 are in column A and use this fact to get "close to" the numbers 100, 300, and 1,000. Ninety-eight (14×7) is the closest multiple of 7 less than 100, so 98 would be in column A, forming 100 to be in column C. Likewise, 497 or 71×7 is in column A, putting 500 in column D. Finally, 994 or 142×7 is in A, indicating that 1000 is in column G.

Each student worksheet has an accompanying commentary page. This sheet provides hints on parallel problems which you might use in the Friday problem-solving session. It is important that students participate actively in this session, and that you

solicit from them their unique and varied approaches to the problems discussed. Only after students have presented their ideas should you provide guidance on the problems and then only if they are having difficulty. Even though there is a commentary provided for each problem, you will have to decide which two to four problems you will cover during this brief session. Concentrate on those which provide a new or unfamiliar strategy. The problem-solving session should last no more than 15 minutes.



Do not be disappointed if a large number of your students begin **SUPERSTARS III** and then significant numbers drop out after a few weeks. This is normal; problem solving requires a great deal of effort and not every student is ready for this challenge. On the other hand, you will notice that some students will choose to stay with **SUPERSTARS III** week after week even though they are not as successful as other students at earning stars. Their participation should be encouraged as they are certainly learning from the experience. Under no circumstances should **SUPERSTARS III** be reserved only for the advanced students in your class.



As a purely practical consideration, students are not to discuss the problems among themselves or with their families prior to the Friday cooperative group session. This allows the "think time" necessary for students to develop into independent thinkers; it also prevents students from earning stars for work that is basically someone else's -- the surest way to disrupt the entire **SUPERSTARS III** program. As the teacher you must monitor this in your classroom and ensure that students abide by the established rule.



It is important that you understand and support the overall philosophy of **SUPERSTARS III**. Do not worry if students encounter problems for which they have not been prepared in class -- such is the nature of true problem solving. Do not provide remedial instruction to ensure that students master certain types of problems. They will meet these same problem types repeatedly in the program. They will likely learn them on their own and from listening to other students at the problem-solving sessions. Enjoy what the students can do and don't worry about what they can't do. Read the general information and philosophy of the program to see how your role fits into the complete system.

Here are some thoughts you might find useful in your support for **SUPERSTARS III**:



- Allow your students to leave the classroom at the designated time on Mondays to turn in their worksheets and pick up new ones.



- Read each week's worksheet and feel free to structure classroom activities that parallel those in the **SUPERSTARS III** problems.



- During the school week students may be allowed to work on their **SUPERSTARS III** problems during their free time, but the only help they may receive is for someone to read the problems to them. Give the students one warning if you find them discussing the worksheets, and take away their papers for the next violation. If it happens another time, suspend them from the program for a month.



- At the Friday problem-solving sessions remember these points:
 - Students come to this session with their worksheets, but without pencils.
 - The session should be brief -- 15 minutes at most. Discuss only the two to four most difficult problems.
 - Help students summarize their own approaches to the problems in a non-judgmental fashion. Offer your own approach last, and only if it is different from the students' strategies. Do not allow answers to be given to the problems.
 - End the session by encouraging students to complete the problems over the weekend. Put your initials beside any problem discussed in class which a student has already successfully completed. The assisting adult will award double stars for these.



Remember that part of the **SUPERSTARS III** philosophy is that students learn responsibility by following the rules of the system. If participation is important to them they will adhere to the rules about where their names go on each paper, no credit awarded if they forget their paper on Monday, and no talking about problems prior to the problem-solving session.



Enjoy **SUPERSTARS III**. Students will impress you with their ability to think and their creative ways to solve problems that appear to be above their level or beyond their experience.



Dear Student,

Welcome to **SUPERSTARS III**, a program designed to enhance your journey through mathematics. Be prepared to face challenging problems which require *thinking!* As you work through the system you will experience many types of problems, stretching and expanding your brainpower in many exciting ways!

Expect to receive one worksheet at the beginning of each week. You will have the rest of the week to think about the problems and come up with strategies for their solutions. The thinking and solutions must be **YOUR VERY OWN!!!** Once a week you will attend a help session to discuss the most challenging problems for the week.

Your journey will be recorded by charting the stars you earn. Each problem is ranked according to its level of difficulty. The more stars you see beside a problem, the higher its level of difficulty and, of course, the more stars you can earn for solving it. You can earn double stars for solving a problem before the weekly sessions.

Your signature is just the beginning.

Good luck as you embark upon this mathematical adventure! The rewards will last a lifetime!



I am ready to begin the **SUPERSTARS III** program. All of the answers I submit will represent my own thinking.

Name: _____





Dear Parents,

Welcome to **SUPERSTARS III**, a program designed to enhance your child's journey through mathematics. By expressing an interest in challenging problem solving experiences, your student has taken the first step toward becoming an independent learner who is willing to address many types of problems.

On Mondays a **SUPERSTARS III** worksheet will be distributed to each child in the program. Each problem in the set is ranked according to its level of difficulty. As the number of stars increases, so does the level of difficulty and the earned stars to be awarded.

Each Friday a help session will be conducted to discuss the most challenging problems of the week. Any problem solved prior to the session will be given double stars. After the session, problems may be reworked before they are submitted the following Monday.

Your role in **SUPERSTARS III** is to encourage and facilitate problem solving. Feel free to offer guidance toward certain strategies, to read the problems to your child, but please, do not give them the answers. In order for this program to be effective, the students must work independently. The thinking must be their own!

It is normal for a student not to be able to complete every problem on every worksheet. The process of interpreting, understanding, and trying different strategies is valuable in the attainment of mathematical power. Remember, no student is expected to know the answer to every problem.

Thank you for allowing your child to embark upon this mathematical adventure; the rewards should last a lifetime!

_____ signature

Parent/Guardian of _____



After you have had a chance to review and use these materials, please take a moment to let us know if the **SUPERSTARS III** material has been useful to you. Your evaluation and feedback is important to us as we continue to work on additional curriculum materials. Please respond to:

Linda Patch
Mathematics & Science Section
NC Department of Public Instruction
301 N. Wilmington Street
Raleigh, NC 27601-2825

Indicate the extent to which you agree with statements 1-4.

	Strongly Disagree	2	Neither Agree nor Disagree	4	Strongly Agree
1. The materials will be helpful in teaching the mathematics goals and objectives set forth in the NC Standard Course of Study.	1	2	3	4	5
2. The materials are appropriate for the grade level indicated.	1	2	3	4	5
3. The problems are interesting and engaging for the students I teach.	1	2	3	4	5
4. The commentaries will encourage use of this material.	1	2	3	4	5
5. I plan to use these materials with my students in grade_____.					
6. Have you ever used earlier versions of the SUPERSTARS material?	YES		NO		

7. How was this program implemented with your students?

8. Additional comments:

SUPERSTARS III

Neptune, I

Name: _____
(This shows my own thinking.)

- ★ 1. A student scores 85, 79, 92 and 100 on her math quizzes. What was her average grade?

Answer: _____

- ★★ 2. Stella bought 4 pencils at the school bookstore. She gave the clerk \$2 and received 16¢ in change. How much did she pay for each pencil?



Answer: _____

- ★★ 3. The circle graph shows Tom's daily activities, and the percentage of time he spends on each.

a. Which two activities together take up half Tom's time?

b. Which activity takes twice as much time as studying?

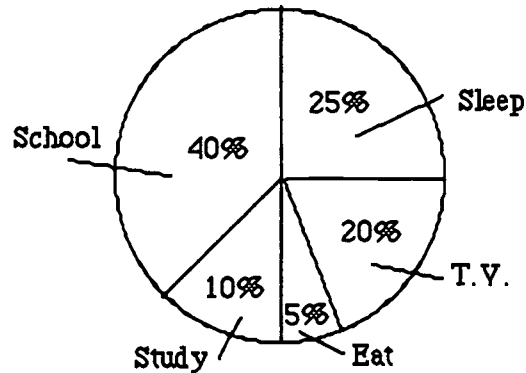

Answer: a. _____ and b. _____

- ★★★★ 4. Russell finds out the winner of the school talent show at 4:00 P.M. on Friday. He calls two seventh grade friends at 4:15 P.M. to tell them. By 4:30 P.M. they each call two 7th grade friends. If each person who is called calls two more 7th graders every fifteen minutes, when will all 176 seventh grade students know the winner?

Answer: _____

★ 5. One number is 7 less than another. Their product is 60. What are the two numbers?

Answer: ____ and ____

★★★ 6. How many different whole numbers can be made with the digits 1, 2, and 3? Any number you make can have 1, 2, or 3 digits in it but you may not repeat a digit in any one number.

Answer: _____

★★ 7. A rectangular yard 80 feet by 60 feet has a fence with a post on every corner and another post every five feet. How many posts are needed for the entire fence? Use the drawing below if it helps.

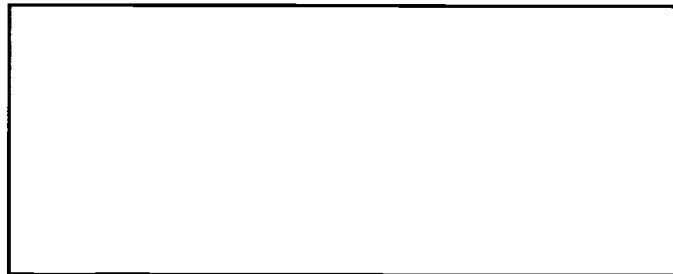

Answer: _____

★★ 8. The blueprint for landscaping a yard has a scale of $\frac{1}{2}$ " to 1 foot. If the blueprint is a rectangle 18 inches by 22 inches, what are the dimensions of the yard?

Answer: _____

★★★ 9. A miniature television is placed on a scale as shown to the right. Then a helium balloon is added. The helium balloon has negative weight since it pulls up on the scale. What is the weight of the helium balloon?

Answer: _____

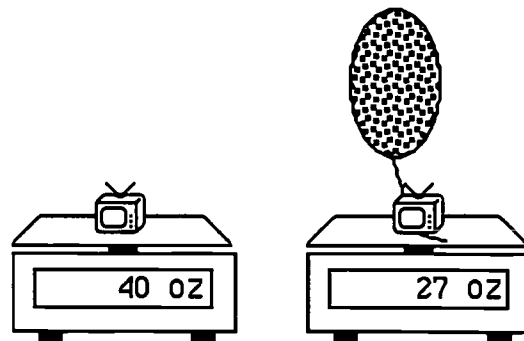

Commentary

Neptune, I

1. (89) Add the four scores, then divide by the number of scores.
2. (46¢ each) Begin with the \$2 Stella gave the clerk and subtract 16¢. Since she bought 4 pencils, divide by 4. (They must have been mechanical pencils!!)
3. (School and studying, t.v.) The only two activities that together equal half his time are "school" and "studying." The activity that takes twice as much time as studying would have to take 20% of his time. The only activity that takes 20% of his time is "T.V."
4. (between 5:30 and 5:45) Since there are only 176 seventh graders, at some point between 5:30 and 5:45 student number 176 was notified, and the remainder of the students called had already been notified by someone earlier. The work below shows this analysis.

Russell finds out at 4:00 P.M.	one 7th grader knows
Russell tells 2 others at 4:15 P.M.	$1+2 = 3$ (7th graders that know)
2 each tell 2 more at 4:30 P.M.	$3+4 = 7$ (7th graders that know)
4 each tell 2 more at 4:45 P.M.	$7+8 = 15$ (7th graders that know)
8 each tell 2 more at 5:00 P.M.	$15+16 = 31$ (7th graders that know)
16 each tell 2 more at 5:15 P.M.	$31+32 = 63$ (7th graders that know)
32 each tell 2 more at 5:30 P.M.	$63+64 = 127$ (7th graders that know)
64 each tell 2 more at 5:45 P.M.	$127+128 = 255$

5. (5, 12) Trial and error would be one way to solve this problem. Try multiplying numbers together that differ by 7. $0 \times 7 = 0$; $1 \times 8 = 8$; $2 \times 9 = 18$; $3 \times 10 = 30$; $4 \times 11 = 44$; $5 \times 12 = 60$ Another method would be to assign the first unknown a value of X and the second variable the value of $X + 7$. You could then solve the equation $X(X + 7) = 60$, to find $X = 5$, $X + 7 = 12$.
6. (15) Students will find it helpful to make a list and keep track of combinations. These include one digit only, two-digit combinations, and three-digit combinations.

1	1-2	3-1	1-2-3	3-1-2	
2	2-1	2-3	2-3-1	2-1-3	
3	1-3	3-2	3-2-1	1-3-2	(For a total of 15 combinations.)

7. (56) One way would be to start at one corner of the rectangle and place a dot (fence post) every five feet. If the dots are counted, they will find that 56 fence posts are needed. If a post is put at one corner of a side, and then posts are put every five feet up to, **but not including**, the other corner, there would be 16 posts on each of the 80 foot-long sides and 12 posts on each of the 60 foot-long sides. That total is 56 posts.
8. (36' by 44') The number of $1/2$ " segments in 18" is 36 so the yard is 36' wide; the number of $1/2$ " segments in 22" is 44 so the yard is 44' long.
9. (-13 oz) The television by itself is 40 oz; with the balloon it's 27 oz. Therefore the balloon must counterbalance 13 oz. Since weight is considered positive, something that counterbalances it would be assigned a negative value. So the helium balloon would be assigned a weight of -13.

SUPERSTARS III
Neptune, II

Name: _____
(This shows my own thinking.)

- ★★ 1. How many different ways can \$0.50 be made with fewer than 8 coins?

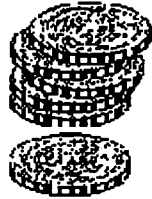

Answer : _____

- ★★ 2. What integer between 10 and 20 is a solution to $(x - 4) + (x + 8) = 36$?

Answer : _____

- ★★ 3. A punch recipe calls for 2 quarts of orange juice, $1\frac{1}{2}$ quarts of apple juice, and $1\frac{1}{2}$ quarts of soda water. How many cups of punch will this recipe make?

Answer: _____

- ★★ 4. Find a pattern and then write the next two terms according to your pattern.

5, 6, 8, 9, 11, 12, 14, 15, 17, 18,

Answer: ____ and ____

- ★★ 5. In the pattern above, what two numbers would come before 5?

Answer: ____ and ____

- ★ 6. Two diagonals are drawn in the rectangle. How many acute angles are there altogether?

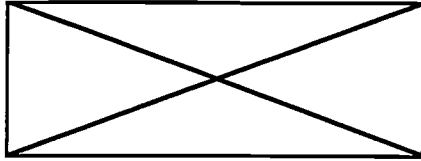

Answer: _____

- ★★ 7. Lisa, Drew, David and Kelly are 11, 12, 13 and 14 years old. David is older than Kelly and younger than Lisa. Drew is younger than David and older than Kelly. How old is each? Use the chart if it helps you.

	11	12	13	14
Lisa				
Drew				
David				
Kelly				

Answer: Lisa is _____, Drew is _____, David is _____, and Kelly is _____.

- ★★★★ 8. Cindy and Bill spend part of their summer vacation at the cottage at the lake. Their mom and dad are very busy in the city, but the children would like to stay at the cottage longer and longer every summer. A new pizza restaurant opened at the lake that served pizzas with different toppings. Mom said that they could stay as many days as the number of different orders of two topping pizzas. With the following toppings, how long can they stay?

Pepperoni
Mushroom
Pineapple
Ham

Sausage
Onion
Bacon
Meatball

Salami
Green Pepper
Avocado

Garlic
Tomato
Tuna Fish

Answer: _____

- ★★★ 9. A major computer company has just purchased the new operating system you created! You have so much money that you decide to give \$2,000,000 away. If you give \$50 away every hour, how long will it take you in years?

Answer: _____

Commentary

Neptune, II

- (8) An organized list would be helpful, such as: 50 , $25 + 25$, $25 + 10 + 10 + 5$, $25 + 10 + 5 + 5 + 5$, $25 + 5 + 5 + 5 + 5 + 5$, $10 + 10 + 10 + 10 + 10$, $10 + 10 + 10 + 10 + 5 + 5$, $10 + 10 + 10 + 5 + 5 + 5 + 5$. The total number of ways is 8.
- (16) *Guess-check-revise* would be a good approach to this problem. Start by guessing a number for x , and check against the conditions. Sixteen works: $(16 - 4) + (16 + 8) = 36$. The algebraic solution involves adding the two x 's and adding the -4 and the $+8$. Then $2x + 4 = 36$. Therefore, $2x = 32$, and $x = 16$.
- (20 cups) 2 quarts + $1\frac{1}{2}$ quarts + $\frac{1}{2}$ quarts = 5 quarts. Since 4 cups = 1 quart, $4 \times 5 = 20$ cups.
- (20, 21) One pattern begins with 5, then adds 1, then 2, then 1, then 2, alternating. The next number in the pattern would add 2, resulting in 20, then add 1, resulting in 21. Another solution is to notice that these are simply the counting numbers, starting with 5, leaving out every 3rd number.
- (2, 3) The notion is to extend the pattern above in the other direction, by reversing the action.

- (10) Draw a rectangle with the two diagonals. Count the acute (less than 90 degrees) angles.

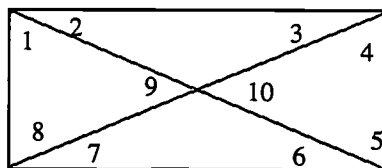

- (14, 12, 13, 11). One good approach is to make a table and proceed by eliminating possibilities. From the first clue, we know that David isn't 11 and isn't 14, so we place X marks in the chart. That same clue tells us that Kelly isn't 14 and Lisa isn't 11. After the first clue, the chart looks like:

	11	12	13	14
Lisa	X			
Drew				
David	X			X
Kelly				X

Another approach is just to line up names, one on top of the other, and manipulate them according to the rules until you find the solution.

- (91 days) Make a table for the different combinations. For example: pepperoni can be combined with the each of the other 13 items, sausage can be combined with the other 12 items, meatball can be combined with the other 11 items and so on. Total the different combinations: $13 + 12 + 11 + 10 + 9 + 8 + 7 + 6 + 5 + 4 + 3 + 2 + 1 = 91$

- (about 4.6 or 4 1/2 years) Divide the \$2,000,000 by \$50 to figure how many times you will give away \$50. You need to give away money for 40,000 hours. Divide the 40,000 hours by 24 (the hours in a day) and then by 365 (the days in a year) to get an answer of about 4.6 years.

SUPERSTARS III
Neptune, III

Name: _____
(This shows my own thinking.)

- ★ 1. How many triangles are in this drawing?

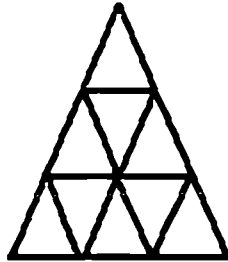

Answer: _____

- ★★ 2. Insert parentheses in the following sentence to make it true.

$$40 - 6 \times 6 - 2 - 6 = 10$$

- ★★★ 3. The telephone company has 25 computer-controlled switching systems. Each system handles 700,000 calls an hour. The system works with 95% accuracy. How many calls would not be accurately answered in one day?

Answer: _____

- ★★ 4. You stop for lunch with your family on the way to the football game. The total bill for lunch is \$15.00. The service is good so you would like to leave the server approximately 20% as a tip. The game is ready to begin, so you quickly figure about how much you should leave! How much is it?

Answer: _____

- ★★ 5. Spaghetti costs 99¢ a pound. A jar of sauce costs \$2.59 and garlic bread is 2 loaves for \$1.39. You have invited friends for dinner and you need 2 pounds of spaghetti, 2 jars of sauce and 3 loaves of bread. To the nearest dollar, how much will it cost?

Answer: _____

- ★★★★ 6. Ricardo wants to cover this 8" by 10" by 5" box with contact paper. How many square inches of contact paper will he need? How much ribbon will he need if the bow itself adds 15 inches?

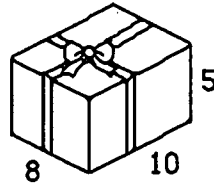

Answer: _____ sq. in. of contact paper and _____ inches of ribbon

- ★★ 7. On the same day in early June, the temperature in Miami, Florida, was 88°F and the temperature in Nome, Alaska was -6°F . How much warmer was it in Miami?

Answer: _____

- ★★ 8. Fabian bought 6 notebooks at the school bookstore. He gave the clerk \$6. If two notebooks cost \$1.77, and the sales tax was 6%, how much change should he receive?

Answer: _____

- ★★ 9. If you start in the right place on this figure, you can trace the whole path without lifting your pencil and without retracing any path. Circle a place to start to do this. You get two stars if you can circle both places where you can start and accomplish this task.

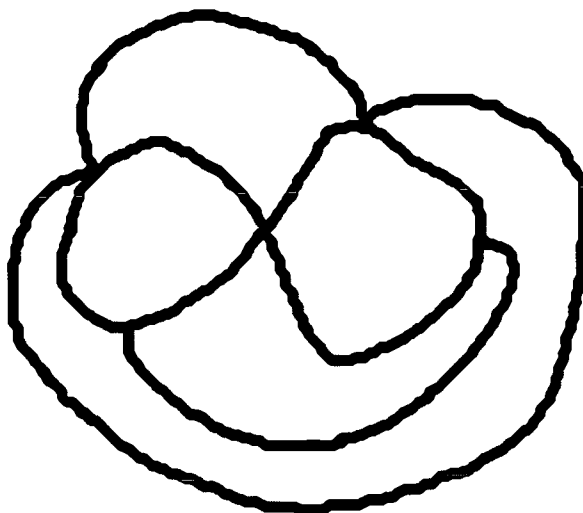

Commentary

Neptune, III

1. **(13)** Organize the information. There are 9 small triangles, 3 medium triangles made from four small ones, and one large triangle.
2. **(40 - 6 × (6 - 2) - 6 = 10)** Students will have to recall the order of operations (multiply and divide first then add and subtract). The solution is then easily found.
3. **(21,000,000)** The total number of calls that can be handled per hour is $25 \times 700,000$ or 17,500,000. Only 5% will be inaccurate. Compute 5% of 17,500,000 which equals 875,000 per hour. This number is multiplied by 24 for the number of calls per day, mishandled.
4. **(\$3)** One way to figure the tip of 20% quickly is to find 10% of \$15, which is \$1.50. 20% would be twice as much, or \$3. Many people know intuitively that 2×15 is 30, so $.2 \times 15$ is 3.0, meaning \$3. Yet a third way is to realize that 20% of \$10 would be \$2, so \$2 plus half of \$2, or $\$2 + \1 , is the tip for \$15.
5. **(\$9)** Estimating spaghetti at about \$1 a pound would give a cost of \$2 for 2 pounds. Sauce is about \$2.50 a jar or 2 jars for \$5. Bread is about 70¢ a loaf, so three loaves would be about \$2. The total to the nearest dollar is \$9.
6. **(340, 71)** The two sides that are 10 by 8 have an area of 80 each for a total of 160. Likewise, the two 8 by 5 and the two 10 by 5 sides have total areas of 80 and 100, respectively. The sum of the six sides gives the amount of contact paper needed. The ribbon needed would be two 10 inch pieces, two 8 inch pieces, four 5 inch pieces, and 15 inches for the bow. This totals 71 inches.
7. **(94°)** The difference between 88° F and -6° F is 94°. So it is warmer by 94 degrees in Miami.
8. **(37¢)** If notebooks cost \$1.77 for two, then 6 cost \$5.31. Multiply \$5.31 by 1.06 to find the cost after sales tax has been added: \$5.63. Subtract \$5.63 from \$6.00 to find the change.
9. The two places where one can start and trace this path, without lifting the pencil, are circled below. These are the only two places with an *odd number* of paths coming into or leaving them. So you can start at either place, and you'll finish at the other place.

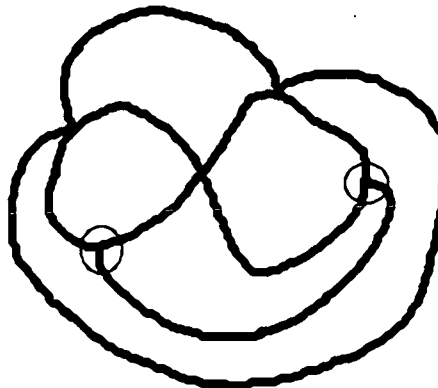

SUPERSTARS III
Neptune, IV

Name: _____
(This shows my own thinking.)

- ★ 1. Sam has to be at work at 6 P.M. He leaves his house at 4:10 P.M. and it takes him 20 minutes to drive to the library. It takes him 25 minutes to drive from the library to work. How much time can he spend at the library?

Answer: _____

- ★★ 2. Remove 8 toothpicks and leave 2 squares. Show the ones to remove by making an X through them.

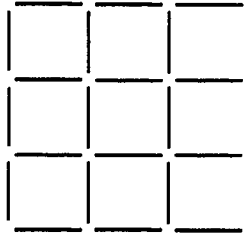

- ★★★ 3. Stamps come in large sheets with perforations in between. How many different ways can you buy 4 attached square stamps? (Two ways to put them together are considered *the same* if one way can be turned or flipped so that its outline looks like the other way.)

Answer: _____ ways

- ★★★ 4. A video arcade offers 6 free games to first time customers. Then each game costs \$.75, and, after every four games, you get a free game. How many games could you play for \$3.00 the first time you are a customer?

Answer:: _____ games

- ★★ 5. Apples sell for \$1.29 a pound, and there is an average of 3 apples per pound. About how many apples would you expect to get for \$5.00?

Answer: _____ 🍏s

★★ 6. A number x is increased by 27 and the result is multiplied by 6, giving 372 as the result.

What was the original number x ? _____

★★★★ 7. A gymnast received the following scores from 5 judges in the state competition:

floor:	8.8, 9.3, 8.1, 8.9, 9.5
bars:	7.6, 8.2, 8.5, 8.2, 8.9
vault:	9.5, 8.9, 9.4, 9.5, 9.0
beam:	8.4, 8.5, 8.4, 7.9, 8.7

Her score for each event is found by computing the average, *after* the high and low scores are thrown out, and rounding the result to the nearest hundredth.

✓ What was her score on each event?

floor: _____ bars: _____ vault: _____ beam: _____

✓ What was her weakest event? _____

✓ What was her strongest event? _____

✓ What was her total score for the day, all 4 events combined? _____

★★★ 8. How many 22 centimeter pieces of string can be cut from a 4.2 meter piece of string?
How many centimeters are left over?

Answer : _____ pieces with _____ cm left over.

★★★★ 9. Some buildings are shown below. If the builder continues this same pattern:

How tall will the tower be in Building 100? _____

How long will each of the two wings be in Building 500? _____

How many blocks will it take to make Building 1000? _____

How many blocks will it take to make Building n , where n can be any whole number? _____

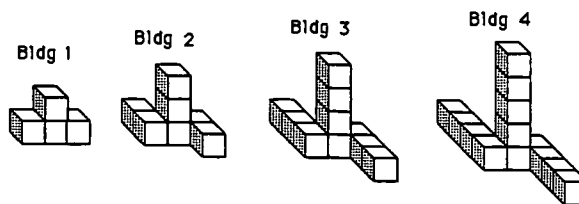

Neptune IV page 2

Commentary

Neptune, IV

1. **(1 hour, 5 minutes)** The difference in 4:10 PM and 6:00 PM is 1 hour and 50 minutes. He spends 45 minutes driving, leaving 1 hour and 5 minutes at the library.

2. **(Answer below.)**

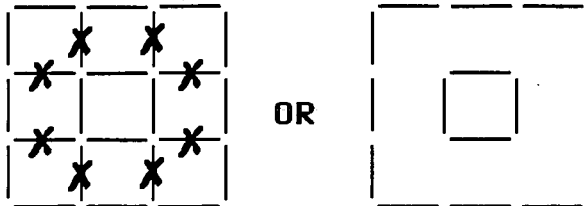

3. **(5)** The 5 possible configurations are below:

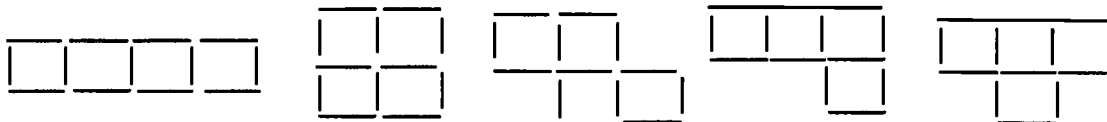

4. **(11)** For a first time customer, the first 6 games are free. Then the customer can play 4 more times for \$3.00 and get a free game. So the total for 11 games is only \$3.00.

5. **(11 or 12)** 3 apples for \$1.29 means that each apple costs $\$1.29 \div 3$ or 43¢. Then $\$5.00 \div 43¢$ is 11.6. Therefore, about 11 or 12 apples, on average, can be purchased for \$5.

6. **(35)** Work backwards: $372 \div 6 = 62$, and $62 - 27 = 35$. So $x = 35$.

7. **(9.0, 8.3, 9.3, 8.43; bars; vault; 35.03)** To find the mean for each event, add the respective numbers:

floor: 8.8; 9.3; and 8.9
 bars: 8.2; 8.2; and 8.5
 vault: 9.4; 9.5; and 9.0
 beam: 8.4; 8.4; and 8.5

and divide by 3. Her lowest score (average) is 8.3 for bars, the highest is 9.3 for vault, so those are her worst and best events. Her total is the sum of all four individual event scores.

8. **(19 pieces, 2.0 cm left)** 4.2 meters is 420 centimeters. $420 \div 22 = 19, r 2$.

9. **(101; 500; 3001; $3n + 1$)** The number of blocks in the tower is always one more than the building number. The number in each wing is the same as the building number. The total number of blocks for a building is found by adding the number of blocks in the tower (building # plus 1) to the number of blocks in the two wings (two times the building number). The total is 3 times the building number, plus 1.

SUPERSTARS III
Neptune, V

Name: _____
(This shows my own thinking.)

- ★★ 1. What is 10% of 20% of 30% of 100?

Answer: _____

- ★ 2. The hundreds digit of a three digit number is $\frac{1}{3}$ of the ones digit and twice the tens digit. What is the number?

Answer: _____

- ★★ 3. How many small cubes are used to make this solid prism?

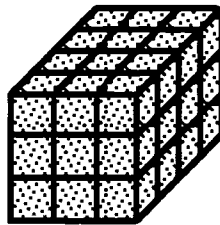

Answer: _____

- ★★★ 4. If the above prism was dipped in green paint, how many small cubes would not have any paint on them?

Answer: _____

- ★★★ 5. A snail starts at the bottom of a 20-foot well. Each day he climbs up $4\frac{1}{2}$ feet, but at night slips back 2 feet. How many days will it take to reach the top of the well?

Answer: _____

- ★★ 6. The highest point in Florida is in Walton county. It is 345 ft. *above* sea level. Sombrero Key is 30 ft *below* sea level. What is the difference, in feet, between these two points?

Answer: _____

- ★★★★ 7. A jar contains 48 marbles, identical except for color. There are twice as many yellow as red marbles and twice as many blue as white marbles. There are 6 more white marbles than red marbles. What is the probability of drawing at random a yellow marble from the jar?

Answer: _____

- ★ 8. Add one operation sign (+, -, ×, or ÷) to make this mathematics statement true.

$$7 \ 0 \ 4 \ 3 \ 8 \ 4 \ = \ 7 \ 1 \ 2 \ 7$$

- ★★★★ 9. How many pencils does it take to balance the jar of paste, given the information below?

Answer: It takes _____ pencils to balance the paste.

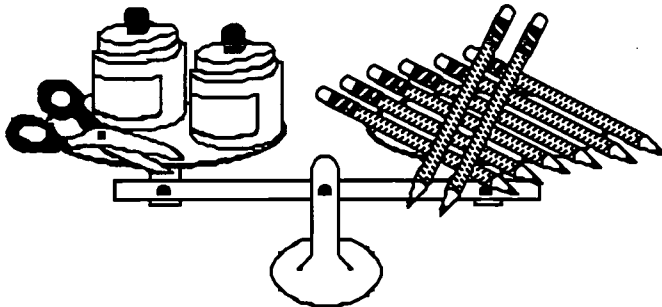
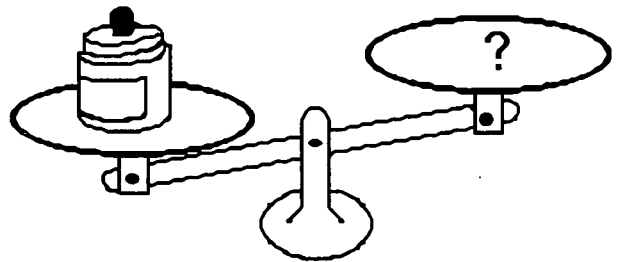

1 pair of scissors and 2 jars of paste balance 8 pencils.

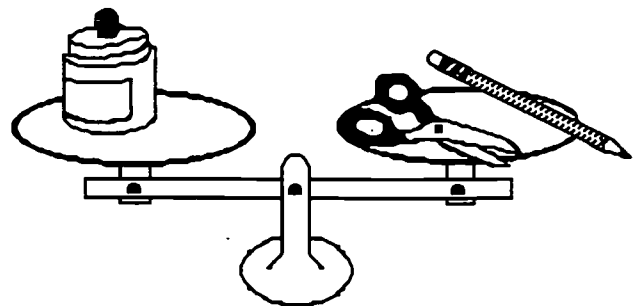

1 jar of paste balances 1 pair of scissors and 1 pencil.

Commentary

Neptune, V

1. (0.6) 30% of 100 is 30, and 20% of 30 is 6. Then 10% of 6 is $\frac{1}{10}$ of 6, or 0.6. Another method involves changing the percents to decimals and solving the mathematical sentence:
 $0.1 \times 0.2 \times 0.3 \times 100 = 0.6$

2. (216) If the hundreds digit is $\frac{1}{3}$ the ones digit, then the ones digit can be only multiples of 3 -- 3, 6, or 9. This means the hundreds digit can be only 1, 2, or 3. The hundreds digit is also two times the tens digit. The only hundreds digit of that group that is twice another whole number is two. If the hundreds digit is two, the tens digit must be one and the ones digit must be six.

3. (36) There are 12 cubes in each level and three levels for a total of 36 cubes. Students may know that volume = length times width times height. $3 \times 4 \times 3 = 36$ cubic units

4. (2) The only cubes without paint would be the two single cubes in the center. To see this, each of the 12 cubes in the top and bottom layer have paint on them. In the middle layer, the 3 on each end, and the 2 on each side, in the center of the side, would have paint. This leaves only 2 out of the layer of 12 with no paint.

5. (7) Drawing a diagram will help students solve this problem. A vertical line best represents the well. Many students will realize that the snail is making progress at $2\frac{1}{2}$ feet per 24-hour period, and can simply start at $2\frac{1}{2}$ and count by $2\frac{1}{2}$ until they get to 20 or beyond.

6. (375) The problem has students find the difference between 345 and -30 on a number line.

7. ($\frac{10}{48}$) One approach is to *guess-check-revise*, knowing that once you chose a number for the red marbles, the other marbles can be obtained and you can check to see if they total 48. If not, revise the guess for the red marbles, and check again.

The solution can be obtained algebraically by letting x be the number of red, $2x$ the number of yellow, $x + 6$ the number of white, and $2x + 12$ the number of blue marbles. The sum of the 4 colors is 48, therefore $x + 2x + x + 6 + 2x + 12 = 48$. Simplifying and solving for x gives $x = 5$. There are 5 red, 10 yellow, 11 white, 22 blue for a total of 48 marbles. The probability of yellow is $\frac{10}{48}$.

8. (+) $7043 + 84 = 7127$

9. (3) This problem will later be solved as a system of equations. At this point, students will reason in a variety of ways to find the answer. One such way is this:

Use the second scale. Double the items on each side, and 2 jars of paste balance 2 scissors and 2 pencils. Substitute 2 scissors and 2 pencils for 2 jars on the left side of the first scale; 2 scissors and 2 pencils and another scissors then balance 8 pencils. Remove 2 pencils from each side of the scale. Then 3 scissors balance 6 pencils, or 1 scissors balances 2 pencils. Substituting 2 pencils for the scissors on the right side of the second scale means that a jar of paste balances 3 pencils.

SUPERSTARS III
Neptune, VI

Name: _____
(This shows my own thinking.)

- ★★★ 1. Arrange 4 quarters, 4 dimes, 4 nickels and 4 pennies in this grid so that each column, each row and each diagonal contains one of each type coin. Place Q, D, N, and P in the grid to show quarters, dimes, nickels, and pennies respectively.

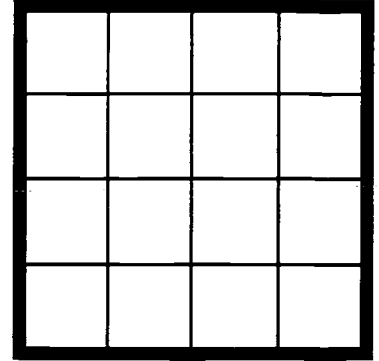

- ★ 2. The football team played fifteen games this season and won three more games than it lost. How many games did the team lose?

Answer: _____

- ★★★ 3. Look for a pattern. Use the pattern to predict the value of $999,999,999 \times 9$.

$$222,222,222 \times 9 = 1,999,999,998$$

$$333,333,333 \times 9 = 2,999,999,997$$

$$444,444,444 \times 9 = 3,999,999,996$$

Answer: $999,999,999 \times 9 =$ _____

- ★★ 4. If three math students do 3 math problems in 3 minutes, how long will it take 33 students to do 33 problems?

Answer: _____

- ★ 5. You are ordering pizza for 10 people. Each pizza has 8 slices. What is the fewest number of pizzas to order so that everyone gets the same number of whole slices?

Answer: _____

- ★★ 6. Add only one arithmetic sign (+, -, ×, ÷) to make the mathematics sentence true.

$$9 \ 3 \ 4 \ 4 \ 6 \ 3 \ = \ 4 \ 3 \ 2 \ 4 \ 4 \ 2$$

- ★★★ 7. What three consecutive numbers have a sum which is $\frac{1}{5}$ of their product?

Answer: _____

- ★★★★ 8. Rose bought some donuts. She gave $\frac{1}{2}$ of her donuts and $\frac{1}{2}$ of a donut to her mom. Then she gave $\frac{1}{2}$ her remaining donuts and $\frac{1}{2}$ of a donut to her brother. Then she gave $\frac{1}{2}$ her remaining donuts and $\frac{1}{2}$ of a donut to her sister. This left her with $\frac{1}{4}$ dozen donuts. How many donuts did Rose originally buy?

Answer: _____

- ★★★★ 9. Lu, Roberto, and Sasha had a 1600-meter rollerblading race. A recording device was attached to each one. The graph of the race was plotted on the same axis system, as shown below.
- What was the order in which they finished, 1st to 3rd? _____, _____, _____
 - Who started off the slowest? _____ The fastest? _____
 - At about what time after the race started did Sasha pass Lu? _____
 - Who raced at the same pace, all the way through? _____

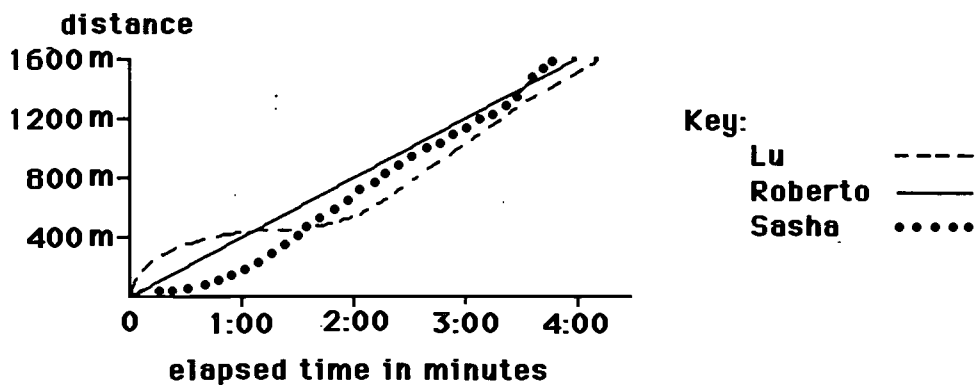

Commentary

Neptune, VI

1. One answer is given below. Others are possible.

Q D N P
P N D Q
D Q P N
N P Q D

2. (6) The question is: "What two numbers add to 15 such that one is three more than the other?". Nine and six fit that description, therefore the team won 9 and lost 6 games.

3. (8,999,999,991) The way most students will find the product is by completing 5 more problems like these 3, filling in the patterns going down. The first digits are just the counting numbers 1, 2, 3, ..., so the first digit in the requested product would be 8. The middle part of the answer would be 8 nines, consistent with the pattern. The last digit follows the pattern of counting down from 8, resulting in 1. The product is then predicted to be 8,999,999,991. Notice that it hasn't been *proved* that this is the product -- it is simply a prediction.

4. (3) If 3 math students do 3 math problems in 3 minutes then 1 math student does 1 math problem in three minutes. If 33 students are doing 33 problems then each student is doing one problem. We know it takes a student 3 minutes to do one problem. Therefore, 33 students can do 33 problems in three minutes.

5. (5) Find the least common multiple of 10 and 8 which is 40. If each pizza has 8 slices and 40 slices are needed, then $40 \div 8 = 5$ pizzas, allowing each person exactly 4 slices.

Or a student might simply ask what is the fewest number of pizzas in which the total number of slices is divisible by ten. One pizza has 8 slices, 2 have 16, 3 have 24, 4 have 32, and 5 pizzas have 40 slices. Since 40 is the first of these multiples of 8 which is divisible by 10, five pizzas is the answer.

6. (×) $934 \times 463 = 432,442$

7. (3, 4, 5) Use mental math to find the sum and product of three consecutive numbers. Beginning with (1, 2, 3), next (2, 3, 4), and continuing in this pattern while keeping track of your results, you find that $3 + 4 + 5 = 12$ and $3 \times 4 \times 5 = 60$. The sum is $1/5$ of the product.

8. (31) Work backwards. She ended with $1/4$ of a dozen, or 3 donuts. If she gave her sister $1/2$ of her donuts and half a donut, she had 7. ($1/2$ of 7 less $1/2 = 3$) If she gave her brother $1/2$ of her donuts plus $1/2$ of a donut she must have had 15. ($1/2$ of 15 less $1/2 = 7$) If she gave her mother $1/2$ of her donuts plus $1/2$ of a donut she must have had 31 to start. ($1/2$ of 31 less $1/2 = 15$)

9. (a. Sasha, Roberto, Lu; b. Sasha, Lu; c. somewhere from 1:30 to 1:45; d. Roberto) The problem involves reading a graph that tells a story over an elapsed span of time. The order of finishing involves finding the one who reached 1600 meters first, timewise. All three stopped at the graph height corresponding to 1600 m; but Sasha's line is to the left of the others, indicating that she took less time.

Sasha started the slowest because her graph at the beginning doesn't rise as fast as the other two -- she doesn't cover as many meters for a given time as the others at the start. Sasha did pass Lu, however, at about 1 and $1/2$ to 1 and $3/4$ minutes. Roberto ran the same pace all the way through, producing a straight line graph indicating a constant speed per unit of time. He covers about 400 m each minute.

SUPERSTARS III
Neptune, VII

Name: _____
(This shows my own thinking.)

★★★ 1. What common fraction is equivalent to $0.\overline{325}$?

Answer: _____

★ 2. What five consecutive odd numbers total 95?

Answer: _____

★★ 3. Lisa had some money. She gave half to her brother and spent half of what she had left. Then she lost 25¢ and only had 50¢ left. How much money did she have when she started?

Answer: _____

★★★ 4. Arrange the digits one through nine in the circles in such a way that each row across and down has the same total.

<input type="text"/>	<input type="text"/>	<input type="text"/>
<input type="text"/>	<input type="text"/>	<input type="text"/>
<input type="text"/>	<input type="text"/>	<input type="text"/>

★ 5. Find a year between 1970 and 1980 where the sum of the digits in the hundreds place and the thousands place equals the sum of the digits in the ones place and the tens place.

Answer: _____

★★ 6. Andy takes a 30 question test. How many questions can he miss and still make at least 75%?

Answer: _____

- ★★★★ 7. If a regular hexagon shares a side with a square, and the perimeter of the hexagon is 72 cm, what is the area of the square?

Answer: _____

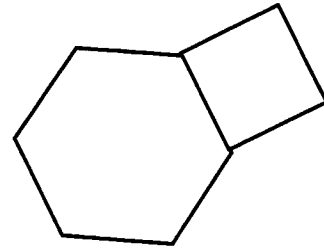

- ★★★★ 8. Put the digits 0, 1, 2, 3, 4, 5, 6, 7, 8 and 9 into each square, using each digit only once.

Make the *sum* of the 2 five-digit numbers as large as possible:

+					

Make the *difference* the smallest possible positive integer:

-					

- ★★★ 9. Write and solve an equation to show each situation below.

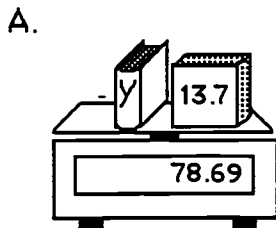

Equation A: _____
 solution: $y =$ _____

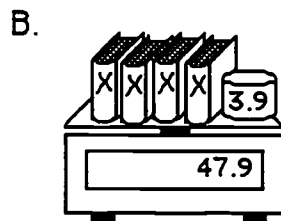

Equation B: _____
 solution: $x =$ _____

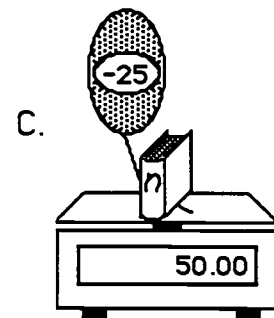

Equation C: _____
 solution: $n =$ _____

Commentary

Neptune, VII

1. ($\frac{325}{999}$) Let n be the number $0.\overline{325}$. Then $1000n$ "moves the decimal" three places to the right, so $1000n$ is $325.\overline{325}$... Notice that when you then subtract n from $1000n$, you get $999n = 325$. Therefore n is $325/999$.

2. (15, 17, 19, 21, 23) This problem can be approached through *guess-check-revise*. Another method involves finding the center number by division: $95 \div 5 = 19$. Therefore, the 5 consecutive odd numbers will be centered on 19.

The problem can also be approached algebraically. The first odd number is x ; the next consecutive odd numbers are $x + 2$, $x + 4$, $x + 6$, and $x + 8$. They total 95; therefore, $x + (x + 2) + (x + 4) + (x + 6) + (x + 8) = 95$. Simplifying and solving the equation gives $5x + 20 = 95$, or $5x = 75$, making $x = 15$. The other numbers are the next four odd numbers in sequence.

3. (\$3) Work backwards: 50¢ plus the 25¢ lost gives 75¢ . She had spent half of what she had and was left with 75¢ , so prior to this step she had $\$1.50$. If she gave half of what she had to her brother and was left with $\$1.50$, then prior to this step she must have had $\$3.00$.

4. One solution is shown below. Other solutions are possible.

$$\begin{array}{r} 4 \quad 9 \quad 2 \\ 8 \quad 1 \quad 6 \\ 3 \quad 5 \quad 7 \end{array}$$

5. (1973) Since all of the years from 1970 to 1980 have the thousands and hundreds digits the same, and their sum is 10, the other two digits must sum to ten. Therefore since a 7 has to be in the tens place to be in the 1970s decade, the units digit is a 3.

6. (7) 75% of 30 is 0.75×30 or 22.5. If he misses 8, his score would be 22 which is less than 75% of 30. So he must miss no more than 7.

70. (144 cm^2) The hexagon has 6 sides. Since $72 \div 6 = 12 \text{ cm}$ per side of the hexagon, the side of the square is 12 cm. The area of the square is side \times side or $12 \text{ cm} \times 12 \text{ cm}$ which equals 144 cm^2 .

8. (See below.) The digits in the addend on the left can be reversed top and bottom, but the answer is unique. Both the answer and the individual numbers are unique in the subtraction problem.

$$\begin{array}{r} 97531 \\ 86420 \\ \hline 183951 \end{array} \qquad \begin{array}{r} 50123 \\ -49876 \\ \hline 247 \end{array}$$

9. (a. $y + 13.7 = 78.69$ and $y = 64.99$; b. $4x + 3.9 = 47.9$ and $x = 11$; c. $n - 25 = 50$ and $n = 75$) The equations result from using a variable y , x , or n to stand for the unknown weight on the scale. In A, a book of unknown weight y , plus 13.7, weighs 78.69. When the weight 13.7 is removed, the scale would show $78.69 - 13.7$, or 64.99. In B, four books and a weight of 3.9 weigh 47.9. When the 3.9 is removed, the four books alone would weigh $47.9 - 3.9$, or 44. If four books weigh 44, then each one must weigh $44 \div 4$ or 11. In C, a helium balloon pulls up on the scale and so has negative weight. Therefore when the helium balloon is removed from the scale, the scale would show $50 + 25$ or 75. So the book weighs 75. 0[Note: Some students may write $x + x + x + x + 3.9 = 47.9$ for B, which is acceptable.]

SUPERSTARS III
Neptune, VIII

Name: _____
(This shows my own thinking.)

- ★★★ 1. On a farm there were 36 heads and 104 legs when counting the cows and chickens. How many chickens were on the farm? How many cows were on the farm?

Answer: _____ chickens and _____ cows

- ★★ 2. Circle the figures that can be folded to make a closed cube.

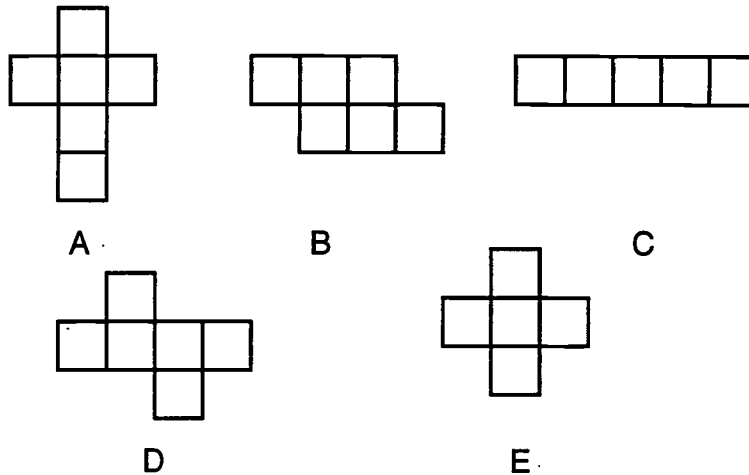

Answer(s): _____

- ★★★ 3. Give the exact number of degrees in the smaller angle formed by the hands of the clock at 5 o'clock. The picture is not accurate enough to be measured with a protractor.

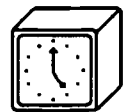

Answer: _____

- ★★★ 4. Your sock drawer has 10 blue socks, 16 red socks and 12 white socks.
- a) In the dark, what is the probability that you will pull out a white sock? _____
- b) If you pull a white sock and put it on, what is the probability that the next sock you put on will also be white? _____

★★ 5. Place the next three numbers in the pattern:

1, 3, 6, 10, 15, _____, _____, _____,

★★ 6. A student has the following grades on a math test: 65%, 90%, and 85%. What is the highest possible average the student can receive if there will be one more test, and all four tests count equally?

Answer: _____

★★★ 7. If it takes 2 dogs 2 minutes to eat 4 bones, how long will it take 4 dogs to eat 24 bones?

Answer: _____

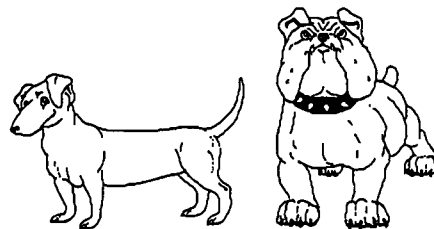

★★ 8. Insert parentheses to make the sentence true: $28 - 20 - 3 - 4 = 7$

★★★ 9. Walter saw this view of his hamburger, fries, and cola when he looked straight at the counter. Tell which view each of the pictures below shows, the view from the right, from the left, or the view from the back of the counter. Write "right," "left," or "back" in the correct blank.

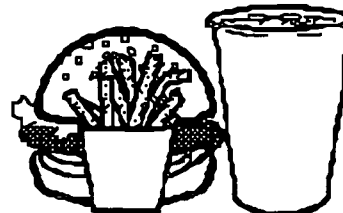
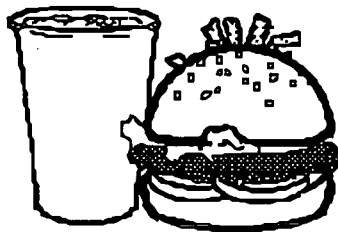
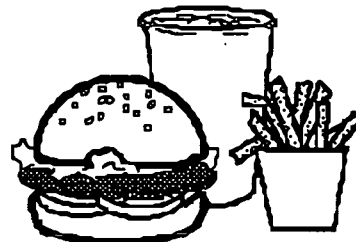

Commentary

Neptune, VIII

1. **(20 chickens, 16 cows)** Most students will solve this by guess-check-revise. The number of chickens plus the number of cows has to be 36 since there are 36 heads. So students can guess numbers of chickens and cows that total 36, compute the number of legs, and adjust their guess accordingly until they reach the correct number.

Another clever approach that some students will use is to reason that since there are at least 2 legs on each of the 36 heads, 72 legs are accounted for already. The extras, $104 - 72$ or 32, must be to make 4-legged animals. That would be 16 pairs of extra legs, so there must be 16 cows. Then the rest, $36 - 16 = 20$, are chickens and have only the two legs given initially.

2. **(A, D)** A closed cube must have 6 faces. C and E have only 5 faces and cannot be closed cubes. B will not fold to make a cube, but A and D will.

3. **(150°)** At 5 o'clock, one hand is on the 12 and the other is on the 5. The portion of the clock covered by this angle is $5/12$ of the clock face, which is a circle of 360° . $(5/12) \times 360^\circ = 150^\circ$.

4. **(12/38 or 6/19; 11/37)** On your first pull, you have 12 chances out of 38 of pulling a white sock. If a white sock is pulled first, then there are only 11 white socks left out of the new total of 37. The chance is then $11/37$.

5. **(21; 28; 36)** The most obvious pattern begins with one and first adds two, then adds three, then adds four, then adds five. This pattern is continued by adding six, then seven, then eight. The next three numbers would be $15 + 6$ or 21, $21 + 7$ or 28, $28 + 8$ or 36. Another way to find the answers is to notice that the n th term is given by $n(n + 1) \div 2$. If students can justify other answers because they noticed other patterns, give them credit.

6. **(85)** The average is the total of all the scores divided by the number of tests. The highest possible average would be achieved by scoring a 100% on test number four. The sum would then be $65 + 90 + 85 + 100 = 340$. The highest possible average would be $340/4 = 85\%$.

7. **(6)** The dogs are eating simultaneously, so it takes each dog 2 minutes to eat 2 bones; that is one bone per minute per dog. So four dogs can eat six bones each, a total of 24 bones, in six minutes.

8. **[28 - (20 - 3) - 4 = 7]**

9. **(back, left, right)** Students who can solve this easily have a good sense of space and their visualization skills are high. The visual clues they will use are the figures which are in front of or behind others, or to the left and right of others.

In the left most picture, the cola is now in front of the other two, whereas it was behind them in the given picture. So this picture is the reverse of the given picture, meaning the view is from the back of the counter. In the center picture, the fries are hidden by the burger -- this would happen only if the view was from the left. In the last picture, the fries are visible in front of the burger -- this implies a view from the right of the original picture. Students might want to experiment with a similar situation, using 3 real objects.

SUPERSTARS III
Neptune, IX

Name: _____
(This shows my own thinking.)

- ★ 1. How many cubes were glued together to create this solid figure?

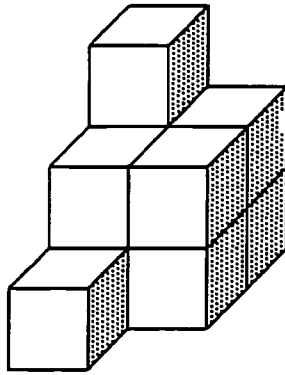

Answer: _____

- ★★★ 2. A CD costs \$14.76, including tax. You give the clerk a twenty dollar bill and a penny.

a) Why would you give the clerk the extra penny?

Answer: _____

b) How much change will you receive?

Answer: _____

- ★★ 3. Estimate a 15% tip for a \$15.32 restaurant bill. About how much money should you leave as a tip?

Answer: _____

- ★★★ 4. Mary calls every three days, Nicole calls every 4 days and Cindy calls every 6 days.
Once in every _____ days, all three will call on the same day.

★ 5. What percent of the rectangle is shaded?

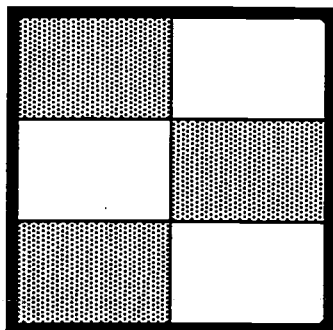

Answer: _____

★★ 6. Estimate to the nearest half hour the time it will take to travel 870 miles at an average speed of 50 miles per hour.

Answer: _____

★★★ 7. The figure below consists of 5 squares of the same size. The area of the figure is 180 square units. What is the perimeter?

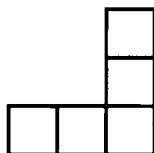

Answer: _____

★★★★ 8. You've heard "Two wrongs don't make a right." But in the puzzle below, two wrongs do make a right! Solve the puzzle by finding the values of the letters W, R, N, G, T, and I.

$$\begin{array}{r}
 \text{W R O N G} \\
 + \text{W R O N G} \\
 \hline
 \text{R I G H T}
 \end{array}
 \qquad
 \begin{array}{l}
 \text{Letter O} = 0 \text{ (zero)} \\
 \text{Letter H} = 8
 \end{array}$$

W = ___ R = ___ N = ___ G = ___ T = ___ I = ___

Commentary

Neptune, IX

1. (10) This problem requires visualizing the blocks that are hidden. In the back left, the blocks are stacked 3 high; back right, front left and front right are stacked two high; there is a single block in front.
2. a) You would give the clerk a penny to get fewer coins back in change.
b) (\$5.25) Your change would be a five-dollar bill and a quarter.
3. (\$2.00 to \$2.50) One way to estimate 15% is to estimate 10% of a number, then add half of that for the other 5%. 10% of \$15.32 would be about \$1.50, and adding half of that would be another 75¢. The total would be about \$2.25. Accept an estimate between \$2.00 and \$2.50.
4. (12) One way to approach the problem is to choose a day to begin counting, and cycle through every 3 days, every 4 days, and every 6 days from that point. Eventually all three counts include a common day, which is 12 days from when you start. You could also solve the problem by finding the least common multiple of 3, 4, and 6, which is 12.
5. (50%) The rectangle is divided into six equal sections, three of which are shaded. This shaded portion could be expressed as $\frac{3}{6}$, $\frac{1}{2}$, 0.5, or 50%, but the problem asks for percent.
6. ($17\frac{1}{2}$) A speed of 50 miles per hour means 100 miles every two hours, or 800 miles in 16 hours. Add another hour for the next 50 miles, and you're up to 17 hours for 850 miles. There's 20 more miles to go, which is close to 25 miles that would take almost a half hour at that speed. So add another half hour to the estimated time.
7. (72) The area of 5 squares is 180, so the area of one square is $180 \div 5$ or 36 square units. If the area of one square is 36 square units, then each side must equal 6 units. There are 12 sides that make up the perimeter of the figure, and $12 \times 6 = 72$.
8. (W=3; R=7; N=9; G=1; T=2; I=4) Trial and error works, but careful analysis helps. Logic will tell you first that G=1 since the column with two zeros added results in another number, which can only be 1. With that start, the puzzle is not difficult to finish.

SUPERSTARS III

Neptune, X

Name: _____

(This shows my own thinking.)

- ★★ 1. At Super Star Middle School, sixty of eighty teachers are female. What percent of the teachers are male?

Answer: _____%

- ★★★ 2. Aurelia has 4 hats; one green, one yellow, one blue and one purple. She has 3 pretty bows for them; one with stripes, one with polka-dots and one with checks. If she must use one bow per hat, how many different hats can she possibly make, assuming she can put any bow on any hat and change them whenever she chooses?

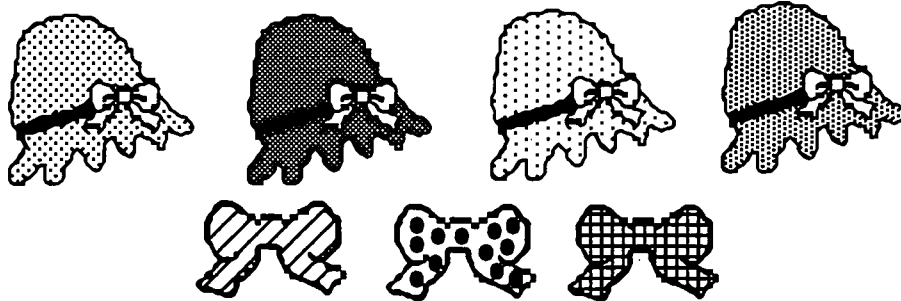

Answer: _____ hats

- ★★ 3. Sam wants to have a Halloween party for 30 of his friends. Jumbo subs cost \$15.99 and can feed 8 people. How much will Sam spend to feed himself and thirty friends, after sales tax of 7% is added?

Answer: \$_____

- ★★★ 4. In her first 20 free-throw attempts, Suzie made 9 baskets. How many baskets must she make in her next 30 attempts to have an overall average of 70%?

Answer: _____ baskets

- ★★★★ 5. The area of the large square made on a wooden geoboard is 81 sq. in. What is the area of the shaded portion?

Answer: _____ sq. in.

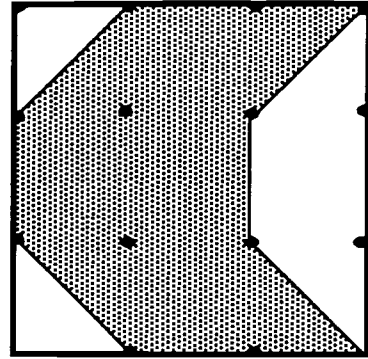

- ★★★ 6. How many terms does the following arithmetic sequence have?

2.5, 4, 5.5, 7,, 17.5

Answer: _____

- ★★ 7. How many squares are shown in the picture below?

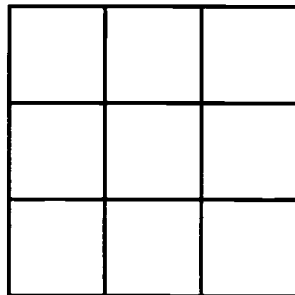

Answer: _____ squares

- ★ 8. Miguel's family wants to go to Disney World. Admission is \$38.00 each. His dad has saved \$75.00. How much more does he need to save for Miguel, his dad, his mother and his sister to go to Disney World?

Answer: \$ _____



Commentary

Neptune, X

1. (25%) If 60 out of 80 teachers are female, then 20 are male. 20 males out of 80 total teachers equals 25%.
2. (12) For each of the four hats, a different bow will make a different hat. 3 different *green* hats + 3 different *yellow* hats + 3 different *blue* hats + 3 different *purple* hats = 12 different hats.
3. (\$68.44) If each sandwich feeds 8 people, he will need 4 sandwiches to feed himself and 30 friends. $\$15.99 \times 4 = \63.96 . Adding sales tax of 7% can be done in one step by multiplying $\$63.96 \times 1.07$ to get \$68.44, when rounded up to the next cent.
4. (26) For her overall average to be 70% she must make 35 out of 50 baskets because $35/50 = 0.70 = 70\%$. Therefore if she needs to make a total of 35 baskets and has already made 9, she needs to make 26 out of her next 30 attempts ($35 - 9 = 26$).

5. (54 sq. in.) There are a number of ways to find this answer. One approach is to determine that each of the nine smaller squares has area $81 \div 9$ or 9, and count whole (4) and half squares (4) in the shaded part for a total area of $4 \times 9 + 4 \times 4.5 = 54$. Another way, once you know each small square has area 9, is to count the whole (1) and half squares (4) in the unshaded part and subtract these amount from 81. Probably the most efficient way is to visualize moving the shaded triangles on the right to the unshaded triangular spaces on the left. This produces a shaded figure that is $2/3$ of the total figure. The shaded part would be $2/3$ of 81, which is 54.

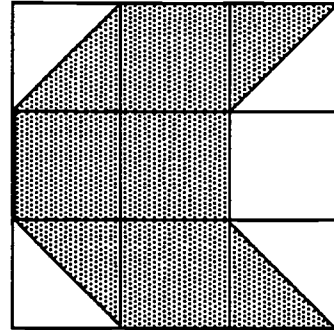

6. (11) Counting by 1.5 makes the full sequence:

2.5, 4, 5.5, 7, 8.5, 10, 11.5, 13, 14.5, 16, 17.5 for a total of 11 terms.

7. (14) Students should be encouraged to start analyzing such figures in an organized way. One such approach for this problem is to start counting the smallest squares first, getting 9. Then move to the next smallest size, which is a 2-by-2 square -- there are 4 of these. The next size square is the large one itself, giving a total number of $9 + 4 + 1$.

8. (\$77) They will need \$152 for 4 admissions to Disney World. Since they already have \$75, they will need to save \$77 more.

SUPERSTARS III

Neptune, XI

Name: _____
(This shows my own thinking.)

- ★★ 1. If a train has 1 engine and 3 other cars, and the engine must always be in front, how many different ways can the 4 cars in the train be arranged?

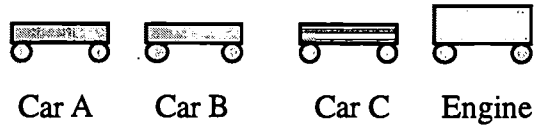

Answer: _____

- ★ 2. Plot these points on the grid below and connect them in order. You should get a familiar picture.

- a. (-3,0) b. (-1,-1) c. (-2,-4) d. (0,-2)
 e. (2,-4) f. (1,-1) g. (3,0) h. (1,0)
 i. (0,3) j. (-1,0) k. (-3,0)

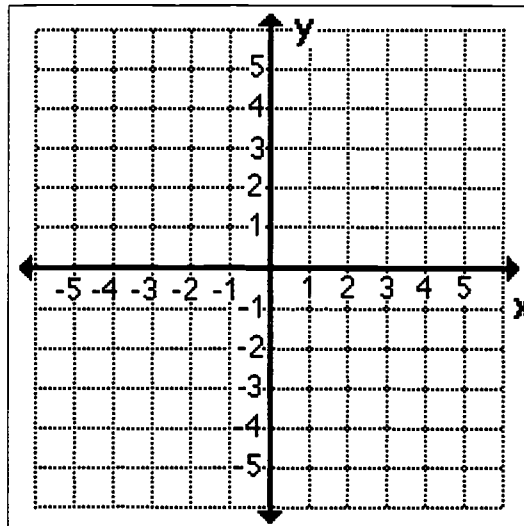

- ★★★★ 3. If point A is multiplied by point B the answer will be point _____.

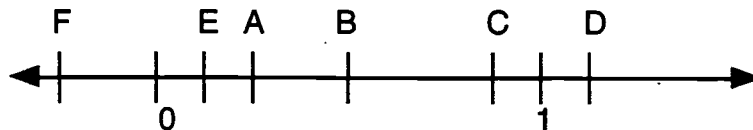

- ★★★ 4. Mike's birthday was 100 days ago. Today is Wednesday. On what day of the week did his birthday fall?

Answer: _____

- ★★★★ 5. David signed a contract that says he must build 10 dog houses for the S.P.C.A. The organization wants them ready within one month. For every dog house David completes he will receive \$40 and for every one he fails to complete he will be fined \$10. At the end of the month David received \$150. How many dog houses did he build?

Answer: _____

- ★★★ 6. Mary starts a project at the library at 9:00 A.M. She estimates that her work will take her about 4 hours. She plans to take a 15 minute break and a 30 minute lunch. Her walk home is about 20 minutes. About what time would she expect to return home?

Answer: _____

- ★★ 7. In 1977, Florida started keeping records on the number of manatees that died each year. The results through 1980 are shown below. What is the average number of manatees that died per year from 1977 to 1980? Round your answer to the nearest whole number.

<u>YEAR</u>	<u>NUMBER DEAD</u>
1977	112
1978	88
1979	80
1980	65

Answer: _____

- ★★★ 8. The scale shows weight in grams. How much does each cup of coffee weigh? Remember that a balloon can have negative weight, if filled with helium.

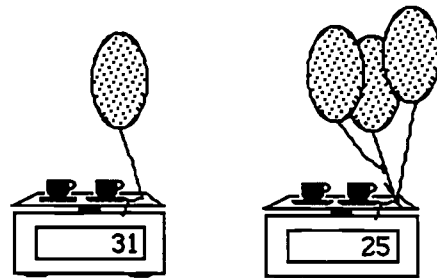

Answer: _____ grams

- ★★★ 9. Write an equation for the situation below. Solve the equation by finding the value for t .

Answer: An equation is: _____. The solution is $t =$ _____

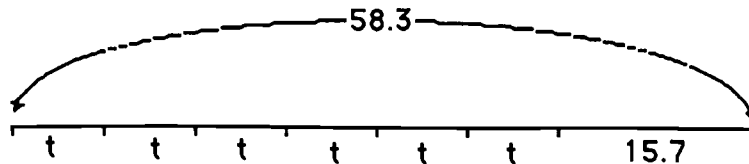

Commentary

Neptune, XI

1. (6) Label the cars, except for the engine, A, B, and C. Then the different arrangements are ABC, ACB, BAC, BCA, CAB, and CBA.

2. (The figure is shown to the right.)

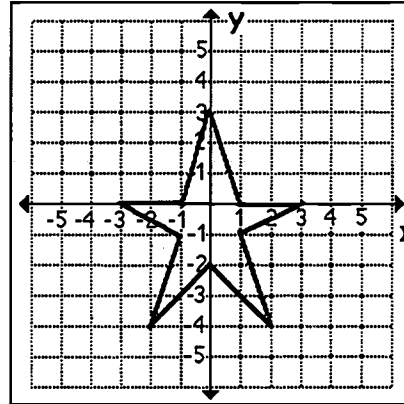

3. (Point E) Point A is $\frac{1}{4}$ and B is $\frac{1}{2}$. Then $\frac{1}{4}$ of $\frac{1}{2}$, or $\frac{1}{8}$, is point E.

4. (Monday) 100 days ago was 14 weeks and 2 days ago. If today is Wednesday, 14 weeks ago was also Wednesday and 2 days before that was Monday.

5. (5) Students might use a chart like this:

<u>BUILT</u>	<u>NOT BUILT</u>	<u>EARNINGS</u>
1	9	-50
2	8	0
3	7	50
4	6	100
5	5	150

Another approach would be algebraic, setting up and solving the equation $40x - 10(10 - x) = 150$, where x is the number of dog houses made.

6. (2:00 P.M.) 4 hours + 15 minutes + 30 minutes + 20 minutes = 5 hours and 5 minutes after 9 A.M. means Mary will return home at 2:05 P.M. Since the question asks "about what time," 2:00 P. M. is a reasonable answer.

7. (86) $112 + 88 + 80 + 65 = 345$, and $345 \div 4 = 86.25$ This answer is rounded to the nearest whole number, 86.

8. (17 grams) Students can reason that the only difference between the two pictures is that 2 more balloons have been attached to one scale, resulting in 6 less grams. This implies that a balloon weighs -3 grams. Using this fact and the first scale, we have that 2 cups of coffee and -3 grams equals 31 grams, so 2 cups of coffee alone would be 3 more grams than 31, or 34 grams. Therefore one cup of coffee is half that amount, or 17 grams.

9. ($6t + 15.7 = 58.3$, $t = 7.1$) Students might write a different form of the equation, such as $t + t + t + t + t + t + 15.7 = 58.3$, which is acceptable.

SUPERSTARS III
Neptune, XII

Name: _____
(This shows my own thinking.)

- ★★ 1. Using 4 fours with any operations or grouping symbols, write an expression that has a value of 9.

4 4 4 4

Answer: _____

- ★★ 2. This figure is made of 24 toothpicks arranged to form 9 small squares. Show how to remove 4 toothpicks, by putting an X on them, to leave 5 small squares.

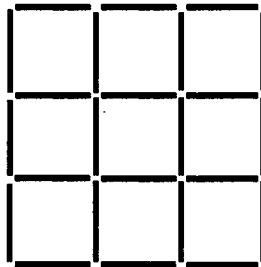

- ★★★ 3. Give an example of 4 different test scores whose median equals the mean.

Answer: _____

- ★ 4. There are 5 students on the bowling team, 8 students on the track team and 4 students on the tennis team. The only students on more than one team are the two students on both the bowling and tennis teams. How many students are participating in these three sports?

Answer: _____ people

- ★★ 5. Before the big flag football game between 7th and 8th grade girls, the ten 7th graders on the team all shake hands with each other. How many handshakes are exchanged?

Answer: _____

★★★

6. A new game has 8 scratch-off spots. The numbers from 1 through 8 have been randomly placed on the spots. To win, you have to scratch off 3 *even numbers* with only 3 scratches allowed. What are your chances of winning?

Answer: _____

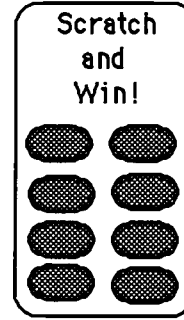

★★★★

7. To make money for the 7th grade end-of-year party, baked goods were to be sold. Herbert was assigned to price the cookies correctly. A small cookie was to sell for 25¢. A giant cookie, whose diameter was 4 times that of the small cookie, was also to be made. Herbert priced the giant cookie based on its area as compared to the area of the small cookie. How much did it sell for?

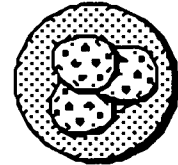

Answer: _____

★★★

8. Shown below are the front view and top view of two buildings made according to a pattern.

- a. How many blocks would it take to build the 5th building in the pattern? _____
- b. How many blocks would it take to build the 10th building in the pattern? _____
- c. If you had 1000 blocks, what the largest building number you could build? _____

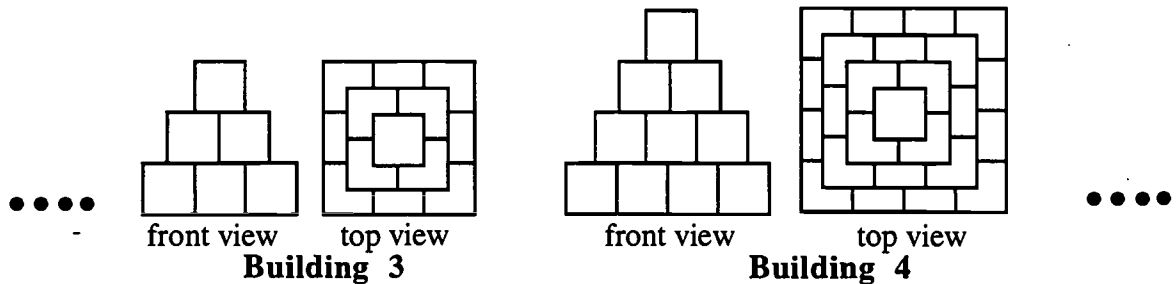

★★

9. How much larger is the sum of the even numbers from 1 to 100, than the odd numbers from 1 to 100?

Answer: _____

Commentary

Neptune, XII

1. (Sample: $4 + 4 + 4 \div 4 = 9$)

2. (One correct answer would be to remove the outside middle segments on each of the 4 sides.) Others may be possible.

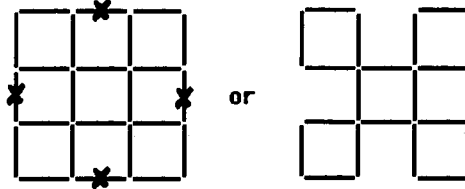

3. (One possible answer: {70, 80, 90, 100} has a mean of 85 and a median of 85.) Other answers are likely. Each answer will have to be checked individually. The mean is found by summing the four numbers and dividing by four. The median is found by ordering the numbers from smallest to largest, and taking the mid-point between the two middle numbers.

4. (15) $5 + 8 + 4 = 17$ and $17 - 2 = 15$. The two students who are on two teams have been counted twice in the total of 17, and they must be removed from the count one time.

5. (45) Person 1 shakes hands with 9 others, person 2 shakes hands with 8 others, and so on. Another approach is to draw a diagram, such as the one started to the right. Lines would be drawn to connect each point with each of the other nine points. The total number of lines is $9 + 8 + 7 + 6 + 5 + 4 + 3 + 2 + 1 = 45$.

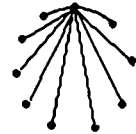

6. ($3/42$ or about 7%) The chances that you will scratch off an even number the first time is $4/8$. If you succeed, the chances that you will scratch an even number is $3/7$, since there are now three even numbers left out of the seven spots. If successful, the chances you'll scratch off an even number the third time in a row is $2/6$. The chances you'll succeed on all three scratches is the product of $4/8$, $3/7$, and $2/6$. This computation results in $3/42$, or 0.07 when rounded, or about 7%.

7. (\$4) The area of the small cookie is πr^2 , where r is the radius of the small cookie. The giant cookie has 4 times the diameter, and hence 4 times the radius, of the small cookie. Therefore, its area is $\pi(4r)^2$ or $16\pi r^2$. Since the new cookie has 16 times the area of the small cookie, it should cost $16 \times 25\text{¢}$ or \$4.

8. (55, 385, 13th) The pattern that students will discover for making a building is to add the square of the building number to the number of cubes in the preceding building. For example, the number of cubes for the third building is $9 + 4 + 1$. The number for the 4th building can be found by adding on to the third building a 4-by-4 bottom layer, or 16 more blocks. The 5th building could then be made by adding a 5-by-5 bottom layer, increasing the number of blocks by 25. The 10th building would then take $1^2 + 2^2 + 3^2 + 4^2 + 5^2 + 6^2 + 7^2 + 8^2 + 9^2 + 10^2$, or 385, blocks. If you continue adding the squares of the next few whole numbers, the sum for building 13 is 819 and that for building 14 is 1015. Therefore, 1000 blocks would be sufficient for building 13, but not for building 14.

9. (50) If you pair each odd number from 1 to 99 with the next even number from 2 to 100, each odd number would be 1 less than its partner. There are 50 such pairs, so the difference is 50.

SUPERSTARS III
Neptune, XIII

Name: _____
(This shows my own thinking.)

- ★ 1. How many cubes were needed to create the solid figure below?

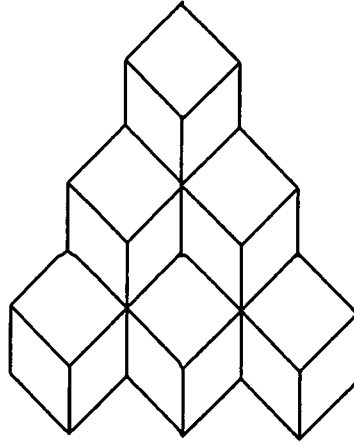

Answer: _____ cubes

- ★★★★ 2. One bus arrives at Mathematics Mall every 16 minutes, while another bus arrives every 20 minutes. If they both arrive at 3:00 P.M. what is the next time they will both arrive at the mall at the same time?



Answer: _____

- ★★★★ 3. A basketball team has players with the following heights:

6'1", 6'3", 6', 5'11"

If the average height of this 5-player team is 6'1", how tall is the fifth player?

Answer: ____ ft. ____ in.

- ★ 4. The sum of the ages of Amy and her sister is 19 and the difference is 5. What is the product of their ages?

Answer: _____

- ★ 5. A battery in a portable T.V. has an expected life of 1000 hours. If you watch such a T.V. every day from 4 P.M. until 10 P.M., about how many months can you expect your T.V. to play using the original battery?



Answer: _____ months

- ★★★ 6. The estimated cost of sending a person to Mars is \$45 billion. This amount is to be shared equally by the 250 million people in the United States. What is each person's share?

Answer: \$_____ per person

- ★★★ 7. Dante made a dart board "baseball game" for his house. As the batter, he would either get a walk (w), a single (s), a double (d) a triple (t), a homerun (hr), or make an out. If his darts land randomly on the board,

- What per cent of the time will he be successful in getting on base? _____
- What per cent of the time will he make an out? _____
- What is the chance that he will make 3 outs in a row? _____

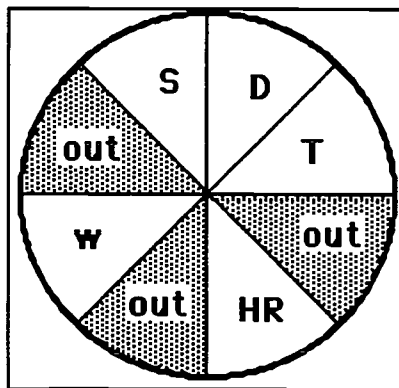

- ★★ 8. Three out of every five students who eat lunch in the cafeteria have chocolate milk. How many students can you expect to drink chocolate milk if 250 students eat lunch in the cafeteria on Friday?

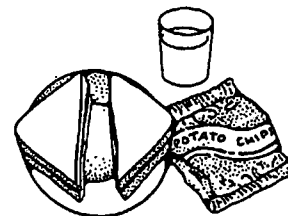

Answer: _____

Commentary

Neptune, XIII

1. **(10 cubes)** 6 on bottom row, 3 in the middle, one on top.
2. **(4:20 P.M.)** Multiples of 16 are 16, 32, 48, 64, and 80. Multiples of 20 are 20, 40, 60 and 80. Therefore in 80 minutes after 3:00 P.M. both buses will arrive at the mall at the same time.
3. **(6'2")** One approach is to convert the heights to inches. If the average height is 73" then the total team height is $5 \times 73" = 365"$. Solve $73" + 75" + 72" + 71" + x = 365"$. The fifth player's height x is then 74" or 6'2". Another approach is to look at the given heights and compare them to the given average -- the first height 6'1" is right on the average, so give it a 0. The 6'3" would be +2, the 6' would be -1, the 5'11" would be -2 from the given average. To get all of these integers back to zero, you need one that's +1. So the last player would have to be 1" more than the average, or 6'2".
4. **(84)** Various strategies may be used including trial and error. Since $12 + 7 = 19$ and $12 - 7 = 5$, the numbers are 12 and 7. Their product is 84.
5. **(about 5 1/2 months)** $1000 \text{ hours} \div 6 \text{ hours per day}$ is approximately 167 days. This is about 5 and one-half months.
6. **(\$180)** $\$45,000,000,000 \div 250,000,000 = \180 .
7. **(a. 63%, b. 38%, c. 5%)** For (a), he will get on base if the dart lands in 5 out of the 8 equal areas, hence the percent is $5 \div 8 = 0.625$ or about 63%. Likewise, he'll make an out $3 \div 8 = 0.375$ or about 38% of the time. He would make 3 outs in a row about $38\% \times 38\% \times 38\%$ of the time, or about 5% of the time.
8. **(150)** Compute $\frac{3}{5} \times 250 = 150$, or change $\frac{3}{5}$ to a decimal and compute $0.6 \times 250 = 150$. For some students, it might be easier to think of working with the ratio in an intuitive fashion. Three out of five means 30 out of 50 by repeating the ratio ten times. But 30 out of 50 would be 150 out of 250, by repeating the ratio five times.

SUPERSTARS III

Neptune, XIV

Name: _____
(This shows my own thinking.)

- ★★ 1. On the average, human beings breathe 980 times each hour. Assume you are average.
- a. About how many breaths per week do you take? _____
- b. About how long would it take you to breathe a million times? _____

- ★ 2. John has 20 dimes and 30 pennies. Ken has the same amount of money in nickels and quarters. If Ken has 8 quarters, how many nickels does he have?

Answer: _____ nickels

- ★★ 3. If the perimeter of a regular octagon is 48 cm, what is the area of the adjacent square?

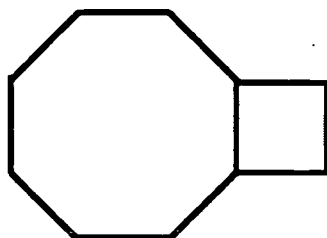

Answer: _____ sq. cm.

- ★ 4. Mark and John drive to work together. They split the cost of parking in a parking garage. How much would each pay to park the car for 7 hours?

PARKING RATES	
FIRST HOUR	\$4.00
EACH ADDITIONAL HOUR	\$1.75

Answer: \$ _____

- ★★★★ 5. Mike has a jar filled with 100 jelly beans. Some are green and some are red. When he shook the jar and removed a handful of jelly beans, he got 10 green and 15 red. Using this information, estimate the number of green and red jelly beans in the jar.

Answer: _____ green

_____ red

- ★★★ 6. Two rectangles below are similar. Find the length x of rectangle B.

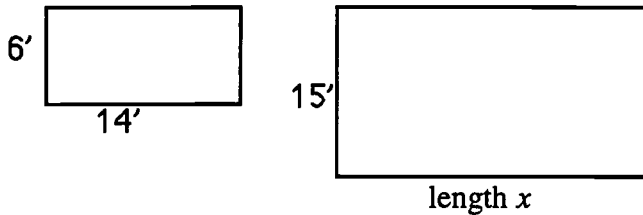

Answer: _____ feet

- ★ 7. Sally traveled on an airplane to visit her cousin Sue. She overheard the flight attendant saying that there were 254 people on board, but the plane wasn't full. She noticed that each row seated 6 people. What is the minimum number of rows needed for the 254 passengers?

Answer: _____ rows

- ★★★★ 8. From 3 P.M. today until 3 P.M. tomorrow, how many times will the hands on the clock coincide?

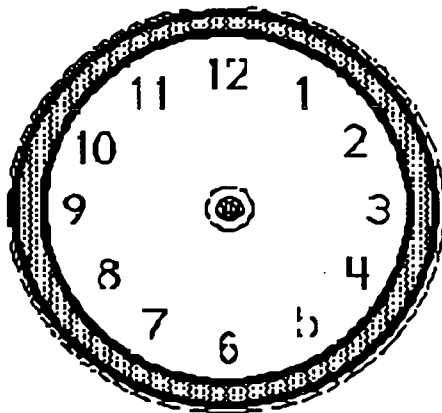

Answer: _____

Commentary

Neptune, XIV

1. **(a. 168,000 - 170,000 b. 6 weeks)** This problem encourages students to use round numbers since these are only estimates. They might begin by rounding 980 breaths per hour to 1000 breaths per hour, and the multiplying this by 24 hours/day and 7 days/week to get 168,000. This amount could be rounded to 170,000. For (b), students can divide 1 million by 168,000 or 170,000 to get about 6 weeks. This answer might be written in an equivalent form, such as 1 1/2 months.
2. **(6)** 20 dimes and 30 pennies is \$2.30. If Ken has \$2.30 with 8 quarters and the rest nickles, then the 30¢ must be all nickles, or 6 nickles.
3. **(36)** If the perimeter is 48 cm, then each side is $48 \div 4$ or 12 cm. Therefore the side of the square is 12 cm, and its area is 144 sq. cm.
4. **(\$7.25)** $\$4.00 + 6(\$1.75) = \$14.50$. $\$14.50 \div 2 = \7.25
5. **(40 green, 60 red)** A possible solution is to set up the given amounts in a ratio. He pulled out 25 jelly beans, and 10 were green. If he grabbed this same amount (25 jelly beans) four times, he would have pulled out all 100 jelly beans. Assume that with each grab 10 jelly beans would have been green ones. This would give a total of 40 green. There must then be 100 - 40 or 60 red jelly beans also.
6. **(35 feet)** Students might solve a proportion to find the length x . In similar rectangles, the sides are proportional, so $\frac{15}{6} = \frac{x}{14}$. Finding a common denominator so that the numerators of the fractions can be compared, we have $\frac{15 \cdot 14}{6 \cdot 14} = \frac{6 \cdot x}{6 \cdot 14}$. This implies that the numerators are equal, or that $15 \cdot 14 = 6x$. Solving for x by dividing both sides by 6, we have that $x = 35$.
7. **(43)** 254 people divided by 6 people/row gives 42 r 2 rows needed. This means that 43 rows were actually needed to hold all 254 passengers.
8. **(22 times)** The hands coincide once every hour except between 11 and 1. Between 11:00 and 1:00 the hands coincide only once.

SUPERSTARS III

Neptune, XV

Name: _____
(This shows my own thinking.)

- ★ 1. Jeremy started out with 7 pogs. In the first game he lost 2, then he won 4. He continued to play and lost 5, won 3, lost 1, won 2, then lost 1. How many more pogs did he have when he finished, than he started with?

Answer: _____ pogs

- ★★ 2. Mrs. Smith had a plaque engraved for the outstanding mathematics student. The engraving cost is 74¢ for the first eight letters and 10¢ for each additional letter.

a. How many letters are in a name that has a total engraving cost of \$1.84? _____

b. You are the outstanding mathematics student. Your name is on the plaque. How much would the engraving for your first and last name cost?

- ★★ 3. A hot-air balloon race started at 10:30 A.M. The timer started a stop watch and let it run for the entire match. When the race ended, the timer noted that 215 minutes had passed. What time did the race end?

Answer: _____

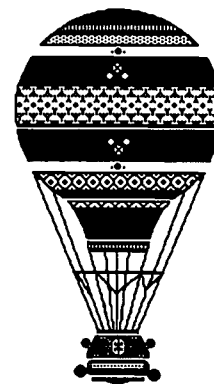

- ★ 4. Four out of five cars in the United States have a tape player and a radio. What percent of American cars do *not* have a tape player or radio?



Answer: _____%

- ★★★ 5. The numbers below the line (-100, -50, 0, 50, and 100) are placed correctly. Three of the numbers above the line are incorrect, but two are about right. Circle the three that are incorrect.

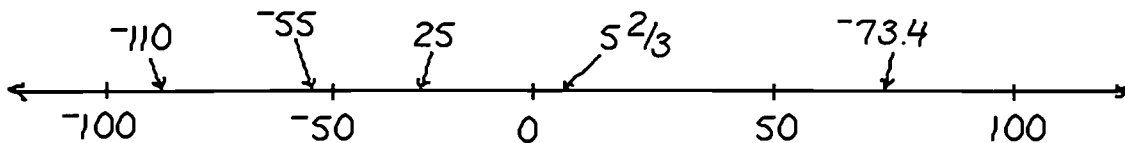

- ★★★★ 6. How many small cubes will fit in the large cube? _____ cubes

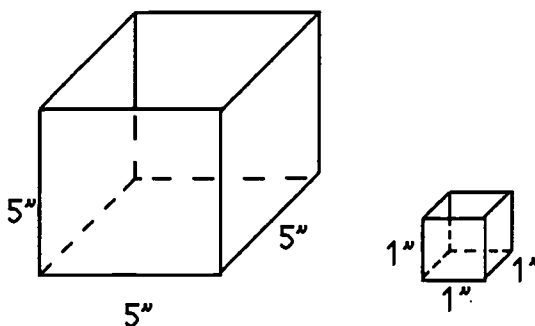

- ★★★★ 7. How many cards must be drawn from a standard deck to be certain that 4 cards of the same suit are drawn? Assume that the cards are not replaced each time.

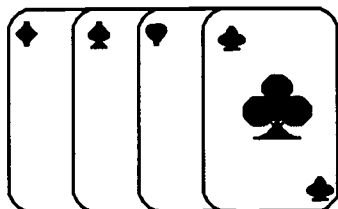

Answer: _____ cards

- ★★ 8. Jim and Rowena spent a total of 28 hours putting up a fence. Rowena worked 4 more hours than Jim. How many hours did each work?

Answer: Rowena: _____ hours
Jim: _____ hours

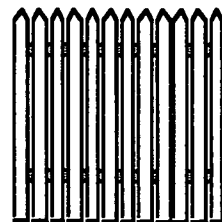

Commentary

Neptune, XV

1. (0) A number sentence for the action is: $7 - 2 + 4 - 5 + 3 - 1 + 2 - 1 = 7$. He had 7 pogs when he started and 7 when he finished.

2. (a. 19; b. answers will vary) (a) The first 8 letters cost 74¢, leaving $\$1.84 - \0.74 or $\$1.10$ for the other letters. At 10¢ each, this comes to 11 more letters. The total number of letters is $11 + 8$ or 19. To check (b), make a chart, such as:

8 or fewer ...	74¢
9 letters	84¢
10 letters	94¢ etc.

Use this chart to check the value of the name at the top of the sheet.

3. (2:05 P.M.) 215 minutes is 3 hours and 35 minutes. Counting 3 hours and 35 minutes from 10:30 AM gives 2:05 PM.

4. (20%) If 4 out of 5 cars have a tape player or radio, then 1 out of 5 do not. One out of five is written $1/5$. Another name for this fraction is $2/10$ or $20/100$, which is 20%.

5. (-110, 25, and -73.4 should be circled) Students can use their number sense to judge where these real numbers should be on a number line. -110 would be to the left of -100. 25 is positive, since there's no negative sign in front of it, so it goes to the right of 0. -73.4 is negative, and hence would be to the left of zero.

6. (125) The volume of the large cube is $5 \times 5 \times 5 = 125$ cubic inches. The volume of the small cube is $1 \times 1 \times 1$ or 1 cubic inch. Therefore 125 small cubes fit into the large cube.

7. (13) Assume the worst case: you might draw 3 clubs, 3 spades, 3 hearts and 3 diamonds, a total of 12 cards, and not have four of one suit yet. On the 13th draw, you will draw the 4th heart, club, diamond or spade.

8. (Rowena: 16; Jim: 12) A student might *guess-check-revise* until they find x and y such that $x + y = 28$ and $x - y = 4$. Guess $x = 20$, and then y must be 8 for the first condition to hold. But $20 - 8$ isn't 4, so $x = 20$ might be revised down. Continue in this fashion.

SUPERSTARS III
Neptune, XVI

Name: _____
(This shows my own thinking.)

- ★ 1. West Side High School graduated 23 boys and 24 girls with honors while there were 210 students who graduated with standard diplomas. What percent of the graduation class were honor students?



Answer: _____%

- ★ 2. If sixty is divided by one half and added to ten, what is the result?

Answer: _____

- ★★★★ 3. A queen-size water bed mattress measures 5 feet wide by 6 feet 6 inches long by 8 inches thick. Water weighs about 62 pounds per cubic foot. To the nearest 50 pounds, how much does such a mattress weigh, when full of water?

Answer: _____ pounds

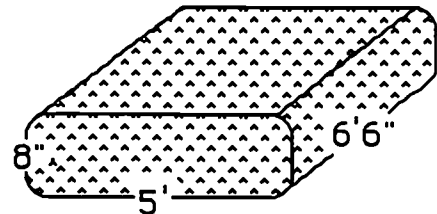

- ★★★ 4. Bob Jones sometimes fishes at the pier. The gulf is 8 feet deep at the pier, but every quarter mile you move away from the pier, the gulf becomes 1 foot deeper. Sometimes Bob takes his boat out to go fishing. When he is 3.25 miles from the pier, how deep is the water?

Answer: _____ feet deep

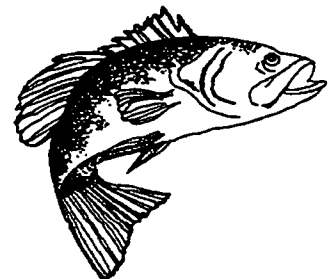

- ★★ 5. If it takes $5\frac{1}{4}$ minutes to make one cut through a log, how long will it take to cut a five foot log into 5 equal lengths?

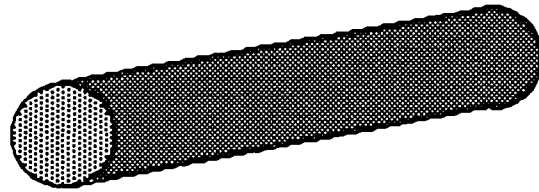

Answer: _____ minutes

- ★★ 6. The picture to the right is composed of squares and isosceles triangles. What percentage of the picture is shaded?

Answer: _____%

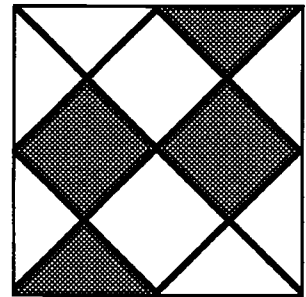

- ★★★ 7. Change this regular hexagon so that it looks like a cube by drawing only 3 additional line segments.

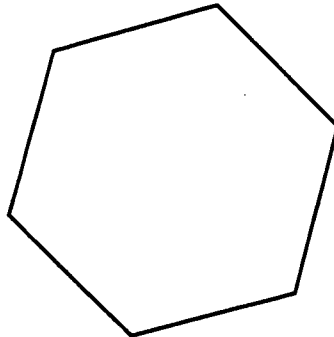

- ★★★★ 8. A candy bar weighs 4 ounces. If you eat only half of the remaining candy bar with each bite, how many bites have you taken when there is exactly 0.125 ounces left.

Answer: _____ bites

Commentary

Neptune, XVI

1. (18%) $23 + 24 = 47$ honor students. There were $47 + 210$ students in all. Therefore the percent of honor students is 47 out of 257, which is $47 \div 257$ or approximately 18%.

2. (130) $60 \div \frac{1}{2}$ is $60 \times \frac{2}{1}$ or 120. $120 + 10 = 130$.

3. (1350) One approach is to convert 8 inches to $\frac{8}{12}$ or $\frac{2}{3}$ of a foot, or approximately 0.667 or 0.67 feet. 6 feet 6 inches is 6.5 feet. The volume of the mattress is then 0.67 feet \times 5 feet \times 6.5 feet or 21.775 cubic feet. This is multiplied by 62 pounds per cubic foot, giving, to the nearest 50 pounds, 1350 pounds as the weight of the water bed mattress. Students might now realize why many buildings will not allow water beds on the second floor of an apartment -- with the frame and two people in the bed, the weight is nearly a ton.

4. (21) $3\frac{1}{4}$ miles = $\frac{13}{4}$ miles. The depth drops one foot for every $\frac{1}{4}$ mile, therefore it drops 13 feet in $3\frac{1}{4}$ miles. $13 + 8 = 21$ feet deep.

5. (21) It will take 4 cuts to cut a log into 5 pieces. $5\frac{1}{4}$ minutes \times 4 gives $20\frac{4}{4}$ or 21 minutes.

6. (37.5%) The isosceles triangles are also half squares. Putting together half squares and squares to make whole squares, the shaded part is three squares. The whole area consists of 8 squares, and $3 \text{ out of } 8 = \frac{3}{8} = .375 = 37.5\%$

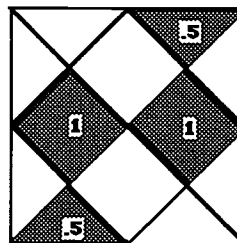

7. (See the figure below.)

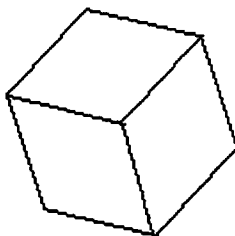

8. (5) As bites are taken, the weight goes down by half each time. The amount remaining after each bite can then be found by multiplying what remains by 0.5, as shown in the chart below.

$0.5 \times 4 = 2$	<i>Bite 1</i>	$0.5 \times 0.5 = 0.25$	<i>Bite 4</i>
$0.5 \times 2 = 1$	<i>Bite 2</i>	$0.5 \times 0.25 = 0.125$	<i>Bite 5</i>
$0.5 \times 1 = 0.5$	<i>Bite 3</i>		

SUPERSTARS III

Neptune, XVII

Name: _____

(This shows my own thinking.)

- ★★★★ 1. At a drive-in movie there is a fixed charge for the driver and one passenger and an extra charge for each additional passenger. If 6 people are in the car, the total charge is \$8.00. If 3 people are in the car, the total charge is \$4.25. What is the fixed charge for the driver and one passenger?

Answer: \$ _____

- ★★★ 2. The owner of a computer company works 7 days a week during the summer when business is booming. He wears a clean shirt to work every day. If he drops off his shirts and picks up the previous week's shirts every Monday after work, how many shirts must he own so that he doesn't run out of clean clothing?

Answer: _____



- ★ 3. Juanita and her family leave home for a vacation at 6:00 A.M. During the day, they stop 3 times to eat for an hour each time, and 4 times for gas and a restroom break for 30 minutes each time. They drive a total of 600 miles and arrive at 9:00 P.M. What is their average rate of speed while the car is moving?

Answer: _____ miles per hour

- ★★ 4. A pizza restaurant offers three choices of cheese, two choices for crust, and four choices for toppings. How many different pizzas can be made using exactly one choice of cheese, crust and topping?

Answer: _____ different pizzas

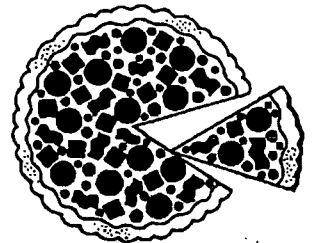

- ★★★★ 5. The figure to the left consists of 6 squares the same size. The area of the figure is 294 square units. When folded, it makes a box as shown to the right. What is the volume of the box?

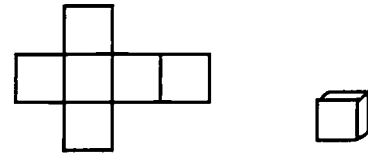

Answer: _____ cubic units

- ★★★ 6. Find numbers for the vertices so that the sum of the numbers of any two vertices is equal to the number in the box on the line joining them. Write each answer in the appropriate circle.

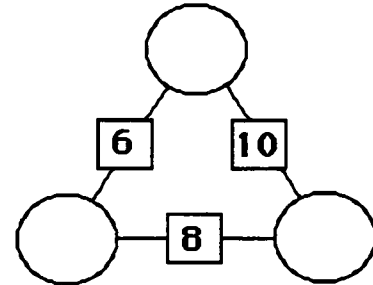

- ★★ 7. A five digit zip code has two identical missing digits x so that it reads: $69x4x$

How many zip codes are possible if the zip code is divisible by 7?

Answer: _____ zip codes

- ★★★ 8. The average of 4 positive whole numbers is 8. If all four numbers are less than 10, what are two possible sets of numbers?

Answer: _____ and _____

- ★★★★ 9. Connect these points with a heavy line:

- connect $(-5, -1)$ to $(-5, -6)$
- connect $(-5, -3)$ to $(-3, -3)$
- connect $(-3, -6)$ to $(-3, -1)$
- connect $(1, -2)$ to $(1, -6)$
- connect $(0, -1)$ to $(-1, -6)$ to $(-2, -1)$
- connect $(-1.5, -3)$ to $(-0.5, -3)$
- draw a big dot at $(1, -1)$

Draw the reflection of these lines about the x axis. You should now have a familiar word.

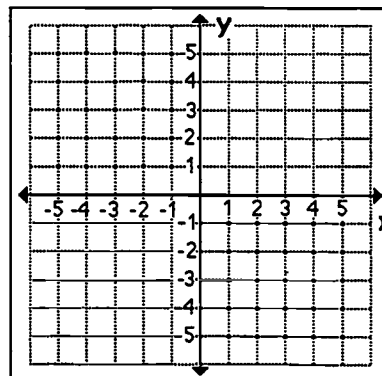

Commentary

Neptune, XVII

1. (**\$3.00**) $\$8.00 - \$4.25 = \$3.75$ for the extra 3 people. Therefore $\$1.25$ is the charge for each additional person. Since $\$4.25$ is the charge for 3 people, and $\$1.25$ is charged for person #3, we know that $\$3.00$ is the charge for the driver and 1 passenger.
2. (**14**) Seven are always at the laundry, and seven clean ones are at home for Tuesday - Monday.
3. (**60**) From 6:00 A.M. until 9:00 P.M. is 15 hours. Since the family spends 3 hours eating and 2 hours for gas and break stops, the actual driving time is $15 - 5 = 10$ hours. $600 \text{ miles} \div 10 \text{ hours} = 60 \text{ miles per hour}$.
4. (**24**) Students might make an organized list, using letters of the alphabet to represent the crust, the cheeses, and the toppings. If so, they should get $3 \times 2 \times 4 = 24$ varieties.
5. (**343**) $294 \div 6$ means that the area of each square is 49 square units. If the area of each square is 49 square units, the side length must be 7 units. The volume of a box is length times width times height, or $7 \times 7 \times 7$.
- 6.

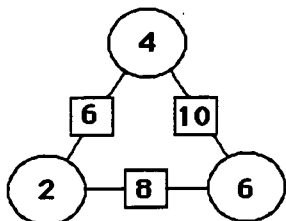

7. (**One**) Use *trial and error*, or a calculator, to find 69545. The possible zip codes are 69141, 69242, 69343, 69444, 69545, 69646, 69747, 69848, 69949, and 69040. The only one divisible by 7 is 69545.
8. (**four 8's; or three 9's and one 5; or two 9's and two 7's; or two 8's, one 9, and one 7**) If the average of 4 whole numbers is 8, the sum of the 4 numbers must equal 32. Since each number is less than 10, we have $9 + 9 + 9 + 5 = 32$, and $8 + 8 + 8 + 8 = 32$, and $9 + 9 + 7 + 7 = 32$, and $8 + 8 + 9 + 7 = 32$ as possibilities. Check student work for other possibilities.
9. (**HA! is the word.**) You should see this:

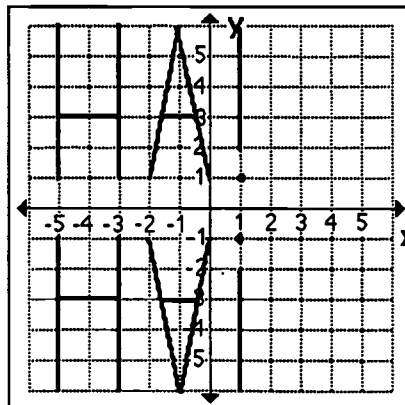

SUPERSTARS III
Neptune, XVIII

Name: _____
(This shows my own thinking.)

- ★★★★ 1. Three “landscape views” of a building made from cubes are shown below. How many cubes were used to make the building? Make such a building if it helps you.

Answer: _____ cubes

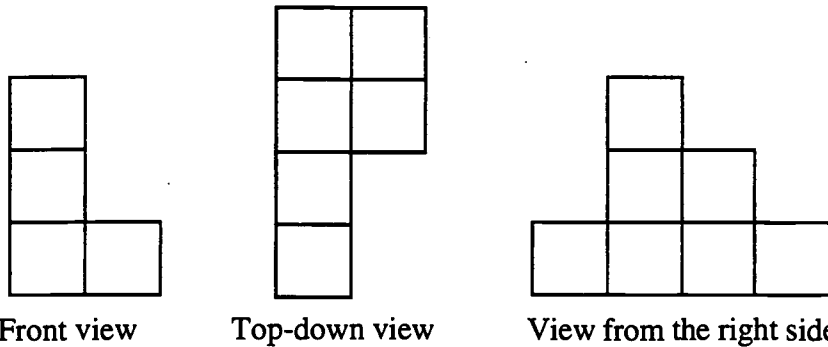

- ★★ 2. A spider made the web shown. How many degrees are in each *central angle* of this web? Note that somehow the spider knows to make all the central angles congruent.

Answer: _____ °

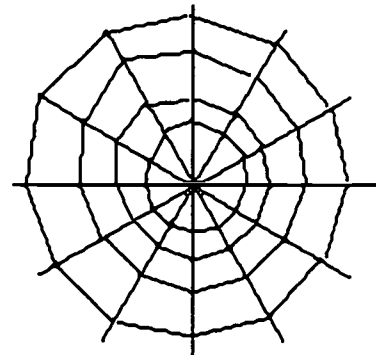

- ★★ 3. The length of each side of the military's pentagon building in Washington, DC, is a whole number of feet. Circle the number below which the perimeter could not be, if this is a *regular* pentagon:

- | | |
|--------------|--------------|
| a) 1990 feet | c) 2900 feet |
| b) 1415 feet | d) 2748 feet |

- ★ 4. You bought 12 tickets to a raffle and your sister bought 4. If 100 tickets were sold, what is the probability that you or your sister will win the raffle?

Answer: _____

- ★★★★ 5. Green Cabs charge \$1.40 for the first quarter mile and \$0.65 for each additional quarter mile. Yellow Cabs charge \$1.00 for the first half mile then a flat rate of \$1.00 for each additional quarter mile. Fill out the chart below to find the cost for each company for a few miles. Graph the rates for both companies. Then answer the questions below the graph.

Cost of:	Green Cab	Yellow Cab
$\frac{1}{4}$ mile		
$\frac{1}{2}$ mile		
$\frac{3}{4}$ mile		
1 mile		
$1\frac{1}{4}$ mile		
$1\frac{1}{2}$ mile		
$1\frac{3}{4}$ mile		
2 miles		

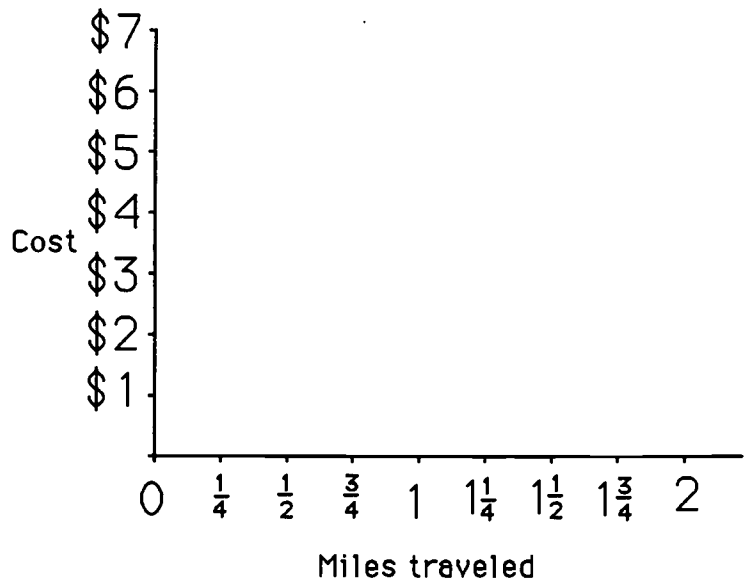

- a. For what trip length are the Green and Yellow Cab fares the same? _____
 b. What happens on the graph when the fares are the same for both?

- ★★★ 6. Attendance at Busch Gardens is down. To increase the daily attendance, the daily admission price of \$30 is reduced by 20%. The plan works and attendance increases, but now the park is overcrowded. To reduce the number of people, the admission price is now raised 20%. How does the new price compare to the original price?

Answer: _____

- ★★★ 7. An English teacher was asked how many fish she caught. She replied:

*When I tried to place a fish upon each dish, I had a fish without a dish.
 When I tried to place two fish upon each dish, I had a dish with no fish.
 You'll never hear boos and hisses, if you can find how many fishes!*

How many did she catch? _____

Commentary

Neptune, XVIII

1. (9 cubes) 6 on bottom, 2 on second level, 1 on top.

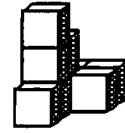

2. (30°) $360^\circ \div 12 \text{ sections} = 30^\circ$.

3. (2748) The perimeter of the building would be 5 times the length of a side, so the perimeter would be a multiple of 5. The only number given which is not a multiple of 5 is 2748.

4. (16/100) The chances are the number of tickets that both have together, divided by the total number. The answer can be expressed in a number of equivalent forms: 0.16, 16%, 8/50, 4/25, etc.

5. (a. 1 1/4 miles; b. the lines coincide or cross) Students should get a star for filling out the chart properly, for making a graph, and for answering each of the two questions. Most students will make a double line graph instead of a step graph, which is technically correct since the fares go up suddenly, rather than gradually, at each quarter mile. However, give students credit for either type of graph, if done correctly. Both types are shown below.

Cost of:	Green	Yellow
1/4 mile	\$1.40	\$1.00
1/2 mile	2.05	1.00
3/4 mile	2.70	2.00
1 mile	3.35	3.00
1 1/4 miles	4.00	4.00
1 1/2 miles	4.65	5.00
1 3/4 miles	5.30	6.00
2 miles	6.05	7.00

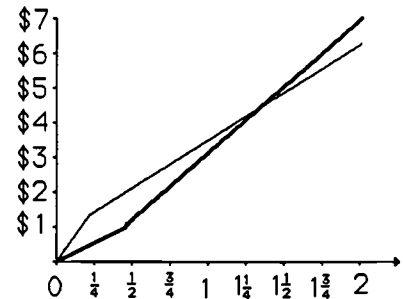
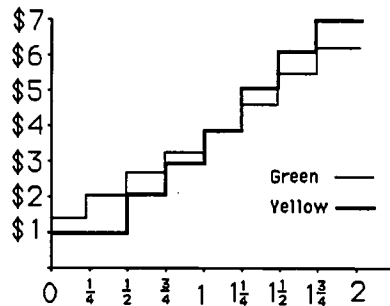

6. (The new price is \$1.20 less.) Reducing \$30 by 20% means the reduced price is \$24. Increasing \$24 by 20% can be done easily by multiplying 24 by 120% or 1.2 on a calculator, giving \$28.80. \$28.80 is \$1.20 less than \$30.

7. (4) There are several clues to consider in the teacher's rhyme. The first sentence says that there is one more fish than dish. The beginning of the second sentence implies there is an even number of fish; otherwise she couldn't place *two* fish upon each dish. So students might begin by guessing and checking from this list, finding that 4 fish and 3 dishes fit the bill.

fish	dish
2	1
4	3
6	5
.	.
.	.
.	.

SUPERSTARS III
Neptune, XIX

Name: _____
(This shows my own thinking.)

- ★★ 1. Which whole number values make this inequality true? Circle your choice.

$$\frac{X}{2} < 10$$

- a) $X = 19, 20, \text{ or } 21$ c) $X = 0, 1, 2, \dots, 19$
b) $X = 41, 42, 43$ d) $X = 21, 22, 23, \dots$

- ★★★★ 2. The figures below form a pattern of squares. The *area* of the 1st figure is $\frac{1}{16}$ inch².

- a. What is the *perimeter* of the 1st figure? _____ inch
b. What is the *area* of the 3rd figure? _____ inch²
c. What is the *perimeter* of the 3rd figure? _____ inches
d. What is the *area* of the 10th figure in the pattern? _____ inches²

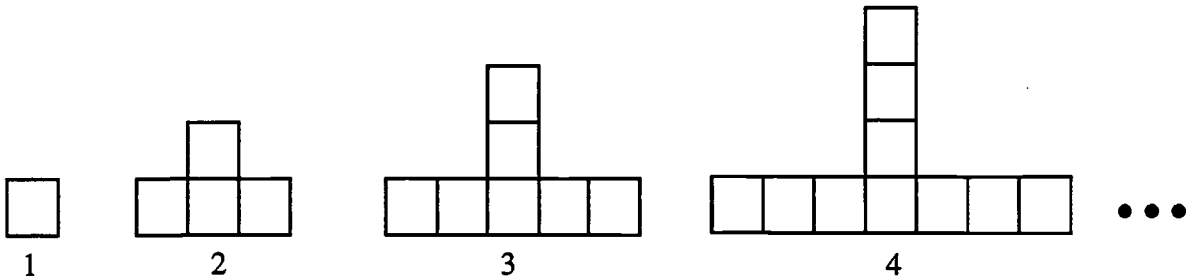

- ★★★ 3. The scale on a map is: $1 \text{ inch} = 16 \text{ miles}$. A National Park is represented on this map by a square whose side is $\frac{1}{8}$ inch. What is the actual area of the park in square miles.

Answer: _____ sq. mi.

- ★★ 4. If $X + 2 = Y$ and $Y + 1 = 5$, then $X =$ _____.

Answer: _____

★★★ 5. If $280 = N$, then $350 =$ _____.

- a) $\frac{N}{4}$ c) $\frac{4N}{3}$
 b) $\frac{4N}{5}$ d) $\frac{5N}{4}$

Answer: _____

★★ 6. In a class of 30, 12 are boys. If 6 more boys join the class, what per cent of the class is then boys?

Answer: _____ %

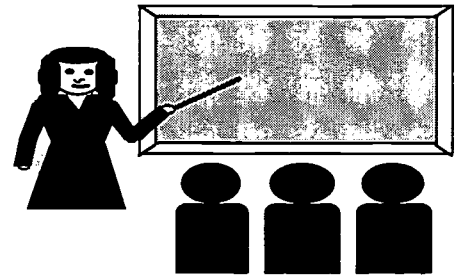

★★★ 7. In the addition shown below, A, B, and C are different non-zero digits. What is the value of C?

$$\begin{array}{r} B \ B \\ + B \ B \\ \hline A \ B \ C \end{array}$$

Answer: _____

★★★ 8. The figure below is made by glueing together 7 cubes. If the figure is dipped in a bucket of red paint and allowed to dry, how many square faces will have paint on them?

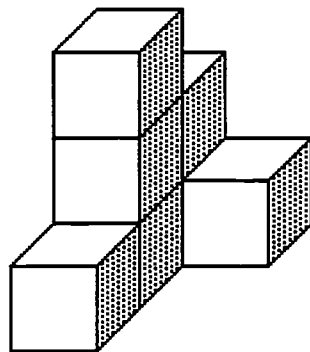

Answer: _____

Commentary

Neptune, XIX

1. (C) For each whole number from 0 to 19 substituted for x , the value of $\frac{x}{2}$ is less than 10.
2. (a. 1; b. $\frac{7}{16}$; c. 4; d. $\frac{28}{16}$) Since the area of the 1st square is $\frac{1}{16}$, each side of the square must be $\frac{1}{4}$ of an inch in length. So the perimeter of figure 1 is $\frac{4}{4}$ or 1 inch. The 3rd figure is made from 7 squares, so its area is $\frac{7}{16}$ inch². Its perimeter can be found by counting the exposed edges, resulting in 16 of the $\frac{1}{4}$ inch lengths or 4 inches total. The figures beyond the ones seen can each be formed by adding 3 squares to the preceding figure. Counting out to the tenth such figure, there would be 28 squares, each $\frac{1}{16}$ inch² in area. Therefore the 10th figure has area $\frac{28}{16}$ inches², or $1\frac{12}{16}$ inches², or $1\frac{3}{4}$ inches².
3. (4) If 1 inch = 16 miles, then $\frac{1}{8}$ inch = $\frac{1}{8}$ of 16 miles or 2 miles. Therefore, the area equals 2 miles \times 2 miles or 4 square miles.
4. (2) If $Y + 1 = 5$, then $Y = 4$. Since $X + 2 = Y$ also, then $X + 2 = 4$, or $X = 2$.
5. (D $\frac{5N}{4}$) Set up a proportion: $\frac{280}{N} = \frac{350}{X}$. Then the relationship between X and N can be determined.

$$280 \times X = 350 \times N$$

$$X = \frac{350N}{280}$$

$$X = \frac{5N}{4}$$
6. (50%) $30 + 6$ gives 36 students in class, of which $12 + 6$ or 18 are boys. Therefore, $\frac{18}{36} = 0.5 = 50\%$
7. (C = 8) Students can try the various digits from 1 to 9 for B , and see if the digit gives a true statement. If so, students will find that 9 is the only such digit.

$$\begin{array}{r} 99 \\ +99 \\ \hline 198 \end{array}$$

8. (28) There are 6 faces on each block, and 7 blocks, resulting in 42 faces altogether. However, some of them are facing other faces and so will have no paint on them. Students might think of each cube individually, and count the number of faces it has that touch other faces, then get a total number of such faces, and subtract from 42. We counted 14 such touching faces, as shown on the block to the right.

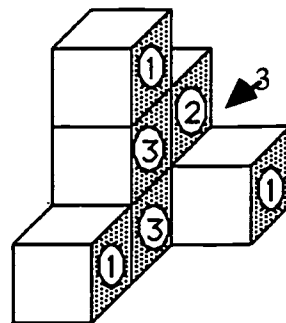

SUPERSTARS III
Neptune, XX

Name: _____
(This shows my own thinking.)

- ★★ 1. The city is planning a new park. Each small square is 1 acre. The shaded portion is set aside for softball diamonds, soccer and football fields, and basketball courts. How many acres of the park will be for these sports?

Answer: _____ acres

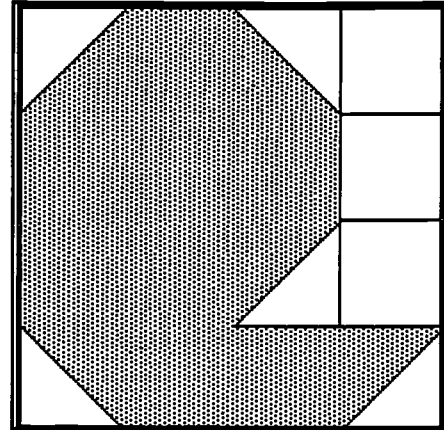

- ★ 2. Hector randomly picks an integer between 0 and 9. Which one of the following is the most likely outcome? Circle your choice.

- a) the number is 5 c) the number is odd
b) the number is 9 d) the number is not 1

- ★★★★ 3. Write a letter from the choices below, to complete the sentence correctly.

The difference between two prime numbers can never equal _____.

- a) 1 c) 7
b) 2 d) 8

- ★★★ 4. Lin's scores on her math tests this period were: 88, 92, 88, 75, 95, 90. Her teacher said she could have her choice of the mean, median, or mode of these scores as her final grade. Which should she pick?

Answer: _____

- ★★ 5. The first term in a sequence (pattern) is 7. Each term in the sequence is 4 more than 2 times the number before. What are the second and third terms in the sequence?

Answer: _____, _____

★★

6. Under the plates, there are 4 coins in a row; a penny, a nickel, a dime and a quarter. The penny is not next to the dime. The nickel is second (from the left) in the row. The quarter is to the left of the dime. Write which coin is under each plate in order from left to right?



Answer: _____

★★★ 7. Baseball cards can be ordered in packages of 8, 64, 512 and so on. If the package sizes continue to increase at the same rate, what is the size for the next larger package?

Answer: _____

★

8. Find the missing number: $\frac{2}{6} + \frac{2}{6} + \frac{2}{6} + \frac{2}{6} = \frac{??}{24}$

Answer: _____

0

★★★

9. A dinosaur and a lion balance a burro. A dinosaur balances an elephant and a lion, and 2 burros balance three elephants. How many lions balance a dinosaur?

Answer: _____

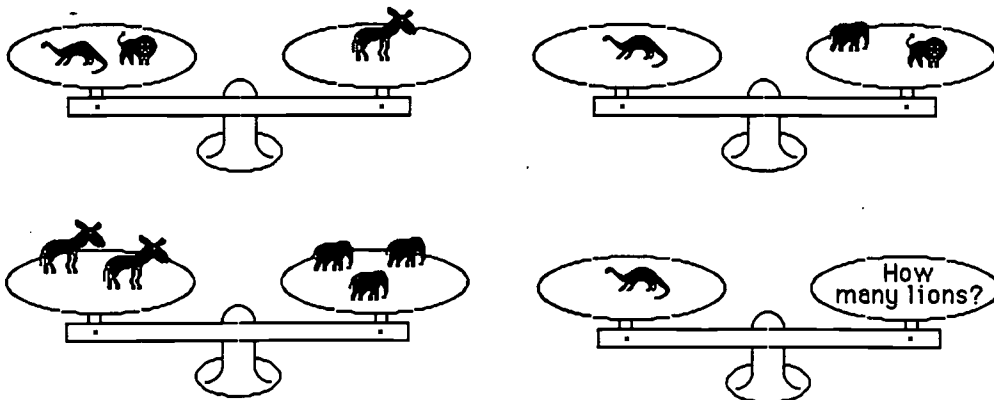

Commentary

Neptune, XX

1. **(10 1/2)** There are several approaches to finding the area. One is to find the area of the whole park first by filling in the grid lines and counting 16 acres. Then subtract the acres and half acres that aren't shaded -- $5 \frac{1}{2}$ -- leaving $10 \frac{1}{2}$ acres for the sports.
2. **(d)** There is 1 chance out of ten the number is 5 and 1 chance out of ten the number is 9. The chance the number is odd is 5 out of ten, and the chance the number is *not* 1 is 9 out of ten.
3. **(c)** The difference between 2 and 3 is 1, so (a) isn't the correct choice. The difference between 3 and 5 is 2, so (b) isn't correct. The difference between 5 and 13 is 8, so (d) isn't correct. (c) is the only other choice, and it is true. For the difference of two primes to be an odd number, one of the primes would have to be even but there's only one even prime -- 2 -- and the difference of two and any prime greater than 9 would have a difference greater than 7.
4. **(Median)** The mode (most often occurring number) is 88. The median (middle) number (after numbers are put in order) is between 88 and 90 or 89. The mean is the sum of the numbers -- 528 -- divided by 6, or 88. So the median is the best option for Lin.
5. **(18 and 40)** Starting with 7, the next term is $2 \times 7 + 4$, or 18. The following term is $2 \times 18 + 4$, or 40. An extension of the problem might be to ask what number could have come before 7.
6. **(Penny, Nickel, Quarter, Dime)** Students can *guess-check-revise* to find the order.
7. **(4096)** The sequence appears to be the powers of 8, in order: $8^1 = 8$; $8^2 = 64$; $8^3 = 512$;
 $8^4 = 4096$
8. **(32)** $\frac{2}{6} + \frac{2}{6} + \frac{2}{6} + \frac{2}{6} = \frac{8}{6} = \frac{32}{24}$. Note that some students will be tempted to say $\frac{8}{24}$, since it appears that the denominators of the fractions have been added to get the denominator 24; the temptation for students is to then add the numerators.
9. **(5)** There are many ways that students will approach this problem. Let the first initial stand for each animal -- D for dinosaur, L for lion, E for elephant, and B for burro -- and what the scales show are these:
(a) $D + L = B$ (b) $D = E + L$ (c) $2B = 3E$
Doubling (a), we know that $2D + 2L = 2B$. But from (c), $2B = 3E$, so combining these, we have (d) $2D + 2L = 3E$. From doubling (b), we have that $2D = 2E + 2L$. Now $2E + 2L$ can be substituted in the previous statement (d) to give $2E + 2L + 2L = 3E$, or $2E + 4L = 3E$. By removing $2E$ from both sides, we're left with $4L = E$. This fact can then be used with (b), substituting $4L$ for E , to give $D = 4L + L$, or $D = 5L$.

SUPERSTARS III

Neptune, XXI

Name: _____
(This shows my own thinking.)

- ★★ 1. Suzie entered an elevator in a tall building. She rode up three floors, down 5 floors, up 7 floors and then down 9 floors. She found herself on the 23rd floor. On what floor did she enter the elevator?

Answer: _____

- ★★★★ 2. The following figures are both made from 10 cubes and so have the same volume. If you had to paint the **outside surfaces** of the cubes, including the bottom surface, which figure would require more paint?

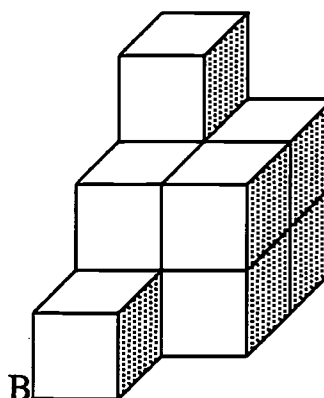
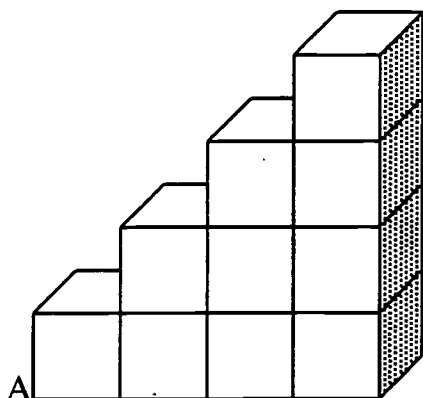

Answer: _____

- ★ 3. A number x is divided by 6 and then 3 is subtracted from the result to give 4. What is the original number x ?

Answer: $x =$ _____

- ★ 4. Fill in the blank from the choices given to make the sentence true:

If the length of each side of a square is a whole number, the perimeter of the square could not be _____.

- | | |
|--------|--------|
| a) 96 | c) 300 |
| b) 152 | d) 462 |

- ★★ 5. The supplement of an obtuse angle is always a(an) _____ angle.

- ★★★ 6. The two points $\frac{4}{10}$ and $\frac{4}{5}$ are shown on the number line. Label the mid-point between them as a fraction in lowest terms.

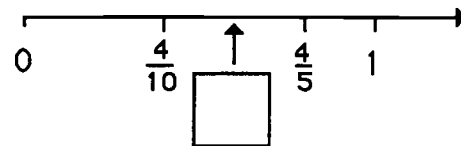

- ★★★ 7. How many 2-inch square tiles are needed to make a square design that is 14 inches on each side, if there are no spaces between tiles?

Answer: _____

- ★★★★ 8. John has 4 more brothers than sisters. How many more brothers than sisters does his sister Mary have?

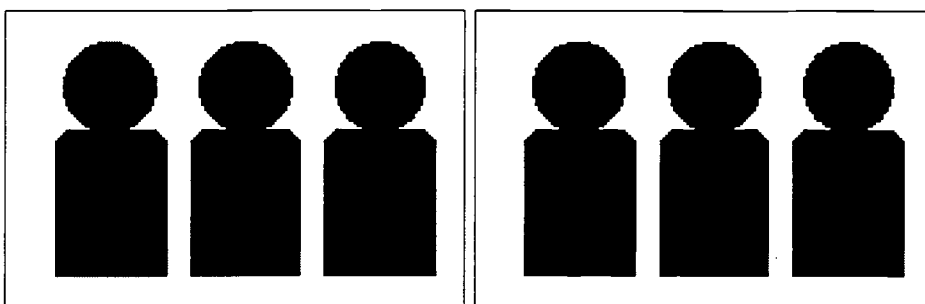

Answer: _____

- ★★★★ 9. Consider the pattern of figures below.

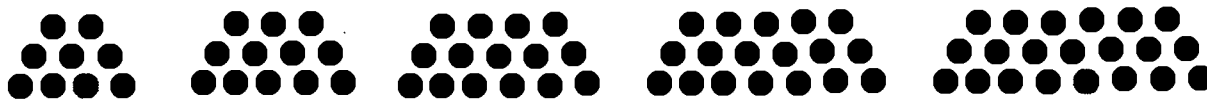

fig. 1

fig. 2

fig. 3

fig. 4

fig. 5

- (a) How many dots are needed to make figure 6? _____
 (b) How many dots are needed to make figure 7? _____
 (c) How many dots are needed to make figure 100? _____
 (d) How many dots are needed to make figure n for any number n ? _____

Commentary

Neptune, XXI

1. **(27th floor)** $27 + 3 + ^{-}5 + 7 + ^{-}9 = 23$. Another approach is to start with floor 23 and reverse the actions: $23 + 9 + ^{-}7 + 5 + ^{-}3 = 27$.

2. **(Figure A)** Figure A has 36 squares as surfaces, and Figure B has 32 squares as surfaces.

Figure A

Front	10
Back	10
Top	4
Bottom	4
Sides	<u>8</u>
Total:	36

Figure B

Front	5
Back	5
Top	5
Bottom	5
Sides	<u>12</u>
Total:	32

3. **(42)** Students can approach this in a number of ways. *Guess-check-revise* for the starting number is one way; another is *working backward*. For the latter, if $x \div 6 - 3 = 4$, then $x \div 6$ must be 7 since $7 - 3 = 4$. But if $x \div 6 = 7$, then x must be 42 since $42 \div 6 = 7$.

4. **(d, 462)** The perimeter of a square is $4s$, where s is the length of one side. This means that the perimeter of a square must be divisible by 4. All of the numbers given except 462 are divisible by 4, with no remainder. But $462 \div 4 = 115.25$, so (d) is the only choice.

5. **(Acute)** An obtuse angle and its supplement equal 180° , and the obtuse angle is $>90^\circ$. Therefore its supplement must be acute ($<90^\circ$).

6. **($\frac{3}{5}$)** Students can add the two numbers shown and divide by two to find the midpoint.

$\frac{4}{5} + \frac{4}{10} = \frac{12}{10}$ and $\frac{1}{2} \times \frac{12}{10} = \frac{6}{10}$ or $\frac{3}{5}$. Note that $4/10 = 2/5$ and $3/5$ is the midpoint between $2/5$ and $4/5$.

7. **(49)** Each 2-inch square tile is a square 2 inches on a side. Seven tiles fit across and 7 tiles fit down. The total number of tiles is then 7×7 or 49.

8. **(6)** John has 4 more brothers than sisters. One way to solve the problem in a concrete fashion would be to assign letters to John's brothers (perhaps A, B, C, D, and E), and let Mary be the only sister. Notice this matches the original condition that John has 4 more brothers (5) than sisters (1). Then the question is how many more brothers than sisters does Mary have? She has 6 brothers, counting John, and no sisters, so she has 6 more brothers than sisters.

9. **(a. 24; b. 27; c. 306; d. $3 \times (n + 2)$)** Students may note that you get from one figure to the next by adding 3 each time. It is therefore easy to get the total for figures 6 and 7. The total for figure 100 probably requires a generalization, looking for the connection between the figure number n and the total number of dots. (d) gives students a chance to express this generalization algebraically. Notice that students may give alternatives to " $3 \times (n + 2)$," such as " $3 \times n + 6$ " and " $n + n + n + 6$."

SUPERSTARS III
Neptune, XXII

Name: _____
(This shows my own thinking.)

- ★★ 1. The first four skating judges gave Mario & Maria a 4.2, 4.3, 4.6 and 5.0. What did the fifth judge give Mario & Maria if their average score from five judges was 4.6?



Answer: _____

- ★★ 2. Which group is ordered from least to greatest? Use your number sense!

a) $\frac{7}{3}$, $\frac{5}{2}$, $\frac{19}{10}$

c) $\frac{2}{6}$, $\frac{2}{8}$, $\frac{2}{10}$

b) $\frac{4}{9}$, $\frac{4}{8}$, $\frac{4}{7}$

d) $\frac{3}{5}$, $\frac{4}{8}$, $\frac{5}{9}$

Answer: _____

- ★★★★ 3. Cathy walks 1 mile in 20 minutes. She runs 1 mile in 10 minutes. At a recent 2-hour practice, to warm up and cool down Cathy walked for one-fourth of the 2 hours; she ran for three-fourths of the 2-hours. How many miles did Cathy travel in the practice session?

Answer: _____

- ★ 4. If 10% of 10% of a certain number x is 2, then x is:

Answer: _____

- ★★★★ 5. Of 20 students in class, 15 have brown hair, 16 have brown eyes, and 12 have both brown hair and brown eyes. How many students have neither brown hair nor brown eyes?



Answer: _____

★★ 6. Draw the next two figures in the pattern below:

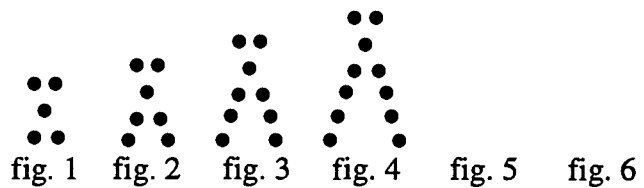

★★★ 7. (a) How many dots would it take to make figure 10 in the pattern above? _____

(b) How many dots would it take to make figure n in the pattern above? _____

★★★★ 8. This figure is made from seven cubes glued together. If the figure was dipped into paint, removed, then separated into cubes, how many square faces would not be painted?

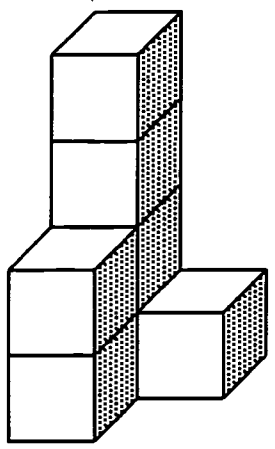

Answer: _____

★ 9. In an airplane, 6 seats are placed in each row. What is the minimum number of 6-seat rows needed to seat 170 people?..

Answer: _____

Commentary

Neptune, XXII

1. **(4.9)** All five scores, when added, must equal 5×4.6 or 23. We know $4.2 + 4.3 + 4.6 + 5.0 = 18.1$, so the missing number is $23 - 18.1$ or 4.9.
2. **(b)** $\frac{4}{9}$, $\frac{4}{8}$, $\frac{4}{7}$ Students should be encouraged to solve this using number sense. For example, in (a) thinking of the fractions as mixed numbers helps to see the answer pretty quickly. For (b) and (c), the numerators are all the same, so the fraction with the smallest denominator is the largest. For (d), the center number is $\frac{1}{2}$, which is less than both of the other two. Some students might forget about number sense and find decimal equivalents first using a calculator (0.4444. . . , 0.5, 0.5714286 ..), and compare the numbers that way.
3. **(10.5 miles)** One-fourth of 2 hours is 30 minutes of walking; three-fourths of 2 hours is 90 minutes of running. The running distance, at 1 mile per 10 minutes, is 9 miles for 90 minutes. The walking distance, at 1 mile per 20 minutes, is 1.5 miles for 30 minutes.
4. **(200)** A strategy would be to "work backward". If 10% of a number is 2, that number must be 20. If 10% of x is 20, then x must be 200.
5. **(1 student)** One strategy is to construct a Venn diagram, working from the overlap area to the outside. First you insert 12 into the overlap area; then work toward the outside.

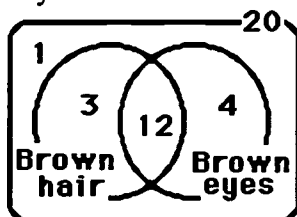

6. **(As shown to the right.)**

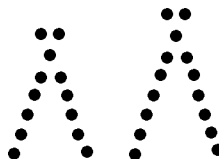

7. **(a. 23; b. $2n + 3$)** As students seek the answer to (a), they will probably simply continue to count the odd numbers till they reach the 10th odd number after 5. Part (b) forces the student to search for a way to express the function algebraically, using the variable n . Watch for alternative versions of $2n + 3$, such as $n + n + 3$ or $(n + 1) + (n + 2)$. If a student writes in English how to find the number for the n th figure, instead of as an algebraic expression, give the student 1 star instead of 2.
8. **(14)** 7 cubes have 6×7 or 42 faces, 28 of which are painted. $42 - 28 = 14$ remain unpainted.
9. **(29)** $170 \div 6 = 28.3$, so 29 rows are needed.

SUPERSTARS III
Neptune, XXIII

Name: _____
(This shows my own thinking.)

- ★★ 1. Draw hands on the clock to show 200 minutes before 2:00 P.M.

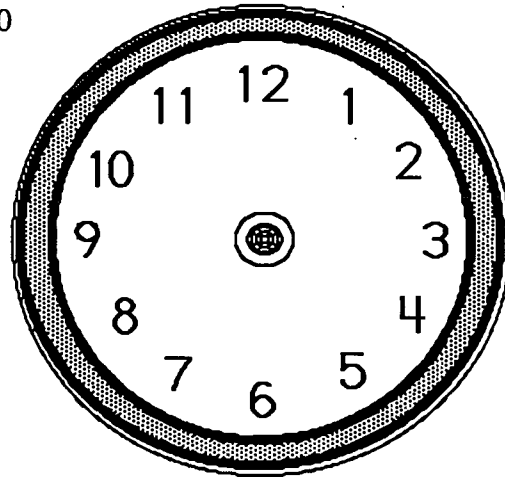

- ★★★★ 2. Think of how the 5 gears below would turn each other—clockwise or counterclockwise—before answering the questions. The 1st gear turns counterclockwise.

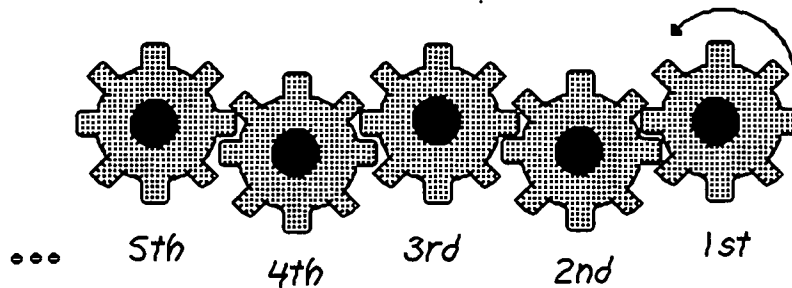

- a. In what direction would the 2nd gear turn? _____
 b. In what direction would the 3rd gear turn? _____
 c. In what direction would the 4th gear turn? _____
 d. In what direction would the 10th gear turn? _____

- ★★ 3. A school offers 2 foreign languages, French and Spanish; 2 computer classes, Logo and BASIC; and 3 physical education classes, volleyball, swimming, and archery. How many different student schedules can be made using exactly one of each of these types of classes?

Answer: _____

- ★★★★ 4. A man has a 10 meter by 10 meter square garden. In the center is a 4 meter by 4 meter square patch he will use as a mulch pile. He uses the remainder for growing carrots, tomatoes, cucumbers and celery. Show in the drawing how to divide the growing land into 4 congruent rectangles, and tell what length and width each will be.

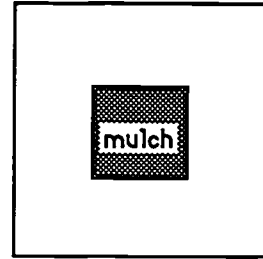

Answer: The length of each rectangle is _____ m
and the width is _____ m.

- ★★ 5. What must be the rate in miles per hour of a truck, if it wants to make a 20 mile trip in 40 minutes?

Answer: _____

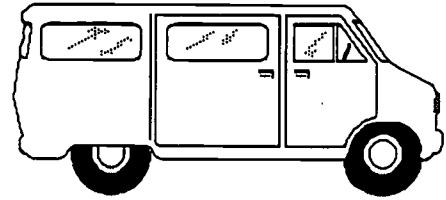

- ★ 6. If $X = 6 + 4 + 3 + 1 + \frac{1}{2} X$, then X must equal:

Answer: $X =$ _____

- ★★★ 7. In which column should -500 go on this chart?

Answer: _____

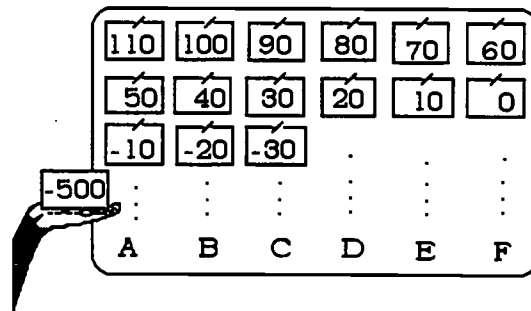

- ★★★★ 8. Write and solve an equation to find the weight of 1 ball b .

Answer: An equation is: _____

The solution is: $b =$ _____

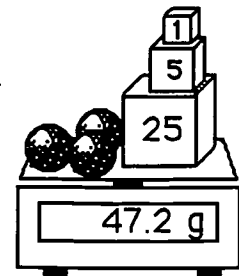

Commentary

Neptune, XXIII

1. (10:40 A.M.) The hands would show the normal position for 10:40.
2. (a. clockwise; b. counterclockwise; c. clockwise; d. clockwise) Students should notice a pattern in this problem. An extension of the problem for the classroom is to define how the n th gear would turn, which depends on whether n is odd or even.
3. (12) Students might approach this by making an organized list. Using the first initial of each course, the list might start with $\{(F, L, v), (F, L, s), \dots\}$. As there are 2 choices for language, 2 for computer course, and 3 for physical education class, there will be $2 \times 2 \times 3$ items in the list.
4. (7, 3. **The drawing is shown to the right.**) From the drawing, with the 4 m square of mulch sitting in the center, the distance from the mulch to the outer edge of the garden is 3 m. From this, the width of the rectangle is 3 m. The length of each is then $3 \text{ m} + 4 \text{ m}$, or 7 m.

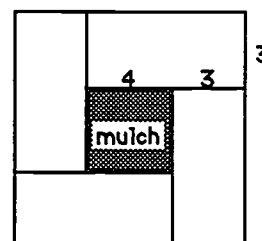

5. (30 miles per hour) 20 miles in 40 minutes is 10 miles in 20 minutes. Taking this rate 3 times means you could travel 30 miles in 60 minutes, or, 30 miles per hour.
6. (28) Students might find this by guess-check-revise, continually guessing what x might be until they are successful with a check. However, they might decide to simplify the equation to $X = 14 + \frac{1}{2} X$, and solve by subtracting $\frac{1}{2} X$ from both sides, getting $\frac{1}{2} X = 14$, or $X = 28$.
7. (B) The pattern is determined by counting by tens in the negative direction. Therefore once you start with -10, -20, -30, ..., you can simply switch to the positive numbers and count by tens as 10, 20, 30, ... and decide where 500 would be in such a count. If you count several such rows, you'll notice that column F is the multiples of 6, with a negative sign and zero added (-60, -120, -180, ...). The closest such number to -500 would be -480, so -480 would go in column F. This means -490 is in A, and -500 is in B.
8. ($3b + 31 = 47.2$; 5.4) Students should see that there are 3 balls on the scale, so $b + b + b$ gives the weight of the 3 balls alone. This amount, added to 31, gives 47.2. This equation might be written as shown above, or in a number of alternate ways, such as $b + b + b + 31 = 47.2$. A student might solve this equation or solve the problem intuitively by removing 31 from the scale and calculating what the new scale would show. Then dividing this amount into 3 equal piles would result in the answer of 5.4.

SUPERSTARS III
Neptune, XXIV

Name: _____
(This shows my own thinking.)

- ★★★★ 1. Bill bought a new Corvette in 1996 for \$42,000. If the car decreases in value 10% each year, in what year will the Corvette be worth less than half of what Bill paid?

Answer: _____



- ★★★★ 2. For a science experiment, Denise was asked to take 170 apples that each weighed the same, and put them in paper bags to make the greatest possible number of bags of different weights. What is the greatest number of bags that Denise can use to hold the apples, if each bag must contain at least one apple, but no two bags may contain the same number of apples?

Answer: _____ bags

- ★★★ 3. The tortoise and the hare had a 3000 meter race. They started at the same time. The hare hops at an average rate of 9 meters per minute while the tortoise averages only 1.5 meters per minute. After one hour, how many meters was the hare ahead of the tortoise?

Answer: _____ m

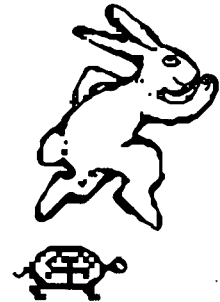

- ★ 4. Al calls me every 3 days, Bob calls me every 4 days and Chris calls me every 6 days. Once in every _____ days all three will call on the same day.

Answer: _____

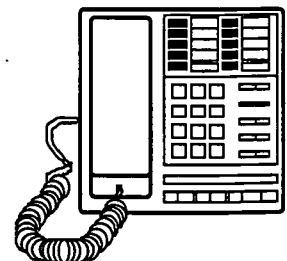

- ★★ 5. The Mason family went to an amusement park. They spent exactly \$56.00 for tickets. The tickets cost \$12 for each adult and \$5 for each child. How many adults and how many children went to the park?

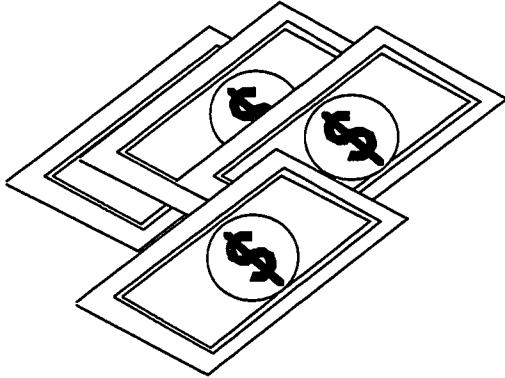

Answer: _____ adults

Answer: _____ children

- ★★ 6. Using 4 fours with any operations or grouping symbols, write an expression that has a value of 3.

4 4 4 4

Answer: _____

- ★ 7. Grades can range from 0 to 100 on a test. If you already have tests with scores of 92% and 84%, what is the lowest possible average you can have for three tests? Round to the nearest whole number.

Answer: _____ %

- ★★ 8. A standard deck of 52 cards is shuffled and then put in a box. What is the probability that, if a card is drawn randomly from the box, it will have a number on it of which 4 is a factor?

Answer: _____

Commentary

Neptune, XXIV

1. (2003) On a calculator, students can use the repeating function concept to repeatedly multiply by 90%, finding the value for each new year in one step. Seven years from 1996 (2003) the car will have a value less than \$21,000.

2. (17) Denise might put one apple in the first bag, two apples in the second bag, three apples in the third bag, and so on. By the sixteenth bag, 136 apples will have been used. If you put 17 in the next bag, which the pattern leads you to do, you would then have 17 left for the 18th bag but this would repeat the number seventeen. However, by placing 34 apples in the 17th bag, the problem is solved.

3. (450) The hare's rate of 9 meters per minute is 9×60 or 540 meters per hour. Likewise, the tortoise's rate is 1.5×60 or 90 meters per hour. So, in one hour the hare was $540 - 90$ or 450 meters ahead. Some students may figure that the hare's rate is 7.5 m/hr faster, so $7.5 \times 60 = 450$ meters.

4. (12) The days that Al will call will follow this pattern: 3, 6, 9, 12, ... The days that Bob will call will follow this pattern: 4, 8, 12, ... The days that Chris will call will follow this pattern: 6, 12, 18, ... Notice that 12 is common to all 3 patterns, so that is a day that all three will call.

5. (3 adults, 4 children) A possible approach to this problem is to make a chart. Fill in possible amounts spent on adult tickets. Decide for each if it's possible to have a whole number of children with the remainder. The only adult possibility is 3 with 4 children.

Adult	Cost	Money left	\$ left for Children \div ticket cost
1	\$12.00	$\$56 - \$12 = \$44$	$\$44 \div \$5 = 8.8$ children (not possible)
2	\$24.00	$\$56 - \$24 = \$32$	$\$32 \div \$5 = 6.4$ children (not possible)
3	\$36.00	$\$56 - \$36 = \$20$	$\$20 \div \$5 = 4$ children (possible)
4	\$48.00	$\$56 - \$48 = \$8$	$\$8 \div \$5 = 1.6$ children (not possible)

6. (One possible solution: $(4 + 4 + 4) \div 4 = 3$) Answers may vary; students can try various operations and record the results.

7. (59) The lowest average would come from making 0 on the last test. The average would then be $(92 + 84 + 0) \div 3 = 58.666...$ or 59 to the nearest whole number.

8. ($\frac{8}{52}$ or $\frac{2}{13}$ or 0.15 or 15%) There are 4 fours and 4 eights, a total of 8 number cards out of 52 that are evenly divisible by 4. Therefore the chances are $\frac{8}{52}$ or one of its equivalent forms.

SUPERSTARS III
Neptune, XXV

Name: _____
(This shows my own thinking.)

- ★ 1. If you already have scores of 83%, 91% and 86% on your first three math tests, what could your highest possible average be after 4 tests? (Assume no extra credit.)

Answer: _____%

- ★★ 2. Using 4 fours with any operations or grouping symbols, write an expression that has a value of 5.

4 4 4 4

Answer: _____

- ★ 3. Figure out a rule which was used to determine which letters go above the line and which letters go below the line. Use that rule to place the rest of the letters correctly.

A E F H I K L M N

B C D G J O

- ★★★★ 4. The perimeter of a square is equal to the circumference of a circle.

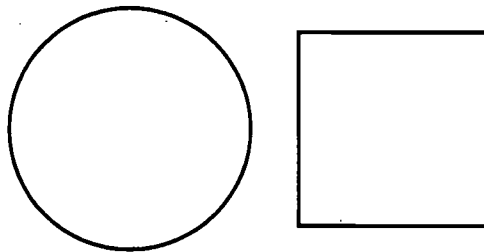

If the diameter of the circle is 8, what is the area of the square?

Answer: _____ sq. units

★★★★ 5. Find 2 patterns. Write the next term according to each of your patterns.

4, 7, 13, 25, 49, _____, . . .

4, 7, 13, 25, 49, _____, . . .

★★★★ 6. How many acute central angles are in this figure? Right angles? Obtuse angles?

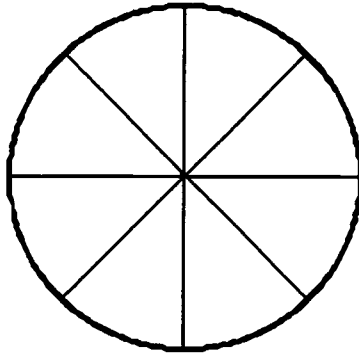

Answer: _____ acute angles

Answer: _____ right angles

Answer: _____ obtuse angles

★★★ 7. Your heart beats approximately 70 times a minute. The life span expectancy of a male is 75 years, and that of a female is 79 years. To the nearest billion, how many times will your heart beat if you live to your life expectancy?

Answer: _____ beats

★★★★ 8. Cookies were missing from the kitchen. They were taken by Sam, Bob, or Sue. Each made a statement to their mother.

Sam said: Bob took the cookies

Bob said: That is true.

Sue said: I did not take the cookies.

If at least one of them lied and at least one told the truth, who took the cookies?

Answer: _____

Commentary

Neptune, XXV

1. **(90)** The highest possible average would mean you made 100% on the last test. Then your average would be $(83\% + 91\% + 86\% + 100\%) \div 4$, or 90%.
2. **(One answer: $(4 \times 4 + 4) \div 4$)** Students will probably try various combinations and compute each to see which are correct.
3. **(Letters above the line are: T, V, W, X, Y, and Z. The others are below the line.)** Some students will get this immediately, and others will struggle trying to find a numerical pattern that underlies the placement of the letters. The rule used is that letters made strictly with line segments are above the line -- those with curves go below the line. If a student does find a numerically-based pattern so that all of the given examples fit, give credit for the problem.
4. **($4\pi^2$ or about 39)** The circumference of the circle is given by πd , where d is the diameter. In this case, the circumference is 8π . If this is also the perimeter of the square, then each side is $8\pi \div 4$ or 2π . Then the area of the square is $(2\pi)^2$ or $4\pi^2$.
5. **(97)** One pattern is that you add 3, then 6, then 12, then 24, doubling what you add each time to get the next number. Another way to describe the pattern is that you double each number and subtract 1 to get the next term. Students may notice other ways to describe this pattern.
6. **(8, 8, and 8)** If you choose one radius shown, you can count one acute angle between that radius and the next radius you meet. Then you move to the next radius and proceed around the circle clockwise until you return to the starting radius. The same procedure will show that there are the same number of right and obtuse angles.
7. **(3,000,000,000)** For a female: $70 \times 60 \times 24 \times 365 \times 79 = 2,906,600,000$ -- for a male: $70 \times 60 \times 24 \times 365 \times 75 = 2,759,400,000$. Each of these numbers rounds to 3 billion.
8. **(Sam)** One way to begin is to ask "what happens if someone is lying?" For example, if Sue is lying, then all three are lying by looking at the other two clues. But all three lying can't happen because of the conditions. So Sue is telling the truth and didn't take the cookies. Then if Sam is lying, he must have taken the cookies because we know that Sue didn't -- this means Bob is lying also, which is possible. Could Sam be telling the truth? If so, then Bob is also telling the truth, which is impossible because all three can't be telling the truth by the conditions. The only possibility, then, is that Sam took the cookies and lied, Bob lied also, and Sue told the truth.

SUPERSTARS III
Neptune, XXVI

Name: _____
(This shows my own thinking.)

- ★★ 1. Using 4 fours with any operations or grouping symbols, write an expression that has a value of 6.

$$4 \ 4 \ 4 \ 4 = 6$$

Answer: _____

- ★★★ 2. If a cube whose edge is 4 inches is placed inside of a cube whose edge is 5 inches, what percent of the space inside the larger cube is filled by the smaller cube?

Answer: _____ %

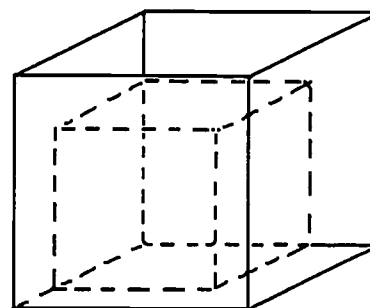

- ★★ 3. A baseball team won 6 out of 12 games and then won the next 6 games. What per cent of their games did they win?

Answer: _____ %

- ★★ 4. On the school track, four laps make a mile. Mark ran 6 laps in 12 minutes. At this rate how long would it take him to run a mile?

Answer: _____ minutes

- ★ 5. If a quart of ice cream is split equally among 4 people, what fraction of a gallon will each person get?

Answer: _____ of a gallon



- ★★★ 6. In the diagram below, lines a and b are parallel. If angle 1 measures 120° find the measures of angles 2, 3, 4, 5, 6, 7, & 8. Record them in the chart below.

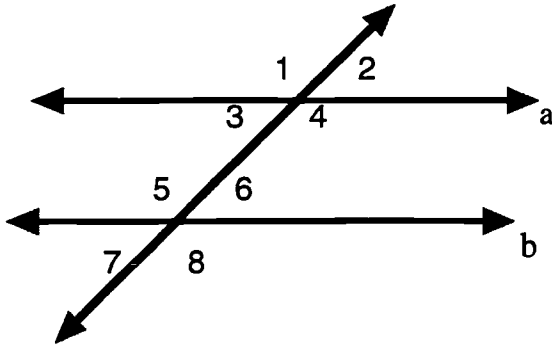

Angle	Measure	Angle	Measure

- ★★★★ 7. On a TV game show there are 3 doors. The grand prize is behind one of them. If you appear on the show for 2 days in a row, what is the probability that you will pick the door with the grand prize both days?

Answer: _____

- ★★★ 8. Human hair grows at an average rate of 2.5 millimeters per week. Suppose that today is your 13th birthday and you have not cut your hair since you were born. Estimate how long your hair would be in meters today.



Answer: _____ meters

- ★★★★ 9. Someone once asked the smartest person in the world, Marilyn vos Savant, this question:

Suppose the earth were smooth, and you could wrap a 25,000-mile-long metal belt snugly around it. Now let's say you lengthen the band by 10 feet, loosening it just a little. What would be the largest thing that could slither under the new band? An amoeba, a worm, a snake, or an alligator?



What was her answer?

Answer: _____

Commentary

Neptune, XXVI

1. (Possible answer: $(4 + 4) \div 4 + 4 = 6$)
2. (About 51%) The volume of the larger cube is 5^3 or 125 cubic inches. The volume of the smaller cube is 4^3 or 64 cubic inches. $64 \div 125 = 0.512$ or about 51%.
3. (about 67%) They won 12 games out of 18 played. $12 \div 18$ is 0.666..., which rounds off to 67%, to the nearest whole percent.
4. (8) Six laps in 12 minutes means 1 lap in 2 minutes. Therefore 4 laps would take 8 minutes.
5. (1/16) Four quarts is 1 gallon, so one quart is 1/4 of a gallon. Then 1/4 of 1/4 of a gallon would be 1/16 of a gallon.
6. (Angles 2, 3, 6, & 7 = 60° ; angles 1, 4, 5, & 8 = 120° .) These angles show what happens when a transversal line cuts a pair of parallel lines.
7. ($\frac{1}{9}$) The first day, there is a 1/3 chance of getting the grand prize. So this should happen 1/3 of the time. Given that it does happen, there's a 1/3 chance that you'll open the right door the second time also. This results in 1/3 of 1/3 of the time that both will hold true, or 1/9 of the time.
8. (1.69) (A calculator will help students get this answer. $2.5 \text{ mm/week} \times 52 \text{ weeks/year} \times 13 \text{ years}$ is 1690 mm. This is 1.69 meters.)
9. (alligator) If the circumference of the belt initially is 25,000 miles, it is 132,000,000 feet. The radius from the center of the earth would then be found by using $C = 2\pi r$. This radius is 21,019,108 feet. With 10 feet added to the circumference, producing 132,000,010 feet, the radius of the loosened belt would be 21,019,109.5 or about a foot and a half more than before. This would be room for an alligator to crawl under.

SUPERSTARS III
Neptune, XXVII

Name: _____
(This shows my own thinking.)

- ★★ 1. Using 4 fours with any operations or grouping symbols, write an expression that has a value of 7.

$$4 \ 4 \ 4 \ 4 = 7$$

Answer: _____

- ★★★ 2. To glue these 9 cubes together, how many square surfaces must be joined?

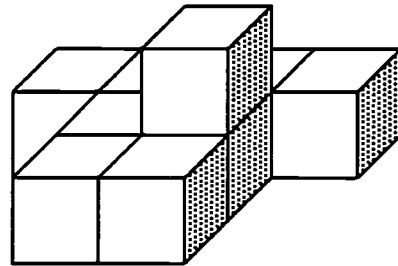

Answer: _____

- ★★ 3. It was 3:00 PM when Akita measured the depth of her fish pond to be three and one half feet. It was filling at a rate of 1 inch per minute. When would it be 8 feet deep so she could turn the pump off?

Answer: _____ o'clock

- ★★★ 4. In a summer camp, counselors often split the campers into 3, 5 or 6 equal groups but they always ended up with one extra camper. Today they split the campers into 7 equal sized groups and there were no campers left over. What is the smallest number of campers at this camp?

Answer: _____ campers

- ★★★ 5. Find the pattern. Use it to write the next 4 terms in the blanks.

1, 1, 2, 3, 5, 8, 13, 21, _____, _____, _____, _____, . . .

- ★★★ 6. The sum of 5 different positive integers is 500. What is the largest possible value for one of these integers .

Answer: _____

- ★★ 7. Four typists can type a total of 200 letters in 2 days. How many letters can two of these typists type in one day?

Answer: _____ letters

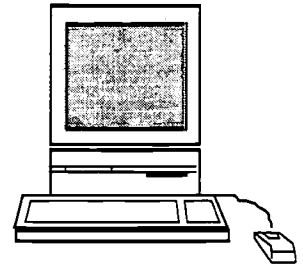

- ★★ 8. In how many ways can the Williams family, shown in the picture, arrange themselves in a line? Don't count the dog as a family member!

Answer: _____ ways

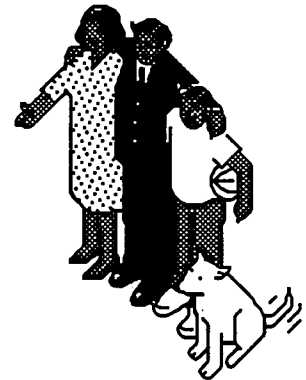

- ★★ 9. Write an equation and solve it to answer the question in this problem.

Fingernails grow about 1.5 inches per year. How many years y would it take to grow a world record nail of 37 inches, starting with your present length of about $\frac{1}{2}$ inch?

Answer: Equation: _____ Solution: $y =$ _____

- ★★★ 10. Write an equation and solve it to answer the question in this problem.

Carrie started saving with a \$10 gift from Grandma. She saved half her allowance a each week. At the end of a year she had \$88. How much per week was her allowance?

Answer: Equation: _____ Solution: $a =$ _____

Commentary

Neptune, XXVII

1. (Sample answer: $4 + 4 - (4 \div 4) = 7$)
2. (20) One way to approach this problem is to consider each cube in turn, asking how many faces it has that are glued to another face. The numbers on the cube faces show the numbers for each cube. Their sum is 20.

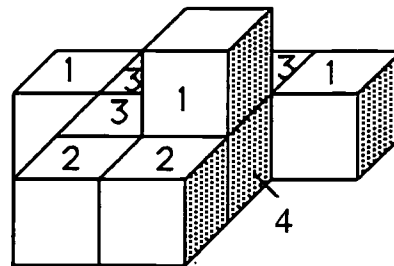

3. (3:54) One inch per minute is a rate of 1 foot in 12 minutes. The depth must go from $3 \frac{1}{2}$ feet to 8 feet, an increase of $4 \frac{1}{2}$ feet. Therefore the number of minutes required is $(4 \frac{1}{2}) \times 12$ or 54 minutes.
4. (91) Students might begin by looking at the multiples of 7, checking to see which of those have a remainder of 1 when divided by 3, 5, and 6. The first of these is 91. ($91 \div 3 = 30 \text{ R } 1$; $91 \div 5 = 18 \text{ R } 1$; $91 \div 6 = 15 \text{ R } 1$; $91 \div 7 = 13$, no remainder)
5. (34, 55, 89, 144) The pattern is the widely-known Fibonacci sequence, which starts with 1, 1. From there on, each term is the sum of the two preceding terms. This sequence has been linked to many natural occurrences on earth.
6. (490) The largest possible such integer would be paired with the four smallest other positive integers. Therefore this number is paired with 1, 2, 3, and 4, and we know it must be 490 since $490 + 1 + 2 + 3 + 4 = 500$.
7. (50) $200 \div 4 = 50$ letters per typist for 2 days, or 25 letters per day per typist. So 2 typists can do 50 letters per day.
8. (6) Denote the three members by A, B, and C. Possible arrangements are: ABC, ACB, BCA, BAC, CAB, CBA.
9. (Equation: $37 = \frac{1}{2} + 1.5y$; $y = 24.3$) Students might write alternate versions of the equation, and 24.3 has been rounded to the nearest decimal. The equation can be solved by intuition or *guess-check-revise*. A formal procedure that involves subtracting $\frac{1}{2}$ from both sides, then dividing both sides by 1.5, to isolate the variable y may be used.
10. (Equation: $88 = 10 + 52\frac{a}{2}$; $a = 3$) Again, students might write alternate forms of the equation. The equation can be solved by intuition or *guess-check-revise*. Again a formal procedure that involves subtracting 10 from both sides, then dividing both sides by 26, to isolate the variable a , is a possibility.

Super Stars

Mercury



Venus



Earth



Mars



Jupiter



Saturn

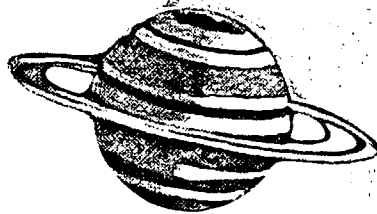

Uranus



Neptune



BEST COPY AVAILABLE

Pluto



★ ACKNOWLEDGMENTS ★

This project, originally designated *Sunshine Math*, is the third in a series of problem solving programs. It was conceived, coordinated and developed through the Florida Department of Education with input from the mathematics staff members of the North Carolina Department of Public Instruction and the South Carolina Department of Education. In addition, it was supported financially through a grant to the School Board of Polk County, Florida. The rich history of these materials and the predecessor programs, **SUPERSTARS** and **SUPERSTARS II** goes back to the early 1980's. Many Florida teachers have been involved in developing and using these materials over the years. The original **SUPERSTARS** programs were adopted and adapted by North Carolina and South Carolina with their teachers contributing to revisions and personalizations for use in their states. Florida educators were primarily responsible for developing, field testing, and publishing *Sunshine Math*. Educators from the Carolinas developed the **MathStars Newsletter** to accompany and enhance this program.

School districts in North Carolina have permission to reproduce this document for use in their schools for non-profit educational purposes. Copies of each grade level are available from the publications unit of the North Carolina Department of Public Instruction. The contact for **SUPERSTARS III** and the **MathStars Newsletter** is Linda Patch, 301 North Wilmington Street, Raleigh, NC 27601-2825 : (919-715-2225).

Michael E. Ward
State Superintendent
North Carolina Department of Public Instruction

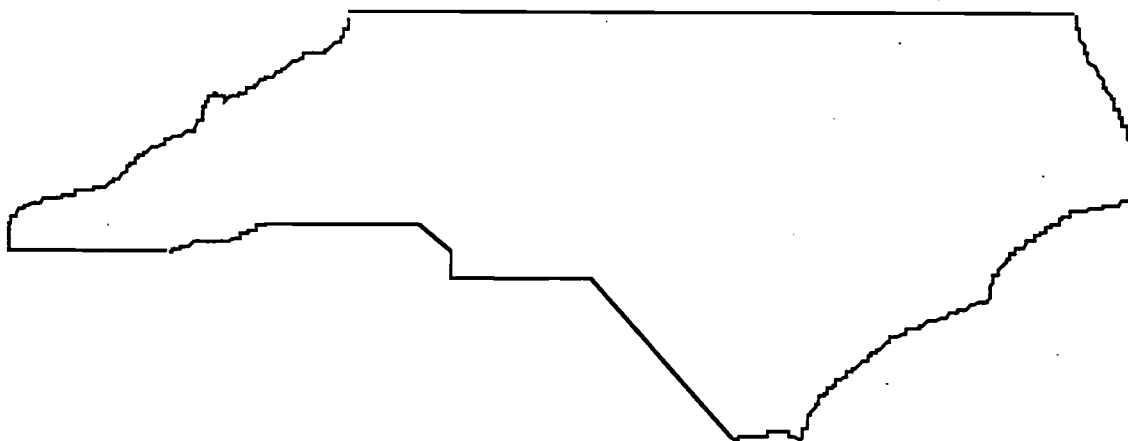

☆ *Preface* ☆

SUPERSTARS III encourages and enhances the positive aspects of students, parents, teachers and administrators working together. This program assumes that students, even young children, are capable of and interested in learning; that teachers want to help them learn to think for themselves; that administrators see their jobs as clearing the path so that quality education is delivered effectively in their schools; and that parents care about their child's learning and are willing to work with the school system toward that goal. Each of these four groups has a vital role to play in implementing **SUPERSTARS III**.

The designer of this program has a long history of working with elementary children. He believes that they are capable of much more than we ask of them, and that many children are on the path to becoming independent learners. A number of children in any classroom are bright, energetic and willing to accept extra challenges.

The basic purpose of **SUPERSTARS III** is to provide the extra challenge that self-motivated students need in mathematics, and to do so in a structured, long-term program that does not impinge on the normal classroom routine or the time of the teacher. The system is not meant to replace any aspect of the school curriculum -- it is offered as a peripheral opportunity for students who identify with challenges and who want to be rewarded for their extra effort. Participation in the program is always optional -- only those students who voluntarily choose to participate will, in the long run, benefit from **SUPERSTARS III**. Any student, regardless of prior academic performance, should be encouraged to participate as long as interest is maintained.

The predecessor program for **SUPERSTARS III** -- the **SUPERSTARS II** program -- has demonstrated that this concept can be extremely useful. What is required are several dedicated adults who devote a few hours each week to operate the system effectively in the school; an administrator who provides highly visible support; teachers who welcome a supplementary experience for their students to engage in higher-order thinking; and a typical classroom of students. If all of those ingredients are present **SUPERSTARS III** will become an integral part of the school fabric.

ORGANIZATION OF THESE MATERIALS

Section I Description of the SUPERSTARS III Program

1. General Information
2. Information/checklist for principals
3. Information/checklist for assisting adults
4. Information for teachers
5. Letter to participating students and their parents.

Section II Student worksheets for SUPERSTARS III

SUPERSTARS III
Jupiter, XXII

Name: _____
(This shows my own thinking.)

**1. If the 24th day of the month falls on Saturday, on what day did the 6th fall?

Answer: _____

***2. There are 4 six-packs of soda in a case. Chris bought 12 of a case and gave 13 of what he had to Dana. How many cans of soda does Chris have left?

Answer: _____ cans

***3. Together, 6 boys and 12 girls weigh 1050 pounds. The boys all weigh the same -- so do the girls. Each girl weighs 85 pounds. What is the weight of one boy?

bbbbbb gggggggggggg

Answer: # _____ pounds

**4. The sum of 3 consecutive numbers is 276. What are the numbers?
(Consecutive numbers differ by one; example: 8, 9, and 10)

Answer: _____ and _____

**5. If a family of 12 spiders wore shoes, how many pairs of shoes would they need?

Answer: _____ pairs.



**6. A tropical storm passed through the town. It began to rain Monday morning at 8:45 AM and did not stop until the next day at 2:30 PM. How long did it rain?

Answer: _____ hours and _____ minutes



**7. There are 3 cars, 4 bicycles, 2 tricycles, and 1 unicycle in the neighbor's garage. How many wheels are there in all? Forget about any "spare tires"!

Answer: _____ wheels

**8. Rosemary bought a sweater on sale for \$6.98. She also bought a skirt for \$9.99. She paid an additional \$1.19 for sales tax. Rosemary gave the sales person a \$20 bill. How much change should she receive?

Answer: _____



**9. Study this pattern. 25 and also 32 would be in column E, if the pattern continued.

a. In which column would 100 appear?
b. In which column would 500 appear?
c. In which column would 1000 appear?

31	22					
14	15	16	17	18	19	20
7	8	9	10	11	12	13
0	1	2	3	4	5	6
A	B	C	D	E	F	G

Section III Commentary for student worksheets for SUPERSTARS III

Commentary
Jupiter, XXII

1. (Tuesday) Students can use a calendar or make a chart with "Su, M, T, W, Th, F, Sa" at the top and begin numbering backward putting 24 under Saturday. They may also realize that the 17th and 10th fall on Saturdays and count back from the 10th.

2. (8) Students can solve this problem by drawing a diagram or by visualizing 24 coins. 1/2 of 24 is 12, and 1/3 of 12 is 4. Therefore Chris gave away 4 of the 12 sodas, leaving 8.

3. (65) Students will probably solve this by first finding the total weight of the 12 girls: 12 x 85 = 1020 pounds. Then they will compute 1050 - 1020 = 30 pounds, the weight of the 6 boys. Then 30 ÷ 6 = 5 pounds per boy.

4. (91, 92, 93) Students may use the guess-check-revise method. Some students might know that the numbers they seek are about 1/3 of the total, and approximate the numbers by dividing 276 by 3. This gives 92, which is the middle number.

5. (48) Students may want to draw a picture to help solve this problem. Spiders have 8 legs, which would be 4 pairs of shoes per spider.

6. (29 hours and 45 minutes) Most students will realize that from 8:45 AM to 8:45 AM the next day is 24 hours. They will then "add on" 5 additional hours to get to 9:45, 10:45, 11:45, 12:45, and 1:45, and then 45 minutes to get to 2:30 PM.

7. (27) There would be 12 wheels on the 3 cars, 8 on the 4 bicycles, 6 on the 2 tricycles, and 1 on the unicycle.

8. (\$18.16) Students will probably add \$6.98 and \$9.99 to get \$16.97, then add the tax of \$1.19 to get \$18.16. They will subtract this amount from \$20.

9. (a, C; b, D; c, G) Hopefully, students will notice that the multiples of 7 are in column A and use this fact to get "close to" the numbers 100, 500, and 1,000. Ninety-eight (14 x 7) is the closest multiple of 7 less than 100, so 98 would be in column A. Forcing 100 to be in column C. Likewise, 497 or 71 x 7 is in column A, putting 500 in column D. Finally, 994 or 142 x 7 is in A, indicating that 1000 is in column G.

SUPERSTARS III: General Information

SUPERSTARS III is a K-8 program designed as an enrichment opportunity for self-directed learners in mathematics. The levels of the program are named for the planets in our solar system:

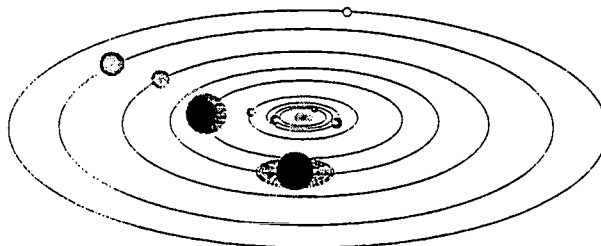

Kindergarten	Mercury	Fourth Grade	Jupiter
First Grade	Venus	Fifth Grade	Saturn
Second Grade	Earth	Sixth Grade	Uranus
Third Grade	Mars	Seventh Grade	Neptune
	Eighth Grade	Pluto	

Students of all ability levels choose on their own to participate in **SUPERSTARS III**. Seeing their names displayed in a prominent place in the school, with a string of stars indicating their success, is one reward students receive for their extra work. In some cases the school may decide to enhance this basic system by awarding certificates of achievement or some other form of recognition to highlight certain levels of success or participation in the **SUPERSTARS III** program.

SUPERSTARS III can function in a school in a number of different ways. A “tried and true” way is for assisting adults (volunteers, aides, etc.) to manage the program for the entire school, with support provided by school administrators and classroom teachers. This system has been adopted at the school level, with varying degrees of success, over the years. The basic model for conducting **SUPERSTARS III** is discussed below, with variations described on the next page.

The basic model

The basic model for **SUPERSTARS III** is for a school to establish a weekly cycle at the beginning of the academic year according to the following guidelines:

On Monday of each week student worksheets are distributed by the assisting adults to students in the program. Students have until Friday to complete the problems working entirely on their own. On Friday the classroom teacher holds a brief problem-solving session for the students in the program. The more difficult problems on the worksheet are discussed with students describing their thinking about strategies to solve the problems. They do not share solutions, only strategies.

Students receive double credit for those problems they have successfully completed prior to the problem-solving session, and regular credit for those they complete successfully over the week-end. On Monday all papers are handed in, checked by the assisting adult, and stars are posted for problems successfully completed. This completes one cycle of the **SUPERSTARS III** program.

SUPERSTARS III is not for every child -- it is only for those who are self-motivated and who are not easily frustrated by challenging situations. This does not diminish the value of the program, but rather makes us realize that there are children of all ability and socio-economic levels who are self-directed learners and who need challenges beyond those of the regular school day. These children will shine in **SUPERSTARS III**.

Variations of the basic model

The first variation that has been used successfully retains the weekly cycle and assisting adult role from the basic model. The teacher however, involves the entire class in the problem-solving discussions. For example, the teacher might select the four most difficult problems on the worksheet (indicated by three or four stars) and work a "parallel" problem with the entire class to open the mathematics lesson on Tuesday through Friday. Using this variation, all students are exposed to the problem-solving strategies, but only those who have chosen to participate in **SUPERSTARS III** will complete and turn in the worksheet on Monday.

A second variation has the assisting adult manage the entire program, including the Friday problem-solving session. This method has been used in situations where teachers lacked commitment to the program and thus implemented it inconsistently. In such cases, the assisting adult must have a progressive view of what constitutes problem solving in elementary mathematics. They should also receive extra assistance from the administration to ensure that students are released from class and that the cycles proceed smoothly.

Yet another variation is for a parent to manage **SUPERSTARS III** at home for his or her own child. The basic rules are the same -- a child gets the worksheet once a week and time to work the problems alone. The parent sets a night to listen to the way the child thought about each problem, offering suggestions or strategies only when the child is unable to proceed. The reward system is basically the same, stars on a chart, but can be enhanced by doing something special with the child, such as a trip to the museum or to a sporting event when the child reaches certain levels of success. If this method is adopted, the parent must not try to teach the child, but rather to stimulate discussion of problem-solving strategies. **SUPERSTARS III** is not a program for adults to teach children how to think.

Other variations exist. The basic model as stated is the best, all other factors being equal, for reaching more children in a consistent fashion than any of the other methods. However, we encourage individual schools, teachers, or parents to get some version started; some starlight is better than none.

SUPERSTARS III: Information for Principals

SUPERSTARS III is a K-8 enrichment package for mathematics designed to be managed by volunteer assisting adults with coordinated support from the classroom teacher and school administrators. The purpose of the program is to give self-motivated students of all ability levels a chance to extend themselves beyond the standard mathematics curriculum. The complete set of materials comes in nine packages, one for each grade K-8. The grade levels are identified by the names of the nine planets in our solar system and their order from the sun:

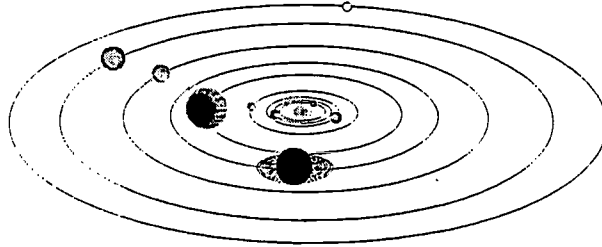

Mercury - Kindergarten

Earth - Second Grade

Jupiter - Fourth Grade

Uranus - Sixth Grade

Venus - First Grade

Mars - Third Grade

Saturn - Fifth Grade

Neptune - Seventh Grade

Pluto - Eighth Grade.

Your support is vital if this program is to succeed. As the school administrator, you need to stay in close contact with the **SUPERSTARS III** program. A “checklist for success” follows:

- Become familiar with the philosophy and component parts of the program.
- Introduce **SUPERSTARS III** to the faculty early in the school year. Ensure that teachers understand the philosophy of the program and have copies of the student worksheets and commentaries appropriate for their grade levels.
- Speak to parents at your school’s first open house of the year, explaining the purpose of **SUPERSTARS III** and the long term value of children working independently on challenging problems.
- Recruit several assisting adults (PTA members, aides, senior citizens, business partners, church members, etc.) who are enthusiastic, dependable people who are willing to manage the program. Early in the academic year, meet with these assisting adults to plan such details as:
 - ✓ A prominent place and format for the STAR CHART.

- ✓ A designated time and place each Monday and Friday for the assisting adults to be in school to meet with students, distribute and collect worksheets, and post stars.
- ✓ A system for the activity sheets to be duplicated each week.
- ✓ A plan for extra incentives for accumulating stars. (“World records” to be kept from year-to-year, a celebration day planned for the end of school, prizes earned by students for attaining certain levels of success -- see the diagram below for examples.)
- ✓ A schedule for the initiation of the program and a decision as to a “start over” point later in the academic year. Review the school calendar and only use weeks that are at least four days long. If there is not enough time in the year to complete all the activity sheets, decide which to eliminate or on a plan to “double up.”
- ✓ A **SUPERSTARS III** cap, name badge, tee-shirt, or other distinction for volunteers, if possible.
- Monitor the program every two weeks to get ahead of unforeseen difficulties. Administrators need to be highly visible and supportive for **SUPERSTARS** to succeed.

SUPERSTARS III is an optional program for students. It should be available to any student who wants to participate, regardless of prior success in mathematics. Typically, a large number of students will begin the program, but a majority will lose interest. A significant number however, will continue their efforts over the life of the program. This is normal and simply means that **SUPERSTARS III** is successfully addressing the needs of the self-directed learner.

Visual reminders help children see this mathematics program is challenging and rewarding. Some ideas are presented here:

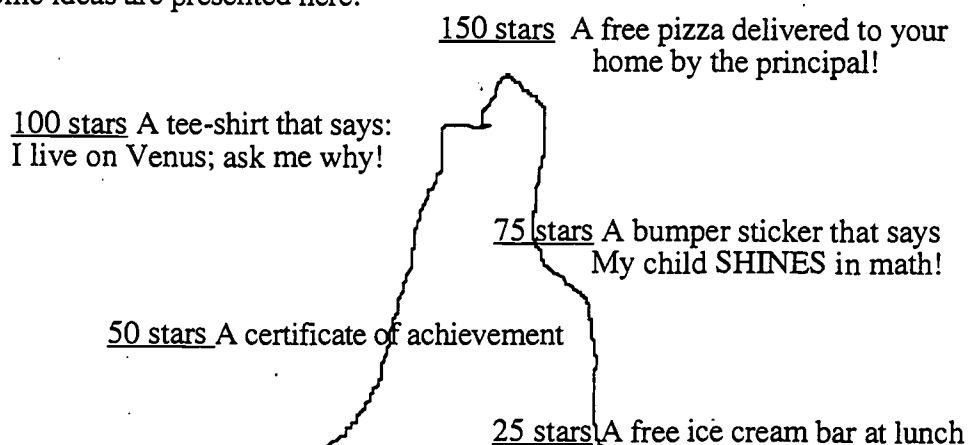

Climb the Mountain this Year!! Join the **SUPERSTARS III** Club

SUPERSTARS III: Information for Assisting Adults

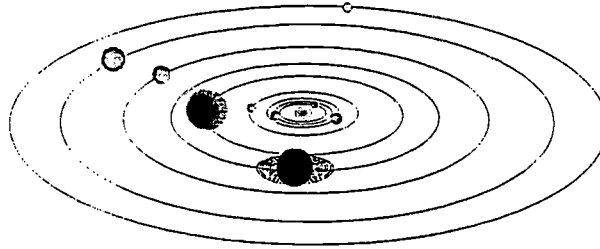

SUPERSTARS III is designed to give assisting adults a well-defined role to play in the school's mathematics program. The success of **SUPERSTARS III** depends upon a team effort among teachers, administrators, parents and you. Reliability and punctuality are important - students will quickly come to depend upon you to be there as scheduled, to check their papers and post their stars, and to listen to alternate strategies and interpretations of problems to help them arrive at solutions. If possible, wear an outfit or badge that fits with the **SUPERSTARS III** theme or logo; students will soon identify you as an important person in their school.



SUPERSTARS III works on a weekly cycle. Each Monday you will collect the worksheets from the previous week and distribute new worksheets to the participating students, all from your **SUPERSTARS III** area of the school. Allow students to see the answers to the problems, discuss any for which their answers differ and allow them credit if their interpretation and reasoning are sound. After checking all the work, you will post the stars earned by students on the STAR CHART.



Participating students have from Monday until Friday to work the problems entirely on their own -- the only help they should receive during that time is for someone to read the problems to them. On Friday the teacher will host a problem-solving session in the classroom where students will describe the strategies they used to approach the more difficult problems. Students who have successfully completed problems before this session will receive double points for their efforts. The teacher's initials on the worksheet will help you identify those problems. The students then have the week-end to complete or correct their problems and turn them in on Monday. All the correct problems thus completed will receive the indicated number of stars.



Be creative when designing your STAR CHART. The basic method of posting stars individually is a good way to begin but eventually you will want a more efficient system. Color coding by grade level, or posting just one star each week with a number in its center are ideas to consider. You may wish to personalize the chart and the entire **SUPERSTARS III** center with student pictures, "smiling faces", a logo, seasonal theme or some other feature that has a mathematical flavor. Occasionally feature a reward for each child such as a cookie or a hand stamp in the shape of a star just for turning in the worksheet. You are helping enthusiastic students develop high-level thinking skills -- be creative and enjoy your role!

Checklist for assisting adults:

- Plan the following with the principal:
- ✓ A prominent place and format for the

STAR CHART

- ✓ The time and place for you to collect, check, and distribute worksheets.
- ✓ A system for duplicating worksheets each week which ensures legible copies. Also a secure storage area for masters and other materials.
- ✓ Any additional incentives ("world records," stickers, coupons, pencils, tee-shirts, etc.) that will be part of the system for rewarding levels of achievement in **SUPERSTARS III**.



- Make the **SUPERSTARS III** center a happy place. Use bright colors, smiles, and cheerful expressions. Show confidence, friendliness, and encouragement to students.



- Collect the letters that are sent home prior to the first worksheet. These need to be signed by each student and a parent. If, in the future, you have evidence that the work submitted does not represent the thinking of the student, discuss the situation with the classroom teacher. These situations are best handled individually, confidentially and in a firm, consistent manner.



- Check the worksheets from the previous week uniformly. If you give partial credit for a problem with several parts do so in a fair way that can be understood by the students. Do not award partial credit for problems with only one answer.



- Have answer sheets available and encourage students to look at the solutions when they submit their worksheets. Allow them to explain their strategy or interpretation if they have arrived at a different answer. Award full credit if they show a unique and plausible interpretation of a problem and follow sound logic in arriving at their response.



- Leave extra worksheets with the classroom teacher for participating students who were absent on Monday. Accept a late-arriving worksheet only if the student was absent on Monday. If a student's name is missing or in the wrong place on the worksheet, check the paper but award stars to "No Name" on the STAR CHART. Adhering strictly to these rules will rapidly teach responsibility to the students and keep your work manageable.



- Keep all returned worksheets. As the same problems are used year after year, and many students have siblings who may later participate in **SUPERSTARS III**, it is important that worksheets do not circulate.



- On weeks when **SUPERSTARS III** is not available post a notice such as "No star problems this week, but please come back after vacation for more!"

SUPERSTARS III: Information for Teachers

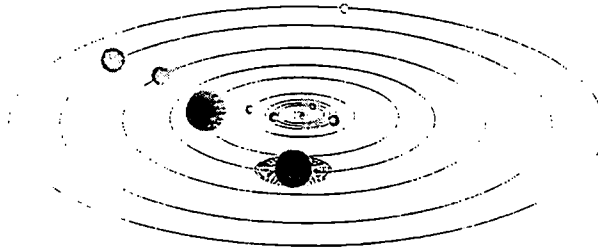

SUPERSTARS III is a program designed to complement your regular classroom mathematics curriculum. It offers a supplemental opportunity for students to practice mathematics skills appropriate for their grade level and at the same time to engage in challenging problem-solving activities. It is an additional challenge to those students who are self-directed learners providing them with an academic extracurricular activity.



Your involvement is essentially as a teacher. **SUPERSTARS III** will remain special to students if it is managed by someone outside of the classroom and if the teacher is viewed as a facilitator in the system, rather than as the authority figure. Your primary role is to monitor the system in your own classroom and to host a brief problem-solving session for **SUPERSTARS III** students on Friday of each week. You will also need to release the participating students from your class at a set time on Mondays to enable them to turn in completed work and receive new problem sets. You might make a special pin or banner for Mondays and Fridays to remind students that those days are special.

SUPERSTARS III
Jupiter, XXXI

Name: _____
(This shows my own thinking.)

***1. If the 24th day of the month falls on Saturday, on what day did the 6th fall?
 Answer: _____

***2. There are 4 six-packs of soda in a case. Chris bought 12 of a case and gave 13 of what he had to Dana. How many cans of soda does Chris have left?
 Answer: _____ cans

***3. Together, 6 boys and 12 girls weigh 1050 pounds. The boys all weigh the same x pounds. Each girl weighs 55 pounds. What is the weight of one boy?
 bbbbbb gggggggggggg
 Answer: $x =$ _____ pounds

***4. The sum of 3 consecutive numbers is 276. What are the numbers?
(Consecutive numbers differ by one; example: 8, 9, and 10)
 Answer: _____ and _____

***5. If a family of 12 spiders wore shoes, how many pairs of shoes would they need?
 spider
 Answer: _____ pairs.

Commentary
Jupiter, XXXI

1. (Tuesday) Students can use a calendar or make a chart with "Su, M, T, W, Th, F, Sa" at the top and begin numbering backward starting 24 under Saturday. They may also realize that the 17th and 10th fall on Saturdays and count back from the 10th.

2. (8) Students can solve this problem by drawing a diagram or by visualizing 24 sodas. $1/2$ of 24 is 12, and $1/3$ of 12 is 4. Therefore Chris gave away 4 of the 12 sodas, leaving 8.

3. (65) Students will probably solve this by first finding the total weight of the 12 girls: $12 \times 55 = 660$ pounds. Then they will compare $1050 - 660 = 390$ pounds, the weight of the 6 boys. Then $390 \div 6 = 65$ pounds per boy.

4. (91, 92, 93) Students may use the guess-check-revise method. Some students might know that the numbers they seek are about $1/3$ of the total, and approximate the numbers by dividing 276 by 3. This gives 92, which is the middle number.

5. (48) Students may want to draw a picture to help solve this problem. Spiders have 8 legs, which would be 4 pairs of shoes per spider.

6. (29 hours and 45 minutes) Most students will realize that from 8:45 AM to 8:45 AM the next day, is 24 hours. They will then "add on" 5 additional hours to get to 9:45, 10:45, 11:45, 12:45, and 1:45, and then 45 minutes to get to 2:30 PM.

7. (27) There would be 12 wheels on the 3 cars, 8 on the 4 bicycles, 6 on the 2 tricycles, and 1 on the motorcycle.

8. (\$18.16) Students will probably add \$6.98 and \$9.99 to get \$16.97, then add the tax of \$1.19 to get \$18.16. They will subtract this amount from \$20.

9. (a, C; b, D; c, G) Hopefully, students will notice that the multiples of 7 are in column A and use this fact to get "close to" the numbers 100, 500, and 1,000. Ninety-eight (14×7) is the closest multiple of 7 less than 100, so 98 would be in column A, forcing 100 to be in column C. Likewise, 497 or 71×7 is in column A, putting 500 in column D. Finally, 994 or 142×7 is in A, indicating that 1000 is in column C.

Each student worksheet has an accompanying commentary page. This sheet provides hints on parallel problems which you might use in the Friday problem-solving session. It is important that students participate actively in this session, and that you

solicit from them their unique and varied approaches to the problems discussed. Only after students have presented their ideas should you provide guidance on the problems and then only if they are having difficulty. Even though there is a commentary provided for each problem, you will have to decide which two to four problems you will cover during this brief session. Concentrate on those which provide a new or unfamiliar strategy. The problem-solving session should last no more than 15 minutes.



Do not be disappointed if a large number of your students begin **SUPERSTARS III** and then significant numbers drop out after a few weeks. This is normal; problem solving requires a great deal of effort and not every student is ready for this challenge. On the other hand, you will notice that some students will choose to stay with **SUPERSTARS III** week after week even though they are not as successful as other students at earning stars. Their participation should be encouraged as they are certainly learning from the experience. Under no circumstances should **SUPERSTARS III** be reserved only for the advanced students in your class.



As a purely practical consideration, students are not to discuss the problems among themselves or with their families prior to the Friday cooperative group session. This allows the "think time" necessary for students to develop into independent thinkers; it also prevents students from earning stars for work that is basically someone else's -- the surest way to disrupt the entire **SUPERSTARS III** program. As the teacher you must monitor this in your classroom and ensure that students abide by the established rule.



It is important that you understand and support the overall philosophy of **SUPERSTARS III**. Do not worry if students encounter problems for which they have not been prepared in class -- such is the nature of true problem solving. Do not provide remedial instruction to ensure that students master certain types of problems. They will meet these same problem types repeatedly in the program. They will likely learn them on their own and from listening to other students at the problem-solving sessions. Enjoy what the students can do and don't worry about what they can't do. Read the general information and philosophy of the program to see how your role fits into the complete system.

Here are some thoughts you might find useful in your support for **SUPERSTARS III**:



- Allow your students to leave the classroom at the designated time on Mondays to turn in their worksheets and pick up new ones.



- Read each week's worksheet and feel free to structure classroom activities that parallel those in the **SUPERSTARS III** problems.



- During the school week students may be allowed to work on their **SUPERSTARS III** problems during their free time, but the only help they may receive is for someone to read the problems to them. Give the students one warning if you find them discussing the worksheets, and take away their papers for the next violation. If it happens another time, suspend them from the program for a month.



- At the Friday problem-solving sessions remember these points:

- Students come to this session with their worksheets, but without pencils.
- The session should be brief -- 15 minutes at most. Discuss only the two to four most difficult problems.
- Help students summarize their own approaches to the problems in a non-judgmental fashion. Offer your own approach last, and only if it is different from the students' strategies. Do not allow answers to be given to the problems.
- End the session by encouraging students to complete the problems over the weekend. Put your initials beside any problem discussed in class which a student has already successfully completed. The assisting adult will award double stars for these.



- Remember that part of the **SUPERSTARS III** philosophy is that students learn responsibility by following the rules of the system. If participation is important to them they will adhere to the rules about where their names go on each paper, no credit awarded if they forget their paper on Monday, and no talking about problems prior to the problem-solving session.



- Enjoy **SUPERSTARS III**. Students will impress you with their ability to think and their creative ways to solve problems that appear to be above their level or beyond their experience.



Dear Student,

Welcome to **SUPERSTARS III**, a program designed to enhance your journey through mathematics. Be prepared to face challenging problems which require *thinking!* As you work through the system you will experience many types of problems, stretching and expanding your brainpower in many exciting ways!

Expect to receive one worksheet at the beginning of each week. You will have the rest of the week to think about the problems and come up with strategies for their solutions. The thinking and solutions must be **YOUR VERY OWN!!!** Once a week you will attend a help session to discuss the most challenging problems for the week.

Your journey will be recorded by charting the stars you earn. Each problem is ranked according to its level of difficulty. The more stars you see beside a problem, the higher its level of difficulty and, of course, the more stars you can earn for solving it. You can earn double stars for solving a problem before the weekly sessions.

Your signature is just the beginning.

Good luck as you embark upon this mathematical adventure! The rewards will last a lifetime!



I am ready to begin the **SUPERSTARS III** program. All of the answers I submit will represent my own thinking.

Name: _____





Dear Parents,

Welcome to **SUPERSTARS III**, a program designed to enhance your child's journey through mathematics. By expressing an interest in challenging problem solving experiences, your student has taken the first step toward becoming an independent learner who is willing to address many types of problems.

On Mondays a **SUPERSTARS III** worksheet will be distributed to each child in the program. Each problem in the set is ranked according to its level of difficulty. As the number of stars increases, so does the level of difficulty and the earned stars to be awarded.

Each Friday a help session will be conducted to discuss the most challenging problems of the week. Any problem solved prior to the session will be given double stars. After the session, problems may be reworked before they are submitted the following Monday.

Your role in **SUPERSTARS III** is to encourage and facilitate problem solving. Feel free to offer guidance toward certain strategies, to read the problems to your child, but please, do not give them the answers. In order for this program to be effective, the students must work independently. The thinking must be their own!

It is normal for a student not to be able to complete every problem on every worksheet. The process of interpreting, understanding, and trying different strategies is valuable in the attainment of mathematical power. Remember, no student is expected to know the answer to every problem.

Thank you for allowing your child to embark upon this mathematical adventure; the rewards should last a lifetime!

_____signature

Parent/Guardian of _____



After you have had a chance to review and use these materials, please take a moment to let us know if the **SUPERSTARS III** material has been useful to you. Your evaluation and feedback is important to us as we continue to work on additional curriculum materials. Please respond to:

Linda Patch
Mathematics & Science Section
NC Department of Public Instruction
301 N. Wilmington Street
Raleigh, NC 27601-2825

Indicate the extent to which you agree with statements 1-4.

	Strongly Disagree	2	Neither Agree nor Disagree	4	Strongly Agree
1. The materials will be helpful in teaching the mathematics goals and objectives set forth in the NC Standard Course of Study.	1	2	3	4	5
2. The materials are appropriate for the grade level indicated.	1	2	3	4	5
3. The problems are interesting and engaging for the students I teach.	1	2	3	4	5
4. The commentaries will encourage use of this material.	1	2	3	4	5
5. I plan to use these materials with my students in grade_____.					
6. Have you ever used earlier versions of the SUPERSTARS material?	YES		NO		

7. How was this program implemented with your students?

8. Additional comments:

SUPERSTARS III

Pluto, I

Name: _____

(This shows my own thinking.)

- ★ 1. Remove the dime from the center position without touching it. Describe how to do it.



Answer: _____

- ★★ 2. There are six digits in a sequence -- two 4's, two 5's, and two 6's. There is one digit between the two 4's; there are two digits between the two 5's; and there are three digits between the two 6's. Write this sequence of numbers.

Answer: _____

- ★★★ 3. While at the park, I saw boys and dogs. Counting heads, I got 32. Counting legs, I got 104. How many boys and dogs were there?

Answer: ____ boys and ____ dogs



- ★★★★ 4. Mary bought some donuts. She gave $\frac{1}{2}$ her donuts and $\frac{1}{2}$ a donut to her mom. Then she gave away $\frac{1}{2}$ her remaining donuts and $\frac{1}{2}$ a donut to her aunt. Then she gave $\frac{1}{2}$ of her remaining donuts and $\frac{1}{2}$ a donut to her sister, Kathy. This left her with $\frac{1}{4}$ of a dozen donuts. How many doughnuts had she bought?

Answer: _____ doughnuts



- ★★ 5. Mr. Barnes is a lumberjack. Using his power saw, he can cut a log into 5 pieces in 6 minutes. How long would it take him to cut the log into 7 pieces?

Answer: _____ minutes

★★★★

6. Five people are going to be seated in a row of seven chairs. How many different ways can they be seated?



Answer: _____ ways

★ 7. Add one line to make this statement true: $1 + 1 + 1 = 110$

★★★ 8. Put the following numbers into the grid so that no single digit appears more than once in any row, column, or main diagonal.

10, 12, 13, 21, 34, 38, 40, 47, 50, 53, 57, 64, 65, 78, 89, 98

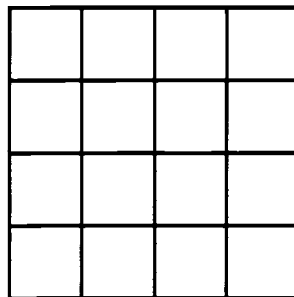

★★★ 9. Fill in the missing number:

2, 8, 27, 85, 260, _____, 2365

★★★★ 10. The numbers in the triangle follow a certain pattern. Figure out the pattern and calculate the numbers that would replace the boxes. Write them inside each box.

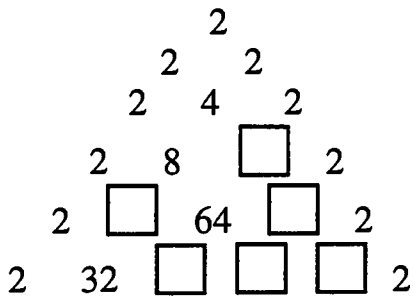

Commentary

Pluto, I

1. (Move the nickel to the right of the quarter OR move the quarter to the left of the nickel.)
2. (645465 or 564546) Students might begin with what they know -- writing 2 4's with a space between them for another digit. From that point, they can *guess and check* to find the position of the other digits.
3. (12, 20) Some students will solve the problem algebraically. Others will guess and check, perhaps starting with 16 boys and 16 dogs (32 heads) which would produce 96 legs -- not enough. Therefore there will be fewer than 16 boys and more than 16 dogs, in order to get more legs. So the guess is revised to increase the number of dogs and decrease the number of boys until a total of 104 legs is reached.
4. (31) Students might work backwards. How many doughnuts were there before 3 were left at the end? It must be 7, so that when you remove half of 7 (3.5) and another half a doughnut, you remove 4, leaving 3. Proceeding backward through the problem in this fashion leads to beginning with 31 doughnuts.
5. (9) It takes 4 cuts to make 5 pieces and 6 cuts to make 7 pieces. If 4 cuts take 6 minutes, each cut takes 1.5 minutes. Therefore 6 cuts would take 6×1.5 or 9 minutes.
6. (2520) It's a combination of 7 things taken 5 at a time which translates into

$$\frac{7!}{2!} = \frac{7 \cdot 6 \cdot 5 \cdot 4 \cdot 3 \cdot 2 \cdot 1}{2 \cdot 1}$$

If students are not familiar with this combination formula, they might reason by labelling the 5 people A, B, C, D, and E, and the two empty chairs F, and G. Then there are 7 ways to fill the first chair, 6 ways to fill the second chair after the first is filled, 5 ways for the next chair, and so on down the line. Therefore there are $7 \times 6 \times 5 \times 4 \times 3 \times 2 \times 1$ ways to fill the seven chairs, but since F and G are indistinguishable, we have counted twice as many ways as are possible. Therefore the above number must be divided by 2.

7. ($1 + 1 + 1 \neq 110$) Add a line through the equal sign to make the "not equal to" sign.
8.

89	47	10	53
13	65	98	40
50	12	34	78
64	38	57	21

 or

53	10	47	89
40	98	65	13
87	34	12	50
21	75	38	64

 or

64	38	57	21
50	12	34	78
13	65	98	40
89	47	10	53

Also, the numbers 89 and 98 and 21 and 12 can be interchanged in any of the boxes given.

9. (786) The pattern is to triple the given number and, starting with the 2, add 2 then add 3, then 4, and so on. To find the number after 260, triple 260 to get 780, then add 6.

10.

		2			
		2	2		
	2	4	2		
2	8	8	2		
2	<u>16</u>	64	<u>16</u>	2	
2	32	<u>1026</u>	<u>1026</u>	<u>32</u>	2

The missing term is determined by the product of the two terms located diagonally above it.

SUPERSTARS III

Pluto, II

Name: _____
(This shows my own thinking.)

- ★★ 1. A sidewalk was built to connect each house below to every other house. How many sidewalks were built?



Answer: _____ sidewalks

- ★ 2. These numbers reflect the variation from normal depth of the water level of Lake Okeechobee for five Mondays. Find the average of these five depths.

19.53

8.72

31.27

-2.71

-22.13

Answer: _____

- ★★★ 3. On a purchase of a pair of athletic shoes, you are offered a 15% discount and a 10% discount to be taken in either order. Which do you ask for first to get the lowest price?

Answer: _____

- ★★ 4. A basketball player is $6\frac{3}{4}$ feet tall. How tall is he in inches?

Answer: _____ inches tall



- ★ 5. I want to buy a pair of jeans that cost about \$32.00, shoes that cost about \$39.00, and a vest that costs about \$16.00. On top of that, there is a 6% tax. To the nearest \$20 bill, how much money should I bring?

Answer: _____



- ★★★★ 6. If I take 9 hours to complete a project and you can complete it in $4\frac{1}{2}$ hours, how long would it take us to complete the project together?

Answer: _____ hours

- ★ 7. If January 1st is on a Friday, what day of the week is February 23rd of that same year?

Answer: _____

- ★★★★ 8. Before the age of technology, the library was overflowing with books. Then during one decade, each book was stored on microfiche. This new storage space was equal to the cube root of the old space. In the next decade, the microfiche were converted to diskettes. This new storage space was equal to the square root of the previous space. Finally, in this decade, each tape has been changed over to a compact disc. The current space is about 23 percent of the previous space. If the current space is equal to 3 books, how many books were in the old library?

Answer: _____ books

- ★★ 9. What geometric solid is this, when the shape is cut out and the lines become the edges of the 3-dimensional shape?

Answer: It's a _____.

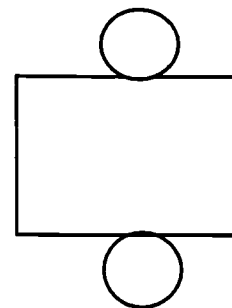

- ★★★ 10. A lizard is at the bottom of a well 27 meters deep. He climbs 5 meters every day, but falls back 3 meters every night. How many days does he take to reach the top?

Answer: _____ days

Commentary

Pluto, II

1. (15 paths)

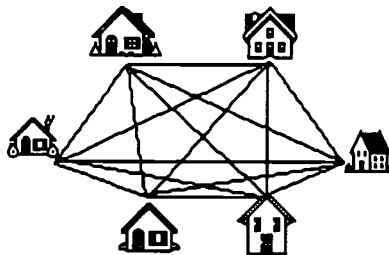

2. (6.936) Adding the numbers gives a total of 34.68. Then divide that total by 5.
3. (It's the same price either way.) Choose any price -- \$100 is easy to work with -- and work it out both ways to find it's the same.
4. (81 in.) $6\frac{3}{4}$ ft. = $(6 \times 12 \text{ inches}) + (\frac{3}{4} \times 12 \text{ inches}) = 72 \text{ inches} + 9 \text{ inches} = 81 \text{ inches}$.
5. (5 twenty dollar bills or \$100) Since the total is about \$93, you would need more than four twenty-dollar bills, but five is enough.
6. (3) One way to reason through this problem follows. You work twice as fast as I do, so our speed working together is three times as fast as my speed alone. I.e., if my rate of work is x , then your rate is $2x$, and together we work at the rate of $3x$. Therefore if we work together, the job should take $1/3$ as long as my doing the job alone. Since $1/3$ of 9 hours is 3 hours, that's how long it takes if we work together. Another way to think of the problem would be to determine the hourly rate. In one hour, working along, I would do one-ninth of the project. In that same hour, you would do two-ninths of the project. Together, we would do three-ninths, or one-third, of the project in an hour. Therefore, it would take three hours to complete the project.
7. (Tuesday) Jan. 29th is a Friday and February 1st is a Monday therefore February 23 is a Tuesday. Students might want to use a calendar to check their reasoning.
8. (4,826,809) One way to approach this problem is by working backward. If you end with 3 books after taking 23% of a number, then $0.23x = 3$ can be solved, giving $x \cong 13$. If 13 books is the square root of the previous number of books, then 13^2 or 169 is the previous number of books. If 169 is the cube root of the previous number of books, then 169^3 is the previous number of books. 169^3 is 4,826,809.
9. (a cylinder) If you cut and unfold a cylinder, you will have a rectangle and the top and bottom are circles.
10. (12) Since he jumps 5m and slides back 3m he is making 2m progress each day. The lizard's daily progress, before sliding back, can be listed at these distances in meters: 5, 7, 9, 11, 13, 15, 17, 19, 21, 23, 25, 27. It takes 12 days for the lizard to get to 27 meters, and out.

SUPERSTARS III
Pluto, III

Name: _____
(This shows my own thinking.)

- ★★ 1. If $A \Delta B = A^2 + 2AB + B^2$, evaluate $4 \Delta 5$.

Answer: _____

- ★ 2. Express 2.7 as a common fraction.

Answer: _____

- ★★ 3. In a factory, a machine can fill 180 jars in 15 minutes. How many jars can be filled in 100 minutes?

Answer: _____ jars

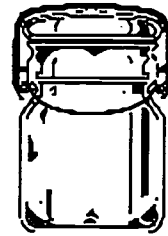

- ★★ 4. What is the mode of this list of 16 numbers? Answer: _____

2 4 7 8 2 10 7 2 5 3 6 8 5 1 0 1

- ★ 5. If I dug a hole 4 meters square and 2 meters deep, how much dirt was in the hole?



Answer: _____ cubic meters

- ★★ 6. Sherry was playing a card game with her friends. She needed to draw a diamond greater than 10 to win the game. If she draws from a full standard deck of cards, what is the probability of her winning?

Answer: _____

★★★ 7. Replace R, M, and S with digits from 0-9 to make a true equation.

$$\begin{array}{r} R R M \\ + S M \\ \hline S M M M \end{array}$$

Answer: R = __, M = __, S = __

★★★★ 8. Study the dart board below. Find the probability of hitting each color when a dart is thrown. Write the answer as a fraction in lowest terms.

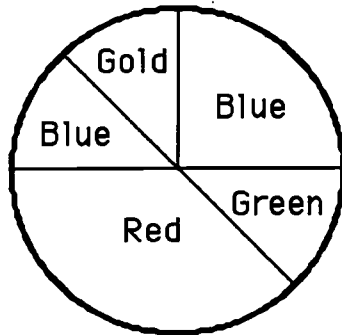

Answer: Gold _____
 Green _____
 Red _____
 Blue _____
 Blue or Gold _____
 Orange _____

★★★★ 9. There are fewer than 6 dozen Blow Pops in my bag. If I count them by 2's, there is 1 left over. If I count them by 3's, there are 2 left over. There are 3 left over if I count by 4's. Four are left if I count by 5's. How many Blow Pops are in my bag?

Answer: _____ Blow Pops

★★★ 10. A bat ate 208 bugs in 4 days. Each day she ate 20 more than the previous day. How many bugs did she eat each day?



Answer: day 1: _____ bugs; day 2: _____ bugs; day 3: _____ bugs; day 4: _____ bugs

Commentary

Pluto, III

1. (81) $4 \Delta 5 = 4^2 + 2 \times 4 \times 5 + 5^2$
 $= 16 + 40 + 25$
 $= 81$

2. (27/10) The problem is simply a translation from 2 and 7/10 to its fractional form.

3. (1200) One approach is to reason that 180 jars in 15 minutes is 180 ÷ 15 jars per minute, or 12. Therefore in 100 minutes, 1200 jars are filled. Another method is to set up and solve a proportion, as shown below:

$$\frac{180 \text{ jars}}{15 \text{ min.}} = \frac{x \text{ jars}}{100 \text{ min.}}$$
$$18000 = 15x$$
$$1200 = x$$

4. (2) Two is the number that appears most often and is therefore the *mode*.

5. (32 cubic meters) Students need to compute the volume of the hole.

6. (4/52 or 1/13 or about 7%) There are 4 such cards in the deck -- the jack, queen, king, and ace of diamonds -- out of 52 cards.

7. (R = 9, M = 0, S = 1) One approach to such problems is to look for numbers that must be zero or one. In this case, S must be 1 due to its far-left position in the answer. R must then be 9, and M be 0, working just with the three left-most digits in the problem.

8. (Gold = $\frac{1}{8}$, Green = $\frac{1}{8}$, Red = $\frac{3}{8}$, Blue = $\frac{3}{8}$, Blue or Gold = $\frac{1}{2}$, Orange = 0) The problem involves translating knowledge of fractional parts of a circle into probability. The dartboard is visually partitioned into areas of 1/4 and 1/8 of the circle -- the answers are then obtained by putting together such regions for each color.

9. (59) Look at lists of the multiples of each number you're dividing by, with the remainder added. Find a number common to all of the lists and it will fit all of the parameters. The first clue (counting by 2's, 1 left over), simply gives the list of odd numbers. The other lists are:

3's with 2 left: 5, 8, 11, 14, 17, 20, 23, 26, 29, 32, 35, 38, 41, 44, 47, 50, 53, 56, 59, ..

4's with 3 left over: 7, 11, 15, 19, 23, 27, 31, 35, 39, 43, 47, 51, 55, 59,

5's with 4 left over: 9, 14, 19, 24, 29, 34, 39, 44, 49, 54, 59, ...

10. (1st day = 22, 2nd day = 42, 3rd day = 62, 4th day = 82) Students might *guess-check-revise*, by guessing what the first number might be, adding 20 to get the second, 40 for the third, and 60 for the fourth. Students would then add to see if the total is 208. If not, they need to revise the original guess and go through the same procedure. Another approach is algebraic, letting x be the first number, $x + 20$, the second, $x + 40$ the third, and $x + 60$ the fourth. Then $x + (x + 20) + (x + 40) + (x + 60) = 208$. This means $4x + 120 = 208$, or that $4x = 88$, so that $x = 22$. Therefore the first day the bat eats 22 bugs; the second day she eats 22 + 20; and so forth.

SUPERSTARS III

Pluto, IV

Name: _____

(This shows my own thinking.)

- ★ 1. Move one of the three popsicle sticks to make a true equation. Use arrows to show which one you move and how you move it.



- ★★★★ 2. You can make up for being late to Mr. Reeves' class if you are well prepared upon arriving. His formula for how many minutes of detention you must serve is $m = 30 - 5x$. This formula allows 5 minutes off the 30-minute punishment for each question you answer correctly in class.

- a. What does x stand for in the formula? _____
- b. What does m stand for in the formula? _____
- c. If you are tardy but answer 2 questions correctly in class, how long is your detention? _____ minutes
- d. If you are tardy, how many questions must you answer in class so that you have no detention to serve? _____ questions

- ★★★ 3. Farmer Henson needs to fence in a small area to make a horse pen. The pen needs to be about 900 ft^2 in area for the horse to be comfortable for a short time. To the nearest foot, how much fencing will he need if the pen is circular in shape? Use 3.14 for π .

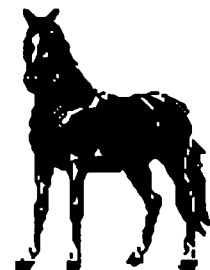

Answer: _____ feet of fencing

- ★★★★ 4. A diver is working 10 feet below the surface of the water. The gap between the water and the deck of his support barge is $\frac{1}{8}$ of the total length of air hose, and $\frac{2}{3}$ of the total length remains on the reel. What is his maximum working depth without a change of equipment?

Answer: _____ feet

- ★ 5. There are twelve \$0.29 stamps in a dozen stamps. How many \$0.32 stamps are in a dozen?

Answer: _____ stamps

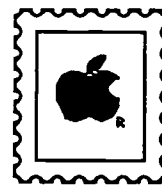

- ★ 6. At a pharmacy, Mrs. Dull paid \$2.35 for a toothbrush, \$ 1.30 for a comb and \$4.99 for shampoo. The sales tax is 6%. Find the change she should receive from a ten-dollar bill.

Answer: _____

- ★★★ 7. Georgia solved a problem in her math homework that gave her an answer of $0.\overline{425}$ but the problem asks for the answer to be a common fraction. What would that fraction be?

Answer: _____

- ★★ 8. How much larger is 3^4 than 4^3 ?

Answer: _____

- ★★★★ 9. Study the relationship between the figure number, its *area*, and its *perimeter*. Then answer the questions below the figures.

Figure Number	1	2	3	4	5	6 ...	33
area	1	3	5	7	9	11 ...	65
perimeter	4	8	12	16	20	24 ...	132



1



2

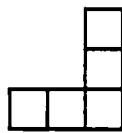

3

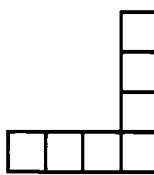

4

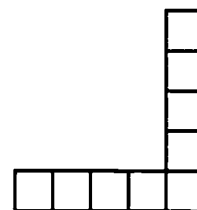

5

- a. What is the area for figure 100? _____ What is its perimeter? _____
- b. What is an algebraic expression for the area of figure number n ? _____
- c. What is an algebraic expression for the perimeter of figure number n ? _____

Commentary

Pluto, IV

1. (■ = ■■■ - ■■) Move one of the bars from the equal sign and place it under the subtraction sign.
2. (a. the number of questions answered correctly in class; b. the number of minutes you have to stay after class; c. 20 minutes; d. 6) The problem shows a real-life use of an equation. It might be interesting to ask some additional questions about this formula, such as "What happens if you answer 7 questions correctly in class, after being tardy?"
3. (106) The area is 900 ft^2 , so $\pi r^2 = 900$ can be solved to find $r = 16.9$. The radius of the pen must be 16.9 ft., and the circumference of the pen is given by $2\pi r$. Therefore the farmer must buy $2 \times \pi \times 16.9$ feet of fencing. When rounded to the nearest foot, this is 106 feet.
4. (42) Drawing a picture of the situation will help students set up an equation to solve. An equation for this situation is: $\frac{2}{3}L + \frac{1}{8}L + 10 = L$, where L is the total length of hose. Solving for L gives a total length of 48 ft., but 6 ft. of that length is taken up hanging over the boat so the length that's usable is 42 ft.
5. (12) There are always 12 in a dozen no matter what the stamps cost.
6. (\$0.84) $2.35 + 1.30 + 4.99 = 8.64$, and $8.64 \times 1.06 = 9.16$. The groceries, with tax, cost \$9.16. Therefore the change from a ten - dollar bill is 84¢.
7. ($\frac{425}{999}$) Let $x = 0.\overline{425}$. Then $1000x = 425.\overline{425}$, and so $1000x - x$, or $999x$, is $425.\overline{425} - 0.\overline{425}$, or 425. Then solving $999x = 425$ gives $x = 425/999$, as a fraction.
8. (17) $3^4 = 81$ and $4^3 = 64$ and $81 - 64 = 17$.
9. (a. 400 and 199; b. $2n - 1$; c. $4n$) The pattern is established in the table. Students who are having difficulty might want to draw the next few figures, and physically count the area and perimeter of each. Tiles can be used instead of squares.

SUPERSTARS III

Pluto, V

Name: _____

(This shows my own thinking.)

- ★★ 1. Show how to make a sum of exactly 100 by using only 15, 21, 24, 27, or 31. Any or all may be used more than once.

Answer: _____

- ★★★★ 2. A 200-pound farmer and his two 100-pound daughters were on one side of a river and had to get to the other side. The only way to cross was on a boat that only held 200 pounds safely.
- a. What is the fewest number of crossings it will take to get them all on the other side?
- b. Describe who goes on each crossing, to get the fewest number of crossings above.

Answer : a. _____

b. _____

- ★★★ 3. From the manufacturer, we know the ratio of yellow M&M's to orange M&M's made is 4 to 7. If 56 orange M&M's are in a large package, about how many yellow M&M's would be in the package?

Answer: _____ yellow M&M's

- ★★ 4. Use a calculator to find the answer to:

$$(13450 + 0.36) - (6 \times 2141.06).$$

Then turn the calculator upside down to find an animal.

Answer: The animal is a _____.

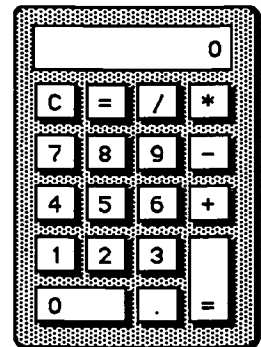

★★★ 5. If $x + y = 12$ and $x - y = 8$, find the product of x and y .

Answer: _____

★★ 6. Lori and Tim bought a new car at an "end of the year closeout sale" for "dealer cost plus 8%." If they paid \$18,036, what was the dealer's cost?

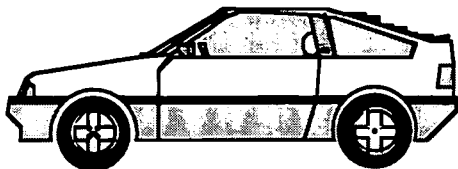

Answer: \$_____

★★★ 7. Jason worked 6 days. The first day he was paid \$200. Each day thereafter he was paid $\frac{1}{2}$ of what he made the day before. What was his total wage?

Answer: \$_____

★★ 8. How many diagonals are in a regular decagon?

Answer: _____ diagonals

★ 9. What common word can be spelled out by the letters on a compass?



Answer: _____

★★★ 10. Approximately what number is represented by each object below:

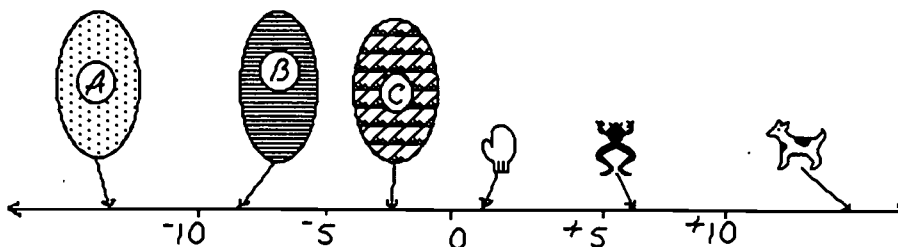

Answer: A is ____; B is ____; C is ____; mitt is ____; frog is ____; dog is ____

Commentary

Pluto, V

1. (21 + 21 + 27 + 31 OR 15 + 27 + 27 + 31) There may be more solutions.
2. (a. 5; b. The daughters cross first, then one daughter returns to the other side and the father comes across. The second daughter joins her sister on the other side and they both cross back over together.) Students will have a better chance at this problem if they draw a sketch of the river crossings.

3. (32) Students might solve a proportion to find the number of yellow M&M's.

$$\begin{aligned}\frac{4}{7} &= \frac{x}{56} \\ 4x &= 224 \\ x &= 32\end{aligned}$$

4. (hog) When you do the computation on a calculator it gives 604, which spells "hog" when held upside down.
5. (20) Students might find the two numbers x and y by looking for numbers that add to twelve, and testing to see if their difference is 8. Two such numbers are 10 and 2, whose product is 20. Another approach is to solve a system of two equations in two unknowns, as shown below.

$$\begin{aligned}\text{Given: } x + y &= 12 \\ x - y &= 8\end{aligned}$$

Add the two equations to get $2x = 20$. Then $x = 10$ and $y = 2$ and $xy = 20$

6. (\$16,700) Since the dealer's cost is multiplied by 1.08 to get the final price, students can take the final price and divide by 1.08 to find the dealer's cost.
7. (\$393.75) Jason makes \$200, then \$100, then \$50, then \$25, then \$12.50 and finally \$6.25. The sum of these numbers is \$393.75.
8. (35) A 4-sided regular polygon (a square) has 2 diagonals, a regular 5-sided polygon (pentagon) has 2 + 3 diagonals, a hexagon (6-sided) has 5 + 4 diagonals, a heptagon (7-sided) has 9+5 diagonals, and so on. Another way to approach the problem is to place 10 dots spaced around a large circle, and draw in all the diagonals. Note that dots that are "neighbors" will not have a diagonal connecting them.
9. (NEWS) The arrows represent map directions North, South, East and West. The beginning letter of each direction is a letter of the word.
10. (-13, -8, -2, 1, 6, 15) Give students credit if their answers are within one whole number of the given answers. They may or may not have "+" in front of the positive numbers.

SUPERSTARS III

Pluto, VI

Name: _____

(This shows my own thinking.)

★★★★

1. On a digital clock showing hours and minutes, how many different readings between 11:00 a.m. and 5:00 p.m. contain at least two 2's?

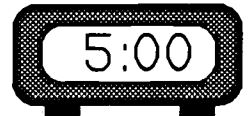

Answer: _____

★

2. A clever woman sat beneath a grape vine watching her husband pick grapes. She noticed that the number of grapes in his basket doubled every minute, and that it was precisely filled at 1:00 p.m. At what time was his basket half full?



Answer: _____

★★★★

3. Bev, Debbie and Jen are friends. Debbie, who always tells the truth, says the youngest woman is her cousin. Bev, who always lies, says she is older than Debbie but younger than Jen. The ages of the women are 40, 36, and 23. Give each woman's age.

Answer: Bev _____ Debbie _____ Jen _____

★★★

4. The faces on a regular decahedral die -- one with ten faces instead of six -- are numbered one through ten. What is the probability of rolling three 8's in succession?

Answer: _____

★★★

5. If $a \star b = \frac{1}{b} - \frac{1}{a}$, express $8 \star 3$ as a common fraction.

Answer: _____

★★ 6. Farmer Benson has a rectangular pig pen. The lengths of the pen's sides are 26 m by 18 m . If the length of each side of the pig pen is tripled, what will happen to the area of the pig pen? Circle the best answer below.

- a. The area will also triple.
- b. The area will be 9 times as much as before.
- c. The area won't change.
- d. The area will double.

★ 7. Stamps are \$0.32. Janice has \$7.00. How many stamps can she buy?

Answer: _____ stamps

★★ 8. For every 5 serves Gabrielle makes, Tammy makes 3. At practice one day, Tammy made 75 serves. How many serves did Gabrielle make?

Answer: _____ serves



★★★★ 9. Ginger watched the man from the carnival ride a very tall bicycle. She wondered about riding it from Mudville to Peoria, a distance of 266 miles. The diameter of the wheels was 83 inches. The pedals were geared so that one complete turn caused the wheel to rotate 8.4 times. If Ginger turns the pedals once every 5 seconds, and can maintain that rate, about how long would it take to make the trip?

Answer: _____ hours

★★★ 10. The story of a skydiver has been jumbled up. Place each letter on a correct position on the horizontal axis of the graph, to show when that event was occurring.

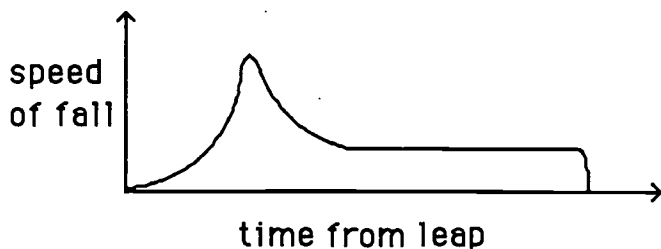

- A. She opened the parachute.
- B. She hit the ground.
- C. She leaped from the plane.
- D. She floated gently down.
- E. She was in "free fall" after jumping.

Commentary

Pluto, VI

- (34) There is only one such time between 11:00 and 12:00, 1:00 and 2:00, 3:00 and 4:00, and 4:00 and 5:00. There are 15 such times between 12:00 and 1:00, and 15 between 2:00 and 3:00.
- (12:59 p.m.) The temptation on the part of students is to associate $\frac{1}{2}$ with the hour factor, rather than with the minutes. If the basket was half-full at 12:59, and doubled the next minute, it would be full at exactly 1:00.
- (Debbie = 40, Bev = 36, Jen = 23) Students might begin this problem by listing, using initials, the three women in their possible orders of ages -- e.g., {B, D, J}, {B, J, D}, {D, B, J}, {D, J, B}, {J, B, D} and {J, D, B}. Then the lists are eliminated one-by-one, using the clues.
- $(\frac{1}{1000})$ $P(8) \times P(8) \times P(8) = \frac{1}{10} \times \frac{1}{10} \times \frac{1}{10} = \frac{1}{1000}$
- $(\frac{5}{24})$ $\frac{1}{3} - \frac{1}{8} = \frac{8}{24} - \frac{3}{24} = \frac{5}{24}$
- (b. The area is nine times as much as before.) The original area is 26×18 or 468 m^2 . The sides become 78 m by 54 m, giving an area of 4212 m^2 . The second pen is nine times the area of the first pen. If we look at it algebraically, if a side A is tripled, it becomes 3A. If a side B is tripled, it becomes 3B. The original area would be $A \times B$ or AB. The new area would be $(3A) \times (3B)$ which is $9AB$.
- (21) $\$7.00 \div \$0.32 = 21.875$. Round down because you can not buy part of a stamp.
- (125 serves) This can be solved by using a proportion. $\frac{5}{3} = \frac{x}{75}$, so $x = (5)(75) \div 3$
- (10.7 hours) Circumference of wheel = $83\pi = 260.8 \text{ in.} = 21.7 \text{ ft.}$; 266 miles = 1,404,480 ft. The number of wheel rotations = $1404480 \div 21.7 = 64722.6$ rotations; the number of pedal turns = $64722.6 \div 8.4 = 7705.1$ turns; the total seconds = $5 \times 7705.1 = 38525.5$; the number of hours = $38525.5 \div 3600 = 10.7$.
- (see below) The positions of C, A, and B should be precisely located as shown. E can be anywhere between C and A, and D can be anywhere between A and B.

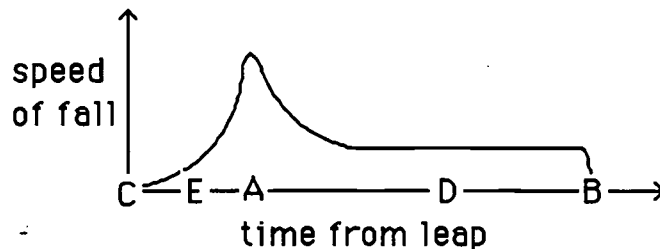

SUPERSTARS III

Pluto, VII

Name: _____

(This shows my own thinking.)

- ★★★ 1. Mrs. Graham's science laboratory has some stools with 3 legs and some chairs with 4 legs. If there is a total of 158 legs on the stools and chairs, and 42 total seats in the room, how many stools and chairs are in Mrs. Graham's science lab?

Answer: _____ stools and _____ chairs

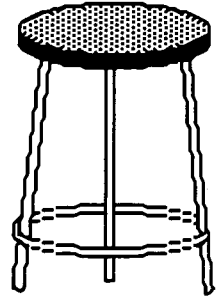

- ★★ 2. Sheila's volleyball team has lost 11 games. The team has won 5 more than they have lost. What is their winning percentage?

Answer: _____ percent

- ★★ 3. Julio was driving from his home to Tampa. The last road sign he saw said it was 177 miles to Tampa. Julio has driven 51 miles since he saw the last road sign. He is now half way to Tampa. How far is it from Julio's home to Tampa?

Answer: _____ miles



- ★★ 4. J, K, and L are circles. Circle J has a 32 inch diameter. The radius of circle J equals the diameter of circle K. The radius of circle K equals the diameter of circle L. How long is the radius of circle L?

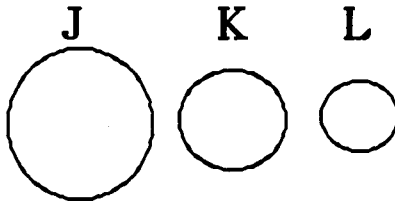

Answer: _____ inches

- ★★★ 5. Molly collects baseball cards. For every card that has a pitcher on it, 12 do not. If Molly has a total of 403 baseball cards, how many of them are of players that are not pitchers?

Answer: _____ cards

★

6. There are 9 rows of student desks in Elizabeth's math class. Each row has the same number of desks. If 15 students just fit into the first 3 rows with no empty seats, how many student desks are there in Elizabeth's math class ?

Answer: _____ desks



★★★★

7. Jack wanted to win the big bicycle race, so he trained hard for a week -- 7 days. Each day he rode 3 miles farther than he had the day before. If he rode a total of 126 miles, how far did he ride on the last day of the week?

Answer: _____ miles

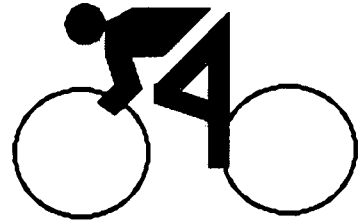

★★★

8. Sue usually makes 6 free throws out of 10 tries. What is the probability she will make her next two free throws?

Answer: _____



★★★

9. Thirty five matchsticks are placed so that they make a spiral that goes counterclockwise. Show how to shift four matchsticks to make the spiral go clockwise. Draw arrows to show how the four matches are moved.

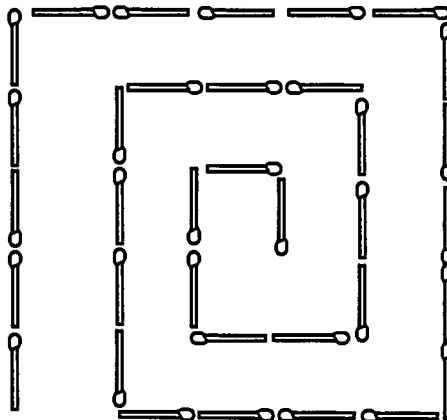

SUPERSTARS III

Pluto, VIII

Name: _____

(This shows my own thinking.)

- ★★★ 1. The faces on a regular number cube are labeled 1 through 6. What is the probability of rolling three four's in succession? Give your answer as a common fraction.



Answer: _____

- ★★ 2. Two girls each had a different number of bracelets. Joyce said, "If you give me 8, I'll have as many as you." Leslie replied, "If you give me 8, I'll have twice as many as you." How many did each have?

Answer: Joyce has _____ bracelets.
Leslie has _____ bracelets.

- ★★ 3. How many different 3-digit numbers can you write using the numbers shown below without repeats?

2 4 7 9

Answer: _____ numbers

- ★★★ 4. Karch gave $\frac{1}{2}$ of his stamp collection to AJ. Then he gave $\frac{3}{4}$ of the remaining stamps to Ricci. If he ended up with 12 stamps, how many did he have when he started?

Answer: _____ stamps

- ★★★★ 5. The Hi-N-Dry Volleyball Company has exclusive rights to make a waterproof volleyball for games at the beach. The company controls the shipment of its balls with a special code. Last week's shipment consisted of 20 cartons -- the first five cartons are numbered in this way: 04343, 08686, 13029, 17372, and 21715. The last 2 cartons shipped were 82517 and 86860. The company is in a panic because every carton that began and ended with an even digit has been lost. How many cartons have been lost and what are the carton numbers?



Answer: a. _____ cartons were lost.

b. The lost numbers were: _____

- ★ 6. You have yarn that is 8 yards long. If it takes you 1 second to make each cut, how long will it take you to cut the yarn into 1 foot pieces ?

Answer : _____ seconds

- ★ 7. The results from a recent survey show that the most popular magazines among men are *Sports Illustrated*, *GQ*, and *Consumer Reports*. Of the men surveyed, 13 subscribe to *GQ* only, 28 to *Sports Illustrated* only, and 19 to *Consumer Reports* only. The survey shows that, of the men who take two magazines only, 17 take both *GQ* and *Sports Illustrated*, 21 take both *Sports Illustrated* and *Consumer Reports*, and 13 take both *GQ* and *Consumer Reports*. Fourteen men subscribe to all 3 magazines. How many men were surveyed?

Answer: _____ men

- ★ 8. Figure A changes to B as C changes to:

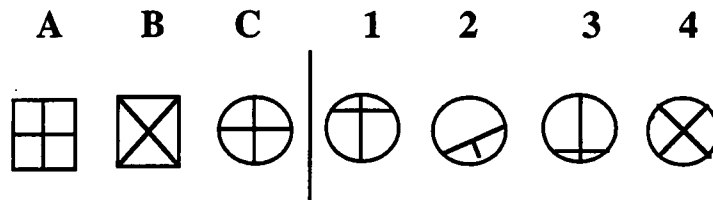

Answer: _____

- ★★ 9. Mentally find the product of $2 \times 48 \times 50$. When you turn in your paper, you will have a problem like this to do in your head.

Answer to later problem: _____

- ★★★ 10. Find the area of a soccer field outside the center circle if the field is 100 m by 50 m and the diameter of the center circle is 15 m.



Answer: _____ m²

- ★★ 11. Write an equation for this situation, using h for the cost of 1 hot dog. Solve the equation.

An 8-pack of hot dogs and a jar of mayonnaise costs \$2.42.
The mayonnaise is \$1.30. What is the cost of each hot dog?

Answer: An equation is: _____ . The solution is: $h =$ _____

Commentary

Pluto, VIII

1. ($\frac{1}{216}$) The chance of rolling a four is $\frac{1}{6}$, so the chance of rolling three in a row is the product of those independent events: $P(\text{three four's rolled}) = \frac{1}{6} \times \frac{1}{6} \times \frac{1}{6} = \frac{1}{216}$
2. (Joyce = 40 and Leslie = 56) Let J represent the number of Joyce's bracelets and L the number of Leslie's bracelets. Joyce's statement would then translate into the equation: $J + 8 = L - 8$. Leslie's reply would translate into $L + 8 = 2(J - 8)$. Solving the system for J gives the answer.
3. (24) Make an orderly list of all possible combinations of numbers. There are six such that begin with 2: 247, 249, 274, 279, 297, and 294. Likewise, there are six that begin with 4, six that begin with 7, and six that begin with 9.
4. (96) Students can work backwards on this problem. If $\frac{1}{4}$ of his stamps was 12, then he had to have (4)(12) stamps prior to that, or 48. Then if 48 were half of what he had previously, he must have had (2)(48) at the beginning.
5. (6 cartons, numbers 08686, 26058, 43430, 60802, 69488, and 86860) Look for a pattern of carton numbers which increase by 4343 each time. Then you can list the twenty numbers, and see which in the list begin and end with an even number. This is a good place to use the automatic constant on the calculator.
6. (23 seconds) It takes 23 cuts to make 24 one foot pieces.
7. (125 men) Set up a Venn diagram showing the shared areas for each type of subscription. As the numbers given are independent of one another, the answer is the sum of all the numbers.

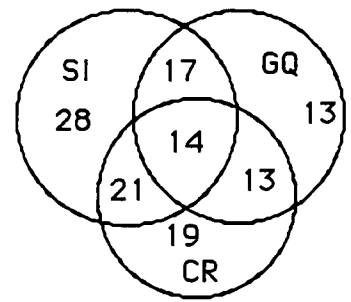

8. (4) The diagonals are rotated to get from A to B. This same factor is true of C and 4.
9. (3200) Give the student this problem when the paper is turned in: $4 \times 32 \times 25$. The student should multiply the *compatible numbers* 4 and 25 to get 100, and 32 times 100 to get 3200.
10. (4823.375 m²) The area of the rectangular field is 100×50 m². The area of the middle circle is πr^2 or $3.14 \times 7.5 \times 7.5$ m². Then subtract the area of the circle from area of rectangle. If a student uses a calculator with a Π key, the answer will be 4823.2854 m².
11. (a. $8h + \$1.30 = \2.42 ; b. 14¢) The equation represents: the cost of 8 hot dogs and \$1.30 gives a total of \$2.42. The solution comes by subtracting \$1.30 from both sides of the equation, giving $8h = \$1.12$, and then dividing both sides by 8 to give $h = \$0.14$ (14¢).

SUPERSTARS III

Pluto, IX

Name: _____

(This shows my own thinking.)

- ★ 1. What is the smallest number of Blow Pops, and of which color, that you would have to add to a bowl full of pops containing 8 cherry and 8 sour apple so that the ratio of cherry to sour apple changes to 1 to 2?

Answer: _____

- ★★★★ 2. Use number sense to match each graph with the number of people at each location. Put the letter of each location in one of the four center circles.

Locations:

A. motel

B. football stadium

C. movie theater

D. shopping mall

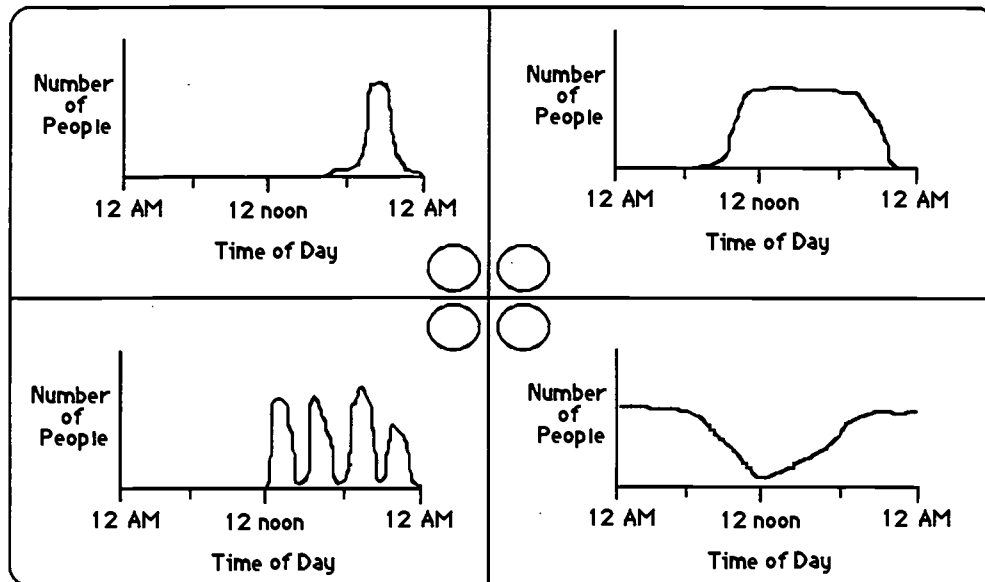

- ★★★ 3. Your Aunt Ada sent you a \$25 gift certificate for Camelot Music. You spot 2 C.D.'s you would like to have. One costs \$16.90 and the other is on special for \$13.10. What percent of the total cost will you have to pay with your own money?

Answer: _____%

- ★★★ 4. The Easter Bunny Academy just graduated 10 new Bunnies, complete with costumes, to work the local malls. As they prepare to leave for their duties at the mall, each bunny shakes hands with each of the other bunnies. How many handshakes will there be?

Answer: _____ handshakes

★★★ 5. Finish these number patterns out to the tenth position, and find the sum:

a. $1 - 2 - 3 - 4 - 5 - 6 - \dots - 10 = \underline{\hspace{2cm}}$

b. $-100 + -90 - 80 + -70 - 60 + \dots + -10 = \underline{\hspace{2cm}}$

c. $2 - 4 + 6 - 8 + 10 - 12 + \dots + 20 = \underline{\hspace{2cm}}$

★ 6. Given $m = 43$ and $n = 27$, evaluate $15m + 12n - 2m$.

Answer:

★★★ 7. While building a medieval castle it cost Sir Bedemere 36 guilders to hire 5 artists and 3 stone masons, or 28 guilders for 3 artists and 5 stone masons. What is the cost of each one?

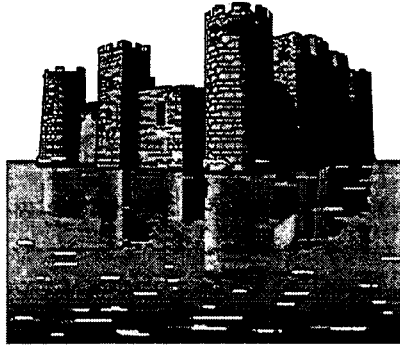

Answer: An artist costs A mason costs

★★★ 8. Kent needed to purchase a new step ladder. The ladder he wanted cost \$42.95 but Kent noticed that it was on sale for 25% off. The sales tax in his county is 6%. What will be the total cost of Kent's ladder?

Answer: \$

★★ 9. What is the square root of the cube root of 729?

Answer:

★★★ 10. On a number line, what is the coordinate of a point $\frac{1}{3}$ the distance from -5 to 13?

Answer:

Commentary

Pluto, IX

1. **(8 sour apple)** The ratio 1 to 2 is the same as the ratio 8 to 16, so you must turn the ratio 8 to 8 into 8 to 16. The easiest way to do that is to add 8 sour apple pops.
2. **(starting at the upper left and going clockwise, the graphs are B, D, A, and C)** Students might start with a familiar situation, such as going to a movie, and discuss what happens to the crowd inside the theater. It goes up and down, about every 2 hours, so its graph would do likewise. At a motel, most people would begin leaving about 6:00 AM, so the number of people at the motel would decrease from 6:00 AM till about noon, and then gradually increase throughout the afternoon. A shopping mall would have a fairly constant crowd from about 10:00 AM through till 10:00 PM. A football stadium (on a game day) might have people come in about 6:00 at night, and stay till 9:00 or 10:00.
3. **(about 17%)** The total for the C.D.'s is \$30, and so you must pay \$5. This amount is about 17% of the total.
4. **(45)** Students might put 10 points around a circle, and connect each pair with a line, but only one line for each pair. If you count the lines from one point, and move around the circle clockwise, you would find this total numbers of lines to connect: $9+8+7+6+5+4+3+2+1$.
5. **(a. 17; b. 50; c. 110)** There are a number of ways to compute each of these patterns of numbers. Students should be encouraged to place together compatible numbers that give "easy sums" to work with, rather than simply moving straight into the computation.
6. **(883)** Substituting 43 for m and 27 for n gives $15 \times 43 + 12 \times 27 - 2 \times 43$.
7. **(artists - 6 guilders, masons - 2 guilders)** One approach is to write the expressions $5a + 3m = 36$ and $3a + 5m = 28$ to express the information, using a as the number of artists and m as the number of masons. If you multiply the first expression by 5 and the second by 3, you get $25a + 15m = 180$ and $9a + 15m = 84$. If you subtract the second expression from the first, you have $16a = 96$, and then $a = 6$. Substituting this value into one of the two original expressions and solving for m reveals that $m = 2$.
8. **(\$34.15)** $\$42.95 \times 75\%$ gives \$32.21, and this amount times 1.06 gives the cost plus the tax. The student's answer may be off by a penny, depending upon the rounding off procedure.
9. **(3)** $9^3 = 729$, $\sqrt{9} = 3$. Students will probably have to guess-check-revise to find that $9^3 = 729$, but this should be relatively quick using a calculator.
10. **(1)** There are 18 units from -5 to 13, and one third of 18 is 6. Counting up 6 units from -5 leaves you at 1 on a number line.

SUPERSTARS III

Pluto, X

Name: _____

(This shows my own thinking.)

- ★ 1. June finishes her math homework 90% of the time. If she has homework for each school day for four full school weeks, how many days will she turn in her homework?

Answer: _____ days in four weeks

- ★★ 2. Write an expression for the area of the rectangle. Evaluate the expression for $x = 10$.

Answer: An expression is: _____

If $x = 10$, the area is: _____

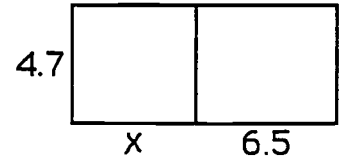

- ★★★★ 3. Lu works as a waitress from 4:00 until 7:30 some days after school. She gets paid \$3.75 an hour plus her tips. Last week Lu worked Monday, Tuesday, and Friday. If she received \$18.75 in tips last week, how much did Lu earn for the week?

Answer: \$ _____



- ★★ 4. Katie broke open her piggy bank and found 3 quarters, 3 nickels, some dimes and a lot of pennies. She counted and found she has \$3.60 in change. She also found that she has just enough pennies to wrap a \$0.50 roll. How many dimes did Katie have in her bank?

Answer: _____ dimes

- ★★★ 5. David put 155 feet of plastic edging around the outside edge of the concrete border surrounding Mrs. Rhum's pool area to keep grass out of the water when he mows her yard. The concrete border has a width of 17.5 feet. How long is the border?

Answer: _____ feet long

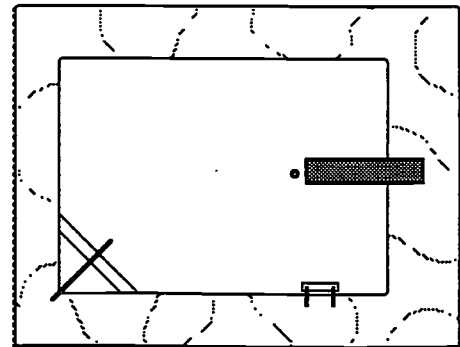

- ★★ 6. Jean said there were 1634 students in River Ridge Middle School. Mr. Brown said that there were 72 more girls than boys. How many girls attend River Ridge Middle School?

Answer: _____ girls

- ★★ 7. With the clock showing 3:30 remaining in the game, Bruno's football team had the ball on their own 35 yard line. In the next 8 plays, they averaged 5 yards a play and 25 seconds per play. On what yard line did they begin the 9th play, and how much time was left?

Answer: _____ yard line with _____ left

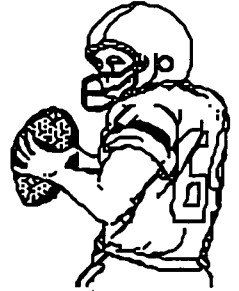

- ★★★ 8. Julie bought some stamps. She paid \$6.00 for every 12 stamps she bought. Later, Julie was offered \$6.00 for every 8 of them. She sold them all and made a profit of \$12. How many stamps did Julie buy and sell?

Answer: _____ stamps bought and sold

- ★ 9. The Guinness Book of World Records says that a dentist from Rome, Italy kept all the teeth he extracted from 1868 until 1904. They were later counted, and totaled 2,000,744. If the dentist worked every day of the year, about how many teeth did he pull per day, to the nearest ten teeth?

Answer: _____



- ★★ 10. Maureen is running a 3-mile race. Her goal is to finish in 18 minutes or less. At the 2-mile mark when her elapsed time reads 11 minutes, 45 seconds. What should her strategy be for the remainder of the race?

Answer: She should _____.

Commentary

Pluto, X

1. **(18)** There would be 20 school days in four full weeks. Ninety percent of 10 days would be nine days, therefore June would miss completing her homework one day every two weeks. So ninety percent of 20 would be 18 days.
2. **($4.7 \times (x + 6.5)$; 77.55)** The expression given is one way to write the area algebraically, but there are also equivalent ways which must be checked. Substituting 10 in for x gives an area of $4.7 \times (10 + 6.5)$ or 4.7×16.5 .
3. **(\$58.12 or \$58.13)** From 4:00 until 7:30 is 3.5 hours, and this would give a total of 10.5 hours Lu worked in three days. At \$3.75 per hour, the total wages amounts to \$39.375. Adding the tip gives \$58.125, which rounds to either \$58.12 or \$58.13, depending on who's doing the rounding (Lu or her employer).
4. **(22)** Three quarters is 75¢, three nickels is another 15¢, and the pennies total 50¢. This total of coins gives \$1.40, and subtracting that from \$3.60 gives \$2.20. This is all in dimes, giving the answer of 22 dimes.
5. **(60)** The perimeter of the pool area -- 155 feet -- is two widths and two lengths. The two widths total $17.5 + 17.5$ or 35 feet, leaving two lengths totaling 120 feet. Then each length is 60 feet.
6. **(853)** There are 1634 total students; let X be the number of boys, $X + 72$ the number of girls. Then $X + (X + 72) = 1634$, so $2X = 1634 - 72$ or 1562. Then $x = 1562 \div 2$ or 781. $X + 72$ or 853 is then the number of girls.
7. **(25 yard line with 10 seconds left)** The yard line can be computed as $35 + (8 \times 5) = 35 + 40 = 75$, but at 50 yards one counts down again to get $75 - 50$ or the 25-yard line of the opponent. At 25 seconds each, the eight plays would consume 200 seconds. Three minutes and 30 seconds is 210 seconds, so there would be $210 - 200$ seconds remaining.
8. **(48)** The per-stamp cost of the stamps purchased is given by $\$6.00 \div 12 = \0.50 . The offered price for each stamp $\$6.00 \div 8$ or \$0.75. The profit is then \$0.25 per stamp. The total profit of \$12 can be divided by \$0.25 to get 48 stamps bought and sold.
9. **(150)** From 1868 until 1904 is 36 years the dentist practiced. This would be a total of 365×36 or 13,140 days. Dividing 2,000,744 teeth by 13,140 days gives about 152.3 teeth extracted per day. Rounded to the nearest ten, this becomes 150.
10. **(keep running at the same pace)** To finish 3 miles in 18 minutes means Maureen will run at a six minute per mile pace. At that pace, she should pass the 2-mile mark at exactly 12 minutes. But she passed the mark a little before 12 minutes had elapsed, which means she's running a little ahead of her pace. She should therefore strive to keep her pace.

SUPERSTARS III

Pluto, XI

Name: _____

(This shows my own thinking.)

- ★ 1. Jill, Joe and Tanya each got different grades in math class. None of them earned less than a C. Jill's grade was better than Tanya's. Joe did not do as well as Tanya. What grade did each student receive?

Answer: Jill _____
Joe _____
Tanya _____

- ★★★★ 2. Jane's aquarium contains goldfish, turtles, and snails. There are 16 legs, 10 shells, and 36 eyes in the aquarium. How many creatures of each type are there in the aquarium? (Hint : Snails have one shell and one leg.)

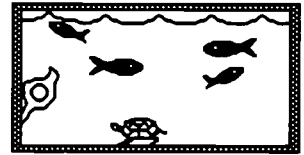

Answer: _____ goldfish, _____ turtles and _____ snails

- ★★★ 3. You have boxes that will hold 1 candy bar, 3 candy bars, 9 candy bars, and 27 candy bars. If each box must be packed full, what is the fewest number of boxes you need to hold 377 candy bars?

Answer: _____ boxes

- ★★ 4. E.J. went to the mall. She picked out some blue jean shorts for \$24.59, an Escher T-shirt for \$17.50, and some sandals for \$11.99. How much tax must she pay for all the items if the sales tax is 6%?

Answer: _____



- ★ 5. E.J. asks her Mom for the money to pay for the clothes, shoes and the taxes on them. To the nearest \$5, for how much money should she ask her Mom to cover all her purchases?

Answer: \$ _____

- ★ 6. In Miami, it rained 71 out of the 92 days of the summer. Given this information only, what is the probability that it rained on July 4th?

Answer: _____

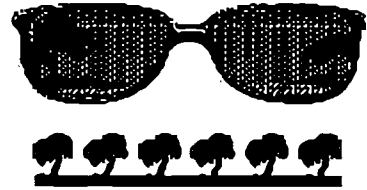

- ★★ 7. The ratio of boys to girls in our math class is 5 to 7. If there are 6 more girls than boys in our class, how many students total are there in our math class?



Answer: _____ students

- ★★★ 8. Richard and Fidel took a trip together. While they traveled, each of them recorded the money he spent for expenses. When they arrived home, they agreed to share the expense equally. Which one owes the other, and how much money does he owe?

Richard spent:

Gas \$73.42
Room \$67.24

Fidel spent:

Tickets \$41.76
Food \$102.50

Answer: _____ owes \$ _____ to _____.

- ★★ 9. A helium balloon floats *up*, and so has negative weight. Each balloon shown to the right exactly balances 13 grams, and so has weight -13 grams. If the balloons were removed from the scale but the tape dispenser and stapler left on, what would the scale read in grams?

Answer: _____

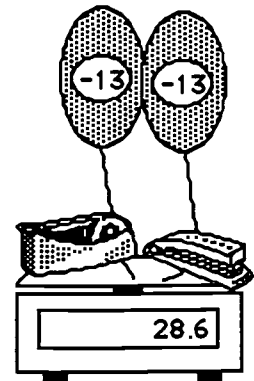

Commentary

Pluto, XI

1. **(Jill A, Joe C, Tanya B)** Lining the students up according to the clues will reveal that Jill got the highest grade, Tanya the next highest, and Joe the least. So, by process of elimination, Joe's was a C, Tanya's a B, and Jill's an A.

2. **(8 goldfish, 2 turtles, 8 snails)** If each creature has 2 eyes, there are 18 animals total. One way to proceed is to *guess-check-revise* knowing the number of snails and turtles must total 10, and their legs must total 16. This results in 2 turtles and 8 snails. Therefore there must be 8 fish also, to have 18 creatures altogether. Another way to solve the problem is to express the numbers of goldfish (g), turtles (t), and snails (s) as below, and solve by substitution.

$$g + t + s = 18; \quad 4t + 1s = 16; \quad s + t = 10$$

3. **(19)** One approach is to fill as many of the largest boxes as possible, working your way down to the smaller boxes. $377 \div 27 = 13$ boxes + 26 candy bars left over; $26 \div 9 = 2$ boxes + 8 candy bars left over; $8 \div 3 = 2$ boxes and 2 candy bars left over; $2 \div 1 = 2$ boxes. There are therefore 19 total boxes used.

4. **(\$3.25)** The sum of the items is \$54.08. $\$54.08 \times 6\% = \3.2448 , which is rounded up by store owners, gives a tax of \$3.25

5. **(\$60.00)** $\$54.08 + \$3.25 = \$57.33$, and you round up to nearest \$5 to cover all purchases.

6. **(71/92 or 0.77 or 77%)** July 4th is one day out of the 92 summer days, so its chance of being one of the 71 rainy days is 71 out of 92.

7. **(36 students)** One approach is to set up a "ratio table" as shown below:

boys	5	10	15	20
girls	7	14	21	28

From the table, the entry that has 6 more girls than boys is the third one, 15 boys and 21 girls. So there are 15 + 21 students altogether in the class.

Another approach is to set up the ratio $\frac{b}{g} = \frac{5}{7}$ and the equation $b + 6 = g$. Solve by substituting $b + 6$ for g in the ratio and solving for b , then subsequently for g .

8. **(Richard owes \$1.80 to David)** Richard spent \$140.66 and David spent \$144.26 for a total of \$284.92. If this amount is divided equally, each should pay \$142.46. If Richard pays another \$1.80 to David, each will have paid this amount.

9. **(54.6)** This gives a practical example of how subtracting a negative is the same as adding a positive of that same absolute value. Removing -13 twice will increase the reading on the scale by 26 grams, giving a total weight of $28.6 + 26$ or 54.6 grams.

SUPERSTARS III

Pluto, XII

Name: _____

(This shows my own thinking.)

- ★★ 1. Caitlin's shadow is 10 feet long at the same time that the shadow of a nearby statue is 24 feet. If Caitlin is 5 feet tall, how tall is the statue?

Answer: _____ feet

- ★★★★ 2. The computerized range-finder on the undersea filmmaker's camera told her that a grouper started 60 fin strokes ahead of a bull shark. The bull shark made two strokes to every three made by the grouper; but the shark's stroke covered as much distance as the grouper covered in seven strokes. How many strokes did the shark take before it swallowed the grouper?

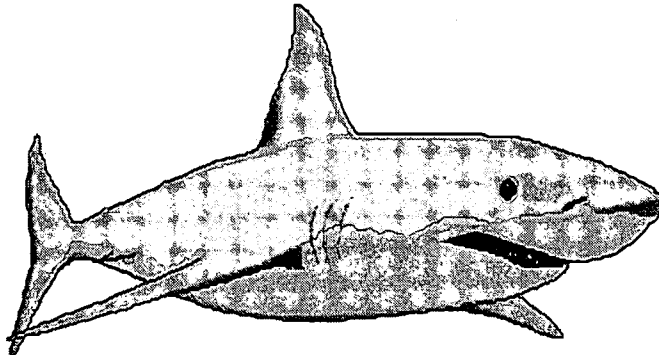

Answer: _____ strokes

- ★★★ 3. If a golf ball weighs 40 grams and half a golf ball, what does a golf ball and a half weigh?

Answer: _____ grams

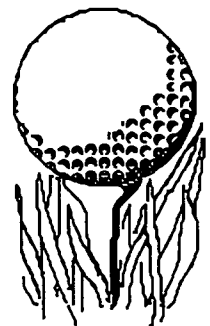

- ★ 4. There are 3 pencils, 4 pens, and 2 markers in Jill's purse, all identical to the touch. What is the probability she will pull out a pencil if she reaches in without looking?

Answer: _____

- ★★★ 5. Craig wants to paint his room royal purple. The length of his room is 15 feet and the width is 10 feet. The walls are 9 feet tall. If one wall has a window that is 3 feet by 2 feet and another has a door that is 3 feet by 8 feet, how many square feet will he be covering with paint?

Answer: _____ square feet

- ★★ 6. Spike Nashbar is shipping volleyball nets to Italy. The nets are 32 feet wide and 3 feet high. The Italians use the metric system -- how long and how high are the nets in meters? (Hint: 1 in. = 2.54 cm)

Answer: _____ meters wide and _____ meters wide



- ★★★ 7. To motivate Reba to work her physics problems correctly, her dad said he'd pay her a quarter for each correct answer and fine her a dime for each incorrect answer. If she received \$3.80 after doing 25 problems, how many problems did Reba answer correctly?

Answer: _____ answered correctly

- ★ 8. A robot arm can attach 300 bolts in 6 minutes. If there are 50 bolts on each item, how many items are completed in an hour?

Answer: _____ items

- ★★ 9. Consider the last two page numbers of a book.

a. Is their sum an even number, or an odd number? _____

b. Is their product an even number, or an odd number? _____

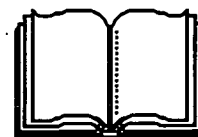

- ★ 10. If a doctor prescribed 36 pills and directed you to take them every 4 hours, how many days would they last?



Answer: _____ days

Commentary

Pluto, XII

1. (12) Students might solve the proportion $\frac{10}{5} = \frac{24}{x}$.
2. (11th stroke) Make a chart showing the strokes for each fish remembering to take into the account the different starting distance. The shark's 2 strokes to the grouper's 3 strokes, distance wise, would be the same as the shark making 14 grouper strokes to the grouper's 3, since the shark's stroke covers 7 times the distance that the grouper's stroke does.

shark strokes	start	2	4	6	8	10	11
shark to grouper	0	14	28	42	56	70	77
grouper	60	63	66	69	72	75	76.5

3. (120 g) Visualize a golf ball balanced by 1/2 a golf ball and a 40-gram weight. The 40 grams is the weight of 1/2 a golf ball, and therefore, the golf ball weighs 80 grams. 1.5×80 grams is the weight of a golf ball and a half.
4. (3/9 or 1/3) There are 3 pencils out of 9 objects, so the chances are 3 out of 9 of drawing a pencil.
5. (420) The area of the 4 walls is $2 \times 9 \times 10 + 2 \times 9 \times 15$, or 450 sq feet. The areas of the door (24 sq feet) and window (6 sq feet) are then removed.
6. (9.75 m wide by 0.91 m high) Change feet to inches, then inches to cm, then cm to m.
7. (18) One way to begin the problem is to find combinations of numbers that add to 25 and *guess and check* using the following procedure. Multiply one of the two numbers by 25¢ and from that product subtract the product of the other multiplied by 10¢. If you get \$3.80, you have the correct number - the one you multiplied by 25¢. If not, try another pair of numbers that sum to 25. An algebraic approach is to let c stand for the number of correct answers, and solve the equation $0.25c - 0.10(25 - c) = \$3.80$. In either approach, you should get 18 as the number of correct answers.
8. (60) 300 bolts in 6 minutes means the robot is working at the rate of 50 bolts per minute. The robot can therefore complete one item per minute, or 60 items in an hour.
9. (a. odd; b. even) The last two pages of a book must be an odd number and an even number. The sum of an odd and even number is always odd, and their product is always even. Students might want to look at the last two pages of a few books and try this out, using a calculator.
10. (6) $36 \text{ pills} \times 4 \text{ hours per pill}$ is a total of 144 hours. This number is divided by 24 to get 6, the number of days the pills will last. Another approach is to determine the number you would take in one day - a 24 hour period. At a pill every four hours, that would be 6 pills per day. Therefore 36 pills would last for 6 days.

SUPERSTARS III

Pluto, XIII

Name: _____

(This shows my own thinking.)

- ★ 1. Pizza Heaven offered to donate pepperoni pizza to give out at the school pep rally. If 1000 students are expected at the pep rally, and each pizza is cut into 8 slices, how many pizzas will Pizza Heaven have to deliver for each student to get 1 piece?

Answer: _____



- ★ 2. When does four come after five, other than when it's written in numerals like 54 or 574?

Answer: _____

- ★★★ 3. The new manager for Dillards was hired with a beginning monthly salary x and told she would be given a 10% raise to \$3000 a month, within 6 months. What was her beginning salary x ?

Answer: $x = \$$ _____

- ★★★ 4. Warrick and Ricardo are reading the same 230-page mystery novel. Ricardo had a speed-reading course last summer and so reads 5 pages for every 2 that Warrick reads. Warrick has read 28 pages -- how many pages does Ricardo have left to read?

Answer: _____ pages



- ★★★★ 5. Michael Jordan is flying from Chicago to Nagasaki, Japan. A non-stop flight takes 17 hours and 20 minutes. On this flight, the plane makes a stop in Sacramento for 2 hours and 15 minutes and another in Honolulu for 1 hour and 40 minutes. Michael left Chicago at 3:45 p.m. on Thursday. What day and time did he land in Nagasaki, Chicago time?

Answer: _____

- ★★ 6. A regular octagon is shown to the right. What is the area of the shaded part, as a fraction of the whole octagon?

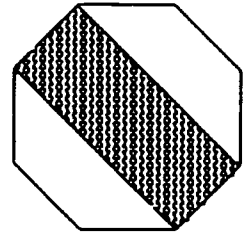

Answer: _____

- ★★ 7. Nelson Construction built a drainage ditch that was 800 feet long, 6 feet wide, and $5\frac{1}{2}$ feet deep. If a truck can carry 2000 cubic feet of dirt, about how many truck loads were needed to carry all the dirt away?

Answer: _____ truckloads

- ★★ 8. Practice doing problems like those below mentally. When you turn in your paper, you will have a chance to do such a problem in your head.

- a. $(3 \times 48 + 3 \times 2) + (25 \times 7 \times 4)$ b. $(5 + 25 \times 7) \times (55 + 45)$
 c. $[(330 \div 10) \times 3] + (250 \times 2)$ d. $(0.50 \times 12 + 4) + (1 + 18 + 1)$

Answer to the problem when I turn in my paper: _____

- ★★ 9. Select the best drawing to illustrate this situation, and find the numerical answer using the drawing.

Lionel fell asleep at the half-way point while riding in a car from Tampa to Ft. Myers. When he awoke, he still had to travel half as far as he traveled while sleeping. If the trip was 200 miles long, for about how many miles was Lionel asleep?

Answer:

The best sketch is _____.

He was asleep about _____ miles.

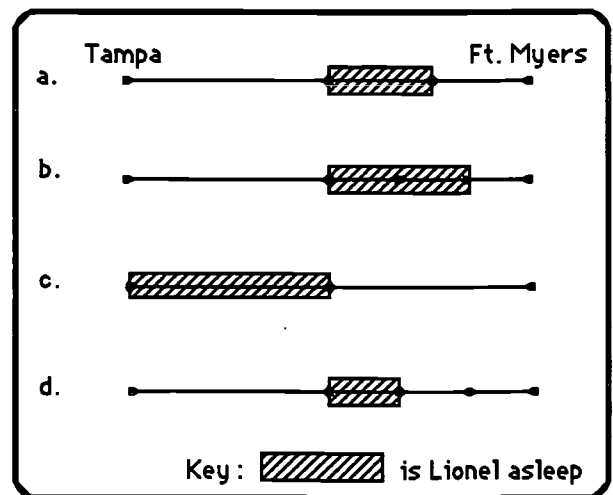

Commentary

Pluto, XIII

1. **(125)** Students can reason that 1000 slices are needed, and 8 slices per pizza means that $1000 \div 8$ gives the number of pizzas required.
2. **(alphabetically, or during a countdown for a missile launch, or ...)** The problem is to have students think of unusual interpretations of words. Accept any answer in which four would logically follow five.
3. **(\$2727.27)** An equation such as $x + 10\%x = 3000$ can be used to find the beginning salary x . This equation becomes $1.1x = 3000$, or $x = 3000 \div 1.1$.
4. **(160)** Solving a proportion such as $5/2 = x/28$ will show that Ricardo has read 70 pages to Warrick's 28. Therefore Ricardo has $230 - 70$ or 160 pages left to read.
5. **(Friday at 1:00 p.m.)** Add the trip time plus the layovers to get a total travel time of 21 hours and 15 minutes. Then add that total to the time of departure.

6. **(1/2)** This relationship is perhaps best seen by sketching 2 other diagonals as shown, and noticing that the small triangles are 45-45-90 triangles. Therefore assign the length of the octagon's side to be $\sqrt{2}$ and the other sides to have length 1. The area of the shaded rectangle is then $\sqrt{2} \times (1 + 1 + \sqrt{2})$. The area of each of the unshaded pieces is $1/2$ of this amount (each small triangle on one unshaded side has an area of $1/2$ and the rectangle between the triangles has an area of $\sqrt{2}$). Therefore, both pieces together have the same area as the shaded part. Therefore the fractional portion of the shaded part to the entire octagon is $1/2$.

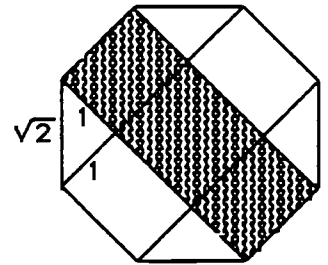

7. **(14)** The volume of dirt taken away is $800 \times 6 \times 5.5$, or 26,400 cubic feet. This amount, divided by 2000, gives 13.2 truckloads of dirt. Give students credit for 13 loads, 13.2 loads, or 14 loads, as removing dirt from a ditch is an approximate science, at best.
8. **(20,000)** Give students this problem when they turn in their papers:

$$(40 + 85 + 60 + 15) \times (5 + 19 \times 5)$$
9. **(b, 66 or 67)** The second drawing best describes the situation. Lionel was asleep about $2/3$ of the last 100 miles, and $2/3$ of 100 miles is about 66 or 67 miles.

SUPERSTARS III

Pluto, XIV

Name: _____

(This shows my own thinking.)

- ★ 1. You want to make a basketball hoop from a metal bar. You can shape the bar without cutting off any part of it. How long would the bar have to be in order to have a hoop with a 20 inch diameter?

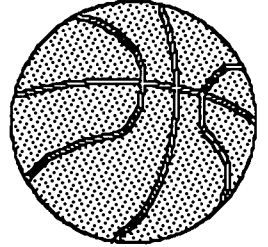

Answer: _____ inches

- ★★★ 2. John is showing his friends a card trick. He first draws a king, does not put it back in the deck, and then draws a second king, supposedly at random. What is the probability of drawing two kings in a row with a regular, well-shuffled deck of cards?

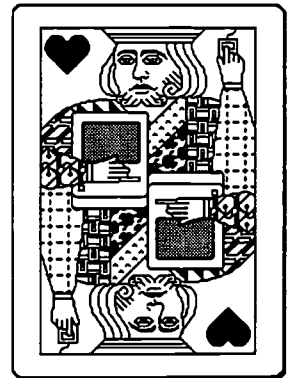

Answer: _____

- ★★★★ 3. A 3-foot cube of Styrofoam is painted purple all over as a prop for a school play. For ease of storage, the big cube is then cut into 27 smaller, 1-foot cubes. How many of the small cubes have paint on exactly 3 faces? On exactly 2 faces? On exactly 1 face? How many of the smaller cubes will be unpainted?

Answer: _____ cubes have 3 faces painted
_____ cubes have 2 faces painted
_____ cubes have 1 face painted
_____ cubes are unpainted

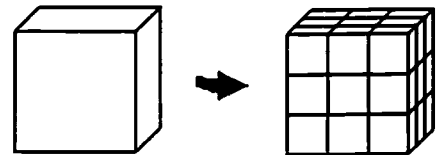

- ★ 4. The scale on a map of Florida is 1 inch to 40 miles. If the distance between Citrus Springs and Homassassa Springs is $7\frac{1}{2}$ inches on the map, what is the distance in miles?



Answer: _____ miles

- ★★★★ 5. Mrs. Nielsen is rewarding her math students for all doing well on a test. She passes out 50 pieces of candy, one-by-one, and starts over in the same order after every student gets one piece. Each student takes a piece of candy, in turn, until the plate is empty. Sherwood gets the first piece and he also gets the next-to-last piece. How many students could be in the class for this to be possible, if the minimum class size in the school is 20 students?

Answer: There could be either ___ or ___ students in the class.

- ★★ 6. A certain number x is greater than 1 but less than 10. When you divide 45, 192, and 353 by x , you get the same remainder. What is the number x ?

Answer: $x =$ _____

- ★★ 7. The River Ridge Middle School gymnasium holds 4000 people. The gym was sold out for every home basketball game. If there were 4 times as many single admission tickets sold as season tickets, how many season tickets were sold?

Answer: _____ season tickets

- ★ 8. Express 53 as the sum of four or less perfect squares.

Answer: _____

- ★★★ 9. A math game to play when you've got time to spare is to pick any two numbers, and combine the two rules *erase the last digit* and *double the number* to change one number into the other. The example on the chalkboard shows that E, D, D, and E is one combination that can change 65 into 2. Find a combination of these rules to change 458 into 14.

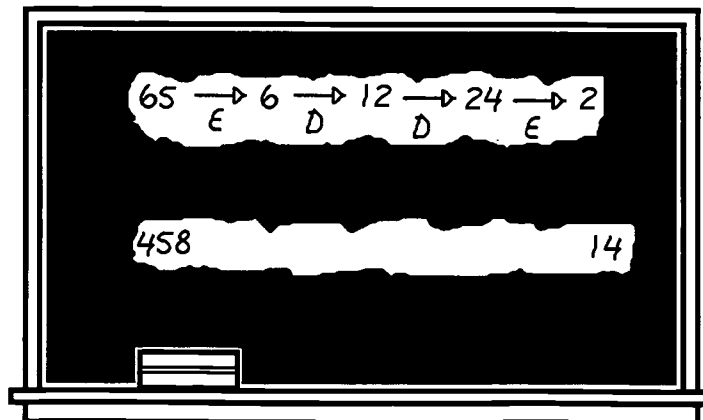

Answer: One combination is: _____

Commentary

Pluto, XIV

1. (**about 62.8 inches**) Circumference = $\pi d = 20\pi$, and $\pi \approx 3.14$. Circumference = $20 \times 3.14 = 62.8$ inches. (63 would be an acceptable answer.)
2. ($\frac{1}{221}$, approximately .005 or .5%) The chance of pulling the first king is $\frac{4}{52}$ or $\frac{1}{13}$, and the probability of pulling the second king, given that the first has been pulled and not replaced, is $= \frac{3}{51}$. The chances of pulling two kings in a row, then, is $\frac{4}{52} \times \frac{3}{51} = \frac{12}{2652} = \frac{1}{221}$ (or $\frac{1}{13} \times \frac{3}{51} = \frac{3}{663} = \frac{1}{221}$ approximately .005 or 0.5%)
3. (**8, 12, 6, and 1, respectively**) Students who have trouble visualizing the cube with its painted faces might want to take 27 sugar cubes or similar blocks, stack them up, and go through the problem in a concrete fashion. The eight corner cubes will have 3 faces painted, the cubes in the middle of each of the 12 edges will have 2 faces painted, the cubes in the center of each of the 6 faces will have 1 face painted, and the cube in the very center of the large cube will be unpainted.
4. (**300 miles**) Students might solve a proportion such as $\frac{1 \text{ inch}}{40 \text{ miles}} = \frac{7.5 \text{ inches}}{x \text{ miles}}$. A student might simply reason that 1 inch = 40 miles, so 7.5 inches is $(7.5)(40)$ or 300 miles.
5. (**24 OR 48**) If Sherwood got the next-to-last piece, he got number 49. This means that the distribution of candy started over again after 48 students. Therefore there were either 48, or half of 48, students in the class.
6. (**7**) *Guess and check* is one approach. Students might list the numbers from 2 to 9, trying different numbers until they find one that works with the other clues. Seven works, since the remainder of 45, 192, and 353 upon division by 7, is 3.
7. (**800**) Let x = season tickets and $4x$ = single admission tickets. Solve the equation $4000 = 4x + x$, or $4000 = 5x$.
8. (**36 + 16 + 1 or 49 + 4 or 25 + 9 + 16 + 1**) Other answers may be possible.
9. (**DEEDDED**) The combination shown produces this sequence of numbers: 458, 916, 91, 9, 18, 36, 72, 7, 14. There are other combinations which will also work. An interesting extension is to find the combination with the fewest number of steps.

SUPERSTARS III

Pluto, XV

Name: _____

(This shows my own thinking.)

- ★★★★ 1. Six bookbags are randomly distributed to the six people who own them. What is the probability that all the people receive the correct bookbag?

Answer: _____

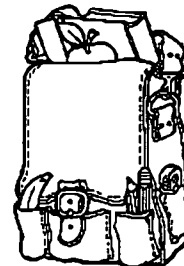

- ★★ 2. A waitress served \$800 worth of dinners at IHOP. She received \$95 in tips. How much less, in tips, did she receive than if she had received her expected rate of 15% of the cost of the meals?

Answer: \$_____

- ★★ 3. Jaime wants to know what grade to expect in science. Her chapter test scores for the quarter were 86, 97, 94, 73, and 88.

- a. What is Jaime's chapter test average?

Answer: _____

- b. If the final exam counts as two chapter tests, what must Jaime make on the final to average 90%, which is an "A" in this course.

Answer: _____



- ★★★★ 4. The U.S. Census taker stopped by the Busselbaum's home to survey their household. In trying to determine the number of children the Busselbaums have, the census taker received this information:

- *each daughter has the same number of brothers as she has sisters, and*
- *each of the boys has twice as many sisters as brothers.*

How many children do the Busselbaums have?

Answer: _____ children

- ★★ 5. Complete the next two terms in the pattern :

1, 2, 9, 64, 625, _____, _____

- ★ 6. Evaluate $6a + 5b - \frac{c^2}{3a}$ when $a = 4$, $b = 12$, and $c = 9$.

Answer: _____

- ★★★★ 7. A six-pointed regular star is formed by two interlocking equilateral triangles. What is the ratio of the area of the entire star to the area of one of the two large interlocking equilateral triangles?

Answer: _____

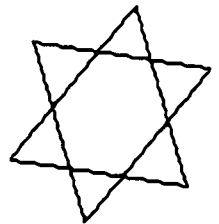

- ★★★★ 8. Mr. Hudson has a box that is 18 cm wide by 36 cm long by 10 cm high. He also has some dice that are 3 cm by 3 cm by 3cm that he wants to store in this box. How many dice can he fit in the box, if he has to put the lid on securely?

Answer: _____ dice

- ★★★★ 9. Two joggers were crossing a railroad bridge when they suddenly heard the sound of an approaching train. They were smart enough to run for safety -- but each one ran in the opposite direction! Happily, each jogger reached his respective end of the bridge just in time to avoid the train.

If they were $\frac{2}{5}$ of the way across the bridge when they heard the train, and the train was going 50 miles per hour, and they both ran at the same speed, how fast did those two guys run?

Answer: _____ miles per hour



Commentary

Pluto, XV

1. (1/720 or 0.1%) The total number of ways the bookbags could be handed out is given by $6 \times 5 \times 4 \times 3 \times 2 \times 1$ or 720. Only one of those is correct.
2. (\$25) $\$800 \times 0.15 = \120 . Therefore she received $\$120 - \95 or \$25 less than expected.
3. (a. 87.6; b. 96) $86 + 97 + 94 + 73 + 88 = 438$, and $438 + 5 = 87.6$, her average of the chapter tests. Since the final exam counts as two chapter tests, in the end she will have a total of 7 test grades. To average 90, she must have a total of 90×7 or 630 points. Since she already has 438, she must obtain 192 more on the final exam, counting it as two tests. Therefore the grade on the final must be 96.
4. (7) From the first clue, you know there is one less son than there are daughters. You can therefore *guess-check-revise* to see which combination of this nature also has the same number of daughters as twice the number of sons, less one. Three boys and four girls is the correct combination.
5. (7776; 117,649) The pattern is: $1^0, 2^1, 3^2, 4^3, 5^4, 6^5, 7^6, \dots, x^{x-1}$
6. (77 1/4 or 77.25) 6×4 is 24, 5×12 is 60, and $81/12$ is $6 \frac{3}{4}$. Adding the first two and subtracting the third term gives $84 - 6 \frac{3}{4}$ or $77 \frac{1}{4}$.
7. (4/3 or 4 to 3) The star has 12 smaller equilateral triangles formed. These 12 make up the area of the entire star, while there are only 9 of these triangles in one of the big overlapping triangles.

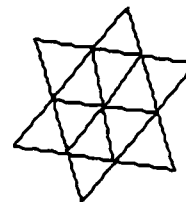

8. (216) The box can hold 72 dice on the bottom layer, since $18 + 3$ is 6, $36 + 3$ is 12. Therefore the length and width of the bottom can hold 6 rows of 12 dice per row. There can be only 2 additional layers added to the bottom one, because 4 layers would be 12 cm high, too high for the lid to fit. The 3 layers with 72 dice per layer comes to 216 dice.
9. (10) The diagrams below show where the joggers are when the train first gets to the bridge and when it gets across the bridge. The men have both run $2/5$ of the way across the bridge in the first picture, so the first jogger barely escapes. The other jogger keeps going, as does the train. This jogger travels the last $1/5$ of the bridge while the train is travelling the whole length of the bridge, at 50 miles per hour. The jogger must be travelling $1/5$ as fast as the train in order to cover $1/5$ the bridge while the train is covering the whole bridge. Therefore the jogger is going $1/5$ of 50 miles per hour, or 10 miles per hour.



SUPERSTARS III

Pluto, XVI

Name: _____

(This shows my own thinking.)

★★★★

1. During her summer vacation, Jenny decided to visit some of her relatives – her cousin, her grandparents, her uncle, her nephew, and her brother – all of whom live in different cities. The five cities they live in are Atlanta, Columbia, Charleston, Tampa, and Myrtle Beach. Jenny used five different types of transportation – car, plane, bus, train, and motorcycle.–



- She arrived by plane and bus at the two cities which are not on the coast.
- Her uncle and her cousin live on the east coast.
- Her nephew met her plane when she arrived.
- She did not arrive at her uncle's city by car and her uncle does not live in Myrtle Beach.
- She did not go by bus to Atlanta or to visit her grandparents.
- She did not go to her cousin's city by train.

Who lives where and how did Jenny arrive?

Answer : She arrived by _____ to visit her _____ who lives in _____

She arrived by _____ to visit her _____ who lives in _____

She arrived by _____ to visit her _____ who lives in _____

She arrived by _____ to visit her _____ who lives in _____

She arrived by _____ to visit her _____ who lives in _____

★★

2. A sandwich costs \$1.12, the chips cost half of what the sandwich cost, and the milk costs one quarter of the price of the sandwich. How much does the whole meal cost?

Answer : \$ _____

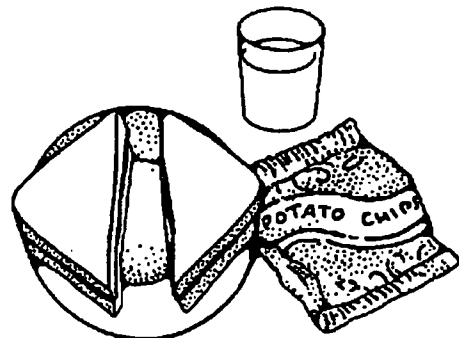

★★★

3. A machinist converts a metric part to 0.443 inch. The parts only come in fractional sizes given to the nearest 64th of an inch. What is the closest fractional size?

Answer : _____ of an inch

- ★★ 4. To double check their estimate of the cost of a job, Jack's Painting Company applies the rule of thumb that materials should constitute 20% of the total cost. If the estimate of a job comes to \$1011.00, about how much should the materials cost ?

Answer: _____



- ★★ 5. Robin threw 5 darts, hitting the target and scoring points on each throw. How many different ways could he have gotten his total score of 120 points?

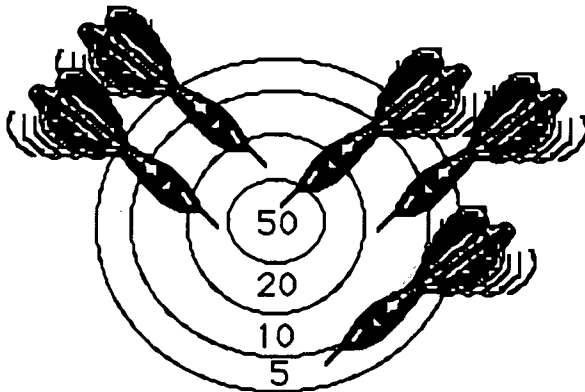

Answer : _____ ways

- ★★ 6. Ms. Fletcher gives her classes a mathematics spelling quiz every Monday, a problem quiz every other Monday, and a mathematics history quiz every third Monday. Ace Jones is in Ms. Fletcher's class, and he received a grade of 100% on all three quizzes today. How many weeks will it be before he again has to take all three quizzes in one day?

Answer: _____ weeks

- ★ 7. Jack is showing Martha a card trick. He has 6 index cards, each one with a letter -- A, B, C, D, E, or F -- typed on it. Every card Jack draws has a letter that is the first letter of the month of a year. What is the probability of Jack drawing three such cards in a row, replacing the card after each draw, without a trick up his sleeve?



Answer : _____

Commentary

Pluto, XVI

1. **Plane - Nephew - Atlanta Car - Grandparents - Tampa**
 Bus - Brother - Columbia Motorcycle - Cousin - Myrtle Beach
 Train - Uncle - Charleston

Suggest that students use a chart and mark off what is known and what is impossible. By the process of elimination, they should eventually solve the logic puzzle in this fashion.

	Cousin	grands	uncle	nephew	brother	car	bus	plane	train	cycle
Atlanta										
Columbia										
Charleston										
Tampa										
Myrtle B.										
car										
plane										
bus										
train										
cycle										

2. **(\$1.96)** $\$1.12 + \$0.56 + \$0.28 = \1.96

3. **(28/64 or 7/16)** Students might reason that 0.443 inches is $x/64$ inches, and solve for x by multiplying 64×0.443 , arriving at $x = 28.352$. Rounding off, this fraction becomes 28/64.

4. **(\$200)** \$1011 is close to \$1000, and 20% of \$1000 is \$200.

5. **(2)** One approach is to make a chart, and distribute 5 darts in such a way as to get 120 total points. The only two possible ways to do this are shown below.

Points	5	10	20	50
darts →	2	1	0	2
darts →	0	1	3	1

6. **(6)** The Least common multiple of 1, 2, and 3 is 6. Another approach is to make a list:

	Mon.	Mon.	Mon.	Mon.	Mon.	Mon.	Mon.	Mon.
spelling	✓	✓	✓	✓	✓	✓	✓	✓
problems	✓		✓		✓			✓
history	✓			✓				✓

The 6th Monday after the first Monday is the next time that all three check marks appear again.

7. **(0.125 or 12% or 13% or 1/8)** The chances of drawing the first card with the letter of a month on it is $3/6$ or $1/2$, since three cards out of the six have letters that begin months of the year: A (April), D (December), and F (February). The chances of drawing two such in a row is $1/2 \times 1/2$, and the chances of drawing three such in a row is $1/2 \times 1/2 \times 1/2$.

SUPERSTARS III

Pluto, XVII

Name: _____
(This shows my own thinking.)

- ★★★ 1. Name two consecutive prime numbers whose product is 667.

Answer : _____

- ★★★★ 2. The town library is being refurbished. The design calls for covering a large square floor, 21 feet on each side, with white, teal, and peach tiles. Each tile is a 1 foot x 1 foot square. The tile in the center of the floor is to be white, and surrounded by a border of 8 teal tiles. The teal border is to be surrounded by a border of 16 peach tiles. The next border is white, then teal, then peach, and so on.

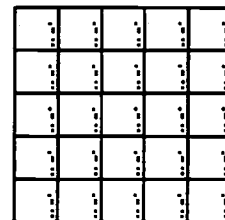

How many tiles of each color will be used in the floor? At a cost of \$2.25 per tile, about how much -- to the nearest \$100 -- will these tiles cost if you have to buy 10% more than the number to be used, to account for breakage?

Answer: _____ white tiles; _____ teal tiles; _____ peach tiles

Estimated cost of the tiles: _____

- ★ 3. You are a subway driver. There are 23 people on the subway at the beginning of your run. At the first stop 3 people get on and 2 get off. At the next stop 5 people get on. At the third stop, 4 get off and 3 get on. At the next stop 3 get off and 2 get on. How many passengers are now on the subway?

Answer : _____

- ★★ 4. 300 students attend the Sweetheart Dance on Valentine's Day. The ratio of boys to girls is 6 to 4. If 30 boys and 20 girls leave, what is the new ratio of boys to girls who are still at the dance?

Answer: _____



- ★ 5. Evaluate $6y^2 - 3x + 5z$ when $x = -2$, $y = 4$, and $z = 10$.

Answer : _____

- ★★ 6. Jocelyn works in a bakery that serves gourmet muffins in different flavors. In one bakery case there are 15 blueberry, 28 apple cinnamon, 22 banana nut, and 35 blackberry muffins. A customer comes in and asks for any type of muffin that *doesn't* have nuts in it. If Jocelyn reaches into the case without looking, what is the probability she will pull out such a muffin -- one without nuts -- on her first try?

Answer : _____

- ★★★ 7. Dylan has a Hardy Nickerson poster he wants to frame. The poster is $2\frac{1}{2}$ feet by 4 feet. If he wants a matted border that is 2 inches wide, what size frame, in inches, will he need?

Answer : _____ in. by _____ in..

- ★★ 8. Wanda's average of her first five test scores was 88. Wanda can only find her first four tests now -- those scores were 80, 92, 85, and 97. What did Wanda make on the fifth test?

Answer : _____

- ★★★★ 9. A magazine has p consecutive pages torn out. Suppose L is the last numbered page before the torn out section and R is the first numbered page after the missing section.

- Is p always an even number, or an odd number? _____
- Is L always an even number, or an odd number? _____
- Is R always an even number, or an odd number? _____
- Write an equation for p in terms of L and R . _____

- ★★ 10. How many different ways can 48 identical desks be placed in rows if all rows have the same number of desks, each desk is in exactly one row, and no row has more than 20 desks or less than 3 desks? (Hint: 8 rows with 6 desks is different from 6 rows with 8 desks.)

Answer: _____ ways

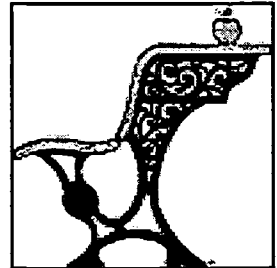

Commentary

Pluto, XVII

1. **(23, 29)** Look at pairs of primes so that, when multiplied, you get the desired product. One way to begin is to find the square root of 667 on a calculator and notice that it is approximately 26. The prime numbers you are searching for will be close to 26, one smaller and one larger.
2. **(145 white; 176 teal, 120 peach; \$1100 estimated cost)** Students might take a sheet of grid paper, and actually color in squares to match the tile pattern. A nice numerical pattern emerges in that the number of tiles in the borders are successive multiples of eight -- 1, 8, 16, 24, 32, 40, 48, 56, 64, 72, and 80. The white tiles are these numbers: $1 + 24 + 48 + 72$ or 145. The teal tiles are $8 + 32 + 56 + 80$ or 176. The peach tiles are $16 + 40 + 64$ or 120. There are $145 + 176 + 120$ or 441 tiles required in all. At \$2.25 each, this totals \$992.25 for the tiles that appear on the floor. An extra 10% must be purchased, however, and $(\$992.25)(1.10)$ gives \$1091.48, or \$1100 when round to the nearest hundred dollars.
3. **(27)** This is a good application of the use of signed numbers.
4. **(3 to 2, or, the same ratio)** Use the original ratio to determine how many boys and girls are there at the dance (180 boys and 120 girls). Then figure out how many of each are left (150 boys and 100 girls) and write the ratio. 150:100 is the same as the original ratio of 6:4, or 3:2, or equivalent ways to express this ratio.
5. **(152)** $6y^2 - 3x + 5z$ when $x = -2$, $y = 4$, and $z = 10$, becomes $(6)(16) - (3)(-2) + (5)(10)$, or $96 + 6 + 50$, or 152.
6. **(78/100 or 39/50 or 0.78 or 78%)** The total number of muffins is 100. Of these, there are 22 muffins that the customer does not want. Therefore there are 78 out of 100 that would be fine.
7. **(34 inches by 52 inches)** The width of the poster and mat will be 2 1/2 feet plus 4 inches, or 34 inches. The height will be 4 feet plus 4 inches, or 52 inches.
8. **(86)** If 5 tests average 88 points, the total points of those 5 tests is $(88)(5)$ or 440. The four scores she knows sum to 354, leaving $440 - 356$ or 86 more points that the last test must be worth.
9. **(a. even; b. even; c. odd; $p = R - L - 1$)** Students might not realize, unless they take a magazine and examine it, that the first page always begins on the right. Therefore all of the right-hand pages are odd numbers, and all of the left-hand pages are even numbers. When sheets of paper are torn out, both sides would be numbered. Therefore an even number of pages would be removed. The last numbered page before the torn-out section would have to be a left-hand page and hence an even number. Then R would have to be an odd number. Students could determine an equation by listing some pages (such as: 1, 2, 3, 4, 5, 6, 7, 8, 9, 10, ..., where the italics represent torn pages), in a concrete fashion, and generalizing to the variables used.
10. **(6)** Look at all the factors of 48 and choose only the options that fit the requirements. Those that do are: 3 by 16, 4 by 12, 6 by 8, 8 by 6, 12 by 4, and 16 by 3.

SUPERSTARS III

Pluto, XVIII

Name: _____

(This shows my own thinking.)

- ★★★★ 1. Use four 4's, grouping symbols (if needed), and any of the four operations to make all the numbers from 0 through 4.

Answers : 0 = _____

1 = _____

2 = _____

3 = _____

4 = _____

- ★ 2. José is very hungry after doing his mathematics homework. He agrees to pay for $\frac{2}{3}$ of a pizza that he and Charlie ordered. The pizza cost \$9.42. How much should José pay ?

Answer: _____

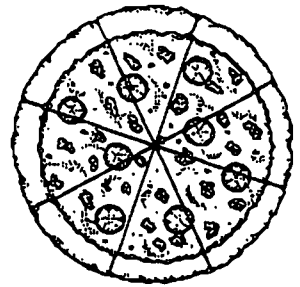

- ★★★★ 3. Marina works as a teller for the city bank. On a slow day she thought up the following problem:

Using pennies, nickels, and dimes. How many ways can you make change for a quarter?

Help Marina find the answer.

Answer: _____ ways



- ★★ 4. An engineer was working on a design for the electrical system in a new building and obtained a value of 728.57 meters for the length of some wiring. Round this to the nearest:

- a) tens
- b) units
- c) tenth

Answers : a) _____
b) _____
c) _____

★★★ 5. How many squares in all?

Answer: _____ total squares

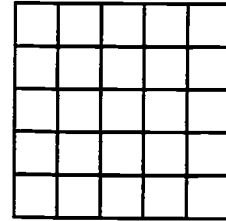

★★ 6. Write $0.\overline{4}$ (or 0.44444....) as a fraction in lowest terms.

Answer : _____

★★ 7. All other factors being equal, a basketball team should win a game if its players are taller than the opposing team. The heights of Cobb Middle School's starting five are: 5'5"; 5'9"; 5'9"; 6'2" and 6'1". The heights of the starting five for Terraset Middle School are: 5'6"; 5'7"; 5'11"; 6'1", and 6'1". Which team should win because it has the tallest average height?

Answer : _____

★ 8. With Easter approaching, the church needed to buy eggs for the big Easter Egg hunt. The secretary ordered *six dozen dozen* instead of what she was asked to order, *a half dozen dozen*. Did she order the right amount, or too many, or too few eggs?

Answer: _____



★★ 9. A middle school that presently has 600 students has been growing at the rate of 23 students per year for the last decade, and this growth rate should continue for another decade. The student population (P) of the school Y years from now is given by this equation:

$$P = 600 + 23Y$$

a. How many students will the school have in 6 years? _____

b. How many students did the school have 5 years ago? _____

Commentary

Pluto, XVIII

1. $0 = (4 - 4) + (4 + 4)$
 $1 = (4 + 4) + (4 + 4)$
 $2 = (4 + 4) + (4 + 4)$
 $3 = (4 + 4 + 4) + 4$
 $4 = 4 + [(4 - 4) + 4]$

The solutions shown to the left are only a few of the ways to do each problem. Students' work will have to be checked individually.

2. (**\$6.28**) $(2/3) \times \$9.42 = \6.28 . Some students might find $2/3$ of \$9, or \$6, and then $2/3$ of 42¢, or 28¢, and add those together.
3. (**12**) Make a chart showing the possibilities. One such chart is shown below:

P	25	20	15	15	10	10	5	5	5	0	0	0
N	0	1	2	0	1	3	4	2	0	5	3	1
D	0	0	0	1	1	0	0	1	2	0	1	2

4. (**a. 730; b. 729; c. 728.6**) The problem is a simple rounding situation.
5. (**55**) Students should be encouraged to begin such a problem in an organized manner. For example, they might first count all the small squares of which there are 25. Then move to the next size square -- 2-by-2 -- and find sixteen. There are nine 3-by-3 squares, four 4-by-4 squares, and the lone 5-by-5 square.
6. (**4/9**) Let $x = 0.4444\dots$, and then $10x = 4.4444\dots$. The equation $10x - x = 4.4444\dots - 0.4444\dots$, or $9x = 4$. Therefore $x = 4/9$. The solution to this type of problem lies in realizing that the decimal point in numbers with repeating decimals can be "adjusted" by multiplying by a power of ten, so that subtraction of one such number from another leaves only whole numbers to the left of the decimal point.
7. (**It's a toss up.**) The average height of both teams is 5'10". Students don't actually have to find the average height -- they can simply find the total height of each team's starting five, and compare those numbers. Some students might compare the two teams by comparing individual players' heights, keeping a running total of how much taller players are when compared individually. In some cases, they might find that one team is taller than the other without actually adding up the heights of all players.
8. (**Too many**) *Six dozen dozen* is $6 \times 12 \times 12$ eggs, and a *half dozen dozen* is $(1/2) \times 12 \times 12$.
9. (**a. 738; b. 485**) Students can substitute 6 into the equation for part (a), and compute $600 + (23 \times 6)$ to get 738. They can then substitute -5 into the equation for part (b), and get $600 + (23 \times -5)$ to get 485.

SUPERSTARS III

Pluto, XIX

Name: _____

(This shows my own thinking.)

- ★ 1. Is 1,000,000 minutes closer to 1 year, 2 years, or 3 years?

Answer : _____ years

- ★★★★ 2. Plot these points on the grid and connect them *in order*. You would get a familiar picture, except one of the points is a little off. Which point is wrong, and what should it be? (The picture should be symmetrical about the y-axis.)

$(-3, 0) \rightarrow (-2, -2) \rightarrow (-2, -4) \rightarrow$
 $(0, -2) \rightarrow (2, -4) \rightarrow (1, -1) \rightarrow$
 $(3, 0) \rightarrow (1, 0) \rightarrow (0, 3) \rightarrow$
 $(-1, 0) \rightarrow (-3, 0)$

Answer: The point _____ is incorrect. It should be the point _____.

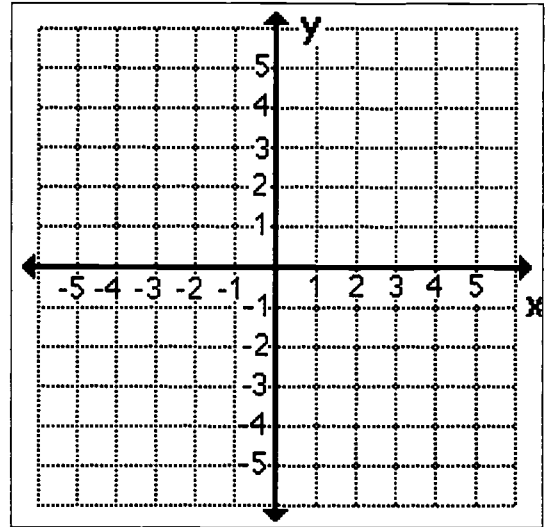

- ★★★ 3. Chad, Missy, Luke and Mary measured their heights. Their heights, not necessarily in order, were 5'3", 5'7", 5'11" , and 5'9". Use the following clues to determine who was 5'9". Missy was taller than Mary, but not the tallest. Luke was taller than Missy, but not as tall as Chad.

Answer : _____ is 5'9"

- ★ 4. Morgan Street is parallel to Jones Street. Blount Street is perpendicular to Edenton Street. Edenton Street is parallel to Morgan Street. Is Blount Street parallel or perpendicular to Jones Street? Answer: _____

- ★★★★ 5. The highest "stunt dives" ever recorded into an air bag are 360 feet for the male record height, and 180 feet for the female height record. Use $v = 5\sqrt{d}$ to find out approximately how fast each of these divers was traveling when they hit the air bag. (d is distance of the fall in feet, and v is velocity in miles per hour)

Answer: The male was going ____ mph; the female was going ____ mph

- ★★★ 6. Jessica wants to add a liquid vitamin to her two dogs' food. The veterinarian told her to add 3 mL per 6 pounds of the dog's body weight. How much will she need if Koko weighs 28 lbs.? How much will she need for Big Dog, who weighs 110 lbs.?

Answer : Koko: _____ mL

Big Dog: _____ mL

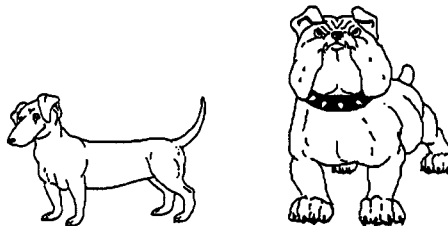

- ★★★★ 7. Mr. Bonti is replacing the square tiles in his bathroom. Each side of the new tile is 3 inches longer than the old tile. Each new tile covers 39 square inches more than an old tile.

- a. How big were the old square tiles?
b. If the area of the room is 5120 square inches, how many new tiles will he need?

Answer : a. ___ in. by ___ in. b. _____ tiles

- ★★ 8. Tidal waves can travel very fast. Their speed is related to the depth of the water by this function: $s = 2\sqrt{d}$, where speed (s) is in mph and the water depth (d) is in feet.

a. Make and graph ordered pairs (d, s) for each of the multiples of 100 shown on the horizontal axis of the graph.

b. Connect the points with a curve.

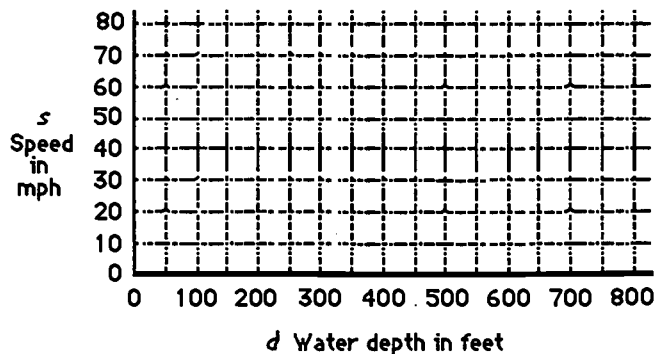

- ★ 9. What is the probability of drawing a card from those pictured where the letter is the first letter of a day of the week ?



Answer : _____

Commentary

Pluto, XIX

1. (2) Computing $((1,000,000 + 60) + 24) + 365$ changes minutes into years, and the result is 1.91 or about 2 years.
2. ((-2, -2) is incorrect; it should be (-1, -1)) The picture should be a star, symmetrical about the y-axis. Making this correction will result in such a picture.
3. (Luke) Make a list of each person and use the clues to arrange them by height. Chad would be the tallest, followed by Luke, Missy, and Mary. Therefore Luke would be 5'9", the second tallest height given.
4. (Perpendicular) Organizing the information in a diagram will help students solve this problem (so will a map of downtown Raleigh!).
5. (95; 67) This is a real world application of mathematics. To find the man's speed, use a calculator to find $\sqrt{360}$ as 18.97 or 19, then multiply by 5 to get 95. To find the woman's speed, find $\sqrt{180}$ as 13.4 and multiply by 5 to get 67.
6. (14 mL, 55 mL) Divide the weight by 6 and multiply by 3 mL. Or, solve the proportions $3/6 = x/28$ and $3/6 = x/110$.
7. (5" by 5", 80 tiles) One way to find the size of the new and old tiles is to look at the areas of tiles which are squares, and find two areas that differ by 39. The first few square numbers are 1, 4, 9, 16, 25, 49, 64, 81, 100, Notice that 25 and 64 differ by 39. So the old and new squares are 5-by-5 and 8-by-8 inches, respectively. Then divide 5120 by 64 to get 80.
8. (See below.) Students should again use a calculator to find the square root of the numbers 100, 200, 300, 400, 500, 600, 700, and 800, and multiply each resulting value by 2. This produces the points (100, 20), (200, 28), (300, 35), (400, 40), (500, 45), (600, 49), (700, 53), and (800, 57) to graph, when the y values are rounded to the nearest whole number.

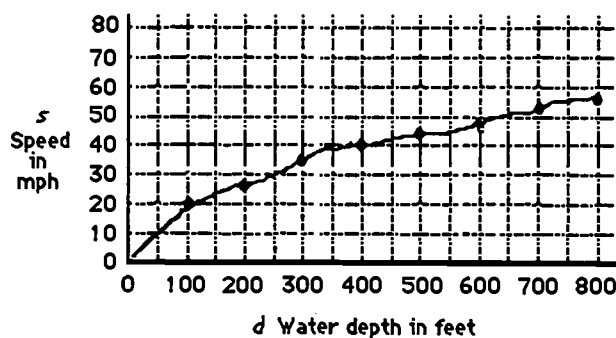

9. (2/6 or 1/3 or 0.33 or 33 1/3%) Two of the six cards have letters on them that could represent days of the week -- S (Saturday or Sunday) and T (Tuesday or Thursday). Then the chances are 2 out of 6 that you will draw one of these cards.

SUPERSTARS III

Pluto, XX

Name: _____

(This shows my own thinking.)

- ★★★★ 1. Use four 4's, grouping symbols (if needed), and any of the four operations to make all numbers 6 through 9.

Answers : 6 = _____ 7 = _____

8 = _____ 9 = _____

- ★★★ 2. Carlos has the 'slow to go' hiccups. The good news is that they are going away. The bad news is that they are still there. When they started, he hiccuped after 1 minute had elapsed, then again after 2 minutes, again after 4 minutes, next after 8 minutes and so on. How many total hiccups did he hiccup in the month of April if they began 12 midnight, April 1st?

Answer : _____ hiccups

- ★★ 3. Julie, Drew, Alex, and LuAnn are great friends. They want their pictures taken in a group -- one row of four -- but they can't decide who should sit where. How many different arrangements do they have to choose from?

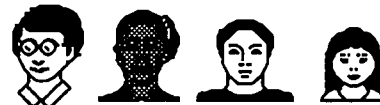

Answer: _____ arrangements

- ★★ 4. Jackie is a cross country runner. She is in a slump this spring and has won only 6 out of 20 races. How many races must she now win in a row to raise her record to 50%? to 75%?

Answer : _____ races for 50%
_____ races for 75%



- ★★ 5. There are 26 members on the baseball team. Of these, 11 can pitch, 6 can play first base, and 5 can do both. How many players can *neither* pitch nor play first base?

Answer: _____ players



- ★★★ 6. To determine how much of an adult medicine to give a child in an emergency, doctors sometimes use **Young's Rule**:

$$C = \frac{y}{y + 12} \times a$$

where C is the child dosage, y is the child's age in years, and a is the adult dose. Answer these questions about this formula:

- An adult dosage of medicine X is 200 mg. How much should a 10-year old child take?
- An adult dosage of medicine Y is 150 mg. How much should a 12-year old take?
- Mr. Wynn had to reverse the formula above -- all he had at home was some Children's Bayer Aspirin. His 5-year old daughter takes 3 such aspirins for a headache. How many should the 30-year old Mr. Wynn take, to have the same effect?

Answers: a. _____ b. _____ c. _____

- ★★★★ 7. $S = (32 - A) \div 2$ is used by doctors to say how many hours of sleep a person needs each day, up to age 18. A represents age, and S is the hours of sleep needed. Fill in the chart for the benchmark ages below, and graph the ordered pairs (A, S) . Connect your points with a line so that you can predict the sleep needed without the formula. Circle the point on the graph that says how much sleep you should get each night.

A	S
2	
5	
10	
14	
17	

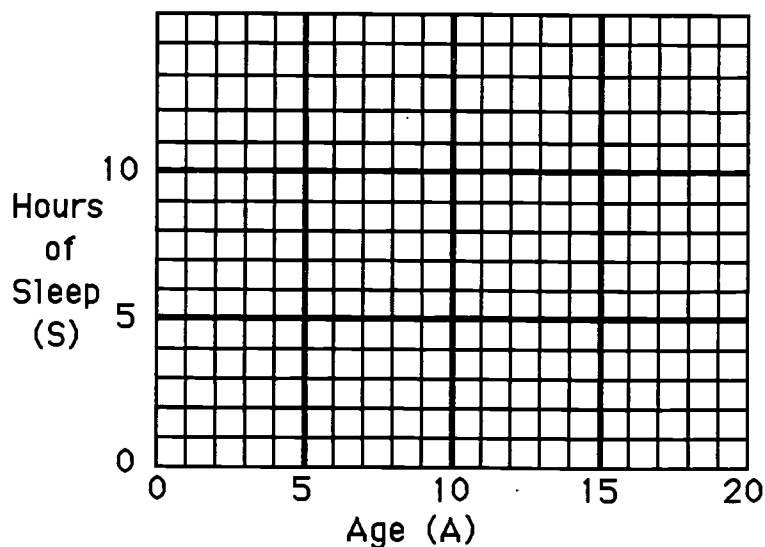

Commentary

Pluto, XX

1. $6 = [(4+4) + 4] + 4$
 $7 = (4+4) - (4-4)$
 $8 = (4+4) + (4-4)$
 $9 = (4+4) + (4+4)$

These are just a few of the many ways of writing these numbers. Each student answer different from these should be checked individually. If no grouping symbols are used, the order of operations rule is:
x or + in order left to right, then + or - in order, left to right
2. (14 or 15) Make a chart for hiccups and minutes accumulated. Then use the information that April has 30 days to determine that April has 43,200 minutes. The minutes pass in a "powers of two" pattern -- 1, 2, 4, 8, 16, ..., or $2^0, 2^1, 2^2, 2^3, 2^4, \dots$ and the total number of minutes accumulated per hiccup follows a "one less than the powers of two" pattern: $2^0-1, 2^1-1, 2^2-1, 2^3-1, 2^4-1, \dots$. The power of two closest to 43,200 is 2^{15} or the 32,768th minute into April. Depending on when the hiccup occurs during that span, either 14 or 15 hiccups is an acceptable answer.
3. (24) Students might either list all of the arrangements using the four names, or realize that there are 4 ways for the first position to be occupied, and, once that's done, 3 ways for the next, two ways for the next, and only one for the last. Therefore there are $4 \times 3 \times 2 \times 1$ ways for them to arrange themselves.
4. (8 races, 36 races) Make a list for the number of wins for each race to keep track of them all. By the 8th additional race, she will have won 14 times out of 28 races, which is 50%. By the 36th additional race, she will have won 42 times out of 56 races, which is 75%.
5. (14) Students might make a Venn Diagram by starting with the 5 players who play both positions. Then there must be 6 who only pitch, and 1 who only plays first base. Therefore there are $26 - 5 - 6 - 1$ players who neither pitch nor play 1st base.
6. (a. 91 mg; b. 75 mg.; c. 10) For (a), compute $(10/12) \times 200$ and round to the nearest whole number. For (b), compute $(12/24) \times 150$. For (c), solve the equation for A by using $3 = (5/17)A$. Then A is $(3 \times 17) \div 5 = 10.2$, which is rounded to 10.
7. (See below.)

A	S
2	15
5	13.5
10	11
14	9
17	7.5

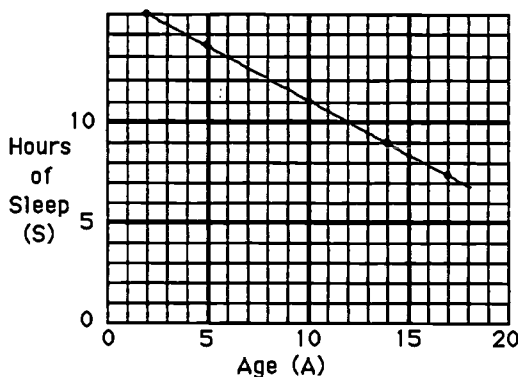

SUPERSTARS III

Pluto, XXI

Name: _____

(This shows my own thinking.)

- ★★ 1. Your silverware drawer has 12 forks, 8 knives, and 15 spoons. If you reach into the drawer without looking, how many pieces of silverware do you need to take out to be certain you have 2 matching pieces (2 forks or 2 knives or 2 spoons)?

Answer : _____ pieces

- ★★ 2. Jimmy and Harry started a "running backwards race" at opposite ends of the gym. After 6 seconds they passed each other at the center of the gym. If they lost no time in turning and kept the same speed, how long after starting would they pass each other again?

Answer : _____ seconds

- ★ 3. The longest frog leap on record was by Ex Lax at the 1975 Calavaras County Jumping Frog Jubilee. It measured 17 feet, 7 inches. How much longer is this than the human record for the standing long jump -- a mere 12 feet, $2\frac{1}{4}$ inches?

Answer: _____ inches longer

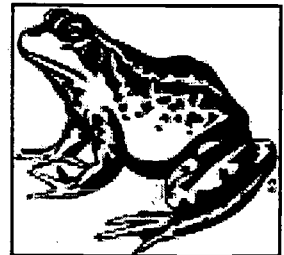

- ★★★★ 4. The earth's radius at the equator is 3960 miles. Imagine a metal band wrapped tight around the earth at the equator. If that band were then made ten feet longer and the band still encircled the earth, what is the largest animal below that could slip under the band?

a. a flea b. a snake c. an alligator d. a horse

Answer : _____



- ★★★ 5. Thirty-two people went to see the U.S. play World Cup soccer in Orlando. Four people rode to the game in each car and 8 people rode the bus. On the way home, 3 people rode in each car and the rest rode the bus. How many people rode the bus on the way home?



Answer : _____ people

- ★ 6. A raft has a weight limit of 500 lbs. Ron weighs 178 lbs., Katie weighs 132 lbs., Jethro weighs 195 lbs., and Amie weighs 118 lbs. Who stayed on shore if the heaviest possible crew, without exceeding the weight limit, took the raft out on the lake?

Answer : _____ stayed.

- ★ 7. There are 215 people in a theater watching Batman Forever. The usher polls each viewer as they leave the theater and 195 people said they "really liked" the film. To the nearest whole percent, what percent of the viewers did not "really like" the film?

Answer : _____

- ★★★ 8. Rolanda wanted to recover her storage chest with some floral paper. It's shaped like a rectangular solid. The volume of the box is 9 cubic feet. Its length is 3 feet and its width is 2 feet. How many square inches of wallpaper will Rolanda need to cover the sides if she doesn't cover the bottom ?

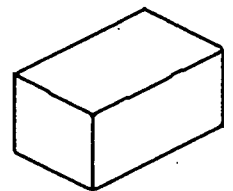

Answer : _____ sq. inches

- ★ 9. Zydeco has \$30 and is shopping for her boyfriend's birthday. She sees several things she would like to buy: a C.D. for \$15.95, a book for \$4.90, a pair of shorts for \$12.98 and a poster for \$2.35. Which three items does she have enough money to purchase?

Answer : _____

Commentary

Pluto, XXI

1. **(4)** It is possible that the first 3 pieces pulled will all be different, but the fourth piece has to match one of the first 3.
2. **(18)** $6 \text{ sec.} + 6 \text{ sec.} + 6 \text{ sec.} = 18 \text{ seconds}$
3. **(5 feet, 4 and 3/4 inches)** The problem involves subtracting 12 feet, 2 and 1/4 inches from 17 feet, 7 inches. Some students might have difficulty subtracting 2 1/4 inches from 7 inches.
4. **(c)** Let the radius of the tight metal band be r_o , and the radius of the band after 10 feet is added to the circumference be r_n . The original circumference of the band is given by $C_o = 2\pi r_o$ and the new circumference is $C_o + 10$. Therefore we have that $2\pi r_o + 10 = 2\pi r_n$. This means that $r_n = (2\pi r_o + 10) / 2\pi$, which means $r_n = r_o + (10 / 2\pi)$. In other words, the new radius is $(10 \text{ feet} / 2\pi)$ longer than the old radius. Therefore the new metal band is about 1.6 feet away from the surface of the earth. So, an alligator could slip under the extended metal band.
5. **(14)** The number of cars can be found by subtracting 8 from 32 and dividing by 4, giving 6 cars. On the trip home, 3 passengers per car means that 18 people road in cars, leaving $32 - 18$, or 14, to ride the bus.
6. **(Katie)** The three heaviest total 505 pounds, Katie being one of those. However, this is too much weight, so Katie must switch with Amie. Therefore Katie must stay on shore.
7. **(9%)** $215 - 195 = 20$, and $20 / 215 = 0.093$ or 9%.
8. **(3024)** Find the depth D by using $3 \times 2 \times D = 9 \text{ ft}^3$, so $D = 1\frac{1}{2}$ feet. The measurement of the box in inches, then is 24-by-36-by-18. The 5 surfaces covered have these areas: two that are (36×18) ; two that are (24×18) ; one that is (24×36) .
9. **(the c.d., poster and book or shorts, poster and book)** The problem involves simply adding that items three at a time, and seeing which have a sum less than \$30.

SUPERSTARS III

Pluto, XXII

Name: _____

(This shows my own thinking.)

- ★★ 1. On a digital clock showing hours and minutes, how many different readings between noon and 6 P.M. contain at least two 4's?

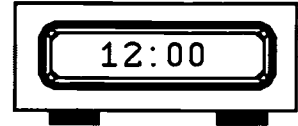

Answer: _____ readings

- ★★★ 2. A person who wins a \$1 million lottery usually gets the money spread out in equal increments over 20 years. Also, the government takes 28% off the top, for taxes. If you won such a lottery, how much could you expect to get each year, after taxes for each of the 20 years?

Answer: _____

- ★★ 3. A school year is usually 180 days long. If you bought your lunch from the cafeteria every school day during your whole K-12 years, and the average cost was \$1.35 per meal, how much would you spend for school lunches? Assume you never missed a day.

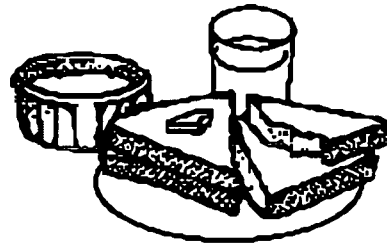

Answer: \$ _____

- ★★★★ 4. Light travels at the "speed limit" for the universe -- 186,000 miles per second.

a. The sun is 93,000,000 miles from earth. How long does it take for light to get from the sun, to earth?

Answer: _____ minutes

b. Scientists use the term *light year* to describe distances in the universe. The nearest star to earth is $4\frac{1}{2}$ light years away. In miles, about how far away is the nearest star?

Answer: _____ miles

- ★★★ 5. For coin collectors, coins are graded on a scale of from 1 to 70 with a score of 70 being perfect. Bob has a coin graded 56. Percentage-wise, how far is it from being perfect?

Answer: _____ %

- ★★ 6. One coin collector found a coin dated 232 B.C. What can you say about such a coin?

Answer: _____

- ★★★★ 7. A popular formula for a person's arm strength S is:

$$S = (d + p)\left(\frac{w}{70} + h - 60\right), \text{ where:}$$

d is dips on a parallel bar	p is pull ups
w is weight in pounds	h is height in inches

Compute S for these students. Place them in order from strongest to weakest.

- a. Dorrie: 5 dips, 7 pull ups, 140 pounds, 66 inches tall.
- b. Reynaldo: 6 dips, 4 pull ups, 130 pounds, 70 inches tall.
- c. Rocky: 2 dips, 3 pull ups, 120 pounds, 64 inches tall.
- d. Evelyn: 6 dips, 8 pull ups, 110 pounds, 62 inches tall.

Answer: From strongest to weakest, they are:

_____, _____, _____, _____

- ★★★★ 8. To the right is a rectangle. The picture below it shows that 1 vertical line produces 3 rectangles, the original plus two smaller ones. The picture below that shows that 2 vertical lines will produce 6 rectangles. Continue with this pattern by drawing a few more such rectangles.

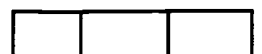
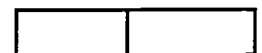

- a. How many rectangles do you get with 3 vertical lines? _____
- b. How many rectangles do you get with 4 vertical lines? _____
- c. How many rectangles do you get with 5 vertical lines? _____
- d. How many rectangles do you get with 100 vertical lines? _____

Commentary

Pluto, XXII

1. **(20)** 12:44, 1:44, 2:44, 3:44, 4:04, 4:14, 4:24, 4:34, 4:40, 4:41, 4:42, 4:43, 4:44, 4:45, 4:46, 4:47, 4:48, 4:49, 4:54, 5:44
2. **(\$36,000)** You would get $\$1,000,000 \div 20$ or $\$50,000$ per year, before taxes. A tax of 28% means that you get to keep 72%, and 72% of $\$50,000$ is $\$36,000$.
3. **(\$3159)** There would be 180×13 years you would attend school, or 2340 days. At $\$1.35$ per lunch, you would spend $\$3159$, or over $\$3000$.
4. **(a. 8 minutes, 20 seconds; b. 264 trillion miles)** For (a) $93,000,000 + 186,000 = 500$ seconds, and 500 seconds is 8 minutes and 20 seconds. For (b), changing 186,000 miles per second into miles per year can be done by computing $186,000 \times 60 \times 60 \times 24 \times 365$, which gives 5,865,696,000,000 miles. (Note that this computation can be done on an 8-digit calculator by leaving off the 0's, and appending them to the product of the significant digits.) Then 4.5 light years would be approximately 264,000,000,000,000 miles. Accept any answer between 250 and 280 trillion miles. In scientific notation, this would be 2.64×10^{14} .
5. **(19% or 20%)** From 72 to 56 is 14, and $14 \div 72 = .19444... \approx 0.20 = 20\%$.
6. **(It was a fake.)** The coin has "B.C." engraved on it, but it would be impossible to put this on a coin prior to the birth of Christ.
7. **(Dorrie, Reynaldo, Evelyn, Rocky)** Students might want to try this formula themselves. The calculations are shown below for the four students listed:

Dorrie: $(5 + 7)(14 + 6) = 240$

Rocky: $(2 + 3)(12 + 4) = 80$

Reynaldo: $(6 + 4)(13 + 10) = 230$

Evelyn: $(6 + 8)(11 + 2) = 182$

8. **(a. 10; b. 15; c. 21; d. 5,151)** Students should make the next few rectangles and count the total for each vertical line, and search for a pattern. The list below shows the first few results.

no. of vertical lines:	0	1	2	3	4	5 ..., x
no. of rectangles:	1	3	6	10	15	21 ..., $\frac{[x+1][x+2]}{2}$

If 100 is substituted for x in the pattern above, we get $(101)(102) \div 2$, or 5151.

SUPERSTARS III

Pluto, XXIII

Name: _____

(This shows my own thinking.)

- ★★ 1. Mrs. Thomas had 12 math books in each of 2 stacks. Her young daughter was staying with her after school one day, so she gave her the challenge of putting the books in 3 stacks so that:

- the first stack had one less than the third stack, and
- the third stack had one less than the middle stack.

How many books should be in each stack?

Answer : 1st stack: ____ ; 2nd stack: ____ ; 3rd stack: ____

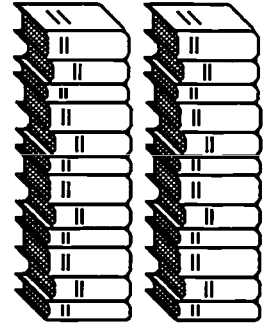

- ★★ 2. The Fahrenheit temperature (T) under the earth's surface is given by $T = 68 + 40k$, for each kilometer k in depth.

- a. How hot would you get if you could walk to the bottom of a 1-kilometer mine shaft?
- b. How far down would you have to go before you could boil water at 212°F ?

Answers: a. _____ b. _____

- ★ 3. Shania needs some ketchup for her family's barbecue. She's comparing prices at the store and finds that a 12-oz. bottle of ketchup is \$1.38 and an 8-oz. bottle is \$1.02. Which is the best buy?

Answer: _____ oz. bottle

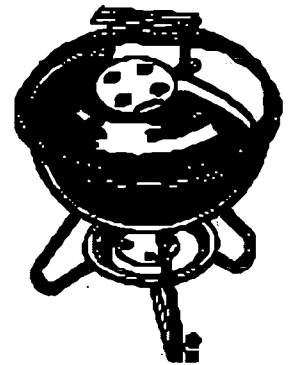

- ★★★★ 4. A compact disk has a $4\frac{1}{2}$ inch diameter. The outer non-playing margin is $\frac{1}{4}$ inch wide, and the non-playing central area is 1 inch in diameter. There are an average of 120 grooves per inch. What is the area of the playing section?

Answer : _____sq. inches

- ★★ 5. The chance of rain on Saturday is given by the weatherman as 50%. The chance of rain on Sunday is also 50%. What is the chance that you will make it through the weekend without rain messing up your plans?

Answer : _____



- ★★ 6. Fingernails grow about 1.5 inches per year.
- Measure the length of your index fingernail. What is it?
 - Write an equation, using y for years, that tells how long (L) your fingernail will be y years from now.
 - The longest fingernail on record is 37 inches. How many years from today will it take for your fingernail to equal the record?

Answers: a. _____ inches b. $L =$ _____ c. _____ years

- ★★★ 7. Bees travel about one hundred forty thousand miles as they make a pound of honey. About three million pounds of honey are produced in the United States and Canada each year. Determine about how far bees had to travel to make all the honey in the United States and Canada in 1996. Write your answer in scientific notation.

Answer : _____ miles

- ★★ 8. The smallest bacteria that can be seen with an ordinary microscope is 0.00002 centimeters in length. Write this number in scientific notation.

Answer : _____ centimeters

- ★★★ 9. One of two 6-sided number cubes has a blank face rather than a face with 2 dots. The other cube has a blank face rather than a face with 5 dots. What is the probability that a sum of seven appears when the cubes are thrown?



Answer : _____

Commentary

Pluto, XXIII

1. (1st - 7 books; 2nd - 9 books; 3rd - 8 books) The stacks are close to $24 + 3$ books high, or 8 books high. Let one of the stacks have 8 and the other two have $8 + 1$ and $8 - 1$.
2. (a. 108° F ; b. 3.6) Part (a) involves substituting 1 for k and computing $T = 68 + 40 \times 1$, or 108. In part (b), the student will have to solve $212 = 68 + 40k$ for k by subtracting 68 from both sides, leaving $144 = 40k$. Then divide both sides by 40, producing $3.6 = k$.
3. (the 12-oz bottle) This involves comparing unit prices. $\$1.38 + 12 = \0.115 per oz., while $\$1.02 + 8 = \0.125 per oz. Since $\$0.115 < \0.125 , the 12 oz. bottle costs less per oz.
4. (3.75π or 11.775 in^2) The diameter of the disk is 4 inches, after the non-playing margin is removed. Its area is then $\pi \times r^2$ or $\pi \times 2^2$. The area of the center part which doesn't play is $\pi \times (\frac{1}{2})^2$.
The difference between these is $4\pi - \frac{1}{4}\pi$ or 3.75π .
5. (1/4 or 25%) The probability it will *not* rain of Saturday is 50%; the probability it will not rain on Sunday is also 50%. Therefore the probability it will not rain on Saturday followed by Sunday is $50\% \times 50\%$, which is 25%. Students might want to convince themselves of this by flipping coins or using some other simulation.
6. (a. Answers will vary; b. $L = a + 1.5y$, where a is the answer from part a; c. Answers will vary.) The students will probably get about 1/2 inch for part (a). This means that part (b) will become $L = 0.5 + 1.5y$. To find (c), students solve the equation in (b), using 37 for L , and searching for y . In the case of $L = 0.5 + 1.5y$, solve $37 = 0.5 + 1.5y$ by subtracting 0.5 from both sides, then dividing both sides by 1.5. The answer in that case would be 24.3 years.
7. (1.2×10^{11}) Multiplying 40,000 by 3,000,000 gives 120,000,000,000. This number is 1.2×10^{11} in scientific notation.
8. (2×10^{-5})
9. (5/36) There are usually six ways to have a sum of seven when two number cubes are thrown: (1, 6); (2, 5); (3, 4); (4, 3); (5, 2); (6,1)
One of the possibilities above would be eliminated by a blank 2 on one cube and a blank 5 on the other; notice that the other 2 and 5 combination would still be possible. Therefore there are only 5 chances out of 36 of throwing a sum of seven.

SUPERSTARS III

Pluto XXIV

Name: _____

(This shows my own thinking.)

- ★★★ 1. A regular hexagon can be divided into six equilateral triangles by connecting the opposite vertices.

a) If the side of the original hexagon is 2 inches, how many non-overlapping equilateral triangles with sides of 1 inch can be drawn inside the hexagon?

Answer: _____

b) If the side of the original hexagon is 4 inches, how many equilateral triangles with sides of 1 inch can be drawn?

Answer: _____

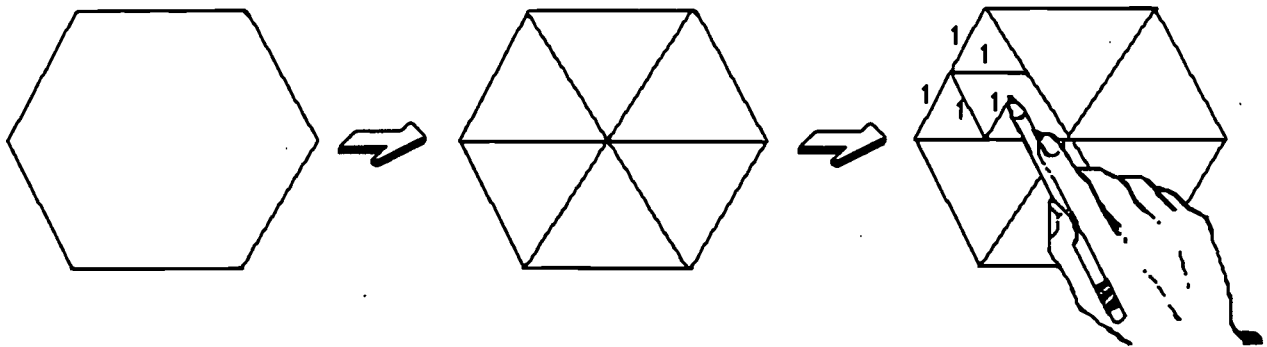

- ★★★ 2. The volume of a sphere is given by $V = \frac{4}{3} \pi r^3$. The earth's radius is about 4000 miles. The sun's radius is about 433,000 miles. Answer (a) and (b) below using scientific notation:

a. What is the approximate volume of the earth? _____ mi^3

b. What is the approximate volume of the sun? _____ mi^3

c. How many earths would fill up the sun? _____

- ★ 3. In his pocket Justin has 13 coins that total \$1. What coins does he have?

Answer: ___ pennies, ___ nickels, ___ dimes, ___ quarters



- ★★ 4. A fast stamp machine can make 360 stamps in 3 seconds. How many stamps can such a machine make in a normal, eight hour workday?



Answer : _____ stamps

- ★★★★ 5. The school policy is to open student lockers regularly to check for illegal items. The following pattern is followed from September through May:

September: Open {2, 4, 6, 8, ..., $2n$, ...}

October: Open {3, 6, 9, 12, ..., $3n$, ...}

November: Open {4, 8, 12, 16, ..., $4n$, ...}

December: Open {5, 10, 15, 20, ..., $5n$, ...}

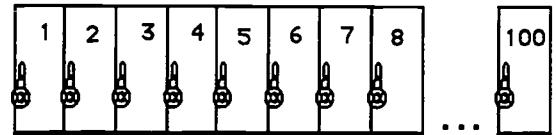

- a. Which lockers would be opened most often? _____
 b. Which lockers from 1-100 would never be opened? _____

- ★★ 6. Juanita spent half of her money on a new skirt. She then spent half of the remaining amount on a new blouse and lunch. If she had \$11.00 left at the end of the day, how much money did she have before her purchase of the new skirt?

Answer : \$ _____

- ★ 7. A sign in a department store says, "Sale! All C.D. players are now 25 % off!" George wants a C.D. player that was originally \$240.00. He can calculate the price he has to pay by multiplying \$240 by which fraction?



Answer : _____

Commentary

Pluto, XXIV

1. (a. 24; b. 96) In the far right figure on the worksheet are pictured 4 triangles with 1-inch sides that would be made in each of the six sections of a hexagon with sides of 2 inches, giving 24 small triangles. The figure to the right represents one section of a hexagon with 4-inch sides. This shows that each section would have 16 triangles.

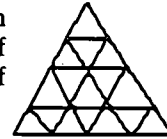

2. (a. 2.68×10^{11} ; b. 3.4×10^{17} ; c. 1,270,000) The earth's volume is found by computing $\frac{4}{3} \pi (4000)^3$, which is 2.68×10^{11} . The sun's volume is $\frac{4}{3} \pi (433,000)^3$ or 3.4×10^{17} . Dividing 3.4×10^{17} by 2.68×10^{11} gives about 1,270,000. Therefore it takes about one and a quarter million earths to fill up the sun.
3. (9 nickels, 3 dimes, and 1 quarter, or 5 pennies, 7 dimes, and 1 quarter) There may be additional answers. Students might make a chart to help them decide on the different possibilities.
4. (3,456,000) One approach is to compute $360 \times 20 \times 60 \times 8$.
5. (a. multiples of 6, 8, and 10; prime numbers greater than 10 but less than 100) The lockers that would be opened most often are the numbers from 2-10 with the most factors. 6, 8, and 10 each have three factors (discounting 1 as a factor), and hence would be opened on three different months. Locker #1 and those numbered with the prime numbers between 10 and 100 would never be opened.
6. (\$44.00) If she had \$11 at the end of the day, she had \$22 prior to that, and \$44 prior to that. You can check that this is correct by taking half of \$44 to get \$22, and then take half of \$22 to get \$11.
7. (3/4) Students with good number sense know that 25% off means you pay 75% of the price; they also know that 75% is 3/4.

SUPERSTARS III

Pluto, XXV

Name: _____

(This shows my own thinking.)

- ★★★ 1. Coach LeBeau ordered jerseys for his soccer team. The company from which he ordered was having a 25% off sale. Coach received another 8% off because of the size of the order and another 5% off for paying cash. The discounts were taken one after the other. If Coach LeBeau paid \$210.85, what was the original price before the discounts?



Answer: _____

- ★ 2. Find this product: $2.658 \times 217.95 \times \frac{758}{1395} \times 0 \times 1.5094 \times -13\frac{2}{3}$.

Answer : _____

- ★★★★★ 3. Suppose that your favorite uncle put \$1,000 in the bank for you the day you were born. The bank account draws 10% simple interest at the end of each year. The interest earned is added back into the account. Use a calculator to find out how much you would have:



- a. at age 5
- b. at age 10
- c. at age 15
- d. at age 21, when you can remove it

Answers: (a) _____ (b) _____ (c) _____ (d) _____

- ★★★ 4. Ann's and Joan's birthdays were approaching, so Harry, Pam, Beth, and Andy wanted to treat them to lunch as a gift. They both agreed to go, but Ann wanted to chip in her fair share to help buy Joan's meal, and Joan wanted to do likewise for Ann's meal. If the total came to \$54, including tax and tip, what would be fair for each person to pay?

Answer : Harry, Pam, Andy and Beth should each pay \$ _____

Joan and Ann should each pay \$ _____.

- ★★★★ 5. Ben printed a flyer to encourage people to vote for him for student council. He used a "chain letter" system where each person who received the flyer agreed to copy it and give the flyer to 5 more students who had not gotten one, within an hour. He passed out the first copy to five friends at 8:00 AM. How much time had elapsed before he could be sure the whole student body of 853 students had gotten his flyer?

Answer : _____ hours

- ★★★ 6. Scott drove his new motorcycle to Atlanta for vacation. He traveled at 80 km per hour for 56 km, 75 km per hour for 60 km, and 92 km per hour for 46 km. What is the average rate of speed over the entire trip?

Answer: _____ km/hour

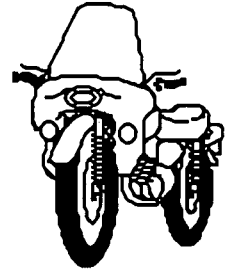

- ★★ 7. Find five consecutive even integers whose sum is -250.

Answer : _____

- ★★ 8. Try this number trick:

*Take the number of people living in your house, and double it.
Add 5, then multiply the result by 10.*

Subtract 50.

Divide by twice as many people as live in your house.

Write your answer here: _____



- ★★★ 9. Nikita earns \$4.50 an hour for her first 40 hours each week, and "time and a half" for every hour beyond 40. She worked 46 hours the week between Christmas and New Year's. How much money did she make?

Answer: _____

Commentary

Pluto, XXV

1. (**\$321.66**) This problem is much easier if students use in their computation the percent that the coach has to pay, not the percent off for each discount. For 25% off, the coach pays 75% of the price; for 8% off, he pays 92%; for 5% off, he pays 95%. The equation $(75\%x)(92\%)(95\%) = \$210.85$ describes the situation, where x is the original price. Then $x = \$210.85 + (0.75 \times 0.92 \times 0.95)$ can be easily computed on a calculator.
2. (**0**) Students with good number sense will look ahead in this problem, rather than blindly charging ahead and computing from the left end. They will see the zero and know that the final answer will therefore be zero.
3. (**a. \$1610.51; b. \$2593.74; c. \$4177.25; d. \$7400.25**) Hopefully students will realize that each year's total is given by multiplying the previous year's total by 1.1, as this automatically adds on the 10% interest to the previous balance.
4. (**\$12.60; \$1.80**) $\$54 \div 6$ means that each of the six meals came to \$9. The four non-birthday folks would then pay \$9 plus their share -- $1/5$ -- of the birthday girls' meals. Each birthday girl would pay her fair share, $1/5$, of the other girl's meal. As $1/5$ of \$9 is \$1.80, Harry, Pam, Andy and Beth each pay $\$9 + \$1.80 + \$1.80$, or \$12.60. Ann and Joan each contribute $1/5$ of \$9, or \$1.80
5. (**5, if you start before 8:00 am and count 8 as the first hour**)
(**4, if you count the hours between 8 am and noon**)

Ben		1 student
by 8:00 a.m.	5 flyers	6 students
by 9:00 a.m.	25 flyers	31 students
by 10:00 a.m.	125 flyers	156 students
by 11:00 a.m.	625 flyers	781 students
by 12:00 noon	3125 flyers	all students

6. (**81**) $\frac{56}{80} = 0.7$ hours for the first leg; $\frac{60}{75} = 0.8$ hours for the second leg; $\frac{46}{92} = 0.5$ hours for the third leg. The total travel time is 2 hours, $\frac{162}{2} = 81$ km/hr
7. (**-46, -48, -50, -52, -54**) Divide -250 by 5 to find the average (middle) and use that to center the others around.
8. (**10**) The number trick is justified by this method, where x is the number of people in the house. First step gives $2x$; second step gives $2x + 5$; third step gives $20x + 50$; fourth step gives $20x$; fifth step gives 10.
9. (**\$220.50**) The expression that gives her earnings is $\$4.50 \times 40 + 1.5 \times \4.50×6 , or $\$180 + \40.50 . The sum of regular pay and overtime is then \$220.50

SUPERSTARS III

Pluto, XXVI

Name: _____

(This shows my own thinking.)

- ★★★★ 1. Mr. Nielsen, a grocer, stacks all of his apples in triangular pyramids. Each layer of apples is in the shape of an equilateral triangle, and the top layer is a single apple.

a. How many apples are in a stack four layers high? _____

b. How many apples are in a stack five layers high? _____

c. How many apples are in a stack six layers high? _____

d. How many apples are in a stack ten layers high? _____

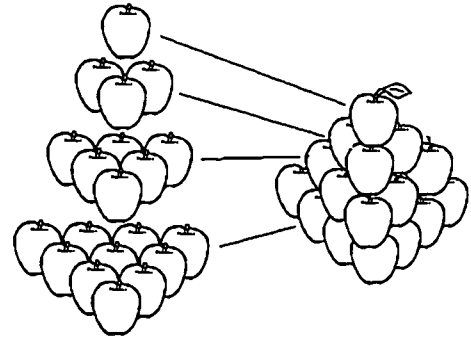

- ★★★★ 2. Every day, I count the fleas on my dog. The first day he had 1 flea, the second day 3, the third day 5, then 7, then 9, and so on.

a. How many fleas were there on the 100th day?
Answer: _____

b. Write an algebraic expression for the number of fleas on the n th day:
Answer: _____



- ★ 3. 1×10^{-4} meters is the thickness of a piece of paper. Write this measurement as a decimal.

Answer : _____ meters

- ★ 4. What fraction of the letters in the word *multiply* are also in the word *product*?

Answer : _____

- ★★★★ 5. Telephone area codes have three digits. The first digit must be chosen from 2 through 9. The second digit must be a 0 or a 1. The third digit cannot be 0. How many area codes are possible?

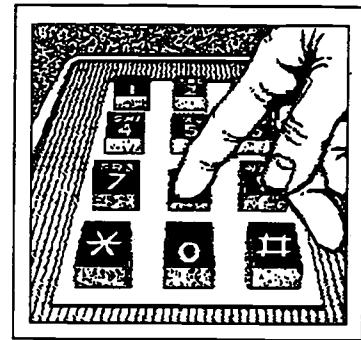

Answer : _____ area codes

- ★★ 6. A 25-foot ladder is placed against the top of an inside wall 20 feet high. How far out from the wall will the foot of the ladder be placed?

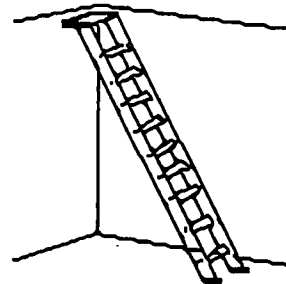

Answer : _____ feet

- ★★ 7. Five identical helium balloons are shown on the scale. They have negative weights since they pull up. Use n to stand for the weight of the newspaper.

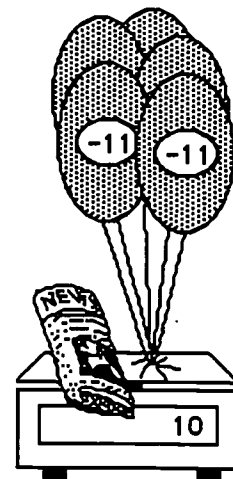

- a. Write an equation for this situation.

Answer: _____

- b. Intuitively, find the weight of the newspaper.

Answer: _____

Commentary

Pluto, XXVI

1. (a. 20; b. 35; c. 56; d. 220) The number of apples in each layer follows the pattern:

1, 3, 6, 10, 15, 21, 28, 36,

You can get from one layer to the next by adding to the previous number the number of the row you are seeking. Or, for the n th layer, $(n)(n + 1) + 2$ gives the number of apples in that layer. Adding the numbers in each layer gives the total in the stack.

2. (a. 199; b. $2n - 1$) The number of fleas each day follows the pattern of odd numbers: 1, 3, 5, 9, 11, ..., $2n - 1$,
3. (0.0001) The number is first given in scientific notation. The student must know how to convert scientific notation to a decimal equivalent.
4. ($\frac{3}{8}$) There are 8 letters in *multiply*, and 3 of them -- u, p, and t -- also appear in *product*.
5. (144) There are 8 possibilities for the first digit, 2 for the second, and 9 for the third. Therefore there are $8 \times 2 \times 9 = 144$ total ways.
6. (15) A right triangle is formed, with the hypotenuse being 25 feet and one leg being 20 feet. Therefore the Pythagorean theorem can be used: $a^2 + b^2 = c^2$. If we know $a = 20$ and $c = 25$, then we can solve for b in this fashion: $b^2 = 25^2 - 20^2 = 625 - 400 = 225$. So $b = \sqrt{225} = 15$. Since this is a right triangle, the ratio of the 20:25 follows the 4:5 ratio of the 3:4:5 right triangle. That means that the missing third side is 15.
7. (a. $n + 5 \times -11 = 10$; b. 65)

BEST COPY AVAILABLE

SUPERSTARS III

Pluto, XXVII

Name: _____

(This shows my own thinking.)

- ★ 1. A study recently revealed that it costs \$2 million more to execute a prisoner, on average, than it does to keep the prisoner in jail for the rest of her or his life. In 1995, there were 55 prisoners executed. How much could the country have saved by giving those prisoners a life term, rather than executing them?

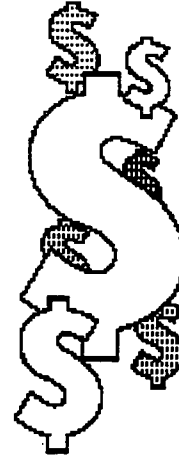

Answer : \$ _____

- ★★★ 2. Find the number represented by N . Begin with 512. Divide by 16. Divide by N . Add 256. The result is 320.

Answer : _____ = N

- ★★ 3. Charles needs 100 hamburger buns for his party. They come in packages of 8 for \$1.10 and 6 for \$0.90. To spend the least amount of money and have enough buns he should buy:

- a. 10 packages of 8 and 4 packages of 6
- b. 11 packages of 8 and 2 packages of 6
- c. 12 packages of 8 and 1 package of 6
- d. 13 packages of 8

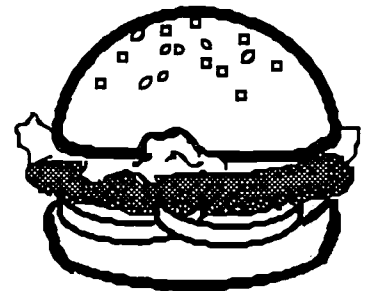

Answer: _____

★★★★★

4. Ralph has 5 baseball trophies, 4 tennis trophies, and 3 soccer trophies. He wants to arrange them on a shelf in the family room so that all the baseball trophies are together on the left end, and all the tennis trophies are together in the middle. How many different arrangements of the trophies on the shelf are possible?

Answer : _____ different arrangements

- ★ 5. Two cars are driving from New Port Richey to Washington. Both cars leave New Port Richey at the same time but the Chevy travels 30 miles in the time the Ford travels 20 miles. At these rates, how far will the Chevy travel when the Ford has gone 90 miles?

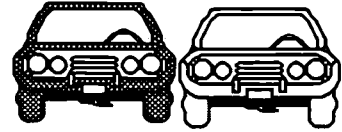

Answer: _____

- ★ 6. Last year the 8th grade class raised \$86.75, \$42.50, \$105.00, and \$70.50 at four car washes. They plan to have more car wash fund raisers this year. On the average, how much should they expect to raise at each car wash?

Answer : \$ _____

- ★★ 7. A number of campers are standing in a circle at summer camp, evenly spaced. They begin to "count off," starting with 1. Camper number 5 hears the one directly opposite her count "seventeen" but is distracted by a bug crawling on her leg. Later she wanted to tell her Dad about the game they played, and quickly figured out how many campers were in the circle. What was the number?

Answer : _____ campers

- ★★ 8. Marcus' Dad made \$42,000 a year in 1993. He was forced to take a 10% pay cut the following year due to the company losing business. The next year, the company did well again and said it was giving all its employees a 10% raise for their loyalty during the hard times. After the 10% cut and a 10% raise, how much was Marcus' Dad to make?

Answer: \$ _____ per year



Commentary

Pluto, XXVII

1. (**\$110 million**) This problem is based on a true statistic. $\$2 \text{ million} \times 55$ is $\$110 \text{ million}$.
2. (.5) $512 + 16 = 32$. Then $(32 + N) + 256 = 320$, therefore $32 + N = 64$.
 $N = 32 + 64$, Or .5
3. (b) a. $\$14.60$; b. $\$13.90$; c. $\$14.10$; d. $\$14.30$
4. (17280) There are $5 \times 4 \times 3 \times 2 \times 1$ ways to arrange the baseball trophies, $3 \times 2 \times 1$ ways to arrange the tennis trophies, and $4 \times 3 \times 2 \times 1$ ways to arrange the soccer trophies. Therefore there are $120 \times 24 \times 6 = 17280$ ways to arrange all the trophies.
5. (135 miles) This is a good problem for proportional reasoning or the use of progressive logic. The Ford travels 10 miles when the Chevy has gone 15 miles. Nine groups of 10 are 90 and nine groups of 15 are 135.
6. (**\$76.19**) $\frac{86.75 + 42.50 + 105 + 70.50}{4} = \76.19
7. (24) There are 11 campers who counted between, but not including, 5 and 17. So there must be that same number of campers between 5 and 17, but on the other half of the circle. 1, 2, 3, 4, 18, 19, 20, 21, 22, 23 and 24 would be the numbers.
8. (**\$41,580**) Many students will have the answer $\$42,000$, thinking that a 10% pay cut and a 10% pay raise should offset each other. However, the base upon which the 10% is taken changes. 10% off of $\$42,000$ means he was making $\$42,000 \times 90\%$, or $\$37,800$. Then a 10% pay raise on that amount gives a salary that is $\$37,800 \times 1.1$, or $\$41,580$.



U.S. DEPARTMENT OF EDUCATION
Office of Educational Research and Improvement (OERI)
Educational Resources Information Center (ERIC)



NOTICE

REPRODUCTION BASIS

This document is covered by a signed "Reproduction Release (Blanket)" form (on file within the ERIC system), encompassing all or classes of documents from its source organization and, therefore, does not require a "Specific Document" Release form.

This document is Federally-funded, or carries its own permission to reproduce, or is otherwise in the public domain and, therefore, may be reproduced by ERIC without a signed Reproduction Release form (either "Specific Document" or "Blanket").