

DOCUMENT RESUME

ED 425 075

SE 061 893

TITLE SUPERSTARS III: 3-5.
 INSTITUTION North Carolina State Dept. of Public Education, Raleigh.
 PUB DATE 1998-03-00
 NOTE 287p.; For related documents, see SE 061 892-894.
 AVAILABLE FROM Public Schools of North Carolina, 301 N. Wilmington Street,
 Room 540, Raleigh, NC 27601-2825.
 PUB TYPE Guides - Classroom - Learner (051) -- Guides - Classroom -
 Teacher (052)
 EDRS PRICE MF01/PC12 Plus Postage.
 DESCRIPTORS Curriculum Enrichment; Elementary Education; *Elementary
 School Mathematics; Enrichment Activities; *Mathematical
 Enrichment; *Mathematics Education; *Mathematics Materials;
 *Problem Solving; *Self Motivation; State Curriculum Guides;
 Student Motivation; Volunteers
 IDENTIFIERS North Carolina

ABSTRACT

SUPERSTARS III is a K-8 program designed as an enrichment opportunity for self-directed learners in mathematics. The basic purpose of SUPERSTARS III is to provide the extra challenge that self-motivated students need in mathematics and to do so in a structured, long-term program that does not impinge on the normal classroom routine or the instructor's time. The program involves teachers, administrators, assisting adult volunteers, and parents in the learning process. Assisting adults devote a few hours each week to operate the system effectively in the school while an administrator provides visible support through coordinating the program in the schools. The levels of the program are named for the planets in the solar system. This packet contains materials for third grade (Mars), fourth grade (Jupiter), and fifth grade (Saturn). Materials within each grade are organized into two sections. Section I contains general information about the program and variations on the basic model, information/checklist for principals, information checklist for assisting adults, information for teachers, and letters to participating students and their parents. Section II is comprised of the student worksheets and adult volunteer commentary for student worksheets. (PVD)

 * Reproductions supplied by EDRS are the best that can be made *
 * from the original document. *

SUPERSTARS III

3 - 5

PERMISSION TO REPRODUCE AND
DISSEMINATE THIS MATERIAL HAS
BEEN GRANTED BY

E. Brumbaugh

TO THE EDUCATIONAL RESOURCES
INFORMATION CENTER (ERIC)

1

U.S. DEPARTMENT OF EDUCATION
Office of Educational Research and Improvement
EDUCATIONAL RESOURCES INFORMATION
CENTER (ERIC)

This document has been reproduced as
received from the person or organization
originating it.

Minor changes have been made to
improve reproduction quality.

Points of view or opinions stated in this
document do not necessarily represent
official OERI position or policy.

Super Stars

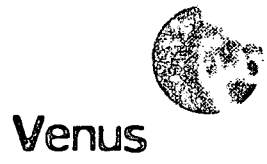

BEST COPY AVAILABLE

★ ACKNOWLEDGMENTS ★

This project, originally designated *Sunshine Math*, is the third in a series of problem solving programs. It was conceived, coordinated and developed through the Florida Department of Education with input from the mathematics staff members of the North Carolina Department of Public Instruction and the South Carolina Department of Education. In addition, it was supported financially through a grant to the School Board of Polk County, Florida. The rich history of these materials and the predecessor programs, **SUPERSTARS** and **SUPERSTARS II** goes back to the early 1980's. Many Florida teachers have been involved in developing and using these materials over the years. The original **SUPERSTARS** programs were adopted and adapted by North Carolina and South Carolina with their teachers contributing to revisions and personalizations for use in their states. Florida educators were primarily responsible for developing, field testing, and publishing *Sunshine Math*. Educators from the Carolinas developed the **MathStars Newsletter** to accompany and enhance this program.

School districts in North Carolina have permission to reproduce this document for use in their schools for non-profit educational purposes. Copies of each grade level are available from the publications unit of the North Carolina Department of Public Instruction. The contact for **SUPERSTARS III** and the **MathStars Newsletter** is Linda Patch, 301 North Wilmington Street, Raleigh, NC 27601-2825 : (919-715-2225).

Michael E. Ward
State Superintendent
North Carolina Department of Public Instruction

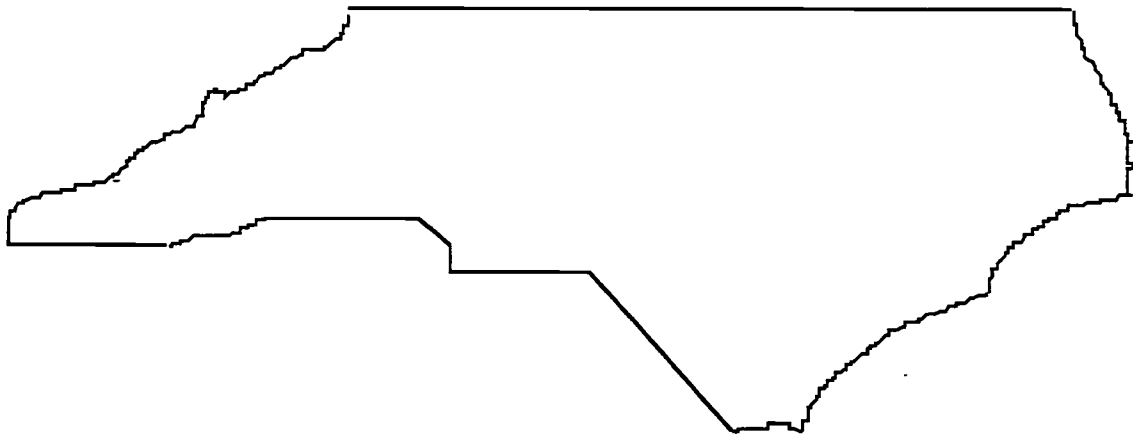

☆ *Preface* ☆

SUPERSTARS III encourages and enhances the positive aspects of students, parents, teachers and administrators working together. This program assumes that students, even young children, are capable of and interested in learning; that teachers want to help them learn to think for themselves; that administrators see their jobs as clearing the path so that quality education is delivered effectively in their schools; and that parents care about their child's learning and are willing to work with the school system toward that goal. Each of these four groups has a vital role to play in implementing **SUPERSTARS III**.

The designer of this program has a long history of working with elementary children. He believes that they are capable of much more than we ask of them, and that many children are on the path to becoming independent learners. A number of children in any classroom are bright, energetic and willing to accept extra challenges.

The basic purpose of **SUPERSTARS III** is to provide the extra challenge that self-motivated students need in mathematics, and to do so in a structured, long-term program that does not impinge on the normal classroom routine or the time of the teacher. The system is not meant to replace any aspect of the school curriculum -- it is offered as a peripheral opportunity for students who identify with challenges and who want to be rewarded for their extra effort. Participation in the program is always optional -- only those students who voluntarily choose to participate will, in the long run, benefit from **SUPERSTARS III**. Any student, regardless of prior academic performance, should be encouraged to participate as long as interest is maintained.

The predecessor program for **SUPERSTARS III** -- the **SUPERSTARS II** program -- has demonstrated that this concept can be extremely useful. What is required are several dedicated adults who devote a few hours each week to operate the system effectively in the school; an administrator who provides highly visible support; teachers who welcome a supplementary experience for their students to engage in higher-order thinking; and a typical classroom of students. If all of those ingredients are present **SUPERSTARS III** will become an integral part of the school fabric.

ORGANIZATION OF THESE MATERIALS

Section I Description of the SUPERSTARS III Program

1. General Information
2. Information/checklist for principals
3. Information/checklist for assisting adults
4. Information for teachers
5. Letter to participating students and their parents.

Section II Student worksheets for SUPERSTARS III

SUPERSTARS III
Jupiter, XXII

Name: _____
(This shows my own thinking.)

**1. If the 24th day of the month falls on Saturday, on what day did the 6th fall?

Answer: _____

***2. There are 4 six-packs of soda in a case. Chris bought 12 of a case and gave 13 of what he had to Dana. How many cans of soda does Chris have left?

Answer: _____ cans

**3. Together, 6 boys and 12 girls weigh 1050 pounds. The boys all weigh the same -- x pounds. Each girl weighs 55 pounds. What is the weight of one boy?

bbbbbb gggggggggggg

Answer: $x =$ _____ pounds

**4. The sum of 3 consecutive numbers is 276. What are the numbers?
(Consecutive numbers differ by one: example: 8, 9, and 10)

Answer: _____ and _____

**5. If a family of 12 spiders wore shoes, how many pairs of shoes would they need?

Answer: _____ pairs.

**6. A tropical storm passed through the town. It began to rain Monday morning at 8:45 AM and did not stop until the next day at 2:30 PM. How long did it rain?

Answer: _____ hours and _____ minutes



**7. There are 3 cars, 4 bicycles, 2 tricycles, and 1 unicycle in the neighbor's garage. How many wheels are there in all? Forget about any "spare tires"!

Answer: _____ wheels

**8. Rosemary bought a sweater on sale for \$6.98. She also bought a skirt for \$9.99. She paid an additional \$1.19 for sales tax. Rosemary gave the sales person a \$20 bill. How much change should she receive?

Answer: _____



**9. Study this pattern. 25 and also 32 would be in column E, if the pattern continued.

a. In which column would 100 appear?
b. In which column would 500 appear?
c. In which column would 1000 appear?

21	22
14	15
16	17
18	19
20	7
8	9
10	11
12	13
0	1
2	3
4	5
6	A
A	B
B	C
C	D
D	E
E	F
F	G

Section III Commentary for student worksheets for SUPERSTARS III

Commentary
Jupiter, XXII

1. (Tuesday) Students can use a calendar or make a chart with "Su, M, T, W, Th, F, Sa" at the top and begin numbering backward putting 24 under Saturday. They may also realize that the 17th and 10th fall on Saturdays and count back from the 10th.
2. (8) Students can solve this problem by drawing a diagram or by visualizing 24 cans. $1/2$ of 24 is 12, and $1/3$ of 12 is 4. Therefore Chris gave away 4 of the 12 sodas, leaving 8.
3. (65) Students will probably solve this by first finding the total weight of the 12 girls: $12 \times 55 = 660$ pounds. Then they will compute $1050 - 660 = 390$ pounds, the weight of the 6 boys. Then $390 \div 6 = 65$ pounds per boy.
4. (91, 92, 93) Students may use the *guess-check-revise* method. Some students might know that the numbers they seek are about $1/3$ of the total, and approximate the numbers by dividing 276 by 3. This gives 92, which is the middle number.
5. (48) Students may want to draw a picture to help solve this problem. Spiders have 8 legs, which would be 4 pairs of shoes per spider.
6. (29 hours and 45 minutes) Most students will realize that from 8:45 AM to 8:45 AM the next day, is 24 hours. They will then "add on" 5 additional hours to get to 9:45, 10:45, 11:45, 12:45, and 1:45, and then 45 minutes to get to 2:30 PM.
7. (27) There would be 12 wheels on the 3 cars, 8 on the 4 bicycles, 6 on the 2 tricycles, and 1 on the unicycle.
8. (\$1.84) Students will probably add \$6.98 and \$9.99 to get \$16.97, then add the tax of \$1.19 to get \$18.16. They will subtract this amount from \$20.
9. (a, C; b, D; c, G) Hopefully, students will notice that the multiples of 7 are in column A and use this fact to get "close to" the numbers 100, 500, and 1,000. Ninety-eight (14×7) is the closest multiple of 7 less than 100, so 98 would be in column A, forcing 100 to be in column C. Likewise, 497 or 71×7 is in column A, putting 500 in column D. Finally, 994 or 142×7 is in A, indicating that 1000 is in column G.

SUPERSTARS III: General Information

SUPERSTARS III is a K-8 program designed as an enrichment opportunity for self-directed learners in mathematics. The levels of the program are named for the planets in our solar system:

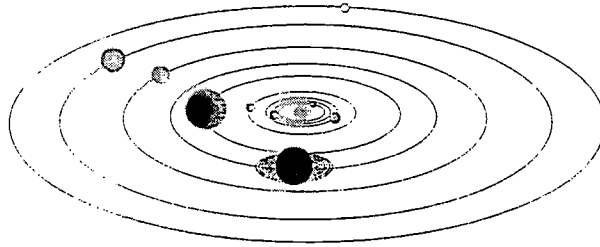

Kindergarten	Mercury	Fourth Grade	Jupiter
First Grade	Venus	Fifth Grade	Saturn
Second Grade	Earth	Sixth Grade	Uranus
Third Grade	Mars	Seventh Grade	Neptune
	Eighth Grade	Pluto	

Students of all ability levels choose on their own to participate in **SUPERSTARS III**. Seeing their names displayed in a prominent place in the school, with a string of stars indicating their success, is one reward students receive for their extra work. In some cases the school may decide to enhance this basic system by awarding certificates of achievement or some other form of recognition to highlight certain levels of success or participation in the **SUPERSTARS III** program.

SUPERSTARS III can function in a school in a number of different ways. A “tried and true” way is for assisting adults (volunteers, aides, etc.) to manage the program for the entire school, with support provided by school administrators and classroom teachers. This system has been adopted at the school level, with varying degrees of success, over the years. The basic model for conducting **SUPERSTARS III** is discussed below, with variations described on the next page.

The basic model

The basic model for **SUPERSTARS III** is for a school to establish a weekly cycle at the beginning of the academic year according to the following guidelines:

On Monday of each week student worksheets are distributed by the assisting adults to students in the program. Students have until Friday to complete the problems working entirely on their own. On Friday the classroom teacher holds a brief problem-solving session for the students in the program. The more difficult problems on the worksheet are discussed with students describing their thinking about strategies to solve the problems. They do not share solutions, only strategies.

Students receive double credit for those problems they have successfully completed prior to the problem-solving session, and regular credit for those they complete successfully over the week-end. On Monday all papers are handed in, checked by the assisting adult, and stars are posted for problems successfully completed. This completes one cycle of the **SUPERSTARS III** program.

SUPERSTARS III is not for every child -- it is only for those who are self-motivated and who are not easily frustrated by challenging situations. This does not diminish the value of the program, but rather makes us realize that there are children of all ability and socio-economic levels who are self-directed learners and who need challenges beyond those of the regular school day. These children will shine in **SUPERSTARS III**.

Variations of the basic model

The first variation that has been used successfully retains the weekly cycle and assisting adult role from the basic model. The teacher however, involves the entire class in the problem-solving discussions. For example, the teacher might select the four most difficult problems on the worksheet (indicated by three or four stars) and work a "parallel" problem with the entire class to open the mathematics lesson on Tuesday through Friday. Using this variation, all students are exposed to the problem-solving strategies, but only those who have chosen to participate in **SUPERSTARS III** will complete and turn in the worksheet on Monday.

A second variation has the assisting adult manage the entire program, including the Friday problem-solving session. This method has been used in situations where teachers lacked commitment to the program and thus implemented it inconsistently. In such cases, the assisting adult must have a progressive view of what constitutes problem solving in elementary mathematics. They should also receive extra assistance from the administration to ensure that students are released from class and that the cycles proceed smoothly.

Yet another variation is for a parent to manage **SUPERSTARS III** at home for his or her own child. The basic rules are the same -- a child gets the worksheet once a week and time to work the problems alone. The parent sets a night to listen to the way the child thought about each problem, offering suggestions or strategies only when the child is unable to proceed. The reward system is basically the same, stars on a chart, but can be enhanced by doing something special with the child, such as a trip to the museum or to a sporting event when the child reaches certain levels of success. If this method is adopted, the parent must not try to teach the child, but rather to stimulate discussion of problem-solving strategies. **SUPERSTARS III** is not a program for adults to teach children how to think.

Other variations exist. The basic model as stated is the best, all other factors being equal, for reaching more children in a consistent fashion than any of the other methods. However, we encourage individual schools, teachers, or parents to get some version started; some starlight is better than none.

SUPERSTARS III: Information for Principals

SUPERSTARS III is a K-8 enrichment package for mathematics designed to be managed by volunteer assisting adults with coordinated support from the classroom teacher and school administrators. The purpose of the program is to give self-motivated students of all ability levels a chance to extend themselves beyond the standard mathematics curriculum. The complete set of materials comes in nine packages, one for each grade K-8. The grade levels are identified by the names of the nine planets in our solar system and their order from the sun:

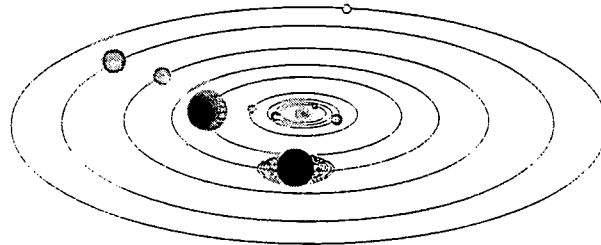

Mercury - Kindergarten

Earth - Second Grade

Jupiter - Fourth Grade

Uranus - Sixth Grade

Venus - First Grade

Mars - Third Grade

Saturn - Fifth Grade

Neptune - Seventh Grade

Pluto - Eighth Grade.

Your support is vital if this program is to succeed. As the school administrator, you need to stay in close contact with the **SUPERSTARS III** program. A “checklist for success” follows:

- Become familiar with the philosophy and component parts of the program.
- Introduce **SUPERSTARS III** to the faculty early in the school year. Ensure that teachers understand the philosophy of the program and have copies of the student worksheets and commentaries appropriate for their grade levels.
- Speak to parents at your school’s first open house of the year, explaining the purpose of **SUPERSTARS III** and the long term value of children working independently on challenging problems.
- Recruit several assisting adults (PTA members, aides, senior citizens, business partners, church members, etc.) who are enthusiastic, dependable people who are willing to manage the program. Early in the academic year, meet with these assisting adults to plan such details as:
 - ✓ A prominent place and format for the STAR CHART.

- ✓ A designated time and place each Monday and Friday for the assisting adults to be in school to meet with students, distribute and collect worksheets, and post stars.
- ✓ A system for the activity sheets to be duplicated each week.
- ✓ A plan for extra incentives for accumulating stars. (“World records” to be kept from year-to-year, a celebration day planned for the end of school, prizes earned by students for attaining certain levels of success -- see the diagram below for examples.)
- ✓ A schedule for the initiation of the program and a decision as to a “start over” point later in the academic year. Review the school calendar and only use weeks that are at least four days long. If there is not enough time in the year to complete all the activity sheets, decide which to eliminate or on a plan to “double up.”
- ✓ A **SUPERSTARS III** cap, name badge, tee-shirt, or other distinction for volunteers, if possible.
- Monitor the program every two weeks to get ahead of unforeseen difficulties. Administrators need to be highly visible and supportive for **SUPERSTARS** to succeed.

SUPERSTARS III is an optional program for students. It should be available to any student who wants to participate, regardless of prior success in mathematics. Typically, a large number of students will begin the program, but a majority will lose interest. A significant number however, will continue their efforts over the life of the program. This is normal and simply means that **SUPERSTARS III** is successfully addressing the needs of the self-directed learner.

Visual reminders help children see this mathematics program is challenging and rewarding. Some ideas are presented here:

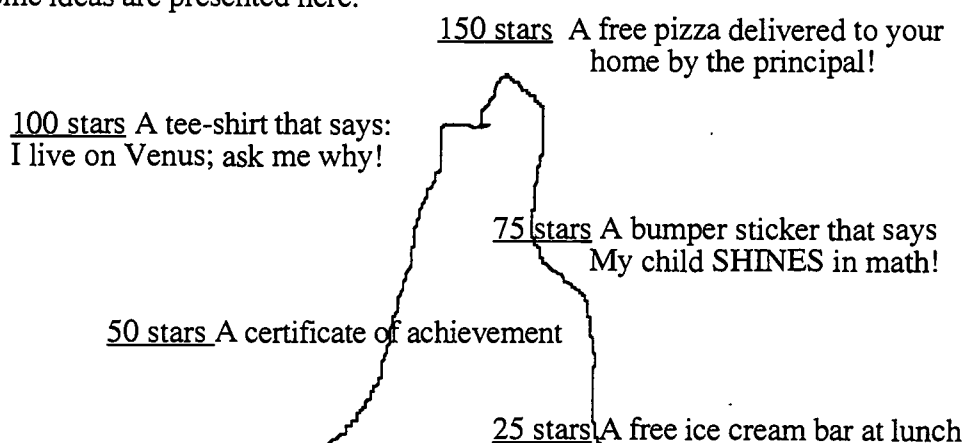

Climb the Mountain this Year!! Join the **SUPERSTARS III** Club

SUPERSTARS III: Information for Assisting Adults

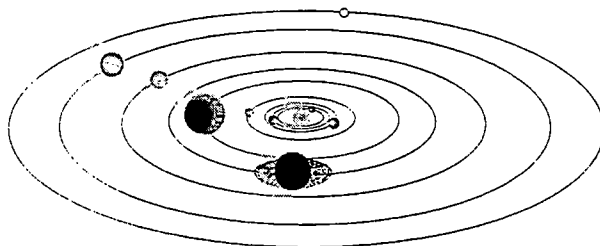

SUPERSTARS III is designed to give assisting adults a well-defined role to play in the school's mathematics program. The success of **SUPERSTARS III** depends upon a team effort among teachers, administrators, parents and you. Reliability and punctuality are important - students will quickly come to depend upon you to be there as scheduled, to check their papers and post their stars, and to listen to alternate strategies and interpretations of problems to help them arrive at solutions. If possible, wear an outfit or badge that fits with the **SUPERSTARS III** theme or logo; students will soon identify you as an important person in their school.



SUPERSTARS III works on a weekly cycle. Each Monday you will collect the worksheets from the previous week and distribute new worksheets to the participating students, all from your **SUPERSTARS III** area of the school. Allow students to see the answers to the problems, discuss any for which their answers differ and allow them credit if their interpretation and reasoning are sound. After checking all the work, you will post the stars earned by students on the STAR CHART.



Participating students have from Monday until Friday to work the problems entirely on their own -- the only help they should receive during that time is for someone to read the problems to them. On Friday the teacher will host a problem-solving session in the classroom where students will describe the strategies they used to approach the more difficult problems. Students who have successfully completed problems before this session will receive double points for their efforts. The teacher's initials on the worksheet will help you identify those problems. The students then have the week-end to complete or correct their problems and turn them in on Monday. All the correct problems thus completed will receive the indicated number of stars.



Be creative when designing your STAR CHART. The basic method of posting stars individually is a good way to begin but eventually you will want a more efficient system. Color coding by grade level, or posting just one star each week with a number in its center are ideas to consider. You may wish to personalize the chart and the entire **SUPERSTARS III** center with student pictures, "smiling faces", a logo, seasonal theme or some other feature that has a mathematical flavor. Occasionally feature a reward for each child such as a cookie or a hand stamp in the shape of a star just for turning in the worksheet. You are helping enthusiastic students develop high-level thinking skills -- be creative and enjoy your role!

Checklist for assisting adults:

- Plan the following with the principal:
- ✓ A prominent place and format for the

STAR CHART

- ✓ The time and place for you to collect, check, and distribute worksheets.
- ✓ A system for duplicating worksheets each week which ensures legible copies. Also a secure storage area for masters and other materials.
- ✓ Any additional incentives ("world records," stickers, coupons, pencils, tee-shirts, etc.) that will be part of the system for rewarding levels of achievement in **SUPERSTARS III**.



- Make the **SUPERSTARS III** center a happy place. Use bright colors, smiles, and cheerful expressions. Show confidence, friendliness, and encouragement to students.



- Collect the letters that are sent home prior to the first worksheet. These need to be signed by each student and a parent. If, in the future, you have evidence that the work submitted does not represent the thinking of the student, discuss the situation with the classroom teacher. These situations are best handled individually, confidentially and in a firm, consistent manner.



- Check the worksheets from the previous week uniformly. If you give partial credit for a problem with several parts do so in a fair way that can be understood by the students. Do not award partial credit for problems with only one answer.



- Have answer sheets available and encourage students to look at the solutions when they submit their worksheets. Allow them to explain their strategy or interpretation if they have arrived at a different answer. Award full credit if they show a unique and plausible interpretation of a problem and follow sound logic in arriving at their response.



- Leave extra worksheets with the classroom teacher for participating students who were absent on Monday. Accept a late-arriving worksheet only if the student was absent on Monday. If a student's name is missing or in the wrong place on the worksheet, check the paper but award stars to "No Name" on the STAR CHART. Adhering strictly to these rules will rapidly teach responsibility to the students and keep your work manageable.



- Keep all returned worksheets. As the same problems are used year after year, and many students have siblings who may later participate in **SUPERSTARS III**, it is important that worksheets do not circulate.



- On weeks when **SUPERSTARS III** is not available post a notice such as "No star problems this week, but please come back after vacation for more!"

SUPERSTARS III: Information for Teachers

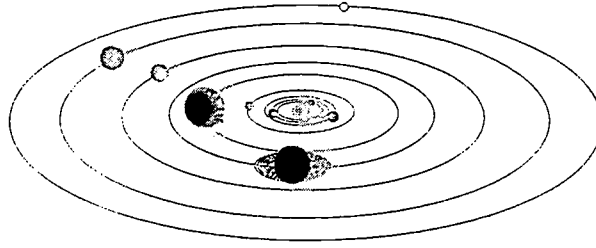

SUPERSTARS III is a program designed to complement your regular classroom mathematics curriculum. It offers a supplemental opportunity for students to practice mathematics skills appropriate for their grade level and at the same time to engage in challenging problem-solving activities. It is an additional challenge to those students who are self-directed learners providing them with an academic extracurricular activity.



Your involvement is essentially as a teacher. **SUPERSTARS III** will remain special to students if it is managed by someone outside of the classroom and if the teacher is viewed as a facilitator in the system, rather than as the authority figure. Your primary role is to monitor the system in your own classroom and to host a brief problem-solving session for **SUPERSTARS III** students on Friday of each week. You will also need to release the participating students from your class at a set time on Mondays to enable them to turn in completed work and receive new problem sets. You might make a special pin or banner for Mondays and Fridays to remind students that those days are special.

SUPERSTARS III Name: _____
Jupiter, XXII *(This shows my own thinking.)*

***1. If the 24th day of the month falls on Saturday, on what day did the 6th fall?

Answer: _____

***2. There are 4 six-packs of soda in a case. Chris bought 12 of a case and gave 13 of what he had to Dana. How many cans of soda does Chris have left?

Answer: _____ cans

***3. Together, 6 boys and 12 girls weigh 1050 pounds. The boys all weigh the same --*n* pounds. Each girl weighs 55 pounds. What is the weight of one boy?

bbbbbb cccccccccccc
 Answer: *n* = _____ pounds

***4. The sum of 3 consecutive numbers is 276. What are the numbers?
(Consecutive numbers differ by one; example: 8, 9, and 10)

Answer: _____ and _____

***5. If a family of 12 spiders wore shoes, how many pairs of shoes would they need?

 Answer: _____ pairs.

Commentary
Jupiter, XXII

1. (Tuesday) Students can use a calendar or make a chart with "Su, M, T, W, Th, F, Sa" at the top and begin numbering backward putting 24 under Saturday. They may also realize that the 17th and 10th fall on Saturdays and count back from the 10th.

2. (8) Students can solve this problem by drawing a diagram or by visualizing 24 cans. 1/2 of 24 is 12, and 1/3 of 12 is 4. Therefore Chris gave away 4 of the 12 sodas, leaving 8.

3. (65) Students will probably solve this by first finding the total weight of the 12 girls: 12 x 55 = 660 pounds. Then they will compute: 1050 - 660 = 390 pounds, the weight of the 6 boys. Then 390 ÷ 6 = 65 pounds per boy.

4. (91, 92, 93) Students may use the guess-check-revise method. Some students might know that the numbers they seek are about 1/3 of the total, and approximate the numbers by dividing 276 by 3. This gives 92, which is the middle number.

5. (48) Students may want to draw a picture to help solve this problem. Spiders have 8 legs, which would be 4 pairs of shoes per spider.

6. (29 hours and 45 minutes) Most students will realize that from 8:45 AM to 8:45 AM the next day, is 24 hours. They will then "add on" 5 additional hours to get to 9:45, 10:45, 11:45, 12:45, and 1:45, and then 45 minutes to get to 2:30 PM.

7. (27) There would be 12 wheels on the 3 cars, 8 on the 4 bicycles, 6 on the 2 tricycles, and 1 on the unicycle.

8. (\$184) Students will probably add \$6.98 and \$9.99 to get \$16.97, then add the tax of \$1.19 to get \$18.16. They will subtract this amount from \$20.

9. (a, c; b, D; e, G) Hopefully, students will notice that the multiples of 7 are in column A and use this fact to get "close to" the numbers 100, 500, and 1,000. Ninety-eight (14 x 7) is the closest multiple of 7 less than 100, so 98 would be in column A, forcing 100 to be in column C. Likewise, 497 or 71 x 7 is in column A, putting 500 in column D. Finally, 994 or 142 x 7 is in A, indicating that 1000 is in column G.

Each student worksheet has an accompanying commentary page. This sheet provides hints on parallel problems which you might use in the Friday problem-solving session. It is important that students participate actively in this session, and that you

solicit from them their unique and varied approaches to the problems discussed. Only after students have presented their ideas should you provide guidance on the problems and then only if they are having difficulty. Even though there is a commentary provided for each problem, you will have to decide which two to four problems you will cover during this brief session. Concentrate on those which provide a new or unfamiliar strategy. The problem-solving session should last no more than 15 minutes.



Do not be disappointed if a large number of your students begin **SUPERSTARS III** and then significant numbers drop out after a few weeks. This is normal; problem solving requires a great deal of effort and not every student is ready for this challenge. On the other hand, you will notice that some students will choose to stay with **SUPERSTARS III** week after week even though they are not as successful as other students at earning stars. Their participation should be encouraged as they are certainly learning from the experience. Under no circumstances should **SUPERSTARS III** be reserved only for the advanced students in your class.



As a purely practical consideration, students are not to discuss the problems among themselves or with their families prior to the Friday cooperative group session. This allows the “think time” necessary for students to develop into independent thinkers; it also prevents students from earning stars for work that is basically someone else’s -- the surest way to disrupt the entire **SUPERSTARS III** program. As the teacher you must monitor this in your classroom and ensure that students abide by the established rule.



It is important that you understand and support the overall philosophy of **SUPERSTARS III**. Do not worry if students encounter problems for which they have not been prepared in class -- such is the nature of true problem solving. Do not provide remedial instruction to ensure that students master certain types of problems. They will meet these same problem types repeatedly in the program. They will likely learn them on their own and from listening to other students at the problem-solving sessions. Enjoy what the students can do and don’t worry about what they can’t do. Read the general information and philosophy of the program to see how your role fits into the complete system.

Here are some thoughts you might find useful in your support for **SUPERSTARS III**:



- Allow your students to leave the classroom at the designated time on Mondays to turn in their worksheets and pick up new ones.



- Read each week's worksheet and feel free to structure classroom activities that parallel those in the **SUPERSTARS III** problems.



- During the school week students may be allowed to work on their **SUPERSTARS III** problems during their free time, but the only help they may receive is for someone to read the problems to them. Give the students one warning if you find them discussing the worksheets, and take away their papers for the next violation. If it happens another time, suspend them from the program for a month.



- At the Friday problem-solving sessions remember these points:

- Students come to this session with their worksheets, but without pencils.
- The session should be brief -- 15 minutes at most. Discuss only the two to four most difficult problems.
- Help students summarize their own approaches to the problems in a non-judgmental fashion. Offer your own approach last, and only if it is different from the students' strategies. Do not allow answers to be given to the problems.
- End the session by encouraging students to complete the problems over the weekend. Put your initials beside any problem discussed in class which a student has already successfully completed. The assisting adult will award double stars for these.



Remember that part of the **SUPERSTARS III** philosophy is that students learn responsibility by following the rules of the system. If participation is important to them they will adhere to the rules about where their names go on each paper, no credit awarded if they forget their paper on Monday, and no talking about problems prior to the problem-solving session.



Enjoy **SUPERSTARS III**. Students will impress you with their ability to think and their creative ways to solve problems that appear to be above their level or beyond their experience.



Dear Student,

Welcome to **SUPERSTARS III**, a program designed to enhance your journey through mathematics. Be prepared to face challenging problems which require *thinking*! As you work through the system you will experience many types of problems, stretching and expanding your brainpower in many exciting ways!

Expect to receive one worksheet at the beginning of each week. You will have the rest of the week to think about the problems and come up with strategies for their solutions. The thinking and solutions must be **YOUR VERY OWN!!!** Once a week you will attend a help session to discuss the most challenging problems for the week.

Your journey will be recorded by charting the stars you earn. Each problem is ranked according to its level of difficulty. The more stars you see beside a problem, the higher its level of difficulty and, of course, the more stars you can earn for solving it. You can earn double stars for solving a problem before the weekly sessions.

Your signature is just the beginning.

Good luck as you embark upon this mathematical adventure! The rewards will last a lifetime!



I am ready to begin the **SUPERSTARS III** program. All of the answers I submit will represent my own thinking.

Name: _____





Dear Parents,

Welcome to **SUPERSTARS III**, a program designed to enhance your child's journey through mathematics. By expressing an interest in challenging problem solving experiences, your student has taken the first step toward becoming an independent learner who is willing to address many types of problems.

On Mondays a **SUPERSTARS III** worksheet will be distributed to each child in the program. Each problem in the set is ranked according to its level of difficulty. As the number of stars increases, so does the level of difficulty and the earned stars to be awarded.

Each Friday a help session will be conducted to discuss the most challenging problems of the week. Any problem solved prior to the session will be given double stars. After the session, problems may be reworked before they are submitted the following Monday.

Your role in **SUPERSTARS III** is to encourage and facilitate problem solving. Feel free to offer guidance toward certain strategies, to read the problems to your child, but please, do not give them the answers. In order for this program to be effective, the students must work independently. The thinking must be their own!

It is normal for a student not to be able to complete every problem on every worksheet. The process of interpreting, understanding, and trying different strategies is valuable in the attainment of mathematical power. Remember, no student is expected to know the answer to every problem.

Thank you for allowing your child to embark upon this mathematical adventure; the rewards should last a lifetime!

_____ signature

Parent/Guardian of _____



After you have had a chance to review and use these materials, please take a moment to let us know if the **SUPERSTARS III** material has been useful to you. Your evaluation and feedback is important to us as we continue to work on additional curriculum materials. Please respond to:

Linda Patch
 Mathematics & Science Section
 NC Department of Public Instruction
 301 N. Wilmington Street
 Raleigh, NC 27601-2825

Indicate the extent to which you agree with statements 1-4.

	Strongly Disagree		Neither Agree nor Disagree		Strongly Agree
1. The materials will be helpful in teaching the mathematics goals and objectives set forth in the NC Standard Course of Study.	1	2	3	4	5
2. The materials are appropriate for the grade level indicated.	1	2	3	4	5
3. The problems are interesting and engaging for the students I teach.	1	2	3	4	5
4. The commentaries will encourage use of this material.	1	2	3	4	5
5. I plan to use these materials with my students in grade_____.					
6. Have you ever used earlier versions of the SUPERSTARS material?	YES		NO		

7. How was this program implemented with your students?

8. Additional comments:

SUPERSTARS III

Mars, I

Name: _____
(This shows my own thinking.)

- ★ 1. Ann was asked to find the number of marbles that were added to the other marble groups to get the total. Can you find the number?

$$3 \text{ marbles} + \underline{\quad} \text{ marbles} + 2 \text{ marbles} = 13 \text{ marbles.}$$

Answer: _____ marbles

- ★★ 2. Joe has 3 quarters, 1 dime and 2 nickels in his piggy bank. How much money does he have to spend in the candy store?

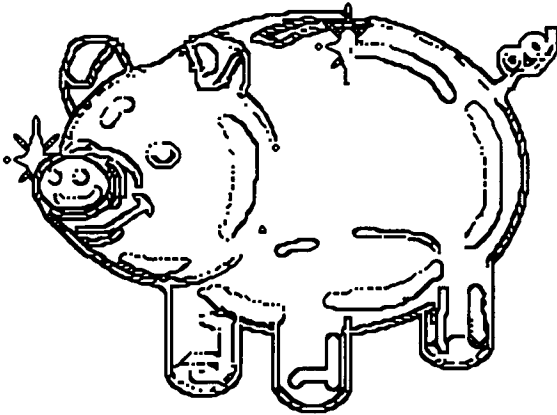

Answer: _____ cents

- ★★ 3. Tom is helping his sick neighbor by taking her dog for a walk every day, bringing her the mail, and doing other odd jobs. Mrs. Burns pays him \$7.50 a week for his help. How much will he earn in 4 weeks?

Answer: _____

- ★★★ 4. Find the pattern in these numbers and then continue the pattern by writing the next three numbers.

1 6 3 8 5 10 7 _____

★★★ 5. Robin gave her friend a puzzle like the one below. Solve the number puzzle yourself!

Find $* + 11$ if you know that $8 + * = 12$.

Answer: $* + 11 = \underline{\hspace{2cm}}$

★ 6. There was a line waiting for movie tickets. Sue realized that there were 6 people in front of her and 6 people behind her in the line. How many people were waiting in line for movie tickets?

Answer: people

★★★★ 7. A turtle crawls up a 12 foot hill after a heavy rainstorm. The turtle crawls 4 feet, but when it stops to rest, it slides back $1\frac{1}{2}$ feet. How many tries does the turtle make before it makes it up the hill?

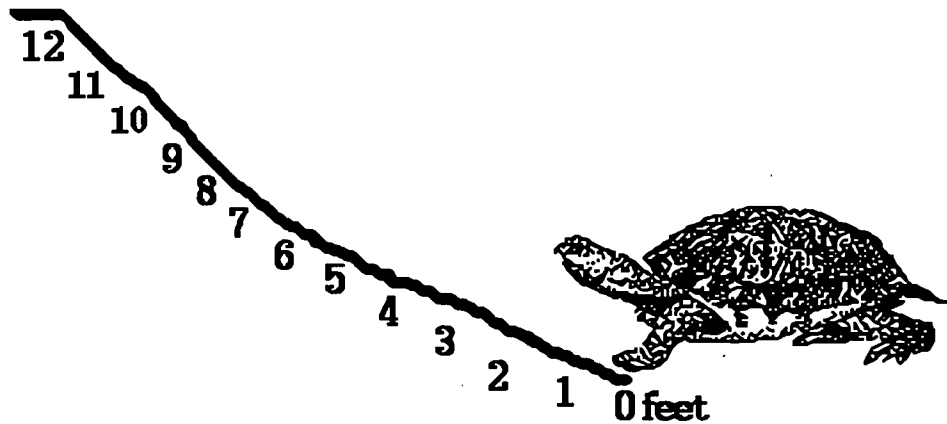

Answer: tries

★★ 8. Four classmates are to stand in order from tallest to shortest. Tom is taller than Sally. Sally is taller than Bob. Maria is taller than Bob but shorter than Sally. Using the clues, place the four friends in order from tallest to shortest.

Answer: Tallest Shortest

Commentary

Mars, I

- (8) Most students will first add the two groups of marbles they have, 3 and 2, to get 5. The students can then subtract $13 - 5$ to find the missing marbles, or use the *counting up* method from 5 to 13.
- (95) The student can use coins to count out the change: 25, 50, 75, 85, 90, 95. The values of each coin can be added for the total: 3 quarters = 75 cents; 1 dime = 10 cents; and 2 nickels = 10 cents, so $75 + 10 + 10 = 95$ cents.
- (\$30) The student can add \$7.50 four times or group by two sums of \$15. Counting the money like change could be used: \$7.50, \$15.00, \$22.50, \$30.00. This leads to the concept of multiplication -- some students might even perform 7.50×4 on their calculator.
- (12, 9, 14) The repeating pattern is to **add 5**, then **subtract 3**. Once discovered, the student should check to see whether the pattern continues for the next few numbers. It does, so he would conjecture that the next three numbers are obtained by: $7 + 5 = 12$; $12 - 3 = 9$; $9 + 5 = 14$.

Notice that there is no way for the students to be sure they have discovered a pattern that always holds true; also note that students might discover another pattern that would give the numbers 1, 6, 3, 8, 5, 10, and 7, thus arriving at different numbers than 12, 9, and 14.

- (15) The student can *count up* from 8 to 12, or solve $12 - 8$ to find that $* = 4$. Then the student substitutes 4 for the $*$ in $* + 11$. So, $4 + 11 = 15$.
- (13) There are 12 people ($6 + 6$) in the movie ticket line, excluding Sue. When Sue is counted in the line there would $12 + 1$ or 13 people.
- (5) The student can physically mark the turtle's progress and slides to get to the top.

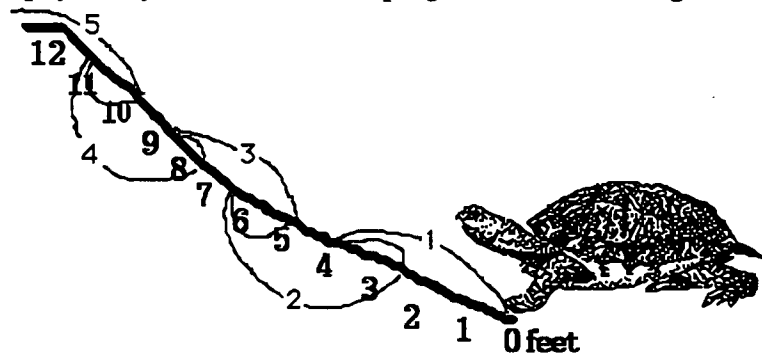

- (Tom, Sally, Maria, Bob) Drawing a picture as each clue is used is a way for the student to find the students' places' from tallest to shortest:

Tom is taller than Sally:

Sally is taller than Bob:

Maria is taller than Bob but shorter than Sally:

Tom Sally

Tom Sally Bob

Tom Sally Maria Bob

SUPERSTARS III

Mars, II

Name _____

(This shows my own thinking.)

- ★★★★ 1. Use the rule given. Write the missing numbers.

Rule: If x is a number in column A, then $x - 7$ is beside it in column B.

A	B
14	
7	
24	
	1

- ★★ 2. One way to add numbers mentally is to add the tens together first, followed by the ones. For example, to find $43 + 25$, you might do this:

$$40 + 20 = 60$$

$$60 + 5 = 65$$

$$65 + 3 = 68$$

Practice these problems using this way to add. You will be asked to work a problem mentally when you turn in your paper.

$47 + 22 =$

$56 + 45 =$

$43 + 27 =$

$44 + 27 =$

Answer for the later problem: _____

- ★★★★ 3. Mrs. Buchanan's third grade class needs 150 paper napkins for a party. A small package of 50 napkins costs \$0.99. A large package of 150 napkins costs \$2.75. How much money would the class save by buying the large package of napkins?

Answer: _____

- ★★★★ 4. Georgia is making a patio in the shape of a rectangle. The width of the patio is 10 feet. The perimeter is 50 feet. What is the length of the patio?

Answer: _____ feet

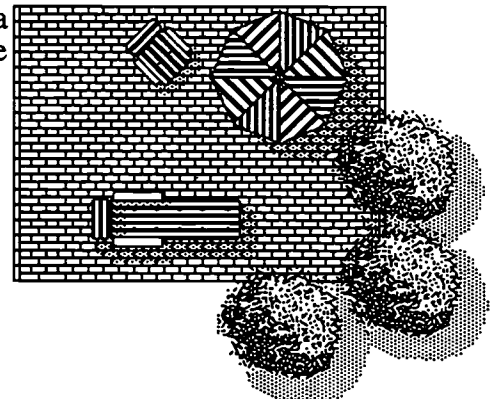

★ 5. At the baseball game, Brian saw a player hit a home run. About how far did the ball go? Circle the most reasonable answer.

- a. 8 feet b. 300 feet c. 2,500 feet

★★★★ 6. Trace each line of this shape without lifting the pencil. You can cross a point several times, but do not retrace a whole line.

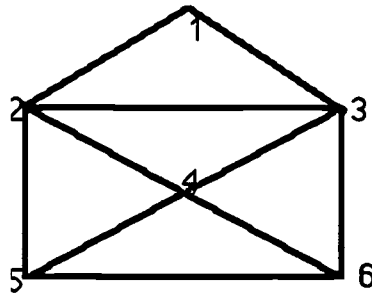

List your numbers in the order that you traced the figure: _____

★★ 7. Look at the spinner.

- a. Which are you more likely to spin, a 2 or a 3? _____
b. Which is more likely, a 1 or a 4? _____

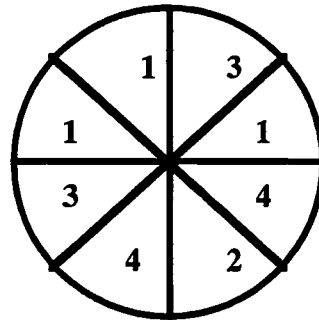

★★★★ 8. On Monday 2 students went to the school store. On Tuesday, 4 students went, and on Wednesday, 8 students. If the pattern continues, how many students will go to the school store on Friday?

Answer: _____ students

Commentary

Mars, II

1. **(7, 0, 17, 8)** A student can subtract 7 from the number in column A to get the number in column B. The student must reverse his thought process to do the last part. Since the number in B is given, he must ask himself “what number, if I subtracted 7, would give me 1.”
2. **(59)** Give the students this problem posted where several can read it at one time:
$$\boxed{34 + 25 = ?}$$
and have them write only the answer on their paper.
3. **(\$0.22)** The class would have to buy 3 small packages of napkins which would cost \$2.97. Most students will find this number by adding 99¢ three times, but some might multiply on a calculator. In either case, they must then subtract \$2.75.
4. **(15)** Students might first label the two sides of the patio for which they know the length. That would be 20 feet of the 50-foot perimeter. Then students would subtract 20 feet from 50 feet and realize they have 30 feet left for the other two sides. They will use various methods to divide 30 feet into two equal pieces.
5. **(300)** 8 feet is not a reasonable length for a home run. 2,500 feet is also not reasonable, as a mile is about 5,000 feet, so 2,500 feet is about 1/2 mile. 300 feet is reasonable — that's the length of a football field.
6. **(6-3-5-6-2-3-1-2-5 is one solution)** All successful solutions have these in common: they either start at 6 and end at 5, or start at 5 and end at 6. That's because 5 and 6 are the only places in this network that have an odd number of paths going in and coming out.
7. **(a. 3; b. 1)** The area for 3 is twice as much as that for 2, so 3 is twice as likely as a landing for the spinner. The area for 1 is also bigger than the area for 4, since there are three equal sized pieces that make up 1 and only 2 pieces for 4.
8. **(32)** It will help if children make a list or complete a chart for this problem. If so, they will probably notice that the number of children is doubling each day. Therefore on Thursday there would be 16, and on Friday there would be 32.

SUPERSTARS III

Mars, III

Name: _____
(This shows my own thinking.)

- ★ 1. Tom had 45 marbles. He gave some to Dan. He had 19 marbles left. How many marbles did he give to Dan?

Answer: _____ marbles

- ★★ 2. Ann gets up at 6:15 AM. It takes her 30 minutes to get ready for school, 10 minutes to eat breakfast, and 5 minutes to walk to the bus stop. At what time does she reach the bus stop?



Answer: _____ AM

- ★ 3. John is emptying tennis balls into a bin for a special sale to help his father. Each can holds 3 tennis balls. How many balls will be in the bin if he empties 7 cans?

Answer: _____ balls

- ★★ 4. Drew has \$2.00 to spend. He wants to buy a box of crayons and a bottle of paste. Use the posted prices below. Does Drew have enough money? Answer *yes* or *no*.

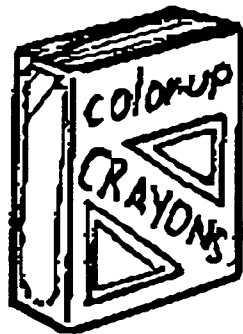

\$1.25



\$0.79

Answer: _____

Mars III page 1

- ★★ 5. David had 1 bug in his insect collection on Monday, 3 bugs on Tuesday, 6 bugs on Wednesday, and 10 bugs on Thursday. If this pattern continues, how many bugs will he have in his collection on Saturday?

Answer: _____ bugs

- ★★★★ 6. Five basketball teams are playing in a tournament. The teams will play each other only one time. How many games will be played by the end of the tournament? (Hint: Draw a picture or make a list of the teams playing.)

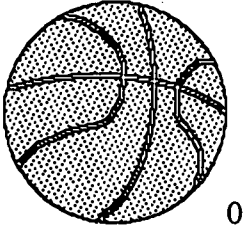

Answer: _____ games

- ★★★ 7. What is the least number of coins that can be used to give a customer 42¢ in change? What are the coins?

Answer: _____ coins

List the coins: _____

- ★★★ 8. Find the missing digits in the following problems. Place your answers in the boxes.

$$\begin{array}{r} \text{A} \\ 2 \square \\ + \square 6 \\ \hline 69 \end{array}$$

$$\begin{array}{r} \text{B} \\ 54 \\ + 2\square \\ \hline \square 1 \end{array}$$

$$\begin{array}{r} \text{C} \\ 65 \\ + \square 3 \\ \hline 13\square \end{array}$$

Commentary

Mars, III

- (26) The student can count up from 19 to 45, or subtract 19 from 45, to get 26.
- (7:00) A clock for hands-on exploration would assist the student in adding 30 minutes to find 6:45, then adding 10 minutes to find 6:55, and finally adding 5 minutes to reach 7:00 AM.
- (21) The student can add 3 groups of 7 or use the multiplication fact, $3 \times 7 = 21$.
- (No) The student could start at \$1.25 and count the change left if buying only the crayons. If 75¢ is left, then the paste for 79¢ would make the cost over \$2.00. Most students will simply add \$1.25 and \$0.79 and realize that \$2.04 is more than Drew has.
- (21) The pattern involves adding one more at each step than the step before. Start with 1 on Monday, then add 2 to get Tuesday's total, then 3 for Wednesday's total, then add 4 for Thursday, 5 for Friday, and finally 6 for Saturday. The total is 21.
- (10) This problem resembles the handshake problem. It can be solved by assigning the 5 teams a letter or number and drawing a picture that shows team A plays B, C, D & E; Team B plays C, D, and E (they've already played A). Team C plays D & E as they have already played A and B. Team D plays E. Then the games are added: $4 + 3 + 2 + 1 = 10$. Repeated work with this type of problem shows a pattern in the solutions.

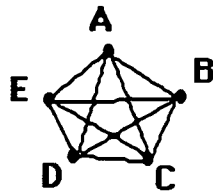

AB	BC	CD	DE
AC	BD	CE	
AD	BE		
AE			

- (5 coins; 1 quarter, 1 dime, 1 nickel, and 2 pennies) Some students may choose 4 dimes and 2 pennies (6 coins) to make 42¢. Extra work with using quarters in making change will increase their skill in determining the least number of coins.
- (The answers are shown below.) Using the concepts of counting up, counting back, or addition and subtraction sense, the missing numbers can be found. Problems B & C involve regrouping ones and tens.

$$\begin{array}{r} \\ 23 \\ + 46 \\ \hline 69 \end{array}$$

$$\begin{array}{r} \\ 54 \\ + 27 \\ \hline 81 \end{array}$$

$$\begin{array}{r} \\ 65 \\ + 73 \\ \hline 138 \end{array}$$

SUPERSTARS III

Mars, IV

Name: _____
(This shows my own thinking.)

- ★★ 1. How many small blocks does it take to build the set of steps below?

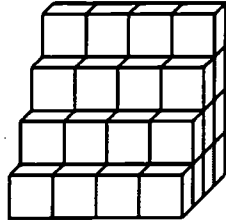

Answer: _____ blocks

- ★★★ 2. Write the correct number or symbol in each box.

$1 = 9 - \square$

$11 = 3 \square 8$

$4 = 4 \square 0$

- ★★ 3. The students in Mrs. Jower's third grade class are taking turns going to the library. Five students went to the library first. When they returned, 10 students went. The third time, 15 students went to the library. If the pattern continues, how many students will go to the library on the fifth trip?

Answer: _____ students

- ★★★ 4. Samantha earns \$2.50 each week for helping her father mow the grass. If she saves all of her money, how much will she have in 6 weeks?

Answer: _____

- ★★★ 5. I am a triangle. My *perimeter* is 96 centimeters. Two sides are 34 centimeters and 25 centimeters long. How long is my third side?

Answer: _____ cm

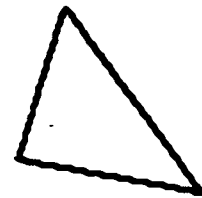

★★

6. Julio's dad didn't have enough candles for Julio's birthday cake, so he let the dark candles stand for 2 years and the white candles for 1 year. How old was Julio?



Answer: _____ years old

★★★★

7. Look at the graph and answer the following questions:

- a. Which children read at least 20 books? Answer: _____
- b. How many more books did John read than Al? Answer: _____
- c. Who read the same number of books? Answer: _____ and _____
- d. If Al read a total of 12 books for May and June, how many books did he read in June? _____

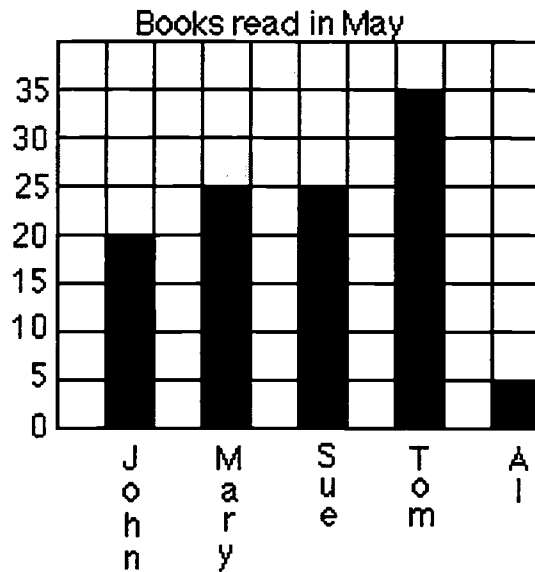

★★

8. Bill, Mark, Maria, Sue, and Julie played a game. Each boy took an *even*-numbered space on the spinner. Each girl took an *odd*-numbered space. Who was more likely to win, a girl or a boy?

Answer: _____ (boy or girl)

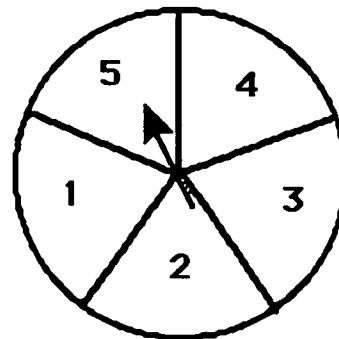

Commentary

Mars, IV

1. **(40)** Students will need good spatial skills to be able to count the cubes that aren't visible, or the students might actually build such a set of steps and count the cubes they use.
2. **(8; +; + or -)**
3. **(25)** The pattern is that the numbers increase by five each time: 5, 10, 15, The next two numbers would be 20 and 25.
4. **(\$15)** There are a number of ways students will solve this problem. One way uses a calculator, adding \$2.50 six times, or possibly multiplying \$2.50 by 6. Another is adding \$2.50 and \$2.50 to get \$5, and then adding \$5 three times.
5. **(37)** Students might add the two sides then subtract from 96. Or they might subtract one side from 96, then the other side from the difference. If students have trouble with the problem, encourage them to label the sides of the triangle shown with the two numbers given.
6. **(13)** Students might count by twos for the dark candles, then count by ones for the light candles.
7. **(a. John, Mary, Sue, and Tom; b. 15; c. Mary and Sue; d. 7)** The problem involves reading and interpreting a bar graph.
8. **(girl)** Since the girls have 3 of the equal-sized areas on the spinner and the boys have 2, the girls have more area on the spinner. Therefore the girls have a better chance of winning. There's a $\frac{3}{5}$ or 60% chance a girl will win any spin, and a $\frac{2}{5}$ or 40% chance that a boy will win.

SUPERSTARS III
Mars, V

Name: _____
(This shows my own thinking.)

- ★★ 1. Write the following in standard form without adding.

$$30 + 700 + 8 + 5,000$$

Answer: _____

- ★★ 2. There are 5 red, 3 green, and 4 blue marbles in a bag. What would be the chance of getting a red marble if the marble was pulled out of the bag without looking?



Answer: _____

- ★★★ 3. The 30 students in Mrs. Brown's third grade class are preparing for a Trivia Contest in the afternoon. Each team will have 4 members. How many teams can the students make if two classmates are absent?

Answer: _____ teams

- ★★★★ 4. Find the number of rectangles in this *visual challenge* presented by David.

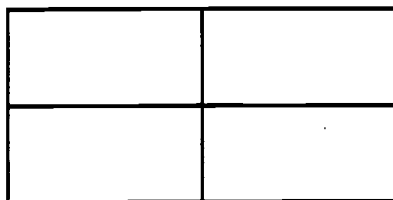

Answer: _____ rectangles

- ★★★★ 5. Look at the top two scales. Decide how many pencils would balance three marbles. Draw that number of pencils on the bottom scale.

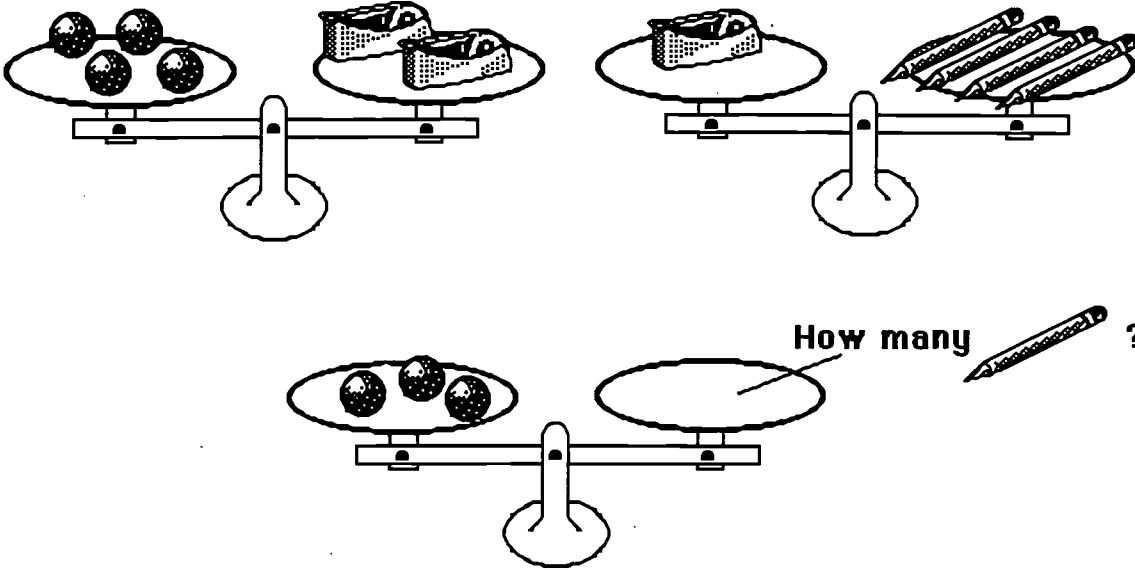

- ★★★ 6. Dan went to the bookstore. He has spent \$17.00 of his \$20.00 already. He needs to buy a few disks. How many can he buy with his remaining money if each disk costs 90¢.



90 ¢ each

Answer: _____ disks

- ★★ 7. Laquinda has a number riddle for you to solve:

- I am a **two-digit number less than 40**. You say me when you count by **fives**. The sum of my digits is **7**. What number am I?

Answer: _____

- ★★ 8. Use the line to the right as 1 unit. Measure the length and width of this paper. Measure to the nearest whole number.



Answer: _____ units long and _____ units wide

Commentary

Mars, V

1. (5,738) The purpose of this problem is for students to unscramble the place values before writing the answer. The student can use a place value chart to check the number.
2. ($\frac{5}{12}$) There are 12 marbles in the bag. Since there are 5 red marbles, there is a 5 in 12 chance of pulling out a red marble. "Five in twelve" can be written as the fraction $\frac{5}{12}$.
3. (7) The 2 absent students can be removed from 30, leaving 28. Then the situation becomes a division problem: $28 \div 4 = 7$. The student could use counters or marks to "act out" the last part of the problem -- taking 28 counters and removing them in groups of four, asking *how many groups are removed*. Many students will not have met division yet..
4. (9) Numbering the small rectangles provides an organized way to count them.

1	2
3	4

1 big rectangle - 1 & 2 & 3 & 4

4 small rectangles - 1, 2, 3, 4

4 medium rectangles - 1 & 2, 3 & 4, 1 & 3, 2 & 4

5. (6) From the top left scale, taking half of each side means that 2 marbles balance 1 tape dispenser. So 2 marbles can be substituted for the tape dispenser in the top right scale. Thus 2 marbles balance 4 pencils, meaning that each marble balances 2 pencils. Therefore 3 marbles balance 6 pencils. This type of thinking is a precursor to algebraic thinking. Students gain an intuitive notion of substituting equal quantities for other quantities, multiplying or dividing both sides of a balanced situation by the same amount, etc.
6. (3) Dan has \$3.00 left to spend (\$20.00 - \$17.00). Each disk costs 90¢ (almost a dollar each). So the student reasons that he can get 3 disks with the remaining \$3.00. The more advanced student might multiply \$0.90 times 3 which is \$2.70.
7. (25) Students might write the numbers less than 40 as they count by 5: 5, 10, 15, 20, 25, 30, 35. The number with digits that add to 7 is 25.
8. (5 measures long; 4 measures wide) Students might mark the length on a piece of paper and use that to measure. Making a small mark at the end of each measure will help them count the number of times this length is used.

SUPERSTARS III

Mars, VI

Name: _____

(This shows my own thinking)

- ★★ 1. How many 2-ounce hot dogs would make a pound?



Answer: _____ hot dogs

- ★★★ 2. Write a true number sentence using all of the given numbers and symbols.

6, 9, 7, 5, 3, =, +, +, -

Answer: _____

- ★3. Without adding, write the following in "standard form."

$70 + 400 + 2 + 3,000 + 80,000 =$

Answer: _____

- ★★ 4. The lunchroom workers are giving away free cookies today. They gave the first graders 4 cookies. They gave the second graders 8 cookies. They gave the third graders 12 cookies. They gave the fourth graders 16 cookies. If the pattern continues, how many cookies will the seventh graders receive?

Answer: _____ cookies

- ★ 5. The students rode a school bus on their field trip. About how many students could ride in 1 bus? Circle your best estimate.

a. 400 students b. 40 students c. 4 students

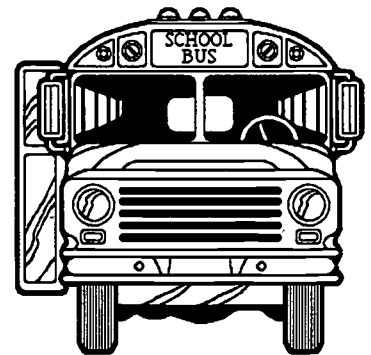

- ★★★ 6. Alexander's back yard is in the shape of a pentagon. The perimeter is 134 meters. Four of the sides measure 20, 21, 32, and 35 meters. What is the length of the fifth side?

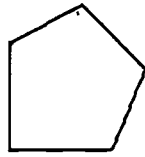

Answer: _____ meters

- ★★ 7. Draw the next figure in the pattern.



- ★ 8. Darrell has a set of animal cards in a covered box. There are 2 giraffes, 5 lions, 2 monkeys, and 4 llamas. Which is more likely that Darrell will pick out of the box without looking, a giraffe card or a llama card?

Answer: _____ card

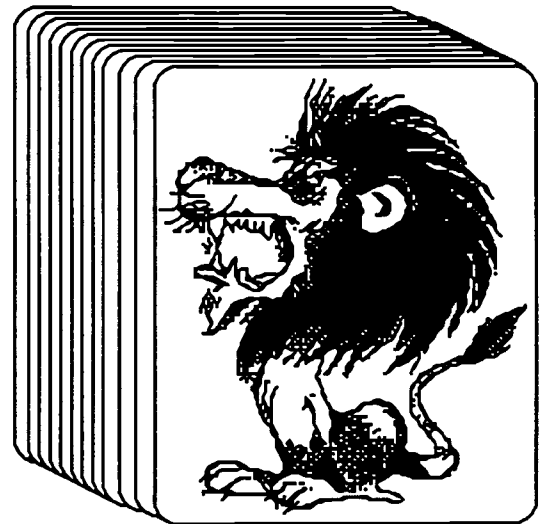

- ★★★★ 9. A magician weighed his twin rabbits and identical hats together and got 18 pounds. He then weighed one hat and got 3 pounds. What was the weight of one rabbit?

Answer: _____ pounds

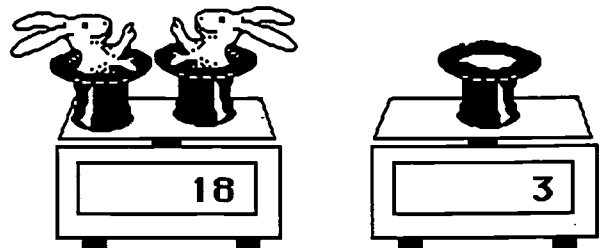

Commentary

Mars, VI

1. **(8)** Students might find this answer by drawing pictures of hot dogs, labeling each one "2 ounces", and counting by twos until they reach sixteen. The problem also relies on students knowing that 16 ounces is one pound -- many third graders might have to be told this.
2. **(7 + 5 - 9 + 3 = 6 is one solution)** Students can try writing the numbers and signs on small pieces of paper or index cards and moving them around until they reach a solution. They might try lining up the numbers in a certain order and just manipulating the signs to see whether they can get a number sentence that works. If not, they can change the order of the numbers and try again.
3. **(83,472)** The problem has students unscramble the order of the numbers given, according to place value.
4. **(28)** The pattern involves increasing the number of cookies by four for each new grade level.
5. **(40)** The problem tests students' number sense. Since 400 is far too many students for a school bus, and 4 is obviously too few, 40 is the only reasonable number.
6. **(26)** The four sides can be added together and that sum subtracted from the perimeter. Some students might prefer to subtract each number in turn from the perimeter.
7. **(The figure is shown below.)** The repeating pattern involves adding another vertical line to the circle, and then another horizontal line to the circle, each time you move to the right.



8. **(llama)** There are 4 llama cards and 2 giraffe cards out of the 13 in the box. This problem does not ask directly what is the probability of pulling each card out of the box, but gives a hint that there is some mathematical basis for such a question. The chances of pulling out a llama card is $\frac{4}{13}$, while the chances of pulling out a giraffe card is $\frac{2}{13}$.
9. **(6)** The problem involves several steps and is a precursor to algebraic thinking. Students know a hat weighs 3 pounds from the scale on the right. On the scale to the left, the two hats would then weigh 6 pounds out of the 18 total, leaving 12 pounds for the two rabbits. Each rabbit then weighs 6 pounds. In later grades, equations such as " $2r + 2h = 18$ and $h = 3$ " might be used to show the existing situations, and students would solve the equations for r .

SUPERSTARS III

Mars, VII

Name: _____
(This shows my own thinking.)

- ★ 1. Find the mystery number (?) using the relationships shown:

$$28 : 7 \qquad 20 : 5 \qquad 16 : 4 \qquad 12 : ?$$

Answer: _____

- ★★ 2. John is helping his father box up used golf balls for a special sale. Each box will hold 6 golf balls. How many boxes will they need to box up 52 golf balls?

Answer: _____ boxes

- ★★★ 3. Solve the following magic squares. The sum across each row, and down each column, must be the same sum as the sum along the diagonal. (Place the numbers in the boxes)

	1	8
	5	3
2		

12		14
	11	
	15	10

- ★★★ 4. Ricardo is 4 years older than his sister Rosa. If their ages are added together, the sum is 14. What are the ages of Ricardo and Rosa?

Answer: Ricardo is _____ years old.

Rosa is _____ years old.

- ★★★★ 5. An index card is shown to the right. How many rectangles are formed on this card?

Answer: _____ rectangles

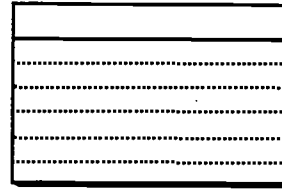

- ★★ 6. What is the starting number in this puzzle?

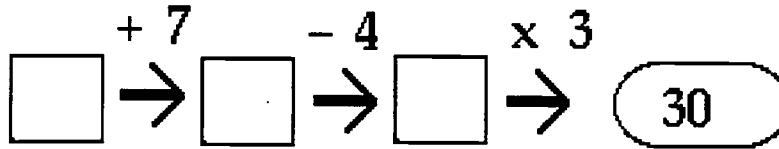

Answer: _____

- ★★ 7. How many 3-digit numbers can be made using the following digits only once in each number?

Use the digits: 2 , 3, 4

Answer: _____ numbers can be made

- ★★★ 8. Pam is using beads to make a necklace. The bowl contains 40 yellow beads, 20 blue beads, and 40 red beads. If she uses *half* of each color that is in the bowl, how many beads of each type will she use?



Answer: She will use _____ yellow, _____ blue, and _____ red beads.

Commentary

Mars, VII

1. (3) The first number in each pair is 4 times the second number. Students who have mastered their multiplication facts might have discovered this pattern. Other students might be having trouble if they are looking for an addition or subtraction relationship.
2. (9) Some students might choose to draw marks or use counters. If so, they will find that 8 boxes are needed for 48 golf balls, and 4 balls are left over. This means a ninth box is needed.
3. The student should first add to find the sum of the diagonal which has all three numbers showing. Then each box can be solved by adding the two numbers and subtracting to find the missing number. See the magic squares below:

6	1	8
7	5	3
2	9	4

12	7	14
13	11	9
8	15	10

4. (9, 5) The *guess and check* method is one that can be used. A quicker method is to think of the fact families of 14 shown at the right.
Then you look for a difference of 4 between the numbers.
The numbers 9 and 5 meet both conditions.
 $7 + 7 = 14$ but $7 - 7 = 0$
 $8 + 6 = 14$ but $8 - 6 = 2$
 $9 + 5 = 14$ and $9 - 5 = 4$ ✓
 $10 + 4 = 14$ but $10 - 4 = 6$
 $11 + 3 = 14$ but $11 - 3 = 8$
 $12 + 2 = 14$ but $12 - 2 = 10$
 $13 + 1 = 14$ but $13 - 1 = 12$
5. (28) Students should be encouraged to approach this problem in an organized way. For example, they might count all of the small rectangles first, those made by the individual lines, and get 7. Then they count all the next larger size, those formed by putting two small rectangles together -- this gives 6. They proceed in this fashion, finding 5 of the next size, 4 of the next, then 3, 2, and finally 1 which is the whole card itself.
6. (7) Either *guess-check-revise* or *working backwards* strategies can be used to find the starting number. With *working backwards*, you would ask yourself "what number multiplied by 3 gives 30?" The answer is 10. You would then ask "what number, minus 4, gives 10; the answer is 14. Finally, what number plus 7 gives 14? The answer is 7.
7. (6) Once students organize their plan, finding these 6 numbers will be easy. Starting with the 2 as the hundreds digit : 234, 243
Starting with the 3 as the hundreds digit: 324, 342
Starting with the 4 as the hundreds digit: 423, 432
The condition of using each number only once limits the number to 6.
8. (20, 10, 20) Students with good number sense can intuitively find half of numbers such as 40 and 20 at this time. Other students might need to actually make 40 or 20 marks on a sheet of paper, or work with cubes or other concrete materials to represent the beads. Students can then divide their drawings or manipulatives into two groups with the same numbers in each group.

SUPERSTARS III

Mars, VIII

Name _____
(This shows my own thinking)

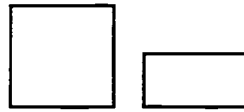

★★ 1. Notice how the two shapes are alike:

Which pair of shapes are alike in the same way? Circle your answer.

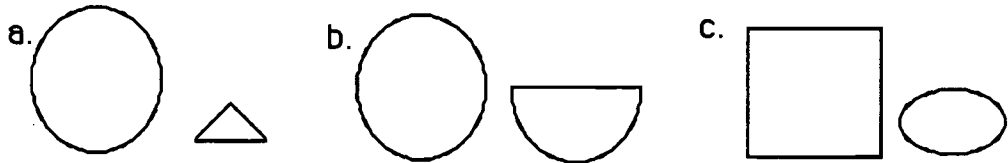

★ 2. Ashley has a set of color tiles in a bag. There are 2 greens, 5 reds, 2 yellows, and 4 blues. Without looking, is Ashley more likely to pick a green tile or a yellow tile?

Answer: _____

★★ 3. How many small cubes are there in the entire collection below?

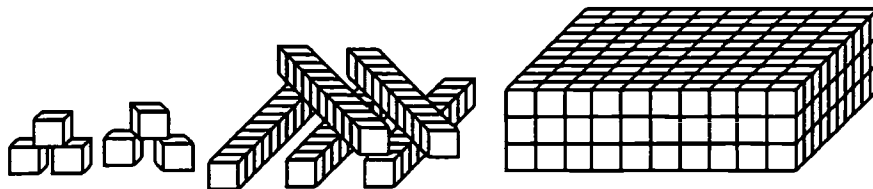

Answer: _____ cubes

★★★ 4. There are 4 bookshelves in the classroom. Each bookshelf has room for 20 books. If Mrs. Hogan has 90 books, how many books will not be able to fit on the shelves?

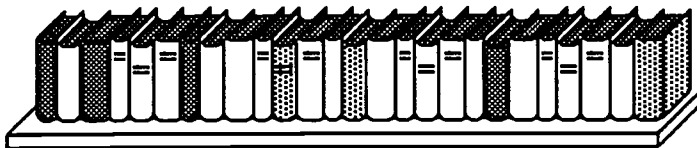

Answer: _____ books

- ★★★ 5. Three rose and two holly bushes are planted at the first stop of the nature trail. Then three rose and two holly bushes are planted at the second stop. Rose and holly bushes are planted in the same way until 20 bushes are planted. How many rose and how many holly bushes are planted?

Answer: _____ rose bushes; _____ holly bushes

- ★★★ 6. Abraham had three stacks of baseball cards. One stack had 25 cards in it, the next stack had 20 cards in it, and the third stack had 30 cards. How many cards would be in each stack if Abraham made them all the same height?

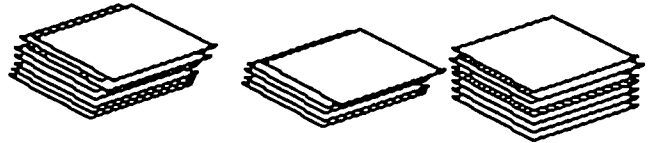

Answer: _____ cards

- ★★★ 7. Solve the magic square. The sum across each row, and down each column, must be the same as the sum along each diagonal.

5		
	6	2
3		7

- ★★★ 8. A can of soup weighs 251 grams. How many cans would weigh about 1 kilogram?

Answer: _____ cans

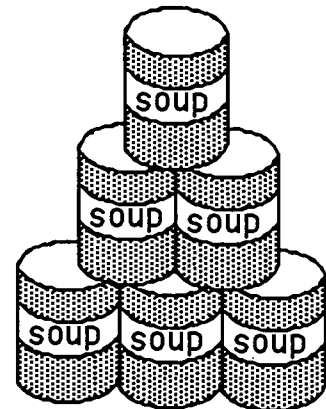

Commentary

Mars, VIII

1. **(b)** The given picture shows a rectangle that is one-half of the square. In (b) the half-circle is one-half of the circle. In (a) and (c), the two shapes are not similar and their areas are not in the same relationship as in the given figure. However, if a student chooses (a) or (c), listen to the reason -- there might have been some logical reason for selecting another choice.
2. **(The chances are the same that she'll pick either color.)** The question is designed to measure both the child's sense of probability and confidence in making a selection. Because the question is asked in such a way that a student would be more likely to want to select one particular color, confidence in knowing how to answer the question accurately is important.
3. **(356)** The challenge is for the student to put the place values in the correct relationship before finding the total. Most textbooks show pictures like this, but generally the tens and hundreds blocks have already been placed in their correct, left-to-right order.
4. **(10)** The students can count by 20's and get to 80 books on 4 shelves. Therefore 10 books, the difference in 80 and 90, will not have a shelf.
5. **(12 rose and 8 holly bushes)** Students might draw pictures of the nature trail, sketching and labeling the five bushes at each stop. They would continue until they have 20 bushes in all and then go back and count the rose and holly bushes separately. Making a chart is an efficient way for students to organize this information.
6. **(25)** Students might make stacks using index cards or some other manipulative. They can then see physically why the answer is 25. This problem is a physical introduction to the concept of the *mean*.
7. **(first row: 5 4 9; second row: 10 6 2; third row: 3 8 7)** Students can begin this magic square by finding the sum along the diagonal which is complete -- 18. Then they look for rows and columns for which there is one missing number. Knowing the sum must be 18, they can find that missing number.
8. **(4)** Some students will not know a key fact here: that 1 kilogram is 1,000 grams. Once they have been reminded of this, they might think of 251 grams as 250 grams, since the problem involves an estimation. Then 250 and 250 is 500, and another 500 would be 1000. Therefore four cans of soup would be about 1000 grams, or 1 kilogram.

SUPERSTARS III

Mars, IX

Name: _____
(This shows my own thinking.)

- ★★ 1. Ann is thinking of a number. She gives Tina this clue:

*If you multiply my number by 4,
and then subtract 3,
the answer is 17.*

What is Ann's number? _____

- ★★★★ 2. Use the symbols = (equal to) , < (less than) , and > (greater than) to compare the problems below. Work each side before deciding which sign to use. Put your answers in the boxes.

a. $23 + 42$ $76 - 15$

b. 5×4 3×6

c. $27 - 13$ $18 + 5$

d. $72 \div 9$ $48 \div 6$

- ★★★ 3. Eighty-four students went on a field trip to another city. The school had one bus that held 68 students. The rest of the students had to travel by car. If 4 students could ride in each car, how many cars were needed?

Answer: _____ cars

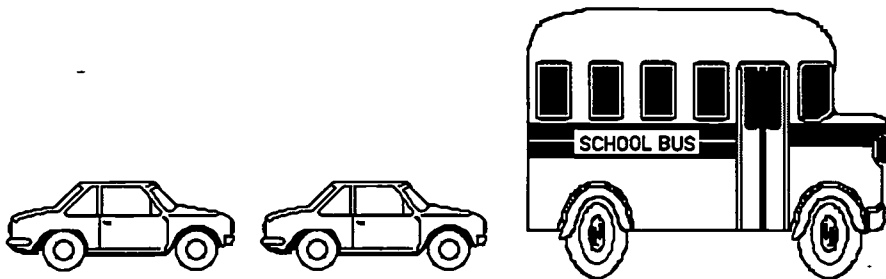

- ★★ 4. Gina is having a birthday party at home. Each time the doorbell rings, two of her friends arrive. If the doorbell rings 4 times, how many people are at the party?





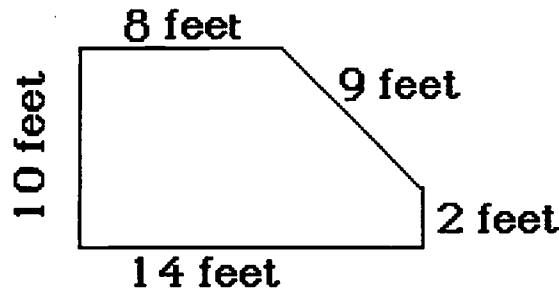



Answer : _____ people



- ★★★ 5. Joe's grandmother is planting a vegetable garden. She needs a fence to keep animals out. She has to know the *perimeter* of her garden to buy the right amount of fencing. How much fence does she need?



Answer: _____ feet

- ★★★★ 6. Study the following puzzle. Then answer the question.

	=				
	=				

How many 's is a  worth?

Answer: _____ 's

- ★ 7. Sergio bought a hand-held game and an adapter for \$28.00. The game cost \$19.00. What was the cost of the adapter?

Answer: _____

- ★★ 8. Tom, Bill, and Joe picked oranges from the tree in their grandfather's yard. Tom picked 12 more oranges than Joe. Joe picked 8 fewer oranges than Bill. Bill picked 23 oranges. How many oranges did they pick together?

Answer: _____ oranges

Commentary

Mars, IX

1. (5) *Working backwards* is one strategy to use. The student asks "what number minus 3 leaves 17?". The answer is 20. Continuing, the student asks "what number multiplied by 4 gives 20?". The answer is 5. By *working backwards* the student arrives at 5.
2. (a. >; b. >; c. <; d. =) If students correctly perform the computation of each side of the box, the following answers will result: (a) 65 on the left and 61 on the right; (b) 20 and 18; (c) 14 and 23; and (d) 8 and 8.
3. (4) The student needs to subtract the 68 students who ride the bus from the total of 84. That leaves 16 students to ride in cars. Since 4 students can ride in each car, counting by 4's will show that four cars are needed.
4. (at least 9) Since the doorbell rang 4 times and 2 friends arrived at each ring, this problem can be solved by multiplying 4×2 , or adding 2 four times. But the student must remember to add Gina herself to the 8 friends, so there are at least 9 people at the party. (There may be more than 9 since Gina might have someone else at her home who attends the party.)
5. (43) The perimeter is found by adding all the sides together. Adding $8 + 9 + 2 + 14 + 10$ gives a perimeter of 43 feet.
6. (6) The student needs to substitute 3 \rightarrow 's for each \otimes . So $3\otimes\otimes = 12\rightarrow$'s. If $2\otimes$'s = 12 \rightarrow 's, then each \otimes is worth 6 \rightarrow 's.
7. (\$9.00) The student should use subtraction since the cost of the game is given. The cost is taken from the total spent ($\$28 - \$19 = \$9$).
8. (65) The student can use the number Bill picked -- 23 -- to find Joe's total, since Joe picked 8 fewer ($23 - 8 = 15$). Tom picked 12 more than Joe's 15, so Tom picked 27 oranges. Adding all of these together gives 65.

SUPERSTARS III

Mars, X

Name: _____

(This shows my own thinking)

- ★★ 1. Shayna has a set of blocks in a bag. There are 2 squares, 5 circles, 2 triangles, and 4 rectangles. What fraction of the blocks represents the squares? Circles?

Answer: _____ of the blocks are squares

Answer: _____ of the blocks are circles

- ★★ 2. Which figure will fold into an open box? Circle it

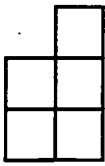

a

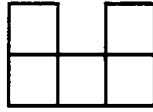

b

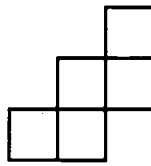

c

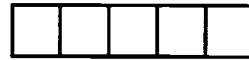

d

- ★ 3. Which digits below are made up of only line segments? Circle them.

2 4 3 5 7

- ★★ 4. Rebecca bought a pack of 12 pencils. About how much did she spend? Circle your answer.

a. \$2.25 b. \$10.25 c. \$0.10

- ★★★ 5. Amanda eats supper from 6:30 to 7:00. Then she watches a half-hour television program. She takes 5 minutes to brush her teeth, 15 minutes to take a bath, and 5 minutes to dress for bed. How much time is left for Amanda to read if she goes to sleep at 8:30?

Answer: _____

- ★★ 6. Five third-grade classes collected cans. The table gives you the data. Complete the bar graph to show the data.

Class	Cans
1	15
2	25
3	25
4	20
5	20

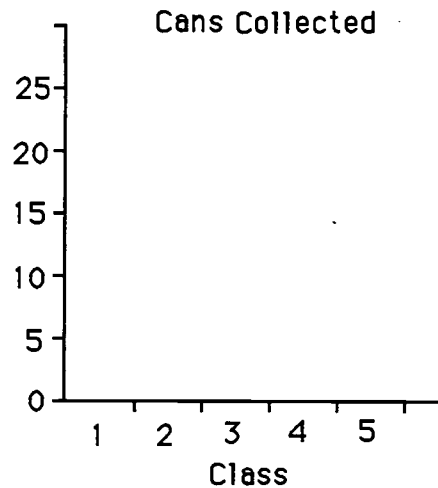

- ★★★ 7. The classes above put all their cans together. Then they divided them equally among the five classes. How many cans did each end up with?

Answer: _____

- ★★ 8. Watch how Marcus multiplies in his head:

*For 2×35 , first I do $2 \times 30 = 60$.
Then I do $2 \times 5 = 10$. Last, I add
10 to 60 to get 70. So $2 \times 35 = 70$.*



Practice doing these problems the way Marcus does, in his head. You will be given a problem to do mentally when you turn in your paper.

$$3 \times 22 =$$

$$3 \times 24 =$$

$$2 \times 45 =$$

Answer for the problem given later: _____

- ★★★ 9. Bart and Luwan prepared the tables for art. They put 2 pieces of poster board and 6 markers on each table. There are 24 markers on the tables. How many pieces of poster board are on the tables?

Answer: _____ pieces

Commentary

Mars, X

1. (2/13; 5/13) It might help students to draw the correct number of each shape mentioned, then look at them as parts of a total set. 2 figures out of 13 figures are squares; 5 figures out of 13 are circles.
2. (c) The figures can be traced and then cut out of paper for students to set how (c) folds into a box. Students who can do this problem without such an aid have very good spatial sense.
3. (4; 7) Line segments do not include curved lines. Therefore 2, 3, and 5 are eliminated.
4. (\$2.25) The problem tests a student's number sense and knowledge of the real world. \$10.25 would be too much for twelve pencils -- that would be almost \$1 per pencil. Likewise, 10¢ is too little -- that would be less than a penny per pencil. \$2.25 is the only reasonable answer -- this would be almost 20¢ per pencil.
5. (35 minutes) Students are likely to start at 7:00, add a half-hour to get 7:30, and then add on the other intervals individually to arrive at 7:55. This leaves her 5 minutes till 8:00 arrives, and 30 minutes after that, or a total of 35 minutes for reading before sleep at 8:30.

6.

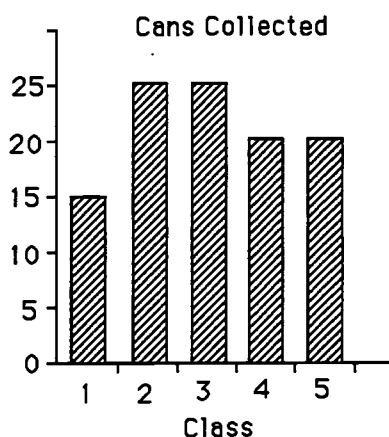

7. (21) The problem is an intuitive introduction to finding the mean of a collection. At this point, students will simply add the number of cans together to get 105, then use their intuition and number sense to divide 105 cans into 5 groups. One concrete way would be to make 105 marks on their paper and divide these marks fairly. A more sophisticated strategy would be to estimate that each group would have 20, which would be 100 marks altogether, and then distribute the remaining five marks.
8. (128) Have the problem 4×32 written on chart paper or index cards so that several students can see it at the same time, when they turn their papers in. They have to do the problem mentally, and put their answers correctly on their papers.
9. (8) This problem is an introduction to the concept of *ratio*. Students might find the answer by drawing the tables and placing the right number of markers on each, until they have used up 24 markers. This would require four tables. Then they would draw 2 pieces of poster board on each table.

SUPERSTARS III

Mars, XI

Name: _____

(This shows my own thinking.)

- ★★ 1. What number belongs in the following number sentences? Write your answer in the boxes.

$$288 + \boxed{} = 395$$
$$579 - \boxed{} = 395$$

- ★★★ 2. Mrs. Brown's third grade class planted 35 tomato seeds in their class garden. Only 4 out of every 5 seeds grew into plants. How many plants were there?

Answer: _____ plants

- ★★ 3. Tom has a stamp album. Each page has 5 rows of 6 stamps. He has stamps in 3 whole rows and one-half of the fourth row. How many *more* stamps can he put on that page?

Answer: _____ stamps

- ★★ 4. Bill needs some computer disks. At the store the plain disks are formatted for IBM. The disks with the Apple are the type he needs. Study the picture. What fraction of the disks should he buy? What fraction of the disks should he not buy?



Answer : _____ of the disks he can buy

_____ of the disks he should not buy

- ★★ 5. Sally bought 4 stamps at 32 ¢ each. How much change should she receive from the dollar and a half she gave the clerk?



Answer: _____

- ★★★★ 6. Symmetry means that a shape can be folded in half and both sides will match perfectly. Draw the lines of symmetry in the shapes below. Some shapes will have more than one line of symmetry.

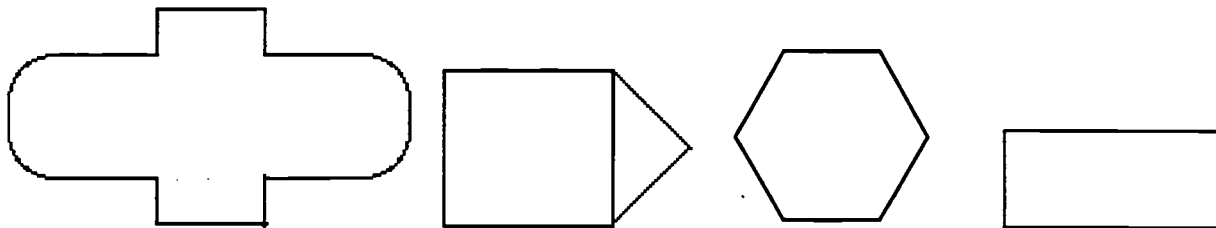

- ★★★ 7. The library at Miller Elementary School has an odd number of tables. Some tables will seat 4 students and some tables that will seat 6 students. A total of 32 students can sit at the tables with no empty seats. What is the number of tables of each type? (Drawing a picture might help).

Answer: _____ tables of 4

_____ tables of 6

- ★★★ 8. Study the pattern of dots. How many dots made the 10th figure, before the paper was cut?

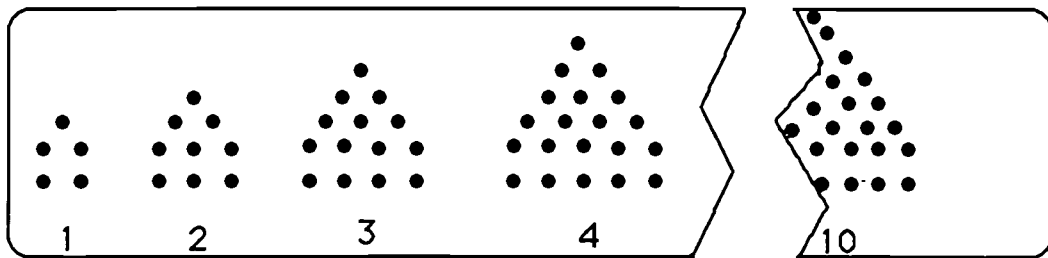

Answer: _____ dots

Commentary

Mars, XI

1. **(107; 184)** The student might subtract 288 from 395 to find the first missing number, 107. Other students might "add on" to 288 till they get to 395. Similar methods will work for the second problem.
2. **(28)** Students can solve this problem by drawing a row of 35 seeds, grouping them into sets of 5, and crossing out one seed in each group. Counting the remaining seeds gives 28.
3. **(9)** The student might draw a picture to help visualize the problem and actually count the places for more stamps. If $3\frac{1}{2}$ rows are full, then $1\frac{1}{2}$ rows are empty. This is one empty row of 6 and another half row of 3, giving 9 more places for stamps.
4. **(5/9; 4/9)** The problem involves writing a part-whole relationship for a collection. The entire collection has 9 disks, so each part is written as a correct numerator over the denominator of 9.
5. **(22¢)** The student must first find out how much Sally spent. 32¢ can be added 4 times or can be multiplied by 4 to give \$1.28. To find the amount of change, the student can count out the change with real or play money, or subtract ($\$1.50 - \$1.28 = \$0.22$).
6. **(There are 11 lines of symmetry as shown below .)**

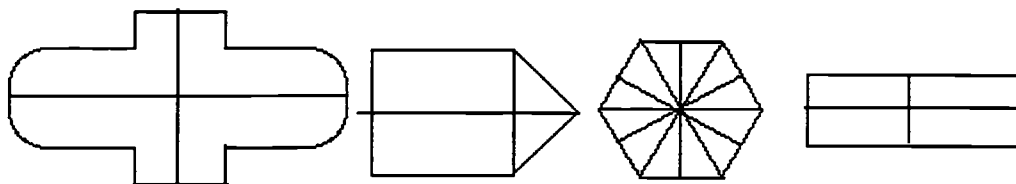

7. **(5; 2)** The student can draw pictures of tables and count the chairs. Since all tables hold at least 4 people, there can be no more than 8 tables, since 8 groups of 4 is 32. But 8 is an even number; therefore there can be no more than 7 tables. Check and see whether it's possible to have a combination of 4- and 6-person tables that total 32 chairs. Seven 4-person tables would be 28 chairs, so take the extra 4 chairs, turn 2 of the tables into 6-person tables, and the problem is solved.
8. **(77)** The pattern of dots is shown below:

dots: -	5	9	14	20	?	?	?	?	?	?
figure:	1	2	3	4	5	6	7	8	9	10 ...

The pattern involves adding successive numbers -- 4, 5, 6, 7, etc. -- each time to get the number of dots for the next figure.

SUPERSTARS III

Mars, XII

Name: _____
(This shows my own thinking)

- ★ 1. Mrs. Boyd baked 22 rolls. She baked 12 *more* muffins than rolls. How many muffins and rolls did she bake together?

Answer: _____ muffins and rolls

- ★★★ 2. Mrs. Smith's class was observing birds in the trees. There were three mockingbirds and two cardinals in each tree. The class left after counting 35 birds. How many mockingbirds and cardinals did they see?

Answer: _____ mockingbirds _____ cardinals



- ★★ 3. Practice these problems using mental math. You will be given a problem to do mentally when you turn in your paper. (Hint: think of money)

$3 \times 25 =$

$4 \times 50 =$

$2 \times 25 =$

$5 \times 25 =$

Answer for the problem given later: _____

- ★★ 4. At the school store, paper costs 35¢; a pencil costs 25¢; and an eraser costs 5¢. Jamie has 50¢. Does Jamie have enough money for paper and a pencil? Katie has 75¢. Can she buy one of each item?

Answer for Jamie: _____ Answer for Katie: _____

- ★★★★ 5. Mazie counted her dimes. When she put them in groups of 4, she had two dimes left over. When she put them in groups of 5, she had one left over. What is the smallest number of dimes she could have, if she has more than 10?

Answer: _____



★★★★

6. Joshua gave Warren a birthday present. How much ribbon did he need to go around the present and make the bow? The bow took 12 inches by itself.

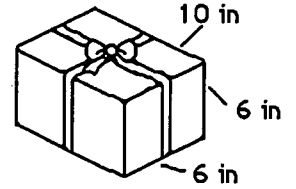

Answer: _____ inches

★★

7. I am a 3-digit number less than 300. My tens digit is less than my ones digit and my ones digit is less than my hundreds digit? Who am I?

Answer: _____

★★★

8. On the grid below, find the point for each number pair. Connect the points in order. Name the figure. (Hint: the first number of each pair says how far *out*; the second how far *up*.)

Here are the number pairs: (1,2) (2,3) (4,3) (4,1) (2,1) (1,2)

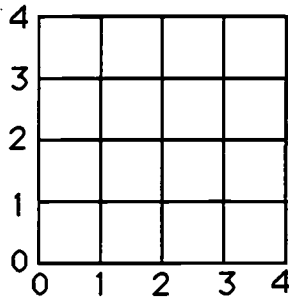

Answer: The figure is a _____.

★★★

9. Dogs, cats, and donkeys had a tug-of-war. Four cats tied with three dogs. Two donkeys tied with six dogs. Which side won when one donkey tugged with five cats?



Answer: _____

Commentary

Mars, XII

1. (56) Some students will add 22 and 22 and then 12 more, and others will add 12 to 22 first, and then add 22 and 34.
2. (21; 14) Students might draw a diagram of trees, label the birds, and count up until they have 35 birds. This would be in the seventh tree. Then they could count the numbers of each type of birds in the seven trees. Another method is to make a chart that shows the ratio, such as the one started to the right.

M	C	total birds
3	2	5
6	4	10
9	6	15
.	.	.
3. (100) Give the problem 4×25 . If students think of this as money, as they were encouraged to do, this would represent 4 quarters, which they should know is 100 cents or 1 dollar.
4. (no; yes) Students will need to add 35¢ and 25¢ to get the amount that Jamie needs -- 60¢. He doesn't have that much. But that total plus another 5¢ would be 65¢ to buy all three items, and Katie has more than enough.
5. (26) Students might work with real or play coins to decide this. More advanced students might write down a list of how many coins she might have under both methods of grouping, and look for a common number.

Grouping by 4, with 2 left: 14, 18, 22, 26, 30, 34, 38, ...

Grouping by 5, with 1 left: 16, 21, 26,

No need to go any further. Since 26 is in both groups, that number of dimes suffices.

6. (68) Students might take an actual box, and draw a ribbon around it and label each part with the correct length. One way, they should find that there are two 10-inch parts and two 6-inch parts for a total of 32 inches. The other way, there are four 6-inch parts for a total of 24 inches. Then, adding the 12 inches for the bow produces 68.
7. (201) Students can use logical reasoning to find this number. Since the number is less than 300, the hundreds digit is a 1 or 2. It must be a 2 so that the ones and tens digits can both be less than the hundreds digit.
8. (pentagon) Other students might name the shape as "arrowhead" or "sideways house," which should be accepted. The most important part of the problem is to see the correct drawing, which is shown to the right.

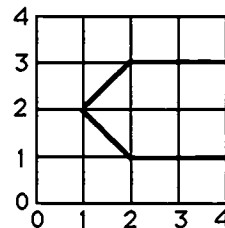

9. (5 cats won) Students' reasoning might proceed along the following lines.

From the second picture, 2 donkeys match 6 dogs so I know that 1 donkey matches with 3 dogs, by dividing both sides in half. Then I can substitute 1 donkey for the 3 dogs in the top picture, and know that 1 donkey matches 4 cats. So in the bottom picture, 5 cats would win over 1 donkey.

This type of reasoning is important when students begin algebraic experiences with equations.

SUPERSTARS III
Mars, XIII

Name: _____
(This shows my own thinking.)

- ★ 1. Sue asked her friend to find the next 3 numbers in the sequence below. Write them on the blanks.

4, 9, 7, 12, 10, 15, 13, _____, _____, _____

- ★★★ 2. Crystal has exactly \$2.40 in quarters, dimes, and nickels. She has the same number of each type of coin. What is that number?

Answer: _____ quarters, dimes, and nickels

- ★★★ 3. Tom, Alan, Bill, and Joe enjoy collecting insects. They made a graph to compare their collections. Study their pictograph and answer the following questions:

- a. Who has the largest insect collection? _____
- b. How many more insects does Alan have than Tom? _____
- c. Who has exactly half the insects that Bill has? _____

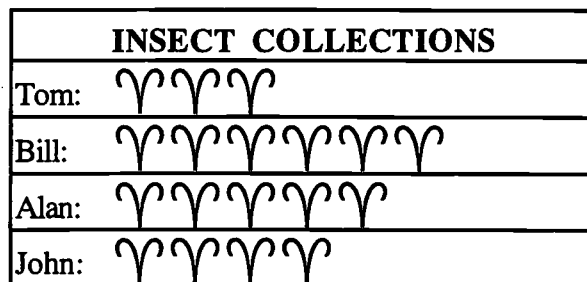

KEY:  = 5 insects

- ★★ 4. Ted started his homework when he got home from school. He worked 45 minutes on his homework. He then walked the dog for 30 minutes. It was 5:00 when he finished walking the dog. At what time did he get home and start his homework?

Answer: _____

- ★★★ 5. Brenda wants new carpet in her room. Her father told her to find the area of the room so they would know how much carpet to buy. Look at the drawing of her room and find the amount of carpet she needs. (*Area* is number of square feet in her room.)

Answer: _____ square feet.

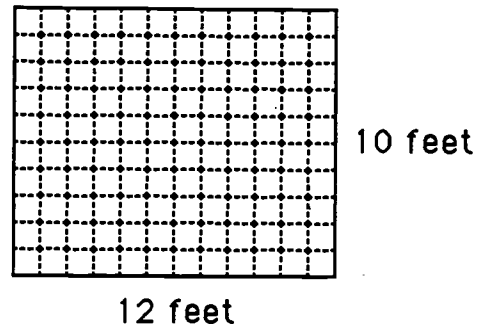

- ★★ 6. Quentin has a bag of numbered blocks. Each of the blocks has a 2, 3, 4, 5, or 6 on it. He pulled 4 different blocks from the bag. The total of the numbers on the 4 blocks was 18. What blocks did he pull out?

Answer: _____

- ★★★ 7. Ellen was dusting her bookcase. The top shelf has 16 books. The second shelf has 23 books. The third shelf has 21 books. The bottom shelf has 28 books. She rearranged the books and put the same number on each shelf. How many books were on each shelf then?

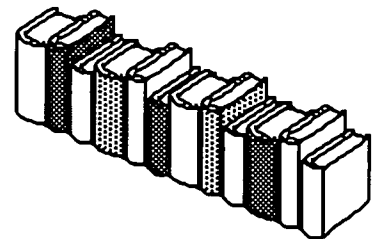

Answer: _____ books

- ★★★★ 8. Pam gave her friend Tammy the number riddle below. Solve it.

I am a 2-digit number less than 84. The sum of my digits is 9. The ones digit is twice the tens digit. What number am I?

Answer: _____

- ★★★ 9. There were 3 cookies on a plate. Henry ate $\frac{1}{3}$ of the cookies on the plate. Marsha ate $\frac{1}{2}$ of what was left. How many cookies were left for Art to eat?

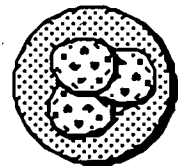

Answer: _____ cookies

Commentary

Mars, XIII

1. (18, 16, 21) The pattern involves adding 5 then subtracting 2. To complete the sequence following this pattern gives: $13 + 5 = 18$; $18 - 2 = 16$; $16 + 5 = 21$.
2. (6) The student can solve this problem by an organized guess-and-check strategy such as below.

#	quarters	dimes	nickels	total
3	75¢	30¢	15¢	\$1.20
4	\$1.00	40¢	20¢	\$1.60
5	\$1.25	50¢	25¢	\$2.00
6	\$1.50	60¢	30¢	\$2.40 ✓

Some students might see that 3 of each is \$1.20, so 6 must be \$2.40. Others might start with 1 of each coin, giving 40¢, and then add 40¢ six times to get \$2.40.

3. (a. Bill; b. 10; c. Tom) The student can see from the pictograph that Bill has the largest collection. A student may answer 2 for how many more Alan has than Tom; but each insect is worth 5, so the answer would be 5×2 or 10 more. Students can see that Tom has half of Bill's, or they may count Bill's as 6 and look for half of that, which is 3.
4. (3:45) A clock can be used to *work backwards* to the time he got home. He walked the dog for 30 minutes, and 30 minutes before 5:00 is 4:30. Counting back 45 minutes from 4:30 might be done in stages. First count back 30 minutes to get to 4:00, then back 15 minutes more would be 3:45.
5. (120) At this grade level area is found by counting square units. The student can count all of the small squares shown, but many will take a short cut and add 12 ten times, or ten 12 times. Some might even multiply, if they have a calculator.
6. (3, 4, 5 and 6) Each block has a different number, so the student can choose 4 of the numbers and add and then choose another 4 if the sum is not 18. The process can be repeated until the sum of $3 + 4 + 5 + 6 = 18$ is reached. (Another approach is to add all 5 of the numbers and get 20, and then see which number to remove to have 18 as the sum.)
7. (22) This problem is one which will later be called *finding the mean*. At this point, students will probably not add the number of books and divide by 4. Instead, they might add the numbers to get 88, and then distribute the 88 in chunks, equally, among the four shelves. For example, they might give 20 to each shelf first, then 1 to each shelf, and then 1 more, exhausting the total of 88 books.
8. (36) A clue that makes this problem accessible is that the sum of the digits is 9. By listing these numbers -- 18, 27, 36, 45, 54, 63, 72, and 81 -- you can then search the list for the number for which the ones digit is twice the tens digit.
9. (1) The problem involves finding a fraction of a set, and then a fraction of a subsequent set, and seeing what is left. One-third of 3 cookies is 1 cookie, so Henry ate 1, leaving 2 cookies on the plate. Marsha ate half of two cookies, so she ate 1. That left 1 on the plate for Art.

SUPERSTARS III

Mars, XIV

Name: _____
(This shows my own thinking)

- ★ 1. Stephanie had 35 crayons. She gave 12 crayons to Brian. How many crayons did Stephanie have left? Circle the number sentence that correctly answers the problem.

a. $35 + 12 = 47$ b. $35 - 12 = 23$ c. $35 - 23 = 12$

- ★★★★ 2. Two dogs together weigh 36 pounds. Fido weighs twice as much as Rex. How much does each dog weigh?

Answer: Fido: _____ pounds

Rex: _____ pounds

- ★★ 3. I am a number between 500 and 600. My ones digit is 5. My tens digit is the difference between my ones and hundreds digits. Who am I?

Answer: _____

- ★★★ 4. Georgia and Samantha baked a cake. They wanted to divide it into two equal parts to take home and share with their families. Which of these ways below show the top of a cake pan divided into equal parts? Circle all the correct ways.



a

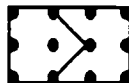

b



c



d

- ★★★★ 5. Should the object be measured in grams or in kilograms?

a. a feather: _____

b. bulldog: _____

c. television set: _____

d. a penny: _____



★★★★

6. There are 4 more oranges than apples in the fruit bowl. There are 5 more apples than bananas. There are 2 bananas. How many of each type of fruit is in the bowl? How many pieces of fruit in all?

_____ bananas

_____ oranges

_____ apples

_____ fruit

★★ 7. Use mental math. Circle the correct amount of change:

Richard gave the cashier \$5.00 for a game that costs \$3.50.

a. \$1.00 b. \$1.25 c. \$1.50

Cameron gave the cashier \$3.00 for marbles that cost \$2.25.

a. \$0.50 b. \$0.75 c. \$0.85

★★★★ 8. What is the area of the triangle below?

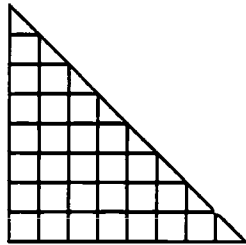

Answer: _____ square units

★★★★

9. Tell the turtle how to go *clockwise* around the postcard. Fill in the blanks with ordered pairs of numbers from the grid.

Start at (14, 9). Turn right 90°.
Go to (____, ____). Turn right 90°.
Go to (____, ____). Turn right 90°.
Go to (____, ____). Turn right 90°.
Go to (____, ____).

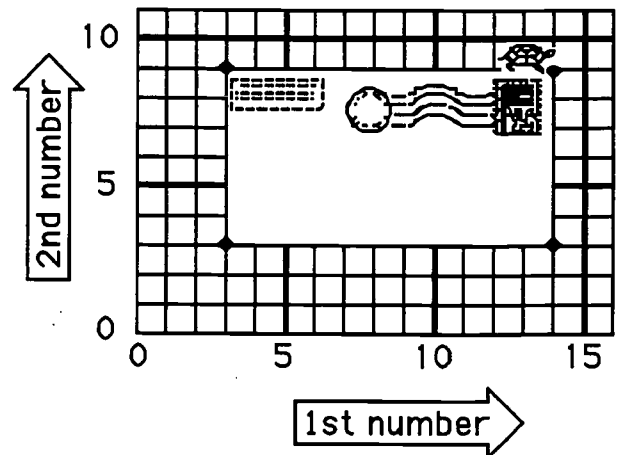

Commentary

Mars, XIV

1. **(b)** The number sentence is a one-step subtraction situation.
2. **(24; 12)** Students might *guess-check-revise* to find an answer. Another way to begin is to write down a list of numbers that sum to 36 and look for two addends such that one is twice as much as the other. In the middle grades, this problem might be solved algebraically by letting x be Rex's weight and $2x$ be Fido's weight, and $x + 2x = 36$ so $3x = 36$. Then $x = 36 \div 3$ or 12, and $2x = 24$.
3. **(505)** A number between 500 and 600 means that the hundreds digit is 5. The ones digit is also 5, so the difference between the two is 0. That gives 505 as the answer.
4. **(a, b, d)** Pan (a) is divided from the corner of one rectangle to the opposite corner, implying the two parts are equal in area. Students might count whole and half squares to find the area of the surface of each of the last three pans, since they aren't divided symmetrically. The area is 3 for each part of a, b, and d. In (c), the two parts have areas of $2 \frac{1}{2}$ and $3 \frac{1}{2}$.
5. **(a. grams; b. kilograms; c. kilograms; d. grams)** The problem solution shows whether or not the student has number sense related to the weight of common objects and the metric units used to measure them.
6. **(2 bananas, 7 apples, 11 oranges, and 20 pieces of fruit)** Students can begin with the fact they know -- 2 bananas -- and find the number of apples by adding 5. Then they can find the number of oranges by adding 4 to the number of apples.
7. **(part one: \$1.50; part two: \$0.75)** The problem encourages students to use mental mathematics, as they must do in such problems in the world outside of school.
8. **(32)** Students have not been introduced to the formula for finding the area of a triangle, so they will find it by counting whole and half unit squares. There are 28 whole unit squares. Then they put together the 8 half squares to make another 4 whole squares for a total of 32.
9. **[(14, 3); (3, 3); (3, 9); (14, 9)]** The problem measures the student's knowledge of the Cartesian coordinate system in which the first number of an ordered pair gives the horizontal distance from the axis, and the second number gives the vertical distance. The problem also involves "clockwise," a term that may be new to some students, and "90°." Some students will associate the problem with the computer program known as Logo, since a turtle's movement around a grid is common to both.

SUPERSTARS III

Mars, XV

Name: _____

(This shows my own thinking.)

- ★ 1. Place the correct sign (=, <, or >) in the box.

$$81 \div 9 \quad \square \quad 5 \times 3$$

- ★★ 2. Ben has 5 marbles. Kate has 7 more marbles than Ben. Tina has 9 more marbles than Kate. Who has the greatest number of marbles? How many marbles do they have in all?

Answer: _____ has the greatest number; there are _____ marbles in all

- ★★★ 3. Ken is buying a bicycle with money he got for Christmas. The bicycle cost \$87.95. Which of the following pictures shows his change from the \$90.00 he gave the clerk? Circle the correct change.

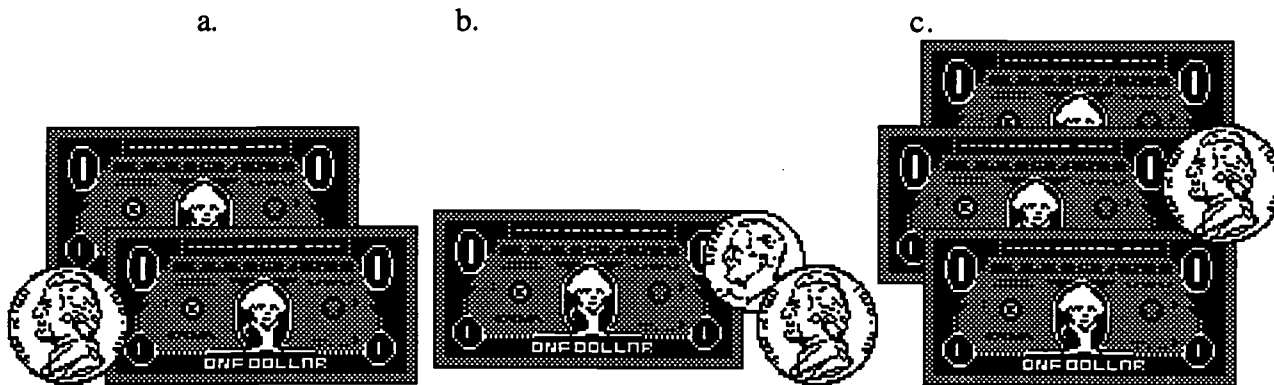

- ★★★ 4. Find the value of each item used in the following sentences.

$$H + C = \$9$$

$$\text{grape} + \text{frog} = \$13$$

$$\text{frog} + \text{frog} = \$18$$

Answer:  = _____  = _____  = _____

- ★★★ 5. Mr. Smith is planning to fence his new garden. He has 24 feet of fencing to use around the perimeter of his garden. He wants the greatest *area* for his garden. Which of the following gardens will give him the greatest area? Circle your choice.

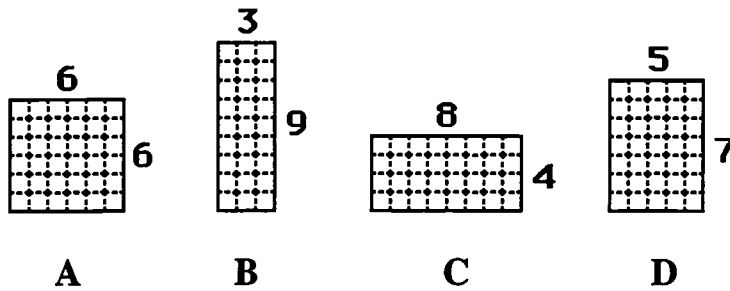

- ★★★ 6. Some nonsense names are given to a group of numbers that are alike in some way. This is an example:

These numbers are *kewees*: 54, 78, 112, 246, 480, 574, 942

These numbers are *not* kewees: 33, 67, 147, 259, 421, 505, 863

Which of these are *kewees*? 43, 58, 166, 369, 620, 891

Answer : _____

- ★★ 7. Sam asked Tim to find 3 consecutive even numbers whose sum is 48. The following are examples of consecutive numbers that do *not* sum to 48:

$$2 + 4 + 6 = 12; \quad 4 + 6 + 8 = 18; \quad 6 + 8 + 10 = 24.$$

Help Tim by finding 3 consecutive even numbers whose sum is 48.

Answer: _____

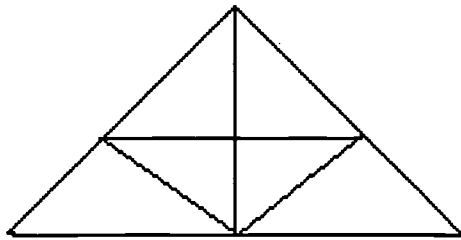

- ★★★★ 8. Look carefully at the triangle puzzle that Paul drew. How many triangles are there?



Answer: _____ triangles

Commentary

Mars, XV

- ($<$) The student should solve each side of the number sentence first. $81 \div 9 = 9$; $5 \times 3 = 15$. When 9 and 15 are compared, $9 < 15$.
- (**Tina; 38 marbles**) The student can find the number of marbles each person has by building on Ben's total of 5. Kate has 7 more than Ben's 5, so she has 12. Tina has 9 more marbles than Kate's 12, so Tina has 21. To find the total, all 3 numbers must be added: $5 + 12 + 21 = 38$ marbles.
- (a) The student might find this problem easier by *counting up* from \$87.95 to \$90.00.
- ( = \$ 5;  = \$4;  = \$9) The student can find the statement that can be solved as it exists, and then solve the rest of the sentences by using that answer.
 $\text{H} + \text{H} = \$18$, so $\text{H} = \$9$; $\text{G} + \$9 = \13 , so $\text{G} = \$4$; $\text{H} + \$4 = \9 , so $\text{H} = \$5$.
- (A) The student must find the area of all the rectangles to find the greatest area. The area can be found by counting unit squares. (A) has 36 ft^2 , B has 27 ft^2 , C has 32 ft^2 , and D has 35 ft^2 . So the square that is 6 by 6 has the greatest area.
- (**58, 166, 620**) The 'kewees' are even numbers, and the odd numbers are not 'kewees'. Once this feature is noticed, the student can look at the numbers: 43, 58, 166, 369, 620, and 891. 58, 166, and 620 are even so they are 'kewees'. 43, 369, and 891 are odd so they are not 'kewees'. Other answers may be possible, as students may notice other characteristics.
- (**14, 16, and 18**) The student can follow the examples and try other even numbers. They would find the $8 + 10 + 12 = 30$; $10 + 12 + 14 = 36$; $12 + 14 + 16 = 42$. Then $14 + 16 + 18 = 48$. A student might notice the increase by 6 in each of the 3 sums and use that to reach 48.
- (**13 triangles**) It helps to number the small triangles as shown below.

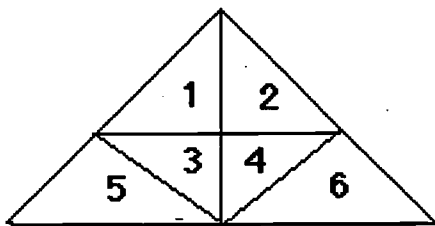

$1 \& 2 \& 3 \& 4 \& 5 \& 6 = 1$ large triangle
 $1; 2; 3; 4; 5; 6 = 6$ small triangles
 $1 \& 2; 1 \& 3; 3 \& 4; 2 \& 4 = 4$ double triangles
 $1 \& 3 \& 5; 2 \& 4 \& 6 = 2$ tri-triangles
 $1 + 6 + 4 + 2 = 13$ triangles.

SUPERSTARS III

Mars, XVI

Name: _____
(This shows my own thinking)

- ★ 1. How many more people like blue than red?

Favorite Colors	
Blue	●●●●●●●●●●●●●●
Green	●●●●●●●●
Red	●●●●●●●●●●
Yellow	●●●●

● = 2

Answer: _____ people

- ★★ 2. Patrick wants to make 6 bows for his Christmas presents. It takes 14 inches of ribbon to make each bow. The ribbon comes in spools of either 70 inches or 125 inches. Which size spool does Patrick need to buy?

Answer: _____

- ★★★ 3. There are four fewer pink crayons than blue crayons in the tub. There are five more blue crayons than brown crayons. There is one less brown crayon than red crayon. There are six red crayons. How many crayons in all are in the tub?

Answer: There are _____ crayons in the tub.

- ★★★ 4. Show how to use four of the "L-shapes" to the left below, to cover the square to the right. Color each "L-shape" a different color, inside the square.

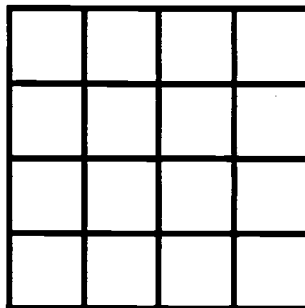
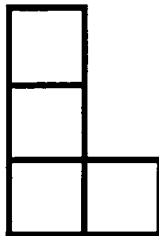

- ★ 5. Practice doing these problems mentally. When you turn in your paper, you will have a problem like these to do in your head.

a. $4 \times 100 =$ _____ b. $15 \times 10 =$ _____ c. $24 \times 10 =$ _____

Answer for the problem given later: _____

- ★★★★ 6. Find the *perimeter* and *area* of each rectangle. Then answer the questions below the grid.

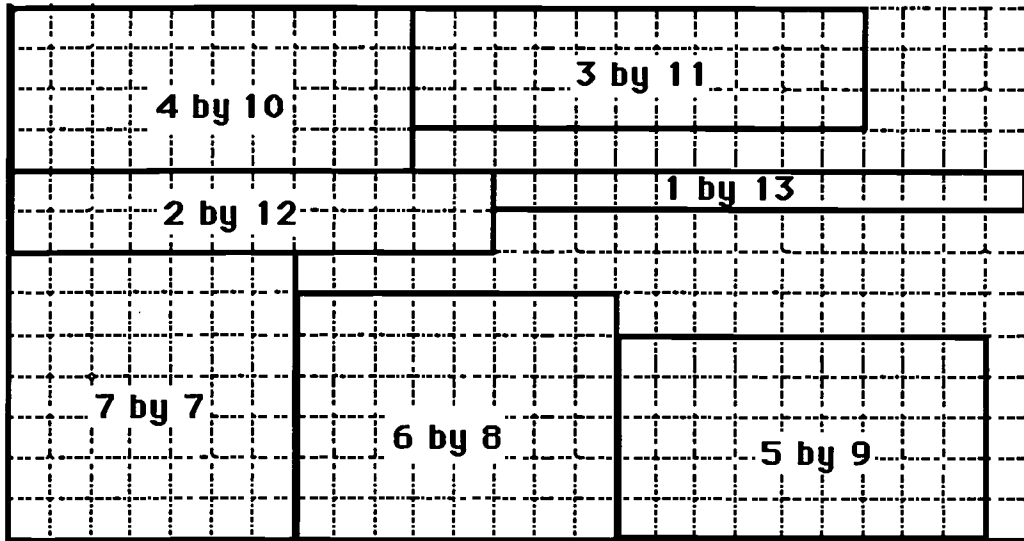

(a) Do all of the rectangles have the same *perimeter*? _____ If so, what is the perimeter? _____

(b) Do all of the rectangles have the same *area*? _____ If so, what is the area? _____

- ★★★ 7. Below each calculator, write a number sentence to give the answer shown. The symbols and digits to use are checked on each calculator.

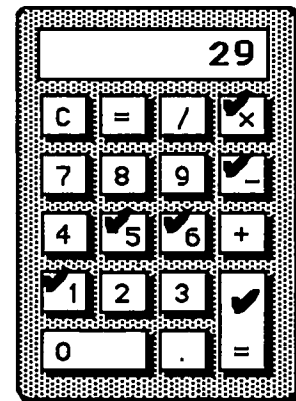
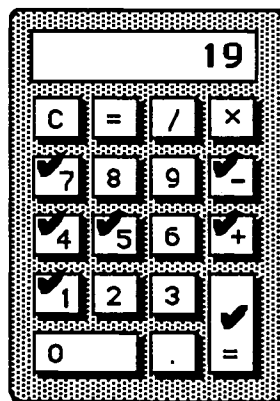
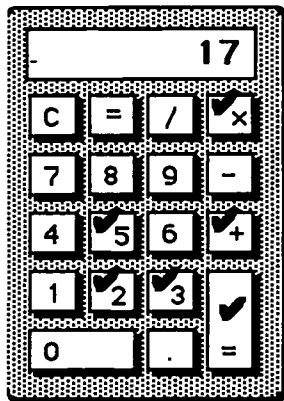

Commentary

Mars, XVI

1. (4) The problem has students read and interpret a graph with a key. Blue has two more dots than red, which indicates 2×2 more people.
2. (125-inch spool) The students can add 14 six times, or multiply 6×14 , to find that 84 inches of ribbon are needed. This is more than the 70-inch roll can supply.
3. (27) This problem encourages students to start a problem where it makes sense, not necessarily with the beginning words. Students can start with what they know -- there are 6 red crayons. Then they can determine the number of brown crayons from that (5), the number of blue crayons (10) from the number of brown, and finally the number of pink (6) from the number of blue.
4. One solution:

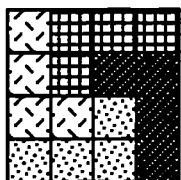

5. (420) Give the problem 42×10 to students as they hand in their papers. They should realize, after practice, that multiplying by ten simply appends a zero, and multiplying by 100 appends two zeros. This is extended, of course, to multiplying by any higher power of ten.
6. (a. Yes, 28; b. no) The problem points out to students that rectangles can have the same perimeter, or distance around the outside, but have different areas.
7. ($3 \times 5 + 2 = 17$; $17 + 4 - 5 = 16$; $6 \times 5 - 1 = 29$) Some students will come up with different, but equivalent, ways to write the number sentences.

SUPERSTARS III
Mars, XVII

Name: _____
(This shows my own thinking.)

- ★ 1. It takes 4 push-pins to hang 3 pictures if the pictures overlap. Ann is hanging up 8 pictures on the wall for her teacher. How many push-pins will Ann need if she overlaps the corners?

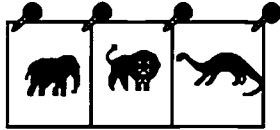

Answer: _____ push-pins

- ★★ 2. Mike has 8 more goldfish than Alan. Alan has 4 fewer goldfish than Suzie. Mike has 12 goldfish. How many goldfish do the 3 friends have all together ?

Answer: _____ goldfish

- ★★★ 3. Use the digits 5, 6, 7, and 8 to create three 4- digit numbers. Each digit can be used only 1 time in a number. Find the 3 highest possible numbers.

Answer: _____

- ★★★ 4. Find the area of the shaded figures below.

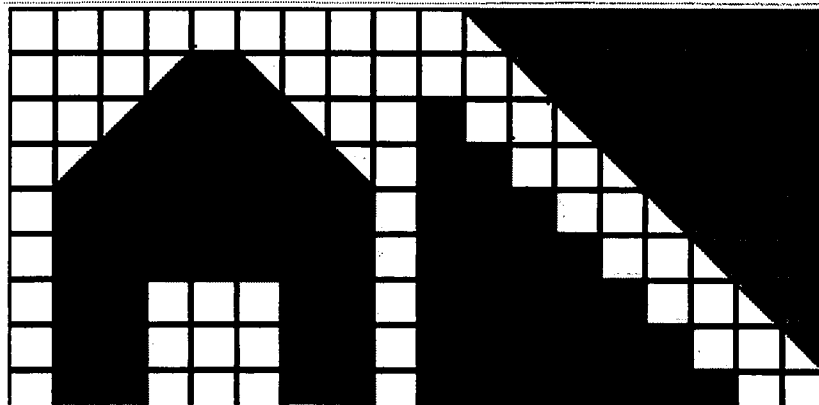

Answer: The garage has _____ ■'s.
The stairs have _____ ■'s.
The triangle has _____ ■'s.

★★★★

5. A family group of 6 went to a show. Tickets for adults are \$6. Tickets for children are \$4. The family spent \$30 for tickets. How many adult and children tickets did they buy?

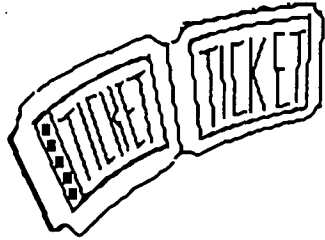

Answer: _____ adult tickets
 _____ children tickets

★★

6. The Tigers played 20 baseball games during the summer. They won 4 more games than they lost. How many games did they win? How many games did they lose?

Answer: _____ games won
 _____ games lost

★★

7. Use a ruler to measure the pencil below from eraser tip to point. Measure it in both centimeters and inches.



Answer: _____ centimeters
 _____ inches

★

8. Study the number crossword. One operation sign (+, -, ×, ÷) belongs in every circle. What operation sign belongs in the circles? Write it in all the circles.

4	○	2	=	8
○	■	○	■	○
4	○	1	=	4
=	■	=	■	=
16	○	2	=	32

Commentary

Mars, XVII

1. (9) The students may need to draw a picture with 8 rectangles and place a dot for the tacks to discover that 9 thumbtacks will be needed to hang all 8 pictures with overlapping corners.
2. (24) The problem states that Mike has 12 goldfish. This fact is used to find the number of Alan's goldfish. If Mike has 8 more than Alan, then Alan has 4 fish ($12 - 8 = 4$). Alan has 4 fewer than Suzie, or Suzie has 4 more than Alan, thus 8 goldfish. Then the student should add the fish together: $12 + 4 + 8 = 24$ goldfish.
3. (8765, 8756, and 8675) The student might first place the digits from greatest to least: 8765. Then if the 6 and 5 are exchanged, the second number is found: 8756. Since there is no other possibility with the 7 as the hundreds' digit, the student should use the 6: 8675. If the student exchanges the 7 and 5, he/she will find the next highest number, 8657, which is not needed for the answer. The student will become skilled with more problems like this one.
4. (Garage = 38 ■'s; Stairs = 28 ■'s; Triangle = 32 ■'s) The student will count the whole squares with little trouble. Then they must reason that 2 halves can be put together to make 1 whole square, and count the rest of the area of the garage and the triangle. Recounting is an excellent method for accuracy.
5. (3 adult and 3 children's' tickets) The *guess-and-check* strategy is excellent for this type of problem. The student might try 2 adult ($2 \times \$6 = \12) and 4 children ($4 \times \$4 = \16). But when \$12 and \$16 are added, \$28, not \$30, is the result. So another guess is needed. Trying 3 adult ($3 \times \$6 = \18) and 3 children ($3 \times \$4 = \12) gives the total of \$18 and \$12 which is \$30 -- the amount the family spent for the tickets!
6. (12 won, 8 lost) The student might make a list of the numbers that add to 20, since the wins and losses taken together must add to twenty. From the list, he/she could select the pair of numbers such that one number is four more than the other. A partial list is demonstrated below:

$$\begin{array}{llll} 10 + 10 = 20 & 10 - 10 = 0 & 13 + 7 = 20 & 13 - 7 = 3 \\ 4 + 6 = 20 & 14 - 6 = 8 & 12 + 8 = 20 & 12 - 8 = 4 \checkmark \\ 11 + 9 = 20 & 11 - 9 = 2 & & \end{array}$$

Some students will become skilled at doing such problems in their heads if they have a strong fact-base-knowledge.

7. (11 cm ; $4 \frac{5}{16}$ inches) The students should receive credit if their answers are close to the above numbers. Accept from 10.9 to 11.1 cm, and $4 \frac{1}{4}$ (or $4 \frac{4}{16}$) as alternate answers.
8. (×) The student might look at several of the equations to ensure that × is the correct sign. It is likely that, as the student places each of the other × signs in the circles, he/she will also check the mathematics quite naturally.

SUPERSTARS III

Mars, XVIII

Name: _____
(This shows my own thinking)

- ★ 1. Wednesday, Ashley practiced her gymnastic routine for 55 minutes. Thursday she practiced for 63 minutes. How much longer did she practice on Thursday than on Wednesday?

Answer: _____

- ★ 2. What is the least three-digit number with a 3 in the tens place?

Answer: _____

- ★★★★ 3. Below is a grid that represents Tracy's neighborhood. Each line is a street. The school is located at point (4,4) and Tracy's house is located at (6,8). Tracy only walks *down* a block or *to the left* a block when going to school.

How many different ways can Tracy to walk to school if he never goes more than 6 blocks?

Answer: _____ ways

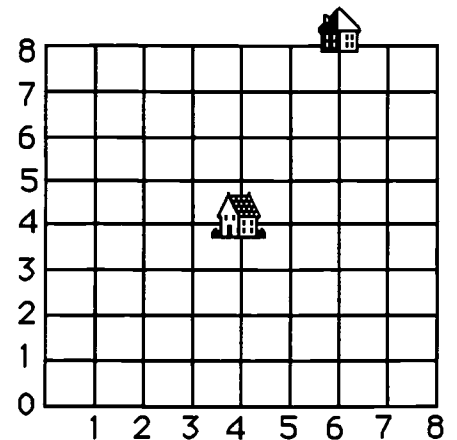

- ★★★ 4. Circle the measurement you would use for these items: (mL = milliliter; L = liter)

- a. fish tank 5 mL or 15 L
- b. medicine dropper 1 mL or 1L
- c. liquid soap bottle 70 mL or 70 L

- ★★★ 5. Darrell and Sara went to the library. On the table, there were twice as many art books as history books. There were two fewer history books than music books. There were four more music books than science books. There were four science books. How many books were on the table?

Answer: _____ books

★★★ 6. How many rectangles are in the figure?

Answer: _____ rectangles



★★ 7. A strategy to add numbers mentally is called *compensation*. You change one number to make it easy to use, then change the answer to *compensate*. This is how Abraham would add $39 + 15$:

"39 is 1 less than 40. $40 + 15 = 55$. 1 less than 55 is 54."

Practice these problems. You will be asked to work a problem mentally when you turn in your paper.

$$49 + 18 = \quad 27 + 29 = \quad 39 + 43 = \quad 56 + 29 =$$

Answer for the problem given later: _____

★★★ 8. Name a time when the hands of a clock form a right angle. Name a time when they form an acute angle. Name a time when they form an obtuse angle.

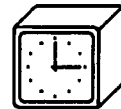

Answer: A right angle is at: _____

An acute angle is at: _____

An obtuse angle is at: _____

★★★ 9. For a waiter, 3 apples balance with 2 tomatoes. Also, 1 cup of soup balances 4 tomatoes. How many apples balance with 1 cup of soup? Draw them on the empty plate.

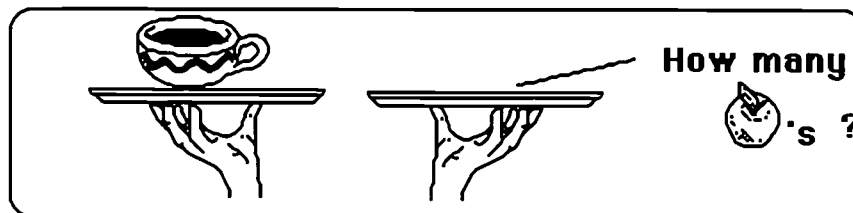
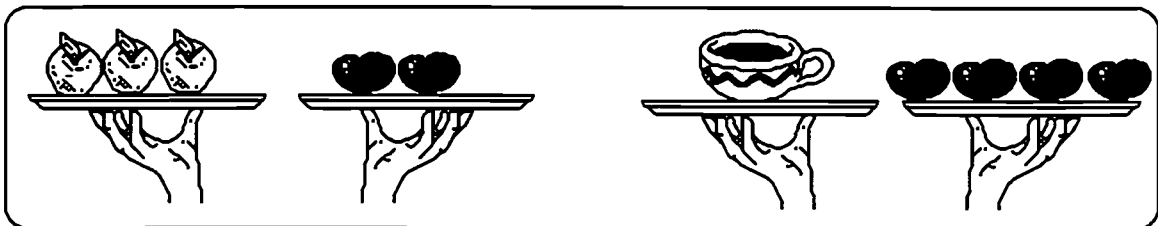

Commentary

Mars, XVIII

1. **(8 minutes)** This is a simple subtraction problem: $63 - 55$. Some students may solve it by *counting up* from 55 to 63.
2. **(130)** A 3-digit number is called for, and the smallest such would have a 1 in the hundreds place, and a zero in the units place.
3. **(12)** Most students will trace the 12 ways on the map itself. A more advanced way to solve the problem would be to label each move to the left as L, and each move down as D. Then the student must make 2 L's and 4 D's to get to school, and they can come in any order. So the question is "how many ways can you arrange 2 L's and 4 D's. The ways are shown below:

LLDDDD; LDLDDD; LDDLDD; LDDDL; LDDDDL;
DDDDL; DDDL; DDLDDL; DLDDL;
DDDL; DDL; DLL

4. **(a. 15L; b. 1mL; c. 70mL)** The problem tests the measuring sense of students. They might need to be reminded that a mL of water is about a large spoonful; a L of water is half a 2-liter bottle of soda .
5. **(30)** Work backwards by starting with what is known, the number of science books--4. Then find from that the number of music books--8. From that we know the number of history books--6, and then the number of art books--12. The total is 30.
6. **(15)** 1 large; 5 small; 4 rectangles made of 2 small; 3 rectangles made of 3 small; 2 rectangles made of 4 small.
7. **(93)** Give the problem $19 + 74 =$
8. **(right angle - 90 degree angle: 3:00; 9:00; and many others.)** As the minute hand moves 12 minutes, the hour hand moves one minute. Check students' answers carefully.
(acute angle - less than 90 degrees) Check individually.
(obtuse angle - more than 90 degrees) Check individually.
9. **(6)** In the top left picture, 3 apples balance 2 tomatoes. Therefore substitute 3 apples for two tomatoes twice in the right hand picture. In the bottom picture, 6 apples then balance with 1 cup of soup.

SUPERSTARS III

Mars, XIX

Name: _____
(This shows my own thinking.)

- ★★ 1. Find the missing numbers in the number sentences below.

a. $164 + x = 259$

b. $357 - y = 259$

Answer: a. $x =$ _____

b. $y =$ _____

- ★★★ 2. Tara's age is twice Sally's age. Joan is twice Tara's age. Tara is 12 years old. How old are Sally and Joan?

Answer: _____ Sally's age

_____ Joan's age

- ★★ 3. Mike is buying boxes of popcorn for himself and his friends at the movie theater. Each box of popcorn is \$1.25 plus 7¢ tax. How much does Mike spend on 3 boxes of popcorn?

Answer: \$ _____



- ★★ 4. Which is heavier, a box or a pyramid?

Answer: A _____ is heavier.

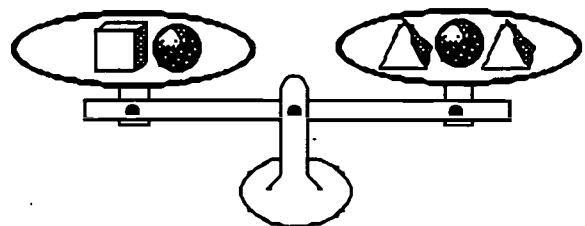

★★★★

5. How many rectangles are in this figure? Lettering them and listing them will help you find all the rectangles.

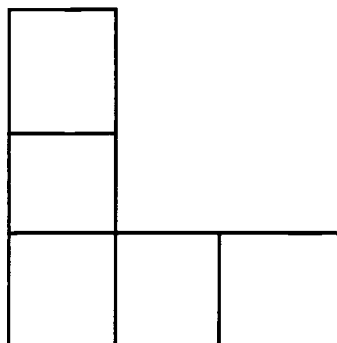

Answer: _____ rectangles.

★★ 6. Use the digits 2, 4, 6, and 8 to complete the two number sentences below. Use each number only once in each sentence. Find the number sentence with the greatest sum. Find a number sentence with the least sum. Write the numbers in the boxes.

$$\square \square + \square \square = \underline{\hspace{2cm}} \text{ (greatest)}$$

$$\square \square + \square \square = \underline{\hspace{2cm}} \text{ (least)}$$

★ 7. Tamika has a secret number. If you subtract her number from 16, the answer is the same as when you subtract 4 from 12. What is Tamika's secret number?

Answer: _____

★★★★

8. Sergiō played a game with bean bags on the playing mat to the right. He added the numbers from 3 throws to get his score. Each bag landed on a different number. His score was 101. On what 3 numbers did his bags land?

5	12	26
35		18
9	40	17

Answer: _____, _____, _____

Commentary

Mars, XIX

1. **(a. 95; b. 98)** The student can use subtraction to find both missing numbers. However, the student might add-on to the smaller number to get the larger number and keep count of how much was added.
2. **(Sally is 6 yrs; Joan is 24 yrs.)** The student can solve this problem by building on the fact that Tara is 12. If Tara's age is double Sally's age, then Sally's age is $12 \div 2 = 6$. If Joan's age is double Tara's age, then Joan's age is $12 \times 2 = 24$.
3. **(\$3.96)** The student can add the tax of 7¢ to $\$1.25$ to get $\$1.32$ for each popcorn box. The student can then add this amount 3 times or multiply by 3. A student might decide to find 3 times $\$1.25$ and then add the tax of 21¢ .
4. **(The box is heavier.)** Solving the problem requires intuition about a balance scale, but this same intuition will help in algebraic thinking. The student can see that the ball is on both sides of the scale; therefore, the ball can be removed and the scale will stay balanced. This means that a box balances two pyramids. Therefore a box is twice as heavy as a pyramid. This will seem strange to some students because there is an *inverse* relationship between the number of items of each and the relative weights.
5. **(11 rectangles)** Labeling the rectangles and listing them as shown below will help the student find them all.

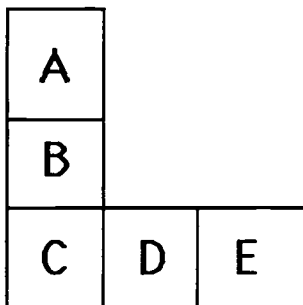

A, B, C, D, E; CD, DE, CDE; AB, BC, ABC

6. **(Greatest: $84 + 62$ or $82 + 64 = 146$; Least: $46 + 28$ or $26 + 48 = 74$)**
The student should place the largest numbers in the ten's place for the largest sum. The student should place the smallest numbers in the ten's place for the smallest sum.
7. **(8)** Reading the problem carefully is a key to success. When 4 is subtracted from 12, the answer is 8. If 8 is subtracted from 16, the answer is also 8. Therefore, the secret number is 8.
8. **(26, 35, 40)** The student might reason as follows. For a score of 101, some of the large numbers need to be chosen. If the student starts with the 2 largest numbers -- 35 and 40 -- the sum is 75. Then 26 is needed to reach 101. Some students might solve the problem the problem simply by *guess-check-revise*.

SUPERSTARS III
Mars, XX

Name: _____
(This shows my own thinking)

- ★ 1. Shayna needs some string to tie up 7 balloons. For each balloon she needs 24 inches of string. Should Shayna buy a 150-inch roll of string or a 200-inch roll?

Answer: _____

- ★★ 2. There were seven brothers and sisters in the Smith family. Five of them went to the theater while the rest stayed home. What fraction of the brothers and sisters went to the theater? What fraction stayed home?

Answer: _____ went to the theater; _____ stayed home.

- ★★★ 3. Rebecca and her brother together ordered a burger and fries, a Jr. salad, and two Cokes. How much money did they spend?

Answer: _____

MENU		
Served with fries:		
Burger	Grilled cheese	Chicken
\$3.50	\$2.95	\$4.50
Jr. Salad		Beverages
\$2.95		\$0.75

- ★★★★ 4. Amanda bought 8 stickers for her sticker book. She bought at least one of each kind. She paid \$0.42 for the stickers. What combination of stickers could she buy?

Answer: _____ animal; _____ sports; _____ space

Stickers	
Animals	6¢
Sports	7¢
Space	4¢

★★★ 5. Name the building located at each numbered pair:

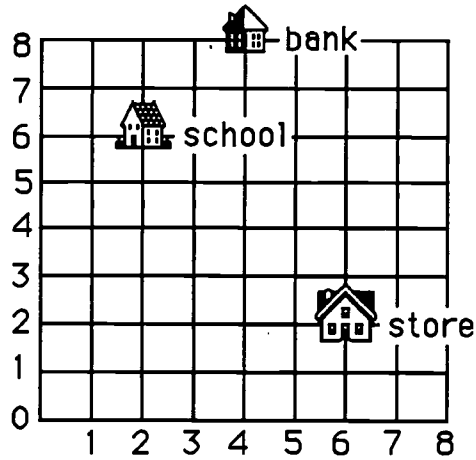

Answer: a. (2, 6) _____ b. (6, 2) _____ c. (4, 8) _____

★★★ 6. Circle the measurement you would choose for the following items:

- | | |
|----------------------|----------------|
| a. bag of potatoes | 5 oz or 5 LB |
| b. a slice of cheese | 1 oz or 10 LB |
| c. large dog | 70 oz or 70 LB |

★★★★ 7. The triangle weighs 5 ounces. The square weighs 4 ounces. How much does each circle weigh?

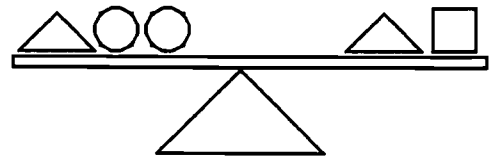

Answer: _____ ounces

★★ 8. Order the line segments from shortest to longest without measuring.

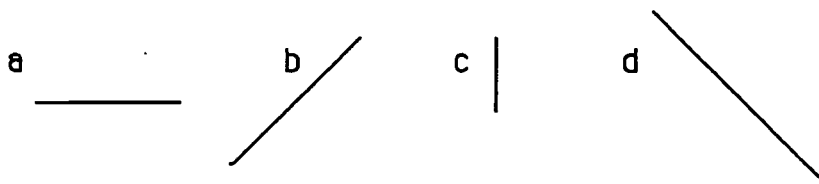

Answer: _____

Commentary

Mars, XX

1. **(200-inch roll)** An estimation strategy would be to round 24 to 25 and think of it in terms of money. Four 25's is 100 and three more is 75; so she will need about 175 inches and will therefore buy the 200-inch roll. The exact answer for how much she needs (168 inches) will be obtained by some students by adding or multiplying.
2. **($\frac{5}{7}$ of the children went to the theater; $\frac{2}{7}$ of the children stayed home.)** The problem is a part:whole ratio problem. Students might want to draw a diagram of the seven children, and partition it accordingly, to find the answer.
3. **(\$7.95)** The problem involves reading a menu and making decisions from the context of the story. The answer is found by adding \$3.50, \$2.95, \$0.75 and \$0.75.
4. **(2, 2, and 4)** *Guess-check-revise* or *make a list* are strategies that can be used with this problem. One creative approach is to notice that "one of each" means that the problem can be simplified by removing that much money (17¢) from the total, leaving 25¢ to be distributed among the three types. An answer of 1, 4 and 2 gives 42¢, but remember that 8 stickers were purchased.
5. **(a. school; b. store; c. bank)** The Cartesian coordinate system is used in this problem. The first number in each ordered pair tells the horizontal distance; the second number tells the vertical distance.
6. **(a. 5 LB; b. 1 oz. c. 70 LB)** This gives students the chance to demonstrate that they have real-world number sense. Unreasonable answers can be eliminated.
7. **(2)** Students should have intuitive knowledge about balance scales for this problem. Since the triangle is on both sides of the scale, it doesn't matter how much it weighs -- it can be removed and the scale still balances. Then the square and two circles must weigh the same amount. Therefore, one circle weighs half as much as a square.
8. **(c, a, b, d)** Visual estimation skills are required for this problem. Students might want to actually measure the lengths to check their estimations.

SUPERSTARS III

Mars, XXI

Name: _____
 (This shows my own thinking.)

- ★ 1. Todd has a number riddle for Bill. Solve it.

I am an odd number. I am greater than the sum of 6 and 9. I am less than the sum of 9 and 9. What number am I?

Answer: _____

- ★★ 2. Maria had 28 pogs. Her brother, José, had 12 pogs. Maria gave some of her pogs to José. Now they have the same number of pogs. How many pogs do they each have now?

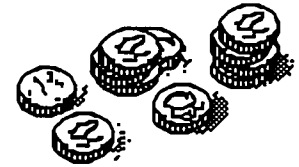

Answer: _____ pogs each

- ★★★ 3. A *right angle* is exactly like the corner of a postcard. An *acute angle* is smaller than a right angle. An *obtuse angle* is larger than a right angle. Each angle is illustrated below. Study them a while and then write inside the angles: *acute*, *right*, or *obtuse*.

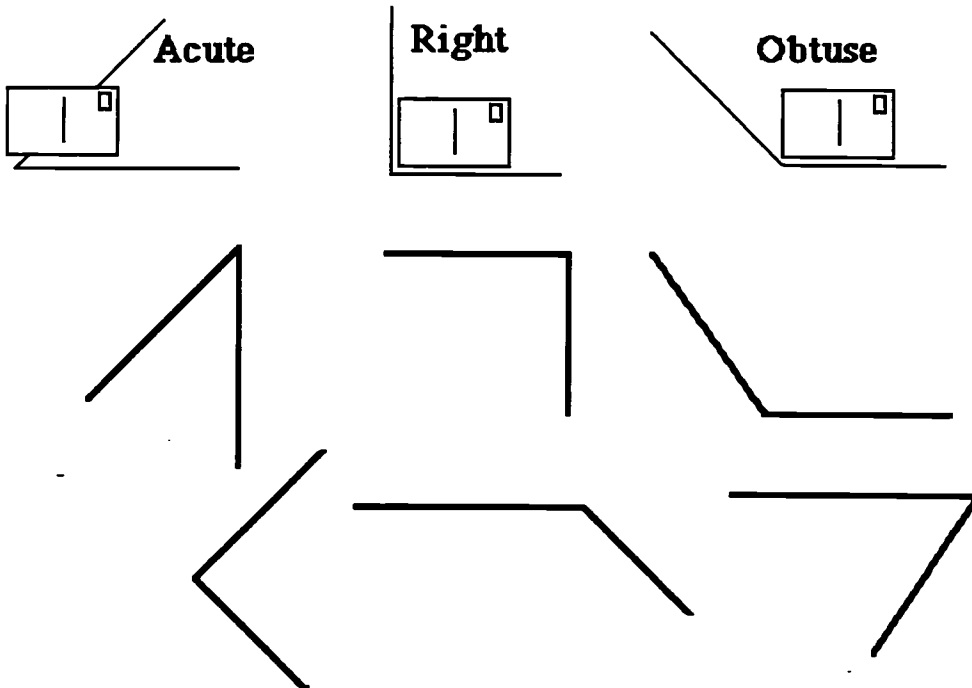

- ★ 4. Find the missing number in this number sentence. Write the number in the box.

$$634 - \square = 509$$

- ★★ 5. Circle the best estimate of the total number of milliliters in all these test tubes. Each test tube holds 59 milliliters.

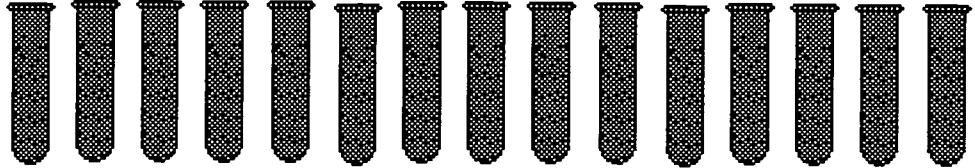

Answer choices:

- a. 59 milliliters b. 60 milliliters c. 1000 milliliters d. 900 milliliters

- ★★★★ 6. Mr. Brown is building 6 shelves in his garage. Each shelf is 8 feet long and costs \$2 per foot. He buys 12 brackets to hang the shelves for \$2 each. How much does he spend for his shelves and brackets?

Answer: _____

- ★★★ 7. What digits would make the sentences true? List each possible number.

a. $562 > 5 \square 2$ Answer: _____

b. $385 < 38 \square$ Answer: _____

c. $472 = \square 72$ Answer: _____

- ★★★ 8. Make 3 rectangles or squares that have a perimeter of 20 units. The *perimeter* is the distance around the edge of a shape. Shade your shapes so that they can be seen easily.

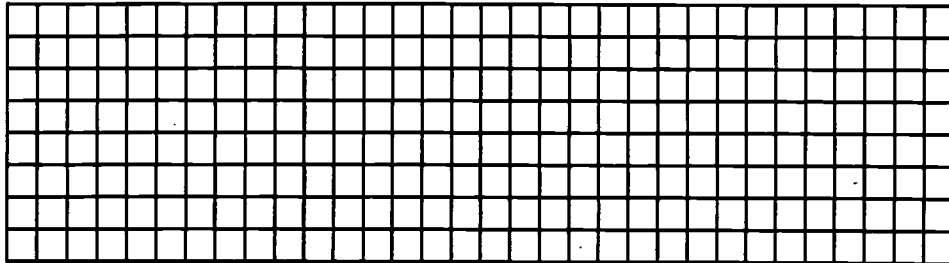

Commentary

Mars, XXI

1. (17) Adding 6 and 9 gives 15. Adding 9 and 9 gives 18. So the odd number is between 15 and 18, making the number 17.
2. (20 pogs) The student needs to find out how many pogs Maria and José have together, so $28 + 12 = 40$. If they have the same number of pogs after Maria gives some pogs to José, then the total of 40 must be divided in half. $40 \div 2 = 20$, so each one has 20 pogs. Some students may solve the problem without computation by simply giving one pog at a time from Maria to José until they both have the same number: 20.
3. (See the answers below.) Most students would use the example angles to help in identification. The students should be encouraged to actually use a sheet of paper with a square corner as an aid.

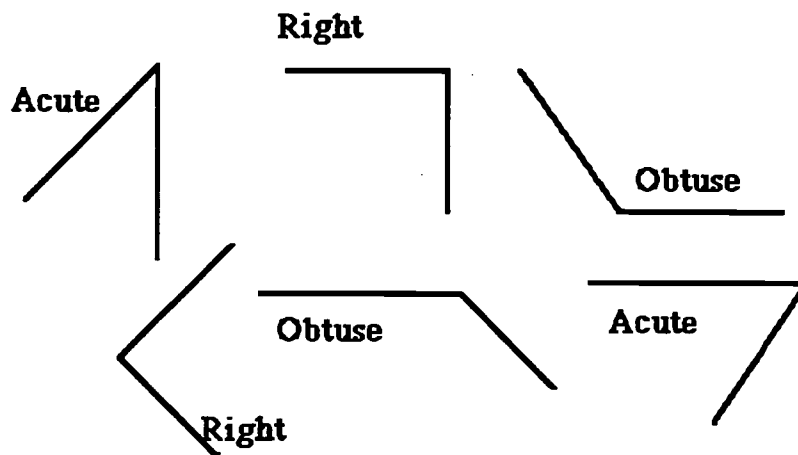

4. (125) Students can either *count up* from 509 to 634 and remember how many they counted, or subtract 509 from 634. Perhaps the most difficult way, but one that many students will use, is to align the problem vertically as in a subtraction problem. This way they find the digits one-at-a-time, going from right to left using the subtraction algorithm.
5. (900) There are many ways for students to estimate the answer. One method is to think of 59 milliliters as 60 milliliters, and then ten of the tubes would hold about 600 milliliters, and the next five tubes would hold half that, or 300 milliliters. All together 15 tubes would hold 900 milliliters.
6. (\$120) Each of the 6 shelves measures 8 feet, so the total feet would be $6 \times 8 = 48$ feet. Each foot of shelving costs \$2 so the 48 feet must be added twice or multiplied by \$2 (\$96). The cost of the brackets can be found by adding \$2 twelve times or multiplying 12 by \$2 (\$24). The last step is to add \$96 and \$24 to find the total Mr. Brown spent.
7. (a. 5, 4, 3, 2, 1, 0) All digits less than 6 will work.
(b. 6, 7, 8, 9) All digits greater than 5 will work.
(c. 4) For the numbers to be equal, the digits must all be the same.
8. (The choices are a 5×5 square; or 7×3 , 4×6 , 2×8 , or 1×9 rectangles.)

SUPERSTARS III

Mars, XXII

Name: _____
(This shows my own thinking)

- ★★★ 1. Watch how Marcus divides in his head:

To do $24 \div 2$, I follow these steps:

1st: $20 \div 2 = 10$

2nd: $4 \div 2 = 2$

3rd: $10 + 2 = 12$

So $24 \div 2 = 12$



Practice these problems the way Marcus does them. You will be asked to solve a division problem mentally when you turn in your paper.

$84 \div 2 =$

$43 \div 2 =$

$36 \div 2 =$

Answer for later problem: _____

- ★★ 2. Draw a figure with 8 sides and 8 angles.

- ★★★ 3. How many squares are inside the circle?

Answer: _____

How many squares are inside the rectangle?

Answer: _____

How many squares are inside the circle and the rectangle?

Answer: _____

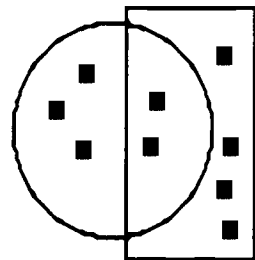

★★★★

4. How much does each item weigh?

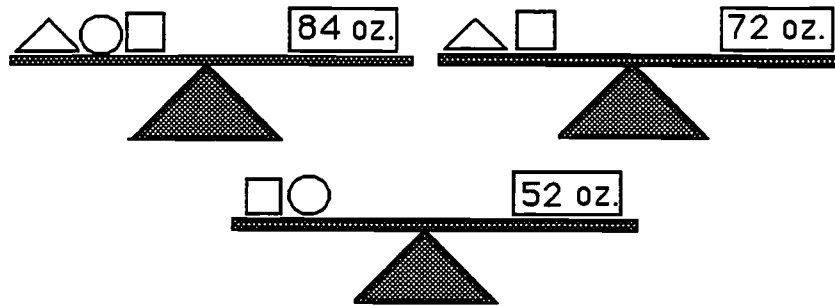

Answer: Triangle: ____ oz. Square: ____ oz. Circle: ____ oz.

★ 5. Matthew brought paper cups for the class party. He used 12 for juice, 17 for soft drinks, and 5 for milk. How many cups were used?

Answer: _____ cups

★★★★

6. Amberly's mother said she could order one sandwich and one drink from the menu. How many different combinations can Amberly order?

<u>Sandwiches</u>	<u>Drinks</u>
Hamburger	Iced tea
Reuben	Soft drink
Grilled cheese	Milk

Answer: _____

★★ 7. The third grade class needs to make cocoa to serve 36 people. How many cups of milk will they need?

Answer: _____ cups

<i>Party Cocoa</i>	
<i>18 servings</i>	
1 cup cocoa	2 cups water
1 cup sugar	12 cups milk
pinch of salt	18 marshmallows

★★ 8. At Wright Elementary, many children walk to school. Janie walks $\frac{1}{2}$ mile. Katie walks $\frac{1}{3}$ mile. Joshua walks $\frac{1}{4}$ mile. Who has the longest walk?

Answer: _____

Commentary

Mars, XXII

1. **(13)** Give the problem $39 \div 3$.
2. **(Any octagonal shape is acceptable)**
3. **(5 inside the circle; 6 inside the rectangle; 2 inside the circle and the rectangle)** The problem involves a Venn diagram. Students first find the number in each separate shape, disregarding the other. Then they find the number of squares in the overlapping area, meaning in both the circle and rectangle.
4. **(triangle -- 32; square -- 40; circle -- 12)** The following is one way to solve the problem -- there are others. The top right scale shows that a triangle and square weigh 72 together. This value (72) can then be substituted for the square and triangle in the top left scale, indicating that the circle plus 72 must weigh 84. Therefore, the circle weighs $84 - 72$ or 12. Then in the bottom scale, 12 can be substituted for the circle. You know that the square plus 12 is 52, therefore the square is $52 - 12$ or 40. Substituting 40 for the square in the top right diagram, the triangle is then $72 - 40$ or 32.
5. **(34 cups)** This is a simple addition problem.
6. **(9)** Students might draw a picture or make a list. Match the hamburger with each drink for 3 combinations. Then match the Reuben with each drink for another 3 combinations. Finally, match the grilled cheese with each drink for the last 3 combinations.
7. **(24)** The recipe is for 18 servings, so it must be doubled to serve 36. Therefore the amount of milk needed must also be doubled.
8. **(Janie walks the farthest at $\frac{1}{2}$ mile)** Students might want to take 3 strings the same length each representing 1 mile. If they then divide each string into either halves, thirds, or fourths, they can cut off $\frac{1}{2}$, $\frac{1}{3}$, and $\frac{1}{4}$ and compare the lengths.

SUPERSTARS III

Mars, XXIII

Name: _____
(This shows my own thinking.)

- ★★ 1. Find the missing digits in each problem. Write the numbers in the boxes.

$$\begin{array}{r} \text{a.} \quad 2 \quad \square \quad 4 \\ + \quad \square \quad 6 \quad \square \\ \hline 7 \quad 2 \quad 1 \end{array}$$

$$\begin{array}{r} \text{b.} \quad 7 \quad \square \quad 1 \\ - \quad \square \quad 4 \quad \square \\ \hline 8 \quad 6 \end{array}$$

- ★ 2. Mrs. Smith is trying to organize her computer disks. She has 46 disks to place in boxes. Each box holds 10 disks. How many boxes does she need to store her disks?

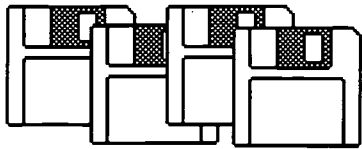

Answer: _____ boxes

- ★★★ 3. John has drawn the stars below. He has asked you to find what fraction each type of star is of the whole group of stars.



Answer: _____ White star _____ Striped star _____ Shaded star

Commentary

Mars, XXIII

- $$\begin{array}{r} 254 \\ + 467 \\ \hline 721 \end{array} \quad \begin{array}{r} 731 \\ - 645 \\ \hline 86 \end{array})$$

The student can use knowledge of addition and subtraction facts and regrouping to solve the problems. Some students may need several tries.
- (5) Students might count by tens to 40 or 50. If only 4 boxes were used, 6 disks would not be protected. Therefore the 5th box is necessary.
- ($\frac{4}{12}$ - white; $\frac{5}{12}$ - striped; $\frac{3}{12}$ - shaded) First the total number of stars is needed for this part-whole situation. Next the number of each different kind of star can be counted and that number compared to the total in the whole group.
- (5 bicycles and 1 tricycle or 2 bicycles and 3 tricycles) The student might use an organized *guess-and-check* strategy, as shown below.

$$\begin{array}{l} 2b + 3t = 4 + 9 = 13 \text{ wheels} \checkmark \\ 3b + 2t = 6 + 2 = 12 \text{ wheels} \\ 4b + 2t = 8 + 6 = 14 \text{ wheels} \\ 5b + 2t = 10 + 6 = 16 \text{ wheels} \\ 5b + 1t = 10 + 3 = 13 \text{ wheels} \checkmark \end{array}$$

- (The answer not given for #4 is called for here.) The purpose of this extension to the previous problem is to show students that many times there are several solutions to a mathematics problem.
- (5, 2, 4, 1, 3) The student might actually write someone a letter and check the steps.
- (34, 35) The student might use an "educated" *guess-and-check* strategy. Reasoning that half of 60 is 30, the page numbers must be around 30. The numbers must also be consecutive. Then 30 + 31, 31 + 32, 32 + 33, 33 + 34, and 34 + 35 can be tried until the numbers add to 69 (34 + 35).

Some students might actually thumb through a book, until they find page numbers that sum to 69. If so, they might notice an interesting pattern in any book they pick up. The odd numbers are always on the right, and the even numbers always on the left. This is because books always begin with page 1 on the right-hand side.

- (See the graph)

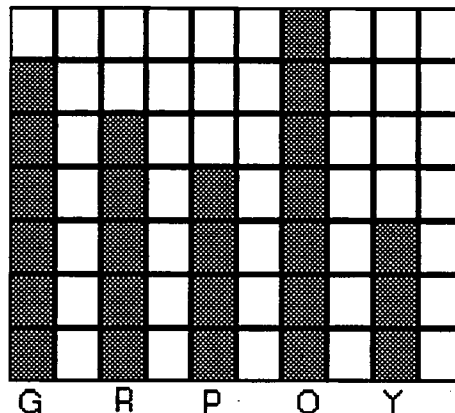

SUPERSTARS III

Mars, XXIV

Name: _____

(This shows my own thinking)

- ★★ 1. Write the starting number in the box.

$$\left(\square + 6 - 4 \right) \times 3 = 21$$

- ★★ 2. Look at the pattern below. How many small squares would make the next largest square?

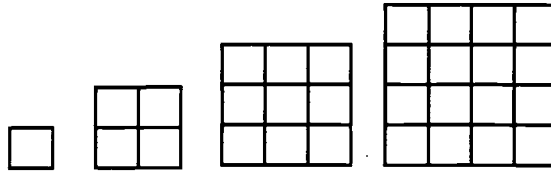

Answer: _____ squares

- ★★★ 3. Mia weighs 75 pounds. Her mother weighs 132 pounds, and her father weighs 184 pounds. The paddle boat can hold 400 pounds. Can Mia and her parents ride at the same time?

Answer: _____

- ★★★★ 4. Each pencil weighs 3 ounces. What could the ruler and the glue weigh? Find as many solutions as you can. Fill in the chart.

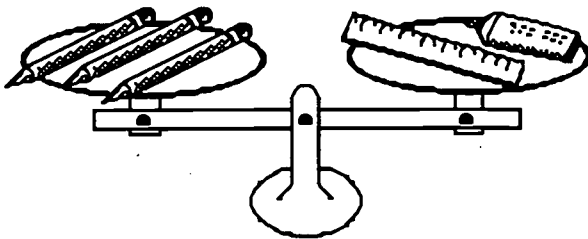

ruler	glue

- ★★★ 5. Fold a piece of paper in half twice. Punch 4 holes in the center. How many holes are in the paper when unfolded?

Answer: _____

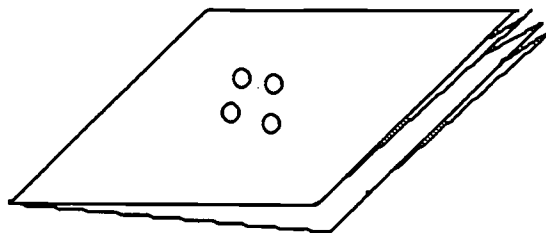

- ★★ 6. Look at the pattern in the puzzle. Complete the puzzle with the correct shapes.

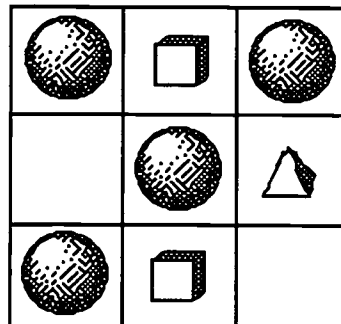

- ★★★ 7. Watch how Marcus adds when one number ends in 9:

To add 48 and 39, first notice that 39 is real close to 40, and 40 is easy to add. So I turn 39 into 40 by adding 1. Then I add $48 + 40$ in my head to get 88. Now I subtract 1 from 88 since I really had 39 to add instead of 40. So $48 + 39$ is 87.



You will be asked to add a problem in your head when you turn in your paper. Practice on these:

$29 + 67$

$38 + 19$

$39 + 25$

$34 + 49$

Answer for later problem: _____

- ★★★★ 8. Write a decimal and a fraction for each part of a dollar below:

a. one cent: _____ c. one nickel: _____

b. one dime: _____ d. one quarter: _____

Commentary

Mars, XXIV

- (5) Students might work backwards by asking: "What number do I multiply by three to get 21? -- It's 7". Then, "What number minus 4 gives 7? -- It's 11". "What number when added to 6 gives 11? -- It's 5." Therefore 5 is the starting number. Another way to solve the problem is to *guess-check-revise*.
- (25) The pattern involves the *square numbers*. These are the numbers 1, 4, 9, 25, 36, and so on. Students might want to draw the next square, which would have 5 small squares on each side.
- (yes) They weigh 391 pounds all together, so they could all get in the boat that holds 400 pounds.
- (See chart below.) Each pencil weighs 3 ounces, so the left-hand pan has 9 ounces. Therefore the ruler and glue together weigh 9 ounces. The student has to find different ways to have 9 ounces. Most will not choose fractions, although that is possible.

ruler	glue
1	8
2	7
3	6
4	5
5	4
6	3
7	2
8	1

Give 1 star for every 2 answers. They may not be arranged in an orderly fashion, as they are in the chart on the left.

- (16) The number of holes doubles with each fold. The problem can be extended to several more folds.
- The two missing figures are checked. If the students come up with a different pattern, have them justify their solution.

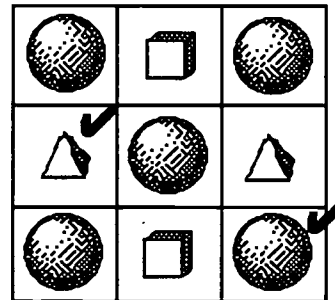

- (65) Give this problem: $36 + 29$
- (a. 0.01 and $\frac{1}{100}$; b. 0.10 and $\frac{10}{100}$; c. 0.05 and $\frac{5}{100}$; d. 0.25 and $\frac{25}{100}$)
This problem is accessible to students if they think of writing the coin values using a dollar sign. Students might give fractional names other than the ones above, such as $1/10$, $1/20$, and $1/4$ for the dime, nickel, and quarter, respectively.

SUPERSTARS III

Mars, XXV

Name: _____

(This shows my own thinking.)

- ★★ 1. Find the value of ■ and ▲. Use the two number sentences below for clues.

$$\blacksquare + \blacksquare + \blacktriangle = 12 \quad \text{and also} \quad \blacktriangle + \blacktriangle + \blacksquare = 15$$

Answer: ■ is _____ ▲ is _____

- ★★★ 2. Write the answers in the _____ in each sentence below.

- Paul saw 5 chickens and 6 cows. He saw _____ legs in all.
- Sue counted 26 legs. She saw 4 cows and _____ chickens.
- Pam counted 40 legs. She saw _____ cows and 8 chickens.

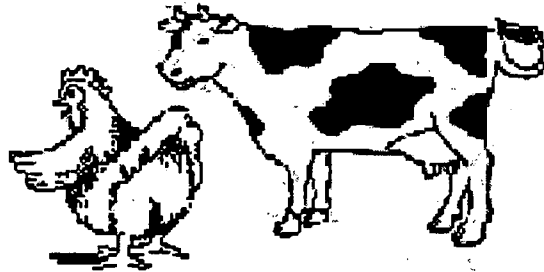

- ★★ 3. Estimate the length of the arrow in centimeters. Then measure the arrow with a ruler. Record both answers.

Answer: Estimate: _____ cm

Actual: _____ cm

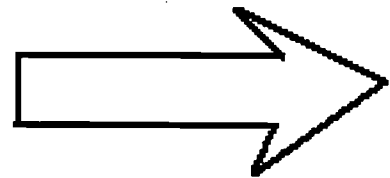

- ★★★ 4. Count the cubes to find the *volume* of the steps. Remember there are some cubes you cannot see.

Answer: The volume is _____ cubes.

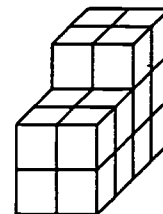

- ★ 5. Study the sequence and fill in the missing numbers.

1, 7, 5, 11, 9, 15, 13, _____, _____, 23, _____

- ★★★ 6. Pam's mother baked a pie for her family. It was divided into 6 pieces. Pam's Dad ate $\frac{1}{2}$ of the pie. Mom ate $\frac{1}{3}$ and Pam ate $\frac{1}{6}$ of the pie. How many pieces did each person eat?

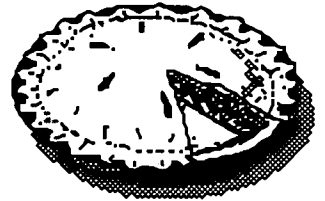

Answer:

Dad: _____ pieces; Mom: _____ pieces; Pam: _____ pieces.

- ★★★ 7. This spinner is divided into 8 parts. Sally and her friends are going to use it to play "Spin the Sum." Study the spinner and the questions. Write your answer as a fraction:

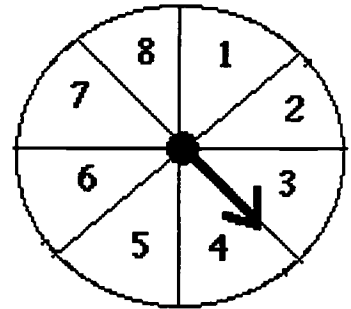

- a. What are the chances of getting a spin higher than 4?
- b. What are the chances of getting a spin higher than 6?
- c. What are the chances of getting a spin lower than 4?

- ★★★ 8. Make 3 rectangles with different lengths and widths. Each rectangle should have an *area* of 24 's.

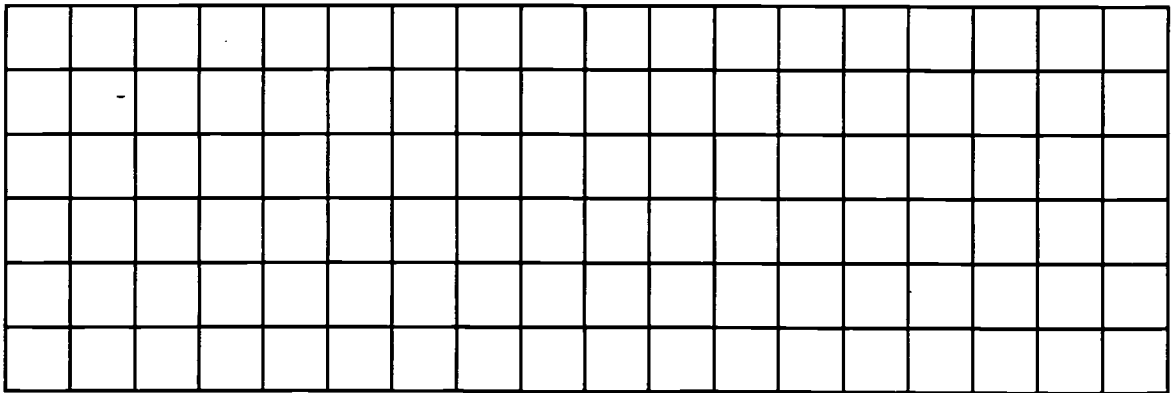

Commentary

Mars, XXV

- (■ is 3; ▲ is 6)** The student can use a *guess-and-check* strategy. If a 4 is used for the ■, then ▲ would also be 4 in the first sentence; but in the second sentence, $4 + 4 + 4 \neq 15$. If 5 is tried for ■ in the first sentence, then ▲ is 2 and the second sentence is again false: $5 + 5 + 2 \neq 15$. When 3 is tried as ■, then ▲ would be 6 from the first sentence, and the second sentence is then true: $6 + 6 + 3 = 15$.
- (a. 34; b. 5; c. 6)** In (a), the student might multiply to get the total number of legs for each kind of animal, and then add: 5×2 plus 6×4 totals 34 legs. Another method is for the student to draw the animals as stick figures and simply count the legs. Similar methods of drawing 26 legs, making 4 four-legged cows, and counting the rest as two-legged chickens, will solve (b). Or the student might multiply 4×4 and subtract the total from 26 to get 10 legs left, and divide by 2 to have 5 chickens. Similar reasoning will produce the answer to (c).
- (accept 4 - 6 cm as a good estimate; 5 cm is the actual measurement)** Students should be encouraged to remember and use a "personal benchmark" for estimating common measures. For example, the width of their finger is about a centimeter. Extra practice using metric measure will make students better at estimating centimeters.
- (20)** The students might physically build this set of stairs if they have trouble visualizing the hidden cubes. They can think of the shape as a set of layers and count the cubes in each layer. The 4 cubes on top are easy to see, and that should help the student visualize the cubes in the other 2 layers. That would give a total of $4 + 8 + 8 = 20$ cubes.
- (19, 17, 21)** Using addition and subtraction to find differences between terms, the repeated procedure of adding 6 and then subtracting 2 will be discovered. Following this procedure: add 6 to 13 and put 19 in the first blank. Take 2 from 19 and put 17 in the second blank. Adding 6 to 17 gives the 23. Take 2 from 23 for 21 in the last blank.
- (3; 2; 1)** Drawing the pie cut into 6 pieces is a natural way to begin this problem. Then $\frac{1}{2}$ of the pie is seen as 3 pieces. Then $\frac{1}{3}$ of the pie is 2 pieces and $\frac{1}{6}$ of the pie is 1 piece. For students who might need more than a drawing, encourage them to cut a circle from cardboard for the pie, divide it into 6 pieces, and use the physical model to find the answers.
- (a. $\frac{4}{8}$ or $\frac{1}{2}$)** The numbers higher than 4 are 5, 6, 7, and 8, or four of the eight sections.
(b. $\frac{2}{8}$ or $\frac{1}{4}$) The numbers higher than 6 are 7 and 8, or two of the eight sections.
(c. $\frac{3}{8}$) The numbers lower than 4 are 1, 2, and 3, or three of the eight sections.
Note: Students should not be expected to find the lowest terms fraction.
- (Rectangles of 2×12 ; 3×8 ; and 4×6)** The 1×24 rectangle with this same area cannot be drawn on this grid. Arrangements will differ from that shown below..

Areas of 24 squares

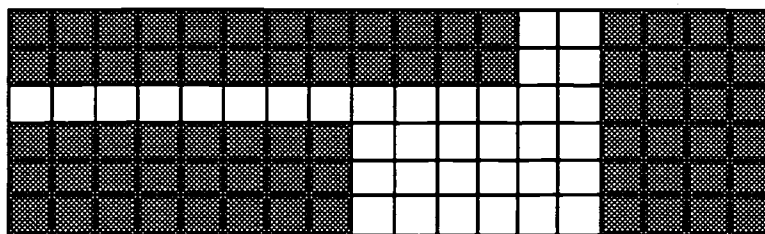

Super Stars



Mercury



Venus



Earth



Mars



Jupiter



Saturn



Uranus



Neptune



Pluto

BEST COPY AVAILABLE



Public Schools of North Carolina
State Board of Education
Department of Public Instruction
Division of Instructional Services

★ ACKNOWLEDGMENTS ★

This project, originally designated *Sunshine Math*, is the third in a series of problem solving programs. It was conceived, coordinated and developed through the Florida Department of Education with input from the mathematics staff members of the North Carolina Department of Public Instruction and the South Carolina Department of Education. In addition, it was supported financially through a grant to the School Board of Polk County, Florida. The rich history of these materials and the predecessor programs, **SUPERSTARS** and **SUPERSTARS II** goes back to the early 1980's. Many Florida teachers have been involved in developing and using these materials over the years. The original **SUPERSTARS** programs were adopted and adapted by North Carolina and South Carolina with their teachers contributing to revisions and personalizations for use in their states. Florida educators were primarily responsible for developing, field testing, and publishing *Sunshine Math*. Educators from the Carolinas developed the **MathStars Newsletter** to accompany and enhance this program.

School districts in North Carolina have permission to reproduce this document for use in their schools for non-profit educational purposes. Copies of each grade level are available from the publications unit of the North Carolina Department of Public Instruction. The contact for **SUPERSTARS III** and the **MathStars Newsletter** is Linda Patch, 301 North Wilmington Street, Raleigh, NC 27601-2825 : (919-715-2225).

Michael E. Ward
State Superintendent
North Carolina Department of Public Instruction

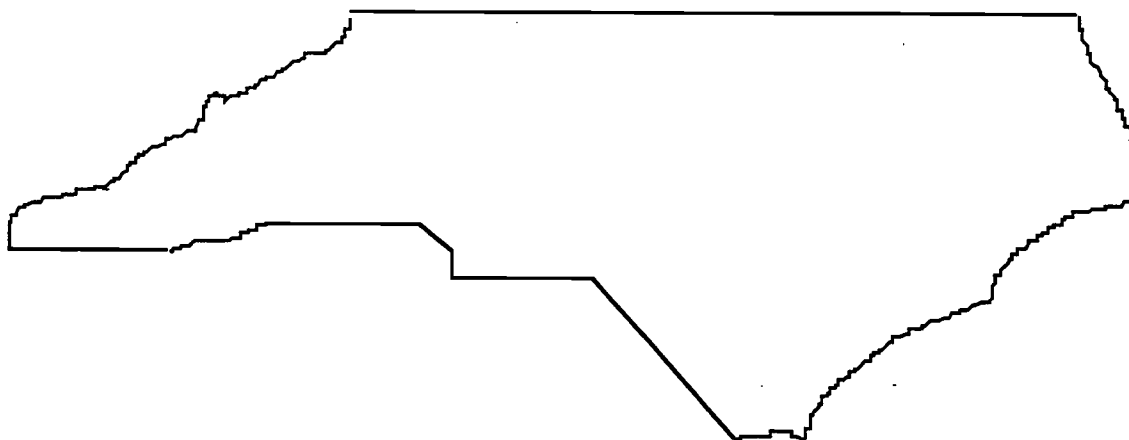

BEST COPY AVAILABLE

☆ *Preface* ☆

SUPERSTARS III encourages and enhances the positive aspects of students, parents, teachers and administrators working together. This program assumes that students, even young children, are capable of and interested in learning; that teachers want to help them learn to think for themselves; that administrators see their jobs as clearing the path so that quality education is delivered effectively in their schools; and that parents care about their child's learning and are willing to work with the school system toward that goal. Each of these four groups has a vital role to play in implementing **SUPERSTARS III**.

The designer of this program has a long history of working with elementary children. He believes that they are capable of much more than we ask of them, and that many children are on the path to becoming independent learners. A number of children in any classroom are bright, energetic and willing to accept extra challenges.

The basic purpose of **SUPERSTARS III** is to provide the extra challenge that self-motivated students need in mathematics, and to do so in a structured, long-term program that does not impinge on the normal classroom routine or the time of the teacher. The system is not meant to replace any aspect of the school curriculum -- it is offered as a peripheral opportunity for students who identify with challenges and who want to be rewarded for their extra effort. Participation in the program is always optional -- only those students who voluntarily choose to participate will, in the long run, benefit from **SUPERSTARS III**. Any student, regardless of prior academic performance, should be encouraged to participate as long as interest is maintained.

The predecessor program for **SUPERSTARS III** -- the **SUPERSTARS II** program -- has demonstrated that this concept can be extremely useful. What is required are several dedicated adults who devote a few hours each week to operate the system effectively in the school; an administrator who provides highly visible support; teachers who welcome a supplementary experience for their students to engage in higher-order thinking; and a typical classroom of students. If all of those ingredients are present **SUPERSTARS III** will become an integral part of the school fabric.

ORGANIZATION OF THESE MATERIALS

Section I Description of the SUPERSTARS III Program

1. General Information
2. Information/checklist for principals
3. Information/checklist for assisting adults
4. Information for teachers
5. Letter to participating students and their parents.

Section II Student worksheets for SUPERSTARS III

SUPERSTARS III
Jupiter, XXII

Name: _____
(This shows my own thinking.)

**1. If the 24th day of the month falls on Saturday, on what day did the 6th fall?

Answer: _____

**2. There are 4 six-packs of soda in a case. Chris bought 12 of a case and gave 13 of what he had to Dana. How many cans of soda does Chris have left?

Answer: _____ cans

**3. Together, 6 boys and 12 girls weigh 1050 pounds. The boys all weigh the same --r pounds. Each girl weighs 55 pounds. What is the weight of one boy?

bbbbbb sssssssssssss

Answer: r = _____ pounds

**4. The sum of 3 consecutive numbers is 276. What are the numbers?
(Consecutive numbers differ by one; example: 8, 9, and 10)

Answer: _____ and _____

**5. If a family of 12 spiders wore shoes, how many pairs of shoes would they need?

Answer: _____ pairs.



**6. A tropical storm passed through the town. It began to rain Monday morning at 8:45 AM and did not stop until the next day at 2:30 PM. How long did it rain?

Answer: _____ hours and _____ minutes



**7. There are 3 cars, 4 bicycles, 2 tricycles, and 1 unicycle in the neighbor's garage. How many wheels are there in all? Forget about any "space tires"!

Answer: _____ wheels

**8. Rosemary bought a sweater on sale for \$6.98. She also bought a shirt for \$9.99. She paid an additional \$1.19 for sales tax. Rosemary gave the sales person a \$20 bill. How much change should she receive?

Answer: _____



**9. Study this pattern. 25 and also 32 would be in column E, if the pattern continued.

a. In which column would 100 appear?
b. In which column would 50 appear?
c. In which column would 1000 appear?

21	22
14	15
16	17
18	19
20	7
8	9
10	11
12	13
0	1
2	3
4	5
6	A
A	B
B	C
C	D
D	E
E	F
F	G

Section III Commentary for student worksheets for SUPERSTARS III

Commentary
Jupiter, XXII

1. (Tuesday) Students can use a calendar or make a chart with "Su, M, T, W, Th, F, Sa" at the top and begin numbering backward putting 24 under Saturday. They may also realize that the 17th and 10th fall on Saturdays and count back from the 10th.
2. (8) Students can solve this problem by drawing a diagram or by visualizing 24 cans. 1/2 of 24 is 12, and 1/3 of 12 is 4. Therefore Chris gave away 4 of the 12 sodas, leaving 8.
3. (65) Students will probably solve this by first finding the total weight of the 12 girls: 12 x 55 = 660 pounds. Then they will compute 1050 - 660 = 390 pounds, the weight of the 6 boys. Then 390 ÷ 6 = 65 pounds per boy.
4. (91, 92, 93) Students may use the guess-check- revise method. Some students might know that the numbers they seek are about 1/3 of the total, and approximate the numbers by dividing 276 by 3. This gives 92, which is the middle number.
5. (48) Students may want to draw a picture to help solve this problem. Spiders have 8 legs, which would be 4 pairs of shoes per spider.
6. (29 hours and 45 minutes) Most students will realize that from 8:45 AM to 8:45 AM the next day, is 24 hours. They will then "add on" 5 additional hours to get to 9:45, 10:45, 11:45, 12:45, and 1:45, and then 45 minutes to get to 2:30 PM.
7. (27) There would be 12 wheels on the 3 cars, 8 on the 4 bicycles, 6 on the 2 tricycles, and 1 on the unicycle.
8. (\$18.16) Students will probably add \$6.98 and \$9.99 to get \$16.97, then add the tax of \$1.19 to get \$18.16. They will subtract this amount from \$20.
9. (a, C); b, D; c, G) Hopefully, students will notice that the multiples of 7 are in column A and use this fact to get "close to" the numbers 100, 500, and 1,000. Ninety-eight (14 x 7) is the closest multiple of 7 less than 100, so 98 would be in column A, forcing 100 to be in column C. Likewise, 497 or 71 x 7 is in column A, putting 500 in column D. Finally, 994 or 142 x 7 is in A, indicating that 1000 is in column G.

BEST COPY AVAILABLE

SUPERSTARS III: General Information

SUPERSTARS III is a K-8 program designed as an enrichment opportunity for self-directed learners in mathematics. The levels of the program are named for the planets in our solar system:

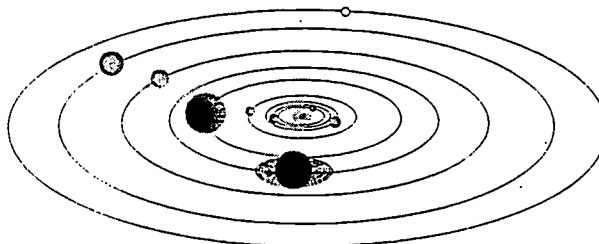

Kindergarten	Mercury	Fourth Grade	Jupiter
First Grade	Venus	Fifth Grade	Saturn
Second Grade	Earth	Sixth Grade	Uranus
Third Grade	Mars	Seventh Grade	Neptune
	Eighth Grade	Pluto	

Students of all ability levels choose on their own to participate in **SUPERSTARS III**. Seeing their names displayed in a prominent place in the school, with a string of stars indicating their success, is one reward students receive for their extra work. In some cases the school may decide to enhance this basic system by awarding certificates of achievement or some other form of recognition to highlight certain levels of success or participation in the **SUPERSTARS III** program.

SUPERSTARS III can function in a school in a number of different ways. A “tried and true” way is for assisting adults (volunteers, aides, etc.) to manage the program for the entire school, with support provided by school administrators and classroom teachers. This system has been adopted at the school level, with varying degrees of success, over the years. The basic model for conducting **SUPERSTARS III** is discussed below, with variations described on the next page.

The basic model

The basic model for **SUPERSTARS III** is for a school to establish a weekly cycle at the beginning of the academic year according to the following guidelines:

On Monday of each week student worksheets are distributed by the assisting adults to students in the program. Students have until Friday to complete the problems working entirely on their own. On Friday the classroom teacher holds a brief problem-solving session for the students in the program. The more difficult problems on the worksheet are discussed with students describing their thinking about strategies to solve the problems. They do not share solutions, only strategies.

Students receive double credit for those problems they have successfully completed prior to the problem-solving session, and regular credit for those they complete successfully over the week-end. On Monday all papers are handed in, checked by the assisting adult, and stars are posted for problems successfully completed. This completes one cycle of the **SUPERSTARS III** program.

SUPERSTARS III is not for every child -- it is only for those who are self-motivated and who are not easily frustrated by challenging situations. This does not diminish the value of the program, but rather makes us realize that there are children of all ability and socio-economic levels who are self-directed learners and who need challenges beyond those of the regular school day. These children will shine in **SUPERSTARS III**.

Variations of the basic model

The first variation that has been used successfully retains the weekly cycle and assisting adult role from the basic model. The teacher however, involves the entire class in the problem-solving discussions. For example, the teacher might select the four most difficult problems on the worksheet (indicated by three or four stars) and work a "parallel" problem with the entire class to open the mathematics lesson on Tuesday through Friday. Using this variation, all students are exposed to the problem-solving strategies, but only those who have chosen to participate in **SUPERSTARS III** will complete and turn in the worksheet on Monday.

A second variation has the assisting adult manage the entire program, including the Friday problem-solving session. This method has been used in situations where teachers lacked commitment to the program and thus implemented it inconsistently. In such cases, the assisting adult must have a progressive view of what constitutes problem solving in elementary mathematics. They should also receive extra assistance from the administration to ensure that students are released from class and that the cycles proceed smoothly.

Yet another variation is for a parent to manage **SUPERSTARS III** at home for his or her own child. The basic rules are the same -- a child gets the worksheet once a week and time to work the problems alone. The parent sets a night to listen to the way the child thought about each problem, offering suggestions or strategies only when the child is unable to proceed. The reward system is basically the same, stars on a chart, but can be enhanced by doing something special with the child, such as a trip to the museum or to a sporting event when the child reaches certain levels of success. If this method is adopted, the parent must not try to teach the child, but rather to stimulate discussion of problem-solving strategies. **SUPERSTARS III** is not a program for adults to teach children how to think.

Other variations exist. The basic model as stated is the best, all other factors being equal, for reaching more children in a consistent fashion than any of the other methods. However, we encourage individual schools, teachers, or parents to get some version started; some starlight is better than none.

SUPERSTARS III: Information for Principals

SUPERSTARS III is a K-8 enrichment package for mathematics designed to be managed by volunteer assisting adults with coordinated support from the classroom teacher and school administrators. The purpose of the program is to give self-motivated students of all ability levels a chance to extend themselves beyond the standard mathematics curriculum. The complete set of materials comes in nine packages, one for each grade K-8. The grade levels are identified by the names of the nine planets in our solar system and their order from the sun:

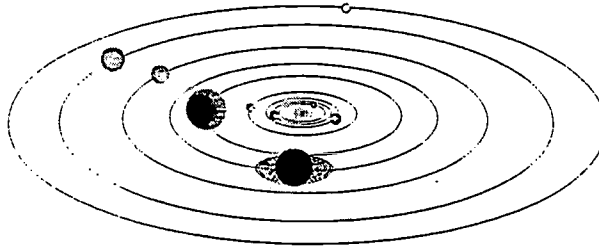

Mercury - Kindergarten

Earth - Second Grade

Jupiter - Fourth Grade

Uranus - Sixth Grade

Venus - First Grade

Mars - Third Grade

Saturn - Fifth Grade

Neptune - Seventh Grade

Pluto - Eighth Grade.

Your support is vital if this program is to succeed. As the school administrator, you need to stay in close contact with the **SUPERSTARS III** program. A "checklist for success" follows:

- Become familiar with the philosophy and component parts of the program.
- Introduce **SUPERSTARS III** to the faculty early in the school year. Ensure that teachers understand the philosophy of the program and have copies of the student worksheets and commentaries appropriate for their grade levels.
- Speak to parents at your school's first open house of the year, explaining the purpose of **SUPERSTARS III** and the long term value of children working independently on challenging problems.
- Recruit several assisting adults (PTA members, aides, senior citizens, business partners, church members, etc.) who are enthusiastic, dependable people who are willing to manage the program. Early in the academic year, meet with these assisting adults to plan such details as:
 - ✓ A prominent place and format for the STAR CHART.

- ✓ A designated time and place each Monday and Friday for the assisting adults to be in school to meet with students, distribute and collect worksheets, and post stars.
- ✓ A system for the activity sheets to be duplicated each week.
- ✓ A plan for extra incentives for accumulating stars. (“World records” to be kept from year-to-year, a celebration day planned for the end of school, prizes earned by students for attaining certain levels of success -- see the diagram below for examples.)
- ✓ A schedule for the initiation of the program and a decision as to a “start over” point later in the academic year. Review the school calendar and only use weeks that are at least four days long. If there is not enough time in the year to complete all the activity sheets, decide which to eliminate or on a plan to “double up.”
- ✓ A **SUPERSTARS III** cap, name badge, tee-shirt, or other distinction for volunteers, if possible.
- Monitor the program every two weeks to get ahead of unforeseen difficulties. Administrators need to be highly visible and supportive for **SUPERSTARS** to succeed.

SUPERSTARS III is an optional program for students. It should be available to any student who wants to participate, regardless of prior success in mathematics. Typically, a large number of students will begin the program, but a majority will lose interest. A significant number however, will continue their efforts over the life of the program. This is normal and simply means that **SUPERSTARS III** is successfully addressing the needs of the self-directed learner.

Visual reminders help children see this mathematics program is challenging and rewarding. Some ideas are presented here:

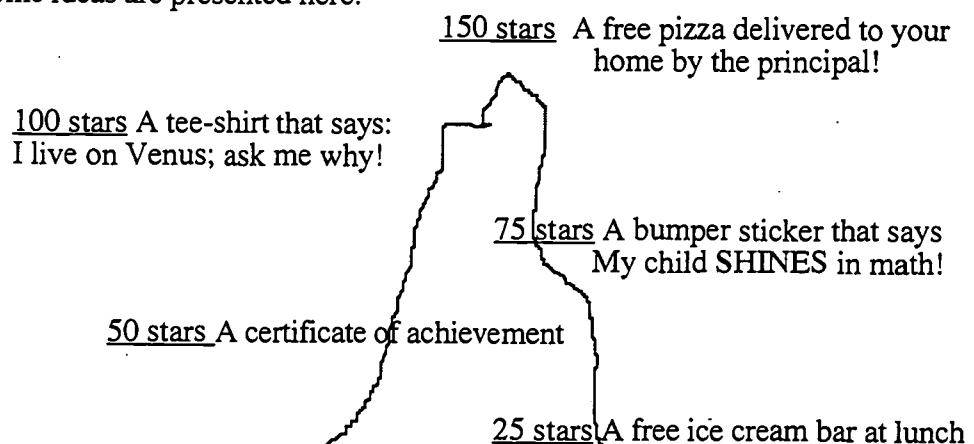

Climb the Mountain this Year!! Join the **SUPERSTARS III** Club

SUPERSTARS III: Information for Assisting Adults

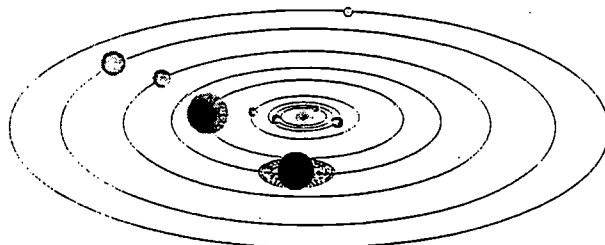

SUPERSTARS III is designed to give assisting adults a well-defined role to play in the school's mathematics program. The success of **SUPERSTARS III** depends upon a team effort among teachers, administrators, parents and you. Reliability and punctuality are important - students will quickly come to depend upon you to be there as scheduled, to check their papers and post their stars, and to listen to alternate strategies and interpretations of problems to help them arrive at solutions. If possible, wear an outfit or badge that fits with the **SUPERSTARS III** theme or logo; students will soon identify you as an important person in their school.



SUPERSTARS III works on a weekly cycle. Each Monday you will collect the worksheets from the previous week and distribute new worksheets to the participating students, all from your **SUPERSTARS III** area of the school. Allow students to see the answers to the problems, discuss any for which their answers differ and allow them credit if their interpretation and reasoning are sound. After checking all the work, you will post the stars earned by students on the STAR CHART.



Participating students have from Monday until Friday to work the problems entirely on their own -- the only help they should receive during that time is for someone to read the problems to them. On Friday the teacher will host a problem-solving session in the classroom where students will describe the strategies they used to approach the more difficult problems. Students who have successfully completed problems before this session will receive double points for their efforts. The teacher's initials on the worksheet will help you identify those problems. The students then have the week-end to complete or correct their problems and turn them in on Monday. All the correct problems thus completed will receive the indicated number of stars.



Be creative when designing your STAR CHART. The basic method of posting stars individually is a good way to begin but eventually you will want a more efficient system. Color coding by grade level, or posting just one star each week with a number in its center are ideas to consider. You may wish to personalize the chart and the entire **SUPERSTARS III** center with student pictures, "smiling faces", a logo, seasonal theme or some other feature that has a mathematical flavor. Occasionally feature a reward for each child such as a cookie or a hand stamp in the shape of a star just for turning in the worksheet. You are helping enthusiastic students develop high-level thinking skills -- be creative and enjoy your role!

Checklist for assisting adults:

- Plan the following with the principal:
- ✓ A prominent place and format for the

STAR CHART

- ✓ The time and place for you to collect, check, and distribute worksheets.
- ✓ A system for duplicating worksheets each week which ensures legible copies. Also a secure storage area for masters and other materials.
- ✓ Any additional incentives ("world records," stickers, coupons, pencils, tee-shirts, etc.) that will be part of the system for rewarding levels of achievement in **SUPERSTARS III**.



- Make the **SUPERSTARS III** center a happy place. Use bright colors, smiles, and cheerful expressions. Show confidence, friendliness, and encouragement to students.



- Collect the letters that are sent home prior to the first worksheet. These need to be signed by each student and a parent. If, in the future, you have evidence that the work submitted does not represent the thinking of the student, discuss the situation with the classroom teacher. These situations are best handled individually, confidentially and in a firm, consistent manner.



- Check the worksheets from the previous week uniformly. If you give partial credit for a problem with several parts do so in a fair way that can be understood by the students. Do not award partial credit for problems with only one answer.



- Have answer sheets available and encourage students to look at the solutions when they submit their worksheets. Allow them to explain their strategy or interpretation if they have arrived at a different answer. Award full credit if they show a unique and plausible interpretation of a problem and follow sound logic in arriving at their response.



- Leave extra worksheets with the classroom teacher for participating students who were absent on Monday. Accept a late-arriving worksheet only if the student was absent on Monday. If a student's name is missing or in the wrong place on the worksheet, check the paper but award stars to "No Name" on the STAR CHART. Adhering strictly to these rules will rapidly teach responsibility to the students and keep your work manageable.



- Keep all returned worksheets. As the same problems are used year after year, and many students have siblings who may later participate in **SUPERSTARS III**, it is important that worksheets do not circulate.



- On weeks when **SUPERSTARS III** is not available post a notice such as "No star problems this week, but please come back after vacation for more!"

SUPERSTARS III: Information for Teachers

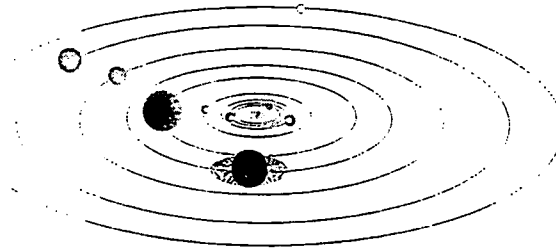

SUPERSTARS III is a program designed to complement your regular classroom mathematics curriculum. It offers a supplemental opportunity for students to practice mathematics skills appropriate for their grade level and at the same time to engage in challenging problem-solving activities. It is an additional challenge to those students who are self-directed learners providing them with an academic extracurricular activity.



Your involvement is essentially as a teacher. SUPERSTARS III will remain special to students if it is managed by someone outside of the classroom and if the teacher is viewed as a facilitator in the system, rather than as the authority figure. Your primary role is to monitor the system in your own classroom and to host a brief problem-solving session for SUPERSTARS III students on Friday of each week. You will also need to release the participating students from your class at a set time on Mondays to enable them to turn in completed work and receive new problem sets. You might make a special pin or banner for Mondays and Fridays to remind students that those days are special.

SUPERSTARS III
Jupiter, XXII

Name: _____
(This shows my own thinking.)

**#1. If the 24th day of the month falls on Saturday, on what day did the 6th fall?
 Answer: _____

***2. There are 4 six-packs of soda in a case. Chris bought 12 of a case and gave 13 of what he had to Dan. How many cans of soda does Chris have left?
 Answer: _____ cans

**#3. Together, 6 boys and 12 girls weigh 1050 pounds. The boys all weigh the same -- pounds. Each girl weighs 55 pounds. What is the weight of one boy?
 bbbbbb cccccccccc
 Answer: s = _____ pounds

**#4. The sum of 3 consecutive numbers is 276. What are the numbers?
(Consecutive numbers differ by one; example: 8, 9, and 10)
 Answer: _____ and _____

**#5. If a family of 12 spiders were shoes, how many pairs of shoes would they need?
 Answer: _____ pairs.

Commentary
Jupiter, XXII

1. (Tuesday) Students can use a calendar or make a chart with "Su, M, T, W, Th, F, Sa" at the top and begin numbering backward putting 24 under Saturday. They may also realize that the 17th and 10th fall on Saturdays and count back from the 10th.

2. (8) Students can solve this problem by drawing a diagram or by visualizing 24 cans. 1/2 of 24 is 12, and 1/3 of 12 is 4. Therefore Chris gave away 4 of the 12 sodas, leaving 8.

3. (65) Students will probably solve this by first finding the total weight of the 12 girls: $12 \times 55 = 660$ pounds. Then they will compute $1050 - 660 = 390$ pounds, the weight of the 6 boys. Then $390 \div 6 = 65$ pounds per boy.

4. (91, 92, 93) Students may use the guess-check-revise method. Some students might know that the numbers they seek are about 1/3 of the total, and approximate the numbers by dividing 276 by 3. This gives 92, which is the middle number.

5. (48) Students may want to draw a picture to help solve this problem. Spiders have 8 legs, which would be 4 pairs of shoes per spider.

6. (29 hours and 45 minutes) Most students will realize that from 8:45 AM to 8:45 AM the next day is 24 hours. They will then "add on" 5 additional hours to get to 9:45, 10:45, 11:45, 12:45, and 1:45, and then a 45 minutes to get to 2:30 PM.

7. (27) There would be 12 wheels on the 3 cars, 8 on the 4 bicycles, 6 on the 2 tricycles, and 1 on the unicycle.

8. (\$1.84) Students will probably add \$6.98 and \$9.99 to get \$16.97, then add the tax of \$1.19 to get \$18.16. They will subtract this amount from \$20.

9. (a, C; b, D; c, G) Hopefully, students will notice that the multiples of 7 are in column A and use this fact to get "close to" the numbers 100, 300, and 1,000. Ninety-eight (14×7) is the closest multiple of 7 less than 100, so 98 would be in column A, forcing 100 to be in column C. Likewise, $497 \div 7 = 71$ is in column A, putting 500 in column D. Finally, $994 \div 142 \times 7$ is in A, indicating that 1000 is in column G.

Each student worksheet has an accompanying commentary page. This sheet provides hints on parallel problems which you might use in the Friday problem-solving session. It is important that students participate actively in this session, and that you

solicit from them their unique and varied approaches to the problems discussed. Only after students have presented their ideas should you provide guidance on the problems and then only if they are having difficulty. Even though there is a commentary provided for each problem, you will have to decide which two to four problems you will cover during this brief session. Concentrate on those which provide a new or unfamiliar strategy. The problem-solving session should last no more than 15 minutes.



Do not be disappointed if a large number of your students begin **SUPERSTARS III** and then significant numbers drop out after a few weeks. This is normal; problem solving requires a great deal of effort and not every student is ready for this challenge. On the other hand, you will notice that some students will choose to stay with **SUPERSTARS III** week after week even though they are not as successful as other students at earning stars. Their participation should be encouraged as they are certainly learning from the experience. Under no circumstances should **SUPERSTARS III** be reserved only for the advanced students in your class.



As a purely practical consideration, students are not to discuss the problems among themselves or with their families prior to the Friday cooperative group session. This allows the “think time” necessary for students to develop into independent thinkers; it also prevents students from earning stars for work that is basically someone else’s -- the surest way to disrupt the entire **SUPERSTARS III** program. As the teacher you must monitor this in your classroom and ensure that students abide by the established rule.



It is important that you understand and support the overall philosophy of **SUPERSTARS III**. Do not worry if students encounter problems for which they have not been prepared in class -- such is the nature of true problem solving. Do not provide remedial instruction to ensure that students master certain types of problems. They will meet these same problem types repeatedly in the program. They will likely learn them on their own and from listening to other students at the problem-solving sessions. Enjoy what the students can do and don’t worry about what they can’t do. Read the general information and philosophy of the program to see how your role fits into the complete system.

Here are some thoughts you might find useful in your support for **SUPERSTARS III**:



- Allow your students to leave the classroom at the designated time on Mondays to turn in their worksheets and pick up new ones.



- Read each week's worksheet and feel free to structure classroom activities that parallel those in the **SUPERSTARS III** problems.



- During the school week students may be allowed to work on their **SUPERSTARS III** problems during their free time, but the only help they may receive is for someone to read the problems to them. Give the students one warning if you find them discussing the worksheets, and take away their papers for the next violation. If it happens another time, suspend them from the program for a month.



- At the Friday problem-solving sessions remember these points:

- Students come to this session with their worksheets, but without pencils.
- The session should be brief -- 15 minutes at most. Discuss only the two to four most difficult problems.
- Help students summarize their own approaches to the problems in a non-judgmental fashion. Offer your own approach last, and only if it is different from the students' strategies. Do not allow answers to be given to the problems.
- End the session by encouraging students to complete the problems over the weekend. Put your initials beside any problem discussed in class which a student has already successfully completed. The assisting adult will award double stars for these.



Remember that part of the **SUPERSTARS III** philosophy is that students learn responsibility by following the rules of the system. If participation is important to them they will adhere to the rules about where their names go on each paper, no credit awarded if they forget their paper on Monday, and no talking about problems prior to the problem-solving session.



Enjoy **SUPERSTARS III**. Students will impress you with their ability to think and their creative ways to solve problems that appear to be above their level or beyond their experience.



Dear Student,

Welcome to **SUPERSTARS III**, a program designed to enhance your journey through mathematics. Be prepared to face challenging problems which require *thinking!* As you work through the system you will experience many types of problems, stretching and expanding your brainpower in many exciting ways!

Expect to receive one worksheet at the beginning of each week. You will have the rest of the week to think about the problems and come up with strategies for their solutions. The thinking and solutions must be **YOUR VERY OWN!!!** Once a week you will attend a help session to discuss the most challenging problems for the week.

Your journey will be recorded by charting the stars you earn. Each problem is ranked according to its level of difficulty. The more stars you see beside a problem, the higher its level of difficulty and, of course, the more stars you can earn for solving it. You can earn double stars for solving a problem before the weekly sessions.

Your signature is just the beginning.

Good luck as you embark upon this mathematical adventure! The rewards will last a lifetime!



I am ready to begin the **SUPERSTARS III** program. All of the answers I submit will represent my own thinking.

Name: _____





Dear Parents,

Welcome to **SUPERSTARS III**, a program designed to enhance your child's journey through mathematics. By expressing an interest in challenging problem solving experiences, your student has taken the first step toward becoming an independent learner who is willing to address many types of problems.

On Mondays a **SUPERSTARS III** worksheet will be distributed to each child in the program. Each problem in the set is ranked according to its level of difficulty. As the number of stars increases, so does the level of difficulty and the earned stars to be awarded.

Each Friday a help session will be conducted to discuss the most challenging problems of the week. Any problem solved prior to the session will be given double stars. After the session, problems may be reworked before they are submitted the following Monday.

Your role in **SUPERSTARS III** is to encourage and facilitate problem solving. Feel free to offer guidance toward certain strategies, to read the problems to your child, but please, do not give them the answers. In order for this program to be effective, the students must work independently. The thinking must be their own!

It is normal for a student not to be able to complete every problem on every worksheet. The process of interpreting, understanding, and trying different strategies is valuable in the attainment of mathematical power. Remember, no student is expected to know the answer to every problem.

Thank you for allowing your child to embark upon this mathematical adventure; the rewards should last a lifetime!

_____ signature

Parent/Guardian of _____



After you have had a chance to review and use these materials, please take a moment to let us know if the **SUPERSTARS III** material has been useful to you. Your evaluation and feedback is important to us as we continue to work on additional curriculum materials. Please respond to:

Linda Patch
 Mathematics & Science Section
 NC Department of Public Instruction
 301 N. Wilmington Street
 Raleigh, NC 27601-2825

Indicate the extent to which you agree with statements 1-4.

	Strongly Disagree		Neither Agree nor Disagree		Strongly Agree
1. The materials will be helpful in teaching the mathematics goals and objectives set forth in the NC Standard Course of Study.	1	2	3	4	5
2. The materials are appropriate for the grade level indicated.	1	2	3	4	5
3. The problems are interesting and engaging for the students I teach.	1	2	3	4	5
4. The commentaries will encourage use of this material.	1	2	3	4	5
5. I plan to use these materials with my students in grade_____.					
6. Have you ever used earlier versions of the SUPERSTARS material?	YES		NO		

7. How was this program implemented with your students?

8. Additional comments:

SUPERSTARS III

Jupiter, I

Name: _____

(This shows my own thinking.)

- ★★★★ 1. The students in Mr. Renick's 4th grade class started a mathematics club and a science club. They drew a Venn diagram to show which students were in each club. Use the Venn diagram below to answer the questions about the clubs.

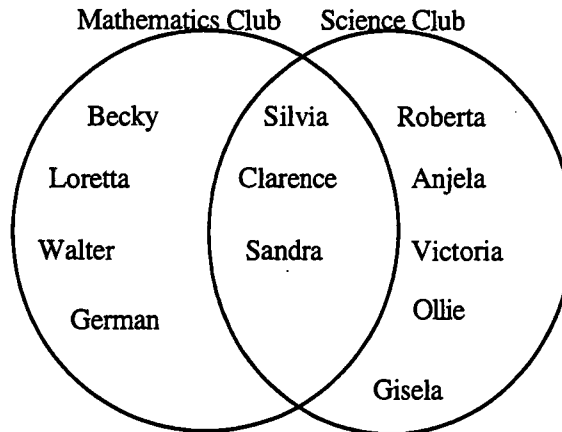

- (a) How many students were in the mathematics club? _____
- (b) How many students were in the science club? _____
- (c) How many students were in both clubs? _____
- (d) If one-half of Mr. Renick's class is in either the math club or the science club or both clubs, what is the total number of students in Mr. Renick's class? _____
- ★★ 2. How many right angles are in this picture of intersecting square frames, including the background?



Answer: _____ right angles

- ★ 3. If the 7th day of a month is on Friday, on what day is the 24th day of the same month?

Answer: _____

★★★★

4. Think about the following list of number pairs. Three is the first number of a pair, and 8 is the second.

3 → 8
4 → 11
5 → 14
6 → 17
.
.
.
10 → 29
.
.
.

- a. If 50 is the first number, what is the second number? _____
- b. If 200 is the first number, what is the second number? _____
- c. If 89 is the second number, what is the first number? _____
- d. If a number n is the first number, what is the second number? _____

★★ 5. The sum of two whole numbers is 72. Their difference is 48. What are the two numbers?

Answer: _____ and _____

★ 6. Henry was at the store, and used his calculator to add up the price for 2 loaves of bread. He got the number shown in the display, but he didn't know exactly how much money that was. How much money would those two loaves cost? Circle the correct answer below.

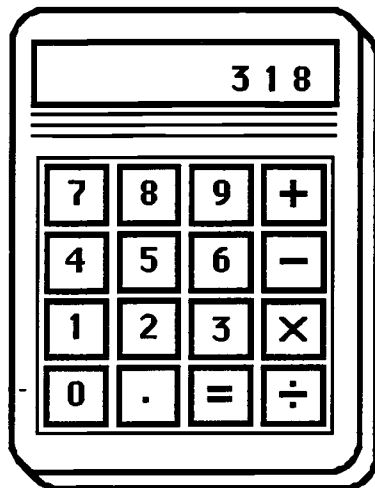

- a. \$318
- b. 3.18¢
- c. \$318.00
- d. \$3.18

★★ 7. In your class, 9 students received an “excellent” on a recent project. Your teacher would like to buy pencils for those 9 students. The school store sells them for 10 cents each or 3 for 25 cents. What is the least amount of money your teacher will have to spend in order to buy one pencil for each of the 9 students?

Answer: _____ cents

Commentary

Jupiter, I

1. (a.7; b. 8; c. 3; d. 24) Students could practice making up their own Venn Diagrams about the class by picking characteristics such as eye color and hair color, or clothing combination. In this problem, the difficult part is (d) -- some students will try to use the numbers 7, 8, and 3 to get the total in the clubs.
2. (30) Dots have been placed in the figure below, to show the right angles.

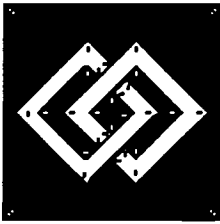

8 dots inside each white square (total of 16)

10 dots in the 3 inner black squares

4 dots in the corners of the big black square

or

(36) One could argue for a total of 36. There may be four more in the larger black squares -- two in each of the corners at the points of overlap. There may also be two more in the V's -- one at the top and one at the bottom of the figure where the white squares overlap. If students justify their answers, they may receive credit.

3. (Monday) Students might make a list -- *S, M, T, W, T, F, S* -- and start counting with Friday as 7 until they get to 24. Students could think of Fridays as the 7th, 14th, and 21st and count on from the 21st.
4. (a. 149; b. 599; c. 30; d. $3 \times n - 1$) The first two parts ask the student to notice that each second number is obtained by multiplying the first number by 3, then subtracting 1. Part (c) asks them to reverse this thinking, and part (d) asks them to generalize the pattern to any number n . The answer for (d) might be written in a number of different, equivalent ways.
5. (60 and 12) Students may use "guess and check" by listing the pairs of addends whose sum is 72. Their guessing should get more precise as they get closer to finding the correct pair. They might get a hint about the starting point by noticing that the difference of 48 means that one of the numbers is above 50.
6. (d. \$3.18) The problem has students use their real-world number sense to get an answer.
7. (75¢) Three for 25¢ means that nine would cost 75¢; 10¢ each means that nine would cost 90¢.

SUPERSTARS III

Jupiter, II

Name: _____

(This shows my own thinking.)

- ★★ 1. Hair grows about $\frac{1}{2}$ inch each month. After you shave your head, how many years will it be until your hair is 1 foot in length?

Answer: _____ years

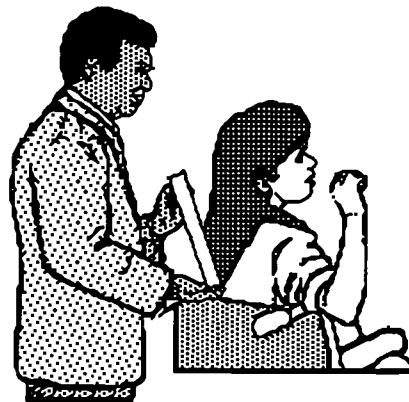

- ★★ 2. Robert received a weekly allowance of \$6 on Monday. He put 50% of his money in his empty piggy bank, but then took out 50% of that money to go to a movie. How much money was left in the piggy bank?

Answer: \$_____

- ★ 3. An arcade video game had a code built in. In order to play the game Tamika had to find the missing numbers. Help her by filling in the pattern below.

113, _____, 95, 86, 77, _____, 59, _____, 41, 32, 23, 14, 5.

- ★★★ 4. Sabrina used a calculator and started adding the whole numbers in order:

$$1 + 2 + 3 + 4 + 5 + \dots$$

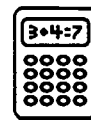

What is the last number she would add that would get the sum on her calculator over 1,000?

Answer: _____

- ★★ 5. Marcus, Aaron, and Jason went to a double-feature movie. The show began at 1:45 pm and lasted for 4 hours and 27 minutes. At what time did the show end?

Answer: _____

- ★ 6. Maria, Colleen, Patsy, and Kenya are 8, 9, 10, and 11 years old.

Maria is older than Patsy and younger than Kenya.

Colleen is younger than Marie and older than Patsy.

What is each girl's age?

Answer: Maria: _____ years old.

Patsy: _____ years old

Colleen: _____ years old

Kenya: _____ years old

- ★★★★ 7. On a game board, landing on blue means to move ahead 1 space, landing on red means to move ahead 2 spaces, and landing on orange means to move back 1 space. If you took 30 spins, about where would you expect to be on the game board, relative to where you started?

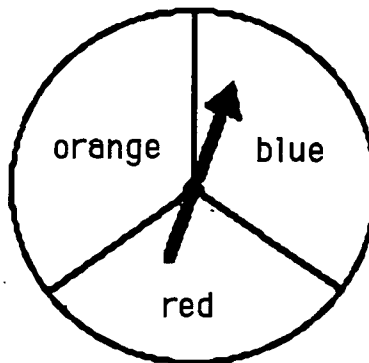

Answer: I would be about _____ spaces _____
(ahead or behind)

- ★★★ 8. Margarit liked to balance things. She balanced 3 pencil sharpeners and 2 one-gram blocks with a 100-gram weight and another one-gram block. She let x stand for the weight of one pencil sharpener, and she claimed that $x = 30$ grams. Was she correct? If not, how much did each pencil sharpener weigh?

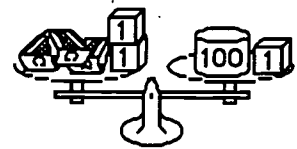

Answer: _____

Commentary

Jupiter, II

1. **(2 years)** One-half inch per month means 1 inch every 2 months. Students can therefore count month's "by twos" until they get to 12 inches. It would take 24 months or 2 years for the hair to reach 12 inches or 1 foot in length.
2. **(\$1.50)** Students at this grade level know intuitively that 50% is $\frac{1}{2}$, and they can find $\frac{1}{2}$ of dollar amounts, usually without any actual computation. $\frac{1}{2}$ of \$6 is \$3, and $\frac{1}{2}$ of \$3 is \$1.50.
3. **(104, 68, 50)** The unusual thing about this pattern is that it is much easier to start at the right end and work to the left. You can see that you are adding 9 at each step.
4. **(45)** Students will likely use a calculator to solve this problem. A few might notice that the sum of the first n counting numbers is $n \times (n + 1) \div 2$. Therefore the problem becomes finding the first or smallest n such that $n \times (n + 1) \div 2 \geq 1000$.
5. **(6:12 pm)** This problem involves elapsed time. Students can add 1:45 and 4:27, but they must remember that they aren't in the decimal system. They should get 5:72, and since 72 minutes is 1 hour and 12 minutes, 5:72 can be rewritten as 6:12.
6. **(Maria: 10; Patsy: 8; Colleen: 9; Kenyada: 11)** Students might make a list, or they may make name cards and act the problem out.
7. **(20 spaces ahead)** Each color should come up about $\frac{1}{3}$ of the time. However, the orange moves and the blue moves cancel each other out. Therefore, about $\frac{1}{3}$ of the time you would move ahead 2 spaces. $\frac{1}{3}$ of 30 spins is 10 spins, and, at 2 spaces each move, you would be ahead 20 spaces.
8. **(She was wrong. $x = 33$ grams)** Students can see intuitively that 1 block can be removed from each side of the balance scale, leaving 3 sharpeners and 1 gram to balance 100 grams. Therefore, the 3 sharpeners must weigh 99 grams, and each would weigh 33 grams. x is used simply to introduce the idea of an unknown quantity as a variable.

SUPERSTARS III

Jupiter, III

Name: _____

(This shows my own thinking.)

★★

1. After filling in the multiplication table below, Parker noticed some number patterns. Fill in the chart and follow the directions beneath it.

×	1	2	3	4	5	6	7	8	9	10
1										
2										
3										
4										
5										
6										
7										
8										
9										
10										

Draw a circle around the line of numbers that has only *square numbers* in it.

★★★ 2. Mr. Jackson is preparing bags of treats to give trick or treaters on Halloween. He has 48 pieces of candy and 60 pieces of gum. He uses all the candy and gum, and he puts the same ratio of candy to gum in each bag. What is the largest number of bags he could have made?

Answer: _____

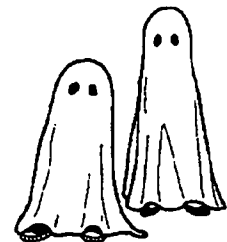

★

3. It is now 10:45. What time will it be in 2 hours and 15 minutes?

- ★★ 4. Six cars are parked in front of a local car dealers lot.

- The red car is parked in front of the green car.
- The black car is between the green car and yellow car.
- The blue car is parked on the right (driver's) side of the red car.
- The orange car is parked in front of the yellow car.

Color the cars to show how they are parked, or write the name of the color on each car.

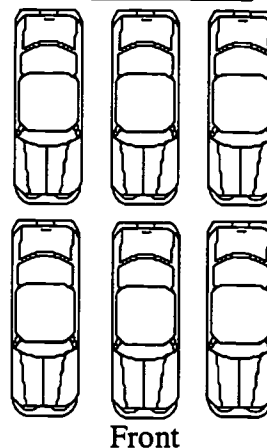

- ★ 5. Susan made \$15.00 baby-sitting. She spent \$11.15 on a birthday present, including tax. To the nearest dollar, how much does she have left ?

Answer: _____

- ★★★★ 6. The Disney Golf Classic starts with 64 golfers. The golfers form pairs and each pair plays a match. The losers drop out and the winners of each pair then form new pairs and play again. Then those winners form pairs and play. This continues until there is one winner.

- a. In how many matches must the winner play? _____
- b. How many matches are played by all the golfers, to determine the winner?

- ★★★ 7. Draw all the lines of symmetry for this polygon.

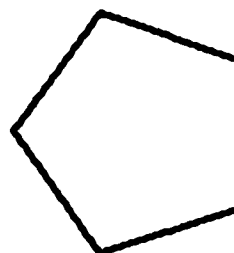

- ★★★ 8. A number has 4 digits.
No digits in the number are repeated.
The digit in the tens place is three times the digit in the thousands place.
The number is odd.
The sum of the digits in the number is 27.

What is the number?

Answer: _____

Commentary

Jupiter, III

1. **(The diagonal from upper left to lower right should be ringed.)** Give students one star for having all the correct products in the chart and another for the correctly-ringed diagonal.
2. **(12)** The ratio of 48 to 60 is the same as the ratio of 24 to 30, or 12 to 15, or 4 to 5. He would get the most bags possible by working with the 4 to 5 ratio, putting 9 items (four pieces of candy and 5 pieces of gum) in each bag. This would give 12 bags, as 12×4 is 48 and 12×5 is 60.
3. **(1:00)** The only difficult part of this problem comes if students try to compute $10:45 + 2:15$, because they are not in the decimal system with time. The sum of 10:45 and 2:15 is 12:60, which is 1:00. Students with good number sense will likely "count on" from 10:45, using hours and then quarter-hours.
4.

Green	Black	Yellow	Students can be encouraged to solve such logic problems by making a chart and proceeding by process of elimination.
Red	Blue	Orange	
5. **(\$4)** Students should have an intuitive feel for this type of problem, rather than subtracting \$11.15 from \$15.00 and rounding the answer. They should know that \$11.15 is close to \$11, and $\$15 - \11 is \$4.
6. **(a. 6; b. 63)** First 64 play. Then the 32 winners of those matches play. Next the 16 winners of those matches play. Then the 8 winners of those matches play. Then the 4 winners of those matches play, and finally the last two winners play. This is 6 rounds of golf, and the winner must play in all of those. Since there are 63 losers, and each one had to play a match to lose, there are 63 matches altogether.
7. There are 5 such lines of symmetry, as shown below.

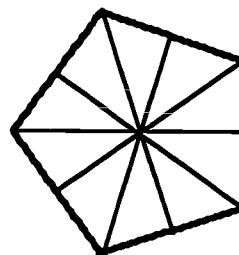

8. **(3,897)** There are several clues that make this *guess-check-revise* problem a little friendlier. Since the sum of the four digits is 27, the average size of the digits must be fairly large. However, the *thousands* digit has to be either a 1, 2, or 3, while the corresponding *tens* digit is a 3, 6, or 9. Choosing the 3 for the thousands digit to begin the search would give 9 for the *tens* digit. Make the last digit a 7, since that's the largest odd digit not already used. If 8 is then put in the *hundreds* place, the sum will be 27, as required.

SUPERSTARS III

Jupiter, IV

Name: _____

(This shows my own thinking.)

★★

1. A school bus makes 7 stops on its trip to school and 7 stops on the trip home.

a. How many stops will the bus make in one full week of school? _____

b. How many stops will the bus make in the 180-day school year? _____

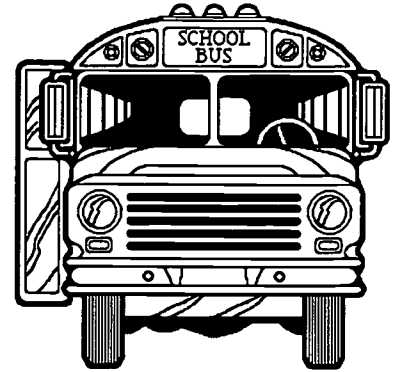

★

2. When Michelle woke up yesterday, the temperature was 72° F. By lunch time, the temperature had risen 15° F. By dinner time, it had fallen 22° F. What was the temperature at dinner time?

Answer: _____ $^{\circ}$ F

★★★

3. Teresa has 4 flower pots in 4 different designs. She likes to display her flower pots in different positions on her window sill. How many different ways can she place her flower pots?

Answer: _____ ways

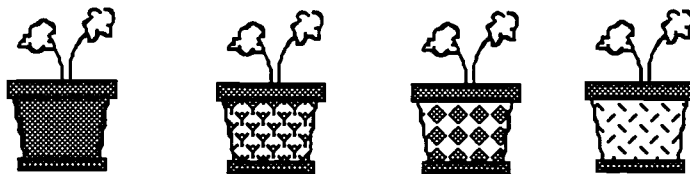

★★

4. What is the mystery number x ?

- x has 3 digits.
- The tens digit is half the hundreds digits.
- The number is odd.
- The sum of the digits is 9.

Answer: $x =$ _____

Jupiter IV page 1

★ 5. If the 7th day of the month is on a Tuesday, on what day is the 25th?

Answer: _____

★★★ 6. On the average your heart beats about 72 times per minute. At this rate, about how many times will it beat:

a. in a 30-day month? _____

b. in a year? _____

c. in your lifetime, if you live to 72 years of age? _____



★★★ 7. The volume of a shape is the number of cubes it will take, all the same size, to make the figure. Each figure is made of stacks of cubes that are 1 centimeter on each side. Find the volume of the figures below.

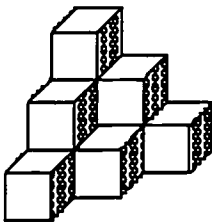

a.

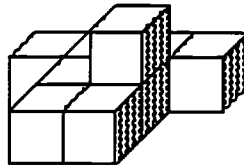

b.

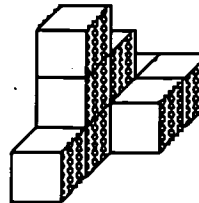

c.

Answer: a. _____ cm^3 Answer: b. _____ cm^3 Answer: c. _____ cm^3

★★★ 8. In a tug of war, 5 donkeys are exactly equal to 2 elephants. In another tug of war, 3 elephants are equal to 1 car. Which team should win if a car and 3 donkeys are matched against 4 elephants?

Answer: _____



Commentary

Jupiter, IV

1. (a. 70; b. 2520) The student can multiply 14 times 5 for (a), and 14 times 180 for (b).
2. (65° F) Students can add 15 to 72, then subtract 22.
3. (24) Students may want to make a list and establish a pattern in order to solve this problem. They might name the pots shown as A, B, C, and D, and then see how many lists they can make, such as ABCD, ABDC, ACBD, ACDB, ADBC, ADCB. Those six are all the orders possible if A is on the left. There would be 6 such arrangements with B starting on the left, 6 with C, and 6 with D also, for a total of 24.
4. (423) *Guess-check-revise* is one way to solve the problem. A starting hint is that since the sum of the digits is nine, their average value is 3. Therefore all of the numbers are small numbers.
5. (Saturday) Students might use a calendar. They may list S, M, T, W, T, F, S, start counting with 7 on Tuesday, and count to 25. They may realize that Tuesdays would also be the 14th and the 21st. Then they could count on to the 25th.
6. (a. 3 million; b. 36 million; c. 2 1/2 billion) The problem situation calls for estimated answers, rather than exact numbers, which would be misleading in such a problem. Students should be allowed leeway in their estimates, since they can vary quite a bit. Hopefully, students will use a calculator to find (a) and continue to use it in finding (b) and (c) by entering only the non-zero digits to fit into the 8-digit calculator.
7. (a. 10; b. 9; c. 9) Students may use cubes or blocks to construct models. Students with good spatial visualization can find the answers from the pictures.
8. (car and donkeys) Students can approach this in a number of ways. Since the car matches 3 elephants in the second picture, three elephants and the car can be "removed" from the last tug of war without affecting the situation. Thus we are left with 1 elephant matched against 3 donkeys and asked which side would win. From the first picture, we see that an elephant pulls as much as 2 1/2 donkeys, so 3 donkeys would out-pull one elephant. Therefore a car and 3 donkeys would out-pull 4 elephants.

SUPERSTARS III

Jupiter, V

Name: _____

(This shows my own thinking.)

- ★★★★ 1. A normal person blinks about 25 times per minute when awake.
- How old will you be on your next birthday?
 - To the nearest million, how many times will you have blinked on your next birthday? Assume you sleep 8 hours each day.



Answers: (a) _____ (b) _____

- ★★ 2. Pablo has \$3.15 in dimes and quarters. He has more quarters than dimes. How many quarters and dimes does he have?

Answer: _____ quarters and _____ dimes

- ★★★★ 3. Use a centimeter ruler and a separate sheet of paper to draw an 8 cm by 6 cm rectangle. List its perimeter on the table below. Then cut out the rectangle and also cut along the diagonal as shown in the picture below. Use your two pieces to create 4 new geometric shapes. After making each shape, determine its perimeter. Below list the names of the shapes made and their perimeters.

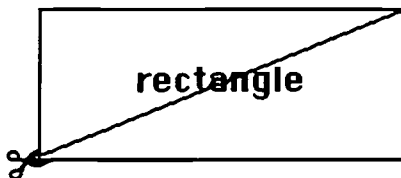

SHAPE	PERIMETER
<u>rectangle</u>	_____
_____	_____
_____	_____
_____	_____
_____	_____

- ★ 4. Fill in the missing digits:

$$\begin{array}{r}
 4 \square 6 8 \\
 \quad 5 \square 6 \\
 + \square 9 4 \square \\
 \hline
 1 1, 1 1 1
 \end{array}$$

- ★ 5. *Century* is to *decade* as *dollar* is to: (a) penny (b) nickel (c) dime (d) quarter

Answer: _____

- ★★ 6. Roberto ate 3 pieces of a pizza and then felt that he should pay only $\frac{1}{4}$ of the cost because that's the fraction he ate. Into how many pieces was the pizza cut?

Answer: _____ pieces

- ★★★ 7. Thomas is playing tic-tac-toe with a computer. It is the computer's turn to place an "X" on the board. If the computer makes its moves at random in the open spaces, what is the chance it will win on this move?

Answer: _____

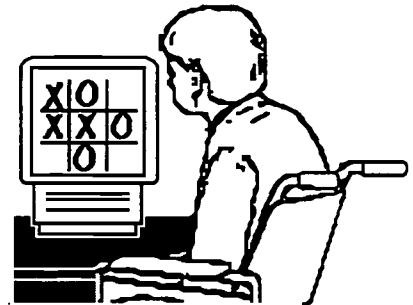

- ★★★★ 8. Answer the questions below using the Venn Diagram showing Ms. Berger's students musical preferences.

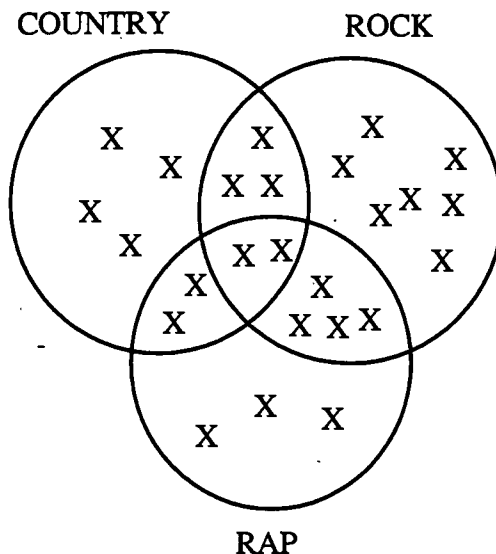

CLASS CENSUS

How many students took part in the all class census?

How many students prefer only rap?

How many students prefer only rock and country?

How many students prefer rap or country but not rock?

Commentary

Jupiter, V

1. (a. Answers will vary -- 10 and 11 are the most common answers; b. Answers will vary.) Students should use a calculator to compute:

$$25 \times 60 \times 16 \times 365 \times (\text{answer for part a})$$

If part a is 10, the answer is 88 million; if part a is 11, the answer is 96 million.

2. (11 quarters, 4 dimes) Some students will randomly use *guess-check-revise*, while others realize that the amount of money in quarters alone should be fairly close to \$3.15. Students may begin with 12 quarters (which will not work) and go backwards from there, using *guess-check-revise*.
3. (rectangle: 28 cm; 2 triangles: 32 and 36 cm; 2 parallelograms: 32 and 36 cm) These are the four most likely answers, but a quadrilateral could also be built with a perimeter of 36 cm. Note: parallelograms cannot be named as rectangles.

4.

$$\begin{array}{r} 4 \boxed{5} 6 8 \\ 5 \boxed{9} 6 \\ + \boxed{5} 9 4 \boxed{7} \\ \hline 1 1, 1 1 1 \end{array}$$

5. (c. dime) A century is ten times a decade; likewise, a dollar is ten times a dime.
6. (12) Students have to consider a problem that is not one usually asked. If 3 is $\frac{1}{4}$ of some number, what number is it?
7. (2 out of 3 chances, or $\frac{2}{3}$, or 67%) There are three spaces left, and two of those will result in a win for the computer. Any of the three spots is equally likely to be selected, so the chance is $\frac{2}{3}$ of a win.
8. (25, 3, 3, 9) Students familiar with a Venn Diagram should have little difficulty with this problem. All the X's are counted for the first answer. Only 3 X's are in the RAP ring only. Three students are in the overlap between rock and country, but not in RAP. There are 9 students that are in the RAP and country circles together but not in the rock circle.

- ★★ 1. Jean went on a vacation with her parents in their family car. They left their home in Florida on Monday at 7:15 a.m. and arrived in North Carolina on Tuesday at 11:45 a.m. How long was their trip?

Answer: _____ hours and _____ minutes

- ★★★ 2. Mr. Brown wanted to put up a fence around his property. How many feet of fencing did he need? The lawn is outlined to the right, but the picture is not drawn to scale.

Answer: _____ feet

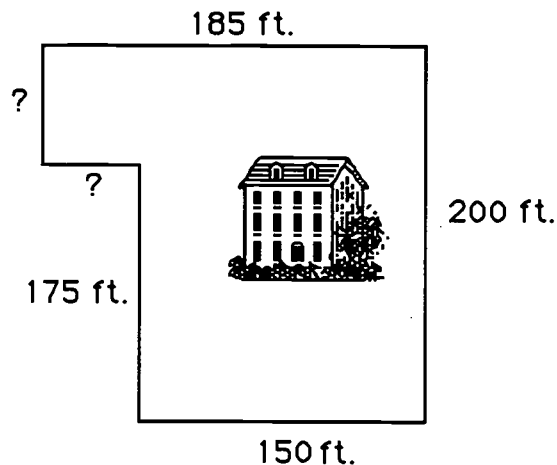

- ★★★ 3. Find the next number in the patterns below.

(a.) \$32.10 → \$32.30 → \$32.50 → \$32.70 → \$32.90 → \$ _____

(b.) 720 → 360 → 180 → 90 → _____

(c.) $\frac{1}{2}$ → $\frac{1}{4}$ → $\frac{1}{8}$ → $\frac{1}{16}$ → _____

- ★★★★ 4. Box A has 3 red marbles and 2 yellow marbles. Box B has 2 red marbles and 1 yellow marble. If you have to pick a red marble to win a prize and you can not look in the box, which box would give you the best chance of winning the prize?

Answer: _____

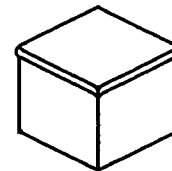
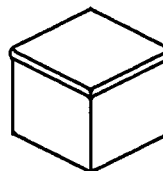

- ★★ 5. You can trace over this figure with a pencil without retracing any path, if you start in the right place. Find the two places where you can do this, and draw circles around them.

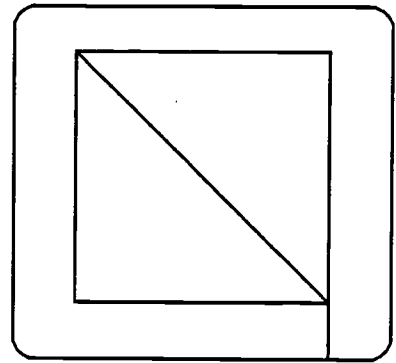

- ★ 6. If 5 is added to a number n and the answer is multiplied by 2, the result will be 24. What is the number n ?

Answer: $n = \underline{\hspace{2cm}}$

- ★★★ 7. Estimate the answers below. Circle the best choice.

a. $3\frac{10}{11} + 2\frac{1}{101}$

Choose: 4 or 5 or 6 or 7

b. $5\frac{2}{47} - 2\frac{1}{35}$

Choose: 2 or 3 or 4 or 5

c. $6\frac{17}{19} \times 7\frac{3}{290}$

Choose: 42 or 49 or 63 or 213

- ★★★ 8. You need $\frac{1}{2}$ cup of sugar to make a three-layer cake. How much sugar would you need for a one-layer cake?

Answer: $\underline{\hspace{2cm}}$



- ★ 9. What is the product of the ten one-digit numbers? $\underline{\hspace{2cm}}$

Commentary

Jupiter, VI

1. **(28 hours, 30 minutes)** Students will probably count from 7:15 one morning to 7:15 the next morning as 24 hours, and then count up by the hour to get to 11:15, finally counting a half hour to 11:45.
2. **(770 feet)** Students may draw the diagram and sub-divide it into two parts. Also, students can figure out the missing lengths. $150 \text{ ft.} + 200 \text{ ft.} + 185 \text{ ft.} + 25 \text{ ft.} + 35 \text{ ft.} + 175 \text{ ft.} = 770 \text{ ft.}$ It is interesting to note that the perimeter of this figure is the same as if the figure were a 185 by 200 foot rectangle.
3. **(a. \$33.10; b. 45; c. 1/32)** The pattern for (a) is that each number increase by 20¢. For (b), each succeeding number decreases by half. Each next number in (c) is also half of the preceding number.
4. **(B)** Box A has a 3 out of 5 chances to win with red. Box B has a 2 out of 3 chances to win with red. If students change ratios so that they are based on the same second number, the result will be obvious. 3 out of 5 is the same as 6 out of 10 or 9 out of 15. 2 out of 3 is the same as 4 out of 6, 6 out of 9, 8 out of 12, and 10 out of 15. But then 10 out of 15 is a better chance than 9 out of ten. Students may run a probability experiment to verify this result.
5. **(See figure below.)** A network of paths such as the one below can be traced without lifting a pencil if it has either 0 or two *odd vertices*. A vertex is *odd* if it has an odd number of paths going in or coming out. Furthermore, if you can trace the network you have to start at one of the odd vertices. You will end up at the other odd vertex. Therefore, the two odd vertices circled below are the only places at which you can start and trace the path.

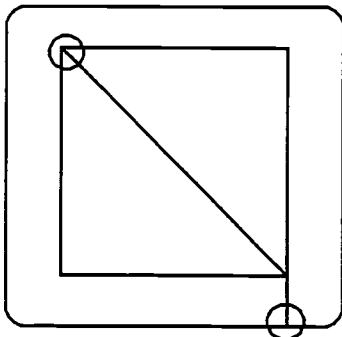

6. **(7)** This can be solved by guess-check-revise, or by working backward.
7. **(a. 6; b. 3; c. 49)** Students with good number sense will notice that the fractions involved are either close to zero or close to 1. This means that each mixed number would be rounded either to the whole number showing or up to the next whole number. In (a), $3 \frac{10}{11}$ rounds to 4 and $2 \frac{1}{101}$ rounds to 2, therefore the sum is close to $4 + 2$ or 6. In (b), $5 \frac{2}{47}$ rounds to 5, and $2 \frac{1}{35}$ rounds to 2, so their difference is close to $5 - 2$ or 3. In (c), $6 \frac{17}{19}$ rounds to 7, and $7 \frac{3}{290}$ rounds to 7, so their product is close to 7×7 or 49.
8. **(1/6)** Students might draw a diagram to show that $\frac{1}{3}$ of $\frac{1}{2}$ is $\frac{1}{6}$
9. **(0)** The ten one-digit numbers include zero. When any one of the factors is zero, the overall product is always zero.

SUPERSTARS III

Jupiter, VII

Name: _____

(This shows my own thinking.)

- ★★★★ 1. One green, one red, and one blue marble are placed in a bag. The days of the week are written on seven pieces of paper and put in another bag. You can draw from either bag for a \$1 million prize. To win, you must either draw a weekend day -- Saturday or Sunday -- or a blue marble. Which bag gives you the best chance of winning, the marble bag or the day-of-the-week bag?



Answer: _____

- ★ 2. One disposable diaper will stay in a landfill, without decomposing, for 2000 years. If you put 4 disposable diapers into a landfill tomorrow, how long will it be before they are all decomposed?

Answer: _____ years

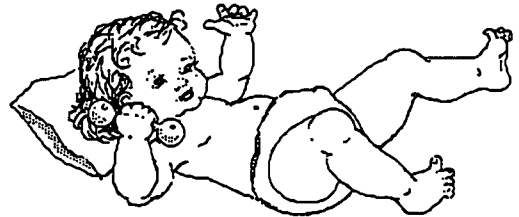

- ★★★ 3. Faye has 20 feet of fencing to make a rectangular pen for her dog. What is the largest area that she can fence in?

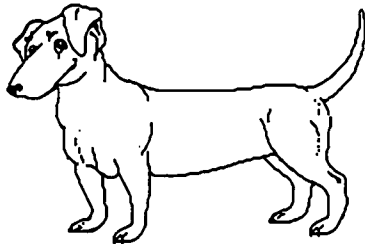

Answer: _____ square feet

- ★★ 4. Herman's lunch came to \$4.27, and he gave the clerk \$5.02. Why did he give the clerk two extra pennies?

Answer: _____

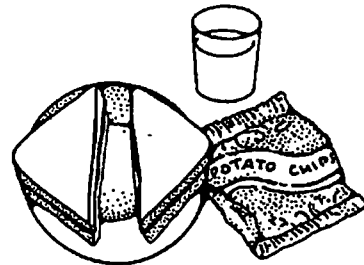

- ★★★ 5. Juan's age is 3 times Derrick's age, and Tyrone is twice as old as Derrick. The sum of their ages is 30. How old is each boy?

Answers: Juan is _____; Derrick is _____; Tyrone is _____

- ★★ 6. Maurice and his 3 friends ride their bikes to football practice each afternoon after school. Maurice leaves his house and goes to each friend's house, and they travel on together. He has timed each part of the trip. Practice starts at 4:00 sharp. Write in each box below when Maurice should arrive, so they won't be late for practice. Also write in the time he should leave his own house.

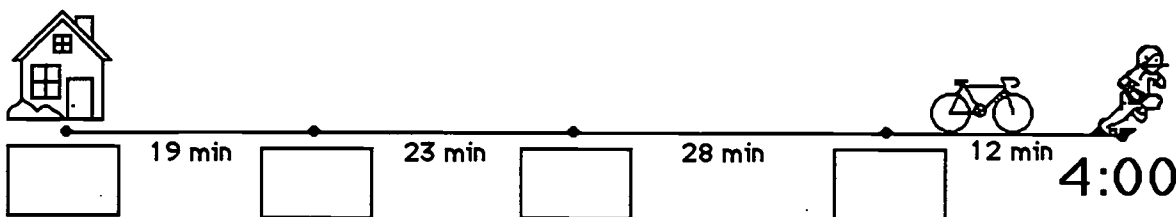

- ★★ 7. This watch is unusual -- it runs *counterclockwise*. What time will it be 4 hours and 45 minutes from the time shown?

For your answer, draw the hour and minute hands where they should be on this watch.

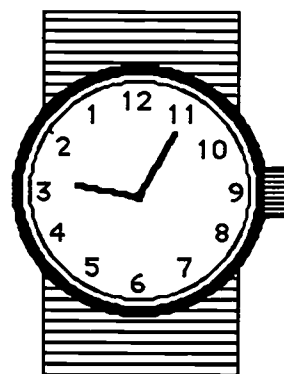

- ★★ 8. An adult has about 5 quarts of blood. When he donates a pint for a sick friend, what fraction of his blood does he give away?

Answer: _____

- ★★ 9. The human body is about 70% water, by weight.

a. How many pounds do you weigh? _____ pounds

b. How many pounds of you is water? _____ pounds

Commentary

Jupiter, VII

1. (**marble bag**) The chance of drawing a blue marble is $\frac{1}{3}$; the chance of drawing a weekend day is $\frac{2}{7}$. We must compare these fractions to see which is larger. Finding a common denominator (21) allows us to compare the fractions by comparing the numerators. $\frac{1}{3}$ is $\frac{7}{21}$, and $\frac{2}{7}$ is $\frac{6}{21}$; thus $\frac{1}{3}$ is greater than $\frac{2}{7}$. Another way to compare the fractions is to use a calculator, change both fractions into decimals, and compare the decimals.
2. (**2000 years**) Many students will think you must multiply 4 and 2000, but the problem doesn't call for any computation if you think carefully about the situation.
3. (**25**) Students can use grid paper to make the rectangles that have 20 as a perimeter. The one with the largest area can then be found by counting unit squares.
4. (**To get back fewer coins**) Many people use a method like that mentioned to avoid carrying extra coins around in their pockets.
5. (**Juan is 15, Derrick is 5, Tyrone is 10**) A suggested strategy is to use *guess-check-revise*. Guess the youngest person's age, double and triple that amount to get the other ages, and add to see if the sum is 30. If not, revise the youngest person's age appropriately.
6. (**2:38; 2:57; 3:20; 3:48**) Students will have to either count backwards or subtract to get each new time. Subtraction involves subtracting across non base-ten numerals.
7. (**See watch to the right.**) The time shown is 2:55, and adding 4:45 to that gives a time of 7:40. Showing 7:40 will be a challenge for many students, on this watch.

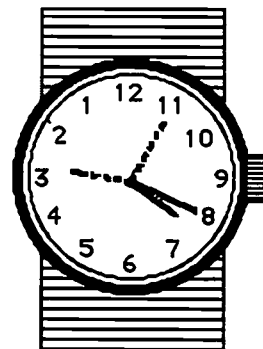

8. (**1/10**) A quart is 2 pints, so 5 quarts is 10 pints. One pint is then $\frac{1}{10}$ of 5 quarts.
9. (**a. answers will vary; b. answers will vary.**) Whatever answer a student gives for (a), use a calculator to find 70% of that number. Be lenient in checking accuracy -- give credit for being within one pound of the right answer for (b). Students will employ a variety of methods for finding 70% of their weight if they don't use a calculator. For example, some might use reasoning and take 7 out of every ten pounds they weigh, adding on some extra for the pounds over the multiples of ten. Others might find 50% or 75% ($\frac{1}{2}$ and $\frac{3}{4}$) of their weights since those are intuitive numbers to work with for many weights. Then they may adjust their answers because 70% is between 50% and 75%, closer to 75%

SUPERSTARS III

Jupiter, VIII

Name: _____

(This shows my own thinking.)

- ★★ 1. What number is as much greater than 36 as it is less than 94?

Answer: _____

- ★★★ 2. Find a pair of numbers for each sum and product. Write your answers in the blanks.

	<u>Numbers</u>	<u>Sum</u>	<u>Product</u>
Example →	5 , 3	8	15
	____ , ____	10	24
	____ , ____	12	20
	____ , ____	14	48
	____ , ____	16	63
	____ , ____	18	45
	____ , ____	31	30

- ★★★ 3. Ashley, Jonathan, Sarah, Carlos, and Tanya all made the finals of the National Math Fair Competition last year. Before the final round began, each one had to shake hands with all the others. How many handshakes were there?

Answer: _____ handshakes



- ★★ 4. Karen's first five grades are: 92, 88, 99, 97, and 89. If she has an average of 94, she'll get an A on her report card. Find Karen's average. Will Karen get an A or a B?

Answer: Karen will get a (n) _____.

- ★ 5. Find the missing digits. Write the completed problem below to the right.

$$\begin{array}{r} 5 \square , 682 \\ - 43,8\square 6 \\ \hline 6,786 \end{array}$$

Answer:

- ★ 6. On the Fourth of July, a typical temperature in Florida during the day would be:

a. 12°C b. 120°F c. 36°C

Answer: _____

- ★★ 7. Rachel mailed out 12 party invitations and the stamps cost \$0.32 each. She paid for her stamps with a five dollar bill. How much change should she receive?



Answer: _____

- ★★★★ 8. In these addends, each letter represents a single digit. Find the numbers. Write the completed problem below, on the right hand side.

$$\begin{array}{r} \text{C E N T} \\ \text{C E N T} \\ + \text{S C E N T} \\ \hline 35128 \end{array}$$

Answer:

- ★★ 9. To change "dog years" to "people years," you multiply the dog's age by 7.

a. How old, in people years, is a 10-year old dog? _____

b. How old are you? _____ How old a dog is equal to you in age? _____



Commentary

Jupiter, VIII

1. (65) Students may use the *guess-check-revise* method. Some students might get the answer by putting the 36 and 94 on a number line, and deciding the point half-way between. Some students may subtract 36 from 94 ($94 - 36 = 58$) and add $1/2$ of 58 to 36 ($29 + 36 = 65$).

2.

4 , 6	or	6 , 4
2 , 10	or	10 , 2
6 , 8	or	8 , 6
7 , 9	or	9 , 7
3 , 15	or	15 , 3
1 , 30	or	30 , 1

 Perhaps the easiest way to solve each of these problems is to focus on the numbers that would give the indicated product, and then see which of those pairs of numbers would give the indicated sum.

3. (10) Students may act out this problem, or they might draw a diagram with A, J, S, C, and T around a circle. They would then connect each letter with each other letter by a line, counting the lines.

4. (B) This is a two-step problem. Students will first have to find the sum of Karen's grades: $92 + 88 + 99 + 97 + 89$ and get 465. Then they will divide 465 by 5 to get 93%, which is a B. Students can use a calculator for such situations.

5.

5 0, 6 8 2
- 4 3, 8 9 6
6, 7 8 6

 The problem involves deducing the two missing numbers, and one way is to work through the standard subtraction algorithm for the numbers. Perhaps the easiest way is to add 6, 786 to 43, 8__ 6, using number sense to determine the result.

6. (36⁰ C) Students should realize that 12°C is too cold, and 120°F is too hot. Therefore by process of elimination, 36°C is the correct choice.

7. (\$1. 16) This is a two-step problem. Students first have to decide how much Rachel spent. She bought 12 stamps at 32 cents each: $12 \times \$0.32 = \3.84 . Next, the students compute what her change would be. \$3.84 from \$5.00 is \$1.16.

8.

8 3 7 6
8 3 7 6
18 3 7 6
35 1 2 8

 Students can start by looking for the T value. Three such numbers must give a sum of 8 in the ones place -- 6 is a good choice. Then knowing that 1 is "carried" to the next place, the student can solve for N. Proceeding in this manner solves the problem.

9. (a. 70; b. answers will vary.) Part (a) involves multiplying 10 and 7. For part (b), take the number that the student put in the first blank, and, using a calculator, divide the number by 7 to get the number in the second blank. The answers will most likely be $9 \div 7 = 1 \frac{2}{7} \approx 1.3$, or $10 \div 7 = 1 \frac{3}{7} \approx 1.4$, or $11 \div 7 = 1 \frac{4}{7} \approx 1.6$. Be lenient in accepting reasonable answers for part (b), since some students will have the right idea but not know how to divide decimals or round their answers.

SUPERSTARS III

Jupiter, IX

Name: _____

(This shows my own thinking.)

- ★★ 1. The *volume* of a box is the number of cubes it would take to fill it up. If each cube is a centimeter on the edges, the volume would be given in *cubic centimeters*. What is the volume of the $4\text{ cm} \times 4\text{ cm} \times 6\text{ cm}$ box to the right?

Answer: _____ cubic centimeters

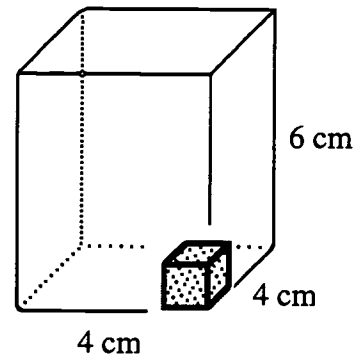

- ★★★ 2. Mario got his \$10.00 weekly allowance on Monday. He spent 25% of his weekly allowance on Tuesday, 15% of his weekly allowance on Wednesday, and 10% more on Thursday. How much money did he have left to spend for the rest of the week?

Answer: _____

- ★★ 3. Shade in $\frac{3}{4}$ of $\frac{1}{2}$ of $\frac{1}{2}$ of the circle. What fraction of the circle is shaded?

Answer: _____ is shaded

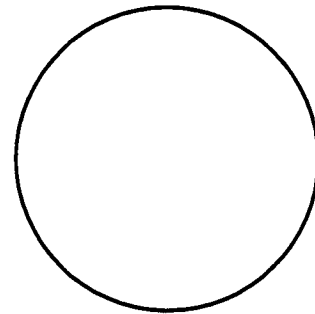

- ★★★★ 4. How many outfit combinations are possible with 1 pair of sneakers, 3 tee-shirts and 2 pairs of jeans? Drawing a diagram might help to illustrate your strategy.

DIAGRAM:

Answer: _____ outfits are possible

- ★★★ 5. Sonya has x amount of money. Bob has three times as much as Sonya has, less \$14.62. Write an expression, using x , that tells how much money Bob has.

Answer \$ _____

- ★ 6. Mr. Harmen graded 56 papers Monday and 87 papers Wednesday. How many papers did Mr. Harmen grade in the two days?

Answer: _____

- ★ 7. Place the letter X on the number line where $\frac{5}{8}$ would be.

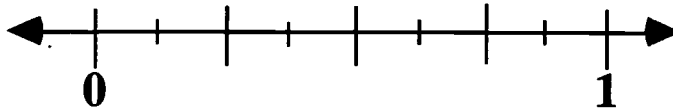

- ★★ 8. Use logic and the clues given to find out who will be sitting in what chair at the Halloween party. Fill each chair with the character's initial.

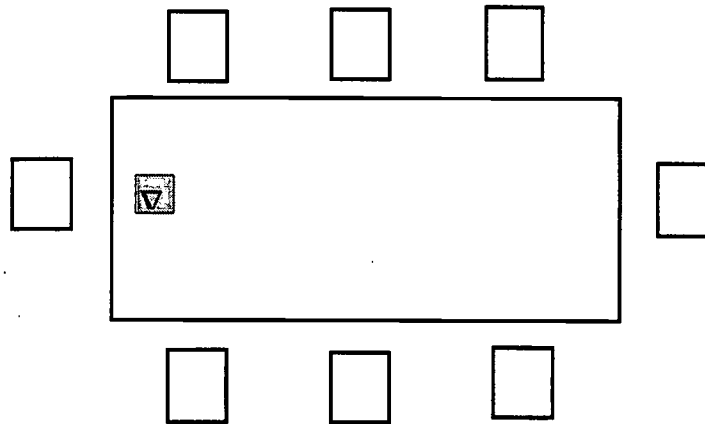

CLUES

- The Jack-o-lantern sits on the Ghost's immediate right.
 Sleeping Beauty sits across from the Prince.
 The Witch is to the right of Sleeping Beauty.
 The Prince sits between the Jack-o-lantern and the Fireman.
 The Ghost sits at the head of the table with the wedge of cheese.
 The Clown sits to the left of the Robot.

Commentary

Jupiter, IX

1. (96) Students can count the cubes in layers. There would be 16 on each of the 6 layers, or 16×6 total cubes.
2. (\$5) Students can compute 25% of \$10, 15% of \$10, and 10% of \$10 and add to get \$5 spent. Then $\$10 - \5 gives \$5 left to spend. Another way is to add the 3 percents (25%, 15%, and 10%) to get 50% spent. Then 50% of \$10 was not spent, and 50% of \$10 is \$5.
3. (See diagram below. 3/16) Students might show the circle cut in half, then one of the halves cut in half to get fourths, then one of those fourths cut into four pieces, and three of them shaded (see below). If so, it would take 16 of the smaller pieces to make the whole circle, so each is 1/16. Three shaded sixteenths would be 3/16.

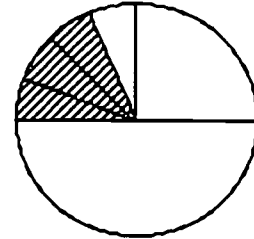

4. (6) One possible diagram is:

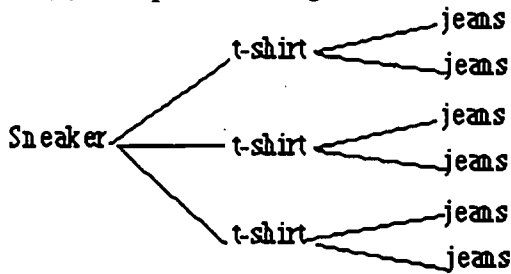

5. ($3x - \$14.62$ or $3 \times x - \$14.62$ or $x + x + x - \$14.62$ or any equivalent expression)
6. (143) Students will add to find the answer.

7.

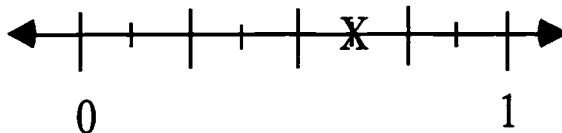

8.

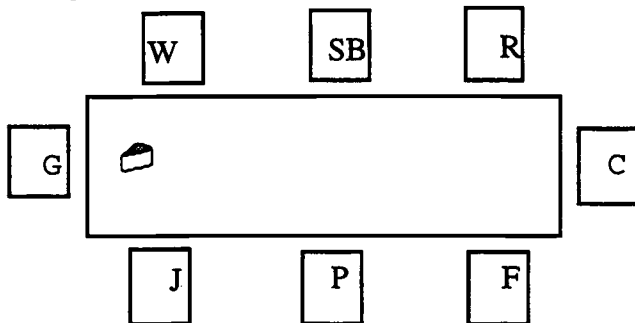

SUPERSTARS III

Jupiter, X

Name: _____

(This shows my own thinking.)

- ★★ 1. Draw the fifth and sixth figures to follow the pattern of dots below.

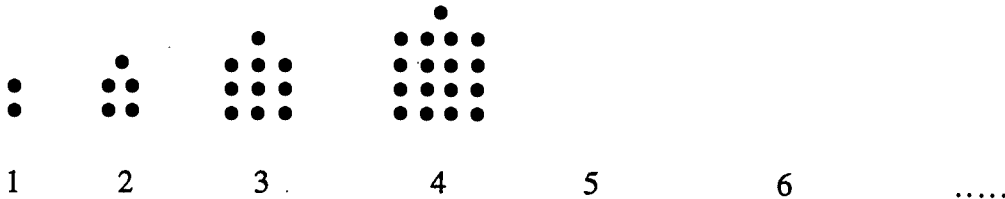

- ★★★ 2. Answer these questions about the pattern in problem 1 above.

- a. How many dots would it take to make the 10th figure in the pattern? _____
- b. What is the number of the figure that is made with 401 dots? _____
- c. Let n stand for any figure number. Use n to tell how many dots there would be in the n th figure. _____

- ★★ 3. Margo's dog had a litter of 7 pups, all alike except for coloring. The mother and one pup weighed 15 pounds. The mother and two pups weighed 17 pounds. How much did the litter of 7 pups weigh by themselves?

Answer: _____ pounds



- ★★★★ 4. In a Magic Square, the sums of the columns, rows and diagonals are all the same. Using the digits 1-9 only once, fill in the blanks to make this figure a magic square with a sum of 15.

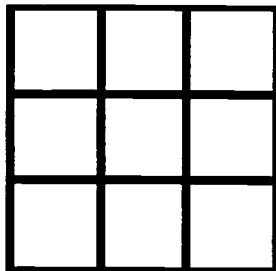

- ★ 5. Back in the old days, couples would enter marathon dance contests to win money. They would dance continuously, with only short breaks for food and drink. Some contests would go on for over a week. How many hours of dancing would there be in a 7-day week?

Answer: _____ hours



- ★★★ 6. Mr. Trumpet would like to offer you a job. He will hire you for ten days. He will pay you one of three ways:
- a. \$1.00 the first day, \$2.00 the second day, \$3.00 the third day and so on.
 - b. 10¢ the first day, 20¢ the second day, 40¢ the third day, and each day twice the amount of the day before.
 - c. \$6.00 each day for all ten days.

Which way would pay you the most money?

Answer: _____

- ★ 7. How many gallon jugs would you need to hold $3\frac{3}{4}$ gallons of lemonade?

Answer: _____ jugs

- ★★★★ 8. Your Mom is a sporting person, so when it's close to your bedtime, she will have a contest with you to see if you get to stay up an extra half-hour to play a computer game. You get to draw a card from a well-shuffled deck. If you draw a face card, an ace, or any heart, she'll "have a heart" and let you stay up. If you draw any other card, you lose and go ahead to bed. Who has the better chance of winning, you or your Mom?

Answer: _____



Commentary

Jupiter, X

1. (See figures below) Note that each figure is a square with the same number of dots on each side as the figure number, plus an extra dot on top.

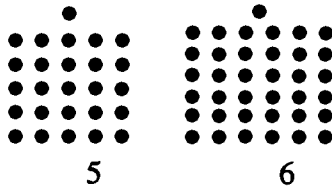

2. (a. 101; b. 20; $n \times n + 1$) This problem encourages students to generalize the number of dots for each figure, rather than drawing them. Each figure is made from this number of dots: the figure number, squared, with 1 dot added on top.
3. (14) If the mother and one pup weighed 15 pounds, and the mother and two pups weighed 17 pounds, then the extra pup in the second weighing must be 2 pounds. Since all the pups are the same weight, 7 pups would weigh 14 pounds.
4. (See below.) There are other solutions. Students may use *Guess-Check -Revise*.

6	1	8
7	5	3
2	9	4

5. (168) Multiply 7 by 24.
6. (b) Students might use a calculator for this problem. For plan (a), you would earn \$55; for (b), you would earn \$102.30; for (c), you would earn \$60. Students are often surprised at how quickly an amount accumulates when doubled continuously.
7. (4)
8. (Mom) Students might take out a deck of cards and count the possibilities. Aces, face cards, and hearts (when counted so that they aren't counted twice), make up 25 of the 52 cards in the deck. There are four aces, twelve face cards, and nine other hearts. The other cards (2 through 10 of spades, diamonds, and clubs) make up 27 of the 52 cards (nine in each suit). Since $27/52$ is a better chance than $25/52$, Mom has a slight advantage.

SUPERSTARS III

Jupiter, XI

Name: _____

(This shows my own thinking.)

- ★★ 1. The corner of this paper measures 90 degrees. Fold the lower right-hand corner of this paper so it represents two 45 degree angles. Trace the fold line with your pencil.

- ★★ 2. Estimate the result of the following problem as a whole number.

$$4\frac{1}{43} + 2\frac{15}{16} - 1\frac{24}{26} + 5\frac{11}{12} - 3\frac{3}{61}$$

Answer: _____

- ★★★ 3. How many ways can 3 students be arranged in three chairs?

Answer: _____ ways



- ★★ 4. Observe the circles in the triangle-shaped stacks. Fill in the missing numbers to show how many circles are in the last two stacks.

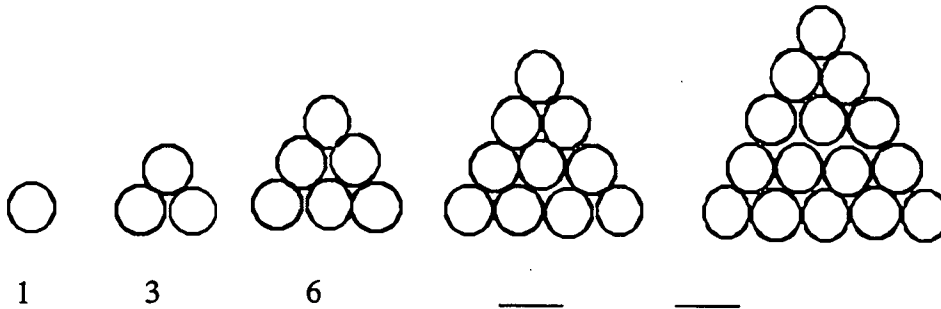

- ★★ 5. Follow the pattern above. Draw the next figure in the pattern to the right.

- ★★★ 6. In the pattern for problem 4, how many circles would be in the 10th figure?

★★★ 7. The Florida Lottery is made up of the numbers 1 - 49. My mother has observed that the winning numbers many times are prime numbers.

a. List the prime numbers from 1 - 49: _____

b. What is the probability of a prime number being picked randomly from the numbers 1 - 49? _____

c. Is the probability of picking a prime number greater than picking a number that is not prime? _____

★★★ 8. Put $<$, $>$, or $=$ in each blank below, to give true statements.

(a) 3030 _____ 3300 (b) $(345 + 253)$ _____ 600 (c) 1.09 _____ 1.090

★★★ 9. Circle the following solid figures that have at least one square face.

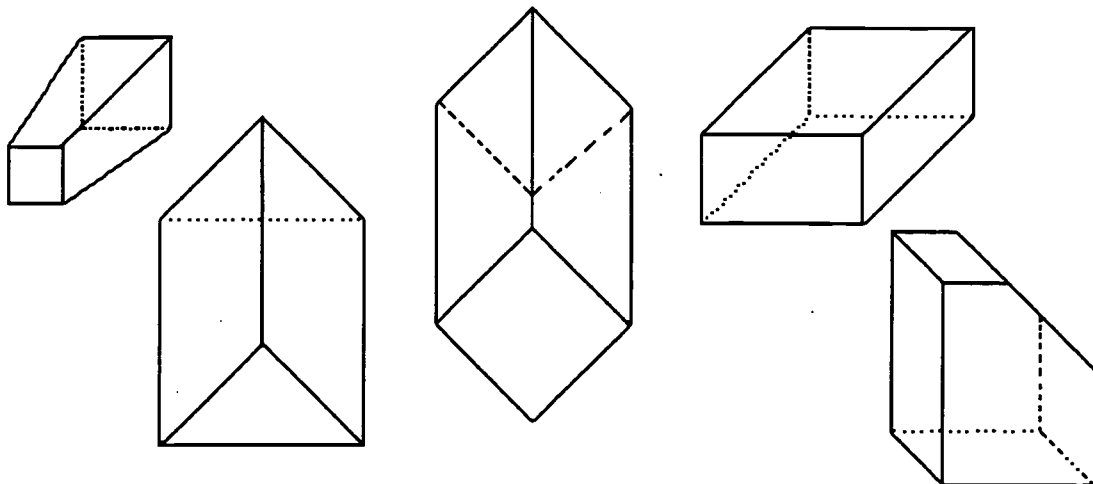

★★ 10. Lu Win likes to balance things. She balanced three 20-gram weights with a 10-gram weight and two new tubes of glue. How much did each tube of glue weigh?

Answer: _____ grams

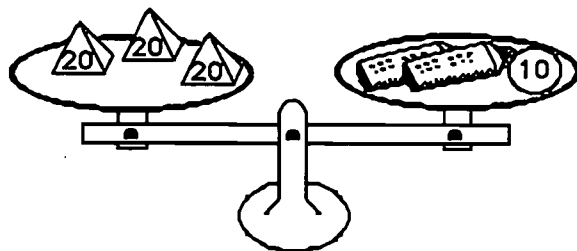

Commentary

Jupiter, XI

1. (The fold line should divide the corner in two equal parts as shown below.)

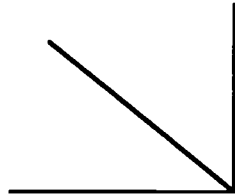

2. (8) The fractions are either close to 0 or close to 1. The mixed numbers can then be rounded to produce the following whole number computation: $4 + 3 - 2 + 6 - 3$, which gives 8.
3. (6) Calling the three students A, B, and C, there are 6 ways: ABC, ACB, BAC, BCA, CAB, and CBA
4. (10, 15) The problem involves simply counting. The next two problems build on this one.
5. (See the shape to the right.)

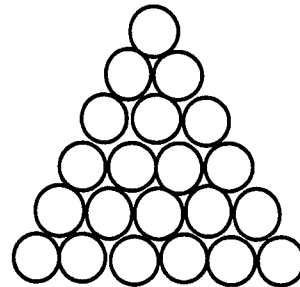

6. (55) The number of circles makes the familiar pattern: 1, 3, 6, 10, 15, 21, 28, 36, 45, 55, ... To get each succeeding term, you add one more than that which you added in the previous term. To get from 1 to 3, you add 2 to 1. To get from 3 to the next number, you add 3. To get the next term, you add 4, then 5, then 6, and so on.
7. (a. 2, 3, 5, 7, 11, 13, 17, 19, 23, 29, 31, 37, 41, 43, 47; b. 15 out of 49 or $\frac{15}{49}$ or any equivalent; c. no) The probability of picking a number that is not prime is $\frac{34}{49}$.
8. (a. $<$; b. $<$; c. =)
9. (From the left, the 1st, 3rd, and 5th figures should be circled.) The first figure has two square faces at its ends. The third figure also has two square bases, although they are "tilted". The fifth figure has only one square face, the one on which it rests.
10. (25) The problem will become, in later years, an algebraic situation of the form $60 = 2x + 10$. In this case, the two tubes of glue must weigh 50 grams since $50 + 10 = 60$. If two tubes of glue weigh 50, then each weighs 25.

SUPERSTARS III

Jupiter, XII

Name: _____

(This shows my own thinking.)

- ★★★ 1. A snail climbs up a wall 20 feet high. Each day the snail climbs 5 feet, but each night it slips backwards 4 feet. How many days will it take for the snail to get to the top of the wall?

Answer: _____ days

- ★★ 2. Raoul got to spin this spinner, to see what chore he had to do Saturday mornings. He could wash the dishes, wash the car, wash the dog, or change the paper in the rabbit cage. What is the chance he will have to wash something Saturday morning, as a fraction and as a percent?

Answer: fraction: _____

percent: _____

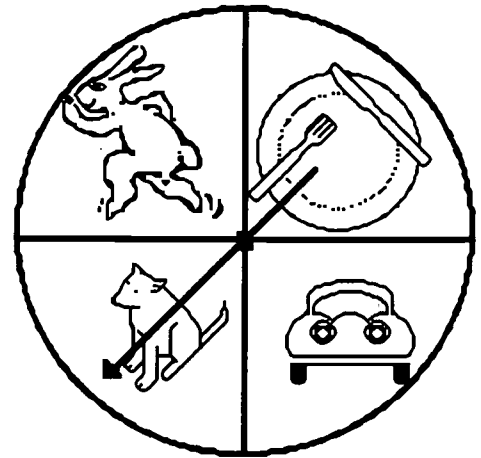

- ★ 3. After Halloween, the witches' costume went on sale for $\frac{1}{2}$ off the marked price of \$25. How much did the costume cost?

Answer: _____



- ★ 4. If today was October 11th, how many days would be left in the current year?

Answer: _____ days

★★★★ 5. What Number Am I ?

I am a three-digit number.
I am less than 200.
I am divisible by 12, and by 9.
My units digit is less than my tens digit.

Answer: _____

★★★★★ 6. Some researchers estimate that humans walk about 10,000 miles in their lifetimes, on average. Assume that the average life span is 70 years.

a. About how many miles per year does the average person walk?

b. About how many *miles* per day does the average person walk? (Express your answer to the nearest tenth.)

c. How many *feet* per day does the average person walk?

d. Your average step is probably about 18 inches. If you are an average person, about how many steps do you take per day?



★★ 7. If you tend to be one of those people who tap their feet, pick their nails, drum their fingers, or move around in their seats, there may be some good news. Although your fidgeting may be annoying to others, researchers at the National Institutes of Health report that one of these habits can burn as much as 800 calories per day. If you want to lose weight, this might help. For someone who fidgets as above, how many calories per hour are burned up? Assume the person sleeps 8 hours per day, and doesn't fidget while asleep.

Answer: _____

★★★ 8. It costs Mr. Kringle \$10 to make 100 giant pretzels for his bakery. If he sells his pretzels for 25¢ each, how much profit will he make after selling all 100 pretzels?

Answer: \$_____ profit

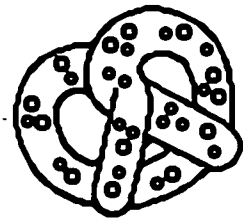

Commentary

Jupiter, XII

1. **(16)** Students may need help recognizing that the snail is climbing and then falling. Students may draw pictures or use a number line. Some students will think the answer is 20 days because the snail is making progress at the rate of 1 foot per day. However, this discounts the fact that once the snail reaches the top on the 16th day, it won't fall back four feet that night.
2. **($\frac{3}{4}$, 75%)** The circle is divided equally into four regions, so the chance of landing on each of those regions is $\frac{1}{4}$. The chance of landing on any of the three of them is then $\frac{3}{4}$.
3. **(\$12.50)** Some students will find half of \$25 as \$12.50, and then subtract that amount from \$25 and get \$12.50 again. Others will simply say that if the item is on sale for $\frac{1}{2}$ off, the price you pay is also $\frac{1}{2}$ of the price showing.
4. **(81)** Students may want to use a calendar or set up a chart in order to solve this problem. There would be 20 days left in October, 30 in November, and 31 in December.
5. **(180)** Students may use the *guess-check-revise* approach. The 2nd clue says that the number is in the hundreds. It is possible then to write down the multiples of 12 that are in the hundreds, checking to see which are also multiples of 9 in which the units digit is less than the tens digit.
6. **(a. about 143 mi.; b. about .4 mi.; c. about 2000 ft.; d. about 1300 steps)** Part (a) involves dividing 10,000 by 70; part (b) involves dividing the answer for (a) by 365; part (c) involves multiplying (b)'s answer by 5280, and part (d) is found by dividing (c)'s answer by 1.5 (18 inches = 1.5 feet).
7. **(50)** Students should divide 800 by 16, which is the number of hours the person is awake and burning calories by fidgeting.
8. **(\$15)** \$10 for 100 pretzels means he makes pretzels for 10¢ each. If he sells them for 25¢ each, he makes 15¢ per pretzel. Therefore 100 pretzels would bring a profit of $100 \times 15¢$ or \$15.

SUPERSTARS III

Jupiter, XIII

Name: _____

(This shows my own thinking.)

- ★★★★ 1. To win \$1 million, you must draw two cards whose sum is nine, from a stack of cards numbered 1 through 10. After the first draw, you replace the card and shuffle the stack again for the second draw. What is the chance that your two cards will have a sum of nine?

Use the chart if it helps you think about the possibilities.

Answer: _____

		first card									
		1	2	3	4	5	6	7	8	9	10
second card	1										
	2										
	3										
	4										
	5										
	6										
	7										
	8										
	9										
	10										

- ★ 2. Joey agreed to help his mom with the summer chores for \$1.50 a day for 20 days. Susan agreed to water the neighbor's indoor plants and feed the cat while they were on summer vacation for \$5.00 a week for 5 weeks. Who made more money over their summer vacation, Joey or Susan?

Answer: _____

- ★★ 3. It's time to plant a spring vegetable garden. $\frac{1}{3}$ will be root plants, $\frac{1}{3}$ will be stalk plants, and $\frac{1}{3}$ will be vine plants. $\frac{1}{2}$ of the stalk and vine plants will be grown organically without fertilizer. What fraction of the garden will be grown organically? Fill in the rectangle to show how the garden can be set up.

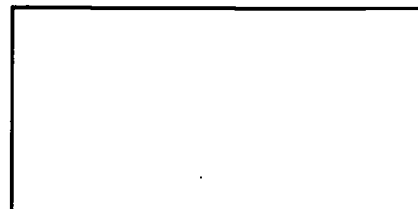

Answer: ____ will be grown organically.

- ★ 4. Juanita has 35 pre-addressed post cards she plans to hand out to her friends so they will write to her while she is away visiting her grandmother. She has 7 friends she'd like to give them to. Write a number sentence to show how Juanita can share her cards equally among her friends.

Answer: _____

★★ 5. Mary Jane called UPS to find a cost estimate for shipping her racing bicycle from Florida to her sister's house in Vermont.



a. The first information requested by the UPS agent was for the dimensions of the bike. Circle the most reasonable answer.

- (a) 14 inches by 6 inches (b) 14 feet by 6 feet
 (c) 5 feet by 4 feet (d) 5 yards by 3 yards

b. The second question the agent asked was the approximate weight of the racing bike. Circle the most reasonable answer.

- (a) 300 grams (b) 15 kilograms (c) 1 metric ton (d) 225 kilograms

★★★ 6. Felicia collected data from her classmates using a tally sheet. She asked each student what types of electronic appliances they had at home. Below are the data Felicia collected and recorded on a pictograph. Answer the questions related to the graph.

- (a) How many different types of appliances are listed? _____
 (b) What is the total number of all electronic appliances listed? _____
 (c) According to the data collected, what are the three most popular electronic appliances?

Answer: _____, _____, _____

ELECTRONIC APPLIANCES AT HOME

ITEM	NUMBER FOUND
Hairdryer	***
Television	****
Washing Machine	***
Computer	*
Food Processor	*
Clock Radio	**
Stereo	***
Walkman	****
Lamps	*****

* = 4 APPLIANCES

★★ 7. Write in the three missing numbers in the pattern.

....., _____, _____, 171, 162, 153, 144, 135, 126, _____,

Commentary

Jupiter, XIII

1. (8 chances out of 100, 8/100, 8%, 8:100, or a reduced form of these answers, such as 4/50, 2/25, and so forth.) Students can obtain such an answer by making a chart of the possibilities. The chart below shows the eight possibilities of success, out of the 100 possibilities for the two cards.

		first card									
		1	2	3	4	5	6	7	8	9	10
second card	1								✓		
	2							✓			
	3							✓			
	4							✓			
	5							✓			
	6							✓			
	7							✓			
	8	✓									
	9										
	10										

2. (Joey) Joey earned $\$1.50 \times 20 = \30.00 ; Susan earned $\$5.00 \times 5 = \25.00 .
3. (2/6 or 1/3) A diagram such as that below will help the student find the answer. The organic portion is 2 pieces out of 6 that would make the whole garden, hence 2/6 or 1/3 is the answer.

root	stalk	vine
	organic	

4. ($35 \div 7 = 5$) The problem is a simple partitioning interpretation of division.
5. (a. 5 feet by 4 feet; b. 15 kilograms) Both problems involve number sense. Students can eliminate all the unreasonable answers simply because of what they know about the size and weight of a bicycle.
6. (a. 9; b. 104; c. Lamps, Television, and Walkman) Students can count the types of appliances directly from the chart for (a). For (b), the total number of ♣ symbols in the chart is 26, and each stands for 4 appliances from the key, so the total is 104. Lamps are most popular with 5 ♣ symbols, followed by Television and Walkman with 4 each.
7. (189, 180, 117) The pattern involves subtracting 9 each time you move one term to the right.

SUPERSTARS III

Jupiter, XIV

Name: _____

(This shows my own thinking.)

- ★★ 1. Charles likes to draw and thinks he will become an architect one day. He is always concerned about the size of the objects he draws. Charles said the areas of the window and picture below were about 27 square units and $23\frac{1}{5}$ square units, respectively. Was he correct? Why or why not?

Answer: _____

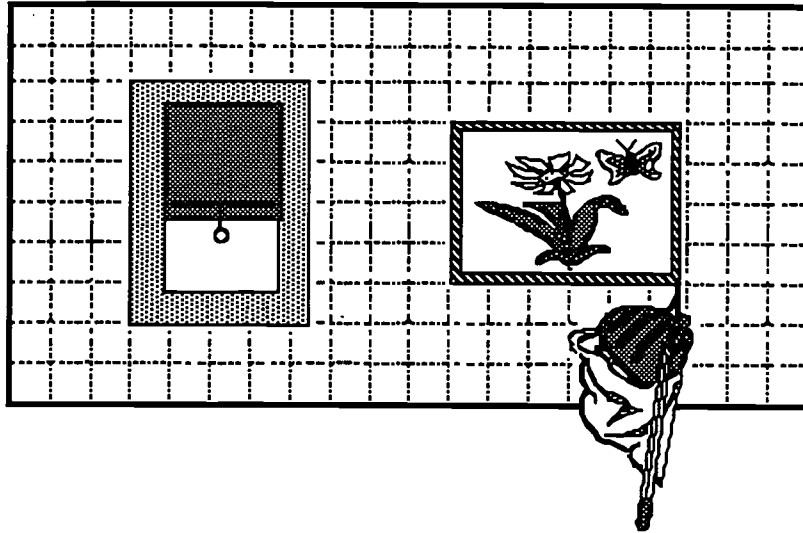

- ★★★ 2. Farmer Brown had some animals. One-fourth were horses, one-half were cows, and the rest were pigs. He had 8 pigs. How many animals did he have altogether?

Answer: _____

- ★★★ 3. To change a Fahrenheit temperature to a Celsius temperature, follow these steps:

- Subtract 32 from the Fahrenheit temperature.
- Divide by 9.
- Multiply by 5.

Use the steps to write the Celsius temperature for each of these Fahrenheit readings:

a. 59°F is _____ $^{\circ}\text{C}$ b. 86°F is _____ $^{\circ}\text{C}$ c. 122°F is _____ $^{\circ}\text{C}$

- ★★ 4. Marilyn used the steps above, and got a Celsius temperature of 60° . What was the Fahrenheit temperature she started with? _____

- ★ 5. How much is this stack of quarters worth?

Answer: _____

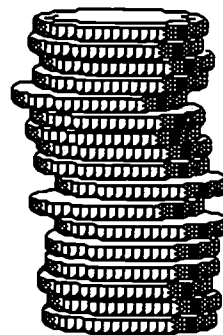

- ★★ 6. The Adams family wants to take a trip to Disneyworld, but can't decide what month to go. They decide to write the names of the months on 12 pieces of paper and put them in a hat. They will draw one piece of paper without looking -- that is the month they will travel.

- a. What is the chance they will go during the summer months of June, July or August? _____
b. What is the chance they will go during the school year, September through May? _____

- ★★ 7. Shown to the right is the way 1 square inch of a newspaper would look, when enlarged so you can see the tiny dots. About how many dots are there per square inch, in a newspaper? Circle the best choice.

- a. 100 b. 500 c. 1000 d. 1500

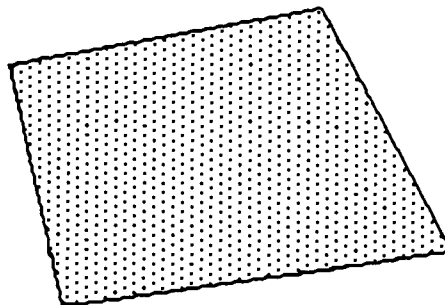

- ★★★★ 8. Consider each of the following. Can the equation $6 \times 3 + 4 = 22$ represent any of these statements? Circle "yes" or "no" beside each statement below.

- yes no a. Six tickets at \$3 each plus a \$4 ticket costs \$17.
yes no b. Six \$3 lunches and a \$4 tip come to \$22.
yes no c. A bike trip of 6 miles in 3 weeks, and 4 more weeks, is 22 miles.
yes no d. Six 3-k races, plus a 4-k race, means he ran 22 kilometers that month.

Commentary

Jupiter, XIV

1. (**Charles was correct.**) The window “edges out” on the right hand side about half a square unit, and there are six of those square units on that side of the window. Therefore the area is 24 square units, plus the six extra half-squares, or 27 square units altogether. The picture is a little short of taking up the sixth square unit on the right-hand end. Measurement shows that it's about $\frac{1}{5}$ of a square unit short on that side, and there are four such squares on that end. Therefore its area is four $\frac{1}{5}$'s short of being 24 square units. Charles desire to be an architect means that he will probably be quite exact in his measurements, as this problem shows.
2. (**32**) The 8 pigs were $\frac{1}{4}$ of the total number of animals, since that is the amount left when $\frac{1}{2}$ and $\frac{1}{4}$ are combined and removed from 1. Then the total number of animals is 4×8 or 32.
3. (**a. 15; b. 30; c. 50**) For (a), $59 - 32 = 27$; $27 \div 9 = 3$; $5 \times 3 = 15$. For (b), $86 - 32 = 54$; $54 \div 9 = 6$; $6 \times 5 = 30$. For (c), $122 - 32 = 90$; $90 \div 9 = 10$; $10 \times 5 = 50$.
4. (**140**) Students might get this by working backwards. To end up with 60 after multiplying by 5, you must have had 12 at the previous step. To have 12 after dividing by 9, you must have had 108 in the previous step. To have 108 after subtracting 32, you must have had 140 to begin.
5. (**\$4.25**) The 17 quarters would be \$4.25.
6. (**a. $\frac{3}{12}$ or $\frac{1}{4}$ or 0.25 or 25%; b. $\frac{9}{12}$ or 0.75 or 75%**) In (a), there are 3 months being considered out of twelve, so the chance is $\frac{3}{12}$ you will get one of those. In (b), the chances are $\frac{9}{12}$ since 9 months out of 12 are being considered.
7. (**c. 1000**) Students can partition the figure into smaller equal-sized pieces, count those, and gain an estimate by multiplying. The figure below has about 120 dots in the section that has been counted, and there are 8 such sections, resulting in 120×8 or 960 dots.

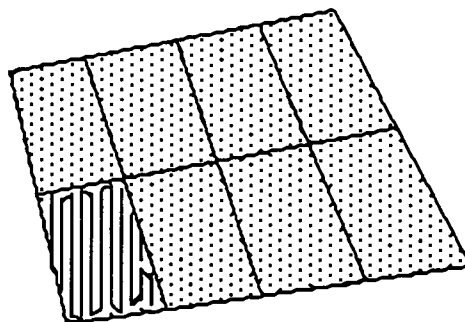

8. (**a. yes; b. yes; c. no; d. yes**) This problem will demonstrate that some students can translate a verbal situation into an equation, but others cannot.

SUPERSTARS III

Jupiter, XV

Name: _____

(This shows my own thinking.)

- ★★★★ 1. You have been asked to paint the outside surface of this figure made of cubes glued together. It will take approximately one pint of paint per square face. You do not have to paint the bottom.

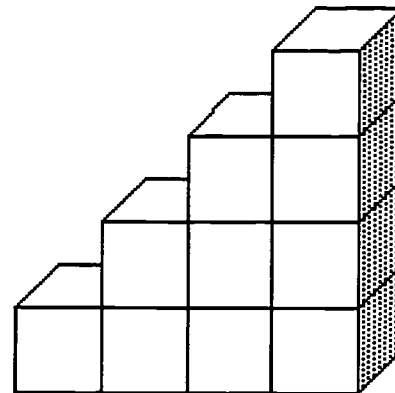

a. How many pints of paint will you need? _____

b. If the paint costs \$4.99 per pint, estimate the cost of the paint to the nearest dollar. _____

- ★★ 2. In the space to the right draw a quadrilateral with only one pair of parallel sides.

The name of this quadrilateral is a: _____

- ★★ 3. Ricardo bought one-half dozen donuts for his family. Family members ate one-half of the donuts. How many were left for Ricardo to eat?

Answer: _____ donuts

- ★★ 4. A commercial says "Four out of five dentists surveyed chose sugarless gum for their patients." If 1000 dentists were surveyed, how many recommended sugarless gum?

Answer: _____

- ★★ 5. What number from 1 to 25 has the most factors? _____

List its factors: _____

- ★★ 6. Fill in the bar graph below with the data given. Write a title and label the bottom axis.

Antonio surveyed his 36 classmates to find the month of their birthdays. He tallied: 5 in January, 4 in February, 1 in March, 2 in April, 1 in May, 4 in June, 4 in July, 2 in August, 3 in September, 4 in October, 0 in November, and 6 in December.

TITLE: _____

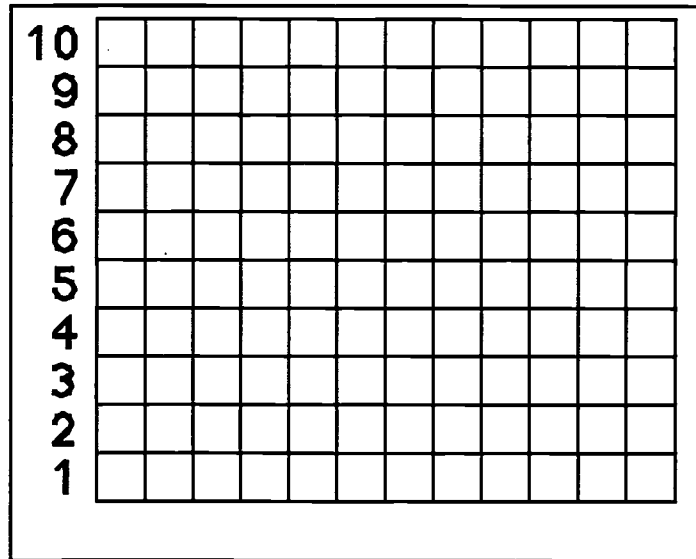

- ★★ 7. A skating rink plays different songs during a two-hour skating party. The songs average 3 minutes each. There is a 15-minute break, without music, when the refreshments are served. How many songs do they need to have ready?

Answer: _____ songs

- ★★ 8. A pencil can draw a line 36 miles long, according to research. Mickey decided to test that theory and draw his 36 miles in the shape of a square, so he would wind up back where he started. How long would each side of the square be?

Answer: _____ miles

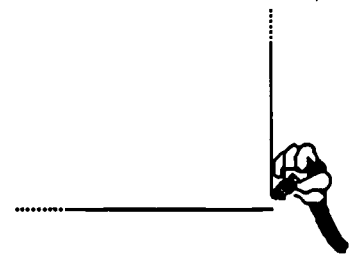

Commentary

Jupiter, XV

1. **(a. 32; b. \$160)** There are 10 faces on the side showing, giving 20 altogether on the two sides. There are 8 faces that make up the "steps," and 4 more on the end. The estimate of the cost can be made by rounding \$4.99 to \$5, and multiplying $32 \times \$5$.
2. **(Any picture of a trapezoid is acceptable.)**

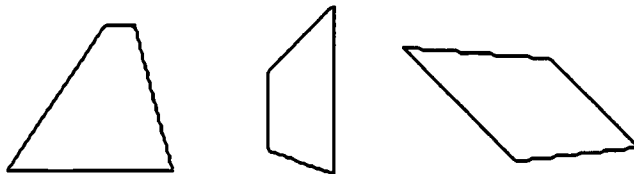

3. **(3)** One-half of a dozen is 6, and one-half of 6 is 3.
4. **(800)** Four out of five is the same ratio as eight out of ten, which is the same as 80 out of 100, which is the same as 800 out of 1000.
5. **(24; its factors are: 1,2,3,4,6,8,12,24)** Students will probably have to *guess-check-revise* to find the number with the most factors.
6. **(See the graph below.)** The title can be anything that makes good sense, such as "Class Birthdays." The labels on the bottom axis should represent the months of the year, probably with an initial.

TITLE: Class Birthdays

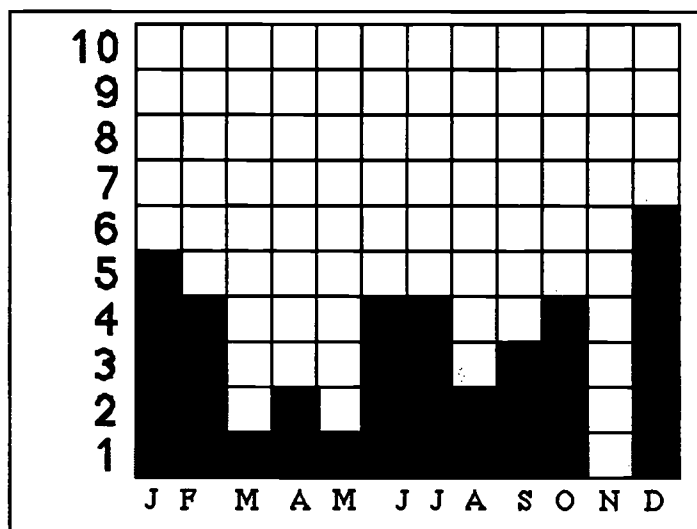

7. **(35)** Two hours is 120 minutes, and the 15-minute break means that 105 minutes are available for music. $105 \div 3 = 35$.
8. **(9)** The perimeter of the square is 36 miles. Therefore the sum of the four equal sides is 36, meaning that each side must be $36 \div 4 = 9$ miles in length.

SUPERSTARS III

Jupiter, XVI

Name: _____
(This shows my own thinking.)

- ★★ 1. Shade part of the diagram below to show $\frac{1}{3}$ of $\frac{1}{3}$ of the whole rectangle.

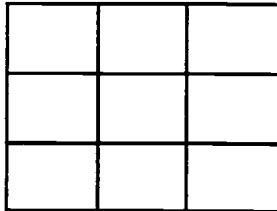

- ★★★★ 2. The table below lists mid-season baseball won-loss records for the Central division of the National League. Answer the questions based on the information provided in the table.

CENTRAL	W	L	TOTAL GAMES
St. Louis	31	40	
Cincinnati	43	25	
Houston	38	31	
Chicago	37	33	
Pittsburgh	30	37	

- Fill in the total games column on the table for each team.
- Which team has the highest winning percentage? _____
- Which team has the lowest winning percentage? _____
- What is the average number of games played per team? _____



- ★ 3. How many squares?

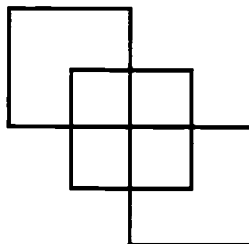

Answer: _____ squares

- ★★★ 4. The Fashion Store is having a Spring sale. The dresses are $\frac{1}{2}$ off and the shoes are $\frac{1}{4}$ off the regular price. Sandy buys a dress that was regularly priced at \$94.50 and shoes to go with the dress that were regularly priced \$29.96. What was the total amount she spent on just these two items? (Assume that there is no tax.)

Answer: _____

- ★★ 5. Make a graph to show the approximate position of the sun during a sunny summer day. The sun rises at 6:00 AM and sets at 9:00 PM.

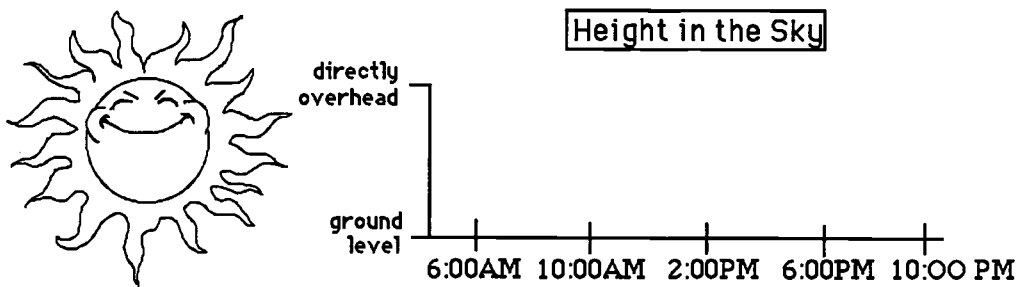

- ★★ 6. Ken is about to eat a bag of M&M's on the 4th of July. The number of each color M&M is listed in the table below. Answer the questions.

green	11
red	8
yellow	13
tan	7
brown	10
blue	5

- a. If Ken picks the first M&M out of the bag without looking, what is the chance he will pick a brown one to match his eyes? _____
- b. What is the chance his first one will match a color in the American flag? _____
- ★★ 7. Mike needs to buy 4 packages of pencils at 89¢ each, 2 packages of paper at \$1.19 each, and an eraser package for 95¢. He has \$10.00. Estimate to the nearest dollar how much money he will have left.



Answer: _____

Commentary

Jupiter, XVI

1. (Any model with one shaded cell is correct.) Students will likely think of dividing the rectangle into thirds either horizontally or vertically, and then one of those thirds into thirds going in the other direction.

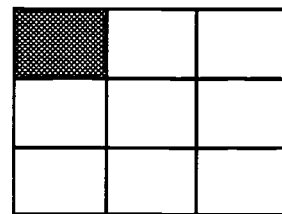

2. (a. 71, 68, 69, 70, 67; b. Cincinnati; c. St. Louis; d. 69) The total number of games comes from adding each team's wins and losses. Students can find the winning percentages by dividing the wins for each team by the total. When rounded off to two decimal places, these percentages are: 0.43, 0.63; 0.55, 0.53, and 0.45 for the teams as listed, top to bottom, in the chart. The highest of these percentages is 0.63 and the lowest is 0.43, corresponding to Cincinnati and St. Louis, respectively. The average number of games played is $(68 + 69 + 70 + 67 + 71) \div 5$, or 69.
3. (7) There are 3 large squares, and 4 smaller ones in the center.
4. (\$69.72) The students first need to find how much each item will cost on sale. They will probably divide the price of the dress by 2 to get the new price, \$47.25. They will probably divide the price of the shoes by 4 to get \$7.49, and subtract that from the regular price to get the sale price, \$22.47. They then add these two sale prices. This is only one way a fourth grader might approach this problem.
5. (See the graph below.)

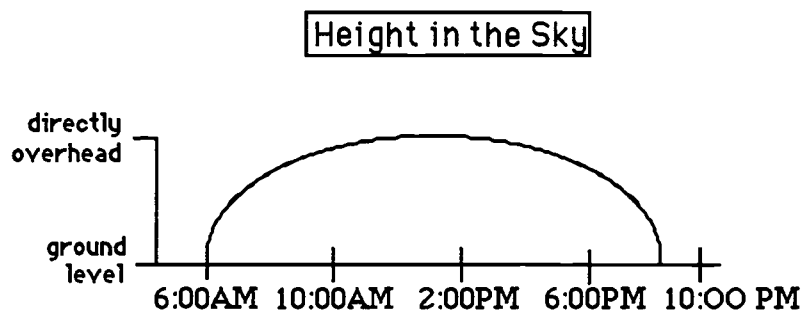

6. (a. 10 out of 54, or 5 out of 27, which can also be written as a ratio, fraction, decimal or percent -- $10:54$ or $10/54$; $5:27$ or $5/27$; or 0.19 or 19%; b. 13 out of 54, which can also be written as a ratio, fraction, decimal or percent -- $13:54$ or $13/54$ or 0.24 or 24%) There are 10 brown M&M's out of 54 in the bag, so that there is a $10/54$ chance of getting a brown one. There are 13 red or blue M&M's and no whites, so the chances of getting a color in the American flag is $13/54$.
7. (\$3) Four packages of pencils cost about \$4, two packages of paper cost about \$2.00, and the eraser package costs about \$1. This totals \$7, so he would have about \$3 left out of \$10.

SUPERSTARS III

Jupiter, XVII

Name: _____

(This shows my own thinking.)

- ★★★ 1. Make big dots on the grid for the following ordered pairs, and label them A, B, C, or D.

A is (2,4); B is (6,4); C is (6,1); D is (2,1)

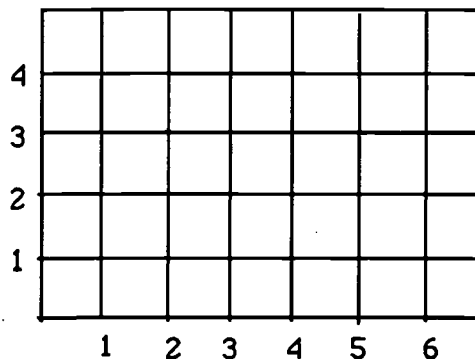

a. Connect A to B to C to D to A with a heavy pencil line.

b. Name the shape you drew. _____

c. Give the *area* of the shape. ____ square units

- ★★ 2. Write in the boxes the numbers to show the arrows' positions on the number line.

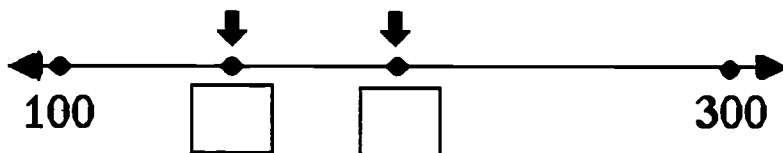

- ★★★ 3. The *Guinness Book of World Records* states that the largest pumpkin on record weighed 671 pounds. If this pumpkin was lifted onto the scales by 11 fourth graders, on average, how much would each student be lifting?

Answer: _____ pounds

- ★★★ 4. The computer tables in a classroom were placed together to form the polygon pictured to the right.

a. Name the polygon that was formed. _____

b. How many angles does this polygon have? _____ angles

c. Are the angles *acute*, *obtuse*, or *right*? _____

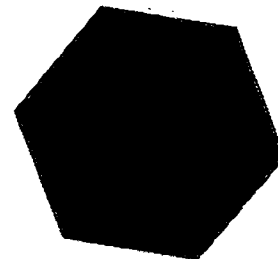

- ★★ 5. In the United States, every 57 minutes an underage drinker is involved in a traffic fatality. A recent report urges a crackdown on teen-age drinking and driving. Estimate the number of underage drinkers involved in traffic fatalities each day.

Answer: _____

- ★ 6. Decide whether an estimate or a precise calculation is appropriate for each situation. Write "estimate" or "precise calculation" in the answer spaces. Use each term once.





Situation 1: *Checking the change you receive after paying for lunch.*

Answer: _____

Situation 2: *Planning the time it will take to travel from one town to another on a trip.*

Answer: _____

- ★★★★ 7. Fill in the total number of rectangles found in each pattern below.

PATTERN	NUMBER OF RECTANGLES
	_____
	_____
	_____6_____
	_____
	_____

- ★★★ 8. Describe how to find each "next number" of rectangles, without drawing the figure:

Answer: _____

- ★★ 9. How many total rectangles will there be if 7 small rectangle are used in the pattern? _____

Commentary

Jupiter, XVII

1. (a. See below; b. rectangle; c. 12)

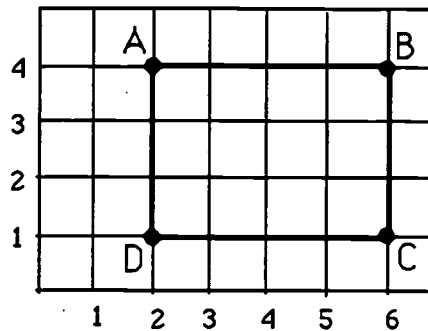

2. (150, 200) Students can measure, with a piece of paper and a pencil, the distance from 100 to the second dot and compare that to the distance from the second dot to 300. They will find the distance to be the same, indicating that the middle dot is half way between 100 and 300, at 200. A similar strategy shows that the first open box holds 150.
3. (61) Students can divide: $671 \div 11 = 61$
4. (a. hexagon; b. 6; c. obtuse)
5. (24 or 25) Students can round 57 minutes to 60 minutes or one hour. There are 24 hours in a day; therefore an estimate of 24 fatalities per day is reasonable. If a student calculates that since 57 is 3 minutes less than 1 hour, there would be 24×3 or 72 extra unaccounted-for minutes, meaning another group of 57 minutes in 24 hours, then 25 is a reasonable estimate also.
6. (precise calculation, estimate) Either answer might be acceptable in each situation, except that the directions say to use each term once. Therefore the student is forced to choose the more appropriate term for each spot.
7. (1, 3, 10, 15)
8. (The number pattern increases by adding one greater number to the total each time. See alternate formula below.) $1 + 2 = 3$ (the next level); $3 + 3 = 6$ (the next level); $6 + 4 = 10$ (the next level); $10 + 5 = 15$; and so on. Most students won't notice this, but they can find each new number without knowing the previous number. If there are n small rectangles, then the total number of rectangles formed is $(n)(n + 1) \div 2$.
9. (28) Following the lead from problem 8, the student can add 6 to 15 to get 21 rectangles with 6 small rectangles, then $7 + 21$ to get the next total. Or, with 7 small rectangles, there are $(7)(8) \div 2$ total rectangles.

SUPERSTARS III

Jupiter, XVIII

Name: _____

(This shows my own thinking.)

★★★★

1. You are playing a card game with a full deck of 52 cards. You win if you draw a *red card* that is a *multiple of 5*. What are your chances of winning on your first draw?



Answer: _____

★★★

2. The Tappens ordered two pizzas for dinner Friday. Dad ate $\frac{3}{4}$ of one pizza, Jenny ate $\frac{1}{8}$ of a pizza, Danny ate $\frac{1}{4}$ of a pizza, and Mom ate $\frac{1}{2}$ of a pizza. What fraction of a pizza was left for a midnight snack?

Answer: _____ of a pizza

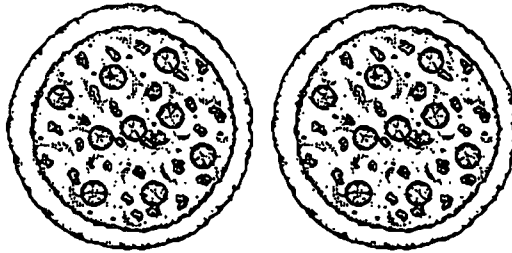

★★★

3. Leah liked to balance objects she found around the house using the science kit she got for Christmas. She found that 3 identical apples and a 5-gram weight exactly balanced a 50-gram weight. Leah said she could tell how much each apple weighed by solving the equation $3a + 5 = 50$. Prove Leah was correct by finding the weight of 1 apple.

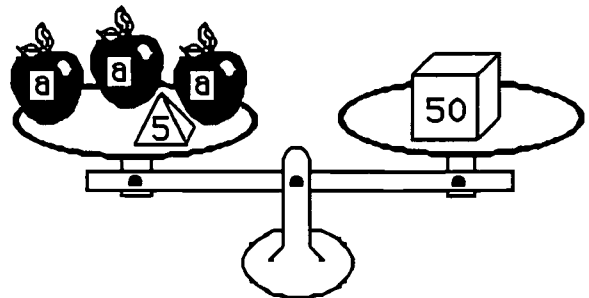

Answer: $a =$ _____

★

4. Apalachee Elementary School has a total of 16 classes. The 104 fourth graders are divided equally among 4 classrooms. How many fourth graders are in each class?

Answer: _____

- ★ 5. If one or both of the numbers in a multiplication problem are *even*, the product will be *even*. Therefore if you open a book and multiply the facing page numbers together, the product will be an _____ (*even* or *odd*) number.

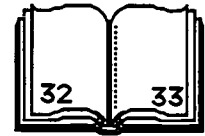

- ★★ 6. Tonya is making friendship bracelets for each girl coming to her sleep-over party. Each bracelet will be braided with 4 purple strings, 3 yellow strings, 2 green strings and 3 blue strings. She is expecting 8 friends to attend her party. Each string costs 10 cents. It takes Tonya about 20 minutes to braid each bracelet.



- a. How much will the string cost Tonya? _____
- b. How long will it take Tonya to make all the bracelets ? ____ hours and ____ minutes
- ★ 7. About how long is it around the outside edge of an ordinary door in your home? Circle the best answer below.

(a) 10 meters (b) 4 meters (c) 15 meters (d) 6 meters

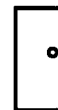

- ★★ 8. Below is a bus schedule showing departure times and arrival times from various cities in Florida to Ft. Lauderdale. How much time does the longest trip take?

DEPARTURES		ARRIVALS	
Jacksonville	8:30 AM	Ft. Lauderdale	3:00 PM
Tallahassee	7:30 AM	Ft. Lauderdale	7:00 PM
Tampa	10:00 AM	Ft. Lauderdale	3:00 PM
St. Augustine	8:00 PM	Ft. Lauderdale	4:00 AM

Answer: _____ hours and _____ minutes

Commentary

Jupiter, XVIII

1. **(4 out of 52, 2 out of 26 or 1 out of 13, which could also be written as a fraction ($\frac{4}{52}$, e.g.), a decimal (approximately 0.08), or a percent (8%))** Out of each suit, there are two cards that are multiples of 5, the 5 and the 10. There are two red suits, diamonds and hearts. Therefore there are four such cards out of 52 in the deck.
2. **($\frac{3}{8}$)** The two pizzas shown have not been divided into eighths yet, as pizzas normally are. The student can divide each of them this way and see that Dad ate 6 pieces, Jenny ate 1 piece, Danny ate 2 pieces, and Mom ate 4 pieces. Therefore 13 pieces were eaten, leaving 3 pieces. Three pieces is $\frac{3}{8}$ of a pizza.
3. **(15)** Students should solve this problem intuitively, not by trying to use the equation. The equation is there simply for them to associate an equation with a real-life situation. They can *guess-check-revise* to find the weight of an apple, or they can deduce the answer logically as they will be called on later to solve such equations. If three apples and 5 grams weigh 50 grams, then 3 apples by themselves must weigh 45 grams. Therefore each apple weighs $45 \div 3$ or 15 grams.
4. **(26 students)** There is extra information in this problem -- 16 classes. The problem is solved by dividing 104 students by 4.
5. **(even)** Students might want to test this out, by opening a book to several different places and multiplying the numbers on the facing pages with a calculator.
6. **(a. \$9.60; b. 2 hours and 40 minutes)** Students can first multiply each color string by 8, add those products to get 96, and then multiply by 10 cents. Or, they might add all the colors together for one bracelet and get 12, multiply that amount by 8, and then multiply by 10 cents. For the second question, students can multiply 20 minutes by 8 to get 160 minutes, converting that to 2 hours and 40 minutes.
7. **(6 meters)** Students might estimate this amount visually -- the height of a door is about 2 meters, and the width is not quite 1 meter. Therefore, the distance around the outside would be about $1 + 2 + 1 + 2$ or 6 meters. Some students might actually measure a door and find approximately the same dimensions. Most interior doors in houses are about 5.5 meters around the outside, which is closer to 6 meters than any of the other answers.
8. **(11 hours 30 minutes)** The trip from Tallahassee takes the longest. Students will most probably "count up" from the departing time to the arrival time, getting 6 $\frac{1}{2}$ hours, 11 $\frac{1}{2}$ hours, 5 hours, and 8 hours, respectively. On the Tallahassee trip, some might get the time by realizing that a 12-hour trip would go from 7:30 AM to 7:30 PM, and this would be $\frac{1}{2}$ hours shorter than that, giving 11 $\frac{1}{2}$ hours for the trip.

SUPERSTARS III

Jupiter, XIX

Name: _____

(This shows my own thinking.)

- ★★ 1. Divide each of the squares below differently so they represent fourths.

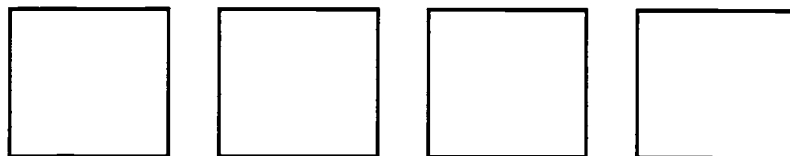

- ★ 2. Tiger roared every time someone passed its home in the zoo. Tiger roared more than 39 times but fewer than 46. It roared an odd number of times. You say the number when you count by 3's and by 5's. How many times did Tiger roar?

Answer: _____ times



- ★★ 3. Paul Lynch holds the world record for one-arm push-ups. Paul once did 3,855 one-arm push-ups in five hours. On average, how many did he do in 1 hour?

Answer: _____ push-ups

- ★★ 4. Trace over the figure of the kite below. Cut along the lines of your tracing that go from vertex to vertex so you have four triangles. Arrange these triangles so they make two quadrilaterals: a square and a rectangle. Find the perimeter of each quadrilateral.

Perimeter of the square: _____ Perimeter of the rectangle: _____

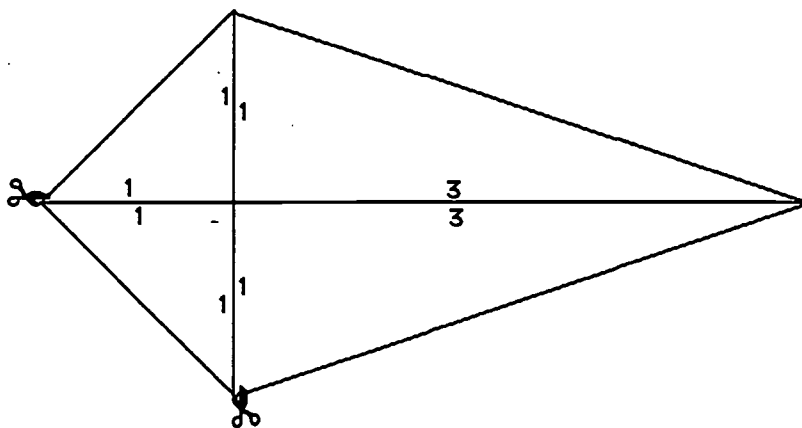

- ★★ 5. The bar graph shows the percent of members of elected parliaments or legislatures in 1988 and 1994 who were women. Fill in the graph to show the percent in the year 2000, if the decline is the same from 1994 to 2000 as it was from 1988 to 1994.

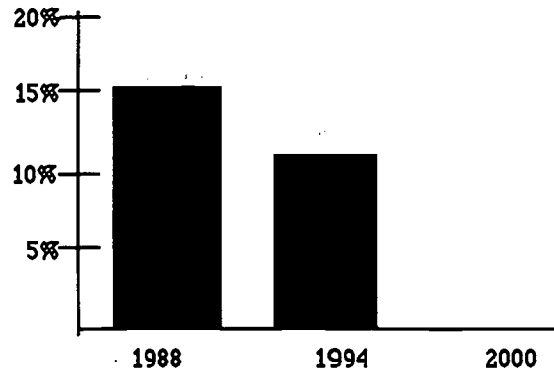

- ★★ 6. Circle the figure below -- B, C, or D -- that shows figure A rotated 270 degrees clockwise.

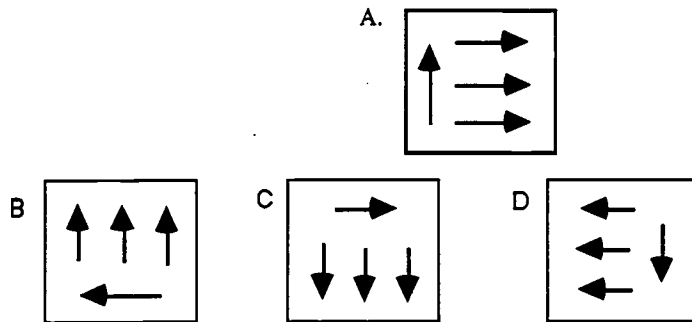

- ★★ 7. During the last week of school, a few students got the silly willies on Monday. On Tuesday, 2 more students than on Monday caught the silly willies. Each day after that, 2 more students than on the day before caught them. On Friday, 12 students caught them. How many students caught the silly willies in 5 days?

Answer: _____ students

- ★★ 8. Arrange the digits 1-7 in the squares so that no two consecutive digits are connected by a line.

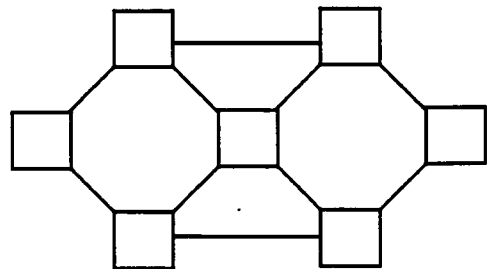

Commentary

Jupiter, XIX

1. (Four possibilities are shown below.) Students can show "fourths" in a number of ways. The square must be divided into 4 parts, and the parts must have the same area. However, the parts do not have to be the same shape.

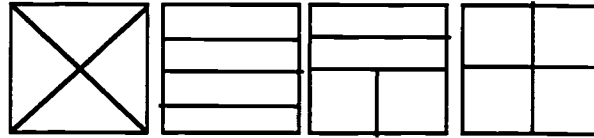

2. (45) Students might start by listing the numbers greater than 39 but less than 46: {40, 41, 42, 43, 44, and 45}. The only number of the list that you count when you count by threes and fives is 45. "It roared an odd number of times." is not necessary as a clue.
3. (771) Students might use a calculator to divide 3855 by 5, getting 771. Students might be challenged to find the approximate number of pushups per minute -- 13 -- and to then approximate the rate of his doing push ups (about 1 every 5 seconds).
4. (square is 4 units; rectangle is 8 units) Some students might misinterpret the problem and try to use all four figures to make the square, and then all four again to make the rectangle. They will find they can't make such a square.
5. (The graph should be approximately equivalent to the one shown.) The change from 1988 to 1994 is from 15% to 11%. That same change from 1994 to 2000 would result in about 7% in 2000.

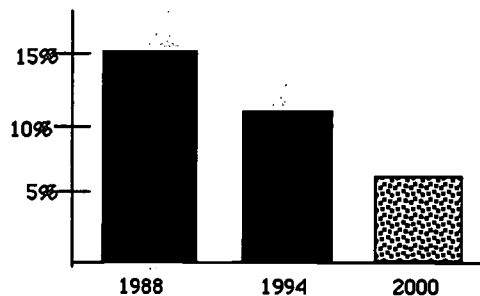

6. (Figure B) Students might find the drawing by tracing over figure A, actually turning it three 90° turns, and matching it up with one of the given drawings.
7. (40 students) This problem can be solved by *working backward* and then adding. On Friday 12 students got the silly willies; therefore on Thursday, 10 students did; Wednesday, 8 did; Tuesday, 6 did; and Monday, 4 did. $12 + 10 + 8 + 6 + 4 = 40$.
8. (One solution is shown.) Students might start by putting 4 in the center and the two numbers that "surround" it, 3 and 5, on the ends.

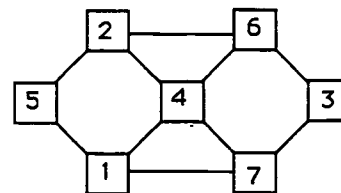

SUPERSTARS III

Jupiter, XX

Name: _____

(This shows my own thinking.)

- ★★★★ 1. The owner of "Pets On The Go" pet store currently has the following animals in his store: 5 dogs, 4 cats, 12 birds, 2 turtles, 3 snakes, 2 giant lizards, 1 pot-bellied pig, and 4 spiders. How many legs were on the 33 animals?

Answer: _____ legs

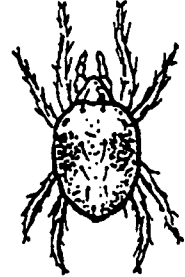

spider

- ★★ 2. Mrs. Ricketts is a farmer. She grows fruits and vegetables. The largest pumpkin she has ever grown weighed 68 pounds. The largest cantaloupe she has ever grown weighed 12 pounds, 8 ounces. What is the difference in weight between the pumpkin and the cantaloupe?

Answer: _____ pounds, _____ ounces

- ★★★ 3. If a customer wanted to buy Mrs. Rickett's largest canteloupe and the price was 50¢ per pound, how much would the customer have to pay?

Answer: _____

- ★ 4. Mark hid a \$10 bill inside his favorite book. He forgot the pages where he hid it. If the sum of the pages where the bill is hidden is 177, on what pages will Mark find his money?

Answer: page _____ and page _____

- ★ 5. Mr. Dexter brought home $\frac{1}{2}$ dozen eggs. He accidentally dropped the carton on the floor and $\frac{1}{3}$ of the eggs broke. How many eggs does he have left?

Answer: _____ eggs

- ★★ 6. If you start in the right place, you can trace this entire map with your pencil without retracing a path between two points. Circle the two points where you can start to do this amazing feat!

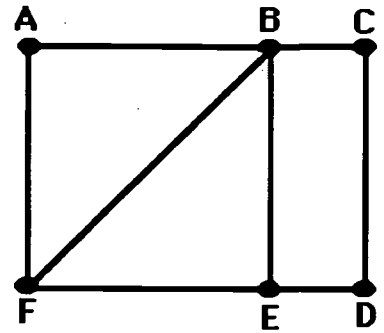

- ★★ 7. The 6 fourth-grade classes at Marathon Elementary School are having a kick-ball tournament. Each class must play each other once in the tournament. How many kick-ball games must be scheduled?

Answer: _____ games

- ★★★ 8. The cafeteria staff at Fairlawn Elementary took a poll of its fourth grade students to find out how many students liked hot dogs, pizza, or tacos. The results are shown in the Venn diagram below.

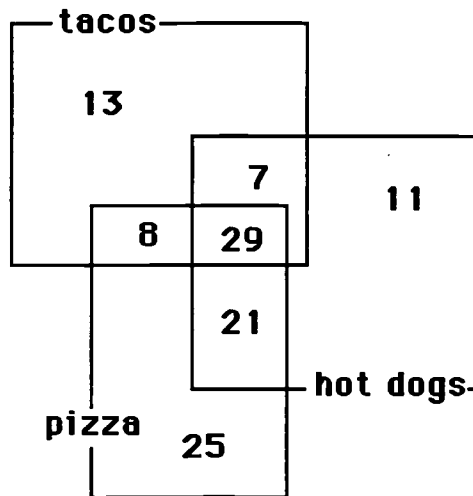

- a. Sixty-eight students liked hot dogs. How many students like tacos? _____ students
- b. How many students liked both pizza and tacos, but not hot dogs? _____ students
- c. How many students liked all three types of food? _____ students

Commentary

Jupiter, XX

1. **(112)** Students may make a chart according to the animal's number of legs. Dogs, cats, turtles, lizards and the pig have 4 legs each, so the total number of legs on the 4-legged creatures is $4 \times (5 + 4 + 2 + 2 + 1)$ or $4 \times 14 = 56$. The 12 birds contribute 24 legs and the 4 spiders have 8 legs each or 32 all together. Therefore there are $56 + 24 + 32 = 112$ legs.
2. **(55 pounds, 8 oz)** Students need to convert 1 pound to 16 ounces in order to be able to subtract. The 68 pounds become 67 pounds, 16 ounces, and then the student can subtract 12 pounds, 8 ounces.
3. **(\$6.25)** Students might multiply $12.5 \times \$0.50$. They might realize that every 2 pounds will cost \$1, therefore 12 pounds will cost \$6. They then realize that 1/2 pound will cost half of 50¢, or 25¢, and combine that with \$6.
4. **(pages 88, 89)** Students may need to be reminded that pages in a book are consecutive. If they divide 177 by 2, they will get a hint that the answer must be 88 and 89.
5. **(4)** Drawing 1/2 dozen eggs, or 6 eggs, will lead to a solution. Then 1/3 of them, or 2 eggs, can be crossed out, leaving 4 eggs.
6. **(E and F should be circled.)** These two points are the only two with an odd number of paths going in and coming out. Consequently, these are the only two places at which you can begin such a network and trace it without backtracking.
7. **(15)** Students can make a chart or diagram to solve this problem. They could make a list such as the one below which uses A, B, C, D, E, and F to represent the six classrooms:

AB, AC, AD, AE, AF, BC, BD, BE, BF, CD, CE, CF, DE, DF, EF
8. **(a. 57; b. 8; c. 29)** For part (a) students add 7, 13, 29, and 8. For (b), they look for the number common to both pizza and tacos, but is not common to hot dogs. For (c), the students locate the number common to all three rectangles.

SUPERSTARS III

Jupiter, XXI

Name: _____

(This shows my own thinking.)

- ★★★1. A cricket and a flea decided to hop on a set of stairs. The flea takes 2 steps in 1 hop. The cricket takes 3 steps in 1 hop. The set of stairs has 12 steps.

- a. On which steps will both the cricket and the flea land?
b. On which steps will neither of them land?

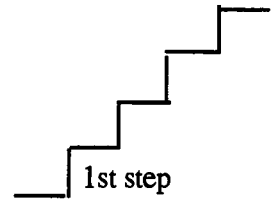

- Answers: a. Both the cricket and the flea will land on these steps: _____
b. Neither the cricket nor the flea will land on these steps: _____

- ★★ 2. Bill Cosby is one of the leading money makers in the entertainment business. If he earns \$92 million for two years' work, how much would he earn for five years' work?

Answer: \$ _____ million

- ★ 3. The answer to problem 2 uses a short word name for a large number. Rewrite the answer to problem 2, but do not use "million." Remember -- this answer involves money!

Answer: _____

- ★★★ 4. Study the bar graph below which shows the average precipitation for the month of June in the United States. Answer the questions pertaining to the graph.

- a. Was June 1995 drier or wetter than normal?

Answer: _____

- b. What is the difference in rainfall between the wettest and driest Junes on record?

Answer: _____ inches

- c. How many years' difference exist between June 1995 and the wettest June on record?

Answer: _____ years

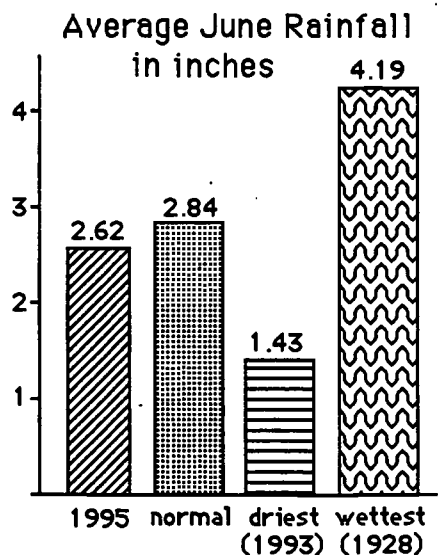

- ★★★ 5. A bricklayer is working with bricks of the size shown to the right. She puts a 2-cm layer of mortar between each two rows of bricks. How high will the wall be when 10 rows have been laid?

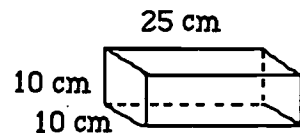

Answer: _____ cm

- ★ 6. It is recommended that children from ages 7 to 10 eat about 2000 calories per day. Andy is 8 years old. Listed below is everything Andy ate Tuesday. Did Andy eat less than, more than, or equal to the recommended amount of calories?

Breakfast

cereal (240 cal.)
milk (225 cal.)
banana (100 cal.)

Lunch

Egg-salad sandwich (230 cal.)
applesauce (53 cal.)
milk (150 cal.)
potato chips (105 cal.)

Snack

cheese (114 cal.)
crackers (20 cal.)
yogurt (180 cal.)

Dinner

lasagna(330 cal.)
milk (150 cal.)
pear (90 cal.)
ice cream (230 cal.)

Answer: _____

- ★★ 7. You can roll two number cubes at a time, a white one and a red one, and there are 36 different ways for the “up faces” to land. The pair of number cubes at the right shows the only way that a sum of two can come up. How many ways will give a sum of 7 on the two up faces?

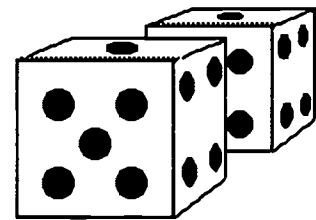

Answer: _____ ways

- ★★★ 8. About how many people lying head-to-toe are needed to stretch around the earth? Is it closest to: (a) 1 million, (b) 25 million, or (c) 100 million? (Hint: The distance around the earth is approximately 25,000 miles.)

Answer: _____



Commentary

Jupiter, XXI

1. **(a. 6th and 12th; b. 1st, 5th, 7th, and 11th)** Students can draw the 12 steps and the two animals jumping as a concrete way to solve the problem. Or they might simply list the steps that each will land on and find the answer that way. Some might write the numbers from 1 to 12, and write "C" or "F" above each number as the cricket or flea lands on it.
2. **(\$230)** This will probably be a two-step problem. Students will probably divide 92 by 2 and then multiply that quotient by 5.
3. **(\$230,000,000.00 or \$230,000,000)** In this answer, look for the dollar sign and the correct number of zeros.
4. **(a. drier; b. 2.76; c. 67)** Part (a) simply involves comparing the 1995 bar with the "normal" bar. Part (b) involves subtracting 1.43 from 4.19; part (c) requires students to subtract 1928 from 1995.
5. **(118)** Students may draw a picture; there are 10 bricks ($10 \times 10 \text{ cm} = 100 \text{ cm}$) and 9 sections of mortar ($9 \times 2 \text{ cm} = 18 \text{ cm}$). The total is then $100 \text{ cm} + 18 \text{ cm}$.
6. **(more than)** The total number of calories listed is 2217. Some students will be able to estimate accurately that the calories sum to more than 2000, without actually getting the total number of calories accurately.
7. **(6)** Out of the 36 ways the number cubes can land, these combinations give a sum of 7: (1,6), (6,1), (2,5), (5,2), (3,4), (4,3).
8. **(b. 25 million)** Students can convert 25,000 miles into 132,000,000 feet using a calculator. If the average person is 5.5 feet tall, this number can be divided into 132,000,000 to get 24 million people necessary. An average height of 5 feet would result in a little more than 26 million people. Therefore the most reasonable answer is about 25 million.

SUPERSTARS III

Jupiter, XXII

Name: _____

(This shows my own thinking.)

- ★★ 1. If the 24th day of the month falls on Saturday, on what day did the 6th fall?

Answer: _____

- ★★★ 2. There are 4 six-packs of soda in a case. Chris bought $\frac{1}{2}$ of a case and gave $\frac{1}{3}$ of what he had to Dana. How many cans of soda does Chris have left?

Answer: _____ cans

- ★★★ 3. Together, 6 boys and 12 girls weigh 1050 pounds. The boys all weigh the same -- x pounds. Each girl weighs 55 pounds. What is the weight of one boy?



Answer: $x =$ _____ pounds

- ★★ 4. The sum of 3 consecutive numbers is 276. What are the numbers?
(Consecutive numbers differ by one: example: 8, 9, and 10)

Answer: _____, _____, and _____

- ★★ 5. If a family of 12 spiders wore shoes, how many *pairs* of shoes would they need?



Answer: _____ pairs.

★★

6. A tropical storm passed through the town. It began to rain Monday morning at 8:45 AM and did not stop until the next day at 2:30 PM. How long did it rain?

Answer: _____ hours and _____ minutes

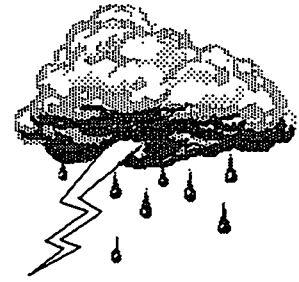

★★

7. There are 3 cars, 4 bicycles, 2 tricycles, and 1 unicycle in the neighbor's garage. How many wheels are there in all? Forget about any "spare tires"!

Answer: _____ wheels

★★

8. Rosemary bought a sweater on sale for \$6.98. She also bought a skirt for \$9.99. She paid an additional \$1.19 for sales tax. Rosemary gave the sales person a \$20 bill. How much change should she receive?

Answer: _____



★★★

9. Study this pattern. 25 and also 32 would be in column E, if the pattern continued.

- a. In which column would 100 appear? _____
- b. In which column would 500 appear? _____
- c. In which column would 1000 appear? _____

.
21	22
14	15	16	17	18	19	20
7	8	9	10	11	12	13
0	1	2	3	4	5	6
A	B	C	D	E	F	G

Commentary

Jupiter, XXII

1. **(Tuesday)** Students can use a calendar or make a chart with “Su, M, T, W, Th, F, Sa” at the top and begin numbering backward putting 24 under Saturday. They may also realize that the 17th and 10th fall on Saturdays and count back from the 10th.
2. **(8)** Students can solve this problem by drawing a diagram or by visualizing 24 colas. $1/2$ of 24 is 12, and $1/3$ of 12 is 4. Therefore Chris gave away 4 of the 12 sodas, leaving 8.
3. **(65)** Students will probably solve this by first finding the total weight of the 12 girls: $12 \times 55 = 660$ pounds. Then they will compute $1050 - 660 = 390$ pounds, the weight of the 6 boys. Then $390 \div 6 = 65$ pounds per boy.
4. **(91, 92, 93)** Students may use the *guess-check-revise* method. Some students might know that the numbers they seek are about $1/3$ of the total, and approximate the numbers by dividing 276 by 3. This gives 92, which is the middle number.
5. **(48)** Students may want to draw a picture to help solve this problem. Spiders have 8 legs, which would be 4 pairs of shoes per spider.
6. **(29 hours and 45 minutes)** Most students will realize that from 8:45 AM to 8:45 AM the next day, is 24 hours. They will then “add on” 5 additional hours to get to 9:45, 10:45, 11:45, 12:45, and 1:45, and then 45 minutes to get to 2:30 PM.
7. **(27)** There would be 12 wheels on the 3 cars, 8 on the 4 bicycles, 6 on the 2 tricycles, and 1 on the unicycle.
8. **(\$1.84)** Students will probably add \$6.98 and \$9.99 to get \$16.97, then add the tax of \$1.19 to get \$18.16. They will subtract this amount from \$20.
9. **(a. C; b. D; c. G)** Hopefully, students will notice that the multiples of 7 are in column A and use this fact to get “close to” the numbers 100, 500, and 1,000. Ninety-eight (14×7) is the closest multiple of 7 less than 100, so 98 would be in column A, forcing 100 to be in column C. Likewise, 497 or 71×7 is in column A, putting 500 in column D. Finally, 994 or 142×7 is in A, indicating that 1000 is in column G.

SUPERSTARS III

Jupiter, XXIII

Name: _____

(This shows my own thinking.)

- ★★ 1. The design to the right was drawn on a piece of clear plastic. The plastic was turned 180° clockwise, which is half of a complete rotation. It was then flipped over on the dotted line. Circle the picture below that shows how the design looks after these movements.

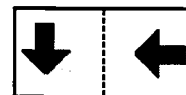
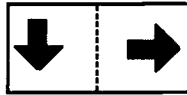

- ★ 2. If the heaviest dog in the world is 310 pounds and the next-heaviest is 14 pounds less, how much does the next-heaviest dog weigh?

Answer: _____ pounds



- ★★ 3. Sunae's group of close friends are going to fifth grade in September. All are going to Belleview Elementary and their homerooms will be rooms 12, 14, or 16. All of her friends but 4 are going to room 12, all but 4 are going to room 14, and all but 4 are going to room 16. Not counting Sunae, how many children are in her group of close friends?

Answer: _____ friends

- ★★★ 4. Sam and Suzie are twins. Sam has as many brothers as he has sisters -- Suzie has at least 1 sister, and twice as many brothers as sisters. How many kids are in the family altogether?

Answer: _____ kids

- ★★ 5. Josh bought a shirt for \$12.95, a belt for \$6.95, and a pair of jeans for \$27.97. The tax came to \$3.35. How much change did he receive if he gave the clerk 2 twenty-dollar bills and 2 ten-dollar bills?

Answer: \$ _____

★★★ 6. Danny's age is 13 and his favorite sport is roller hockey. Answer the questions about roller hockey participants using the circle graph below.

a. How many ages are included in Danny's age group? _____

b. List the age groups from greatest to least based upon their percent of participation.

Age Group	% Participation
_____	_____
_____	_____
_____	_____
_____	_____
_____	_____

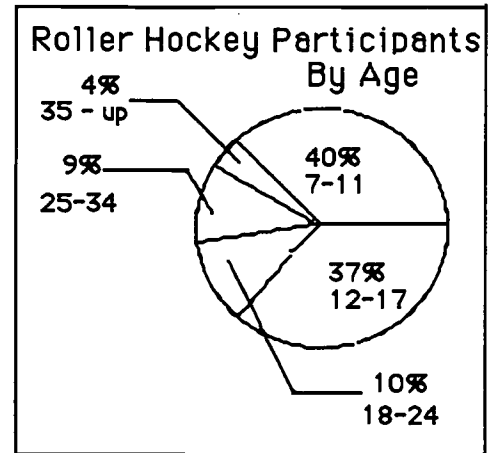

c. Use the data from part (b) to make a conclusion about participation in roller hockey as you get older:

Answer: _____

★★ 7. What number am I?

Answer: _____

- I am even.
- I am not 7×10 or less.
- I am not a multiple of 4.
- I am not a multiple of 3.
- I am less than $10 \times 10 - 20$.

★★★★ 8. Four identical books and a 5-ounce weight balance 37 ounces. The equation $4x + 5 = 37$ expresses this situation, where x is the weight of 1 book. How much does 1 book weigh?

Answer: $x =$ _____ ounces

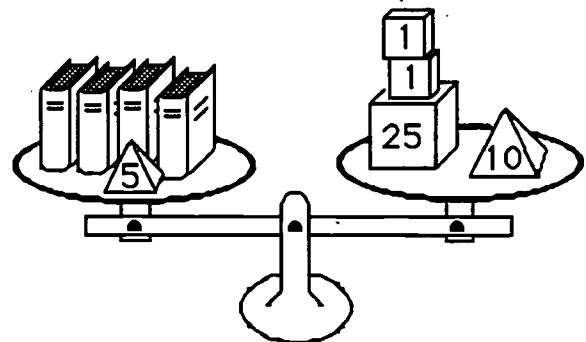

Commentary

Jupiter, XXIII

1. **(3rd from the left is circled.)** Students with good spatial visualization can find the right card by imagining the turns. Others might draw the figure on a card or sheet of paper, and make the turns.
2. **(296 pounds)** $310 - 14 = 296$.
3. **(6)** One way to begin the problem is to write down the room numbers 12, 14, and 16, and *guess-check-revise*. If there are 2 friends in each room, then there will always be four friends in the other two rooms.
4. **(7 kids, 4 boys and 3 girls)** Sam and Suzie are included in the number of brothers or sisters. One way to begin is to write list "B" and "G" for boys and girls, and *guess-check-revise*. The number under B must be more than 1 since Sam has at least one brother, making 2 boys at least. So try 2 for B, which means Sam has 1 sister, giving Suzie 0 sisters. But this contradicts what is given, so revise the guess under B to 3. This gives Sam 2 brothers and 2 sisters, and Suzie 1 sister. But then Suzie has 3 brothers, which is not twice as many as her 1 sister. Revise the guess under B to 4, giving Sam 3 brothers and 3 sisters, and Suzie 2 sisters and 4 brothers. This meets the conditions of the problem.
5. **(\$8.78)** He spent a total of \$47.87 plus \$3.35 in tax. This totals \$51.22. Subtract \$51.22 from \$60.00.
6. (a. 6; b.

Age Group	% Participation
7-11	40%
12-17	37%
18-24	10%
25-34	9%
35-up	4%

; c. The older you get, the less likely you are to be in roller hockey.)
7. **(74)** Students can use the second clue and the last clue to list the numbers from 71 to 79. The first clue eliminates the odd numbers, leaving 72, 74, 76, and 78. But 72 and 76 are both divisible by 4, and 78 is divisible by 3. Hence, by process of elimination, 74 is the answer.
8. **(8)** Students should try to find the weight of a book without manipulating the variable x in the equation. They can reason that the 4 books alone must contribute 32 ounces to the weight on the left, since those books plus 5 ounces weigh 37 ounces. Then if 4 books weigh 32 ounces, each book must weigh 8 ounces.

SUPERSTARS III

Jupiter, XXIV

Name: _____

(This shows my own thinking.)

- ★★★ 1. The Daily News costs \$0.35 at the news stand and is published Monday through Friday. You can also buy a four-week subscription for \$4.75. If you bought a four-week subscription, how much would you save over buying it for four weeks at the daily rate?

Answer: _____

- ★★★ 2. Put > or < in the box.

$$\frac{1}{2} + \frac{3}{4} \quad \square \quad \frac{2}{3} + \frac{1}{2}$$

- ★★ 3. If you drink 1 can of soda each day, about how many milliliters would you drink in one year? (A can of soda is 354mL. Round your answer to the nearest ten thousand mL.)

Answer: _____ mL

- ★★★ 4. There are 6 rectangles formed by the lines in this figure:

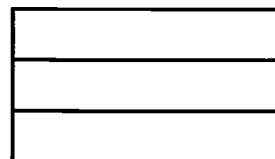

How many rectangles are formed by the lines in this figure?

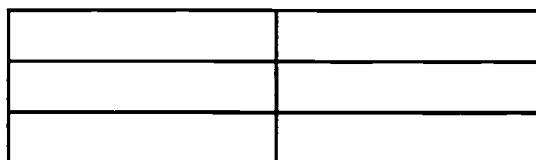

Answer: _____ rectangles

- ★★ 5. 4 weeks 3 days 13 hours 21 minutes
- 2 weeks 6 days 19 hours 31 minutes

★★★ 6. Which pair of numbers, whose sum is 35, have the largest product?

Answer: _____

★★ 7. Fill in the missing letter of the alphabet in this pattern:



M V E M J S U N _____

★★★★ 8. Here are the first three triangle numbers: 3, 6, and 10.

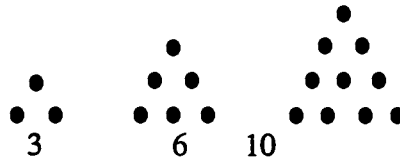

What are the next four triangle numbers? Answer: _____, _____, _____, _____

★★★ 9. Everybody in the world has one of the eight blood types shown in the circle graph. The size of the region gives you an idea of the percent of people in the world with that type of blood. O⁺ (read "oh positive") occurs more often than any other blood type -- 36% of the people in the world have O⁺ blood. Answer the questions below.

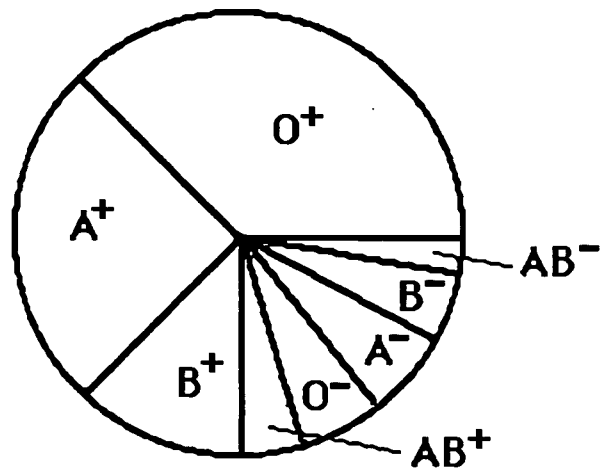

- About what percent have A⁺ blood? _____
- What is the most rare blood type? _____
- If a person in your school were picked at random, would they be more likely to have AB⁺ or O⁻ blood? _____

Commentary

Jupiter, XXIV

1. (**\$2.25**) Four weeks at a daily rate would be $\$0.35 \times 5 \times 4 = \7.00 . A 4-week subscription is $\$4.75$. $\$7.00 - \4.75 is $\$2.25$.
2. (**>**) $1/2 + 3/4$ is $5/4$ or $1 \frac{1}{4}$. $2/3 + 1/2$ is $4/6 + 3/6$ or $7/6$, or $1 \frac{1}{6}$. $1 \frac{1}{4}$ is greater than $1 \frac{1}{6}$ since $1/4$ is greater than $1/6$. Some students will get the answer by focusing on $3/4$ and $2/3$ -- since $1/2$ is part of each side, it can be ignored. $3/4 > 2/3$, so $1/2 + 3/4$ must be greater than $1/2 + 2/3$.
3. (**130,000**) $354 \times 365 = 129,210$. When rounded to the nearest ten thousand, the answer is 130,000.
4. (**18**) Students need to draw figures and look for rectangles of different sizes.
If,

--

 = 1 unit, then the # of 1 unit rectangles = 6
of 2 unit rectangles = 7
of 3 unit rectangles = 2
of 4 unit rectangles = 2
of 6 unit rectangles = 1
18 total
5. (**1 week 3 days 17 hours 50 minutes**) This problem involves "borrowing" in a non-base ten system. The time "4 weeks, 3 days, 13 hours, 21 minutes" can be rewritten as "3 weeks, 9 days, 36 hours, 81 minutes". The the smaller number can be subtracted.
6. (**18 and 17**) Students can find the answer by making a list of pairs of numbers that sum to 35 and comparing the products of those pairs. They will notice that the closer the numbers in the pairs become to each other, the higher the product.
7. (**P**) The pattern is not a numerical pattern, which will confuse some students. *M V E M J S U N P* represents the first letter of each of the planets in our solar system, in order of their position from the sun -- Mercury, Venus, Earth, Mars, Jupiter, Saturn, Uranus, Neptune, and Pluto. Many adults memorized a saying such as "My very educated mother just served us nine pickles" to remember this sequence.
8. (**15, 21, 28, 36**) Students may make a drawing of the next four triangular numbers and count the dots in each. They will notice that each new figure in the pattern adds a row on the bottom, with one more dot in it than in the bottom row of the previous figure.
9. (**a. about 25%; b. AB⁻; c. O⁻**) For part (a), students can turn the graph and readily see that A⁺ is about 1/4 or 25%. The most rare type is the one with the smallest area. Careful observation, or perhaps tracing the regions of each and comparing the tracing, shows that AB⁻ is slightly smaller than AB⁺. For (c), AB⁺ is smaller than O⁻, so the chances of O⁻ are greater.

SUPERSTARS III

Jupiter, XXV

Name: _____

(This shows my own thinking.)

- ★★ 1. When the Space Shuttle lifts off, it has moved 3 km by the time you clap your hands once. By the time you clap twice, the Shuttle has moved 9 km. By the 3rd clap, it has moved 27 km, and by 4 claps and it has moved 81 km. If this pattern continues, how many km has it moved by the time you have clapped 10 times?

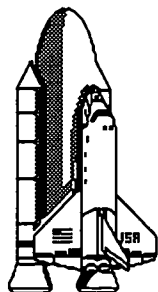

Answer: _____ km

- ★ 2. Maria needed some magazine pictures for a social studies project. She cut out pages 20, 21, 47, 48, and 104. How many sheets of paper did she remove from the magazine?

Answer: _____

- ★★★ 3. Draw four different ways to put four square tiles together. Each tile must be connected to at least one other tile along an entire side. What is the perimeter of each arrangement? What is the area of each arrangement?

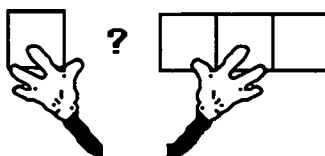

Drawing 1

perimeter: _____

area: _____ sq units

Drawing 2

perimeter: _____

area: _____ sq units

Drawing 3

perimeter: _____

area: _____ sq units

Drawing 4

perimeter: _____

area: _____ sq units

- ★★ 4. Ms. Croskey has just put her students in groups of three. Tia, Jonathon, and Courtney are in a group together and are arguing over who is going to sit by whom. How many ways can the three students be arranged in the chairs?



Answer: _____ ways

- ★★★ 5. Two pieces of cake weigh as much as one apple and one cherry. One apple weighs as much as five cherries and one piece of cake. How many cherries weigh as much as one apple?

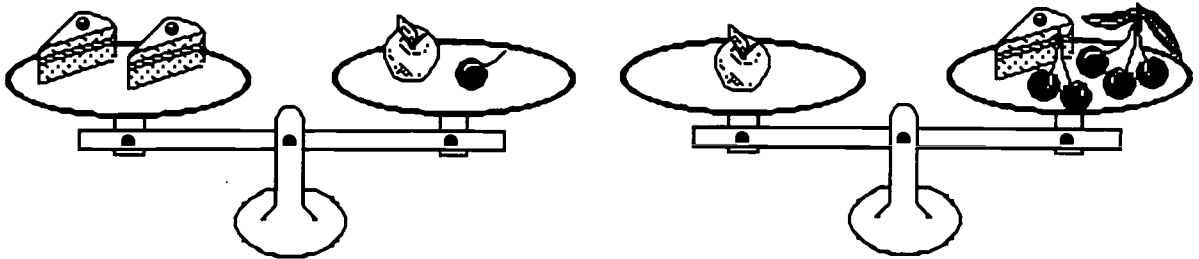

Answer: ____ cherries = 1 apple

- ★★ 6. Fill in the Venn Diagram to represent the data provided.

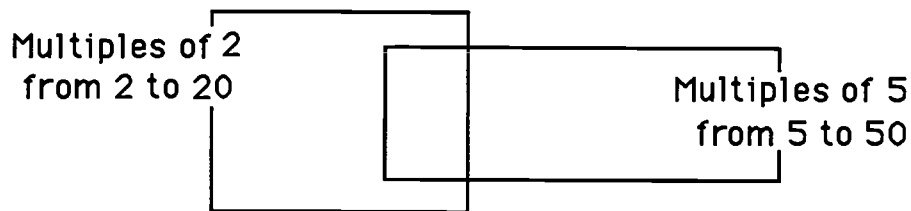

- ★★ 7. Find two numbers that add to 19 and multiply to 84.

Answer: _____ and _____

- ★★★ 8. Shirley has 18 coins. One sixth of the coins are quarters, one third of the coins are dimes, and one half of the coins are nickels. What is the value of Shirley's coins?

Answer: _____

Commentary

Jupiter, XXV

1. (59,049) Students may make a list to find a pattern. The pattern is increasing: with each clap the previous distance is multiplied by 3. This is also 3^{10} , which can be computed quickly on a calculator with a repeating function by this process:

$$\boxed{3} \boxed{\times} \boxed{3} \boxed{=} \boxed{=} \boxed{=} \boxed{=} \boxed{=} \boxed{=} \boxed{=} \boxed{=} \boxed{=} \boxed{=}$$

claps - km	claps - km	claps - km
1 - 3	4 - 81	7 - 2,187
2 - 9	5 - 243	8 - 6,561
3 - 27	6 - 729	9 - 19,683
		10 - 59,049

2. (4) Pages 47 and 48 are back-to-back, but 20, 21, and 104 are all individual pages.
3. (There are 5 basic ways to arrange the tiles, as below.) Students can draw the five basic configurations and count to find the perimeter -- the area is always 4, since 4 tiles are used. One basic configuration is a square, another two are 3 tiles in a row and another one on the side somewhere, a fourth is 4 tiles in a row, and the fifth is a zig-zag shape

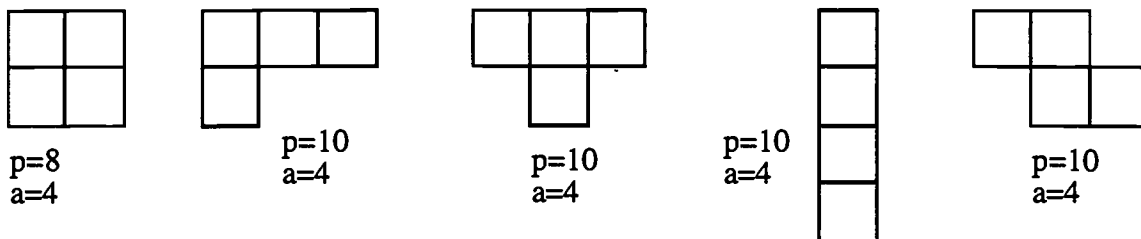

4. (6) Students can use the first initials and make a list: TJC, TCJ, CJT, CTJ, JCT, JTC
5. (11 cherries) Students may draw pictures or use letters. From the right-hand scale, we know that a piece of cake and 5 cherries can be substituted for an apple because they weigh the same. Therefore a piece of cake and 5 cherries can replace the apple in the right-hand pan of the left-hand scale. Therefore 2 pieces of cake balance 1 piece of cake and 6 cherries. One piece of cake is removed from each side of this scale, leaving 1 piece of cake balancing 6 cherries. This means that 6 cherries can replace the piece of cake on the right-hand pan of the right-hand scale, leaving 1 apple to balance 6 + 5 or 11 cherries. There are other ways to reach this same conclusion. Such problems are important foundations for later work with algebra.
6. (2, 4, 6, 8, 12, 14, 16, and 18 in left area; 10 and 20 in intersection; 5, 15, 25, 30, 35, 40, 45, and 50 in right area.) A Venn diagram is a way to show visually the intersection of two sets. The intersection contains elements common to both sets.
7. (7 and 12) Students may use trial and error with addends or factor pairs. Some may solve the problem by listing the numbers that add to 19, checking to see whether their product is 84.
8. (\$1.80) $1/6$ of 18 is 3 quarters or \$0.75; $1/3$ of 18 is 6 dimes or \$0.60 and $1/2$ of 18 is 9 nickels or \$0.45. Students might want to draw 18 coins and physically circle $1/3$, $1/6$, and $1/2$ of the set.

Super Stars



Mercury



Venus



Earth



Mars



Jupiter

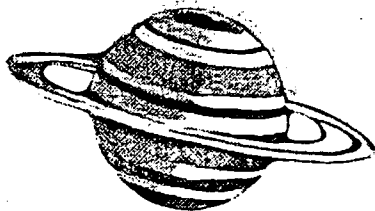

Saturn



Uranus



Neptune



BEST COPY AVAILABLE

Pluto



★ ACKNOWLEDGMENTS ★

This project, originally designated *Sunshine Math*, is the third in a series of problem solving programs. It was conceived, coordinated and developed through the Florida Department of Education with input from the mathematics staff members of the North Carolina Department of Public Instruction and the South Carolina Department of Education. In addition, it was supported financially through a grant to the School Board of Polk County, Florida. The rich history of these materials and the predecessor programs, **SUPERSTARS** and **SUPERSTARS II** goes back to the early 1980's. Many Florida teachers have been involved in developing and using these materials over the years. The original **SUPERSTARS** programs were adopted and adapted by North Carolina and South Carolina with their teachers contributing to revisions and personalizations for use in their states. Florida educators were primarily responsible for developing, field testing, and publishing *Sunshine Math*. Educators from the Carolinas developed the **MathStars Newsletter** to accompany and enhance this program.

School districts in North Carolina have permission to reproduce this document for use in their schools for non-profit educational purposes. Copies of each grade level are available from the publications unit of the North Carolina Department of Public Instruction. The contact for **SUPERSTARS III** and the **MathStars Newsletter** is Linda Patch, 301 North Wilmington Street, Raleigh, NC 27601-2825 : (919-715-2225).

Michael E. Ward
State Superintendent
North Carolina Department of Public Instruction

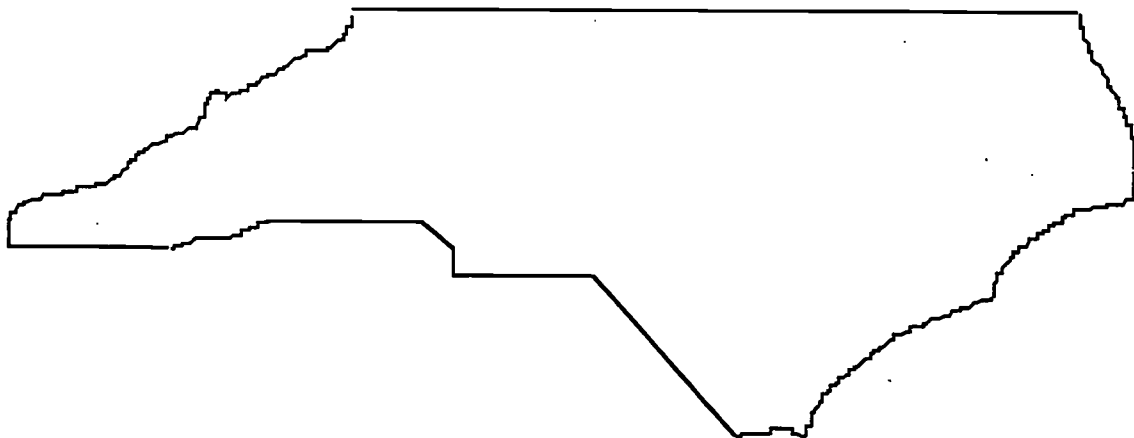

☆ *Preface* ☆

SUPERSTARS III encourages and enhances the positive aspects of students, parents, teachers and administrators working together. This program assumes that students, even young children, are capable of and interested in learning; that teachers want to help them learn to think for themselves; that administrators see their jobs as clearing the path so that quality education is delivered effectively in their schools; and that parents care about their child's learning and are willing to work with the school system toward that goal. Each of these four groups has a vital role to play in implementing **SUPERSTARS III**.

The designer of this program has a long history of working with elementary children. He believes that they are capable of much more than we ask of them, and that many children are on the path to becoming independent learners. A number of children in any classroom are bright, energetic and willing to accept extra challenges.

The basic purpose of **SUPERSTARS III** is to provide the extra challenge that self-motivated students need in mathematics, and to do so in a structured, long-term program that does not impinge on the normal classroom routine or the time of the teacher. The system is not meant to replace any aspect of the school curriculum -- it is offered as a peripheral opportunity for students who identify with challenges and who want to be rewarded for their extra effort. Participation in the program is always optional -- only those students who voluntarily choose to participate will, in the long run, benefit from **SUPERSTARS III**. Any student, regardless of prior academic performance, should be encouraged to participate as long as interest is maintained.

The predecessor program for **SUPERSTARS III** -- the **SUPERSTARS II** program -- has demonstrated that this concept can be extremely useful. What is required are several dedicated adults who devote a few hours each week to operate the system effectively in the school; an administrator who provides highly visible support; teachers who welcome a supplementary experience for their students to engage in higher-order thinking; and a typical classroom of students. If all of those ingredients are present **SUPERSTARS III** will become an integral part of the school fabric.

ORGANIZATION OF THESE MATERIALS

Section I Description of the SUPERSTARS III Program

1. General Information
2. Information/checklist for principals
3. Information/checklist for assisting adults
4. Information for teachers
5. Letter to participating students and their parents.

Section II Student worksheets for SUPERSTARS III

SUPERSTARS III
Jupiter, XXXI

Name: _____
(This shows my own thinking.)

*#1. If the 24th day of the month falls on Saturday, on what day did the 6th fall?

Answer: _____

***2. There are 4 six-packs of soda in a case. Chris bought 12 of a case and gave 13 of what he had to Dana. How many cans of soda does Chris have left?

Answer: _____ cans

***3. Together, 6 boys and 12 girls weigh 1050 pounds. The boys all weigh the same - x pounds. Each girl weighs 55 pounds. What is the weight of one boy?

bbbbbb gggggggggggg

Answer: $x =$ _____ pounds

*#4. The sum of 3 consecutive numbers is 276. What are the numbers?
(Consecutive numbers differ by one: example: 8, 9, and 10)

Answer: _____ and _____

*#5. If a family of 12 spiders wore shoes, how many pairs of shoes would they need?

Answer: _____ pairs.



*#6. A tropical storm passed through the town. It began to rain Monday morning at 8:45 AM and did not stop until the next day at 2:30 PM. How long did it rain?

Answer: _____ hours and _____ minutes



*#7. There are 3 cars, 4 bicycles, 2 tricycles, and 1 unicycle in the neighbor's garage. How many wheels are there in all? Forget about any "spare tires"!

Answer: _____ wheels

*#8. Rosemary bought a sweater on sale for \$6.98. She also bought a skirt for \$9.99. She paid an additional \$1.19 for sales tax. Rosemary gave the sales person a \$20 bill. How much change should she receive?

Answer: _____



***9. Study this pattern. 25 and also 32 would be in column E, if the pattern continued.

a. In which column would 100 appear?
b. In which column would 500 appear?
c. In which column would 1000 appear?

21	22
14	15
7	8
0	1
A	B
C	D
E	F
G	H

Section III Commentary for student worksheets for SUPERSTARS III

Commentary
Jupiter, XXXI

1. (Tuesday) Students can use a calendar or make a chart with "Su, M, T, W, Th, F, Sa" at the top and begin numbering backward putting 24 under Saturday. They may also realize that the 17th and 10th fall on Saturdays and count back from the 10th.

2. (8) Students can solve this problem by drawing a diagram or by visualizing 24 cans. $1/2$ of 24 is 12, and $1/3$ of 12 is 4. Therefore Chris gave away 4 of the 12 sodas, leaving 8.

3. (65) Students will probably solve this by first finding the total weight of the 12 girls: $12 \times 55 = 660$ pounds. Then they will compute $1050 - 660 = 390$ pounds, the weight of the 6 boys. Then $390 \div 6 = 65$ pounds per boy.

4. (91, 92, 93) Students may use the guess-check-revise method. Some students might know that the numbers they seek are about $1/3$ of the total, and approximate the numbers by dividing 276 by 3. This gives 92, which is the middle number.

5. (48) Students may want to draw a picture to help solve this problem. Spiders have 8 legs, which would be 4 pairs of shoes per spider.

6. (29 hours and 45 minutes) Most students will realize that from 8:45 AM to 8:45 AM the next day, is 24 hours. They will then "add on" 5 additional hours to get to 9:45, 10:45, 11:45, 12:45, and 1:45, and then 45 minutes to get to 2:30 PM.

7. (27) There would be 12 wheels on the 3 cars, 8 on the 4 bicycles, 6 on the 2 tricycles, and 1 on the unicycle.

8. (\$1.84) Students will probably add \$6.98 and \$9.99 to get \$16.97, then add the tax of \$1.19 to get \$18.16. They will subtract this amount from \$20.

9. (a, C) b, D) c, (7) Hopefully, students will notice that the multiples of 7 are in column A and use this fact to get "close to" the numbers 100, 500, and 1,000. Ninety-eight (14×7) is the closest multiple of 7 less than 100, so 98 would be in column A. Forcing 100 to be in column C. Likewise, 497 or 71 \times 7 is in column A, putting 500 in column D. Finally, 994 or 142×7 is in A, indicating that 1000 is in column G.

SUPERSTARS III: General Information

SUPERSTARS III is a K-8 program designed as an enrichment opportunity for self-directed learners in mathematics. The levels of the program are named for the planets in our solar system:

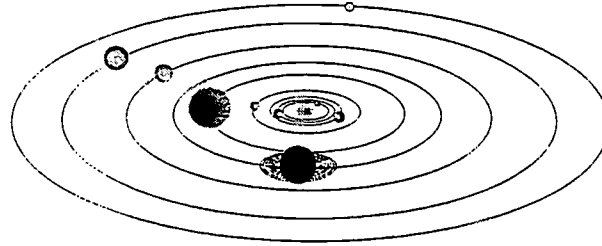

Kindergarten	Mercury	Fourth Grade	Jupiter
First Grade	Venus	Fifth Grade	Saturn
Second Grade	Earth	Sixth Grade	Uranus
Third Grade	Mars	Seventh Grade	Neptune
	Eighth Grade	Pluto	

Students of all ability levels choose on their own to participate in **SUPERSTARS III**. Seeing their names displayed in a prominent place in the school, with a string of stars indicating their success, is one reward students receive for their extra work. In some cases the school may decide to enhance this basic system by awarding certificates of achievement or some other form of recognition to highlight certain levels of success or participation in the **SUPERSTARS III** program.

SUPERSTARS III can function in a school in a number of different ways. A “tried and true” way is for assisting adults (volunteers, aides, etc.) to manage the program for the entire school, with support provided by school administrators and classroom teachers. This system has been adopted at the school level, with varying degrees of success, over the years. The basic model for conducting **SUPERSTARS III** is discussed below, with variations described on the next page.

The basic model

The basic model for **SUPERSTARS III** is for a school to establish a weekly cycle at the beginning of the academic year according to the following guidelines:

On Monday of each week student worksheets are distributed by the assisting adults to students in the program. Students have until Friday to complete the problems working entirely on their own. On Friday the classroom teacher holds a brief problem-solving session for the students in the program. The more difficult problems on the worksheet are discussed with students describing their thinking about strategies to solve the problems. They do not share solutions, only strategies.

Students receive double credit for those problems they have successfully completed prior to the problem-solving session, and regular credit for those they complete successfully over the week-end. On Monday all papers are handed in, checked by the assisting adult, and stars are posted for problems successfully completed. This completes one cycle of the **SUPERSTARS III** program.

SUPERSTARS III is not for every child -- it is only for those who are self-motivated and who are not easily frustrated by challenging situations. This does not diminish the value of the program, but rather makes us realize that there are children of all ability and socio-economic levels who are self-directed learners and who need challenges beyond those of the regular school day. These children will shine in **SUPERSTARS III**.

Variations of the basic model

The first variation that has been used successfully retains the weekly cycle and assisting adult role from the basic model. The teacher however, involves the entire class in the problem-solving discussions. For example, the teacher might select the four most difficult problems on the worksheet (indicated by three or four stars) and work a "parallel" problem with the entire class to open the mathematics lesson on Tuesday through Friday. Using this variation, all students are exposed to the problem-solving strategies, but only those who have chosen to participate in **SUPERSTARS III** will complete and turn in the worksheet on Monday.

A second variation has the assisting adult manage the entire program, including the Friday problem-solving session. This method has been used in situations where teachers lacked commitment to the program and thus implemented it inconsistently. In such cases, the assisting adult must have a progressive view of what constitutes problem solving in elementary mathematics. They should also receive extra assistance from the administration to ensure that students are released from class and that the cycles proceed smoothly.

Yet another variation is for a parent to manage **SUPERSTARS III** at home for his or her own child. The basic rules are the same -- a child gets the worksheet once a week and time to work the problems alone. The parent sets a night to listen to the way the child thought about each problem, offering suggestions or strategies only when the child is unable to proceed. The reward system is basically the same, stars on a chart, but can be enhanced by doing something special with the child, such as a trip to the museum or to a sporting event when the child reaches certain levels of success. If this method is adopted, the parent must not try to teach the child, but rather to stimulate discussion of problem-solving strategies. **SUPERSTARS III** is not a program for adults to teach children how to think.

Other variations exist. The basic model as stated is the best, all other factors being equal, for reaching more children in a consistent fashion than any of the other methods. However, we encourage individual schools, teachers, or parents to get some version started; some starlight is better than none.

SUPERSTARS III: Information for Principals

SUPERSTARS III is a K-8 enrichment package for mathematics designed to be managed by volunteer assisting adults with coordinated support from the classroom teacher and school administrators. The purpose of the program is to give self-motivated students of all ability levels a chance to extend themselves beyond the standard mathematics curriculum. The complete set of materials comes in nine packages, one for each grade K-8. The grade levels are identified by the names of the nine planets in our solar system and their order from the sun:

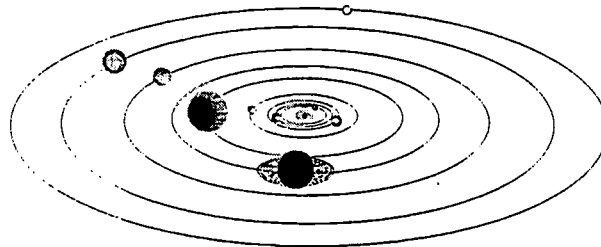

Mercury - Kindergarten

Earth - Second Grade

Jupiter - Fourth Grade

Uranus - Sixth Grade

Venus - First Grade

Mars - Third Grade

Saturn - Fifth Grade

Neptune - Seventh Grade

Pluto - Eighth Grade.

Your support is vital if this program is to succeed. As the school administrator, you need to stay in close contact with the **SUPERSTARS III** program. A “checklist for success” follows:

- Become familiar with the philosophy and component parts of the program.
- Introduce **SUPERSTARS III** to the faculty early in the school year. Ensure that teachers understand the philosophy of the program and have copies of the student worksheets and commentaries appropriate for their grade levels.
- Speak to parents at your school’s first open house of the year, explaining the purpose of **SUPERSTARS III** and the long term value of children working independently on challenging problems.
- Recruit several assisting adults (PTA members, aides, senior citizens, business partners, church members, etc.) who are enthusiastic, dependable people who are willing to manage the program. Early in the academic year, meet with these assisting adults to plan such details as:
 - ✓ A prominent place and format for the STAR CHART.

- ✓ A designated time and place each Monday and Friday for the assisting adults to be in school to meet with students, distribute and collect worksheets, and post stars.
- ✓ A system for the activity sheets to be duplicated each week.
- ✓ A plan for extra incentives for accumulating stars. (“World records” to be kept from year-to-year, a celebration day planned for the end of school, prizes earned by students for attaining certain levels of success -- see the diagram below for examples.)
- ✓ A schedule for the initiation of the program and a decision as to a “start over” point later in the academic year. Review the school calendar and only use weeks that are at least four days long. If there is not enough time in the year to complete all the activity sheets, decide which to eliminate or on a plan to “double up.”
- ✓ A **SUPERSTARS III** cap, name badge, tee-shirt, or other distinction for volunteers, if possible.
- Monitor the program every two weeks to get ahead of unforeseen difficulties. Administrators need to be highly visible and supportive for **SUPERSTARS** to succeed.

SUPERSTARS III is an optional program for students. It should be available to any student who wants to participate, regardless of prior success in mathematics. Typically, a large number of students will begin the program, but a majority will lose interest. A significant number however, will continue their efforts over the life of the program. This is normal and simply means that **SUPERSTARS III** is successfully addressing the needs of the self-directed learner.

Visual reminders help children see this mathematics program is challenging and rewarding. Some ideas are presented here:

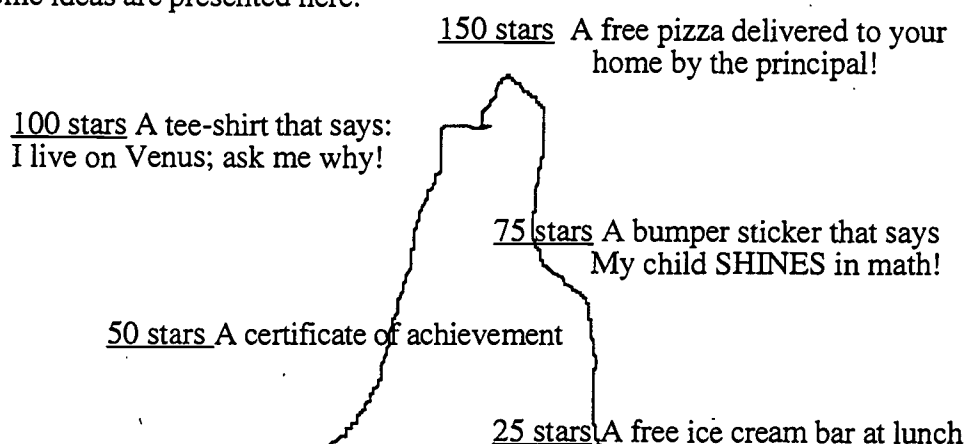

Climb the Mountain this Year!! Join the **SUPERSTARS III** Club

BEST COPY AVAILABLE

SUPERSTARS III: Information for Assisting Adults

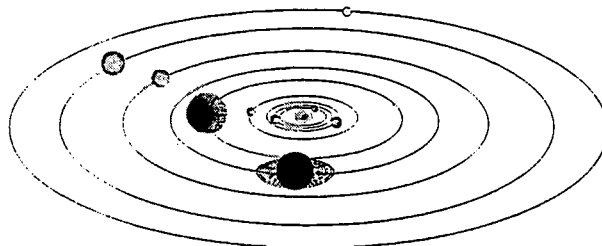

SUPERSTARS III is designed to give assisting adults a well-defined role to play in the school's mathematics program. The success of **SUPERSTARS III** depends upon a team effort among teachers, administrators, parents and you. Reliability and punctuality are important - students will quickly come to depend upon you to be there as scheduled, to check their papers and post their stars, and to listen to alternate strategies and interpretations of problems to help them arrive at solutions. If possible, wear an outfit or badge that fits with the **SUPERSTARS III** theme or logo; students will soon identify you as an important person in their school.



SUPERSTARS III works on a weekly cycle. Each Monday you will collect the worksheets from the previous week and distribute new worksheets to the participating students, all from your **SUPERSTARS III** area of the school. Allow students to see the answers to the problems, discuss any for which their answers differ and allow them credit if their interpretation and reasoning are sound. After checking all the work, you will post the stars earned by students on the STAR CHART.



Participating students have from Monday until Friday to work the problems entirely on their own -- the only help they should receive during that time is for someone to read the problems to them. On Friday the teacher will host a problem-solving session in the classroom where students will describe the strategies they used to approach the more difficult problems. Students who have successfully completed problems before this session will receive double points for their efforts. The teacher's initials on the worksheet will help you identify those problems. The students then have the week-end to complete or correct their problems and turn them in on Monday. All the correct problems thus completed will receive the indicated number of stars.



Be creative when designing your STAR CHART. The basic method of posting stars individually is a good way to begin but eventually you will want a more efficient system. Color coding by grade level, or posting just one star each week with a number in its center are ideas to consider. You may wish to personalize the chart and the entire **SUPERSTARS III** center with student pictures, "smiling faces", a logo, seasonal theme or some other feature that has a mathematical flavor. Occasionally feature a reward for each child such as a cookie or a hand stamp in the shape of a star just for turning in the worksheet. You are helping enthusiastic students develop high-level thinking skills -- be creative and enjoy your role!

Checklist for assisting adults:

Plan the following with the principal:

✓ A prominent place and format for the

STAR CHART

✓ The time and place for you to collect, check, and distribute worksheets.

✓ A system for duplicating worksheets each week which ensures legible copies. Also a secure storage area for masters and other materials.

✓ Any additional incentives ("world records," stickers, coupons, pencils, tee-shirts, etc.) that will be part of the system for rewarding levels of achievement in **SUPERSTARS III**.



Make the **SUPERSTARS III** center a happy place. Use bright colors, smiles, and cheerful expressions. Show confidence, friendliness, and encouragement to students.



Collect the letters that are sent home prior to the first worksheet. These need to be signed by each student and a parent. If, in the future, you have evidence that the work submitted does not represent the thinking of the student, discuss the situation with the classroom teacher. These situations are best handled individually, confidentially and in a firm, consistent manner.



- Check the worksheets from the previous week uniformly. If you give partial credit for a problem with several parts do so in a fair way that can be understood by the students. Do not award partial credit for problems with only one answer.



- Have answer sheets available and encourage students to look at the solutions when they submit their worksheets. Allow them to explain their strategy or interpretation if they have arrived at a different answer. Award full credit if they show a unique and plausible interpretation of a problem and follow sound logic in arriving at their response.



- Leave extra worksheets with the classroom teacher for participating students who were absent on Monday. Accept a late-arriving worksheet only if the student was absent on Monday. If a student's name is missing or in the wrong place on the worksheet, check the paper but award stars to "No Name" on the STAR CHART. Adhering strictly to these rules will rapidly teach responsibility to the students and keep your work manageable.



- Keep all returned worksheets. As the same problems are used year after year, and many students have siblings who may later participate in **SUPERSTARS III**, it is important that worksheets do not circulate.



- On weeks when **SUPERSTARS III** is not available post a notice such as "No star problems this week, but please come back after vacation for more!"

SUPERSTARS III: Information for Teachers

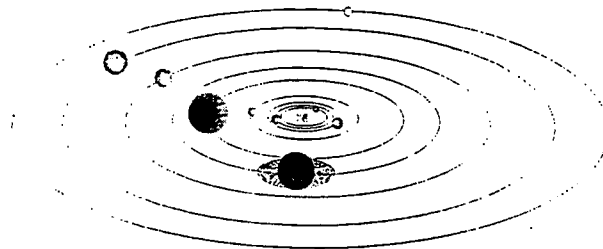

SUPERSTARS III is a program designed to complement your regular classroom mathematics curriculum. It offers a supplemental opportunity for students to practice mathematics skills appropriate for their grade level and at the same time to engage in challenging problem-solving activities. It is an additional challenge to those students who are self-directed learners providing them with an academic extracurricular activity.



Your involvement is essentially as a teacher. **SUPERSTARS III** will remain special to students if it is managed by someone outside of the classroom and if the teacher is viewed as a facilitator in the system, rather than as the authority figure. Your primary role is to monitor the system in your own classroom and to host a brief problem-solving session for **SUPERSTARS III** students on Friday of each week. You will also need to release the participating students from your class at a set time on Mondays to enable them to turn in completed work and receive new problem sets. You might make a special pin or banner for Mondays and Fridays to remind students that those days are special.

<p>SUPERSTARS III <i>Jupiter, XXI</i></p> <p>Name: _____ <i>(This shows my own thinking.)</i></p> <p>***1. If the 24th day of the month falls on Saturday, on what day did the 6th fall?</p> <p style="text-align: center;">Answer: _____</p> <p>***2. There are 4 six-packs of soda in a case. Chris bought 12 of a case and gave 13 of what he had to Dana. How many cans of soda does Chris have left?</p> <p style="text-align: center;">Answer: _____ cans</p> <p>***3. Together, 6 boys and 12 girls weigh 1050 pounds. The boys all weigh the same -- x pounds. Each girl weighs 55 pounds. What is the weight of one boy?</p> <p style="text-align: center;">bbbbbb gggggggggggg Answer: $x =$ _____ pounds</p> <p>***4. The sum of 3 consecutive numbers is 276. What are the numbers? <i>(Consecutive numbers differ by one: example: 8, 9, and 10)</i></p> <p style="text-align: center;">Answer: _____ and _____</p> <p>***5. If a family of 12 spiders were shoes, how many pairs of shoes would they need?</p> <p style="text-align: center;">Answer: _____ pairs.</p>	<p style="text-align: center;">Commentary <i>Jupiter, XXI</i></p> <p>1. (Tuesday) Students can use a calendar or make a chart with "Su, M, T, W, Th, F, Sa" at the top and begin numbering backward starting 24 under Saturday. They may also realize that the 17th and 10th fall on Saturdays and count back from the 10th.</p> <p>2. (8) Students can solve this problem by drawing a diagram or by visualizing 24 cans. $1/2$ of 24 is 12, and $1/3$ of 12 is 4. Therefore Chris gave away 4 of the 12 sodas, leaving 8.</p> <p>3. (65) Students will probably solve this by first finding the total weight of the 12 girls: $12 \times 55 = 660$ pounds. Then they will compute $1050 - 660 = 390$ pounds, the weight of the 6 boys. Then $390 \div 6 = 65$ pounds per boy.</p> <p>4. (91, 92, 93) Students may use the guess-check-revise method. Some students might know that the numbers they seek are about $1/3$ of the total, and approximate the numbers by dividing 276 by 3. This gives 92, which is the middle number.</p> <p>5. (48) Students may want to draw a picture to help solve this problem. Spiders have 8 legs, which would be 4 pairs of shoes per spider.</p> <p>6. (29 hours and 45 minutes) Most students will realize that from 8:45 AM to 2:45 AM the next day, is 24 hours. They will then "add on" 5 additional hours to get to 9:45, 10:45, 11:45, 12:45, and 1:45, and then 45 minutes to get to 2:30 PM.</p> <p>7. (27) There would be 12 wheels on the 3 cars, 8 on the 4 bicycles, 6 on the 2 tricycles, and 1 on the unicycle.</p> <p>8. (51.84) Students will probably add 56.98 and 99.99 to get 516.97, then add the tax of 51.19 to get 518.16. They will subtract this amount from 520.</p> <p>9. (a, C); b, D; c, G) Hopefully, students will notice that the multiples of 7 are in column A and use this fact to get "close to" the numbers 100, 500, and 1,000. Ninety-eight (14×7) is the closest multiple of 7 less than 100, so 98 would be in column A, forcing 100 to be in column C. Likewise, 497 or 71×7 is in column A, putting 500 in column D. Finally, 994 or 142×7 is in A, indicating that 1000 is in column G.</p>
---	---

Each student worksheet has an accompanying commentary page. This sheet provides hints on parallel problems which you might use in the Friday problem-solving session. It is important that students participate actively in this session, and that you

solicit from them their unique and varied approaches to the problems discussed. Only after students have presented their ideas should you provide guidance on the problems and then only if they are having difficulty. Even though there is a commentary provided for each problem, you will have to decide which two to four problems you will cover during this brief session. Concentrate on those which provide a new or unfamiliar strategy. The problem-solving session should last no more than 15 minutes.



Do not be disappointed if a large number of your students begin **SUPERSTARS III** and then significant numbers drop out after a few weeks. This is normal; problem solving requires a great deal of effort and not every student is ready for this challenge. On the other hand, you will notice that some students will choose to stay with **SUPERSTARS III** week after week even though they are not as successful as other students at earning stars. Their participation should be encouraged as they are certainly learning from the experience. Under no circumstances should **SUPERSTARS III** be reserved only for the advanced students in your class.



As a purely practical consideration, students are not to discuss the problems among themselves or with their families prior to the Friday cooperative group session. This allows the "think time" necessary for students to develop into independent thinkers; it also prevents students from earning stars for work that is basically someone else's -- the surest way to disrupt the entire **SUPERSTARS III** program. As the teacher you must monitor this in your classroom and ensure that students abide by the established rule.



It is important that you understand and support the overall philosophy of **SUPERSTARS III**. Do not worry if students encounter problems for which they have not been prepared in class -- such is the nature of true problem solving. Do not provide remedial instruction to ensure that students master certain types of problems. They will meet these same problem types repeatedly in the program. They will likely learn them on their own and from listening to other students at the problem-solving sessions. Enjoy what the students can do and don't worry about what they can't do. Read the general information and philosophy of the program to see how your role fits into the complete system.

Here are some thoughts you might find useful in your support for **SUPERSTARS III**:



- Allow your students to leave the classroom at the designated time on Mondays to turn in their worksheets and pick up new ones.



- Read each week's worksheet and feel free to structure classroom activities that parallel those in the **SUPERSTARS III** problems.



- During the school week students may be allowed to work on their **SUPERSTARS III** problems during their free time, but the only help they may receive is for someone to read the problems to them. Give the students one warning if you find them discussing the worksheets, and take away their papers for the next violation. If it happens another time, suspend them from the program for a month.



- At the Friday problem-solving sessions remember these points:

- Students come to this session with their worksheets, but without pencils.
- The session should be brief -- 15 minutes at most. Discuss only the two to four most difficult problems.
- Help students summarize their own approaches to the problems in a non-judgmental fashion. Offer your own approach last, and only if it is different from the students' strategies. Do not allow answers to be given to the problems.
- End the session by encouraging students to complete the problems over the weekend. Put your initials beside any problem discussed in class which a student has already successfully completed. The assisting adult will award double stars for these.



Remember that part of the **SUPERSTARS III** philosophy is that students learn responsibility by following the rules of the system. If participation is important to them they will adhere to the rules about where their names go on each paper, no credit awarded if they forget their paper on Monday, and no talking about problems prior to the problem-solving session.



Enjoy **SUPERSTARS III**. Students will impress you with their ability to think and their creative ways to solve problems that appear to be above their level or beyond their experience.



Dear Student,

Welcome to **SUPERSTARS III**, a program designed to enhance your journey through mathematics. Be prepared to face challenging problems which require *thinking!* As you work through the system you will experience many types of problems, stretching and expanding your brainpower in many exciting ways!

Expect to receive one worksheet at the beginning of each week. You will have the rest of the week to think about the problems and come up with strategies for their solutions. The thinking and solutions must be **YOUR VERY OWN!!!** Once a week you will attend a help session to discuss the most challenging problems for the week.

Your journey will be recorded by charting the stars you earn. Each problem is ranked according to its level of difficulty. The more stars you see beside a problem, the higher its level of difficulty and, of course, the more stars you can earn for solving it. You can earn double stars for solving a problem before the weekly sessions.

Your signature is just the beginning.

Good luck as you embark upon this mathematical adventure! The rewards will last a lifetime!



I am ready to begin the **SUPERSTARS III** program. All of the answers I submit will represent my own thinking.

Name: _____





Dear Parents,

Welcome to **SUPERSTARS III**, a program designed to enhance your child's journey through mathematics. By expressing an interest in challenging problem solving experiences, your student has taken the first step toward becoming an independent learner who is willing to address many types of problems.

On Mondays a **SUPERSTARS III** worksheet will be distributed to each child in the program. Each problem in the set is ranked according to its level of difficulty. As the number of stars increases, so does the level of difficulty and the earned stars to be awarded.

Each Friday a help session will be conducted to discuss the most challenging problems of the week. Any problem solved prior to the session will be given double stars. After the session, problems may be reworked before they are submitted the following Monday.

Your role in **SUPERSTARS III** is to encourage and facilitate problem solving. Feel free to offer guidance toward certain strategies, to read the problems to your child, but please, do not give them the answers. In order for this program to be effective, the students must work independently. The thinking must be their own!

It is normal for a student not to be able to complete every problem on every worksheet. The process of interpreting, understanding, and trying different strategies is valuable in the attainment of mathematical power. Remember, no student is expected to know the answer to every problem.

Thank you for allowing your child to embark upon this mathematical adventure; the rewards should last a lifetime!

_____signature

Parent/Guardian of _____



After you have had a chance to review and use these materials, please take a moment to let us know if the **SUPERSTARS III** material has been useful to you. Your evaluation and feedback is important to us as we continue to work on additional curriculum materials. Please respond to:

Linda Patch
Mathematics & Science Section
NC Department of Public Instruction
301 N. Wilmington Street
Raleigh, NC 27601-2825

Indicate the extent to which you agree with statements 1-4.

	Strongly Disagree	2	Neither Agree nor Disagree	4	Strongly Agree
1. The materials will be helpful in teaching the mathematics goals and objectives set forth in the NC Standard Course of Study.	1	2	3	4	5
2. The materials are appropriate for the grade level indicated.	1	2	3	4	5
3. The problems are interesting and engaging for the students I teach.	1	2	3	4	5
4. The commentaries will encourage use of this material.	1	2	3	4	5
5. I plan to use these materials with my students in grade_____.					
6. Have you ever used earlier versions of the SUPERSTARS material?	YES		NO		

7. How was this program implemented with your students?

8. Additional comments:

SUPERSTARS III

Saturn, I

Name: _____

(This shows my own thinking.)

- ★★★★ 1. A worm is at the bottom of a 10 foot hill. He crawls up the hill $4\frac{1}{2}$ feet a day. At night when he rests, he slides down $2\frac{1}{2}$ feet. How long does it take the worm to crawl up the hill? (Hint: Draw a picture.)



Answer: _____ days

- ★★★ 2. Jennifer was shopping, and used a calculator to find the price of a can of soda. She got the number shown on the display, but didn't know exactly how much money that was. How much money would the can of soda cost? Circle the correct answer or answers shown below.

- (a) \$6
- (b) \$.06
- (c) \$0.60
- (d) 60¢
- (e) 0.60¢

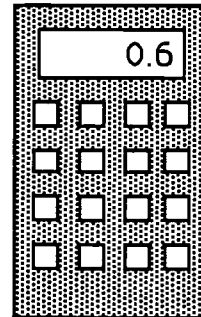

- ★ 3. If the 9th day of a month is on Tuesday, on what day is the 25th?

Answer: _____

- ★★★ 4. Put one digit from {1, 0, 3, 7} in each box to get the correct long division problem.

$$\begin{array}{r} 43 \\ \square \overline{) \square \square \square} \end{array}$$

- ★ 5. Use this calculator in geometry. Circle two sides you could use to draw a set of *parallel* lines.

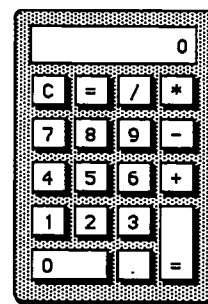

- ★★ 6. Use a ruler and measure the pencil below to the nearest millimeter.



Answer: _____ mm

- ★★★★ 7. Mrs. Jones had some white paint and some green paint, and a bunch of wooden cubes. Her class decided to paint the cubes by making each face either solid white or green. Juan painted his cube with all 6 faces white--Julie painted her cube solid green. Hector painted 4 faces white and 2 faces green. How many cubes could be painted in this fashion, so that each cube is different from the others? Two cubes are alike if one can be turned so that it exactly matches, color for color on each side, the other cube.

Answer: _____ cubes can be painted so they are different

- ★ 8. Letia bought a milk shake at the ice cream shop, and gave the clerk a \$10 bill. She got \$9.61 in change. Is this reasonable? Why or why not?

Answer: _____

- ★★★ 9. The sum of my two digits is 13. I am not divisible by 2. List all possible numbers I could be.

Answer: _____

Commentary

Saturn, I

1. (4 days) Students can draw a diagram for the worm's trip. The first day he reaches 4.5 feet but then slips back to 2 feet level at night. The next day he reaches 6.5 feet but then slips back to 4 feet at night. The 3rd day he reaches 8.5 feet but then slips back to 6 feet. On the fourth day he reaches 10 feet and is on top of the hill. Thus 4 days answers the question.
2. (c and d) Problems such as this one should help students realize that their answers should make sense in terms of the real world. Knowing that a soda costs around 60¢, students have to decide which of these choices is (are) the correct one(s) to interpret the calculator display. This problem might lead to a class discussion about common misuse of the decimal point in advertising, such as writing “.60¢” for “60¢” and “\$199” for “\$1.99.”
3. (Thursday) Students might list the days of the week and count from Tuesday as the 9th. The students might realize the 16th and 23rd would also be on Tuesday, making the 25th a Thursday.
4. ($7\overline{)301}$) This problem can be approached through *guess-check-revise*.
5. (Either the top and bottom can be circled, or the two sides) A set of parallel lines are lines that never cross. These can be demonstrated by having students use pieces of spaghetti to represent lines. They might be encouraged to look for parallel lines immediately around them--notebook paper, the top and bottom of classroom walls, etc.
6. (96 mm) Students should use metric rulers rather than ones marked in inches. Measuring from the eraser to the tip of the pencil, they might count each centimeter mark as 10 millimeters and then add the extra millimeters.
7. (10 ways) Sugar, unifix or wooden cubes can be used for students to go through the experiment in a concrete way. The faces can be colored with a crayon or magic marker, or simply labelled “G” and “W.” At home, students can use any box they can find. However, using only 1 box over-and-over means that they must be careful in keeping track of the different cubes already made.

Combinations: 1 cube each--6 W; 6 G; 1 G and 5 W; 5G and 1W

2 ways each--2 G and 4 W; 2 W and 4 G; 3 G and 3 W

8. (NO) Students should realize a milk shake costs more than \$0.39, unless there's a special. If students mention this, they should receive credit also.
9. (85, 67, 49) Students might list all the pairs of single digits with a sum of 13. Each such pair of digits make up 2 two-digit numbers. Only the resulting numbers with the odd digit in the units place is not divisible by 2.
 $8 + 5 = 13$, giving 85 as a solution (but not 58)
 $6 + 7 = 13$, giving 67 as a solution (but not 76)
 $4 + 9 = 13$, giving 49 as a solution (but not 94)

SUPERSTARS III

Saturn, II

Name: _____

(This shows my own thinking.)

- ★★★ 1. Use each of these digits one time in the number sentence below: 2, 4, 6, and 8. Fill in the blanks to produce the answer "14." Remember that you compute inside parentheses first.

$$(___ \div ___) + (___ \times ___) = 14$$

- ★★ 2. How many squares can be found in the figure to the right?

Answer: _____ squares

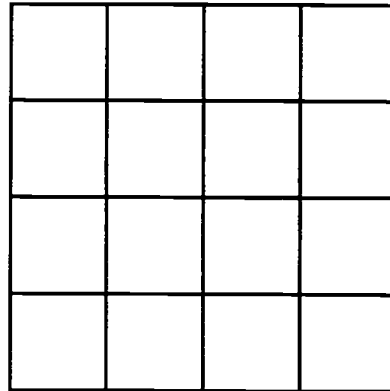

- ★ 3. Tamisha did a problem two different ways on her calculator. She got two different answers. Which of the two answers below represents the larger number? Circle it.

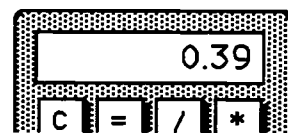
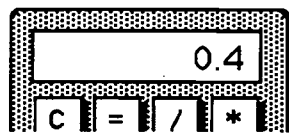

- ★★ 4. The girl scouts were going on a field trip to the zoo. There are 25 people going. They rented vans and each van has only 7 seat belts. How many vans do they need?

Answer: _____ vans

★ 5. Write the standard numeral: $9000 + 700 + 8 + 0.6 =$ _____

★★★★ 6. What do you know about metrics? Circle the answers below that would make sense.

- a. The weight of a pineapple: 1 kg 1 g 1 mg
- b. The capacity of a can of soda: 35 mL 3.5 mL 350 mL
- c. The temperature on a summer day: 30° C 3° C - 3° C
- d. The distance from New York to Miami: 2200 cm 2200 km 2200 mm

★★★ 7. A class of 25 students has 10 boys. Three boys have braces and 4 girls have braces.

- a. What is the ratio of boys with braces to boys in class? _____
- b. What is the ratio of girls with braces to girls in class? _____
- c. Which group has the larger ratio of students with braces to students in class -- boys or girls? _____

★★★★ 8. The price and the sales tax are given. Compute the total cost. Tell how much change you would receive from \$5.00.

Answer: _____ Total Cost

Answer: _____ Change

Beach Ball

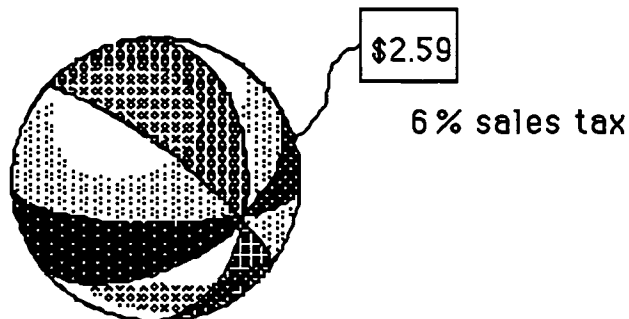

Commentary

Saturn, II

1. $[(8 + 4) + (6 \times 2) = 14]$ Students can use *trial and error* to find the correct order.
2. **(30 squares)** There are 16 small squares, 9 squares in which 4 of the small squares are put together, 4 squares consisting of 9 small ones together, and the one large square itself.
3. **(left-hand calculator)** Students who have trouble with this problem might be encouraged to think of money. The 0.4 might be $\frac{4}{10}$ of a dollar or 40¢, whereas 0.39 might be 39¢. Another way would be for a student to subtract each number from the other on a calculator. The way which gives a positive number on the display means the larger number was entered first.
4. **(4)** Students might divide the total number of people going by the number of people that can fit in one van, with one person per seat belt. If so, they should realize that 21 people can go in 3 vans, but an extra van is needed for the remaining 4 people. This is a case in which the answer to a division problem requires rounding the decimal remainder up, rather than to the nearest whole number.
5. **(9708.6)** This task is a simple recognition of place value.
6. **(1 kg; 350 mL; 30° C; 2200 km)** Students should be encouraged to use “bench mark” metric measurements to estimate reasonable answers. For example, their math book weighs about a kilogram; a mL is a few drops from an eyedropper; a comfortable room temperature is between 25°C and 30°C; and the distance across the United States is about 5000 km.
7. **(3 to 10, 3:10, or $\frac{3}{10}$; 4 to 15, 4:15, or $\frac{4}{15}$; boys)** Any of these answer forms is acceptable. To find which ratio is larger, 3:10 or 4:15, students can be encouraged to transform the ratios by doubling, tripling, etc., until they get two ratios with the same size comparison group. By doubling, 3 boys out of 10 is the same as 6 boys out of 20. By tripling, you get the ratio 9 boys out of 30. By doubling, 4 girls out of 15 is the same as 8 out of 30. Since 9 out of 30 is more than 8 out of 30, *the boys with braces* represents a larger ratio.
8. **(\$2.75 total cost and \$2.25 change)** Sales tax of 6% can be interpreted by students as paying \$.06 on each dollar spent. On \$2 spent, the tax would be \$0.12 and on 59¢, the tax would be another 4¢. Sales tax is a real-life example in which partial amounts of money are *rounded up*, rather than to the *nearest*, penny. The total cost would then be $\$2.59 + 12¢ + 4¢$ or \$2.75; the change from \$5 would then be \$2.25.

SUPERSTARS III
Saturn, III

Name: _____
(This shows my own thinking.)

- ★★ 1. Toni works in the school store. She sold 36 notebooks and 42 book covers. The notebooks cost \$2.38 each, and the book covers cost \$1.75 each. What is the total cost of Toni's sales?

Answer: _____

- ★ 2. A lot of students like to ride horses. Use the chart below to compare the primary grade riders (grades 1-3) with the intermediate grade riders. What is the difference in the number of riders between these two groups?

Horseback Riders

1st Grade	Ω Ω Ω Ω
2nd Grade	Ω Ω Ω Ω Ω
3rd Grade	Ω Ω
4th Grade	Ω
5th Grade	Ω Ω Ω Ω Ω Ω Ω Ω

Answer: _____

Key: Each Ω = 3 students

- ★★ 3. You have \$100. You spend $\frac{1}{4}$ of your money to buy a new pair of jeans. You want to save $\frac{1}{5}$ of what you have left. How much will you save?

Answer: _____

- ★★★ 4. Use these digits only once: 1, 2, 4, and 8. Write a number sentence and use any of the operations (+, -, ×, ÷) as many times as you like. You must get 0 as an answer. Use parentheses if you like.

Answer: My number sentence is: _____

★★

5. Draw all the *lines of symmetry* of the figures below.

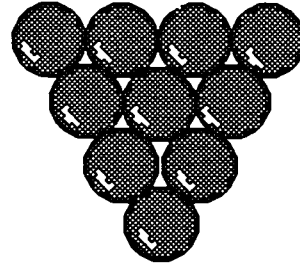

★

6. Below is a *line of symmetry*. Draw a figure around it for which the line is a *line of symmetry*.

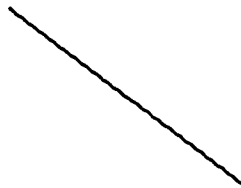

★★★

7. Students arrived for school in groups. Bill was the first to arrive--consider him the "first group". Each group that arrived after Bill had two more people than the group that arrived before it. How many people were in school after 20 groups arrived?

Answer: _____

★

8. How much does the can of paint weigh, by itself? Answer: _____

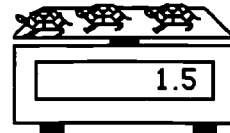
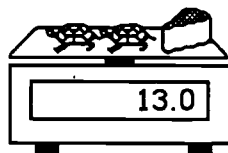
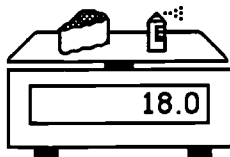

Commentary

Saturn, III

1. (\$159.18) Multiply 36 times \$2.38 and 42 times \$1.75. Add the two totals together.
2. (6 students) Students can count the number of students for each grade, adding grades 1-3 together and grades 4-5 together, and subtract to find the difference. Or they might count the total number of symbols in each group, subtract and find a difference of 2 symbols, then multiply by 3.
3. (\$15) Students might find $\frac{1}{4}$ of \$100, getting \$25. They have \$75 left. They can find $\frac{1}{5}$ of \$75 by dividing 75 into five equal shares, getting \$15 per share. That's the amount saved.
4. [(8+4) - (2+1) is one possibility.] This is a *guess-check-revise* problem. They must substitute until they come up with the correct order.
5. Answers shown below.

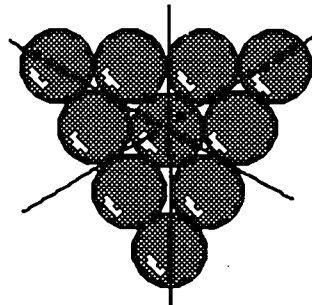
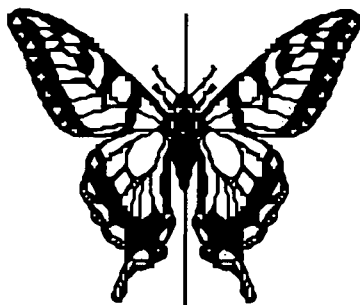

6. Answers will vary. To decide if the figure is symmetric about the line, fold the figure on the line and see if the sides match up.
7. (400) Students might make a list to organize the approach to this problem. Such a list as the one below helps to observe a pattern:

<u>Group number</u>	<u>People in group</u>	<u>Total</u>
1	1	1
2	3	4
3	5	9
4	7	16
.	.	.
.	.	.
20	39	.

If students don't notice the pattern that the total after n groups is n^2 , they can still solve the problem by adding the "people in each group" column. Notice that $1+39 = 40$, $3+37=40$, $5+35=40$, etc. There are ten such subtotals of 40, giving 400.

8. (6) Students might find this in a variety of ways. One way is to look at the third scale and conclude that 1 turtle weighs 0.5, and then from the second scale the 2 turtles would weigh 1, leaving the cake to weigh 12. Then from the first scale, you know that the can must weigh 6 since the cake weighs 12.

SUPERSTARS III
Saturn, IV

Name: _____
(This shows my own thinking.)

- ★★ 1. One, three, and six are triangular numbers. List all the other triangular numbers up to 36.



Answer: _____

- ★ 2. Jennifer earns \$5.25 an hour. Starting Monday she will get a raise to \$5.85 an hour. She works 40 hours each week. How much more will she make next week than she made last week?

Answer: _____

- ★★ 3. A diagonal joins two vertices of a polygon. Draw all the diagonals in the polygon to the right.

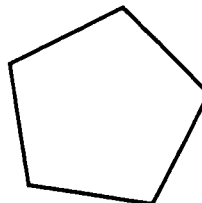

- ★★ 4. Marti plans to save 25% of the money she makes over the summer washing cars.

a. Shade in about 25% of the figure to the right to show how much she will save from every dollar she earns.

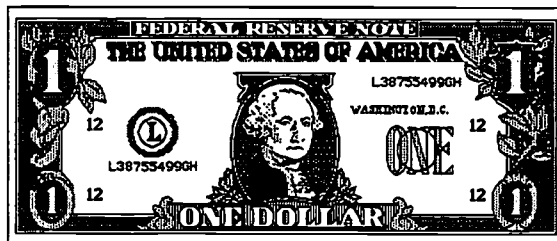

b. How much will Marti save for each car she washes for \$5? _____

- ★★ 5. The Phillips family want to fence their backyard. They know the yard has a perimeter of 24 meters, and an area of 32 square meters. What is the yard's length and width?

Answer: The length is _____ meters, and the width is _____ meters.

- ★★★ 6. Y stands for the weight of 1 can of tuna fish on the scale. Find Y .

Answer: $Y =$ _____

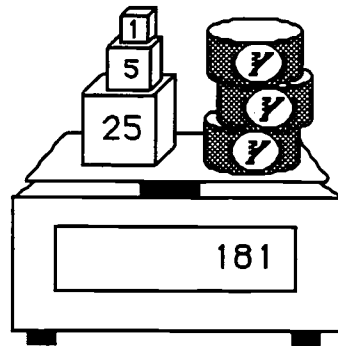

- ★★★ 7. Write the problems and answers below each calculator:

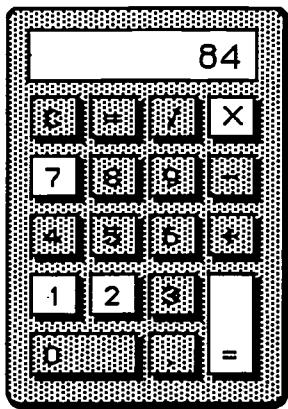

_____ =

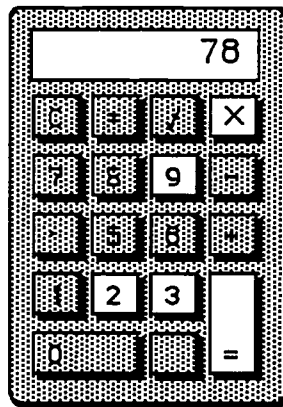

_____ =

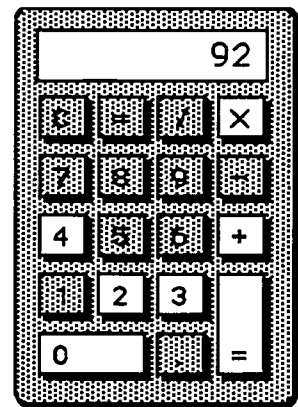

_____ =

- ★★ 8. Look at the pattern below. How many squares would be in the 10th shape in the pattern?

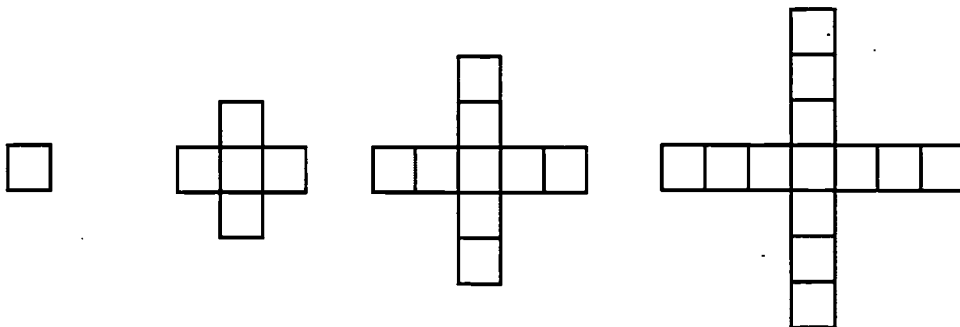

Answer: _____ squares

Commentary

Saturn, IV

1. **(10, 15, 21, 28, 36)** Triangular numbers can be found by arranging a number of dots in a pattern, and the pattern forms an equilateral triangle.
2. **(\$24.00 more)** $\$5.25 \times 40 = \210 , $\$5.85 \times 40 = \234 , and $\$234.00 - 210.00 = \24.00 . Another approach would be to notice that there's a difference of 60¢ in the hourly rate, and $40 \times \$0.60 = \24.00 .
3. **(5 diagonals)**

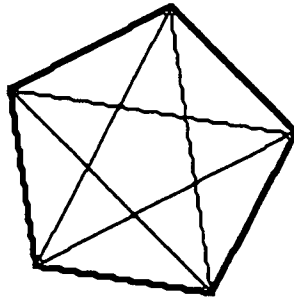

4. **(One fourth of the dollar bill should be shaded. \$1.25)** Students can shade in $\frac{1}{4}$ of the dollar bill in several different ways. The only criterion is that the dollar bill be divided into 4 equal pieces with 1 part shaded. Hopefully students will realize that $\frac{1}{4}$ of the dollar bill is equivalent to a quarter. This will enable them to find the answer to the second part.
5. **(8 meters and 4 meters)** The students will guess all the pairs of numbers that can be multiplied together to give 32. Then they have to see if the pairs can be added and doubled to get a perimeter of 24. Drawing a picture helps.
6. **(50)** This problem is a precursor to solving an equation of the form $3Y + 31 = 181$. Students intuitively know that they can remove the 31 from the scale, and have 3 cans that weigh 150. Dividing 150 by 3 gives each can a weight of 50. So $Y = 50$ solves the equation.
7. **($7 \times 12 = 84$; $39 \times 2 = 78$; $((20 + 3) \times 4 = 92)$** The problems can be found by using number sense and estimating mentally. Some students might not use parentheses in writing the last problem. In fact, on most calculators it's not necessary to use parentheses for this problem. However, writing the problem out to be done by hand requires parentheses. Without parentheses, *order of operations* would require multiplying 3×4 first, then adding that to 20, and getting a result of 32. The last calculator sequence could also indicate $0 + 4 \times 23 = 92$
8. **(37)** The numerical pattern for the number of squares is: 1, 5, 9, 13, 17, Adding 4 more squares to each figure produces the next figure. Algebraically, if the figure number is n , the number of squares could be written as $4n - 3$.

SUPERSTARS III

Saturn, V

Name: _____

(This shows my own thinking.)

- ★★ 1. Big Al has a set of non-metric wrenches that have these numbers on the end:

$$\frac{7}{16} \quad \frac{1}{4} \quad \frac{9}{16} \quad \frac{3}{8} \quad \frac{5}{16} \quad \frac{1}{2}$$

Which of his wrenches fits the largest nut? Which fits the smallest nut?

Answer: _____ fits the largest

_____ fits the smallest



- ★★★ 2. Jennifer bought a blender for her mother. The blender was on sale for $\frac{1}{3}$ off the marked price. The regular price of the blender was \$18.00. How much will she pay for the blender, including sales tax of 6%?



Answer: _____

- ★ 3. Melissa and Sarah arranged the music hall for a concert. They made 42 rows with 35 chairs in each row, and 12 rows with 25 chairs per row. How many chairs did they use in all?

Answer: _____ chairs

- ★★ 4. The "square corners" on a sheet of writing paper are 90 degree angles. You can use these corners to estimate the measure of other angles.

About what is the angle of the piece of pizza being removed in the picture?

Answer: _____ degrees

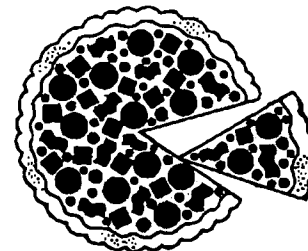
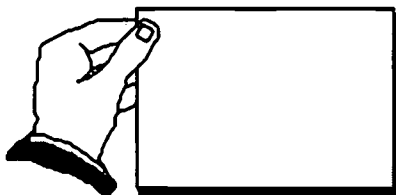

★★ 5. In the month of April 9.45 inches of rain fell in Tallahassee. During the month of May 9.6 inches of rainfall fell. Which month had the most rainfall, and what was the total for the two months?

Answer: _____ had the most; the total was _____ inches

★ 6. Complete the addition. Convert your answer to smallest units. (i.e., change inches into feet and feet into yards, if possible)

$$\begin{array}{r} 2 \text{ yd. } 2 \text{ ft. } 3 \text{ in.} \\ + 1 \text{ yd. } 2 \text{ ft. } 11 \text{ in.} \\ \hline \end{array}$$

★★★ 7. Eli's Dad made him a birthday cake, but forgot to buy candles. He could only find a few. But Eli was smart in math, so his Dad said "the ratio of candles to years is 3 to 5." That gave him the right number.



How old was Eli? _____

★★★ 8. Kenya, Matt, Tia, and Justin live on the same street. Their houses are gray, green, blue, and white, but not necessarily in that order. Justin lives next door to the gray house. Matt and Justin live across the street from the green house. Tia's house is blue. Circle the one who lives in the white house.

- a. Kenya b. Matt c. Tia d. Justin

★★★ 9. Answer the questions after studying this pattern. Notice when the pattern starts repeating.

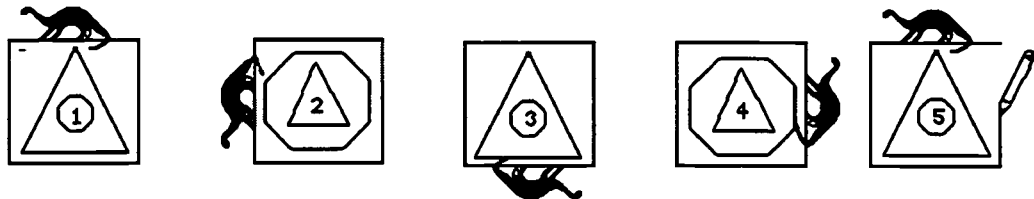

- a. Circle the figure above that would be the same as figure 15 in the pattern.
 b. List the numbers of 5 figures not shown that would be just like number 1: _____
 c. What is the number of the figure above that is just like the 100th figure in line? _____

Commentary

Saturn, V

1. ($\frac{9}{16}$; $\frac{1}{4}$) This is a real world example where students need to find a common denominator to be able to do the problem mathematically. It might be nice to bring such a set of wrenches so that, when students turn in their papers, they can actually compare their results with what the wrenches tell them. Some students might solve this problem using real wrenches at home, avoiding the mathematics altogether.
2. (**\$12.72**) Find a third of \$18, and then subtract that amount to leave \$12. Six percent of \$12 is \$0.72, which is added. Another way to approach the problem is to multiply \$12 by 1.06, which gives the total cost, including sales tax.
3. (**1770**) Students can compute 42×35 and add that to 12×25 .
4. (**45**) A corner of a sheet of paper can be placed over the hole where the piece of pizza is being removed. It is easy to see that this hole is about half of the square corner.
5. (**May with 9.6; 19.05**) For students to be successful, they need to understand that zeros can be added to the right end of a decimal without changing its value. Therefore 9.6 can be thought of as 9.60, and 9.60 is easy to compare with 9.45. It is also easy to add the two, once they have the same number of decimal places.
6. (**4 yd. 2 ft. 2 in.**) Add and get a total of inches, feet and yards. Then convert each measurement to the next higher measurement.
7. (**15**) Candles can be counted in groups of 3. Each group of three candles represents 5 years. The nine candles on the cake give three groups of 3, which corresponds to 15 years.
8. (**d. Justin**) Make a chart. The chart could have four columns across and four down. The top could be labeled gray, green, blue, and white. The side could then be labeled Tia, Matt, Kenya, and Justin. Eliminate things that can't be true, resulting in the final choice.
9. (**3 is circled; 9, 13, 17, 21, 25 or any number 1 more than a multiple of 4; 4**)
It is hoped that students will notice as they count to find the answers that there is a numerical pattern that underlies these figures. The pattern repeats every four figures, so number 4 will always be like the other multiples of 4 in the pattern. Number 1 will be like the multiples of four plus 1, and so on.

SUPERSTARS III
Saturn, VI

Name: _____
(This shows my own thinking.)

- ★★ 1. The Adams family uses a spinner each night to see who does the dishes. Carla is assigned number 4.

a. What is Carla's chance of having to do the dishes on any given night? _____

b. What is Carla's chance that she won't have to do the dishes on any given night? _____

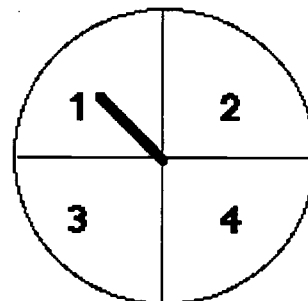

- ★★★★ 2. Bonita has 6 coins. All of them are pennies or dimes. What are the possible amounts of money she might have?

Answer: She might have _____¢, _____¢, _____¢, _____¢, _____¢, _____¢, or _____¢

- ★★ 3. Compute this answer. $8 \times (7.5 + 2\frac{1}{2})$

Answer: _____

- ★★ 4. Solve this problem if you have enough information. If there is not enough information tell what you need to know in the space below.

Kimberly buys a sweatshirt. as a gift. The shirt costs \$25.99 plus the cost for wrapping. Kimberly paid with a \$100 bill. How much change did she get back?

Answer: _____

- ★ 5. Use a ruler to draw a segment 52mm long, in the space below.

★★★ 6. Use the following graph to answer these questions.

- What is the total number of animals on the William's farm? _____
- What is the difference in the number of cattle and the number of pigs? _____
- How many more pigs do they need to equal the total number of cattle and sheep? _____

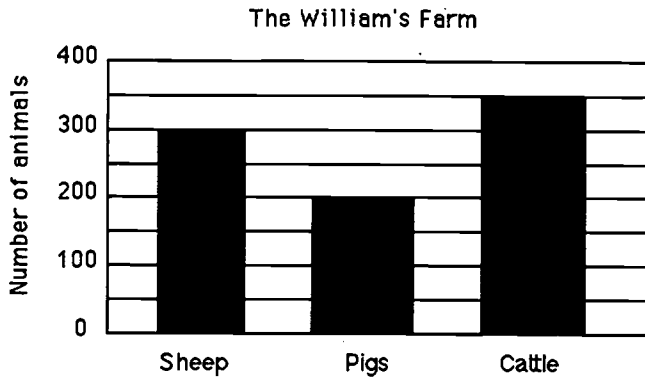

★★★ 7. Maria's bike odometer read 63 miles. She rode her bike to school and back 4 days last week. On Saturday she rode to the park and back, a total distance of 3 miles. At the end of those five trips, her odometer showed 74 miles. Find the distance d from her house to school and back. You can find d by using your number sense and the diagram below.

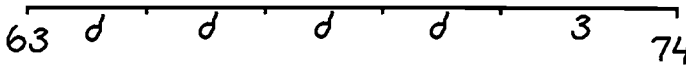

Answer: $d =$ _____ miles

★★ 8. Maria made a graph of the total distance she travelled last week on her bike. Which day of the week did she not ride her bike to school?

Answer: _____

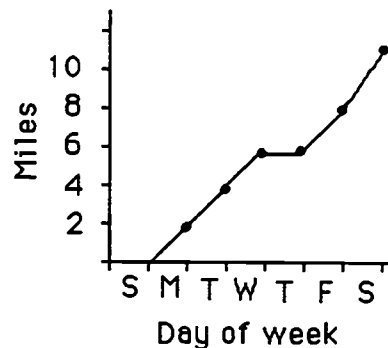

★★ 9. There are 34 classes in a school and each class could have between 23 and 30 children.

- What is the school's highest possible student population? _____
- What is the school's lowest possible student population? _____

Commentary

Saturn, VI

1. ($\frac{1}{4}$, $\frac{3}{4}$) There are four numbers on the spinner. Therefore, the chances of getting 4 is one out of four or $\frac{1}{4}$. The chances of not getting a 4 is 3 out of 4, or $\frac{3}{4}$. These could also be written as percentages.

2. (6¢, 15¢, 24¢, 33¢, 42¢, 51¢, and 60¢) Students can make a chart or list of the possible combinations of coins that would fit the criteria. A chart like the one below might be made:

pennies	6	5	4	3	2	1	0	
dimes		0	1	2	3	4	5	6
money		6¢	15¢	24¢	33¢	42¢	51¢	60¢

3. (80) Computing inside the parenthesis is important. The problem is written so that students can use number sense to compute inside the parenthesis easily -- 7.5 is $7\frac{1}{2}$, and $7\frac{1}{2} + 2\frac{1}{2}$ gives 10. Then 8×10 is 80.

4. (Not enough information -- you need to know the cost to wrap the sweatshirt.)

5. (Measure the student's line. It should be 52 mm.)

6. (850; 150; 450) For (a), find $350 + 300 + 200$ or 850. For (b), compute $350 - 200$ to get 150. To find (c), add 350 and 300 to get 650; then subtract 200 to get 450.

7. (2) This problem can lead to algebraic thinking. A variable d is introduced, along with a diagram that students can use to find the value of the variable. They can *guess-check-revise* to find d , or solve the situation logically as they would the equation $4d + 3 = 11$, by subtracting 3 from 11 and then dividing what's left by 4. The problem is intended to help students see a real-life situation that would later lead to an equation, and know that in such cases their solution to the equation should make sense in the real world.

8. (Thursday) Students can tell from the graph that the total distance did not change on Thursday, because the line was horizontal at that point. Therefore that is the day that she did not ride her bike to school.

9. (a. 1,020; b. 782) For (a), multiply the highest number of students per class by 34. For (b), multiply the lowest number of students per class by 34.

SUPERSTARS III
Saturn, VII

Name: _____
(This shows my own thinking.)

- ★★ 1. What is the sum of these mixed numbers? $5\frac{2}{3}$, $3\frac{3}{4}$, $13\frac{1}{6}$, $8\frac{1}{2}$

Answer: _____

- ★★★ 2. Artesia found a sale on skates. She got $\frac{1}{5}$ off the regular price of \$34.50. What was the sale price of her skates?

Sale on skates!

Answer: \$ _____

- ★★★ 3. John needed two more shapes to complete his project. How much will each shape cost? Compute the cost of each shape using the key -- write the cost on each tag.

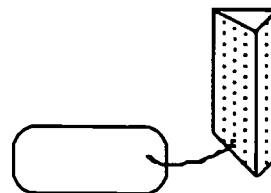
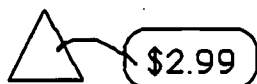
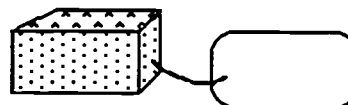

- ★★★★ 4. Put $>$, $<$, or $=$ between each pair of numbers.

a. 34.63 _____ $34\frac{1}{2}$

b. $3\frac{2}{5}$ _____ $1\frac{12}{5}$

c. 12.443 _____ 1.2443

d. 0.09 _____ 0.9

- ★★ 5. Mike and Sam are running a 26 mile marathon. They started out at 8:15 a.m.. They both crossed the finish line at 1:26 p.m.. How long did it take them to finish the race?

Answer: _____ hours and _____ minutes



- ★★★ 6. a. How many \$1 bills are in \$1,000,000? _____
 b. How many \$100 bills are in \$1,000,000? _____
 c. How many \$1,000 bills are in \$1,000,000? _____

- ★★★★ 7. Find the numbers that each letter stands for in the problem below.

$$\begin{array}{r} \text{EFGH} \\ \times \quad 4 \\ \hline \text{HGFE} \end{array}$$

E = _____

F = _____

G = _____

H = _____

- ★ 8. Jim was putting carpet in his son's house. He needed to find the area of the floor however, he was having trouble with the multiplication. The measurements were 4.2 meters by 6.3 meters. Do the multiplication to help him find the area.

Answer: _____ meters²

- ★★ 9. Rewrite this riddle so it's easily understood.

The middle 3/5 of SHOWS.	The middle 1/5 of TRAPS.
The first 1/3 of DOODLE.	The first 6/6 of TURKEY.
The first 3/5 of YOURS.	The middle 1/2 of PINS.
The first 1/2 of KEEPSAKE.	The first 8/11 of SUSPENSEFUL.

Answer: The riddle is: _____

A good answer to the riddle might be:

Commentary

Saturn, VII

1. ($31 \frac{1}{12}$) Students will need to find a common denominator for the fractions. 12 is the smallest such, although others (24, 36, etc.) would work also. If the fractions are converted into those with denominator 12, they will sum to $25/12$ or $2\frac{1}{12}$. When added to the whole number parts, the answer is $31\frac{1}{12}$.
2. (**\$27.60**) Students can find one-fifth of \$34.50 by dividing by 5. They then subtract this from \$34.50. Another way would be to find four-fifths (or 80%) of \$34.50.
3. (**\$9.34 and \$10.75**) Students will have to use their visual acuity to see the sides of the figures that aren't shown. The top figure has two square faces at \$1.49 each, and four rectangular faces at \$1.59 each. Its price is given by: $(\$1.49 \times 2) + (\$1.59 \times 4) = \$9.34$. The other figure has two triangular pieces at \$2.99 each, and three rectangular pieces at \$1.59 each. Its total price is given by $(\$2.99 \times 2) + (\$1.59 \times 3) = \$10.75$.
4. (a. > b. = c. > d. <) In (a), the students can change $1/2$ to 0.50 and compare 34.63 to 34.50. In (b), students can think of 1 as $5/5$, so by taking 2 whole units from $3\frac{2}{5}$ and changing them into fifths, they would get $10/5$. Or, $3\frac{2}{5} = 2\frac{7}{5} = 1\frac{12}{5}$. In (d), students have to realize that $9/100$ is smaller than $9/10$.
5. (**5 hours 11 minutes**) Count the hours from 8:15 to 1:15, then the minutes from 1:15 to 1:26.
6. (a. **1,000,000**; b. **10,000**; c. **1,000**) This is a good problem to check on *number sense* for students. Students who have trouble with (b) and (c) might profit from starting with smaller numbers in similar problems.
7. (**E = 2; F = 1; G = 7; H = 8**) Students might start by noticing several critical features of this problem. E must be either 1 or 2, since the answer does not carry over into the ten thousands place. They might further guess that $E \neq 1$ since this would result in $H = 4$. If $H = 4$, then $4 \times 4 = 16$ and E would be 6. This is not possible. Choose $E = 2$ and assume $H = 8$; then proceed from there.
8. (**26.46**) Multiplication is called for to find the area of the carpet. $6.3 \times 4.2 = 26.46$
9. (**How do you keep a turkey in suspense?**) This riddle is a fun way for students to practice finding a fractional part of a set. Some possible answers are: "I'll tell you tomorrow!" and "Delay Thanksgiving one day!"

SUPERSTARS III
Saturn, VIII

Name: _____
(This shows my own thinking.)

★★★ 1. Write true, sometimes, or false.

- a. Perpendicular lines intersect. _____
- b. Two sides of a triangle are parallel. _____
- c. Two lines that are parallel to the same line are parallel to each other. _____

★★ 2. Solve:

$$9 \div (1 + 2) + 9 \div 3 = ?$$

Answer: _____

★ 3. Lisa and Sandy were comparing sticks. Lisa's stick was $\frac{2}{3}$ of a yard long. Sandy's stick was $1\frac{10}{12}$ of a foot long. Who's stick was the longest, and by how much?

Answer: _____ was longer, by _____.

★★★★ 4. What fraction of the large square is shaded?

Answer: _____ is shaded

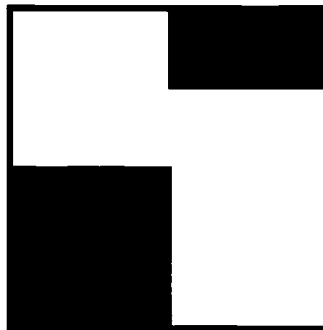

★★ 5. Adrienne left home at 8 a.m.. She arrived in Los Angeles at 1:28 p.m.. Her friend Erica left home at 10 a.m.. She arrived in Los Angeles at 2:45 p.m.. Assume they are in the same time zone the whole trip. Altogether, how many hours did Adrienne and Erica spend traveling?

Answer: _____ hours, _____ minutes

- ★★ 6. Mike had eighteen jellybeans in a bag. 12 of them were green, 1 was blue, 1 was black, 1 was white, 1 was pink, and 2 were orange. If he stuck his hand into the bag without looking, what is the probability of his pulling out an orange jellybean? Write your answer as a fraction.

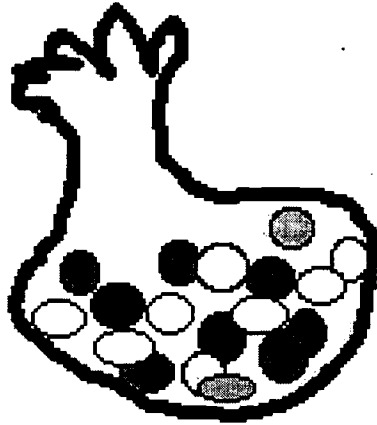

Answer: _____

- ★★★★ 7. Write a number sentence. Use every digit in the circle only once. Insert math symbols (+, -, ×, ÷) and end with the number three. Use parenthesis if necessary.

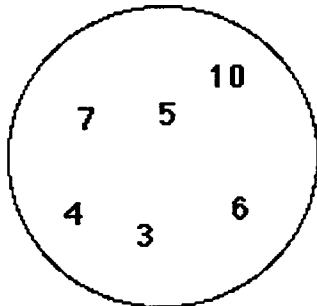

Answer: _____ = 3

- ★★ 8. Joe and Christine each bought a six pack of colas. Joe gave $\frac{2}{3}$ of his away to friends, and Christine gave away $\frac{1}{2}$ as many as Joe. How many more colas did Christine have than Joe?

Answer: She had ____ more.

- ★ 9. Lo Ann's softball team had 16 players. One day it started raining at practice, and all but 5 players squeezed into the refreshment stand, out of the rain. How many were left to get wet?

Answer: _____ were left outside and got wet.

Commentary

Saturn, VIII

1. (a. true, b. false, c. true) Perpendicular lines intersect and form right angles. Parallel lines do not cross or intersect. Students can draw diagrams or work with spaghetti to see whether these statements seem true to them. For the last one, they might consider the lines on a sheet of notebook paper, for verification.
2. (6) This problem can verify that students can use *order of operations*. Work the parenthesis first, divide, then add. Notice that if students do this problem left to right, as if entering it in a calculator, they would get the answer $20/3$.
3. (Lisa's stick, by 2 inches) Lisa's stick is $2/3$ of a yard, which is 2 feet. Sandy's is $1\frac{10}{12}$ feet, or 1 foot, 10 inches. 2 feet is longer than 1 foot, 10 inches by 2 inches.
4. ($\frac{3}{8}$) The square can be divided into eight equal parts. If the square in the lower left corner were partitioned into two parts, three-eighths would be shaded.
5. (10 hours, 13 minutes) Adrienne traveled 5 hours 28 minutes. Erica traveled 4 hours, 45 minutes. The only difficult part is to rename the total minutes, 73, as 1 hour, 13 minutes.
6. ($\frac{2}{18}$ or $\frac{1}{9}$) There are 18 jellybeans in the bag. Two of them are orange. The chances of pulling out an orange jellybean would be 2 out of 18. In lowest terms, the answer would be 1 out of 9.
7. ($4 + 3 - 7 + [6 + (10 + 5)]$ is one possibility.) There are many other solutions. Check each answer. Students may use parenthesis.
8. (2) Joe gave away $2/3$ of six colas, or 4 colas, leaving him 2. Christine gave away half as many as Joe, so she gave away 2 colas, leaving her with 4. So she had 2 more than Joe, in the end.
9. (5) The problem will show whether some students mistakenly apply the traditional method of solving subtraction word problems -- "*how many left* means to subtract." In this case, the number left is the same as the number who couldn't squeeze into the refreshment stand.

SUPERSTARS III
Saturn, IX

Name: _____
(This shows my own thinking.)

- ★★ 1. Sandra has eight coins which total \$0.87. What coins does she have? (Hint: make a chart or a list.)

Answer : _____

- ★★ 2. Practice doing some problems like this. You will be given one when you turn in your paper, and you can only write the answer down. You'll have to use mental math.

Answer later: _____

Lonny has \$15 to buy some groceries for his mom. Milk costs \$2.39, bread costs \$1.29, eggs cost \$0.79, and mayonnaise costs \$2.49. If he buys one of each item, can he expect to have \$10 left?
_____ (yes or no)

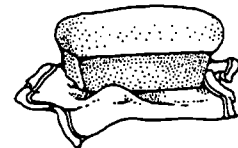

- ★★ 3. Jack wants to buy an equal number of green, blue and white ornaments for his holiday tree. Green ornaments come in packages of 3; blue ornaments come in packages of 6; the white ones come in packages of 4. What is the least number of packages of each color he must he buy?

Answer: _____ packages of green
_____ packages of blue
_____ packages of white

- ★★ 4. Mickey made a space ship on his geoboard.
- a. Draw any lines of symmetry on the space ship.
- b. Find the area of the space ship by counting whole and partial square units.

Answer: The area is _____ square units

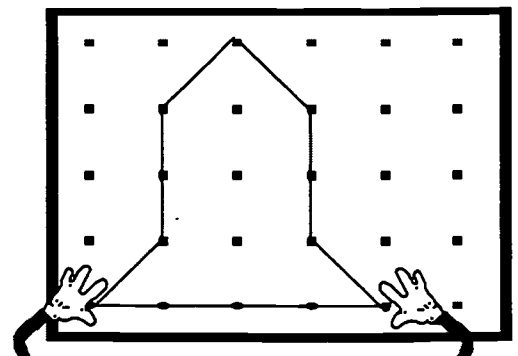

★★★ 5. Use each digit from 1 to 9 to make each line sum to 15. Use each digit only once.

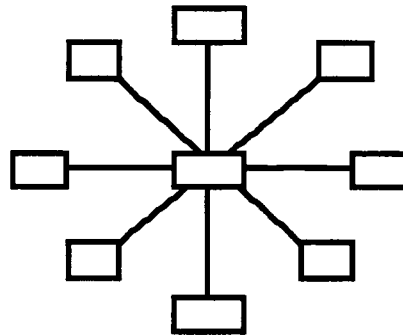

★★★ 6. Use the graph to answer the questions about Florida's growing population.

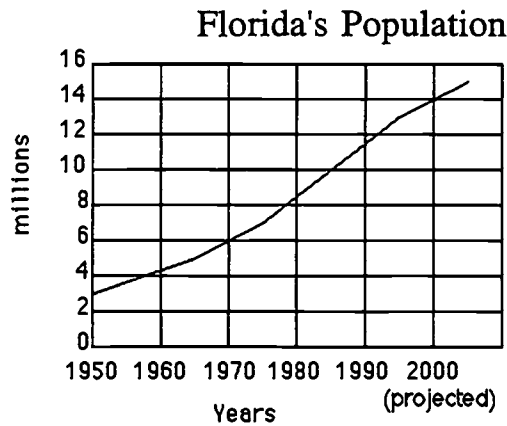

- What is the increase in population from 1950 to 2000? _____
- What was the approximate population in 1980? _____
- At the current rate of increase, what would the population to be in 2010? _____

★★★ 7. Think about these spinners to answer the questions below.

- Put a ✓ on the spinner that gives the white team the best chance to win.
- What is the white team's chance of winning on the spinner with ✓? _____
- What is the chance the white team would not win, on the spinner with ✓? _____

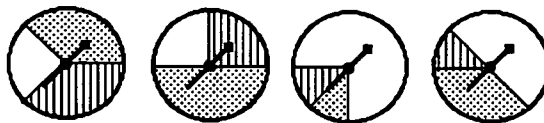

Commentary

Saturn, IX

1. (2 quarters, 3 dimes, 1 nickel, 2 pennies or 1 half dollar, 2 dimes, 3 nickels, 2 pennies) Students can experiment with coin values to find the answer. It helps to write down some headings -- half dollars, quarters, dimes, nickels, pennies -- and begin listing coins under them that sum to 87¢, checking to see whether you have eight coins. If not, modify the list. Notice that right away you can tell that you have to have at least two pennies.

2. (No. Yes, to the problem below.) Write this problem on several 3 by 5 cards so students can read the problem privately, estimate, and write their answer down when they hand in their paper:

Martin has \$20. He wants to buy a magazine for \$3.95, a baseball cap for 5.99, and a cola for 89¢. Will he have enough left to spend \$6 on a movie ticket?

3. (4 green, 2 blue, 3 white) Finding the least common multiple will help students determine that Jack must buy 12 of each color ornament. An intuitive way for students to find the *least common multiple* is: Start with the largest number, 6, and look at its multiples, 6, 12, 18, and so on. When you find a number that is also a multiple of both other numbers, you've found the *least common multiple*.

4. (vertical line down the middle, 8) The "fold line" or *line of symmetry* splits the space ship in half along the vertical. The area is found by counting 6 whole squares and 4 half squares, for a total area of 8.

5. (The center number is 5. Numbers in "opposite boxes" total 10) Students might solve this by guess and check, or they might think of what must be true for 3 numbers to sum to 15. Their average would have to be 5, so start by placing 5 in the center box. Then the other two numbers along each line have to total 10 for the whole line, including 5, to sum to 15. So just pick numbers for "opposite boxes" that sum to 10.

6. (a. 11 million b. 8.5 million c. 16 million) Answers may vary somewhat from these given, particularly (b), but they should be close to these numbers.

7. (a. 3rd from left b. $\frac{3}{4}$ or 75% c. $\frac{1}{4}$ or 25%) In this problem, the chances of winning are related to the area of the circular space. The white team's space is about $\frac{1}{4}$ of the area of the circle in the 1st and 2nd spinners, about $\frac{1}{2}$ in the 4th spinner, and about $\frac{3}{4}$ of the area in the 3rd spinner.

Superstars III
Saturn, X

Name: _____
(This shows my own thinking)

- ★★ 1. The Wright Brothers each had two flights on that famous day at Kitty Hawk. Orville flew 120 ft. and 585 ft. Wilbur flew 340 ft. and 852 ft. What was the average distance flown that day? At that rate, how many flights would it have taken them to fly a mile? (rounded to the nearest whole number)

Average distance: _____

Flights to travel a mile: _____

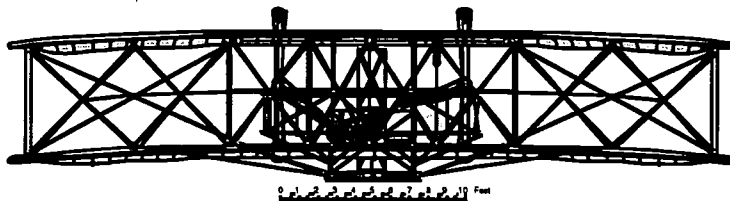

- ★ 2. Use the scale underneath the plane above to find its wingspan, tip to tip. Answer: ____ ft.

- ★★ 3. The regular season for professional baseball is 162 games. A player was at bat 3 times in each game, and he played in $\frac{2}{3}$ of the games.

a. How many times was the player at bat during the season?

Answer : _____

b. The player hit 0.250, which means he got a hit 25% of the time, or once in every four at bats. How many hits did he get during the year?

Answer: _____

- ★★ 4. John needs to build a fence around his yard which is 96 ft. wide and 120 ft. deep.

a. How much fence must he buy to enclose all four sides?

Answer : _____

b. If the fence costs \$12.87 for an 8 ft. length, how much will the entire fence cost before the tax is added?

Answer: _____

- ★ 5. A bag has 6 marbles in it. Each marble is either red, blue, or green. What is the least number of marbles that you must pull out of the bag to be sure you have two marbles the same color?

Answer: _____

- ★ 6. You will be given a problem like the one below when you turn in your paper. To earn your star, you'll have to estimate the answer in your head. Make up and practice some problems like this one.

Answer later: _____

The store where Janice and Kanisha shop is having a sale on summer clothes. Each of the girls wants to buy 2 pairs of shorts and three tops. If shorts and tops are on sale for \$11.50 each, what is the best estimate of how much each girl will spend? Circle your answer.

- a. \$40 b. \$50 c. \$60 d. \$120

- ★★ 7. What whole number does X stand for if the number sentence below is true?

$$(X + 5) + (3 \times 2) = 18$$

Answer : _____

- ★★★ 8. Danny earns \$5 a week. Use the graph to answer the questions below.

- a. How much money does Danny spend on snacks? _____
- b. How much money does Danny save? _____
- c. How much money does Danny spend on entertainment? _____

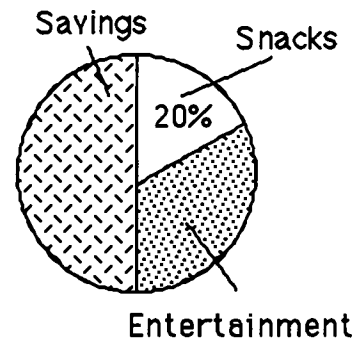

- ★★★ 9. Franklin School has 3 boys for every 4 girls in the fifth grade. There are 140 students in the fifth grade.

- a. How many are boys? _____ b. How many are girls? _____

Commentary

Saturn, X

1. (474.25 or 474 1/4 feet, Flights--about 11) The first part of this problem is simply averaging the four distances given -- 120, 585, 340, and 852. Students might have to look up the number of feet in a mile -- 5,280. Then they can divide that number by their average and round off the answer.
2. (39 or 40 feet) The scale shows 10 feet. Measuring accurately gives 39.5 feet, so accept an answer anywhere between 39 and 40 feet. It might be interesting to extend the thinking by asking questions such as -- would this plane fit in your classroom? In your garage?
3. (a. 324 times b. 81) Students might first find $1/3$ of 162 games, then double that amount for $2/3$. That answer of 108 is then multiplied by 3, obtaining 324. Very few students will notice that $3 \times 2/3 \times 162$ can be found by simply multiplying 2×162 . For part (b), students can either find $1/4$ of 324 by dividing by 4, or find 25% of 324 by multiplying 324 by 0.25.
4. (a. 432 ft. b. \$694.98) Students might profit from drawing a sketch of the yard, and labeling the four sides with their lengths. The first answer is obtained by simply adding 96, 120, 96, and 120. The second can be found by dividing 432 by 8 and then multiplying by \$12.87.
5. (4) It is possible to pull out one of each color marble on the first three draws. Therefore, the fourth marble will match one of the first three.
6. (\$95) Have the problem below written on several 3 by 5 cards for students to read prior to handing in their paper. They must do the problem in their heads, and simply write the answer in the space provided. Number sense will play a role here, as \$18.95 is about \$1 less than \$20. So 5 times \$18.95 should be close to $5 \times \$20$, less \$5.

Chris needs to buy five new shirts for a vacation trip coming up over Thanksgiving. The shirts are on sale for \$18.95 each. What is the best estimate of what the five shirts might cost?

- a. \$75 b. \$85 c. \$95 d. \$105

7. (7) Students should be encouraged to *guess-check-revise* to find the value of X. They might try $X = 1$ to start. They will see that this results in less than 18 when used in the left side of the number sentence. So they would adjust their guess up, continuing until they found that $X = 7$ produces 18. Calculating the parenthetical expression gives 6. Six added to 5 is 11. What must be added to 11 to give 18?
8. (a. \$1 b. \$2.50 c. \$1.50) Snacks consume 20% of Danny's money, and 20% of \$5 is $1/5$ of \$5, or \$1. The graph is divided so that his savings are half of his money, and half of \$5 is \$2.50. The percent spent on entertainment can be found by adding 50% and 20% to get 70%. The rest of the chart must then be 30%. The entertainment money is 30% of \$5, or \$1.50.
9. (a. 60 b. 80) Drawing a picture might help students interpret what "3 boys for every 4 girls" means. They can put together two such groups and know that "6 boys for every 8 girls" is the same ratio, but with larger numbers. Continuing in this fashion, by using ten such groups, they would have the proper number overall -- 140 students, consisting of 60 boys and 80 girls.

Superstars III
Saturn, XI

Name: _____
 (This shows my own thinking.)

- ★★ 1. Jacqueline, Kanisha, Howard, and Billy have jobs in their group. The jobs are Recorder, Materials Manager, Time Keeper, and Reporter. Kanisha sits across from the Recorder and next to the Materials Manager. Billy hurt his hand and cannot record the work done. Jacqueline is best friends with the Reporter, and lives down the street from the Recorder. Billy rides the bus with both the Materials Manager and the Reporter. What is the task of each student?

_____ Recorder _____ Materials Manager
 _____ Time Keeper _____ Reporter

- ★★ 2. A sheet of plywood measures 4 feet by 8 feet. Armand wants to build a dog house using one whole sheet of plywood for the floor.

a. Armand needs to put a "2 by 4" under the outer edge all the way around the floor, and another "2 by 4" that runs down the middle lengthwise, to give support to the plywood. If "2 by 4's" are sold in 8-foot lengths, how many should he buy? _____

b. If he carpets the floor also, how many square feet of carpet should he buy? _____

- ★★★ 3. Pine Elementary School Chorus needs tapes to record their musical for the members. Tapes cost \$7.95 for a package of 2 tapes and \$11.75 for a package of 3 tapes. If 23 members want copies of the tape, what is the least amount they will have to spend?

Answer: _____

- ★★★★ 4. If each sphere has a mass of 120 gm, what is the mass of a pyramid? _____ gm

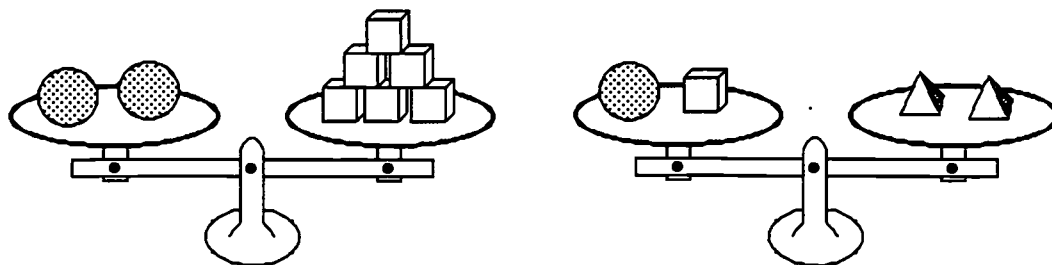

- ★★ 5. Sunny Ridge Elementary School was collecting cans for a food drive. The first two days of the drive, they collected 103 cans. They collected 5 cans more on the first day than on the second day. How many cans did they collect each day?

Answer : _____ 1st day _____ 2nd day

- ★ 6. Josie found a pair of shoes she wanted priced at \$55, but she did not want to pay that much. A few weeks later, the same shoes were marked down 20%. Including the 6% sales tax, how much will she pay if she buys the shoes on sale?



Answer: _____

- ★★★★ 7. People who learn to multiply mentally usually do the opposite of what they do with paper-and-pencil. They start multiplying the "big numbers" first, and then add on the product of the smaller numbers. Watch James below:



To multiply 63×45 , first multiply 60×40 to get 2400. Then add on 60×5 or 300, and you have 2700. Then add on 3×40 or 120, and you're up to 2820. Next add 3×5 or 15, and you have 2835. So 63×45 is 2835.

Practice multiplying this way with 2-digit by 2-digit multiplication problems that you make up. When you turn in your paper, you can earn 4 stars by doing a problem like this.

Answer later: _____

- ★★★ 8. Circle the best answer for the length of each line segment.

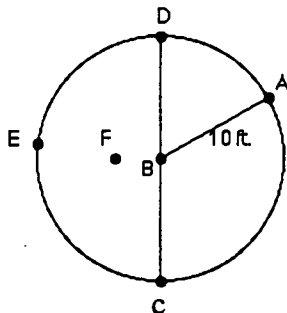

\overline{FE}	12 ft.	10 ft.	8 ft.
\overline{CD}	15 ft.	30 ft.	20 ft.
\overline{BF}	5 ft.	4 ft.	1 ft.

Commentary

Saturn, XI

1. (**Howard--Recorder, Jacqueline--Materials Manager, Billy--Time Keeper, Kanisha--Reporter**) Students might make a chart crossing out the jobs that each student does not have. From the statement "Kanisha sits across from the Recorder and next to the Materials Manager," for example, we can determine that Kanisha has neither of those jobs. A chart and *process of elimination* can therefore be used to match each job with the child.

2. (**a. 4; b. 32**) It would help for students to draw and label a diagram of the floor. For (a), they need a separate 2 by 4 for each 8-ft. side of the plywood sheet and another to go down the middle. They can buy one more 8-ft. 2 by 4 and cut it in half to get two 4-ft lengths for the short sides of the plywood. This is a total of four 2 by 4's. For (b), the area of the plywood sheet gives the amount of carpet to purchase-- 4×8 or 32 square feet.

3. (**\$90.20**) First, students need to be sure that tapes are cheaper if bought in packages of 3 than in packages of 2. Then the strategy - "first buy all the packages of 3 you can and then finish out with packages of 2" - can be used. Seven packages of 3 tapes per package can be purchased for \$82.25. Two more tapes are needed to total 23, and one package of 2 will add \$7.95 for a total of \$90.20.

4. (**80 gm**) 2 spheres (240 gm) equal 6 boxes, so a box must equal 40 gm. If one sphere and one box ($120 + 40$) equal 2 pyramids, then each pyramid is half of that sum, or 80.

Students might be encouraged to begin writing an explanation of how they solve these types of problems using a variable as shorthand notation. For example, they might show the steps above as:

$$2s = 240 = 6b, \text{ so } 1b = 40 \text{ from the left scale.}$$

$$1s + 1b = 120 + 40 = 160 = 2p, \text{ so } 1p = 80 \text{ from the right scale.}$$

5. (**1st day--54 cans, 2nd day--49 cans**) Students might estimate half of the cans collected as 50 and adjust that number up or down for the two days, using *guess and test* to meet the conditions of the problem.

6. (**\$46.64**) Students with good number sense might think of 20% as $\frac{1}{5}$, and one-fifth of \$55 is \$11 off, so the sale price of the shoes is \$44. Tax is \$2.64. Another way to approach the problem, particularly if a calculator is handy, is to realize that she will pay 80% of the regular price and compute $\$55 \times 80\%$. This amount is then multiplied by 1.06 to "add on" the sales tax in one step.

7. (**735**) It's interesting for students to realize that people who work mentally in arithmetic sometimes follow the "reverse procedure" from what they are taught to do with paper-and-pencil. In this case, James works with the larger numbers first, and works his way down to the smaller numbers. Notice that if he makes a mistake somewhere down the line, he'll probably be close to the right answer because he dealt with the larger number first.

Have this problem on 3 x 5 index cards for students to see when they hand in their paper. A student is allowed to write only the answer on the worksheet: 21×35 .

8. (**FE = 8 ft.; CD = 20 ft.; BF = 4 ft.**) Students can find FE by noticing that it is visually a little shorter than AB. CD is exactly twice AB. BF is less than half of AB visually, but not enough less to be 1.

SUPERSTARS III

Saturn, XII

Name _____
(This shows my own thinking.)

- ★★★ 1. Bob's garden is a 20 ft. x 10 ft. rectangle. Bob plants tomatoes in half of his garden. $\frac{1}{4}$ of the remainder is radishes. $\frac{1}{2}$ of what is left contains cucumbers. The last area is planted in peppers. What part of the garden is planted in peppers?
(Hint: draw a picture)

Answer: _____

- ★ 2. St. Augustine was founded in 1565 by Pedro Menendez de Aviles. The oldest house in that city still standing was built in 1703. How old is this house now?

Answer: _____

- ★★ 3. For your weekend at the beach, you have packed one pair each of red shorts, blue shorts, and tan shorts. You have also packed a white shirt, and a red shirt. How many outfits can you make with these clothes?

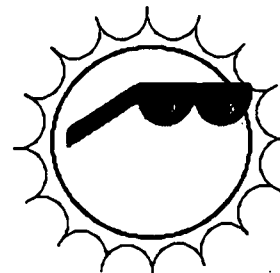

Answer: _____

- ★★★ 4. A number n is divided by 3 and the result is multiplied by 7. Then 6 is subtracted from the result to give 36. What is the original number n ?

$$[(n \div 3) \times 7] - 6 \text{ gives } 36. \text{ What is } n?$$

Answer: $n =$ _____

- ★★ 5. Which fraction is closest in value to 1? Circle the correct answer.

- a. $\frac{3}{5}$ b. $\frac{2}{3}$ c. $\frac{1}{2}$ d. $\frac{7}{10}$

★★ 6. There are 5,280 feet in a mile. If an airplane is flying at 35,000 feet above sea level, how high is it? Bubble in the correct choice.

- 0 7 miles high
- 0 a little less than 7 miles high
- 0 a little more than 7 miles high

★★★ 7. Juan entered a bike race in which he was to ride 45 miles, stopping at certain intervals during the race to check in with the scorers. He checked in 9 times before he crossed the finish line. If the intervals were equally spaced throughout the race, how far apart were they?

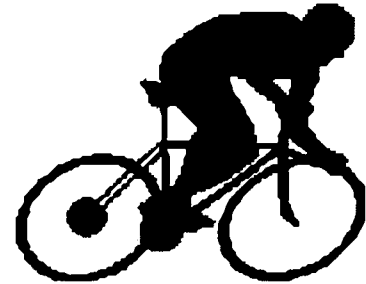

Answer: The intervals were spaced every _____ miles.

★★★★ 8. The graph shows Juan's speed during the race, not counting when he stops at the checkpoints. Answer the questions below the graph.

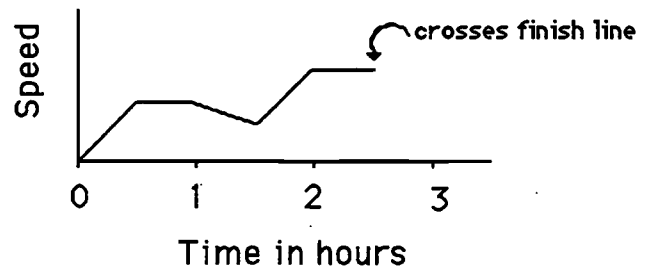

a. About how long did Juan take to finish the race? Answer: _____

b. What can you say about Juan's speed during the first half hour of the race?

Answer: _____

c. What can you say about Juan's speed during the second half hour of the race?

Answer: _____

d. During what part of the race was Juan going the fastest?

Answer: _____

Commentary

Saturn, XII

1. (3/16) Students are encouraged to make a diagram. If they do so, they can find the area of the peppers in several ways. The tomatoes take up $1/2$, and the radishes $1/4$ of what is left or $1/8$ of the total garden. This leaves $3/8$ of the garden for the cucumbers and peppers, to be split evenly. Thinking of $3/8$ as $6/16$, it's easy to see that half of that is $3/16$.

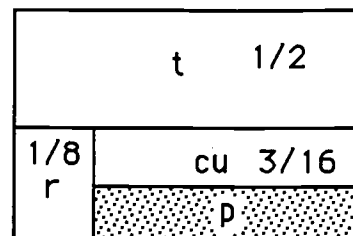

2. (In 1997, 294 years; in 1998, 295 years; etc.) This subtraction problem can be enhanced with a little history about St. Augustine, the oldest city in the United States.

3. (6 outfits) One strategy is to make a chart, as below. Another is to make a diagram.

	red shorts	white shorts	blue shorts
red shirt	✓	✓	✓
white shirt	✓	✓	✓

4. (18) One strategy is to work backwards, asking students what they would have if they had not subtracted 6. They should see that they would have 42. Therefore, something times 7 equals 42. Knowing that the something must be 6, they will recognize that 18 divided by 3 equals 6.

Another approach is to *guess-check-revise*. They could start by guessing a number like 30 for n , and check to see that 30 is too high because $[(30+3) \times 7 - 6]$ gives 64, not 36. So they would adjust the guess down and try again.

5. (D, or 7/10) Students could place these numbers on a number line or divide a piece of paper into pieces for comparison. Another method would be to change them all to fractions that have a common denominator (30 is the least such) and compare the resulting numerators.

6. (a little less than 7 miles high) 5,280 is a little more than 5,000. 5,000 goes into 35,000 exactly 7 times. So 5,280 would go into 35,000 a little less than 7 times.

7. (4.5 mi.) The 45-mile race would have no checkpoints at the start and finish lines. A picture will show that there are 9 checkpoints, resulting in 10 spaces between "start" and "finish."

8. ($2\frac{1}{2}$ hours; increasing; constant; last half hour) This problem has students look at a line graph and interpret it visually. The graph stops at about $2\frac{1}{2}$ hours along the time axis, meaning it took him about $2\frac{1}{2}$ hours to finish. The line is going up at a constant rate during the first half hour, so his speed is increasing. During the second-half hour, the line is horizontal, indicating that his speed was constant. The line is at its highest point during the last half hour, showing that during this time period he was traveling at his greatest speed.

An extension activity would be for students to make their own graphs of his trip, matching stories they make up about his speed, including his check-point stops.

SUPERSTARS III

Saturn, XIII

Name _____
(This shows my own thinking)

- ★ 1. Mr. McMathy needs 129 seats for his 5th grade program. If the seats are arranged in rows of 10 seats, how many rows will he need?

Answer: _____ rows

- ★★★ 2. In the United States, 154,000,000 tons of garbage are produced annually. On an average, about how many pounds is that each month for each person in the United States? The population of the United States is about 250 million.

Answer: _____ pounds

- ★★★★ 3. The horizontal, vertical, and diagonal columns of a magic square all add to the same sum. Use the digits 1 - 9 one time each to make a magic square.

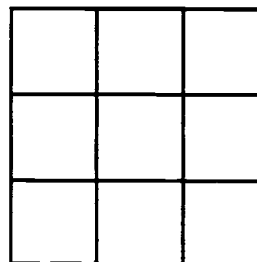

- ★★★ 4. A *square number* is a number in which the dots can be arranged to form a square.

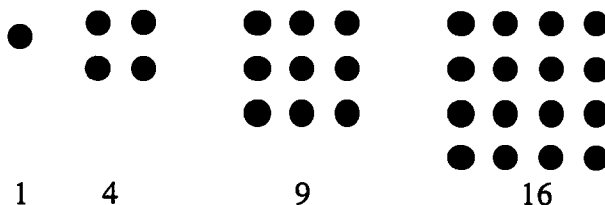

- a. Find the next three square numbers. _____
- b. Is 100 a *square number*? _____
- c. Is 200 a *square number*? _____

- ★★ 5. How many different rectangles exist which have whole numbers as the length and width, and also have an area of 36 sq. cm?

Answer: _____ rectangles

★★★ 6. You offer to do the dishes for your family for the next month. You suggest that they can pay you in one of three ways:

- a. \$0.50 each day
- b. \$0.10 the first day, \$0.20, \$0.30 the 3rd day, and so on.
- c. \$0.01 the first day, \$0.02 the second day, \$0.04 the third day, and so on, doubling every day

If the month has 31 days, which rate of pay would be best for you? Circle your choice.

★★ 7. You place these cards in a bag, and choose one without looking.

a. What is the chance you will pull out a red card?

Answer: _____

b. What is the chance you will pull out a ♣?

Answer: _____

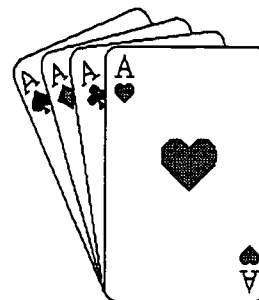

★★ 8. Marcia drew the design to the right on a piece of clear plastic. She turned it 90° clockwise, then flipped it over horizontally and flipped it again vertically. Which is her card below? Circle it.

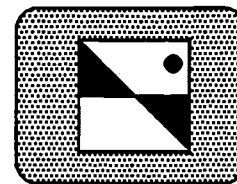
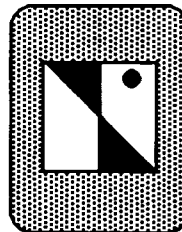
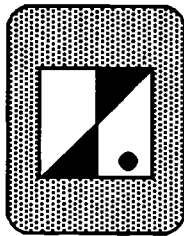
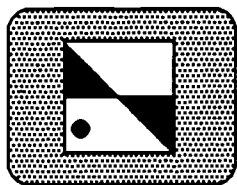
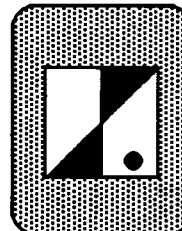

★ 9. Find the product: $5.7 \times 17.3 \times 651 \times 387 \times 0 \times 82.1 =$ _____

Commentary

Saturn, XIII

1. (13) Students might forget that the 9 remaining when 129 is divided by 10 represents seats which are needed for the class. Twelve rows would not be sufficient.
2. (about 100 pounds per month) Students will need to read carefully--the amount produced annually is given in tons, but the answer is asked for in pounds. Students can multiply tons of garbage per year by 2,000 to get pounds per year and then divide by 12 to get pounds per month. This result is then divided by 250 million to get each person's share per month. The result of the above computation is about 103 pounds per month, but any reasonable answer should be accepted.
3. (1st row: 8, 1, 6; 2nd row: 3, 5, 7; 3rd row: 4, 9, 2) There are several possible solutions to this magic square. One possibility is given. Students may be encouraged to use number tiles to help solve the problem. One strategy that would help is to assume the center number might be 5, which is the middle number of 1-9. Then you know that "opposite diagonal numbers" must sum to 10; therefore, place 8, 6, 4, and 2 in the corners in this fashion. Continue making good guesses, checking, and making adjustments as called for.
4. (25, 36, 49; yes; no) Students can continue making figures by hand, if necessary, but we hope that they will notice a relationship between the number of the figure (1st, 2nd, 3rd, ...) and the total number of dots in the figure (1, 4, 9, ...). The next figure in the pattern would have 5 dots on each side and thus 25 in all, and so on. 100 is a square number because a 10-by-10 square can be formed from 100 dots. 200 is not a square number -- a 14-by-14 square would have 196 dots, and a 15-by-15 would have 225.
5. (5) The rectangles are: 1×36 ; 2×18 ; 3×12 ; 4×9 ; 6×6
6. (c) Students would enjoy experimenting with these three ways of earning money, using a calculator. (a) would give you only $\$0.50 \times 31$ or \$15.50 for the month. (b) would give you the sum of the numbers from 1 to 31, multiplied by \$0.10, or \$49.60. (c) shows the power of doubling -- by the 15th day, for example, you would make \$163.84 on that day alone. Using the calculator, your group will notice the rapidity with which the product increases when the number doubles daily.
7. (2/4 or 1/2; 1/4) Since the four aces have two red ones (hearts and diamonds), the chance of pulling a red card at random is 2 in 4 (written either 2/4, 1/2, or 50%). There is one club out of the four cards, so the chance of pulling a club at random from the bag is 1 in 4, written as 1/4 or 25%.
8. (far right card) Students with good spatial visualization skills will find this card quite readily. Other students may profit from actually drawing the design on a thin sheet of paper, following the steps in order while holding the paper up to the light to see the results.
9. (0) If students "look ahead" in the problem, those with good operation sense will realize that the answer is zero. Any number multiplied by zero results in zero. Therefore, if zero is one of the factors shown in a multiplication problem such as this, the answer is automatically zero.

SUPERSTARS III



Saturn, XIV

Name: _____
(This shows my own thinking.)

★★★ 1. Complete each sentence by drawing a picture in the space beside it.

a.  is to  as  is to

b.  is to  as  is to

c.  is to  as  is to

★ 2. Fill in the missing fractions. The same fraction is used in both spaces.

$$\left(\frac{4}{8} - \quad \right) + \left(\frac{5}{8} - \quad \right) = \frac{7}{8}$$

★ 3. Solve if there is enough information. If not, tell what is missing. Becky bought a pack of paper that cost \$5.95. Tony bought a pack that cost \$6.49. Who bought the most paper?

Answer: _____

★★★★

4. Akeen works at the community relief center every summer. He is a really good worker. He earns \$8.00 per hour for his regular 40-hours a week. Last week he worked 47 hours. How much did Akeem earn if he gets "time and a half" for overtime?

Answer: _____



- ★★★ 5. Complete the chart below. Each of the three students earns \$5.75 per hour.

Employee work schedule and amount earned

Employee	In	Out	Hours	Amt. Earned
Bachie	8:00 A.M.	6:00 P.M.		
Dustin	12:30 P.M.	5:00 P.M.		
Monica	9:00 A.M.	5:30 P.M.		

- ★★★★ 6. This pattern of buildings is made with blocks. Building 1 is made from 1 block, Building 2 from 4 blocks, and so on.

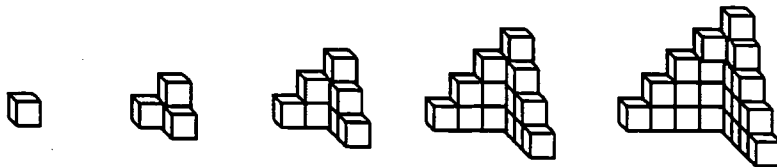

Bldg. 1 Bldg. 2 Bldg. 3 Bldg. 4 Bldg. 5 Bldg. 6

- How many blocks are needed for Building 3? _____
- How many blocks are needed for Building 4? _____
- How many blocks are needed for Building 10? _____
- How many blocks for Building n , where n could stand for any number? _____

- ★ 7. Fold this sheet of paper so that you *bisect* the angle. *Bisect* means that you exactly cut it in half. With your pencil, darken-in the crease in the paper. The line you draw is the *bisector* of the angle.

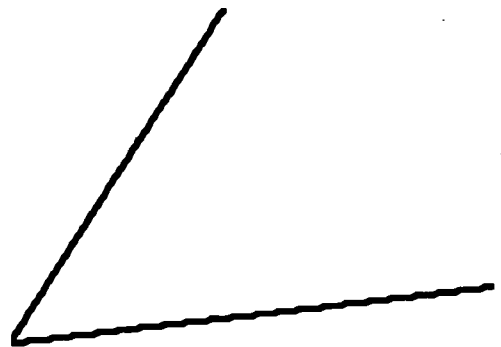

- ★★★ 8. Open a book and look at the two page numbers.
- Is their sum an *even* number, or an *odd* number? _____
 - Is their product an *even* number, or an *odd* number? _____
 - If you opened the book to two different pages, would your answers to (a) and (b) be the same? _____

Commentary

Saturn, XIV

1. (answer shown below) These visual puzzles become increasingly difficult, but notice that some students will see the analogies immediately. In (a), the figure goes simply from unshaded to shaded. In (b), only two-thirds of the figure is considered, and it also goes from unshaded to shaded. In (c), the figure turns 180° .



2. ($\frac{1}{8}$) Students might guess-check-revise to find the fraction, or they might notice that $\frac{4}{8} + \frac{5}{8}$ will give $\frac{9}{8}$, so $\frac{2}{8}$ must be removed to produce $\frac{7}{8}$. Since there are two fractions to be subtracted, $\frac{1}{8}$ can be written in each of the spaces, fulfilling the conditions.

3. (Missing information -- How much paper is in each pack?) There is not enough information given to solve the problem.

4. (\$404) There are a number of ways that students might approach this problem. Akeem makes $\$8 \times 40 = \320 for his regular work week. The remaining 7 hours is overtime, at "time and a half." Time and a half means $\$8 + \4 for each hour, instead of $\$8$. So the overtime pay is $\$12$ per hour. $\$12 \times 7 = \84 . $\$320 + \$84 = \$404$.

5. (Bachie -- 10 hrs, \$57.50; Dustin -- 4.5 hrs, \$25.88; Monica -- 8.5 hrs, \$48.88) Students can count from the In time to the Out time to find the hours worked. These hours might be written as a fraction also. Multiplying the hours worked by $\$5.75$ gives the resulting amount earned. This is easy to do using a calculator if the hours are written as a decimal instead of as a fraction. Dustin's and Monica's "amount earned" have been rounded up to the nearest cent.

6. (9, 16, 100, $n \times n$ or n^2) Students might be encouraged to build these figures out of cubes, and look at the pattern that occurs.

7. This problem encourages students to internalize what it means to *bisect an angle* before meeting the term later and are expected to use a compass to perform the task. They can hold the sheet of paper up to a light source, and fold the paper so that the two sides of the angle match up. Paper folding can also be used to teach terms such as *perpendicular bisector of a line segment*.



8. (odd, even, same) Opening an actual book and looking at the page numbers will enable students to internalize what this problem means. Books universally start with page 1 on the right-hand side. The right-hand page numbers from there on, therefore, are always *odd*. The left-hand page numbers are always *even* numbers. An *odd* added to an *even* always gives an *odd* number. An *odd* times an *even* always produces an *even* number.

SUPERSTARS III

Saturn, XV

Name: _____
(This shows my own thinking.)

- ★★ 1. Ms. Hill and Mr. Booth both had \$500 to invest in the stock market. Ms. Hill bought shares of Sugarloaf at \$10 per share while Mr. Booth bought shares of Dandy's Butter at \$20 per share. Ms. Hill's shares went up in value \$0.20 per share. Mr. Booth's shares went up \$0.50 per share. How much did each earn on their shares?



Answer: Ms. Hill \$ _____ , Mr. Booth \$ _____

- ★★★ 2. Tiffany has \$20 more than Ivan. Travis has \$20. All three together have \$41. How much money does Tiffany have? _____ How much does Ivan have? _____

- ★ 3. What number do you need to add to these numbers to get 1000? Try solving these in your head. Then practice some more like these that you make up. Use your BRAIN POWER. When you turn in your paper you will be asked to solve a problem like these in your head.

a. $300 + \underline{\hspace{2cm}} = 1000$ b. $210 + \underline{\hspace{2cm}} = 1000$

c. $450 + \underline{\hspace{2cm}} = 1000$ d. $636 + \underline{\hspace{2cm}} = 1000$

Answer for the problem given when you turn in your paper: _____

- ★★★★ 4. You are having a pool party and invite 2 of your best friends. These two friends each invite 2 other people. Each of these 2 people invite 2 people that have not been invited. How many people will be invited if this process continues for 4 rounds? (Hint: Draw a diagram.)

Answer: _____ people



- ★ 5. Which equation has the same solution as the first equation? Circle it.

$$n + 13 = 21$$

a. $t - 13 = 21$

b. $17 = 25 - p$

c. $9 + d = 16$

- ★★ 6. A box will hold 23 puzzles. How many boxes are needed to hold 238 puzzles?

Answer: _____ boxes

- ★ 7. A jacket Jason wants is priced at \$18.99. The sales tax is 8%. What is the total cost of the jacket, including tax?

Answer: \$ _____

- ★ 8. Write the correct numbers in the boxes:

$$\begin{array}{r} 4 \square \\ \times 35 \\ \hline 2 \square 5 \\ 1410 \\ \hline 1 \square 4 \square \end{array}$$

- ★★★ 9. Connect the points with a heavy line as described below. Flip the page over to see what is spelled.

- Connect (10, 1) to (10, 7)
- Connect (2, 1) to (5, 1)
- Connect (7, 4) to (10, 4)
- Connect (7, 7) to (7, 1)
- Connect (2, 7) to (5, 7)
- Connect (3.5, 1) to (3.5, 7)

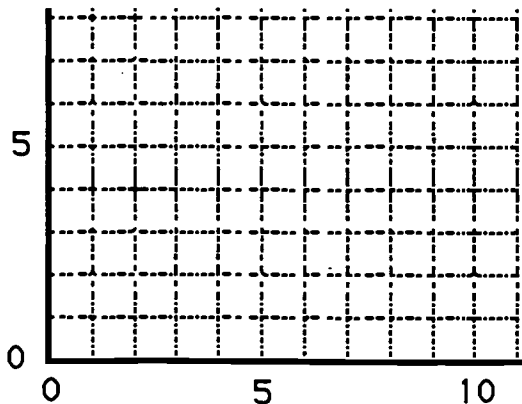

Commentary

Saturn, XV

1. (Ms. Hill - \$10, Mr. Booth - \$12.50) Ms. Hill buys 50 shares for \$500, and makes \$0.20 on each for a total of \$10. Mr. Booth buys 25 shares for \$500, and makes \$0.50 on each for a total of \$12.50.

2. (Tiffany has \$20.50, Ivan has \$0.50) Subtracting \$20 from \$41 leaves \$21 for Tiffany and Ivan together. Therefore, Ivan must have \$0.50. Any other amount would mean Tiffany has more or less than \$20 more than Ivan.

3. (265) When the students turn in their paper, have this problem on 3x5 cards for them to solve: $735 + \underline{\quad} = 1000$ Students MAY NOT use pencil, paper, or a calculator.

4. (30 people) A diagram such as the one to the right will help students realize that 30 have been invited altogether.

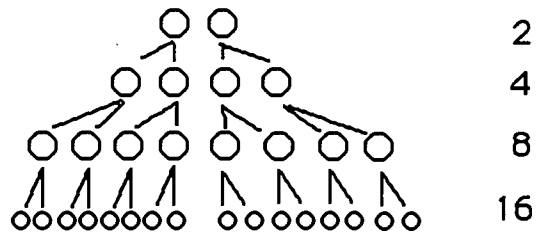

5. (B) $17 = 25 - p$ has the solution 8, which is the same solution as for $n + 13 = 21$. Students might be encouraged to think of the variable as representing a number they are searching for in order to make the given statement a valid one. They can solve these by *guess-check-revise*.

6. (11) Students might divide 238 by 23 and get 10 r 8. They could add 23 until they get close to 238, counting the number of times they add. In any approach, 10 boxes hold 230 puzzles, with 8 puzzles left for the 11th box.

7. (\$20.51) One approach is to multiply \$18.99 times 8%, rounding up to get the tax on the jacket. Add this tax to the price. A one-step approach is to multiply \$18.99 by 1.08.

8. (The answer is shown to the right.) Students can use number clues to narrow down the choices for the box on the top row. Once that box is determined, the rest can be obtained by computation.

$$\begin{array}{r}
 4\boxed{7} \\
 \times 35 \\
 \hline
 2\boxed{3}5 \\
 1410 \\
 \hline
 1\boxed{6}4\boxed{5}
 \end{array}$$

9. ("HI" is spelled out, backwards)

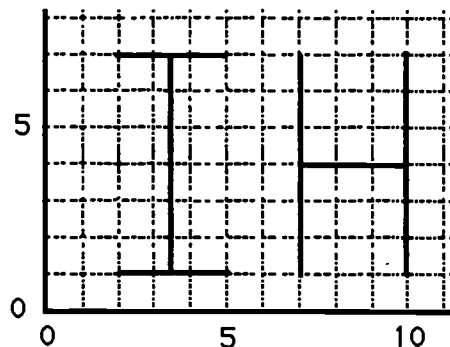

SUPERSTARS III
Saturn, XVI

Name: _____
 (This shows my own thinking.)

- ★★ 1. Find the missing measurement. The total perimeter of the polygon is 27 cm.

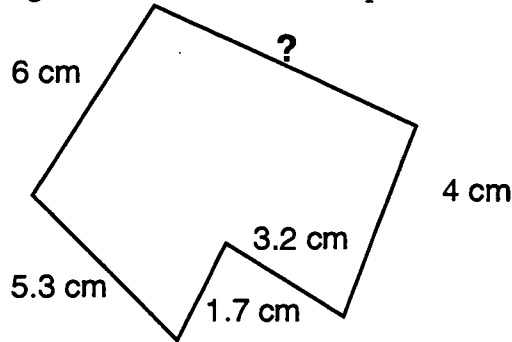

Answer: _____ cm

- ★★ 2. Fill the missing numbers in the division problem.

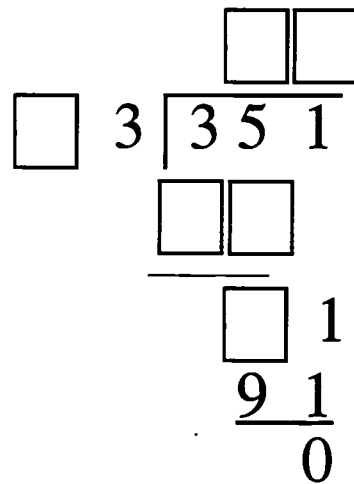

- ★★★ 3. When you divide, you sometimes get a larger number than the one with which you started. Show that you understand this by placing the decimals in the answers below. The numbers in the answers are correct: placing the decimal point correctly will complete the equation.

a. $1.25 \div 0.5 = 250$

b. $0.84 \div 0.7 = 120$

c. $13 \div 0.1 = 1300$

- ★★ 4. Report cards are coming out in three days. Your homework grades are 100, 90, 85, 78, 0, 80, and 92. The 0 occurred when you forgot to do your homework one night. What is the average of your homework grades?

Answer: _____

- ★★ 5. Using the grades from problem 4, what would your average be if you had done your homework that night, and made a 77 instead of a 0?

Answer: _____

- ★★★★ 6. Write an algebraic expression for each phrase below. Use the variable suggested.

- twice as old as Max's age, a , less three years _____
- 10 times higher than the chair's height, h , plus 3 inches _____
- \$3 more than half of what Jason makes, d _____
- five trips of x miles each, plus another 5.8 miles _____

- ★★ 7. Kalia skateboards 5 blocks west and 8 blocks north to get to her friend's house. Each block is $\frac{1}{8}$ mile in length.



- How far does she travel in a round trip? _____ miles
 - Rounded to the nearest whole mile, how far is a round trip? _____ miles
- ★ 8. Bailey has physical education class $1\frac{1}{4}$ hours on Monday, Wednesday, and Friday. How many minutes is he in physical education class each week?

Answer: _____ minutes

- ★★★★ 9. Box A has 3 black marbles and 2 white marbles.
Box B has 2 black marbles and 1 white marble.

If you have to close your eyes and pick a *black* marble to win a prize, which box gives you the better chance of winning? Bubble-in your answer.

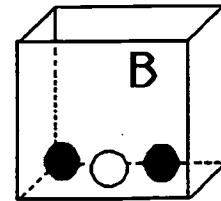
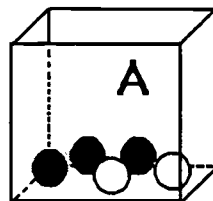

- Box A gives the better chance.
- Box B gives the better chance.
- The boxes give the same chance of winning.

Commentary

Saturn, XVI

1. (6.8 cm) One approach is to add sides given and subtract the sum from the total perimeter. Another is to subtract each known side individually from the total.

2. (See the worked-out problem to the right.) Students who are new to this type of problem might begin at the end, and “work backward.” (i.e., the box above 9 must have a 9 in it, which means that the box above it must be a 6 since that’s what subtracts from 5 to get 9.) A few clever guesses and checks from this point will result in the solution.

$$\begin{array}{r} 27 \\ 13 \overline{)351} \\ \underline{26} \\ 91 \\ \underline{91} \\ 0 \end{array}$$

3. (2.50; 1.20; 130.0) If students have not been taught to move the decimal point in divisor and dividend, they can think of these problems as explained below.

a. $1.25 \div 0.5$ means how many $\frac{1}{2}$ s are in $1 \frac{1}{4}$. They can draw a diagram to find that the answer is $2 \frac{1}{2}$.

b. There would have to be about one $\frac{7}{10}$ in $\frac{8}{10}$ because they’re about the same size. So the only reasonable choice is 1.20.

c. They can think of (c) along these lines: there are 10 one-tenths in 1 whole, so there would be 13×10 one-tenths in 13. Therefore the answer is 130.

4. (75) The average would be found by adding 100, 90, 85, 78, 0, 80, and 92, and dividing by 7. Some students may mistakenly think that 0 doesn’t count and divide by 6 instead.

5. (86) You would follow the same steps as in number 4, but replace 0 with 77. Students should realize how important it is not to have a 0 included when their grades are averaged.

6. (a. $2a - 3$; b. $10h + 3$; c. $3 + \frac{1}{2}d$; d. $5x + 5.8$) Note that alternatives to the answers given should be accepted. For example, other common ways of writing (a) include $a + a - 3$ and $2 \times a - 3$. Students need much practice in expressing these types of verbal situations mathematically, using variables.

7. ((a.) $\frac{26}{8}$ or $3\frac{2}{8}$ or $3\frac{1}{4}$ (b) 3) Drawing a picture will help students count the 26 total blocks, and see that there are twenty-six $\frac{1}{8}$ ’s in the total length. Therefore, their only task is to express this amount as a fraction, mixed number, or possibly a decimal.

8. (225) Three $1\frac{1}{4}$ ’s make $3\frac{3}{4}$ total hours. That is $3 \times 60 + 45$ minutes.

9. (B) The chance of drawing a black marble is 3:5 for A, and 2:3 for B. Doubling, tripling, etc., these ratios until you find a “common unit” for the comparison is a good strategy. 3:5 is the same as 6:10, 9:15, etc. 2:3 is the same as 4:6, 6:9, 8:12, and 10:15. Notice we finally have a common unit -- 15 -- for comparison purposes. Since 10:15 is a higher ratio than 9:15, box B gives the better chance.

SUPERSTARS III
Saturn, XVII

Name: _____
(This shows my own thinking.)

- ★★ 1. Learn to use mental math to do these problems with a 1-digit divisor. When you turn in your paper, you will have a chance to do one like these and write your answer below.

$2\overline{)10678}$ $3\overline{)2145}$ $5\overline{)2540}$ $6\overline{)12018}$ $4\overline{)2128}$ $7\overline{)4949}$

Answer later: _____

- ★★ 2. Marcus drives a delivery truck and spent \$89 on gas his first week. If he drives for 8 months using about this much gas each week, how much would he spend on gas? Use estimation to find the answer to the nearest \$1000.

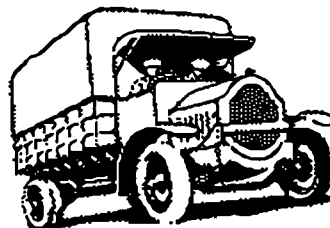

Answer: _____

- ★ 3. These numbers are examples of palindromic numbers.

232 11 505 325523

Find four other numbers that are palindromic.

Answer: _____, _____, _____, _____

- ★ 4. What do the numbers above have in common with this sentence?

A man, a plan, a canal, Panama!

Answer: _____

- ★★ 5. Someone your age has an average pulse rate of 70 beats per minute and is ten years old. This means that, for an average person your age, the heart has already beat about how many times? Round your answer to the nearest hundred million.

Answer: _____

★★★ 6. Marcus noticed that at 3:00 o'clock, the hour and minute hands on his watch made a *right angle*. He was curious about the angles formed inside the right angle, when the second hand was pointing at the 2:00 o'clock marker. What two angles would this make inside the right angle?

Answer: _____ degrees and _____ degrees

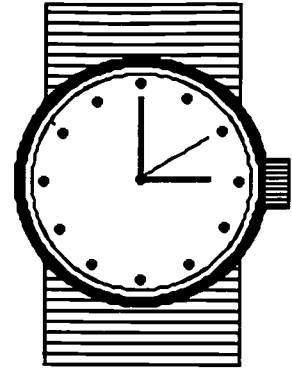

★★★ 7. On a 12-digit calculator, $3 \div 7$ will give the answer shown. The calculator can't show the division process any farther. But the digits continue to repeat in this manner.

- a. What will the 13th digit be? _____
- b. What will the 14th digit be? _____
- c. What will the 100th digit be? _____

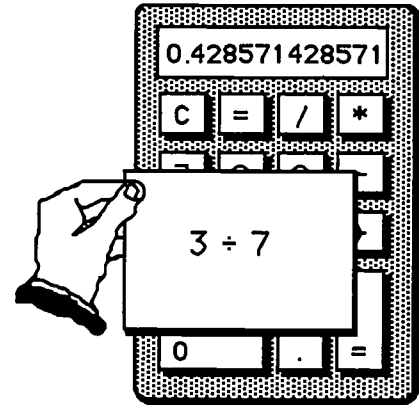

★★ 8. When Bonita makes a fruit salad, she always uses cherries and peaches. This time she has 11 pieces of fruit. If she uses at least one of each and more cherries than peaches, show all possible combinations by filling in the chart below.

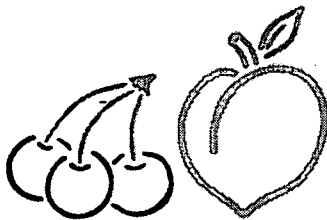

cherries					
peaches					

★★★ 9. A bracelet costs \$33.50. The earrings cost \$12.65. How much does it cost to purchase the set if you get 10% off for buying both, and the sales tax is 6%?

Answer: \$ _____

Commentary

Saturn, XVII

1. (604) Have this problem --

4	2416
---	------

 -- prepared on 3x5 cards to give to students when they are about to hand in their paper. They may write only the answer on their worksheets, doing the division mentally.
2. (\$3000) \$89 is about \$90, and $\$90 \times 4$ weeks per month $\times 8$ months = \$2880, or \$3000 to the nearest thousand.
3. (131, 767, 505, 8998 are examples of correct answers) Check to see whether the numbers written are the same when the numbers are reversed, left to right.
4. (This sentence is a palindrome made from letters instead of numbers.) Some students who might not have seen the visual pattern in problem 3 will see the pattern here, and then can return to problem 3. Single words can be palindromes -- MOM, POP, BOB-- for example.
5. (400,000,000) Students can multiply $70 \times 60 \times 24 \times 365$ on a calculator, but the display will then be filled on an 8-digit model by 36,792,000. Multiplying this by 10 can be done mentally, giving 367,920,000. Rounded, the answer is 400,000,000.
6. (60 and 30) Students will need to realize that a right angle has 90° , and that the 2 equally spaced marks for 1:00 and 2:00 divide the 90° angle into three equal parts. The second hand pointing at 2:00 divides the 90° angle into $\frac{2}{3}$ of 90° and $\frac{1}{3}$ of 90° .
7. (4, 2, 5) The 13th digit will be the next one in line, and the pattern is ready to repeat again. Therefore the 13th and 14th digits will be 4 and 2. To find the 100th digit, notice the pattern repeats every 6 digits. $6 \times 16 = 96$, so the pattern will be ready to start repeating again with the 97th digit. The 97th digit is 4, the 98th is 2, the 99th is 8, and the 100th is 5.
8. (One arrangement of the chart is shown below.) The entries could be rearranged, but the sum of the numbers in each column must be 11, and the larger number must be on top.

cherries	10	9	8	7	6
peaches	1	2	3	4	5

9. (\$44.03) Students may go through steps of finding the per cent and sales tax as separate processes, adding or subtracting them to the base figure they're working from. Or they might take a shortcut of taking 90% of the total cost of \$46.15, and then multiplying by 1.06. On a calculator, this can become an easily done 2-step problem.

SUPERSTARS III
Saturn, XVIII

Name: _____
(This shows my own thinking.)

- ★★ 1. In the third grade, some students have dogs as pets, some have fish, and some have both. Use the Venn diagram to answer the questions.

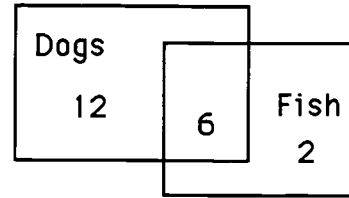

- a. How many students have fish? _____
 b. How many students have fish and dogs? _____

- ★★ 2. You ran 1.5 miles before you decided you were running in the wrong direction. You turned around and ran back to where you started. Then you ran 2.75 miles in the other direction. How many miles did you run in all?

Answer: _____ miles

- ★★ 3. It takes about 735 turns of an average 5th grader's bicycle tire to go 1 mile. To the nearest thousand, how many times would your tire turn around if you biked beside the runners in a 26-mile marathon?

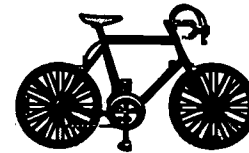

Answer: _____ turns

- ★★★ 4. The graph below shows what a bicycle's speed might look like for a 26-mile marathon. The race started at 8:00 AM. Answer these questions about the graph.

- a. How long did the race last? _____ hours and _____ minutes
 b. At what time did the rider stop to get water? _____ A.M.
 c. What is happening to the rider's speed between 10:00 and 10:30? _____

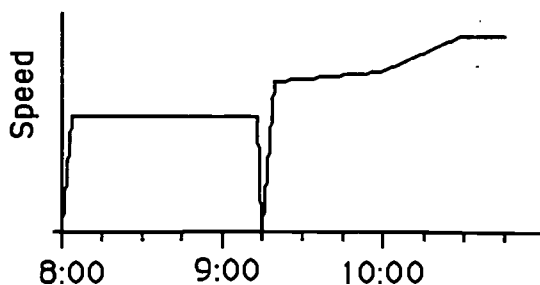

- ★★★ 5. Mrs. Jones' science class had to record the total amount of rain that fell the last week of school. It rained 1.66 inches on Monday, 0.23 inches on Tuesday, 0.76 inches on Wednesday, 1.2 inches on Thursday, and the skies were clear on Friday. What was the average amount of rain that fell from Monday to Friday? Round your answer to the nearest hundredth.

Answer: _____ inches

- ★ 6. Take a sheet of paper and fold it in half, fold it again, fold it again, fold it again, and then fold it again in half. If you opened the paper, how many sections would you have?

Answer: _____ sections

- ★★ 7. During the summer, Julio promised his Dad he would read 3 novels every 2 weeks. How many novels would that be during the 3-months of summer?



Answer: _____

- ★★ 8. Write two numbers in the spaces below to show what the two "tick marks" stand for on the number line, between 3 and 4.

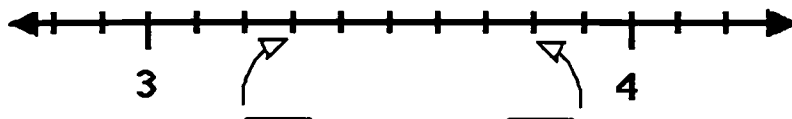

- ★★ 9. Mary had 10 yards 2 feet of ribbon. She needed to cut pieces for her 3 friends. If each friend got the same amount of ribbon, how much did each get? In your answer, the inches cannot be as many as or more than 12.

Answer: _____ yards, _____ foot, _____ inches

(Note: in your answer, inches must be converted to feet, if possible, and feet to yards.)

Commentary

Saturn, XVIII

1. (a. 8; b. 6) There is only a 2 in the section for fish, meaning that there are 2 children with only fish for pets. There are 6 kids in the overlap area of dogs and fish, which mean that 6 have both dogs and fish. So there are 8 altogether who have fish.
2. (5.75) The distance you ran before turning around plus the distance back to the starting point was 3 miles. Then 2.75 is added to the first 3 miles.
3. (19,000) Multiplying 735 times 26 gives 19,110. Since this is only an approximation situation, rounding to the nearest thousand turns makes sense. 19,110 is closer to 19,000 than to 20,000, so it is rounded to 19,000.
4. (2 hours, 45 minutes; 9:15; increasing) The problem involves looking at a graph over time, and making judgements about the real-world situation from the shape of the curve. The curve stops at the 3rd "tick mark" after 10:00, and each tick mark stands for 15 minutes. So the race must end at 10:45, and lasted 2 hours 45 minutes. The rider stopped when the speed drops to zero, which is at 9:15. The line is steadily on the rise between 10:00 and 10:30, so his speed is increasing.
5. (0.77) There are 3 typical ways that students might make mistakes here. First, they might not "line up the decimal points" when adding the numbers -- if using a calculator, this won't be a problem. Second, they might divide by 4 instead of dividing by 5, forgetting to count Friday as the fifth day, with 0.00 inches. And last, they might try to "round off the answer", although it's unnecessary since it's already only to the hundredths place. The computation $(1.66 + 0.23 + 0.76 + 1.2) \div 5 = 0.77$ shows how to successfully solve the problem.
6. (32) Students can actually fold a sheet of paper to find the answer, if they don't have good visual skills.
7. (18) This can be thought of as a ratio problem. Three books every two weeks means 6 books every 4 weeks (or 1 month). Six books each month means 18 books for three months (or the summer).
8. (3.3 and 3.8) The line is divided into 10 parts. The arrows point to the 3rd and 8th *tick marks*. The answers can be written either as decimals (3.3 and 3.8) or mixed numbers ($3\frac{3}{10}$ and $3\frac{8}{10}$).
9. (3 yards, 1 foot, 8 inches) There are several ways to approach this problem. One way is to convert 10 yards, 2 feet into 384 inches, divide that by 3 to get 128 inches for each girl, then convert 128 inches into feet and yards by dividing first by 12, then by 3. Another, more challenging way is to solve the long-division problem below:

$$3 \overline{) 10 \text{ yards } 2 \text{ feet } 0 \text{ inches}}$$

The challenge above is in renaming the number obtained after the subtraction step of the process, and joining it with the next unit.

SUPERSTARS III
Saturn, XIX

NAME: _____
(This shows my own thinking.)

- ★★★★ 1. How many different squares are in each figure? Count the smallest squares first, then move up to the next size, and so on. Record the total number of squares below each figure and look for a pattern.

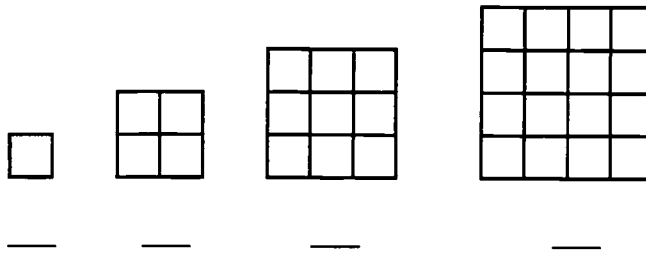

- ★★ 2. Herman thought he noticed a pattern to the problem above. The total number of squares is always the sum of the square numbers up to the figure number. For the 3rd figure, for example, the total number of squares is 14, which is also $1^2 + 2^2 + 3^2$.

- a. Does this pattern work for the next figure, the 5th? _____
b. What is the total number of squares in the 10th figure? _____

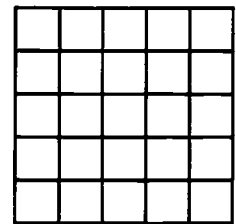

- ★ 3. Aki bought a new calculator for school. What is the cost of the calculator including sales tax of 6%? Round your answer up to the next cent, as a store would.

Answer: _____

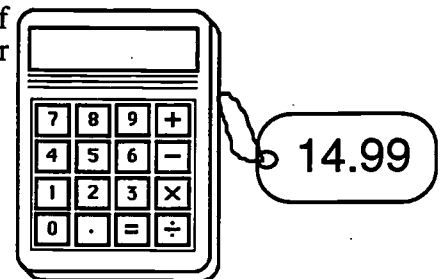

- ★★★★ 4. Complete the chart below by putting a check in each column by which the number is divisible. You may have more than one number checked in each row or column. The first one is started for you.

	2	3	4	5
a. 6,945		✓		
b. 1,236,240				
c. 54,208				

- ★ 5. Draw the other half of the shape to make it symmetrical. If it helps you, fold the page along the vertical *line of symmetry*, hold it up to the light, and trace.



- ★★★★ 6. Complete the crossnumber puzzle.

DOWN

1. $(28 \times 126) - 21$
3. $? + 716 = 4220$
5. $6521 + 9963 - 12321 + 42896 + 30286$
6. $(364 \times 265) - 41282$
7. Average of 4728, 9630, 7465, and 725
11. $\sqrt{100489}$

ACROSS

2. $6000 - ? = 5486$
4. $280644 \div (300 + 64)$
6. $35^3 + 100^2 + 170$
8. $3 \times 10^3 + 3 \times 10^2 + 7 \times 10^1 + 6 \times 10^0$
9. Age the second year as a teenager
10. $\{[(238 \div 14) + 20] \times 1560\} + 18$

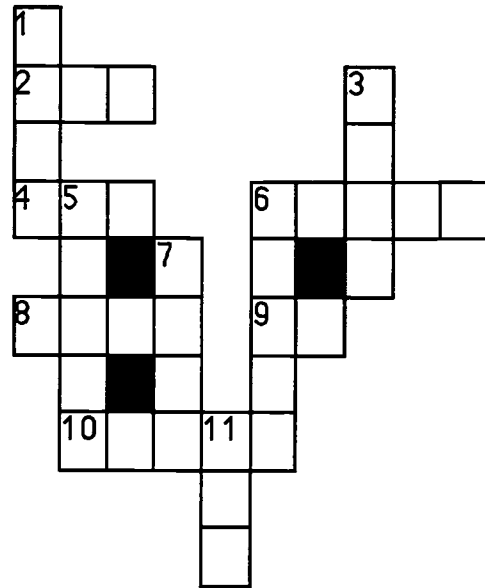

- ★★★★ 7. This weird kid from another planet multiplies differently from us! She gets the right answer, but her work doesn't look like anyone else's in class. Here's what she does:



Given:	Multiply 2×38 :	Multiply 40×38 :	Add:
42	42	42	42
$\times 38$	$\times 38$	$\times 38$	$\times 38$
	76	76	76
		1520	+1520
			1596

Do these problems this way:

14	31	27	62
$\times 26$	$\times 53$	$\times 42$	$\times 135$

Commentary

Saturn, XIX

1. (1, 5, 14, 30) Students can find these answers by actually counting squares. They are encouraged to do so in an organized fashion, starting with the smallest individual squares, then moving up to count larger squares.

2. (yes, 385) The pattern does work for the next figure in line -- students can verify this by actually counting individual squares again. Assuming the pattern holds, the 10th figure would have $1^2 + 2^2 + 3^2 + 4^2 + 5^2 + 6^2 + 7^2 + 8^2 + 9^2 + 10^2 = 385$ squares.

3. (\$15.89) Multiply the price of the calculator times 6% and add that amount to the cost of the calculator. Or, you could do this all in one step on a calculator, by multiplying $\$14.99 \times 1.06$, rounding up the answer.

4. (See the chart to the right.)

	2	3	4	5
a.	6,945	✓		✓
b.	1,236,240	✓	✓	✓
c.	54,208	✓		

5. (See drawing to the right.)

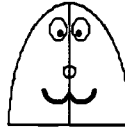

6. (The completed puzzle is shown to the right.)

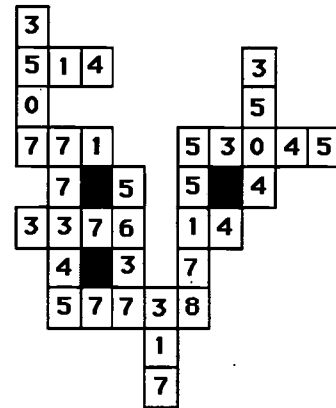

7. (The completed problems are shown below.) Look carefully at the partial products, as well as the answer. The partial products are where the differences show up.

$$\begin{array}{r} 14 \\ \times 26 \\ \hline 104 \\ 260 \\ \hline 364 \end{array}$$

$$\begin{array}{r} 31 \\ \times 53 \\ \hline 53 \\ 1590 \\ \hline 1643 \end{array}$$

$$\begin{array}{r} 27 \\ \times 42 \\ \hline 294 \\ 840 \\ \hline 1134 \end{array}$$

$$\begin{array}{r} 62 \\ \times 135 \\ \hline 270 \\ 8100 \\ \hline 8370 \end{array}$$

SUPERTARS III

Saturn, XX

Name: _____

(This shows my own thinking.)

- ★★★ 1. A *perfect number* is one which is the sum of its proper divisors. Six is the smallest *perfect number*: $6 = 3 + 2 + 1$. The next smaller *perfect number* is between 20 and 30. Find it!

Answer : _____

- ★★ 2. Find the missing digits in this problem.

$$\begin{array}{r} 317 \text{ r } 25 \\ 2 \overline{) \quad \quad 584} \\ \underline{\quad \quad 1} \\ \quad \quad 48 \\ \quad \quad \underline{2} \\ \quad \quad \quad 214 \\ \quad \quad \quad \underline{18} \\ \quad \quad \quad \quad 25 \end{array}$$

- ★★★ 3. Carlos wants to learn to play golf, but he wants some information before he begins. He learned that the local 18 hole golf course is 6,550 yards long. It is a "par 72" course, which means that a good golfer should play the entire course with a total of 72 strokes.



- a. What is the average distance (rounded off) for each hole? _____
- b. What is the average number of strokes required per hole? _____
- c. For his first round, Carlos scored 108. How many strokes over par was he? _____

- ★ 4. A can of soda contains approximately (circle the best answer)

350 l

350 ml

350 cl

- ★★★ 5. Shomika was helping her family pick oranges in their grove. She took some oranges home to share with three friends. She gave 3 more than half to Jennifer. Angela got half of the remainder and 3 more. She gave Josie half of the remainder plus 3. When she got home, she had only 10 oranges left. How many did she have when she left the grove?

Answer : _____

- ★ 6. Solve this problem:

$$3 \times (8 + 6) - 8 = Y$$

Answer: $Y =$ _____

- ★★ 7. Joann's class is planning a math celebration after half the class scores at least 100 stars in Sunshine Math Superstars. She surveyed the class to find out how many like chocolate cupcakes and how many like vanilla cupcakes. She organized the information to give to her mom, who is going to do the baking. Her results are shown to the right:

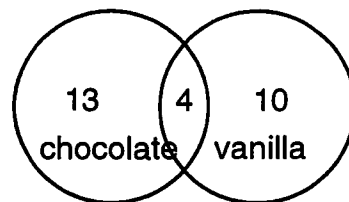

- a. How many students were surveyed? _____
- b. What percent (rounded to the nearest whole percent) like chocolate cupcakes? _____ %
- ★ 8. Fold your paper to show a line that is *perpendicular* to the one below .

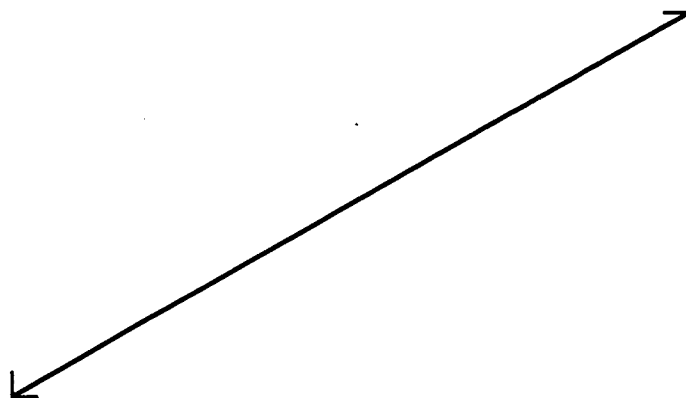

- ★ 9. Five fifth graders decided to clean up their community on Earth Day. Armed with dozens of garbage bags, they began work at 8:30 AM. They took two 15 minute breaks and a half-hour lunch break. When they had worked 5 hours, they knew it was time to go home. What time did they quit working?

Answer: _____

- ★★ 10. 3 weeks, 4 days, 13 hours, 21 minutes
- 1 week, 5 days, 18 hours, 30 minutes
___ week, ___ days, ___ hours, ___ minutes

Commentary

Saturn, XX

1. (28) Encourage students to experiment with several other numbers less than 10, to check and see whether they are *perfect numbers*. This will give them a feel for what they are seeking. The proper factors of 28 are 1, 2, 4, 7, and 14, and their sum is 28.

2. (See problem to the right.)

Working backwards will help the students find the missing digits quickly.

$$\begin{array}{r} 317 \text{ r } 25 \\ 27 \overline{)8584} \\ \underline{81} \\ 48 \\ \underline{27} \\ 214 \\ \underline{189} \\ 25 \end{array}$$

3. (a. 364 yards, b. 4 strokes c. 36 strokes) Students unfamiliar with golf might profit from looking at a golf score card from a local course. Usually those cards have a picture of the course, with the yardage for each hole and the par for the hole. Looking at such a card and discussing the game in general -- how long a good drive might be, etc. -- will help them understand the terms. The average distance per hole is found by computing $6550 \div 18$; the average number of strokes per hole is given by $72 \div 18$; Carlos was $108 - 72$ or 36 strokes over par.

4. (350 ml) Students can simply look at a can of soda. They might also be encouraged to visualize a can of soda as about $\frac{1}{3}$ liter.

5. (122 oranges) *Working backwards* is one strategy. Shomika had 26 oranges so that she could give Josie $\frac{1}{2}$ of that, plus 3, leaving 10. Shomika had 58 oranges so she could give Angela half, plus 3, leaving 26. Shomika started with 122 oranges so she could give half, plus 3, to Jennifer, leaving 58. A different way to begin the problem is to *guess-check-revise*. You might begin by guessing 100, checking to see if Shomika winds up with 10 in the end. If not, revise the guess either higher or lower, depending on the result.

6. (34) Students should perform the operation inside the parentheses first; next multiply; and last subtract, following the rules for the *order of operations*.

7. (a. 27 b. 63%) There are $13 + 4 + 10$ or 27 students. The diagram shows that 17 students like chocolate cupcakes. 17 out of 27 is the same as $\frac{17}{27}$ or $17 \div 27$, which is 63% when rounded to the nearest whole percent.

8. (The fold line should show a line that forms 90° angles with the one given). Students can find such a fold line by holding the paper up to a light source, and folding it so that the lines seen through the paper fall on top of each other. This problem can be expanded into finding the *perpendicular bisector* of a line segment. In this case, the endpoints of the segment would also have to line up in order to be sure that the fold cuts the segment exactly in half.

9. (2:30) The boys worked five hours and had a total of another hour of breaks. Therefore they were at the clean-up site for 6 hours, having started at 8:30.

10. (1 week, 5 days, 18 hours, 51 minutes) This problem asks students to rename given units of time before subtracting. The value is that students will see that regrouping for subtraction requires them to think about the units involved.

SUPERSTARS III

Saturn, XXI

Name: _____

(This shows my own thinking.)

- ★★★ 1. Use the numbers 1, 2, and 4 to make the numbers from 1 to 9. Use each of the three numbers only once and use only the four arithmetic operations. The first one is done for you.

Example: $4 - 2 - 1 = 1$ _____ = 4 _____ = 7
 _____ = 2 _____ = 5 _____ = 8
 _____ = 3 _____ = 6 _____ = 9

- ★★ 2. Race car driver Brad Heath was interviewed about his car's fuel use. He told the reporter that his car averages 3 miles per gallon. If his car holds 22 gallons of fuel, how far can he race on a tank of fuel?

Answer: _____ mi.

Racing fuel costs \$3.40 per gallon. How much does the tank of fuel cost?

Answer : _____

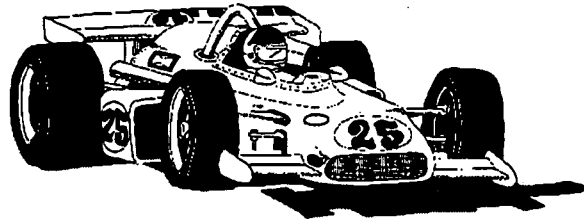

- ★★ 3. Jan's class is entering a contest. The winner will receive tickets for the student and parents to visit the city of their choice. Jan lives in Buffalo, NY, so she would travel from New York. The distance in miles from New York to four European cities is given to the right.

Berlin	3,965
London	3,458
Paris	3,624
Moscow	4,665

- a. What is the difference between the nearest and furthest European cities?

Answer: _____ miles

- b. Jan's mother flies to Paris and back to New York once every month. How many miles does she fly each year? (Round to nearest 1000 miles.)

Answer: _____ miles

- ★ 4. One acre of land will grow 11,000 heads of lettuce. If a farmer has 1,500 acres of land and he plants lettuce on half of his farm, how many heads of lettuce can he expect to grow?

Answer: _____ heads

- ★★★ 5. Harry and William bought a pizza for \$8.99. Harry ate five pieces and William ate 3. Based on how much each one ate, how much should each pay?

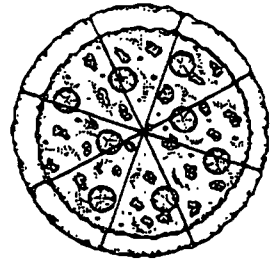

Answer: Harry should pay _____ ; William should pay _____.

- ★★ 6. Use the clues to locate these points on Second Street.

W _____ E
Second Street

The antique store is at the mid point of the street.
 The museum is 2 cm west of the restaurant.
 The restaurant is 4 cm east of the antique store.
 The gift store is 8 cm west of the restaurant.
 The theater is halfway between the antique store and the museum.

- ★★★ 7. Draw arrows to show how to rearrange exactly 2 of these toothpicks so that you will have 4 squares instead of 5. Each square is to be the same size as the ones shown.

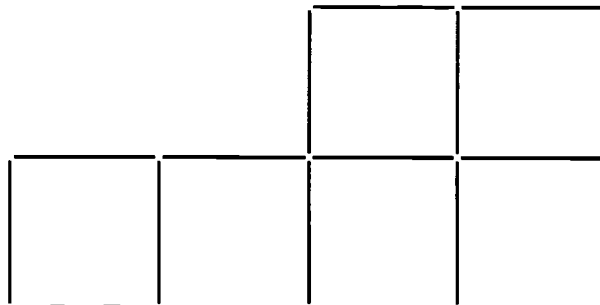

- ★★★ 8. How much change will I get back from a \$5 bill if I buy three pairs of socks selling as advertised? Sales tax is 6%.

SALE!!
Socks ...2 pairs for \$1.98

Answer: _____

- ★ 9. $\frac{3}{4} + \frac{1}{2} + \frac{5}{6} - \frac{1}{3} + \frac{7}{12} = \square$ (Be careful -- $\frac{1}{3}$ is being subtracted!)

Commentary

Saturn, XXI

1. Mental math should help students solve this problem. Below is one possible set of answers. Accept other correct solutions.

$$4 - 2 \times 1 = 2$$

$$4 - 2 + 1 = 3$$

$$4 + (2 - 1) = 4$$

$$4 + 2 - 1 = 5$$

$$4 + 2 + 1 = 6$$

$$2 + 1 + 4 = 7$$

$$4 \times 2 + 1 = 8$$

$$4 \times 2 + 1 = 9$$

2. (66 mi., \$74.80) If Brad can go 3 miles on each gallon, he can go 3×22 miles on 22 gallons. If each gallon costs \$3.40, then 22 gallons cost $\$3.40 \times 22$.

3. (a. 1,207 miles, b. 87,000 miles) The nearest city is London, at 3,458 miles. The furthest is Moscow at 4665 miles. The difference is $4,665 - 3,458$, or 1,207 miles. Round trip to Paris is $3,624 \times 2$; that distance 12 times is 86,976 miles, or about 87,000 miles.

4. (about 8,250,000 heads of lettuce) Multiply $11,000 \times 1,500 \times 1/2$. Drawing a picture of the acreage might benefit some students.

5. (Harry: \$5.62 and William: \$3.37) There are a number of ways to approach this problem. One is to divide \$8.99 by 8, getting \$1.12375 per slice. Then multiplying by the number of slices will produce the answers. (If you round off \$1.12375 to \$1.12 per slice, the answer will be \$5.60, rather than \$5.62.) Another way is to realize that Harry ate $5/8$ and William $3/8$, convert each of those into a decimal or a percent, and each by \$8.99 to get the answers.

6. (See picture below.) Students will use clues and measuring skills. Measure to be sure that the distances are correct. Answer below gives correct relational locations, but distances are approximations.

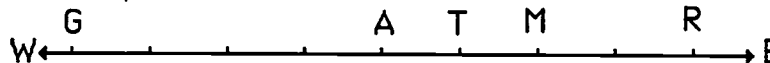

7. (See picture below.)

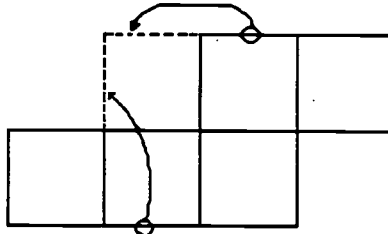

8. (\$1.85) Two pair for \$1.98 means another pair can be purchased for half that, or \$0.99. The total is then \$2.97. Adding tax can be done by multiplying by 1.06 on a calculator, giving a total cost of \$3.15. The change can be "counted up" from \$3.15 to \$5, getting \$1.85.

9. ($\frac{28}{12}$ or $2\frac{4}{12}$ or $2\frac{1}{3}$) Students can use the common denominator 12, convert each fraction to that denominator, and add or subtract the numerators. An interesting real-life problem for these numbers would be to use several 12-paks of colas to show the fractions.

SUPERSTARS III

Saturn, XXII

Name: _____
(This shows my own thinking.)

- ★ 1. Let p stand for the weight of a whole pie. The equation $\frac{3}{4}p = 30$ shows the situation on the scale. How much did the whole pie weigh? Use your number sense.

Answer: $p =$ _____

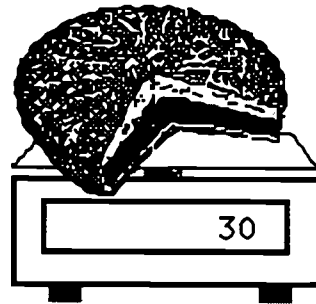

- ★★★ 2. A square inch is shown to the right.

Circle the best estimate below of the area, in square inches, of this sheet of paper.

50 in² 90 in²

125 in² 150 in²

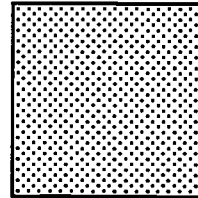

- ★★ 3. Make a *line graph* of the world population figures shown below. Use the graph paper to the right. Then answer this question: *If the population continues to increase as the graph shows, what will it be in 2000 AD?* _____

World Population

date:	millions:
1 AD	300
1000	350
1600	450
1700	700
1800	1,000
1900	1,700

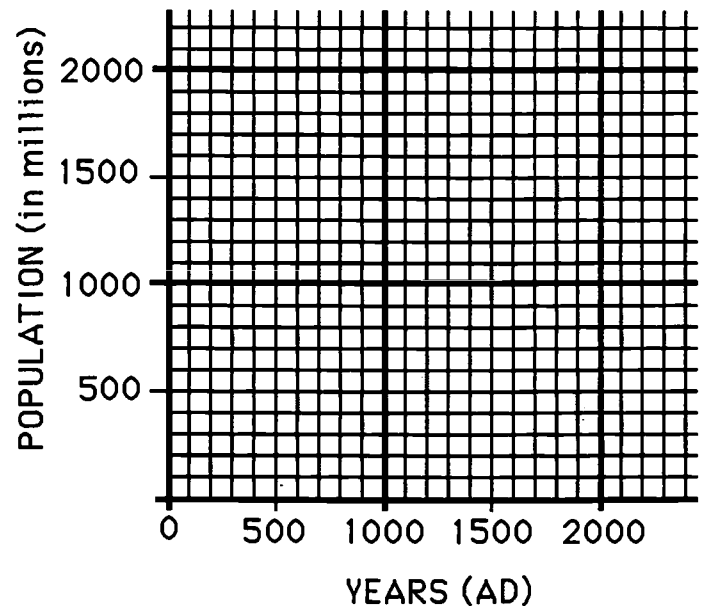

- ★★★★ 4. A machine changes the first number into the second number. Study the pattern and predict the rule the machine uses to change one number into another.

1	⇒	7
2	⇒	10
3	⇒	13
⋮	⋮	⋮
⋮	⋮	⋮
10	⇒	34
⋮	⋮	⋮
⋮	⋮	⋮
100	⇒	304

- a. What will the machine produce for 40? _____
- b. What will the machine produce for 50? _____
- c. The machine produced 904. What number did it start with? _____
- d. Describe the way the machine changes a number n :

- ★★ 5. There are about 3,400 species of frogs and toads, and scientists tell us that they represent 90% of the amphibian species in the world. Using this information, what is the total number of amphibian species scientists believe are in the world? (Round your answer to the nearest 100.)

Answer : _____

- ★ 6. Suzanne ordered a sandwich and a soda. The total, plus tax, came to \$4.76. Suzanne gave the clerk \$5.01. What is a good reason for Suzanne to give the clerk the extra penny?

Answer: _____

- ★★ 7. The missing digits for this problem are 0, 2, 4, 6, and 8. Put them in their correct boxes.

$$\square \square \square \square \times \square = 32,208$$

- ★★★★ 8. Draw this pattern on scratch paper.

a. How many dots in the next 3 figures?
_____, _____, and _____

b. How many dots for the 50th figure?

c. How many dots for the 1000th figure?

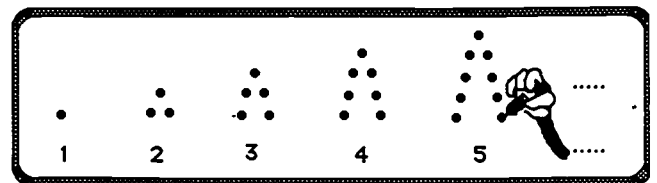

Commentary

Saturn, XXII

1. (40) Rather than trying to solve this equation through computation, students might think of solving it by asking "what number could p be so that so $3/4$ of its weight is 30?" Intuition will lead most students to think of trying 40 for p , and asking "Is $3/4$ of 40 equal to 30?" Proportional reasoning is an excellent method: 3 is to 4 as 30 is to what?

2. (90 in²) Students might cut out a sheet of paper this size and line it up repeatedly to approximate the area. Some students might think of marking off inches along the length and width and computing with those numbers. A few might know that a sheet of paper like this is 8.5 by 11 inches, giving an actual area of 93.5 in².

3. (Line graph shown to the right. Accept any answer over 2 billion for population in 2000 AD) This problem might draw students into a discussion about the world's population and what will happen if it continues to grow unchecked.

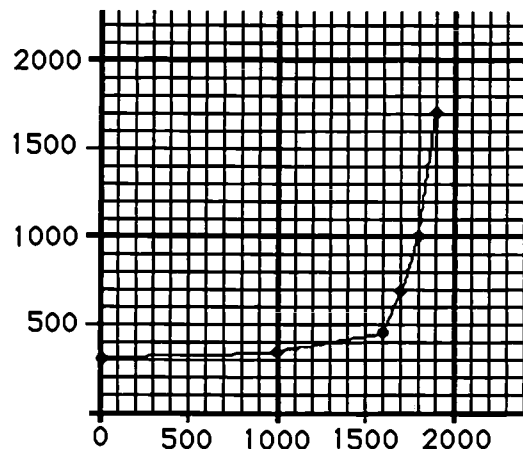

4. (124, 154, 300, $3 \times n + 4$) It's difficult to tell what the machine is doing by looking at what happens to the first few numbers. A hint as to what the machine is doing (multiplying by 3, then adding 4) can be gained by looking at what happens to 10 and 100.

5. (3,800) If 3,400 is 90% of the number sought, then 3,400 can be divided by 0.90 and rounded to the nearest 100. Students may discover other ways to find this number, such as guessing what number from {3500; 3600; 3700; 3800; 3900; ...} might work, and checking to see whether 90% of each gives 3400. Allow them to feel comfortable with their methods.

6. (... so that she would get back only one coin, a quarter, in change) This is a common practice among people who have good number sense. It should be encouraged for students since it provides continuous practice with mental mathematics in a real-world setting.

7. (4026×8) One way to approach such a problem is to begin by seeking digits that would produce 32 in the thousands place of the answer, 4 and 8. From that point, *guessing and checking* will lead to the answer.

8. (a. 11, 13, and 15; b. 99; c. 1999) It's easy for students to go from one figure to the next, in progression. They will notice that these are the odd numbers in sequence. To find the number of dots in the 50th figure, some will actually count the odd numbers that far, while others will begin to approach the problem analytically -- the 50th odd number is one less than twice the number. This type of generalization is almost a necessity for obtaining the number of dots in the 1000th figure. An extension is to ask students: "Given the figure number n , what algebraic expression tells the number of dots needed? "

SUPERSTARS III
Saturn, XXIII

Name: _____
(This shows my own thinking.)

- ★ 1. Laquinda and her 2 friends wanted a pizza after school. They did not have enough money, but Laquinda's mother promised to give them what they needed once they put their money together. Laquinda had \$2.45; one friend had \$3.72; the other friend had \$0.87. How much did Laquinda's mother have to pay for the pizza if the total cost was \$9.95?



Answer: _____

- ★★★ 2. Use number sense to solve each equation. Find out what a single object weighs.

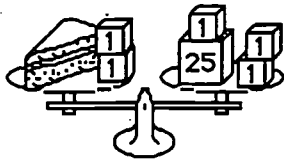

A piece of cake weighs:
 $x + 2 = 28$
 $x = \underline{\quad}$

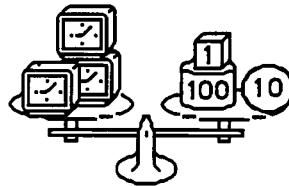

A clock weighs:
 $3y = 111$
 $y = \underline{\quad}$

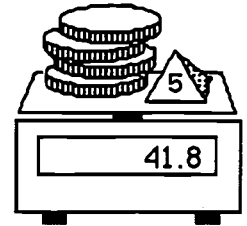

A coin weighs:
 $4z + 5 = 41.8$
 $z = \underline{\quad}$

- ★ 3. Circle the best estimate below for the sum of $13\frac{38}{39}$, $7\frac{16}{17}$, $4\frac{1}{9}$, and $4\frac{1}{42}$.
- a. 28 b. 30 c. $28\frac{23}{46}$ d. 20

- ★★ 4. Raoul's "school days" picture was accidentally made with a grid behind it. Estimate the area of the part of his body that is showing. Circle the best estimate below.



- a. 40 sq. units c. 60 sq. units
 b. 50 sq. units d. 80 sq. units

- ★★ 5. 100 adult customers were surveyed to determine which type of shop in the mall -- clothing store or shoe store -- they liked better. Forty-seven liked clothing stores better. Twenty-three preferred shoe stores. Fourteen liked both equally well. The rest did not like either type of store. Write the 4 numbers in appropriate sections of the Venn diagram below to show these statistics.

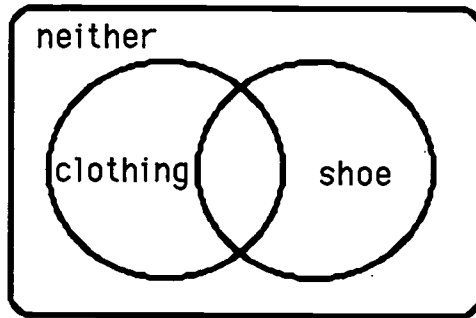

★

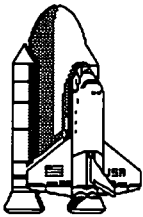

6. Space shuttle Atlantis has traveled a distance of 2,000 miles one and a half minutes into its flight. If it continues to travel at this speed, how far will it have traveled in six minutes?

Answer: _____ miles

★★

7. Joseph has a nickel and a penny in one pocket and two nickels and two pennies in the other pocket. Which pocket gives him the better chance of pulling out a penny?

Answer : _____

★

8. Betty Jean has 18 coins. One sixth of the coins are quarters, one third of the coins are dimes, and one half of the coins are nickels. What is the value of Betty Jean's coins?

Answer: \$ _____

★★★

9. Write the area of each geoboard figure on the line below the figure.

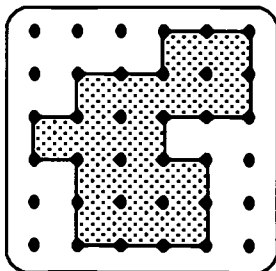

area = _____

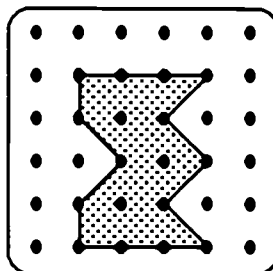

area = _____

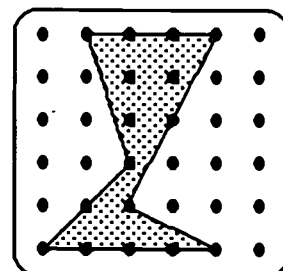

area = _____

Commentary

Saturn, XXIII

1. (**\$2.91**) The three girls' combined money is \$7.04. Subtract this from the \$9.95.
2. ($x = 26$; $y = 37$; $z = 9.2$) These problems present solving simple equations in a way in which students can follow the logic of the steps typically involved. In the first, removing 2 from each side of the scale leaves the scale still balanced, and the cake weighing 26. This is called *isolating the variable*. In the second picture, intuitively you divide both sides of the scale by 3 to find what one clock weighs. In the last picture, if you remove 5 from the scale, 4 coins remain and weigh $41.8 - 5 = 36.8$. Then dividing by 4 means that each coin would weigh 9.2
3. (b. 30) $13\frac{38}{39}$ and $7\frac{16}{17}$ both have fractions that are very close to 1, so these mixed numbers can be rounded to 14 and 8. $4\frac{1}{9}$ and $4\frac{1}{42}$ have fractions close to zero, and so each can be rounded down to 4. The estimated sum is then $14 + 8 + 4 + 4$ or 30. This is a good measure of *number sense*.
4. (a. 40 sq. units) In this problem, students can estimate the area of a figure visually. There are a number of ways to do this. One is to count whole and then partial squares, putting together partial ones to get whole ones. Another way is to count all the whole ones, and then just count the partial squares and divide by two, which assumes that the partial squares will average about $\frac{1}{2}$ sq unit each. There are many other ways to get the estimate.

5. (See the diagram at the right.) The difficult part for some students will be to remember to put in the diagram the number of people who liked neither store.

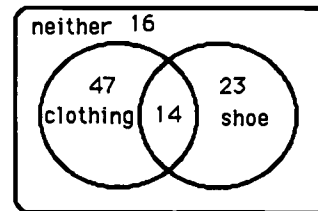

6. (8,000 mi.) This can be thought of in several ways. One approach is to reason as a ratio -- 2,000 miles in 1.5 minutes is 4,000 in 3 minutes, 6,000 in 4.5 minutes, and 8,000 in 6 minutes. Another approach, if a calculator is handy, is to find out, by dividing 2000 by 1.5, that the shuttle is travelling 1333.33 miles per minute. In six minutes this would be 8,000 miles.
7. (Neither) The probability of pulling out a penny is 1 out of 2, in both cases.
8. (\$1.80) Students can find $\frac{1}{6}$ of 18 coins and know that there are 3 quarters, $\frac{1}{3}$ of 18 is 6 dimes, and $\frac{1}{2}$ of 18 is 9 nickels. These coins add to \$1.80.

9. (15, 9, $8\frac{1}{2}$) These 3 figures get progressively more difficult to find the area by counting unit squares. The first and second, when grid lines are drawn in, can be found by counting whole squares and half squares. The third figure can be partitioned so that rectangles are drawn around certain triangular parts. Since the area of each triangle is half of the surrounding rectangle, the partial areas can be found this way and summed for the total. One way to do this is shown.

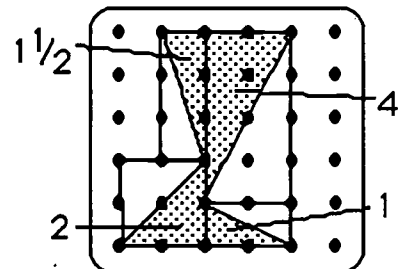

SUPERSTARS III

Saturn, XXIV

Name: _____

(This shows my own thinking.)

- ★★ 1. There were 22,600 tickets sold for the Magic's first game. 4,800 fewer people showed up for the second game. If tickets were \$25 each, how much money was brought in by the two games?

Answer: _____

- ★★★★ 2. Marshall makes \$20,000 a year. His budget is shown at the right.

a. What is the sum of the percents on the graph? _____

b. Does Marshall spend more money on education or on food? _____

c. How much money does he spend on his car? \$_____

d. What is the total amount of money Marshall spends on clothing, entertainment, and savings? \$_____

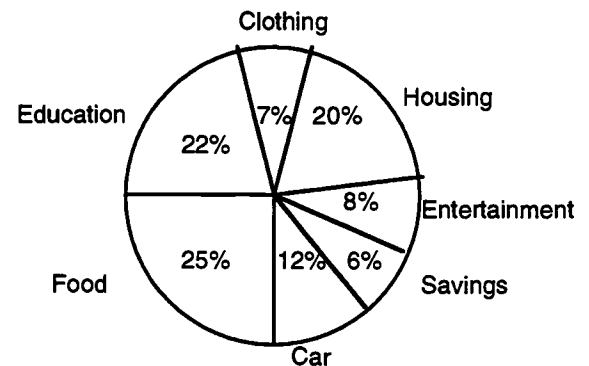

- ★★ 3. Juanita could not see the classroom clock hung on the back wall of the room without turning around in her seat. But one day she discovered that she could see it by using the mirror in her purse. If this is what she saw, what time was it?

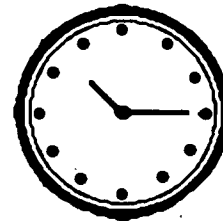

Answer: _____

- ★ 4. Emily and Morris were discussing how fast a baseball travels. They asked Emily's Dad to hit a ball. The machine measured the ball's speed at 98.70465 miles per hour. Round this speed to the nearest hundredth mile per hour.

Answer: _____ mph



- ★★★ 5. Write an algebraic expression for each situation below, using the variable given.
- a. three times as high as the stack of books, x , plus 2 feet: _____
 - b. \$100, less twice Taria's money saved, s : _____
 - c. one-half of Marcia's time, t , less 2 minutes: _____

- ★★ 6. Patti helped her Mom plan a patio. Estimate about how many bricks they should order. Circle the best estimate below, to have a few left over for breakage.

- a. 800
- b. 600
- c. 1000
- d. 700

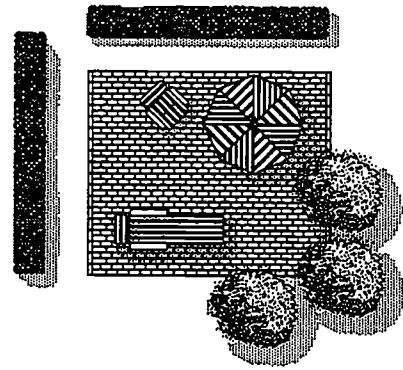

- ★★ 7. Spring is the time for snorkeling. Marcus enjoys snorkeling around the beach area at Panama City. Circle the temperature when he might enjoy this sport the most.

- a. 0°C
- b. 25°C
- c. 50°F
- d. 25°F



- ★★★★ 8. A man walking through the woods has a goose, a fox, and a bag of corn with him. He comes to a river, but there is only one boat available for crossing. The boat will hold only the man and one other thing each time it crosses the river. The man can't leave the fox and goose alone on the river bank, because the fox will eat the goose. He can't leave the goose and corn alone, because the goose will eat the corn. What's the lowest number of crossings he can make in the boat, to get everything on the other side? (A *crossing* means going from one side of the river to the other.)

(Hint: draw a diagram.)

Answer: _____ crossings

Commentary

Saturn, XXIV

1. (**\$1,010,000**) Students can perform arithmetic to find that 40,400 attended those two games. Students might enjoy investigating such large amounts of money for several sports events in large facilities in their state or across the country.
2. (**a. 100%, b. food, c. \$2,400 d. \$4,200**) (a) Students should recognize that the whole circle always represents 100% (b) Compare the percents for food and education. (c) Multiply 12% times \$20,000. (d) Add 7%, 8%, and 6%, then find 21% of \$20,000.
3. (**1:45**) Students with good spatial sense will probably get this answer immediately, if they realize that a mirror reverses images left-to-right. Students who have trouble visualizing the situation can actually hold the paper up to a mirror to see the time for themselves. They may also hold the paper to a light source, turn it over, and look at the clock from the back side.
4. (**98.70 mph**) Round to the nearest hundredth.
5. (**a. $3 \times x + 2$, b. $100 - 2 \times s$, c. $\frac{1}{2} \times t - 2$**) The importance of students being able to rephrase real-world situations using a variable makes problems like this extremely valuable. It is unlikely at this stage that the students will have encountered the "shorthand notation" of writing $3 \times x$, $2 \times s$, and $\frac{1}{2} \times t$ as $3x$, $2s$, and $\frac{1}{2}t$. It is unnecessary for them to use such conventions at this age.
6. (**a. 800**) Students can count the bricks along the length and width, and find that there are 36 rows with 21 in each row, for a total of 756 bricks. Notice that students can't count them all because of the lawn furniture and trees partially blocking the view. 800 would give some extras, but not so many as to cost a great deal more money. 700 is obviously too few.
7. (**b. 25°**) 25° C (or 77° F) is about room temperature. Most swimmers begin when the weather gets that warm. Students should develop benchmark temperatures in both Fahrenheit and Celsius -- such numbers as when water freezes and boils, their own body temperature, a cold drink, and so on.
8. (7) A drawing of the trips across, and what is left on the bank each time, is shown below:

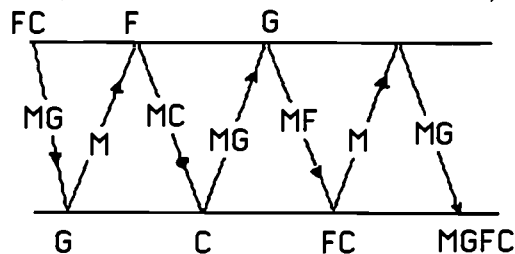

SUPERSTARS III

Saturn, XXV

Name: _____

(This shows my own thinking.)

- ★★ 1. The Drew Elementary School softball team needs bats and mitts for their team. If bats cost \$12 and mitts cost \$15, what is the greatest number of items they can buy for \$200 if they buy at least one of each?

SALE!	
Bats	\$12
Mitts	\$15

Answer: _____

- ★★★ 2. The numerator and denominator of a fraction are single digits which total 13. When you divide the numerator by the denominator, the answer is 0.86 rounded to the nearest hundredth. What is the fraction?

Answer: _____

- ★★★ 3. Use the menu to answer the questions.

<i>Hamburger</i>	\$1.49	<i>Hot Dog</i>	\$1.25
	<u>Small</u>	<u>Large</u>	
<i>Fries</i>	\$.75	\$.95	
<i>Cola</i>	.79	.99	
<i>Shake</i>	1.25	1.75	

- a. If you buy a hamburger, small fries, and small cola, what will your bill be after adding the 7% sales tax? (Remember, stores will round any part of a cent *up!*)

Answer : _____

- b. If you give your server \$5.00, how much change will you receive?

Answer : _____

- c. If you had \$2, what combinations of food would you be able to buy with no items the same, if your friend agrees to pay the tax for you?

Answer : _____

- ★ 4. Elvira was solving a complicated math problem. In her last step she divided by 5 and got the answer 13. Then she realized she should have multiplied by 5 instead of dividing by 5. What should her answer really have been? _____

- ★★★ 5. Mason was told by the vet to keep up with the weight of his 6 pups, which all looked alike. He weighed them by putting them all in a wooden box and weighing them together -- the scale showed 50 pounds. Then he weighed the box by itself -- it weighed 8 pounds. Answer the questions about Mason's equation for finding out how much each pup weighed.

$$\text{Equation: } 6 \times x + 8 = 50$$

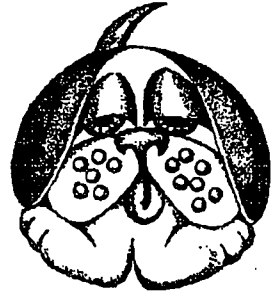

- What does x stand for in the problem? _____
- Why is x multiplied by 6 in the equation? _____
- What value for x solves the equation? _____

- ★★★ 6. Maxine's family wanted to build a pool in their backyard. The pool itself was to be 20 feet by 30 feet, and they wanted a 5-foot wide concrete border around it.

- What are the dimensions of the whole area, pool plus concrete walk? _____ by _____
- Before buying water sealer for the concrete walk, they need to know how many square feet of concrete they'll have to seal. How many square feet of concrete will there be? _____

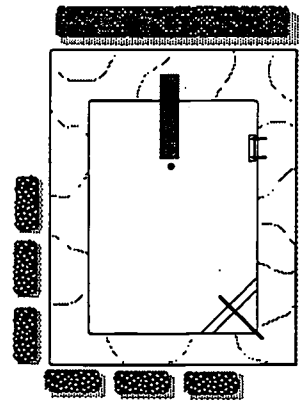

- ★★ 7. Label the sections of the spinner R for red, B for blue, and G for green so that you will land on red one-fourth of the time, on blue half the time, and on green one-fourth of the time.

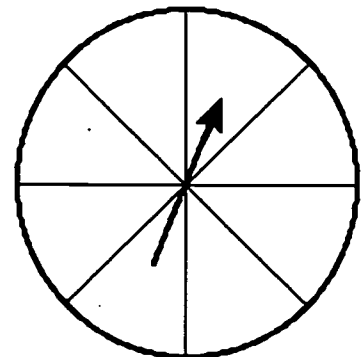

Commentary

Saturn, XXV

1. (16 items -- 15 bats, 1 mitt) One approach is to make a chart of all of the combinations which could be purchased, and select the entry which gives the largest number of items. Another approach is to realize that the way to get the largest number of items is to purchase only one at the higher price, and spend the rest of the money on the lower priced items.

2. (6/7) Students can use *guess, check, revise* to find their answer. Number sense will tell them that the numerator is not bigger than the denominator and that the numerator must be fairly close to the denominator in size.

3. (a. \$3.25 b.\$1.75 c. see list below)

- small fries, hot dog*
- small fries, small cola*
- small fries, large cola*
- small fries, small shake*
- large fries, small cola*
- large fries, large cola*

4. (325) Elvira will have to multiply 13 by 5 to return to the previous stage in the problem, and multiply by 5 again to finish the problem correctly. The real answer, then, is 13 times 25 or 325.

5. (a. the weight of one pup; b. the weight of all 6 pups is $6 \times x$; c. 7 pounds) This problem is designed for students to see a real-world use of algebraic equations, but one which they can solve by using *number sense*. At this point, they should attempt to find the value for x in any intuitive way that makes sense to them. Some will want to subtract 8 from 50, then divide by 6. This is the typical method that will be taught later and is fine if done intuitively. It's also acceptable for students at this point to simply search for a replacement value for x that makes sense. They can use *guess-check-revise* for this approach.

6. (a. 30 by 40; b. 600 ft²) Part (a) of the problem is easily solved by simply labelling the diagram of the pool, and adding on the extra 10 feet to each dimension. Students might approach part (b) in several ways. One is to calculate the area in square feet of the 30 by 40 pool and walk combined, and then subtract the area of the 20 by 30 pool itself. Another approach is to partition the concrete walk itself into smaller pieces, find the area of each, and add them together -- there are several ways to partition the walk in this fashion. Both approaches are shown below:

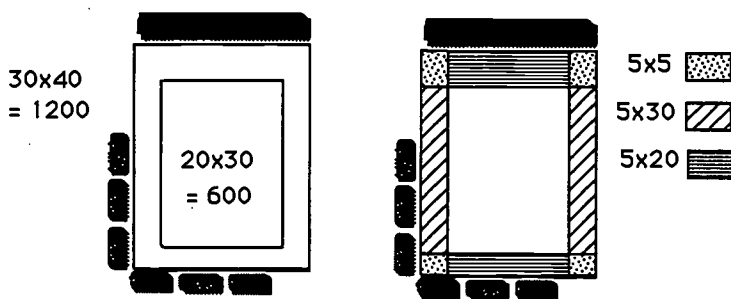

7. (2 sections will be red, 4 will be blue, and 2 will be green.) This problem should help students see a real-world example in which $1/4 = 2/8$ and $1/2 = 4/8$ is intuitively obvious. If they shade $1/4$ or $1/2$ of the spinner, they can count the sections.

SUPERSTARS III

Saturn, XXVI

Name: _____

(This shows my own thinking.)

- ★★ 1. Saturn's diameter is about 71,000 miles. Its rings extend from the surface another 35,000 miles into space. What is the distance from the center of Saturn to the outer edge of its rings?



Answer: _____ miles

- ★★★★ 2. The circle shown here has four congruent angles drawn at the center. The angles are congruent to the 90° angle off to the side.

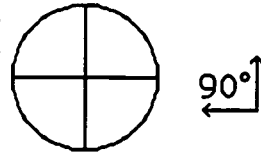

Draw as many angles as possible at the center of these circles which are congruent to the angles shown. All angles within each circle must share sides.

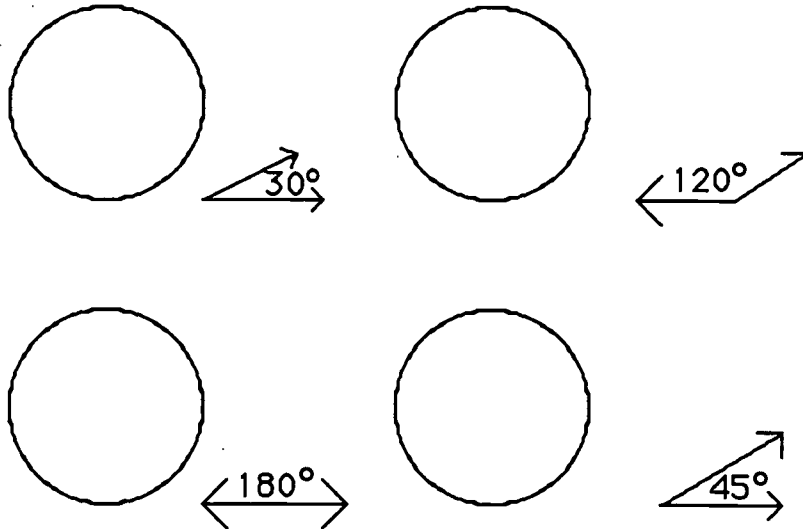



- ★★ 3. Find the pattern and write the next three numbers. Then answer this question: What number comes three numbers before the 2 if the pattern were extended to the left? _____

$$2, 1, \frac{1}{2}, \frac{1}{4}, \underline{\hspace{1cm}}, \underline{\hspace{1cm}}, \underline{\hspace{1cm}}, \dots$$

- ★★ 4. Anne has duplicates of 125 stamps in her collection. She gives 50 to Sam, then she divides the remainder evenly among five friends. If two of her friends put their stamps together, how many will they have?

Answer : _____ stamps

- ★★★ 5. Henri spun a 3-color spinner 45 times. He filled in this tally chart and needs to complete it. Fill in the information he forgot.

Red		$\frac{13}{45}$
Blue		
Green		

- ★★ 6. Complete the problem.

$$\begin{array}{r}
 92 \square \\
 \times \square 8 \\
 \hline
 \square \square 76 \\
 \square 2 \square \\
 \hline
 16,59 \square
 \end{array}$$

- ★★★ 7. Susan's age is 3 times Andrea's age. Barbara is twice as old as Andrea. The sum of their ages is 30. How old is each girl?

Susan is ____ years old; Andrea is ____ years old; Barbara is ____ years old.

- ★★★ 8. Andy wants to run a 3-mile race at the same pace all the way through the race. He knows he can do this in 24 minutes. He stations his Dad at the 2-mile mark to give him his time as he passes by. His Dad calls out 15:30 as he passes by. What else did his Dad say? Circle the best choice:

- Great! You're right on time!
- Slow down! You're ahead of your pace!
- Speed up! You're lagging behind your pace!

Commentary

Saturn, XXVI

1. (**70,500 miles**) Drawing a diagram will help students see that, to find the distance from the center to the outer edge of the rings, they need to find the radius of the planet, or 35,500 miles. This number is then added to the distance to the edge of the rings, 35,000.

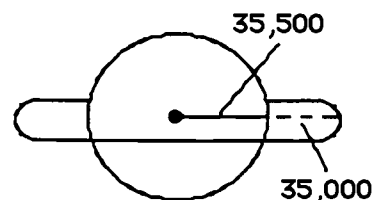

2. (**The circles will appear as shown below.**) Students might try tracing the angles given using a dark pencil or ink pen, so the angle will show through from the underside of the paper. They can then use this dark angle to trace the angles in their circle.

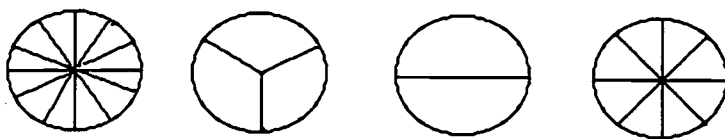

3. ($\frac{1}{8}$, $\frac{1}{16}$, $\frac{1}{32}$; **16 comes three numbers before 2**) Students should notice that each number of the pattern is one half the previous number. Making a rectangle and sketching in $\frac{1}{4}$ will help them find $\frac{1}{2}$ of $\frac{1}{4}$, and then $\frac{1}{2}$ of that, and so on. In this manner they will have a visual image to show that taking half of a fraction doubles the denominator. The pattern still holds going to the left -- each number is twice as large as the one to its right.

4. (**30 stamps**) Anne gave the first 50 stamps to Sam, leaving 75 stamps to divide. Each of the five friends would then receive 15 stamps.

5. ($\frac{12}{45}$, **20 tally marks**, $\frac{20}{45}$) The fraction $\frac{13}{45}$ combines the tally mark information with the number of spins, 45. In a similar fashion, the second fraction would then be $\frac{12}{45}$. The tally marks for green must then be 20 as they all sum to 45. The missing fraction is then $\frac{20}{45}$.

6. (**The completed problem is shown to the right.**) Students might find it easier to work backwards on this problem. If so, they can fill in the lower boxes first, simply by finding missing addends. Then number sense can take over and they can find the two missing numbers in the two numbers being multiplied.

$$\begin{array}{r} 922 \\ \times 18 \\ \hline 7376 \\ \underline{9220} \\ 16596 \end{array}$$

7. (**Susan is 15, Andrea is 5, and Barbara is 10**) Using *guess, check, revise* as a strategy, students may try various ages. It's probably easier always to start guessing with the youngest person's age, compute the others from that, and check against the conditions.

8. (**b. Slow down! ...**) Students will use different approaches in this problem. One obvious one is to divide 24 minutes by 3 miles and get that Andy needs to run each mile in 8 minutes. Therefore he needs to run 2 miles in 16 minutes, and he is running faster than that. Some students might have a difficult time accepting the strategy of slowing down in a race, if they have never run a long distance.

SUPERSTARS III

Saturn, XXVII

Name: _____
(This shows my own thinking)

- ★ 1. Brandon counted 13 kids ahead of him in line to buy concert tickets. He then counted 17 behind him in line. Five more kids got "heads" from someone ahead of him, but then 2 kids behind him dropped out. How many kids were in the line at that point?

Answer : _____

- ★★ 2. Juan had 7 pennies, 4 dimes, and 3 nickels in his pocket. If he reached into his pocket 10 times, putting the previous coin back each time, which number best indicates how many times you would expect him to pull out a penny? Circle your answer.

a. 7 b. 10 c. 1 d. 5

- ★★★★ 3. Place each number from 1 through 10 in a box. Each box must contain a number that is the *difference* of two boxes above it, if there are two above it.

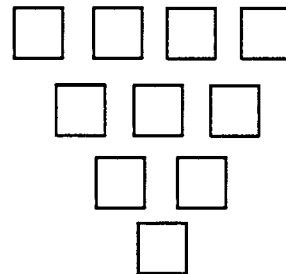

- ★★ 4. What are the whole numbers that Y might represent which will make this number sentence true:

$$Y + 3 < 8$$

Answer: _____

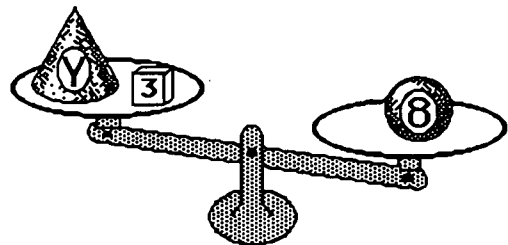

- ★★★★ 5. The first 500 people to visit the baseball game were given their choice of an autographed ball, a cap, a pennant, or a cup with the team logo. $\frac{1}{4}$ chose the ball, $\frac{1}{2}$ chose a cap, $\frac{1}{10}$ chose a pennant. How many of each gift were given away?

Answer: _____ balls, _____ caps, _____ pennants, and _____ cups

- ★★ 6. Circle the sensible measurement for each item.

thickness of a book	28 mm	28 cm	28 m
height of a flagpole	10 cm	10 m	10 km
distance walked in 1/2 hour	3 mm	3 kg	3 km
length of a field	30 dm	30 km	30 mm

- ★ 7. Jay earns \$10 each week during the summer mowing lawns in his neighborhood. His parents require him to save 25% of his earnings. If he works 9 weeks during the summer, how much can he expect to save by the end of the summer?

Answer: _____

- ★★★★ 8. The fifth grade was surveyed to find which pets they liked. The diagram shows the results:

- How many like dogs and birds but not cats? _____
- How many like only cats? _____
- How many like dogs, cats, and birds? _____
- What is the ratio of students who like all pets to those who answered the survey? _____

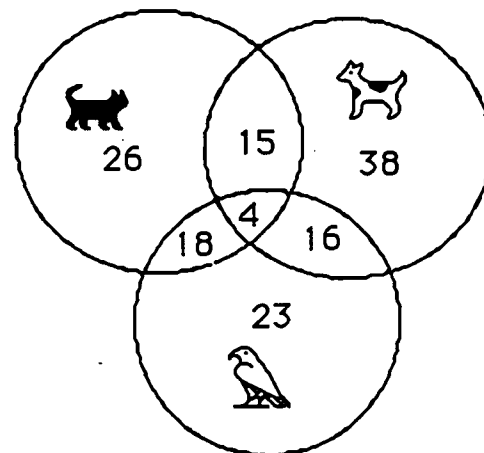

Commentary

Saturn, XXVII

1. (34) The problem is not difficult to solve, except that some students will forget to count Brandon himself.
2. (d) There are 14 coins, 7 of which are pennies. Therefore a penny will be drawn about half the time. So out of 10 draws, you would expect to get 5 pennies. Students might enjoy testing this theory by actually drawing coins at random.

3. (See one solution to the right.) This computational puzzle is one which has a number of different solutions. Students will enjoy coming back to this puzzle throughout the year, and will usually get a different answer each time. One hint which might get students started is to realize that 10 must go in the top row, because it can't be the difference of two other numbers.

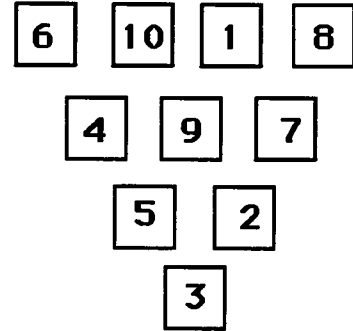

4. (0, 1, 2, 3, 4) Students can intuitively see that y must be a whole number less than 5. Some students might not include 0 in the solution because the physical situation -- an object on a scale -- would naturally have some weight. Give them credit if they do not include 0, but be sure they understand that some things (Styrofoam and plastic wrap used in grocery stores to wrap meat, for example) have such a miniscule weight that they are counted as 0.
5. (125; 250; 50; 75) There are a number of ways students can use *number sense* to find $1/4$ of 500, $1/2$ of 500, and $1/10$ of 500. One hint for a student having trouble is to think of the 500 as 500 pennies, or \$5. Once they determine the first three fractional parts of 500, they can then find the remaining number -- the cups -- by subtraction.
6. (28 mm; 10 m; 3 km; 30 dm) Students should be encouraged to remember benchmark measures for distances in the metric system and use those for estimation purposes. They should remember something that is a millimeter long, a centimeter long, a decimeter long, a meter long, and a kilometer long.
7. (\$22.50) Students should use the form of a percent that makes sense for a given problem. In this case, knowing 25% is equivalent to $1/4$ might enable them easily to find one week's savings, as they can divide \$10 into 4 equal shares. \$2.50 a week for 9 weeks is \$22.50.
8. (a. 16 b. 26 c. 4 d. 4 to 140) For students who are new to Venn diagrams, it would be helpful for them to start with some simple ones -- limited to 2 circles -- to understand what the various numbers mean, in overlap areas. They can gradually increase the difficulty.

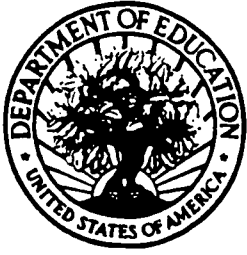

U.S. DEPARTMENT OF EDUCATION
Office of Educational Research and Improvement (OERI)
Educational Resources Information Center (ERIC)



NOTICE

REPRODUCTION BASIS

This document is covered by a signed "Reproduction Release (Blanket)" form (on file within the ERIC system), encompassing all or classes of documents from its source organization and, therefore, does not require a "Specific Document" Release form.

This document is Federally-funded, or carries its own permission to reproduce, or is otherwise in the public domain and, therefore, may be reproduced by ERIC without a signed Reproduction Release form (either "Specific Document" or "Blanket").