

DOCUMENT RESUME

ED 423 115

SE 061 635

TITLE Seismic Sleuths. Earthquakes: A Teacher's Package for Grades 7-12.

INSTITUTION American Geophysical Union, Washington, DC.

SPONS AGENCY Federal Emergency Management Agency, Washington, DC.

PUB DATE 1995-10-00

NOTE 329p.

CONTRACT EMW-92-K-3892

AVAILABLE FROM FEMA, P.O. Box 70274, Washington, DC 20024.

PUB TYPE Guides - Classroom - Teacher (052)

EDRS PRICE MF01/PC14 Plus Postage.

DESCRIPTORS Building Design; Constructivism (Learning); Cooperative Learning; Design Requirements; \*Earth Science; \*Earthquakes; Emergency Programs; Geology; \*Geophysics; Hands on Science; Natural Disasters; \*Science Activities; Secondary Education; \*Seismology; Teaching Guides

ABSTRACT

This teacher package for grades 7-12 takes a broad approach in preparing students for earthquakes. "Hands-on/minds-on", inquiry-driven activities are balanced by library research and visits with disaster planning officials. Emphasis is placed on cooperative learning and the constructivist approach to teaching. Students not only study the causes of earthquakes but also study building construction and forces that damage buildings, then construct model buildings to test their knowledge. Students explore how their community prepares for emergencies and how it is empowered with tools to bring about change in community disaster preparedness. Some activities are interdisciplinary. Each unit section contains an overview of the contents and package layout. Each unit in turn has an introduction that gives specific information on the unit content. Lessons and activities include complete procedures, material lists, and master pages for the students. Unit 1 contains the introduction that serves as a foundation for the other units by pre-assessing student knowledge of earthquakes and hazards preparedness. Unit 2 covers causes of earthquakes, geologic time, and side effects of earthquakes. Unit 3 explores the science and history of seismology. Unit 4 covers building design and how earthquake forces act on various designs. Unit 5 focuses student attention on earthquake preparedness. Unit 6 offers a variety of summative and assessment activities. (PVD)

\*\*\*\*\*  
\* Reproductions supplied by EDRS are the best that can be made \*  
\* from the original document. \*  
\*\*\*\*\*

# Seismic Sleuths

PERMISSION TO REPRODUCE AND  
DISSEMINATE THIS MATERIAL HAS  
BEEN GRANTED BY

*J. Hedlund*

TO THE EDUCATIONAL RESOURCES  
INFORMATION CENTER (ERIC)

1

U.S. DEPARTMENT OF EDUCATION  
Office of Educational Research and Improvement  
EDUCATIONAL RESOURCES INFORMATION  
CENTER (ERIC)

This document has been reproduced as  
received from the person or organization  
originating it.

Minor changes have been made to  
improve reproduction quality.

Points of view or opinions stated in this  
document do not necessarily represent  
official OERI position or policy.

SECRET

FEDERAL EMERGENCY MANAGEMENT AGENCY



# SEISMIC SLEUTHS

SECRET

AMERICAN GEOPHYSICAL UNION

S E I S M I C



S L E U T H S

# EARTHQUAKES

A Teacher's Package for Grades 7-12

Produced by

The American Geophysical Union  
2000 Florida Avenue, N.W.  
Washington, DC 20009

Supported by the

Federal Emergency Management Agency  
Washington, DC 20472

*This product was developed by the American Geophysical Union (AGU) with financial support from the Federal Emergency Management Agency (FEMA) under Cooperative Agreement EMW-92-K-3892. AGU is solely responsible for the accuracy of statements and interpretations contained herein.*

*Funding for this publication was allocated to FEMA by The United States Congress, under the Earthquake Hazards Reduction Act of 1977, as amended. FEMA maintains a royalty-free, nonexclusive and irrevocable right to reproduce, publish or otherwise use and to authorize others to use, the work for public education purposes. FEMA hereby authorizes and encourages the educational community to reproduce this product in its entirety and to disseminate it at no cost to the recipient.*

*Single copies of this publication may be obtained from FEMA at no cost by contacting the FEMA Warehouse -*

*Toll free number: 1-800-480-2520 ♦ Fax: 301-497-6378  
Mailing address: P.O. Box 2012, Jessup, MD 20794-2012.*

## **AGU/FEMA EARTHQUAKE CURRICULUM**

---

### **Project Director:**

M. Frank Watt Ireton, Manager of Pre-college Education, American Geophysical Union

### **Associate Project Director:**

Karen Lee Spaulding, Manager of Professional and Continuing Education, American Geophysical Union

### **Project Editor:**

Mary Liston Liepold, Washington, District of Columbia

### **Copy Editor:**

Pam Knox, Senior Copy Editor, American Geophysical Union

### **Authors and Reviewers:**

Roy Q. Beven, Science Teacher, San Juan Capistrano, California

Jane Nelson Crowder, Science Teacher, Bellevue, Washington

Jo Ellen Dodds, Science Teacher, Twin Falls, Idaho

Lynda Vance, Science Teacher, Boise, Idaho

James F. Marran, Social Studies Teacher, Wilmette, Illinois

Ronald. H. Morse, Science Teacher, Cicero, New York

Walter L. Sharp, Science Teacher, Camillus, New York

James D. Sproull, Science Teaching Consultant, Kirkland, Washington

### **Consultants and Reviewers:**

Charles Ault, Science Educator, Lewis and Clark College, Portland, Oregon

Robert A. Christman, Geologist and Science Educator, Western Washington University, Bellingham, Washington

Henry J. Lagorio, Architectural Engineer, Orinda, California

Sue J. Nava, Seismologist, University of Utah, Salt Lake City, Utah

Martin Stout, Engineering Geologist, Whittier, California

Keith A. Sverdrup, Seismologist, University of Wisconsin, Milwaukee, Wisconsin

Diana Todd, Structural Engineer, National Institute of Science and Technology, Gaithersburg, Maryland

Monte D. Wilson, Geologist, Boise State University, Boise, Idaho

### **Design by:**

Auras Design, Washington, District of Columbia

### **Illustrators:**

Susie Duckworth, Falls Church, Virginia

Max Karl Winkler, Silver Spring, Maryland

### **Graphic Artist:**

Gregg Sekscienski, Albuquerque, New Mexico

### **Project Officer:**

Marilyn P. MacCabe, Mitigation Directorate, Federal Emergency Management Agency

## **ACKNOWLEDGMENTS**

---

The American Geophysical Union (AGU) and the Federal Emergency Management Agency (FEMA) acknowledge with gratitude the many individuals who provided technical experience, teaching knowledge, and classrooms for field testing in the development of this project. Along with the authors and consultants, they provided continuous feedback in the development of these materials. Without the assistance of these individuals and the students who participated in the field test this volume would not have been possible.

### **Technical Reviewers:**

William Chavez, Geological Engineer, New Mexico Institute of Mining and Technology, Socorro, New Mexico  
Lucy Jones, Seismologist, United States Geological Survey  
David Love, Environmental Geologist, New Mexico Bureau of Mines and Mineral Resources, Socorro, New Mexico  
Mary Ellen Williams, Earthquake Program Specialist, United States Geological Survey, Woods Hole, Massachusetts

### **Curriculum Reviewers:**

Allen Bone, Science Teacher, Butte, Montana  
William Kraye, Science Teacher, Gaithersburg, Maryland  
Sharon Stroud, Science Teacher, Colorado Springs, Colorado

### **Field Test Teachers:**

Roger Alsup, Jim Anderson, Richard Arrington, Joann Ball, Allen Bone, Gail Chaid, Linda Dudley, Jo Dodds, Elizabeth Ellis, George Foley, John Gallagher, Melody Green, Paul Grogger, Kay Kidder, Paul Jamerson, Larry Madden, Lloyd Magnuson, Gay Ann Masolo, Sue Ayn Moore, Becky Orahood, Doyle Orrell, Nancy Sallee, Sandy Shutey, Jack Staker, Ann Sullivan, Edith Thurman, Maris Ward, Leslie Wehner, Ronald Wieland, and Walt Woolbaugh.

Teachers who participated in the two 1994 Seismic Sleuths Leadership Institutes also conducted field testing and review of the lessons during the institutes. The suggestions and additions by the initial field test and institute teacher participants have contributed to a stronger curriculum package.

A special note of thanks to Katharyn E. K. Ross, whose comprehensive Fourth Edition of *Earthquake Education Materials for Grades K - 12* contributed greatly to the unit resource lists in this package, and to Sean Cox, teacher, Salem High School, New Hampshire, who provided the appendix to Unit Six.



American Geophysical Union

2000 Florida Avenue, N.W.  
Washington, D.C. 20009  
Phone (202) 462-6900  
TWX 710-822-9300  
FAX 202-328-0566

October 1995

Dear Colleague,

The American Geophysical Union (AGU) and the Federal Emergency Management Agency (FEMA) are pleased to present *Seismic Sleuths—A Teacher's Package for Grades 7-12*. Apprehension about what will happen during and after an earthquake can be alleviated with education and preparation. The goal of *Seismic Sleuths* is to provide the tools to prepare students for earthquakes and other natural disasters that may interrupt their lives and to help them get their lives back to normal after the event.

This package was developed as a joint effort of classroom teachers, research scientists, pedagogical specialists, AGU, and FEMA. The team approach was taken to ensure that the materials developed would be appropriate for classrooms, have correct and current content information, and reflect national science education reform efforts. In the introductory pages you will find matrices designed to help you match *Seismic Sleuths* materials with the National Science Teaching Standards content section. You will also find a matrix that indicates which lesson in *Seismic Sleuths* includes instruction material relative to discipline content.

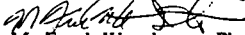
*Seismic Sleuths* take a broad approach in preparing students for earthquakes. Hands-on/minds-on inquiry driven activities are balanced by library research and visits with disaster planning officials. Emphasis has been placed on cooperative learning and the constructivist approach to teaching. Students not only study the causes of earthquakes, they also study building construction and forces that damage buildings, then construct model buildings to test their knowledge. Students explore how their community is preparing for emergencies and are empowered with tools to bring about change in community disaster preparedness. Some of the activities may also be shared with others in your building, such as the social studies, language arts, mathematics, and industrial arts teachers.

A common thread connects the six units of *Seismic Sleuths*, but individual activities can be adapted to enhance your lessons already in place. The general introduction and overview of units sections will give you an idea of the content and layout of *Seismic Sleuths*. Each unit in turn has an introduction that gives you specific information about the unit's contents. Lessons and activities are written to give you complete procedures, material lists, and master pages for the students. Lessons are flexible and designed to be adapted to your teaching style and your students' learning ability.

When you choose a lesson or topic to include in your schedule, study it carefully to determine the activity's nuances. You will recognize some of the lessons as adaptations from other sources that have been rewritten for the *Seismic Sleuths* project. Many of the lessons are especially designed for *Seismic Sleuths*, and you will need to carefully follow directions to make them work in your classroom. While detailed instructions for students may be necessary in some cases, many of the activities can be adapted as a jumping off place for student exploration of the topic. In all cases, use the lessons as a departure for further study.

With desktop publishing technology these materials can easily be modified and new editions produced. While field testing and rewriting of lessons has been extensive, there will always be room for improvement. It is our wish to provide you with the most usable materials possible with current information. If you have comments or suggestions for future editions please forward them to my office.

My sincere thanks and congratulations to all the individuals involved in the project. A special thanks goes to FEMA for the forethought to fund the production of these vital teaching materials.

  
M. Frank Watt Ireton, Ph.D.

AGU/FEMA Earthquake Project Director

The American Geophysical Union encompasses the Earth and space sciences:  
Geodesy, Seismology, Atmospheric Sciences, Geomagnetism and Paleomagnetism,  
Ocean Sciences, Hydrology, Volcanology, Geochemistry, and Petrology,  
Tectonophysics, Planetary, Solar-Planetary Relationships



Earthquakes are mystifying events. They are as unpredictable as they are powerful, and not even seismologists fully understand the forces within the Earth that set them in motion. As an educator, you can capitalize on that mysterious appeal to engage your students' interest.

Ultimately, however, the purpose of these lessons is to demystify earthquakes, and to counter the fatalism that frequently accompanies ignorance about natural phenomena. Interactive lessons invite students to discover what is known about quakes—the considerable body of knowledge that deals with their causes, the patterns of their occurrence, and what human beings can do to minimize their catastrophic effects on themselves and their communities.

The units in this package follow a pattern of zooming in and out, beginning with concerns closest to home, moving to general principles and global perspectives, then homing in again to engage students in evaluating their personal preparedness and that of their families, schools, neighborhoods, and communities. Look for the magnifying glass symbols opposite the text, which indicate essential vocabulary and helpful hints (Teaching Clues and Cues).

Units 1 and 6 deal most specifically with the personal and local, but every unit contains a mixture of general information and specific, local applications. A healthy respect for the power of earthquakes requires both kinds of understanding. Units 4 and 5 feature interactive lessons in architecture and engineering, topics seldom dealt with in grade 7-12 curriculum materials.

You may not find time to teach every lesson in this package. For teachers who must pick and choose, most of the lessons are designed to stand on their own. Take time to familiarize yourself with the outline, however. Read the unit introductions; take advantage of the background readings provided and of the unit resource lists. The Teacher Preparation section in each lesson outlines things you need to do before class begins, in addition to assembling the items on the materials list. Plan ahead now for the

cooperation you will need in Unit 1, the materials you will need in Unit 4, and the field trips you will make in Unit 5. You'll see a burst of learning to reward your efforts and a wealth of ideas to enrich your science and social studies teaching.

Theory takes a back seat to hands-on experience in most of these lessons. As its name implies, this Seismic Sleuths package focuses on discovery. Ideally, the process of discovery will ripple through the town or city outside your classroom. Beginning in Unit 1, students will be interacting with a wide range of public officials. Please initiate and encourage these relationships. They will benefit the students, the school, and the community.

Through interacting with adults in positions of responsibility, students will develop a realistic sense of how their community functions day to day and how it would function in the aftermath of an earthquake or other natural disaster. Most will find it enormously reassuring to learn that emergency plans are in effect. Moreover, they will be empowered by the knowledge that their individual and collective actions can make a difference. Cultivating relationships within their community will also expose students to a variety of careers they might never have considered and provide a motivation to stay in school. In the long range, these activities will prepare today's students to be tomorrow's concerned and informed participants in democracy.

The school will benefit from these relationships by widening the pool of local adults who take an active interest in education, share their expertise and experience, and serve as role models for students. The community at large will benefit greatly, whether or not it is in an area known to be seismically active. Most of the kinds of emergency planning that students will learn about, and model in Unit 6, would be appropriate not only in the event of an earthquake but also in case of flood, hurricane, or other large-scale disaster. In just the last few years, almost every section of the country has experienced destructive natural events.

**Unit 1.** This three-part introductory unit sets the stage for what follows. Every teacher should take time to include some of the materials contained in this unit. The introductory lesson assesses students' knowledge of earthquakes. In lesson two students describe their own experiences and tell how they would prepare for an earthquake. Lesson three requires students to make contact with emergency personnel in their community to ascertain emergency preparedness plans. Lessons in this unit are referred to in future units.

**Unit 2.** This five-part unit moves students beyond their personal survival into the causes of earthquakes. This unit sketches the big picture, building on students' knowledge from earth science or other science classes. The unit begins with students modeling stress buildup in the crust, followed by lessons on how earthquakes and other evidence tell scientists about the structure of the Earth. In the third lesson, students contrast historic time with the vastness of geologic time and simulate techniques of paleoseismology. The unit concludes with lessons on some potential side effects of earthquakes, such as tsunami, liquefaction, and landslides. Students study how the geology of an area influences the destructive effects and how high population density at unsafe sites can increase the amount of damage during an earthquake.

**Unit 3.** In this four-part unit, students learn about the different wave motions during an earthquake and how these motions are studied. A historical piece on the development of seismology adds background to students' knowledge. Students study and simulate the measurement of earthquakes using the Richter and Mercalli scales to find out how seismologists arrive at earthquake measurements.

This unit concludes with activities that plot the distribution of earthquakes worldwide, then focuses in on local earthquakes, first in Japan, then in the United States. It offers a variety of lessons in science, mathematics, and social studies.

**Unit 4.** This five-part unit is designed to allow students to construct an understanding of how buildings respond to earthquakes. Lessons on building design and how earthquake forces act on various designs provide students with information on how to build earthquake resistant structures. Students then apply this knowledge by constructing testing devices and testing their designs. This unit is critical for developing students' understanding of why buildings collapse and what can be done to make buildings safer.

**Unit 5.** This five-part unit focuses students' attention on what to do before, during, and after an earthquake. By studying historical earthquakes as reported in the press, students learn how people have responded to earthquakes in the past. Students then learn what their response should be during an earthquake by planning and practicing earthquake drills. Students conduct safety assessments of their home, classroom, and community and see how secondary disasters associated with earthquakes can also be alleviated.

**Unit 6.** This concluding four-part unit offers a variety of summing-up and assessment activities. Writing activities, a fast paced quiz game, and a high pressure simulation allow students a chance to show off what they have learned in this curriculum. An extensive resource list provides detailed instructions for conducting a communitywide disaster simulation that becomes realistic and dramatic with the involvement of community disaster officials.

# SEISMIC SLEUTHS MATRICES FOR THE NATIONAL SCIENCE EDUCATION STANDARDS

A *Seismic Sleuths* development team has put together the matrices on the following pages to use in correlating the *Seismic Sleuths* materials with the National Science Education Standards. The National Science Education Standards, under development by the National Research Council since 1993, will be released in late 1995. The Standards have been developed through consensus building among K-12 teachers, teacher education faculty, scientists, and other education specialists. Through this process a document that represents the broad thinking of the science education community is being developed as to what students should know, how they should be taught, and how they should be assessed. The Standards are meant to be descriptive rather than prescriptive and designed to be a tool to strengthen science education.

### Using the *Seismic Sleuths* Standards matrices

The development team, working with the November 1994 draft of the National Science Education Standards, examined *Seismic Sleuths* section by section identifying correlations to the Science Content areas listed in the Standards. Two criteria were used: the section made a strong and direct connection to that content area, or the section made an indirect connection. A strong, direct connection is shown in bold faced type.

The following matrices are provided. Below is a summary of *Seismic Sleuths* and the content areas listed in the Standards. This page shows at a glance the correlations between *Seismic Sleuths* and the Standards. The next six pages describe more detailed correlations between *Seismic Sleuths* and the Standards using wording from the Standards. In some cases the development team felt that where a particular concept was not listed in the wording of the Standards a possible connection could be shown in parentheses.

When using the matrices it should be kept in mind the descriptive nature of the Standards. The connections shown in these matrices are suggested connections based on the development team's experience working with *Seismic Sleuths*. Many other correlations can be made and will become evident as the curriculum materials are used. Additionally, connections can also be made between *Seismic Sleuths* and *Benchmarks for Science Literacy*, (AAAS, 1993), *Content Core*, (NSTA, 1992), and *Earth Science Content Guidelines Grades K-12*, (AGI, 1991). The user is referred to these documents for further connections.

SEISMIC SLEUTHS SECTIONS	SCIENCE AS INQUIRY	PHYSICAL SCIENCE	EARTH AND SPACE SCIENCE	SCIENCE AND TECHNOLOGY	SCIENCE IN PERSONAL AND SOCIAL PERSPECTIVES	HISTORY AND NATURE OF SCIENCE	UNIFYING CONCEPTS AND PROCESSES
1.1	■	□	□	□	■	□	□
1.2		□		□	■		□
1.3				□	■		
2.1	■	■	□		□		□
2.2	□	□	■	□	□	□	□
2.3	□	□	■		□	□	□
2.4	□	■	■		■	□	□
2.5	□		□	□	■		□
3.1	■	■	□	■	□		□
3.2	■	□	■	■	■	■	■
3.3	■	■	■	■	■	■	□
3.4	■	■	□				■
4.1	□	■		■	■		■
4.2	■	■		■	■	□	□
4.3	■	■		■	■	■	■
4.4	■	■		■	□	□	■
4.5	■	■		■	■	□	■
5.1	■			■	■	■	□
5.2		□		■	■		
5.3		□		■	■		
5.4		□		■	■		
5.5		□		■	■		
6.1		□		■	■		■
6.2		□		■	■		
6.3						■	□
6.4	■	□	□	■	■		■

■ Direct connection

□ Indirect connection

**SEISMIC SLEUTHS MATRICES  
FOR THE NATIONAL SCIENCE EDUCATION STANDARDS**

**UNIT 4: Can Buildings Be Made Safer? Students construct an understanding of how ground shaking during an earthquake can damage buildings and how buildings can be made better able to withstand this shaking.**

<b>SEISMIC SLEUTHS SECTIONS</b>	<b>SCIENCE AS INQUIRY</b>	<b>PHYSICAL SCIENCE</b>	<b>EARTH AND SPACE SCIENCE</b>	<b>SCIENCE AND TECHNOLOGY</b>	<b>SCIENCE IN PERSONAL AND SOCIAL PERSPECTIVES</b>	<b>HISTORY AND NATURE OF SCIENCE</b>	<b>UNIFYING CONCEPTS AND PROCESSES</b>
<p><b>4.1 Building Fun</b></p> <p>Students investigate the physical properties of building materials and design while considering how these might affect the way a structure withstands forces.</p>	Abilities related to scientific inquiry	<p><i>Properties &amp; changes in matter (physical)</i></p> <p>Motions and Forces</p>		<p><i>Abilities of technological design</i></p>	Natural and human-induced hazards		Evidence, models, and explanation
<p><b>4.2 Structural Reinforcement: The Better Building</b></p> <p>Students learn how additional structural elements strengthen a structure to carry forces resulting from earthquake shaking.</p>	<i>Understanding about scientific inquiry</i>	Forces and motions		<p><i>Abilities of technological design</i></p> <p><i>Understanding about science and technology</i></p>	Natural and human-induced hazards	Nature of scientific knowledge	Evidence, models, and explanation
<p><b>4.3 The BOSS Model: Building Oscillation Seismic Simulation</b></p> <p>Students investigate how energy enters a structure and discover the phenomenon of resonance. They measure the natural frequencies of the different height rod assemblies of the BOSS Models and correlate these motions to those of buildings and earthquakes.</p>	<p><i>Abilities related to scientific inquiry</i></p> <p><i>Understanding about scientific inquiry</i></p>	<p>Forces and motions</p> <p><i>Interactions of energy and matter</i></p>		<i>Understanding about science and technology</i>	Natural and human-induced hazards	<i>Nature of scientific knowledge</i>	Evidence, models, and explanation
<p><b>4.4 Earthquake in a Box</b></p> <p>In cooperative groups, students construct an inexpensive shake table for testing structures they have built.</p>	<i>Understanding about scientific inquiry</i>	<p>Forces and motions</p> <p><i>Interactions of energy and matter</i></p>		<p><i>Abilities of technological design</i></p> <p><i>Understanding about science and technology</i></p>	Natural and human-induced hazards	Nature of science	Evidence, models, and explanations
<p><b>4.5 The Building Challenge</b></p> <p>Students design and construct a structure then test it for the ability to withstand forces that could be encountered in an earthquake. This can be used as a performance assessment of the entire unit.</p>	<p>Abilities related to scientific inquiry</p> <p><i>Understanding about scientific inquiry</i></p>	<p><i>Properties &amp; changes in matter (physical)</i></p> <p>Forces and motions</p> <p><i>Interactions of energy and matter</i></p>		<p><i>Abilities of technological design</i></p> <p><i>Understanding about science and technology</i></p>	Natural and human-induced hazards	Science as a human endeavor	Evidence, models, and explanations

**SEISMIC SLEUTHS MATRICES  
FOR THE NATIONAL SCIENCE EDUCATION STANDARDS**

**UNIT 3: How Do People Learn About Earthquakes? Students explore the science and history of seismology.**

SEISMIC SLEUTHS SECTIONS	SCIENCE AS INQUIRY	PHYSICAL SCIENCE	EARTH AND SPACE SCIENCE	SCIENCE AND TECHNOLOGY	SCIENCE IN PERSONAL AND SOCIAL PERSPECTIVES	HISTORY AND NATURE OF SCIENCE	UNIFYING CONCEPTS AND PROCESSES
<p><b>3.1 The Waves of Quakes</b></p> <p>Students explore waves and discover how waves transfer energy. During this exploration, students connect this understanding to primary and secondary waves.</p>	<p><i>Abilities related to scientific inquiry</i></p> <p><i>Understanding about scientific inquiry</i></p>	<p>Motions and forces</p> <p><i>Interactions of energy and matter</i></p>	<p>Structure of the Earth system</p>		<p>Natural and human-induced hazards</p>		<p>Change, constancy, and measurement</p>
<p><b>3.2 Pioneering Ideas</b></p> <p>Students explore the early work of three scientists.</p>	<p><i>Understanding about scientific inquiry</i></p>	<p>Forces and motions</p> <p>Interactions of energy and matter</p>	<p><i>Energy in the Earth system</i></p> <p><i>Origin and evolution of the Earth system</i></p>	<p><i>Understanding about science and technology</i></p>		<p><i>Science as a human endeavor</i></p> <p><i>Nature of scientific knowledge</i></p> <p><i>Historical perspectives</i></p>	<p><i>Evidence, models, and explanation</i></p>
<p><b>3.3 Sizing Up Earthquakes: The Mercalli Scale, Calling Station KWAT</b></p> <p>In this simulation of a radio talk show after an earthquake, students learn how seismologists establish earthquake intensity based upon damage people observe and report.</p>	<p><i>Abilities related to scientific inquiry</i></p> <p><i>Understanding about scientific inquiry</i></p>	<p><i>Motions and forces</i></p> <p>Interactions of energy and matter</p>	<p><i>Energy in the Earth system</i></p>	<p><i>Abilities of technological design</i></p>	<p><i>Natural and human-induced hazards</i></p>	<p><i>Science as a human endeavor</i></p> <p><i>Nature of scientific knowledge</i></p>	<p>Change, constancy, and measurement</p>
<p><b>3.4 Distribution of Earthquakes</b></p> <p>Three activities on plotting the locations of earthquakes on map and making a 3-D model.</p>	<p>Abilities related to scientific inquiry</p> <p>Understanding about scientific inquiry</p>		<p>Structure of the Earth system</p> <p>Energy in the Earth system</p>		<p><i>Natural hazards</i></p> <p><i>Risks and benefits</i></p>	<p>Historical perspectives</p>	<p><i>Evidence, models, and explanation</i></p>

**SEISMIC SLEUTHS MATRICES  
FOR THE NATIONAL SCIENCE EDUCATION STANDARDS**

**UNIT 2: What Happens When The Earth Quakes? An exploration of earthquake processes, including causes and measurement.**

<b>SEISMIC SLEUTHS SECTIONS</b>	<b>SCIENCE AS INQUIRY</b>	<b>PHYSICAL SCIENCE</b>	<b>EARTH AND SPACE SCIENCE</b>	<b>SCIENCE AND TECHNOLOGY</b>	<b>SCIENCE IN PERSONAL AND SOCIAL PERSPECTIVES</b>	<b>HISTORY AND NATURE OF SCIENCE</b>	<b>UNIFYING CONCEPTS AND PROCESSES</b>
<b>2.1 Stick-Slip Movement</b> Students model movement along a fault.	<i>Abilities related to scientific inquiry</i> <i>Understanding about scientific inquiry</i>	<i>Motions and forces (friction and energy)</i>	Energy in the Earth system (Dynamic crust)		Natural hazards		Evidence, <i>models</i> , and explanation
<b>2.2 Shifting Plates and Wandering Poles</b> A three-part exploration about how scientists determine if the Earth's crust is in motion.	Abilities related to scientific inquiry Understanding about scientific inquiry	<i>Properties &amp; changes in matter (magnetism)</i> <i>Motions and Forces</i>	<i>Structure of the Earth system</i> <i>Energy in the Earth system</i> <i>Origin and evolution of the Earth system</i>	Understanding about science and technology	Natural hazards	Nature of scientific knowledge	Evidence, <i>models</i> , and explanation
<b>2.3 Earthquakes in Geologic Time</b> Students explore long time intervals and use models to study earthquakes in the past.	Abilities related to scientific inquiry Understanding about scientific inquiry	Motions and forces	<i>Earth's history</i> <i>Origin and evolution of the Earth system</i>		Natural hazards	Historical perspectives	Evidence, <i>models</i> , and <i>explanation</i> , maps
<b>2.4 Earthquake Hazards</b> Students use models, research, and mathematics to study earthquake hazards.	Abilities related to scientific inquiry Understanding about scientific inquiry	<i>Forces and motion (gravity, waves, &amp; energy)</i> <i>Interactions of energy and matter</i>	<i>Energy in the Earth system</i>		<i>Natural hazards</i>	Historical perspectives	Evidence, <i>models</i> , and <i>explanation</i> Change, constancy, and measurement
<b>2.5 Quake-Smart Siting</b> Students interpret soil and earthquake related maps.	Abilities related to scientific inquiry Understanding about scientific inquiry		Structure of the Earth system	<i>Abilities of technological design</i>	<i>Natural hazards</i>		Evidence, <i>models</i> , and <i>explanation</i> , maps



**SEISMIC SLEUTHS MATRICES  
FOR THE NATIONAL SCIENCE EDUCATION STANDARDS**

**UNIT 1: What's It All About? Pre-assessment of student's knowledge of earthquakes and hazards preparedness.**

<b>SEISMIC SLEUTHS SECTIONS</b>	<b>SCIENCE AS INQUIRY</b>	<b>PHYSICAL SCIENCE</b>	<b>EARTH AND SPACE SCIENCE</b>	<b>SCIENCE AND TECHNOLOGY</b>	<b>SCIENCE IN PERSONAL AND SOCIAL PERSPECTIVES</b>	<b>HISTORY AND NATURE OF SCIENCE</b>	<b>UNIFYING CONCEPTS AND PROCESSES</b>
<p><b>1.1 What Do You Know About Earthquakes?</b></p> <p>Students explore their conceptions of earthquakes by writing about a hypothetical earthquake as seen through the eyes of a reporter, a scientist, and a member of the general public.</p>	<p><i>Abilities related to scientific inquiry</i></p> <p>Understanding about scientific inquiry</p>	Motions and forces	Structure of the Earth system Energy in the Earth system	Abilities of technological design	<p><i>Personal and community health</i></p> <p><i>Natural and human-induced hazards</i></p> <p>Risks and benefits</p> <p>Science and technology in local, national, and global challenges</p>	Science as a human endeavor Nature of scientific knowledge	Evidence, models, and explanation Change, constancy, and measurement
<p><b>1.2 It Could Happen Here</b></p> <p>Students consider their needs in an emergency and their preparation for an emergency.</p>		Motions and forces		Understanding about science and technology	<p><i>Personal and community health</i></p> <p><i>Natural and human-induced hazards</i></p> <p><i>Risks and benefits</i></p>		Order and organization
<p><b>1.3 Investigating Community Preparedness</b></p> <p>Students investigate their community's preparedness.</p>				Abilities of technological design	<p><i>Personal and community health</i></p> <p><i>Natural and human-induced hazards</i></p> <p><i>Risks and benefits</i></p>		

**SEISMIC SLEUTHS MATRICES  
FOR THE NATIONAL SCIENCE EDUCATION STANDARDS**

**UNIT 5: What Should People Do Before, During, and After An Earthquake?**

<b>SEISMIC SLEUTHS SECTIONS</b>	<b>SCIENCE AS INQUIRY</b>	<b>PHYSICAL SCIENCE</b>	<b>EARTH AND SPACE SCIENCE</b>	<b>SCIENCE AND TECHNOLOGY</b>	<b>SCIENCE IN PERSONAL AND SOCIAL PERSPECTIVES</b>	<b>HISTORY AND NATURE OF SCIENCE</b>	<b>UNIFYING CONCEPTS AND PROCESSES</b>
<p><b>S.1 Predicting Earthquakes</b></p> <p>Students explore the tantalizing possibilities of earthquake prediction.</p>	<p>Abilities related to scientific inquiry</p> <p><b>Understanding about scientific inquiry</b></p>			<p><b>Understanding about science and technology</b></p>	<p>Personal and community health</p> <p><b>Natural hazards</b></p>	<p><b>Nature of science</b></p> <p>Historical perspectives</p>	<p><b>Evidence, models, and exploration</b></p>
<p><b>S.2 Starting Here, Starting Now</b></p> <p>Students learn how to react in the event of an earthquake.</p>		Motions and Forces		<p><b>Understanding about science and technology</b></p>	<p><b>Natural hazards</b></p>		
<p><b>S.3 Find and Fix the Hazards</b></p> <p>Students study home construction and retrofitting techniques.</p>		Motions and Forces		<p><b>Understanding about science and technology</b></p>	<p><b>Natural hazards</b></p>		
<p><b>S.4 Rapid Visual Screening in the Community</b></p> <p>Students evaluate the potential earthquake damage to various structures in the their community.</p>		Motions and Forces		<p><b>Understanding about science and technology</b></p>	<p>Personal and community health</p> <p><b>Natural hazards</b></p>		
<p><b>S.5 Are the Lifelines Open?</b></p> <p>Students assess their community's vulnerability to earthquake damage.</p>		Motions and Forces		<p><b>Understanding about science and technology</b></p>	<p>Personal and community health</p> <p><b>Natural hazards</b></p>		



**SEISMIC SLEUTHS MATRICES  
FOR THE NATIONAL SCIENCE EDUCATION STANDARDS**

**UNIT 6: Now You Know It, Can You Show It? A variety of summing-up and assessment activities that showcase students' knowledge.**

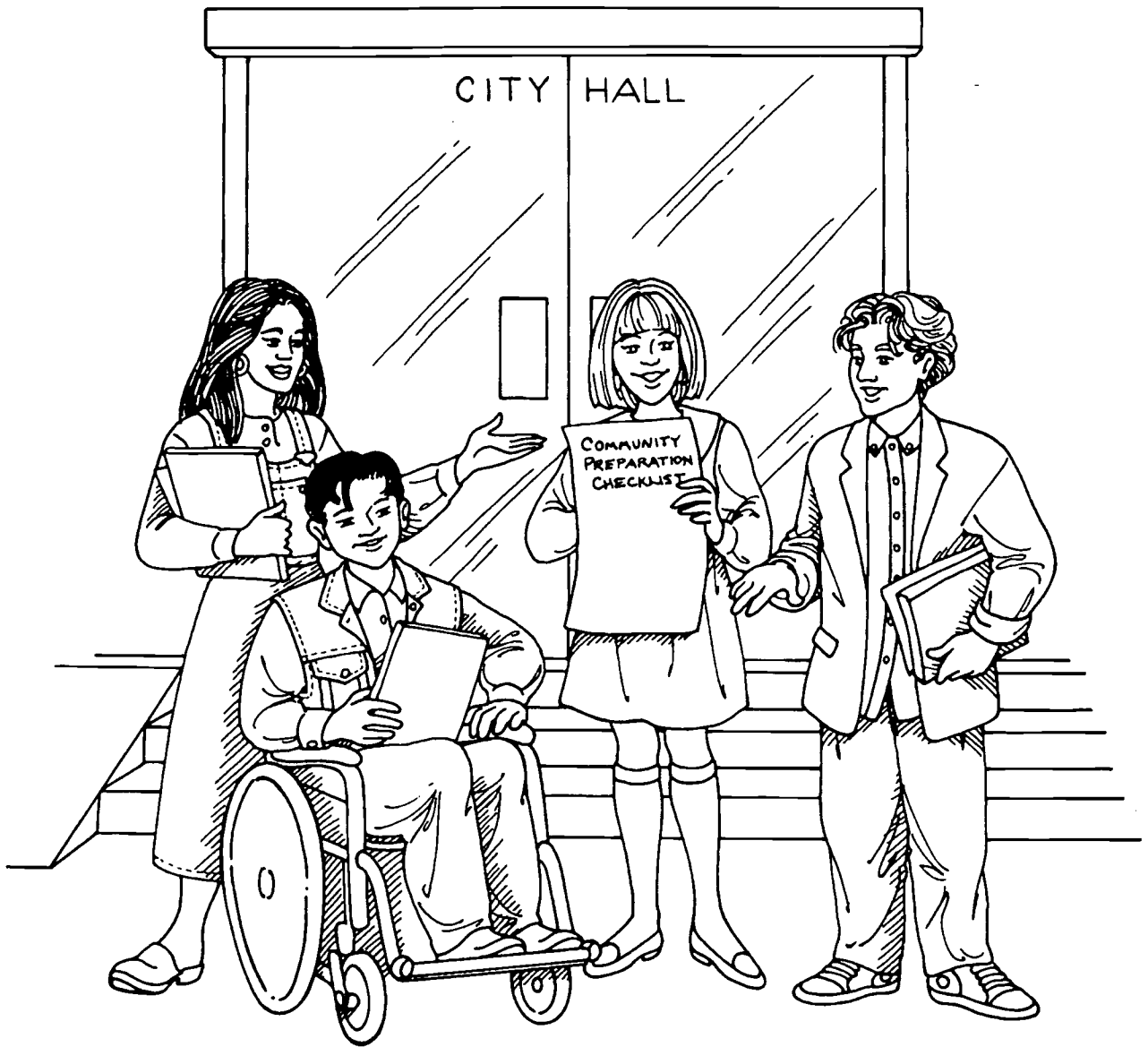
<b>SEISMIC SLEUTHS SECTIONS</b>	<b>SCIENCE AS INQUIRY</b>	<b>PHYSICAL SCIENCE</b>	<b>EARTH AND SPACE SCIENCE</b>	<b>SCIENCE AND TECHNOLOGY</b>	<b>SCIENCE IN PERSONAL AND SOCIAL PERSPECTIVES</b>	<b>HISTORY AND NATURE OF SCIENCE</b>	<b>UNIFYING CONCEPTS AND PROCESSES</b>
<p><b>6.1 Preparing for the Worst</b></p> <p>Students assume the roles of emergency planning officials in a hypothetical community.</p>		Forces and motions		<p><i>Abilities of technological design</i></p> <p><i>Understanding about science and technology</i></p>	<p><i>Personal and community health</i></p> <p><i>Natural and human-induced hazards</i></p>		<p>Order and organization</p> <p><i>Evidence, models, and explanation</i></p>
<p><b>6.2 Earthquakes Simulation: Putting Plans into Action</b></p> <p>An emergency simulation exercise.</p>		Motions and forces		<p><i>Understanding about science and technology</i></p>	<p><i>Personal and community health</i></p> <p><i>Natural and human-induced hazards</i></p> <p>Science and technology in local, national, and global challenges</p>		
<p><b>6.3 What's Your E.Q., I.Q.?</b></p> <p>A quiz show format for assessment.</p>						<p><i>Nature of scientific knowledge</i></p>	Evidence, models, and explanation
<p><b>6.4 Hey, Look at Me Now!</b></p> <p>An assessment activity that repeats the writing exercise in 1.1</p>	<p>Abilities related to scientific inquiry</p> <p><i>Understanding about scientific inquiry</i></p>	Motions and forces	<p>Structure of the Earth system</p> <p>Energy in the Earth system</p> <p>Origin and evolution of the Earth system</p>	<p><i>Understanding about science and technology</i></p>	<p><i>Personal and community health</i></p> <p><i>Natural and human-induced hazards</i></p> <p><i>Science and technology in local, national, and global challenges</i></p>		<p><i>Evidence, models, and explanation</i></p>

# TABLE OF CONTENTS

## SEISMIC SLEUTHS CURRICULUM PACKAGE

<b>Unit 1. What's It All About?</b> .....	<b>2</b>
1. What Do You Know about Earthquakes? .....	3
2. It Could Happen Here .....	11
3. Investigating Community Preparedness .....	17
Unit Resources .....	25
<b>Unit 2. What Happens When the Earth Quakes?</b> .....	<b>38</b>
1. Stick-Slip Movement .....	39
2. Shifting Plates and Wandering Poles .....	45
3. Earthquakes in Geologic Time .....	67
4. Earthquake Hazards .....	89
5. Quake-Smart Siting .....	127
Unit Resources .....	137
<b>Unit 3. How Do People Learn about Earthquakes?</b> .....	<b>142</b>
1. The Waves of Quakes .....	143
2. Pioneering Ideas .....	151
3. Sizing Up Earthquakes .....	161
4. Distribution of Earthquakes .....	193
Unit Resources .....	221
<b>Unit 4. Can Buildings Be Made Safer?</b> .....	<b>226</b>
1. Building Fun .....	227
2. Structural Reinforcement: The Better Building .....	232
3. The BOSS Model: Building Oscillation Seismic Simulation .....	247
4. Earthquake in a Box .....	257
5. The Building Challenge .....	263
Unit Resources .....	270
<b>Unit 5. What Should People Do Before, During, and After an Earthquake?</b> .....	<b>272</b>
1. Predicting Earthquakes .....	273
2. Starting Here, Starting Now .....	289
3. Find and Fix the Hazards (Wood Frame Homes) .....	299
4. Rapid Visual Screening (RVS) in the Community .....	311
5. Are the Lifelines Open? Critical Emergency Facilities and Lifeline Utility Systems .....	319
Unit Resources .....	327
<b>Unit 6. Now You Know It, Can You Show It?</b> .....	<b>330</b>
1. Preparing for the Worst: A Simulation .....	331
2. Earthquake Simulation: Putting Plans into Action .....	341
3. What's Your E.Q. I.Q.? .....	345
4. Hey, Look at Me Now! .....	353
Unit Resources .....	355
<b>Appendix: Earthquake Drill</b> .....	<b>356</b>
<b>Earthquake Glossary</b> .....	<b>360</b>

U N I T O N E



# What's It All About?

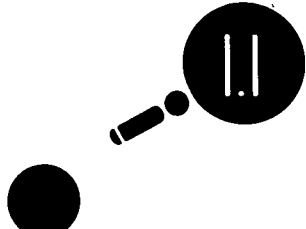
Every teacher, no matter how busy, should take time to cover some of the material in this three-part introductory unit. Through brainstorming and new contacts within the community, students move from planning for their own safety to learning firsthand about critical facilities and lifeline systems that serve large numbers of people.

Please read through all the lessons well in advance, especially noting the Teacher Preparation section at the beginning of each Procedure. In this unit you will build a foundation for the units and lessons ahead by enlisting the cooperation of your school's administrators, your fellow teachers, and emergency personnel throughout the community and even beyond. Take time to scan the rest of the units too. You may want to let parents know now that you will be asking for their help in the Unit Five field trips and home safety activities. If you plan to involve the school community and outside experts in the culmination of Unit Four, also include this information in the initial contacts you make during this unit.

Lesson one, which students may complete either individually or in small groups, provides an assess-

ment of what students already know about earthquakes plus experience with both scientific and popular ways of describing them. The worksheets provided will make this activity easier for students who aren't thoroughly comfortable with writing. In lesson two, students distinguish between luxuries and necessities, describe their own experience with natural hazards and how they and their families obtained the necessities, and come to see how preparedness can help individuals and families cope effectively in the event of an earthquake or other natural disaster. In the following units, students will learn some strategies for risk reduction.

Lesson three, which requires the cooperation of a number of emergency personnel in the community at large, calls for some extra effort on the part of your students. Teachers who have tried it report that the outcome is worth the effort. The contacts you and your students make now will be vital through the units that follow and even after this curriculum is completed. Your students, their families, and your entire community will be empowered to prepare wisely for the possibility of an earthquake or other destructive natural phenomenon.



# What Do You Know about **EARTHQUAKES?**

## **RATIONAL**

---

This preassessment activity is designed to focus your students on what they are about to learn, assess their current knowledge, and later provide them and you with a gauge of what they have learned from this earthquake curriculum.

## **FOCUS QUESTIONS**

---

What do you know about earthquakes and earthquake preparedness? What would you like to learn from these lessons?

## **OBJECTIVES**

---

**Students will:**

1. Use various writing styles to describe a hypothetical earthquake.
2. Anticipate what they will learn in this study of earthquakes.

## **MATERIALS**

---

- Writing paper and pens
- Student copies of Master 1.1a, Writing Outlines (three pages)
- Classroom computers (*optional*)
- Pictures or slides of earthquake damage (*optional: See Unit Resources.*)

## **PROCEDURE**


---

### **A. Introduction**

Show a selection of images to familiarize students with the kind of damage earthquakes can cause. Tell students that they are going to draw on the knowledge they already have about earthquakes to invent a specific quake and imagine themselves in it. Distribute copies of the writing outlines, Master 1a, and ask each student to note the date and time of their quake, its location, how much damage it caused, and other basic information at the top of page 1.

## **TEACHING CLUES AND CUES**

---



At the end of this activity, collect the assignments and hold onto them until you have done the last lesson you plan to teach from this curriculum before the postassessment activity. You will use them again in postassessment.

## B. Lesson Development

Now tell students that each of them is going to write about his or her hypothetical earthquake from three different points of view: that of a news reporter, a scientist, and an individual directly affected by the quake. Each of the three accounts will describe the same earthquake, but the styles of the three will vary.

*News Reporter*—a short, concise article describing the who, what, where, and when of the earthquake and providing information the public needs.

*Scientist*—a scientific account stating what is objectively known about the earthquake: its causes, its effects, its magnitude and/or intensity, and the likelihood of its recurrence, if known.

*Eyewitness*—a personal letter to a friend telling about being in an earthquake. This will describe what happened to the student, to the building in which the student was, to family members and pets, and to the family home during the earthquake. Have students describe what they had done before the earthquake to be prepared, how effective their preparations were, what life was like in the two weeks following the earthquake, and what they would do differently in preparation for the next earthquake.

Tell students to feel free to make up information, quotations, etc., but to keep the basic facts consistent from one essay to another. Since, in real life, compositions of the second and third type are likely to be written later than news accounts, however, some discrepancies in details are to be expected.

## C. Conclusion

Ask students to talk about the experience of writing the accounts. Ask:

- Did you feel you had enough information to do the job in each case?
- Did some of you wish you knew more? Is there anything specific you'd like to find out?
- Was one point of view more comfortable than the others? Were some accounts easier to write?

Discuss the validity of the different points of view. Emphasize that each kind of account is valuable in its own right.

## ADAPTATIONS AND EXTENSIONS

1. If time is short, form groups of three students each. Have each student develop one point of view and share it with the group.
2. If this assessment reveals that students have very little basic information about earthquakes, you may want to spend class time with some of the books or videos in the Unit 2 resource list before proceeding.
3. Invite students to write about an earthquake from a premodern point of view, such as that of a Native American in North America before Columbus. Alternatively, students may write from the viewpoint of a traditional culture with which they are familiar.

## TEACHING CLUES AND CUES




The newspaper accounts on Master 5.1a are examples of how news articles are written.



This activity is purely diagnostic. Explain to students that you do not expect professional scientific writing—only their best try on the basis of what they already know.

4. Invite students to bring in samples of writing about earthquakes and classify them as journalistic, scientific, or informal. This could make a long-term bulletin board display. ▲

#### **TEACHING CLUES AND CUES**

 If you have access to enough computers, encourage students to compose their accounts on a classroom computer and save the files. This will make it easy to rewrite them later as a postassessment activity.





Name \_\_\_\_\_ Date \_\_\_\_\_

*Just the facts:*

Date and time of the hypothetical earthquake \_\_\_\_\_

Location (city, state, country) \_\_\_\_\_

Estimated strength and impact

Richter magnitude \_\_\_\_\_ Deaths \_\_\_\_\_

Injuries \_\_\_\_\_ Property damage \$ \_\_\_\_\_

Maximum Mercalli intensity if known (I–XII) \_\_\_\_\_

Date of last earthquake in this region \_\_\_\_\_

*Use these same facts in each of the three variations that follow.*

**1. Newspaper account:** intended for the general public, who need practical information. May appear immediately after the quake, while aftershocks are still occurring and emergency conditions are still in effect.

Dateline (place and time of filing story) \_\_\_\_\_

Lead sentence—must be catchy, attention-grabbing. May be a particularly startling fact or a quotation (make it up) from a person in authority, an expert, or an eyewitness.

Rest of lead paragraph—must answer what, where, when, who was affected, and how. (May use quotations.)

One or more body paragraphs—provide background. Add more details on effects, quotations from more people, possible explanation, analysis. (Think of what people need to know—what to do, where to go, what to watch for.)

Final sentence—the clincher; ends story with a punch. (Possibly a warning about aftershocks?)



**2. Scientific account:** intended for specialists; will probably appear well after the dust has settled.

**Lead paragraph**—must answer what, where, when, who was affected, and how. Likely to be heavy with data instead of quotations. (Make them up too, but keep them consistent with the basic data at the top of page 1.)

**One or more body paragraphs**—provide background and analysis, More details on effects, maybe quotations from experts, scientific explanations, and hypotheses. (Will probably compare original and revised estimates of severity and effects, compare earthquake to other quakes.)

**Final paragraph**—summarizes what scientific knowledge has been gained or what plans are underway to gather information as a result of the earthquake.

**3. Informal account:** intended for a friend, usually also written after the worst is over; may include humor or exaggeration.

*[inside address]*

Name

Street no., Apt. no.

City/State/Zip

Date

Dear [name],

Your friend,

---

# It Could Happen Here!

## RATIONALE

Students will consider the range of their needs and the state of their personal preparedness for an emergency.

## FOCUS QUESTIONS

What do people need to survive?

What kinds of natural events can prevent people from meeting their basic needs?

How does society cope with these events?

## OBJECTIVES

**Students will:**

1. Distinguish between luxuries and necessities.
2. Describe their own experience with severe weather or natural disasters, and how they and their families fared.
3. Explain why preparedness can help individuals and families cope effectively in the event of an earthquake or other natural disaster.

## MATERIALS

- Chart paper
- Felt markers
- Student copies of Master 1.2a, Three-Day Survival Pack
- Transparency made from Master 5.5b, A Chain of Disasters (*optional*)
- Overhead projector (*optional*)
- Materials for assembling the Three-Day Survival Pack (*optional*)

## PROCEDURE

### A. Introduction

Ask students to consider which of all the things they use and consume every day are really essential to their survival. Discuss, and develop a class listing on chart paper. (Answers may include variations on water, food, clothing, and shelter.)

## VOCABULARY



**Earthquake:** a sudden shaking of the ground caused by the passage of seismic waves. These waves are caused by the release of energy stored in the Earth's crust.

**Natural hazard:** any of the range of natural Earth processes that can cause injury or loss of life to human beings and damage or destroy human-made structures.

Ask: How do you meet these needs? (Answers will include faucets, restaurants, grocery stores or parents' refrigerators, school cafeterias, clothing stores, parents' homes.) Now ask students to name some natural occurrences that could cut them off from these sources, and describe their own experiences with snowstorms, hurricanes, floods, or earthquakes. Beyond their own experience, what events of this type have they heard or read about in the last two years? Develop a list of events.

## B. Lesson Development

1. Elicit a definition of natural hazards from the class. Emphasize that earthquakes, volcanoes, floods, hurricanes, tsunami, and similar events are the result of natural processes in the life of our dynamic Earth. These processes have shaped our Earth and created the beauty of mountains, valleys, lakes, and rivers. Be sure students understand the difference between natural events and those caused by human activity.

2. Ask: If an earthquake occurs in an uninhabited region, and has no impact on human beings or human property, is it a disaster? (Not for human beings, though it may be for other life forms.) Are we able to control natural events, or accurately predict when they will occur? (No, but students may be aware of instances in which human activity has influenced natural events, as in the relationship between dams and floods, and of our relative success in predicting some meteorological events.) Lead students to the conclusion that because our ability to control natural events, or even predict when they will occur, is still very limited, people have a responsibility to plan how they would cope if an earthquake or other destructive event struck their community.

3. Ask students how they and their families coped with any destructive events they have experienced. Were their homes equipped with everything they needed? Did they have to leave their homes? Were the roads open? Were the stores open? Who provided help? (If personal experiences are lacking, discuss recent news accounts of earthquakes, floods, and storms.)

4. Look again at the list of vital necessities and widen the discussion to include the needs of communities as well as individuals. Ask: If a major earthquake occurred in or near your community, what necessities would have to be added to the first list? (Answers may include medical care, electrical power and other utilities, and essential transportation—for hospital workers, police, firefighters, and people who supply food, water, and other necessities.)

Emphasize that a damaging earthquake would disrupt all or most of the community's lifelines—its supplies of water and power and its transportation and communications systems. Emergency services, such as police, fire departments, and emergency medical technicians, would be severely taxed and unable to answer all calls for assistance. For this reason, individuals, families, and neighborhoods must be prepared to be self-sufficient for at least 72 hours.

## TEACHING CLUES AND CUES



Please save the lists students develop in this lesson. You will use them again later in this lesson and in Unit 5, lesson 5.



To help students understand why electricity, natural gas, and other services would be disrupted by an earthquake, you may want to project a transparency made from Master 5.5b, A Chain of Disasters.



Many scientists prefer the term *natural hazard* to *natural disaster* because proper preparation can avert disaster, preventing or minimizing injury and damage. This curriculum encourages students to take a proactive role in preparing themselves and their community to survive destructive natural events.

### C. Conclusion

Distribute student copies of Master 1.2a, Three-Day Survival Pack. Explain its purpose. The Federal Emergency Management Agency (FEMA) and law enforcement authorities recommend that every family assemble a pack like this and keep it handy in their home for emergencies, checking it periodically to keep it up to date. (Batteries may need replacing, family needs may have changed.) Compare this list with the lists students have developed. If your school is in a high-risk zone, you may want to prepare a variation of the survival pack to keep in your classroom.

Ask students to take the sheet home and encourage the members of their household to cooperate in filling a clean trash can or other suitable container with these supplies. Make sure that everyone knows its location.

Tell students that in the following lessons they will learn more about one type of natural hazard, earthquakes. They will also research their own community's potential to survive destructive natural events, especially earthquakes.

### ADAPTATIONS AND EXTENSIONS

1. In section A., Introduction, instead of a class discussion, you might ask individuals or small groups to develop lists of essentials they would need to survive 72 hours without access to power, running water, roads, stores, and so on. Then challenge each student or group to justify the items on their list, and develop a class list from the items that most students agree are essential. Compare this list with Master 1.2a when it is distributed.

2. Make a list of the daily activities that involve electricity, water, natural gas, telephone, and transportation. Then enlist the cooperation of parents in an at-home recovery simulation. For a period of 24 hours (representing 72 hours), ask students to do without things that would not be available after an earthquake—telephone or other communication, nonessential transportation, electricity, gas, and running water. Alternatively, consider involving the administration and the other teachers in an in-school simulation. With preplanning, heat or cooling could be turned down, lessons in every subject could be earthquake-related, and lunch could feature emergency rations. ▲

### TEACHING CLUES AND CUES



In assembling the survival pack, group can openers and other utensils in one container so they'll be easy to find.



Suggest that families assemble a smaller version of the pack to keep in the trunk of the car.

**TOP OF THE BARREL**

**Flashlight and radio with batteries**  
**First aid kit, including:**

**Medicines**

Antibiotic ointment  
 Aspirin, acetaminophen, or ibuprofen  
 Ipecac (to induce vomiting)  
 Kaopectate™  
 Prescription medications (insulin, heart tablets)

**Other supplies**

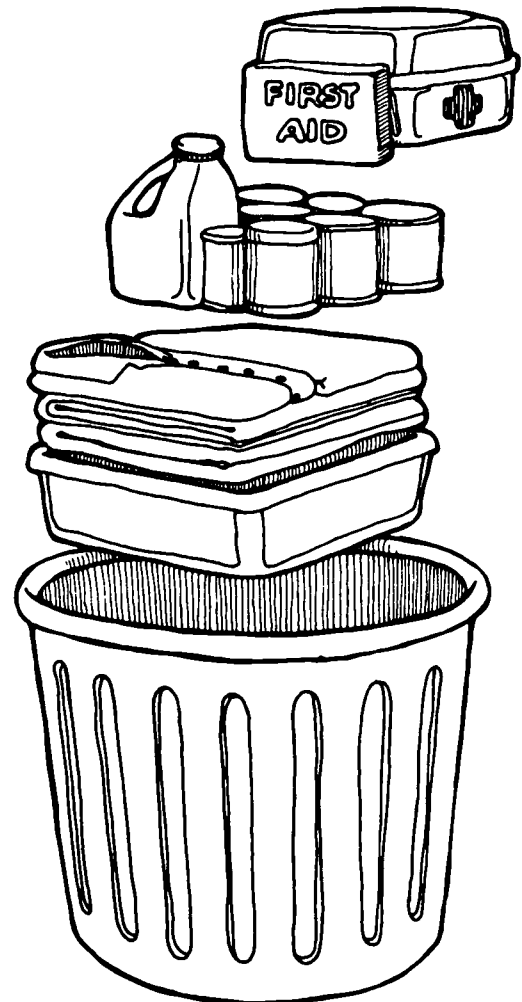
Scissors  
 Tweezers  
 Thermometer  
 Petroleum jelly  
 Rubbing alcohol  
 Tissues & toilet paper  
 Pocketknife  
 First-aid handbook

**Dressings**

Adhesive tape, 2" wide roll  
 Sterile bandage, 2" and 4" rolls  
 Large triangular bandages  
 Band-aids™  
 Cotton-tipped swabs  
 Sterile absorbent cotton  
 Ace bandage  
 Butterfly bandages  
 Gauze pads, 4" x 4"  
 Latex gloves

**Emergency instructions**

Waterproof page with phone numbers, when & how to turn off utilities, meeting places, etc.

**MIDDLE OF THE BARREL**

**Water (4 liters [about 1 gal] per person)**

**Three-day supply of food**

- Choose food that does not require refrigeration.
- Date all food items.
- Write out a menu for each day.

**Suggested foods (1/2 lb. per person):**

Canned tuna	Graham crackers
Canned beans	Dried apricots
Nonfat dry milk	Peanut butter
Powdered juice mixes	Pet food if necessary
Canned juices	

**BOTTOM OF THE BARREL****Bedding**

Sleeping bags or blankets  
 Plastic sheet or tarp

**Personal supplies**

Toiletries  
 Towel  
 Books  
 Paper and pencil  
 Cash

**Infant supplies, if necessary****Fuel and light**

Matches  
 Candle  
 Signal flare  
 Canned heat (Sterno™)  
 Extra batteries

**Equipment**

Can opener  
 Dishpan  
 Disposable dishes  
 Disposable utensils  
 Ax  
 Shovel  
 Bucket and plastic bag liners

**Other**

Water purification tablets  
 Chlorine bleach  
 Eye dropper

**Clothing**

One change per person

- Place pack in convenient place known to all family members. Keep a smaller version in the trunk of your car.
- Keep items in airtight bags.
- Change stored water every three months. Check and rotate food every six months. Mark dates on your calendar.
- Rethink kit once a year. Update supplies and replace batteries, outgrown clothing, and perishables.

# Investigating Community Preparedness

## RATIONALE

Now that students have thought seriously about individual survival in the event of a natural disaster, it is time for them to learn about their community's survival plans.

## FOCUS QUESTIONS

How would your community cope in the event of an earthquake or other natural disaster?

Who are the people responsible for your community's survival and recovery?

## OBJECTIVES


**Students will:**

1. Adopt and begin to research individual roles in community earthquake planning, management, and follow-up.
2. Set up a classroom map for further elaboration.
3. Begin a process of learning through and with the community that continues throughout this entire curriculum.

## MATERIALS

- Master 1.3a, Preparedness People
- Local map
- Transparency made from Master 1.3b, U.S. Earthquake Hazard Map
- Extra transparency sheets
- Overhead projector
- A square of sturdy paper, 1 m x 1 m or larger
- Paper, pens, envelopes, and stamps for writing letters
- Markers in a variety of colors

## TEACHING CLUES AND CUES

 The other early lessons in Unit 1 will be revisited in Unit 6. This one will culminate in a major simulation in Unit 6, but it will also be woven throughout Units 2 to 5. The classroom map will play a major role in this continuing development, so it is worth the time you spend on it now.

## PROCEDURE

### Teacher Preparation

1. Look at Master 1.3a, Preparedness People, and add or subtract items as necessary to fit your community and the number of students in each class. Make a transparency from your list.
2. Find a map, or a portion of a map, that includes your students' homes and one or more local governments. Copy the map onto a transparency sheet.
3. Decide whether to assign roles, allow students to choose them, or hold elections, at least for the major roles. If the class is very large, you may want to assign more than one student for some roles.
4. Find out who is responsible for emergency response in your school building. Notify this person of your plans to teach about earthquakes. Notify the administration and fellow teachers as well, and enlist their cooperation for the long term.

### A. Introduction

Ask students if they have ever heard the emergency broadcast system go into effect on radio or TV. Do they know who is responsible for emergency response in their school? If they don't know, tell them, and briefly describe the procedures that would be followed during an earthquake. (In most schools, students would drop, cover, and hold until the shaking stopped, following their classroom teacher's directions. Then the principal would direct an evacuation similar to that during a fire drill. See Unit 5, Lesson 2 for more details.)

Remind students that an earthquake or other natural disaster in their own area would impact large numbers of people. Tell them that in Unit 6 each of them will play the role of someone with responsibility for the community's emergency planning and survival. In this unit they will adopt that role and begin to learn about it.

### B. Lesson Development

1. Project the U.S. Earthquake Hazard Map, Master 1.3b, and determine how great a seismic hazard is shown for your state or region.
2. Project the Preparedness People master, and go over the list of roles students could assume throughout this curriculum. Incorporate student suggestions in developing the final list, then distribute the roles.
3. Assign students to contact their mentors and set up interviews. Each student will interview one individual to learn what the person does and what role he or she plays in the community's earthquake preparedness plan. Students may tailor their questions to the person, but every interview should include these questions:
  - What are the current emergency plans for this area?
  - Have they ever been implemented?
  - What is your role during an emergency?
  - How many people answer to you?

## TEACHING CLUES AND CUES



If you and your class determine that the seismic risk for your area is very low, you may want to expand your focus to include hazards of greater local concern, such as tornadoes or other storms or flooding. Keep earthquakes in focus as well, however. Remind students that most of them will move several times in the course of their lives and that earthquakes can happen anywhere.



Outside of class, write or call the "preparedness people" in your community to let them know that students will be contacting them and why and to enlist their cooperation.



This map is drawn along state lines for ease of use. A map drawn along geological boundaries would look quite different and might put parts of some states in another hazard category.



- What are the lines of communication during an emergency?
- What is the budget of this department or organization?
- How much of this is dedicated for emergency preparedness and actual emergencies?
- May I call you again if I have additional questions?
- Would you be willing to speak to my class?

Encourage students to take notes, to review their notes after the interview, and to make follow-up calls if they find they are missing any information.

4. Assign students to write letters thanking their mentors for the interviews. Review the format of a business letter, if necessary. Tell students that each letter must include details from the notes taken during the interview, so that both the recipient and you, the teacher, will know the time was well spent. Collect the letters and mail them from the school.

5. Fasten the large, sturdy sheet of paper to the wall and project the map transparency onto the paper. Move the projector away from the paper until the image reaches the desired size, then trace the image on the paper.

6. With the class, work out a way to represent all of the following on the large area map you have prepared:

- Hospitals and nursing homes
- Fire and police stations
- Power, sewage, and water plants
- Gas, water, electric, and sewage trunk lines
- Railroads and other mass transit systems
- Major roads and highways
- Telephone systems and other communications systems
- Schools

All of these are considered critical facilities or lifeline utility systems. Schools are important both because they may house large populations to be evacuated and because they frequently serve as centers for emergency shelter and the distribution of supplies.

### C. Conclusion

Display the local map prominently in the front of the classroom. Students will add to this map, and to their role knowledge, as they gain information throughout these lessons.

### TEACHING CLUES AND CUES

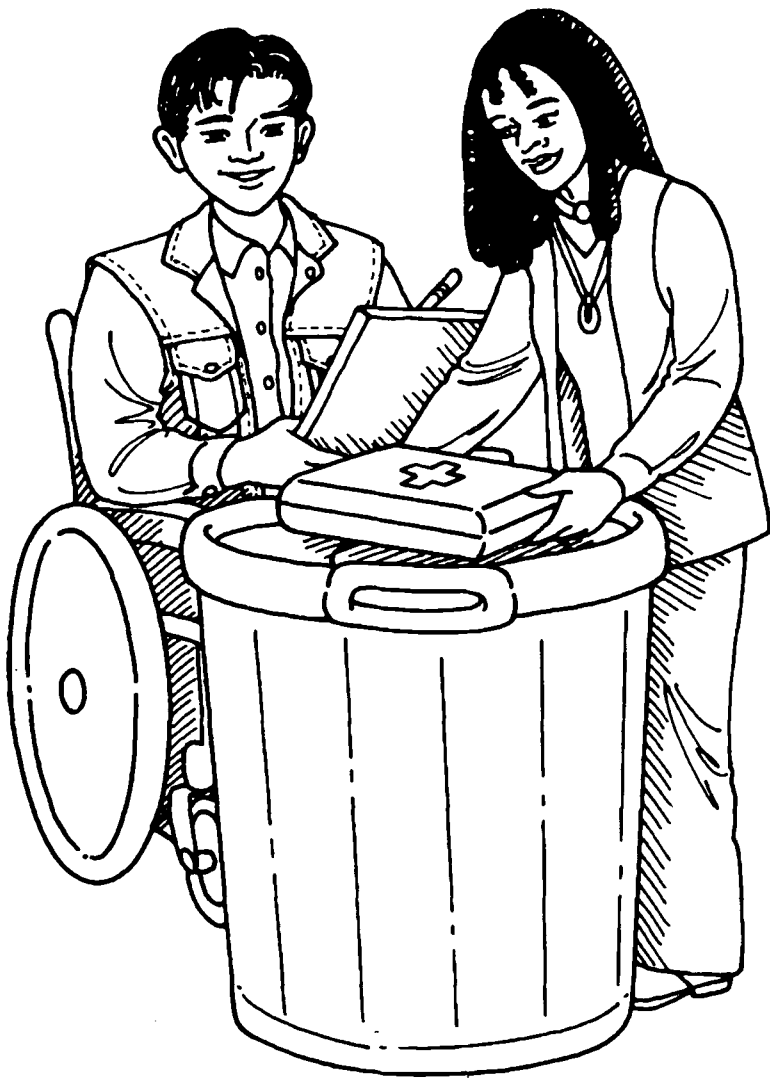


If more than one class is doing this activity, consider sending a group for each interview (for example, one "mayor" from each class to interview the mayor together).

## ADAPTATIONS AND EXTENSIONS

---

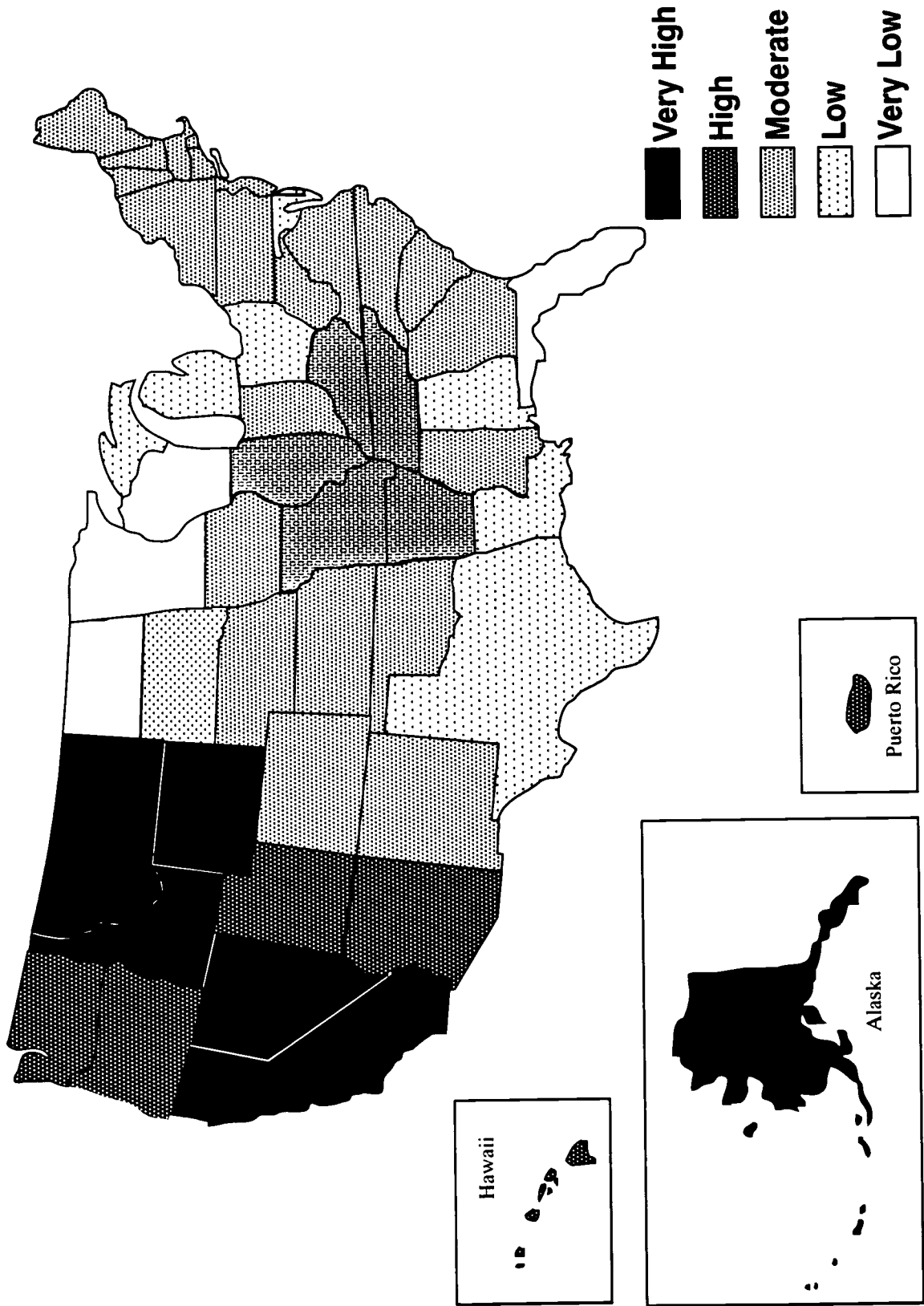
1. If your city or metropolitan area is a large one, divide it into regions and assign one to each of several classes. If it is small, extend your investigation into the surrounding communities.
2. Assign students to learn as much as they can about disasters that have impacted their town or area in the past. They can begin by interviewing long-time residents and searching the newspaper archives.
3. If you do not plan to teach all the units in order, you may want to introduce Unit 5, Lesson 5 at this time. ▲



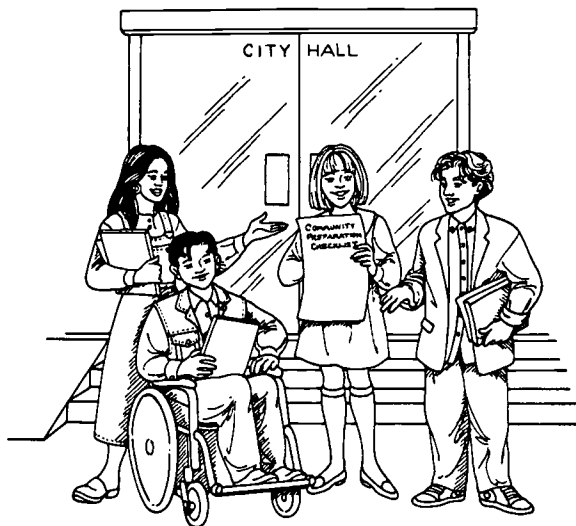
All these people and more may play a role in your community's disaster preparedness planning and response.

- Mayor or City Administrator
- City Manager
- Public Information Officer
- Chief of Police
- Fire Chief
- Emergency Services Coordinator
- Superintendent of Schools
- School District Risk Manager
- City Building Code Inspector
- City Council Members
- City Geologist
- City Planner
- Coordinator of Roads and Transportation
- Director of Public Health
- Director of Public Works
- Superintendent of the Sewage Plant
- Superintendent of the Water Department
- Electric Company Emergency Officer
- Gas Company Emergency Officer
- Telephone Company Emergency Coordinator
- Hospital Safety and Security Manager

# U.S. EARTHQUAKE Hazard Map



Source: Based on NEHRP [National Earthquake Hazards Reduction Program] Recommended Provisions for New Buildings.



### **BIBLIOGRAPHIES**

National Center for Earthquake Engineering Research (NCEER) Information Service. (1995). "Teachers Packets, 9-12." Buffalo, NY: State University of New York at Buffalo.

*Seismology Resources for Teachers.* Seismological Society of America, 21 Plaza Professional Building, El Cerrito, CA 94530; 415-525-5474. Includes software, databases, and video listings.

World Amateur Seismological Society. "Reference List for Amateur Seismologists." A list of references intended to serve as an introduction to the literature of seismology.

### **BOOKS**

American Red Cross, Los Angeles Chapter. (1985). *The Emergency Survival Handbook*. In English and Spanish. A simple, practical, and easy-to-use guide.

Federal Emergency Management Agency/National Science Teachers Association. *Earthquakes—A Teacher's Package for K-6 (Tremor Troop)*. (FEMA 159, 1992). Washington, DC: FEMA/NSTA. (FEMA Publications, 500 C St. SW, Washington, DC 20472.)

*The Homeowners Guide to Earthquake Safety.* Sacramento, CA: California Seismic Safety Commission (1900 K Street, Sacramento, CA 95814).

Kimball, Virginia. (1992). *Earthquake Ready: The Complete Preparedness Guide*. Malibu, CA: Roundtable Publishing, Inc., A practical, non-technical guide to preparation and survival.

*Movers and Shakers.* An educational program for grades K-12 that includes a video and a two-sided classroom poster. Available free to educators by writing to Movers and Shakers (E-8), State Farm Insurance Companies, One State Farm Plaza, Bloomington, IL 61710-0001.

Plafker, George, and Galloway, John P., eds. (1989). *Lessons Learned from the Loma Prieta Earthquake of October 17, 1989*. Denver, CO: U.S. Geological Survey, Circular # 1045. Excellent photographs, maps, and illustrations.

Yanev, P. (1991). *Peace of Mind in Earthquake Country: How to Save Your Home and Your Life*. San Francisco, CA: Chronicle.

### **PAMPHLETS AND PERIODICALS**

American Red Cross, Los Angeles Chapter. *27 Things to Help You Survive an Earthquake*. Los Angeles, CA: American Red Cross. (2700 Wilshire Blvd., Los Angeles, CA 90057; 213-739-5200.) Poster in English and Spanish lists 4 things to do during an earthquake, 6 to do afterwards, 14 survival items to keep on hand, and 3 essential things to know.

*Earthquakes and Volcanoes.* An attractive, nontechnical magazine published bimonthly by the U.S. Geological Survey to provide current seismological information. Washington, DC: U.S. Government Printing Office; 202-783-3238; \$8/yr.

Federal Emergency Management Agency pamphlets. "Family Earthquake Drill and Home Hazard Hunt," FEMA 113; "Earthquake Safety Checklist," FEMA 46.

Harris, J.W. (1980). "Building a Firm Foundation—Educating about Geologic Disasters." *The Science Teacher* 47, 9: 22–25.

"May 18th, 1980: Eyewitness Accounts by *Cobblestone Readers*." *Cobblestone* (May 1981): pp. 20–23. By and for readers 8–14. This issue has several good features on earthquakes.

"Scientists Predict: Big Quake Will Strike Eastern U.S." *Current Science* (Jan. 6, 1989): p. 7. For readers 10–16.

*Teacher's Packet of Geologic Materials*. A collection of leaflets, booklets, and reference lists provided free by the U.S. Geological Survey, Geologic Inquiries Group, 907 National Center, Reston, VA 22092. Send request on school letterhead, indicating the subject and grade level you teach.

Westrup, H. "Giant Quake: When Will It Strike?" *Current Science* (Sept. 7, 1990): pp. 4–5. For readers 10–16.

**NON-PRINT MEDIA**

*Earthquake Slides*. Photographs of earthquake effects, copies of seismograms, and seismicity maps can be obtained from the National Geophysical and Solar Terrestrial Data Center, Code D62, NOAA/EDS, Boulder, CO 80302.

Earthquake Sound Cassette Tape. Emergency Preparedness Committee, Utah State PTA, 1037 East South Temple, Salt Lake City, UT 84102; 801/359-3875. A one-minute tape available for \$2, including postage.

EERI Videotapes and Slide Sets. Oakland, CA: Earthquake Engineering Research Institute. For information, phone 510-451-0905, or fax 510-451-5411.

National Earthquake Information Center Seismicity Maps. Full-color maps available from USGS/NEIC, PO Box 25046, Federal Center, MS 967, Denver, CO 80225-0046; 303-273-8477. \$5–\$15 plus \$2 shipping.

Nur, Amos, and MacAskill, Chris. (1991). *The Walls Came Tumbling Down: Earthquakes in the Holy Land*. Stanford, CA: ESI Productions. Video provides a tour along an active fault from the north of Israel to Jerusalem.

*Steinbrugge Collection*. Richmond, CA: Earthquake Engineering Research Center. Over 10,000 photographs and 5,000 slides of earthquake damage. The library will provide copies to teachers and researchers. Call 510-231-9401 for information.

USGS posters plus seismicity maps for most of the states. USGS Map and Book Distribution, PO Box 25286, Federal Center, Building 10, Denver, CO 80225; 303-236-7477.

*World Seismicity Map*. Large 48" x 36" wall map shows epicenters, depths of foci, and dates and magnitudes of large quakes. Ward's Natural Science Establishment, Inc., 5100 W. Henrietta Road, PO Box 92912, Rochester, NY 14692-9012; 800-962-2660.

*Note: Inclusion of materials in these resource listings does not constitute an endorsement by AGU or FEMA.*

# Earthquake Information Resource List

## State Geological Survey Offices

Geological Survey of Alabama  
420 Hackenberry Lane  
P.O. Box O  
Tuscaloosa, AL 35486-9780  
205-349-2852

Alaska State Geological Survey  
794 University Avenue  
Suite 200  
Fairbanks, AK 99709-3645  
907-474-7147  
FAX: 907-479-4779

Arizona Geological Survey  
845 North Park Avenue  
Suite 100  
Tucson, AZ 85719  
602-882-4795

Arkansas Geological Commission  
Vardelle Parham Geology Center  
3815 West Roosevelt Road  
Little Rock, AR 72204  
501-324-9165

California Division of Mines & Geology  
801 K Street  
Mail Stop 14-33  
Sacramento, CA 95814-3532  
916-323-5336

Colorado Geological Survey  
1313 Sherman Street  
Room 715  
Denver, CO 80203  
303-866-2611  
FAX: 303-866-2115

Geological Survey of Connecticut  
Dept. of Environmental Protection  
Natural Resources Center  
165 Capitol Avenue  
Room 553  
Hartford, CT 06106  
203-566-3540

Delaware Geological Survey  
University of Delaware  
Delaware Geological Survey Building  
Newark, DE 19716  
302-831-2833  
FAX: 302-831-3579

Geologist of Washington, DC  
Univ. of the District of Columbia  
Dept. of Environmental Science  
4200 Connecticut Avenue, NW  
Washington, DC 20008-1154  
202-282-7380  
FAX: 202-282-3675

Florida Bureau of Geology  
Florida Dept. of Natural Resources  
903 West Tennessee Street  
Tallahassee, FL 32304  
904-488-9380

Georgia Geologic Survey  
Georgia Dept. of Natural Resources  
Environmental Protection Div.  
19 M.L. King Jr. Drive, Room 400  
Atlanta, GA 30334  
404-656-3214

Hawaii Geological Survey  
Div. of Water/Land Development  
Dept. of Land & Natural Resources  
P.O. Box 373  
Honolulu, HI 96809  
808-587-0230  
FAX: 808-587-0219

Idaho Geological Survey  
University of Idaho  
Morrill Hall, Room 332  
Moscow, ID 83843  
208-885-7991  
FAX: 208-885-5826

Illinois State Geological Survey  
Natural Resources Building  
615 East Peabody Drive  
Champaign, IL 61820  
217-333-5111  
FAX: 217-244-7004

Indiana Geological Survey  
Dept. of Natural Resources  
611 North Walnut Grove  
Bloomington, IN 47405  
812-855-9350  
FAX: 812-855-2862

Iowa Dept. of Natural Resources  
Geological Survey Bureau  
123 North Capitol Street  
Iowa City, IA 52242  
319-335-1575  
FAX: 319-335-2754

Kansas Geological Survey  
University of Kansas  
1930 Constant Avenue  
Campus West  
Lawrence, KS 66047  
913-864-3965  
FAX: 913-864-5317

Kentucky Geological Survey  
University of Kentucky  
228 Mining & Minerals Resources Bldg.  
Lexington, KY 40506-0107  
606-257-5500  
FAX: 606-257-1147

## UNIT RESOURCES

Louisiana Geological Survey  
Louisiana State University  
P.O. Box G  
Baton Rouge, LA 70893  
504-388-5320  
FAX: 504-388-5328

Maine Geological Survey  
Dept. of Conservation  
State House Station #22  
Augusta, ME 04333  
207-287-2801  
FAX: 207-287-2353

Maryland Geological Survey  
Maryland Dept. of Natural Resources  
2300 St. Paul Street  
Baltimore, MD 21218  
410-554-5504

Massachusetts Office of the  
State Geologist  
Commonwealth of Massachusetts  
100 Cambridge Street, 20th Floor  
Boston, MA 02202  
617-727-9800  
FAX: 617-727-2754

Michigan Dept. of Natural Resources  
Geological Survey Div.  
Box 30028  
Lansing, MI 48909  
517-334-6923  
FAX: 517-334-6038

Minnesota Geological Survey  
University of Minnesota, Twin Cities  
2642 University Avenue  
St. Paul, MN 55114-1057  
612-627-4780  
FAX: 612-627-4778

Mississippi Office of Geology  
Mississippi Dept. of  
Environmental Quality  
P.O. Box 20307  
2380 Highway 80 West  
Jackson, MS 39289-1307  
601-961-5500  
FAX: 601-961-5521

Missouri Dept. of Natural Resources  
Division of Geology & Land Survey  
P.O. Box 250  
Buehler Bldg/111 Fairgrounds Road  
Rolla, MO 65401  
314-368-2100  
FAX: 314-368-2111

Montana Bureau of Mines & Geology  
Montana Coll. of Min. Sci. & Tech.  
West Park Street  
Main Hall  
Butte, MT 59701  
406-496-4180

Nebraska Geological Survey  
University of Nebraska - Lincoln  
Conservation and Survey Division  
901 North 17th Street  
113 Nebraska Hall  
Lincoln, NE 68588-0517  
402-472-3471

Nevada Bureau of Mines & Geology  
University of Nevada, Reno  
Mail Stop 178  
Reno, NV 89557-0088  
702-784-6691  
FAX: 702-784-1709

New Hampshire Geological Survey  
University of New Hampshire  
Dept. of Earth Science  
117 James Hall  
Durham, NH 03824  
603-862-3160  
FAX: 603-862-2030

New Jersey Geological Survey  
New Jersey Division of  
Science & Research  
CN 029  
Trenton, NJ 08626  
609-633-6587  
FAX: 609-633-1004

New Mexico Bureau of Mines &  
Mineral Resources  
N.M. Inst. of Mining & Technology  
Campus Station  
Socorro, NM 87801  
505-835-5420  
FAX: 505-835-6333

New York State Geological Survey  
3136 Cultural Education Center  
Albany, NY 12230  
518-474-5816  
FAX: 518-473-8496

North Carolina Geological Survey  
Dept. of Environment, Health &  
Natural Resources  
Box 27687  
Raleigh, NC 27611  
903-733-3833

North Dakota Geological Survey  
600 East Boulevard  
Bismarck, ND 58505-0840  
701-224-4109  
FAX: 701-224-3682

Ohio Dept. of Natural Resources  
Division of Geological Survey  
4383 Fountain Square Drive Building  
Columbus, OH 43224-1362  
614-265-6576  
FAX: 614-447-1918

Oklahoma Geological Survey  
University of Oklahoma  
100 East Boyd  
Energy Center, Room N-131  
Norman, OK 73019-0628  
405-325-3031  
FAX: 405-325-3180

Oregon Dept. of Geology &  
Mineral Industries  
800 NE Oregon Street, #28  
Suite 965  
Portland, OR 97232  
503-731-4100  
FAX: 503-731-4066

Pennsylvania Geological Survey  
Box 2357, 9th Floor  
Harrisburg, PA 17105  
717-787-2169  
FAX: 717-783-7267

Geological Survey of Puerto Rico  
Dept. de Recursos Naturales  
Munoz Rivera Ave., Stop 3  
San Juan, PR 00906  
809-724-8774

Geological Survey of Rhode Island  
University of Rhode Island  
Geology Dept.  
315 Green Hall  
Kingston, RI 02881  
401-792-2265

South Carolina Geological Survey  
South Carolina Mapping Services  
5 Geology Road  
Columbia, SC 29210-9998  
803-737-9440

South Dakota Geological Survey  
University of South Dakota  
Dept. of Water & Natural Resources  
Science Center  
Vermillion, SD 57069-2390  
605-677-5227  
FAX: 605-677-5895



## UNIT RESOURCES

Tennessee Division of Geology  
Dept. of Environment & Conservation  
Dept. of Geology  
701 Broadway, Suite B-30  
Nashville, TN 37243  
615-742-6689  
FAX: 615-742-6594

Texas Bureau of Economic Geology  
University of Texas, Austin  
University Station, Box X  
Austin, TX 78713-7508  
512-471-1534  
FAX: 512-471-0140

Utah Geological Survey  
Utah Dept. of Natural Resources  
2363 South Foothill Drive  
Salt Lake City, UT 84109-1491  
801-467-7970  
FAX: 801-467-4070

Vermont Geological Survey  
Agency of Natural Resources  
103 South Main Street  
Center Building  
Waterbury, VT 05671-0301  
803-244-5164  
FAX: 802-244-4528

Virginia Division of Mineral Resources  
Dept. of Mines, Minerals & Energy  
Alderman & McCormick Roads  
Charlottesville, VA 22903  
804-293-5121  
FAX: 804-293-2239

Washington Dept. of Natural Resources  
Geology/Earth Resources  
Mail Stop PY-12  
Olympia, WA 98504  
206-459-6372  
FAX: 206-459-6380

West Virginia Geological &  
Economic Survey  
P.O. Box 879  
Morgantown, WV 26507-0879  
304-594-2331

Wisconsin Geological & Natural  
History Survey  
University of Wisconsin - Extension  
3817 Mineral Point Road  
Madison, WI 53705  
608-262-1705  
FAX: 608-262-8086

Geological Survey of Wyoming  
State of Wyoming  
P.O. Box 3008, University Station  
Laramie, WY 82071  
307-766-2286  
FAX: 307-766-2605

### Selected Regional & Other USGS Offices

Albuquerque  
Earth Data Analysis Center  
University of New Mexico  
Albuquerque, NM 87131-6031  
505-227-3622

Anchorage  
Room 101  
4230 University Drive  
Anchorage, AK 99508-4664  
907-786-7011

Fairbanks  
Box 12, Federal Building  
101 12th Avenue  
Fairbanks, AK 99701  
907-456-0244

Lakewood  
MS 504, Room 1813  
Building 25, Federal Center  
Denver, CO 80225-0046  
303-236-5829

Menlo Park  
MS 532, Room 3128  
Building 3  
345 Middlefield Road  
Menlo Park, CA 94025-3591  
415-329-4309

Reston  
US Geological Survey  
507 National Center  
Reston, VA 22092  
703-648-6045

Rolla  
MS 231  
1400 Independence Road  
Rolla, MO 65401-2602  
314-341-0851

Salt Lake City  
USGS-ESIC  
2222 W. 2300 South  
Salt Lake City, UT 84138-1177  
801-524-5652

Sioux Falls  
EROS Data Center  
Sioux Falls, SD 57198-0001  
605-594-6151

Spokane  
Room 135  
US Post Office Building  
W. 904 Riverside Avenue  
Spokane, WA 99201-1088

Stennis Space Center  
Building 3101  
Stennis Space Center, MS 39529  
601-688-3541

US Department of the Interior  
Room 2650  
1849 C Street NW  
Washington, DC 20240  
202-208-4047

Eastern Region  
Assistant Chief Geologist  
US Geological Survey  
953 National Center  
Reston, VA 22092  
703-648-6660

Northeastern Regional Hydrologist  
Water Resources Division  
433 National Center  
Reston, VA 22092  
703-648-5813

Southeastern Regional Hydrologist  
Water Resources Division  
Suite 160  
3850 Holcomb Bridge Road  
Spalding Woods Office Park  
Norcross, GA 30092  
404-409-7700

Mapping Applications Center  
12201 Sunrise Valley Drive  
Reston, VA 22092  
703-648-6002

Central Region  
Director's Representative &  
Assistant Chief Geologist  
Box 25046  
911 Denver Federal Center  
Denver, CO 80225  
303-236-5438

Central Region Hydrologist  
Water Resources Division  
Box 25046  
406 Denver Federal Center  
Denver, CO 80225  
303-236-5920

## UNIT RESOURCES

Mid-Continent Mapping Center  
1400 Independence Road  
Rolla, MO 65401  
314-341-0880

Rocky Mountain Mapping Center  
Box 25046  
Denver Federal Center  
Denver, CO 80225  
303-236-5825

EROS Data Center  
Sioux Falls, SD 57198-0001  
705-594-6123  
(For map and book orders)

Branch of Distribution  
Box 25286  
Building 810  
Denver Federal Center  
Denver, CO 80225  
303-236-7477

ESIC Open-File Report Sales  
Box 25286, Building 810  
Denver Federal Center  
Denver, CO 80225  
303-236-7476  
(For report orders)

Western Region  
Director's Representative  
MS 144  
US Geological Survey  
345 Middlefield Road  
Menlo Park, CA 94025  
415-329-4002

Western Region Hydrologist  
Water Resources Division  
MS 470  
US Geological Survey  
345 Middlefield Road  
Menlo Park, CA 94025  
415-329-4414

Western Mapping Center  
US Geological Survey  
345 Middlefield Road  
Menlo Park, CA 94025-3591  
415-329-4524

Special Assistant to the Director for  
Alaska  
4230 University  
Anchorage, AK 99508-4664  
907-786-7001

Alaska Volcano Observatory  
4200 University Drive  
Anchorage, AK 99508  
907-786-7497

Branch of Atlantic Marine Geology  
Gosnold Building  
Quissett Campus  
Woods Hole, MA 02543  
508-548-8700

Cascades Volcano Observatory  
David A. Johnston Building  
5400 MacArthur Blvd.  
Vancouver, WA 98661  
206-696-7693

Center for Coastal and Regional  
Marine Studies  
600 Fourth St. S.  
St. Petersburg, FL 33701  
813-893-3100

Flagstaff Field Center  
2255 N. Gemini Drive  
Flagstaff, AZ 86001  
602-556-7151

Hawaiian Volcano Observatory  
Volcanoes National Park  
Hilo, HI 96718  
808-967-7328

Hydrologic Information Unit  
US Geological Survey  
419 National Center  
Reston, VA 22092  
703-648-6817

Geologic Inquiries Group  
US Geological Survey  
907 National Center  
Reston, VA 22092  
703-648-4383

USGS Library  
US Geological Survey  
950 National Center  
Reston, VA 22092  
703-648-4302

Minerals Information Office  
Corbett Building, Room 340  
North Sixth Avenue  
Tucson, AZ 85705-8325  
602-670-5544

Minerals Information Office  
Room 133  
W. 904 Riverside Avenue  
Spokane, WA 99201  
509-353-2649

Minerals Information Office  
Mackay School of Mines  
University of Nevada  
Reno, NV 89557-0047  
702-784-5552

Minerals Information Office  
Room 2647  
Main Interior Building  
1849 C St. NW  
Washington, DC 20240  
202-208-5512  
(a joint USGS/US Bureau of Mines  
office)

National Earthquake Information  
Center  
MS 967  
Denver Federal Center  
Box 25046  
Denver, CO 80225  
303-273-8500

National Landslide Information Center  
MS 966  
Denver Federal Center  
Box 25046  
Denver, CO 80225  
303-273-8587

National Water Data Exchange  
US Geological Survey  
421 National Center  
Reston, VA 22092  
703-648-5016

Office of Water Data Coordination  
US Geological Survey  
417 National Center  
Reston, VA 22092  
703-648-5016

*Source: American Geological Institute*

**U.S. Department of Agriculture  
Soil Conservation Service  
State Offices**

State Conservationist  
USDA Soil Conservation Service  
665 Opelika Road  
Auburn, AL 36830  
205-821-8080, x535

## UNIT RESOURCES

State Conservationist  
USDA Soil Conservation Service  
949 E. 36th Avenue - Suite 400  
Anchorage, AK 99508-4302  
907-271-2424

State Conservationist  
USDA Soil Conservation Service  
201 E. Indianola Avenue - Suite 200  
Phoenix, AZ 85012  
602-640-2247

State Conservationist  
USDA Soil Conservation Service  
5404 Federal Building  
700 W. Capitol Street  
Little Rock, AR 72201  
501-324-5964

State Conservationist  
USDA Soil Conservation Service  
21221-C Second Street - Suite 102  
Davis, CA 95616-5475  
FTS-757-8200  
916-757-8200

State Conservationist  
USDA Soil and Conservation  
655 Parfet Street - E200C  
Lakewood, CO 80215-5517  
303-236-0295

State Conservationist  
USDA Soil Conservation Service  
16 Professional Park Road  
Storrs, CT 06268-1299  
203-487-4013

State Conservationist  
USDA Soil Conservation Service  
1203 College Park Drive - Suite A  
Dover, DE 19901-8713  
302-678-4160

District Conservationist  
Cooperative Extension Service  
901 Newton Street, NE  
Washington, DC 20017  
202-576-6951

State Conservationist  
USDA Soil Conservation Service  
401 SE 1st Avenue - Suite 248  
Gainesville, FL 32601  
904-377-0946

State Conservationist  
USDA Soil Conservation Service  
Federal Building, Box 13  
355 E. Hancock Avenue  
Athens, GA 30601  
FTS-250-2272  
404-546-2272

Director, Pacific Basin  
USDA Soil Conservation Service  
602 GCIC Building  
414 W. Soledad Avenue  
Agana, Guam 96910  
671-472-7490

State Conservationist  
USDA Soil Conservation Service  
300 Ala Moana Blvd - Suite 4316  
Honolulu, HI 96850  
808-541-2601

State Conservationist  
USDA Soil Conservation Service  
3244 Elder Street - Suite 124  
Boise, ID 83705  
208-334-1601

State Conservationist  
USDA Soil Conservation Service  
1902 Fox Drive  
Champaign, IL 61820  
217-398-5267

State Conservationist  
USDA Soil Conservation Service  
6013 Lakeside Blvd  
Indianapolis, IN 46278  
317-290-3200

State Conservationist  
USDA Soil Conservation Service  
693 Federal Building  
210 Walnut Street  
Des Moines, IA 50309  
515-284-4261

State Conservationist  
USDA Soil Conservation Service  
760 South Broadway  
Salina, KS 67401  
913-823-4570

State Conservationist  
USDA Soil Conservation Service  
771 Corporate Drive - Suite 110  
Lexington, KY 40503-5479  
606-233-2749

State Conservationist  
USDA Soil Conservation Service  
3737 Government Street  
Alexandria, LA 71302  
318-473-7751

State Conservationist  
USDA Soil Conservation Service  
5 Godfrey Drive  
Orono, ME 04473  
207-581-3446

State Conservationist  
USDA Soil Conservation Service  
301 John Hanson Business Center  
339 Busch's Frontage Road  
Annapolis, MD 21401  
410-757-0861

State Conservationist  
USDA Soil Conservation Service  
451 West Street  
Amherst, MA 01002  
413-256-0441

State Conservationist  
USDA Soil Conservation Service  
1405 S. Harrison Road - Suite 101  
East Lansing, MI 48823-5202  
517-337-6702

State Conservationist  
USDA Soil Conservation Service  
600 Farm Credit Building  
375 Jackson Street  
St. Paul, MN 55101-1854  
612-290-3675

State Conservationist  
USDA Soil Conservation Service  
1321 Federal Building  
100 W. Capitol Street  
Jackson, MS 39269  
601-965-5205

State Conservationist  
USDA Soil Conservation Service  
Parkade Center - Suite 250  
601 Business Loop, 70 West  
Columbia, MO 65203  
314-876-0903

State Conservationist  
USDA Soil Conservation Service  
443 Federal Building  
10 E. Babcock Street  
Bozeman, MT 59715-4704  
406-587-6813

## UNIT RESOURCES

State Conservationist  
USDA Soil Conservation Service  
345 Federal Building  
100 Centennial Mall North  
Lincoln, NE 68508-3866  
402-587-6813

State Conservationist  
USDA Soil Conservation Service  
Bldg. F - Suite 201  
5301 Longley Lane  
Reno, NV 89511  
702-784-5863

State Conservationist  
USDA Soil Conservation Service  
Federal Building  
Durham, NH 03824  
603-868-7581

State Conservationist  
USDA Soil Conservation Service  
1370 Hamilton Street  
Somerset, NJ 08873  
908-246-1662

State Conservationist  
USDA Soil Conservation Service  
517 Gold Avenue, NW - Suite 3301  
Albuquerque, NM 87102-3157  
505-766-2173

State Conservationist  
USDA Soil Conservation Service  
771 Hanley Federal Building  
100 S. Clinton Street  
Syracuse, NY 13260-7248  
315-423-5521

State Conservationist  
USDA Soil Conservation Service  
4405 Bland Road - Suite 205  
Raleigh, NC 27609  
919-790-2888

State Conservationist  
USDA Soil Conservation Service  
278 Federal Building  
220 E. Rosser Avenue  
Bismarck, ND 58502-1458  
701-250-4421

State Conservationist  
USDA Soil Conservation Service  
200 N. High Street - Suite 522  
Columbus, OH 43215-2478  
614-469-6962

State Conservationist  
USDA Soil Conservation Service  
Agriculture Center Building  
Farm Road & Brumley Street  
Stillwater, OK 74074  
405-624-4360

State Conservationist  
USDA Soil Conservation Service  
1640 Federal Building  
1220 SW 3rd Avenue  
Portland, OR 97204  
503-326-2751

State Conservationist  
USDA Soil Conservation Service  
1 Credit Union Place - Suite 340  
Wildwood Center  
Harrisburg, PA 17110-2993  
717-782-2202

Director, Caribbean Area  
USDA Soil Conservation Service  
P.O. Box 364868  
San Juan, PR 00936-4868  
809-766-5206

State Conservationist  
USDA Soil Conservation Service  
46 Quaker Lane  
West Warwick, RI 02893  
401-828-1300

State Conservationist  
USDA Soil Conservation Service  
950 Thurmond Federal Building  
1835 Assembly Street  
Columbia, SC 29201  
803-765-5681

State Conservationist  
USDA Soil Conservation Service  
Federal Building  
200 Fourth Street, SW  
Huron, SD 57350-2475  
605-353-1783

State Conservationist  
USDA Soil Conservation Service  
675 Kefauver Federal Building  
801 Broadway Street  
Nashville, TN 37203  
615-736-5471

State Conservationist  
USDA Soil Conservation Service  
Poage Federal Building  
101 S. Main Street  
Temple, TX 76501-7682  
817-774-1214

State Conservationist  
USDA Soil Conservation Service  
4402 Bennett Federal Building  
125 S. State Street  
Salt Lake City, UT 84138  
801-524-5050

State Conservationist  
USDA Soil Conservation Service  
69 Union Street  
Winooski, VT 05404  
802-951-6785

State Conservationist  
USDA Soil Conservation Service  
9201 Federal Building  
400 N. 8th Street  
Richmond, VA 23240  
804-771-2455

State Conservationist  
USDA Soil Conservation Service  
Rock Pointe Tower II  
W. 316 Boone Avenue - Suite 450  
Spokane, WA 99201-2348  
509-353-2337

State Conservationist  
USDA Soil Conservation Service  
75 High Street - Suite 301  
Morgantown, WV 26505  
304-291-4151

State Conservationist  
USDA Soil Conservation Service  
6515 Watts Road - Suite 200  
Madison, WI 53719-2726  
608-264-5577

State Conservationist  
USDA Soil Conservation Service  
3124 Federal Building  
100 East B Street  
Casper, WY 82601  
307-261-5201

*Source: U.S. Department of Agriculture*

### **FEMA Regional Earthquake Program Managers**

Earthquake Program Manager  
FEMA Region 1 - NT  
442 J.W. McCormack POCH  
Boston, MA 02109-4595

Earthquake Program Manager  
FEMA Region 2 - NT  
26 Federal Plaza  
New York, NY 10278-0002

## UNIT RESOURCES

Earthquake Program Manager  
FEMA Caribbean Office  
P.O. Box 70105  
San Juan, PR 00936

Earthquake Program Manager  
FEMA - Region 3  
105 S. Seventh St.  
Philadelphia, PA 19106-3316

Earthquake Program Manager  
FEMA - Region 4 - NT  
1371 Peachtree Street, NE  
Atlanta, GA 30309-3108

Earthquake Program Manager  
FEMA Region 5 - NT  
175 West Jackson  
Chicago, IL 60604-2698

Earthquake Program Manager  
FEMA Region 6 - NT  
800 North Loop 288  
Denton, TX 76201-3698

Earthquake Program Manager  
FEMA Region 7 - NT  
911 Walnut Street  
Kansas City, MO 64106-2085

Earthquake Program Manager  
FEMA Region 8 - NT  
Denver Federal Center  
Denver, CO 80225-0267

Earthquake Program Manager  
FEMA Region 9 - NT  
Presidio of SF, Bldg 105  
San Francisco, CA 94129-1250

Earthquake Program Manager  
FEMA Region 10, NT  
130 - 228th St., S.W.  
Bothell, WA 98021-9796

### State Emergency Management Directors and State Earthquake Program Managers

#### Alaska

Director  
Alaska Division of Emergency Services  
New Anchorage Armory  
Building 49000, Suite B-210  
P.O. Box 5750  
Fort Richardson, AK 99505-5750  
907-428-7000  
(FAX) 907-428-7009

Earthquake Program Manager  
907-428-7022  
(FAX) 907-428-7009

#### Arizona

Director  
Arizona Division of Emergency Services  
5636 E. McDowell Road  
Phoenix, AZ 85008  
602-231-6245  
(FAX) 602-231-6231

Earthquake Program Manager  
602-231-6238  
(FAX) 602-231-6231

#### Arkansas

Director  
Arkansas Office of Emergency Services  
P.O. Box 758  
Conway, AR 72032  
501-329-5601  
(FAX) 501-327-8047

Earthquake Preparedness Program  
Supervisor  
Earthquake Preparedness Program  
501-329-5601  
(FAX) 501-327-8047

#### California

Director  
Governor's Office of Emergency  
Services  
State of California  
2800 Meadowview Road  
Sacramento, CA 25832-1499  
916-427-4990  
(FAX) 916-427-4215

Deputy Director  
Governor's Office of Emergency  
Services  
1110 E. Green Street, Suite 300  
Pasadena, CA 91106  
818-304-8388  
(FAX) 818-795-2030

Northern/Bay Area/Coastal  
Earthquake Program Manager  
101 8th Street, Suite 152  
Oakland, CA 94607  
510-540-2713

Southern California  
Earthquake Program Manager  
1110 East Green Street  
Suite 300  
Pasadena, CA 91106  
818-304-8383

#### Colorado

Director  
Office of Emergency Management  
Camp George West  
Golden, CO 80401-3997  
303-273-1622  
(FAX) 303-273-1795

#### Connecticut

State Director  
Office of Emergency Management  
360 Broad Street  
Hartford, CT 06105  
203-566-3180/4338  
(FAX) 203-247-0664

#### Georgia

Executive Director  
Georgia Emergency Management  
Agency  
P.O. Box 18055  
Atlanta, GA 30316-0055  
404-624-7000  
(FAX) 404-624-7205

Earthquake Program Manager  
404-624-7000  
(FAX) 404-624-7205

#### Guam

Director of Civil Defense  
Guam Emergency Services Office  
Territory of Guam  
P.O. Box 2877  
Agana, Guam 96910  
671-477-9841  
(FAX) 671-477-3727

Earthquake Program Manager  
Civil Defense  
671-477-9841/9842  
(FAX) 671-477-3727

# UNIT RESOURCES

## Hawaii

Vice Director of Civil Defense  
Department of Defense  
3949 Diamond Head Road  
Honolulu, HI 96816  
808-734-2161  
(FAX) 808-737-4150

Earthquake Program Manager  
Hawaii State Civil Defense  
808-734-2161  
(FAX) 808-737-4150

## Idaho

State Earthquake Program  
Coordinator  
Idaho Bureau of Disaster Services  
650 West State Street  
Boise, ID 83720  
208-334-3460  
(FAX) 208-334-2322

Earthquake Program Manager  
208-334-3460  
(FAX) 208-334-2322

## Illinois

Acting Director  
Illinois Emergency Management Agency  
110 East Adams Street  
Springfield, IL 62706  
217-782-2700  
(FAX) 217-782-2589

Chief, Division of Planning  
217-782-4448  
(FAX) 217-782-2589

## Indiana

Director  
Indiana State Emergency  
Management Agency  
Indiana Government Center  
Center South, Suite E-208  
302 West Washington Street  
Indianapolis, IN 46204  
317-232-3830  
(FAX) 317-232-3895

## Iowa

Administrator  
Iowa Emergency Management  
Division  
Hoover State Office Building  
Level A, Room 29  
Des Moines, IA 50319  
515-281-3231  
(FAX) 515-281-7539

## Kansas

Deputy Director  
Division of Emergency Preparedness  
P.O. Box C-300  
Topeka, KS 66601  
913-266-1400  
(FAX) 913-266-1129

## Kentucky

Executive Director  
Kentucky Disaster and Emergency Services  
EOC Building, Boone Center  
Frankfort, KY 40601-6168  
502-564-8680  
(FAX) 502-564-8614

Earthquake Program Manager  
502-564-8628  
(FAX) 502-564-8614

## Maine

Director  
Maine Emergency Management  
Agency  
State House Station 72  
Augusta, ME 04233  
207-289-4080  
(FAX) 207-289-4079

Earthquake Program Manager  
207-2870-4029

## Massachusetts

Director  
Massachusetts Emergency  
Management Agency  
400 Worcester Road  
P.O. Box 1496  
Framingham, MA 01701  
508-820-2003  
(FAX) 508-820-2030

Earthquake Program Manager  
Massachusetts Earthquake Hazards  
Reduction Program  
508-820-2000  
(FAX) 508-820-2030

## Mississippi

Director  
Mississippi Emergency Management Agency  
P.O. Box 4501, Fondren Station  
Jackson, MS 39296-4501  
601-352-9100  
(FAX) 601-352-8314

Earthquake Program Manager  
601-960-9978  
(FAX) 601-352-8314

## Missouri

Director  
State Emergency Management Agency  
P.O. Box 116  
Jefferson City, MO 65102  
314-751-9779  
(FAX) 314-634-7966

Earthquake Program Manager  
314-751-9574  
(FAX) 314-634-7966

## Montana

Administrator  
Montana Disaster and Emergency  
Services Division  
P.O. Box 4789  
Helena, MT 59604-4789  
406-444-6911  
(FAX) 406-444-6965

Earthquake Program Manager  
406-444-6911

## Nebraska

Assistant Director  
Nebraska Civil Defense Agency  
1300 Military Road  
Lincoln, NE 68508-1090  
402-473-1410  
(FAX) 402-473-1433

Earthquake Program Manager  
402-473-2101  
(FAX) 402-473-1433

## Nevada

Director  
Nevada Division of Emergency  
Management  
2525 South Carson Street/Capitol  
Complex  
Carson City, NV 89710  
702-887-7302  
(FAX) 702-887-7246

Earthquake Program Manager  
702-687-4240  
(FAX) 702-687-6788

## New Hampshire

Director  
New Hampshire Office of Emergency  
Management  
State Office Park South  
107 Pleasant Street  
Concord, NH 03301  
603-271-2231  
(FAX) 603-225-7341

## UNIT RESOURCES

Natural Hazards Program Specialist  
603-271-2231  
(FAX) 603-225-7341

### New Jersey

Deputy State Director  
Office of Emergency Management  
New Jersey State Police  
P.O. Box 7068  
West Trenton, NJ 08628  
609-538-6050  
(FAX) 609-538-0345

New Jersey Office of Emergency  
Services  
609-538-6012

### New Mexico

Bureau Chief  
New Mexico Emergency  
Management Bureau  
Department of Public Safety  
4491 Cerrillos Road  
P.O. Box 1628  
Santa Fe, NM 87504  
505-827-3456

Earthquake Program Manager  
505-827-9254  
(FAX) 505-827-3381

### New York

Director  
New York State Emergency  
Management Office  
Public Security Building  
State Campus  
Albany, NY 12226-5000  
518-457-2222  
(FAX) 518-22457-9930

Earthquake Project Coordinators  
518-457-9959

### North Carolina

Director  
North Carolina Division of  
Emergency Management  
116 West Jones Street  
Raleigh, NC 27603-1335  
919-733-3867  
(FAX) 919-733-7554

Lead Planner, Natural Hazards  
919-733-3627  
(FAX) 919-733-7554

### Oklahoma

Director  
Oklahoma Department of Civil  
Emergency Management  
P.O. Box 53365  
Oklahoma City, OK 73152  
405-521-2481  
(FAX) 405-521-4053

Oklahoma Earthquake Program Officer  
405-521-2481  
(FAX) 405-521-4053

### Oregon

Administrator  
Oregon Emergency Management  
Division  
Executive Department  
595 Cottage Street, N.E.  
Salem, OR 97310  
503-378-4124  
(FAX) 503-588-1378

Earthquake Program Coordinator  
503-378-2911 ext. 237

### Pennsylvania

Director  
Pennsylvania Emergency Management  
Agency  
P.O. Box 3321  
Harrisburg, PA 17105-3321  
717-783-8016  
(FAX) 717-783-7393

PMD Chief/Earthquake Program  
Manager  
Pennsylvania Emergency Management  
Transportation and Safety  
Building B-151  
Harrisburg, PA 17120  
717-783-1048  
(FAX) 717-783-9223

### Puerto Rico

Director  
State Civil Defense Agency  
Commonwealth of Puerto Rico  
P.O. Box 5217  
San Juan, PR 00906

Deputy Executive Director  
Earthquake Safety Commission  
Commonwealth of Puerto Rico  
P.O. Box 5887  
Puerta de Tierra Station  
San Juan, PR 00906  
809-722-8784

### Rhode Island

Director  
Rhode Island Emergency Management  
Agency  
State House, Room 27  
Providence, RI 02903  
401-421-7333  
(FAX) 401-751-0827

Earthquake Program Manager  
Rhode Island Earthquake Project  
401-421-7333  
(FAX) 401-751-0827

### South Carolina

Director  
South Carolina Emergency Preparedness  
Division  
1429 Senate Street  
Columbia, SC 29201-3782  
803-734-8020  
(FAX) 803-734-8062

Earthquake Program Manager  
803-734-8020  
(FAX) 803-734-8062

### Tennessee

Director  
Tennessee Emergency Management  
Agency  
3041 Sidco Drive  
Nashville, TN 37204  
615-741-0001  
(FAX) 615-242-9635

Earthquake Program Manager  
615-741-4299  
(FAX) 615-741-0498

### Utah

Director  
Utah Division of Comprehensive  
Emergency Management  
State Office Building, Room 1110  
Salt Lake City, UT 84114  
801-538-3400  
(FAX) 801-538-3770

Epicenter Manager  
801-538-3786

## UNIT RESOURCES

### Vermont

Director  
Vermont Emergency Management Agency  
103 Main Street  
Waterbury, VT 05676  
802-244-8721  
(FAX) 802-244-8655

Earthquake Program Manager  
Vermont Earthquake Program  
802-244-8721  
(FAX) 802-244-8655

### Virgin Islands

Director  
Virgin Islands Emergency Management  
Agency  
VITEMA  
131 Gallows Bay  
Christiansted, VI 00820  
809-733-2244  
(FAX) 809-778-8980

Chief of Planning  
VITEMA  
2C Este Conte  
A & Q Buildings  
Charlotte Amalie  
St. Thomas, VI 00802  
809-774-2244

### Virginia

State Coordinator  
Office of Emergency Services  
310 Turner Road  
Richmond, VA 23225-6491  
804-674-2497  
(FAX) 804-674-2490

Earthquake Program Manager  
804-674-2442  
(FAX) 804-674-2431

### Washington

Assistant Director  
Washington State Department of  
Community Development  
Emergency Management Division  
4220 East Martin Way, PT-11  
Olympia, WA 98504  
206-923-4901  
(FAX) 206-438-7395

State Earthquake Program  
Coordinator  
206-923-4976  
(FAX) 206-923-4991

### West Virginia

Director  
West Virginia Office of Emergency  
Services  
State Capitol Building, EB-80  
Charleston, WV 25305  
304-558-5380  
(FAX) 304-344-4538

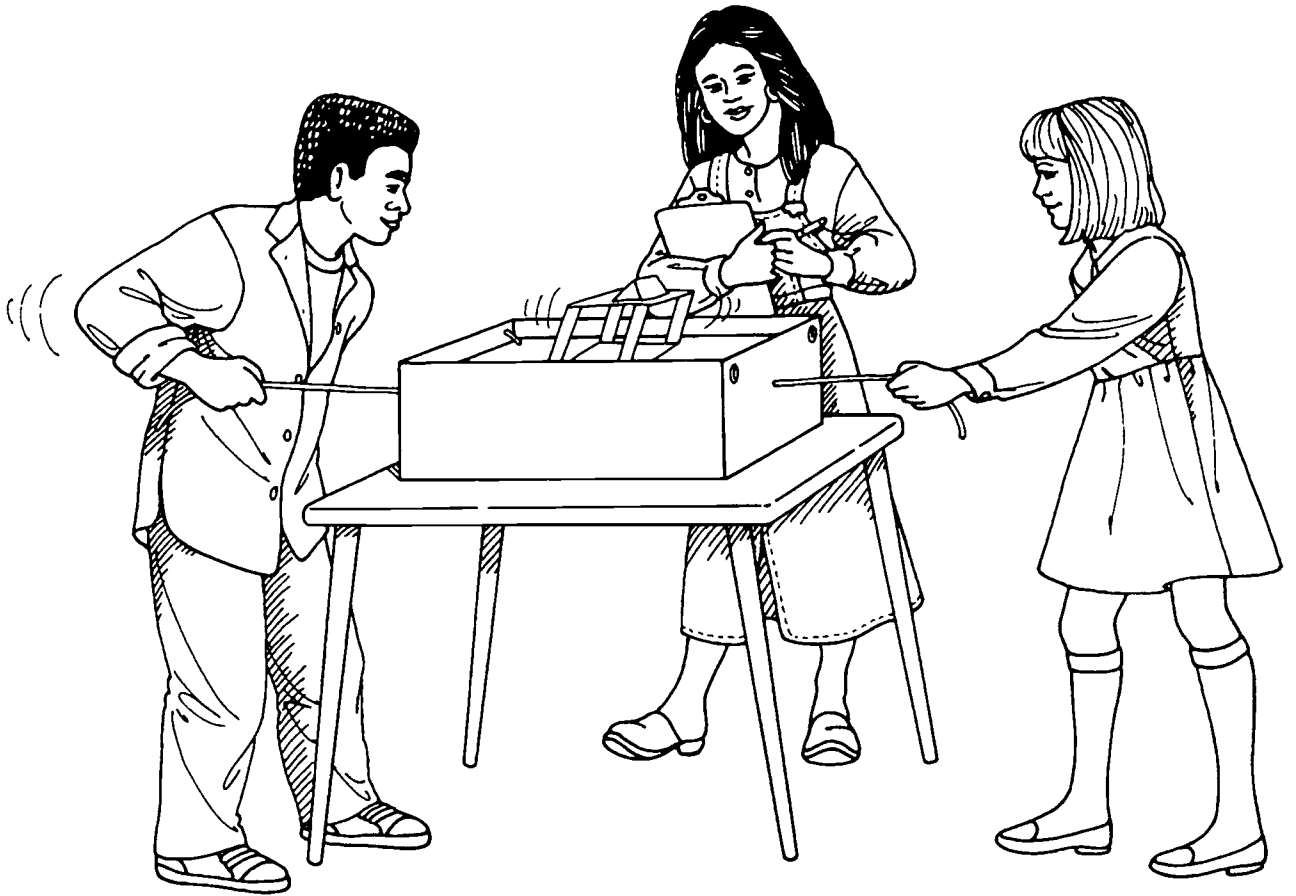
### Wyoming

Coordinator  
Wyoming Emergency Management  
Agency  
P.O. Box 1709  
Cheyenne, WY 82003  
307-777-7566  
(FAX) 307-635-6017

*Source: Federal Emergency Management  
Agency*



U N I T T W O





# What Happens When the **EARTHQUAKES?**

In this unit students will move beyond their own personal survival and that of their community, the focus of Unit 1, to the big picture of earthquakes in space and time. Since the Seismic Sleuths curriculum is intended to supplement, and not to replace, your school's own syllabus, it sketches this big picture without filling in all the basic earth science background. Your preparation to teach these lessons must begin with an assessment of your students' readiness. If they have no familiarity with rocks and minerals or with faulting and other processes that form landscapes, you may need to provide a brief introduction from the first few chapters of a high school geology or earth science textbook.

Unit 2 begins with a hands-on activity that models what happens when the stresses accumulated at a fault are released in an earthquake. Using a box, a board, sandpaper, and other simple materials, students apply scientific method and basic math skills to measure movement, calculate averages, and plot their information on a graph.

The second lesson includes three activities and an overview of what is now known about Earth's ever-shifting surface and its layered inner structure. In the first activity, students will reproduce the magnetic evidence for the migration of Earth's poles in the course of tectonic movement. In the second, they see how this record is written in the rocks at mid-ocean ridges. In the third, they create a map

showing the arrangement of the continents 120 million years ago, and compare it with the map of the world today. As students consider several alternative explanations for tectonic plate movement, remind them that earth science, like the Earth it studies, is constantly in motion. Scientific knowledge moves forward through questioning and the development of hypotheses into theories; its goal is never to provide dogmatic answers.

The third lesson begins with an exercise in which students contrast the small scope of historic time with the vastness of geologic time. In the second activity, Paleoseismology, they simulate the techniques seismologists use to read the record of relatively recent earthquakes.

The amount of damage an earthquake causes depends on the strength and duration of the earthquake, on population density, on methods of construction (to be dealt with in Unit 4), and on the geophysical/geological characteristics of the impacted area. Lesson 4 progresses to three of the most potentially destructive earthquake effects: liquefaction, landslides, and tsunamis. Each occurs when a seismic shock impacts an area with certain physical characteristics. Lesson 5 underlines the importance of site, as students interpret maps highlighting different features of the landscape. They will draw on their new knowledge to make additions to the local map they began in Unit 1.

# Stick-Slip Movement

## RATIONALE

---

Students will operate a model to observe the type of motion that occurs at a fault during an earthquake and explore the effects of several variables.

## FOCUS QUESTIONS

---

How much energy will a fault store before it fails?

Is this quantity constant for all faults?

## OBJECTIVES

---

### Students will:

1. Model the frictional forces involved in the movements of a fault.
2. Measure movement, calculate averages, and plot this information on a graph.
3. Explore the variables of fault strength vs. energy stored.

## MATERIALS

---

*for each small group*

- 1 copy of Master 2.1a, Stick-Slip Data Sheet
- 4 sandpaper sheets, 23 cm x 28 cm (9 in. x 11 in.), in 60, 120, and 400 grit (12 sheets)
- Scissors
- Strapping tape
- 1-lb box of sugar cubes
- 8 thumbtacks
- A box of rubber bands
- 2 large paper clips
- Yardstick or meter stick
- At least 2 m of string
- Large dowel or empty tube from a roll of paper towels

- Marking pen
- Scales
- Pine board, approx. 2.5 cm x 30 cm x 1.8 m (1 in. x 12 in. x 6 ft.)
- Several books to support one end of the board
- Protractor for measuring angles
- 1 brick (*optional*)

## PROCEDURE

### Teacher Preparation

To assure success, construct the model ahead of time and rehearse the activity. Then arrange materials for student models in a convenient place.

### A. Introduction

Elicit a definition of *fault* from the class, supplementing students' information as necessary until the essential elements have been covered.

Explain to students that when an earthquake occurs and movement begins on a fault plane, the movement will not proceed smoothly away from the focus. Any change in the amount of friction along the fault will cause the fault movement to be irregular. This includes changes along the length of the fault and with depth, changes in rock type and strength along the fault, and natural barriers to movement, such as changes in the direction of the fault or roughness over the surface of the fault plane.

Rupture along a fault typically occurs by fits and starts, in a type of sporadic motion that geologists call *stick-slip*. As energy builds up, the rock on either side of the fault will store the energy until its force exceeds the strength of the fault. When the residual strength of the fault is exceeded, an earthquake will occur. Movement on the fault will continue until the failure reaches an area where the strength of the rock is great enough to prevent further rupture. In this manner, some of the energy stored in the rock, but not all of it, will be released by frictional heating on the fault, the crushing of rock, and the propagation of earthquake waves.

### B. Lesson Development

1. Divide the class into working groups of at least four students each. Distribute one copy of Master 2.1a, Stick-Slip Data Sheet, to each group. Tell students that they are going to model a process, record data for each trial, and then vary the process, changing only one variable at a time.
2. Allow groups to assemble their materials, then give these directions:
  - a. Fold each piece of 120-grit sandpaper in half lengthwise and cut, to produce eight strips of sandpaper, each 11.5 cm x 28 cm (4.5 in. x 11 in.) in size.
  - b. Wrap one of the strips around the box and secure it around the sides (not the top and bottom) with two rubber bands. (See diagram.) Weigh and record box mass.

## VOCABULARY



**Fault:** a break or fracture in Earth's crust along which movement has taken place.

**Friction:** mechanical resistance to the motion of objects or bodies that touch.

**Stick-slip movement:** a jerky, sliding movement along a surface. It occurs when friction between the two sides of a fault keeps them from sliding smoothly, so that stress is built up over time and then suddenly released.

**Variable:** in a scientific experiment, the one element that is altered to test the effect on the rest of the system.

c. Tape the seven remaining strips of 120-grit sandpaper into one long strip. (Be sure to use tape only on the back of the sandpaper.) Now attach the sandpaper lengthwise down the center of the pine board, using two thumbtacks at each end and being sure the sandpaper is drawn tight.

d. Attach one paper clip to one of the rubber bands around the box.

e. Tie one end of the string onto another paper clip and place a mark on the string about 1 cm from the clip. Use one rubber band to join the paper clip on the box with the paper clip on the string. Tie the free end of the string around the dowel or paper towel roll.

f. Tape the meter stick onto the sandpaper strip on the board.

g. Position the box at one end of the board so it is centered on the sandpaper. Use books to raise the other end of the board approximately 10 cm (4 in.). Measure and record the height.

h. Gently roll the string onto the dowel until the string lifts off the paper and becomes taut. Note the location of the mark on the string relative to the meter stick. Take care to keep the dowel in the same position during rolling and measurement.

i. Continue to roll the string onto the dowel until the box moves. The box should move with a quick, jumping motion. Record the new location of the mark on the string (the distance the box moved) on the data table. Continue rolling up the string and recording jump distance until the box hits the meter stick. The meter stick can be pulled upwards to allow the box to continue to be pulled.

j. Subtract the beginning measurement from the ending measurement or add up the jump measurements to find out how far the box moved. Divide by the number of jumps to calculate an average jump distance.

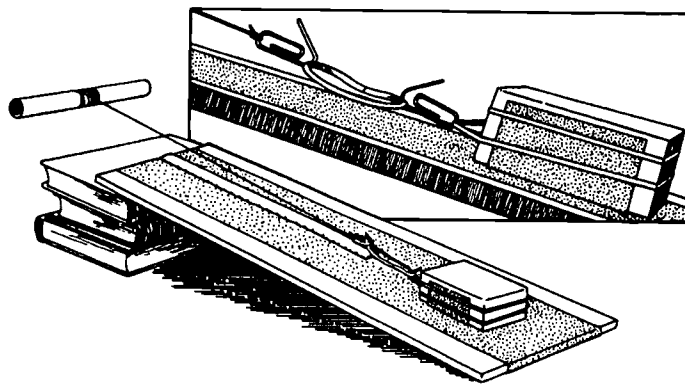
3. Instruct other students in the same group to change one variable, repeat the procedure, and average the distance of the jumps. Students may vary the model by adding one or more rubber bands, adding more books to change the angle of the board, substituting the brick for the box, or using sandpaper of a different grit. If time allows, give every student a chance to operate the model with each of the variations.

4. Ask students to complete their data sheets.

### C. Conclusion

Ask the class:

- What might the different variables represent in terms of earthquakes and landscape conditions? (Number of rubber bands—different amounts of energy released; angle of the board—steepness of the fault; sandpaper grit size—differences in the amount of



### TEACHING CLUES AND CUES



This part of the activity requires a very steady hand.



Controlling the tension on the string works best if the string is rolled onto the dowel until the dowel rests on the books and is against the edge of the board.

force required for a fault to move—the amount of friction.) Emphasize that different faults can store different amounts of energy before they fail. Some faults have the potential for generating larger earthquakes than others.

- Do the rubber band and string go totally slack after each movement? (No.) What does this tell you about the release of stored energy on a fault when an earthquake occurs? (No earthquake ever releases all the energy stored in the Earth at a particular point. It is because some stored energy always remains that one quake may have numerous foreshocks and aftershocks, and earthquakes recur frequently in some active areas.) ▲



Name \_\_\_\_\_ Date \_\_\_\_\_

	Trial 1	Trial 2	Trial 3	Trial 4	Trial 5
<b>Box Weight</b>					
<b>Board Height</b>					
<b>Sandpaper Grit</b>					
<b>Beginning Distance</b>					
<b>Jump 1</b>					
<b>Jump 2</b>					
<b>Jump 3</b>					
<b>Jump 4</b>					
<b>Jump 5</b>					
<b>Jump 6</b>					
<b>Jump 7</b>					
<b>Jump 8</b>					
<b>Jump 9</b>					
<b>Jump 10</b>					
<b>Jump 11</b>					
<b>Jump 12</b>					
<b>Jump 13</b>					
<b>Jump 14</b>					
<b>Jump 15</b>					
<b>Total Distance</b>					
<b>Average Distance</b>					

# Shifting Plates & Wandering Poles

## RATIONALE

To understand earthquakes students need to understand the structure of the Earth. The theory of plate tectonics has contributed to an understanding of how the Earth's plates move and how that movement can cause earthquakes.

## FOCUS QUESTIONS

How does the shape of the continents indicate that they were once joined?

What are some of the ways to tell the continents are moving?

## OBJECTIVES


Students will:

1. Model magnetic reversal patterns.
2. Use paleomagnetic data to demonstrate plate motion.

## MATERIALS

- Master 2.2a, Tectonics Background
- Transparency of Master 2.2b, Earth Cross Section
- Overhead projector
- Master 2.2c, Reading the Patterns
- Master 2.2d, Continental Pieces, two copies for each small group
- Master 2.2e, World Map Grid
- Master 2.2f, World Map Grid, 120 MYA
- Classroom world map
- for each small group*
- Bar or cow magnet
- Large nail
- Paper clips or staples
- Clamp with a handle

## VOCABULARY

 **Paleomagnetism:** the natural magnetic traces that reveal the intensity and direction of Earth's magnetic field in the geologic past.



- Bunsen burner, cigarette lighter, or other direct heat source
- One 3 x 5 file card and sheets of blank paper
- Twenty 9 cm (3-4 in.) lengths of audiocassette tape (Use an old tape.)
- A roll of clear tape
- Scissors and a ruler
- Pens or pencils
- Maps of South America and Africa (*optional*, but desirable)
- Map of the Pacific Ocean floor (*optional*, but desirable)

## PROCEDURE

### Teacher Preparation

Practice the magnetizing demonstration before class. Prepare the nail by stroking it with a magnet until it will pick up paper clips or staples on one end. Place the nail in a clamp and heat it in the middle until the clips drop off.

Read Master 2.2a, Tectonics Background, and decide how much time you will need to spend presenting this information to your students. If they are already familiar with its outlines, you may just want to connect the illustrations with the stick-slip movement students saw in the previous activity.

## PART ONE

### POLES AT PLAY

#### A. Introduction

Pass out copies of Master 2.2a, Tectonics Background. Project Master 2.2b, Earth Cross Section, and review the first two major sections of Master 2.2a with the students. Point out to students that on a world map continental land masses seem to have a jigsaw fit. Early mapmakers noted this long ago when drawing the first maps of the new world.

#### B. Procedure

1. Ask the students how magnets work. Some may already know that alignment of atomic forces creates the magnetic “pull,” or force field. Tell students that when a magnet is heated it loses its magnetic force, and when it cools down it again picks up the faint trace of the Earth’s magnetic field. Demonstrate this with a nail by stroking it with a magnet and then heating it, as explained above. Ask students where rocks are heated (in volcanoes and deep within the Earth). Tell them that in the next two activities they are going to simulate the process of using paleomagnetism to study plate tectonics.

2. Tell students that in 1963, two English geophysicists, Vine and Matthews, were using extremely sensitive magnetometers to make measurements of the seafloor across the Mid-Atlantic Ridge. Scientists already knew that over the 4.6 billion years of Earth’s history, its magnetic poles have changed directions more than once, so that the

#### TEACHING CLUES AND CUES



You may want to take students through a quick review of magnetic properties and the rule of attraction and repulsion of poles.

#### TEACHING CLUES AND CUES



Be sure students understand that it is the magnetic poles that have changed, not the physical ends of the Earth.

south pole and the north pole have actually switched places. When a volcano erupts, the volcanic rocks record the direction of the poles at that time. The rocks are magnetized in somewhat the same way as the nail was by the magnet in your demonstration. What Vine and Matthews discovered was a pattern of polar reversal stripes on both sides of the ridge. The purpose of this activity is to simulate those patterns.

3. For each group of two or three students, pass out 20 audiotape strips, one 3 by 5 card, glue or tape, and a magnet.

4. Give these instructions:

a. Tape 6 or 7 strips of audiotape to the card by one end, so they are parallel to each other and about 1 cm apart. One end will be loose, as shown on the illustration.

b. Stroke one of the strips with one pole of the magnet. Then stroke the next strip with the other pole of the magnet.

When the magnet is passed over the loose ends of the tape, the strips will move. Their direction will depend on which end of the magnet they were stroked with.

c. Create patterns of magnetism by mixing up the order in which you stroke the strips of tape, then give the cards to other groups to interpret.

### C. Conclusion

After they have had a chance to create patterns and share them with other groups, ask students if they were able to interpret the other groups' patterns. How did the tape strips record the direction of the magnetism? (Magnetic particles are embedded in the tape.)

*This activity was adapted from a workshop on earth science activities presented at the Exploratorium in San Francisco, CA.*

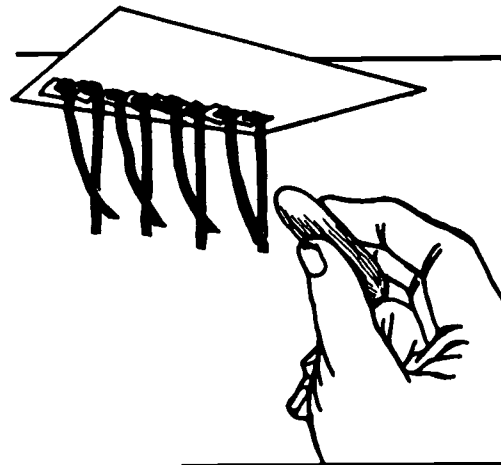
## PART TWO

### RECORDS IN THE ROCK

#### A. Introduction

Review the structure of the Earth's interior with the class, drawing on Master 2.2a. Remind students that in the last activity they saw how patterns of magnetic polarity can be recorded. What Vine and Matthews saw, as they explored the Mid-Atlantic Ridge with their instruments, was a similar pattern recorded in volcanic rocks.

Looking at these patterns on one side of the ridge, they noticed that the opposite side showed a mirror image of reversals. Their next step was to collect rock samples from the sea floor and determine the age of the rocks, to find out when the volcanoes that formed the rocks erupted. They discovered not only that the patterns of ages were mirrored on the two sides, but also that the rocks on both sides were progressively older as they moved away from the ridge. The



#### TEACHING CLUES AND CUES



This activity works best if the card is held upside down with the tape hanging down.



Be sure all strokes on the individual strips are in the same direction. Do not touch again when testing polarity.

next activity will help students understand the process Vine and Matthews followed.

### B. Procedure

1. Give each group a copy of Master 2.2c, Reading the Patterns, and a pair of scissors. Give these instructions:

- a. Cut the reversal pattern off the bottom of the sheet and trim away everything outside the dotted outline.
- b. Cut the reversal pattern along the dashed horizontal line in the center to form two strips. Place the two strips together with the patterned bands facing in, making sure that the arrows on both strips face the same way. Tape ends together.
- c. Insert the scissors at one of the black dots on the map and carefully cut a slit along the axis of the mid-ocean ridge, following the broken line between the two dots. Insert the open end of the folded reversal pattern into the slit from underneath, holding onto the stub, and carefully pull the first several centimeters of paper through (up to the first dark line). Crease the strip along the dark line so the first pattern is showing, bend it flush with the paper on one side of the ridge, and label it with a 1 in red ink. Do the same thing on the other side of the ridge.

Tell students that this represents a volcanic eruption during which the rocks adopt the magnetic field of the Earth at that time. Then, announce that a reversal of the poles has occurred.

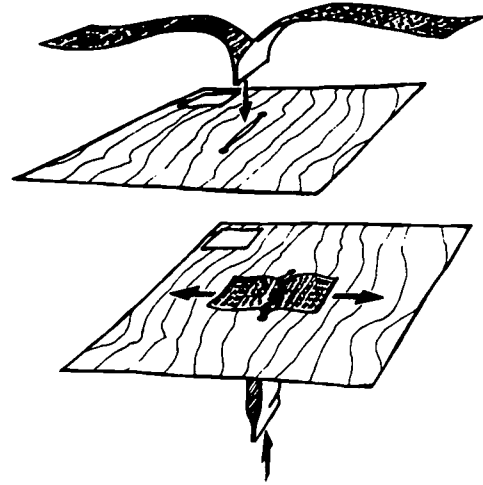
d. Pull up the second pattern on the strip, bend it over, and label it 2. Repeat with the other side. Continue this process until all the patterns have been pulled up and labeled.

2. When all the bands have been labeled, ask students:

- What does each fold of paper represent as it is pulled up from below? (new rock being erupted from inside the Earth by volcanic action)
- Which pattern represents the oldest volcanic rock? (Number 1)
- Is the pattern of the reversals and the ages mirrored on the two sides of the ridge? (Yes.)
- Why do the pattern bands vary in width? (Their width is determined by how much volcanic activity occurred before the reversal and how long the reversal of polarity lasted.)
- Can you tell which way the poles were oriented during any given age on your model? (Yes.)

### C. Conclusion

Conduct a quick drill to be sure students understand how the models show what direction the poles were oriented in. Call out a number and ask students to answer with a direction. Go on until students can respond rapidly.



### TEACHING CLUES AND CUES



There should be nine bands on each side of the ridge.

## PART THREE

### MAPPING PREHISTORY

#### A. Introduction

Tell students that in the last activity they modeled the creation of new ocean floor at a spreading mid-ocean ridge. Project the transparency of Master 2.2b and review the section of Master 2.2a entitled Three Kinds of Plate Movement, Four Kinds of Boundaries, and discuss. Then discuss the driving mechanism for plate tectonics, so students understand some of the complicated forces and that scientists are still exploring how these forces work. Tell the class that in this last activity they will look at one more line of evidence that the continents have been moving. Review the process of magnetism and how rocks pick up the polar orientation during their formation. Explain that sensitive instruments called magnetometers can analyze samples of rock to discover where the north pole was located during their formation. In this next activity, students will use magnetic data collected from several different locations to establish plate motions.

#### B. Procedure

1. To each small group, pass out scissors, tape, a ruler, two copies of Master 2.2d, Continental Pieces, and one each of Master 2.2e, World Map Grid, and Master 2.2f, World Map Grid, 120 MYA. Point out that there are two north arrows on each of the continental pieces. The N stands for north today and the PN stands for paleonorth, or the approximate location of the north pole 120 million years ago (MYA). The line that lies across the arrow, labeled G, represents grid north, and should always line up so it is parallel to longitude (see example on Master 2.2e, World Map Grid.) The numbers in the tables on the grid masters tell the distance to the north pole from the tip of the arrow point at the time that sample was collected.
2. Give these instructions:
  - a. Cut out the continents on one copy of Master 2.2d along the dotted continental outlines.
  - b. To place the continents on Master 2.2e, World Map Grid, begin with any continent. Place the ruler alongside the present day north arrow line (N) on the continent to align it with the intersection of the Prime Meridian (O) and the north edge of the map. Next, align the grid north line (G) so it is parallel to the nearest longitude. When both arrows are aligned, measure the distance from the pole to the point where the two arrows cross. Tape the continent in place.
  - c. Repeat the process until all the continents are in place. This creates a map of the world as it appears today.
  - d. Now repeat the process with a new copy of Master 2.2d, Continental Pieces, and a copy of Master 2.2f, World Map Grid 120 MYA, this time lining up the PN arrows. This creates a map of the world as it may have appeared 120 million years ago.

### TEACHING CLUES AND CUES



To demonstrate paleo-magnetic alignment, make large blowups of the South American and African continents, or draw their outlines on the overhead. Demonstrate the process of alignment and distance measurements.



Be sure to pass out two copies of Master 2.2d to each group.



Make sure that the grid north line remains parallel to the longitude lines while you complete step 2.b.

3. When they have completed both tasks, ask students if they could tell which continent moved the most. (India) Point out that the continents do not fit together perfectly and ask them for some possible reasons. (Students may suggest that the scale could be wrong, the drawings may not be quite accurate, or our measurements may be inaccurate.) Let students discuss the possibilities. If necessary, ask if they think the continents have always had the same outline as they do today. (No. The sliding, colliding, and converging movement of the plates has added new material in some places and worn the edges away in others. Point out western North America and the place where India collided with Asia to form the Himalayas.)

If a wall chart or map of the oceans is available, point out the continental shelves. Explain that geologically each continent extends to the edge of its continental shelf. Does the jigsaw puzzle fit together better if the edges of the shelves are used as continental boundaries? (Yes.)

### C. Conclusion

Review the steps in using magnetism to find the ancient location of the continents. Point out to students that this evidence was not available during Wegener's time. In this series of activities they have experienced some of the ways scientists established the theory of plate tectonics. Ask:

- If this information had been available, would it have helped Wegener's case? (Yes.)
- How does the last map differ from a map of today? (Discuss.)
- At the rate of drift (5 to 15 cm, or 2-7 inches in a year), about how long would it take today's continents to join into one supercontinent? (Answers will vary.)

### ADAPTATIONS AND EXTENSIONS

1. Challenge students to find out how magnetometers work and how scientists use them, then report to the class.

2. On a map of the Pacific Ocean floor, locate the Hawaiian Islands and the chain of islands that forms the Emperor Seamounts. Note the sharp bend in the line of seamounts. Ask students:

- What could have caused the bend? (a change in the direction of plate movement)
- What does this bend, and the long pattern of reversals illustrated in the earlier activities, indicate about the possibility of the Pacific Ocean closing? (With plates constantly changing directions, it may not close.)

3. *Scientific American* published a series of articles on plate tectonics in the late 1960s which were published as a collection in 1970 (see Wilson, unit resources). Provide students with copies and ask them to prepare a report to the class on the evolution of the theory.

### TEACHING CLUES AND CUES



You may want to project some of the students' completed maps during this discussion.

### TEACHING CLUES AND CUES



Students will learn more about Alfred Wegener in the next unit, in lesson 3.2.

4. Ask volunteers to compare and contrast continental drift, plate tectonics, and sea floor spreading, or to show the relationships among plate boundaries, earthquakes, and volcanoes.

5. Invite students to build models to demonstrate the four types of plate boundaries.

6. A group of students could create giant cardboard models of the continental pieces by enlarging them to scale. They or another group could perform a Drift Dance, moving in various patterns until the pieces lined up more or less as they are today.

7. Ask the class: If earthquakes are only supposed to happen in the vicinity of plate boundaries, why did the 1811 and 1812 New Madrid, Missouri, earthquakes occur? (New Madrid is located on a failed rift zone that tried to split North America apart.) Was it an isolated occurrence, or could the same thing happen in other such areas? (There may be other such rift zones that have not yet been discovered.) ▲



To understand why earthquakes happen, we need to understand two basic facts about the planet we live on: that it is made up of layers, and that its surface is broken into irregular pieces called plates. Much of what we know about the composition of Earth has been learned by studying how earthquake waves travel in and through it.

### **Earth's Layers**

Just for a moment, imagine the Earth as if it were a hard-boiled egg. It has a thin crust (the shell); a thick middle layer, or mantle (the white); and a core (the yolk). The crust and the uppermost portion of the mantle together form the lithosphere. The plates are called lithospheric plates because they belong to this region. Scientists divide the mantle into zones and the core into an inner and outer core. (See Master 2.2b.)

#### *Crust and Lithosphere*

Earth's crust varies in thickness from about 30 km to between 70 and 80 km on the continents to only 6 km on the ocean floor. Even at its thickest point, the crust is not nearly as thick in relation to the whole bulk of the Earth as the shell of an egg is in relation to the egg. Remember that the crust is 70–80 km thick at its thickest point, and the radius of the Earth is about 6,371 km.

The oldest rocks of the crust found so far have been dated by radioactive decay (isotopic dating) at about 4 billion years. Earth scientists assume that the Earth was much hotter billions of years ago than it is today, and that the lithosphere (crust plus upper mantle) broke into plates as it cooled and hardened.

The lithosphere extends to an average depth of about 100 km. It is deepest under the continents and shallowest at the mid-ocean ridges.

#### *Mantle*

The mantle contains several zones, or layers with different properties. Its upper portion is a region with a plastic, semisolid consistency, called the asthenosphere. The thickness of the asthenosphere is still a matter of debate. Estimates of the distance to the base of the asthenosphere range from about 200 km to 700 km. The mantle accounts for approximately 67% of Earth's mass. Information from earthquake waves indicates that this region generally behaves as a plastic; that is, it will bend and flow in response to pressure. Temperature and pressure continue to increase as we move through the mesosphere to approach the core, at a depth of about 2,890 km.

#### *Core*

Both layers of the core are thought to be composed primarily of iron, with lesser amounts of nickel and possibly silicon, sulfur, or oxygen. Scientists have measured the velocity of earthquake waves passing through the core, and reason that such movement would be possible through materials with the physical properties of these elements. The liquid outer core, which might be compared to the outer two-thirds of an egg's yolk, reaches from a depth of about 2,890 km to 5,150 km. The solid inner core goes the rest of the way to the center of the Earth.

Earth's core is very hot. Its high temperatures are due to the tremendous pressure of the layers above it, heat generated by the impact of other bodies during the formation of the planet, and radioactive decay. Evidence collected from mines and deep wells shows that the average increase in temperature is about 1° C for every 40 meters of depth. If this rate held constant to the center of the Earth, theoretically, the temperature of the core would be about 150,000° C. According to the evidence we have, however, the actual temperature is between 3,000 and 4,000° C at the core-mantle boundary, and about 5,000° C at the boundary of the outer and inner cores—roughly the same temperature as the surface of the Sun!

### **Earth's Plates**

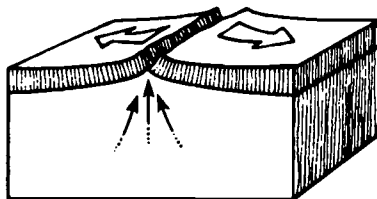
Most earthquakes and volcanoes are associated with large-scale movements of Earth's plates, and occur at the boundaries between plates. There are 12 major plates and a number of smaller ones. The plates are named after

continents (the North American Plate), oceans (the Pacific Plate), and geographic areas (the Arabian Plate).

The plates are in very slow but constant motion, so that seen from above by a patient observer, Earth's surface might look like a slowly moving spherical jigsaw puzzle. The plates move at rates of 5 to 15 cm (2–7 inches) in a year—about as fast as our fingernails grow. On a human scale, this is a rate of movement that only the most sophisticated instruments can detect, but on the scale of geological time, it is a dizzying speed. The oldest rocks in the crust, formed 3.8 billion years ago, could have traveled around the Earth 14 times at this rate.

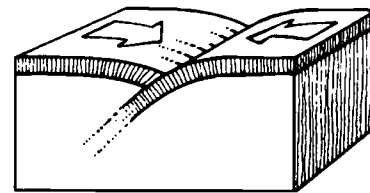
*Three Kinds of Plate Movement, Four Kinds of Boundaries*

Plate movement is generally one of three kinds: spreading, colliding, or sliding. Earthquakes can accompany all three kinds of movement, but the most forceful quakes generally result from colliding and sliding movements.



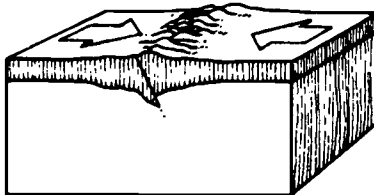
A.

When plates are spreading, or separating from each other, earth scientists call their movement divergent. The type of boundary that results (A) is a ridge, like the Mid-Atlantic ridge system.



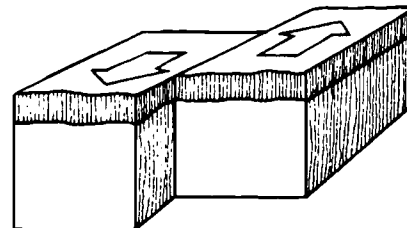
B.

When plates are colliding, or pushing against each other, scientists call the movement convergent. If an oceanic plate converges with a continental plate or another oceanic plate, the oceanic plate is forced down into the mantle, creating an ocean trench (B). The Alaskan trench and the Aleutian Islands were formed in this way; so were



C.

the Andes Mountains. If two continental plates converge, neither will be forced into the mantle. Instead, their edges will crumple and a large mountain chain may result (C). The Himalayas arose when India collided with Asia.



D.

Movement in which plates slide past each other is called lateral (or transform) plate movement (D). This kind of movement is occurring along the San Andreas Fault in California.

**Continental Drift: 1910 to 1960**

The theory of continental drift originated early in this century, but it did not gain general acceptance until the late 1960s. Between 1910 and 1912, the German meteorologist, geophysicist, and explorer Alfred L. Wegener formulated the theory called continental drift. He collected evidence from the rocks, fossils, and climatic records of several continents to show that they had once been joined together. Wegener knew little about the oceanic crust, which had not yet been explored, and thought that the continents merely moved horizontally, plowing through the oceanic crust.

**Plate Tectonics: 1960 to the Present**

In the early 1960s, British geophysicists Fred Vine and Drummond Matthews used magnetic data to show that the ocean floor is spreading apart at the mid-ocean ridges. As they shared the evidence for the process they called sea-floor spreading, scientists began to realize that the continents were also moving. By 1968, a new explanation for the dynamics of Earth's surface had been created, combining Wegener's hypothesis with evidence from the ocean floor. Scientists call it the theory of plate tectonics.



### **The Mechanism of Plate Tectonics**

Although the theory of plate tectonics is generally accepted, no one completely understands how the process works. Wegener thought that centrifugal force, caused by the rotation of the Earth, and tidal forces caused continental drift. Modern scientists have rejected this theory and replaced it with several others. Three mechanisms called convection, ridge push, and slab pull may play a role.

#### *Convection Currents*

Convection currents are systems of heat exchange that operate in the mantle as it is heated by the core. The mantle's plastic-like material moves upward as it is heated, and sinks when it cools. You can see this kind of movement if you boil water in a clear glass pot. Even though the heat on the stove is constant, the water on the bottom of the pot is the hottest. As it heats, it becomes less dense and rises, while relatively cooler water from the top of the pot takes its place on the bottom. This continuous exchange creates convection currents in the water.

According to this theory, convective movement acts as a drag on the underside of the plates. As mantle material moves in large convection cells, the plates are rafted along the top of the cells, being pulled apart where the cell rises and colliding where it sinks.

#### *Ridge Push*

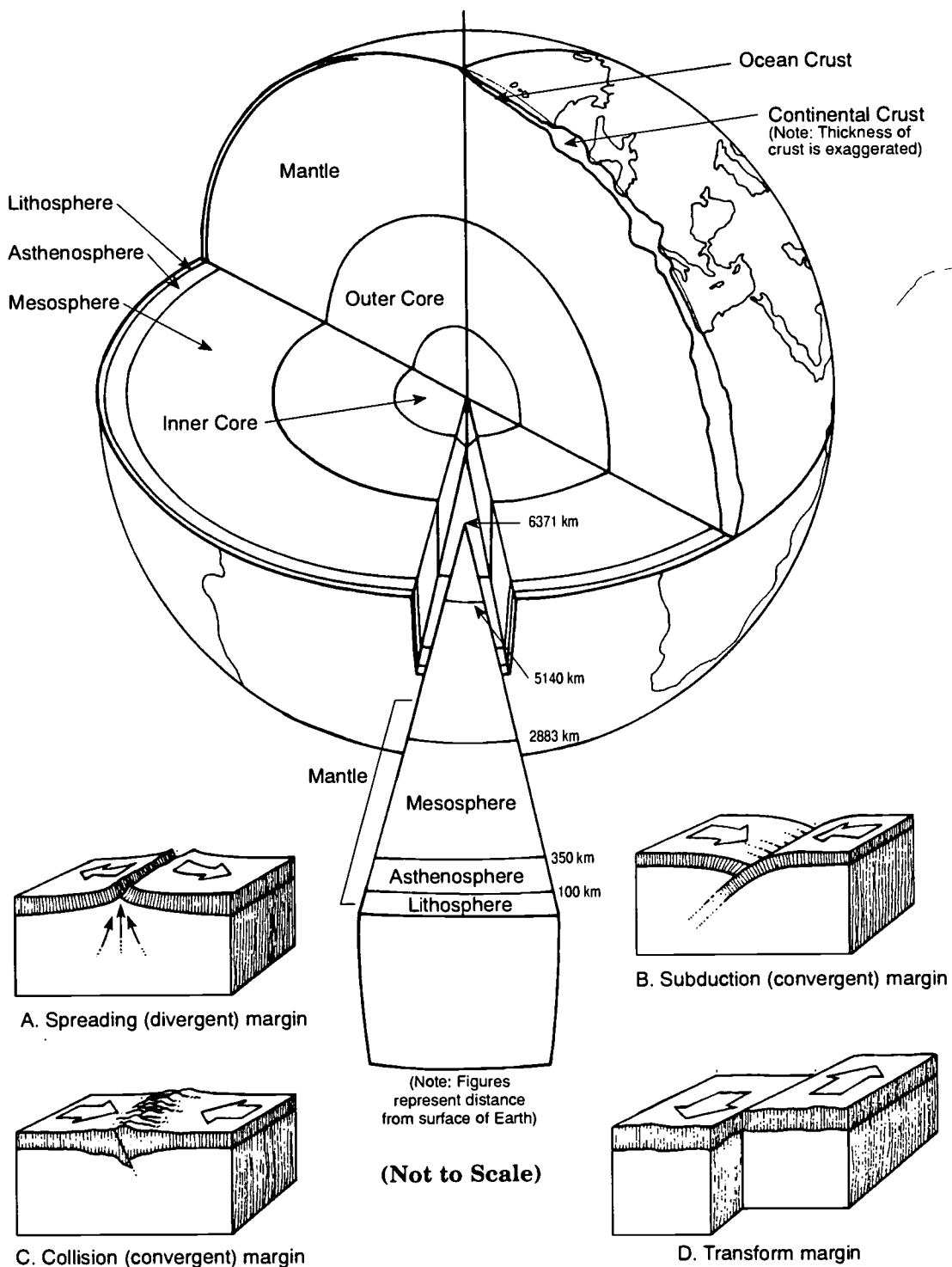
The ridge-push mechanism derives from the bulging of the undersea ridge crest as the oceanic lithosphere below it expands. The lithosphere expands because it is heated by mantle material pushing upward from below. As the lithosphere is pushed up at the ridge, a large portion of a plate may come to rest on an inclined plane. Gravity will cause this portion to slide down the inclined plane and push on the rest of the plate.

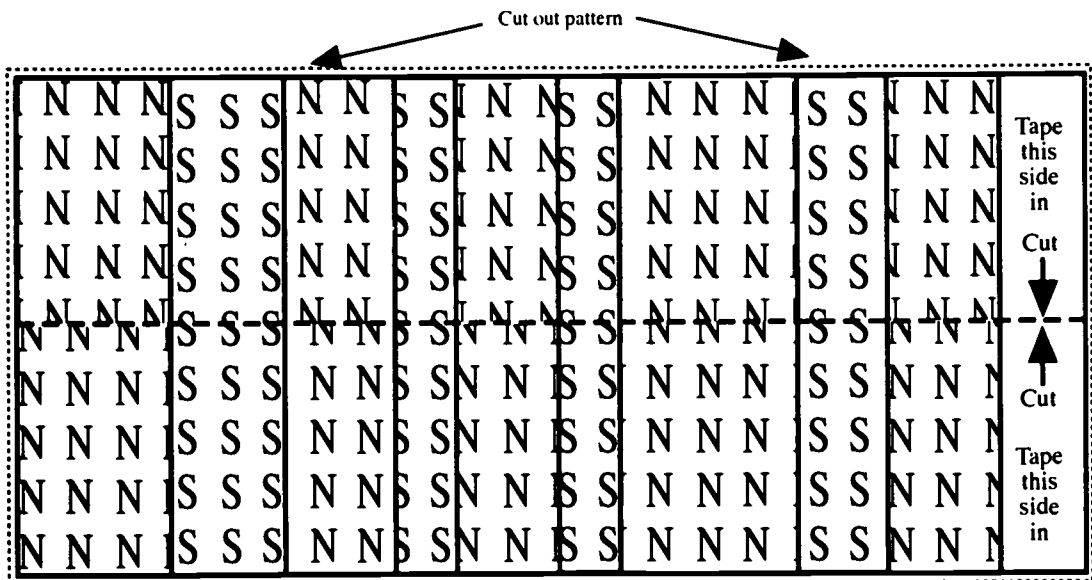
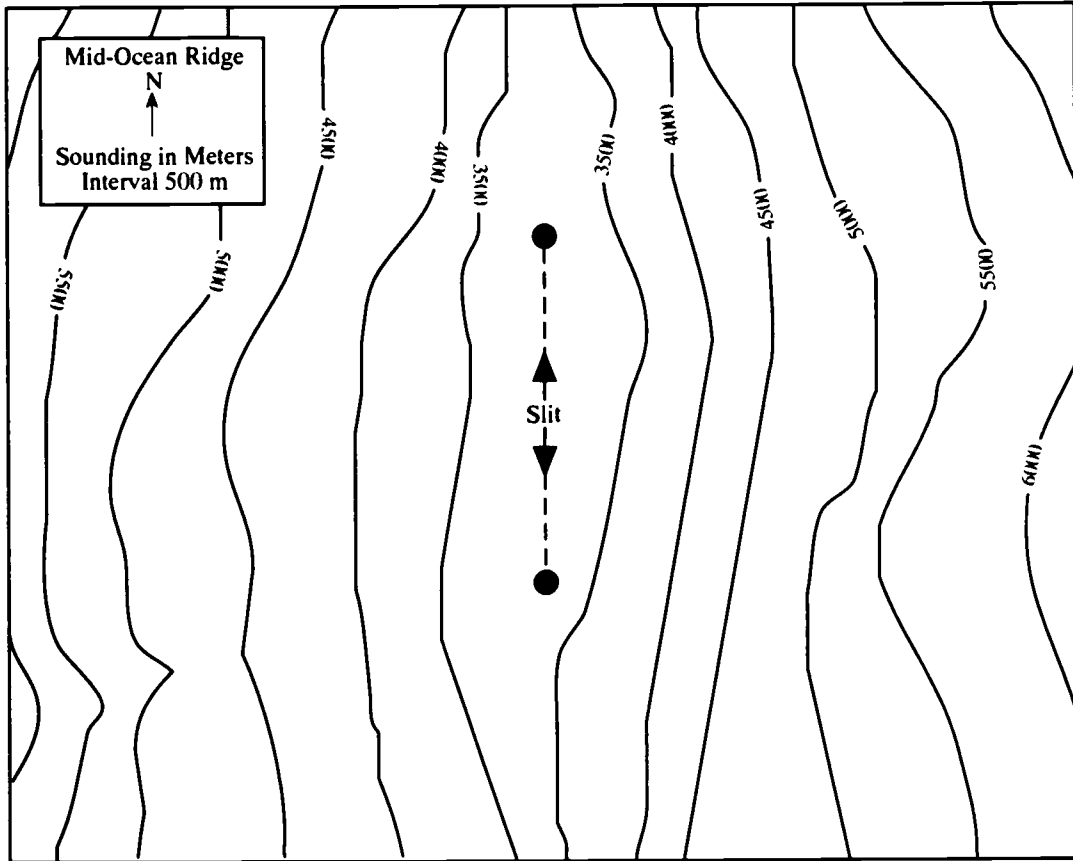
#### *Slab Pull*

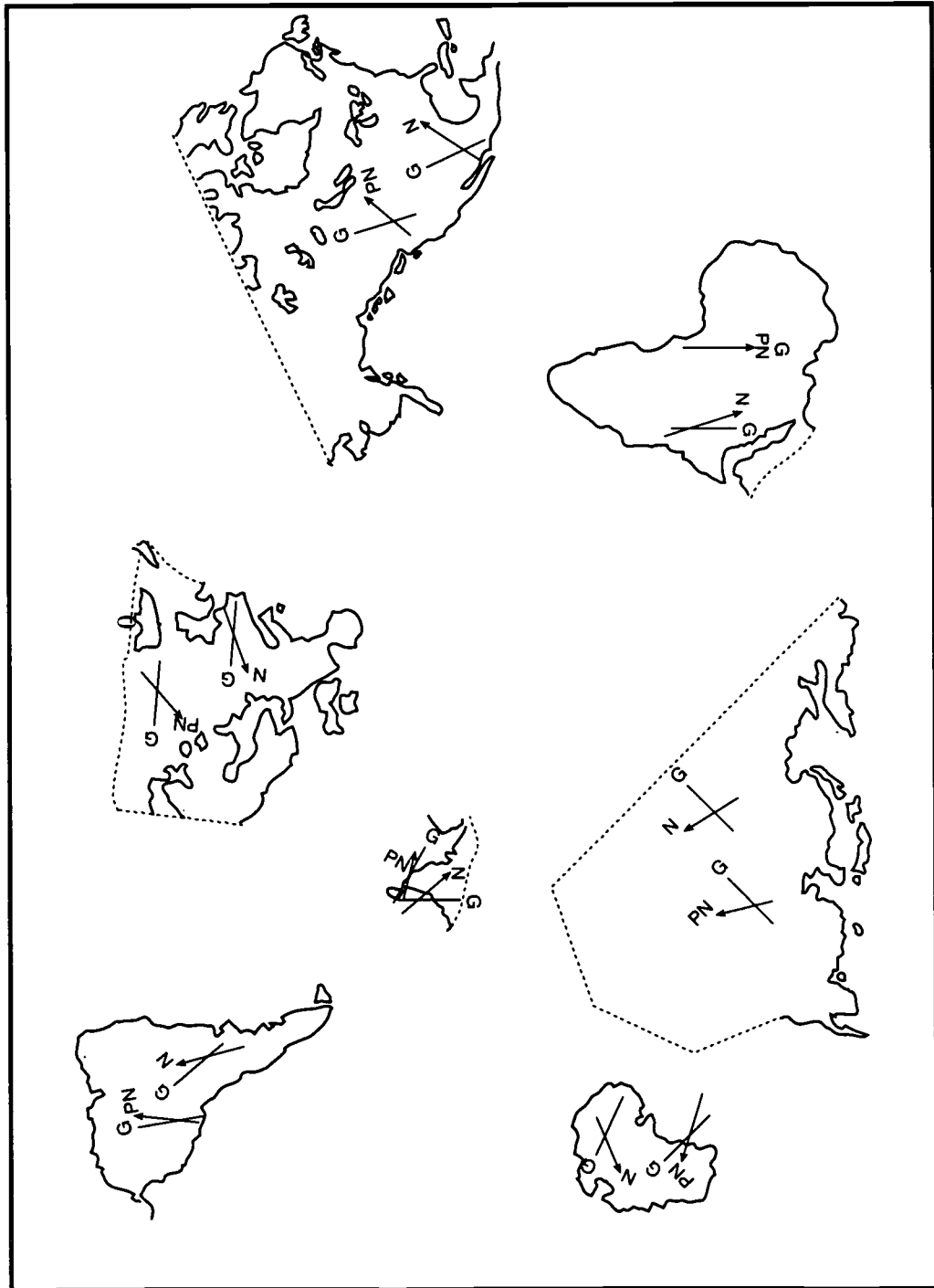
Once this slab of oceanic lithosphere moves away from the ridge crest (and from the heat that is rising at the ridge), it will cool and contract, increasing in density. It will also thicken as underlying mantle material cools and attaches itself to the bottom of the slab. Eventually, the slab of lithosphere becomes denser than the underlying asthenosphere and sinks into the mantle. As it sinks, it pulls the rest of the plate along with it. At about 200 to 300 km, the difference in density between the descending slab and the mantle is at its greatest, so the slab pull force is also at its greatest. Below this point, the mantle material becomes stronger and the resistance to sinking also becomes stronger.

### **A Natural Cycle**

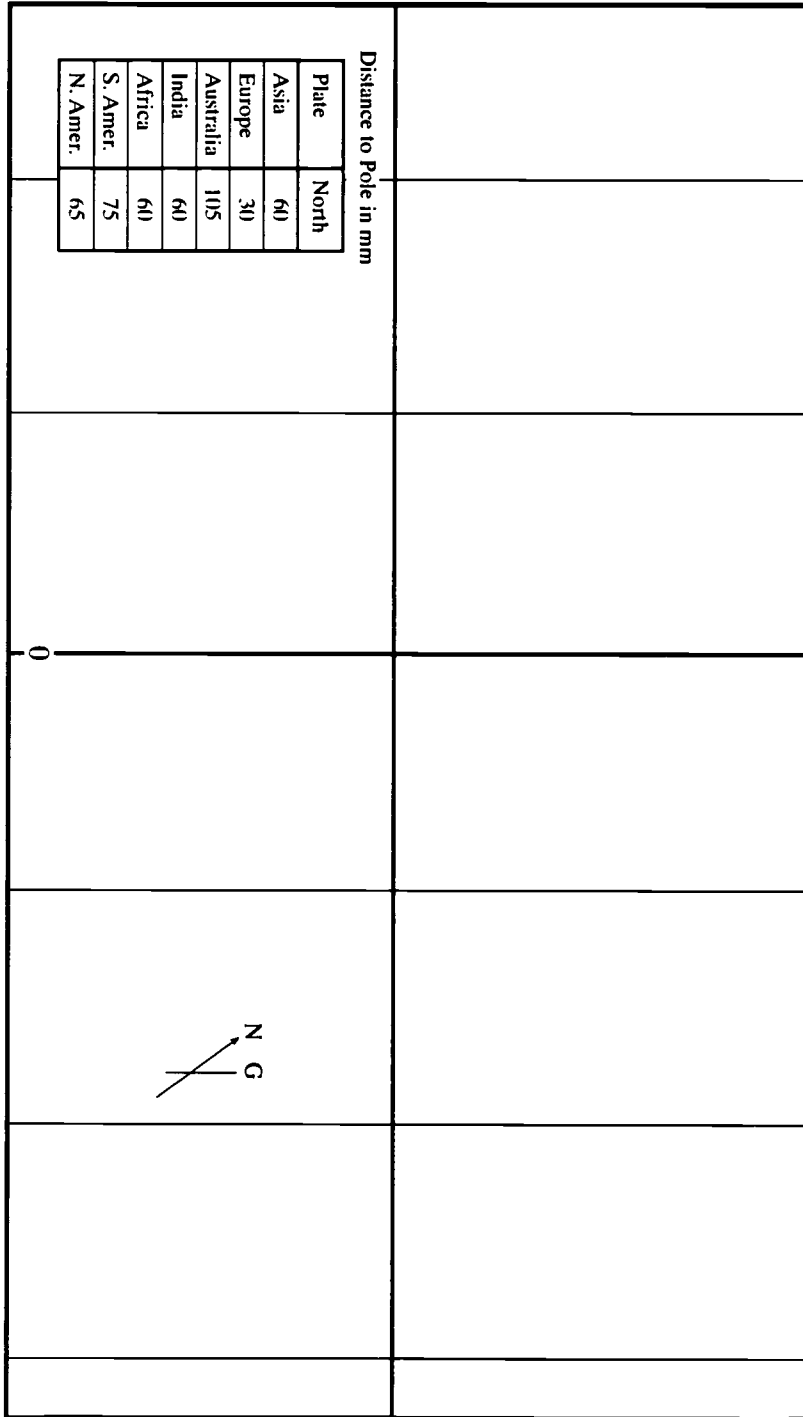
One result of all this slow, steady motion is the gradual opening and closing of ocean basins. As tectonic processes rearrange the surface of the planet, shifting lands and seas over millions of years, they also cause earthquakes. Now, and for the foreseeable future, human beings have no way to affect these mighty tectonic processes. By understanding them, however, we can learn to conduct our own lives in ways that minimize our risk from any disturbances they may cause.



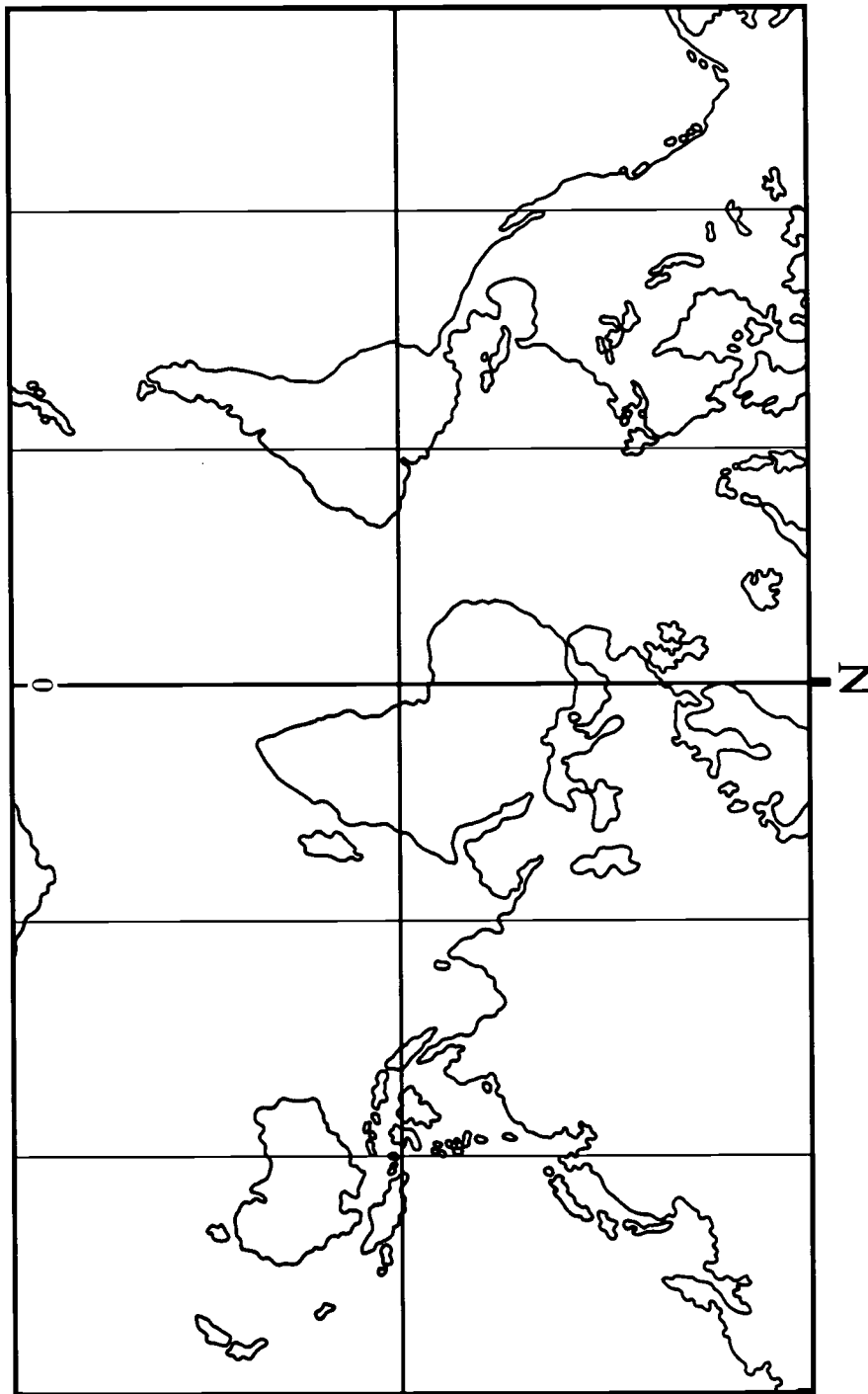




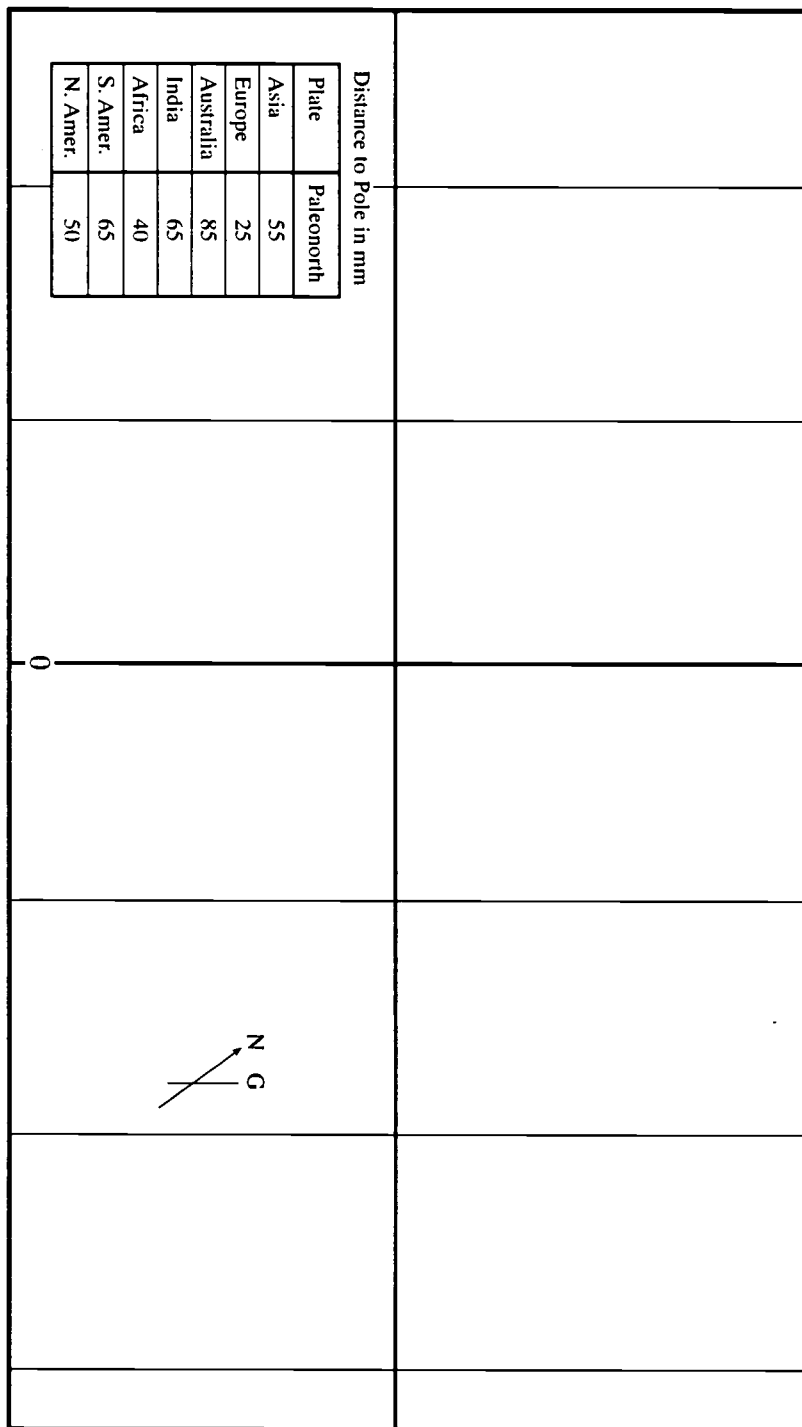
Name \_\_\_\_\_ Date \_\_\_\_\_

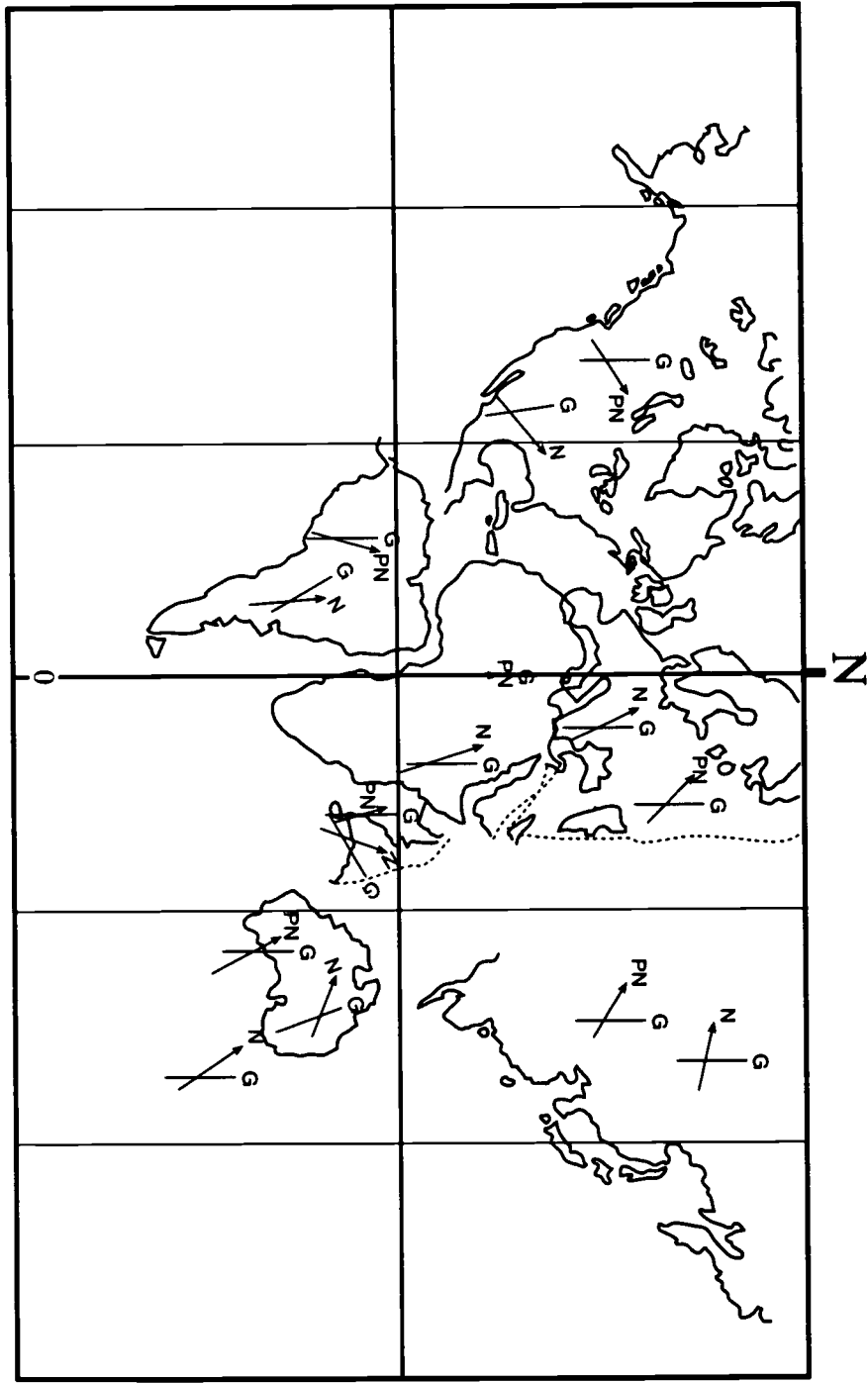


70



Name \_\_\_\_\_ Date \_\_\_\_\_







# EARTHQUAKES in Geologic Time

## ACTIVITY ONE

### TWENTY CENTURIES

#### RATIONALE

Students have a difficult time comprehending how short the span of human history is in relation to Earth's geological history. This lesson sets the stage for paleoseismology by providing a context in geological time.

#### FOCUS QUESTION

If no earthquakes have been recorded in my area since it was settled, does that mean earthquakes never happen here?

#### OBJECTIVE

Students will compare the time period of their own lives and that of human history to the age of the Earth and events in Earth's history.

#### MATERIALS

- Student copies of Master 2.3a, Centuries Worksheet
- Twelve 500-sheet reams (one case) of standard copier paper
- Student copies of Master 2.3b, Selected Events in Human History
- Student copies of Master 2.3c, Earth History Events
- Scissors

#### PROCEDURE

##### Teacher Preparation

1. Obtain 12 reams of standard-size paper and stack them on a desk where they will be visible to all students. Unwrap only the top ream. On each of the lower reams, cut a strip 7 to 10 cm wide from the side of each wrapper so the paper shows through. The results should be a column of exposed paper edges 11 reams high. Stack the unwrapped twelfth ream neatly on top, and place a copy of the Centuries Worksheet on top of the stack.

74

#### VOCABULARY



**Index fossil:** a fossil that, because its approximate date is known, allows scientists to determine the age of the rock in which it is imbedded.

**Radiometric dating:** the process of using natural radioactivity to determine the age of rocks.

**Strata (s. stratum):** layers of rock or other materials formed at different periods in geologic time.

2. Make a copy of Master 2.3c, Earth History Events, and cut it into strips along the dashed lines.

### A. Introduction

Ask the students to tell you what they mean when they say that something happened “a long time ago.” (Answers will range from a few months to centuries and beyond.) Ask students if it was “a long time ago” that dinosaurs became extinct, and our earliest human ancestors first appeared. Then ask them to guess the order in which these events occurred. Record their guesses without comment.

Emphasize that scientists seek proof of how long ago different events occurred by studying things that record the passage of long periods of time, such as the layers in rocks (strata) and index fossils. Index fossils represent species that existed only during specific time periods, so their presence is an index to the age of the rocks. Radiometric dating techniques can also reveal how long ago rocks were formed. The dating of events that occurred a long time ago and the sequence in which they occurred are among the puzzles scientists must solve. We are constantly adding to our knowledge of Earth history.

### B. Lesson Development

1. Distribute copies of the Centuries Worksheet (Master 2.3a). Holding up the copy you placed on top of the paper stack, tell the students that the stack is 12 reams high, and that every single page in it stands for the same length of time. Explain that every dot on the sheet stands for one year. The first dot on the top line represents this year. Each dot after that one is a previous year. The entire sheet contains 2,000 dots. Ask the students to circle the dot representing the year in which they were born.

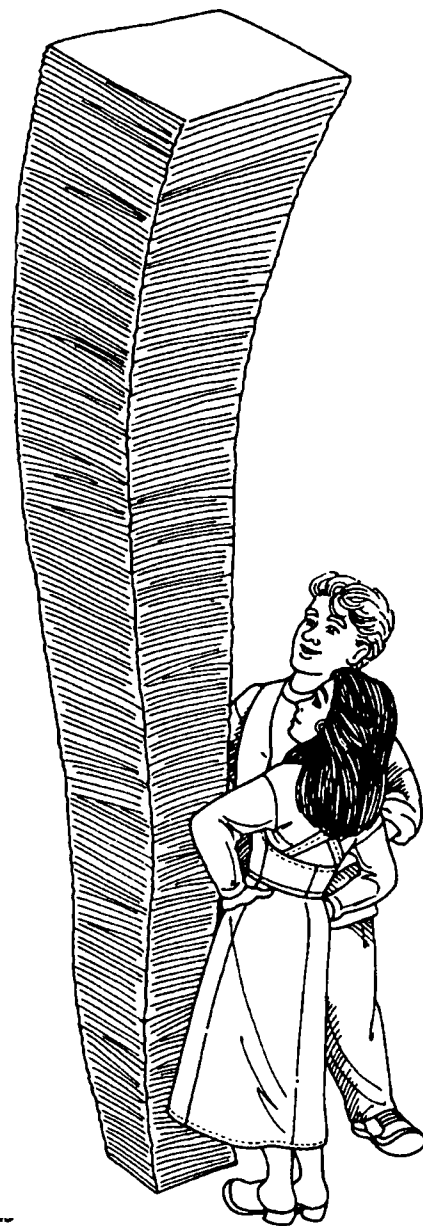
2. Distribute copies of Master 2.3b, Selected Events in Human History. With these sheets and their Centuries Worksheets in front of them, have students place the number of each event on Master 2.3b on or near the dot that represents its year.

3. Tell the class that geologic time calls for a different scale than historical time. From now on, one dot equals one hundred years. Each sheet of paper in the 12-ream stack now represents 200,000 years. The farther down the stack a sheet is, the farther back in history the time it represents. Ask the students to determine how far down the stack a sheet representing one million years ago is located. (It will be five sheets down.)

4. Ask students how many dots there would be in a ream of 500 sheets of paper if each sheet had 2,000 dots. (1,000,000 dots). If each dot represents 100 years, how many years would one ream of sheets represent? (100 years x 1,000,000 dots per ream = 100,000,000 years.)

5. Distribute the strips of paper cut from Master 2.3c, having each student choose one. Give students these directions:

a. Calculate how many years an inch of paper represents. Look at your paper strip and decide if the event it names will fit within the span of years represented by the reams of paper (1.2 billion years).



- b. If it does, calculate how far down the paper stack to place your individual marker, then come forward to place it at the correct depth.
  - c. If it does not, use the math we have already done to calculate how much more paper would be needed. Share your findings with the class.
6. Elicit ideas from the class on the age of the Earth. (The answer, about 4.54 billion years, is on Master 2.3c.) Ask: How many reams of paper like the ones in the front of the classroom would it take to represent that many years? (46 reams)

### C. Conclusion

Ask the class: Now that you have an idea of the age of the Earth, would you describe the human race as young or old? (relatively young) Which occurred more recently, the extinction of the dinosaurs or the appearance of human beings? (the appearance of humans) Compare these facts with the students' earlier guesses. Emphasize that terms like young and old, long ago and recent can have very different meanings in different contexts. Because an event such as an earthquake has not taken place in historical time does not mean it is impossible, given the great sweep of geological time.

## ACTIVITY TWO

### PALEOSEISMOLOGY, OR READING THE CLUES

#### RATIONALE

By using models, students will learn how geologists apply present knowledge to understand seismic history.

#### FOCUS QUESTION

How do we know about earthquakes that happened long ago?

#### OBJECTIVES

**Students will:**

1. State and explain several basic geologic principles.
2. Model the procedure geologists use to determine earthquake recurrence intervals.

#### MATERIALS

- Transparencies made from Master 2.3d, Sag Pond, 1830 to 1994
- Overhead projector
- Newspapers for covering desks
- Play clay or modeling clay, in red, blue, yellow, and white
- Student copies of Master 2.3e, Sag Pond Template
- 15-cm (6-in) lengths of dowel or other small cylinders for rolling play dough (*optional*)
- Knives for cutting the clay (Plastic picnic knives will do.)

#### TEACHING CLUES AND CUES



The two parts of this activity use the same materials and take approximately the same length of time. It may be convenient to do them in sequence. Alternatively, you may want to have half the class do the first activity and the rest do the second.

- Transparencies made from Master 2.3f, Ditch Creek, 1830 to 1994
- Student copies of Master 2.3g, Ditch Creek Template

## PART ONE

### SAG POND

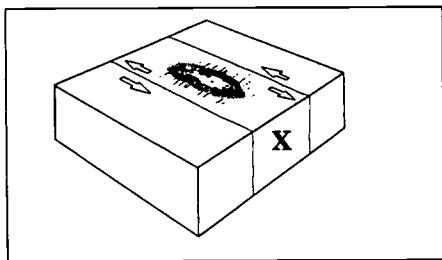
#### PROCEDURE

##### A. Introduction

Ask students: Have your parents or grandparents experienced an earthquake in their lifetime? Explain: Geologists assume that the earthquakes we observe today are similar to those that happened 50 years ago, 100 years ago, and even before human beings recorded history. Their impact may be different because of differences in human population patterns, but geologic processes and the natural principles that govern them have operated in essentially the same way throughout geological time. This assumption is expressed in the principle of uniformitarianism. By studying the traces of recurring earthquakes, those that have happened numerous times in the same area, we can speculate about the history of very old earthquake events and even make general predictions about the future. Introduce the principle of superposition and the principle of cross-cutting relationships. The activity that follows uses a generalized model of a strike-slip fault to illustrate these principles.

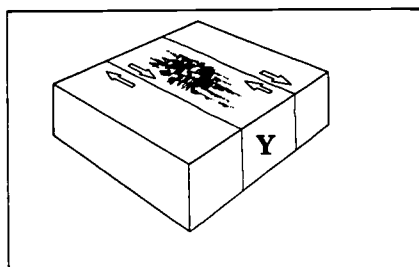
##### B. Lesson Development

1. Project the first transparency made from Master 2.3d, Sag Pond, 1830 to 1993. Tell students that the diagrams they see show the effect of faulting in successive earthquakes. Because faulting causes surface dislocations, certain types of faulting will form hills and valleys in the Earth's surface. With strike-slip faulting, if movement occurs as shown by the arrows, the following topography can be created:



**Right Lateral Strike-Slip Fault**

*X = area where ground is being pulled apart or extended, forming a sagpond.*



**Left Lateral Strike-Slip Fault**

*Y = area where ground is being squeezed or compressed, forming a hill or ridge.*

#### VOCABULARY



**Paleoseismology:** the study of ancient earthquakes.

**Peat:** a deposit of semicarbonized plant remains in a water-saturated environment. Peat is an early stage in the development of coal.

**Principle of crosscutting relationships:** the principle stating that a rock is always younger than any other rock across which it cuts. Earthquake faulting illustrates this principle: Faults are always younger than the rocks they cut.

**Principle of superposition:** the principle upon which all geologic chronology is based, stating that in any sequence of sedimentary layers that has not been overturned or faulted, each layer is younger than the one beneath, but older than the one above it.

**Principle of uniformitarianism:** the fundamental principle stating that geologic processes have operated in essentially the same way throughout geological time.

**Recurrence interval:** the actual or estimated length of time between two earthquakes in the same location.

**Sag pond:** a small body of water occupying an enclosed depression formed by strike-slip fault movement.

**Strike-slip faulting:** faulting in which movement is horizontal.



#### TEACHING CLUES AND CUES

If students have questions at this point, tell them that the activity that follows may answer them. Any questions that are not answered by the activity can be dealt with in the concluding discussion.

2. As you point to each of the figures, 1 through 6, read the accompanying text aloud to the class.

3. Divide the class into working groups of three to five students each. Distribute paper for covering desks, clay, knives, rollers (if available), and one copy of Master 2.3e, Sag Pond Template, to each group. Give these directions:

a. Pat or roll two clay patties, one white and one red, to a thickness of about 1 cm (.3 in.). Using the template provided, trim the patties to fit within the confines of the circle marked on the grid, then remove them.

b. Now make two sag pond peat deposits, one white and one blue, each 0.5 cm thick and sized according to the small sag pond template at the upper left of the grid.

c. Place the large white layer on the grid template between A-B and C-D as outlined. Place the blue clay sag pond deposit on top of this first layer, aligning the long axis of the sag pond layer with fault line E-F, and centering it between A-B and C-D. Cut both layers along the fault line E-F. Lift the A-B side and raise it to the position marked Offset Line.

d. Place the red layer of clay over the offset layers and center a second sag pond deposit (the white one), as in the step above. Cut (or trench, as geologists say) all the clay patties along line A-D. Carefully separate the sides so you have a good cross-section view and draw a cross section of each side. Compare the layers on the two sides of the fault A-D.

### C. Conclusion

Build a class discussion around these questions:

- How is the principle of superposition applied in this activity?
- How is the principle of crosscutting relationships applied in this activity?
- How is the principle of uniformitarianism applied in this activity?
- What does the difference in thickness and spacing of the peat layers on the two sides of the fault indicate? (that the terrain has been disturbed)
- In what year do we know an earthquake occurred on this fault? (1857)

## PART TWO

### DITCH CREEK

#### PROCEDURE

---

##### A. Introduction

Tell students: By using age-dating methods on peat deposits and very old stream channels, geologists can determine earthquake recurrence intervals dating back several thousands of years. The shorter its recurrence interval, the more likely an area is to experience an earthquake in your lifetime. This activity is another illustration of the principles you saw in the last one. Like the previous



73

activity, it is based on a generalized model of a strike-slip fault.

### B. Lesson Development

1. Project the first transparency made from Master 2.3f, Ditch Creek. Tell students that the diagrams they see show the effect of faulting in successive earthquakes. As you point to each of the figures, 1 through 5, read the accompanying text aloud to the class.

2. Divide the class into working groups of three to five students each. Distribute paper for covering desks, clay, knives, rollers (if available), and one copy of Master 2.3g, Ditch Creek Template, to each group. Give these directions:

a. Make three layers of clay, one white, one yellow, and one red, patting or rolling the clay to a thickness of about 1 cm (1/3 in.) and trimming it to fit within the confines of Area 1 on the grid. Place the white layer on the Area 1 part of the grid and remove the others. Make a pencil-thick string of blue clay and lay it along the line marked on the grid as Stream Line, running the length of the first layer. With the knife, cut along the E-F fault line marked on the grid, which is perpendicular to the stream. Now offset the C-D section of the model, moving it to the position marked 1857 on the grid. This offset represents the movement along the fault of 1857.

b. Now place the yellow layer on top of the white layer and the offset stream. Be sure to place this second layer within the grid marks. Make another pencil-thick stream out of blue clay and place it on the same stream line indicated on the grid. Cut the layers again along the same fault line as in the previous step. Offset the C-D section to the position marked 1906.

c. Repeat this one more time with the red clay layer and one additional blue stream line.

### C. Conclusion

Build a class discussion around these questions:

- How is the principle of superposition applied in this activity?
- How is the principle of crosscutting relationships applied in this activity?
- How is the principle of uniformitarianism applied in this activity?
- Would you build your home in 1994 or later near this fault?

### ADAPTATIONS AND EXTENSIONS

Provide a small-scale map of a seismic area and ask students to locate other streams along fault lines and identify offset stream channels. For example, on a map of the Grand Canyon, locate Bright Angel Canyon and point out the place where it meets the Colorado River. Ask: What caused the Bright Angel Creek to cut a canyon where it did? (The Bright Angel fault caused a weak place in the rock for the water to erode.) ▲

### TEACHING CLUES AND CUES



Remind students that arrows placed on fault diagrams show the relative direction of the motion.



You may want to cover the copy at the bottom of the master (Figure 2, p. 85) while you ask students to describe what they think has happened to produce the new picture.

Name \_\_\_\_\_ Date \_\_\_\_\_

A large grid of 20 columns and 30 rows of small black dots, intended for handwriting practice.

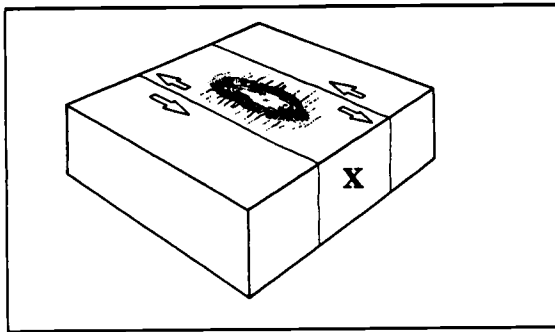
1. \_\_\_\_\_—My great grandmother is born. (Estimate.)
2. 1776—U.S. Congress adopts the Declaration of Independence.
3. 1936—Inge Lehmann demonstrates the presence of an inner core.
4. 1492—Columbus reaches the Americas.
5. 1909—Andrija Mohorovicic discovers discontinuity at crust/mantle boundary.
6. 1989—Loma Prieta quake rocks World Series fans.
7. 1811/1812—New Madrid quakes, greatest ever in continental U.S., estimated at over 8.0 on the Richter scale.
8. 1755—Offshore earthquake near Lisbon, Portugal. Earthquake, 40-foot tsunami, and fires kill 60,000 people.
9. 132—Chinese scholar Chang Heng invents seismoscope to detect earthquakes.
10. 1556—The most disastrous earthquake on record, at Shen-Shu, China, kills 830,000 people.
11. 1889—First record of a distant earthquake was received at Potsdam, Germany.



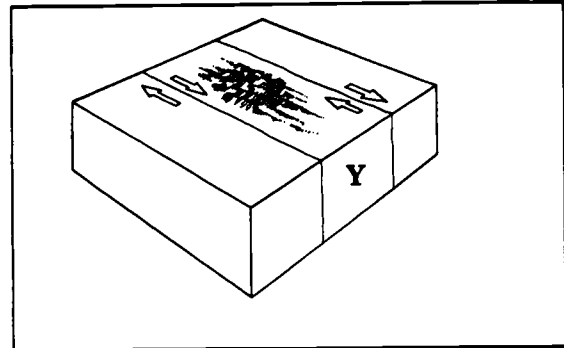
1. Earth formed—approximately 4.54 billion years ago
2. North and South America joined by the closing of the Isthmus of Panama—approximately 2,800,000 years ago
3. Last trilobites died out—approximately 225 million years ago
4. Earliest known humanoid (our early ancestor) fossils deposited—approximately 2 million years ago
5. Earliest known animal fossils (jellyfish-like organisms) deposited—approximately 1.2 billion years ago
6. New Madrid rift zone opened—approximately 500 million years ago
7. Earliest known reptile fossils deposited—approximately 290 million years ago
8. Earliest known bird fossils deposited—approximately 160 million years ago
9. Earliest known mammal fossils deposited—approximately 200 million years ago
10. Earliest known flowering plant fossils deposited—approximately 135 million years ago
11. Earliest known trilobite fossils deposited—approximately 600 million years ago
12. Present day Appalachian Mountains formed—approximately 250 million years ago
13. Rocky Mountains formed—approximately 70 million years ago
14. Mass extinction of dinosaurs and other forms of life occurred—approximately 65 million years ago
15. Breakup of Pangaea began—approximately 180 million years ago
16. Earliest known fossils of land animals deposited—approximately 390 million years ago
17. Last Ice Age ended—approximately 10,000 years ago
18. Oldest known rock on Earth formed in southwest Greenland—approximately 3.2 billion years ago
19. Himalayas begin forming as India joined Asian continent—approximately 30 million years ago
20. Formation of iron, copper, and nickel ores—1 billion years ago
21. Much of continental land masses underwater—330 million years ago
22. Active volcanoes in New England—210 million years ago
23. Earliest microfossils formed in South African chert—3.2 billion years ago
24. Algal stromatolites formed in Rhodesian limestones—3 billion years ago



	Reams (and/or) Pages		Total Pages
1.	46	—	23,000
2.	—	14	14
3.	2	125	1,125
4.	—	10	10
5.	12	—	6,000
6.	5	—	2,500
7.	2	450	1,450
8.	1	300	800
9.	2	—	1,000
10.	1	175	675
11.	6	—	3,000
12.	2	250	1,250
13.	—	350	350
14.	—	325	325
15.	1	400	900
16.	3	450	1,950
17.	—	1	1
18.	32	—	16,000
19.	—	150	150
20.	10	—	5,000
21.	3	150	1,650
22.	2	50	1,050
23.	32	—	16,000
24.	30	—	15,000



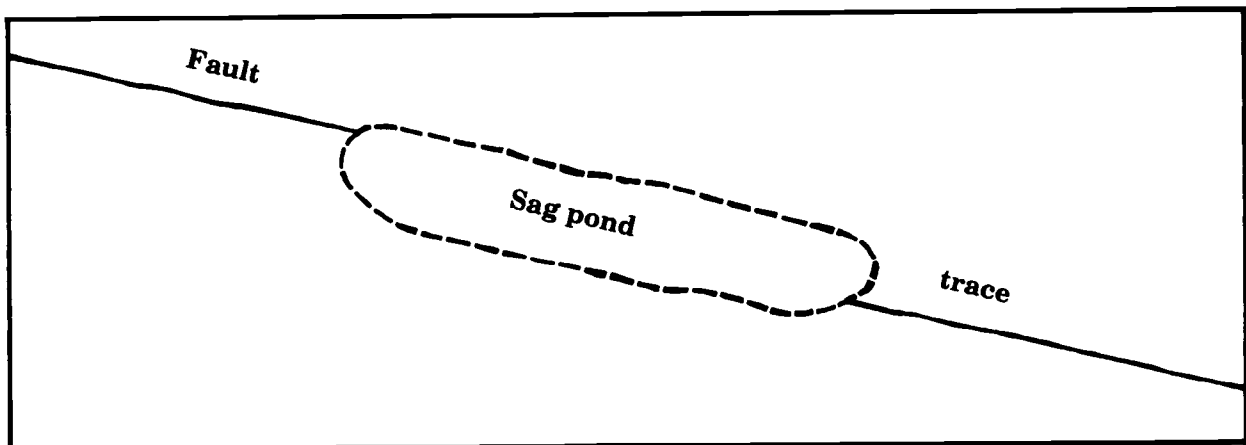
*Right Lateral Strike-Slip Fault*



*Left Lateral Strike-Slip Fault*

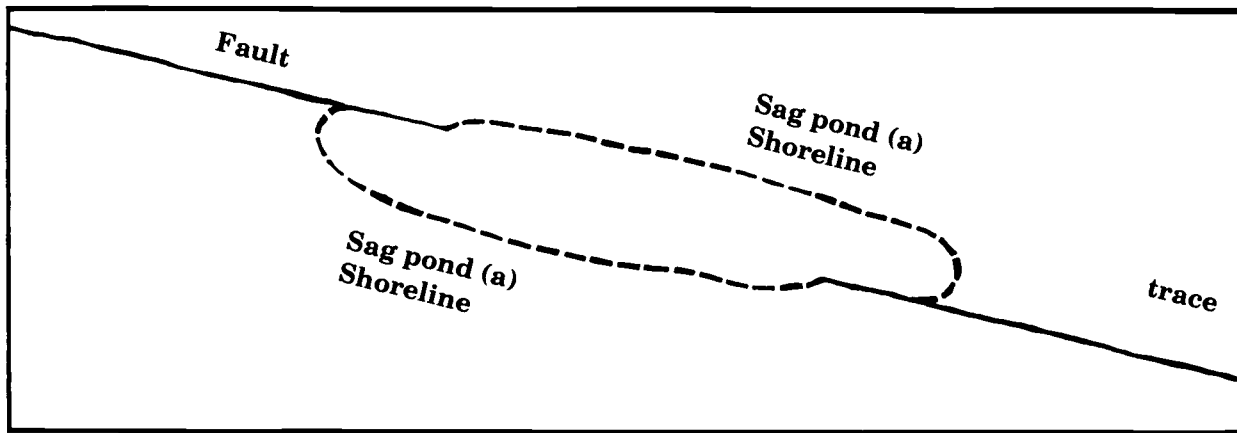
**Figure 1, Sag pond**

In the left-hand side of Figure 1 (X), there is a place where the ground has pulled apart. The depression caused by this "pull-apart" basin is called a sag pond. This is a very narrow, long or elongated pond or basin. Sag ponds are generally aligned with the long axis parallel to the faults. In the right-hand drawing, (Y), a ridge is being formed by squeezing, or compression.



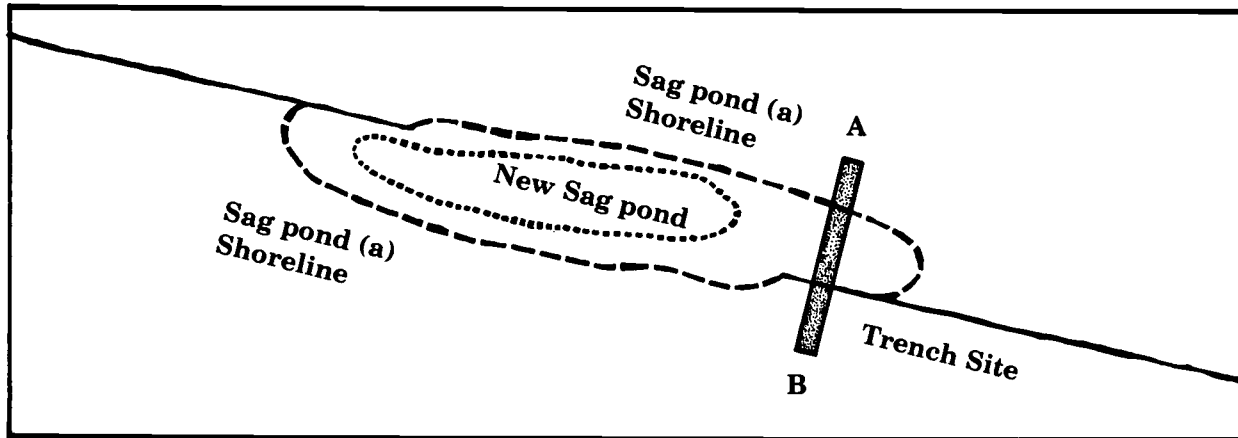
**Figure 2, Sag pond 1830**

Fault slippage has formed a sag pond, which has filled with water containing reeds, cattails, and algae. These organic materials die and accumulate rapidly on the bottom of the sag pond in the form of peat. Peat can accumulate as much as several centimeters per year.



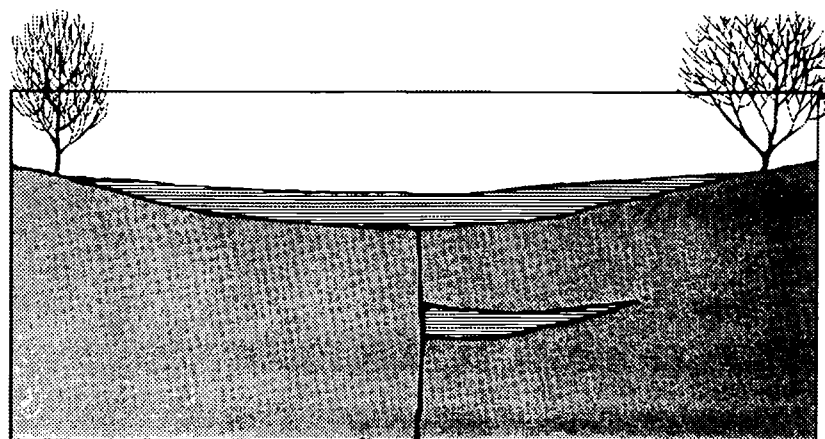
**Figure 3, Sag pond 1857**

Fault moves, offsetting shorelines of sag pond and organic materials (peat) on bottom.



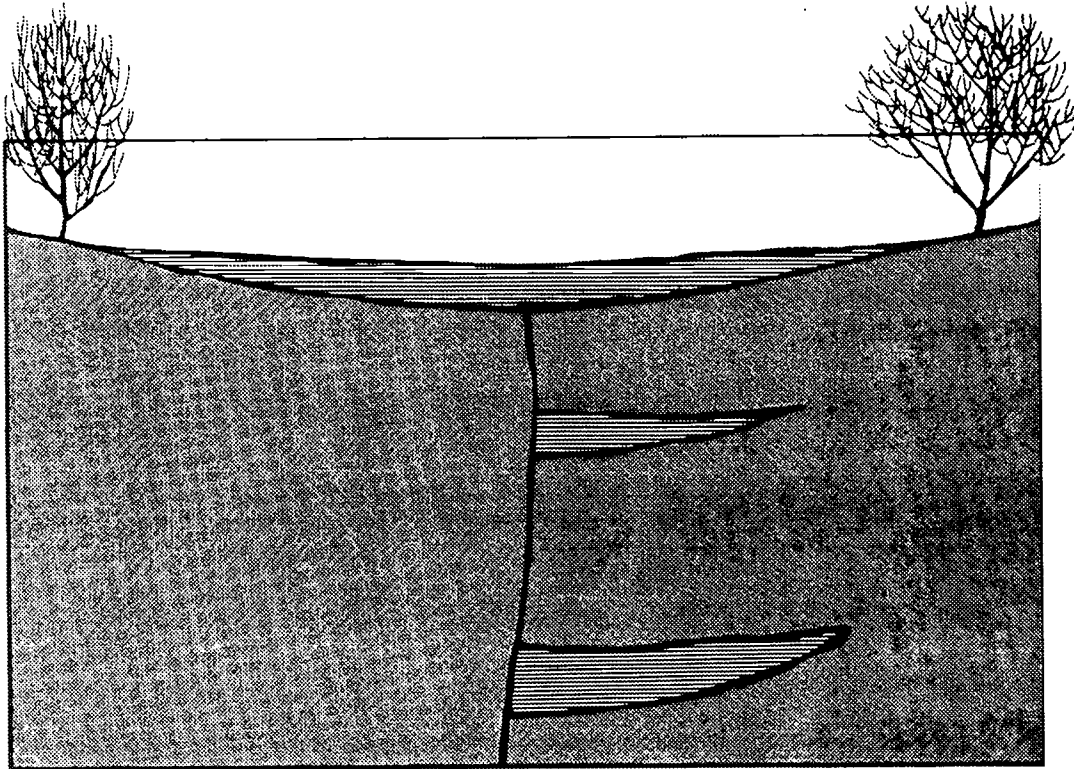
**Figure 4, Sag pond 1994**

Shortly after the faulting, a new sag pond forms with more reeds, cattails, and algae. Peat continues to accumulate. In 1994 the sag pond is pumped dry, and a shallow trench (A-B) is dug with excavation equipment perpendicular to the fault. A sketch of one side of the trench is reproduced below (see Figure 5).



**Figure 5, Trench Log 1, 1994**

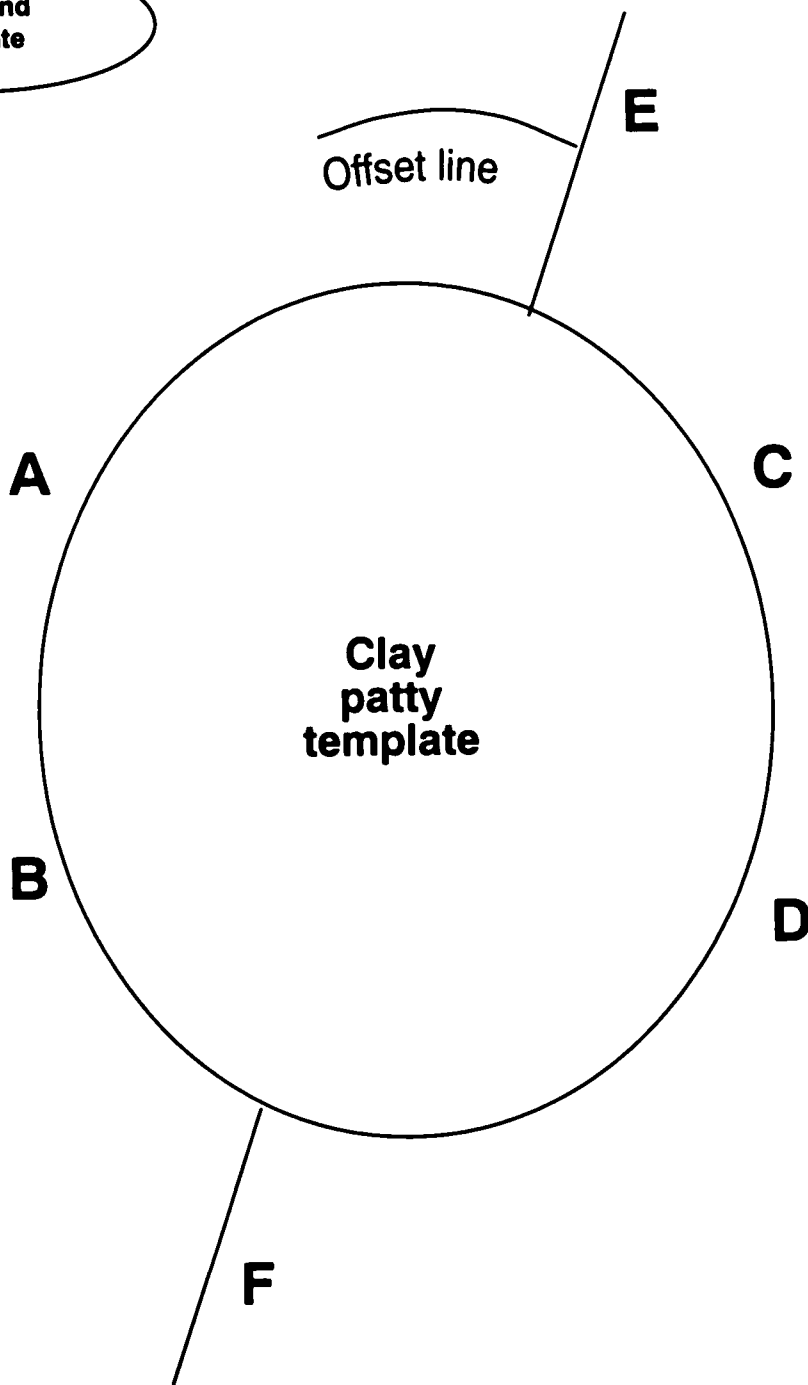
Later that same year, a deeper trench is excavated across the same sag pond, and the following trench log is obtained:

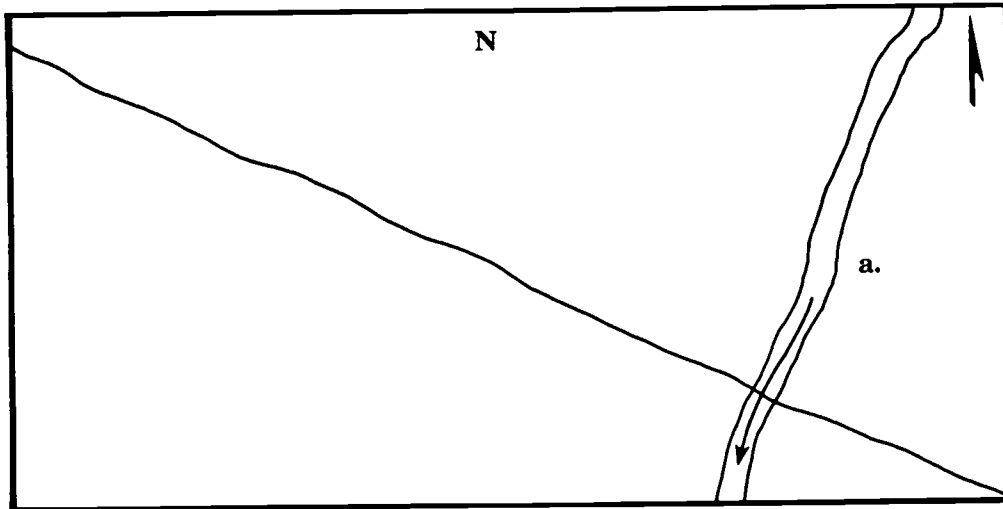


**Figure 6, Trench Log 2, 1994**

What are your conclusions regarding the pre-1830 seismic history (the paleoseismology) of this fault? (The peat layer shows that faulting has taken place. The depth of the layers can be measured, and the distance between the layers can be measured.)

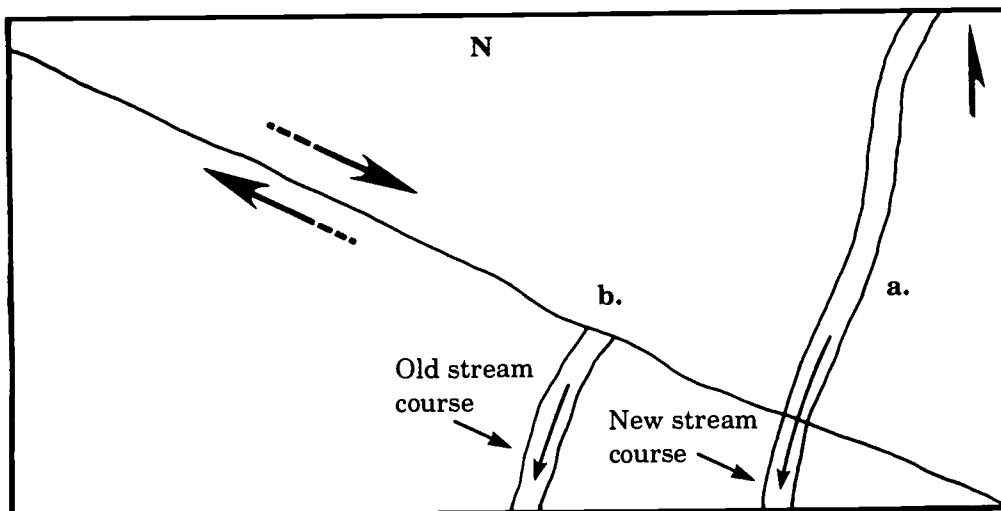
Sag pond  
template





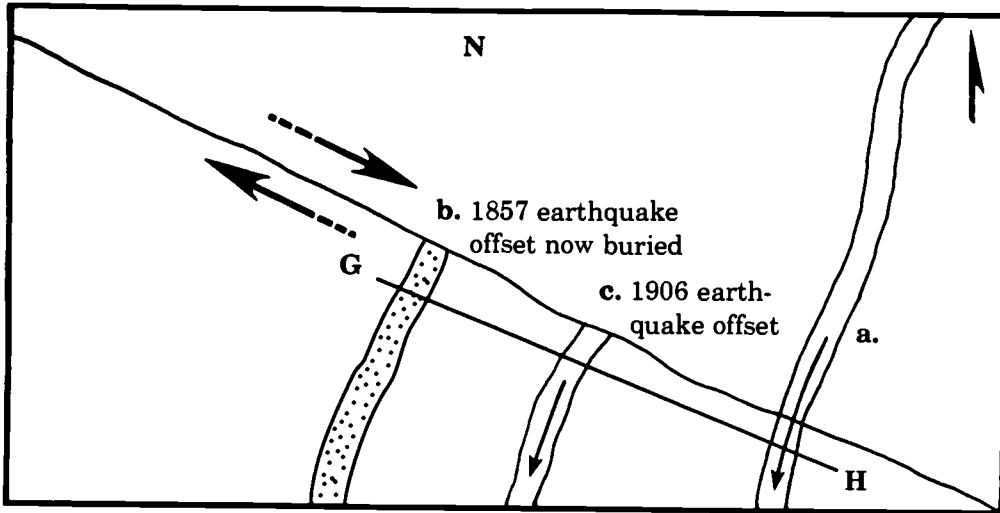
**Figure 1 1830**

A stream (a) flows across a strike-slip fault.



**Figure 2 1857**

An earthquake with movement along the fault in 1857 causes displacement of stream (a) as shown. The amount of displacement probably represents the amount of offset the earthquake caused. As the years go by, soil and sand may bury and cover up parts of the original stream course (b).

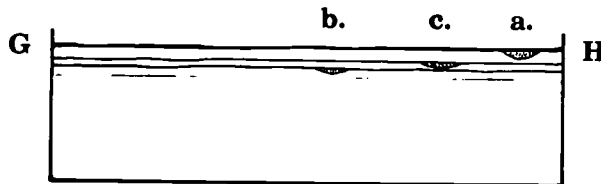


**Figure 3 1906**

Another earthquake with movement along the same fault in 1906 causes further offset of the course of the stream. Soil and sand will continue to bury and cover up parts of the 1857 (b), and the 1906 (c) offset. A shallow trench (line G-H) cut parallel to and south of the fault in 1994 might show the following relationship (Figure 4) on the southern side of the trench:

**SECTION VIEW**

Ground surface

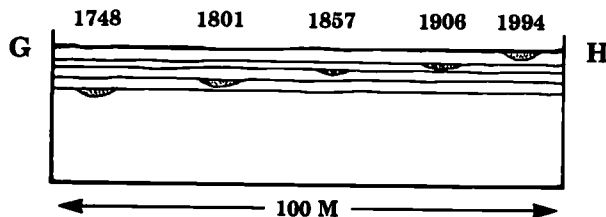


**Figure 4 Trench Log 1, 1994**

The rate of movement and timing of earlier earthquakes can be determined from the age of the sand and gravel deposits in the stream channel.

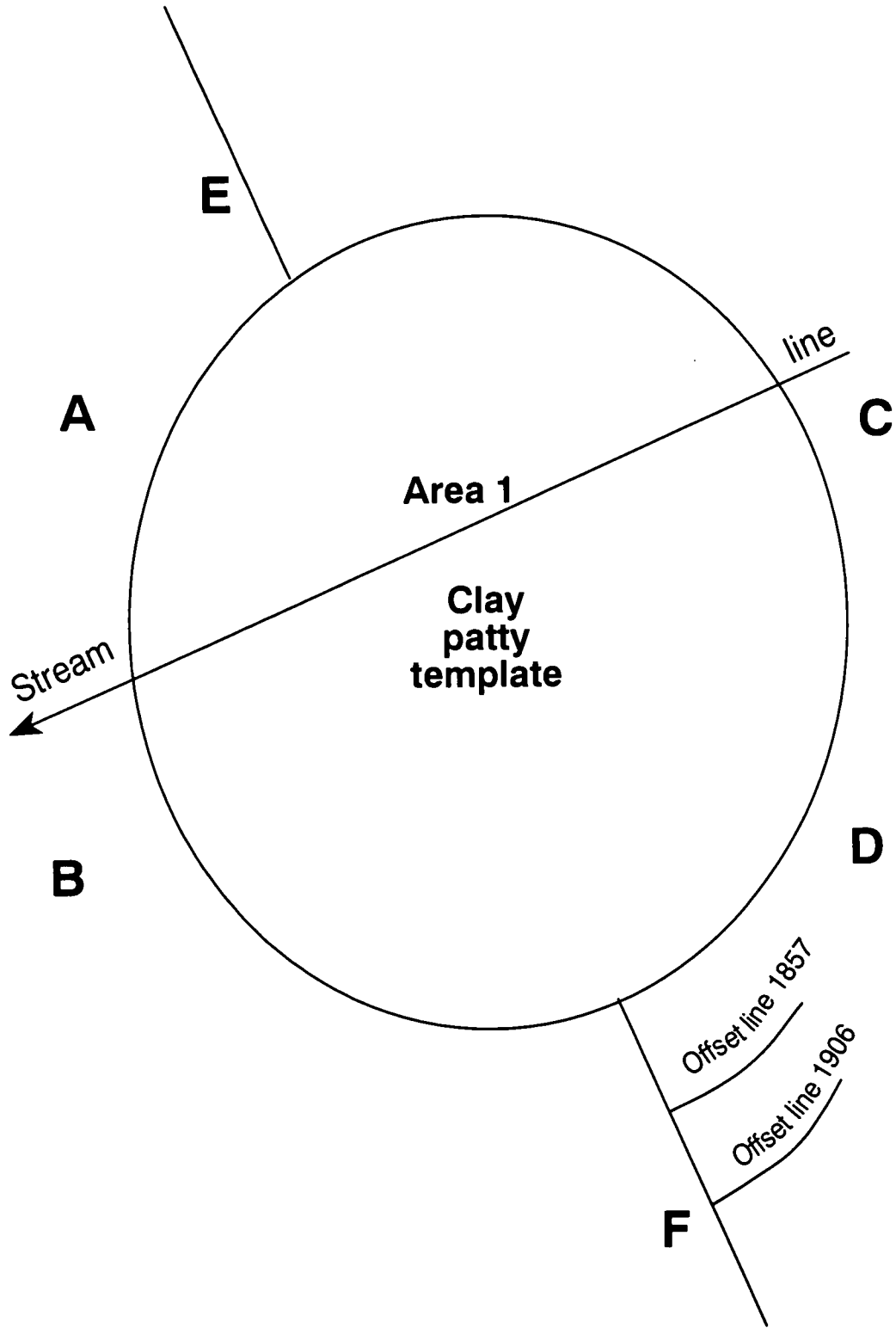
If a second longer and deeper trench is excavated in the area of trench G-H, the following log might be obtained (Figure 5):

**SECTION VIEW**



**Figure 5 Trench Log 2, 1994**





# EARTHQUAKE Hazards

## ACTIVITY ONE

### LIQUEFACTION: THAT SINKING FEELING

#### RATIONALE

Like other earthquake-related phenomena, liquefaction may cause the loss of property and even injury or death. This model allows instructors and students to observe the effects of liquefaction and the phenomenon of sand boils on a small scale.

#### FOCUS QUESTION

What happens when a damaging earthquake strikes areas prone to liquefaction?

#### OBJECTIVES

##### Students will:

1. Construct a model to demonstrate liquefaction.
2. Distinguish between soil liquefaction and soil saturation.
3. Assess potential damage to homes, lifelines, and schools.

#### MATERIALS


##### for the teacher

- Master 2.4a, Teacher Background Reading: Liquefaction
- Master 2.4b, New Madrid Narrative

##### for each small group

- 226 g (about 8 oz) of well-sorted fine sand [Sandbox sand works well.]
- One .25-l (9 oz) clear plastic cup
- One pie plate, diameter 23 cm (9 in.)
- 225 ml (5 oz) of water in a pitcher
- Sinker or comparable small object weighing at least .06 kg (2 oz)
- One 250-ml beaker
- Newspapers to cover work surface

#### TEACHING CLUES AND CUES

 If possible, substitute a small, hollow, ceramic house, measuring approximately 5 x 5 x 7 cm, for the sinker. These are sold at hobby shops for Christmas scenes, and can be filled with BBs to add weight.

## PROCEDURE

### Teacher Preparation

Read Master 2.4a, Teacher Background Reading: Liquefaction, and Master 2.4b, New Madrid Narrative. Decide how you will share this information with your students. Students who like to read will find the New Madrid Narrative delightful.

Gather enough materials so you can have two students per station. Before class, cover work areas with newspapers, set up the stations, and practice each activity at least once to be sure everything works.

### A. Introduction

Tell students that an earthquake with a magnitude of 5.0 or greater may cause saturated sand or clay soils to liquefy. During the winter of 1811 and 1812, a series of earthquakes affected the central portions of the United States that we now know as Missouri, Arkansas, Kentucky, Illinois, and Tennessee. As the soft sediments along the rivers were violently shaken, tremendous volumes of sand were liquefied and ejected onto the Mississippi River flood plain. These sand boils, as they are called, are still visible in the rural countryside today. Fortunately the area of the earthquakes was not heavily populated in 1811-12, so loss of life, injuries, and loss of property were minimal.

During the 1989 World Series in San Francisco, a 7.1 earthquake struck the Bay Area. Millions of people viewed firsthand the fires and severe damage to buildings in the Marina District. Some of this damage occurred because soil liquefaction caused lifelines to rupture and buildings to collapse.

### B. Lesson Development

1. Write the word *liquefaction* on the board, and ask student to identify its root word (*liquid*). Emphasize that liquefaction does not cause an earthquake, but is the result of an earthquake. Liquefaction occurs only in highly saturated sand or clay soils. An earthquake with a magnitude of 5.0 or greater is usually needed to cause liquefaction. Earthquake vibrations cause soil particles to lose contact with each other, so the soil takes on the characteristics of a liquid.
2. Assign a partner to each student and designate a work station for each team. Give these directions:
  - a. Cut off about 5 mm from the bottom portion of the plastic cup.
  - b. Invert the cup and place it in the middle of the pie pan.
  - c. Holding the cup firmly, slowly pour the sand into the bottom of the cup to a level of 10-20 mm from the top. (One student may hold while another pours.) Level the sand with your fingers. *Do not shake the cup to settle or level the sand.*
  - d. Lightly place the sinker, model house, or other weight onto the leveled surface of the sand.

## TEACHING CLUES AND CUES



Students may be aware that the flooding of the Mississippi and Missouri Rivers in the summer of 1993 caused mud boils in some places. Explain that these eruptions, somewhat similar to sand boils, were caused by extreme saturation of muddy soils in combination with the force of the torrential rains. Mud boils, like sand boils, can also be caused by earthquakes over magnitude 5.0.

## VOCABULARY



**Consolidated:** tightly packed, composed of particles that are not easily separated.

**Ground water:** subsurface or underground water.

**Lifeline:** a service that is vital to the life of a community. Major lifelines include transportation systems, communication systems, water supply lines, electric power lines, and petroleum or natural gas pipelines.

**Liquefaction:** the process in which a solid (soil) takes on the characteristics of a liquid as a result of an increase in pore pressure and a reduction in stress.

**Sand boil:** a forcible ejection of sand and water from saturated soil, caused by an earthquake or heavy flooding.

**Saturated:** having absorbed water to the point that all the spaces between the particles are filled, and no more water can enter.

**Unconsolidated:** loosely arranged, not cemented together, so particles separate easily.

e. Again holding the cup, slowly pour the entire 225 ml of water into the pie pan around the outside of the cup and sand.

f. Observe what happens and record the time it takes for the soil to reach saturation.

g. Once the soil is saturated, one student will hold the cup firmly in place while the other gives the side of the cup several sharp taps to simulate earthquake shaking. Observe what happens to the weight.

### **C. Conclusion**

Help students to clean up and then initiate the discussion. Ask: If the weight in our experiment were an occupied building, and liquefaction occurred over a large inhabited area, as it did in the San Francisco Bay Area in 1989, what would be the effect on:

- People?
- Private homes?
- Schools?
- Buried lifelines (gas, water, electrical, oil, sewage)?
- Agricultural lands?
- Medical facilities, fire stations, police stations?
- Large urban areas (Memphis, San Francisco, Boston)?
- Industrial areas?
- Materials that had been discarded in old sand boils? (These could range from dead cows to old refrigerators to poisonous waste.)

### **ADAPTATIONS AND EXTENSIONS**

1. Make sand of various particle sizes and objects of different masses available for student experiments. Investigate the degree of liquefaction each will exhibit and the effects on the structures that rest upon them. (A layer of diatomaceous earth under the sand will bubble up when the table is rapped. Try it!)
2. Invite students to find ways to vary the amount of force they apply to the sand and water mix in the model.
3. Provide an aquarium or plastic gallon jars so students can experiment with larger models. Use transparent containers of any size—even a plastic sandwich box—for an interesting side view.
4. Bury objects in the sand and observe the results.
5. Develop models of overhead power lines, pipelines, sewage lines, light posts, and highways, and observe how liquefaction affects them.
6. Challenge students with this question: If a building has already been constructed on soil that has a potential to liquefy, what can be done to reduce the likelihood of damage? Invite them to design and test model structures that would reduce structural damage during liquefaction.

## ACTIVITY TWO

### LANDSLIDES: SLIP-SLIDING AWAY

#### RATIONALE

---

Earthquakes dramatically increase the potential for landslides in areas where landslides are common, such as those where sedimentary rocks lie just under the soil. Structures on cliffs and ridges need to be designed to the highest earthquake standards, and should be fully insured.

#### FOCUS QUESTIONS

---

How can an earthquake trigger a landslide?

What factors affect the probability of an earthquake-related landslide?

#### OBJECTIVES

---

##### Students will:

1. Construct a model to simulate an earthquake-related landslide.
2. Investigate the variables that affect an earthquake-related landslide, such as the strength of the slope materials, the steepness of the slope, and the intensity of ground shaking.
3. Explain why the steepness of a slope determines how the force of gravity acts on an area of ground and how it is related to frictional forces.

#### MATERIALS

---

##### *for the teacher*

- Slides or photos of landslide damage (in your geographic area, if available)
- Slide projector and screen or blank wall space (*optional*)
- Pasteboard or cardboard arrows in three colors, cut to the correct lengths to illustrate the 30° angle (*optional*)

##### *for each small group*

- A pine board, approx. 2.5 cm x 25 cm x 1.0 m (1 in. x 10 in. x 3 ft.)
- A meter stick
- Two plastic dishes, approx. 19 cm in radius, with sides 3.5 cm high
- Enough dry sand to fill the two dishes
- 500 ml of water in a beaker or other suitable container
- Newspapers to cover work surfaces
- A sensitive bathroom scale that can register weights as low as 1 Newton (less than 2 lbs)
- Paper towels for cleaning the board between trials
- Master 2.4c, Landslide Data Table
- Master 2.4d, Landslide Activity Sheet
- Pencils or pens

#### TEACHING CLUES AND CUES

---



The width of the board can vary, but it must be 1 m long.



The inexpensive clear plastic dishes sold to put under potted plants will be ideal. The dish must be a little smaller than the board.

- Transparency made from Master 2.4e, Components of the Force of Gravity
- Overhead projector
- Soil, gravel, or other materials for the extension (*optional*)

## PROCEDURE

### Teacher Preparation

Assemble slides and/or photos. Assemble the other materials ahead of time and experiment with them to get a feeling for how various angles will affect their movement. Cover work surfaces with newspapers.

### A. Introduction

Ask the students: Can an earthquake cause a landslide? Promote a discussion of their experiences and ideas. Show any images you have gathered of earthquake-related landslides, especially those that have affected your local environment.

Explain to the students that not all landslides are earthquake related; many are caused by other natural factors. Landsliding, or mass movement, occurs when the forces that hold materials in place are exceeded by the force of gravity in the direction of motion. The forces that hold sand, soil, rocks, and buildings in place are related to the strength of the materials. The balance of these forces may be affected by the intensity of ground shaking during an earthquake. The steepness of the slope on which the materials rest determines how much the force of gravity acts in the direction of motion.

### B. Lesson Development

1. Divide the class into cooperative groups of three or more students. Distribute one copy of Master 2.4c, Landslide Data Table, to each group. Ask one member from each group to collect a dish of sand and the other materials.
2. Tell the students they will be conducting this investigation in a scientific manner. That is, they are to control all the variables, manipulate only one, and measure or observe the response. When students have completed the experiment, it is very important that they use only their results to develop an explanation and that their explanation relates only to this particular model. Point out that the questions toward the end of the Landslide Activity Sheet relate to the scientific process they are employing.
3. Instruct students to set up a ramp, as illustrated on Master 2.4c, and begin to explore the effect of the ramp's angle on the weight the scale reads. Explain that the less weight the scale records, the greater the force of gravity parallel to the ramp and the weaker the force of friction that holds the material in place. Give these instructions:
  - a. Place the scale at the bottom end of the ramp and place a dish of sand right side up on top of it.
  - b. Raise one end of the ramp to the height corresponding to the first angle indicated on the Landslide Data Table. As you move from one angle to another, record the scale readings in the Landslide Data Table.

## VOCABULARY



**Friction:** mechanical resistance to the motion of objects or bodies that touch.

**Gravity:** the force of attraction between any two objects with mass. Gravity is especially noticeable when an object of great mass, such as Earth, attracts an object of lesser mass.

**Landslide:** an abrupt movement of soil and bedrock downhill in response to gravity. Landslides can be triggered by earthquakes or other natural causes.

**Loess:** an unstratified, wind-blown mixture of clay, sand, and organic matter, usually crumbly and buff or yellow-brown in color.

**Mass movement:** the movement of surface material caused by gravity.

**Variable:** in a scientific experiment, the one element that is altered to test the effect on the rest of the system.

## TEACHING CLUES AND CUES



If you do not have enough scales you may do this section as a demonstration. You may also choose to simply describe the forces and use the factors in the data table below to describe how the measured weight of the material changes as the angle of the ramp changes. Whether you do the weighing or the students do, be sure to convert pounds into the metric unit Newtons (2.2 pounds = 9.8 Newtons).

4. Stop the groups when they have completed the scale measurements and explain that the ramp breaks the force of gravity up into two components. Project the transparency of Master 2.4e, Components of the Force of Gravity, to illustrate. One of the components operates in a direction perpendicular to the ramp; that is the force they just measured. The other force operates along the ramp. That is the force of gravity, which will cause the landslide. These two components of gravity form two sides of a right triangle. Depending on the angle of the ramp, the force of friction may or may not cancel the force of gravity.

5. To investigate the effect of slope on material with and without a simulated earthquake, ask the students to remove the scale. Show them how to place the dish of sand upside down at one end of the board without spilling the sand. First, place the board on top of the dish. Then, while holding the board down over the dish, carefully flip the board over. The dish should be upside down on the board with all the sand still in the dish.

6. When all the groups have accomplished this, ask students to vary the angle of the ramp as they did before, this time by slowly raising the end of the board with the dish of sand. Instruct students to record the height at which the sand starts to slide, then lower the ramp by about 5 cm and tap on the ramp to simulate an earthquake.

7. Give these instructions to test the effect of water on the sand:

a. Again cover the dish with the board, flip the dish right side up, and add 225 ml of water to the sand.

b. Flip the dish of wet sand back onto the ramp and repeat step 6 to see the effect each new angle of the ramp has on the wet sand.

c. Continue to record your data and observations in the Landslide Data Table. Use the transparency of Master 2.4e, Components of the Force of Gravity, and Master 2.4d, Landslide Activity Sheet to answer the questions about force.

### C. Conclusion

Allow time for students to respond to the last questions on the Landslide Activity Sheet, which ask them to develop an explanation for what they have observed. When they have finished, ask the groups to share their explanations, being certain to justify their explanations by citing their data.

Ask the class if they think the work they have just done is similar to what scientists do. Ask them what the scientific community would do with a variety of explanations and varying data for the same procedure. Impress upon students that their investigation is one aspect of science and their reporting is another. Explain that it would take a great deal of time and many replications for any of their explanations to be accepted as a landslide theory. If they try the extension activities and want to carry their investigation of landslides still further, they will have to connect this model to real landslide data.

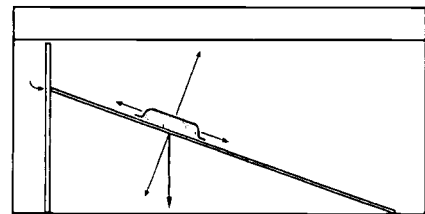
### TEACHING CLUES AND CUES



If you made the arrows listed in the materials section, use them now to help students visualize these angles. Explain that the science of trigonometry deals with the mathematics of right triangles. Here you will simply measure and calculate the forces.



From 0-20 degrees not much will happen, but above 20 degrees, the students should begin to see some distinct motion.



Finally, review and summarize the forces involved in landslides, referring to the illustrations on the handouts. Show the photos or slides again, and ask students to explain what they observe in terms of physical forces.

### **ADAPTATIONS AND EXTENSIONS**

Invite students to test the effect of the material by repeating steps 6 and 7 above with dishes of potting soil, gravel, and other materials.

## **ACTIVITY THREE**

### **TSUNAMI: WAVES THAT PACK A WALLOP**

#### **RATIONALE**

Underwater earthquakes can cause very powerful seismic sea waves commonly called tsunami or (incorrectly) tidal waves. These waves can devastate a coastal community because of the tremendous amount of energy they carry.

#### **FOCUS QUESTIONS**

- How do earthquakes cause seismic sea waves?
- What kinds of energy transfers are involved?
- What precautions can people take to limit tsunami damage?

#### **OBJECTIVES**

##### **Students will:**

1. Prepare and present a class report that reflects their own research on seismic sea waves.
2. Describe the characteristics of an average seismic sea wave in terms of speed, wavelength, and period, and predict its effects on a coastal community.
3. Calculate the energy of the disturbance (sea floor motion) that causes an average seismic sea wave.

#### **MATERIALS**

- Master 2.4f, Teacher Background Material
- Student copies of Master 2.4g, Tsunami Event Reports
- Student copies of Master 2.4h, Seismic Sea Waves Activity Sheet
- Transparency of Master 2.4i, Wave Characteristics and Energy
- Overhead projector
- Student copies of Master 2.4j, Seismic Sea Waves Energy Analysis
- Copies of Master 2.4k, Seismic Sea Waves Research and Report Form, one for every two students
- A large coil, telephone cord, or hose for demonstrating wave action
- Numerous student copies of Master 2.4l, Grading Matrix

#### **VOCABULARY**



**Amplitude:** a measurement of the energy of a wave. Amplitude is the displacement of the medium from zero or the height of a wave crest or trough from a zero point.

**Period:** the time between two successive wave crests.

**Run-up elevation, or height:** the highest altitude above the tide line, in meters, that the water reaches as it is forced up on land by a tsunami.

**Seismic sea wave:** a tsunami generated by an undersea earthquake.

**Tsunami:** a potentially destructive ocean wave created by an earthquake or other large-scale disturbance of the ocean floor. This Japanese word has the same form in both the singular and the plural.

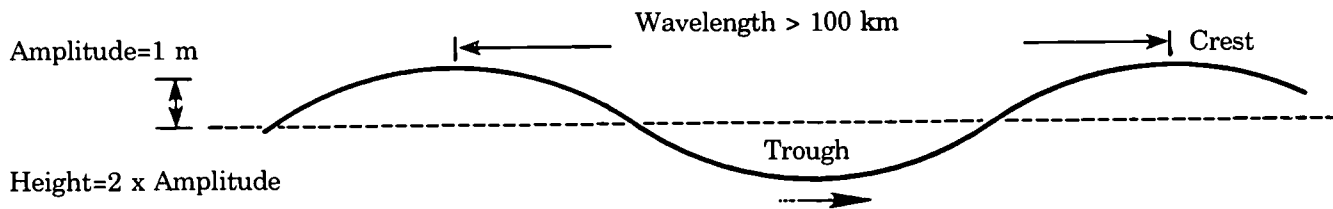
**Wave crest:** the highest point a wave reaches. The lowest point is called its *trough*.

**Wave height:** the vertical distance in meters from a wave's crest to its trough. (This measurement will be twice the amplitude measured for the same wave.)

**Wavelength:** the horizontal distance between two successive crests, often measured in meters.



- Poster board or chart paper, markers, and audiovisual equipment as available
- Video camera (*optional*)



## PROCEDURE

### Teacher Preparation

Read the teacher background information on tsunami. Locate some before and after photos of tsunami, and either make transparencies or have them available to pass around the room.

Check your school and community libraries for the periodicals listed at the end of this lesson and in the Unit Resources. Also look for beginning oceanography textbooks and back issues of *Scientific American*.

### A. Introduction

If you have photos, share them with the class. Then pass out copies of Master 2.4g, *Tsunami Event Reports*. Have students take turn reading the accounts aloud. Ask students what they think causes tsunami.

### B. Lesson Development

1. To provide the students with some common language, pass out Master 2.4h, the *Seismic Sea Wave Activity Sheet*, and help the class work through it. Project the upper half of Master 2.4i, *Wave Characteristics and Energy*. Ask students to tell you what belongs in each blank, and label the wave form accordingly. Point out that waves never stand still, so we have to be very clever to measure their characteristics.
2. Pose this question: How can a fault movement of only one meter in the depths of the ocean cause a huge wave to strike land? Promote student discussion until someone mentions the energy involved. At that point, project the lower half of Master 2.4i, and show students how the uplift of one meter actually involves lifting a column of water the same size as the area of seafloor uplifted.
3. Pass out copies of Master 2.4j, *Seismic Sea Waves Energy Analysis*. Work through the activity as a class or have students complete the worksheets in pairs, depending on their previous preparation.

### TEACHING CLUES & CUES



You may want to review scientific notation before handling the large numbers in this activity.

4. Challenge students to explain how a wave that is only one meter high in the ocean can grow so high as to overwhelm the land. Again direct their attention to the lower half of 2.4i, and point out the energy involved. (As the wave nears shore, in shallow water, the energy is forced upward, or refracted. See Master 2.4f for more detail.)

5. Invite students to do some research on actual tsunami drawn from the table of Notable Tsunami (below) or from other sources. Hand out one Seismic Sea Waves Research and Report Form (Master 2.4k) to every two students, explaining that each team is to research a specific topic and report what they learn to the class. Two students will report on tsunami warning systems; the others will report on a particular tsunami drawn from the list below. Set a due date and establish how you are going to evaluate the report. If you will use the matrix provided, explain it now.

#### **Notable Tsunami by Place Reported**

November 1, 1755	Lisbon, Portugal
April 2, 1868	Hilo, Hawaii
June 15, 1896	Sanriku, Japan
August 13, 1868	Arica, Peru
August 27, 1883	Java, eruption of Krakatau (also spelled Krakatoa)
March 2, 1933	Sanriku, Japan
April 1, 1946	Hilo, Hawaii
March 9, 1957	Hilo, Hawaii
May 23, 1960	Southern California
March 28, 1964	Crescent City, California
November 29, 1975	Hilo, Hawaii
May 26, 1983	Minehama, Honshu, Japan
July 12, 1993	Aonae, Japan

6. Invite discussion of preventive measures that can be taken to minimize seismic sea wave damage. As students progress in their research, they may be able to suggest guidelines. The presentations on early warning systems will address this topic directly.

7. When the due date for presentations is near, review how you will evaluate the presentations and specify the time limit for each. Provide poster board or chart paper and markers, overhead transparencies and pens, and slide or video apparatus if available.

#### **C. Conclusion**

Have the students present their reports. Before each presentation, distribute copies of the grading matrix. Ask students to use one matrix sheet for each presentation, taking notes in the space allotted and evaluating their peers' presentations on the same criteria by which theirs will be graded. A respectful classroom atmosphere will ensure the success of these presentations.

#### **TEACHING CLUES AND CUES**



You may want to videotape the presentations by setting the camera up on a tripod very close to the presenters. If you film your first class, you can use this footage to show other classes what you are looking for.

## **ADAPTATIONS AND EXTENSIONS**

---

Challenge one pair of students to research and describe the compressional waves that have been associated with underwater earthquakes in terms of the wave's characteristics and its effect on ships. ▲

**How Liquefaction Occurs during Quakes**

Liquefaction happens during an earthquake when vibrations cause the pressures to build up in the ground water that occupies the pore spaces between the grains of sand, silt, or loess. The longer the duration of the earthquake, the more likely that liquefaction will be induced. The only solid strength of such a deposit is provided by the friction between grains touching each other. When the pressure in the water that fills the pore space between the grains is sufficient to spread them apart, the solid nature of the sand, silt, or loess deposit is changed into that of a viscous liquid: “quicksand” or “quickclay.”

Because it takes time for the pressures that produce liquefaction to build up underground, and because quicksand is a heavy, thick fluid that moves slowly, conditions of liquefaction, sand boiling, and associated phenomena may not be apparent during the shaking. In fact, they often do not manifest until after the shaking has already passed, sometimes not until 10-20 minutes later. The quick conditions or boiling of the sand can persist for hours or even days after the quake, sometimes as much as a week.

**How Big Does It Take & How Near to the Quake?**

A natural question regarding seismically induced liquefaction is how big an earthquake is required to induce quick conditions and how close it has to be for such effects to be possible. With regard to size, several technical publications suggest that liquefaction does not occur for earthquakes less than Richter magnitudes of 5.2. However, minor liquefaction effects in areas underlain by particularly ideal predisposing conditions (loose sand deposits saturated with a near-surface water table) have been observed for earthquakes as small as 4.7 on the Richter scale in the New Madrid Seismic Zone. Minor damage to vulnerable structures has occurred in such areas.

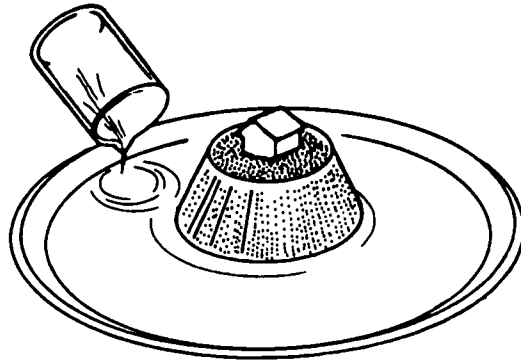
With regard to distance, an earthquake in June of 1987 of magnitude 5.2 in southeastern Illinois caused liquefaction phenomena near Bell City, Missouri, 150 miles (240 km) from the epicenter. A swimming pool, two large grain bins, a carport, and three houses were damaged (one severely). There was also fissuring and lateral spreading. At the same time, points nearer the epicenter of that quake did not experience such ground failures. Three years later in 1990 this same area experienced no liquefaction phenomena when a 4.7 earthquake struck only 20 miles (32 km) away.

Nearness to the epicenter implies greater amplitudes of ground motion, but distance implies a longer duration of shaking, since the wave train consists of many waves traveling at a variety of speeds. The epicenter of the magnitude 8.1 earthquake that struck Mexico City in 1985 was 240 miles (384 km) away and induced liquefaction that severely damaged some buildings. Although lasting less than a minute at its distant source, that quake lasted several minutes in Mexico City. Ground shaking amplitudes within the city were never large, yet 400 buildings collapsed, resonating with the long-lasting wave train (or sequence of waves) amplified by underlying clays.

The New Madrid earthquakes of 1811-12 induced extreme examples of liquefaction, manifesting as sand boils and explosion cratering in the area of St. Louis, Missouri, and across the river in the flood plain of Illinois. Liquefaction also occurred from those quakes as far as Cincinnati, Ohio, more than 300 miles (480 km) away.

**Three Ways to Induce Liquefaction**

Liquefaction in soils can be stimulated three ways: seismically, mechanically, and hydrologically. Seismically-induced liquefaction is caused by seismic waves. Mechanically-induced liquefaction is caused by vibrations that come from railroad trains, motor vehicles, tractors, and other mechanical sources of vibratory ground motion. Hydrologically-induced liquefaction occurs when ground-water pressures increase due to rising stream levels during flooding conditions. This type of liquefaction most commonly



occurs on properties protected by levees, where rivers can rise to levels above the land surface without actually flooding the land. Most of the New Madrid Seismic Zone falls into this category, being surrounded by levees that flank the rivers and drainage ditches throughout the area. Because of this, seismically-induced sand boils become hydrologically active during river flood stages, and can turn into quicksand and boil again, just as they did during the earthquakes that formed them. Similarly, tractors, trains, and trucks crossing over sand fissures during times of high water table can mechanically induce liquefaction, causing highways to sag, railroad tracks to get out of parallel, and farm equipment to sink into the ground.

*Note: Adapted from Stewart, David, and Knox, Ray, The Earthquake That Never Went Away: The Shaking Stopped in 1812, but the Impact Goes On, Marble Hill, MO: Gatlinburg-Richter Publications, 1993.*

# New Madrid Narrative

## (A 1912 Account of the 1811–1812 Earthquakes)

### The First Day

At 2:30 on the morning of December 16, 1811, a tremendous earthquake occurred whose epicentral region is thought to have been just west of the location of present day Blytheville, Arkansas, a city that did not exist at the time. Had it been there, it would have been devastated totally, as evidenced by the numerous earthquake boils and fissures that visibly surround the city today. The Richter surface wave magnitude is thought to have been 8.6. President James Madison, 800 miles (1280 km) away in the White House in Washington, DC, was shaken out of bed by the quake.

Many aftershocks immediately followed, some probably magnitude 6.0 or greater. At least two more of the December 16 shocks are thought to have equaled 8.0 on the Richter scale.

Then, some time around 11:00 a.m., another great shock occurred in the vicinity of present-day Caruthersville, which to the residents there at the time seemed worse than the first. This one is thought to have been another magnitude 8.0. However, present-day Caruthersville wasn't there at the time. It was not founded until 1857. In 1811 another village occupied that site. It was called Little Prairie, Missouri.

### The River Rampages, and Towns Disappear

The Mississippi River was churned into a virtual maelstrom, with miles of banks caving in, boats being swamped and sunk, and even entire islands disappearing along with their human occupants.

Two towns disappeared at this time. One settlement to disappear on December 16, 1811, was Big Prairie, Arkansas. At the confluence of the Mississippi and St. Francis Rivers, the town site liquefied and sank, but slowly enough for all residents to safely escape. There were about 100 people there at the time. The Mississippi River now occupies that site.

Another community destroyed that day was Little Prairie, Missouri, near present-day Caruthersville. Eyewitness accounts of the horror tell us of people being violently thrown from their beds in the middle of the night. It had been a bright full moon, but shortly after the shock everything became pitch black because of the dust. People were injured and bleeding, and some were even knocked temporarily unconscious.

The earth continued to jerk and rumble through the darkness until daylight, when, around 8:00 a.m. the second hard shock hit the area. Throughout the morning more shocks continued, with the ground heaving and cracking, sometimes opening and then suddenly slamming shut, spewing ground water over the tops of tall trees. In some places the ground literally exploded, blasting debris high into the air, raining sand and carbonized wood particles down upon the heads of those nearby, while leaving a deep crater in the ground where smooth land had been before. Sometimes the earth formed spreading crevasses beneath the bases of large trees, splitting their trunks from their roots upwards beyond the levels of their limbs. At one point during the morning a great fissure began to form within the town. The townspeople stood around that pit and watched, horrified, as dark, viscous fluids gurgled from beneath the earth while gaseous fumes and the smell of sulfur and brimstone filled the air.

Many were thinking that the end of the world was at hand and that the very gates of hell itself were opening up to take their village. Amidst the terror, after the third great shock around 11:00 a.m., the soils of their settlement began to turn into quicksand, with dark waters oozing from the pores of the earth. As their whole town began to sink, their streets and cabins were flooded, not from the river, but from the ground itself.

### Escape from Little Prairie

Hastily, the residents of Little Prairie gathered what meager possessions they could hold, lifted small children to their shoulders, and waded westward. Looking ahead of themselves, they could see the rising waters far off on the horizon. For eight miles (12.8 km) they waded through waist-deep waters, never knowing from one step to the next if they were going to plunge headlong into an unseen crevasse or trip over a buried stump, all the while surrounded by snakes, coyotes, and other wild creatures swimming for their lives in that turgid flood. During their escape, they did not know if they would live through the day or not, but all did survive.

### The First Day Was Over, but the Worst Was Yet to Come

What has been described, thus far, was only the first day of the Great New Madrid Earthquake series. More and bigger tremors were yet to come. At about 9:00 a.m. on January 23, 1812, another of the really big ones hit. This was probably centered north of Little Prairie and south of Point Pleasant, a small settlement there at the time. It is thought to have been an 8.4 magnitude earthquake.

The Mississippi River bank, on which the village of Point Pleasant was situated, collapsed during the January 23 event. Fortunately, the residents had all evacuated the site prior to that catastrophe so that none were injured. The town, however, was lost forever.

The January 23 event also caused several huge sand boils in Tennessee that created a dam across Reelfoot Creek. This created "Reelfoot Lake."

On February 7, 1812, came the largest quake of all. At about 3:15 in the morning the region was rocked by an 8.8 magnitude shock. Outside of Alaska, that is the largest earthquake in American history and one of the largest in the world.

This is the quake that caused the Mississippi River to run backwards. It caused such towering waves of water to be thrown over the banks that thousands of acres of trees were shattered into splinters and stumps. It threw boats up on dry land along St. John's Bayou at New Madrid. And it created two temporary waterfalls. These falls had a vertical drop of about six feet (2 m) followed by a mile (2 km) or so of shallow rapids.

During the largest of the New Madrid earthquakes, the river is said to have boiled, whirled, and heaved with massive waves bashing from one bank to the other, sweeping boats and debris into oblivion. Some eyewitnesses from the banks said they actually saw the river open up in yawning chasms, into which the swirling waters disappeared, drawing hapless flat boats and their passengers into the maelstrom, never to be seen again. Others said water spouts would shoot upwards from the water's surface, like tall fountains.

The earthquakes had literally destroyed the landscape with sand deposits, crevasses, and permanent flooding. Most residents of the region abandoned their properties and moved away. The boot-heel portion of Missouri was nicknamed "Swampeast Missouri" sometime after the quakes.

### Two More Towns Gone Forever

The February 7 quake destroyed two other towns, wiping them forever from the face of the earth. One was Fort Jefferson, Kentucky, swept away by landslides. These slumps are still visible today along Highway 51 leading into Wickliffe. The other lost town was New Madrid itself. What was left of the settlement slumped downward 15-20 feet (5-10 m) into the water's edge and was washed away by the spring floods of 1812.

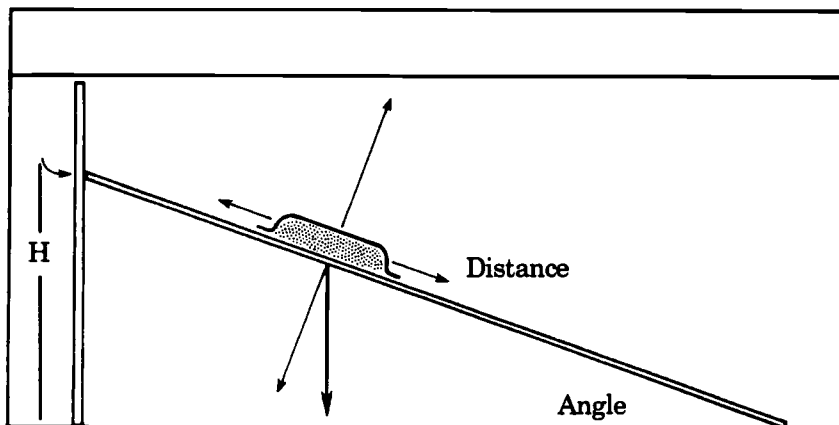
The throbs and throes of terra firma wrought by the Great New Madrid Earthquakes of 1811-12 trouble us no more. Though the motions of these gargantuan ground vibrations ceased in 1812, their impact goes on. Permanent traces of their violence lie scattered over a 5,000 square mile (12,000 sq km) area spanning five states.

*Note: This account was adapted with only minor changes from Fuller, Myron L., The New Madrid Earthquakes of 1811-1812, A Scientific Factual Field Account, USGS Bulletin 494, Washington, DC: Government Printing Office, 1912; reprinted by Southwestern Missouri University Center for Earthquake Studies, 1990. Please keep in mind that the numerical Richter magnitudes quoted in this book were not determined by instrumental measurements as they are today, because these events predated the invention of reliable seismographs.*

Name \_\_\_\_\_ Date \_\_\_\_\_

**Ramp and Force Measurements**

Angle	Height	Force
10°		
20°		
30°		
40°		
50°		
60°		

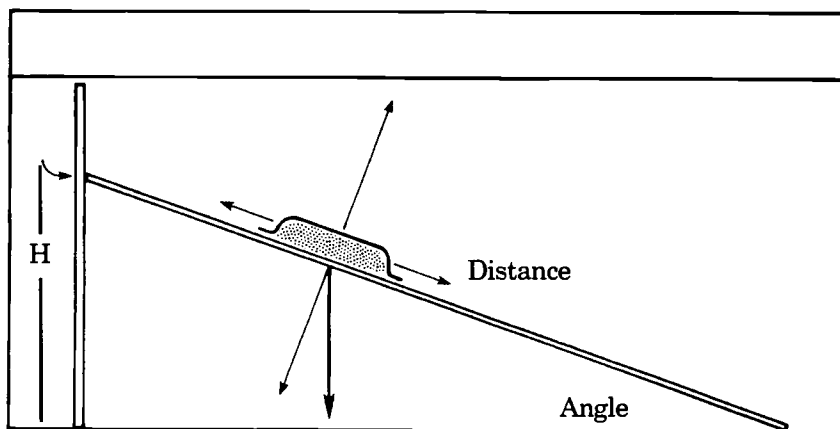
**Effect of Height on Materials**

Material	Angle	Height	Effect of simulated earthquake (1 tap)
Dry Sand			
Wet Sand			
Dry Soil			
Wet Soil			
Other			
Other			



**Ramp and Force Measurements**  
(Note: answers will vary)

Angle	Height	Force
10°	17 cm	
20°	34 cm	
30°	50 cm	
40°	64 cm	
50°	77 cm	
60°	87 cm	



**Effect of Height on Materials**  
(Note: answers will vary)

Material	Angle	Height	Effect of simulated earthquake (1 tap)
Dry Sand	30°	40-50 cm	Sand moved about 1 cm per knock
Wet Sand	30°-40°	55-65 cm	Sand moved about 2 cm per knock
Dry Soil	30°-40°	50-60 cm	Sand moved about 1 cm per knock
Wet Soil	30°-40°	50-60 cm	Sand moved about 2 cm per knock
Other			
Other			

Name \_\_\_\_\_ Date \_\_\_\_\_

Group Names/Roles

\_\_\_\_\_  
\_\_\_\_\_

1. Why do you think the scales measure less weight as one end of the ramp is raised?

\_\_\_\_\_  
\_\_\_\_\_  
\_\_\_\_\_

2. At what height or what angle does the dry sand slide?

\_\_\_\_\_

Why do you think it slides then, in terms of forces?

\_\_\_\_\_  
\_\_\_\_\_

3. What effect does the simulated earthquake (knocking on the ramp) have on the dry sand?

\_\_\_\_\_

Why do you think the simulated earthquake has that effect?

\_\_\_\_\_  
\_\_\_\_\_

4. Before testing wet sand, what effect do you think wetting the sand will have on the slide angle? Why?

\_\_\_\_\_  
\_\_\_\_\_  
\_\_\_\_\_

5. What effect did wetting the sand have on its slide angle? Why?

\_\_\_\_\_  
\_\_\_\_\_  
\_\_\_\_\_

6. What effect does the simulated earthquake (knocking on the ramp) have on the wet sand?

\_\_\_\_\_  
\_\_\_\_\_  
\_\_\_\_\_

7. How did you control the following variables?

a. height or angle

---

b. quantity of material

---

c. amount of moisture

---

d. surface condition

---

e. other

---

8. How did you insure that only one variable was changed at a time?

---

---

---

9. From your data, try to explain how earthquakes affect landslides in as much detail as possible.

---

---

---

10. How could you test your explanation?

---

---

---

11. What was interesting or unexpected in the investigation? Why?

---

---

---

Date:

1. Why do you think the scales measure less weight as one end of the ramp is raised?

*Some of the weight is acting along the ramp. The scale doesn't record that weight.*

---



---

2. At what height or what angle does the dry sand slide?

*40-50 cm, or about 30 degrees.*

Why do you think it slides then, in terms of forces?

*The force of gravity along the ramp is greater than the frictional forces.*

---

3. What effect does the simulated earthquake (knocking on the ramp) have on the dry sand?

*The sand slides a bit with each knock.*

Why do you think the simulated earthquake has that effect?

*It must reduce the frictional forces because gravity remains constant.*

---

4. Before testing wet sand, what effect do you think wetting the sand will have on the slide angle? Why?

*It will probably slide more easily because the water reduces the friction.*

---



---

5. What effect did wetting the sand have on its slide angle? Why?

*The sand seemed to stick to the ramp, so it required a sharper angle to make it slide.*

*Surface tension causes the sand to adhere to the ramp.*

---

6. What effect does the simulated earthquake (knocking on the ramp) have on the wet sand?

*It slid further with each knock.*

---



---

7. How did you control the following variables?

a. height or angle

*Used a meter stick according to the table.*

b. quantity of material

*Filled the dish full each time.*

c. amount of moisture

*Measured 225 ml.*

d. surface condition

*Used only one type of sand.*

e. other

8. How did you insure that only one variable was changed at a time?

*We carefully observed and recorded after each change.*

9. From your data, try to explain how earthquakes affect landslides in as much detail as possible.

*An earthquake will cause a "slidable" piece of material to move a certain amount for each jolt.*

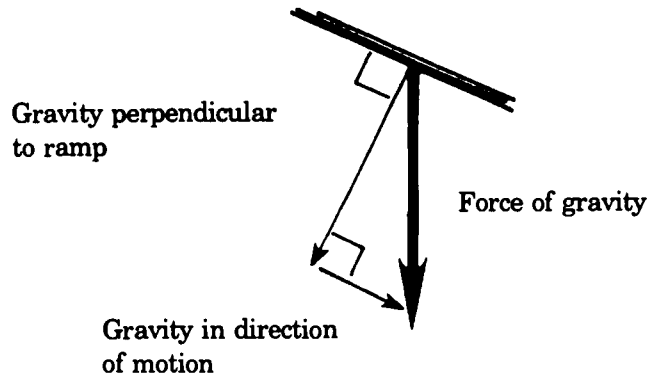
10. How could you test your explanation?

*Repeat the investigation. Compare our explanation to others. Look into real landslide data.*

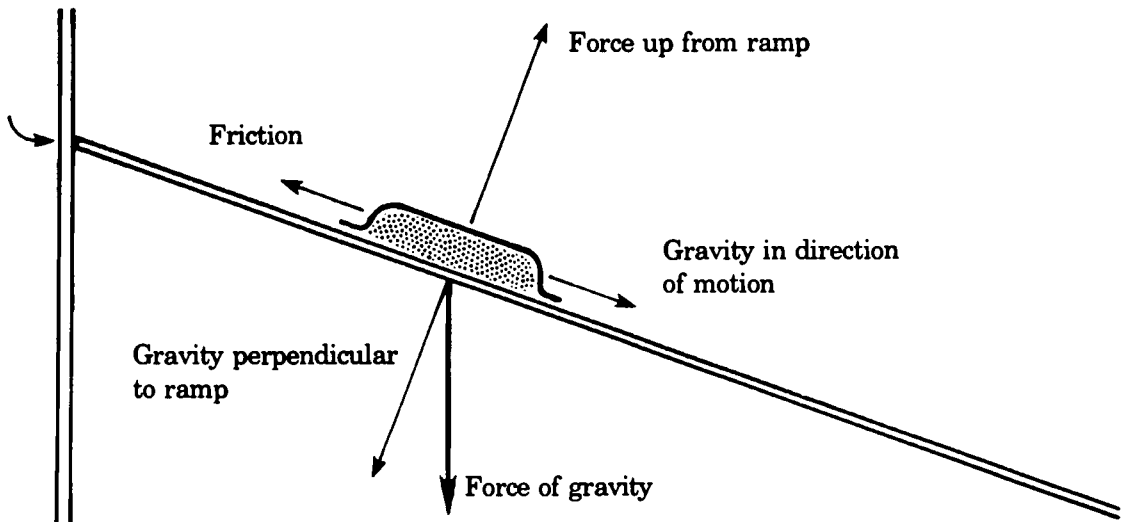
11. What was interesting or unexpected in the investigation? Why?

*The addition of water did not lower the angle required for the sand to slide.*

# Components of the Force of Gravity



**Components of the Force of Gravity**



**Force Analysis When Not Moving**

# Teacher Background Reading

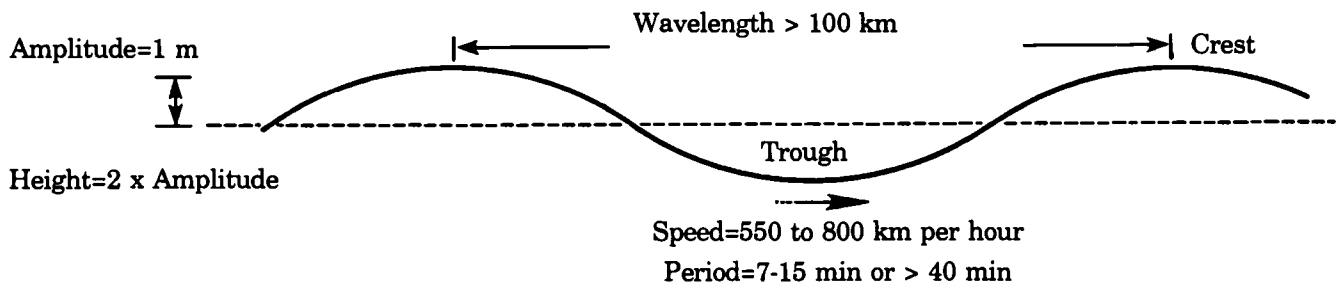
## Seismic Sea Wave

A seismic sea wave is created when a fault in the ocean floor moves vertically. The energy of the lifted or lowered water radiates outward as very long shallow water waves commonly (and erroneously) called “tidal waves.” Because these waves have nothing to do with the attraction of the Moon or the Sun, scientists prefer the Japanese word tsunami, which means “wave in the harbor,” or the English term seismic sea wave.

Most seismic sea waves, like most earthquakes, occur around the Pacific Ocean, but there have been great seismic sea waves in most regions of the Earth.

The great destructive power of these waves comes from the huge energy imparted to the water by fault movement. To equate this energy to mechanical work, we can imagine the work needed to lift an average volume of ocean water a distance ( $d$ ) of 1 meter. The average depth of the ocean ( $h$ ) is 3.8 km. The average surface area ( $A$ ) of the ocean floor moved up or down by such an event, according to seismic sea wave research, is 20,000 square kilometers—a 200 km x 100 km piece of seafloor about the size of New Jersey. The volume ( $V$ ) of seawater lifted would then be 76,000 cubic kilometers. If we take  $1.03 \text{ kg/m}^3$  as the density ( $D$ ) of seawater, the mass ( $m$ ) of that seawater would be about 78 billion metric tons. To lift this much water by 1 m would take  $7.6 \times 10^{14}$  Joules, the energy of 183 kilotons of TNT. See Master 2.4j for a complete quantitative analysis.

This energy radiates outward from the epicenter as a wave train of low waves, not as a single large wave. Each of these seismic sea waves has an average amplitude of 1 meter, wavelengths over 100 km, and periods of 7-15 minutes (for short-period tsunami) or over 40 minutes (for long-period tsunami). These waves travel at speeds between 550 and 800 kilometers per hour before encountering land.



### Seismic Sea Wave Characteristics

Seismic sea waves are very different from wind-generated sea waves. Normal wind waves rarely have wavelengths over 300 meters, and generally travel under 100 km/hr. A medium-sized tsunami can have wavelengths of 150 km and travel at 550–800 km an hour. Tsunami are like tides in that a low tide is followed by a high tide, but in the case of a tsunami dramatic high and low tides can be only tens of minutes apart. This may be the origin of the expression tidal wave.

As seismic sea waves encounter land, they cause rapid tide-like motion. The trough of the waves causes very low tides, while the wave crests may cause a run as high as 32 meters. Sometimes seismic sea waves can cause enormous breaking waves. The mechanism for these waves is very similar to that of wind waves; the friction of the ocean bottom slows the troughs and the crests move over them and break. Thus the character-

istics of seismic sea waves when they hit land, like those of wind waves, are very much related to the characteristics of the near-shore ocean bottom and the shoreline.

The depth of the ocean water also controls the speed of seismic sea waves. As the depth changes, the wave's speed and direction change, resulting in the phenomenon we call refraction—the change in direction of a wave as it moves from one medium to another.

Extensive international cooperation has developed a tsunami early warning system for the Pacific Islands. A system for the U.S. Pacific Coast is being developed. The older system is centered at the Pacific Tsunami Warning Center in Honolulu, where data are collected from seismic observatories across the globe. The Center evaluates the potential of a tsunami and institutes special observations at various tsunami watch stations. All these data are verified and emergency preparation procedures are put into effect when necessary.

### **Causes Other Than Earthquakes**

Not all destructive sea waves are caused by earthquakes. Some are caused by landslides and volcanic eruptions and some are artificially created by events like underwater nuclear explosions. In 1883, the Krakatoa Island volcano erupted, blowing the island away down to a depth of about 43 m below sea level. This event caused giant waves that killed some 36,000 people in Java and Sumatra.



1. On July 12, 1993, the Hokkaido-Nansei-Oki earthquake of magnitude 7.8 produced one of the largest seismic sea waves in Japan's history. The tsunami hit the Okushiri coast within five minutes after the main shock, causing waves at the shoreline between 15 and 30 m high. The town of Aonae on the island of Okushiri suffered extensive damage. At least 185 people were killed, with property damage estimated at \$600 million.

2. The Prince William Sound, or Anchorage, Alaska, earthquake of March 27, 1964, caused seismic sea waves generated by an underwater landslide. At Valdez, the earthquake triggered a landslide that deepened the harbor by as much as 100 m in one place and caused a tremendous tsunami. In addition, the earthquake uplifted the sea floor by as much as 4 meters. The tsunami killed 119 people in Alaska, Hawaii, and California and caused over \$282 million in damage.

3. On April 1, 1946, at 53.5° north and 163° west, 130 km southeast of Unimak Island, Alaska, a large earthquake occurred 4,000 m below the ocean surface in the Aleutian Trench, causing an undersea landslide. Four and one half hours later, a tsunami reached Oahu, Hawaii, after traveling 3,600 km at 800 km/hr. Water rose 12 m above the high tide line on Oahu and 18 m on Hawaii (the "Big Island"). This seismic sea wave demolished 488 homes and damaged 936 others, with property loss estimated at \$25 million and 173 people killed.

4. An earthquake on the ocean floor may also cause a compressional wave that can severely damage ships close to the epicenter of the event. Even though we consider fluids as non-compressional in systems like automobile brakes, compressional waves can travel in seawater under the tremendous pressures and accelerations of the water in underwater seismic events. Ships struck by these waves report an experience similar to running aground or striking another vessel.

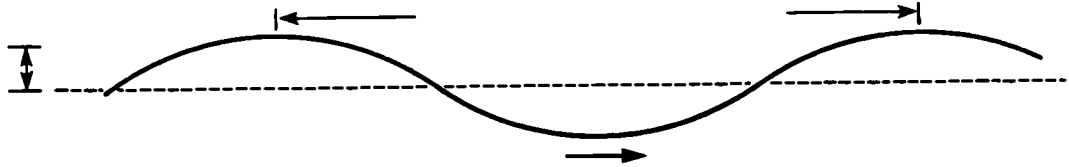
In 1969, a magnitude 8.0 earthquake west of Gibraltar caused compressional waves that struck the 32,500-ton tanker *Ida Knudsen*, sailing in 4,900 m of water. The tanker was 35 km from the epicenter of the earthquake and suffered so much damage that at first it was declared a total loss. The ship was later extensively rebuilt.

# Seismic Sea Waves Activity Sheet

Name \_\_\_\_\_ Date \_\_\_\_\_

## Characteristics of a Seismic Sea Wave

Label the following characteristics and state the average values.



## A Possible Tsunami Scenario

Imagine that a magnitude 6.8 earthquake occurs 1,625 km from a coastal town on a strike-slip fault in the ocean floor, where the water is 3.8 km deep. A wave train is generated with a speed of 650 km/hr and wavelengths of 150 km. The National Tsunami Warning Center alerts the townspeople.

1. How long will it take the tsunami to hit the coastal town?

\_\_\_\_\_

2. The first wave hits at 2:00 p.m. Does Jen have time to rescue the boom box left on the beach before the next wave hits? Calculate the period of the waves. (Period is wavelength divided by speed.)

\_\_\_\_\_

\_\_\_\_\_

3. Describe what might happen when this seismic sea wave encounters the coastal town.

\_\_\_\_\_

\_\_\_\_\_

\_\_\_\_\_

4. What could be done to prepare for this tsunami?

\_\_\_\_\_

\_\_\_\_\_

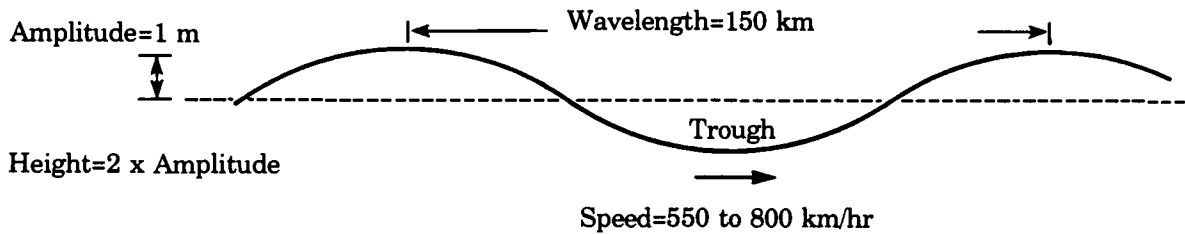
\_\_\_\_\_



# Seismic Sea Waves Activity Sheet (key)

### Characteristics of a Seismic Sea Wave

Label the following characteristics and state the average values.



### A Possible Tsunami Scenario

Imagine that a magnitude 6.8 earthquake occurs 1,625 km from a coastal town on a strike-slip fault in the ocean floor, where the water is 3.8 km deep. A wave train is generated with a speed of 650 km/hr and wavelengths of 150 km. The National Tsunami Warning Center alerts the townspeople.

1. How long will it take the tsunami to hit the coastal town?

$$\text{Time} = \text{Distance} / \text{Speed} = \frac{1,625 \text{ km}}{650 \text{ km/hr}} = 2.5 \text{ hours}$$

2. The first wave hits at 2:00 p.m. Does Jen have time to rescue the boom box left on the beach before the next wave hits? Calculate the period of the waves. (Period is wavelength divided by speed.)

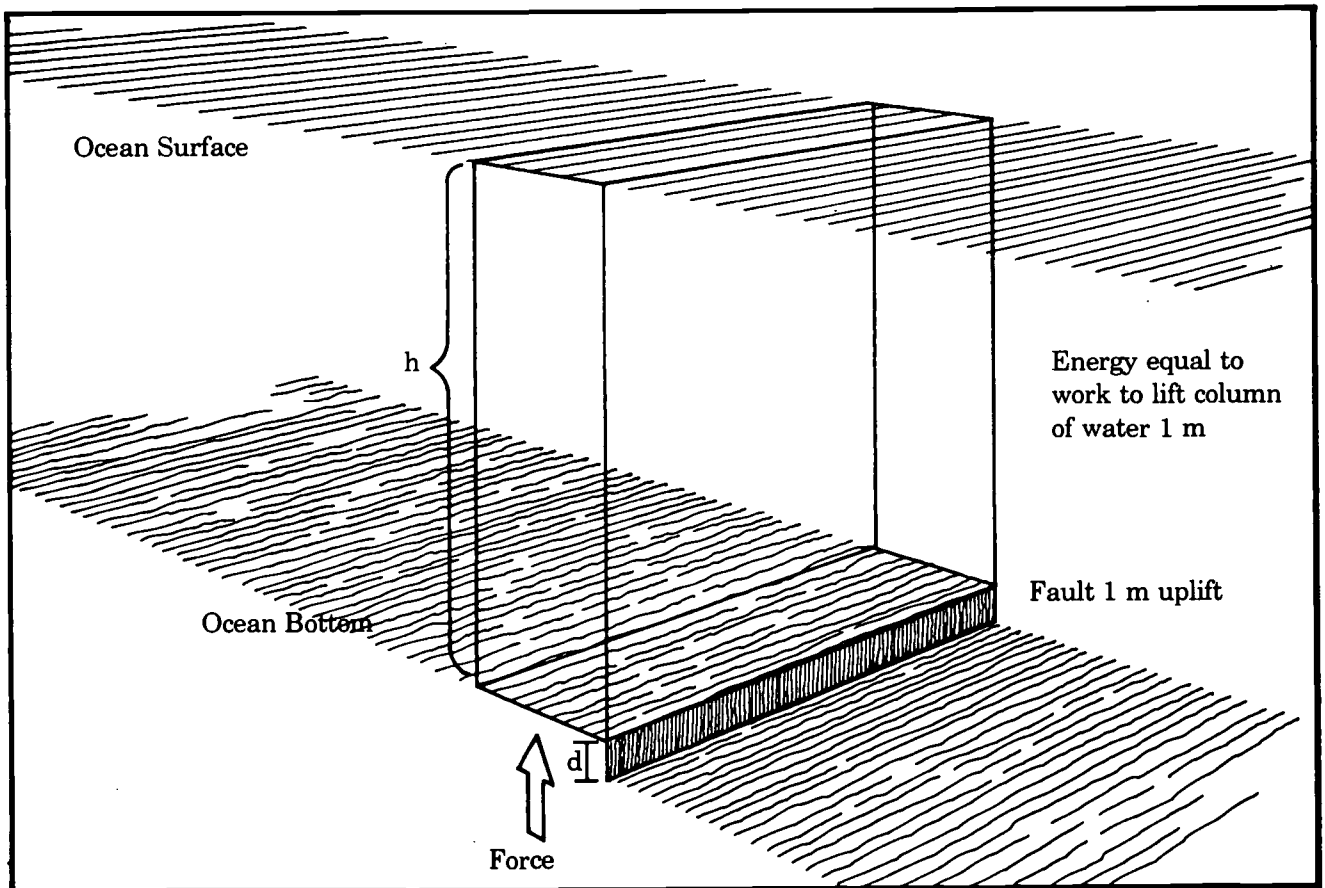
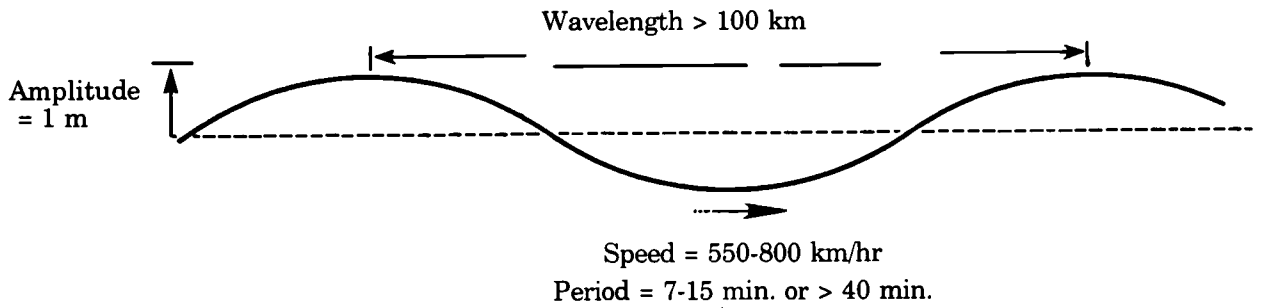
$$\text{Period} = \text{Wavelength} / \text{Speed} = \frac{150 \text{ km}}{650 \text{ km/hr}} = .23 \times 60 = 13.8 \text{ min}$$

3. Describe what might happen when this seismic sea wave encounters the coastal town.

*There would be very high and very low water with only minutes in between.*

4. What could be done to prepare for this tsunami?

*People could be warned to move to high ground.*



# Seismic Sea Waves Energy Analysis

Name \_\_\_\_\_ Date \_\_\_\_\_

*To calculate the minimum energy needed to cause an average seismic sea wave, we can calculate the work needed to give a particular volume of ocean water some gravitational potential energy. In essence, this means calculating the product of the force needed to lift a particular volume of water and the height to which it is lifted. Using the average values from tsunami research to carry out the following steps, calculate the energy released by an earthquake on the sea floor that starts a seismic sea wave.*

1. What is the average sea floor area that moves in an earthquake that results in a seismic sea wave?
2. Knowing that the average ocean depth ( $h$ ) is 3.8 km, what volume ( $V$ ) of water is moved in the disturbance that causes a seismic sea wave? (Use the formula  $V = Ah$ .)
3. This volume of ocean water has a certain mass. Knowing the density ( $D$ ) of ocean water to be  $1.03 \text{ kg/m}^3$ , calculate the mass ( $m$ ) of the water moved by the quake. (Use the formula  $m = DV$ .)  
(note:  $1 \text{ km}^3 = 1 \times 10^9 \text{ m}^3$ )
4. To lift that mass of ocean water requires a force that is at least equal to water's weight. Using  $9.8 \text{ m/s}^2$  as the acceleration due to gravity ( $g$ ), calculate the force ( $F$ ) needed to lift that much ocean water.

5. Supposing that volume of ocean water is lifted an average height (d) of one meter, how much work (W) is done? This value represents the energy imparted to the seismic sea wave by the earthquake.

6. How much energy is this in equivalent tons of TNT? 1 Ton TNT =  $4.18 \times 10^9$  Joules

7. Imagine this much energy spreading over the same area, but then being applied to say only 3.8 meters of water instead of 3.8 kilometers. How high might the 3.8 meters of water be lifted?

# Seismic Sea Waves Energy Analysis (key)

1. What is the average sea floor area that moves in an earthquake that results in a seismic sea wave?

$$A = 20,000 \text{ km}^2$$

2. Knowing that the average ocean depth (h) is 3.8 km, what volume (V) of water is moved in the disturbance that causes a seismic sea wave?

$$\begin{aligned} \text{Volume of seawater: } V &= Ah = (20,000 \text{ km}^2)(3.8 \text{ km}) = 7.6 \times 10^4 \text{ km}^3 \\ &= 76,000 \text{ km}^3 \end{aligned}$$

3. This volume of ocean water has a certain mass. Knowing the density (D) of ocean water to be 1.03 kg/m<sup>3</sup>, calculate the mass (m) of the water moved by the quake. To convert km<sup>3</sup> to m<sup>3</sup>, multiply by 10<sup>9</sup> m<sup>3</sup>/km<sup>3</sup>.

$$\text{Density of seawater: } D = 1.03 \times 10^3 \text{ kg/m}^3$$

Mass of seawater lifted:

$$\begin{aligned} m &= DV = (1.03 \times 10^3 \text{ kg/m}^3)(7.6 \times 10^4 \text{ km}^3) = (1.03 \times 10^3 \text{ kg/m}^3) (7.6 \times 10^4 \text{ km}^3) (10^9 \text{ m}^3/\text{km}^3) \\ &= 7.8 \times 10^{16} \text{ kg or } 78 \text{ trillion metric tons} \end{aligned}$$

$$\text{(note: } 1 \text{ km}^3 = 1 \times 10^9 \text{ m}^3)$$

4. To lift that mass of ocean water requires a force that is at least equal to water's weight. Using 9.8 ms<sup>-2</sup> as the acceleration due to gravity (g), calculate the force (F) needed to lift that much ocean water.

$$\text{Acceleration due to gravity: } g = 9.8 \text{ m/s}^2$$

Force due to gravity or weight of seawater:

$$F = mg = (7.8 \times 10^{16} \text{ kg})(9.8 \text{ m/s}^2) = 7.6 \times 10^{17} \text{ Newtons}$$

5. Supposing that volume of ocean water is lifted an average height (d) of one meter, how much work (W) is done? This value represents the energy imparted to the seismic sea wave by the earthquake.

*Distance lifted:  $d = 1\text{ m}$*

*Work done against gravity:*

$$W = Fd = (7.6 \times 10^{17} \text{ N})(1 \text{ m}) = 7.6 \times 10^{17} \text{ Joules.}$$

6. How much energy is this in equivalent tons of TNT?

*Conversion factor:  $4.18 \times 10^9 \text{ Joules} = 1 \text{ Ton TNT}$*

$$W = \text{Energy} = (7.6 \times 10^{17} \text{ Joules}) (1 \text{ Ton TNT} / 4.18 \times 10^9 \text{ Joules})$$

$$\text{Energy} = 1.8 \times 10^8 \text{ Tons TNT or } 180 \text{ Megatons TNT}$$

7. Imagine this much energy spreading over a great area, but then being applied to say only 3.8 meters of water instead of 3.8 kilometers. How high might the 3.8 meters of water be lifted?

*If all the energy were applied to only 3.8 meters of water (1/1,000th), then the water would rise 1,000 meters instead of only one meter. The energy spreads out very rapidly, so maybe only 1/100th of the energy reaches the 3.8 meters of water. In this case the water would rise 30 meters—quite a sizeable wave.*



# Seismic Sea Wave Research and Report Form

Name \_\_\_\_\_ Date \_\_\_\_\_

**Event**

---

---

---

**Cause**

---

---

---

**Characteristics of the tsunami**

---

---

---

**Damage**

---

---

---

**What could have been done to prevent the damage?**

---

---

---

**Information Source**

Title: \_\_\_\_\_

Author: \_\_\_\_\_

Publisher and place of publication: \_\_\_\_\_

Date: \_\_\_\_\_

**Score 4 points**

Students clearly communicate all the facts about their event, covering each of the categories on the Seismic Sea Wave Research and Report Form. While reporting the wave's characteristics and energy, students connect the Wave Characteristics and Effects activity sheet and the Energy Analysis activity to their event. The students employ logical thought processes and a knowledge of today's safety practices in their discussion of damage prevention. They use some visual method of communicating their ideas, such as the board, an overhead, a video, a poster, or a demonstration.

**Score 3 points**

Students clearly communicate all the facts about their event, covering each of the categories on the Seismic Sea Wave Research and Report Form. They do not effectively connect the Wave Characteristics and Effects activity sheet and the Energy Analysis activity to their event. The students' discussion of preventive measures is good. They use the board, an overhead, a video, a poster, or a demonstration in their report.

**Score 2 points**

Students clearly communicate all the facts about their event, covering each of the categories on the Seismic Sea Wave Research and Report Form. They superficially mention wave characteristics, wave energy, and preventive measures, or they cover one of these three, but not the others. They rely mainly on the spoken word to communicate their information and ideas.

**Score 1 point**

Students report the facts of their event by reading directly from the Seismic Sea Wave Research and Report Form. They hardly mention wave characteristics and energy. The discussion of preventive measures, if any, is incomplete. They do not use any visual communication aides.

**Score 0 points**

Students report incorrect information. The Seismic Sea Wave Research and Report Form was poorly completed and the presentation to the class is poor. Statements about the wave's characteristics, its energy, and damage prevention are missing or inaccurate.

# QUAKE—Smart Siting

## RATIONALE

---

City planners, developers, builders, and buyers need information about soil and subsoil geology in order to choose sites and design structures that will best withstand ground shaking and other earthquake hazards.

## FOCUS QUESTIONS

---

What are the important geologic considerations when choosing a building site and designing or reinforcing a building for earthquake survivability?

Have these considerations been taken into account in the planning of towns and cities?

## OBJECTIVES

---

### Students will:

1. Interpret soil- and earthquake-related geologic maps.
2. Apply these interpretations in choosing a building site and an earthquake-resistant building design.
3. Locate information about the soils and geology of their local community and apply the same process to interpret it.

## MATERIALS

---

- Student copies of Master 2.5a, Background Reading: Site Characteristics
- Unit 1 Resource List
- Master 2.5b, Soil and Geologic Maps and Map Sources
- Student copies of Master 2.5c, Surface Map, Soil Map, Geologic Map, and Hazard Map (4 pages)
- Transparencies made from Master 2.5c, Surface Map, Soil Map, Geologic Map, and Hazard Map (4 pages)
- Overhead projector
- Local map prepared in Unit 1

## TEACHING CLUES AND CUES

---



Sample maps are provided so students can do this activity without any special preparation. However, the activity will be most meaningful to students if they can relate it to their own area. Master 2.5b, Soil and Geologic Maps and Map Sources, suggests types of maps that would be appropriate and where to get them. The Unit 1 resource list suggests many other sources. If you have trouble locating maps, call your county or state geology office or the USDA Soil Service and ask for help.

## PROCEDURE

### Teacher Preparation *(optional but highly recommended)*

If at all possible, gather a selection of local geologic and soil maps in advance. Make student copies of these maps or the appropriate portions of them. If you are not familiar with maps of this type, invite a local geologist or soil scientist to explain them.

### A. Introduction

Have students read Master 2.5a, Background Reading: Site Characteristics, as homework, or read it with them in class. Explain and amplify any unfamiliar terms. Discuss the relationship between soils, subsoil geology, and the suitability of a site for building. Explain that the locations of roads, utility lines, reservoirs, and other facilities also involve seismic considerations.

### B. Lesson Development

1. Divide students into small groups. Give each group one copy of Master 2.5c, Surface Map, Soil Map, Geologic Map, and Hazard Map (4 pages). Use the map keys to review the special symbols and markings on each map. Instruct students to interpret the information shown on the specialized maps and transfer it to the surface map.
2. As a class, discuss what type of building would be most earthquake resistant in each area of the maps the groups have developed. Ask: Are there some areas where construction is not advisable no matter what the building materials? Instruct students to add these notations to the maps.
3. When all the maps have been completed, site hazards have been noted, and construction recommendations have been made, regroup students into three or four large groups. Within each large group, students can quiz each other about the potential of various sites on their maps.
4. Ask for a volunteer from each large group to report on the group's findings and recommendations. Ask students: What would be the best way to share your recommendations if these maps represented your own area of the country?

### C. Conclusion

Stack the three specialized maps on the projector at the same time so the various kinds of information are all displayed simultaneously. Discuss the conclusions that students have drawn and answer any questions. Extend the discussion to the geologic history and hazard potential of your own region.

*(optional but highly recommended)*

Direct students' attention to the local map they prepared in Unit 1. Have them follow the process they used above to transfer information from local soil maps to the classroom map, noting any implications for building and the location of critical facilities. If this process arouses concerns about safety during an earthquake, ask students to contact the local officials they interviewed in Unit 1 to express their concerns and find out if these concerns have been taken into consideration. Ask these students to report back to the class on what they learn. ▲

## VOCABULARY



**Fault:** a break or fracture in Earth's crust along which movement has taken place.

**Landfill:** a site where soil has been deposited by artificial means—often, where garbage or rubbish has been disposed of, then covered with dirt and compacted.

**Landslide:** an abrupt movement of soil and bedrock downhill in response to gravity. Landslides can be triggered by an earthquake or other natural causes.

**Liquefaction:** the process in which a solid (soil) takes on the characteristics of a liquid as a result of an increase in pore pressure and a reduction in stress.

**Sedimentary deposits:** accumulations of solid particles that originated from the weathering of rocks and that have been transported or deposited by wind, water, or ice.

**Seismic:** of or having to do with earthquakes.

**Slump:** a type of landslide in which a block of rock or soil moves along a curved surface and rotates.

**Tsunami:** a potentially destructive ocean wave created by an earthquake or other large-scale disturbance of the ocean floor; a seismic sea wave. This Japanese word has the same form in both the singular and the plural.

“Earthquakes don’t kill people, buildings do.”

Architects and engineers consider this a fair one-sentence summary of earthquake-related deaths, injuries, and damage. Yet, underneath every building is the Earth, which can shake and damage or destroy the building. In the final analysis, the cause of the death and destruction may not be the earthquake or the building, but rather someone’s lack of knowledge about the soil and subsoil under the building. Much of the scientific study surrounding earthquakes is focused on the geological characteristics of building sites, the relationship of building sites to earthquake damage, and how buildings respond to ground shaking induced by earthquakes. Location is just as important as building design for making sure that a building can survive an earthquake. Geological site considerations include the location and history of faults, sedimentary deposits, landfill, liquefaction, steep slopes and landslides, tsunami, and human-made hazards.

### **Faults: Displacement and Ground Shaking**

Earthquakes happen when two sides of a fault are displaced, releasing energy in waves. Buildings can be damaged either by direct displacement on the fault or by ground shaking.

Geologists have mapped the locations of many of the most dangerous fault zones in the U.S., yet many faults are not yet recognized. A building within a fault zone can be severely damaged by an earthquake on that fault, but this kind of damage is rare. Most buildings are not in fault zones, and the recurrence interval for any particular fault may be hundreds or thousands of years. The most common cause of damage in earthquakes is the ground shaking caused by the earthquake waves. These attenuate, or die off, with distance, so the two most important factors controlling the amount of shaking are the magnitude of the earthquake and the distance of the building from the fault.

The distance from the fault, not from the epicenter, determines the amount of damage. Energy is produced by all the parts of the fault that move in an earthquake. Because in big earthquakes the fault can be hundreds of miles long, a structure may be hundreds of miles from the epicenter and still be on top of the quake’s impact zone.

Several other factors can affect the amount of shaking. Waves do not travel evenly in all directions from the fault, so the orientation of the fault and the way in which displacement on the fault occurs can change the characteristics of the waves. Even more important are variations in local topography—the lay of the land—including the subsoil layers, which may trap or amplify seismic energy, and the type of rock and soil that underlie buildings.

### **Sediments and Landfill**

Ground shaking is greatest on soil that has arrived in place fairly recently, whether it was put there by natural processes (in which case, geologists call it *sediment*) or by artificial ones (in which case, it is called *landfill*). Unfortunately, most of the world’s urban centers are sited on relatively young, loose, sedimentary deposits. Sediment age and particle size are important in predicting how soil will respond to shaking during an earthquake. Areas near the shores of rivers and oceans are especially likely to contain young sediments washed there by the water.

Structures located on former watercourses (such as old river beds) or on sites that have been artificially filled with sand dredged up from the bottom of a body of water are among the worst locations for construction in earthquake country because the soil can shift so easily. In Mexico’s devastating 1985 earthquake, Mexico City, 320 km (200 miles) from the epicenter, suffered far more damage than the shoreline towns closer to the epicenter. The shoreline is made of solid rock, but Mexico City is built on the sediments of an ancient lakebed.

Old watercourses are usually low and wet, so they are frequently filled when someone wants new land to build on and sell. Landfill is usually a mixture of soil, rock, and decaying organic material in particles of

varying sizes. Because it is not natural to the area where it has been put, landfill in one spot is likely to be of a different composition from landfill in another spot nearby. When seismic waves are transmitted through landfill, they are amplified and their period is lengthened. Long earthquake waves are particularly destructive to some types of surface structures. Landfills commonly will settle and sink during a strong earthquake.

### **Liquefaction**

Whenever poorly consolidated soil or fine sand becomes saturated, an earthquake is likely to cause soil liquefaction. Earthquake vibrations compact the soil, causing water mixed with sand to flow upward. Structures may settle several feet or even topple, causing considerable damage. In a related phenomenon, sandy or muddy soils may behave like liquids, flowing out onto the surface as sand boils or mud boils.

### **Slopes and Landslides**

Structures on cliffs and ridges are also at high risk for earthquake damage, even if they are built on strong bedrock. Earthquake waves appear to be reflected and amplified by topographic highs like cliffs and ridges. Earthquakes also dramatically increase the potential for landslides in areas where landslides are common, such as those where sedimentary rocks lie just under the soil. The probability of an earthquake-related landslide depends on the strength of the slope materials, the steepness of the slope, and the extent and duration of ground shaking. Structures on cliffs and ridges need to be designed to the highest earthquake standards, and should be fully insured.

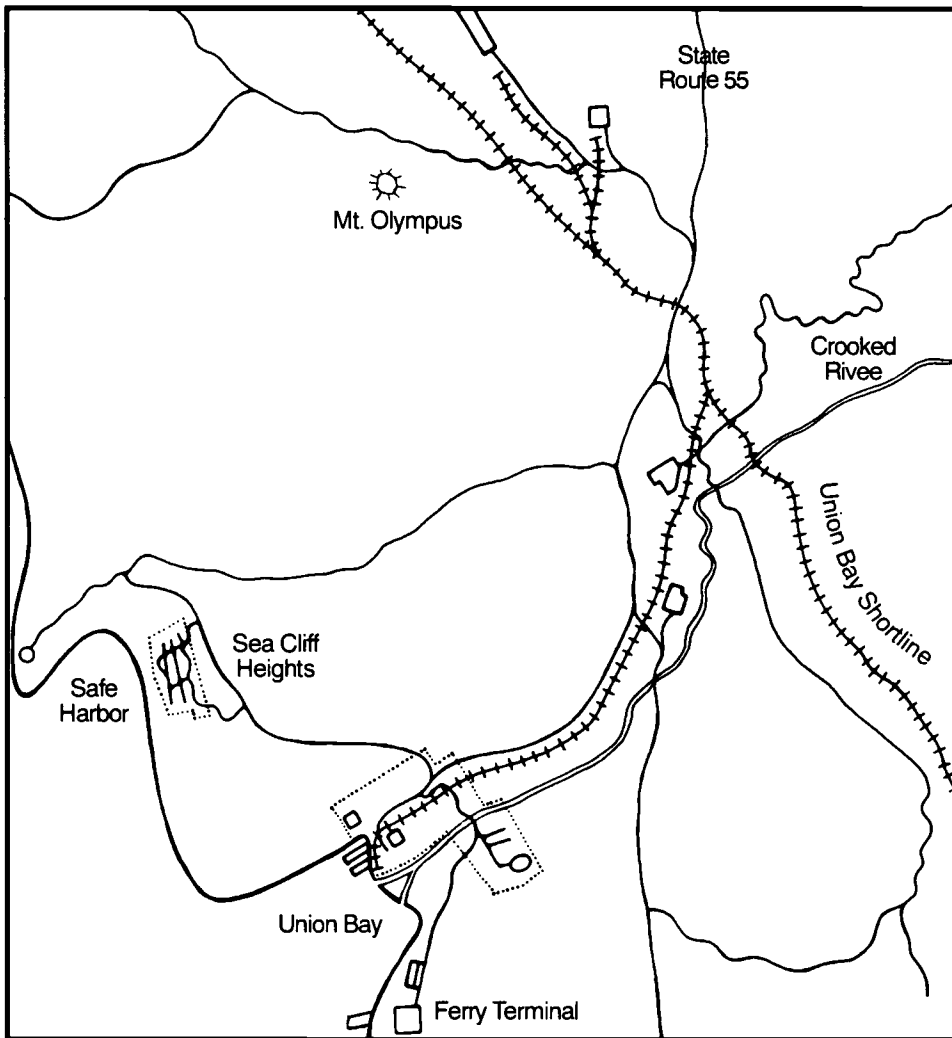
### **Tsunami**

Tsunami are caused by faulting and the abrupt movement of the ocean floor during an underwater earthquake. A wave generated by this movement can travel as fast as 640 km/hr (400 mph) on the open ocean, where it may not be much above normal height. When it approaches the shore, however, it may attain a height of 15-20 m (50 feet)—in some cases, even 32 m. Tsunami present a distinct hazard to low-lying coastal areas, particularly the west and northwest shorelines along the western North American coast and the northerly facing coast of Hawaii. Low-lying waterfront properties in these areas are at high risk from tsunami.

### **Human-Made Structures**

Human-made structures, such as dams, reservoirs, water tanks, and tall buildings, can present special earthquake hazards, and need to be considered during site selection. Every building decision needs to consider the exposure to geologic hazard and the probability of an earthquake, bearing in mind that earthquakes are possible anywhere in the world at any time.

- USGS topographical maps of your area
- Detailed USGS seismic maps that specifically identify earthquake fault traces (available only for areas of high seismic risk)
- Maps issued by state departments of geology or natural resources
- Land use policy or development maps, available from county or city zoning offices. The use of these maps is mandatory for all nonresidential and large-scale residential construction. They may be referred to as “special studies zones” maps
- Seismic risk maps. These are based on the location, number, and magnitude of historic earthquake events that have taken place and been recorded during the last 200 years
- Maps indicating areas of structurally defective ground, generally developed by state or local agencies to include (a) poor soils and (b) landslide areas
- Landslide susceptibility maps, available from USGS for specific regions in the U.S. The U.S. Department of Housing and Urban Development also has data and maps of landslide problems.
- Maps noting geologic hazards; may be included in your local building codes
- Microzonation maps include data on the anticipated maximum earthquake intensity, active faults, geologic units, special studies zones, ground response, liquefaction susceptibility, landslide susceptibility, and zones of potential tsunami inundation. Available from zoning offices.
- Soil studies of the area produced for agricultural purposes, either by USDA or local agencies
- Soil maps produced by the Soil Conservation Service

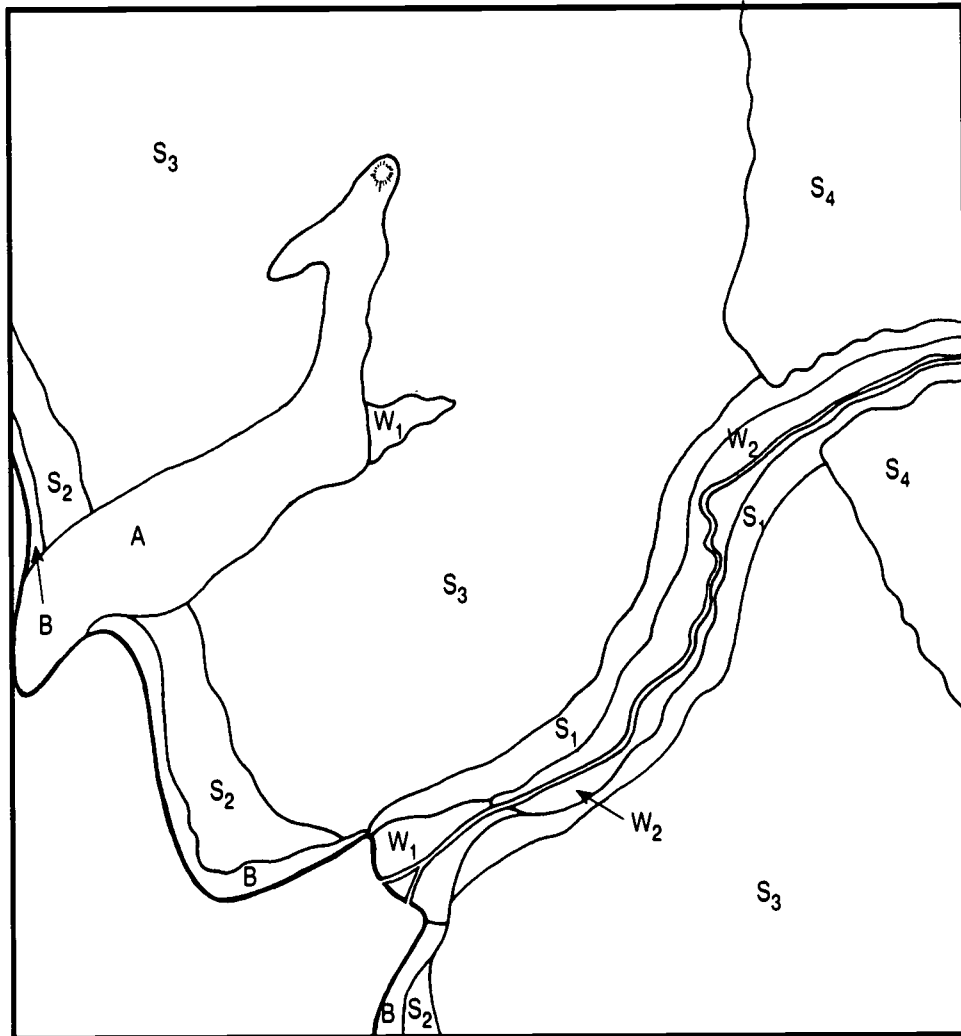


### Map Key

	Railroad
	Highway
	City Limits
	Building
	River

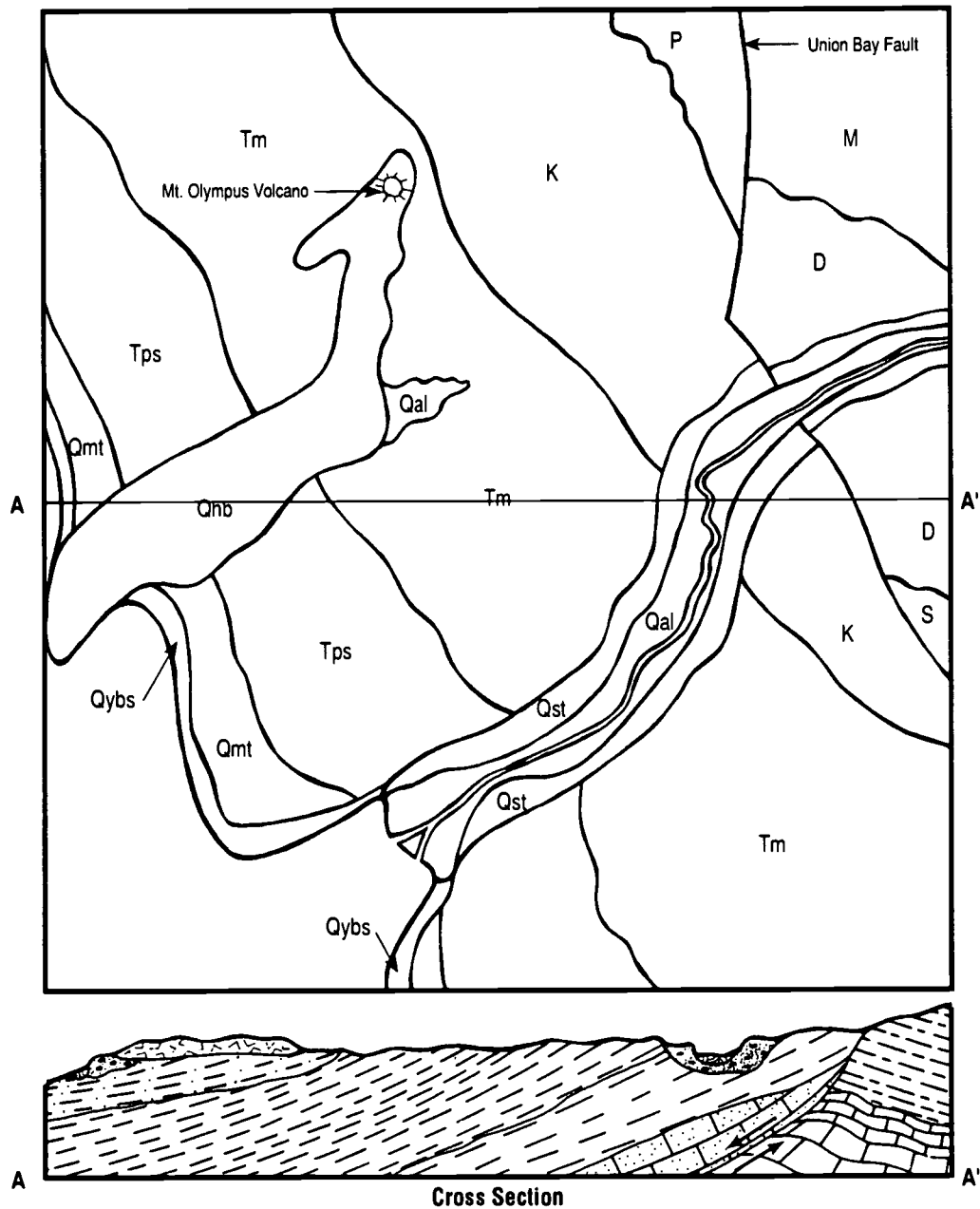


















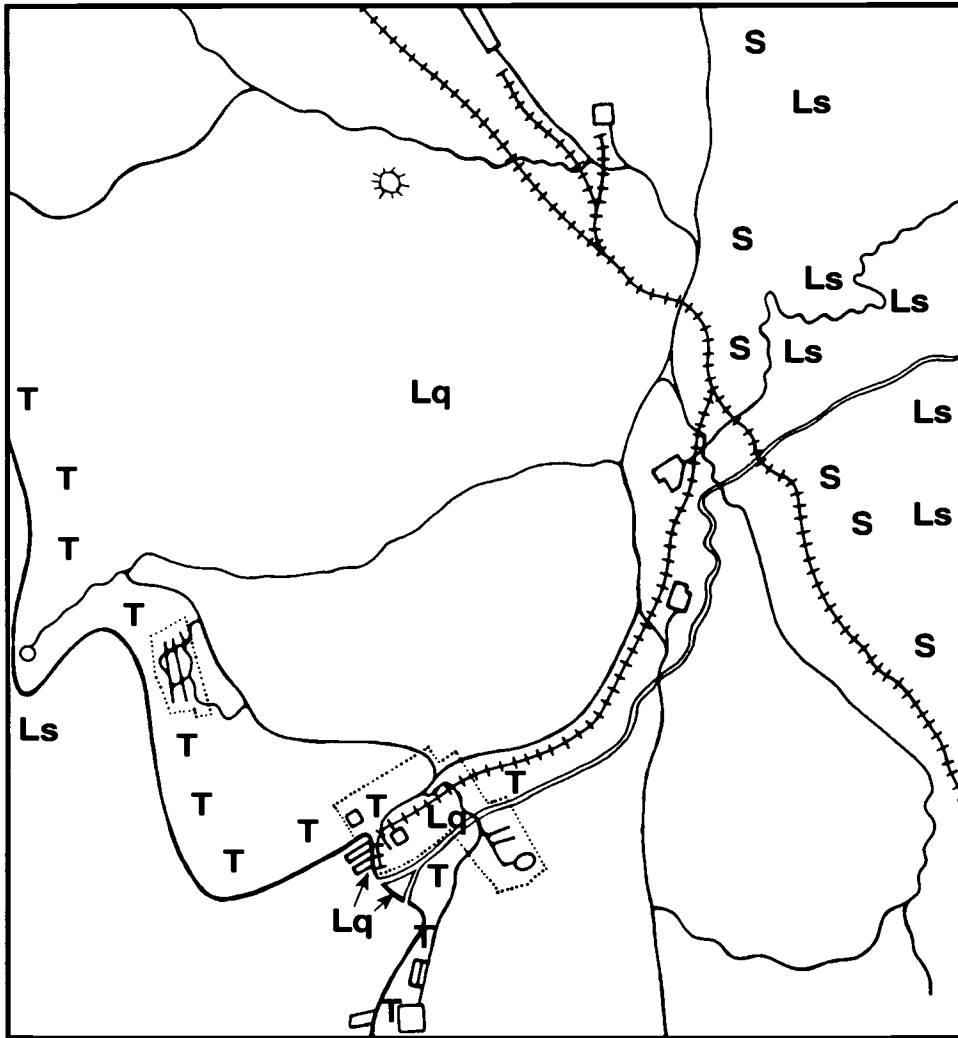
**Map Key**

- A – exposed bedrock
- B – beach and dune sand
- W<sub>1</sub> – saturated soils, fine grained
- W<sub>2</sub> – wet soils with seasonal fluctuation in moisture content, fine to medium texture
- S<sub>1</sub> – thin gravelly soils
- S<sub>2</sub> – thin sandy soils
- S<sub>3</sub> – loam 1.3 to 3 m (4 to 6 ft.) thick on gentle terrain, good for farming
- S<sub>4</sub> – sandy, rocky soils .3 to 1 m (1 to 3 ft.) ft. thick on moderate to steep terrain, mostly forested



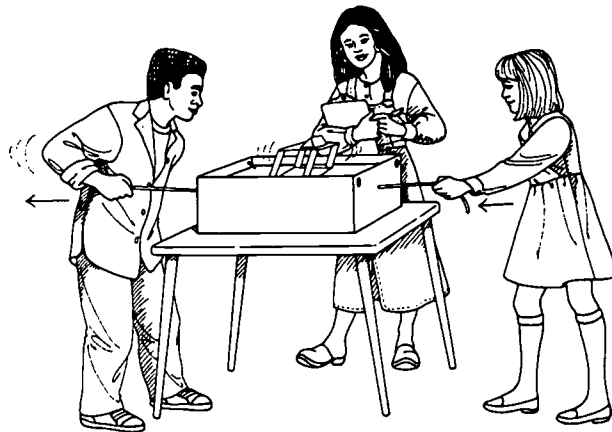
## Map Key

 <b>Qybs</b> – young beach sediments, mostly sand, some reworked by wind	 <b>Qst</b> – stream terraces, gravel	 <b>P</b> – Permian sandy limestone
 <b>Qal</b> – floodplain and delta sediments, clay, silt, and fine sand	 <b>Tps</b> – Pliocene siltstone	 <b>M</b> – Mississippian limestone
 <b>Qhb</b> – Holocene basalt flow	 <b>Tm</b> – Miocene shale with several lignite beds	 <b>D</b> – Devonian shale
 <b>Qmt</b> – marine terrace deposits, sand, and gravel	 <b>K</b> – Cretaceous shale with thin coal beds	 <b>S</b> – Silurian rocks



### Map Key

- Ls – landslide hazard
- Lq – liquefaction hazard
- S – slump hazard
- T – tsunami hazard



### BOOKS FOR YOUNG READERS

Asimov, I. (1978). *How Did We Find Out about Earthquakes?* New York: Walker.

Aylesworth, T.G., and Aylesworth, V.L. (1983). *Moving Continents—Our Changing Earth*. Hillside, N.J.: Enslow.

Eicher, D.L. (1976). *Geologic Time*. Englewood Cliffs, NJ: Prentice Hall.

Eicher, D.L. (1984). *The History of the Earth's Crust*. Englewood Cliffs, NJ: Prentice Hall.

Fodor, R.V. (1978). *Earth in Motion: The Concept of Plate Tectonics*. New York: William Morrow.

Iacopi, R. (1974). *Earthquake Country*. Menlo Park, CA: Lane Book Company.

National Geographic Society. (1982). *Our Violent Earth*. Washington, DC: National Geographic Society.

Poynter, M. (1990). *Earthquakes: Looking for Answers*. Hillside, NJ: Enslow.

Walker, B. (1981). *Earthquake*. (Planet Earth series) Alexandria, VA: Time-Life Books.

### BOOKS

Adams, M. W., editor. (1970). *Tsunamis in the Pacific Ocean*. Honolulu, HI: East-West Center Press.

Bolt, Bruce A. (1993). *Earthquakes*. New York: W. H. Freeman and Co. General information on earthquakes in a readable style. Probably the best single source currently available.

Bolt, Bruce, A. (1982). *Inside the Earth*. San Francisco: W.H. Freeman and Co. More technical than the later *Earthquakes*, but highly readable for adults and advanced students. Includes excellent historical information; portraits of Beno Gutenberg, Inge Lehmann, and other pioneers of seismology; plus challenging activities and exercises.

Bonini, W.E., and Bonini, R.R. (1986). "Andrija Mohorovicic: Seventy Years Ago an Earthquake Shook Zagreb." In *History of Geophysics*, Vol. 2, edited by C. Stewart Gillmor. Washington, DC: American Geophysical Union, pp. 83–88.

Earthquake National Research Council. (1986). *Active Tectonics*. Washington, DC: National Academy Press. An anthology of technical discussions, part of the Studies in Geophysics series.

Eiby, G.A. (1980). *Earthquakes*. Auckland, New Zealand: Heineman.

Georgi, Johannes. (1934). *Mid-Ice: The Story of the Wegener Expedition to Greenland*. London, England: K. Paul, Trench, Trubner, and Co., Ltd.

Gere, J.M., and Shah, H.C. *Terra Non Firma: Understanding and Preparing for Earthquakes*. New York: W.H. Freeman.

Gubbins, David. (1990). *Seismology and Plate Tectonics*. New York: Cambridge University Press. An undergraduate textbook. Readable, with useful illustrations, many advanced math activities, and some 60 seismograms.

- Levin, H.L. (1978). *The Earth through Time*. Philadelphia, PA: W.B. Saunders.
- Moore, Gwendolyn B., and Yin, Robert K. (November 1984). *Innovations in Earthquake and Natural Hazards Research: Determining Soil Liquefaction Potential*. Washington DC: Cosmos Corporation (202-728-3939).
- Nance, John J. (1989). *On Shaky Ground: America's Earthquake Alert*. New York: Avon Books.
- National Academy of Sciences. (1985). *Liquefaction of Soils during Earthquakes*. Washington, DC: National Academy Press.
- Federal Emergency Management Agency/National Science Teachers Association (NSTA)/FEMA. (1988). *Earthquakes—A Teacher's Package for K-6*. FEMA 159. Washington, DC: FEMA Publications (500 C St. SW, Washington, DC 20742).
- Oakeshott, G.B. (1976). *Volcanoes and Earthquakes: Geologic Violence*. New York: McGraw Hill.
- Pakiser, Louis. (1989). *Earthquakes*. Washington, DC: U.S. Government Printing Office. An illustrated pamphlet of general information, prepared for the U.S. Geological Survey, Department of the Interior.
- Scholtz, Christopher H. (1990) *The Mechanics of Earthquakes and Faulting*. Cambridge, England: Cambridge University Press. A technical reference for teachers interested in exploring further.
- U.S. Department of Commerce, Coast and Geodetic Survey. (1965). *Tsunami! The Story of the Seismic Sea Wave Warning System*. Washington, DC: U.S. Government Printing Office. An exciting story with fine illustrations, at a student's reading level.
- Wegener, Alfred (1966). *The Origin of Continents and Oceans*. New York: Dover.
- Wegener, Else. (1939). *Greenland Journey: The Story of Wegener's German Expedition to Greenland in 1930-1931*. London and Glasgow: Blackie and Son Ltd.

#### ARTICLES AND PAPERS

- Evaluating Earthquake Hazards in the Los Angeles Region—An Earth Science Perspective*. U.S. Geologic Survey Professional Paper #1360, 1985, pages 375-413, "Evaluating Tsunami Potential."

- Gore, R. (1985). "Our Restless Planet Earth." *National Geographic* 168: 142-181. Includes map, "Earth's Dynamic Crust."
- Lowman, P.; Wilkes, K.; and Ridky, R.W. (1978). "Earthquakes and Plate Boundaries." *Journal of Geological Education* 26: 69-72.
- Matthews, Samuel, W. (1973) "This changing Earth." *National Geographic* 143: 1-37.
- McCredie, Scott. (March 1994). "Tsunami: The Wrath of Poseidon." *Smithsonian Magazine* 24, 12:28-39.
- Peterson, Ivars. (Oct. 12, 1985). "Liquid Sand." *Science News*.
- U. S. Geological Survey, 904 National Center, Reston, Virginia, 22092; 703/648-6078. See especially "Pacific Tsunami Warning System," Volume 18, Number 3, 1986, and "Devastating Tsunami Inspires Efforts to Reduce Future Tsunami Destruction," Volume 19, Number 2, 1987.
- Wilson, J.T., ed. (1970). *Continents Adrift: Readings from Scientific American*. New York: W.H. Freeman and Co.

#### NONPRINT MEDIA

- California Earthquake Education Project. Earthquake kits and group materials. Lawrence Hall of Science, University of California, Berkeley, CA 94720; 415/327-6017.
- The Drift Globe*. Burlington, NC: Omni Resources, Inc. (919/227-8300). A 12"-diameter globe with velcro fasteners and velcro continents. Instruction guide is illustrated with cartoons.
- The Earthquake Connection*. A live-action video in two parts. Available from Ward's Natural Science Establishment, Inc., 5100 W. Henrietta Road, PO Box 92912, Rochester, NY; 800-962-2660. Ward's also has earthquake filmstrips and slides.
- Earthquake Effects: A Computer Animation and Paper Model*. U.S. Geological Survey Open-File Report 92-200B, by Tau Rho Alpha, Robert A. Page, and Leslie C. Gordon. Order from U.S. Geological Survey, PO Box 25425, Denver, CO 80225; 303-236-4476.

## UNIT RESOURCES

*Earthquake Simulator.* A program for the Apple II series. Available from Ward's Natural Science Establishment, Inc., 5100 W. Henrietta Road, PO Box 92912, Rochester, NY; 800-962-2660.

*Earthquake Slides.* Photographs of earthquake effects, copies of seismograms, and seismicity maps can be obtained from the National Geophysical and Solar Terrestrial Data Center, Code D62, NOAA/EDS, Boulder, CO 80302.

*Earthquake Sounds.* A cassette tape of sounds recorded in various earthquakes, available with a catalog from Seismological Society of America, 201 Plaza Professional Building, El Cerrito, CA 94530; 415-525-5474.

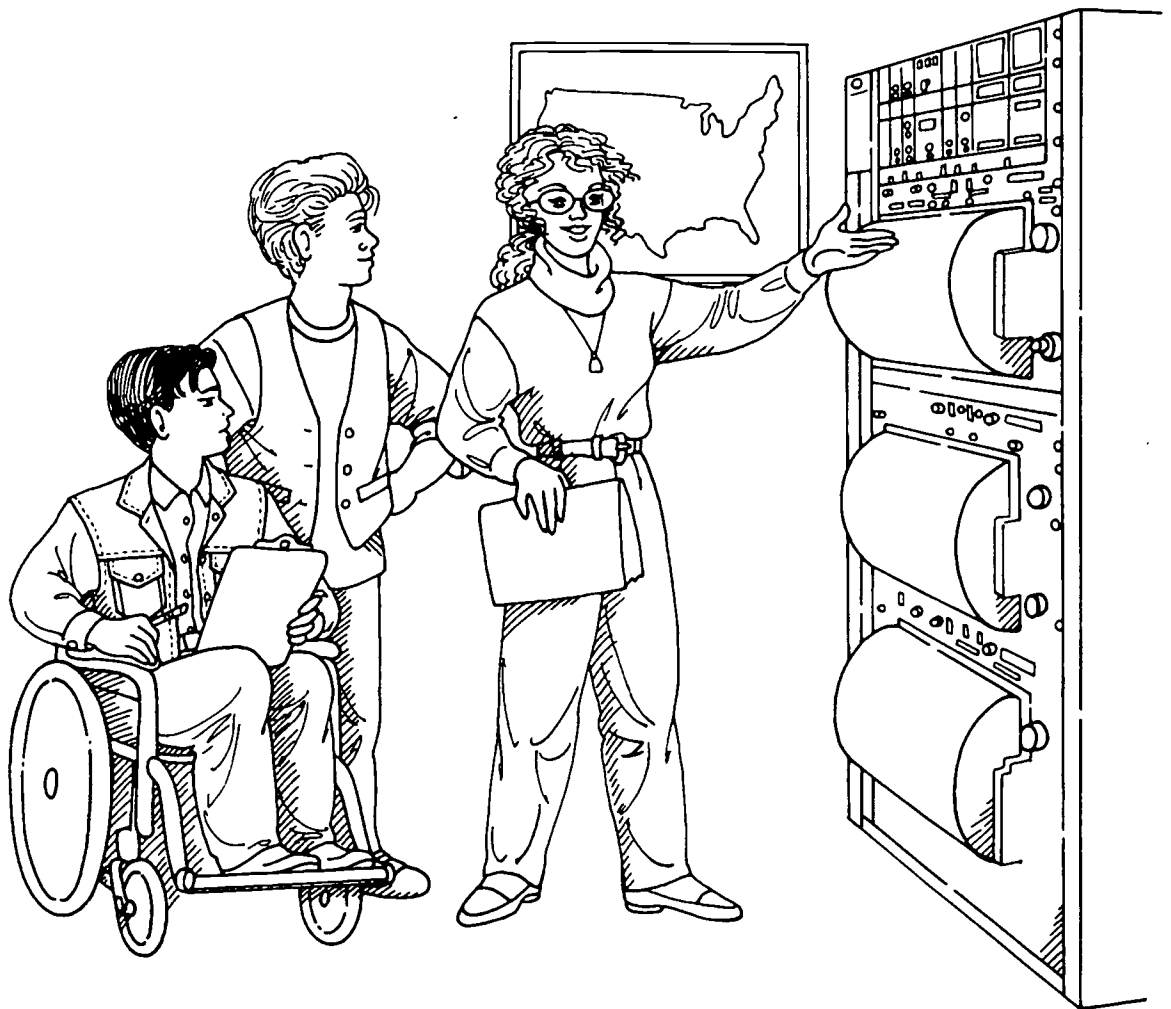
*Earthquakes: Environments and Effects.* A 15-minute interactive videotape available from CALEEP, 510-642-8718.

EERI Videotapes and Slide Sets. Oakland, CA: Earthquake Engineering Research Institute. For information, phone 510-451-0905, or fax 510-451-5411.

*Steinbrugge Collection.* Richmond, CA: Earthquake Engineering Research Center. Over 10,000 photographs and 5,000 slides of earthquake damage. The library will provide copies to teachers and researchers. Call 510-231-9401 for information.

*Note:* Many of the references for Unit 3 may also be useful for teaching this unit. Inclusion of materials in these resource listings does not constitute an endorsement by AGU or FEMA.

U N I T T H R E E



# How Do People Learn about **EARTHQUAKES?**

In the first lesson, students will learn about the movement of earthquake waves in our Earth and on its surface. It was the study of this movement, by Mohorovicic, Lehmann, and others, that developed our current understanding of the interior of the Earth. Activities illustrate the movement of P and S waves. Background material on Love and Rayleigh waves is also provided.

The second lesson in Unit 3 is built around biographical sketches of three individuals who made major contributions to our knowledge of the Earth's inner structure: the German meteorologist Alfred Wegener, who amassed evidence for the controversial theory of continental drift; the Croatian seismologist Andrija Mohorovicic, who demonstrated the existence of the discontinuity between crust and mantle that bears his name; and the Danish seismologist Inge Lehmann, who demonstrated the existence of the inner core. A timetable of other relevant discoveries is included as teacher background material.

Lesson 3 begins with a pair of activities that contrast the two systems most commonly used to characterize earthquakes—the Modified Mercalli scale, which assigns a number on the basis of observed effects, and the Richter scale, which assigns a number on the basis of instrument readings. Students draw isoseismals on a map in the first activity. In the second they compare

Richter magnitudes from several seismograph stations for the same earthquake. In the third activity, they practice reading seismograms.

Lesson 4 has three parts, moving from the worldwide distribution of earthquakes to one seismically active area of Japan and then home to the United States. At all three stages, students plot actual earthquake data in order to gain an experiential understanding of where earthquakes occur. In the second activity they construct a plot in three dimensions. Most students will be surprised to learn that earthquakes are everyday occurrences on a global scale, and that they may originate from foci as deep as 700 km inside the Earth—1/9 of the way to its center.

Like the previous unit, this one offers a variety of experiences in scientific observation, computation, and the application of social science principles. It also presents factual information that will stand students in good stead as consumers of media information and as future property owners.

Social studies teachers may be especially interested in the second lesson of this unit. Mathematics teachers will find applications of algebra and geometry in many of the others. The lessons in this unit can stand on their own, but taken together, they provide an excellent preparation for learning to mitigate the effect of earthquakes on the human environment, in Unit 4.



# The Waves of **QUAKES**

## **RATIONALE**

To understand earthquakes and their effects on Earth's surface, and to understand how scientists have learned about Earth's interior, students must begin to understand the properties of waves.

## **FOCUS QUESTION**

How does matter transmit energy in the form of waves?

## **OBJECTIVES**

**Students will:**

1. Compare and contrast the two main types of earthquake waves and draw sketches to illustrate them.
2. Describe the manner in which each of the two types transfers energy and moves Earth particles.

## **PART ONE**

### **PRIMARY WAVES (P WAVES)**

## **MATERIALS**


- Student copies of Master 3.1a, Earthquake Wave Background
- Slinky toys (One for every two students is ideal.)
- White plastic tape
- String
- Unlined paper
- Pencils


## **PROCEDURE**

### **Teacher Preparation**

Put the Slinky toys and the tape in a central location where they will be available to students. Students will mark the coils so they can see the movement of energy along their length.

## **TEACHING CLUES AND CUES**

 Metal Slinkies will be more effective than plastic ones for this activity. If you use plastic Slinkies, tape two together, with about 7.5 cm of overlap, for each pair of students.

 It will be helpful to refer to Master 2.2b, Earth Cross Section, as you talk about waves moving through the Earth. You may want to project the transparency.

## A. Introduction

Explain: It is the energy from earthquakes that puts human beings and human structures in danger. This energy is transmitted through the Earth in the form of waves. Distribute copies of Master 3.1a, Earthquake Wave Background. Go over the Body Waves section of the background material with the class.

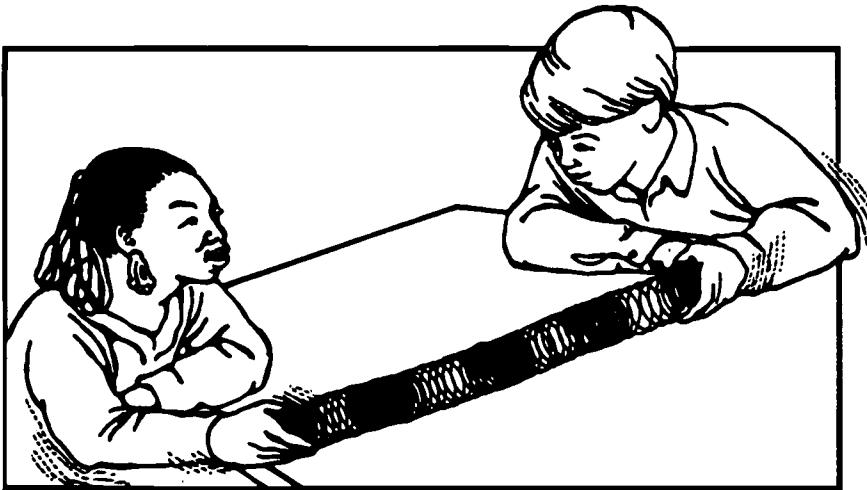
## B. Lesson Development

1. Ask students:

- Where is the energy of an earthquake released? (along the fault plane where tectonic stress is released)
- In what form is the energy from an earthquake released? (in the form of waves)

2. Divide students into pairs or groups of even numbers, depending on the number of Slinkies available. Direct students to pick up their Slinkies and mark two spots on each, near the center of the coil, with white plastic tape. The two pieces of tape should be at the tops of adjacent loops.


3. Two students will hold each Slinky, one on either end. Instruct them to stretch it out to a length of approximately three meters on the floor or a long counter. Have students take turns compressing between 10 and 20 coils and then releasing them rapidly while they continue to hold the Slinky.



4. After several repetitions, ask students to describe what they saw happen with the coil and the tape. Then ask:

- What kind of earthquake waves does this movement resemble? (longitudinal body waves, or P waves)
- How is the movement of the spring like the movement of the waves? (It moves by contracting and expanding—by compression and expansion.)

## VOCABULARY

 **Body waves:** waves that move through the body (rather than the surface) of the Earth. P waves and S waves are body waves.

**Compression:** squeezing, being made to occupy less space. P waves are also called compressional waves because they consist of alternating compressions and expansions.


**Longitudinal waves:** waves that move particles back and forth in the same line as the direction of the wave (P waves).

**P waves:** primary waves, arrive at a station first because they travel faster than S waves, or secondary waves. These waves carry energy through the Earth in the form of longitudinal waves.

**S waves:** secondary waves; waves that carry energy through the Earth in the form of very complex patterns of transverse waves. These waves move more slowly than P waves (in which the ground moves parallel to the direction of the wave). In an earthquake S waves are usually bigger than Ps.

**Transverse waves:** waves that vibrate particles in a direction perpendicular to the wave's direction of motion (S waves).

## TEACHER CLUES AND CUES

 Activity 3 in lesson 2.4 deals with tsunami, destructive water waves often caused by earthquakes. If you have not taught this lesson, refer to it now.

- In what direction does the energy move? (It moves out from the point at which the energy is released—the focus.)
- What happens within the body of the Earth when energy moves through it in this way? (Energy is transmitted from any material near the focus to particles away from the source in the form of waves.)

### C. Conclusion

Challenge pairs of students to decide what a P wave would look like and draw one on the top half of a sheet of paper. Tell them to use pencil, so if they change their minds later they can revise the drawing. (There are several acceptable ways to do this.)

### ADAPTATIONS AND EXTENSIONS

1. With students who show special interest, assign all of the reading on Master 3.1a and add Rayleigh waves and Love waves to your discussion.
2. Research and discuss (a) the intermolecular forces that provide the means of transmitting energy in longitudinal waves and (b) the speed of P waves traveling in the Earth's crust. Ask:
  - How does the density of materials affect the speed of P waves? (The more dense the material, the faster the waves move.)
  - As P waves travel deeper into the Earth, does their speed change? (P waves, like S waves, move faster in the mantle than in the crust, because the mantle is more dense. The rocks that compose the Earth at great depths, however, are plastic, so they slow down the waves.)
  - Why can P waves travel through liquids, while S waves cannot? (P waves travel by compression, and S waves travel by shearing at right angles to the direction of motion. Water cannot spring back after it is sheared, so the S waves die out in water.)
  - How are P waves similar to sound waves? (A sound wave in the ground is a P wave; a P wave in the air is a sound wave. Both are compressional waves.)


## PART TWO

### SECONDARY, OR SHEAR WAVES (S WAVES)

#### MATERIALS

- 7.6 m (25 ft) of coiled telephone cord, available at electronics or phone stores and some discount stores
- Two different colors of plastic tape, about 1 cm (.5 in.) wide
- Masking tape
- Two empty soda cans

### TEACHING CLUES AND CUES



Point out that in a P wave the movement of each coil of the Slinky is parallel to the wave motion (the length of the Slinky). In an S wave, the movement is perpendicular to the length of the Slinky. This difference may be easier for students to see than compression and dilation.

## PROCEDURE

### A. Introduction

Ask students:

- What type of body wave did the Slinky exercise illustrate? (P waves, also known as compressional waves or longitudinal waves)
- What is the other type of body wave? (S waves, also known as shear waves or transverse waves)

### B. Lesson Development

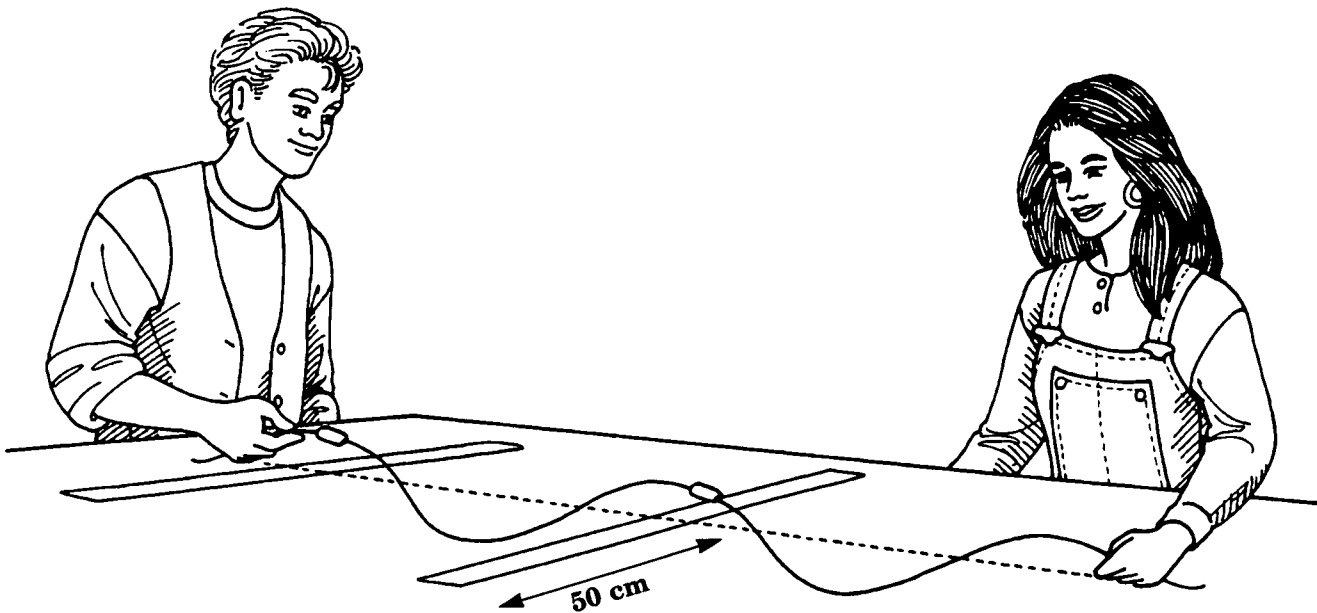
1. Give these instructions for demonstrating single shear waves (S waves).

- a. Place a band of bright colored tape halfway along the coiled telephone cord. Place another band close to one end. Lay the cord straight along a smooth surface. Have two students hold the ends of the cord firmly so it will not move.
- b. With plain masking tape, mark a 50-cm line perpendicular to one end of the cord. Mark another line of the same length at the cord's halfway point, directly under the center band of tape. This will provide you with a reference line.
- c. Pick up the end of the rope at the center of the first perpendicular tape line, then move your hand back and forth quickly along the masking tape. As you expected, a wave travels down the rope (or transmitting medium). Observe the motion of the colored tape while waves are moving by. Students may take turns holding the ends of the cord.

## TEACHING CLUES AND CUES



Students may be confused by the array of synonyms for P waves and S waves. Help them to understand that each term provides additional information about one type of wave. P waves, or primary waves, are also called compressional waves and longitudinal waves. S waves, or secondary waves, are also called shear waves and transverse waves. Both P and S waves are body waves.



d. Place two empty soda cans upright on either side of the cord on the center tape line. Both cans should be the same distance from the cord—about 30 cm (1 ft). When a wave of sufficient amplitude is sent along the cord between these cans, what will happen? (The same piece of cord, as indicated by the colored tape marker, will knock over both cans.)

2. Point out that although students may only see motion in one direction, the transverse wave they have just observed vibrates in a direction perpendicular to its direction of motion. Remind students that S waves within the Earth are not just in one plane, and don't all have the same frequencies and amplitudes. In an earthquake, a jumble of S waves passes through a particular volume of Earth at the same time. Since S waves reach the surface from below, a special pendulum seismograph would show ground motion for S waves as a very complex, seemingly random pattern of horizontal (back and forth) motions.

### C. Conclusion

Ask students:

- Which type of wave does this activity illustrate? (S waves)
- What are some differences between P waves and S waves?  
(P waves are longitudinal and S waves are transverse. P waves can be transmitted through solids, liquids, and gases, while S waves can only be transmitted through solids.)

Now ask students, working in the same pairs as for part one, to decide what a diagram of an S wave would look like and draw one on the other half of the page they used in part one. They may want to revise their drawings of a P wave at this time. When they have finished, ask each pair of students to exchange their drawings with another pair and discuss the similarities and differences.

### **ADAPTATIONS AND EXTENSIONS**

---

1. If students have also discussed Rayleigh waves and Love waves, ask them to draw these on the backs of their pages at this time and follow the procedure for exchanging diagrams as above.
2. Invite students to research and discuss the intermolecular forces that provide the means of transmitting energy in transverse waves, and why S waves can not be transmitted through liquids, including Earth's outer core. ▲

The major types of seismic waves are classified as body waves and surface waves. The two have different shapes and properties. All waves in matter depend upon the interaction of forces among the particles of some material. These forces transmit movement of one particle to movement in adjacent particles.

### Body Waves

Body waves, so called because they travel through the body of the Earth, consist of two types: primary (P) and secondary (S). S waves are also called shear waves and transverse waves.

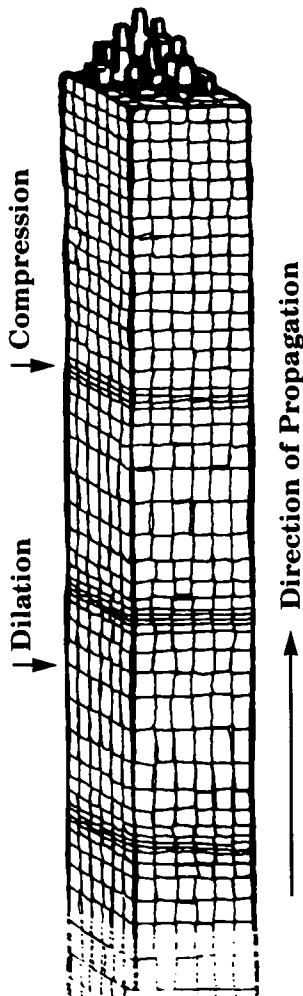
Primary (P) waves consist of alternating compressions and expansions (dilations), so they are also referred to as compressional waves. P waves are longitudinal; they cause particle motion that is back and forth, in the same linear direction as energy transfer. These waves carry energy through the Earth, usually at the rate of 3.5–7.2 km/sec in the crust and 7.8–8.5 km/sec in the mantle.

Secondary (S) waves are transverse; the particle motion they cause is perpendicular to the direction of energy transfer. Their usual speed is 2.0–4.2 km/sec in the crust and 4.5–4.9 km/sec in the mantle.

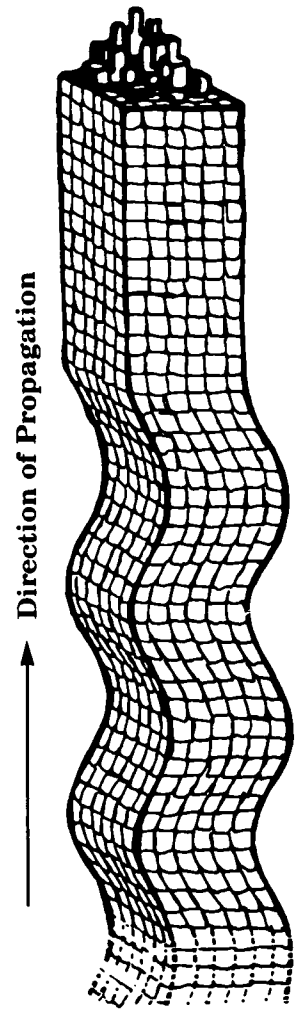
Longitudinal (P) waves can be transmitted through solids, liquids, and gases, while transverse (S) waves (with the exception of electromagnetic waves) can only be transmitted by solids. Waves can be reflected and refracted (bent) when they move from material of one density to that of another density. Wave energy can also be changed to other forms. As they move through the Earth, the waves decrease in strength, or attenuate. Waves attenuate more slowly in solid rocks than in the basins full of sediment so common in the West. Because of this, an earthquake in the crust of the eastern United States is felt over a wider area than a quake the same size in the rocks of the western states.

### Surface Waves

Seismograph stations detect surface waves from many, but not all, quakes. Whether a station detects them or not depends on the strength of the quake's energy release, the depth of the quake, and the station's distance from the focus.



P Waves



S Waves

Unlike body waves, which travel through the Earth, surface waves travel around it. The two main types of surface waves are called Rayleigh waves and Love waves. These surface waves travel more slowly than S and P waves, and attenuate more quickly.

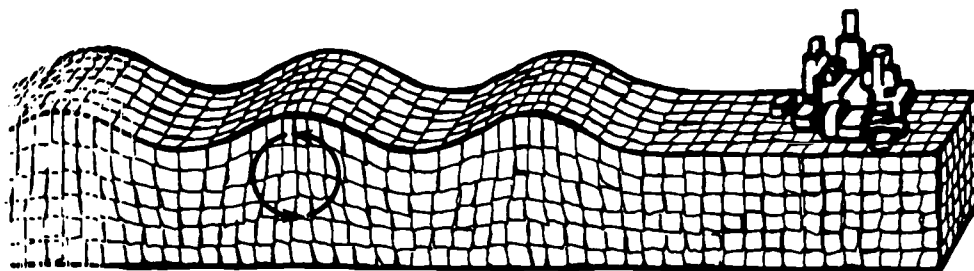
Within Rayleigh waves, Earth particles move in elliptical paths whose plane is vertical and set in the direction of energy transfer. When an Earth particle is at the top of the ellipse, it moves toward the energy source (seemingly backwards), then around, downward, and forward, away from the source. It then moves around and upwards back to its original position. This produces a ripple effect at the Earth's surface that is similar to ripples on a pond. The orbits, or paths, of these particles become smaller and finally die out at a certain depth within the Earth.

Love waves move particles in a back and forth horizontal motion as the energy moves forward. If you

could see a Love wave inside the Earth, you would notice a zigzag horizontal motion.

**Putting Them Together**

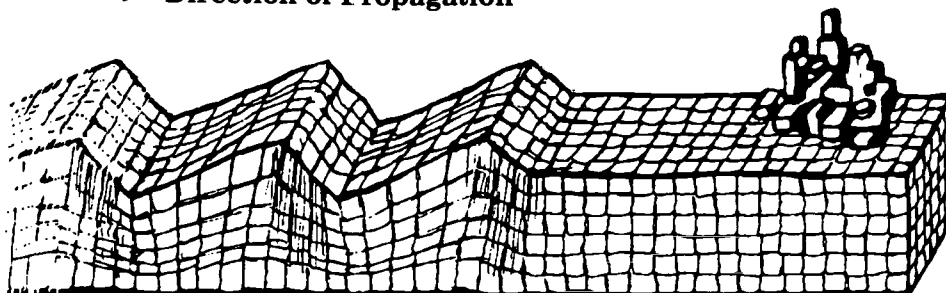
Since these four types of waves shake a location on Earth's surface in various ways and directions, a seismic station needs at least three seismographs to glean a reasonably good image of ground shaking at that location. One seismograph is built to measure vertical motions, and two others, aligned perpendicular to each other, measure horizontal motions. Although P, S, and Rayleigh waves may be recorded on all three seismographs, P waves are best recorded on the vertical component and S waves on the horizontal. Love waves are only recorded on the horizontal components, but Rayleigh waves are recorded on all three.



Rayleigh Waves

→ Direction of Propagation

Love Waves



# Pioneering Ideas

## RATIONALE

The people who have shaped our idea of the Earth are pioneers, just as truly as those who struck out in new directions across its surface. This idea may be new to students.

## FOCUS QUESTION

Could a person be a pioneer without leaving home?

## OBJECTIVES

### Students will:

1. Read a biographical sketch about a pioneer of earth science.
2. Identify the characteristics of a pioneer.
3. Be able to tell why Wegener, Mohorovicic, and Lehman were pioneers.

## MATERIALS

- Student copies of Master 3.2a, Three Pioneers (3 pages)
- Master 3.2b, Chronology: The Beginnings of the Seismological Age
- Overhead projector and transparencies (*optional*)
- Reference books for research (See Unit Resources.)
- Paper and pens

## PROCEDURE

### Teacher Preparation

Assemble a classroom reference shelf of biographical encyclopedias, studies on continental drift and plate tectonics, and books on earthquakes. (See Unit Resources.)

### A. Introduction

Tell students that you would like them to explore the notion of *pioneer*. Write the word on the chalkboard or overhead projector and ask the class to brainstorm about the meaning of the word and its implications. Be prepared to accept any reasonable suggestion. Such

## VOCABULARY



### Continental drift:

the theory, first advanced by Alfred Wegener, that Earth's continents were originally one land mass, pieces of which split off and gradually migrated to form the continents we know.

**Epitaph:** an inscription on a tombstone, often intended to sum up the achievements of a person's life.

**Meteorology:** the study of Earth's atmosphere.

**Pioneer:** a person who moves into new and uncharted territory.

**Plate tectonics:** the theory that Earth's crust and upper mantle (the lithosphere) are broken into a number of more or less rigid, but constantly moving, segments, or plates.

**Seismology:** the scientific study of earthquakes.

**Topography (adj. topographic):** the shape of the land; the contours and the arrangement of surface features that characterize a region.



ideas as risk-taker, adventurer, initiator, innovator, frontier person, and explorer are likely to come forward. You may want to use these terms to build a concept map.

During the course of the brainstorming, remind the class that in a historical sense, we tend to think of pioneers as men and women who have moved beyond the edge of settlement. Daniel Boone was such a person, and so were Lewis and Clark and Matthew Henson, the polar explorer. There are other types of pioneers, however—those who are willing to advance new ideas and suggest new theories to explain physical or cultural phenomena. Albert Einstein, with his theory of relativity, is a good example of this kind of pioneer. So is Marie Curie, who worked to develop radium therapy and conducted some of the earliest experiments with radiation.

### **B. Lesson Development**

1. When the brainstorming session has ended, ask each student to write a one-sentence definition of the term *pioneer*, using the list generated by the class as a reference. Then have students share their responses to learn if a consensus has developed about the meaning of the term. From the collection of definitions presented by class members, write what seems to be a representative definition on either the board or the overhead. Here are some likely definitions:

A pioneer is a person who is on the cutting edge, someone with the courage and the vision to try something new.

A pioneer is the first person to suggest a new idea or to try something that has never been tried before.

A pioneer is a person who prepares the way for others because of his/her courage and foresight.

2. Divide the class into groups of three students each. Provide each group with one copy of Master 3.2a, *Three Pioneers*. Each of the students may read one essay. When students have finished reading, ask them to give the essay a title and to write a two- or three-sentence summary of the essay in the space provided.

3. With this as context, remind students that when each of these discoveries was first published, it created discussion and even controversy. To understand the kind of excitement each advance in science causes, have half of the students who read about each scientist research the evidence that person offered to support the new theory and the other half research the views of his or her critics or the reasons why it may not have been accepted immediately. Later in the same period or the next day, invite the groups to present and discuss opposing points of view culled from their reading.

### **C. Conclusion**

Return to the consensus definition of pioneer that the class developed and ask students to apply that definition to these three individuals. To do this, they should write epitaphs for the tombstones of the three scientists. Remind students that the purpose of an epitaph

### **TEACHING CLUES AND CUES**



Use Master 3.2b, *Chronology: The Beginnings of the Seismological Age*, for your own reference and to help students place the work of these three scientists in the context of other dis-

is to summarize a person's life in a brief and pithy fashion. Post the epitaphs on the bulletin board to present the variety of impressions class members have about Wegener, Mohorovicic, and Lehmann.

### **ADAPTATIONS AND EXTENSIONS**

---

1. Make a time line from the information on Master 3.2b, Chronology: The Beginnings of the Seismological Age. You could do this either before class or during class with student participation.
2. As a class, brainstorm suitable epitaphs for some of the other pioneers mentioned in this lesson and those students know about from other areas of study.
3. Encourage students to read biographies of intellectual explorers and learn about some of the challenges pioneers have faced. ▲



Name \_\_\_\_\_ Date \_\_\_\_\_

1. In 1912, when Alfred Wegener proposed in print that Earth's continents floated on denser and more stable material below, he was openly ridiculed and even scorned by his colleagues. Not until several decades later did his ideas receive any acceptance. Today he stands as the forefather of modern plate tectonics because of his theory of continental drift. His widely accepted theory of land displacement holds that Earth's continents have been in motion throughout geological time.

Wegener believed that there was once a single supercontinent, which he called Pangea (or Pangaea). He said that Pangea broke apart millions of years ago to form two large continents. He called the one in the northern hemisphere Laurasia and the one in the southern hemisphere Gondwanaland. After a very long span of centuries, Wegener said, Laurasia split to form North America, most of Asia, Greenland, and a large section of Europe. Gondwanaland became Africa, South America, Australia, India, and Antarctica. Wegener believed that the land masses drifted for millions of years before assuming their present shapes and arriving at their present locations. He was led to this notion by the congruity he observed in the shorelines of the lands bordering the Atlantic Ocean and several other kinds of evidence. Further, he said, the process of continental drift is still going on—the continents are still on the move.

Alfred Wegener, who was educated to be a meteorologist and an Arctic climatologist, insisted that his theory was correct because of the evidence he saw. To support his ideas about continental drift, Wegener pointed to the similarities in the fossils of the southern continents. Fossils of the same sort from ferns and

freshwater reptiles had been found in all of the southern continents. He saw this as evidence that all the lands south of the equator has once been part of a single land mass. He argued that such land-based life forms could never have crossed the thousands of miles of open ocean that now separate these land masses. His critics scoffed because the physical model that Wegener proposed to explain the movement of continents did not fit what was then known about the physics of the Earth.

For the next 30 years or so, scientists paid little attention to Wegener's theory. In the 1960s, however, geologists discovered that the ocean floors had been spreading, thus influencing the shapes and sizes of the continents. This new theory, called plate tectonics, provided a mechanism that made sense in physical terms to account for Wegener's idea of continental drift. Although the continents themselves do not drift, as Wegener proposed, he was correct in his thesis that Earth's surface is not fixed. He was a man well ahead of his time whose insight went beyond safe and conventional thinking. So important is Wegener to our current understanding of plate tectonics that in the 1970s a crater on the dark side of the moon was named for him, to honor his courage and vision.

Tragically, Alfred Wegener never lived to see his ideas accepted by the scientific community. He perished while attempting to cross Greenland from a camp on the ice cap in the winter of 1930. His purpose was to learn more about atmospheric conditions in the Arctic in order to better predict world weather patterns.

What title would you give this essay?

\_\_\_\_\_  
\_\_\_\_\_  
\_\_\_\_\_

Write a two- or three-sentence summary of the essay, then add a one-sentence comment.

\_\_\_\_\_  
\_\_\_\_\_  
\_\_\_\_\_  
\_\_\_\_\_  
\_\_\_\_\_  
\_\_\_\_\_  
\_\_\_\_\_

Name \_\_\_\_\_ Date \_\_\_\_\_

2. "In the earth's interior, where seismic waves travel invisibly and inaudibly, they can be followed only by mathematical equations."

Dragutin Skoko, Mohorovicic's biographer

The boundary separating Earth's crust from its upper mantle is called the Mohorovicic discontinuity, or the Moho, for short, in honor of the Croatian seismologist Andrija Mohorovicic. In 1909, he used data on the travel time of earthquake waves to demonstrate that their velocity changes at about 50 km beneath the surface. Others later refined the study of crust and upper mantle and applied new methods, but Mohorovicic paved their way.

Mohorovicic's father, also named Andrija (or Andrew), was a maker of anchors. The young Mohorovicic loved the sea, and married a sea captain's daughter. He taught for nine years at the Royal Nautical School in Baka. After becoming director of the Meteorological Observatory in Zagreb, in 1891, he studied and wrote primarily about clouds, rainstorms, and high winds. After a severe earthquake in 1901, however, Mohorovicic and his colleagues petitioned their government to establish a seismic station in Zagreb. In 1910, Mohorovicic published his account of the earthquake of November 9, 1880. In it, he plotted a now-standard transit time graph—arrival time versus epicenter distance to recording station—using the data for 29 stations that ranged to a distance of 2,400 km from the epicenter.

After plotting data for a large number of earthquakes over a wide area, he had begun to notice that the P wave arrivals required two curves on his graph. Because it was not possible to have P waves traveling in the same medium at different velocities, and the earlier P arrivals were only seen at some distance from the epicenter, he reasoned that the two different arrival times represented two different phases of P waves traveling different paths. After working out the refraction equations and tests to determine optimal values for the depth of the focus, the ray paths of the two P waves, the corresponding two S phases, and their reflection paths, he concluded that at approximately 50 km there must be an abrupt change in the material that composes the interior of the Earth, because he observed an abrupt change in the velocity of the earthquake waves. Although

this conclusion was not accepted immediately, Beno Gutenberg was able to confirm it with his own research as early as 1915.

Even after earthquakes became one of his primary interests, as chief of the observatory, Mohorovicic was responsible for recording all the meteorological data for Croatia and Slovenia—precipitation, tornadoes, whirlwinds, thunderstorms, and more—with only an occasional assistant. He was responsible for all the mathematics involved in keeping records and for answering hundreds of letters and requests for assistance, as well as teaching classes at the University. He was patient and precise in his collection and analysis of data, but he loved good scientific instruments, and was frequently frustrated at the inadequacy of the instruments available and the difficulty of obtaining new ones. An accurate clock was particularly important to his research, because in studying earthquakes, an error of one second in the time of arrival means an error of 5.6 km in estimating the length of its travel, making it impossible to accurately locate the focus of an earthquake. By 1913 he had finally obtained a crystal clock with a radio receiver that allowed him to synchronize with the Paris Observatory, but in 1914, during World War I, the army commandeered it for military use. When the clock was returned to him, after the war, he also received a new radio receiver that took two railroad cars to transport.

Mohorovicic published a paper in 1909 on the effect of earthquakes on buildings that described periods of oscillation (see lesson 4.3). In this he was at least 50 years ahead of the times both in his own country and elsewhere. Croatia's first national Provisional Engineering Standards for Construction in Seismic Areas were published in 1964.

During his lifetime, Mohorovicic maintained contacts with seismologists all over the world. He retired in 1922, but remained active until shortly before his death in 1936. His only grandchild, André, remembers that he was always good natured—a kind and peaceful man. Mohorovicic, like Alfred Wegener, received the honor of having his name given to a crater on the dark side of the moon.

What title would you give this essay?

\_\_\_\_\_  
\_\_\_\_\_  
\_\_\_\_\_

Write a two- or three-sentence summary of the essay, then add a one-sentence comment.

\_\_\_\_\_  
\_\_\_\_\_  
\_\_\_\_\_

Name \_\_\_\_\_ Date \_\_\_\_\_

3. By 1936, scientists had learned from the study of earthquake waves that the Earth has three layers, crust, mantle, and core. Denmark's Inge Lehmann was the first to demonstrate the existence of a change in composition midway through the core, dividing it into an inner core and an outer core. This division is now known as the Lehmann discontinuity.

As a girl, at the turn of the century, Lehmann attended the first coeducational school in Denmark, which was founded and run by Hanna Adler. (Adler's nephew, Neils Bohr, was the first to describe the physical makeup of the atom.) At that school, Lehmann wrote many years later, "No difference between the intellect of boys and girls was recognized—a fact that brought me disappointments later in life when I found that this was not the general attitude."

Lehmann studied at Oxford, earned a master's degree in mathematics from the University of Copenhagen, and went to work as an actuary, calculating life expectancies and statistical risks for insurance companies. Beginning in 1925, however, she also served as a staff member of the Danish Geodetic Institute, helping to establish seismological stations in Greenland and in Copenhagen—a part of the world not noted for its seismicity. Seismology soon became her life work, and for 25 years, until just before her retirement, she was the only Danish seismologist.

As early as 1910 scientists had noticed a shadow zone in the Earth's interior, but seismographs had not been refined enough to explain this observation. In the course of the 1930s more and more sensitive seismographs were being developed. At the Copenhagen Seismological Observatory, Lehmann studied waves reflected through the core from earthquakes in Japan. In 1936,

after 10 years of studying seismograms, she interpreted the newly revealed data to confirm the existence of a relatively small inner core in the center of the Earth. The paper in which she reported her findings has one of the shortest titles in the history of seismology, if not of all science: It was called "P'."

Lehmann was among the founders of the Danish Geophysical Society in 1936, and served as its president from 1941 until 1944. She helped to formulate the constitution of the European Seismological Federation and was elected its first president in 1950. She found time to attend most of the meetings of the International Union of Geodesy and Geophysics, and served on the executive committee of the International Seismological Association from 1936 to 1944, from 1951 to 1954, and from 1957 to 1960. International cooperation in the sciences was one of her passions. She was active in national and international scientific organizations, and traveled in France, the Netherlands, Belgium, and Germany, where she worked with some of the leading seismologists of the day. In Canada, she worked at Ottawa's Dominion Observatory, and in the United States she conducted research at the Seismological Laboratory, California Institute of Technology; the University of California at Berkeley; and the Lamont-Doherty Geological Observatory, Columbia University, New York.

She loved hiking, skiing, and mountain climbing. Her favorite place indoors, aside from her own cottage in Denmark, was an art gallery. She loved to visit galleries and look at paintings wherever she traveled, and she traveled widely, especially after her retirement in 1953. She also loved music and gardening. Inge Lehmann died in February, 1993, at the age of 105, leaving a worldwide network of friends.

What title would you give this essay?

\_\_\_\_\_  
\_\_\_\_\_  
\_\_\_\_\_

Write a two- or three-sentence summary of the essay, then add a one-sentence comment.

\_\_\_\_\_  
\_\_\_\_\_  
\_\_\_\_\_  
\_\_\_\_\_  
\_\_\_\_\_  
\_\_\_\_\_  
\_\_\_\_\_

# Chronology: The Beginnings of the Seismological Age

- 1883: The English seismologist John Milne hypothesized that with the proper equipment, it should be possible to detect seismic waves from a large earthquake occurring anywhere on Earth.
- 1889: Milne's 1883 hypothesis was proven correct when E. von Rebeur Paschwitz used delicate pendulum seismographs to record the April 18, 1889, Tokyo earthquake in Potsdam and Wilhelmshaven, Germany.
- 1897: Richard Dixon Oldham noticed that seismograms from earthquakes consistently showed three different disturbances, the first and second "preliminary tremors" (now known as P waves and S waves, respectively) and the "large waves" that followed the preliminary tremors, and that the difference in arrival time between the "large waves" and the "preliminary tremors" increased in a predictable fashion with increasing distance from the earthquake.
- 1900: Oldham established that the "preliminary tremors" (P and S waves) have travel paths that take them through the body of Earth (we now call them body waves), and that the "large waves" (now called surface waves) travel along Earth's surface.
- 1906: Oldham used evidence from earthquake waves to demonstrate the existence of a large central core at a depth of about 3,821 km beneath the surface.
- 1909: Andrija Mohorovicic, a Croatian seismologist, used seismic waves to discover a discontinuity at a depth of about 50 km beneath the surface. This marks the boundary between what we now call the Earth's crust and the underlying mantle. In his honor, we call the boundary separating the crust from the mantle the Mohorovicic discontinuity, or the Moho for short.
- 1914: Beno Gutenberg used an extensive data set of earthquake wave travel times to compute the average distance to the top of the core at about 2,900 km.
- 1926: Harold Jeffreys' measurements of tides in the solid Earth suggested that the Earth was less rigid than had been previously assumed. This led to the assumption that the core is fluid.
- 1936: Inge Lehmann, Danish seismologist, demonstrated the presence of an inner core.

# Sizing Up EARTHQUAKES

## ACTIVITY ONE

### THE MERCALLI SCALE: CALLING STATION KWAT

#### RATIONALE

Students need to know how seismologists establish earthquake intensity in order to understand how much damage earthquakes can cause and how building codes are developed.

#### FOCUS QUESTION

How do seismologists determine the intensity of an earthquake?

#### OBJECTIVES

##### Students will:

1. Interpret the Modified Mercalli scale and assign values on the basis of descriptions by citizen observers during and after a quake.
2. Use the assigned values to construct an isoseismal map.

#### MATERIALS

- Overhead projector
- Student copies of Master 3.3a, Modified Mercalli Intensity Scale
- Transparency made from Master 3.3a, Modified Mercalli Intensity Scale
- Back of Master 3.3a, Teacher Background Reading: Richter vs. Mercalli
- Student copies of Master 3.3b, Wattsville Map
- Transparency made from Back of Master 3.3b, Wattsville Map Key
- One copy of Master 3.3c, KWAT Television Script, cut into strips
- Student copies of Master 3.3c, KWAT Television Script
- Colored pencils and lead pencils

#### VOCABULARY



**Epicenter:** the point on Earth's surface directly above the focus of an earthquake.

**Focus (pl. foci):** the point within the Earth that is the origin of an earthquake, where stored energy is first released as wave energy.

**Intensity:** a subjective measure of the amount of ground shaking an earthquake produces at a particular site, based on geologic effects, impact on human structures, and other human observations. Mercalli intensity is expressed in Roman numerals.

**Isoseismal line:** a line on a map that encloses areas of equal earthquake intensity.

**Magnitude:** a number that characterizes the size of an earthquake by measuring the motions on a seismograph and correcting for the distance to the epicenter of the earthquake. Magnitude is expressed in Arabic numbers.

## PROCEDURE

### A. Introduction

Ask students on what basis scientists classify earthquakes. Many students may be aware of the Richter Scale and some may be aware of the Mercalli Scale. Explain that the Richter Scale is a quantitative measure of the energy released by an earthquake, while the Mercalli Scale is a qualitative measure of the amount of damage it does. The Richter rating is referred to as a quake's magnitude, and the Mercalli rating is referred to as its intensity. The original Mercalli Scale was developed in 1902 by the Italian geologist Giuseppe Mercalli. Wood and Neumann adapted it to U.S. conditions and introduced the Modified Mercalli Scale in 1931. Both the Richter and the Mercalli scales have their uses. Have students give other examples of quantitative vs. qualitative measurements.

### B. Lesson Development

1. Project the transparency of the Modified Mercalli Scale and distribute student copies. Share the background information about the two earthquake scales (back of Master 3.3a) with the class and discuss the importance of intensity in establishing building codes. Briefly discuss each of the values assigned on the Mercalli scale. If some students in the class have experienced an earthquake, ask them to estimate its intensity from the scale.
2. Have the students compare and contrast the differences between the two types of measurements. Ask: Why do you think magnitude is more often reported than intensity? (Most earthquake-prone areas have equipment already in place to determine magnitudes, so this measurement can be quickly established. Mercalli ratings are sometimes not arrived at until several days later, when a full estimate of the damage can be made.) Point out to students that the lack of news accounts reporting intensity does not diminish its value to city planners and engineers.
3. Tell students that in this activity they will be using data adapted from reports of an earthquake that struck California in 1971. Distribute copies of Master 3.3b, Wattsville Map. Appoint one student to be Jake Wilde, the television news anchor, and tell the other students that they are citizens of Wattsville and the surrounding area. The town has just been struck by an earthquake.
4. Distribute the strips cut from Master 3.3c and have students take turns reading them in order, starting with the news anchor's report. Distribute student copies of the script as well.
5. As each student reads a part, have the other students locate the site of the report on their maps, scan the Modified Mercalli Intensity Scale, and mark a Mercalli intensity in pencil next to the location.
6. After the last student has read, have students draw blue lines enclosing areas with equal intensity ratings to develop an isoseismal map. (They will be drawing a series of concentric lines.)

## VOCABULARY



**Modified Mercalli scale of 1931:** a qualitative scale of earthquake effects that assigns an intensity number to the ground shaking for any specific location on the basis of observed effects. Mercalli intensity is expressed in Roman numerals.

**Qualitative:** having to do with perceived qualities; subjective. Examples: large, cold.

**Quantitative:** having to do with measurable quantities; objective. Examples: 10 m long, 5° C.

## TEACHING CLUES AND CUES



Have students listen carefully for significant phrases in the callers' reports. They will be found in the Mercalli scale (Master 3.3a).



It may take class discussion to reach agreement on the values for some of the reports. Have students read the descriptions on the Mercalli scale carefully, and reread them as necessary, checking with the script as they proceed.



7. Project the transparency of Master 3.3b, Wattsville Map, and have students take turns giving you the values to draw on the transparency. Then draw in the isoseismals according to their interpretation of the data.

### C. Conclusion

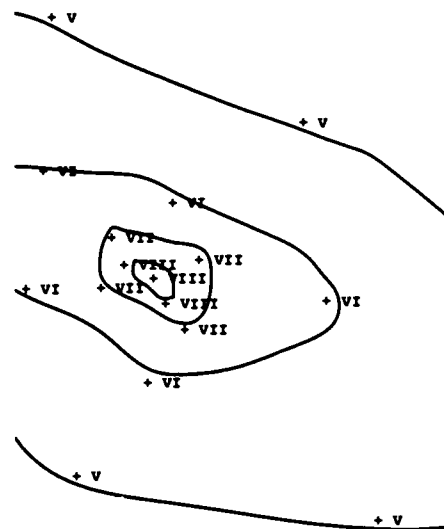
Ask students to find the area where the damage was most intense and color this area red. Then build a class discussion around these questions:

- Where do you think the epicenter of the earthquake is located? (Most students will think that the area with the most damage is the epicenter. In certain cases this is a false assumption. Damage may be related to siting or construction practices. An example of this is the 1985 Mexico City earthquake in which the fault was over 350 km away.)
- Why did some buildings near the epicenter withstand the shocks better than others? (perhaps because their structures were sounder or the soil under them was more firm)
- What are some advantages of the Mercalli rating procedure? (In ideal conditions, it can be done quickly, and it doesn't require any instruments. It describes the impact in human terms: on human beings and their structures.)
- What are some disadvantages to this procedure? (It requires human observers, so it could not assign an intensity to an earthquake in the middle of an ocean or in a deserted place. It also requires the exchange of information over a fairly wide area. To arrive at Mercalli ratings today, an official survey is conducted through the U.S. mail. It is not as precise or objective as instrument readings; different people might describe the same situation differently.)

Now place the answer key transparency on the overhead so it overlays student data. If there is a discrepancy between the isoseismals shown on the master and those students produced, they will see one of the drawbacks to this system of measurement. Ask students for suggestions to solve this problem.

### ADAPTATIONS AND EXTENSIONS

1. Write a modern-day version of the 1931 Mercalli Intensity Scale.
2. Go to the library and search newspapers for qualitative information on an earthquake in your area. Construct an isoseismal map for the earthquake.



## ACTIVITY TWO

### RICHTER MAGNITUDE

#### RATIONALE

To determine Richter magnitude, we need to know both the maximum wave amplitude as recorded on the seismogram and the distance between the seismograph station and the earthquake, which can be calculated by finding the lag time.

#### FOCUS QUESTION

How do scientists determine the size of an earthquake?

#### OBJECTIVES

##### Students will:

1. Interpret seismograms to calculate Richter magnitude.
2. Compare Richter magnitudes from several seismograph stations for the same earthquake.

#### MATERIALS

- Transparency made from the first page of Master 3.3d, Five Seismograms
- Overhead projector
- Transparency marker
- Copies of Master 3.3d, Five Seismograms (simplified) (3 pages), one set for every two students
- Copies of Master 3.3e, Distance, Magnitude, Amplitude, one for every two students
- Paper and pencils or pens
- Rulers or straightedges
- Transparency made from Master 3.3e, Distance, Magnitude, Amplitude
- Transparency made from back of Master 3.3d (page 2), Richter Data Table, Answer Key

#### PROCEDURE

##### A. Introduction

Tell students that Richter magnitude is a quantitative measure that is related to the amount of energy released during the earthquake and is not affected by factors such as population, building materials, or building design. Ask them to name some other kinds of quantitative measures (minutes, hours, centimeters, dollars). Be sure they understand the distinction between quantitative and qualitative description.

##### B. Lesson Development

1. Divide students into pairs. Give each pair a ruler and copies of Master 3.3d, Five Seismograms, and Master 3.3e, Distance,

#### VOCABULARY



**Amplitude:** a measurement of the energy of a wave. Amplitude is the displacement of the medium from zero or the height of a wave crest or trough from a zero point.

**Duration:** the length of time that ground motion at a given site shows certain characteristics. Most earthquakes have a duration of less than one minute, in terms of human perceptions, but waves from a large earthquake can travel around the world for hours.

**Lag time:** the difference between the arrival time of P waves ( $T_p$ ) and S waves ( $T_s$ ).

**Magnitude:** a number that characterizes the size of an earthquake by recording ground shaking on a seismograph and correcting for the distance to the epicenter of the earthquake. Magnitude is expressed in Arabic numbers.

**Richter magnitude:** the number that expresses the amount of energy released during an earthquake, as measured on a seismograph or a network of seismographs, using the scale developed by Charles Richter in 1935.

**Seismogram:** the record of earthquake ground motion recorded by a seismograph.

Magnitude, Amplitude. Tell students that they are going to be working with five seismograms, all recorded for one earthquake on September 2, 1992, with its epicenter at St. George, Utah. Explain that the seismographs have been enlarged and simplified for their use but that this has also changed the scale, so they must use the vertical scale for all measurements. You will be demonstrating the steps to determine magnitude by using the first seismogram on Master 3.3d. They will record their data on the bottom of the third page of seismograms.

2. Project a transparency of Master 3.3d, page 1, and demonstrate how to measure amplitude. (See vocabulary definition.) Using the scale on the left side of the graph (the y axis) determine the greatest deflection in millimeters above or below zero of the largest seismic wave. Record this measurement in the amplitude column on the data table.

3. After all students have measured amplitude, start the next part of the activity by asking them which earthquake wave travels fastest and therefore should be the first wave recorded on the seismogram. Most of them should be aware from previous lessons that it is the P wave. On the transparency of Master 3.3d, page 1, point out the arrival of the P and S waves. Ask students what the difference between the arrival of the two waves is called (lag time ( $T_s - T_p$ )). Ask students what should happen to the lag time recorded at stations farther from the earthquake. Offer a hint by comparing the progress of the waves to a race between the family car and a race car. The longer the race is, the more of an advantage the race car will have.


4. Using the projection of Master 3.3d, page 1, demonstrate how to determine distance to the earthquake recorded by the first seismogram. Using the scale at the top of the graph (the x axis), measure the difference between P wave and S wave arrival times in seconds. Use the formula


$$\text{Distance} = (T_s - T_p) \times (8 \text{ km/sec}) \text{ or } (4.96 \text{ mi/sec})$$


to convert time to distance. Have students record this in their data tables. Give students time to calculate the distances for the other four seismograms, following the procedure you have modeled.

5. Project the transparency of Master 3.3e and demonstrate how to find the magnitude of the earthquake. To do this, place the left end of the ruler on the left scale at the distance calculated in step 4. Holding the left edge of the ruler in place, move the right edge of the ruler to the correct point for the base-to-peak amplitude. Read the Richter magnitude on the center scale where the ruler crosses the graph and record it in the data table. Have students repeat this process on their own for the other stations. Average the magnitudes from the five locations to determine the final magnitude for this earthquake, and record it in the data table.

## TEACHING CLUES AND CUES

 The seismograms on Master 3.3d are seismograms that have been simplified and enlarged for classroom use. The printed millimeter scale has also been enlarged proportionately.

 Do not use rulers for this step or the measurement will be inaccurate. (Be sure they make all their measurements on the same wave cycle, not the crest from one and the trough from another. The diagram on p.116 will be helpful.)

 To measure the amplitude, have students lay a piece of paper across the wave and mark the high and low peaks, then use the scale on the y axis or the scale printed at the bottom of the seismogram to measure the amplitude or distance.

### C. Conclusion

Project the back of Master 3.3d, Richter Data Table, Answer Key, and allow students to compare their calculations with the actual data. Ask students how a more accurate magnitude could be calculated. (by collecting more data points or by averaging the class averages of the calculated magnitude)

### ADAPTATIONS AND EXTENSIONS

Seismologists today use a variety of magnitude scales and many types of instruments to record precise information on earthquakes. Interested students can read about P wave or body wave magnitude (called  $m_b$ ), surface wave magnitude ( $M_s$ ), moment magnitude ( $M_w$ ), as well as the concept of seismic moment, drawing on materials in the unit resources list and others from local libraries.



## ACTIVITY THREE

### FIND THE EPICENTER: DECODING SEISMOGRAMS

#### RATIONALE

---

Students can find the location of an earthquake by triangulation if they know the distances from at least three seismograph stations.

#### FOCUS QUESTION

---

How do seismologists use seismograms to locate the epicenter of an earthquake?

#### OBJECTIVES

---

##### Students will:

1. Calculate the distance from an earthquake to a seismograph station.
2. Use five calculated distances to triangulate the location of the earthquake's epicenter.

#### MATERIALS

---

- Student copies of Master 3.3f, Several Seismographs
- Student copies of Master 3.3g, Sample Seismograms
- Student copies of Master 3.3h, Map of Station Locations
- Transparency made from one page of Master 3.3g, Sample Seismograms
- Overhead projector
- Transparency made from Master 3.3h, Map of Station Locations
- Student copies of Master 3.3i, Time/Distance Reference Table
- Drawing compasses
- Metric rulers with millimeter scales

#### PROCEDURE

---

##### Teacher Preparation

Make one copy of each of the masters (3.3f through 3.3i) for every two students in your class.

##### A. Introduction

Ask students chosen at random to explain the difference between an earthquake's focus and its epicenter and between a seismograph and a seismogram. Review these distinctions if necessary.

Distribute copies of Master 3.3f, Several Seismographs, then project a transparency of Master 3.3f and describe their operation.

##### B. Lesson Development

1. Divide the class into pairs of students. Distribute a set of seismograms (Master 3.3g, 3 pages), one map (Master 3.3h), and copies of the Time/Distance Reference Table (Master 3.3i) to each pair. Tell stu-

#### VOCABULARY

---



**Epicenter:** the point on Earth's surface directly above the focus of an earthquake.

**Focus (pl. foci):** the point within the Earth that is the origin of an earthquake, where stored energy is first released as wave energy.

**Seismogram:** the record of earthquake ground motion recorded by a seismograph.

**Seismograph:** an instrument that records vibrations of the Earth, especially earthquakes.

**Triangulation:** using data from three or more known points to locate an unknown point, in this case the epicenter of an earthquake.

dents that all the seismograms are from the same earthquake, a quake that occurred on January 14, 1993, with a magnitude of 3.3, but each was recorded by a different seismograph in the seismograph network.

2. Project transparencies of one seismogram and the map. Model the procedure for students as necessary.

3. Give these directions for finding the epicenter of the earthquake recorded on the five seismograms:

a. On the first seismogram, use the second scale to measure the time-distance from the nearest 10-second mark to the P wave arrival of the earthquake. Record the P wave arrival times in the table to the nearest second.

b. Repeat for the S wave, measuring from the same minute mark.

c. Find the  $T_s - T_p$  time by subtracting the arrival time of the P wave from the arrival time of the S wave. Record this time in the table.

d. Use the time/distance table on Master 3.3i to determine the distance to the epicenter.

e. Repeat this procedure for all of the stations.

f. For each seismogram, draw a circle on the map with the compass, using the distance you calculated as the radius of the circle. Place the point of the compass at zero on the map scale and adjust the compass width to the calculated distance. With the distance set, place the point of the compass on the station and draw a circle. Mark the outer edge of each circle with a letter to identify the station.

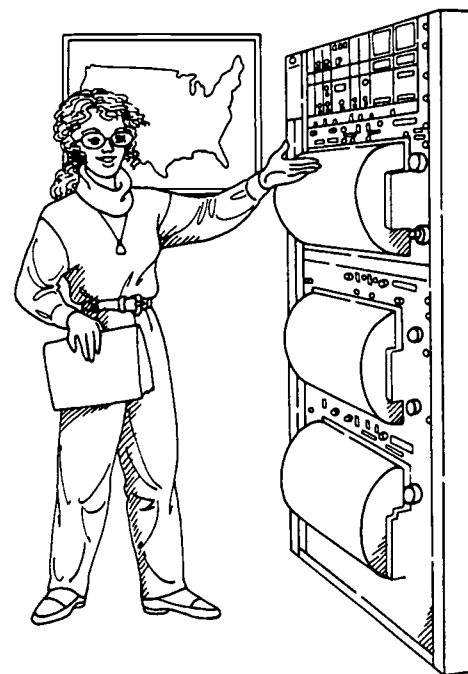
g. Repeat, setting the compass and drawing circles for all five stations.

4. Instruct students to circle the area where all the circles intersect. Ask: What is this area called? (It is the epicenter of the earthquake.)

### C. Conclusion

Build a class discussion around these questions:

- What information can be obtained from one seismogram? (The distance from that seismograph in a 360° circle.)
- After the arcs for stations TRYN and FGTV were drawn, where was the epicenter of this earthquake? Explain. (We don't know yet. It could be at either place where the two arcs cross. They are the common points.)
- After all the stations were drawn, where was the actual epicenter of this earthquake? Where was its focus? (In the area where the arcs cross just south of station BHT. Directly under the epicenter.)
- Why is it necessary to have measurements from at least three different stations to locate the epicenter of an earthquake? (Answers will vary but should relate to the above questions.)
- Why don't all of the arcs pass through the same point? (Answers will vary. Accuracy in measurement and drawing should be two



### TEACHING CLUES AND CUES



Emphasize the importance of accurate measurement, particularly the need to set the compass accurately for distance. Don't worry if the circles don't intersect perfectly, however. Remind students that an earthquake actually occurs along a fault, not at one single point.

most common. Also, an earthquake does not occur at one point but along a fault surface. Have students speculate as to the location and strike of the fault.)

- Which station was closer to the earthquake's epicenter, BBG or FGTV? Cite two kinds of evidence from the seismograms to support your conclusion. (BBG. Evidence: amount of lag time and amplitude difference.)
- Would it be possible for an earthquake at this location to be felt where you live? Why or why not? (Answers will vary; will depend on distance from the focus and the magnitude of the quake.)
- P waves travel at an average velocity of 6 km/sec in the Earth's crust. How long would it take for the P waves from this quake to reach a seismic station in your city, if they continued to travel at a constant speed? (Answers will vary. Multiply 6 km/sec times the distance to your city.)

#### **ADAPTATIONS AND EXTENSIONS**

---

1. Challenge students to research these questions:

- Would a seismograph work on the moon?
- Have scientists placed seismographs on the moon and other planets?
- If so, which planets? Have quakes been detected there?

2. Interested students may research several types of seismographs and build their own models.▲

## Intensity Value &amp; Description

- I. Not felt except by a very few under especially favorable circumstances.
- II. Felt only by a few persons at rest, especially on upper floors of buildings. Delicately suspended objects may swing.
- III. Felt quite noticeably indoors, especially on upper floors of buildings, but many people do not recognize it as an earthquake. Standing automobiles may rock slightly. Vibration like passing of truck. Duration estimated.
- IV. During the day felt indoors by many, outdoors by few. At night some awakened. Dishes, windows, doors disturbed; walls make creaking sound. Sensation like heavy truck striking building. Standing automobiles rocked noticeably.
- V. Felt by nearly everyone, many awakened. Some dishes, windows, and so on broken; cracked plaster in a few places; unstable objects overturned. Disturbances of trees, poles, and other tall objects sometimes noticed. Pendulum clocks may stop.
- VI. Felt by all, many frightened and run outdoors. Some heavy furniture moved; a few instances of fallen plaster and damaged chimneys. Damage slight.
- VII. Everybody runs outdoors. Damage negligible in buildings of good design and construction; slight to moderate damage in well-built ordinary structures; considerable in poorly built or badly designed structures; some chimneys broken. Noticed by persons driving cars.
- VIII. Damage slight in specially designed structures; considerable in ordinary substantial buildings, with partial collapse; great in poorly built structures. Panel walls thrown out of frame structure. Chimneys, factory stacks, columns, monuments, walls may fall. Heavy furniture overturned. Sand and mud ejected in small amounts. Changes in well water. Persons driving cars disturbed.
- IX. Damage considerable in specially designed structures; well-designed frame structures thrown out of plumb; great in substantial buildings, with partial collapse. Buildings shifted off foundations. Ground cracked conspicuously. Underground pipes broken.
- X. Some well-built wooden structures destroyed; most masonry and frame structures destroyed with foundations; ground badly cracked. Rails bent. Landslides considerable from river banks and steep slopes. Shifted sand and mud. Water splashed, slopped over banks.
- XI. Few, if any (masonry) structures remain standing. Bridges destroyed. Broad fissures in ground. Underground pipelines completely out of service. Earth slumps and land slips in soft ground. Rails bent greatly.
- XII. Damage total. Waves seen on ground surface. Lines of sight and level distorted. Objects thrown into the air.





# Teacher Background Reading

## Richter vs. Mercalli

When an earthquake occurs, we often hear news reporters describing it in terms of magnitude. Perhaps the most common question at a news conference is “What was the magnitude of the quake?” In addition to calculating the magnitude of an earthquake, however, we can describe the effect it had at a particular location by measuring its intensity. Magnitude and intensity are both measures of an earthquake, but they describe different characteristics. Each measurement has its uses.

Magnitude is a measurement of the amplitude of the earthquake waves, which is related to the amount of energy the earthquake releases. Magnitude is calculated from the size of the earthquake waves arriving at a seismic station. The most commonly used scale for magnitude is the Richter scale, developed by Charles Richter in 1935. The Richter scale is a logarithmic measurement of the maximum wave amplitude recorded at a seismograph station, corrected for distance from the epicenter. It is theoretically open-ended, although the largest quakes recorded in this century had a magnitude of 8.9. Each whole number increase in Richter magnitude indicates an increase in the severity of the ground shaking by a factor of 10. Thus a magnitude 6 earthquake will produce shaking 10 times more severe than that produced by a magnitude 5 earthquake. Magnitude can also be related to the amount of energy an earthquake releases. Each whole number increase in Richter magnitude indicates an increase in the amount of energy released by a factor of roughly 30. Thus a magnitude 6 earthquake releases about 30 times more energy than a magnitude 5 earthquake, and roughly 900 times as much as a magnitude 4 earthquake. These factors are seldom described correctly in news accounts.

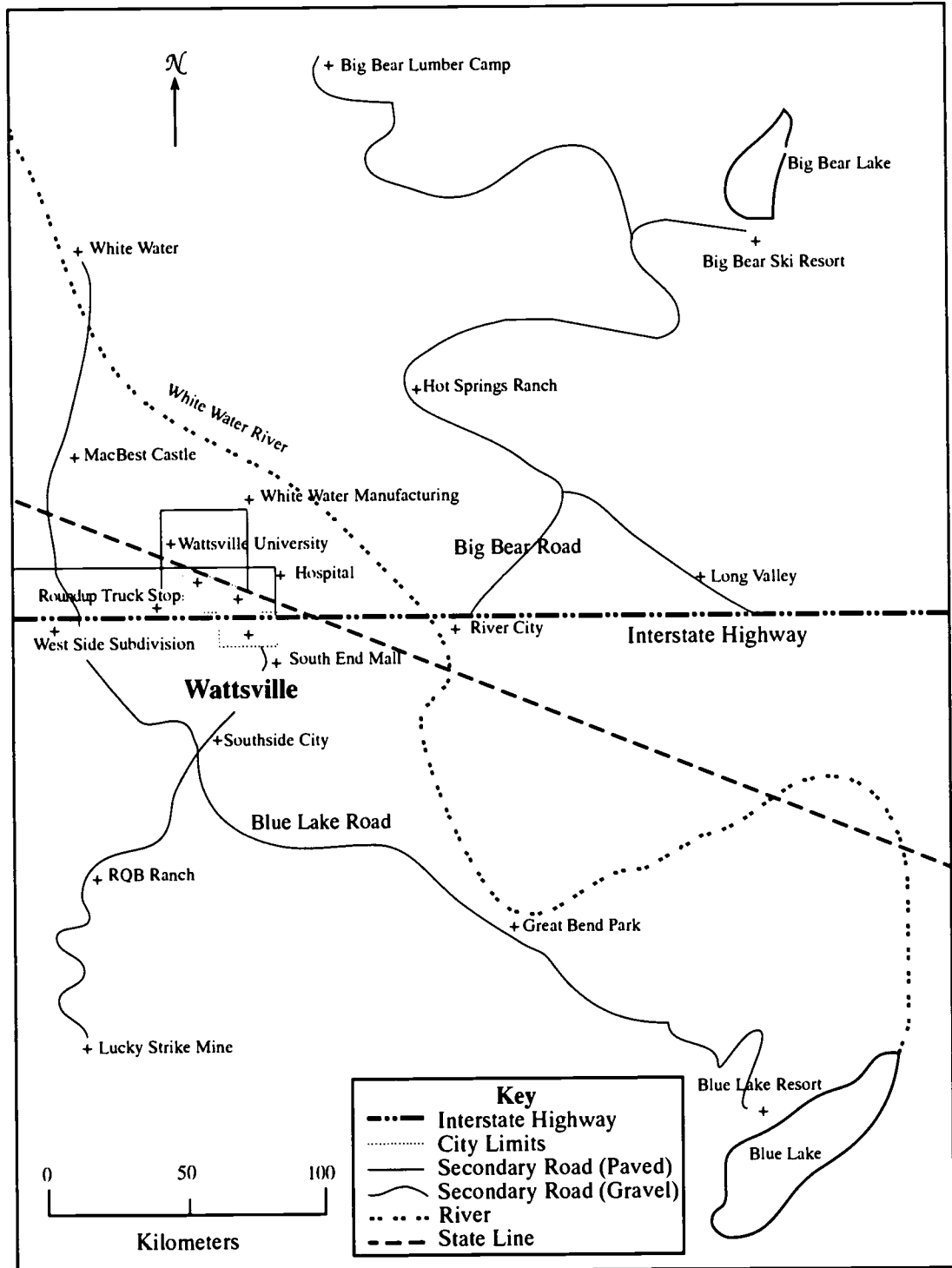
Each earthquake has a single magnitude that is independent of the location of the observer. If a magnitude 6.0 event strikes some location in the South Pacific, then that event will be described as a magnitude 6.0

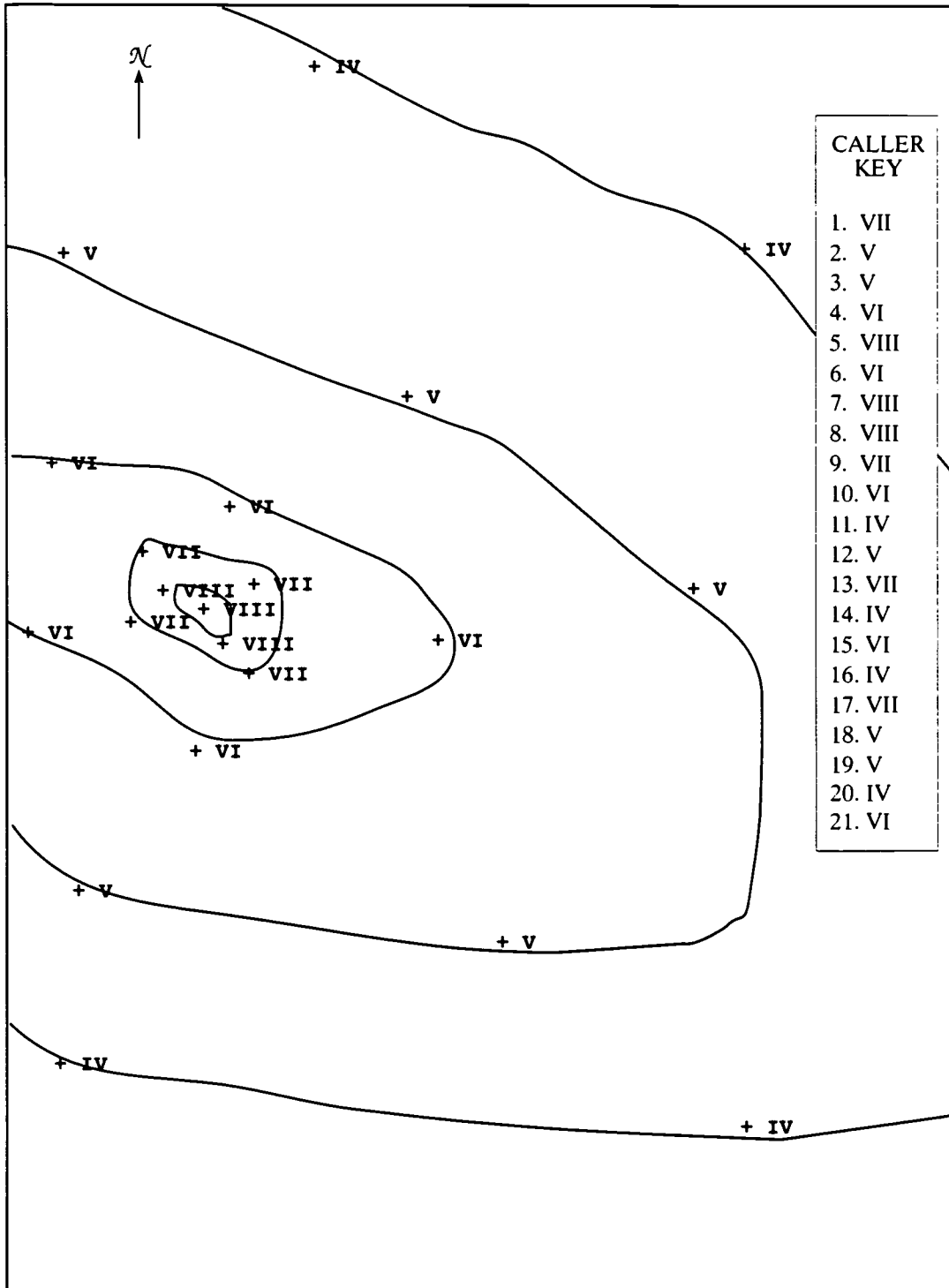
by observers all over the world. Because magnitude is independent of observer location, it is a convenient measure to use in reporting the occurrence of an earthquake. No matter where it happened, or where you are, you get a feeling for the relative size of the earthquake by simply knowing its magnitude. This is why the press is so quick to report this number.

Intensity is a measure of the effect that the vibration had on natural and human-made structures. The most common measurement of intensity is the Modified Mercalli Intensity scale, originally developed in 1902 by Giuseppe Mercalli, an Italian geologist. Wood and Neumann adapted it to “modern” conditions in 1931. The intensity scale ranges from I, the lowest perceptible intensity, to XII, the greatest intensity. Intensity is a function of many variables, including magnitude, depth of the earthquake, distance from the earthquake, local geological conditions, and local construction practices. Generally speaking, the intensity felt at a given location will increase with increasing magnitude, decreasing depth, decreasing distance from the earthquake, and a decrease in the quality of construction. If an earthquake is shallow, its intensity will be greater. If it affects an area built on soft sediments, such as landfills or sedimentary basins, the intensity will also be greater. A single quake will produce a range of intensities that typically decrease with increasing distance from the earthquake. An isoseismal map illustrates this range.

Intensity is more useful than magnitude as a measure of the impact that an earthquake had at any given location. Consequently, it is important to the professionals who establish building codes and insurance rates. If the maximum expected intensity in a given area is VII, for example, the building codes should specify construction practices that make buildings able to withstand this intensity, and property insurance rates will probably be high. If the maximum expected intensity is only III, the area can relax its building codes, and property insurance rates will be moderate.

Name \_\_\_\_\_ Date \_\_\_\_\_





Note: Isoseismal lines and locations may vary.

-----

**Jake Wilde:** “We interrupt our regularly scheduled programming on KWAT to bring you a special bulletin. This is KWAT news anchor Jake Wilde, and moments ago the town of Wattsville was shaken by a strong earthquake. Residents in the KWAT broadcast area are invited to call our emergency response number, 324-KWAT, and give us your name, your location, and a brief summary of what you experienced during the quake. Stay tuned for the latest reports of what your neighbors saw and felt. To report your observations, again, call 324-KWAT. We have caller number 1 on the line.”

-----

**Caller 1:** “Hi, this is Charles from the hospital. Everyone ran outdoors and we only had moderate damage thanks to a well-built building.”

-----

**Caller 2:** “Hello my name is Roy, and I’m calling from RQB Ranch. Everything that wasn’t nailed down in our tack room got turned upside down by the shaking. Some plaster is cracked too.”

-----

**Caller 3:** “Hi, this is Bob at Long Valley Mercantile, and we have a mess here. When the quake struck, it knocked over all of our displays, and broke windows out of the store. All the trees and poles were moving.”

-----

**Caller 4:** “Hi Jake, I’m Jane calling in from West Side Subdivision. Damage was slight here—only some plaster shaken off the walls and the heavy furniture moved around.”

-----

**Caller 5:** “Hi. This is Jo. I’m calling from the north end of town and we need some help down here. The water in our well has changed its level and we are trying to put out fires with buckets.”

-----

**Caller 6:** “Hello Jake, Lynda from Southside City Junior High School. Students felt it and did the drop, cover, and hold drill. We only had slight damage to the building, with some fallen plaster.”

-----

**Caller 7:** “Hi, this is Hank and I’m calling on my car phone. I just heard the news and thought I would report that right after I turned south into town off the Interstate, I felt a big bump—but there were not any potholes in the road. It was disturbing.”

-----

**Caller 8:** “Hello, this is Mary, and I’m calling from the basement of the First Bank in the center of Wattsville. The building has partially collapsed and people are trapped down here. Please send help.”

-----

**Caller 9:** “Hi this is Jim. We were at the mall when the quake struck. Everyone panicked and ran outside. Luckily no one was hurt, and damage was slight.”

-----

-----  
**Caller 10:** "Hi, this is Ron. I work at the MacBest Castle. Many of the tourists were frightened and ran outdoors, and our chimneys were damaged."  
-----

**Caller 11:** "Hello Jake. My name is Sue and I'm calling from the Big Bear Lumber Camp. The walls of our house were swaying and creaking during the earthquake."  
-----

**Caller 12:** "Hi. This is Len. We were picnicking at the Great Bend Park. Shortly after the quake struck we saw trees, telephone poles, and the flagpole swaying back and forth."  
-----

**Caller 13:** "Hi. This is Jim out at the Roundup Truck Stop. When the quake hit, our chimney broke and fell over."  
-----

**Caller 14:** "Hello, Jake. This is Marty up at Big Bear Ski Resort. The quake rattled our dishes and windows, and the walls made creaking sounds."  
-----

**Caller 15:** "Hi Jake. This is Keith in River City. Our chimney is damaged and some plaster has fallen."  
-----

**Caller 16:** "Hi. This is Diana calling from the Lucky Strike Mine. Over here, we thought that a big truck had struck the building."  
-----

**Caller 17:** "Hi Jake. This is Monte from Wattsville University. Everyone in our class felt the quake, and some of the older, more poorly built buildings have suffered considerable damage."  
-----

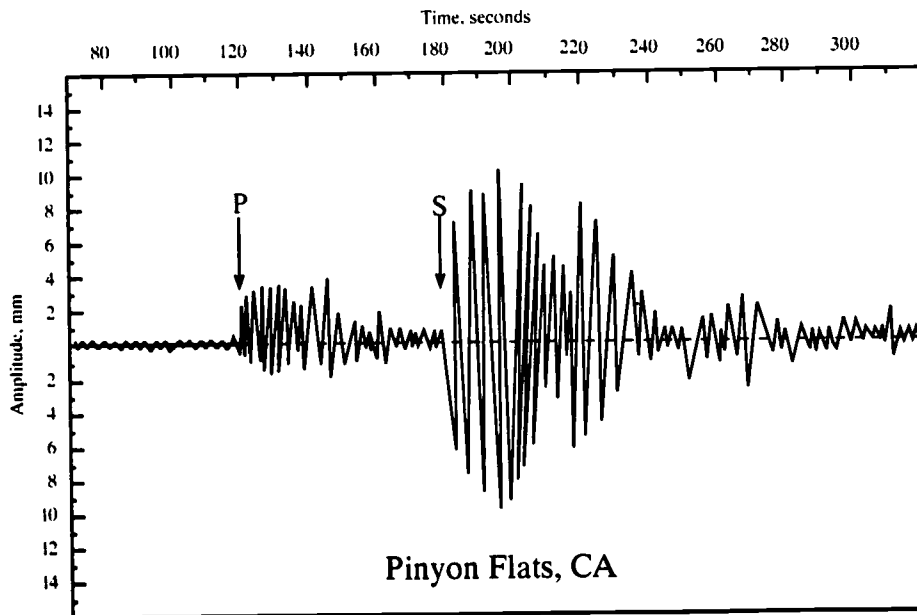
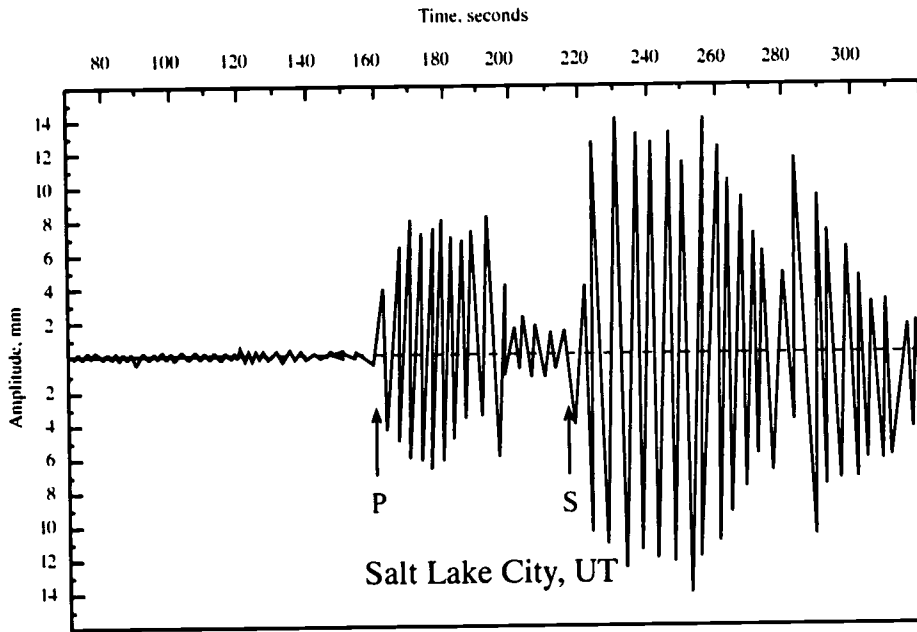
**Caller 18:** "Hello. My name is Marilyn, and I'm calling from Hot Springs Ranch. The strangest thing happened! Our big pendulum clock stopped dead when the quake struck."  
-----

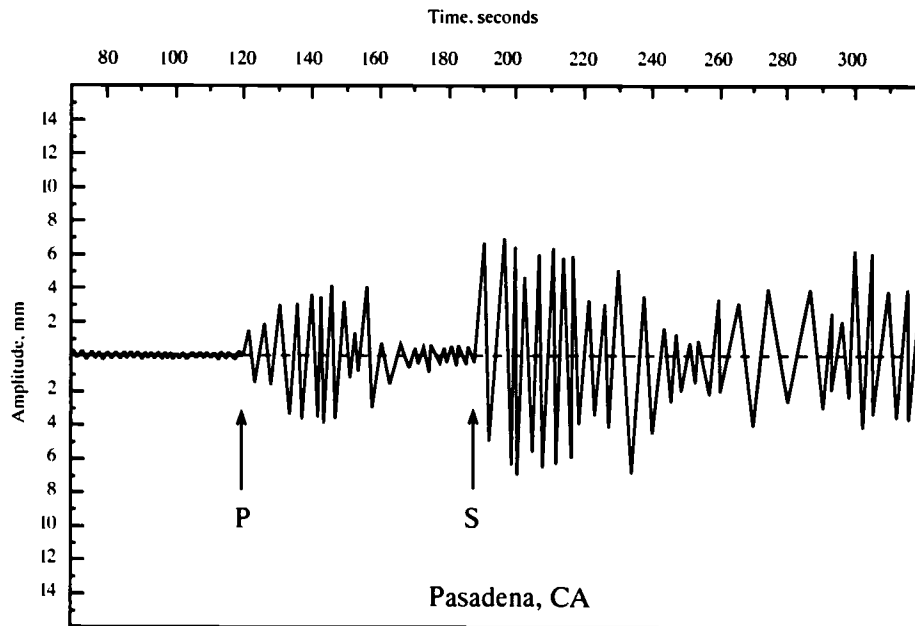
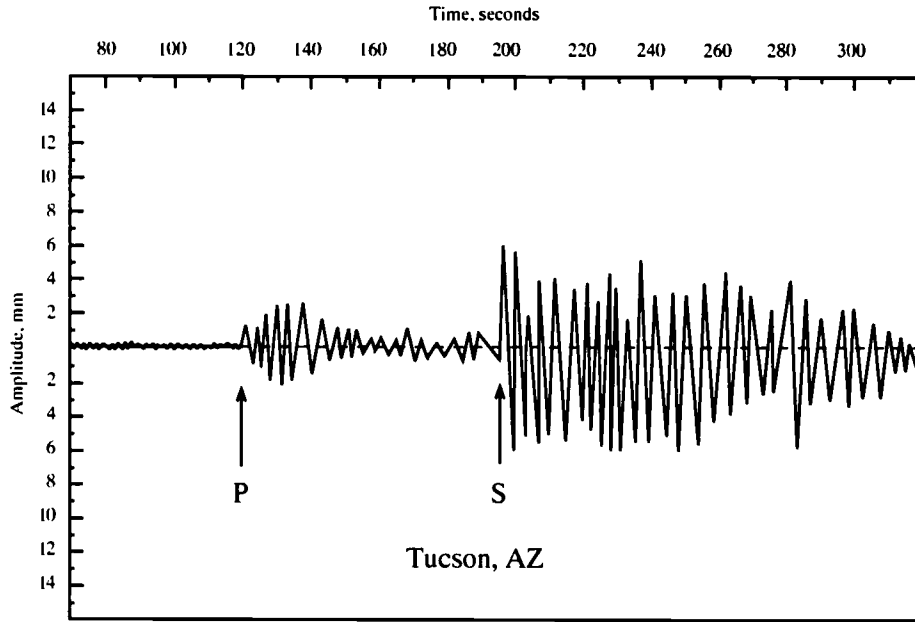
**Caller 19:** " Hi Jake, this is Karen. When the quake hit, I was in White Water visiting a friend. Nearly everyone felt it and we had a lot of windows broken. They were frightened, and I was too!"  
-----

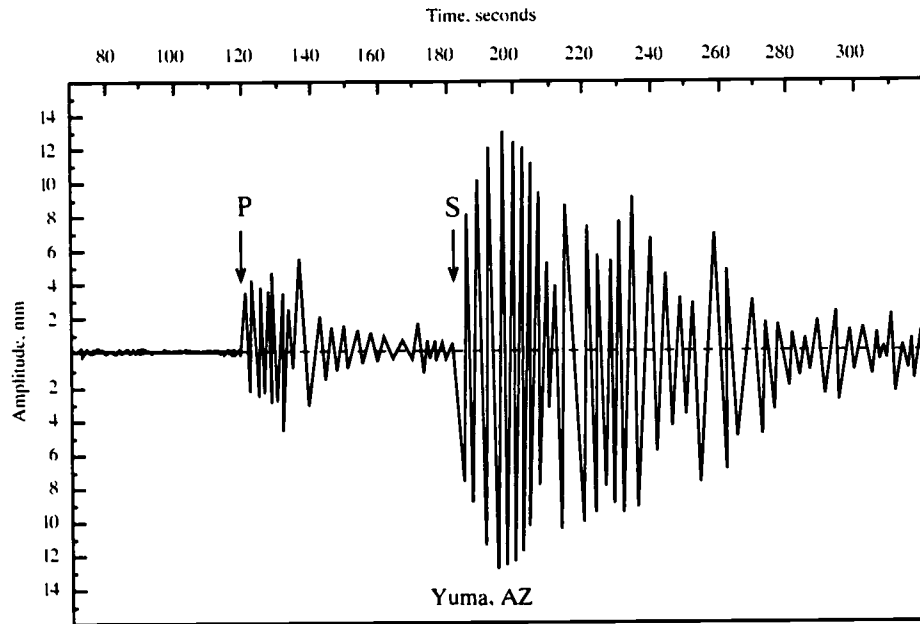
**Caller 20:** " Hello Jake. This is Frank. I was at Blue Lake Resort when all the cars in the parking lot started rocking back and forth."  
-----

**Caller 21:** " Jake, this is Gene at White Water Manufacturing. All of the heavy furniture in the showroom was moved by the quake, and some of the plaster fell off the walls."  
-----

Name \_\_\_\_\_ Date \_\_\_\_\_







Richter Magnitude Data Table

Location	Amplitude	$T_S - T_P$	Distance	Magnitude
Salt Lake City, UT	mm	sec	km	
Pinyon Flats, CA	mm	sec	km	
Tucson, AZ	mm	sec	km	
Pasadena, CA	mm	sec	km	
Yuma, AZ	mm	sec	km	
Final magnitude (average of 5)				





Richter Data Table, Answer Key

LOCATION	AMPLITUDE	$T_S - T_P$	DISTANCE	MAGNITUDE
Salt Lake City, UT	14.0 mm	56 sec	448 km	5.6
Pinyon Flats, CA	10.0 mm	59 sec	472 km	5.7
Tucson, AZ	6.0 mm	75 sec	600 km	5.8
Pasadena, CA	7.0 mm	68 sec	544 km	5.7
Yuma, AZ	13.0 mm	62 sec	496 km	5.8
Final magnitude				5.7

*Note: Answers will vary.*

### St. George, Utah, Earthquake Data

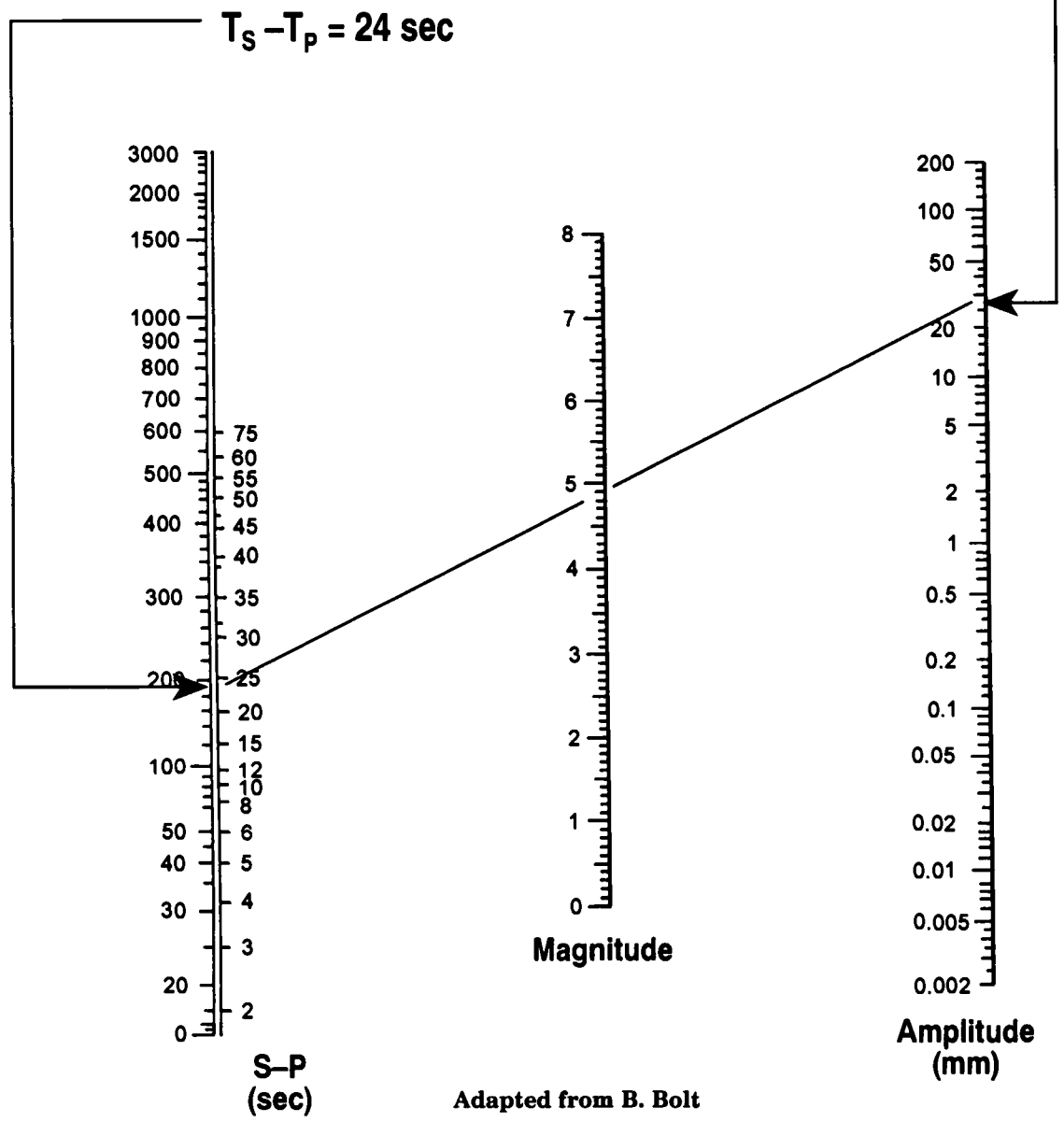
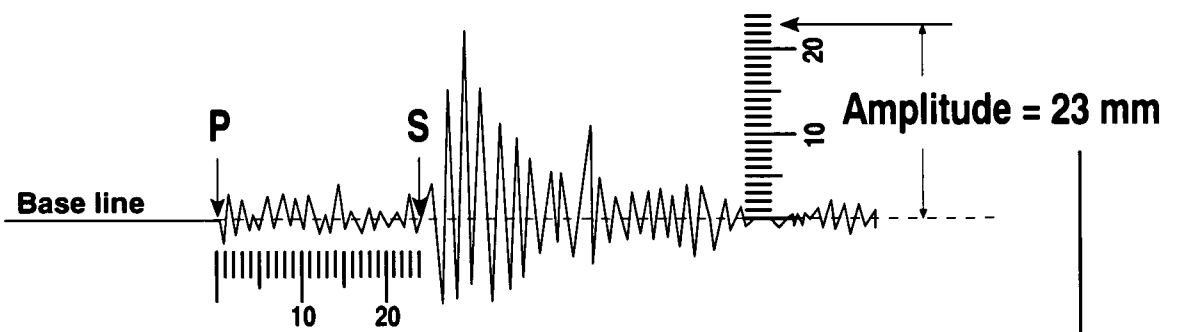
September 2, 1992 10:26 UTC

Location: 37 ° 5.4 ' N latitude, 113 ° 28.3' W longitude

Final Magnitude: 5.8

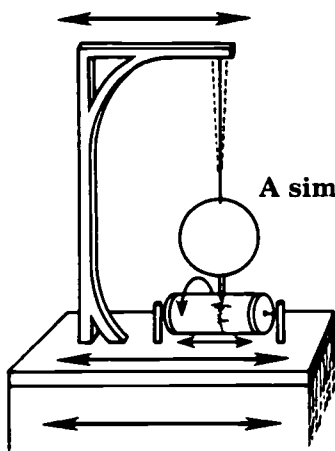
(Determined by University of Utah based on readings from 18 stations.)

# Distance, Magnitude, Amplitude



Adapted from B. Bolt

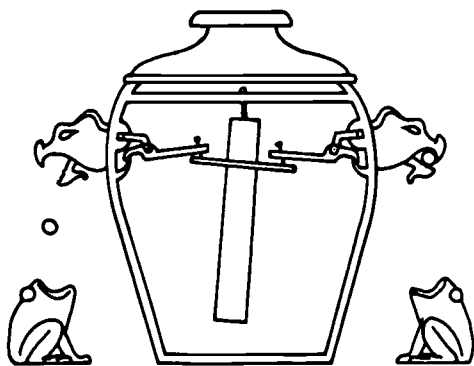
## Several Seismographs



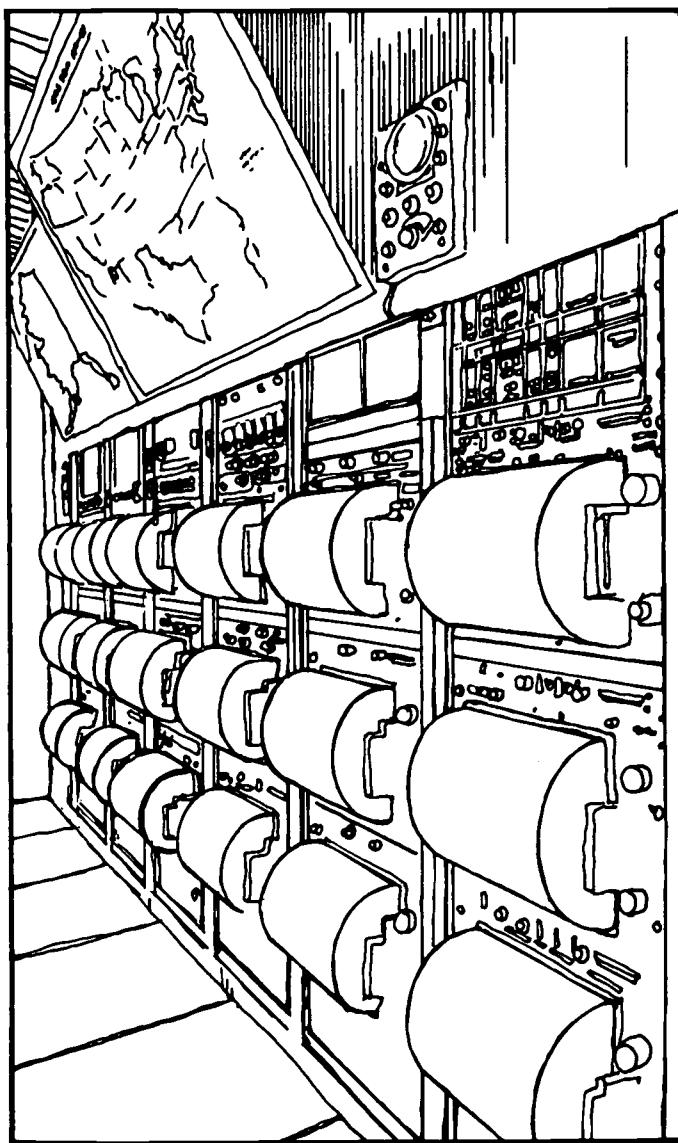
A simple pendulum seismograph



Chinese seismoscope, 132 A.D. The direction in which the first ball fell was thought to indicate the direction of the epicenter.



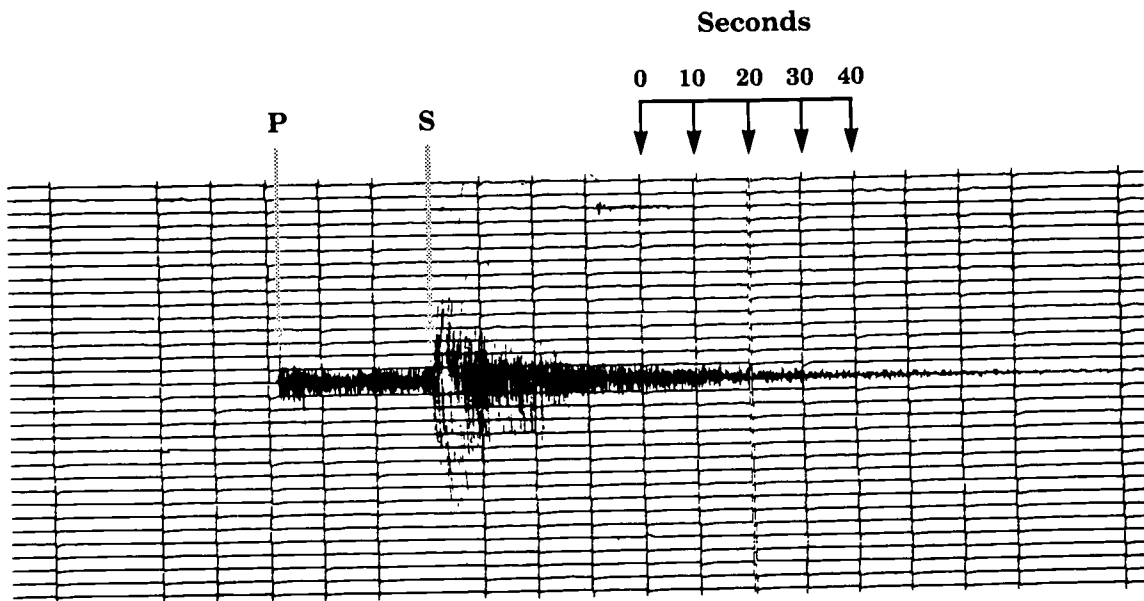
Inside view



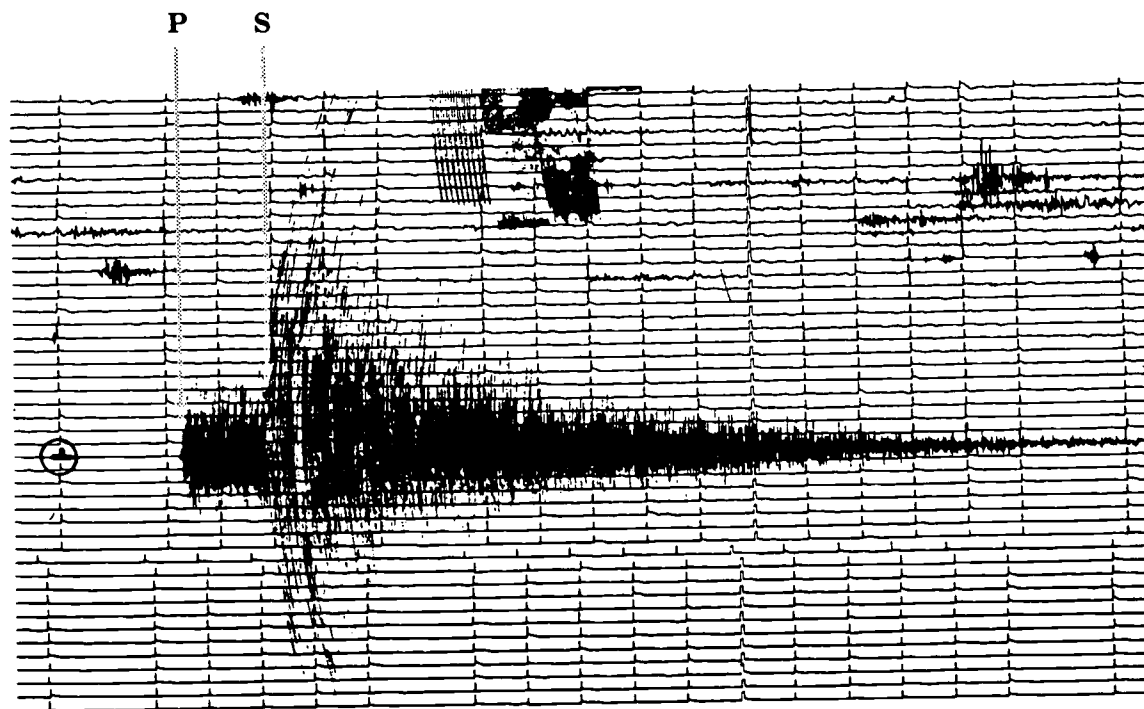
Modern seismographs



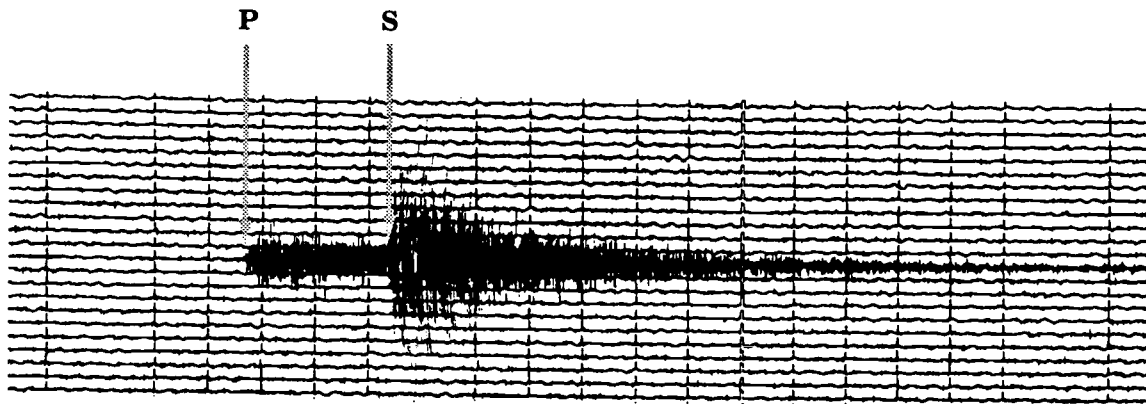
Name \_\_\_\_\_ Date \_\_\_\_\_



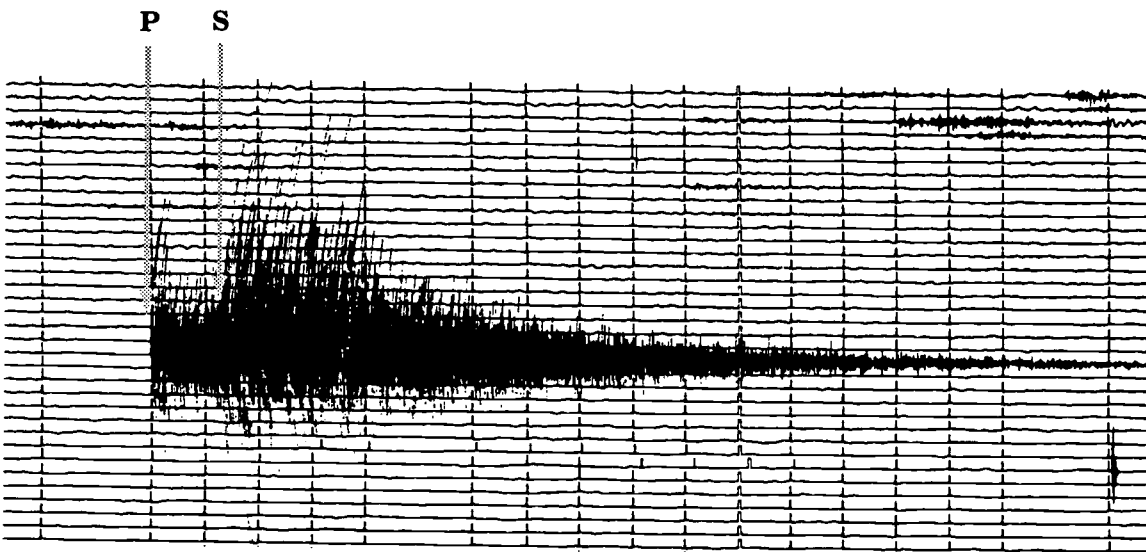
**TRYN**  
S-P ~ 30 sec  
Distance ~  
240 km



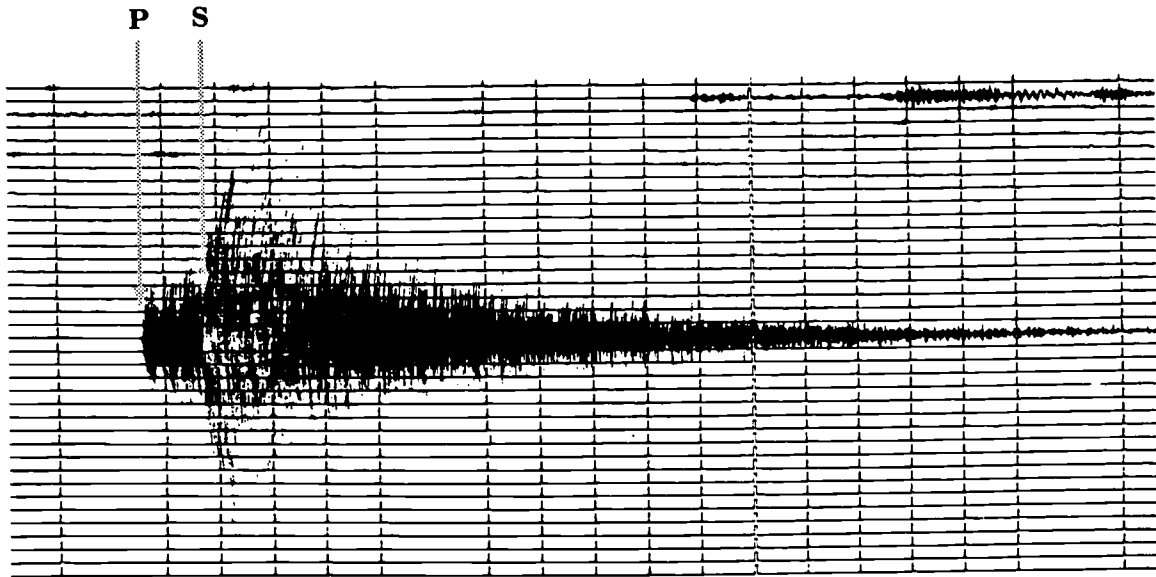
**TKL**



FGTN



BBG



BHT

Note: Seismogram source: Center for Earthquake Research and Information, Memphis State University.

STATION	$T_p$	$T_s$	$T_s - T_p$	DISTANCE
TRYN	2 sec	32 sec	30 sec	240 km
TKL				
FGTN				
BBG				
BHT				



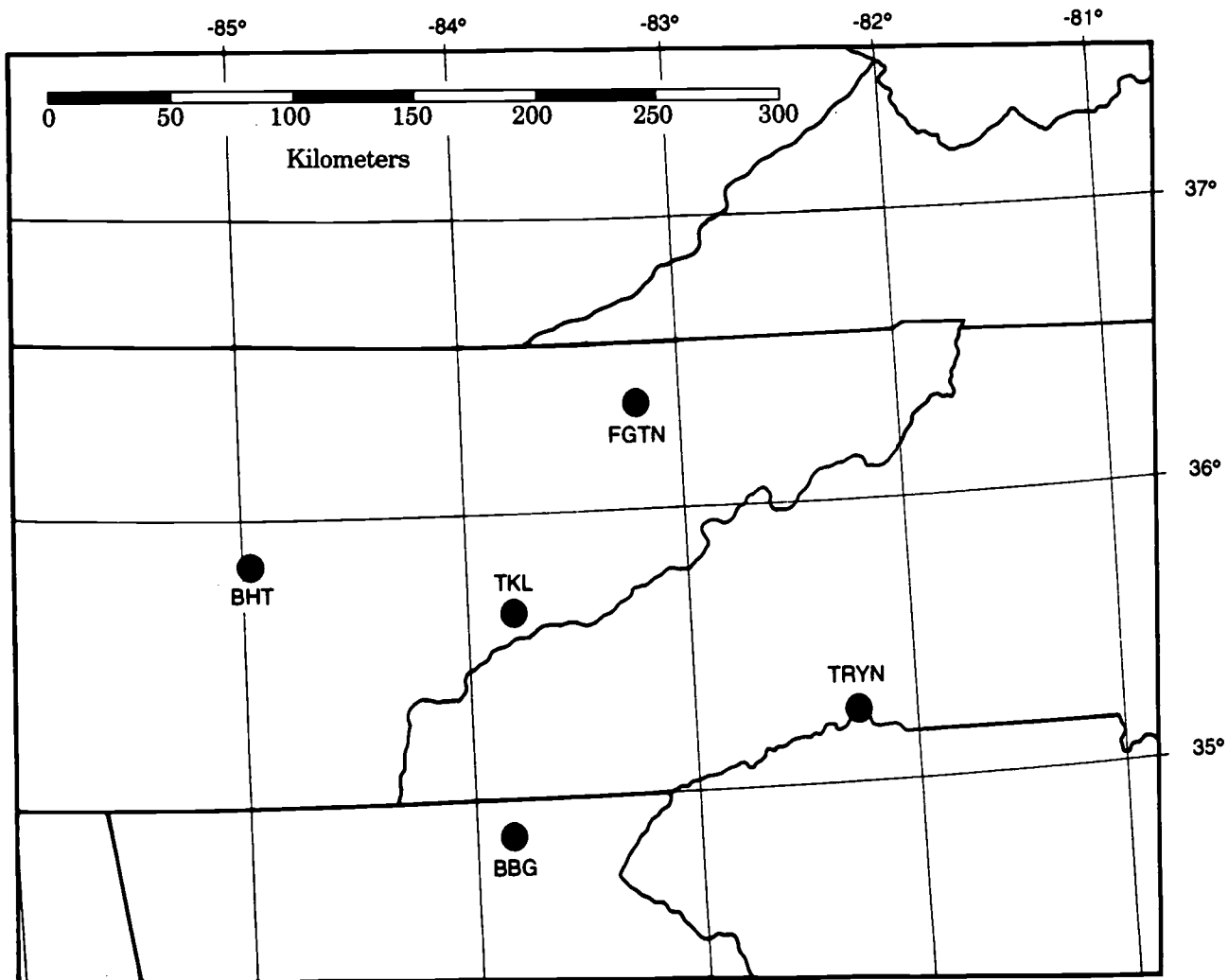
# Sample Seismograms (key)

STATION	S-P	DISTANCE (kilometers)	RADIUS OF ARC IN MM (assuming 1mm=3km)	
TRYN	30	240		80
TKL	15	120		40
FGTN	27	216		72
BBG	12	96		32
BHT	11	88		29

*Note: Answers will vary.*

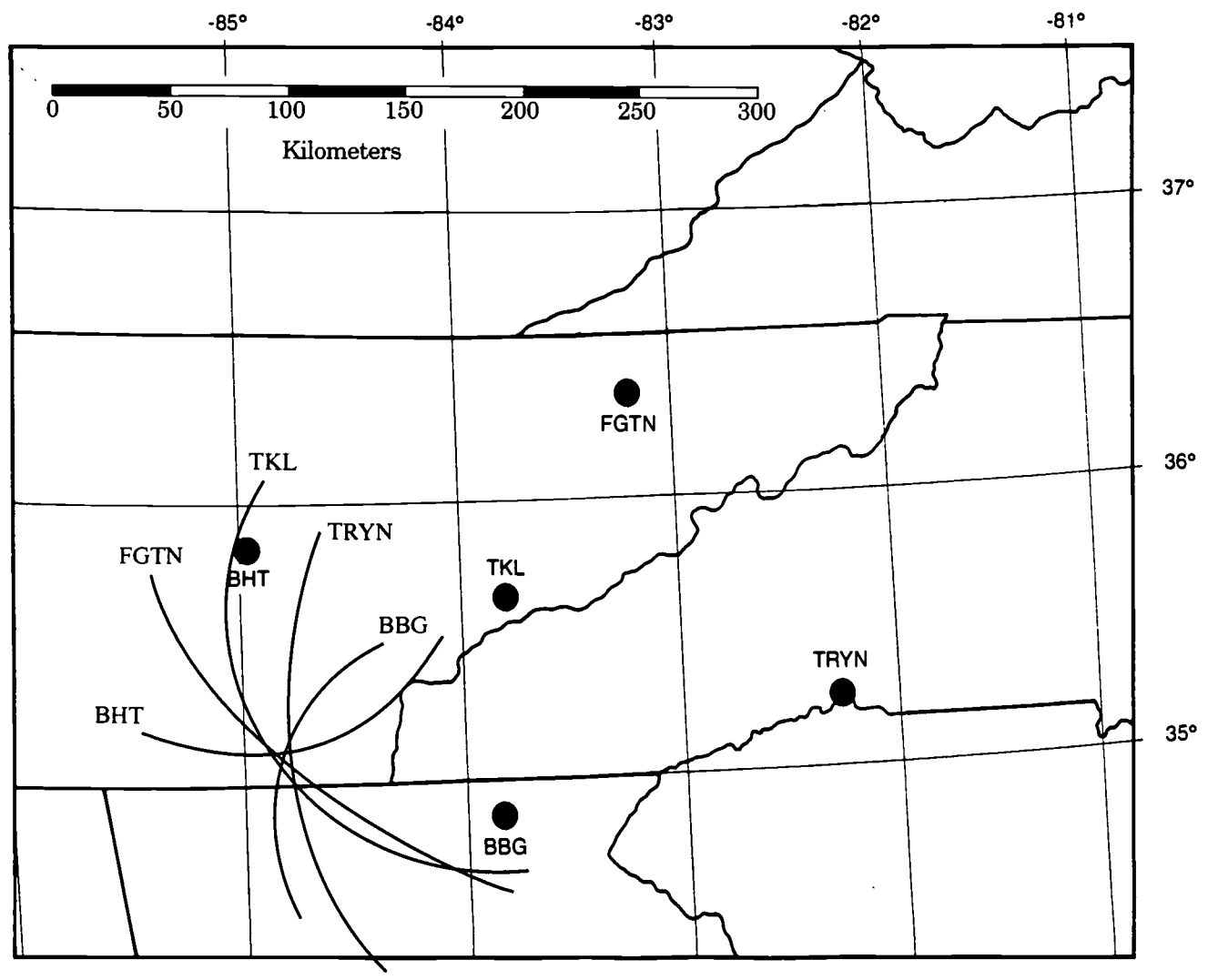
# Map of Station Locations

Name \_\_\_\_\_ Date \_\_\_\_\_

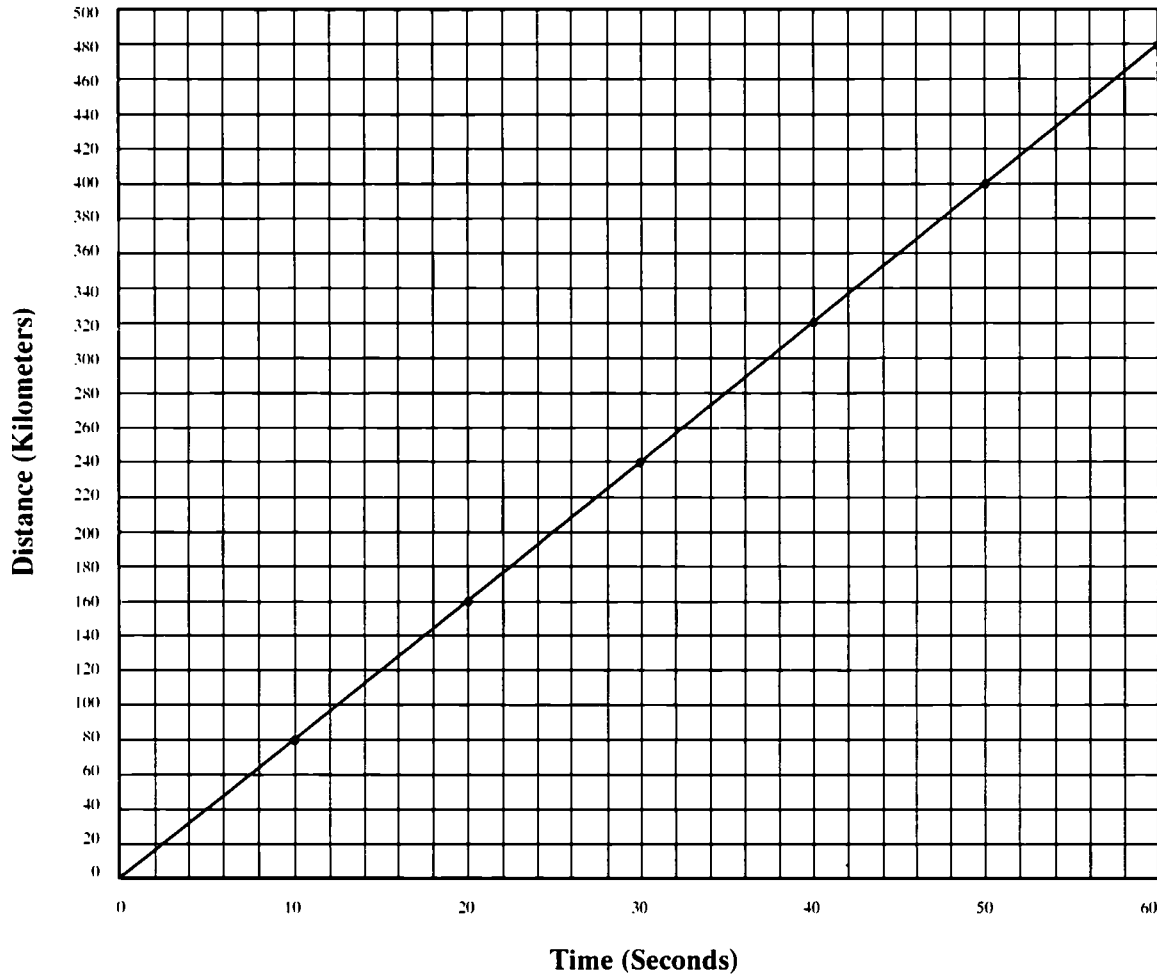




# Map of Station Locations (key)



*Note: Answers will vary.*



The slope of this line is based on the equation

$$(T_s - T_p) \times 8 = D$$

**Examples**

$$(60 - 50) \times 8 = 80$$

$$(60 - 40) \times 8 = 160$$

$$(60 - 30) \times 8 = 240$$

$$(60 - 20) \times 8 = 320$$

$$(60 - 10) \times 8 = 400$$

180

# Distribution of EARTHQUAKES

## ACTIVITY ONE

### WHERE IN THE WORLD?

#### RATIONALE

Knowing where earthquakes occur will allow students to formulate theories about what causes earthquakes and why earthquakes occur more commonly in particular locations.

#### FOCUS QUESTIONS

Where have earthquakes been known to occur?  
Do earthquakes occur randomly, or mainly in specific areas?

#### OBJECTIVES

##### Students will:

1. Locate and plot the epicenters of earthquakes by latitude and longitude.
2. Recognize a pattern in the distribution of most earthquakes.
3. Postulate how the occurrence of earthquakes may be related to plate tectonic activity.
4. Postulate how deep earthquakes may be related to plate tectonic activity.

#### MATERIALS

- Student copies of Master 3.4a, Earthquakes of the Day, Tables 1–8 (one set of eight, plus extras as needed)
- One copy of Master 3.4b, Notable World Earthquakes, 1900–1992
- Eight copies of Master 3.4c, World Map (2 pages)
- Scissors and transparent tape
- Atlases, globes, or geography textbooks with detailed maps
- Pencils or pens, both black and red
- Four transparencies made from each page of Master 3.4c, World Map.

#### VOCABULARY



**Epicenter:** the point on Earth's surface directly above the location (focus) of the earthquake below the surface.

**Focus (pl. foci):** the point within the Earth that is the origin of an earthquake, where stored energy is first released as wave energy.

**Latitude:** the location of a point north or south of the equator, expressed in degrees and minutes. Latitude is shown on a map or globe as east-west lines parallel to the equator.

**Longitude:** the location of a point east or west of the prime meridian, expressed in degrees and minutes. Longitude is shown on a map or globe as north-south lines left and right of the prime meridian, which passes through Greenwich, England.

#### TEACHING CLUES AND CUES



Do not reduce the map to one page. The scale will be too small to be of use.

- Three black transparency markers and three red ones
- Overhead projector
- Student copies of Master 2.2e, World Map Grid (key)

## **PROCEDURE**

### **Teacher Preparation**

Borrow a number of globes and/or atlases in addition to the ones you keep in the classroom, so students can locate cities and countries as they plot latitude and longitude.

### **A. Introduction**

Briefly review the system of latitude and longitude and how these coordinates are used to pinpoint geographic locations. Ask the students what country or region of the world they think has the largest number of earthquakes in any given year. Note their answers on the chalkboard or on poster paper, but do not comment. Tell them that in this activity they will be working with real earthquake data.

### **B. Lesson Development**

1. Divide students into eight roughly equal groups. Distribute one of the eight tables in Master 3.4a, Earthquakes of the Day, to each group. Explain that each of the tables lists the earthquakes that occurred around the world on one day; all were recorded on the monthly listing from the U.S. Department of the Interior/U.S. Geological Survey, Preliminary Determinations of Epicenters. Give Master 3.4b, Notable World Earthquakes, to the group with Table 1 (1/1/90), along with one blank transparency.

2. Give each group a copy of Master 3.4c, World Map. Have students cut and tape the two pages together. Do not reduce to one page. Students in each group may take turns finding the epicenters and marking the maps.

3. Instruct students to distinguish the locations of earthquakes below 40 km from the more common shallow earthquakes by drawing rings around the dots that represent them with the red pencil or pen.

4. Distribute the other three transparency maps and markers to the three groups that complete their work first. Instruct students in each group to transfer the positions on their maps onto the transparency, using the black and red markers as above, and write the dates of the earthquakes depicted on the map. As each group completes its work it may pass the transparency on to another group until all the earthquakes from all nine tables have been recorded on the three transparencies.

5. Instruct the group working with Master 3.4b to plot those earthquakes on their separate transparency and label it.

6. Collect the transparency maps. Stack the three depicting earthquakes of the day (Tables 1–8) on the projector so that they are displayed simultaneously. Then distribute copies of Master 2.2e, the key to the World Map Grid from lesson 2.2.

## **TEACHING CLUES AND CUES**



If your class is very large, you may want to give each group more than one copy of the tables and the map so students can work in smaller subgroups.

## **TEACHING CLUES AND CUES**



Do not reduce the map to one page. The scale will be too small to be of use.

182

7. Ask students to compare the world map you have just distributed with the stacked transparencies. Ask:

- Can you detect any relationship between the locations of earthquakes below 40 km and the outlines of Earth's plates? (These earthquakes occur under the continents on the landward side of plate boundaries.)
- Do all the earthquakes occur at or near plate boundaries? (Some earthquakes occur in places that seem unrelated to plate boundaries.)
- Were any of the students correct in judging where earthquakes occur most frequently, at the beginning of class?

8. Ask students to note how earthquakes are distributed among the four geographic areas: north latitude/west longitude, north latitude/east longitude, south latitude/west longitude, and south latitude/east longitude. Ask them to speculate on the reasons for this distribution. (The northeast quadrant has the highest concentration of quakes. The main portion of the Ring of Fire is in this quadrant.)

9. Remind students that the eight tables represent earthquakes that occurred on just eight days. Ask them to count the total number of quakes and estimate how many earthquakes occur each year. (Students should calculate that more than 15,000 significant earthquakes occur each year.)

10. Ask students where the world's most powerful earthquakes have occurred. Record their hypotheses, then place the transparency of Master 3.4b on top of the others as a check. Ask students to predict where major earthquakes will occur in the future.

### C. Conclusion

Sum up in a discussion. Ask the class:

- Are people who live near the boundaries of major tectonic plates the only ones who have to worry about earthquakes? Why or why not? (No. The majority of earthquakes occur along plate boundaries, but some quakes do occur within the plates.) Invite students to speculate about the causes of intraplate earthquakes and faulting.
- Does the amount of damage an earthquake does depend only on its magnitude? (No. Population density, soil conditions, building types, and other factors determine the amount of damage. Students will learn more about these factors in subsequent units.)

### ADAPTATIONS AND EXTENSIONS

1. Obtain copies of Preliminary Determinations of Epicenters and have students plot other kinds of data on fresh copies of the map, such as:

- a. Earthquakes having magnitudes greater than magnitude 5 for (1) the world; (2) a particular region of the country, or (3) a particular state or local area.
- b. Earthquakes that have caused the greatest damage or loss of life.

### TEACHING CLUES AND CUES



Don't tell students how to calculate the total; challenge them to find a way. One procedure is for each group to report the numbers on its map (Tables 1 through 8), then for students to add the numbers and average them. The average of 42 quakes a day, multiplied by 365, yields a figure of 15,630.

## ACTIVITY TWO

### THE PLOT THICKENS: PLOTTING EARTHQUAKE FOCI IN THREE DIMENSIONS

#### RATIONALE

This activity graphically illustrates the patterns in the distribution of earthquake foci in one relatively small area.

#### FOCUS QUESTION

What would the pattern of earthquakes in one region look like if it could be observed in three dimensions over a period of time?

#### OBJECTIVE

Students will plot location and depth for one group of earthquakes and observe their relationships.

#### MATERIALS

*for the teacher*

- One copy of Master 3.4d, Central Japan (2 pages, left and right)
- Stiff cardboard, 30 cm x 60 cm (1 ft. x 2 ft.)
- Phillips screwdriver to punch holes for hanging
- Four pieces of cord or other support (See Teacher Preparation.)
- Glue or transparent tape
- Wall map of Japan or student atlases

*for each small group*

- One copy of Master 3.4d, Central Japan (2 pages, left and right)
- One copy of Master 3.4e, Selected Earthquakes Since 1980, Japan
- Pencils, pens, and metric rulers
- Transparent tape
- Small craft beads such as 12 mm or 8 mm
- Dental floss or other strong, fine string
- Scissors
- One size 8-d nail

#### PROCEDURE

##### Teacher Preparation

Use a copier to enlarge the two-part map until it can cover most of the cardboard. Glue or tape the map to the top side of the cardboard. Attach cord to the four corners and hang it from the ceiling, or rest it on supports above the floor at a height that will be about eye level for most students. Make standard-size copies of the two-part map for desk use.

#### VOCABULARY



**Epicenters:** the point on Earth's surface directly above the focus of an earthquake.

**Focus (pl. foci):** the point within the Earth that is the origin of an earthquake, where strain energy is first released as wave energy.

**Magnitude:** a number that characterizes the size of an earthquake by recording ground shaking on a seismograph and correcting for the distance to the epicenter of the earthquake. Magnitude is expressed in Arabic numbers.

## A. Introduction

Tell students that earthquakes occur in many locations and at different depths. The study of earthquakes has provided most of what we now know about the Earth's structure. The patterns of their locations provided much of the evidence that led geologists to hypothesize the existence of plates.

## B. Lesson Development

1. Divide the class into the same groups as for Activity One of this lesson. Give each group one copy of Master 3.4d, Central Japan (two pages, left and right) and Master 3.4e, Selected Earthquakes Since 1980, Japan. Instruct students to cut the left page of Master 3.4d along the dotted line and tape it to the right page.

2. Divide the list of earthquakes into as many equal sections as you have student groups, and assign one section to each group. It is not necessary to use all the earthquakes. (If you have eight groups, each will be responsible for 10 quakes.) Instruct students to begin plotting their assigned quakes from Master 3.4e on the map of Japan by latitude and longitude, then mark each epicenter with its reference number, depth, and magnitude. Point out that 10 small squares on their maps represent one degree of longitude and one degree of latitude.

3. When the first group has located all the quakes on its own section of the list, it can transfer those locations to the hanging map. Other groups can follow as they complete their sections. Give these instructions for transferring data to the hanging map:

- a. For each earthquake, take two beads of the same color. Use one bead to represent the epicenter of each quake and the other bead to represent its focus.
- b. Locate the latitude and longitude of the first quake on the hanging map. Mark its epicenter and punch a hole all the way through the cardboard with the nail. Thread dental floss through the small bead and tie a knot to hold the bead at the correct location. Calculate the distance below the map at which the large ball will be hung (the depth of the focus) by letting 1 cm stand for 5 km. The bead representing earthquake #1 will hang 2 cm below its epicenter. Tie knots to hold the beads in place.
- c. Repeat this procedure until all the quakes have been plotted on the map. When students have finished, invite them to view this 3-D plot from many directions.

4. Ask:

- What pattern do you see? Where do the earthquakes concentrate? (on the lower right)
- What do you think is happening to the Earth's crust in this area? (Old crust is being broken off and pushed under the edges of the plate, in the process geologists call subduction.)

## TEACHING CLUES AND CUES



Deep-focus earthquakes produce seismograms very different from those produced by shallow-focus earthquakes. EPIC and some of the other non-print media sources listed in the resources for Units 2 and 3 can provide examples of both for you to show your students.

### C. Conclusion

Call students' attention to the atlas or wall map of Japan. Ask them if they view the map differently now that they can see what it represents in three dimensions. What kind of information would clarify their view further?

## ACTIVITY THREE

### WHERE IN NORTH AMERICA?

#### RATIONALE

---

By plotting earthquake epicenters on a map, students will learn where earthquakes occur on the North American continent and that they can occur almost anywhere.

#### FOCUS QUESTIONS

---

Where in North America do earthquakes occur?

How often do earthquakes occur in specific locations on the North American continent?

#### OBJECTIVES

---

**Students will:**

1. Interpret data tables and plot locations on a map.
2. Discover that most areas are prone to earthquakes.

#### MATERIALS

---

- Master 3.4f, North American Epicenters, 1990
- Classroom wall map of North America or transparency made from Master 3.4g, Map of North America
- Overhead projector
- Transparency markers in red, green, and blue
- Three transparencies made from Master 3.4g, Map of North America

*for each small group*

- Student copies of Master 3.4g, Map of North America
- One strip of earthquake epicenters cut from Master 3.4f
- Pencils or pens

#### PROCEDURE

---

**Teacher Preparation**

Make a copy of Master 3.4f. Cut it into as many horizontal sections as you have groups, dividing the list of epicenters so each group has approximately the same number of earthquakes to plot.



## A. Introduction

From the other activities in this lesson, students have discovered where earthquakes occur worldwide and how seismologists locate them. Ask the class where earthquakes occur on the North American continent. Most of them will probably name California. Accept this, but try to elicit other locations as well. Some may be aware of the New Madrid, Missouri, earthquakes in the 19th century, or of other earthquakes close to home.

Remind students that earthquakes sometimes occur where volcanoes are present. Ask: Where on the North American Continent are volcanoes found? Students will probably identify the western United States. Tell them that at one time volcanoes erupted in the eastern part of the continent. The famous Palisades, a line of steep cliffs along the Hudson River in New York and New Jersey, were caused by volcanic activity. Tell students that in this activity they will use selected data from the U. S. Geological Survey to plot the locations of earthquakes of magnitude 4 or larger that occurred during 1990 on the North American continent.

## B. Lesson Development

1. Divide the class into groups of three or four students each.
2. Distribute copies of Master 3.4g, the blank map, and the epicenter strips. Review latitude and longitude if necessary.
3. Have students plot the locations of the epicenters on their maps. Give these directions:
  - a. As you locate each point, mark it with a small dot. Then write the depth and magnitude of the earthquake next to it in small numbers.
  - b. When you finish, transfer your data to one of the three transparencies of Master 3.4g, using the colored pens to code for magnitude. Green will represent magnitude 4, blue magnitude 5, and red magnitude 6 or greater. Mark each earthquake with an X in the appropriate color.
4. When all the data have been plotted, stack the transparencies on the overhead so you can display them simultaneously. Ask students to comment on the pattern they observe, and compare it with their findings in Activity One. Do they see a similar pattern? They should see once again that earthquakes occur primarily near plate boundaries (for the U.S., on the west coast) but are not limited to those areas. Is there a pattern to the depth of the earthquakes? (The deepest quakes occur at plate margins under continents. This pattern may not be evident in this data.)

## C. Conclusion

Remind students that these data are for one year only, and only for earthquakes of magnitude 4 or greater. Have them discuss what they would need to prepare an earthquake risk map for building codes or insurance rates. (The obvious answer will be more data, but point out to students some of the things they have already learned

## TEACHING CLUES AND CUES



In the EPIC Data Base, times are given in 24-hour Universal Time (UT) and carried out to eight places—210117.90, for example, which would be approximately 9:01 pm. In Master 3.4f they have been shortened to four places (2101).

about earthquakes, such as how waves travel through the Earth, and tell them that in later lessons they will learn about engineering to improve structural resistance to earthquakes.)

### **ADAPTATIONS AND EXTENSIONS**

---

1. Obtain a copy of the EPIC software (free demonstration files are available) or the EPIC CD-ROM, and have students research earthquakes of different magnitudes and different locations. See the unit resource list.
2. Have students contact the National Earthquake Information Center (NEIC) and report back to class on data and services available. See the Unit 2 resource list.
3. Have students contact the Incorporated Research Institutions for Seismology (IRIS) and report back to class on data and services available. See the Unit 2 resource list.
4. The NEIC and IRIS maintain remote bulletin boards. Have students find out how to access them and research earthquakes. ▲

**Table 1. Earthquakes That Occurred on January 1, 1990  
as listed in "Preliminary Determinations of Epicenters," USGS-NEIC**

Time*	Latitude	Longitude	Depth (in km)	Magnitude**	Location
<b>North Latitudes and West Longitudes</b>					
0:22	62 N	150 W	39	2.9	Southern Alaska
1:10	16 N	63 W	33	3.6	Leeward Islands
13:22	37 N	122 W	15	2.6	California
18:03	7 N	73 W	158	5.3	Colombia
22:59	33 N	115 W	4	3.2	California/Mexico
23:17	38 N	119 W	11	3.1	California
23:29	52 N	179 W	33	4.4	Aleutian Islands
<b>North Latitudes and East Longitudes</b>					
2:47	36 N	27 E	145	3.3	Dodecanese Islands
3:25	44 N	7 E	10	1.6	Northern Italy
6:34	42 N	19 E	10	3.3	Albania
9:03	36 N	141 E	68	4.8	East coast, Honshu Japan
9:30	40 N	29 E	10	-	Turkey
16:20	43 N	13 E	10	-	Italy
16:38	47 N	10 E	5	3.1	Switzerland
17:13	50 N	174 E	33	4.6	Aleutian Islands
18:19	45 N	7 E	10	2.3	Italy
18:25	44 N	9 E	10	-	Italy
18:36	35 N	51 E	10	-	Iran
18:46	44 N	8 E	10	1.7	Italy
19:04	40 N	29 E	5	-	Turkey
19:50	44 N	7 E	10	1.7	Italy
<b>South Latitudes and West Longitudes</b>					
7:49	22 S	179 W	600	5.2	Fiji Islands region
9:38	24 S	180 W	541	4.8	South of Fiji Islands
19:31	33 S	72 W	10	-	Off coast, Chile
<b>South Latitudes and East Longitudes</b>					
14:10	9 S	107 E	32	4.7	South of Java
14:49	11 S	161 E	37	5.2	Solomon Islands
16:07	7 S	125 E	527	5.2	Banda Sea
17:21	19 S	167 E	10	5.2	New Hebrides

\*Greenwich time.

\*\*Value is the maximum magnitude determined for the event. A dash indicates that data were not available.

Table 2. Earthquakes That Occurred on January 2, 1990 as listed in "Preliminary Determinations of Epicenters," USGS-NEIC

Time*	Latitude	Longitude	Depth (in km)	Magnitude**	Location
<b>North Latitudes and West Longitudes</b>					
6:30	43 N	1 W	10	1.0	Pyrenees
8:01	37 N	122 W	10	2.5	California
9:50	34 N	117 W	13	3.4	California
11:41	63 N	150 W	109	-	Alaska
12:13	61 N	146 W	32	-	Alaska
12:54	62 N	151 W	55	-	Alaska
13:50	43 N	1 W	10	1.2	Pyrenees
17:45	37 N	115 W	5	3.1	Nevada
22:09	46 N	111 W	1	3.7	Montana
<b>North Latitudes and East Longitudes</b>					
0:15	44 N	7 E	10	1.6	Italy
1:25	8 N	127 E	41	5.4	Philippine Islands
4:10	45 N	7 E	10	1.6	Italy
6:26	23 N	121 E	10	-	Taiwan
08:23	40 N	27 E	10	-	Turkey
13:23	36 N	146 E	33	-	Off coast, Honshu Japan
15:20	8 N	127 E	69	4.4	Philippine Islands
16:26	45 N	146 E	73	4.6	Kuril Islands
16:44	44 N	7 E	10	1.9	France
17:50	39 N	28 E	10	-	Turkey
18:50	48 N	17 E	10	2.1	Austria
20:21	13 N	144 E	136	5.7	Mariana Islands
20:35	39 N	24 E	10	4.6	Aegean Sea
20:43	44 N	7 E	10	1.7	Italy
21:03	39 N	24 E	10	-	Greece
21:38	41 N	79 E	10	4.9	Xinjiand, China
21:46	36 N	27 E	5	3.6	Dodecanese Islands
22:36	44 N	7 E	10	1.7	Italy
22:54	43 N	28 E	13	-	Bulgaria
22:57	44 N	7 E	10	1.7	Italy
23:24	37 N	26 E	26	4.4	Dodecanese Islands
<b>South Latitudes and West Longitudes</b>					
2:19	22 S	13 W	10	4.7	Atlantic Ridge
6:44	25 S	70 W	33	-	Chile
12:14	31 S	69 W	10	-	Argentina
20:51	33 S	72 W	10	4.7	Off coast, Chile
<b>South Latitudes and East Longitudes</b>					
1:36	38 S	175 E	249	-	New Zealand
2:27	12 S	122 E	33	4.1	Sulu Sea
4:33	3 S	146 E	33	4.6	Bismarck Sea
7:02	19 S	169 E	243	4.7	New Hebrides
7:36	11 S	166 E	140	4.7	Santa Cruz Islands
8:22	6 S	146 E	33	5.1	Near Papua, New Guinea
15:34	3 S	129 E	33	4.7	Ceram Sea
21:38	3 S	128 E	34	5.4	Ceram Sea

\*Greenwich time.

\*\*Value is the maximum magnitude determined for the event. A dash indicates that data were not available.

**Table 3. Earthquakes That Occurred on January 1, 1991 as listed in "Preliminary Determinations of Epicenters," USGS-NEIC**

Time*	Latitude	Longitude	Depth (in km)	Magnitude**	Location
<b>North Latitudes and West Longitudes</b>					
0:06	18 N	106 W	35	6.6	Off coast, Mexico
2:19	18 N	106 W	33	5.0	Off coast, Mexico
3:19	18 N	106 W	36	5.9	Off coast, Mexico
10:28	39 N	120 W	12	3.4	California/Nevada
15:50	55 N	158 W	33	5.2	Alaska
16:59	61 N	152 W	97	-	Alaska
17:21	4 N	76 W	97	3.5	Colombia
19:49	4 N	76 W	10	2.6	Colombia
<b>North Latitudes and East Longitudes</b>					
0:11	35 N	28 E	42	4.9	Dodecanese Islands
3:51	43 N	19 E	10	4.0	Yugoslavia
4:18	40 N	24 E	10	-	Greece
4:50	29 N	139 E	402	4.4	South Honshu, Japan
5:53	44 N	19 E	13	2.8	Yugoslavia
7:29	48 N	8 E	10	2.6	Switzerland
7:30	41 N	23 E	10	-	Greece
8:25	38 N	22 E	10	2.8	Greece
9:26	38 N	22 E	19	2.8	Greece
10:42	23 N	144 E	25	5.2	Volcano Islands
12:01	43 N	19 E	10	2.0	Yugoslavia
12:06	36 N	141 E	58	5.1	Off coast, Honshu Japan
12:14	1 N	126 E	78	4.4	Molucca Passage
14:03	39 N	15 E	28	-	Adriatic Sea
14:25	43 N	19 E	10	2.2	Yugoslavia
16:31	37 N	30 E	10	-	Turkey
17:43	43 N	22 E	10	2.1	Yugoslavia
19:18	43 N	22 E	10	1.9	Yugoslavia
19:18	40 N	48 E	61	4.9	Iran—Northern border
19:28	48 N	8 E	10	2.2	Switzerland
19:55	41 N	23 E	10	1.8	Macedonia
19:55	40 N	29 E	10	2.8	Turkey
20:40	5 N	96 E	66	4.6	Sumatra
23:57	37 N	71 E	33	4.2	Afghanistan—N.W. border
<b>South Latitudes and West Longitudes</b>					
2:03	10 S	78 W	33	4.2	Off coast, Peru
8:27	29 S	70 W	121	4.9	Chile/Argentina
11:15	15 S	172 W	33	4.9	Samoa Islands
16:42	17 S	69 W	188	4.4	Peru/Bolivia
17:28	21 S	174 W	29	5.7	Tonga Islands
20:40	20 S	177 W	487	5.1	Fiji Islands
<b>South Latitudes and East Longitudes</b>					
3:03	19 S	134 E	10	-	Australia
5:09	7 S	156 E	41	4.9	Solomon Islands
14:10	17 S	177 E	33	4.4	Fiji Islands
21:37	3 S	38 E	10	4.2	Kenya

\*Greenwich time.

\*\*Value is the maximum magnitude determined for the event. A dash indicates that data were not available.

Table 4. Earthquakes That Occurred on January 2, 1991 as listed in "Preliminary Determinations of Epicenters," USGS-NEIC

Time*	Latitude	Longitude	Depth (in km)	Magnitude**	Location
<b>North Latitudes and West Longitudes</b>					
1:27	4 N	76 W	33	3.1	Colombia
1:42	3 N	75 W	33	3.7	Colombia
5:31	37 N	119 W	2	3.1	California/Nevada
5:37	14 N	93 W	59	4.8	Off coast, Mexico
8:30	6 N	74 W	10	-	Colombia
10:16	59 N	137 W	9	-	Alaska
12:07	39 N	120 W	7	3.5	Nevada
12:16	39 N	120 W	2	2.3	Nevada
12:26	39 N	120 W	8	3.4	Nevada
12:46	39 N	120 W	6	3.4	Nevada
14:38	4 N	77 W	33	3.1	Coast of Colombia
16:29	39 N	120 W	3	3.8	Nevada
16:59	62 N	150 W	41	-	Alaska
17:21	4 N	76 W	10	4.2	Colombia
19:49	4 N	76 W	110	2.8	Colombia
21:02	3 N	80 W	33	2.1	Galapagos Islands
21:17	4 N	76 W	10	2.7	Colombia
22:19	66 N	26 W	10	4.9	Iceland
23:16	39 N	120 W	6	4.7	Nevada
23:23	37 N	4 W	10	2.4	Spain
23:44	39 N	120 W	10	3.5	Nevada
<b>North Latitudes and East Longitudes</b>					
0:13	43 N	29 E	10	-	Black Sea
1:08	40 N	20 E	10	2.9	Greece/Albania
1:34	59 N	161 E	33	4.5	Coast, Kamchatka
2:48	53 N	161 E	33	4.5	Coast, Kamchatka
2:58	38 N	100 E	13	5.1	Qinghai, China
5:37	43 N	21 E	10	2.4	Yugoslavia
7:17	30 N	21 E	5	3.5	Greece
8:37	48 N	155 E	33	4.4	Kuril Islands
9:35	40 N	29 E	10	2.7	Turkey
12:16	41 N	22 E	10	-	Greece
12:51	43 N	6 E	10	2.8	France
12:59	41 N	23 E	10	-	Greece
14:02	40 N	28 E	10	2.8	Turkey
14:04	41 N	22 E	10	-	Albania
15:48	40 N	29 E	10	2.7	Turkey
18:48	46 N	3 E	10	2.2	France
20:29	45 N	1 E	10	3.0	France
23:16	39 N	24 E	10	2.8	Aegean Sea
23:19	24 N	121 E	10	3.6	Taiwan
<b>South Latitudes and West Longitudes</b>					
1:48	22 S	69 W	33	-	Chile/Bolivia
4:54	18 S	79 W	115	-	Coast of Chile
15:16	23 S	66 W	10	-	Argentina
16:58	20 S	71 W	46	5.0	Coast of Chile
18:30	34 S	179 W	33	4.7	Kermadec Islands
<b>South Latitudes and East Longitudes</b>					
3:50	11 S	167 E	33	5.0	Santa Cruz

\*Greenwich time.

\*\*Value is the maximum magnitude determined for the event. A dash indicates that data were not available.

Table 5. Earthquakes That Occurred on January 1, 1992 as listed in "Preliminary Determinations of Epicenters," USGS-NEIC

Time*	Latitude	Longitude	Depth (in km)	Magnitude**	Location
<b>North Latitudes and West Longitudes</b>					
1:11	41 N	124 W	5	3.0	California
5:35	20 N	70 W	33	-	Dominican Republic
9:09	35 N	118 W	10	3.2	California
13:43	60 N	154 W	168	3.4	Alaska
14:28	37 N	119 W	5	2.9	California/Nevada
16:44	16 N	61 W	33	2.8	Leeward Islands
17:03	36 N	118 W	5	3.0	California
17:10	38 N	4 W	10	2.9	Spain
19:15	15 N	92 W	10	-	Mexico/Guatemala
20:39	60 N	153 W	101	-	Alaska
21:11	13 N	90 W	33	-	Off El Salvador
22:30	71 N	8 W	10	4.2	Jan Meyer Islands
23:46	18 N	99 W	10	-	Mexico
23:55	39 N	1 W	5	2.7	Spain
<b>North Latitudes and East Longitudes</b>					
0:50	45 N	7 E	10	2.1	Italy
5:54	54 N	159 E	92	4.3	Kamchatka
7:47	45 N	151 E	29	4.9	Kuril Islands
8:00	43 N	18 E	10	2.6	NW Balkan region
8:03	68 N	15 E	10	3.6	Norway
8:13	45 N	152 E	33	4.7	East of Kuril Islands
8:38	68 N	15 E	10	2.6	Norway
8:41	43 N	13 E	10	-	Italy
10:07	43 N	19 E	10	1.9	NW Balkan region
10:12	45 N	10 E	10	3.4	Italy
10:15	68 N	15 E	10	2.5	Norway
10:30	42 N	19 E	10	1.2	NW Balkan region
11:28	43 N	2 E	10	3.2	Pyrenees
11:38	45 N	10 E	10	-	Italy
14:45	42 N	20 E	5	2.2	NW Balkan region
15:18	43 N	18 E	8	4.3	NW Balkan region
16:34	38 N	7 E	10	3.9	Mediterranean Sea
16:38	14 N	96 E	33	4.1	Near Andaman Islands
16:40	44 N	10 E	10	2.7	Italy
17:32	41 N	24 E	5	-	Greece
21:23	45 N	11 E	18	2.6	Italy
21:35	43 N	19 E	10	1.7	NW Balkan region
21:46	26 N	100 E	33	4.4	Yunnan, China
22:01	43 N	18 E	5	2.4	NW Balkans
<b>South Latitudes and West Longitudes</b>					
3:32	34 S	71 W	70	3.4	Chile/Argentina
5:38	19 S	69 W	106	4.9	Chile
11:04	34 S	71 W	33	3.2	Chile
17:49	34 S	72 W	10	3.4	Chile
19:45	24 S	174 W	33	4.5	Tonga Islands
22:46	23 S	179 W	600	4.4	So. of Fiji Islands
23:43	22 S	178 W	366	4.9	So. of Fiji Islands
<b>South Latitudes and East Longitudes</b>					
15:30	8 S	155 E	370	4.4	Solomon Islands

\*Greenwich time.

\*\*Value is the maximum magnitude determined for the event. A dash indicates that data were not available.

**Table 6. Earthquakes That Occurred on January 2, 1992 as listed in "Preliminary Determinations of Epicenters," USGS-NEIC**

Time*	Latitude	Longitude	Depth (in km)	Magnitude**	Location
<b>North Latitudes and West Longitudes</b>					
0:05	54 N	161 W	33	4.6	Alaska
6:10	18 N	61 W	10	3.4	Leeward Islands
7:42	35 N	119 W	10	2.3	California
11:41	62 N	150 W	45	3.1	Alaska
11:45	33 N	105 W	5	5.0	New Mexico
13:32	11 N	63 W	109	4.4	Venezuela
14:13	65 N	134 W	10	3.8	Yukon
16:05	62 N	146 W	34	3.1	Alaska
16:40	49 N	129 W	10	6.0	West of Vancouver Island
18:12	16 N	61 W	55	4.4	Leeward Islands
19:16	11 N	64 W	33	3.9	Coast of Venezuela
19:41	6 N	74 W	134	5.8	Colombia
21:29	16 N	60 W	22	2.9	Leeward Islands
22:09	49 N	129 W	10	3.9	West of Vancouver Island
<b>North Latitudes and East Longitudes</b>					
0:05	51 N	98 E	45	4.7	Russia/Mongolia
2:15	44 N	6 E	7	3.0	France
2:35	34 N	89 E	33	4.8	Tibet/China
4:07	51 N	98 E	32	4.7	Russia/Mongolia
5:28	51 N	98 E	33	-	Russia/Mongolia
5:37	41 N	71 E	33	5.2	Tajkistan
5:50	41 N	72 E	33	4.5	Kyrgyzstan
6:09	46 N	2 E	10	1.4	France
6:36	37 N	29 E	10	-	Turkey
8:09	41 N	20 E	5	2.9	Albania
10:20	46 N	27 E	137	-	Romania
10:49	45 N	152 E	33	4.7	East of Kuril Islands
12:30	45 N	10 E	25	3.5	Italy
12:59	51 N	98 E	33	4.6	Russia/Mongolia
13:44	45 N	10 E	27	3.5	Italy
17:06	35 N	27 E	63	3.9	Crete
19:59	13 N	125 E	33	4.9	Philippine Islands
21:17	0 N	122 E	167	4.7	Celebes
22:06	50 N	98 E	33	-	Russia/Mongolia
23:13	45 N	146 E	110	4.5	Kuril Islands
23:55	39 N	1 E	10	-	Spain
<b>South Latitudes and West Longitudes</b>					
1:47	34 S	70 W	10	4.3	Chile/Argentina
4:25	33 S	71 W	10	3.3	Chile
23:21	27 S	68 W	33	-	Chile/Argentina
<b>South Latitudes and East Longitudes</b>					
3:28	6 S	150 E	59	4.4	New Britain
4:49	7 S	151 E	51	4.8	New Britain
6:17	9 S	150 E	33	4.1	New Guinea
7:41	6 S	150 E	33	4.3	New Britain
22:17	22 S	180 E	673	4.6	So. of Fiji Islands
23:33	32 S	111 E	33	-	West of Australia
23:37	38 S	176 E	238	-	New Zealand

\*Greenwich time.

\*\*Value is the maximum magnitude determined for the event. A dash indicates that data were not available.



**Table 7. Earthquakes That Occurred on January 1, 1993  
as listed in "Preliminary Determinations of Epicenters," USGS-NEIC**

Time*	Latitude	Longitude	Depth (in km)	Magnitude**	Location
<b>North Latitudes and West Longitudes</b>					
2:09	36 N	5 W	10	2.9	Strait of Gibraltar
4:12	60 N	153 W	10	3.1	Alaska
5:08	36 N	82 W	4	3.0	North Carolina
5:36	31 N	114 W	10	3.6	Gulf of California
6:07	18 N	64 W	10	4.0	Virgin Islands
14:55	64 N	149 W	6	2.8	Alaska
15:57	48 N	112 W	5	3.4	Montana
<b>North Latitudes and East Longitudes</b>					
1:35	39 N	29 E	10	2.7	Turkey
2:05	39 N	29 E	10	2.8	Turkey
2:23	4 N	126 E	86	4.4	Talau Islands
4:18	39 N	22 E	10	-	Greece
4:30	53 N	158 E	170	4.2	Kamchatka
5:35	38 N	15 E	10	-	Sicily
5:40	43 N	6 E	10	2.4	Coast of France
5:43	44 N	8 E	10	-	Italy
7:30	39 N	29 E	10	2.8	Turkey
8:19	39 N	143 E	37	4.7	Coast of Japan
14:25	38 N	27 E	10	3.1	Turkey
16:11	42 N	20 E	10	2.7	Albania
18:46	42 N	14 E	10	3.8	Italy
19:16	45 N	7 E	10	2.0	Italy
20:49	38 N	27 E	10	3.1	Aegean Sea
21:00	43 N	5 E	10	3.6	Coast of France
21:26	3 N	122 E	536	4.4	Celebes Sea
21:46	35 N	33 E	13	3.4	Cyprus region
23:49	23 N	95 E	96	4.3	India/Myanmar
<b>South Latitudes and West Longitudes</b>					
3:46	32 S	178 W	33	5.1	Kermadec Islands
4:02	32 S	68 W	100	-	Argentina
4:34	31 S	179 W	48	4.7	Kermadec Islands
5:48	28 S	177 W	65	4.7	Kermadec Islands
8:26	33 S	176 W	33	4.7	So. of Kermadec Islands
9:17	32 S	69 W	120	3.5	Argentina
9:56	32 S	72 W	27	5.4	Chile
10:06	36 S	74 W	100	4.0	Chile
13:09	25 S	178 W	203	5.2	So. of Fiji Islands
17:29	31 S	68 W	10	-	Argentina
<b>South Latitudes and East Longitudes</b>					
2:56	26 S	28 E	5	2.5	Rep. of So. Africa
5:00	7 S	128 E	33	-	Banda Sea
5:19	7 S	131 E	68	4.6	Banda Sea
6:24	6 S	147 E	74	4.7	New Guinea
8:58	7 S	144 E	23	5.2	New Guinea
10:56	7 S	132 E	122	-	Indonesia
12:35	39 S	177 E	59	4.4	New Zealand
12:48	38 S	179 E	182	-	New Zealand
21:36	67 S	164 E	10	5.6	Balleny Islands

\*Greenwich time.

\*\*Value is the maximum magnitude determined for the event. A dash indicates that data were not available.

**Table 8. Earthquakes That Occurred on January 2, 1993  
as listed in "Preliminary Determinations of Epicenters," USGS-NEIC**

Time*	Latitude	Longitude	Depth (in km)	Magnitude**	Location
<b>North Latitudes and West Longitudes</b>					
1:57	7 N	76 W	24	4.5	Colombia
2:39	7 N	80 W	10	4.3	So. of Panama
5:45	19 N	67 W	19	-	Mona Passage
6:03	18 N	66 W	70	-	Puerto Rico
6:39	45 N	111 W	5	3.5	Yellowstone, WY
6:44	10 N	83 W	10	3.8	Panama/Costa Rica
7:09	61 N	150 W	41	2.5	Alaska
8:54	62 N	151 W	72	-	Alaska
9:49	60 N	153 W	122	-	Alaska
14:32	39 N	124 W	3	3.1	California
<b>North Latitudes and East Longitudes</b>					
1:48	39 N	29 E	10	3.1	Turkey
2:32	39 N	29 E	10	2.6	Turkey
3:42	31 N	50 E	33	4.3	Iran
7:55	44 N	6 E	10	2.2	Coast of France
8:39	30 N	51 E	36	4.7	Iran
14:53	29 N	81 E	15	4.9	Nepal
15:10	34 N	142 E	44	4.6	Coast of Japan
17:45	37 N	24 E	33	3.3	Greece
22:09	46 N	3 E	10	1.9	France
22:38	41 N	23 E	10	-	Greece
<b>South Latitudes and West Longitudes</b>					
3:09	31 S	69 W	132	-	Chile/Argentina
4:04	30 S	177 W	10	4.9	Kermadec Islands
6:15	33 S	71 W	80	3.1	Chile/Argentina
11:35	34 S	71 W	33	4.2	Chile
13:40	34 S	71 W	60	3.3	Chile
14:31	33 S	72 W	25	3.4	Chile
15:00	33 S	72 W	10	3.1	Chile
16:24	33 S	71 W	33	3.5	Chile
17:48	29 S	67 W	161	-	Argentina
<b>South Latitudes and East Longitudes</b>					
1:07	38 S	176 E	253	-	New Zealand
4:55	9 S	121 E	84	4.5	Savu Sea
6:29	40 S	86 E	10	5.5	SE Indian Ridge
9:30	7 S	129 E	173	3.8	Banda Sea
9:49	9 S	123 E	150	4.3	Indonesia
11:12	39 S	176 E	142	-	New Zealand
12:32	38 S	176 E	224	5.0	New Zealand
17:56	6 S	151 E	54	4.1	New Britain
19:01	7 S	130 E	33	-	Banda Sea
19:29	39 S	175 E	249	-	New Zealand

\*Greenwich time.

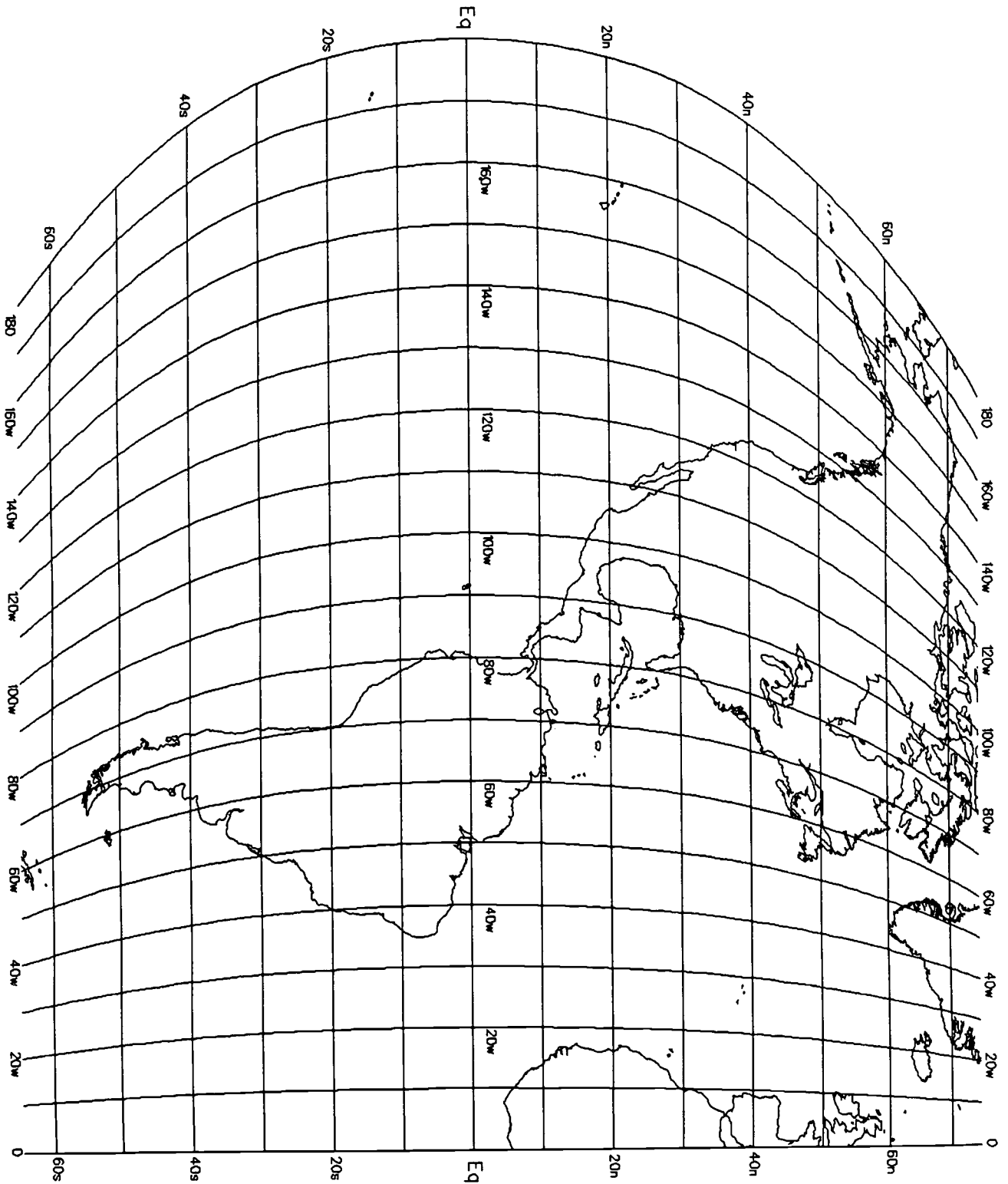
\*\*Value is the maximum magnitude determined for the event. A dash indicates that data were not available.

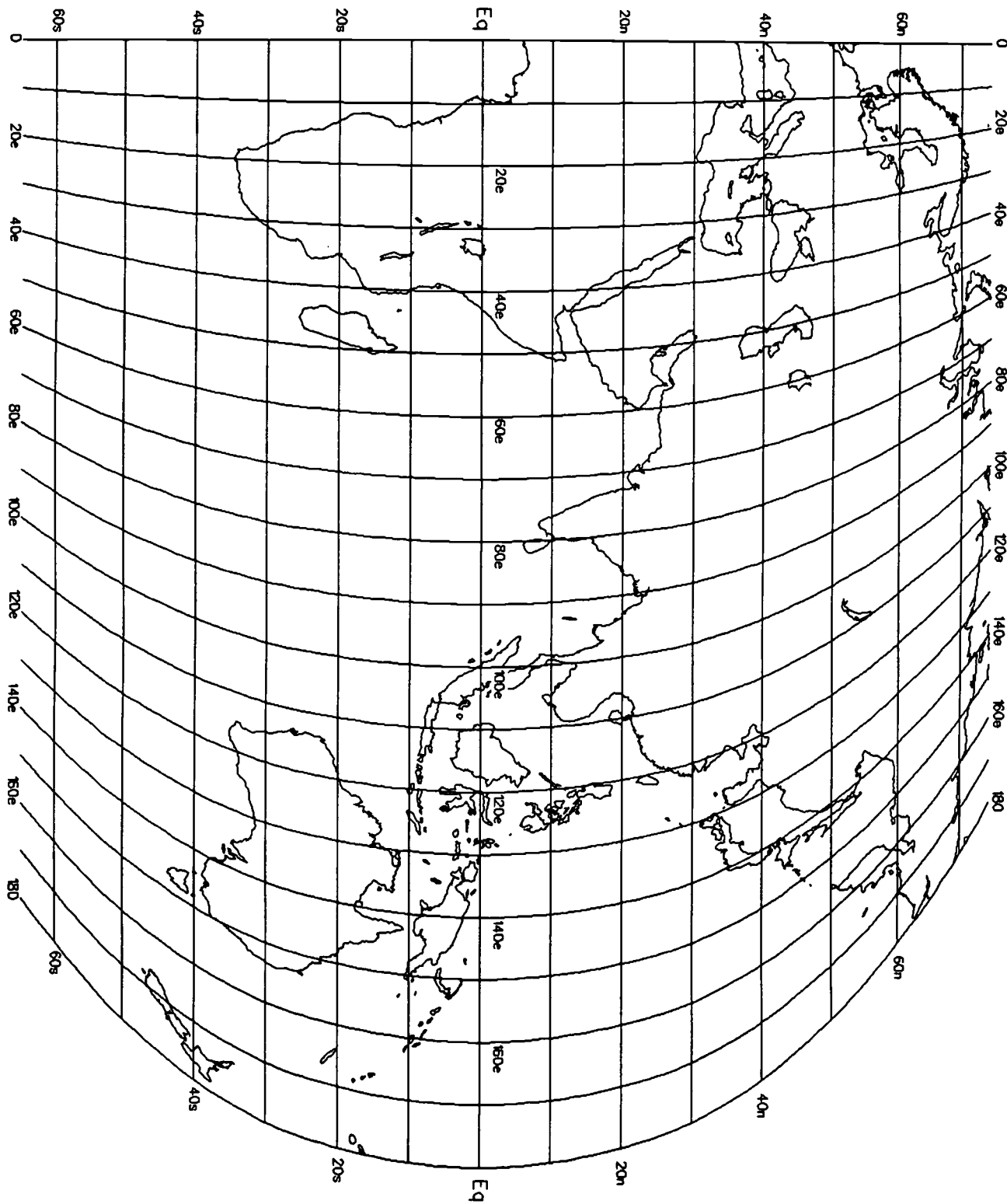
# Notable World Earthquakes 1900-1992\*

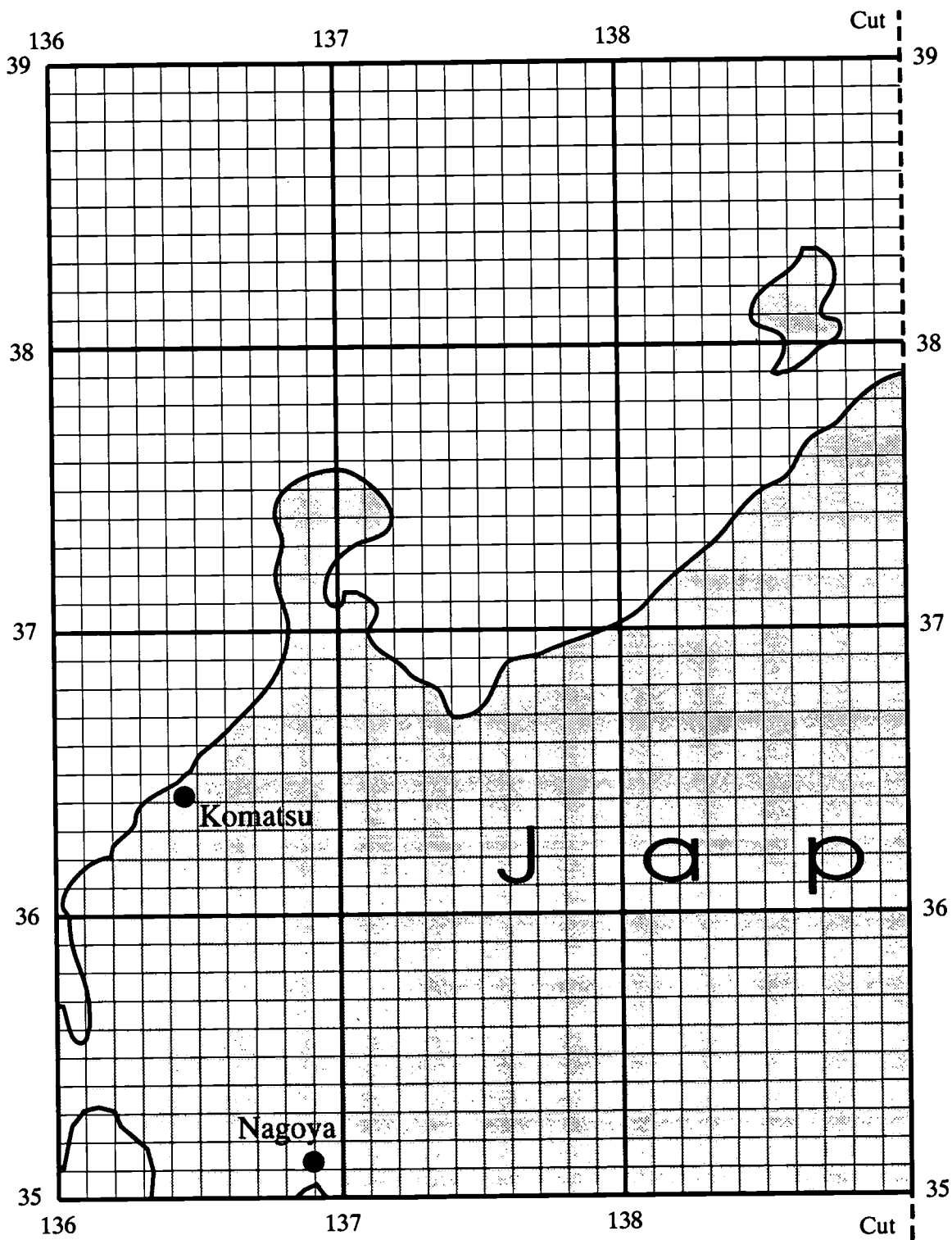
Time	Latitude	Longitude	Depth (in km)**	Magnitude	Location	Deaths
<b>North Latitudes and West Longitudes</b>						
4/18/06	38 N	123 W	-	8.3	San Francisco, CA	700
2/29/60	30 N	10 W	-	5.9	Morocco	14,000
3/28/64	61 N	148 W	33	8.5	Alaska	131
2/9/71	34 N	118 W	13	6.7	San Fernando, CA	65
12/23/72	12 N	86 W	5	6.2	Nicaragua	5,000
2/4/76	15 N	89 W	5	7.5	Guatemala	22,000
9/19/85	18 N	103 W	-	8.1	Mexico	9,500
10/10/86	14 N	89 W	8	5.4	El Salvador	1,000
3/6/87	0 N	78 W	33	6.9	Ecuador	1,000
10/18/89	37 N	122 W	19	7.1	Loma Prieta, CA	63
6/28/92	34 N	117 W	-	7.1	Landers, CA	1
<b>North Latitudes and East Longitudes</b>						
12/28/08	38 N	15 E	-	7.5	Messina, Italy	120,000
1/13/15	42 N	13 E	-	7.5	Central Italy	30,000
12/16/20	37 N	106 E	-	8.5	China	180,000
9/1/23	35 N	140 E	-	8.2	Kwanio, Japan	143,000
12/25/32	40 N	97 E	-	7.6	China	
12/26/39	40 N	40 E	-	8.0	Turkey	23,000
6/28/48	36 N	136 E	20	7.3	Honshu, Japan	5,121
9/1/62	36 N	50 E	20	7.3	Iran	14,000
7/26/63	42 N	22 E	5	6.0	Macedonia	1,200
8/31/68	34 N	59 E	13	7.3	Iran	11,600
2/4/75	41 N	123 E	33	7.4	China	"Few"
5/6/76	46 N	13 E	9	6.5	Italy	
7/14/76	40 N	118 E	23	7.8	Tangshan, China	250,000
3/3/77	46 N	27 E	94	7.2	Romania	2,000
10/10/80	36 N	1 E	10	7.4	Algeria	
11/23/80	41 N	15 E	10	6.9	Italy	3,000
6/11/81	30 N	58 E	33	6.9	Iran	3,000
7/28/81	30 N	58 E	33	7.3	Iran	1,500
5/28/83	41 N	139 E	24	7.8	Japan	107
10/30/83	40 N	42 E	33	6.9	Turkey	1,342
8/20/88	27 N	87 E	71	6.6	Nepal	1,450
11/6/88	23 N	100 E	10	7.6	Burma	730
12/7/88	41 N	44 E	10	6.8	Armenia	25,000
6/20/90	38 N	50 E	10	7.6	Iran	<40,000
7/16/90	16 N	121 E	36	7.7	Philippines	1,700
<b>South Latitudes and West Longitudes</b>						
1/25/39	36 S	72 W	60	8.3	Chillan, Chile	30,000
8/6/49	2 S	78 W	60	6.8	Ecuador	6,000
5/22/60	40 S	73 W	-	8.5	Chile	5,700
5/31/70	9 S	79 W	43	7.8	Peru	66,000
12/12/79	2 S	79 W	32	7.9	Ecuador	600
3/3/85	33 S	72 W	-	7.8	Chile	177
<b>South Latitudes and East Longitudes</b>						
8/5/49	2 S	119 E	3	8.0	Indonesia	3
8/1/89	5 S	139 E	33	5.9	New Guinea	90
12/27/89	33 S	152 E	15	5.4	Australia	13

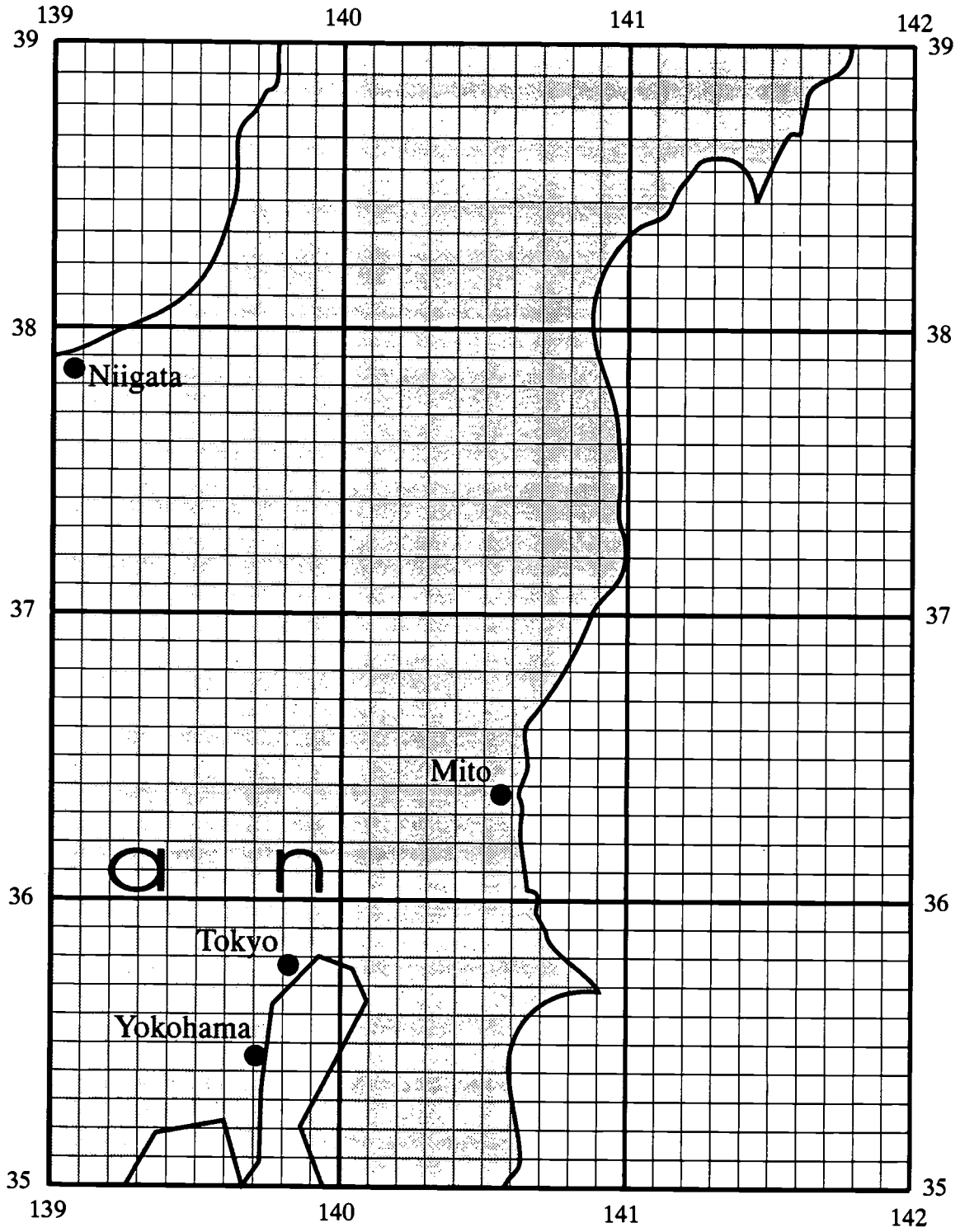
\* From Bolt, 1993, and "Catalog of Significant Earthquakes 2000 B.C.- 1990," a NOAA publication in preparation.

\*\* Where data are lacking, assume earthquakes were shallow.









201

# Selected EARTHQUAKES

## Since 1980, Japan

This is a listing of events of Magnitude 5 which occurred in the polygon bounded by 34N 144E, 38N 134E, 39N 136E, and 35N 146E, centered around Tokyo, Japan. Data are from 1980 to 1993. Use the reference number in the first column (under the heading Evt, for Event) to mark the location of each earthquake on your map.

Evt	Mo	Da	Hr	Min	Yr	Lat	Long	Dpth	Mag	#Stns
1	12	7	9	38	90	37.22 N	138.48 E	10	5.4	179
2	12	30	0	38	86	36.66 N	137.89 E	10	5.5	260
3	2	7	13	27	93	37.63 N	137.25 E	11	6.6	673
4	8	9	0	46	82	35.67 N	142.02 E	13	5.5	293
5	8	26	15	43	85	36.21 N	142.35 E	13	5.5	267
6	7	23	17	54	82	36.10 N	141.89 E	14	6.2	499
7	2	15	16	51	93	37.61 N	137.26 E	15	5.0	117
8	12	7	9	40	90	37.31 N	138.46 E	15	5.1	64
9	10	16	10	39	83	37.19 N	137.91 E	17	5.1	93
10	4	8	4	34	89	36.38 N	141.96 E	21	5.0	67
11	3	24	12	49	87	37.44 N	137.86 E	23	5.7	339
12	12	13	10	13	90	35.50 N	140.93 E	23	5.0	59
13	7	23	15	5	82	36.19 N	141.97 E	24	5.1	169
14	5	22	13	31	82	35.22 N	141.22 E	25	5.0	51
15	10	18	3	22	85	37.64 N	136.90 E	25	5.9	546
16	8	6	14	49	91	35.72 N	141.04 E	29	5.9	404
17	5	9	16	51	87	36.22 N	141.89 E	30	5.2	365
18	7	16	10	8	90	36.12 N	141.35 E	33	5.0	108
19	5	18	15	31	81	37.02 N	137.71 E	35	5.4	28
20	1	6	18	52	88	36.38 N	141.80 E	36	5.0	172
21	7	25	9	10	82	36.21 N	142.03 E	36	5.0	86
22	8	23	16	40	82	36.35 N	141.48 E	36	5.8	273
23	7	23	14	23	82	36.19 N	141.70 E	37	6.8	271
24	9	3	19	39	81	35.29 N	141.08 E	37	5.7	378
25	2	10	16	23	87	35.58 N	143.01 E	38	5.2	114
26	10	4	4	11	81	35.23 N	140.96 E	38	5.0	85
27	7	25	8	1	82	36.41 N	141.79 E	39	5.5	454
28	1	17	11	13	84	36.44 N	141.22 E	40	5.6	218
29	11	28	22	29	86	36.34 N	141.17 E	41	5.7	272
30	2	11	17	46	90	36.33 N	140.91 E	46	5.4	228
31	12	8	17	23	89	36.55 N	140.91 E	47	5.4	235
32	1	29	2	44	83	36.70 N	141.51 E	50	5.1	166
33	3	11	3	1	85	36.41 N	141.01 E	50	5.8	179
34	8	6	5	58	85	36.44 N	141.03 E	50	5.3	307
35	8	15	16	58	82	36.49 N	141.03 E	50	5.4	223
36	10	2	0	32	83	36.46 N	141.18 E	50	5.1	145
37	1	27	1	30	87	35.57 N	140.94 E	51	5.1	277
38	7	23	14	29	82	36.37 N	141.24 E	51	5.3	87
39	9	2	9	24	81	35.82 N	141.02 E	51	5.6	443
40	9	13	1	20	81	36.14 N	141.17 E	51	5.0	218
41	3	16	0	45	84	36.76 N	141.56 E	52	5.0	179
42	6	4	21	11	84	36.45 N	141.18 E	52	5.0	157
43	12	1	16	15	80	35.90 N	140.95 E	52	5.0	118
44	1	3	10	2	88	35.33 N	140.88 E	53	5.0	67

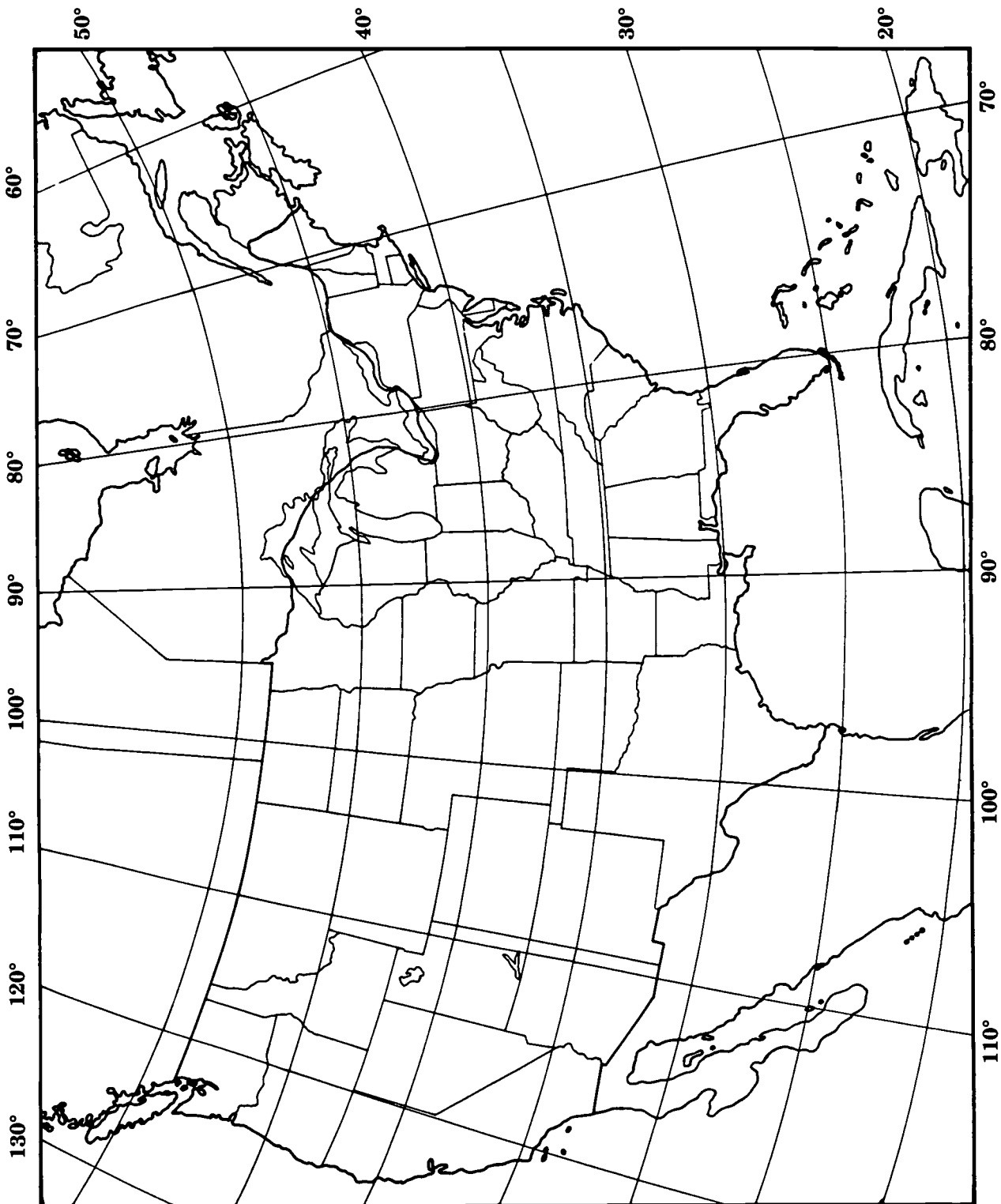


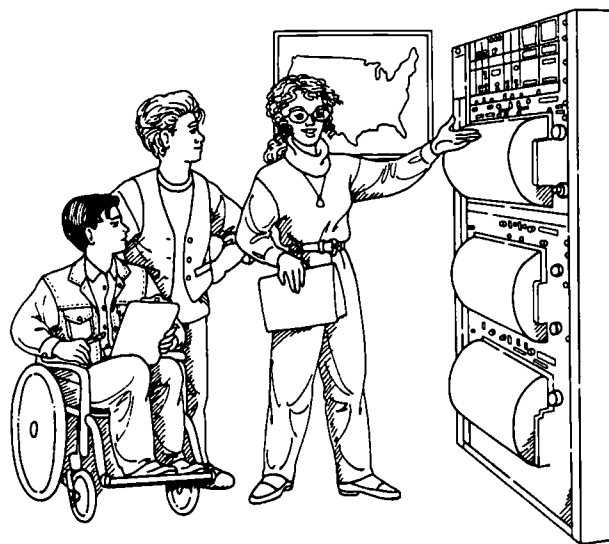
**M A S T E R P A G E**

45	8	13	21	14	82	36.53 N	141.11 E	55	5.4	381
46	4	14	3	3	92	36.17 N	139.78 E	57	5.0	158
47	9	2	3	5	83	36.68 N	141.01 E	57	5.2	227
48	12	30	2	30	83	35.69 N	140.66 E	58	5.4	378
49	5	11	10	7	92	36.46 N	140.52 E	59	5.2	208
50	8	13	21	15	82	36.45 N	140.93 E	59	5.4	194
51	2	13	10	1	87	36.64 N	140.96 E	60	5.1	324
52	2	19	12	27	88	35.96 N	139.78 E	60	5.5	287
53	9	10	15	25	83	35.60 N	140.64 E	60	5.0	45
54	2	3	10	11	88	36.57 N	141.13 E	62	5.0	22
55	6	25	3	49	91	36.60 N	140.88 E	62	5.0	147
56	8	27	4	9	92	36.11 N	139.81 E	63	5.0	132
57	5	3	7	45	90	36.44 N	140.51 E	64	5.4	269
58	6	10	2	0	80	35.89 N	139.55 E	64	5.1	64
59	10	15	2	58	83	36.11 N	139.81 E	64	5.1	52
60	5	28	17	58	92	35.63 N	140.52 E	65	5.0	131
61	9	20	3	4	86	36.47 N	140.70 E	66	5.1	252
62	1	7	18	18	83	36.07 N	139.87 E	67	5.1	168
63	6	1	1	22	90	35.52 N	140.33 E	67	5.8	367
64	6	29	22	9	84	36.17 N	139.79 E	67	5.4	22
65	7	26	4	30	84	36.17 N	139.98 E	67	5.0	88
66	12	5	19	47	84	36.41 N	140.66 E	67	5.0	82
67	2	21	23	23	81	36.47 N	140.72 E	68	5.0	146
68	3	6	23	14	82	36.48 N	140.61 E	68	5.6	386
69	4	10	10	59	87	36.12 N	139.81 E	68	5.1	287
70	6	30	9	17	87	36.17 N	139.98 E	70	5.0	159
71	10	28	1	50	83	36.21 N	139.98 E	70	5.2	247
72	3	10	0	37	87	36.44 N	140.83 E	76	5.1	122
73	2	27	12	14	83	35.93 N	140.08 E	78	5.9	566
74	4	17	7	33	87	35.72 N	140.07 E	78	5.1	324
75	10	10	6	28	88	35.56 N	140.10 E	78	5.0	152
76	7	3	18	3	90	35.92 N	140.04 E	79	5.1	139
77	12	17	14	49	84	35.57 N	140.09 E	81	5.1	204
78	2	21	11	51	84	36.15 N	140.09 E	83	5.1	241
79	10	4	12	25	85	35.84 N	140.09 E	83	6.2	648
80	9	23	19	10	80	35.98 N	139.78 E	88	5.4	362
81	11	9	23	37	82	36.57 N	140.62 E	111	5.0	72
82	7	14	14	19	91	36.41 N	138.33 E	188	5.2	102
83	9	18	21	42	88	37.15 N	136.96 E	262	5.1	276
84	5	17	1	4	90	37.06 N	136.88 E	267	5.2	340
85	3	11	22	22	84	38.39 N	135.48 E	351	5.3	307

203

MO.	DAY	TIME (UTC)	LAT. (N)	LONG. (W)	DEPTH (KM)	MAGNITUDE
01	11	0122	35.22	118.22	4	4.1
01	13	0547	30.22	114.44	10	4.6
01	13	2005	27.60	115.09	10	5.1
01	15	0529	37.99	118.21	5	5.0
01	24	1820	38.13	86.43	5	4.1
01	26	0220	26.08	110.12	10	4.8
01	27	0628	30.12	113.73	10	4.2
01	28	0459	43.31	102.50	5	4.0
01	29	1316	34.46	106.88	12	4.8
01	31	0108	34.44	106.86	10	4.0
02	18	1552	33.51	116.45	9	4.1
02	28	2343	34.14	117.70	5	6.2
03	01	0323	34.15	117.72	11	4.8
03	02	1726	34.14	117.69	6	4.6
03	07	0716	37.47	118.62	11	4.0
03	10	1600	37.11	116.06	0	5.1
03	10	1726	37.11	116.06	0	4.0
03	16	1552	24.90	109.04	10	6.1
03	16	1646	24.40	108.80	10	4.7
03	20	0707	24.50	109.10	10	4.3
03	31	2259	32.38	115.24	6	4.3
04	04	0854	32.97	117.81	6	4.5
04	17	2232	34.11	117.72	4	4.7
05	20	1715	20.27	63.26	78	4.3
06	11	0452	27.39	111.26	10	4.8
06	13	1600	37.26	116.42	0	5.7
06	21	1047	33.16	115.63	1	4.0
06	21	1815	36.99	116.00	0	4.3
07	12	0903	24.02	108.52	10	4.7
07	12	1327	23.02	108.96	10	4.2
07	25	1500	37.21	116.21	0	4.7
08	17	2101	36.79	83.34	10	4.0
08	31	0338	33.25	116.05	8	4.2
09	06	0524	27.20	110.56	10	4.1
09	26	1318	37.17	89.58	12	5.0
10	11	0314	21.18	99.69	10	4.0
10	12	1730	37.25	116.49	0	5.6
10	13	0356	31.72	115.91	6	4.0
10	19	0701	46.47	75.59	13	5.1
10	24	0615	38.05	119.16	12	5.7
10	25	0324	23.83	108.71	10	5.1
11	05	0716	38.03	119.17	10	4.2
11	08	1046	34.45	106.86	6	4.4
11	14	1917	37.23	116.37	0	5.4
11	15	1347	47.13	76.22	18	4.1
11	28	0248	38.67	116.46	10	4.3
11	30	1130	47.77	113.16	5	4.0
12	18	1656	35.37	118.85	6	4.2
12	24	0254	44.78	111.20	5	4.0
12	31	0353	47.58	72.56	18	4.4





To obtain U.S. Department of the Interior/U.S. Geological Survey Preliminary Determinations of Epicenters, write to the Superintendent of Documents, U.S. Government Printing Office, Washington, DC 20402. Annual subscription, \$21.

#### BOOKS AND REPORTS

Bolt, Bruce A. (1993). *Earthquakes*. New York: W.H. Freeman & Co. Probably the single most useful basic text on earthquakes.

Christman, Robert A. (1980). "Epicenters of the 1964 Alaskan Earthquake" and "Time Travel: Earthquake Waves and Horses." In *Activities for Earth Science*, edited by V. Mayor. Columbus, OH: ERIC Clearinghouse (1929 Kenny Road, Columbus, OH 43210-1079; 614-292-7784).

Davison, Charles. (1978). *The Founders of Seismology*. New York: Arno Press.

Herbert-Gustar, A.L., and Mott, P.A. (1980). *John Milne: Father of Modern Seismology*. Tenterden, England: Paul Norburg Publishers Ltd.

Penick, J. (1981). *The New Madrid Earthquake of 1811-1812*, revised edition. Columbia, MO: University of Missouri Press.

Ross, Katherine E., editor. *Making Earthquake Education Come Alive—The Development and Use of Low Cost Models in the Classroom*. Buffalo, NY: NCEER, State University of New York; 716-636-3391. In press.

Simon, Ruth B. (1981). *Earthquake Interpretation: A Manual for Reading Seismograms*. Los Altos, CA: William Kaufmann, Inc.

Steinbrugge, K.V. (1982). *Earthquakes, Volcanoes, and Tsunamis*. New York: Scandia America Group.

Stewart, David, and Knox, Ray. (1993). *The Earthquake That Never Went Away: The Shaking Stopped in 1812, but the Impact Goes On*. Marble Hill, MO: Gutenberg-Richter Publications.

Utah Geological Survey. (October 1992, Revised). *Places with Hazards*. Salt Lake City, UT: Utah Department of Natural Resources; 801/467-7970. A teacher's handbook on natural hazards in Utah for secondary earth science classes. Includes a geologic hazard slide set. Identifies and defines nine types of soil and rock conditions that pose geologic hazards in Utah and their locations.

#### ARTICLES AND PAPERS

Barker, Gary Keith. (1987). "Interfacing the Lehmann Seismograph with an Apple Computer." *Journal of Geological Education* 4, 35: 126-128. Provides plans for interfacing the Lehmann seismograph with an Apple computer and printer through an analog/digital converter.

Barker, Gary. (September 1983). "A Working Seismograph for the Classroom." *Michigan Earth Scientist. Journal of the Michigan Earth Science Teachers Association*.

"The Bigger One." (Nov. 29, 1987). *Los Angeles Times Magazine*. A fictional account of a magnitude 7.5 earthquake, worst-case scenario, on the Newport-Inglewood Fault.

Brownlee, Shannon. (July 1986). "Waiting for the Big One." *Discover* 7, 52-71. Worth looking for—a highly readable account of the state of earthquake prediction, with excellent illustrations.

Christman, Robert A. (1975). "Understanding and Interpreting the Bellingham Seismograms of the 1964 Alaskan Earthquake." Bellingham, WA: Western Washington State College. Available from Creative Dimensions, PO Box 1393, Bellingham, WA 98227 (206-733-5024). Design your own classroom activities for the interpretation and understanding of a seismogram. Written explanations and questions are included.

Fuller, Myron L. (1990 reprint). *The New Madrid Earthquake Scientific Factual Field Account*. USGS Bulletin 494. Washington, DC: Government Printing Office, 1912. (Reprinted by the Southwestern Missouri University Center on Earthquake Studies)

Gerencher, J.J., and Jackson, R.F. (1991). "Classroom Utilization of a Multi-Axis Lehman Seismograph System." *Journal of Geological Education* 39: 306-310. Also see Seismological Data Acquisition Software below.

Kerr, R.A. (1979). "Earthquake Prediction: Mexican Quake Shows One Way to Look for the Big Ones." *Science* 201: 1001-1003.

Kroll, Lawrence. (1987). "Construction Modifications of the Lehmann Seismograph." *Journal of Geological Education* 4, 35: 124-125. Modifications and building tips for the Lehmann seismograph built from common materials.

"Inge Lehmann." *Current Biography*, 1962, pp. 251-253.

Plude, C. (April 1986). "Charles Richter: Earthquake Man." *Cobblestone*, p. 22. Written for readers 8-14. This issue contains other articles of interest as well.

Proujan, C. (Nov. 29, 1985). "Build a Model Tiltmeter—An Earthquake Warning System." *Science World*, pp. 8-9. For ages 12-15.

Raleigh, C.B., et al. (March 1983). "Forecasting Southern California Earthquakes." *California Geology* 36. California Division of Mines and Geology; 916-323-5336.

Simon, Ruth. "A Personal Memoir of Inge Lehmann (1888-1993)." *Eos* (November 2, 1993): 510-512.

"Tsunami Data." National Geophysical Data Center, NOAA, Code E/GCI. 325 Broadway, Boulder, CO 80303; 303-497-633.

Williams, R.L. (1983). "Science Tries to Break New Ground in Predicting Great Earthquakes." *Smithsonian* 14, 4: 41-50.

### PERIODICALS

*Earthquakes and Volcanoes*, a bimonthly magazine published by the U.S. Geological Survey, 904 National Center, Reston, Virginia, 22029; 703/648-6078. See especially "Pacific Tsunami Warning System," Volume 18, Number 3, 1986, and "Devastating Tsunami Inspires Efforts to Reduce Future Tsunami Destruction," Volume 19, Number 2, 1987.

*Eos, Transactions, American Geophysical Union*. A weekly newspaper of geophysics. American Geophysical Union, 2000 Florida Avenue NW, Washington, DC 20009; 800-966-2481. See especially August 17, August 24, and September 14, 1993.

### NON-PRINT MEDIA

EPIC Retrieval Software for the Global Hypocenter Data Base CD-ROM. United States Geological Survey, National Earthquake Information Center. A demonstration disk and information packet are available free: Phone 303-273-8406; Fax 303-273-8450; E-Mail hdf@neis.cr.usgs.gov (Internet). Federal Center, Box 25046, Mail Stop 967, Denver, CO 80225-0046. Through EPIC, you can access enormous amounts of national and international data ranging from 2100 BC to last month.

Jones, Alan L. *The Dynamic Seismicity Program*. version 1.00 level 93.03.02. New York: State University of New York, at Binghamton, 1993. Three computer disks and instruction manual. Also, PC shareware available on Internet @sunquakes.geol.binghamton.edu.

*Hidden Fury: The New Madrid Quake Zone*. 27-minute video available from Bullfrog Films, P.O. Box 149, Oley, PA 19547; 1/800-543-FROG.

## UNIT RESOURCES

IRIS Database. United States Geological Survey, National Earthquake Information Center, Incorporated Research Institutions for Seismology, 1616 North Fort Myer Drive, Suite 1050, Arlington, VA 22209-3019.

Seismograph Model. For sale by Nasco, 800/558-9595. Includes a recording needle, a support with a suspended weight, a recording tape, and a teachers guide.

Science ToolKit, Module 2: Earthquake Lab. Broderbund Software (Dept. 15, PO Box 6125, Novato, CA 94948-6125), 1986, for the Apple. Grades 4–12. Requires Science ToolKit Master Module.

*Seismological Data Acquisition Software.* Described in the Gerencher and Jackson article above. Apple software and 64-page user's manual available from J. J. Gerencher, Physics and Earth Sciences, Moravian College, 1200 Main Street, Bethlehem, PA 18018-6650.

*Note: Inclusion of materials in these resource listings does not constitute an endorsement by AGU or FEMA.*

U N I T



F O U R



# Can Buildings Be Made Safer?

This unit is designed to allow students to construct an understanding of how the shaking of the ground during an earthquake causes damage to buildings and how buildings can be made better able to withstand this shaking. The activities and experiments of this unit culminate in an exciting performance assessment. Like the activities in Unit 1, these require considerable teacher preparation and will be enhanced by the widest possible involvement of community members outside the classroom.

Lesson 1, Building Fun, is designed as an attention-grabber, allowing students to discover the physical properties of some materials, practice working together, and most of all, have fun while establishing the need for constraints in building performance requirements. Students are given Styrofoam strips and a variety of connection devices and asked to build a stable structure of any kind.

Lesson 2 provides students with real experience in reinforcing or bracing a wall to carry the horizontal loads of an earthquake. They learn three engineering techniques and experiment with them on a model wall. Students develop the ability to make load path diagrams to predict and describe how static and dynamic forces travel through a wall.

Lesson 3, Building Oscillation Seismic Simulation, or BOSS, is an opportunity for students to explore the phenomenon of resonance while performing a scientific experiment that employs mathematical

skills. The students are intrigued by a discrepant event involving the BOSS Model and are then set to work experimenting with the natural frequencies of structures. They experience how structures behave dynamically during an earthquake.

Lesson 4, Earthquake in a Box, engages students in constructing and using an instrument similar to one scientists use to model the impact of earthquake shaking. The materials and the procedure are both uncomplicated. This activity reinforces the major role of horizontal (lateral) forces in an earthquake and the importance of designing structures to withstand them.

In Lesson 5, The Building Challenge, students apply what they have learned in the first four activities. They are challenged to build a Styrofoam structure that can sustain the maximum horizontal load possible. The students' performance in this building contest is an authentic assessment of the ideas developed in Unit 4.

Take time to do all the activities in this unit with your class. They are all important, not only because this unit is more closely integrated than the other units, but also because it deals with an aspect of earthquake safety that is usually not treated elsewhere in high school and junior high learning materials. It will kindle your students' enthusiasm for science, architecture, and engineering.



# Building Fun

## RATIONALE

Students investigate the physical properties of building materials and design while considering how these might affect the way a structure withstands forces.

## FOCUS QUESTIONS

What kind of structure would you build for fun?

What are the properties of some uncommon building materials?

How do structures stand up to extra forces?

## OBJECTIVES

Students will:

1. Build a model structure.
2. Describe what may happen to a structure when a load is applied.
3. Describe the physical properties of some materials.

## MATERIALS

*for the teacher*

- Master 4.1a, Building Engineering: Teacher Background Information
- Photos, books, slides, and/or videos with images of earthquake damage (See Unit 1 Resources.)
- Band saw or other saw
- One brick

*for each small group*

- 6 or more sticks of Styrofoam, 2.5 cm x 2.5 cm x 15 cm (1 in. x 1 in. x 6 in.)
- 3 pieces of string, each 30 cm long (*optional*)
- 10 paper clips (*optional*)
- About 20 toothpicks
- Masking tape for labels

## TEACHING CLUES AND CUES



The lessons in this unit are a set. Plan time to do them all, for maximum learning and enjoyment.



Give yourself plenty of time for gathering and cutting materials. There is potential for some mess, so leave time for the students to clean up.



If you are not able to obtain visuals to introduce this lesson, do a quick demonstration with a deck of cards instead. Build card houses and let students take turns knocking them down by shaking the surface they rest on, or invite them to build and test the structures. The point is only that buildings need more than walls and a roof to withstand stress.

## PROCEDURE

### Teacher Preparation

1. You may want to invite an architect, engineer, geologist, or seismologist to visit your class during Lesson 4 of this unit, when students will again design model buildings. The guest expert could initiate the building challenge and help students to understand the concepts involved.
2. Read the teacher background information on Master 4.1a. If possible, assemble visuals from among those listed in the Unit 1 Resources.
3. Draft a few students to cut the Styrofoam into pieces, or ask the industrial arts instructor to help. (Styrofoam is easily cut on a band saw.) Finally, collect the building materials for this lesson and put them into piles on a table in the front of the room.

### A. Introduction

Set the stage by asking students to tell what they know about the effect of earthquakes on buildings and other structures, both from personal experience and from reading, television, movies, or other sources. Be protective of their right to say what they remember, even if it may sound exaggerated to other students. If you have pictures or slides of earthquake damage, show them now.

### B. Lesson Development

1. Divide the class into cooperative working groups of three to five students each. Explain that throughout this unit the groups will be known as seismic engineering teams, or SETs. Encourage each SET to choose a name.
2. Ask the groups to collect materials and build the strongest structures they can with the materials and the time allotted. Do not direct or criticize their efforts. This activity is for fun. When students try again in Lesson 4, they will be able to apply what they have learned in this unit.
3. After 20 to 30 minutes, call a halt to construction. Have a spokesperson for each group bring its structure to the materials table in the front of the room and describe the structure to the class. Ask students to explain why they built what they did.
4. With all the structures on one table, ask the class what would happen if you were to place a brick on top of each structure. Have the brick in hand, but do not actually crush any structure. Explain to the students that the brick is simulating the static force of gravity (vertical load) that every structure must carry. In this case, the Styrofoam is quite strong for its weight, so the brick can also represent the weight of all the nonstructural elements of a building, such as floors, wall coverings, and electrical wiring. Expect the students to protest because they were not told their structures had to support a brick. Explain that this activity was only an introduction and a chance to discover the physical properties of the materials.

## VOCABULARY



### Horizontal load:

the sum of horizontal forces (shear forces) acting on the elements of a structure.

**Load:** the sum of vertical force (gravity) and horizontal forces (shear forces) acting on the mass of a structure. The overall load is further broken down into the loads of the various parts of the building. Different parts of a building are designed and constructed to carry different loads.

**Vertical load:** the effect of vertical force (gravity) acting on the elements of a structure.

## TEACHING CLUES AND CUES



Cut more Styrofoam than you will need for this lesson—about 35 strips per group—since you will also use these strips in Lesson 4. If some of the strips are less than uniform, use them now, saving the best ones for Lesson 4.

5. Now ask the students what would happen if you shook the base of each building. Test a few gently while the students observe. What if you held the base of each structure and pushed horizontally on the top? Test a few, but again, try not to break any structure. Explain that buildings experience horizontal loads or dynamic forces during earthquakes. One way to simulate these forces is simply to push or pull a structure from the side.

### C. Conclusion

Tell students that at the end of this unit there will be another building activity, but this time it will be a contest to design and build structures that can support a horizontal load. What they learn in this unit can be applied in the contest. Let them know there will be clearly defined parameters and all groups will have an equal opportunity to succeed. Label the structures with SET names and put them aside for the contest at the end of this unit. ▲



During an earthquake, a marked spot on the Earth might be seen to move erratically, tracing out a random path resembling that of a wandering insect. “Ground motion” is a literal description, since the ground moves (generally for a distance measured only in centimeters) relative to its starting point. The ground motion that is important in determining the forces on a building is acceleration. As the seismic waves move through the ground, the ground moves back and forth. Acceleration is the rate at which ground movement changes its speed.

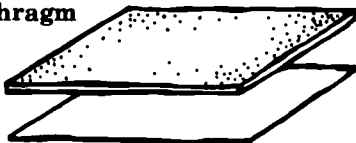
Two other unit measures are directly related to acceleration. Velocity, measured in centimeters per second, refers to the rate of the motion at a given instant. Displacement, measured in centimeters, refers to the distance an object is moved from its resting position. If you move your hand back and forth rapidly in front of your face, it might experience a displacement of 20 to 30 centimeters in one second and its acceleration and velocity may be quite high, but no damage will be done because the mass of your hand is low. In a building with a mass in the thousands of metric tons, tremendous forces are required to produce the same motion. These forces are transmitted throughout the structure, so if the movement repeats for some minutes the building may shake to pieces.

To overcome the effects of these forces, engineers rely on a small number of components that can be combined to form a complete load path. In the vertical plane, three kinds of structural systems are used to resist lateral forces: shear walls, braced frames, and moment-resistant or rigid frames. In the horizontal plane, diaphragms (generally formed by the floor and roof planes of the building) or horizontal trusses are used. Diaphragms are designed to receive lateral force between the vertical resistance elements (shear walls or frames). Shear walls are solid walls designed to carry the force to the vertical resistance system. In a simple building with shear walls at each end, ground motion enters the building and moves the floor diaphragms. This movement is carried by the shear walls and transmitted back down through the building to the foundation. Braced frames act in the same manner as shear walls, but may not carry as much load depending on their design. Bracing generally takes the form of steel rolled sections (I-beams), circular bar sections (rods), or tubes. Rigid frames rely on the capacity of joints to carry loads from columns to beams. Because these joints are highly stressed during movement the details of their construction are important. As a last-resort strategy, rigid frames use the energy absorption obtained by deformations of the structure before it ultimately fails.

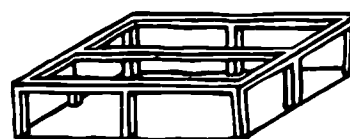
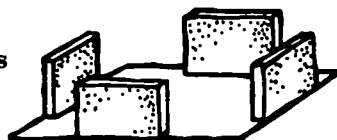
Architecturally, rigid frames offer a certain advantage over shear walls or braced frames because they tend to provide structures that are much less obstructed internally than shear wall structures. This allows more freedom in the design of accompanying architectural elements, such as openings, exterior walls, partitions, and ceilings, and in the placement of building contents, such as furniture and loose equipment. Nevertheless, moment-resistant frames require special construction and detailing and therefore, are more expensive than shear walls or braced frames.

*Note: Adapted from FEMA 99, October 1990, Non-technical Explanation of the NEHRP Recommended Provisions.*

Diaphragm

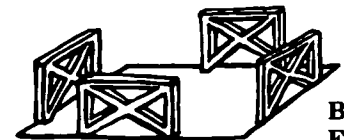


Shear Walls



Moment Resistant Frame

214



Braced Frame

# Structural Reinforcement:

## The Better Building

### RATIONALE

Students will learn how diagonal braces, shear walls, and rigid connections strengthen a structure to carry forces resulting from earthquake shaking.

### FOCUS QUESTION

How may the structure of a building be reinforced to make it better able to withstand earthquake shaking?

### OBJECTIVES

#### Students will:


1. Recognize some of the structural elements of a building.
2. Describe how the horizontal and vertical structural elements carry the horizontal and vertical loads of a building.
3. Describe how diagonal braces, shear walls, and rigid connections provide paths for the horizontal load resulting from an earthquake.
4. Observe how added structural elements strengthen a model wall to withstand shaking.


### MATERIALS

*For the teacher: Materials for one model wall*

- Master 4.2a, Building a Model Wall
- 21 jumbo craft sticks, about 15 cm x 2 cm x 2 mm thick
- Electric drill with 3/16" bit
- Goggles for eye protection
- 1 piece of thin wood (about 2 mm thick) 45 cm x 6 cm (about 18 in. x 2 in.)
- 1 piece of sturdy wood (2 x 6) for a base, about 45 cm (18 in.) long
- 16 machine bolts, 10 x 24, about 2 cm long (.75 in.)
- 16 machine screw nuts, 10 x 24
- 32 washers, #8

### TEACHING CLUES AND CUES

 Jumbo craft sticks are available at craft and hobby stores. They are larger than ice cream sticks, about the size of tongue depressors.

 You may want to build this model and the one in Lesson 4.3 at the same time, and introduce them both in the same class period. This would allow two groups to be actively engaged with the models at the same time.

- 7 small wood screws

*reinforcing elements for one wall*

- 2 pieces of string, each approximately 25 cm (10 in.) long
- 1 piece of thin wood (about as thick as the craft sticks) 20 cm x 2 cm (about 8 in. x 1 in.)
- 1 piece of lightweight cardboard, about 15 cm x 15 cm (a little less than 6 in. square)
- 8 small paper clamps to fasten wood and cardboard

*for each small group*

- One set of the above supplies if they are each building a model wall
- One copy of Master 4.2b, Load Paths Worksheet
- Pens and pencils

## PROCEDURE

### Teacher Preparation

Assemble the model wall, following the diagram on Master 4.2a, Building a Model Wall, and try it out before class. Be sure the bolts are just tight enough to hold the structure upright when no force is applied.

### A. Introduction

Tell students that this lesson is designed to demonstrate how the structural elements of a wall carry forces. The activity deals with three structural elements that carry the lateral shear forces caused by ground shaking during an earthquake: diagonal bracing, shear walls, and rigid connections. It is designed around an apparatus called the model wall. Remind the students that this is a model, designed to demonstrate only certain characteristics of real walls.

### B. Lesson Development

1. Show students the model and tell them that it represents part of the frame of a building. Describe the components of the wall, and ask them, "What holds this wall up?" The answer is in the interaction of the vertical and horizontal elements, but try to keep the students focused on discovery, since in this activity they will see the architectural principles demonstrated. Explain to students that what they refer to as weight will be called the force of gravity in this lesson.
2. Now ask students to predict what would happen if you quickly pushed the base of the wall, simulating an earthquake. Remind them that an earthquake may cause ground shaking in many directions, but for now we are modeling shaking in one direction only.
3. Divide the class into the same seismic engineering teams (SETs) as for Lesson 1 and give each group one copy of Master 4.2b, Load Paths Worksheet. Invite students to take turns investigating the model's response in their small groups.

## VOCABULARY



**Braces or Bracing:** structural elements built into a wall to add strength.

These may be made of various materials and connected to the building and each other in various ways. Their ability to withstand stress depends on the characteristics of the materials and how they are connected.

**Load:** the sum of vertical forces (gravity) and horizontal forces (shear forces) acting on the mass of a structure. The overall load is further broken down into the loads of the various parts of the building. Different parts of a building are designed and constructed to carry different loads.

**Load path:** the path a load or force takes through the structural elements of a building.

**Rigid connections:** connections that do not permit any motion of the structural elements relative to each other.

**Shear force:** force that acts horizontally (laterally) on a wall. These forces can be caused by earthquakes and by wind, among other things. Different parts of a wall experience different shear forces.

**Shear walls:** walls added to a structure to carry horizontal (shear) forces. These are usually solid elements, and are not necessarily designed to carry the structure's vertical load.

**Structural elements or structural features:** a general term for all the essential, non-decorative parts of a building that contribute structural strength. These include the walls, vertical column supports, horizontal beams, connectors, and braces.

a. Instruct one student in each group to push at the bottom of the model from the lower right or left side. (When pushed just fast enough, the model should collapse at the first floor only.) Ask students why the other floors didn't collapse. (The first floor collapsed because it was too weak to transfer enough horizontal force to move the upper stories. It could not transfer the shaking to the upper stories.)

b. Direct students' attention to the load path diagrams on Master 4.2b and explain that pushing the base of the building is equivalent to applying force horizontally to the upper stories. A force applied horizontally to any floor of a building is called the shear force on that floor. Shear forces can be caused by the ground shaking of an earthquake as well as by high winds. Invite students to carefully apply horizontal forces at different points on the model to simulate earthquake shaking. (Earthquakes affect buildings at ground level.)

4. Ask students how they could add structural elements to create a path for the load to follow to the ground when strong forces act upon the structure. Help the students discover the effect of adding a shear wall, diagonal bracing, and rigid connections, using string, cardboard, extra wood, and clamps, as in the diagrams on the master. On each of the three diagrams provided, have students draw a force arrow (a vector) and trace the path the force takes to the ground.

5. Challenge students to design and build three different arrangements of the six structural elements depicted on the worksheet. Each time they modify the design they must modify the diagram to show the new load path. Check each structure and diagram until you are sure that students understand the concepts. When a structure is well reinforced, you should be able to push on the upper story and slide the whole structure without any of the walls failing.

6. Either have the groups discuss the questions on the master, with one student recording each group's response, or ask individual students to write responses to specific questions. After all the groups finish the questions, have a reporter for each SET present its response to one of the questions. Allow the class to come to some consensus on their responses to that question, then proceed to another group until all the questions have been discussed.


### C. Conclusion


As a closing activity, challenge a volunteer to remove an element (a craft stick) that, according to the load path diagram, is not carrying any load. Have the student unbolt one end of that element and push the reinforced structure to see if it holds. It will, if the load path is correct.


Finally, help the students connect the behavior of their model walls to their mental images of real buildings during an earthquake.

Emphasize that the back and forth, horizontal component (or shearing) of ground shaking is the force most damaging to buildings. Buildings are primarily designed to carry the downward pull of

### TEACHING CLUES AND CUES

 This activity is designed as a demonstration or as a group activity. If you decide to have each group build a model wall you will need more materials.

 Encourage students to choose roles within their SETs and later report their results by role, with the technician reporting the data, the engineer describing the calculations, the scientist explaining the relationships, and the coordinator facilitating.

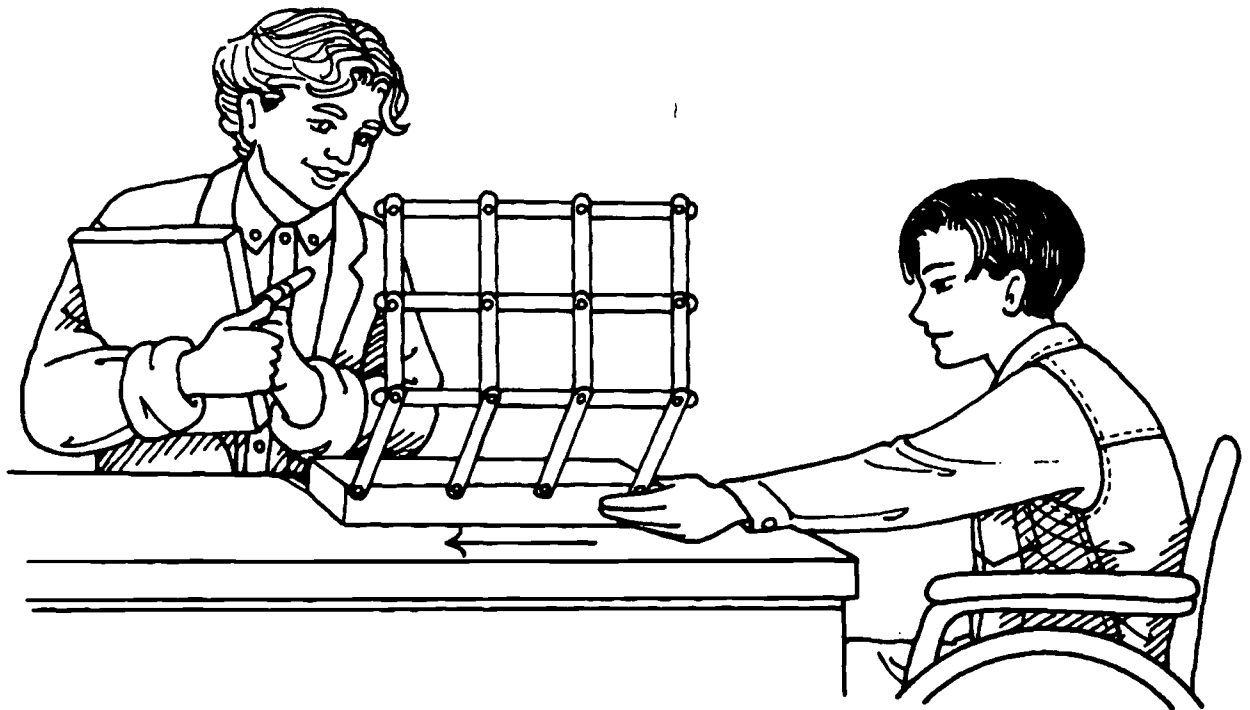
 Students may try both pushing the structure directly and moving the table. Shaking the table on which the structure rests would simulate the transfer of energy from the ground to the building.

217

gravity, but to withstand earthquake shaking they need to be able to withstand sideways, or horizontal, pushes and pulls.

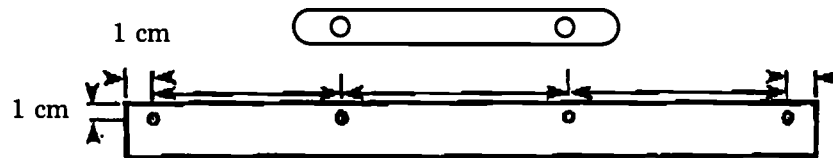
### **ADAPTATIONS AND EXTENSIONS**

1. Challenge students to find the minimum number of diagonal braces, shear walls, or rigid connections that will ensure horizontal stability in their models.
2. Invite students to design, construct, and test other structural elements that could make buildings earthquake-resistant, such as square rigid connections. Some might try putting wheels or sleds on the bottom of their buildings.
3. If you have some very interested students, you may give them access to all your building supplies and challenge them to design and construct larger structures. Ask students to consider how they could design a building so that the ground shaking does not transfer to the building. There are new technologies that allow the ground to move, but not the building. One of these is called base isolation. Have students research this topic in periodicals. (See Unit Resources.) ▲

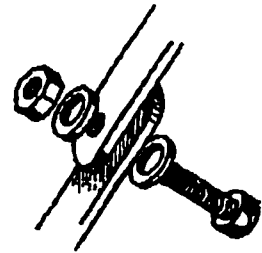
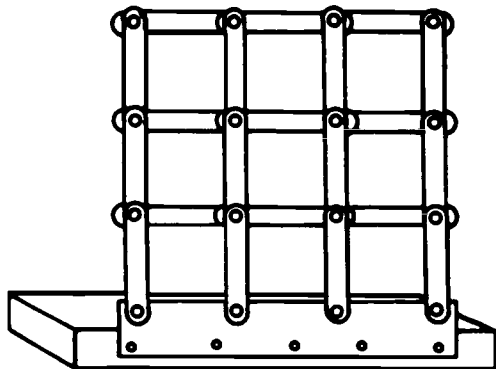




1. Stack 21 craft sticks one on top of the other. Wrap a rubber band around the center to hold them together. Using a  $3/16$  in. bit, carefully drill a hole through all the sticks at once, 1 cm from the end of the stack. Drill slowly to avoid cracking the wood.
2. Select the thinner of the two large pieces of wood (45 cm x 6 cm). Drill a  $3/16$  in. hole 1 cm from one end and 1 cm from the edge. Measure the distance between the holes drilled in the craft sticks and space three more  $3/16$  in. holes at that distance 1 cm from the edge so that a total of four holes are drilled (see illustration).
3. Use the small wood screws to mount this piece of wood on the base (the 2 x 6), fastening at the bottom and in the center. Leave the pre-drilled holes sticking up far enough above the top to accept the drilled craft sticks.



4. Using the bolts, washers, and nuts, assemble the craft sticks to build a model wall.
5. Experiment with tightening bolts and washers until they are just tight enough for the wall to stand on its own.



Name \_\_\_\_\_ Date \_\_\_\_\_

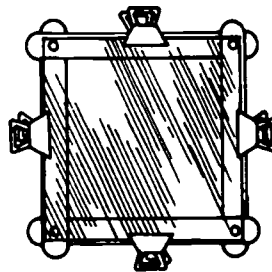
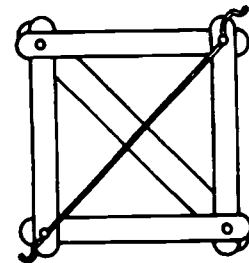
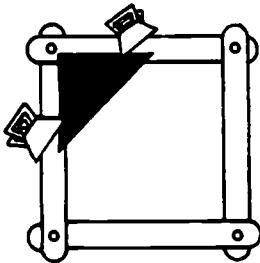
**A. Failing Wall**

Observe and explain how the wall fails when its base is shaken rapidly back and forth, simulating the motion of a building hit by S waves during an earthquake. Tighten all the nuts just enough to allow the joints to move. Sharply push the base a few centimeters horizontally (right or left).

1. What part of the wall fails first? \_\_\_\_\_
2. Imagine how the horizontal force you applied to the base travels to the upper parts of the wall. What caused the first structural failure? \_\_\_\_\_

**B. Load Paths with Additional Structural Elements**

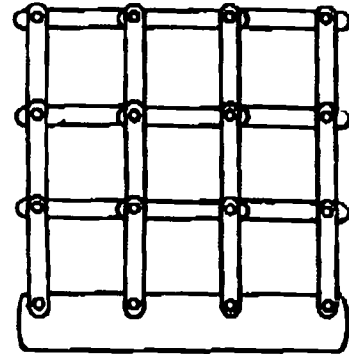
1. Pick up the two rigid connections, one shear wall (cardboard), one solid diagonal brace, and two pieces of string. Add structural elements to your wall to provide paths for the horizontal forces, or loads, to travel through the wall. Study the diagrams below to see how these structural elements provide load paths.



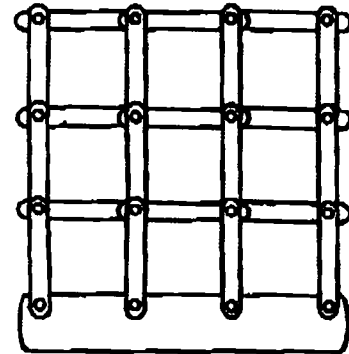
Use arrows to show the load path on each diagram.

220

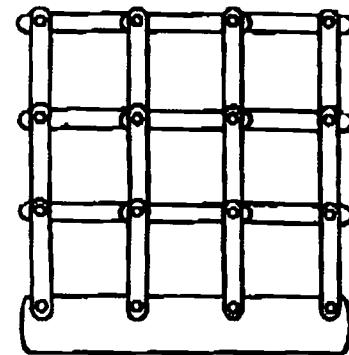
2. Put additional structural elements on your wall and push the third level. If the elements you added provided a load path to the base, the base of the wall should move. If they do not, the wall will fail somewhere. When you discover a setup that works, diagram it and sketch the load paths with arrows. Have your instructor look it over before you continue.



3. Design and build another set of additional structural elements. Sketch the load path here and have your instructor check it. Be sure each member of the team designs a set. The base of the model wall should move when lateral force is applied to the top elements.



4. Design and build a third set of additional structural elements. Use as few additional elements as possible. Sketch the load path and have your instructor check it. Be sure each member of the team designs a set. Test your load paths by removing elements not in the path to see if the building will stand up to a force.



**C. Summary**

1. What is a load path? \_\_\_\_\_  
\_\_\_\_\_  
\_\_\_\_\_  
\_\_\_\_\_

2. Why must additional structural elements be added to a wall before it can carry horizontal forces?  
\_\_\_\_\_  
\_\_\_\_\_  
\_\_\_\_\_

3. How many additional elements did you need to add? \_\_\_\_\_  
\_\_\_\_\_  
\_\_\_\_\_  
\_\_\_\_\_

4. Why doesn't the force take some path other than the one you diagrammed? \_\_\_\_\_  
\_\_\_\_\_  
\_\_\_\_\_  
\_\_\_\_\_

**A. Failing Wall**

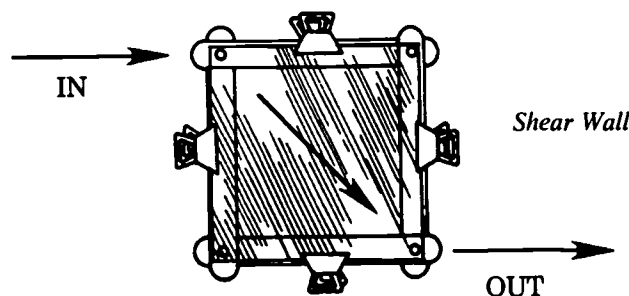
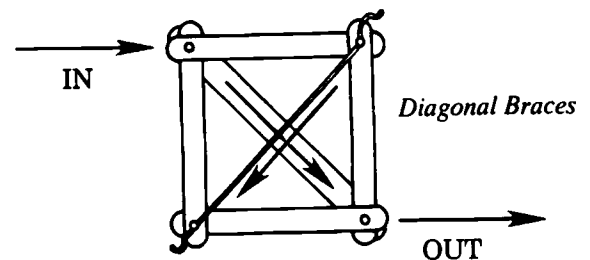
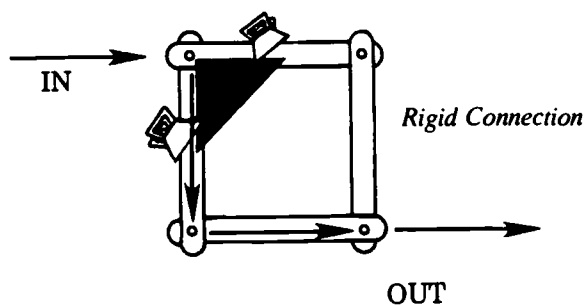
Observe and explain how the wall fails when its base is shaken rapidly back and forth, simulating the motion of a building hit by S waves during an earthquake. Tighten all the nuts just enough to allow the joints to move. Sharply push the base a few centimeters horizontally (right or left).

1. What part of the wall fails first? *The first floor*

2. Imagine how the horizontal force you applied to the base travels to the upper parts of the wall. What caused the first structural failure? *The first floor has to carry all the load to the upper stories. It transfers forces to move the upper stories.*

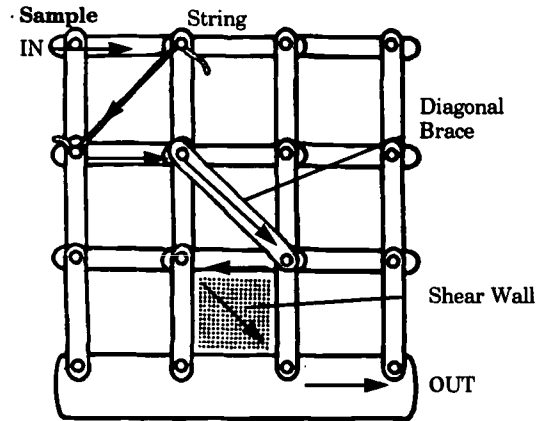
**B. Load Paths with Additional Structural Elements**

1. Pick up the two rigid connections, one shear wall (cardboard), one solid diagonal brace, and two pieces of string. Add structural elements to your wall to provide paths for the horizontal forces, or loads, to travel through the wall. Study the diagrams below to see how these structural elements provide load paths.

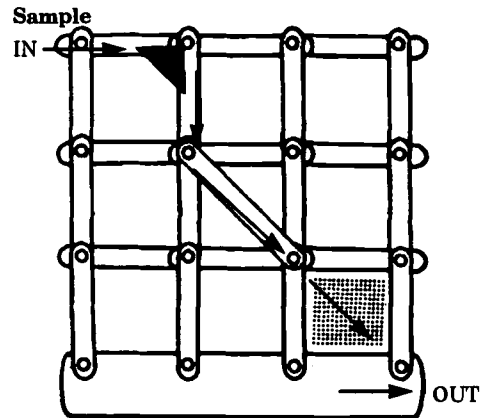


Use arrows to show the load path on each diagram.

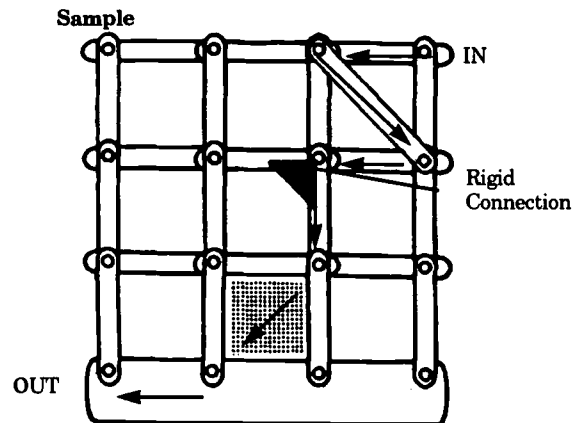
2. Put additional structural elements on your wall and push the third level. If the elements you added provided a load path to the base, the base of the wall should move. If they do not, the wall will fail somewhere. When you discover a setup that works, diagram it and sketch the load paths with arrows. Have your instructor look it over before you continue.



3. Design and build another set of additional structural elements. Sketch the load path here and have your instructor check it. Be sure each member of the team designs a set. The base of the model wall should move when lateral force is applied to the top elements.



4. Design and build a third set of additional structural elements. Use as few additional elements as possible. Sketch the load path and have your instructor check it. Be sure each member of the team designs a set. Test your load paths by removing elements not in the path to see if the building will stand up to a force.



### C. Summary

1. What is a load path?

*The path that the load (or force) follows through the structural elements of a building.*

2. Why must additional structural elements be added to a wall before it can carry horizontal forces?

*Normally, buildings only have to support vertical force (gravity). When horizontal forces are applied, as in an earthquake, additional elements are needed to carry them.*

3. How many additional elements did you need to add?

*Each joint needs only one additional structural element. Only one joint on each floor needs to carry the horizontal force, in this model.*

4. Why doesn't the force take some path other than the one you diagramed?

*The diagram shows the places that are strong enough to carry the load. If there were more than one place, the load (or force) would travel through both.*

# The BOSS Model:

## Building Oscillation Seismic Simulation

### RATIONALE

During an earthquake, buildings oscillate. If the frequency of this oscillation is close to the natural frequency of the building, resonance may cause severe damage. The BOSS model allows students to observe the phenomenon of resonance.

### FOCUS QUESTION

Why do buildings of different heights respond differently in an earthquake?

### OBJECTIVES

Students will:

1. Predict how a structure will react to vibrations (oscillations) of different frequencies.
2. Perform an experiment to establish the relationship between the height of a structure and its natural frequency.
3. Describe the phenomenon of resonance.

### MATERIALS

*for one BOSS Model*

- Master 4.3a, BOSS Model Assembly
- 4 pieces of wood, 1 x 4, each 15 cm (6 in.) long
- 1 piece of wood, 2 x 4, for a base, about 45 cm (18 in.) long
- 2 threaded rods, 10 x 24, each 96 cm (36 in.) long
- 2 threaded rods, 10 x 24, each 61 cm (2 ft.) long
- Goggles for eye protection
- Hacksaw or power saw with metal-cutting blade
- Electric drill or hand drill with  $\frac{1}{8}$ -in. and  $\frac{3}{8}$ -in. wood bore bits
- Hammer
- 8 wing nuts, 10 x 24
- 8 tee nuts, 10 x 24

### TEACHING CLUES AND CUES



As noted in lesson 4.2, you may want to have one group of students working with this model while another is working with the model wall.

### TEACHING CLUES AND CUES



Since the rods can break with rough handling, you may want to buy one or two extra.



- 8 washers, #8
- A wide permanent marker in any color that will contrast with the wood
- Poster paints: red, green, blue, black, and white, and 5 brushes (optional)

for each small group

- One copy of Master 4.3b, BOSS Worksheet
- Pencils or pens
- Stopwatch
- Meter stick

## PROCEDURE

### Teacher Preparation

Build the BOSS model by following the directions on Master 4.3a. Practice with your model until you've got a feel for each frequency and you can get any of the rod assemblies to resonate. One technique is to use a firm push first, then watch the number you want and wiggle the base very lightly at its natural frequency to get resonance.

### A. Introduction

Find out what students already know about the concepts of amplitude, frequency, and resonance. If they are not familiar with these terms, introduce them by building on what students already know from other areas. They may know, for example, that resonance and frequency are used in describing the tone of musical instruments and the quality of sound produced by different recording techniques and players. The phenomenon of resonance also accounts for laser light and for the color of the sky.

### B. Lesson Development

1. Direct students' attention to the BOSS model, and explain its name. Ask the students to predict which numbered rod assembly will oscillate the most when you wiggle the base. Have them hold up 1, 2, 3, or 4 fingers to indicate their prediction. (They will probably say number 1 because it is the tallest.)
2. Oscillate the BOSS model so that some rod assembly resonates other than the one most students predicted. This will baffle the students, so let them predict again. Again make the rod resonate for an assembly they did not predict. Finish this demonstration after several tries by making the rod resonate for the assembly most of the students did predict, so that they get it right. Invite discussion.
3. Relate the blocks and rods to buildings of various heights in an earthquake. Ask students if they think buildings would oscillate like this in an earthquake. (They always do, and in some earthquakes the effect is especially pronounced. In the 1985 Mexico City earthquake, the ground shaking resonated with the natural frequencies of 8-to-10-

## VOCABULARY



**Amplitude:** a measurement of the energy of a wave. Amplitude is the displacement of the medium from zero or the height of a wave crest or trough from a zero point. (In this activity it's how far to the side the block moves.)

**Frequency:** the rate at which a motion repeats, or oscillates. The frequency of a motion is directly related to the energy of oscillation. In this context, frequency is the number of oscillations in an earthquake wave that occur each second. In earthquake engineering, frequency is the rate at which the top of a building sways.

**Hertz (Hz):** the unit of measurement for frequency, as recorded in cycles per second. When these rates are very large, the prefixes *kilo* or *mega* are used. A kilohertz (kHz) is a frequency of 1,000 cycles per second and a megahertz (MHz) is a frequency of 1,000,000 cycles per second.

**Oscillation or vibration:** the repeating motion of a wave or a material—one back and forth movement. Earthquakes cause seismic waves that produce oscillations, or vibrations, in materials with many different frequencies. Every object has a natural rate of vibration that scientists call its natural frequency. The natural frequency of a building depends on its physical characteristics, including the design and the building materials.

**Resonance:** an increase in the amplitude (in this case, the distance the top of a building moves from its rest position) of a physical system (such as a building) that occurs when the frequency of the applied oscillatory force (such as earthquake shaking) is close to the natural frequency of the system.

story buildings. The effect was severe damage to medium-height buildings that had the same frequency as the ground shaking and resonated with it. Higher and lower buildings were hardly damaged.) Use the BOSS model as a visual aid when describing this event. You may also want to draw attention to the photos or books you used in Lesson 1 of this unit.

4. Divide students into seismic engineering teams (SETs) and distribute one copy of Master 4.3b, BOSS Worksheet, to each group. Tell students that they will take turns performing an experiment with the model, recording their data, and providing the answers asked for on the data sheet. Give these directions:

a. Hold the base stationary, pull the wooden number 1 out several centimeters to the side, and release it. As the rod oscillates, use a stopwatch to measure the time for 10 oscillations. Record this number.

b. Practice until you can get almost the same swing each time, then repeat the measurement four times. Calculate the average of these four times. Now calculate the natural frequency of the number by dividing 10 cycles by the average time. Record it. Repeat this procedure for the other three numbers.

c. Measure the height of each assembly from the base to the top, and record it.

d. Plot height versus natural frequency on the graph provided. (Students should come up with a hyperbola, a curve representing an inverse relationship in which, as the height of the structure increases, its natural frequency decreases.)

e. Ask the class: From what you have learned, do the earthquakes with the highest numbers on the Richter Scale always do the most damage? (Students should already know that the amount of damage has to do with population density and other factors, but now they will be aware of something new. To illustrate the relationship of frequency and resonance, use the example of someone pushing a child in a swing. The person pushes a little at a time, over time, and soon the swing goes very high without a big push. Each small push is at the right frequency. Similarly, a building may vibrate with a great amplitude without big earthquake vibrations because the smaller vibrations came at that structure's natural frequency.)

5. Ask the SETs to share and discuss their results. Again point out the connection between the experimental results and the way real buildings resonate. Other things being equal, taller buildings have lower natural frequencies than short buildings.

### C. Conclusion

Review the terms and concepts introduced in this lesson. Explain that seismic waves caused by earthquakes produce oscillations, or vibrations, in materials with many different frequencies. Every object has a natural rate of vibration that scientists call its natural frequency. The natural frequency of a building depends on its physi-

### TEACHING CLUES AND CUES



You may choose to have students build models in class. In that case, you will need to make student copies of Master 4.3a, and assembly will become step 1 under Lesson Development. You will also need more materials.



Instruct students to start the stopwatch as a numbered block reaches its maximum swing and start counting with zero. Often students will start counting with one when they start the stopwatch and end up with only nine swings.

cal characteristics, including the design and the building materials. Resonance is a buildup of amplitude in a physical system that occurs when the frequency of an applied oscillatory force is close to the natural frequency of the system. In the case of an earthquake, the ground shaking may be at the same frequency as the natural frequency of a building. Each vibration in the ground may come at or dangerously close to the natural frequency of the structure.

Ask the class to hypothesize what would happen when buildings of two different heights, standing next to each other, resonate from an earthquake. Wiggle the BOSS model so that assemblies 2 and 3 vibrate greatly, and let students see how buildings hammer together during powerful earthquakes. If you have some images of this effect from actual earthquakes, show them now.

Entice students to further investigation by leaving them with the question: "How could you add structural elements to reduce resonance in a building?"

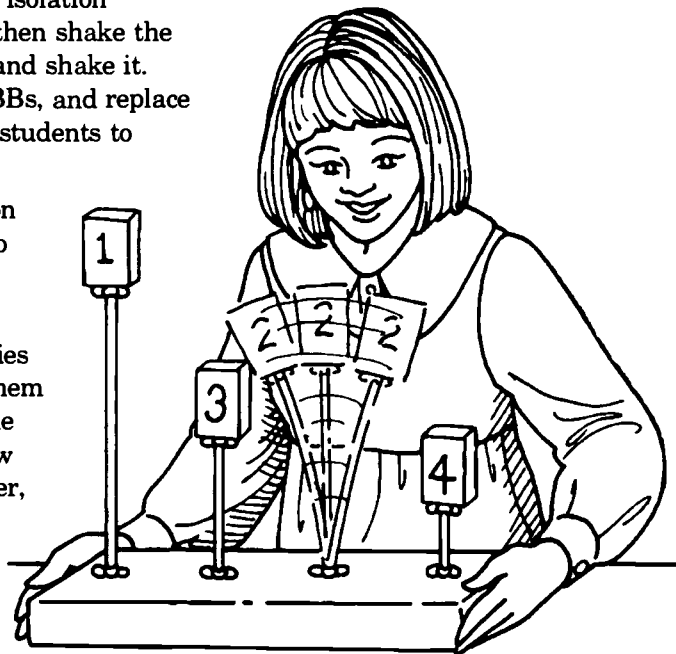
### **ADAPTATIONS AND EXTENSIONS**

1. Tell students that one way to protect a building from resonating with an earthquake is to isolate its foundation, or base, from the ground with devices much like wheels. This technique is called base isolation. Structural engineers are now developing the technology to place buildings on devices that absorb energy, so that ground shaking is not directly transferred to the building.

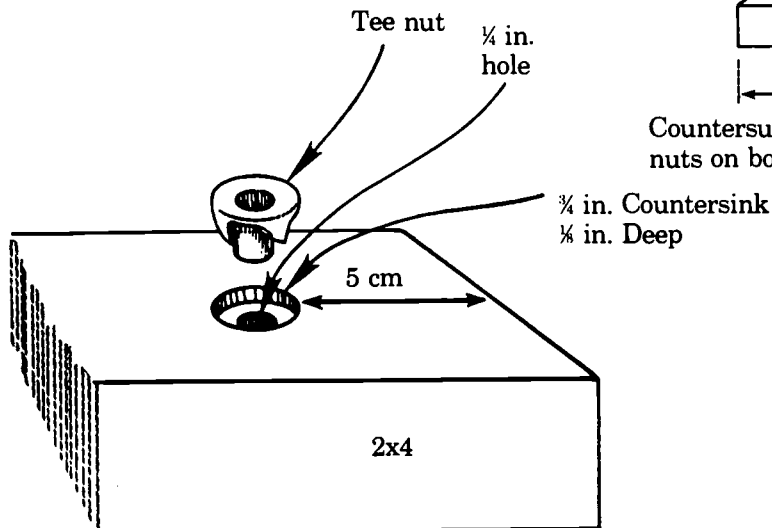
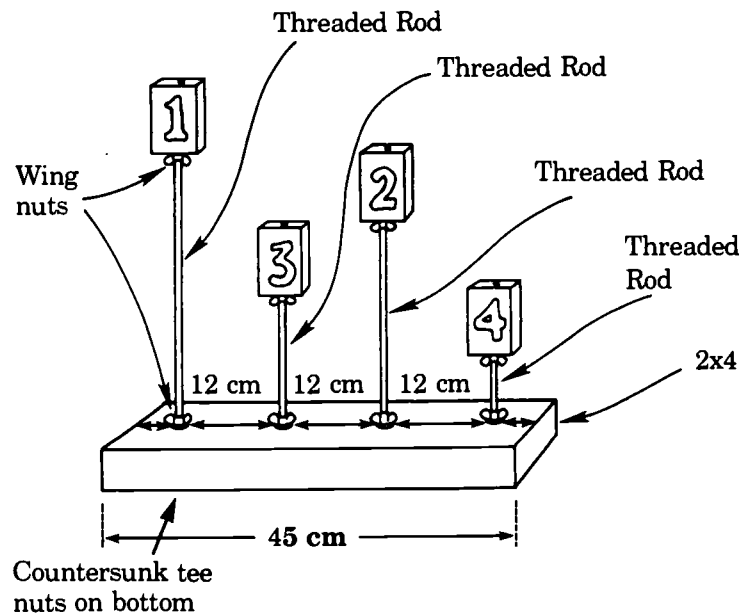
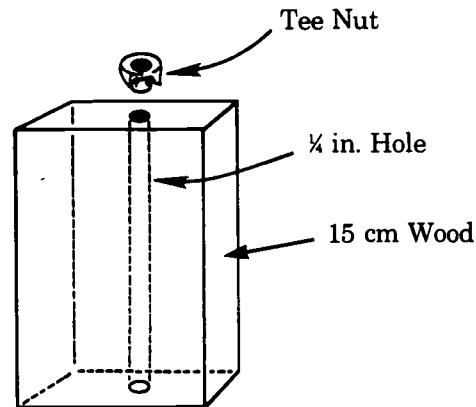
Invite students to add standard small wheels from a hardware store to their models as an illustration of one of the many base isolation technologies, or add wheels to your own BOSS model, then shake the table. Better yet, place the model in a low box or tray and shake it. Then take out the model, fill the box with marbles or BBs, and replace the model on this base. Now shake the box. Challenge students to come up with other base isolation techniques.

2. If any of your students have studied harmonic motion in a physical science or physics class, challenge them to explain how the BOSS model is an example of an inverted pendulum.

3. To help students connect the numbered rod assemblies to actual buildings, make paper sleeves and decorate them to resemble buildings in your area. At some point in the lesson, slide the sleeves over the rod assemblies to show how buildings can collide, or hammer against each other, during an earthquake. ▲



1. Cut one of the meter-long threaded rods down to 75 cm, leaving the other full length.
  2. Cut one of the 61-cm threaded rods down to 45 cm, leaving the other full length.
  3. Drill a .63-cm (1/4 in.) hole through the center of one of the short sides in each of the 15-cm pieces of wood. (See assembly diagram.)
  4. Hammer a tee nut into the hole on one end of each 15-cm piece.
  5. Countersink four 3/4-in. holes about 1/8 in. deep into the 45-cm 2 x 4 at 12-cm intervals, as marked on the diagram. (This will allow you to countersink the nuts so they don't scratch the surface where the model rests.)
  6. Drill four 1/4-in. holes in the 45-cm 2 x 4 in the countersunk holes.
  7. Hammer a tee nut into each countersunk hole. Turn the board over so the tee nuts are on the bottom.
  8. Assemble the rods and the base as shown on the diagram.
  9. Use the permanent marker to label the 15-cm 1 x 4 blocks in order, 1, 2, 3, and 4.
- Optional:* Paint the four 15-cm pieces of wood in four different colors. When they are dry, number them with the white paint.



Name \_\_\_\_\_ Date \_\_\_\_\_

Cooperative Group \_\_\_\_\_ Scientist \_\_\_\_\_

Coordinator \_\_\_\_\_ Technician \_\_\_\_\_

Engineer \_\_\_\_\_

Record oscillation times in the data table below in the appropriate place for each rod assembly. These times are measured in seconds per 10 cycles. Repeat the measurement four times to minimize human error, then record.

*Caution: Start the stopwatch as a numbered block reaches its maximum swing and start counting with zero, otherwise you will end timing only nine swings. Practice this until your times for 10 oscillations are fairly close to each other.*

Calculate the **average time** for each oscillation by adding four measurements and dividing by four. Record.

Calculate the natural **frequency**. Divide 10 cycles by the average time (do not simply move the decimal point). Frequency is measured in hertz, or cycles per second. Record.

### A. Data Table: Oscillation Times

Rod Assembly	Oscillation Time (sec/10 cycles)				Avg. Oscillation Times (sec/10 cycles)	Natural Frequency Hertz (cycles/sec)
	Trial 1	Trial 2	Trial 3	Trial 4		
#1						
#2						
#3						
#4						

1. How much variation do you notice among the four trials? \_\_\_\_\_

2. What relationship do you notice, if any, between the height of the rods and their natural frequencies?

\_\_\_\_\_

\_\_\_\_\_

### B. Heights of the Rod Assemblies

1. Measure the height of each rod assembly from the base to the top of the block and record it.

Rod Assembly	Height (cm)
#1	
#2	
#3	
#4	

2. What is the approximate difference in height between #1 and #2, #2 and #3, and so on?

\_\_\_\_\_

3. Plot the height versus the natural frequency of each rod assembly on the graph provided. You should have four data points. Connect the points with the best fitting straight or curved line you can.

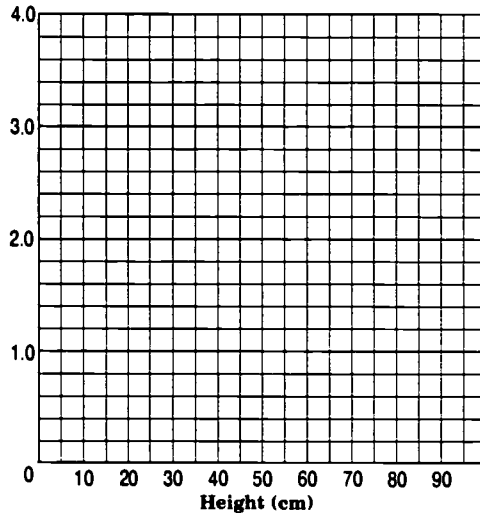
4. What kind of line did you get from your data?

\_\_\_\_\_

5. As the height of the rod assemblies gets larger, what happens to their natural frequency?

\_\_\_\_\_  
\_\_\_\_\_  
\_\_\_\_\_  
\_\_\_\_\_

Frequency  
(cycles/sec  
or Hz)



**C. Summary**

1. What variable is manipulated in this experiment? (How do the four rod assemblies differ from each other?)

2. What is the responding variable in this experiment? (What did you measure?)

3. What does oscillate, or vibrate, mean?

4. Define *frequency*.

5. Why does only one rod assembly oscillate greatly (or resonate) when you wiggle the base?

6. What is resonance?

7. How are the rod assemblies like buildings?

8. (*extra credit*) How can a building be protected from resonating with seismic vibrations?

Record oscillation times in the data table below in the appropriate place for each rod assembly. These times are measured in seconds per 10 cycles. Repeat the measurement four times to minimize human error, then record.

*Caution: Start the stopwatch as a numbered block reaches its maximum swing and start counting with zero, otherwise you will end timing only nine swings. Practice this until your times for 10 oscillations are fairly close to each other.*

Calculate the **average time** for each oscillation by adding four measurements and dividing by four. Record.

Calculate the natural **frequency**. Divide 10 cycles by the average time (do not simply move the decimal point). Frequency is measured in hertz, or cycles per second. Record.

### A. Data Table: Oscillation Times

Rod Assembly	Oscillation Time (sec/10 cycles)				Avg. Oscillation Times (sec/10 cycles)	Natural Frequency Hertz (cycles/sec)
	Trial 1	Trial 2	Trial 3	Trial 4		
#1					11	0.9
#2					6.7	1.5
#3					5	2.0
#4					3	3.3

1. How much variation do you notice among the four trials? Oscillation times vary by less than 10 percent.

2. What relationship do you notice, if any, between the height of the rods and their natural frequencies?

The shorter the rod, the higher the natural frequency. The taller the rod, the lower the natural frequency.

### B. Heights of the Rod Assemblies

1. Measure the height of each rod assembly from the base to the top of the block and record it.

Rod Assembly	Height (cm)
#1	89
#2	73
#3	57
#4	42

2. What is the approximate difference in height between #1 and #2, #2 and #3, and so on?

Approximately 15 cm, the height of the wooden rectangle at the top of each rod assembly.

**Note:** Data will vary with specific BOSS model and student. Values in the tables are to assist the teacher and are **not** to be used in evaluating students.

3. Plot the height versus the natural frequency of each rod assembly on the graph provided. You should have four data points. Connect the points with the best fitting straight or curved line you can.

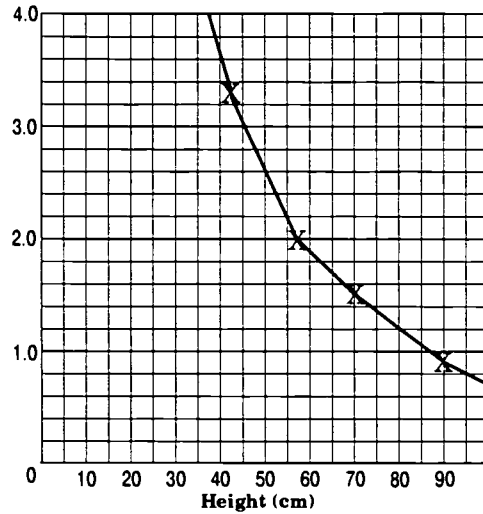
4. What kind of line did you get from your data?

A symmetrical curve, or hyperbolic curve.

5. As the height of the rod assemblies gets larger, what happens to their natural frequency?

As the height increases, the natural frequency decreases.

Frequency  
(cycles/sec  
or Hz)



### C. Summary

1. What variable is manipulated in this experiment? (How do the four rod assemblies differ from each other?)

The height of the rods varies.

2. What is the responding variable in this experiment? (What did you measure?)

The natural frequency of each rod assembly.

3. What does oscillate, or vibrate, mean?

Wiggle back and forth, or move repetitively.

4. Define frequency.

In this case, the frequency is the number of oscillations per second.

5. Why does only one rod assembly oscillate greatly (or resonate) when you wiggle the base?

The vibration only adds up in one rod, or only one rod will resonate at each shaking.

You have found the rod's natural frequency.

6. What is resonance?

When a structure is vibrated at its natural frequency, the vibrations add up. This is called resonance.

7. How are the rod assemblies like buildings?

They have mass that is attached to the base by a structure.

Or—They have fixed bases attached to freely oscillating tops by tall, stiff structures.

8. (extra credit) How can a building be protected from resonating with seismic vibrations?

Dampen the building's vibration with something like the shock absorbers on a car.

Isolate the base of the building from the ground. (Accept other reasonable suggestions.)



# EARTHQUAKE in a Box

## RATIONALE

In cooperative SETs (seismic engineering teams), students will construct an inexpensive shake table for testing structures they have built.

## FOCUS QUESTION

How do earthquake engineers use shake tables to model the effects of an earthquake on buildings, bridges, and other structures?

## OBJECTIVES

### Students will:

1. Construct a model of a shake table.
2. Design structures of various types and use the shake table to test their seismic survivability.
3. Analyze the failures of their design models and suggest ways to reduce damage.

## MATERIALS

for each small group

- One copy of Master 4.4a, Shake Table Directions
- One piece of cardboard approx. 28 cm by 38 cm (11 in. x 15 in.)
- Wide packaging tape
- Hole-punching tool
- Metric ruler
- One cardboard box with flaps removed, approx. 30 cm by 40 cm by 20 cm (12 in. x 16 in. by 8 in. deep)
- Dark blue or black marker
- Phillips screwdriver
- 3 strands of packaging string, one about 30 cm long (12 in.) and two about 60 cm long (24 in.)
- 4 heavy-duty rubber bands

## VOCABULARY



**Retrofitting:** making changes to a completed structure to meet needs that were not considered at the time it was built; in this case, to make it better able to withstand an earthquake.

**Variable:** in a scientific experiment, the one element that is altered to test the effect on the rest of the system.

## TEACHING CLUES AND CUES



Use corrugated cardboard for greatest strength.



The size of the box may vary, as long as the size of the cardboard varies with it.

- Paper clips
- Two craft or ice cream sticks
- VCR and videotapes (*optional*; see adaptations)
- A variety of materials for building structures, such as sugar cubes, ice cream sticks, small interlocking blocks, peanut butter (for mortar), dry spaghetti, straws, pipe cleaners, paper clips, cardboard, string, aluminum foil, and Styrofoam

## PROCEDURE

### Teacher Preparation

1. Several days before you plan to do this activity, ask students to bring cardboard boxes and building materials from home. Suggest the items at the end of the materials list; students may think of others on their own. Gather the remaining materials, including extra odds and ends for students who forget, and arrange them in a convenient place.
2. Following the directions on Master 4.4a, build one shake table to use as a demonstration model.

### A. Introduction

Tell the class that earthquake engineers use devices called shake tables to model the effects of an earthquake on buildings, bridges, and other structures. In this lesson, students will build simple shake tables and use them to test their own model structures.

### B. Lesson Development

1. Direct students to gather into SETs as for the other lessons in this unit.
2. Distribute one copy of Master 4.4a, Shake Table Directions, to each team. Invite students to assemble their materials and build the shake tables. Offer assistance only as needed.
3. When all the groups have completed their tables, list these 10 variables on the chalkboard or poster paper:
  - shape of structure
  - height of structure
  - construction materials
  - shape of structural elements (triangle or rectangle)
  - nonstructural exterior features (overhanging moldings, heavy decorative panels)
  - foundation strength
  - siting (type of soil structure is built on)
  - duration (how long the earthquake lasts)
  - intensity (how intense earth shaking is at the building's site)
  - frequency

### TEACHING CLUES AND CUES



A gallon plastic jug with the top cut off makes an excellent storage container for the dry materials.

### TEACHING CLUES AND CUES



Give students plenty of time to complete this step.



Use a paper clip to anchor one end of the rubber band, and a second paper clip as a needle to thread the rubber bands through the holes.

Ask each SET to select three variables from the list and design one model to test their impact, singly or in combination, when the structures are placed on the shake table. Remind students to include lifelines like bridges and electrical wires with their supports, as well as houses and other buildings.

4. Have students in each SET take turns operating the model, while the other members of the team record their observations.

5. Assign each SET to write a brief report, based on the notes from testing, that includes

- a summary of the team's observations
- reasons why their design suffered and/or resisted damage
- suggestions for making each design more quake resistant
- suggestions for retrofitting structures, where applicable
- diagrams illustrating all of the above

### C. Conclusion

Invite one representative from each SET to share the highlights of the team's report. When all the reports have been given and discussed, conduct open discussion around one or more of these topics:

- How do municipalities develop building codes for earthquake-prone areas?
- Should schools, senior citizen homes, hospitals, fire stations, police stations, and other essential facilities be forced to follow tougher earthquake codes? Why? Why might governments encounter resistance to these standards? (because of the expense involved, among other factors)
- Is it possible to develop a classification system for types of structures and their reaction to an earthquake? What factors would such a system include?

### ADAPTATIONS AND EXTENSIONS

1. If a VCR is available, have each team record its experiments and play them back in slow motion for detailed observation. Try to determine the frequency of each structure.

2. Challenge students to develop improved shake table designs, based on this model and their own ideas. Some students may choose to develop a shake table and test their best model structures as a science fair project.

3. Interested students might design a lifelines model that effectively illustrates the impact of a damaging earthquake upon buried pipe, sewer, gas, oil, water, and electrical lines.

4. As a research project, students might assess, in dollars and cents, the loss of property that has occurred in specific earthquakes because of structural and nonstructural failures, then research the cost and availability of earthquake insurance in:

### TEACHING CLUES AND CUES



Work with the class to standardize the operating procedure as much as possible. Have them practice pulling the string in one short jerk, and be sure that everyone uses approximately the same kind of pull. This will allow you to compare the work of various groups, and make students' results reproducible.

- your respective area
- New Madrid, Missouri
- San Francisco, California
- Boston, Massachusetts
- Anchorage, Alaska
- Kona, Hawaii
- Charleston, South Carolina
- Syracuse, New York
- other geographic areas of interest

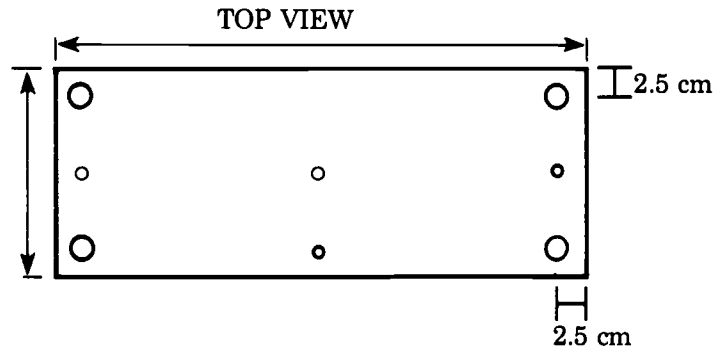
Do the insurance policies have the same premiums and regulations in all of the above geographic areas? Explain. Is all earthquake damage covered by insurance? Why or why not? ▲

*Note: This activity was inspired by one developed by Katharyn E. K. Ross, (1993), "Using Shake Tables in The Pre-College Classroom: Making The Impact of Earthquakes Come Alive." Proceedings: 1993 National Earthquake Conference, Central United States Earthquake Consortium, Memphis, TN, Vol. 1, pp. 423-429.*



**A. The Shake Platform**

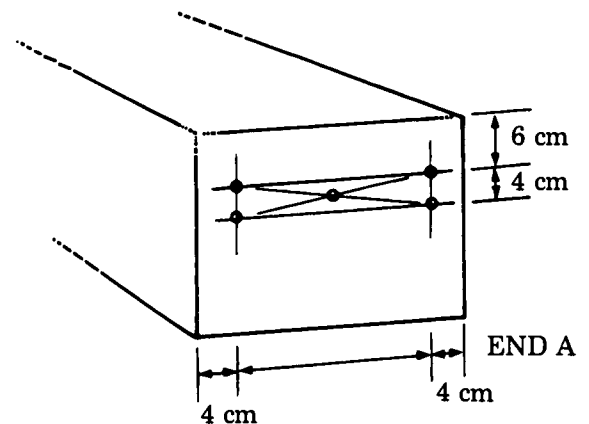
1. Reinforce the cardboard by covering all four edges with packaging tape or doubling the thickness.
2. Center a hole in each corner of the piece of cardboard 2.5 cm (1 in.) from both edges.



3. Locate the center of the long side of the cardboard by measuring halfway between the two holes you made at the corners in step 2. Punch a hole at that center point, one inch from the outside edge on one side. Repeat for the two short sides. Punch a hole in the exact center of the cardboard. You now have a total of eight holes in the platform.

**B. The Shake Box**

1. On one of the two ends of the box that is 30 cm across (one of the shorter sides), measure 6 cm (about 2.5 in.) down from the top and mark this point. Draw a straight line through the point all the way across this end of the box. Measure 4 cm (about 1.5 in.) in from the right edge along the line and mark this point. Punch a hole there with the Phillips screwdriver. Punch another hole in the center of the box bottom.



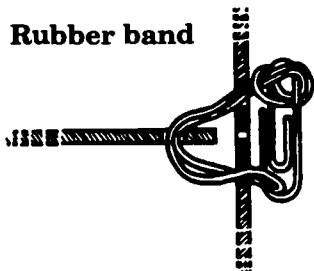
*Note: Size of platform should be 5-8 cm less than box dimensions to allow room for shaking. Dimensions will vary with box size.*

2. Measure 4 cm from the left edge on the same line and punch another hole, as illustrated. Punch two more holes 4 cm beneath the top two. Then, measure to find the point at the center of all four holes on this side. Mark that point and punch one small hole.

3. Follow the same procedure on the opposite end of the box.

**C. Putting It Together**

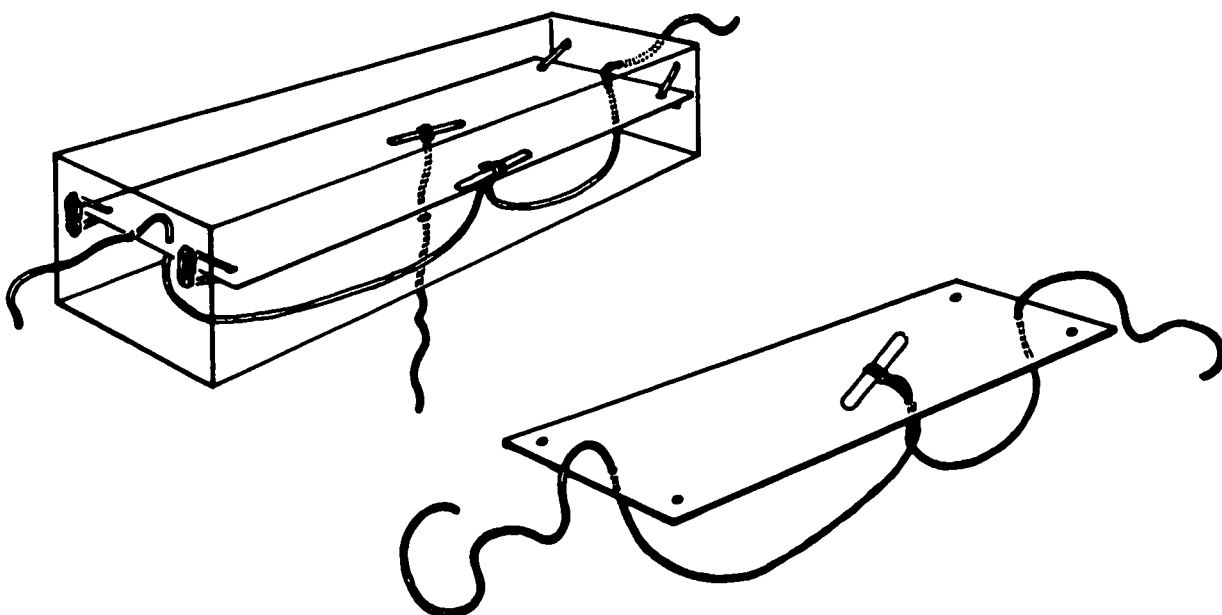
1. Tie the 30-cm length of string securely to the center of a craft or ice cream stick. Pull the free end of the string down through the center hole on the top of the shaking platform. The stick will keep the string from pulling through the hole. Leave enough string to pull through to the outside of the box.



2. Tie the two longer pieces to the center of a craft or ice cream stick. Pull them down through the center hole on the long side of the platform, then out through the center hole on the short sides of the platform. Reinforce the stick with tape if desired. When the table is fully assembled, you will pull on these strings to shake the platform.

3. While one student holds the platform in place inside the box, parallel to the floor, another student will thread a rubber band through the right upper hole in the A end of the box and the right outer hole of the shake platform, then out the lower hole in the box.

Use a paper clip to hold the rubber band in place. Do the same thing with the opposite holes on End A. Then, turn the box and repeat with End B. Pull the loose ends of both strings out through the center holes.



# The Building Challenge

## RATIONALE

A model structure can demonstrate the effects of diagonal bracing, shear walls, and rigid connections on a building's ability to carry loads similar to those created by an earthquake.

## FOCUS QUESTION

How can you design and build a model structure to carry vertical and horizontal loads?

## OBJECTIVES

**Students will:**

1. Use diagonal bracing, shear walls, and rigid connections to provide load paths in a structure.
2. Design and build a structure that will carry both vertical and horizontal loads caused by ground shaking.
3. Measure the magnitude of the shear force or horizontal load a structure can carry.

## MATERIALS

for each small group (SET)

- Structures from Lesson 4.1
- 20 Styrofoam sticks, 2.5 cm x 2.5 cm x 15 cm, precut in preparation for Lesson 4.1
- 3 pieces of string, each 30 cm long
- 10 paper clips
- 20 toothpicks
- Any materials from Lesson 4.4 that students want to use
- 1 square of tag board, 17.5 cm x 17.5 cm (about 7 in. square), to act as a shear wall
- 2 right triangles of tag board, cut from a 6-cm square, to act as rigid connections

## VOCABULARY



**Braces, or Bracing:** structural elements built into a wall to add strength. These may be made of various materials and connected to the building and each other in various ways. Their ability to withstand stress depends on the characteristics of the materials and how they are connected.

**Diagonal braces:** structural elements that connect diagonal joints. These braces may be made of solid materials or flexible materials. How they function depends on what they are made of and how they are connected.

**Load:** the sum of vertical forces (gravity) and horizontal forces (shear forces) acting on the mass of a structure. The overall load is further broken down into the loads of the various parts of the building. Different parts of a building are designed and constructed to carry different loads.

**Rigid connections:** connections that do not permit any motion of the structural elements relative to each other.

**Shaking:** in this lesson, rapid horizontal vibration of the base of the model, simulating an earthquake. In an actual earthquake, of course, shaking occurs in many directions.

- 1 square of cardboard, 30 cm x 30 cm or larger (about 1 ft square) to serve as the base
- One copy of Master 4.5a, Building Challenge Design and Analysis Sheet

*for the teacher*

- Hot glue and glue gun (to be used by one group at a time, under direct supervision)
- Shaking table from Lesson 4.4
- A dog leash or other nylon strap about 2.5 cm wide and at least 60 cm long
- Several meters of string
- A small pulley
- Weights, either a kilogram mass set or a small basket and pennies
- Master 4.5b, Certificate of Achievement
- Slides of videoa from the unit resource lists (*optional*)

## PROCEDURE

### Teacher Preparation

1. If you want to make the testing of student models a special event, make plans now. See Adaptation 1. If you have arranged to involve guest experts, remind them of the date.
2. Prepare the testing setup. Collect all the materials and have them ready to distribute.

### A. Introduction

Briefly review with students what they have experienced so far in this series of activities. Especially promote discussion of the ideas developed in Lesson 4.2. Be careful to leave the applications of those ideas very open, to avoid giving students the impression that there is only one right way to design a structure.

### B. Lesson Development

1. Direct students to gather in the seismic engineering teams (SETs) they formed in Lesson 1 of this unit. You may want to have students choose roles within the teams, like coordinator, engineer, and technician, to organize the effort and to assign accountability for timing, design, construction, and describing the performance of the structure.
2. Return to each team the structure members built in Lesson 1. Challenge the teams to design and build a new structure that will be tested in a controlled environment. Hand out the worksheets and give students time to design their structures before they receive their materials. Circulate among the groups and approve step 1 and step 2 of the designs as they are completed.
3. Demonstrate the procedure you will use to test the structures.

## VOCABULARY

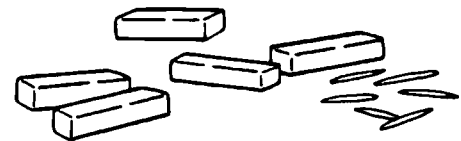


**Shear force:** force that acts horizontally (laterally) on a wall.

These forces can be caused by earthquakes and by wind, among other things. Different parts of a wall experience different shear forces.

**Shear walls:** walls added to a structure to carry horizontal shear forces. These are usually solid elements, and are not necessarily designed to carry the structure's vertical load.

**Structural elements or Structural features:** a general term for all the essential, non-decorative parts of a building that contribute structural strength. These include the walls, vertical column supports, horizontal beams, connectors, and braces.





4. Hand out all the materials except the glue guns, being certain every team receives the same set of materials. Allow some time for experimentation with the materials before students finalize their load path diagrams. Be sure students in each group have drawn force arrows on their design (step 3) to predict how they think earthquake shear forces will travel through (or load) their structure.

5. Establish how much time the SETs will have to build their structures, either by setting a uniform time for all or by inviting each SET to commit to a time limit and appoint one member of the team to keep track of time. (This could simulate the process of bidding on contracts, and add an extra element of competition.) Then give the signal to begin.

6. When building is finished, use one of the models from Lesson 1 to demonstrate fastening the structures to the center of the cardboard bases with hot glue. Have groups bring their models to the materials table to use the glue gun so you can supervise the process.

### C. Conclusion

As the teams in turn bring their models to the front of the room for testing, test every model two ways—with the shaking table and by applying weight. Tell students they are not allowed to touch their structures during testing.

Ask two students from each team to hold the cardboard base down while you test their model with weights. Use the strap to add horizontal stress in any increment the group specifies. Call out the weights and keep a record on the board of the greatest weight each structure held. Award the certificate of achievement to the teams whose structures withstand the shaking table and hold the greatest stress before breaking. (This may be one team or two.)

Ask one member of each team to describe how their structure behaved in testing. Where did it fail? Why?

Close by connecting the images students have of earthquake damage to buildings with how their structures were damaged by the artificial earthquakes of this event. Slides or videos would help to make this real.

### ADAPTATIONS AND EXTENSIONS

1. After you have done this with one class and feel comfortable with it, you may want to make the testing of student models a special event. Create some award for the structure that carries the greatest shear force. Invite your local newspaper reporters and school board members, arrange to use the auditorium, tape appropriate music, and plan refreshments. Take videos of the structure tests. Ask the principal to apply the weights and judge the event, and invite local emergency services officials to attend.

2. The experiences and materials the students developed in this unit make a fine portfolio. Invite students to include drawings of their designs and evaluate their learning by describing how they would build a structure next time or how they would retrofit their structure. ▲

### TEACHING CLUES AND CUES



This design stage may take a full class period.



Trace the structure's outline with a pencil or pen, put glue on the cardboard along the outline, and press the structure down firmly. The hot glue may melt the Styrofoam if applied directly. Warn students not to drip the glue on their hands.



This activity will generate considerable excitement. Let students enjoy it, but maintain order to be sure all students have fun and are treated equally.

# Building Challenge Design and Analysis Sheet

Name \_\_\_\_\_ Date \_\_\_\_\_

Cooperative Group \_\_\_\_\_

Coordinator \_\_\_\_\_

Engineer \_\_\_\_\_

Scientist \_\_\_\_\_

Technician \_\_\_\_\_

1. Sketch a design for your structure in the space provided below.

2. Use this space to show what it will look like from the front.

3. Use this space to show what it will look like from the side.

4. Do a load path diagram for your structure on the back of this page.

In all your drawings, show clearly how the joints will be made.

*Get your instructor's approval for all four drawings before actually building your structure.*

**Seismic Engineering Team  
Certificate of Achievement**

Presented to the **SEU** of

\_\_\_\_\_ for  
**Excellence in Design**

\_\_\_\_\_ Date

\_\_\_\_\_ School

\_\_\_\_\_ Teacher

\_\_\_\_\_ Principal

*M. Paul Smith*  
Education Programs, **SEU**

*Abdulrahman Al-Masri*  
Earthquake Education Program, **FEMA**



### Books

Arnold, Christopher, and Reitherman, Robert. (1982). *Building Configuration and Seismic Design*. New York: John Wiley and Sons.

Federal Construction Council Consulting Committee on Civil and Structural Engineering. (1992). *Base Isolation for Seismic Safety: Summary of a Symposium*. Washington, DC: National Academy Press. Summaries of nine papers describing the theory and practice of base isolation.

Federal Emergency Management Agency. (October 1990). *Non-Technical Explanations of the NEHRP Recommended Provisions*. FEMA 99. Washington, DC: Building Seismic Safety Council. Explains the necessity of a building code and how earthquakes affect buildings.

Lagorio, Henry J. (1990) *Earthquakes—An Architect's Guide to Nonstructural Seismic Hazards*. New York: John Wiley and Sons.

Moore, Gwendolyn B., and Yin, Robert K. (1984). *Innovations in Earthquake and Natural Hazards Research: Synthetic Accelerograms*. Washington DC: Cosmos Corporation (202-728-3939). Discusses the use of computer-derived earthquake simulations to predict how buildings will respond to earthquake shaking.

Plafker, G., and Galloway, J.P., eds. (1990). *Lessons Learned from the Loma Prieta, California, Earthquake of October 17, 1989*. U.S. Geological Survey Circular 1045. Washington, DC: U.S. Geological Survey.

Salvadori, M. (1990). *The Art of Construction*. Chicago, IL: Chicago Review Press. Simple and readable, expressly written for young readers.

### Periodical Articles

Bedway, B. (Feb. 23, 1990). "Building for a Landscape on the Loose." *Science World*, pp. 9+. For ages 12–15.

Boraiko, A.A. (1986). "Earthquake in Mexico." *National Geographic* 169: 655–675.

Brady, Gerry. "Desk Top Model Structure for Dynamic Earthquake Demonstrations." U.S. Geological Survey. Applies simple models to predict natural frequency. Plans provided for constructing models of strong column/weak beam and weak column/strong beam buildings, plus descriptions of buildings' reactions to earthquakes and explanations for the results.

Robison, Rita. (November 1989). "Isolated Examples." *Civil Engineering*: 64–67. Describes base isolation in practice.

Rosenstock, L. (March 17, 1989.) "Can Buildings Be Made to Survive Earthquakes?" *Current Science*, pp. 6–7. For ages 10–16.

Tarics, Alex. (April 1993). "First U.S. Application of Seismic Base Isolation." *Phenomenal News: Natural Phenomena Hazards Newsletter*: 1–4.

### Non-Print Media

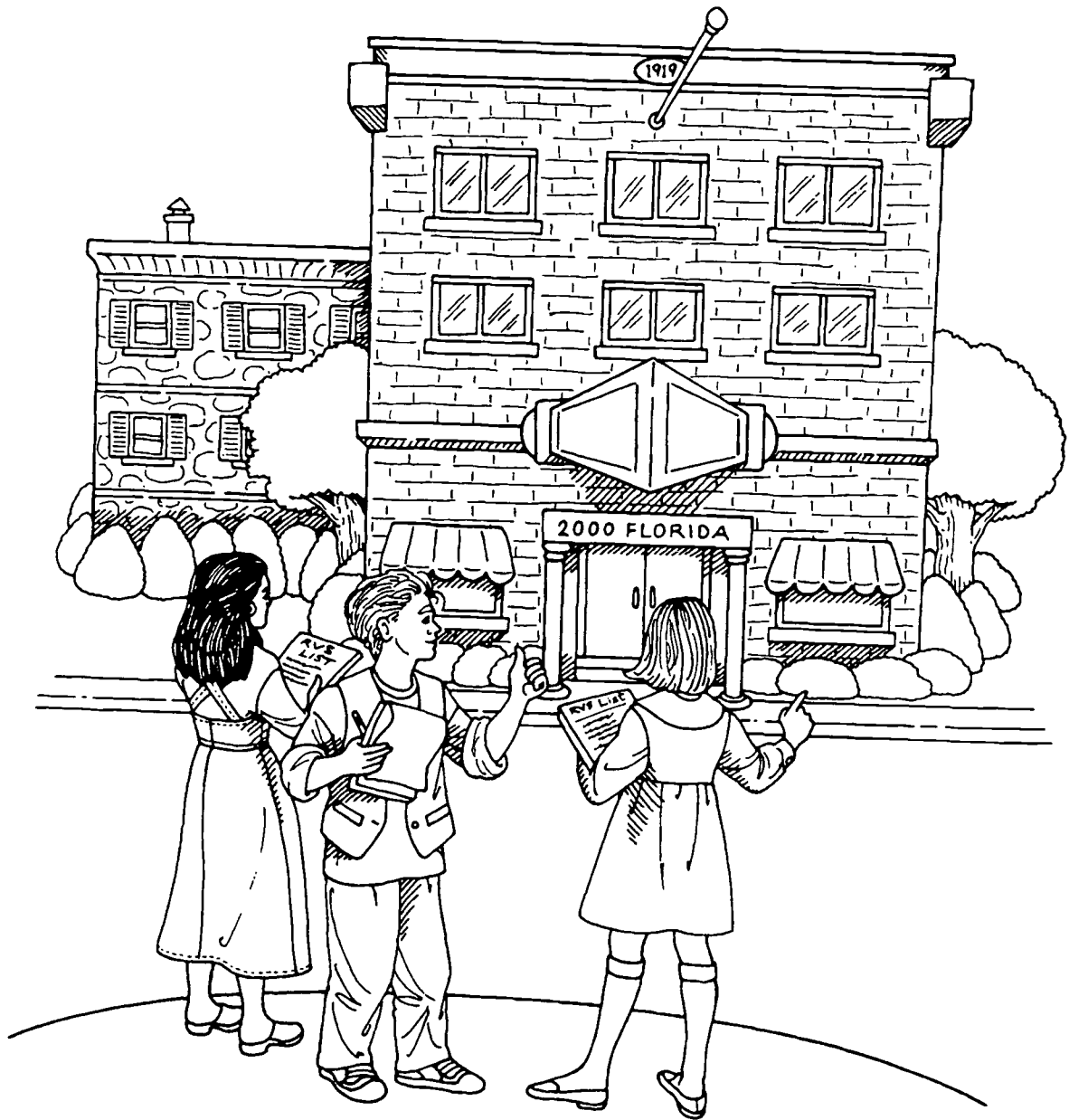
*The Great Quake of '89*. Videodisc and Macintosh software. Includes segments taken from ABC news coverage showing actual damage to the Bay Bridge, Highway 880, the San Francisco Marina, and the downtown. The Voyager Company, Santa Monica, CA; 310-451-1383.

*Note: Inclusion of materials in these resource listings does not constitute an endorsement by AGU or FEMA.*

U N I T



F I V E



# What Should People Do Before, During, and After an Earthquake?

Following the pattern established in earlier units, this set of lessons returns students from model structures to the actual structures in their own community. Some of the activities will require outside help. The relationships with experts in the community that you and your students established in Unit 1 and have developed in subsequent units will stand you in good stead.

In Lesson 1, students explore the tantalizing possibilities of earthquake prediction. The first activity is based on an actual series of events stemming from one rather ambivalent recent prediction of an earthquake on the New Madrid Fault, the site of the most widely felt earthquake in U.S. history in 1811-1812. Students read accounts of the prediction and its aftermath, discuss the reactions of different groups, and learn how to evaluate such a prediction. In the second activity they consider levels of probability and categorize various scientific and nonscientific approaches to predicting earthquakes. When they have finished these activities, they will realize they cannot place their faith in any warning system currently available. Their best bet, wherever they live, is to be prepared for earthquakes and other natural disasters.

Lesson 2 begins where the students are, in school and at home. The first activity is an earthquake and evacuation drill, followed by a classroom hazard assessment. The earthquake and evacuation drill is

absolutely basic for your students' safety; *do not omit this lesson*. Even if your students do not live in an earthquake-prone area now, they may someday.

Students develop a checklist for home hazard assessment in the second activity of Lesson 2. In Lesson 3, they learn the elements in the construction of a typical wood frame house by visiting a house to inspect its foundation and other structural elements. They complete a checklist and take home detailed instructions for reinforcement projects they can do with the assistance of a parent or other adult.

Moving out into the community, in Lesson 4 students evaluate the potential earthquake damage to various structures in their community. They will conduct a sidewalk survey to estimate vulnerability of buildings to earthquake damage. Engineers and other experts you contacted earlier will provide valuable assistance in this project. They can not only help students to generate data, but also advise them on how to interpret it.

Lesson 5 builds directly on work students did in Unit 1 to assess their own community's vulnerability. In this activity they will see the relationships of various secondary disasters to the earthquake that initiates them and describe how local emergency services would work together to alleviate their effects. The community map begun in Unit 1 and elaborated in Unit 2 will be further developed in this activity.

# Predicting EARTHQUAKES

## ACTIVITY ONE

I READ IT IN THE NEWSPAPER

### RATIONALE

By reading newspaper accounts of an earthquake “prediction” or forecast that proved to be false, students will learn to be critical consumers of media reports. They will analyze the content of articles spanning more than a year and compare the varying reactions of different people and groups.

### FOCUS QUESTION

What would you do if an earthquake was predicted for your town?

### OBJECTIVES

**Students will:**

1. Read media accounts analytically.
2. Visualize the effect of an earthquake prediction on a community.
3. Know how to obtain reliable earthquake information from the appropriate government agencies.

### MATERIALS

- Student copies of Master 5.1a, Newspaper Accounts (6 pages)
- Paper and pencils or pens

### PROCEDURE

#### Teacher Preparation

Read the articles before you distribute them to students. Outline the highlights of each article, especially noting the effects of the forecast upon the community, how the forecast is reported slightly different in each story, and the response of governmental agencies.

#### A. Introduction

Tell the class that in the fall of 1989, climatologist Iben Browning

### VOCABULARY



**Prediction:** a statement that something is likely to happen based on past experience. A prediction is usually only as reliable as its source.

**Probability:** in mathematics, the ratio of the number of times something will probably occur to the total number of possible occurrences. In common usage, an event is probable, rather than merely possible, if there is evidence or reason to believe that it will occur.

**Retrofitting:** making changes to a completed structure to meet needs that were not considered at the time it was built; in this case, to make it better able to withstand an earthquake.

### TEACHING CLUES AND CUES



According to the Federal Emergency Management Agency (FEMA), an earthquake prediction must include time, place, magnitude, and probability. An earthquake forecast is much less precise.

reportedly predicted that an earthquake of magnitude 6.0 or greater would occur on December 3, 1990, plus or minus 48 hours. However, his forecast also said that the earthquake would occur between the 30° N and 60° N lines of latitude, an area that encircles the Earth. According to scientists, the probability that a seismic event of magnitude 6.0 or greater will happen in such a broad zone of the Earth's surface is actually very high.

However, the media reported that Browning had specifically predicted a catastrophic earthquake in the highly seismic area of New Madrid, Missouri, which in 1811-12 was the epicenter of the most powerful earthquakes ever recorded in the continental United States. People in the New Madrid area reacted to the continual flow of media coverage about the impending quake by stocking up on food and water, purchasing expensive earthquake insurance, making plans to travel to distant places, developing emergency community preparedness plans, and retrofitting buildings. School systems even scheduled "earthquake breaks." On the day of the predicted seismic event, the little midwestern town of New Madrid was overrun by the television and newspaper media.

## B. Lesson Development

1. Divide the class into groups of four or five students each and distribute at least two newspaper articles on Master 5.1a to each group. Instruct students to read the articles and take notes individually, then discuss what they have read. Student notes should answer the following questions:

- How did government agencies react to the prediction?
- How did the scientific community react?
- How did some entrepreneurs react (people who saw an opportunity to make money)?
- How did many laypeople react?

2. Now ask students in each group to pool their notes and write a brief team report that covers the following points:

- How did Iben Browning arrive at his prediction?
- How did the people of the New Madrid seismic zone and surrounding areas react to the media coverage?
- How did the scientific community react?
- How did the news media react?
- In your opinion, which governmental agencies should citizens consult to obtain information about the accuracy of earthquake forecasting?
- How would you personally react to headlines and newspaper accounts of a devastating earthquake that was forecast for your home town?

3. Invite teams to orally present their reports to the class. When all groups have reported, discuss and analyze the teams' conclusions in light of new information from other teams. Encourage students to point out discrepancies among the various reports. (Iben Browning's

## TEACHING CLUES AND CUES



The second activity in this lesson, Faulty Reasoning, reviews the federal government's official protocol for assessing earthquake predictions.





doctoral degree, for example, is variously reported as being in physiology, in climatology, in zoology, in biology, and in genetics and bacteriology.) Point out, however, that the pages were originally arranged in chronological order, so it takes the full set to tell the full story. No one group will have as much information as the class as a whole.

### C. Conclusion

Invite discussion of the nature of Browning's earlier "successful" predictions. Could they have been of the same open-ended nature as this one? How difficult is it to successfully predict an earthquake after it has happened?

Be sure students know where to obtain accurate earthquake information: from the U. S. Geological Survey, the Federal Emergency Management Agency, their state office of emergency services, and the state geological surveys. (The latter have various names, such as the California Governor's Office of Emergency Services, the Missouri Emergency Management Agency, the Vermont Division of Emergency Management, and the Utah Division of Comprehensive Emergency Management.) Check the resource list in Unit 1 and your local telephone books for these listings.

### ADAPTATIONS AND EXTENSIONS

---

1. According to the articles, Browning specified a time period that would coincide with the Moon's maximum gravitational attraction upon the Earth. Ask students how they would set up a test to demonstrate that the Moon affects earthquake or volcano activity.
2. Distribute copies of the August 1991 article, the last in the set, to every student, or read it aloud with the class. Discuss the conclusion that the scientific community was partly to blame.

## ACTIVITY TWO

### FAULTY REASONING

#### RATIONALE

---

Because of the randomness of seismic events and the fact that scientific understanding about earthquake-generating mechanisms is still evolving, earthquake prediction today is imprecise, indeed even speculative.

#### FOCUS QUESTION

---

Why is predicting earthquakes not an exact science?

#### OBJECTIVES

---

##### Students will:

1. Explain the purpose of predicting earthquakes.
2. Identify several types of seismic predictions.
3. Explain why earthquake prediction is complex and based largely on probability.

#### VOCABULARY

---



**Generalization:** a statement made after observing occurrences that seem to repeat and to be related.

## MATERIALS

---

- Chalkboard or overhead projector, chalk or markers
- Student copies of Master 5.1b, Approaches to Predicting Earthquakes
- Student copies of Master 5.1c, Levels of Generalization: Classification Chart
- Back of Master 5.1c, Answer Key

## PROCEDURE

---

### A. Introduction

Tell students that with increasing numbers of the world's people living in active earthquake zones, earthquake prediction or forecasting has been receiving more and more attention in recent years. Begin by asking students to name some advantages of being able to predict earthquakes. Record responses on the overhead or chalkboard.

(Likely answers will include saving lives and reducing property loss and damage, providing guidelines for development and human settlement, providing valuable data for the scientific community, helping people to prepare for earthquakes on both a short-term and a long-term basis, and allowing communities to return to normal more quickly after an earthquake.)

Ask: Would there be any disadvantages to being able to predict or forecast earthquakes? (Answers might include financial losses to businesses forced to close and the anxiety people would feel if they knew an earthquake was imminent.)

### Lesson Development

1. Ask: Are we, in fact, able to predict or forecast earthquakes with any certainty? Students may have heard of some theories and attempts at prediction, but they will also know that earthquakes have claimed lives and property in recent years. If earthquake prediction was an exact science, these losses would have been greatly reduced.

Remind students that while significant efforts at developing systems of accurate prediction are underway in earthquake-prone countries like Japan, the United States, and the People's Republic of China, seismologists are still a long way from accurate prediction. Point out that of the several types of phenomena that may predict an earthquake, many may be due to other causes and yield false alarms.

2. Organize the class into groups of three or four students each. Have all the students in each group list these terms at the top of a blank sheet of notebook paper: time, magnitude, place, and probability. Ask each group to write briefly how they think these terms relate to seismic prediction and why they are important. Also discuss the idea of coincidence versus that of causality. For example, a sunrise occurs within 24 hours of every earthquake, but sunrises cannot be said to cause earthquakes.

## TEACHING CLUES AND CUES

---



Point out that the degree of probability is an essential element in prediction. You can predict with a probability of 99.9% that an earthquake of magnitude 2 will occur in southern California tomorrow. For larger quakes, the degree of probability drops sharply.

253

3. After several minutes, ask one student in each of the groups to summarize the group's findings. While answers may vary, the pattern of response should consistently indicate how helpful such precise information would be to surviving an earthquake with minimum loss of life and property damage.

4. Write this statement on the overhead or chalk board: "Earthquake prediction or forecasting takes place at several levels of generalization and involves various approaches." Stress the term generalization, so students will recognize that prediction is broadly based and in many instances, largely theoretical.

5. Distribute copies of Master 5.1b and instruct students to classify each of the approaches to predicting earthquakes listed into one of the three categories on the table that follows. Their challenge is to organize the data about earthquake predictions into a chart classifying different kinds of information.

6. When the students have developed the charts, allow time for sharing and comparing answers. The important element in this part of the activity is not that students make the "right" classification, but that they can defend their reasoning.

### C. Conclusion

Explain to the class the federal government's official protocol for evaluating earthquake predictions.

The National Earthquake Prediction Evaluation Council (NEPEC) convenes to hear evidence for the prediction of an earthquake above magnitude 5.5. If the NEPEC validates the prediction, the following will occur:

*Issuance of Earthquake Predictions. The Director of the United States Geological Survey (USGS) is hereby given the authority, after notification of the Director of the Federal Emergency Management Agency (FEMA), to issue an earthquake prediction or other earthquake advisory as he [sic] deems necessary. ... The Director [of FEMA] shall have responsibility to provide state and local officials and residents of an area for which a prediction has been made with recommendations of action to be taken.*

Public Law 95-124, Earthquake Hazards Reduction Act,  
as amended [P.L. 96-472]

Add that the USGS also issues earthquake advisories. The state of California has its own earthquake prediction evaluation council and its own notification protocol.

Ask students to review the notes they have taken and the chart data they have organized, then select the theory or approach that seems most plausible to them. As homework or in class, each may write a personal prediction of how this approach will be developed and refined in the coming years. Students may want to defend their predictions in a class discussion.

### TEACHING CLUES AND CUES



According to Bruce Bolt (*Earthquakes*, 1993 edition, p. 185), the methods of prediction that currently show the most promise require elaborate equipment and many workers, so that their cost is likely to be prohibitive.

## **ADAPTATIONS AND EXTENSIONS**

---

1. It may be useful to illustrate the concept of mathematical probability with dice or the toss of a coin. The probability of heads in a coin toss is 50-50.
2. Invite interested students to learn more about some of the scientific prediction methods, such as creep meters and radon monitoring, and report back to the class. Consult the unit resources and your local libraries. ▲



# The Earthquake Reporter

Volume 1

"News of Geologic Importance"

Issue 1

From the *Arkansas Democrat*,  
November 29, 1989

## New Madrid tremors due, forecast says

MEMPHIS, TN—A climatologist who predicted the San Francisco earthquake Oct. 17 says the New Madrid Fault region could be in for serious tremors next year.

Iben Browning is a Tijeras, NM, scientist who develops long-range weather forecasts for businesses. He bases his quake predictions on the theory that tidal forces of the Sun and Moon produce stress in the Earth.

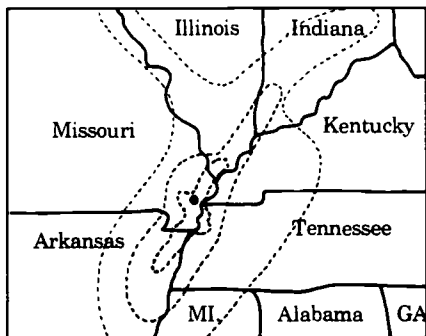
Browning, an inventor with a doctorate in physiology, has studied weather for 30 years, but does not publish his findings in scientific journals. He is better known in business circles, and publishes a monthly newsletter. His New Madrid forecast is based on a 179-year cycle of tidal forces last felt in 1811. Browning said the conditions will be ripe for tremors Dec. 3, 1990.

"The configuration will be the same as it was the year the original earthquake went off," Browning said Monday.

That isn't to say tidal forces would cause a major earthquake next year south of St. Louis to a point north of Memphis, he said.

Experts have predicted a major earthquake in the New Madrid zone could cause major damage to match that of the recent California quake.

Dr. Arch Johnston, director of the Center for Earthquake Research and Information at Memphis State University, said the tidal force theory is backed by some scientific data, but isn't conclusive by any means.



From the *Dallas Morning News*, July 22, 1990

## Prediction prompts residents to wonder, worry

THE NORTHEAST ARKANSAS TOWN OF 25,000—a county seat with Air Force base and several small industries—is perched directly over the site of [Iben Browning's earthquake] prediction. Knowing what lies beneath the flat delta farmland clearly makes some uneasy.

"Our fire chief told our firemen they can't take a vacation. Some already asked," said Mr. Edwards, a Fire Department lieutenant. "He said we could ship our families out, but we're staying. It was said kind of in a jest, but I think that everyone is actually pretty serious about this."

One geophysicist studying Dr. Browning's methods says the projection can't be ignored because he had predicted other earthquakes—including last October's California temblor.

But most experts dismiss the warning. They acknowledge that there is a 50-50 chance that a destructive quake will hit the fault by decade's end, but they say the projection lacks scientific validity.

"It seems like people are becoming worried about it for no reason at all," said Dr. Brian Mitchell, chairman of the Department of Earth and Atmospheric Sciences at St. Louis University.

At the center of the furor is an ailing 72-year-old inventor from Tijeras, NM, who has spent much of the last 20 years offering clients advice on the esoteric topic of future world climates.

Dr. Browning declined to be interviewed. But his daughter, Evelyn Browning Garriss, said her father began forming his wide-ranging theories while working at Sandia Laboratories in Albuquerque, NM. Dr. Browning has a doctorate in biology from the University of Texas, and Ms. Garriss said his interests range across many fields. She said he has been a test pilot and developed weaponry and TV technology.

Ms. Garriss said the ideas that spawned her father's latest projection arose from research for the U.S. government on peaceful uses for atomic bombs. While studying

how explosions affect the atmosphere, she said, he became fascinated with volcanoes. He found that volcanoes are triggered by the same gravitational pulls that cause ocean tides, and he "discovered that the same forces that trigger volcanoes also trigger earthquakes," she said.

That theory produced his projection of an earthquake on the New Madrid Fault. Although rejected by most scientists, Dr. Browning's new warning has gained attention from many in a region already worried about the New Madrid Fault's potential for destruction.

Some earthquake-preparedness efforts have been underway for six years because seismologists warned in the early 1980s that a temblor measuring 6.0 on the Richter scale had a 50-50 chance of occurring before 2000. Indiana, Kentucky, Missouri, and the cities of Carbondale, IL, Memphis, TN, and St. Louis have approved seismic building codes in the past two years.

Since 1984, seven states and the Federal Emergency Management Agency have developed a regional emergency response system through the Central U.S. Earthquake Consortium in Memphis.

Most state officials place little stock in the prediction, but they hesitate to reject it for fear of encouraging complacency about real threats posed by the fault. Mississippi officials are accelerating preparedness planning. And in Illinois, officials are forming a plan to address panic that might result if any detectable tremors hit the region near the predicted date, said Tom Zimmerman, the state's emergency planning director.

To further soothe regional concerns, state emergency officials want scientific experts to formally evaluate the prediction. Several state officials said they have asked the National Earthquake Prediction Evaluation Council, based in California, to address the issue.

The council of pre-eminent earth scientists has turned down the request.

"They don't want to glorify the prediction," Dr. Mitchell said.

San Francisco Chronicle, July 25, 1990

# What If He's Right?

by Jerry Carroll

ALBUQUERQUE, NM—The scariest man in America walked through the door with his daughter, looking with his bald head and spectacles like everybody's idea of a nice grandpa. Given what we were going to talk about, I half expected to see Iben Browning in long robes and a tall wizard's hat.

He told audiences before last October's earthquake that the earth was going to move in the Bay Area, and now he says there is a 50-50 chance there'll be a major earthquake December 3 on the New Madrid Fault in Missouri, on the Haywood Fault in East Bay, or in Tokyo.

Browning bases his forecasts—which he calls mathematical calculations about the pressures the Sun and Moon exert on the Earth's surface—on forces he says have a profound if little known effect on the course of civilization.

While his projections fascinate the media, they leave the science community with a healthy dose of skepticism.

"No evidence," say some.

Scientists who have studied tidal influences of the Sun and the Moon have come up with no evidence that they trigger earthquakes, said James Dorman, associate director of the Center for Earthquake Research and Information at Memphis State University. In 1972, Dorman studied 30,000 earthquakes looking for a correlation, but failed to find one. "Browning has not convinced anyone he knows what he's doing," he said.

But Browning has his believers.

The New Madrid Fault was responsible in 1812 for the mightiest earthquake in American history. Estimated at more than 8.5 on the Richter Scale, it toppled chimneys in Cincinnati, made church bells ring in Boston, and awakened James Madison in the White House and Thomas Jefferson in Monticello. A similar quake today could claim hundreds of thousands of lives and cause more than \$50 billion in damages.

The South Mississippi County School District No. 57 in Arkansas, for one, thought enough of Browning's warning to cancel classes December 3 and 4. The Missouri and Arkansas National Guards are planning earthquake exercises those days.

In a memorandum last month to mid-western earthquake experts and the Missouri Emergency Management Agency, David Stewart of the Center for Earthquake Studies at Southeast Missouri State University in Cape Girardeau, MO, wrote: "That he was correct in the Loma Prieta event is a verifiable fact."

Furthermore, Stewart continued, "He was also apparently correct within a few days of

predicting the eruption of Mount St. Helens on May 18, 1980. In this latter instance he was speaking before a group of several hundred in Portland, OR, on May 15, 1980 when he told them it would go in about a week." The volcano, dormant for 123 years, had been threatening to blow since March 27.

Stewart said: "His calculations had also picked the dates of Sept. 19, 1985, and Nov. 13, 1985, upon which the Mexico City earthquake and the Nevado del Ruiz volcano eruption in Columbia, respectively, occurred."

The memo, which was leaked, got Stewart in hot water. "He swallowed Browning's story hook, line, and sinker," Dorman said. "Stewart did not boost his own stock in the scientific community."

## A Visionary?

So who is this man and how can he appear to do with a sharp pencil what seismologists can't, for all their high-tech laser beams, strain gauges, and tilt and creep meters? Is he a seer, a visionary who screws his eyes shut and holds a finger to his temple?

Do we lump him in the same category as Jim Berkland, the Santa Clara County geologist who says he predicts earthquakes using a theory based in part on how many pets run away from home?

"He has an intellect like a giant," said Dwaine W. Rogge, president and founder of the Commerce Financial Group in Lincoln, NE. "He must have an IQ of 200-plus," said agricultural specialist Roger Spencer, a first vice-president of Paine-Webber of Chicago.

The two of them, like the majority of Browning's clients and the subscribers to his monthly newsletter, rely on him for help in investments and business decisions based on Browning's analysis of climatic trends. Before diabetes limited his mobility, Browning shared top billing at business and economic conferences with the likes of Milton Friedman and Henry Kissinger. He spoke 40 to 50 times a year, getting \$2,500 for his talks. "Earthquake projections," Browning told me, "are purely a sideline, one that has really become a nuisance."

He said that he made only seven projections about earthquakes or volcanoes erupting and has been right each time. It doesn't bother him that his fellow scientists ignore him. Given his lack of formal credentials in the field, it's to be expected, he said. "Anyway, I'm not talking to them. I'm talking to my clients."

## Scientist, Master Consultant

Browning is primarily an inventor. He has 67 patents, the most recent for a high-definition television system licensed to the Japanese. He has been a consultant for business in the

fields of bio-engineering, computers, electronics, environmental systems, information theory, microbics, microminiaturization, optics, and space navigation.

"I was a test pilot in Victorville [CA], flying two-engine and four-engine airplanes." While fellow pilots drank beer after work, Browning, who has total recall, stuffed his mind with the Encyclopedia Britannica. "I read articles at random, integrating them into what I already knew." By war's end, he had read more than a thousand.

After the war, he got a master's degree from the University of Texas in physics and bacteriology and a doctorate there in genetics and bacteriology.

## Military Consultant

When he wasn't inventing, Browning worked as a consultant for defense industries. But while studying the effects of atomic bombs for the Sandia National Laboratories in 1957, he realized they were puny compared to the power unleashed by volcanic eruptions.

That's when he began his study of climate, immersing himself in several scientific disciplines in a manner not often done in an age of narrow specialization. The data he consulted ranged from magnetic field intensities during ancient Egyptian dynasties to records of lynx pelts bought from trappers by Hudson Bay Co. in the 17th century.

He became convinced that earthquakes and volcanic eruptions were triggered by sunspot activity and the pull of the Sun and Moon on the Earth's brittle crust—the tidal effect.

Seismologist William Ellsworth of the U.S. Geological Survey in Menlo Park, a major leader in quake research, says, "If there is a tidal effect, it clearly is not something either universal or of any practical importance."

At least two other scientists agree.

Brian Mitchell of the Department of Earth and Atmospheric Sciences at St. Louis University and Arch Johnson of the Center for Earthquake Research in Memphis wrote disaster officials in the New Madrid Fault area pointing out that of five earthquakes Browning said were triggered by tidal forces, only one occurred during a high-tide period.

"I don't think the prediction is anything we should pay attention to," Mitchell said.

## Not Over Yet

Browning says that even if December 3 (when tidal forces hit a 27-year high) arrives and it turns out that seismic pressures here, in Missouri, and Japan haven't yet built to the point where earthquakes are triggered, that doesn't mean we're out of the woods. January 19, 1992, will bring on the highest highs in more than 1,600 years.

You're a pessimist, I said. "No I'm not," Browning replied with equanimity. "Man will survive. He always has."

257

The Dallas Morning News, July 26, 1990

## Experts to evaluate earthquake warning

by Lee Hancock

The U.S. Geological Survey will officially evaluate a New Mexico man's warning that an earthquake may rock the central United States on Dec. 3, 1990, an agency official said Wednesday.

Walter Hays, an official with the Geological Survey in Washington, said the agency would convene a panel of geologists and seismologists from throughout the central United States to study the prediction.

"We're not at all impressed with this forecast," he said. "On the surface we would not expect there is any basis for concern. But we do want to set people at ease and be satisfied in our own minds that we haven't overlooked something."

The location of the predicted earthquake is along the New Madrid Fault, which runs between Marked Tree, AR, and Cairo, IL, and has branches in West Tennessee and the Missouri boot heel.

Scientists say it is impossible to predict

exactly when an earthquake will occur. However, they say they are trying to estimate the probability of an earthquake along several highly active faults in the United States.

The decision to evaluate the prediction follows a plea for help by the region's seven-state earthquake response coalition, an agency that has been struggling for more than a month to address growing regional fears about the prediction by Iben Browning, a self-styled climatologist from Tijeras, NM.

Dr. Hays said U.S. Geological Survey scientists have considered about 300 predictions since 1977 that ranged from the scientific to the ridiculous. But he said that the widespread public concern makes Dr. Browning's prediction unique and that it was the primary reason for the evaluation.

Dr. Hays said the study probably would be completed by the end of September.

The National Earthquake Prediction

Council, an advisory board of earth science experts set up by the U.S. Geological Survey, last month refused to evaluate Dr. Browning's prediction. "They didn't want to glorify it," one mid-south seismologist said.

Dr. Hays said the 13-member council would evaluate the findings of the regional scientists' group at the request of the federal geological agency.

"On the surface we don't expect to see any basis for this to be a credible prediction," he said. "But you have to go through a process."

The council has officially endorsed 13 predictions since its creation in 1980, said Dr. Hays, deputy chief for research applications in the Geological Survey's office of earthquakes, volcanoes, and engineering. The endorsed predictions, which project activity along faults in Alaska and California over periods ranging from four to 30 years, are still pending, Dr. Hays said.

The New York Times, August 20, 1990

## Midwest Quake Is Predicted

by William Robbins

NEW MADRID, MO., AUG. 15—Life on the fault line is always interesting, as people in this trembly old Mississippi River town often say, but a prediction by a man named Iben Browning is making life hereabouts downright exciting.

Dr. Browning, a climatological consultant from New Mexico, has calculated that on Dec. 3, give or take 48 hours, this area could once again be the center of a destructive earthquake. People in Missouri and neighboring states are taking his prediction seriously enough to plan events like National Guard drills and informational town meetings, to store food, and to consider closing schools on the appointed day.

There is considerable skepticism among experts and residents of this area about Dr. Browning's prediction, which involves calculations of tidal forces resulting from the gravitational effects of the Earth, the Moon, and the Sun. But New Madrid is conditioned by its history to take a sober view of warnings.

This town is near the epicenter of one of the most devastating earthquakes ever recorded in North America. A series of quakes, beginning with a colossal shock, struck at 2 a.m. on Dec. 16, 1811, while settlers and Indians in the Mississippi River frontier slept. Tremors shook the earth almost continuously for months, and two even greater shocks struck on Jan. 23 and Feb. 7, 1812.

### Debate on Predictability

Seismologists say it is impossible to predict when another big earthquake might strike. But based on what they know of geologic conditions, they calculate that there is a 50 percent chance for a 6.3-magnitude quake by the end of the decade and a 90 percent chance for such a quake by 2040.

Most scientists doubt the ability to pinpoint the date of an earthquake. But at least one, David Stewart, director of the Earthquake Information Center at Southeast Missouri State University in nearby Cape Girardeau, says he has looked into Dr. Browning's previous predictions and accords him respect.

Dr. Browning's previous warnings have been widely reported in another quake-skittish locale, San Francisco. He is known to have predicted the 1989 San Francisco earthquake a week in advance in an appearance before about 500 business executives and their wives at a convention. He is also said to have predicted the eruption of Mount Saint Helens in 1980.

Like the experts, the people with the biggest stake in the debate, those who live here, are also divided on Dr. Browning's prediction.

Don Lloyd, the city administrator, typified the most optimistic stance. "We know it's coming sometime, but it's just as likely to happen

tomorrow as next Dec. 3," he said the other day.

Most people are like the police chief, Jimmy Helmes, or officials of the National Guards of Missouri and Arkansas. While they are not panicking, they see nothing wrong with taking precautions, either.

Missouri's Army National Guard is planning earthquake exercises Oct. 13 to 14, and the Arkansas National Guard is planning a similar drill Dec. 1 to 5. "We were planning an exercise anyway," said Maj. Cissy Lashbrook, the Arkansas Guard's public information officer. "But Browning has attracted so much attention, this looked like a good time to let people know we do have a plan."

Mr. Helmes has planned to store food and water supplies in a warehouse and to station school buses nearby for emergency transportation. Mayor Dick Phillips and Mr. Lloyd are planning a town meeting at which Dr. Stewart will discuss precautions.

In addition, officials of a few schools in nearby towns are considering closing them for the day. Gerald Murphy, a high school coach, wants his wife, Beth, to take their baby and get out of town, and James and Gloria Taylor of nearby Lilbourn are planning to take their daughter and son-in-law on a trip on the first weekend in December.

See Quake (next page)

**Quake** (from previous page)

The talk has naturally focused attention on the man who made the prediction.

Dr. Browning's academic background is in mathematics, physics, and microbiology, and his doctorate, in biology, is from the University of Texas. He is also a self-taught climatologist and serves as a consultant on the subject to many businesses and executives.

**"No Public Pronouncements"**

"I make no public pronouncements," the 72-year-old scientist said in a telephone interview from his home in Sandia Park, NM. "What I say is for my clients." He said predictions that have surfaced publicly have been recounted by members of private audiences.

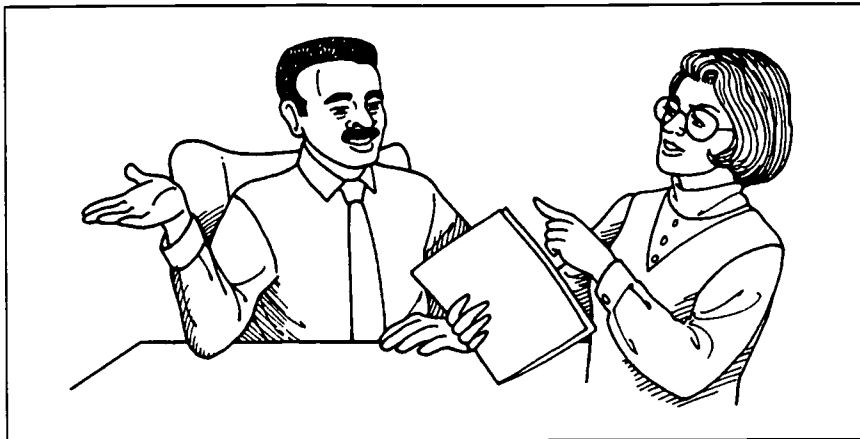
It was at a convention of the Equipment Manufacturers Institute in San Francisco that he said his calculations indicated an earthquake there about Oct. 16, the day before it occurred, and one on Dec. 3 in the New Madrid area.

Emmett Barker, president of the institute, was present and heard the predictions.

Regarding Dr. Browning's method, Brian Mitchell, chairman of the Department of Earth and Atmospheric Sciences at St. Louis University, said, "Recent studies with the best available data show no correlation between tidal forces and earthquakes."

And Pat Jorgenson, a spokeswoman for the United States Geological Survey in Menlo Park, CA, said scientists there "are not at this time doing any research into earth tides and any possible relation to seismic activity," although they are aware "that this is a much-discussed proposition." She said that the agency's scientists had conducted studies on the claims but that these "proved inconclusive."

Still, Dr. Stewart, of Southeast Missouri State, said he thinks Dr. Browning's method should not be summarily rejected. "Here's a man who has hit several home runs," he said. "Will he hit another on Dec. 3? We don't know, but that's no excuse for not being prepared."



*The Wall Street Journal*, September 18, 1990

**Will the Earth Move on Dec. 3?**

**Midwest Is Rattled By a Scientist's Prediction of a Major Earthquake**

by Michael J. McCarthy

MEMPHIS, TENN.—Friday nights used to be slow at The Fault Line, a nightclub here on busy Poplar Avenue. But after word spread that a major earthquake was forecast for Dec. 3 in the Midwest, The Fault Line began throwing earthquake parties.

On Friday nights now, hundreds of patrons pour into the club to swig "Earthquake Shooters" and sign up to win December Earthquake Escape Packages to the Bahamas or Hot Springs, AR.

But even as Memphians whoop it up, the prediction that the Big One may come this December is triggering tremors up and down the Mississippi River Valley. Shaken, thousands of people are crowding into earthquake survival classes. In Arnold, MO, 3,000 people showed up for one course.

In Missouri and Arkansas, some schools and businesses have announced plans to close in early December. Entrepreneurs are hawk- ing quake survival insurance, survival kits, and gas-line safety gadgets.

Some people are planning to flee. "You can't run from everything," says Tammy McCormick, a nurse in Bytheville, AR, who will take her two youngsters and spend several days with the relatives in North Carolina. "But it seems stupid to stay on a fault line with a prediction like this one."

Iben Browning, a 72-year-old scientist, predicted October's Bay Area quake a week before it happened, say people who heard him speak to the Equipment Manufacturers Institute. And he predicted "geological disaster" on Sept. 19, 1985, along a band of latitude that included Mexico City—where a massive quake struck on that day.

Mr. Browning, who has a Ph.D. in physiology, genetics, and bacteriology, writes a climate newsletter out of New Mexico. He has

clients, such as Paine-Webber, Inc., who have long paid for his wisdom on how the weather will affect their agricultural investments.

Since 1971, Mr. Browning says, he has picked the correct dates of four large earthquakes, two volcanoes—and one day with both a volcano and an earthquake.

He bases his forecasts on tidal forces caused by the positions of the Sun and the Moon—an old theory, critics say, that doesn't wash. On Dec. 3, those forces are expected to be at a 27-year high. Mr. Browning says that will exert pressure that could trigger faults already ripe to fail.

**A Skeptical Majority**

Skepticism abounds. "No responsible scientist can predict an exact day for an earthquake," says Brian Mitchell, a quake expert at St. Louis University, echoing the majority opinion.

But Mr. Browning shouldn't be written off so quickly, says Southeast Missouri State's Mr. Stewart, who recently spent four days with Mr. Browning. "He has a methodology that can determine, plus or minus a window of a day or two, an enhanced probability of a volcano or an earthquake in certain latitudes," says Mr. Stewart. "No one else is able to replicate it, but that doesn't mean it's wrong."

Mr. Browning says it's not easy being on record with predictions that few other scientists will support. "I feel like a lonely little petunia in a cabbage patch," he says. But asked if he enjoys being right, he says, "It's the only damn thing that matters. If one is a business consultant, they don't pay you for being wrong."

Mr. Browning says he is tentatively booked to give a talk in Minneapolis on Dec. 3, and he doesn't plan to go there via St. Louis. But he adds: "I highly recommend against panic. That will kill more people than earthquakes."



253



The New York Times, October 19, 1990

## Panel of Scientists Finds No Basis For Prediction of Missouri Quake

ST. LOUIS, OCT. 18 (AP)—Projections of a major earthquake in the Midwest in early December are without scientific basis, a group of scientists said today.

The 11 scientists reporting to the United States Geological Survey said there was a long-term possibility of a major earthquake along the New Madrid Fault, but said there was no credibility in the widely circulated projection made by Iben Browning, a climatologist and business consultant based in Sandia Park, NM, of a 50-50 chance it will happen Dec. 3.

Public anxiety over Mr. Browning's New Madrid projection has been widely reported, coupled with reports that Dr. Browning had also warned of last year's Northern California earthquake a week in advance in an appearance before about 500 business executives and their wives at a convention in San Francisco.

The scientific group said today that it had found no evidence that Mr. Browning had predicted last year's earthquake. Mr. Browning has said the reports of his predictions are based on accounts from members of the private audiences that he addresses.

A woman who answered the telephone Thursday at Mr. Browning's home and identified herself as his wife said he was unavailable for comment.

The scientists said a transcript of his Oct. 10, 1989, speech showed that "his statement was 'there will probably be several earthquakes around the world, Richter 6 plus, and there may be a volcano or two.' No mention is made of an earthquake occurring in the San Francisco area or even California."

The scientific group issued its finding at a news conference in St. Louis. The scientists who contributed to the report were brought together from universities and governmental agencies to evaluate the scientific validity of Mr. Browning's projection.

"Such a projection, especially at the predicted 50-50 chance level, implies a level of detailed knowledge that simply does not exist for the New Madrid or any other fault zone in the world," the group said in its reports for the National Earthquake Prediction Evaluation Council.

Mr. Browning bases his projections on the

forces of tides and gravity. He has said that for 48 hours before and after Dec. 3, these forces will be particularly strong.

"Browning's correlation of earthquake activity with danger periods at times of highs in tidal forces does no better at predicting earthquakes of magnitudes greater than 6.5 than does random guessing," the scientists' report said.

The New Madrid Fault runs from Marker Tree, AR, across southeastern Missouri to southern Illinois, and produces hundreds of small quakes every year, most hardly felt. It is named for the Missouri town of New Madrid, about 140 miles south of St. Louis.

In 1811-1812, a series of quakes estimated at up to 8 on the Richter scale of ground motion struck the New Madrid region, causing the Mississippi River to appear to flow backward and ringing church bells in Washington, DC.

Southeast Missourian, Cape Girardeau, MO, Dec. 3, 1990

## 'Circus' comes to New Madrid: Projection puts town in spotlight

by David Hente, Staff Writer

NEW MADRID—For the past several months, tiny New Madrid has been the focus of growing national and international attention. On Sunday, the media circus came to town.

The attention was touched off by the projection of climatologist Iben Browning that a major earthquake could occur along the geological fault named after the town.

Residents of New Madrid and others who live along the fault will learn today if Dr. Browning's projection comes to pass.

New Madrid, population 3,204, is located at the head of a large bend in the Mississippi River, in the Missouri boot heel.

Until recently, few people outside of this area had heard very much about New Madrid, and even fewer knew how to pronounce the name of the town correctly (New MAD-rid).

But Browning's projection caught the attention of the news media, and New Madrid is now on the minds of people throughout the nation and the world.

Over the weekend, tourists, visitors, and the news media have flocked into the town.

"I've seen more tourists in the past two weeks than I had seen in the past six months," said Jean Hanner, manager of Rick's Texaco, located on Main Street a few blocks from the river.

As Dec. 3 approached, the media continued to swarm into town. By midday Sunday, more than 20 satellite transmission trucks and vans were parked along the New Madrid levee and in other parts of town. A network technician said that was more than were at the Super Bowl Game last year.

The four major networks, CBS, ABC, NBC, and Cable News Network, along with television stations from Atlanta, GA, Chattanooga, TN, Louisville, KY, Dallas-Fort Worth, TX, Nashville, TN, Kansas City, and St. Louis were preparing to transmit live coverage Sunday and Monday via satellite. Numerous other radio stations and print media reporters were also on hand.

200

Research News, August 1991

## The Lessons of Dr. Browning

by Richard A. Kerr

*When a self-taught climatologist predicted a major quake for the Midwest, seismologists ignored him, but leaving the field to pseudoscience proved a big mistake.*

BOULDER, COLORADO—Jill Stevens wanted to alert millions of Midwesterners to the earthquake threat beneath their feet. As head of the information side of the Center for Earthquake Research and Information at Memphis State University, she had been warning, with limited success, that much remained undone to protect the citizenry from rare but lethal quakes. But to the average Midwesterner, earthquake country stopped at the California border, so why worry—until the winter of 1989, when one Dr. Iben Browning came along.

A self-taught climatologist, Browning did Stevens' job for her—and more. He predicted that a catastrophic earthquake would strike the Mississippi Valley during the first week of December 1990. The media leaped on the prediction and suddenly the populace became all too aware of the threat. That might have been to the good, says Stevens, except that the prediction was scientifically groundless—and so specific and apocalyptic as to provoke near-hysteria. Stevens recalls a 6-year-old girl whose earthquake fears could not be soothed on the phone, and elderly callers to her center who

worried how they would get back in their wheelchairs after the big one struck. Schools and factories closed on the target day, 3 December, and groups such as the Red Cross wasted precious funds in their efforts to calm the public.

Although ultimate responsibility for the misleading quake prediction has to rest with Browning (who died 3 weeks ago), Stevens and others who gathered here last month for the 16th Annual Hazards Research and Applications Workshop lay a healthy share of blame at the feet of a group that wanted no part of Browning or his prognostications: the scientific community. "If I have any criticism," said Lacy Suiter, director of the Tennessee Emergency Management Agency, "it's why the scientific community that had the ultimate responsibility didn't call Browning a quack early on." And it was this concern that led participants of the meeting to hope that the next time a bogus earthquake prediction surfaces—and there are sure to be more—scientists will recognize its potential for touching off a frenzy and promptly do their part to squelch it.

261

Attempts to predict or forecast earthquakes have been based on these approaches, among others:

1. Recognizing that seismic activity concentrates in zones of plate tectonic activity
2. Observing and recording the abnormal behavior of animals
3. Monitoring seismic activity at plate boundaries
4. Observing and recording persistent changes in the elevation of given topographic survey points
5. Locating and monitoring faults in places other than plate boundaries
6. Compiling data on the seismic history of a given area and measuring the intervals between previous quakes
7. Monitoring the changes in emission of radon (radioactive gas) from rocks by electronic monitoring of deep wells
8. Monitoring the level of the water in wells
9. Measuring variations in the magnetic field of large rock formations
10. Trenching across a fault to uncover evidence of past earthquake movement
11. Detecting strain in the rocks of the Earth's crust by geodetic surveys
12. Using creep meters (wire strands extending across a fault) to indicate stress and movement
13. Recording variations in the speed of waves in the swarms of tremors that frequently precede earthquakes
14. Talking to earthquake survivors and recording their descriptions of past quakes
15. Observing foreshocks and measuring variations in P waves
16. Placing a network of seismograph stations on the ocean floor across the continental shelf and an ocean trench
17. Monitoring selected sites in an area that has no history of major seismic activity to detect micro-earthquakes
18. Monitoring changes in the occurrence of micro-earthquakes.

# Levels of Generalization Classification Chart

Name \_\_\_\_\_ Date \_\_\_\_\_

Directions: Place the number of each item on the preceding list in the category you think is most appropriate.

**Subjective Observation****Seismic Zone Analysis****Instrumentation and Measurement**

203



# Levels of Generalization Classification Chart (key)

*Suggested answers*

*(Note that some items may belong in either of the last two categories.)*

**Subjective Observation**

2, 14

**Seismic Zone Analysis**

1, 3, 6, 10, 12, 16

**Instrumentation and Measurement**

4, 5, 6, 7, 8, 9, 11, 12, 13, 15, 16, 17, 18

264

# Starting Here, Starting Now

## ACTIVITY ONE

### LEARNING THE DRILL

#### RATIONALE

Students who have rehearsed what to do in the event of an earthquake are more likely to stay calm and proceed rationally than students who have not.

#### FOCUS QUESTION

If an earthquake happened here, right now, what would you do?

#### OBJECTIVES

##### Students will:

1. Describe and recognize the early signs of an earthquake.
2. Drop, cover, and hold until a quake is over.
3. Evacuate the school or other building in an orderly fashion.
4. Describe procedures for coping with various earthquake hazards.

#### MATERIALS

- Materials to produce sound effects (*optional*)
- Standard first-aid manual

#### PROCEDURE

##### Teacher Preparation

1. Choose an open area outside the school where your class would be safe in the aftermath of an earthquake. You may also want to let teachers in neighboring classrooms know that your class will be holding an earthquake and evacuation drill.
2. Review basic emergency procedures in a standard first-aid manual, such as how to apply pressure for bleeding and how to handle injured people.

#### VOCABULARY



**Aftershock:** an earthquake that follows a larger earthquake, or main shock, usually originating in the same fault zone as the main shock.

**Foreshock:** an earthquake that precedes a larger earthquake, or main shock, usually originating in the same fault zone as the main shock.

## A. Introduction

Tell students that instead of a fire drill, they are going to have an earthquake drill. Impress them with the seriousness of this exercise; like a fire drill, it could literally save their lives. Explain that when they hear the signal *Drop, cover, and hold*, every student is to follow this procedure:

- Get under the table or desk.
- Turn away from the windows.
- Cover the back of your neck with one hand.
- Tuck your head down.
- Hold onto a leg of the table or desk, and move with it if it moves.

Reinforce the list of actions by writing one word for each action on the board and asking students to repeat the three words Drop, Cover, and Hold. Remind them that earthquake shaking typically lasts less than a minute, so they will not be uncomfortable for long.

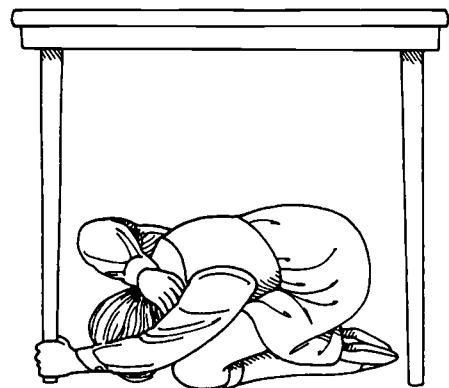
## B. Lesson Development

1. Have several students demonstrate the drop, cover, and hold drill for the class, then have students practice it all together.
2. Ask for a volunteer to describe the beginning of the earthquake, complete with sound effects, if the student chooses, and then to signal drop, cover, and hold. (Students will be familiar with earthquake sights and sounds by this time, so most of them should be prepared for this task.) Instruct the volunteer to begin talking at your signal, and to call out “Drop, cover, and hold” after just a moment or two of description.
3. When the student signals, take cover, begin counting, and count slowly up to 60. (Remember, most earthquakes last less than a minute.) Then tell students that the earthquake is over, but they must be prepared for aftershocks. Ask them to evaluate their performance.
4. If either you or the students believe the class could have done better, tell them an aftershock is beginning and repeat the procedure with a different volunteer. Emphasize the need for a quick response.
5. When you are satisfied with the students’ response, tell them that the shaking has stopped and it is time to evacuate the building. Follow your normal fire drill route (or a safer route) to the outside of the building and lead the class to the spot you have chosen.
6. When everyone is gathered outside, explain to the class that they will stay there for the rest of the period. It would not be safe to go back into the building until it has been inspected. Ask students to name some hazards they might have encountered along the way if an earthquake had occurred (fallen lockers or trophy cases, fires, smoke, fumes from laboratory chemicals or broken equipment, live electrical wires). Discuss procedures for dealing with these hazards. Then brainstorm responses to some other contingencies that might develop,

## TEACHING CLUES AND CUES



Most moderate-to-large earthquakes are followed, within the ensuing hours, days, and months, by numerous smaller earthquakes (aftershocks) in the same vicinity.



indoors or out. Ask students what they would do if:

- their normal evacuation route is blocked by wreckage? (Take time now to plan an alternate route with the class and be sure that everyone understands it.)
- an aftershock occurs while they are outside or en route? (drop and cover)
- a student or teacher is injured and can't walk? (Don't try to move the person unless there is immediate danger of fire or flooding. Instead, cover him or her with a sturdy table or whatever is available and send someone for medical help after the earthquake shaking stops.)
- someone is cut by shattered glass and is bleeding severely? (Apply pressure to stop the bleeding.)
- someone is hit by a falling lamp or brick? (If the person is conscious and able to walk, take him or her to a first-aid station as soon as possible. Even if the person appears to be unhurt, assign someone to stay close and watch for signs of dizziness or nausea.)

7. If any time remains in the class period, use it to review first-aid procedures and listen to the students' feelings about the possibility of an earthquake or other natural disaster. Better yet, arrange for the school nurse or a Red Cross trainer to present this information.

### C. Conclusion

The next day, back in the classroom, ask students to name some of the other places they might be when an earthquake occurs, and suggest safety procedures for each situation. Answers might include:

- Outdoors (Find an open place away from trees, buildings, power lines, and other structures. Kneel or sit until the shaking passes.)
- In a car (Stop as soon as possible, ideally in a level place away from buildings, power lines, bridges, and highway overpasses and underpasses. Passengers should stay in the car and hold on to doors and seats. The vehicle's shock absorbers may cushion some of the shaking.)
- On the bus or subway (Stay calm and follow instructions from the driver or conductor.)
- In an open mall, a gymnasium, or other indoor place with no shelter (Move to an inside wall. Kneel next to the wall, facing away from windows. Bend head close to knees, cover sides of head with elbows, and clasp hands behind the neck. If you are carrying a coat, a notebook, a package, or even a towel, hold it over your head for protection from debris or flying glass.)

Conclude with time for questions and discussion.

### TEACHING CLUES AND CUES



This simulation may arouse feelings of fear or anxiety for some students. Encourage students to express their feelings freely and to be supportive of each other's feelings. Emphasize that these reactions are normal and healthy, but that learning how to avoid injury will increase their chances of survival and those of everyone around them. Be aware that inappropriate optimism ("It can't happen to me") is just as unrealistic as extreme fear and anxiety.



Do not excuse students with special needs from participating in earthquake drills. It may not be possible for students with impaired mobility to get under a desk or table. They can, however, learn to react quickly and turn away from windows, move away from light fixtures and unsecured bookcases, and use their arms or whatever is handy to protect their heads. Encourage other students to plan procedures to assist them with immediate protection and evacuation.



## **ADAPTATIONS AND EXTENSIONS**

---

1. Some students may enjoy making an audiotape to use in step 2 of Lesson Development, above.
2. Encourage students to take classes in first aid and cardiopulmonary resuscitation (CPR) from the Red Cross or other community organization, and to update training they already have. If a number of students are interested, arrange for a trainer to visit your class or provide presentations for the entire school. Students will gain confidence as well as competence.
3. Invite the school's health instructor or a representative from the Red Cross or other emergency agency to participate in the earthquake drill.
4. Invite the class to join you in setting up a schoolwide earthquake drill. Involve the school administration and local emergency services officials with whom you established contacts in Unit 1.
5. If you repeat this drill in Unit 6 as part of the community earthquake simulation, vary it by putting up signs at one point along the evacuation route to indicate that the route is blocked. Lead the class out by the alternate route you planned in step 6, above.

## **ACTIVITY TWO**

### **RVS AT YOUR ADDRESS: RAPID VISUAL SCREENING OF SCHOOL AND HOME FOR EARTHQUAKE HAZARDS**

#### **RATIONALE**

---

Every teacher wants the classroom to be a safe environment for students. In this activity, you and your students will assess the safety of your classroom and make plans to remedy any earthquake hazards. Students will also assess their own homes.

#### **FOCUS QUESTIONS**

---

Can you imagine what your classroom would be like during an earthquake?

How could you make your classroom and your school a safer place to be?

How could you make your home safer?

#### **OBJECTIVES**

---

**Students will:**

1. Distinguish between structural and nonstructural features of a building.
2. Recognize nonstructural earthquake hazards in the classroom.
3. Develop a rapid visual screening format to use in their homes.
4. Devise methods to reduce earthquake hazards in school and at home.

## **VOCABULARY**

---



**Hazard:** an object or situation that holds the possibility of injury or damage.

**Nonstructural feature:** an element of a building that is not essential to its structural design and does not contribute structural strength. Examples are windows, cornices, and parapets.

**Rapid visual screening (RVS):** a method of assessing risk that relies on external observation. An observer who is trained in RVS can derive enough information from a quick visual assessment to know if closer examination is necessary.

**Retrofitting:** making changes to a completed structure to meet needs that were not considered at the time it was built; in this case, to make it better able to withstand an earthquake.

## MATERIALS

- Paper and pencils or pens
- Chalkboard and chalk or overhead projector and markers
- Student copies of Master 5.2a, RVS Checklist for the Classroom, one for each small group
- Student copies of master 5.2b, RVS Checklist for the Home

## PROCEDURE

### Teacher Preparation

Write a brief letter telling parents that you are teaching a unit on earthquakes and encouraging their participation in a rapid visual screening of their home.

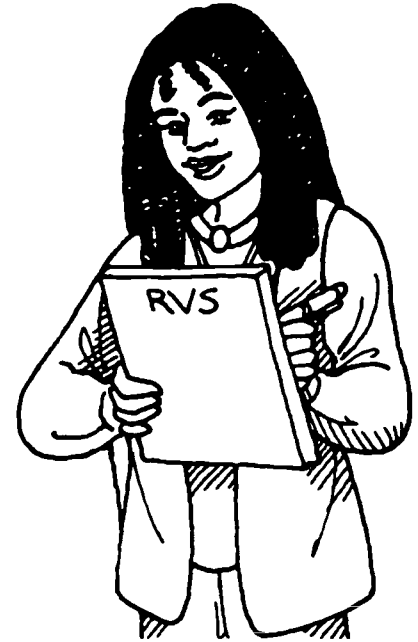
Using the checklist on Master 5.2a, look around your classroom and note any items that could harm you and your students if an earthquake suddenly started to shake the room. Do not make any changes at this time unless you see a situation that needs immediate correction.

### A. Introduction

1. Place several books on a desk. Have a student come up to the front of the room and shake the desk. Ask students to describe what they observed.
2. Remind students that in earlier lessons they have demonstrated the importance of structural features in increasing building safety. Ask them to name some structural features. (girders, beams, floors, load-bearing walls, columns, foundations)
3. Ask: Are these the only features of buildings that are affected by an earthquake? Explain that nonstructural features—outside brick walls that don't bear weight, decorative overhangs, and panels added after construction; and inside cabinets, bookshelves, desktop computers, laboratory equipment, hanging light fixtures, wall decorations, aquariums, potted plants, and windows—can also injure people and damage property if they are not properly fastened to survive a strong earthquake.

### B. Lesson Development

1. Ask students to quickly scan the classroom and each write down the name of at least one object or nonstructural feature that could be a hazard during earthquake shaking. Tell them they have just completed a rapid visual screening, or RVS.
2. On the chalkboard or overhead projector, compile a list of the items students noted. Build a class discussion around the observations, asking students to specify why they considered particular items hazardous.
3. Divide students into small groups and distribute copies of Master 5.2a, RVS Checklist for the Classroom. Give students about 10 minutes to complete the checklist. When they have finished, ask: Did



## TEACHING CLUES AND CUES



If students made a shaking table in Unit 4, have volunteers demonstrate on the shaking table instead.

the list suggest any items we overlooked in our own assessment? If so, add these items to the class list.

4. Ask students to share the methods they proposed to make the classroom safer during an earthquake. Many will be as simple as relocating or removing furnishings. Others may require tie downs, anchors, or fasteners to hold them in place during the shaking.

Help the class reach consensus on a short list of changes to improve their own classroom for earthquake safety.

5. Give students class time to develop an RVS checklist for their homes, based on their own screening of the classroom and Master 5.2b. Assign students to screen their homes, with the cooperation of their families, and write brief reports of their findings, including suggestions for what they could do to make their homes safer during an earthquake.

### C. Conclusion

Let colleagues know that your students are available to do hazard screenings of other classrooms. Assign teams of students to screen the classrooms of any interested teachers and develop plans to retrofit those classrooms for earthquake safety.

### ADAPTATIONS AND EXTENSIONS

1. Encourage your students to present their data, analysis, and suggestions for retrofitting to the school's principal, staff, or parent teacher organization and to their families. Both in school and at home, students may volunteer to do all or some of the work.

2. Invite interested students to develop a one-minute radio or television spot to inform their community about rapid visual screening. ▲



270



Name \_\_\_\_\_ Date \_\_\_\_\_

### Instructions

1. Check yes or no for each of the following items. Skip any items that are not applicable to your classroom.
2. Go back and circle all the nos. These are the items that you have identified as potentially dangerous to you and your classmates.
3. For each no, suggest a way to remove the danger. (Use the *comments* space.)
4. For each yes, explain why your team thinks the feature is earthquake resistant.

Yes

No

Are desks and tables located where they cannot slide and block exits?  
comments:

Are large, heavy office machines secured to the wall or floor and located where they cannot slide, fall, or block exits?  
comments:

Are the tops of tall (4- or 5-drawer) file cabinets securely attached to the wall?  
comments:

Do file cabinet doors have latches?  
comments:

Are desktop computers securely fastened to work spaces?  
comments:

Are bookshelves, cabinets, and coat closets secured to the wall and/or attached to each other?  
comments:

Are display cases or aquariums protected against overturning or sliding off tables?  
comments:

Is floor-supported, freestanding shop equipment secured against overturning or sliding?  
comments:

Is freestanding equipment on wheels protected against rolling?  
comments:

- | Yes                      | No                       |   |
|--------------------------|--------------------------|---|
| <input type="checkbox"/> | <input type="checkbox"/> | Are all wall-mounted objects that weigh more than five pounds firmly anchored to the building's structural framing?<br>comments:  |
| <input type="checkbox"/> | <input type="checkbox"/> | Are all heavy, sharp, or breakable wall decorations securely mounted, with closed-eye hooks, for example?<br>comments:  |
| <input type="checkbox"/> | <input type="checkbox"/> | Do books or materials stored on shelves have adequate restraints to keep them from flying off the shelves?<br>comments:   |
| <input type="checkbox"/> | <input type="checkbox"/> | Are laboratory chemicals on shelves restrained? Are potentially hazardous chemicals stored securely? Are chemical storage areas vented, and located away from exits and corridors? Is there an up-to-date inventory of all chemicals stored?<br>comments: |
| <input type="checkbox"/> | <input type="checkbox"/> | Are the fluorescent light fixtures merely resting on the hung ceiling grid, or do they have other supports?<br>comments:  |
| <input type="checkbox"/> | <input type="checkbox"/> | Are decorative ceiling panels or latticework securely attached?<br>comments:  |
| <input type="checkbox"/> | <input type="checkbox"/> | Will hanging light fixtures swing freely without hitting each other if allowed to swing a minimum of 45 degrees?<br>comments:   |
| <input type="checkbox"/> | <input type="checkbox"/> | Are fire extinguishers securely mounted?<br>comments:   |
| <input type="checkbox"/> | <input type="checkbox"/> | If there are potted plants and other heavy items on top of file cabinets or in other overhead locations, are they restrained?<br>comments:  |
| <input type="checkbox"/> | <input type="checkbox"/> | Do you see other hazards not included on this list? Specify.<br>comments:   |

27.2

Name \_\_\_\_\_ Date \_\_\_\_\_

- 1. Place beds so that they are not next to large windows.
- 2. Place beds so that they are not below hanging lights.
- 3. Place beds so that they are not below heavy mirrors.
- 4. Place beds so that they are not below framed pictures.
- 5. Place beds so that they are not below shelves with objects that can fall.
- 6. Replace heavy lamps on bed tables with light, nonbreakable lamps.
- 7. Change hanging plants from heavy pots into lighter pots.
- 8. Use closed hooks on hanging plants, lamps, etc.
- 9. Make sure hooks for hanging plants, lamps, etc. are attached to studs.
- 10. Remove all heavy objects from high shelves.
- 11. Remove all breakable things from high shelves.
- 12. Replace latches, such as magnetic touch latches on cabinets, with latches that will hold during an earthquake.
- 13. Take glass bottles out of medicine cabinets and put on lower shelves.  
(PARENT NOTE: If there are small children around, make sure you use childproof latches when you move things to lower shelves.)
- 14. Remove glass containers that are around the bathtub.
- 15. Move materials that can easily catch fire so they are not close to heat sources.
- 16. Strap water heater to the studs of the nearest wall.\*
- 17. Move heavy objects away from exit routes in your house.
- 18. Block wheeled objects so they cannot roll.
- 19. Attach tall heavy furniture, such as bookshelves, to studs in walls.
- 20. Use flexible connectors where gas lines meet appliances such as stoves, water heaters, and dryers.
- 21. Attach heavy appliances such as refrigerators to studs in walls.
- 22. Nail plywood to ceiling joists to protect people from chimney bricks that could fall through the ceiling.
- 23. Make sure heavy mirrors are well fastened to walls.
- 24. Make sure heavy pictures are well fastened to walls.
- 25. Make sure air conditioners are well braced.
- 26. Make sure all roof tiles are secure.
- 27. Brace outside chimney.
- 28. Bolt house to the foundation.\*
- 29. Remove dead or diseased tree limbs that could fall on the house.
- 30. Install plywood reinforcements.\*

\* See Master 5.3c, *Strengthening Your Wood Frame House*, for materials and instructions.

# Find and Fix the Hazards

## (Wood Frame Homes)

### RATIONALE

Relatively simple modifications can greatly increase the safety of a wood frame house. Even students who do not currently live in such houses may at some future time.

### FOCUS QUESTIONS

What are some structural earthquake hazards in a typical wood frame home?

What can be done to reduce structural hazards in these homes?

### OBJECTIVES


**Students will:**


1. Assess risk factors in an existing wood frame house.
2. Name several ways to strengthen an existing wood frame construction.

### MATERIALS

- Classroom map of the local area, from Unit 1
- Master 2.5b, Soil and Geologic Maps and Map Sources (*optional*)
- Student copies of Master 5.3a, Structural Checklist
- Student copies of Master 5.3b, Wood Stud Frame Construction
- Flashlights
- Goggles or other eye protection
- Head protection (helmet or hard hat)
- Clip board, paper, and pencil for notes
- Knee pads (*optional*)
- Student copies of Master 5.3c, Strengthening Your Wood Frame House

### TEACHING CLUES AND CUES

 If possible, prepare your students for this activity and the others in this lesson, then conduct one field trip that combines several of the activities.

 This activity emphasizes wood frame houses because they are common single-family dwellings in many parts of the country. If you are not teaching all the lessons in this unit, be sure students understand that other types of structures also pose serious hazards.

## PROCEDURE

### Teacher Preparation

Contact a local realtor to find a nearby wood frame house that students can visit to conduct their assessment, or arrange with a contractor to visit a building site. If no vacant home is available, plan to use your own home or that of a friend or colleague. Arrange for transportation and permissions as necessary.

### A. Introduction

Survey the class, asking: How many students live in wood frame houses? How many have friends or relatives who live in wood frame houses? How many have lived in such houses at some point in their lives? (Be sure students understand that the frame of the house may be wood even if the outside sheathing is stucco, decorative brick, brick veneer, stone, or some other material.) Record a count of student answers on the board.

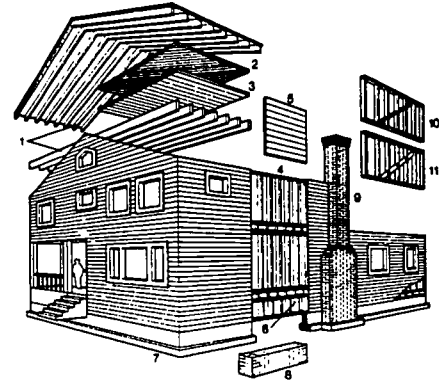
Tell the class that many homes in regions across the country are constructed of wood frame systems. These wooden structures are lightweight and flexible, and properly nailed joints are excellent for releasing earthquake energy and resisting ground shaking. Nevertheless, frame houses are sometimes damaged by an earthquake, causing a great deal of unnecessary trouble and expense for homeowners. This damage is unnecessary because most often it could have been prevented by some very basic alterations. It pays to find out if your home needs rehabilitation or strengthening and what can be done to lessen the earthquake hazard.

### B. Lesson Development

1. Tell students that they are going to play the role of potential home buyers. Each of them has just landed a new job at a higher salary, and has decided to buy a new wood frame house. First, however, they must conduct a visual inspection of each home they consider buying to identify potential earthquake hazards. In this lesson they will learn what to look for in the foundation and other structural components.

2. Ask: What seismic hazard designation has been applied to the area where we live? (In Unit 3, Lesson 3, you noted this information on the classroom local map. It is also available on Master 1.3b, U.S. Earthquake Hazard Map.) Explain that the degree of earthquake risk in any structure depends on where it is located as well as how it is built. If your school is located in a region identified on Master 1.3b as one of low seismic hazard, however, remind students that this map depicts what has happened; it does not predict what *may* happen. Earthquakes can occur anywhere in the world. Moreover, most Americans move several times in the course of their lives.

3. If you did Lesson 2.5, students will also know the soil characteristics of their own region. If this information is not on your classroom map, refer students to local maps of soil characteristics, and





ask them to characterize the soil of the site they will be visiting. (See Master 2.5b, Soil and Geologic Maps and Map Sources.) Emphasize again that the site and the mode of construction interact.

4. Distribute copies of Master 5.3a, Structural Checklist, and Master 5.3b, Wood Stud Frame Construction. Point out the numbered areas on the drawing, and tell students that these are among the things they will be inspecting on their field trip.

5. Travel with your class to the site you have chosen. Direct pairs or small groups of students to conduct inspections. When one group has finished, those students can complete their worksheets while the others proceed.

### C. Conclusion

If you are in a moderate- or high-risk area, and your students find that their own homes could be reinforced to better withstand an earthquake, distribute copies of Master 5.3c, Strengthening Your Wood Frame House. Assign students to take home these simple directions for four inexpensive projects. High school students and their parents can follow the steps on these pages to reinforce their wood frame homes.

### ADAPTATIONS AND EXTENSIONS

If a majority of your students live in wood frame houses, you may assign this activity as an out-of-class exercise. Cover the information in the introduction with the whole class, then hand out copies of Master 5.3a, Structural Checklist. Ask students to assess the stability of their own homes and complete a report to share with their families and/or their classmates. Have students check on local building laws or talk to the city building inspector. Invite the building inspector to visit your class and talk about local building codes. ▲

*Note: Master 5.3c, Strengthening Your Wood Frame House, is adapted from An Ounce of Prevention: Strengthening Your Wood Frame House for Earthquake Safety, with permission from the Bay Area Regional Earthquake Preparedness Project, 101 8th Street, Room 152, Oakland, CA 94607.*

### TEACHING CLUES AND CUES



Engineers and architects are the people best qualified to assess the strength of structures and their resistance to earthquakes. If your students have serious concerns, encourage them to discuss with their parents the possibility of bringing in a professional. Even the first modification on Master 5.3c is best undertaken after structural analysis, especially an analysis of foundation soils.

Name \_\_\_\_\_ Date \_\_\_\_\_

*Instructions: Rate each component listed on a scale from 1 (good) to 5 (poor).*

1. The foundation must react as one unit for maximum earthquake resistance. The best foundations are steel-reinforced concrete that reach down to bedrock. Examine the foundation.

- Is it wood, brick, or concrete?
- Is there any sign of steel reinforcement?
- Are there holes or pits in the foundation?
- Is the concrete powdery or crumbly?
- Are there signs of water damage?
- Are there visible cracks longer than 1 cm?

Rating (Circle one):    1    2    3    4    5

2. The wood plate (also known as a sill plate or a mudsill). This is the first structural wooden member placed on the foundation. Examine the wood plate.

- Is it bolted to the foundation?
- How far apart are the bolts? (The standard spacing is about four feet apart.)
- Is the wood plate fastened or reinforced with metal plates?

Rating (Circle one):    1    2    3    4    5

3. Short stud walls (cripple walls)

- Are they made of wood, brick, or another material?
- Are they braced to resist earthquake-generated lateral forces?
- Are they connected to the wood plates?
- How is the floor frame fastened to the stud wall?

Rating (Circle one):    1    2    3    4    5

4. Exterior walls (shear walls)

- What are the exterior walls made of? (brick, block, wood siding?)
- Are they tied together?
- If the walls are brick, block, or stone, what is the condition of the mortar?
- Are they braced to resist earthquake-generated lateral forces?

Rating (Circle one):    1    2    3    4    5

5. Masonry fireplace chimneys. An unreinforced brick chimney is the weakest part of a house when earthquake shaking begins.

- Does the house have one or more chimneys?
- Is each chimney's foundation part of the house?
- What are the chimneys made of?
- Are they reinforced and designed to be earthquake resistant?

Rating (Circle one):    1    2    3    4    5

6. Utilities and their mountings

- Is the gas main mounted on flexible pipes?
- Is the electrical service firmly mounted?
- Is the main water shutoff accessible?

Rating (Circle one):    1    2    3    4    5

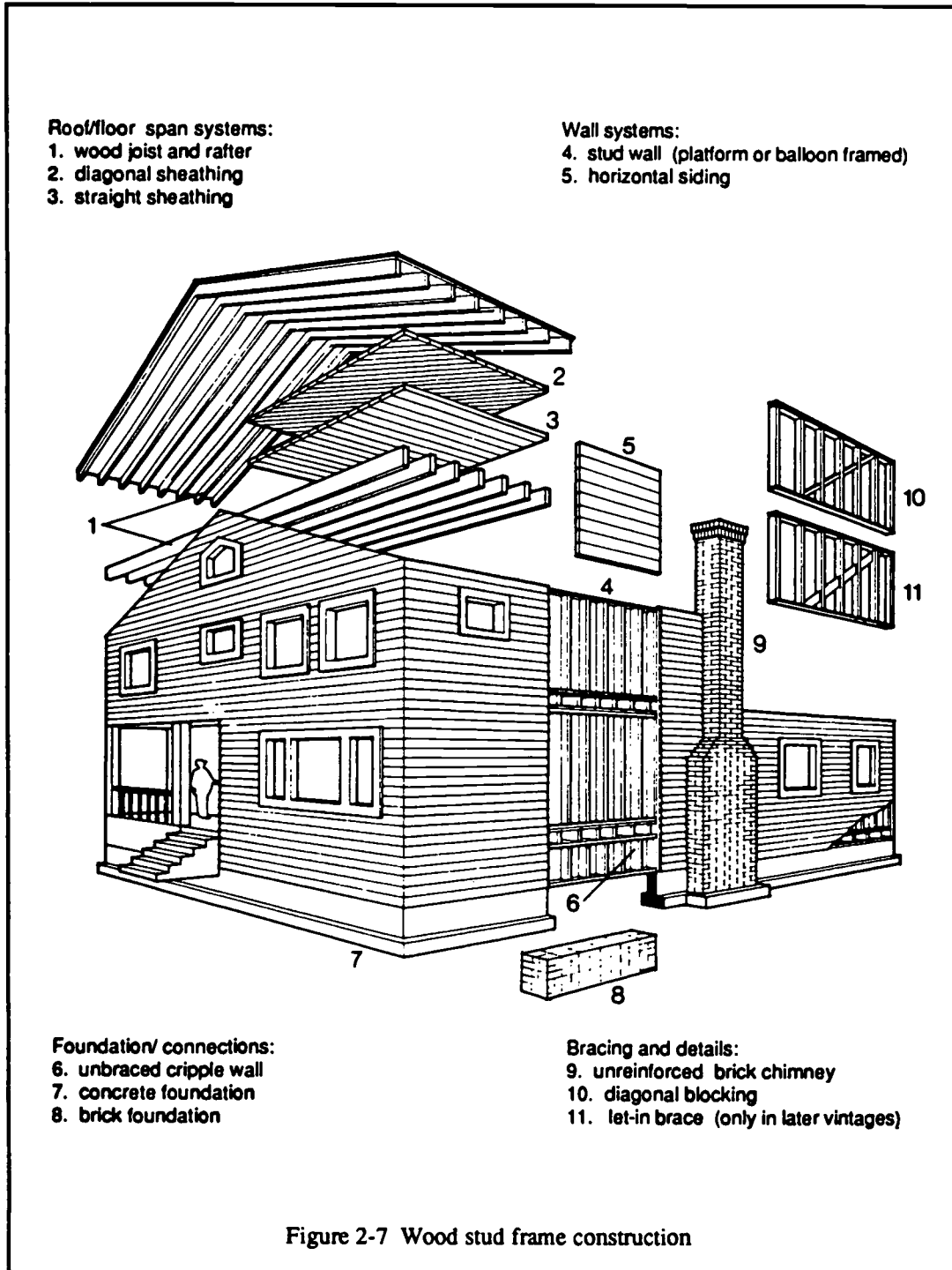
7. Exterior porches

- Does the house have one or more porches?
- Is the porch or porches attached to the house? How?
- Is the foundation of the porch attached to the foundation of the house?

Rating (Circle one):    1    2    3    4    5

8. Make specific recommendations on how to correct any seismic deficiencies identified.

277



Reproduced from Rapid Visual Screening of Buildings for Potential Seismic Hazards: A Handbook, *FEMA Earthquake Hazard Reduction Series 41*.

# Strengthening Your Wood Frame House: Four Projects

*adapted with permission of the Bay Area Regional Earthquake Preparedness Project*

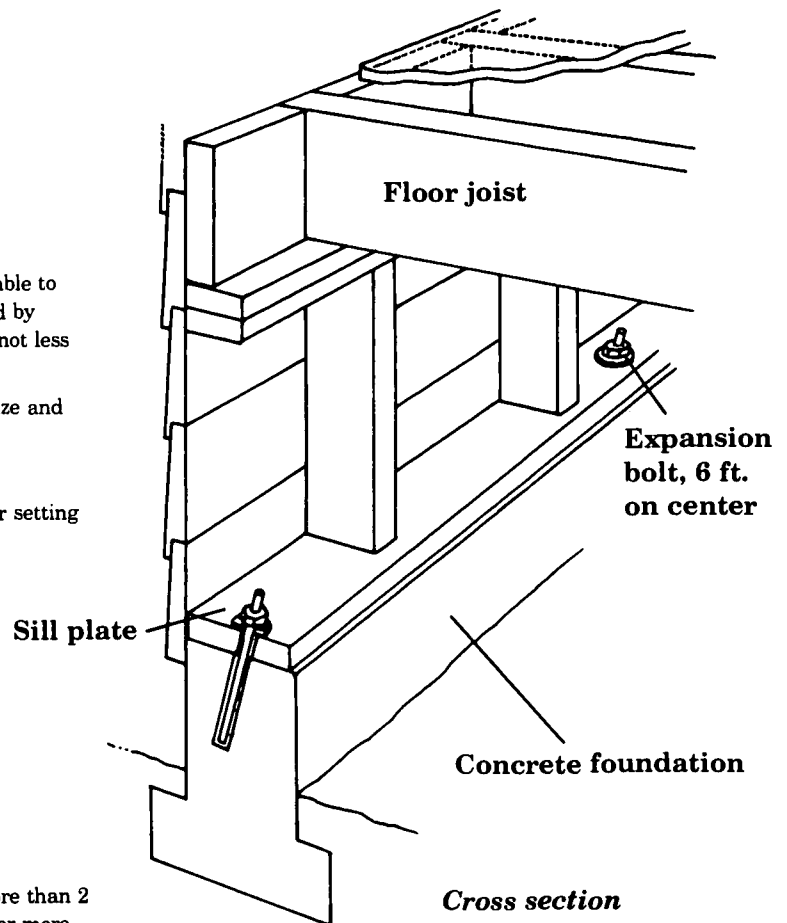
## Step 1: Steel Plate Bolting

### Materials and Tools Needed

- 1 cm (1/2 in.) diameter expansion bolts of a style acceptable to the local building department. Length of bolt determined by depth of hole, thickness of sill plate, and a projection of not less than 2.5 cm (1 in.) above sill plate
- Masonry drill bit with carbide tip. Size determined by size and style of expansion bolt.
- Electric rotary impact drill or heavy-duty drill
- Short-handled sledge hammer or carpenter's hammer for setting the bolts.
- 1 cm (3/8 in.) diameter plastic tubing
- Adjustable crescent wrench
- Chalk or lumber crayon
- Measuring tape
- Eye protection
- Noise protection
- Dust mask

### Installation Instructions for Step 1

1. Lay out bolt locations. Bolts should be spaced at not more than 2 m (6 ft) apart. Begin layout at not less than 10 cm (4 in.) or more than 30 cm (12 in.) from the end of any section of sill plate.
2. Drill holes through the sill plate and into the foundation with a carbide drill bit of the size recommended for the style of expansion bolt used. Drill holes a minimum of 11.5 cm (4.5 in.) into foundation wall.
3. After drilling a hole, clean out the concrete dust by inserting the plastic tubing into the hole and blowing out the dust.
4. Place a cut washer over the bolt so it rests on top of the sill plate. Place the nut on the bolt and turn until the top of the nut is even with the top of the bolt. Insert expansion bolt into the hole until it stops. Using the sledge hammer or carpenter's hammer, strike the top of the hole.
5. Using a crescent wrench, tighten the nut until the sill plate begins to crush under the washer.



**Step 2: Install Blocking at Sill Plate**

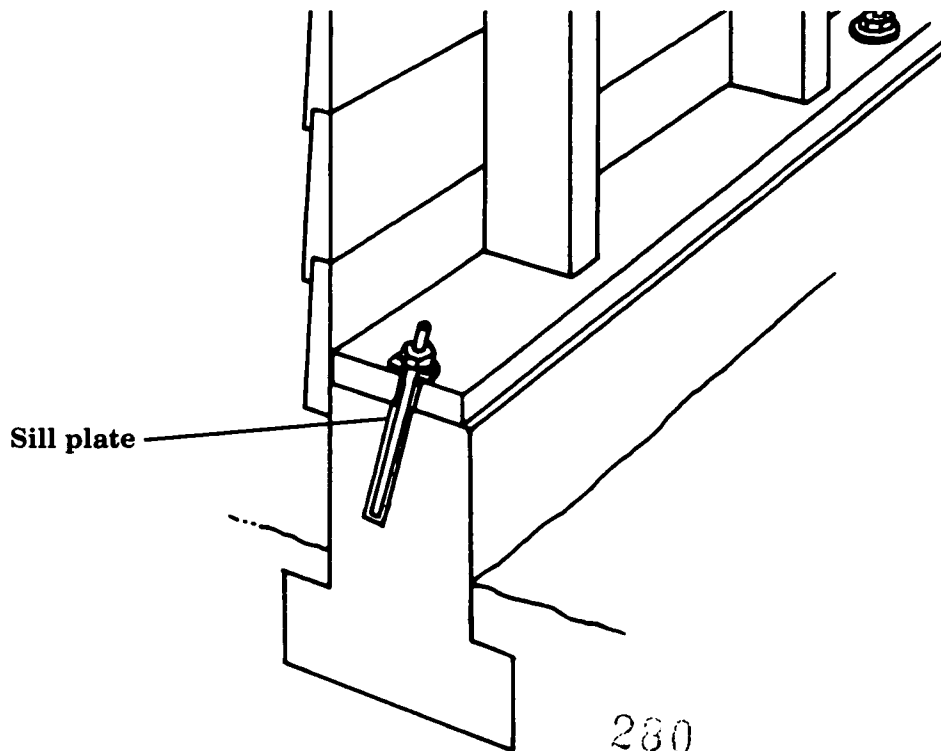
Note: This blocking is necessary only when the depth of the studs is different from the width of the sill plate, such as 2 x 4 studs attached to a 2 x 6 sill. If the stud depth and the sill plate width are the same, skip this step.

**Materials and Tools Needed**

- Nominal 5 cm (2 in.) thick lumber (actually 4 cm, or 1.5 in. thick) the same depth as the studs
- 16d (16-penny) common nails
- Electric drill to pre-drill holes for nails, if necessary
- 0.2 cm (1/16 in.) diameter drill bits for pre-drilling nail holes and a bit at least 0.2 cm (1/16 in.) larger than the diameter (point-to-point distance across) of the anchor bolt nut
- Carpenter's hammer
- Measuring tape
- Pencil
- Eye protection
- Dust mask

**Installation Instructions for Step 2**

1. Measure distance between studs.
2. Cut pieces of blocking from 5 cm (2 in.) thick piece of lumber, the same depth as the studs, equal to the distance between studs, that the blocking fits snugly.
3. In those stud spaces, where a new anchor bolt has been installed, mark the bolt location on the bottom of the blocking and drill a hole large enough that the blocking fits over the bolt and rests fully on the sill plate.
4. Nail the blocking to the sill plate with between 3 and 6 16d nails. If blocking begins to split while the nail is driven, remove the nail and drill pilot holes for each nail with the 0.2 cm (1/16 in.) diameter drill bit.



### Step 3: Install Plywood

#### Materials and Tools Needed

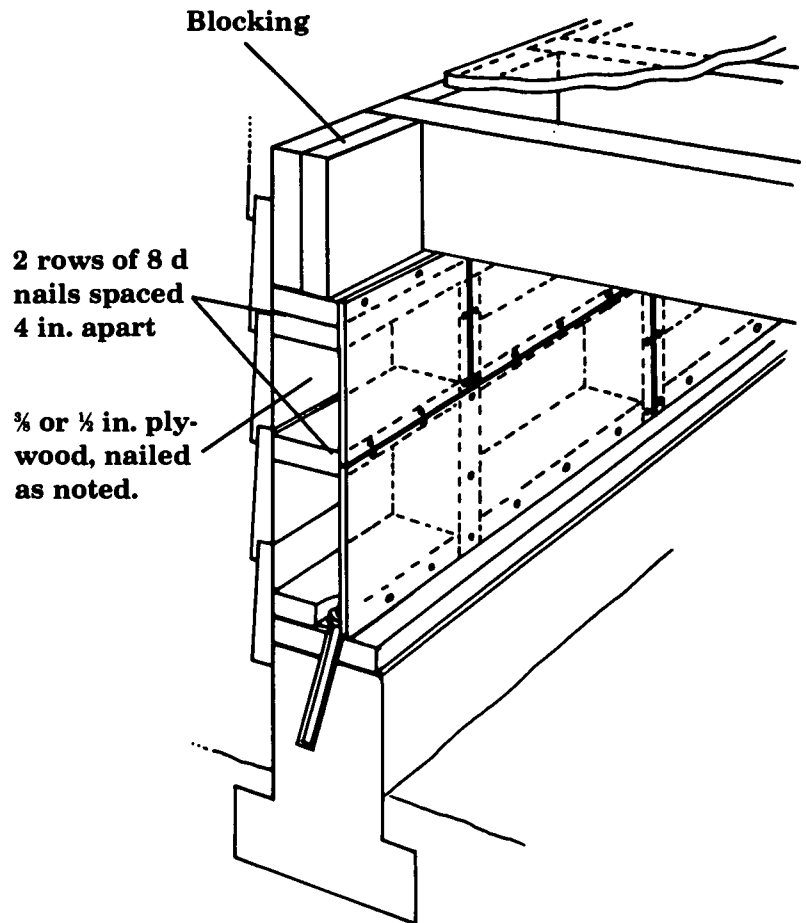
- 1 cm (3/8 in.) or 1.2 cm (15/32 in.) thick plywood of Structural I or CDX grade
- Nominal 5 cm (2 in.) thick lumber (actually 4 cm or 1.5 in. thick) the same depth as the studs. This will be used for blocking, if required.

Note: The size of access to the average crawl space frequently doesn't allow large pieces of plywood. You may need to use two or more smaller pieces of plywood. When multiple pieces are used to cover the height of the wall, blocking must be installed at the joint and completely nailed. If a single piece of plywood can be installed the full height of the reinforcing wall, blocking will not be necessary.

- 8d common nails for use with 1 cm (3/8 in.) plywood
- 10d common nails for use with 1.2 cm (15/32 in.) plywood
- 16d common nails for use with blocking, if required
- Electric circular saw
- Electric drill
- 0.2 cm (1/16 in.) diameter drill bit for pre-drilling nail holes if blocking is required
- Nail gun or carpenter's hammer
- Measuring tape
- Chalk, lumber crayon or pencil
- 4 cm to 5 cm (1.5 in. to 2 in.) diameter hole saw

#### Installation Instructions for Step 3

1. If access to the crawl space under the house is such that full-width sheets, or sheets cut to the height of the cripple studs, will not fit, cut plywood sheets lengthwise to a width not less than 46 cm (18 in.).
2. If sheets need to be cut, blocking will be necessary. Cut the 5 cm (2 in.) nominal thickness lumber to fit snugly between the studs. Nail each block to the studs with 2 16d nails at each end. Nails should be driven into the side of the stud. Pre-drilling for the nails will make this operation easier. Blocking should be installed at the same height for the full length of the plywood sheet.
3. Starting at a corner, measure across the studs to find a stud where the sheets of plywood can butt. In order to do this, find the stud closest to, but not less than 1.2 m (4' ft.) or closest to, but not more than 2.4 m (8 ft.) from the corner. Measure the location of all ventilation vents and cut out holes in the plywood to match the vents.
4. Mark the location of each stud at the top plate and on the foundation wall with chalk or lumber crayon.
5. After cutting the plywood to fit, lay it up against the studs and hammer a nail in each corner of the plywood to hold it in place. Using a nail gun, or a carpenter's hammer, place a nail every 10 cm (4 in.) around the perimeter of the plywood sheet. Then place a nail every 15 cm (6 in.) along each stud. Use the nails appropriate for the thickness of the plywood.
6. Once the plywood has been fully nailed, drill a 4 cm to 5 cm (1.5 in. to 2 in.) diameter hole above and below the blocking.



**Intermediate blocking  
(toe-nail with two 16d nails  
at each end into studs)**

Water Heater (top view)

**Step 4: Strap Water Heater**

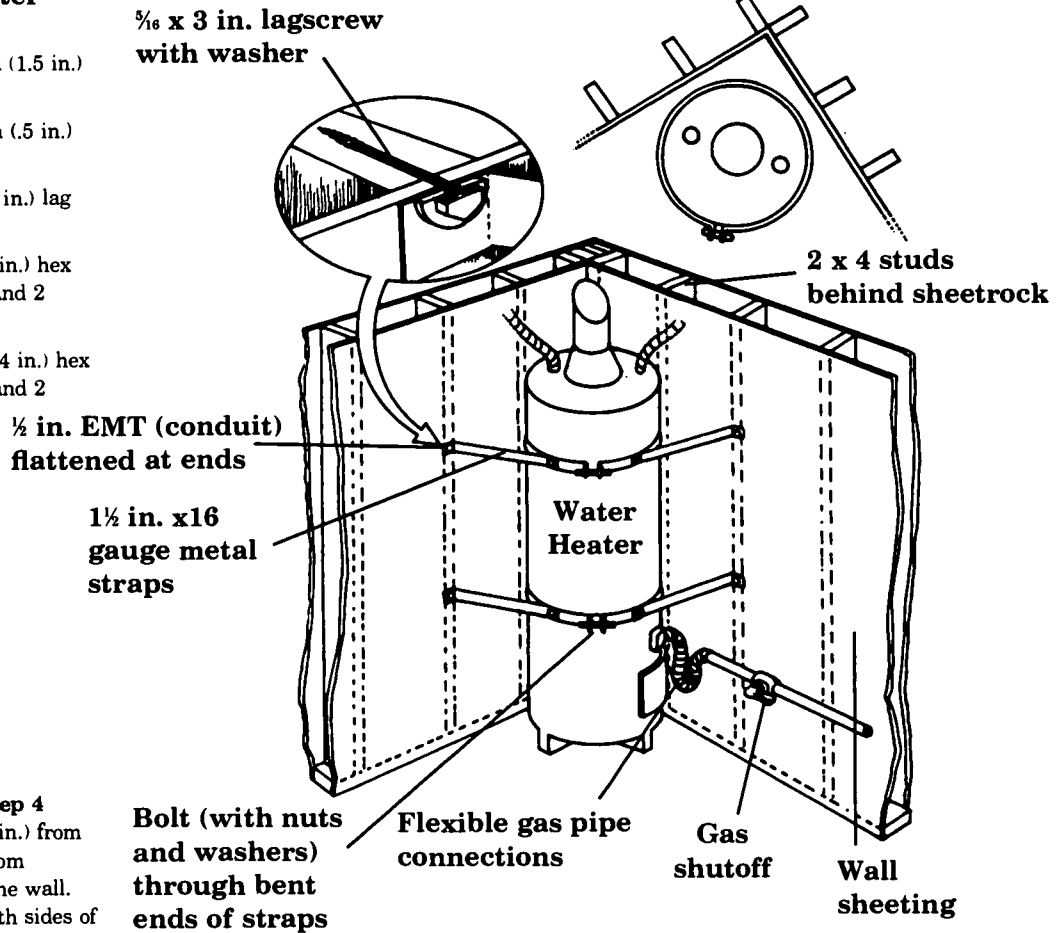
**Materials and Tools Needed**

- Two 1.8 m (6 ft.) lengths of 4 cm (1.5 in.) gauge pre-drilled strap
- One 3.1 m (10 ft.) length of 1 cm (.5 in.) EMT tube (conduit)
- Four 1 cm x 7.5 cm (5/16 in. x 3 in.) lag screws with washers
- Two 1 cm x 2 cm (5/16 in. x 3/4 in.) hex head machine bolts with 1 nut and 2 washers each
- Two 1 cm x 3 cm (5/16 in. x 1-1/4 in.) hex head machine bolts with 1 nut and 2 washers each
- Electric drill
- Tape measure
- Hammer
- Hacksaw
- Crescent wrench
- Vise or clamp
- Power drill
- 1 cm (3/8 in.) drill bit
- Center punch

**Installation Instructions for Step 4**

1. Mark water heater at 15 cm (6 in.) from top and about 46 cm (18 in.) up from bottom. Transfer these marks to the wall. Locate the studs in the wall on both sides of the water heater.
2. Drill a 0.5 cm (3/16 in.) hole 7.5 cm (3 in.) deep through the wall sheathing and into the center of the wood studs at the four marks made in step 1.
3. Measure around the water heater and add 7.5 cm (3 in.) to the measurement. Using a hacksaw, cut the two 4 cm (1.5 in.) 16-gauge metal straps to this length for encompassing water heater.
4. Mark 4 cm (1.5 in.) from each end of metal straps, insert them in a vise, and bend the ends outward to approximately a right angle. Bend the straps into a curve.
5. Measure the distance from a point midway on each side of the water heater to the hole drilled in the wall (probably two different lengths). Add 4 cm (1.5 in.) to these measurements. Using a hacksaw, cut two pieces of tube to each of these two lengths.
6. Using a hammer, flatten approximately 4 cm (1.5 in.) at each end of the four pieces of tubing by laying the tube on a flat metal or concrete surface and striking with the hammer. Be sure you flatten both ends on the same plane.
7. Insert the flattened ends of the tubes, one at a time, into a vise or clamp. With the hammer and center punch make a mark 2 cm (3/4") from each end at the center of the flattened area of the tube. Drill 1 cm (3/8 in.) holes in each end of all four tubes (8 holes). Be sure tubes are clamped down while drilling. Bend each end to about 45 degrees.
8. Wrap the straps around the heater and insert a 1 cm x 3 cm (5/16 in. x 1.25 in.) bolt with washers into the bent ends. Tighten nuts with fingers. Insert 1 cm x 2 cm (5/16 in. x 3/4 in.) bolts through straps from the inside at the mid-point on each tube strut to a protruding bolt, add washer and nut, and tighten with fingers. Insert 1 cm (5/16 in.) lag screws in the opposite end of each tube strut and insert on hole in the wall stud. You may need to tap the lag screw gently into the hole to start it, then tighten with crescent wrench.
9. Adjust the straps to the proper height and tighten nuts snugly. If the nuts are too tight, the straps could tilt the heater.

**Note:** Flexible gas and water supply lines to the water heater will greatly reduce the danger of water pipe leaks and fire or explosion from a gas leak after an earthquake. If your water heater does not have a flexible gas line, contact a licensed plumber to install one. These instructions are for a 30 to 40 gallon water heater within 30.5 cm (12 in.) of a stud wall.



# Rapid Visual Screening (RVS) in the Community

## RATIONALE

Students will perform an informal RVS (rapid visual screening) to determine the nonstructural hazards to people and property that could be caused by buildings in their community during an earthquake.

## FOCUS QUESTION

What buildings in my town or city might pose a serious risk of casualties, property damage, and/or severe curtailment of public services, if a damaging earthquake happened here?

## OBJECTIVES

**Students will:**

1. Conduct a sidewalk survey of nonstructural building hazards in their community.
2. Record their observations on data collection forms.

## MATERIALS

- Transparency from Master 1.3b, U.S. Earthquake Hazard Map
- Classroom wall map of your own region which includes seismic hazard designations. This may have been prepared in Unit 1.
- Overhead projector (*optional*)
- Transparency made from Master 5.4a, Nonstructural Hazards
- Student copies of Master 5.4a, Nonstructural Hazards
- Student copies of Master 5.4b, RVS Observation Sheet, six for each team
- Clipboard for holding observation sheets and drawing paper
- Pens or pencils
- Blank drawing paper
- Straightedge or ruler for drawing sketches

## VOCABULARY



**Canopy:** a covered area that extends from the wall of a building, protecting an entrance.

**Cantilever:** a beam, girder, or other structural member which projects beyond its supporting wall or column.

**Cladding:** an external covering or skin applied to a structure for aesthetic or protective purposes.

**Cornice:** the exterior trim of a structure at the meeting of the roof and wall.

**Glazing:** glass surface.

**Masonry veneer:** a masonry (stone or brick) facing laid against a wall and not structurally bonded to the wall.

**Parapet:** part of a wall which is entirely above the roof.

**Portico:** a porch or covered walk consisting of a roof supported by columns.

**Veneer:** an outside wall facing of brick, stone, or other facing materials that provides a decorative surface but is not load-bearing.



- Camera, preferably instant (*optional*; if available, replaces sketches)
- Tape or stapler, for affixing photo (*optional*)
- Red marking pen

## **PROCEDURE**

---

### **Teacher Preparation**

Select site(s) for the class field assignments, choosing the nearest large concentration of buildings. Students may choose buildings to survey or they may be assigned.

### **A. Introduction**

Tell students that they are going to assume the role of building inspectors in completing an informal sidewalk survey of buildings in their community.

### **B. Lesson Development**

1. Ask students whether their region of the country is thought to be at low, moderate, or high risk for earthquakes. If you do not have this information on your classroom map, project the transparency made from Master 1.3b, U.S. Earthquake Hazard Map. If your school is located in a region pictured on the map as one low seismic hazard, remind students that they may not always live where they live now, and other natural disasters may affect the buildings.
2. Tell students that a building may be structurally sound but its exterior decorations may create a hazard. These are called nonstructural hazards. Project the transparency made from Master 5.4a, Non-structural Hazards, and elicit student descriptions of nonstructural hazards on the outside of buildings in the drawing.
3. Tell students that for the purpose of this exercise, they will assume that a major earthquake is likely in their area in the next several years. They will take a walk and record their observations of nonstructural hazards.
4. Assign each student a partner. Distribute six copies of Master 5.4b, RVS Observation Sheet, to each pair, and ask each pair of students to complete the following steps for six buildings, noting all the information on their observation sheets.
  - a. Record a description of the building and its address or location.
  - b. Note materials used in construction.
  - c. Estimate the year of its construction.
  - d. Record its size (number of floors, area, shape, and other information).
  - e. Determine the current use (business, apartments or other).
  - f. List the readily visible nonstructural hazards.
  - g. Sketch or photograph the building.

284

5. Back in the classroom, suggest ways for students to fill in any missing information. Individuals may volunteer to call their mentors in the chamber of commerce, the local building department, or the public works department. Students could also call the firm that developed or manages a building. Then instruct all the students who filled out forms on the same building to compare their data and discuss any discrepancies. The goal of this process should be an assessment of each building surveyed that represents the students' best consensus.

### **C. Conclusion**

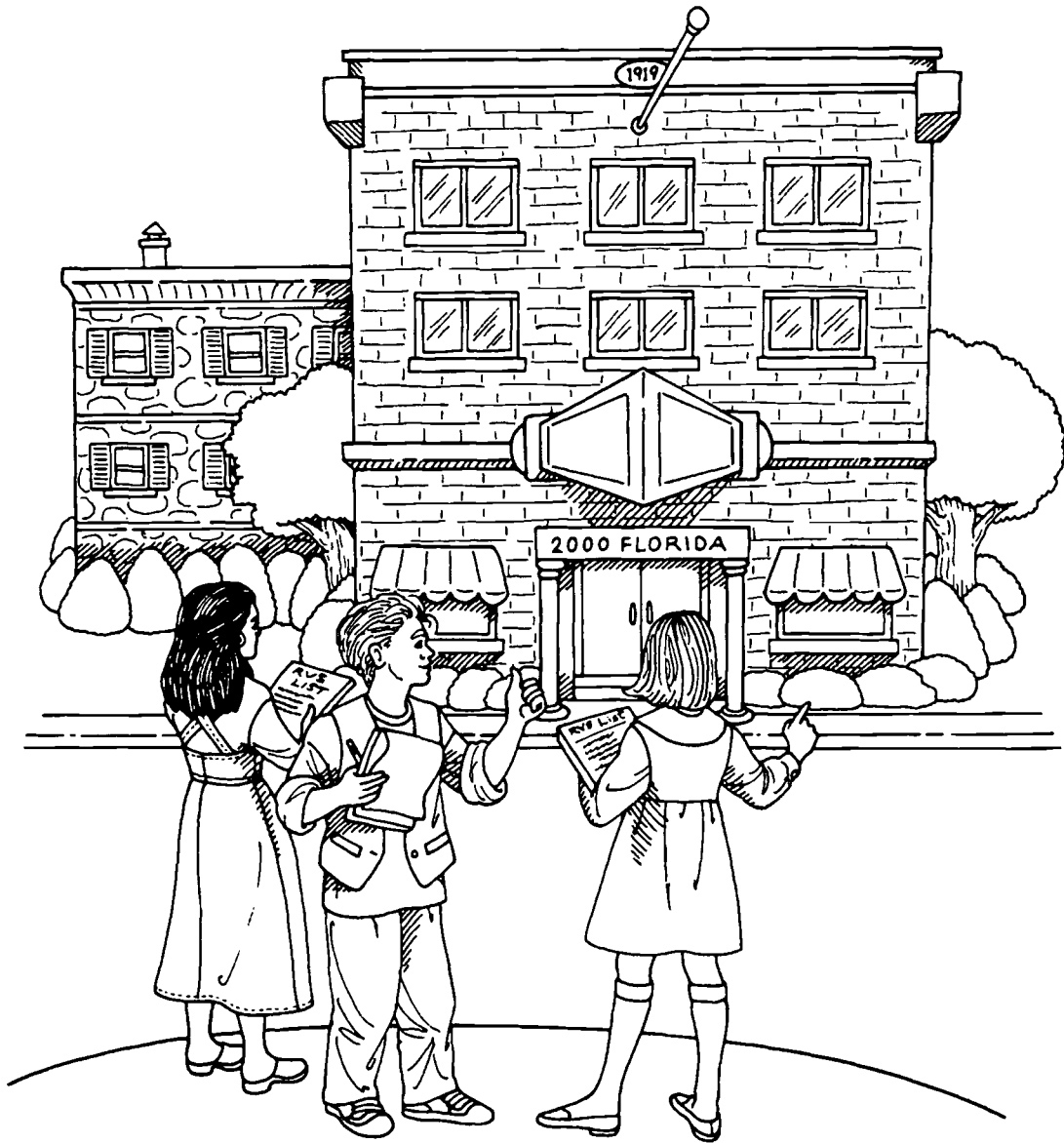
On the classroom local map you started in Unit 1, use a red marker to circle any block or group of blocks where concentrated nonstructural damage could be expected in the event of an earthquake. Open a class discussion of what students have learned. If students have not already expressed an opinion, ask if the sidewalks they traveled would be safe places to be during an earthquake. Generally, the most dangerous place to be is at building exits and directly adjacent to buildings (on the sidewalks, for example).

### **ADAPTATIONS AND EXTENSIONS**

---

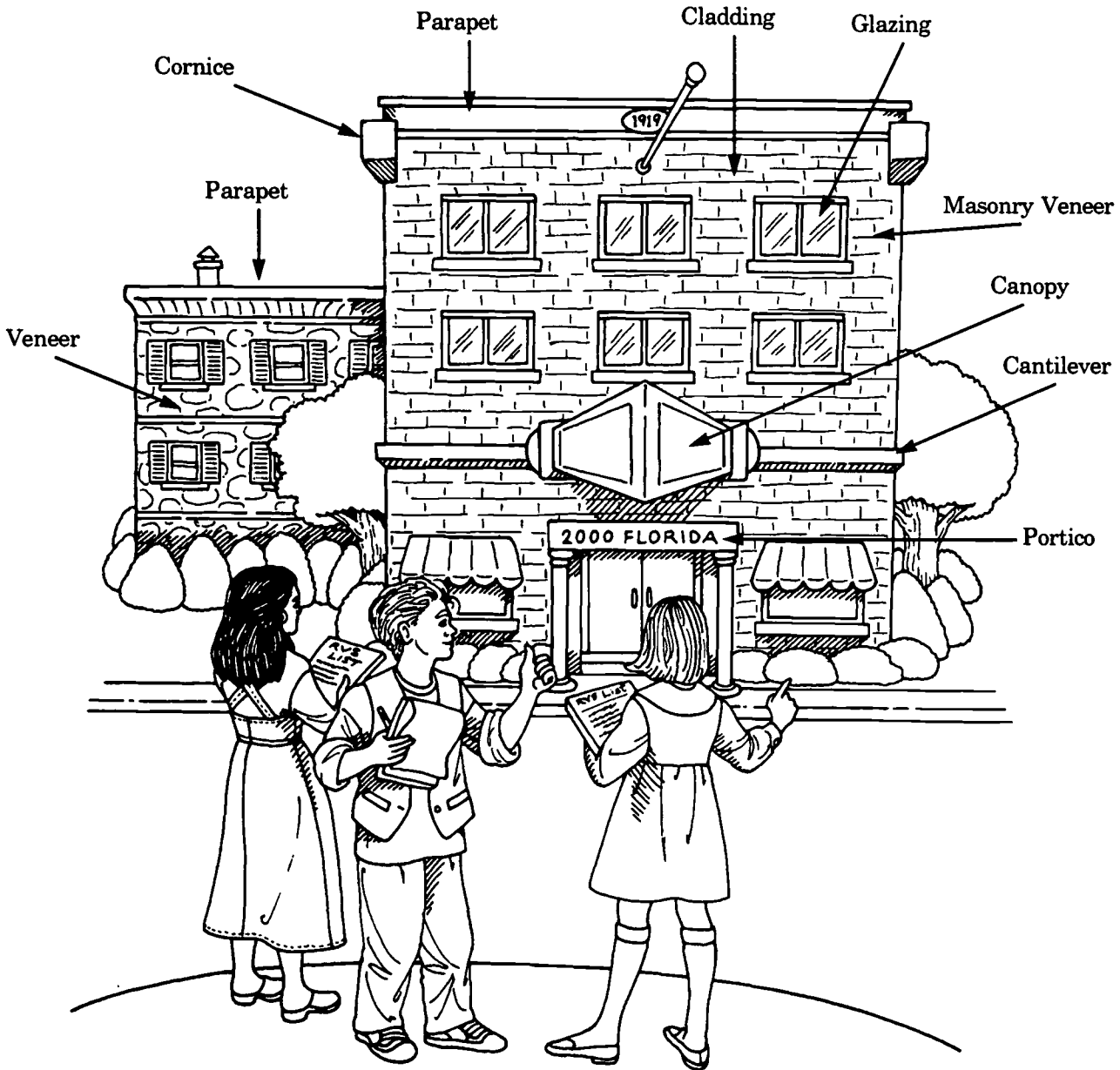
1. If a structural engineer is present or structural information is available from the building manager, students may also informally judge which buildings could be expected to withstand heavy earthquake shaking.
2. If structural information is available from the building manager, students may also list the type of building construction used (wood, steel, masonry, cement, or other building materials.) ▲

Name \_\_\_\_\_ Date \_\_\_\_\_



# Nonstructural Hazards (key)

Date:



Name \_\_\_\_\_ Date \_\_\_\_\_

1. Building name \_\_\_\_\_

2. Street address \_\_\_\_\_

3. Materials used in construction \_\_\_\_\_

4. Year of construction \_\_\_\_\_

5. Size (number of floors), area, and shape \_\_\_\_\_

6. Current use \_\_\_\_\_

7. List nonstructural hazards (see Master 5.4a and vocabulary for illustrations and definitions)

a. \_\_\_\_\_

b. \_\_\_\_\_

c. \_\_\_\_\_

d. \_\_\_\_\_

e. \_\_\_\_\_

f. \_\_\_\_\_

g. \_\_\_\_\_

h. \_\_\_\_\_

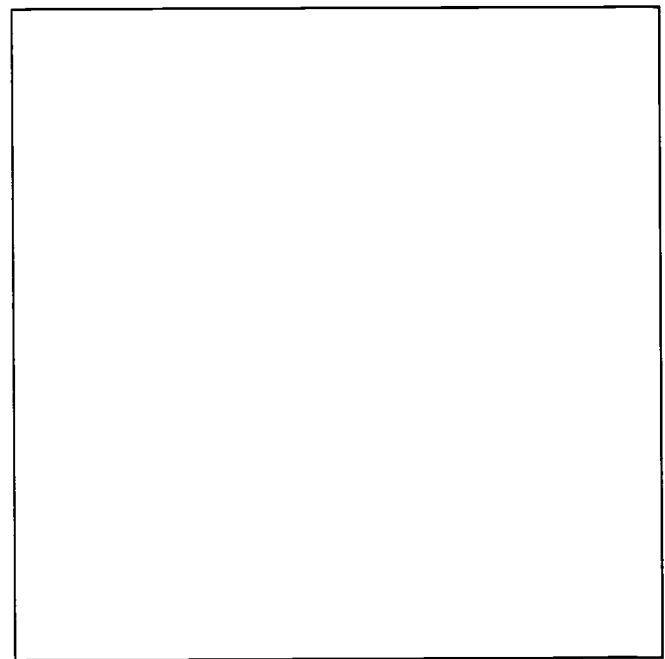
i. \_\_\_\_\_

j. \_\_\_\_\_

k. \_\_\_\_\_

l. \_\_\_\_\_

m. \_\_\_\_\_



*Sketch building or attach photo.*

(Continue on back if necessary)

# Are the Lifelines Open?

## Critical Emergency Facilities and Lifeline Utility Systems

### RATIONALE

How well a community recovers from a damaging earthquake depends on the survival of critical emergency facilities and major utility systems (“lifelines”). In this lesson, students resume their focus on community preparedness.

### FOCUS QUESTIONS

Where are the critical emergency facilities and major lifelines in my community, and how vulnerable are they?

How would my community survive a damaging earthquake?

### OBJECTIVES

**Students will:**

1. Name and locate the critical emergency facilities and lifelines in their community, and evaluate their sites for geological hazards.
2. Contact civic leaders, heads of emergency facilities, and public utility officials to learn about their emergency plans, or renew existing contacts.
3. Report to the class and the community on what they have learned.

### MATERIALS

- Brainstorming list of survival necessities from Unit 1, Lesson 2
- Master 5.5a, Lifelines and Critical Emergency Facilities
- Back of Master 5.5a, Problem Areas
- Master 5.5b, A Chain of Disasters
- Local map(s) showing locations of major emergency facilities and lifeline systems
- Classroom local map developed in Lesson 1.3, with notes on soil conditions from Lesson 2.5
- Red marking pen
- Local telephone directories

### VOCABULARY



**Lifeline:** a service that is vital to the life of a community. Major lifelines include transportation systems, communication systems, water supply lines, electric power lines, and petroleum or natural gas pipelines.

### TEACHING CLUES AND CUES



If your students have not developed a map of your own area that contains information on faults and soil types, use the maps on Master 2.5c to show them how this kind of information is presented visually.

## PROCEDURE

### Teacher Preparation

Read Master 5.5a, *Lifelines and Critical Emergency Facilities*. Decide how you will group students for this activity. If necessary, combine categories, such as natural gas and petroleum fuels, so that together the groups cover all the areas. For each group, make one copy of the local map(s) with locations of major emergency facilities and lifeline systems. Also make one copy of a local map showing geological hazards, if your classroom map does not already have this information.

### A. Introduction

Display the list of necessities for survival that students developed in Unit 1, Lesson 1. Review the list with the class and ask if they have anything to add, or if anything they included at that time now seems less than essential. When the class has reached consensus, display Master 5.5a or distribute copies. Does the list include anything students have omitted? To reinforce the connections among the many kinds of damage earthquakes can cause, display Master 5.5b, *A Chain of Disasters*. Have students revise their list of necessities again to incorporate anything they may have missed.

Emphasize the importance of emergency facilities—such as hospitals, fire stations, and police departments—and of public utilities—such as telephone lines, electric power systems, water supply systems, and transportation into and out of the affected area.

### B. Lesson Development

1. Divide the class into small groups and assign one or more of the 10 systems listed on Master 5.5a to each group. Individual student's responsibilities will reflect their mentor's areas.

2. Distribute one set of maps to each group. Instruct students to compare the lifeline maps to the classroom local map and note any geological features in their service area that might constitute a hazard. Invite them to develop their own system for indicating relative degrees of risk on the lifeline maps: coding by color, by number, or by different kinds of symbols, for example. When they have worked out a system that satisfies everyone, students can transfer this information to the classroom map.

3. Instruct students in each group to plan reports on the community's plans for surviving the first 72 hours after an earthquake. They may need to renew their contacts with key people in their assigned service areas and schedule phone interviews. Give students class time to prepare lists of questions for their interviews. Then ask each group to exchange its list with another group and critique the questions.

4. When every group's questions have been reviewed and students are satisfied that they will elicit the necessary information, ask students to make the phone calls outside of class and take notes on what they learn.

5. The next time the class meets, allow 10 minutes for students in each group to pool their information. Then invite a representative

## TEACHING CLUES AND CUES



If your community is in one of the parts of the country where earthquakes have not been recorded, students can learn about preparations for other kinds of natural hazards, such as floods, hurricanes, and tornadoes. In many cases the same systems would be affected and the same kinds of preparations will have been made. Fire departments will be an excellent source of emergency information.

## TEACHING CLUES AND CUES



Emphasize that every student is to make at least one phone call. Calling several people in each system will increase the amount and quality of information students receive. Students are also likely to find what they learn reassuring—for example, that local hospitals have emergency backup generators.

from each group to report to the class on how the system that group studied would operate during an emergency.

### **C. Conclusion**

On the classroom local map, use red ink to indicate any lifelines or critical facilities that may be at high risk in the event of an earthquake or other natural disaster.

Discuss students' reactions to what they have learned. If they are pleased with the community's level of preparedness, overall or in any of the separate systems, encourage them to write letters of congratulation to the appropriate officials or to the newspaper. If they are concerned that preparation seems inadequate, or if they have concerns about siting and geological hazards, they may write letters expressing their concern and recommending improvements.

Direct students to put their notes from this activity away in a safe place. They will need this information again in the Unit 6 role-playing activity.

### **ADAPTIONS AND EXTENSIONS**

---

1. If you know that your area is one of low seismicity, try to locate flooding maps, erosion maps, or maps of other types that are particularly relevant to your area. Have students learn about 100-year floods, the effect of windstorms over time, or other hazards that are specific to your community.
2. Provide maps of the state or the region surrounding your local area. Challenge students to identify alternate emergency facility locations and alternate transportation routes and map them out for classroom display. ▲



## **A. Critical Emergency Facilities**

1. Medical facilities: hospitals, blood banks
2. Emergency response facilities: police stations, fire departments
3. Local office: emergency operations center

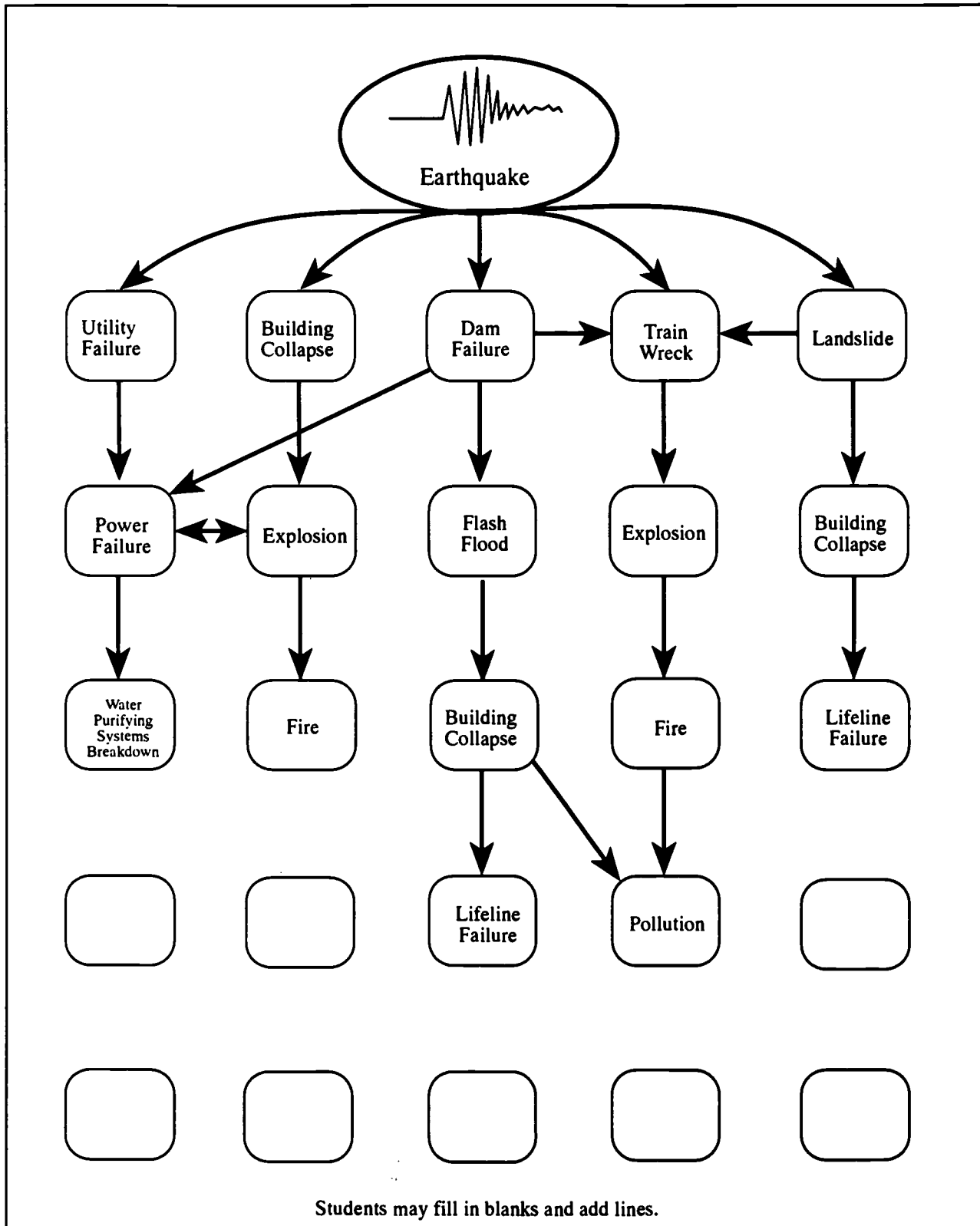
## **B. Lifeline Utility Systems**

1. Transportation systems: highways, freeways, bridges, airports, railroads, docks and marinas
2. Communication systems: telephones, radio, television, newspapers
3. Water supply: dams and reservoirs, aqueducts, distribution lines
4. Waste water: treatment plants, holding tanks, collection lines, effluent lines
5. Electric power: transmission towers and lines, switching stations, power generating plants, local distribution lines
6. Natural gas: holding tanks, pipeline distribution lines
7. Petroleum fuels: refineries, tank farms, pipelines

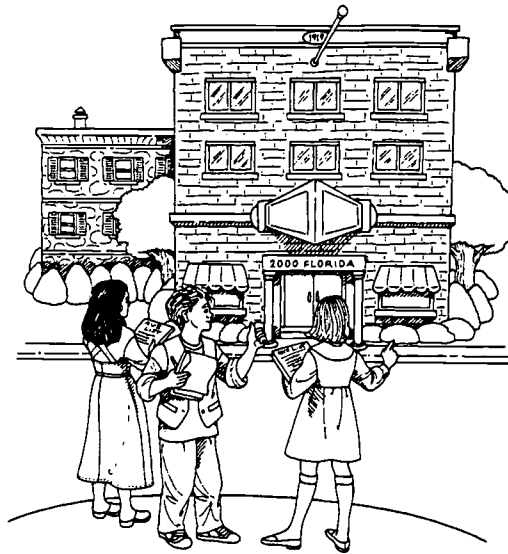


Name \_\_\_\_\_ Date: \_\_\_\_\_

1. If electricity is cut off, electric appliances will not function. Without refrigeration, large amounts of food and medicine will be liable to spoil. Gasoline pumps and auto service stations will be unable to pump gasoline. Without power, airport control towers will have to rely on backup systems. Airports may function at limited capacity or not at all.
2. If water distribution systems fail, the community will have no clean drinking water. Water may be limited or unavailable for fighting fires.
3. If hospitals are damaged, they will not be able to provide care and treatment for injuries and casualties. Even if a building's structure survives, its services may be limited by lack of water and electricity and lack of transportation. Modern hospitals rely heavily on technology.
4. Rupture of petroleum fuel or natural gas pipelines may cause serious fires in the community and outlying areas, as well as shortages of heat and power.
5. If sewer systems fail, lack of sanitation may cause epidemics, such as cholera.



Students may fill in blanks and add lines.



### Books

American Red Cross, Los Angeles Chapter. (1985). *The Emergency Survival Handbook*. In English and Spanish. A simple, practical, and easy-to-use guide; includes disaster planning, first aid, and survival skills.

Bay Area Regional Earthquake Preparedness Project (BAREPP). (1990). *An Ounce of Prevention: Strengthening Your Wood Frame House for Earthquake Safety*. Oakland, CA: CA-OES, 415-540-2713.

Federal Emergency Management Agency (FEMA). (September 1986). "Family Earthquake Safety—Home Hazard Hunt and Earthquake Drill." FEMA 113. Tips on safe places and danger zones in the house, earthquake drills, and what should be done before and after.

Federal Emergency Management Agency (FEMA). (1990). "Guidebook for Developing a School Earthquake Safety Program." FEMA 88. Washington DC: FEMA Publications, 500 C St., SW, Washington, DC 20472. This 50-page guide covers earthquake hazard identification; drills; response, communication, & shelter planning.

Federal Emergency Management Agency. (1993). "Identification & Reduction of Nonstructural Hazards in Schools." FEMA 241.

Federal Emergency Management Agency. (October 1990). *Non-Technical Explanation of the NEHRP Recommended Provisions*. FEMA 99. Washington, DC: Intended to help individuals assess how earthquakes affect buildings & how enforcement of building codes helps to minimize loss.

Federal Emergency Management Agency. (July 1988). *Rapid Visual Screening of Buildings for Potential Seismic Hazards: A Handbook*. FEMA 154. Washington, DC: FEMA Describes the technique of rapid visual screening of buildings for potential seismic hazard.

Federal Emergency Management Agency. (1989). *Seismic Considerations: Elementary and Secondary Schools*. FEMA 149. Washington, DC: Building Seismic Safety Council. Covers the costs & benefits of applying seismic design in the construction of new school facilities. Explains how damage occurs to nonstructural components & building contents.

Helfant, David Benaroya. (1989). *Earthquake Safe: A Hazard Reduction Manual for Homes*. Berkeley, CA: Builders Booksource. A little book with reasonable explanations, detailed procedures, and plentiful illustrations.

Lagorio, Henry J. (1990). *Earthquakes*. New York: John Wiley and Sons, Inc. An architect's guide to nonstructural seismic hazards. Focuses on site planning, building design, urban planning and design, rehabilitation of existing buildings, and disaster recovery and reconstruction.

Matthys, Levy, and Salvadori, Mario. (1992). *Why Buildings Fall Down*. New York and London: W.W. Norton and Company.

Wesson, R.L., and Wallace, R.E. (1985). "Predicting the Next Great Earthquake in California." *Scientific American* 252, 2: 35-43.

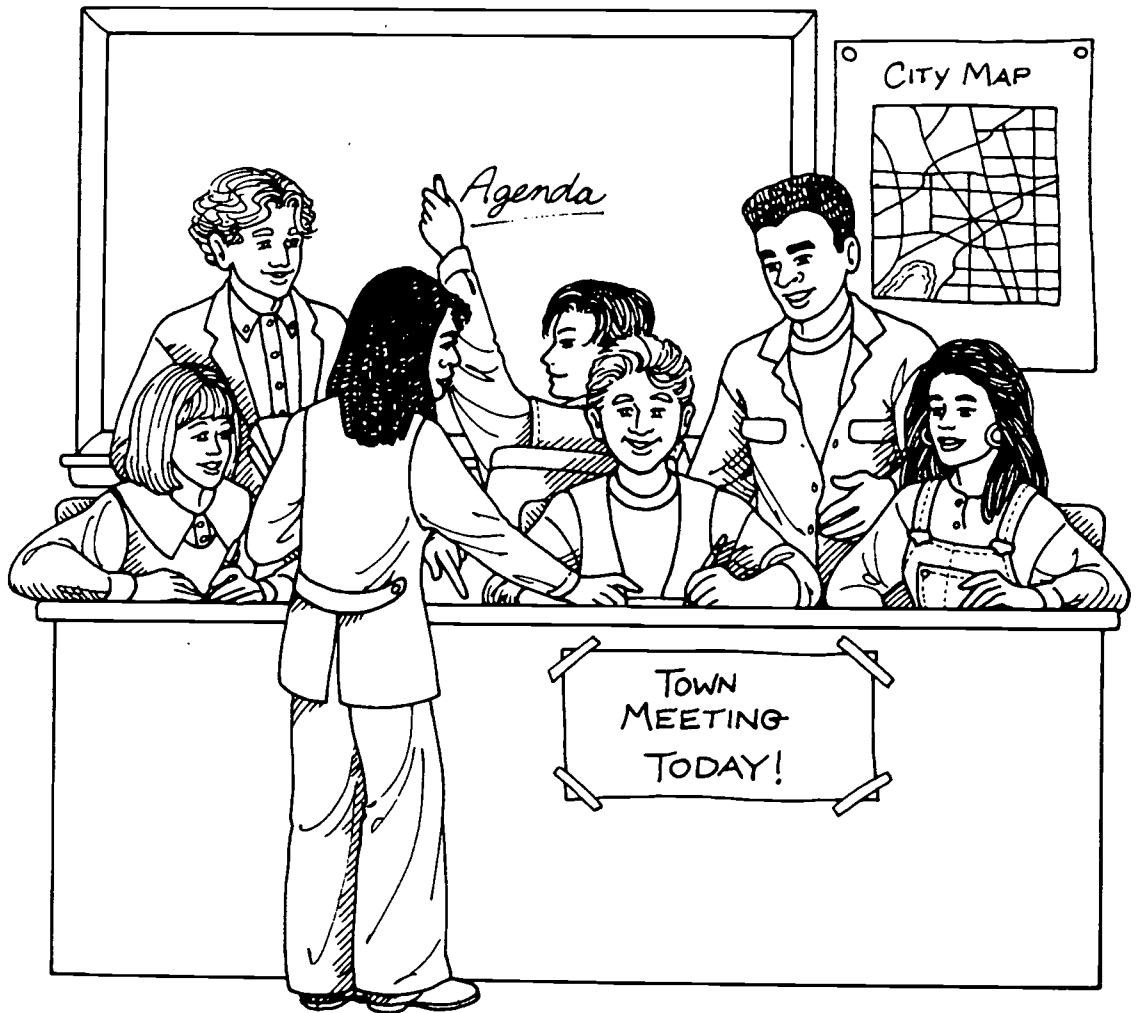
## UNIT RESOURCES

### Nonprint Media

*Microstation, V. 5.* A computer-assisted drafting program for student use. Order from Intergraph Corporation, Huntsville, AL, 1-800-345-4856. \$150 with educational discount.

*Reducing Nonstructural Earthquake Damage—A Practical Guide for Schools.* Video (13:00 min).  
*Schools & Earthquakes—Building Schools to Withstand Earthquakes.* Video (14:27 min). Both available from FEMA.

*Note: Inclusion of materials in these resource listings does not constitute an endorsement by AGU or FEMA.*



# Now You Know It, Can You Show It?

The concluding unit of this curriculum offers a variety of summing-up and assessment activities. Students will feel pride in their accomplishments after a pair of high-pressure simulations, a fast-paced quiz game, and finally, a reprise of the writing activity in Unit 1. The appendix to this unit provides materials from an intensive, communitywide simulation developed by Vermont teacher Sean Cox and adapted with his permission. You can use these materials to enrich your students' experience of Lesson 6.2.

Students who have developed relationships with people responsible for emergency preparedness will particularly enjoy the opportunity to role-play in the first two lessons. In the first they will enact a meeting of a crisis team charged with developing a comprehensive local earthquake preparedness plan. In the second, Earthquake Simulation, they will put that plan into practice.

How much your students and your community benefit from Lesson 2, in particular, depends on how much you and they have invested in the curriculum up to this point. With the full

involvement of community disaster officials and at a locale outside the school, this activity can be incredibly realistic and dramatic, as the experience of Sean Cox and his community makes clear.

After the excitement of Lesson 2, students will welcome the purely intellectual stimulation of Lesson 3, Test Your E.Q. I.Q. The questions are designed to test attitudes as well as information, and to reinforce knowledge by repetition.

Both you and your students will be pleased to see how much information they can add to their Unit 1 compositions in the final postassessment activity. This process reinforces essential writing and thinking skills.

Now that students have completed this series of lessons, encourage them to continue to read and write about earthquakes and disaster preparedness. Some of the topics that have been introduced in these units may lead to science projects, college majors in related topics, and future careers. The information students have gained may even save their lives.

# Preparing for the Worst: A Simulation

## **RATIONALE**

---

When natural disasters occur, many communities are totally unprepared because they lack a comprehensive emergency management program. Coordinated planning is essential if the stricken community is to return to a normal state of affairs.

## **FOCUS QUESTION**

---

What kinds of plans need to be in place to serve a community in the event of a natural disaster?

## **OBJECTIVES**

---

### **Students will:**

1. Recognize the importance of advance planning for a community's emergency response.
2. Simulate the development of a community emergency plan for preparing for, responding to, and recovering from a natural disaster.

## **MATERIALS**

---

- Transparency made from Master 6.1a, Edenton Map and Profile
- Transparency made from back of Master 6.1a, Edenton Map and Profile
- Overhead projector
- Student copies of Master 6.1a, Edenton Map and Profile (2 sides)
- Master 1.3a, Preparedness People (from Unit 1)
- Master 6.1b, Planning Roles (*optional*, for reference only)
- Self-adhesive name tags, one for each student
- Transparency made from Master 6.1c, Phases of an Effective Management Plan
- Transparency markers in four colors



## PROCEDURE

### A. Introduction

Begin by asking students what they would do if an earthquake struck the area where their school is located. Help them to recognize that the most important immediate response is not to panic and to seek cover as quickly as possible. The most available cover in the classroom is the protection offered by the desks and tables the students are using, so “drop, cover, and hold” is the first response. If you have not done so recently, conduct a drop-and-cover drill now, using the instructions in Unit 5, Lesson 2.

Now expand the discussion to determine what students think would happen in their community if the earthquake was powerful enough to cause both loss of life and major property damage.

- How would the community respond?
- Who would be in charge of managing the rescue operation?
- Who would be in charge of long-term recovery?
- What plans are already in place to assure that the emergency would be responsibly managed?

### B. Lesson Development

1. Explain the purpose of the simulation and tell students that they will be playing the roles of community leaders charged with developing an outline for emergency management in the event of a disaster resulting from a natural or human-made hazard. They are meeting to develop a system to manage the effects of an emergency, preserve life and minimize damage, provide necessary assistance, and establish a recovery system in order to return the city to its normal state of affairs as quickly as possible. Their plan must define clearly who does what, when, where, and in what order to deal with the community crisis.

Each student will adopt the role that she or he began learning about in Lesson 3 of Unit 1. For this activity, however, they are citizens of Edenton, a mid-size city located in an area of moderate risk for earthquake activity. In the late summer and fall, brush and forest fires also pose a threat to the community. Other disaster situations could develop from terrorism, civil disorder, a major transportation accident like a bus or train wreck, or an accident involving the release of hazardous materials. When the emergency exceeds the local government’s capability to respond, city officials may also call on state and federal governments for assistance.

2. Project the back of Master 6.1a, Edenton Map and Profile, and go over the information with the class. Then project the map. Distribute copies of both sides for students’ reference.

3. Direct students’ attention to the map of Edenton on Master 6.1a. On the basis of the information provided, and other knowledge of the community they have gained from the profile, ask students to identify

## TEACHING CLUES AND CUES



In most parts of the country, there has not been any significant effort to coordinate community resources to respond to a major civic emergency like an earthquake. This planning scenario is intended to address an emergency resulting from an earthquake, but the process will yield procedures for dealing with other kinds of disasters as well.



all of the following. (The student who is playing the role of city manager will mark the transparency as indicated, using a different color for each type of information.)

- a. at least one area where you could expect landslides, liquefaction failures, and/or fault ruptures. (These areas should be outlined and numbered.)
  - b. at least two groups of blocks where you could expect concentrated building damage. Include at least one commercial and one residential block group. (These areas should also be outlined and numbered, and may be referred to as Concentrated Damage Area 1,2,3, and so forth.)
  - c. major facilities, such as hospitals, schools, government buildings, and high rise buildings that might be rendered at least temporarily unusable by an earthquake or other natural disaster.
  - d. highway overpasses, roads, and other transportation facilities that might collapse or be left impassable by an earthquake.
4. As a review, and to focus students on the roles they have been learning about, ask each to prepare a brief job description. Have students exchange their job descriptions with each other and ask and answer questions until they are clear about the functions and responsibilities of each. Master 6.1b contains some sample job descriptions for your reference.
5. Once roles have been reviewed and job descriptions written, project Master 6.1c, Phases of an Effective Management Plan. Have the city manager convene the Edenton Emergency Management Planning Committee and call the meeting to order.
6. Students will work together to develop a plan. The city manager, referring to the Phases transparency, will remind the group that every plan must have three parts:
- a. Before: preparations to be made before an emergency strikes, such as purchasing safety equipment, upgrading building codes, and educating the public.
  - b. During: strategies for emergency response during an earthquake or other crisis. Lines of communication will be particularly critical in this phase.
  - c. After: recovery plans for returning the community to conditions as normal as possible.
7. When the group has completed its emergency management plan, provide time for students to report the details of their plan. Help them to evaluate their plan by asking these questions:
- Is the plan realistic and timely?
  - Is it comprehensive?
  - Is it cost-effective?
  - Do we have the resources to implement it? If not, how might we obtain additional resources?

## TEACHING CLUES AND CUES



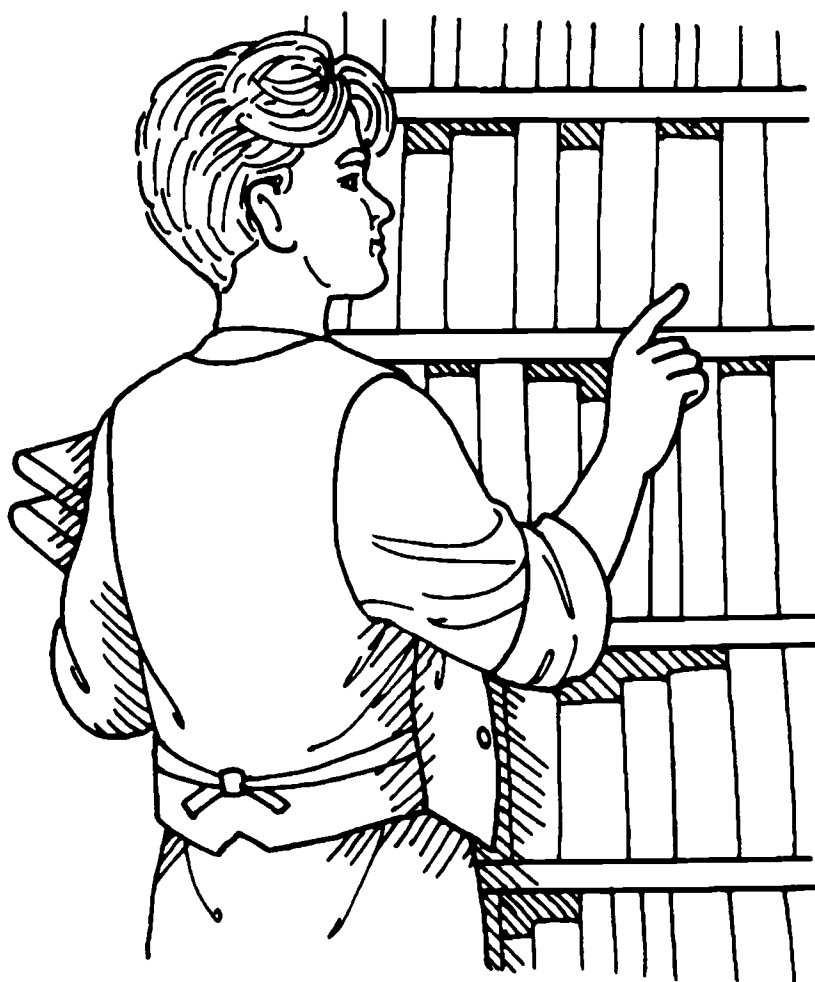
Be sure students understand that the lines they draw around these areas are only rough indications. In reality, each would be surrounded by a zone of influence, in which repercussions would also be felt.

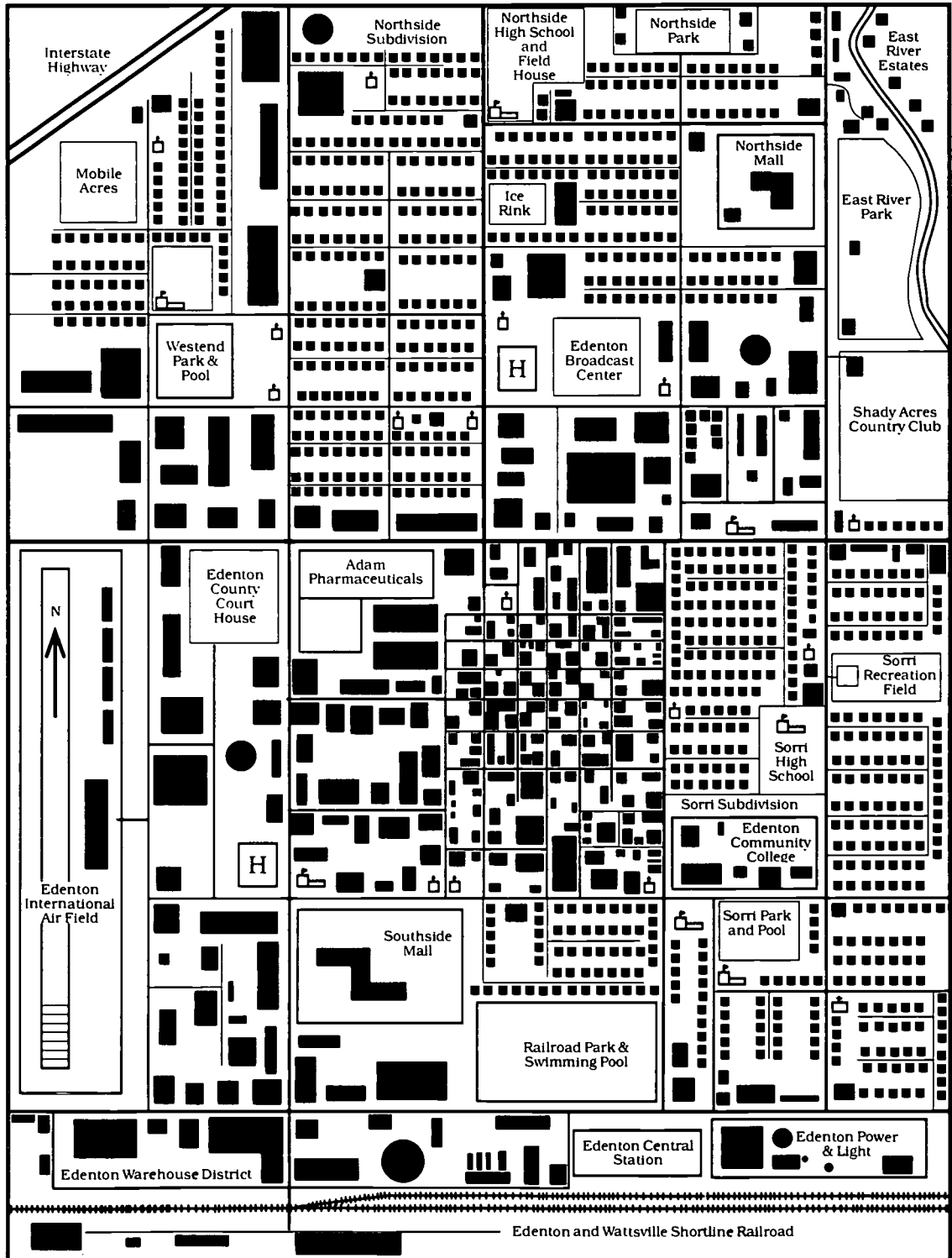


Students may choose whether to work in committees for part of the planning period or to remain in one group.

### C. Conclusion

Ask each student to augment her or his written job description with any particular responsibilities that will develop during a community crisis. Tell students that in the next activity they will have a chance to implement their plan. If questions arose in the planning process about how their city would function in an emergency, encourage students to contact their mentors before the next class meeting. ▲







Edenton, the county seat of Belle County, has a population of 150,000. The county itself has 300,000 citizens. As Belle County's only city, Edenton is the focal point of almost all services and activities. Its economy depends on a railroad repair facility operated by Amtrak and a large pharmaceutical manufacturing plant. These two operations are the city's largest employers. Because of its pleasant climate year round, its easy accessibility by interstate highways from all parts of the state, and a landscape that invites hunting, fishing, hiking, cycling, and camping, tourism in recent years has become an increasingly important part of the local economy.

### Vital Statistics

Population—150,000

#### Schools

- 8 elementary schools
- 4 middle schools
- 2 high schools
- 1 community college

#### Communications

- 3 AM stations
- 1 FM station
- 1 television station
- 1 daily newspaper (The Lark)

Hospitals—2 (Mercy Hospital is a trauma center)

Police Department—150 officers/20 civilian employees

Fire Department—50 firefighters/10 civilian employees

#### Recreational System

- 8 city parks
- 3 swimming pools
- 4 fieldhouses
- 1 golf course

Houses of Worship—24

Airport—1 (within city limits; single runway; provides jet service)

Railroads—service by Amtrak

Highways—2 interstates converge five miles north of the city

Hotels—2 in center city, Motels—20, most in the areas served by the interstates

Libraries—Main library with 8 neighborhood branches (all single-story buildings)

Day Care Centers—10 licensed facilities

Nursing Homes—4

Retirement Communities—2

Mobile Home Parks—3

Shopping Malls—2

Power Plants—1 (oil/gas)

Water Supply—Aqueducts, pipelines, 2 pumping stations, 2 water treatment plants

**Chief of Police**

The police chief is responsible for protecting lives and property in the area he serves. Specific responsibilities include preserving the peace, preventing criminal acts, enforcing the law, and arresting violators. The chief is under oath to uphold the law 24 hours a day. He or she makes many of the final decisions dealing with budgets and services provided by the police force.

**Fire Chief**

This official is responsible for protecting lives and property from the hazards of fire. Responsibilities include fighting fires, rescuing trapped individuals, conducting safety inspections, and conducting fire drills and fire safety education. The fire chief also assists in other types of emergencies and disasters in community life. He or she makes many of the final decisions dealing with budgets and services provided by the fire department. The fire chief usually comes through the ranks, starting as a firefighter.

**Director of Public Works**

This official is responsible for the maintenance of systems built at public expense for the common good, such as highways and dams. In some communities these responsibilities may be dealt with separately by officials responsible for highway safety and community transportation services, water and sewage, and other areas; in some, they may be combined in one office.

**Director of Public Health**

This official, usually a physician, is responsible for controlling the spread of communicable disease in the community and for mitigating any threats to the public safety, such as the contamination of public water supplies. He or she also engages in proactive education and advocacy to encourage positive behaviors, such as proper nutrition, and discourage negative ones, such as smoking and the abuse of alcohol and other drugs.

**Coordinator of Community Transportation Services**

This official is responsible for the safety of public transportation and both public and private vehicles. He or she arranges for registration, licensing, and state inspections. The coordinator inspects public vehicles and coordinates operation and maintenance of equipment, storage facilities, and repair facilities. She or he directs the recording of expenses and controls purchasing and repair spending. This official also helps plan and direct transportation safety activities.

**Public Information Officer**

This official supervises a staff of public relations workers, directs publicity programs designed to inform the public, and directs information to appropriate groups. He or she clarifies the local government's points of view on important issues to community or public interest groups and responds to requests for information from news media, special interest groups, and the general public. In an emergency, this function assumes added importance.

**Superintendent of Schools**

This official is responsible for managing the affairs of an entire public school district. He or she oversees and coordinates the activities of all the schools in the district in accordance with standards set by the board of education. Responsibilities include selecting and hiring staff, negotiating contracts with union employees, and settling labor disputes. He or she creates and implements plans and policies for educational programs, and, when necessary, interprets the school system's programs and policies. The superintendent is also responsible for the development and administration of a budget, the maintenance of school buildings, and the purchase and distribution of school supplies and equipment, and oversees the school's transportation system and health services.

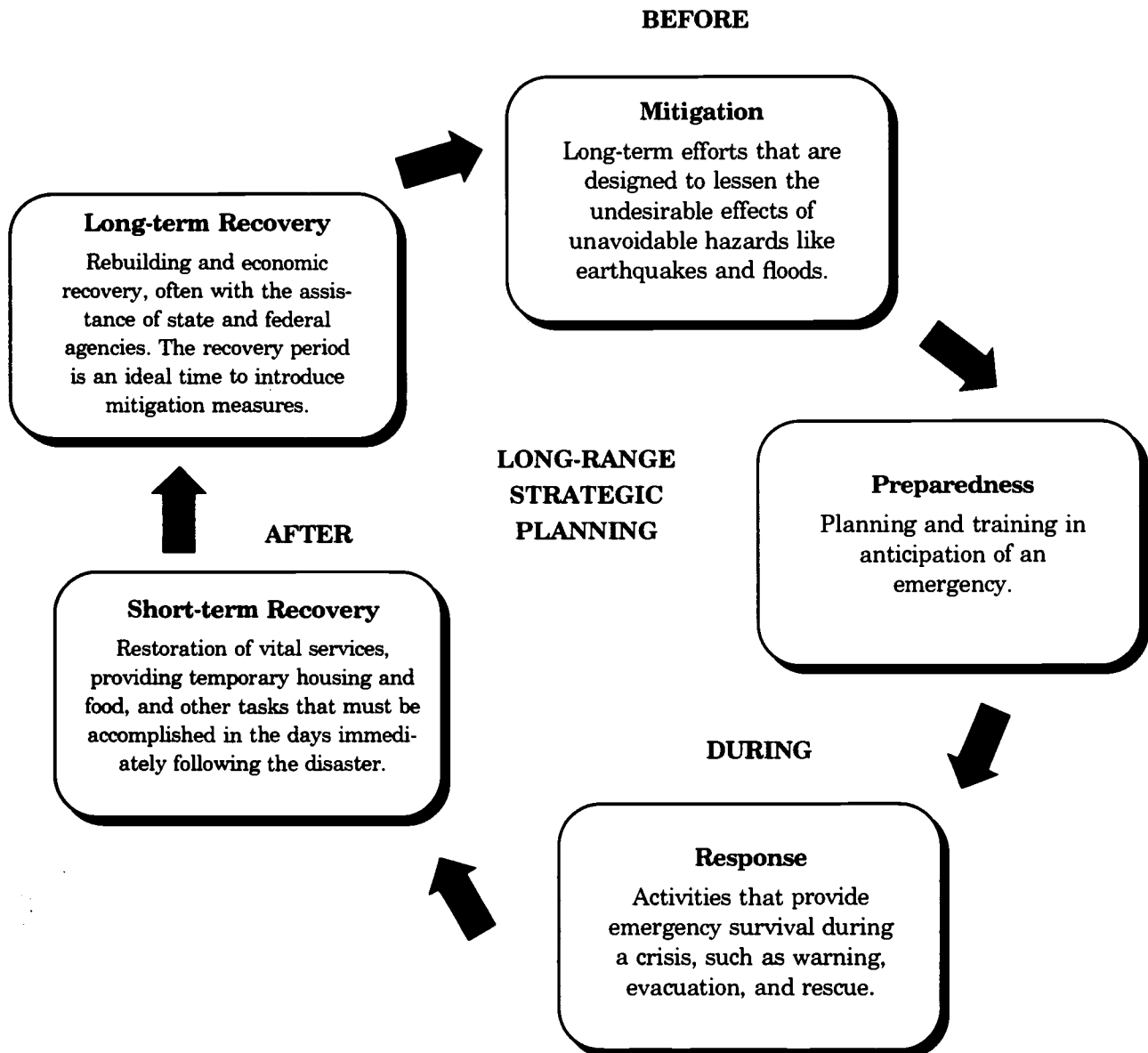
**City Manager or Mayor**

This professional in public administration has general responsibility for the overall operation of the city. All department heads answer to this official, who serves as the city's chief executive officer. A city manager is hired by the city council and serves at its discretion. A mayor is elected by the voters, but holds many of the same responsibilities.

**Members of the City Council (as needed)**

Each member determines the needs of the ward or district he or she represents by seeking out interviews, responding to constituents' phone calls and letters, and referring persons to specific agencies for services. The member speaks before neighborhood groups to establish communication and rapport between the members of the community and the service agencies available. The members of the council also have the responsibility to help resolve problems facing the community at large, in such areas as housing, urban renewal, education, welfare, unemployment, disaster response, and crime prevention.

# Phases of an Effective Management Plan



# EARTHQUAKE Simulation:

## Putting Plans into Action

### RATIONALE

---

Most emergency preparedness plans are never put into effect. In this activity students will have a chance to test the plans they have made, while also testing their own locality's state of emergency preparedness. By the end of this session, students should have a good geographic sense of their community and some understanding of how the rest of the community will react to emergencies.

### FOCUS QUESTION

---

How current, comprehensive, and effective are your community's emergency preparedness plans?

### OBJECTIVES

---

**Students will:**

1. Understand how a community government works and how it responds to emergencies.
2. Evaluate their locality's earthquake emergency preparedness plans.
3. Suggest changes in the existing emergency preparedness plan to reflect what has been learned.
4. Develop a personal earthquake emergency response.

### MATERIALS

---

- Master 6.2a, Disaster Script
- Classroom community map (from Unit 1)

### PROCEDURE

---

#### Teacher Preparation

Secure the cooperation of at least some of the mentors who have been working with your students throughout this curriculum. If possible, arrange for a place outside of school, such as a city government building, where students can conduct this simulation. Work with the mentors to develop a disaster script, using Master 6.2a as a



beginning. Arrange to have at least one emergency preparedness official in attendance for this exercise and the debriefing that follows. If your class has developed the community map they began in Unit 1, they will have a strong sense of their own community's physical and social arrangements. If not, you may want to work with the class to prepare a community profile similar to the Edenton Profile in Lesson 1 of this unit.

### A. Introduction

Tell students that in this last unit of the Seismic Sleuths curriculum they will have a chance to draw on all that they have learned. Agree on a place to serve as the emergency command center. This may be a room at city hall, if you have made previous arrangements; your school auditorium; or a circle of chairs in the front of your own classroom. The community map will be the focal point of this area.

### B. Lesson Development

1. Have the student who is playing the role of mayor or city manager convene a meeting of the preparedness council established in the last lesson. The purpose of this meeting is to discuss the budget of each department and clarify each administrator's role in an emergency. Focus on the lines of communication and each person's response to specific emergency situations (major fire, tornado, flood, earthquake, chemical plant disaster, etc.—focus on those most likely in your community). Whoever conducts the meeting will use the large community map to plot where each person's main area of interest lies and what geographic areas are essential to maintaining the continuity of essential services, such as water treatment, sewage treatment, and electrical power.
2. After 10 minutes or more, when the main points have been reviewed, but without warning, tell the students that an earthquake is occurring. Conduct a drop, cover, and hold drill, following the instructions in Unit 5, Lesson 2. Immediately after the drill, begin reading the script. Explain the time frame of the exercise. Students should then begin to take control of the situation and implement their emergency plans.

### C. Conclusion

At the next class meeting, set aside some time for a debriefing and evaluation. Give students class time to write thank-you letters to their mentors and other members of the community who participated in this exercise and/or in earlier lessons. Mail the letters from school.

## ADAPTATIONS AND EXTENSIONS

1. Encourage students who have shown particular interest to maintain contact with their mentors, perhaps through volunteer work, a part-time job, or a request for career information. This association may inspire some students' choice of a career.
2. Write your own letters of appreciation to any community helpers who have not worked directly with individual students. With encouragement, some of these individuals may maintain an interest in the school and become valuable resources for students and faculty. ▲

## TEACHING CLUES AND CUES



This activity can be as elaborate as you choose to make it. You may want to set aside a half day, or even a full day.



The appendix that follows this unit is a report of an actual teacher-planned community earthquake preparedness drill. This is incorporated as a framework to use in constructing such an activity for your community.

303

At 10:05 a.m. today, Tuesday, September 26, 1995, a magnitude 7.0 earthquake struck the community. At noon, the following damage had been reported:

The downtown area was hardest hit. People have reported that most shelves, bookcases and display stands were knocked over. Masonry structures have sustained major damage, brick facades are collapsing, chimneys are falling, and some buildings have serious structural cracks. No fatalities have yet been reported.

The hospital reports that its three-story gerontology unit has “pancaked,” causing the second and third floors to collapse on the first floor. At the time of collapse, 34 persons—29 patients and 5 staff members—were in that part of the building. Other parts of the hospital suffered nonstructural damage, some disruption to power, and an end to all but lifesaving procedures. The latest information indicates that the hospital will be at 50% operational capacity by 2:30 this afternoon.

Of the three fire stations, two have stayed operational. The downtown station has been destroyed. Fire department personnel were able to move only one pumper wagon before the building collapsed on the ladder truck, ambulance, and emergency generator truck.

*This can be changed, embellished, tailored, and expanded for your community and your students. Additional effects that may be included:*

- Large fire has broken out in downtown area
- Water mains are cut
- 20% of the population has sustained injuries
- Utility lines are down
- Animals in the zoo have escaped from their cages
- Looters are rampaging through downtown
- Sewers have backed up, endangering public health

# What's Your E.Q. I.Q.?

## **RATIONALE**

Students will review and solidify what they have learned in the preceding units by answering questions in cooperative teams.

## **FOCUS QUESTION**

How well can students recall and apply what they have learned?

## **OBJECTIVES**

Students will:

1. Ask and answer questions about earthquakes and earthquake preparedness.
2. Keep score.
3. Learn from incorrect responses as well as correct ones.

## **MATERIALS**

- Master 6.3a, Earthquake Review Questions
- Back of Master 6.3a, Answer Key
- Minute timer
- Chalkboard and chalk for recording the score
- Tag board and laminating materials (*optional*)

## **PROCEDURE**

### **Teacher Preparation**

Copy Master 6.3a and cut the pages apart into cards. You may want to back them on tag board and/or laminate them for durability.

### **A. Introduction**

Divide the class into teams of four or five students each and give each team a number or a name.

Give groups about 15 minutes to review the earthquake materials in their notebooks and ask each other questions as a warm-up.

## **TEACHING CLUES AND CUES**



Students may enjoy competing in the teams they established for the unit 4 activities (SETs).

## **B. Lesson Development**

1. Call two teams at a time to the front of the room. Instruct students to arrange chairs in two rows facing each other. Hand the deck of question cards to one team. For the first round, this team will ask and the other team will answer.
2. Asking and answering both begin with the student on the left. The first asker reads a question out loud and starts the timer. The first student on the opposing team tries to answer it. If that student cannot answer the question, play passes to the second student on the same team, then to the third, if necessary, and so on until one minute is up. The questioning team keeps score, tallying one point for each correct answer.
3. When any member of the team that is up answers incorrectly, play passes to the other team and the roles are reversed. When a member of the second team answers incorrectly, call two new teams to the front of the room.

## **C. Conclusion**

When all the teams have had a chance to play, the team with the highest score may challenge any other team to a new round. If another team exceeds their score, they become the new challengers. The team with the highest score at the end of the period wins.

## **ADAPTATIONS AND EXTENSIONS**

---

Invite students to write questions and answers of their own to add to the deck. Be sure that all members of a group agree on the answer and the phrasing of the question before the card is put into play. ▲

## **TEACHING CLUES AND CUES**

---



When all the cards have been used once, shuffle them and begin again. Repetition reinforces learning.

# EARTHQUAKE

## Review Questions

SEISMIC SLEUTHS



1. According to geologic studies, approximately how old is the Earth?

- [a] 2 thousand years
- [b] 7 thousand years
- [c] 2 million years
- [d] 4.54 billion years

SEISMIC SLEUTHS



5. Although earthquakes occur almost everywhere, strong, damaging quakes are especially common in the:

- [a] Eastern United States
- [b] Pacific Ring of Fire
- [c] Mediterranean Region
- [d] Great African Rift

SEISMIC SLEUTHS



2. All of the following people made major contributions to our knowledge of the Earth's physical history and structure except:

- [a] Alfred Wegener
- [b] Inge Lehmann
- [c] Anna Maria Alberghetti
- [d] Andrija Mohorovičić

SEISMIC SLEUTHS



6. Which of these statements best describes the relationship between earthquakes and volcanoes?

- [a] Earthquakes cause volcanoes.
- [b] Volcanoes cause earthquakes.
- [c] Volcanoes and earthquakes both occur along the margins of Earth's tectonic plates.
- [d] Volcanoes only occur in hot countries.

SEISMIC SLEUTHS



3. Earthquakes are caused by:

- [a] strain energy that builds up and is suddenly released
- [b] tides
- [c] bad vibrations
- [d] the Richter scale

SEISMIC SLEUTHS



7. Scientists can accurately predict earthquakes in the short range by studying:

- [a] the behavior of animals
- [b] changes in radon emissions
- [c] Rayleigh waves
- [d] none of the above

SEISMIC SLEUTHS



4. Approximately how many earthquakes large enough to be rated significant by the U.S. Geological Survey occur worldwide during a calendar year?









- [a] More than 20
- [b] More than 100
- [c] More than 1000
- [d] More than 15,000

SEISMIC SLEUTHS



8. The Richter scale measures an earthquake's:

- [a] magnitude
- [b] amplitude
- [c] pulchritude
- [d] intensity

<p>SEISMIC SLEUTHS</p>  <p>b</p>	<p>SEISMIC SLEUTHS</p>  <p>d</p>
<p>SEISMIC SLEUTHS</p>  <p>c</p>	<p>SEISMIC SLEUTHS</p>  <p>c</p>
<p>SEISMIC SLEUTHS</p>  <p>d</p>	<p>SEISMIC SLEUTHS</p>  <p>a</p>
<p>SEISMIC SLEUTHS</p>  <p>a</p>	<p>SEISMIC SLEUTHS</p>  <p>d</p>



9. How much greater is the amount of energy released by a magnitude 7 earthquake than the amount released by a magnitude 6 quake?

- [a] twice as great
- [b] 10 times as great
- [c] about 30 times as great
- [d] 100 times as great



13. In which one of these states are strong and potentially damaging earthquakes relatively frequent?

- [a] Texas
- [b] Florida
- [c] Wisconsin
- [d] Alaska



10. The method architects and structural engineers use to quickly assess a building's earthquake resistance is called:

- [a] eyeballing
- [b] sedimentation
- [c] rapid visual screening
- [d] estimating



14. If a strong earthquake struck while you were inside a building, what would you do to protect yourself?

- [a] run outside
- [b] dial 911
- [c] drop, cover, and hold
- [d] freeze



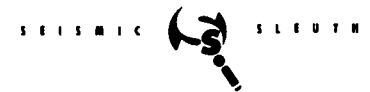
11. The earthquake waves that are the first to arrive at the epicenter are called:

- [a] P waves
- [b] A waves
- [c] First waves
- [d] Love waves



15. How much damage a building suffers in an earthquake depends upon:

- [a] how close it is to the fault
- [b] what it is built of and how it is built
- [c] what kind of soil it is built on
- [d] all three











12. About how long does the violent shaking last in a typical earthquake?

- [a] 20 seconds
- [b] one minute
- [c] five minutes
- [d] 30 minutes



















16. To make a room safer in an earthquake, you would:

- [a] fasten all unsecured heavy objects
- [b] remove all pets
- [c] turn on the radio
- [d] lock the doors and windows

<p>SEISMIC SLEUTHS</p>  <p>d</p>	<p>SEISMIC SLEUTHS</p>  <p>c</p>
<p>SEISMIC SLEUTHS</p>  <p>c</p>	<p>SEISMIC SLEUTHS</p>  <p>c</p>
<p>SEISMIC SLEUTHS</p>  <p>d</p>	<p>SEISMIC SLEUTHS</p>  <p>a</p>
<p>SEISMIC SLEUTHS</p>  <p>a</p>	<p>SEISMIC SLEUTHS</p>  <p>a</p>



<p style="text-align: center;">SEISMIC  SLEUTHS</p> <p>17. A break in the Earth's crust along which earthquake movement has occurred is called:</p> <p>[a] a gap [b] a fault [c] an epicenter [d] an isoseismal</p>	<p style="text-align: center;">SEISMIC  SLEUTHS</p> <p>20. All of the following are good sources of earthquake information except:</p> <p>[a] United States Geological Survey [b] The National Enquirer [c] Federal Emergency Management Agency [d] National Earthquake Prediction Evaluation Council</p>
<p style="text-align: center;">SEISMIC  SLEUTHS</p> <p>18. A gigantic ocean wave caused by an earthquake is called:</p> <p>[a] a samurai [b] a sand boil [c] a tsunami [d] a surface wave</p>	<p style="text-align: center;">SEISMIC  SLEUTHS</p> <p>21. Resonance is a buildup of amplitude in a physical system that occurs when the frequency of an applied oscillatory force is close to the natural frequency of the system.</p> <p>[a] true [b] false [c] sometimes [d] don't know</p>
<p style="text-align: center;">SEISMIC  SLEUTHS</p> <p>19. All of the following are structural elements except:</p> <p>[a] windows [b] bearing walls [c] braces [d] horizontal beams</p>	<p style="text-align: center;">SEISMIC  SLEUTHS</p>
<p style="text-align: center;">SEISMIC  SLEUTHS</p>	<p style="text-align: center;">SEISMIC  SLEUTHS</p>

<p>SEISMIC SLEUTHS</p>  <p>b</p>	<p>SEISMIC SLEUTHS</p>  <p>b</p>
<p>SEISMIC SLEUTHS</p>  <p>a</p>	<p>SEISMIC SLEUTHS</p>  <p>c</p>
<p>SEISMIC SLEUTHS</p>  <p>a</p>	<p>SEISMIC SLEUTHS</p>  <p>a</p>
<p>SEISMIC SLEUTHS</p>  <p>a</p>	<p>SEISMIC SLEUTHS</p>  <p>a</p>

# HEY, Look at Me Now!

## RATIONALE

---

This activity is designed to serve students and teachers as a gauge of what they have learned from this curriculum.

## FOCUS QUESTIONS

---

What have you learned about earthquakes and earthquake preparedness?

What will you do differently as a result of these lessons?

## OBJECTIVE

---

Students will correct, elaborate, and refine their earlier writings by applying information they have gained from this curriculum.

## MATERIALS

---

- Writing paper and pens or computers and printers

## PROCEDURE

---

### A. Introduction

Explain that in this postassessment activity each student is to complete the same task he or she did in the preassessment activity. In rewriting each of the three passages, however, students are urged to draw upon what they have learned from the unit. Remind the students to focus on how their new knowledge has changed their way of thinking about earthquakes and earthquake preparedness.

### B. Lesson Development

As they did in Unit 1, students will invent a specific quake. Each of their three accounts will describe the same earthquake, but the styles of the three will vary.

*News Reporter*—a short, concise article describing the who, what, where, why, and when of the earthquake.

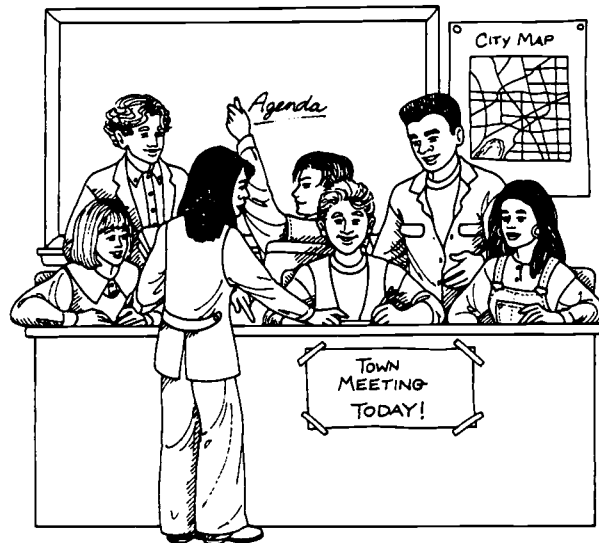
*Scientist*—a scientific account stating what is objectively known about the earthquake: its causes, its Modified Mercalli and Richter ratings, and the possibility of aftershocks or more large earthquakes.

318

*Eyewitness*—a personal letter to a friend telling about being in an earthquake. This will describe what happened during the earthquake to the student, the building in which the student was, family members and pets, and the family home. Describe what you had done before the earthquake to be prepared, how effective your preparations were, and what you would do differently in preparation for the next earthquake. Also describe what life was like in the two weeks following the earthquake.

### **C. Conclusion**

After collecting the papers, pair each student's postassessment writings with the same student's preassessment writings, and hand them out to a different student. Assign students the task of reading both sets and commenting on what the writer has learned from the unit. Follow with a class discussion of these comparisons, either the same day or the next. ▲



### Books

Davis, James F.; Bennett, John H.; Borchardt, Glenn A.; Kahle, James E.; Rice, Salem J.; and Silva, Michael A. (1982). *Earthquake Planning Scenario for a Magnitude 8.3 Earthquake on the San Andreas Fault in the San Francisco Bay Area*. San Francisco: California Department of Conservation, Division of Mines and Geology. Although the maps and much of the discussion are specific to California, the sections on transportation, communications, water and waste, electrical power, natural gas, and petroleum fuels would be helpful for planning in other areas.

Federal Emergency Management Agency. *Central City: A Model Community*. Integrated Emergency Management Course. Emmitsburg, MD: Federal Emergency Management Agency, 1988. (SM 171.1)

Plafker, G., and Galloway, J.P., eds. (1990). *Lessons Learned from the Loma Prieta, California, Earthquake of October 17, 1989*. (U.S. Geological Survey Circular 1045). Reston, VA: U.S. Geological Survey, 703-648-6891.

Steinbrugge, Karl V.; Bennett, John H.; Lagorio, Henry J.; Davis, James F.; Borchardt, Glenn A.;

and Topozada, Tousson R. (1987). *Earthquake Planning Scenario for a Magnitude 7.5 Earthquake on the Hayward Fault in the San Francisco Bay Area*. San Francisco: California Department of Conservation, Division of Mines and Geology.

Although the maps and much of the discussion are specific to California, the sections on hospitals, schools, transportation, communications, water and waste, electrical power, natural gas, and petroleum fuels would be helpful for planning in other areas.

Watson, R.W.; Poda, J.H.; Miller, C.T.; Rice, E.S.; and West, G. (1990) *Containing Crisis: A Guide to Managing School Emergencies*. Bloomington, IN: National Educational Service.

### Non-Print Media

*Silent Quake: Preparedness for the Hearing-Impaired*. A videotape using American sign language, captioning, and voice-overs. Developed by the American Red Cross, Los Angeles, CA, available on loan from BAREPP, Oakland, CA; 415-327-6017.

*Note: Inclusion of materials in these resource listings does not constitute an endorsement by AGU or FEMA.*

# EARTHQUAKE Drill:

## A Critical Skills Exercise

by Sean P. Cox, Teacher  
Salem High School, Salem, New Hampshire

### Abstract

Earth science students at Salem High School have participated in an environment of critical skills. Events are student centered, learning stresses both process and curriculum content, and the foundation for activity is problem-solving projects. This particular project had students designing and rehearsing part of an emergency management plan in response to a hypothetical earthquake affecting Salem, NH. Students assumed the roles of town officials in a three-hour drill held in Salem's Emergency Operations Center (EOC). The drill was sponsored by the town of Salem and the New Hampshire Office of Emergency Management. Project origin, planning, performance, and follow-up are detailed in this paper.

### Introduction

For seven months students in this class spent more than 100 hours not only learning about specific topics in Earth science but also learning specific strategies for learning and working together. In March, as our plate tectonics unit progressed, the time to apply our learning had arrived. A project was designed in cooperation with our town's emergency management director and the New Hampshire Office of Emergency Management.

In this project students were to design, document, and use a hazard plan to be added to Salem's Emergency Management Plan for earthquake response. Students did extensive research and documentation, preparing a plan and also preparing themselves to play roles as decision makers in a disaster. The teacher, the emergency management director, and Office of Emergency Management staff members met and communicated many times to finalize the details.

The actual drill, held in Salem's Emergency Operations Center (EOC), greatly surpassed all expectations. Students handled crisis after crisis as part of a three-hour drill that included mass destruction, dam failure, utility outages, looting, hospital closings, and multiple evacuations. Groups of students rotated through three one-hour shifts filling various roles in turn, including those of the school superintendent, reporters, and selectmen. There was confusion and near hysteria as a myriad of details crowded the EOC. Students struggled at times to prioritize and solve problems. All the participants and observers came away with a new respect for each other and a new appreciation of the need to be prepared for the worst.

### How It All Began

Teaching in this class proceeds from the philosophy that learning is a very complex behavior. Learning is different for each individual, and schools need to recognize these differences. Schools also need to teach not only the "what" but also the "how" of learning. With this in mind, these 96 people were provided a student-centered environment that made them ultimately responsible for their learning both as individuals and as a group. Students spent many class periods doing activities that provided experience with various learning styles. Projects were used to create concrete and abstract opportunities for learners, including reading, writing, coordinating, prioritizing, and communicating.

Emphasis is placed on the belief that there are often many viable solutions to a problem. For this reason, creativity is strongly fostered, as students are urged to produce quality work from their own base of knowledge and experience. The teacher is not the "fountain of knowledge." Students must find their own answers that they can support fiercely and intimately. Guidance and direction are given in the form of specific teacher questions. As students gain experience and comfort completing curriculum-based projects in this student-centered class, they begin to take more control of their education, needing less teacher input. With greater student responsibility, the teacher's goal is to balance content and process so that each remains equally valued in learning.

### Earthquake in Salem, NH

So why dabble with earthquakes, not to mention the town's Emergency Management Plan? Because high school students are interested in earthquakes. Earthquakes are unpredictable, damaging, and loud—characteristics admired and even shared by many teenagers. Moreover, the teachers saw a need for earthquake education, preparedness, and response within the community.

In preparation for this major project, classes throughout the year dealt with process strategies and critical skills. Skills including decision making, problem solving, communication, cooperation, and documentation were addressed, rehearsed, refined, and incorporated into our classes. Additionally, students carried out many short-term projects in the field of plate tectonics and seismology. Specifically, students researched, modeled, and demonstrated types of seismic waves, seismic forecasting, hazard assessment, and New England's seismic history.

The next step in the project involved a contact with the person in Salem responsible for emergency management. The teacher had to determine if the anticipated needs existed and whether or not direct community involvement was possible. Salem's fire chief, who also serves as its emergency management director, acknowledged a void in the town's disaster response and was completely open to student input and community cooperation. As the teacher and the director discussed their needs, the project evolved into what they hoped would be a truly meaningful experience. Ninety-six of Salem's teenagers might permanently and positively affect their community.

The teacher expressed the following goals:

- A. Students will develop and implement a solution with an educational component to a real problem in our community. They will:
  1. do community-based research
  2. incorporate many information-gathering techniques
  3. use a maximum number of resources
  4. use pre-existing models and/or plans where appropriate
- B. Students will select, implement, and refine certain process skills, such as decision making, problem solving, communication, cooperation, and documentation.
- C. Students will be able to describe all major theories on plate tectonics as well as how those theories relate to earthquakes.
- D. Students will be able to describe New England's earthquake history and its susceptibility to future seismic activity.
- E. The adults will empower students to come up with their own plan in an open environment with a minimum of restrictions.

### Planning, Planning, and More Planning

The director suggested a drill that would test the students' solutions as a way of summing up and evaluating the project. This drill would not only satisfy the teacher's desire to test students, but also provide a rehearsal of the town's Emergency Management Plan. The teacher and the director outlined the town's need for a hazard plan and discussed the specific ways in which students might meet that need. A time and date for the drill were set, and a letter to the students was drafted, recognizing their recent experiences in these areas and requesting their aid.

The next task was kicking off this 15-day extravaganza by arranging for expert speakers to come into the school. Issues discussed included seismology, engineering, hazard assessment, emergency response planning, and plan implementation. All of our guest experts graciously supplied printed materials to supplement their presentations.

On kick-off day, the educators and the experts decided students needed additional guidelines to properly design a hazard plan. The design of the plan was separated into five areas—communication, evacuation, hazard assessment, private resources, and public resources. As the first few days passed, students struggled to prioritize the components of the problem and divide up responsibilities. The teacher carefully guided students by questioning them and challenging them to use skills and knowledge they had already developed.

Meanwhile, the director scripted the drill, provided the teacher with the roles and titles students would assume during the drill (see list below), and secured access to a wide variety of resources. The resources included a college text, Federal Emergency Management Agency (FEMA) pamphlets, and a blank hazard plan illustrating plan design. Also made available were the telephone numbers of the town's department heads and of state and regional emergency management personnel, and lastly, the most precious resource of all, personal attention and dedication. The New Hampshire Office of Emergency Management and its natural hazards program specialist also provided generous amounts of both time and materials.

## UNIT RESOURCES

### EOC Town Officials and Staff Roles

#### TOWN OFFICIALS

Chairman, Board of Selectmen  
Members, Board of Selectmen (4)  
Town Manager  
Emergency Management Director  
Fire Chief  
Police Chief  
Public Works Director  
Health Officer  
Chief Building Inspector  
Director of Human Resources (Welfare)  
American Red Cross Director  
Superintendent of Schools

#### EOC STAFF

Message Loggers (2)  
Message Runners (2)  
Updater, Status Board (1)  
Radio Communications (2)  
EOC Security (2)  
EOC Logistics (2)  
Public Information Officer  
Reporters (3)

As the project continued, the teacher noticed an ever-increasing level of student anxiety and misdirection. Therefore, the teacher and the director arranged for a debriefing of the project's progress. The students presented their ideas and findings to a panel consisting of the director, educators, and the New Hampshire natural hazards specialist. The panel was able to give students valuable feedback on their plan's strengths and weaknesses. This day-long debriefing also allowed students a chance to look at the project from a critical point of view, breathing new life into their design and implementation efforts.

At the beginning of the second week, the teacher finalized student sign-up for the roles they were to assume in a three-shift rotation. Each student selected (1) a decision making role, where he or she would play an active part in the Emergency Operations Center (EOC), and (2) an EOC staff role or a role with rescue equipment and media presentations. Each student also had to identify one shift during which to start a journal, recording not only observations of the drill's varied actions and reactions, but also an introspective analysis of the project's progression from start to finish.

The director coordinated the attendance of the town's department heads, the school superintendent, the American Red Cross representative, a utility company representative, and the media, as well as state and regional emergency management officials. The director and the teacher finalized details and made arrangements for physically disabled and motivationally disabled students, school and community rules implementation, lunch, and debriefing.

#### It's D-Day!

At 8:30 a.m. on D-Day (Drill Day), students anxiously gathered materials and boarded the bus to Salem's EOC, not knowing quite what to expect. Upon arrival at the Main Street fire station housing the EOC, students heard building rules and consequences, dropped off their coats, and positioned themselves for the first shift of the drill. With Salem's youth in place as fire and police chiefs, building inspector, school superintendent, radio operator, message runners, EOC security, and newspaper reporters, the EOC opened and the drill began.

The script for the day explained that the EOC had been opened in response to an earthquake at 7:50 a.m., measuring 7.5 on the Richter scale and centered in nearby Hudson, NH. With Salem's adult department heads as advisors, students enacted their plan, prioritizing needs, communicating with counterparts, and solving problems, all while using the town's minimal remaining resources as judiciously as possible.

An excerpt from the drill script details the crisis students were reacting to.



**SHIFT CHANGE - STATUS REPORT**

It is now 8:00 am (the second morning).

During the night, the public works department began repairs on the known broken water mains. The water towers are back up to capacity, but water service is provided to only a small portion of the town (Main St./Depot area and Lawrence Rd./Cluff Rd. area).

The sewer system is completely out of service and sewerage is beginning to leak into some streams and onto roads. All power in town went out for most of the night and is beginning to come on in sections. Cable TV is still out. The cracks in the dam at Arlington Pond appear to be worsening.

The evacuation center has housed approximately 200 people who are in need of food.

The Police Department spent a long night dispersing looters and making arrests. Approximately 20 people are in custody.

The Fire Department responded to several building collapses, two house fires, numerous downed power lines, and 15 ambulance calls. Most of the patients were taken to a temporary first aid station.

Two relatively minor aftershocks were felt during the night.

Decisions are made, aid is rendered, and nerves are wracked as each shift struggles with a seemingly endless onslaught of high-priority problems. At times, the EOC becomes a jumble of noise and confusion. Internal communication deteriorates and priorities temporarily blur. Selectmen try to solicit information from the building inspector, only to find him tied up with both the public works director and the health official. Finally, the emergency management director shouts for order, quieting the din and returning the EOC to a semblance of organization. After 180 minutes, simulating 24 hours of emergency responses highlighted by a telephone call from the Director of FEMA, Mr. Stickney, the drill concludes with a press conference.

As we await the arrival of lunch, all participants are relieved, excited, exhausted, and slightly saddened to know the project has reached its end. Students share the disasters and the responses of each shift. Some write feverishly in their journals, not wanting to forget a single moment. As the 30 pizzas arrive, students and staff alike enjoy a carefree lunch and conversation.

With lunch cleared away, the group assembles for the anticipated critique and debriefing. Town and state emergency management officials have many kind words for the students, followed by praise from Salem's emergency management director and the teacher. In spite of the positive input, students decide that their hazard plan can be improved, and request permission to keep the document for that purpose.

At 1:15 p.m., the students, document in hand, say their good-byes and their thanks as the teachers and directors shake hands. After a short ride, the once and future emergency managers are back in school, heading off to their last-period class. These 96 young teens have had the experience of a lifetime, gaining a priceless perspective on their community and themselves.

**Project Strengths and Weaknesses**

The success of the project far exceeded all expectations. Students were able to not only synthesize a plan for dealing with a natural disaster, but also put their plan into action. There were some areas of concern, however.

Even though the plan allotted 15 decision-making roles, representing town officials, and another 15 staff roles in the EOC, there were several students who had to double up in order to participate in the EOC's operation. The EOC was always overcrowded with students, adult advisors, state and regional observers, and media.

The strengths were numerous. This activity was truly student centered. Students took the initiative in researching and preparing the plan, several times even meeting after school and on weekends. Additionally, students had to make dozens of community contacts to gather materials and information. There was a rush of positive public relations for both the school and the town of Salem. Print media from Lawrence, MA, and Salem, NH, as well as TV news from Manchester, NH, covered the drill. Most satisfying to the teacher, the students ended the experience still wanting to do more, as they communicated through their lengthy and detailed journals.

# EARTHQUAKE Glossary

**Aftershock**—an earthquake that follows a larger earthquake, or main shock, usually originating along the same fault as the main shock.

**Amplitude**—a measurement of the energy of a wave. Amplitude is the displacement of the medium from zero or the height of a wave crest or trough from a zero point.

**Body waves**—waves that move through the body (rather than the surface) of the Earth. P waves and S waves are body waves.

**Braces or Bracing**—structural elements built into a wall to add strength. These may be made of various materials and connected to the building and each other in various ways. Their ability to withstand stress depends on the characteristics of the materials and how they are connected.

**Canopy**—a covered area that extends from the wall of a building, protecting an entrance.

**Cantilever**—a beam, girder, or other structural member which projects beyond its supporting wall or column.

**Cartographer**—a map maker.

**Cladding**—an external covering or skin applied to a structure for aesthetic or protective purposes.

**Cornice**—the exterior trim of a structure at the meeting of the roof and wall.

**Compression**—squeezing, being made to occupy less space. P waves are called *compressional waves* because they consist of alternating compressions and dilations, or expansions.

**Consolidated**—tightly packed, composed of particles that are not easily separated.

**Continental drift**—the theory, first advanced by Alfred Wegener, that Earth's continents were originally one land mass, pieces of which split off and gradually migrated to form the continents we know.

**Diagonal braces**—structural elements that connect diagonal joints. These braces may be made of solid materials or flexible materials. How they function depends on what they are made of and how they are connected.

**Duration**—the length of time that ground motion at a given site shows certain characteristics. Most earthquakes have a duration of less than one minute, in terms of human perceptions, but waves from a large earthquake can travel around the world for hours.

**Earthquake**—a sudden shaking of the ground caused by the passage of seismic waves. These waves are caused by the release of energy stored in the Earth's crust.

**Earthquake hazard**—any geological or structural response to an earthquake that poses a threat to human beings and their environments.

**Elevation**—in architecture, a flat scale drawing of one side of a building.

**Epicenter**—the point on Earth's surface directly above the location (focus) of the earthquake below the surface.

**Epitaph**—an inscription on a tombstone, often intended to sum up the achievements of a person's life.

**Fault**—a break or fracture in Earth's crust along which movement has taken place.

**Focus (pl. foci)**—the point within the Earth that is the origin of an earthquake, where stored energy is first released as wave energy.

**Force**—the cause or agent that puts an object at rest into motion or affects the motion of a moving object. On Earth, gravity is a vertical force; earthquake shaking includes both horizontal and vertical forces.

**Foreshock**—an earthquake that precedes a larger earthquake, or *main shock*, usually originating along the same fault as the main shock.

**Friction**—mechanical resistance to the motion of objects or bodies that touch.

**Frequency**—the rate at which a motion repeats, or oscillates. The frequency of a motion is directly related to the energy of oscillation. In this context, frequency is the number of oscillations in an earthquake wave that occur each second. In earthquake engineering, frequency is the rate at which the top of a building sways.

**Generalization**—a statement made after observing occurrences that seem to repeat and to be related.

**Glazing**—glass surface.

**Gravity**—the force of attraction between any two objects with mass. Gravity is especially noticeable when an object of great mass, such as Earth, attracts an object of lesser mass.

**Ground water**—subsurface or underground water.

**Hazard**—an object or situation that holds the possibility of injury or damage.

**Hertz (Hz)**—the unit of measurement for frequency, as recorded in cycles per second. When these rates are very large, the prefixes *kilo* or *mega* are used. A *kilohertz* (kHz) is a frequency of 1,000 cycles per second and a *megahertz* (MHz) is a frequency of 1,000,000 cycles per second.

**Horizontal load**—the sum of horizontal forces (shear forces) acting on the elements of a structure.

**Index fossil**—a fossil that, because its approximate date is known, allows scientists to determine the age of the rock in which it is imbedded.

**Infill**—a construction method that starts with a structural steel or reinforced concrete frame and fills the empty spaces between structural elements with brick or hollow concrete block.

**Intensity**—a subjective measure of the amount of ground shaking an earthquake produces at a particular site, based on human observations of the effect on human structures and geologic features. The Modified Mercalli Intensity scale uses Roman numerals from I to XII.

**Isoseismal line**—a line on a map that encloses areas of equal earthquake intensity.

**Joint**—a break or fracture in the Earth's crust along which movement has not taken place.

**Joists**—the parallel planks or beams that hold up the planks of a floor or the laths of a ceiling.

**Lag time**—the difference between the arrival time of P waves ( $T_p$ ) and S waves ( $T_s$ ).

**Landfill**—a site where soil has been deposited by artificial means—often, where garbage or rubbish has been disposed of, then covered with dirt and compacted.

**Landslide**—an abrupt movement of soil and bedrock downhill in response to gravity. Landslides can be triggered by an earthquake or other natural causes.

**Latitude**—the location of a point north or south of the equator, expressed in degrees and minutes. Latitude is shown on a map or globe as east-west lines parallel to the equator.

**Lifeline**—a service that is vital to the life of a community. Major lifelines include transportation systems, communication systems, water supply lines, electric power lines, and petroleum or natural gas pipelines.

**Liquefaction**—the process in which a solid (soil) takes on the characteristics of a liquid as a result of an increase in pore pressure and a reduction in stress.

**Load**—the sum of vertical force (gravity) and horizontal forces (shear forces) acting on the mass of a structure. The overall load is further broken down into the loads of the various parts of the building. Different parts of a building are designed and constructed to carry different loads.

**Load path**—the path a load or force takes through the structural elements of a building.

**Loess**—an unstratified, windblown mixture of clay, sand, and organic matter, usually crumbly and buff or yellow-brown in color.

**Longitude**—the location of a point east or west of the prime meridian, expressed in degrees and minutes. Longitude is shown on a map or globe as north-south lines left and right of the prime meridian, which passes through Greenwich, England.

**Longitudinal waves**—p-waves. This term is used to emphasize that p-waves move particles back and forth in the same line as the direction of the wave.

**Love waves**—surface waves that move in a back and forth horizontal motion.

**Magnitude**—a number that characterizes the size of an earthquake by recording ground shaking on a seismograph and correcting for the distance to the epicenter of the earthquake. Magnitude is expressed in Arabic numbers.

**Masonry**—stone, brick, or concrete building materials.

**Masonry veneer**—a masonry (stone or brick) facing laid against a wall and not structurally bonded to the wall.

**Mass movement**—the movement of surface material caused by gravity.

**Meteorology**—the study of Earth's atmosphere.

**Modified Mercalli scale of 1931**—a qualitative scale of earthquake effects that assigns an intensity number to the ground shaking for any specific location on the basis of observed effects. Mercalli intensity is expressed in Roman numerals.

**Natural hazard**—any of the range of natural Earth processes that can cause injury or loss of life to human beings and damage or destroy human-made structures.

**Nonstructural feature**—an element of a building that is not essential to its structural design and does not contribute structural strength. Examples are windows, cornices, and parapets.

**Oscillation or vibration**—the repeating motion of a wave or a material—one back and forth movement. Earthquakes cause seismic waves that produce oscillations, or vibrations, in materials with many different frequencies. Every object has a natural rate of vibration that scientists call its *natural frequency*. The natural frequency of a building depends on its physical characteristics, including the design and the building materials.

**P waves**—primary waves, so called because they travel faster than S waves, or secondary waves and arrive at the station first. These waves carry energy through the Earth as longitudinal waves, moving particles in the same line as the direction of the wave.

**Paleomagnetism**—the natural magnetic traces that reveal the intensity and direction of Earth's magnetic field in the geologic past.

**Paleoseismology**—the study of ancient earthquakes.

**Parapet**—part of a wall which is entirely above the roof.

**Path, or Load path**—the direction in which energy is distributed throughout a structure. In most structures, it should be directed toward the ground.

**Peat**—a deposit of semicarbonized plant remains in a water-saturated environment. Peat is an early stage in the development of coal.

**Period**—the time between two successive wave crests.

**Pioneer**—a person who moves into new and uncharted territory.

**Plate tectonics**—the theory that Earth's crust and upper mantle (the lithosphere) are broken into a number of more or less rigid, but constantly moving, segments, or plates.

**Portico**—a porch or covered walk consisting of a roof supported by columns

**Prediction**—a statement that something is likely to happen based on past experience. A prediction is usually only as reliable as its source.

**Principle of crosscutting relationships**—the principle stating that a rock is always younger than any other rock across which it cuts. Earthquake faulting illustrates this principle: Faults are always younger than the rocks they cut.

**Principle of superposition**—the principle upon which all geologic chronology is based stating that in any sequence of sedimentary layers that has not been overturned or faulted, each layer is younger than the one beneath, but older than the one above it.

**Principle of uniformitarianism**—the fundamental principle stating that geologic processes have operated in essentially the same way throughout geological time.

**Probability**—in mathematics, the ratio of the number of times something will probably occur to the total number of possible occurrences. In common usage, an event is probable, rather than merely possible, if there is evidence or reason to believe that it will occur.

**Qualitative**—having to do with perceived qualities; subjective. Examples: large, cold.

**Quantitative**—having to do with measurable quantities; objective. Examples: 10 m long, 5° C.

**Radiometric dating**—the process of using natural radioactivity to determine the age of rocks.

**Rapid visual screening (RVS)**—a method of assessing risk that relies on external observation. An observer who is trained in RVS can derive enough information from a quick visual assessment to know if closer examination is necessary.

**Rayleigh waves**—surface waves that carry energy along Earth's surface by elliptical particle motion, which appears on the surface as a ripple effect.

**Recurrence interval**—the actual or estimated length of time between two earthquakes in the same location.

**Resonance**—an increase in the amplitude (a measurement of wave size) in a physical system (such as a building) that occurs when the frequency of an applied oscillatory force (such as earthquake shaking) is close to the natural frequency of the system.

**Retrofitting**—making changes to a completed structure to meet needs that were not considered at the time it was built; in this case, to make it better able to withstand an earthquake.

**Richter magnitude**—the number that expresses the amount of energy released during an earthquake, as measured on a seismograph or a network of seismographs, using the scale developed by Charles Richter in 1935.

**Rigid connections**—connections that do not permit any motion of the structural elements relative to each other.

**Rotation**—turning from side to side.

**Run-up elevation or height**—the highest altitude above the tide line, in meters, that the water reaches as it is forced up on land by a tsunami.

**S waves**—secondary waves; waves that carry energy through the Earth in very complex patterns of transverse (crosswise) waves. These waves move more slowly than P waves (in which the ground moves parallel to the direction of the wave). In an earthquake S waves are usually bigger Ps.

**Sag pond**—a small body of water occupying an enclosed depression formed by fault movement.

**Sand boil**—a forcible ejection of sand and water from saturated soil, caused by strike-slip an earthquake or heavy flooding.

**Saturated**—having absorbed water to the point that all the spaces between the particles are filled, and no more water can enter.

**Sediment**—material that has been transported by wind, water, or ice and come to rest in a new location.

**Sedimentary deposits**—accumulations of small solid particles that originated from the weathering of rocks and that have been transported or deposited by wind, water, or ice.

**Seismicity**—earthquake activity.

**Seismic**—of or having to do with earthquakes.

**Seismic sea wave**—a tsunami generated by an undersea earthquake.

**Seismic zone**—a region in which earthquakes are known to occur.

**Seismogram**—the record of earthquake ground motion recorded by a seismograph.

**Seismograph**—an instrument that records vibrations of the Earth, especially earthquakes.

**Seismograph station**—a site at which an array of seismographs is set up and routinely monitored.

**Seismology**—the scientific study of earthquakes.

**Shaking**—rapid horizontal vibration of the base of the model, simulating an earthquake. In an actual earthquake, of course, shaking occurs in many directions.

**Shear force**—force that acts horizontally (laterally) on a wall. These forces can be caused by earthquakes and by wind, among other things. Different parts of a wall experience different shear forces.

**Shear walls**—walls added to a structure to carry horizontal (shear) forces. These are usually solid elements, and are not necessarily designed to carry the structure's vertical load.

**Sill plate**—the structural member at the base of a wood frame building that joins the building to its reinforced concrete foundation.

**Slump**—a type of landslide in which a block of rock or soil moves along a curved surface and rotates.

**Soft stories**—stories in a building, usually lower stories with many openings, that are poorly supported or braced, and hence vulnerable to collapse.

**Stick-slip movement**—a jerky, sliding movement along a surface. It occurs when friction between the two sides of a fault keeps them from sliding smoothly, so that stress is built up over time and then suddenly released.

**Strata (s. *stratum*)**—layers of rock or other materials formed at different periods in geologic time.

**Strike-slip faulting**—fault movement in which the fault is horizontal.

**Structural elements or structural features**—a general term for all the essential, non-decorative parts of a building that contribute structural strength. These include the walls, vertical column supports, horizontal beams, connectors, and braces.

**Studs**—upright pieces in the outer or inner walls of a building to which panels, siding, laths, etc. are nailed or bolted.

**Subduction**—the process in which one lithospheric plate is forced down under another plate and drawn back into the Earth's mantle.

**Surface waves**—waves that move over the Earth at its surface. Rayleigh waves and Love waves are surface waves.

**Topography (adj. *topographic*)**—the shape of the land; the contours and the arrangement of surface features that characterize a region.

**Torsion**—twisting or turning. A building must be resistant to extreme torsion to resist earthquake damage.

**Transverse waves**—waves that vibrate particles in a direction perpendicular to the wave's direction of motion (S waves).

**Triangulation**—using data from three or more known points to locate an unknown point, in this case, the epicenter of an earthquake.

**Tsunami**—a potentially destructive ocean wave created by an earthquake or other large-scale disturbance of the ocean floor; a seismic sea wave. This Japanese word has the same form in both the singular and the plural.

**Unconsolidated**—loosely arranged, not cemented together, so particles separate easily.

**Unreinforced masonry**—brick, stone, or adobe walls without any steel reinforcing rods or other type of reinforcement. Buildings of this type were probably built before 1940.

**Variable**—in a scientific experiment, the one element that is altered to test the effect on the rest of the system.

**Veneer**—an outside wall facing of brick, stone, or other facing materials that provides a decorative surface but is not load-bearing.

**Vertical load**—the effect of vertical force (gravity) acting on the elements of a structure.

**Wave height**—the vertical distance from a wave's crest to its trough. (This measurement will be twice the amplitude measured for the same wave.)

**Wave crest**—the highest point a wave reaches. The lowest point is called its *trough*.

**Wavelength**—the horizontal distance between two successive crests, often measured in meters.



U.S. Department of Education  
Office of Educational Research and Improvement (OERI)  
National Library of Education (NLE)  
Educational Resources Information Center (ERIC)



# REPRODUCTION RELEASE

(Specific Document)

## I. DOCUMENT IDENTIFICATION:

Title: <i>SEISMIC SLEUTHS. FEMA-253, 2ND EDITION, A TEACHER'S PACKAGE FOR GRADES 7-12</i>	
Author(s): <i>Project Director, Frank Irpton, Ph.D. AGU; Various Authors</i>	
Corporate Source: <i>American Geophysical Union / FEMA</i>	Publication Date: <i>1995</i>

## II. REPRODUCTION RELEASE:

In order to disseminate as widely as possible timely and significant materials of interest to the educational community, documents announced in the monthly abstract journal of the ERIC system, *Resources in Education (RIE)*, are usually made available to users in microfiche, reproduced paper copy, and electronic media, and sold through the ERIC Document Reproduction Service (EDRS). Credit is given to the source of each document, and, if reproduction release is granted, one of the following notices is affixed to the document.

If permission is granted to reproduce and disseminate the identified document, please CHECK ONE of the following three options and sign at the bottom of the page.

The sample sticker shown below will be affixed to all Level 1 documents

PERMISSION TO REPRODUCE AND DISSEMINATE THIS MATERIAL HAS BEEN GRANTED BY

*Sample*

TO THE EDUCATIONAL RESOURCES INFORMATION CENTER (ERIC)

1

Level 1



Check here for Level 1 release, permitting reproduction and dissemination in microfiche or other ERIC archival media (e.g., electronic) and paper copy.

The sample sticker shown below will be affixed to all Level 2A documents

PERMISSION TO REPRODUCE AND DISSEMINATE THIS MATERIAL IN MICROFICHE, AND IN ELECTRONIC MEDIA FOR ERIC COLLECTION SUBSCRIBERS ONLY, HAS BEEN GRANTED BY

*Sample*

TO THE EDUCATIONAL RESOURCES INFORMATION CENTER (ERIC)

2A

Level 2A



Check here for Level 2A release, permitting reproduction and dissemination in microfiche and in electronic media for ERIC archival collection subscribers only

The sample sticker shown below will be affixed to all Level 2B documents

PERMISSION TO REPRODUCE AND DISSEMINATE THIS MATERIAL IN MICROFICHE ONLY HAS BEEN GRANTED BY

*Sample*

TO THE EDUCATIONAL RESOURCES INFORMATION CENTER (ERIC)

2B

Level 2B



Check here for Level 2B release, permitting reproduction and dissemination in microfiche only

Documents will be processed as indicated provided reproduction quality permits. If permission to reproduce is granted, but no box is checked, documents will be processed at Level 1.

I hereby grant to the Educational Resources Information Center (ERIC) nonexclusive permission to reproduce and disseminate this document as indicated above. Reproduction from the ERIC microfiche or electronic media by persons other than ERIC employees and its system contractors requires permission from the copyright holder. Exception is made for non-profit reproduction by libraries and other service agencies to satisfy information needs of educators in response to discrete inquiries.

Sign here, → please

Signature: <i>Julie A. Hedlund</i>	Printed Name/Position/Title: <i>JULIE A. HEDLUND, MGR.</i>	
Organization/Address: <i>AMERICAN GEOPHYSICAL UNION</i>	Telephonic: <i>202-462-6900</i>	FAX: <i>202-328-0506</i>
	E-mail Address: <i>jhedlund@kosmos.uqu.org</i>	Date: <i>9/3/98</i>

