

DOCUMENT RESUME

ED 420 406

PS 026 572

AUTHOR Kelty, Joanne Mary
 TITLE An Examination of Hispanic Parent Involvement in Early Childhood Programs.
 PUB DATE 1997-00-00
 NOTE 40p.; Master's Project, Grand Valley State University.
 PUB TYPE Dissertations/Theses (040) -- Tests/Questionnaires (160)
 EDRS PRICE MF01/PC02 Plus Postage.
 DESCRIPTORS Cultural Differences; Hispanic American Culture; *Hispanic Americans; *Kindergarten; *Parent Attitudes; Parent Background; Parent Participation; Parent Role; *Parent School Relationship; Parent Teacher Conferences; Parent Workshops; *Preschool Education; Preschool Evaluation; School Surveys; Spanish Speaking

ABSTRACT

A bilingual survey was developed to register the feelings of parents toward involvement in their children's preschool and kindergarten and to determine the unique needs of parents during interactions with the schools. The survey was tested with 50 parents, and the results were tabulated to determine differences between the feelings of Hispanic and non-Hispanic parents. Findings indicated that Hispanic parents are comfortable with the parent activities at the child development center their children attend. The Spanish-speaking parents are most comfortable with the parent conference format and the interactive workshop format, but less comfortable with the home visit format. The degree of outreach success of various school activities was noted and included the enrollment process, open house, home visits, parent conference, telephone conference with a teacher, and the Friendship Celebration. Important issues parents considered before participating in these events included child care, transportation, and personal contact with the school. Hispanic parents rated personal contact with the school prior to an event as the most important element in making them feel comfortable. Based on the findings, recommendations are offered for further encouraging Hispanic parents to participate in school activities. (Spanish and English language versions of the survey are included, as well as sample comments from both groups of parents.) (JPB)

 * Reproductions supplied by EDRS are the best that can be made *
 * from the original document. *

ED 420 406

U.S. DEPARTMENT OF EDUCATION
Office of Educational Research and Improvement
EDUCATIONAL RESOURCES INFORMATION
CENTER (ERIC)

This document has been reproduced as received from the person or organization originating it.

Minor changes have been made to improve reproduction quality.

Points of view or opinions stated in this document do not necessarily represent official OERI position or policy.

AN EXAMINATION OF HISPANIC PARENT INVOLEMENT IN EARLY CHILDHOOD PROGRAMS

Joanne Mary Kelty

Fall, 1997

MASTERS PROJECT

Submitted to the graduate faculty at

Grand Valley State University

in partial fulfillment of the Masters of Education

PERMISSION TO REPRODUCE AND
DISSEMINATE THIS MATERIAL HAS
BEEN GRANTED BY

Joanne M.
Kelty

TO THE EDUCATIONAL RESOURCES
INFORMATION CENTER (ERIC)

1

026572

TABLE OF CONTENTS

ABSTRACT.....	1
DEDICATION.....	2
CHAPTER ONE - PROJECT PROPOSAL	
PROBLEM STATEMENT.....	3
IMPORTANCE AND RATIONALE FOR STUDY.....	4
BACKGROUND OF THE STUDY.....	5
STATEMENT OF PURPOSE.....	7
CHAPTER TWO - LITERATURE REVIEW	
RESEARCH ON PARENT INVOLVEMENT.....	8
RESEARCH ON HISPANIC PARENT INVOLVEMENT.....	12
CHAPTER THREE - PROJECT DESIGN, METHODOLOGY, RESULTS, CONCLUSIONS, AND RECOMMENDATIONS	
PROJECT COMPONENTS.....	18
PROJECT METHODOLOGY, DATA AND RESULTS.....	19
CONCLUSIONS.....	26
RECOMENDATIONS AND DISSEMINATIONS.....	28
REFERENCES.....	29
APPENDIX # 1 - Parent Survey in English	
APPENDIX #2 - Parent Survey in Spanish	
APPENDIX #3 - Summary of parent comments	

ABSTRACT

This project developed a bilingual parent survey to register the feelings of a group of pre-school and kindergarten parents. The results of the survey were tabulated to determine whether there were differences between the feelings of the Hispanic parents and the non Hispanic parents. The information acquired would be used to develop parent involvement activities that reflect and respect Hispanic culture.

DEDICATION

**This project is dedicated to my children, Kate and Tim
who have always give me a reason to keep learning.
A special thanks to Tim for his technology assistance.**

CHAPTER 1 - *PROJECT THESIS PROPOSAL*

A. PROBLEM STATEMENT

The importance of family involvement in a child's education has been well documented and imbedded as an important component in many Early Childhood Programs. The problem is that most involvement programs are not reaching the parents who need it the most - those who are poor, non white, and speak a language other than English (Liontas, 1992). What are the reasons for this? What do we as educators of this population need to do to make sure that these parents get and stay involved from an early age? This project will attempt to discover what is unique about this population's needs by asking for parental input on a survey dealing with three aspects of parental involvement; home visits, parent conferences, and parent involvement activities. This will enable us to design a system that makes these parents feel comfortable and gets them and keeps them involved in their young child's education right from the beginning.

B. IMPORTANCE AND RATIONALE FOR STUDY

“Successful education requires that schools and families function as full partners in the education of children” (Nicolau and Ramos, 1990). Presently many schools have been unsuccessful in establishing this partnership especially when the parents are poor and of Hispanic descent. In fact, the report “Make Something Happen: Hispanics and Urban High School Reform” stated that “the interaction of poor Hispanic parents and the schools their children attend ranged from low to non existent (1984). This certainly is the case at the Roosevelt Park Child Development Center in Grand Rapids, Michigan where 65% of 190 students (3 to 6 year olds) are poor and of Hispanic descent. Roosevelt Child Development Center staff frequently identify lack of parent involvement as the number one programmatic weakness.

Is it that these Hispanic parents don't care about their children or that the staff hasn't done enough, or could it be that we need to adapt the parent components of the program to reflect and respect the culture of our clientele? Studies tell us that Hispanic parents certainly do care and want their children to be successful, but certain issues relating to their culture may be misinterpreted by educators (Nicolau and Ramos, 1990). It is important to uncover these issues and devise a system for getting input from parents so that we are giving parents what they need and creating relationships of trust and mutual respect.

C. BACKGROUND OF THE STUDY

In September of 1996 a report prepared for President Bill Clinton entitled Our Nation on the Fault Line: Hispanic American Education detailed eleven specific factors that affect the educational achievement of Hispanic Americans (President's Advisory Commission on Education Excellence for Hispanic Americans (PACEEHA),1996). Of these eleven factors was the need for increasing parental involvement. This report states clearly that "failure to involve parents is closely related to many other factors affecting Hispanic American educational attainment, in turn, failure to work with families as partners perpetrates the problem" (PACEEHA, 1996). It appears as though the mandate is clear. In order for educators to build these partnerships with parents it is necessary and most advantageous for the success of the child to begin as early as possible. In a public testimony given in 1995, Mrs. Hilda Maldonado reminds us that "years of experience have led us to believe that the best intervention must be initiated as early as possible and it must comprise a firm commitment and involvement of parents" (PACEEHA,1996). We must reach these low income Hispanic parents and get them involved from the beginning of their child's education. The National Association for the Education of Young Children certainly endorses this practice when it clearly states in its position statement on Developmentally Appropriate Practice that the best practice in Early Childhood Education should include "knowledge of the social and cultural contexts in which the children live to insure that learning experiences are respectful for the participating children and their families (Bredekamp and Copple, 1997).

Several researchers have analyzed how dealing with low income Hispanic parents can be different from dealing with the mainstream population (Nicolau and Ramos, 1990). They have discovered a multitude of factors that effect why low income Hispanic parents do not participate in their children's schooling. These factors include many issues that deal not only with the issue of language differences, but with the uniqueness of the Hispanic culture, the parent's past school experiences, and the parent's perceptions of their role in the schools. They warn us that the Hispanic culture is unique and that "those unfamiliar with Hispanic parenting practices, do not understand the cultural strengths of the Hispanic family" (Nicolau and Ramos, 1990), and may wrongfully misinterpret signals sent from home to school.

Many different types of programs attempting to boost parental involvement within the Hispanic community has been detailed in the literature. Nicolau and Ramos (1990) in their culminating report entitled Together is Better, Building Strong Relationships Between Schools and Hispanic Parents detail 41 separate program's attempts to improve parental participation (Nicolau and Ramos, 1990). It is clear from this and other information that oftentimes a new approach is needed with this population. This can best be accomplished by attempting to gather information from the parents and build relationships that meet their needs and respect their culture.

The statistics are staggering and impossible to ignore. By the year 2020 Hispanics will be the largest minority in the United States (PACEEHA, 1996). Hispanics historically suffer lower average incomes and higher rates of unemployment and poverty than the general population and drop out of school at much higher rates and much earlier

than other minorities (PACEEHA, 1996). We must attempt to find out the cause and turn this around.

D. STATEMENT OF PURPOSE

The purpose of this study is to develop a bilingual parent inquiry survey that will evaluate the parent's comfort level with the existing format of home visits, parent conferencing and parent meetings. This document will also inquire about any changes in format or content the parents would like to see implemented in these three requirements of their child's preschool program. It is hoped that by gaining the input of these parents (primarily Hispanic and low income) and obtaining the parent's feedback on home visits, parent conference and parent meetings, they will more willingly participate in their child's education.

The sample group will be the parents of the State funded four year old Readiness program at the Roosevelt Child Development Center in Grand Rapids, Michigan and parents of the Grand Rapids Public School kindergarten program also housed at the Roosevelt site. These 190 parents will be given a survey in English and Spanish containing 10 questions. These questions will pertain to home visits, parent conferences and parent meetings.

The survey will be analyzed by establishing the percentage of responses for each of the questions. The comments were and grouped according to categories.

CHAPTER 2 - *LITERATURE REVIEW*

“The more people get together, the more they interact, the more they interact, the more they like each other, the more people like each other, the more they will interact”(Homans, 1950). With mounting evidence that when parents are involved in their children’s education, the children perform better in school” (Walberg, 1984), this group work theory conceived by Homans over 50 years ago still appears relevant in regards to the power and importance involved in bringing parents and their children’s schools together. In order to effectively understand parental involvement in the Hispanic community and its importance to us as educators, we must look not only at the child in front of us, but take a more “ family systems” approach to looking at each child. We must look at the influences that have shaped and are shaping each child we teach. We must recognize the mutual interest and overlapping influence of schools and families and the roles that schools must play to develop and maintain partnerships with students’ families (Epstein, 1992).

First, the literature on parental involvement was reviewed. Next, we will look at the uniqueness of the Hispanic population and what special challenges this population brings to the concept of parental involvement. Lastly, we will review the literature on specific ways that early childhood programs attempt to involve parents and hypothesize about whether these practices might be successful within the Hispanic population.

The relationship between schools and family has evolved over time. Less than fifty years ago, theorists like Parsons and Weber thought that schools and families were most

efficient and effective when their leaders maintained and pursued independent goals, standards, and activities (as cited in Epstein, 1992). This “separate influence” theory gave way to what is referred to as “sequenced influence”. This “sequenced influence” theory identifies a sequence of critical stages in which parents and teachers contribute in turn to a child’s development and education. This theory based on the teachings of Piaget, Inhelder, and others has the underlying assumption that the early years of life determine later success and gives the parents the responsibility for the first crucial stages that prepare children for school (as cited in Epstein, 1992). With growing evidence that shows that when parents are involved in their children’s education, the children perform better in school, (Walberg, 1984), the model began to broaden and the “embedded influence” model began to appear. Mr. Urie Bronfenbrenner gave us this more ecological way of looking at the influence that multiple environments have on the individual and the connections between them. This model focuses on the psychology of individual development and the influence of other settings, like family and school, which are in turn part of a broader cultural system (as cited in Epstein, 1992). Bronfenbrenner’s theory has often been referred to as the nested connections theory and is represented pictorially by concentric circles with the individual/child at the center. Bronfenbrenner saw the child nested at the center influenced by several broader cultural systems. Bronfenbrenner’s theory gave way to the extensive parent involvement component of the Head Start Program. The Head Start program begun in the 1960’s as part of the War on Poverty offers us some of the best data suggesting that the most effective way to benefit young children is to improve their family and community environment (Ziegler and Muenchow, 1992). “Head start’s parental involvement component has functioned as a powerful form

of support, increasing parent confidence and competence both as parents and individuals” (Ziegler, 1992). Although the results of the studies have been disputed at times, many researchers including Gordon, Olmsted, Rubin and True, and Valentine and Stark, and Ziegler have reported positive effects on parents and young children as a result of an early intervention program like Head Start (as cited in Epstein, 1992). The research on Head Start supported the importance of active parental involvement components in early childhood programs.

In the late 1980’s, Joyce Epstein who studied the effects of disadvantaged youngsters expanded on Bronfenbrenner’s theory. This perspective is referred to as the “overlapping spheres of influence” (Epstein, 1992). This model too can be represented by spheres, but these spheres can be pulled apart by practices and interpersonal forces in each environment. The extent of overlap is affected by time - to account for changes in the ages and grade levels of students, and the influence of historic change on environments, and by behavior- to account for the background characteristics, philosophies and practices of each environment (Epstein, 1987).

This theory of “overlapping influence” integrates the “embedded influence” theory and the “sequential theory”, but it also uses some additional theories to help explain the mechanisms for building family and school relations and the resulting variations in the connections between the institutions and their members (Epstein, 1987).

The first additional theory it uses is Mead’s symbolic interactionism theory (as cited in Epstein, 1987). This theory assumes that self (concept, personality, values, and beliefs) are products of our interactions with others. We learn how others perceive and anticipate our goals and behaviors and we fashion our behavior to fulfill the expectations of others

and to receive recognition. This implies that if teachers do not interact with parents, they cannot be informed about nor understand the parent's expectations for their children and for their teachers, and therefore cannot shape their teaching behavior to be responsive to those expectations. Consequently if parents avoid teachers, they cannot be informed about or understand the school's expectations for their children or for the parents and cannot shape their behavior to provide useful assistance to the student and teachers (Epstein, 1987).

Epstein's "overlapping influence" theory also integrates "reference group" theory. Reference groups are defined as a collectivity or an individual who is taken into consideration by another group or individual to influence their attitudes and behaviors. This happens when one group or individual recognizes the importance of the other or admires the position and actions of the other (as cited in Epstein, 1987). In relation to parent involvement, this translates the idea that if a teacher considers the part the parents play in the child's development, the teacher holds the parents as an important reference group and conversely if the parent considers the role the teacher plays in the child's development then the teacher becomes an important reference group (Epstein, 1987).

The three main theories, "separate influence", "sequenced influence", and "embedded influence" explain the basic differences in philosophies and approaches of teachers and parents that produce more or fewer, shallower or deeper family-school connections. "Overlapping influence" theory, using these other supplementary theories, the symbolic interactionism theory and the reference group theory also helps to explain the motivations to remove or reinforce boundaries between families and schools. It is important to note that the overlapping spheres theory is based on the assumption that

children's learning, development, and success (broadly defined) are the main reasons for home school partnerships. Productive connections may contribute to improving children's academic skills, self esteem, positive attitudes toward learning, independence, other achievements, accomplishments and other behaviors, characteristic of successful individuals (Epstein, 1987). Students are not passive in this process. When schools and families work in partnership, students hear that school is important from their parents and teachers and perceive that caring people in both environments are investing and coordinating time and resources to help them succeed (Epstein, 1992). Early childhood programs were the leaders in recognizing the importance of these family/school partnerships. The National Association for the Education of Young Children lists establishing reciprocal relationships with families as one of their main goals (Bredekamp and Copple, 1997).

Unfortunately this partnering is low to non existent in a growing percentage of our school population - the Hispanic population. Let's look at who these people are. The Hispanics are not a homogenous group. Although united by a common language and an origin in Spanish colonization, they are separated by age, socioeconomic status, geography, the nature of their arrival in the United States - immigration, migration, exile, or asylum -, and by their length of residency (Nicolau & Ramos, 1990). They include Mexican Americans, Puerto Ricans, Central and South Americans, Cuban Americans and those from the Caribbean and various others. By the year 2,000, Hispanics will make up about 10% of the United States population and by the year 2050, Hispanics will be the largest U.S. minority and comprise 25% of total population (as cited in PACEEHA, 1996). As a whole Hispanics have lower than average incomes and higher than average

rates of unemployment and poverty than the general population (Nicolau & Ramos, 1990). Since much of the research confirms that lower socioeconomic status and lower education negatively influence parent involvement and parent involvement is directly related to academic success, we need to examine this population carefully (as cited in Epstein, 1992).

In a report published in 1984 entitled “Make Something Happen” which was a culmination of three years of research on school reform, it was determined that the interaction of poor Hispanic parents and the schools their children attend ranged from low to non-existent (as cited in Nicolau & Ramos, 1990). As a result of the research confirming the lack of involvement, the Hispanic Policy Development Project (HPDP) set out to discover why Hispanic parents and schools so seldom make the crucial connection. As might be suspected, linguistic difference was identified as one of the factors that influences the interaction of Hispanic parents and their schools. It was reported that many Hispanic parents feel powerless to make a difference in their children’s education because they feel unable to participate effectively (Curiel, 1991), but the literature tells us there is much more to it than simply the language barrier (Nicolau & Ramos, 1990). The Hispanic Policy Development Project of 1990 reported that because of their own backgrounds and upbringings, Hispanic parents are unaware of specific practices - such as talking and reading to children and engaging their curiosity - that lay the academic skills foundation. Hispanic culture tends to emphasize obedience and to value respect for adult authority. A directive style of communication between parent and children is most common, with little collaborative conversation, elaborated speech models, or early literacy experiences (Espinosa & Lesar, 1994; Liontos, 1992).

Consequently, language development of Hispanic children is frequently behind that of their American middle class peers when they enter kindergarten (Espinosa, 1995). This is a cultural difference, not a lack of interest on the part of Hispanic parents as it is oftentimes interpreted.

Additionally, Hispanic parents often have a more “separate influence” perspective in regard to their children’s schooling . Throughout Hispanic culture there is a widespread belief of the absolute authority of the school and teachers. In most Latin American countries it is considered rude for a parent to intrude into the life of the school. Parents believe that is the school’s job to educate and the parent’s job to nurture and that the two jobs do not mix (Espinosa, 1995). Lastly, many Hispanic parents have had extremely unsuccessful school experiences and the entire school experience makes them anxious (Liontos, 1992).

We must find ways to work with Hispanic parents that both respect their culture and empower them to help their children succeed. The education professionals tell us that “most, if not all, Hispanic parents want their children to succeed in school. Nicolau and Ramos have called Hispanic parents a great “untapped resources” (Nicolau & Ramos, 1990). Linda Espinosa sums up the feelings of many of the professionals in the field, by indicating the importance of building genuine relationships with Hispanic parents as early as possible in a child’s school career (Espinosa, 1995). Espinosa feels as though it is important “that a teacher spend the time to discover the particular values, beliefs and practices of the families in their community”(Espinosa, 1995). She further feels as though teachers must examine their own attitudes about working with a minority group that speaks a different language from their own and may not share the values of their own

culture. In order to establish genuine partnerships with these parents, relationships must be built on a foundation of mutual trust and openness.

As early childhood educators, if we are going to begin to involve parents early and build this foundation of mutual trust and openness, the home visit is one of our primary opportunities. Research tells us that meeting in comfortable, relaxed environment opens communication between parents, child and teacher, and can set the tone for a positive home school relationship (Hildebrand, 1980). Is the traditional home visit an appropriate venue for interacting with Hispanic parents? The literature tells us that Hispanics, as a whole, have strong family ties, believe in family loyalty, and have a collective orientation that supports community life; and have been found to have a sensitivity to nonverbal indicators of feeling. Culturally this is represented by warm, personalized styles of interaction, a relaxed sense of time, and a need for an informal atmosphere for communication (Zuniga, 1992). It would seem as though a home visit would be an appropriate atmosphere to begin to foster this more relaxed relationship that the Hispanic parent needs. The literature suggest that most American teachers tend to be task-oriented in their style which may be in contrast to the needs of the Hispanic parent (Espinosa, 1995). The writer would like to determine from the parent exactly what they are comfortable with.

The home visit is just one way to begin to build that crucial parent/teacher relationship. Many professionals have identified additional strategies that are successful in involving Hispanic parents. These can be summed up in the following list:

1. Personal Touch - It is crucial to use face to face communication in the Hispanic parents' primary language when first making contact. Written flyers or articles

have proven to be ineffective even when written in Spanish. Home visits have been identified as a particularly good way to begin to develop rapport.

2. **Non-Judgmental Communication** - In order to gain the trust and confidence of Hispanic parents, teacher must avoid making them feel they are to blame or are doing something wrong. Parents need to be supported for their strengths, not judged for perceived failings
3. **Perseverance in Maintaining Involvement** - To keep Hispanic parents actively engaged, activities planned by the early childhood program must respond to a real need or concern of the parents.
4. **Bilingual Support** - All communication with Hispanic parents, written and oral, must be provided in Spanish and English.
5. **Strong Leadership and Administrative Support** - Flexible policies, a welcoming environment and a collegial atmosphere all require administrative leadership and support.
6. **Staff Development focused on Hispanic Culture** - All staff must understand the key features of Hispanic culture and its impact on their students' behavior and learning styles. It is the educators obligation to learn as much about the children and their culture and background as possible.
7. **Community Outreach** - Many Hispanic families could benefit from family literacy programs, vocational training, ESL programs, improved medical and dental services and other community-based social services (Espinosa, 1995, Liontos, 1992 and Nicolau & Ramos, 1990).

Equipped with the knowledge of the correlation between parent involvement and student achievement coupled with the astronomically rising numbers of Hispanic children entering our school systems and continuing to do so till well into the next century, it is essential that building relationships between Hispanic parents and their schools must be a number one priority. It is critical that early childhood programs demonstrate successful approaches to working with Hispanic families by forging closer communication and bridging the cultural gap between home and school(Espinosa, 1995). It is imperative that we do whatever it takes to turn this around.

CHAPTER 3 - *PROJECT DESCRIPTION, METHODOLOGY, RESULTS, CONCLUSIONS, AND RECOMENDATIONS*

A. PROJECT COMPONENTS

Roosevelt Child Development Center located in Grand Rapids Michigan was the site chosen for the dissemination of this survey. Roosevelt Child Development Center consists of sixty percent Hispanic families and 40 percent non Hispanic families. Ninety percent of the students qualify for free or reduced price lunch under the federal school lunch program. The survey was disseminated to the entire building consisting of 190 students. The building contains eight classrooms of four year olds identified as being “at risk” for educational failure. These preschoolers receive services through a state funded readiness grant. The building also contains two sessions of kindergarten funded through the Grand Rapids Public Schools. Since the writer’s research focused on involvement of Hispanic parents, the writer has broken down the responses to parents that are Spanish speaking and those that are non-Spanish speaking.

This survey gathered the opinions and input of the parents and consisted of ten questions. It was prepared in both Spanish and English. The instrument was prepared with visual cues to enable parents with limited literacy, in either Spanish or English, the opportunity to participate. The first seven questions rated the parent’s comfort level with the activities held thus far at the Center. Question number eight asked for input regarding services that might enable parents to participate more fully. Question number nine sought out family information including ethnic and language background. Question ten provided an opportunity for the parent to offer their comments or suggestions. See Appendix #1

and Appendix #2 for a copy of the questionnaire in both English and Spanish. Appendix #3 contains a summary of the comment section.

B. PROJECT MEHODOLOGY, DATA, AND RESULTS

Surveys disseminated	190
Surveys returned	50
% of return	26.3%
% Spanish Speaking surveys returned	46%
% Non-Spanish Speaking surveys returned	50%

The following pages contain a question by question analysis of the questionnaire. The writer has prepared it graphically to see the difference between the Spanish speaking parent and the non-Spanish speaking parent. An analysis of the information will follow each graph.

QUESTION #1 When I first entered Roosevelt Child Development Center to enroll my child, I felt...

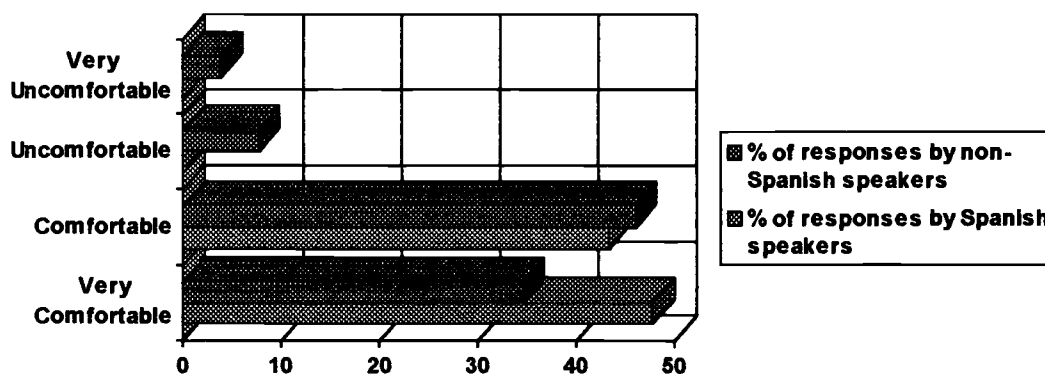

Results of Question #1

Question #1 one shows the majority of parent responses in the very comfortable and comfortable categories. The Spanish speakers show no responses in the negative categories. Enrollment is done on a one-on-one basis. All forms are in Spanish and English and a translator is provided for those who need assistance.

QUESTION #2 When I came to Roosevelt Child Development Center for Open House, I felt...

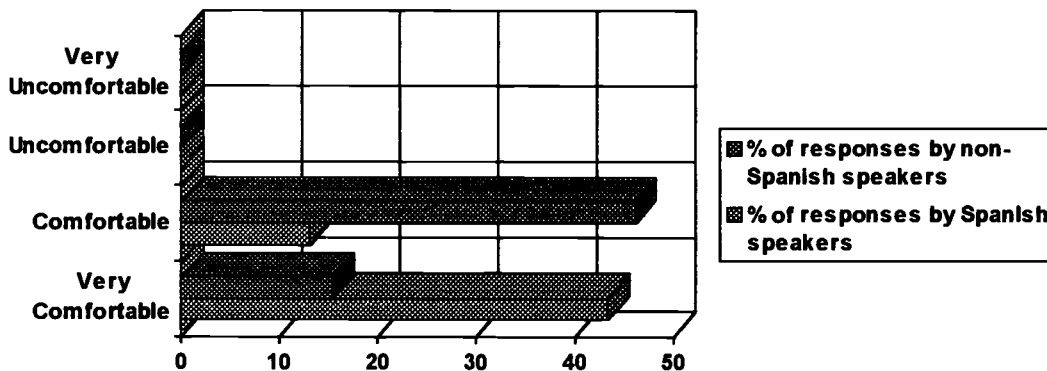

Results of Question #2

Question #2 shows all parent responses in the comfortable and very comfortable categories for both Spanish speakers and non-Spanish speakers. The Open House is an event where the child and the parent go through an abbreviated pre-school day.

QUESTION #3 When I came to Roosevelt for Dental Fun Night, I felt...

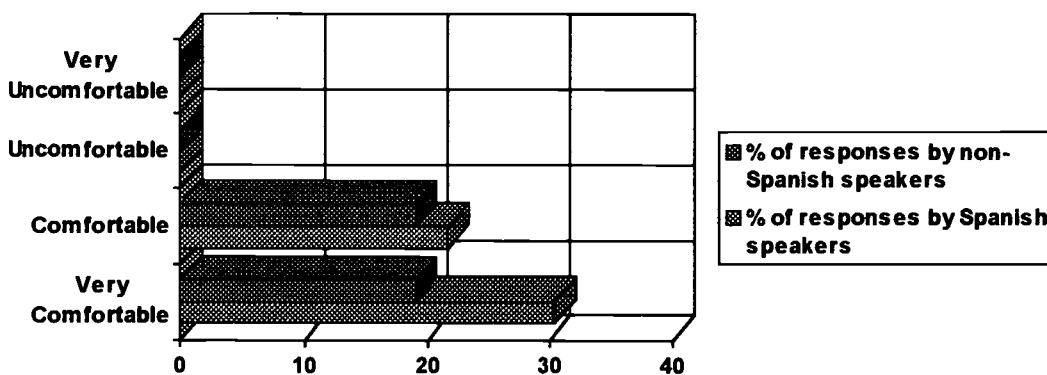

Results of Question #3

Question # 3 showed all respondents, both Spanish Speaking and non-Spanish speaking, in the comfortable and very comfortable range. Dental Fun Night is an event

where both parent and child are read a story about dental health and then the children participate in interactive activities while parents receive information in a lecture format from a dental professional. This program was done in English with a Spanish translation.

QUESTION #4 When my child’s teacher arrived at my home for the first home visit, I felt...

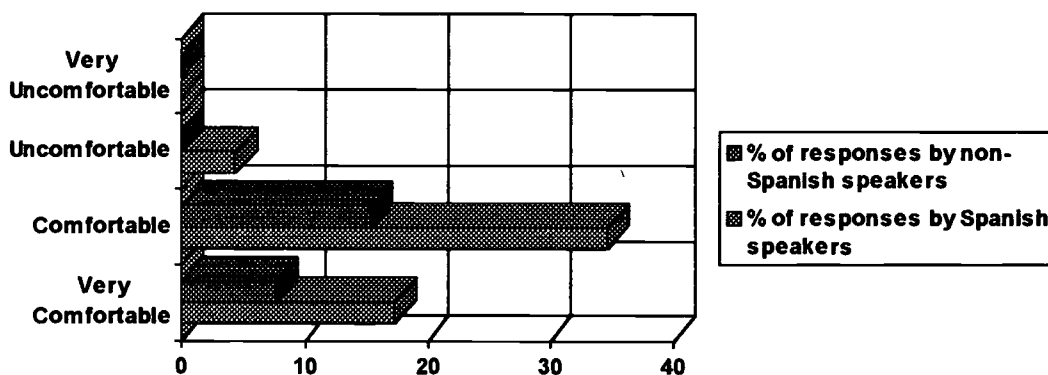

Results of Question #4

Question #4 shows that more Spanish speaking parents felt comfortable with the home visit format compared to the non-Spanish speaker. The home visit entails the teacher and the paraprofessional coming to the home to share activities with the parent and child. There is always a Spanish speaking individual present. These visits are announced whenever possible.

QUESTION #5 When I came to Roosevelt for parent/teacher conferences, I felt...

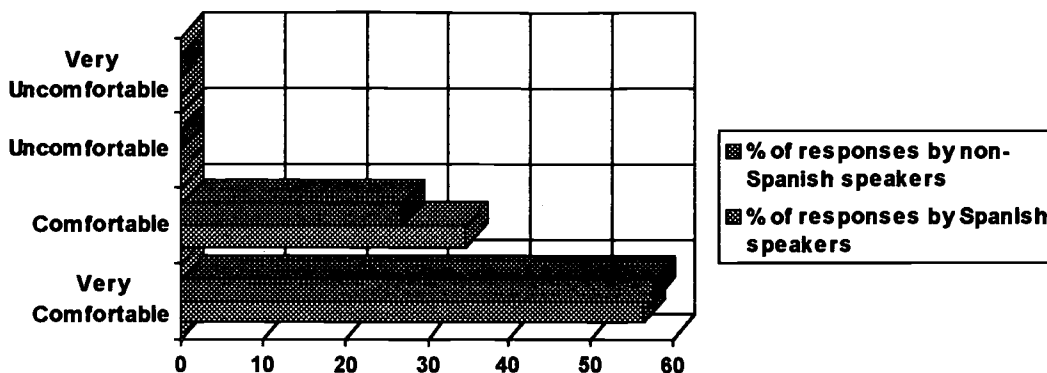

Results of Question #5

Question # 5 shows both Spanish and non-Spanish responses in the very comfortable and comfortable range. It should be noted that at conferences, parents are given the option to conduct their conference in Spanish or English.

QUESTION #6 When I have talked on the phone to the Roosevelt staff, I felt...

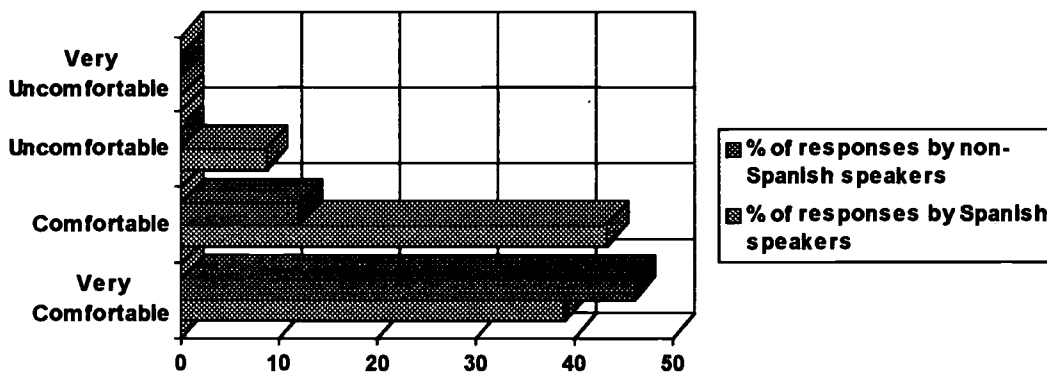

Results of Question #6

Question #6 shows that although the majority of phone experiences are in the positive range, both Spanish and non-Spanish speakers have experienced some negative feelings in regards to contacts on the telephone.

QUESTION #7 When I came to Roosevelt for the Friendship Celebration, I felt...

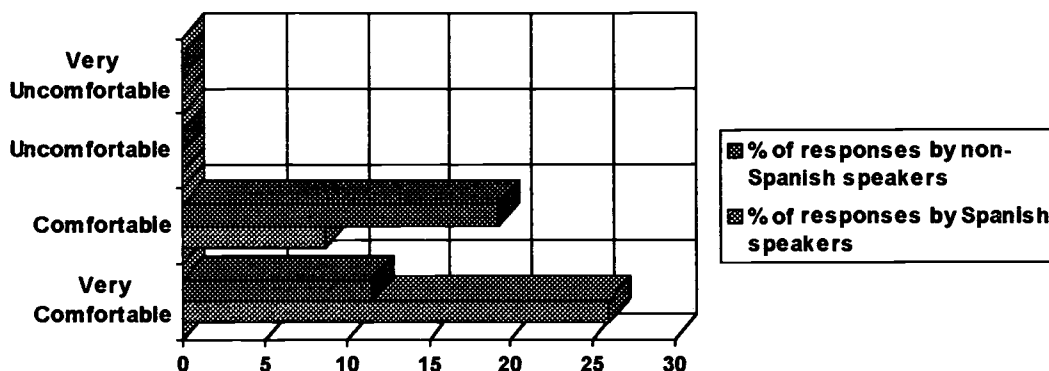

Results of Question #7

The Friendship Celebration which was an interactive workshop on helping parents learn how to break down the barriers associated with building relationships with those that are different from themselves, was a more comfortable format for the Spanish speaking parents. All parents, both Spanish speaking and non-Spanish speaking, responded positively to this question.

QUESTION #8 Question # 8 asked for input that would help parents to participate more fully and feel more comfortable. Input was requested on event location, additional Spanish speaking personnel, child care for siblings, holding functions at different times, providing transportation, and the need for a personal invitation by school personnel.

The results re summarized in the following table.

	Spanish Speaker		Non-Spanish Speaker	
	YES	NO	YES	NO
LOCATION	17.3%	39.1%	0%	61.5%
ADD'L SPANISH PERSONNEL	47.8%	21.7%	7.6%	57.5%
CHILD CARE	34.7%	21.8%	30.7%	38.5%
DIFFERENT TIMES	39.1%	30.4%	19.2%	46.1%
TRANS.	43.4%	17.3%	11.5%	53.8%
PERSONAL PHONE CONTACT	69.5%	17.3%	15.3%	50.0%

Part A - Location

In analyzing the data in regards to the location of parent involvement activities, it is apparent that some Spanish speaking families felt that holding events other than at school should be considered (17.3%). It is important to note that the non-Spanish speakers felt very strongly that events should be at school.

Part B - Spanish speaking personnel

As would be expected, the Spanish speakers felt more strongly that more Spanish speaking personnel would add to their comfort level (47.8%).

Part C - Child Care

Child care for siblings during events seemed to be of equal concern for both Spanish and non-Spanish speakers.

Part D - Time of events

The Spanish speakers seemed to have a bigger issue with the scheduling of events. More Spanish speakers (39.1%) wanted events held at times other than when they are presently held. Events are held primarily in the evenings. The suggestions included a combination of morning and afternoon hours.

Part E - Transportation

The issue of transportation is of much greater concern for Hispanic families. 43.4% of Spanish speakers felt as though transportation would help them participate more fully compared to 11.5% of non-Hispanics.

Part F - Personal Contact

The issue of personal contact prior to an event is where we see the greatest difference between the Spanish and non Spanish speakers. The Hispanics strongly feel (69.5%) that a personal contact by school personnel would improve their ability to feel comfortable compared to the non-Hispanics that felt almost as strongly (50%) that a personal contact was not needed.

QUESTION # 9 Question # 9 required the giving of general information used in determining who used Spanish as their primary language, their education level, and their relationship to the child.

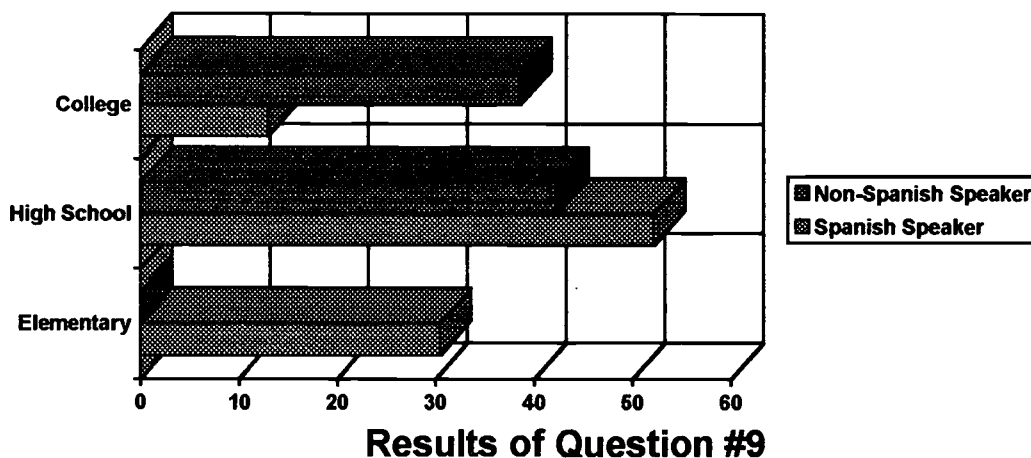

As can be seen by the graph, the Hispanics tend to be less educated. 90% of the surveys were filled out by the child's mother and the education level would reflect the person filling out the survey.

QUESTION #10 Question # 10 simply asked for comments or suggestion. A verbatim translation of the comments is available in Appendix # 3.

C. CONCLUSIONS

The problem presented in Chapter one stated that the research tells us that most parent involvement programs are not reaching parents that need it the most, those who are poor, non white and speak a language other than English (Liontas, 1992). The results of the writer's survey seem to contradict these findings. In summarizing the data, it seems as though generally those Hispanics that responded to the survey, are in fact very comfortable or comfortable with the parent involvement activities held at the Center. The Spanish speaking parents are most comfortable with the parent conference format, the interactive workshop format and a bit less comfortable with the home visit format. Contact with school personnel on the telephone elicits the most negative response.

In looking more particularly at each activity/function it makes sense based on a review of the literature which activities seem to elicit the most positive outcomes. The literature review summarized the work of Espinosa (1995), Liontas (1992) and Nicolau and Ramos (1990). These researchers emphasized the ideas of having information in both Spanish and English, providing a "personal" touch, and providing for warm personalized styles of interaction. What follows is a question by question review of what made each activity more successful or less successful.

Enrollment is done on a one on one basis. The forms are in both languages and if needed a staff person will sit down with the parent and go through the forms. This format reinforces the idea of having information in both English and Spanish and providing that personal touch.

The Open House provided a casual, relaxed, "fun" type atmosphere for the parent and the child to enjoy together. The Open House format obviously provides that warm

personalized touch that the literature refers to that is so important with the Hispanic population.

Dental Fun Night was facilitated by a dental professional from a clinic located in the Hispanic community. The bilingual format registered positive feelings from the Hispanic parents participating. This format and facilitator helped to alleviate the feelings of alienation that Spanish speaking parents feel as referred to in the literature by Nicolau and Ramos, (1990).

According to the literature, the one on one personalized format of the home visit would seem to be the format that the Hispanic parent would seem most comfortable, but this did not seem to be the case. Although most seemed comfortable, there definitely was an element of discomfort. The home visit component is a state required element of the program and further investigation would be appropriate to determine what element of the home visit elicits discomfort.

The format of the parent conference with its one to one experience with bilingual support available, once again reinforces what the literature says about the “personal” touch and warm personalized styles being the most effective with the Hispanic parent (Zuniga, 1992).

The Hispanic parents definitely experienced some negative feelings during telephone contacts with the program. The linguistic difference that Nicholau and Ramos (1990) refer to so often in their research definitely seems to be the issue here. Spanish speaking personnel are always available, but they do not answer the phone and this uncertainty may be what makes the Hispanic parent less comfortable. This item requires a closer investigation.

The Friendship Celebration with its warm interactive personalized style reinforces what Zuniga (1992) discusses as an important technique to use with Hispanic families.

As far as what would help parents to participate more fully, it appears that the issue of child care during the events is one of concern to the Spanish and non-Spanish speakers. The issue of transportation to events and the time of events is of more importance to the Spanish speakers and should be investigated further. The difference in the desire of the Hispanics to receive a personal contact from the school prior to an event most clearly emphasizes the cultural differences that the literature emphasizes time and time again (Espinosa (1995), Nicolau and Ramos (1990), and Lontos (1992). The Hispanics rated personal contact prior to an event as the most important element in making them feel more comfortable where non-Hispanics rated it very low.

D. RECOMENDATIONS/DISSEMINATION

It appears as though based on the information received in the survey, the activities the Center sponsors are generally meeting the needs of the Hispanic parents that responded. The results of the survey will be shared with the principal and the staff at the Roosevelt Child Development Center. The results will also be submitted to the Clearinghouse on Elementary and Early Childhood Education (ERIC). The writer would recommend that a plan be made to increase personal contact with Hispanic families. Investigation should begin on the feasibility of providing child care for siblings during Center sponsored events and also the feasibility of the district supporting transportation to and from events and also doing further investigation into altering the times of Center sponsored events to accommodate all families. The writer would also recommend that a device be put in to place to regularly access parent's feelings and gather parental input.

WORKS CITED

- Brdekamp, S. and C. Copple. (Eds.). (1997). Developmentally Appropriate Practice in Early Childhood Programs. Washington, D.C.: National Association for the Education of Young Children.
- Curiel, H. (1991) Strengthening Family and School Bonds in Promoting Hispanic Children's School Performance. In M. Sotomayor (Ed.), Empowering Hispanic Families: A Critical Issue for the "90's, Milwaukee: Family Service America.
- Epstein, J. (1987). Toward a Theory of Family - School Connections: Teacher Practices and Parent Involvement In Hurrelman, Kaufmann, Losel (Eds.), Social Intervention: Potential and Constraint, Berlin, New York: Walter de Gruyter.
- Epstein, J. (1992). School and Family Partnerships In M. Alkin (Ed.), Encyclopedia of Educational Research, Sixth Edition. New York: Macmillan.
- Espinosa, L and S. Lesar, (1994). Increasing Language-Minority Family and Child Competencies for School Success. Paper presented at the Annual Meeting of the American Educational Research Association. New Orleans, LA, April 4.
- Espinosa, L.M. (1995). Hispanic Parent Involvement in Early Childhood Programs. Urbana, Il: ERIC Clearinghouse on Elementary and Early Childhood Education.(ED 382 412).
- Hildebrand, V. (1980). Guiding Young Children. New York: Macmillan.
- Homans, G.C. (1950). The Human Group. New York: Harcourt, Brace, Jovanovich.
- Liontos, L.B. (1992). At Risk Families and Schools: Becoming Partners. Eugene, OR: ERIC Clearinghouse on Education Management.(ED 342-055).
- Nicolau, S. and C.L. Ramos. (1990). Together is Better: Building Strong Relationships Between Schools and Hispanic Parents. New York: Hispanic Policy Development Project. (ED325 543).
- PACEEHA, President's Advisory Commission on Educational Excellence for Hispanic Americans. (1996). Our Nation on the Fault Line: Hispanic American Education. Washington, D.C.: White House Initiative in Educational Excellence for Hispanic Americans.
- Walberg, H.J. (1984). Families as Partners in Educational Productivity. Phi Delta Kappan, 397-400.

Ziegler, E. and S. Muenchow (1992). Headstart: the Inside Story of America's Most Successful Educational Experiment. New York: Basic Books.

Zuniga, R. (1992) Latino Families. In E.W. Lynch and M.J. Hanson (Eds.), Developing Cross Cultural Competence, Baltimore, MD: Paul H. Brooks, (ED346 190).





INSTRUCTIONS

Circle the one that most closely represents how you felt. If you did not participate in the event, just leave blank.



1. When I first entered Roosevelt Child Development Center to enroll my child, I felt

			
very comfortable	comfortable	uncomfortable	very uncomfortable

2. When I came to Roosevelt CDC for the Open House, I felt

			
very comfortable	comfortable	uncomfortable	very uncomfortable

3. When I came to Roosevelt CDC for Dental Fun Night, I felt

			
very comfortable	comfortable	uncomfortable	very uncomfortable

4. When my child's teacher arrived at my home for the first home visit, I felt





			
very comfortable	comfortable	uncomfortable	very uncomfortable

This visit was arranged ahead of time yes _____ no _____

5. When I came to parent/teacher conferences at Roosevelt CDC, I felt

			
very comfortable	comfortable	uncomfortable	very uncomfortable

6. When I have talked on the phone to the Roosevelt CDC staff, I felt

			
very comfortable	comfortable	uncomfortable	very uncomfortable

7. When I came to Roosevelt CDC for the Friendship Celebration, I felt



very comfortable



comfortable



uncomfortable



very uncomfortable

8. Check which of the following things would help you to participate more fully and feel more comfortable.

Hold events somewhere other than school yes _____ no _____

Have more Spanish speaking personnel yes _____ no _____

Child care for siblings yes _____ no _____

Hold functions at different times yes _____ no _____

When? _____

Have transportation to events yes _____ no _____

Have a personal phone call from teacher
or school personnel prior to event yes _____ no _____

9. General Information

How many children other than the preschooler are in you home? _____

What is the primary language spoken in the home? English _____ Spanish _____ Other _____

What is your highest educational level? Elementary _____ High School _____ College _____

What is your relationship to the child? Mother _____ Father _____ Other _____

10. Additional comments or suggestions _____

INSTRUCCIONES:

Circule las que mas claramente muestran como usted se siente. Pero si usted no participo en este evento, dejelo en blanco.

1. Cuando fui al Roosevelt por la primera vez para alistar mi niño, me sentí



muy cómodo



cómodo



incómodo



muy incómodo

2. Cuando vine a Roosevelt por la noche de Bienvenida (Open House), me sentí



muy cómodo



cómodo



incómodo



muy incómodo

3. Cuando vine a Roosevelt por la "Dental Fun Night", me sentí



muy cómodo



cómodo



incómodo



muy incómodo

4. Cuando el maestro de mi niño llego a mi casa para la primera visita, me sentí



muy cómodo



cómodo



incómodo



muy incómodo

¿ Fue esta visita arreglada antes de mano?

sí _____

no _____

5. Cuando vine a las conferencias entre padres y maestros en el centro, me sentí



muy cómodo



cómodo



incómodo



muy incómodo

6. Cuando hablo por telefono con miembros del centro mi senti



muy cómodo



cómodo



incómodo



muy incómodo

7. Cuando vine Roosevelt por la celebracion de amistad (Peace Celebration), me senti

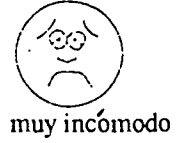

8. Indique cual de las siguientes surgerencias lo ayudaria a participar mas y a sentirse mas comodo

eventos en otros lugares sí _____ no _____

mos empleados que hablan Espanol sí _____ no _____

nincros para hermanos pequenos sí _____ no _____

eventos a horas diferenter sí _____ no _____

cuando _____

transpotacion a los eventos sí _____ no _____

llamadas telefonicas de los maestros antes de los eventos sí _____ no _____

9. Informacion general

¿ Cuantos otros ninos tiene? _____

¿ Cual es el lenguaje hablado en su casa?
Ingles _____ Espanol _____ otros _____

¿ Cual es nivel de educacion?
elemental _____ escuela secundaria _____ universidad _____

¿ Cual es su relacionado al nino?
madre _____ padre _____ otra _____

10. Otros comentarios o sugestione

APPENDIX #3

SPANISH SPEAKING COMMENTS AND SUGGESTIONS

When you don't have classes could you please call me because we work in the afternoon.

Thank you for the time and attention of all the teachers. All the parents agree with the activities that you do.

No comments

As a mother, I am very happy with everything you do for my child.

Please, no events on Wednesday, Friday or Saturday. We go to church.

Have events after 3:00 p.m. in the afternoon.

My wife and I feel happy for your work with our child

NON-SPANISH SPEAKING COMMENTS AND SUGGESTIONS

I plan to be as involved as I possibly can with my daughter's education. The only things keeping me from attending all functions are my work and previous commitments.

I think having another language spoken around my child is great. Will definitely benefit her in the long run.

Our family really enjoys the events CDC has.

I have a very high respect for your program. My daughter comes home everyday with much enthusiasms from her learning experiences from all different areas of your school. Your school has had a most positive effect on me as a single parent.

My daughter has adjusted well and is talking a lot more.

You are doing a great job

More advance notice of events in writing.

Roosevelt is an excellent school and my son enjoys it very much.

My son is excellerating very well and seems much happier

APPENDIX #3 CON'T

NON-SPANISH SPEAKING COMMENTS AND SUGGESTIONS CON'T

No comments

I feel that the events should be held at the school where the kids go. I don't feel we need a phone call. The notes sent home are more than enough notice.

I would love to participate along with my daughter. Maybe events could be earlier so mothers and fathers that work late hours can also enjoy fun events with their child.

I really like the way CDC teachers children.

GRAND VALLEY STATE UNIVERSITY

ED 695 DATA FORM

NAME: Joanne Mary Kelty

MAJOR: (Choose only 1)

Ed Tech
 Elem Ed
 Elem LD

Ed Leadership
 G/T Ed
 Sec LD
 Read/Lang Arts

Sec/Adult
 Early Child
 SpEd PPI

TITLE: AN EXAMINATION OF HISPANIC PARENT INVOLVEMENT IN EARLY CHILDHOOD
PROGRAMS

PAPER TYPE: (Choose only 1)

SEM/YR COMPLETED: Fall, 1997

Project
 Thesis

SUPERVISOR'S SIGNATURE OF APPROVAL *Joanne Mary Kelty* Jan 26, 1998

Using the ERIC thesaurus, choose as many descriptors (5 - 7 minimum) to describe the contents of your paper.

- | | |
|------------------------------|--------------|
| 1. Parent involvement | 6. Bilingual |
| 2. Early Childhood Education | 7. |
| 3. Hispanic | 8 |
| 4. Pre-School | 9. |
| 5. Hispanic culture | 10. |

ABSTRACT: Two to three sentences that describe the contents of your paper

This project developed a bilingual parent survey to register the feelings
of a group of pre-school and kindergarten parents. The results of the survey
were tabulated to determine whether there were differences between the feelings
of the Hispanic parents and the non-Hispanic parents. The information acquired
would be used to develop parent involvement activities that reflect and respect

Hispanic culture.
** Note: This page must be included as the last page in your master's paper.



U.S. DEPARTMENT OF EDUCATION
Office of Educational Research and Improvement (OERI)
Educational Resources Information Center (ERIC)



REPRODUCTION RELEASE
(Specific Document)

I. DOCUMENT IDENTIFICATION:

Title: <i>AN EXAMINATION OF HISPANIC PARENT INVOLVEMENT IN EARLY CHILDHOOD PROGRAMS</i>	
Author(s): <i>JOANNE MARY KELTY</i>	
Corporate Source:	Publication Date:

II. REPRODUCTION RELEASE:

In order to disseminate as widely as possible timely and significant materials of interest to the educational community, documents announced in the monthly abstract journal of the ERIC system, *Resources in Education* (RIE), are usually made available to users in microfiche, reproduced paper copy, and electronic/optical media, and sold through the ERIC Document Reproduction Service (EDRS) or other ERIC vendors. Credit is given to the source of each document, and, if reproduction release is granted, one of the following notices is affixed to the document.

If permission is granted to reproduce the identified document, please CHECK ONE of the following options and sign the release below.



Sample sticker to be affixed to document

Sample sticker to be affixed to document



Check here

Permitting microfiche (4" x 6" film), paper copy, electronic, and optical media reproduction.

"PERMISSION TO REPRODUCE THIS MATERIAL HAS BEEN GRANTED BY _____

Sample

TO THE EDUCATIONAL RESOURCES INFORMATION CENTER (ERIC)"

Level 1

"PERMISSION TO REPRODUCE THIS MATERIAL IN OTHER THAN PAPER COPY HAS BEEN GRANTED BY _____

Sample

TO THE EDUCATIONAL RESOURCES INFORMATION CENTER (ERIC)"

Level 2

or here

Permitting reproduction in other than paper copy.

Sign Here, Please

Documents will be processed as indicated provided reproduction quality permits. If permission to reproduce is granted, but neither box is checked, documents will be processed at Level 1.

"I hereby grant to the Educational Resources Information Center (ERIC) nonexclusive permission to reproduce this document as indicated above. Reproduction from the ERIC microfiche or electronic/optical media by persons other than ERIC employees and its system contractors requires permission from the copyright holder. Exception is made for non-profit reproduction by libraries and other service agencies to satisfy information needs of educators in response to discrete inquiries."

Signature: <i>Joanne M Kelly</i>	Position: <i>Teacher</i>
Printed Name: <i>JOANNE MARY KELTY</i>	Organization: <i>Grand Rapids Public Schools</i>
Address: <i>1428 Fourth St. NW Grand Rapids, MI 49504</i>	Telephone Number: <i>(616) 453-6733</i>
	Date: <i>3-2-98</i>

026572



III. DOCUMENT AVAILABILITY INFORMATION (FROM NON-ERIC SOURCE):

If permission to reproduce is not granted to ERIC, or, if you wish ERIC to cite the availability of the document from another source, please provide the following information regarding the availability of the document. (ERIC will not announce a document unless it is publicly available, and a dependable source can be specified. Contributors should also be aware that ERIC selection criteria are significantly more stringent for documents that cannot be made available through EDRS.)

Publisher/Distributor:	
Address:	
Price Per Copy:	Quantity Price:

IV. REFERRAL OF ERIC TO COPYRIGHT/REPRODUCTION RIGHTS HOLDER:

If the right to grant reproduction release is held by someone other than the addressee, please provide the appropriate name and address:

Name and address of current copyright/reproduction rights holder:
Name:
Address:

V. WHERE TO SEND THIS FORM:

Send this form to the following ERIC Clearinghouse:

If you are making an unsolicited contribution to ERIC, you may return this form (and the document being contributed) to:

ERIC Facility
1301 Piccard Drive, Suite 300
Rockville, Maryland 20850-4305
Telephone: (301) 258-5500