

DOCUMENT RESUME

ED 418 570

EF 005 026

TITLE District of Columbia Public Schools: Availability of Funds and the Cost of FY 1997 Roof Projects. Report to the Chairman, Subcommittee on Oversight of Government Management, Restructuring and the District of Columbia, Committee on Governmental Affairs. U.S. Senate.

INSTITUTION General Accounting Office, Washington, DC. Accounting and Information Management Div.

REPORT NO GAO/AIMD-98-82

PUB DATE 1998-03-00

NOTE 63p.

AVAILABLE FROM U.S. General Accounting Office, P.O. Box 37050, Washington, DC 20013; phone: (202) 512-6000; <http://www.gao.gov> (first copy free; additional copies, \$2; quantity discounts).

PUB TYPE Reports - Research (143)

EDRS PRICE MF01/PC03 Plus Postage.

DESCRIPTORS \*Construction Costs; Construction Programs; Educational Finance; Elementary Secondary Education; Facility Improvement; \*Public Schools; Quality Control; \*Roofing; \*School Buildings; \*School Maintenance

IDENTIFIERS \*District of Columbia

ABSTRACT

In 1997, the Congressional subcommittee responsible for oversight of schools in the District of Columbia asked for information regarding school roof repairs in the District. The subsequent report to that committee is presented. It focuses on the availability of funds to repair roofs, and it offers plans for roof repair in 1998. Although sufficient funding existed in the summer of 1997 to repair 10 schools, the District of Columbia's Public Schools division had not completed sufficient planning to begin the work. Contributing factors to the delay included the almost complete turnover in technical capital project staff during the school year and difficulty in securing bids. Repair costs exceeded estimates and reasons for this are provided. The average cost per square foot was about \$20 with costs at individual schools ranging from about \$4 to \$77. Tables throughout the report summarize the work performed, cost per square foot, and other information for the roof work. Five appendixes offer further information on key dates related to fiscal year 1997 roof repairs, a typical District of Columbia school with multiple roof areas, comments from the General Services Administration, and other information. (Includes a glossary of technical terms.) (RJM)

\*\*\*\*\*  
\* Reproductions supplied by EDRS are the best that can be made \*  
\* from the original document. \*  
\*\*\*\*\*

EF

GAO

Report to the Chairman, Subcommittee on Oversight of Government Management, Restructuring and the District of Columbia, Committee on Governmental Affairs, U.S. Senate

March 1998

DISTRICT OF COLUMBIA PUBLIC SCHOOLS

Availability of Funds and the Cost of FY 1997 Roof Projects

ED 418 570



EF 005 026

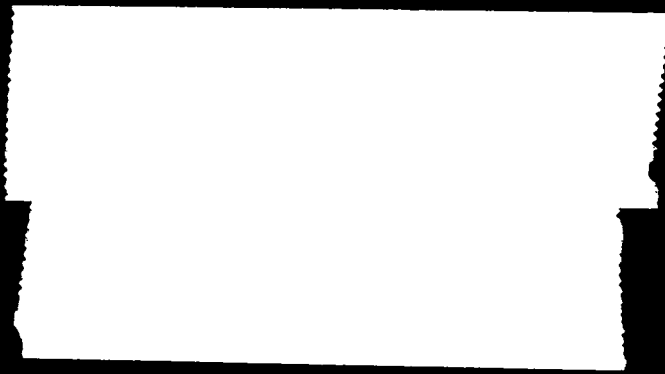

U.S. DEPARTMENT OF EDUCATION  
Office of Educational Research and Improvement  
EDUCATIONAL RESOURCES INFORMATION CENTER (ERIC)

This document has been reproduced as received from the person or organization originating it.

Minor changes have been made to improve reproduction quality.

• Points of view or opinions stated in this document do not necessarily represent official OERI position or policy.



Accounting and Information  
Management Division

B-278471

March 9, 1998

The Honorable Sam Brownback  
Chairman, Subcommittee on Oversight of  
Government Management, Restructuring  
and the District of Columbia  
Committee on Governmental Affairs  
United States Senate

Dear Mr. Chairman:

In a September 30, 1997, letter, you requested that we review the District of Columbia Public Schools' (DCPS) efforts to repair<sup>1</sup> school roofs during the summer of 1997. You indicated that your Subcommittee had received widely varying information on the cost of the roof repair work ranging from \$11 to \$19 per square foot, and that there were divergent views on when funds were available to do that work, ranging from as early as April 1997 to July 1997. Consistent with your request, we focused on the conflicting information presented to the Subcommittee on the availability of funds to pay for the roof work and the cost, including the cost per square foot, of the work completed in fiscal year 1997. This report also provides information on DCPS' plans for roof work during fiscal year 1998 and beyond.

This report contains technical terms concerning roofing structures and repairs, which are defined in the glossary at the end of this report. In addition, key events and related dates pertaining to the fiscal year 1997 roof repairs are in appendix I.

## Background

The District of Columbia Public Schools' draft Long-Range Facilities Master Plan, dated July 17, 1997, states that the majority of District public schools were built over 50 years ago, generally have not been well maintained, and consequently, substantial deferred maintenance exists. In addition, concerns about safety and problems with leaky school roofs have been widely reported. We have documented the less-than-adequate condition of the District's public schools in several reports.<sup>2</sup> In 1992,

<sup>1</sup>As discussed in this report, roof work was done at 61 schools during fiscal year 1997.

<sup>2</sup>School Facilities: Condition of America's Schools (GAO/HEHS-95-61, Feb.1, 1995); School Facilities: America's Schools Report Differing Conditions (GAO/HEHS-96-103, June 14, 1996); School Facilities: Profiles of School Condition by State (GAO/HEHS-96-148, June 24, 1996); and District of Columbia Draft Emergency Supplemental Funding Request for District of Columbia Public Schools (GAO/HEHS-97-116R, May 5, 1997).

Parents United for the District of Columbia, an education advocacy group, filed a lawsuit in the Superior Court of the District of Columbia naming several city officials and alleging their failure<sup>3</sup> to perform their duties with respect to the D.C. public schools, including but not limited to, their duties related to hundreds of fire code violations in aging D.C. school buildings.<sup>4</sup>

In an effort to respond to these concerns, the Congress included legislative provisions on this matter in recently enacted legislation: Secs. 2550-2552 of the District of Columbia School Reform Act of 1995,<sup>5</sup> called for the Administrator of the General Services Administration (GSA) to provide technical assistance to the District public schools in the area of facilities management and for the Mayor and the District of Columbia Council, in consultation with the Administrator of GSA, the Financial Responsibility and Management Assistance Authority (Authority), the Board of Education, and the Superintendent of Schools, to design and implement a comprehensive long-term program for the repair, improvement, maintenance, and management of District public school facilities and to designate or establish an agency within the District of Columbia government to administer the program. The plan also was required to include short-term and long-term funding sources.

Section 603(e)(2)(A) of the Departments of Labor, Health and Human Services, and Education, and Related Agencies Appropriations Act, 1997,<sup>6</sup> authorized the Authority to establish an account to receive the proceeds from privatization of certain government entities to carry out the District of Columbia School Reform Act of 1995 (which provides for the repairs and improvement of District schools) and to finance public elementary and secondary school facility construction and repair within the District of Columbia. Section 5201 of the Omnibus Consolidated Appropriations Act of 1997<sup>7</sup> authorized the Authority to contract with private entities to carry

<sup>3</sup>This includes allegations that the Fire Department failed to inspect schools regularly and that the Mayor and Council failed to adequately fund the DCPS capital budget to eliminate fire code violations.

<sup>4</sup>On November 3, 1997, a settlement was reached between Parents United and the Mayor. Pursuant to the agreement, within 5 years, DCPS will perform work, at an estimated cost of \$487 million, to complete the "stabilization" and "functionality" repairs required by the draft DCPS Long-Range Facilities Master Plan.

<sup>5</sup>As enacted by the Omnibus Consolidated Rescissions and Appropriations Act of 1996, Public Law No. 104-134, sec. 101(b), Title II, 110 Stat. 1321-141 through 1321-143 (April 26, 1996). D.C. Code Ann. §§ 31-2853-50 through 31-2853-52 (1997 Supp.).

<sup>6</sup>As enacted by the Omnibus Consolidated Appropriations Act of 1997, Public Law No. 104-208, Division A, Title I, sec. 101(e), 110 Stat. 3009-233, 3009-293.

<sup>7</sup>Public Law No. 104-208, 110 Stat. 3009-501 (September 30, 1996), D.C. Code Ann. § 31-2851 note (1997 Supp.).

out a program of school facility repair of District public schools, in consultation with GSA.

On November 15, 1996, the Authority restructured DCPS, installing a nine-member Emergency Transitional Education Board of Trustees and a Chief Executive Officer (CEO), both as Agents of the Authority. The Authority also delegated its authorities to oversee all facilities and property to the new Board of Trustees. The Authority removed the then Superintendent of Schools and gave the CEO responsibility for all the authorities, powers, functions, exemptions, and immunities of the former Superintendent. The CEO established an office of Chief Operating Officer (COO)/Director of Facilities and hired a COO in January 1997 to manage and implement the school facilities improvement program.<sup>8</sup>

To assist in this effort, GSA updated a study,<sup>9</sup> by developing a comprehensive facilities revitalization plan, Determination and Prioritization of the District of Columbia Public Schools Projects,<sup>10</sup> which was delivered to DCPS on February 18, 1997. The plan described problems such as leaky roofs, inoperable boilers, numerous fire code violations, and the absence of a long-range facilities master plan and estimated the cost of upgrading the school infrastructure to be \$2 billion. The February 1997 plan and the underlying work were the basis for the long-range facilities master plan. To develop the long-range facilities master plan, a task force was formed including representatives from DCPS, the Office of the Mayor, and the 21st Century School Fund.<sup>11</sup> A February 28, 1997, draft report of the long-range plan was submitted to the D.C. Council in February, and was resubmitted with changes in April, and again in July. The Council did not vote on the plan,<sup>12</sup> and DCPS submitted it to the Congress to meet the congressionally mandated submission date of April 25, 1997. The draft

<sup>8</sup>The United States Court of Appeals for the District of Columbia Circuit recently ruled that the Authority's creation of, and delegation of certain powers to, the Board of Trustees were ultra vires (beyond the powers of the Authority). *Shook v. District of Columbia Financial Responsibility and Management Assistance Authority*, No. 97-7087 1998 WL 1796, at 10 (Jan. 6, 1998).

<sup>9</sup>This study (3DI-AEPA Facilities Assessment Study) was performed from 1991 to 1992 by 3DI-AEPA Architects and Engineers.

<sup>10</sup>GSA issued a task order on a previously competitively bid contract with the architectural and engineering firm of Daniel, Mann, Johnson, and Mendenhall (DMJM) to assist in the development of the comprehensive facilities revitalization plan.

<sup>11</sup>The 21st Century School Fund is a nonprofit organization, which focuses on the modernization of public school facilities.

<sup>12</sup>In a statement on January 23, 1998, the Chief Operating Officer of DCPS stated that the Council did not act to either approve or reject the plan. According to a Council official, the plan did not adequately address the prioritization of the capital program, including roof repairs.

---

long-range facilities master plan considered roof replacement to be the number one priority.

GSA contracted for and managed roof work at 10 schools—initially 7 schools at the Authority's request. In June 1997, DCPS requested GSA's assistance, and GSA managed work on an additional three schools. DCPS oversaw work on another 51 schools for which roof work was completed in fiscal year 1997.

---

## Results in Brief

Sufficient funding was available to begin roof work when schools were closed for the summer on June 20, 1997. The District's records show that the Authority had about \$18 million available in March 1997 for DCPS-managed roof work, with the available amount increasing to about \$38 million by June 1997.

A series of events preceeding the efforts to repair D.C. school roofs contributed to the delayed start. Although it was decided that DCPS would manage the majority of this work, DCPS was not prepared to start immediately because it had not completed sufficient planning, such as determining the scope of work on individual projects which would be the basis for seeking bids for that work. A contributing factor to this delay was the almost complete turnover in technical capital project staff during the school year. These problems were compounded by difficulties in securing bids, resulting in DCPS-managed work not starting until the third week of July. DCPS told us that at the time the long-range plan was submitted in February 1997, it had expected to complete roof work by the end of October 1997 but accelerated it in response to a court order that roof work not be done while classes were in session. Consequently, the work was accomplished under a highly compressed schedule.

Our review showed that DCPS spent about \$37 million for roof replacement/repair in fiscal year 1997. As discussed in this report, this included an extensive amount of work not only on the roofs, but also on the adjacent upper portions of the buildings to achieve structurally sound, watertight facilities. As a result, the costs were higher than what would have been incurred for roofing work only. Considering all of these costs, the average cost per square foot of roof surface replaced or repaired was about \$20, with DCPS-managed contracts somewhat higher than those managed by GSA. Some factors that contributed to the cost difference between GSA- and DCPS-managed work include:

- GSA was able to issue task orders against its existing architectural and engineering, and construction contracts, and did not have to seek bids when the market was saturated with roof work,
- GSA-managed projects were done over longer time frames, calling for less overtime work, and
- GSA managed only flat roof work, not higher cost multiple roof areas and materials.

Insufficient data exist to ascertain with any certainty the added cost associated with the degree of deferred maintenance encountered in this extensive project. Years of neglect and inadequate repair and maintenance practices all served to increase costs over what could be expected in well-managed, adequately financed entities. Further, material suppliers would not provide or honor extended warranties unless prescribed roof-related and other preventive maintenance was completed concurrently with the roofing repairs or replacement. GSA, DCPS, and the architectural and engineering firm overseeing the work all agreed that this combination of factors precluded a more economical solution to the school roofing project in fiscal year 1997.

DCPS plans for fiscal year 1998 show additional roof work at 40 more schools at an approximate cost of \$35 million. In addition, DCPS proposed Capital Improvement Program Plan for Fiscal Years 1999-2004<sup>13</sup> indicates that an additional \$63 million is anticipated for roof replacement/repairs during this period.

## Objectives, Scope, and Methodology

Our objectives were to determine (1) when funds were made available to pay for roof repairs, (2) the cost of the roof repairs, including the cost per square foot, and (3) whether there are additional roofs to be repaired in fiscal year 1998 and beyond.

To determine when the capital funds were available to pay for roof repairs, we reviewed documents provided by the U.S. Department of Education, Authority, District CFO's office, and DCPS CFO. In addition, we reviewed funding request modification documents prepared by DCPS and approved by the District's Office of Budget and Planning, monthly reports produced by the District's Financial Management System, and other financial documents provided by DCPS.

<sup>13</sup>This plan has not yet been approved by the Congress.



---

To determine the cost of the roof repairs, we obtained and reviewed information from the contract files at DCPS for fiscal year 1997 projects, which included information on each school, such as the dollar amount and other terms of each contract, types of roofing material used, size of the area replaced/repaired, modifications (change orders), daily inspection sheets, invoices submitted for payment and actual amounts paid to contractors.

In addition, we compared design and construction cost estimates prepared by a DCPS engineering consultant and GSA to the contract amount and change orders for the schools' roofs replaced/repaired. We held discussions with DCPS officials to obtain reasons for any significant variances from the cost estimates.

We also interviewed District Government officials, including officials from the Authority, the Chief Financial Officer for the District, the Deputy Chief Financial Officer for the District's Office of Budget and Planning, the Chief Operating Officer of DCPS and his Capital Project Division staff, the Chief Financial Officer of DCPS, and District Council officials. In addition, we interviewed officials from the General Services Administration, the U.S. Department of Education, a DCPS consultant,<sup>14</sup> Parents United, and the 21st Century School Fund to obtain additional information to satisfy our objectives.

To determine whether additional roofs required repairs, we reviewed DCPS' fiscal year 1997 Capital Improvement Program priority lists of schools needing roof work and various facility assessments prepared by contractors, and we discussed modifications/changes to the plans with DCPS officials. We also reviewed the DCPS' proposed Capital Improvement Program Plan for fiscal years 1999-2004, including roof replacement prioritization schedules, to determine the extent of roofing repair projects planned for fiscal year 1998 and future years.

While we reviewed the information contained in the contract files to determine the cost per square foot of roofs replaced/repaired, we did not independently verify the accuracy of the square footage estimates but instead relied on the measurements prepared by GSA and DCPS engineering consultant. We did not review support for payments made to contractors to determine validity nor did we attempt to determine whether the cost of individual projects was reasonable. We reviewed the work performed by

---

<sup>14</sup>Daniel, Mann, Johnson, and Mendenhall (DMJM) is the architectural and engineering firm that provided technical advice and field inspection. DMJM is an independent term contractor, under contract with GSA, which was made available for DCPS' use.



the District's independent public accounting firm<sup>15</sup> on DCPS capital project funds.

We requested comments on a draft of this report from the Authority, DCPS, the District's CFO, GSA, and the U.S. Department of Education. Written comments were received from the Authority, DCPS, and GSA and are reprinted in appendixes III, IV, and V, respectively. Oral comments were obtained from the District's CFO and the Department of Education. Those comments have been considered and incorporated in our report as appropriate. We conducted our work from October 1997 through February 1998 in accordance with generally accepted government auditing standards.

## Availability of Funding for Roof Repairs

Based on our review of the information obtained from the Authority, the District's Chief Financial Officer, the Department of Education, and the District of Columbia Public Schools' Chief Financial Officer, funds were available to begin roof repairs on June 20, 1997, when D.C. Public Schools closed for the summer vacation. Table 1 shows the sources, dates, and amounts of funds received by the Authority. By June 1997, the Authority had received on behalf of DCPS a total of \$49.7 million in capital funds, as follows: \$11.5 million in October 1996 from fiscal year 1996 general obligation bond proceeds, approximately \$18 million in March 1997 from the federal government's sale of the College Construction Loan Insurance Association (Connie Lee), and \$20 million from the June 1997, general obligation bond proceeds. In addition, in September 1997, the Authority received about \$36.8 million<sup>16</sup> from the sale of Student Loan Marketing Association (Sallie Mae) stock warrants, making the total received in fiscal year 1997 for capital projects about \$86.5 million.

<sup>15</sup>The District's independent auditor for the fiscal year 1997 financial statement audit of DCPS was KPMG Peat Marwick LLP.

<sup>16</sup>The Sallie Mae funds are being used to satisfy fiscal year 1998 capital program needs.

**Table 1: Funds Received in Fiscal Year 1997 for DCPS Capital Projects**

Month	Source of funds	Funds received by the Authority
October 1996	1996 Bond Proceeds	\$11,500,000
November 1996		
December 1996		
January 1997		
February 1997		
March 1997	Connie Lee Proceeds	18,252,080
April 1997		
May 1997		
June 1997	1997 Bond Proceeds	20,000,000
July 1997		
August 1997		
September 1997	Sallie Mae	36,789,516
<b>Total</b>		<b>\$86,541,596</b>

Source: The Authority, District of Columbia CFO, and DCPS CFO.

Prior to DCPS assuming responsibility for managing the fiscal year 1997 capital program work, the Authority had engaged GSA to oversee roof repair and other work, such as installing boilers and chillers. On November 19, 1996, the Authority entered into a memorandum of agreement with GSA to provide contract administration and program management services for those contracts. On November 27, 1996, GSA issued a task order to an architectural and engineering consultant (DMJM) for design work related to five schools. In February 1997, construction work began on those five schools. According to GSA and DCPS officials, the \$11.5 million that the Authority had received in October 1996 was earmarked for GSA-managed contracts.

According to DCPS' Chief Operating Officer (COO), when he assumed his position in January 1997, neither funds nor technical capital project staff<sup>17</sup> were available to prepare or manage the preparation of scope of work, drawings, and cost estimates. While the Authority records showed that additional funds were available in March 1997, the COO stated that he began to hire technical capital staff to address capital program needs in April 1997 after being told that funds were available. We were not provided

<sup>17</sup>In the fall of 1996, the then Superintendent dismissed most of the technical capital project staff. While DCPS had had an ongoing contractual relationship with Service Master since 1993, according to DCPS, Service Master was only responsible for custodial and maintenance services.

---

any documentation indicating when DCPS was notified that additional funds were available for capital projects on the school facilities.

In its audit report on the District's financial statements for fiscal year 1997, the District's independent auditors identified a material weakness concerning control over transactions involving the Authority. The report indicated that the District has not developed adequate procedures to account for funds held by the Authority and does not effectively reconcile the amounts which are recorded. The auditor noted that the District and the Authority have not developed procedures to notify each other of amounts anticipated or actually received by the Authority on behalf of the District.

On May 19, 1997, DCPS issued a Request for Qualifications (RFQ)<sup>18</sup> for capital projects it intended to manage, which resulted in prequalification of nine contractors. In June 1997, DCPS authorized consulting architectural and engineering firm, DMJM, which had a competitively bid contract with GSA, to provide scope of work for roof replacement at 48 schools. This work was performed from the beginning of June to mid-July and included surveying each roof, reviewing and photographing existing conditions, and developing technical specifications to establish quality standards and a cost estimate.

On July 1, 1997, DCPS issued an Invitation for Bid and Contract (IFBC) for a single (or package) contract for roof replacement at 15 schools and for work on boilers and chillers at five schools. DCPS officials told us that they were not initially successful in obtaining bidders because contractors were hesitant to bid on such a large package, involving such diversity of work. On July 11, 1997, DCPS issued an addendum to the IFBC, resulting in eight separate, smaller packages, two of which included the boiler and chiller work. The other six included roof replacements on 48 schools. Contracts for two of those six packages (15 schools) were awarded. The remaining four packages (33 schools) were reissued as another addendum covering 23 schools. The remaining 10 schools were deferred at that time. Of these 10 schools, 2 were repaired by DCPS in-house maintenance staff. The addendum for the 23 schools allowed prequalified contractors to bid on one or more of those schools; work on 19 schools was awarded on that basis for a total of 34 schools under contract. Roof work for the remaining 12 DCPS managed projects completed during fiscal year 1997 included 3 from the original IFBC and 9 others. DCPS officials told us they urged

---

<sup>18</sup>An RFQ is used to determine whether potential contractors possess the resources and expertise for construction work.

contractors to submit bids. Based on our analysis of contract documents, the majority (46 schools) of the roof repair work started the third week in July or later.

The draft Long-Range Facilities Master Plan called for roof replacement work at 50 schools. According to the COO, when the Plan was presented at the end of February 1997, he had believed that the work could not be completed until the end of October 1997 but had hoped that a substantial number of schools could be completed prior to September 30, 1997. The COO advised us that on July 10, 1997, he had informed the Superior Court that the estimated completion dates based on the best available data, ranged from mid-August 1997 through September 20, 1997. He said that these estimates did not consider the July 11, 1997, court ruling that this type of work could not be performed while schools were occupied. Ultimately, because of the large number of schools involved, it was decided to delay the opening of D.C. public schools until September 22, 1997.

## Cost of Roof Repairs

DCPS records show that as of February 4, 1998, the total cost of the fiscal year 1997 roof repair project, including change orders and consulting fees, was about \$37 million. A significant, but not determinable amount of these costs was attributable to factors other than what would be strictly interpreted as roof replacement/repair work. Among these were structural integrity, fire damage, the general deterioration from deferred maintenance, and warranty stipulations concerning deferred maintenance. Extensive work was performed to repair and replace masonry, cornices, flashing, coping, and cupolas, as well as cleaning drains. For ease of presentation, we have characterized this work as roof and roof-related work.

Based on our review and analysis of the data, the average cost per square foot for roof repair work performed on schools managed by both DCPS and GSA in fiscal year 1997 was about \$20 per square foot—with costs at individual schools ranging from about \$4 to \$77. The average cost per square foot for GSA-managed contracts was about \$13, whereas the average cost per square foot for DCPS-managed contracts was about \$22 per square foot.

As part of its fiscal year 1997 Capital Program budget, DCPS had initially budgeted \$22 million for roof work to be performed in fiscal year 1997. According to DCPS officials, the \$22 million was a preliminary estimate and

did not include amounts for work such as repairing flashing, masonry, or cornices. In addition, the \$22 million did not include costs to address the complexity of the roof areas and other issues discussed below, such as the compressed time schedule. Further, the priority list of schools on which the \$22 million estimate was based was modified several times during fiscal year 1997. DCPS officials were aware that they would have to pay a premium for labor and materials because of the various factors that affected costs.

Table 2 summarizes the work performed, cost per square foot, and other information for the roof work managed by both DCPS and GSA. In total, roof work was completed at 61 schools. DCPS capital project staff managed roof projects at 46 schools, and its in-house maintenance staff performed minor work at 7 schools (Cardozo Senior High, Cleveland Elementary, Eaton Elementary, Eliot Junior High, Hart Junior High, Janney Elementary, and Winston Elementary). GSA managed roof projects at 10 schools. Included were two schools (Tyler and Spingarn) where DCPS and GSA managed separate projects. Table 2 does not include data for minor work performed at the seven schools because the cost data were not complete. Accordingly, that work, which DCPS officials estimated to have cost about \$189,000, is not included in our computations of total cost or cost per square foot.

**Table 2: Summary of Roof Work and Estimated Cost per Square Foot, Fiscal Year 1997**

School <sup>a</sup>	Year built	Roof areas <sup>b</sup>	Material used
<b>DCPS-managed contracts</b>			
1. Adams ES	1930	6	2-ply modified bitumen and slate.
2. Aiton ES	1960	7	2-ply modified bitumen.
3. Anacostia SHS	1935	22	2-ply modified bitumen and metal.
4. Bancroft ES	1924	4	2-ply modified bitumen and clay.
5. Barnard ES	1926	6	2-ply modified bitumen.
6. Beers ES	1942	13	2-ply modified bitumen.
7. Bell Multicultural SHS	1915	16	2-ply modified bitumen.
8. Benning ES	1976	6	2-ply modified bitumen.
9. Birney ES	1950	11	2-ply modified bitumen.
10. Browne JHS	1931	20	2-ply modified bitumen and metal.
11. Bruce-Monroe ES	1973	9	2-ply modified bitumen and metal.
12. Bunker Hill ES	1938	10	2-ply modified bitumen and slate.
13. Burrville ES	1980	4	2-ply modified bitumen.
14. Cook JF ES	1921	4	2-ply modified bitumen.
15. Deal JHS	1931	18	2-ply modified bitumen, slate, and metal.
16. Dunbar SHS	1977	37	2-ply modified bitumen.

BEST COPY AVAILABLE

Roof-related work <sup>c</sup>	Period of work <sup>d</sup> (1997)	Days	Estimated square feet <sup>e</sup>	Amount of contract & change orders as of 2/4/98 <sup>f</sup>	Estimated cost per square foot
Replace damaged gutters, masonry joints, and downspouts, and repaint roof.	7/23-8/27	35	2,952	\$63,000	\$21.34
Repair counter flashing.	7/29-9/3	36	24,722	540,000	21.84
Clean drains and piping for free flow of water. Clean and reseal mortar joints. Replace 2 ventilators and 2 vent hoods with new units. Remove entire skylights, reframe openings, and make watertight. Replace flashing.	7/23-9/9	48	34,679	486,750	14.04
Touch up metal roof with paint. Reinforce roof structure to redirect water flow.	7/24-9/7	45	19,405	289,047	14.90
Repair metal roof and trim.	8/1-9/7	37	23,249	474,620	20.41
Complete minor repairs to masonry.	7/29-9/3	36	32,550	689,889	21.19
Repaint skylights, repoint masonry, seal counter flashing, and clean roof of debris.	8/12-9/9	28	30,365	537,500	17.70
No additional work done.	7/23-9/7	46	34,414	635,000	18.45
Clean drains, repair mortar joints, and remove skylights and replace with new metal covers.	7/23-9/3	42	21,814	474,000	21.73
Repair metal flashing, cornices, and downspouts. Replace drains and various masonry.	8/1-9/10	40	76,079	1,467,291	19.29
Remove skylights and replace with new metal covers, clean drains, repair mortar joints, repoint masonry, and replace ventilator curb and tank.	7/23-8/20	28	40,993	699,700	17.07
Install new stainless steel ridge and flashing. Replace downspouts. Install new tapered insulation on all roofs.	7/29-9/9	42	15,522	463,434	29.86
Install base layer and tapered insulation over concrete, and clean and recoat metal roof.	7/23-8/31	39	42,844	1,088,000	25.39
Seal limestone coping and flashing, repair ornamental cornice, replace glazing in skylight, and replace and paint fascia boards.	8/1-9/3	33	8,366	646,432	77.27
Clean, prime, and repaint metal roof. Replace glazing at skylight. Replace cupola and clean drains and repair gutters.	8/1-9/9	39	30,425	1,150,000	37.80
Clean metal roof, prime and repaint, seal skylight glazing joints, and replace existing mezzanine covers with new membranes.	7/29-9/10	43	93,744	2,380,000	25.39

(continued)



School <sup>a</sup>	Year built	Roof areas <sup>b</sup>	Material used
17. Fletcher-Johnson ES	1980	10	Ethylene Propylene Diene Monomer (EPDM, i.e., rubber roof).
18. Francis JHS	1927	14	2-ply modified bitumen.
19. Gage-Eckington ES	1977	15	2-ply modified bitumen and metal.
20. Garfield ES	1868	15	2-ply modified bitumen, slate, and metal.
21. Green ES	1965	6	2-ply modified bitumen.
22. Jefferson JHS	1940	13	2-ply modified bitumen, slate, and metal.
23. Ketcham ES	1909	13	Slate and tin roof.
24. Lafayette ES	1931	24	2-ply modified bitumen, slate, and metal.
25. Langdon ES	1930	8	2-ply modified bitumen and slate.
26. Leckie ES	1970	1	2-ply modified bitumen.
27. Lee MD SES	1971	14	2-ply modified bitumen.
28. Ludlow-Taylor ES	1969	7	2-ply modified bitumen.
29. MacFarland JHS	1923	15	2-ply modified bitumen.
30. Maury ES	1890	8	2-ply modified bitumen, slate, and metal.
31. Nalle ES	1959	5	2-ply modified bitumen.
32. Orr ES	1974	8	2-ply modified bitumen.
33. Park View ES	1916	10	2-ply modified bitumen, metal, and slate.

Roof-related work <sup>c</sup>	Period of work <sup>d</sup> (1997)	Days	Estimated square feet <sup>e</sup>	Amount of contract & change orders as of 2/4/98 <sup>f</sup>	Estimated cost per square foot
Repair ventilator hoods, masonry walls, parapets, and concrete walkway. Repair skylight and counter flashing. Install counter strips. Reseal parapets. Improve drainage.	7/29-8/27	29	41,901	610,135	14.56
Repair masonry joints and coping. Replace roof drains and storm drain piping on two roofs.	8/1-9/10	40	53,030	577,255	10.89
Repair gutters.	8/1-9/8	38	22,818	687,740	30.14
Install new tapered insulation on 2 built-up roofs. Remove and replace all slate, over new felt, on 11 roofs.	7/29-9/7	40	23,267	670,000	28.80
Replace counter flashing and repair concrete.	7/30-9/3	35	26,269	617,500	23.51
Repair cupola and base, clean drains, repoint masonry, replace skylights, provide splash blocks, and repair electrical and mortar joints. Replace drains and reseal coping, move satellite dish, and reseal chimney.	7/23-8/26	34	19,099	547,250	28.65
Replace flat seam copper.	7/23-9/3	42	45,155	189,000	4.19
Replace gutters, downspouts, ridge, and flashing. Clean drains; repair mortar and coping joints; and replace skylights.	7/23-9/9	48	15,228	522,400	34.31
Repair gutters, flashing, and pitch pockets. Seal coping, repoint masonry, clean drains, reinstall cornice, and repaint two cupolas.	9/9-9/27	18	8,700	287,000	32.99
Repair damaged flashing.	9/11-9/14	3	8,800	112,600	12.80
Replace domed skylight.	7/23-8/31	39	34,178	909,000	26.60
Install new tapered insulation on 7 built-up roofs.	7/29-8/30	32	30,331	525,851	17.34
Repoint masonry and replace broken brick. Replace severely cracked parging on parapet walls with new parging or metal panels. Remove and recover skylights. Repair flashing. Replace stone coping. Clean drains.	7/23-9/10	49	11,647	750,675	64.45
Repair roof structure and masonry, and repaint cornices.	7/23-8/31	39	17,670	413,000	23.37
No additional work performed.	7/23-8/27	35	33,122	281,708	8.51
Remove old built-up roof and install new roof over tapered insulation. Install new drains.	7/23-9/8	47	39,724	488,300	12.29
Install 2 new metal roofs over old metal.	7/29-9/8	41	29,110	838,458	28.80

(continued)

School <sup>a</sup>	Year built	Roof areas <sup>b</sup>	Material used
34. Phelps SHS	1934	20	2-ply modified bitumen and slate.
35. Randle-Highlands ES	1912	6	2-ply modified bitumen and slate.
36. Roosevelt SHS	1932	24	2-ply modified bitumen, copper, and slate.
37. Ross ES	1896	1	Slate tiles and metal.
38. Shaed ES	1971	3	2-ply modified bitumen.
39. Spingarn SHS	1941	14	2-ply modified bitumen and slate.
40. Stuart-Hobson MS	1927	14	2-ply modified bitumen.
41. Truesdell ES	1908	9	Metal.
42. Tyler ES	1949	3	2-ply modified bitumen.
43. Washington MM CDC SHS	1912	15	2-ply modified bitumen and metal.
44. West ES	1978	1	Asphalt shingle.
45. Wilson SHS	1935	16	2-ply modified bitumen and slate.
46. Young ES	1931	8	2-ply modified bitumen and slate.
<b>Total DCPS-managed contracts (average days and average cost per square foot)</b>			
<b>GSA-managed contracts</b>			
47. Cooke HD ES	1909	2	Fiberglass asphalt and 2-ply modified bitumen.
48. Houston ES	1961	3	2-ply modified bitumen.
49. Merritt ES	1976	11	4-ply modified bitumen.
50. Meyer ES	1962	3	2-ply modified bitumen.

Roof-related work <sup>c</sup>	Period of work <sup>d</sup> (1997)	Days	Estimated square feet <sup>e</sup>	Amount of contract & change orders as of 2/4/98 <sup>f</sup>	Estimated cost per square foot
Install new tapered insulation on 18 built-up roofs. Install new drains.	8/1-9/10	40	64,637	1,464,700	22.66
Repair or replace gutters and downspouts, clean drains, and repoint masonry. Move cellular equipment.	7/23-9/10	49	25,664	596,700	23.25
Replace damaged slate roof and replace skylight glazing. Repair parapet, cupola, and vents.	8/12-9/10	29	82,186	2,596,820	31.60
Replace existing gutters and coping. Install copper snow guards on slate roof.	7/23-8/26	34	8,000	122,224	15.28
Install new tapered insulation. Remove and reinstall metal coping.	7/29-9/9	42	18,139	395,000	21.78
Seal glazing, replace missing ridge flashing, repoint chimney, and install new coping. Repair expansion joints, and clean and repaint metal steps. Repair gutters, skylights, and flashing.	8/1-9/10	40	35,928	1,300,000	36.18
Repair flashing and coping.	7/23-8/20	28	41,031	663,800	16.18
Install new metal roofing over old. Install new tapered insulation on 3 built-up roofs.	8/1-9/9	39	29,623	697,810	23.56
No additional work performed.	1/27-2/12	16	17,500	129,075	7.38
Wire brush and repaint metal roof, and install stone ballast and metal scupper guard.	7/23-8/20	28	24,041	411,000	17.10
No additional work performed.	5/27-6/20	24	21,000	96,850	4.61
Install stainless steel coping. Repoint masonry wall. Install metal flashing around cupola base.	7/19-9/7	50	25,189	450,366	17.88
Replace exterior cladding on cupola. Replace aluminum coping and repair coping joints. Lower and replace drains.	8/1-9/3	33	31,786	632,563	19.90
		<b>36</b>	<b>1,416,896</b>	<b>\$30,669,443</b>	<b>\$21.65</b>
Adjust parapets and replace gravelstop, gutter, downspouts, and flashing.	2/26-5/17	80	27,870	\$329,636	\$11.83
Replace gutters, flashing, parapets, and downspouts.	2/26-6/18	112	36,255	512,480	14.14
Install new tapered insulation. Repair substrate as needed.	8/4-9/10	37	57,000	641,800	11.26
Replace gutters, flashing, parapets, and downspouts, and repaint metal roofing.	2/26-6/6	100	26,100	315,827	12.10

(continued)

School <sup>a</sup>	Year built	Roof areas <sup>b</sup>	Material used
51. River Terrace ES	1952	1	2-ply modified bitumen.
52. Shadd ES	1955	6	4-ply modified bitumen.
53. Sharpe Health SES	1959	6	4-ply modified bitumen.
54. Spingarn SHS Gym <sup>g</sup>	1941	1	4-ply modified bitumen.
55. Turner ES	1946	1	2-ply modified bitumen.
56. Tyler ES <sup>g</sup>	1949	3	4-ply modified bitumen.
<b>Total GSA-managed contracts (average days and average cost per square foot)</b>			
<b>Average days, total square feet, total cost, and average cost per square foot</b>			
Consulting, contract administration and construction management fees			
<b>Total, including fees</b>			

<b>Roof-related work<sup>c</sup></b>	<b>Period of work<sup>d</sup> (1997)</b>	<b>Days</b>	<b>Estimated square feet<sup>e</sup></b>	<b>Amount of contract &amp; change orders as of 2/4/98<sup>f</sup></b>	<b>Estimated cost per square foot</b>
Replace gutters, flashing, parapets, and downspouts.	2/26-5/23	86	39,809	467,571	11.75
Install new tapered insulation. Repair substrate as needed.	7/14-8/26	43	31,000	312,950	10.10
Install new tapered insulation. Install new flashing.	7/26-9/7	43	41,000	442,015	10.78
Replace all roofing materials, including entire roof deck, which had been destroyed by fire. Replace all skylights, blocking, flashing, and downspouts.	6/17-7/25	38	12,000	329,200	27.43
Replace gutters, flashing, parapets, and downspouts.	2/26-5/17	80	26,700	352,626	13.21
Install new tapered insulation. Repair substrate as needed. Emergency replacement of a section of wall.	7/10-8/31	52	17,500	343,687	19.64
		<b>67</b>	<b>315,234</b>	<b>\$4,047,792</b>	<b>\$12.84</b>
		<b>42</b>	<b>1,732,130</b>	<b>\$34,717,235</b>	<b>\$20.04</b>
				2,176,054	
				<b>\$36,893,289</b>	

BEST COPY AVAILABLE

Note: This table includes scope of work and change order information. We did not independently determine whether the scope of work or change orders were appropriate.

<sup>a</sup>CDC - Career Development Center.  
ES - Elementary School.  
JHS - Junior High School.  
MS - Middle School.  
SES - Special Education School.  
SHS - Senior High School.

<sup>b</sup>Generally, replacement is defined as the removal from the entire roof of all existing roofing materials, exposing the roof's structural substrate, followed by the installation of all new materials. A roof may be partially replaced, e.g., one-half, is replaced and the remainder repaired or left as is.

<sup>c</sup>Roof-related work includes repairs and maintenance deemed necessary—in most cases, long-deferred maintenance.

<sup>d</sup>The date on which work began is the date specified in DCPS's Notice to Proceed (NTP) to the contractor, or the date of the NTP if no beginning date was specified. The date on which work ended is the date, provided by DCPS, on which all work at that school passed a "water test" with no leaks or only minor leaks. We did not determine the time required for design work for 7 of the 10 GSA-administered projects.

<sup>e</sup>Estimates of work area, in square feet, to be replaced or repaired were prepared mostly from the beginning of June to mid-July 1997 (five GSA-administered schools were estimated in late 1996) by an architectural and engineering consultant or, in a few instances, by DCPS or GSA staff working with contractors. Estimates were based on field observations to determine existing conditions and the specific location and extent of required work, and included diagrams (and photographs at most schools) of each roof, narrative descriptions, quality specifications of material to be installed, and a cost estimate for each school.

<sup>f</sup>Contract amount consists of original contract amount plus the amount of subsequent changes to work specifications (change orders). Change order costs include those identified by GAO through February 4, 1998, at which time DCPS was continuing to review and approve additional change orders as received.

<sup>g</sup>This table shows 56 roofing projects. There were 54 schools where roof replacements or major repairs were done by contractors in 1997. Spingarn SHS and Tyler ES were each worked on under separate contracts at separate times by DCPS and GSA contractors.

Source: Information obtained from District of Columbia Public Schools, DCPS Capital Projects Division, and General Services Administration.

Table 2 indicates a wide range of costs per square foot by school and by responsible agency (DCPS or GSA). The roofs worked on by DCPS contractors had square foot costs ranging from a low of \$4.19 (Ketcham Elementary) to a high of \$77.27 (Cook Elementary) per square foot. In contrast, costs for schools worked on by GSA's contractors ranged from a low of \$10.10 per square foot (Shadd Elementary) to a high of \$27.43 per square foot (Spingarn Gym, where, according to GSA officials, as a result of a fire, a new roof deck and supporting structure were installed and a significant amount of asbestos was removed).

BEST COPY AVAILABLE



DCPS officials provided various explanations for the wide range in costs per square foot among schools such as Cook Elementary (\$77.27), MacFarland Junior High School (\$64.45), and Ketcham (\$4.19). According to DCPS officials, less than 20 percent of Cook's total cost pertains to roof replacement. The majority of the cost was due to repairing an ornamental cornice around most of the building just below the roof level. The cornice had deteriorated and portions of it were at risk of falling off; therefore, Cook was considered a major safety concern. In addition, the cornice had to be repaired from a crane. Further, DCPS stated that much work was done to repair the skylight and to repair coping with new stainless steel covering.

According to DCPS officials, work at MacFarland Junior High was awarded to the low bidder of a package, covering nine schools. DCPS officials and engineering consultants stated that large amounts of masonry repair (repointing and replacement of broken brick), installation of metal panels on high parapet walls, and skylight repair were performed. The engineers' original scope of work describes badly deteriorated mortar joints, broken brick, and severely cracked parging on parapet walls—with resulting leaks. In addition, according to DCPS, repairs were performed on the flashing; the stone coping was replaced; and the drain was cleaned. On the other hand, Ketcham was awarded at the low end. According to DCPS officials, the contractor did not give full consideration to the condition of the roof or the complexity of the work to be done.

## Several Factors Result in Higher Square Foot Costs for Repairs

Several factors contributed to the costs being considerably higher than what GSA officials stated has been their experience for roofing work in the Washington, D.C., metropolitan area. GSA's estimates ranged from \$8 to \$10 per square foot and reflect work required to repair and renovate typical flat, large, built-up roof systems that generally have had a good repair record. However, a combination of factors resulted in substantially higher per square foot cost for the D.C. Public Schools. Among these are the compressed schedule under which most of the 1997 roof work was performed; the diversity and complexity of the roofs on the D.C. public school buildings; the extensive deferred maintenance and other roof-related work, including additional work required to secure the long-term warranties from materials suppliers and contractors; and other factors such as the District's history of paying vendors.

## Compressed Time Schedule

DCPS-managed work was completed within extremely narrow time frames. This tight schedule was caused by the lack of (1) technical capital project

staff, (2) advance project planning to provide an adequate basis for seeking bids, and (3) the fast approaching opening of schools slated for September 2, 1997. This situation resulted in DCPS scrambling to get contractors in what they found to be a tight summer market and selecting an approach that while faster for getting the work done on time, could have been more costly.

To accelerate the roof work, DCPS relied exclusively on the design-build approach versus the traditional method. Under the traditional method, management separately performs or contracts for project design to provide the drawings, specifications, reports, and other materials needed to obtain bids for the actual repair work. Thus, separate procurements are involved in first designing and then contracting for the renovation work. This approach tends to stretch out the time frame, but provides a great measure of detail to the prospective bidder, thus lowering the risk. In contrast, the design-build method involves the winning bidder providing both the design and performing the renovation work. One of the primary advantages of using the design-build approach is that the project can be completed in a shorter time frame because the design phase can be done concurrently with the construction phase. However, since the contractor assumes more risk for the job under the design-build approach because of unforeseen difficulties, the costs can be higher. Given the level of deferred maintenance and the limited time available both for submitting bids and performing the work, it would appear that the risk assumed was substantial.

GSA's earlier involvement allowed it an average of 67 days to complete its 10 projects. In contrast, all of the DCPS-managed work was completed in well under the 67-day average of GSA's work, with the longest project taking 50 days and the average being 36 days. The shortest DCPS project took 3 days. Despite taking less time, our analysis of the data on table 2 shows that the DCPS-managed work involved more roof areas and, as discussed later in greater detail, more complex work.

GSA was able to secure contracts earlier in the year as it stated when the market was not saturated with roof work, which typically results in lower cost. Similarly, neighboring school systems in the Washington, D.C., metropolitan area pointed out that they did not typically attempt to complete roofing projects in the short time frames accomplished by DCPS during 1997. According to a Montgomery County Public Schools roofing specialist, roof replacement work would typically be done over the full summer session, from about June 20 to August 31. In addition, according

to the Fairfax County Public Schools engineer, contracts are usually awarded in the early part of the year for work to begin in June and they normally operate on a 2-year planning horizon. The Fairfax County Public Schools Director of Design and Construction also told us that depending on the size of the building and material used, a roofing replacement can take from 6 weeks to 6 months. The Fairfax County Public Schools engineer further stated that the cost is generally 20 to 30 percent higher when a project is put out for bid in the summer.

DCPS was unsuccessful in obtaining bids on a larger package advertised on July 1, 1997, for 15 schools and subsequently repackaged all planned work into 8 smaller packages, which went out in mid-July. DCPS officials advised us that they actively solicited bids to get the work performed and that 2 out of 16 vendors involved were from outside the Washington, D.C., metropolitan area, including one brought in purposely to handle the clay tile roof project at Bancroft Elementary.

DCPS also used a sole source procurement in fiscal year 1997 for one project, which it performed on an emergency basis. Work was completed in 18 days, involving extensive overtime. DCPS officials advised us that the Langdon Elementary School project was initiated after the DCPS Quality Assurance Task Force identified a potential structural problem shortly before school was to open. Work started on September 9, and was substantially completed on September 27, 1997, at a cost of \$32.99 per square foot.

While a common denominator of much of this work was the premium time (labor costs) involved, DCPS officials told us that they did not believe they had any clear alternatives. According to the COO, it could not cut back on the number of schools or the scope of work at those schools because of the court's mandate regarding fire code violations.

## Complexity and Diversity of the Roofs

GSA and the DCPS engineering and architectural consultant agreed that DCPS roof renovation work was not typical since the roofs were diverse and complex and had significantly deteriorated. According to DCPS officials and the DCPS engineering consultant, the diversity and complexity of the roofs on the schools resulted in higher costs. These officials stated that the roofs were not generally the typical flat roofs used on more recently built schools but instead are made up of multiple roof areas and materials. To illustrate, Fairfax and Montgomery County school engineers pointed out that 90 percent of their roofs are generally flat, and use modified bitumen. In contrast, 18 of the 56 DCPS and GSA-managed projects worked on during

fiscal year 1997 involved two types of material, such as modified bitumen and slate, and 7 involved three types of roofing material. Inherent in these contrasts are that the newer suburban structures have larger, flat, easier and safer-to-work on surfaces versus DCPS often smaller and sloped surfaces using metal and slate.

The number of roof areas is also a factor. The number of roof areas that were replaced/repaired at each school ranged from 1 (at Leckie Elementary) to as many as 37 roof areas (at Dunbar Senior High School). Forty had 6 or more areas repaired; 25 had at least 10; and 6 had 20 or more. (Appendix II illustrates a typical District of Columbia public school roof, where multiple roof areas were replaced/repaired. It also highlights some of the technical features, including cupolas and skylights.)

According to the DCPS engineering consultant, different types of roofing specialists were required to address the diversity of the roofs. The material that was most frequently used to replace these roofs was two-ply modified bitumen.<sup>19</sup> Table 2 reveals that in addition to two-ply modified bitumen, a variety of materials were used to repair the roofs, such as slate tiles, clay tiles, metal, asphalt shingle, and fiberglass asphalt. Some materials are more expensive than others. Metal and slate roofs are commonly considered more expensive than a modified bitumen roof. In addition, DCPS officials stated that a subcontractor was brought in from another state to repair clay tiles since no local firm was available at the time work had to be completed.

## Deferred Maintenance and Warranties

In recent years, it has been widely documented<sup>20</sup> that the majority of DCPS roofs were badly deteriorated because maintenance had been deferred for many years. DCPS officials stated that the \$22 million, which was budgeted for roof repairs at the beginning of fiscal year 1997 did not assume funding for deferred maintenance and the 20-year manufacturers' warranties. The manufacturers' warranties were conditional on certain deferred maintenance and other roof-related work being done.

Table 2 reveals that for the majority of the schools, a substantial amount of roof-related or deferred maintenance work was performed. For instance,

<sup>19</sup>A roof membrane (the waterproofing layer between the roof substrate and the top surface) with two layers (plies) of fiberglass or saturated felt, applied with alternate layers of asphalt or coal tar mixture (bitumen), which has been rubberized or plasticized (modified) to improve durability. According to DCPS, two-ply modified bitumen was primarily used because it was recommended by its consultant and the Environmental Protection Agency as sufficient for the District's climate and as relatively simple and more economical to install than three or four plies.

<sup>20</sup>See footnotes 2 and 10 in this report.

common roof-related work included replacing skylights and gutters, repairing coping and flashing, repointing masonry, and cleaning drains. In addition, many roofs required tapered insulation, resealing or repointing of parapets, and structural reinforcement of the roof to redirect the water flow. According to DCPS officials, many of the roofs and supporting structures had to be completely replaced because they were badly deteriorated and beyond patching. They stated that patching would have been only a short-term solution to a long-standing problem. For example, Spingarn Senior High School repairs<sup>21</sup> averaged \$36.18 per square foot because of the major structural work required. DCPS officials informed us that the entire slate roof was badly deteriorated and that daylight could be seen from inside the attic. Slate on 14 roof areas was replaced. To support the new slate, new wood blocking was required and 700 feet of new coping was installed. In addition, we were told that numerous roof expansion joints were repaired and that the triangular pediment over the colonnade at the front entrance was also repaired.

The bid solicitation process used in the replacement of DCPS roofs required contractors to provide 2-year guarantees on workmanship and 20-year manufacturers' warranties on materials. DCPS officials stated that the deferred maintenance work was necessary to obtain the guarantees/warranties that they had required.<sup>22</sup> According to DCPS officials, manufacturers perform site inspections to ensure that the roofs are installed according to their design specifications and that factors, such as flashing and caulking, which can contribute to premature roof failure, are up to industry standards. DCPS officials told us that as of January 26, 1998, it had received 20-year manufacturers' warranties for 44 roof projects and 2-year contractor guarantees for 35 roof projects.

DCPS officials also stated that while some of the school roofs that were replaced this summer may have had existing warranties, they believe that since the roofs were not well maintained and protected, DCPS would not have prevailed in a warranty claim.<sup>23</sup> For example, the officials cited numerous cases in which inspections of leaky roofs disclosed that large amounts of debris, or even mattresses, had been allowed to accumulate.

---

<sup>21</sup>DCPS managed this project at Spingarn Senior High School.

<sup>22</sup>In order for these warranties to remain in force, DCPS is required to perform regular preventive maintenance. DCPS officials informed us that school maintenance personnel are now required to inspect each roof every 6 months and to perform any needed repairs.

<sup>23</sup>In addition, DCPS officials stated that because of poor recordkeeping, they could not identify schools that were under existing manufacturers' warranties. However, they informed us that they had started the process to assemble a database of information on the roof replacements and repairs and that they will include information on warranties.

To the extent that such items retain water, they keep the roof surface saturated, thus accelerating deterioration of the roof membrane and substrate.

## Other Factors

The District had a well-publicized poor payment history in recent years. For example, in fiscal years 1994, 1995, and 1996, the District delayed payments owed to vendors and Medicaid providers because it had cash flow problems. Consequently, contracting firms have expressed reluctance to do business with the District, and this, according to DCPS officials, became quite evident in the summer of 1997 when it issued its invitation for bids. Contractors were particularly reluctant to submit bids for large contracts (packages), fearing that DCPS would not be able to honor its obligations. Therefore, according to DCPS officials, contractors had to be urged to submit proposals, which DCPS officials believe could have resulted in DCPS paying a higher than normal cost to repair the roofs.

## Cost Estimates Versus Contract Amounts and Change Orders

Given the nature of the work and the circumstances involved, the costs have not differed significantly from what was expected before contracting for this work. The aggregate estimated cost for the roof work managed by both GSA and DCPS in fiscal year 1997 was approximately \$31.7 million, about 3.5 percent less than the \$32.7 million contract amounts. As of February 4, 1998, DCPS had provided us with change orders totaling about \$2 million, which brings the preliminary total to about \$34.7 million, or about 10 percent over the consultants' cost estimates. In addition, DCPS incurred about \$2.1 million for consulting, contract administration, and construction management fees.<sup>24</sup>

Prior to contracting out the roof work, DCPS had engaged an architectural and engineering firm, with whom GSA had a contract under which it could issue task orders, to develop cost estimates of the roof replacement/repair work. Almost all estimates were prepared by one of two architectural and engineering consultants,<sup>25</sup> and in a few instances DCPS or GSA staff worked with contractors to prepare estimates. Estimates were based on field observations to determine existing conditions and the specific location and extent of required work, and included diagrams (and, for most schools, photographs) of each roof, narrative descriptions, quality

<sup>24</sup>Of this amount, about \$1.6 million went to DMJM, about \$300,000 to GSA, and about \$300,000 to Sverdrup Facilities, Inc.

<sup>25</sup>The two architectural and engineering firms are DMJM and Sverdrup. Sverdrup prepared scope of work and estimates for the first five of the GSA-managed contracts.



specifications of material to be installed, and a cost estimate for each school.

As of February 4, 1998, DCPS had received proposals for change orders pertaining to 27 schools for a total of about \$2 million. In most cases, the proposals resulted from requiring additional work beyond the original scope of work, such as structural repairs of decks and work to clean or replace drains, flashing, and coping. About 60 percent, or \$1.2 million, of the change orders are associated with additional costs at two schools, Browne Junior High and Roosevelt Senior High. About 35 percent of this \$1.2 million was a result of premium labor rates required to accelerate the work, and the remainder was primarily for additional masonry work, installation of a new metal roof, and drain and gutter repairs.

## Planned Roof Repairs

As of February 4, 1998, the DCPS Capital Improvement Program budget indicates that about \$35 million is expected to be spent on 40 school roof projects in fiscal year 1998. According to the DCPS COO, DCPS has about \$41.8 million<sup>26</sup> available to enable it to get an early start with the procurement process.

According to DCPS officials, on October 31, 1997, they engaged an engineering consultant to (1) identify the scope of work and (2) develop cost estimates. The scope of work and cost estimates for 12 schools were completed in fiscal year 1997. DCPS officials told us that as of February 27, 1998, the engineering consultant had inspected an additional 19 school roofs and developed scope of work and cost estimates that reflect direct labor and materials costs and other costs, such as overhead, general conditions, bond and insurance, and contingencies. According to DCPS officials, scope of work and cost estimates for the remaining nine schools will be prepared in May 1998.

DCPS officials informed us that as of November 3, 1997, they had completed roof repair work on five schools for which the scope of work and cost estimates had been completed in fiscal year 1997.<sup>27</sup> DCPS officials anticipate that roof repair work at the remaining 35 schools will begin in the spring and will be completed during the summer 1998 recess. Because the lawsuit from which the court ruling on performing roof work while the schools are occupied has been settled, DCPS expects to be able to work during the

<sup>26</sup>This amount is the proceeds from the sale of Sallie Mae stock warrants (\$36.8 million) and the proceeds (\$5 million) from the continued use of the name Sallie Mae as a trademark.

<sup>27</sup>These five schools are Garnet-Patterson, Paul, Taft, Leckie, and Ballou.



school year using similar precautions as are employed in neighboring school jurisdictions. It advised us that in the event of emergency roof repairs, DCPS has a plan that involves relocating students so that the necessary work can be completed during the school year. This earlier start than for fiscal year 1997 should allow more time to have roof work conducted under normal conditions, possibly resulting in lower costs to the District Government.

The District of Columbia Public Schools proposed Capital Improvements Plan for fiscal years 1999-2004 indicates that an additional \$63 million in roof replacement is anticipated during this period. According to a Facilities Planning, Programming and Quality Assurance Division official, the \$63 million projection is an estimate for budget and planning purposes and the amount is not associated with particular schools.

DCPS expects to use proceeds from the sale of schools to help finance fiscal year 1998 and later school projects. Section 5206(a) of the Omnibus Consolidated Appropriations Act, 1997, authorizes the Authority to dispose of certain school property and deposit the proceeds in the Board of Education Real Property Maintenance and Improvement Fund.<sup>28</sup>

Currently, DCPS has 45 closed schools, which it intends to either sell, lease, lease with the option to buy, or develop as public/private partnerships. DCPS sold 1 school in the fall of 1997<sup>29</sup> and expects to generate \$20 million from the sale of an additional 15 schools in fiscal year 1998. In addition, the Authority has agreed to commit a minimum of 27.5 percent of the District's general fund long-term financing authority (annual bond proceeds) toward completion of the repairs required by the Long Range Facilities Master Plan.

## Comments and Our Evaluation

We received comments from the Authority, the District's Chief Financial Officer, DCPS, GSA, and the U.S. Department of Education on a draft of this report. Written comments from the Authority, DCPS, and GSA are reprinted in appendixes III, IV, and V, respectively.

Those commenting generally agreed with the facts presented in this report. The Authority noted that most of the significant events and time frames outlined in the report are consistent with its records. DCPS stated that our major findings on the cost and conduct of the 1997 upper building

<sup>28</sup>Public Law No. 104-208, 110 Stat. 3009-508, D.C. Code Ann. § 47-392.25.

<sup>29</sup>Dent Elementary was sold for \$410,000.

stabilization program are accurate. The District's CFO, GSA and the U.S. Department of Education agreed with the report as related to their respective activities.

Both the Authority and DCPS offered their perspectives on the availability of funds issue discussed in the report. DCPS stated that funds were not available to DCPS for capital projects until April 1997. In that regard, the Authority stated that it advises the Office of the Chief Financial Officer of the District regarding the availability of funds which, in turn, is responsible for communicating with District agencies, including DCPS.

The Authority and DCPS also suggested additional discussion of the impact of the D.C. Superior Court ruling related to the roof repair projects. The Authority noted that the additional requirements imposed by the court ruling increased the difficulty of project management and added to the cost of the repair program. Similarly, in several sections of its comments to our draft report, DCPS referred to the July 11, 1997, court order as imposing restrictions, compressing the work schedule, and ultimately delaying the opening of all District public schools until September 22, 1997.

Regarding the availability of funds to DCPS during fiscal year 1997, as discussed in the report, we were not provided documentation that would establish when DCPS was notified that the Authority had funds available for capital projects. This communication issue, which apparently is not isolated to the DCPS capital projects funding, was highlighted in the most recent report of the independent public accounting firm hired by the District. As noted in our report, the independent auditors identified a material weakness concerning control over transactions involving the Authority. The report indicated that the District has not developed adequate procedures to account for funds held by the Authority and does not effectively reconcile the amounts which are recorded. The auditor noted that the District and the Authority have not developed procedures to notify each other of the amounts anticipated or actually received by the Authority on behalf of the District.

Concerning the impact of the court involvement, as discussed in our report, there were a number of factors that were either within or outside the managerial control of the Authority and current or former DCPS management. We do not offer any view on whether any one of these factors was the dominant reason for either the cost or timing issues

---

concerning the roof repairs or whether current DCPS management could have reasonably mitigated those effects.

---

As agreed with your office, unless you publicly announce the contents of this report earlier, we plan no further distribution until 15 days from the date of the report. At that time, we will send copies of this report to the Ranking Minority Member of your Subcommittee and the Chairmen and Ranking Minority Members of the Senate and House Committees on Appropriations and their Subcommittees on the District of Columbia and the Subcommittee on the District of Columbia of the House Committee on Government Reform and Oversight. We will also send copies to the Chairman of the District of Columbia Financial Responsibility and Management Assistance Authority, the Chief Financial Officer of the District of Columbia, and the Chief Executive Officer of the District of Columbia Public Schools. Copies will be made available to others upon request.

Major contributors to this report are listed in appendix VI. If you or your staff need further information, please call me at (202) 512-4476.

Sincerely yours,

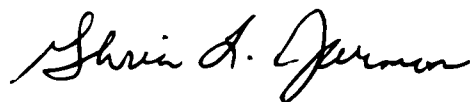

Gloria L. Jarmon  
Director, Health, Education, and Human  
Services Accounting and Financial  
Management Issues

---

# Contents

---

Letter	1
Appendix I Key Dates Related to Fiscal Year 1997 Roof Repairs at D.C. Public Schools	34
Appendix II A Typical District of Columbia School With Multiple Roof Areas	38
Appendix III Comments From the District of Columbia Financial Responsibility and Management Assistance Authority	40
Appendix IV Comments From the District of Columbia Public Schools	43
Appendix V Comments From the General Services Administration	54

---

<b>Appendix VI</b>		55
<b>Major Contributors to This Report</b>		
<b>Glossary</b>		56
<b>Tables</b>		
	Table 1: Funds Received in Fiscal Year 1997 for DCPS Capital Projects	8
	Table 2: Summary of Roof Work and Estimated Cost per Square Foot, Fiscal Year 1997	12

---

---

**Abbreviations**

CEO	Chief Executive Officer
COO	Chief Operating Officer
DCPS	District of Columbia Public Schools
DMJM	Daniel, Mann, Johnson, and Mendenhall
GSA	General Services Administration
IFBC	Invitation for Bid and Contract
NTP	Notice to Proceed
RFQ	Request for Qualifications

# Key Dates Related to Fiscal Year 1997 Roof Repairs at D.C. Public Schools

March 3, 1992	Parents United for the District of Columbia, an education advocacy group, filed a lawsuit against the former Mayor, the District of Columbia, and the Fire Chief of the D.C. Fire Department alleging failure of the D.C. officials to adequately inspect for and remedy violations of the District of Columbia Fire Prevention Code and other safety hazards in the public schools.
May 2, 1994	A trial was held regarding the Parents United lawsuit.
June 10, 1994	The trial resulted in a D.C. Superior Court Order requiring: (1) the D.C. Fire Chief to conduct semiannual inspections of every public school in the District and to submit reports of fire code violations to the Court and the plaintiffs, (2) the Fire Chief to order the immediate closing of any public school building in D.C. with life threatening fire code violations, including ruptured ceilings, and (3) the plaintiffs to file reports with the Court detailing the abatement or the abatement plan for the fire code violations noted.
August 14, 1995	The District of Columbia Public School Superintendent's Task Force on Education Infrastructure for the 21st Century issued the Preliminary Facilities Master Plan 2005 for the District of Columbia Public Schools. The task force was established by the Superintendent of D.C. schools to address the aging and physical deterioration of the D.C. public schools.
April 26, 1996	Public Law 104-134 was enacted, requiring the General Services Administration to provide technical assistance to the District of Columbia Public Schools and to assist the District of Columbia Public Schools in developing a facilities revitalization plan. The General Services Administration was to consider the Preliminary Facilities Master Plan 2005 for the District of Columbia Public Schools in the development of the facilities revitalization plan.
July 25, 1996	A Memorandum of Understanding between the General Services Administration and the Superintendent of the District of Columbia Public Schools was signed, requiring the General Services Administration to provide technical assistance and related services to the District of Columbia in the development of a repair and capital improvement program for the District of Columbia Public Schools.
September 9, 1996	Public Law 104-194, the 1997 Appropriations Act for the District of Columbia, was enacted, providing \$9.2 million for school repairs in a restricted line item.
September 30, 1996	Public Law 104-208 was enacted, providing Student Loan Marketing Association (Sallie Mae) and College Construction Loan Insurance Association (Connie Lee) funds as well as transferring the \$9.2 million from Public Law 104-194 to the Authority to finance D.C. public school facility construction and repair. The law also gave the Authority authorization to contract out for public school repair, in consultation with the General Services Administration. Further, the General Services Administration was required to assist in the short-term management of the repairs and capital improvements.

(continued)

**Appendix I**  
**Key Dates Related to Fiscal Year 1997 Roof**  
**Repairs at D.C. Public Schools**

October 3, 1996	The Authority received \$11.5 million from fiscal year 1996 general obligation bond proceeds to be used for D.C. public school repairs and capital improvements.
November 15, 1996	The Authority restructured the District of Columbia Public School by establishing a Board of Trustees and replacing the then Superintendent of Schools with a new Chief Executive Officer.
November 19, 1996	A Memorandum of Understanding between the General Services Administration and the Authority was signed, requiring the General Services Administration to provide program management services to assist in the short-term management of the repairs and capital improvements for the District schools, per Public Law 104-208.
January 1, 1997	The District of Columbia Public School Chief Executive Officer hired a Chief Operating Officer to manage and implement the school facilities improvement program.
February 18, 1997	The General Services Administration provided the District of Columbia Public Schools with a facilities revitalization plan as agreed to in the Memorandum of Understanding dated July 25, 1996.
February 26, 1997	The General Services Administration issued Notices to Proceed to roofing contractors for certain D.C. public schools.
February 28, 1997	The District of Columbia Public Schools submitted a draft Long-Range Facilities Master Plan to the D.C. Council for approval. The plan included a priority listing of 50 schools to receive roof replacement in Fiscal Year 1997.
March 4, 1997	The Authority received \$18.25 million from the federal government's sale of Connie Lee to be used for D.C. public school repairs and facility construction.
April 4, 1997	The District of Columbia Public Schools submitted a request to D.C. Office of Budget and Planning for \$28.5 million for capital improvements.
April 7, 1997	District of Columbia Public School Chief Operating Officer hired a Chief of Capital Projects to direct the program management, program planning and control, and design review team managers.
April 14, 1997	The Authority requested \$36.85 million in supplemental funds from Congress for emergency public school facility improvements. Congress declined to provide any additional funds.
April 25, 1997	The District of Columbia Public Schools submitted a revised Long-Range Facilities Master Plan to the D.C. Council for approval. The plan was also submitted to the Congress. The plan included a priority list of 50 schools to receive roof replacement in fiscal year 1997. The priority list changed slightly—Tyler was added to the list of school roof projects to be managed by the District of Columbia Public Schools, and Spingarn no longer appeared on the list of school roof projects to be managed by the General Services Administration.
May 19, 1997	The District of Columbia Public Schools issued a Request for Qualifications to pre-qualify potential roofing contractors.

(continued)



**Appendix I  
Key Dates Related to Fiscal Year 1997 Roof  
Repairs at D.C. Public Schools**

June 4, 1997	The Authority received \$20 million from the May 28, 1997, general bond proceeds to be used for school repairs and capital improvements.
June 20, 1997	District of Columbia Public Schools recessed for summer vacation.
July 1, 1997	The District of Columbia Public Schools issued an Invitation for Bid and Contract notice seeking a single contractor to perform 15 roof repair projects and 5 boiler/chiller projects. No bids were received.
July 10, 1997	The District of Columbia Public School Chief Operating Officer testified before D.C. Superior Court that there were 47 school roof repair projects scheduled and that some roofs would not be completed before September 20, 1997. The 47 schools listed differed from the priority list included in the April 25, 1997, Long-Range Facilities Master Plan. For example, the 47 school roof repair projects did not indicate that roof repairs would be performed at 13 of the schools on the roof repair list included in the Long-Range Facilities Master Plan, dated April 25, 1997.
July 11, 1997	A District of Columbia Superior Court judge reiterated the June 10, 1994, Order and stated that schools would be closed while roof work was performed. The Order also required the District of Columbia Public Schools to submit a plan, by August 18, 1997, to the Superior Court detailing alternative sites for students to report to on September 2, 1997, the first day of the 1997-1998 school year.
July 11, 1997	The District of Columbia Public Schools issued an amendment to the July 1, 1997, Invitation for Bid and Contract notice. The amended Invitation for Bid and Contract notice divided the required construction work into packages. There were six roof repair packages at a total of 48 schools, and two boiler/chiller packages at a total of 16 schools. Contractors were asked to submit bids on one, more, or all project packages.  The schools scheduled for roof repairs indicated on the Invitation for Bid and Contract differed somewhat from the schools scheduled for roof repairs indicated on the July 11, 1997, Order. For example, the Invitation for Bid and Contract included roof repair projects at seven schools that were not listed on the July 11, 1997, Order.
July 14, 1997	The District of Columbia Public Schools submitted a request to D.C. Office of Budget and Planning for an additional \$20 million for capital improvements.
July 17, 1997	The District of Columbia Public Schools submitted a revised Long-Range Facilities Master Plan to the D.C. Council for approval. The plan included a priority listing of 56 schools to receive roof replacement in fiscal year 1997. The priority list included thirteen schools that were not indicated in the July 11, 1997, Court Order and 6 schools that were not on the amended (July 11, 1997) Invitation for Bid and Contract.
July 23, 1997	The District of Columbia Public Schools issued first Notices to Proceed to roofing contractors.

(continued)

BEST COPY AVAILABLE

---

**Appendix I**  
**Key Dates Related to Fiscal Year 1997 Roof**  
**Repairs at D.C. Public Schools**

---

---

August 18, 1997	The District of Columbia Public Schools submitted a report to the Superior Court stating that there was no contingency plan for relocating students and staff who attend those schools where roof repairs were taking place, and that the plan was to delay the start of the school year until roof repairs were completed (September 22, 1997).
September 2, 1997	The Authority received \$36.8 million of Sallie Mae proceeds (from stock warrants) to be used for school repairs and capital improvements.
September 22, 1997	District of Columbia public schools opened, commencing the 1997-1998 school year.
October 6, 1997	The Authority received \$5 million of Sallie Mae proceeds (from the sale of naming rights) to be used for school repairs and capital improvements.
November 3, 1997	A settlement was reached among Parents United, the Mayor, the Fire Chief, and the District of Columbia Public Schools Chief Executive Officer, which laid the foundation for ensuring that D.C. public schools were free of Fire Code violations and requiring the District of Columbia Public Schools to continue the necessary repairs and capital improvements to the school buildings, as indicated in the Long-Range Facilities Master Plan.

---

BEST COPY AVAILABLE

# A Typical District of Columbia School With Multiple Roof Areas

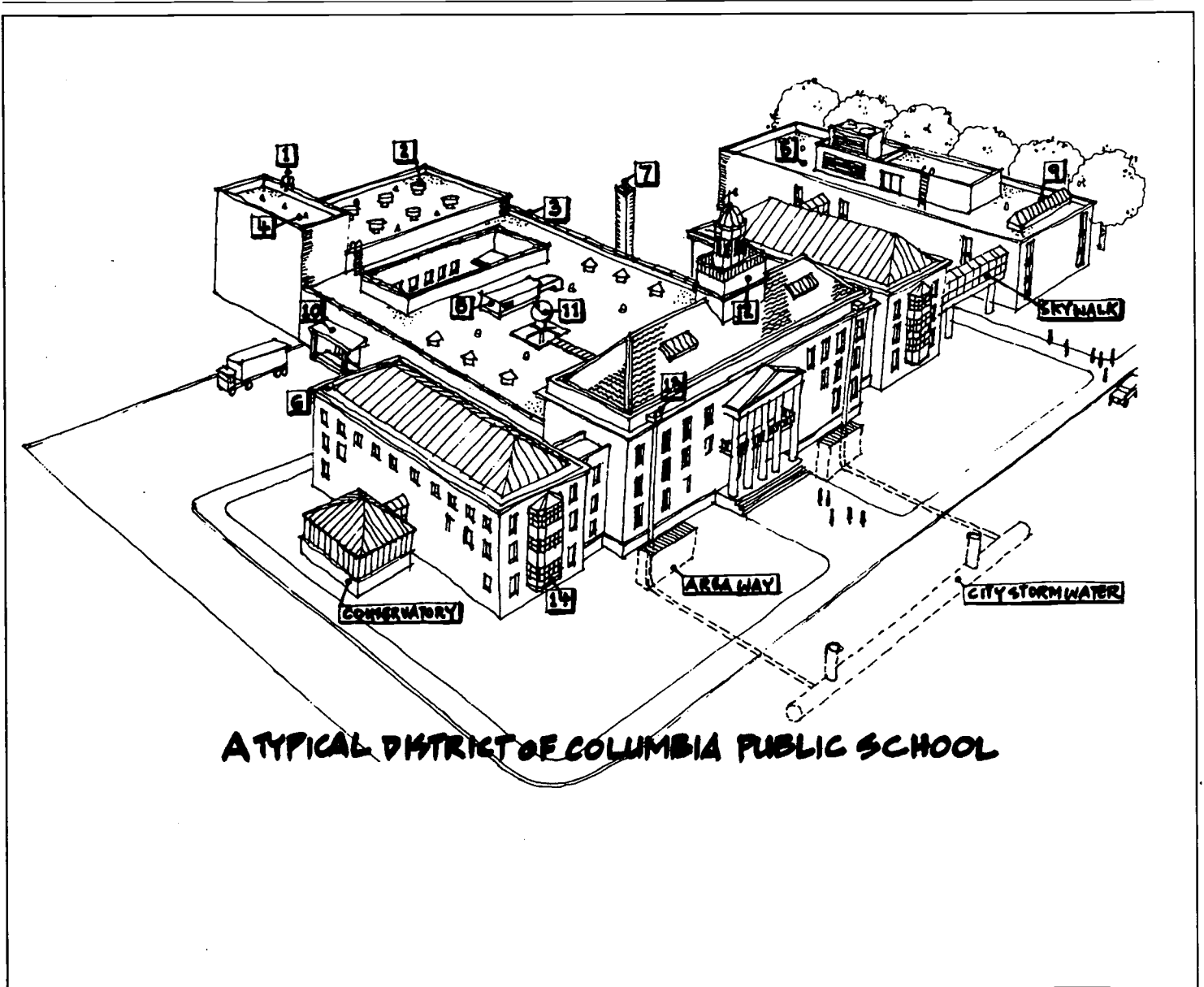

Appendix II  
 A Typical District of Columbia School With  
 Multiple Roof Areas

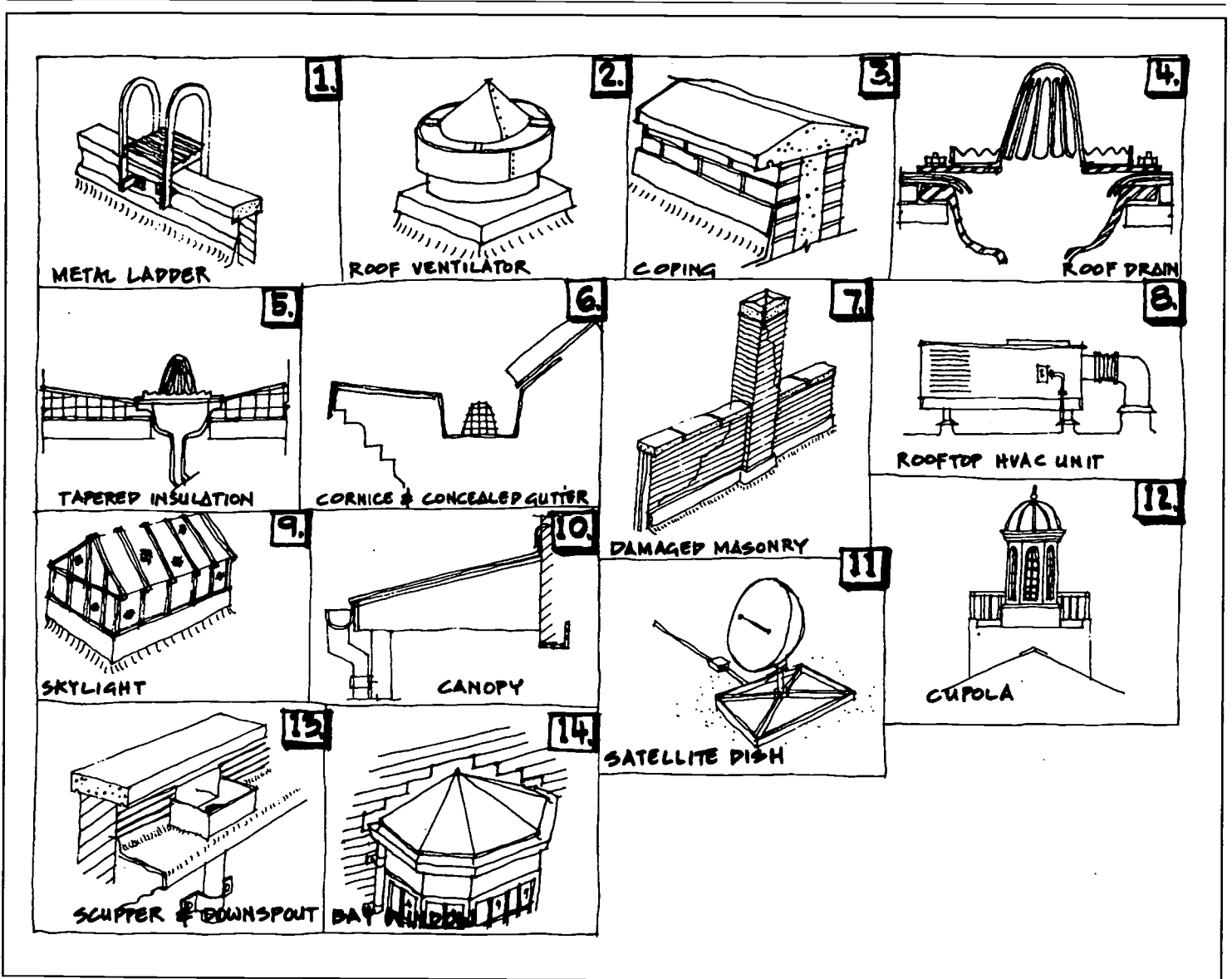

Source: DCPS Capital Program Division.

BEST COPY AVAILABLE

# Comments From the District of Columbia Financial Responsibility and Management Assistance Authority

Note: GAO comments supplementing those in the report text appear at the end of this appendix.

District of Columbia Financial Responsibility  
and Management Assistance Authority  
Washington, D.C.

February 20, 1998

Mr. Gene L. Dodaro  
Assistant Comptroller General  
United States General Accounting Office  
Washington, D.C. 20548

Dear Mr. Dodaro :

This letter provides the views of the District of Columbia Financial Responsibility and Management Assistance Authority ("Authority") regarding the draft report of the General Accounting Office titled, *"District of Columbia Public Schools: Availability of Funds, and the Cost of FY 1997 Roof Projects"*.

Most of the significant events and time frames outlined in the draft report are consistent with the records of the Authority. However, the draft report does not refer to the April 14, 1997, request of the Authority, to the President and the Congress, for additional funding. That request included \$36.85 million for the District of Columbia Public Schools ("DCPS"). This amount, when combined with the \$49.75 million anticipated from other sources, would have provided a total funding of \$86.6 million for the emergency school repair program during the summer of 1997.

The work originally contemplated under the emergency school repair program was not limited to roof repairs but included repairs to boilers and chillers, and work that was required for compliance with the Americans with Disabilities Act ("ADA"). The DCPS capital program staff developed a plan to utilize these funds. Congress passed the supplemental appropriations bill for Fiscal Year 1997 on June 12, 1997. This bill did not include the requested funds for school capital improvements. Therefore, the emergency school repair program had to be redesigned to accommodate the reduced funding level of \$49.75 million. This occurred eight days before school was dismissed for the summer.

The Authority recommends that the report include a discussion of the effect of the changes required by the District of Columbia Superior Court. These additional requirements added to the cost of the repair program, and increased the difficulty of project management. For example, the court held that no persons including students, teachers, or janitorial personnel, could occupy the buildings during roof repairs. Additionally, the court decided to review and approve all work, before the work could begin. As a result, the plan was constantly modified to accommodate the directives of the court.

One Thomas Circle, N.W. • Suite 900 • Washington, D.C. 20005 • (202) 504-3400

See comment 1.

See comment 1.

See comment 2.

**Appendix III  
Comments From the District of Columbia  
Financial Responsibility and Management  
Assistance Authority**

See comment 2.

It is important to note the policy of the Authority regarding notification of the availability of funds. The Authority advises the Office of the Chief Financial Officer of the District ("OCFO") of the availability of funds. It is the responsibility of the OCFO to communicate with the financial personnel in District agencies, including DCPS. Financial personnel in the agencies are a part of and report directly to the OCFO.

See comment 3.

Finally, we suggest that the draft report refer to the efforts of the Authority to increase the amount of future capital funding for DCPS. During the development of the Fiscal Year 1998 capital budget for the District, the Authority, with the support of Mayor Barry and the Council of the District of Columbia, increased the capital allocation for DCPS to \$30 million. Additionally, on October 6, 1997, the Authority received, and reported to the District, an additional \$5 million from Sallie Mae.

We appreciate this opportunity to provide comments before the report is finalized.

Sincerely,

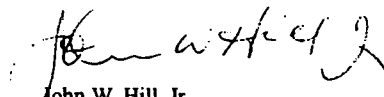

John W. Hill, Jr.  
Executive Director

---

**Appendix III  
Comments From the District of Columbia  
Financial Responsibility and Management  
Assistance Authority**

---

The following are GAO's comments on the District of Columbia Financial Responsibility and Management Assistance Authority's letter dated February 20, 1998.

---

**GAO Comments**

1. Our report does not address whether ample funding was available for the emergency school repair program during fiscal year 1997. However, table 1 in the report shows that DCPS had about this same amount of funds (\$86.5 million) available for capital projects during the fiscal year.
2. This point is discussed in the Comments and Our Evaluation section of the report.
3. We have augmented our discussion in the Planned Roof Repairs section of the report to refer to the additional \$5 million from Sallie Mae. The report refers to the Authority's commitment to provide a minimum percentage of the District's general fund long-term financing authority (annual bond proceeds) for completion of repairs required by the Long-Range Facilities Master Plan.



# Comments From the District of Columbia Public Schools

Note: GAO comments supplementing those in the report text appear at the end of this appendix.



**DISTRICT OF COLUMBIA  
PUBLIC SCHOOLS**

*Office of the Chief Operating Officer /  
Director of Facilities*  
415 12th Street, N.W.  
Room 903  
Washington, D.C. 20004  
(202) 724-4202  
FAX (202) 724-5580

February 17, 1998

Mr. Gene L. Dodaro  
Assistant Comptroller General  
General Accounting Office  
Washington, D.C. 20548

Dear Mr. Dodaro:

We received your draft report of the District of Columbia Public Schools: Availability of Funds and Cost of Fiscal Year 1997 School Roof Projects. We have provided our comments as requested.

We have appreciated the professionalism displayed by the team lead by Gloria L. Jarmon on this audit.

Sincerely,

Charles E. Williams  
Chief Operating Officer/Director of Facilities

Attachment

*Children First*

DCPS COMMENTS TO DRAFT GAO REPORT

In response to the draft report entitled "District of Columbia Public Schools: Availability of Funds and Cost of Fiscal Year 1997 School Roof Projects," DCPS submits the following comments. We do not disagree with the majority of the subsidiary findings set forth in the body of the draft report. However, we believe that the principal findings set forth in the section entitled "Results in Brief" are incomplete. Additionally, we are providing the following comments to set forth our understanding of the exact sequence of events which preceded the initiation of the roof replacement and upper building stabilization program in the summer of 1997, as well as the circumstances we confronted in managing that program.

1. PRINCIPAL FINDINGS

a. Availability of funds.

In the section entitled "Results in Brief," the draft report states that the "District's records show that about \$18 million was available in February 1997 for DCPS-managed roof work with the available amount increasing to about \$38 million by June 1997." (Draft report at page 6). However, as set forth in page 11 of the draft report, those funds were only made available to the District of Columbia Financial Responsibility and Management Assistance Authority in February 1997 and June 1997. In contrast, our records show that DCPS received \$18.2 million in budget authority from the privatization of the College Construction Loan Insurance Association (Connie Lee) on April 11, 1997, and that DCPS received \$20 million on July 22, 1997 from the sale of general obligation bonds. As discussed in greater detail in these comments, this budget authority was used as soon as DCPS had authorization to utilize those funds. Prior to the transfer of those funds from the Authority to DCPS, we did not have the required authorization to utilize those funds to initiate procurement actions or to hire employees to replenish our capital construction projects staff.

b. Impact of court proceedings.

We must emphasize that the court's July 11, 1997 order in *Parents United for the District of Columbia v. Barry, et al.* (C.A. No. 92-3478) played a critical role in the initiation and management of DCPS' 1997 summer roof replacement and upper building stabilization program. Under the terms of this order, DCPS was prohibited from opening any school that had been scheduled for any roof work in Fiscal Year 1997 even though all known fire code violations had been abated by July 10, 1997 and even though it was common practice to conduct roof repair or roof replacement work in occupied buildings. As discussed in greater detail, this order resulted in the establishment of a compressed work schedule for the completion of all required roof replacement work or upper building stabilization work in the summer of 1997 and it ultimately resulted in postponing the opening of all District schools until September 20, 1997.

See comment 1.

See comment 1.

See comment 1.

## 2. GENESIS OF THE PROGRAM

### a. *The State of Emergency.*

On November 15, 1996, the District of Columbia Financial Responsibility and Management Assistance Authority declared a state of emergency and appointed an Emergency Board of Trustees and a Chief Executive Officer to administer the D.C. Public Schools. The Authority took this drastic step because, among other things, DCPS had "failed to provide a...safe environment in which to learn." Specifically, the Authority found that the DCPS management of its facilities had been characterized by: "numerous fire code violations, preventing all District schools from opening on time... continued use of aging facilities, mismanagement of capital funds for repair and renovation; failure to close unneeded schools; and lack of a comprehensive facilities plan, resulting in numbers of under-utilized and poorly maintained schools facilities..." (See Resolution, Order and Recommendation Concerning District of Columbia School System). Due to the state of emergency and the need to take immediate, emergency action, the CEO selected General Charles E. Williams, who had over thirty years of experience in managing major construction and rehabilitation programs under difficult conditions, in December 1996.

### b. *DCPS Resources and initial funding level.*

When General Williams assumed office in January 1997, DCPS did not have the staff and resources required to devise and manage an extensive capital improvement program. As stated in the draft report, prior to November 1996, virtually the entire capital (*i.e.* construction management) staff had been terminated, and all available capital funds --\$11.5 million--had been obligated for construction contracts managed by the General Services Administration (GSA) or had been earmarked to pay prior year bills. Additionally, DCPS was the subject of court supervision as a result of a lawsuit filed by Parents United for the District of Columbia, an advocacy group, which alleged that DCPS and other District agencies had failed to discover or abate fire code violations such as leaking roofs which could result in electrical fires.

Despite this lack of resources, DCPS released its first Draft Long-Range Facilities Master Plan on February 28, 1997, the findings in the plan and subsequent assessments revealed that 50 per cent of DCPS 157 buildings were unsafe. Additionally, there were over 1,600 fire code violations. In the draft plan, DCPS had concluded that in addition to the roof replacement work managed by GSA, approximately 50 schools required roof replacement work in Fiscal Year 1997. Since DCPS had neither the funding nor the staff to support new capital construction projects on February 28, 1997, DCPS believed that these projects could not be fully completed prior to October 30, 1997 even though it hoped that a substantial number of these projects would be completed prior to September 30, 1997.

Appendix IV  
Comments From the District of Columbia  
Public Schools

In the meantime, on February 26, 1997, GSA issued "Notices to Proceed" which authorized roofing contractors that had been supported by the \$11.5 million in obligated funds to begin construction at five District schools. These contractors were firms that had been retained by GSA to perform construction work through "indefinite quantity" contracts that had been awarded at earlier date. In order to receive services from these retained firms, GSA simply issued "task orders" directing the firms to begin work as instructed.

Construction at the five schools was based on designs that had been prepared by a retained architectural firm pursuant to task orders issued by GSA on November 26, 1996. However, further design and construction work could not be initiated by DCPS without additional capital funding.

*c. Connie Lee proceeds.*

On April 11, 1997, further funding to support capital improvement projects became available when \$18.2 million resulting from the sale of Connie Lee was entered into the DCPS Financial Management System (FMS). Prior to the entry of those funds in the DCPS FMS system, those funds could not be used to support additional contracts even if the funds may have been available to the Authority at an earlier date. Meantime, on April 7, 1997, the Chief of the Capital Projects Division was hired and began to recruit and hire employees to initiate and manage capital construction projects. By the end of May 1997, six additional employees had been hired to manage DCPS' capital construction projects.

On May 19, 1997, DCPS issued a Request for Qualifications (RFQ) to pre-qualify (i.e., determine whether potential contractors possessed the resources and expertise for construction work) contractors. In June 1997, Daniel, Mann, Johnson, and Mendenhall (DMJM), an architectural and engineering firm retained by GSA was instructed to survey roofs, develop technical specifications for roof repair or upper building stabilization and to devise a government cost estimate for the construction work required for roof replacement at 48 buildings.

During this period, DCPS also asked GSA to use its retained contractors to perform additional construction work. Ultimately, GSA agreed to use contractors to perform roof replacement work at three additional schools and to complete four boiler/chiller projects at three additional schools. However, GSA would not direct its contractors to perform additional work unless DCPS transferred funds and budget authority directly to GSA. GSA was unwilling to continue the practice of allowing DCPS to retain funding authority while it was responsible for directing its retained contractors to perform work on behalf of DCPS. In doing so, GSA was merely resuming its customary, past practice. GSA had not followed its past practice in the limited number of projects that it had managed on behalf of DCPS due to the emergency conditions confronted by DCPS.

Appendix IV  
Comments From the District of Columbia  
Public Schools

Additionally, as indicated by Mr. William Lawson, Assistant Regional Administrator of GSA, during his testimony on January 23, 1998, it is doubtful if the contractors retained by GSA would have been willing or able to perform additional services for DCPS within the time frames required by DCPS or under conditions found in this report and discussed below. Since DCPS was prohibited by Authority instructions from transferring funds to other entities, all additional construction projects were managed as well as funded by DCPS.

On July 1, 1997, DCPS issued an Invitation for Bid and Contract (IFBC) for a contract to design and build boilers and chillers in five schools and for roof replacement or upper building stabilization in 15 schools. As used in these comments, "upper building stabilization" or "upper building construction" refers to the repair or renovation of non-roof structures on the upper portion of buildings as well as roof replacement or roof repair. As discussed in greater detail below, non-roof related repair or renovation which occurred in the summer of 1997 included the repair or replacement of masonry, cornices, flashing, coping, and cupolas as well as work such as clearing drains.

Thereafter DCPS did not receive any bids in response to its initial invitation because, in our opinion, the IFBC sought mechanical work in the form of boiler and chiller replacement as well as roof replacement. As discussed below, the IFBC was later amended.

*d. Court proceedings.*

During the period from January 1997 through June 1997, DCPS officials were ordered to testify and attend hearings or pre-hearing conferences in the case of *Parents United for the District of Columbia v. Barry, et al.* (C.A. No. 92-3478). Initially, the hearings or conferences were scheduled for one day each week. Thereafter, the hearings and conferences were scheduled for two days a week. By July 1997, however, the pre-hearing conferences were scheduled for each day from July 1 to July 9, 1997.

On July 10, 1997, General Williams testified that all 1,600 of the fire code violations that had been identified on or after he began service in January 1997 had been abated. However, as set forth in the Long Rang Master Facilities Plan, he also testified that DCPS planned to replace the roofs on approximately 50 schools. The completion dates for these projects, excluding the period of time required for Fire Marshal inspection or for "punch-list" work, were August 15, 1997, August 31, 1997, and September 20, 1997. The completion dates that were the subject of testimony were estimated completion dates based on the best available information. They were not meant to be predictions of the actual completion of the work, the removal of all equipment, the completion of all required finishing work. Additionally, these dates assumed that the buildings would be fully occupied and fully utilized during the period of the roof replacement effort.

Appendix IV  
Comments From the District of Columbia  
Public Schools

Because, in the Court's opinion, the planned work would result in fire code violations and would endanger occupants of the buildings, on July 11, 1997, the Court prohibited DCPS from opening 50 schools until the Fire Marshal had cleared and approved the schools for opening. The Court took this step even though it is common practice to perform roof repair or replacement work in occupied buildings and even though the Superior Court building itself was occupied during its own roof repair effort.

The Court's order of July 11, 1997 had three drastic consequences for DCPS, its students, and the public. First, the order delayed the opening of all school buildings from September 2, 1997 to September 20, 1997 since it was impossible to find sufficient space to accommodate the students and faculty from 50 schools. Second, as a practical matter, the Court's order essentially prohibited DCPS from pursuing the strategy of temporarily patching roofs since there was no reason to believe that patchwork would be sufficient to abate all potential fire code violations. By July 11, 1997, DCPS was well aware that the failure to abate all potential and known fire code violations would lead to the imposition of the drastic sanction of ordering the closure of additional schools.

*e. The revised construction schedule.*

As a result of and following the July 10, 1997 hearing, on July 11, 1997, DCPS amended its initial Invitation for Bid and Contract and issued additional IFBC's. The amended IFBC separated boilers and chillers from roof packages, and sought bids for a total of six roof replacement and upper building construction packages for the 48 schools closed by the Court's order. The amended procurement packages also sought bids for roof replacement or upper building construction at seven additional schools. DCPS had no difficulty in attracting highly qualified bidders to respond to the IFBC's. For this reason, DCPS must disagree with the report's statement indicating that DCPS "continued to experience difficulty in attracting bidders and urged contractors to submit bids."

Thereafter, on July 22, 1997, DCPS entered an additional \$20 million in capital construction funds into the FMS. As soon as the \$20 million in capital construction funding authority became available, DCPS issued notices to proceed to roofing contractors on July 23, 1997. The contractors were instructed to complete work prior to the time the buildings were originally scheduled to become occupied on September 2, 1997.

*3. The upper building construction program.*

DCPS believes that the report's major findings on the cost and conduct of the 1997 upper building stabilization program are accurate. The following comments are provided only to amplify the findings set forth in the report.

*a. Cost of the program.*

The report notes that DCPS had initially estimated that \$22 million would be required for roof work in Fiscal Year 1997.

See comment 2.

**Appendix IV  
Comments From the District of Columbia  
Public Schools**

This preliminary estimate is contained in the Draft Long-Range Facilities Master Plan released on February 28 1997. However, as General Williams, his staff, the engineering consultant and the contractors uncovered more and more information about the actual state of DCPS' buildings, it became clear that safety and habitability required repair or construction work on the entire upper portion of many of the buildings. Such work involved repairing damage to the actual structure of the building caused by years of deferred maintenance, and repairing non-roof structures such as flashing, masonry, or cornices.

Additionally, the report correctly points out that the initial \$22 million estimate did not include costs flowing from the complexity of DCPS' roof structures and costs associated with the amount of work to be performed within a compressed time schedule. This compressed time schedule was a direct effect of the Court's July 11, 1997 order, which required the completion of all roof replacement work before those schools could be open for occupancy, and delay in the availability of required funding. While it may be true that funds had been transferred to the Authority at an earlier date, it is also true that DCPS could not utilize those funds until they were entered into DCPS' FMS system.

Moreover, in addition to the factors cited by the report, the wide disparity in cost per square foot between GSA managed projects and DCPS managed projects is largely attributable to the relative simplicity of the GSA projects and the absence of a compressed work schedule flowing from the July 11, 1997 court order. The contrast between the DCPS and GSA projects is compelling. While DCPS was required to replace slate, metal, asphalt, and bitumen roofs with multiple heights, multiple angles, multiple materials and a poor maintenance record, GSA was only required to replace flat roofs using one type of material. Additionally, DCPS was required to perform extensive and expensive non-roof work such as repairing the cornice and skylight at J.F. Cook Elementary School which was significantly more difficult than performing roof replacement work. In contrast, the GSA projects were not significantly burdened with non-roof work.

Finally, we note that the MacFarland Junior High School project, cited as an example of a high cost DCPS project, was included in a contract solicitation package which included roof replacement work and non-roof work at nine schools. As required by all applicable procurement rules, this contract was awarded to the lowest bidder.

***b. Compressed time schedule.***

As a result of the Court's order of July 11, 1997, DCPS made every conceivable effort to complete all roof repair or roof replacement work by the original scheduled opening date of September 2, 1997.



Appendix IV  
Comments From the District of Columbia  
Public Schools

After it became evident that all required roof replacement or upper building construction could not be completed by September 2, 1997 and after it became clear that it would be impossible to relocate the faculty and students from 50 of 146 schools, DCPS reluctantly determined that it was required to delay the opening of all schools until September 20, 1997 in order to comply with the Court's edict which prohibited the opening of schools until all roof replacement and upper building construction had been completed.

As a practical matter, the Court's order established a work schedule of July 23, 1997 (one day after all required funds became available) and September 20, 1997 (the delayed school opening date) to complete all required design and construction work at 50 schools. The report's findings confirm that DCPS met this difficult schedule. The report found that GSA had an average of 66 days to complete its 10 projects while DCPS' projects were completed well under the 66 day average. We would point out that the time differential identified in the report is even greater since the 66 day average for GSA managed projects *only included construction* while the DCPS managed projects included both design and construction. As the report noted, the design phase of the GSA projects began on November 27, 1996 and the construction phase began on February 26, 1997, three months later. In contrast, both the design and the subsequent construction phases of the DCPS projects began on July 23, 1997.

DCPS agrees that in order to expedite the completion of all required work, it relied on the design-build construction method. DCPS, however, disagrees that such an approach is inherently more expensive than the "traditional" approach where separate procurement actions are initiated for design and construction. With respect to this issue, we believe that the cost of the upper building stabilization program was driven by factors such as the need to replace or repair a number of non-roof related structures, the complexity and diversity of DCPS' roofs as well as the compressed time schedule, but, we do not believe that the cost of the program was due to reliance on the Design Build method.

DCPS also disagrees with the statement that it experienced difficulty in securing bids due to the size of its contract solicitation packages. While there may have been some hesitancy in bidding on a package, which included boiler and chiller replacements as well as roof replacement work, there was no lack of bidders for contract packages, which only sought roof and upper building stabilization contractors. This is confirmed by the fact that DCPS ultimately awarded at least three contracts, which covered multiple schools. One package covered nine schools, a second package covered six schools, and a third package covered five schools.

With one exception, all of the contracts were awarded in Fiscal Year 1997 were awarded on the basis of competition. The one exception occurred in the case of the Langdon School. As discussed in the report, in this instance, a sole source contract was awarded after DCPS' own quality assurance task force discovered a potential structural problem and recommended immediate repair work prior to the opening of school in order to abate a potential safety hazard.

See comment 3.

See comment 2.

Appendix IV  
Comments From the District of Columbia  
Public Schools

Finally, due to the Court's order that closed 50 schools on July 11, 1997, DCPS could not reduce the scope of its work and was required to complete work at all 50 schools before those schools could be opened and occupied. Such a course of action was mandated by Court's order. It was not a matter of preference or choice.

*c. Complexity and diversity.*

We agree with the report's findings that demonstrate and confirm that DCPS was required to replace, renovate, and stabilize an atypical, complex and diverse set of roof and upper building structures during the summer of 1997. As set forth in the report, DCPS does not have the "typical" flat, routinely maintained, safe structures with one building material that are found in the suburban jurisdictions cited in the report. In contrast, DCPS buildings often had multiple roof areas that had not been routinely maintained, sloping structures, and multiple building materials. The report correctly finds that renovation and repair of these structures often required the services of several different roofing specialists and a variety of expensive building materials.

*d. Deferred maintenance, warranties and payment history.*

We agreed that the majority of the DCPS roofs were badly deteriorated as a result of deferred or inadequate maintenance for many years. We also agree with findings which demonstrate that DCPS significantly guaranteed the continued maintenance of its roofs by insisting that contractors provide 2-year workmanship guarantees and 20-year manufacturers' warranties on building materials. As of January 26, 1998, DCPS had received 20-year manufacturers' warranties for 47 roof projects and contractors' guarantees for 37 roof projects. To our knowledge, no administration in DCPS' history has obtained such an extensive program of warranty protection for repair, renovation or construction work conducted on behalf of DCPS.

We would amplify these findings, however, by pointing out that we are convinced that the other technical and non-technical factors cited in the report also significantly contributed to the cost of the upper building stabilization effort. The technical factors which contributed to the cost of the upper building stabilization effort include the absolute need to perform costly additional upper building renovation work such as replacing skylights and gutters, repairing mortar joints and flashings, repointing masonry, and repairing cornices as well as roof replacement. A significant portion of this upper building stabilization work was more costly and difficult than the roof replacement work itself. Other technical factors include the complex and diverse nature of the roof structures, the need to use multiple building materials, and the need to use the services of several different types of roof specialists.

The primary non-technical factors, which contributed to the cost of the stabilization effort, centered around the compressed work schedule resulting from the Court's July 11, 1997 order. Other non-technical factors such as the District's payment history also played a role in determining the cost of this effort.

*e. Cost estimates versus contract amounts and change orders*

We agree with the report's findings which show that the difference between the estimated and actual cost of the construction projects conducted by DCPS was below ten per cent. In our opinion such a difference is well within the ten percent industry standard for construction projects and that such a difference is relatively minor given the size and number of the construction projects initiated and completed in the summer of 1997.

We also believe that the number of change orders associated with those projects was negligible. As demonstrated by the findings in the report, the vast majority of the changes orders for 27 schools was caused by the need to repair, renovate or replace upper building structures unrelated to roofs such as decks, drains or flashings.

*f. The 1998 upper building repair program.*

In 1998 DCPS has programmed approximately \$35 million for 40 roof or upper building stabilization projects in Fiscal Year 1998. The report's findings confirm that there are significant differences between the planned 1998 program and the 1997 program.

- Initially, the lawsuit filed by Parents United for District of Columbia has been settled and an advisor who has significant construction experience has been appointed under the agreement to advise DCPS on compliance with the agreement. Due to the settlement of the case, DCPS will be able to conduct required upper building construction under an expanded time frame and will be able to conduct such work while the buildings are occupied.
- Unlike Fiscal Year 1997, when DCPS did not receive funding to support new capital projects until April 1997 and only received \$18.2 million in new, uncommitted funding in April 1997, DCPS has already received about \$40 million in budget authority to support the capital improvement program. DCPS also expects to receive \$ 20 million in additional funding from the disposition of 15 schools in Fiscal Year 1998. Additionally, the Authority has committed \$42 million in D.C. Fiscal Year 1998 bond proceeds for school construction.
- Unlike Fiscal Year 1997, when DCPS had no capital project staff members until April 1997 and only six additional staff members by the end of May 1997, DCPS has now formed a planning staff, a capital execution staff, as well as a contract review and document control staff to administer the capital program.

For these reasons, we are convinced that the non-technical difficulties encountered by DCPS in the summer of 1997 will not recur in the conduct of the 1998 program.

---

The following are GAO's comments on the District of Columbia Public Schools' letter dated February 17, 1998.

---

## **GAO Comments**

1. This point is discussed in the Comment and Our Evaluation section of the report.
2. We modified this section of the report slightly. Of the 46 schools at which DCPS-managed roof work during fiscal year 1997, DCPS received three to five bids for 29 schools; 2 bids for each of 9 schools; and one bid for each of the remaining 8.
3. We modified the report to provide additional information concerning bidder risk associated with the extensive deferred maintenance and the short time frames provided for submitting bids and completing the work.

# Comments From the General Services Administration



General Services Administration  
National Capital Region  
Washington, DC 20407

FEB 26 1998

Mr. Gene Dodaro  
Assistant Comptroller General  
Accounting and Information Management Division  
General Accounting Office  
441 G Street, N.W.  
Washington, D.C. 20648

Dear Mr. Dodaro:

This letter is in reference to your draft audit report titled "DCPS Availability of Funds and the Cost of FY97 Roof Projects". First and foremost, I wish to express my appreciation to your office for providing General Services Administration (GSA) the opportunity to comment on the subject Draft Report.

After reviewing the draft audit report and your recent adjustments, we find it to be acceptable with regard to issues related to GSA and take no exceptions to those sections. If we can be of any further assistance, please do not hesitate to contact me or Mr. Frank Miles of my staff.

Sincerely,

A handwritten signature in black ink, appearing to read "William R. Lawson".

William R. Lawson, FAIA  
Assistant Regional Administrator  
Public Buildings Service

Federal Recycling Program  Printed on Recycled Paper

---

# Major Contributors to This Report

---

**Accounting and  
Information  
Management Division,  
Washington, D.C.**

Hodge Herry, Assistant Director  
Barbara Shields, Audit Manager  
Bonnie Derby, Senior Auditor  
Fred Evans, Senior Auditor  
Lou Fernheimer, Senior Evaluator  
Kwabena Ansong, Auditor  
Mel Mench, Senior Assistant Director  
Meg Mills, Communication Analyst

---

**Office of General  
Counsel**

Richard Cambosos, Senior Attorney

---

# Glossary

---

<b>Asphalt</b>	A petroleum compound, dark brown or black in color, used in the manufacture of roofing products.
<b>Ballast</b>	Coarse stone, gravel slag, etc., used as an underlayer for poured concrete.
<b>Bitumen</b>	Asphalt or coal-tar pitch.
<b>Blocking</b>	Sections of wood built into a roof assembly, usually attached above the deck and below the membrane or flashing, used to stiffen the deck around an opening, act as a stop for insulation, support a curb, or to serve as a nailer for attachment of the membrane and/or flashing.
<b>Built-Up Roofing</b>	A continuous semiflexible roof covering of lamination, or plies, or saturated or coated plies alternated with layers of bitumen, surfaced with mineral aggregate or asphaltic materials.
<b>Cant Strip</b>	A continuous strip of flashing forming a triangle with a structural deck and a wall or other vertical surface.
<b>Cladding</b>	A material used as the exterior wall enclosure of a building.
<b>Colonnade</b>	A number of columns supporting one side of a roof.
<b>Coping</b>	Top covering of a wall that is exposed to the weather, usually made of metal, masonry, or stone. It is preferably sloped to shed water back onto the roof.
<b>Counterflashing</b>	Metal strips used to prevent moisture from entering the top edge of roof flashing, as on a chimney or wall.
<b>Cupola</b>	A terminal structure, square or round, rising above a main roof. While generally ornamental, a cupola can provide for ventilation.
<b>Cornice</b>	The molded and projecting horizontal member that crowns a wall.

---

---

Deck	The structural surface to which a roof covering system is applied.
Design	The architectural concept of a building as represented by plans, elevations, renderings, and other drawings.
Design-Build	The design-build approach gives a single contractor the responsibility for both designing and constructing a project rather than separating the responsibilities among a number of contractors.
Downspout	A conduit that carries runoff water from a scupper, conductor head, or gutter of a building to a lower level, or to the ground or storm water runoff system.
Drain	An outlet or other device used to collect and direct the flow of runoff water from a roof area.
EPDM	Ethylene Propylene Diene Monomer (rubber roof).
Estimate (Scope)	A forecast of construction cost based on a detailed analysis of materials and labor. Also referred to as a conceptual estimate or parametric estimate.
Expansion Joint	A structural separation between two building elements that allows free movement without damage to the roofing or waterproofing system.
Fascia	A vertical or steeply sloped roof or trim located at the perimeter of a building. Typically, it is a border for the low-slope roof system that waterproofs the interior portions of the building.
Flashing	Strips of copper, aluminum, galvanized sheet metal, or similar materials used along walls, dormers, valleys, and chimneys to prevent moisture seepage.

---



---

<b>Flood Test</b>	The procedure in which a controlled amount of water is temporarily retained over a horizontal surface to determine the effectiveness of the waterproofing.
<b>Glazing</b>	Cutting and fitting panes of glass into frames.
<b>Gravel Stop</b>	A low profile upward-projecting metal edge flashing with a flange along the roof side, usually formed from sheet or extruded metal, designed to prevent loose gravel from washing off the roof and to provide a finished edge detail for the built-up roofing assembly.
<b>Gutter</b>	A channelled component installed along the downslope perimeter of a roof to carry runoff water from the roof to the drain leaders or downspouts.
<b>Insulation</b>	Materials designed to reduce the flow of heat either into or from a building.
<b>Masonry</b>	Anything constructed of material such as brick, stone, concrete blocks, or ceramic blocks.
<b>Modified Bitumen</b>	A roofing bitumen which generally has been rubberized or plasticized to provide greater elasticity, flexibility, and improved working characteristics.
<b>Parapet</b>	A low, retaining wall at the edge of a roof. Usually an upward extension of a building's exterior curtain wall.
<b>Parging</b>	In masonry construction, a coat of cement (generally containing dampproofing ingredients) on the face of rough masonry, the earth side of foundation, or basement walls.
<b>Pediment</b>	A triangular face forming the gable of a two-pitched roof.
<b>Pitch</b>	The incline, or slope, of a roof.

---

---

Pitch Pocket	A flanged metal container placed around a column or other roof penetrating element and filled with flashing cement to seal the area around the penetration.
Ply	A single layer of organic or inorganic roofing material in a roof membrane or roof system.
Replacement	The practice of removing an existing roof system down to the roof deck and replacing it with a new roofing system.
Repointing	The process of removing deteriorated mortar from an existing masonry joint and troweling new mortar or other filler into the joint.
Reroofing	The process of recovering, or tearing off and replacing an existing roof system.
Ridge	Where the rising sides of the roof come together. The highest point of the roof.
Roofing System	An assembly of interacting roof structures and components designed to be weatherproof, and normally to insulate the building's top surface.
Saddle	A relatively small raised substrate or structure that directs surface water to drains or a valley; is often constructed like a small hip roof or like a pyramid with a diamond shaped base.
Scupper	An opening cut through the wall of a building through which water can drain from a floor or roof.
Shingle	Roof covering made from asphalt, fiberglass, wood, aluminum, tile, slate, or other water-shedding material.

---

---

Glossary

---

Skylight	A roof accessory, set over an opening in the roof, designed to admit light. Normally transparent, and mounted on a raised framed curb.
Splash Block	A small masonry block laid on the ground below a downspout to carry roof drainage away from a building.
Substrate	See Deck.
Tapered Insulation	A strip used to elevate and slope the roof at the perimeter and at the curbs.
Traditional Method	In traditional project organization, the owner hires the services of a design team and a construction team. The design team is responsible for transmitting owner/user needs in plan documents describing the physical form for the construction team to assemble.
Valley	Where two roofs coming from different horizontal directions meet and form an internal angle.
Wing	Roof section broadly extended or projecting at an angle from the main building.

---

---

### Ordering Information

The first copy of each GAO report and testimony is free. Additional copies are \$2 each. Orders should be sent to the following address, accompanied by a check or money order made out to the Superintendent of Documents, when necessary. VISA and MasterCard credit cards are accepted, also. Orders for 100 or more copies to be mailed to a single address are discounted 25 percent.

**Orders by mail:**

U.S. General Accounting Office  
P.O. Box 37050  
Washington, DC 20013

**or visit:**

Room 1100  
700 4th St. NW (corner of 4th and G Sts. NW)  
U.S. General Accounting Office  
Washington, DC

Orders may also be placed by calling (202) 512-6000 or by using fax number (202) 512-6061, or TDD (202) 512-2537.

Each day, GAO issues a list of newly available reports and testimony. To receive facsimile copies of the daily list or any list from the past 30 days, please call (202) 512-6000 using a touchtone phone. A recorded menu will provide information on how to obtain these lists.

For information on how to access GAO reports on the INTERNET, send an e-mail message with "info" in the body to:

[info@www.gao.gov](mailto:info@www.gao.gov)

or visit GAO's World Wide Web Home Page at:

<http://www.gao.gov>

United States  
General Accounting Office  
Washington, D.C. 20548-0001

Bulk Rate  
Postage & Fees Paid  
GAO  
Permit No. G100

Official Business  
Penalty for Private Use \$300

Address Correction Requested

SHIP TO:  
CHRISTINA ROWSOME  
ERIC PROCESSING & REF FACILITY  
2ND FL  
1100 WEST ST  
LAUREL MD 207073587

Request # 4003767 39 3

03/25/98 / 15:50 m  
03/25/98 / 21:05 f



4003767011p205  
Item Document Number  
1 AIMD-98-82



**U.S. DEPARTMENT OF EDUCATION**  
*Office of Educational Research and Improvement (OERI)*  
*Educational Resources Information Center (ERIC)*



## NOTICE

### REPRODUCTION BASIS

This document is covered by a signed "Reproduction Release (Blanket)" form (on file within the ERIC system), encompassing all or classes of documents from its source organization and, therefore, does not require a "Specific Document" Release form.

This document is Federally-funded, or carries its own permission to reproduce, or is otherwise in the public domain and, therefore, may be reproduced by ERIC without a signed Reproduction Release form (either "Specific Document" or "Blanket").