

DOCUMENT RESUME

ED 408 711

EA 028 458

AUTHOR Tamang, H. D.; Dharam, K. C.  
TITLE Innovation in Primary School Construction: Community Participation in Seti Zone, Nepal. Educational Building Report 20. A Case Study.  
INSTITUTION United Nations Educational, Scientific and Cultural Organization, Bangkok (Thailand). Principal Regional Office for Asia and the Pacific.  
PUB DATE 95  
NOTE 147p.; Photographs may not reproduce clearly.  
PUB TYPE Reports - Research (143)  
EDRS PRICE MF01/PC06 Plus Postage.  
DESCRIPTORS Building Design; Construction Costs; Construction Management; Construction Materials; Construction Needs; \*Construction (Process); Construction Programs; Developing Nations; \*Educational Facilities Design; \*Educational Facilities Improvement; \*Educational Facilities Planning; Efficiency; Elementary Education; Foreign Countries; School Buildings; \*School Construction  
IDENTIFIERS \*Nepal

ABSTRACT

Nepal is one of the poorest countries in the world. In 1981 the Education for Rural Development in Seti Zone Project--more commonly known as the "Seti Project"--was part of the Nepalese government's effort to develop a system of basic education in that far western region of Nepal. The early success of the project provided the impetus for the development of the Primary Education Project, which is supported by the World Bank/International Development Association. This publication is part of the UNESCO Principal Regional Office for Asia and the Pacific (PROAP) series on innovations in primary school construction. The series focuses on how to get the most value for money invested in educational buildings. The experience of Nepal and its project Education for Rural Development in the Seti zone is an example of how people can contribute to their own development. The project is based on the premise that such self-development is mainly fueled by knowledge. Mobilizing community interest, maintaining community confidence, and creating technically satisfactory buildings is a major challenge for all participatory development programs. The report gives a chronological review of the work and describes the project's origins, the context for the building design, the management approach, the school-construction program planning, program implementation, and program achievements. A total of 27 illustrations, 2 maps, 3 figures, and 4 tables are included. (LMI)

\*\*\*\*\*  
\* Reproductions supplied by EDRS are the best that can be made \*  
\* from the original document. \*  
\*\*\*\*\*

U.S. DEPARTMENT OF EDUCATION  
Office of Educational Research and Improvement  
EDUCATIONAL RESOURCES INFORMATION  
CENTER (ERIC)  
 This document has been reproduced as  
received from the person or organization  
originating it.  
 Minor changes have been made to  
improve reproduction quality.

- Points of view or opinions stated in this  
document do not necessarily represent  
official OERI position or policy.

PERMISSION TO REPRODUCE AND  
DISSEMINATE THIS MATERIAL  
HAS BEEN GRANTED BY

*C. Villanueva*

TO THE EDUCATIONAL RESOURCES  
INFORMATION CENTER (ERIC)

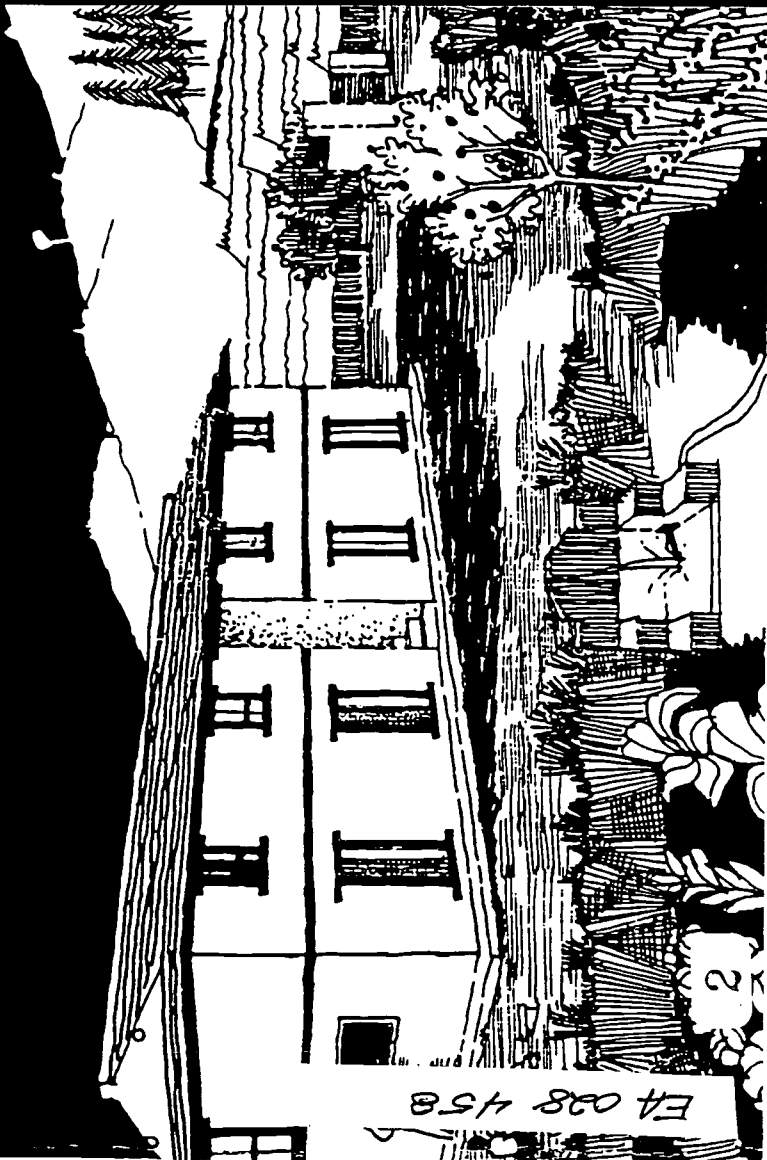

EA 028 458

2

# INNOVATION IN PRIMARY SCHOOL CONSTRUCTION :

## Community Participation in Seti Zone, Nepal



EDUCATIONAL BUILDING REPORT 20  
UNESCO PRINCIPAL REGIONAL OFFICE  
FOR ASIA AND THE PACIFIC, Bangkok

UNESCO. Principal Regional Office for Asia and the Pacific.  
*Innovation in primary school construction: community participation in Seti Zone, Nepal; a case study*, by H.D. Tamang and Dharam K.C. Bangkok, 1995.  
68 p. (HMG/UNESCO/UNDP/UNICEF Education for Rural Development Project, NEP/86/008)

1. EDUCATIONAL FACILITIES. 2. PRIMARY SCHOOLS. 3. PRIMARY EDUCATION. 4. EDUCATIONAL BUILDINGS. 5. COMMUNITY PARTICIPATION. 6. NEPAL. I. Tamang, H.D. II. K.C., Dharam. I. Title.

727.1



# INNOVATION IN PRIMARY SCHOOL CONSTRUCTION :

## Community Participation in Seti Zone, Nepal

A case study by  
H.D. Tamang and Dharam K.C.

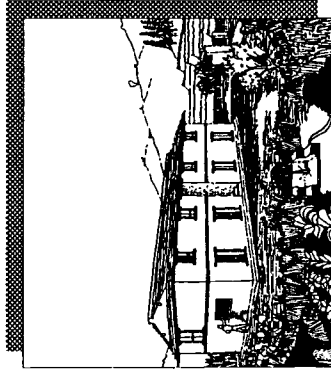

HMG/UNESCO/UNDP/UNICEF  
Education for Rural Development Project  
NEP/86/008  
Rajpur, Dipayal, Seti Zone



UNESCO PRINCIPAL REGIONAL OFFICE FOR ASIA AND THE PACIFIC, Bangkok, 1995  
Report printed under UNESCO-AGFUND Regional Project, Development of Educational Facilities in Asia and the Pacific

© UNESCO 1995

Published by the  
UNESCO Principal Regional Office for Asia and the Pacific  
P.O. Box 967, Prakanong Post Office  
Bangkok 10110, Thailand

Printed in Thailand

*The designations employed and the presentation of material throughout the publication do not imply the expression of any opinion whatsoever on the part of UNESCO concerning the legal status of any country, territory, city or area or of its authorities, or concerning its frontiers or boundaries.*

## PREFACE

The UNESCO PROAP series on innovations in primary school construction has brought to the attention of Member States a series of initiatives on how to get the most value for money invested in educational buildings. The intention of this series is that it can make designers and managers aware of how others have attacked their problems.

The experience of Nepal in its project Education for Rural Development in the Seti zone is an exceptional example of how people can contribute to their own development. It is based on the premise that such self development is mainly fueled by knowledge. The school construction programme within the project played a key role in rallying community members to make a direct personal commitment through contributing their time and their strength to collecting building materials and carrying out much of the less skill demanding labour.

This report gives a chronological review of the work so that the reader can "live through" all the learning experiences of the project managers. Mobilizing community interest, maintaining community confidence and achieving technically satisfactory buildings is a major challenge for all participatory development programmes.

Two champion groups emerged from this experience; the villagers and the young technicians who trained the villagers and oversaw the buildings as they were realized. They could not have arrived at these accomplishments, however, without the guidance and support of their fellow field workers who followed the project's literacy and other educational programmes.

Finally, from the capital Kathmandu the project also received significant support. Dr. Ishwar Upphadaya now Permanent Secretary for Education was one of the project designers when he was joint secretary for planning. His personal steady support throughout the life of the project has ensured the government's resources for this pioneering work. UNICEF raised funds for various project components including the subsidies provided to the communities for school construction.

The project itself was funded by UNDP and executed by UNESCO.

## CONTENTS

Chapter One :	The Origins of the Project	1
Chapter Two :	Context for Building Design	5
Chapter Three :	Approach to Management	9
Chapter Four :	School Construction Programme Planning	13
Chapter Five :	Programme Implementation	29
Chapter Six :	Achievements	64

**Illustrations**

<b>Mark I</b>	4 bay single storey building : elevations . . . . .	19
	4 bay single storey building : ground floor plan . . . . .	20.
	5 bay single storey building : ground floor plan . . . . .	21
	5 bay single storey building : elevations . . . . .	22
	cross section of single storey building . . . . .	23
	4 bay double storey building : first and ground floor plans . . . . .	24
	5 bay double storey building : first and ground floor plans . . . . .	25
	4 bay double storey building : elevations . . . . .	26
	cross section of double storey building . . . . .	
<b>Mark II</b>	5 bay single storey building : ground floor plan . . . . .	33
	4 bay single storey building : ground floor plan . . . . .	34
	4 bay single storey building : elevations . . . . .	35
	5 bay single storey building : elevations . . . . .	36
	cross section of single storey building . . . . .	37
	4 bay double storey building . . . . .	38
	5 bay double storey building . . . . .	39
	4 bay double storey building . . . . .	40
	5 bay double storey building . . . . .	41
	cross section of double storey building . . . . .	42
	illustration to villagers regarding measurement . . . . .	43
	illustration to villagers enclosed with drawing . . . . .	44
	illustration on door, window and almira . . . . .	45
	illustration on how to construct pit latrine . . . . .	
<b>Mark III</b>	5 bay single storey building : ground floor plan . . . . .	54
	4 bay double storey building . . . . .	55
	4 bay double storey building and 3 bay single storey building . . . . .	56
	5 bay double storey building : first and ground floor plans . . . . .	57

**Maps**

Map 1 :	Nepal Planning Regions . . . . .	3
Map 2 :	Nepal Physiographic Regions . . . . .	4

**Figures**

Figure 1 :	Management Process and Responsibilities . . . . .	10
Figure 2 :	Development of School Construction Programme . . . . .	14
Figure 3 :	Four Stages of Payment . . . . .	48

**Tables**

Table 1 :	Calculation of Construction Subsidies 1991-1992 . . . . .	12
Table 2 :	Improved Payment System . . . . .	32
Table 3 :	Detailed Area Analysis of Mark III Designs . . . . .	53
Table 4 :	Efficiency of Different Types of Buildings . . . . .	65



# THE ORIGINS OF THE PROJECT

**Background.** The Kingdom of Nepal has been undergoing important social and economic changes for the past four decades. It was only in the 1950s that the capital of Kathmandu could first be reached by road; many areas of the country are still inaccessible to motorized vehicles. This long isolation has contributed to the maintenance of a rich and unique culture, dominated by traditional religious beliefs. Each village has its temple and many more sacred places are found on hilltops, at springs, and along the trails which traverse the entire country. The richness of the culture and influence of religious beliefs are constantly seen in daily life: in the exotic sculptures and wood carvings of the temples and the sophisticated yet simple elegance of village architecture.

Nepal's economy is based upon systems of traditional agriculture which involve men, women and children alike in the daily struggle to wring survival from the forests, the high pastures, and the narrow terraces carved out of precipitous hillsides. The growth of the population in the hills took place over several centuries and has resulted in the clearing of valuable forests, and increasing erosion of precious topsoil. Some two-thirds of the country's 19.1 million people live in these hilly and mountainous regions, often in isolated communities, days' and even weeks' walk from the nearest road. The remaining one-third live on the plains of the terai, where migrants from the hills are rapidly converting the tropical forests into fields.

The immense endurance of the people has yet to be rewarded with prosperity or an easy life. During the last three decades the government has initiated strong measures to encourage developments that would raise living standards, but the annual GNP per capita income is still no more than US\$170.00.

Basic human needs have still not been met. Less than 20 per cent of the population has access to a permanent supply of clean water; basic sanitation is almost totally lacking. Water-related diseases account for approximately 32 per cent of the deaths and 40 per cent of all serious illness suffered by children under four years of age. In the hilly and mountainous regions, the mortality rate for those under five years of age is 165 per 1,000; life expectancy for the country as a whole is 50 years.

**The education system.** Prior to the 1950s, only a tiny minority of Nepal's population had access to any form of education. In the past 35 years, and particularly since the early 1970s, great progress has been made, and a network of schools now exists within reach of virtually every village in the Kingdom. By 1988, nearly 19,000 schools had been established, including over 13,000 primary schools. Unfortunately, improvements in the quality and relevance of education have failed to keep pace with the quantitative expansion of the system. Although there are nearly 60,000 teachers currently employed at the primary level, only 35 per cent are trained and only 10 per cent of these are women.

The Ministry of Education reports that 86 per cent of the country's children aged six to ten years are enrolled in primary school, however, this figure is greatly inflated by the large number of underage and overage children. A recent demographic survey suggests that the actual enrolment figures for boys and girls in the primary age-group are no more than 50 per cent and 30 per cent respectively. In some of the more remote districts of the country's mid- and far-western regions, the figures for girls' enrolment are probably no higher than five to ten per cent. Even at the national level, official figures for enrolment of girls in the age groups corresponding to the lower and secondary grades are only ten and seven per cent respectively. In most remote of areas, no more than 50 per cent of the children enrolled in primary grades attend school regularly. Over 45 per cent of the children who do enter primary education drop out after grade 1 - the retention rate between grades 1 and 5 is a mere 31 per cent. The national literacy rate is only 35 per cent and, among women, it is no higher than 18 per cent.

Professional standards and personal morale are low among teachers, who are sorely ill-equipped to perform the key role required of them in the nation's development. The irregularity and poor quality of instruction, together with the perceived irrelevance of much of what is taught in the primary classroom, constitute important underlying causes for poor attendance and high drop-out rates. The primary school structures themselves, erected by the communities, often lack even the barest of basic accommodations: a damp earthen floor and windows too small to provide adequate illumination for ease of reading and writing.

Social-cultural traditions and taboos pose real problems for the development of the education system, particularly for the education of girls. The institutions charged with the responsibility for the administration of the system are poorly funded and inadequately staffed. The government, in confronting these problems, is hampered by formidable funding constraints in what is one of the poorest countries in the world.

**The Seti Project.** The launching in 1981 of the Education for Rural Development in Seti Zone Project – more commonly known as ‘the Seti Project’ – was part of the government’s effort to combat these problems and develop a system of basic education appropriate to the needs and resources of the country. The early success of the project provided the impetus for the development of the Primary Education Project, which is supported by the World Bank/International Development Association (IDA) and currently operates in six of the country’s districts and is likely to be expanded to include 20 more. Experience derived from both projects has strongly influenced the design of the government’s Basic Needs Programme for Education – a major nationwide initiative launched in 1986 as part of a much wider national campaign to meet the minimum basic needs of the Nepalese people by the year 2000 – which focuses attention on: the promotion of girls’ education; improvements in the quality of supervision, teaching and the curriculum; improvements in the physical facilities of schools; increases in the number of schools across the country; and increases in the level of adult literacy.

Seti Zone, located in the far-western development region of Nepal, comprises five districts. Doti, Bajhang, Bajura and Achham are in the hills, while Kailali is located on the plains bordering India. Of the 75 districts in Nepal, the four hill districts of Seti Zone rank in the bottom 15 per cent in terms of level of development. The government has determined that the quality of life in such areas as those in Seti Zone can only be improved if the people themselves become the prime moving force in their own development. Different forms of education are required to impart new skills and develop a new consciousness of the role that the people must play. With this objective in mind, the government requested assistance from UNDP, UNICEF and UNESCO in carrying out a pilot ‘education for rural development’ programme.

The first phase of the project began in 1981 and produced a series of innovative approaches which were tested on a limited scale. During the second phase, which started in mid-1987, the project expanded the scale of its operation and assisted the government in incorporating the most successful of these new approaches into a national programme.

The uniqueness of the Seti project is its comprehensive approach towards meeting the needs of the communities served and improving the quality and relevance of education to a point where even five years of schooling can make a most significant contribution to an improved life. This is done by attacking the problem on all fronts: teachers, parents, teaching-learning materials and learning environments. Specially, the project attempts to:

- train a new type of teacher, skilled not only in teaching but also in primary health care and agriculture, who can use these skills in the service of the people;
- exploit the potential of the primary school curriculum as a force for rural development;
- develop and conduct functional literacy programmes for adults and out-of-school girls which address in a very practical way some of the major problems of rural life;
- promote literacy and community-based development initiatives through the establishment of a network of village reading centres;
- establish a network of resource centres which provides training facilities, supervision and a channel for supplying materials to functional literacy programmes and ‘satellite schools’;
- establish mechanisms which enable appropriate public institutions to assume responsibility for the routine implementation of innovative activities developed under the project; and
- assist local communities in constructing a new type of school facility, one which incorporates basic sanitation and health care needs (latrines, a clean water supply) and agricultural interests (fruit and other tree plantations, vegetable gardens).

**Community Participation Principle.** The cornerstone of the Seti project lies in developing a new basic education system by building on the strengths of village society itself. The project, therefore, aims to mobilize maximum participation from the people.

Communities as poor as those in Seti Zone could not be expected to provide significant financial contributions, but what they can offer is their time, their labour, and their personal commitment to the activities of the project. In the attempt to mobilize the communities of Seti Zone, one activity – the construction of school buildings – has been especially successful.

Map 1: NEPAL PLANNING REGIONS

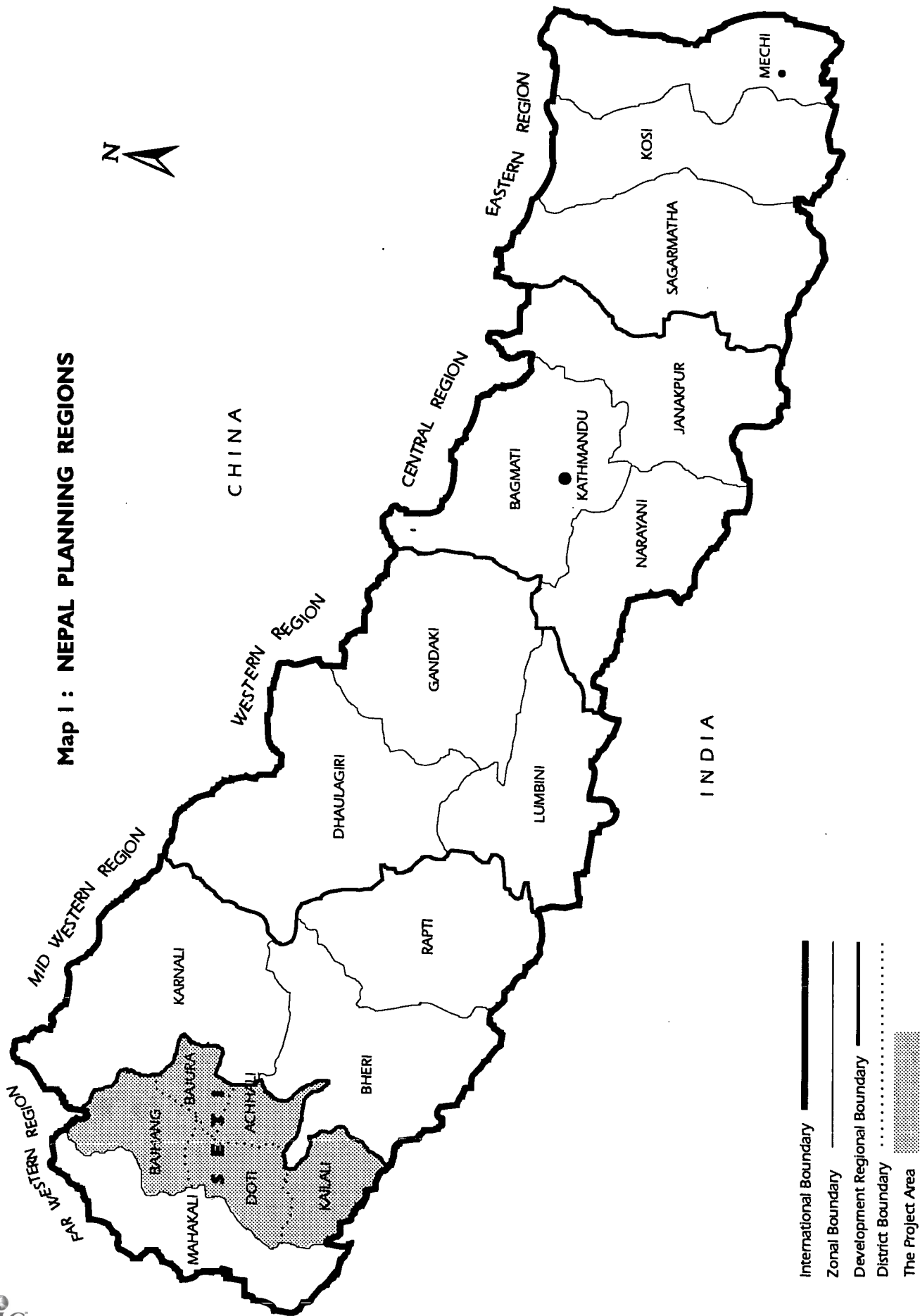

- International Boundary ———
- Zonal Boundary ———
- Development Regional Boundary ———
- District Boundary ·····
- The Project Area [shaded box]

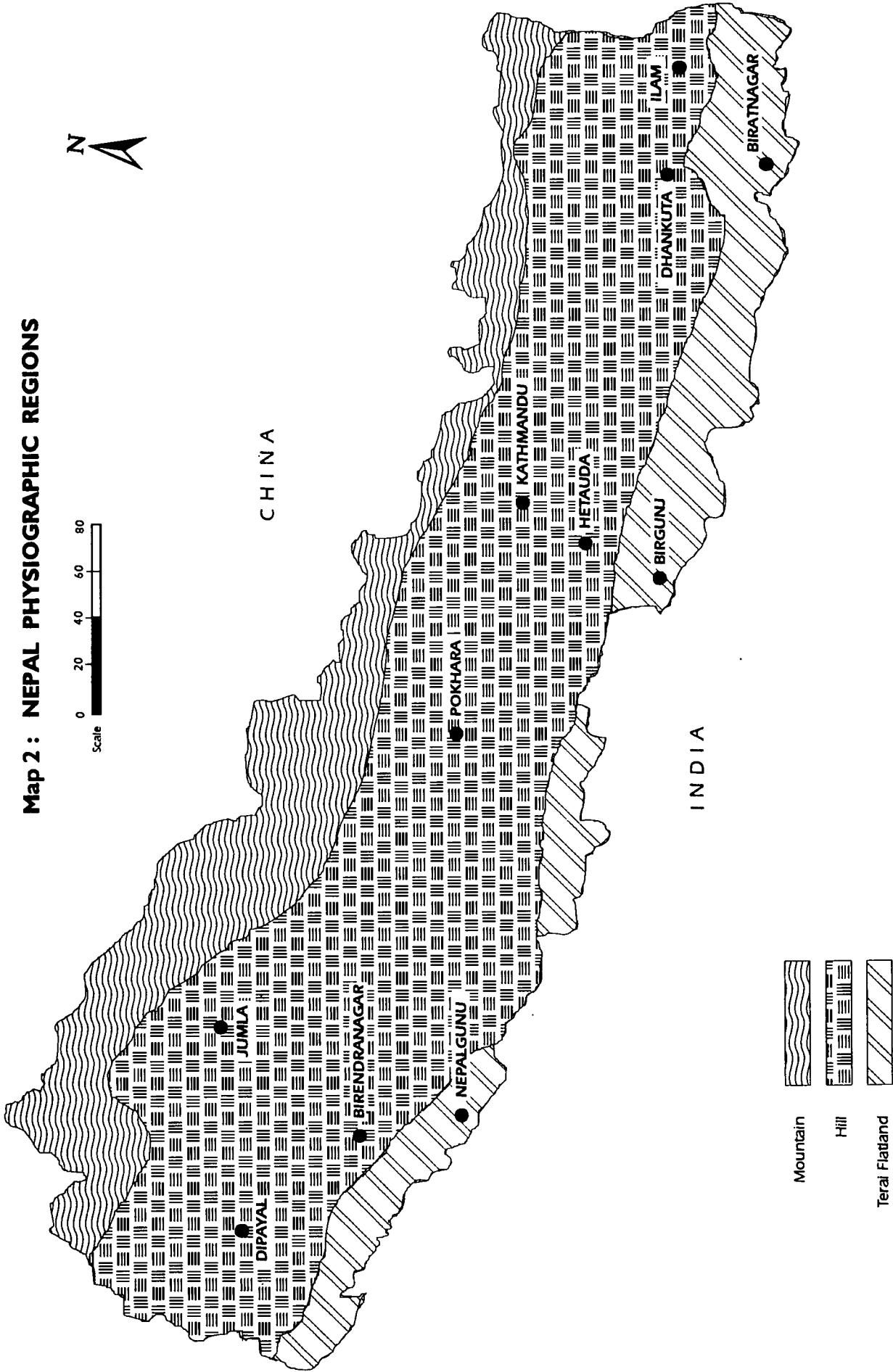

## CONTEXT FOR BUILDING DESIGN

**School Building and Physical Improvement Programme.** Many of the primary schools in rural areas of Nepal are both physically and educationally of poor standard. Physically, they are poor because of the lack of a structurally sound school building for teaching purposes. School sites may also be unsuitably located and lack sufficient space for extracurricular activities. Learning conditions are poor for several reasons: traditional teaching methods are employed; there is difficulty finding qualified teachers; and teaching-learning materials are neither readily available nor effectively used. The activities of the Seti project were developed and implemented as a specific response to these conditions, which are especially prevalent in the remote far-western development region.

The School Building and Physical Improvement Programme is one of the most successful of the project's programmes. In continuous operation from 1982 to 1992, this programme covered all five of the rural districts. The seven activities promoted under this programme include: new school building construction; playground construction; a compound wall for each school; a drinking water supply to each school; support for maintenance of resource centres; latrine construction; and construction of village reading centres.

Even construction of residential homes within the villages is extremely poor: walls are cracked, roofs leak, ceilings are low, and doors and windows in most of the buildings are very small. Villagers lack adequate building skills, and this lack of knowledge results in poor construction: consequently, schools are seldom in any better condition and, as public buildings, are often in even worse condition than other structures. Like temples, school buildings have traditionally been erected on hilltops, which results in roofs being blown away by the strong winds; and drinking water, which must be piped to the school, is almost never available. To resolve these and other problems, the objectives of the programme are to:

- encourage rural communities to experience and, hence, understand their own potential to bring about substantial progress and change in their lives through their own efforts;
- develop the school facility, with its vegetable gardens, trees, latrines, neat compound, clean drinking water, and well-tended buildings, as a source of community pride;
- improve the school's learning environment; and
- improve construction standards for both communal and private buildings.

Prior to developing this programme, a comprehensive review of locally available materials and skills was conducted. The possibility of providing maintenance assistance for existing structures was rejected because so many of the facilities are in such poor condition that the best solution is to dismantle them and recycle usable materials in the construction of improved facilities. Also, because poor maintenance has substantially contributed to the derelict state of many of the buildings, it was felt that to repair existing structures might result in a mistaken impression that assistance is available for repairs – which in turn might be misconstrued as support for non-performance. The construction of new buildings according to a limited number of standard designs is also an attractive solution administratively, as it is comparatively simple to implement and minimize possibilities of misuse.

**Traditional Buildings.** A distinct variation in building styles exists from north to south and east to west within the country. This can be attributed to the extreme range of geographical conditions, as well as to varying levels of economic and social development. Three geographical bands may be identified: the cold high mountains to the north, the very hot terai plains to the south and the temperate foothills in between (see Map 2). From east to west, not only is there a climatic difference, with the east receiving heavier monsoon rains from June to October, but there is also a distinct difference in the level of economic and social development. East and central Nepal enjoy a higher standard of education, communication and transportation. Consequently, buildings in the east and central parts of the country are characterized by higher quality



workmanship and the use of factory-made materials, such as cement and corrugated galvanized steel (CGI) sheets. A general view of the building types in each area is necessary to a basic understanding of the constraints which affect the design of new buildings.

## Mountains

**Design Considerations:** The buildings in the mountains have to withstand an extremely harsh climate – very cold, dry and windy. Flat mud roofs are supported by wooden beams, creating spaces with very low ceilings. Thick walls and only a few, small openings are typical building features of the area. In many cases, rear walls form part of the natural ground slope with no excavation or leveling of the land. Rooms, especially those on the ground floor, are dark and damp. In house, dampness not be such a serious factor, because the ground floor is usually used as an animal shelter, but in schools, it is a more serious problem, one resolved by using stone or mud benches (internal *peti*) or wooden planks. In houses, a small outlet for smoke provides light at the centre of the room, but this sort of provision is not found in school buildings.

**Materials:** The three main materials are stone, mud and timber. The timber available is pine, which is often used crudely and excessively. In some areas, flat-stone roofing is available, although this is not as popular in the mountains as it is in the hills because quarrying and portage costs make it a much more expensive solution than mud roofs. Since rainfall is very low in mountainous regions, shedding rain is not as important a consideration as allowing sunlight to enter a room. For this purpose, the traditional flat mud roof is perfectly appropriate. The mountain region also covers the area above the snow line (11,500 feet), where stone and timber are not readily available; here, houses are built with mud and the use of timber is minimized.

## Hills

**Design Considerations:** The 'hill zone' with its high ridges and deep river valleys has a more variable climate, resulting in a variety of design solutions. Buildings must be designed to resist heat, rain, wind and snow. The buildings which are constructed are solidly built, with walls of stone at least 18 inches thick and often with slate roofs. Thatch and CGI sheets are used if slate is not available. Because of the limited availability of land and the villagers' domestic needs, their houses are two-storey; however, schools are generally 'L' or 'C' shaped single-storey structures, with government-supplied CGI sheets for roofing.

Ceiling height is low, as is the height of doors and windows. Small balconies in front of upper floor windows are often extended to provide a place to sit in the winter sun, as well as a shaded, cool place in summer. Roofs are always pitched and a small overhang is extended across the gable wall to protect the mud mortar from being washed away.

**Materials:** Stone is the predominant material used in the hills. The quality determines the style of wall construction; random rubble in mud mortar is very common. The roof covering may be thatch or CGI sheets, but most often roofs are a composite of stone slabs set in mud supported by a layer of rough timber.

Timber, another major structural material, is used for all upper floor and roof supports, doors and windows. But, because timber in the hill regions is not as readily available as it is in the terai, hard wood is more difficult to obtain.

## Terai

**Design Considerations:** The hot terai plain is mostly populated by recent immigrants. Most of the rural houses have a wattle and daub structure and a pitched thatch or clay tile roof. Care is taken to protect the building from the sun's intense heat by providing an overhang or verandah and making the ceiling high. Often the upper portion of the wall is left open or replaced by a bamboo mesh permitting adequate natural light and ventilation; sometimes a bamboo mesh is installed to provide some security.

Most of the urban structures – including all office and many school buildings and houses belonging to some of the more wealthy individuals – are of a higher standard. These buildings have brick walls or columns and a flat reinforced brick concrete (RBC) or reinforced cement concrete (RCC) slab roof allowing for the eventual addition of another storey.

Because of climatic conditions, ceilings are high, and verandahs and overhangs above the windows are large and often unshuttered. (This is especially true of school buildings.) To overcome water logging and dampness in the walls, the plinth level is often raised with brick soling, and a cement finish is given to floors. A damp proof course (DPC) in the form of a concrete band is provided at the plinth level.

**Materials:** Clay bricks and tiles are locally manufactured in almost all parts of the terai and are commonly used throughout the area. But, because of the high cost of these materials, many people have to depend on wood, bamboo and thatch. (This may soon change, as wood is now also expensive and difficult to obtain.) Because there is good transportation through the terai, the use of such manufactured materials as cement and steel is also feasible. These materials have been used by the wealthy and for government-supported construction activities. CGI sheets – although not a good choice for climatic reasons – are visible on many buildings, especially schools, which receive them free of charge from the government.

**Problems with Existing School Buildings.** Until recently, there were few primary schools in the country. When His Majesty's Government (HMG) implemented the National Education System in the early 1970s, primary schools spread to every village of the country. The stipulation was made that there must be a building constructed by the people to accommodate the school before formal recognition would be given by the Government and this put pressure on people to begin constructing buildings on their own, without any knowledge of design and without proper planning or technical support from the government. In this way, thousands of schools were constructed during the past 15 to 20 years - resulting, quite naturally, in many of the problems experienced today.

**Planning and design:** Seti Zone lies within Nepal's earthquake destruction area. Ten years ago a severe earthquake killed hundreds of people and caused extensive property damage in the area. Light tremors are common and occur several times each year. Because people are aware of this danger, some precautions have been taken.

To minimize the damage from earthquakes, many schools are single-storey structures. However, many of these are 'L' or 'C' shaped and are therefore more likely to incur damage from earthquakes than are linear buildings. Also, these two designs lead to problems in corner rooms which can only be entered through another room: lighting is inadequate and ventilation is poor. The rooms themselves are often small and so, consequently, are doors.

These factors, together with a dark interior surface of brown mud finish, result in very poor light distribution, which is further hindered by the improper orientation of the building, which is often dictated by ground contours.

A lot of schools are constructed on hillsides where the earth has been cut to level the ground. The resulting embankment behind the school building usually collapses and earth builds up along the rear wall. This, together with the lack of a damp proof course in the construction, causes damp floors and walls and creates an unhealthy environment for students.

**Standards of Construction:** The standard of masonry and carpentry work is very poor. Walls are not vertical. Small stones are used with a lot of mud and few crossbonding stones. These practices result in an unstable structure. Joints in the timber frame, although generally adequate, are poorly made, and a large amount of timber is wasted. Roof timbers are rarely jointed and members rest on top of each other, providing no real stability.

The quality of wood used varies. Salwood, a better quality local hardwood, is used at lower altitudes where it can be easily obtained from forests. At higher altitudes, pinewood trees are available and sometimes other varieties of local timber. All of these

timbers are unseasoned and therefore, except for the better salwood variety, are particularly susceptible to insect and fungal attack.

The roof is another area in which poor construction has caused problems. This is partially due to the local architecture which dictates shallow pitch roofs that are vulnerable to wind and rain. Other problems come from materials and workmanship.

Many roofs use flat stones from one-half inch to two and one-half inches thick, often incorrectly referred to as slates. These are quarried locally and dressed into rectangular shapes, then fixed in place by traditional methods. After the roof timbers are put into place, battens of wood (split so as to have a cross section of one to two inches thick) are placed side by side between the timbers. These are covered with a layer of mud into which the flat stones are uniformly placed side by side in overlapping straight rows. Each joint between adjacent stones is then covered with a smaller flat stone.

This is a critical point in the roof construction, as it is there that water leakage most often occurs, soaking the mud layer which in turn causes the wood battens to rot.

Some roofs are made with galvanized steel sheets. As the technology for installing these materials is not well understood, they are often installed with inadequate laps and insufficient fixings.

These errors result in water leakage and wind damage. Other disadvantages of tin roofs are the noise created during heavy rains, the heat in the summer, and the cold during the winter.

**Maintenance:** Refixing doors and window shutters, replacing broken slates or floor joists, levelling the floor, etc. are the major routine maintenance works necessary in school buildings in Seti Zone, but maintenance is almost non-existent, except for occasional remudding of walls and floors.

Generally, schools are constructed through people's participation, often with some financial help from the district development committee (previously known as Panchayat) and other agencies. Once school buildings have been built, people in the communities regard them as government property and feel that the government should maintain the structures. Most communities are not prepared to do any work, unless money is available.

Because one school serves two or three villages, everyone regards the school as a public building; yet no one feels responsible for maintenance work. In some cases, funds are provided for such maintenance, but these are often mismanaged: funds may be entrusted to a person who then persuades the people to work voluntarily or for low wages; when the people realize that money has been improperly utilized, they lose faith in the leaders and refuse to come back to work when the next appeal is made.

Minor maintenance work and cleaning of rooms could be performed regularly but, because of lack of initiative by school management committees and staffs, many schools in Seti Zone have been allowed to deteriorate to such a condition that some rooms are now unusable and classes are set up in other rooms or outside on the ground.

The project has a small maintenance programme, but only for the resource centre schools, which are generally well established with a good site plan, and where other building elements, as well as the size of rooms, are also acceptable.

**Photograph 1.**

*An existing L-shaped school building with the leaking roof and problem of access to the corner room. It has damp floors and cold rooms because of the small windows.*

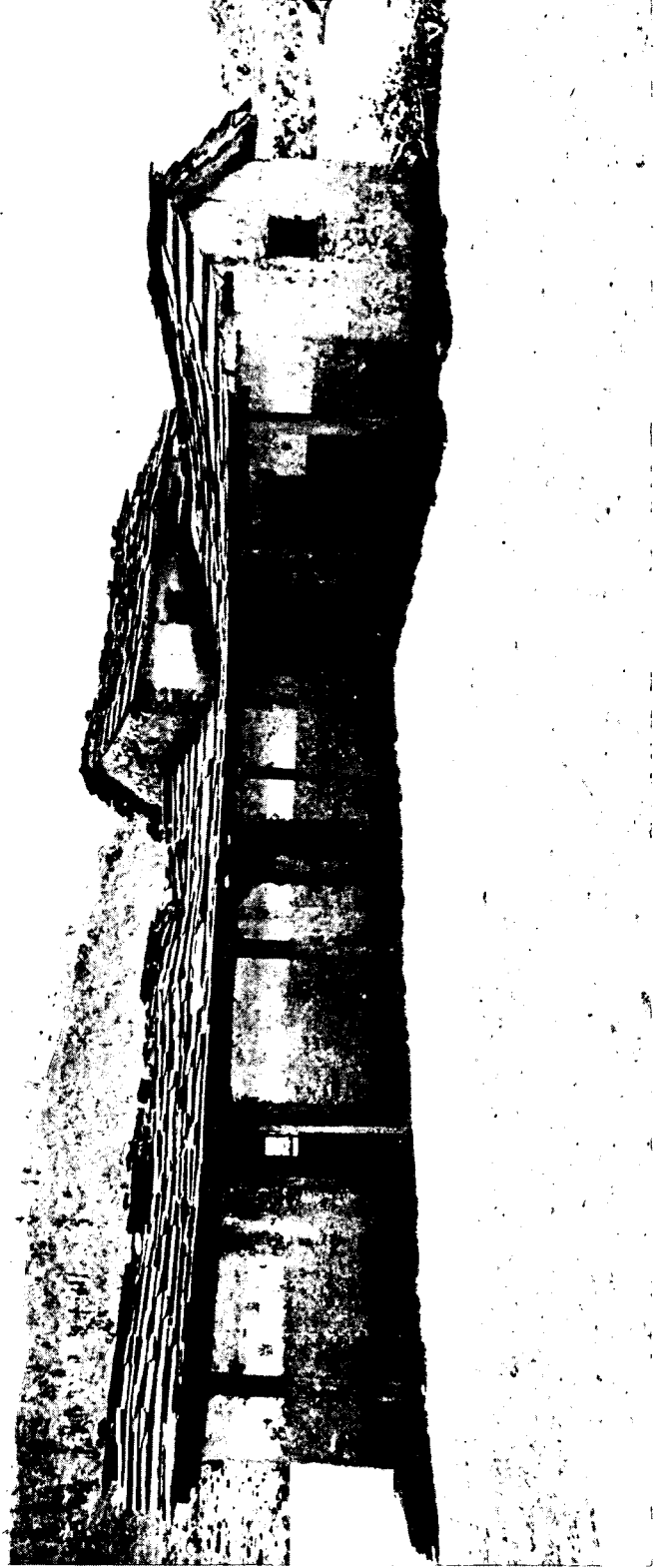



## APPROACH TO MANAGEMENT

**The Project "Actors"**. Management of 'aided self-help' schemes such as this one require an unusually clear definition of responsibilities, because no one person or office is fully in charge and because much of the input is voluntary and, consequently, not subject to the usual obligations and penalties associated with regular contracting.

In this project, a number of 'actors' in the process were identified:

- the regional education directorate (RED)<sup>1</sup>, which monitors and co-ordinates activities in the district;
- the district education committee (DEC), a body which has an overview of education development throughout the district;
- the District Authority is the principal people's representative body at district level and is both a political forum and the main body responsible for the co-ordination of development activities and input;
- the district education office (DEO)<sup>2</sup>, an administrative body responsible for the channelling of government support and for ensuring the proper implementation of the education code;
- the school management committee (SMC), a local body created to manage the affairs of each school;
- the Seti project staff, a group of specialists and field workers who advise and support DEOs, villagers and teachers in all aspects of project implementation;
- the engineering unit, a technical group within the Seti project staff, which supervises construction; and
- workers – skilled workers hired to work on the school building and/or non-skilled workers from the villager who volunteer their time and labour.

The identification of functions and the sequence in which they are to be carried out can be studied in the Figure 1 on Management Process and Responsibilities. The responsibilities of the project's three principal participants are detailed in the following pages of this Chapter.

**Role of Engineering Unit.** The success of any aided self-help programme depends on the effectiveness of the technical support unit. As the responsible element for the DEO project office implementation and follow-up of the programme, the Seti Zone project engineering unit has been directly involved in every stage of the construction programme process. Since all of the programmes are community based and schools are community buildings, the role played by the technical staff is much more than a simple technical function. Technicians are expected to be highly disciplined, honest and dedicated.

Furthermore, they must work not only as technicians but also as educators and motivators. They spend about three weeks a month in the communities supervising the various school construction programmes.

Duties of the engineering unit include programme planning, design, estimation, survey, supervision, reporting, and records maintenance. However, most of their work is in the field.

The work conducted by the Seti project staff, particularly the engineering unit and the field co-ordinators, during their field visits is difficult and often dangerous. They must be prepared to trek between ten and thirty miles a day – shouldering a rucksack weighing ten to fifteen kilograms – to visit one to four schools along the way. When in the field they often begin the day's journey at 6 a.m. and continue until dark, working seven days a week (see Photograph 2, 3)

1 now called Regional Education Inspector's (REI's) Office.

2 now called the District Education Inspector's Office (DEIO).



**Photograph 2.** (top). The project technician is going to visit schools in Burgal area in Bajhang walking through a vast landslide. It is 2-3 days walk from the district headquarters to Burgal.

**Photograph 3.** (bottom). All in a days work for the site overseers. A small branch of Seti river on the way to Dhuli-Kanda schools, Bajhang district suddenly flooded and blocked the trail at 5.30 p.m. The overseer who had two more hours' walk to reach his next school site, fortunately found a fallen tree to serve as a

The whole project area is one of the most remote and disadvantaged parts of the Kingdom, and even a nominal amount of food and shelter is often hard to find. The path is often very narrow and steep; sometimes it passes through a heavy jungle and sometimes through landslide areas. From June to September the trek is especially risky.

When in the office for short periods, the technicians complete office work, keep records and prepare budgets; working after and before office hours is normal for many staff on this project. The entire working system differs greatly from that in construction offices of other projects where the pace of work is gentler. Technicians have no problem obtaining less demanding jobs in other offices, and this is the main reason for the high turnover among the project staff

**Figure 1 :** Management Process and Responsibilities

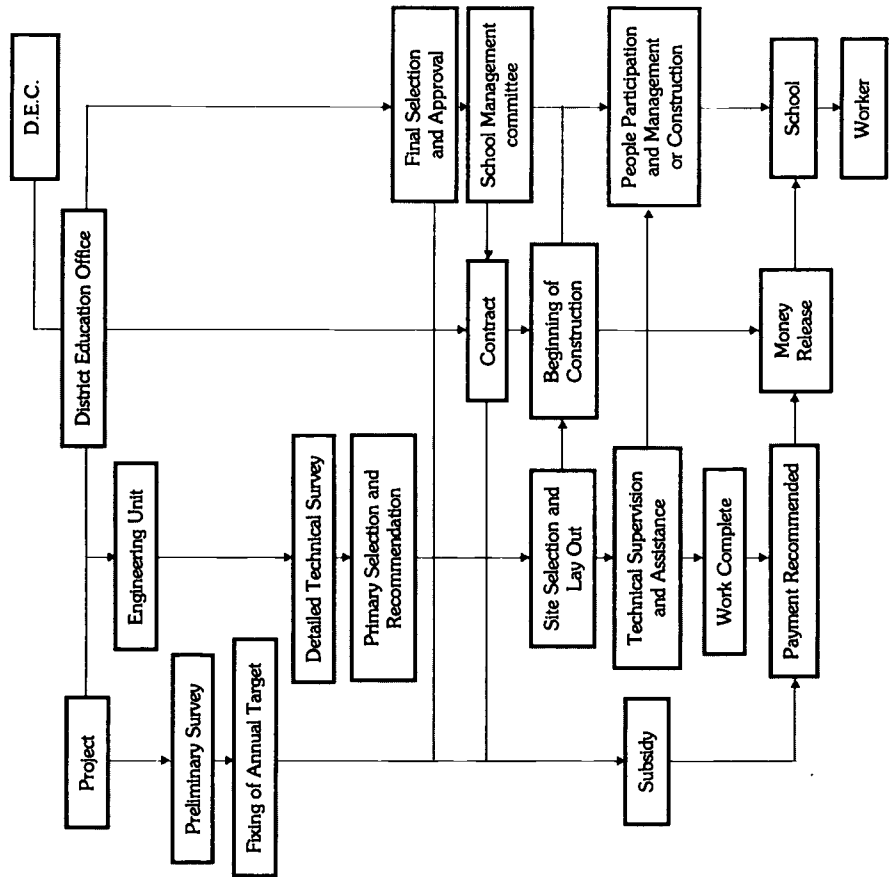

**Role of District Education Office (DEO).** The relationship with the DEO, which supervises and controls all education activities in a district, has increased considerably since the beginning of the project. The involvement of the DEOs has developed from a consultative to an executive role and, through a process of 'institutionalization' in its second phase, the project has steadily increased their authority and responsibility.

In 1988/89, the project's separate district offices were abolished and the technicians, as well as the senior field co-ordinators, are now directly attached to the DEOs and work under the direct control of the district education officer. As a result, the role of the DEOs in the overall planning and implementation has been further emphasized. Nonetheless, the role of the technicians has not diminished; and the DEOs will not be in a position to take full responsibility for the implementation of these programmes until provision of the necessary technical power and financial resources can be routinely made available by the government.

**Role of School Management Committee.** Because this is a community-based programme, the community itself plays the central role. As the 'construction manager', the community provides materials and recruits labourers to carry out the construction tasks. Generally, contractors are not used for construction purposes. Instead, the chairman of the school management committee agrees in writing with the district education officer that the SMC will be responsible for the construction programme.

A separate 'construction committee' is then organized. This is a special committee consisting of honest, energetic and dedicated village or group representatives who have as their sole objective the timely construction of a well-built facility. This committee formulates the overall construction plan. Typically, the main problems faced by the committee involve securing timber, roofing slates, and skilled carpenters and masons to carry out the construction.

The task of obtaining materials is generally shared by many community members, who physically transport the materials from a forest or quarry to the school site; however, finding skilled workers remains a problem. Management committees do make use of the one or two craftsmen who may be available in a community, but skilled workers have to be paid and are expensive. To help reduce costs, the SMC typically uses semi-skilled workers from the local community; project-supplied tools and supervision are therefore of considerable importance to the community in the construction of the school building.

The project advises that, in its work plan, the committee should specify a plan for the provision of voluntary work under which each family should contribute a specified number of working days. The number of days depends on the amount of work required

to complete the building and the size or population of the community. The committee should prepare a planned budget to ensure the proper utilization of the project subsidy.

The committee's plan should divide contributions to building construction into two groups. The *Shramadan* (voluntary) group should be responsible for demolishing the existing structure, levelling and cleaning the site, felling trees, obtaining quarry stone, carrying materials, and securing labour in support of skilled workers. The *Anudan* (subsidy) group should carry out masonry, carpentry and roofing work and buy roofing slates.

Follow-up and day-to-day supervision of all types of work is generally the responsibility of the chairman or secretary of the committee. Frequent on-site visits by project technicians ensure that a satisfactory construction speed is maintained and that major errors are corrected before construction is too far advanced.

**Financial and Cost Considerations.** The government is the main source of funding for primary education in Nepal, although there are other sources which directly and indirectly support the school. Local communities are primarily responsible for construction of a school. As a rule, a 'good' building must be in place prior to formal government recognition of a school. Initially, no funds are available for construction and all expenditures are met by the community. In the second stage, however, once a school has been officially recognized, funds can be obtained from different sources for a variety of purposes, although the district Panchayat usually provides funds for construction. Funding can be obtained from the following sources.

- His Majesty's Government (HMG): The government provides 100 per cent financial support to the primary level of education, covering the salaries of teachers, the provision of textbooks and a limited number of teaching-learning materials, and a contribution towards miscellaneous expenses (i.e. stationery, postage, etc.)
- District Panchayat: District Panchayats have their own budgets and sources of income. They also receive grants from the central government which may be used for different developmental and educational activities. Monies expended for educational purposes usually involved new furniture, repair work, or new construction.
- Village Panchayat: Another source of funding to the primary school is the village Panchayat, which also has its own budget. Village Panchayats collect money through local taxation, donations, etc. Some of the monies are provided to schools for furniture, repair work, textbooks, etc. The amount allotted depends on the financial status of the Panchayat. Most of the Panchayats in the remote districts are poor and are, therefore, in no position to provide financial support to their own school.

- Local Community: In many places in Nepal, students and teachers organize cultural shows, games and other activities to collect money which can be added to the school budget and spent as needed. Other people provide cash donations to the schools or donate land for playground use or as school building sites. Still others provide construction materials (timber, slates, etc.). In this way, local communities are a main source of funding for the primary school.

The Seti project has implemented its school building construction programme by providing technical support and financial subsidies to the community.

To prevent the inappropriate utilization of funds, the project has developed and tested a system of 'Payment by Result', which is common to all of the activities it supports. In the case of the school construction programme, money is released in stages, and only after a specified amount of work has been completed, inspected on-site, and certified by project technicians.

Initially, these stage payments were phased as follows:

1. stone masonry up to plinth level (including the foundation);
2. door and window frames fixed, and superstructure wall up to lintel level;
3. fixing of floor joist and first-floor construction complete;
4. superstructure walls complete, and roof timbers fixed;
5. slating on roof complete and commencement of door and window shutters; and
6. fixing of door and window shutters and final finishing complete, and latrine and compound wall constructed.

When work on a given stage is complete, the community requests a project technician to visit the site to inspect work progress and verify that the work has been completed as specified. If a stage of work has been completed as specified and if a stage of work has been completed satisfactorily, a recommendation for payment will be made.

Neither recommendation nor payment is made if the work has not progressed as specified.

One of the main goals of the Seti project school building programme is to achieve low cost. The design is based entirely on the use of locally available materials (stone, wood, slate) and local architectural traditions.

The community is expected to provide voluntary labour and materials equivalent to 59 per cent of the total building cost, with the balance of 41 per cent being met by the

project by means of a cash subsidy. Because no factory-made materials (cement, steel, etc.) are used in construction, a considerable sum – normally expended for the purchase and transportation of materials – is saved.

Most project-supported construction activities take place in primary schools in rural areas where both construction materials and labour are cheaper than in the headquarter's and urban areas.

In view of this, project costings include a standard deduction of 25 per cent from the official government rate. Most of the schools reuse certain quantities of stone, wood and slate obtained from the demolition of existing buildings. To allow for this, the project has deducted an additional 10 per cent of the total cost.

A summary of the calculation of the actual cost and project subsidy of a four-bay double-storey building, with a 144-pupil capacity, for the 1990-1991 construction year is shown in the Table 1.

The cost estimate is based on current government rates for construction materials and labour in the districts. Each June, the end of the construction year, there is a provision to review the cost (as well as design and other procedures). Between 1982-1983 and 1990-1991 six revisions were made to the total cost estimate and subsidy.

**Table 1.** Calculation of Construction Subsidies 1991-1992

	(nrRs)				
	Doti	Bajhang	Bajura	Achhan Kailali	
<b>Total estimated building cost</b>	1,134,466.27	102,249.15	100,076.97	.112,825.55	113,466.27
<b>Net estimated cost (after 35% deductions for remote areas and available materials)</b>	73,753.08	66,461.95	65,050.03		73,336.62
<b>Gross subsidy amount (41% of net estimated cost of building plus latrine)</b>	30,588.76	27,943.40	27,370.51		30,768.04
<b>Approved Subsidy (1US\$ = 43 nrRs.)</b>	30,500.00	28,000.00	28,000.00		30,500.00
	(\$709)	(\$651)	(\$651)		(\$709)



# SCHOOL CONSTRUCTION PROGRAMME PLANNING

**First Design.** Because of its experimental nature, the Seti project has maintained a cycle of need assessment, innovation, evaluation, revision and renewed innovation. Furthermore, the project was designed to begin in a single district on a trial basis, before expansion to other districts. This feature of the project applies to all its components, not only building.

Figure 2 on the following page shows the sequence in which the programme developed between 1981 and 1991. These stages are discussed in detail in this Chapter. The chart also helps to illustrate the complexity of implementing such a programme, and shows how feedback from evaluation can be used to improve project performance.

The school building component of the project was developed as a response to a long history of failures and still-born ideas. When communities constructed school buildings independently, very poor results were achieved regarding light, classroom size and structural integrity.

External assistance had been given; UNICEF provided sheet metal roofs through the Ministry of Panchayat and Local Development, but the UNESCO-provided designs were not followed and it was quickly found that steel trusses (fabricated in Europe and delivered to the school site by plane) and corrugated steel roof sheets were expensive and ill-adapted to Nepal's conditions.

To break this cycle of failures, UNESCO and UNICEF invited five Nepalese officials to a workshop in Bangkok in 1981. In one week, these specialists had produced a report which provided the first set of general ideas as to how the building design problem might be confronted.

This information was then used in a field workshop staged in March 1982 in Fulote, a Seti Zone village that is a full day's walk from the nearest airport and, at the time, a four-day walk from the nearest road.

This second workshop comprised 14 participants from UNESCO (Bangkok), the Norway/HMG/UNESCO project for constructing hostels for girls, the Ministry of Education and Culture, and the Seti project. Because the number of classes and the

number of students varied from school to school, student enrolment, attendance and dropout patterns were carefully analyzed and six designs were developed to suit each different set of requirements, with bigger classrooms for the lower grades and variations in building lengths and number of floors.

Local architecture, building methods and available materials were studied and adopted within the designs. As a result, the overall design developed by the workshop included the following features.

- The six designs developed (types A through F) were intended to cater to enrolments of 40 to 216 pupils; the maintenance of flexibility was considered an important principle, and this was to be achieved through removable internal timber partitions.
- The concept of two-storey buildings was introduced to reduce land needs, avoid problematic 'L' and 'C' shaped designs, and conform to local architecture.
- To control dampness in floor and walls, a plinth height was fixed at a one-foot minimum from ground level in hilly areas, with a plastic damp-proof membrane to be used under the ground floor.
- An earthquake lintel of wood was used in both ground and first floors to improve stability.
- Access from the outside to the first floor was provided by means of a verandah.
- The only materials to be used in construction was stone, timber, slate and mud.
- To improve light in the classroom, splayed sections were proposed for doors and windows, and interior whitewash was specified.
- In many schools, winter classes are held outside on the open ground in the warm sun. It was felt necessary that a certain area be designated and developed for this purpose. Thus, the design includes an outdoor teaching area with space for sitting and a place for hanging blackboards.

Figure 2 : Development of School Construction Programme

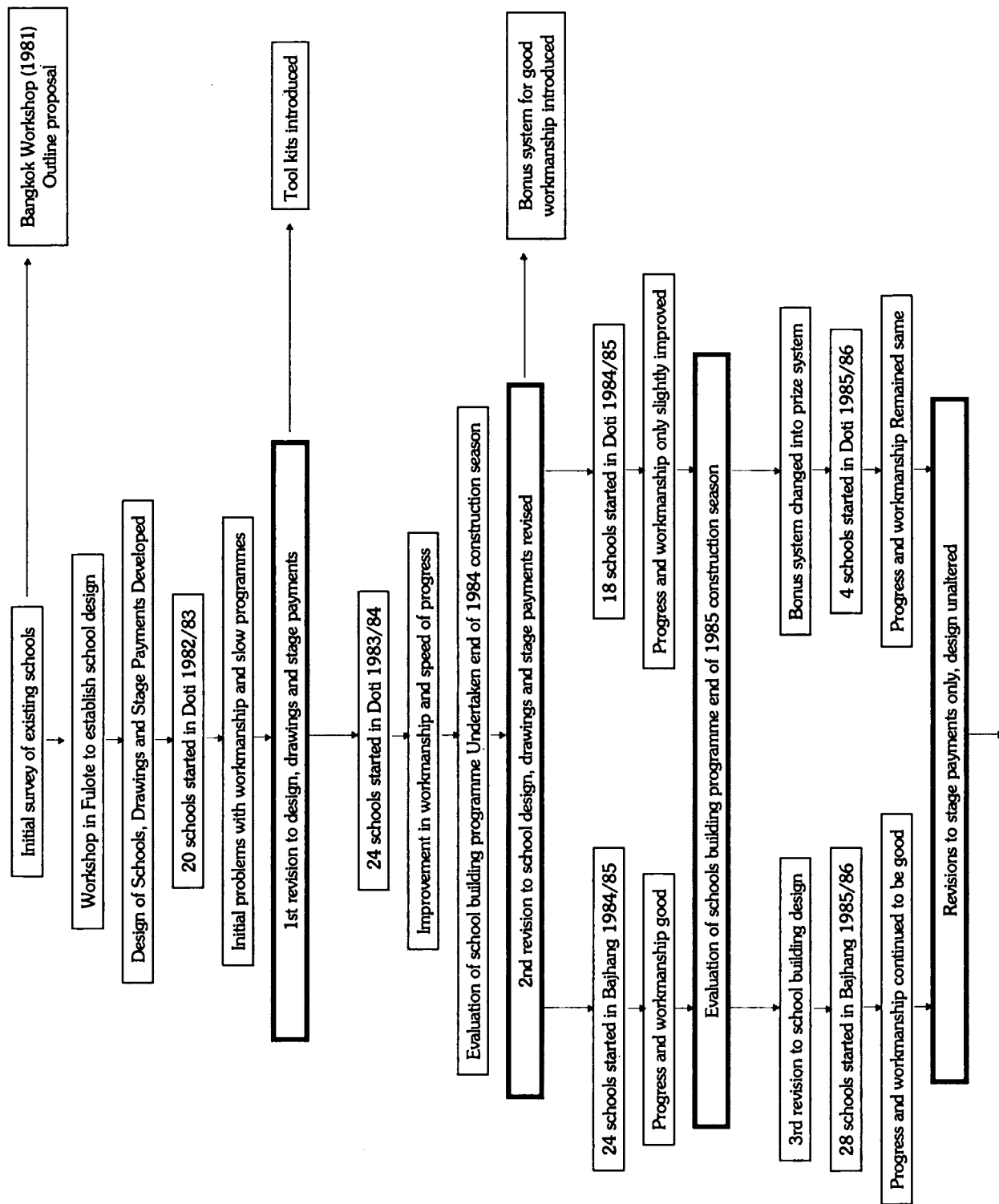

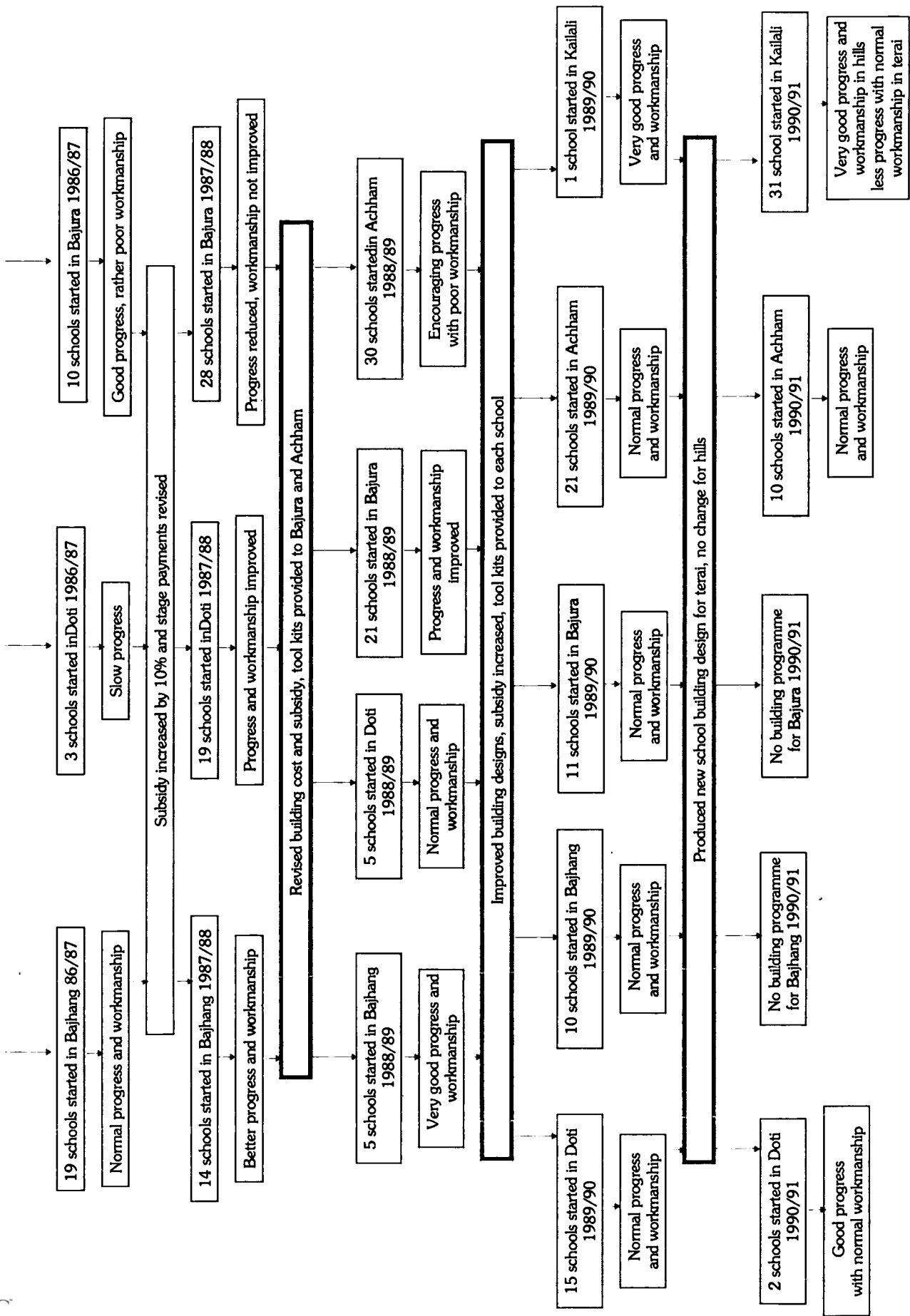

- To provide a hygienic environment in the school, a latrine was designed and arrangements for providing safe, drinkable water were planned.
- In the site plan, land area was set aside for school gardens, fruit trees and a playground.
- A compound wall was proposed, first to designate clearly which land belonged to the school and, second, to prevent animals from entering the schools grounds and grazing in the school garden.

Of the six designs, the one designated as Type A was a four-bay, single-storey structure, capable of accommodating forty students; Type B was a four-bay, double-storey structure, capable of accommodating 88 students. Of the six rooms in the four-bay, two-storey building, two large ones were designated for grades 1 and 2 in recognition of higher enrolment in these levels. The remaining smaller classrooms measured eight feet by fifteen feet and could accommodate fifteen students at a rate of six square feet per student, which was sufficient for the observed enrolment and attendance rates at that time. Other designs were for five-bay single- and double-storey structures, and seven-bay single- and double-storey structures, able to accommodate 64, 136, 112 and 216 students respectively. The cost of these buildings, based on the government rates for Doti District, averaged Rs. 55 per square foot.

An information package consisting of three booklets was prepared. This set included:

- an illustrated booklet for the villagers written in elementary Nepali language and depicting the problems of existing school facilities and the benefits to be derived through project assistance;
- a set of construction drawings; and
- an administrative manual describing payment methods and including the contract to be signed by the community.

The overall project subsidy was fixed at 41 per cent of the total construction cost, to be paid in instalments; the remaining 59 per cent was to be contributed by the villagers, in the way of free labour and materials. The construction season in Nepal takes place outside of the monsoon, from November to May; it was initially decided that three to four months would be adequate to construct a building.

In each participating village, a meeting of the chairman of the school management committee, the village Panchayat *pradhan* and the ward chairman was held before the project's programmes were implemented. At that time, the concept of the project, its programmes, the community's role in development, and the benefits to be derived by the community were highlighted by a project representative. Detailed information regarding the process of construction, project support, the system of payment, and the type of voluntary services expected also was provided.

In addition to the 41-per-cent financial support, technical help to the community was provided by the project. Project technicians visited the school, provided advice to the people, and helped them to develop a proper work plan, especially as regards the following stages of work, for which visits were most necessary:

- selection of site and building layout;
- foundation work and determination of plinth and sill levels;
- first-floor timber arrangement and second-floor door and window fixing;
- fixing roofing timbers; and
- roofing and final finishing.

Given the lack of skilled manpower, the quality of work at the village level was traditionally very poor. In some cases, craftsmen had been brought in from nearby districts to do the construction work. To avoid this type of situation, a set of carpentry tools was given to the school and introductory training was provided to semi-skilled carpenters and masons from participating communities.

For constructing the compound wall, the project insisted that locally available materials be used. As a result, the standard compound wall was dry random rubble – a three-foot minimum height and two-foot minimum width. For the first year, the project gave a flat subsidy for a maximum of 700 square feet only

Most existing schools lacked a level playground. A project technician would visit the school to prepare the cost estimate for earth moving. The usually 41-per-cent subsidy would be given by the project and applied towards the total estimated cost. Initially, a maximum subsidy of Rs. 6,000 was fixed.

Almost none of the existing schools had drinking water and, typically, the nearest available water source was thirty minutes' to an hour's walk distant. The project budgeted to provide up to one kilometre of polythene pipe and two bags of cement to each school so that water would be permanently available within the school compound. Before issuing these materials, project technicians would visit the school to determine the location of permanent, pure water sources, the feasibility of the planned alignments and the length of pipe required.

After the field visit, and at schools where a water supply was feasible, the project would agree to provide necessary materials, subject to the following conditions.



materials were to be collected by the school itself from the nearest road head, and no subsidy for portage charges would be provided.

- Sand, stone and other materials would be collected by the school through community participation.
- Trench digging and pipe laying also would be done by the community without benefit of subsidy.
- Technical advice provided by the project would be followed.

To ensure that effective health and sanitation measures would be instituted in the schools, latrine construction was made an integral part of each new school building programme. Until latrines had been completed, building construction work would be considered incomplete and the last instalment withheld. Even schools not slated for new building construction were given a subsidy to construct a latrine.

### **Implementation Process.** A ten step procedure was adopted by the project.

1. **Preliminary survey.** Prior to implementing the school construction programme, a preliminary survey was carried out to collect general information about the district. The survey team consisted of a field co-ordinator and a construction technician (overseer) - the former collected information on educational aspects, while the latter collected information on such construction aspects as geographical features, design considerations, general condition of existing school buildings, labour rates and availability of labour, local construction materials, and scope for people's participation.
2. **Area selection and collection of applications.** On the basis of preliminary survey data and budget allocations, an application form developed by the project would be distributed to specific schools. These applications would be returned with the joint signature of the school headmaster and chairman of the school management committee either through the district education committee or directly to the project.
3. **Detailed survey.** Each school submitting an application would be surveyed in detail. For this survey, an experienced building technician would visit the school and community to collect information regarding:
  - the suitability of the site (i.e. distance between existing school location and the school community; suitability as regards area, steepness of slope, security, etc.) and availability of an alternative site, if required;
  - the physical condition of the existing school building (i.e. structural and architectural aspects;

- the physical condition of existing associated facilities (i.e. compound wall, playground, water supply, garden and tree plantation);
- education data (i.e. number of teachers and classes, student enrolment and attendance, school-age population in the community, and number of families and villages in the school catchment area);
- construction materials and labourers (i.e. availability of stone, wood and slate; availability of skilled and unskilled workers); and
- community participation (i.e. how the existing school buildings were constructed, pledged and support by district Panchayats and communities, community participation in other development activities in the villages, and care and maintenance of the existing building).

During this survey, community leaders and other concerned individuals would be closely consulted, and the site would be properly inspected and measured. All details, including a site plan of the school, would be recorded on a standard form. The technician would prepare a detailed report for each school, which would then be discussed at a meeting attended by the district education officer, the engineering unit staff and project management representatives.

4. **Selection recommendation to DEO.** There is a district level education committee in each district of Nepal; the district development committee chairman serves as committee chairman and the district education officer serves as secretary. On the basis of survey findings, the project would recommend names of schools to be constructed and a formal proposal would be made by the DEO to the DEC for approval. In this way, co-ordination between the district development committee, the district education office and the project was ensured.
5. **Information to schools.** Formal letters would be dispatched to appropriate schools after confirmation of DEC approval. The letter would include instructions for collecting building materials, obtaining a suitable site for construction, levelling the site, etc. Project technicians would visit the selected locations fifteen to twenty days after the dispatch of letters to determine whether materials were being collected and the designated site was available.
6. **Contract.** Contract forms developed by the project specified strict conditions to be adhered to by the SMC. These contracts were mutually agreed to by the SMC and the DEO. A Seti project representative witnessed contractual agreements. No contract would be made if a school site suitable for construction could not be found, or if materials specified in the instruction letter could not be collected. No work could commence until the formal contract was signed. The amount of subsidy for each stage of payment would be clearly recorded in the contract, as would terms and conditions for all instalments.

7. **Final site selection and layout.** After the signing of the contract, the project technician would visit the school and advise on selection of the construction site according to certain criteria – centrally located to all of the villages to be served: near at least one village; good land, so as to avoid flooding, landslides and future erosion; sunny place for winter season, but not on a hilltop or other windy place; and availability of nearby drinking water. Once the site was selected, a layout of the building would be prepared, according to standard design.

8. **Supervision of work.** High priority was given to regular supervision to improve quality and ensure that work was carried out according to specifications. Project technicians would visit the schools upon commencement of the construction work. Because the foundation is vital to proper building construction, technicians devoted particular attention to this work (three to five days, or more). At the same time, villagers would receive explanations about the drawings, the amount of construction work to be completed before receipt of each stage payments, etc. Thereafter, the technicians would visit each site regularly (twice a month, if possible and appropriate) to give technical advice and conduct measurements of the work for recommendation of payment. If any variation from the drawing was found, they would advise the local people on ways to correct the work.

9. **Payment recommendations.** The project technician would take measurements when visiting the school. The technician also would review the quality and progress of work and, if satisfied, would recommend payment. No payment would be made prior to completion of each stage, or where the quality of work was unsatisfactory.

10. **Release of money.** Having received the recommendation for a stage payment, the district education office would deposit the money to the bank account of the individual school to which it was to be paid.



Photograph 4. Mark I. Design built in 1983, in Bandunggrisain school in Doti.

**MARK I  
4 BAY SINGLE STOREY BUILDING**

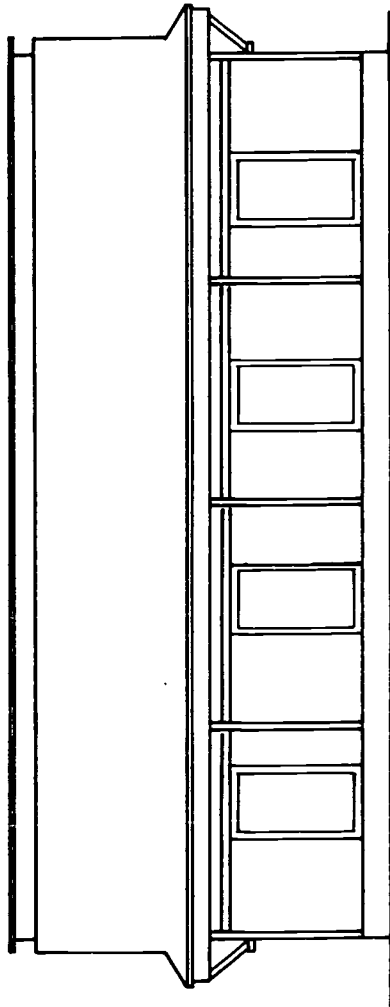

**FRONT ELEVATION**

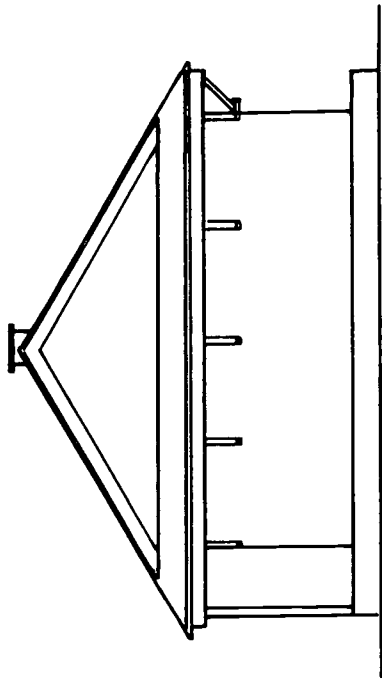

**SIDE ELEVATION**

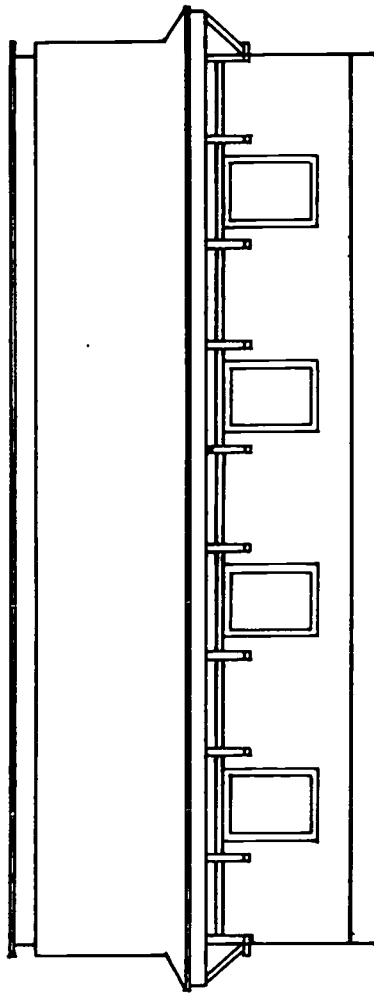

**REAR ELEVATION**

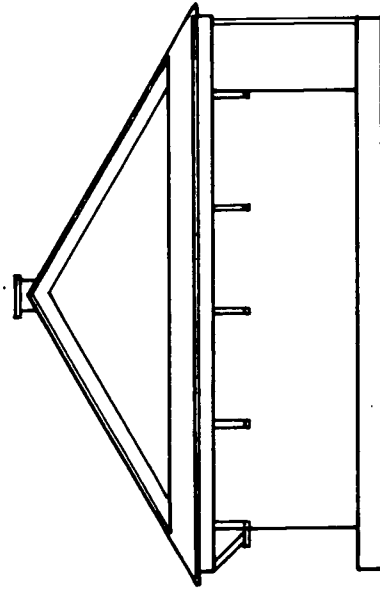

**SIDE ELEVATION**

MARK I  
 4 BAY SINGLE STOREY BUILDING  
 5 BAY SINGLE STOREY BUILDING

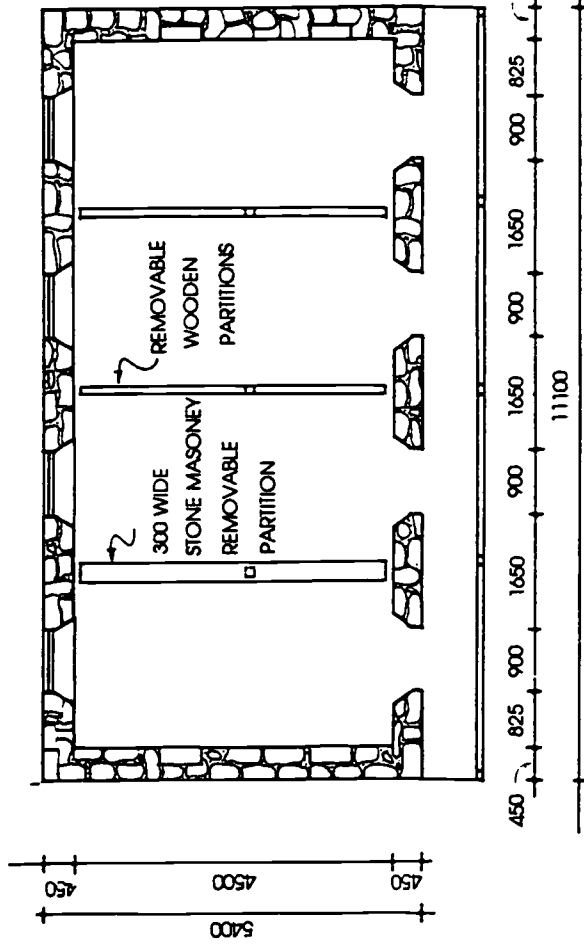

GROUND FLOOR PLAN

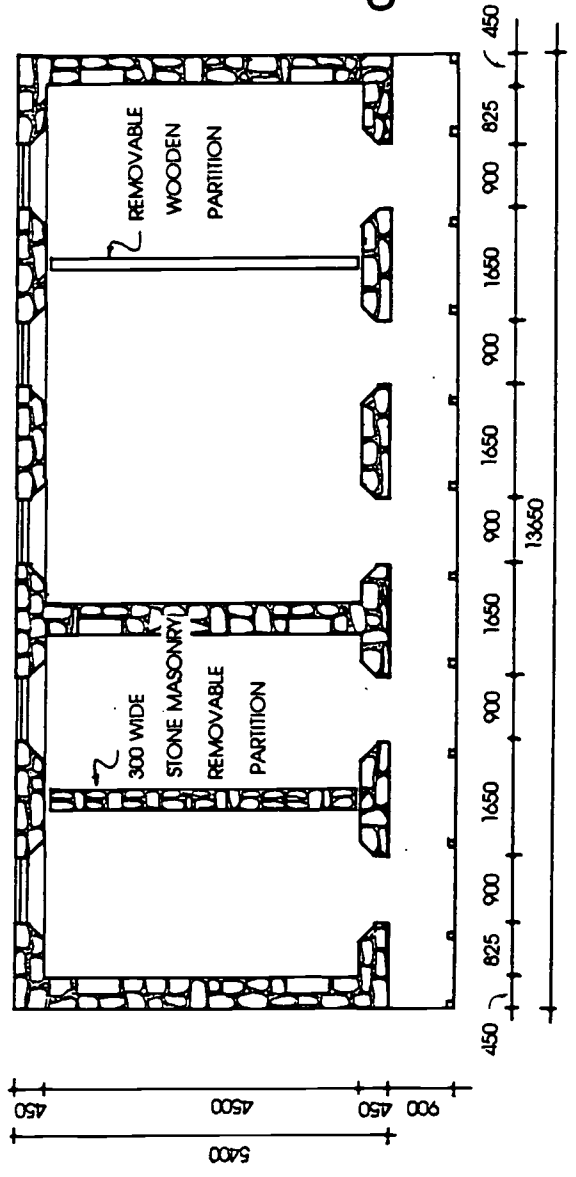

GROUND FLOOR PLAN

54

55

**MARK I**  
**5 BAY SINGLE STOREY BUILDING**

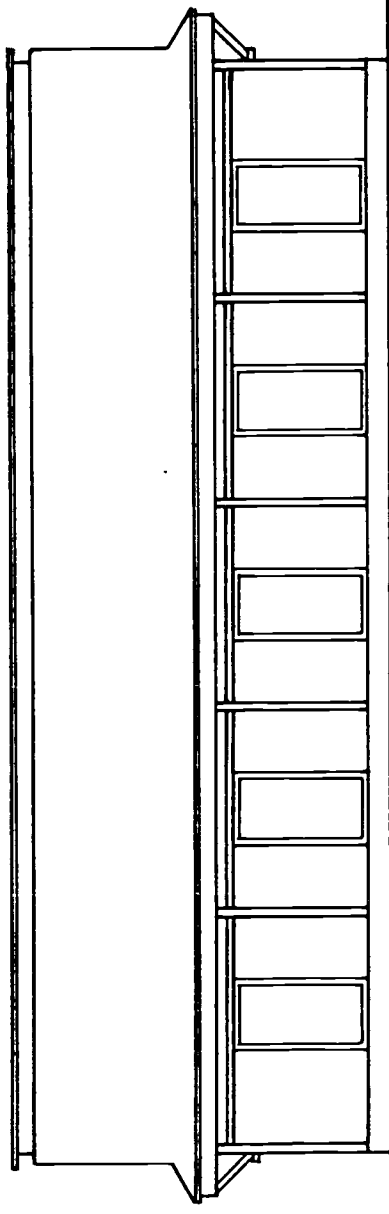

**FRONT ELEVATION**

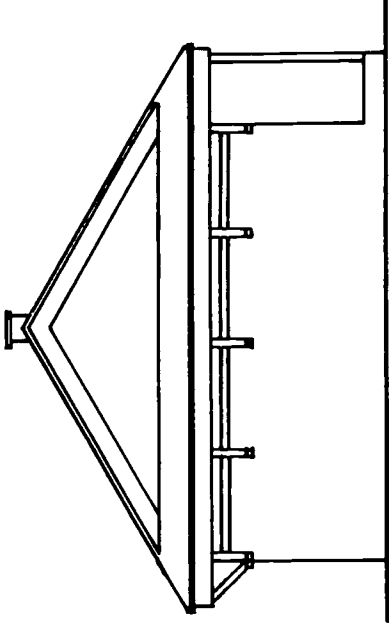

**SIDE ELEVATION**

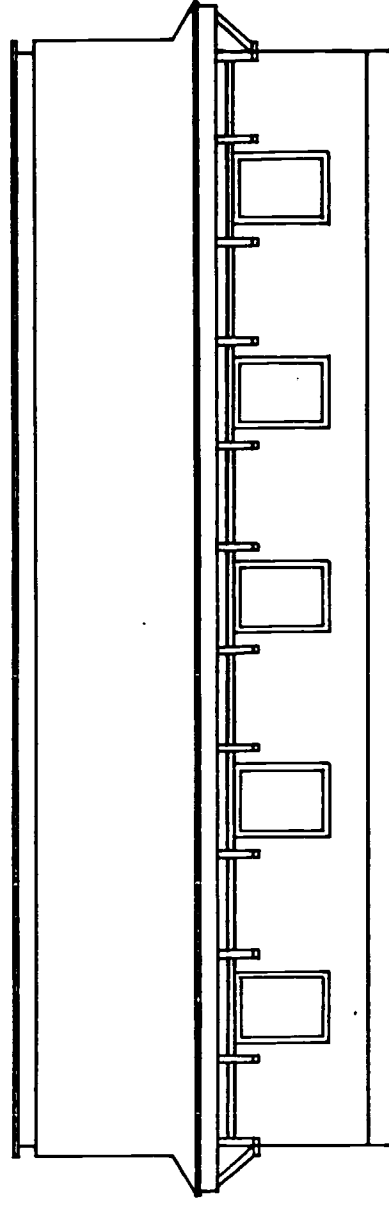

**REAR ELEVATION**

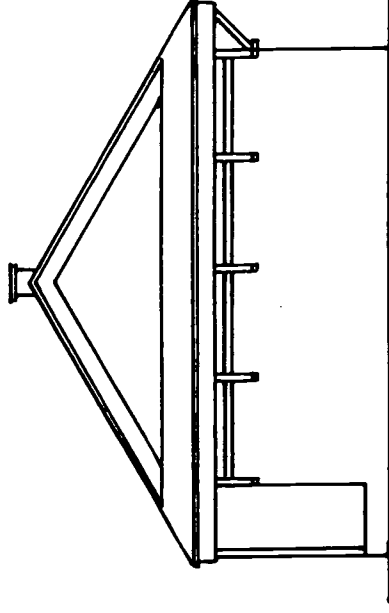

**SIDE ELEVATION**

**MARK I  
CROSS SECTION  
OF SINGLE STOREY BUILDING**

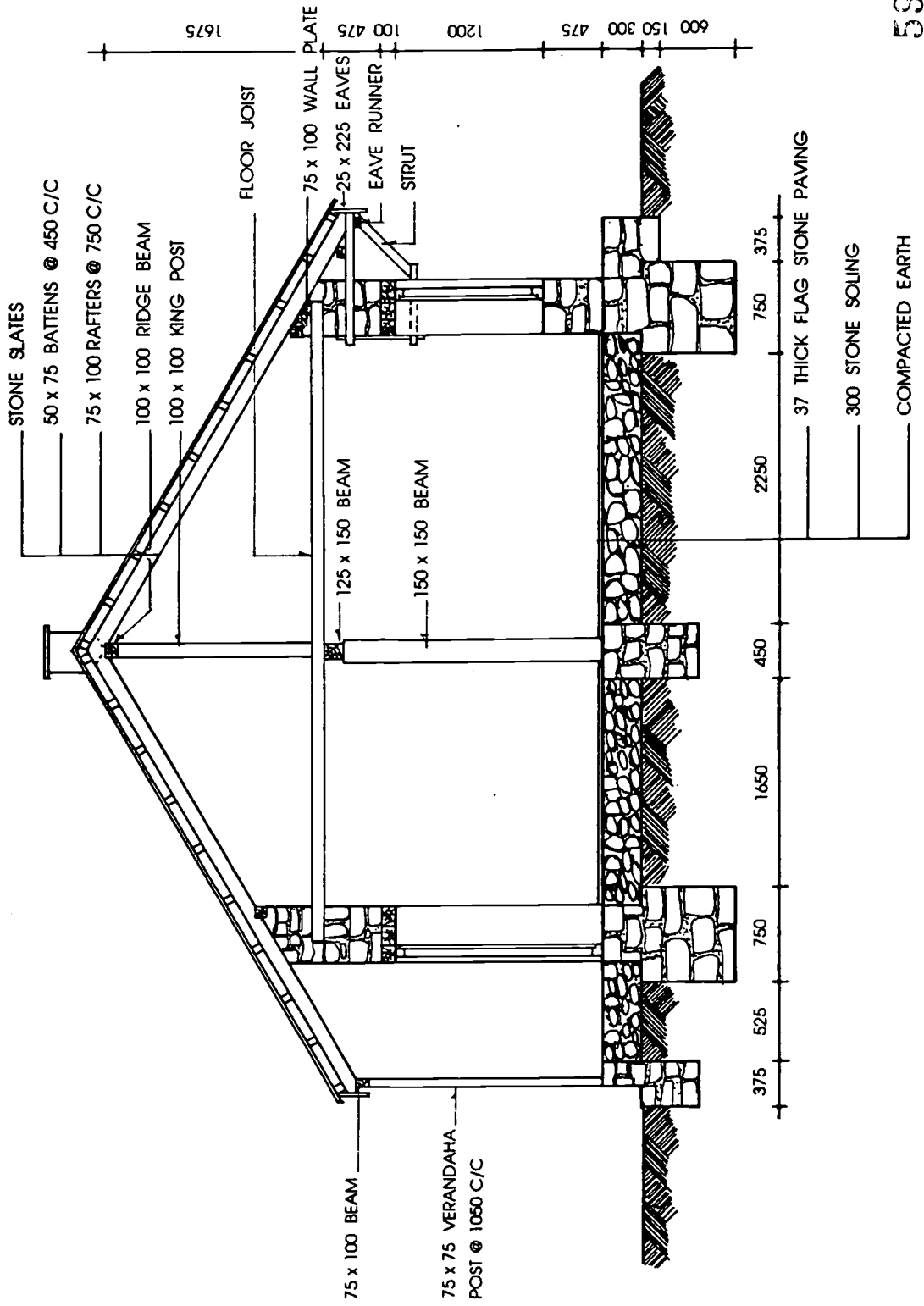

MARK I  
4 BAY DOUBLE STOREY BUILDING

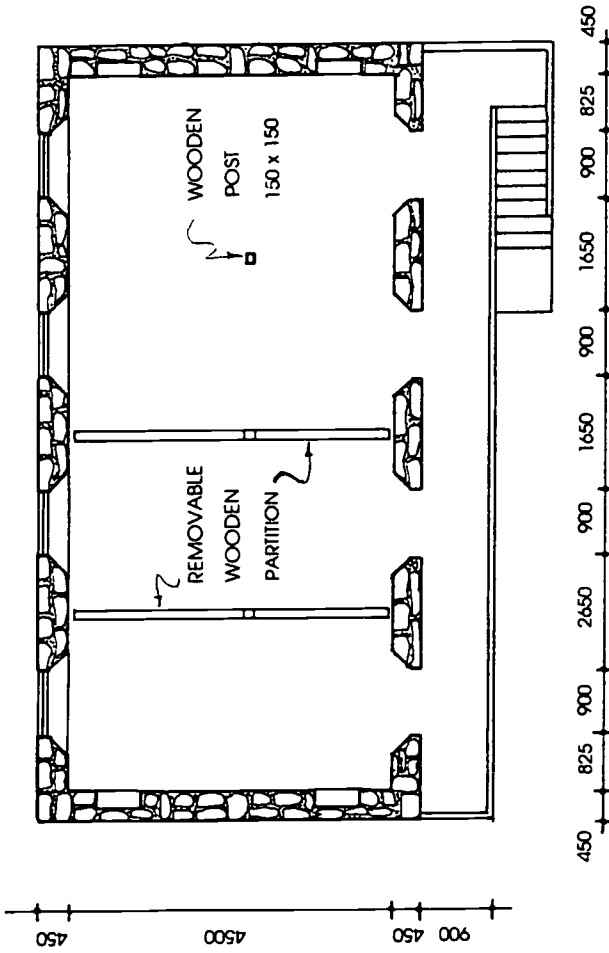

FIRST FLOOR PLAN

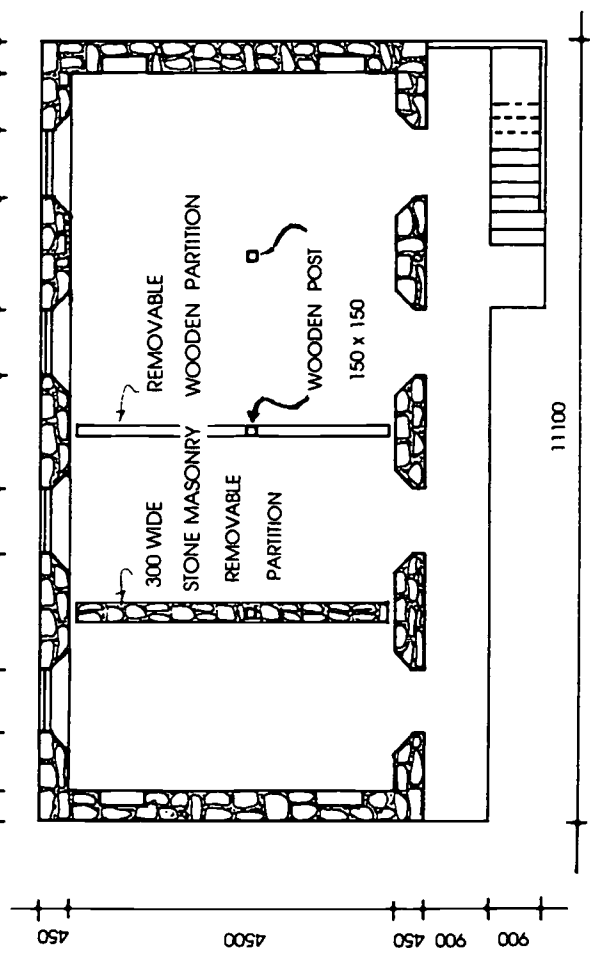

GROUND FLOOR PLAN

**MARK I  
5 BAY DOUBLE STOREY BUILDING**

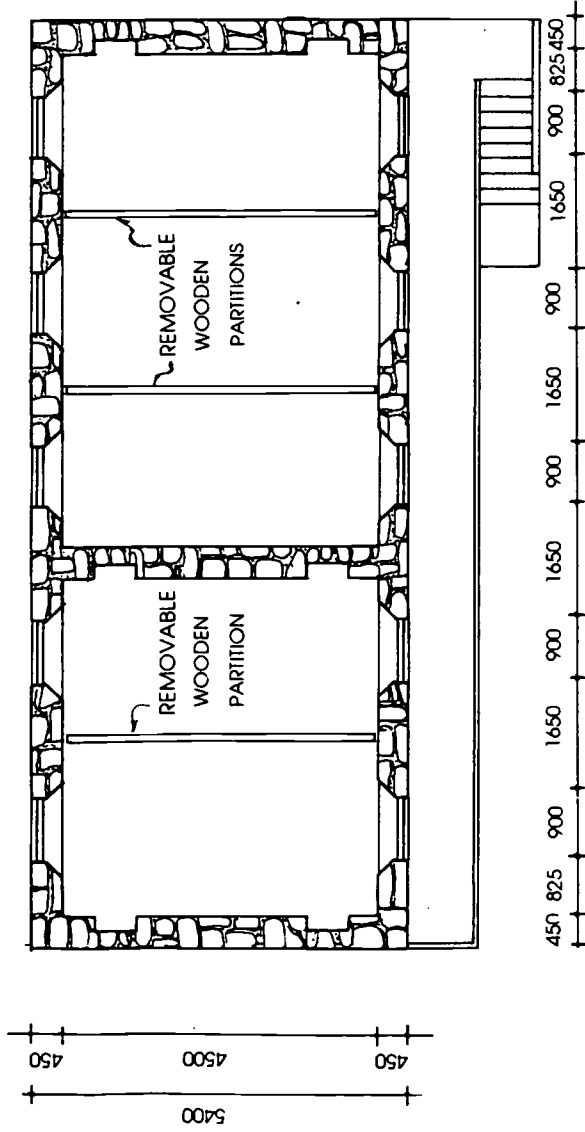

**FIRST FLOOR PLAN**

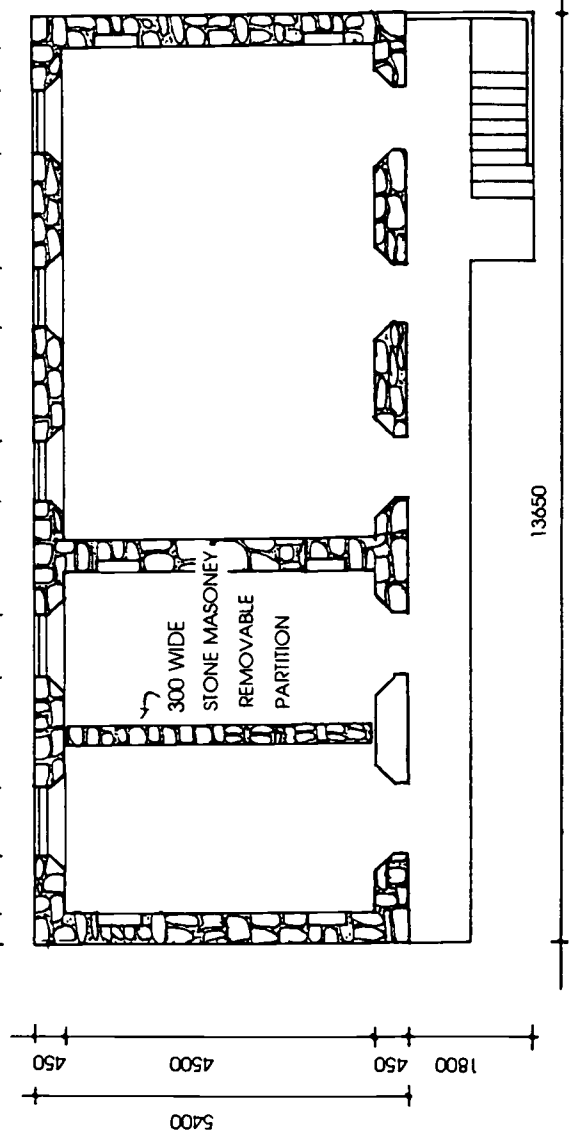

**GROUND FLOOR PLAN**

62

63



MARK I  
4 BAY DOUBLE STOREY BUILDING

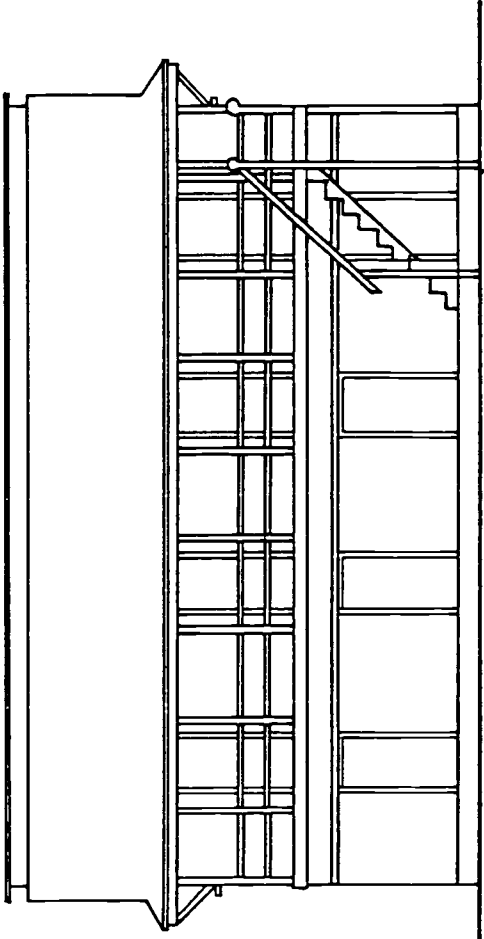

FRONT ELEVATION

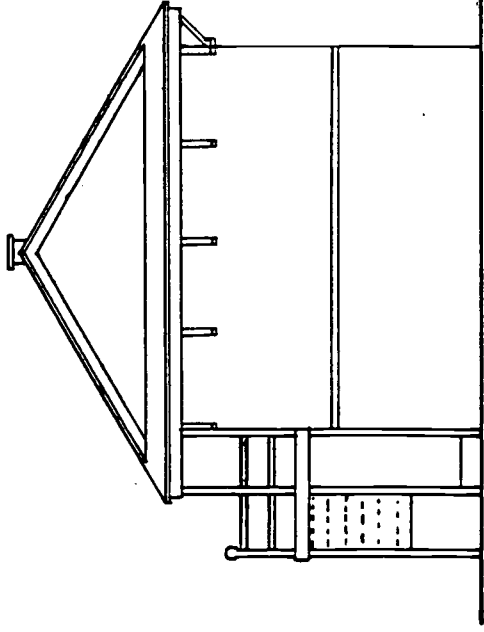

SIDE ELEVATION

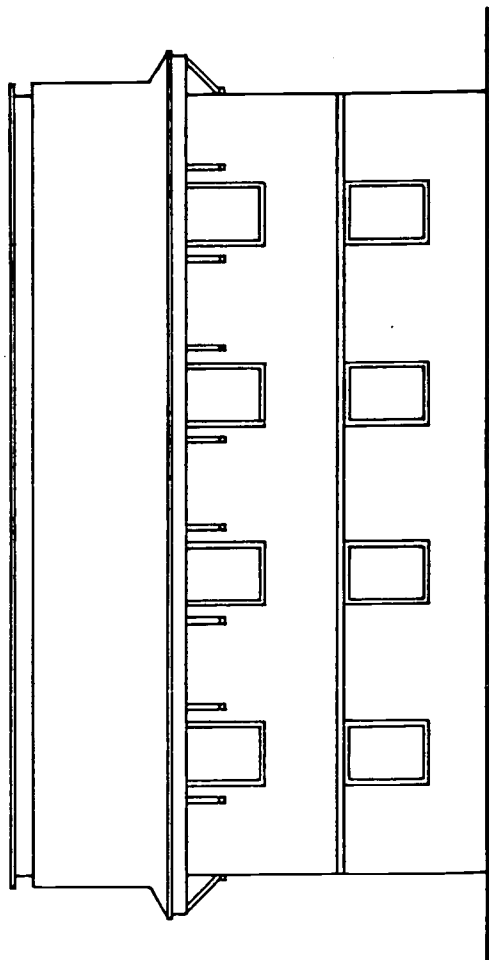

REAR ELEVATION

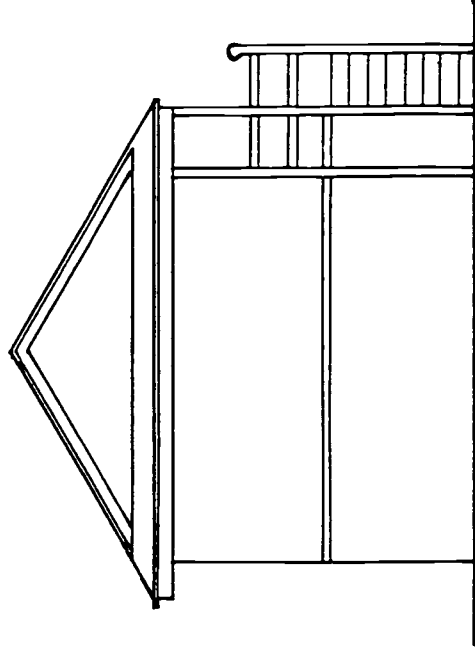

SIDE ELEVATION

**MARK I  
CROSS SECTION  
OF DOUBLE STOREY BUILDING**

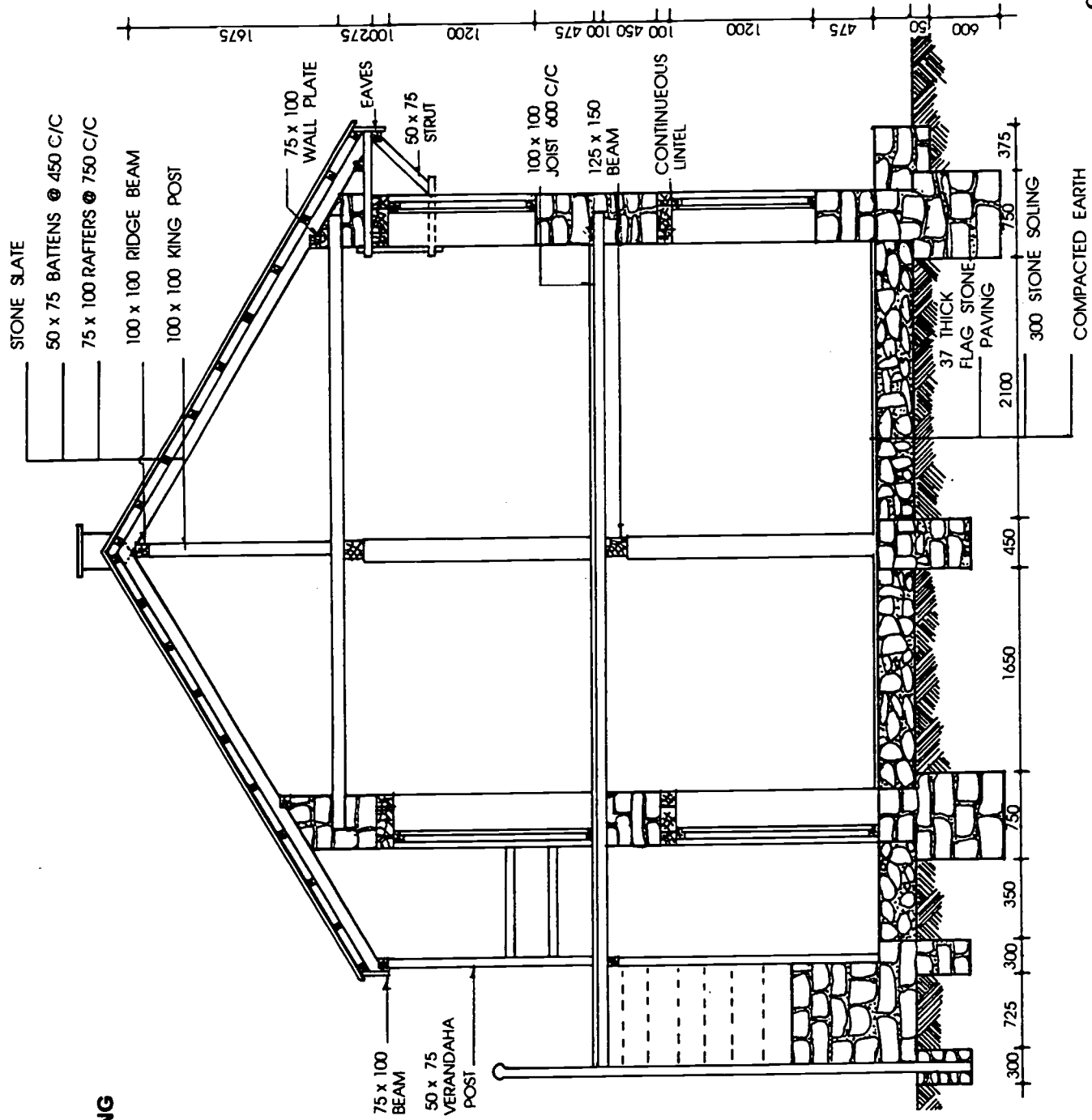

# PHOTO GALLERY I



**Photograph 5.** A small existing school building with very small window, damp floor and leaking roof.



**Photograph 6.** A temporary shade built by the community for the primary classes.

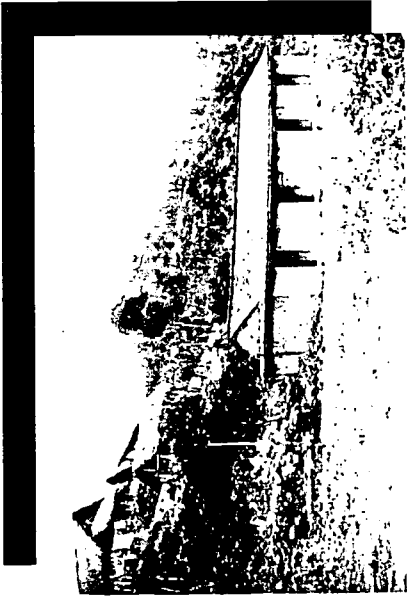

**Photograph 7.** The project built a 4-bay single storey building where two classrooms and a staff room is available.

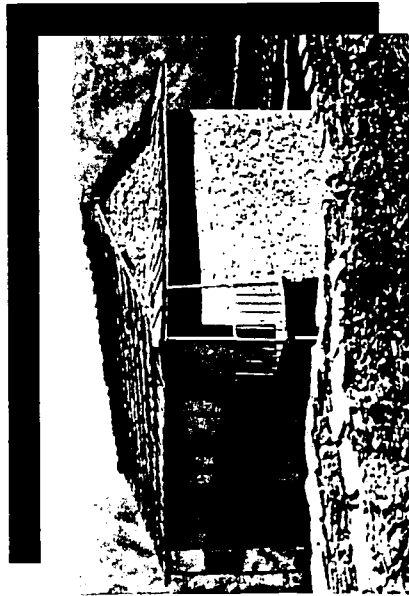

**Photograph 8.** This is the project supported building built at Bagthata school located below Silgashi bazar in 1983 in Doti district.

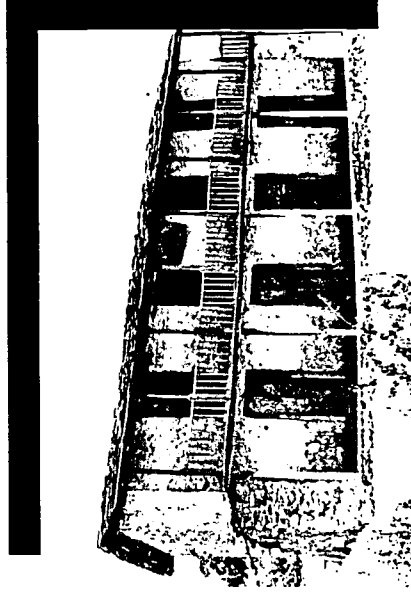

**Photograph 9.** 4-bay double storey building with wooden verandah built in 1983 at Bandungrtsain school in Doti district.



**Photograph 10.** Rear view of the building with its compound and Seti River behind it.

# PROGRAMME IMPLEMENTATION

The school construction component of the project is an innovative programme; therefore, at the end of each construction season, the results are reviewed and revised actions are decided for the next year. Although a survey of the whole project area was made before preparing the design and a workshop of concerned people was held to make the design relevant to the area served, many things were based on assumptions that needed to be tested in practice. In fact, substantial improvements have been made in the programme during the last few years, with a considerable increase in scale and area covered.

An annual construction target is fixed every year and, year by year, the programme has increased in scale as it has expanded to new areas or districts. The technical staffs are arranged according to the annual work load. In 1982-1983, only 20 new buildings were begun, with four overseers looking after five sites each.

By 1989-1990, the following is the work load undertaken

Construction Activities	Carry over from Previous Year	New Undertaking
1. School building	106	60
2. Compound wall	25	55
3. Playground	16	25
4. Water supply	11	25
5. Latrine	18	40
6. V.R.C. Building	33	40
7. Repair (RC support)	5	12
<b>Total</b>	<b>214</b>	<b>257</b>

70

This is handled by a staff of 22 technical personnel, including:

Senior overseer (unit head)	1
Overseer	5
Sub-overseer	12
Water technician	2
Building supervisor	2
<b>Total</b>	<b>22</b>

It is very difficult to find good overseers and keep them in the project for a long period. This results in a shortage of overseer personnel and means that sometimes a single technician has to conduct follow-up activities for more than 50 sites.

The annual programmes, their results and revisions, are briefly described in this Chapter.

## 1982-1983

### Programme

- On the basis of the first design and estimate, twenty double-storey school buildings were begun in Doti.
- A set of technical drawings, noted in the English language, was produced; this was issued to both overseers and communities.
- An illustrated booklet in Nepali, which pointed out the problems with existing school buildings and depicted ways in which new facilities could be provided to enhance the school environment was produced and distributed to both communities and overseers.
- A small English-language booklet explaining administrative procedures and the contract with the community was issued to district education offices.
- P.V.C. sheets were provided for the damp-proof course.

71

## Result

- Many communities could not agree on a school site; consequently, many buildings were not laid out until late in the construction calendar.
- Education in the project area was very poor; consequently, the people did not recognize the benefits to be derived from the school construction and, therefore, were not interested in participating in the programme.
- Communities tended to ignore any design that was different from local style (e.g. splaying of door and window, position of centre post at the centre line of the building, introduction of a verandah and earthquake lintel).
- Technical drawings in the English language were not understood, even by the teachers.
- Because none of the schools was roofed before the monsoon began in 1983, many collapsed due to heavy rains on unprotected walls of mud mortar.
- Levels of workmanship were poor.

## Revision

- The beam running down the centre of the building to support the first floor at mid-span was changed to three separate ones running across the building width. This gave more stability to front and rear walls and placed the main bearing members at a location above which future classroom dividing partitions would be built.
- Improved plan, elevation, sections and details were prepared for the four-bay, double-storey (six rooms) variant, which was the most commonly used, and all drawings were noted in Nepali script and numerals.
- A standard set of carpentry tools, including a six-foot saw, was introduced.
- The subsidy was increased in line with inflation and the number of payment stages was reduced from six to five. The subsidy for the compound wall (100 feet by 2 feet by 3 feet) was included in the payment for the final stage.

72

## 1983-1984

### Programme

- Twenty-four schools were started in Doti.
- Revised drawings noted in Nepali were given to the villagers and overseers.
- A five-bay, single-storey design was introduced.
- Construction of compound walls, playground facilities, and repair work on resource centres also were begun.

### Result

- Progress and workmanship improved slightly.
- A few schools were roofed before the 1984 monsoon.
- Poor structural timber work was noted – timbers tended to be thinner than specified.
- Poor carpentry work was observed in door and window frames, and particularly in the verandah, which had a negative affect on the safety and appearance of the building.
- Because of a lack of skill and knowledge, new project tools were not much used and the villagers continued to depend on their traditional tools.

### Revision

By the end of the 1984 construction season in June, the achievements were evaluated. The most serious problems highlighted by this evaluation included the following.

- The removable wooden partition was not properly built and caused serious acoustic problems.
- The first floor and the roof structure were much too complicated, with large wooden sections and too many joints.
- The teachers found the small one-bay classrooms and odd shape and had difficulty arranging students in front of the blackboards.
- Although much better than existing buildings, the new schools were still dark inside, because of a common failure to cut away enough ground at the rear to allow light to penetrate into ground-floor rooms and the shadowing effect of the verandah at the front.
- The design required a large amount of timber. It also required large sections, long lengths and good quality for crossbeams, posts and purlins.

remotely serviceable earthquake lintel had been built. In fact, only longitudinal exterior members were placed, which would do nothing to increase resistance to earthquakes.

- The building did not seem very stable as its strength was largely dependant on the wood work, which was often very poor.

It was decided that these problems justified an extensive rethinking of the basic design. During the 1984 monsoon period, a revised design (called Mark II) was produced to be used in the 1984-1985 building programme. The main features of the new design included the following items (see drawings on page 37-41).

- Two classrooms, one big and one small, were put on the first floor, reached by an internal staircase between them. This meant that the balcony/verandah could be eliminated, and that the staircase would be safer, as a balustrade, shown in the original design but rarely built, would not be required.
- All separating walls between classrooms were specified as stonework to solve the sound transmission problem. This also helped to brace the front and rear walls of the building, and first-floor joints would bear directly on them, reducing the complexity and amount of timber required for the first-floor structure.
- As there were now cross walls on each side of the staircase, built up to roof level, there would be shorter unbraced lengths of front and rear walls. Furthermore, the three roof purlins could be installed in the shorter sections. The number of centre post/crossbeam/purlin prop configurations would be reduced from three to two.
- The building height was decreased to reduce the danger of instability caused by non-vertical walls, as well as reduce the amount of work/materials required, while still producing teaching spaces of adequate height.
- One-bay classrooms were made slightly wider and shorter.
- A simpler form of main roof structure was suggested with short crossbeams supporting the two mid-span purlins and a taller centre post.
- A storeroom was added.

The improved building had a slightly increased floor area, compared to the first design, requiring 20 per cent less timber but 30 per cent greater volume of stone. A cost exercise using government building rates indicated that the notional costs of old and new designs were almost identical. However, while obtaining stone in west Nepal is easy, obtaining timber is difficult.

After UNESCO is approval of the preliminary designs, a comprehensive set of working drawings was produced which could be bound into a small booklet particular to each of the four size variants now used in the programme. Freehand drawings were made as simple and easy to read as possible, with notes and dimensions entirely in Nepali. The amount of information was increased to include the following: (see drawings on page 42-45)

- dimensioned foundation, ground floor and first floor plans;
- detailed, dimensioned cross-section with extensive note;
- window/door frames and shelf alcove details;
- latrine and water tap stand construction details;
- three-dimensional drawings showing the amount of work to be done for each stage;
- a sheet explaining feet and inch measurement and how they relate to local ways of measuring; and
- a cover page showing the completed building.

The payment system was again revised in an effort to ensure that the money became payable when it was most needed. The first stage sum was increased greatly to encourage commencement of construction and provide funds for immediate continuation (see Table 2).

The slating of the roof was made a separate stage of a sizeable amount to help the communities pay for this normally very expensive work.

The length of compound wall included in the last stage of work was increased to 150 feet with provision for an additional 550 feet (maximum) length to be subsidized under a separate compound wall programme. The number of payment stages returned to six as follows:



**Table 2** Improved Payment System

Stage No.	Work to be completed	(Amount Rs.)				
		4-bay 2-storey	5-bay 2-storey	4-bay 1-storey	5-bay 1-storey	5-bay 1-storey
1	Ground floor door/window frames fixed and walls to mid-door height. Wood for first-floor door, window frames collected.	6,000	7,400	4,500	6,000	
2	First-floor door/window frames fixed and walls to mid-height	4,500	5,400	n/a	n/a	
3	Walls finished and roof timbers fixed	3,500	4,400	3,000	3,600	
4	Roof slated	3,500	4,400	3,000	3,800	
5	Shutters fixed and mud plastering done	1,500	1,800	600	800	
6	Latrine and 150-foot compound wall built	2,000	2,200	1,500	1,800	
	<b>Total</b>	<b>21,000</b>	<b>25,600</b>	<b>1,200</b>	<b>16,000</b>	

**Bonus System**

Two bonus payments also were introduced as a reward for a good standard of work being achieved.

(Amount Rs.)

4-bay 2-storey	500	600	250	300
5-bay 2-storey	600	600	250	300
4-bay 1-storey				
5-bay 1-storey				

**Bonus 1:** Payable after the third stage payment for good stone work with large/through stones, a minimum of mud mortar and straight vertical walls

**Bonus 2:** Payable after fifth stage payment for good timber work, with correctly sized, good quality timbers and skilled workmanship.

**Subsidy**

There had been another increase in government construction rates, so the total subsidies were increased. As the one-storey building was found to have been oversubsidized in previous programmes, its subsidy increased less than the two-storey ones. No more tool kits were to be provided.

**MARK II**  
**5 BAY SINGLE STOREY BUILDING**  
**4 BAY SINGLE STOREY BUILDING**

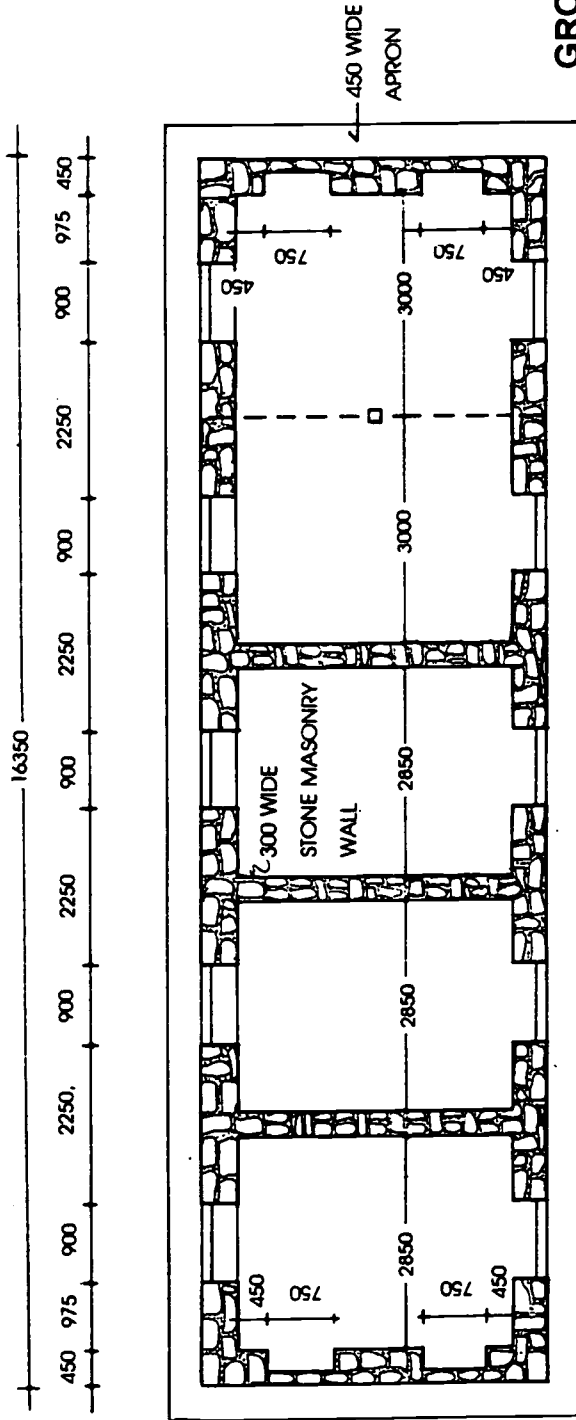

**GROUND FLOOR PLAN**

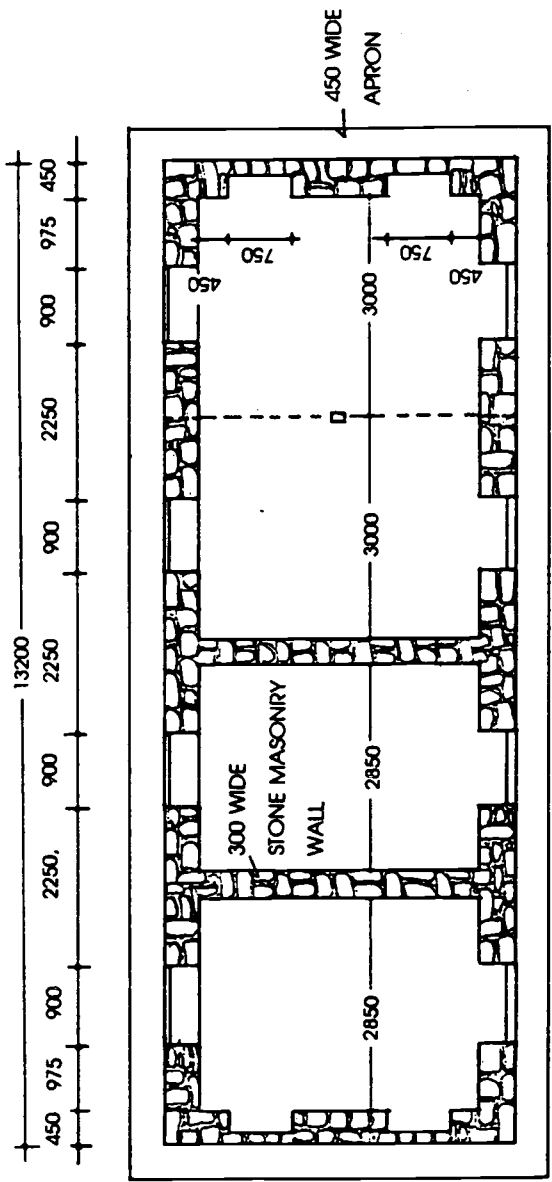

**GROUND FLOOR PLAN**

78

79



**MARK II  
4 BAY SINGLE STOREY BUILDING**

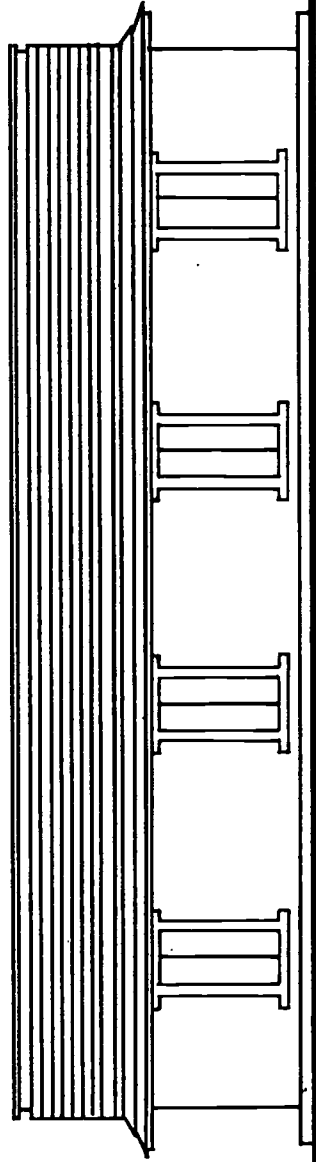

**FRONT ELEVATION**

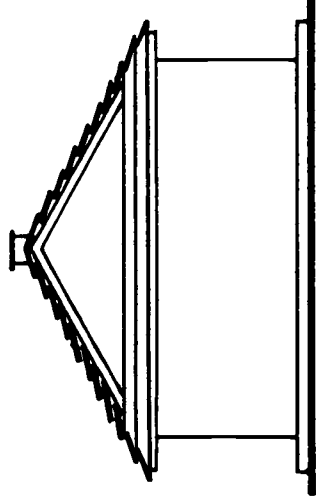

**SIDE ELEVATION  
( BOTH SIDES )**

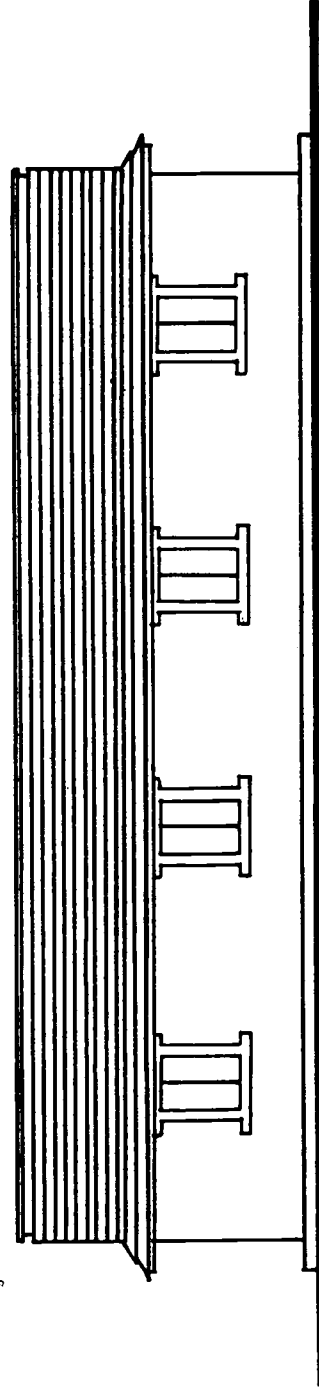

**REAR ELEVATION**

80

81

MARK II  
5 BAY SINGLE STOREY BUILDING

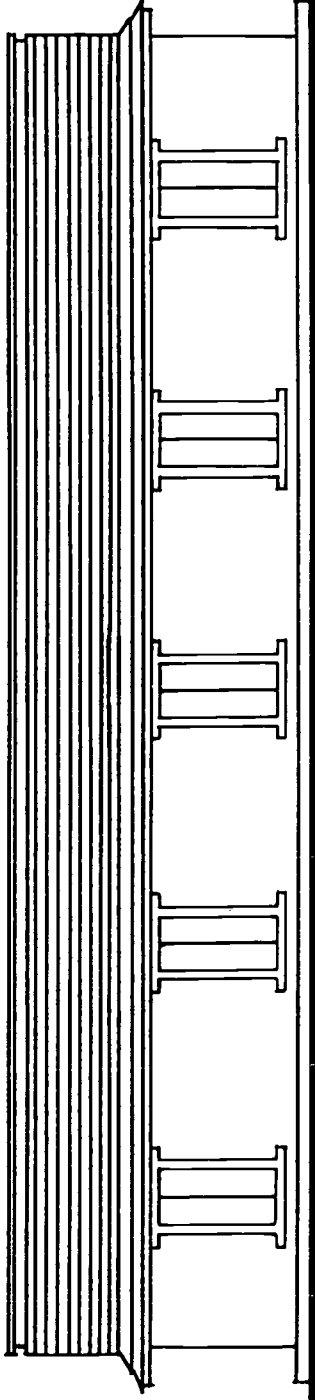

FRONT ELEVATION

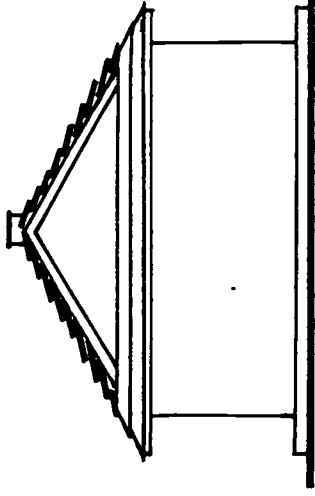

SIDE ELEVATION  
( BOTH SIDES )

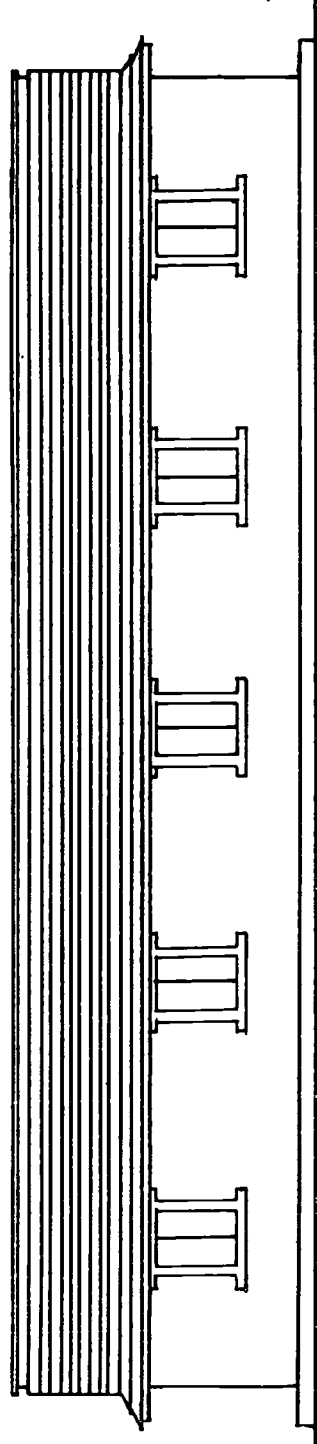

REAR ELEVATION

83

82

**MARK II  
CROSS SECTION  
OF SINGLE STOREY BUILDING**

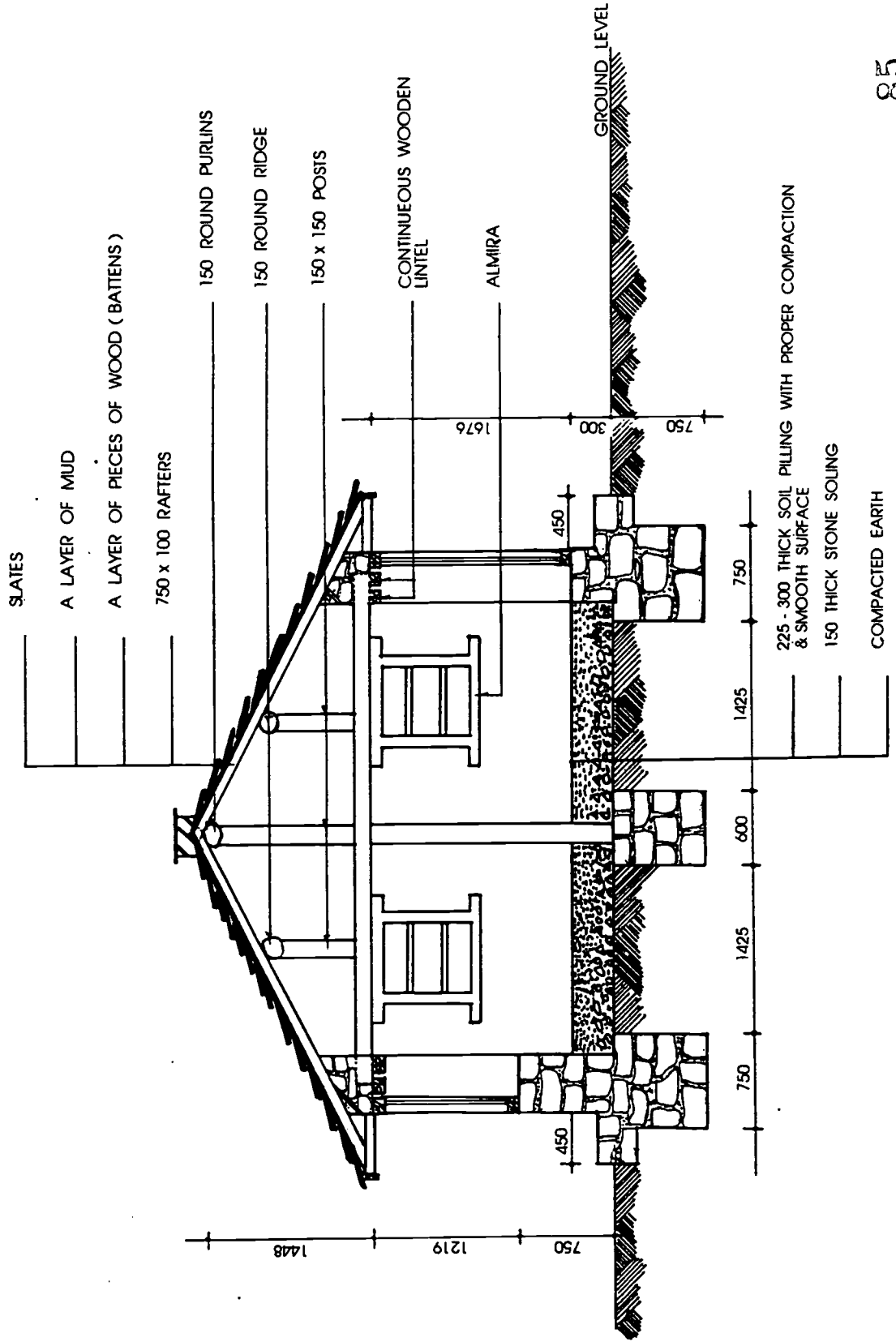

84

85

MARK II  
4 BAY DOUBLE STOREY BUILDING

FIRST FLOOR PLAN

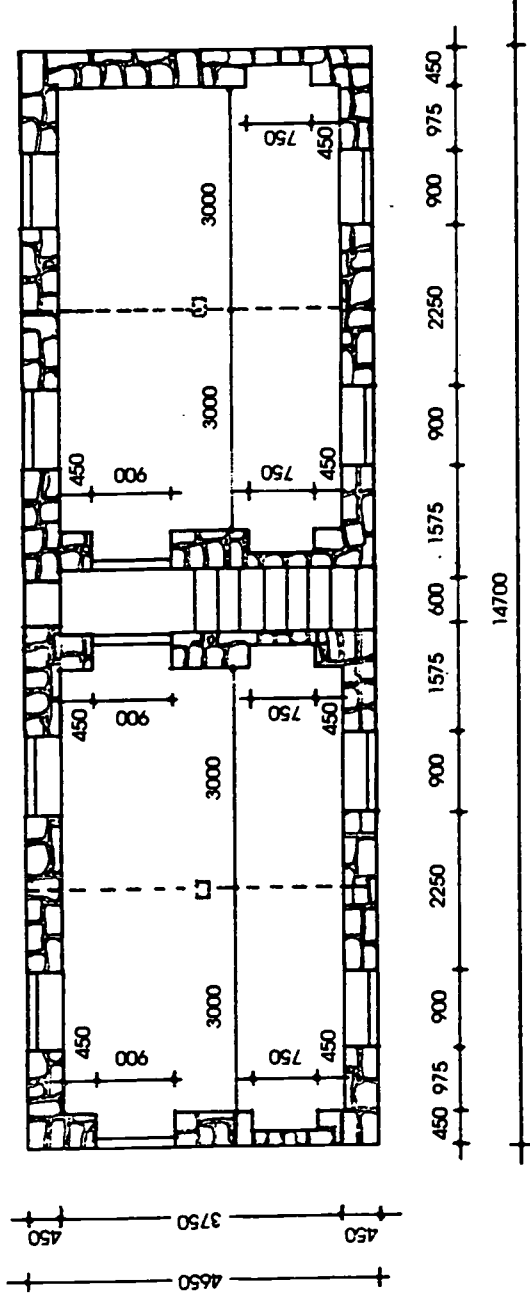

GROUND FLOOR PLAN

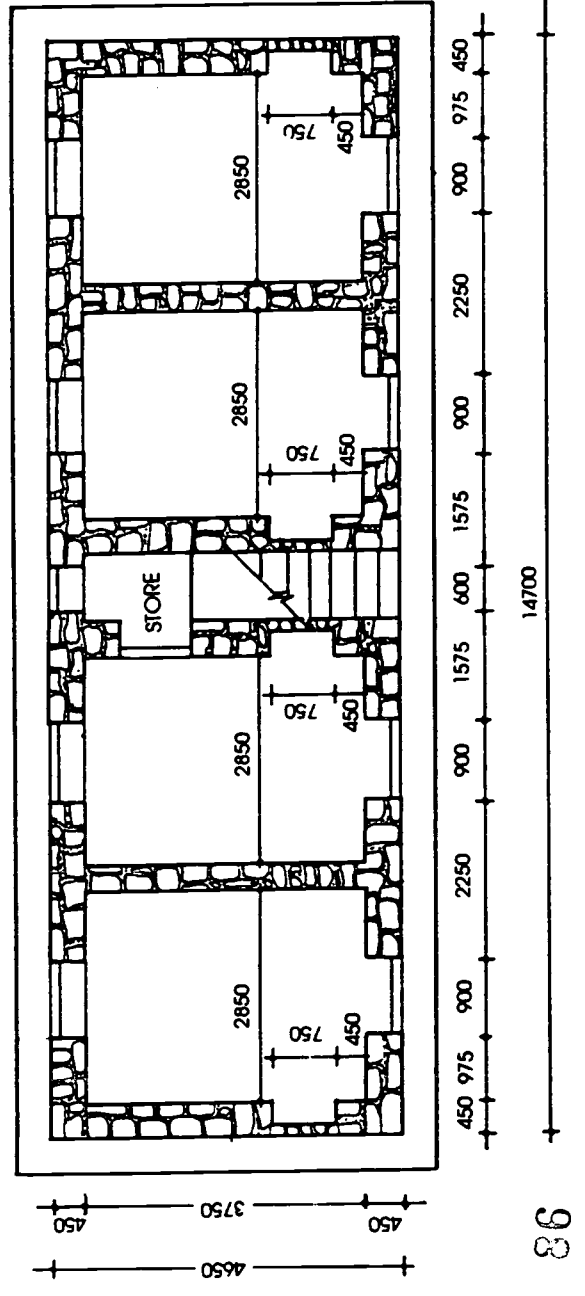

MARK II

5 BAY DOUBLE STOREY BUILDING

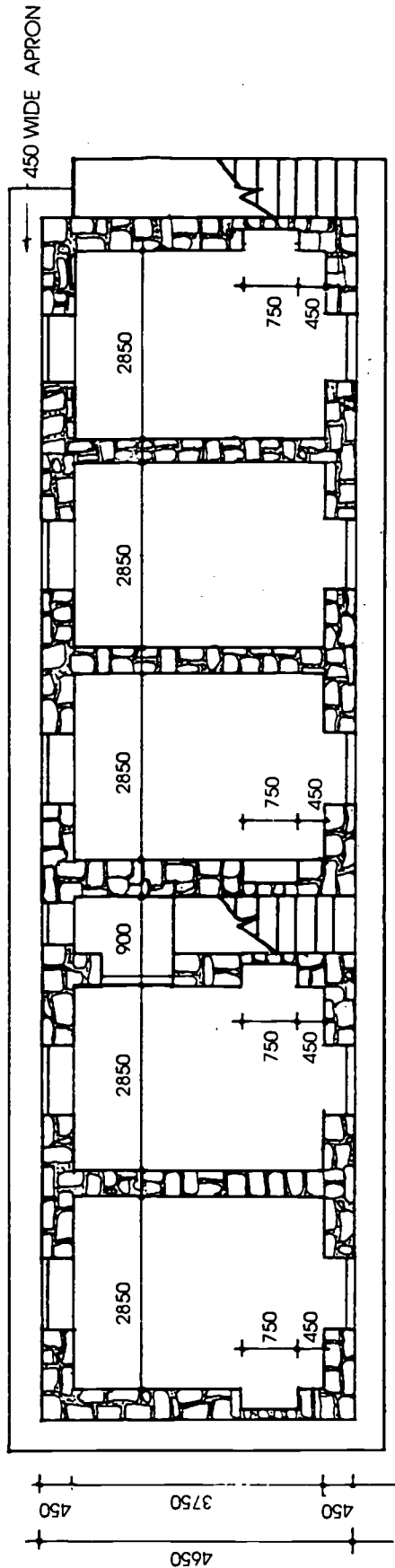

450 975 900 975 300 975 900 975 300 975 900 975 300 975 900 975 300 975 900 975 300 975 900 975 450

17850

GROUND FLOOR PLAN

450 975 900 975 2250 900 1425 900 1425 900 1425 900 2250 900 975 300 975 900 975 300 975 900 975 450

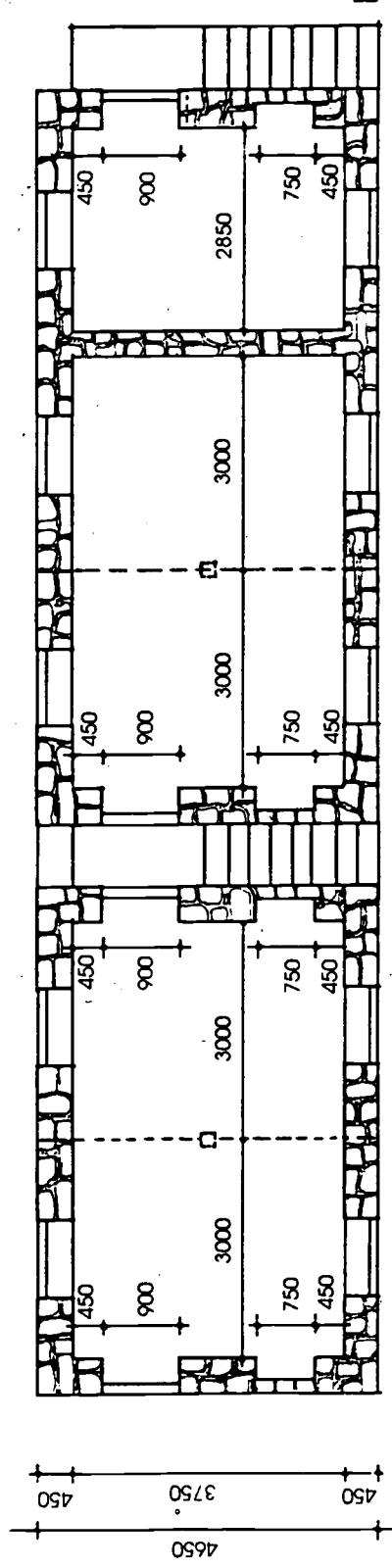

450 975 900 975 2250 900 1425 900 1425 900 2250 900 975 300 975 900 975 300 975 900 975 450

17850

FIRST FLOOR PLAN

MARK II  
4 BAY DOUBLE STOREY BUILDING

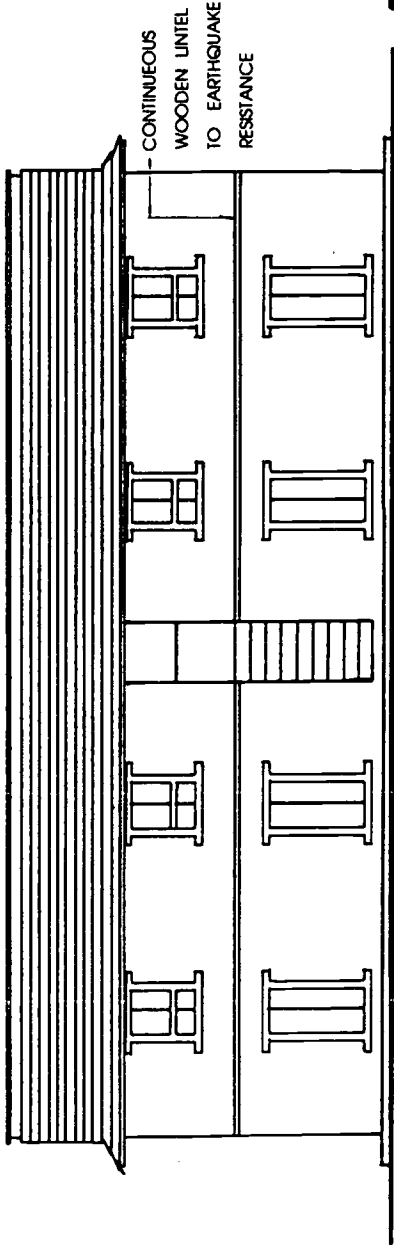

FRONT ELEVATION

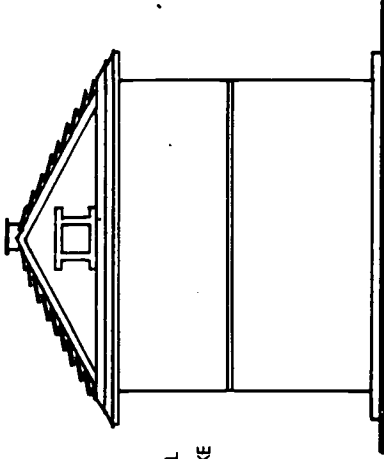

SIDE ELEVATION  
( GABLE END )

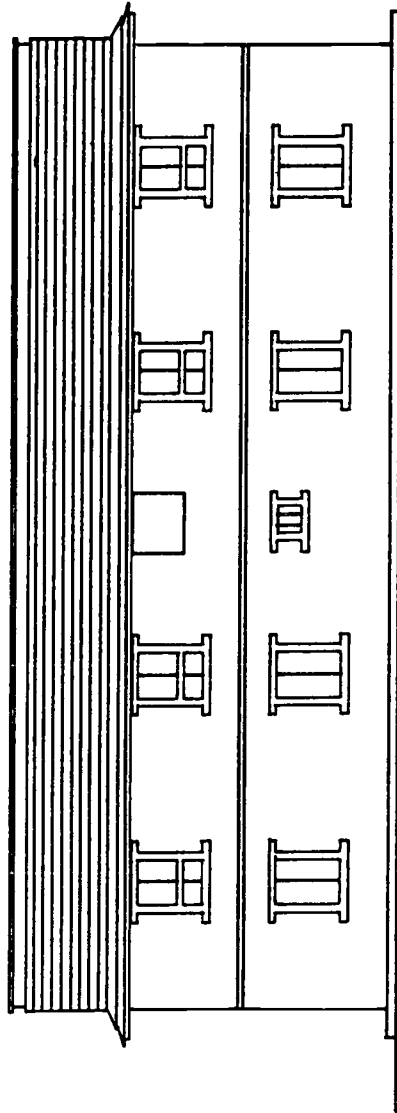

REAR ELEVATION

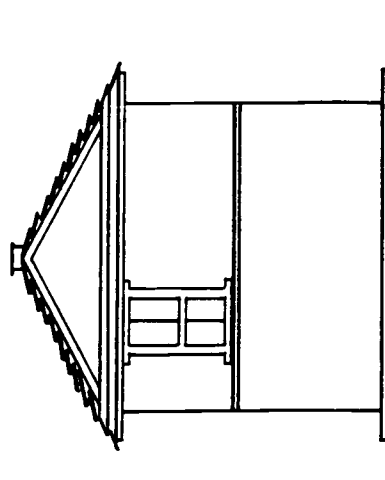

SIDE ELEVATION  
( GABLE END )

90

91



**MARK II  
5 BAY DOUBLE STOREY BUILDING**

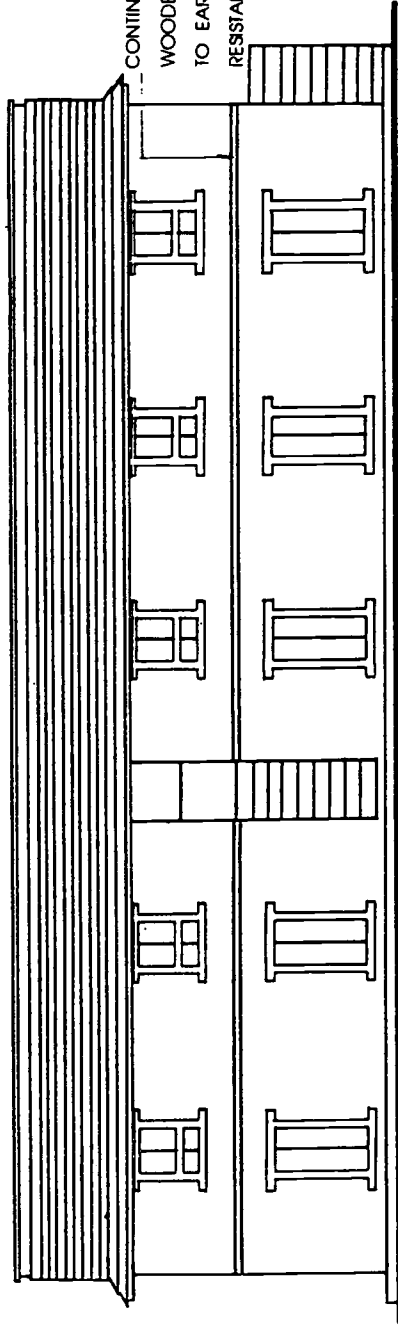

**FRONT ELEVATION**

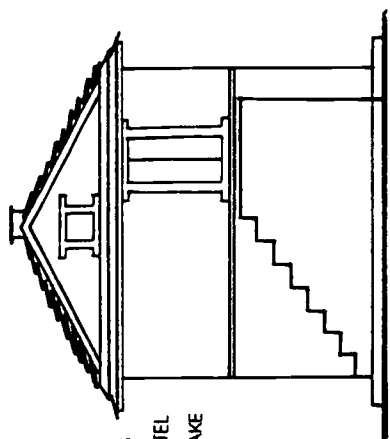

**SIDE ELEVATION**

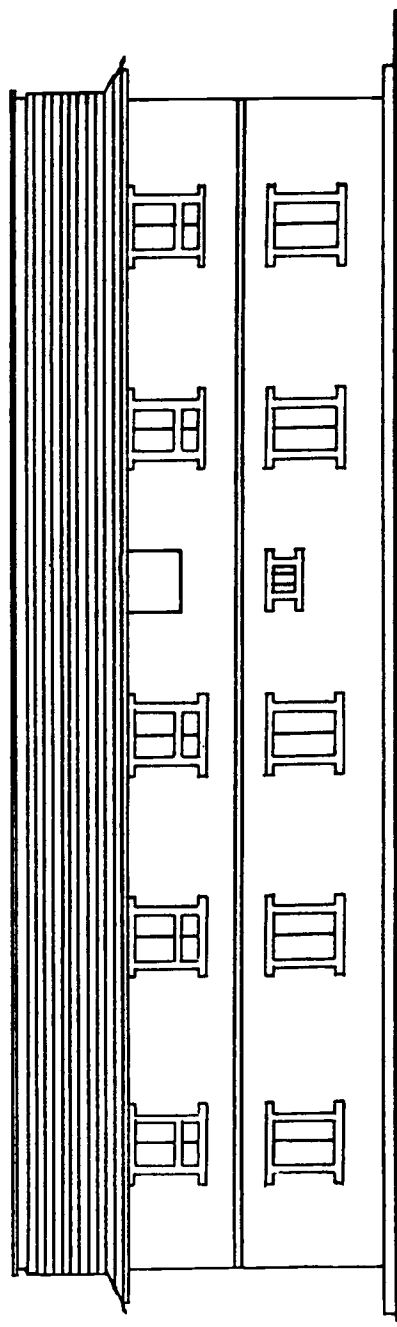

**REAR ELEVATION**

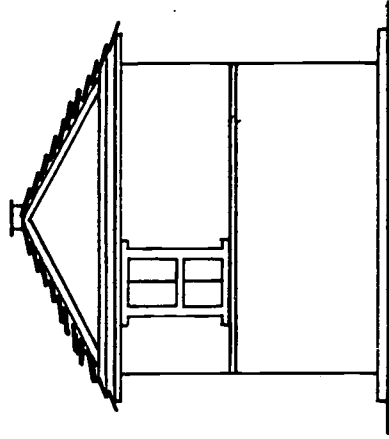

**SIDE ELEVATION**

**MARK II  
CROSS SECTION  
OF DOUBLE STOREY BUILDING**

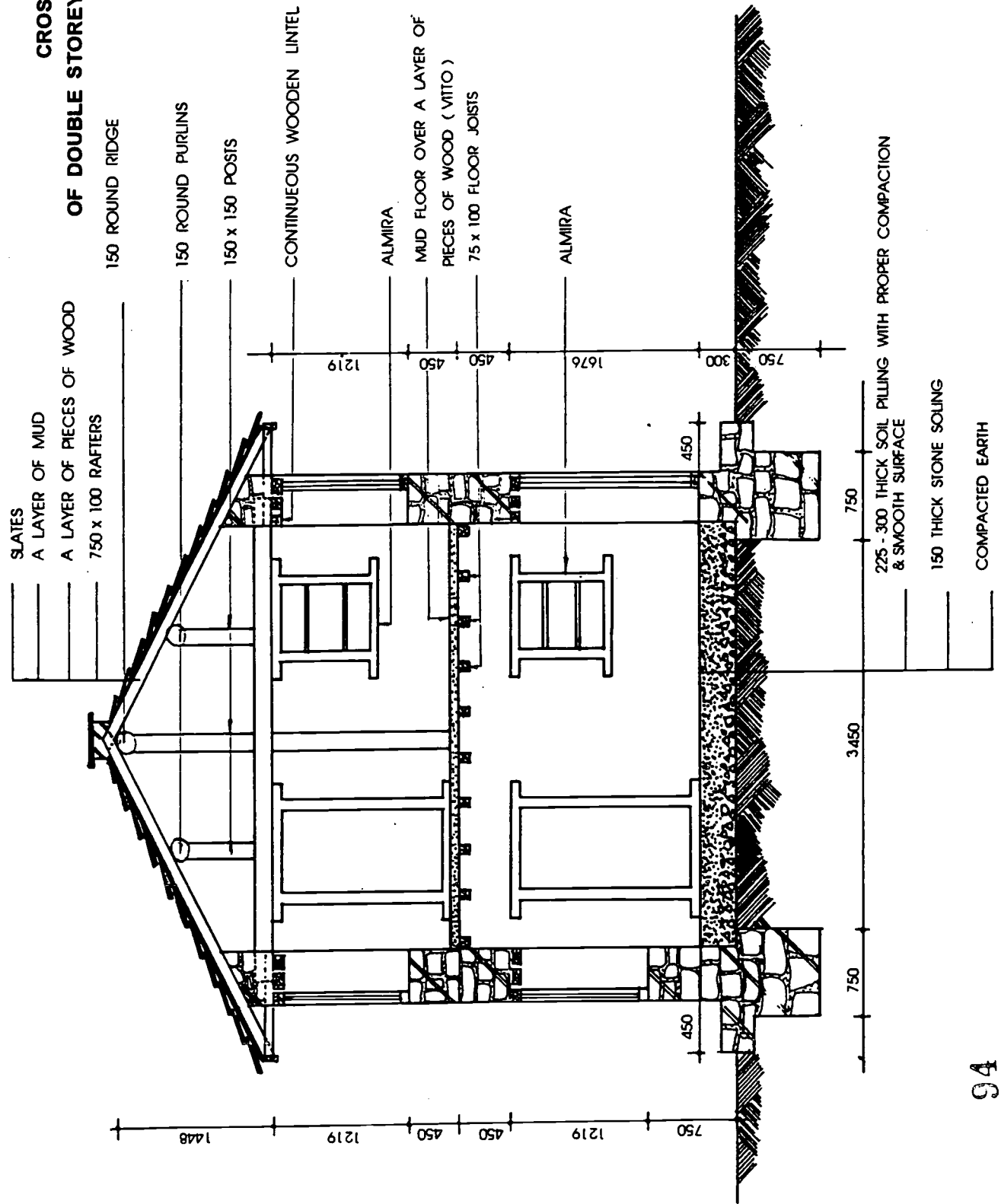

94

95

**MARK II  
ILLUSTRATION TO VILLAGERS  
REGARDING MEASUREMENT**

DIFFERENT PEOPLE HAVE  
VARIATIONS IN LENGTH OF  
THEIR HAND FOR ACCURATE  
MEASUREMENT A MEASURING  
TAPE SHOULD BE USED

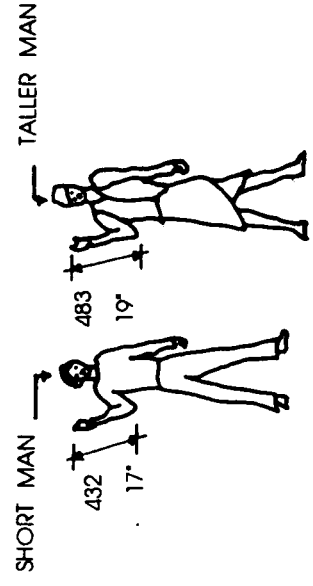
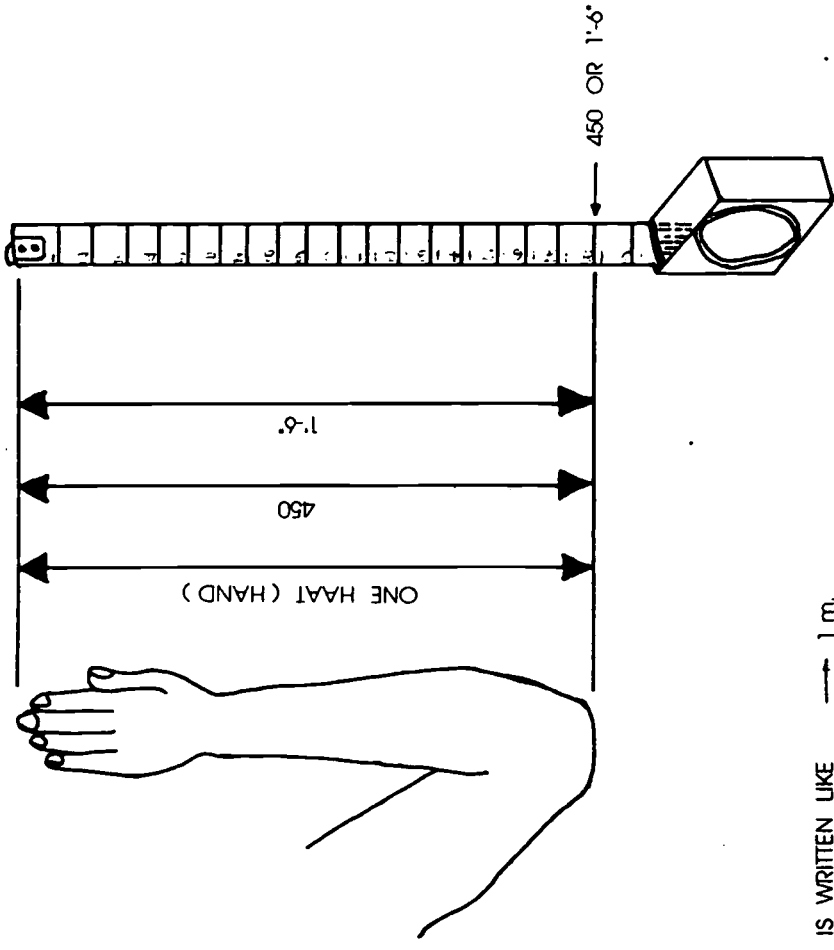

- 1' = 12" (INCHES)
- 2' = 24"
- 3' = 36"
- 4' = 48"
- 5' = 60"
- 6' = 72"

METER IS WRITTEN LIKE  $\rightarrow$  1 m.  
FOOT IS WRITTEN LIKE  $\rightarrow$  1'  
INCHES ARE WRITTEN LIKE  $\rightarrow$  1"

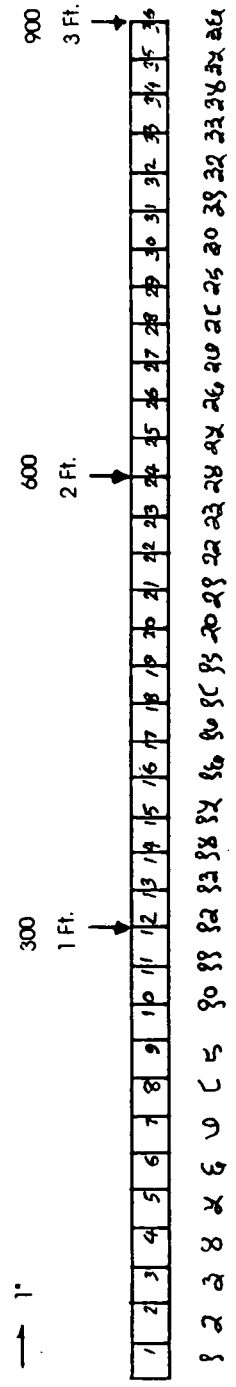

ENGLISH NUMBERS  
NEPALI NUMBERS



**MARK II  
ILLUSTRATION TO VILLAGERS  
ENCLOSED WITH DRAWING**

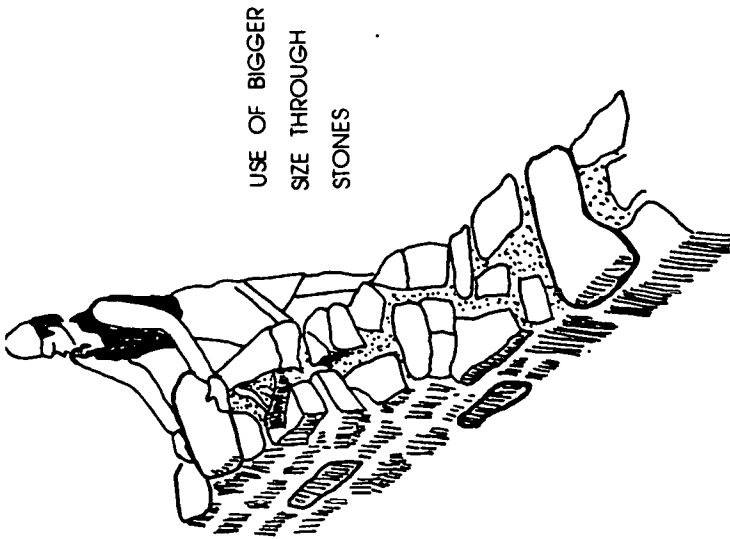

USE OF BIGGER  
SIZE THROUGH  
STONES

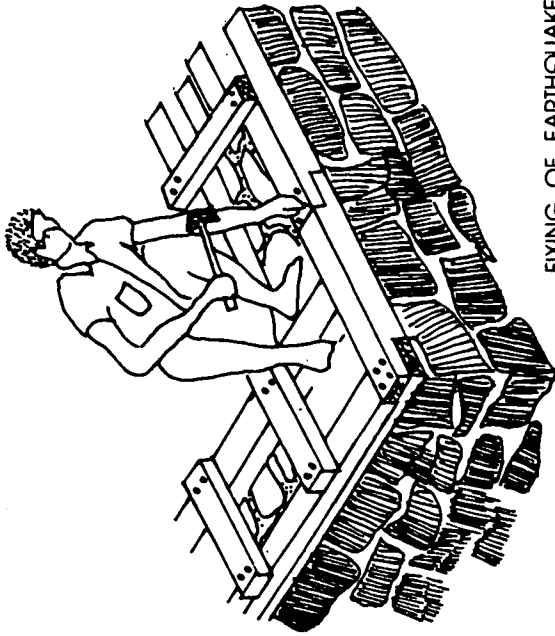

FIXING OF EARTHQUAKE  
LINTEL

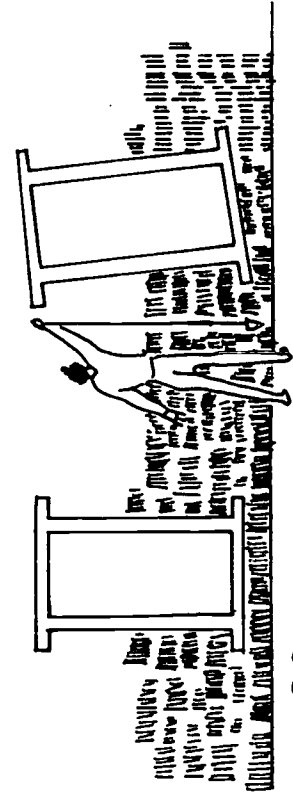

DOOR FRAME FIXING

58 GOOD

BAD

59

MARK II  
ILLUSTRATION ON  
DOOR, WINDOW, AND ALMIRA

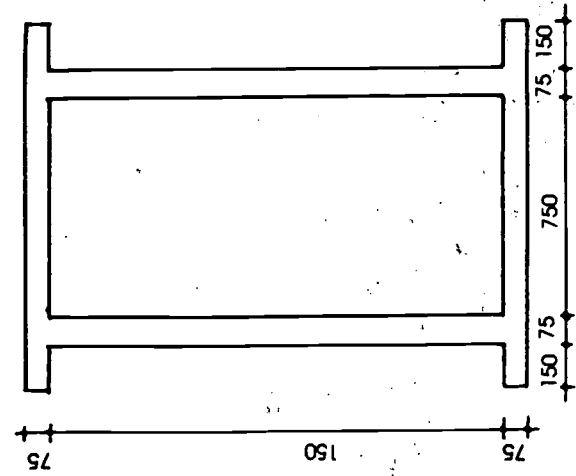

DOOR

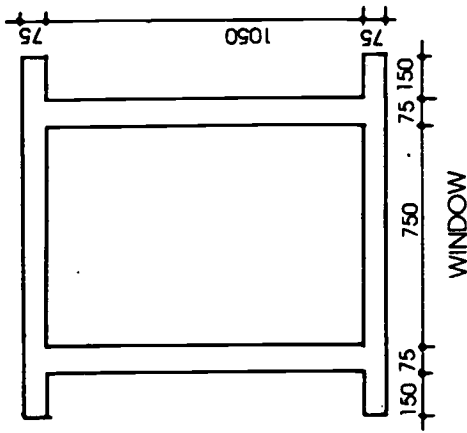

WINDOW

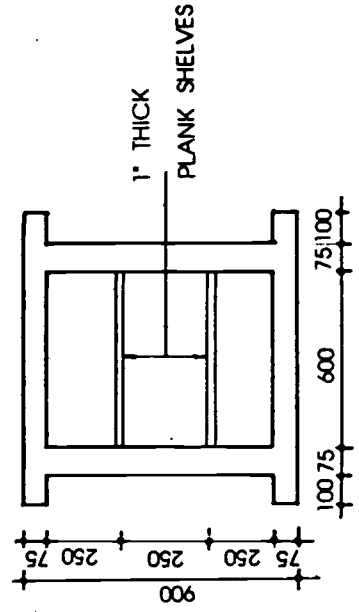

ALMIRA

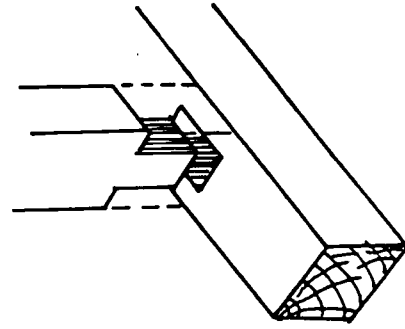

DOOR AND WINDOW FRAME  
JOINT DETAILS

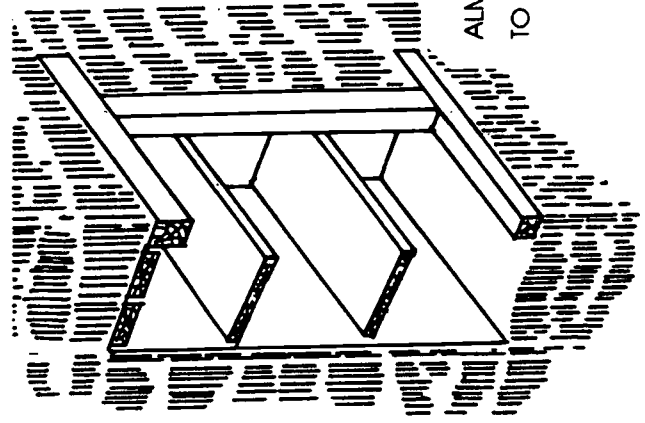

ALMIRA FIXED  
TO THE WALL

**MARK II  
ILLUSTRATION ON  
HOW TO CONSTRUCT PIT LATRINE**

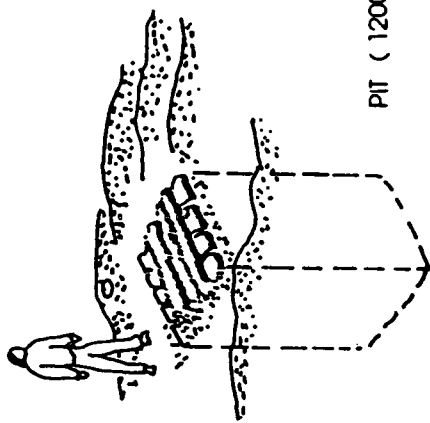

PIT ( 1200 x 1200 )

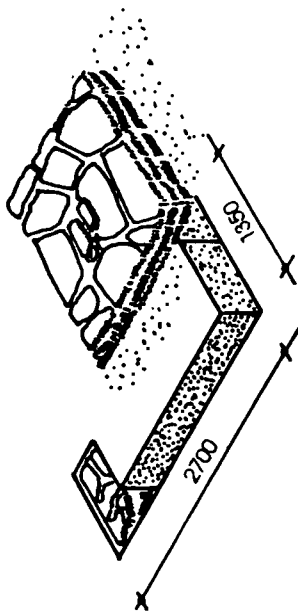

PLAN AT FLOOR LEVEL

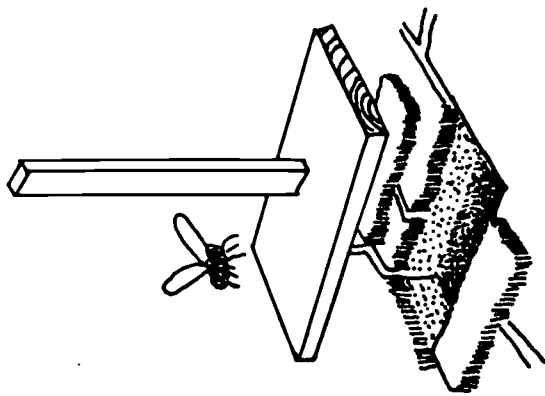

COVER TO KEEP

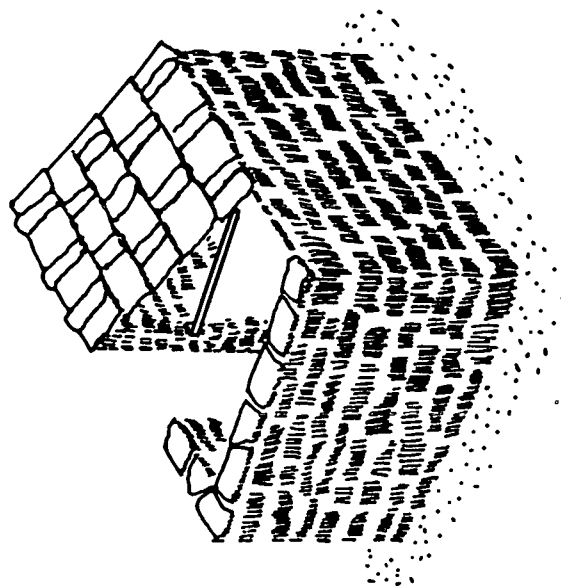

COMPLETED  
LATRINE

102

103

## 1984-1985

### Programme

- Eighteen schools started in Doti and 24 schools started in Bajhang.
- Revised drawings distributed.
- Programme started soon after the monsoon.
- A cardboard model of the revised four-bay, two storey building made and shown to the villagers.
- Bonuses for high standards of woodwork and stonework introduced.
- School water supply and village reading centre buildings also started in Doti.

### Result

- About half of the total schools begun in Bajhang were roofed before the 1985 monsoon; a few took only three to four months to build.
- In Doti, progress and workmanship was slightly improved.
- The cardboard model proved to be very useful and helped the villagers to understand the design and construction.
- The appearance of the new design was happily accepted and appreciated by many.
- The PVC damp proofing was expensive, difficult to deliver and not always correctly used.

### Revision

- The staircase was moved towards the centre of the building, making two halls in the upper floor and further increasing the structural rigidity while simplifying construction.
- Shelves were placed in each room.
- The bonus system was changed to a prize system.
- It was decided to stop giving PVC sheet for the damp-proof course.

104

## 1985-1986

### Programme

- Four schools in Doti and 28 schools in Bajhang were started.
- A water supply programme was started in Bajhang.
- During the peak construction season, the staffing situation became critical, as all of the overseers who had worked for the first few years had left the project and the British architect recruited through Voluntary Service Overseas (VSO), who made a significant contribution to the programme during his two-year stay in the project, also completed his service. Until April 1986, there were only two new sub-overseers and a construction supervisor working in the programme; in April, a new VSO engineer and two more overseers joined the project.

### Result

- Progress and workmanship in Bajhang continued to be good, but in Doti it continued to give cause for concern.
- Only three of the 28 schools started in Bajhang were completed at the end of 1985. In many schools started in previous years in Doti and Bajhang, the last two stages remained incomplete, although the buildings were already in use. The reasons for the incompleteness were that some of the work included in the final stages (shuttering, mud plastering, a latrine and part of the compound wall) were not important for the functioning of the buildings, and the payments for the stages were not big enough to provide an incentive for completion.

105



## Revision

- Stage payments were reduced from six to four, making the first and last stages more attractive; latrine construction was moved from the last stage to the first stage; the 150-foot compound wall was removed from the last building payment stage, assuming that the whole compound wall would be built under a separate contract and Rs. 1300 was deducted from the subsidy for each type of building accordingly. The revised stage payment are as follows:

Stages of payment	Work to be completed	(Amount Rs.)				
		4-bay 2-storey	5-bay 2-storey	4-bay 1-storey	5-bay 1-storey	5-bay 1-storey
1	Walls up to mid-height of ground-floor door and a latrine built	6,700	8,300	4,700	6,500	n/a
2	Walls constructed up to mid-door height on 1st floor	4,500	5,400	n/a	n/a	n/a
3	Roof timbers erected	3,800	4,700	3,300	3,900	3,900
4	Roof slated, shuttering, mud plastering done and site cleaned	4,700	5,900	3,300	4,300	4,300
	<i>Total</i>	19,700	24,300	11,300	14,700	14,700

## 1986-1987

### Programme

- Three schools in Doti, 19 in Bajhang, and ten in Bajura were started.
- Compound walls, playgrounds in Bajura and village reading centre buildings were started in Bajhang.

### Result

- Progress and workmanship continued to be satisfactory in Bajhang, but progress in Doti was slow. In Bajura, progress was good but workmanship showed room for improvement.

## Revision

- Subsidy increased by ten per cent and stage payments revised, making the first and last stages even more attractive. The revised payments were:

Stages of payment	Work to be completed	(Amount Rs.)				
		4-bay 2-storey	5-bay 2-storey	4-bay 1-storey	5-bay 1-storey	5-bay 1-storey
1	Walls up to mid-height of ground-floor door and a latrine built	7,500	9,000	5,000	7,000	7,000
2	Walls constructed up to mid-door height on 1st floor	5,000	6,000	n/a	n/a	n/a
3	Roof timbers erected	3,700	4,700	3,400	4,200	4,200
4	Roof slated, shuttering, mud plastering done and site cleaned	5,500	7,000	4,000	5,000	5,000
	<i>Total</i>	21,000	26,700	12,400	16,200	16,200

## 1987-1988

### Programme

- Nineteen schools in Doti, 14 in Bajhang and 28 in Bajura were started.
- A water supply was started in Bajura.
- Turnover of the staff continued, creating supervision problems in Bajhang and Bajura where the programmes were larger.
- During the construction season, twenty sets of carpentry tools were provided to schools in Bajura.

### Result

- Better progress and workmanship in Doti and Bajhang, due in part to the active involvement of the DEOs, but in Bajura the situation remained largely unchanged.
- Many schools were completed within the one construction season.
- As distribution was late and training not given, the tools provided to Bajura schools were inadequately used.
- In practice, it was found that the latrine was usually not completed until after the school building was finished, because the villagers concentrated on the school construction and any remaining materials were used to build the latrine.

Figure 3. Four Stages of Payment

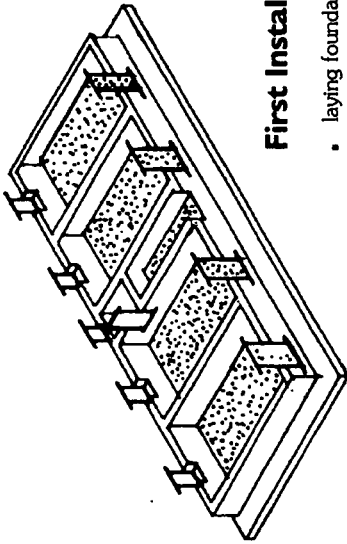

### First Installment

- laying foundation.
- collection of wood for window and door frames.
- walls construction plus installation of door and window frames.

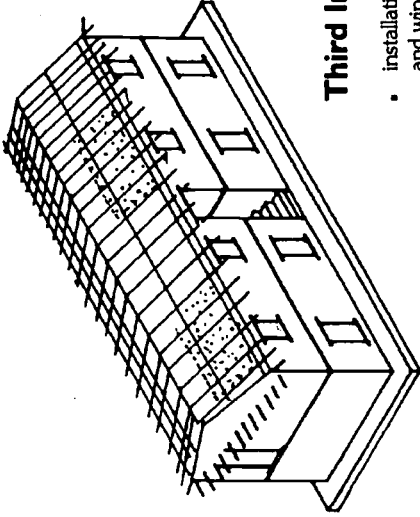

### Third Installment

- installation of fitted cupboards, and window in gable wall.
- erecting wall to full height.
- installation of roof timbers.

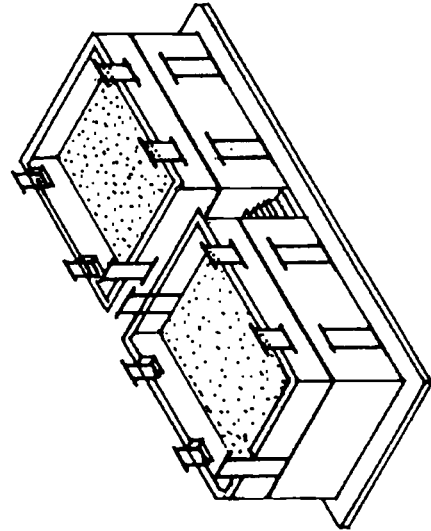

### Second Installment

- installation of fitted cupboards and completion of wall construction for the first floor.
- laying joists.
- construction of second floor wall to half height and installation of door and window frames.
- making of stairs.
- installation of ring beam.

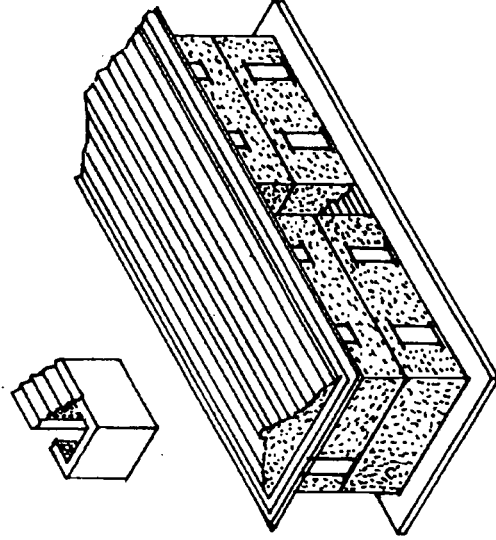

### Fourth Installment

- completion of roofing and laying of slates.
- completion of doors and window shutters.
- cleaning inside, outside and around the building.
- latrine construction.
- construction of "petti".

PHOTO GALLERY II



Photograph 11. Wooden tie beam used for earthquake resistance at lintel level.

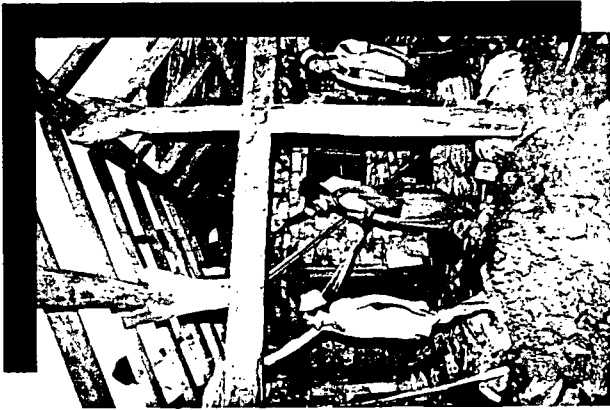

Photograph 12. Roof timbers have been fixed and the people are supplying roofing materials - Bhitto (mud & chirpea - rough pieces of wood) and slate to the workers on roof.



Photograph 14-15. The community workers are working on roofing.



Photograph 16. Teachers are now in the staff room; thanks to a shelf built in the wall they have arranged few furniture for their use.



Photograph 13. A small portion of roof is still to be slated and the building is still under construction but since they do not have another building the teachers and students have started to use the room (see Photo 16-17).



Photograph 17. Flooring, plastering, shuttering in door, windows are missing but the students started to study in the room.

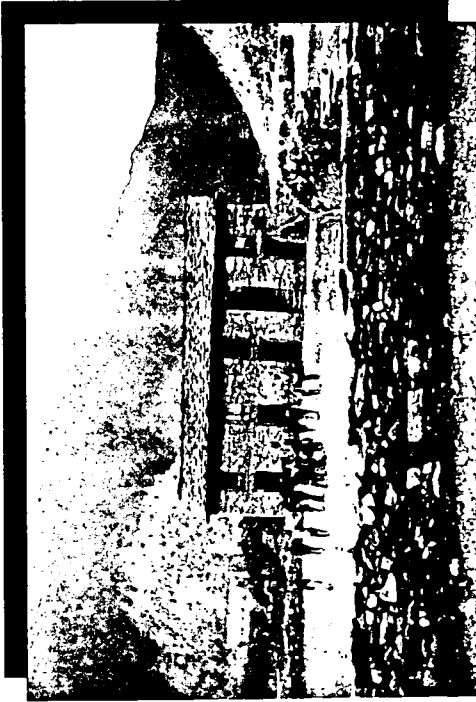

**PHOTO GALLERY II**

**Photograph 18.**  
A 4-bay double storey building (Mark II) built at Ontungra school in Doti.



**Photograph 19.**  
This school in Bajhang district which initially had no buildings now has a 4 bay two storey building (Mark II), with a boundary wall and play space for the children inside the wall.



**Photograph 20.**  
A 4-bay single storey building built at Gaira lower secondary school (Doti) for its additional primary classes. The existing building is in front.



**Photograph 21.**  
A Mark II school building with a nice compound wall built at Sirkhalisainc school in Doti.



- Building costs and subsidies were revised district by district using government norms; and, for the first time, differentiated subsidy rates for the same building work were adopted as follows:

Location	(Amount Rs.)				
	4-bay 2-storey	5-bay 2-storey	4-bay 1-storey	5-bay 1-storey	
Doti	27,500	33,000	18,500	22,500	
Bajhang	25,500	30,000	16,500	20,000	
Bajura	26,000	31,000	17,500	21,000	

- The target for completion of school buildings was changed from one year to two years, with 60 per cent completion anticipated in the first year and 40 per cent in the second.
- The design of the latrine was revised, and its construction moved from the first stage of building work to the last. The revised design included: the use of a vertical pit instead of a sloping stone chute; a curtain of plastic, cloth or jute sackings instead of a wooden door and an extended surrounding wall in front of the latrine; and provision of a more complete and better illustrated latrine construction handbook.
- The handbook of school building drawings was expanded to include the revised latrine drawings; detailed guidelines were also included explaining the construction procedure step by step, and suggesting better construction management and community participation.
- A 14-inch thick layer of earth filling, stone soiling with mud finishing was specified and shown in the drawings for the ground floor.
- A separate introductory booklet to the programme was produced and circulated to each school, as well as to concerned offices in the project area.

## 1988-1989

### Programme

- Five school buildings in Doti, five in Bajhang, 25 in Bajura and 30 in Achham started.
- In Bajura and Achham, 20 compound walls, 14 playgrounds, 21 water supplies and 25 latrines were started.
- Another large turnover of the technical staff occurred when the majority had to be replaced. Several new sub-overseers and two new overseers joined the project in late 1988, all of whom were posted in the four districts to undertake the programme.
- Thirty sets of carpentry tools were provided to Achham schools, and one day of training for local carpenters was also organized.
- Under the process of institutionalization, the staff of the Engineering Unit was attached to the district education offices which were directly responsible for the programme.

### Result

- Progress and workmanship was normal in Doti, very good in Bajhang, improved in Bajura, and an encouraging beginning was made in Achham.
- Because of the sudden, unexpected crisis of timber not being freely available through government sources, many schools could not be roofed in time and, in the 1989 monsoon, a few of them suffered damage. (The government later decided to provide 100 cubic feet maximum for each school, exempting 50 per cent of the total cost from royalty for 1989-1990. The staffing of the Engineering Unit stabilized, with only three out of seventeen staff leaving.)
- The people were enthusiastic to use the modern tools but, as the level of skill of the local carpenters was very low, the one-day training was not sufficient.
- After reviewing student-teacher ratios, government established a new policy that school buildings should be adapted for multigrade teaching.
- For those few primary schools with large enrolments and for primary sections in high schools which have resource centres, classrooms were found to be too small.
- The need was identified for improvements in blackboard and seating arrangements.



## Revision

At the end of the construction season in July 1989, a staff workshop was held in the project's head office during which the existing design was reviewed and the following revisions recommended. (Mark III Design, see page 52-54)

- Two rooms are to be interconnected by an extra door between the rooms, and existing doors moved to the corner to improve the seating arrangement inside the room.
- Realizing the difficulty of constructing one-foot thick random rubble stone walls with mud mortar and the risk of failure in case of poor workmanship, the thickness of the intermediate wall is to be increased to 18 inches and the shelves for both rooms integrated into the wall.
- Provisions are to be made for locating a cement blackboard; furniture layout in each classroom is to be marked clearly in the drawing.
- Provisions are to be made for outdoor teaching, for which purpose it was agreed to leave a certain space on both gable ends of the building at the time of site layout and have a blackboard fixed on both.
- A new combination of buildings, one two-storey with four classrooms and one single-storey with one classroom and an administration room, was designed to meet the demand for having four larger size rooms each with a capacity of 24 students, suitable for grade teaching. The buildings are planned to meet the needs of a large five-teacher primary school; they may also be used for resource centre schools.
- The existing five-bay double-storey buildings is to be amended on the same basis.
- To improve the quality of construction, the following programme was agreed upon:
  - train local, "mistries" (carpenter/mason) more intensively and effectively in the use of carpentry tools;
  - building supervisors to regularly visit trainees at the schools where they are working;
  - for these special duties, employ a number of building supervisors with carpentry skills; and
  - increase the building subsidy in the line with inflation.
- Later the project decided to increase the subsidy of the buildings for 1989/90 schools and to add a small amount to 1988/89 schools to recover the increased cost of timber.

## Revised subsidy rates (nRs.) for 4 bay double storey:

Doti	-	30,500
Bajhang	-	28,000
Bajura	-	28,000
Achham	-	30,500
Kailali	-	30,500

The project sent out several circulars to advise on the role of the communities in carrying out the project. Two circulars extracted from the construction manual are reproduced on pages 56 to 57. These are intended as advice to the community and warn them against using local contractors.

## 1989-90

### Programme

- 15 school buildings in Doti, 10 in Bajhang, 11 in Bajura, 21 in Achham and 1 in Kailali started.
- A large number of other associated facilities were allocated in Achham and an experiment of "Lek Blok" adopted from the AIT was started in Terai region of Kailali district.
- A block-making machine was purchased from the AIT and a short training to the project technicians and the community workers on operation and production was conducted at Lohagadh Village in Kailali
- A design workshop was held in Kathmandu in November 1989 to finalize the Terai design for Kailali.
- One set of the carpentry tools was distributed for each new school building programme in all five districts.
- 3 new building supervisors, all expert in woodwork, joined the project to train the local carpenters (misbi) and supervise the buildings especially woodwork.

**Table 3. Detailed Area Analysis of Mark III Designs**

	Grade 1	Grade 2	Grade 3	Grade 4	Grade 5	Grade 6-7	Office	Store	Total
<p>2 Teacher ( 59' / 1 storey ) floor area capacity</p>	219 40	150 24	150 24	- -	- -	- -	119 -	- -	638 88
	<p>3 Teacher ( 59' / 1 ) floor area capacity</p>	219 40	150 24	150 24	- -	- -	- -	119 -	- -
<p>3 Teacher ( 50' / 2 ) floor area capacity</p>		250 48	119 16	119 16	119 16	119 16	- -	250 -	13.5 -
	<p>4 Teacher ( 50' / 2 ) floor area capacity</p>	250 48	250 48	119 16	119 16	119 16	- -	119 -	13.5 -
<p>5 Teacher ( 39' / 2 + 33' / 1 ) Single storey floor area capacity Double storey floor area capacity</p>		219 40	150 24	150 24	- -	- -	- -	119 -	13.5 -
	<p>5 Teacher ( 61' / 2 ) floor area capacity</p>	250 48	157.5 24	157.5 24	157.5 24	157.5 24	- -	- -	13.5 -
<p>5 Teacher ( 61' / 2 ) floor area capacity</p>		250 48	250 48	119 16	119 16	119 16	- -	119 -	13.5 -



**MARK III  
5 BAY SINGLE STOREY BUILDING  
( 2 - 3 TEACHER SCHOOL )**

450 WIDE  
APRON

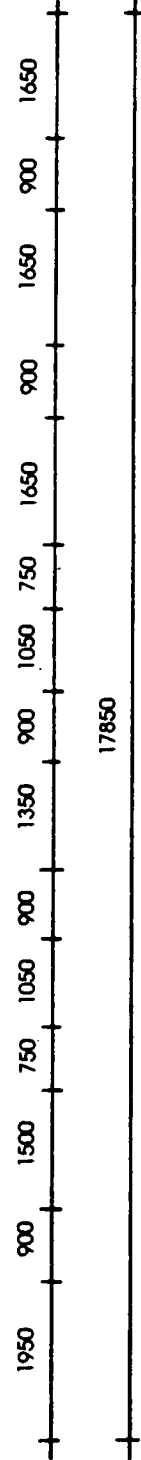
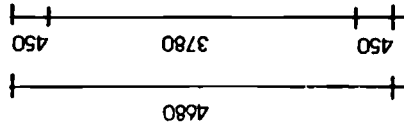
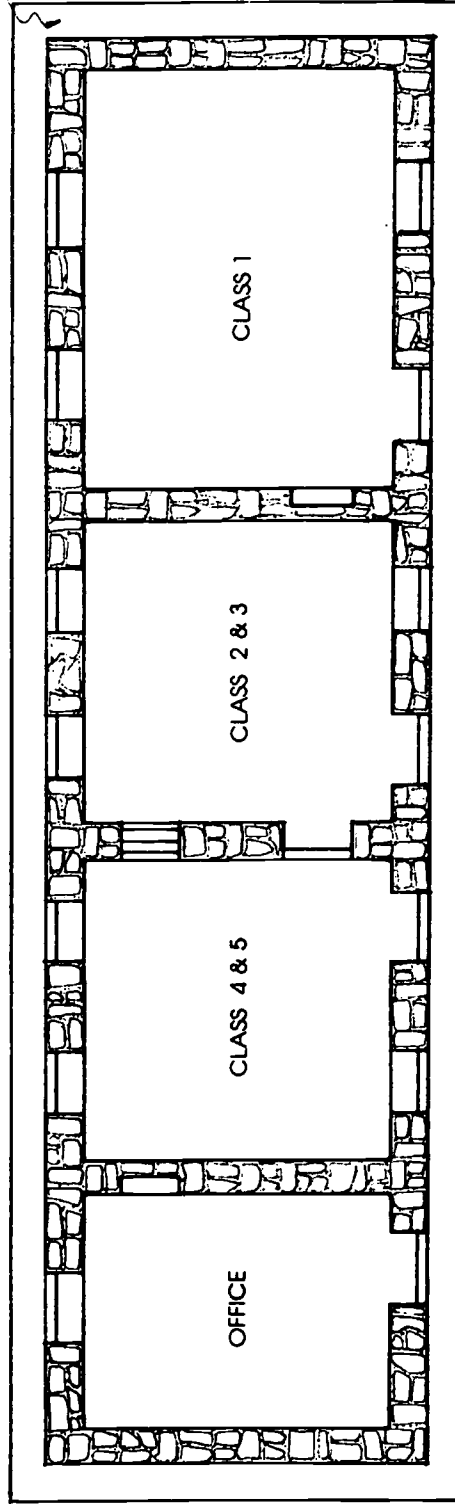

120

GROUND FLOOR PLAN

121

**MARK III  
4 BAY DOUBLE STOREY BUILDING  
(3-4 TEACHER SCHOOL)**

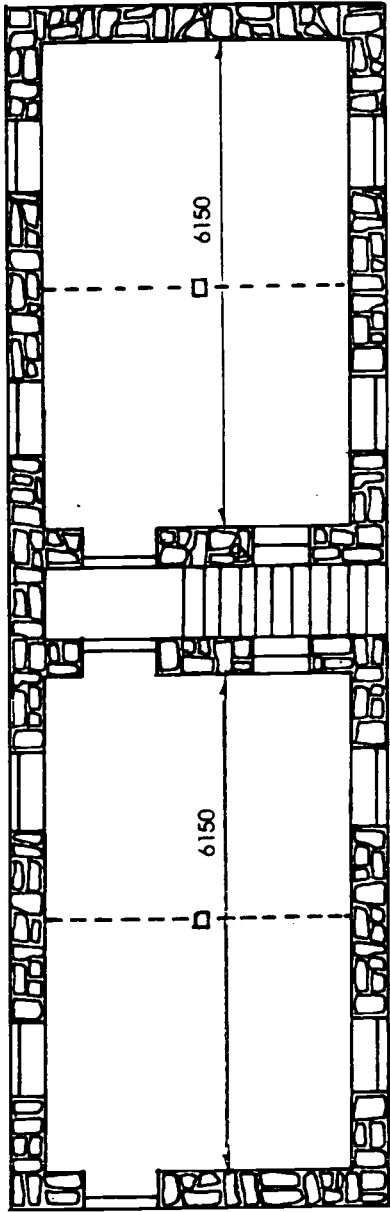

15000

**FIRST FLOOR PLAN**

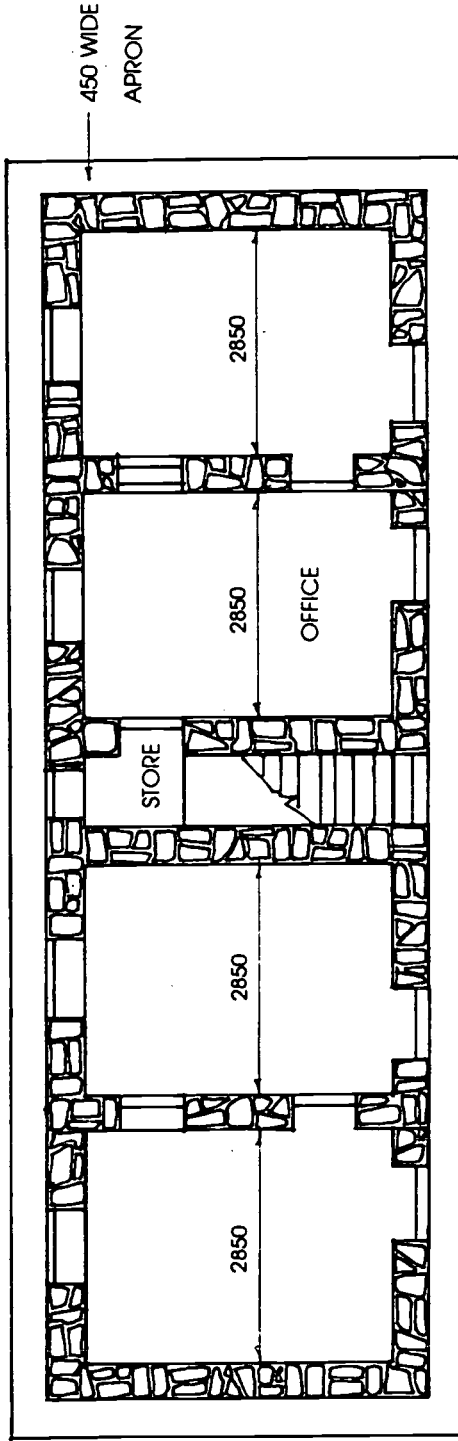

4680  
450  
3780  
450

450 WIDE  
APRON

2850

2850

2850

2850

OFFICE

STORE

1950 900 1350 900 1950 900 1950 900 15000

**GROUND FLOOR PLAN**

123

122

**MARK III  
4 BAY DOUBLE STOREY BUILDING  
AND 3 BAY SINGLE STOREY BUILDING (5 TEACHER SCHOOL)**

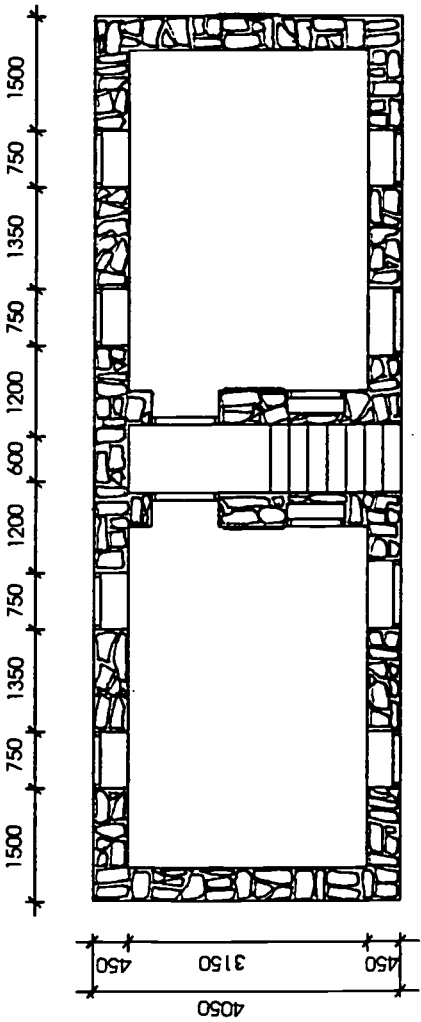

**FIRST FLOOR PLAN**

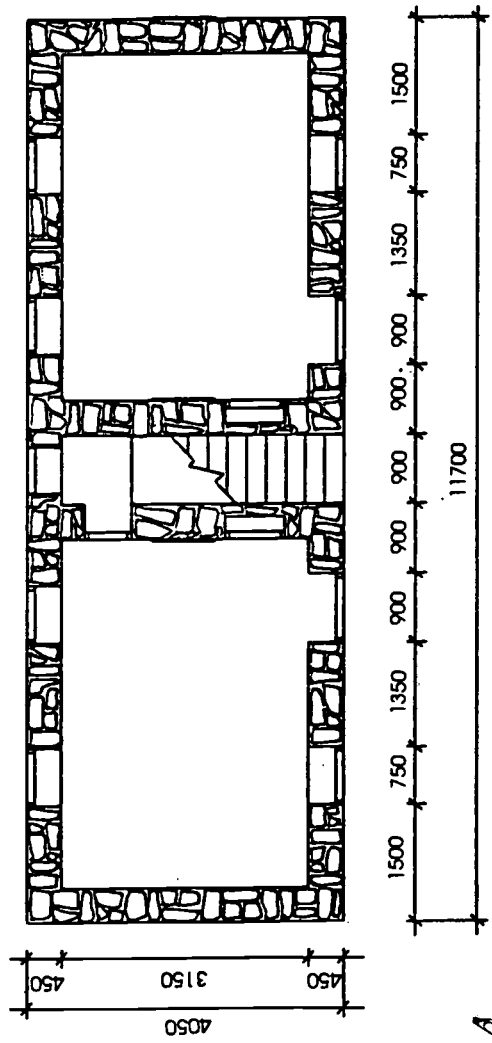

**GROUND FLOOR PLAN**

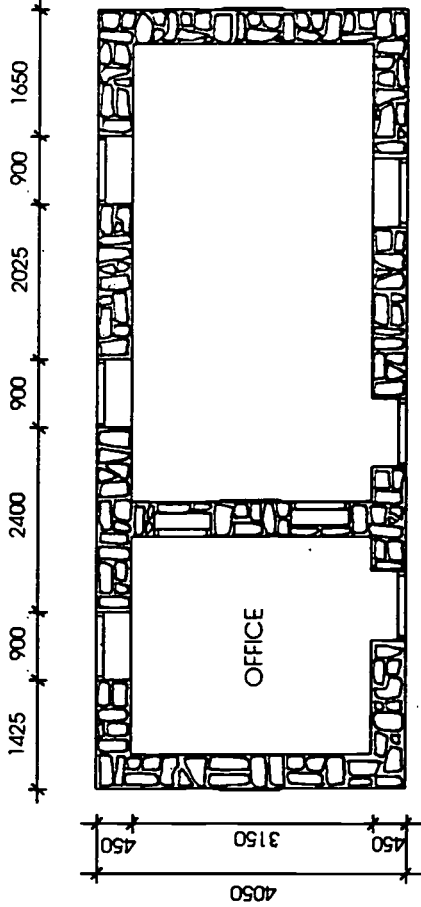

**GROUND FLOOR PLAN**

MARK III  
5 BAY DOUBLE STOREY BUILDING  
( 5 TEACHER SCHOOL )

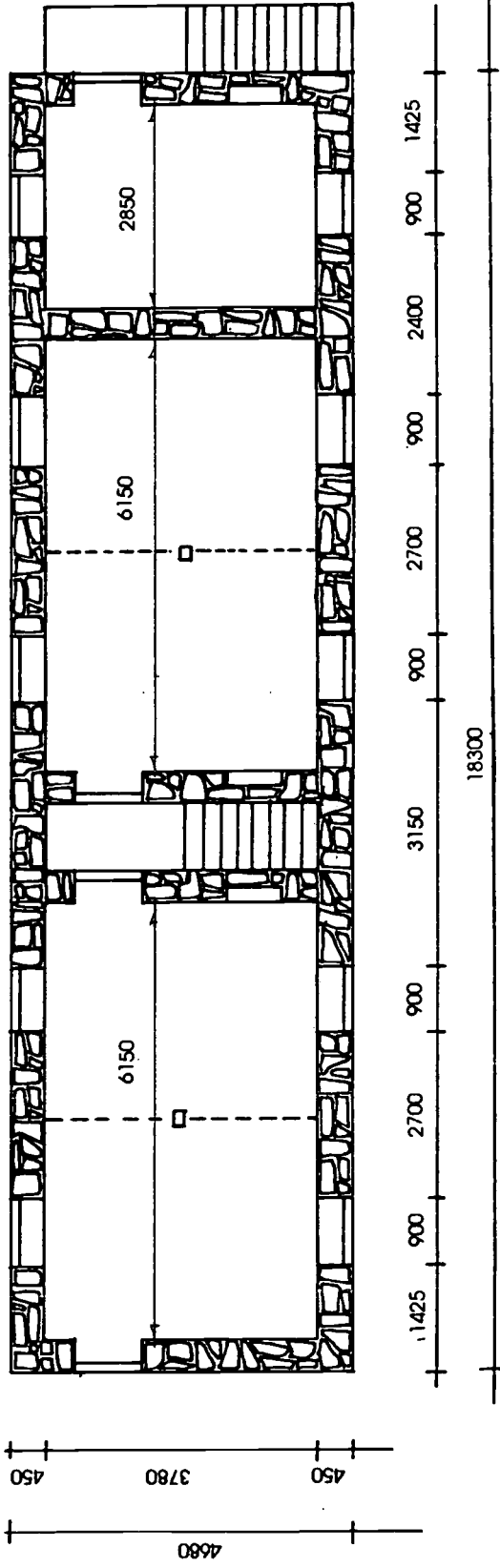

FIRST FLOOR PLAN

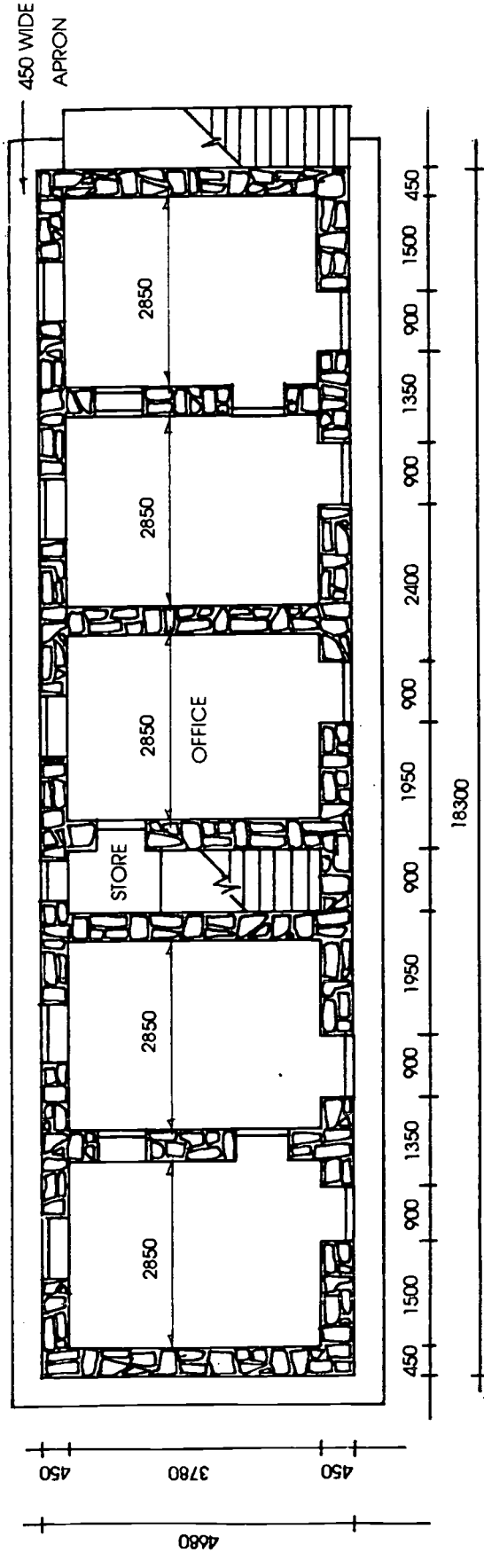

## Result

1990-1991

- Progress and workmanship was normal in Doti, Bajhang and Bajura while in hill area of Kailali, progress of workmanship of the building and the compound works was very encouraging.
- Two out of three building supervisors left the project during the construction season which made the project unable to train the local 'misbis' as was expected.
- The new 5 teacher school building design was used in few schools in Bajura.
- As the Government allowed only 50 per cent exemption in timber royalty to the school (since 1988/89 F.Y.) and many school buildings had remained under construction at the end of 1988/89 F.Y. the project added small amount to 1988/89 - schools in order to recover the remaining cost of the timber.
- In Terai part of Kailali approx. 2000 stabilized soil blocks were produced and a 3 room single storey building was set out.

## Revision

- The preliminary Terai design was revised and revised on the basis of the findings in detailed survey of the schools.
- The project's co-ordination committee decided to experiment the complete 'Lok Bild System' in 5 schools and traditional brick buildings in other 5 schools in Kailali (Terai).
- Building with larger rooms (floor area) also designed for resource centres.

## Programme

- 2 school buildings in Doti, 10 in Achham and 31 in Kailali started but no building programme allocated in Bajhang and Bajura.
- Out of 31 buildings in Kailali 2 block buildings, 6 brick buildings and 2 resource centre (RC) buildings started in Terai as an experimented programme.
- Carpentry tools again distributed to Achham and Kailali - hill schools.
- Moulds to manufacture R.C.C. door-window frames and joists purchased from AIT a training similar for the block production conducted for the project technicians.

## Result:

- Very good progress and workmanship achieved in hills of Kailali while it was less in Terai, normal in Achham and good in Doti.
- Out of 8 brick buildings started in Terai only 2 completed and out of 2 block buildings started one roofed with cement tiles and 2600 blocks produced for another building.
- The project subsidy was examined too low and insufficient especially for Terai school building programme where the majority of the construction materials have to be purchased.
- Quality of the cement tiles was not good due to the poor management.
- The experience showed that the *experimentation and the institutionalization can not go together successfully*. Quality of supervision and the management of the construction was poor.

**PHOTO GALLERY III**



**Photograph 22.** A 4-bay 2 storey building (Mark III) built at Karaban school in Doti with playground and spaces for fruit trees plantation in front of the building.



**Photograph 23.** Rear view of the school building with its boundary wall and latrine.

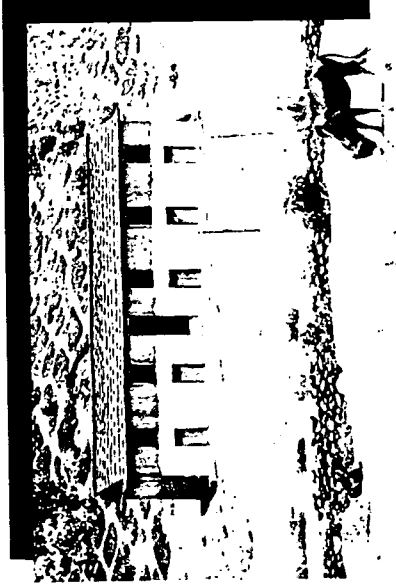

**Photograph 24.** At Talikat lower secondary school a new 5 bay double storey building has been built



**Photograph 25-26.** The village women, even in Dipayal (for Western Regional Headquarters), have to carry water from Seti river; they need to carry it to make mud mortar for the building masonry which is being erected as a separate primary section of Dipayal High School.

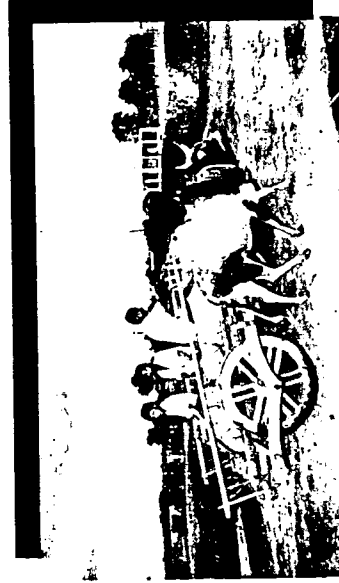

**Photograph 27.** The situation in the Terai is much difficult from the hill; the villager in Terai can use their bullock carts for carrying the materials.



**Photograph 28.** Terai (Kailati) has plenty of wood which the school can get easily and in many cases without cost. Many schools are able to pay the carpenters. This is why furniture can be seen in almost every school in the Terai but not in primary schools in the hills.

## **Request to Communities for People's Participation in School Construction and Utilization of the Project Subsidy**

The experience of the Seti Project has clearly shown that only active and enthusiastic schools can mobilize community participation. This is true of all Seti Project activities, not only school construction.

To complete school construction activities in a timely manner, improve the school-community relationship and make the community responsible for maintenance of the facility, it is very important to obtain maximum community support and utilization of local materials, labour and skill.

To avoid possible delays in work progress and maintain quality, proper planning and utilization of the project subsidy is necessary. Because the project is particularly strict as regards the following two points, special care needs to be taken.

- Payment is NOT made until the specified work is satisfactorily completed.
- There is NO extra money or increase in the original subsidy under any circumstance, including cases of unavailability or expensive materials/labourers, damage of the building during construction, etc. This is mentioned in the agreement form which is made between the chairman of the school management committee (SMC) and the District Education Officer.

In practice, construction is generally carried out in one of three ways:

- total work by a local petty contractor;
- skilled work, such as carpentry, masonry and roofing, by petty contractors, and the rest by community participation; and
- total work by community participation.

**Difficulties stemming from using contractors.** A number of problems might arise if all of the work is given to a contractor. The following examples have occurred in the project-supported schools.

- There will be much less control by the SMC over the construction work. The contractor is discouraged by the project's principle of payment by results: the contractor starts to seek work elsewhere and the school construction is delayed. In many cases, it has been shown that the SMC eventually has to give extra money to the contractor to complete the work.
- When the building is not according to drawings and specification, the project stops payment, but the contractor will still be asking for the money as promised by the SMC. In such cases, there may be no other solution than to pay the contractor from the SMC's own resources.
- The contractor may go away taking the community's money but leaving the work incomplete.
- A contractor always works for his profit, but the project's subsidy does not allow for any individual benefit or profit. The only way for the contractor to make a profit is to use cheaper, inferior materials and reduce the quality.
- The maintenance needed after completion of the building has been a big problem in almost all schools. In fact, it is completely the local community's responsibility to maintain the building and it would be easier to obtain participation for maintenance in such schools where the original construction was carried out through community involvement/support. A contractor does not do any maintenance unless he again gets extra money, but a community which has provided all the resources and donated the labour will not like to see a lack of maintenance cause wastage of their labour and resources, and would be more likely to carry out regular maintenance, as they do for their own houses.



Thus, using a contractor without community participation does not seem appropriate or beneficial to the local community, as in this way the project's limited subsidy goes to an individual's pocket – the individual is often from outside the school area – and the local community may be disappointed with the result and this may cause division within the community.

The experience of the Seti Project shows that the use of contractors in school construction causes a lot of problems and the result is often quite unsatisfactory; hence, this project strongly recommends and requests that no school apply this method to their construction activities under any circumstance.

**Mixed community and hired skilled workers.** If no one in the community has the necessary specialized skills, then skilled carpenter/masons may be employed from neighbouring communities and all other work carried out by the local community.

**Total work by community participation.** Regarding the long-term value of the programme, the best result can be achieved only by this method, and this is why the project stresses and recommends its adoption. If there are a few persons with the necessary skills, there is no reason to use contractors. All work can be completed by community efforts. The skilled workers may be paid, but they should accept a lower subsidy rate because, as members of the community, they too should share the voluntary contribution required for the school construction.

Much of the building construction work can be completed by voluntary labourers, while the cash subsidy is used for only very specific purposes. However, the situation may vary from place to place. The following model should be considered as a general guideline.

The *Shramadan* (voluntary) group is responsible for the demolition of the existing structure, levelling and clearing the site, felling trees and cutting the trees into pieces, obtaining and breaking quarry stone, carrying construction materials, primary (ordinary) dressing of stone, preparing the mortar and supplying it to the mason, and assisting the carpenters and masons. the *Anudan* (subsidy) group does the masonry, carpentry and roofing work and the quarrying of slate.

#### *Voluntary (Sramadan)*

1. Demolition of the existing structures.
2. Levelling and clearing the site.
3. Felling trees and cutting the trees in pieces.
4. Obtaining and beaming quarry stone.
5. Carrying construction materials.
6. Primary (ordinary) dressing of stone.
7. Preparing the mortar and supplying it to the mason.
8. Assisting the carpenters and masons.

#### *Subsidy (Anudan)*

1. Masonry
2. Carpentry
3. Roofing work
4. Quarrying of slate

## Construction Procedure

1. Dig a foundation 2'6" wide and 2'6" deep.
2. Using large, flat stones, complete the foundation masonry up to ground level.
3. Leave 6" on either side and start to erect a 1'6" wide stone wall at the centre of the foundation.
4. When the front wall is 1' high, fix the door frames. The frames should NOT be fixed at ground level.
5. When the rear wall is 2'6" high, fix window frames.
6. When the side walls and stair walls are 3'6" high, fix the frames for the shelves.
7. The top frames of all the doors, windows and shelves should be at the same level.
8. All external walls, intermediate walls and the staircase should be erected simultaneously. The staircase and the intermediate walls should not be left to be erected later.
9. When all walls, and the staircase are at the top level of the frames (6'6" from ground level), place the lintels for doors, windows and shelves. Do NOT place floor joists at this level.
10. When the walls are 1' high from the top of the ground-floor frames, fix the earthquake lintel. Size of the main wooden members must be 3" x 4" and they MUST be interconnected and tied to each other (as illustrated in the handbook).
11. On top of the earthquake lintel, place ten joists (3" x 4") at 1'3" c/c.
12. Fix the upper-floor doors at the floor level, windows at 1'6" high and shelves at 2'6" high.
13. When the walls are at the level of the top frames, place the lintels for all doors, windows and shelves, and place 3' long eaves brackets (2" x 3") at 1'6" c/c.
14. Position a centre post and a crossbeam in halls – size of both MUST be 6" x 6". If smaller size is used, then the roof sags, leaks and eventually collapses.
15. Erect all walls up to roof level. Gable walls must be 4' higher than longitudinal walls.
16. Erect roof timbers. All purlins should have 6" depth, and the size of king post and struts also should be 6" x 6"; size of all rafters must be 3" x 4" and their spacing should not be more than 1'6" c/c. It is quite important to consider the above size and spacing of the roof timbers. If it is ignored, the roof will not be durable; it will leak soon and collapse.
17. Place the pieces of adzed rough timber (like firewood) on the rafters and mud over the layer of wooden pieces and then embed the slates on the layer of mud. The wooden pieces should be thick enough and compacted and the mud should be well prepared. It should be ensured that the slates are properly embedded on mud with the sufficient 'overlap'.
18. The upper flooring should be done properly so that the mud will not fall down and the floor is durable. For this, place a thick layer of wooden pieces on joists, then a layer of fern, leaves, etc., and then thick layer of well-prepared mud with proper levelling and a good finish on top. Overall thickness of the floor should be 6" to 9".
19. Do a 9" thick stone soling with mud finishing on the ground floor.
20. Extend 1'6" wide apron round the building and erect it 6" from ground level; if there is a mounted earth or rock behind the building, cut that at least 5' from the building.
21. Fix shutters in all doors and windows; fit door locking iron chain and wooden locking system (from inside) for the windows; arrange pad-locks for each door.
22. Do mud plastering inside and outside of the building and apply *camero* (a local material for whitewash) finish; clear/clean the site.

# ACHIEVEMENTS

Keeping financial support to a bare minimum, utilizing local resources and mobilizing the people to create the 'learning environment' in the schools are the major achievements of the programme. Furthermore, by 1991, about 100 per cent of the requests for new school buildings from Doti, Bajhang and Bajura and 90 per cent from Achham been satisfactorily fulfilled.

The work achieved in Doti Bajhang and Bajura has dramatically improved the condition of the schools. A decade ago, the poorest buildings in the community was the school. Today, it is the nicest building, surrounded by an organized compound.

A large part of the needs of the various districts for new school buildings has been met. The progress of different construction activities made between the Project's beginning and mid-July 1991 are shown below.

## Programmes of Physical Improvement in Seti Zone

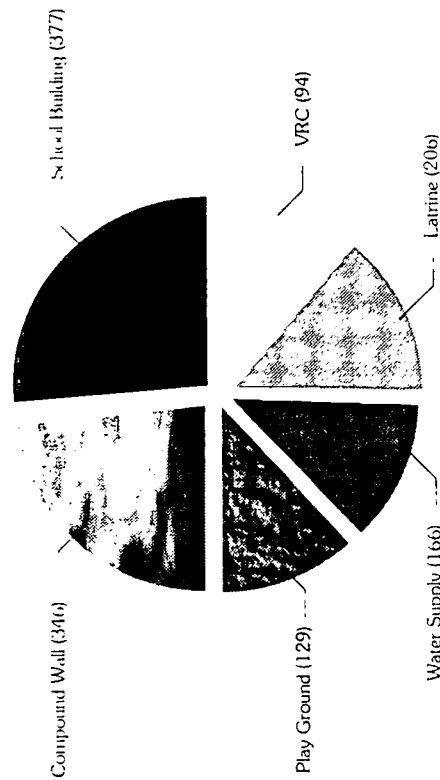

## Achievements by District 1982-1991

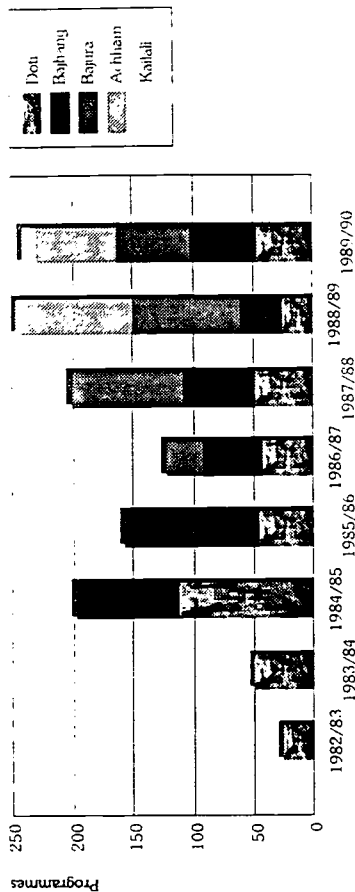

## Physical Progress by Sub-component as of July 1991

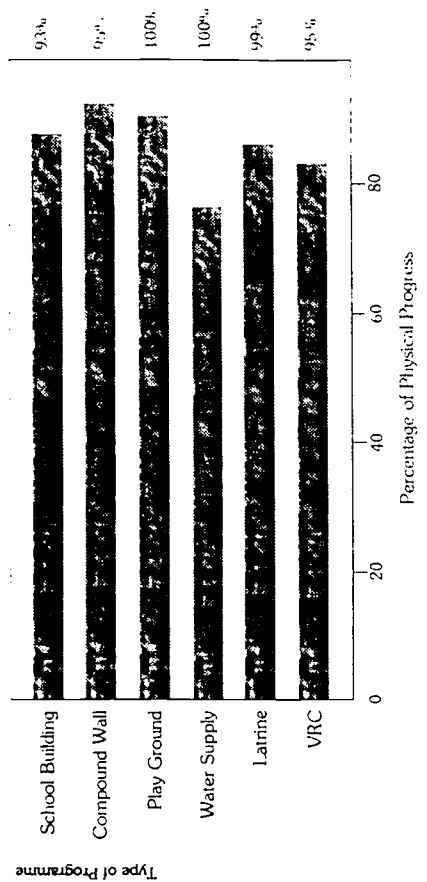

building costs have been calculated on the basis of locally available materials and labourers only. As there are no allowances for any profit or tax one were to apply the government's design norms and the standard rates. However, it comes 41 per cent according to the project's own analysis, which reflects the specific designs used in the project and rates based on actual costs incurred by communities in building according to these designs. The table (see page 12) and graphs show the evolution of cost and the subsidies for 4-bay 2-storey of design as an example. The increase in cost since the beginning of the project reflects inflationary trends over that period (see page 66, 67).

The designs that have evolved are highly economical in the use of space, yet they are major improvements over the small and dark rooms typical of the villages schools constructed before the project began. Improvements have also been achieved in the course of the project. For example, a 4-bay, double-storey school of MARK I Design had a total built-up area of 18.00 square feet per place, of which 61.2 per cent was

useable floor area (classroom and office). An equivalent Mark III design building has only 10.56 square feet per place, the area for circulation (verandah and stairs) has been reduced from 260 square feet to 28 square feet.

Table 4 shows the relevant efficiency of the three main designs used in the project.

**Subsidies\* for 4-bay 2-storey**

1982/83	15000	1986/87	19700
1983/84	17000	1987/88	21700
1984/85	19700	1988/89	26000
1989/90	30500	1990/91	30500

\* costs not adjusted for inflation

**Table 4. Efficiency of Different Types of Buildings**

Type of Building	Size of Building	1		2	3	4	5	6	7	8	
		Built-up Area (sq.ft)	Useable Area								
4/1	37'0" X 18'0"	777	480	480	40	11000	19.43	12.00	275	14.16	
5/1	45'6" X 18'0"	956	589	589	64	14000	14.94	9.20	219	14.64	
4/2	37'0" X 18'0"	1592	975	975	88	17000	18.09	11.08	193	10.68	
5/2	44'9" X 18'0"	1916	1177	1177	136	20000	14.09	8.65	147	10.44	
<b>Mark II Design 1988/89</b>											
4/1	44'0" X 15'6"	682	488	488	64	17500	10.65	7.68	273	25.66	
5/1	54'6" X 15'6"	845	606	606	80	21000	10.56	7.58	263	24.85	
4/2	49'0" X 15'6"	1490	989	989	144	26000	10.35	6.86	181	17.45	
5/2	59'6" X 15'6"	1816	1226	1226	176	31000	10.32	6.96	176	17.04	
<b>Mark III Design 1989/90</b>											
60.5/1 (5/1)	58'0" X 15'6"	938	681	681	88	25000	10.65	7.74	284	26.65	
50/2 (4/2)	50'0" X 15'6"	1521	1001	1001	144	30500	10.56	6.35	212	20.05	
61/2 (5/2)	61'0" X 15'6"	1862	1238	1238	176	36000	10.58	7.03	205	13.33	
34/1	34'0" X 15'6"	527	369	369	144	13400	10.82	7.03	232	21.44	
39/2	39'0" X 13'6"	1031	643	643	144	20000	10.82	7.03	232	21.44	

# BUILDING SUBSIDIES: 4 bay 2 storey

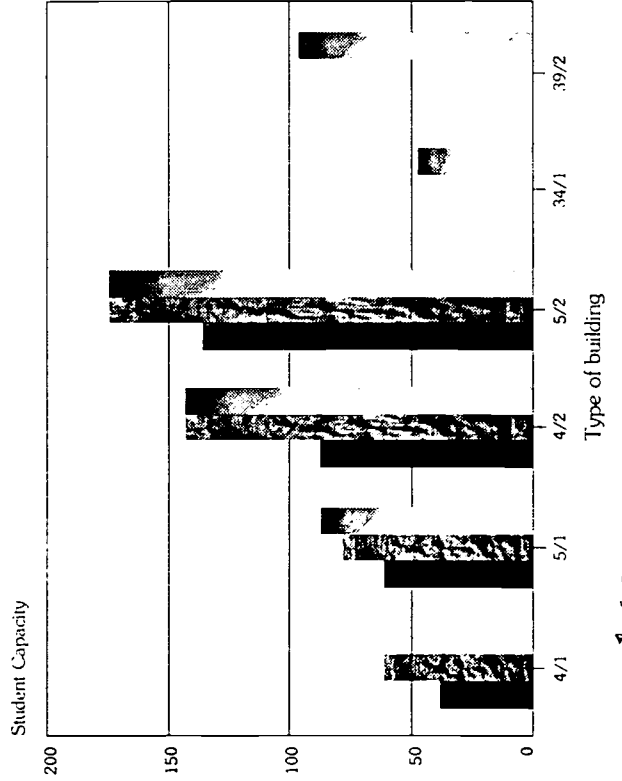
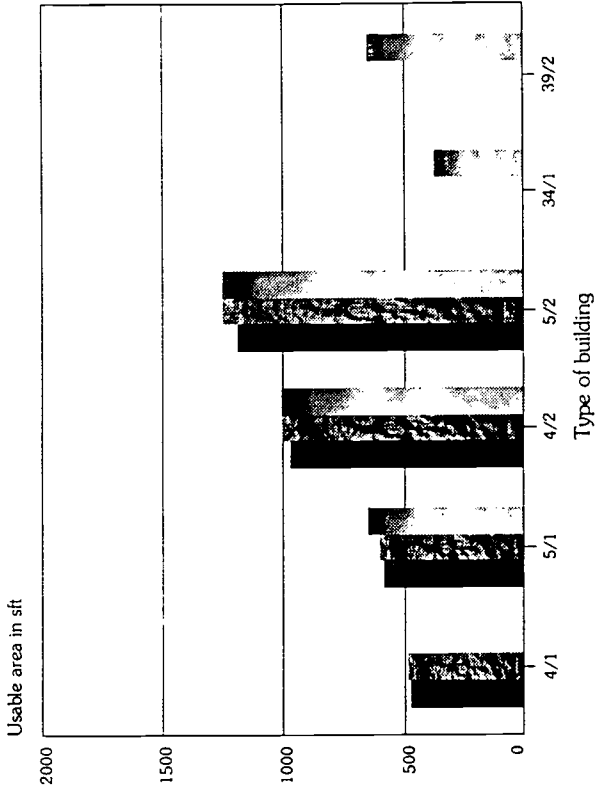
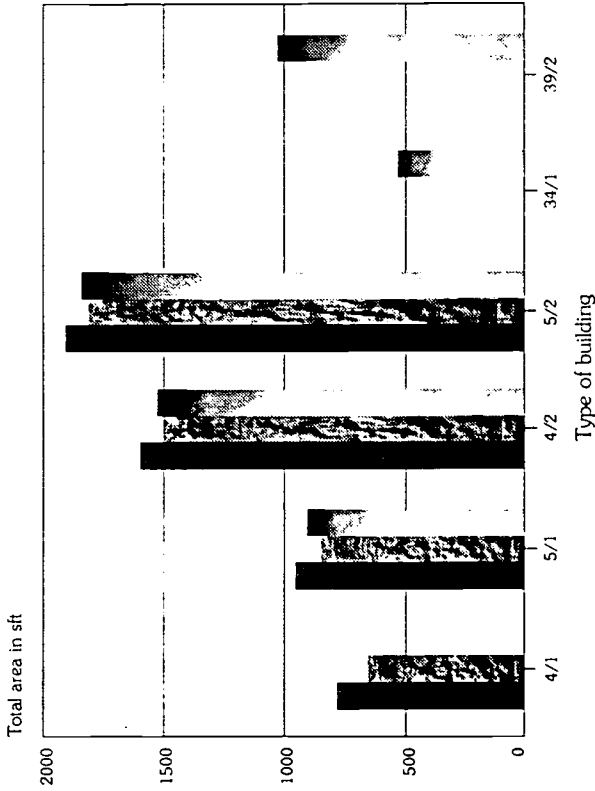

Usable Area per place in sft

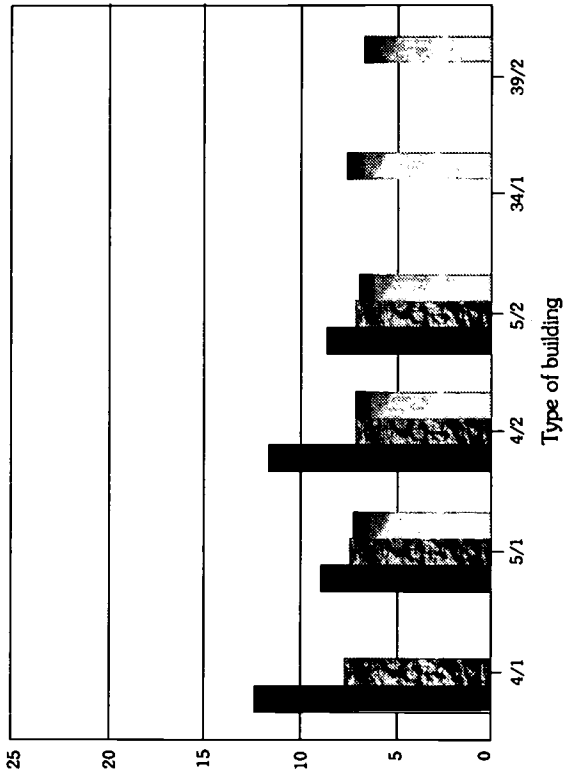

Subsidy per place in NRS (unadjusted)

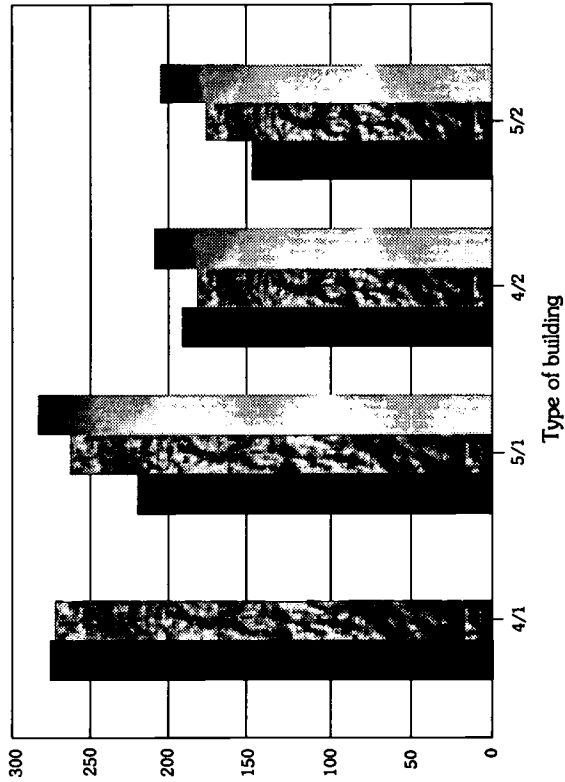

Key :

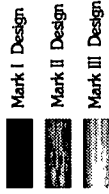

Area per place in sft

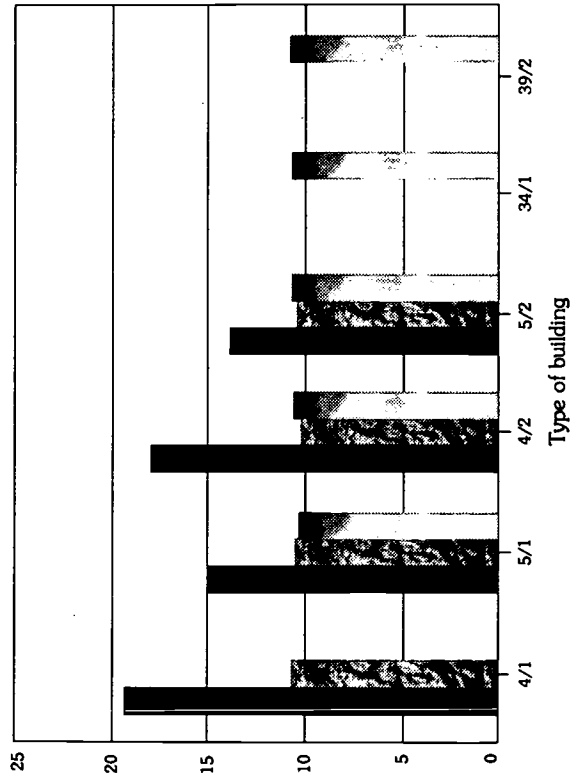

Subsidy per sft in NRS (unadjusted)

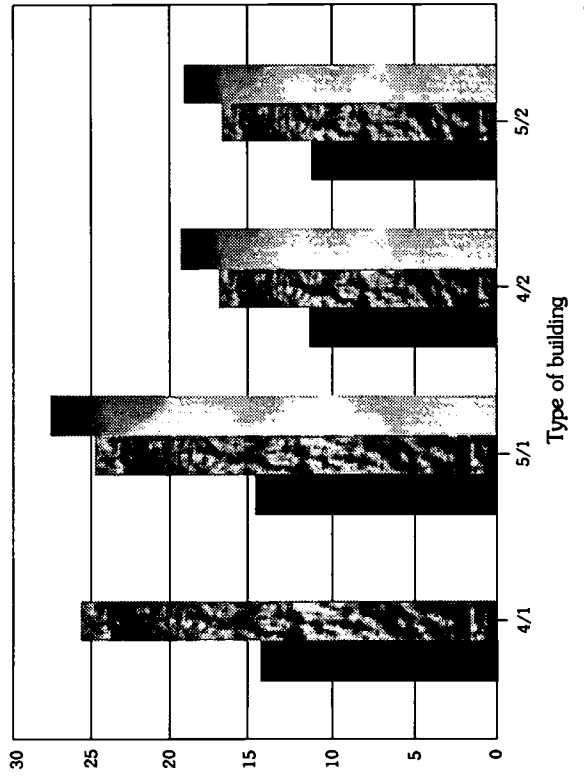



The school designs set out to use the local traditional architecture on which the communities are obliged to depend, but at the same time improve this architecture and make it suit the special requirements of school buildings. Through a process of annual analysis and revision, a set of standard designs has evolved. These designs have been experimentally proved and consequently are appreciated and happily accepted by the schools. The last set of designs, reflects the new government policy of providing one teacher for each 20-30 encouraging multigrade teaching in small schools. The flexibility of the set of standard designs can be seen in Table 3 (see page 53).

The project has effectively used the principle of Payment by Result. Through this approach it has controlled quality and prevented any known misuse or corruption of the project subsidy. Considering that a total of 311 schools have been constructed, this is a significant measure in overall success of the programme.

**Community awareness.** The project through its various school construction activities has developed a new concept for the 'school environment'. The people now understand the importance of the physical facilities and appreciate their own abilities to create them. By using only local resources, an ideology of self-dependence has been realized among the community. Since detailed and specific information is available as regards work to be done, and the payment criteria is clear to everyone, communities can easily identify if anyone is cheating or slacking off and initiate corrective action. The community members report that they have learned good lessons from the project staff and have been highly impressed by the procedures used.

The school-community relationship has been much enhanced by the project. In order to cover their 59 per cent share of the total cost, the school construction committees have to persuade the community to make voluntary contributions. The community is thereby mobilized and invests its funds and energy into school construction. Thus a mutual relationship has been established between community leaders and community members.

Learning by doing has indirectly trained local people. Being involved in the project's construction programmes, a large number of local people who were originally unskilled or unfamiliar with modern tools and techniques have now learned many things and have been indirectly trained.

The project has proven that community participation can work. Although there is a provision for community participation in many projects, in practice the whole work is often carried out entirely under the subsidy. This results in poor quality or incomplete work. The fair system of project execution in the Seti project results in the communities happily participating. They now make a large contribution in the programme.

Some very concrete impacts can also be seen in the way the villagers now handle not only the construction of the project school, but their own dwellings.

1. **Foundations.** For their own dwellings, the local people often do not dig a foundation and in those cases where they do, it is not more than one foot deep. By digging the 2'6" deep foundation, they have learned that the 'foundation should be deep enough'.

2. **Door/window size and lighting in the room.** The door/window opening in existing classrooms were too small to let enough light enter to permit easy reading; seeing the larger size door/window and adequate natural lighting in the rooms in the project-supported buildings, the people have now got a new knowledge about door and window sizes necessary for educational spaces to be used for their intended purposes.

3. **Damp proofing.** Ground floors in village houses and schools are often damp. In the project supported buildings, a one-foot thick layer of stone filling (soling) has been specified. This prevents dampness on the floor.

4. **Cutting around the building and drainage.** The rear wall of the existing residential buildings is sometimes a part of the natural ground slope. This eventually causes dampness on the wall as well as on the floor. In the project supported buildings, a minimum distance of 5' must be provided between the hill slope and the walls.

5. **'Through' stones.** It was a tradition, particularly in Bajhang, to build walls using smaller stones, even if this meant breaking the larger ones. The project emphasized the use of larger "through stones" that go through the wall. The local people are beginning to appreciate the advantages which are increased stability, quicker construction progress, and a more attractive appearance.

8. **Tool kits and skill training.** By using the standard set of hand tools now generally distributed to each building site in accordance with advice given during visits by the project technicians, the people learn the handling of tools.

7. **Use of roofing slates.** The communities have learned that the corrugated galvanized iron (CGI) sheets freely distributed to the schools throughout the Kingdom are less suitable as roof covering than is their own traditional roofing slates which are available throughout the hill area of Seti Zone.

Not all development programmes in Nepal are a success. The Seti project seems to have achieved many of its aims because the communities which it serves have come to believe in the sincerity of the project and the people who work in it. Thus trust, in turn, has fostered the concept of self-reliance through using local resources and improving upon traditional solutions rather than rejecting them. One day, modern facilities and a more robust economy may reach the Seti Zone, at which time modern ideas and materials may become effective and welcome. But until that they comes, 'aided self-help' using local materials is certainly the most economical and effective approach.





**U.S. DEPARTMENT OF EDUCATION**  
*Office of Educational Research and Improvement (OERI)*  
*Educational Resources Information Center (ERIC)*



## NOTICE

### REPRODUCTION BASIS

This document is covered by a signed "Reproduction Release (Blanket)" form (on file within the ERIC system), encompassing all or classes of documents from its source organization and, therefore, does not require a "Specific Document" Release form.

This document is Federally-funded, or carries its own permission to reproduce, or is otherwise in the public domain and, therefore, may be reproduced by ERIC without a signed Reproduction Release form (either "Specific Document" or "Blanket").