

ED 406 127

SE 052 747

TITLE Science 26: Teacher Resource Manual. Integrated Occupational Program. Interim 1991.

INSTITUTION Alberta Dept. of Education, Edmonton. Curriculum Branch.

REPORT NO ISBN-1-55006-216-6

PUB DATE 91

NOTE 295p.; For Mathematics 26 Teacher Resource Manual, see SE 052 746.

PUB TYPE Guides - Classroom Use - Teaching Guides (For Teacher) (052) -- Tests/Evaluation Instruments (160)

EDRS PRICE MF01/PC12 Plus Postage.

DESCRIPTORS Communication Skills; Cooperative Learning; Curriculum Design; Curriculum Guides; Educational Strategies; Foreign Countries; High Schools; Inquiry; Instructional Materials; Integrated Activities; Integrated Curriculum; \*Learning Activities; Lesson Plans; Manipulative Materials; Problem Solving; Resource Materials; School Community Relationship; Science Activities; Science and Society; Science Education; \*Science Instruction; Science Projects; \*Secondary School Science; Student Projects; Teaching Guides; Teaching Methods; Thinking Skills

IDENTIFIERS Alberta

## ABSTRACT

The Integrated Occupation Science 26 Program is an optional program designed to allow students in Alberta, Canada to meet the credit requirements of the Certificate of Achievement and facilitate transfer to the General High School Diploma Program. This Teacher Resource Manual is provided to assist classroom teachers to implement the Science 26 Program. Teachers can use this manual as a practical planning and instructional tool in translating the intentions of the science program into classroom practice. The manual provides: (1) information about the goals of the science program, (2) four themes that address the development of prescribed concepts, skills, and attitudes, (3) suggestions for planning the program, relating the science instruction to essential life skills, developing communication and thinking skills, and utilizing community resources throughout the science program, (4) strategies for solving problems, conducting scientific inquiry, resolving societal issues, and assessing student progress, and (5) suggestions for planning experiential learning activities. The document is divided into four sections. The Introduction describes the manual's purpose and modes of utilization, gives a scope and sequence for Science 26, and explains how it relates to other programs. The second section describes the sub-themes of personal health and lifestyle, materials in daily life, technology in transportation, and energy and the environment. The next section presents the program emphases of the nature of science, science and technology, related societal issues, communication skills, and evaluation. The last section contains three appendices listing resources, consumer affairs offices, and regional offices of education. (MDH)

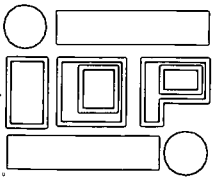

# INTEGRATED OCCUPATIONAL PROGRAM

## Teacher Resource Manual

ED 406 127

# SCIENCE 26

**U.S. DEPARTMENT OF EDUCATION**  
Office of Educational Research and Improvement  
**EDUCATIONAL RESOURCES INFORMATION CENTER (ERIC)**

This document has been reproduced as received from the person or organization originating it.  
 Minor changes have been made to improve reproduction quality.

• Points of view or opinions stated in this document do not necessarily represent official OERI position or policy.

INTERIM - 1991

"PERMISSION TO REPRODUCE THIS MATERIAL HAS BEEN GRANTED BY  
S. Wolodko

TO THE EDUCATIONAL RESOURCES INFORMATION CENTER (ERIC)."

# CURRICULUM

SE052747

# Teacher Resource Manual

## Science 26

**INTERIM - 1991**

**NOTE:** This publication is a support document. The advice and direction offered is suggested only. Consult the Program of Studies/Curriculum Guide to identify the prescriptive contents of the Science 26 Program.

**ALBERTA EDUCATION CATALOGUING IN PUBLICATION DATA**

Alberta. Curriculum Branch.

Science 26: teacher resource manual.

ISBN 1-55006-216-6

1. Science -- Study and teaching (Secondary).

I. Title. II. Integrated Occupational Program.

Q181.5.A333t 1991

507

Copyright © 1991, the Crown in Right of Alberta, as represented by the Minister of Education. Alberta Education, 11160 Jasper Avenue, Edmonton, Alberta, T5K 0L2. All rights reserved. Additional copies may be obtained from the Learning Resources Distributing Centre.

**COPYRIGHT**

The materials contained in this Teacher Resource Manual have been derived from numerous sources and are designed to provide specific support to selected areas of the curriculum. Every effort has been made both to provide proper acknowledgement of the original source and to comply with copyright regulations. If cases are identified where this has not been done, it would be appreciated if Alberta Education could be notified to enable appropriate corrective action to be taken.

# ACKNOWLEDGEMENTS

---

Alberta Education acknowledges with appreciation the contributions of the following individuals and school jurisdictions to the development and validation of this publication:

**ASSOCIATE DIRECTOR:** A. A. (Scotty) Day

**INTEGRATED OCCUPATIONAL PROGRAM MANAGER:** Michael Alpern

**PROGRAM MANAGER, SCIENCE:** Gary Bertrand

**CONTRIBUTING WRITER:** Deborah MacFadyen

**INTEGRATED OCCUPATIONAL PROGRAM PROJECT TEAM**

Jeanne Cooper  
Lorraine Crawford  
Marilyn Dyck  
Darlene Garnier  
Selwyn Jacob  
Jan Marvin  
Kathy McCabe  
Paul McNair  
Linda Snow

**INTEGRATED OCCUPATIONAL PROGRAM REVIEW COMMITTEE**

Stuart Adams	- County of Strathcona No. 20
Pat Boon-Anderson	- Lac La Biche School Division No. 51
Christopher Harrison	- Alberta Vocational College, Edmonton
Ed (Edwin) Holt	- Conference of Alberta School Superintendents
Wayne Nixon	- Alberta Career Development and Employment
Hugh Sanders	- Alberta Education
William Smolak	- Alberta Teachers' Association
Carol Steen	- Lethbridge School District No. 51
Doug Tarney	- Wetaskiwin School District No. 264

**EDITING:** Elizabeth McCardle

**DESKTOP PUBLISHING:** Lin Gray  
Dianne Hohnstein  
Esther Yong

**ILLUSTRATOR:** Jennifer Annesley

**SECRETARIAL:** Rita Flint  
Marcie Whitecotton-Carroll

# TABLE OF CONTENTS

---

	Page
<b>INTRODUCTION</b>	
Purpose .....	1
How to Use the Teacher Resource Manual .....	2
Program Planning .....	3
Scope and Sequence for Science 16-26 .....	8
Learning Resources for Science 26 .....	13
Correlation of Basic Learning Resources to Science 26 .....	20
Safety in the Science Classroom .....	22
Equipment and Materials .....	25
Interpersonal Skills and Cooperative Learning .....	27
Relationship of Science 16-26 to Science 14-24 .....	29
<b>THEMES</b>	
<b>A. Personal Health and Lifestyle .....</b>	<b>31</b>
Overview .....	32
Instructional Strategies .....	36
<b>B. Materials We Use .....</b>	<b>75</b>
Overview .....	76
Instructional Strategies .....	80
<b>C. Technology in Transportation .....</b>	<b>103</b>
Overview .....	104
Instructional Strategies .....	108
<b>D. Energy and the Environment .....</b>	<b>135</b>
Overview .....	136
Instructional Strategies .....	140
<b>PROGRAM EMPHASES AND METHODOLOGY</b>	
<b>NATURE OF SCIENCE .....</b>	<b>155</b>
<b>A Model for Conducting Investigations in Science .....</b>	<b>156</b>
<b>Useful Strategies and Skills .....</b>	<b>157</b>
Understanding the Problem .....	158
Developing and Carrying Out a Plan .....	161
Reviewing and Applying Results .....	167
<b>Suggestions for Planning Investigative Activities .....</b>	<b>169</b>
<b>Sample Lesson Plan .....</b>	<b>171</b>

	Page
<b>SCIENCE AND TECHNOLOGY</b> .....	181
The Relationship Between Science and Technology .....	182
Distinguishing Between Science and Technology .....	182
Interactions Between Science and Technology .....	183
A Model for Solving Technological Problems .....	184
Suggestions for Planning Problem-Solving Activities .....	186
<b>SCIENCE, TECHNOLOGY AND SOCIETAL ISSUES</b> .....	197
Interactions Among Science, Technology and Society .....	198
Recognizing How Science and Technology Influence Society .....	198
Recognizing How Society Influences Science and Technology .....	199
A Model for Making Informed Decisions .....	201
Suggestions for Examining Relevant Community Issues .....	203
<b>COMMUNICATION SKILLS</b> .....	221
Reading and Viewing Science Materials .....	222
Summarizing, Evaluating and Communicating Ideas in Science .....	224
<b>ASSESSMENT/EVALUATION</b> .....	265
Observation .....	266
Interviews .....	267
Inventories/Checklists .....	269
Anecdotal Records .....	271
Individual and Group Projects .....	272
Written Assignments .....	274
Laboratory Write-Ups and Reports .....	274
Diagnostic Writing Assignments .....	274
Paper-and-Pencil Tests .....	275
Self and Peer Evaluation .....	277
<b>APPENDICES</b>	
Appendix A: Annotated List of Video Resources .....	287
Appendix B: Government Agencies .....	289
Appendix C: Regional Offices of Education .....	290

# INTRODUCTION

---

## PURPOSE

This *Teacher Resource Manual (TRM)* has been developed to assist classroom teachers to implement the Integrated Occupational Science 26 program. Teachers are encouraged to use this manual as a practical planning and instructional tool in translating the intentions of the science program, as outlined in the *Science 26 Program of Studies/Curriculum Guide*, into classroom practice. Although shaded statements or segments within this manual indicate prescriptive content of the Program of Studies, all other advice and direction provided are suggested only and are not legally binding.

This TRM provides:

- further information about the goals and objectives of the science program
- four themes that address the development of prescribed concepts, skills and attitudes
- suggestions for planning and implementing the program
  - instructional strategies
  - sequenced activities
  - a correlation of strategies and activities to learning resources
- suggestions for relating science instruction to essential life skills and other applications across the curriculum
- suggestions for utilizing community resources throughout the science program
- situational and concrete approaches for developing an understanding of the interactions among science, technology and society
- strategies for organizing thought and action when conducting scientific inquiry, solving problems and resolving societal issues
- suggestions for developing thinking and communicating skills
- suggestions for assessing and evaluating student progress.

The binder format was chosen for this manual to enable teachers to add strategies, samples of student work and other activities that have through experience, proven effective. During cooperative planning sessions, pages may be easily removed and shared with other Integrated Occupational Program teachers. This exchange will facilitate awareness of content in other subject areas, thereby increasing opportunities for students to relate science competencies to applications in everyday life, the occupational courses and other academic disciplines.



## HOW TO USE THE TEACHER RESOURCE MANUAL

This manual has been organized to provide ready access to both thematic units and suggestions for addressing program emphases and methodology within the Science 26 program.

### THEMES

Four thematic units of instruction that address prescribed concepts, skills and attitudes in Science 26 have been placed at the beginning of this manual. The themes can be accessed by using the first tab along the side of the manual.

The chart below indicates the nature of investigations within themes developed for Science 26, and illustrates their relationship to investigations outlined in themes developed for Science 16.

	SCIENCE 16	SCIENCE 26
Theme A LIFE FORMS AND CHANGES	SYSTEMS OF THE HUMAN BODY	PERSONAL HEALTH AND LIFESTYLE
Theme B USING MATERIALS AND PRODUCTS	CHEMISTRY FOR THE CONSUMER	MATERIALS WE USE
Theme C TECHNOLOGY AT WORK	USING SYSTEMS AND TECHNOLOGIES	TECHNOLOGY IN TRANSPORTATION
Theme D UNDERSTANDING OUR ENVIRONMENT	CARING FOR ENVIRONMENT AND RESOURCES	ENERGY AND THE ENVIRONMENT

Teachers are encouraged to examine each theme and its corresponding activities and learning resources well in advance of instruction. The activities and suggestions provided within each theme are numerous. Advance planning should include a synthesis of effective strategies from the teacher's repertoire of personal experience, together with the suggestions in this manual considered most appropriate to student needs.

### PROGRAM EMPHASES AND METHODOLOGY

Suggestions for addressing program emphases and methodology within the Science 26 program are provided in the five sections that follow the themes. These sections of the manual can also be accessed by using tabs, and are identified as:

- Nature of Science
- Science and Technology
- Science, Technology and Societal Issues
- Communication Skills
- Assessment/Evaluation.

Each of these sections clarifies the intent of a particular component of instruction, and suggests teaching practices that will assist students to acquire an understanding of prescribed concepts, skills and attitudes. Teachers are encouraged to reference the ideas provided throughout these sections of the manual as they plan learning activities within each theme of the science program.

# PROGRAM PLANNING

## GENERAL COURSE PLANNING

Themes and their related concepts, skills and attitudes may be sequenced at the teacher's discretion in a developmentally appropriate way. Course planning should establish a conceptual framework consistent with students' interests, abilities, and preferred ways of approaching tasks. The four themes developed in the *Teacher Resource Manual* are intended to be descriptive rather than prescriptive. Teachers may choose to modify these themes or replace them with other locally developed material in addressing individual student needs.

Through cooperative conferencing, teachers may find that students are required to use certain science-related competencies in other courses before they are learned in science class. Joint planning and negotiation with teachers of other courses will be required in establishing an integrated program that places consistent expectations upon the student.

Course planning should focus attention on the nature of science, as well as an understanding of the role of science and technology in society. Instruction must nurture the development of thinking skills, and assist students to acquire appropriate strategies for conducting inquiry, solving problems and making informed decisions. The activities suggested throughout both the *Program of Studies/Curriculum Guide* and *Teacher Resource Manual* are numerous, but by no means exhaustive. Be prepared to add, delete, and modify activities in adapting instructional materials and methodology to the particular circumstances of the classroom and student.

## TIME ALLOCATION

Science 16 and 26 are each three-credit courses. Instructional time for each course is to be allocated at the discretion of the school or jurisdiction administration to reflect the needs of individual students.

The chart below suggests time distribution among themes developed in the *Teacher Resource Manual*. These suggestions are intended to provide guidance for the teacher.

THEME	ELECTIVE COMPONENT	SUGGESTED TIME ALLOCATION
PERSONAL HEALTH AND LIFESTYLE	R E M E D I A T I O N  A N D  O R  E N R I C H M E N T	$\frac{1}{4}$
MATERIALS WE USE		$\frac{1}{4}$
TECHNOLOGY IN TRANSPORTATION		$\frac{1}{4}$
ENERGY AND THE ENVIRONMENT		$\frac{1}{4}$

## **COMMUNITY PARTNERSHIPS**

The science program should enable students to recognize the relevance of scientific knowledge in daily life experiences within the home, community and work environments. Within this context, students will be expected to demonstrate competencies that will enable them to:

- apply scientific concepts and skills to practical situations
- set goals, solve problems and make informed decisions
- prepare for a chosen occupation or career.

Community partnerships (i.e., community-based learning experiences) will foster an appreciation of science for its usefulness and relevance. Community involvement will assist students to transfer specific concepts and skills to more generalized situations in everyday life and the world of work. Guest speakers, field trips, job shadowing and mentorship are a few examples of meaningful community associations.

Suggestions for relevant community partnerships in the science program include:

- inviting guest speakers from government, business, the professions and the trades to discuss topics related to those studied in thematic investigations
- visiting local business and industry for first-hand observation and real-life experience in areas related to the themes studied
- walking through the community in search of practical applications made of concepts and skills being studied
- investigating career and employment opportunities in areas that require specific scientific competencies (e.g., job shadowing, mock employment interviews).

Community agencies, groups and facilities that may provide meaningful contributions to the science program include:

- service groups concerned with personal and environmental health (e.g., doctors, nurses, nutritionists, pharmacists, social workers, police officers, agriculturalists, wildlife officers)
- government officials (e.g., councillors, MLA's)
- local businesses and industries that make application of scientific concepts and skills (e.g., hair care, dry cleaning, automotives, agriculture, food preparation, construction, electrical repair)
- local utility plants (e.g., power generating plants, sewage treatment plants, water purification plants, waste disposal sites)
- natural phenomena (e.g., local river valley, meadow, or wooded area).

Additional suggestions for inviting members of the community into the classroom, or having students involved in the community by way of meaningful activity linked to science are provided throughout each theme developed in this manual. These suggestions may be effective in furthering the objectives of each theme, as well as in reducing classroom barriers to "real life" experience.

## CURRICULAR INTEGRATION

Course content should be presented within the context of its application in daily living, the occupational program and other academic disciplines. Curricular integration will become a motivating factor as students recognize the relevance and utility of course content. Student ability to transfer concepts, skills and attitudes to a variety of situations in everyday life and the world of work will improve as a result of contextualized learning experiences that link prescribed content with "real life" applications.

Teachers need to be familiar with science competencies required of students in everyday life, the occupational program and other academic disciplines. Cooperative planning and conferencing with other teachers is central to understanding differing contexts in which basic concepts and skills are used, and will assist teachers in providing practical learning experiences that encourage transfer of knowledge and skill.

### EXAMPLES OF CURRICULAR INTEGRATION BASED ON A SCIENCE COMPETENCY

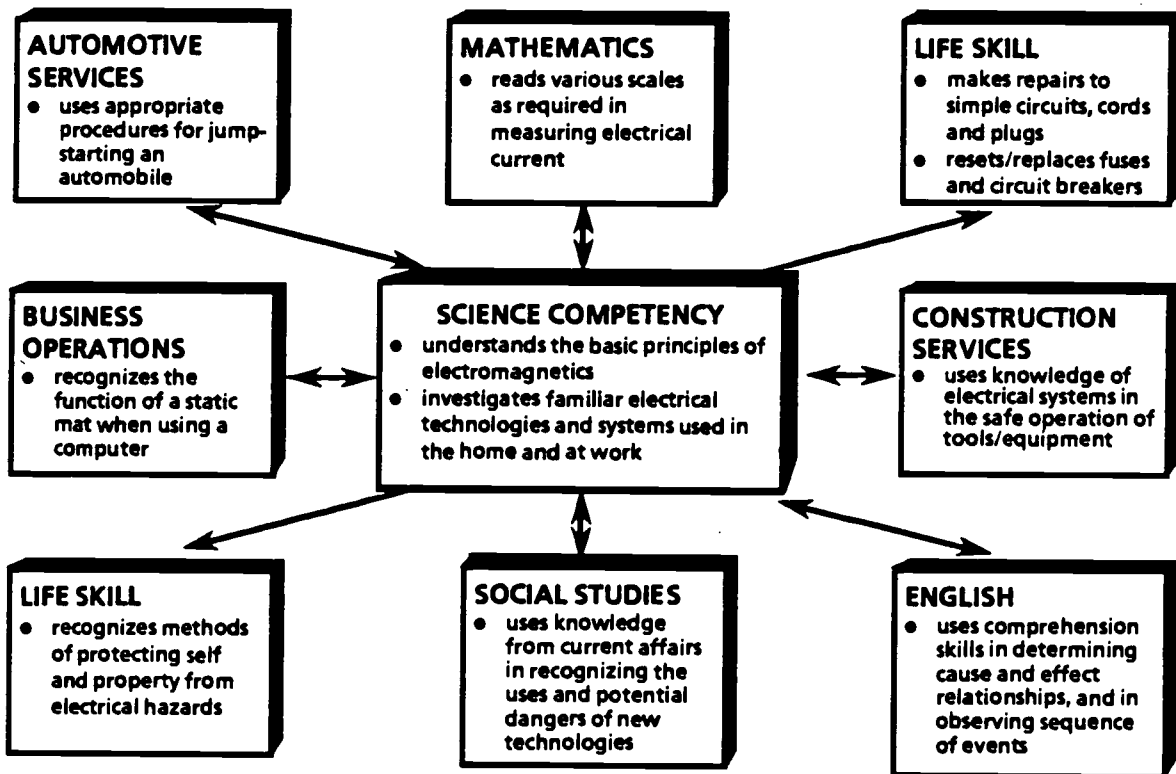

Basic principles governing the operation of electromagnetic systems are developed in science and related to their applications in other areas. While in this instance application is shown in all subject areas, some competencies may have a more limited range of applications.

The *Program of Studies/Curriculum Guide* provides suggestions for relating prescribed content to daily life skills and to applications in other subject areas across the curriculum. Additional suggestions and approaches for linking prescribed content with practical applications are provided throughout this manual.

## PLANNING AN INTEGRATED UNIT OF INSTRUCTION

A variety of factors need to be considered when expanding upon an existing theme or developing a new thematic unit. The guidelines that follow provide a useful structure for developing integrated units of instruction.

**1. Identify a possible theme, based on:**

- curriculum goals and objectives
- student needs/interests/abilities
- availability of suitable learning resources.

**2. Develop a purpose for the theme. Include:**

- thematic objectives
- a checklist of concepts, skills and attitudes that lend themselves to the theme. Identify those skills that may need some focused/direct teaching.

**3. Consider suitable resources:**

- books, pamphlets, monographs
- appropriate laboratory equipment
- computer software, films, videos
- resources from the occupational program
- community resources
- newspapers and periodicals
- other resources that students may have access to.

**4. Design activities:**

- allocate activities to the purposes developed in Step 2
- develop a checklist of process objectives to be emphasized in the theme
- separate activities into lessons with general and specific objectives
- sequence the lessons.

**5. Develop ongoing strategies to build community partnerships into your theme:**

- field trips
- guest speakers.

**6. Plan for evaluation:**

- students' self-evaluations
- teacher's ongoing (formative) and summative evaluations
- peer evaluations.

**7. Share the unit:**

- celebrate achievement
- share thematic units with other teachers
- expand, update and revise units as they are used
- develop strategies to evaluate the updated and revised activities with a variety of student groups.

## MAKING UNIT AND DAILY LESSON PLANS

Preliminary plans for a thematic unit can be organized in a variety of ways. One possible format is illustrated below. This format provides a useful overview of intended learning outcomes, methodology, student activities and learning resources, and facilitates more detailed planning prior to each daily lesson.

THEME: _____		NUMBER OF CLASS PERIODS: _____		
Period	Learning Objectives and General Activity Description	Evaluation Technique	Student Activity	Required Resources (e.g., print materials, audiovisual materials, laboratory equipment and supplies)
1				
2				
3				

The format of daily lesson plans may vary from one class period to the next, and can be adjusted to suit instructional objectives and the interests/needs of students. However, each lesson plan should:

- emphasize student involvement/activity
- give explicit guidelines for developing knowledge and process components
- establish evaluation criteria.

A sample lesson plan that illustrates the integration of these components is provided in a subsequent section of this manual (see Nature of Science, "Sample Lesson Plan").

## SCOPE AND SEQUENCE FOR SCIENCE 16-26

The scope and sequence chart provided on the following pages outlines the concepts, skills and attitudes that are addressed throughout Science 16 and 26. As students differ in the rate at which they acquire competencies in science, the chart is intended to assist teachers in assessing present levels of student performance, and in diagnosing individual strengths and weaknesses.

In using the scope and sequence, it should be noted that:

- attitudes and skills are developmental through Science 16 and 26 (i.e., the spiral approach). Students will refine and extend the attitudes and skills developed in Science 16 through more extensive applications in Science 26.
- concepts developed in the Science 16 program are in most cases discrete from concepts developed in the Science 26 program. Effort has been made to apportion concepts throughout Science 16 and Science 26 on the basis of their cognitive demand.
- the attitudes, skills and concepts are interdependent at each grade level, and are not meant to be developed in isolation. Although some concepts and skills may be mastered more effectively through discrete instruction, this approach is not advocated as a primary focus of instruction. The thematic structure permits the linking of concepts, skills and attitudes.
- most students will continue to use concrete operational thinking, depending upon personal and tangible experience in order to link ideas. Instruction should generally begin with an operational understanding of ideas at the Science 16 level, and encourage students to extend their thinking to more abstract levels that are cognitively appropriate at the Science 26 level. (The *Teacher Resource Manuals* for Science 16 and 26 provide for the development of thinking skills through themes that reflect increasing levels of analysis and critical thought.)

Prescribed components of the science program outlined in the scope and sequence chart should be appropriately clustered and applied to progressively difficult and/or age-appropriate situations as students advance through senior high school. Teachers are encouraged to organize for instruction in ways that are consistent with the abilities, needs and interests of students, using relevant sections of the *Program of Studies/Curriculum Guide*, thematic units provided in this manual, locally developed themes, or a combination of approaches.

Teachers are encouraged to examine the Scope and Sequence chart for the IOP junior high school science program (Grades 8 and 9). An understanding of the developmental progression of concepts, process and skill occurring in Grade 8 and Grade 9 will facilitate articulation between the junior high and senior high science programs.

LIFE FORMS AND CHANGES

	SCIENCE 16 SYSTEMS OF THE HUMAN BODY	SCIENCE 26 PERSONAL HEALTH AND LIFESTYLE
A T T I T U D E S	<p>Students will be encouraged to:</p> <ul style="list-style-type: none"> <li>display a positive attitude toward the learning of concepts and skills in science</li> <li>appreciate the intricate workings and balance within the human body</li> <li>appreciate the contributions of science and technology to human health</li> <li>value knowledge gained for its usefulness on a personal level</li> <li>appreciate the need for informed decision making at both personal and societal levels</li> <li>appreciate that ethical dilemmas may arise from the application of scientific research and/or medical technologies</li> <li>display responsible attitudes toward personal health through nutrition, exercise, safety and lifestyle.</li> </ul>	
	S K I L L S	<p>Students will be expected to demonstrate an ability to:</p> <ul style="list-style-type: none"> <li>collect data related to critical life functions, body systems and lifestyle factors through observation, interview and/or research</li> <li>design an experiment, through class discussion, to examine induced variations in the functioning of a body system</li> <li>use selected technological processes, instruments and/or products in collecting data about personal health and fitness factors</li> <li>analyze and assess personal health, fitness and lifestyle factors by identifying relationships, by considering consequences, and by examining a variety of viewpoints</li> <li>infer potential threats to personal health that may be caused by lifestyle factors</li> <li>apply the results of investigation to personal situation, identifying appropriate strategies for monitoring and maintaining personal health.</li> </ul>
C O N C E P T S		<p>Students will be expected to demonstrate an understanding that:</p> <ul style="list-style-type: none"> <li>the human body is a product of a number of body systems working together to perform critical life functions</li> <li>each body system has specific structures that enable it to perform a critical life function</li> <li>functional relationships among systems of the human body are critical to life</li> <li>medical technology can be used to monitor body conditions and personal health factors</li> <li>relationships exist between the diagnosis, prevention and treatment of malfunctions within body systems</li> <li>societal issues may arise from the use of technologies in preserving balance among systems of the human body.</li> </ul>



# USING MATERIALS AND PRODUCTS

A  
T  
T  
I  
T  
U  
D  
E  
S

SCIENCE 16 CHEMISTRY FOR THE CONSUMER	SCIENCE 26 MATERIALS WE USE
--	--------------------------------

Students will be encouraged to:

- display a positive attitude toward the learning of concepts and skills in science
- value scientific principles and processes for their usefulness in providing explanations of everyday phenomena
- appreciate the usefulness of measurement skills in real life and work-related situations
- appreciate how technology may facilitate the solving of practical problems, and create new problems
- appreciate the usefulness and potential hazards of common household materials
- display a respect for personal safety and the safety of others when handling potentially hazardous materials
- appreciate the contributions of science and technology to the development of a variety of materials and products that we depend upon and use each day.

S  
K  
I  
L  
L  
S

Students will be expected to demonstrate an ability to:

- conduct experiments that illustrate the properties of familiar substances and materials
- design experiments, through class discussion, that illustrate predictability in the behaviour of substances and materials that are investigated
- effectively use apparatus and equipment when conducting experiments
- make qualitative and quantitative observations when conducting experiments
- identify patterns and relationships in the behaviour of substances and materials, and use this information to explain the application of particular consumer products in everyday situations
- predict heat exchange in practical situations, and use appropriate procedures for protecting living organisms and other materials from excessive heat transfer
- accurately read product labels and consumer reports in order to determine the composition and intended use of familiar household products
- apply appropriate techniques for identifying acids, bases and other hazardous substances
- use safe procedures for handling and storing potentially dangerous substances.

C  
O  
N  
C  
E  
P  
T  
S

Students will be expected to demonstrate an understanding that:

- the properties of household solutions are different than those of pure substances
- permanent suspensions have useful properties and a variety of applications in the home
- acids and bases have useful properties and a variety of applications in the home
- solubility varies with temperature
- many chemical reactions may require or emit energy in the form of heat
- heat flows from areas of high temperature to areas of lower temperature
- handling, storing and using potentially hazardous chemical products requires knowledge and care.

Students will be expected to demonstrate an understanding that:

- models and other conceptual inventions are useful in explaining the composition and behaviour of matter
- the properties of the materials and products we use are determined by their composition
- materials and products are derived from both natural and synthetic sources
- the properties of materials determine their suitability for particular applications
- our use of natural and synthetic materials affects both environment and resources
- the process of biodegradation reduces the impact of some products on the environment
- technological products and processes develop in response to societal needs, and are often accepted and used before the full extent of benefits/problems resulting from their use can be known.



# TECHNOLOGY AT WORK

	SCIENCE 16 USING SYSTEMS AND TECHNOLOGIES	SCIENCE 26 TECHNOLOGY IN TRANSPORTATION
A T T I T U D E S	<p>Students will be encouraged to:</p> <ul style="list-style-type: none"> <li>● display a positive attitude toward the learning of concepts and skills in science</li> <li>● appreciate that science and technology have application in everyday situations, and may facilitate the solving of practical problems</li> <li>● develop confidence in personal ability to understand and solve practical problems through the use of science and technology</li> <li>● display a concern for safety and accept the need for rules and regulations governing the use of particular technologies</li> <li>● appreciate that ethical dilemmas may arise from the application of scientific research and/or technological developments</li> <li>● appreciate the relationships among science, technology and society.</li> </ul>	
	<p>Students will be expected to demonstrate an ability to:</p> <ul style="list-style-type: none"> <li>● observe and analyze the operation of familiar devices and systems, identifying component parts and scientific principles that are utilized</li> <li>● prepare systems diagrams that illustrate how component parts and/or subsystems within a technological device work together in accomplishing a task</li> <li>● test and evaluate the performance of a familiar device by               <ul style="list-style-type: none"> <li>- identifying basic principles governing its operation and use</li> <li>- inferring potential malfunctions and appropriate maintenance/repair procedures</li> <li>- suggesting ways to improve efficiency of design and/or operation</li> </ul> </li> <li>● design and construct a simple technological device or process by               <ul style="list-style-type: none"> <li>- identifying a relevant need or problem not satisfied by technology</li> <li>- identifying alternative approaches/designs to deal with the problem</li> <li>- selecting a design and constructing the device</li> <li>- testing and troubleshooting the device</li> </ul> </li> <li>● infer how specific technologies have personal application and solve practical problems.</li> </ul>	
S K I L L S		
C O N C E P T S	<p>Students will be expected to demonstrate an understanding that:</p> <ul style="list-style-type: none"> <li>● technology may facilitate the solving of practical problems through application of scientific knowledge</li> <li>● basic scientific principles are associated with the functioning of technological devices</li> <li>● many technological systems consist of combinations of subsystems that work together in accomplishing a particular task</li> <li>● science can be used to advance technology and technology can be used to advance science</li> <li>● new and emerging technological products/processes often reflect current needs and wants in society</li> <li>● products of technology are often used by society before the full extent of benefits/problems resulting from their use can be known.</li> </ul>	<p>Students will be expected to demonstrate an understanding that:</p> <ul style="list-style-type: none"> <li>● the automobile is a technological system consisting of a number of subsystems that work together</li> <li>● basic scientific principles are associated with the functioning of subsystems in an automobile</li> <li>● simple maintenance procedures contribute to the efficient performance and general safety of an automobile</li> <li>● the nature of injuries sustained in an automobile accident can be anticipated by considering the effects of first and second collisions</li> <li>● technology has contributed to safe travel through the development of highway/automobile safety features</li> <li>● political, ethical and economic perspectives often interact with science and technology, influencing choices and decisions that are made about safe travel.</li> </ul>

# UNDERSTANDING OUR ENVIRONMENT

A  
T  
T  
I  
T  
U  
D  
E  
S

S  
K  
I  
L  
L  
S

C  
O  
N  
C  
E  
P  
T  
S

SCIENCE 16 CARING FOR ENVIRONMENT AND RESOURCES	SCIENCE 26 ENERGY AND THE ENVIRONMENT
<p>Students will be encouraged to:</p> <ul style="list-style-type: none"> <li>● display a positive attitude toward the learning of concepts and skills in science</li> <li>● appreciate the fragility of the biosphere</li> <li>● appreciate the interdependence of self with other living forms and the environment</li> <li>● appreciate that environmental issues involve significant relationships among science, technology and society</li> <li>● realize our inability to anticipate the environmental effects of human activities</li> <li>● appreciate that the collective action of individuals can have significant impact</li> <li>● develop a sense of personal responsibility in relation to environmental issues.</li> </ul>	
<p>Students will be expected to demonstrate an ability to:</p> <ul style="list-style-type: none"> <li>● identify an environmental issue related to the local use of natural resources</li> <li>● gather information related to the issue through observation, interview and/or research</li> <li>● design an investigation, through class discussion, that illustrates how particular practices or products are related to the issue and influence environmental quality</li> <li>● analyze and assess information by identifying patterns and relationships, by judging the reliability/validity of information gathered and by considering consequences</li> <li>● communicate the results of investigation verbally, through the use of models and diagrams, and/or through written expression</li> <li>● take an informed position on the issue, identifying strategies that may be used to deal with the situation.</li> </ul>	
<p>Students will be expected to demonstrate an understanding that:</p> <ul style="list-style-type: none"> <li>● the biosphere is a thin layer on the surface of the earth, able to support life</li> <li>● a continuous supply of solar energy is essential to life</li> <li>● life depends upon recycling processes</li> <li>● living organisms interact with each other and with the physical environment</li> <li>● individuals and society influence the quality of the environment</li> <li>● developments in science and technology may have unforeseen consequences on society and the environment</li> <li>● individuals and society can become involved in the resolution of ecological problems that arise.</li> </ul>	<p>Students will be expected to demonstrate an understanding that:</p> <ul style="list-style-type: none"> <li>● different forms of energy are used at home and in work-related situations</li> <li>● there are renewable and non-renewable sources of energy</li> <li>● energy systems have input, conversion and output components</li> <li>● the total energy of a system is conserved</li> <li>● energy efficiency ratings describe the portion of input energy that is converted to useful energy</li> <li>● consumption of electrical energy in the home can be analyzed and monitored</li> <li>● energy conservation involves the interaction of economic, political and ethical perspectives with science and technology.</li> </ul>

BEST COPY AVAILABLE

# LEARNING RESOURCES FOR SCIENCE 26

## STUDENT RESOURCES

### BASIC LEARNING RESOURCES

The learning resources listed below address the majority of the goals and learning objectives identified in the *Program of Studies/Curriculum Guide*. Because of the modular format of the learning resources, they have been listed separately for each theme within the science program.

#### Theme A: Personal Health and Lifestyle

Hutton, Glen, ed. *Food Power*. ISIS Individualized Science Instructional System (Booklet). Revised. Scarborough, Ontario: Globe/Modern Curriculum Press, 1989.

#### Theme B: Materials We Use

Hutton, Glen, ed. *Materials and Molecules*. ISIS Individualized Science Instructional System (Booklet). Revised. Scarborough, Ontario: Globe/Modern Curriculum Press, 1989.

#### Theme C: Technology in Transportation

Hutton, Glen, ed. *Arrive Alive*. ISIS Individualized Science Instructional System (Booklet). Revised. Scarborough, Ontario: Globe/Modern Curriculum Press, 1989.

#### Theme D: Energy and the Environment

Hutton, Glen, ed. *Energy for Living*. ISIS Individualized Science Instructional System (Booklet). Revised. Scarborough, Ontario: Globe/Modern Curriculum Press, 1989.

### SUPPORT LEARNING RESOURCES

The learning resources listed below assist in addressing some of the learning objectives identified in the *Program of Studies/Curriculum Guide*. Because of the modular format of the learning resources, they have been listed separately for each theme. Multiple copies (but not necessarily class sets) of each resource may be desired.

#### Theme A: Personal Health and Lifestyle

Mooney, Libby, and Andy Rivers. *Sports Science*. Science at Work Series, Third Edition (Booklet). Harlow, England: Longman Group Limited, 1989.

#### Theme B: Materials We Use

Goulcher, Pat. *Fibres and Fabrics*. Science at Work Series, Third Edition (Booklet). Harlow, England: Longman Group Limited, 1989.

#### Theme C: Technology in Transportation

Rowlands, David, and George Snape, eds. *Structures and Machines*. Science at Work Series, Third Edition (Booklet). Harlow, England: Longman Group Limited, 1990.

## Theme D: Energy and the Environment

Rowlands, David, and George Snape, eds. *Energy*. Science at Work Series, Third Edition (Booklet). Harlow, England: Longman Group Limited, 1990.

### OTHER LEARNING RESOURCES

Other learning resources potentially useful in implementing the Science 26 program are identified below. These resources have not undergone the standard review procedures of Alberta Education, and their listing is not to be construed as an explicit or implicit departmental approval for use. These titles are provided as a service only to assist local jurisdictions in identifying potential learning resources. The responsibility for evaluating these resources prior to selection and use rests with the local jurisdiction according to local policy.

Alberta Education. *Automotive Services 26 Student Workbook*. Edmonton, Alberta: Alberta Education, 1991.

Alberta Education. *Service Station Services 26 Student Workbook*. Edmonton, Alberta: Alberta Education, 1991.

Alberta Motor Association. *About Your Car*. Edmonton, Alberta: AMA, 1985.

Health and Welfare Canada. *Food Additive Pocket Dictionary*. Ottawa, Ontario: Department of National Health and Welfare, 1987.

Heimler, Charles. *Principles of Science, Book 1*. Columbus, Ohio: Charles E. Merrill Publishing Company, 1986.

Heimler, Charles. *Principles of Science, Book 2*. Columbus, Ohio: Charles E. Merrill Publishing Company, 1986.

Mardall, O. J., et al. *Science Networks: Biology*. Toronto, Ontario: Globe/Modern Curriculum Press, 1982.

Mardall, O. J., et al. *Science Networks: Physical Science*. Toronto, Ontario: Globe/Modern Curriculum Press, 1983.

Robertson, Alan. *Choices for Health*. Scarborough, Ontario: Nelson Canada, A Division of International Thomson Limited, 1983.

Taylor, John (Project Director). *Science at Work Series*. Harlow, England: Longman Group Limited.

Booklets: *Building Science* (1985, revised edition pending)  
*Photography* (1989)  
*Telecommunications* (1987)  
*You and Your Mind* (1989)

Wilde, George. *Applied Science, Book 1*. Melbourne, Australia: Longman Cheshire Limited, 1986.

Wilde, George. *Applied Science, Book 2*. Melbourne, Australia: Longman Cheshire Limited, 1989.

## TEACHER RESOURCES

The teacher resources listed below are designed to assist classroom teachers in using the BASIC and SUPPORT learning resources.

### ISIS Individualized Science Instructional System

Hutton, Glen, ed. *ISIS Individualized Science Instructional System Teacher Resource Guide*. Revised. Scarborough, Ontario: Globe/Modern Curriculum Press, 1989.

Hutton, Glen. *Arrive Alive, Evaluation and Resource Package*. Scarborough, Ontario: Globe/Modern Curriculum Press, 1990.

Hutton, Glen. *Energy for Living, Evaluation and Resource Package*. Scarborough, Ontario: Globe/Modern Curriculum Press, 1990.

Hutton, Glen. *Food Power, Evaluation and Resource Package*. Scarborough, Ontario: Globe/Modern Curriculum Press, 1990.

Hutton, Glen. *Materials and Molecules, Evaluation and Resource Package*. Scarborough, Ontario: Globe/Modern Curriculum Press, 1990.

### Science at Work Series

Goulcher, Pat. *Fibres and Fabrics Teachers' Guide*. Science at Work Series. Harlow, England: Longman Group Limited, 1989.

Mooney, Libbey, and Andy Rivers. *Sports Science Teachers' Guide*. Science at Work Series. Harlow, England: Longman Group Limited, 1989.

Rowlands, David, and George Snape, eds. *Energy Teachers' Guide*. Science at Work Series. Harlow, England: Longman Group Limited, 1990.

Rowlands, David, and George Snape, eds. *Structures and Machines Teachers' Guide*. Science at Work Series. Harlow, England: Longman Group Limited, 1990.

Other teacher resources identified as useful in addressing major goals and learning objectives within the science program are listed below.

Aikenhead, Glen. *Science in Social Issues: Implications for Teaching*. Ottawa, Ontario: Supply and Services Canada, 1980.

Alberta Education. *Clarification of Statements Prohibiting the Use of Human Body Substances in the Alberta Science Curriculum*. Edmonton, Alberta: Alberta Education, 1988.

Alberta Education. *Learning Contexts for Junior High Science*. Edmonton, Alberta: Alberta Education, 1989.

Alberta Education. *STS Science Education: An Opportunity for Unifying the Goals of Science Education*. Edmonton, Alberta: Alberta Education, 1989.

- Alberta Energy. *The Energy News Kit*. Edmonton, Alberta: Alberta Energy, 1989.
- Alberta Energy. *Heat: Home Energy Analysis and Tutorial*. Edmonton, Alberta: Alberta Energy, 1988.
- Alberta Energy. *Somebody Should Do Something About This! A Teacher's Resource Book on Energy and the Environment*. Edmonton, Alberta: Alberta Energy, 1990.
- Armour, Margaret-Ann, et al. *Hazardous Chemicals: Information and Disposal*. Edmonton, Alberta: University of Alberta, 1985.
- Bisacre et al. (Editors). *The Illustrated Encyclopedia of Technology*. New York, New York: Marshall Cavendish Books Limited, 1984.
- Durie, Bruce. *Visual Science (Series)*. London, Ontario: MacDonald Educational, 1987.
- Liem, Tik L. *Invitations to Science Inquiry, Second Edition*. Lexington, Massachusetts: Ginn Custom Publishing, 1987.
- Science Education Consultants' Council. *Evaluation of Student Progress, A Workshop Manual for Administrators and Teachers*. Edmonton, Alberta: Alberta Education, 1985.
- Science Education Consultants' Council. *Safety and Organization in School Science Facilities, Second Edition*. Edmonton, Alberta: Alberta Education, 1990.
- Science Education Consultants' Council. *WHMIS: Abridged Guidelines for Schools*. Edmonton, Alberta: Alberta Education, 1989.

## **TECHNOLOGY AND MEDIA**

There is a growing collection of technology and media materials (e.g., films, videos, computer software, kits, pamphlets) that support the development of specific learning objectives within the science program. Some of these resources have been identified below. Teachers are encouraged to contact local media services, libraries and government agencies in obtaining these and other resources considered appropriate to the science program.

### **OTHER LEARNING RESOURCES**

#### **Video Programs**

The video programs that follow are potentially useful in addressing some of the learning objectives identified in the *Program of Studies/Curriculum Guide*. These resources have not undergone the standard review procedures of Alberta Education, and their listing is not to be construed as an explicit or implicit departmental approval for use. Titles are provided as a service only to assist local jurisdictions in identifying potential learning resources. The responsibility for evaluating each resource prior to selection and use rests with the local jurisdiction according to local policy.

*Acme School of Stuff (Series)*. TV Ontario, 1988.  
*Chemistry in Everyday Life*. Britannica, 1987.  
*Greenhouse Effect*. Canadian Broadcasting Corporation, 1984.  
*How the Motor Car Works Series*. Shell Oil, 1977.  
*The Human Body Series*. National Geographic, 1988.  
*The Problem-Solving Film*. Omega, 1988.  
*Science and Technology: Acting in Turn*. Shell Oil, 1974.  
*Science Edition II*. TV Ontario, 1987.  
*The Scientific Method*. VEC, 1987.

These programs are available through ACCESS NETWORK and/or local resource centres. A description of each program is provided in Appendix A.

### Computer Software

An annotated list of computer software that may be useful in implementing the Science 26 program is provided in Alberta Education's catalogue of *Computer Courseware Evaluations* (Alberta Education, 1986) and annual supplements.

### Government Agencies

Local, provincial and federal government agencies are often able to provide information relevant to learning objectives within the science program. Government agencies that may provide resource materials appropriate to themes in Science 26 include:

Alberta Alcohol and Drug Abuse Commission (AADAC)  
Alberta Consumer and Corporate Affairs  
Alberta Economic Development and Trade  
Alberta Energy  
Alberta Technology, Research and Telecommunications  
Alberta Transportation and Utilities  
Environment Council of Alberta  
Health and Welfare Canada.

Information that will assist teachers in contacting these government agencies is provided in Appendix B.

### ACCESS NETWORK

ACCESS offers a variety of resources and services to teachers. For a nominal dubbing and tape fee, teachers may obtain copies of educational programs directly from ACCESS NETWORK. ACCESS also offers a service called "Night Owl Dubbing". This allows educators to tape selected educational programs directly from their own televisions.

ACCESS publishes both an *Audio-Visual Catalogue* and a comprehensive schedule of programming, available on request.

For additional information, contact ACCESS NETWORK, Media Resource Centre, 295 Midpark Way S.E., Calgary, Alberta, T2X 2A8 (from outside of Calgary, telephone toll free, 1-800-352-8293; in Calgary, telephone 256-1100).



## **LOCAL RESOURCE/MEDIA CENTRES**

There are a number of resource/media centres serving the needs of different geographical areas across Alberta. Each centre carries audio and visual resources, and publishes its own catalogue listing the resources in its collection. These centres operate as libraries, and lend materials for specified time periods. For more information, contact the resource/media centre in your area.

### **Regional Resource Centres**

- Zone I**                      **Zone One Regional Resource Centre**  
P.O. Box 6536 / 10020 – 101 Street  
Peace River, Alberta  
T8S 1S3  
Telephone: 624-3187
- Zone II and III**              **Central Alberta Media Services (CAMS)**  
2017 Brentwood Boulevard  
Sherwood Park, Alberta  
T8A 0X2  
Telephone: 464-5540 / 467-8896
- Zone IV**                      **Alberta Central Regional Education Services (ACRES)**  
County of Lacombe No. 14  
Box 3220 / 5140 – 49 Street  
Lacombe, Alberta  
T0C 1S0  
Telephone: 782-5730
- Zone V**                      **South Central Alberta Resource Centre (SCARC)**  
Westmount School  
Box 90 / Wheatland Trail  
Strathmore, Alberta  
T0J 3H0  
Telephone: 934-5028
- Zone VI**                      **Southern Alberta Learning Resource Centre (SALRC)**  
909 – 3rd Avenue North, Room #120  
P.O. Box 845  
Lethbridge, Alberta  
T1J 3Z8  
Telephone: 320-7807

### **Urban Media Centres**

- Bonnyville**                      **Area Superintendent**  
Lakeland Public School District No. 5460  
Postal Bag 1001  
Bonnyville, Alberta  
T9N 2J7  
Telephone: 826-3145

- Calgary**                    **Supervisor, Education Media**  
**Calgary Board of Education**  
**3610 – 9th Street S.E.**  
**Calgary, Alberta**  
**T2G 3C5**  
**Telephone: 294-8540**
- Calgary**                    **Supervisor, Instructional Materials**  
**Calgary Separate School Board**  
**6220 Lakeview Drive S.W.**  
**Calgary, Alberta**  
**T3E 6T1**  
**Telephone: 246-6663**
- Edmonton**                **Supervisor, Curricular Resources**  
**Edmonton Catholic Schools**  
**St. Anthony's Teacher Centre**  
**10425 – 84 Avenue**  
**Edmonton, Alberta**  
**T6E 2H3**  
**Telephone: 439-7356**
- Edmonton**                **Learning Resources Consultant**  
**Edmonton Public School Board**  
**Centre for Education**  
**One Kingsway**  
**Edmonton, Alberta**  
**TSH 4G9**  
**Telephone: 429-8320**
- Medicine Hat**            **Instructional Materials Centre Manager**  
**Medicine Hat School District**  
**601 First Avenue S.W.**  
**Medicine Hat, Alberta**  
**T1A 4Y7**  
**Telephone: 526-1323**
- Red Deer**                    **Coordinator of Instruction**  
**Red Deer Public School Board**  
**4747 – 53 Street**  
**Red Deer, Alberta**  
**T4N 2E6**  
**Telephone: 343-1405**
- Sherwood Park**            **Director, Learning Resource Service**  
**County of Strathcona**  
**2001 Sherwood Drive**  
**Sherwood Park, Alberta**  
**T8A 3W7**  
**Telephone: 464-8235**

## CORRELATION OF BASIC LEARNING RESOURCES TO SCIENCE 26

A correlation of four booklets within the ISIS Individualized Science Instructional System to themes developed for Science 26 is provided below. The correlation chart illustrates how the booklets can be used to address prescribed learning objectives within each theme of the science program.

### SCIENCE 26 THEMES

#### ISIS BOOKLET: *FOOD POWER*

1. The Carbohydrate Connection
2. Fats and Proteins Are Nutrients Too
3. Vitamins, Minerals and Nutrition
4. Food Record – Feeling Full Is Not Enough
5. Weight Right Here
6. A Sensible Way to Control Your Weight
7. Additives, Labels and Technology
8. Nutrition and Drugs
9. Food Technology

#### ISIS BOOKLET: *MATERIALS AND MOLECULES*

1. A Matter of Molecules
2. Metals – Qualities and Uses
3. Hello Alloys
4. Metal Corrosion
5. Protective Metal Coatings
6. Pine, Panelling and Paper
7. From Sheep to Shawl
8. Grading Biodegradability
9. Cotton, Polyester and Enzymes
10. Plastics and Other Polymers
11. Kevlar, A Clever Composite
12. Medical Matters
13. Dentistry Developments

Personal Health and Lifestyle	Materials We Use	Technology In Transportation	Energy and the Environment
p. 5			
p. 14			
p. 19			
p. 29			
p. 36			
p. 45			
p. 50			
p. 57			
-			
	p. 5		
	p. 11		
	p. 14		
	p. 17		
	p. 22		
	p. 26		
	p. 31		
	p. 37		
	p. 41		
	p. 46		
	p. 55		
	p. 60		
	p. 65		

## SCIENCE 26 THEMES

### ISIS BOOKLET: *ARRIVE ALIVE*

1. The Second Collision
2. Sudden Stops Hurt
3. Eggs and Brains
4. Modelling and Testing Vehicle Safety Technologies
5. Seat Belts – Verdict Please
6. Conservation of Energy in Crashes
7. Calculating Collision Momentum
8. Wheels, Human Error and Alcohol
9. Society, Technology and Transportation Concerns
10. Building Safer Highways

### ISIS BOOKLET: *ENERGY FOR LIVING*

1. Energy from Oxygen and Food
2. Energy and a Sugar Called Glucose
3. Food, Plants and the Sun
4. Marshmallows, Kilojoules and You
5. Counting Kilojoules
6. The Many Faces of Energy
7. Watts and Kilowatts
8. Volts and Amperes
9. Energy from Fossil Fuels
10. Fossil Fuels and the Environment
11. Renewable and Non-Renewable Energy

Personal Health and Lifestyle	Materials We Use	Technology in Transportation	Energy and the Environment
		p. 5 p. 8 p. 16 p. 19  p. 26 p. 32 p. 38 p. 47 p. 56  p. 63	
p. 5 p. 8  p. 18 p. 26			p. 11  p. 36 p. 41 p. 47 p. 53 p. 59 p. 71

## **SAFETY IN THE SCIENCE CLASSROOM**

Safety must be a major consideration as students become actively involved in experimental procedures and laboratory settings. An awareness of safety should be developed through a common sense approach. Students should recognize that specific hazards can be avoided through advance planning and an awareness of hazardous materials and situations. No laboratory work should be expected of students if they are not fully aware of possible hazards and preventative measures.

When conducting experiments and investigations, students will be expected to display a concern for safety by:

- following directions exactly as given
- understanding the import of what they are doing
- maintaining order and neatness when using equipment
- using prior knowledge to make judgments
- asking for advice when in doubt.

Students should be encouraged to transfer the safety knowledge and attitudes developed in school to potentially dangerous situations they may encounter at home, at work and in the community.

### **RESPONSIBILITIES OF THE TEACHER**

Teachers must provide adequate supervision of students at all times, and emphasize accident prevention. Students must be alerted to situations they may create that are unsafe or hazardous.

The most effective method of teaching safety is by example. The procedures and attitudes modelled by the teacher influence students more than actually teaching a unit on safety. The teacher must be conscious of the example being set and, through modelling, assist students to develop appropriate safety habits and attitudes, including:

- careful observation and alertness at all times
- application of safety procedures and techniques
- advance identification of safety responsibilities associated with experimental procedures that are planned.

### **RESPONSIBILITIES OF THE STUDENT**

Students must be alerted to general safety precautions and procedures early in the science program. Specific hazards and precautions related to the use of equipment and chemicals must be discussed as the materials are used. Students should learn to plan their laboratory investigations and procedures in ways that will minimize the possibility of accidents. All accidents and unexpected events that occur should be reported and discussed with the teacher.

It is recommended that a Student Safety Contract be issued early in the school year, after students have been alerted to general safety precautions and procedures. Use of a safety contract will increase the students' awareness of personal responsibilities in the safety of self and others. A sample student safety contract is provided on the following page.

## STUDENT SAFETY CONTRACT

I will:

- Follow all safety instructions given by the teacher.
- Protect eyes, face, hands and body while conducting class activities.
- Carry out good housekeeping practices.
- Be able to locate first-aid and firefighting equipment
- Conduct myself in a responsible manner at all times in a laboratory situation.

I, \_\_\_\_\_, have read and agree to abide by the safety regulations as set forth above and any additional verbal and printed instructions provided by the teacher and/or school.

Date \_\_\_\_\_

Signature \_\_\_\_\_

## SAFETY GUIDELINES AND POLICIES

Teachers must be familiar with safety policies and statements adopted by their employing board. In the absence of such statements, teachers should be aware of specific hazards that students face in the science program and take suitable precautions to avoid such hazards.

Teachers must also be familiar with policy and information provided in Alberta Education's monograph *Clarification of Statements Prohibiting the Use of Human Body Substances in the Alberta Science Curriculum*, 1988. (Due to the potential risk of infection from hepatitis and AIDS, all activities involving the extraction and analysis of samples of human fluid or tissue are prohibited in Alberta schools.)

Additional safety information that should be available in every school is provided in:

- *Safety and Organization in School Science Facilities, A Resource Book for Elementary and Secondary Schools* by Science Education Consultants' Council, Alberta Education, 1990.
- *Hazardous Chemicals: Information and Disposal*, a resource by Margaret-Ann Armour, Lois Browne and Gordon Weir. Published by the University of Alberta, Edmonton, 1985.

While no set of safety rules can be complete, the suggestions that follow may provide direction in establishing a set of appropriate safety procedures for the science program:

- e.g.,
- Supervise students at all times.
  - Ensure that students use correct laboratory techniques.
  - Strictly enforce rules with regard to behaviour.
  - Avoid any laboratory procedure if there is any doubt as to its safety.

- Locate and teach the use of appropriate safety equipment (e.g., eyewash, first-aid kit, fire blanket, fire extinguisher).
- Provide medical attention immediately if there is any question as to its need.
- Ensure that students carry out a procedure only after they understand how it is to be done.
- Ensure that students are properly dressed (e.g., wearing protective glasses or aprons if required; no loose clothing or hair that will interfere with equipment and materials).
- Provide instruction in appropriate procedures for using possibly hazardous equipment and supplies such as bunsen burners, alcohol lamps, candles, acids/bases or solvents.
- Provide adequate ventilation, working space and suitable equipment for each investigation.
- Label all chemicals clearly.
- Store potentially dangerous chemicals and apparatus in a locked and well-organized storeroom.
- Insist on well-planned and organized procedures, and on cleanliness of hands, benches, tables and equipment.
- Avoid the use of concentrated acids or bases, volatile solvents, sodium, potassium, phosphorus or hydrogen.
- Use pyrex glassware when heating substances.
- Avoid heating test tubes over an open flame.
- Use 110 volt electricity only in CSA approved apparatus.
- Use care when inserting glass tubing through rubber stoppers.
- Avoid activities that involve the extraction or analysis of human tissue or fluid (e.g., cell scrapings, blood samples).

## **WORKPLACE HAZARDOUS MATERIALS INFORMATION SYSTEM**

The Workplace Hazardous Materials Information System (WHMIS) is a hazard communications program designed to protect workers across Canada from injuries and illnesses caused by exposure to chemicals. School jurisdictions must have WHMIS guidelines implemented. WHMIS uses federal and provincial legislation to ensure:

- the labelling of hazardous materials
- the provision of material safety data sheets (MSD's) by suppliers of hazardous materials
- worker education/instruction programs.

WHMIS provides a way for teachers to obtain information about hazardous materials that may be used in the science program. Science teachers should consult WHMIS in order to identify the hazards of various materials and the precautions to take when using these materials. Additionally, all secondary school students should receive instruction about WHMIS, and use the system in their work. WHMIS instruction is probably of greatest value at opportune times before and during students' use of controlled products, rather than as an individual topic of study.

Policy and information on WHMIS is provided in *WHMIS: Abridged Guidelines for Schools*, a resource booklet prepared by the Science Education Consultants' Council, Alberta Education, 1989. Posters, booklets and pamphlets that describe features of WHMIS are available at no cost from the nearest Regional Office of Alberta Occupational Health and Safety.

Other resource materials on WHMIS include a videotape *WHMIS: Working for You* and a reference manual *WHMIS Core Material: A Resource Manual for the Application and Implementation of WHMIS (1989 Revised Edition)*. These materials can be ordered through the Alberta Association of Safety Personnel/Canadian Society of Safety Engineers Provincial Body at the address provided below.

AASP/CSSE Provincial Body  
 P.O. Box 262, Main Post Office  
 Edmonton, Alberta  
 T5J 2J1

## EQUIPMENT AND MATERIALS

An activity-based science program requires pre-planning and the gathering of equipment and materials. Assuming a standard science laboratory with basic equipment, the materials required for Science 26 are for the most part simple, inexpensive and easily obtained. Each investigation suggested within the student learning resources provides a list of materials that are required in order to conduct the activity.

Teachers are encouraged to examine each theme and its corresponding activities well in advance of instruction in order to determine laboratory items that will be required. The guidelines that follow are intended to assist teachers when planning for equipment and materials relevant to each theme of the science program.

- Ensure that equipment and material quantities are sufficient for small group work, thus facilitating maximum student participation.
- Ask each student to take home a "scrounging list" of needed equipment and materials. Some items collected from home may be used "as is", and others may be reconstructed as substitutes for more expensive laboratory equipment. The processes of improvisation and construction can provide valuable learning experiences for students as they practise basic skills and techniques, and see the results of their endeavours in the equipment they use.
- Identify equipment and materials relevant to the science program that are also used in occupational courses. Consider a loan of these items for demonstrations and/or related activities.
- Consult administration about establishing a petty cash system that will facilitate the purchase of inexpensive and disposable items available from the local hardware store, drugstore or supermarket. Most of the chemicals used in the science program are common household substances and need not be of a special laboratory grade.
- When making major purchases of equipment or materials, consult local wholesalers and distributors for better buys than may be available through scientific supply companies.
- Provide students with alternative learning environments within the community, for studying science. "Out-of-school" environments are often valuable in illustrating applications of scientific concepts and skills, and may eliminate the need for expensive laboratory equipment within the classroom.

The list of suggested apparatus and supplies that follows is intended to provide guidelines for furnishing a science room with materials that support instructional activities referenced throughout this manual. Teachers should recognize that the list is not exhaustive, and that every item may not be required. Equipment and material needs will be determined by the nature of the investigations conducted throughout the program.

### SUGGESTED APPARATUS

ammeter  
apron  
battery (car)  
beaker (25 mL, 100 mL,  
250 mL, 500 mL)

beaker tongs  
candle  
chemical scoop  
clamp  
collection of jars  
cooler (or access to  
refrigerator/freezer)

dishpan or pneumatic  
trough  
dry cell (1.5 volt)  
electric motor (for  
disassembly)  
eyedropper  
eyewash bottle

fabric samples (assorted  
natural and synthetic)  
filmstrip projector  
fire blanket  
fire extinguisher  
first aid kit  
flask (250 mL)



## SUGGESTED APPARATUS (continued)

funnel (e.g., 65 mm × 11 mm)	overhead projector	rubber tubing (1/4 × 1/16)	test tube holder
glass tubing (8 × 1.1 mm)	pencil sharpener (wall mount)	ruler	test tube rack
goggles	petri dish	screwdriver and screws	thermometer
graduated cylinder (100 mL)	plastic or metal ball (7 mm diameter)	sphygmomanometer	triple beam balance
hotplate	protective gloves/mittens	stethoscope	tweezers
light bulb (1.5 volts)	pulleys (assorted)	stirring rod	voltmeter
lumber scraps	ramp (about 1.5 m long, 30 cm wide)	stopwatch (or clock with second hand)	watch glass
magnets (assorted)	retort stand	electrical switches (assorted)	wire gauze pad
magnifying glass	ring clamp	tape recorder (optional)	wire (insulated copper)
metal strips (assorted)	rubber stopper	test tubes (15 mm × 125 mm; 20 mm × 150 mm)	
metre stick	rubber stopper (1-hole, 2-hole)		
microscope			
mirror (concave)			
nails (galvanized and ungalvanized)			

## SUGGESTED SUPPLIES

aluminum foil	drinking straws	markers (large, assorted colours)	rubber band
baking soda	dry yeast	markers (waterproof, assorted colours)	slat
Benedict's solution	egg (raw)	matches (wooden)	sand
butter	ethyl alcohol solution	orange	sawdust
cabbage leaves	filter paper	paper clips	soda crackers
carbonated (bottled) pop	fructose solution	paper (pH)	staples
carrot top	flour	paper towel	starch
catalogue collection	fuse (assorted)	peanut butter	steel wool
celery stick	gelatin	pebbles/gravel	sugar (cube, granular)
chalk	glucose solution	pencil crayons	sulfuric acid (dilute)
cheese	grease pencil	petroleum jelly (small tube)	syrup
citrus/fruit juices	honey	plastic baggies (sandwich)	tacks
clay (modelling)	iodine solution	popsicle sticks	tape (masking)
coat hanger	iron filings	potato	tape (transparent)
coleus plant	jam	powdered milk	toothpicks
construction paper (poster size)	labels (self-sticking)	recording tape/cassettes (optional)	twine
cooking oil	labels from processed foods		vinegar
copper strips	lemon juice		wooden splints
cup (opaque or styrofoam)	limewater		writing paper and envelopes
distilled water	litmus paper (red and blue)		zinc strips
	magazine collection		zinc sulphate solution

## INTERPERSONAL SKILLS AND COOPERATIVE LEARNING

Many science activities provide opportunities for students to develop strategies and skills by working in cooperative learning situations. Group work often provides students with a less threatening environment, where they may be more willing to take the risks associated with inquiry, problem solving and decision making. Students participating in group activities can learn new strategies from others, and refine their own processing skills.

Skills best learned in group settings may include the ability to:

- clarify one's own ideas
- consider alternative ideas and approaches
- compare and assess alternatives.

### CLARIFICATION/EXAMPLE

#### **A Paired Problem-Solving Strategy<sup>1</sup>**

Students are divided into pairs (problem solver, recorder) in order to work together in solving a problem. The use of a "thinking-aloud" procedure allows the student to see how their partner thinks and solves problems. Thinking steps are thus open to view and can be observed and communicated. The procedure used is:

1. One member (the problem solver) "thinks aloud" while solving a given problem.
2. The other member (the recorder) listens carefully, noting the steps taken in the solving of the problem. At the end of this "think aloud" procedure, the recorder may ask clarification questions of the problem solver and/or may point out errors made in the problem-solving process.
3. Roles are reversed, repeating the same problem.
4. The modification/extension of both strategies are discussed, with each person (or both if agreement is reached) documenting the best "modified" strategy.

This strategy could be expanded to include three people by subdividing the recorder's role into recorder and questioner. The three roles would rotate.

Interpersonal skills can also be enhanced through cooperative learning experiences. As students work in group settings, problems in social interaction may arise. A strategy for systematically analyzing a social problem is provided on the next page. This strategy helps students to identify:

- reasons for the difficulty/conflict
- strategies that may avoid the difficulty/conflict another time.

Teacher modelling and student use of this strategy may enable students to gain confidence in their ability to interact effectively and communicate with one another.

1. Adapted from *SPELT: A Strategies Programme for Effective Learning/Thinking: Inservice Edition*, SPELT International, Ltd., p. 197. Copyright 1987 by R. Mulcahy, K. Marfo, D. Peat and J. Andrews. Reprinted by permission.

# SPOT (SOCIAL PROBLEM-SOLVING STRATEGY)

## Description of Strategy

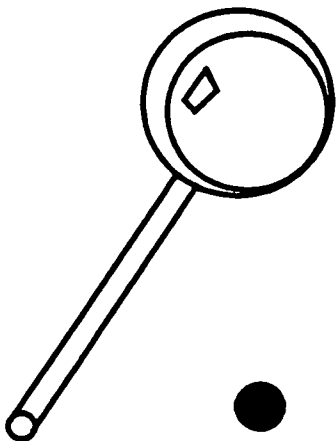

- S:** Setting: Who? What? Where? When?
- P:** Problem: What's the situation to be solved?
- O:** Order of action: What happened?
- T:** Tail End: What can be done next time?

## Problem-Solving Chart:

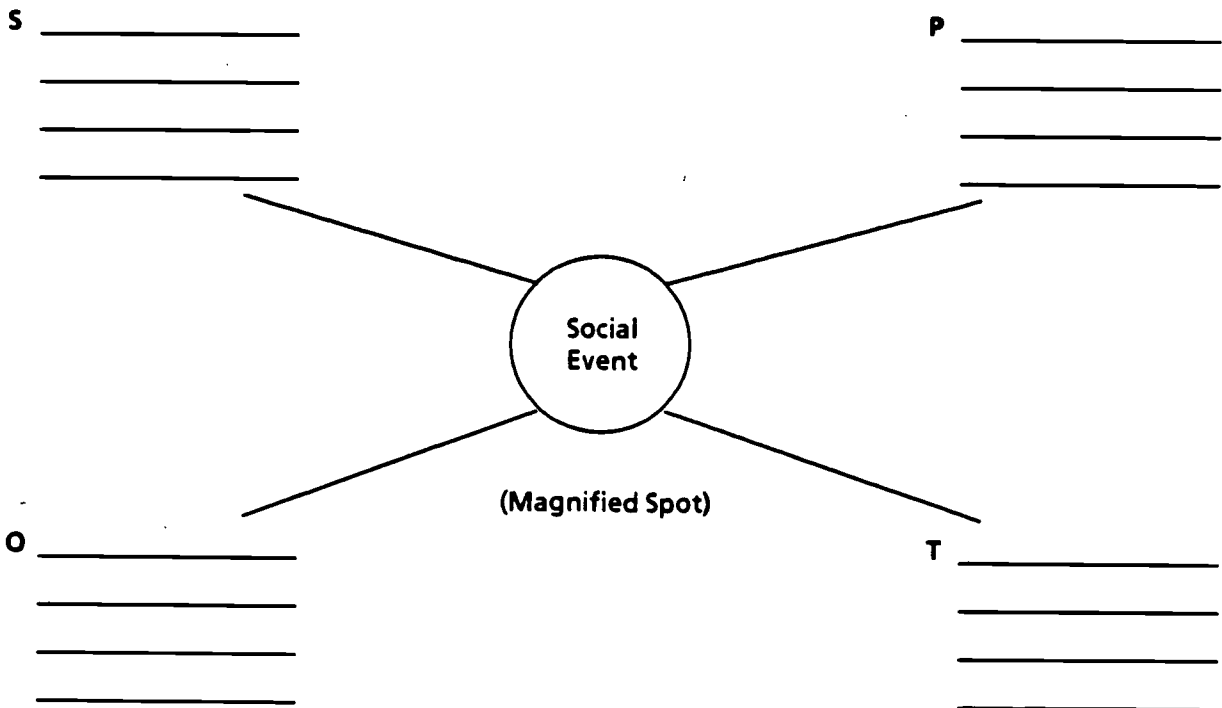

From *Strategies for Teaching Students with Learning and Behaviour Problems* by Dr. C. Boss, and S. Baughn. Copyright 1988 by Boston, Allyn and Bacon. Reprinted by permission.

# RELATIONSHIP OF SCIENCE 16-26 TO SCIENCE 14-24

## RATIONALE

As outlined in the *Guide to Education: Senior High Handbook* (1991-92), Science 16 is designed to allow students to meet the credit requirements of the Certificate of Achievement. Science 26 is optional, allowing students to develop their knowledge and skills in science more fully, and facilitates transfer to the General High School Diploma program. In contrast, the Science 14-24 program is designed to allow students to meet the credit requirements of the General High School Diploma.

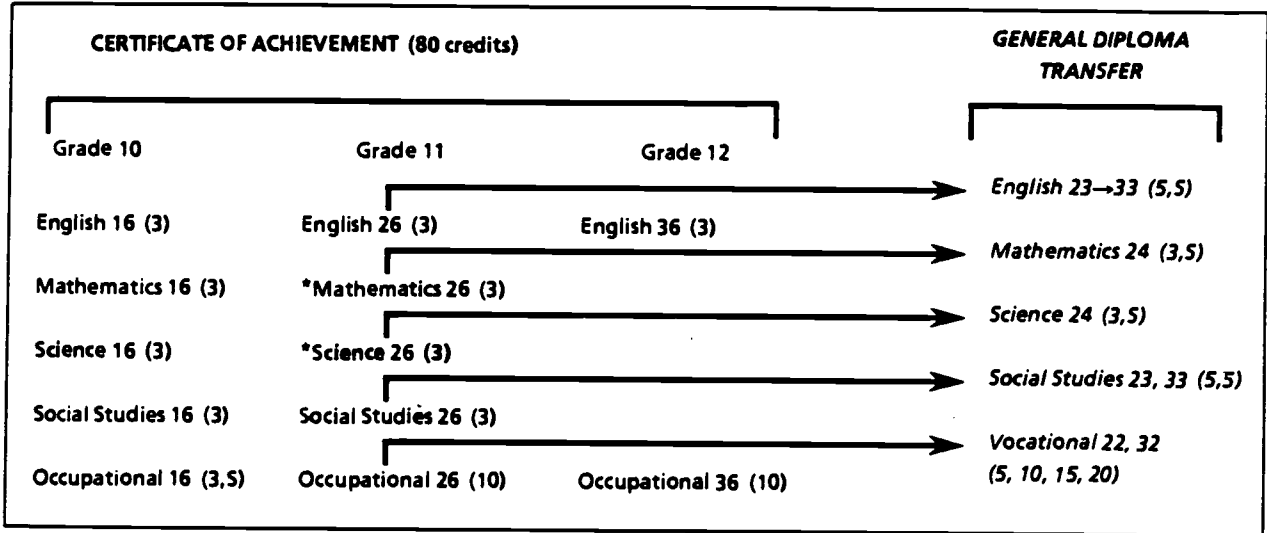

\* Mathematics 26 and Science 26 - These courses are designed to prepare students for possible transfer to the General High School Diploma route. While not required as part of the Certificate of Achievement, I.O.P. students may choose to enrol in these course and may apply the credits as part of their unspecified course requirements (13 credits).

Both Science 16-26 and Science 14-24 have been developed on the basis of their appropriateness to the developmental levels of students, and provide:

- potential for students to transfer to higher level science courses
- an emphasis on the utility and application of concepts and skills in science.

## COURSE DESIGN

Both course sequences are activity-based, using themes to provide concrete and situational learning experiences. Each theme establishes a context for the integrated development of concepts, skills and attitudes. Student learning resources authorized for use in Science 16-26 and Science 14-24 are common, and support instruction in a manner consistent with the way each course sequence has been designed.

## INSTRUCTIONAL EMPHASES

Instructional emphases within the Science 16-26 and Science 14-24 course sequences are consistent with one another, and focus attention on:

- science as a disciplined way to develop explanations for natural phenomena
- interactions between science and technology
- how science and technology influence and are, in turn, influenced by societal issues
- the development of thinking skills appropriate to conducting scientific inquiry, solving problems, and making informed choices in society.

## CONCEPTS, SKILLS AND ATTITUDES

Concepts developed in Science 16-26 are similar to those developed in Science 14-24; both course sequences contribute to an understanding of major ideas in the natural sciences. Science 16-26 focuses attention on developing an operational understanding of concepts in relevant and concrete situations. Science 14-24 provides a similar practical and concrete orientation; in this course sequence, however, students are encouraged to extend their thinking about concepts to more abstract levels.

Both course sequences develop thinking skills through scientific inquiry, problem solving and informed decision making. Thinking skills are developed through structured learning experiences in Science 16-26. Research activities that require independent application of thinking skills become an important component of Science 14-24.

In both course sequences, students are encouraged to develop attitudes that enable them to:

- successfully study and practise science
- appreciate the impacts of science in society.

## COGNITIVE DEMAND

Cognitive demands within the two course sequences differ in the level of analysis and abstract thought processes expected of students. Applications in Science 16-26 generally focus on the transfer of concepts, skills and attitudes to daily life and work-related situations. Many of the applications in Science 14-24 encourage students to apply concepts, skills and attitudes in more abstract situations. Cognitive demands within each course will be further influenced by the needs and abilities of individual students.

## TRANSFERABILITY

Although prescribed content in Science 16-26 is less extensive than prescribed content in Science 14-24, the Science 16-26 course sequence will develop concepts, skills and attitudes that facilitate potential transfer from Science 26 to Science 24. Program sequences and potential transfer points are illustrated below.

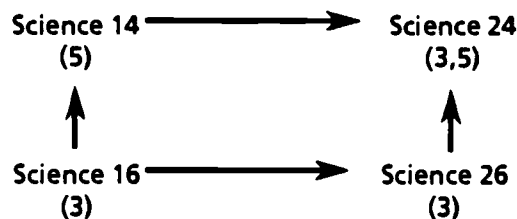

Additional information about transfer routes from the Integrated Occupational Program to the General High School Diploma program is provided in *Guide to Education: Senior High Handbook* (1991-92).

# THEME A

## PERSONAL HEALTH AND LIFESTYLE

This theme will assist students to develop strategies for acquiring and maintaining healthful lifestyles. Students will investigate the effects of nutrition and exercise on personal health, and identify other factors in their personal lives that may promote/hinder the efficient functioning of body systems. A number of technological and societal elements influence our choice of foods, use of leisure time, and other decisions made on a daily basis. Students will develop an understanding of the implications of various technological and societal factors for health and fitness, and will assess the appropriateness of their own decisions in relation to health and lifestyle.

A major emphasis will be placed on developing a process for considering alternatives and making informed choices in everyday situations affecting personal health. Students will apply previously developed knowledge of human body systems (see Science 16: Systems of the Human Body) throughout this theme as they consider the effects of various lifestyle factors on biological processes. Learning objectives interrelate with investigations performed in a subsequent theme, Energy and the Environment, and will assist students to develop an understanding of how various energy alternatives and environmental issues have impact upon personal health or the health of others in society.

Teachers are encouraged to reference the Program Emphases and Methodology section of this manual when planning for instruction. Suggestions particularly relevant to the learning objectives addressed in this theme can be found in:

- Science, Technology and Societal Issues
- Communication Skills
- Assessment/Evaluation.

### A FRAMEWORK FOR MAKING INFORMED CHOICES ABOUT LIFESTYLE FACTORS

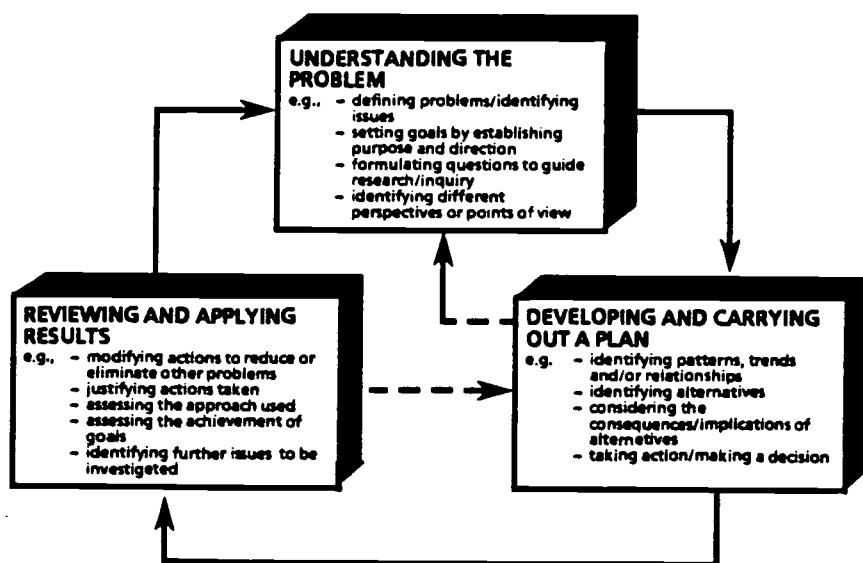

## CONCEPTS, SKILLS AND ATTITUDES

### CONCEPTS

Students will be expected to demonstrate an understanding that:

- **personal diet should include minimal amounts of certain foods in order to maintain health**
  - describes the function of nutrients (carbohydrates, fats, proteins, vitamins, minerals) in the human body
  - identifies foods/food groups that are a common source of major nutrients and add fibre content to diet
  - cites examples of good nutrition as defined in the Canada Food Guide
  - explains how diets that include excessive amounts of certain foods (e.g., diets high in cholesterol, fat, salt, sugar) may influence personal health
- **much of our food, particularly processed food items, contain additives**
  - identifies and describes the functions of additives present in familiar processed foods
  - outlines Canada's labelling laws regarding additive listing
  - interprets label information on familiar processed foods, distinguishing between nutritional and non-nutritional ingredients
- **drugs, alcohol and tobacco may affect nutritional requirements and cause related disease**
  - describes how drugs, alcohol and tobacco can affect appetite, nutritional requirements and the functioning of body systems
  - gives examples of specific diseases related to drug, alcohol and tobacco abuse
- **a relationship exists between caloric intake, energy output and body weight**
  - compares daily caloric intake to calorie requirements suggested by personal data (e.g., body mass index, basal metabolic rate, activity level)
  - describes strategies for maintaining or increasing/decreasing present body weight through caloric intake and energy output
- **physical activity can contribute to cardiovascular and respiratory health**
  - explains how level of fitness (e.g., endurance, strength, flexibility) is influenced by physical activity
  - identifies relationships between the level of fitness and the functioning of cardiovascular/respiratory systems
- **personal and societal factors can have both positive and negative effects on one's health and well-being**
  - identifies personal and social factors that influence attitudes and behaviours (e.g., needs, values, emotions, peers)
  - explains how particular attitudes/behaviours may involve varying degrees of risk to personal health and well-being

- interrelationships exist among lifestyle factors/choices and personal health
  - identifies lifestyle factors and choices that affect personal health (e.g., diet, physical activity, substance use/abuse, stress)
  - infers the consequences of inappropriate nutrition, level of activity and weight on personal health (e.g., minor deficiencies/imbbalances, life threatening conditions)
  - describes a personal action plan designed to improve one or more aspects of personal health and lifestyle.

## **SKILLS**

Students will be expected to demonstrate an ability to:

- collect data related to critical life functions, body systems and lifestyle factors through observation, interview and/or research
- design an experiment, through class discussion, to examine induced variations in the functioning of a body system
- use selected monitoring technological processes, instruments and/or products in collecting data about personal health and fitness factors
- analyze and assess personal health, fitness and lifestyle factors by identifying relationships, by considering consequences, and by examining a variety of perspectives
- infer potential threats to personal health that may be caused by lifestyle factors (e.g., diet, level of activity)
- apply the results of investigation to personal situation, identifying appropriate strategies for monitoring and maintaining personal health.

## **ATTITUDES**

Students will be encouraged to:

- display a positive attitude toward the learning of concepts and skills in science
  - shows interest and curiosity through willingness to ask questions, share observations and ideas, and seek answers
  - performs investigations and completes assignments independently and in cooperation with others
- appreciate the intricate workings and balance within the human body
- appreciate the contributions of science and technology to human health
- value knowledge gained for its usefulness on a personal level
- appreciate the need for informed decision making at both personal and societal levels
- appreciate that ethical dilemmas may arise from the application of scientific research and/or medical technologies
- display responsible attitudes toward personal health through nutrition, exercise, safety and lifestyle.



## **INTEGRATION ACTIVITIES**

Teachers are encouraged to identify ways to integrate the content of this theme with activities that may be undertaken by students in other subject areas. The references provided below are intended to facilitate curricular integration by establishing a base for cooperative planning among teachers.

### **ENGLISH**

Students will use a variety of communication skills throughout activities in this theme. Instructional activities will require students to:

- use comprehension skills when gathering information related to personal health and lifestyle factors
- give and follow instructions when designing/conducting investigations
- use viewing/reporting/note-making skills when gathering, organizing and communicating data obtained through research and experimentation.

Teachers are encouraged to identify appropriate strategies for developing these skills through cooperative conferencing with teachers of language arts. Suggestions for developing related skills are provided in the "Communication Skills" section of this manual.

### **MATHEMATICS**

Students will use mathematical skills when they:

- measure height/weight/distance/ capacity/time
- interpret statistics that involve ratio and percent
- interpret and display data in table, chart and graph form.

Science teachers are encouraged to confer with the mathematics teachers in establishing appropriate strategies for applying mathematical concepts/skills. Plan activities that will enable students to use mathematics class to interpret and display data they gather through experiments performed in science.

### **SOCIAL STUDIES**

Students will develop an awareness of environmental and lifestyle factors that influence personal health through activities in current affairs. Cooperative planning between the science and social studies teachers might provide opportunities for students to investigate:

- recent contributions of science and technology to medical diagnosis and treatment
- the social costs of technological advancements in the field of medicine and health care
- services offered by health and fitness facilities in the local community.

### **OCCUPATIONAL COURSES**

Students will develop an awareness of the effect of health and lifestyle factors on:

- job performance and attendance at work
- finding and keeping a job.

Both science and occupational teachers should emphasize the negative effects of substance abuse on personal safety, work performance and job retention.

### **CALM**

Students will develop an awareness of current health concerns in society, with emphasis on anorexia nervosa, bulimia, substance abuse and sexually transmitted diseases.

## COMMUNITY PARTNERSHIP OPPORTUNITIES

The local community may offer resources that contribute to the development of learning objectives within this theme. Suggestions for utilizing community resources, and for involving students in the community by way of meaningful activities linked to the science program are provided below.

- Invite a nutritionist to discuss the facts, fads and fallacies of eating habits and diets.
- Invite a doctor (or nurse) to discuss the relationship between nutrition, fitness and lifestyle. Ask this person to outline special nutritional needs of adolescents and young adults.
- Visit the local supermarket and read the ingredient labels on frequently eaten foods. Make special note of any preservatives or additives contained in these foods.
- Invite medical experts, the police, social workers and/or rehabilitated clients to discuss the misuse and abuse of alcohol, drugs and tobacco.
- Invite a representative from the Alberta Alcohol and Drug Abuse Commission (AADAC) to speak to the class about the effects of alcohol, drugs and tobacco on the human body.
- Invite a local fitness expert to discuss:
  - personal fitness measures
  - strategies for maintaining/improving fitness.
- Interview an athletic trainer. Ask this person to discuss:
  - the nutritional needs of athletes in training
  - types of exercises that increase endurance/strength/flexibility
  - appropriate training programs.
- Obtain health/fitness pamphlets and brochures from a local doctor, the school nurse or a community agency responsible for health.
- Invite the school nurse to demonstrate appropriate techniques for monitoring body functions and personal health (e.g., blood pressure, pulse rate).
- Invite a pharmacist to discuss:
  - prescription and non-prescription drugs
  - their effects on the body
  - the interpretation of label directions and dosages
  - drug safety in the home.
- Invite a representative of Consumer and Corporate Affairs to discuss Canada's food labelling laws.
- Visit a local health/fitness centre and investigate conditioning principles that govern the use of exercise bicycles, rowing machines and/or aerobic routines.
- Invite a health care specialist to discuss the contributions of science and technology in health care, disease prevention and the extension of human life (e.g., pacemakers, artificial organs, medicine/drugs, immunization).

## LEARNING RESOURCE CORRELATION

### BASIC RESOURCE

ISIS Individualized Science Instructional System  
Booklets: *Energy for Living*  
*Food Power*

### SUPPORT RESOURCES

Science at Work Series  
Booklet: *Sports Science*

### OTHER RESOURCES

*Applied Science, Book 1*  
Unit 19 - Using Food

*Applied Science, Book 2*  
Unit 20 - The Drug Scene

*Choices for Health*  
Chapter 4 - Learning About Yourself  
Chapter 6 - Alcohol, Tobacco, and Other Drugs

*Food Additive Pocket Dictionary*

*The Human Body Series* (video program)

*Principles of Science, Book 2*  
Chapter 6 - Nutrition  
Chapter 7 - Disease  
Chapter 8 - Drugs

Science at Work Series  
Booklet: *You and Your Mind*

*Science Education II* (video program)

*Science Networks: Biology*  
Unit 2 - The Necessities of Life

## SUGGESTED ACTIVITIES

The student learning resources identified above provide a variety of instructional activities that support learning objectives within this theme. The activities that follow complement those provided in the student learning resources. Teachers should be selective in their use, and consider students' interests/abilities and preferred methods of learning in planning appropriate instructional activities.

**LEARNING OBJECTIVE**

**DEMONSTRATES AN UNDERSTANDING THAT PERSONAL DIET SHOULD INCLUDE MINIMAL AMOUNTS OF CERTAIN FOODS IN ORDER TO MAINTAIN HEALTH.**

- Describes the function of nutrients (carbohydrates, fats, proteins, vitamins, minerals) in the human body.
- Identifies foods/food groups that:
  - are a common source of major nutrients
  - add fibre content to diet.
- Cites examples of good nutrition as defined in the Canada Food Guide.
- Explains how diets that include excessive amounts of certain foods (e.g., diets high in cholesterol, fat, salt, sugar) may influence personal health.

**RESOURCE CORRELATION**

**BASIC RESOURCE**

*Food Power*

- Chapter 1 - The Carbohydrate Connection
- Chapter 2 - Fats and Proteins Are Nutrients Too
- Chapter 3 - Vitamins, Minerals and Nutrition
- Chapter 4 - Food Record: Feeling Full Is Not Enough

**SUPPORT RESOURCE**

*Teacher Resource Manual*

- Resource 1: Canada Food Guide
- Resource 2: How Do Your Meals Score?

1. Identify nutrients that are essential for good health and the functions performed by these nutrients in the human body. Summarize the results of investigation in a chart similar to the one illustrated below.

NUTRIENT	FUNCTION
carbohydrates	
fats	
proteins	

2. Invite a doctor, nurse, dietitian or home economist into the classroom. Ask this person to describe the functions performed by carbohydrates, fats, proteins, vitamins/minerals and fibres in the human body.
3. Ask students to make note of and record the foods they eat over a period of several days. Compare foods eaten to nutritional guidelines provided in Resource 1: Canada Food Guide. Does personal diet include each of the major food groups identified in the Canada Food Guide?  
  
Provide opportunities for students to evaluate their daily eating habits using Resource 2: How Do Your Meals Score?
4. Read and interpret the ingredient labels on a variety of familiar food products. Observe patterns in the way ingredients are listed. Infer reasons for listing the ingredients in this way.
5. Ask students to make a list of their favourite snack foods (e.g., soda pop, potato chips, candy). Research the ingredients present in each of these foods. Evaluate the nutritional value of these foods, and consider alternative snacks that have greater nutritional value.
6. Make a bulletin board display entitled "Nutrition and Health". Collect supermarket advertisements for appealing food products and classify these food items into the four basic food groups. Plan appealing meals/snacks that include appropriate foods from each group.

BEST COPY AVAILABLE

7. Make a list of frequently eaten fast foods (e.g., hamburger and fries, fried chicken, pizza). Consider the nutritional value of these foods by identifying major nutrients present in each.

Infer the effects of an excess intake of fat, cholesterol, salt and sugar. To what extent are these ingredients present in fast foods that are frequently eaten? Formulate strategies for reducing intake of fat, cholesterol, salt and sugar while at the same time maintaining or increasing the intake of other nutrients.

8. Identify and discuss variables that need to be considered when planning personal diet:

- e.g.,
- personal food preferences
  - nutritional/caloric requirements
  - lifestyle
  - financial resources.

9. Suggest ways in which diets that are high in cholesterol, fat, salt or sugar may affect the functioning of major systems of the human body (e.g., respiratory system, circulatory system, digestive system, nervous system). Invite medical experts to discuss recent findings related to the effect of these food substances on personal health.

#### LEARNING OBJECTIVE

#### RESOURCE CORRELATION

<p><b>DEMONSTRATES AN UNDERSTANDING THAT MUCH OF OUR FOOD, PARTICULARLY PROCESSED FOOD ITEMS, CONTAIN ADDITIVES.</b></p> <ul style="list-style-type: none"> <li>● Identifies and describes the functions of additives present in familiar processed foods.</li> <li>● Outlines Canada's labelling laws regarding additive listing.</li> <li>● Interprets label information on familiar processed foods, distinguishing between nutritional and non-nutritional ingredients.</li> </ul>	<p><b>BASIC RESOURCE</b></p> <p><i>Food Power</i> Chapter 7 - Additives, Labels and Technology</p> <p><b>SUPPORT RESOURCE</b></p> <p><i>Teacher Resource Manual</i> Resource 3: <i>Technology and Food</i></p>
--	--

1. Collect ingredient labels from a variety of foods. Underline the additives/supplements named on each label. Determine why the additives and supplements were used:

- e.g.,
- to preserve food
  - to enhance colour/flavour
  - to enrich food
  - to reduce calorie content.

Discuss health problems that may result from the use of particular food additives and supplements.

2. Identify examples of "artificial foods" (e.g., soya meat substitute, "low calorie" soft drinks). Why are these foods popular? Research the ingredients of artificial foods, and relationships that have been discovered between the use of some additives/supplements and certain health problems. Identify additives no longer used because of their carcinogenic properties.
3. Investigate ways in which technology has affected our food products (see Resource 3: Technology and Food).

Evaluate the effects of various technological developments on diet and personal health by using critical thinking strategies and comparative webbing activities suggested in the Communication Skills section of this manual.

For example:

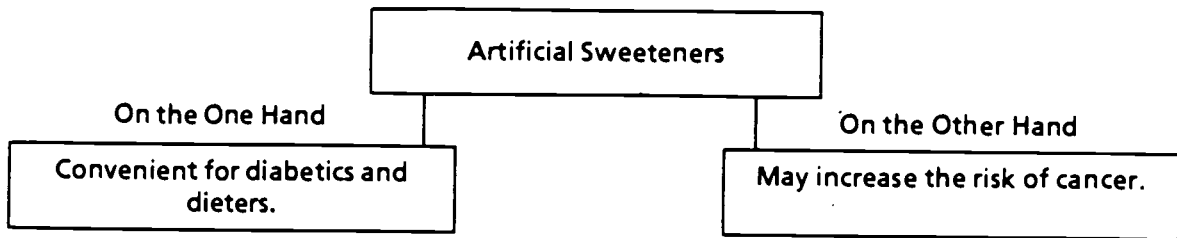

**LEARNING OBJECTIVE**

**DEMONSTRATES AN UNDERSTANDING THAT DRUGS, ALCOHOL AND TOBACCO MAY AFFECT NUTRITIONAL REQUIREMENTS AND CAUSE RELATED DISEASE.**

- Describes how drugs, alcohol and tobacco can affect appetite, nutritional requirements and the functioning of body systems.
- Gives examples of specific diseases related to drug, alcohol and tobacco abuse.

**RESOURCE CORRELATION**

**BASIC RESOURCE**

*Food Power*  
Chapter 8 – Nutrition and Drugs

1. Gather information about the effects of drugs/alcohol/tobacco on health and fitness by using a variety of community resources:
  - e.g., - books, pamphlets, periodicals
  - films, videotapes, kits
  - guest speakers

Students may respond more positively to the advice given by community "experts" in this area than to advice given by the teacher. A variety of services are available free upon request:

  - e.g., - Health and Welfare Canada
  - Alberta Alcohol and Drug Abuse Commission.
2. Examine claims made in product advertisements for drugs/alcohol/tobacco. What roles and feelings are portrayed in these advertisements? Identify stereotypes, clichés and emotional factors used in persuading people to use these products.
3. Design and perform an experiment that will compare the heartbeat recovery rate of smokers and non-smokers. Structure investigation, using strategies provided in Nature of Science, "Strategies and Skills Used in Scientific Inquiry".
4. Distinguish between familiar drugs that are stimulants and those that are depressants. Discuss how alcohol may:
  - be used as both a stimulant and depressant
  - interact with other drugs (e.g., antihistamines, cold remedies, tranquilizers, sleeping pills).

- Identify a variety of familiar household drugs. Classify these drugs according to use (e.g., pain relievers, digestive aids, antibiotics, antihistamines, external remedies). Discuss label directions and safe dosages for each drug.

Invite a doctor/pharmacist to answer questions about:

- the safe use of household drugs
  - reactions of the human body to continued use of pain relievers, tranquilizers and sleeping pills
  - health hazards related to the use of household and other types of drugs.
- Use information gathered about alcohol/drugs/tobacco to create a "Public Awareness" display. Include information related to:
    - the effects of these substances on nutritional requirements and appetite
    - health hazards and diseases associated with the use of these substances
    - social and legal issues that arise from substance abuse
    - local agencies that provide assistance and counselling for victims of substance abuse.

**LEARNING OBJECTIVE**

**RESOURCE CORRELATION**

**DEMONSTRATES AN UNDERSTANDING OF THE RELATIONSHIP THAT EXISTS BETWEEN CALORIC INTAKE, ENERGY OUTPUT AND BODY WEIGHT.**

- Compares daily caloric intake to calorie requirements suggested by personal data (e.g., body mass index, basal metabolic rate, activity level).
- Describes strategies for maintaining or increasing/decreasing present body weight through caloric intake and energy output.

**BASIC RESOURCES**

*Energy for Living*

- Chapter 1 – Energy from Oxygen and Food
- Chapter 2 – Energy and a Sugar Called Glucose
- Chapter 4 – Marshmallows, Kilojoules and You
- Chapter 5 – Counting Kilojoules

*Food Power*

- Chapter 5 – Weight Right Here

**SUPPORT RESOURCE**

*Teacher Resource Manual*

- Resource 4: Body Mass Index
- Resource 5: Weight Watching
- Resource 6: Facts About Food
- Resource 7: Nutrition and Athletic Performance

- Provide an opportunity for students to evaluate their present body weight according to the guidelines suggested in Resource 4: Body Mass Index.

Formulate personal strategies for acquiring/maintaining a healthy body weight. Identify factors that must be considered in balancing calorie intake with calorie requirements (e.g., basal metabolic rate, activity level).

Information that may assist students to formulate personal strategies for monitoring calorie intake and body weight are provided in Resource 5: Weight Watching.

- Conduct research on various "fad" diets that claim to help an individual reduce or gain weight. Evaluate each of these diets in terms of:
  - nutritional content of foods eaten
  - effect on personal health.

3. Invite a doctor, nurse or dietitian to discuss the relationship between calorie intake, body weight and personal health. Identify diet, exercise and other lifestyle factors that affect personal health and life span.

Ask students to write an informal essay entitled "My Personal Health and Lifestyle Plan". The essay should describe strategies for maintaining/acquiring a healthy body through appropriate diet and exercise. When formulating strategies, remind students to consider personal factors such as:

- lifestyle
- nutritional/caloric requirements
- food preferences
- financial resources.

Structure writing activities by using the suggestions provided in Communication Skills, "Summarizing, Evaluating and Communicating Ideas in Science".

4. Provide opportunities for students to assess their knowledge of nutrition by responding to the statements provided in:
  - Resource 6: Facts About Food
  - Resource 7: Nutrition and Athletic Performance.

#### LEARNING OBJECTIVE

#### RESOURCE CORRELATION

**DEMONSTRATES AN UNDERSTANDING THAT PHYSICAL ACTIVITY CAN CONTRIBUTE TO CARDIOVASCULAR AND RESPIRATORY HEALTH.**

- Explains how level of fitness (e.g., endurance, strength, flexibility) is influenced by physical activity.
- Identifies relationships between level of fitness and the functioning of cardiovascular/respiratory systems.

#### SUPPORT RESOURCES

*Sports Science*

Chapter 3 – Fitness

Chapter 4 – Muscles and Movement

*Teacher Resource Manual*

Resource 8: Heartbeat Recovery Rates

Resource 9: Exercises

1. Design and perform experiments that will test endurance. Compare personal results with accepted norms.

Students may wish to take a fitness pre-test, undertake a fitness routine, and evaluate fitness gains through post-test activity.

2. Investigate the pumping function of the heart through use of a stethoscope borrowed from the school nurse. Ask students to locate their pulse beats, and to tabulate pulse rates under varying conditions.

Identify emotional and physical variables that may affect pulse rate (e.g., exertion, fear, excitement, anger). Predict changes in respiratory requirements that will occur under varying emotional or physical conditions.

An activity that requires students to graph the relationship between heartbeat recovery rate and resting time is provided in Resource 8: Heartbeat Recovery Rates.

Teachers must be aware of recommended "exertion" limits with respect to blood pressure/pulse rate, and ensure that students do not exceed these limits in their investigations.



- Design a chart that illustrates different types of exercise/activity that one could undertake to develop endurance, strength and flexibility. Include references to different parts of the body developed through each exercise/activity.

A variety of suggestions for maintaining cardiovascular and respiratory health are provided in Resource 9: Exercises.

- Visit the school gym/local fitness centre and investigate the nature of various fitness programs. Ask a fitness instructor to describe the function of a personal fitness profile. Assist students to develop exercise programs that are tailored to individual needs.

**LEARNING OBJECTIVE**

**RESOURCE CORRELATION**

**DEMONSTRATES AN UNDERSTANDING THAT PERSONAL AND SOCIETAL FACTORS CAN HAVE BOTH POSITIVE AND NEGATIVE EFFECTS ON ONE'S HEALTH AND WELL-BEING.**

- Identifies personal and social factors that influence attitudes and behaviours (e.g., needs, values, emotions, peers).
- Explains how particular attitudes/behaviours may involve varying degrees of risk to personal health and well-being.

**SUPPORT RESOURCE**

*Teacher Resource Manual*

Resource 10: Basic Human Needs  
 Resource 11: Maslow's Hierarchy of Primary and Secondary Needs  
 Resource 12: Self-Concept

- Identify a variety of basic human needs (see Resource 10: Basic Human Needs, and Resource 11: Maslow's Hierarchy of Primary and Secondary Needs). Through discussion, illustrate and explain how our attempts to satisfy these needs influence attitudes and behaviours.

Ask each student to rate the following needs on a scale of 1 to 5 (e.g., give a rating of "1" to those needs of greatest importance to you, and a rating of "5" to those needs of least importance to you).

- Independence (i.e., being able to make your own decisions) .....
- Self-esteem (i.e., feeling good about yourself) .....
- Love and affection (i.e., feeling wanted and loved) .....
- Social contacts (i.e., having friends to socialize with) .....
- Safety and health (i.e., having your physical needs satisfied) .....
- Intellectual (i.e., having opportunities to develop your ability to reason and think) .....

Encourage students to compare their ratings with a friend, and to understand that:

- while individuals have common needs, the importance of these needs may vary among individuals
- personal health and well-being may be dependent upon the satisfaction of needs most important to an individual.

2. Ask students to read the information provided in Resource 12: Self-Concept. Brainstorm and list the behaviours that one might expect from a person who has:
- a positive self-concept
  - a negative self-concept.

**CLARIFICATION/EXAMPLE**

POSITIVE SELF-CONCEPT BEHAVIOURS	NEGATIVE SELF-CONCEPT BEHAVIOURS

3. Working in small groups of 2 or 3, ask students to brainstorm and list on chart paper factors that contribute to:
- an inner feeling of well-being (e.g., physical, social, psychological)
  - what they consider to be a healthy lifestyle right now (e.g., money, friends, dates, freedom, clothes, body image, recreation, part-time jobs)
  - what they may consider to be a healthy lifestyle in the next 3–5 years (e.g., security, employment/income, friends, food, shelter, vehicle, leisure activities, family).

Discuss and compare each group's perception of well-being and a healthy lifestyle.

**LEARNING OBJECTIVE**

**DEMONSTRATES AN UNDERSTANDING THAT INTERRELATIONSHIPS EXIST AMONG LIFESTYLE FACTORS/CHOICES AND PERSONAL HEALTH.**

- Identifies lifestyle factors and choices that affect personal health (e.g., diet, physical activity, substance use/abuse, stress).
- Infers the consequences of inappropriate nutrition, level of activity and weight on personal health (e.g., minor deficiencies/ imbalances, life threatening conditions).
- Describes a personal action plan designed to improve one or more aspects of personal health and lifestyle.

**RESOURCE CORRELATION**

**BASIC RESOURCE**

*Food Power*  
Chapter 6 – A Sensible Way to Control Your Weight

**SUPPORT RESOURCES**

*Sports Science*  
Chapter 6 – Sports Injuries and Medicine

*Teacher Resource Manual*  
Resource 13: Compute Your Nutrition Condition  
Resource 14: How Have Causes of Death Changed Since 1900?

1. Identify variables in diet and lifestyle that may affect personal health and fitness:

e.g.,

Diet  
carbohydrates  
fats  
salt  
cholesterol  
sugar

Lifestyle  
drugs  
exercise  
smoking  
stress  
recreational patterns

2. Ask students to evaluate dietary and lifestyle choices they make by considering the effects of these choices on personal health and life span. Consider alternative routines and habits that may improve personal nutrition and fitness.

A variety of strategies that will assist students to evaluate lifestyle choices are provided in Communication Skills, "Using Critical Thinking Skills":

e.g.,

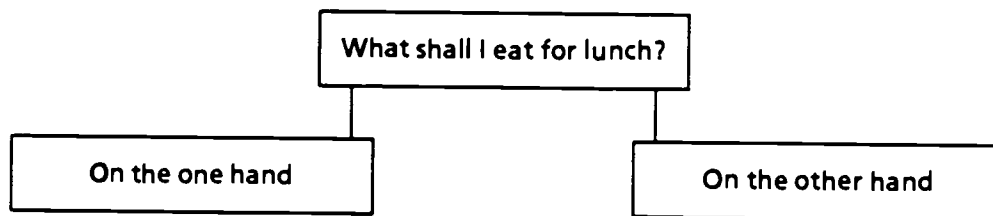

3. Consider influences of technology on the foods we eat and on fitness levels in society. Identify personal strategies whereby one can benefit from technological conveniences, yet maintain an appropriate level of health and fitness.

Sample activities that illustrate how science and technology influence lifestyle factors are provided in the Science, Technology and Societal Issues section of this manual (e.g., Resource 2: How Have Our Choices in Leisure Activities Changed?).

4. A variety of pamphlets/monographs/films/videos that provide information on nutrition, fitness and personal health are available free upon request from government agencies (see Appendix B):

e.g., - Alberta Consumer and Corporate Affairs  
- Health and Welfare Canada

Obtain current and relevant resources from these agencies. Provide opportunities for students to read/view the materials and report their findings to the class.

5. Invite the school nurse to discuss health problems that may result from improper diet, weight control and exercise routines.

Ask students to evaluate their personal diet by responding to the questionnaire provided in Resource 13: Compute Your Nutrition Condition.

6. Identify and discuss health concerns that may result from a preoccupation with "the slim look". Identify ways in which our daily eating choices and habits are influenced by society:

- fashion/style/trends
- advertising/media
- our peers.

**7. Research the symptoms, causes and treatments for severe eating disorders:**

- e.g., - anorexia nervosa  
- bulimia.

Information on eating disorders can be obtained by contacting the following agencies:

Anorexia Nervosa and Bulimia Foundation of Canada Incorporated  
Box 3074  
Winnipeg, Manitoba  
R3C 4E5  
Phone: (204) 783-6786

Canadian Association of Anorexia Nervosa and Associated Disorders  
c/o Nigel Avenue  
Vancouver, British Columbia  
V5Y 2L8  
Phone: (604) 875-9690

National Eating Disorder Information Centre  
200 Elizabeth Street  
College Wing 2-332  
Toronto, Ontario  
M5G 2C4  
Phone: (416) 253-7421

Bulimia Anorexia Nervosa Association  
c/o University of Windsor  
Faculty of Human Kinetics  
Windsor, Ontario  
N9B 3P4  
Phone: (519) 253-7421

**8. Investigate ways in which technology has improved health standards in society, and ways in which it has created new hazards and risks (see Resource 14: How Have Causes of Death Changed Since 1900?).**

Provide opportunities for students to express their opinions on current health problems/issues through informal writing activities. Encourage students to:

- elaborate on an opinion they hold with regard to a health problem/issue
- provide detail that will support their opinion/point of view.

Suggestions for structuring and evaluating informal writing assignments are provided in Communication Skills, "Informal Essay Writing".

# Eat a variety of foods from each group every day

## milk and milk products

Children up to 11 years 2-3 servings

Adolescents 3-4 servings

Pregnant and nursing women 3-4 servings

Adults 2 servings

## meat, fish, poultry and alternates

2 servings

## bread and cereals

3-5 servings

Whole grain or enriched

## fruits and vegetables

4-5 servings

Include at least two vegetables

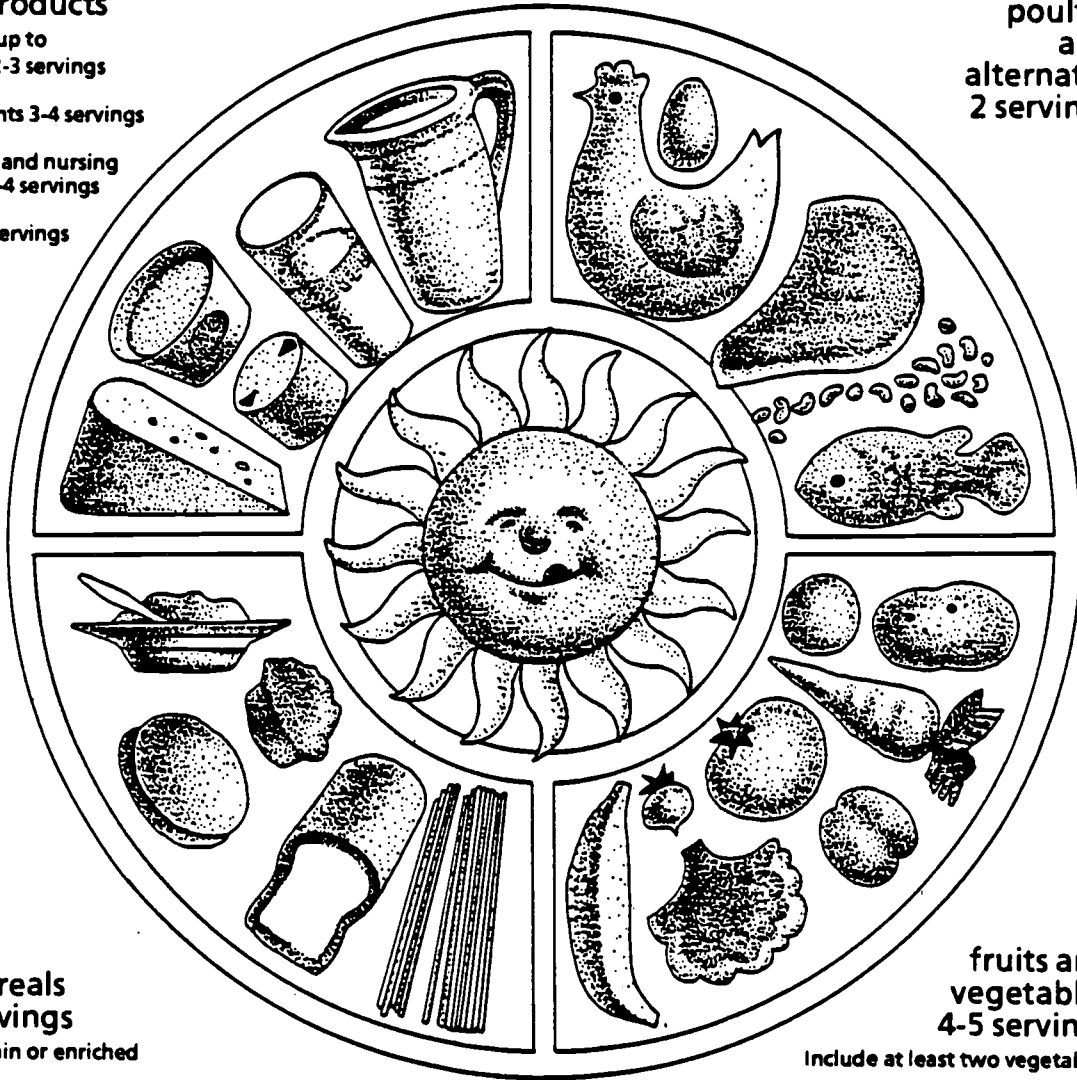

# RESOURCE 1: CANADA FOOD GUIDE (continued)

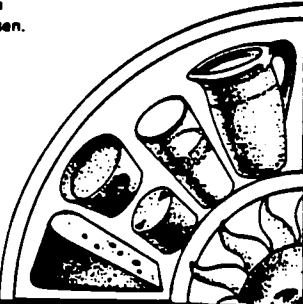
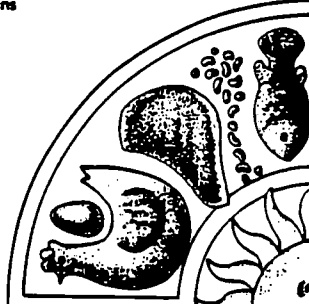
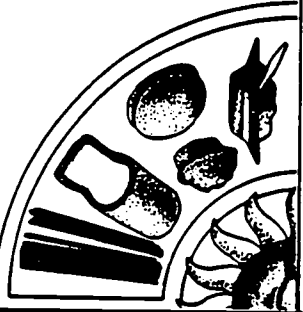
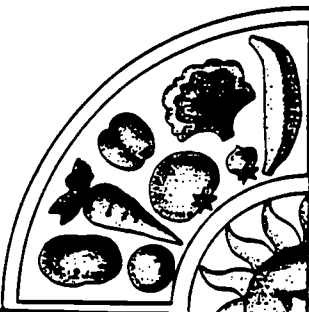
<h2>Variety</h2> <p>Choose different kinds of foods from within each group in appropriate numbers of servings and portion sizes.</p>	<h2>Energy Balance</h2> <p>Needs vary with age, sex and activity. Balance energy intake from foods with energy output from physical activity to control weight. Foods selected according to the Guide can supply 4000-6000 kJ</p>	<h2>Moderation</h2> <p>Select and prepare foods with limited amounts of fat, sugar and salt. If alcohol is consumed, use limited amounts.</p>							
<h3>milk and milk products</h3> <table border="0"> <tr> <td>Children up to 11 years</td> <td>2-3 servings</td> </tr> <tr> <td>Adolescents</td> <td>3-4 servings</td> </tr> <tr> <td>Pregnant and nursing women</td> <td>3.4 servings</td> </tr> <tr> <td>Adults</td> <td>2 servings</td> </tr> </table> <p>Skim, 2%, whole, buttermilk, reconstituted dry or evaporated milk may be used as a beverage or as the main ingredient in other foods. Cheese may also be chosen.</p> <p><b>Some examples of one serving</b>                  250 mL (1 cup) milk                  175 mL (¾ cup) yogurt                  45g (1½ ounces) cheddar or process cheese</p> <p>In addition, a supplement of vitamin D is recommended when milk is consumed which does not contain added vitamin D.</p> 	Children up to 11 years	2-3 servings	Adolescents	3-4 servings	Pregnant and nursing women	3.4 servings	Adults	2 servings	<h3>meat, fish, poultry and alternates</h3> <h2>2 servings</h2> <p><b>Some examples of one serving</b>                  60 to 90g (2-3 ounces) cooked lean meat, fish, poultry or liver                  60 mL (4 tablespoons) peanut butter                  250mL (1 cup) cooked dried peas, beans or lentils                  125 mL (½ cup) nuts or seeds                  60g (2 ounces) cheddar cheese                  125mL (½ cup) cottage cheese                  2 eggs</p> 
Children up to 11 years	2-3 servings								
Adolescents	3-4 servings								
Pregnant and nursing women	3.4 servings								
Adults	2 servings								
<h3>breads and cereals</h3> <h2>3-5 servings</h2> <p>Whole grain or enriched. Whole grain products are recommended.</p> <p><b>Some examples of one serving</b>                  1 slice bread                  125mL (½ cup) cooked cereal                  175mL (¾ cup) ready-to-eat cereal                  1 roll or muffin                  125 to 175mL (½-¾ cup) cooked rice, macaroni, spaghetti or noodles                  ½ hamburger or wiener bun</p> 	<h3>fruits and vegetables</h3> <h2>4-5 servings</h2> <p>Include at least two vegetables.</p> <p>Choose a variety of both vegetables and fruits - cooked, raw or their juices. Include yellow, green or green leafy vegetables.</p> <p><b>Some examples of one serving</b>                  125mL (½ cup) vegetables or fruits - fresh, frozen or canned                  125mL (½ cup) juice - fresh, frozen or canned                  1 medium-sized potato, carrot, tomato, peach, apple, orange or banana.</p> 								

Canada Food Guide, Health and Welfare Canada, 1983. Reproduced with permission of the Minister of Supply and Services Canada.

## RESOURCE 2: HOW DO YOUR MEALS SCORE?

This is a score sheet, designed for use by teenagers and by expectant and nursing mothers. It provides a quick and reliable method of rating your daily food intake for a period of from one to seven days.

For each Food Group, based on the Canada Food Guide, there is a maximum score. Fruits and vegetables are essentially interchangeable so they are grouped together with a maximum allowance of 40 points.

Do not give yourself more than the allotted number of points in each group. Extra foods in one group do not compensate for too few in another.

Some equivalent foods are suggested in each group. You can easily determine other equivalents.

Try to recall the menus for the day and the foods included. Was there a salad, a stew, or a casserole? Did they contain foods from the meat, vegetable, cereal, or milk group? Many meals are "all-in-one" and count points in several groups.

Score the point value of the foods eaten from each group during the day. Place the correct number of points in the box at the end of the sheet. Rate your daily food intake accordingly.

In striving to achieve top performance and glowing health, use this easy method of determining where your food selection needs to be improved.

### GROUP I – MILK AND MILK PRODUCTS

Maximum 20 points

Total your point score for milk taken as a beverage, for milk contained in other foods and for cheese. Count points as indicated. Maximum: 20 points.

Milk taken as a beverage (1 cup = 8 fluid ounces):

1L (4 cups) – 20 points

750 mL (3 cups) – 15 points

500 mL (2 cups) – 10 points

250 mL (1 cup) – 5 points

The calcium value of the following foods is equal to that of 1 cup of milk. Two half-portions count as one full portion:

45 g (1 1/2 oz.) cheddar cheese (two 1" cubes)

45 g (1 1/2 oz.) processed cheese

375 g (12 oz.) cottage cheese

60 mL (4 tbsp.) skim milk powder

125 mL (1/2 cup) canned salmon (with bones)

250 mL (1 cup) cream soup

250 mL (1 cup) milk pudding

250 mL (1 cup) ice cream

### GROUP 1 – MAXIMUM COUNT, 20 POINTS

YOUR DAILY SCORE							DAILY AVERAGE
DAY 1	DAY 2	DAY 3	DAY 4	DAY 5	DAY 6	DAY 7	

## RESOURCE 2: HOW DO YOUR MEALS SCORE? (continued)

### GROUP II – FRUITS AND VEGETABLES

Maximum 40 points

How many servings of fruits and vegetables did you have? Maximum: 20 points.

5 servings – 20 points  
 4 servings – 16 points  
 3 servings – 12 points

2 servings – 8 points  
 1 serving – 4 points

Did these fruits and vegetables include a good source of vitamin C? Maximum: 10 points.

Count 10 points for:

1/2 grapefruit  
 1 fresh orange  
 125 mL (1/2 cup) orange, grapefruit, or  
 vitaminized apple juice  
 1/4 cantaloupe  
 10 strawberries  
 125 mL (1/2 cup) cauliflower  
 125 mL (1/2 cup) spinach  
 125 mL (1/2 cup) turnip  
 125 mL (1/2 cup) Brussels sprouts  
 1 large potato (cooked in skin)

Or 5 points for:

1/4 honeydew melon  
 1 medium tomato  
 1/4 medium green pepper  
 6 spears asparagus  
 125 mL (1/2 cup) green beans  
 125 mL (1/2 cup) cabbage  
 125 mL (1/2 cup) peas  
 125 mL (1/2 cup) sweet potato

Were any of the vegetables green (providing iron and vitamin A), or were any of the fruits and vegetables yellow (providing vitamin A)? Maximum: 5 points.

Did you have raw fruits or vegetables during the day? Maximum: 5 points.

### GROUP 2 – MAXIMUM COUNT, 40 POINTS

YOUR DAILY SCORE							DAILY AVERAGE
DAY 1	DAY 2	DAY 3	DAY 4	DAY 5	DAY 6	DAY 7	

### GROUP III – BREAD AND CEREALS

Maximum 20 points

Did you have three or more servings of a whole grain or enriched cereal in any form, or their equivalent in bread or bread alternatives? Count 5 points per serving. Maximum: 15 points.

Whole Grain or Enriched Cereals:

Rolled Oats  
 Quick Cream of Wheat  
 Shredded Wheat  
 Muffets  
 Special K

Grapenuts  
 All-Bran  
 Raisin Bran  
 Bran Flakes



## RESOURCE 2: HOW DO YOUR MEALS SCORE? (continued)

Mixed whole grains, e.g., Vita B, Brex, Red River  
Bread (one slice per serving):

White enriched  
Whole wheat  
Cracked wheat

Oatmeal  
Rye  
Raisin or Fruit breads

Bread Alternatives:

1 Muffin or Roll  
3 Ry-Krisp  
2 Oatmeal Cookies  
1 slice Fruitcake

2" piece of Gingerbread  
250 mL (1 cup) Spaghetti  
250 mL (1 cup) Macaroni  
250 mL (1 cup) Noodles

Did you have butter or fortified margarine with your meals? Count 5 points. Maximum: 5 points.

### GROUP 3 – MAXIMUM COUNT, 20 POINTS

YOUR DAILY SCORE							DAILY AVERAGE
DAY 1	DAY 2	DAY 3	DAY 4	DAY 5	DAY 6	DAY 7	

### GROUP IV – MEAT AND ALTERNATIVES

Maximum 20 points

Your point score will be 10 points for each serving of meat, fish, poultry, or alternatives. Maximum: 20 points.

Alternatives (two half-portions count as one full serving):

3 eggs  
60 mL (4 tbsp.) peanut butter  
90 g (3 oz.) cheese

250 mL (1 cup) cooked lima, navy, kidney or  
other dried beans

### GROUP 4 – MAXIMUM COUNT, 20 POINTS

YOUR DAILY SCORE							DAILY AVERAGE
DAY 1	DAY 2	DAY 3	DAY 4	DAY 5	DAY 6	DAY 7	

## RESOURCE 2: HOW DO YOUR MEALS SCORE? (continued)

### GROUP V – VITAMIN D

Maximum 10 points

Aim for a total daily intake of 400 International Units of vitamin D, either from your meals or from vitamin D preparations in tablet, capsule or drop form. Check labels on fluid milk, evaporated milk, and margarine, for the number of units they supply.

Count 1 point for each 40 International Units you receive. Maximum: 10 points.

#### GROUP 5 – MAXIMUM COUNT, 10 POINTS

YOUR DAILY SCORE							DAILY AVERAGE
DAY 1	DAY 2	DAY 3	DAY 4	DAY 5	DAY 6	DAY 7	

### YOUR TOTAL POINT SCORE

Maximum 110 points

Total your point score from each of the five groups and enter the totals here:

#### MAXIMUM TOTAL COUNT – 110 POINTS

YOUR DAILY SCORE								DAILY AVERAGE
GROUP	DAY 1	DAY 2	DAY 3	DAY 4	DAY 5	DAY 6	DAY 7	
1								
2								
3								
4								
5								
TOTAL								

You may now rate your daily food intake based on your daily average. If your score is below 80, you must definitely strive to improve your food selection.

FAIR	GOOD	VERY GOOD
Below 80	80-94	95 or over

From *How Do Your Meals Score?* by the Manitoba Department of Health. Reprinted by permission.

## RESOURCE 3: TECHNOLOGY AND FOOD

---

### PURPOSE

To illustrate how technology has affected our food products.

### MATERIALS

Freeze-dried, fresh and canned or frozen samples of the same foods.

### PROCEDURE

- A. Check grocery store shelves and outdoor recreation catalogues for products now available to consumers because of technology developed through the space program. One example is the product known as Tang which was originally developed for the space program.
- B. Working in small groups, plan a "space picnic" using the products discovered in Part A.
- C. Do these "space" foods taste as good as our "old" foods? Prepare a blind taste test to compare a reconstituted freeze-dried food with the "original" product.
  - (1) Reconstitute a freeze-dried food.
  - (2) Prepare samples of the fresh or canned or frozen food. Label each sample only A or B so that the taster does not know which sample it is.
  - (3) Taste and compare the products. Record the results.
- D. Are these "space" foods as nutritious as our "old" foods? Compare labels and nutrition charts and record the results.
- E. How do these "space" foods compare in price with our "old" foods? Compare price per gram or ounce and record the results.
- F. Answer the following questions.
  - (1) Which product did you prefer for taste? For nutrition? For cost? Why?
  - (2) Why are freeze-dried foods used on space flights? On extended wilderness trips on Earth?

### RESULTS

Freeze-dried foods were first developed for space travel. The food is frozen in a vacuum. Foods usually available on grocery store shelves include powdered fruit drinks and various kinds of freeze-dried food. Outdoor recreation specialty stores will have a wide variety of freeze-dried foods including eggs, fruits and even ice cream.

---

From *Science Syllabus for Middle and Junior High Schools (Block J: Science, Technology and Society)*, p. 30, by the University of the State of New York/State Education Department. Copyright 1985 by the University of the State of New York/State Education Department. Reprinted by permission.

## RESOURCE 4: BODY MASS INDEX

### HOW TO FIND YOUR BMI – IT'S EASY

1. Mark an X at your height on line A.
2. Mark an X at your weight on line B.
3. Take a ruler and join the two X's.
4. To find your BMI, extend the line to line C.

#### FOR EXAMPLE:

- If Michael is 5'11" (1.80 m) and weighs 188 lbs. (85 kg), his BMI is about 26.
- If Irene is 5'4" (1.60 m) and weighs 132 lbs. (60 kg), her BMI is about 23.

**Under 20** A BMI under 20 may be associated with health problems for some individuals. It may be a good idea to consult a dietitian and physician for advice.

**20-25** This zone is associated with the lowest risk of illness for most people. This is the range you want to stay in.

**25-27** A BMI over 25 may be associated with health problems for some people. Caution is suggested if your BMI is in this zone.

**Over 27** A BMI over 27 is associated with increased risk of health problems such as heart disease, high blood pressure and diabetes. It may be a good idea to consult a dietitian and physician for advice.

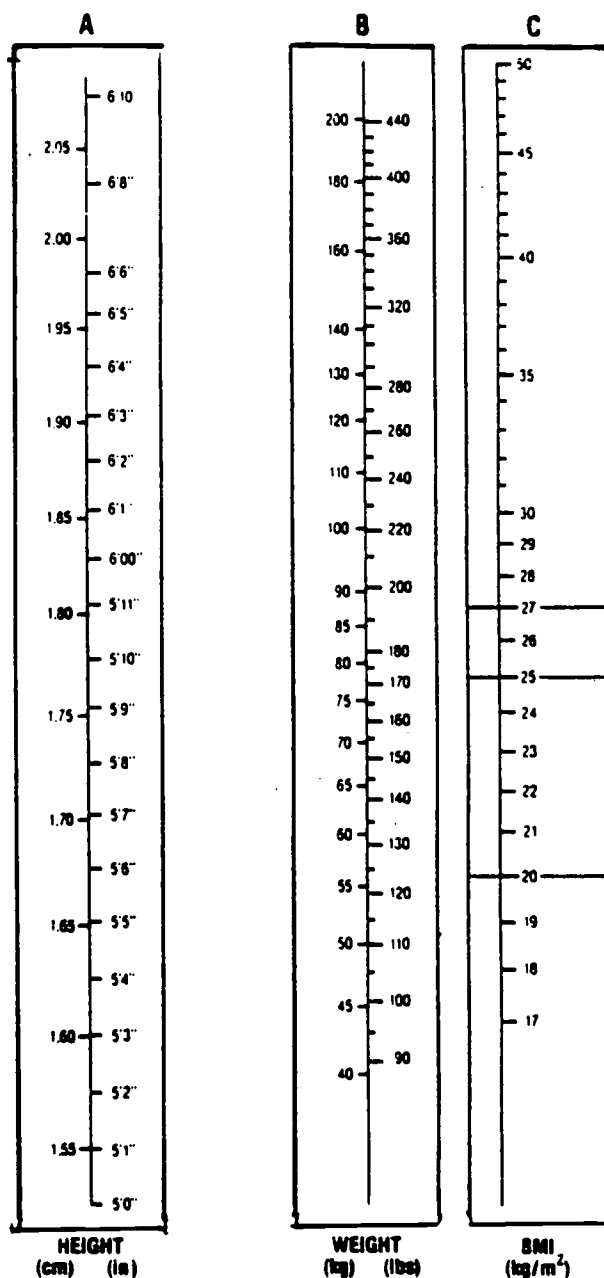

### IF YOU FALL BELOW 20 OR ABOVE 27 ON THE BMI RANGE ...

It's time to reduce your chance of developing health problems. The first and most important thing is to determine why you are not within the healthy weight range and seek the assistance of your physician and dietitian/nutritionist.

Reprinted with the permission of the Canadian Dietetic Association.

## RESOURCE 5: WEIGHT WATCHING

---

Weight watching has become one of the national pastimes. Very often the anxiety of "being overweight" is connected to improper eating habits. How can we eat well, grow slim and be healthy?

### EVERYBODY'S DIFFERENT

Each person's body and psyche is unique. This is why it's important for anyone planning to lose more than 10 pounds to visit a doctor in whom they have confidence. Here are some of the ways in which we are different individuals.

#### Age

With advancing age there is a decrease in the rate at which the body burns fuel, which results in a lower caloric requirement.

#### Activity

As people grow older, activity decreases, so a gain in body weight is even more likely. A brisk 25 minute walk each day will burn up 450 grams of body fat in a month – 4.5 kilograms in a year.



#### Body Types and Metabolism

Because there are such variations, any chart of desirable weights is only a guideline. The "right" weight is that at which an individual functions best without fatigue or irritability.

A metric chart is included so you can figure out your new measurements! Start with a metric tape measure to find your height and then check the corresponding weight.

## RESOURCE 5: WEIGHT WATCHING (continued)

MEN		WOMEN	
HEIGHT (cm)	WEIGHT (kg)	HEIGHT (cm)	WEIGHT (kg)
158	55.0 – 60.5	148	43.0 – 48.0
160	56.0 – 61.5	150	44.0 – 50.0
162	57.5 – 63.0	152	48.0 – 53.5
164	58.5 – 64.0	154	49.0 – 55.0
166	60.0 – 65.5	156	50.5 – 56.0
168	61.5 – 67.0	158	52.0 – 57.5
170	63.0 – 68.5	160	53.0 – 59.0
172	64.0 – 70.0	162	54.5 – 60.5
174	65.5 – 72.0	164	56.0 – 62.0
176	67.0 – 73.5	166	57.5 – 63.5
178	68.0 – 75.5	168	59.0 – 65.0
180	70.0 – 77.0	170	60.0 – 66.5
182	71.5 – 79.0	172	61.5 – 68.0
184	73.0 – 80.5	174	63.0 – 69.5
186	74.5 – 82.5	176	64.5 – 71.0
188	76.0 – 84.5	178	66.0 – 72.5
190	77.5 – 86.0	180	67.5 – 74.0
192	79.5 – 88.0	182	68.5 – 75.5
194	81.5 – 90.0	184	70.0 – 77.0

### Psychological Situation

Sometimes a person will gain weight in reaction to a stressful situation. Then it's important to understand what's happening so that overeating can be controlled.

### Eating Habits

Eating habits are developed from childhood onward. For a continued weight loss, food habits need to be altered; new food likes and dislikes need to be developed. This takes a lot of hard work but is one of the most promising ways to keep weight off.

### WEIGHT LOSS

Diets number in the hundreds. Some are good but most are fad diets which promise fast weight loss with little or no effort.

Diets abound. They range from one or two food diets such as rice diet, grapefruit diet or milk diet to one food group – high protein, no carbohydrate plans to liquid protein diets.

Although they all are very different these fad diets do share some common weakness. Most actually zero in on one food or food type and ignore the principles of good nutrition balance. Monotony also makes it difficult to stick to many of the diets. The largest problem is that these diets don't really do anything about changing your normal eating habits that caused the problem to begin with.

## RESOURCE 5: WEIGHT WATCHING (continued)

Consequently even dieters who use these diets successfully, tend to get on a "yo-yo" cycle of weight control – diet, lose weight, regain it and diet again.

Exercise is the other factor in weight loss. Increasing your activity level has a cumulative effect. In order to lose 450 grams, you must burn up approximately 3,500 calories. Following is a chart indicating time required for various activities to burn off 100 calories.

ACTIVITY	FEMALE 57 kg	MALE 73 kg
Clean windows	30 min.	25 min.
Garden	20 min.	16 min.
Calisthenics	20 min.	19 min.
Bicycle, 8 km/h	20 min.	19 min.
Bicycle, 20 km/h	13 min.	9 min.
Bowl (non-stop)	20 min.	14 min.
Ping-Pong	30 min.	24 min.
Run, 15 km/h	9 min.	6 min.
Run (in place)	5 min.	4 min.
Swim (crawl) 20 m/min.	25 min.	20 min.
Tennis (moderately)	16 min.	13 min.
Dance (moderately)	30 min.	23 min.
Walk (fast pace)	19 min.	14 min.

### MAINTAINING WEIGHT LOSS

Food habits need to be adjusted so that foods with good nutrition and moderate calories become "second nature". Cutting out foods just because of calories may mean cutting out needed nutrients. So check the total nutrient content before deleting foods from your diet.

Keep an eye on the scales – and take a look at your body in a full-length mirror. The moment that the scales show you're 2-3 kg over your goal weight – that's the day to cut down on some high calorie foods.

Exercise! Strenuous exercise (with the doctor's permission) will help you keep extra weight off and feel better.

Regular exercise can be worked into your daily routine without having to go near a gym. Use the stairs instead of the elevator for a start, then try parking a short distance away from the office building or store. A short, brisk walk will get you ready for the day and you'll find it easier to park!

Walking, jogging, bicycling and swimming are some of the more popular activities. Keep a steady, brisk pace in all of them and start off with short distances. You'll soon find the distance increasing with a minimum of effort.

## RESOURCE 5: WEIGHT WATCHING (continued)

---

### FOODS FOR WEIGHT WATCHING

When you're selecting foods remember to always weigh and measure so you know what you eat. Cut favourite foods down rather than eliminating completely.

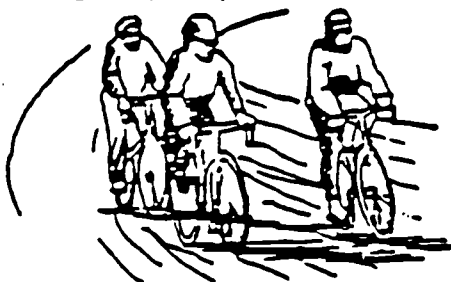

#### Vegetables and Fruits

Many fruits and vegetables such as cabbage, tomatoes, spinach, strawberries and melons offer very few calories but lots of nutrition.

Use fresh fruit and fruit canned in its own juices as much as possible.

For desserts use fruit, a low-calorie gelatin or develop your own recipes.

#### Meats and Dairy Products

Choose beef cuts such as round steak, rump roast, flank steak and liver; they contain less fat. Lean cuts of pork and lamb are good choices.

Be wary of convenience foods such as packaged casseroles. They often contain such ingredients as dextrose, lactose, potato starch, cornstarch, vegetable oil and shortening which contribute calories you don't count on.

Choose plain yogurt, buttermilk (made from skim milk), cottage cheese and skim milk cheese.

#### Diet Foods

The label of a food intended for a special diet always indicates for which diet the food is recommended. When you are following a reducing diet look on the label for a statement that says "for calorie restricted diets" or "for reducing diets".

According to Food and Drug regulations, foods recommended for reducing diets must contain fewer calories than normal foods but they are not calorie free. The label specifies the calories in a unit of ready-to-serve foods or in 100 grams for foods recommended for a calorie restricted diet.

The special foods tend to be more expensive than regular foods.

#### Snack Foods

There is nothing wrong with snacking on a diet. In fact, snacking has become a way of life for many people. It's therefore more reasonable to work on changing snacks rather than the eating pattern.



## RESOURCE 5: WEIGHT WATCHING (continued)

---

Dieters could plan low calorie snacks so as not to be tempted by a gooey Danish or candy bars. Yogurt, cheese and crackers or a bran muffin will contribute some calories but can be planned so as to supplement the "other" meals of the day.

Try reserving parts of your other meals as snacks. Desserts from mealtimes can be saved for a moment of weakness later!

Prepare snacks ahead of time so they are ready when we "need" them. Raw vegetables such as carrots, cauliflower, celery, green peppers and radishes contain very few calories so make ideal diet snacks.

Therefore, although the word snack is often associated with "junk foods", or high calories/low nutritive foods, if chosen wisely, snacks can contribute important nutrients to our diet without adding a significant number of calories.

### Eating Out

More and more meals are eaten outside the home but that doesn't mean you have to go "off your diet".

Avoid the high calorie traditional favourites such as pizza (1/2 of medium cheese – 900 calories), Big Mac (557 calories) or a banana split (580 calories).

When eating out, order your meat baked, broiled or roasted and trim off all visible fat. Deep frying adds hidden fats and therefore increases the calories it contains.

The same goes for potatoes. Order them baked – they contain about the same number of calories as an apple if you don't add butter or sour cream. Avoid high calorie beverages as well. Tea, coffee and skim milk will quench your thirst just as well as soft drinks or milkshakes.

---

From *Consumer's Guide, Co-op Consumer Counsellor*, p. F5-F6, by Federated Co-operatives Limited. Copyright 1983 by Federated Co-operatives Limited. Reprinted by permission.

## RESOURCE 6: FACTS ABOUT FOOD

---

Please circle True (T) or False (F) or Unsure (U) for the following:

- T F U 1. Cardiovascular (heart) disease and cancer are two of the major killers in North America today.
- T F U 2. Skipping breakfast regularly is a good way to lose a few excessive pounds.
- T F U 3. Using liquid diets is a sensible way to lose weight.
- T F U 4. TV, magazines and advertising in general can influence our feelings about the way we look.
- T F U 5. The three energy-yielding macronutrients are proteins, carbohydrates, and vitamins.
- T F U 6. Taking an extra amount of one nutrient can make up for a shortage of another.
- T F U 7. About half of your diet should consist of protein.
- T F U 8. Cheese and fish are good sources of protein.
- T F U 9. Fibre is a digestible form of carbohydrate.
- T F U 10. Carbohydrate is our main source of energy.
- T F U 11. Large amounts of vitamins are necessary to provide the body with needed energy.
- T F U 12. Because minerals and certain vitamins can be stored in the body, taking a lot of vitamin and mineral supplements can be dangerous.
- T F U 13. Over half of our body weight is water.
- T F U 14. Fruits and vegetables are usually good sources of vitamins A and C.
- T F U 15. Milk and milk products are generally high in calcium.
- T F U 16. Meats are a good source of Vitamin C.

## RESOURCE 6: FACTS ABOUT FOOD (continued)

---

- T F U 17. Canada's Food Guide recommends 3 servings from the fruit and vegetables food group daily.
- T F U 18. A hard-boiled egg is an example of one serving from the meat alternatives food group.
- T F U 19. Breads and cereals are generally low in iron.
- T F U 20. Fruits provide carbohydrate but little or no fat.
- T F U 21. Extra calcium is needed during the growth spurt in adolescence.
- T F U 22. "Empty Calorie" foods contain many important nutrients but few calories.
- T F U 23. A high fat and/or salt intake may lead to heart disease.
- T F U 24. Fast foods are usually low in fat, salt and kilocalories.
- T F U 25. In order to lose weight, your energy input must be greater than your energy output.

### ANSWER KEY

- |          |          |           |           |           |
|----------|----------|-----------|-----------|-----------|
| 1. True  | 6. False | 11. False | 16. False | 21. True  |
| 2. False | 7. False | 12. True  | 17. False | 22. False |
| 3. False | 8. True  | 13. True  | 18. True  | 23. True  |
| 4. True  | 9. False | 14. True  | 19. False | 24. False |
| 5. False | 10. True | 15. True  | 20. True  | 25. False |

Reprinted with the permission of the Athabasca Health Unit.

## RESOURCE 7: NUTRITION AND ATHLETIC PERFORMANCE

---

There are many misconceptions about nutrition in athletic performance. Read the following statements and circle what you believe is the correct answer.

1.    T        F        The athlete's diet is very different from the diet of a moderately active person.
2.    T        F        Carbohydrates include sugars, starches and fibre.
3.    T        F        Athletes have increased needs for protein. Very large amounts of protein are needed to build muscles.
4.    T        F        Carbohydrates should be the main portion of a pre-exercise meal.
5.    T        F        Protein is the best used source of energy for the athlete.
6.    T        F        Athletes should make sure they do not drink water until after exercise is finished to avoid cramping.
7.    T        F        Salt replacements are usually not required to replace sodium lost in sweating, unless sweating is so severe as to cause a marked weight loss (2-4 kg or 4 1/2-9 lbs).
8.    T        F        Carbohydrate loading, a method of storing large amounts of easy-to-use energy in the body, is useful for sprinting events (running under 400 metres).
9.    T        F        A steak dinner eaten 2-3 hours before an athletic event is the best type of meal to aid in good performance.
10.   T        F        Alcoholic beverages will improve athletic performance.
11.   T        F        For athletes such as wrestlers, where it is important to fit into certain weight categories, dehydration is not an ideal method to use to lose weight.
12.   T        F        Weight loss can be achieved by increasing energy output or decreasing input (food). A combination of these works best in weight loss.
13.   T        F        Athletes do not need to take vitamin supplements. Any extra needs they might have will likely be taken care of because of their increase in food consumption.

## RESOURCE 7: NUTRITION AND ATHLETIC PERFORMANCE (continued)

---

14. T F Two friends are the same height. Just because the athlete may weigh more than their non-active friend, it does not mean that the athlete is above a desirable weight. Muscle weighs more than fat.
15. T F Eating honey, sugar, soft drinks, or a candy bar is an excellent way to get quick energy just before competition or practice.

### ANSWER KEY

1. False The diet for the athlete and the moderately active person should be based on the principles of Canada's Food Guide. The athlete may have a greater need for energy, so may have a greater overall intake.
2. True
3. False There is a misconception that high protein diets improve athletic performance. This leads many individuals to eat excessively large amounts of meat and to use special protein supplements. The requirement for protein does not increase with exercise except to a slight degree when muscle mass increases. Any increased need for protein will easily be met with the increase in food intake to meet energy requirements.
4. True Carbohydrates are the most efficient source of energy for the body and they are also the most easily absorbed of the three macronutrients (carbohydrate, fat and protein).
5. False See above
6. False Water is the most important nutrient for your athletes – especially during hot weather. Even ice cold water does not cause cramps or stomach upset. However, a lack of water may slow your athletes down.

Athletes should drink 1/2 cup of cool, plain water every 10-15 minutes during exercise to replace body fluids lost as sweat.

## RESOURCE 7: NUTRITION AND ATHLETIC PERFORMANCE (continued)

---

7. True Prolonged heavy exercise in hot weather or a heated room can lead to the loss of enough salt in the sweat to disturb fluid and electrolyte balance. Most individuals involved in sports and exercises, however, will lose only small amounts of sodium which will be replaced at the next meal.
- If perspiration is extremely heavy, indicated by a 2 to 4 kg loss of body weight during an athletic event, salt may have to be replaced. This can be done by adding a small amount of salt (2mL/L) to the drinking water. The use of salt tablets should be avoided because they may be harmful. They can irritate the stomach lining and cause nausea and vomiting.
8. False Carbohydrate loading may be useful in endurance activities lasting more than 30-60 minutes.
9. False See #4.
10. False Alcohol acts as a depressant; it may affect co-ordination, ability to process oxygen, and muscle strength. Obviously, this will have a negative effect on performance.
11. True Dehydration cannot be corrected in a few hours between weigh-in and competition. The body will not be able to meet the energy demands during the event and the loss of potassium with the water will cause muscle weakness. Such practices may also affect the growth rate of the young athlete.
12. True
13. True
14. True
15. False In fact, eating these foods before competition may decrease the amount of energy in the form of carbohydrate, available to your body. (Remember that carbohydrate is the most efficient fuel for the body to use.)

---

Reprinted with the permission of the Athabasca Health Unit.

## RESOURCE 8: HEARTBEAT RECOVERY RATES

Your pulse rate provides information about your health. In this investigation, you will be required to collect data about your personal health by determining your pulse rate after various kinds of activity. Pulse rate can be determined by counting the number of times your heart beats in 15 seconds and multiplying by 4. You will also be required to construct a line graph which will be used to summarize the data you collect about your health.

- A. In the following activity, you will find your pulse rate when at rest and after a period of exertion. Perform each activity listed in the chart. Record your pulse rate after performing each activity. Always take your pulse while sitting down.

ACTIVITY	PULSE RATE (BEATS PER MINUTE)
1. Sit for 3 minutes.	-----
2. Stand and sit 10 times.	-----
3. Sit for 3 minutes.	-----
4. Touch your toes 10 times.	-----
5. Sit for 3 minutes.	-----
6. Jump 20 times, clapping your hands above your head.	-----
7. Sit for 3 minutes.	-----
8. Run on the spot for 1 minute.	-----
9. Sit for 3 minutes.	-----
10. Sit for another 3 minutes.	-----

- B. Using the information that you recorded in Part A, draw a line graph illustrating changes in your pulse rate.
- C. What observations can you make about the speed at which your heart recovered from the activities undertaken?
- D. Compare your heartbeat recovery rate following certain activities with the recovery rates noted by other members of the class.

## RESOURCE 9: EXERCISES

---

Eighty percent of adult Canadians are unfit. Fifty percent or more of adult Canadians are overweight.

A noted physical education researcher has said, "For the ordinary Canadian child physical fitness seems to be a decreasing function of age from the time we put him behind a desk in our schools."

Looking and feeling fit is important and only part of the story. Good health and a longer life expectancy complete it. The type of lifestyle we live is a contributing factor and influences the risk of our contracting some diseases. For example, if we smoke, chances of our contracting lung cancer are greater. If we don't eat a nutritious diet and if we don't get enough of the right kind of exercise our risk of suffering from coronary heart disease is increased. These have been called diseases of choice. By choosing a lifestyle which predisposes us to contracting them we really choose not to protect ourselves.

Being fit means: muscles strong enough to carry the body easily with good posture and appearance; good coordination between the brain and muscles and good balance; flexible joints and muscles to make moving easy and graceful; and stamina, the most important ingredient of physical fitness, enabling the heart, lungs and blood vessels to endure continuous and sustained activity, and to be able to withstand sudden demands on the system without damage.

### YOUR FAMILY'S FITNESS

Most people underestimate their fitness level. A fit person gets enough vigorous exercise (jogging, walking, skiing, etc.) to raise their heartbeat from 135 to 150 beats per minute (depending on age); they sustain this level of activity without stopping for 15 to 30 minutes and they do this at least three times a week. A fit person is also physically active for about 60 minutes over the course of a day, everyday - moving, walking, climbing stairs, running for the bus, mowing the lawn, etc.

List all the activities each member of your family did in the last 48 hours. Are they fit according to the above? If not, get the family together to discuss the importance of fitness and begin today to alter the lifestyle of your family. Plan to do some things as a family. One of the first things you could do is to order a Fit-Kit. It is an individual and family physical fitness program in a package and contains a test to determine fitness level, as well as a walk-run distance calculator to work out a personal exercise program, a fitness chart, and health and fitness information. It makes getting fit fun and something the family can do together. Remember, it's not necessary to spend a lot of money on suitable clothing or equipment. For example, fast walking doesn't cost a cent and is as easy as going out the door.

### AN EXERCISE PROGRAM

If you have been generally inactive, are over 40, or have a medical problem, check with your doctor before starting on an exercise program. Start slowly and build up as your fitness increases. Each exercise session should be made up of three parts: warming up (walking, bending, stretching); vigorous exercise for 15 to 30 minutes; and a cooling down period (walking, jogging, slowly). Too fast a start or an abrupt end to vigorous exercise will put a strain on the body.



## RESOURCE 9: EXERCISES (continued)

---

Exercises to build muscle strength include: sit-ups and leg raises to firm stomach muscles; push-ups for arms and upper body; using weights to strengthen legs and arms; and climbing stairs for the legs and frame muscles.

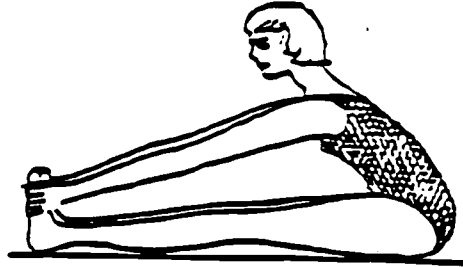

For flexibility and coordination stretch, reach, bend and twist. Touching the toes, reaching up to left and right and back and forth will "loosen up" the joints. Muscle soreness is often due to lack of flexible muscles and joints. Working at flexibility and exercises helps to get the brain and muscles working together and improves coordination.

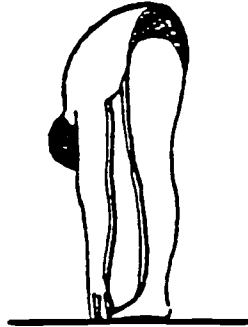

Stamina or cardiorespiratory fitness means the lungs have the ability to draw enough oxygen into the blood and to the heart so that it can supply oxygen to the muscles quickly and efficiently and for long periods of time without beating too fast. If you puff after running up a flight of stairs or dancing a polka, your cardiorespiratory system is inefficient and the heart will have to work very hard to get oxygen from the lungs into the bloodstream and to the muscles.

As you become fitter the heart muscle, like other muscles, becomes larger and more powerful. It is able to do the same work with fewer beats per minute and with much less exertion. Your lungs have a much greater capacity for oxygen and the blood vessels stay supple and large and blood flows smoothly and easily through the body. To improve your cardiorespiratory system, you must do exercises that make you breath hard and perspire. Fast walking, running, jogging, skipping rope, cross-country skiing and swimming are examples of this type of exercise.



## RESOURCE 9: EXERCISES (continued)

---

To be beneficial, the activity you choose should increase the heart rate (taken right after the exercise) up to 80% of its maximum. A general guide to finding 80% of the maximum is to subtract your age from 220 and then divide by 6 to find how many beats there should be in 10 seconds. For example, 80% of maximum for a 20-year-old would be  $220 - 20 = 200$ . The number of beats in 10 seconds should be  $200 \div 6 = 34$ . The fitter you are, the harder you will have to work to get the heartbeat up to 80% of its maximum. This means it is becoming more efficient.

### BENEFITS OF FITNESS

Besides looking and feeling better, you will have a general feeling of well-being both physically and mentally; an abundance of energy, and thus be more productive and able to work and play with enjoyment. You will sleep better, and have better resistance to disease, stress, tension and being overweight.

#### Exercise, Stress and Fatigue

In small doses, stress provides energy to get things done and after a particularly stressful day you may experience muscle tension in the neck and shoulders (maybe causing a headache) and fatigue. A good night's rest usually solves the problem. However, if stress and fatigue are a part of every day, general health will begin to suffer. Activity, particularly physical activity helps to reduce stress because it removes you from the stressful situation and you stop thinking about it. As well, tight muscles will loosen during activity and some of the physical symptoms of stress are relieved. Done regularly, physical activity will help to control the effects of stress on the body.

#### Exercise and Weight Control

Weight control is a simple matter of balancing food (calorie) intake with energy output. If you eat more than you use, you gain weight. Any kind of physical activity uses up energy in the form of calories. For example, swimming at the rate of two miles per hour will use up 553 calories in an hour; washing dishes for an hour will use up 70 calories; and vacuuming for an hour will use up 189 calories. The more physically active you are the more you will be able to eat without gaining weight. To lose weight, simply increase your physical activity. To lose weight faster, also reduce the number of calories you consume. Be sure the foods you eat are nutritious. Refer to the Co-op Consumer Counsellor Information Sheets: "Weight Watching", and "Food Groups" for more information.

Physical fitness is preventative medicine.

---

From *Consumer's Guide*, Co-op Consumer Counsellor, pp. L1-L2, by Federated Co-operatives Limited. Copyright 1983 by Federated Co-operatives Limited. Reprinted by permission.

## RESOURCE 10: BASIC HUMAN NEEDS

---

All human beings share a set of basic needs. A basic human need is something that a person must have in order to survive or function. These needs are common to all human beings regardless of gender, age, ethnic origin or beliefs. We all behave as we do because we are continuously trying to satisfy one or more basic needs.

The chart that follows outlines basic human needs of people throughout various stages of the life cycle.

STAGE	AGE	NEED	DESCRIPTION
prenatal	conception to birth	protection	a safe environment for growth and development
infant	birth to 1 year	trust	a sense that the world is dependable and good
toddler	1-3 years	independence	a sense of deciding and doing for oneself
preschooler	3-5 years	initiative	a sense of discovery in the world around oneself
school Age	5-12 years	industry	a sense of being able to achieve or do well
adolescent	12-18 years	identity	a sense of self, apart from family and friends (e.g., discovery)
early adult	18-30 years	intimacy	establishing close, meaningful relationships (e.g., friendships, marriage)
middle adult	30-65 years	productivity	choosing lifestyles and responsibilities
late adult	65 years and up	integrity	a sense of order and meaning in one's life

## RESOURCE 11: MASLOW'S HEIRARCHY OF PRIMARY AND SECONDARY NEEDS

A psychologist, Abraham Maslow, developed a theory that helps us understand how basic needs affect people's lives. Maslow presented his ideas in a model to help people understand his theory. The model illustrates:

- a "heirarchy" of basic human needs in the shape of a triangle or pyramid
- "primary" (physical) needs at the bottom of the triangle
- "secondary" needs in the upper part of the triangle
- the relationship between primary and secondary human needs. According to Maslow, secondary needs can only be met after each of the primary needs have been met.

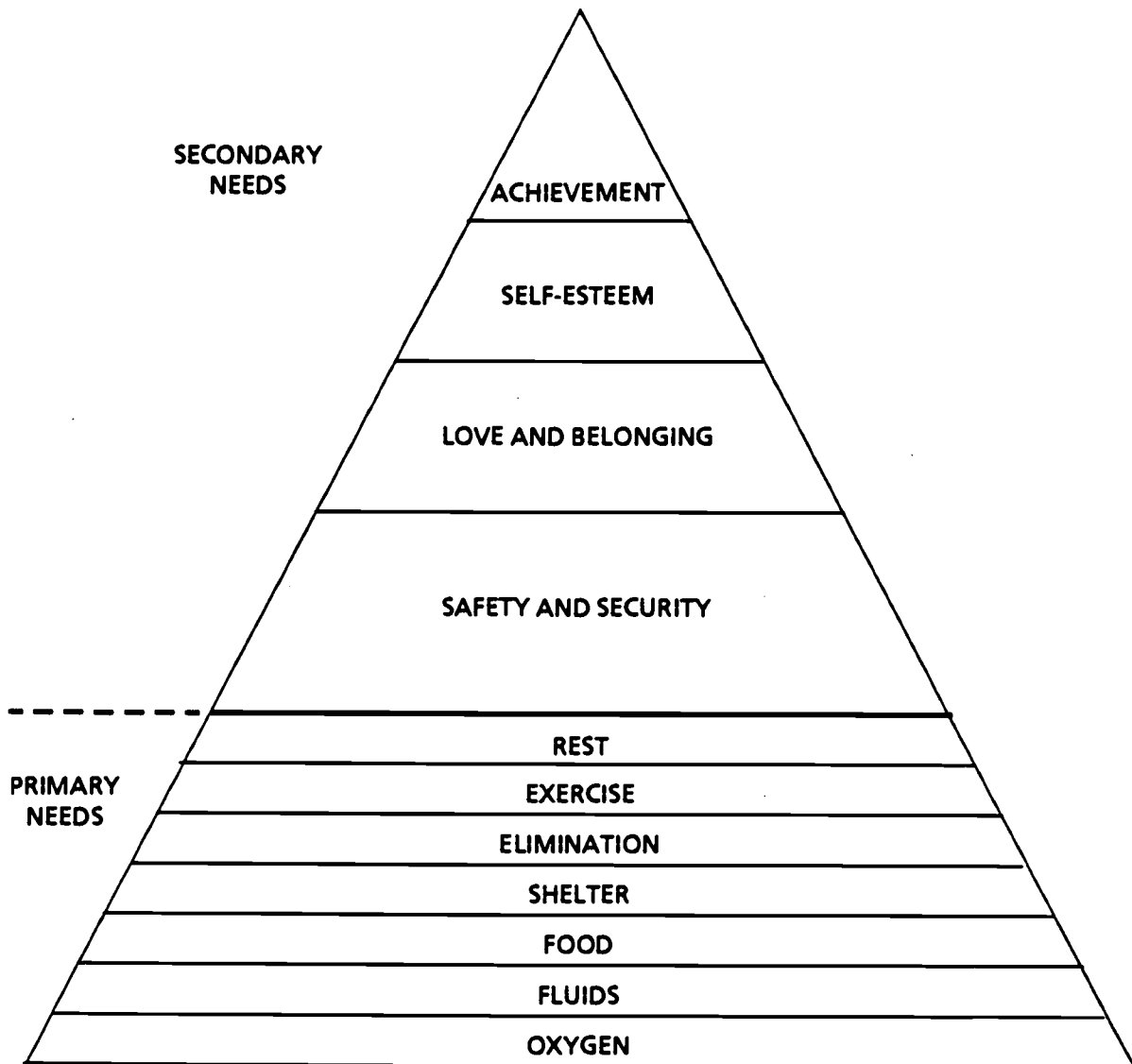

According to the theory, it is not necessary that each human need be met each day. However, the greater the number of needs that are met, the better the quality of life, health and well-being of the individual. Humans tend to use a variety of problem-solving and decision-making strategies each day in attempting to satisfy these basic needs.

## RESOURCE 12: SELF-CONCEPT

---

Self-concept is a term used to describe how we feel about ourselves. A **POSITIVE SELF-CONCEPT** suggests that we feel good about ourselves and our relationship with others. A **NEGATIVE SELF-CONCEPT** suggests that we may be unsure of our worth, and may experience difficulty relating to others.

Self-concept may affect an individual's:

- feelings
- interpersonal relationships
- learning
- ability to deal with difficulties
- appearance
- diet
- personal health and well-being.



Self-concept develops as a person begins to compare him or herself with others. By the time a child reach 8-10 years, he/she will have formed a self-concept based on relationships with:

- parents or guardians
- siblings (e.g., brothers, sisters)
- extended family members (e.g., grandparents, aunts, uncles, cousins)
- peers (e.g., playmates, classmates)
- care givers (e.g., baby-sitters, teachers).

As young people develop physically and emotionally, they tend to seek the attention of others. The type of attention they receive causes them to make judgments about their abilities, appearance and self-worth. A positive self-concept is fostered when relationships with others are based upon trust, respect and acceptance.

## RESOURCE 13: COMPUTE YOUR NUTRITION CONDITION

	RARELY	SOMETIMES	OFTEN
<b>DO YOU:</b>			
1. Participate in regular physical activity	1	3	5
2. Choose foods from the milk group	1	3	5
3. Eat breakfast	1	3	5
4. Drink carbonated beverages	5	3	1
5. Eat raw fruits and vegetables	1	3	5
6. Use foot power instead of horse power	1	3	5
7. Eat candy	5	3	1
8. Salt your food	5	3	1
9. Choose whole grain cereal or bread	1	3	5
10. Maintain ideal weight	1	3	5
11. Eat fried foods	5	3	1
12. Skip meals	5	3	1
13. Try new sports	1	3	5
14. Binge/overeat	5	3	1
15. Avoid unfamiliar foods	5	3	1
16. Drink water	1	3	5
17. Eat processed snack foods	5	3	1
18. Try fad diets	5	3	1
19. Eat a variety of protein foods	1	3	5
20. Get adequate sleep	1	3	5

Score:

- 80 or above ..... You're a nutrition-conscious individual  
 70-80 ..... You're doing O.K.  
 Below 70 ..... Try to change your eating habits and lifestyle

Written by the American Dietetic Association.

## RESOURCE 14: HOW HAVE CAUSES OF DEATH CHANGED SINCE 1900?

---

### PURPOSE

To illustrate that technological advances in medicine have reduced the rate of, or eliminated, some causes of death, while other causes of death have increased in rate, some because of technology.

### MATERIALS

- graph paper
- pencils
- reference sources.

### PROCEDURE

- Compare the two charts on the following page which list the leading causes of death.
  - What diseases on the 1900 chart have disappeared from the 1980 chart?
  - What diseases have been added to the 1980 chart?
- Make a bar graph of the five diseases that appear in both charts. Use different, but side-by-side bars for the 1900 data and the 1980 data.
- From the bar graph, answer the following questions:
  - Which diseases increased in death rate over time? By how many did the number of deaths increase for each?
  - Which diseases decreased in death rate over time? By how many did the number of deaths decrease for each?
- Use reference materials to answer the following questions:
  - For each disease that increased in death rate, list three factors that may have influenced the increase.
  - For each disease that decreased in death rate, list three factors that may have influenced the decrease.
  - What disease not included in these charts has been eradicated in your lifetime?

**RESOURCE 14: HOW HAVE CAUSES OF DEATH CHANGED SINCE 1900? (continued)**

Ten Leading Causes of Death in 1900		Ten Leading Causes of Death in 1980	
Cause	Deaths per 100,000 Population	Cause	Deaths per 100,000 Population
cancer	65	stroke	85
kidney disease	85	pneumonia and influenza	40
stroke	110	liver disease	30
diphtheria	40	homicide	15
senility	55	diabetes	35
accidents	75	heart disease	340
pneumonia and influenza	215	accidents	95
tuberculosis	185	cancer	185
diarrhea	140	suicide	20
heart disease	130	artery disease	25

From *Science Syllabus for Middle and Junior High Schools (Block J: Science, Technology and Society)*, p. 48, by the University of the State of New York/State Education Department. Copyright 1985 by the University of the State of New York/State Education Department. Reprinted by permission.



## THEME B

### MATERIALS WE USE

Activities will focus attention on the materials and products used by students in their everyday lives. By carrying out a series of controlled experiments, students will investigate the composition and properties of a variety of natural and synthetic materials used at home and in work-related situations. Students will be expected to develop strategies for:

- safely handling potentially dangerous materials, and situations encountered within the home and work environments
- selecting consumer products on the basis of their composition, properties and suitability for particular applications.

A major emphasis will be placed on gathering information about familiar materials and products through research and experiment. A focus on the nature of science and the inquiry process will enable students to understand the way in which knowledge of the properties of different materials is gathered, as well as use appropriate processes to conduct investigations of their own.

Students will apply previously developed knowledge of chemical substances and reactions (see Science 16: Chemistry for the Consumer) throughout this theme as they investigate the properties of familiar materials. Learning objectives interrelate with investigations performed in a subsequent theme, Technology in Transportation, and will enable students to extend the understanding of the role of science and technology in developing new products and processes, and the ways in which products of technology change many aspects of society.

Teachers are encouraged to reference the Program Emphases and Methodology section of this manual when planning for instruction. Suggestions particularly relevant to the learning objectives addressed in this theme can be found in:

- Nature of Science
- Communication Skills
- Assessment/Evaluation.

#### A FRAMEWORK FOR INVESTIGATING FAMILIAR MATERIALS

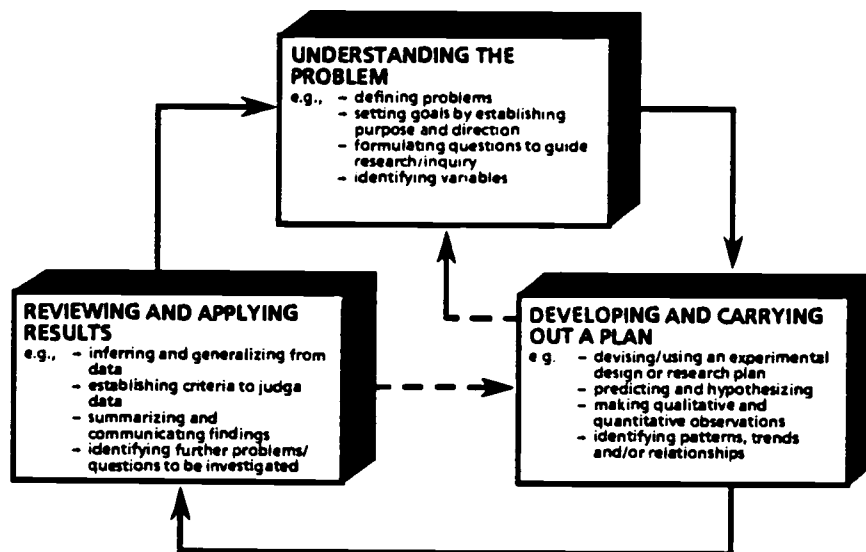

---

## CONCEPTS, SKILLS AND ATTITUDES

### CONCEPTS

Students will be expected to demonstrate an understanding that:

- models and other conceptual inventions are useful in explaining the composition and behaviour of matter
  - illustrates, through the use of models, how atoms and molecules represent structural units of matter
  - relates the behaviour of atoms and molecules in familiar substances to the Kinetic Molecular Theory
  - interprets symbols/formulas that represent the most common elements and simple compounds familiar to the student
- the properties of the materials and products we use are determined by their composition
  - describes the composition of two or more familiar materials in terms of their elements, atoms, molecules and compounds
  - relates the properties of two or more familiar materials to their composition
- materials and products are derived from both natural and synthetic sources
  - identifies products in every day use that are derived from both natural and synthetic sources
  - describes the industrial process involved in the manufacture of at least one natural product and at least one synthetic product
- the properties of materials determine their suitability for particular applications
  - describes the properties of familiar materials used at home and in work-related situations (e.g., metals/alloys, wood/paper products, fibres/fabrics, plastics/polymers, composite materials)
  - cites the advantages and/or disadvantages of familiar materials, relative to their suitability for particular applications
- our use of natural and synthetic materials affects both environment and resources
  - cites advantages and/or disadvantages associated with the use of a familiar natural and synthetic product, relative to the industrial processing of resources to form the product and the effect of the product's disposal on the environment
  - infers the need for biodegradable products and recyclable products
- the process of biodegradation reduces the impact of some products on the environment
  - explains the process of biodegradation
  - describes how non-biodegradable materials may harm the environment
  - distinguishes between familiar materials/products that are biodegradable and non-biodegradable

- technological products and processes develop in response to societal needs, and are often accepted and used by society before the full extent of benefits/problems resulting from their use can be known
  - describes a situation in which science and technology have assisted in solving a practical problem through the development of a new material
  - identifies a current issue/problem in society arising from the application of a technological product or process.

## SKILLS

Students will be expected to demonstrate an ability to:

- conduct experiments that illustrate the properties of familiar natural and synthetic materials
- through class discussion, design experiments that illustrate corrosive reactions among familiar substances/products, the insulation values of familiar fibres, and the biodegradability of familiar materials/products
- use apparatus and equipment effectively when conducting experiments
- make qualitative and quantitative observations when conducting experiments
- identify patterns and relationships in the behaviour of natural and synthetic materials, and use this information to explain applications of particular consumer products in everyday situations.
- predict heat exchange in practical situations, and use appropriate procedures for protecting living organisms and other materials from excessive heat transfer
- accurately read product labels and consumer reports in order to determine the composition and intended use of familiar household products
- apply appropriate techniques for identifying acids, bases and other hazardous materials
- use safe procedures for handling and storing potentially dangerous substances.

## ATTITUDES

Students will be encouraged to:

- display a positive attitude toward the learning of concepts and skills in science
  - shows interest and curiosity through willingness to ask questions, share observations and ideas, and seek answers
  - performs investigations and completes assignments independently and in cooperation with others
- value scientific principles and processes for their usefulness in providing an understanding of everyday phenomena
- appreciate the usefulness of measurement skills in real life and work-related situations
- appreciate how technology may facilitate the solving of practical problems, and create new problems
- appreciate both the usefulness and potential hazards of common household materials
- display a respect for personal safety and the safety of others when handling potentially hazardous materials
- appreciate the contributions of science and technology to the development of a variety of materials and products that we depend upon and use each day.

## INTEGRATION ACTIVITIES

Teachers are encouraged to identify ways to integrate the content of this theme with activities that may be undertaken by students in other subject areas. The references provided below are intended to facilitate curricular integration by establishing a base for cooperative planning among teachers.

### ENGLISH

Students will use a variety of communication skills throughout investigations that are undertaken in this theme. Through cooperative conferencing, English and science teachers may wish to plan integrated activities that will enable students to:

- write directions for special safety procedures (e.g., mixing reagents) and sequential tasks (e.g., lighting a bunsen burner)
- prepare laboratory reports for experiments that have been performed.

Suggestions and ideas that may assist students to develop and use communication skills in science are provided in another section of this manual (see Communication Skills).

### MATHEMATICS

Students will use mathematical skills when they:

- measure mass, capacity, time and temperature
- use ratio and proportion to describe the composition of various materials and products
- interpret measures of central tendency
- interpret and display data in table, chart and graph form.

Science teachers are encouraged to confer with the mathematics teacher in establishing appropriate strategies for applying mathematical competencies. Teachers may wish to plan integrated activities that will enable students to:

- use appropriate statistical methods to interpret and display data gathered through experiments performed in science class
- use ratio, proportion and percent to describe the composition of familiar materials and products.

### SOCIAL STUDIES

Students will develop an awareness of issues related to the use of natural and synthetic materials through activities in current affairs. Cooperative planning between social studies and science teachers may provide opportunities for students to investigate:

- appropriate applications of recently developed materials
- related safety considerations
- environmental concerns associated with the use of certain materials.

### OCCUPATIONAL COURSES

A variety of materials and products are used in the workplace. Students are given opportunities to develop appropriate strategies for handling, storing and disposing of materials frequently used in work-related situations.

Conferencing among science and occupational teachers will assist in planning integrated activities that enable students to investigate the properties and applications of materials they use in work-related situations. Such materials and products may include:

- metals/alloys
- wood/paper products
- fibres
- plastics/polymers.

## COMMUNITY PARTNERSHIP OPPORTUNITIES

The local community may offer resources that contribute to the development of learning objectives within this theme. Suggestions for utilizing community resources, and for involving students in the community by way of meaningful activities linked to the science program are provided below.

- Invite a clothing manufacturer/salesperson to speak to the class about natural and synthetic fabrics used in the clothing industry. This person might discuss:
  - the properties and applications of familiar natural and synthetic fabrics
  - appropriate care strategies for natural and synthetic fabrics
  - the advantages and/or disadvantages of using a particular fabric for a given application.
- Visit a local sportswear shop. Ask a sales clerk (or other knowledgeable person) to describe applications of various natural and synthetic fabrics in the manufacturing of sportswear (e.g., ski jackets, jogging pants). Discuss the advantages and/or disadvantages of using various fabrics when making sportswear for a given purpose.
- Visit local business/industry (e.g., service station, construction site) and observe the use of:
  - natural and synthetic materials
  - biodegradable and non-biodegradable materials.

Ask a knowledgeable person involved in each business/industry to discuss the properties and applications of the materials being used.

- Collect "litter" samples by taking a walking tour of the local area. Back in the classroom, classify litter samples as "biodegradable" and "non-biodegradable".
- Invite an environmentalist to speak to the class about environmental problems caused by the disposal of non-biodegradable materials and products.
- Plan a field trip into the local community and observe:
  - the kinds of materials that are used in local buildings/structures
  - instances where materials and products have weathered and/or corroded.
- Visit local industry and make note of the technological processes involved in producing a familiar material or product.
- Visit a recycling centre. Investigate procedures that are used in sorting and recycling solid wastes.
- Invite a local doctor or health nurse to discuss:
  - the potential dangers of using certain natural and/or synthetic materials (e.g., asbestos)
  - recovery techniques and emergency treatment for errors in handling hazardous materials.
- Invite a paramedic/fire chief to discuss:
  - the hazards and safe handling/storage techniques for potentially dangerous products found in the home and workplace
  - methods of minimizing the occurrence of fires in the home and workplace
  - appropriate methods of extinguishing different types of fires.
- Use a local/national newspaper to identify current environmental issues related to the use of non-biodegradable materials (e.g., Should we continue to manufacture and sell "disposable diapers"?). Provide opportunities for students to discuss and debate issues that are identified.
- Visit local stores and gather/interpret information provided on the labels of familiar household products (e.g., hazardous chemical symbols, product composition, applications, directions for use, recovery techniques for errors in handling).

## LEARNING RESOURCE CORRELATION

### BASIC RESOURCE

ISIS Individualized Science Instructional System  
Booklet: *Materials and Molecules*

### SUPPORT RESOURCES

Science at Work Series  
Booklet: *Fibres and Fabrics*

### OTHER RESOURCES

*Acme School of Stuff* (video program)  
Program 12

*Applied Science, Book 1*  
Unit 6 - Ceramics  
Unit 7 - Timber

*Applied Science, Book 2*  
Unit 3 - Shelter For Man and Beast  
Unit 6 - Man Improves on Nature - Maybe  
Unit 7 - Metals - Mining and Exploration  
Unit 8 - Using Metals

*Chemistry in Everyday Life* (video program)

*Principles of Science, Book 1*  
Chapter 1 - Science and Measurement  
Chapter 2 - Matter  
Chapter 3 - Energy and Changes in Matter

*Principles of Science, Book 2*  
Chapter 10 - Matter  
Chapter 13 - Chemical Technology  
Chapter 14 - Heat

Science at Work Series  
Booklet: *Building Science*

*Science Networks: Physical Science*  
Unit 1 - The Structure of Matter  
Unit 3 - Heat  
Unit 7 - Measurement in the Metric System

*The Scientific Method* (video program)

## SUGGESTED ACTIVITIES

The student learning resources identified above provide a variety of instructional activities that support learning objectives within this theme. The activities that follow complement those provided in the student learning resources. Teachers should be selective in their use, and consider students' interests/abilities and preferred methods of learning in planning appropriate instructional activities.

**LEARNING OBJECTIVE****RESOURCE CORRELATION**

**DEMONSTRATES AN UNDERSTANDING THAT MODELS AND OTHER CONCEPTUAL INVENTIONS ARE USEFUL IN EXPLAINING THE COMPOSITION AND BEHAVIOUR OF MATTER.**

- Illustrates, through the use of models, how atoms and molecules represent structural units of matter.
- Relates the behaviour of atoms and molecules in familiar substances to the Kinetic Molecular Theory.
- Interprets symbols/formulas that represent the most common elements and simple compounds familiar to the student.

**BASIC RESOURCE**

*Materials and Molecules*  
Chapter 1 – A Matter of Molecules

1. Physical and mental models provide a useful method of describing the composition of matter. Construct diagrams/physical models that illustrate:
  - the atom as a structural unit of matter
  - the molecular structure of given substances.
2. Discuss and interpret symbols/formulas that represent:
  - the most common elements
  - simple compounds familiar to students.

Describe familiar substances used within the home or workplace in terms of their elements, atoms, molecules and compounds.

3. Conduct library research on the work of scientists who have contributed to our present knowledge of the molecular structure of matter. Structure research activities using suggestions provided in Communication Skills, "Reading and Viewing Science Materials".
4. Simulate Brownian motion and heat in solids, liquids and gases by vibrating marbles (or other small spherical objects) on an overhead projector.

Construct physical models/diagrams of the molecular arrangement in solids, liquids and gases.

5. Relate the expansion/contraction of materials to the Kinetic Molecular Theory. Apply knowledge of the expansion/contraction of materials in explaining principles governing the operation of familiar technological products/processes.

- e.g.,
- radiator caps
  - special purpose thermometers
  - expansion joints
  - tire inflation
  - thermostats.

BEST COPY AVAILABLE

6. Demonstrate the effects of heat on the behaviour of molecules by performing the investigation described below.
  - a. Obtain a metal can with a screw-top lid. Remove the lid and place a small amount of water in the bottom of the can.
  - b. Place the metal can containing water over a heat source. Apply heat until the water inside the can begins to boil and water vapour begins to escape from the top of the can.
  - c. Remove the can from the heat and tightly replace the screw-top lid.
  - d. Allow the can and water to cool. Closely observe what happens.

Ask questions that will cause students to relate phenomena observed in this investigation to the Kinetic Molecular Theory. Encourage and assist students to explain:

- the behaviour of atoms/molecules throughout each step of the investigation
  - why the can buckled as it cooled.
7. Design and conduct an experiment that will compare the molecular motion in hot water to the molecular motion in cold water.

Guidelines for designing an experiment are provided in Nature of Science, "Developing and Carrying Out a Plan".

8. Prepare a report on the contributions of Benjamin Rumford to the Kinetic Molecular Theory.

Useful suggestions for preparing reports are provided in Communication Skills, "Summarizing, Evaluating and Communicating Ideas in Science".

#### LEARNING OBJECTIVE

**DEMONSTRATES AN UNDERSTANDING THAT THE PROPERTIES OF THE MATERIALS AND PRODUCTS WE USE ARE DETERMINED BY THEIR COMPOSITION.**

- Describes the composition of two or more familiar materials in terms of their elements, atoms, molecules and compounds.
- Relates the properties of two or more familiar materials to their composition.

#### RESOURCE CORRELATION

##### BASIC RESOURCE

*Materials and Molecules*  
Chapter 1 – A Matter of Molecules

1. Collect a variety of materials/products used around the home (e.g., ceramics, metals, plastics, wood, paper, fabrics/textiles, concrete, brick, plaster, glass). Ask students to:
  - examine each material and identify its properties
  - relate the properties of each material to its function or use within the home.

BEST COPY AVAILABLE



Record the results of this activity in a chart similar to the one illustrated below.

MATERIAL	PROPERTIES (e.g., colour, texture, strength, hardness)	FUNCTION/USE

Attribute guides provide a structure for the observation of materials/products. A sample attribute guide is provided in Nature of Science, "Gathering Data". This guide can be modified by selecting attributes that are appropriate to the materials being examined.

2. Identify materials frequently used in the construction of bridges, roads, homes and other buildings within the local community (e.g., wood, stone, brick, concrete, metal, plastic, glass). Investigate how the composition and properties of these materials determine their function/use by constructing a chart similar to the one illustrated above.
3. Investigate the properties and composition of a variety of natural and synthetic materials. Plan and conduct laboratory activities, using suggestions provided in Nature of Science, "Strategies and Skills Used in Scientific Inquiry". Laboratory activities may involve:
  - examining/testing the properties of a variety of materials  
e.g.,
    - testing/observing the malleability, lustre, hardness and strength of several different metals
    - identifying metals by flame colour
    - identifying fabrics by burning them
    - observing fabrics under a microscope and drawing the shape of their fibres
    - testing different fabrics with respect to ease of washing, drying time, resistance to wrinkles, shrinkage
    - testing the strength of different types of mortar/concrete
  - using appropriate techniques to make familiar materials  
e.g.,
    - extracting a pure metal from an oxide of the metal
    - making a natural or synthetic fibre
    - making mortar or concrete
    - making a plastic or polymer
    - making paper
  - investigating and designing technologies that may be used to protect metals from corrosion  
e.g.,
    - testing the effectiveness of different types of protective metal coatings
    - galvanizing a metal object.

**LEARNING OBJECTIVE**

**DEMONSTRATES AN UNDERSTANDING THAT MATERIALS AND PRODUCTS ARE DERIVED FROM BOTH NATURAL AND SYNTHETIC SOURCES.**

- Identifies products in everyday use that are derived from both natural and synthetic sources.
- Describes the industrial process involved in the manufacture of at least one natural product and at least one synthetic product.

**RESOURCE CORRELATION****BASIC RESOURCE***Materials and Molecules*

- Chapter 2 – Metals: Qualities and Uses
- Chapter 3 – Hello Alloys
- Chapter 4 – Metal Corrosion
- Chapter 5 – Protective Metal Coatings

**SUPPORT RESOURCES***Fibres and Fabrics**Teacher Resource Manual*

- Resource 1: Natural and Synthetic Fibres
- Resource 2: Care of Fibres and Fabrics
- Resource 3: Garment Survey Form

1. Provide opportunities for students to distinguish between materials made from natural sources and those made from synthetic sources. Conduct an inventory of materials/products used in the home and workplace. Classify these materials as natural, synthetic or both.
2. Assemble a classroom display of natural and synthetic materials/products. Ask students to bring materials for the display from home. The display may include:
  - natural and synthetic fabrics/textiles
  - wood, paper and plastic products
  - metals and alloys
  - composite materials.
3. Discuss the role of science and technology in developing synthetic materials. Ask students to identify several recently developed synthetic materials used in their homes (e.g., garments made from synthetic fibres, a plastic or composite material that is used in place of wood). Through discussion, assist students to develop an understanding of:
  - societal needs that led to the development of each product
  - scientific principles and technological processes used in the manufacture of each product
  - the advantages/disadvantages of each product when compared with a similar product made from natural sources.

Sample activities that illustrate how synthetic products are developed through interactions between science and technology are provided in Science and Technology, "The Relationship Between Science and Technology".
4. Assemble a display of familiar fabric/textile samples. Classify the samples as natural, synthetic or a mix. Label each sample as to its:
  - content
  - useful characteristics
  - appropriate applications.

Information and activities relevant to the characteristics and applications of a variety of natural and synthetic fabrics is provided in Resource 1: Natural and Synthetic Fibres, and Resource 2: Care of Fibres and Fabrics.

5. Design and perform experiments with natural and synthetic fabrics. Investigations should enable students to:
- distinguish between natural and synthetic fibres
  - identify desirable characteristics of each type of fibre
  - identify problems associated with the use of each type of fibre.

Guidelines for structuring laboratory investigations are provided in Nature of Science, "A Model for Conducting Scientific Inquiry".

6. Discuss and debate the advantages of using consumer products manufactured from natural materials versus consumer products manufactured from synthetic materials:

- e.g.,
- cotton garments versus polyester garments
  - paper packaging versus plastic packaging
  - metals products versus products made from synthetic polymers (e.g., Teflon, PVC).

Structure discussion and debate using suggestions provided in Communication Skills, "Strategies for Discussing and Debating". Throughout discussion, encourage students to consider:

- the suitability of each type of material for specific applications
  - the effects of using each type of material on resources and the environment.
7. Visit a local clothing store and examine the labels on garments made of both natural and synthetic materials (e.g., fibre content, care instructions). Consider the advantages and disadvantages of purchasing each garment, relative to the characteristics of the material of which the garment is made. Structure this activity and record the results of investigation, using Resource 3: Garment Survey Form.

#### LEARNING OBJECTIVE

**DEMONSTRATES AN UNDERSTANDING THAT THE PROPERTIES OF MATERIALS DETERMINE THEIR SUITABILITY FOR PARTICULAR APPLICATIONS.**

- Describes the properties of familiar materials used at home and in work-related situations (e.g., metals/alloys, wood/paper products, fibres/fabrics, plastics/polymers, composite materials).
- Cites the advantages and/or disadvantages of familiar materials, relative to their suitability for particular applications.

#### RESOURCE CORRELATION

##### BASIC RESOURCE

##### *Materials and Molecules*

- Chapter 6 - Pine, Panelling, and Paper
- Chapter 7 - From Sheep to Shawl
- Chapter 10 - Plastics and Other Polymers
- Chapter 11 - Kevlar, A Clever Composite

##### SUPPORT RESOURCES

##### *Fibres and Fabrics*

##### *Teacher Resource Manual*

- Resource 4: Textile Labelling
- Resource 5: Combustible and Flammable Materials
- Resource 6: WHMIS Hazard Symbols for Controlled Products
- Resource 7: Hazard Symbols for Consumer Products
- Resource 8: Hazard Symbols Record Chart

1. Research the development of one or more of the following materials:

- a metal or alloy
- a wood or paper product
- a natural or synthetic textile
- a plastic or polymer
- a composite material.

When conducting research, gather information on production techniques, useful properties of the material and appropriate applications. Summarize the results of research using strategies provided in Communication Skills, "Summarizing, Evaluating and Communicating Ideas in Science".

2. Conduct an inventory of metals and alloys used in the home or workplace. Ask students to identify:

- useful properties of metals/alloys in each application
- plastics, polymers or composite materials that may replace the use of these metals/alloys.

3. Consider the advantages and disadvantages of replacing products made from metals and alloys with products made from plastics, polymers and composite materials. Consider factors such as:

- durability/strength
- ease of repair
- corrosive resistance
- availability/cost
- recyclability of the material
- biodegradability.

Structure discussion using suggestions provided in Communication Skills, "Using Critical Thinking Skills".

4. Investigate appropriate cleaning and care strategies for natural and synthetic fabrics:

- e.g.,
- Should the fabric be washed in hot or cold water?
  - Is the material colourfast?
  - Should the material be scotch-guarded?
  - Should the material be dry cleaned?
  - How does the material react with bleach/dye?
  - Will the material shrink or wrinkle?
  - How can stains be removed?

Assist students to find answers to these questions by designing and conducting experiments. Model strategies that will enable students to include experimental control in their investigations. Suggestions for planning laboratory investigations are provided in Nature of Science, "Strategies and Skills Used in Scientific Inquiry".

5. Discuss the "Textile Labelling Act". What information must be provided on textile labels? Examine and interpret standard clothing care labels. Identify appropriate strategies for the care of garments bearing these labels.

Information about the Textile Labelling Act and descriptions of standard clothing care symbols are provided in Resource 4: Textile Labelling.

6. Investigate the properties and applications of recently developed synthetic materials/products used in the local community:

- e.g.,
- wafer board, particle board and styrofoam insulation in the building industry
  - plastic pipe in the plumbing industry
  - plastics/fibreglass in automobiles and boats
  - polymers and composite materials in prosthetic limbs, safety glass, protective clothing, sporting equipment and airplane parts.

- Identify and describe safe procedures for handling and storing materials/products that are potentially dangerous. Discuss the "Hazardous Product Act" and labelling standards that are used for hazardous products found in the home and workplace.

Relevant information regarding the safe handling and storing of potentially hazardous materials is provided in:

- Resource 5: Combustible and Flammable Materials
- Resource 6: WHMIS Hazard Symbols for Controlled Products
- Resource 7: Hazard Symbols for Consumer Products
- Resource 8: Hazard Symbols Record Chart.

#### LEARNING OBJECTIVE

#### RESOURCE CORRELATION

**DEMONSTRATES AN UNDERSTANDING THAT OUR USE OF NATURAL AND SYNTHETIC MATERIALS AFFECTS BOTH ENVIRONMENT AND RESOURCES**

- Cites advantages and/or disadvantages associated with the use of a familiar natural and synthetic product, relative to:
  - the industrial processing of resources to form the product
  - the effect of the product's disposal on the environment.
- Infers the need for biodegradable products and recyclable products.

#### BASIC RESOURCE

*Materials and Molecules*  
Chapter 8 - Grading Biodegradability

- Survey the classroom and prepare a list of familiar materials/products that are being used. Classify these materials as biodegradable and non-biodegradable.

Collect "litter" samples by taking a walking tour of the local area (or by examining garbage found in the classroom or school cafeteria). Classify litter samples as biodegradable and non-biodegradable.

Collect magazine/catalogue pictures of biodegradable and non-biodegradable materials. Make a collage or bulletin board display of the pictures collected.

- Encourage students to recognize the value of biodegradable materials/products in protecting the environment. Discuss and debate the use of:

- paper products rather than plastic products
- natural fibres rather than synthetic fibres
- organic cleaning agents rather than chemical cleaners
- peat moss/manure rather than chemical fertilizers.

Structure discussion and debate using guidelines provided in Communication Skills, "Strategies for Discussing and Debating".

BEST COPY AVAILABLE

**LEARNING OBJECTIVE**

**DEMONSTRATES AN UNDERSTANDING THAT THE PROCESS OF BIODEGRADATION REDUCES THE IMPACT OF SOME PRODUCTS ON THE ENVIRONMENT.**

- Explains the process of biodegradation.
- Describes how non-biodegradable materials may harm the environment.
- Distinguishes between familiar materials/products that are biodegradable and non-biodegradable.

**RESOURCE CORRELATION****BASIC RESOURCE**

*Materials and Molecules*  
Chapter 9 - Cotton, Polyester, and Enzymes

1. Plan and conduct laboratory investigations that will illustrate:

- how natural substances are biodegraded
- the role of enzymes in the biodegradation process
- practical methods of decomposing waste materials (e.g., composting).

Structure investigations, using suggestions provided in Nature of Science, "Strategies and Skills Used in Scientific Inquiry".

2. Discuss the importance of recycling materials and products whenever possible. Visit a local recycling centre. Identify and describe:

- types of materials most suited to recycling
- procedures used for sorting and cleaning used materials
- potential uses of recycled materials.

3. Contact local government agencies (e.g., Alberta Energy, Environment Council of Alberta) for current information relevant to:

- biodegradable and recyclable products
- local and provincial recycling initiatives.

A variety of related activities are provided in *Somebody Should Do Something About This! A Teachers' Resource Book on Energy and Environment*, Alberta Energy, 1990. Copies of this resource are available free upon request from Alberta Energy, Energy Efficiency Branch.

**LEARNING OBJECTIVE**

**DEMONSTRATES AN UNDERSTANDING THAT TECHNOLOGICAL PRODUCTS AND PROCESSES DEVELOP IN RESPONSE TO SOCIETAL NEEDS, AND ARE OFTEN ACCEPTED AND USED BY SOCIETY BEFORE THE FULL EXTENT OF BENEFITS/PROBLEMS RESULTING FROM THEIR USE CAN BE KNOWN.**

- Describes a situation in which science and technology have assisted in solving a practical problem through the development of a new material.
- Identifies a current issue/problem in society arising from the application of a technological product or process.

**RESOURCE CORRELATION****BASIC RESOURCE**

*Materials and Molecules*  
Chapter 12 - Medical Matters  
Chapter 13 - Dentistry Developments

1. Encourage students to recognize how the materials and products developed by science and technology have changed many aspects of life. Ask students to predict how various aspects of their lives would change if all plastic and other synthetic materials were removed from the home. Write an informal essay entitled "Life Without Synthetic Materials".

Structure writing assignments using suggestions provided in Communication Skills, "Summarizing, Evaluating and Communicating Ideas in Science".

2. Developments in science and technology usually occur in response to societal factors. Identify societal factors that may have led to the development of:
  - nylon, dacron and other synthetic fibres
  - rubber products
  - kevlar
  - safety glass
  - semiconductors and superconductors
  - fibre optic materials.

Discuss impacts of the development of:

- nylon on the silk stocking industry
- plastics/polymers on medical technology
- composite materials on space exploration.

3. Invite an environmental scientist or forest ranger to class. Discuss and debate current issues related to the use of particular materials and products in society:

- e.g.,
- depletion of natural resources
  - effect of non-biodegradable materials on the environment.

## RESOURCE 1: NATURAL AND SYNTHETIC FIBRES

### NATURAL FIBRES

Fibre and Source	Characteristics	Suggested Care
<p><b>Cotton</b> Seed Pod or Boll of Cotton Plant</p>	<p>Strong, even when wet Naturally absorbent Dries quickly Affected by mildew and sunlight Wrinkles and shrinks Easily washable Good affinity for dyes Good durability Poor elasticity and resiliency Economical and versatile Comfortable Flammable</p>	<p>Most cottons can be washed by machine, regular cycle, warm water Chlorine bleach can be used if care instructions permit Tumble-dry at regular setting Use moderately hot iron Iron while damp Iron dark garments on wrong side</p>
<p><b>Linen</b> Flax Plant Stem</p>	<p>Excellent strength Absorbent Wrinkles unless treated Bright, deep colours may run Some tendency to shrink and stretch Deteriorated by mildew and sunlight Lint-free Dries quickly Poor drape, elasticity, and resiliency Natural lustre Versatile Easy to care for - washable - bleachable - ironed at high temperatures without scorching</p>	<p>Dry clean only when necessary Wash in hot or cold water Dry at regular cycle Iron while damp Use high ironing and pressing temperatures Scorches easily</p>
<p><b>Silk</b> Silkworm cocoons</p>	<p>Strong Absorbent Naturally wrinkle resistant Good affinity for dyes, but may bleed Elastic</p>	<p>Usually dry cleaned If washable, usually done by hand in mild soap or detergent Avoid chlorine bleach Do not wring or twist Iron at low temperature setting, without steam, on the wrong side or use a press cloth</p>
<p><b>Asbestos</b></p>	<p>Mineral fibre Non-burning</p>	<p>No longer used</p>
<p><b>Rubber</b></p>	<p>Elastic Water repellent</p>	<p>Hand wash or wipe with a damp cloth</p>



## RESOURCE 1: NATURAL AND SYNTHETIC FIBRES (continued)

### SYNTHETIC FIBRES

Fibre and Source	Characteristics	Suggested Care
<p>Acetate Celara Dicel Celacrimp Eastron Sayfr Satin Taffeta</p>	<p>Medium weight fibre Relatively weak when wet Resilient and absorbent Subject to atmospheric fading Resists stretching, shrinking, moths, mold and mildew Accumulates static electricity Luxurious feel Wide range of lustres and colours Good colourfastness with some dyes Excellent drapability and softness Poor durability and elasticity Flame resistant Holds creases well Heat sensitive</p>	<p>Usually dry cleaned or carefully laundered by hand Should not be twisted or wrung out Use low setting if tumble dried Press while damp on wrong side with cool iron or use press cloth Avoid chlorine bleach</p>
<p>Acrylic Acrilan Creslan Orlon Zefran</p>	<p>Good strength, but weak when wet Low absorbency Good affinity for dyes Accumulates static electricity Tends to pill Heat sensitive Soft, warm, and lightweight High bulking power Good resilience and elasticity Quick drying Resistant to sunlight, weather, chemicals, abrasion, moths, and mildew Wrinkle resistant Non-allergenic</p>	<p>Some acrylics can be dry cleaned, but laundering is often recommended Wash by hand or machine in warm water Tumble dry at low temperature Reduce static electricity by using fabric softener Often needs no ironing if removed from dryer before cycle is completed; if required, use moderately warm iron</p>
<p>Modacrylic Dynel Verel SEF</p>	<p>Medium weight fibre Good durability, elasticity and resiliency Good drape Highly resistant to sunlight, weathering, chemicals, and flame Lustrous Extremely sensitive to heat Resists moths and mildew Non-allergenic Dries quickly Soft, warm, and pleasant to handle Easy to dye</p>	<p>Deep pile garments should be dry cleaned For washable items, wash in lukewarm water If dryer is used, use low setting and remove as soon as cycle is completed Avoid ironing; if required, use lowest setting to prevent melting</p>
<p>Nylon Antron Cadon Cumuloft Enkaloft Qiana</p>	<p>Lightweight fibre Excellent durability Good elasticity and resiliency Good drape Resists wrinkling, soil, abrasion, mildew, and moths Tends to pill Accumulates static electricity Exceptionally strong Low in moisture absorbency Dyes well but fades in sunlight Picks up stray dyes and greys easily Melts under high heat Quick drying Heat sensitive</p>	<p>Most items can be machine or hand washed in warm water Use fabric softener to reduce static electricity Tumble dry at low setting or drip dry if hand washed If ironing is required, use low temperature</p>

## RESOURCE 1: NATURAL AND SYNTHETIC FIBRES (continued)

### SYNTHETIC FIBRES (continued)

Fibre and Source	Characteristics	Care
<p>Polyester Dacron Encron Fortrel Kodel Trevira</p>	<p>Medium weight fibre Good durability and elasticity Excellent pleat and crease retention Strong Low absorbency Resists wrinkling, stretching, shrinking, abrasion, moths, mildew, and most chemicals Accumulates static electricity Easily washed May pill and attract lint Resilient Holds oil-based soils</p>	<p>Most items are washable in warm water by hand or machine Dry at low setting or drip dry Reduce static electricity by using fabric softener If ironing is desired, use a moderately warm setting</p>
<p>Rayon Absorbit Avril Bemberg Coloray Durafil Fibro Viloft Vincel Zantrel</p>	<p>Medium weight fibre Fair to good durability Loses strength when wet Very poor elasticity and resiliency Absorbent, but dries slowly Good affinity for dyes Wrinkles, shrinks, or stretches unless treated Soft and comfortable Versatile and economical Moth resistant</p>	<p>Many rayons require dry cleaning Washable items are washed by hand or machine in lukewarm water Do not wring or twist Press while damp on the wrong side, using moderate settings Avoid chlorine bleach</p>
<p>Spandex Glospan Lycra Numa</p>	<p>Lightweight fibre Great elasticity Good stretch and recovery Readily dyed Resists deterioration from perspiration, lotions, detergents, and sunlight Soft, smooth, and supple Poor strength Damaged by bleaching, air exposure, and heat</p>	<p>Hand or machine wash in lukewarm water Avoid chlorine bleach Drip dry or tumble dry at low setting Iron rapidly at low temperature setting</p>
<p>Triacetate Arnel Tricel</p>	<p>Medium weight fibre Luxurious hand Excellent drape Good resiliency Poor durability, elasticity, and abrasion resistance Resists wrinkling, shrinking, fading, pilling, and moths Good affinity for dyes Retains heat-sensitive pleats and creases Easily washed Maintains whiteness</p>	<p>Hand or machine wash in warm water Drip dry pleated items: tumble dry other styles Iron at high temperature setting</p>

BEST COPY AVAILABLE

# RESOURCE 2: CARE OF FIBRES AND FABRICS

EXAMPLE

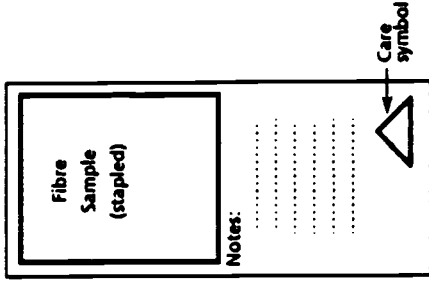

- Each time you perform an experiment on a given fibre:
- staple the sample in the appropriate box
- make a note of your observations in the same box
- draw and colour the care symbol in the bottom right-hand corner of the same box
- under "Other Comments" write additional care instructions that you may have read or experienced yourself.

Fibre Type	Washing	Bleaching	Drying	Ironing	Dry Cleaning	Acetone	Other Comments
Wool							

# RESOURCE 3: GARMENT SURVEY FORM

101 102

Type of Garment	Location of Care Label	Location of Content Label	Fibre Content	Care Instructions	Origin of Garment	Price	Would You Buy this Garment? Why or Why Not?



## RESOURCE 4: TEXTILE LABELLING

Fibres are at times difficult to identify from their appearance. Manufacturers provide labels or hand-tags to assist consumers in identifying their products' properties, and how to care for them.

In Canada, the Textile Labelling Act and Regulations require that manufacturers list the following information on their labels:

- types of fibres, by generic name, present in the fabric stated in both English and French
- fibre content listed by the percentage of weight composition (if weighing five percent or more of the total weight)
- fibres listed in descending order of proportion - largest to smallest
- dealer identified by name and address OR by a registered identification number
- country of origin.

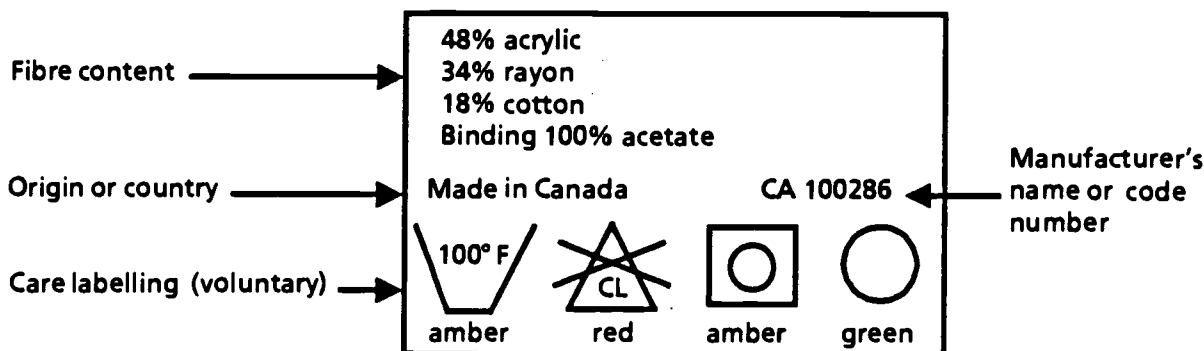

Most Canadian producers also attach a permanent care label directly to garments to provide information about the recommended care and cleaning procedures. The voluntary Care Labelling System uses five basic symbols for the specific cleaning operations. The addition of various temperatures and the use of the three "traffic light" colours further describes the recommended cleaning procedures.





























### Five Basic Symbols



By following the care label instructions, consumers are assured that their garment will not stretch, shrink, or change colour beyond acceptable standards. The care labels also help consumers in the selection of garments by indirectly indicating the time and expense required to maintain the article in good condition.

# Follow the Signs

These symbols tell you which procedures to use or avoid when washing, drying, ironing and dry cleaning.

	Stop	Be careful	Go ahead	
 Washing	 Do not wash	 Hand wash in lukewarm water  Machine wash in lukewarm water at a gentle setting—reduced agitation  Machine wash in warm water at a gentle setting—reduced agitation	 Machine wash in warm water at a normal setting  Machine wash in hot water at a normal setting	
 Chlorine Bleaching	 Do not use chlorine bleach	 Use chlorine bleach as directed		
 Drying		 Dry flat  Tumble dry at low temperature	 Tumble dry at medium to high temperature  Hang to dry  Drip dry	
 Ironing	 Do not iron	 110°C or  Iron at low setting	 150°C or  Iron at medium setting	 200°C or  Iron at high setting
 Dry Cleaning	 Do not dry clean	 Dry clean—tumble dry at low temperature	 Dry clean	

BEST COPY AVAILABLE

## RESOURCE 5: COMBUSTIBLE AND FLAMMABLE MATERIALS

---

### THE FIRE TRIANGLE

Combustion requires that the three elements illustrated below be present at the same time.

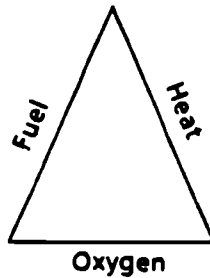

If any one of these three elements is missing, combustion cannot occur. Therefore, if any one of these elements is removed from a fire it will be extinguished.

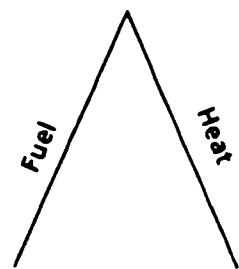
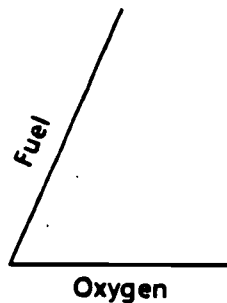
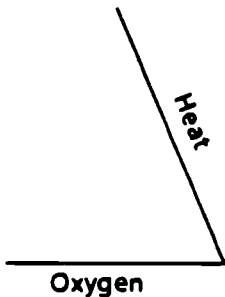

### TYPES OF FIRES

Two words that describe materials that burn are **combustible** and **flammable**. If something is combustible or flammable it will burn easily. Combustible and flammable materials found in the workshop may include paint, oil and cloth rags.









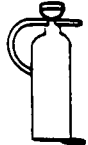
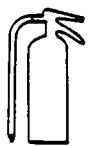

Fires are identified by the type of fuel or burning material.

- TYPE 'A' FIRES**      - occur in ordinary combustible materials  
                                 e.g., wood, paper and cloth
  
- TYPE 'B' FIRES**      - occur with flammable liquids  
                                 e.g., grease, gasoline, paint and oil
  
- TYPE 'C' FIRES**      - occur in electrical equipment and wiring  
                                 e.g., motors, electrical outlets and electrical switches

## RESOURCE 5: COMBUSTIBLE AND FLAMMABLE MATERIALS (continued)

### CONTROLLING COMBUSTION







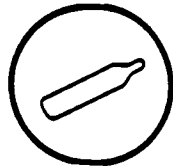

Fire extinguishers are frequently used to control combustion. The type of fire extinguisher selected to put out a fire should be determined by the type of fire. The chart indicates what type of extinguisher should be used for each type of fire.

TYPE OF EXTINGUISHER		TYPE OF FIRE			RANGE	HOW TO OPERATE
		<b>A</b> ORDINARY COMBUSTIBLES • wood • paper • cloth, etc	<b>B</b> FLAMMABLE LIQUIDS • gasoline • paints (oil based) • oils, etc	<b>C</b> ELECTRICAL EQUIPMENT • motors • switches		
<b>WATER</b>	Water based tank 1-1/2-2-1/2 gallon		<b>NO</b>	<b>NO</b>	9m to 12m	Place foot on footrest, pump handle and direct stream at base of flame.  Pull pin, rupture cartridge if applicable, squeeze nozzle to release agent. Direct discharge at base of flames in a sweeping motion, then direct it gradually forward or at remaining material that is burning.
	Water based foam		<b>NO</b>	<b>NO</b>	9m to 12m	
<b>CO<sub>2</sub></b>		<b>NO</b>			1m to 1.5m	
<b>HALON</b>		<b>YES</b> (if classification rating is 1A or greater)			2.5m to 4.5m	
<b>DRY CHEMICAL</b>	ABC-10-15	<b>NO</b>			1.5m to 6m	
	ABC-20-30				5m to 7.5m	

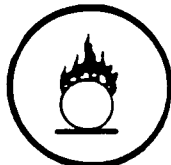
From *Know Your Fire Extinguisher*. Copyright by General Safety Services Division, Alberta Labour. Reprinted by permission.



## RESOURCE 6: WHMIS HAZARD SYMBOLS FOR CONTROLLED PRODUCTS

CLASS	CONTROLLED PRODUCT	SYMBOL
A	COMPRESSED GAS	
B	FLAMMABLE AND COMBUSTIBLE	
C	OXIDIZING MATERIAL	
D	POISONOUS AND INFECTIOUS MATERIAL 1. MATERIAL CAUSING IMMEDIATE AND SERIOUS TOXIC EFFECTS 2. MATERIAL CAUSING OTHER TOXIC EFFECTS 3. BIOHAZARDOUS INFECTIOUS MATERIAL	  
E	CORROSIVE MATERIAL	
F	DANGEROUSLY REACTIVE MATERIAL	

## RESOURCE 7: HAZARD SYMBOLS FOR CONSUMER PRODUCTS

---

The Hazardous Product Act was developed to help control the number of poisonings and injuries from household products occurring to small children and adults. Since 1969, the Department of Consumer and Corporate Affairs has been active in regulating hazardous products, banning those which are found to be injurious to health.

The Act divides hazardous products into two categories.

The first category deals with products that are so dangerous that they would expose the public to unacceptable hazards and are banned. There are twenty-three items listed under Part 1, including: poisonous jequirity beans, scarlet and black beans used as decoration on toys or in beaded jewellery; children's furniture and other children's articles painted with coatings containing harmful amounts of lead and other chemical compounds; textile fibres which are highly flammable (children's sleepwear has even stricter standards than other fibres); baby teethers and pacifiers containing contaminated liquids; non-safety glass on shower doors, storm doors and bathtub enclosures; and hockey helmets that do not meet prescribed safety standards.

The second category of the Act deals with products that may be imported, advertised and sold in Canada only under conditions stipulated in the regulations. Some of these products are: bleaches, cleansers and sanitizers containing chlorine; products containing petroleum distillates, antifreeze, turpentine, acids, alkalines and methyl hydrate; aerosol containers; glazed ceramics; science education sets; children's car seats; charcoals, matches; and electric kettles.

### LABELLING OF HOUSEHOLD PRODUCTS











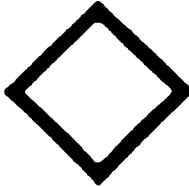
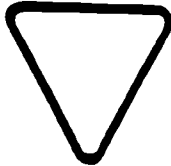





Household chemicals, listed under Part 2 of the Hazardous Product Act (cleaners, bleaches, polishes, glues, sanitizers, antifreeze and aerosol cans) must be labelled to indicate any hazards, including combinations, and the recommended first aid instructions if mishandled. An easily understood set of symbols was designed.

Three degrees of hazard have been established:

- DANGER (it could kill you)
- WARNING (it could make you ill or hurt you); and
- CAUTION (it could make you ill).

Four types of hazards have been determined: poisonous, flammable, explosive, and corrosive. Put together, they make the accompanying 12 basic symbols:

RESOURCE 7: HAZARD SYMBOLS FOR CONSUMER PRODUCTS (continued)

	 Danger	 Warning	 Caution
 Poison			
 Flammable			
 Explosive			
 Corrosive			

HERE IS AN EXAMPLE: For one type of volatile paint thinner, two symbols would be used: a skull and crossbones in an octagon meaning danger, poison; a flame in a diamond meaning warning, flammable. The first aid treatment must be stated this way, "Contains petroleum distillate. If swallowed, do not induce vomiting. Call physician immediately. If patient is unconscious, give him air".

From *Consumer's Guide, Co-op Consumer Counsellor*, pp. C17-C18, by Federated Co-operatives Limited. Copyright 1983 by Federated Co-operatives Limited. Reprinted by permission.

## RESOURCE 8: HAZARD SYMBOLS RECORD CHART

Identify hazardous materials used and stored in your lab or workplace. Record, in the chart below, the appropriate hazard symbol, its meaning, and safe storage/handling procedures for each hazardous material.

HAZARDOUS MATERIAL	APPROPRIATE HAZARD SYMBOL AND MEANING	SAFE STORAGE/HANDLING PROCEDURE
e.g., 40 volume hydrogen peroxide	 Warning Explosive	Dark brown glass or synthetic container. Stored in cool, dark, closed cupboard.

# THEME C

## TECHNOLOGY IN TRANSPORTATION

The automobile is one of the most commonly used technologies in today's society. Its use may be the first major responsibility in many students' lives. Activities within this theme will enable students to develop an understanding of:

- scientific principles governing the operation of an automobile
- appropriate strategies for maintaining a safe automobile
- issues related to automobile safety, driver protection and the environment.

Emphasis will be placed on developing an understanding of relationships between science and technology, as well as developing a process for solving practical problems involving science and technology. A focus on problems that incorporate hands-on activities in their solution will foster active involvement in the problem-solving process.

Students will apply previously developed knowledge of technological systems (see Science 16: Using Systems and Technologies) throughout this theme as they investigate the functioning of different subsystems in an automobile. Learning objectives interrelate with investigations performed in a prior theme, Materials We Use, and will enable students to extend their understanding of the role of science and technology in developing new products and processes, and the ways in which products of technology change many aspects of society. Learning objectives also interrelate with a subsequent theme, Energy and the Environment, and will contribute to an understanding of current issues involving our use of energy and the environment.

Teachers are encouraged to reference the Program Emphases and Methodology section of this manual when planning for instruction. Suggestions particularly relevant to the learning objectives addressed in this theme can be found in:

- Science and Technology
- Communication Skills
- Assessment/Evaluation.

### A FRAMEWORK FOR SOLVING PROBLEMS INVOLVING SCIENCE AND TECHNOLOGY

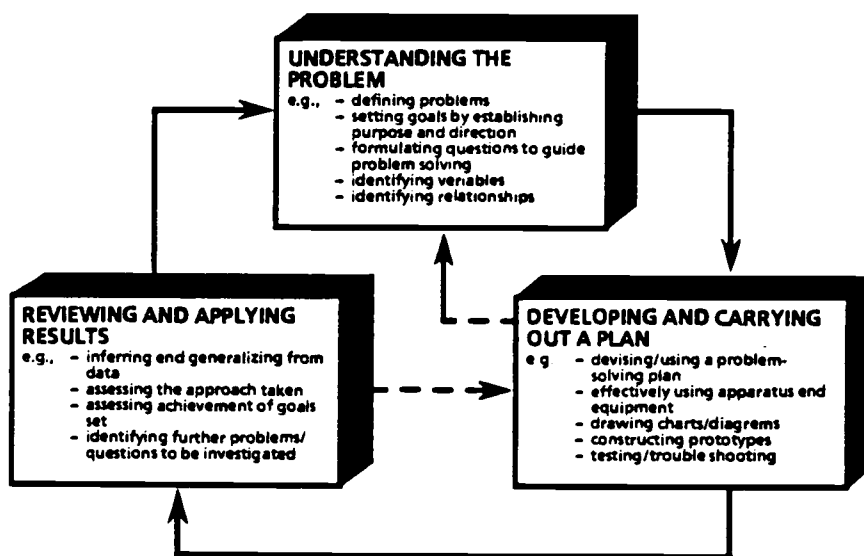

## CONCEPTS, SKILLS AND ATTITUDES

### CONCEPTS

Students will be expected to demonstrate an understanding that:

- the automobile is a technological system consisting of a number of subsystems working together
  - describes the basic function of different subsystems in an automobile, including the electrical system, cooling system, fuel system, lubrication system and tire/braking system
  - illustrates how subsystems in an automobile work together by tracing energy flow/transformation through two or more subsystems
- basic scientific principles are associated with the functioning of subsystems in an automobile
  - explains the operation of one or more subsystems in an automobile, citing relevant scientific facts, laws and theories
- simple maintenance procedures contribute to the efficient performance and general safety of an automobile
  - identifies subsystems / component parts that require routine maintenance checks
  - describes common malfunctions that indicate service and/or repairs are required (e.g., muffler noise, steering problems)
  - outlines procedures to follow in "winterizing" an automobile
- the nature of injuries sustained in an automobile accident can be anticipated by considering the effects of first and second collisions
  - relates Newton's laws of motion to the effects of first and second collisions in automobile accidents
  - outlines energy conversions in an automobile collision, and relates energy transferred in a collision to the direction of moving objects involved
- technology has contributed to safe travel through the development of highway and automobile safety features
  - explains principles that govern the operation of automobile safety technologies, including safety belt systems, padded dashboards and air bag systems
  - describes other features of automobile design and highway design that contribute to safe travel
- political, ethical, and economic perspectives often interact with science and technology, influencing choices and decisions that are made about safe travel
  - summarizes recent statistical data that relate risk of automobile injury to travel speed, alcohol consumption and the use/non-use of seat belts
  - identifies local laws, safety standards and licensing requirements that are designed to reduce risk of automobile injury
  - identifies other perspectives (e.g., economic, environmental) that influence the development of automobile technologies and safety features.

## SKILLS

Students will be expected to demonstrate an ability to:

- observe and analyze the operation of one or more subsystems in an automobile (e.g., electrical system, cooling system, fuel system, lubrication system, tire/braking system), identifying component parts and scientific principles that are used
- prepare system diagrams that illustrate how component parts and/or subsystems within an automobile work together in accomplishing a task
- test and evaluate the performance of one or more technological devices/systems in an automobile
  - identifies basic principles governing its/their operation and use
  - infers potential malfunctions and appropriate maintenance/repair procedures
  - suggests ways to improve efficiency of design and/or operation
- use a problem-solving strategy to design and construct a simple safety technology
  - identifies a safety problem
  - considers alternative approaches/designs to deal with the problem
  - selects a design and constructs the device
  - tests and troubleshoots the device
  - evaluates the product and the process
- infer how specific technologies related to the automobile have personal application and solve practical problems.

## ATTITUDES

Students will be encouraged to:

- display a positive attitude toward the learning of concepts and skills in science
  - shows interest and curiosity through willingness to ask questions, share observations and ideas, and seek answers
  - perform investigations and complete assignments independently and in cooperation with others
- appreciate that science and technology have application in many everyday situations, and may facilitate the solving of practical problems
- develop confidence in personal ability to understand and solve practical problems through the use of science and technology
- display a concern for safety and accept the need for rules and regulations governing the use of particular technologies
- appreciate that ethical dilemmas may arise from the application of scientific research and/or technological developments
- appreciate the relationships among science, technology and society.

## **INTEGRATION ACTIVITIES**

Teachers are encouraged to identify ways to integrate the content of this theme with activities that may be undertaken by students in other subject areas. The references provided below are intended to facilitate curricular integration by establishing a base for cooperative planning among teachers.

### **ENGLISH**

Students will use a variety of communication skills throughout investigations in this theme. Activities in science will require students to:

- give and follow directions when planning/conducting investigations
- use comprehension skills when identifying patterns/relationships, predicting and hypothesizing
- use critical and creative thinking skills when designing, constructing and assessing a simple safety technology.

Teachers are encouraged to identify appropriate strategies for developing these skills through cooperative conferencing with English teachers. Suggestions and ideas for developing related skills are also provided in the Communication Skills section of this manual.

### **MATHEMATICS**

Students will use mathematical concepts and skills when they:

- measure distance, mass and time
- interpret statistical data that describes risk of automobile injury
- interpret and display data in table, chart and graph form
- use equations and/or formulas to describe scientific phenomena and relationships.

Science teachers are encouraged to confer with mathematics teachers in establishing relevant contexts and appropriate methodology for reinforcing the mathematical competencies that students will use throughout this theme.

### **SOCIAL STUDIES**

Students will develop an awareness of current issues related to automobile safety and driver protection through activities in current affairs. Cooperative planning between the science and social studies teachers may provide opportunities for students to:

- identify laws governing vehicle design and travel safety
- recognize political and economic perspectives that affect decisions made about travel safety
- appreciate how developments in the automobile industry have affected personal lifestyle
- identify employment opportunities related to the transportation industry
- investigate future challenges in the automobile industry.

### **OCCUPATIONAL COURSES**

Students will use mechanical, electrical, thermal and fluid technologies in their occupational courses. Cooperative conferencing among science and occupational teachers will assist in planning integrated activities that enable students to:

- investigate scientific principles that govern the operation of technologies used in occupational courses
- develop appropriate strategies for using, maintaining and repairing technologies in work-related situations.



## COMMUNITY PARTNERSHIP OPPORTUNITIES

The local community may offer resources that contribute to the development of learning objectives within this theme. Suggestions for utilizing community resources, and for involving students in the community by way of meaningful activities linked to the science program are provided below.

- Visit a local garage/automotive shop and examine the subsystems and component parts in an automobile. Ask a mechanic to:
  - demonstrate the operation of different subsystems
  - discuss appropriate procedures for maintaining each system of the family car.
- Visit a local autobody shop and investigate the effects of corrosion on parts of an automobile. Ask an attendant to discuss practical strategies for:
  - repairing corroded parts
  - inhibiting/controlling corrosion.
- Visit a local automobile dealership. Ask a sales representative to illustrate and describe various safety technologies that have been developed for new cars.
- Invite a representative from the Alberta Motor Association or a local "driver education" program to discuss:
  - the risks of highway travel
  - strategies for driving safely.
- Invite a local MLA, alderman or councillor to discuss recent laws/regulations/debate with respect to safety on the highway.
- Invite a police officer and/or insurance agent to discuss:
  - general statistics related to automobile accidents
  - the most common causes of automobile accidents
  - penalties for various driving offences
  - safe driving practices that will reduce the risk of automobile accidents/injuries.
- Invite a representative of the Motor Vehicles Branch to discuss legal/safety factors related to owning and operating a vehicle. Obtain copies of the booklet *Driver Basic Licence Information* from the Motor Vehicles Branch, and discuss regulations that relate to driver and vehicle safety.
- Invite a school bus driver, truck driver or taxi driver to discuss:
  - automobile and highway safety features
  - strategies for driving safely.
- Arrange visits/interviews with scientists and engineers. Distinguish between the nature of the work performed by scientists and engineers. Discuss the contributions made by Canadian scientists and engineers to the transportation industry.
- Interview an engineer who designs highways and ask him or her to discuss various safety features that are incorporated into highway design.
- Ask students to make a list of various automobile and highway safety features they encounter on their way to school each day:
  - e.g., - seat belts
  - traffic signs
  - lane control systems.

## LEARNING RESOURCE CORRELATION

### BASIC RESOURCE

ISIS Individualized Science Instructional System  
Booklet: *Arrive Alive*

### SUPPORT RESOURCES

Science at Work Series  
Booklet: *Structures and Machines*

### OTHER RESOURCES

*About Your Car*

*Acme School of Stuff* (video program)

*Applied Science, Book 1*

- Unit 2 - Pressure in Fluids
- Unit 4 - Machines Make Work Easier
- Unit 12 - Electricity

*Applied Science, Book 2*

- Unit 1 - Automobile Engines
- Unit 2 - Heavy and Light, Floating and Sinking

*How the Motor Car Works Series* (video program)

IOP Occupational Component Student Workbooks  
*Automotive Services 26 Student Workbook*  
*Service Station Services 26 Student Workbook*

*Principles of Science, Book 1*

- Chapter 4 - Work and Energy
- Chapter 5 - Machines
- Chapter 6 - Motion
- Chapter 7 - Fluids and Pressure

*Principles of Science, Book 2*

- Chapter 14 - Heat
- Chapter 16 - Magnetism and Electricity

*The Problem Solving Film* (video program)

*Science and Technology: Acting in Turn* (video program)

*Science Networks: Physical Science*

- Unit 3 - Heat
- Unit 4 - Electricity

## SUGGESTED ACTIVITIES

The student learning resources identified above provide a variety of instructional activities that support learning objectives within this theme. The activities that follow complement those provided in the student learning resources. Teachers should be selective in their use, and consider students' interests/abilities and preferred methods of learning in planning appropriate instructional activities.

**LEARNING OBJECTIVE**

**DEMONSTRATES AN UNDERSTANDING THAT THE AUTOMOBILE IS A TECHNOLOGICAL SYSTEM CONSISTING OF A NUMBER OF SUBSYSTEMS WORKING TOGETHER.**

- Describes the basic function of different subsystems in an automobile, including the electrical system, cooling system, fuel system, lubrication system and tire/braking system.
- Illustrates how subsystems in an automobile work together by tracing energy flow/transformation through two or more subsystems.

**RESOURCE CORRELATION****SUPPORT RESOURCE**

*Structures and Machines*

**OTHER RESOURCES**

*About Your Car*

Chapter 1 - How Your Car Works

*How the Motor Car Works Series*

1. Brainstorm a list of subsystems that are essential to the operation of an automobile. Investigate and describe:
  - the function of each subsystem
  - the interdependence of subsystems.

Design a webbing configuration that illustrates relationships among subsystems in an automobile. Sample webbing configurations are provided in Communication Skills, "Reading and Viewing Science Materials".

2. Ask students to predict how a malfunction in one system of an automobile may affect other systems:
  - e.g. - a dead battery
  - inadequate lubrication
  - a broken fan belt
  - an underinflated tire.

Sample activities that will assist students to recognize relationships among components of a technological system are provided in Science and Technology; Resource 6: What is a Technological System?

3. Collect pictures and brochures from car dealerships/automotive repair shops that illustrate and describe various subsystems in an automobile. Organize material in a display that summarizes the function of each major subsystem in an automobile.
4. Examine (or obtain a model of) a four-stroke engine. Disassemble the engine and make note of:
  - the cylinders, pistons and crank system
  - energy flow and transformation through the engine.

Summarize the results of investigation, using diagrams and flow charts.

5. Arrange a visit to a local garage/automotive shop or the automotive classroom. Ask a mechanic or the automotive teacher to:
  - explain the function of component parts in selected subsystems of the automobile
  - illustrate energy flow/transformation through component parts of each subsystem.

6. Obtain an old/non-functional gasoline-powered lawn mower (or other similar machine). Examine component parts of the lawn mower and make note of the way in which energy is transmitted through each part. Consider how energy flow/transformation in this technological system is similar to the automobile.
7. Assist students to develop an understanding of technical vocabulary encountered in this theme by relating new words to personal experience whenever possible. Additional suggestions for dealing with technical vocabulary are provided in Communication Skills, "Developing Technical Vocabulary".

#### LEARNING OBJECTIVE

**DEMONSTRATES AN UNDERSTANDING THAT BASIC SCIENTIFIC PRINCIPLES ARE ASSOCIATED WITH THE FUNCTIONING OF SUBSYSTEMS IN AN AUTOMOBILE.**

- Explains the operation of one or more subsystems in an automobile, citing relevant scientific facts, laws and theories.

#### RESOURCE CORRELATION

##### SUPPORT RESOURCE

*Structures and Machines*

##### OTHER RESOURCES

*About Your Car*  
Chapter 1 – How Your Car Works

*How the Motor Car Works Series*

1. Visit a local garage/automotives shop or the automotives classroom. Observe the component parts of major subsystems in the automobile. Ask a mechanic or the automotives teacher to:
  - demonstrate the function/operation of each subsystem
  - explain relevant scientific facts, laws and/or theories
  - discuss appropriate strategies for maintaining each subsystem.

Upon returning to science class, ask students to draw and label simple diagrams that illustrate component parts of each subsystem.

2. Investigate the basic function of major components in the electrical system of an automobile (e.g., spark plugs, ignition coil, alternator, starter motor, battery, distributor).

#### CLARIFICATION/EXAMPLE

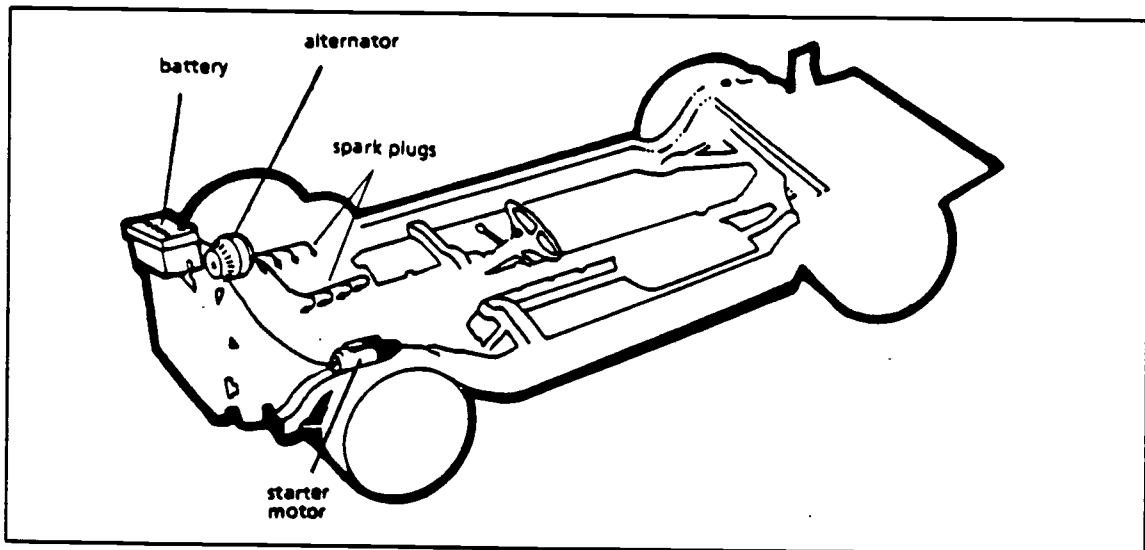

Discuss the use of chemical action in producing an electric current in an automobile battery. Identify and demonstrate appropriate strategies for charging, jumping and maintaining an automobile battery.

- Investigate how an automobile's cooling system disperses engine heat produced by combustion and friction. Ask students to explain the function of each component in the cooling system of an automobile (e.g., radiator, fan, thermostat, engine block), and to trace the flow of coolant through these components. Suggest reasons for using antifreeze in the cooling system of an automobile. Explain factors that may cause the engine to overheat and seize if the cooling system is not functioning efficiently.

#### CLARIFICATION/EXAMPLE

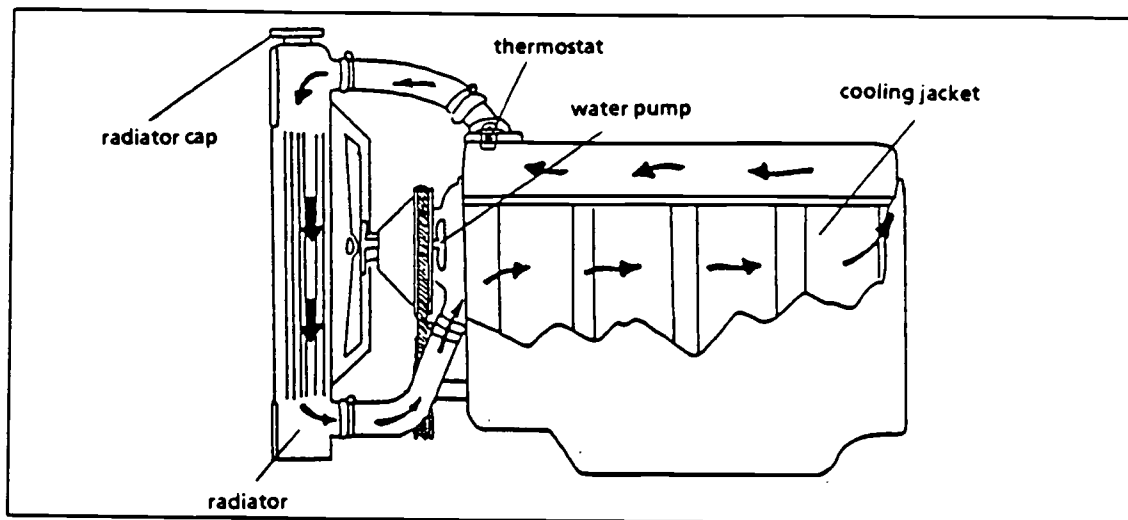

- Draw and label a simple diagram that illustrates the major components in the fuel system of an automobile (e.g., carburetor, engine, air filter, fuel pump, fuel line, fuel tank). Discuss the basic function of each component and trace the flow of fuel from fuel tank to combustion chamber.

#### CLARIFICATION/EXAMPLE

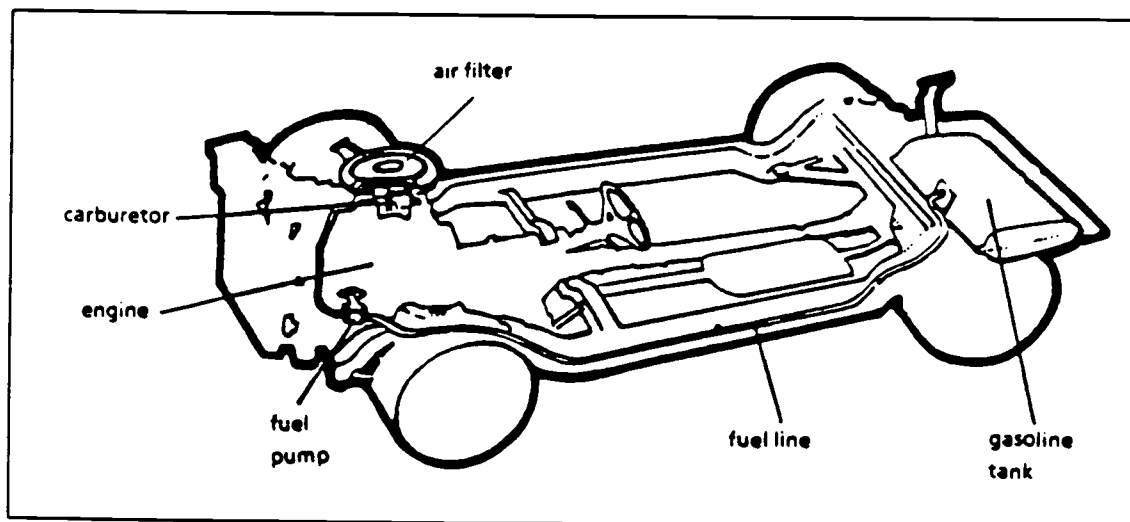

Investigate the cost per litre of different types of automobile fuels. Identify advantages/disadvantages of using each type of fuel.

5. Discuss the importance of using lubricants to reduce friction between moving parts of an automobile. Provide opportunities for students to perform experiments that monitor the effects of different types of motor oil and other semi-solid lubricants (e.g., grease) on heat and friction.

Identify parts of the automobile that require lubrication. Discuss maintenance routines that will ensure adequate lubrication within each of these parts.

#### CLARIFICATION/EXAMPLE

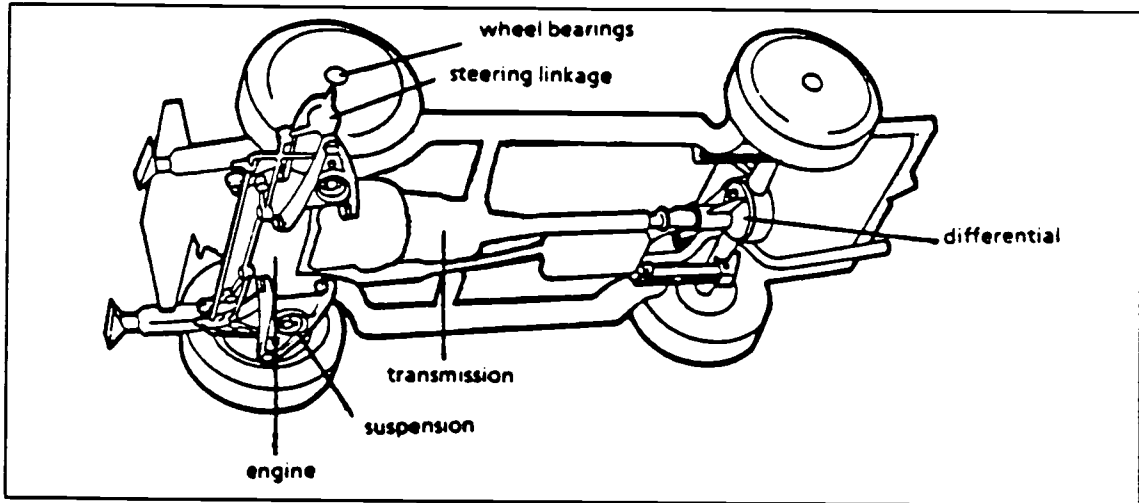

Investigate the viscosity of different types of motor oils, and the use of SAE numbers in describing oil viscosity (e.g., SAE 5 describes a very light/low viscosity oil, SAE 50 describes a very heavy/high viscosity oil). Identify situations that require the use of motor oil with a high SAE rating, and other situations that require the use of a motor oil with a low SAE rating. What are the advantages of using a multi-grade motor oil?

6. Investigate the role of friction in the tire/braking system of an automobile. Describe the effects of tire inflation on:
- tire wear
  - traction, road handling and safety
  - fuel efficiency.

Guidelines for purchasing and maintaining automobile tires are provided in Resource 1: Tires.

7. Read and discuss the information provided in Resource 2: Minor Tune-ups. The information provided in this article will help students to diagnose problems that may occur in major subsystems of the automobile.

#### LEARNING OBJECTIVE

**DEMONSTRATES AN UNDERSTANDING THAT SIMPLE MAINTENANCE PROCEDURES CONTRIBUTE TO THE EFFICIENT PERFORMANCE AND GENERAL SAFETY OF AN AUTOMOBILE.**

- Identifies subsystems/component parts that require routine maintenance checks.
- Describes common malfunctions that indicate service and/or repairs are required (e.g., muffler noise, steering problems).
- Outlines procedures to follow in "winterizing" an automobile.

#### RESOURCE CORRELATION

##### SUPPORT RESOURCE

*Teacher Resource Manual*

- Resource 1: Tires
- Resource 2: Minor Tuneups
- Resource 3: Safe Care Maintenance
- Resource 4: Winter Driving

##### OTHER RESOURCES

*About Your Car*

- Chapter 2 – How You Can Care For Your Car
- Chapter 3 – How You Can Obtain Professional Automobile Help

1. Discuss the importance of performing routine maintenance checks on an automobile. Suggest possible consequences of not monitoring the operation/condition of components within each subsystem:
  - e.g., - mechanical failure
  - safety hazards
  - costly repairs.

General guidelines for vehicle care and maintenance are provided in Resource 3: Safe Car Maintenance.

2. With the assistance of a local mechanic or the automotives teacher, organize an "Automobile Car Clinic". Discuss and demonstrate appropriate strategies for performing routine maintenance checks, using an automobile obtained for demonstration purposes. Ask students to examine and make note of:
  - level of engine oil
  - level of power steering/transmission fluid
  - level of battery fluid
  - level of coolant in the radiator
  - tire pressure
  - signs of wear on belts/pulleys
  - the operation of all lights and gauges.

3. Invite a local mechanic or the automotives teacher to discuss common trouble signs that indicate the need for automobile maintenance/repair:

- e.g.,
- tire noise
  - failing lights/brakes
  - muffler noise
  - engine flooding
  - a blown fuse
  - alignment/steering problems.

Identify component parts of the automobile associated with each trouble sign and possible maintenance/repairs that may be required.

4. Discuss reasons for "winterizing" your car. Identify parts of the car that need to be winterized and the equipment/processes that are used:

- e.g.,
- cooling system (e.g., antifreeze, thermostat)
  - engine (e.g., block heater)
  - tire/braking system (e.g., appropriate tires for traction)
  - fuel system (e.g., gas line antifreeze).

Guidelines for winterizing a vehicle and for winter driving are provided in Resource 4: Winter Driving.

#### LEARNING OBJECTIVE

**DEMONSTRATES AN UNDERSTANDING THAT THE NATURE OF INJURIES SUSTAINED IN AN AUTOMOBILE ACCIDENT CAN BE ANTICIPATED BY CONSIDERING THE EFFECTS OF FIRST AND SECOND COLLISIONS.**

- Relates Newton's laws of motion to the effects of first and second collisions in automobile accidents.
- Outlines energy conversions in an automobile collision, and relates energy transferred in a collision to the direction of moving objects involved.

#### RESOURCE CORRELATION

##### BASIC RESOURCE

##### *Arrive Alive*

- Chapter 1 - The Second Collision
- Chapter 2 - Sudden Stops Hurt
- Chapter 3 - Eggs and Brains

1. Identify and distinguish between "first" and "second" collisions in car accidents. Discuss the results of each kind of collision. Describe how changes in speed and direction affect a car and its passengers.
2. Investigate the effects of Newton's first and second laws of motion on the passengers in an automobile:
  - e.g., - What happens to a loose object in a moving car if the car stops or turns suddenly?
  - What happens to a loose object when a car at rest is hit from behind?
  - How does speed affect the results of a car crash?
  - How is the law of conservation of energy illustrated in a car crash?

Draw simple diagrams that illustrate how each of Newton's laws of motion affects passengers in an automobile accident.

3. Ask students to design and perform experiments that illustrate Newton's laws of motion during first and second collisions. Plan and structure investigations, using guidelines provided in Nature of Science, "Strategies and Skills Used in Scientific Inquiry".

Investigate a recent automobile collision by examining newspaper reports/pictures of the accident. Use Newton's laws of motion to explain the results of the collision.

4. Ask students to design a method for packaging a raw egg that will protect it through a free fall of three to six metres. Encourage students to share the design and testing procedures they use with other members of the class, and to evaluate each other's work.

Use Newton's laws of motion to identify and interpret forces that act upon the egg as it falls and collides with the floor.

#### LEARNING OBJECTIVE

**DEMONSTRATES AN UNDERSTANDING THAT TECHNOLOGY HAS CONTRIBUTED TO SAFE TRAVEL THROUGH THE DEVELOPMENT OF HIGHWAY AND AUTOMOBILE SAFETY FEATURES.**

- Explains principles that govern the operation of automobile safety technologies, including safety belt systems, padded dashboards and air bag systems.
- Describes other features of automobile design and highway design that contribute to safe travel.

#### RESOURCE CORRELATION

##### BASIC RESOURCE

##### *Arrive Alive*

- Chapter 4 - Modelling and Testing Vehicle Safety Technologies
- Chapter 5 - Seat belt: Verdict Pleas
- Chapter 6 - Conservation of Energy in Crashes
- Chapter 7 - Calculating Collision Momentum

1. Identify automobile safety features/devices developed to reduce risk factors involved in highway travel:

- e.g., - seat belt systems
- padded dash boards
- air bag systems
- shatter-proof windshields
- anti-burst door latches
- energy-absorbing steering columns.

BEST COPY AVAILABLE



Invite a salesperson from a local automobile dealership to discuss automobile design/safety features that are present on recent models of cars. Compare these features with those present on older models. Discuss societal factors that may have caused car manufacturers to develop these design/safety features.

2. Draw diagrams that illustrate principles governing the operation of safety belt systems, padded dashboards and air bag systems. Relate forces involved in the operation of each technology to Newton's laws of motion. Evaluate these technologies by asking questions such as:
  - What are the advantages of a padded dash over an unpadded dash?
  - What are the advantages of a seat belt-shoulder system over a seat belt system?
  - How do air bag systems protect passengers from injuries during an accident?
3. Research the development and testing of one or more automobile safety technologies. Gather information about:
  - the design of the safety technology
  - experiments used to test the safety technology
  - factors that may have caused the technology to be accepted/rejected
  - government supervision of the development/testing/production process.

Structure research activities, using suggestions provided in Communication Skills, "Reading and Viewing Science Materials".

4. Provide opportunities for students to design, construct and test a simple safety technology. Ask students to:
  - identify a safety problem
  - consider alternative approaches/designs that might solve the problem
  - select a design and construct the safety device
  - test/troubleshoot the device
  - evaluate the product/process.

General guidelines for this problem-solving activity are provided in Science and Technology, "A Model For Solving Technological Problems".

5. Identify other highway design/safety features and discuss their function in reducing automobile accidents:
  - e.g., - barrels of life
  - guard rails
  - break-away poles
  - run-away lanes
  - divided highways
  - lane markings
  - rumble strips
  - entry/exit ramps on major highways.

Invite a highway design engineer, school bus driver and/or truck driver to describe safety features incorporated into the design of local roads and highways.

6. Invite a representative from the local police department or Motor Vehicles Branch to:
- present statistical evidence of the effect of various automobile and highway safety features on automobile injuries
  - describe driver regulations and penalties that relate to the use or non-use of various safety technologies.

**LEARNING OBJECTIVE**

**DEMONSTRATES AN UNDERSTANDING THAT POLITICAL, ETHICAL, AND ECONOMIC PERSPECTIVES OFTEN INTERACT WITH SCIENCE AND TECHNOLOGY, INFLUENCING CHOICES AND DESIGNS THAT ARE MADE ABOUT SAFE TRAVEL.**

- Summarizes recent statistical data that relates risk of automobile injury to travel speed, alcohol consumption and the use/non-use of seat belts.
- Identifies local laws, safety standards and licensing requirements that are designed to reduce risk of automobile injury.
- identifies other perspectives (e.g., economic, environmental) that influence the development of automobile technologies and safety features.

**RESOURCE CORRELATION**

**BASIC RESOURCE**

*Arrive Alive*

- Chapter 8 - Wheels, Human Error, and Alcohol
- Chapter 9 - Society, Technology, and Transportation Concerns
- Chapter 10 - Building Safer Highways

1. Discuss and debate the use of seat belt systems. Encourage students to distinguish between facts and opinions involved in the seat belt debate, and to provide arguments for and against a seat belt law.

Structure discussion and debate, using guidelines provided in Communication Skills, "Strategies for Discussing and Debating".

2. Investigate statistical evidence of the dangers associated with alcohol/drug consumption and operating a vehicle.

Invite a representative from the local police department or Motor Vehicles Branch to explain how alcohol and drugs may cause automobile accidents through their effect on the drivers':

- judgment
- reaction time
- vision/coordination.

Discuss penalties for impaired driving offences.

3. Discuss the effects of recent developments in highway and automobile design on travel speed. Interpret statistical data that relates travel speed to:

- braking distance
- the types of injuries sustained in automobile accidents.

4. Identify laws and regulations governing safe travel that have resulted from the interaction of political, moral and economic perspectives with science and technology. Laws and regulations may relate to:

- alcohol/drug consumption
- eyesight/general health
- vehicle condition
- driver training/experience
- use of child restraint systems.

Identify and explain societal factors that have interacted with science and technology in establishing each of these controls. Activities that illustrate how science and technology are influenced by societal issues are provided in Science, Technology and Societal Issues, "Recognizing How Society Influences Science and Technology".

5. Through brainstorming, identify a variety of technological developments that have occurred in the automobile industry over the last 20-30 years:

- e.g.,
- more powerful engines
  - compact cars
  - impact-absorbing bumpers
  - safety belts
  - unleaded gasoline
  - anti-pollution devices.

Evaluate each development by considering its positive/negative impacts on society. Guide students through the process of analysis and critical thought, using strategies provided in Communication Skills, "Using Critical Thinking Skills".

6. Collect a variety of brochures/pamphlets from local automobile dealerships that describe the features and technologies present in recent models of automobiles. Consider the advantages/disadvantages of these technological developments in terms of:

- travel comfort
- efficient use of energy
- personal safety
- the environment.

## RESOURCE 1: TIRES

---

Tires take an amazing amount of abuse in their lifetime and for the most part they stand up very well. They bend and straighten out several hundred times per minute and carry extremely heavy loads. As with any consumer goods, if a tire fails or wears out prematurely, it is blamed on faulty workmanship. Many tire failures however, can be traced back to misapplication and improper maintenance.

### BUYING TIRES

#### Construction Types

- **Radial tires** form the largest segment of the tire industry. At the present time virtually all original equipment tires are radial ply construction and represent the majority of tires sold in the replacement market.

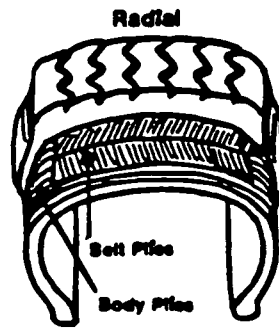

The construction is unique in that the body ply cords run across the tire at right angles to the tread rather than diagonally. A separate set of belts such as fibreglass or steel are laid under the tread to stiffen and reinforce it. This type of construction, although technically most complicated, also gives the most positive results. Advantages include more precise and faster steering response, improved fuel efficiency, excellent tread wear and better traction under all conditions.

Few people in this energy conscious world argue that the radial tire is by far the best design currently available. Its most obvious disadvantage is price. A consumer faced with the expense of buying new tires for an older car may quite logically see better economic sense in purchasing a bias tire. Radials may cause problems in older cars with suspensions not designed for radials.

- **Bias Ply** is the oldest, simplest and least expensive type of tire. They may have two, four or more body plies whose cord material crisscrosses diagonally on the bias across the tire from bead to bead. This type of tire is best suited for use on older model cars, second family cars, or for drivers who rarely use their vehicle.

The main advantages of bias construction are dependability at a low price, damage resistant sidewalls and a smooth low speed ride. Disadvantages include a shorter tread life and higher fuel costs caused by rolling resistance. This rolling resistance results from the squirming action of the tread as it comes in contact with the road surface.

## RESOURCE 1: TIRES (continued)

---

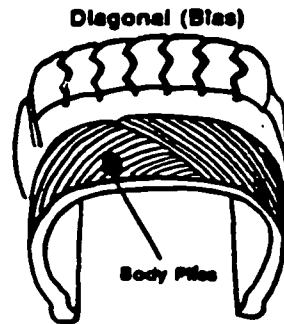

- **Bias belted tires** have a similar body to the bias ply tire, but two or more "belts" (located under the tread) have been added. They fall in between bias ply and radial ply tires. When comparing performance characteristics the main advantages come from adding the belts. The belts provide better road hazard protection, reduce tread squirm, and help hold tread grooves open for better traction. Disadvantages include slightly harsher ride and more expensive construction. It is felt by many people that the cost of belted bias construction make it more attractive for the consumer to buy the much better radial tire.



### All Season Tires

All season radial tires perform exceptionally well year round on dry or wet road surfaces and in mud or snow conditions. They are slightly noisier than conventional summer rib radials, due to their more aggressive tread design. However, tread wear is comparable to and traction capabilities are much superior to summer rib radials under virtually every driving condition. Another advantage is that the inconvenience of spring and fall tire changeovers is avoided. One is prepared for any sudden change in weather and/or road conditions.

### Winter Tires

For many people, the question is not what type of winter tire to buy but whether to buy them at all. Winter tires do represent an extra expense and tend to be slightly noisier than other tread designs. The positive side to this is the fact that winter tires do provide better traction in heavy mud and snow. The more aggressive tread design and new chemicals used in the extra traction compounds provide these characteristics.

## RESOURCE 1: TIRES (continued)

---

### Guidelines for Purchasing Tires

The following guidelines should be considered when purchasing tires:

- Never put on a smaller size than that which came with the car.
- The same type or construction should be used on all four wheels to avoid vehicle handling and stability problems.
- When replacing only a pair of tires, they should be put on the rear axle for better traction, handling and extra protection against flats.
- If the car came with radial tires, you never replace with bias ply.
- Front-wheel drive vehicles should have four winter tires, not just two.

### TIRE CARE

#### Tire Inflation

Tire industry studies show that on an average, one out of four cars on the road have at least one tire seriously underinflated. Improperly inflated tires wear faster and flex more frequently increasing chances of tire separation and blowout. Driving on tires that are underinflated by 5 p.s.i., (when compared to vehicle manufacturer's recommendations) will wear 25% faster than normal. Fuel economy will be reduced by 2.5%.

At the other end of the scale, overinflation produces more cuts, impact breaks and more wear at the center of the tread.

Get a hand held air pressure gauge and check air pressure at least once a month or before long trips. Remember to check the air pressure when the tires are cool. Normal heat buildup during driving causes air pressure to increase.

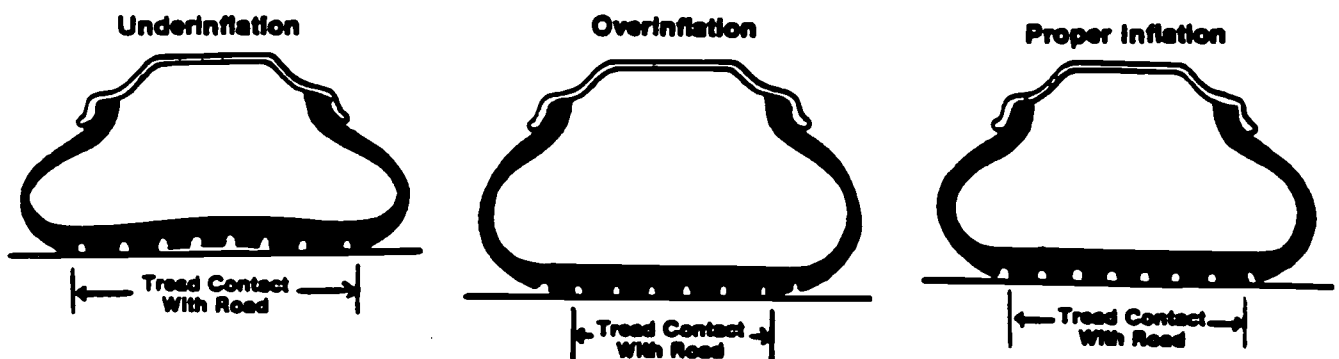

## RESOURCE 1: TIRES (continued)

---

### Balancing

Out of balance tires cause the vehicle to shimmy and shake. In addition, tire life will be shortened. Be sure your tires are accurately balanced on a electronic spin balancer.

### Alignment

Improper alignment significantly reduces tread life potential. Tires will wear much faster as they scuff down the road.

### Tire Tread

The absolute minimum for tread depth is 1/16" (1.5 mm). On anything less, you're inviting big trouble. On a wet surface, bald tires will "hydroplane" which means they actually ride along on top of a layer of water that is trapped between the tire and road surface. Under these circumstances, loss of vehicle control is likely to result.

### Rotate Tires

Front tires do more work in turning and braking so they tend to wear faster. Rotate your tires every 10,000-13,000 kilometres or as recommended in your owner's manual.

Tire rotation for front wheel drive vehicles is crucial if the full tread life potential of a tire is to be realized. Front tires on a FWD vehicle wear approximately 22% faster than front tires on a rear wheel drive vehicle.

### Driving Habits

Avoid driving habits that promote rapid tire wear such as "jack-rabbit" starts and sudden stops, hard cornering, riding the pavement edge or hitting curbs and potholes. Speeding is one of the worst offenders. It not only wastes gasoline, but wears tires out at a much faster rate.

The following is a warning issued by the Rubber Manufacturers' Association: Excessive wheel spin should be avoided when traction difficulties are experienced on ice, snow or mud. A tire spinning at an indicated speed above 65 km/h may disintegrate with explosive force sufficient to cause severe personal injury or extensive vehicle damage. Therefore, the motorist should be advised to never exceed 65 km/h indicated speed when spinning a tire.

---

From *Consumer's Guide, Co-op Consumer Counsellor*, pp. D49-D50, by Federated Co-operatives Limited. Copyright 1983 by Federated Co-operatives Limited. Reprinted by permission.

## RESOURCE 2: MINOR TUNEUPS

The following information is not intended to turn you into a top-notch mechanic, but it may help you diagnose and repair simple vehicle failures. Depending on the situation, the knowledge of a few simple techniques could save the cost of a tow truck or garage labour.

### BASIC ENGINE COMPOSITION

Not all motors will look alike, but the basic composition is the same. The following diagram points out some of the engine parts where common problems occur.

Consult your owner's manual for specific details about the type of engine your vehicle has.

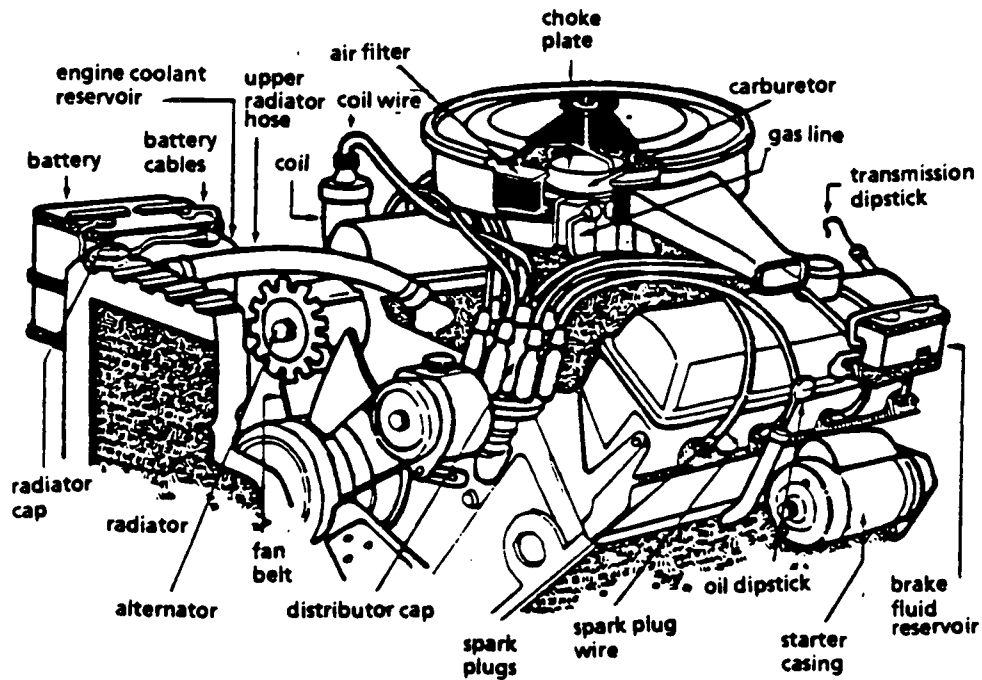

### SOME COMMON ENGINE TROUBLES

**Your Vehicle Won't Start.** You've turned the key and absolutely nothing happens. Check the following:

- **Gear Shift Lever.** Make sure you haven't left your vehicle in gear. It should be in park. Try starting the vehicle in neutral if it won't start in park.
- **Battery.** If the above point fails, the problem could be with your battery. Check the battery by turning on your headlights. If the lights are weak, the problem may simply be a loose connection. Tap the terminals with a shoe or a piece of wood. This may be enough to get the vehicle started. If the terminals look dirty or corroded, loosen the clamps with a pair of pliers. Lift the cables off, **negative terminal first**. Clean the terminals with a pocket knife or a nail file. Put the cables back in place, attaching the **positive terminal first**. If the battery is definitely dead, you will probably need a jump start.



## RESOURCE 2: MINOR TUNEUPS (continued)

---

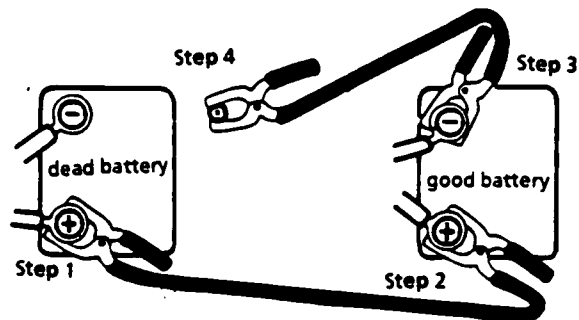

Remember, the last connection must be to a ground terminal. Do not attach it to the negative terminal of the weak battery.

- **Starter.** If you hear a click-click sound when you turn the key, you may be facing starter problems. Try tapping the starter case with a shoe. This may bring the wiring back into alignment. If tapping doesn't work, the starter will probably have to be replaced.
- **Your ignition system.** If the motor turns over but still won't start, the problem could be a faulty ignition system. The distributor cap, coil, coil wire and spark plug contacts must be kept free of moisture. Pay special attention to the coil wire. If it becomes wet, nothing will work. Take a clean, dry rag and dry the contacts. Also wipe the inside of the distributor cap if it is moist. Take care not to disturb any of the connection wires.

Loose connections are also a common problem with ignition systems, especially with spark plug wires. If you find any loose connections, simply push them back into place. Correct loose connections with the ignition turned to the off position. Make sure any cracked wiring is replaced.

- **Your fuel system.** If, in your thwarted attempts to start your vehicle, you can smell gasoline, your engine has flooded. Press the accelerator to the floor. Keeping the accelerator depressed, try to start the car. Do not continue for any more than 10 seconds. If the vehicle still won't start, remove the air filter and wedge open the butterfly plate in the carburetor. Use a screw driver, a comb, or a pencil. Try to start the car again. If it starts, remove the wedge and replace the air filter. If you are being assisted in the attempt to start the vehicle, make sure that the person checking the engine stands clear while it is being started.

If, upon removing the air filter, you find that the butterfly plate is open, tap the carburetor near the gas line. This may clear a blocked fuel line. You may also try pouring a small container of gas line antifreeze into the gas tank.

## RESOURCE 2: MINOR TUNEUPS (continued)

---

### Warning Lights and Gauges

- **Temperature light or temperature gauge.** If the light comes on, or the gauge rests at H (hot), this indicates that your engine is overheating. Pull off the road to a safe place and turn the vehicle off. Check the following:
  - Wait for about 10 minutes and check the coolant. Remove the radiator cap with a glove or a towel wrapped around your hand. If the level is low, add water and drive to the nearest garage and have the proper coolant added.
  - Check for leaks in the radiator or the heater hose. Let the engine cool down and wrap the problem area with tape. Top up the radiator with water and drive slowly to the nearest garage.
  - Check for a broken fan belt. If you don't have a spare fan belt, but the radiator is full, drive until the temperature indicator comes on again. Stop and let the engine cool off. It may take some time, but you can eventually get to a service station. Pantyhose, twisted into a cord and tied lightly around the pulley, can work as an emergency fan belt.
- **Alternator light.** When this light comes on, it is an indication that the battery is not recharging. Turn off all electrical devices and drive to the nearest garage. The problem may simply be a loose fan belt.
- **Oil pressure light.** If the light flickers, the problem could be one of two things. Your engine idle speed could be set too low, or the oil level may be too low.

If the light comes on and stays on, pull off the road and turn the car off. Check the oil level. If it is too low, add oil. Before doing so, however, check the oil filter and the oil drain plug to make sure oil is not leaking out.

If the light stays on after you have added oil, turn the car off. Do not drive until the engine can be properly serviced.

- **Brake light.** If the brake light comes on, pull off the road and check the brake fluid cylinder. You may need to add brake fluid. If the light comes on again after you have driven a short distance, have your vehicle checked. You could have a leak in the brake line.

### CAUTION AND PRECAUTION

Have your vehicle serviced regularly. Understand what the indicator lights on the dashboard mean and what you can do about the problems they indicate. If you are on a busy highway when a problem occurs, do not pull off the road unless there is room to do so safely. Continue on slowly until you can find a safe place. It is better to do a little more damage to your car than to risk your life.

## RESOURCE 2: MINOR TUNEUPS (continued)

---

### CHECK LIST FOR A ROADSIDE REPAIR KIT

- Jumper cables
- Flashlight
- Flares
- Black electrician's tape
- Plastic water container
- Flat head screw driver
- Pliers
- Nail file
- Pocket knife
- Spare hoses
- Spare fan belt
- Can of oil
- Can of brake fluid
- Blanket
- Gloves

### Roadside Repair Kit

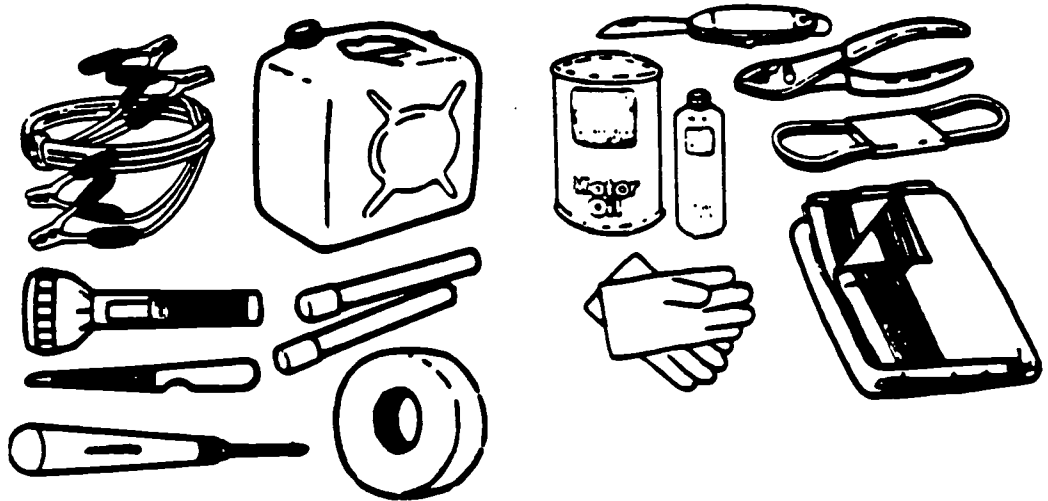

From *Consumer's Guide, Co-op Consumer Counsellor*, pp. D39-D40, by Federated Co-operatives Limited. Copyright 1983 by Federated Co-operatives Limited. Reprinted by permission.

591

## RESOURCE 3: SAFE CAR MAINTENANCE

---

Driving your vehicle in a safe, courteous manner will reduce your chances of having an accident, but far too many mishaps are still the result of mechanical failures. Statistics show that the majority of these mechanical problems are due to owner neglect!

The following are some general recommendations for the care and maintenance of your vehicle. Remember that certain vehicles may require special maintenance operations. Therefore, it is important to read your operator's manual.

### TIRES

Although tire failure is one of the least common accident-causing problems, blowouts do occur and are potentially hazardous. Tires which are worn or those with low air pressure are more prone to blowouts.

**Air Pressure.** Check the air pressure of your tires (including the spare) every two weeks or before long trips. You can use a hand-held tire gauge. Incorrect pressure should be adjusted to the maximum pressure recommended by the manufacturer of your vehicle (in accordance with tire size and load to be carried). Check the pressure when the tires are cold. Make sure the valve cap is in place as it acts as a second air seal and prevents dirt and other road grime from entering the valve stem. Never lower the air pressure for added traction as this is a misconception and can be very dangerous. Lower air pressure not only increases the risk of a blowout, but it also reduces gas mileage.

**Wearing.** Check the condition of the tread every few thousand kilometres. If the centre of the tread is wearing faster than the shoulder (sides), reduce the air pressure by 20 kPa (3 p.s.i.). Note the tread depth of the tire. If the grooves are worn so that the tread wear indicators are showing, have the tires replaced. Tires with inadequate tread depth provide poor traction, especially in wet or slippery conditions.

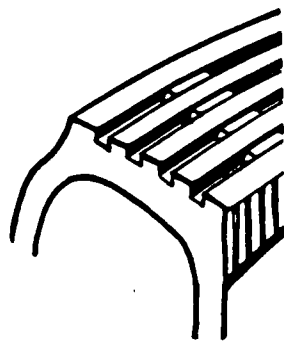

Tread-wear indicators (raised bars of rubber) are equally spaced around the tire in each tread groove.

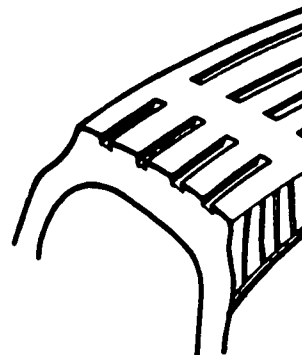

Tire should be replaced when the tread-wear indicators appear as pictured above.

## **RESOURCE 3: SAFE CAR MAINTENANCE (continued)**

---

Uneven tread wear indicates problems with air pressure, wheel balance, wheel alignment, wheel bearings or tire rotation. Have your serviceman identify and correct the problem.

Make a visual inspection of your tires every few weeks to look for deep cuts in the tread, sidewalls, or on the valve stem.

**Purchase.** When buying tires, never mismatch tire sizes or mix radials with other tire construction types such as bias ply or bias belted tires. Replace valve stems when the tire is replaced. Rotate your tires as per manufacturer's recommendations and note that this practice is different for radials and bias ply tires.

**Changing Tires.** Always carry necessary tire change items – wrenches, jack, jack handle, something to remove hubcaps, etc. It may be wise to carry additional items such as blocks to prevent the vehicle from rolling, special wrenches with long handles, and a flashlight. Be certain that all items are fastened down securely while travelling. After changing a tire remember to check the tightness of the wheel nuts periodically thereafter.

### **BRAKES**

Check the fluid level in the brake reservoir every three months, or if oil stains appear on the insides of the tires or on the pavement. If brakes are adjusted properly you should not have excessive pedal travel and should be able to come to a stop in a straight line even without your hands on the steering wheel. For vehicles with self adjusting brakes, step on the brakes firmly several times while traveling in reverse. If the self adjusting mechanism still does not correct the problem, or if you have to add fluid more than twice a year, consult your mechanic.

Brake linings wear out faster in city driving than highway driving so have them checked periodically and replace as necessary. Keep the parking brake adjusted properly and keep all pedal covers intact.

Wet brake linings have very little stopping power so dry off your brakes by braking gently after your travel through deep water or snow.

### **VISIBILITY**

Many accidents are caused because drivers can not see or be seen clearly. When you fill with gas inspect all lights and signals to see that they are working correctly. Replace defective lamps and broken lenses or reflectors. Always keep them clean, remove mud and/or snow before driving. It may be necessary to aim the headlights periodically.

Replace cracked windows and mirrors promptly. Before driving adjust the seat and mirrors. If rear vision is obscured by cargo or a trailer, install additional outside mirrors. Keep all windows clean and remove stickers that impair vision. Replace worn windshield wipers, and keep the windshield washer reservoir filled with fluid. Remember to add windshield washer antifreeze before the temperature dips below the freezing point.

## **RESOURCE 3: SAFE CAR MAINTENANCE (continued)**

---

### **ELECTRICAL**

If the battery requires water more than once every few months, or if the lights dim when the engine slows down you should suspect that there is a malfunction in the electrical system. In view of our severe winter climate, a heavy-duty battery should seriously be considered. It provides significantly more power to the vehicle during cold weather start ups. Keep the top of the battery and terminals clean. Fill the cells up to the level indicator ring molded inside each cell opening with distilled water every month.

### **ENGINE**

A vehicle which stalls or hesitates in traffic is a safety hazard. Tune up the engine when it does not perform well. The cost will be more than offset by the additional fuel economy and safety. If mechanical problems develop, have them corrected immediately.

Check the exhaust system for leaks every few months. On a cool damp morning, or in the winter, a trail of white vapour will appear from leaks when the engine is started. The carbon monoxide in the exhaust is colourless, odourless, tasteless, and can be fatal even in small concentrations. Never warm up your vehicle inside a garage. Check that all gauges and/or warning lamps are functioning properly. While cranking an engine all warning lamps should illuminate (if vehicle is so equipped).

### **BODY**

Be certain that all door, hood and trunk latches close and lock properly. Remember to add lock de-icer in cold weather. Fasten down all tools, jacks and cargo, as well as weights if you carry them during the winter months. Secure the spare tire with the valve stem up so the air pressure can be checked periodically. Never leave loose objects on the dash, seats and particularly on the rear window shelf. These objects could become dangerous projectiles, even in a minor collision.

Inspect the condition of passenger restraints and seat belts. Replace any which show signs of wear, cuts or broken fibres. The evidence that seat belts reduce injury is overwhelming, so use them! Restrain small children with approved child car seats designed for their size and weight.

The operator's manual supplied with your vehicle lists in detail the maintenance procedures required for the safe and economical operation of your vehicle. If certain procedures are not clear to you, or if you cannot find certain parts of your automobile consult your dealer or your serviceman.

## RESOURCE 3: SAFE CAR MAINTENANCE (continued)

---

### SAFETY CHECKLIST

#### Each time you start your vehicle:

Check tire appearance.  
Look for oil spots beneath the vehicle.  
Look for hidden obstacles.  
Adjust seat.  
Check brake pedal depression.  
Check gauges and indicator lamps.

#### When you see oil spots beneath the vehicle:

Have brakes and all fluid levels checked.  
Determine source of oil spot(s).

#### Each time you fill with gas:

Check engine oil level.  
Check operation of lights and signals.  
Add gasline antifreeze if required.  
Fill windshield washer reservoir; add antifreeze if required.

#### Every two to four weeks:

Check tire pressure.  
Inspect tires and valves for cuts and abrasions.  
Check cooling system level.  
Check radiator hoses.  
Check belt tensions and condition.  
Check transmission oil level.

#### Every three months:

Check brake fluid level.  
Check battery fluid level.  
Check power steering fluid level.  
Inspect exhaust system.  
Check parking brake.  
Inspect passenger restraints.  
Inspect tire tread wear pattern.  
Inspect windshield wipers.

#### Yearly:

Flush cooling system.  
Check radiator cap.  
Check shock absorbers.  
Have the condition of steering gear checked.

#### Periodically or as required:

Balance wheels.  
Align steering.  
Aim headlights.  
Replace fan belts.

**Perform Schedules Maintenance. Read the operator's manual supplied with the vehicle.**

---

From *Consumer's Guide, Co-op Consumer Counsellor*, pp. D37-D38, by Federated Co-operatives Limited. Copyright 1983 by Federated Co-operatives Limited. Reprinted by permission.

## RESOURCE 4: WINTER DRIVING

---

Simple mechanical failure or an elementary driving error may lead to a fight for your life during winter's frigid temperatures. A sensible driver will be prepared by knowing what to do and knowing what to take along to ensure survival in such situations.

### VEHICLE WINTERIZING

Once you get into your vehicle, you are depending upon it to get you to your destination. Regular maintenance is important but winter preparation is essential to ensure good performance during cold weather. The following parts should be winterized:

**Battery** power drops substantially in cold weather so have yours tested. Get a charge or a new battery if necessary. Every month, fill the cells with distilled water or good clean drinking water, to within 1 cm of the bottom of the filler spout.

**Brakes** must be faultless for winter driving safety. Have your mechanic check the equalization. A pull to either side may cause a dangerous skid.

**Cooling System** fluid levels should be checked and sufficient antifreeze added to protect against the coldest expected weather. For efficient operation, the system should be flushed.

**Heater/Defroster** operation should be checked and cleaned. Keep the fan on high speed during cold weather and adjust the temperature if necessary. Once the car is warmed up, the defroster should keep the entire window area clear.

**Gasline** antifreeze should be added each time the tank is filled when temperature is below freezing. To reduce condensation in the tank, keep it filled.

**Exhaust System** failure will allow deadly carbon monoxide gas to seep into the passenger compartment. Have the whole system checked for leaks because during winter, you drive with windows closed.

**Tires** designed especially for winter driving should be installed before snow falls. Winter-grip tires, studded tires, or tire chains are alternatives to either regular or radial tires. Contrary to popular belief, summer radials are not adequate for winter use. Never mix radial tires and conventional tires on the same vehicle. This would lead to highly unstable handling. Make sure that wheel lugs are not overtightened so that anyone can change a tire if necessary.

**Windshield** cleanliness is essential for good visibility. Add windshield washer antifreeze to windshield washer system and keep it full. Check and replace worn wiper blades.

### WINTER DRIVING

**Clear Vision** is very important. Before you start your car, clear all windows. Brush snow off, clear the air intake in front of the windshield and free frozen wiper blades before driving.



## RESOURCE 4: WINTER DRIVING (continued)

---

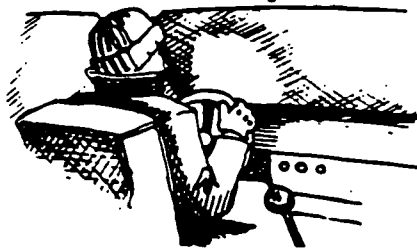

Use your windshield washers to clean off road spatters from slush and salted wet roads. Allow the car to warm up for a few minutes to avoid smearing and freezing washer fluid.

Stop occasionally to clean headlights and tail-lights to improve their efficiency.

Stopping in winter requires extra distance.

The following are braking distances required under various conditions at 30 km/h:

Dry pavement	6.0 m
Glare ice – regular tires	45.0 m
Glare ice – rear snow tires	45.5 m
Glare ice – studded rear snow tires	39.0 m
Glare ice – reinforced rear tire chains	22.5 m

For total stopping distance, add 8.2 m for distance travelled from the time you see the hazard to the time you begin to brake (reaction time).

Stopping distances are reduced somewhat in loose snow and packed snow, but don't be fooled by a thin film of loose snow covering ice or packed and polished snow underneath.

Anticipate stops, flash brake lights to warn the driver behind and slow down gradually, especially when approaching intersections.

Intersections are more hazardous because of the polishing effect stopping and starting traffic has on snow and ice.

Brake only after shifting to neutral (or depressing the clutch on standard transmission vehicles) to eliminate any uncontrolled braking. Then apply just enough brake pressure to prevent the wheels from locking. If the wheels lock, release pressure just enough to permit the wheels to roll again. This "threshold method" takes some practice, but is much more effective than just pumping the brakes.

Steering errors are close behind excessive speed and hard braking in causing skids.

Change directions gradually and try not to make any sudden movements on slippery surfaces. Anticipate turns and slow down well ahead of time, then turn smoothly.

## RESOURCE 4: WINTER DRIVING (continued)

---

Skidding your vehicle can be stopped by:

Taking your foot off the gas smoothly. Steer in the direction the rear of the vehicle is skidding. Don't oversteer. When you feel the car regaining a grip on the road straighten your wheels. Never hit the brakes.

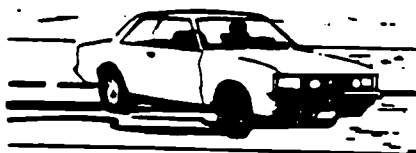

A stuck vehicle may be freed by doing the following:

- Turn your front wheels from side to side a few times to push snow out of the way, or shovel snow away from the wheels.
- Place sand, coarse rock salt, pieces of carpet or wire traction mats under the rear wheels for increased traction.
- Make sure your parking brake is completely off.
- Start in drive, or second gear with a manual transmission.
- Use a very light touch on the gas pedal. Heavy acceleration will only spin your wheels, and prolonged spinning can cause overheating and transmission damage. Take a break, and allow the tires to cool off and the ice to refreeze in order to increase traction.
- Keep the wheels straight and ease forward gently.
- If the above steps meet with no success, get out your tow chain and ask for help.

**NOTE:** If you try "rocking" a car with an automatic transmission, make sure you follow the manufacturer's recommendations.

### EMERGENCY EQUIPMENT

Being prepared means having the equipment you might need in an emergency. All vehicles should carry the following basic equipment for winter operation:

- Properly inflated spare tire
- Wheel wrench
- Tripod type jack (single leg jacks are unstable when ground conditions are poor)
- Rubber mallet
- Sturdy shovel
- Tire wedges
- Bag of sand, wire traction mat or some other suitable abrasive substance
- First aid kit
- Fire extinguisher
- Pliers, screwdrivers, wrench
- Windshield scraper

## RESOURCE 4: WINTER DRIVING (continued)

---

- Snow brush
- Flashlight
- Tow chain
- Flares or reflectors
- Supply of gasoline antifreeze
- A set of battery jumper cables
- Large box of facial tissues

Keep a second set of car keys located outside the passenger and trunk compartments. Car keys can be easily lost in deep snow.

For out-of-town trips, supplement the above equipment with:

- Blankets or sleeping bags
- Lined winter boots and hat
- A supply of rags
- Twelve wide candles
- Waterproof matches
- Blizzard ration kit
- Sesame seed bars
- Beef jerky
- Gorp (nut and raisin mix)
- Candle holder
- Container for melting snow

### EMERGENCY PROCEDURES

If you are stopped on the highway, there are a number of procedures you should follow to ensure your safety.

Pull over to the side of the road if at all possible. Turn on four-way flashers or set out flares or markers to indicate your location.

Stay inside the car and keep dry. You will have a better chance of survival protected from the elements and chilling effects of high winds. Run the motor occasionally to warm the car, but open a window slightly to prevent the possibility of carbon monoxide poisoning. If you become drowsy or develop a headache, turn off the motor immediately and get fresh air into the car.

Turn off the engine if snow piles up underneath and is high enough to block the exhaust. Carbon monoxide is odourless and colourless and can cause death. If you can close out the weather, and are properly dressed, an ordinary candle can provide enough warmth to keep you from freezing. Try to prevent the accumulation of moisture in your clothing.

Exercise will increase circulation to your limbs. Stay inside the car, but stamp your feet, or slap or rub your hands. Remove your shoes and sit on your feet if they get very cold.

---

From *Consumer's Guide, Co-op Consumer Counsellor*, pp. L35-L36, by Federated Co-operatives Limited. Copyright 1983 by Federated Co-operatives Limited. Reprinted by permission.

# THEME D

## ENERGY AND THE ENVIRONMENT

This theme focuses attention on the students' use of energy, and examines applications of energy systems in everyday living. Students will investigate renewable and non-renewable energy sources, and consider the environmental and societal implications of various energy alternatives. Students will also formulate strategies for monitoring personal consumption of electrical energy in the home, and develop an understanding of the impact of an increasing population on energy requirements and environment.

A major emphasis will be placed on developing a process for resolving energy-related issues through research, discussion and debate. A focus on local issues that involve use of energy and the environment will foster active involvement in the decision-making process.

Students will apply previously developed knowledge of ecology and the biosphere (see Science 16: Caring for Environment and Resources) throughout this theme as they consider the effects of alternative energy use practices on the environment. Learning objectives interrelate with a prior theme, Personal Health and Lifestyle, and will assist students to understand how environmental factors may influence personal health. Learning objectives also interrelate with Technology in Transportation, and contribute to an understanding of current energy issues related to automobile technology and travel.

Teachers are encouraged to reference the "Program Emphases and Methodology" section of this manual when planning for instruction. Suggestions particularly relevant to the learning objectives addressed in this theme can be found in:

- Science, Technology and Societal Issues
- Communication Skills
- Assessment/Evaluation.

### A FRAMEWORK FOR EXAMINING ENERGY-RELATED ISSUES

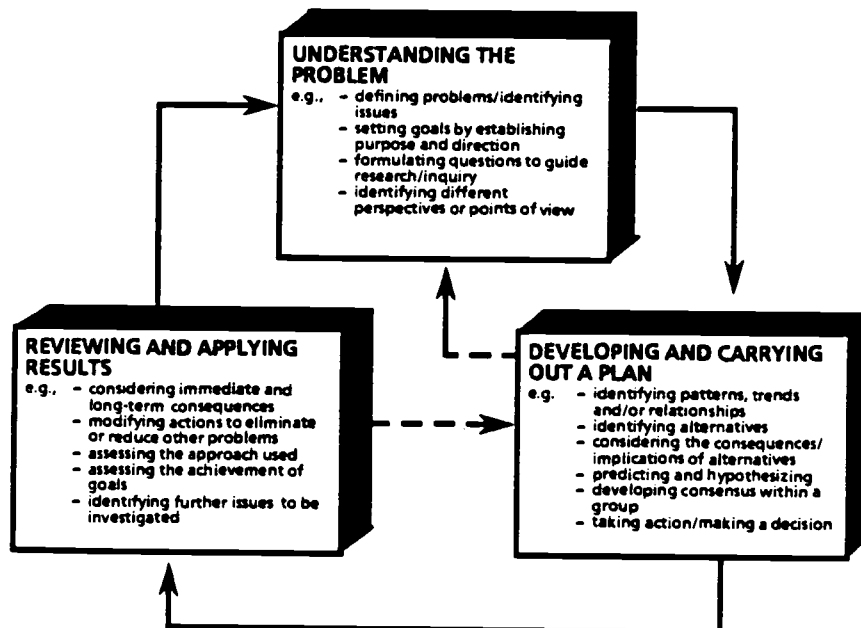

---

## CONCEPTS, SKILLS AND ATTITUDES

### CONCEPTS

Students will be expected to demonstrate an understanding that:

- different forms of energy are used at home and in work-related situations
  - identifies major forms of energy (e.g., mechanical, light, sound, heat, electrical, chemical) and explains their applications in familiar technologies
  - distinguishes between potential energy (i.e., stored energy) and kinetic energy (i.e., energy of movement) in practical situations
- there are renewable and non-renewable sources of energy
  - gives examples of renewable energy sources (e.g., solar, wind, geothermal) and their value in providing for energy requirements
  - gives examples of non-renewable energy sources (e.g., fossil fuels) and societal issues arising from their use
- energy systems have input, conversion and output components
  - explains how living organisms (e.g., plants, the human body) are energy systems having input, conversion and output components
  - traces energy flow in a simple technological system, identifying input, conversion and output components
- the total energy of a system is conserved
  - illustrates, by referring to a simple energy system model, how energy is neither created nor lost, but converted from one form to another in energy systems
  - constructs energy chains that trace forms of energy used in familiar technologies back to other sources
- energy efficiency ratings describe the portion of input energy that is converted to useful energy
  - compares and contrasts two simple energy systems in terms of their overall efficiency
  - suggests ways of improving the efficiency rating of a familiar energy system through modifications in design
- consumption of electrical energy in the home can be analyzed and monitored
  - identifies major components of electrical energy systems used in the home (i.e., energy source, distribution system, conversion and output components)
  - determines the amount and cost of electrical energy consumer by familiar appliances/ technologies in the home
  - interprets electric utility meters and account statements
  - describes appropriate strategies for reducing consumption of electrical energy.

- energy conservation involves the interaction of economic, political and ethical perspectives with science and technology
  - explains how energy conservation practices must include consideration of a number of factors (e.g., the availability/supply of energy resources, the effects of alternative forms of energy on the environment, the cost of producing different forms of energy, efficient use of energy at local/national/international levels)
  - describes recent contributions of science and technology to the field of energy conservation.

## SKILLS

Students will be expected to demonstrate an ability to:

- identify an environmental issue related to the local use of energy resources
- gather information related to the issue through observation, interview and/or research
- design an investigation, through class discussion, that illustrates how particular practices and/or products are related to the issue and influence environmental quality
- analyze and assess information by identifying patterns and relationships, by judging the reliability/validity of information gathered, and by considering consequences
- communicate the results of investigation verbally, through the use of models and diagrams, and/or through written expression
- take an informed position on the issue, identifying strategies that may be used to deal with the situation.

## ATTITUDES

Students will be encouraged to:

- display a positive attitude toward the learning of concepts and skills in science
  - shows interest and curiosity through willingness to ask questions, share observations and ideas, and seek answers
  - performs investigations and completes assignments independently and in cooperation with others
- appreciate the fragility of the biosphere
- appreciate the interdependence of self with other living forms and with the environment
- appreciate that environmental issues involve significant relationships among science, technology and society
- realize our inability to anticipate the environmental effects of human activities
- appreciate that the collective action of individuals can have significant impact
- develop a sense of personal responsibility in relation to environmental issues.

## **INTEGRATION ACTIVITIES**

Teachers are encouraged to identify ways to integrate the content of this theme with activities that may be undertaken by students in other subject areas. The references provided below are intended to facilitate curricular integration by establishing a base for cooperative planning among teachers.

### **ENGLISH**

Students will use a variety of communication skills throughout activities in this theme. Activities will require students to use:

- comprehension skills when gathering and interpreting data about energy use and the environment
- reporting and note-taking skills when recording and organizing the information they gather
- inquiry skills when monitoring the impact of energy use on the environment.

Teachers are encouraged to discuss strategies that foster the development of these skills with English teachers. Strategies for developing communication skills in science are also provided in the "Communication Skills" section of this manual. Learning activities that develop an awareness of the interrelationships among science, technology and society may involve research and writing activities that can be integrated with the English program.

### **MATHEMATICS**

Students will use a variety of mathematical skills in gathering and interpreting data. These skills may include:

- measuring mass, capacity and temperature
- interpreting and displaying data in tables, charts and graphs
- using ratio and percent to interpret energy efficiency ratings
- interpreting and/or calculating measures of central tendency.

Cooperative planning will provide opportunities for students to apply mathematical skills in a scientific context. Data obtained in science class can be organized and analyzed in mathematics class.

### **SOCIAL STUDIES**

Students can increase their knowledge and awareness of current energy-related issues through activities in current affairs. Investigations might focus attention on:

- impacts of energy-use practices on local populations and the environment
- alternative strategies for resolving energy-related issues.

The study of politics in social studies will provide additional opportunities for students to recognize their potential to influence and resolve environmental issues through the democratic process.

### **OCCUPATIONAL COURSES**

Students will develop an understanding of their use of energy in the workplace. Learning activities that will enable students to:

- recognize applications of various sources/types of energy in occupational courses and the workplace
- use appropriate units/tools to measure heat energy and electrical energy
- estimate the cost of energy used in producing a product or providing a service
- identify appropriate strategies for conserving energy in the workplace.

## COMMUNITY PARTNERSHIP OPPORTUNITIES

The local community may offer a variety of resources that contribute to the development of learning objectives within this theme. Suggestions for using these resources, and for developing an understanding of local energy and environmental issues through situational and concrete learning experiences in the community are provided below.

- Visit a local business/industry and observe how energy is used in various technologies (e.g., service station, manufacturing plant, construction site, farm). Ask students to identify:
  - major types/sources of energy that are being used
  - energy input, conversion and output in the technologies observed
  - effective energy conservation practices.
- Visit a local power generating plant and make note of the energy transformations/technologies used in producing electrical energy.
- Invite a representative from the local electrical or natural gas utility company to discuss energy consumption, costs and conservation in the home.
- Visit local companies involved in extracting, refining or using fossil fuels. Investigate the effects of these processes on the environment.
- Visit a solar efficient building or a local facility that harnesses wind energy. Discuss energy transformation/conservation as it relates to these technologies.
- Invite an automotives expert to class. Ask this person to discuss the meaning and significance of energy efficiency ratings for automobile engines.
- Invite a public health nurse, doctor or nutritionist to class. Discuss energy input/conversion/output within the human body, and relationships between caloric intake, activity level and weight increase/ decrease.
- Identify energy-related issues of local significance in newspapers and magazines. Conduct further investigation of these issues by:
  - interviewing local citizens/companies directly involved with the issues
  - contacting government agencies
  - conducting library research.
- Visit a residential construction site and observe the electrical circuits that have been installed prior to the drywall stage. Discuss the function of these circuits in distributing electrical energy throughout the home.
- Invite an engineer/environmental scientist to discuss local issues that relate to energy supply and use.
- Invite local aldermen, councillors or MLA's to discuss current policy/debate/legislation that relates to energy supply and the environment.
- Obtain media resources (e.g., pamphlets, films, videos) on current energy-related issues by contacting local and provincial government agencies.



## LEARNING RESOURCE CORRELATION

### BASIC RESOURCE

ISIS Individualized Science Instructional System  
Booklet: *Energy For Living*

### SUPPORT RESOURCES

Science at Work Series  
Booklet: *Energy*

### OTHER RESOURCES

*Applied Science, Book 1*  
Unit 3 - Energy

*The Energy News Kit*

*Greenhouse Effect* (video program)

*Principles of Science, Book 1*  
Chapter 3 - Energy and Changes in Matter  
Chapter 19 - Food and Energy

*Principles of Science, Book 2*  
Chapter 14 - Heat  
Chapter 22 - People and Resources

*Science Networks: Physical Science*  
Unit 6 - Wise Use of Energy

*Somebody Should Do Something About This! A Teacher's Resource*  
*Book on Energy and the Environment*

## SUGGESTED ACTIVITIES

The student learning resources identified above provide a variety of instructional activities that support learning objectives within this theme. The activities that follow complement those provided in the student learning resources. Teachers should be selective in their use, and consider students' interests/abilities and preferred methods of learning in planning appropriate instructional activities.

**LEARNING OBJECTIVE**

**DEMONSTRATES AN UNDERSTANDING THAT DIFFERENT FORMS OF ENERGY ARE USED AT HOME AND IN WORK-RELATED SITUATIONS.**

- Identifies major forms of energy (e.g., mechanical, light, sound, heat, electrical, chemical) and explains their applications in familiar technologies.
- Distinguishes between potential energy (i.e., stored energy) and kinetic energy (i.e., energy of movement) in practical situations.

**RESOURCE CORRELATION**

**BASIC RESOURCE**

*Energy for Living*  
Chapter 6 – The Many Faces of Energy

**SUPPORT RESOURCE**

*Energy*  
Chapter 2 – Forms of Energy  
Chapter 4 – Stored Energy

1. List major forms of energy across the top of a large wall chart (e.g., mechanical, light/sound, heat, electrical, chemical). Through brainstorming, identify applications of each form of energy in technologies frequently used at home and within the workplace. Record applications/uses of each form of energy within appropriate columns of the wall chart.

Design a collage of pictures and articles to accompany the wall chart. The collage might illustrate the use of major forms of energy identified in the wall chart.

2. Ask students to record their activities over a period of one day, and to consider the forms of energy that were used in completing each activity. Record the results of this assignment in a chart similar to the one illustrated below.

**CLARIFICATION/EXAMPLE**

TIME	ACTIVITY	ENERGY SOURCE/Form
07:30	wake up to clock radio	electric, mechanical, sound
07:45	shower	
08:00		

3. Assist students to understand that the sun is the original source of energy by constructing flow charts that trace each major form of energy back to the sun.

Encourage students to consider their dependence on the sun's energy by asking them to write an informal essay entitled:

"The Day the Sun Stopped Shining."

Structure the writing assignment using suggestions provided in Communication Skills, "Summarizing, Evaluating and Communicating Ideas in Science".

4. Through brainstorming, identify examples of potential and kinetic energy. Make a poster that provides illustrations of each kind of energy.

5. Investigate the conversion of potential energy (i.e., stored energy) to kinetic energy (i.e., energy of movement) and vice versa when:

- a pendulum swings back and forth
- a ball rolls down a U-shaped track.

**CLARIFICATION/EXAMPLE**

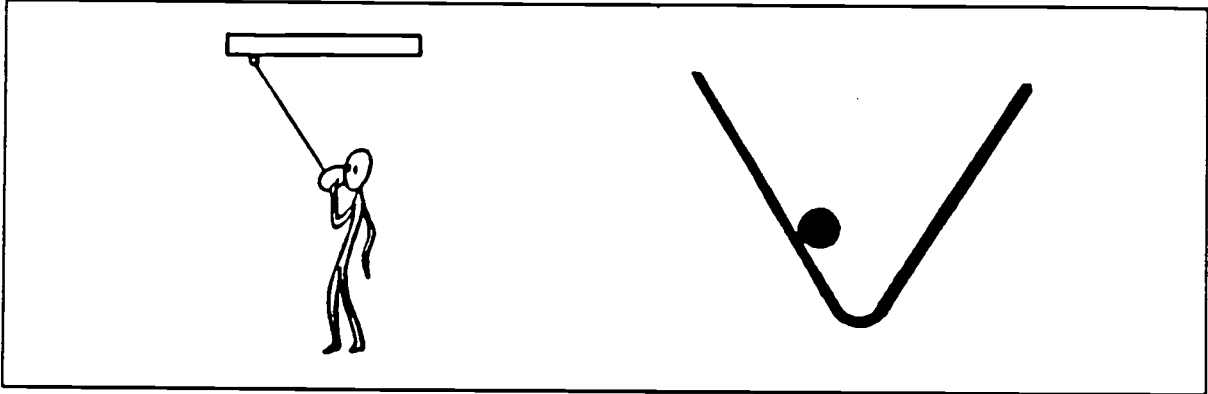

Encourage students to generate questions about the phenomena they observe through the use of suggestions provided in Nature of Science, "Understanding the Problem".

6. Discuss applications of potential energy and kinetic energy in familiar household technologies. Record the results of this activity in a chart similar to the one illustrated below.

**CLARIFICATION/EXAMPLE**

TECHNOLOGY	POTENTIAL ENERGY	KINETIC ENERGY
clock	spring or battery	movement of clock hands
electric motor		
bicycle		

**LEARNING OBJECTIVE**

**DEMONSTRATES AN UNDERSTANDING THAT THERE ARE RENEWABLE AND NON-RENEWABLE SOURCES OF ENERGY.**

- Gives examples of renewable energy sources (e.g., solar, wind, geothermal) and their value in providing for energy requirements.
- Gives examples of non-renewable energy sources (e.g., fossil fuels) and societal issues arising from their use.

**RESOURCE CORRELATION**

**BASIC RESOURCE**

*Energy for Living*  
 Chapter 9 - Energy from Fossil Fuels  
 Chapter 11 - Renewable and Non-renewable Energy

**SUPPORT RESOURCE**

*Energy*  
 Chapter 1 - Fuels

1. Distinguish between non-renewable and renewable energy resources. Ask students to explain why:
  - fossil fuels are non-renewable energy resources
  - hydro, solar and wind energy are renewable energy resources.
2. Identify non-renewable energy resources for which supply and environmental impact are of current concern:
 

e.g., fossil fuels

  - diminishing supply
  - thermal pollution
  - greenhouse effect
  - oil spills
  - toxic waste disposal.
3. Research some alternative energy sources that may be effective in meeting future energy needs:
 

e.g.,

  - solar cells
  - geothermal energy
  - fusion
  - wind energy
  - energy from trash.

Assess these alternatives by considering potential advantages/disadvantages:

- e.g.,
- environmental impact
  - availability/cost
  - usefulness.

Structure related discussion, using suggestions provided in Communication Skills, "Using Critical Thinking Skills".

4. Identify areas on a map of Alberta or Canada where renewable and non-renewable energy resources are found. Gather information about one renewable energy resource and one non-renewable energy resource by writing letters to locations identified on the map.
5. Investigate potential strategies for harnessing solar energy by:
  - describing how a greenhouse makes efficient use of the sun's energy
  - visiting a solar efficient building and making note of the ways in which radiant energy is stored and used
  - discussing principles that govern the operation of a solar cell
  - identifying present/potential uses of solar energy.

**LEARNING OBJECTIVE**

**RESOURCE CORRELATION**

**DEMONSTRATES AN UNDERSTANDING THAT ENERGY SYSTEMS HAVE INPUT, CONVERSION AND OUTPUT COMPONENTS.**

- Explains how living organisms (e.g., plants, the human body) are energy systems having input, conversion and output components.
- Traces energy flow in a simple technological system, identifying input, conversion and output components.

**BASIC RESOURCE**

*Energy for Living*  
 Chapter 3 – Food, Plants, and the Sun  
 Chapter 7 – Watts and Kilowatts

**SUPPORT RESOURCE**

*Energy*  
 Chapter 5 – Energy and Your Body  
 Chapter 6 – Energy and Plants

1. Discuss photosynthesis in terms of energy input, energy conversion and energy output. Investigate how plants convert light energy into sugars/starches and the importance of these foods in providing energy for other living organisms.

Analyze a simple 3-step or 4-step food pyramid. Describe the source of energy, and what happens to the energy at each level in the pyramid. Draw and label a diagram of the energy cycle.

2. Invite a public health nurse or doctor to visit your classroom. Ask this person to describe energy input, energy conversion and energy output within the human body.

Students should recognize that in order to maintain body weight, one must balance energy intake and energy output (i.e., balance diet and exercise). Evaluate the energy content of personal diet, and compare daily energy intake to daily energy output.

3. Assume that after having eaten a hamburger, an apple and 250 mL of skim milk, you play a game of basketball. Investigate the relationship between energy input and energy output in this situation by:

- determining the energy value of your meal in kilojoules
- describing how your body converts the energy content of this food into the kind of energy you use in playing basketball
- determining how many minutes of basketball you will play in order to use the energy provided by your meal.

Discuss what may happen if you use more or less energy than that provided by your meal (e.g., a decrease or increase in body weight).

4. Analyze the energy input, conversion and output components in familiar technological systems (e.g., kitchen appliance, lawn mower). Identify and describe:

- the form of energy used to power the technology (i.e., energy input)
- the form of energy produced by the technology (i.e., energy output)
- the energy transformation/conversion process (i.e., what happens between energy input and energy output).

Construct a chart that outlines energy components within each system that is analyzed.

#### CLARIFICATION/EXAMPLE

TECHNOLOGICAL SYSTEM	INPUT ENERGY	CONVERSION PROCESS	OUTPUT ENERGY
kitchen toaster	electricity	electrical resistance	heat, light

LEARNING OBJECTIVE

RESOURCE CORRELATION

**DEMONSTRATES AN UNDERSTANDING THAT THE TOTAL ENERGY OF A SYSTEM IS CONSERVED.**

- Illustrates, by referring to a simple energy system model, how energy is neither created nor lost, but converted from one form to another in energy systems.
- Constructs energy chains that trace forms of energy used in familiar technologies back to other sources.

**BASIC RESOURCE**

*Energy for Living*  
Chapter 3 – Food, Plants, and the Sun

1. Construct energy chains that trace forms of energy used in various household technologies back to their original source.

Discuss energy conversion/conservation as it relates to familiar situations:

- e.g.,
- a competitive long-distance runner
  - a T-bar ski lift
  - an automobile.

2. Make a list of energy conversions in an automobile. Discuss and illustrate how energy is converted from one form to another, but is neither created nor lost.

3. Conduct research on the contributions of James P. Joule to the development of the Law of Conservation of Energy.

Structure research activities, using suggestions provided in Communication Skills, "Reading and Viewing Science Materials".

4. Devise a simple energy system that demonstrates both the conversion and conservation of energy:

- e.g., A windmill uses the wind's kinetic energy to pump water uphill into storage tanks or reservoirs. The water can then be made to flow downhill through large turbines to generate electrical energy.

Illustrate the energy system through diagrams, and provide an opportunity for students to construct a model of the system. Plan and structure this activity, using guidelines provided in Science and Technology, "A Model for Solving Technological Problems".

LEARNING OBJECTIVE

RESOURCE CORRELATION

**DEMONSTRATES AN UNDERSTANDING THAT ENERGY EFFICIENCY RATINGS DESCRIBE THE PORTION OF INPUT ENERGY THAT IS CONVERTED TO USEFUL ENERGY.**

- Compares and contrasts two simple energy systems in terms of their overall efficiency.
- Suggests ways of improving the efficiency rating of a familiar energy system through modifications in design.

**SUPPORT RESOURCE**

*Teacher Resource Manual*  
Resource 1: Energy Efficient Housing

1. Discuss efficiency as the ratio of output energy to input energy in an energy system. Compare and contrast the overall efficiency of:
  - a pulley system with an inclined plane
  - a bicycle with a wheel chair
  - a large car with a small car
  - a fluorescent lamp with an incandescent lamp
  - a forced air heating system with a hot water heating system
  - a gas stove with an electric stove.
2. Major household appliances (e.g., stoves, refrigerators, clothes dryers) are often given an efficiency rating. Conduct a comparative study on the efficiency ratings for competing makes/models of a major appliance. Gather information by reading consumer reports or visiting local appliance stores.

Invite a representative from the local natural gas and/or electrical utility company to discuss:

- the meaning of an energy efficiency rating
  - efficient energy-use practices in the home.
3. Design and construct simple energy systems that serve a useful function and illustrate:
    - conservation of energy
    - efficiency in design.

Provide opportunities for students to share the results of their efforts with other members of the class and to suggest ways in which each device might be made to function more efficiently.

**LEARNING OBJECTIVE**

**RESOURCE CORRELATION**

**DEMONSTRATES AN UNDERSTANDING THAT CONSUMPTION OF ELECTRICAL ENERGY IN THE HOME CAN BE ANALYZED AND MONITORED.**

- Identifies major components of electrical energy systems used in the home (i.e., energy source, distribution system, conversion and output components).
- Determines the amount and cost of electrical energy consumed by familiar appliances/technologies in the home.
- Interprets electric utility meters and account statements.
- Describes appropriate strategies for reducing consumption of electrical energy.

**BASIC RESOURCE**

*Energy for Living*  
 Chapter 7 – Watts and Kilowatts  
 Chapter 8 – Volts and Amperes

**SUPPORT RESOURCES**

*Energy*  
 Chapter 3 – Electrical Energy

*Teacher Resource Manual*  
 Resource 2: An Inventory of Electrical Consumption

1. Investigate methods by which electrical energy is produced for local use. Research activities may include:
  - identifying and demonstrating scientific principles that govern the operation of the generator
  - visiting a local power generating plant for first-hand observation of related technologies.

Summarize the results of investigation by preparing diagrams and through short written assignments (see Communication Skills, "Summarizing, Evaluating and Communicating Ideas in Science").

2. Discuss methods used to distribute electrical energy:

- from the electrical generating plant to the home
- through electrical circuits within the home.

Invite an electrician or representative from the local electrical utility company to explain how electricity is distributed throughout the home and community. Prepare a wall chart/bulletin board display that summarizes the results of discussion.

3. Visit a new home under construction. Ask an electrician to explain the function of various components in the "rough-in" electrical system which is visible prior to the drywall stage.

Ask students to analyze a portion of their home electrical system. Prepare models/diagrams that illustrate components within the system.

4. Ask students to perform the activities outlined in Resource 2: An Inventory of Electrical Consumption. Identify strategies that might be effective in reducing energy consumed by household appliances that are "high energy users".

5. Provide opportunities for students to monitor their personal use of electrical energy in the home by:

- reading/interpreting electric utility meters and account statements
- determining the amount of energy consumed by familiar appliances/technologies
- computing energy costs related to performing familiar household tasks
- formulating strategies for reducing energy consumption.

Ask students to read their household electric meters, and to keep daily/weekly/monthly records of electrical consumption. Students may wish to calculate energy costs on the basis of these records, and compare their calculations to those provided on statements received from the utility company.

6. Invite a guest speaker from the local electrical utility company to discuss strategies for:

- monitoring personal use of electrical energy in the home
- determining the cost of electrical energy used in performing various tasks
- conserving electrical energy.

LEARNING OBJECTIVE

**DEMONSTRATES AN UNDERSTANDING THAT ENERGY CONSERVATION INVOLVES THE INTERACTION OF ECONOMIC, POLITICAL AND ETHICAL PERSPECTIVES WITH SCIENCE AND TECHNOLOGY.**

- Explains how energy conservation practices must include consideration of a number of factors, including:
  - the availability/supply of energy resources
  - the effects of alternative forms of energy on the environment
  - the cost of producing different forms of energy
  - efficient use of energy at local, national and international levels.
- Describes recent contributions of science and technology in the field of energy conservation.

RESOURCE CORRELATION

**BASIC RESOURCE**

*Energy for Living*

- Chapter 9 - Energy from Fossil Fuels
- Chapter 10 - Fossil Fuels and the Environment
- Chapter 11 - Renewable and Non-renewable Energy

**SUPPORT RESOURCES**

*Energy*

- Chapter 7 - Energy for the Future

*Teacher Resource Manual*

- Resource 3: An Electrical Survey



1. Encourage students to develop an awareness of the impact of various forms of energy on their lives. Ask students to monitor their activities for a day, and record/describe the ways in which they use renewable/non-renewable sources of energy.

Activities that will encourage students to recognize their dependence upon electrical energy in the home are provided in Resource 3: An Electrical Survey.

2. Discuss and evaluate the effectiveness of a variety of strategies in conserving energy in the home.

- e.g.,
- basement, wall and attic insulation
  - vapour barriers
  - use of thermostats and timers
  - landscaping.

Strategies for reducing home energy costs are described in Resource 1: Energy Efficient Housing.

3. Ask students to express their opinions on local issues/problems related to energy and the environment through informal writing projects. When planning writing projects, encourage students to:

- formulate an opinion/action plan related to a local issue/problem
- provide details that support their point of view
- anticipate the long-term/short-term consequences of the actions they suggest.

Suggestions for investigating environmental issues and evaluating alternative courses of action are provided in Science, Technology and Societal Issues, "A Model for Making Decisions in Society".

Pre-writing activities that will help students to plan and organize their thoughts are provided in Communication Skills, "Summarizing, Evaluating and Communicating Ideas in Science".

4. Discuss and debate the following topic:

"How should Canada respond to foreign demands for its fossil fuels?"

Encourage students to consider both long-term and short-term consequences for the action plans they adopt.

- e.g.,
- Might there be a future shortage of fossil fuels?
  - Are there financial/political considerations to be made?
  - How will decisions affect Canada's environment?

Structure discussion and debate using strategies provided in Communication Skills, "Strategies for Discussing and Debating".

5. Students need to understand that although many issues related to energy and the environment have been caused by developments in science and technology, solutions to these problems are also frequently provided through scientific research and technological development.

- e.g.,
- the development of alternative sources of energy
  - more efficient engines for automobiles.

Consider the relationship between science/technology and local environmental issues by using ideas provided in Science, Technology and Societal Issues, "Interactions Among Science, Technology and Society".

## RESOURCE 1: ENERGY EFFICIENT HOUSING

---

Consumers are becoming more concerned with discovering ways to reduce energy consumption. An increasingly common method of conserving energy is to construct energy efficient houses and renovate existing homes to be more energy efficient.

### FACTORS AFFECTING ENERGY CONSUMPTION

**Climate.** In Western Canada, the climate is the most difficult factor to control because of the broad temperature range over the course of the year. An energy efficient home should be capable of maintaining a comfortable temperature for all days of the year.

**Housing Style** affects energy demands. In general, single detached dwellings consume more energy per square metre than attached units or apartments. Conserve energy by designing a compact floor plan that minimizes exterior surface area.

**Building Location.** The ideal orientation of a home is due south, with no large obstructions present which may block sunshine in the winter. A building facing north should limit front window area, locating large windows on the south-facing side.

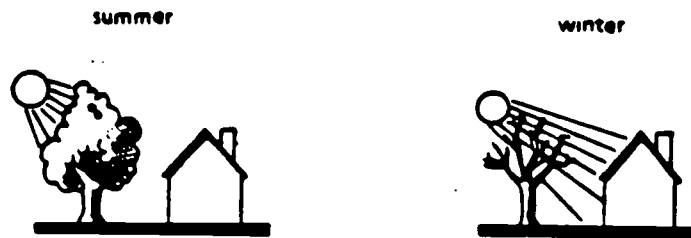

**Landscaping.** Locate deciduous (leaf-bearing) trees to the south of the building. They will provide shade in the summer, but allow sunlight to penetrate in the winter. Coniferous (evergreen) trees are best located on the north side where they will provide protection from the winds. Trees, shrubs, lawns, swimming pools and ponds lower summer temperature because they release water vapour.

### ENERGY SAVERS

**Heating Systems.** Install a properly sized heating system in an energy efficient house. An oversized heating system leads to frequent on/off operation reducing both efficiency of fuel use and service life of heating equipment.

**Windows** of energy efficient homes should be located so that viewing, ventilating, natural lighting and passive solar aspects are satisfied. Keep window areas to a minimum because of their poor insulating values. Orient the majority of the windows to the south, with the area not exceeding 6 to 8% of the total living area of your home. If the window area is greater than this, increase mass of the walls by adding a planter, feature wall or fireplace, etc. Mass absorbs and releases heat slowly.

Install overhangs designed to block sunlight and control overheating by shading windows in the summer and allowing the sun to shine through in the winter.

## **RESOURCE 1: ENERGY EFFICIENT HOUSING (continued)**

---

Use a window insulating device to prevent heat loss at night or during sunless periods and to prevent excessive heat gain in the summer. These devices include: shutters (both inside and outside); thermal curtains, shades and blinds; between-the-glazing insulation and rolling shutters.

### **AIR MANAGEMENT**

A well-sealed house must have some provision for bringing fresh air into the house. The air management system of a house involves two components: ventilation and distribution. Ventilation is achieved by removing stale air from the house and replacing it with fresh air. Its purpose is to maintain satisfactory air quality in the house. The distribution system ensures that fresh air is circulated to all parts of the house.

Allowances for a supply of fresh air must be made for combustion purposes with fireplaces, furnaces or any other fuel-burning appliances. Unvented appliances such as gas stoves produce moisture and carbon dioxide, both of which must be controlled in an air-tight house.

An air to air heat exchanger is a device that extracts heat from the stale exhaust air leaving the house and passes it to the incoming fresh air, thereby reducing ventilation heat loss. Commercially made units are capable of extracting 70% or more of the heat from the exhaust air.

### **SOLAR HEATING**

To complement a well-insulated and sealed home, many people are exploring solar energy as an alternate form of heating.

#### **How Solar Energy Works**

Glass is the substance that makes solar heating possible. Once sunlight passes through a window, it is transformed into heat energy inside, and this heat is not readily radiated back out. An absorptive surface below the glass helps trap the solar radiation as heat.

#### **Types of Systems**

- **Passive solar systems** rely on proper planning and construction techniques to lower energy requirements. Conventional building components are utilized, rather than expensive solar equipment. Large south-facing windows act as collectors. Often a concrete wall or floor located where sunlight falls, acts as a "thermal mass" or heat storage area. Ceiling-mounted fans and open-area interiors contribute to air circulation. Insulated window shutters keep the heat in at night. Although the passive systems are low in cost as compared to the active systems, they cannot provide more than 10-15% of the home's total heating load. Therefore, a backup heating system is essential.

## RESOURCE 1: ENERGY EFFICIENT HOUSING (continued)

---

An Active System

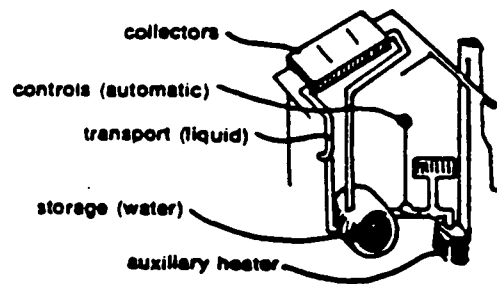

- **Active solar systems use specially designed equipment consisting of four major components. The collector converts sunlight into useable heat by absorption on a suitable surface. The transport component circulates this heated fluid throughout the system via pumps, valves, and ducts. A storage component stores heat on sunny days for use at night or on sunless days. The control component, whether automatic or manual, maintains and monitors the performance of each operation. An auxiliary heating system is available for backup heating during extended sunless periods.**

From *Consumer's Guide, Co-op Consumer Counsellor*, pp. E1-E2, by Federated Co-operatives Limited. Copyright 1983 by Federated Co-operatives Limited. Reprinted by permission.

## RESOURCE 2: AN INVENTORY OF ELECTRICAL CONSUMPTION

Perform an inventory of electrical consumption in your residence. Rank appliances found in your home/apartment, using the numbers from 1 to 15, according to the amount of electrical energy you think they use (e.g., 1 = the least energy consumed, 15 = the most energy consumed). Then determine the actual ranking of these appliances by using consumption rates provided in pamphlets available from local utility companies.

APPLIANCE	YOUR RANKING	ACTUAL RANKING
Hair Dryer		
Refrigerator/Freezer		
Coffeemaker		
Television		
Dishwasher		
Clothes Dryer		
Washing Machine		
Toaster		
Microwave Oven		
Electric Stove		

Examine your results and identify:

- those appliances that are "high energy users"
- strategies that may be effective in reducing electrical energy consumed in your home/apartment.

## RESOURCE 3: AN ELECTRICAL SURVEY

---

### A. An Electrical Survey Form

Identify all the devices in your residence that use electricity and classify them according to the categories provided below.

ESSENTIAL DEVICES	DEVICES THAT ARE NICE TO HAVE (could do without, but with difficulty)	UNNECESSARY DEVICES

### B. Discussion Questions

1. Examine the technologies listed in Column 1. What did people do before electricity was available? Are you sure these devices are essential?

---

---

2. How can you monitor electrical consumption in your residence? How much electricity do you use in a day? month? year?

---

---

3. What are some practical ways that you can decrease electrical consumption in your home/apartment? Try these ideas and evaluate their effectiveness by monitoring electrical consumption in your residence.

---

---

# NATURE OF SCIENCE

---

Learning to understand natural objects and events and to apply knowledge gained to a variety of practical situations is emphasized throughout the science program. Today's society requires that students are active investigators, possessing the critical and creative thinking skills that will enable them to interpret and evaluate information gathered through the senses. A focus on the nature of science and the inquiry process will enable students to understand the way in which scientific knowledge is gathered, as well as use this knowledge in conducting investigations of their own.

Learning activities used throughout the science program will enable students to demonstrate an understanding that:

- science is a disciplined way to develop explanations for the events and objects of the natural world
- science is comprised not only of an accumulated body of knowledge, but also of the processes by which that knowledge is developed
- empirical evidence plays an important role in the development of scientific knowledge
- physical laws and conceptual inventions that are theoretical and tentative in nature attempt to explain the universe
- proposed theories may be supported, modified or falsified by experimental evidence
- scientific knowledge is cumulative and subject to change.

Additionally, the science program should encourage students to display:

- curiosity about events and objects in the natural world
- an appreciation of the beauty and complexity of the natural world
- a concern for accuracy and supporting evidence
- honesty and completeness in reporting and evaluating evidence
- open-mindedness in considering alternative ideas and interpretations
- critical-mindedness in evaluating inferences and conclusions
- confidence in personal ability to design and conduct a scientific investigation.

A variety of teaching and learning strategies that nurture an understanding of the nature of science have been included in this section of the manual. The strategies support active involvement in the inquiry and problem-solving processes, and include:

- A Model for Conducting Investigations in Science.
- Useful Strategies and Skills
  - Understanding the Problem
  - Developing and Carrying Out a Plan
  - Reviewing and Applying Results.
- Suggestions for Planning Investigative Activities.
- A Sample Lesson Plan.

## A MODEL FOR CONDUCTING INVESTIGATIONS IN SCIENCE

Critical to conducting investigations in science is the attitude with which students approach the task. People are often uneasy and hesitant to involve themselves in situations where procedures are not easily determined and outcomes are not evident. Appropriate attitudes must be nurtured through an atmosphere that provides encouragement, flexibility and acceptance. Discussion and activity should foster student curiosity about natural events and an interest in trying to understand them. Students must be persuaded to take risks in planning investigative procedures and to develop a concern for accuracy, honesty and evidence in the investigations they perform. Students will be supported in their understanding of the inquiry process when investigations that relate to personal experience, interest and need are selected.

A model for conducting investigations in science is suggested below. This model provides a starting point and some ways of organizing efforts.

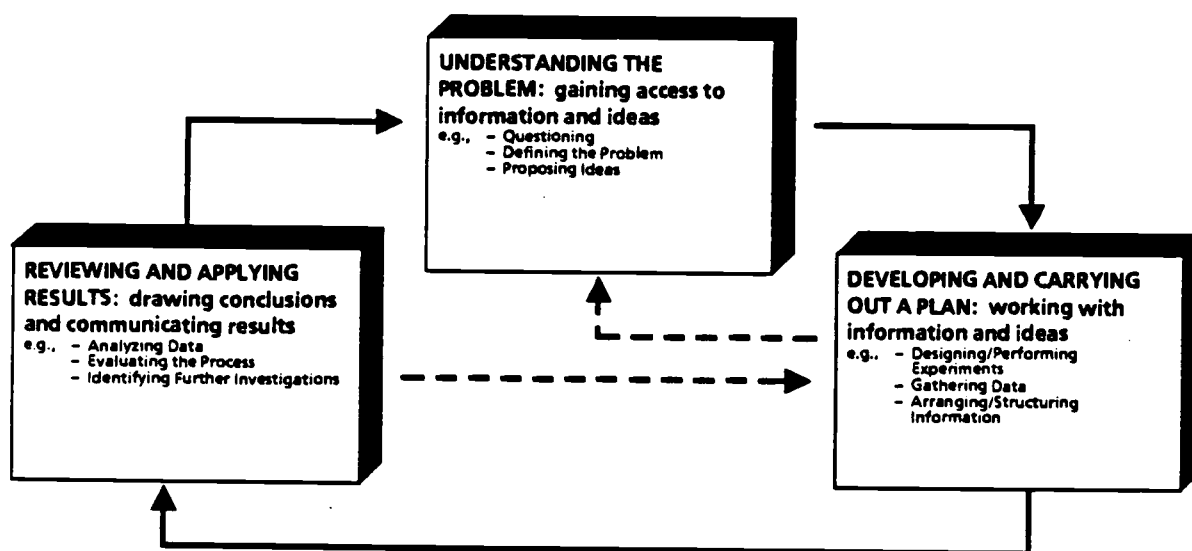

Specific actions suggested at each stage within the model represent possible strategies that might be used in conducting an investigation. Students may not always use each stage of the process and will select only those actions that are appropriate to purpose and ability. Students should, however, recognize the investigative process as a series of interrelated actions that lead to an outcome.

By bringing thought processes to the metacognitive level (e.g., helping students to become aware of the thinking skills and thought processes that they and others use), students will be better able consciously to select and use those strategies and skills that are appropriate to the situations they encounter. Research strongly supports the teaching practice of:

- modelling (talking through) the processes and skills that are appropriate to an investigation
- discussing the processes and skills that the student is presently in the habit of using (e.g., raising the level of metacognitive awareness)
- encouraging students to develop additional strategies that will structure and support the thought process.

This model for conducting investigations in science can be explicitly presented to students as an overall process and then used as a teaching and learning model.



## USEFUL STRATEGIES AND SKILLS

Students need to develop and apply a range of strategies and thinking skills in order to investigate natural phenomena, solve practical problems and resolve science related issues. Some skills involve the use of formal operations (i.e., hypothetical thinking), and must be developed through carefully planned learning experiences that focus on their use. The process of mediation (e.g., asking appropriate questions, modelling and "talking through" complete thought processes) will assist students to develop and consciously use strategies and skills that are appropriate to the situations they encounter. Learner ability will determine the degree to which skills are applied at an independent level throughout investigations undertaken in the science program.

The list of skills suggested below serves to guide the design of learning experiences and the construction of assessment schemes. These skills are not intended to be developed separately or sequentially but, rather, concurrently with concept and attitude components within the science program.

Students will be expected to demonstrate an ability to:

- distinguish between relevant and irrelevant information  
e.g.,
  - define problems/identify issues
  - set goals by establishing purpose and direction
  - formulate questions to guide research/inquiry
  - identify variables
- gather information or data  
e.g.,
  - use an experimental design or research plan
  - make qualitative and quantitative observations
  - effectively use apparatus and equipment
- arrange or structure information so it can be readily understood or presented  
e.g.,
  - classify
  - order and identify patterns/trends
  - draw charts/graphs/diagrams
  - express data in the form of a simple mathematical relationship
- analyze data or information  
e.g.,
  - identify main ideas/attributes/components
  - identify patterns and relationships
  - identify errors
  - detect bias
- make connections among new ideas and prior knowledge, and generate information beyond that which is given  
e.g.,
  - explain and elaborate
  - predict and hypothesize
  - infer and generalize from the data or information
  - design experiments or devise a plan for research
  - identify further problems, questions and issues to be investigated
- integrate new information with prior knowledge  
e.g.,
  - summarize and communicate findings
  - develop consensus within a group
  - make a decision or develop a conclusion/solution
- assess the logic and quality of ideas/information  
e.g.,
  - consider consequences
  - establish criteria to judge data
  - assess a design or approach taken to inquiry, problem solving or decision making
  - assess the achievement of goals set.

## UNDERSTANDING THE PROBLEM

### QUESTIONING/DEFINING THE PROBLEM

Questioning recognizes the need of the student to take an active role in initiating an investigation. Questioning may originate when the student recognizes a discrepant or unexplained event in the environment. Skill in questioning is built on the student developing ability to reflect on the discrepant event, to analyze the event in light of previous experience, and to formulate questions in a way that probes for specific meaning or knowledge. Initially the student may ask questions in terms that are difficult to answer, but with guidance and practice learns to evaluate, rephrase and redirect questions so that answers can be found, often on one's own. Questioning skill leads to skill in problem definition, a step which the student takes in assuming increased responsibility for finding answers.<sup>1</sup>

Questioning techniques modelled by the teacher are effective in developing an awareness of, and ability to ask relevant questions. In preparing students for an activity, teachers can:

- begin with divergent questions, so as to allow for a large number of answers and to provide for critical/creative thinking
- use convergent questions if students seem to be having difficulty
- ask questions that require students to engage in thinking at all levels (e.g., recall, application, analysis, synthesis, evaluation)
- encourage participation and thought by allowing an appropriate "response time" for each question that is asked.

### CLARIFICATION/EXAMPLE

#### Questions That Involve Students in Investigation

- What are we looking for?
- What do we want to explain/investigate?
- What do you notice about this ...?
- What do you think might happen if ...?
- Why did ...?
- What should we do first?
- What is stopping us?
- If this is so, then ...?

#### Questions That Stimulate Creative Response

- What is my next step?
- How will I do that?
- How can I design a better ...?
- What is the relationship between ... and ...?
- Why did ... happen after ...?
- How would you design an experiment to ...?
- What might happen if you use ... instead of ...?
- What is the likelihood that ...?

1. Adapted from *Science Process Skills and the Alberta Science Curriculum (A Position Paper)*, written by Bernie Galbraith and sponsored by Alberta Education, p. 18, 1983.

## CLARIFICATION/EXAMPLE

### Questions That Stimulate Analysis and Evaluation

- How did you know that ...?
- What does the data indicate?
- What caused ... to happen?
- How does ... apply to ...?
- How could you explain ... in another way?
- How might you use these results?
- How could we make our work easier another time?
- How could we improve it or make it better?
- What should we tell others?

Students should be given frequent opportunity to generate questions that are based upon the observations they make and the information they gather. The strategy that follows may be useful in developing student ability to formulate questions related to information they have read. Teachers may wish to modify this strategy according to nature of the investigation and the information being examined.

## CLARIFICATION/EXAMPLE

### A Strategy for Generating Questions<sup>1</sup>

1. Provide students with a copy of some reading material.
2. Ask students to read the first paragraph silently. Monitor students to ensure that they have read the paragraph by asking questions related to the outcome of the paragraph.
3. Ask students to go back to the beginning of the paragraph and silently read the first sentence again.
4. Encourage students to generate as many questions as possible that are based upon the first sentence. The teacher should respond to each question that is asked.
5. Reverse the roles of student and teacher. The teacher now asks questions of the students that are based upon the first sentence. Questions asked by the teacher should be of different categories than those asked by students (e.g., knowledge, comprehension, application, analysis, synthesis, evaluation). Students should answer each question asked by the teacher, or give a reason for not being able to answer. The teacher should provide responses for questions the student cannot answer.

1. Adapted from *SPELT: A Strategies Programme for Effective Learning/Thinking: Inservice Edition*, SPELT International Ltd., p. 114. Copyright 1987 by R. Mulcahy, K. Marfo, D. Peat and J. Andrews. Reprinted by permission.

## PROPOSING IDEAS

Strategies that establish a sense of direction to inquiry are identified in this skill area. Establishing a sense of direction is critically important to the inquiry process for, in science, answers to questions do not normally emerge spontaneously. Generally they emerge as the result of ideas that have been proposed and then tried to see if they work. The proposing of ideas is not always an external process, nor is it always done in a rational way. Ideas emerge out of a combination of reflection on what the learner already knows or supposes to be true. Whether by conscious rational thought, or by intuition, the student then takes the fundamental step of mentally associating two or more objects, events, properties and/or living things in the context of some type of relationship. The process of making this type of association may be a nearly instantaneous one, taking place in the fraction of a second after a question has been asked. For more difficult questions the process may be considerably extended, taking as long as several days or months, depending on the difficulty of the problem and the tenacity of the learner. Once "proposed", an idea may lead to formal investigation, or on further reflection may be rejected as unlikely or inappropriate. A number of ideas may be "proposed" within the student's mind, but only the most favoured one used to direct further thought and investigation.

The relationship between the two component skills of "hypothesizing" and "predicting" is a complex one. If we all thought on the basis of formal logic, it would seem necessary for us to hypothesize before we could predict, for it is only logical that we should recognize a relationship before we can apply that relationship to a prediction. In actual patterns of thought (and particularly for the student who has not advanced beyond a "concrete operational" stage), conscious thought may appear to transcend the step of hypothesizing and go directly to predicting. This does not mean that the student cannot and does not hypothesize. It may only mean that the student is incapable of reflecting on mental processes and is thus incapable of describing those processes to us. The ability to reflect consciously on an hypothesis and the related ability to state an hypothesis may not develop until relatively late in the student's school career. It is thus appropriate that a student's ability to hypothesize during the early years be gauged indirectly through ability to predict.<sup>1</sup>

Encourage students to identify problems and propose ideas that are based upon their personal observations of familiar objects/events. Arouse curiosity and guide students' thoughts through discussion and the use of appropriate questioning techniques (see "Questioning/Defining the Problem", page 158).

The statements that follow provide additional suggestions for developing student ability to generate ideas about possible relationships and devise simple statements that can be tested by observation or experiment:

- Assist students to formulate questions/problems that arise from personal observations they have made. (e.g., Why did this group of plants grow so much taller than the others?)

---

1. Adapted from *Science Process Skills and the Alberta Science Curriculum (A Position Paper)*, written by Bernie Galbraith and sponsored by Alberta Education, pp. 18-19, 1983.

- Through discussion, generate ideas about possible relationships between objects/events that have been observed. (e.g., These plants may have grown taller because ... .)
- Encourage students to describe the relationships they propose with simple statements. (e.g., If I do ....., then .... will happen.)
- Distinguish between guessing and predicting. Use patterns/trends/repeated observations to predict the next occurrence of an event (e.g., According to previous observations, which of these plants would you expect to grow taller? What is the basis of your prediction?).
- Provide opportunity for students to confirm/reject predictions they make through observation, measurement or experiment.
- Coach students in devising tentative explanations by asking appropriate chains of questions (e.g., What factors seem to affect the growth of plants? Can plant growth be maximized by ... ?).
- Do not expect students to formulate sophisticated hypotheses. Encourage students to select suitable hypotheses from sets of alternatives they are given, and in some instances to formulate simple hypotheses of their own. The abstract process of "hypothesizing" will be difficult for students who are functioning at a concrete level.

## DEVELOPING AND CARRYING OUT A PLAN

### DESIGNING/PERFORMING EXPERIMENTS

This skill area identifies those thoughts and actions by which the student tries out an idea that has been proposed. At an early level of skill, the student may not consciously reflect on the techniques used to "find out". Rather, the student may proceed directly to a procedure that fits the concept of what is needed to demonstrate the relationship already believed to exist. The tendency to jump to conclusions appears to be natural at early ages, with experience used only to support foregone conclusions rather than to evaluate them critically. It is only as the student advances in ability to think critically that reflective attention is given to the procedures used in experimenting. When the student reaches this stage, the concept of a fair test can be introduced. This concept can then be expanded by introduction of the related concepts of manipulated variable, responding variable and control variables.<sup>1</sup>

The process of designing an experiment is complex and requires the student to "plan" an investigation in order to obtain a solution to a problem or test an hypothesis. Planning an investigation requires the student to:

- identify the kinds of observations/measurements that are required to answer the question or problem. (e.g., If we were to investigate the idea that the amount of soil affects the growth of a plant, what should we do? What things would we want to measure? How should we measure them?)

1. Adapted from *Science Process Skills and the Alberta Science Curriculum (A Position Paper)*, written by Bernie Galbraith and sponsored by Alberta Education, p. 19, 1983.

- identify and control variables so as to make the experiment a "fair test" of the given question or problem (e.g., Does it make any difference to the experiment if some plants are watered more frequently than others? What things should we do to make our experiment a fair test?).
- develop methods for collecting data and selecting apparatus and supplies that will be required
- devise sequential procedures to be followed and techniques for manipulating the apparatus and supplies
- decide upon the manner in which data will be recorded
- consider safety procedures that must be followed.

The process of designing an experiment can be modelled through teacher demonstrations that involve relationships familiar to the student. Following these demonstrations, plan other investigations through discussions that involve the whole class. As students develop an understanding of the process of designing an experiment, provide opportunities for students to plan and conduct simple experiments of their own.

#### CLARIFICATION/EXAMPLE

##### A Sample Outline for Designing an Experiment

1. Ask a question.
2. Write an hypothesis that answers the question.
3. Plan procedures that will be used to verify the hypothesis:
  - identify one variable to be tested
  - identify other variables that might be tested at another time
  - identify all controls that are necessary.
4. Select the apparatus and supplies that will be used.
5. Using words/diagrams, describe sequential procedures for performing the experiment.
6. Identify appropriate procedures for recording/communicating data that is gathered.

Students may be given procedures for many of the experiments they are to perform. Prior to conducting these experiments, provide opportunities for students to:

- understand the "thinking" behind the investigation
- consider alternative designs/procedures that might also be effective in answering the question or solving the problem.

Additional suggestions for designing an investigation are provided at the end of this section in:

- Resource 1: Writing a Lab Report
- Resource 2: A Sample Lab Report
- Resource 3: A Sample Evaluation Guide for Lab Reports.

## GATHERING DATA

Observing is in some ways the most fundamental skill to science and it is usually the first skill that the student develops to a relatively high level of proficiency. In some ways younger students may be better observers than we adults, as they generally are more ready to accept a wide range of sensory input as worthy of their attention. Nevertheless, the skill is very much subject to development and improvement. One of the principal means by which the student improves skill is by developing the ability to focus thought and attention. Rather than relying on random observations of events, the student begins to recognize patterns of events and conceptualizes observations in terms of these patterns. The student also learns to quantify observations, or in effect, to measure. Measurement skills develop mainly with practice.

The recording of observations and measurements has been included here as a major aspect of this skill. Initially the recording may be the listing of observations in a relatively unstructured way. With practice, the student learns to describe observations in the form of a sequenced narrative of actions and events. At a further level of sophistication the observations may be abstracted from the procedures and described in analytical or point form. At the most advanced level, the student is able to select an appropriate procedure for recording observations where the format is chosen on the basis of clarity rather than conformity to a rigid pattern.

Skills in drawing pictures and diagrams are also part of the data gathering phase. Younger students are generally very ready to use pictorial representations to convey meanings that they have gleaned from their experiences. Initially the drawings may be more impressionistic than precise, with obvious shortcomings in the way relationships between elements have been treated and with obvious inaccuracies in proportion. The drawings nevertheless serve as a basis for the student to express and summarize experiences. As the student advances in skill (which will happen naturally given opportunities to practice), ability to show relationships and proportions gradually improves. At some point the formal skills of diagramming can be introduced, with considerable spin-off benefits to the student's interest and ability to examine objects critically.<sup>1</sup>

Provide opportunities for students to practise making both qualitative and quantitative observations through direct use of the senses, as well as through the use of specialized observation tools (e.g., microscopes, thermometers, balance scales). Attribute guides are useful in establishing a structure for observations, and provide an outline that students can follow in describing their observations. In preparing an attribute guide, select attributes that are appropriate to the nature of the observations being made.

---

1. Adapted from *Science Process Skills and the Alberta Science Curriculum (A Position Paper)*, written by Bernie Galbraith and sponsored by Alberta Education, pp. 19-20, 1983.

## CLARIFICATION/EXAMPLE

**An Attribute Guide for Describing an Object<sup>1</sup>**

Object to be described: \_\_\_\_\_

Colour:

Shape:

Size (e.g., height, width, thickness):

Weight:

Texture:

Temperature:

State of Motion (e.g., speed, evenness, relationship to other things):

Aroma:

Taste:

Measurement is the process of determining the dimensions/quantity of an object or event, using standard units, numbers and spatial relationships. Science activities should provide opportunities for students to:

- make accurate measurements using metric units of length, capacity, mass, temperature and time
- develop estimation skills by making comparisons to a known standard
- combine familiar units of measure into other measurable dimensions (e.g., density, pressure, velocity)
- interpret the calibrations on measuring instruments used in the laboratory (e.g., beakers, thermometers, spring scales)
- select units and tools of measurement that are appropriate to the task performed
- recognize the approximate nature of measurement and evaluate the precision/accuracy of the measurements that are made
- design/construct simple measuring instruments that are useful in particular applications.

Teachers are encouraged to familiarize themselves with the measurement strategies suggested in the mathematics program, and use these strategies when developing related skills in the science program.

Additional suggestions for gathering and describing scientific data are provided in:

- Resource 4: Observing and Describing
- Resource 5: An Evaluation Guide for Observations.

1. Adapted from *SPELT: A Strategies Programme for Effective Learning/Thinking: Inservice Edition*, SPELT International Ltd., p. 102. Copyright 1987 by R. Mulcahy, K. Marfo, D. Peat and J. Andrews. Reprinted by permission.



## ARRANGING/STRUCTURING INFORMATION

Arranging and structuring information includes all those manipulations that are performed with data in order to make interpretations. Classifying is included as it is seen as a skill that leads to data interpretation. Classifying skill is also closely related to observation in that classification may be based on the observation of similarities and differences. As the student advances in classification skill, many classification decisions that were previously a matter of conscious deliberation come to be made automatically as a part of observation. Thus the distinction between classification, observation and interpretation may at times be blurred. Nevertheless, there appears to be a progression of classification skill from the use of simple category systems to the use of multiple category systems. There is also a progression in the conceptual level of the characteristics used as elements in the classification system.

Other skills in this area are those which allow the student to obtain meaning from collections of data, where the meaning may not be evident in isolated observations or measurements. Skills to be developed are largely mathematical, but the development of skills of presentation and layout of data are also significant.<sup>1</sup>

One of the first steps in arranging information involves organizing "rough" data into more compact and meaningful forms. Provide opportunities for students to organize the data they collect by:

- ordering objects/events according to observable properties
- making qualitative and quantitative comparisons of objects/events
- classifying objects/events on the basis of observable similarities and differences
- performing simple calculations.

When classifying, assist students to recognize similarities, differences and interrelationships among the objects/concepts/events being examined, by using simple diagrammatic representations (e.g., concept circles, concept maps).

### CLARIFICATION/EXAMPLE

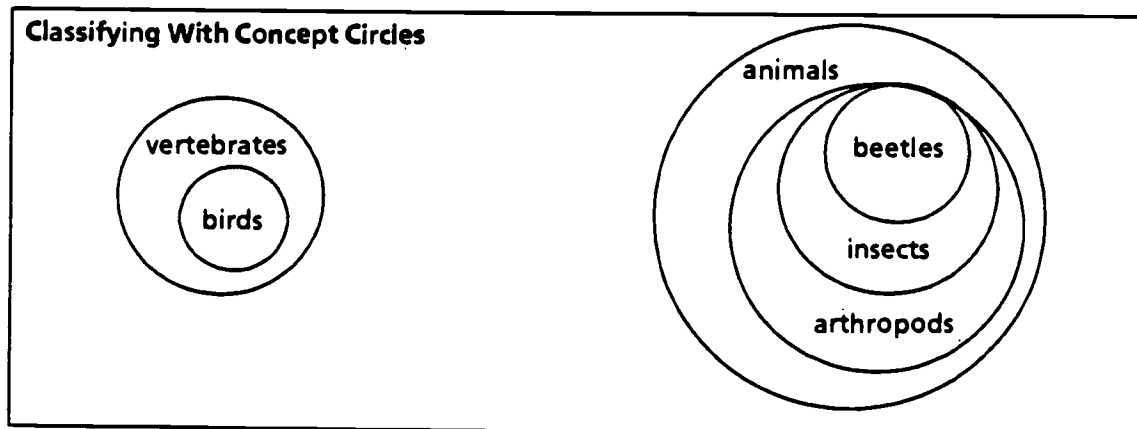

1. Adapted from *Science Process Skills and the Alberta Science Curriculum (A Position Paper)*, written by Bernie Galbraith and sponsored by Alberta Education, p. 20, 1983.

## CLARIFICATION/EXAMPLE

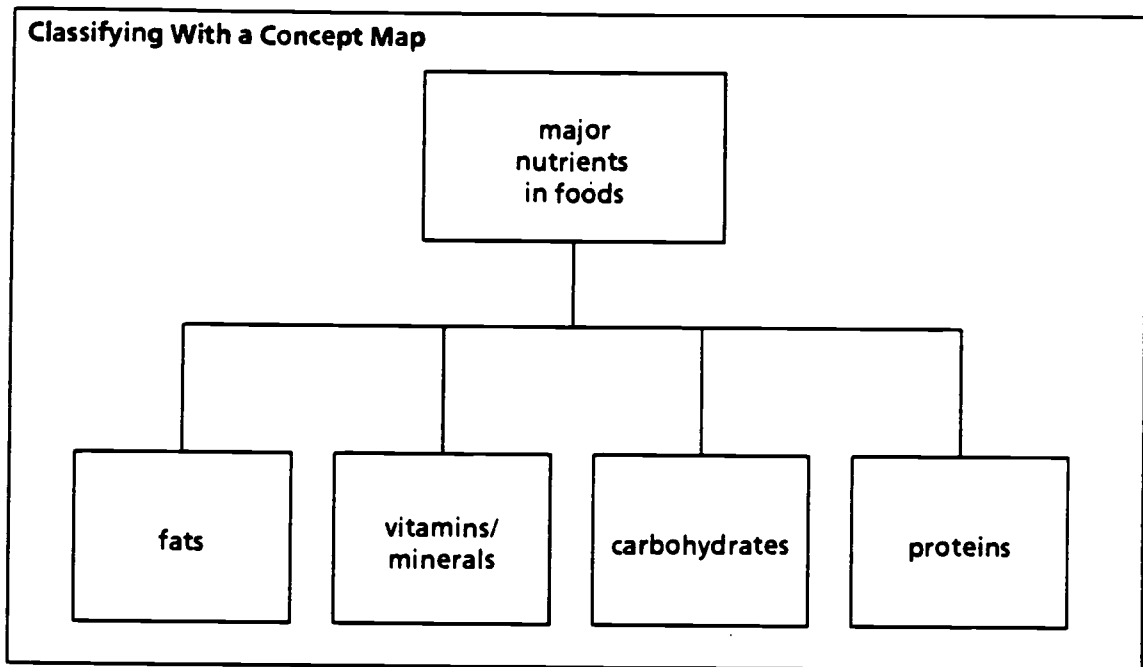

When presenting data, encourage students to illustrate the information they have collected in an organized and systematic manner, thus enabling anyone to understand its significance. Presentation methods should be chosen that are appropriate to the nature of the investigation and information collected. Students should gain experience in presenting data through the use of:

- oral reports/written reports that follow established guidelines
- sketches/pictures/diagrams
- simple tables/charts/graphs.

As students display their data, it may become apparent that there are recognizable patterns or trends in the data collected. Encourage students to identify these patterns or trends, and to make inferences and predictions that are based upon the patterns they observe.

## REVIEWING AND APPLYING RESULTS

### ANALYZING DATA

The student must give meaning to the observations that have been made by analyzing and interpreting data. A first stage of analyzing data is inferring, a step in which the student makes a judgment about the evidence obtained in relation to original ideas or proposals. Inferring means making a judgment about a proposed relationship between objects, events, properties and/or living things. At an early level, the student may tend to make a categorical judgment, often inaccurate, on the basis of very little evidence. As skill level advances, the student will likely require much more evidence before making an inference. The inferences made by the more skilled student will likely be expressed in language that is more tentative and more contextual than for a less skilled student. There will be fewer statements of the kind that begins "This proves ..." and more statements of the kind "The data indicates that ...".

The conceptualization of inferred relationships is also included as part of this skill area. This "mental modelling" may take a variety of forms. It may involve the use of some familiar physical system as a model or metaphor for another; it may use some type of spatial model as "a picture" of what the data has shown; it might also be in the form of a mathematical model. As skill in formulating models develops, the student is increasingly able to generate models characterized by a high level of abstraction.<sup>1</sup>

Students should have an opportunity to examine data and formulate their own interpretations before "answers are given". Emphasis should be placed on formulating an explanation rather than the explanation. The process of analyzing data will require students to:

- generalize data by inferring relationships
- distinguish between inference and observation
- develop appropriate explanations/theories/models based on data that is gathered
- evaluate the hypothesis in terms of the existing data.

Assist students to identify cause and effect relationships in familiar natural events. Students should realize that there may be more than one cause for certain events. Encourage students to identify as many causes as possible for a given problem. Questions like "What might happen if ...?" and "How does ... apply to ...?" will encourage students to consider cause and effect relationships and apply these to related situations.

Physical and mental models often provide a useful method of describing unfamiliar phenomena in terms of something that is familiar. Physical models are particularly worthwhile in aiding comprehension of difficult concepts. Examples of models that students may find helpful include:

- a picture of an eroded area in the environment
- a diagram of a human body system
- a physical model of an electric circuit
- a mental model of an atom.

1. Adapted from *Science Process Skills and the Alberta Science Curriculum (A Position Paper)*, written by Bernie Galbraith and sponsored by Alberta Education, p. 21, 1983.

In order to evaluate a hypothesis, students must consider the "fit" of the data they collect with the original hypothesis. On the basis of evidence collected, students will decide to confirm or reject their hypothesis. It may be necessary to modify or restate the hypothesis and undertake further investigation. Encourage students to relate knowledge gained from their interpretation of data to related situations.

### **EVALUATING THE PROCESS**

Subsequent to conducting an investigation, provide opportunities for students to examine critically the procedures/thought processes they have used and to compare their views with those of other students. Ask questions that will encourage students to:

- consider the adequacy of the data in supporting inferences that were made
- distinguish between reasonable inferences and unsupported guesses
- identify possible sources of error in the data collected
- identify intervening/uncontrolled variables that may have affected data collection and results
- recognize limits to interpretations that are based on sample size.

### **IDENTIFYING FURTHER INVESTIGATIONS**

Further problems/questions are often identified as a result of experiments that are performed. Additional investigations may serve to:

- increase the level of confidence in the inferences/explanations that were made
- test the range of applicability of the explanation
- study the effect of different variables/conditions
- examine discrepant events
- solve new problems that have been identified as a result of experimentation.

As time permits, provide opportunities for students to undertake further investigations. These investigations may take the form of:

- demonstrations/experiments
- projects for a science fair
- field trips
- interviews/class visitors.

## SUGGESTIONS FOR PLANNING INVESTIGATIVE ACTIVITIES

Themes developed in this manual provide opportunities for students to conduct investigations within a variety of meaningful contexts. Students should recognize that the strategies and skills they use in conducting investigations are "lifetime tools" and, when chosen according to purpose and need, are useful in a variety of practical situations.

The following suggestions may be useful in helping students to plan and conduct investigations within the science program.

- Share the model for conducting investigations with all students. The model provides structure to the overall process, as well as specific strategies/skills that can be used at each stage of the process. Familiarity with the model will increase the student's repertoire of strategies that can be used in performing an investigation.
- Encourage students to be creative and experimental in their approach to investigations. While useful in the structure it provides, the model should not be interpreted as consisting of fixed stages and strategies. Its use will depend on individual problems and individual students.
- Ensure that investigations do not become tedious or unrealistically complex. Data related to the phenomena investigated must be readily available, and should be relevant to student interest and experience.
- Foster the development of attitudes and behaviours that promote student thinking and ability to monitor progress through the inquiry process:
  - open-mindedness in considering alternative ideas and interpretations
  - concern for accuracy and evidence
  - honesty and completeness in reporting and evaluating evidence
  - critical mindedness in evaluating inferences and conclusions
  - sub-vocal rehearsal/self-talk (e.g., "Where was I?", "Am I done with this?", "What comes next?").
- Encourage students to recognize how the model for conducting investigations in science provides a general plan for action that is also effective in guiding investigations in English, mathematics, social studies and the occupational program, and how specific skills used at each stage within the model may vary according to the nature of the problem or investigation.

When planning laboratory investigations, provide variation in student activities so as to ensure greater interest and participation. Plan activities that:

- require formal laboratory write-ups, and others that are short involving no formal write-up
- involve individual work, and others that involve group work
- focus on the development of only one strategy or skill, and others that involve several strategies and skills
- acquaint students with a variety of phenomena through a "work stations" approach.

Although laboratory activities and experiments represent an important part of the investigative process, they should not become the sole teaching strategy. A successful lesson may often include the use of more than one teaching strategy:

- e.g.,
- questioning
  - laboratory activities
  - individual and group projects
  - class discussions
  - teacher modelling/demonstrations
  - case studies and debates
  - community partnerships
  - games and simulations
  - technology and the media resources

The sequence of activities outlined below may assist teachers in planning investigative lessons that involve a variety of teaching and learning strategies.

- Pose a problem.
- Establish an experimental design aimed at solving the problem.
- Provide (or have students gather) data required to solve the problem.
- Have students study and interpret their data. Guide activities through the use of leading questions that focus student attention on relevant aspects of the data.
- Formulate generalizations on the basis of data collected. Use questioning techniques that will facilitate the student's use of personal reasoning skills.
- Have a class discussion on the meaning and limitations of the data, the relationship of the data to other problems, and possible applications to everyday life.
- Use questions that may have arisen to extend learning to new areas.

## SAMPLE LESSON PLAN

This sample lesson plan illustrates how the model for conducting investigations in science may be used to structure learning situations. Although this investigation relates to heat and its effects on familiar materials, similar methodology could be used in developing other concepts in the science program. The sequence of activities outlined would require the use of several class periods and may need to be modified according to student needs and local circumstances.

### OBJECTIVES

- To investigate the effects of heat on familiar materials.
- To recognize everyday applications of the expansion and contraction of materials.

#### I. UNDERSTANDING THE PROBLEM: GAINING ACCESS TO INFORMATION AND IDEAS

- Facilitate a class discussion. Develop an anticipatory mental set for the problem at hand. Relate the problem to personal experience (e.g., "You have just purchased a jar of relish and are unable to open it. What are some procedures you might use to remove the lid?"). Ask questions and cite examples that relate to the effects of heat on solids, liquids and gases. **QUESTIONING**  
**IDENTIFYING THE PROBLEM**
- Discuss the Kinetic Molecular Theory and its use in explaining the behaviour of matter. Make an analogy that illustrates this theory (e.g., "If one hundred people were placed in a room, it might be crowded but they would fit. If they were asked to do some warm-up exercises, they would need more room. That is, they would expand the need for space."). **GATHERING INFORMATION**
- Gain additional information by reading about heat and its effects on matter. **FORMULATING QUESTIONS**
- Ask students to identify instances in their personal life where materials used are affected by heat and temperature. Encourage students to consider related situations/tools/materials encountered in their occupational program, at home and in the natural environment. Identify questions or problems experienced by students in these situations (e.g., removing a radiator cap, inflating a bicycle tire). **DEFINING PROBLEMS**

#### II. DEVELOPING AND CARRYING OUT A PLAN: WORKING WITH INFORMATION AND IDEAS

- Ask students to formulate simple hypotheses about their personal experiences with heat and matter. **FORMULATING HYPOTHESES**
- Provide opportunities for experimentation with heat and matter in situations involving solids, liquids and gases. Design experiments that will validate hypotheses. Students often find this difficult and may require assistance in designing their experiment. Discuss observations to be made in the experiment, measurements that might be taken in determining change in the materials and a method for recording data. **PLANNING AND EXPERIMENTING**  
**GATHERING AND ARRANGING DATA**
- Students who are unable to design their own experiments should be given opportunity to pursue investigations and procedures that are teacher-directed.

### III. REVIEWING AND APPLYING RESULTS: DRAWING CONCLUSIONS AND COMMUNICATING RESULTS

- Discuss and evaluate hypotheses that have been made after considering the outcomes of student investigation. Were predictions correct? Provide opportunities for students to communicate their inferences verbally, in written form or through models and diagrams. EVALUATING  
MAKING  
INFERENCES  
COMMUNICATING
- Discuss the beneficial and detrimental effects of expansion and contraction (e.g., produces soil out of rock but also causes deterioration of sidewalks). IDENTIFYING  
CAUSE AND EFFECT
- Through brainstorming, identify a number of technologies that apply principles of expansion and contraction. Examine technologies used by students at home and in their occupational program (e.g., internal combustion engine, thermometers, food preservation). APPLYING  
INFERENCES
- Discuss positive and negative effects of these technologies on our lives. Should any of these technologies be rejected by society because of harmful effects on man or environment? DRAWING  
CONCLUSIONS/  
MAKING  
DECISIONS
- Identify personal/societal needs that might be met by new technologies that apply principles of expansion and contraction. Challenge students to devise such technologies. IDENTIFYING  
FURTHER  
PROBLEMS/  
QUESTIONS TO  
INVESTIGATE
- Apply related concepts to other areas in the science program (e.g., electrical-thermal systems).

### EVALUATION CRITERIA

SAMPLE EVALUATION MATRIX			
Criteria Score	Investigative Skills	Participation	Product
5	<ul style="list-style-type: none"> <li>● Understands problem/ investigation/assignment</li> <li>● Selects necessary strategies</li> <li>● Evaluates appropriateness of solution/conclusion/product</li> </ul>	<ul style="list-style-type: none"> <li>● Gets involved quickly</li> <li>● Stays involved</li> </ul>	<ul style="list-style-type: none"> <li>● Complete and correct</li> <li>● Commands respect</li> <li>● Neatly done</li> </ul>
4	<ul style="list-style-type: none"> <li>● As above but fails to evaluate solution/conclusion/opinion/ product</li> </ul>	<ul style="list-style-type: none"> <li>● Needs a start</li> <li>● Stays involved</li> </ul>	<ul style="list-style-type: none"> <li>● Mostly complete</li> <li>● Correct and neat</li> <li>● Good work</li> </ul>
3	<ul style="list-style-type: none"> <li>● Errors evident but strategies selected led to a solution/ conclusion/product</li> </ul>	<ul style="list-style-type: none"> <li>● Needs periodic reminding to stay on task</li> </ul>	<ul style="list-style-type: none"> <li>● Somewhat complete</li> <li>● Minor errors</li> <li>● Satisfactory</li> </ul>
2	<ul style="list-style-type: none"> <li>● Errors evident</li> <li>● No solution/conclusion/product provided</li> </ul>	<ul style="list-style-type: none"> <li>● Needs constant reminding to stay on task</li> </ul>	<ul style="list-style-type: none"> <li>● Incomplete</li> <li>● Major errors</li> <li>● Untidy</li> </ul>
E	Acceptably Excused from the Assignment		
0	Not Done or Handed in		



## RESOURCE 1: WRITING A LAB REPORT

---

You have probably written lab reports in the past. A report is often a brief summary of an event. In the case of a scientific report, the event is usually staged or created in a controlled environment and called an experiment.

All experiments start with a guess, or as the scientist calls it, a hypothesis. The hypothesis determines what investigation is carried out because it contains the question which must be answered by the experiment.

Although students may not prepare formal laboratory write-ups for each experiment they perform, the following headings suggest one way to structure a lab report.

<b>Title</b>	A few words indicating the nature of the investigation.
<b>Object</b>	A sentence or two that describes what the experimenter wishes to find out.
<b>Apparatus</b>	A list of materials used. Apparatus can be reused after the investigation.
<b>Supplies</b>	A further list of materials used. Supplies, unlike apparatus, are consumed during the experiment.
<b>Procedure</b>	The steps taken to carry out the investigation. It is customary to number the steps in the sequence in which they should be carried out.
<b>Observations</b>	<p>The findings of your investigation. Observations may be qualitative or quantitative. Quantitative observations, also called data, involve numbers and are often collected in tables, charts or graphs. A sample quantitative observation would be, "The solution boils at 108° C".</p> <p>Qualitative observations do not involve numbers and may be written in either sequence or paragraph form. A sample qualitative observation might be, "A red-brown gas escaped".</p>
<b>Interpretations/ Conclusions</b>	The answer to the question raised in the object section. It is based on your observations and data collected during the investigation. It will either prove or disprove the hypothesis.

The structure used for lab reports should not become stereotyped. Format should be appropriate to the information gathered and the use to which it will be put.

---

From the *Junior Secondary Science Curriculum Guide and Resource Book* by the British Columbia Ministry of Education. Copyright 1983 by the British Columbia Ministry of Education. Reprinted by permission.

## RESOURCE 2: A SAMPLE LAB REPORT

---

### THE EFFECT OF DISSOLVED SALT ON THE BOILING POINT OF WATER

- Object** To determine the effect of sodium chloride (NaCl) on the boiling point of water.
- Apparatus** 500 mL beaker, support stand, ring clamp, wire gauze, bunsen burner, flint striker, thermometer, triple beam balance, 500 mL graduated cylinder, watch with a second hand, stirring rod, beaker tongs or oven mitts.
- Supplies** Distilled water, filter paper, NaCl.
- Procedure**
- Part A: Control**
1. Measure 300 mL of distilled water in a graduated cylinder. Pour the water into the beaker.
  2. Attach the ring clamp to the support stand at a height of about 20 cm. Place the wire gauze on the ring clamp.  
**Safety Note:** Be certain to clear the bench area of any paper, books, or other inflammable materials.
  3. Set up a bunsen burner and light it before placing it beneath the ring clamp. Now adjust the height of the flame and the height of the ring clamp so that the tip of the blue inner flame is about 1 cm from the lower surface of the wire gauze. Finally, set the burner under the gauze.
  4. Record the initial temperature of the water to the nearest degree.
  5. Place the beaker on the wire gauze and record the temperature every two minutes until a constant temperature is obtained for at least three consecutive readings.  
**Safety Note:** Do not stir the solution with the thermometer because repeated tapping of the tip against the wall of the beaker may cause the thermometer to break. Use a stirring rod.
  6. Using oven mitts or beaker tongs, remove the beaker from the stand and place it on a heat resistant pad. Empty the beaker and let it cool to room temperature before starting Part B.
- Part B: Salt at 1 g/100 mL**
1. Weigh 3 g of NaCl on a piece of filter paper.
  2. Measure 300 mL of distilled water and pour it into the beaker.
  3. Dissolve the 3 g salt in the water by stirring.
  4. Record the initial water temperature.
  5. If necessary, adjust the height of the heating apparatus as in step 3 of Part A.
  6. Place the solution on the wire gauze. As before, record the temperature of the solution every two minutes until a constant temperature is obtained for at least three consecutive readings.
  7. Remove the beaker from the stand using tongs or mitts. Empty the solution. Rinse and dry the beaker before starting Part C.
- Part C: Salt at 2 g/100 mL**
1. Weigh 6 g of NaCl on a piece of filter paper.
  2. Repeat steps two to seven in Part B using 6 g instead of 3 g of salt.

## RESOURCE 2: A SAMPLE LAB REPORT (continued)

---

- Observations**
1. Boiling appeared to be the same in all three experimental solutions.
  2. The solutions appeared to heat at approximately the same rate.
  3. The table below illustrates the temperatures recorded while heating the three solutions.

**DATA TABLE**

Time in Minutes	Temperature (° C)		
	300 mL water	300 mL water and 3 g NaCl	300 mL water and 6 g NaCl
0	20	21	20
2	25	27	26
4	38	40	40
6	50	49	52
8	70	69	71
10	93	88	90
12	100	102	103
14	101	102	103
16	100	102	103

**Interpretations/  
Conclusions**

1. Dissolving NaCl in water tends to increase the boiling point.
2. It appears that the higher the concentration of NaCl, the higher the boiling point. However, the experiment should be repeated with several solutions of higher concentration before this inference can be confirmed.

---

From the *Junior Secondary Science Curriculum Guide and Resource Book* by the British Columbia Ministry of Education. Copyright 1983 by the British Columbia Ministry of Education. Reprinted by permission.

## RESOURCE 3: A SAMPLE EVALUATION GUIDE FOR LAB REPORTS

To assess how well you wrote your laboratory report answer the questions listed below and give yourself a mark up to the maximum score for the item in question. Then add up your score and read the marking scale below.

	Possible Score	My Score
1. Does your report have the following components each with its own heading? Title                      Procedure Object                      Observations Apparatus                  Data table Supplies                    Conclusions	6	
2. Is the object consistent with the hypothesis?	5	
3. Is the procedure listed as a series of chronological events?	4	
4. Could another student repeat your experiment with your report as the only instructions?	4	
5. Are your qualitative observations easily understood?	3	
6. Are your qualitative observations in complete sentences?	4	
7. Are your quantitative observations displayed in a data table?	2	
8. Does the data table have a title?	2	
9. Does the data table have column headings?	3	
10. Are the units clearly indicated in the data table?	2	
11. Are your conclusions consistent with the data collected and observations made?	<u>5</u>	
<b>Total</b>	<b>40</b>	

## RESOURCE 3: A SAMPLE EVALUATION GUIDE FOR LAB REPORTS (continued)

---

### Scale Point

- One** The report is incomplete. The format does not follow the model. The lab report is rated at 0 to 14 points.
- Two** There are some omissions and format problems. The report needs revision. It is rated at 15 to 24 points.
- Three** The lab report is almost complete and attention has been made to format. The report is rated at 25 to 32 points.
- Four** The lab report has a clear, careful presentation in the standard format. It is rated at 33 to 40 points.

---

From the *Junior Secondary Science Curriculum Guide and Resource Book* by the British Columbia Ministry of Education. Copyright 1983 by the British Columbia Ministry of Education. Reprinted by permission.

## RESOURCE 4: OBSERVING AND DESCRIBING

---

Observations can be recorded through descriptive writing. You should be accurate and precise without using unnecessary words. Moreover, the description should state only what is observed, never what is suspected, inferred or believed. Eliminating these interfering opinions is often difficult but in time you will become quite conscious of them.

There are two basic types of observations.

- **Qualitative observations** describe the general characteristics of an object. An example is "The automobile is a blue sedan."
- **Quantitative observations** involve measurement of an object. An example is "The automobile was 2.5 m long."

Scientists must be precise and attempt to gather as many quantitative observations as possible. This is why people often say that "mathematics is the language of science".

Observations, sometimes reported in paragraphs, are most often written as complete sentences in lists. If a series of quantitative observations are collected they are usually put in a chart so that the reader can get an overview of the data at a glance. The chart may also be converted to a line graph or a bar graph to illustrate the pattern indicated by the data.

### ASSIGNMENT 1

Your teacher will give you and your partner an everyday object such as a candle or a paper cup. Your task is to write the best series of observations to describe the object. Keep your qualitative and quantitative observations separate. It should be possible for you to list at least 50 or 60 observations in 30 minutes.

### ASSIGNMENT 2

Working as an individual, you will be assigned something for observation. As you did in the previous activity, record as many qualitative and quantitative observations as possible on separate lists.

---

From the *Junior Secondary Science Curriculum Guide and Resource Book* by the British Columbia Ministry of Education. Copyright 1983 by the British Columbia Ministry of Education. Reprinted by permission.

## RESOURCE 5: AN EVALUATION GUIDE FOR OBSERVATIONS

Your assignments in Resource 4 can be marked using the list of criteria below. Try answering the questions and marking your assignments yourself; then revise your observations to obtain a better mark.

	Possible Score	My Score
1. Did you list qualitative observations and quantitative observations? Have you presented them separately?	4	
2. Is each observation presented in a full sentence? If you read each one separately, can you tell what it means without referring to the others?	4	
3. Are any of your statements not observations? Deduct one mark each time you find: <ul style="list-style-type: none"> <li>● an opinion</li> <li>● an inference</li> <li>● a belief, or</li> <li>● a suspicion.</li> </ul> <p>Check separately for each of them.</p>		
4. Did you collect any quantitative data that can be tabulated? Have you presented these in a data table? <p>Be sure your table has:</p> <ul style="list-style-type: none"> <li>● a title</li> <li>● a heading for each column and</li> <li>● a unit expressed for each.</li> </ul>	2 3 2 <hr/>	
<b>Total:</b>	<b>15</b>	

### Scale Point

- One** The lists offer little accurate description. The description obtains 0 to 9 points.
- Two** Accurate description has been provided, but either the format of the presentation is weak or a great deal of irrelevant material – opinions, inferences, beliefs, suspicions – has been included. The description obtains 10 to 12 points.
- Three** Accurate description has been effectively presented. Data are appropriately tabulated. The description obtains 13 to 15 points.

From the *Junior Secondary Science Curriculum Guide and Resource Book* by the British Columbia Ministry of Education. Copyright 1983 by the British Columbia Ministry of Education. Reprinted by permission.

# SCIENCE AND TECHNOLOGY

---

Science and technology combine to affect almost every aspect of our lives. Students need to understand what science and technology are, and how they interact in producing familiar products and processes. Students also need to become familiar with the technological problem-solving process, and gain experience in using this process to solve practical problems involving science and technology.

Learning activities used throughout the science program will enable students to demonstrate an understanding that:

- technology facilitates the solving of practical problems
- technological development includes both products and processes
- the functioning of products and processes may be explained using scientific knowledge
- science can be used to advance technology, and technology can be used to advance science
- existing and emerging technologies have application in many everyday and work-related situations
- scientific knowledge and technology have limitations.

Problem-solving activities should be selected on the basis of the opportunities they provide for students to:

- develop confidence in personal ability to solve practical problems
- use critical and creative thinking skills
- recognize and respect alternative strategies that may be used in solving problems
- use psychomotor skills
- appreciate efficiency and design in technological products/processes
- appreciate how science and technology work to help one another.

A variety of teaching and learning strategies that illustrate interactions between science and technology and their influence on our daily lives have been included in this section of the manual. The suggestions support active involvement in solving practical problems involving science and technology, and focus attention on:

- The Relationship Between Science and Technology
  - Distinguishing Between Science and Technology
  - Interactions Between Science and Technology.
- A Model for Solving Technological Problems.
- Suggestions for Planning Problem-Solving Activities.



# THE RELATIONSHIP BETWEEN SCIENCE AND TECHNOLOGY

## DISTINGUISHING BETWEEN SCIENCE AND TECHNOLOGY

Science is the process of answering questions that arise from curiosity about natural phenomena. Science orders our knowledge of the natural world and allows us to predict the outcome of natural events. Technology, on the other hand, is the process of using scientific knowledge and other resources to develop products and processes. When we engage in technology, we attempt to solve practical problems in order to meet the needs of an individual or society. An engineering approach rather than a scientific approach is used in technology.

### CLARIFICATION/EXAMPLE

#### Examples of Science Include:

- finding out how something "works"
- investigating the cause of acid rain
- classifying plants on the basis of observable characteristics.

#### Examples of Technology Include:

- the development of vaccines to control disease
- the development of consumer products (e.g., home appliances, canned foods, automobiles)
- the development of a new computer game.

The science program should provide opportunities for students to distinguish between familiar situations involving science and those involving technology, and to recognize how technology influences various aspects of their everyday lives (e.g., food, shelter, clothing, transportation, health). The chart that follows compares the scientific and technological processes and may be useful in structuring related activities.

	SCIENCE	TECHNOLOGY
<b>TYPE OF ACTIVITY:</b>	Theoretical	Practical
<b>PROBLEMS ARISE FROM:</b>	Curiosity about events and phenomena in the natural world	Wants/needs of individuals and society to accomplish specific tasks
<b>RELATED QUESTIONS:</b>	<ul style="list-style-type: none"> <li>● Why does ... ?</li> <li>● How do we know that ... ?</li> </ul>	<ul style="list-style-type: none"> <li>● What can we do to ... ?</li> <li>● Will it work?</li> </ul>
<b>STRATEGY:</b>	Scientific Inquiry	Technological problem solving
<b>OUTCOMES/ SOLUTIONS:</b>	Knowledge about natural phenomena	Products and processes designed to achieve intended purposes
<b>EXAMPLES:</b>	Why does my coffee cool so quickly? (Heat energy is transferred by conduction, convection and radiation.)	How can I keep my coffee hot? (A thermos is designed and constructed to keep liquids hot longer.)

Sample activities that will help students to distinguish between science and technology are provided at the end of this section in:

- Resource 1: How Does Technology Affect Our Everyday Lives?
- Resource 2: How Frequently Do I Make Choices About Technology?
- Resource 3: How Are Science and Technology Different?
- Resource 4: What Do Engineers and Scientists Do?

## **INTERACTIONS BETWEEN SCIENCE AND TECHNOLOGY**

Science and technology interact and advance one another. Scientific principles frequently contribute to the development of technological devices and processes. These technologies, in turn, may identify significant questions that lead to the discovery of other scientific principles. Sometimes a technological device or process is developed without knowledge of the scientific principle behind it. This technology may then lead to the discovery of new scientific principles.

**SCIENCE**  **TECHNOLOGY**

Teachers are encouraged to focus attention on the interaction of science and technology at appropriate times throughout the science program. By asking relevant scientific and technological questions, students can be encouraged to make logical connections between science and technology, and to recognize:

- the scientific principles upon which familiar technologies are based
- technological products/processes that are based upon scientific principles being studied
- how science and technology not only "solve" existing problems, but also "create" new problems.

Activities that illustrate how science and technology interact are provided at the end of this section in:

- Resource 5: What is the Scientific Basis for Technology?
- Resource 6: What is a Technological System?

## A MODEL FOR SOLVING TECHNOLOGICAL PROBLEMS

Critical to solving problems involving science and technology is the attitude with which students approach the task. Students may be hesitant to involve themselves in situations where procedures are not easily determined and solutions are not evident. Appropriate attitudes can be nurtured through an atmosphere that provides encouragement, flexibility and acceptance. Discussion and activity should foster student interest and desire to solve practical problems. Students need to be persuaded to take risks that are associated with inventing new solutions to practical problems. Students also need to understand the importance of planning and testing alternative ideas when designing a product or process that serves an intended purpose. Particular emphasis should be given to practical problems that incorporate hands-on activities in their solution.

A model for solving practical problems involving science and technology is suggested below. This model provides a starting point and some ways of organizing problem-solving efforts.

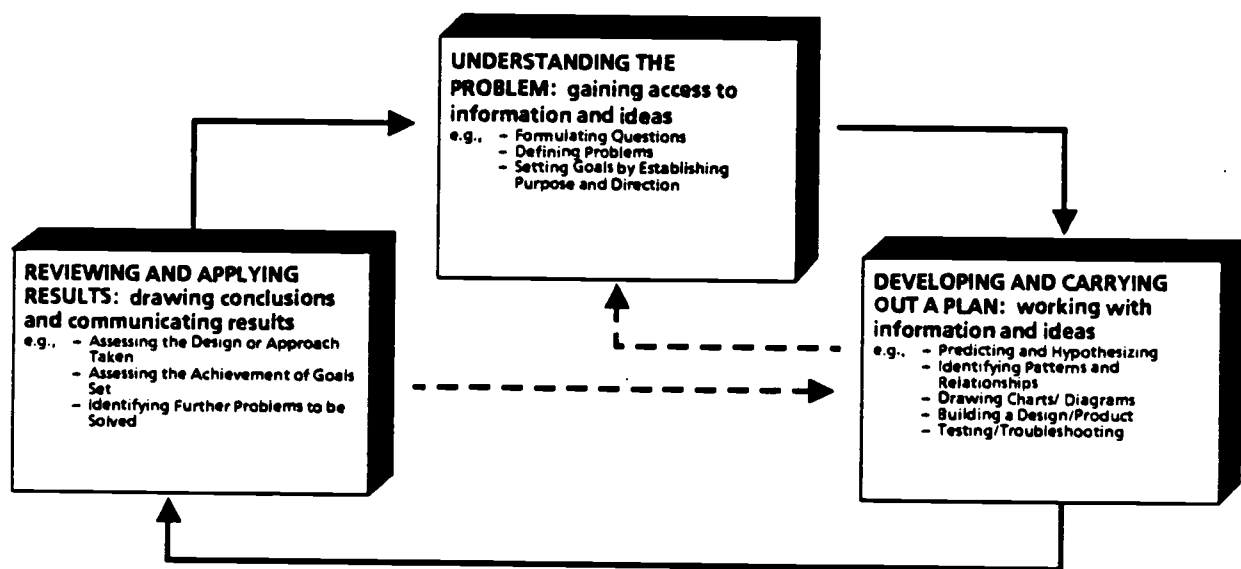

Specific actions identified at each stage of the problem-solving process represent possible strategies that might be used in solving a problem. Students may not always use each stage of the process, and will select only those actions that are appropriate to purpose and ability. Students should, however, recognize problem solving as a series of interrelated actions that lead to a solution or outcome.

By helping students to become aware of the thinking skills and thought processes that they and others use, students will be better able consciously to select and use those strategies and skills that are appropriate to the situations they encounter. Teachers are encouraged to:

- model (talk through) the processes and skills that are appropriate to solving a particular type of problem
- discuss the processes and skills that students are presently in the habit of using
- coach students in developing additional strategies that will structure and support appropriate thought process.

This model for solving technological problems can be explicitly presented to students as an overall process and then used as a teaching and learning model in problem-solving situations.

The chart that follows suggests student activities that may be appropriate at each stage of problem solving represented in the model.

<b>UNDERSTANDING THE PROBLEM</b>	<ul style="list-style-type: none"> <li>● identifying problems</li> <li>● identifying sub-problems</li> <li>● asking questions</li> <li>● identifying relationships</li> </ul>
<b>DEVELOPING AND CARRYING OUT A PLAN</b>	<ul style="list-style-type: none"> <li>● identifying alternative approaches/designs for solving the problem</li> <li>● developing/interpreting simple diagrams that illustrate problem-solving designs</li> <li>● developing/interpreting flow charts that represent approaches to problem solving</li> <li>● constructing prototypes</li> <li>● testing/troubleshooting</li> <li>● carrying out a problem-solving approach</li> </ul>
<b>REVIEWING AND APPLYING RESULTS</b>	<ul style="list-style-type: none"> <li>● evaluating a design</li> <li>● evaluating a problem-solving approach</li> <li>● evaluating a prototype</li> <li>● proposing improvements</li> </ul>

Activities that illustrate applications of the technological problem-solving process and offer opportunities for "hands-on" experience in solving practical problems are provided in:

- Resource 7: How is a Technological Product Developed?
- Resource 8: Can I Make a Better Paper Airplane?

## SUGGESTIONS FOR PLANNING PROBLEM-SOLVING ACTIVITIES

Themes developed in this manual provide opportunities for students to solve practical problems involving science and technology in a variety of meaningful contexts. Students should recognize that the strategies and skills they use in solving technological problems are "lifetime tools" and, when chosen according to purpose and need, are useful in a variety of everyday situations.

The following suggestions may be useful in planning problem-solving activities throughout the science program.

- Share the problem-solving model with all students. The model provides structure to the overall process as well as specific strategies/skills that might be used at each stage of the process. Familiarity with the model will increase the student's repertoire of strategies that can be used in solving a problem.
- Encourage students to be creative and experimental in their approach to problem solving. While useful in the structure it provides, the model for problem solving should not be interpreted as consisting of fixed stages and strategies. Its use will depend upon individual problems and individual students.
- Assist students to become aware of the thinking skills and thought processes that are useful in solving problems. Ask questions that encourage students to discover their own answers, and model (talk through) complete thought processes that are used in problem solving.
- Select problems that are relevant in the local community and that relate to the student's personal experience. Gather data related to relevant problems through a variety of methods:
  - e.g., - direct observation
  - reading/viewing
  - interview/discussion/debate
- Ensure that problem solving does not become tedious or unrealistically complex. Data related to the problem should be readily available. Remember that technology includes not just the "big things" that are the focus of societal issues, but also the "little things" that people do every day.
  - e.g., - how a bicycle or toy is repaired
  - how dishes are stacked for drying
  - how clothes are arranged in a closet or drawerSince these kinds of technologies are most relevant to students, include them in your instruction.
- Provide opportunities for students to learn from each other. Individual students often have knowledge of particular processes/devices and should be encouraged to share this knowledge with others.
- Research some important contributions made by Canadian scientists and engineers to the field of science and technology:
  - e.g., - What problem stimulated the scientist/engineer to do the work?
  - What problem-solving strategies were used to find a solution?
  - What is the domestic/international significance of this contribution?
- Arrange for a scientist/engineer from a local university/hospital/research station to visit the class and discuss:
  - the kinds of problems they solve
  - the strategies/skills they use in solving problems
- Encourage students to recognize how the model for solving problems in science provides a general plan for action that is also effective in guiding problem-solving efforts in English, mathematics, social studies and the occupational program, and how specific skills used at each stage within the model may vary according to the nature of the problem.

# RESOURCE 1: HOW DOES TECHNOLOGY AFFECT OUR EVERYDAY LIVES?

---

## PURPOSE

To recognize how technology affects our daily activities.

## PROCEDURE

1. Make a list of the products of technology that you encounter:

- on the way to school in the morning
- during the school day
- during after-school activities
- at home in the evening.

2. Classify your products according to human needs such as:

- water
- food
- shelter
- transportation.
- communication
- health
- recreation

## RESULTS

A typical list of technological products might look like the following:

Group	Products
water	running water (especially hot water for bathing)
food	frozen and canned foods, snacks, milk and ice cream, fresh vegetables, toaster, stove, refrigerator, microwave oven
shelter	furnace, house, electric blanket
transportation	cars, buses, subways, trains, roads, traffic lights
communication	radio, books, television, pens and pencils, paper, telephone, movies, micro-computer
health	toothpaste, vitamins
recreation	sports equipment, stereo systems, games

From *Science Syllabus for Middle and Junior High Schools (Block J: Science, Technology and Society)*, p. 27, by the University of the State of New York/State Education Department. Copyright 1985 by the University of the State of New York/State Education Department. Reprinted by permission.

## RESOURCE 2: HOW FREQUENTLY DO I MAKE CHOICES ABOUT TECHNOLOGY?

---

### PURPOSE

To illustrate the many technological processes or products a person chooses among in a typical day.

### PROCEDURE

1. On a chart like the one shown, make a list of the activities you engage in over the course of a day. Describe the choices of technology available to you in doing each activity, and your actual choice.

Activity	Choices Available	Your Choice
brushing teeth	manual toothbrush/ electrical toothbrush	
drying hair	hair dryer/towel and air	

2. Answer the following questions;
  - a. How many technological devices do you use in a day?
  - b. How many activities offer no choice of alternative technological devices? One choice? Two choices? Three or more choices? Make a bar graph of this data.
  - c. Would you say that technology offers you increased choices in your life? Why or why not?

From *Science Syllabus for Middle and Junior High Schools (Block J: Science, Technology and Society)*, p. 59, by the University of the State of New York/State Education Department. Copyright 1985 by the University of the State of New York/State Education Department. Reprinted by permission.

## RESOURCE 3: HOW ARE SCIENCE AND TECHNOLOGY DIFFERENT?

---

### PURPOSE

To distinguish between science and technology.

### MATERIALS

Collect pictures and/or descriptions of people engaged in science or technology. Suggested pairs of pictures showing people engaged in science and technology include:

SCIENCE	TECHNOLOGY
Galileo observing motion of objects rolling down an inclined plane.	Young people coasting downhill in a soap box racer.
A chemist heating a test tube over a bunsen burner.	Someone using a stove to heat food.
A microbiologist looking through a microscope.	A doctor or nurse immunizing a patient against disease.

### PROCEDURE

1. Show pictures or read descriptions to students. Are the people pictured or described engaged in science or technology? Use student responses to discuss the relationship and difference between science and technology.

Use the pictures/descriptions to make a bulletin board display. Classify each situation as "science" or "technology".

2. Ask students to collect additional pictures or write their own descriptions of people engaged in science or technology. Encourage students to share these with the class and add them to the bulletin board display.

---

From *Science Syllabus for Middle and Junior High Schools (Block J: Science, Technology and Society)*, p. 30, by the University of the State of New York/State Education Department. Copyright 1985 by the University of the State of New York/State Education Department. Reprinted by permission.



## **RESOURCE 4: WHAT DO ENGINEERS AND SCIENTISTS DO?**

---

### **PURPOSE**

To provide concrete examples of how an engineer and a scientist solve problems.

### **PROCEDURE**

- A. Invite one or two engineers to speak to the class about the work they do. It is helpful if the engineers are working on a project that is of interest to students, such as a new product students might use. (An engineer can be located through local industry, or a student's parent may be an engineer.)
- B. Provide the engineers with information on what the class is studying, including the problem-solving model. Remind the engineers of the students' grade level and ask them to use a problem they are working on to illustrate the problem-solving model. Encourage the engineers to bring some physical representations of the problem, such as the design and the prototype.
- C. Several days before the class visit, ask students to make a list of questions they would like to ask the engineers. Appoint one or two students to act as hosts/hostesses and to introduce the guest speakers.
- D. Repeat A-C by inviting one or two scientists to speak to the class about how they use inquiry and problem solving.
- E. Discuss the similarities and differences between engineers and scientists. Are their work roles totally separate? Is there overlap between what they do?

---

From *Science Syllabus for Middle and Junior High Schools (Block J: Science, Technology and Society)*, p. 32, by the University of the State of New York/State Education Department. Copyright 1985 by the University of the State of New York/State Education Department. Reprinted by permission.

## RESOURCE 5: WHAT IS THE SCIENTIFIC BASIS FOR TECHNOLOGY?

---

### PURPOSE

To identify the scientific concepts that are associated with technological devices or processes.

### PROCEDURE

Consider your list of technologies in Resource 1 or the list below. Discuss the scientific concept that each technological device or process is based upon.

#### Device or Process:

- |                   |                          |
|-------------------|--------------------------|
| 1. Pasteurization | 6. Electric meter        |
| 2. Ball bearing   | 7. Microscope            |
| 3. Barometer      | 8. Solar Cell            |
| 4. Thermometer    | 9. Christmas tree lights |
| 5. Thermostat     | 10. Hot air balloon      |

### RESULTS

Scientific principles that govern the operation of the technologies listed above are provided below. Other lists can easily be made from the content of individual themes in the science program.

1. Heat kills bacteria.
2. Friction can be reduced by decreasing the area of surface contact.
3. The pressure of columns of different static fluids at the same level must be the same.
4. Most substances expand when heated.
5. Different substances expand by different amounts when heated.
6. Magnets exert a force on electric current.
7. Lenses refract light to focus images.
8. Electrons in solids can be excited to higher energy levels when they absorb light.
9. If enough heat is generated by passing an electric current through a filament, light is given off.
10. Archimedes' principle.

### ALTERNATIVE ACTIVITY

Describe a scientific concept/principle and ask students to identify familiar technological devices/processes that demonstrate use of the principle.

---

From *Science Syllabus for Middle and Junior High Schools (Block J: Science, Technology and Society)*, p. 34, by the University of the State of New York/State Education Department. Copyright 1985 by the University of the State of New York/State Education Department. Reprinted by permission.

## RESOURCE 6: WHAT IS A TECHNOLOGICAL SYSTEM?

---

### PURPOSE

To distinguish among the components of a technological system.

### MATERIALS

- bimetallic strip
- simple electric circuit
- light bulb
- heat source
- reference materials.

### PROCEDURE

- A. Demonstrate what happens to a bimetallic strip when it is heated.
- B. Connect the bimetallic strip into an electrical circuit containing a light bulb. Using the electric circuit as an analogy, ask students how the bimetallic strip regulates temperature when used in a thermostat.
- C. How do a thermostat and furnace comprise a technological system? Use a diagram to show how their relationship can be represented in terms of input, processing, output, feedback and comparison/control.
- D. Ask students to use reference materials and to survey the appliances in their homes to determine what other technological systems have thermostats. **Caution:** When surveying appliances, *do not* take them apart. Simply analyze how they work, to determine if a thermostat is involved.
- E. Ask students to consider an automobile and its driver as a system. What are the input(s), process(es), output(s) and feedback associated with each of the following parts of the system: carburetor, engine, pistons and driver?

### RESULTS

A bimetallic strip works in the following way: when heated, it bends and opens the circuit, and the furnace shuts off. Upon cooling, it straightens out and closes the circuit, and the furnace turns on.

## RESOURCE 6: WHAT IS A TECHNOLOGICAL SYSTEM? (continued)

A diagram of the thermostat-furnace system might look like this:

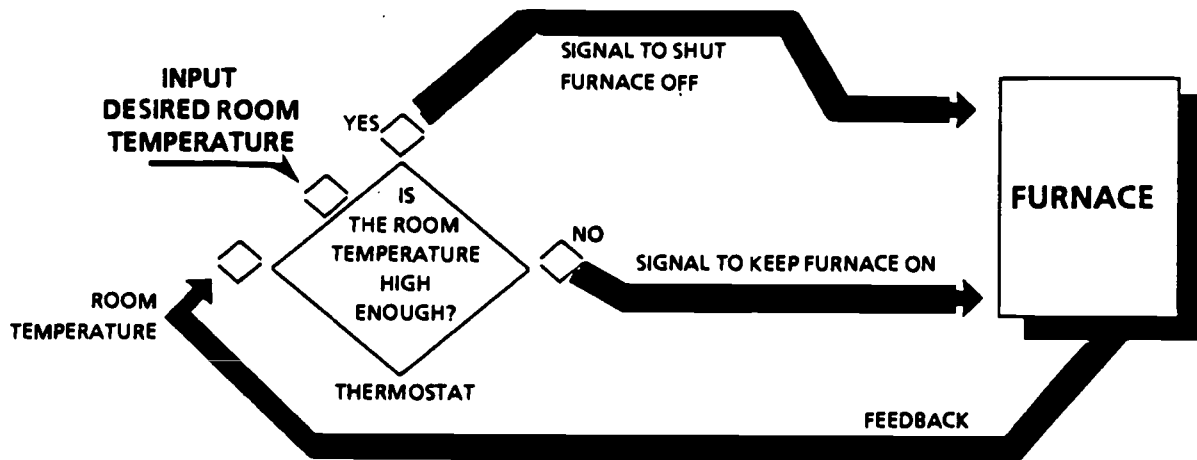

The components of the driver automobile system are show in the table and diagram below.

PART	INPUT	PROCESS	OUTPUT	FEEDBACK
carburetor	air and gas	mix air and gas	air-gas mixture	motion of car
engine	air-gas mixture and spark	combustion	heated gas	-
pistons	heated gas	response to heated gas	motion	-
driver	motion of car	decide on changes in speed	accelerator depression	car speeds up

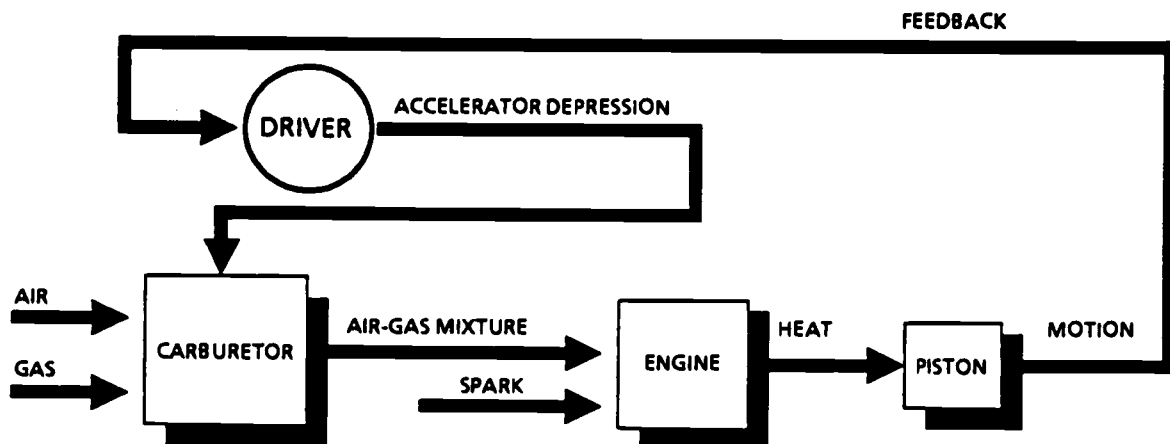

From *Science Syllabus for Middle and Junior High Schools (Block J: Science, Technology and Society)*, p. 35, by the University of the State of New York/State Education Department. Copyright 1985 by the University of the State of New York/State Education Department. Reprinted by permission.

## RESOURCE 7: HOW IS A TECHNOLOGICAL PRODUCT DEVELOPED?

---

### PURPOSE

To illustrate that fairly uniform steps are followed in developing a technological product.

### MATERIALS

Library reference books and magazines.

### PROCEDURE

- A. Divide the class into groups of three students each. Ask each group to choose one of the following technological products:
- airplane
  - automobile
  - bicycle
  - electric motor
  - radio
  - television
  - telephone
  - light bulb
  - microcomputer
  - stereo.
- B. Using library resources, have each group research the development of its chosen product and answer the following questions.
1. What need was the product designed to fulfil?
  2. How did the idea for the product first come into the mind of the inventor(s)?
  3. What kind of research was done before the product was developed?
  4. What were the main features of the product's design?
  5. Describe the prototype or initial form of the product that was constructed.
  6. How was the prototype tested?
  7. In what ways was the prototype modified before the product was mass produced?
- C. Ask each group to report its findings to the class and respond to other students' questions.

### RESULTS

Students should realize that most technological products are developed using methods that are quite fundamental to problem solving.

---

From *Science Syllabus for Middle and Junior High Schools (Block J: Science, Technology and Society)*, p. 32, by the University of the State of New York/State Education Department. Copyright 1985 by the University of the State of New York/State Education Department. Reprinted by permission.

## RESOURCE 8: CAN I MAKE A BETTER PAPER AIRPLANE?

---

### PURPOSE

To develop and use technological problem-solving skills.

### MATERIALS

paper  
reference books  
safety glasses

### PROCEDURE

1. Working in groups of three to four, use problem-solving skills to design and produce paper airplanes.
  - a. **Identify the need or problem:**  
What is the problem you want to solve or need you want to meet? Examples might include:
    - Is there an accurate way to get wastepaper into a wastebasket?
    - How can we make a device that will stay in the air the longest?
    - What device will fly the furthest distance?
  - b. **Develop a plan or idea:**  
Discuss ways to solve your problems (e.g., getting paper to a wastebasket by folding it into a shape like an airplane is a possible idea).
  - c. **Research the plan or idea:**  
What additional information do you need? (e.g., What type of paper is best? What plans have others developed?)
  - d. **Develop a design:**  
Based on the principles of flight, design an airplane to solve your problem or meet your need.
  - e. **Build a prototype:**  
Build the airplane from your design.
  - f. **Test the prototype:**  
Decide what tests you will use on your prototype. Carry out the tests and keep accurate records. (e.g., How many times did the airplane go into the wastebasket?)
  - g. **Evaluate the prototype:**  
How well did the prototype perform? (e.g., Did it consistently hit the wastebasket?) Can its performance be improved by redesign? If so, redesign it.

## RESOURCE 8: CAN I MAKE A BETTER PAPER AIRPLANE? (continued)

---

**h. Acceptance and production:**

If the prototype is accepted (with or without redesign) it is then ready for production. If the prototype is rejected, you may wish to go back and start again at (b).

**2. Answer the following questions:**

- a. When problem solving is used in industry and business, who identifies the need or problem? Who evaluates the product?
- b. Are consumers ever involved in need identification? In evaluation?

**Note:** At the end of this activity, an airplane-flying contest can be held for each problem identified by students. The contest can be compared to market competition where planes are examined for their design superiority.

---

From *Science Syllabus for Middle and Junior High Schools (Block J: Science, Technology and Society)*, p. 31, by the University of the State of New York/State Education Department. Copyright 1985 by the University of the State of New York/State Education Department. Reprinted by permission.

# SCIENCE, TECHNOLOGY AND SOCIETAL ISSUES

---

Science and technology influence many issues that we deal with individually and as members of society. Societal needs and concerns often influence technological problem solving and scientific inquiry. The science program must develop an understanding of the interactions among science, technology and society, and encourage students to appreciate the contributions and limitations of scientific and technological knowledge in resolving societal issues. Students should become familiar with the decision-making process and gain experience in its use by examining relevant issues in the local community that involve science and technology.

Learning activities used throughout the science program should enable students to demonstrate an understanding that:

- science and technology have impact on our lifestyle, occupational choice, environment and welfare
- technological products and processes develop in response to societal needs and wants
- economic, political and ethical perspectives often interact with science and technology and exert significant influence on each
- often the products of science and technology are accepted and used by society before the full extent of benefits/problems resulting from their use can be fully known
- scientific, technological and societal aspects of an issue help to inform the societal decision-making process
- compromises are often needed in order to arrive at workable solutions involving science and technology in society.

Issues selected for investigation throughout the science program should provide opportunities for students to:

- appreciate the need for informed decision making at both personal and societal levels
- develop confidence in using scientific and technological knowledge to inform personal decision making
- appreciate the legitimacy of many different perspectives in the decision-making process
- respect the perspectives and viewpoints of others
- realize that the solution to one problem may result in the creation of another problem
- appreciate the beauty and complexity of living things
- appreciate the interdependence of life forms
- appreciate the need for conservation of our environment.

A variety of teaching and learning strategies that illustrate how science and technology influence and are influenced by societal issues have been included in this section of the manual. The suggestions support active involvement in the decision-making process, and focus attention on:

- Interactions Among Science, Technology and Society
  - Recognizing How Science and Technology Influence Society
  - Recognizing How Society Influences Science and Technology.
- A Model for Making Informed Decisions .
- Suggestions for Examining Relevant Community Issues.



# INTERACTIONS AMONG SCIENCE, TECHNOLOGY AND SOCIETY

## RECOGNIZING HOW SCIENCE AND TECHNOLOGY INFLUENCE SOCIETY

We live in a rapidly changing society that is highly dependent upon science and technology. In fact, our world changes so rapidly that we sometimes fail to recognize that much of what we now take for granted existed only in the imaginations of people a few decades ago. Advances in science and technology will make much of today's science fiction become reality within our lifetime. Furthermore, the changes that we experience and have become accustomed to are occurring at an increasing rate. It is predicted that these changes will continue and accelerate as we enter the twenty-first century.

### CLARIFICATION/EXAMPLE

#### Developments in Science and Technology That Influence Society

- New biomedical advances make it possible to replace defective hearts, kidneys and other organs.
- The first flight lasted only a few seconds. Now, a little more than half a century later, space vehicles travel thousands of miles an hour to explore distant planets.
- Nuclear technology, of interest a few years ago because of its destructive potential, could soon provide us with almost limitless supplies of energy for peacetime needs.
- Computer technology has made it possible to solve, in seconds, problems that only a decade ago required many human lifetimes.
- Science and technology may, in the future, make it possible for us to control weather and other natural phenomena to varying degrees.

The science program should provide opportunities for students to recognize the impact of science and technology on the nature of their lifestyle, their employment and career opportunities, as well as the quality of their environment. The activities that follow suggest ways of demonstrating how science and technology influence individuals and society within various themes of the science program.

- Ask students to identify situations in which a particular technology has:
  - improved their lifestyle
  - had a negative effect on their quality of life

Structure discussion and guide students through the processes of analysis and critical thought by using a "PMI" or a "CAF" (see Communication Skills, "Using Critical Thinking Skills").

Activities provided in Resource 1: What Were the "Good Old Days" Really Like? and Resource 2: How Have Our Choices in Leisure Activities Changed? may be useful in examining the positive and negative effects of science and technology on society.

- Identify a familiar development in the area of science, technology or society. Ask students to predict possible effects of this development on the other two areas.

Encourage students to recognize how science, technology and society are each part of an interdependent system, and how science and technology play a major role in society.

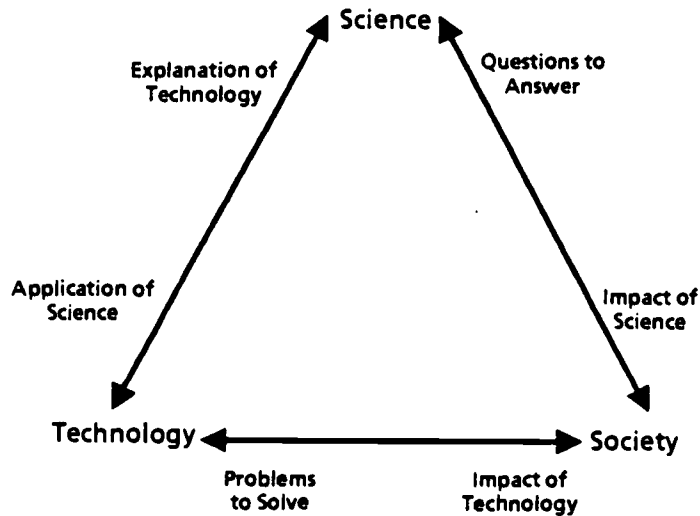

Activities that focus attention on how changes in either science, technology or society affect the other two areas are provided in Resource 3: How Do Science, Technology and Society Affect Each Other?

- Investigate the effects of technology on employment and career opportunities within each theme of the science program. Ask students to identify employment and career opportunities that:
  - have been created by technological change in the past ten years
  - have been modified by technological change in the past ten years
  - have become obsolete due to technological change in the past ten years.

The activities provided in Resource 4: How Have Jobs and Careers Changed in the Last Thirty Years? and Resource 5: Where Are the Jobs and Careers? will assist students to understand how science and technology have affected business, industry and employment.

## RECOGNIZING HOW SOCIETY INFLUENCES SCIENCE AND TECHNOLOGY

Science and technology do not act independently of society. Although the achievements of science and technology exert considerable influence on society, so does society either support or limit the progress of science and technology. Societal needs and concerns often initiate or direct technological problem solving and scientific inquiry. As societal values and attitudes change, so may motivation and support for research and development in particular areas change.

Learning activities should focus attention on how society influences science and technology at appropriate times throughout the science program, and should enable students to recognize that:

- technological processes and devices are usually developed in response to the needs of individuals and society
  - e.g., - vaccines against diseases
  - fast food restaurants
  - facsimile machines

- the use of a technological process or device may depend upon the attitudes of individuals or society toward it
  - e.g., - food products such as the "chicken hot dog"
  - the recumbent bicycle
  - front-wheel drive automobiles
- society often influences science and technology through the public funds it provides to support research and development in certain areas
  - e.g., - space exploration
  - medical research
  - environmental research.

Sample activities that illustrate how society influences scientific research and technological development are provided in:

- Resource 6: Would You Eat Irradiated Food?
- Resource 7: Have We Accepted Unit Pricing and Generic Goods?
- Resource 8: Why Are Some Inventions Not Accepted by Society?

## A MODEL FOR MAKING INFORMED DECISIONS

Although science and technology give us tremendous ability, individuals and society must assume the responsibility of using this ability wisely. Some developments in science and technology, if inappropriately used, may force us to pay a price in terms of their effect on society and the environment. For example:

- the world's natural resources are being rapidly depleted
- our water and air are no longer pure and clean
- thousands of plant and animal species are threatened with extinction.

This does not imply that we should try to halt scientific and technological advancements. Rather, it draws attention to the importance of the decision-making process and the role of choice in resolving related problems in society. Issues influenced by science and technology need to be examined within the context of choosing the most appropriate actions for existing circumstances. Resolving these issues involves considering alternative proposals for action and evaluating their consequences. Scientific and technological knowledge can help inform deliberation about these proposals.

The science program should provide opportunities for students to examine relevant societal issues that involve science and technology, and to develop a process for resolving these issues and making informed decisions. A model for resolving societal issues is suggested below. This model provides a starting point and some ways of organizing thought and action.

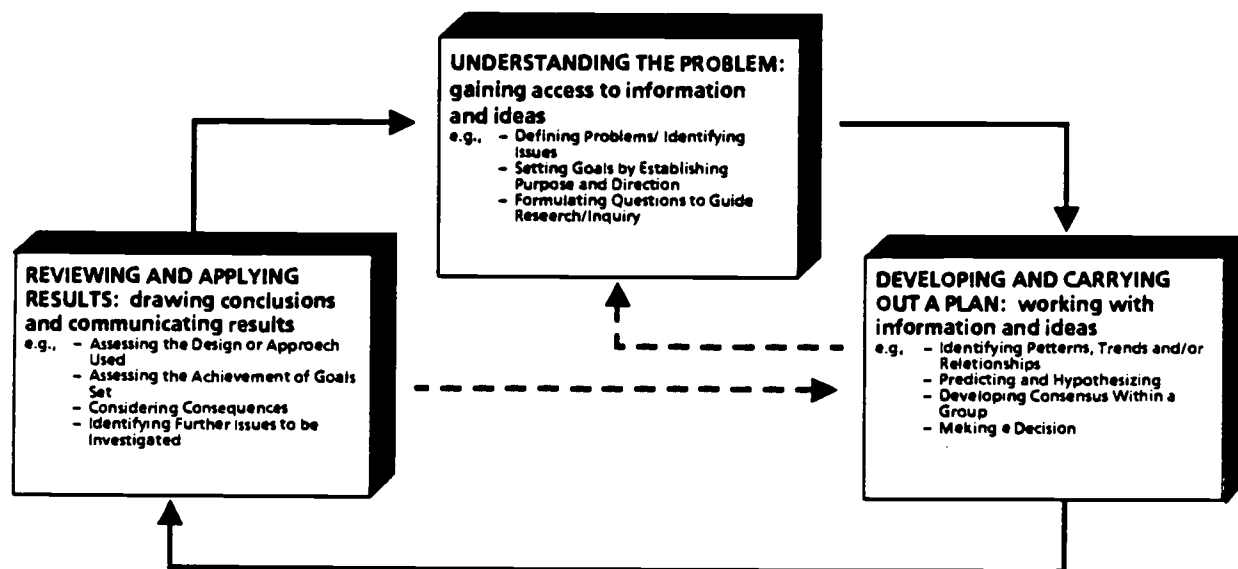

Specific actions identified at each stage of the decision-making process represent possible strategies that might be used in deliberating and making a decision to act in a certain way. Students may not always use each stage of the process and will select only those actions that are appropriate to purpose and ability. Students should, however, recognize decision making as a series of interrelated actions that lead to a defensible outcome.

By helping students to become aware of the thinking skills and thought processes that they and others use, students will be better able consciously to select and use those strategies and skills that are appropriate to the situations they encounter. Teachers are encouraged to:

- model (talk through) the processes and skills that are appropriate to analyzing a particular issue
- discuss the processes and skills that students are presently in the habit of using
- coach students in developing additional strategies that will structure and support the thought process.

This model for decision making can be explicitly presented to students as an overall process and then used as a teaching and learning model when analyzing societal issues. The chart that follows suggests student activities that may be appropriate at each stage of decision making represented in the model.

<b>UNDERSTANDING THE PROBLEM</b>	<ul style="list-style-type: none"> <li>● identifying issues</li> <li>● identifying/interpreting relationships</li> <li>● asking questions</li> <li>● identifying different perspectives or points of view (e.g., economic, political, ethical, scientific, technological).</li> </ul>
<b>DEVELOPING AND CARRYING OUT A PLAN</b>	<ul style="list-style-type: none"> <li>● researching issues               <ul style="list-style-type: none"> <li>- identifying alternatives</li> <li>- examining different perspectives on each alternative</li> <li>- gathering information about alternative technological products/processes related to an issue</li> <li>- identifying/applying appropriate scientific knowledge</li> </ul> </li> <li>● reflecting and deciding               <ul style="list-style-type: none"> <li>- considering the consequences/implications of the alternatives</li> <li>- evaluating technological products/processes from different perspectives</li> <li>- evaluating the defensibility of an action</li> <li>- consensus building</li> </ul> </li> <li>● taking action.</li> </ul>
<b>REVIEWING AND APPLYING RESULTS</b>	<ul style="list-style-type: none"> <li>● evaluating the immediate effects of actions taken</li> <li>● evaluating the long-term consequences of actions taken</li> <li>● modifying actions to reduce or eliminate other problems</li> <li>● justifying/defending actions taken</li> <li>● evaluating the decision-making process.</li> </ul>

As students investigate relevant societal issues involving science and technology, focus attention on:

- the probable long- and short-term consequences of particular technologies and/or actions
- strategies for assessing particular technologies and/or actions in terms of their advantages and disadvantages
- an awareness of various perspectives/possible solutions to complex issues.

Sample activities that provide opportunities for students to examine societal issues and develop skills appropriate to the decision-making process are provided in:

- Resource 9: How Should We Access a Technological Process or Device?
- Resource 10: Who Receives an Organ Transplant?
- Resource 11: How Do We Make Decisions About Technology?

## SUGGESTIONS FOR EXAMINING RELEVANT COMMUNITY ISSUES

Themes developed in this manual provide opportunities for students to investigate relevant issues involving science and technology in the local community. Students should recognize that the strategies and skills they use in making informed decisions are "lifetime tools" and, when chosen according to purpose and need, are useful in many everyday situations.

The following suggestions may be useful when analyzing local issues involving science and technology.

- Share the decision-making model with all students. The model provides structure to the overall process as well as specific strategies/skills that might be used at each stage of the process. Familiarity with the model will increase the student's repertoire of strategies that can be used in resolving issues.
- Encourage students to be flexible in their approach to decision making. While useful in the structure it provides, the model should not be interpreted as consisting of fixed stages and strategies. Its use will depend upon individual issues and individual students.
- Make students aware of the thinking skills and thought processes that are useful in analyzing issues. Ask questions that encourage students to discover their own answers and model (talk through) complete thought processes that are used in resolving issues and making informed decisions.
- Select issues that are relevant in the local community and that relate to the student's personal experience. Gather data related to relevant issues through a variety of methods:  
e.g.,
  - direct observation
  - reading/viewing
  - interview/discussion/debate

Ensure that students consider current perspectives on the issues they investigate by using the local media (e.g., newspaper, periodicals, television, radio).

- Encourage students to consider advantages and disadvantages associated with the issues they investigate and to avoid taking simple "for" and "against" positions. Students should recognize that there are often several ways to resolve complex issues. The model below illustrates the complexity of some issues and offers a useful framework for their examination from different perspectives.

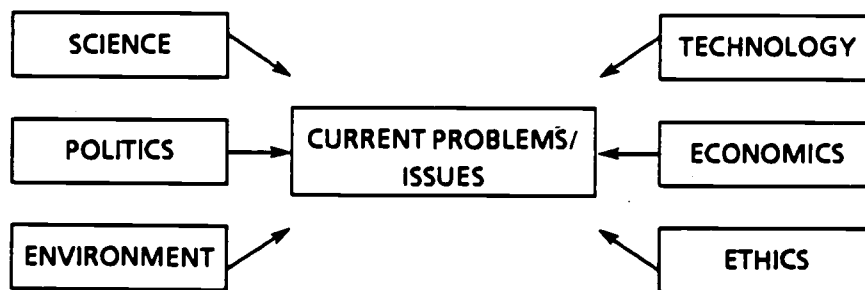

- Structure discussion and debate, using the guidelines provided in Communication Skills, "Strategies for Discussing and Debating". Debating is a good technique to use in encouraging students to think through complex issues carefully. Deal appropriately with students who may dominate conversation and encourage others who are hesitant to express their ideas; to become involved. Ensure that discussion does not become a clash of personalities.

- Ask questions that will challenge students to use higher-level reasoning skills and to explore ideas they may not have considered. Useful types of questions include:
  - Can you tell me more about ...?
  - What else might happen if ...?
  - If ... then ...?
  - How did you arrive at that conclusion?
  - What made you ask that question?
  - Why do you say that?
  - How did you think of that?
- Provide opportunities for students to clarify their ideas and justify the positions they adopt through writing activities. Guidelines for structuring writing activities are provided in Communication Skills, "Summarizing, Evaluating and Communicating Ideas in Science".
- Encourage students to recognize how the model for examining issues in science provides a general plan for action that is also effective when examining other kinds of issues in English, mathematics, social studies and the occupational program, and how specific skills used at each stage within the model may vary according to the nature of the issue.

The following chart provides a comparison of the scientific, technological and societal processes as they occur in practical situations.

	SCIENCE	TECHNOLOGY	SOCIETY
<b>TYPE OF ACTIVITY:</b>	Theoretical	Practical	Practical
<b>PROBLEMS ARISE FROM:</b>	Curiosity about events and phenomena in the natural world	Wants/needs of individuals and society to accomplish specific tasks	Consideration of a broad range of interests in terms of the "common good"
<b>RELATED QUESTIONS:</b>	<ul style="list-style-type: none"> <li>● Why does ...?</li> <li>● How do we know that...?</li> </ul>	<ul style="list-style-type: none"> <li>● What can we do to ...?</li> <li>● Will it work?</li> </ul>	<ul style="list-style-type: none"> <li>● What alternatives and consequences are there?</li> <li>● What should we do?</li> </ul>
<b>STRATEGY:</b>	Scientific Inquiry	Technological problem solving	Deliberation/consensus building
<b>OUTCOMES/ SOLUTIONS:</b>	Knowledge about natural phenomena	Products and processes designed to achieve intended purposes	A defensible decision in the particular circumstances
<b>EXAMPLES:</b>	<p>Why does milk sour?</p> <p>(Bacteria grows in milk. This bacterial growth causes illness and also causes milk to sour.)</p>	<p>What can we do to keep milk from souring and causing illness?</p> <p>(The process of pasteurization makes milk safe to drink and produces milk that tastes good.)</p>	<p>Should we require standards for the processing and handling of milk?</p> <p>(All commercial milk supplies must be pasteurized. The containers must be dated.)</p>

## RESOURCE 1: WHAT WERE THE "GOOD OLD DAYS" REALLY LIKE?

---

### PURPOSE

To illustrate that science and technology have changed society and our lifestyles a great deal in the past century.

### MATERIALS

Reference books.

### PROCEDURE

1. Work in groups of three. With the help of reference books, your teacher and other adults, answer the following questions:
  - a. Using the fastest transportation available, how long would it have taken you to reach Toronto, Ontario in 1889? How long would it take you today?
  - b. How quickly would you have been able to contact a relative living in Vancouver, B.C. in 1889? How long would it take today?
  - c. What would you have used to go shopping in a town ten kilometres from your home in 1889? What would you use today? How long would a round trip have taken in 1889? How long would it take today?
  - d. What might you have done to entertain yourself in 1889? For how many hours per week would you have been engaged in such leisure in 1889?
  - e. What might you do to entertain yourself today? For how many hours per week would you engage in such leisure today?
  - f. How many years would you have expected to live in 1889? How many years do you expect to live today?
  - g. What diseases that might have threatened you in 1889 have been virtually eliminated as threats today?
  - h. What careers might you pursue today that were not available to you in 1889?
2. Review and compare group responses to the above questions in class. Summarize your discussion with the following questions:
  - a. In what ways have our lives been made better by achievements in technology over the last century?
  - b. What good things have been lost through the impact of technology over the past century?



## RESOURCE 1: WHAT WERE THE "GOOD OLD DAYS" REALLY LIKE? (continued)

---

### RESULTS

Students, in comparing the possibilities in 1889 and today, will realize that vast improvements have occurred in transportation, communication, health care and personal opportunities. However, some may realize that such progress has come at the expense of the environment, national security and the extended family. The key concept is that science and technology invariably change society.

---

From *Science Syllabus for Middle and Junior High Schools (Block J: Science, Technology and Society)*, p. 47, by the University of the State of New York/State Education Department. Copyright 1985 by the University of the State of New York/State Education Department. Reprinted by permission.

## RESOURCE 2: HOW HAVE OUR CHOICES IN LEISURE ACTIVITIES CHANGED?

---

### PURPOSE

To show that technology has greatly increased the number of ways we can spend our leisure time.

### MATERIALS

Reference books.

### PROCEDURE

1. Make a list of the ways you can spend your leisure time (e.g., after school, evenings, weekends).
2. Place a check next to the ways which were also available to your parents when they were your age.
3. Place a second check next to the ways which were available to your grandparents when they were your age.
4. Place a third check next to the ways which were available to the earliest settlers in Canada.
5. Place an asterisk in front of the ways which depend on technology.
6. Observe some relationships between the asterisks, check marks and activities in your list.

### RESULTS

Student lists may look like the following:

* ✓	Television
* ✓ ✓	Movies
*	Video games
* ✓ ✓ ✓	Visit with friends
*	Watch movies at home on the VCR
* ✓ ✓ ✓	Eat
* ✓ ✓ ✓	Read
* ✓ ✓ ✓	Play games (non-video)

From *Science Syllabus for Middle and Junior High Schools (Block J: Science, Technology and Society)*, p. 60, by the University of the State of New York/State Education Department. Copyright 1985 by the University of the State of New York/State Education Department. Reprinted by permission.

## RESOURCE 3: HOW DO SCIENCE, TECHNOLOGY AND SOCIETY AFFECT EACH OTHER?

---

### PURPOSE

To show that changes in either science, technology or society also affect the other two areas.

### PROCEDURE

Ask your students to suggest situations in which changes in science have affected technology and society and also situations in which changes in society have affected science and technology. If they encounter difficulty, you might offer hints from the examples below.

#### CHANGES IN SCIENCE THAT HAVE AFFECTED TECHNOLOGY AND SOCIETY:

SCIENCE	TECHNOLOGY	SOCIETY
laws of motion	space travel	new products, greater knowledge of universe
electricity	electrical appliances	more leisure time
electromagnetic waves	radio and TV	home entertainment
chemistry (chemical bonds)	synthetic materials	new products
radioactivity	nuclear medicine	better health
nuclear fission	nuclear reactors	reduced dependence on oil
structure of matter	microelectronics	increased calculative capability

#### CHANGES IN SOCIETY THAT HAVE AFFECTED SCIENCE AND TECHNOLOGY:

SOCIETY	SCIENCE	TECHNOLOGY
funding of medical research	medical research	new diagnostic techniques
prohibition of genetic engineering laboratories	restricted research	slow technological development

From *Science Syllabus for Middle and Junior High Schools (Block J: Science, Technology and Society)*, p. 45, by the University of the State of New York/State Education Department. Copyright 1985 by the University of the State of New York/State Education Department. Reprinted by permission.

## RESOURCE 4: HOW HAVE JOBS AND CAREERS CHANGED IN THE LAST THIRTY YEARS?

---

### PURPOSE

To investigate changes in business, industry, career choices, and employment brought about by science and technology.

### PROCEDURE

1. Interview a retired person and ask the following questions. Record the answers.
  - a. What was your first full-time job?
  - b. How long did you continue to do that type of work?
  - c. If you changed the type of work you did, what was the reason?
  - d. How many different types of work did you do?
  - e. Of all the types of work you did, how many of those jobs are still available today?
  - f. What has replaced the jobs no longer available?
2. Interview someone who has been working in the same job at least ten years and ask the following questions. Record the answers.
  - a. What changes have you seen in your job in the past ten years?
  - b. Have computers affected your job?
  - c. What changes do you expect to see in your job in the next ten years?
3. Interview a person who has been employed full-time for less than ten years and ask the following questions. Record the answers.
  - a. Was your job newly created by some technological advance or was it performed by someone else before you?
  - b. Do you use computers on your job?
  - c. What changes do you expect to see in your job in the next ten years?

4. Tabulate class results.

Retired persons:

- Number with same type of job entire life \_\_.
- Number with two different types of jobs \_\_.
- Number with more than two different types of jobs \_\_\_.
- Total number of types of jobs \_.
- Number still available today \_\_\_.

Persons working ten years:

- Number of changes in jobs in the last ten years \_\_\_.
- Number affected by computers \_\_\_.
- Number with changes in jobs expected in the next ten years \_\_\_.

## RESOURCE 4: HOW HAVE JOBS AND CAREERS CHANGED IN THE LAST THIRTY YEARS? (continued)

---

Persons working less than ten years:

- Number of jobs newly created by a technological advance \_\_\_\_\_.
  - Number of jobs previously performed by someone else \_\_\_\_\_.
  - Number of jobs using computers \_\_\_\_\_.
  - Number with changes in jobs expected in the next ten years \_\_\_\_\_.
5. Plan a field trip to industries that are utilizing new technological devices or processes. If possible, select a company that has an employee "retraining" program. Observe the work people are doing.
  6. Write a brief paragraph describing your observations in question 5.
  7. Look at the class data from question 4 and your raw data from questions 1, 2 and 3. Write two or three paragraphs that summarize how science and technology have affected business, industry, career choices and employment in the last 30 years.

---

From *Science Syllabus for Middle and Junior High Schools (Block J: Science, Technology and Society)*, p. 49, by the University of the State of New York/State Education Department. Copyright 1985 by the University of the State of New York/State Education Department. Reprinted by permission.

## RESOURCE 5: WHERE ARE THE JOBS AND CAREERS?

---

### PURPOSE

To use newspaper classified sections to see what jobs and careers are available and what training is necessary for them.

### MATERIALS

Classified sections from local and large city newspapers.

### PROCEDURE

1. From the classified sections of the newspapers, cut out ten "Help Wanted" ads.
2. Describe the training necessary to obtain each of the jobs.
3. As a class, discuss the following questions:
  - a. How can an individual obtain the training necessary to obtain or change jobs?
  - b. What can students do to prepare for a changing job market?
  - c. Which of the jobs or careers interest you most? Why?

---

From *Science Syllabus for Middle and Junior High Schools (Block J: Science, Technology and Society)*, p. 50, by the University of the State of New York/State Education Department. Copyright 1985 by the University of the State of New York/State Education Department. Reprinted by permission.

## RESOURCE 6: WOULD YOU EAT IRRADIATED FOOD?

---

### PURPOSE

To illustrate that acceptance of a technological process or device depends on the attitudes of individuals toward it.

### MATERIALS

Newspaper and magazine articles on irradiated foods.

### INTRODUCTION

Everywhere in the world, we throw away large amounts of food every day because the action of microorganisms has caused the food to become moldy or rotten. If we used ionizing radiation on these foods to kill the microorganisms, the loss of food would be significantly reduced. But the use of ionizing radiation in Canada is controversial, even though other countries already irradiate food.

### PROCEDURE

1. Read the following passage:

There is cooked ham on the table in the food-testing laboratory. It has been there for two months covered only by a piece of plastic wrap. It looks as if it had just come out of the oven but it is not hot. There is a note next to it which says it was irradiated 52 days ago. The note also indicates that the ham was part of a test on preserving food by radiation and that the ham has been in the same spot ever since. The test has shown that the radiation has killed all the bacteria which could cause the ham to spoil but has not affected the taste of the ham or made it radioactive. You are invited to have some of the ham for lunch.

2. In a group of three or four, discuss and answer the following questions:
  - a. How do you feel about eating the ham?
  - b. Why do you feel that way?
  - c. What questions would you ask the scientists who tested the ham before making your decision?
3. Have one member from each group report how the members of the group felt about eating the ham.
4. Read at least two articles on irradiated foods and take notes.
5. Write a report that summarizes the evidence for and against eating irradiated food. Include in your report a statement about whether or not you would eat irradiated food. Explain your decision.

217

## RESOURCE 6: WOULD YOU EAT IRRADIATED FOOD? (continued)

---

### RESULTS

Some of the evidence for and against eating irradiated food is cited below.

#### Evidence for:

- Studies over 30 years find the process safe if irradiation levels are controlled.
- Studies indicate that no radioactive residue results and there is no reduction in nutritional content of foods.
- Irradiation of food eliminates the need for chemical preservatives. (Some, like ethylene dibromide and nitrites, have been controversial in themselves.)

#### Evidence against:

- Some changes do occur in foods, producing new substances which may be harmful.
- Studies have not been conducted over a long enough time.
- Irradiation may increase aflatoxin, a suspected carcinogen.
- Government may not require the labelling of irradiated food.

---

From *Science Syllabus for Middle and Junior High Schools (Block J: Science, Technology and Society)*, p. 52, by the University of the State of New York/State Education Department. Copyright 1985 by the University of the State of New York/State Education Department. Reprinted by permission.



## RESOURCE 7: HAVE WE ACCEPTED UNIT PRICING AND GENERIC GOODS?

---

### PURPOSE

To show that the acceptance of a technological product/process depends upon the attitudes of individuals toward it.

### PROCEDURE

1. Take a chart similar to the one provided on the following page to two different supermarkets. At each supermarket, examine the unit pricing on ten name-brand items and also a generic brand for each item. Where possible, include at least two package sizes for each item. Record the unit price on the chart as you examine each item.
2. Survey at random twelve shoppers from each supermarket. Ask the following questions:
  - a. Do you use unit pricing in selecting what you buy?
  - b. Do you buy generic goods? If so, do you feel that buying generic goods saves you money without sacrificing quality?
3. Summarize the results for the entire class. Answer the following questions:
  - a. Which of the brands would you purchase in each supermarket? Why?
  - b. Which supermarket appears to have better values?
  - c. Does your survey of shoppers indicate that they use unit pricing while making their purchases?
  - d. Do the shoppers at one supermarket seem more conscious of unit pricing than those at the other supermarket? If so, give a possible reason.
  - e. Does your survey of shoppers indicate that they buy generic goods?
  - f. Do the shoppers at one supermarket seem more conscious of generic goods than those at the other supermarket? If so, give a possible reason.

**RESOURCE 7: HAVE WE ACCEPTED UNIT PRICING AND GENERIC GOODS?**  
 (continued)

ITEM	Name Brand		Generic Brand	
	Store #1	Store #2	Store #1	Store #2
1.				
2.				
3.				
4.				
5.				
6.				
7.				
8.				
9.				
10.				

From *Science Syllabus for Middle and Junior High Schools (Block J: Science, Technology and Society)*, p. 55, by the University of the State of New York/State Education Department. Copyright 1985 by the University of the State of New York/State Education Department. Reprinted by permission.

## RESOURCE 8: WHY ARE SOME INVENTIONS NOT ACCEPTED BY SOCIETY?

---

### PURPOSE

To consider why certain technological designs were never widely accepted.

### PROCEDURE

1. Consider the following list of patented inventions:
  - a fake cigarette package that coughs loudly when picked up
  - children's forks and spoons whose handles are made into musical whistles
  - a beauty mask for women to wear at night while sleeping
  - parakeet diapers
  - a firecracker fire alarm
  - a golf ball that sends out a smoke signal when it lands to help locate it
  - a gun whose curved barrel extension allows it to shoot around corners
  - a coffin with a tube for fresh air and an alarm
  - an automatic baby-burper
  - a gold trap which, when swallowed, is supposed to catch tapeworms.
2. Discuss why each of the above inventions has not become widely accepted.
3. Suggest an invention that might be useful and describe it to the class.
4. Poll the class to determine which student inventions are most popular. Which appear to be most useful?

### RESULTS

Each week, thousands of inventions are registered. Millions of patents have been issued since 1790. Clearly, many of these innovations were thought to be more important by their inventors than by the society which neglected to use them.

(Patented inventions were selected from *Patents Ridiculous and Sublime* by Stacy, V. Jones, Quadrangle/The New York Times Book Co., 1973.)

---

From *Science Syllabus for Middle and Junior High Schools (Block J: Science, Technology and Society)*, p. 56, by the University of the State of New York/State Education Department. Copyright 1985 by the University of the State of New York/State Education Department. Reprinted by permission.

## RESOURCE 9: HOW SHOULD WE ASSESS A TECHNOLOGICAL PROCESS OR DEVICE?

### PURPOSE

To develop a process for assessing a technological process or device.

### PROCEDURE

1. Using the chart provided, describe the benefits and burdens placed upon people and the environment when each of the technological processes/devices are put into use in our society.
2. Place an asterisk in front of each technological process/device for which you feel the benefits outweigh the burdens. Be prepared to discuss your reasons.
3. How often did you and your classmates agree that a particular process or device should be (or should have been) adopted?
4. How can people assess whether or not to adopt a technological process/device?

DATA TABLE

Technological Process or Device	Benefit	Burden
nuclear energy	(additional electricity)	(risk of war, radioactive wastes)
mass transportation	(less pollution, less energy used)	(personal inconvenience, large cost)
robotics	(modernized, efficient industry)	(loss of jobs)
drugs	(treat diseases)	(dependence through abuse)
pesticide/insecticide	(increased agricultural yields)	(extinction of helpful species)
product packaging with synthetic materials	(fresher food)	(nonbiodegradable waste in landfills)
computers	(increased ability to process data)	(loss of jobs, health problems from video display terminals)
space travel	(increased knowledge)	(high financial cost)
life-sustaining devices	(keep people alive)	(how to decide when to use or remove them)
organ transplants	(increased life span)	(cost, decision as to who receives them)
automobile	(increased mobility)	(increased pollution, deaths)
chemical fertilizers	(increased agricultural yields)	(eutrophication of lakes)
artificial sweeteners	(convenience for diabetics and dieters)	(increased risk of cancer)

## RESOURCE 9: HOW SHOULD WE ASSESS A TECHNOLOGICAL PROCESS OR DEVICE? (continued)

---

### RESULTS

Indicated in parentheses. Students should begin to realize that it is possible to assess technological processes/devices by the burdens and benefits they create. However, assessment depends on an ability to predict future consequences. We do not always possess this ability. When a decision is made to adopt or reject a particular process/device, there may not be total agreement about that decision.

---

From *Science Syllabus for Middle and Junior High Schools (Block J: Science, Technology and Society)*, p. 46, by the University of the State of New York/State Education Department. Copyright 1985 by the University of the State of New York/State Education Department. Reprinted by permission.

## RESOURCE 10: WHO RECEIVES AN ORGAN TRANSPLANT?

---

### PURPOSE

To show the serious issues which may surround the use of a technological process.

### MATERIALS

Recent newspaper and magazine articles about organ transplants.

### PROCEDURE

1. Read several articles about organ transplants.
2. As a class, discuss the following questions:
  - a. There are more patients in need of organ transplants than there are organs available. What is the fairest way of deciding who gets the organs that are available? Who should decide?
  - b. If a person offered to sell a part of his or her body to someone in need of that part, should this be permitted?
  - c. Organ transplant operations and related equipment and health care are very expensive and serve a relatively small number of people. What responsibility does government or society have for assuming the financial burden of these expensive procedures?
  - d. A person can survive if only one of the two kidneys in the body is functional. Should it be legally required that parents or children contribute one of their healthy kidneys to another member of the family if that is required to save the person's life?
3. In your reading about organ transplants, what other issues did you find concerning transplants? Which of these are moral or ethical issues? Which are governmental or legal issues? Why?
4. Are the issues you have just discussed and read about easy to resolve? Why or why not?

### RESULTS

Students should be encouraged to understand that there are different issues surrounding the use of many technological processes and devices. These issues are controversial and there are generally no easy solutions.

---

From *Science Syllabus for Middle and Junior High Schools (Block J: Science, Technology and Society)*, p. 68, by the University of the State of New York/State Education Department. Copyright 1985 by the University of the State of New York/State Education Department. Reprinted by permission.

## **RESOURCE 11: HOW DO WE MAKE DECISIONS ABOUT TECHNOLOGY?**

---

### **PURPOSE**

To show that a complex technological issue has several possible solutions and that trade-offs are often made among these solutions.

### **MATERIALS**

Reference books and magazine, recent newspaper articles about technological issues.

### **PROCEDURES**

1. Read several magazine and newspaper articles about one of the following technological issues:
  - the need for additional amounts of energy
  - disposal of toxic wastes
  - disposal of radioactive wastes
  - contamination of ground water supplies
  - artificial organs.
2. As a class, discuss and describe alternative courses of action for the technological issue.
3. As a class, decide which alternative courses of action should be followed. You may have to come up with a compromising course of action.
4. Answer the following questions:
  - a. How difficult was it to make a group decision about the proper course of action?
  - b. To what degree did individuals have to make compromises?
  - c. If experts were to become involved in making decisions about this issue, from what disciplines might they come? To what extent do you think these experts would agree on the solution?
5. Invite a person who is involved with policy making to speak to the class about how individuals and government make decisions and set policy.

---

From *Science Syllabus for Middle and Junior High Schools (Block J: Science, Technology and Society)*, p. 70, by the University of the State of New York/State Education Department. Copyright 1985 by the University of the State of New York/State Education Department. Reprinted by permission.

# COMMUNICATION SKILLS

The strands of language (i.e., listening, speaking, reading, writing and viewing) play an important part in the teaching and learning of science. Not only is language a means of communication, but it is also part of the thinking process used to combine ideas, find relationships, ask questions and solve problems. Language development in Science 16-26 must parallel its development in English 16-26, through use of strategies that are often similar to those used in the English class.

A variety of teaching and learning strategies useful in gathering, interpreting, recording, evaluating and communicating ideas in science are provided in this section of the manual. Teachers are encouraged to familiarize themselves with these strategies. By teaching and modelling appropriate "learning to learn" strategies within each theme of the science program, teachers can support students in their use of language and thinking skills.

## CLARIFICATION/EXAMPLE

### An Approach to Teaching a Learning Strategy (Deshler, 1979)<sup>1</sup>

1. Test students on a task that requires the use of the strategy to be taught. Discuss the results with students and point out strategy deficiencies.
2. Describe the steps involved in the target strategy. Details should include appropriate behaviours, their sequence and ways in which the strategy will help the student.
3. Model the strategy for students. Teachers should "think aloud" so that students can become aware of all processes involved in the strategy.
4. Ask students to "verbally rehearse" the strategy.
5. Provide opportunities for students to practise using the strategy through controlled activities. Use instructional materials that match the students' reading level.
6. Provide positive and corrective feedback to students as they apply the strategy.
7. Provide opportunities for students to apply the strategy using more difficult materials that are grade-appropriate.
8. Provide positive and corrective feedback to students as they practice applying the strategy to grade-appropriate material.
9. Retest students on their use of the strategy. Use the test given in Step 1 with different instructional materials.

The teaching and learning strategies provided on the pages that follow are similar to those used in developing communication skills in other subject areas, and focus attention on:

- Reading and Viewing Science Materials
  - A Study Guide for Reading in the Content Areas
  - Assessing the Readability of Science Materials
  - Comprehension Strategies
  - Developing Technical Vocabulary
  - Using Advance Organizers/Conceptual Overviews
- Summarizing, Evaluating and Communicating Ideas in Science
  - Making Summaries
  - Using Critical Thinking Skills
  - Giving and Following Directions
  - Strategies for Discussing and Debating
  - Informal Essay Writing.

1. Alley, Gordon and Deshler, Donald, *Teaching the Learning Disabled Adolescent: Strategies and Methods*, Love Publishing Co., 1979.



## READING AND VIEWING SCIENCE MATERIALS

The precision of vocabulary and symbols used in science may be a source of difficulty for students. The everyday meanings associated with words often interfere with an understanding of the special meanings that words have in science. Each theme of the science program should be analyzed in order to identify demands relative to symbolic content. Discussion of common base words, prefixes and suffixes will assist students to identify/recall the meanings of technical words that are used. Consider the following questions when planning activities that provide for an understanding of technical vocabulary.

- How does this vocabulary relate to everyday usage?
- How does it conflict with everyday usage?
- How does it relate to previously studied science terms?

The role of experience in developing concepts must be recognized in vocabulary development activities. Definitions may be developed as summarizing statements of ideas that have been understood, but should not be used as introductions to new vocabulary or symbols. Encourage students to explain the meanings of new words in their own language, and to draw upon personal experience in giving examples of how the word is correctly used. The following instructional sequence will foster meaningful vocabulary development, and ensure that each word or symbol introduced becomes part of the student's active or "working" vocabulary.

- Discuss real life examples from the student's environment where the word/symbol might be used.
- Simulate concrete and transitional models where the word/symbol might be appropriately used.
- Discuss and list distinguishing characteristics of the word/symbol.
- Record the word/symbol and its distinguishing characteristics (meaning) in a personal science "glossary".

When reading and viewing science material for content, students must assimilate new material into their existing knowledge structure. Introductory questions and activities that focus attention on "what I already know" can prepare the student for reading material that provides answers to "what I need to know". Students can be guided in reading/viewing for content and information through activities that include the following steps:

- Decide on a purpose for reading/viewing. State the purpose as a question.
- Skim the whole section to get an idea of how it is organized.
- Notice various "aids to reading/viewing" that have been used in the material (e.g., headings, colour, bold print, diagrams, charts, coloured pages).
- After reflecting on purpose, decide which sections need intensive study and which may be delayed or skipped.
- Engage in "active" reading/viewing of the material (e.g., ask questions; think of examples; rephrase in everyday language).

Inquiry and problem solving often necessitate that relationships and patterns be identified through reading and viewing. Through discussion and related activities, teachers are encouraged to assist students in identifying major and supporting ideas, their relationships, and in making inferences/predictions on the basis of information gathered. "Semantic webs" and "concept circles" are useful in structuring comprehension activities, and can be used to help students organize, interpret and integrate information.

**CLARIFICATION/EXAMPLE**

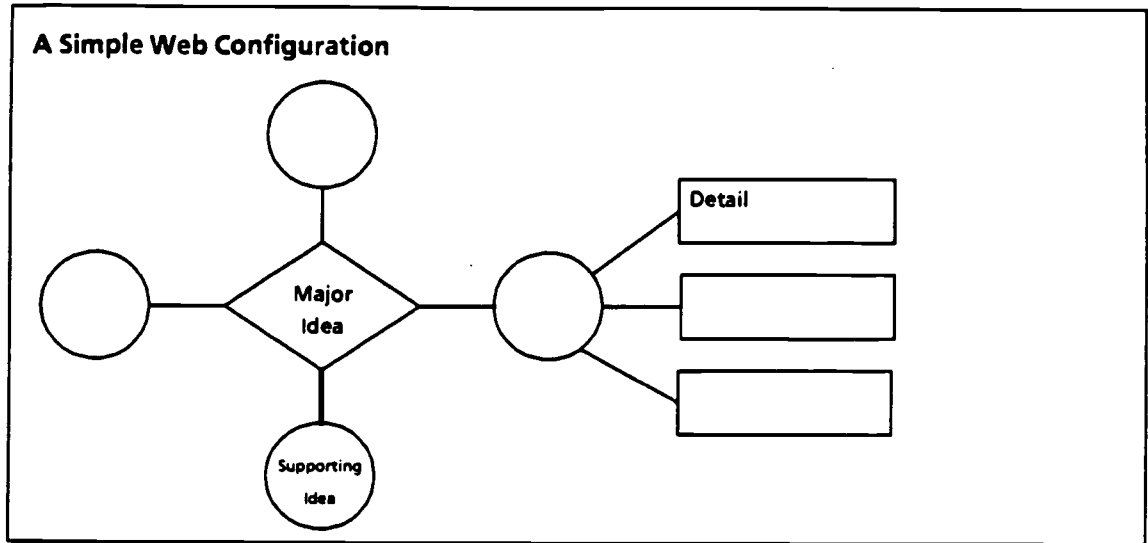

**CLARIFICATION/EXAMPLE**

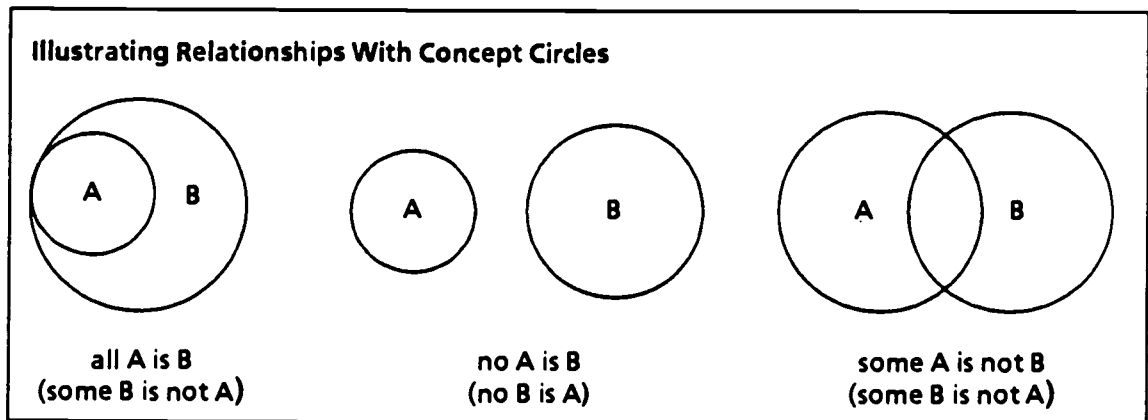

Additional suggestions for developing reading and viewing skills in science class are provided in:

- Resource 1: A Study Guide for Reading in the Content Areas
- Resource 2: Assessing the Readability of Science Materials
- Resource 3: Comprehension Strategies
- Resource 4: Developing Technical Vocabulary
- Resource 5: Using Advance Organizers/Conceptual Overviews.

## SUMMARIZING, EVALUATING AND COMMUNICATING IDEAS IN SCIENCE

Communication skills used in summarizing, evaluating and communicating ideas in science are similar to the skills required of students in other subject areas. Students should be given opportunities to describe relationships, patterns and the results of investigations that are undertaken through a variety of writing activities. The use of language can be strengthened through questions that probe for explanations rather than stimulate recall of information. Students should frequently be asked why, and be encouraged to use writing skills to express their ideas and interpretations.

### CLARIFICATION/EXAMPLE

#### Questions That Involve Students in Investigation

- What are we looking for?
- What do we want to explain/investigate?
- What do you notice about this ...?
- What do you think might happen if ...?
- Why did ...?
- What should we do first?
- What is stopping us?
- If this is so, then ...?

#### Questions That Stimulate Creative Response

- What is my next step?
- How will I do that?
- How can I design a better ...?
- What is the relationship between ... and ...?
- Why did ... happen after ...?
- How would you design an experiment to ...?
- What might happen if you use ... instead of ...?
- What is the likelihood that ...?

#### Questions That Stimulate Analysis and Evaluation

- How did you know that ...?
- What does the data indicate?
- What caused ... to happen?
- How does ... apply to ...?
- How could you explain ... in another way?
- How might you use these results?
- How could we make our work easier another time?
- How could we improve it or make it better?
- What should we tell others?

A variety of writing activities should be used within each theme of the science program. These activities can provide for experience in:

- summarizing (e.g., note-taking)
- describing (e.g., recording observations)
- giving and following directions (e.g., logical sequencing)
- writing a laboratory report (e.g., writing directions/descriptions)
- informal essay writing (e.g., expressing an opinion, supporting a point of view).

Of particular importance are skills in summarizing or note-taking because the way students record information in class can have a major effect on how well they process and remember it. Note-taking from books, lectures, visual presentations and laboratory experiments causes students to arrange and structure knowledge, enhances memory and also maintains attention during instruction. Although note-taking styles may vary according to purpose and ability, teachers can help students to develop and extend their note-taking skills by:

- modelling the use of appropriate note-taking styles. Show students how you would take notes.
- taking notes together with the class. Illustrate a note-taking process, using a text reading, a filmstrip, or even an experiment. Compare and contrast your notes with those of the students.
- asking students to take their own notes while you closely monitor their work. Correct their mistakes when necessary.
- requiring students to take notes independently during class. Give assignments that require note-taking. Include a note-taking passage on each exam.

#### CLARIFICATION/EXAMPLE

##### A Note-Taking Style

In the "herring bone" style, a fish spine becomes a visual analogy to describe a specific scientific topic. Each bone holds a word that requires an explanation. Students may record very little information on one bone, and a lot of information on another bone. They may write above and below the bones.

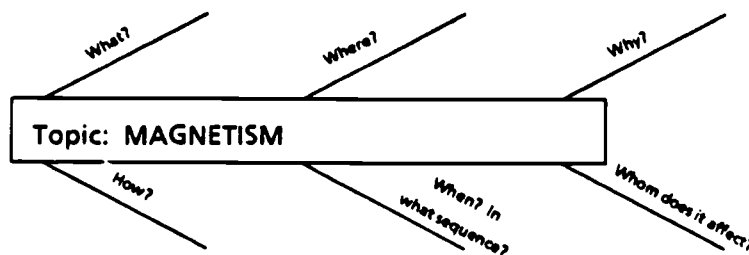

- What? - What is magnetism?
- Where? - Where does it occur?
- Why? - Why does it work the way it does?
- Who? - Who is affected?
- When? - When does it work? In what sequence?
- How? - How does it work?

Additional suggestions for summarizing, evaluating and communicating ideas in science are provided in:

- Resource 6: Making Summaries
- Resource 7: Using Critical Thinking Skills
- Resource 8: Giving and Following Directions
- Resource 9: Strategies for Discussing and Debating
- Resource 10: Informal Essay Writing.

## RESOURCE 1: A STUDY GUIDE FOR READING IN THE CONTENT AREAS

### STUDY GUIDE

1. Suggest a different title for the article you have just read. Try to capture the essence of the article in your title, but keep it short.
2. Two key ideas or concepts discussed in this article are:
  - \_\_\_\_\_
  - \_\_\_\_\_
3. Three details or facts you would like to remember from this article are:
  - \_\_\_\_\_
  - \_\_\_\_\_
  - \_\_\_\_\_
4. What did you find especially interesting or surprising in the article?
5. What word or words from this article do you think the author chose rather carefully?
6. Indicate any words, sentences or paragraphs in the article you would like to discuss in class or have explained:  
Page: \_\_\_\_\_ Line: \_\_\_\_\_
7. If you could talk to the author of this article, what questions would you ask or what comments would you make to him or her?
8. What mental images did you form while you were reading this article?
9. Rate this article by marking an X on the line at the point that indicates your evaluation.

Very ←————→ Not very

Interesting: \_\_\_\_\_  
Informative: \_\_\_\_\_  
Easy to Read: \_\_\_\_\_

This study guide by Smith<sup>1</sup> can be modified to suit the needs and abilities of students, the characteristics of the reading assignment and the instructional objectives. Note that the type of questions asked of students does not permit simply scanning the selection to find answers. Students enjoy sharing their responses in small groups or through class discussion.

1. Smith, Richard J., *A Study Guide for Extending Students' Reading of Social Studies Material*, The Social Studies Vol. 78, No. 2, pp. 85-87.

## RESOURCE 2: ASSESSING THE READABILITY OF SCIENCE MATERIALS

---

Teachers are encouraged to supplement textbook activities with appropriate articles and materials from other sources. In assessing the overall readability of these materials, it is important to recognize factors that may contribute to the ease or difficulty with which students can read and comprehend the material. Reading involves complex interactions between student and text.

Student-related considerations include:

- background knowledge/preparedness for the reading task
- motivation
- interest.

Text-related considerations include:

- vocabulary (e.g., level of difficulty, word length, jargon, technical language)
- conceptual depth
- syntax (e.g., sentence structure)
- format (e.g., margins, bold type, italics, headings, underlinings)
- organization (e.g., chapter summaries, pre- and post-questions, word lists, glossaries)
- key visuals (e.g., pictures, charts, graphs, tables).

Acknowledging and making necessary adjustments to the student- and text-related considerations listed above will result in a supportive, appropriately challenging reading environment in science. Readability data should be used to alert teachers to areas of possible difficulty and the need to provide reading comprehension aids.

### READABILITY FORMULAS: SMOG AND FRY

Readability formulas generally reflect text difficulty in terms of the length of sentences and words. Formulas provided for use by the teacher include:

- the SMOG Formula
- the Fry Readability Graph.

These formulas can be used in conjunction with other methods of assessing the appropriateness of reading materials in science.

#### THE SMOG FORMULA

This formula, described by McLaughlin (1969) as a "simple measure of gobbledegook", is a simple technique:

1. Near the beginning of the text, count 100 consecutive words; then count 100 consecutive words in the middle and 100 near the end of the text (approximately five sentences in each section).
2. Tabulate the number of words consisting of three or more syllables. If a word is repeated it should be included in the count.

## **RESOURCE 2: ASSESSING THE READABILITY OF SCIENCE MATERIALS (continued)**

---

3. Determine the square root of the number of the polysyllabic words that have been counted. McLaughlin suggests that this be done by taking the square root of the nearest perfect square. If the count lies roughly between two perfect squares, choose the lower number.
4. Finally, add 3 to the estimated square root. The resulting number will give an estimate of the reading level a student should have attained (independent level) in order to fully comprehend the material.

### **THE FRY READABILITY GRAPH**

1. Randomly select three sample passages and count out exactly 100 words in each, starting with the beginning of a sentence. Include proper nouns, initializations and numerals.
2. Count the number of sentences in each passage of one hundred words, estimating length of the last sentence as a fraction to the nearest tenth.
3. Count the total number of syllables in each 100-word passage. If you don't have a hand counter available, simply put a mark above every syllable over one in each word. Then count the number of marks and add 100. A calculator can also be used as a counter by pushing the number "1" and the "+" sign for each word or syllable when counting.
4. Determine the average number of sentences and average number of syllables per 100 words. Plot a point where the two lines intersect on the readability graph provided on the next page. The area where the dot is plotted represents the approximate grade level.
5. If a great deal of variability is found in the syllable count or the sentence count, it may be desirable to put more samples into the average.
6. A word is defined as a group of symbols with a space on either side; thus, Joe, IRA, 1945, and & are each one word.
7. A syllable is defined as a phonetic syllable. Generally, there are as many syllables as vowel sounds. For example, stopped is one syllable and wanted is two syllables. When counting syllables for numerals and initializations, count one syllable for each symbol. For example, 1945 is four syllables, IRA is three syllables, and & is one syllable.

RESOURCE 2: ASSESSING THE READABILITY OF SCIENCE MATERIALS (continued)

THE FRY READABILITY GRAPH

Average Number of Syllables per 100 Words

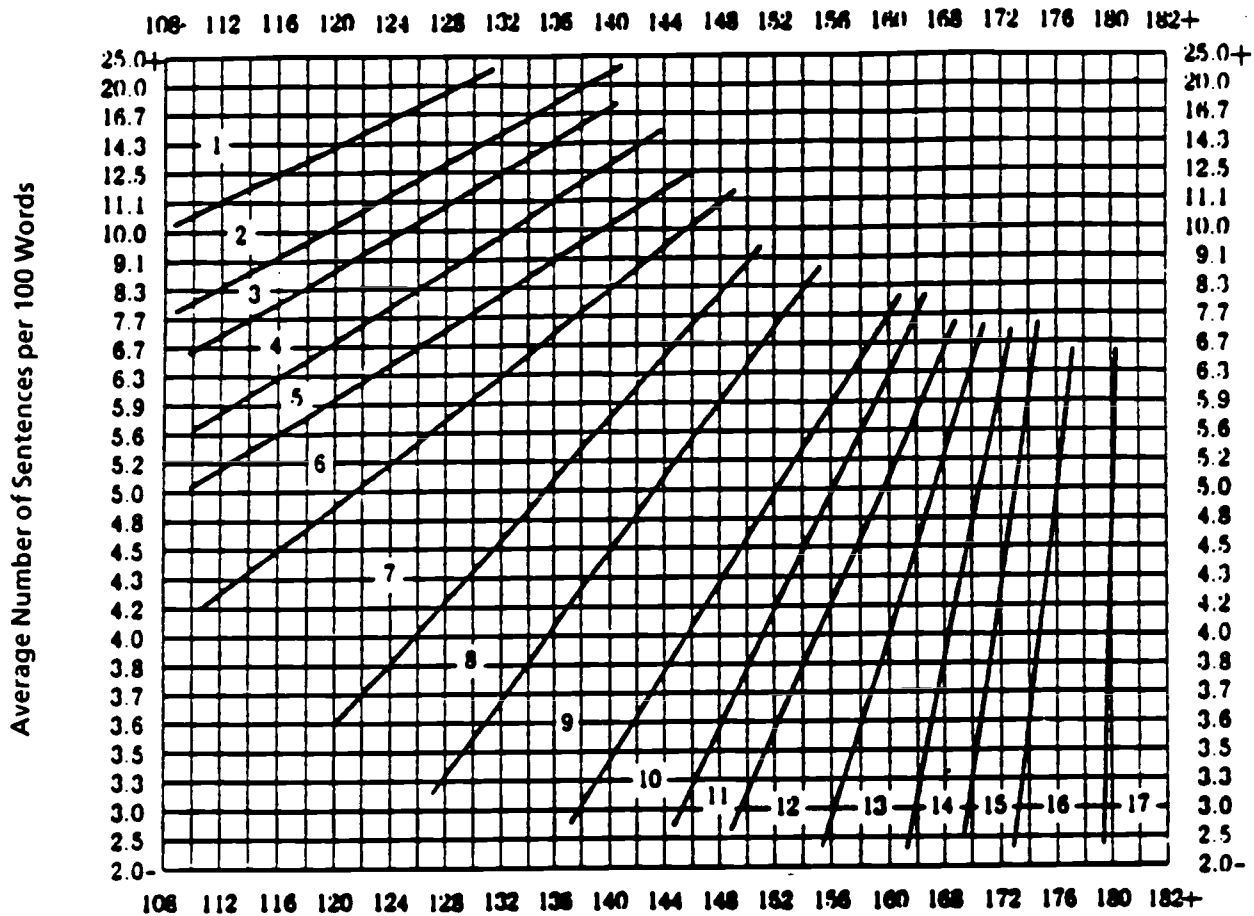

075



## RESOURCE 2: ASSESSING THE READABILITY OF SCIENCE MATERIALS (cont'd)

---

### USING A CLOZE PROCEDURE

The cloze procedure was developed by Wilson Taylor (1963)<sup>1</sup> as a tool for testing reading comprehension. In a modified form, the procedure may be suitably used in science to:

- measure readability
- test for comprehension
- diagnose individual reader's abilities or deficiencies.

### PROCEDURE FOR DEVELOPING AND ADMINISTERING A MODIFIED CLOZE

1. Choose a reading passage of approximately 350 words. The passage should be one that students have not previously read.
2. Leave the first two sentences intact and delete every seventh word thereafter (A, an and the are not to be deleted. Instead delete the next word.) Leave the last sentence intact.
3. Retype the selection replacing the deleted word with a blank of standard length (12 letter spaces).
4. Have the students read the passage and fill in the blanks. This activity should not be timed.
5. Count the number of correct responses. The wording must match the original exactly. Spelling, however, does not count.
6. Calculate the percentage of correct responses.
7. Use the following guidelines to estimate students' ability to read narrative-style material effectively. (These scores are not to be treated as rigid cutoff points).

60-100 percent:	independent level – the student can read without help
45-60 percent:	instructional level – the student can read with help
0-45 percent:	frustration level – unsuitable for reading

8. Use these guidelines to estimate students' ability to read expository-style material (e.g., material containing explanations of concepts).

55-100 percent:	independent level
40-55 percent:	instructional level
0-40 percent:	frustration level

---

1. Taylor, W.L. "Cloze Procedure: A New Test for Measuring Readability". Journalism Quarterly, 30, Fall, 1963, pp. 415-433.

## RESOURCE 2: ASSESSING THE READABILITY OF SCIENCE MATERIALS (continued)

---

### ALTERNATIVE TECHNIQUES FOR USING THE CLOZE PROCEDURE

#### 1. The Maze Technique (Feely, 1975)<sup>2</sup>

Offer a multiple choice format for each blank. Three alternatives are provided for each blank in random order: 1) the correct word; 2) an incorrect word of the same grammatical class (e.g., verb, noun, preposition); and 3) an incorrect word of a different grammatical class. The maze is more difficult to prepare, but it is less threatening and easier for students to complete than the cloze procedure previously described.

e.g., Many \_\_\_\_\_ (numbers, varieties, sleek) of wild cats are found on the continents of Africa and Asia including lions, tigers and leopards.  
(answer - varieties)

Suggested maze readability cutoff points are:

92-100 percent:	independent level
80-91 percent:	instructional level
75 percent or less	frustration level

#### 2. The Cloze Procedure with a Word List

Prepare a reading passage following the steps previously outlined. Provide a list of the deleted words, in random order, from which students can select the appropriate word for each blank. This alternative may also prove less threatening to students. A sample cloze procedure with a word list follows.

**Note:** *With all techniques, the key to using the cloze as a tool for developing reading skill is discussion after completion of the exercise. Students should be encouraged to verbalize reasons for selecting a particular word. Immediate reinforcement and feedback regarding the correctness of the students' guesses and the strategies the students used to arrive at their answers will make the cloze an excellent teaching technique in science.*

---

2. Feely, T.M. "How to Match Reading Material to Student Reading Levels: The Cloze and the Maze", Social Studies, 66, 6, November/December, 1975, pp. 249-252.

## RESOURCE 2: ASSESSING THE READABILITY OF SCIENCE MATERIALS (continued)

### A SAMPLE CLOZE PROCEDURE

#### CAREERS<sup>3</sup>

The transportation technology industry offers a variety of occupational opportunities. Jobs in this field include service station attendants, technical assistants, skilled and semiskilled workers, service and repair personnel, scientists, inventors and engineers.

The amount and type of training \_\_\_\_\_ with each job. So does the \_\_\_\_\_ you can expect to earn.

#### Professional

\_\_\_\_\_, researchers, engineers, teachers and high-level \_\_\_\_\_ are examples of professional positions. College \_\_\_\_\_ is required for these careers.

#### Mechanics

Mechanics \_\_\_\_\_ small engines that are used to \_\_\_\_\_ lawn mowers, garden machines and \_\_\_\_\_ small machines.

A mechanic must know \_\_\_\_\_ to use hand tools and measuring \_\_\_\_\_. A mechanic must be able to \_\_\_\_\_, to disassemble engines, to examine parts \_\_\_\_\_ defects and to repair or replace \_\_\_\_\_ parts.

#### Skilled Workers

Skilled workers include diesel, \_\_\_\_\_ and aircraft mechanics. Lengthy on-the-job \_\_\_\_\_ and/or apprenticeship programs are required.

\_\_\_\_\_ machine operators are classified as semiskilled \_\_\_\_\_. A machine operator requires considerable on-the-job \_\_\_\_\_.

Little or no training is required \_\_\_\_\_ unskilled workers. Labourers, labour helpers and \_\_\_\_\_ station attendants fall into this group.

#### Self-Employment

\_\_\_\_\_ small engine technicians are self-employed. \_\_\_\_\_ often begin on a part-time \_\_\_\_\_. They learn about small engines by \_\_\_\_\_ their own engines and those of \_\_\_\_\_ friends and neighbors. Then they expand their \_\_\_\_\_ to other customers.

Operating your own business \_\_\_\_\_ many advantages. You do not have \_\_\_\_\_ report to anyone else. You \_\_\_\_\_ set your own hours. You keep \_\_\_\_\_ the profits. However, owning your own \_\_\_\_\_ is very hard work. It requires business skills as well as mechanical skills.

## RESOURCE 2: ASSESSING THE READABILITY OF SCIENCE MATERIALS (continued)

---

### WORD LIST

varies	how	workers	their
salary	tools	training	business
scientists	troubleshoot	for	offers
managers	for	gas	to
education	defective	many	can
repair	automotive	they	all
power	training	basis	business
other	basic	servicing	

A total of 31 words were omitted from the foregoing selection. Using the guidelines for expository style material:

- a score of 18 or better indicates the student is reading at the independent level
- a score of 10 to 17 indicates the student is reading at the instructional level
- a score of 0-9 indicates the student is reading at the frustration level.

---



3. For permission to adapt copyrighted material, grateful acknowledgement is made to Glencoe Publishing Company, Los Angeles, U.S. for the excerpts from *General Industrial Education*, by Los Angeles Unified School District, 1988, p. 54.

## RESOURCE 3: COMPREHENSION STRATEGIES

### QUESTION-ANSWER-RELATIONSHIP (QAR) STRATEGY

Students may have difficulty comprehending text if they lack strategies for answering questions related to the print material. The Question-Answer-Relationship Strategy (Raphael, 1982)<sup>1</sup> assists students to connect the questions to the text or to present knowledge they possess. In addition, QAR is a strategy students may use to locate the information needed to answer questions.

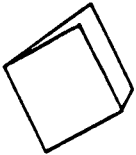
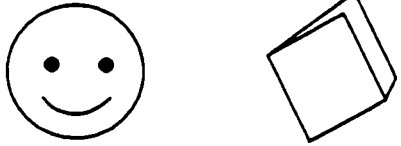
Throughout all three QAR question types, students must first determine the location of the answer. The answers to Type 1 questions are explicit in the passage and may be found by scanning the text. Students must integrate known information with the text to answer Type 2 questions. Type 3 questions provide opportunities for students to make inferences. Practice in using the following three QARs have been shown to significantly improve students' ability to process print information.

WHERE IS THE ANSWER FOUND?	
<p>Type 1</p> 	<p><b>Right There</b></p> <p>The answer is explicit in the story and therefore easy to find. The words used to make the question, and the words that form the answer are "Right There" in the same sentence.</p>
<p>Type 2</p> 	<p><b>Think and Search</b></p> <p>The answer is in the story, but is a little more difficult to find. The words in the question and the words in the answer are never in the same sentence. Students would have to "Think and Search" for the answer.</p>
<p>Type 3</p> 	<p><b>On My Own</b></p> <p>The answer will not be told by words in the story. Rather, it must be found using background information and/or predictions. Students will think, "I have to answer this question 'On My Own'". The story will not be very helpful."</p>

#### TEACHING SUGGESTIONS:

1. Introduce the QAR concept and terminology. Use the above figures to discuss the difference between text-based and knowledge-based responses. Stress the differences between the two text-based strategies.

1. Raphael, Taffy E. "Question-Answering Strategies for Children", The Reading Teacher, Nov. 1982, pp. 186-190.

## RESOURCE 3: COMPREHENSION STRATEGIES (continued)

---

2. Practise the strategies with reading materials using a question from each QAR category. (The specific type of QAR should be identified for the students.) Discuss why the questions and answers represent their respective QARs.
3. Select and distribute reading materials in science with questions. Have students identify the QAR for each question. It is important for students to develop the ability to justify their responses on the basis of the text and individual background knowledge.
4. Continue to practise the strategies with longer selections of written material (600-800 words), from science.

### PARAPHRASING (RAP) STRATEGY<sup>2</sup>

#### DESCRIPTION OF STRATEGY

- R - The students read the paragraph silently to themselves.
- A - After reading the paragraph, the students stop and ask themselves what they just read (e.g., Does it make sense? How does it relate to what I already know? How does it relate to what I have already read? What is the main idea the author is trying to get across?).
- P - Notes are then written based on what has been read and asked, using the student's own words.

#### SUGGESTED APPLICATION

This strategy can be used to help students remember more of what they read. The strategy is particularly useful for material with much detail, material that is abstract, for note taking and for studying.

#### TEACHING SUGGESTIONS

Give students an article to read. Ask them to remember what they've read. The next day, give them comprehension questions based on the article. Record their scores. After RAP has been taught, give students an article and ask them to "RAP" it. The comprehension questions are given again the next day. A comparison of scores should illustrate the effectiveness of "RAP" for improving both comprehension and retention.

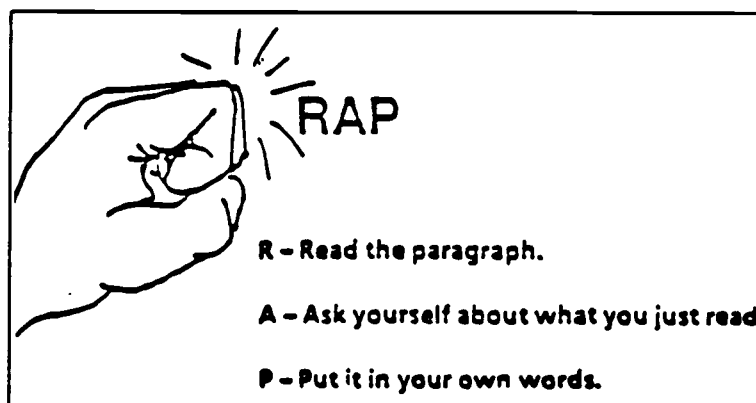

2. Adapted from *SPELT: A Strategies Programme for Effective Learning/Thinking: Inservice Edition*, SPELT International Ltd., p. 145. Copyright 1987 by R. Mulcahy, K. Marfo, D. Peat, and J. Andrews. Reprinted by permission.

## RESOURCE 3: COMPREHENSION STRATEGIES (continued)

---

### CHAPTER ATTACK (SQ3R) STRATEGY

SQ3R is a study method designed by Robinson (1946)<sup>3</sup>, and represents "Survey, Question, Read, Recite, Review". The steps involved in the SQ3R approach are:

1. **Survey.** Notice chapter titles and main headings before you actually read the assignment. Then read introductory and summary paragraphs, and study graphs, charts, etc. This initial survey provides a framework for organizing facts.
2. **Question.** Formulate a list of questions to be answered when reading the passage.
3. **Read.** Read the passage to answer the questions.
4. **Recite.** Try to answer the questions without looking at the material you have read.
5. **Review.** Verify or correct your recited answers by rereading the passage and noting the main points and the relationships that exist among various points.

This method helps students remember content material. SQ3R works well with more competent readers.

#### SQ3R (Chapter Attack Strategy)

1. **Survey – quickly read;**
  - a) chapter introduction (BEGINNING)
  - b) chapter summary (END)
  - c) first sentence in each paragraph
  - d) visual aids (pictures, graphs, diagrams)
2. **Question – ask a question based on each subtitle**
3. **Read – read each section to find the answer to your question**
4. **Recite – write down the answer**
5. **Review – say or write a summary of what you've learned**

3. Robinson, F.P., *Effective Study*, Harper Brothers, New York, 1946.

## RESOURCE 3: COMPREHENSION STRATEGIES (continued)

---

### STRATEGIES FOR USING CONTEXT CLUES

Extracting meaning from context clues involves understanding the redundancy features of language. Students must shift from seeing reading as a process of decoding print to seeing reading as a process of extracting meaning.

Smith (1978)<sup>4</sup> states that redundancy has four components:

- the visual system – what the word looks like
- the semantic system – the meaning of the word
- the syntactic system – the use of grammar
- the orthographic system – the spelling of the word.

All readers need to make use of these four systems to ensure success at extracting meaning from context clues.

Model a strategy for using semantic clues by talking aloud to explain the thinking process. (Explicit teacher explanations are associated with higher awareness of lesson content and greater achievement.)

While instructing students to look for context clues, the teacher may say:

T: "... look for clues in the context. Remember, the context refers to the words before the new word or the words after the new word. Sometimes they are words in a different sentence close to the new word."

The teacher continues to verbalize personal thoughts while using the strategy and emphasizes that a mental process is to be used:

T: "... put the clues together with what you already know about that word and decide on the meaning."

Finally, the teacher should emphasize learning the skill and process so that it can be used to read outside of the class:

T: "This is a skill you can use while reading material such as the newspaper, your science book or a library book. Any time you find a word that is new to you, use this skill to determine its meaning."

Supervised practice with a modelled strategy is necessary to ensure its continued use and transferability.

---

4. Smith, Frank. *Understanding Reading*. Holt, Rinehart and Winston, N.Y., 1978.



## RESOURCE 4: DEVELOPING TECHNICAL VOCABULARY

---

### VOCABULARY SELF-COLLECTION STRATEGY

Senior high school increases the demands that are placed upon students to acquire an expanded and refined vocabulary. Developing technical language and gaining understanding of the specialized meanings of common words are examples of these demands.

In order to assist students to develop their vocabulary, instruction should:

- be directed toward vocabulary students need to know - students can often identify these words themselves
- provide students with the skills that are necessary for continued and independent vocabulary growth.

The Vocabulary Self-Collection Strategy (Haggard, 1982)<sup>1</sup> satisfies both of these conditions. Follow these steps:

1. Have each student identify two words they believe the entire class should understand. The teacher will also bring two words. Students are encouraged to choose words they hear or see in their own environment (e.g. words heard on television, in conversation, in a textbook, in a magazine or in the newspaper), thus placing an emphasis on words in context.
2. Ask students write their words on the chalkboard. Each student will identify their own words, where they were found and why the class should understand these words.
3. Reduce the number of words on the chalkboard by eliminating duplications and words that are known by the majority of class members. Keep high frequency words or words judged to be highly important by the majority of the students.
4. Ask individual students to suggest meanings for the words remaining on the chalkboard.
5. Discuss the definitions with the class so as to clarify, refine or extend word meanings. During this process, students should record the words in a personal vocabulary journal, along with their meanings as discussed in class. (Individual students may choose to retain one or more words which were eliminated from the original list.)
6. Use the new words in a variety of ways to provide practice (e.g., make or solve crossword puzzles, write sentences and dialogues).
7. Test student retention of vocabulary at the end of the week. Repeat the cycle as necessary.

One value of this strategy is that it helps to identify words that may be problematic for students. Often, the words identified by students do not coincide with those a teacher or textbook author would isolate as being difficult.

---

1. Haggard, Martha. "The Vocabulary Self-Collection Strategy: An active approach to word learning", Journal of Reading, December 1982, pp. 203-207.

## RESOURCE 4: DEVELOPING TECHNICAL VOCABULARY (continued)

---

### TEACHER INTERACTION TECHNIQUE

The teacher interaction technique (Eeds and Cockrum, 1985)<sup>2</sup> is designed to connect a new word to existing schema in each student's repertoire of vocabulary knowledge. This technique of word meaning instruction helps learners fit new words into an already existing conceptual framework through the following sequence of steps:

1. Prior to beginning a reading assignment, identify the difficult words in the reading selection and choose the words that may become internalized using this strategy (e.g., words lacking in contextual support from which students can determine meanings on their own).
2. Organize a situation where a conceptual network common to most students will be activated (e.g., a situation for the word "peculiar" may be presented as follows: "Have you ever had an experience that made you sit back and say that it was one of the strangest experiences you have ever had? Tell me about it". Listen to several examples of strange happenings and label them "peculiar").
3. Have students write about an event they have heard of or experienced which they personally found very peculiar.
4. Encourage students to write about something that is *not* peculiar (a non-example).
5. Ask students to define "peculiar" in their own words.

These five steps -- identifying difficult words, activating common experiences, connecting the new word to individual experience, contrasting with a non-example, and translating the meaning into personal language, appear to positively influence the acquisition of new vocabulary.

Research indicates that students using this strategy outperformed other students who were given the same vocabulary items to learn using the dictionary to gain meaning or who were left to gain meaning incidentally by reading for context clues.

---

2. Eeds, Maryann and Ward A. Cockrum. "Teaching Word Meanings by Expanding Schemata vs Dictionary Work vs Reading in Context", Journal of Reading, March, 1985, pp. 492-497.

## RESOURCE 4: DEVELOPING TECHNICAL VOCABULARY (continued)

---

### VOCABULARY SORTING

The steps that follow suggest a strategy for developing an understanding of technical vocabulary through the use of "word sorting" activities:

- Give students a list of vocabulary items and ask them to categorize the words. Alternatively, ask students to generate their own list of technical or specialized vocabulary from a science topic studied.
- Give category headings, or ask students to decide on their own headings. Indicate to students that more than one classification scheme is possible and that any tabulation scheme which they can justify is acceptable.
- Record any questions that arise during the categorization process.
- If vocabulary items are new to students (i.e., this would be a pre-reading activity), it is best to present the words in context. Students should scan the text, list the new words and then use this as a basis for the vocabulary sorting exercise.

### EXAMPLES OF VOCABULARY SORTING ACTIVITIES

The following vocabulary items are commonly used in the study of technologies related to the automobile.

1. points	plugs	tune-up	condenser	motor
2. cables	battery	terminals	acid	plates
3. steering	ball joints	tie rod	front suspension	seals
4. fender	trunk	hood	grill	body
5. lubrication	grease	oil	filter	drain
6. accessories	air conditioning	AM-FM	defogger	clock
7. tire	hubcap	jack	flat	wrench
8. gauges	odometer	alternator	temperature	fuel
9. bench	bucket	seat	front	rear
10. coolant	thermostat	drain	radiator	cooling system

1. Have students circle the "Main Idea" word in each of the ten groupings above.
2. Extract the "Main Idea" words from the groupings above and present them as category heading. Scramble the rest of the vocabulary items and have students sort them under the headings.
3. Scramble all of the vocabulary items, and have students attempt to identify both the "Main Idea" words (i.e., category headings) and the "sub-topic" words.

## RESOURCE 4: DEVELOPING TECHNICAL VOCABULARY (continued)

---

### MAKING A CROSSWORD PUZZLE OR A WORD FIND

- Step 1:** Identify a given list of words or make a list of words that pertain to a particular topic.
- Step 2:** Write the words on the grid, interlocking letters as often as possible, going across and down the page.
- Step 3:** Lay another sheet of paper over the grid and trace only those squares that contain letters. Or, with a felt tip marker, shade unused squares to form dark background.
- Step 4:** Number the first square of each word in the upper left corner.
- Step 5:** Number the "clues" or definitions in the same order as the words are numbered on the grid and place clues at the bottom or on a separate sheet of paper.

Crossword Puzzle Grid

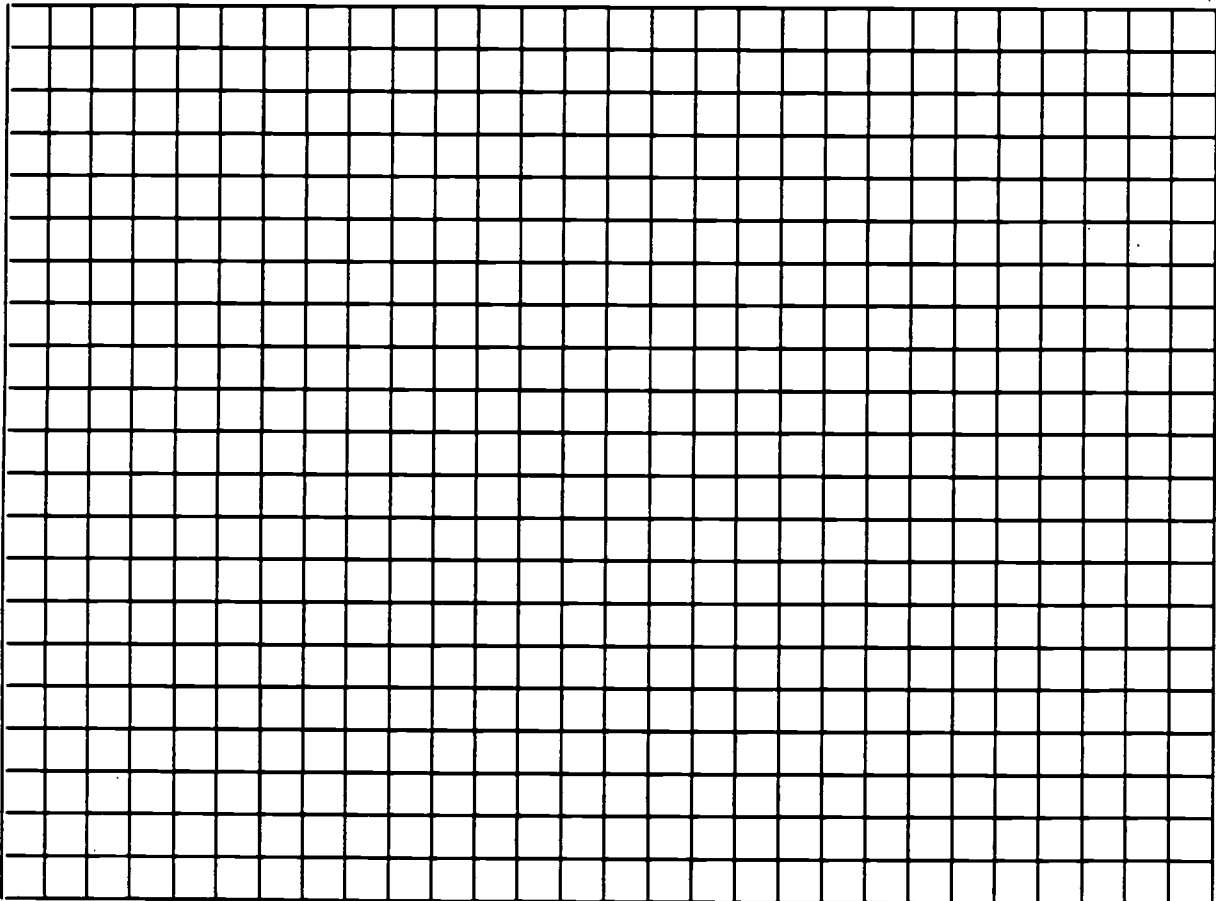

### **Word Identification Strategy (WIS)<sup>3</sup>**

#### **Description of Strategy**

To be used as a word attack strategy when you don't know how to read a word.

**Step 1 – Look at the word in the sentence. Can I guess what it is by reading the words around it?**

**Step 2 – Look for a prefix. Look at the beginning of the word. Say it.**

**Step 3 – Look for a suffix. Look at the end of the word. Say it.**

**Step 4 – Locate the stem. Look at what's left after locating the prefix and the suffix.**

**Step 5 – Attack the stem. You do this by:**

a) Using the rule of 2's and 3's. If the stem starts with a vowel, say it with 2 letters; if with a consonant, say it with 3 letters.

b) Two vowels together sound like one – try both sounds.

**Step 6 – Look in a dictionary, Or**

**Step 7 – Ask someone.**

3. Adapted from *SPELT: A Strategies Programme for Effective Learning and Thinking Inservice Edition*, SPELT International Ltd. Copyright 1987 by R. Mulcahy, K. Marfo and D. Peat and J. Andrews. Reprinted by permission.

## RESOURCE 5: USING ADVANCE ORGANIZERS/CONCEPTUAL OVERVIEWS

---

### SEMANTIC WEBS AND MAPS

A semantic web or map is a graphic display of the relationship between major and minor ideas. A basic web consists of a core question and a network of strands which, when taken together, display the relationship of the whole to the parts and the parts to the whole.

Semantic webbing activities will:

- assist students to process new information they read by providing a graphic organizer
- help to structure discussion
- assist students to organize and integrate information.

The teacher may also use webbing as a diagnostic tool. It is useful in determining:

- the information students derive from material they read
- the students' understanding of categories and relationships.

The semantic webbing strategy can be used as:

- a pre-reading activity:
  - students can brainstorm and make predictions about the reading
  - an advance organizer to introduce new/difficult vocabulary. The web or map may be constructed on the chalkboard and partially completed prior to the activity
- an activity during reading:
  - the teacher partially constructs a descriptive/narrative/expository web and distributes this to the students. The students complete the web as they read, verifying from the text reasons for their selections. As they locate explicit and implicit text clues, they write these in the boxed nodes or strands
- an activity after reading:
  - students can modify/correct a pre-reading web to verify and extend their knowledge
- a pre-writing planning activity:
  - students may use a semantic web to organize ideas used in a writing assignment

The purpose of the activity will determine when and how semantic webbing strategies are used. The pages that follow provide examples of:

- a descriptive or thematic web
- a narrative sequential map
- a comparative and contrastive web.

A DESCRIPTIVE OR THEMATIC WEB

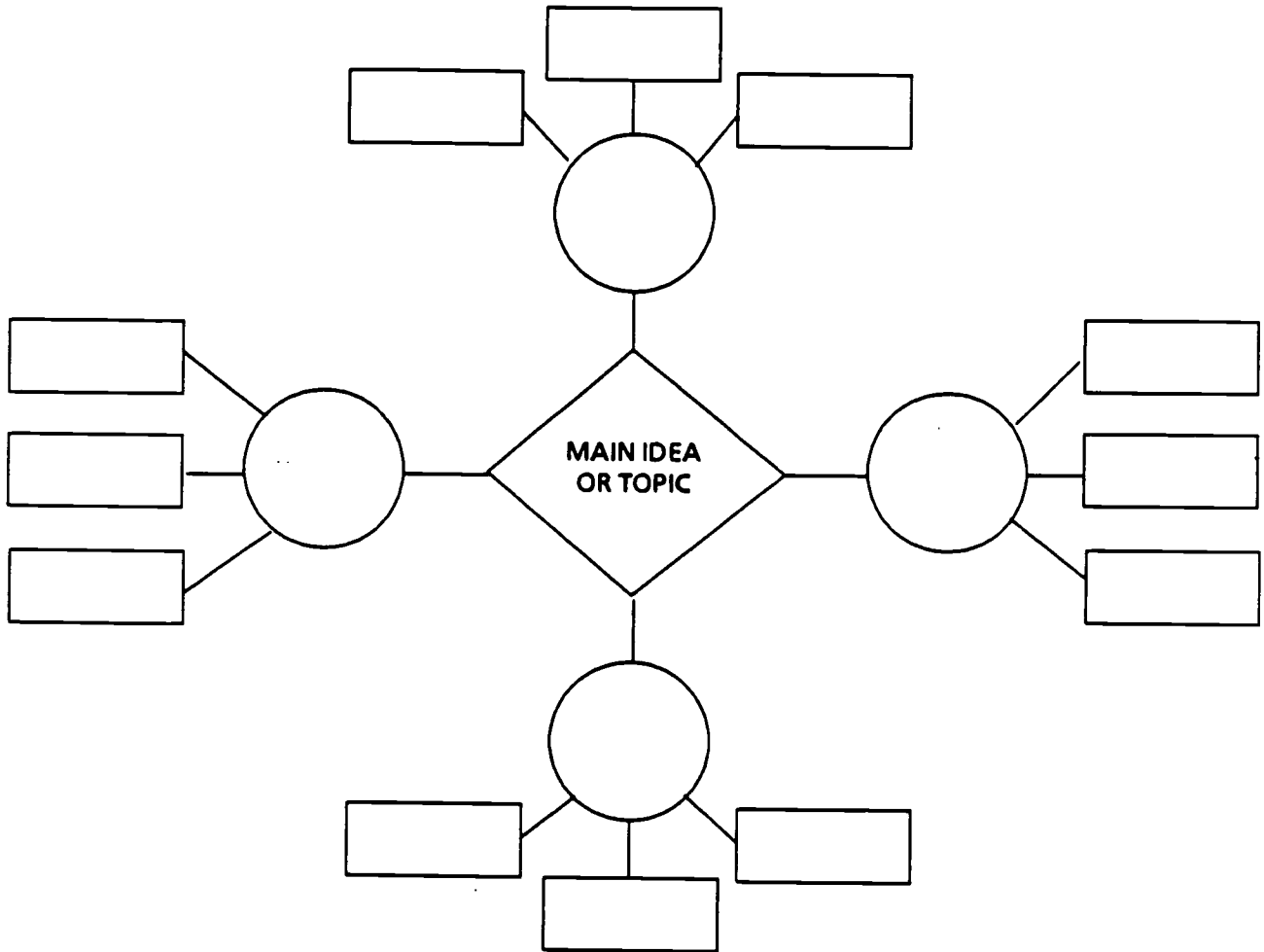

## RESOURCE 5: USING ADVANCE ORGANIZERS/CONCEPTUAL OVERVIEWS (continued)

---

### A NARRATIVE SEQUENTIAL MAP (time order)

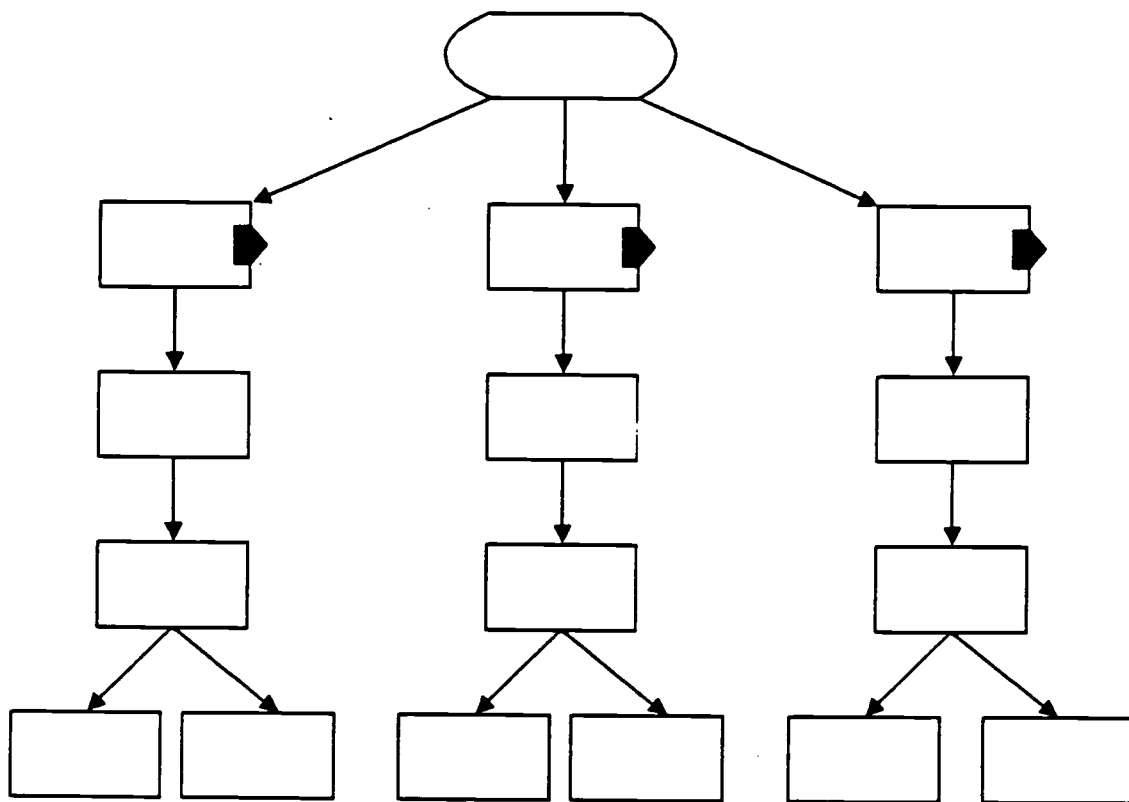

This "map" configuration can be used to visually display:

- the steps in following instructions (e.g., following directions for an experiment)
- the chronological order of a sequence of events (e.g., explaining the operation of a technological device).

Teachers may wish to revise this web according to the difficulty of the activity or complexity of the sequence of events (e.g., the bottom six figures may be removed).



**RESOURCE 5: USING ADVANCE ORGANIZERS/CONCEPTUAL OVERVIEWS**  
(continued)

---

**A COMPARATIVE AND CONTRASTIVE WEB**

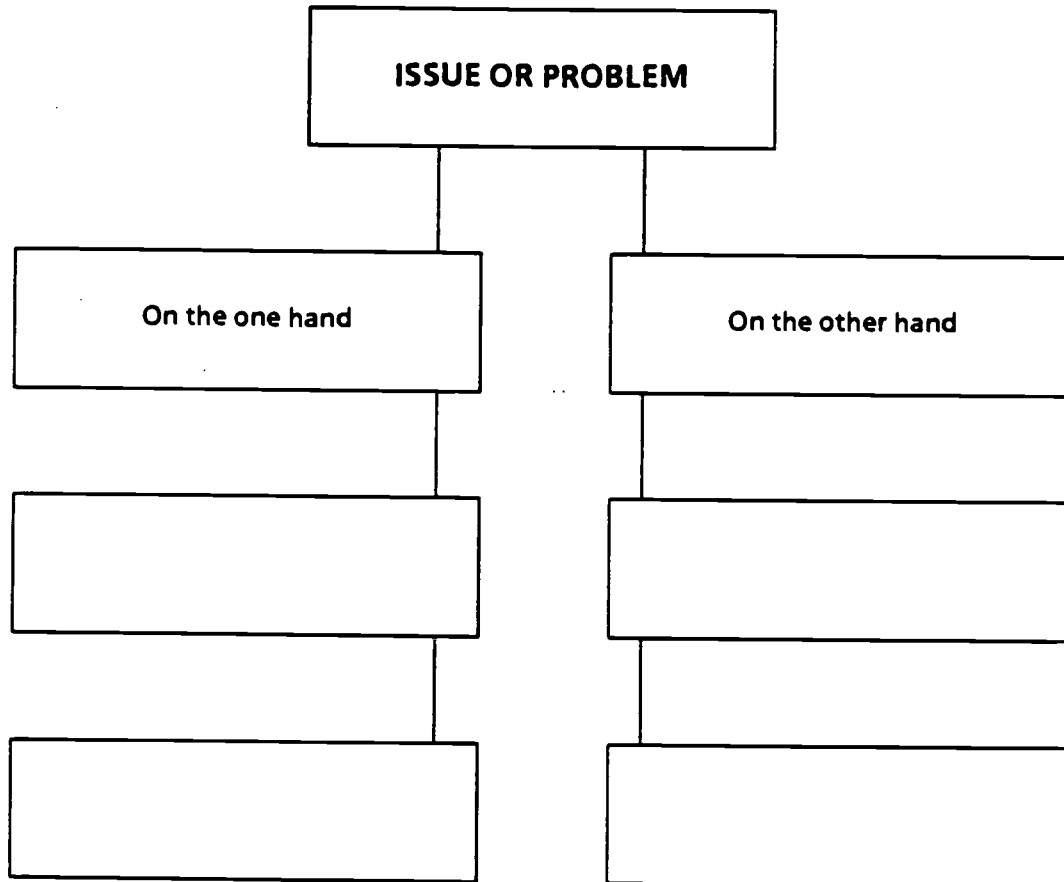

## RESOURCE 5: USING ADVANCE ORGANIZERS/CONCEPTUAL OVERVIEWS (continued)

---

### CONCEPT CIRCLES<sup>1</sup>

Students can be encouraged to organize and identify relationships among concepts they study through the use of concept circles. The steps that follow represent a strategy for drawing concept circles:

1. Let a circle represent any science concept.
2. Print the name of that concept (e.g., plant, temperature) inside the circle.
3. When you want to show that one concept is included within another concept (e.g., all birds are vertebrates), draw a smaller circle within a larger circle. Label the smaller circle by printing the name of the narrower, more specific concept within it. Label the larger circle by printing the name of the broader, more general concept within it.
4. When you want to show that some instances of one concept are part of another concept (e.g., water contains minerals), draw partially overlapping circles. If you want to show that one of the concepts is more inclusive (e.g., broader) than the other, use a larger circle for that one. Label each circle.
5. When you want to show that two concepts are not related (e.g., no crustacean is a vertebrate), draw separate circles and label each one.
6. You may use up to five concept circles in your diagram. They can be separate, overlapping, included, or superimposed. Label each one.
7. The relative sizes of the circles in your diagram can show the level of specificity for each concept. Bigger circles can be used for more general concepts.
8. Coloured pens, markers, pencils or highlighters may be used to colour your concept circle diagram in order to make the relationships between concepts easier to visualize, understand and recall.
9. When the concept circle is finished, a title describing it should be written in the upper left-hand corner of the page and a sentence that summarizes what the diagram shows should be written in the area directly beneath the diagram.

Sample concept circles are provided on the following page.

---

1. From *Drawing Concept Circles: A New Way to Teach and Test Students*, by James H. Wandersee. Copyright 1987 by James H. Wandersee. Adapted by permission of the author.

**RESOURCE 5: USING ADVANCE ORGANIZERS/CONCEPTUAL OVERVIEWS**  
(continued)

---

**SAMPLE CONCEPT CIRCLES**

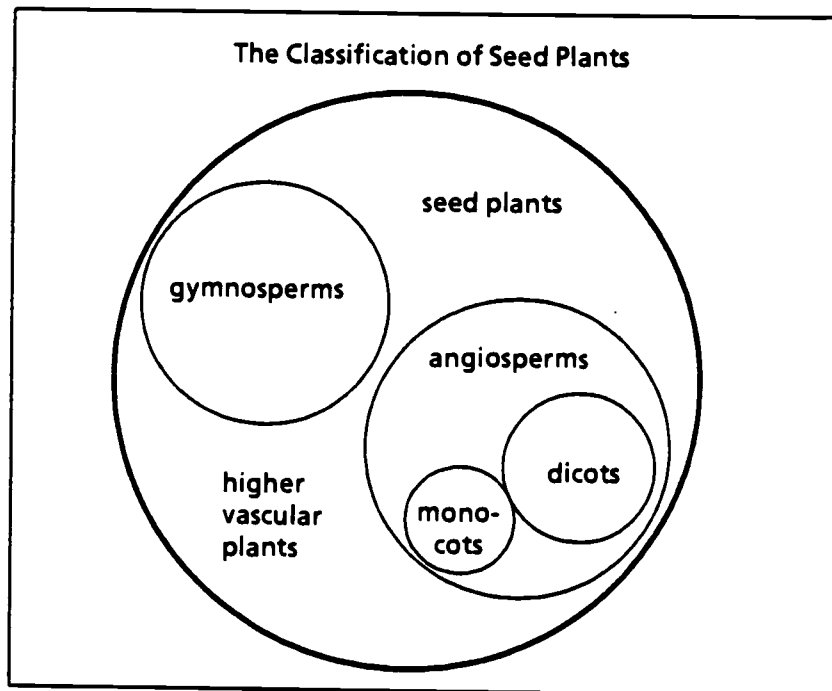
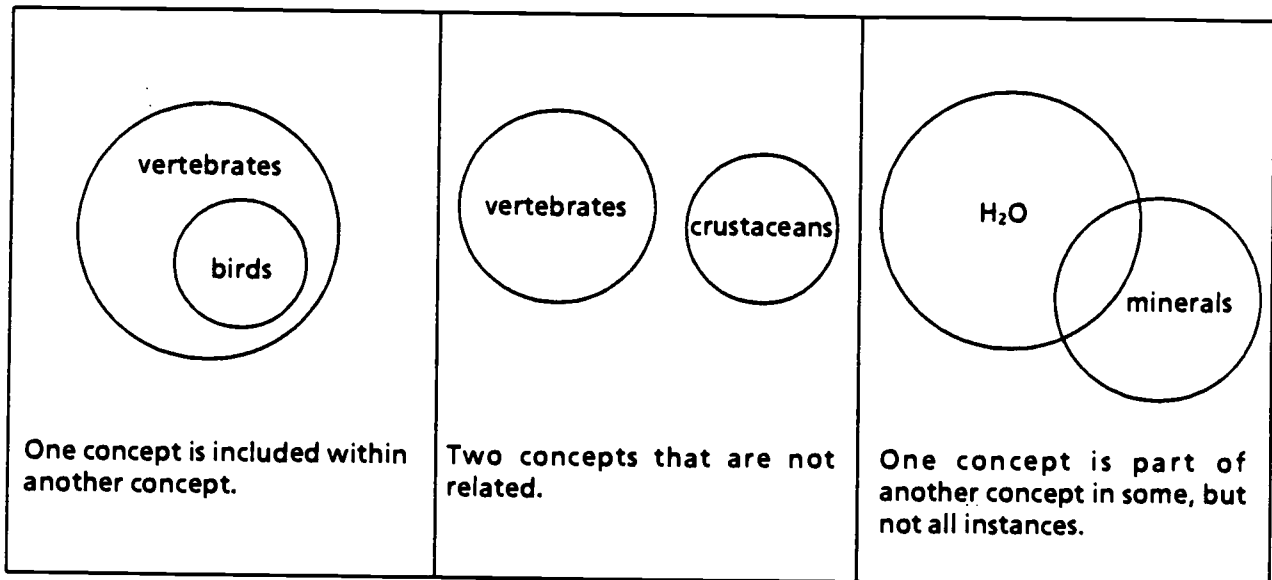

## RESOURCE 6: MAKING SUMMARIES

### USING OUTLINES AND IDEA DIAGRAMS

Outlines similar to the one illustrated below may aid students in organizing their thoughts during the pre-writing phase of a writing assignment or in summarizing material that has been studied.

\_\_\_\_\_ Title \_\_\_\_\_

I. Main Idea \_\_\_\_\_

    A. fact/supporting detail \_\_\_\_\_

    B. fact \_\_\_\_\_

II. \_\_\_\_\_

    A. \_\_\_\_\_

    B. \_\_\_\_\_

Idea diagrams (e.g., semantic webs/maps, comparative/contrastive maps) can also be used in summarizing and pre-writing activities. Two simple configurations are offered as examples.

#### SEMANTIC WEB/DESCRIPTIVE MAP

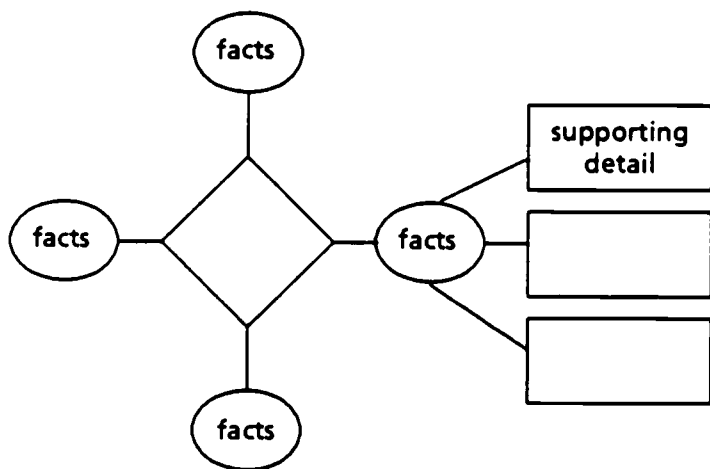

#### COMPARATIVE AND CONTRASTIVE MAP

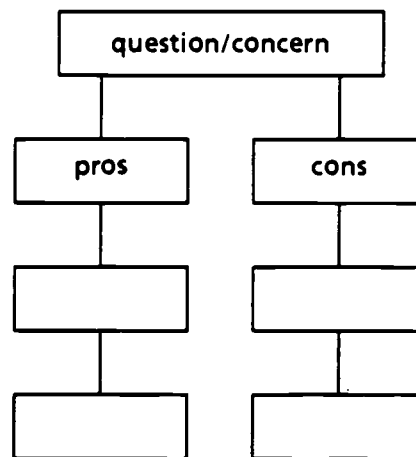

## RESOURCE 6: MAKING SUMMARIES (continued)

### EVALUATION GUIDE FOR SUMMARIZING<sup>1</sup>

Your summary will be marked on the basis of three criteria:

- identification of the main topic
- identification of other details that are relevant, and
- classification of the details to the main ideas and in relation to each other.

Your assignment will be scored out of 20 marks. The scale at the bottom of the page will help you interpret your score.

	Possible Score	My Score
1. Did you correctly identify the main topic? Did you present it clearly and briefly?	5	
2. Did you include all the important subheadings? Are they of equal importance?	5	
3. Did you relate other relevant information to each appropriate subheading? Have you omitted any important information? Have you included any unimportant information?	5	
4. Did you use an appropriate semantic web or skeletal outline?	3	
5. Is the overall organization of your notes easy to follow and understand?	<u>2</u>	
<b>TOTAL</b>	<b>20</b>	

### Scale Point

- One** The summary is incomplete. It fails to include most relevant information. The summary scores zero to five points.
- Two** There are serious omissions of subheadings or there is a failure to include information below the subheadings. Information may be presented at an inappropriate level. The summary scores six to ten points.
- Three** Generally, main topic and most subheadings are present but there may be several omissions of relevant details. There may be some inconsistencies. The summary scores 11 to 15 points.
- Four** The main topic is correctly identified. No more than one major subheading is omitted. Most relevant information is included. The summary scores 16 to 20 points.

1. From the *Junior Secondary Science Curriculum Guide and Resource Book* by the British Columbia Ministry of Education. Copyright 1983 by the British Columbia Ministry of Education. Reprinted by permission.

## RESOURCE 7: USING CRITICAL THINKING SKILLS

### de BONO'S TOOLS FOR TEACHING THINKING<sup>1</sup>

"Thinking is a skill, and like a skill, it can be developed and improved if one knows how."

– Edward de Bono

There are many proponents of direct teaching of thinking as a skill and Edward de Bono is among the internationally recognized authorities in the field. He proposes a "tools method" whereby techniques for guiding the thinking processes are taught as discrete skills, practised in elementary contexts and later applied spontaneously and independently to real problems. The real life problems may change, but the tools to solve those problems remain applicable. A list of thinking tools follows.

**PMI Tool** This tool reminds the thinker, first to direct attention to the **Plus** points, then to the **Minus** points and finally to the **Interesting** points of a new idea. The thinker is encouraged to make an honest and thorough search in each direction to complete the thinking process relative to the problem.

Example:  
What would happen if the two holiday months were July and January?

Plus	Minus	Interesting
<ul style="list-style-type: none"> <li>● winter ski holiday</li> <li>● increase in types of winter recreation</li> </ul>	<ul style="list-style-type: none"> <li>● indoors during warm months</li> <li>● more travel during potentially dangerous winter months</li> </ul>	<ul style="list-style-type: none"> <li>● new types of family holidays</li> <li>● studying, concentrating on school during August</li> </ul>

A PMI can be used to clarify and assess alternatives in a variety of everyday situations.

- e.g.,
- Should I complete my homework or go to the hockey game?
  - Should I attend the dance when my parents would be unhappy with my decision?
  - Should I lend a friend my new sweater?

**RESOURCE 7: USING CRITICAL THINKING SKILLS (continued)**

---

**C and S (Consequences and Sequels):**

- listing the immediate, short-term and long-term effects of a choice to help make a decision.

Immediate Consequence	Short Term Consequence	Long Term Consequence

**CAF (Consider All Factors):**

- brainstorming and listing everything that needs to be considered in thinking about a problem, formulating a plan, organizing the input and making a decision.

CAF

**FIP (First Important Priorities)**

- making and examining a list and prioritizing items in the list.

FIP

**AGO (Aims, Goals, Objectives)**

- developing an action plan and/or making a decision by examining the desired outcomes.

AGO

## RESOURCE 7: USING CRITICAL THINKING SKILLS (continued)

---

### APC (Alternatives, Possibilities, Choices)

- searching for alternatives and extending beyond the obvious in order to consider other possibilities and choices.

APC

### OPV (Other People's View)

- collecting, examining and considering the views of others.

OPV

Teachers are encouraged to:

- provide opportunities for students to practise using these tools in meaningful and novel problem-solving contexts
- discuss with students which tools would be most appropriate in particular problem situations.

---

1. de Bono, Edward. "The Practical Teaching of Thinking Using the CoRT Method", Special Services in the School, Vol. 3 No. 1/2, Fall/Winter 1986, pp. 33-47.



## RESOURCE 7: USING CRITICAL THINKING SKILLS (continued)

### A CRITICAL THINKING WORKSHEET

Choose a topic/issue that you would like to examine critically. Following the steps of critical thinking outlined below, examine the topic/issue and record the results of your analysis.



#### SOME STEPS FOR CRITICAL THINKING

1. Choose a topic/issue to examine: \_\_\_\_\_  
\_\_\_\_\_
  
2. Ask questions about the topic/issue:
  - (a) What are the positive characteristics of this topic/issue? \_\_\_\_\_  
\_\_\_\_\_
  
  - (b) What are the negative characteristics? \_\_\_\_\_  
\_\_\_\_\_
  
3. Gather additional information as required. \_\_\_\_\_  
\_\_\_\_\_
  
4. Review the information. Are there more positive characteristics than negative? More negative characteristics than positive? \_\_\_\_\_  
\_\_\_\_\_
  
5. How will you react to this issue? \_\_\_\_\_  
\_\_\_\_\_

## RESOURCE 8: GIVING AND FOLLOWING DIRECTIONS.

---

Directions vary in terms of their level of difficulty. The directions outlined below have been categorized according to their level of difficulty.

EASY	MEDIUM	DIFFICULT
<ul style="list-style-type: none"><li>● following sewing patterns</li><li>● taking medicine</li><li>● following traffic directives</li><li>● preparing packaged foods (e.g., TV dinners, macaroni dinners)</li><li>● heeding warning signals on equipment (e.g., oil light in car)</li></ul>	 <ul style="list-style-type: none"><li>● following recipes</li><li>● building a model</li><li>● following laundering instructions</li><li>● operating common household appliances (e.g., oven timer, vacuum cleaner)</li><li>● following rules for board games (e.g., Monopoly, Clue)</li><li>● maintaining and using sports equipment (e.g., bikes)</li><li>● operating equipment from a rental shop (e.g., carpet cleaner)</li><li>● using household chemicals and cleaners (e.g., oven cleaner, drain cleaner)</li></ul>	 <ul style="list-style-type: none"><li>● assembling furniture</li><li>● operating electronic equipment (e.g., VCR, stereo)</li><li>● filling out government forms</li><li>● maintaining major home appliances/equipment (e.g., furnace)</li></ul>

### ACTIVITIES

1. Ask students to identify directions that they must follow in science class. Categorize these directions as easy, medium or difficult.
2. Ask students to identify the components of good directions and strategies that will help them to give and to follow directions in an appropriate manner.
3. Provide opportunities for students to describe the safety risks involved in giving poor instructions or not following instructions precisely in laboratory situations.
4. Identify self-monitoring strategies that can be used when giving directions to someone else. (e.g., asking the receiver questions in order to determine if directions are understood.)
5. Invite appropriate community members to attend a class and explain directions that they follow in performing routine tasks at home or at work. These tasks might relate to:
  - changing oil in a vehicle
  - repairing a mechanical/electrical device
  - using a special-purpose tool
  - caring for a pet
  - using a chemical product.

## RESOURCE 8: GIVING AND FOLLOWING DIRECTIONS (continued)

### WRITING DIRECTIONS<sup>1</sup>

#### SITUATION

Imagine that it is September 1st, and you have just arrived in science class. Your new lab partner has never been able to use a triple beam balance correctly and is always asking you to do it. You are fed up with doing all the lab work, so you decide to write an excellent set of directions on how to properly determine the mass of an object using a triple beam balance.

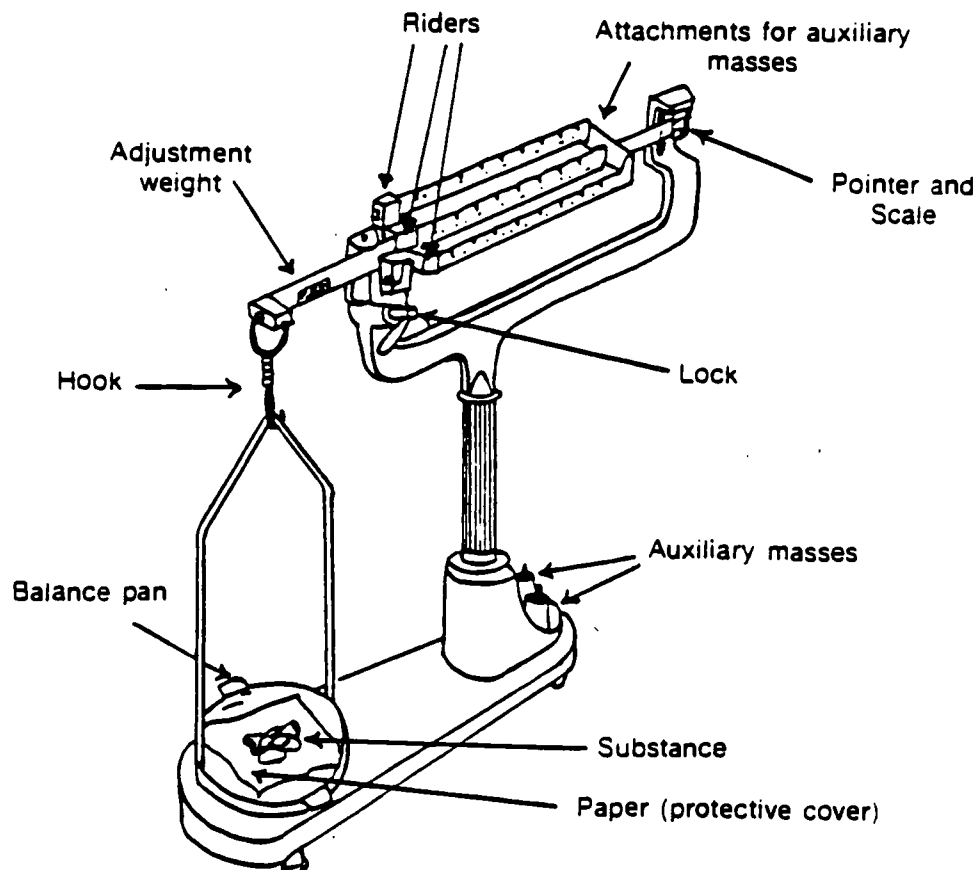

#### ASSIGNMENT

Write a clear set of directions for your partner. If you ask, your teacher will provide you with a balance. When you have written the directions, examine the evaluation guide provided and revise your directions.

1. From the *Junior Secondary Science Curriculum Guide and Resource Book* by the British Columbia Ministry of Education. Copyright 1983 by the British Columbia Ministry of Education. Reprinted by permission.

## RESOURCE 8: GIVING AND FOLLOWING DIRECTIONS (continued)

### AN EVALUATION GUIDE FOR WRITING DIRECTIONS<sup>2</sup>

The marking criteria listed below will be used to measure your ability to write directions for laboratory procedures. Score your assignment to the maximum number shown on the right of each statement.

	Possible Score	My Score
1. The title is present and gives an indication of the purpose of the directions. An example might be, "How to Fly a Kite".	2	
2. Supplies and equipment are all identified and correctly classified.	2	
3. The instructions are listed:		
● in complete sentences	3	
● in the correct sequence	4	
● without any omissions	4	
● in a numbered order	2	
● using present tense	2	
● without addressing 'you'.	1	
4. Safety hazards, if they exist, are identified and noted in the appropriate location.	2	
5. The overall organization is easy to follow.	<u>*3 or 5</u>	
<b>Total</b>	<b>25</b>	

\* Score 3 if identification of safety hazards is necessary and 5 if it is not.

#### Scale Point

- One** The directions are incomplete and/or in an inappropriate format. The directions obtain zero to 10 points.
- Two** There are serious problems with format and there may be omissions. The directions obtain 11 to 15 points.
- Three** The instructions are logical although there may be some weaknesses in format. The directions obtain 16 to 19 points.
- Four** A clear set of directions is presented in a standard format. The directions obtain 20 to 25 points.

2. From the *Junior Secondary Science Curriculum Guide and Resource Book* by the British Columbia Ministry of Education. Copyright 1983 by the British Columbia Ministry of Education. Reprinted by permission.

## RESOURCE 9: STRATEGIES FOR DISCUSSING AND DEBATING

---

### PREPARING FOR GROUP DISCUSSION

Many science activities centre around discussion groups and provide opportunities for verbal communication among students. Students may lack experience in the give-and-take of discussion groups. Some direct teaching of discussion skills may prove useful.

#### SETTING RULES

Members of the discussion group may increase their involvement if they feel they have some ownership of the rules. Have student generate discussion rules and post these as reminders. Rules may change according to the goals of the group, but ensure that everyone understands them.

#### GROUP SIZE AND SEATING ARRANGEMENTS

Groups of five are ideally suited to discussion. A circle formation permits all members to participate equally.

#### DECISION MAKING

Reinforce the process by which decisions will be made: consensus, majority vote, compromise, expert or authority in the group. The strongest decisions are those arrived at by group consensus, yet consensus is often difficult to achieve.

#### MEMBERS' ROLES

Students may require assistance in determining their roles and functions in the group (e.g., a recorder takes notes, a chairperson keeps the topic on track and encourages all members to get involved). The natural leader of the group may need assistance to avoid replacing the "appointed leader".

#### GROUP GOALS

Remind students of the specific goal of the group discussion and teach them strategies for keeping the discussion directed at reaching the goal (e.g., calling attention to and recording major ideas).

#### GROUP PROCESS SKILLS

Students may require assistance in developing the following group process skills:

- asking probing questions
- intervening when a member becomes disruptive
- calling attention to major ideas
- keeping time
- remaining on topic
- asking for opinions, information and suggestions from others
- offering opinions, information and suggestions
- correcting others
- asking for clarification.
- releasing tension in the group.

## RESOURCE 9: STRATEGIES FOR DISCUSSING AND DEBATING (continued)

---

### CHECKLIST FOR SELF-EVALUATION IN GROUP DISCUSSIONS

The following checklist can be used to evaluate personal participation in group discussions. Take a few minutes to reflect honestly on your contribution to the class. Put a check (✓) next to those statements that are true of you in today's discussion and fill in the blank spaces appropriately.

1.  I contributed ideas without waiting to be asked.  
One idea I contributed was \_\_\_\_\_  
\_\_\_\_\_
2.  I kept my remarks on topic.
3.  I supported my ideas and remarks with specific details (e.g., I gave an example).
4.  I listened carefully and thoughtfully.
5.  I can recall other group members' ideas.  
One important idea was \_\_\_\_\_  
\_\_\_\_\_
6.  I encouraged other group members to tell more about their ideas.
7.  I asked other group members questions about their ideas.
8.  I respected other members' ideas and opinions even if I disagreed.
9.  I let other members finish speaking without interrupting.
10.  I changed my mind about something as a result of listening to other members' opinions.  
I changed my mind about \_\_\_\_\_  
\_\_\_\_\_
11.  I think I might have made someone else change their mind about something as a result of an idea I contributed.  
The issue was \_\_\_\_\_  
\_\_\_\_\_
12.  I have a clearer picture of my own concerns/problems as a result of this group discussion.
13.  I have a better understanding of other people's concerns/problems as a result of this group discussion.
14.  Here is something I learned from today's discussion: \_\_\_\_\_

## **RESOURCE 9: STRATEGIES FOR DISCUSSING AND DEBATING (continued)**

---

### **FORMAL AND INFORMAL DEBATES**

Debating is a good technique to use to get students to think through complex issues carefully. While debates can take many forms, the following procedures have proven particularly effective in the classroom.

#### **INFORMAL DEBATE**

The class will form two teams – one in support of and one against the debate statement. The teams should be seated facing one another.

Arguments are presented by a team member from one side, then a team member from the other side. Arguments are presented alternately until all students have had an opportunity to speak. Each speaker will be allowed one minute. (A person should be selected to be timekeeper.)

This debate should be a spontaneous activity. Teams should not prepare in advance but try to develop the arguments as the debate progresses. Each student will need to listen carefully to the arguments that are presented and introduce his or her own new idea. The object is to try to think and organize ideas quickly. It is almost like brainstorming where someone presents an idea and that idea leads to another idea. Each debater can build his or her idea from the previous idea or present a totally different idea.

After all arguments have been presented, the class will then discuss some of the main points that were brought out by each side. What were the best arguments presented by each team?

#### **FORMAL DEBATE**

##### **Organization**

##### **Judges**

A minimum of three members of the class should serve as judges (or preferably, invite three persons from outside the class). One of the judges must serve as timekeeper and monitor the length of each of the presentations. A second judge should act as the presiding judge and supervise the proceedings. He or she will be responsible for keeping the debate orderly and calling on the presenters in turn.

##### **Teams**

After the judges have been selected, the remainder of the class should form two equal teams -- one supporting the debate statement and the other opposing the statement. Each team should elect a coordinator whose responsibility will be to organize the team members. The recorder will take notes on the group's activities and decisions. The recorder and coordinator may be the same person, depending on the size of the task.

##### **Preparing for the Debate**

Team members will meet to develop the arguments for their position. Each team will first make a list of the major arguments (abbreviated statements) supporting its position. The coordinator will review the list to make sure that all the important arguments have been included and no argument is duplicated. There should be as many arguments as there are team members. If there are too many, the least important should be eliminated. If there are too few, additional ones should be developed.

Make two copies of your team's list and exchange one copy for the list from the other team.

## RESOURCE 9: STRATEGIES FOR DISCUSSING AND DEBATING (continued)

Each team member will select an argument from his or her own list to develop into a short, two- to three-minute defence. He or she will also select an argument from the list submitted by the other team and prepare a two- to three-minute rebuttal (counter argument). Each person will thus be responsible for two arguments: one that supports his or her team's position and the other that answers/attacks the other team's position.

### The Debate

The debaters make their presentations in the following order:

3 min. – Team 1 presents argument

3 min. – Team 2 presents rebuttal

3 min. – Team 2 presents argument

3 min. – Team 1 presents rebuttal.

The sequence is repeated until all debaters have presented their arguments and rebuttals. A five-minute summation speech is then given by a member (usually the coordinator) from each team. This summation reiterates the most important points made by the team members.

### Judging

A convenient method for judging the debate is to evaluate each set of arguments in turn. After each argument and counter argument is presented, the judges will determine which one of the debaters delivered the most effective and convincing argument. Each judge will set up a score sheet similar to that shown below and assign points as follows:

SCORE SHEET

	Team 1 (Pro)	Team 2 (Con)
Argument 1		
Argument 2		
Argument 3		
Argument 4		
Total Points		

4 points = excellent    3 points = good    2 points = fair    1 point = poor

### DEBATING POINTERS

The following tips may be helpful to your students in their preparation for, and presentation of, a debate argument.

- Skilful debating is skilful communication. Make sure your argument is clearly stated and well supported by evidence.
- Explain why your argument is important. This is best conveyed by presenting examples of possible effects.
- Present the argument in a logical sequence, making the most important points first and backing them with sound evidence.
- Speak clearly and slowly so that your argument can be followed by all listeners.
- Be forceful and imaginative. Concentrate on conveying the main issues of your argument.



## RESOURCE 10: INFORMAL ESSAY WRITING

---

### WRITING AN INFORMAL ESSAY<sup>1</sup>

#### SITUATION

Each month we read of the health hazards and environmental damage caused by improper handling of chemicals: the train derailment at Mississauga, Ontario; the spillage of chlorine gas on Main Street in Vancouver; and the use of urea formaldehyde foam as household insulation, are three recent examples.



#### ASSIGNMENT

Locate a newspaper article that describes the hazards associated with an environmental issue. After considering both sides of the issue, write a letter in which you state your opinion on the matter, the reasons for it, and your recommendations. Your letter should not exceed 250 words. Send your letter to an appropriate government official.

1. From the *Junior Secondary Science Curriculum Guide and Resource Book* by the British Columbia Ministry of Education. Copyright 1983 by the British Columbia Ministry of Education. Reprinted by permission.

## RESOURCE 10: INFORMAL ESSAY WRITING (continued)

---

### AN EVALUATION GUIDE FOR INFORMAL ESSAY WRITING<sup>2</sup>

Your assignment will be marked on the basis of two criteria.

- A clear statement of opinion is made.
- Supporting statement. Supply evidence for your opinion by relating an incident, giving an example or explaining relevant information.

#### Scale Point

- One** No opinion is stated. The essay or letter is not on topic.
- Two** Opinion is/are offered but with little or no relevant support.
- Three** Opinion(s) is/are stated with support, but the essay or letter loses effectiveness because supporting statements are wordy, trite, or overgeneralized.
- Four** The opinion(s) is/are stated clearly and concisely. The type of data selected is especially convincing; generally more than three pieces are provided.

---

2. From the *Junior Secondary Science Curriculum Guide and Resource Book* by the British Columbia Ministry of Education. Copyright 1983 by the British Columbia Ministry of Education. Reprinted by permission.

# ASSESSMENT/EVALUATION

---

The goal of science education during the 1980's, as stated by the National Science Teachers' Association, is to develop scientifically literate individuals who understand how science, technology and society influence one another, and who are able to use this knowledge in their everyday decision making. Furthermore, the 1984 Science Council of Canada report, *Science for Every Student*, recommends that:

- science education provide a more accurate view of the practice, uses and limitations of science
- science education include study of how science, technology and society interact
- students be taught how Canadians have contributed to science and how science has affected Canadian society
- teachers and curriculum planners evaluate students' progress in all the goals of science education, not just their learning of scientific content.

These recommendations have formed the foundation for the goals of the Science 16-26 program. Assessment and evaluation practices should provide feedback and evidence of progress toward these instructional goals. A singular assessment technique cannot provide this evidence. Assessment must go beyond determining the percent of correct responses on a test based on scientific facts, and needs to reflect:

- how students approach "doing" science
- interactions among science, technology and society
- applications of science in practical situations.

It is important to recognize that through the process of evaluation we evaluate students' performances and not the students themselves. This understanding helps one avoid permanently classifying a student as a good student or a poor student. Performance can and does change, and teachers should be aware of these changes.

Suggestions and ideas for assessing and evaluating students' performance have been included in this section of the manual, and focus attention on the use of:

- Observation
- Interviews
- Inventories/Checklists
- Anecdotal Records
- Individual and Group Projects
- Written Assignments
  - Laboratory Write-Ups and Reports
  - Diagnostic Writing Assignments
  - Paper-and-Pencil Tests
- Self and Peer Evaluation.

The evaluation strategies suggested in this manual are not intended to be discrete, and should be used in conjunction with other strategies. For example, a checklist may be used to document desirable problem-solving behaviour in the classroom, and to guide discussion and evaluate performance in an interview. Furthermore, teachers are encouraged to extend the application of these evaluation strategies to situations beyond those that are discussed.

Additional suggestions for assessment and evaluation within the science program are provided in:

- *Evaluation of Student Progress, A Workshop Manual for Administrators and Teachers* (by Science Education Consultants, Alberta Education, and available at Regional Offices of Education)
- *Individualized Science Instructional System Teacher Resource Guide* (by Glen Hutton, Globe/Modern Curriculum Press, and available through the Learning Resources Distributing Centre)
- *Making the Grade, Evaluating Student Progress* (by the Board of Education for the City of Etobicoke, Prentice-Hall Canada Inc., and available through the Learning Resources Distributing Centre).

## OBSERVATION

Although teachers make observations all the time, when observations are documented their effectiveness as an evaluation strategy increases immensely. Documented observations can provide the raw data required for analysis and diagnosis, and establish a basis on which to make remediation or enrichment decisions.

Science lessons usually have a component in which students work on assignments and projects individually or in small groups. At this time teachers can observe students at work, looking for specific behaviours or outcomes, asking questions and making suggestions. Elements of the learning process that might be monitored through observation include:

- understanding of concepts/skills
- method of attacking problems
- work habits
- level of independence with work
- interpersonal skills and social growth.

Documentation of behaviours that are observed may occur in the form of anecdotal records or checklists. Teachers can file anecdotal records and checklists in a student folder where samples of daily work, project reports and other artifacts are also placed.

### CLARIFICATION/EXAMPLE

Anecdotal Record				
Name	Date	Situation	Behaviour	Comment
Nitan	1/17	investigation of electromagnetism, variables affecting strength of the electromagnet	quick to help neighbouring students	understands basic concepts of electromagnetism
	1/25	researching/reporting local methods of producing electrical energy	unable to organize and communicate information gathered	use more pre-writing activities (e.g., semantic mapping, topical outlines)

A sample checklist that can be used in observing student behaviours is provided as Resource 1: Observational Checklist of Student Behaviours.

Audiotapes or videotapes can also be used to provide records of specific learning outcomes. Photographs are useful in providing a record of project work. In addition to providing the tangible items that parents like to see at conference time, these records of student performance enable the teacher to measure progress with more objectivity than simply through remembering what was done.

## INTERVIEWS

A planned interview with a student or group of students is an effective technique for assessing knowledge, understanding, thinking style, attitude or personal interests. An interview removes the restriction of writing, and enables the teacher to delve more deeply into students' thought patterns and how they go about finding an answer or solving a problem. Although written responses on an assignment may indicate areas of concern, more information is often required before appropriate remediation can be provided. Remediation strategies that are based solely upon the analysis of written responses may in fact be inappropriate at times. Holding interviews with students can reveal both surprising strengths and unsuspected weaknesses in their understanding of scientific thought processes.

Some guidelines for conducting interviews are provided below.

- Establish an atmosphere of acceptance. Students must feel comfortable enough to verbalize their ideas freely. By accepting a student's responses without judgment, but with encouragement to elaborate further, you are communicating not only respect for the student's thinking but also a curiosity to learn more. Whether right or wrong, each response has the potential of providing information about the student's level of understanding.
- Ask probing questions. During the interview, ask questions and introduce materials that will cause the student to extend and apply concepts/skills to new areas. Rephrase questions using vocabulary familiar to the student so as to clarify both your intent and the student's thinking. Although some of the questions you ask should be planned, others should be invented spontaneously in order to test your hunches about the student's thinking. Questions asked may take some of the following forms:
  - How did you ...?
  - Why did you ...?
  - How do you know that ...?
  - Tell me more about ...?
  - What else might happen if ...?
  - Can you describe ...?
  - What made you ask that question?
  - How do you feel about ...?
- Pace the interview appropriately. By allowing an adequate pause following each question before repeating or rephrasing it, you are giving the student time to interpret the question and construct the response. On some tasks, the student may need more than a thirty-second pause, whereas on others, three seconds will suffice. Also, by allowing an adequate pause following the student's response, you are indirectly encouraging him or her to elaborate on his or her initial response.
- Be prepared to coax and encourage the student to make a response. A frequent response given by the student may be "I don't know" or "I forgot". Sometimes an extended pause can coax out productive thinking. At other times, the teacher can encourage a response to questions about which the student is unsure by saying:
  - "I know it's not easy to think about. Just give me your best idea."
  - "Pretend that you did know. How do you think it might be done?"

Interviews should have a definite purpose and both teacher and student should be aware of that purpose. Interviews must be planned in advance. In preparing for an interview, the teacher should consider:

- What questions will I ask?
- What basic understandings will I initially assess?
- How can I incorporate the use of manipulative materials?
- How can I vary the task and questions to obtain different perspectives on the student's ability?

#### **CLARIFICATION/EXAMPLE**

##### **A Structured Interview**

1. Identifying and Understanding the Problem
  - Can you describe what you were asked to do in this assignment?
2. Selecting and Using Appropriate Strategies
  - What methods did you use to do this assignment?
  - How did you decide which methods to use?
  - Which methods worked the best?
3. Selecting and Using Data
  - What specific information did you obtain by conducting this investigation?
  - How do you intend to use this information?
4. Solving or Answering the Problem
  - What was the outcome of this investigation?
  - What steps did you go through in completing this assignment?
5. Determining the Reasonableness of the Solution
  - How did you decide if the outcome of this investigation/assignment was reasonable?

Maximum benefits can be gained from an interview by reflecting on your interaction after listening to an audiotape playback. Considerable value can also be gained from sharing your tape with a colleague. By discovering how students interpret and view a problem, the teacher will be better able to make effective on-the-spot decisions in the classroom.

Guides for conducting different types of interviews have been provided at the end of this section, and include:

- Resource 2: Gaining Information from Text
- Resource 3: Interview Guide for Inquiry/Problem Solving
- Resource 4: Interview Guide for Project Work.

## INVENTORIES/CHECKLISTS

Inventories and checklists are documentation strategies that can be used conjunctively with other evaluation strategies. They can be easily designed and customized to meet different needs and situations. Generally a matrix is created with indicators of desirable behaviours/outcomes on one side and ratings/skill levels along another side. As teachers note a particular behaviour, they need only check the appropriate column that evaluates or rates that behaviour.

Checklists lend themselves very well to documenting elements of the program that include:

- comprehension of a concept
- mastered knowledge, skills or process
- work habits
- use of inquiry/problem-solving/decision-making strategies
- social skills.

### CLARIFICATION/EXAMPLE

<b>Checklist/Inventory of Social Skills</b>			
<b>Behaviour to be Observed</b>	<b>Frequently</b>	<b>Sometimes</b>	<b>Never</b>
Is sensitive to the needs and problems of others.			
Willingly shares ideas/materials.			
Accepts suggestions and help.			
Listens while others speak.			
Adheres to group plans/decisions.			
Works cooperatively with others.			
Considers the viewpoints of others.			
Respects the property of others.			
Appears to like group work.			
Speaks clearly/expresses ideas clearly.			

Checklists and inventories can also be used to evaluate the products/outcomes of activities such as laboratory reports, oral presentations, library research and projects involving design and construction. By establishing indicators of outcomes along a scoring scale, a variety of different evaluation matrices that are appropriate to specific situations can be developed.

**CLARIFICATION/EXAMPLE**

<b>SAMPLE EVALUATION MATRIX</b>			
<b>Activity</b>  <b>Score</b>	<b>Problem-Solving Skills</b>	<b>Participation</b>	<b>Product</b> (e.g., laboratory report, oral presentation, collage, model)
<b>5</b>	<ul style="list-style-type: none"> <li>● Understands problem/ investigation/issue/ assignment</li> <li>● Selects necessary strategies</li> <li>● Evaluates appropriateness of solution/conclusion/opinion/ product</li> </ul>	<ul style="list-style-type: none"> <li>● Gets involved quickly</li> <li>● Stays involved</li> </ul>	<ul style="list-style-type: none"> <li>● Complete and correct</li> <li>● Commands respect</li> <li>● Neatly done</li> </ul>
<b>4</b>	<ul style="list-style-type: none"> <li>● As above but fails to evaluate solution/conclusion/opinion/ product</li> </ul>	<ul style="list-style-type: none"> <li>● Needs a start</li> <li>● Stays involved</li> </ul>	<ul style="list-style-type: none"> <li>● Mostly complete</li> <li>● Correct and neat</li> <li>● Good work</li> </ul>
<b>3</b>	<ul style="list-style-type: none"> <li>● Errors evident but strategies selected led to a solution/ conclusion/opinion/product</li> </ul>	<ul style="list-style-type: none"> <li>● Needs periodic reminding to stay on task</li> </ul>	<ul style="list-style-type: none"> <li>● Somewhat complete</li> <li>● Minor errors</li> <li>● Satisfactory</li> </ul>
<b>2</b>	<ul style="list-style-type: none"> <li>● Errors evident</li> <li>● No solution/conclusion/opinion/ product provided</li> </ul>	<ul style="list-style-type: none"> <li>● Needs constant reminding to stay on task</li> </ul>	<ul style="list-style-type: none"> <li>● Incomplete</li> <li>● Major errors</li> <li>● Untidy</li> </ul>
<b>E</b>	<b>Acceptably Excused from the Assignment</b>		
<b>0</b>	<b>Not Done or Handed in</b>		

Other checklists and inventories that can be used to document particular elements of the science program are provided at the end of this section in:

- Resource 5: Inventory of Inquiry Skills/Attitudes
- Resource 6: Checklist for Assessing Writing Assignments.

Teachers may wish to modify and adapt these checklists in order to monitor and evaluate other components of the science program.



## ANECDOTAL RECORDS

Anecdotal records refer to the spontaneous documentation of notable behaviour, effort and achievement. These records provide specific and dated information that can form the basis for conclusions and assessments. Anecdotal records often prove invaluable in clarifying assessments and add credibility to observations and recommendations being offered in student, parent and/or teacher meetings.

Anecdotal records may include observations on:

- attitude/work habits
- social skills
- effort and homework
- changes in performance
- specific strengths/deficiencies
- communication skills.

### CLARIFICATION/EXAMPLE

<b>Anecdotal Record Card</b>	
Student: <u>Sue Jones</u>	Date: <u>04/10</u>
Comments:	
<ul style="list-style-type: none"><li>- demonstrates an understanding of concepts studied through questions that she asks</li><li>- follows directions accurately, but is unable to establish/plan her own procedures for an investigation</li><li>- shows interest in helping others; excellent group worker</li><li>- has difficulty in selecting laboratory apparatus that is appropriate to a particular task</li></ul>	

Anecdotal records may be kept in a daily or weekly diary, in student files, in the marks' record book or in a common file of short, dated notes.

## INDIVIDUAL AND GROUP PROJECTS

Individual and group projects provide opportunities for students to demonstrate their ability to use a variety of skills through activities that may involve research in the library/community, experimental work in the laboratory or combinations of these and other activities. Students usually enjoy project work as it provides them with an opportunity to direct their own learning. Teachers should be prepared to assist students in planning their projects and in obtaining information, materials and equipment that may be required.

The quality of student work will be improved if students understand the criteria on which their projects will be evaluated. Teachers may wish to evaluate students in terms of their ability to:

- plan and design the project
- use appropriate processes/skills.

### CLARIFICATION/EXAMPLE

<b>Criteria for Evaluating a Plan/Design</b>	
<u>Criteria</u>	<u>Score</u>
Devises a good plan for research/investigation. Plan is clear, concise and complete.	9 - 10
Devises a plan for research/investigation that needs some modification. Understands the overall approach.	7 - 8
Devises an acceptable plan for research/investigation with some help.	5 - 6
Devises an inappropriate plan for research/investigation that needs considerable modification. Does not understand purpose/overall approach.	3 - 4
Has little idea of how to plan for research/investigation. Must be directed through each step.	1 - 2

**CLARIFICATION/EXAMPLE**

**Criteria for Evaluating Process and Skill**

<u>Criteria</u>	<u>Score</u>
A. Creative Thought .....	10
Does the project show creative/original thought in:	
- questions asked?	
- the approach to problem solving?	
- the analysis/interpretation of data?	
- use of equipment?	
- the construction/design of a device or process?	
B. Scientific Thought .....	10
Does the project display an understanding of:	
- the purpose/problem?	
- a procedural plan?	
- variables and controls?	
- conclusions that may be drawn from data collected?	
- the limitations of data collected?	
C. Strategies and Skills .....	10
Did the student:	
- demonstrate knowledge and skill in using necessary equipment?	
- use locally available sources of information?	
- complete the project with minimal assistance?	
- understand and use appropriate technical vocabulary?	
- complete the project in a neat and orderly manner?	
D. Thoroughness/Clarity .....	10
Does the project:	
- carry out its purpose to completion?	
- have appropriate notes/diagrams/illustrations?	
- present data clearly and in sequential order?	
- explain itself?	
Can the student:	
- discuss the project?	
- explain the purpose, procedure and conclusions in a clear and concise manner?	

## WRITTEN ASSIGNMENTS

### LABORATORY WRITE-UPS AND REPORTS

Students may be asked to demonstrate their understanding of concepts and skills by preparing laboratory write-ups and other written reports. Guidelines for evaluating these kinds of written assignments are provided throughout other sections of this manual and include:

- An Evaluation Guide for Lab Reports (see Nature of Science).
- An Evaluation Guide for Observations (see Nature of Science).
- An Evaluation Guide for Summarizing (see Communication Skills).
- An Evaluation Guide for Writing Directions (see Communication Skills).
- An Evaluation Guide for Informal Essay Writing (see Communication Skills).

### DIAGNOSTIC WRITING ASSIGNMENTS

Diagnostic writing assignments require students to respond to questions in an expressive writing style. Written responses often force the students to examine their own understanding of concepts and will communicate to teachers how much students really know about a concept. Written responses also provide insight into how students think. These assignments have proven successful as a diagnostic tool. Appropriate remedial and enrichment activities may be determined on the basis of the understanding demonstrated for a given concept.

#### CLARIFICATION/EXAMPLE

**Applying Knowledge of Electrical Circuits**

Circle the diagram below that represents a closed circuit. Explain why each of the other diagrams do not represent closed circuits, and how you would make the lamp work in each situation.

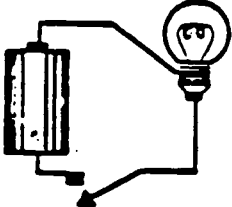
A. 

B. 

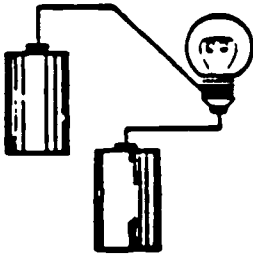
C. 

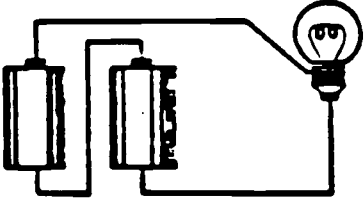
D. 

These kinds of writing assignments should not be graded for a mark but, rather, be assessed for understanding (diagnosis). Students might be awarded bonus points based on their effort and presentation.

#### CLARIFICATION/EXAMPLE

0 points	- no effort
1 point	- mediocre attempt with little or no understanding
2 points	- good attempt, but with some lack of understanding
3 points	- high level of effort and understanding

Diagnostic writing assignments can be kept in a student diary or logbook, and might be assigned on a regular basis (once or twice a week) or in lieu of a regular quiz.

### PAPER-AND-PENCIL TESTS

Traditional paper-and-pencil tests are probably the most widely used method of evaluating student performance. While effective in assessing factual and procedural knowledge, these tests often elicit feelings of inadequacy and self-doubt for students who have experienced previous difficulty or failure. These negative feelings affect test performance and may cause a cycle of repeated failure to continue.

Students may have learned the information presented in class, but are unable to demonstrate the knowledge because of poor reading skills, visual perception problems, inadequate reasoning and comprehension, fine-motor difficulties or other related deficiencies. Special needs of the student can be met through minor alterations in the construction of teacher-made tests. Constructing tests according to special needs can mean the difference between success and failure of some students.

The suggestions that follow will assist teachers to construct their tests according to the needs of individual students.

#### TEST DIRECTIONS

- Keep directions simple and avoid unnecessary words.
- Define words that are unfamiliar or abstract.
- Give an example of how the student is to respond whenever possible.
- Avoid oral directions as the only means of communication. Read directions orally as well as clearly writing them on the test.

#### TEST ITEMS

- Provide manipulative materials that make situations more concrete whenever possible.
- Avoid mixing different question formats in the same section of the test.
- Design questions that:
  - are relevant to the students' personal experience
  - consist of simple sentences and familiar words.
- Underline or circle key words in a question.
- Ask students to circle the correct response in multiple choice items. This reduces the possibility of copying errors when transferring letters to blanks. Arrange the answers and distractors vertically on the page.

- Keep all matching items brief, and have only one correct answer for each item. Use no more than ten items in the matching lists. If you have more than ten items, group them by concepts in clusters of ten.
- Provide visual prompts that will assist students to recall and process information.

#### CLARIFICATION/EXAMPLE

Write two hypotheses you might make on the basis of this picture.

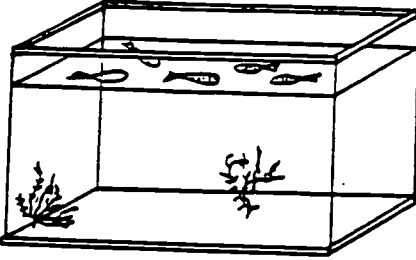

#### TEST DESIGN

- Construct the test in logical sequential order, from simple to complex problems.
- Use test items that reflect the content taught and techniques used to teach.
- Prepare a study guide for the test that matches the design of the actual test.
- Design the test to reflect the student's knowledge rather than ability to follow complicated directions, to use difficult vocabulary, or to work under time constraints.
- Adjust the readability level of the test to meet student needs.
- Prepare the test in short sections that can be administered individually if necessary.

## SELF AND PEER EVALUATION

Self and peer evaluation involves having students rate their own work or the work of others, using clearly defined criteria and guidelines supplied by the teacher. This process encourages students to examine their work in some depth, and facilitates the development of analytical and critical thinking skills. As students often perceive their classmates as more accepting of their thoughts and ideas than teachers, peer evaluation may reduce fear of failure and help students to develop confidence about expressing their ideas.

### GUIDELINES FOR IMPLEMENTING SELF AND PEER EVALUATION

- Do not assume that students can evaluate their own or others' work with little or no preparation. Provide clearly defined criteria and guidelines for students to use in making judgments about a piece of work (e.g., a checklist of what to look for, a list of simple questions that students should ask themselves, a sample solution).
- Provide students with concrete examples of student work that differ in quality, and explain how particular criteria and guidelines were used to determine each mark. Teachers may wish to coach the class in marking a sample assignment, using established guidelines.
- Organize for peer evaluation in partner situations or in small groups (3-5 students). Provide for an appropriate selection of students in each group by assigning membership rather than letting students form their own groups. Group membership may be changed from one peer evaluation session to another.
- Throughout the process of self and peer evaluation, encourage students to focus attention on:
  - positive features of the work being evaluated
  - aspects of the work that are not clear, incomplete and/or incorrect
  - specific suggestions for improvement.

#### CLARIFICATION/EXAMPLE

##### Sample Criteria/Guidelines for Peer Response

1. What do you like best about this piece of work?
2. What thoughts, ideas and/or feelings are communicated by this work?
3. What would you like to know more about?
4. Complete the PMI chart by listing positive, negative and interesting points about the assignment.

P Plus	M Minus	I Interesting

5. Complete the COPS chart to evaluate technical quality of the assignment.

C Capitalization	O Overall Appearance	P Punctuation	S Spelling

6. What suggestions could you make for improving this work?

## RESOURCE 1: OBSERVATIONAL CHECKLIST OF STUDENT BEHAVIOURS

### LEVEL OF INDEPENDENCE WITH WORK:

	ALWAYS	OFTEN	SOMETIMES	NEVER
● Settles down to work upon entering class.				
● Spends time on task; has satisfactory attention span.				
● Takes responsibility for making up work after absences.				
● Takes responsibility for supplies and equipment.				
● Follows directions; completes tasks with minimal assistance.				
● Asks for and accepts help when needed.				
● Accepts a challenge; works productively on tasks of increasing difficulty.				
● Displays self-confidence and pride in work.				

### UNDERSTANDING OF CONCEPTS AND SKILLS:

● Uses the necessary vocabulary and concepts.				
● Uses appropriate operations, strategies and principles.				
● Asks questions, volunteers answers.				
● Answers questions that involve thought (e.g., What do you think?).				
● Demonstrates understanding through ability to generalize and apply.				
● Displays curiosity about objects, events, concepts and relationships.				
● Works independently on projects and research.				



**RESOURCE 1: OBSERVATIONAL CHECKLIST OF STUDENT BEHAVIOURS (continued)**

**ABILITY TO INVESTIGATE AND SOLVE PROBLEMS:**

	ALWAYS	OFTEN	SOMETIMES	NEVER
● Understands and defines problems/issues.				
● Develops a systematic plan of attack.				
● Gathers information using a variety of sources.				
● Carries out plans and procedures, seeking help when necessary.				
● Uses appropriate strategies and processes.				
● Considers alternatives before reaching a solution/decision.				
● Evaluates solutions to the problem and decisions made.				
● Considers other ideas/opinions/solutions.				
● Defends personal statements/position on the basis of logical evidence.				

**INTERPERSONAL SKILLS AND SOCIAL GROWTH :**

● Resists aggressive and impulsive behaviours.				
● Volunteers to work in group situation.				
● Cooperates and contributes to group goals.				
● Listens to peers; considers the opinions of others.				
● Participates in oral discussions.				
● Willingly helps others.				

## RESOURCE 2: GAINING INFORMATION FROM TEXT

---

Select a chapter of a science textbook. The textbook should be one currently in use in the student's science program.

### WORD IDENTIFICATION

Ask the student to read aloud a passage of about 200 words. Note the number of words identified correctly. \_\_\_% of words are identified correctly.

If the student identified 90% or more of the words correctly, proceed with the interview. If the student identified less than 90% of the words correctly, select an easier textbook. Hesitations and self-corrections should not be counted as errors.

### SURVEY OF STRATEGIES

Ask the student to show you how he/she would study the chapter in order to gain information. Ask him/her to verbalize his/her thoughts during the course of reading. Note the strategies employed by placing a check (✓) in the blank space.

- Skimmed: introduction \_\_\_\_\_
- headings \_\_\_\_\_
- figures and illustrations \_\_\_\_\_
- italics \_\_\_\_\_
- conclusion \_\_\_\_\_
- prior to reading the chapter \_\_\_\_\_
- Read the chapter from beginning to end \_\_\_\_\_
- Began to read chapter, then gave up \_\_\_\_\_
- Spontaneously asked himself/herself questions while reading \_\_\_\_\_
- Used study questions as a guide for reading \_\_\_\_\_
- Picked out the main ideas or important points while reading \_\_\_\_\_
- Paraphrased main ideas or important points \_\_\_\_\_
- Looked up unknown words in the dictionary \_\_\_\_\_
- Underlined or highlighted important information \_\_\_\_\_
- Made notes \_\_\_\_\_

Other: \_\_\_\_\_  
\_\_\_\_\_  
\_\_\_\_\_  
\_\_\_\_\_

**RESOURCE 2: GAINING INFORMATION FROM TEXT (continued)**

**PROBES**

Some students have strategies in their repertoire that they do not use unless directed to do so. Select a different chapter in the same textbook and rate the student's skill on the following directed procedures.

	Excellent	Adequate	Inadequate	Notes
Getting appropriate information from: introduction headings figures and illustrations italics conclusions Self-questioning Paraphrasing of main ideas Identifying words not understood Looking up words in the dictionary				

Comments: \_\_\_\_\_

\_\_\_\_\_

\_\_\_\_\_

\_\_\_\_\_

For permission to reprint copyright material, grateful acknowledgement is made to the following: Division for Learning Disabilities, *Learning Disabilities Focus* for the material adapted from "Alternatives in the Assessment of the Learning Disabled Adolescent: A Learning Strategies Approach" by Judith Wiener, adapted by permission of the publisher, *Learning Disabilities Focus*, Spring 1986.

## **RESOURCE 3: INTERVIEW GUIDE FOR INQUIRY/PROBLEM SOLVING**

---

1. Establish rapport to help the student feel comfortable.
2. Ask the student to "talk about what he or she is doing or thinking" while conducting an investigation or solving a problem. Explain that this will enable you to help the student to develop effective inquiry/problem-solving strategies.
3. As the student attempts to understand the problem and design procedures, observe the student and ask questions such as the following, if appropriate:
  - a. What did you do first when given the problem? Next?
  - b. What are the important facts and conditions in this situation? Do you need to obtain additional information that has not been provided?
  - c. Is there anything you don't understand about the problem or situation?
4. As the student develops and carries out a plan, remind him or her again to talk about it and ask questions such as the following, if appropriate:
  - a. What do we want to investigate/explain/construct?
  - b. What do you think might happen if . . . ?
  - c. What is the relationship between . . . and . . . ?
  - d. What strategy are you using? Have you thought about using other strategies? Which ones?
  - e. Where are you having difficulty? What should you do next?
5. As the student proceeds to carry out the plan, observe the ways, if any, in which he or she monitors and evaluates progress. Ask questions such as:
  - a. What caused . . . to happen?
  - b. What does the data indicate?
  - c. Are you sure this is the correct answer to the problem? Why?
  - d. Do you think it is important to check your answer? Why?
6. After the student has solved the problem, ask questions such as:
  - a. Can you describe your findings/outcomes?
  - b. Is this problem like any other problem you've solved? How?
  - c. Do you think there are other ways of dealing with this situation? What are your ideas?
  - d. How could you make your work easier another time?
  - e. How did you feel while you were solving this problem? How do you feel now that you have found a solution?

## RESOURCE 4: INTERVIEW GUIDE FOR PROJECT WORK

---

### THE TASK ENVIRONMENT

1. How did you select this investigation/project? \_\_\_\_\_  
\_\_\_\_\_
2. Are you interested in it?  
\_\_\_ very \_\_\_ somewhat \_\_\_ not at all
3. What did the teacher do when giving out the assignment? \_\_\_\_\_  
\_\_\_\_\_

- Examples:
- give verbal guidelines
  - give written guidelines
  - select the topic
  - provide a strategy
  - increase your interest

4. Who do you expect will examine the results of your investigation/project? \_\_\_\_\_  
\_\_\_\_\_

### PREVIOUS KNOWLEDGE

5. Have you undertaken an investigation/project like this before?  
\_\_\_ yes \_\_\_ no
6. What did you know about this topic before you started? \_\_\_\_\_  
\_\_\_\_\_
7. Which of the following scientific processes did you use in carrying out your investigation/project?  

_____ recognizing patterns	_____ gathering information
_____ defining problems	_____ formulating hypotheses
_____ predicting events	_____ making a plan
_____ performing experiments	_____ collecting data
_____ controlling variables	_____ making observations
_____ taking measurements	_____ organizing data
_____ using arithmetic	_____ classifying
_____ making inferences	_____ identifying cause/effect
_____ making a model	_____ making decisions

### PLANNING

8. How did you plan your investigation/project? \_\_\_\_\_  
\_\_\_\_\_

## RESOURCE 4: INTERVIEW GUIDE FOR PROJECT WORK (continued)

---

9. Did you make an outline of the steps you would take?

\_\_\_ yes    \_\_\_ no

What kind of thinking did you do first? \_\_\_\_\_  
\_\_\_\_\_

10. Did you do any research? \_\_\_\_\_ yes    \_\_\_ no

What sources of information did you use? \_\_\_\_\_  
\_\_\_\_\_

### REVIEWING AND APPLYING

11. What strategies did you find most helpful in completing your investigation/project?

Examples:

- \_\_\_\_\_ reading
- \_\_\_\_\_ following directions received
- \_\_\_\_\_ explanations from the teacher
- \_\_\_\_\_ studying diagrams/models
- \_\_\_\_\_ performing experiments
- \_\_\_\_\_ watching films/filmstrips
- \_\_\_\_\_ having a group discussion
- \_\_\_\_\_ listening to a guest speaker
- \_\_\_\_\_ other

12. Explain three ways that you might make use of the results of your investigation in everyday life.

\_\_\_\_\_  
\_\_\_\_\_  
\_\_\_\_\_

### EVALUATING

13. What have you learned in completing this investigation/project? \_\_\_\_\_  
\_\_\_\_\_

14. What grade did you think you would get? \_\_\_\_\_  
Why? \_\_\_\_\_

15. What was the teacher's evaluation? \_\_\_\_\_  
How was this evaluation different from your anticipated grade? \_\_\_\_\_  
\_\_\_\_\_

For permission to reprint copyrighted material, grateful acknowledgement is made to the following: Division for Learning Disabilities, *Learning Disabilities Focus* for the material adapted from "Alternatives in the Assessment of the Learning Disabled Adolescent: A Learning Strategies Approach" by Judith Wiener, Spring 1986.

## RESOURCE 5: INVENTORY OF INQUIRY SKILLS/ATTITUDES

### INQUIRY SKILLS:

	Applies Skill Independently	Needs Periodic Assistance	Needs Constant Assistance	Does Not Participate
● Asks questions about natural phenomena.				
● Formulates problems/makes hypotheses.				
● Designs/conducts experiments.				
● Makes inferences/predictions.				
● Makes/records accurate observations.				
● Makes comparisons.				
● Uses measurement skills.				
● Classifies objects in a variety of ways.				
● Uses appropriate methods to gather/record information.				
● Interprets tables/charts/graphs.				

### INQUIRY ATTITUDES:

	Consistently	Frequently	Occasionally	Rarely
● Shows interest in studying natural phenomena.				
● Demonstrates an objective attitude by considering evidence for and against an idea.				
● Demonstrates curiosity about observations by asking questions and conducting investigations.				
● Demonstrates, through discussion, an understanding of the differences between hypotheses, solutions, facts and inferences.				
● Changes an opinion when confronted with evidence.				
● Appreciates that a correlation does not necessarily mean a cause and effect relationship.				
● Critically examines experimental procedures and outcomes.				

## RESOURCE 6: CHECKLIST FOR ASSESSING WRITING ASSIGNMENTS

### IDEAS AND ORGANIZATION:

	Excellent	Adequate	Inadequate	Not Applicable
● Understands the purpose of the writing activity.				
● Uses an appropriate title.				
● Uses pre-writing activities to plan work.				
● Demonstrates an understanding of content.				
● Chooses an organizational pattern that suits the purpose.				
● Writes a clear/concise topic sentence.				
● Provides supporting details and examples.				
● Expresses ideas in an appropriate sequence.				
● Clarifies ideas by using pictures/charts/diagrams.				
● Concludes assignment by recalling the main points and summarizing.				

### EXPRESSION AND MECHANICS:

	Excellent	Adequate	Inadequate	Not Applicable
● Uses appropriate vocabulary.				
● Avoids spelling errors.				
● Includes sentence variety.				
● Avoids shifts in personal pronoun use/verb tense.				
● Maintains agreement of person, number and gender in subject and verb.				
● Uses correct punctuation.				
● Completes assignments legibly and neatly.				



## APPENDIX A: ANNOTATED LIST OF VIDEO RESOURCES

---

The video resources described below are available through ACCESS NETWORK and/or Regional Resource Libraries. Their listing is not to be construed as an explicit or implicit departmental approval for use. These titles are provided as a service only to assist local jurisdictions in identifying potentially useful learning resources. The responsibility for evaluating each resource prior to selection rests with the local jurisdiction.

**Acme School of Stuff (Series)**. Toronto, Ontario: TV Ontario, 1988. A series of thirteen 25-minute programs that explore the science and technology in everyday items. The host uses a variety of household objects and homemade gadgets to provide explanations of technological products and processes. Very effective in demonstrating the relationship between science and technology.

- Program 01 – deals with cassette tapes, chocolate and microwave ovens
- Program 02 – deals with telephones, sewage treatment and video
- Program 03 – deals with batteries, water and fuel injection
- Program 04 – deals with records, neon and the cathode-ray tube
- Program 05 – deals with light bulbs, the Canadian Standards Association and modems
- Program 06 – deals with electricity, glass bottles and brakes
- Program 07 – deals with history, manufacturing and testing of the toilet
- Program 08 – deals with cable television, the subway and engineering
- Program 09 – deals with traffic signals, a natural gas pipeline and alternating current
- Program 10 – deal with digital computers, folding paper cartons and the electric shaver
- Program 11 – deals with electronics, the body shop and coin units in vending machines
- Program 12 – deals with composite substances, piano rolls and automobile alignment
- Program 13 – deals with engines, wire and satellites

**Chemistry in Everyday Life**. Britannica, 1987. A 15-minute video that illustrates practical applications of chemistry in everyday life. Fosters an understanding of the composition, structure and properties of familiar substances, as well as transformations they undergo. Effective in helping students to understand the science of chemistry.

**Greenhouse Effect**. Canadian Broadcasting Corporation, 1984. A 30-minute video that explores the causes and consequences of the Greenhouse Effect.

**How the Motor Car Works Series**. Shell Oil, 1977. A series of three 18-minute videos that deal with the automobile and its functioning. Provides a detailed look at the engine and the carburetor, and is suitable for the general motoring public. Videos within the series include The Engine, Engine Lubrication and The Carburetor.

**The Human Body Series**. Mississauga, Ontario: National Geographic, 1988. A series of 17-minute videos that explore the functioning of different systems within the human body. Videos within the series that are particularly relevant to Science 16 include Circulatory and Respiratory Systems, Digestive System, Muscular and Skeletal Systems and Nervous Systems.

*The Problem-Solving Film.* Omega, 1988. An 18-minute video that demonstrates how critical thinking skills are vital to solving practical problems. Uses a humorous analogy of how detectives solve a case to illustrate appropriate strategies for solving problems. Effective in providing structure for problem-solving activities.

*Science and Technology: Acting in Turn.* Shell Oil, 1974. A 19-minute video that traces the development of the gear from its use in crude form over two thousand years ago to its vastly extended utilization today. Demonstrates how the gear, cam and crank change the axis of rotary movement in familiar technologies.

*Science Edition II.* TV Ontario, 1987. A 50-minute video that explores impacts of science and technology on society. Focuses particular attention on artificial limbs, the technology of neon, basic genetic engineering and developments in visual aid.

*The Scientific Method.* VEC, 1987. A 23-minute video that traces the evolution of knowledge gained through the scientific method. Demonstrates the processes of observation, theorizing or hypothesizing, and testing the hypothesis through experimentation. Effective in helping students to understand the nature of the scientific enterprise.

## APPENDIX B: GOVERNMENT AGENCIES

---

The government agencies listed below may be able to provide various types of information relevant to learning objectives within the science program.

**Alberta Alcohol and Drug Abuse  
Commission (AADAC)**

8th Floor, Energy Square Building  
10109 – 106 Street  
Edmonton, Alberta  
T5J 3L7  
Telephone: 427-4267

**Alberta Consumer and Corporate  
Affairs**

3rd Floor, Capilano Centre  
9945 – 50 Street  
Edmonton, Alberta  
T6A 0L4  
Telephone: 427-5782

**Alberta Economic Development  
and Trade**

6th Floor, Sterling Place  
9940 – 106 Street  
Edmonton, Alberta  
T5K 2P6  
Telephone: 427-0670

**Alberta Energy**

2nd Floor, Highfield Place  
10010 – 106 Street  
Edmonton, Alberta  
T5J 3L8  
Telephone: 427-5200

**Alberta Technology, Research and  
Telecommunications**

12th Floor, Pacific Plaza  
10909 Jasper Avenue  
Edmonton, Alberta  
T5K 2J6  
Telephone: 422-0567

**Alberta Transportation and  
Utilities**

Twin Atria Building  
1999 – 98 Avenue  
Edmonton, Alberta  
T6B 2X3  
Telephone: 427-7674

**Environment Council of Alberta**

8th Floor, Weber Centre  
5555 Calgary Trail, Southbound NW  
Edmonton, Alberta  
T6H 5P9  
Telephone: 427-5792

**Health and Welfare Canada**

Education Services  
Health Protection Branch  
Department of National Health and Welfare  
Ottawa, Ontario  
K1A 0L2  
Telephone: (613) 957-1827

## APPENDIX C: REGIONAL OFFICES OF EDUCATION

---

### Grande Prairie Regional Office

12th Floor, 214 Place  
9909 - 102 Street  
Grande Prairie, Alberta  
T8V 2V4  
Telephone: 538-5130  
FAX: 538-5135

### Edmonton Regional Office

7th Floor, Westcor Building  
12323 Stony Plain Road  
Edmonton, Alberta  
T5N 3Y5  
Telephone: 427-2952  
FAX: 422-9682

### Red Deer Regional Office

3rd Floor West, Provincial Building  
4920 - 51 Street  
Red Deer, Alberta  
T4N 6K8  
Telephone: 340-5262  
FAX: 340-5305

### Calgary Regional Office

Room 1200, Rocky Mountain Plaza  
615 Macleod Trail, S.E.  
Calgary, Alberta  
T2G 4T8  
Telephone: 297-6353  
FAX: 297-3842

### Lethbridge Regional Office

Provincial Building  
200 - 5th Avenue, South  
Lethbridge, Alberta  
T1J 4C7  
Telephone: 381-5243  
FAX: 381-5734

## COPYRIGHT ACKNOWLEDGEMENTS

Alberta Education wishes to thank the following authors, publishers, and agents for granting permission to include copyrighted materials:

Alberta Education and Bernie Galbraith for adaptations from Science Process Skills and the Alberta Science Curriculum (A Position Paper), 1983.

Alberta Environment for illustrations from the Focus On Series.

Athabasca Health Unit for adaptations from Facts About Food and Nutrition and Athletic Performance.

Dr. C. Bos and S. Baughn for an excerpt from Strategies for Teaching Students with Learning and Behaviour Problems. Copyright 1988 by Boston, Allyn and Bacon. Reprinted by permission of the authors.

British Columbia Ministry of Education for excerpts from the Junior Secondary Science Curriculum Guide and Resource Book, 1983.

Canadian Dietetic Association for permission to reproduce the Body Mass Index.

Federated Co-operatives Limited for excerpts from Consumer's Guide, Co-op Consumer Counsellor, 1983.

Glencoe Publishing Company for excerpts from General Industrial Education by Los Angeles Unified School District, 1988.

Learning Disabilities Focus (Publisher) for adaptations from Alternatives in the Assessment of the Learning Disabled Adolescent: A Learning Strategies Approach by Judith Wiener, 1986. Adapted by permission of the publisher.

Manitoba Department of Health for excerpts from How Do Your Meals Score?

Mulcahy, Marfo, Peat and Andrews for adaptations from SPELT: A Strategies Programme for Effective Learning/Thinking: Inservice Edition, SPELT International Limited, 1987. Reprinted by permission of the authors.

University of the State of New York/State Education Department for adaptations from Science Syllabus for Middle and Junior High Schools (Block J: Science, Technology and Society), 1985.

James H. Wandersee for adaptations from Drawing Concept Circles: A New Way to Teach and Test Students, 1987. Adapted by permission of the author.