

DOCUMENT RESUME

ED 399 160

SE 058 814

TITLE Science, Society, and America's Nuclear Waste: The Waste Management System, Unit 4. Teacher Guide. Second Edition.

INSTITUTION Department of Energy, Washington, DC. Office of Civilian Radioactive Waste Management, Washington, DC.

REPORT NO DOE/RW-0364-TG-Rev-1

PUB DATE Jul 95

NOTE 295p.; For Units 1-3, see SE 058 811-813.

AVAILABLE FROM U.S. Department of Energy, Office of Civilian Radioactive Waste Management, National Information Center, Curriculum Department, Suite 760, 600 Maryland Avenue, S.W., Washington, DC 20024.

PUB TYPE Guides - Classroom Use - Teaching Guides (For Teacher) (052)

EDRS PRICE MF01/PC12 Plus Postage.

DESCRIPTORS Interdisciplinary Approach; Lesson Plans; *Nuclear Energy; Nuclear Physics; Nuclear Power Plants; Radiation Effects; Radioisotopes; *Science Curriculum; Secondary Education; Social Studies; *Units of Study; World Problems

IDENTIFIERS *Nuclear Wastes

ABSTRACT

This guide is Unit 4 of the four-part series, Science, Society, and America's Nuclear Waste, produced by the U.S. Department of Energy's Office Civilian Radioactive Waste Management. The goal of this unit is to explain how transportation, a geologic repository, and the multi-purpose canister will work together to provide short-term and long-term protection of people and the environment. These concerns are introduced by three lesson plans. The second section provides ten lesson plans that explore other issues related to transportation and storage of high-level nuclear waste. Activity sheets for students, transparencies for the lesson plans, and background notes are included in the third section followed by the unit test. Answers keys and a glossary are also included. Contains 11 references. (DDR)

 * Reproductions supplied by EDRS are the best that can be made *
 * from the original document. *

ED 399 160

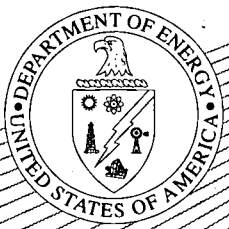

Science, Society, and America's Nuclear Waste

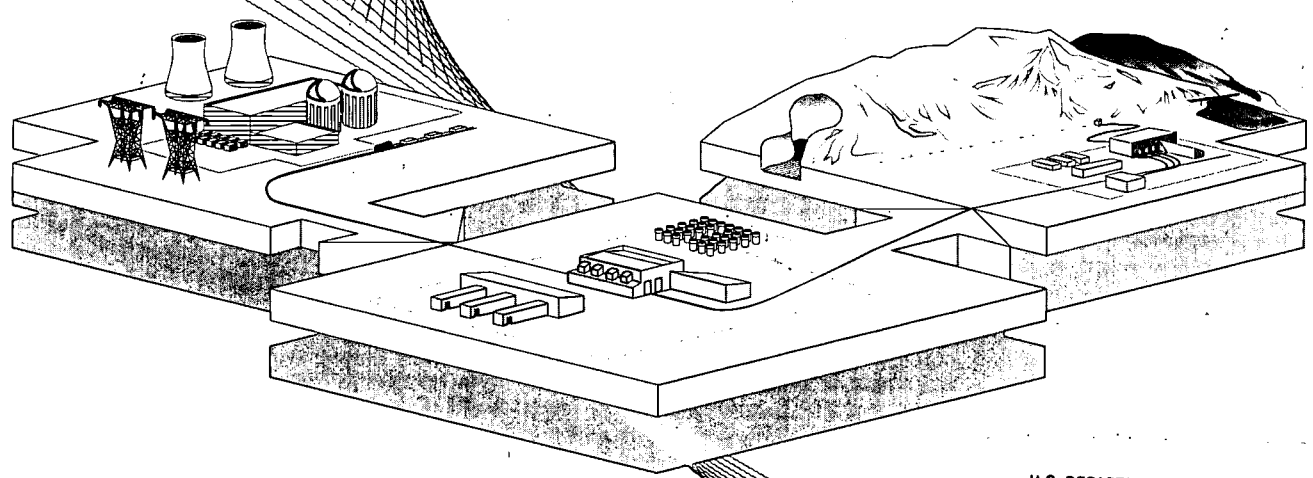

U.S. DEPARTMENT OF EDUCATION
Office of Educational Research and Improvement
EDUCATIONAL RESOURCES INFORMATION
CENTER (ERIC)

- This document has been reproduced as received from the person or organization originating it.
- Minor changes have been made to improve reproduction quality.
- Points of view or opinions stated in this document do not necessarily represent official OERI position or policy.

The Waste Management System

Unit 4 Second Edition
Teacher Guide

“Science, Society and America’s Nuclear Waste” is a four-unit secondary curriculum. It is intended to provide information about scientific and societal issues related to the management of spent nuclear fuel from generation of electricity at nuclear powerplants and high-level radioactive waste from U.S. national defense activities. The curriculum, supporting classroom activities, and teaching materials present a brief discussion of energy and electricity generation, including that produced at nuclear powerplants; information on sources, amounts, location, and characteristics of spent nuclear fuel and high-level radioactive waste; sources, types, and effects of radiation; U.S. policy for managing and disposing of spent nuclear fuel and high-level radioactive waste and what other countries are doing; and the components of the nuclear waste management system. The four units are:

Unit 1 - Nuclear Waste

Unit 2 - Ionizing Radiation

Unit 3 - The Nuclear Waste Policy Act

Unit 4 - The Waste Management System

In the study of nuclear waste management, or any other scientific and social subject, individuals are encouraged to seek differing perspectives and points of view.

This resource curriculum was produced by the U.S. Department of Energy’s (DOE) Office of Civilian Radioactive Waste Management (OCRWM) and has been reviewed by selected staff, faculty, and/or workshop participants from: Louisiana State University; the University of Nevada, Reno and Las Vegas; the University of Tennessee; Pennsylvania State University; Hope College in Michigan; the University of South Florida School of Medicine; the New York State Department of Education, Science, Technology, and Society Education Project; the Nevada Science Project; the National Council for the Social Studies, Science and Society Committee; and the First International Workshop on Education in the Field of Radioactive Waste Management — At the Crossroads of Science, Society, and the Environment — co-sponsored by the multinational Organization for Economic Cooperation and Development/ Nuclear Energy Agency, U.S. Department of Energy’s OCRWM, and the Swiss National Cooperative for the Storage of Radioactive Waste (NAGRA). The international workshop was attended by educators and information specialists from Austria, Belgium, Canada, Finland, France, Germany, Japan, the Netherlands, Spain, Sweden, Switzerland, the United Kingdom, and the United States. This curriculum was field tested through team-teaching by science and social studies teachers in Alabama, Florida, Georgia, Louisiana, Mississippi, South Carolina, and Texas.

For further information about this curriculum, please call 1-800-225-6972 (within Washington, DC, 202-488-6720) or write to:

**OCRWM National Information Center
Attention: Curriculum Department
600 Maryland Ave., SW
Suite 760
Washington, DC 20024**

The 1977 DOE Reorganization Act authorizes education and training activities necessary to ensure that the Nation has an adequate technical work force in energy-related research and production fields. These fields include mathematics, physics, geology, chemistry, zoology, biology, and other areas of basic and applied research. The DOE Science Enhancement Act (part of the 1991 National Defense Authorization Act) expands the Department’s authorization to support science education and amends the 1977 legislation to make support for science education a major mission of the Department. Traditionally, the DOE educational emphasis has been on university-level education, with the agency providing graduate student fellowships and research appointments at DOE facilities. More recently, the education mission was expanded to include precollege education and science literacy.

DOE has been working diligently to make its contribution toward achieving our National Education Goals since their development following the 1989 Education Summit in Charlottesville, Virginia. Although DOE’s work indirectly supports all the goals, DOE is especially involved in Goal # 4: “By the year 2000, U.S. students will be first in the world in science and mathematics achievement.”

DOE sponsors a number of national and local energy education programs, in addition to this curriculum, through its national laboratories, energy technology centers, and various DOE program elements. For further information about these programs, please write to: U.S. Department of Energy, Office of Science Education and Technical Information, Washington, DC 20585.



*Science, Society, and
America's Nuclear Waste*

*The Waste
Management System*

Unit 4 Second Edition
Teacher Guide

July 1995



Department of Energy
Washington, DC 20585

To the Teacher:

This Second Edition of the Teacher Guide accompanies the resource curriculum *Science, Society, and America's Nuclear Waste*. The curriculum, produced by the United States Department of Energy's (DOE's) Office of Civilian Radioactive Waste Management (OCRWM), is designed to assist science and social studies teachers in presenting issues related to the safe management and disposal of America's nuclear waste. The curriculum was developed, reviewed, and tested by teachers for use in grades 8 through 12.

The *Science, Society, and America's Nuclear Waste* curriculum provides information and background on energy and waste-management issues. It is suitable for use in technology and environmental science classes and in social studies classes in middle, high school, and advanced lower grades. Its content and focus are consistent with national goals to strengthen and update math and science curriculum and broaden public science literacy.

Since the curriculum was first made available to the public in 1992, and as of August 1995, more than 20,000 Teacher Guides and approximately 200,000 Student Readers have been requested by and distributed to educators of diverse disciplines in all 50 States and in 48 foreign countries.

Ancillary materials, such as videotapes, a computer diskette, and other materials referenced in the document, may be obtained by calling the OCRWM National Information Center at 1-800-225-6972 (in Washington, D.C., 202-488-6720).

Sincerely,

A handwritten signature in cursive script that reads "E. J. Deshields".

Evangeline Deshields, Manager
Office of Civilian Radioactive Waste Management
National Information Center



Notice To Educators

These **Second Edition Teacher Guides** contain statistical updates that are current as of October 1, 1994. **First Edition Student Readers** are available upon request. Since very few statistical changes were required in the Student Readers, **Second Edition Student Readers** were not printed. Minor differences between the two editions are underlined in your Student Reader material contained in these Teacher Guides.

References to a Monitored Retrievable Storage (MRS) Facility and the Office of the Nuclear Waste Negotiator

You will note that throughout units 3 and 4 of the curriculum references are made to the concept of a Monitored Retrievable Storage (MRS) facility. The Nuclear Waste Policy Amendments Act of 1987 (the Act) authorized the siting, construction, and operation of such a storage facility as an integral part of the Federal waste management system. The Act gave the Secretary of Energy the authority to survey and evaluate sites for a storage facility then designate one. The Act also created the Office of the Nuclear Waste Negotiator to seek a State or Indian Tribe willing to volunteer a technically suitable site, under reasonable terms to be approved by Congress.

To counter a concern that interim central storage on the surface might become permanent, Congress linked the selection of a storage site to the recommendation of a repository site to the President by the Secretary. Under this limitation, construction of a storage site cannot begin until the Nuclear Regulatory Commission issues a license for construction of a repository. In 1989, the Department of Energy announced a delay in the recommendation of a repository site until 2001, and a delay in the expected date of repository operations until the year 2010. The Secretary also told Congress that if the linkage between the MRS facility and the repository were modified, then waste acceptance at the facility could begin by 1998. This was based on the assumption that a site would be available by then. However, the linkage remains in place, the Nuclear Waste Negotiator has not been able to find a volunteer candidate site, and accumulated political experience suggests that a volunteer site for interim storage is not likely. In the absence of interim central storage, waste acceptance and offsite transport could not occur until the start of repository operations in 2010.

The Fiscal Year 1995 budget does not provide funding to OCRWM for activities related to interim storage, and the statutory authority for the Office of the Nuclear Waste Negotiator expired in January 1995. However, references to an MRS facility are still included in the Second Revision, as the concept is still included in the Nuclear Waste Policy Act, as mentioned.

Because of the changes mentioned above, this edition's lesson in Unit 4, formally titled *The Role of the Monitored Retrievable Storage Facility*, has been replaced with the lesson *The Role of the Multi-Purpose Canister*. However, most of the other references to an MRS facility found throughout the curriculum have remained intact, most notably in Unit 3. Please take special note of this new information as you plan lessons around the concept of an MRS facility.

Please note that referenced videotapes and support materials can be obtained free of charge through the **OCRWM National Information Center at 1-800-225-6972 (in Washington, DC, 202-488-6720)**.

2

7

THE WASTE MANAGEMENT SYSTEM

Text/Activities

Unit Grid	v
Unit Guide	vii
Student Reader Introduction	xi
What Measures Ensure Safe Transportation of High-Level Nuclear Waste?	
Lesson Plan	1
Reading	SR-1-8
What Measures Ensure Safe Transportation of High-Level Nuclear Waste? -Answers	3
What Will A Geologic Repository Be Like?	
Lesson Plan	5
Reading	SR-9-16
What Will A Geologic Repository Be Like? -Answers	7
<u>The Role of the Multi-Purpose Canister in the Waste Management System</u>	
<u>Lesson Plan</u>	<u>11</u>
<u>Reading</u>	<u>SR-17-22</u>
Unit Summary	SR-23-24

Enrichment

Designing for Safety	
Lesson Plan	19
Designing for Safety - Answers	21
Transporting Hazardous Materials	
Lesson Plan	23
Rock Characteristics Important in Repository Siting	
Lesson Plan	25
Reading	SR-25-32
Rock Characteristics Important in Repository Siting - Permeability, Porosity Solubility, Thermal Stability and Sorptive Capacity - Background Notes	29
Important Rock Characteristics - Answers	31
Rock Characteristics Important in Repository Siting - Answers	33
Porosity and Permeability	
Lesson Plan	35
Porosity and Permeability - Answers	41
Porosity - Answers	45
Permeability - Answers	46
Solubility	
Lesson Plan	47
Solubility - Answers	51
Mineral Solubility	
Lesson Plan	55
Mineral Solubility - Answers	57

TABLE OF CONTENTS *Science, Society, and America's Nuclear Waste*

Thermal Stability	
Lesson Plan	63
Thermal Stability - Background Notes	65
Thermal Stability - Answers	67
Ion Exchange and Zeolites	
Lesson Plan	71
Zeolites - Background Notes	73
Reading	SR-33-34
Ion Exchange and Zeolites -Answers	75
Topographic Map Skills - Part I	
Lesson Plan	79
Topographic Map Skills - Background Notes	83
Contours and Cornflakes - Background Notes	85
Reading	SR-35-43
Topographic Map Skills - Answers	87
Practice with Scale, Latitude, and Longitude - Answers	89
Contouring - Answers	91
Topographic Maps of Landscapes - Answers	93
Topographic Map Skills - Part II	
Lesson Plan	95
Topography of the Yucca Mountain Site	
Reviewing Map Skills - Answers	99
Part A — Locating a Point on a Topographic Map - Answers	101
Part B — Drawing a Topographic Profile - Answers	105
Considerations for Siting the High-Level Nuclear Waste Repository	
Erosion - Answers	111
Ground Water - Answers	115
Population Density and Distribution - Answers	121
Site Ownership and Control - Answers	123
Crossword Puzzle - Answers	125
Glossary	SR-45-49
Index	SR-51-52
Bibliography	SR-53
Transparency Masters/Activities	
Where is Radioactive Material Shipped - Transparency Master	127
Standards for Spent Fuel Casks - Transparency Master	129
Factors Considered in Selecting Highway Routes - Transparency Master	131
Information Provided to States and Indian Tribes About Shipments of Radioactive Materials - Transparency Master	133
U.S. Department of Energy <u>Regional Coordinating Offices</u> <u>Emergency Operations Centers</u> -Transparency Master	135
Multiple Barriers - Transparency Master	137
Rock Strata - Transparency Master	139

What Measures Ensure Safe Transportation of High-Level Nuclear Waste?
 - Activity 141

What Will A Geologic Repository Be Like? - Activity 143

What is the Role of the Multi-Purpose Canister in the Waste Management System?
 - Activity 147

You Are Invited... The Stakeholders Public Meeting - Activity 149

Designing for Safety - Activity 169

Analyzing State Highway Maps - Activity 171

Planning Hazardous Materials Shipment Routes - Activity 175

Important Rock Characteristics - Activity 179

Rock Characteristics Important in Repository Siting - Activity 181

Porosity and Permeability - Activity 183

Porosity - Activity 187

Permeability - Activity 189

Solubility - Activity 191

Mineral Solubility - Activity 195

Thermal Stability - Activity 201

Ion Exchange and Zeolites - Activity 207

Topographic Map Skills - Activity 211

Practice with Scale, Latitude, and Longitude - Activity 213

Contouring - Activity 215

Topographic Maps of Landscapes - Activity 217

Topography of the Yucca Mountain Site
 Reviewing Map Skills - Activity 219

Part A—Locating a Point on a Topographic Map - Activity 221

Part B—Drawing a Topographic Profile - Activity 225

Repository Shape 227

Graph Paper 229

Engineer's Scale 231

Considerations for Siting the High-Level Nuclear Waste Repository 233

Erosion - Activity 235

Ground Water - Activity 239

Population Density and Distribution - Activity 245

Site Ownership and Control - Activity 247

Crossword Puzzle 249

Metric and U.S. Unit Conversions 253

Unit Review Test

Test 257

Answers 261

UNIT IV: Waste Management System

Lesson	Focus	Activities/Materials Provided	Content Area/ Grade Level
<p>What Measures Ensure Safe Transportation of High-Level Nuclear Waste?</p>	<p>Gives students an in-depth look at the transportation of high-level nuclear waste.</p>	<p>Transparencies (5) Reading Lesson Activity Sheet Videotape (26 minutes) Enrichments (3) • Map Activity • Experiment</p>	<p>Social Studies (Grades 9-12)</p>
<p>What Will a Repository Be Like?</p>	<p>Familiarize students with the natural and engineered barriers that will permanently isolate spent nuclear fuel produced by commercial nuclear powerplants and high-level radioactive waste generated by the Nation's defense activities. Acquaints students with the basic conceptual design, construction, and operation plans for the Nation's first geologic repository.</p>	<p>Reading Lesson Activity Sheet Transparencies (2) Videotapes (2) Enrichments • Reading Lesson (3) • Activity Sheets (9) • Experiments (7) • Map Activities</p>	<p>Social Studies & Science (Grades 9-12)</p>

UNIT IV: Waste Management System

Lesson	Focus	Activities/Materials Provided	Content Area/ Grade Level
<p>The Role of the Multi-Purpose Canister in the Waste Management System (three 50-minute class periods)</p>	<p>Examines the effectiveness of the multi-purpose canister for safely transporting, storing, and disposing of spent fuel from nuclear powerplants.</p> <p>Involves students in the public participation process as stakeholders in an issue concerning the transportation of nuclear waste.</p>	<p><u>Reading Lesson</u> <u>Activity Sheets</u> <u>Videotape</u> <u>Blank Newspaper</u> <u>Master/Computer</u> <u>Diskette Template</u></p>	<p><u>General Science & Social Studies (Grades 8-12)</u></p>

WASTE MANAGEMENT SYSTEM

Unit Purpose:

By the time students begin a study of "Waste Management System," they should have a good grasp of what high-level nuclear waste is and why it requires very long-term isolation from the accessible environment. The purpose of this unit is to explain how the elements of the overall management system – transportation, a geologic repository, and the multi-purpose canister – will work together to provide both short-term and long-term protection of people and the environment. Special attention is given to transportation safety and factors that will help students gain an appreciation for the complexity of a geologic environment.

Unit Concepts:

The key elements of the integrated system for high-level nuclear waste management are transportation, disposal at a geologic repository, and use of a multi-purpose canister for containing spent fuel.

1. The safe and permanent disposal of high-level nuclear waste is a complicated process, which involves many steps.
2. Every aspect of transporting high-level nuclear waste is regulated.
3. Spent fuel and high-level waste are potentially hazardous for thousands of years.
4. The high-level waste disposal system is required to include a system of multiple barriers that will protect the public from exposure to these wastes over a long period of time.
5. The repository will have surface facilities for waste handling and subsurface facilities for disposal.
6. A multi-purpose canister (MPC) could be used to store, transport, and dispose of spent fuel from nuclear powerplants.
7. Public meetings and press conferences are held by DOE to inform and involve the public in significant issues relating to the waste management program.

Duration of Unit:

Five 50-minute periods

Unit Objectives:

As a result of participation in this unit of study, the learner will be able to:

1. discuss the measures that ensure the safe transportation of high-level nuclear waste;
2. explain ways in which any geologic site can act as part of the multiple barrier system;
3. summarize the three elements that comprise the multiple barrier system;
4. describe and/or define various aspects of the design, construction, and operation plans for the geologic repository;
5. explain the purpose of the MPC;
6. list the advantages of the MPC;
7. identify concerns of stakeholders regarding the use of the MPC;
8. locate pertinent information in reference materials;
9. understand the issues/concerns of several groups holding a stake in the conceptual design of the MPC;

10. discuss the importance of scientific understanding and communication for all groups involved in technological advances that affect society.

Unit Skills:

Analyzing, communicating, cooperating, describing, discussing, explaining, group dynamics, listing, matching, reading, roleplaying, summarizing, synthesizing

Unit Vocabulary:

Accessible environment, alloy, backfill, borehole, borosilicate glass, cask, cladding, Code of Federal Regulations (CFR), containment, contamination, corrosion, criticality, cumulative, drift, encapsulated, engulfed, full-scale, grout, host rock, hydrologic, overpack, multi-purpose canister (MPC), Nuclear Regulatory Commission (NRC), polymer, pour canister, shaft, simulated, staging, stakeholder, tuff, zeolites, zirconium

Unit Materials:

Reading Lessons

What Measures Ensure Safe Transportation of High-Level Nuclear Waste?, p. SR-1

What Will a Geologic Waste Repository Be Like?, p. SR-9

The Role of the Multi-Purpose Canister in the Waste Management System, p. SR-17

Activity Sheets

What Measures Ensure Safe Transportation of High-Level Nuclear Waste?, p. 141

What Will a Geologic Repository Be Like?, p. 143

What Is the Role of the Multi-Purpose Canister in the Waste Management System?, p. 147

You Are Invited... The Stakeholders Public Meeting, p. 149

Role Cards, p. 151

The Giventakenne Gazette (blank newspaper master, also available on computer diskette),
p. 165

Masters for Transparencies

Where is Radioactive Material Shipped?, p. 127

Standards for Spent Fuel Casks, p. 129

Factors Considered in Selecting Highway Routes, p. 131

Information Provided to States and Indian Tribes about Shipments of Radioactive Materials,
p. 133

U.S. Department of Energy Regional Coordinating Offices Emergency Operations Centers,
p. 135

Multiple Barriers, p. 137

Rock Strata, p. 139

Videotapes

Engineered for Safety (26 minutes)

The U.S. Department of Energy Office of Civilian Radioactive Waste Management Multi-Purpose Canister System (Order from the OCRWM Information Center, 1-800-225-NWPA)

Fitting the Pieces (12 minutes 45 seconds)

The Science of Yucca Mountain (14 minutes)

Clips from the 1992 and 1994 Nationwide Teacher Teleconferences

(Available free of charge from the OCRWM National Information Center, 1-800-225-6972; within Washington, DC, 202-488-6720)

Enrichment Activities/Readings

Designing for Safety, p. 19

Transporting Hazardous Materials, p. 23

Rock Characteristics Important in Repository Siting, p. 25

Porosity and Permeability, p. 35

Solubility, p. 47

Mineral Solubility, p. 55

Thermal Stability, p. 63

Ion Exchange and Zeolites, p. 71

Topographical Map Skills Part 1, p. 79

Topographical Map Skills Part 2, p. 95

Crossword Puzzle, p. 249

Metric and U.S. Unit Conversions, p. 253

Other

Demonstration/experiment supplies (See individual activity sheets)

INTRODUCTION

A Complex Undertaking

The permanent disposal of our Nation's high-level nuclear waste is a challenging and complex undertaking. It is an undertaking that will affect not only the present generation but generations to come. First, the high-level waste must be safely transported to a disposal site. At the disposal site, the high-level waste must be handled safely, properly prepared for disposal, and stored in the geologic repository. Finally, the repository must permanently isolate the high-level waste from the public and the environment for tens of thousands of years.

Applying What We Know

To safely dispose of high-level nuclear waste, we must apply all that we know about radiation and nuclear waste. We have sophisticated instruments that detect and measure all types of ionizing radiation, permitting us to monitor the performance of waste packages and waste disposal systems. We know a great deal about ionizing radiation itself and its effect on humans. In fact, we know more about the biological effects of ionizing radiation than we do about the effects of other hazardous materials. We also know a lot about radiation shielding and how to safely package high-level waste for shipment. Finally, we have a very sophisticated knowledge of the elements, how they act in a controlled environment, and how they act in nature.

Developing a successful waste management system for high-level waste will be a difficult and time-consuming task. If site characterization shows the proposed repository site to be suitable,

it will be at least 2010 before spent fuel and/or high-level waste can be placed in the Nation's first geologic repository.

National Energy Strategy

The National Energy Strategy, published in February 1991 by the U.S. Department of Energy (and updated in 1992 and 1993), lays the foundation for a more efficient; less vulnerable, and an environmentally sustainable energy future. It provides a roadmap to a more secure and cleaner energy future through greater energy and economic efficiency and new technology.

Among the goals contained in the National Energy Strategy are key goals to establish an effective high-level nuclear waste program by siting, obtaining a license for, and operating a permanent waste repository, and to develop options to ensure the availability of a transportation system for safe transport of spent fuel and high-level radioactive waste to the facilities. The National Energy Strategy includes a plan for developing the U.S. nuclear waste management system called for in the Nuclear Waste Policy Act of 1982, and amendments, and as described in this unit.

Unit 3 discusses initiatives and accomplishments as a result of the Strategy related to implementation of the Nuclear Waste Policy Act.

In Unit 4, you will look in depth at the key elements of a successful high-level waste management system — the safe transportation of high-level waste, the geologic repository, and the multi-purpose canister system. Emphasis will be

on the public safety aspects of transporting spent fuel and high-level radioactive waste, the technical considerations involved in permanent disposal in a repository, and the design and proposed uses of a multi-purpose canister within the waste management system.

WHAT MEASURES ENSURE SAFE TRANSPORTATION OF HIGH-LEVEL NUCLEAR WASTE?

Purpose:

This lesson gives students a more in-depth look at the transportation of high-level nuclear waste.

Concepts:

1. The safe and permanent disposal of high-level nuclear waste is a complicated process involving many steps.
2. Every aspect of transporting high-level nuclear waste is regulated.

Duration of Lesson:

One 50-minute class period

Objectives:

As a result of participation in this lesson, the learner will be able to:

1. discuss the measures that ensure the safe transportation of high-level nuclear waste.

Skills:

Discussing, reading, synthesizing

Vocabulary:

Cask, containment, engulfed, full-scale, simulated

Materials:

Reading Lesson

What Measures Ensure Safe Transportation of High-Level Nuclear Waste?, p. SR-1

Activity Sheets

What Measures Ensure Safe Transportation of High-Level Nuclear Waste?, p. 141

Transparencies

Where is Radioactive Material Shipped?, p. 127

Standards for Spent Fuel Casks, p. 129

Factors Considered in Selecting Highway Routes, p. 131

Information Provided to States and Indian Tribes about Shipments of Radioactive Materials, p. 133

U.S. Department of Energy Regional Coordinating Offices Emergency Operations Centers, p. 135

Videotape

Engineered for Safety (26 minutes) (available free of charge from the OCRWM National Information Center, 1-800-225-6972; within Washington, DC, 202-488-6720)

Suggested Procedure:

1. The reading assignment entitled *What Measures Ensure Safe Transportation of High-Level Nuclear Waste?* can be read individually. Discuss the reading and have students complete the reading review entitled *What Measures Ensure Safe Transportation of High-Level Nuclear Waste?*
2. Transparency masters may be helpful for introducing or reviewing the reading lesson.
3. As a followup, you may wish to watch and discuss the videotape *Engineered for Safety*, a 26-minute videotape that describes steps involved in safely transporting the Nation's spent fuel and high-level radioactive wastes. Cask design and testing procedures are reviewed.

Sample Videotape Questions - *Engineered for Safety*

- a) How does the energy produced from one fuel pellet compare with the energy produced from an equal amount of coal or oil?
 - b) Compare the radioactivity of fresh and spent fuel.
 - c) What do we currently do with spent fuel in the United States?
 - d) By what means do we transport spent fuel in the United States?
 - e) Describe the designing and testing process for transportation casks.
4. Have students write a few sentences synthesizing the various aspects of the waste management system and the importance of transportation in this system.

Teacher Evaluation of Learner Performance:

Discussion participation and response to reading review worksheet will indicate level of student comprehension.

Enrichment:

Designing for Safety, p. 19

Analyzing State Highway Maps, p. 171

Planning Hazardous Materials Shipment Routes, p. 175

WHAT MEASURES ENSURE SAFE TRANSPORTATION OF HIGH-LEVEL NUCLEAR WASTE?

The safe transportation of spent nuclear fuel from utilities and high-level nuclear waste from defense activities is essential to the protection of the public and the environment. Many measures ensure that workers, the public, and the environment will not be exposed to hazards from spent fuel or defense high-level nuclear waste during shipments.

4.1 Safety Record

Radioactive material has been safely shipped in this country for over 40 years. Each year there are about 2 million shipments of radioactive materials of all kinds. Only a small fraction (less than 1/10%) of these shipments are spent fuel or defense high-level waste. Over the years, there have been some accidents involving shipments of radioactive materials. Any injuries in these accidents were like those of other transportation accidents, and none of the injuries were related to the radioactive nature of the cargo. This excellent 40-year record is due to shippers strictly following regulations as well as to the well-designed packages or casks used to carry the materials.

4.2 Minimizing Transportation Risk

Spent fuel shipping casks are designed, built, and maintained to ensure that they will *contain* and shield their contents, even under severe accident conditions. Before shipment, casks are specially sealed and then labeled to clearly identify the hazard of the contents. The radiation level of each shipment is checked to be sure it is within regulatory limits. The cask is also checked for contamination on the outside both before it departs and after it reaches its destination. These shipping casks are the main protection against any potential radiation exposure for transportation workers and the public.

Special routing procedures are used for spent fuel shipments, and shipping papers with detailed information about cask

How long have radioactive material shipments been made in the United States?

What is the safety record?

What are some steps taken to ensure safety?

Contain — To keep within limits...*Full-scale tests proved that the casks would contain their contents even under severe accident conditions.*

What protects workers and the public from radiation exposure?

contents as well as emergency contacts and telephone numbers accompany each shipment. Drivers of spent fuel shipments must update their required training every 2 years. Special training is provided to State and local teams about emergency response for all hazardous materials shipments. Finally, the Department of Energy (DOE) and other Federal agencies maintain emergency response teams to assist State and local teams if needed.

4.3 Agencies with Responsibility

The U.S. Department of Transportation (DOT) has the main responsibility for the safe transportation of **all** hazardous materials, including radioactive material. It regulates every aspect of transportation—packaging, handling, all paper work and labeling, loading and unloading, and routing. The U.S. Nuclear Regulatory Commission (NRC) also has some responsibility for the transportation of spent fuel. It sets strict standards for the design and performance of the casks that carry spent fuel. Both the DOT and the NRC base their regulations on

Who has responsibility for safe transportation of all hazardous materials in the United States?

What is the NRC responsible for?

What are U.S. standards based on?

What are estimates of maximum exposures?

Who will be responsible for shipments to a repository or storage facility?

radiation safety standards issued by the International Atomic Energy Agency and adopted by the United Nations.

Under the Nuclear Waste Policy Act of 1982, the U.S. Department of Energy (DOE) will be responsible for shipments of spent fuel and other high-level nuclear waste to a repository or storage facility. DOE will use casks certified by the NRC and will follow DOT regulations for these shipments.

Maximum Exposure Estimates

The maximum exposures per shipment for people living less than 30.3 meters (100 feet) of the route of a vehicle carrying spent fuel would be about 0.0005 millirem.^{*} If 100 spent fuel shipments went by the same house every year, the increase in radiation exposure to people living in the house would be much less than one percent of the exposure they already get from background radiation. It's also about half the radiation exposure people receive annually from watching television.

**Source: U.S. Department of Energy, Transporting Radioactive Materials...Answers to Your Questions (DOE/EM10097), 1993.*

4.4 Cask Testing

Shipping casks provide both containment and *shielding* during transport. The amended Nuclear Waste Policy Act requires that spent nuclear fuel and high-level waste from defense activities be transported to a repository or storage facility in casks certified by the Nuclear Regulatory Commission. To be certified, a cask design must withstand a sequence of four tests that measure its performance in severe accident conditions.

Shielding — Material used to protect people or living things from ionizing radiation...Lead can act as shielding for gamma waves.

The ability of a cask design to withstand these tests can be shown by engineering analysis (such as computer tests) or by scale-model or full-scale testing. In most cases, a combination of tests is used. Every cask is not tested. That would be an expensive and time-consuming process. Instead, a scale model of a cask is thoroughly tested. If the model passes all required tests, that cask *design* is certified.

How are cask designs certified?

Proposed GA-4 Legal-Weight Truck Shipping Cask

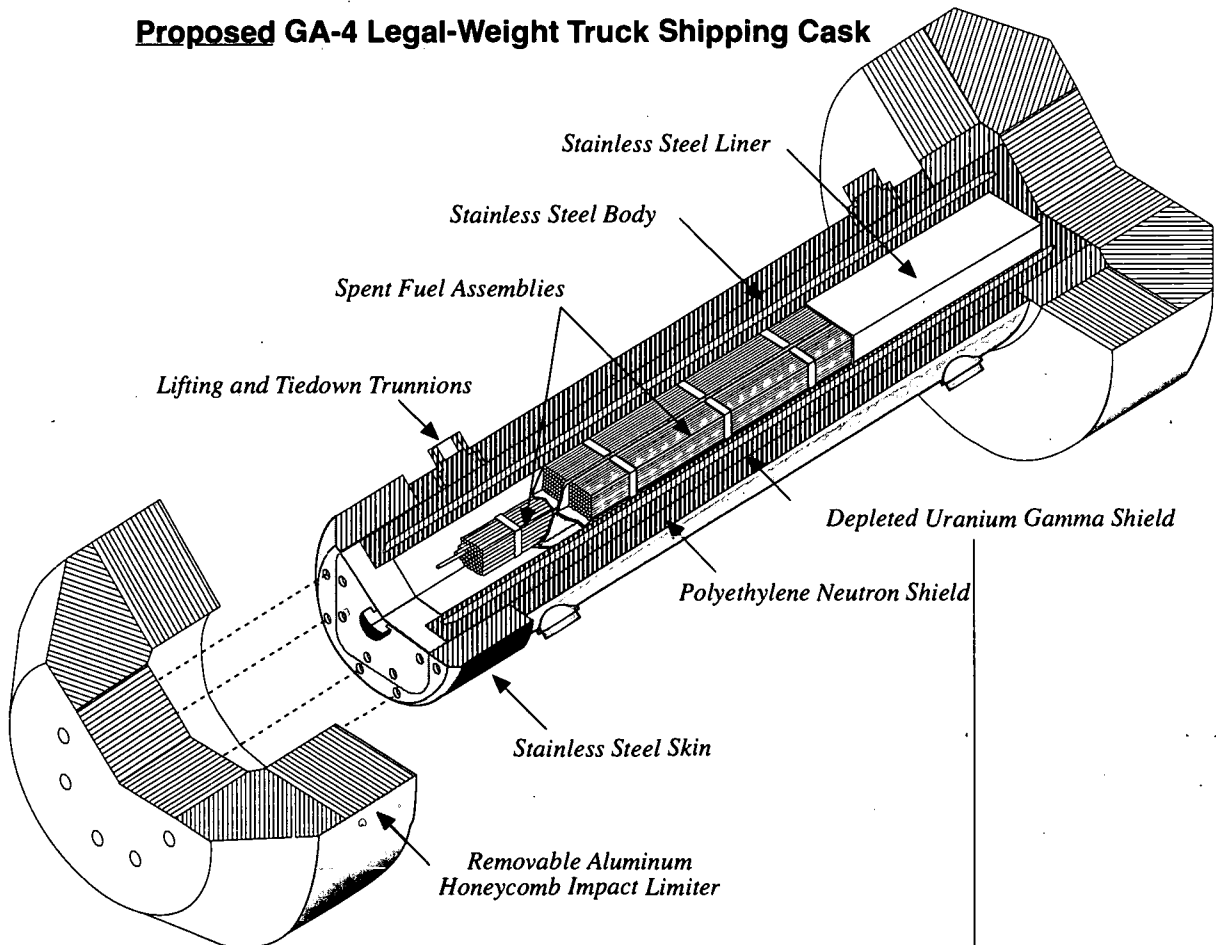

How are casks tested?

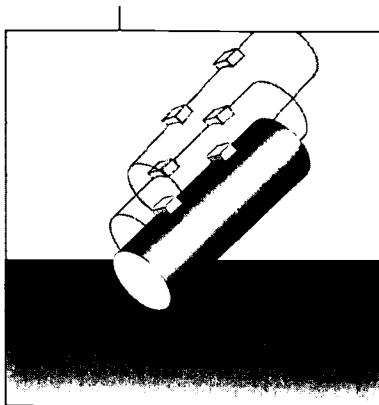

Free Drop — The cask is dropped from 9 meters (30 feet) onto a flat, unyielding, horizontal surface so that the cask strikes its weakest point.

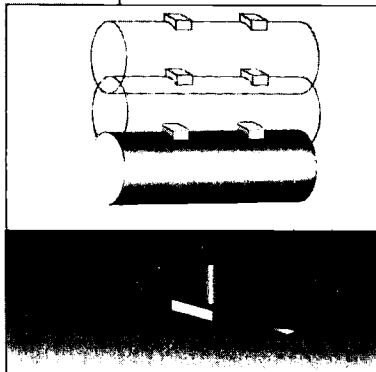

Puncture — The cask is dropped from 1 meter (40 inches) onto a steel bar 20 centimeters (8 inches) high and 15 centimeters (6 inches) in diameter at a point where damage is most likely to occur.

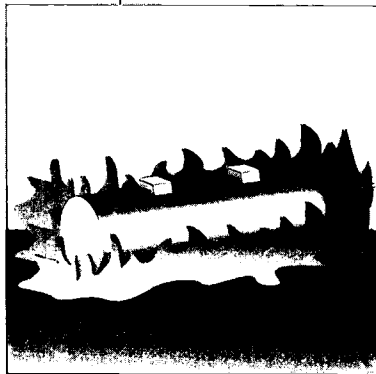

Thermal — The entire cask is kept for 30 minutes in a jet fuel fire burning at a temperature of 800 °C (1,475 °F).

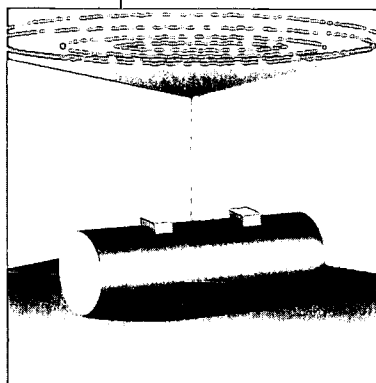

Water Immersion — The cask is totally immersed under 0.9 meters (3 feet) of water for at least 8 hours.

— In a separate test, another cask is tested below 15 meters (50 feet) of water for at least 8 hours.

Tests of spent fuel casks show that they can withstand severe accident conditions.

4.5 Full-Scale Tests

A series of full-scale tests conducted in the United States during the mid-1970's showed that spent fuel casks could successfully protect their contents in the most severe accidents. The tests included crashing two tractor-trailers, each loaded with a cask, into a concrete wall. One crash, conducted at 98 kilometers per hour (kph) (61 miles per hour [mph]), had no effect on the cask. Another crash, at 135 kph (84 mph), slightly damaged the cask, but it did not release the *simulated* (imitation) "radioactive material" it was carrying.

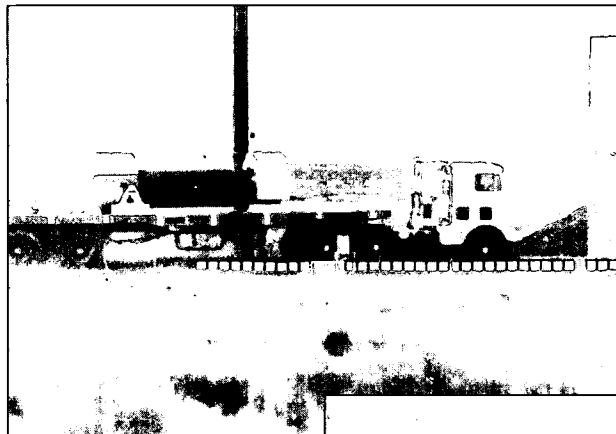

Simulate — To have or take on the appearance or form of...*Material that simulates radioactive material is used in full-scale tests instead of actual radioactive material.*

What full-scale tests were conducted?

What were the results of the full-scale tests?



A railcar carrying a cask was crashed into a massive concrete barrier at 130 kph (81 mph) and was then engulfed in a jet fuel fire for 125 minutes. A crack about the thickness of a dollar bill occurred, but the cask retained its shielding ability. The material substituted for actual radioactive material remained inside the cask. In another test, a cask dropped from a helicopter crashed into the desert at 378 kph (235 mph). Some paint scratches were the only damage.

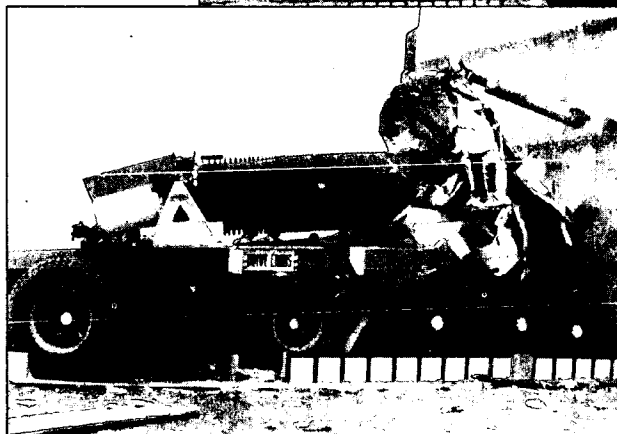

In a 1984 test conducted in the United Kingdom, a locomotive was crashed at 161 kph (100 mph) into a railcar carrying a nuclear waste shipping cask. The locomotive was wrecked in the head-on collision, but the shipping cask suffered only minor scratches, despite being thrown 61 meters (200 feet).*

In each of these tests, damage to the casks was external. If they had contained spent fuel, none of the casks would have released its contents. The tests are important because they verify (demonstrate the accuracy of) predictions of computer models. They also show that the regulations for casks provide safety.

Why are the tests important?

What are some advantages of new cask designs?

4.6 New Cask Designs

DOE is developing new casks for shipping spent fuel.

With a multi-purpose canister concept, spent fuel assemblies would be placed inside a metal canister and sealed. The canister would then be placed inside a separate steel container called a cask for shipment or storage. At a repository, the canister would be placed inside a metal container for permanent disposal.

The canister concept would reduce the need for handling and could be used to store spent nuclear fuel at powerplants. Multi-purpose canisters would also provide an additional barrier between spent fuel and the environment. A more complete discussion of multi-purpose canisters is included in the reading lesson *The Role of the Multi-Purpose Canister in the Waste Management System*.

Another approach would use high-capacity cask designs, placing more spent fuel in each cask while meeting weight limits. Fewer spent fuel shipments would be required, reducing the potential for accidents.

*Source: U.S. Department of Energy, *Transporting Spent Nuclear Fuel: An Overview (DOE/RW-0065)*, 1986.

4.7 Shipping Routes

In 1982, the U.S. Department of Transportation established rules for determining highway routes for shipments of high-level radioactive materials. After thorough studies, "preferred routes" for these shipments were identified. A preferred route consists of highways of the interstate system, including bypass routes around cities where possible, or an alternate route selected by a State or Indian Tribe. As part of the process of naming an alternate route, a State or Indian Tribe must first consult with neighboring States, Indian Tribes, and affected cities or towns. An alternate route must provide adequate protection to the public.

Shippers and railroad companies that operate between the origin and destination select routes for rail shipments. They base routes on safety, the best tracks available, schedule efficiency, and cost.

4.8 Notification of States

The Governor (or other designated State official) receives written notice in advance of certain shipments of nuclear waste and spent fuel within or through that State. The advance notice is designed to help emergency preparedness. Written notice includes the planned shipping schedule, route, shipment description, and name and address of the carrier. Also, the U. S. Department of Energy (DOE) operates a satellite tracking system to monitor certain shipments from their origin to their destination. With this system, officials have quick access to information about the shipment at all times.

4.9 State and Local Roles

State and local governments are responsible for the safety of people within their areas. Their responsibilities include such things as highway construction and maintenance, vehicle inspections, enforcement of traffic laws, and emergency response. State and local governments also provide input to

What routes are used for highway shipments?

Can a State or Indian Tribe select an alternate route?

How are railroad routes chosen?

Are States notified about shipments in advance?

How can shipments be tracked?

What are State and local governments responsible for?

proposed Federal transportation regulations. DOE consults with State, local, and Tribal representatives about the transportation system.

The amended Nuclear Waste Policy Act requires DOE to provide assistance

and funds to States for the training of public safety officials of affected local governments and Indian Tribes. The training covers procedures for routine transportation under normal conditions as well as emergency response for accidents.

State and Local Laws

Many State and local governments have passed laws with special requirements for transporting radioactive material within their boundaries. The laws may stand if 1) they are consistent with Federal law, and 2) they do not make it difficult or impossible to carry on commerce or business. However, if a law interferes with general commerce or the conduct of business or if it is inconsistent with Federal laws or regulations, it may be preempted (voided or set aside) by the courts.

How will public safety officials receive training?

WHAT MEASURES ENSURE SAFE TRANSPORTATION OF HIGH-LEVEL NUCLEAR WASTE?

Directions: Use what you have learned in your reading lesson to answer the following questions.

1. What aspects of the transportation of radioactive materials are regulated?

(All aspects are regulated: packaging, handling, labeling, loading and unloading, and routing.)

2. Describe the tests that are performed on a cask to certify its safety.

(Tests include a free drop from 9 meters [30 feet]; a puncture test from 1 meter [40 inches] onto a steel bar; exposure to a 800 °C [1,475 °F] fire for 30 minutes; and total immersion under 0.9 meters [3 feet] of water for 8 hours and then below 15 meters [50 feet] of water for 8 hours.)

3. Why is it important to perform cask testing?

(It is important to test casks to verify that the cask designs can withstand severe accident conditions without releasing radioactive materials to the environment.)

4. What are the advantages of the new cask designs?

(The multi-purpose canister concept would reduce the need for handling and could be used to store spent nuclear fuel. It would also provide one more barrier between spent fuel and the environment. High-capacity casks would carry more fuel per cask, requiring fewer shipments.)

5. What Federal agencies are responsible for the regulations that apply to the transportation of radioactive waste?

(The U.S. Department of Transportation regulates all aspects of shipping. The Nuclear Regulatory Commission certifies casks.)

6. A series of "full scale" crash tests were conducted in the United States during the mid-1970's. Describe one of the tests and its results.

(Test include crashing two tractor-trailers, each loaded with a cask, into a concrete wall. One crash, conducted at 98.19 kph [61 mph], had no effect on the cask. Another crash at 135.24 kph [84 mph], slightly damaged the cask, but did not release the simulated radioactive material it was carrying.)

WHAT WILL A GEOLOGIC REPOSITORY BE LIKE?

Purpose:

This lesson will familiarize students with the natural and engineered barriers that will permanently isolate spent nuclear fuel produced by commercial nuclear powerplants and high-level radioactive waste generated by the Nation's defense activities.

Concepts:

1. Spent fuel and high-level waste are potentially hazardous for thousands of years.
2. The disposal system is required to include a system of multiple barriers that will protect the public from exposure to these wastes over a long period of time.
3. The repository will have surface facilities for waste handling and subsurface facilities for waste disposal.

Duration of Lesson:

One 50-minute class period

Objectives:

As a result of participation in this lesson, the learner will be able to:

1. explain ways in which any geologic site can act as part of the multiple barrier system;
2. summarize the three elements that comprise the multiple barrier system; and
3. describe and/or define various aspects of design, construction, and operation plans for the geologic repository.

Skills:

Describing, discussing, explaining, listing, matching, reading, summarizing

Vocabulary:

Accessible environment, alloy, backfill, borehole, borosilicate glass, contamination, corrosion, drift, grout, host rock, hydrologic, polymer, pour canister, shaft, tuff, zeolites, zirconium

Materials:

Reading Lesson

What Will a Geologic Repository Be Like?, p. SR-9

Activity Sheets

What Will a Geologic Repository Be Like?, p. 143

Transparencies

Multiple Barriers, p.137

Rock Strata, p. 139

Videotapes

Fitting the Pieces (12 minutes 45 seconds)

The Science of Yucca Mountain (14 minutes)

(available free of charge from the OCRWM National Information Center, 1-800-225-6972; within Washington, DC, 202-488-6720)

Suggested Procedure:

1. Allow 10 minutes for reading of the lesson entitled *What Will a Geologic Repository Be Like?*
2. Assign the reading review that accompanies this lesson.
3. You may wish to conclude this lesson with a class discussion on what a geologic repository will look like, why the multiple barrier system will be implemented, and how this will be done.
4. Have students write a short paragraph explaining the significance of this lesson.

Teacher Evaluation of Learner Performance:

Completion of reading reviews and participation in class discussion will indicate understanding.

Enrichment:

Working in small groups, students should design a system to warn repository intruders of the future about the location and hazards of the sealed geologic repository.

Additional Enrichment:

Rock Characteristics Important in Repository Siting, pp. SR-27, 181

Porosity and Permeability, pp. 183-189

Solubility, p. 191

Mineral Solubility, p. 195

Thermal Stability, p. 201

Ion Exchange and Zeolites, pp. SR-35, 207

Topographic Map Skills Part 1, pp. SR-37, 211

Topographic Map Skills Part 2, pp. 219-227

WHAT WILL A GEOLOGIC REPOSITORY BE LIKE?

High-level nuclear waste is potentially hazardous for thousands of years. Under current plans, the United States will dispose of this waste deep underground in a geologic repository that must isolate the waste so that present and future generations and the environment will be protected from harmful exposure to ionizing radiation. To ensure the necessary long-term protection, the repository will include a system of multiple barriers.

4.10 Introduction

A geologic repository will resemble a large mining complex. The repository will combine two types of industrial facilities. A facility at the surface will be used for waste handling. A facility built about 305 meters (1,000 feet) below the surface will be used for permanent disposal of waste in special containers.

Surface facilities will include waste handling buildings, office buildings, fire and medical stations, water and sewage treatment plants, warehouses, repair and maintenance shops, and a security office. Shafts and ramps will connect the surface and underground areas.

The underground facilities will include main tunnels leading to the areas where the waste will be placed. The disposal area will consist of smaller tunnels called *drifts* with *boreholes* in the wall or floor to accept the canisters of waste, or direct placement in the floor of the drifts. There will also be some service areas underground.

The earliest a repository is expected to begin operation is the year 2010.

Waste disposed of at the repository will

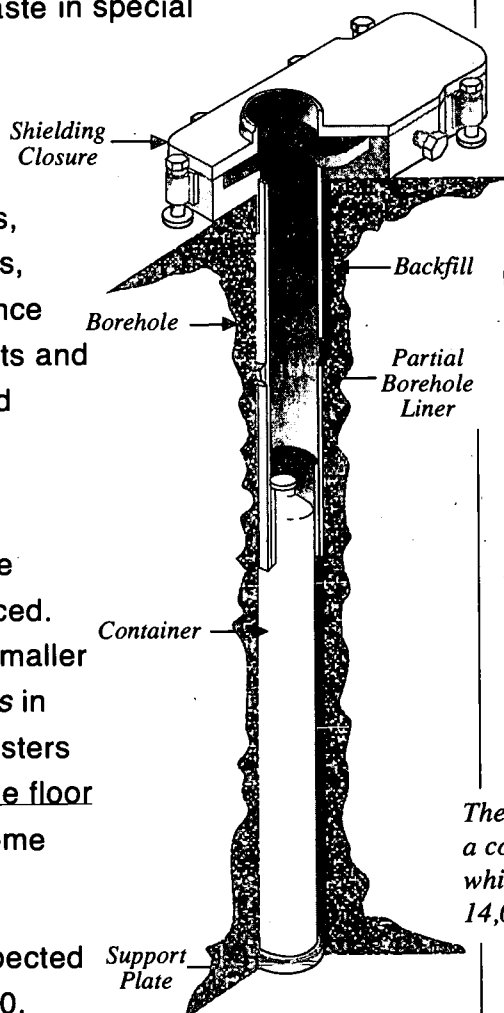

What will a geologic repository look like?

What type of facilities will be at the surface?

What will the underground facility be like?

The borehole will accommodate a container about 16 feet high, which may hold as much as 14,000 pounds of spent fuel.

Will future generations be alerted?

be retrievable for 50 years. During this time, the performance of the disposal system will be evaluated. After the repository is closed, steps will be taken to alert future generations about the location of the repository and why it should not be disturbed.

What agencies developed requirements for repository performance?

What are some key requirements?

4.11 Performance Standards

The purpose of a repository is to protect present and future generations and the environment from the potential hazards of high-level waste. Scientists understand these hazards very well. Based on scientific understanding of the nature of high-level waste and radiation, the U.S. Environmental Protection Agency (EPA) and the Nuclear Regulatory Commission (NRC) developed specific requirements for the performance of a geologic repository. The purpose of performance standards is to prevent radiation exposures as the result of high-level waste disposal and to prevent contamination of certain sources of ground water near the disposal facilities. EPA standards, which the NRC is responsible for enforcing, require that the disposal system must be designed to provide a reasonable expectation that, during 10,000 years, cumulative (total accumulated) releases of radioactive isotopes to the environment will be kept within specific limits. Also, the waste packages must provide substantially complete containment of the waste for 300 to 1,000 years. Both the EPA and the NRC require the use of a system of multiple barriers.

Radioactive Decay Over Time

Why must the waste package provide "substantially complete" containment for the first 300 to 1,000 years of disposal? The fission product radioactivity in high-level waste decreases by more than 1,000 times in 300 years. It is almost gone in 1,000 years. The fission products react readily with other elements and, if they were allowed to, they would probably "migrate," or move away from the site of their disposal, toward the accessible environment. Therefore, during the period when their activity is high, they should be prevented from migrating. It is true that the "new" elements formed by the decay of the fission products may ultimately migrate, but they are not radioactive.

The other elements in high-level waste remain radioactive for tens of thousands of years. However, they are less chemically active and less likely to migrate.

4.12 Multiple Barriers

The *multiple barrier system* will include both engineered (manmade) and natural barriers. It will consist of 1) the waste package, 2) the repository itself, and 3) the "host rock" or geologic environment in which the repository is built. The use of a series of manmade and natural barriers is referred to as "defense in depth" because protection won't depend on one barrier only. Instead, the multiple barriers will work together to prevent or retard the release of radioactive material to the *accessible environment* — the environment outside the controlled area at a repository.

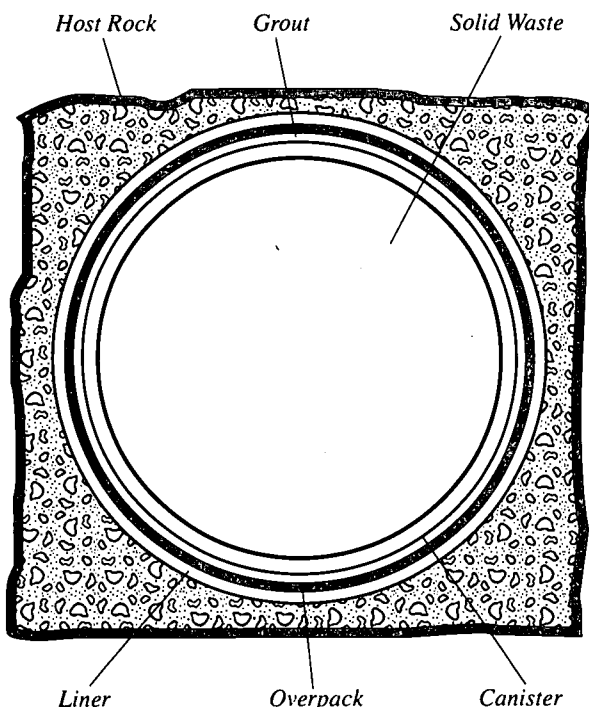

What are the three parts of the multiple barrier system?

The multiple barrier system will include both manmade (engineered) and natural barriers. A waste package placed in a borehole will look something like this, but details of the design are not yet decided.

What is the accessible environment?

4.13 The Waste Package as a Barrier

The waste package itself is the first barrier. The form of the waste is a key part of the waste package. Both spent fuel and defense waste will be disposed of as solids. No liquids will be disposed of in the repository. This decreases the potential for releases of radioactivity. The total package consists of the solid waste and everything that separates the waste from the host rock — containers, shielding, seals, packing, or any absorbent materials.

What will the physical form of the waste be?

Will liquids be disposed of in the repository?

Waste Form for Spent Fuel

Spent fuel consists of ceramic pellets of uranium oxide that have been used in a reactor to produce electricity. The pellets are sealed in hundreds of metal tubes made from an alloy

How does the structure of a spent fuel assembly contribute to waste isolation?

Corrosion — Slow dissolving or eating away, especially by chemical action, such as rusting... *Corrosion slowly ruined the body of the car, which rusted away.*

(mixture of metals) that is mostly zirconium. This alloy resists *corrosion* and can withstand heat. Hundreds of the metal tubes, called fuel rods, are bundled together to form a fuel assembly. The spent fuel assembly is an important barrier because the waste remains "locked" in the pellets and tubes.

Waste Form for High-Level Defense Waste

The long-term durability of glass and ceramics is shown by ancient artifacts.

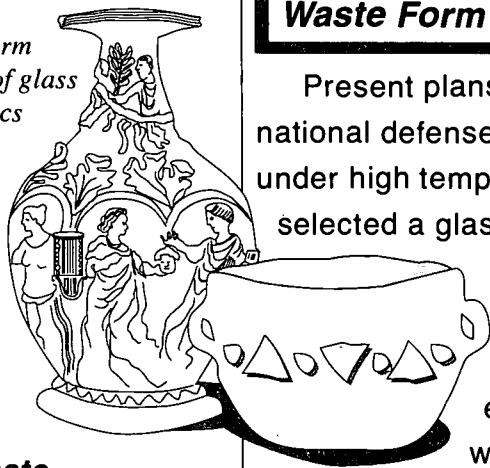

Present plans call for high-level nuclear waste generated in national defense activities to be solidified in a protective material under high temperatures. The U. S. Department of Energy selected a glass made of boron and silicon as the protective material designed to "immobilize" high-level nuclear waste. This material was selected for several reasons. 1) It is stable. 2) It is strong enough to be used in a repository. 3) It withstands *leaching* under conditions that could potentially exist in a repository. 4) It is suitable for large-scale, remote operations with highly radioactive waste.

What waste form will be used for disposal of defense high-level waste?

Why is glass a good waste form?

To solidify the waste, a mixture of high-level waste and molten glass will be poured into stainless steel canisters. After the glass cools to a solid, the canister will be plugged, welded shut, tested for leaks, decontaminated, and transferred to a temporary storage vault.

Leaching — Removal of parts that dissolve by the action of a liquid that seeps or drains through a porous substance... *As a result of leaching, the water leaving the garden carried pesticides into the nearby soil.*

Containers for Disposal

Another engineered barrier is the disposal container. "Pour canisters" containing the solid glass form of defense waste will be sealed in special disposal containers. Spent fuel assemblies will also be placed in specially designed disposal containers (See lesson on Multi-Purpose Canisters). The disposal containers will be designed to prevent or delay exposing the wastes to any underground water that might be present. The containers will be made of materials that resist corrosion.

What will disposal containers be like?

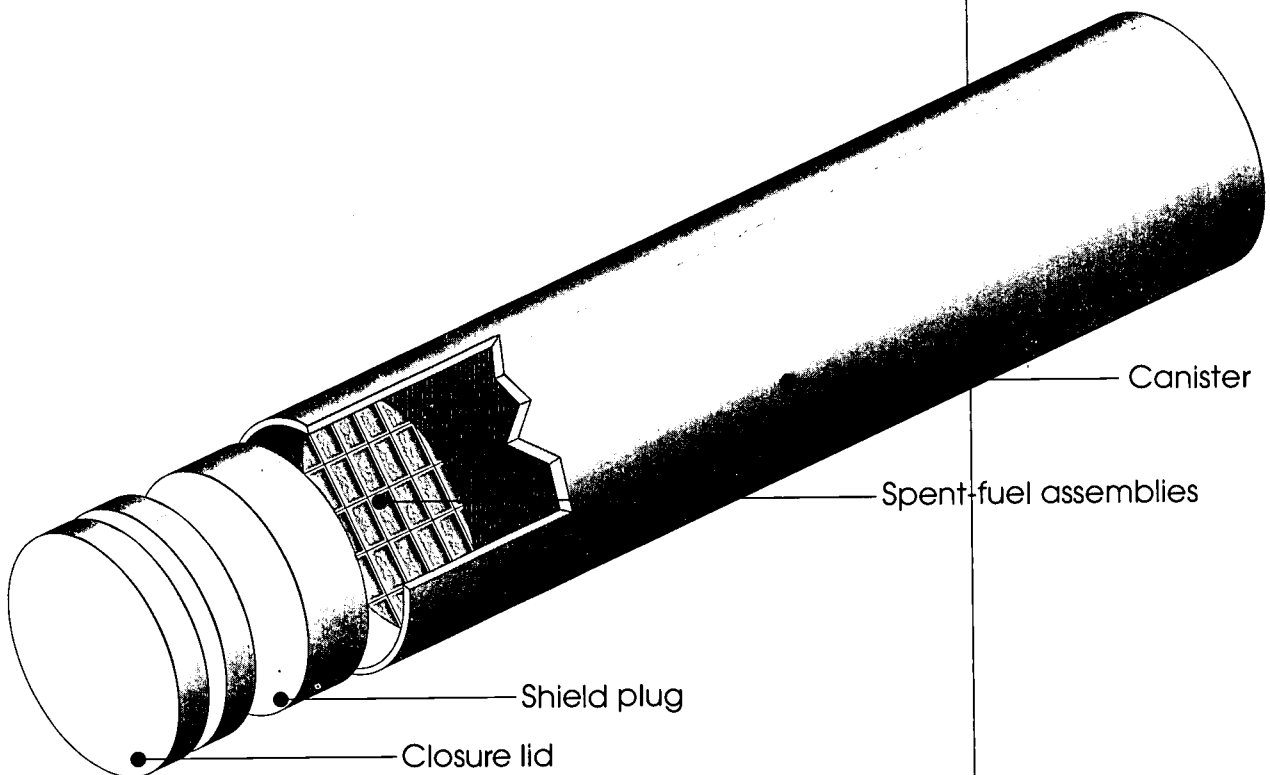

4.14 The Repository as a Barrier

The repository portion of the multiple barrier system consists of engineered barriers that are not part of the waste package. Material used to *backfill* (or refill) underground storage rooms, passageways, ramps, and shafts is a major repository barrier used to limit or control movement of underground water.

What is the repository part of the multiple barrier system?

Borehole and Shaft Seals

What are boreholes and shafts?

A *borehole* is a hole drilled into the earth, often for exploratory purposes. Boreholes are usually small in diameter. A *shaft* is a vertical excavation made for mining rock, raising rock, lowering workers and materials, or ventilating underground areas.

How will they be sealed?

Borehole seals and shaft seals are not included as part of the engineered system from a regulatory standpoint. However, borehole and shaft seals will be used to prevent or substantially reduce movement of water. These seals will also keep people from getting into the repository after operations have ceased. Tests are being conducted to identify materials that have the required engineering properties for seals. Materials being tested include clays, polymers, and cement grouts. (*Grout* is the type of material used as a filler for cracks or crevices with bricks or tiles. *Polymers* include rubber, resin, plastic, nylon, and other compounds with structures of long chemical chains.)

Besides acting as a barrier, backfill materials also serve other purposes in a repository. For example, backfill could enhance transfer of heat from the waste to the surrounding rock. It could be used to relieve or *mitigate* (make less severe) mechanical pressures or forces on the waste package. It could also provide structural support to the host rock surrounding the repository. Right now, the plan is to use some of the rock removed during mining for backfill. The backfill materials can be tailored to meet specific conditions by adding other materials, such as clays.

4.15 The Host Rock as a Barrier

How does the geologic setting serve as part of the multiple barrier system? What site features are important?

The site of the geologic repository plays a crucial role in isolating the buried waste from the accessible environment. It is the third major component of the multiple barrier system. Three features of a site that affect long-term isolation of waste are especially important: 1) the suitability of the host rock for construction of the repository and containment of waste; 2) the hydrology (water) and chemistry of the site and its environment and how they might interact with the waste; and 3) the time required for ground water to flow from the repository to the accessible environment. A geologic setting is very complex, and the factors that will serve as barriers depend on the characteristics of the specific site. The features of a site that affect long-term isolation of waste are being studied during site characterization.

Because a repository is more or less a special mine, some desirable site characteristics are related to mining and mine safety. Others include low ground water flow rates and long pathways from a repository to the accessible environment. It would be primarily through ground water flow that nuclear waste would migrate from the repository. Evidence of long-term geologic stability is desirable. The ability of the rock to conduct heat away from the waste package is particularly important. Radioactive waste is thermally hot and would heat the waste package, as well as the surrounding rock. Because heated rock tends to drive away water, this would help to reduce any migration of nuclear waste into the environment. Rock properties that prevent or slow movement of harmful substances are also desirable. Finally, as much as possible, the site selected should reduce the possibility of human intrusion.

What are some desirable site features?

4.16 If Yucca Mountain Is Suitable and Approved

The candidate site for a repository is Yucca Mountain, Nevada. This site is being studied to determine whether it is suitable. If this site is approved for development as a repository, the repository complex will use about 2,307 hectares (5,700 acres) that will include a controlled area 5 kilometers (3 miles) wide surrounding the outer perimeter. Utilities, roads, and a railroad line will be extended to the site.

If the site is chosen, the surface facilities will probably be on the east side of Yucca Mountain and will cover from 61 to 162 hectares (150 to 400 acres). Gently sloping ramps connecting the underground and surface facilities will allow shielded transport vehicles to carry waste packages to the underground disposal area. Underground facilities will be located about 1.5 kilometers (1 mile) west of the surface complex and will cover an underground area of about 567 hectares (1,400 acres). They will be about 305 meters (1,000 feet) beneath the surface.

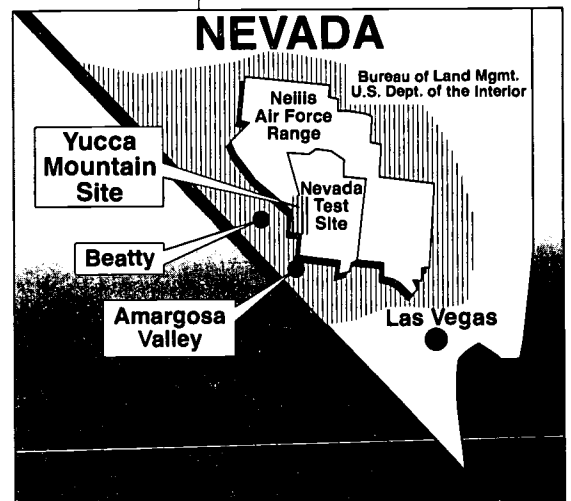

If the Yucca Mountain site is approved, about how much land will be needed?

Unsaturated Zone

What are some distinctive features of the Yucca Mountain site?

The Yucca Mountain site has several distinctive features that may help to ensure that waste is isolated from the accessible environment if a repository is actually built there. Among these features are that the tuff rock deposits there are durable, and able to be mined. In addition, the proposed repository would lie in the *unsaturated zone*, 201 to 396 meters (660 to 1,300 feet) above the water table (the area of rock saturated with ground water). This feature would help to decrease water migration into the repository environment, and the flow of ground water at Yucca Mountain is being carefully studied to make sure that, if a repository is built there, the waste will remain isolated. However, other issues such as the potential for volcanic activity and earthquakes must also be considered.

Zeolites

Why is the presence of zeolites desirable?

Another distinctive feature of the Yucca Mountain site is that the repository would be located above a natural formation of minerals called *zeolites*. Zeolites are often used in water softeners. Because zeolites absorb minerals that make the water "hard," they could be helpful in removing certain radioactive ions, such as cesium-137 or strontium-90, if they should migrate from the waste package in a repository environment. Because the zeolites are positioned above the water table, radioactive elements coming from the repository could be filtered, preventing or delaying migration of waste into the water table. Through the friction of water moving through their tiny channels, zeolites would also slow down any contaminated ground water movement from the repository to the accessible environment.

The potential location of the repository in the unsaturated zone and the presence of zeolites are desirable features of the Yucca Mountain site that could contribute to long-term isolation of waste.

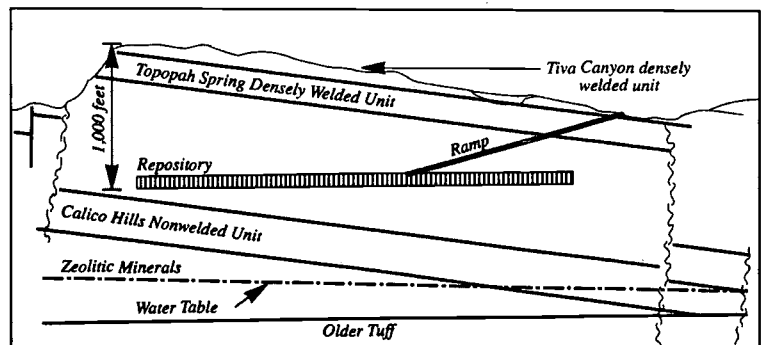

WHAT WILL A GEOLOGIC REPOSITORY BE LIKE?

Part I

Directions: Put the number of the phrase or term from column B in the space provided next to the appropriate item in column A.

- | | |
|--|---|
| <p><u>7</u> A. substantially complete waste containment by waste package</p> <p><u>13</u> B. Yucca Mountain, Nevada</p> <p><u>12</u> C. geologic repository resembles</p> <p><u>1</u> D. total land required for a repository</p> <p><u>8</u> E. land required for above ground facilities</p> <p><u>11</u> F. land required for subsurface facilities</p> <p><u>9</u> G. manmade barrier</p> <p><u>10</u> H. surface facility</p> <p><u>4</u> I. will move waste to underground facility</p> <p><u>3</u> J. main access tunnel</p> <p><u>5</u> K. when repository will be closed</p> <p><u>2</u> L. depth beneath surface for disposal facilities</p> | <p>1. <u>2,307 hectares</u> (5,700 acres)</p> <p>2. about <u>305 meters</u> (1,000 feet)</p> <p>3. ramp</p> <p>4. shielded transport vehicle</p> <p>5. at least 50 years after emplacement begins</p> <p>6. electric train</p> <p>7. 300 to 1,000 years</p> <p>8. <u>61-162 hectares</u> (150 to 400 acres)</p> <p>9. disposal container</p> <p>10. used for handling waste</p> <p>11. about <u>567 hectares</u> (1,400 acres)</p> <p>12. large mining complex</p> <p>13. candidate site to be studied for a repository</p> <p>14. at least 100 years after disposal begins</p> <p>15. 10,000 years</p> |
|--|---|

Part 2

Directions: Use the reading lesson *What Will a Geologic Repository Be Like?* to answer the following questions in the spaces provided.

1. What Federal Government agencies will regulate a nuclear repository?

(Nuclear Regulatory Commission and Environmental Protection Agency)

2. Describe the facility of a geologic repository.

Above ground:

(Resembles mining complex; 2,307 hectares (5,700 acres); 5 kilometers (3-mile) controlled area surrounding perimeter; roads and rail line coming in. Waste handling; utility buildings; fire and medical stations; administrative offices; repair shops; water and sewage treatment plants; warehouse; security posts.)

Below ground:

(Sloping ramps to subsurface area; main access tunnels; and disposal areas.)

3. What are the three components of the multiple barrier system?

(The waste form, the repository, and the geologic medium—host rock.)

4. Describe the waste form for spent fuel. How does its form act as a barrier to releases of radioactivity?

(Spent fuel assemblies consisting of fuel rods holding ceramic pellets; metal used for fuel rods is corrosion and heat resistant. In this form the waste package resists external water damage from the heat produced by the decaying waste.)

5. Describe the waste form for high-level waste from defense activities. How does its form act as a barrier to releases of radioactivity?

(Waste is immobilized in borosilicate [boron and silicon] glass, which resists corrosion and contains radioactive material.)

6. What are advantages of glass for immobilizing waste?

(The glass form selected is made of the elements boron and silicon. It is stable, strong enough to resist stresses of disposal, withstands leaching, and is suitable for large-scale, remote production.)

7. What materials are being considered for the disposal containers? Why?

(Corrosion resistant materials under consideration are carbon steel, stainless steel, copper-based alloys.)

8. What are the two main reasons that boreholes and shafts will be sealed?

(To prevent or minimize water migration and thwart human intrusion.)

9. Explain ways in which any geologic site can act as part of the multiple barrier system.

(The host rock/geologic medium can provide strength for the mine and containment for the waste; retard movement of water to and away from repository; conduct heat from disposal container; and contribute to slowing movement of contaminants to accessible environment.)

10. List and explain three features of the Yucca Mountain site that might help to ensure that waste would remain isolated from the accessible environment if a repository were built there.

(Tuff is durable; repository would be in an unsaturated zone away from water table; zeolites could "filter" waste water, removing contaminants.)

THE ROLE OF THE MULTI-PURPOSE CANISTER IN THE WASTE MANAGEMENT SYSTEM

Purpose:

This lesson introduces students to the public participation process by involving them as stakeholders in an issue concerning the transportation and storage of nuclear waste. They will consider the effectiveness of the multi-purpose canister (MPC) for safely transporting, storing, and disposing of spent nuclear fuel from nuclear powerplants. This activity can be used as a model for public meetings on other topics.

Concepts:

1. The United States Department of Energy (DOE) is developing methods to reduce risk to the public, employees, and the environment during packaging, handling, storage, transportation, and disposal of spent nuclear fuel from nuclear powerplants.
2. An MPC could be used to store, transport, and dispose of spent nuclear fuel from nuclear powerplants.
3. Public meetings are held by DOE to inform and involve the public in significant issues relating to the waste management program.

Duration of Lesson:

Three 50-minute class periods — depending on students' experience in roleplaying situations
One additional class period may be required to lay out the Special Edition of the *Giventakenne Gazette*

Objectives:

After participating in this lesson, the student will be able to:

1. explain the purpose of the MPC;
2. list the advantages and/or disadvantages of the MPC;
3. identify concerns of stakeholders regarding the use of the MPC;
4. locate pertinent information in reference materials;
5. understand the issues/concerns of several groups holding a stake in the conceptual design of the MPC; and
6. discuss the importance of scientific understanding and communication for all groups involved in technological advances affecting society.

Skills:

Analyzing, communicating, cooperating, group dynamics, roleplaying

Vocabulary:

Cladding, Code of Federal Regulations (CFR), criticality, multi-purpose canister (MPC), Nuclear Regulatory Commission (NRC), overpack, stakeholder

Materials:

Reading Lesson

The Role of the Multi-Purpose Canister in the Waste Management System

Activity Sheets

What Is the Role of the Multi-Purpose Canister in the Waste Management System?

You Are Invited...The Stakeholders Public Meeting

Role Cards

Videotape*

The Multi-Purpose Canister System - 11-1/2 minutes

Blank newspaper master or computer diskette template

The Giventakenne Gazette

Reference Materials*

DOE OCRWM Multi-Purpose Canister System Fact Sheet Series:

Storage of Spent Nuclear Fuel

Transportation of Used Fuel

Nuclear Waste Policy Act and Amendments

The Civilian Radioactive Waste Management System

Radiation

Safety: The Key to Success

Spent Nuclear Fuel

Multi-Purpose Canister System - one or two class sets

*These materials may be ordered, free of charge, by contacting:

**OCRWM National Information Center
600 Maryland Avenue, SW
Suite 760
Washington, DC 20024
1-800-225-6972
(within Washington, DC, 202-488-6720)**

Suggested Procedure:

Day 1

1. Assign the reading lesson *The Role of the Multi-Purpose Canister in the Waste Management System* before your class meets for the first time to discuss the MPC. This is advanced reading that likely covers new information for your students. To guide their reading, distribute the activity worksheet *What is the Role of the Multi-Purpose Canister in the Waste Management System?* and have students complete it as they read.
2. During the first 15 minutes of class, discuss the role of the MPC in the Civilian Radioactive Waste Management System and student responses to *What Is the Role of the Multi-Purpose Canister in the Waste Management System?*
3. After students seem comfortable with the definition and proposed uses of the MPC, introduce the premise of their roleplay. In small groups of two or three, students will take on the roles of stakeholders—that is, interested parties—in the conceptual design and implementation of the MPC.
4. Assign each group of students a role for the Stakeholders Public Meeting by distributing a *Role Card* and a copy of the activity meeting rules *You Are Invited... The Stakeholders Public Meeting*, to each group.
5. Stakeholders fall into four groups—DOE personnel (including a public affairs representative), concerned residents of the community of Giventakenne, staff from the Giventakenne Nuclear Powerplant, and staff from the *Giventakenne Gazette*, the local newspaper. Discuss possible concerns of each stakeholder group.
6. At this point explain your expectations for each stakeholder group. Although the workload for this activity is fairly well distributed among groups, responsibilities vary by stakeholder group.

DOE Personnel — The DOE staff will have the most premeeting preparation. Explain that the technical staff will be evaluated on their presentations during the public meeting and their ability to respond to audience questions.

The DOE public affairs representative will be evaluated on the organization of the public meeting and the summary article prepared for the *Giventakenne Gazette*.

Residents of Giventakenne — Before the public meeting, Giventakenne residents should be preparing a list of questions for the DOE personnel based on the concerns of their role. Each resident may ask up to five questions. Residents should take notes during the public meeting and during the response to their questions. Following the meeting, residents will be writing a letter to the editor (300 - 500 words) of the *Giventakenne Gazette* outlining their concerns and DOE's responses as part of their evaluation.

Staff from the Giventakenne Nuclear Powerplant — The staff from the Giventakenne Nuclear Powerplant will have split responsibilities. The managing official will ask questions and write a letter to the *Giventakenne Gazette* (300-500 words) describing the advantages and disadvantages the MPC might bring the powerplant. The onsite storage expert will be making an official presentation.

Editor and Reporters from the *Giventakenne Gazette* — Before the public meeting, the *Giventakenne Gazette* staff should meet to discuss their assignments and deadlines. Reporters should prepare a list of questions to ask at the meeting— up to five questions. After the meeting, reporters will need to write their assigned story (300-500 words).

The editor is responsible for reading and correcting stories from his or her reporters, collecting letters to the editor from Giventakenne residents and powerplant personnel, collecting a meeting summary from the DOE public affairs representative, and composing a short editorial expressing the opinion of the paper (200-300 words).

Day 2

1. Allow student groups to prepare for the Public Meeting roleplay. It might be useful to make the *DOE OCRWMMulti-Purpose Canister System Fact Sheet Series* available for students to use as research tools. For additional resource materials available at no cost, please contact the OCRWM National Information Center at 1-800-225-6972. The Information Center staff can help you identify information products that will meet your research needs.
2. Give students as much time as they need to understand their roles and prepare their presentations and questions. It might be a good idea to spend some time with each group discussing their approaches and questions.
3. Encourage each group to use imagination. Costumes, name tags, and other props will add to the authenticity and fun of the roleplay.

Day 3

1. By the day of the stakeholders public meeting, the DOE public affairs representative should have an agenda completed and ready to share with the class. The representative should also be prepared to time presentations and lead the meeting.
2. Students should bring any props they have prepared to contribute to their roles. They should also bring any charts or graphs they plan to present. The reporters may want to take photographs to support their stories.
3. To begin the meeting, one of DOE's public relations staff should remind the group of the rules.
4. Students who are not making a presentation should take notes. These notes will help them complete their final assignment.
5. After each group has given its presentation and all questions have been answered, have students write their assigned articles, letters to the editor of the *Giventakenne Gazette*, and a *Giventakenne Gazette* editorial.
6. The *Giventakenne Gazette* editor should collect all student assignments and, with the help of the newspaper staff, the editor should lay out, print, and distribute the special Stakeholders Public Meeting Edition of the *Giventakenne Gazette*.
7. Blank master pages, including a front page and additional pages of the *Giventakenne Gazette*, are provided. Students can paste articles, diagrams, and photographs in place to create the *Gazette*. A computer diskette with a PageMaker® template for the *Giventakenne Gazette* is available if your students have access to a Macintosh computer equipped with PageMaker® software. Please contact the OCRWM National Information Center to order the diskette.

8. Encourage students to take their copies of the *Giventakenne Gazette* home to discuss the roleplay with their friends and relatives.

Teacher Evaluation of Learner Performance:

Student presentations at the Stakeholders Public Meeting and written contributions to the special edition of the *Giventakenne Gazette* will demonstrate their understanding.

WHAT IS THE ROLE OF THE MULTI-PURPOSE CANISTER IN THE WASTE MANAGEMENT SYSTEM?

Answer the following questions as you read the lesson *The Role of the Multi-Purpose Canister in the Waste Management System*.

1. What is a multi-purpose canister (MPC)?

(A large, metal container shaped like a cylinder and designed to hold spent fuel from nuclear powerplants.)

2. How is spent fuel presently stored at reactor sites?

(Underwater in specially designed spent fuel pools. Where pools are full, utilities use some form of dry storage.)

3. How would an MPC be used in DOE's waste-management system?

(With appropriate outer containers or overpacks, the MPC would be used for dry storage at reactor sites or a temporary storage facility, for transport, and for final disposal of spent fuel.)

4. List at least two advantages and/or disadvantages the MPC offers to spent fuel management.

(The MPC would minimize the handling of spent fuel assemblies. It would also ensure compatibility with dry-storage systems used at reactor sites and at DOE facilities.)

5. The MPC is designed to be shipped by rail from the different sites where spent fuel is stored. How does the waste management system ensure that it will satisfy those needs?

(Two canister sizes have been proposed to meet the special requirements of the utilities where spent fuel is stored. Provisions are included in the conceptual design for some utilities to ship uncanistered fuel in transportation casks to an area where it could be repackaged in an MPC.)

6. How might the MPC be handled at a geologic repository?

(At a geologic repository, the MPC would be unloaded from the transportation cask and placed in a disposal overpack. The canister and its overpack would then be placed on the floor of an underground disposal room.)

7. The Nuclear Regulatory Commission (NRC) regulations require that the MPC design meet specific standards. List as many NRC requirements as you can.

(The MPC must be capable of withstanding hypothetical accident scenarios. The temperature of the fuel inside the MPC must not exceed 340 °C (644 °F). Neutrons must be absorbed inside the canister to avoid criticality of the remaining fissionable fuel.)

8. If DOE decides to use the MPC, when is it projected to be available for storage at a reactor site? When is the transportation cask projected to be ready?

(The first canister is projected to be available for possible use at a reactor site in Fall 1998.

The transportation cask is projected to be ready by January 2000.)

9. The MPC will cost more than other storage canister designs. How would additional costs be offset?

(Because of standardization, savings in other parts of the waste management system will be realized. Fewer employees would be needed to manage spent fuel at different stages of the system.)

10. Who are the stakeholders in a decision to use the MPC? What are the concerns of each?

(utilities – lower costs of storage; less exposure to workers

public interest groups – costs, environmental safety protection, public health and safety

equipment manufacturers – increased workload, new equipment requirements

industry and utility organizations – costs, employee safety

regulators – costs, safety)

THE ROLE OF THE MULTI-PURPOSE CANISTER IN THE WASTE MANAGEMENT SYSTEM

In 1994, the U.S. Department of Energy (DOE) began developing a plan for managing spent fuel that would use one type of container for storing, transporting, and disposing of high-level radioactive nuclear waste. This container, called a multi-purpose canister (MPC), allows flexibility in making future plans for dealing with spent fuel. The MPC design reduces the amount of contact technicians have with the spent fuel rods, making transfer of waste from one location to another a safer process. The fact that one MPC design can be used throughout the storage, transport, and disposal stages adds to the overall efficiency of the waste management system.

4.17 Introduction

DOE is considering the use of a system for managing spent fuel that relies on placing the used fuel assemblies into a specially designed canister that would be welded shut. Once inside this container, the spent fuel could be stored in an upright or horizontal position, transported to another location, or permanently disposed on a geologic repository. Because the canister would serve these different functions, it has been called a multi-purpose canister (MPC).

Whether in storage at a reactor site or at a permanent repository, or during transportation, the spent fuel would stay inside the MPC. A different outer container, or cask, would be used in each situation.

- For temporary storage at a reactor site, the MPC would be put inside a storage cask that could be placed on its side (horizontal) or on one end (vertical).
- For transportation to another site, the MPC would be packed into a transportation cask.
- For final disposal, such as in a geologic repository, the spent fuel would stay in the MPC and be enclosed in a disposal cask.

What is a multi-purpose canister?

What are the possible uses of the MPC?

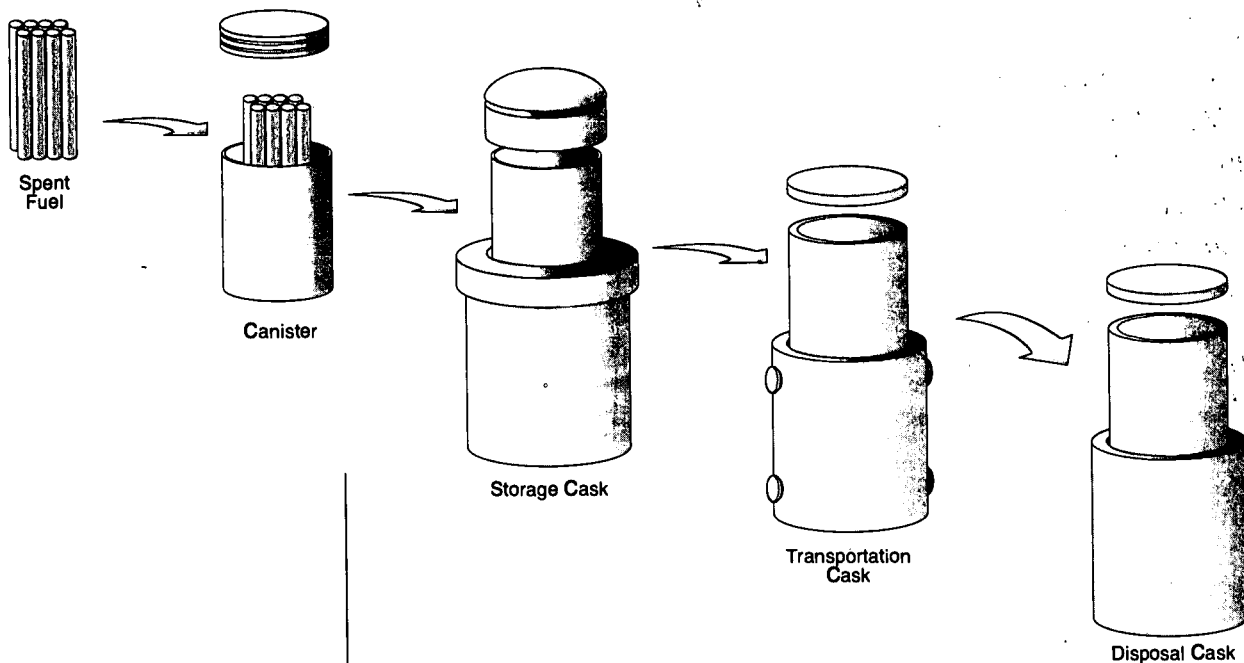

An MPC loaded with spent fuel may be used in either of three different casks for storage, transportation, or disposal.

Each type of outer cask for the MPC is a kind of overpack, a protective outer covering that contains the inner material and shields the outer environment.

A big advantage of the MPC is that it minimizes the handling of spent fuel, which reduces costs and the workers' exposure to radiation. The MPC has also been designed to hold a larger number of spent fuel assemblies than other cask models and thus it will reduce the total number of waste shipments, saving money and time.

4.18 The MPC Design and Standards

The Nuclear Regulatory Commission (NRC) regulates the design for the MPC. Among their regulations is the need for great structural strength. This is so that the MPC inside a transportation cask can withstand a transportation accident and maintain safe radiological limits. The overall structure of an MPC

What are some advantages of the MPC?

Who regulates the design of the MPC?

What are some of the design regulations?

is a large steel cylinder, opening on one end only. Inside the MPC is a fuel basket, a metal grid assembly that holds the spent fuel rods in place and prevents a criticality by absorbing neutrons released from the remaining fissionable fuel. It also transfers heat to the outer surface and adds strength to the MPC. This basket must also remain intact under hypothetical accident conditions.

Once the inner basket is loaded with spent fuel rods, a heavy metal shield plug is welded in place over the open end of the MPC, followed by a closure lid, which is also welded in place.

Multi-Purpose Canister

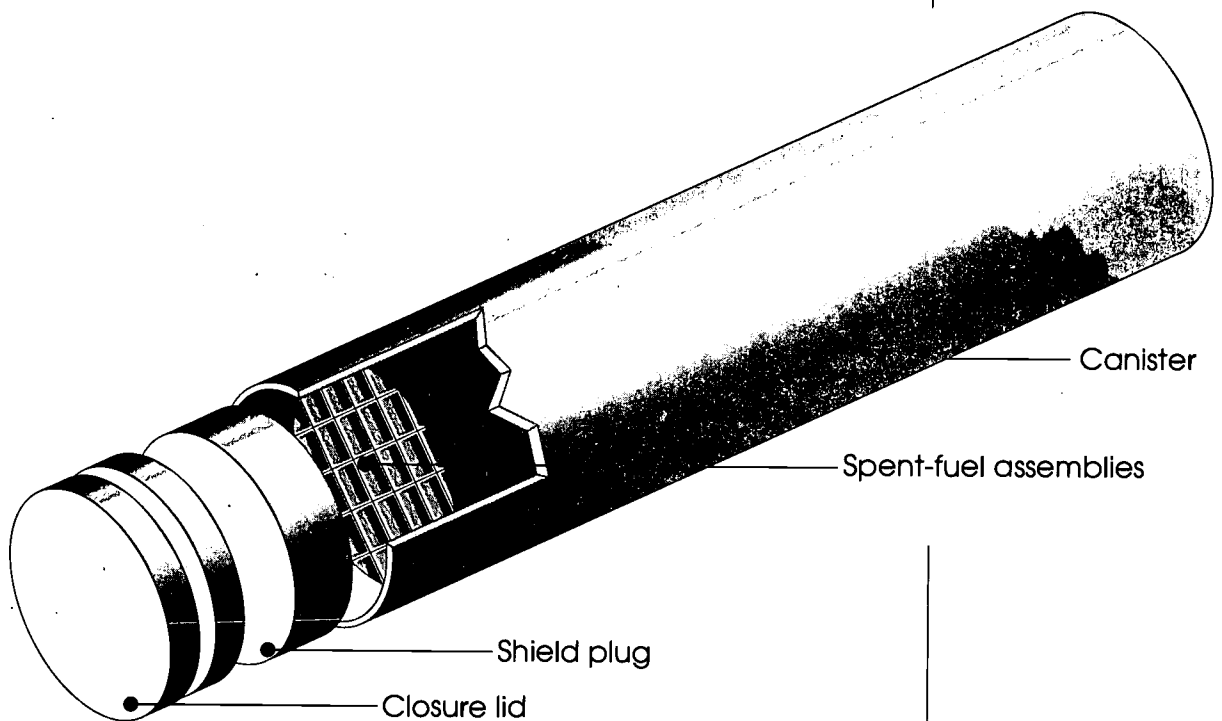

Another regulatory requirement for storage that the MPC must meet is that the temperature of the fuel cladding inside the canister may not exceed 340 °C (644 °F).

4.19 Spent Fuel Storage

The only waste carried by an MPC is spent fuel rods from commercial nuclear powerplants in the United States. Most of these sites currently store spent fuel in large pools of water reinforced with concrete and steel. The water provides a barrier against the high radioactivity of the fuel rods. But rods can also be stored in a dry environment, such as heavy containers or casks made of steel or concrete, usually in above-ground facilities. The MPC is intended to supplement the available space for storing spent fuel. The MPC's design is based on storage technologies already proven to be safe.

How could the MPC be used at a commercial reactor site?

To make the best use of the MPC for storage, the canisters must be filled with the maximum number of spent fuel assemblies. In order to fill up an MPC, the commercial reactor sites must have the appropriate equipment, including cranes for lifting and moving the MPCs. Not all reactor sites are made the same or operate in the same way. The MPC's design, however, is such that it can be used at most reactor sites. Two sizes of the MPC have been proposed to satisfy the needs of the different types of commercial nuclear reactors.

4.20 Transportation

Until a permanent geologic repository is ready, MPCs may be used for dry storage of spent fuel at nuclear reactor sites. Provisions have also been made so that some utilities can ship uncanistered fuel in transportation casks to a temporary facility where spent fuel could be repackaged into an MPC. Most of the U.S. nuclear powerplants are accessible by rail, and most MPCs transporting spent fuel will leave reactor sites by rail. However, the sites without rail access will be able to load smaller MPCs with spent fuel, which will then be carried away by heavy-haul trucks or barges to the nearest rail access point. Once it leaves the reactor site, a full MPC can travel to a temporary storage site or a permanent disposal facility, such as a repository.

How is the MPC transported from a reactor site?

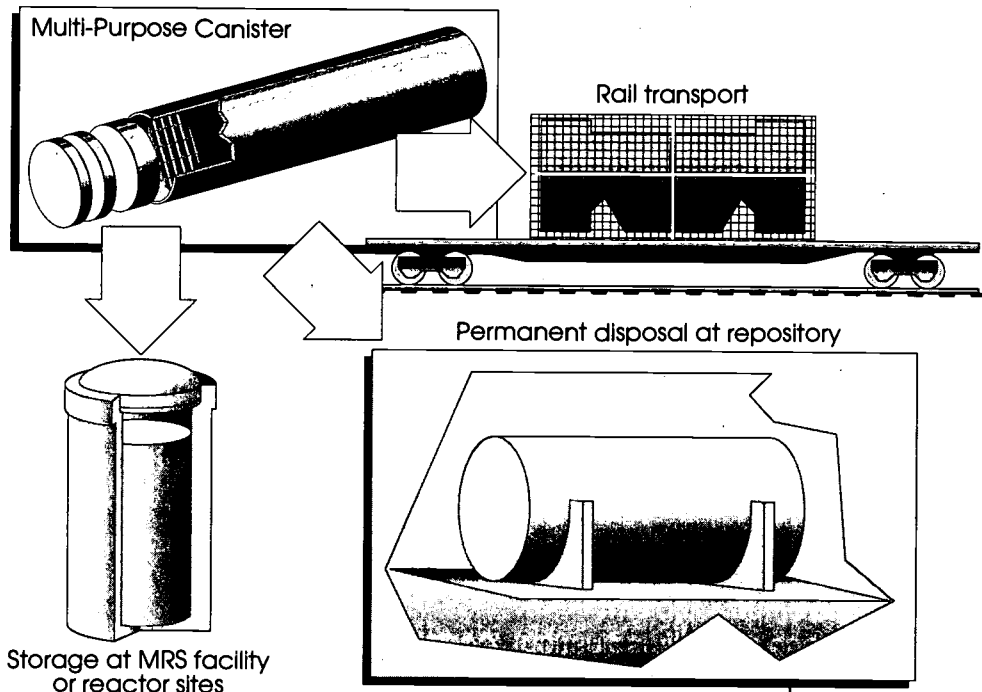

4.21 At a Geologic Repository

At a geologic repository, the MPC would be unloaded from the transportation overpack and placed into a disposal overpack, which would be welded shut. This package would then be moved down a ramp to the designated underground disposal area.

4.22 Schedule and Cost

The first MPC should be available for use at a reactor site in fall 1998. The first transportation cask for transporting an MPC to a storage facility should be ready by January 2000.

An MPC and its storage overpack will cost more than a cask designed for storage only. This is mainly because of the high structural strength needed to meet the transportation accident conditions and because of the need for special aluminum in the fuel basket to control criticality. The costs, however, are offset by the savings in the overall waste management system that

What happens to the MPC once it reaches a repository?

When will the MPC be ready for use at reactor sites?

Why is the MPC considered a cost-saving measure?

would result from the use of a standardized container like the MPC. Personnel requirements and safety concerns would also be significantly reduced because of the limited amount of waste handling work that would result from using the MPC.

4.23 Stakeholders Involvement

What is a stakeholder?

Who are the primary stakeholders in the MPC issue? Why?

DOE believes it is important to involve stakeholders — people who are potentially affected by nuclear waste management — in major decisions. With the MPC, the primary stakeholders are the utilities that operate commercial nuclear reactors because they would be directly involved in using the canisters. Utilities would have the benefits of lower costs for waste storage and less exposure to workers. Utilities also would benefit from greater levels of transport and storage safety. Other stakeholders include public interest groups, equipment manufacturers, industry and utility organizations, cooperative agreement groups, and government regulators. These groups are concerned with such issues as environmental safety and public health, employee safety, costs, workloads, and equipment requirements.

DOE regularly holds workshops and public meetings to involve stakeholders in two-way discussions about design reports, opinions, and concerns.

SUMMARY

4.24 Transporting Spent Fuel

The U.S. Department of Transportation (DOT) and the Nuclear Regulatory Commission (NRC) work together to ensure that the transportation of spent fuel and defense high-level waste is safe. The DOT regulates every aspect of transporting the spent fuel. The NRC sets standards for the design and performance of the casks that carry the spent fuel during transport. The Department of Energy will follow these agencies' standards and regulations in shipments of nuclear waste to a repository or storage facility.

Transportation Casks

Casks are designed to contain spent fuel rods during shipment and to shield transportation workers, the public, and the environment from radiation under normal and extreme transport conditions. To ensure the ability of casks to contain their radioactive contents, computer modeling, as well as scale model and full-scale tests are performed on the casks. These tests simulate severe accident situations. During testing, casks have suffered only minor damages and have not released their simulated "radioactive" contents.

Shipments of high-level nuclear waste must follow preferred routes. States receive advance notice of any shipments. In addition, public safety officials are trained in procedures for routine transportation and for emergency response to accidents.

4.25 The Geologic Repository

The United States plans to dispose of spent fuel and high-level radioactive waste in a geologic repository deep beneath the surface of the earth. The Environmental Protection Agency (EPA) has developed standards for isolating the waste from the environment for 10,000 years after disposal. The NRC is

What are the U.S. Department of Transportation's responsibilities for transporting nuclear waste?

Why is spent fuel shipped in casks?

How does the U.S. propose to dispose of spent fuel and high-level radioactive waste?

responsible for enforcing the EPA standards. Both agencies require the use of a system of multiple barriers to isolate the waste.

Multiple Barriers

What are the multiple barriers that will block radionuclide transport after disposal?

Before disposal, the waste must be in a solid form. This form will inhibit the release of radioactivity. The waste will be packaged in metal containers that will be designed to isolate the waste from the host rock. Borehole and shaft seals will be used to reduce water migration to the waste container. The repository itself will act as a barrier to waste movement. Underground ramps and shafts will be backfilled to reduce the possibility of ground water access to the waste package, support the overlying host rock, decrease stress on the waste package, and transfer heat from the waste package to the surrounding rock. Features of the host rock, such as its response to heat and water, may act as part of the multiple barrier system to limit movement of waste.

What Will the Repository Look Like?

What site is currently being studied for the high-level nuclear waste repository?

On the surface the repository will look like a large mining complex. There will be surface facilities for handling the waste, which will be connected to the subsurface disposal facility by ramps. Following the closing of the repository, measures will be taken to alert future generations to the location and hazards of the repository.

No repository site has been selected, but studies have begun to determine the suitability of Yucca Mountain, Nevada. In 1987, the United States Congress directed the U.S. Department of Energy to study this site, which is located about 161 kilometers (100 miles) northwest of Las Vegas. Characteristics of the host rock, the chemistry of the site, and the flow of ground water will all be important in deciding if the site is suitable.

DESIGNING FOR SAFETY

Purpose:

This activity calls upon students to model the development and engineering of transportation casks for spent fuel assemblies.

Concepts:

1. When designing a cask to transport spent nuclear fuel, engineers consider the most extreme conditions of temperature and pressure.
2. Tests verify engineering design.

Duration of Lesson:

One 50-minute class period

Objectives:

As a result of participation in this lesson, the learner will be able to:

1. design and build a "cask" for a raw egg;
2. demonstrate the integrity of his/her cask design; and
3. explain important factors engineers must consider when designing a cask for the transport of spent nuclear fuel.

Skills:

Constructing, designing, drawing, evaluating, observing, testing, working in groups

Vocabulary:

Cask

Materials:

Activity Sheets

Designing for Safety, p. 169

Other

- 1 raw egg (per group)
- 2 sheets of 8 1/2"x11" paper (per group)
- 1 meter of tape (per group)
- plastic sheet
- meter stick

Suggested Procedure:

1. It is suggested that students work in groups of two to four to derive maximum benefit from this experiment. Each student should be prepared to make predictions, set up the experiment, and record data as the experiment progresses.
2. Students should follow directions listed in the activity to build the protective "cask" around their eggs.
3. After the test drop, give each group time to look at the successful casks and record their observations.
4. Have students draw their conclusions.
5. You may wish to ask groups to share and discuss their conclusions with the class.

Teacher Evaluation of Learner Performance:

Completion of experiment and worksheet will indicate understanding.

DESIGNING FOR SAFETY

During the past 40 years, nuclear materials, including nuclear waste, have been transported safely. Scientists and engineers work together to design and build casks that will ensure the safety of workers, the public, and the environment during the transportation of nuclear waste. Casks used to transport spent fuel rods are designed and constructed to contain radioactivity under normal travel conditions and in situations that may result in the event of a rail or highway accident.

In tests conducted to certify the safety of casks, the most vulnerable point of a cask must withstand an impact with a flat unyielding surface after a 9-meter (30-foot) drop, and must withstand hitting a steel rod that is 15 centimeters (6 inches) in diameter and at least 20 centimeters (8 inches) tall after a 1-meter (40-inch) drop. The entire cask is also exposed to a 800 °C (1,475 °F) fire for 30 minutes.

The realistic applicability of these test results has been verified by full-sized, scale, and computer modeling of actual accident situations. In each case, damage to the casks proved to be superficial, and the cargo remained isolated from the environment.

To help you understand designing for safety, you and your team will design and build a "cask" for the protection of a raw egg. Under the supervision of your instructor, you will test your cask by dropping it from a height of 2 meters (6.6 feet) onto a plastic sheet.

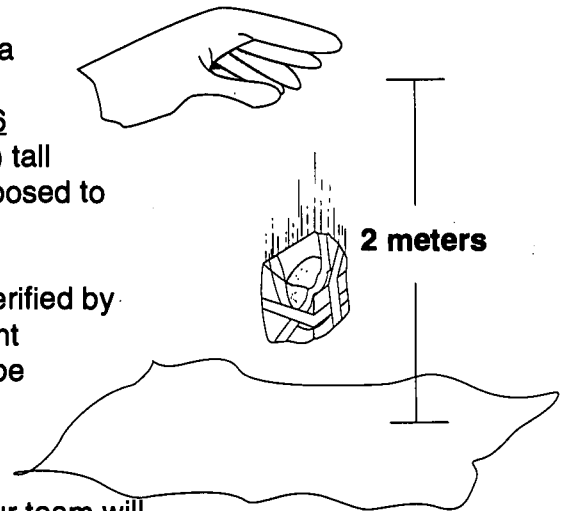

Purpose:

What is the purpose of this activity?

(The purpose of this activity is to model the development and engineering of transportation casks for spent fuel assemblies.)

Materials:

Each Group

1 raw egg
2 sheets of 8 1/2" x 11" paper
1 meter of tape

Whole Class

plastic sheet
meter stick

Procedures:

1. As a group, discuss and agree upon a design for your "cask" that will protect your egg from all angles during the test drop. Draw your cask in the observation section.
2. Construct your cask. You do not need to use all of the materials provided, but you may not use any additional materials.
3. Decide as a group the most vulnerable point of your cask. Mark this spot to identify it.
4. When all teams have completed building their casks, one member of your team will drop your cask in the testing area on its most vulnerable spot from a height of 2 meters (6.6 feet).
5. Eggs that survive the 2-meter (6.6 feet) drop will have travelled in safe casks. Take time to observe the strengths of the casks in your class that survived the drop.

Observations:

Draw the design for your cask below. Label the point you have chosen as the most vulnerable.

1. Did your egg survive the fall? Why or why not?

(Answers will vary.)

2. List the qualities you have observed of the casks that survived the drop.

(Answers will vary. Encourage students to think carefully.)

Conclusion:

1. If you were forced to make improvements on your cask whether it survived the drop or not, what changes would you make? (Assume the same supply of materials.)

(Answers will vary. Encourage students to be as detailed as possible.)

2. What factors do engineers need to consider when designing a cask to transport spent fuel?

(Engineers need to consider the most extreme conditions of temperature and pressure. They must also design tests to prove the capabilities of their cask design.)

TRANSPORTING HAZARDOUS MATERIAL

Purpose:

This lesson introduces students to general considerations used to select routes for highway transportation of hazardous materials. Students explore the complexities of hazardous materials transportation route selection and simulate selection of highway routes in their home State.

Concepts:

1. Transportation of hazardous materials requires special safety considerations.
2. Many factors are considered in selecting routes for highway shipments of hazardous materials, including spent fuel.

Duration of Lesson:

Two 50-minute class periods

Objectives:

As a result of this lesson, the learner will be able to:

1. read and use a State highway map;
2. identify interstate and State highways and secondary routes in his/her State;
3. interpret the map legend;
4. calculate mileage estimates using both the mileage chart and the mileage numbers on the map;
5. distinguish between cities of various sizes on the map;
6. identify the Federal, State, and local agencies responsible for the safe transportation of nuclear waste;
7. identify general criteria considered in selecting routes for highway transportation of hazardous materials; and
8. select potential highway transportation routes into and through his/her State, using existing criteria.

Skills:

Critical thinking, discussing, map reading, simulation, working in groups

Vocabulary:

Interstate, interstate bypass, scale

Materials:

Activity Sheets

Analyzing State Highway Maps, p. 171

Planning an Alternative Hazardous Materials Shipment Route, p. 175

Other

State highway maps

Suggested Procedure:

1. Have students read the introduction to the activity entitled *Analyzing State Highway Maps*.
2. When students have completed the introduction have them begin the activity. Students may work in small groups or independently, depending on the number of highway maps available.
3. When students have completed the activity, discuss their answers as a class.
4. Students may complete the activity entitled *Planning an Alternative Hazardous Materials Shipment Route*. Again, they may work independently or in small groups.
5. After students have completed their activities, invite a representative for transportation of hazardous materials to discuss actual routes, procedures, safety records, etc. within your State.
6. Since answers to this activity will vary by State, no answer sheets have been provided.

Teacher Evaluation of Learner Performance:

Student participation in class discussion and completion of the activities will indicate understanding.

ROCK CHARACTERISTICS IMPORTANT IN REPOSITORY SITING

Purpose:

This lesson will introduce students to some of the characteristics or properties that are important in repository performance: porosity, permeability, solubility, and thermal stability. Students will develop insights relating to the complexity of a geologic environment.

Concepts:

1. Individual rock characteristics are interrelated in complex ways.
2. Measurement of one or two rock properties is not sufficient to truly characterize the rock's ability to act as a geologic repository host.

Duration of Lesson:

One 50-minute class period

Objectives:

As a result of participation in the lessons entitled *Rock Characteristics*, the learner will be able to:

1. define various properties of rocks;
2. discuss the complex interrelationships of individual rock characteristics;
3. explain why measurement of one or two rock characteristics is not sufficient to truly characterize a rock's ability to act as a repository host; and
4. discuss and analyze the complexity of a geologic environment and the effect this has on planning for a geologic repository.

Skills:

Analyzing, completing, defining, discussing, drawing conclusions, explaining, matching

Vocabulary:

Compressive strength, containment, devitrified, effective porosity, fluid, ion exchange, mineral, multiple barrier, permeability, plasticity, porosity, rock, solubility, sorptive capacity, thermal alteration, welded tuff, zeolite

Materials:

Reading Lesson

Rock Characteristics Important in Repository Siting, p. SR-27

Activity Sheets

Important Rock Characteristics, p. 179

Rock Characteristics Important in Repository Siting, p. 181

Transparencies

Rock Strata, p. 139

Background Notes

Rock Characteristics Important in Repository Siting Permeability, Porosity, Solubility, Thermal Stability and Sorptive Capacity, p. 29

Videotape

The Tuff Library (available free of charge from the OCRWM National Information Center, 1-800-225-6972; within Washington, DC, 202-488-6720)

Suggested Procedure:

1. Before students begin the reading lesson, it may be helpful to introduce the vocabulary words and explain that they will be defined in the lesson.
2. It may be worthwhile to define a fluid and differentiate between gaseous and liquid fluids. For example, a fluid takes on the shape of its container whether that container is a coffee cup or the pore space in a rock. A gas is a fluid which will expand to fill all available space in the container, whereas a liquid, another type of fluid, will not necessarily fill the container. In the case of a nuclear waste repository, there are several "containers" to be considered.
3. A review of the definitions of a rock and a mineral may be useful. Since rocks are simply mixtures of minerals, it is more important to define a mineral. Although no two definitions will agree, a useful definition of a mineral is "*A naturally occurring, inorganically formed solid with a definitive chemical composition and an ordered atomic arrangement.*"

Looking at this definition in detail, we see that liquids and gases cannot be minerals. Manmade solids that do not occur naturally cannot be minerals. The restriction that the mineral be inorganically formed means that the solid must occur naturally outside a biological system. This excludes the solids formed by plants and animals, as part of their structure or skeleton in the non-biological environment.

4. Students should understand from the reading lesson and class discussion that the host rock can be considered a "container" because some of the properties of the rock act to restrict the movement of waste bearing fluids (e.g., porosity, permeability, and physical sorption). Those same properties also act to limit access to the wastes by outside fluids. Furthermore, the host rock, in addition to being a barrier, can act as a chemical filter (by chemical sorption/ion exchange) to selectively remove contaminants from a moving fluid.
5. The fundamental point to get across to students is that no host rock will be the ideal container or chemical filter. Strengths as a container may compensate for weaknesses as a chemical filter and vice versa.
6. Students may be interested in learning more about the methods employed by geologists who sample, store, and study the tuff samples from Yucca Mountain. You may wish to show the videotape entitled *The Tuff Library* at this time.

Sample Videotape Questions - *The Tuff Library*

- a.) In what type of rock will the proposed repository be mined if Yucca Mountain is chosen as the site for the Nation's first high-level nuclear waste repository?
 - b.) How is the Sample Management Facility like a library?
 - c.) How are the core samples from Yucca Mountain processed?
7. After completion of the reading lesson and discussion, assign the reading review entitled *Rock Characteristics Important in Repository Siting* and the activity entitled *Important Rock Characteristics* in which students will complete a definition-matching exercise to reinforce the reading material. Emphasize the importance each characteristic has in relation to a repository in any type of host rock.
8. Direct students to choose partners or separate into small groups. Allow approximately 10 minutes for groups to discuss their understanding of the significance of rock characteristics to the geologic repository, and draw a conclusion to be shared with their classmates.

Teacher Evaluation of Learner Performance:

Discussion participation and response to reading review worksheets will indicate level of student comprehension.

ROCK CHARACTERISTICS IMPORTANT IN REPOSITORY SITING

4.26 Introduction

All rocks are not created equal. Two rocks may look alike yet be very different in many ways. So, the characteristics of the rock at any site are carefully evaluated in determining whether that site is suitable for a repository. In addition, the design of the waste disposal container and the repository itself will take the characteristics of the host rock into account.

It is important to realize that while no rock is perfect in all ways, strengths in one characteristic may compensate for weaknesses in another. Also, remember that a rock is simply a combination of individual minerals that have properties. Taken together, the properties of all the individual minerals yield the rock characteristics.

4.27 Characteristics Important for Mining and Mine Safety

A repository is first and foremost a special mine. Rock properties that make mine construction safe and reasonably easy are important. One key property is *compressive strength*. Rocks with high compressive strength resist breaks or fractures even when stressed or "squeezed."

4.28 Technical Questions

4.28a Rock Mechanics

The reaction of the rock to the heat produced by the nuclear waste is the major concern. How well does the rock move or conduct heat away from the fuel? How does the rock react to heat physically? How does heat affect the rock chemistry?

Are all rocks the same?

What determines the characteristics of a rock?

What characteristics contribute to mine safety?

What is the early technical concern?

What is the concern later on?

Over the very long periods of time required for high-level waste disposal, there will be much less heat. But rock properties that contribute to waste isolation continue to be vital. Numerous rock characteristics can work to prevent or slow movement of fluids (either gases or liquids) that might be carrying wastes. For example, how much empty space is there in the rock that fluids can get into? (How porous is the rock?) How hard or easy is it for fluids to flow through, or permeate, the rock? What physical or chemical rock properties might slow the movement of the waste?

4.28b Rock Characteristics Related to Heat

What properties are related to how heat affects a rock?

Rock characteristics that have something to do with how a rock responds to heat include *thermal conductivity*, *plasticity*, and *thermal stability*.

What is thermal conductivity?

Thermal Conductivity

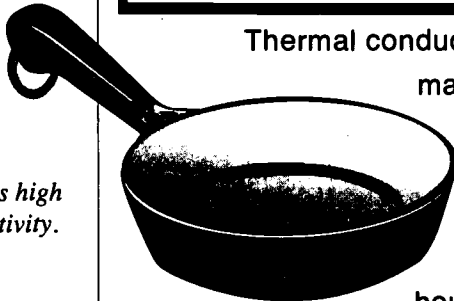

A frying pan has high thermal conductivity.

Thermal conductivity is a measure of how well any material will transmit or move heat. A well-made cooking pan transmits the heat from the burner very well, while the attic insulation in your house is very inefficient at transmitting heat from the house to outdoors in winter. Most rocks are better insulators than conductors. They tend to let heat and temperatures build up near a heat source (such as buried waste). They lose heat slowly.

Plasticity

What is plasticity?

If temperatures rise enough, the strength of the host rock can be affected. We usually think of rocks

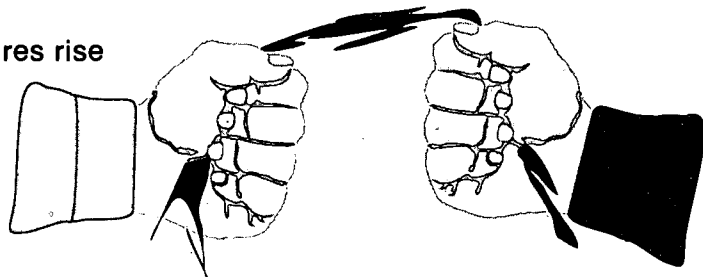

Plastic clay has high plasticity. It will flow if heated and does not break easily. However, it will break if pulled too far.

as solids. However, at elevated temperatures and pressures, rocks will actually flow, though at slower rates than water, mud, or clay. The term for this property is plasticity. Plasticity may have both advantages and disadvantages. During flow, fractures in rocks may be closed. However, if pushed too far, too fast, the rock may develop cracks that do not seal. This can affect the strength of the rock. At a repository, it could also make safe retrieval of waste more difficult.

Thermal Stability

Many minerals in the rock may be changed by exposure to heat. How much change there is depends on the mineral in question. Minerals such as zeolites and clays give off water when heated and their ion exchange properties change, usually decreasing. Water circulation through the rock is an effective way to conduct heat away from the repository. Also, the solubility of minerals may increase or decrease in heated water.

4.28c Rock Characteristics Related to Flow of Gases or Liquids

Numerous rock characteristics will work to prevent or slow the flow of fluids—either gases (air) or liquids (ground water). Some key characteristics related to the flow of fluids in rocks are sorptive capacity, porosity, permeability, effective porosity, and solubility.

Sorptive Capacity

Sorption is a process for removing dissolved material from solution by “attaching” the dissolved solids to the surface of another solid. Sorptive capacity of a rock is a measure of the ability of its surfaces to remove dissolved material from solutions passing through the rock, by sorption. The sorptive capacity of the rock will work to limit waste movement.

Sorptive capacity includes both chemical and physical processes. The chemical processes include all those

Why is plasticity important?

How can heat affect the minerals that make a rock?

What rock characteristics are related to flow of air or liquid?

What is sorption?

What is ion exchange?

mechanisms that can take atoms or molecules of waste and attach them to rock (mineral) surfaces. An example of a chemical process of sorption is *ion exchange*. In ion exchange, particles with an electrical charge (ions) in water change places with ions that were attached to a mineral called a zeolite. The waste ions are removed from the water and harmless ions go into the water.

Many people are familiar with ion exchange because it is the chemical process used in water softening devices to remove unwanted minerals from "hard" water in many sections of the country.

A physical sorption process might be the physical trapping of water molecules in small pores. In these small pores, water molecules are stuck between the molecule and the wall of the pore.

Sorptive Process

Chemical sorption: As a result of the chemical process of ion exchange, cesium-137 (Cs) and strontium-90 (Sr) may attach to a zeolite, which is a part of the pore wall structure. The replaced calcium (Ca) and potassium (K) ions move into the water.

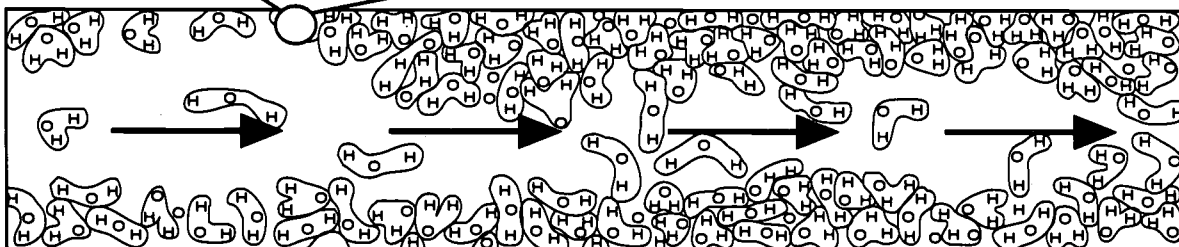
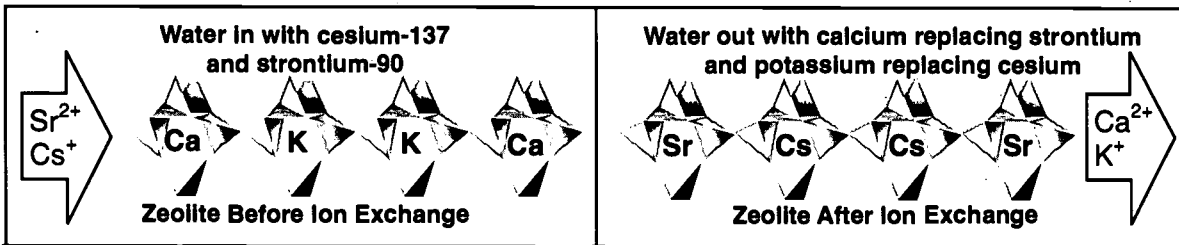

Physical sorption: In physical sorption, water molecules in small pores are immobilized due to frictional forces between the molecule and the pore wall, in effect decreasing the size of the pore.

Porosity and Permeability

Porosity and permeability are related but different. *Porosity* is a measure of the ability of anything, in this case a rock, to hold a fluid. Strictly, it is the ratio of open space in a volume of rock divided by the total volume of the rock (open space plus solids).

$$\frac{\text{Volume of pores}}{\text{Total rock volume}} \times 100 = \text{porosity (\%)}$$

The open spaces in all rocks are filled with a fluid from the time of rock formation. Most porous rocks were formed by individual particles that settled out of suspension in sea water. Over time periods ranging from a few years to a few million years, the particles cemented together to form a rock. Formation of the rock may reduce the amount of porosity, but it does not completely eliminate porosity. The pore spaces in rocks formed in this way are filled with sea water. The type of rock being studied in Nevada to see if it will be suitable for a repository is *tuff*. The particles that make up a tuff rock formation are often deposited on land. The particles settle out of the atmosphere after a volcanic eruption. The pore spaces between particles are filled with air at first. The air may be replaced by fresh water as rain flows through the pores that are connected to one another.

Permeability is a measure of the ease of flow of a fluid through a porous solid. The important connection between porosity and permeability is just that: connection. If the pores are not connected, fluid cannot flow between pores and out of the rock. For example, think of a grouping of unopened soup cans. Porosity (the ratio of fluid holding volume to total volume) is very high. But without connections between the "pores," in this case, cans, there is no flow. Permeability is zero.

Rocks can have porosity, but if the pores are so small that you have difficulty pushing a fluid through, the rock has essentially no permeability. On the other hand, a rock containing a few wide open cracks may have a low calculated porosity, but a high permeability.

What are porosity and permeability?

Are they related?

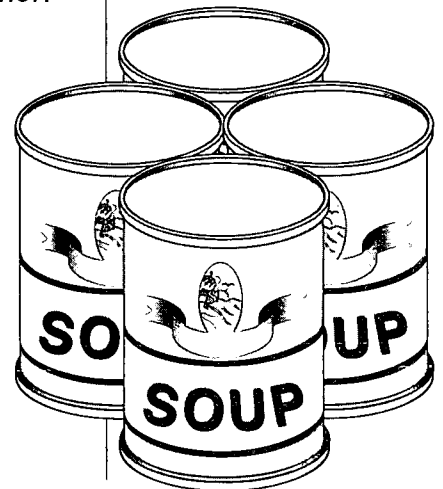

Unopened soup cans have very high porosity, but because there are no connections between "pores," there is no flow. Permeability is zero.

Effective Porosity

What is effective porosity?

All rocks have porosity and permeability. But in some cases, the values for these properties are so very small that we say the rocks are non-porous and impermeable. Sometimes a rock is described as having effective porosity that is less than its true porosity as defined earlier. Effective porosity considers only those pores that are connected and large enough to permit fluid flow. In other words, only the fraction of total porosity that contributes to the permeability is considered when evaluating effective porosity.

Solubility

What is solubility?

Solubility is a measure of the tendency for a solid to dissolve. If the minerals making up the rock of the repository site are soluble and will dissolve, such as in a salt formation, movement of water may open larger pores and make connections between pores. This creates porosity and enhances permeability.

What factors determine solubility?

Solubility depends on properties of both the solid and the liquid. For example, table salt (NaCl) is very soluble in fresh water, less soluble in sea water, and even less soluble in Great Salt Lake water. It is practically insoluble in pure alcohol (isopropyl alcohol). In any rock, some minerals will be more soluble or less soluble than others for any given solution passing through. A point to remember—as the minerals dissolve, the composition of the solution changes. Its ability to dissolve more of the same or other minerals also changes, usually decreasing. Tuff, the host rock at Yucca Mountain, has a very low solubility factor. At some point, the solution cannot dissolve any more minerals because it is completely saturated.

Can solubility change?

4.29 Tuff

What is tuff?

The host rock at the site being studied to see if it is suitable for a repository is described as a “welded and devitrified” tuff. What do those words mean in terms of the rock characteristics important in repository siting?

Tuff is formed when a volcano erupts and throws a cloud of hot, small particles of molten rock into the air. As the particles cool and become solid, they fall back to the ground. There they accumulate as a layer called an "ash-fall tuff." Sometimes, the particles in the cloud are so numerous that the cloud acts more like a fog that doesn't rise very much above the volcano summit before it starts to flow down the slope. As it flows, the melt droplets cool and solidify, and the particles fall to the ground to accumulate as a layer of ash-flow tuff.

Welded Tuff

Depending on the thickness of the layer and how much the particles cooled while falling, the layer will retain greater or lesser amounts of heat. Just as a human welder uses heat to connect two pieces of metal, the heat and the weight of overlying material will weld the individual particles together. The result is a welded tuff. It is denser (less porous) and stronger than a non-welded tuff. The welding process gives the tuff strength (important in mining) and reduces the original porosity and permeability.



How is the tuff formed?

What is a welded tuff?

Rapid Cooling of Liquid Rock

When molten tuff is thrown out of a volcano and exposed to the atmosphere, the masses of liquid rock cool rapidly. The atoms that will form into minerals in the rock particles cannot move very far before the melt cools and becomes solid. There isn't much time to form a few larger mineral crystals, so lots of very small, almost invisible crystals form. Most of the atoms in the melt may not have time to form even minute crystals. They are frozen in place by the rapid cooling. The cooled rock particles have a glass-like appearance because crystals didn't have time to form or they are too few and too small to be seen.

How does rapid cooling affect the rock that forms?

Volcanic Glass

How does devitrification affect volcanic rock?

Volcanic glass is unstable when exposed to ground water and atmospheric gases. The glassy material reacts with water. Through a complex process called *devitrification*, the atoms in the glass are rearranged into minerals like zeolites and cements (opal or calcite). Ion exchange capacity increases. Porosity and permeability decrease. New minerals formed from the volcanic glass contain large amounts of water and are bulkier than the original glass. They fill up more pore space and make the interconnections smaller. Most of the minerals formed during devitrification are not soluble in water. However, they tend to give off water and lose ion exchange capacity when exposed to heat.

4.30 Rock Characteristics and the Overall Repository Design

How do rock properties fit into the overall design for safety?

Selecting a site for a repository requires consideration of the properties of the host rock in which the repository will be located. The characteristics of the host rock at the repository will be considered, not only in the design of the repository as a mine, but also in relation to its special purpose of safely isolating waste from the environment. As important as rock characteristics are, the host rock is only one part of a multiple barrier system required for the disposal system. The barriers will be both natural and engineered (manmade). The multiple barrier system consists of 1) the waste package (manmade), 2) the repository itself (manmade), and 3) the host rock (natural). The total system will be designed so that the parts of the multiple barrier system work together to maximize safety.

ROCK CHARACTERISTICS IMPORTANT IN REPOSITORY SITING—PERMEABILITY, POROSITY, SOLUBILITY, THERMAL STABILITY, AND SORPTIVE CAPACITY

The purpose of a geologic repository is to safely isolate high-level radioactive wastes from the surface environment. Students should understand what factors must be considered prior to determining that isolation can be accomplished. Wastes will be carried from the repository in fluids, either gases or liquids. The fluid of primary concern is ground water that may ultimately become drinking water. You may wish to highlight recent concerns over radon gas build-up in buildings to illustrate gas phase transport of a radioactive contaminant.

In the history of the radioactive waste repository selection process, the Yucca Mountain site is unique. It is the only site to receive serious consideration that is above the local water table; i.e., in the unsaturated zone. The pore spaces in the rocks surrounding the repository are not filled with water, but with air. This situation gives the site several advantages, but it also raises a few interesting questions.

Advantages in building the repository above the local ground water table include easier construction and less need for manmade barriers to keep water from immediately entering the repository. Over the long term, it is less likely that corrosive waters will interact with and degrade the waste containers. In a similar vein, it is more likely that water soluble components of the waste are not going to be mobile in a dry environment.

On the other hand, air-filled pores will not absorb and dissipate as much of the heat generated by radioactive decay as effectively as water-filled pores might. Heat build-up in the rocks near the repository may be a problem. Finally, the possibility of gas phase transport of a few radioactive species (e.g., iodine-129) has to be considered. Gas phase transport was never a very important consideration in a saturated zone repository wherein the water solubility of a gas and its subsequent transport in solution were prime considerations.

Isolating nuclear wastes from the environment requires methods of long-term containment. Containment implies containers, or barriers, that act to stop the movement of the wastes. The high-level waste repository will incorporate the multiple barrier containment concept. Multiple barriers act like containers within containers. The innermost waste container is the solidified waste form itself. The solidification process reduces the solubility of the wastes, thereby making them less mobile. The next containment barriers are the engineered (or manmade) canister and the engineered canister receptacle that is built into the host rock. The container of primary interest in this reading material is the host rock itself.

From the standpoint of rock characteristics important in repository siting, the chemical composition and atomic ordering of the minerals are critical to the chemical sorption and ion exchange capabilities of the rock. Slight, allowable variations in the chemical composition within the fixed atomic arrangement can dramatically increase or decrease the exchange capacity of the mineral and, thereby, the rock.

IMPORTANT ROCK CHARACTERISTICS

Directions: The rock in which the repository is built must be appropriate for a repository. Some basic properties of rocks important for consideration in determining the appropriateness of the tuff at Yucca Mountain are listed below. On the blank before the property, write the letter of the definition that best describes the property. Then explain why each characteristic is important to consider when planning the repository.

- D 1. Plasticity *(Plastic deformation may help to seal fractures in the rock, but when pushed too far rocks will fracture rather than flow plastically.)*
-
- H 2. Solubility *(Highly soluble rock may lead to greater permeability and porosity as minerals dissolve and are carried away.)*
-
- B 3. Sorptive capacity *(Rock surfaces with high sorptive capacities may be able to chemically or physically remove radionuclides from any possible waste streams.)*
-
- F 4. Compressive strength *(Rocks with high compressive strength will resist fracture and maintain low levels of permeability and porosity.)*
-
- C 5. Thermal stability against chemical decomposition *(The greater the thermal stability, the greater the ability of many rocks and minerals to maintain chemical sorptive capacity.)*
-
- G 6. Permeability *(The degree of interconnectedness of pores is important in limiting possible waste stream flow.)*
-
- E 7. Porosity *(A large amount of connected pore space may contribute to the ability of radionuclides to migrate away from the repository.)*
-
- A 8. Heat conductivity *(Since the waste package will be thermally hot, the ability of surrounding rocks to dissipate heat is important to avoid extreme temperatures that may fracture rock or damage the waste package.)*
-

DEFINITIONS

- A** - the ability to transmit heat
B - the extent to which a rock can adsorb or absorb from solution
C - the degree of resistance to heat causing a chemical change
D - the ability of a solid to flow, especially under influence of pressure and/or temperature
E - the percentage of the total volume of pores or spaces in a rock or soil to its total volume
F - the extent to which a material can be squeezed without breaking or fracturing
G - the capacity of a medium (rock, sediment, or soil) to transmit fluid (gas, liquid such as ground water); depends on the size and shape of the pores in the medium and how they are interconnected
H - susceptibility to being dissolved; tendency to dissolve

ROCK CHARACTERISTICS IMPORTANT IN REPOSITORY SITING

Directions: Use what you have learned in your reading lesson to answer the following questions.

True or False: If the answer is false, correct it to make it true.

- false 1. Waste solutions will almost always begin to dissolve the rock through which they pass.
(Waste solutions may dissolve the rock through which they pass, depending upon the composition of the solution or the rock.)
- true 2. All rocks are porous and permeable.
- false 3. Non-welded tuff is stronger and denser than welded tuff.
(Welded tuff is stronger and denser than non-welded tuff.)

Matching:

- c 4. A measure of how well any material will transmit heat.
- a 5. A measure of the deforming effect of heat on any material.
- b 6. A measure of the transforming effect of heat on any material.

a. *plasticity* b. *thermal stability* c. *thermal conductivity* d. *porosity*

Completion:

7. Waste can flow from one location to another in what two forms?

(gas or air) and (liquid or ground water)

8. Why would the compressive strength of rocks be a consideration in selecting a site for a nuclear waste repository?

(Answers will vary but should relate to the integrity of the mine: would not want the repository or mine to collapse; would not want anything to break through from the surface.)

9. Describe an example of a chemical sorptive process.

(An example of a chemical sorptive process would be ion exchange like that used in water-softening devices.)

10. Describe an example of a physical sorptive process.

(Immobilization of water molecules in small pores by frictional forces between molecule and pore wall is an example of a physical sorption.)

11. Describe the process by which welded tuff is formed.

(A cloud of small particles of molten rock erupts from a volcano. Rock particulates from the cloud cool and solidify. The particles fall to the ground and accumulate as a layer.)

12. Compare porosity and permeability.

(Porosity is a measure of the ability of anything to hold a fluid. Permeability is a measure of the ease of flow of a fluid through a porous solid.)

POROSITY AND PERMEABILITY

Purpose:

This lesson will give students an opportunity to measure and calculate the porosity and permeability of a rock sample. Students will also be able to demonstrate the effect of grain size on porosity and permeability.

Concepts:

1. Permeability and porosity are related characteristics of rocks.
2. Permeability and porosity are related to the size, number, and interconnectedness of openings in a rock.

Duration of Lesson:

Two 50-minute class periods

Objectives:

As a result of participation in the activities entitled *Porosity and Permeability* (experiment), *Porosity* (worksheet), and *Permeability* (worksheet), the learner will be able to:

1. identify factors affecting permeability and porosity;
2. calculate percent porosity given total volume and volume of open space;
3. calculate surface area; and
4. relate surface area to permeability.

Skills:

Analyzing, calculating, drawing conclusions, hypothesizing, measuring, observing, recording data, working in groups

Vocabulary:

Permeability, porosity, sediment

Materials:

Activity Sheets

Porosity and Permeability, p. 183

Porosity, p. 187

Permeability, p. 189

Videotape

Science, Society, and America's Nuclear Waste Teleconference Videotapes (available free of charge from the OCRWM National Information Center, 1-800-255-6972; within Washington, DC, 202-488-6720)

Other

1-liter soda bottle	stopwatch	plastic tubing - short length
1 graduated cylinder (1-liter) or other liquid measure	clean sand	glass tubing - short length
marbles (uniform size, not too large)	rubber bands	pinch clamp
cheesecloth	copper shot (BB's)	rubber stopper with hole

Suggested Procedure:

1. The relationship between porosity and permeability is often difficult to understand without some sort of demonstration. It is difficult for anyone to understand that two sediments composed of different grain-sized materials can have very similar porosities and yet very different permeabilities. The purpose of this activity is to make the students think about the relationship of porosity and permeability in analyzing the results of the experiments.
2. The total volume of the sediment is an approximate calculation assuming the funnel approximates a cylinder and the non-cylindrical parts are insignificant. You may want to treat the non-cylindrical part as half of a sphere to get a more accurate volume calculation. It may make for an interesting discussion to compare the assumptions and acceptable errors in these approximations.
3. The porosity of a sediment composed of spherical particles depends on the packing of those particles. In their closest packing arrangement, the porosity will be approximately 27%. In a more open packing the porosity may approach 45-50%. In the experiment the bulk of the particles will naturally move into a closest-packed arrangement. However, near the walls of the funnel this arrangement is disrupted and this disruption is more pronounced with larger grain sizes. Therefore, the porosity will vary with grain size in this experiment because of the "wall effects." However, as grain size decreases, the wall effects on packing diminish and measured porosity will approach the theoretical closest-packing porosity.
4. The measure for permeability used in this experiment is very simplistic but adequate for the purpose of illustration. It is critical that the flow rate be measured using the same initial volume for all three sediments to allow valid comparisons. The weight of overlying water in the sediment forces water out. As the amount of overlying water decreases during the experiment, the flow rate in this apparatus will decrease. The suggested range of volume (50-100 mL) may be too large. Use smaller, convenient volumes at your discretion.
5. The percentage of total porosity volume recovered will also vary with the grain size. As grain size decreases, the surface area increases and pore size decreases. The water that is not recovered in a reasonable amount of time is water attached to surfaces, physically sorbed, and trapped in small pores and pore openings. It is important to mention that this water does not move under normal conditions and, although it went into determining the total porosity of the sediment, it is not part of the effective porosity.
6. Before students begin the experiment entitled *Porosity and Permeability*, it may be helpful to discuss the general concepts of permeability and porosity. The following suggested discussion questions may help students understand the purpose of this experiment, and formulate educated hypotheses.

Suggested Discussion Questions:

1. Explain porosity.

(Students should mention that porosity is the open space in a material that could be filled by a fluid. Students may think of fluids only as liquids. You may want to remind them that air is also a fluid.)

2. Can you think of an example of something porous that is not a rock?

(A building is porous, rooms act as pores, bread has air pockets, a sponge, etc.)

3. Explain permeability.

(Permeability is a measure of the ease of flow of a fluid through a material.)

4. Can you think of an example of a permeable substance that is not a rock?

(A building is also permeable, halls connect rooms, the air pockets in bread may be connected like tunnels, etc.)

Once students seem to understand and transfer the concepts of porosity and permeability, have them read through the experiment independently.

It may be necessary to ask students procedural questions to ensure that they understand what they will do.

5. What variable(s) will be changing during this experiment: water volume, sediment volume, and/or grain size?

(Grain size.)

6. How do you think porosity relates to the grain size of a sample?

(Students will probably say that increasing grain sizes will increase porosity, but this is not true in an actual measure of porosity. In a sample of spherical particles all the same size, the porosity is not related to the size of the particles making up the sample. Porosity depends on the packing of those particles.)

To ensure that students understand that porosity is not related to grain size if the grains in a sample are spherical and the same size, as in this experiment, but rather to the packing of those grains, it may be helpful to use the following demonstration.

- a. Use approximately six large spherical objects such as basketballs and six smaller spherical objects, tennis balls perhaps.
- b. Stack both sized objects in their closest packing arrangement as illustrated on page 38. Have students leave their seats to examine the amount of pore space left open in each set of spheres.

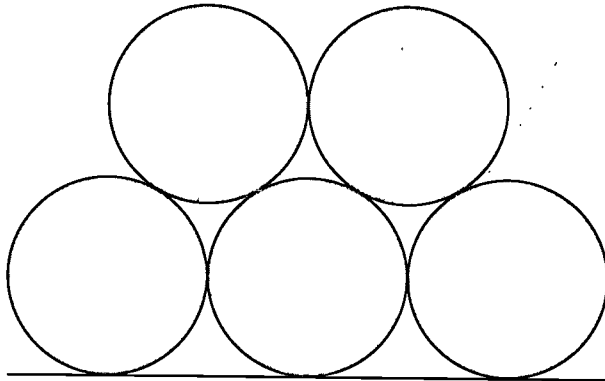

Closest packing arrangement

- c. Encourage students to compare the amount of pore space they observed to the total volume of the stacked spheres to determine a relative porosity for each stack. Ask what percent would be left open as pore space if the stack represented the entire volume of rock.

(Students should estimate a similar percent of pore space for each set of spheres.)

- i. If each stack represented a rock, and each sphere a grain in that rock, how would you describe that rock?

(All grains are the same in each separate rock, all grains are spherical in shape.)

- ii. Do you think that, if these were rocks, porosity would be different between the two?
(No, it wouldn't be.)

- d. In this experiment, the bulk of the particles will naturally move into a closest packed arrangement. However, near the walls of the funnel this arrangement is disrupted. This disruption is more pronounced with larger grain sizes. Therefore, the porosity will vary with grain size in this experiment because of the "wall effects." However, as grain size decreases, the wall effects on packing diminish and measured porosity will approach the theoretical closest-packing arrangement.

- e. You can demonstrate wall effects using two boxes. One box should be large enough to disrupt the packing of the large spheres and the smaller box should do the same for the smaller spheres. See diagram below.

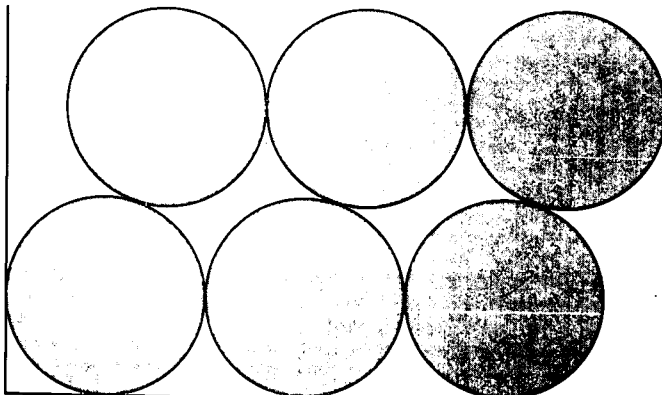

Wall effects disrupt closest packing arrangement

- f. Put each size sphere in the appropriate box and have students compare the amount of pore space available to the total volume of the boxes for each grain size. Have students observe where and how the closest packing arrangement is disrupted by the sides of the box.

(Students should recognize that pore spaces increase due to wall effects as grain size increases.)

7. State a rule relating grain size to porosity.

(In a sample of spherical particles all the same size, porosity is not related to grain size but it is related to particle packing.)

8. What role do you expect wall effects to play in this experiment?

(Wall effects may effect porosity in this experiment. They will be most pronounced in the larger grain-sized samples.)

9. How will you measure the porosity for each grain size?

(The volume of water needed to just cover the top layer of sediment will equal the volume of pore space in each sample.)

If students have difficulty with this question, remind them of this procedural step and ask them where the water goes.

10. In this experiment, will permeability be affected by grain size?

(Yes. As grain size increases, pore spaces will be larger and allow easier water flow. In addition, porosity will increase with grain size due to wall effects and, thus, permeability will increase.)

11. How will you measure permeability for each grain size?

(Rate of flow will be a measure of permeability. The greater the flow rate, the greater the permeability.)

7. Allow students time to write the purpose of the experiment and their hypotheses regarding the outcome. Then take a short time to discuss their answers before allowing activity to begin.

8. Upon completion of this experiment students should complete the activity worksheet entitled *Porosity* and the activity worksheet entitled *Permeability* for homework. These activities involve simple mathematical calculations that will serve to reinforce the concepts stressed in the discussion and the experiment. The porosity activity worksheet will give students practice at calculating percent porosity for several rock types. The permeability activity worksheet illustrates the relationship between grain size and surface area.

Teacher Evaluation of Learner Performance:

Student participation in experiment/activity and completion of related activity sheets will indicate understanding.

POROSITY AND PERMEABILITY

Porosity and permeability are related properties of any rock or loose sediment. Both are related to the number, size, and connections of openings in the rock. More specifically, porosity of a rock is a measure of its ability to hold a fluid. Mathematically, it is the open space in a rock divided by the total rock volume (solid and space). **Permeability** is a measure of the ease of flow of a fluid through a porous solid. A rock may be extremely porous, but if the pores are not connected, it will have no permeability. Likewise, a rock may have a few continuous cracks which allow ease of fluid flow, but when porosity is calculated, the rock doesn't seem very porous.

Directions: In this activity, you will use loose sediment of varying sizes to demonstrate the relationships between porosity and permeability. Answer the following questions before you begin your experiment.

Purpose:

What is the purpose of this experiment?

(Answers will vary but encourage students to be specific. The purpose of this experiment is to demonstrate the relationship between porosity and permeability.)

Hypothesis:

What do you expect to find as the relationship between porosity and permeability?

(Answers will vary but encourage students to be specific.)

Materials:

1-liter soda bottle	copper shot (BB's)
2 graduated cylinders (1-liter) or other liquid measure	cheesecloth
marbles (uniform size, not too large)	stopwatch
rubber stopper with hole	clean sand
short length of rubber tubing	rubber bands
plastic tubing	short length of glass tubing
pinch clamp	petroleum jelly (Vaseline®)

Procedure:

1. Cut the bottom off the soda bottle.
2. Place several layers of cheesecloth over the small opening and put a rubber band over it to hold it in place.
3. Place the rubber stopper in the opening over the cheesecloth.
4. Carefully place the glass tubing in the rubber stopper. Do not push it through the cheesecloth. It may help to lubricate the glass tubing with petroleum jelly.
5. Attach the rubber or plastic tubing to the exposed glass tubing. Place the pinch clamp on the rubber tubing to act as a faucet valve.
6. Place the bottle upside down so it can be used as a funnel. Then make a mark on the side of the bottle about 10 centimeters (3.9 inches) from the small opening to ensure that you will use the same volume of sediment each time.
7. Fill the funnel up to the mark with the marbles. Make sure the top of the sediment is as flat as possible.
8. Fill the graduated cylinder with water. Make a note of the volume. Slowly fill the funnel with water until the level of the water is just above the top layer of sediment. Record the volume of water poured into the funnel as V_1 , Trial 1 in Table 2. Be careful to avoid trapping air in the pores. Tap the sides of the funnel to release any air that may be trapped in the pores.
9. Place the empty graduated cylinder under the funnel. When one partner removes the pinch clamp, a second partner should begin timing the flow of water. Stop the timer when the first 50 - 100 mL are collected in the cylinder. Record the time as Flow Time, Trial 1 in Table 1. The volume you collect should be easy to time with the stopwatch. Regardless of the volume measured, measure the same volume for each trial and each sediment type. Record this volume as Measured Volume of Water in Table 1.
10. Let the funnel drain completely (within reason) and record the total volume of water collected as V_2 , Trial 1 in Table 3.
11. Repeat steps 7 - 10 for Trials 2 and 3.
12. Remove the sediment and thoroughly clean the funnel. Put another type of sediment in the funnel and repeat the experiment and record the same data for the remaining two sediment types.
13. Calculate the Average Flow Time in Table 1, Average V_1 in Table 2, and the Average V_2 in Table 3 for each sediment type.

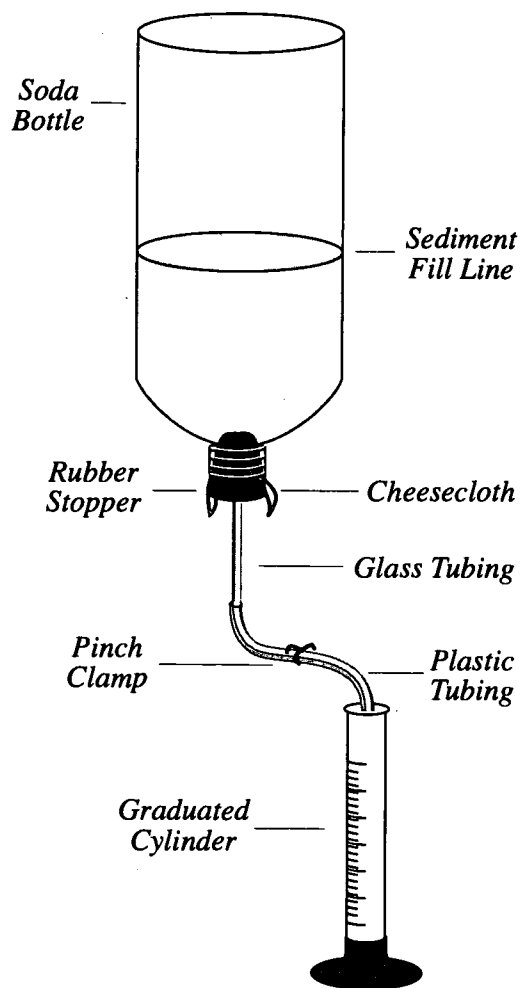

Observations:

Table 1 - Permeability

Sediment Type	Measured Volume of Water (mL)	Flow Time (sec) Trial 1	Flow Time (sec) Trial 2	Flow Time (sec) Trial 3	Average Flow Time (sec)	Flow Rate (mL/sec)
Marbles						
Shot						
Sand						

Table 2 - Porosity

Sediment Type	Original Volume of Water, V_1 (mL) Trial 1	Original Volume of Water, V_1 (mL) Trial 2	Original Volume of Water, V_1 (mL) Trial 3	Average Original Volume of Water, V_1 (mL)	Total Volume of Sediment (mL)	Percent Porosity
Marbles						
Shot						
Sand						

Table 3 - Effective Porosity

Sediment Type	Recovery Volume, V_2 (mL) Trial 1	Recovery Volume, V_2 (mL) Trial 2	Recovery Volume, V_2 (mL) Trial 3	Average Recovery Volume, V_2 (mL)
Marbles				
Shot				
Sand				

Conclusion:

1. In order to calculate percent porosity for each sediment type, you must know the volume of sediment you used each time. Since you marked your funnel at the sediment fill line, calculate the volume of sediment necessary to fill that space. Assume that your bottle approximates a cone. Use the following formula:

$$V_{\text{cone}} = \frac{\pi r^2 h}{3}$$

Measure the radius and height of the cone in centimeters (cm). Express the volume you calculate in milliliters (mL); remember that 1 cm³ = 1 mL. To check the accuracy of your answer put the lid on the funnel and fill it with water up to the sediment fill mark. Empty the water into one of your graduated cylinders and read the volume. Record this value as Total Volume Sediment in Table 2.

2. Porosity for a sediment made of spherical particles, regardless of particle size, depends on the way the spheres are packed and will vary from almost 50% to approximately 27%. Based on the total volume sediment, (determined above) calculate the porosity for each sediment type in the experiment.

$$\% \text{ Porosity} = \frac{V_1 \text{ (volume pores or average volume water)}}{\text{Total sediment volume}} \times 100$$

Record your answers in Table 2. Are they significantly different from each other? If so, suggest a reason.

(Values will probably be most different for larger grain sizes because of "wall effects" that will disrupt particle packing.)

3. How do the rate-of-flow values compare for the three sediments? What does this tell you about the permeability of the different sediment types?

(Rate of flow should be highest for large grain sizes—lowest for small grain sizes.)

Permeability stringly depends upon size of pores and surface area of sediment grains.)

4. How do the recovery volumes compare for the three sediment types? Explain the differences and relate it to your explanation of permeability.

(Recovery volume is largest for large grain sizes, and smallest for small grain sizes. Smaller pores and larger surface areas in samples with small grain sizes mean more water held by frictional forces.)

POROSITY

Directions: In the following table, the volume of open space is given for a 1 cubic meter sample of a given rock type. Calculate the porosity as a percent for each rock type by using the following formula:

$$\frac{\text{Volume of pores}}{\text{Total rock volume}} \times 100 = \text{porosity (\%)}$$

One cubic meter(m³) = 1,000,000 cubic centimeters (cm³)

Rock type	Typical Vol. open space (cm ³)	Porosity (%)
Fractured basalt	5.5 x 10 ⁴	<u>5.5</u>
Granite	1.0 x 10 ⁴	<u>1.0</u>
Limestone	1.5 x 10 ⁵	<u>15.0</u>
Sandstone	2.5 x 10 ⁵	<u>25.0</u>
Shale	1.0 x 10 ⁵	<u>10.0</u>
Tuff (non-welded, Yucca Mt. area)	4.5 x 10 ⁵	<u>45.0</u>
Welded Tuff (proposed repository host rock)	1.2 x 10 ⁵	<u>12.0</u>

- What does the scientific notation 10⁴ mean in the example for fractured basalt?
(multiply 5.5 times 10,000 [10 x 10 x 10 x 10] to 55,000.)

- What does the notation (cm³) in column 2 tell you?
(units for volume are cubic centimeters.)

- Which rock type listed above is most porous? *(non-welded tuff)*

- Why is the porosity of tuff important in siting the repository?
(Fluids must move through the open spaces, pores, in a rock. If porosity, i.e., the number of pores, is small, flow usually will be restricted. Because the most likely way radioactive materials from a repository could reach the environment is through ground water, characteristics of the rock related to flow of water to or away from the repository are very important to consider.)

PERMEABILITY

Permeability is a measure of the ease of flow of a fluid, like water, through a porous rock. Water flowing next to the pore wall will be slowed by friction and may actually attach to the wall. The non-moving water is a small fraction of the total amount of water flowing in a coarse-grained rock, but it is increasingly important as grain size decreases.

As grain size decreases, the volume of solids, and porosity, may remain constant, but surface area always increases. More surface area means more places for water to attach, thereby reducing flow through, and permeability of, the rock.

A simple geometric calculation illustrates the relationship between grain size and surface area.

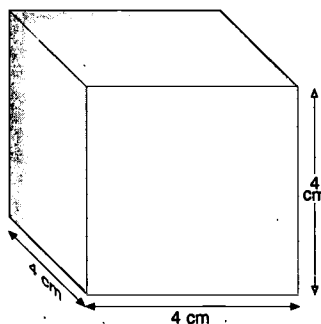

Directions: Start with a single grain from a porous rock. Imagine that the grain is a perfect cube 4 centimeters (1.6 inches) on a side.

Helpful Formulas

Surface Area_{Cube} = Area on face (l x w) x Number of faces (6) $S.A. = (l \times w) \times 6$

Volume_{Cube} = length (l) x width (w) x height (h) $V = l \times w \times h$

1. Calculate the surface area and volume of the grain.

Surface area $(= (4\text{cm} \times 4\text{cm}) \times 6 = 96\text{cm}^2)$

Volume $(= (4\text{cm} \times 4\text{cm}) \times 4\text{cm} = 64\text{cm}^3)$

2. Without changing the amount of solid volume, surface area can be increased by cutting the cube into eight equal, but smaller, cubes. Demonstrate through a calculation that the area is now greater than the original.

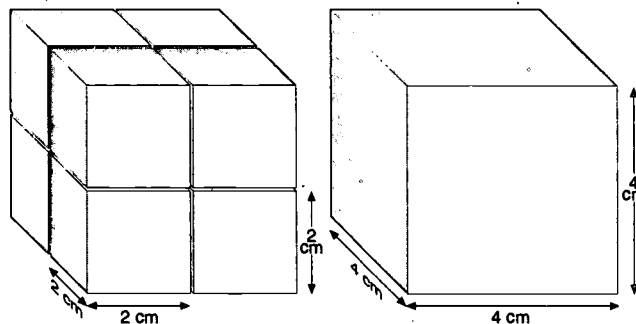

$(S.A. = [(2\text{cm} \times 2\text{cm}) \times 6] \times 8 = 192\text{cm}^2)$ By how much? $(192\text{cm}^2 - 96\text{cm}^2 = 96\text{cm}^2)$

3. What is the total volume of the new, smaller cubes? $([2\text{cm} \times 2\text{cm} \times 2\text{cm}] \times 8 = 64\text{cm}^3)$

4. Why does an increase in surface area mean an increase in friction between pore walls and water and, therefore, an increase in resistance to water flow through the rock?

(More surface area means that more water molecules will be attached to surfaces, not moving, which will slow other water molecules.)

5. Why is permeability important to consider in evaluating a host rock for a repository?

(Flow rate is directly related to permeability. Fluid flow from a repository should be very slow to non-existent to prevent waste from reaching the environment.)

SOLUBILITY

Purpose:

This activity will give students an opportunity to observe the solubility of a solid in various liquids.

Concepts:

1. Solubility depends on properties of both the solids and the liquids forming a solution.
2. Solubility of the host rock is important to repository performance.

Duration of Lesson:

One 50-minute class period.

Objectives:

As a result of participation in the lesson entitled *Solubility*, the learner will be able to:

1. determine the relative solubility of a mineral in a given solution; and
2. apply his/her observations and conclusions to the significance of the solubility of minerals to the geologic repository.

Skills:

Drawing conclusions, hypothesizing, measuring, observing, recording data, working in groups

Vocabulary:

Saturated, soluble, solubility

Materials:

Activity Sheets
Solubility, p. 191

Videotape

Science, Society, and America's Nuclear Waste Teleconference Series (available free of charge from the OCRWM National Information Center, 1-800-225-6972; within Washington, DC, 202-488-6720)

Other

sodium chloride (NaCl — table salt)
distilled water
salts for making artificial sea water
anhydrous isopropyl alcohol (>99%)
balance (capable of weighing as little as 0.1 gram)
graduated cylinders (50 - 100 mL)

3 clear glass containers (vials, beakers, etc.)
laboratory stirring rod (or coffee stirrer)
glassware for mixing sea water
grease pen or pen and stick-on labels

Suggested Procedure:

1. The purpose of this activity is to demonstrate, visually, the range of solubility of a common mineral in three different liquids. The mineral used in this activity is halite or common table salt. It is an ionic solid with sodium cations (Na^+) ionically bound to chloride anions (Cl^-).
2. Ionic solids are most soluble in "polar" liquids, like water, where the liquid molecules have charged "sides." Non-polar liquids, such as isopropyl alcohol, cannot effectively dissolve an ionic solid.
3. Before students begin this experiment, it may be helpful to discuss the concept of solubility and how it relates to siting the geological repository. The following suggested discussion questions may prepare students to better understand the purpose of this experiment and to formulate educated hypotheses.

Suggested Discussion Questions:

1. What happens to salt when it dissolves in a polar liquid like water? Has it magically vanished? Is it no longer there?

(Students should understand that the salt does not "vanish," but that it breaks up into smaller portions, sodium and chlorine ions. These ions are attracted to the positive and negative poles of the water molecules.)

2. Many substances are soluble in water. Can you think of examples of such substances?

(Answers should vary widely. Sugar, powdered tea, hot-chocolate mix, instant coffee, etc.)

3. Do all solids dissolve easily in water? Can you think of examples of a substance that does not dissolve easily in water?

(No. Flour, cocoa, butter, oil, etc.)

4. Is there a limit to the amount of solid that you could dissolve in a certain volume of water?

(Yes, at a certain point the water will become saturated with the dissolved ions and the solid will remain undissolved.)

5. How does heat affect the solubility of a substance? Think about putting sugar into coffee or tea or even about dissolving a packet of jello mix.

(Usually, more of a solid can be dissolved into a liquid when it is warm than when it is cold.)

6. Can you think of any other factors that might improve the solubility of a substance?

(Shaking or stirring may improve solubility.)

4. Once students seem to understand some basic concepts relating to solubility, have them read through the experiment independently.
5. It may be necessary to ask students procedural questions to ensure that they understand what they will do in this activity.
6. Before beginning the activity, it may be useful to discuss how distilled water becomes Great Salt Lake water. Remind students that they are modeling the process through which minerals are weathered and incorporated into sea or lake water. Rainwater, not very different from distilled water, reacts with rock minerals and dissolves the soluble parts. This results in the mineral slowly falling apart and the original rainwater, which is now river or ground water, getting saltier. The water continues to react with other minerals and dissolves those parts that it can until it becomes saturated with dissolved salts and is no longer able to react. By making such a concentrated solution, students are modeling the natural process of evaporation which concentrates weathered minerals like salts in sea or lake water.
7. It is suggested that students work in groups of two to four to derive maximum benefit from this experiment. Each student should be prepared with activity sheets and his/her text to make predictions, set up the experiment, and record data as the experiment progresses.
8. Students should be able to follow directions listed in the activity to set up and perform the experiment. Encourage students to allow the NaCl the same amount of time to dissolve in each vial and to stir each vial uniformly.

**Caution students that isopropyl alcohol is a flammable liquid
and that they should avoid breathing large quantities of the fumes.**

9. To conclude this activity, you may want to discuss the conclusion questions once students have had time to answer them.

Teacher Evaluation of Learner Performance:

Student participation in classroom discussion and experiment/activity will indicate understanding.

SOLUBILITY

Solubility is the susceptibility of a rock to being dissolved. The solubility of any particular rock is dependent on the minerals that constitute the rock as well as the liquid that may dissolve these minerals. This activity demonstrates this important interdependence.

Directions: Review the activity, then answer the following questions before performing the experiments.

Purpose:

What is the purpose of performing this experiment?

(The purpose of this activity is to show that the solubility of a rock depends on its mineral constituents and the liquid that may dissolve it.)

Hypothesis:

State your hypothesis regarding the outcome of this experiment.

(Answers will vary, but encourage students to be specific.)

Materials:

- sodium chloride (NaCl — table salt)
- graduated cylinders (50 and 100mL)
- distilled water
- 3 clear glass containers (vials, beakers, etc.)
- salts for making artificial sea water
- anhydrous isopropyl alcohol (>99% pure)
- laboratory stirring rods (or coffee stirs)
- balance (capable of weighing as little as 0.1 gram)
- glassware for mixing sea water
- grease pen or pen and stick on labels

Procedure:

1. Make artificial Great Salt Lake water by dissolving 20 grams (0.7 ounces) of NaCl in 100 milliliters (0.2 pints) of distilled water. (Stir until all the salt goes into solution.)
2. Weigh out 3 separate 5-gram (0.2 ounces) samples of NaCl.

3. Measure 14 mL (0.03 pints) **each** of distilled water, artificial Great Salt Lake water, and anhydrous isopropyl alcohol into the 3 clear glass containers. Be sure to label each container.
4. Add 1 of the 5-gram (0.2 ounces) samples of NaCl to each liquid and stir. (Use a separate stirring rod for each container.)
5. Note the amount of any solid remaining in the container.

Observations:

Describe your attempt to dissolve the 5 gram (0.2 ounces) NaCl sample in each of the following:

Distilled Water:

(NaCl sample should dissolve completely.)

Great Salt Lake Water:

(About one half of the NaCl sample will dissolve.)

Anhydrous Isopropyl Alcohol:

(Very little of the NaCl sample will dissolve.)

Conclusion:

1. Explain your results. Why do you think this happened?

(NaCl is an ionic solid, soluble in polar liquids, like water. GSL water, already near saturation, is unable to dissolve as much NaCl as distilled water.)

2. Why did the experiment call for distilled water instead of tap water?

(Distilled water contains no dissolved salts. Tap water, depending on your area of the country, may contain some salts which would lead to less NaCl solubility.)

3. Anhydrous alcohol is alcohol that is essentially waterless. Why was it important to use "waterless" alcohol?

(NaCl solubility is high in water. By using anhydrous alcohol we observe the behavior of NaCl in a pure, non-polar liquid.)

4. How does this demonstration show that solubility depends on the properties of both the liquid and the solid?

(NaCl is ionic and soluble in polar liquids like water. It is not soluble in non-polar liquids like alcohol. Solubility in water is limited by the salt content of the water.)

5. Why is the solubility of a rock important in siting a repository?

(As soluble minerals dissolve, they change the composition of the water by adding ions that compete for ion exchange sites. Further, dissolving minerals leave voids that increase porosity and may increase permeability.)

6. Water, moving through a rock of uniform composition, will initially dissolve some minerals. As the water travels farther through the rock its ability to dissolve minerals decreases and eventually becomes zero. Why?

(At the start of its journey, the water is undersaturated with respect to the minerals. As the water moves, it reacts with minerals but is continuously exposed to fresh minerals. At some point during its journey, the water becomes saturated with respect to each mineral and cannot dissolve more.)

MINERAL SOLUBILITY

Purpose:

This activity will give students an opportunity to measure and calculate the solubility of several substances.

Concepts:

1. Different minerals differ in their tendency to dissolve in a given solution.
2. Solubility of a mineral can be measured and calculated.
3. Solubility of the host rock is important to repository performance.

Duration of Lesson:

One and one half 50-minute class periods

Objectives:

As a result of participation in the lesson entitled *Mineral Solubility*, the learner will be able to:

1. calculate the solubility of a mineral in water; and
2. apply his/her observations and conclusions to the significance of the solubility of minerals to the geologic repository.

Skills:

Calculating, drawing conclusions, hypothesizing, measuring, observing, recording data, working in groups

Vocabulary:

Anion, cation, ion, ionic solid, mineral, soluble, solubility

Materials:

Activity Sheets

Mineral Solubility, p. 195

Videotape

Science, Society, and America's Nuclear Waste Teleconference Series (available free of charge from the OCRWM National Information Center, 1-800-225-6972; within Washington, DC, 202-488-6720)

Other

Epsom salts ($\text{MgSO}_4 \cdot 7\text{H}_2\text{O}$)
table salt (NaCl)
sodium bicarbonate (NaHCO_3) (Baking Soda)
plaster of Paris ($\text{CaSO}_4 \cdot 1/2 \text{H}_2\text{O}$)
eight (8) oven-safe glass containers (100 mL or larger)
funnel
filter paper
oven
balance (capable of weighing to 0.1 g)

Suggested Procedure:

1. This experiment is a bit more difficult than *Solubility*. Students will be required to take measurements carefully if they are to come up with reasonable results. If this activity is done before or without *Solubility*, it may be helpful to go over the Suggested Discussion Questions (1-6) presented with that activity as an introduction to the concept of solubility.
2. It might be helpful to review the purpose, necessary materials, and procedure for this activity with students before directing them to set up the experiment.
3. Have each group independently determine the volumes of water in which they will be dissolving minerals and discourage them from using 100 mL for each mineral. A constant volume of 100 mL would make solubility calculations in Step 10 of the procedure unnecessary.
4. It may be helpful to suggest to students that they choose the largest possible volumes of water in which to dissolve the sodium bicarbonate and the plaster of Paris since they are the least soluble of the four minerals. When dissolving the plaster students should be cautioned not to add too much powder. They may easily create a jar of "rock". Smaller volumes of water will suffice for the table salt and the Epsom salts.
5. Have students complete the experiment. They should calculate solubilities and compare their calculated values to the known values (see answers). You may wish to list the known values on the board for comparison after students have completed their calculations.

Teacher Evaluation of Learner Performance:

Student participation in experiment/activity will indicate understanding.

MINERAL SOLUBILITY

Minerals differ in their tendency to dissolve in water. This concept is of importance when applied to repository rocks and minerals. Solubility, as measured in the laboratory, is the amount of mineral that will dissolve in a fixed amount of water, at a certain temperature, and is a property unique to each mineral composition. In a natural system, the solubility of any mineral is a function of the composition of the liquid surrounding it. Only rarely will that liquid be pure water. If a mineral in a rock dissolves, it leaves behind an open space, which increases the porosity of the rock. Permeability may be increased as minerals dissolve and connections between pores are widened.

In the following activity you will use commonly available ionic solids (solids which, when dissolved, yield a solution of cations and anions) to demonstrate a range of solubilities of single minerals.

Directions: Answer the following questions before beginning your experiment.

Purpose:

What is the purpose of this experiment?

(The purpose of this experiment is to learn how to determine the solubility of a mineral and to compare the solubility of a single mineral in solution to that of several minerals.)

Hypothesis:

Which of the four compounds listed in the Materials (next page) do you expect to be the most soluble. Why?

Which do you expect to be the least soluble. Why?

(Answers will vary. Encourage students to explain their answers.)

Materials:

Epsom salts ($\text{MgSO}_4 \cdot 7\text{H}_2\text{O}$)
 table salt (NaCl)
 sodium bicarbonate (NaHCO_3) (baking soda)
 plaster of paris ($\text{CaSO}_4 \cdot 1/2 \text{H}_2\text{O}$)
 8 oven safe glass containers (100 mL or larger)
 funnel
 filter paper (coffee filters will work)
 oven
 balance (capable of weighing to 0.1 g)

Procedures:

1. Label two containers for each mineral. One will be A, the other B. (Example: Epsom salts A, Epsom salts B, etc.)
2. Fill each container in set A with 50 to 250 mL (0.1 - 0.5 pints) of tap water. Each container should have a different volume of water. Record the volume for each mineral in Table 1. It is important that you accurately measure and record the volume of water that you use.
3. Weigh the empty labeled containers in set B. Record these masses in Table 1 as M_1 .
4. Add approximately 1 Tablespoon of the Epsom salts to the appropriate container in set A. Stir the solution to dissolve the Epsom salts. Continue adding Epsom salts 1 Tablespoon at a time and stirring until solid mineral remains on the bottom of the container and will not dissolve. The solution is now saturated with Epsom salts.
5. Pour the saturated solution through the funnel lined with filter paper into the correspondingly labelled, empty container in set B.
6. Repeat steps 4 and 5 for table salt, sodium bicarbonate, and plaster of Paris.
7. Put the containers in set B, now holding the saturated solutions, in an oven capable of maintaining approximately 95 °C (approximately 200 °F) overnight. Avoid oven temperatures of 100 °C or greater. You do not want the liquid to boil as solutions may splash over the sides and be lost from your final mass measurement.
8. When all of the water has evaporated and the containers have been cooled to room temperature, weigh the containers. Record these masses in Table 1 as M_2 .
9. Find the mass of the dissolved mineral by subtracting the mass of the containers in set B (M_1) from their mass with the remaining dissolved mineral after drying (M_2). Record the results in Table 1 as "Mass Mineral."
10. Solubility is expressed in terms of grams of mineral dissolved in 100 mL (0.2 pints) of water. Calculate the solubility of each of the pure minerals in this exercise and record your answers as Solubility in Table 1.

Observations:

Table 1. Single Mineral Solubilities

Mineral	Volume of Water	Mass Containers Set B, M_1	Mass Containers Set B, M_2	Mass Mineral $M_2 - M_1$	Solubility g/100mL
Epsom Salts					71.0 at 20°C
Table Salt					35.7 at 0°C
Sodium Bicarbonate					6.9 at 0°C
Plaster of Paris					0.3 at 20°C

Conclusion:

1. Compare your calculated values to the standards given by your teacher. Are there any major differences between your calculated values and those supplied by your instructor? If so, can you suggest an explanation for the differences?

(Answers will vary. Encourage students to come up with an explanation of any observed differences.)

2. If your oven temperature was too hot and your solutions began to boil, how might the outcome of your experiment be affected?

(Solutions may bubble and some liquid containing dissolved mineral might splash out of the container if the solution boiled. M_2 would be lower and so would the solubility.)

3. If you did not measure and record the volumes of water that you used accurately, how might the outcome of your experiment be affected?

(It would be difficult to calculate an actual solubility if the amount of water were unknown. A volume greater than that recorded would indicate greater solubility; a volume less than recorded would show less solubility.)

4. If you add too much solid mineral to your solutions; how might the outcome of your experiment be affected?

(It would not be affected since the amount dissolved will not change. There will only be more undissolved mineral at the bottom of the container.)

5. What sources of error did you observe in your experiment? What effect did error have on the outcome of your experiment?

(Answers will vary. Encourage students to consider questions 2, 3, 4 in answering this question.)

6. What information would you need to determine the solubility of minerals in the proposed repository rock?

(The types of minerals surrounding the repository.)

Common Ions

+2	+1	-1	-2
Mg ²⁺	Li ⁺	Cl ⁻	S ²⁻
Ca ²⁺	Na ⁺	OH ⁻ (hydroxide)	SO ₄ ²⁻ (sulfate)
Sr ²⁺	K ⁺	HCO ₃ ⁻ (bicarbonate)	CO ₃ ²⁻ (carbonate)
Ba ²⁺	H ⁺		

7. Use the table of common ions shown on the previous page to determine the cation and anion found in a solution including the minerals listed below.

Mineral	Formula	Cation	Anion
Epsom Salts	$MgSO_4 \cdot 7H_2O$	Mg^{2+}	SO_4^{2-}
Table Salt	$NaCl$	Na^+	Cl^-
Sodium Bicarbonate	$NaHCO_3$	Na^+	HCO_3^-
Plaster of Paris	$CaSO_4 \cdot 1/2 H_2O$	Ca^{2+}	SO_4^{2-}

8. Why is the solubility of a rock important in siting a repository?

(Solubility is related to permeability. If the minerals in a rock dissolve, the spaces left behind increase the porosity and probably the permeability of the rock. This may increase the possibility of radionuclide migration.)

9. Water, moving through a rock of uniform composition, will initially dissolve some minerals. As the water travels farther through the rock, its ability to dissolve minerals decreases and eventually becomes zero. Why?

(Because it eventually cannot carry another single ion and no more complex ions are possible.)

THERMAL STABILITY

Purpose:

This experiment will help students observe and understand the phenomenon of thermal alteration.

Concepts:

1. A sudden temperature increase is sufficient to dewater clay, but depending on the interlayer cation, the physical responses of the clays are significantly different.
2. Some of the repository minerals most susceptible to thermal alteration are the same minerals responsible for sorption characteristics important to repository performance.

Duration of Lesson:

One-and-one-half 50-minute class periods (See item 3 in suggested procedure section.)

Objectives:

As a result of participation in the lesson entitled *Thermal Alteration*, the learner will be able to:

1. discuss the range of response by one clay mineral to a sudden temperature increase; and
2. explain why an understanding of how heat may affect a rock is important in planning for a geologic repository.

Skills:

Hypothesizing, measuring, observing, recording data, working in groups

Vocabulary:

Dehydration, exfoliation, vermiculite

Materials:

Activity Sheets

Thermal Stability, p. 201

Background Notes

Thermal Stability, p. 65

Videotape

Science, Society, and America's Nuclear Waste Teleconference Videotapes (available free of charge from the OCRWM National Information Center, 1-800-225-6972; within Washington, DC, 202-488-6720)

Other

flake vermiculite
saturated KCL solution (table salt substitute)
2 aluminum pans (or oven-safe containers)
candles
drying oven
pot holder
two 250 mL beakers

Suggested Procedure:

1. Before students begin this activity it may be wise to review the concepts of ions, hydrated ions and ion exchange. The only difference between the two clays used in this activity is the exchangeable cation. See the attached *Background Note* for a discussion which may be useful in preparing a background lecture.
2. The activity requires several heat sources. One is an oven for slowly drying the two clay samples. This oven should be able to maintain a constant temperature of 110°C (225°F) (+ or - 50). The second heat source must provide a rapid means for boiling the interlayer water. This entails a rapid and large temperature increase such as that provided by a candle, Bunsen burner, or the broiler element in a toaster oven. Alternatively, a microwave oven selectively heats the water molecules to boiling and produces the same effect.
3. Making the potassium saturated vermiculite and oven drying the two clay samples may require starting the activity on one day and completing it the following day.
4. You may wish to discuss the reasons for using the Mg-saturated clay sample. The behavior of the untreated sample is used to compare against the other sample of vermiculite. Students should understand the importance of controls in any scientific experiment.

Teacher Evaluation of Learner Performance:

Student participation in experiment/activity will indicate understanding.

THERMAL STABILITY

Some of the repository minerals most susceptible to thermal alteration (change due to exposure to heat) are the same minerals responsible for sorption characteristics important to repository performance. Many of the minerals that are important in sorption and ion exchange reactions (e.g., clay minerals and zeolites) contain large amounts of water as part of the mineral structure. When these minerals are heated, the water is boiled off and contributes to the volume of water that can transport soluble wastes away from the repository. If the minerals are exposed to a large and rapid temperature rise, they may be irreversibly altered in ways that often reduce their sorption and ion exchange capacities. In this activity, we use the clay mineral vermiculite to demonstrate one mineral's dramatic range of responses to heat exposure.

Naturally occurring vermiculite is saturated with magnesium ions and, thus, loaded with interlayer water. If such a vermiculite is exposed to a solution containing potassium during ion exchange, the Mg^{2+} is expelled along with its water and K^+ enters the interlayer. However, without the cushion of surrounding water molecules, the clay mineral layers collapse around the K^+ . Once the mineral structure collapses, the cation exchange capacity of the vermiculite decreases--especially toward hydrated cations like Mg^{2+} .

If magnesium and potassium saturated vermiculites are exposed to a substantial (300-400 °C [570-750° F]) temperature rise, the large amounts of water surrounding the magnesium ion and small amounts of interlayer water trapped within the potassium saturated vermiculite will be vaporized and leave the clay. However, the reactions of the two clays to heat are dramatically different. The Mg-vermiculite behaves like popcorn and the K-vermiculite behaves like a grilled cheese sandwich. Water inside a popcorn kernel, when heated, ruptures the kernel in its effort to escape as steam. The steam violently escaping from the Mg-vermiculite structure "pops" the clay structure. On the other hand, when K-vermiculite is exposed to the same heat, the small amount of water escapes quietly and the clay layers move closer together just as the slices of bread (clay layers) move together as the interlayer cheese melts.

THERMAL STABILITY

Purpose

What is the purpose of this experiment?

(The purpose of this experiment is to demonstrate the thermal stability of a clay mineral —

vermiculite — and to compare the differences in thermal stability between two different types of vermiculite.)

Hypothesis:

State your hypothesis regarding the thermal stability of the clay mineral vermiculite. Be sure to mention how you expect the KCl-saturated vermiculite to differ from the untreated vermiculite.

(Answers will vary but encourage students to be as specific as possible.)

Materials:

2 aluminum pans

candles

drying oven

pot holder

flake vermiculite

saturated KCl (table salt substitute) solution

two 250 mL beakers (or oven-safe containers)

Procedure:

1. Label beakers A and B.
2. Fill beaker A about half way with water. Make a saturated solution of KCl by pouring the KCl into the water and stirring to dissolve it. Continue adding the KCl and stirring until solid that will not dissolve remains at the bottom of the beaker.
3. Make some potassium saturated vermiculite by placing a small amount of the flake vermiculite in beaker A with the saturated KCl solution. Place the same amount of vermiculite in the empty beaker. By soaking the vermiculite in the KCl solution, you are allowing potassium cations to replace the naturally occurring magnesium cations in the interlayer of the mineral's structure.

4. Allow the vermiculite to soak in the KCl solution for at least 48 hours. Then pour off the liquid and spread the vermiculite in both beakers on separate cookie sheets and dry it in an oven set at 110°C (approximately 225°F). This will take 2-3 hours. Stir the drying vermiculite occasionally.
5. Using the oven-dried samples of Mg^{2+} -saturated and the K^{+} -saturated vermiculite, place a few flakes of each in separate aluminum pans.
6. Light the candle. Using the pot holder to protect your hands place the clay-containing pans over the hottest part of the flame. Observe and record the changes in the clay.

Observations:

Describe the K^{+} -saturated vermiculite.

Before drying:

After drying:

During and/or after exposure to heat:

Describe the Mg^{2+} -saturated vermiculite (untreated).

Before drying:

After drying:

During and/or after exposure to heat:

Conclusion:

1. Do the two types of clay behave differently? If so, how are they different and how can that explain their different behaviors?

(Yes. The untreated vermiculite is saturated with Mg^{2+} ions. K^+ ions have taken the place of the Mg^{2+} ions in the vermiculite saturated with KCl. Because the Mg^{2+} saturated vermiculite holds its waters of hydration more strongly than the K^+ saturated vermiculite, there is more water incorporated into its structure. The greater amount of water available leads to a greater degree of thermal stability.)

2. What is the source of the heat that must be considered when planning and designing the repository?

(The radioactive decay of spent fuel produces thermal heat. A major technical problem that has to be dealt with in siting the repository is the effect of heat from the radioactive decay process on the rock in which the repository will be located.)

3. Why is it necessary to consider thermal stability of potential repository minerals?

(The loss of thermal stability of repository minerals may reduce their sorption and ion exchange capabilities. The water released from some minerals during thermal alteration may also have a cooling effect on the thermal heat produced by decaying spent fuel but may also have corrosive effects on the waste-containing canister.)

ION EXCHANGE AND ZEOLITES

Purpose:

This lesson demonstrates ion exchange so that students will better understand how the chemical process of ion exchange can remove undesired ions from water. This experiment models a natural process that may occur if zeolites are present in the rock surrounding the proposed repository.

Concepts:

Zeolites can help protect the environment and people by removing contaminants from ground water.

Duration of Lesson:

One 50-minute class period

Objectives:

As a result of participation in this lesson, the learner will be able to explain the significance of ion exchange capability when siting the high-level waste repository.

Skills:

Comparing, drawing conclusions, hypothesizing, measuring, observing

Vocabulary:

Cation exchange resin, insoluble, ions, ion exchange, zeolite

Materials:

Reading Lesson

Ion Exchange and Zeolites (advanced reading), p. SR-35

Activity Sheet

Ion Exchange and Zeolites, p. 207

Background Notes

Zeolites, p. 73

Videotape

Science, Society, and America's Nuclear Waste Teleconference Videotapes (available free of charge from the OCRWM National Information Center, 1-800-225-6972; within Washington, DC, 202-488-6720)

Other

1 cup cation exchange resin or zeolite	3 bottles that will hold 2 cups of water
caps or stoppers for the bottles	soap (not detergent)
clean, dry 1-liter plastic soda bottle	cheesecloth
strong rubber bands	knife
scissors	measuring cup
1/4 teaspoon measuring spoon	support stand for soda bottle
hard water (or one liter [2 pints] distilled water + 3.3 grams [0.12 ounces] Epsom salts)	

Suggested Procedure:

1. Before beginning the experiment, it may be helpful to review the definition of ions as particles with an electrical charge and the concept that particles with opposite electrical charges are attracted to one another.
2. Most municipal water systems in the United States have hard water. However, if your municipal water is naturally soft or if water in the school is softened, you will need to make your own hard water for this activity. You can make a representative hard water by dissolving 3.3 grams (0.1 oz.) of Epsom salts ($MgSO_4 \cdot 7H_2O$) in one liter (approximately 1 quart) of distilled water or your softened tap water.
3. Cation exchange resin or zeolites should be available from a water treatment (softening) company. This exercise assumes that the resin supplied is a cation exchange resin in the sodium (Na^+) form; i.e., the resin comes saturated with sodium cations. It is possible that the resin supplier will offer you a cation exchanger in the hydrogen (H^+) form. This will make no difference in the result of the experiment. But point out that Ca^{2+} and Mg^{2+} are replaced in the water by H^+ .
4. Before use, the cation exchange resin should be soaked in tap water for at least 24 hours.
5. After students complete the experiment, they should understand that ions of calcium and/or magnesium, which react with the soap molecules to form an insoluble material, have been replaced by ions of sodium, which do not react with the soap molecules, and that the source of the sodium ions is the cation resin. Explain to the students that an ion exchange resin is a manmade product that works the same way as naturally occurring zeolites. The visual result of the ion exchange is the forming of soap bubbles. Students may be familiar with the process of ion exchange as water softening.
6. Upon completion of the activity, you may wish to discuss with students how ion exchange due to the presence of zeolites can contribute to the safety of the environment at the geologic repository.
7. After use, the resin may be recharged by soaking it in salt water and storing it in a sealed container. Before using the resin again, rinse it several times with fresh water.

Teacher Evaluation of Learner Performance:

Student participation in experiment/activity, and participation in class discussion will indicate understanding.

ZEOLITES

A zeolite is a naturally occurring ion exchanger. In the case of a zeolite, the negatively charged frame is the aluminosilicate (aluminum/silicon) skeleton. The aluminosilicate skeleton is built up of neutral silicate tetrahedra wherein a silicon atom is surrounded by four oxygen atoms. The resulting arrangement of atoms looks like a pyramid with a triangular base. The oxygen atoms are located at each apex of each triangular face. The negative charge on the framework arises when an aluminum atom substitutes for a silicon atom. This is possible because the aluminum and silicon atoms are very similar in size. However, the valence (i.e., the maximum charge) of aluminum is +3, whereas the valence of silicon is +4. The result of aluminum substitution for silicon is a deficiency of positive charges or, in other words, an excess of negative charges on the aluminosilicate skeleton.

Balancing positive charges are supplied by positively charged ions (cations) attracted from the solution surrounding the zeolite, which attach by electrical attraction to the zeolite skeleton. In most naturally occurring zeolites, the charge-balancing cations are sodium (Na^+), potassium (K^+), and calcium (Ca^{2+}).

The charge-balancing cations are called "exchangeable cations" because, depending upon the composition of the water bathing the zeolite, they may exchange places with cations in solution. The exchangeable cations are not all held with equal strength by the zeolite. Multivalent (e.g., divalent Ca^{2+}) cations are usually held more tightly than univalent (e.g., Na^+) cations.

Zeolite Structure

The building blocks for the aluminosilicate framework of zeolites are silica tetrahedra—a central silicon atom surrounded by four oxygen atoms. The valence (maximum charge) of silicon is +4, whereas the valence of each oxygen atom is -2. The tetrahedron, SiO_4 then should have a charge of -4 [$+4 + 4(-2)$] and would be classified as a complex anion. A complex anion, such as SiO_4 , is composed of two or more elements which act as an inseparable charged unit. A simple anion, such as Cl^- , is a single, charged atom. However, in the zeolite structure, each oxygen is shared with a neighboring tetrahedron. The effect is that each silicon atom, rather than

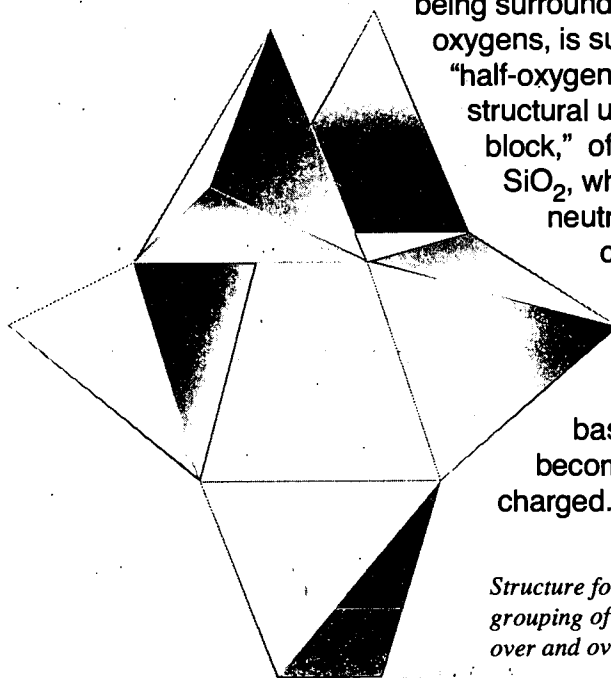

being surrounded by four oxygens, is surrounded by 4 "half-oxygens." The basic structural unit, the "building block," of the zeolite is then SiO_2 , which is electrically neutral. (You do the calculation.) If an aluminum atom (valence +3) substitutes for a silicon atom, that basic building block becomes negatively charged.

Structure for part of a zeolite. This grouping of tetrahedra is repeated over and over to form a zeolite.

ION EXCHANGE AND ZEOLITES

4.31 Introduction

Ion exchange is based on the simple idea that electrically charged particles (ions) with unlike charges attract each other. Ions with a negative charge are anions. Ions with a positive charge are cations.

4.32 Dissolving Ionic Compounds

If you place table salt (NaCl) in water, the salt dissolves. What happens is that water molecules, H_2O , are very effective at breaking the ionic bonds and keeping Na^+ and Cl^- separated (dissolved) in solution. The water molecule is electrically neutral, but, because the molecule is bent, one side has a slight negative charge while the other side has a slight positive charge. This makes the water molecule a "polar" molecule. Its positive pole is attracted to anions like Cl^- while its negative pole is attracted to cations like Na^+ . In solution, water molecules surround the cations and anions and keep them separated. Because ionic compounds dissolve readily in water, any radioactive isotopes that can exist as ions in water will move with the water.

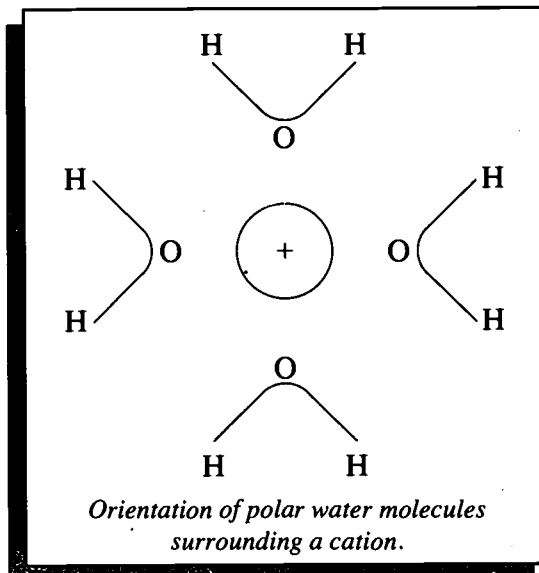

What is the basis of ion exchange?

What happens when salt dissolves in water?

Precipitation

What are the two ways to remove ions from a solution?

What happens when ions are removed from water by precipitation?

Removing ions from solution is done in two ways, *precipitation* or *ion exchange*. If the amount of water is decreased, there are fewer water molecules to separate and isolate ions from one another. One way to decrease the amount of water in a solution is to evaporate the water, usually by heating it. The water molecules leave as water vapor (steam) and the ions are concentrated in the remaining water. Eventually, there won't be enough water remaining to keep all the ions from attracting each other. The ionic compounds, containing cations and anions, will begin to *precipitate* (fall out of solution).

Ion Exchange

What happens during ion exchange?

What is a zeolite?

A second way to remove ions from solution is by ion exchange. A cation ion exchanger is basically a framework with a negative charge that has positive cations attached to it. The framework is like the bars of a cage which carry a negative charge, and cations fill the open spaces. A zeolite is a naturally occurring ion exchanger.

How would a zeolite remove contaminants from water?

Depending on the composition of the water around a zeolite, cations attached to a zeolite can change places with cations in the water. If water containing waste were released from the repository, it might be carrying the radioactive cations cesium-137 and strontium-90. Cesium-137 is similar in behavior to potassium (K^+), and strontium-90 is similar in behavior to calcium (Ca^{2+}). As the waste passes the zeolite, the cesium-137 and strontium-90 would displace loosely held exchange cations (Na^+) on the zeolite. The result is that the radioactive cations would attach to the zeolite, and the water leaving the zeolite zone would contain the displaced, non-radioactive cations.

ION EXCHANGE AND ZEOLITES

Ions are particles that have an electrical charge. Ion exchange depends on the fact that particles with opposite electrical charges are attracted to each other (i.e., positively charged particles attract negatively charged particles and vice versa). The ions that make hard water, usually high concentrations of calcium (Ca^{2+}) and magnesium (Mg^{2+}), react with soap molecules to form an insoluble material. As a result, soap does not lather well and loses its effectiveness as a cleanser. The ion exchange process replaces the Ca^{2+} and Mg^{2+} with sodium (Na^+), which does not react with the soap molecules. This is the purpose of home and municipal water softening systems.

Purpose:

What is the purpose of this activity?

(To enhance understanding of how the chemical process of ion exchange can remove undesired ions from water.)

Hypothesis:

In which solution do you expect to observe the greatest degree of ion exchange? How will you know that ion exchange has taken place?

(Answers will vary, but encourage students to be specific.)

Materials:

237 milliliters (1 cup) cation exchange resin or zeolite
 3 bottles that will hold 474 milliliters (2 cups) of water, caps or stoppers for the bottles
 soap flakes (not detergent) (pea sized shavings of Ivory® soap bars will work)
 hard water (or 1-liter [2 pints] distilled water + 3.3 grams [0.1 ounce] Epsom salts)
 clean, dry 1-liter plastic soda bottle
 cheesecloth
 strong rubber bands
 knife
 scissors
 support stand for soda bottle
 measuring cup
 1/4 teaspoon measuring spoon

Procedure:

1. Pour 237 milliliters (one cup) of the hard water into one of the glass bottles.
2. Add 1.2 milliliters (1/4 teaspoon) of soap flakes. Allow this mixture to stand for three minutes.
3. Cap the mixture and shake.
4. Observe and describe the quantity and the quality of the suds. (Are there many? How long do they last?)
5. Cut the bottom off the soda bottle to create a funnel.
6. Cap the bottle/funnel, put it in the stand, and pour 237 milliliters (one cup) of the hard tap water into it. Allow it to stand undisturbed for three minutes.
7. Cover the mouth of the second glass jar with several layers of cheesecloth and secure the cheesecloth with several rubber bands. Remove the cap from the bottle/funnel, allow the water to run through the cheesecloth, and collect the water in the glass bottle.
8. Repeat steps 1 - 4 using the liquid you collected in the second glass jar. Compare your results with the results in step 1. Did the type of container or the cheesecloth have any effect on the results?
9. Put the cap on the bottle/funnel. Place 237 milliliters (1 cup) of the exchange resin in the funnel.
10. Pour 237 milliliters (1 cup) of hard tap water into the funnel and allow it to stand for three minutes.
11. Cover the mouth of the third bottle with several layers of cheesecloth and secure the cheesecloth with several rubber bands. Remove the cap of the funnel and allow the water to run through the cheesecloth into the third glass bottle.
12. Repeat steps 1 - 4 using the liquid you collected in the third glass jar. Compare your results with the results from the liquid in jars one and two.

Observations:

Jar #1: Hard water and soap

(Soap will not dissolve well. There will be a few short-lived suds.)

Jar #2: Hard water and soap filtered through cheesecloth

(Soap will not dissolve well. There will be a few short-lived suds.)

Jar #3: Hard water and soap filtered through zeolites and cheesecloth

(Soap will dissolve fairly easily. There will be numerous, long-lasting suds.)

Conclusion:

1. Compare the suds created in the three jars. Which had the most and longest lasting suds?

(The third jar had the most and longest-lasting suds.)

2. Did pouring the water through the cheesecloth have any effect on the quality of the soap suds? Why or why not?

(No. Suds quality did not improve after pouring the water through the cheesecloth. This physical filtering did not remove the magnesium ions.)

3. Did pouring the water through the resin have any effect on the quality of the soap suds? Why or why not?

(Yes. The quality and quantity of suds improved after exposing the hard water to the resin. The resin must have chemically removed the Mg^{2+} ions from the hard water.)

4. Why might ion exchange capability be an important consideration when siting the high-level waste repository?

(If rocks surrounding the repository have ion exchange capability, they would present a natural barrier to the movement of radionuclides by exchanging harmless ions within their structure for the radionuclides moving past them.)

TOPOGRAPHIC MAP SKILLS - Part I

Purpose:

This exercise will acquaint students with the skills necessary to use and understand topographic maps.

Concepts:

A topographic map is the projection of a landscape onto a piece of paper; showing detailed surface features of the Earth such as elevation and slope.

Duration of Lesson:

Two 50-minute class periods (one 50-minute class period if activities are assigned for homework)

Objectives:

As a result of participation in this lesson, the learner will be able to:

1. understand the importance of reading topographic maps in repository site characterization;
2. locate prominent points on a map;
3. measure and calculate horizontal distances;
4. determine differences in elevation between different locations; and
5. describe the location of points using latitude and longitude coordinates.

Skills:

Analyzing, calculating, constructing, determining contour intervals, finding scale, longitude and latitude, visualizing

Vocabulary:

Conventional notation, degree, equator, geophysical pole, hour, latitude, longitude, meridian, minute, notation, prime meridian, second, symbol

Materials:

Reading Lesson

Topographic Map Skills, p. SR-37

Activity Sheets

Topographic Map Skills, p. 211

Practice with Scale, Latitude, and Longitude, p. 213

Contouring, p. 215

Topographic Maps of Landscapes, p. 217

Background Notes

Topographic Map Skills, p. 83

Contours and Cornflakes, p. 85

Other

U.S. Geological Survey topographic map (7-1/2 or 15-minute version) - See p.81 for ordering instructions

12- or 18-inch English or metric ruler, preferably both
Pencil, graph paper

Suggested Procedure:

1. Before beginning the reading lesson you may wish to review the meaning of meridian, longitude, and latitude. It may also be helpful to review notation for degrees, minutes, and seconds and to discuss symbols. The following definitions may be useful:
 - a) *meridian* — a great circle of the Earth's surface, passing through both geophysical poles.
 - b) *latitude* — the angular distance north or south of the equator, measured in degrees along a meridian.
 - c) *longitude* — the angular distance (on the Earth, a globe, or a map) east or west of the prime meridian at Greenwich, England, to a point on the Earth's surface for which the longitude is being determined, expressed in degrees or in hours, minutes, and seconds.
 - d) *conventional notation* — used to signify degrees ($^{\circ}$), minutes ($'$), and seconds ($"$). For example, $115^{\circ}30'21"$ means 115 degrees, 30 minutes, and 21 seconds. Remember that each degree contains 60 minutes and each minute contains 60 seconds.
 - e) *symbols* — both natural and manmade features are indicated by symbols. The shape, size, location, and color all have special significance. Symbols for water features are blue, and man-made objects (roads, railroads, buildings, etc.) are black. Green distinguishes wooded areas from clearings. Contour lines are brown. Many map symbols are pictographs, resembling the objects they identify.
2. When students have completed the reading, it may be helpful to be sure they understand the information presented by reviewing Figure 5 and by having them identify features mentioned (i.e., mountainous terrain, flat terrain, elevation of contours) on the sample map in Figure 5.
3. After students have completed the reading lesson they can do the exercises in small groups or individually. Begin with the activity entitled *Practice with Scale, Latitude and Longitude*. It may be necessary to review answers before continuing.
4. Learning to get an overall impression of what the landscape represented by a topographic map looks like takes some practice and imagination. Do the exercises entitled *Topographic Maps of Landscapes* to practice visualizing what the topographic map for a given landscape looks like.
5. Have students construct a topographic map by connecting points of equal elevation on the handout entitled *Contouring*.
6. When students have completed their topographic maps, have them describe the land feature that it represents.

(River Valley cutting between two peaks.)

7. When students have completed these activities they should be ready to look at and discuss a topographic map. Give each group a map and discuss the following as a class.

Metric equivalents have not been provided for this lesson because the topographic maps available through the U.S. Geological Survey (USGS) are not metric.

Suggested Discussion Questions: "U.S. Geological Survey topographical map"

1. Determine the contour interval and scale of the topographic map of Busted Butte.

(Contour interval is 20 feet; scale is 1: 24,000.)

2. What are the dimensions of the map in latitude and longitude?

(7-1/2 minutes by 7-1/2 minutes)

3. Find the latitude and longitude grid ticks along the edge of the map and in the interior of the map. What are the dimensions of the map segments defined by these grid ticks?

(2-1/2 minutes x 2-1/2 minutes)

4. Calculate the length (in feet or miles) of any two adjacent borders of the map by using the scale 5280 feet = 1 mile.

(Measure the length on the map using a ruler accurate to a tenth of an inch. Suppose this happens to be 18.3 inches. If the scale of the map is 1:24,000, then 1 inch on the map equals 24,000 inches on the ground. Therefore, the distance represented by 18.3 inches is $18.3 \times 24,000$ inches = 439,000 inches. 439,000 inches divided by 12 inches [1 foot] = 36,600 feet. If you want the answer in miles: 36,600 divided by 5280 [feet per mile] = 6.9 miles.)

5. Calculate the length (in meters or kilometers) of the same two borders of the map using the scale and a metric ruler.

(Suppose the measurement is 46.3 centimeters. A scale of 1 : 24,000 means that one centimeter on the map equals 24,000 centimeters on the ground. Therefore, $46.3 \times 24,000$ centimeters = 1,111,200 centimeters. Divide by 100 [centimeters per meter] to get 11,112 meters. If you want the answer in kilometers, divide by 1000 [meters per kilometer] to get 11.1 kilometers.)

6. Look at the map carefully and try to find:
- the highest and lowest areas on the map
 - areas of relatively steep slopes
 - areas of relatively gentle slopes
 - areas where ephemeral (i.e., very short-lived) streams or storm runoff might flow and the direction of that flow

(Answers may vary.)

Teacher Evaluation of Learner Performance:

Student participation in class discussion and completion of activities will indicate understanding.

TOPOGRAPHIC MAP SKILLS

Topographic maps of any area of the United States may be obtained from the U.S. Geological Survey by calling the map sales office in the Denver Federal Center at (303) 236-7477 and requesting the Index Map and Order Form for the State or States of interest. Indexes and order forms are free and usually take about a week to arrive. The index map shows all topographic map coverage (and some other special purpose maps which may be of interest to the students). Order individual maps by following the instructions in the order form or by listing the map names in a letter. Orders must be prepaid by check or money order payable to U.S. Department of the Interior/U.S.G.S. A pamphlet of Topographic Map Symbols is also available at no cost. Allow four to six weeks for delivery. Mail to:

U.S. Geological Survey
Map Distribution Center
Federal Center, Building 810
Lakewood, CO 80225

CONTOURS AND CORNFLAKES *

by Joseph W. Bencloski

The interpretation of certain slope types on a topographic map is sometimes difficult for students with no prior map reading experience. This teaching tip suggests a method of demonstrating concave and convex slopes by using a simple bowl with contour lines drawn on the inside and outside.

The four basic slope types depicted by contour lines on a topographic map include uniform gentle, uniform steep, concave, and convex. Most instructors begin teaching slope characteristics on topographic maps by explaining that the wide spacing of contour lines indicates a gentle slope, while the close spacing of contour lines indicates a steep slope. Armed with this basic information, students can progress to an understanding of the four basic slope types.

The visualization of uniform gentle and uniform steep slopes on a topographic map usually poses no problems for students. A uniform gentle slope is illustrated by contours that are evenly spaced but far apart, while a uniform steep slope is illustrated by contour lines that are evenly spaced but close together. Concave and convex slopes, on the other hand, are more difficult for students to visualize and locate on a topographic map. Before asking students to examine a topographic map, these slopes can be demonstrated by drawing contour lines on both the inside and outside of a bowl or pie plate. Right side up, the bowl illustrates the characteristics of a concave slope. That is, beginning at the rim (the highest elevation), there is a steep drop down the side of the bowl to the gently sloping bottom. Using the rule for slope steepness and the spacing of contour lines, the instructor or students can draw contour lines on the inside of the bowl to illustrate a concave slope. Progressing down the steep sides of the bowl from the rim, the contour lines will first be spaced close together, and then farther apart on the nearly flat bottom.

If the bowl is turned upside down, it can be used to illustrate the characteristics of a convex slope. That is, beginning at the top center, the slope is first gentle, and then steepens as one descends the sides to the bottom. The drawn contour lines would be widely spaced near the top, and closely spaced on the sides of the inverted bowl.

The bowl can also be used to illustrate two topographic features shown by contour lines: a hill and a depression. A hill can be illustrated by turning the bowl upside down, and drawing contour lines in the form of closed loops inward from the rim toward the center. Similarly, a depression can be illustrated by drawing closed contours with hachures on the inside of the bowl turned right side up. While these demonstrations are simple, they provide students with a vivid mental image of the spacing of contour lines on a familiar object. The technique also reinforces learning because students are reminded of topography while consuming their breakfast cornflakes.

** The original version of this article was published in Teaching Geography (Oct. 1985) under the title "Demonstrating Slope Types."*

(Joseph W. Bencloski is editor of Perspective and a professor in the Department of Geography and Regional Planning at Indiana University of Pennsylvania.)

TOPOGRAPHIC MAP SKILLS

Topographical maps are essential tools in the first stages of site characterization. A topographic map gives the field team information on the layout of the area under study. From this, they can learn more about surface water drainage and the geologic origins of the area. The location of lakes, swamps, and springs also gives the team some information about the potential depth and flow of ground water beneath the site. With information learned by studying topographic maps, researchers can determine areas where further study will be required.

4.33 Types of Maps

Maps are devices used to represent the surface of Earth so that we can tell such things as where we are, how to travel to other locations, or who owns or controls various pieces of land. There are many kinds of maps, each made for a particular purpose. A road map, for example, shows the roads and highways we might use to drive from one town to another. There are probably maps around your school which show the United States or the world. These maps might be political maps that use colors to designate States or countries in order to show who controls various regions of the world.

What is a map?

How can maps help us?

4.34 Topographic Maps

Another special type of map is the *topographic map*. The word "topographic" is of Greek origin and means "to describe or draw a place." Essentially, a topographic map is the projection of a

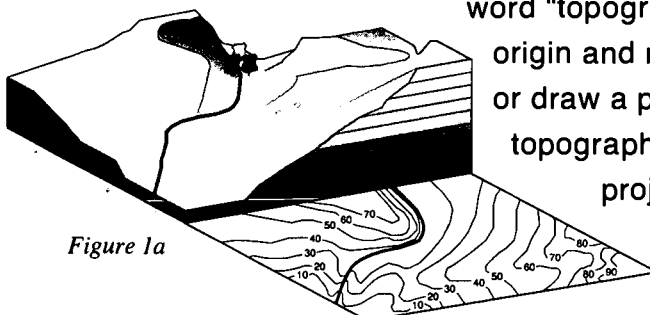

Figure 1a

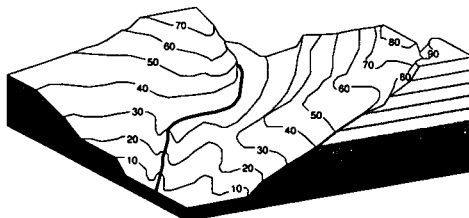

Figure 1b

landscape onto a piece of paper (Figures 1a and 1b). Both natural and manmade features are indicated by symbols. The

distinctive characteristic of a topographic map is the information

What is a topographic map?

What is the distinctive characteristic of a topographic map?

it provides about the shape of Earth's surface. Topographic maps show detailed surface features, such as elevation and slope.

Figures 2a and 2b introduce some important features of topographic maps. Figure 2a is from a map of an area in South Carolina, and Figure 2b is a portion of a map of an area in Nevada. Included with each figure is a sketch of the landscape represented by the map. These maps show contour lines and contour intervals and quickly give a general impression about the land represented.

Figure 2a

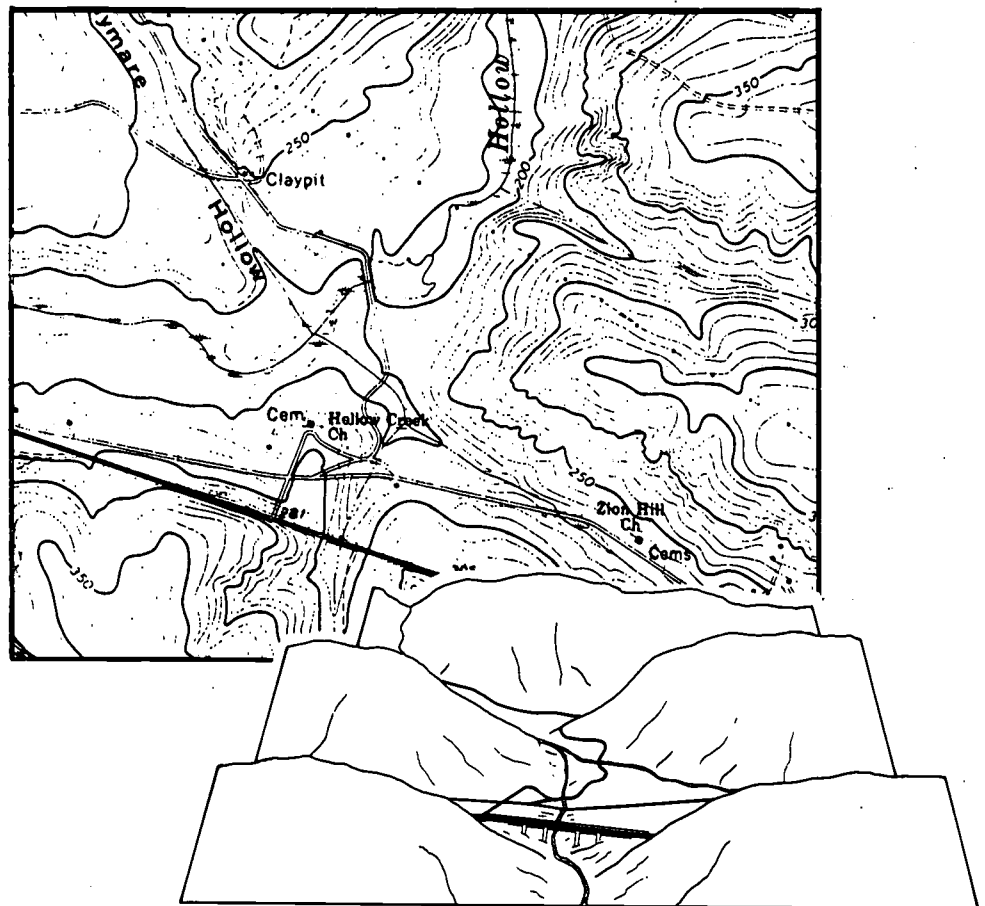

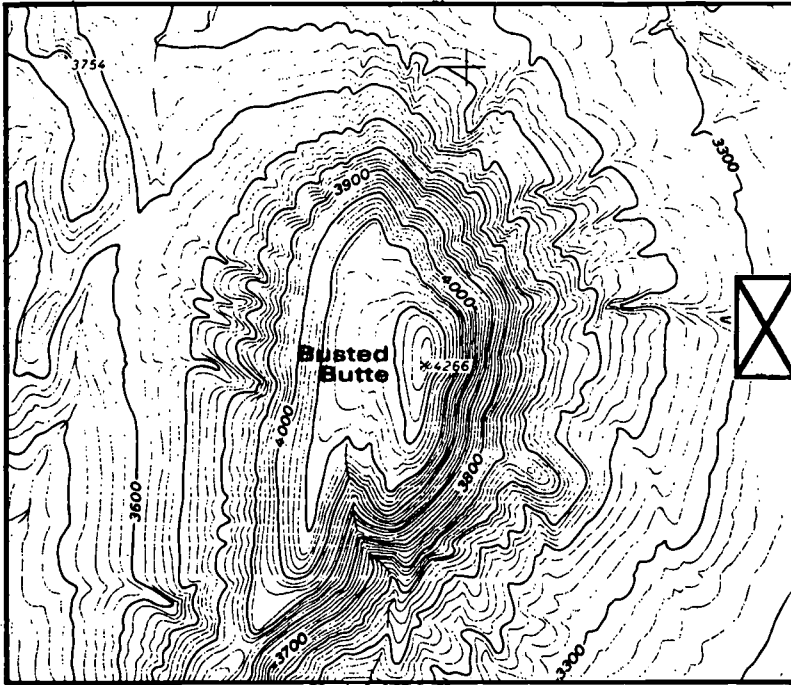
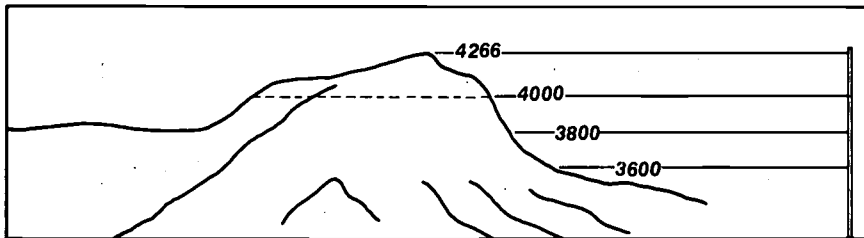

Figure 2b



4.35 What are contour lines?

Define contour lines.

When you look at the maps in Figures 2a and 2b, you will see that they are just a collection of lines. These are called *contour lines*. Like the boundary lines for States, contour lines are imaginary lines. On topographic maps they are printed in brown and follow the land surface at a constant elevation.

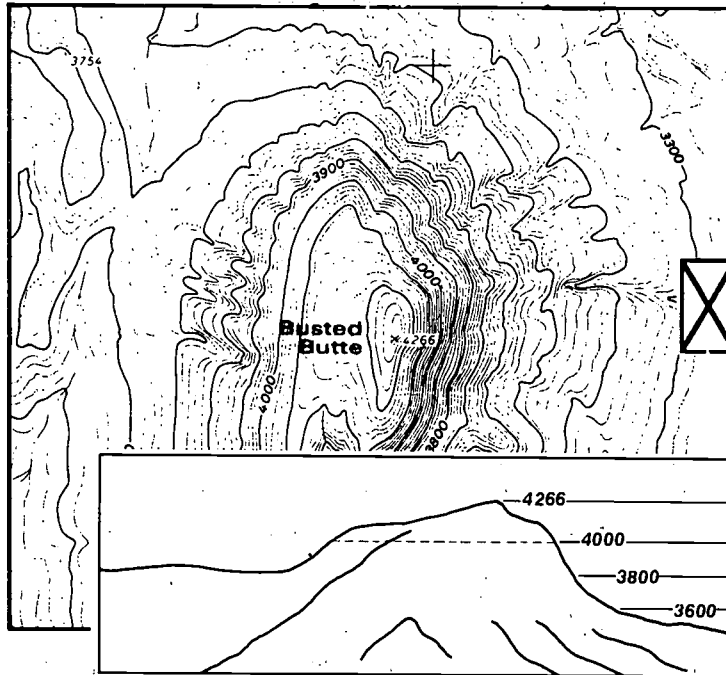

Figure 2b

Do contour lines change elevation?

Examine Figure 2b to see exactly what contours are. The important thing to remember is that a contour line never changes elevation. In Figure 2b, the contour labeled 4000 is an imaginary line that follows the land surface at 4,000 feet above sea level. If you were on the ground directly on this contour, you could walk along the contour and circle Busted Butte without ever having to go up or down. If you had friends in a helicopter looking at Busted Butte from directly above the X shown on the map, they would see your progress as shown in the sketch.

If your friends wanted a view similar to the one represented on the map, they would have to fly to a much higher elevation directly over Busted Butte. This tells us another interesting fact about topographic maps: they portray the landscape as if you were looking directly down onto the Earth's surface from high above the land. In fact, most topographic maps made today are developed from aerial photographs.

Contour Interval

Another important feature of topographic maps is the contour interval, which is the elevation difference between adjacent contour lines. The contour interval for a given map is a constant distance, usually given in feet or meters. Look at the 3,900 foot contour line in Figure 2b. Now count the contour lines between the 3,900 foot line and the 4,000 foot line. There are four contour lines between the 3,900 and 4,000 foot contours. This means there are five intervals (count them if you like) in the 100 feet between 3,900 and 4,000 feet. We know that the distance between lines on the map is constant. Therefore, we can figure the contour interval by dividing the total distance of 100 feet (4,000 feet to 3,900 feet) by the number of intervals (which is 5): 100 feet divided by 5 intervals = 20 feet per interval. Each contour line is 20 feet different (either higher or lower) from the ones adjacent to it. Therefore, we say this map has a contour interval of 20 feet.

Contour interval may be different from map to map because it is chosen to show sufficient elevation differences without cluttering the map or obscuring other features. Generally, mountainous terrain is shown with larger contour intervals and flat terrain is shown with smaller contour intervals. The reason for this can be understood by comparing the maps in Figures 2a and 2b.

The contour interval for the map of Busted Butte in Figure 2b is 20 feet. You can see how close together the contour lines are here. This is because the slope is very steep. Now look at Figure 2a. The contour interval of this map is 10 feet. If the contour interval for Figure 2b were 10 feet, there would be so many lines that we could not read the map in the steep areas. If the contour interval for Figure 2a were 20 feet, we could read the map easily but a lot of detail would be missing. (Imagine the figure with every other contour line missing.)

The contour interval of a topographic map is clearly shown on the bottom margin of the map. On the map itself, contour elevations are labeled in the same units (feet or meters) that are used to specify the contour intervals. Note that every fourth or fifth contour is in bold print. This is simply to make the contours easier to read.

What is a contour interval?

How many feet is each contour line?

Visual Impression of Contours

How is the visual impression of contours used?

The visual impression of contours allows the user to gain an understanding of the lay of the land without reading the elevation of every single contour. Steep slopes will have closely spaced contours while gentle slopes will have widely spaced contours (Figure 3).

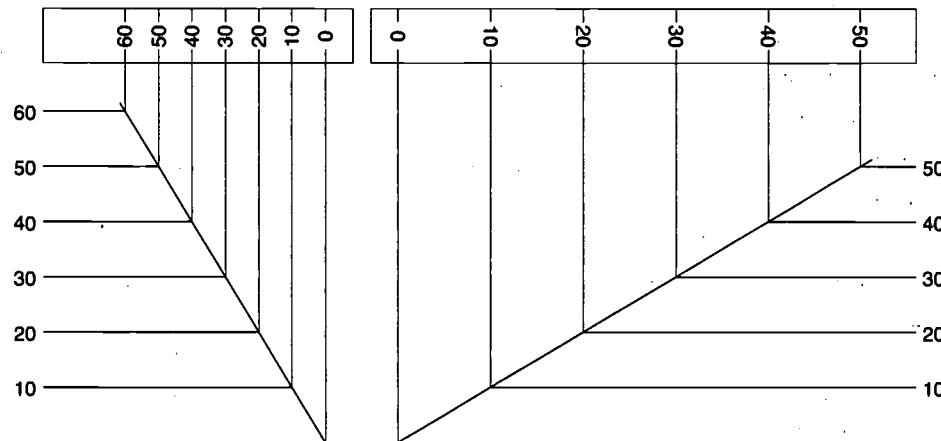

Figure 3

Flow Direction of Rivers or Streams

What is used to show the direction flow of rivers, streams, and creeks?

The flow direction of rivers, streams, or creeks can be determined by the shape of the contours as they cross the water. The contour always makes a sharp V-shaped turn which points upstream. This can be seen in Figure 4, which shows the flow of a stream. The contours make sharp V-shaped bends as they cross the streams. These V's always point upstream, as shown in the sketch.

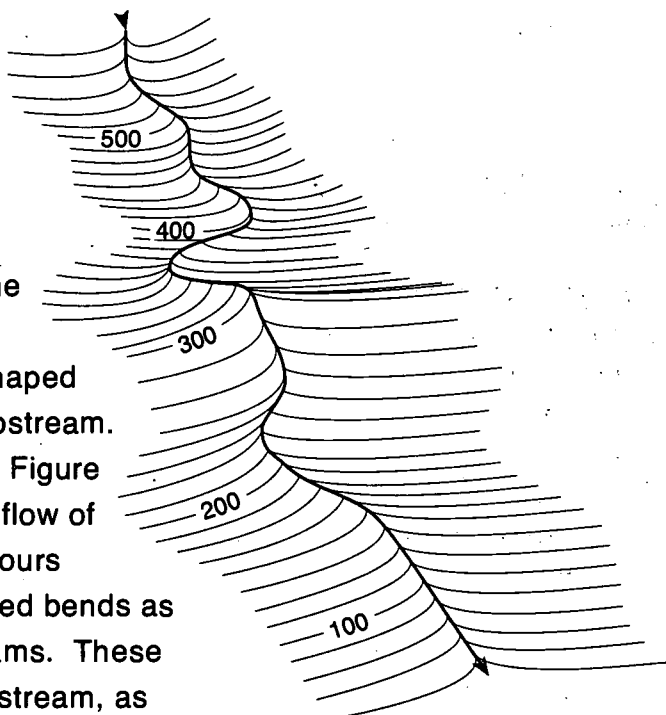

Figure 4.

4.36 Scale

The other fundamental characteristic of a topographic map besides the contour interval is the scale. The scale is also prominently displayed along the bottom margin. The scale of the map is the relationship between distance on a map and the corresponding distance on the ground.

The graphic representation of the scale is easy to understand. One mile on the ground is represented on the map by the length of the appropriate bar scale. The scale expressed as a ratio is more useful because it allows the user to determine distances with a greater degree of precision by doing the appropriate calculation. For instance, 1:24,000 may mean one inch on the map is 24,000 inches on the ground. Dividing 24,000 by 12 to get feet tells us that one inch on the map equals 2,000 feet on the ground.

Now the distance between any two points on the map can be determined by measuring with a suitable ruler and multiplying. If a ruler accurate to a tenth-of-an-inch measures the distance between two points as 8.3 inches, then the distance on the ground is $8.3 \times 2,000$ feet = 16,600 feet. Since the scale is a ratio, its general meaning applies to any suitable unit of length. Therefore, the easiest way to think of the scale is this: one unit on the map is 24,000 units on the ground. Units can be U.S. or metric.

4.37 Map Coordinates

The dimensions of standard U. S. Geological Survey (USGS) topographic maps are measured in degrees, minutes, and seconds of latitude and longitude. A USGS map is always oriented with true north in the vertical direction at the top of the map. The coordinates of each corner are shown in the margins of the map. The dimensions of a standard 1:24,000 scale map are 7-1/2 minutes of latitude by 7-1/2 minutes of longitude. The maps are further subdivided into 2-1/2-minute sections by two small ticks along each edge of the map and four cross ticks in the interior of the map (Figure 5). By using these ticks to lightly pencil in the 2-1/2-minute sections, it is possible to determine the coordinates of any point on the map to one second of latitude and longitude. The only additional tool required is an engineer's scale with appropriate divisions.

What is scale?

Where is it indicated?

How is scale represented?

Why is scale expressed by a ratio useful?

What is the easiest way to think of the scale of a map?

What are the units of measurement used in standard USGS maps?

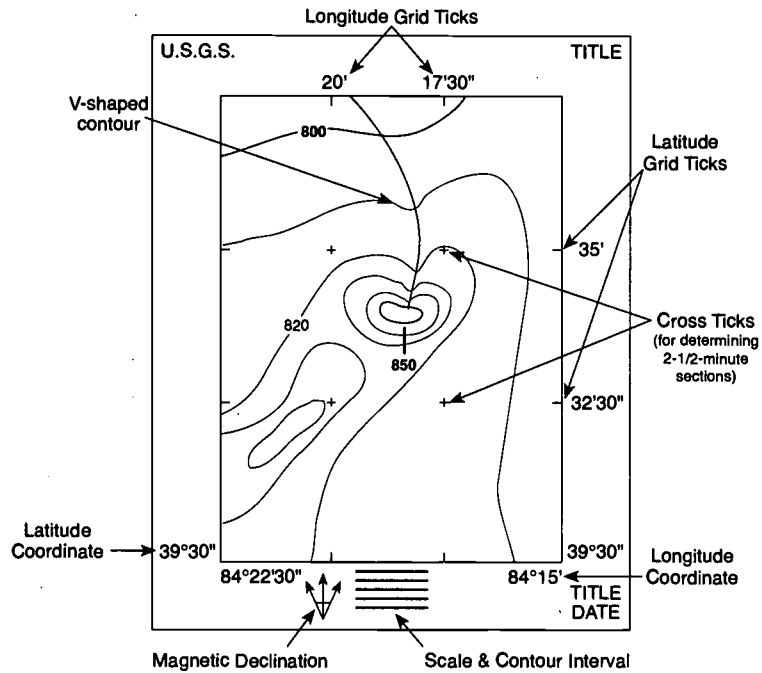

Figure 5. 7-1/2-Minute Map

How does one divide the 5x5 minute section into 300 divisions?

Locating a point's coordinates on a map is demonstrated schematically in Figures 6 and 7 below. On this 15-minute map, each section would have dimensions of 5 minutes of latitude by 5 minutes of longitude. The location of a point in this section can be determined to the nearest second if we can divide the section into 300 divisions (60 seconds per minute \times 5 minutes = 300 seconds). By using the 50 division scale on the engineer's scale, it is possible to effectively divide the 5 x 5 minute section into 300 divisions. This is done by laying the scale down with the zero on one line of longitude and the 300 on the other line of longitude while making sure the point we are interested in lies along the edge of the scale. (To do this, slide the scale until all three points are as illustrated.) This effectively divides the section longitudinally into 300 divisions (Figure 6).

The same method is used to divide the section of latitude into 300 divisions by laying the scale down with the zero on one line of latitude and the 300 on the other line of latitude, while keeping the point along the edge of the scale (Figure 7).

Where do you find the coordinates of each corner? These directions are for a 15-minute map. The procedure for locating a point's coordinates on a 7-1/2-minute map are the same, except

Science, Society, and America's Nuclear Waste

that the dimensions of the sections are 2-1/2 minutes by 2-1/2 minutes. Therefore, each section needs to be divided into 150, not 300, divisions (60 seconds per minute x 2-1/2 minutes =150).

Longitude or Latitude

In the example in Figure 6, suppose the point lies adjacent to 142 on the scale. This means the longitude of that point is 142 seconds east of the line 115 ° 30'. Convert this to 2 minutes, 22 seconds east of 115 degrees 30 minutes (142 seconds divided by 60 seconds per minute = 2 minutes, 22 seconds). Subtracting 2 minutes, 22 seconds from 115 degrees, 30 minutes gives 115 degrees, 27 minutes, 38 seconds. We subtract here because longitude is measured from east to west. In other words, higher numbers are farther west. How far west is the point from the line 115 ° 25'? (There are a couple of ways to figure this out.)

The latitude of a point is determined in a similar way, as is shown in Figure 7. First, find the distance from the line of latitude. Convert to minutes and seconds. If a point is north of a known latitude, we add. If a point is south of a known latitude, we subtract.

What is the procedure for locating a point's coordinates on a 7 1/2 minute map?

How is the longitude or latitude determined?

When do you add? Subtract?

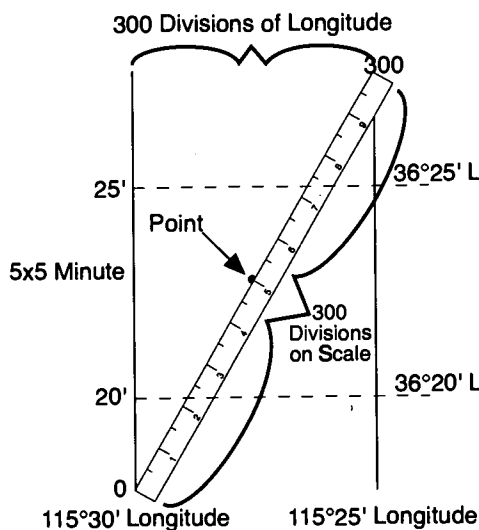

Figure 6.
Locating a point's longitude
on a 15-minute map

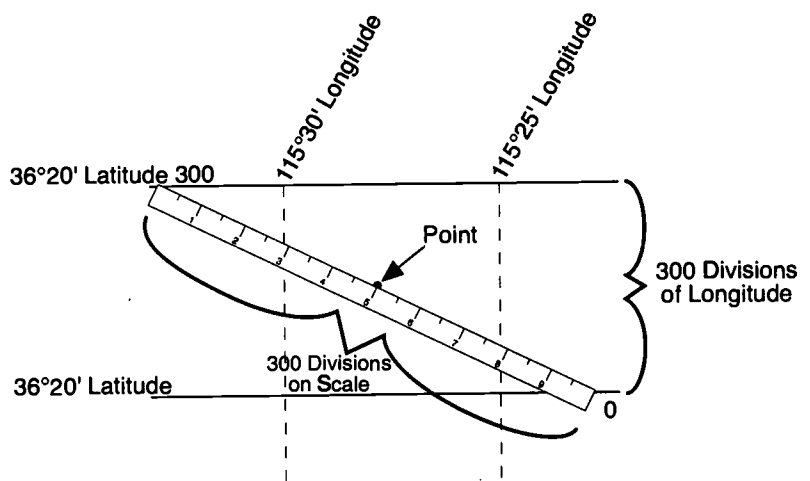

Figure 7.
Locating a point's latitude
on a 15-minute map

TOPOGRAPHIC MAP SKILLS

Directions: Use what you have learned in your reading lesson to answer the questions below.

True or False: If the answer is false, correct it to make it true.

- T 1. A topographic map shows details of the Earth's surface.
- T 2. The contour interval remains constant on any one topographic map.
- T 3. A standard USGS map is always oriented to true north.
- F 4. Lines of latitude are the lines on the map that run from the north geographic pole to the south geographic pole. (*Longitudinal lines run north to south.*)
- T 5. The magnetic declination, scale, and coordinates are found at the bottom of the map or in the margins.
- F 6. A contour line spirals from sea level to the highest elevation of a mountain. (*A contour line never changes elevation.*)
- F 7. A V-shaped bend in the contour line indicates flow of a body of water and points downstream. (*The V-shaped bend indicates an upstream direction.*)
- T 8. A topographic map scale can be expressed by the length of a bar scale or as a ratio.
- T 9. Topographic maps can be measured in minutes and seconds.
- F 10. You would use an ordinary ruler to determine coordinates of any point on a map. (*You would use an engineer's scale.*)

Bonus Question:

If a point lies 60" east of the longitudinal line of $120^{\circ} 12'$, what would be the longitudinal location of that point in degrees, minutes, and seconds? ($120^{\circ} 11'$)

PRACTICE WITH SCALE, LATITUDE, AND LONGITUDE

Directions: These problems will give you practice in using map skills involving scale, latitude, and longitude. In doing the problems, remember that more than one step may be necessary to answer the questions. For problems 4-7, it may help to draw a picture.

1. The distance between Chicago, Illinois, and Cleveland, Ohio, on a map of the United States at a scale of 1:2,500,000 is 7.75 inches. What is the true distance between the two cities in miles?

$$\frac{1 \text{ in.}}{2,500,000 \text{ in.}} = \frac{7.75 \text{ in.}}{x \text{ in.}}$$

$$x = 2,500,000 \text{ in.} \times 7.75 \text{ in.} = 19,375,000 \text{ in.}$$

$$x = 19,375,000 \text{ in.} \left(\frac{1 \text{ ft.}}{12 \text{ in.}} \right) \left(\frac{1 \text{ mi.}}{5,280 \text{ ft.}} \right) = 305.8 \text{ mi.}$$

$$x = 305.8 \text{ mi.}$$

Answer: First we determine how many miles per inch at this scale. Remember the meaning of scale: 1 inch on the map equals 2,500,000 inches on the ground. So 2,500,000 inches divided by 12 inches per foot tells us that 1 inch equals 208,333.3 feet. Now we divide 208,333.3 feet by 5,280 feet per mile to get 39.46 miles.

Now we know that 1 inch on the map equals 39.46 miles on the ground. The distance between Chicago and Cleveland is found by multiplying the distance in inches times the number of miles per inch: 7.75 inches \times 39.46 miles = 305.8 miles.

2. The distance between San Francisco, California, and Durango, Colorado, is 25.7 centimeters on a map whose scale is 1:5,000,000. What is the true distance between the two cities in kilometers?

$$\frac{1 \text{ cm.}}{5,000,000 \text{ cm.}} = \frac{25.7 \text{ cm.}}{x \text{ cm.}}$$

$$x = 5,000,000 \text{ cm.} \times 25.7 \text{ cm.} = 128,500,000 \text{ cm.}$$

$$x = 128,500,000 \text{ cm.} \left(\frac{1 \text{ m.}}{100 \text{ cm.}} \right) \left(\frac{1 \text{ km.}}{1,000 \text{ m.}} \right) = 1,285 \text{ km.}$$

$$x = 1,285 \text{ km.}$$

Answer: First we determine how many kilometers per centimeter at this scale. Remember the meaning of scale: 1 centimeter on the map equals 5,000,000 centimeters on the ground. So 5,000,000 centimeters divided by 100 centimeters per meter tells us that 1 centimeter equals 50,000 meters. Now we divide 50,000 meters by 1,000 meters per kilometer to get 50 kilometers.

Now we know that 1 centimeter on the map equals 50 kilometers on the ground. The distance between San Francisco and Durango is found by multiplying the distance in centimeters times the number of kilometers per centimeter: 25.7 centimeters \times 50 kilometers per centimeter = 1,285 kilometers.

3. Use the method outlined in Figures 6 and 7 in the reading entitled *Topographic Map Skills* to determine the longitude of a point between $81^{\circ} 30'$ and $81^{\circ} 32' 30''$. If you want to determine the longitude to the nearest second ($''$), how many divisions do you need on your scale?

(First determine the interval between two lines of longitude by subtracting: $81^{\circ} 32' 30'' - 81^{\circ} 30' = 2' 30''$. Now determine the number of seconds in $2' 30''$, which determines the number of seconds between the two lines of longitude. Since there are 60 seconds per minute, there must be $60 \text{ seconds} \times 2 \text{ minutes} + 30 \text{ seconds} = 120 \text{ seconds} + 30 \text{ seconds} = 150 \text{ seconds}$. Therefore, we need 150 divisions on our scale to read to the nearest second.)

4. Using a scale, you determine that a point is 35 seconds west of longitude $113^{\circ} 28' 31''$. What is the longitude of the point?

$$\begin{array}{r} 113^{\circ} 28' 31'' \\ + \quad 35'' \\ \hline 113^{\circ} 28' 66'' = 113^{\circ} 29' 6'' \end{array}$$

5. Using a scale, you determine that a point is $1' 10''$ east of longitude $78^{\circ} 14' 02''$. What is the longitude of the point? ($78^{\circ} 14' 02'' = 78^{\circ} 13' 62''$)

$$\begin{array}{r} 78^{\circ} 13' 62'' \\ - \quad 1' 10'' \\ \hline 78^{\circ} 12' 52'' \end{array}$$

6. Using a scale, you determine that a point is $5' 12''$ north of latitude $36^{\circ} 30' 00''$. What is the latitude of the point?

$$\begin{array}{r} 36^{\circ} 30' 00'' \\ + \quad 5' 12'' \\ \hline 36^{\circ} 35' 12'' \end{array}$$

7. Using a scale, you determine that a point is $11' 20''$ south of latitude $22^{\circ} 10' 28''$. What is the latitude of the point?

$$\begin{array}{r} 22^{\circ} 10' 28'' \\ - \quad 11' 20'' \\ \hline 21^{\circ} 59' 08'' \end{array}$$

CONTOURING

Directions: On a topographic map contour lines connect points of equal elevation. Make a topographic map by connecting points of equal elevation to form contour lines. Start with the highest contour.

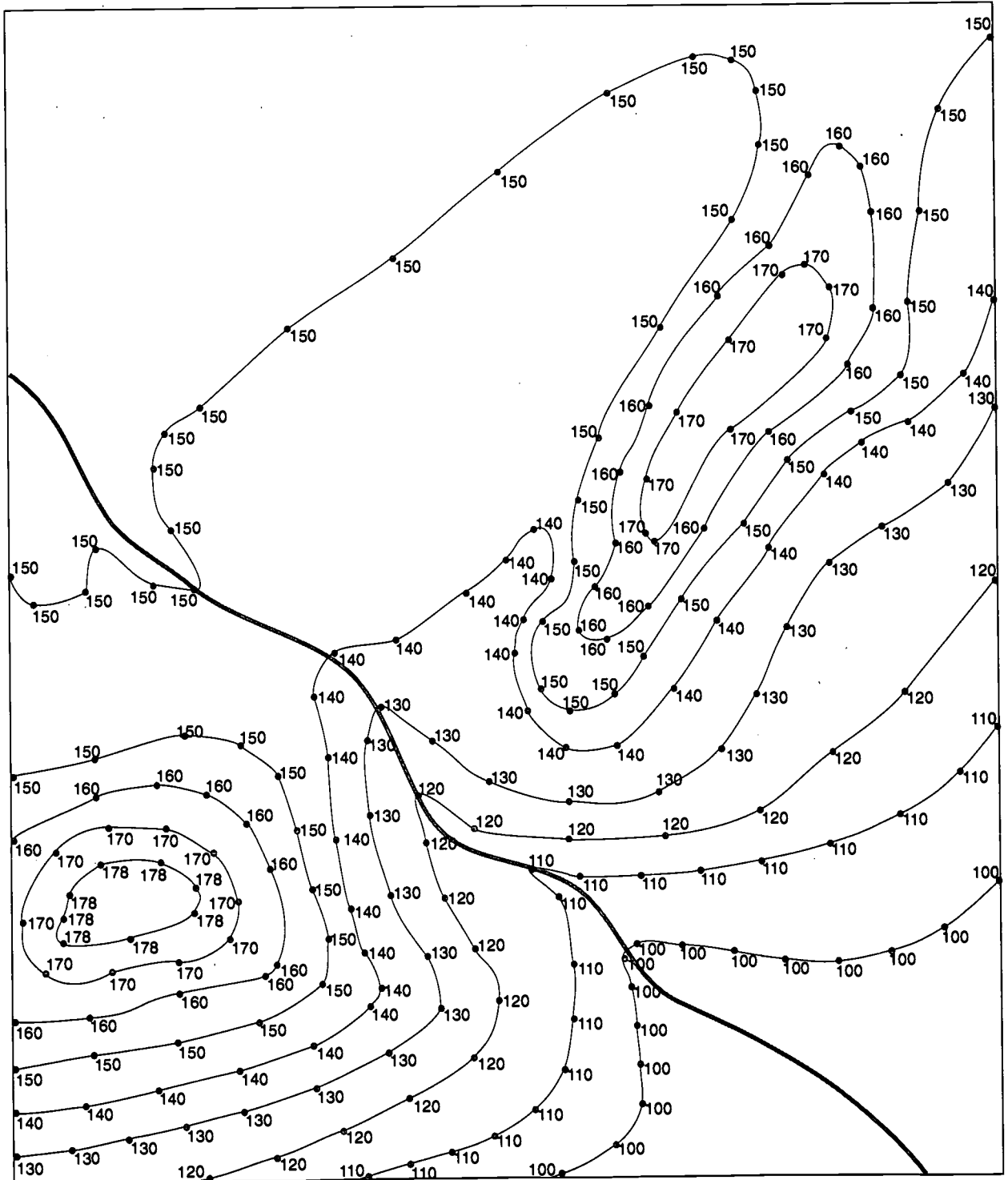

TOPOGRAPHIC MAPS OF LANDSCAPES

Directions: Look at the block diagrams that represent landscapes and match them to the correct topographic maps by writing the letter of the map in the blank.

Block Diagrams

Topographic Maps

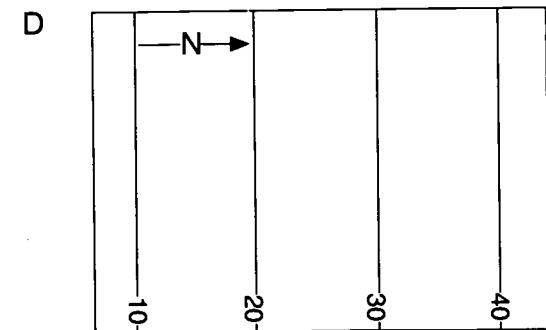
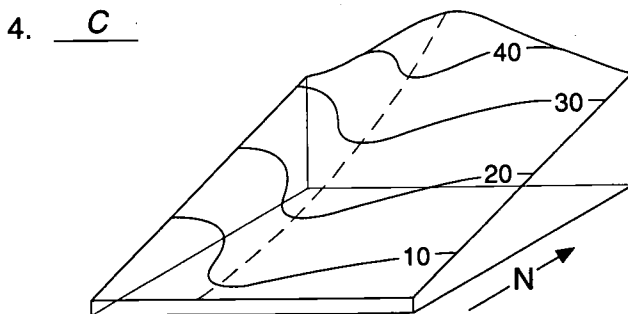
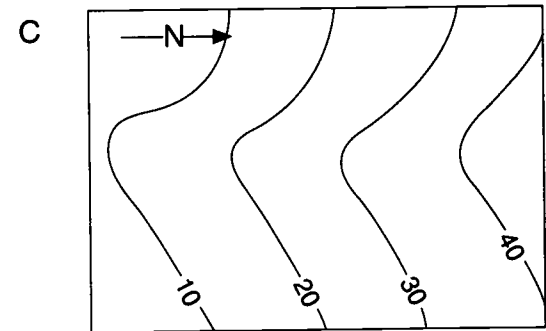
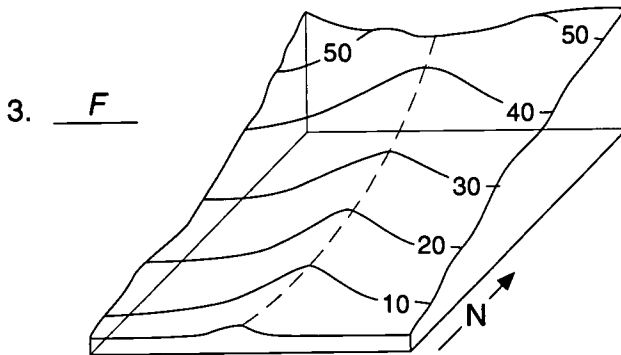
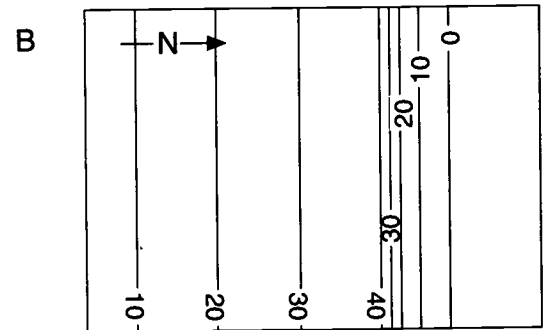
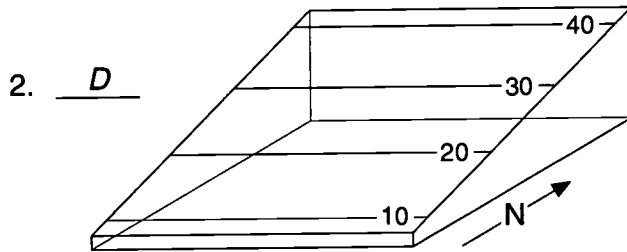
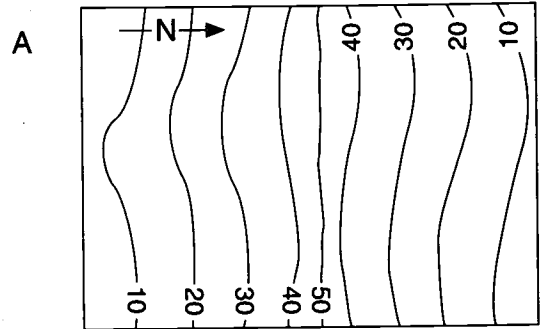
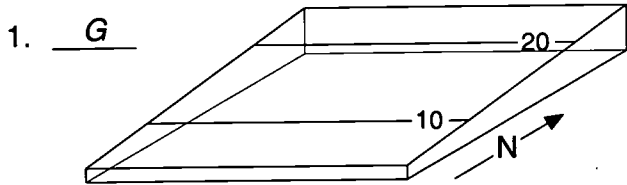

Block Diagrams

Topographic Maps

5. H

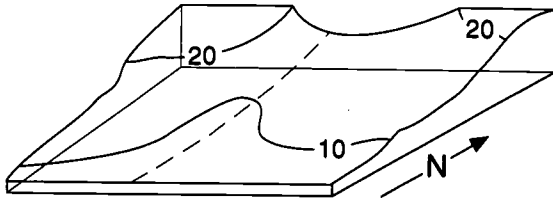

E

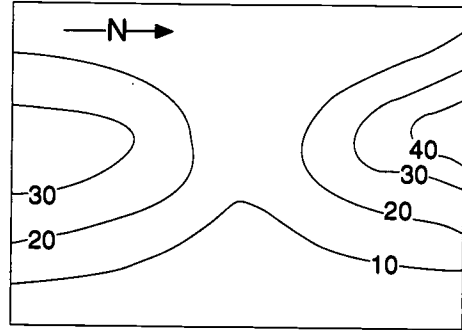

6. B

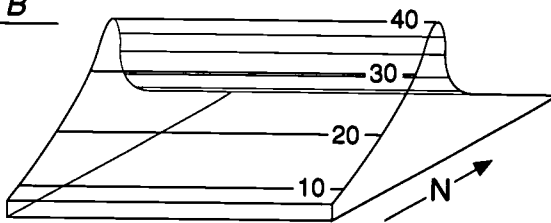

F

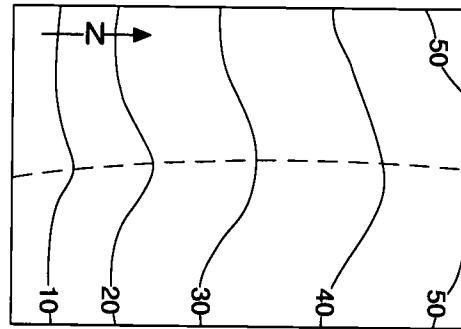

7. A

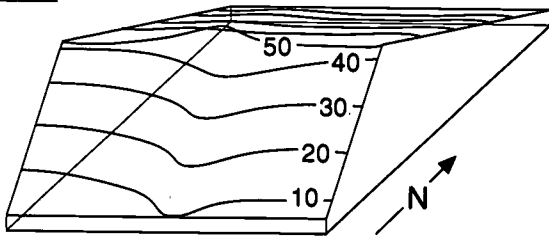

G

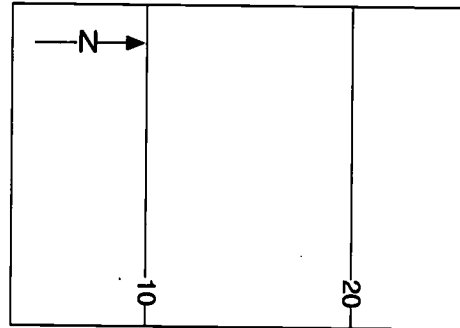

8. E

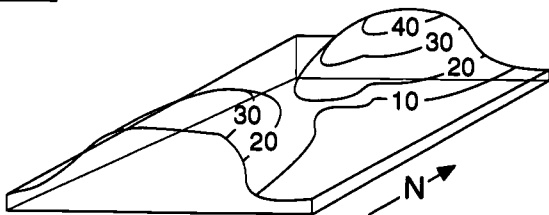

H

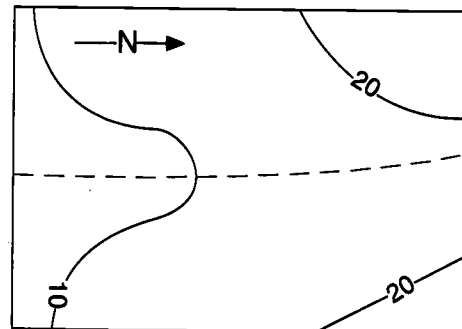

TOPOGRAPHIC MAP SKILLS - Part II

Purpose:

The purpose of this exercise is to demonstrate the usefulness of topographic maps and to examine the topography of the Yucca Mountain site by using a U.S. Geological Survey 7-1/2-minute topographic map. By participating in the exercise, the student will acquire a detailed knowledge of the Yucca Mountain site and an understanding of the size and depth of the potential repository. The student will also use prominent features on the map to aid him/her in thinking about guidelines for a repository published in the *Code of Federal Regulations (10 CFR part 60)* concerning erosion, hydrology, population density and distribution, and site ownership and control.

Concepts:

1. A topographic map is the projection of a landscape onto a piece of paper showing detailed surface features of the Earth such as elevation and slope and the presence of water.
2. Given the coordinates of a point on a topographic map, points of orientation such as map borders and grid ticks can be used to locate that point on the map.
3. A topographic map can be used to produce a profile of the topography between two points.
4. A topographic map includes the placement of existing buildings and information regarding general ownership of the land.
5. A topographic map can be used to develop working hypotheses regarding land use.

Duration of Lesson:

Five 50-minute class periods

Objectives:

As a result of participation in this lesson, the learner will be able to:

1. interpret topographic map scale and symbols;
2. draw a topographic profile; and
3. synthesize information from the topographic map and *The General Guidelines for the Recommendation of Sites for the Nuclear Waste Repositories* to make judgments relating to repository siting.

Skills:

Analyzing, calculating, constructing topographic profiles, decision making, determining contour intervals, finding scale, graphing, using longitude and latitude, plotting map coordinates, synthesizing

Vocabulary:

Accessible environment, aquifer, brine, dike, dissolution, erosion, evapotranspiration, exhumation, fault, flux, fold, geohydrology, geomorphic, hydraulic, hydraulic gradient, Quaternary Period, radionuclide, shear, sill, stratigraphic

Materials:

Activity Sheets

Topography of the Yucca Mountain Site, p. 219.

Considerations for Siting the High Level Nuclear Waste Repository, p. 233

Other

U.S. Geological Survey topographic map (7-1/2-minute version) Busted Butte, Nevada
Quadrangle

Engineers scale with divisions of 10 through 60 per inch (available from drafting or mechanical drawing classes) or the paper scale

Pencil

Graph paper

Plain paper

Blue pencil

Repository shape cut out

Optional

Federal Register, Thursday, December 6, 1984 (10CFR Part 960), Nuclear Waste Policy Act of 1982; *Guidelines for the Recommendation of Sites for the Nuclear Waste Repositories; Final Siting Guidelines* (order free of charge from the OCRWM National Information Center, 1-800-225-6972; within Washington, DC, 202-488-6720)

Suggested Procedure:

1. As a reading review have students complete the first part of *Topography of the Yucca Mountain Site, Reviewing Map Skills*. Discuss student answers to ensure that they are prepared to continue with *Part A: Locating a Point on a Topographic Map* and *Part B: Drawing a Topographic Profile*.
2. *Part A: Locating a Point on a Topographic Map* will take approximately one class period to complete. Advanced students may be able to follow directions and complete this activity independently. It may be necessary to work through locating point 1, step by step, with students who have not been exposed to these map skills before. An overhead projector and transparencies of the activity sheets and map would be helpful. Laminating the map so that magic markers can be used and erased after every demonstration may be an alternative to using overhead projection. After locating point 1 as a group, students should be able to follow the same procedure to locate point 2 on their own.
3. *Part B: Drawing a Topographic Profile* will also take approximately one class period to complete. Again, advanced students may be able to follow directions and complete this activity independently. Students may need to share available topographic maps in groups, but have each student produce his/her own profile. If necessary, work through this activity step by step with students. Encourage students to accurately record the position of contour lines and their elevation.
4. In order to complete *Considerations for Siting the High-Level Nuclear Waste Repository* students will need to have their completed profiles. Since this activity is very long, it is suggested that it be completed in separate parts.

5. It may be helpful to read the excerpts from *General Guidelines for the Recommendation of Sites for the Nuclear Waste Repositories* for each section as a group. (These are included as part of the exercise, or students can use the original document.) Discuss each condition to ensure that students understand the terminology. Give students an opportunity to work through the questions following each excerpt in small groups. When each group is finished, discuss answers. Students should realize that they are following a very similar, yet simplified, procedure to that used by geologists who are actually involved in site characterization studies at Yucca Mountain.
6. *Erosion* should take one 50-minute class period to complete. *Ground water* will take two class periods to complete. (Only one if students are able to complete part for homework.) During class discussion, bring students' attention to the fact that they drew the lines representing the water tables on their profiles based on well J-12. Relate drawing this line to the nature of scientific understanding as discussed in the course introduction, and the process of doing science. Be sure students understand that scientists sometimes make assumptions that they cannot really prove, as a starting point or a working hypothesis.
7. *Population Density and Distribution* and *Site Ownership and Control* can be completed in one class period. The pamphlet *Topographic Map Symbols* available from the U. S. Department of the Interior, Geologic Survey (see Background Notes) will help students answer questions in these sections.
8. Metric equivalents have not been provided for this lesson because the topographic maps available through the U.S. Geological Society (USGS) are not metric.

Teacher Evaluation of Learner Performance:

Student participation in class discussions and completion of the activities in Part II of this lesson will indicate understanding.

Additional Enrichment:

Have students create their own topographic map using what they have learned in the Reading Lesson *Topographic Map Skills* and the activities from Parts I and II. They should include the following details on their maps:

Scale: 1: 24,000 (English or Metric units)

Size: 7-1/2 minutes x 7-1/2 minutes

Latitude: Pick your own

Longitude: Pick your own

Magnetic Declination: 12°

Terrain: Use appropriate symbols to show mountains, depressions, steep slopes, gentle slopes, flat areas, and water.

Color and Symbols: Use the appropriate color and symbols to illustrate property ownership and control and population density and distribution.

Cross Ticks: Place them and label them for latitude and longitude.

Map Title: Make up your own fictional location.

Date: Date the map was created

Bar Scale: Create a bar scale relating the map scale to the actual area of the map.

Contour Lines: Create, indicate, and use the contour interval to show terrain.

After students have created their maps, have them consider *Erosion, Groundwater, Population Density and Distribution* and *Site Ownership and Control* to site a high-level waste repository somewhere on their map. Students should be prepared to defend their choice with evidence based in the *General Guidelines for the Recommendation of Sites for the Nuclear Waste Repositories*.

If time permits, it may be interesting to give students an opportunity to create and role play a *Potentially Adverse Condition* relating to *Site Ownership and Control*. Students may choose to be private landowners, representatives for Indian tribes, representatives for the affected State or DOE officials. As part of the role play, they should either resolve the dispute or decide to consider another site for characterization. Decisions and conclusions for each group should be made based on discoveries made during participation in this curriculum.

TOPOGRAPHY OF THE YUCCA MOUNTAIN SITE

The purpose of this activity is to demonstrate the usefulness of topographic maps and to examine the topography of the Yucca Mountain site by using a U.S. Geological Survey 7-1/2 minute topographic map. By participating in the exercises, you will acquire a detailed knowledge of the Yucca Mountain site and an understanding of the size and depth of the potential repository. You will also use prominent features on the map to aid you in thinking about guidelines for evaluating potential repository sites that apply to hydrology, erosion, population density and distribution, and site ownership and control.

Directions: Use the U.S. Geological Survey 7-1/2 minute topographic map titled Busted Butte, Nevada, 1961, photo-revised 1983 to answer the questions below.

Reviewing Map Skills

- Determine the scale and contour interval of the map.

Scale: (1:24,000)

Contour interval: (20 feet)

- What does 1" on this map represent on the ground? (Show the answer both in inches and converted to feet.)

(One inch on the map represents 24,000 inches on the ground; this is equal to 2,000 feet.)

- Locate the information that shows the direction of true north and magnetic north on the map. Where is the information located on the map?

(It is located in the bottom margin to the left of the scale.)

- What are the latitude and longitude coordinates of the southeast and northwest corners of the map?

(Southeast—latitude N36° 45', longitude W116° 22' 30"

Northwest corner—latitude N36° 52' 30", W116° 30')

5. What is the purpose of the latitude and longitude grid ticks? List each set of grid ticks separately. (See Figure 1.)

(The latitude and longitude grid ticks divide the map into nine 2-1/2-minute by 2-1/2-minute sections. They are used to help locate or find the coordinates of any point on the map.)

Latitude Grid Ticks: (N36° 50', N36° 47' 30")

Longitude Grid Ticks: (W116° 27' 30", W116° 25')

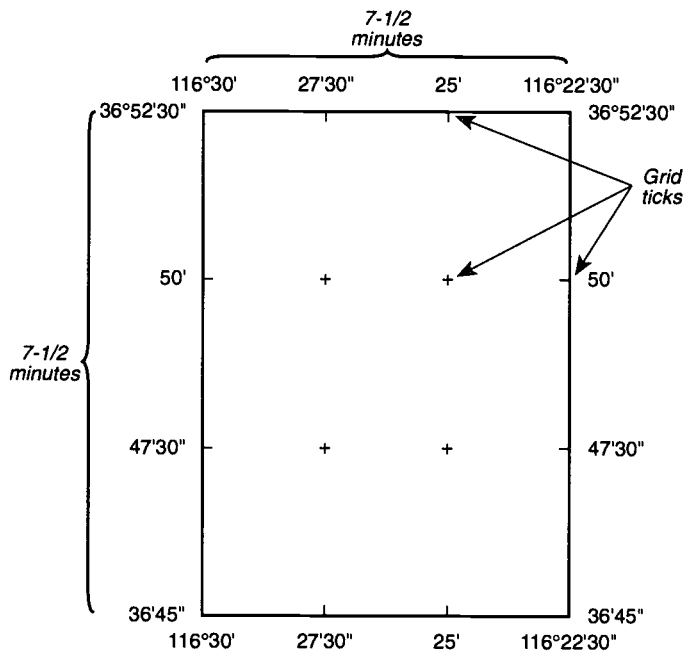

Grid ticks divide a 7-1/2-minute map into 2-1/2-minute sections

Figure 1

Part A: Locating A Point On A Topographic Map

Directions: Use the map, an appropriately scaled ruler, and the following latitude/longitude coordinates to locate two points on the map. You will locate each point by finding where a line of latitude and a line of longitude cross.

Point 1: Lat N36° 50' 44", Long W116° 29' 34"

Point 2: Lat N36° 51' 12", Long W116° 23' 28"

Point 1

- Point 1 falls on Lat N36° 50' 44". Between which orienting points of latitude (grid ticks and/or map borders) does point 1 fall?

(N36° 50' and N36° 52' 30")

Draw a line through the necessary orienting point(s) to separate this section of latitude from the rest of the map. (See Figure 2.)

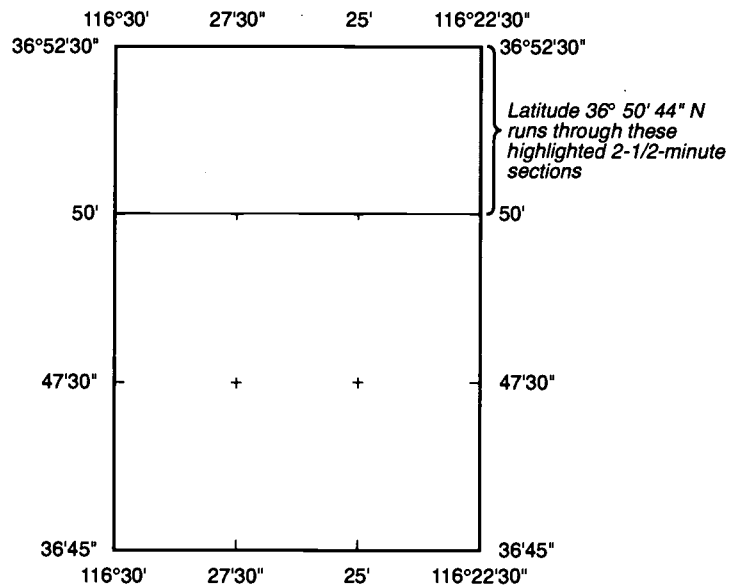

Figure 2

2. Point 1 falls on Long $W116^{\circ} 29' 34''$. Between which orienting points of longitude does point 1 fall?
($W116^{\circ} 30'$ and $W116^{\circ} 27' 30''$)
-

Draw a line through the necessary orienting point(s) to separate this section of longitude from the rest of the map. (See Figure 3.)

At this point, one section of the map should be separated from the rest of the map. This section is 1/9th of the whole quadrangle map and it contains point 1. (See Figure 4.)

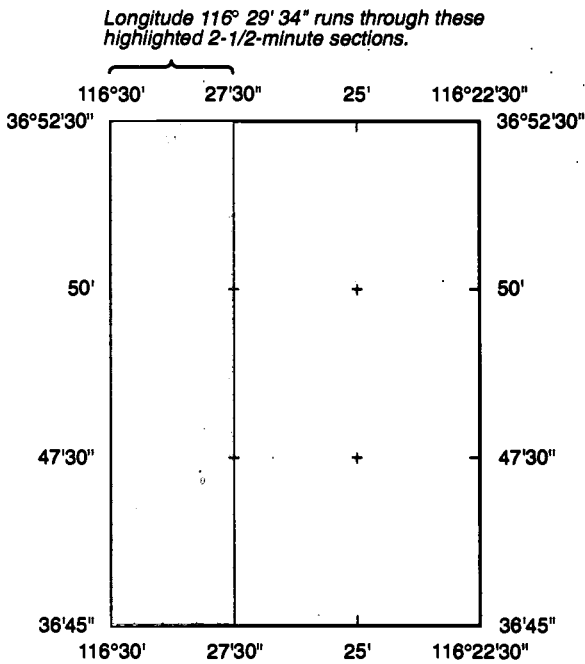

Figure 3

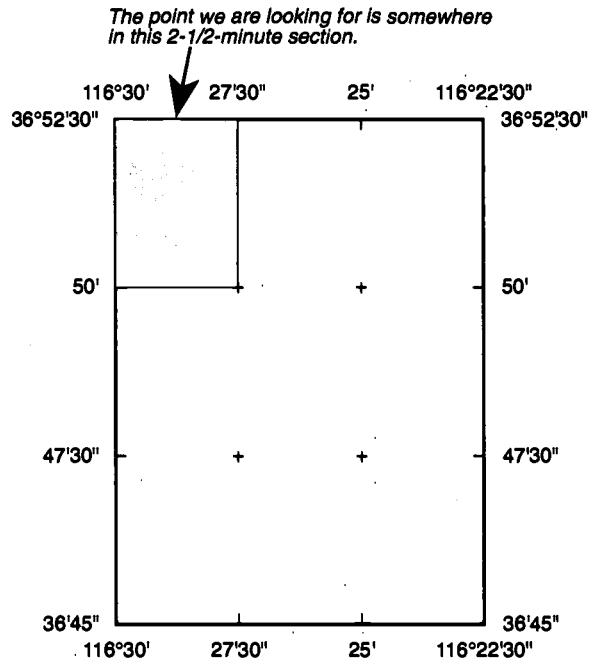

Figure 4

3. In which section of the map will you find point 1?

NW	NC	NE
WC	C	EC
SW	SC	SE

(The NW section.)

4. What are the dimensions of this section of the map in minutes? Convert to seconds.

Minutes $(2\text{-}1/2 \text{ minutes} \times 2\text{-}1/2 \text{ minutes})$

Seconds $(150 \text{ seconds} \times 150 \text{ seconds})$

5. How many seconds north of the $N36^\circ 50'$ line of latitude is $N36^\circ 50' 44''$?

$(36^\circ 50' 44'' - 36^\circ 50' = 44'')$

6. Use the engineer's rule or cut out the paper engineering ruler provided that has 150 divisions. Since the section of the map that includes point 1 is 2-1/2 minutes by 2-1/2 minutes or 150 seconds by 150 seconds, you will be able to use this ruler to find point one or any unknown point within a section. (Each division equals one second.)

Using the ruler, locate any two points 44" (44 divisions) north of Lat $N50'$. You will need to hold the ruler vertically with the 0 mark on Lat $N50'$ and the 150 mark on the top border of the map. (See Figure 5.)

Connect the points. Point 1 is somewhere on this line.

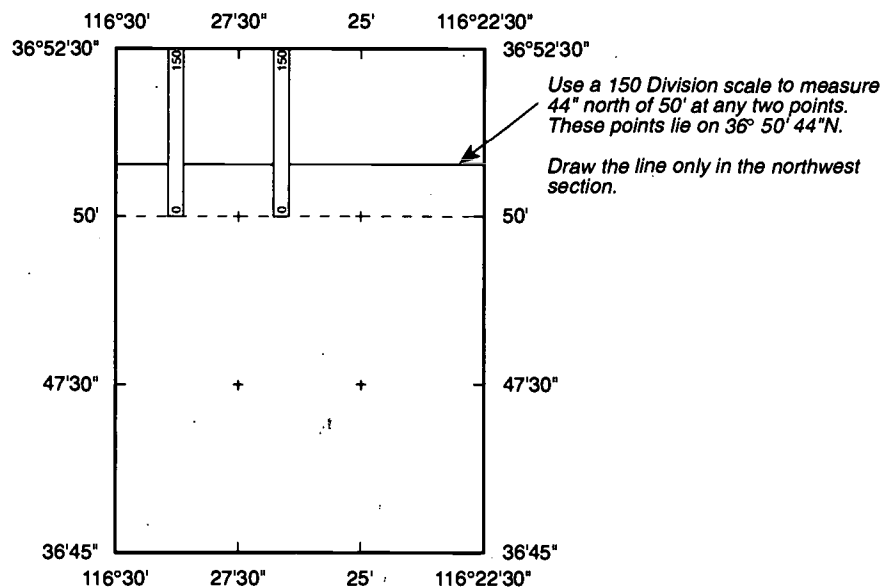

Figure 5

7. How many minutes west of the 27' 30" line of longitude is W116° 29' 24"?

Minutes $(116^{\circ} 29' 34'' - 116^{\circ} 27' 30'' - 2' 4'')$

Seconds $(2'' 4' = 124'')$

You can subtract distances in degrees, minutes, and seconds but remember that you are working in base 60. One degree is equal to 60 minutes, and one minute is equal to 60 seconds.

8. Using the ruler, locate any two points 124" (124 divisions) west of Long W27' 30". This time you will need to hold the ruler diagonally as illustrated in Figure 6. It is important that you align either the 0 or 150 mark on the ruler with the 27' 30" line. You must align the other division mark (0 or 150) on the western boundary of the map. Count 124" west of 27' 30" and mark a point on the map. Although both ends of the ruler need to be aligned properly, they do not necessarily need to fall within the boundaries you have drawn for this section. Move the ruler, align it again, and make a second mark.

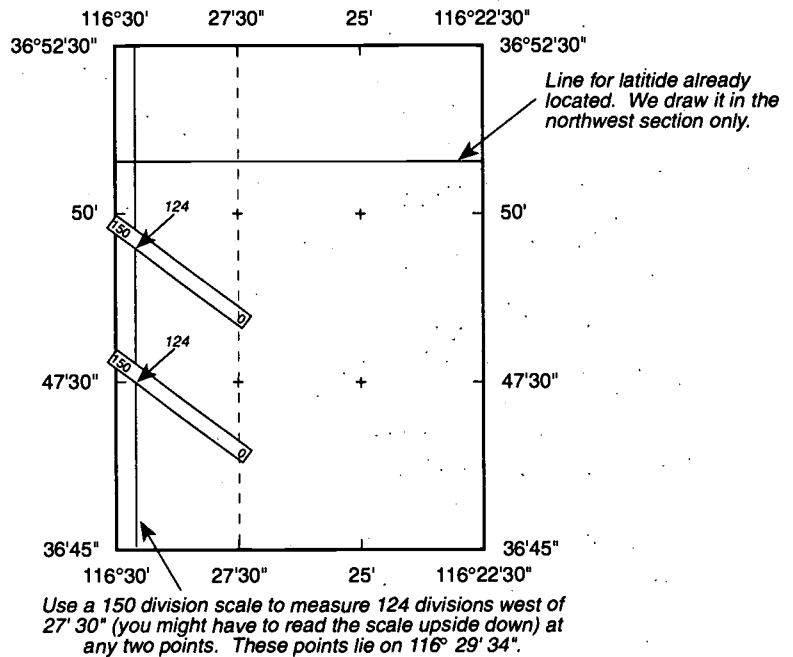

Figure 6

Connect the two points making sure the line that connects them extends through the NW section of the map. Point 1 is where the line of longitude crosses the line of latitude you drew in step 6.

Point 2

9. Use the same approach to locate point 2.

Using a blue pencil, connect points 1 and 2.

Part B: Drawing A Topographic Profile

If we could cut the Earth in half along the line that connects points 1 and 2, and then look at the planet's profile, we could clearly see peaks and valleys and get a good three-dimensional view of the topography of the land in this area. A much simpler way to gather the same information from a two-dimensional drawing is to construct a topographic profile.

1. What is the contour interval on your Busted Butte, Nevada, map?

(Contour interval = 20 feet)

2. Using a sheet of paper that is at least 15" long on one side, align it so that the edge of the paper lines up with the line connecting points 1 and 2. (If necessary, tape two 8-1/2" x 11" sheets together.)

3. Make a mark on the paper where every dark brown (100) contour line crosses the line connecting points 1 and 2. (See Figure 7.) Record each line's elevation next to each mark. You may need to follow some contour lines quite a distance to determine their elevation. Where 100 contour lines are great distances apart, mark all others to get a greater degree of accuracy in your profile. Also record the location of jeep trails or roads where they cross the line of section.

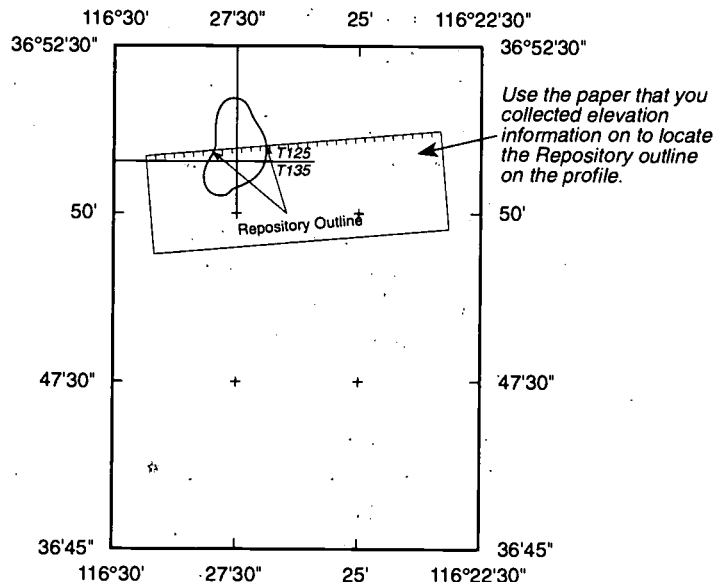
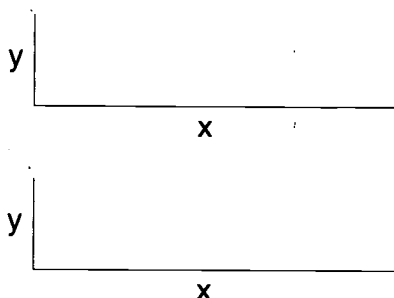

Figure 7

5. Draw two x and y axes on the graph paper as indicated below. The x-axis will represent the distance from point 1 to 2. The y-axis will represent different scales for each graph. One graph will have a scale of 1" = 500' while the other will have a scale of 1" = 2000'.



6. Line up the piece of paper that shows where contour lines cross the line connecting points 1 and 2, with the X-axis of your first graph as indicated below. At each mark along the X-axis, make a mark, at the appropriate elevation, as read on the y-axis. Do this for all points. Then connect the dots using a smooth line.
7. Repeat this procedure for the second graph using the second scale.

What effect does the different vertical scale have on each profile?

(The different scales enable you to see the same thing in two ways. The 1":500' scale shows sharper peaks. The 1":2000' scale looks flatter.)

Which profile appears more like it would naturally occur?

(An exaggerated profile is a way of magnifying the elevation data. This allows you to see more subtle changes in slope that you might miss on a profile drawn to scale.)

Which profile emphasizes the subtle aspects of the surface along the profile by showing more details of the landscape?

(1":500')

8. A pattern that represents the outline of the underground repository as it might appear in a final design is included. Cut out the pattern and use the lines drawn on the cut-out to locate it on the map. Transfer the shape to the map using a blue pencil. Now plot the locations on the topographic profile where the repository outline intersects the profile.

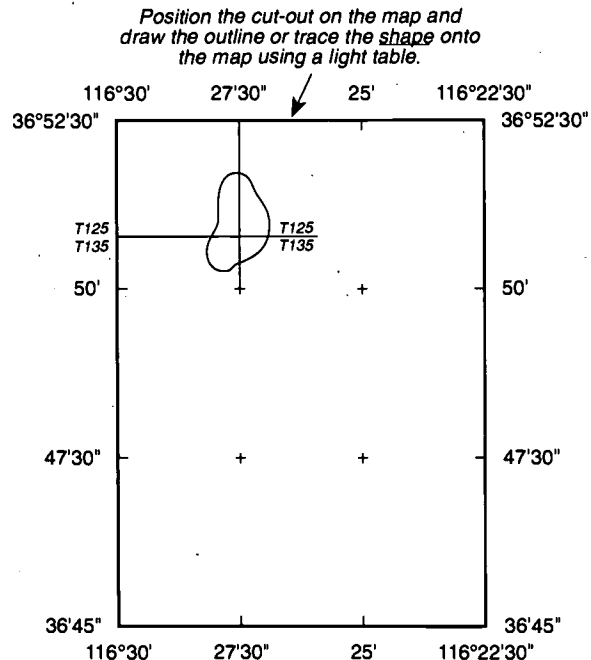
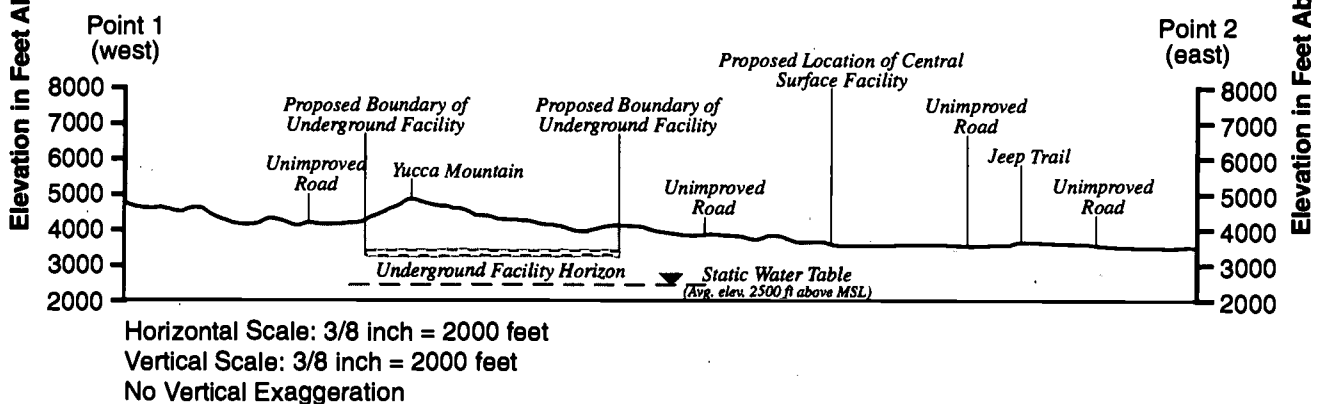
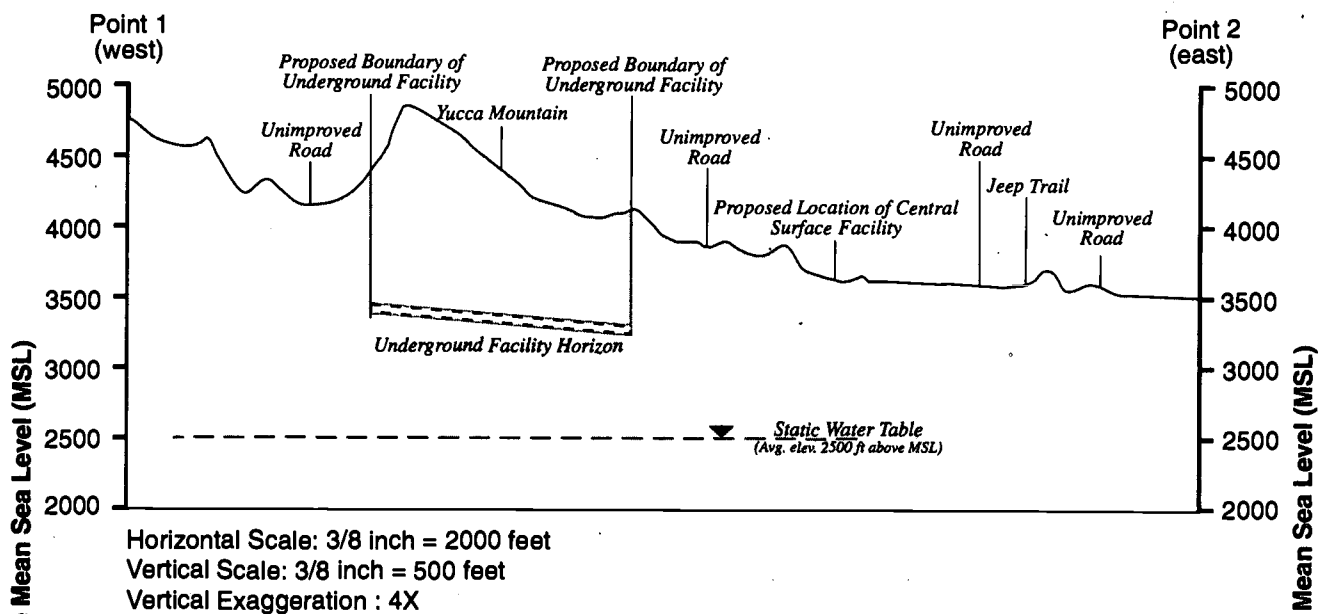

Figure 8

East-West Topographic Profiles Across Yucca Mountain



Since the vertical scale (VS) is larger than the horizontal scale (HS), the top profile is exaggerated. The vertical exaggeration (VE) of the profile is easily determined by the following relationship:

$$VE = \frac{HS}{VS}$$

where both the HS and VS are in the same units (i.e., feet, inches). The VE for the top profile is: $2000/500=4$, which is written as 4X. The lower profile is said to have no VE since the HS and VS are equal (1 inch = 2000 feet).

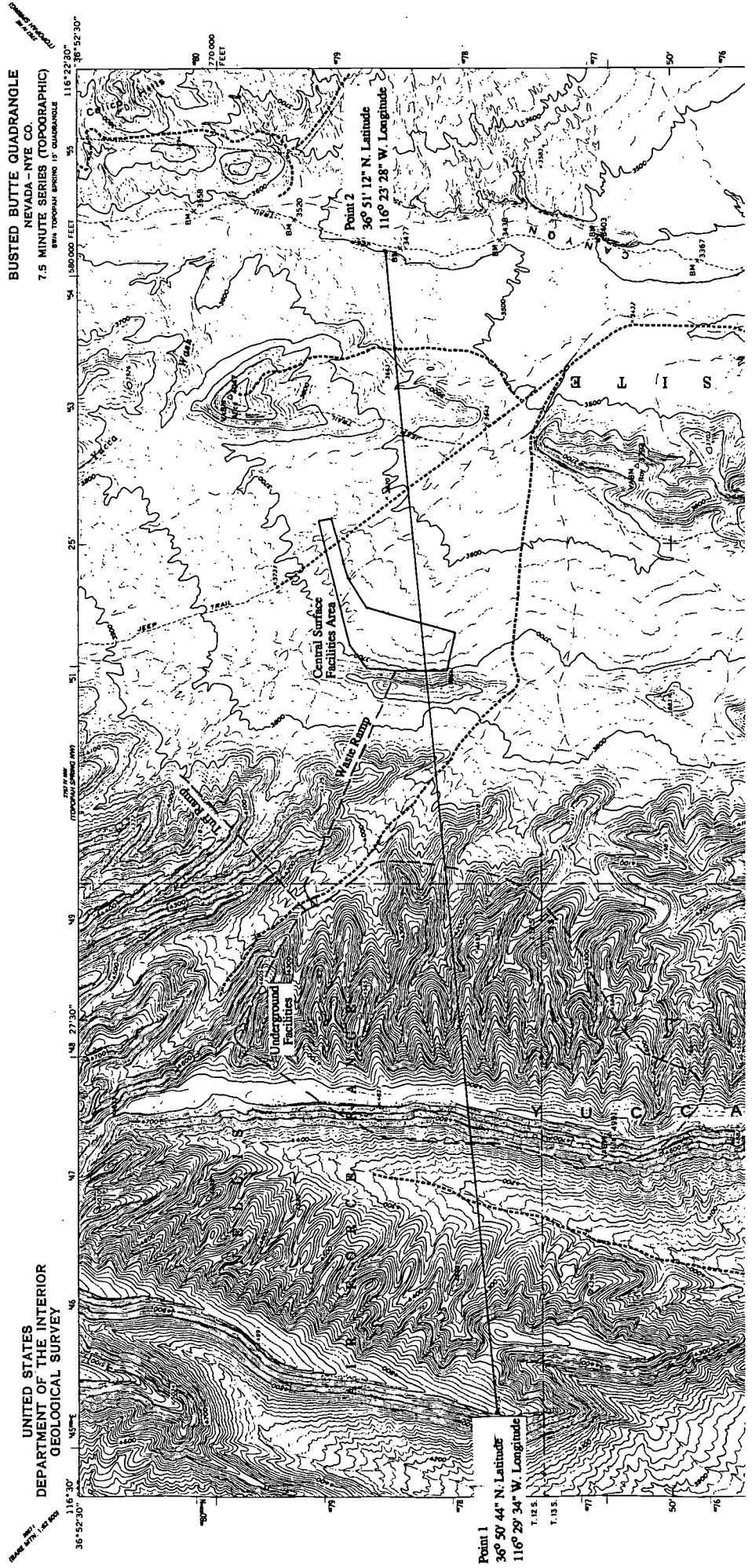

EROSION

Directions: Read the excerpt from *General Guidelines for the Recommendation of Sites for the Nuclear Waste Repositories: Final Siting Guidelines*, below, using it to answer the questions that follow.

960.4-2-5 Erosion

(a) *Qualifying Condition.*

The site shall allow the underground facility to be placed at a depth such that erosional processes acting upon the surface will not be likely to lead to radionuclide releases greater than those allowable under the requirement specified in Guideline 960.4-1. In predicting the likelihood of potentially disruptive erosional processes, the DOE will consider the climatic, tectonic, and geomorphic evidence of rates and patterns of erosion in the geologic setting during the Quarternary Period.

(b) *Favorable Conditions.*

- (1) Site conditions that permit the emplacement of waste at a depth of at least 300 meters below the directly overlying ground surface.
- (2) A geologic setting where the nature and rates of the erosional processes that have been operating during the Quarternary Period are predicted to have less than one chance in 10,000 over the next 10,000 years of leading to releases of radionuclides to the accessible environment.
- (3) Site conditions such that waste exhumation would not be expected to occur during the first one million years after repository closure.

(c) *Potentially Adverse Conditions.*

- (1) A geologic setting that shows evidence of extreme erosion during the Quarternary Period.
- (2) A geologic setting where the nature and rates of geomorphic processes that have been operating during the Quarternary Period could, during the first 10,000 years after closure, adversely affect the ability of the geologic repository to isolate the waste.

(d) *Disqualifying Condition.*

The site shall be disqualified if site conditions do not allow all portions of the underground facility to be situated at least 200 meters below the directly overlying ground surface.

1. What is the lowest ground surface elevation along your topographical profile within the possible repository boundary?

(The lowest ground surface elevation is 1,250 meters [4,100 feet].)

2. According to Favorable Condition (1) above, how deep should the repository be in meters? How many feet is this? (Remember that 1 meter = 3.28 feet.)

(The repository should be 300 meters below the surface. 300 meters equals 984 feet.)

3. At what depth (in meters and feet) within the possible repository boundary could the repository be built to satisfy Favorable Condition (1)? Draw a line on your topographical profiles to represent this placement of the repository.

(Since the lowest elevation within the boundaries is 1,250 meters [4,100 feet], the repository would need to be placed at about 950 meters [3,100 feet] to satisfy this condition.)

4. According to the Disqualifying Condition above, what is the minimum allowable depth for the repository in meters? How many feet is this?

(The repository must be at least 200 meters below the surface. 200 meters equals 656 feet.)

5. At what depth (in meters and feet) within the possible repository boundary could the repository be built to satisfy the Disqualifying Condition? Draw a line on your topographical profiles to represent this placement of the repository.

(The repository would need to be placed at or below 1,006 meters [3,300 feet].)

6. Calculate the maximum rate of erosion that would uncover a repository at a depth of 200 meters, and a repository at 300 meters, during a time span of 10,000 years.

$$\frac{(200 \text{ meters})}{10,000 \text{ years}} = 0.02 \text{ meters/year} = 2 \text{ centimeters/year}$$

10,000 years

$$\frac{(300 \text{ meters})}{10,000 \text{ years}} = 0.03 \text{ meters/year} = 3 \text{ centimeters/year}$$

10,000 years)

GROUND WATER

1. According to a hydrologic atlas published by the U.S. Geological Survey:
 - 1) The State of Nevada has a mean precipitation of 9 inches per year, the lowest statewide mean in the United States.
 - 2) An average of less than 1 inch of this precipitation either recharges aquifers or runs off.
 - 3) In 84 percent of the State, drainage is to low areas in enclosed basins rather than to the sea. Flow in the larger rivers generally decreases downstream as water is lost to evaporation and infiltration.

Directions: Use these three facts and the topographic map, as necessary, to answer the questions below.

- a. Of the 9 inches of annual precipitation, how much is evaporated?

(Since an average of 1 inch infiltrates, then 8 inches evaporate.)

- b. Examine the topographic map looking for evidence of running water (runoff). What do you think the blue dashed and dotted lines represent?

(The blue dashed and dotted lines represent intermittent flow of water that occurs when

runoff exceeds losses from evaporation and infiltration.)

- c. Look at the area east of Yucca Mountain toward Fortymile Canyon and Fortymile Wash. What happens to runoff from Yucca Mountain when it reaches Fortymile Wash, southeast of Busted Butte?

(Only runoff from intense rainstorms reaches Fortymile Wash. Eventually it will evaporate

and infiltrate. There are no continuously flowing streams and/or rivers that reach the

ocean or a permanent lake from this part of Nevada.)

- d. Explain why you think flow decreases downstream, rather than increases, in this area of the country.

(Streamflow decreases because more water is lost due to infiltration and evaporation than is contributed by rainfall.)

- e. Use an almanac or other reference book to find the mean annual precipitation for the State of South Carolina. What is the annual precipitation? Why do you think streams and rivers flow continuously in this State even during long periods without rainfall?

(The mean annual precipitation for South Carolina is about 50 inches/year. This volume creates a surplus of water that is carried to the ocean in continuously flowing streams.

Groundwater inflow from the saturated zone supplies much of the surplus water.)

2. One of the important considerations in siting the repository is the elevation of the water table. The water table separates the saturated zone from the unsaturated zone. Examine Figure 10, which shows how water is obtained from wells drilled into the saturated zone beneath the surface of the ground. Assume Figure 10 represents conditions as they exist in this part of Nevada. Now look in the south-east corner of the Busted Butte topographic map for Well J-12. At what surface elevation is Well J-12? Based on the evidence provided by the topographic map alone, what is the maximum depth of the water table in this region?

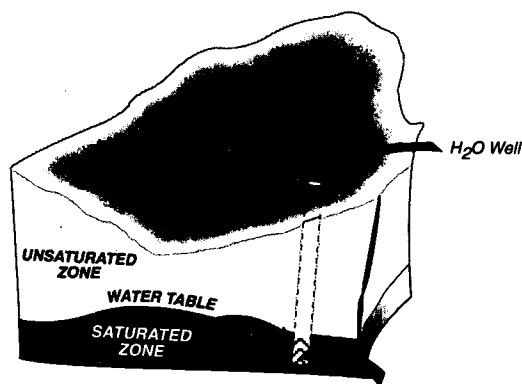

Water wells pump water from the saturated zone beneath the water table.

Figure 10

(Well J-12 is at elevation 3,130 feet. The water table elevation must be 3,130 feet at the most.)

3. What are other indications of the depth of the water table?

(Other areas of low elevation, lack of running water.)

4. Do any of the items you listed in question 3 suggest that the water table is deeper than what was suggested by the location of Well J-12?

(Yes. There is a contour near Fortmile Wash at 3,120 feet.)

5. Using the water table elevation that you determined in question 2, draw a line at this elevation across the entire length of the topographic profiles that you prepared and label it "MAXIMUM POSSIBLE WATER TABLE ELEVATION BASED ON WELL J-12."
6. What assumptions are we making when we draw this line?

(This line is only a guess about the elevation of the water table along the profile line. This is why it should be clearly labeled as directed. We assume (1) the conditions in the Well J-12 area are the same as in the NW corner of the map, and (2) the water table is at a constant elevation.)

7. How certain are you that this line represents a real water table elevation?

(Answers will vary, but should indicate that we cannot be certain.)

8. Why draw this line at all?

(We draw this line as an educated guess. It might give us some ideas about determining the true elevation of the water table.)

9. How would you obtain a much more precise value for the elevation of the water table in the vicinity of Well J-12? How would you obtain a much more precise depth for the water table along the topographic profile that you drew?

(The water table elevation can be determined by measuring the depth to the water in Well J-12. To obtain the water elevation along the line of profile, it would be necessary to drill wells at various locations along the line of profile and measure the depth of the water table.)

Directions: Read the excerpt from *General Guidelines for the Recommendation of Sites for the Nuclear Waste Repositories: Final Siting Guidelines*, below, using it to answer the questions that follow.

960.4-2-1 Geohydrology**(a) Qualifying Condition.**

The present and expected geohydrologic setting of a site shall be compatible with waste containment and isolation. The geohydrologic setting, considering the characteristics of and the processes operating within the geologic setting, shall permit compliance with

- (1) the requirements specified in 960.4-1 for radionuclide releases to the accessible environment and
- (2) the requirements specified in 10 CFR 60.113 for radionuclide releases from the engineered-barrier system using reasonably available technology.

(b) Favorable Conditions.

- (1) Site conditions such that the pre-waste-emplacment ground-water travel time along any path of likely radionuclide travel from the disturbed zone to the accessible environment would be more than 10,000 years.
- (2) The nature and rates of hydrologic processes operating within the geologic setting during the Quaternary Period would, if continued into the future, not affect or would favorably affect the ability of the geologic repository to isolate the waste during the next 100,000 years.
- (3) Sites that have stratigraphic, structural, and hydrologic features such that the geohydrologic system can be readily characterized and modeled with reasonable certainty.
- (4) For disposal in the saturated zone, at least one of the following pre-waste-emplacment conditions exist:
 - (i) A host rock and immediately surrounding geohydrologic units with low hydraulic conductivities.
 - (ii) A downward or predominantly horizontal hydraulic gradient in the host rock and in the immediately surrounding geohydrologic units.
 - (iii) A low hydraulic gradient in and between the host rock and immediately surrounding geohydrologic units.
 - (iv) High effective porosity together with low hydraulic conductivity in the rock units along paths of likely radionuclide travel between the host rock and accessible environment.
- (5) For disposal in the unsaturated zone, at least one of the following pre-waste-emplacment conditions exists:
 - (i) A low and nearly constant degree of saturation in the host rock and in the immediately surrounding geohydrologic units.
 - (ii) A water table sufficiently below the underground facility such that the fully saturated voids continuous with the water table do not encounter the host rock.
 - (iii) A geohydrologic unit above the host rock that would divert the downward infiltration of water beyond the limits of the emplaced waste.
 - (iv) A host rock that provides for free drainage.

- (v) A climatic region in which the average annual historical precipitation is a small fraction of the average annual potential evapotranspiration.

(c) *Potentially Adverse Conditions.*

- (1) Expected changes in geohydrologic conditions—such as changes in the hydraulic gradient, the hydraulic conductivity, the effective porosity, and the ground water flux through the host rock and the surrounding geohydrologic units—sufficient to significantly increase the transport of radionuclides to the accessible environment as compared with pre-waste-emplacment conditions.
- (2) The presence of ground water source, suitable for crop irrigation or human consumption without treatment, along ground water flow paths from the host rock to the accessible environment.
- (3) The presence in the geologic setting of stratigraphic or structural features—such as dikes, sill, faults, shear zones, folds, dissolution effects, or brine pockets—if their presence could significantly contribute to the difficulty of characterizing or modeling the geohydrologic system.

(d) *Disqualifying Condition.*

A site shall be disqualified if the pre-waste-emplacment ground water travel time from the disturbed zone to the accessible environment is expected to be less than 1,000 years along any pathway of likely and significant radionuclide travel.

10. Pretend that the water table elevation on your topographic profile is accurate. Do you think the repository elevations on your profile are favorable according to the geohydrology guidelines?

(The purpose of these questions is to allow students to think about the information presented in the activity and wrestle with one of the more complex guidelines. The students may not understand all of the terms in the geohydrology guidelines.)

11. Section (b)(5) lists pre-waste-emplacment conditions for the unsaturated zone. Which, if any, of these conditions exist at Yucca Mountain according to your profile and the information you have acquired in this activity? Explain your answers.

(Of the five conditions under section (b)(5), the student should be able to argue that conditions (ii) and (v) are present. Valid arguments can also be made for the presence of the other conditions, especially if the student has completed and understood the activity Rock Characteristics Important in Repository Siting.)

12. Based on your calculated water table, if the repository were sited for an elevation of 1,021 meters (3,350 feet), would it be located in the saturated or unsaturated zone?

(Probably in the unsaturated zone.)

13. Would a repository at 1,021 meters (3,350 feet) conflict with the erosion or the geohydrology guidelines? Why or why not?

(It would be very near the 200 meter [656 feet] minimum depth limit in the erosion guidelines.)

14. Based on your determined water table, if the repository were sited for an elevation of 884 meters (2,900 feet), would it be located in the saturated or unsaturated zone?

(It would be located in the unsaturated zone.)

15. Would a repository at 884 meters (2,900 feet) conflict with either the erosion or the geohydrology guidelines? Why or why not?

(No. The repository would be well below the favorable 300 meter [984 feet] depth, and it would still be in the unsaturated zone.)

16. Suppose you had to choose between putting the repository at 1,021 meters (3,350 feet) or at 884 meters (2,900 feet) and assume that the water table elevation on your profile is accurate. In making your decision, how would you balance the requirements of the erosion and geohydrology guidelines?

(The purpose of this question is to stimulate thought about trade offs that might have to be made in siting the repository. The student should notice that a repository at 1,021 meters [3,350 feet] is well within the unsaturated zone, but is very near the 200 meter [656 feet] minimum depth limit. The repository at 884 meters [2,900 feet] is below the favorable 300 meter [984 feet] depth, but is in the saturated zone.)

The water table under Yucca Mountain occurs in the fractured tuff of the Calico Hills or the Crater Flat units; it slopes to the southeast from an elevation of 792 to 732 meters (2,600 to 2,400 feet) above sea level. Current estimates are that only a small part of the rain that falls on Yucca Mountain percolates through the matrix of the unsaturated zone. The regional direction of ground water flow is south to southwest. As elsewhere in the southern Great Basin, the ground water basins tend to be closed, with no external drainage into rivers or major bodies of surface water. (Source: Consultation Draft Site Characterization Plan Overview Yucca Mountain Site, Nevada Research and Development Area, Nevada DOE/RW-0161, 1988.)

POPULATION DENSITY AND DISTRIBUTION

Directions: Read the excerpt from *General Guidelines for the Recommendation of Sites for the Nuclear Waste Repositories: Final Siting Guidelines*, below, using it to answer the questions that follow.

960.5-2-1 Population Density and Distribution

(a) *Qualifying Condition.*

The site shall be located such that, during repository operation and closure,

- (1) the expected average radiation dose to members of the public within any highly populated area will not be likely to exceed a small fraction of the limits allowable under the requirements specified in 960.5-1(a)(1), and
- (2) the expected radiation dose to any member of the public in an unrestricted area will not be likely to exceed the limit allowable under the requirements specified in 960.5-1(a)(1).

(b) *Favorable Conditions.*

- (1) A low population density in the general region of the site.
- (2) Remoteness of site from highly populated areas.

(c) *Potentially Adverse Conditions.*

- (1) High residential, seasonal, or daytime population density within the projected site boundaries.
- (2) Proximity of the site to highly populated areas, or to areas having at least 1,000 individuals in an area 1 mile by 1 mile as defined by the most recent decennial count of the U.S. census.

(d) *Disqualifying Conditions.*

A site shall be disqualified if-

- (1) Any surface facility of a repository would be located in a highly populated area; or
- (2) Any surface facility of a repository would be located adjacent to an area 1 mile by 1 mile having a population of not less than 1,000 individuals as enumerated by the most recent U.S. census; or
- (3) The DOE could not develop an emergency preparedness program which meets the requirements specified in DOE Order 5500.3 (Reactor and Non-Reactor Facility Emergency Planning, Preparedness, and Response Program for Department of Energy Operations) and related guides or, when issued by the NRC, in 10 CFR Part 60, Subpart I, "Emergency Planning Criteria."

1. Nevada has a 1980 population of 799,000 and a land area of 109,889 square miles. What is the population density of the State?

(The population density is the number of people in the State divided by the land area of the State: $1,201,832$ persons divided by $109,889$ square miles = 10.9 persons per square mile.)

2. According to the population density guidelines sections (a) and (b), what other information would you need to determine if the Yucca Mountain site is in a region of low population density?

(You would want to know the distance to nearby cities, communities, or homes and their respective populations.)

3. Examine the topographic map for habitable structures and estimate the population density of the area covered by the map. (The area of the map is approximately 59 square miles.)

(No habitable structures appear on the map except for two buildings near the eastern edge of the map. If we assume these buildings are pump houses or storage sheds, then the population of the area is zero. If one of your students argues that these buildings may be occupied continuously by security or maintenance personnel, a reasonable estimate might be three persons in each building. The area of the map is approximately 59 square miles. Therefore, the population density would be 0.1 person per square mile. Note that even 30 people in each building would yield a population density of only 1 person per square mile. The area of the map can be determined by measuring the distance along the long and short border in feet, converting to miles, and multiplying 1 mile = 5,280 feet.)

SITE OWNERSHIP AND CONTROL

Directions: Read the excerpt from the *General Guidelines for the Recommendation of Sites for the Nuclear Waste Repositories: Final Siting Guidelines*, below, using it to answer the questions that follow.

960.5-2-2 Site Ownership and Control.

(a) *Qualifying Condition.*

The site shall be located on land for which the DOE can obtain, in accordance with the requirements of 10 CFR 60.121, ownership, surface and subsurface rights, and control of access that are required in order that surface and subsurface activities during repository operation and closure will not be likely to lead to radionuclide releases to an unrestricted area greater than those allowable under the requirements specified in 960.5-1(a)(1).

(b) *Favorable Condition.*

Present ownership and control of land and all surface and subsurface mineral and water rights by DOE.

(c) *Potentially Adverse Condition.*

Projected land-ownership conflicts that cannot be successfully resolved through voluntary purchase-sell agreements, nondisputed agency-to-agency transfers of title, or Federal condemnation proceedings.

- Who controls most of the land area of the Busted Butte Quadrangle map?

(The black-dash dot symbols that partition most of the map represent national or State park, reservation, or monument boundaries.)

- Can you determine the ownership of all of the land area on the map?

(No.)

- Will the proposed repository site meet the ownership and control guidelines? Why or why not?

(It will if this area is located on national reserve. State-owned reserve may be a potentially adverse condition. In fact, the land where the candidate site is located is Federally owned/controlled.)

CROSSWORD PUZZLE

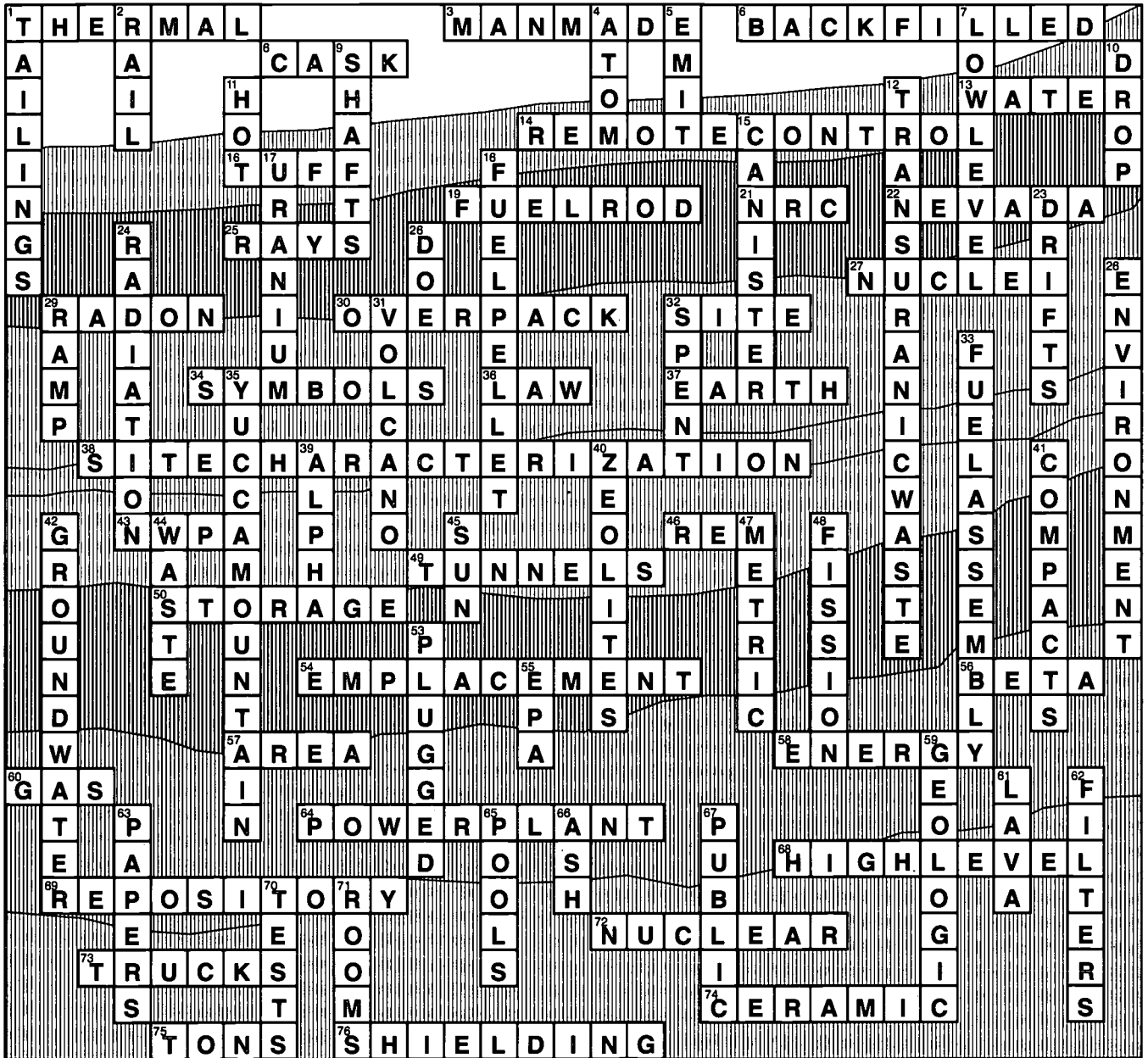

Glossary

- accessible environment** — The area surrounding a nuclear waste disposal site.
- alloy** — A mixture of two or more metals or a mixture of a metal and something else.
- anion** — A negatively charged ion.
- aquifer** — A subsurface rock layer that readily yields water.
- backfill** — To place removed or new materials into excavated areas.
- borehole** — A hole drilled into the Earth.
- borosilicate glass** — A glass used to immobilize liquid high-level waste in a solid form. It is made from sodium silicate containing some boric acid.
- brine** — Water saturated with salt.
- cask** — A container for shipping spent nuclear fuel or high-level radioactive waste.
- cation** — A positively charged ion.
- cation exchange resin** — An artificial material used for water softeners that displaces positively charged ions from solution and attaches other, less desirable, ions.
- cladding** — A layer of some metal or alloy bonded to a metal.
- Code of Federal Regulations (CFR)** — The CFR contains Federal regulations covering various activities including transportation and storage of spent fuel.
- compressive strength** — The ability of a substance to withstand compression without breaking or fracturing.
- containment** — The confinement of radioactive materials within a vessel or structure.
- contamination** — Something that will make other things unfit for use when it comes into contact with them.
- conventional notation** — In mapping, used to signify degrees (°), minutes ('), and seconds (").
- corrosion** — Slow dissolving or eating away, especially by chemical action, such as rusting.
- criticality** — A condition sufficient to sustain a nuclear reaction.
- cumulative** — Made up of accumulated parts.
- degree** — One of the divisions marked on a scale of a measuring instrument. There are 360 degrees in a circle. Also used as a measure of temperature.
- dehydration** — The process of removing water from a substance.

devitrification — A complex process in which cooled, volcanic rock reacts with water and the atmosphere, forming minerals like zeolites and cement; tuff at Yucca Mountain is devitrified volcanic rock and has a vitreous or glass-like appearance.

dike — A body of molten rock (magma) that cuts across the layers of existing rock.

dissolution — The act or process of dissolving.

drift — A horizontal passage underground. A drift follows the "vein" of the material being excavated, as opposed to a crosscut, which intersects it.

effective porosity — The amount of interconnected pore space and fracture openings available for fluids to move through.

encapsulate — To enclose in a capsule.

engulf — To flow over and enclose.

equator — The great circle of a sphere that is perpendicular to the axis.

erosion — The action or process of wearing away by the act of water, wind, or glacial ice.

evapotranspiration — Loss of water from the soil both by evaporation and transpiration from plants growing in the soil.

exfoliation — The process of coming off in thin sheets.

exhumation — The process of removing a substance from beneath the Earth.

fault — A break in the Earth's crust accompanied by movement of the Earth on one side of the break with respect to the other. The movement may be a few inches or many miles.

fluid — A substance (as a liquid or gas) tending to flow or take the shape of its container.

flux — Movement.

fold — A rock layer bent by pressure.

full-scale — Having the usual or normal size.

geohydrology — A science that deals with the character, source, and mode of underground water.

geomorphic — Relating to the form of the Earth or another celestial body.

geophysical pole — Either of the regions adjacent to the extremities of the Earth's rotational axis, the North Pole or the South Pole.

gradient — The rate of change of temperature or pressure.

ground water — Water found underground in porous rock strata and soils, as in a spring.

grout — A thin mortar used to fill in spaces.

host rock — The geologic formation in which the nuclear waste repository is located.

hydraulic — Operated, moved, or affected by means of water.

hydraulic gradient — The direction of ground water flow in response to differences in pressure. From points of higher pressure to points of lower pressure.

hydrology — The study of the distribution, circulation, and properties of the waters of the Earth.

insoluble — Incapable of or having difficulty being dissolved in a liquid.

interlayer water — Water trapped between rock layers, or strata.

interstate highway — A highway connecting two or more States.

interstate bypass — Highway that goes around or to one side of a congested area or obstruction.

ion — Atom, molecule, or molecular fragment carrying a positive or negative electrical charge.

ion exchange — The process in which an ion in solution takes the place of another ion in a natural or man-made material.

ionic solid — Solid that yields a solution of cations and anions when dissolved.

latitude — Angular distance north or south from the Earth's equator measured through 90 degrees.

longitude — Angular distance measured east or west of the prime meridian.

meridian — The great circles of a sphere, such as the Earth, passing through the poles.

mineral — A crystalline chemical compound that occurs naturally; a rock is an assemblage of minerals that determine its characteristics.

minute — Term used in mapping; the 60th part of a degree.

multiple barrier system — The series of barriers inhibiting radionuclide transport from spent fuel or high-level waste placed in a disposal facility; includes both natural and engineered barriers designed to work together.

multi-purpose canister (MPC) — A metal container used to hold spent fuel. Combined with outer casks the MPC could be used to store, transport, and dispose of spent fuel.

notation — A system of characters, symbols, or abbreviated expressions used to express technical facts or quantities.

Nuclear Regulatory Commission (NRC)— A Federal agency charged with the responsibility for regulating the use of nuclear energy and radioactive materials, including the licensing and regulating of storage facilities, shippers, and carriers.

overpack — Any receptacle, wrapper, box, or other structure that is an integral part of a radioactive waste package and is used to enclose a waste container in order to provide additional protection or to meet the requirements of acceptance or isolation criteria for a specific site.

permeability — In hydrology, the capacity of a medium (rock, sediment, or soil) to transmit ground water. Permeability depends on the size and shape of the pores in the medium and how they are interconnected.

plasticity — Capacity for being molded or altered.

polymer — A naturally occurring or manmade substance consisting of large molecules formed from smaller molecules of the same substance.

porosity — The ratio of the total volume of voids or empty space in a rock or solid to its total volume, usually expressed as a percentage.

pour canister — Disposal container for the solid glass form of defense high-level waste. This container will be sealed inside a disposal canister.

prime meridian — The meridian of 0° longitude which runs through the original site of the Royal Observatory in Greenwich, England.

Quaternary Period — Geologic time period beginning at the end of the Tertiary Period and continuing until the present.

radionuclide — A radioactive isotope.

rock — A naturally formed mineral mass.

saturated — To cause to be thoroughly penetrated.

scale — The proportion that a map or model bears to the thing it represents.

second — In mapping, one 60th of a minute. The exact position of a geographic point is described in degrees, minutes, and seconds for both latitude and longitude.

sediment — Matter deposited by water or wind.

shaft — A vertical excavation made for mining rock.

shear — Stress applied parallel to an object.

sill — A body of molten rock (magma) that moves parallel to the existing layers of rock.

simulated — Made to look real.

solubility — A measure of how much of a given substance will dissolve in a liquid. Usually measured in weight per unit volume.

soluble — Capable of being dissolved in a fluid.

sorption — To soak up or stick to.

sorptive capacity — A measure of the ability of the surfaces of a rock to remove dissolved material from solutions passing through the rock. Dissolved material may be removed from solutions by ion exchange, precipitation, or immobilization of water molecules in small pores by friction.

staging — To arrange for and send shipments of spent fuel to a repository.

stakeholder — A person or group of people affected by the outcome of a proposed plan or series of events. In issues concerning the management of nuclear waste, the stakeholders would include utilities, industry, government, and public interest groups.

stratigraphic — Relating to the arrangement of rock layers.

symbol — Something that stands for something else, as the symbols on a map represent actual objects.

Tertiary Period — The period of Earth's development approximately 70,000,000 years ago during which the Alps and the Himalayas were formed and mammals reached dominance on land.

thermal alteration — Changes brought about as the result of increases in temperature.

tuff — A medium-grained rock formed of compacted volcanic ash and dust. The welding process accompanying compaction and cooling gives the rock strength and reduces porosity and permeability.

vermiculite — Lightweight water-absorbent clay mineral.

welded tuff — Hardened volcanic ash in which the constituent glassy shards and other fragments have become welded together, apparently while still hot and plastic after deposition.

zeolite — A generic term for a group of alumino-silicates of sodium, calcium, barium, strontium, and potassium that are characterized by easy and reversible loss of electron-pair bonded water and the property of swelling when heated. Many zeolites have significant capacities for ion-exchange.

zirconium — A steel-gray, strong metallic element. It melts only at high temperatures and is very resistant to corrosion.

Index

Backfill materials, 14

Borehole and shaft seals, 14, *figure 9*

Cask

- certification, 2-3
- new designs, 6
- sample, *figure 3*
- testing, 3-6, *figure 4, photo 5*

Federal agencies

- cooperation in transportation regulation, 2
- U.S. Department of Transportation, 2
- U.S. Environmental Protection Agency, 10
- U.S. Nuclear Regulatory Commission, 2, 10

Geologic repository

- alerting future generations of presence, 10
- backfill materials, 14
- borehole and shaft seals, 14, *figure 9*
- design standards, 10
- features, 9, 15
- and multiple barriers, 11-15
- performance standards, 10
- rock characteristics, *enrichment 25-32*
- schedule for operation, 9-10
- tuff rock formation, *enrichment 30-32*
- welded tuff, *enrichment 31*

International Atomic Energy Agency, 2

Multiple barriers, 11, *enrichment 32*

- host rock as barrier, 14-15
- waste package, 11-13
- repository as barrier, 13-14

Multi-purpose canister, 17-22

- advantages, 18, 21
- cost, 21
- design and standards, 18-19
- and dry storage, 20
- functions of, 17
- and a repository, 17, 20-21
- and spent fuel, 17, 19-20
- and stakeholders, 22
- transportation of, 17, 20

Nuclear Waste Policy Act of 1982, 2, 8
public safety training for transporting nuclear waste, 8

Radiation exposure, 2

Rock characteristics, *enrichment 25-32*
compressive strength, *enrichment 25*
dissolving ionic compounds, *enrichment 33*
effective porosity, *enrichment 30*
ion exchange and zeolites, *enrichment 33-34*
permeability, *enrichment 29*
plasticity, *enrichment 26-27*
porosity, *enrichment 29-30*
precipitation, *enrichment 34*
related to fluid flow, *enrichment 27-30*
related to heat, *enrichment 26-27*
solubility, *enrichment 30*
sorptive capacity and ion exchange, *enrichment 27-28, figure 28*
thermal conductivity, *enrichment 26*
thermal stability, *enrichment 27*

Safety

- alerting future generations of repository's presence, 10
- exposure during transportation, 2
- through multiple barrier system, *enrichment 32*
- transportation, 1

Schedule for repository operation, 9-10

Topographic maps

- contour intervals, *enrichment 39, figure 40*
- contour lines, *enrichment 38*
- features, *enrichment 35, figures 35-38*
- flow direction of rivers and streams, *enrichment 40, figure 40*
- map coordinates, *enrichment 41-43*
- map types, *enrichment 35*
- scale, *enrichment 41*

Transportation

casks, 1, 3-6
highway routing on preferred routes, 7
maximum exposure estimates, 2
and MPC, 17, 20
notification of States, 7
number of shipments of radioactive material, 1
public safety training assistance and funding, 8
rail routing, 7
responsibilities of State and local governments, 7-8
responsible agencies, 2
safety measures in shipments, 1-2
safety record, 1
satellite tracking of selected shipments, 7

Tuff, 30-31

U.S. Department of Transportation, 2

U.S. Environmental Protection Agency, 10

**U.S. Nuclear Regulatory Commission,
2, 10, 18**

**Volcanic glass formation and devitrification,
enrichment 32**

Waste package, 12-13

containers for disposal, 13, *figure 13*
waste form for defense waste, 12
waste form for spent fuel, 11-12

Yucca Mountain site

features, 16
land requirements and description of potential repository, 15-16

Zeolites, 16

Bibliography

Unit 4

Bencloski, J. "Demonstrating Slope Types," *Teaching Geography*, 1985.

Code of Federal Regulations (10 CFR Part 960), General Guidelines for the Recommendation of Sites for the Nuclear Waste Repositories; Final Siting Guidelines (1984).

DOE's Yucca Mountain Studies (DOE/RW-0293P). Washington, DC: U.S. Department of Energy, 1990.

League of Women Voters Education Fund. *The Nuclear Waste Primer: A Handbook for Citizens* (OCRWM/PI-056). Washington, DC: OCRWM National Information Center, 1993.

The Multiple Barrier System of Geologic Disposal of Spent Nuclear Fuel and High-Level Radioactive Waste (DOE/RW-0285P). Washington, DC: U.S. Department of Energy, 1990.

Murray, Raymond. *Understanding Radioactive Waste*. Columbus, OH: Battelle Press, 1994. Fourth Edition.

National Energy Strategy, Executive Summary, First Edition (DOE/S-0083P). Washington, DC: U.S. Department of Energy, 1991/1992, and *One Year Later*, February 1992. Reprint.

OCRWM Factsheet Series (OCRWM/PI-054). Washington, DC: U.S. Department of Energy, 1991.

Site Characterization Plan Overview—Yucca Mountain Site, Nevada Research and Development Area, Nevada. Washington, DC: U.S. Department of Energy, 1988.

Transporting Radioactive Materials...Answers to Your Questions (DOE/EM-0097). Washington, DC: U.S. Department of Energy, April 1993.

Transporting Spent Nuclear Fuel: An Overview (DOE/RW-0065). Washington, DC: U.S. Department of Energy, 1986.

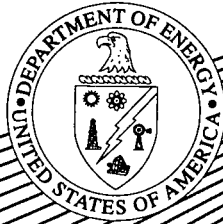

Science, Society, and America's Nuclear Waste

Transparency Masters &

Student Activities

What Measures Ensure Safe
Transportation of High-Level Nuclear
Waste?

What Will a Geologic Repository Be
Like?

What Is the Role of the Multi-Purpose
Canister in the Waste Management
System

You Are Invited... The Stakeholders
Public Meeting

Designing for Safety

Analyzing State Highway Maps

Planning Hazardous Materials
Shipment Routes

Important Rock Characteristics

Porosity & Permeability

Solubility, Mineral Solubility

Thermal Stability

Ion Exchange & Zeolites

Topographic Map Skills

Practice with Scale, Latitude, and
Longitude

Contouring

Topographic Maps of Landscapes

Topography of the Yucca Mountain Site

Considerations for siting the
High-Level Nuclear Waste Repository

Crossword Puzzle

Metric & U.S. Unit Conversions

The Waste Management System

Unit 4 Second Edition
Teacher Guide

Where Is Radioactive Material Shipped?

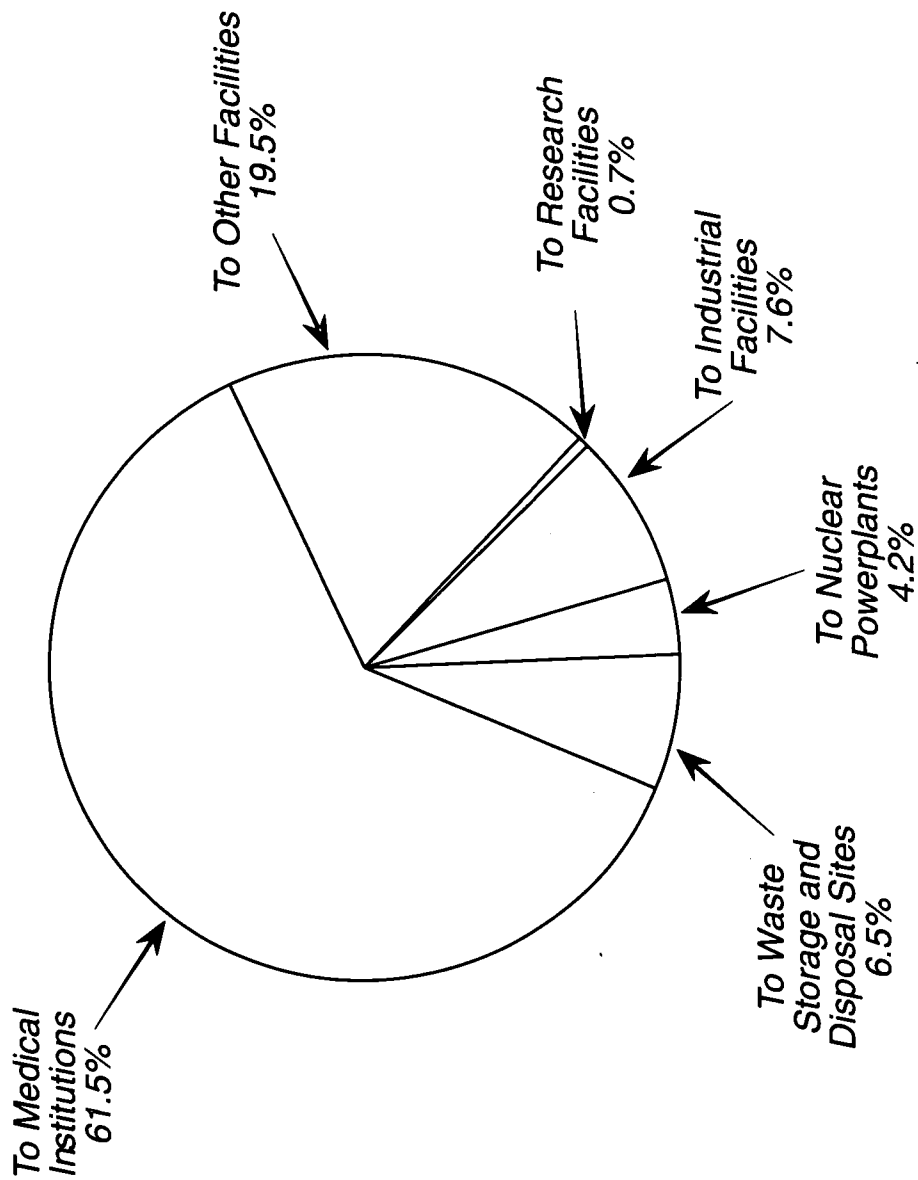

Source: Transporting Radioactive Materials . . . Answers to Your Questions (DOE/EM-0097), April 1993. 188

Standards for Spent Fuel Casks

Mechanical

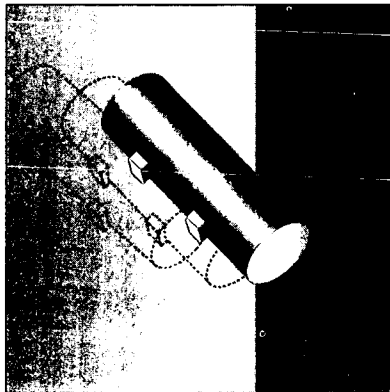

Free Drop – Nine meter (30-foot) drop of the spent fuel cask onto a flat, horizontal, unyielding surface with the cask positioned so that its weakest point is struck. Drop tests have been conducted at much greater heights 610 meters (2,000 feet) without breaching the cask containment.

Puncture – One meter (40-inch) free drop of the cask onto a 15 centimeters (6-inch) diameter steel bar at least 20 centimeters (8 inches) long; the bar is to strike at its most vulnerable spot.

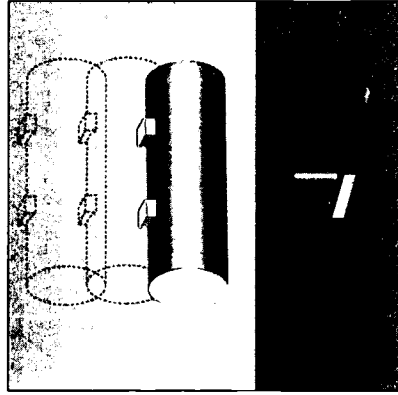

Thermal

Fire – After the mechanical tests are completed, the package is totally engulfed in a fire or furnace at 800°C (1,475°F) for 30 minutes.

Water Immersion

Immersion of all packaging surfaces under at least 1-meter (3 feet) of water for 8 hours; immersion of entire packaging under 15 meters (50 feet) of water for 8 hours.

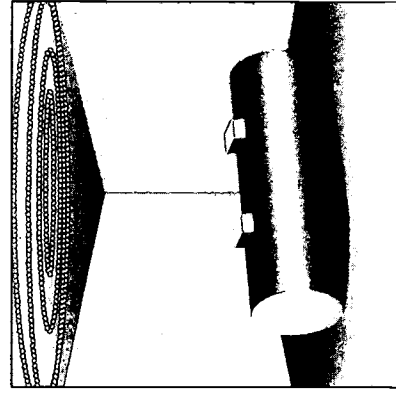

Factors Considered in Selecting Highway Routes

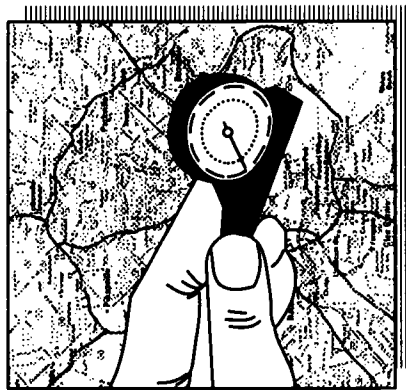

Transit Time



Population Density

DECEMBER	
	1
3	4
10	11
17	18
24	25
31	30

Time of Day and Week

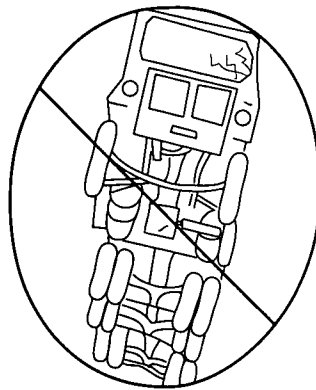

Accident Rates

191 The carrier must consider accident rates, transit times, population density and activities, and time of day and week when selecting a shipping route.

Source: *Transporting Radioactive Materials. . . Answers to Your Questions (DOE/EM-0097), April 1993* 92

Information Provided to States and Indian Tribes About Shipments of Radioactive Materials

- Planned Schedule
- Route
- Description
- Carrier Name and Address

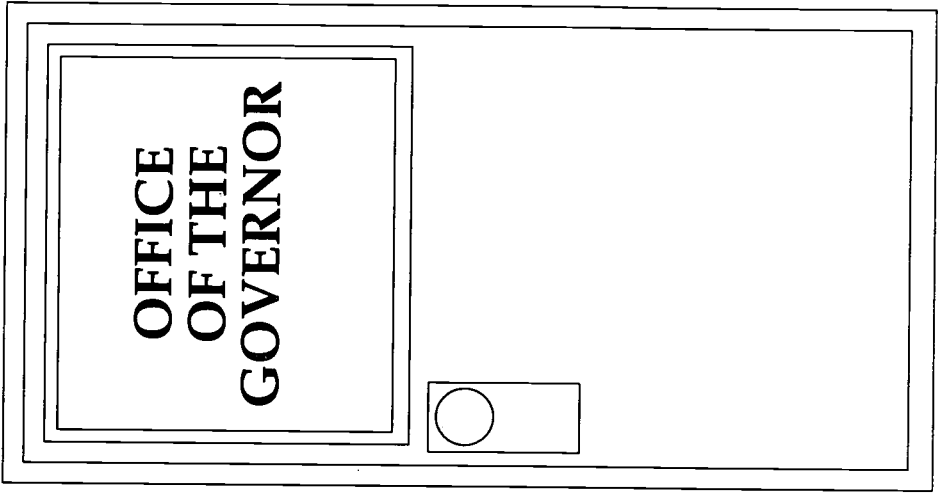
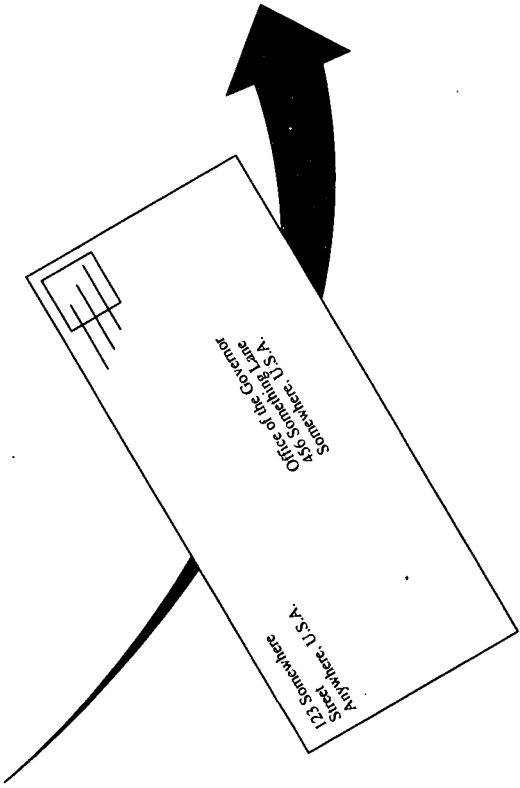

The Governor, designated State official, or Tribal representative receives written notice in advance of transporting certain radioactive material shipments through State or Tribal lands.

Source: *Transporting Radioactive Materials... Answers to Your Questions* (DOE/EM-0097), April 1993.

U.S. Department of Energy Regional Coordinating Offices Emergency Operations Centers

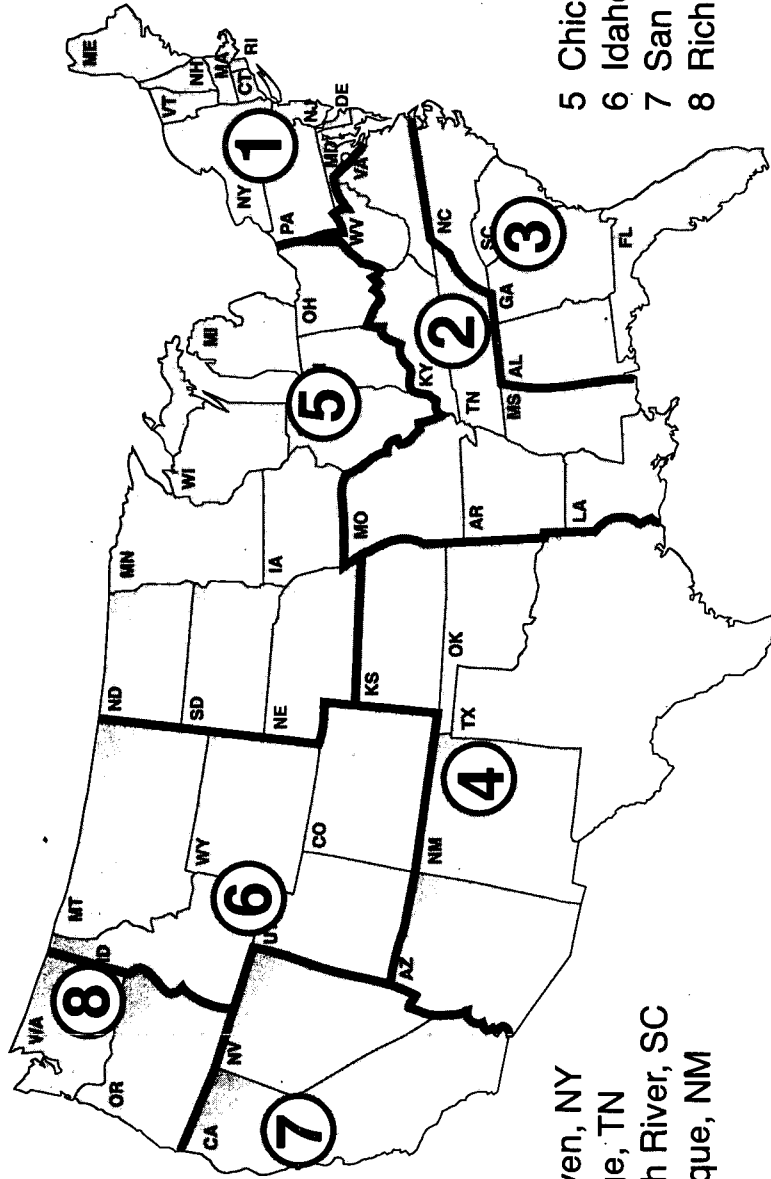

- 1 Brookhaven, NY
- 2 Oak Ridge, TN
- 3 Savannah River, SC
- 4 Albuquerque, NM

- 5 Chicago, IL
- 6 Idaho Falls, ID
- 7 San Francisco, CA
- 8 Richland, WA

There are eight DOE Regional Coordinating Offices and Emergency Operations Centers that can dispatch radiological assistance teams to support State and local responders.

Source: *DOE/Oak Ridge Regional Coordinating Office and Emergency Operations Center, 1994.*

Multiple Barriers

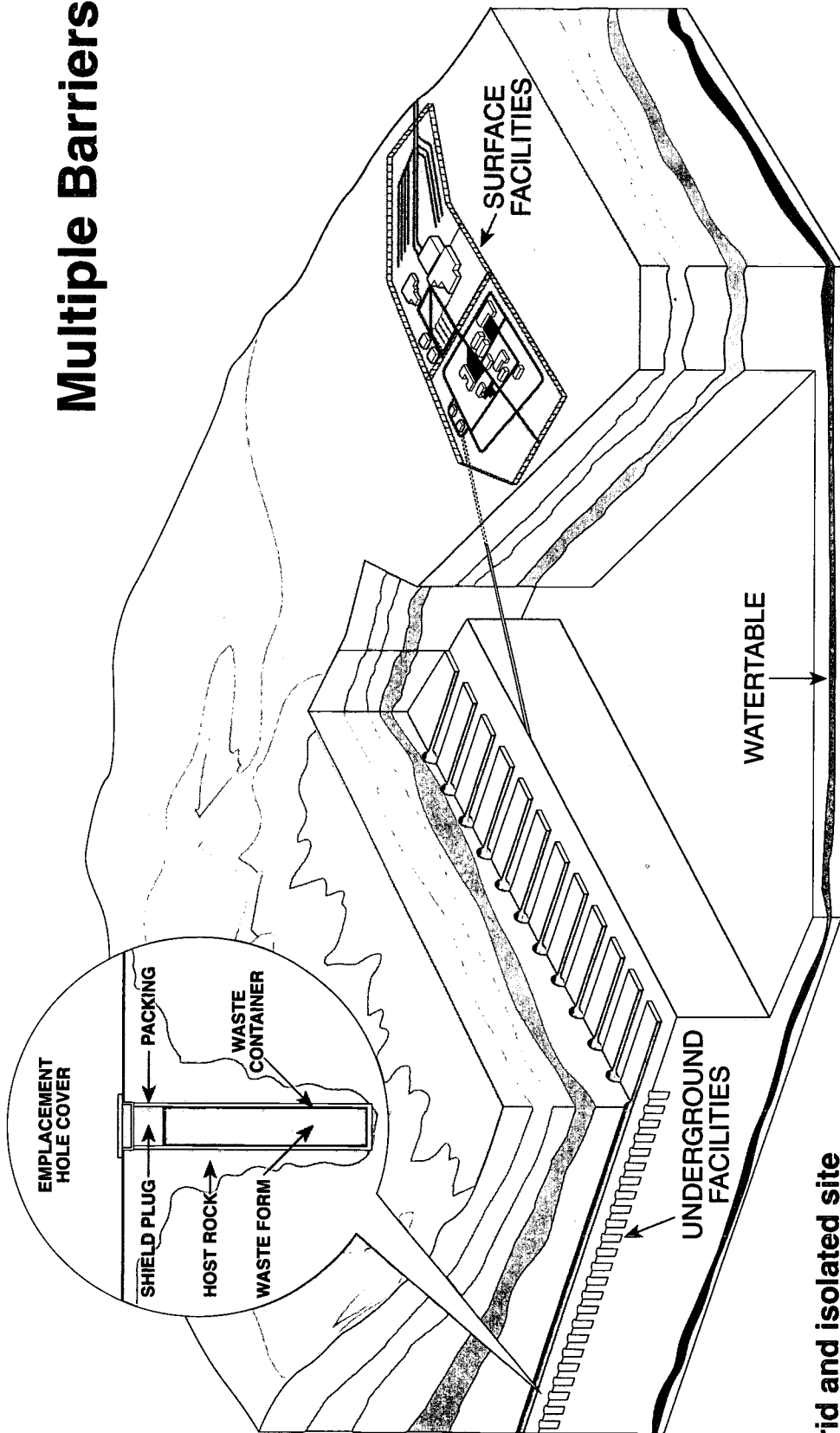

Arid and isolated site

- average rainfall is 9" per year
- most rainfall runs off or evaporates

Rock formation

- volcanic tuff rock is located in the unsaturated zone
- repository would be above water table
- zeolite minerals can trap radioactive contaminants

Multiple barriers provide protection of the environment. The natural barriers will be teamed with engineered barriers.

Rock Strata

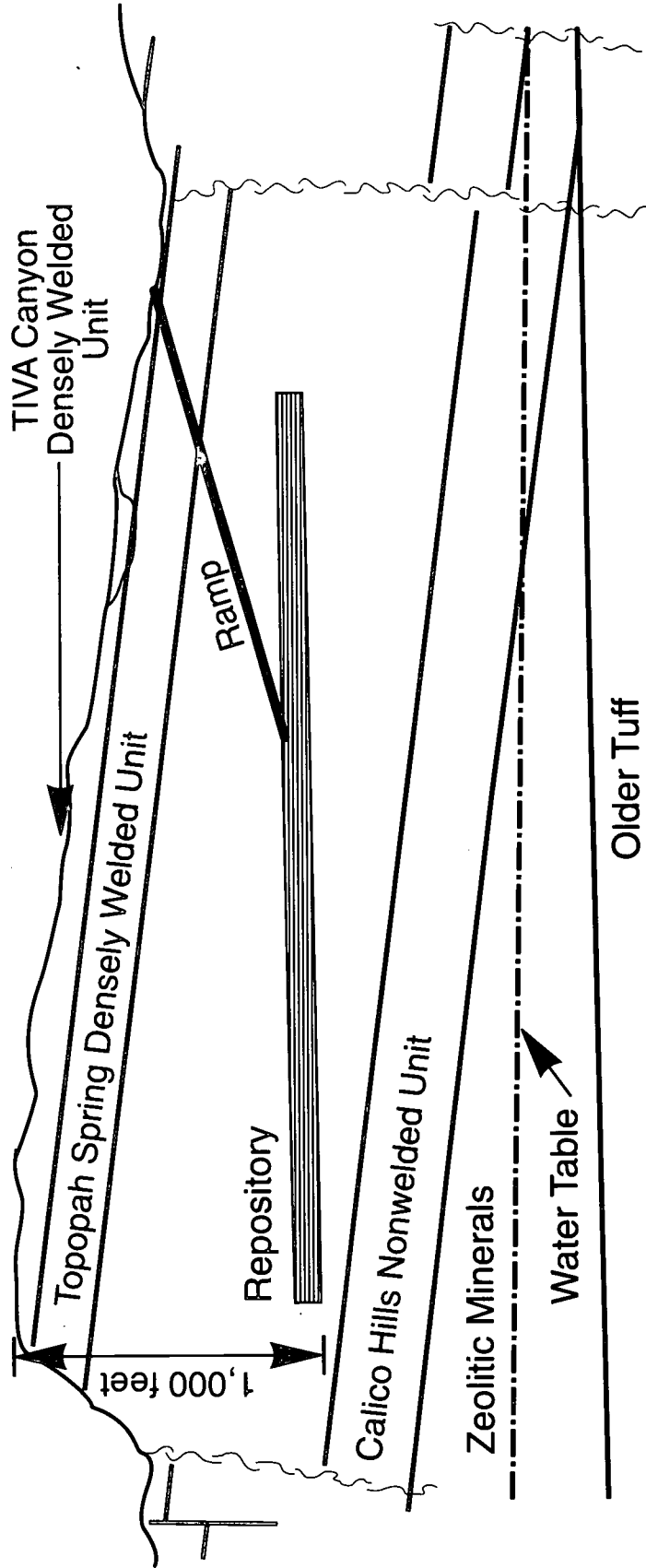

Yucca Mountain features can contribute to long-term isolation of waste

- unsaturated environment
- probable occurrence of zeolite minerals that could trap radionuclides

WHAT MEASURES ENSURE SAFE TRANSPORTATION OF HIGH-LEVEL NUCLEAR WASTE?

Directions: Use what you have learned in your reading lesson to answer the following questions.

1. What aspects of the transportation of radioactive materials are regulated?

2. Describe the tests that are performed on a cask to certify its safety.

3. Why is it important to perform cask testing?

4. What are the advantages of the new cask designs?

5. What Federal agencies are responsible for the regulations that apply to the transportation of radioactive waste?

6. A series of "full scale" crash tests were conducted in the United States during the mid-1970's. Describe one of the tests and its results.

WHAT WILL A GEOLOGIC REPOSITORY BE LIKE?

Part I

Directions: Put the number of the phrase or term from column B in the space provided next to the appropriate item in column A.

- | | |
|--|---|
| <p>___ A. substantially complete waste containment by waste package</p> <p>___ B. Yucca Mountain, Nevada</p> <p>___ C. geologic repository resembles</p> <p>___ D. total land required for a repository</p> <p>___ E. land required for above ground facilities</p> <p>___ F. land required for subsurface facilities</p> <p>___ G. manmade barrier</p> <p>___ H. surface facility</p> <p>___ I. will move waste to underground facility</p> <p>___ J. main access tunnel</p> <p>___ K. when repository will be closed</p> <p>___ L. depth beneath surface for disposal facilities</p> | <p>1. <u>2,307 hectares</u> (5,700 acres)</p> <p>2. about <u>305 meters</u> (1,000 feet)</p> <p>3. ramp</p> <p>4. shielded transport vehicle</p> <p>5. at least 50 years after emplacement begins</p> <p>6. electric train</p> <p>7. 300 to 1,000 years</p> <p>8. <u>61-162 hectares</u> (150 to 400 acres)</p> <p>9. disposal container</p> <p>10. used for handling waste</p> <p>11. about <u>567 hectares</u> (1,400 acres)</p> <p>12. large mining complex</p> <p>13. candidate site to be studied for a repository</p> <p>14. at least 100 years after disposal begins</p> <p>15. 10,000 years</p> |
|--|---|

Part 2

Directions: Use the reading lesson *What Will a Geologic Repository Be Like?* to answer the following questions in the spaces provided.

1. What Federal Government agencies will regulate a nuclear repository?

2. Describe the facility of a geologic repository.

Above ground:

Below ground:

3. What are the three components of the multiple barrier system?

4. Describe the waste form for spent fuel. How does its form act as a barrier to releases of radioactivity?

5. Describe the waste form for high-level waste from defense activities. How does its form act as a barrier to releases of radioactivity?

6. What are advantages of glass for immobilizing waste?

7. What materials are being considered for the disposal containers? Why?

8. What are the two main reasons that boreholes and shafts will be sealed?

9. Explain ways in which any geologic site can act as part of the multiple barrier system.

10. List and explain three features of the Yucca Mountain site that might help to ensure that waste would remain isolated from the accessible environment if a repository were built there.

WHAT IS THE ROLE OF THE MULTI-PURPOSE CANISTER IN THE WASTE MANAGEMENT SYSTEM?

Answer the following questions as you read the lesson *The Role of the Multi-Purpose Canister in the Waste Management System*.

1. What is a multi-purpose canister (MPC)?

2. How is spent fuel presently stored at reactor sites?

3. How would an MPC be used in DOE's waste management system?

4. List at least two advantages and /or disadvantages the MPC offers to spent fuel management.

5. The MPC is designed to be shipped by rail from the different sites where spent fuel is stored. How does the waste management system ensure that it will satisfy those needs?

6. How might the MPC be handled at a geologic repository?

7. The Nuclear Regulatory Commission (NRC) regulations require that the MPC design meet specific standards. List as many NRC requirements as you can.

8. If DOE decides to use the MPC, when is it projected to be available for storage at a reactor site? When is the transportation cask projected to be ready?

9. The MPC will cost more than other storage canister designs. How would additional costs be offset?

10. Who are the stakeholders in a decision to use the MPC? What are the concerns of each?

208

209

YOU ARE INVITED... THE STAKEHOLDERS PUBLIC MEETING

The United States Department of Energy (DOE) invites you to attend a stakeholders public meeting. The purpose of this meeting is to introduce the conceptual design for a waste management system that uses a multi-purpose canister for transporting, storing, and disposing of spent fuel from nuclear powerplants.

The public meeting will be held at the Giventakenne Community Center. The Giventakenne community was selected as the site for the meeting because of the proximity of the Giventakenne Nuclear Powerplant. In addition, the Giventakenne community members are consistently active in nuclear waste management issues.

In small groups, you will be playing the roles of stakeholders attending this public meeting. Stakeholders in the decision to use a multi-purpose canister for temporary storage, transportation, and final disposal of spent fuel from nuclear powerplants include:

- DOE public affairs representatives and technical personnel specializing in waste management;
- Giventakenne residents;
- Giventakenne Nuclear Powerplant Personnel; and
- *Giventakenne Gazette* staff.

The meeting will be led by a DOE public affairs representative. DOE will plan and publish the meeting program. The Public Meeting will include six presentations given by DOE and Giventakenne Nuclear Powerplant personnel. After they have finished you will have an opportunity, as your character, to ask questions about, or comment on, the multi-purpose canister and its role in the overall waste management system.

Meeting Rules

1. Speakers will be introduced by a DOE Public Affairs representative. Do not attempt to make your group's presentation or ask questions unless your speaker has been called on by DOE.
2. Each presenting group will have 3 minutes to complete its presentation. Three minutes is not much time, so your presentation should be well organized before the day of the public meeting.
3. After the six presentations, the remaining class time will be used for questions from other participants. Each group may ask up to five questions. The answering group will have no more than one minute to respond to each question.
4. If a member of another group interrupts a presentation, that member's group will be penalized for each interruption by forfeiting the opportunity to ask one of its group's questions.

Public Affairs Representative

As a person experienced in communicating with the public, you will be responsible for organizing and running the Stakeholders Public Meeting. You will develop the meeting schedule and distribute it to the stakeholders expected to attend. You will also time presentations and maintain order during the meeting.

You are familiar with scientific and political issues relating to the transport of radioactive waste, especially the concept of a multi-purpose canister (MPC). You are acquainted with most of the guests attending this meeting, and you have a general feel for everyone's opinions.

As the meeting leader, your primary concern is to bridge the understanding gaps between the public, the press, and Department of Energy (DOE) representatives. In preparation for the meeting, try to anticipate as many concerns as possible and be prepared to respond to questions if necessary. Pay close attention to the scheduled presentations as well as questions and responses because you will be writing a summary of this public meeting for the local newspaper.

Engineer

You work for the Department of Energy (DOE) as one of the multi-purpose canister (MPC) designers. Your part in the meeting is to do a short presentation on the MPC. Your primary concern is to show how it can improve plans for the safe, efficient transportation, storage, and disposal of spent fuel from nuclear powerplants. To help the audience visualize the MPC concept, make models or visual aids for your presentation.

During your presentation you should describe the tests the MPC must pass to ensure its safety during routine transport and in case of a serious accident. These tests are described in detail in your reading for this lesson. You may set aside a few seconds of your presentation to show the videotape of these tests.

Risk Assessor

You have been invited to the meeting to do a short presentation on the risks of transporting and handling nuclear waste. Be informed about highway and railroad accidents as well as the handling that takes place when loading and unloading waste packages. Your primary concern is to show how the multi-purpose canister (MPC) reduces handling and, therefore, decreases risk.

You should illustrate your point by using a diagram to illustrate how many times another canister design would require loading/unloading in comparison to plans for an MPC during the transportation/interim storage/final disposal process.

To support your understanding of risk assessment, consult *Science, Society, and America's Nuclear Waste - Unit 3, The Nuclear Waste Policy Act*, pp. SR-15-22.

Permanent Repository Expert

You have been asked to speak on the operations at a permanent geologic repository facility for spent nuclear fuel and high-level radioactive waste. Explain how the multi-purpose canister (MPC) would be used in the disposal process. Follow an MPC from unloading and handling of the transportation cask to the final disposal.

Explain the MPC's role in safely handling nuclear waste. Be sure to demonstrate how the MPC becomes part of the final shielded package. To support your understanding of a geologic repository, consult *Science, Society, and America's Nuclear Waste - Unit 4, The Waste Management System*, pp. SR-9-16.

Resident of Giventakenne, USA

In response to an overwhelming increase in electricity demands in Giventakenne, the local electric utility put a nuclear powerplant on line about 15 years ago. The plant is about 5 miles from your home.

As a resident of Giventakenne, you are concerned about the regulations governing the onsite handling and transportation of spent nuclear fuel. You are constantly seeking information concerning how these activities could affect you and your family. Although you think the multi-purpose canister (MPC) is a good idea in concept, you are skeptical of the Federal government, and you hesitate to believe that the spent fuel will be handled properly. Your primary concern is how the MPC will protect you and your family while in storage at the reactor site and while the MPC is being transported.

Truck Driver

You are a truck driver living in Giventakenne. You are considering specialized training that would enable you to transport spent fuel when a permanent disposal or temporary storage facility is completed. You are particularly interested in how the multi-purpose canister (MPC) will contribute to the safety of spent fuel transportation. Your concerns focus on how well MPCs are shielded and how the MPC is expected to perform in case of a serious accident.

Although you trust that officials and scientists know what precautions need to take place, you are concerned about them possibly cutting corners on a product that could directly affect your life.

Giventakenne Resident Living Near Probable Transportation Route for Spent Nuclear Fuel from the Powerplant

You have read the Nation's radioactive waste management plan, and you expect that the highway in front of your home will likely be used to transport spent nuclear fuel to a temporary storage facility or a final disposal facility, such as a geologic repository.

You are concerned about how an increase in transportation of spent nuclear fuel will affect the safety of people like you living on a route connecting nuclear powerplants, a temporary facility, and a permanent repository. Since this meeting is about MPCs, you want to know how they will be transported and the regulations governing them.

The Mayor of Giventakenne

Because you have a nuclear powerplant near your community, you are well aware of safety concerns associated with storage and transport of spent fuel.

Throughout your term in office, you have maintained communication with the Giventakenne Nuclear Powerplant officials. After all, the utility employs nearly one third of the residents of Giventakenne. It also provides a valuable service to the community and pays significant property taxes.

Your concerns are twofold. On the one hand you want to be sure that the multi-purpose canister (MPC) will not endanger the health and safety of the residents of the Giventakenne community. On the other hand, you support the powerplant, and you wonder whether the MPC design will place an overwhelming burden on its capabilities.

Giventakenne Emergency Response Team Leader

You are in charge of the Giventakenne Emergency Response Team. You have been trained to handle potential accidents involving spent nuclear fuel from the nuclear powerplant in your community. As a result, you know about radiation and its effects on living organisms.

You want to know if the multi-purpose canister (MPC) will require new training programs for your emergency response team. You are also concerned about how the MPC will ensure the safe transport of spent nuclear fuel.

To support your understanding of radiation's effects, consult *Science, Society, and America's Nuclear Waste - Unit 2, Ionizing Radiation*, pp. SR-21-29.

Onsite Spent Fuel Storage Expert

You are in charge of spent fuel storage at the Giventakenne reactor site. As an informed administrator, you are well acquainted with the multi-purpose canister (MPC) and its role in the storage of spent fuel at a reactor site.

In your presentation, explain the various steps involved in placing spent nuclear fuel assemblies into MPCs and in transporting them to the storage facility at the reactor. You are acutely aware of the public concern over how nuclear waste has been handled and will focus your presentation on how the plan addresses the concerns of the public through responsible engineering.

Managing Official for the Giventakenne Nuclear Powerplant

You are anxious about how the multi-purpose canister (MPC) concept will affect operations at the Giventakenne Nuclear Powerplant. It is your responsibility to provide your company's customers with reliable, reasonably priced electricity. You are concerned about additional costs that the powerplant may have to face if it uses the MPC. You are not sure if the plant's lifting system or local transportation routes are adequate. You wonder if the Department of Energy (DOE) conceptual design for a waste management program involving an MPC is flexible enough to adapt to your powerplant's equipment limitations.

Newspaper Reporter

You are a reporter for the *Giventakenne Gazette*. You know that the multi-purpose canister (MPC) has a part in the permanent storage of spent nuclear fuel. Your article will focus on how the MPC will be accepted, handled, and disposed of at a permanent geologic repository.

You are also curious about where a permanent repository would be located. Ask about the Department of Energy's (DOE) progress in identifying a site for the repository.

Be prepared to ask five questions following the Public Meeting presentations. Your article should be 300-500 words long.

Giventakenne Gazette Editor

This is a special edition of your paper focusing on the information offered by Department of Energy (DOE) experts and others at the Stakeholders Public Meeting. You will be responsible for collecting staff articles and letters to the editor from Giventakenne residents and laying out this edition of the *Gazette*.

At the Public Meeting, you are interested in identifying issues of importance to the Giventakenne community. You will be responsible for writing an editorial for the special edition on this topic.

SPECIAL EDITION

Given taken ne Gazette

VOLUME I • NUMBER 1

GIVENTAKENNE, USA

1995

STAKEHOLDERS PUBLIC MEETING

DESIGNING FOR SAFETY

During the past 40 years, nuclear materials, including nuclear waste, have been transported safely. Scientists and engineers work together to design and build casks that will ensure the safety of workers, the public, and the environment during the transportation of nuclear waste. Casks used to transport spent fuel rods are designed and constructed to contain radioactivity under normal travel conditions and in situations that may result in the event of a rail or highway accident.

In tests conducted to certify the safety of casks, the most vulnerable point of a cask must withstand an impact with a flat unyielding surface after a 9-meter (30-foot) drop, and must withstand hitting a steel rod that is 15 centimeters (6 inches) in diameter and at least 20 centimeters (8 inches) tall after a 1-meter (40-inch) drop. The entire cask is also exposed to a 800 °C (1,475 °F) fire for 30 minutes.

The realistic applicability of these test results has been verified by full-sized, scale, and computer modeling of actual accident situations. In each case, damage to the casks proved to be superficial, and the cargo remained isolated from the environment.

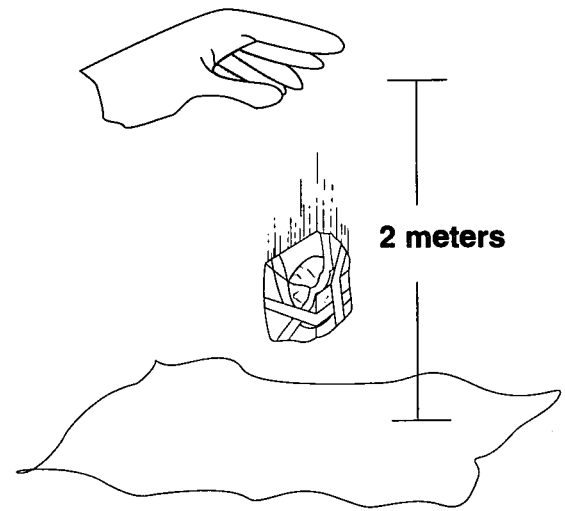

To help you understand designing for safety, you and your team will design and build a "cask" for the protection of a raw egg. Under the supervision of your instructor, you will test your cask by dropping it from a height of 2 meters (6.6 feet) onto a plastic sheet.

Purpose:

What is the purpose of this activity?

Materials:

Each Group

1 raw egg
2 sheets of 8 1/2" x 11" paper
1 meter of tape

Whole Class

plastic sheet
meter stick

Procedures:

1. As a group, discuss and agree upon a design for your "cask" that will protect your egg from all angles during the test drop. Draw your cask in the observation section.
2. Construct your cask. You do not need to use all of the materials provided, but you may not use any additional materials.
3. Decide as a group the most vulnerable point of your cask. Mark this spot to identify it.
4. When all teams have completed building their casks, one member of your team will drop your cask in the testing area on its most vulnerable spot from a height of 2-meters (6.6 feet).
5. Eggs that survive the 2-meter (6.6 feet) drop will have travelled in safe casks. Take time to observe the strengths of the casks in your class that survived the drop.
6. Eggs that survive the 2-meter (6.6 feet) drop should then be dropped from a second-story window. Take time to observe the strengths of the casks in your class that survived the drop.

Observations:

Draw the design for your cask below. Label the point you have chosen as the most vulnerable.

1. Did your egg survive the fall? Why or why not?

2. List the qualities you have observed of the casks that survived the drop.

Conclusion:

1. If you were forced to make improvements on your cask whether it survived the drop or not, what changes would you make? (Assume the same supply of materials.)

2. What factors do engineers need to consider when designing a cask to transport spent fuel?

ANALYZING STATE HIGHWAY MAPS

Under the Nuclear Waste Policy Act of 1982 and its amendments, the U.S. Department of Energy (DOE) is responsible for the transportation of spent fuel and high-level radioactive waste to a monitored retrievable storage (MRS) facility and a permanent geologic repository. Three modes of transportation are being evaluated by DOE: Highway, rail, and barge. Route selection issues are being addressed by DOE in cooperation with the U.S. Department of Transportation (DOT) and variety of Federal, State, local, industry, and public agencies.

In 1982, the DOT established final routing regulations, amended in 1990, for highway transportation of hazardous materials, including radioactive materials. Under DOT regulations, carriers must use "preferred highway routes" in order to reduce the time in transit of the hazardous materials. Preferred routes include 1) the interstate highway system, including interstate bypasses and beltways around major cities; and 2) alternative routes selected by a "State routing agency."

In considering and alternate route, State routing agencies are required to follow certain DOT guidelines. The first consideration is the overall risk which the transportation of hazardous materials poses to the public. Alternate route planners attempt to minimize the public's risk during hazardous materials shipments by considering such factors as the total distance and time the waste travels in the State; the time of day, week, and year of the shipments; the density and type of population along the transportation route, the type of roads involved, and the probability of accidents along the route; and the anticipated emergency response time in the event of an accident along the route.

Directions: Using a highway map for your State, answer the following map orientation questions.

Part A

1. What is the scale of the map in inches to miles?

2. What symbol is used to represent national interstate highways?

3. What color is used to represent national interstate highways on the map?

4. Identify two different ways that you can calculate the mileage between two points on the map.

5. Identify two different ways that you can determine the relative sizes of towns and cities in your State.

6. In what directions can one generally travel while on an even-numbered interstate?

7. In what directions can one generally travel while on an odd-numbered interstate?

8. Identify the interstate highways in your State.

9. Identify the major State highways in your State.

10. What types of interstates have three-digit numbers?

Part B

Directions:

1. Assume that hazardous materials are to be shipped through your State. Which interstate(s) will they probably be transported on if they travel into your State from:
 - a. the south? _____
 - b. the north? _____
 - c. the east? _____
 - d. the west? _____

2. Calculate the number of miles that hazardous materials will travel on each of these interstates you listed above if a shipment passes directly through the State on the same interstate.
 - a. _____
 - b. _____
 - c. _____
 - d. _____

3. Approximately how long will it take the hazardous materials to travel through the State by these routes, assuming that the trucks travel 55 mph?
 - a. _____
 - b. _____
 - c. _____
 - d. _____

4. Name the major cities in your State that will be passed by if hazardous materials are transported on these interstates. Give the population for each city.

PLANNING HAZARDOUS MATERIALS SHIPMENT ROUTES

States have the responsibility of determining highway routes for the shipment of hazardous materials based on the U.S. Department of Transportation (DOT) regulations. The DOT encourages the use of the interstate highway system whenever possible, but each State may devise alternate routes.

Directions: Assume that, as the governor of your State, you have decided to suggest routing for hazardous materials shipments through your State. You and your group of emergency, technical, and transportation experts must plan what you consider to be the safest route, using the Federal, State, and local guidelines which must be followed during highway shipments. The final destination is a fictitious site in an undetermined State in a direction chosen by your group. Assume that the hazardous materials cross into your State on an interstate highway. It is up to you to plan the rest of the route, keeping in mind the factors that are cited in the Introduction to this lesson. You may use interstate highways, alternate State highways, or a combination.

I. General Considerations

A. Time of transport

1. What time(s) of day and week do you consider the least desirable time(s) to transport hazardous materials through your State? Why?

2. What times of day and week do you consider the most desirable times to transport hazardous materials? Why?

3. What times of year do you consider to be the least desirable times to transport hazardous materials?

The most desirable? Why?

4. What types of roads would probably be the least desirable to transport hazardous materials?

B. Population

1. What, if any, cities, towns, or areas should be bypassed during the transportation of hazardous materials along this route? Why?

C. Route Selection

1. Describe the route by which you will allow hazardous materials to travel into, through, and out of your State.

2. What factors did your group consider to be most important in this route selection?

3. Calculate the number of miles that will be traveled on this route.

4. What steps will your State take to protect the public along this route?

5. How long will it take to travel this route, assuming that the trucks transporting the hazardous materials travel at an average of 55 mph?

D. Contingencies

1. Suppose that you are confronted with the following situations. What adjustments, if any, would you make to your route or to your shipment procedures?

A. arrival in a major city at morning or evening rush hour:

B. road construction and delays on interstate and/or State highways:

C. adverse weather conditions (snow and ice, rainstorms, fog, etc.):

D. 11:30 p.m. concert traffic in or near a major city:

IMPORTANT ROCK CHARACTERISTICS

Directions: The rock in which the repository is built must be appropriate for a repository. Some basic properties of rocks important for consideration in determining the appropriateness of the tuff at Yucca Mountain are listed below. On the blank before the property, write the letter of the definition that best describes the property. Then explain why each characteristic is important to consider when planning the repository.

- ___ 1. Plasticity _____

- ___ 2. Solubility _____

- ___ 3. Sorptive capacity _____

- ___ 4. Compressive strength _____

- ___ 5. Thermal stability against chemical decomposition _____

- ___ 6. Permeability _____

- ___ 7. Porosity _____

- ___ 8. Heat conductivity _____

DEFINITIONS

- A** - the ability to transmit heat
- B** - the extent to which a rock can adsorb or absorb from solution
- C** - the degree of resistance to heat causing a chemical change
- D** - the ability of a solid to flow, especially under influence of pressure and/or temperature
- E** - the percentage of the total volume of pores or spaces in a rock or soil to its total volume
- F** - the extent to which a material can be squeezed without breaking or fracturing
- G** - the capacity of a medium (rock, sediment, or soil) to transmit fluid (gas, liquid such as ground water); depends on the size and shape of the pores in the medium and how they are interconnected
- H** - susceptibility to being dissolved; tendency to dissolve

ROCK CHARACTERISTICS IMPORTANT IN REPOSITORY SITING

Directions: Use what you have learned in your reading lesson to answer the following questions.

True or False: If the answer is false, correct it to make it true.

- _____ 1. Waste solutions will almost always begin to dissolve the rock through which they pass.
- _____ 2. All rocks are porous and permeable.
- _____ 3. Non-welded tuff is stronger and denser than welded tuff.

Matching:

- _____ 4. A measure of how well any material will transmit heat.
- _____ 5. A measure of the deforming effect of heat on any material.
- _____ 6. A measure of the transforming effect of heat on any material.

- a. *plasticity* b. *thermal stability* c. *thermal conductivity* d. *porosity*

Completion:

- 7. Waste can flow from one location to another in what two forms?

_____ and _____

- 8. Why would the compressive strength of rocks be a consideration in selecting a site for a nuclear waste repository?

- 9. Describe an example of a chemical sorptive process.

10. Describe an example of a physical sorptive process.

11. Describe the process by which welded tuff is formed.

12. Compare porosity and permeability.

POROSITY AND PERMEABILITY

Porosity and permeability are related properties of any rock or loose sediment. Both are related to the number, size, and connections of openings in the rock. More specifically, porosity of a rock is a measure of its ability to hold a fluid. Mathematically, it is the open space in a rock divided by the total rock volume (solid and space). **Permeability** is a measure of the ease of flow of a fluid through a porous solid. A rock may be extremely porous, but if the pores are not connected, it will have no permeability. Likewise, a rock may have a few continuous cracks which allow ease of fluid flow, but when porosity is calculated, the rock doesn't seem very porous.

Directions: In this activity, you will use loose sediment of varying sizes to demonstrate the relationships between porosity and permeability. Answer the following questions before you begin your experiment.

Purpose:

What is the purpose of this experiment?

Hypothesis:

What do you expect to find as the relationship between porosity and permeability?

Materials:

1-liter soda bottle	copper shot (BB's)
2 graduated cylinders (1-liter) or other liquid measure	cheesecloth
marbles (uniform size, not too large)	stopwatch
rubber stopper with hole	clean sand
short length of rubber tubing	rubber bands
plastic or rubber tubing	short length of glass tubing
pinch clamp	petroleum jelly (Vaseline®)

Procedure:

1. Cut the bottom off the soda bottle.
2. Place several layers of cheesecloth over the small opening and put a rubber band over it to hold it in place.
3. Place the rubber stopper in the opening over the cheesecloth.
4. Carefully place the glass tubing in the rubber stopper. Do not push it through the cheesecloth. It may help to lubricate the glass tubing with petroleum jelly.
5. Attach the rubber or plastic tubing to the exposed glass tubing. Place the pinch clamp on the rubber tubing to act as a faucet valve.
6. Place the bottle upside down so it can be used as a funnel. Then make a mark on the side of the bottle about 10 centimeters (3.9 inches) from the small opening to ensure that you will use the same volume of sediment each time.
7. Fill the funnel up to the mark with the marbles. Make sure the top of the sediment is as flat as possible.
8. Fill the graduated cylinder with water. Make a note of the volume. Slowly fill the funnel with water until the level of the water is just above the top layer of sediment. Record the volume of water poured into the funnel as V_1 , Trial 1 in Table 2. Be careful to avoid trapping air in the pores. Tap the sides of the funnel to release any air that may be trapped in the pores.
9. Place the empty graduated cylinder under the funnel. When one partner removes the pinch clamp, a second partner should begin timing the flow of water. Stop the timer when the first 50 - 100 mL are collected in the cylinder. Record the time as Flow Time, Trial 1 in Table 1. The volume you collect should be easy to time with the stopwatch. Regardless of the volume measured, measure the same volume for each trial and each sediment type. Record this volume as Measured Volume of Water in Table 1.
10. Let the funnel drain completely (within reason) and record the total volume of water collected as V_2 , Trial 1 in Table 3.
11. Repeat steps 7 - 10 for Trials 2 and 3.
12. Remove the sediment and thoroughly clean the funnel. Put another type of sediment in the funnel and repeat the experiment and record the same data for the remaining two sediment types.
13. Calculate the Average Flow Time in Table 1, Average V_1 in Table 2, and the Average V_2 in Table 3 for each sediment type.

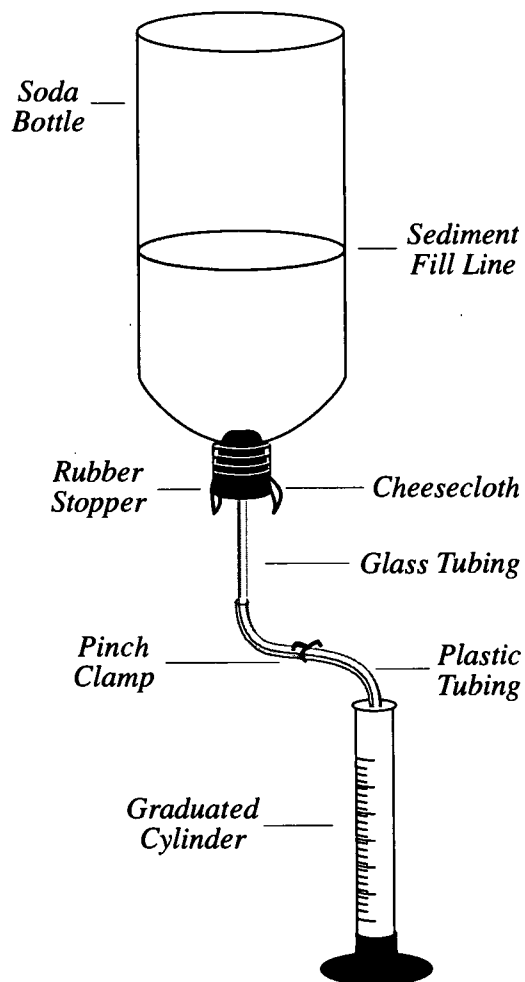

Observations:

Table 1 - Permeability

Sediment Type	Measured Volume of Water (mL)	Flow Time (sec) Trial 1	Flow Time (sec) Trial 2	Flow Time (sec) Trial 3	Average Flow Time (sec)	Flow Rate (mL/sec)
Marbles						
Shot						
Sand						

Table 2 - Porosity

Sediment Type	Original Volume of Water, V_1 (mL) Trial 1	Original Volume of Water, V_1 (mL) Trial 2	Original Volume of Water, V_1 (mL) Trial 3	Average Original Volume of Water, V_1 (mL)	Total Volume of Sediment (mL)	Percent Porosity
Marbles						
Shot						
Sand						

Table 3 - Effective Porosity

Sediment Type	Recovery Volume, V_2 (mL) Trial 1	Recovery Volume, V_2 (mL) Trial 2	Recovery Volume, V_2 (mL) Trial 3	Average Recovery Volume, V_2 (mL)
Marbles				
Shot				
Sand				

Conclusion:

1. In order to calculate percent porosity for each sediment type, you must know the volume of sediment you used each time. Since you marked your funnel at the sediment fill line, calculate the volume of sediment necessary to fill that space. Assume that your bottle approximates a cone. Use the following formula:

$$V_{\text{cone}} = \frac{\pi r^2 h}{3}$$

Measure the radius and height of the cone in centimeters (cm). Express the volume you calculate in milliliters (mL); remember that 1cm³= 1 mL. To check the accuracy of your answer put the lid on the funnel and fill it with water up to the sediment fill mark. Empty the water into one of your graduated cylinders and read the volume. Record this value as Total Volume Sediment in Table 2.

2. Porosity for a sediment made of spherical particles, regardless of particle size, depends on the way the spheres are packed and will vary from almost 50% to approximately 27%. Based on the total volume sediment (determined above), calculate the porosity for each sediment type in the experiment.

$$\% \text{ Porosity} = \frac{V_1 \text{ (volume pores or average volume water)} \times 100}{\text{Total sediment volume}}$$

Record your answers in Table 2. Are they significantly different from each other? If so, suggest a reason.

3. How do the rate-of-flow values compare for the three sediments? What does this tell you about the permeability of the different sediment types?

4. How do the recovery volumes compare for the three sediment types? Explain the differences and relate it to your explanation of permeability.

POROSITY

Directions: In the following table, the volume of open space is given for a 1 cubic meter sample of a given rock type. Calculate the porosity as a percent for each rock type by using the following formula:

$$\frac{\text{Volume of pores}}{\text{Total rock volume}} \times 100 = \text{porosity (\%)}$$

One cubic meter(m³) = _____ cubic centimeters (cm³)

Rock type	Typical Vol. open space (cm ³)	Porosity (%)
Fractured basalt	5.5 x 10 ⁴	_____
Granite	1.0 x 10 ⁴	_____
Limestone	1.5 x 10 ⁵	_____
Sandstone	2.5 x 10 ⁵	_____
Shale	1.0 x 10 ⁵	_____
Tuff (non-welded, Yucca Mt. area)	4.5 x 10 ⁵	_____
Welded Tuff (proposed repository host rock)	1.2 x 10 ⁵	_____

1. What does the scientific notation 10⁴ mean in the example for fractured basalt?

2. What does the notation (cm³) in column 2 tell you?

3. Which rock type listed above is most porous? _____

4. Why is the porosity of tuff important in siting the repository?

PERMEABILITY

Permeability is a measure of the ease of flow of a fluid, like water, through a porous rock. Water flowing next to the pore wall will be slowed by friction and may actually attach to the wall. The non-moving water is a small fraction of the total amount of water flowing in a coarse-grained rock, but it is increasingly important as grain size decreases.

As grain size decreases, the volume of solids, and porosity, may remain constant, but surface area always increases. More surface area means more places for water to attach, thereby reducing flow through, and permeability of, the rock.

A simple geometric calculation illustrates the relationship between grain size and surface area.

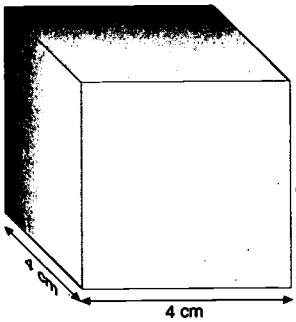

Directions: Start with a single grain from a porous rock. Imagine that the grain is a perfect cube 4 centimeters (1.6 inches) on a side.

Helpful Formulas

$$\text{Surface Area}_{\text{Cube}} = \text{Area on face } (l \times w) \times \text{Number of faces } (6) \quad S.A. = (l \times w) \times 6$$

$$\text{Volume}_{\text{Cube}} = \text{length } (l) \times \text{width } (w) \times \text{height } (h) \quad V = l \times w \times h$$

1. Calculate the surface area and volume of the grain.

Surface area _____

Volume _____

2. Without changing the amount of solid volume, surface area can be increased by cutting the cube into eight equal, but smaller, cubes. Demonstrate through a calculation that the area is now greater than the original.

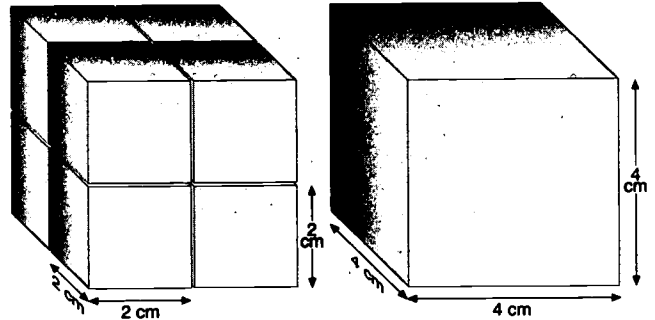

By how much? _____

3. What is the total volume of the new, smaller cubes? _____

4. Why does an increase in surface area mean an increase in friction between pore walls and water and, therefore, an increase in resistance to water flow through the rock?

5. Why is permeability important to consider in evaluating a host rock for a repository?

SOLUBILITY

Solubility is the susceptibility of a rock to being dissolved. The solubility of any particular rock is dependent on the minerals that constitute the rock as well as the liquid that may dissolve these minerals. This activity demonstrates this important interdependence.

Directions: Review the activity, then answer the following questions before performing the experiments.

Purpose:

What is the purpose of performing this experiment?

Hypothesis:

State your hypothesis regarding the outcome of this experiment.

Materials:

- sodium chloride (NaCl — table salt)
- graduated cylinders (50 and 100mL)
- distilled water
- 3 clear glass containers (vials, beakers, etc.)
- salts for making artificial sea water
- anhydrous isopropyl alcohol (>99% pure)
- laboratory stirring rods (or coffee stirs)
- balance (capable of weighing as little as 0.1 gram)
- glassware for mixing sea water
- grease pen or pen and stick on labels

Procedure:

1. Make artificial Great Salt Lake water by dissolving 20 grams (0.7 ounces) of NaCl in 100 milliliters (0.2 pints) of distilled water. (Stir until all the salt goes into solution.)
2. Weigh out 3 separate 5-gram (0.2 ounces) samples of NaCl.
3. Measure 14 mL (0.03 pints) **each** of distilled water, artificial Great Salt Lake water, and anhydrous isopropyl alcohol into the 3 clear glass containers. Be sure to label each container.

4. Add 1 of the 5-gram (0.2 ounces) samples of NaCl to each liquid and stir. (Use a separate stirring rod for each container.)
5. Note the amount of any solid remaining in the container.

Observations:

Describe your attempt to dissolve the 5 gram (0.2 ounces) NaCl sample in each of the following:

Distilled Water:

Great Salt Lake Water:

Anhydrous Isopropyl Alcohol:

Conclusion:

1. Explain your results. Why do you think this happened?

2. Why did the experiment call for distilled water instead of tap water?

3. Anhydrous alcohol is alcohol that is essentially waterless. Why was it important to use "waterless" alcohol?

4. How does this demonstration show that solubility depends on the properties of both the liquid and the solid?

5. Why is the solubility of a rock important in siting a repository?

6. Water, moving through a rock of uniform composition, will initially dissolve some minerals. As the water travels farther through the rock its ability to dissolve minerals decreases and eventually becomes zero. Why?

MINERAL SOLUBILITY

Minerals differ in their tendency to dissolve in water. This concept is of importance when applied to repository rocks and minerals. Solubility, as measured in the laboratory, is the amount of mineral that will dissolve in a fixed amount of water, at a certain temperature, and is a property unique to each mineral composition. In a natural system, the solubility of any mineral is a function of the composition of the liquid surrounding it. Only rarely will that liquid be pure water. If a mineral in a rock dissolves, it leaves behind an open space which increases the porosity of the rock. Permeability may be increased as minerals dissolve and connections between pores are widened.

In the following activity you will use commonly available ionic solids (solids which, when dissolved, yield a solution of cations and anions) to demonstrate a range of solubilities of single minerals.

Directions: Answer the following questions before beginning your experiment.

Purpose:

What is the purpose of this experiment?

Hypothesis:

Which of the four compounds listed in the Materials (next page) do you expect to be the most soluble. Why?

Which do you expect to be the least soluble. Why?

Materials:

Epsom salts ($\text{MgSO}_4 \cdot 7\text{H}_2\text{O}$)
table salt (NaCl)
sodium bicarbonate (NaHCO_3) (baking soda)
plaster of paris ($\text{CaSO}_4 \cdot 1/2 \text{H}_2\text{O}$)
8 oven safe glass containers (100 mL or larger)
funnel
filter paper (coffee filters will work)
oven
balance (capable of weighing to 0.1 g)

Procedures:

1. Label two containers for each mineral. One will be A, the other B.
(Example: Epsom salts A, Epsom salts B, etc.)
2. Fill each container in set A with 50 to 250 mL (0.1 -0.5 pints) of tap water. Each container should have a different volume of water. Record the volume for each mineral in Table 1. It is important that you accurately measure and record the volume of water that you use.
3. Weigh the empty, labeled containers in set B. Record these masses in Table 1 as M_1 .
4. Add approximately 1 Tablespoon of the Epsom salts to the appropriate container in set A. Stir the solution to dissolve the Epsom salts. Continue adding Epsom salts 1 Tablespoon at a time and stirring until solid mineral remains on the bottom of the container and will not dissolve. The solution is now saturated with Epsom salts.
5. Pour the saturated solution through the funnel lined with filter paper into the correspondingly labelled, empty container in set B.
6. Repeat steps 4 and 5 for table salt, sodium bicarbonate, and plaster of Paris.
7. Put the containers in set B, now holding the saturated solutions, in an oven capable of maintaining approximately 95 °C (approximately 200 °F) overnight. Avoid oven temperatures of 100 °C or greater. You do not want the liquid to boil as solutions may splash over the sides and be lost from your final mass measurement.
8. When all of the water has evaporated and the containers have been cooled to room temperature, weigh the containers. Record these masses in Table 1 as M_2 .
9. Find the mass of the dissolved mineral by subtracting the mass of the containers in set B (M_1) from their mass with the remaining dissolved mineral after drying (M_2). Record the results in Table 1 as "Mass Mineral."
10. Solubility is expressed in terms of grams of mineral dissolved in 100 mL (0.2 pints) of water. Calculate the solubility of each of the pure minerals in this exercise and record your answers as Solubility in Table 1.

Observations:

Table 1. Single Mineral Solubilities

Mineral	Volume of Water	Mass Containers Set B, M_1	Mass Containers Set B, M_2	Mass Mineral $M_2 - M_1$	Solubility g/100mL
Epsom Salts					
Table Salt					
Sodium Bicarbonate					
Plaster of Paris					

Conclusion:

1. Compare your calculated values to the standards given by your teacher. Are there any major differences between your calculated values and those supplied by your instructor? If so, can you suggest an explanation for the differences?

2. If your oven temperature was too hot and your solutions began to boil, how might the outcome of your experiment be affected?

3. If you did not measure and record the volumes of water that you used accurately, how might the outcome of your experiment be affected?

4. If you add too much solid mineral to your solutions, how might the outcome of your experiment be affected?

5. What sources of error did you observe in your experiment? What effect did error have on the outcome of your experiment?

6. What information would you need to determine the solubility of minerals in the proposed repository rock?

Common Ions

+2	+1	-1	-2
Mg ²⁺	Li ⁺	Cl ⁻	S ²⁻
Ca ²⁺	Na ⁺	OH ⁻ (hydroxide)	SO ₄ ²⁻ (sulfate)
Sr ²⁺	K ⁺	HCO ₃ ⁻ (bicarbonate)	CO ₃ ²⁻ (carbonate)
Ba ²⁺	H ⁺		

7. Use the table of common ions shown on the previous page to determine the cation and anion found in a solution including the minerals listed below.

Mineral	Formula	Cation	Anion
Epsom Salts			
Table Salt			
Sodium Bicarbonate			
Plaster of Paris			

8. Why is the solubility of a rock important in siting a repository?

9. Water, moving through a rock of uniform composition, will initially dissolve some minerals. As the water travels farther through the rock, its ability to dissolve minerals decreases and eventually becomes zero. Why?

THERMAL STABILITY

All minerals and the rocks that contain them undergo some alteration as a result of exposure to elevated temperature. In most cases, the alteration is not very dramatic until very high temperatures are reached. However, some minerals, particularly the minerals involved in ion exchange reactions, are susceptible to alteration at fairly low temperatures. Because clay minerals and zeolites — major factors in a rock's ion exchange capacity — contain a lot of water in their structure, they are susceptible to dehydration or water loss at temperatures as low as 100 °C. Dehydration not only changes the exchange capacity of a mineral, it also generates liquid water in the pores surrounding the repository that may act to conduct heat produced by decaying radioactive waste. The same water may also have a corrosive effect on the canisters containing the spent fuel rods.

A dramatic demonstration of dehydration is offered by the exfoliation or flaking of vermiculite, a commonly occurring clay mineral. Although vermiculite is not a common mineral in the rocks of the proposed repository, its behavior when exposed to a sudden temperature increase is a graphic example of a type of thermal alteration. Clay minerals are aluminum-silicon compounds (aluminosilicates) like zeolites but, unlike zeolites, are constructed of layers held together by interlayer, exchangeable cations — just as mortar holds the cinderblocks together to construct the foundation of a house. Vermiculite has a large capacity for cation exchange.

Cations in water are surrounded by oriented water molecules. Some cations like the magnesium ion, (Mg^{2+}) which is an interlayer cation of vermiculite, hold this water, called "waters of hydration," tightly. This attraction is weaker between water molecules and other cations like the potassium ion (K^+). During the cation exchange reaction, the magnesium ion keeps its waters of hydration and leaves the interlayer, whereas the potassium ion loses its water of hydration and takes its place. Much of the water in clay minerals is found in the interlayer and is associated with exchange ions such as Mg^{2+} .

The purpose of this activity is to demonstrate a dramatic mineral alteration resulting from exposure to a sudden temperature increase. It is important to realize that the temperature rise used in this experiment is much larger than any anticipated in and around the proposed repository.

Purpose

What is the purpose of this experiment?

Hypothesis:

State your hypothesis regarding the thermal stability of the clay mineral vermiculite. Be sure to mention how you expect the KCl-saturated vermiculite to differ from the untreated vermiculite.

Materials:

- 2 aluminum pans
- candles
- drying oven
- pot holder
- flake vermiculite
- saturated KCl (table salt substitute) solution
- two 250 mL beakers (or oven-safe containers)

Procedure:

1. Label beakers A and B.
2. Fill beaker A about half way with water. Make a saturated solution of KCl by pouring the KCl into the water and stirring to dissolve it. Continue adding the KCl and stirring until solid that will not dissolve remains at the bottom of the beaker.
3. Make some potassium saturated vermiculite by placing a small amount of the flake vermiculite in beaker A with the saturated KCl solution. Place the same amount of vermiculite in the empty beaker. By soaking the vermiculite in the KCl solution, you are allowing potassium cations to replace the naturally occurring magnesium cations in the interlayer of the mineral's structure.
4. Allow the vermiculite to soak in the KCl solution for at least 48 hours. Then pour off the liquid and spread the vermiculite in both beakers on separate cookie sheets and dry it in an oven set at 110 °C (approximately 225 °F). This will take 2 - 3 hours. Stir the drying vermiculite occasionally.

5. Using the oven-dried samples of Mg^{2+} -saturated and the K^{+} -saturated vermiculite, place a few flakes of each in separate aluminum pans.
6. Light the candle. Using the pot holder to protect your hands place the clay-containing pans over the hottest part of the flame. Observe and record the changes in the clay.

Observations:

Describe the K^{+} -saturated vermiculite.

Before drying:

After drying:

During and/or after exposure to heat:

Describe the Mg^{2+} -saturated vermiculite (untreated).

Before drying:

After drying:

During and/or after exposure to heat:

Conclusion:

1. Do the two types of clay behave differently? If so, how are they different and how can that explain their different behaviors?

2. What is the source of the heat that must be considered when planning and designing the repository?

3. Why is it necessary to consider thermal stability of potential repository minerals?

ION EXCHANGE AND ZEOLITES

Ions are particles that have an electrical charge. Ion exchange depends on the fact that particles with opposite electrical charges are attracted to each other (i.e., positively charged particles attract negatively charged particles and vice versa). The ions that make hard water, usually high concentrations of calcium (Ca^{2+}) and magnesium (Mg^{2+}), react with soap molecules to form an insoluble material. As a result, soap does not lather well and loses its effectiveness as a cleanser. The ion exchange process replaces the Ca^{2+} and Mg^{2+} with sodium (Na^+), which does not react with the soap molecules. This is the purpose of home and municipal water softening systems.

Purpose:

What is the purpose of this activity?

Hypothesis:

In which solution do you expect to observe the greatest degree of ion exchange? How will you know that ion exchange has taken place?

Materials:

237 milliliters (1 cup) cation exchange resin or zeolite
 3 bottles that will hold 474 milliliters (2 cups) of water, caps or stoppers for the bottles
 soap flakes (not detergent) (pea sized shavings of Ivory soap bars will work)
 hard water (or 1-liter [2 pints] distilled water + 3.3 grams [0.1 ounce] Epsom salts)
 clean, dry 1-liter plastic soda bottle
 cheesecloth
 strong rubber bands
 knife
 scissors
 support stand for soda bottle
 measuring cup
 1/4 teaspoon measuring spoon

Procedure:

1. Pour 237 milliliters (one cup) of the hard water into one of the glass bottles.
2. Add 1.2 milliliters (1/4 teaspoon) of soap flakes. Allow this mixture to stand for three minutes.
3. Cap the mixture and shake.
4. Observe and describe the quantity and the quality of the suds. (Are there many? How long do they last?)
5. Cut the bottom off the soda bottle to create a funnel.
6. Cap the bottle/funnel, put it in the stand, and pour 237 milliliters (one cup) of the hard tap water into it. Allow it to stand undisturbed for three minutes.
7. Cover the mouth of the second glass jar with several layers of cheesecloth and secure the cheesecloth with several rubber bands. Remove the cap from the bottle/funnel, allow the water to run through the cheesecloth, and collect the water in the glass bottle.
8. Repeat steps 1 - 4 using the liquid you collected in the second glass jar. Compare your results with the results in step 1. Did the type of container or the cheesecloth have any effect on the results?
9. Put the cap on the bottle/funnel. Place 237 milliliters (1 cup) of the exchange resin in the funnel.
10. Pour 237 milliliters (1 cup) of hard tap water into the funnel and allow it to stand for three minutes.
11. Cover the mouth of the third bottle with several layers of cheesecloth and secure the cheesecloth with several rubber bands. Remove the cap of the funnel and allow the water to run through the cheesecloth into the third glass bottle.
12. Repeat steps 1 - 4 using the liquid you collected in the third glass jar. Compare your results with the results from the liquid in jars one and two.

Observations:

Jar #1: Hard water and soap

Jar #2: Hard water and soap filtered through cheesecloth

Jar #3: Hard water and soap filtered through zeolites and cheesecloth

Conclusion:

1. Compare the suds created in the three jars. Which had the most and longest lasting suds?

2. Did pouring the water through the cheesecloth have any effect on the quality of the soap suds? Why or why not?

3. Did pouring the water through the resin have any effect on the quality of the soap suds? Why or why not?

4. Why might ion exchange capability be an important consideration when siting the high-level waste repository?

TOPOGRAPHIC MAP SKILLS

Directions: Use what you have learned in your reading lesson to answer the questions below.

True or False: If the answer is false, correct it to make it true.

- ___ 1. A topographic map shows details of the Earth's surface.
- ___ 2. The contour interval remains constant on any one topographic map.
- ___ 3. A standard USGS map is always oriented to true north.
- ___ 4. Lines of latitude are the lines on the map that run from the north geographic pole to the south geographic pole.
- ___ 5. The magnetic declination, scale, and coordinates are found at the bottom of the map or in the margins.
- ___ 6. A contour line spirals from sea level to the highest elevation of a mountain.
- ___ 7. A V-shaped bend in the contour line indicates flow of a body of water and points downstream.
- ___ 8. A topographic map scale can be expressed by the length of a bar scale or as a ratio.
- ___ 9. Topographic maps can be measured in minutes and seconds.
- ___ 10. You would use an ordinary ruler to determine coordinates of any point on a map.

Bonus Question:

If a point lies 60" east of the longitudinal line of $120^{\circ} 12'$, what would be the longitudinal location of that point in degrees, minutes, and seconds? _____

PRACTICE WITH SCALE, LATITUDE, AND LONGITUDE

Directions: These problems will give you practice in using map skills involving scale, latitude, and longitude. In doing the problems, remember that more than one step may be necessary to answer the questions. For problems 4-7, it may help to draw a picture.

1. The distance between Chicago, Illinois, and Cleveland, Ohio, on a map of the United States at a scale of 1:2,500,000 is 7.75 inches. What is the true distance between the two cities in miles?
2. The distance between San Francisco, California, and Durango, Colorado, is 25.7 centimeters on a map whose scale is 1:5,000,000. What is the true distance between the two cities in kilometers?

3. Use the method outlined in figures 6 and 7 in the reading entitled *Topographic Map Skills* to determine the longitude of a point between $81^{\circ} 30'$ and $81^{\circ} 32' 30''$. If you want to determine the longitude to the nearest second ($''$), how many divisions do you need on your scale?

4. Using a scale, you determine that a point is 35 seconds west of longitude $113^{\circ} 28' 31''$. What is the longitude of the point?

5. Using a scale, you determine that a point is $1' 10''$ east of longitude $78^{\circ} 14' 02''$. What is the longitude of the point?

6. Using a scale, you determine that a point is $5' 12''$ north of latitude $36^{\circ} 30' 00''$. What is the latitude of the point?

7. Using a scale, you determine that a point is $11' 20''$ south of latitude $22^{\circ} 10' 28''$. What is the latitude of the point?

CONTOURING

Directions: On a topographic map contour lines connect points of equal elevation. Make a topographic map by connecting points of equal elevation to form contour lines. Start with the highest contour.

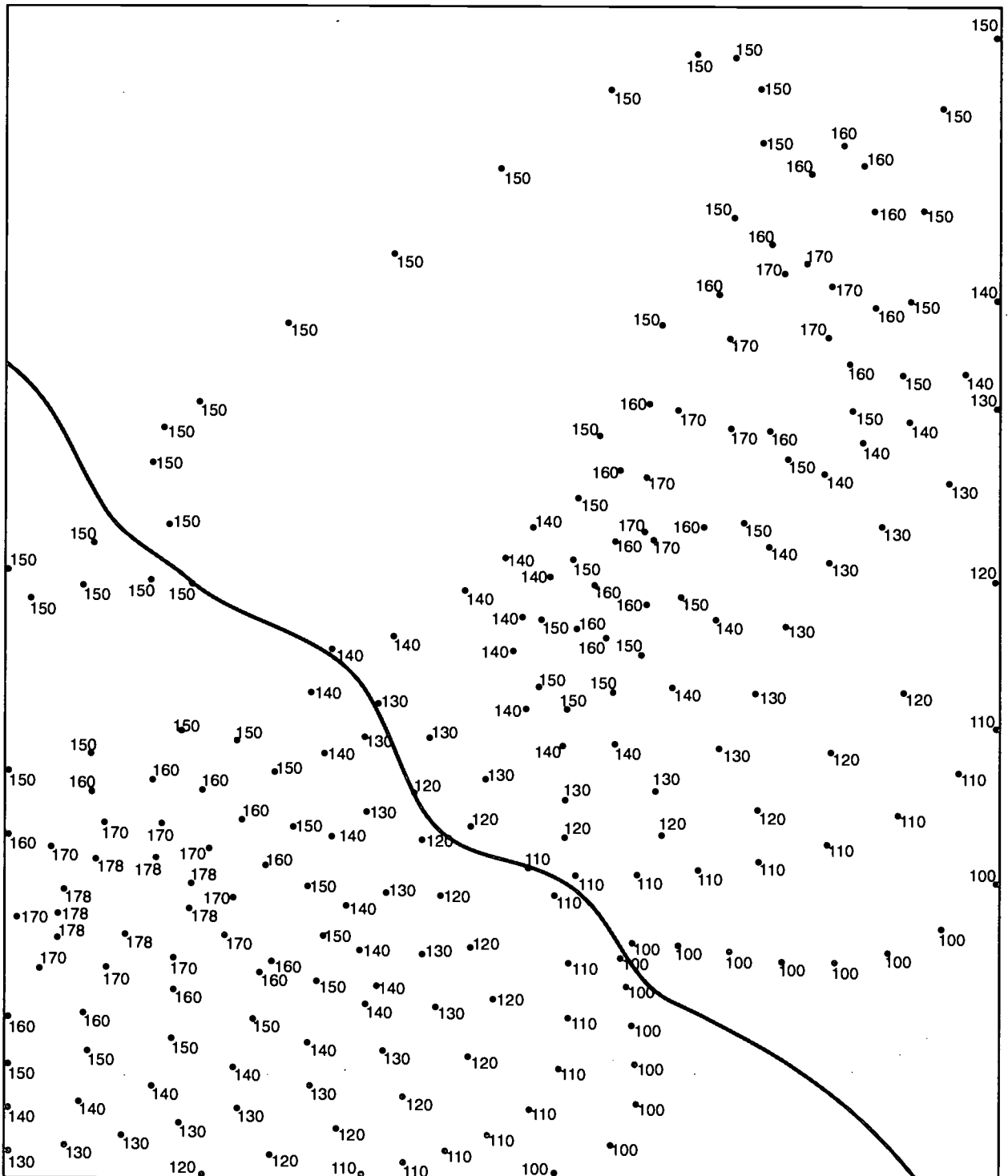

TOPOGRAPHIC MAPS OF LANDSCAPES

Directions: Look at the block diagrams that represent landscapes and match them to the correct topographic maps by writing the letter of the map in the blank.

Block Diagrams

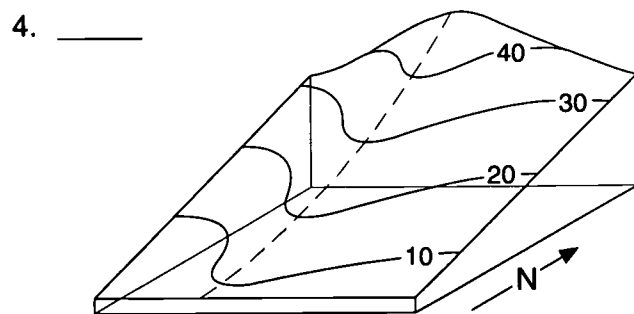
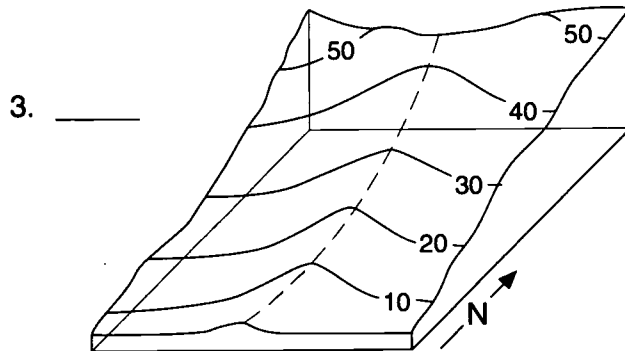
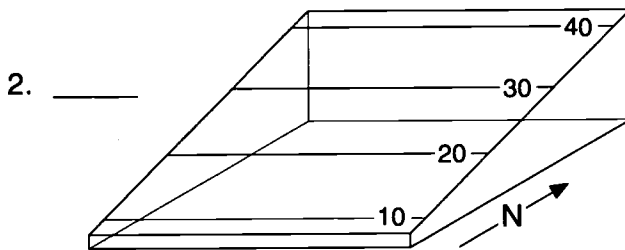
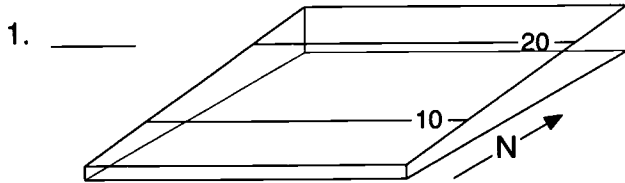

Topographic Maps

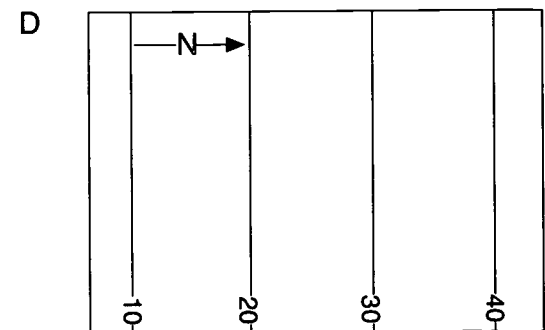
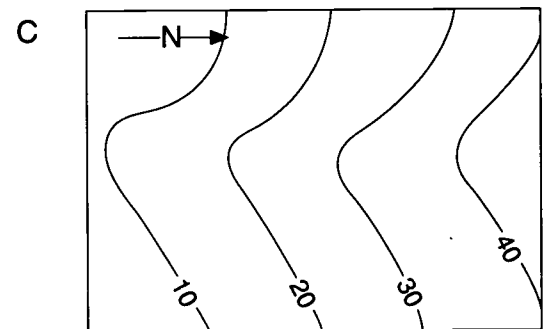
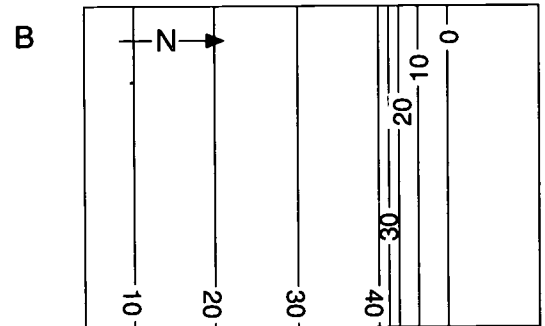
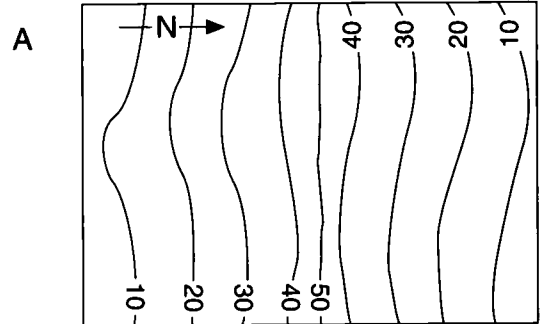

Block Diagrams

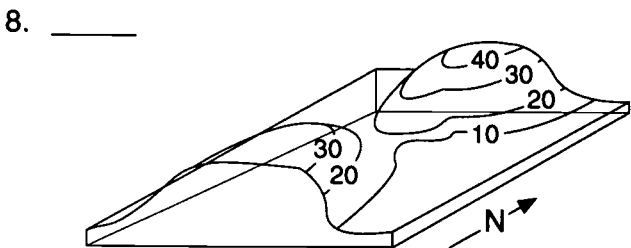
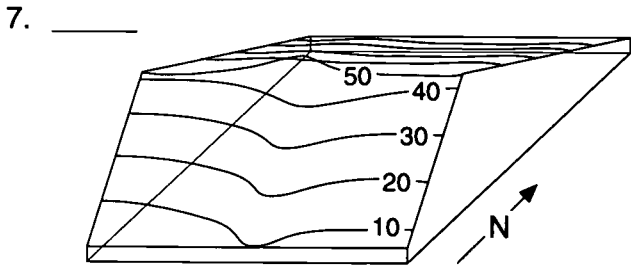
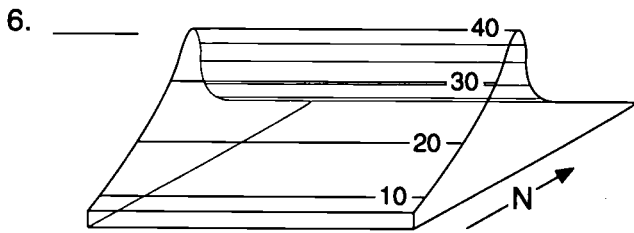
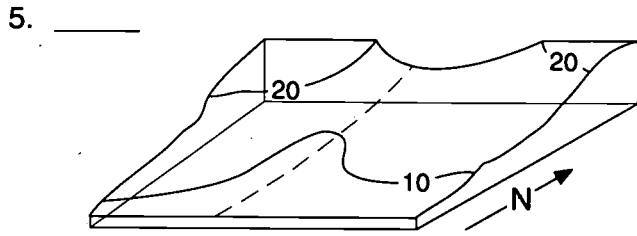

Topographic Maps

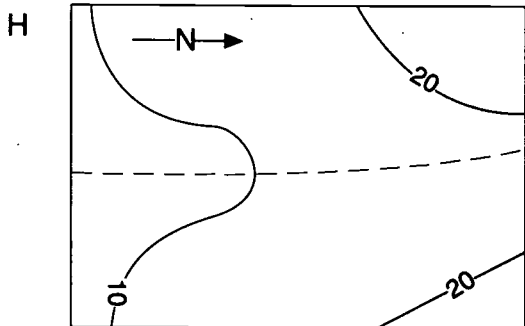
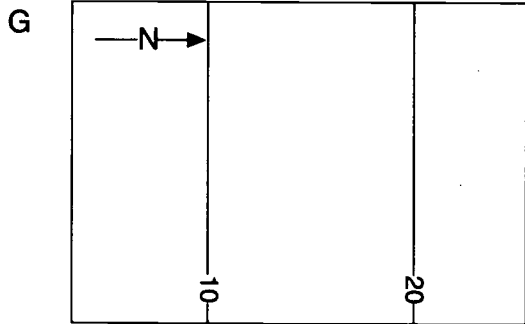
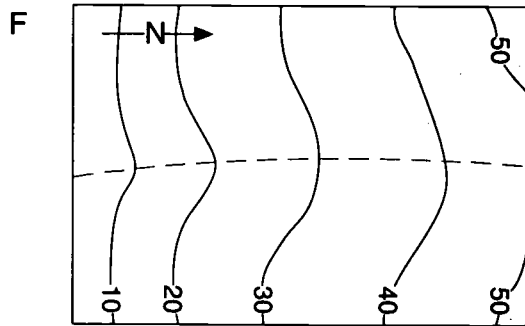
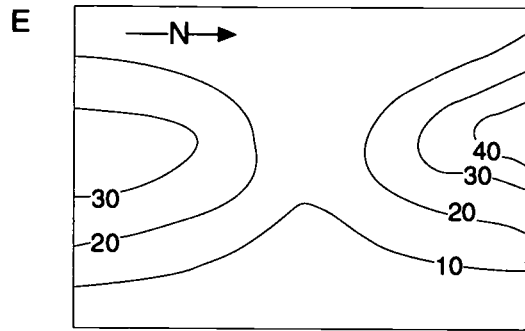

TOPOGRAPHY OF THE YUCCA MOUNTAIN SITE

The purpose of this activity is to demonstrate the usefulness of topographic maps and to examine the topography of the Yucca Mountain site by using a U.S. Geological Survey 7-1/2-minute topographic map. By participating in the exercises, you will acquire a detailed knowledge of the Yucca Mountain site and an understanding of the size and depth of the potential repository. You will also use prominent features on the map to aid you in thinking about guidelines for evaluating potential repository sites that apply to hydrology, erosion, population density and distribution, and site ownership and control.

Directions: Use the U.S. Geological Survey 7-1/2-minute topographic map titled Busted Butte, Nevada, 1961, photo-revised 1983 to answer the questions below.

Reviewing Map Skills

- Determine the scale and contour interval of the map.

Scale: _____

Contour interval: _____

- What does 1" on this map represent on the ground? (Show the answer both in inches and converted to feet.)

- Locate the information that shows the direction of true north and magnetic north on the map. Where is the information located on the map?

- What are the latitude and longitude coordinates of the southeast and northwest corners of the map?

5. What is the purpose of the latitude and longitude grid ticks? List each set of grid ticks separately. (See Figure 1.)

Latitude Grid Ticks:

Longitude Grid Ticks:

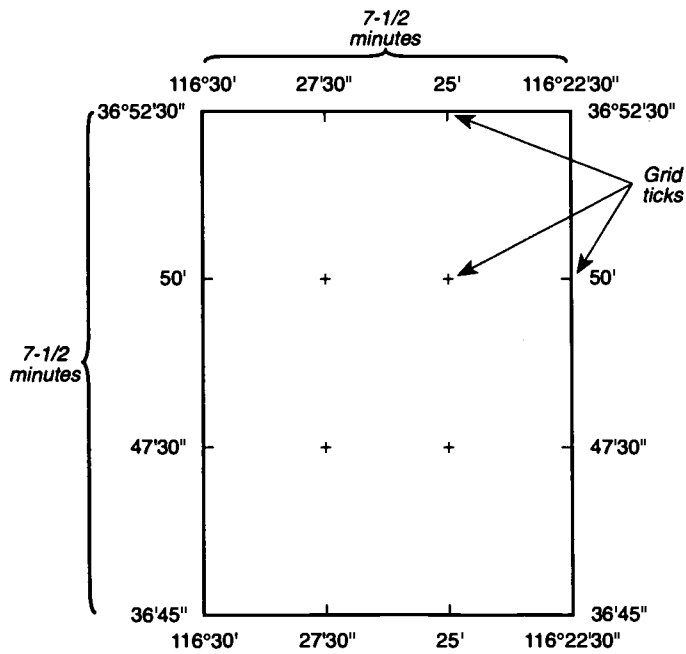

Grid ticks divide a 7-1/2-minute map into 2-1/2-minute sections

Figure 1

Part A: Locating A Point On A Topographic Map

Directions: Use the map, an appropriately scaled ruler, and the following latitude/longitude coordinates to locate two points on the map. You will locate each point by finding where a line of latitude and a line of longitude cross.

Point 1: Lat N36° 50' 44", Long W116° 29' 34"

Point 2: Lat N36° 51' 12", Long W116° 23' 28"

Point 1

- Point 1 falls on Lat N36° 50' 44". Between which orienting points of latitude (grid ticks and/or map borders) does point 1 fall?

Draw a line through the necessary orienting point(s) to separate this section of latitude from the rest of the map. (See Figure 2.)

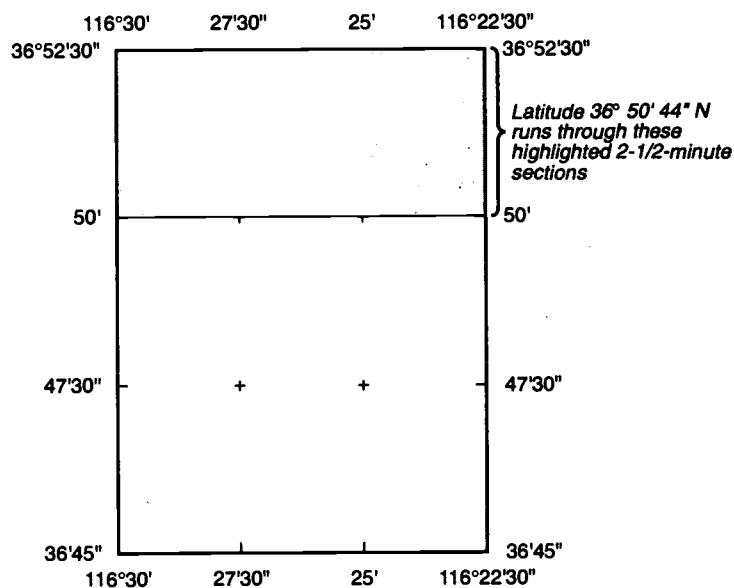

Figure 2

2. Point 1 falls on Long W116° 29' 34". Between which orienting points of longitude does point 1 fall?

Draw a line through the necessary orienting point(s) to separate this section of longitude from the rest of the map. (See Figure 3.)

At this point, one section of the map should be separated from the rest of the map. This section is 1/9th of the whole quadrangle map and it contains point 1. (See Figure 4.)

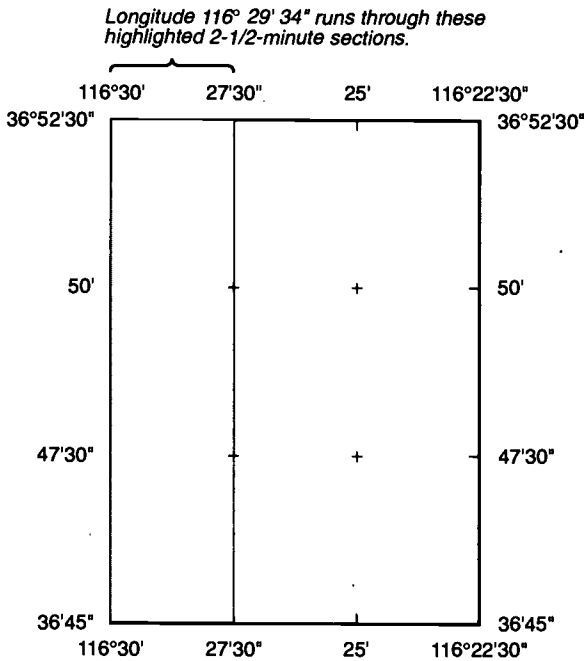

Figure 3

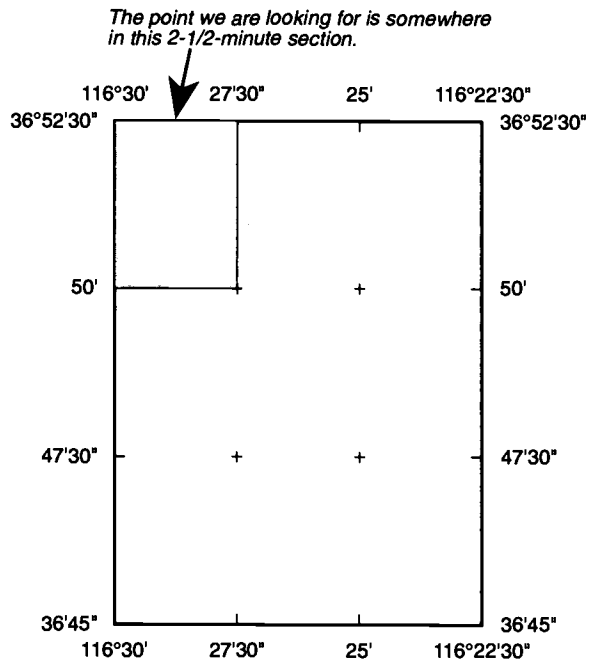

Figure 4

3. In which section of the map will you find point 1?

NW	NC	NE
WC	C	EC
SW	SC	SE

4. What are the dimensions of this section of the map in minutes? Convert to seconds.

5. How many seconds north of the N36 ° 50' line of latitude is N36 ° 50' 44"?

6. Use the engineer's rule or cut out the paper engineering ruler provided that has 150 divisions. Since the section of the map that includes point 1 is 2-1/2 minutes by 2-1/2 minutes or 150 seconds by 150 seconds, you will be able to use this ruler to find point one or any unknown point within a section. (Each division equals one second.)

Using the ruler, locate any two points 44" (44 divisions) north of Lat N50'. You will need to hold the ruler vertically with the 0 mark on Lat N50' and the 150 mark on the top border of the map. (See Figure 5.)

Connect the points. Point 1 is somewhere on this line.

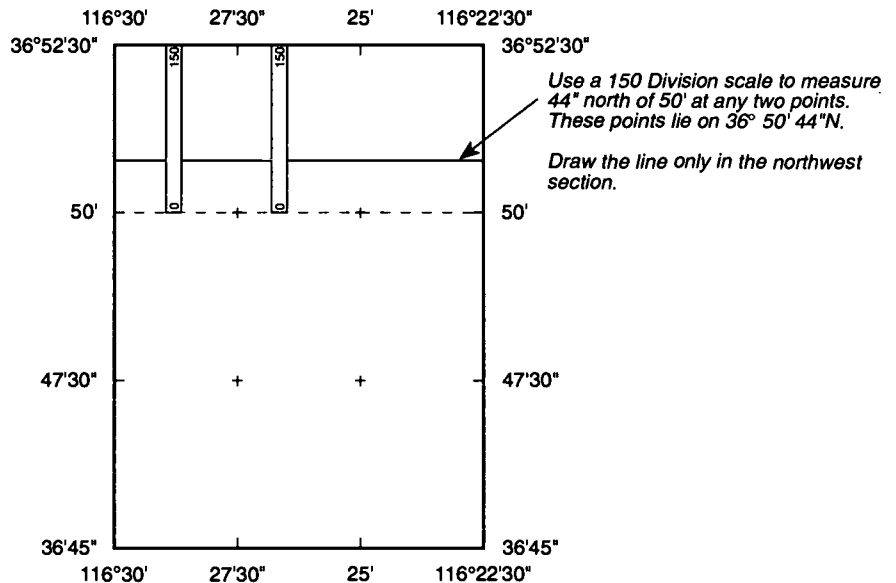

Figure 5

7. How many minutes west of the 27' 30" line of longitude is W116° 29' 24"?

You can subtract distances in degrees, minutes, and seconds but remember that you are working in base 60. One degree is equal to 60 minutes, and one minute is equal to 60 seconds.

8. Using the ruler, locate any two points 124" (124 divisions) west of Long W27' 30". This time you will need to hold the ruler diagonally as illustrated in Figure 6. It is important that you align either the 0 or 150 mark on the ruler with the 27' 30" line. You must align the other division mark (0 or 150) on the western boundary of the map. Count 124" west of 27' 30" and mark a point on the map. Although both ends of the ruler need to be aligned properly, they do not necessarily need to fall within the boundaries you have drawn for this section. Move the ruler, align it again, and make a second mark.

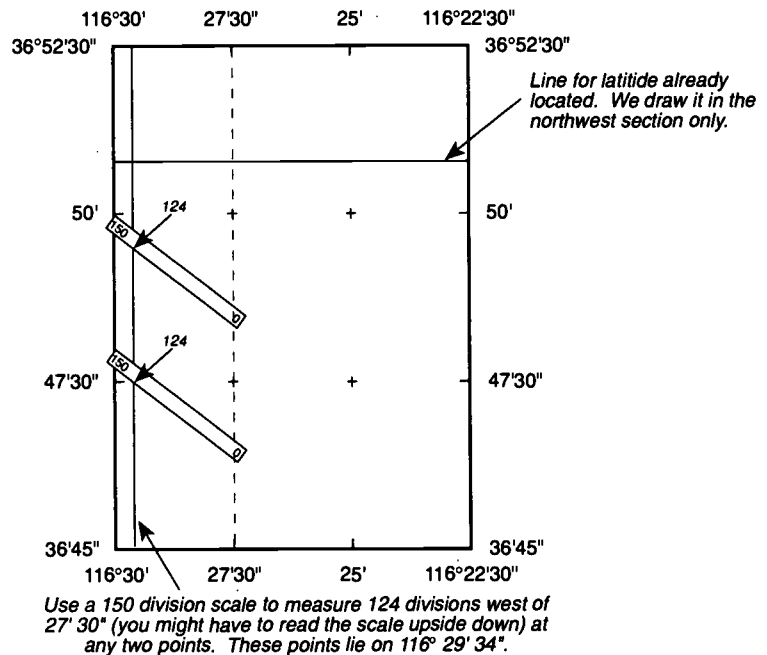

Figure 6

Connect the two points making sure the line that connects them extends through the NW section of the map. Point 1 is where the line of longitude crosses the line of latitude you drew in step 6.

Point 2

9. Use the same approach to locate point 2.

Using a blue pencil, connect points 1 and 2.

Part B: Drawing A Topographic Profile

If we could cut the Earth in half along the line that connects points 1 and 2, and then look at the planet's profile, we could clearly see peaks and valleys and get a good three-dimensional view of the topography of the land in this area. A much simpler way to gather the same information from a two dimensional drawing is to construct a topographic profile.

1. What is the contour interval on your Busted Butte, Nevada, map?

2. Using a sheet of paper that is at least 15" long on one side, align it so that the edge of the paper lines up with the line connecting points 1 and 2. (If necessary, tape two 8 1/2" x 11" sheets together.)

3. Make a mark on the paper where every dark brown (100) contour line crosses the line connecting points 1 and 2. (See Figure 7.) Record each line's elevation next to each mark. You may need to follow some contour lines quite a distance to determine their elevation. Where 100 contour lines are great distances apart, mark all others to get a greater degree of accuracy in your profile. Also record the location of jeep trails or roads where they cross the line of section.

4. Tape two pieces of graph paper together so that the length of one edge is at least 15".

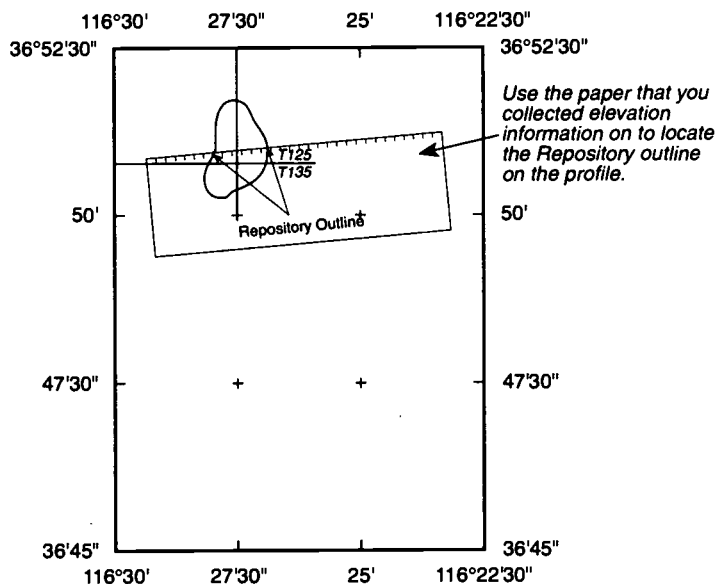
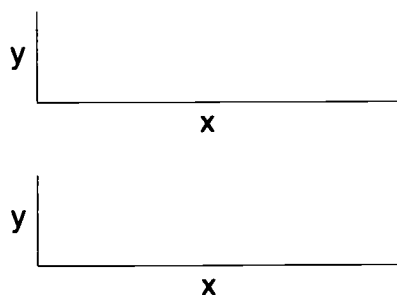

Figure 7

5. Draw two x and y axes on the graph paper as indicated below. The x-axis will represent the distance from point 1 to 2. The y-axis will represent different scales for each graph. One graph will have a scale of 1" = 500' while the other will have a scale of 1" = 2000'.



6. Line up the piece of paper that shows where contour lines cross the line connecting points 1 and 2, with the X-axis of your first graph as indicated below. At each mark along the X-axis, make a mark, at the appropriate elevation, as read on the y-axis. Do this for all points. Then connect the dots using a smooth line.
7. Repeat this procedure for the second graph using the second scale.

What effect does the different vertical scale have on each profile?

Which profile appears more like it would naturally occur?

Which profile emphasizes the subtle aspects of the surface along the profile by showing more details of the landscape?

8. A pattern that represents the outline of the underground repository as it might appear in a final design is included. Cut out the pattern and use the lines drawn on the cut-out to locate it on the map. Transfer the shape to the map using a blue pencil. Now plot the locations on the topographic profile where the repository outline intersects the profile.

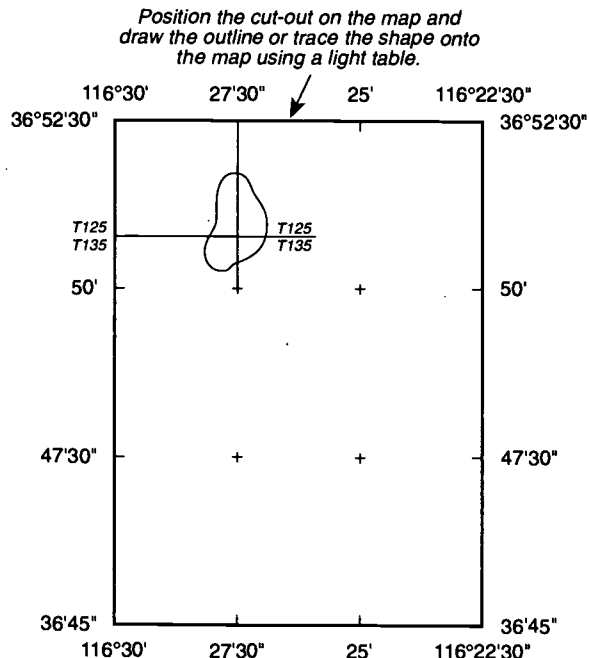
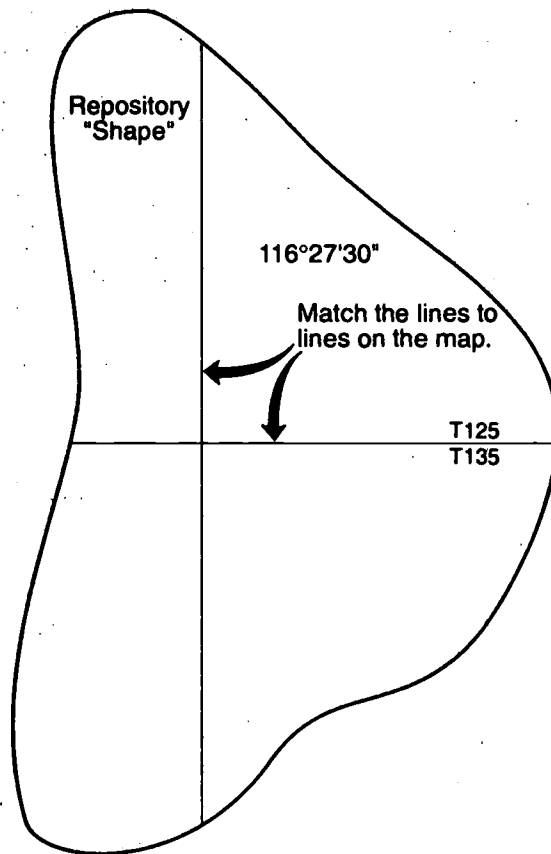
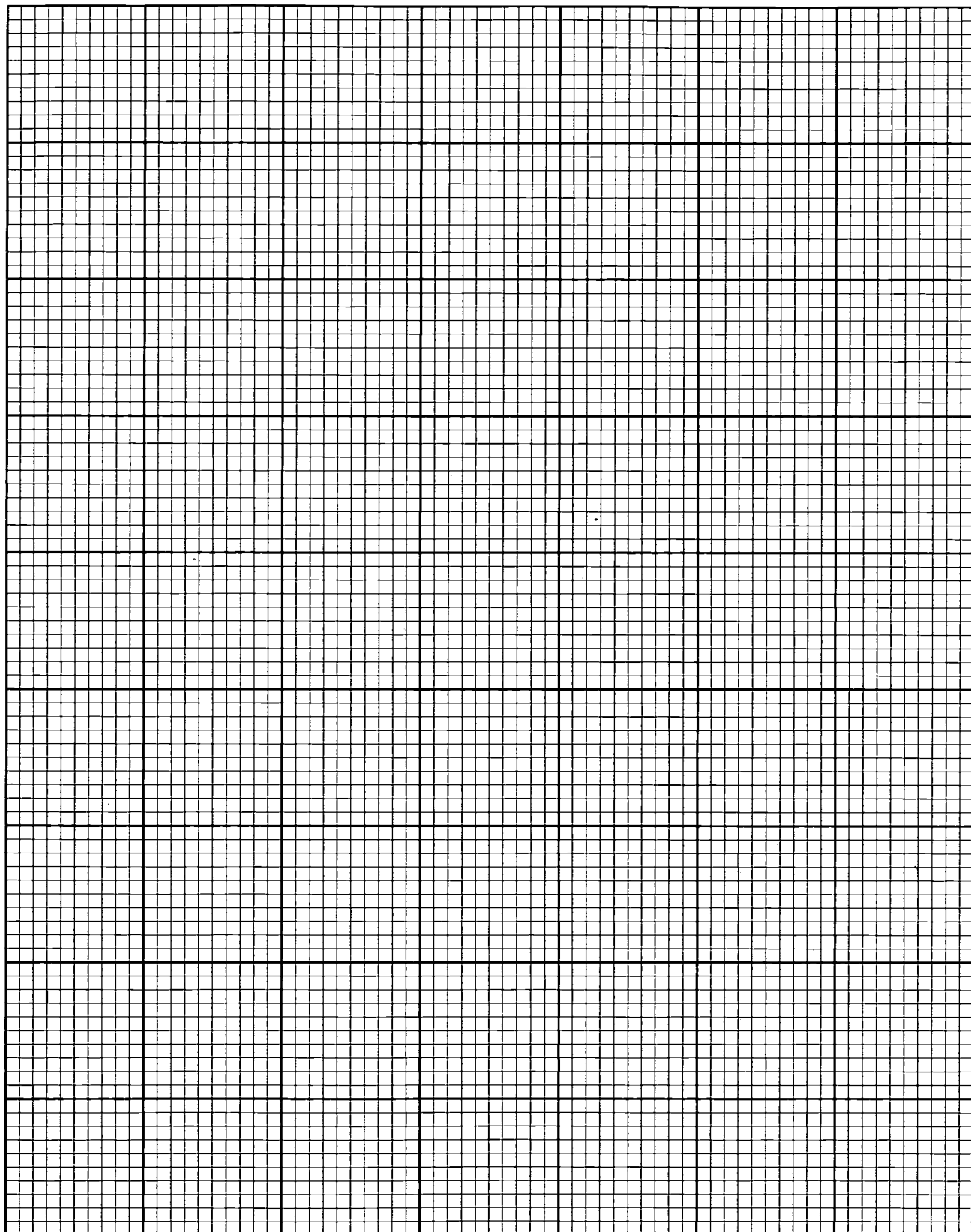

Figure 8



Cut out and locate on map at the intersection of 116° 27' 30" and township boundary line.



If an engineers scale is unavailable, this paper scale can be used to construct a topographical profile and determine latitude and longitude coordinates of points on the map. Note that each number on the scale represents 10. To use, fold along line with marks.

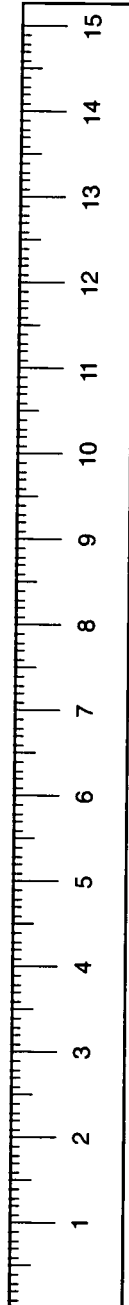

(Use 150 divisions for a 7-1/2-minute map.)

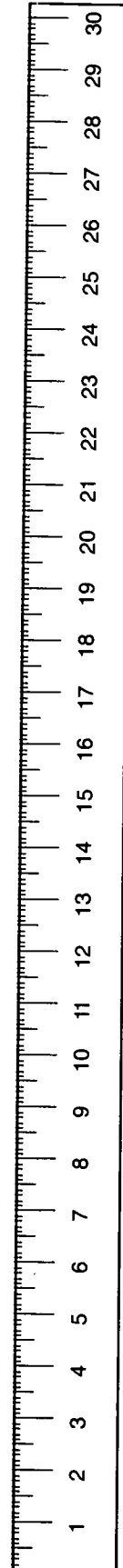

(Use 300 divisions for a 15-minute map.)

CONSIDERATIONS FOR SITING THE HIGH-LEVEL NUCLEAR WASTE REPOSITORY

Siting the Nation's first high-level nuclear waste repository is a very complicated project. Research personnel need to consider such factors as *geochemistry* (the chemical composition and possible chemical changes in the Earth's crust), *geohydrology* (the character and source of ground water), rock characteristics, climate, tectonics, human interference, population density and distribution, site ownership and control, meteorology, environmental quality, socioeconomic impacts, transportation, and the presence of natural resources. The goal of the site characterization studies is to determine if Yucca Mountain, the proposed site for the repository, will be suitable to protect the surrounding environment from dangerous levels of radiation for 10,000 years after the repository is closed.

Although developing a thorough understanding of even one of these factors is very complicated and takes many years, some very useful information can be gathered from a topographic map of the area. During this activity you will use your topographic profile and your United States Geological Survey map of the Busted Butte Quadrangle to take a first hand look at some of the factors relating to repository siting: 1) erosion, 2) ground water and geochemistry, 3) population density and distribution, and 4) site ownership and control.

EROSION

Directions: Read the excerpt from *General Guidelines for the Recommendation of Sites for the Nuclear Waste Repositories: Final Siting Guidelines*, below, using it to answer the questions that follow.

960.4-2-5 Erosion

(a) *Qualifying Condition.*

The site shall allow the underground facility to be placed at a depth such that erosional processes acting upon the surface will not be likely to lead to radionuclide releases greater than those allowable under the requirement specified in Guideline 960.4-1. In predicting the likelihood of potentially disruptive erosional processes, the DOE will consider the climatic, tectonic, and geomorphic evidence of rates and patterns of erosion in the geologic setting during the Quarternary Period.

(b) *Favorable Conditions.*

- (1) Site conditions that permit the emplacement of waste at a depth of at least 300 meters below the directly overlying ground surface.
- (2) A geologic setting where the nature and rates of the erosional processes that have been operating during the Quarternary Period are predicted to have less than one chance in 10,000 over the next 10,000 years of leading to releases of radionuclides to the accessible environment.
- (3) Site conditions such that waste exhumation would not be expected to occur during the first one million years after repository closure.

(c) *Potentially Adverse Conditions.*

- (1) A geologic setting that shows evidence of extreme erosion during the Quarternary Period.
- (2) A geologic setting where the nature and rates of geomorphic processes that have been operating during the Quarternary Period could, during the first 10,000 years after closure, adversely affect the ability of the geologic repository to isolate the waste.

(d) *Disqualifying Condition.*

The site shall be disqualified if site conditions do not allow all portions of the underground facility to be situated at least 200 meters below the directly overlying ground surface.

1. What is the lowest ground surface elevation along your topographical profile within the possible repository boundary?

2. According to Favorable Condition (1) above, how deep should the repository be in meters? How many feet is this? (Remember that 1 meter = 3.28 feet.)

3. At what depth within the possible repository boundary could the repository be built to satisfy Favorable Condition (1)? Draw a line on your topographical profiles to represent this placement of the repository.

4. According to the Disqualifying Condition above, what is the minimum allowable depth for the repository in meters? How many feet is this?

5. At what depth within the possible repository boundary could the repository be built to satisfy the Disqualifying Condition? Draw a line on your topographical profiles to represent this placement of the repository.

6. Calculate the maximum rate of erosion that would uncover a repository at a depth of 200 meters, and a repository at 300 meters, during a time span of 10,000 years.

GROUND WATER

1. According to a hydrologic atlas published by the U.S. Geological Survey:
 - 1) The State of Nevada has a mean precipitation of 22.9 centimeters (9 inches) per year, the lowest statewide mean in the United States.
 - 2) An average of less than 2.5 centimeters (1 inch) of this precipitation either recharges aquifers or runs off.
 - 3) In 84 percent of the State, drainage is to low areas in enclosed basins rather than to the sea. Flow in the larger rivers generally decreases downstream as water is lost to evaporation and infiltration.

Directions: Use these three facts and the topographic map, as necessary, to answer the questions below.

- a. Of the 22.9 centimeters (9 inches) of annual precipitation, how much is evaporated?

- b. Examine the topographic map looking for evidence of running water (runoff). What do you think the blue, dashed and dotted lines represent?

- c. Look at the area east of Yucca Mountain toward Fortymile Canyon and Fortymile Wash. What happens to runoff from Yucca Mountain when it reaches Fortymile Wash, southeast of Busted Butte?

- d. Explain why you think flow decreases downstream, rather than increases, in this area of the country.

- e. Use an almanac or other reference book to find the mean annual precipitation for the State of South Carolina. What is the annual precipitation? Why do you think streams and rivers flow continuously in this State even during long periods without rainfall?

2. One of the important considerations in siting the repository is the elevation of the water table. The water table separates the saturated zone from the unsaturated zone. Examine figure 10, which shows how water is obtained from wells drilled into the saturated zone beneath the surface of the ground. Assume Figure 10 represents conditions as they exist in this part of Nevada. Now look in the South-east corner of the Busted Butte topographic map for Well J-12. At what surface elevation is Well J-12? Based on the evidence provided by the topographic map alone, what is the maximum depth of the water table in this region?

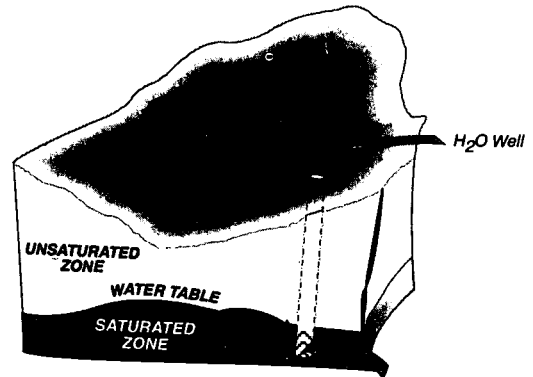

Water wells pump water from the saturated zone beneath the water table.

Figure 10

3. What are other indications of the depth of the water table?

4. Do any of the items you listed in question 3 suggest that the water table is deeper than what was suggested by the location of Well J-12?

5. Using the water table elevation that you determined in question 2, draw a line at this elevation across the entire length of the topographic profiles that you prepared and label it *"MAXIMUM POSSIBLE WATER TABLE ELEVATION BASED ON WELL J-12."*

6. What assumptions are we making when we draw this line?

7. How certain are you that this line represents a real water table elevation?

8. Why draw this line at all?

9. How would you obtain a much more precise value for the elevation of the water table in the vicinity of Well J-12? How would you obtain a much more precise depth for the water table along the topographic profile that you drew?

Directions: Read the excerpt from *General Guidelines for the Recommendation of Sites for the Nuclear Waste Repositories: Final Siting Guidelines*, below, using it to answer the questions that follow.

960.4-2-1 Geohydrology

(a) *Qualifying Condition.*

The present and expected geohydrologic setting of a site shall be compatible with waste containment and isolation. The geohydrologic setting, considering the characteristics of and the processes operating within the geologic setting, shall permit compliance with

- (1) the requirements specified in 960.4-1 for radionuclide releases to the accessible environment and
- (2) the requirements specified in 10 CFR 60.113 for radionuclide releases from the engineered-barrier system using reasonably available technology.

(b) *Favorable Conditions.*

- (1) Site conditions such that the pre-waste-emplacement ground-water travel time along any path of likely radionuclide travel from the disturbed zone to the accessible environment would be more than 10,000 years.
- (2) The nature and rates of hydrologic processes operating within the geologic setting during the Quaternary Period would, if continued into the future, not affect or would favorably affect the ability of the geologic repository to isolate the waste during the next 100,000 years.
- (3) Sites that have stratigraphic, structural, and hydrologic features such that the geohydrologic system can be readily characterized and modeled with reasonable certainty.
- (4) For disposal in the saturated zone, at least one of the following pre-waste-emplacement conditions exist:
 - (i) A host rock and immediately surrounding geohydrologic units with low hydraulic conductivities.
 - (ii) A downward or predominantly horizontal hydraulic gradient in the host rock and in the immediately surrounding geohydrologic units.
 - (iii) A low hydraulic gradient in and between the host rock and immediately surrounding geohydrologic units.
 - (iv) High effective porosity together with low hydraulic conductivity in the rock units along paths of likely radionuclide travel between the host rock and accessible environment.
- (5) For disposal in the unsaturated zone, at least one of the following pre-waste-emplacement conditions exists:
 - (i) A low and nearly constant degree of saturation in the host rock and in the immediately surrounding geohydrologic units.
 - (ii) A water table sufficiently below the underground facility such that the fully saturated voids continuous with the water table do not encounter the host rock.
 - (iii) A geohydrologic unit above the host rock that would divert the downward infiltration of water beyond the limits of the emplaced waste.
 - (iv) A host rock that provides for free drainage.

- (v) A climatic region in which the average annual historical precipitation is a small fraction of the average annual potential evapotranspiration.

(c) *Potentially Adverse Conditions.*

- (1) Expected changes in geohydrologic conditions—such as changes in the hydraulic gradient, the hydraulic conductivity, the effective porosity, and the ground water flux through the host rock and the surrounding geohydrologic units—sufficient to significantly increase the transport of radionuclides to the accessible environment as compared with pre-waste-emplacment conditions.
- (2) The presence of ground water source, suitable for crop irrigation or human consumption without treatment, along ground water flow paths from the host rock to the accessible environment.
- (3) The presence in the geologic setting of stratigraphic or structural features—such as dikes, sill, faults, shear zones, folds, dissolution effects, or brine pockets—if their presence could significantly contribute to the difficulty of characterizing or modeling the geohydrologic system.

(d) *Disqualifying Condition.*

A site shall be disqualified if the pre-waste-emplacment ground water travel time from the disturbed zone to the accessible environment is expected to be less than 1,000 years along any pathway of likely and significant radionuclide travel.

- 10. Pretend that the water table elevation on your topographic profile is accurate. Do you think the repository elevations on your profile are favorable according to the geohydrology guidelines?

- 11. Section (b)(5) lists pre-waste-emplacment conditions for the unsaturated zone. Which, if any, of these conditions exist at Yucca Mountain according to your profile and the information you have acquired in this activity? Explain your answers.

12. Based on your calculated water table, if the repository were sited for an elevation of 1,021 meters (3,350 feet), would it be located in the saturated or unsaturated zone?

13. Would a repository at 1,021 meters (3,350 feet) conflict with the erosion or the geohydrology guidelines? Why or why not?

14. Based on your determined water table, if the repository were sited for an elevation of 2,900 feet, would it be located in the saturated or unsaturated zone?

15. Would a repository at 884 meters (2,900 feet) conflict with either the erosion or the geohydrology guidelines? Why or why not?

16. Suppose you had to choose between putting the repository at 1,021 meters (3,350 feet) or at 884 meters (2,900 feet) and assume that the water table elevation on your profile is accurate. In making your decision, how would you balance the requirements of the erosion and geohydrology guidelines?

The water table under Yucca Mountain occurs in the fractured tuff of the Calico Hills or the Crater Flat units; it slopes to the southeast from an elevation of 792 to 732 meters (2,600 to 2,400 feet) above sea level. Current estimates are that only a small part of the rain that falls on Yucca Mountain percolates through the matrix of the unsaturated zone. The regional direction of ground water flow is south to southwest. As elsewhere in the southern Great Basin, the ground water basins tend to be closed, with no external drainage into rivers or major bodies of surface water. (Source: Consultation Draft Site Characterization Plan Overview Yucca Mountain Site, Nevada Research and Development Area, Nevada DOE/RW-0161, 1988.)

POPULATION DENSITY AND DISTRIBUTION

Directions: Read the excerpt from *General Guidelines for the Recommendation of Sites for the Nuclear Waste Repositories: Final Siting Guidelines*, below, using it to answer the questions that follow.

960.5-2-1 Population Density and Distribution

(a) *Qualifying Condition.*

The site shall be located such that, during repository operation and closure,

- (1) the expected average radiation dose to members of the public within any highly populated area will not be likely to exceed a small fraction of the limits allowable under the requirements specified in 960.5-1(a)(1), and
- (2) the expected radiation dose to any member of the public in an unrestricted area will not be likely to exceed the limit allowable under the requirements specified in 960.5-1(a)(1).

(b) *Favorable Conditions.*

- (1) A low population density in the general region of the site.
- (2) Remoteness of site from highly populated areas.

(c) *Potentially Adverse Conditions.*

- (1) High residential, seasonal, or daytime population density within the projected site boundaries.
- (2) Proximity of the site to highly populated areas, or to areas having at least 1,000 individuals in an area 1 mile by 1 mile as defined by the most recent decennial count of the U.S. census.

(d) *Disqualifying Conditions.*

A site shall be disqualified if-

- (1) Any surface facility of a repository would be located in a highly populated area; or
- (2) Any surface facility of a repository would be located adjacent to an area 1 mile by 1 mile having a population of not less than 1,000 individuals as enumerated by the most recent U.S. census; or
- (3) The DOE could not develop an emergency preparedness program which meets the requirements specified in DOE Order 5500.3 (Reactor and Non-Reactor Facility Emergency Planning, Preparedness, and Response Program for Department of Energy Operations) and related guides or, when issued by the NRC, in 10 CFR Part 60, Subpart I, "Emergency Planning Criteria."

1. Nevada has a 1980 population of 799,000 and a land area of 109,889 square miles. What is the population density of the State?

2. According to the population density guidelines sections (a) and (b), what other information would you need to determine if the Yucca Mountain site is in a region of low population density?

3. Examine the topographic map for habitable structures and estimate the population density of the area covered by the map. (The area of the map is approximately 59 square miles.)

SITE OWNERSHIP AND CONTROL

Directions: Read the excerpt from the *General Guidelines for the Recommendation of Sites for the Nuclear Waste Repositories: Final Siting Guidelines*, below, using it to answer the questions that follow.

960.5-2-2 Site Ownership and Control.

(a) *Qualifying Condition.*

The site shall be located on land for which the DOE can obtain, in accordance with the requirements of 10 CFR 60.121, ownership, surface and subsurface rights, and control of access that are required in order that surface and subsurface activities during repository operation and closure will not be likely to lead to radionuclide releases to an unrestricted area greater than those allowable under the requirements specified in 960.5-1(a)(1).

(b) *Favorable Condition.*

Present ownership and control of land and all surface and subsurface mineral and water rights by DOE.

(c) *Potentially Adverse Condition.*

Projected land-ownership conflicts that cannot be successfully resolved through voluntary purchase-sell agreements, nondisputed agency-to-agency transfers of title, or Federal condemnation proceedings.

1. Who controls most of the land area of the Busted Butte Quadrangle map?

2. Can you determine the ownership of all of the land area on the map?

3. Will the proposed repository site meet the ownership and control guidelines? Why or why not?

CROSSWORD PUZZLE

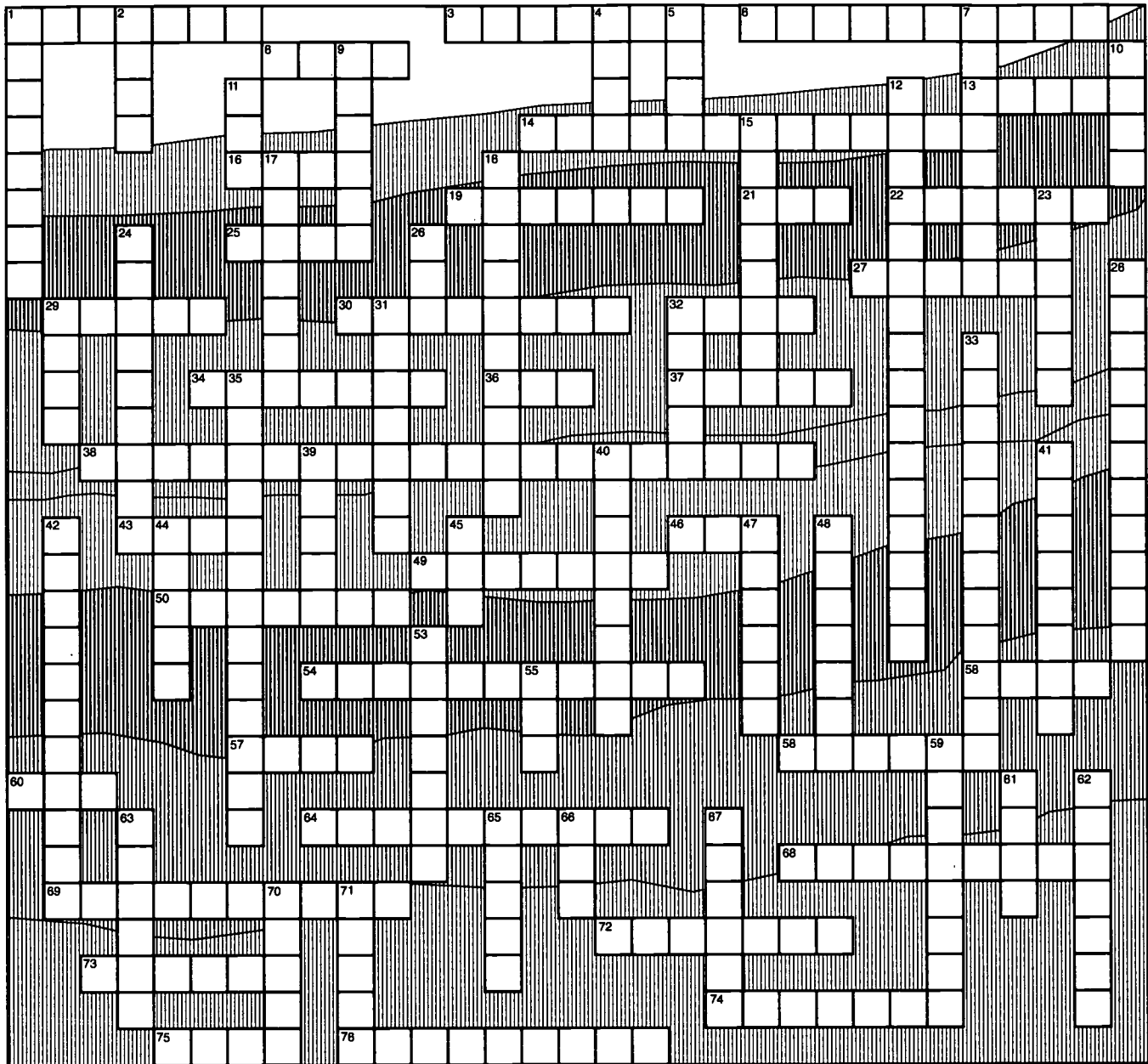

ACROSS

1. A transportation cask is exposed to a jet fuel fire to test its _____ properties.
3. Microwave ovens are a _____ source of radiation.
6. When the repository reaches its capacity, the shafts will be plugged, _____ and sealed.
8. The primary protection against radiation exposure during transportation.
13. One of four tests administered on a cask: _____ immersion.
14. Most high-level waste must be handled by _____. (2 words)
16. The rock type being studied at Yucca Mountain.
19. A hollow metal tube in which fuel pellets are sealed. (2 words)
21. The government agency that certifies casks. (abbr.)
22. The State in which Yucca Mountain is located.
25. One source of natural background radiation is from cosmic _____.
27. When neutrons split the _____ of atoms, energy is released.
29. A radioactive gas that results from the decay of radium.

30. A secondary external packaging that may be used to surround the waste canister.
32. Yucca Mountain is the _____ currently being studied for the repository.
34. These will be used to note the location and significance of the repository.
36. The Nuclear Waste Policy Act is a _____.
37. The repository will be located about 1,000 feet beneath the surface of the _____.
38. Detailed studies being performed at Yucca Mountain. (2 words)
43. Directs DOE to site, design, construct, and operate a geologic repository. (abbr.)
46. Measures the effect on human tissue from a dose of radiation. (abbr.)
49. Drifts
50. A facility will be built deep underground for permanent _____ of the waste.
54. Putting into position for permanent storage.
56. Radiation that can be stopped by a thin sheet of aluminum.
57. The repository will cover an _____ of about 5,700 acres.
58. An unstable atom releases _____ in the form of either electromagnetic waves or fast-moving particles.
60. Radon is a radioactive _____.
64. Uses uranium to generate electricity.
68. _____ - _____ waste loses radioactivity rapidly.
69. Spent fuel and defense high-level nuclear waste will be disposed of in a _____.
72. _____ waste results from using radioactive material.
73. One type of carrier that may be used to transport waste to the repository.
74. The fuel for a nuclear powerplant consists of _____ pellets of uranium.
75. Through 1990, about 22,000 metric _____ of spent fuel were in storage.
76. High-level waste is handled behind protective _____.
12. Consists of elements with atomic numbers higher than uranium's. (2 words)
15. For disposal, fuel rods are placed in a _____.
17. The fuel for nuclear reactors.
18. Each of these is about the size of your fingertip. (2 words)
23. Tunnels.
24. There are three types of ionizing _____.
26. The U.S. government agency responsible for disposing of spent fuel and defense high-level nuclear waste. (abbr.)
28. The waste will be stored in a repository to isolate it from the _____.
29. Used in transporting the waste from the surface to the underground facility at the repository.
31. Tuff is formed from the eruption of a _____.
32. Used fuel is called _____ fuel.
33. Contains fuel rods. (2 words)
35. The site being studied for the geologic repository. (2 words)
39. The most energetic, but least penetrating form of radiation.
40. A group of minerals within tuff that have the capability to remove radioactive materials from water.
41. Regional organizations formed to dispose of low-level waste.
42. _____ flow at Yucca Mountain will be studied extensively.
44. Nuclear _____ will be stored deep underground in a repository.
45. A natural source of radiation.
47. The current amount of radioactive waste is measured in _____ tons.
48. The remains of split atoms: _____ products.
53. Before closure of the repository, the shafts will be _____, backfilled, and sealed.
55. Environmental Protection Agency. (abbr.)
59. Radioactive waste will be disposed of in a _____ repository.
61. The fluid resulting from a volcanic eruption.
62. Low-level waste includes items such as rags and _____.
63. _____, resins, and discarded protective clothing are also low-level radioactive waste.
65. Spent fuel is stored in concrete _____ filled with water at reactor sites.
66. Tuff is composed of compacted _____ produced by volcanoes.
67. State, local government and _____ participation are provided for by the NWPA and Amendments Act.
70. A cask must pass a series of _____ before it can be certified.
71. Spent fuel and high-level waste are handled by remote control in shielded _____ to protect workers.

DOWN

1. The byproducts of mining and milling uranium.
2. Waste may be shipped by truck, barge, or _____.
4. When an unstable _____ changes to a different form, the process is called radioactive decay.
5. Spent fuel will _____ some radiation for thousands of years.
7. _____ - _____ waste results from many commercial, medical, and industrial processes.
9. Vertical _____ will be constructed at the repository for ventilation, personnel and equipment use.
10. Type of test administered on a cask: free _____.
11. When spent fuel is removed from the reactor, it is thermally _____.

METRIC AND U.S. UNIT CONVERSIONS

Both metric and U.S. equivalent units have been used in this curriculum, as appropriate to the issues being discussed. For example, inventories of spent fuel are routinely reported in the United States in terms of metric tons,* even though most Americans are familiar with the short ton (2,000 pounds). Classroom experiments are usually conducted using metric units as well. Yet the standards and tests for spent fuel transportation casks are written using temperature in degrees Fahrenheit, miles per hour, and other similar units.

While the United States is working to increase its use of the metric system, both systems will be used during the transition period. To familiarize yourself with potentially unfamiliar metric units, conversion charts are provided here. Use Table 1 to convert a metric unit into its U.S. equivalent. To convert an U.S. unit into its metric equivalent, use Table 2.

For example, using Table 1 to convert 1,000 kilograms into its equivalent in pounds, multiply by 2.205 to get 2,205 pounds ($1,000 \text{ kg} \times 2.205 \text{ lb/kg} = 2,205 \text{ lb}$). Alternately, using Table 2, 2,000 pounds is equivalent to 907.2 kilograms ($2,000 \text{ lb} \times 0.4536 \text{ kg/lb}$).

* One metric ton is equal to 1,000 kilograms (or 2,205 pounds).

Table 1. Approximate Conversions from Metric to English Units

If you know...

Length	→ multiply by →	to get
millimeters (mm)	0.03937	inches (in)
centimeters (cm)	0.03281	feet (ft)
centimeters (cm)	0.3937	inches (in)
meters (m)	39.37	inches (in)
meters (m)	3.281	feet (ft)
meters (m)	1.094	yards (yd)
kilometers (km)	3,281.0	feet (ft)
kilometers (km)	0.5396	nautical miles (mi)
kilometers (km)	0.6214	statute miles (mi)
 Area		
hectares (ha)	2.471	acres
hectares (ha)	1.076 X 10 ⁵	square ft (ft ²)
 Weight (mass)		
grams (gm)	0.03527	ounces (oz)
grams (gm)	0.002205	pounds (lb)
kilograms (kg)	2.205	pounds (lb)
metric tons (t)	1.102	short tons
metric tons (t)	0.984	long tons
 Pressure		
kilopascals (kPa)	6.9	pounds/square inch (lb/in ²)
 Volume		
cubic centimeters (cm ³)	0.06202	cubic inches (in ³)
cubic meters (m ³)	3.531	cubic feet (ft ³)
cubic meters (m ³)	1.307	cubic yards (yd ³)
liters (L)	2.113	pints* (pt)
liters(L)	0.2642	gallons* (gal)
 Temperature		
Celsius	9/5, [then add 32]	Fahrenheit
 Electric Current		
ampere (A)	1	ampere (A)
 Energy, Work, Heat		
joule (J)	9.480 x 10 ⁻⁴	BTU
 Power		
watt (W)	1	watt (W)
watt (W)	3.4129	BTU per hour
watt (W)	1.341 x 10 ⁻³	horsepower

Common Prefixes for Metric Units:

mega = million = 10 ⁶	deci = one-tenth
kilo = thousand	centi = one-hundredth
hecto = hundred	milli = one-thousandth
deka = ten	micro = one-millionth

Examples: kilogram = 1,000 grams
 milliliter = 1/1,000 liter

*liquid measure

Table 2. Approximate Conversions from English to Metric Units

If you know...

Length	→ multiply by →	to get
inches (in)	2.54	centimeters (cm)
feet (ft)	30.48	centimeters (cm)
feet (ft)	0.3048	meters (m)
miles (mi)	1.609	kilometers (km)
yards (yd)	0.9144	meters (m)
 Area		
square inches (in ²)	6.5	square centimeters (cm ²)
square feet (ft ²)	0.09	square meters (m ²)
square yards (yd ²)	0.8	square meters (m ²)
acres	0.4047	hectares (ha)
square miles (mi ²)	2.6	square kilometers (k ²)
 Weight (mass)		
ounces (oz)	28.349527	grams (gm)
pounds (lb)	0.4536	kilograms (kg)
tons (long)	1.016	metric ton (t)
 Pressure		
pounds per square inch	70.31	grams per square centimeter
pounds per square inch	0.145	kilopascals
 Volume		
cubic feet (ft ³)	0.02832	cubic meters (m ³)
cubic inches (in ³)	16.387	cubic centimeters (cm ³)
cubic yards (yd ³)	0.765	cubic meters (m ³)
gallons* (gal)	3.785	liters (L)
pints* (pt)	0.473	liters (L)
quarts* (qt)	0.946	liters (L)
 Temperature		
Fahrenheit	[subtract 32, then multiply by 5/9]	Celsius
 Electric Current		
ampere (A)	1	ampere (A)
 Energy, Work, Heat		
BTU	1,055	joules (J)
 Power		
watt (W)	1	watt (W)
BTU per hour	0.293	watt (W)
horsepower	745.712	watt (W)

*liquid measure

NAME _____

Direction: Circle the letter of the answer that best completes the statement given.

1. The agency with the main responsibility for regulating transportation of all hazardous materials, including radioactive materials, is the:
 - a. U.S. Department of Energy (DOE).
 - b. U.S. Department of Transportation (DOT).
 - c. U.S. Environmental Protection Agency (EPA).
 - d. U.S. Nuclear Regulatory Commission (NRC).

2. The Nuclear Waste Policy Act of 1982 gave the responsibility for shipping spent fuel and high-level nuclear waste to a repository or storage facility to the:
 - a. U.S. Department of Energy (DOE).
 - b. U.S. Department of Transportation (DOT).
 - c. U.S. Environmental Protection Agency (EPA).
 - d. U.S. Nuclear Regulatory Commission (NRC).

3. Casks used to transport high-level waste and spent fuel to a repository or storage facility must be certified by the:
 - a. U.S. Department of Energy (DOE).
 - b. U.S. Department of Transportation (DOT).
 - c. U.S. Environmental Protection Agency (EPA).
 - d. U.S. Nuclear Regulatory Commission (NRC).

4. Cask designs can be tested using:
 - a. full scale test.
 - b. computer models.
 - c. scale-model testing.
 - d. all of the above.

5. Scale-model testing of a cask design includes a free drop test, a puncture test, a water immersion test, and exposure to:
 - a. extremely low temperatures.
 - b. corrosive chemicals.
 - c. jet-fuel fire.
 - d. all of the above.

6. New cask designs are being developed to ship spent fuel that has been removed from the reactor core for 10 years or more. One advantage of the new cask design is that the new casks will:
 - a. be more attractive.
 - b. be smaller so that the load per shipment will be reduced.
 - c. not be reusable.
 - d. carry a larger load so that the number of shipments can be reduced.

7. An example of an engineered barrier is:
 - a. zeolite.
 - b. the waste package.
 - c. the host rock.
 - d. absence of ground water.

8. An example of a natural barrier is:
 - a. the host rock.
 - b. the waste package.
 - c. the repository.
 - d. the waste form.

9. The waste form for spent fuel from nuclear reactors is:
 - a. glass made of boron and silicon and poured into stainless steel canisters.
 - b. zeolite mixed with strong alloys.
 - c. ceramic pellets sealed in strong alloy tubes.
 - d. a liquid poured into a zirconium canister.

10. The waste form for high-level waste produced in national defense activities is:
 - a. glass made of boron and silicon and poured into stainless steel canisters.
 - b. zeolite mixed with strong alloys.
 - c. ceramic pellets sealed in strong alloy tubes.
 - d. a liquid poured into a zirconium canister.

11. An advantage of using a glass form for disposal is that it is:
 - a. easily leached by escaping fluid.
 - b. recyclable.
 - c. not easily leached by groundwater.
 - d. difficult to produce due to lack of raw materials.

12. Backfilling the drifts after the waste is in place may:
 - a. enhance the transfer of heat from the waste to the surrounding rock.
 - b. relieve mechanical pressure on the waste package.
 - c. provide structural support for the overlying host rock.
 - d. all of the above.

13. When siting a repository, groundwater is an important consideration because:
 - a. groundwater can carry waste to the environment.
 - b. groundwater cannot carry waste to the environment.
 - c. repository workers will need drinking water.
 - d. groundwater is not present in dry climates.

14. The presence of zeolites at a repository site would be an advantage because they:
 - a. are not too expensive.
 - b. could filter waste from water.
 - c. make the mine stronger.
 - d. make mining easier.

15. The multiple barrier system consists of:
 - a. the host rock, shafts, and seals.
 - b. backfill, the host rock, and tunnels.
 - c. the waste package, the repository, and the host rock.
 - d. shafts, seals, and the waste package.

16. The underground facilities at a repository will be about _____ beneath the surface.
 - a. 50 feet
 - b. 100 feet
 - c. 500 feet
 - d. 1,000 feet

17. If 100 spent fuel shipments went by the same house every year, the increase in exposure to radiation would be:
 - a. more than the exposure received annually from watching TV.
 - b. about half the exposure received annually from watching TV.
 - c. about the same as exposure from background radiation.
 - d. about twice the average exposure from background radiation.

18. To help improve emergency preparedness, before certain shipments of spent fuel or nuclear waste are made, written notice is sent to:
 - a. the President of the U.S.
 - b. the Secretary of Defense.
 - c. the Governor or official of the State.
 - d. the State Head of Civilian Defense.

19. What is the name for the container that is usable throughout the transportation and storage activities leading to the disposal of spent nuclear fuel?
 - a. The Storage and Transportation Container (STC)
 - b. The Compatible Containment Unit (CCU)
 - c. The Multi-Purpose Canister (MPC)
 - d. The Spent Fuel Shipping Cask (SFSC)

20. People affected by decisions on waste management, such as an environmental organization or city government, are called:
 - a. Shareholders
 - b. Overseers
 - c. Onlookers
 - d. Stakeholders

- | | |
|--------------|--------------|
| 1. <u>B</u> | 11. <u>C</u> |
| 2. <u>A</u> | 12. <u>D</u> |
| 3. <u>D</u> | 13. <u>A</u> |
| 4. <u>D</u> | 14. <u>B</u> |
| 5. <u>C</u> | 15. <u>C</u> |
| 6. <u>D</u> | 16. <u>D</u> |
| 7. <u>B</u> | 17. <u>A</u> |
| 8. <u>A</u> | 18. <u>C</u> |
| 9. <u>C</u> | 19. <u>C</u> |
| 10. <u>A</u> | 20. <u>D</u> |

**The following number is for OCRWM Records Management purposes only
and should not be used when ordering this publication.**

Accession No.: HQO-920603-0004



U.S. DEPARTMENT OF EDUCATION
Office of Educational Research and Improvement (OERI)
Educational Resources Information Center (ERIC)



NOTICE

REPRODUCTION BASIS

This document is covered by a signed "Reproduction Release (Blanket)" form (on file within the ERIC system), encompassing all or classes of documents from its source organization and, therefore, does not require a "Specific Document" Release form.

This document is Federally-funded, or carries its own permission to reproduce, or is otherwise in the public domain and, therefore, may be reproduced by ERIC without a signed Reproduction Release form (either "Specific Document" or "Blanket").