

ED 398 961

JC 960 496

AUTHOR Armstrong, William B.
 TITLE Matriculation in the SDCCD: Student Satisfaction and Equity in Matriculation Services.
 INSTITUTION San Diego Community Coll. District, CA. Research and Planning.
 PUB DATE 93
 NOTE 63p.; For matriculation reports for San Diego Mesa College and San Diego Miramar College, see JC 960 497-498.
 PUB TYPE Reports - Research/Technical (143) --
 Tests/Evaluation Instruments (160)

EDRS PRICE MF01/PC03 Plus Postage.
 DESCRIPTORS Community Colleges; Counseling Services; Multicampus Districts; *Participant Satisfaction; *Program Effectiveness; School Orientation; *Student Attitudes; Student Educational Objectives; *Student Personnel Services; Two Year Colleges; Two Year College Students
 IDENTIFIERS *San Diego City College CA

ABSTRACT

To determine students' awareness of and satisfaction with matriculation services, California's San Diego Community College District (SDCCD) surveyed 20,448 re-enrolling credit students in fall 1991 and spring 1992 at the District's City, Mesa, and Miramar Colleges and Educational Cultural Complex. Specifically, the survey sought data on student demographics, educational background, and satisfaction with orientation, assessment and placement, counseling and advising, and other matriculation services. From the original sample, a final sample was selected of students who originally enrolled in fall 1990, were transfer or degree oriented, and had used at least one service. The result was a pool of 7,086 responses. Study findings, focusing on responses for San Diego City College (SDCC) compared to results for the rest of the District, included the following: (1) 81% of SDCC respondents rated orientation as good or excellent, compared to 79% for the rest of the District; (2) although 69% of SDCC respondents rated advisement and counseling as good or excellent, 30% rated them as fair or poor; (3) 78.7% of SDCC respondents agreed that the services they received had helped them to clarify their educational goals, compared to 75% for the rest of the District; and (4) 31.7% of SDCC students indicated that they used all the matriculation services. Graphs of districtwide responses by student ethnicity and the survey instrument are appended. (HAA)

 * Reproductions supplied by EDRS are the best that can be made *
 * from the original document. *

ED 398 961

Matriculation in the SDCCD:

Student Satisfaction and Equity in Matriculation Services

William B. Armstrong

*Research & Planning
1993*

BEST COPY AVAILABLE

U.S. DEPARTMENT OF EDUCATION
Office of Educational Research and Improvement
EDUCATIONAL RESOURCES INFORMATION
CENTER (ERIC)

This document has been reproduced as received from the person or organization originating it.
 Minor changes have been made to improve reproduction quality.

Points of view or opinions stated in this document do not necessarily represent official OERI position or policy.

PERMISSION TO REPRODUCE AND
DISSEMINATE THIS MATERIAL
HAS BEEN GRANTED BY

W.B. Armstrong

TO THE EDUCATIONAL RESOURCES
INFORMATION CENTER (ERIC)

960 496

Matriculation in the SDCCD: Student Satisfaction and Equity in Matriculation Services Student Survey

Purpose

This study responds to state guidelines regarding the evaluation of Matriculation programs and services. One method outlined in guidance from the State Chancellor's Office of the California Community Colleges (SCOCCC) to evaluate matriculation services is to gather student satisfaction data (SCOCCC, 1989). This study seeks to determine the level of awareness, use, and satisfaction with certain components of the Matriculation services offered by the colleges in the San Diego Community College District.

This study was conducted using a survey instrument following the guidelines recommended in the Matriculation Local Research Options guide produced by the Southern California Community College Institutional Research Association (SCCCIRA) and the Northern California Community College research organization, (NORCAL)¹ under sponsorship from the SCOCCC. However, because of space limitations and the survey methodology used, many questions included in the model survey were not included or modified. Thus the survey results reported here provide an overview of the most general indicators of satisfaction and awareness reported by respondents.

Method

Using a suggested format obtained from the Local Research Options Project (SCOCCC, 1989) a survey was developed and attached to the registration mailer sent

¹ These two groups have now merged into a single statewide organization called the Research and Planning (RP) Group of the California Community Colleges.

to all continuing credit students attending City, Mesa, or Miramar Colleges or the Educational Cultural Complex (ECC). The questionnaire contained demographic and educational background questions, and questions pertaining to student satisfaction with several important components of matriculation. These components include orientation, assessment and placement, counseling and advising, and educational plan development. Students were asked to complete the questionnaire and return it with their registration materials. The survey instrument was detached from the mail-in registration form by admissions staff at the colleges and forwarded to Research and Planning for data input, coding, analysis, and reporting.

Sample

The data in this report include students re-enrolling during either the Fall, 1991, or Spring, 1992, semesters. After the surveys were returned to the Research and Planning office, staff keypunched the survey responses into an electronic database which was then converted for analysis with SPSS statistical software. The preliminary results of the first round of data collection from the fall, 1991 student sample (N=8,000) was presented to the student services deans and matriculation coordinators from each of the colleges, ECC, and the central office during summer, 1992. This group recommended that a second semester of data (spring, 1992) be included in order to increase the reliability of the findings and to compensate for non-respondents. They also suggested that the criteria for inclusion in the study be limited to students enrolling after fall, 1988 because of the differences in the phase-in of the various Matriculation components at each of the colleges. Data entry was begun for the spring, 1992 students shortly thereafter in September, 1992. This second phase of data entry included 12, 448 surveys. The fall, 1991 and spring, 1992 files were merged and converted for coding and statistical analysis. In total, 20,448 surveys were entered for analysis.

The relatively large size of the original sample proved to be important once the criteria for inclusion in the study were applied. As described above, the purpose of the survey was to gauge the level of awareness, use, and satisfaction with certain

matriculation services offered at in the SDCCD. Thus, the target group for this study was non-exempt² continuing students in the SDCCD. Although a student may know whether they are "exempt" from Matriculation, it is also possible that such technical jargon may mean little to them. They often will know however if they participated in an orientation session for new students, or took an assessment test, saw a counselor, and worked out a course of study to meet their educational goal. The survey did not ask students if they were "matriculating," but matriculants were identified by their responses to several questions related to matriculation status. These included first term of enrollment, educational goal, and use of any matriculation services. This construct of selected responses was used to identify matriculating students for the study.

The target group was all non-exempt SDCCD students enrolling after matriculation services were in place at the colleges and who received the basic services of orientation, assessment, counseling, and educational plan development. Although the SDCCD has been offering matriculation services for the last several years at each of the colleges, it was decided that students first enrolling in fall, 1990 would be selected. This reduced the original sample of 20,448 to 12,002. The second criterion applied was that only students indicating a educational goal of the Associate's degree or transfer to a four-year college or university would be included. This further reduced the sample from 12,002 to 8,062. Finally, students had to indicate that they used at least one of the matriculation services identified on the survey. This reduced the sample from 8,062 to 7,086, or approximately 35% of the original survey sample. Even with these criteria, not all students could identify or respond to questions about certain matriculation components either because they had not participated in that component, or perhaps knew of the service by a different name. For example, a clear majority of students could identify and rate their satisfaction with the assessment process, but far fewer could respond to and

² "Non-exempt" refers to students who are required to participate in matriculation services such as assessment, counseling, and educational plan development. This is generally students with a degree goal. "Exempt" students are those who enroll for personal or avocational reasons, or those who already have a degree.

rate the orientation services satisfaction question. Students need to have a skill level in order to enroll in several degree and transfer applicable courses, and most of the time these skill levels are obtained from scores on assessment tests in conjunction with counselor judgment. However, orientation, while strongly recommended for students, is not required to enroll in classes, thus many students may not take advantage of this service. Or, students might have attended an orientation session, but identify it by another name. Thus, the satisfaction data reported below include only students who responded to the question. This may assist college and district staff to identify areas where awareness seems low and make adjustments accordingly.

The following graphs compare City College and the rest of the district (SDCCD) in students' response to the survey questions.

Matriculation Services Survey

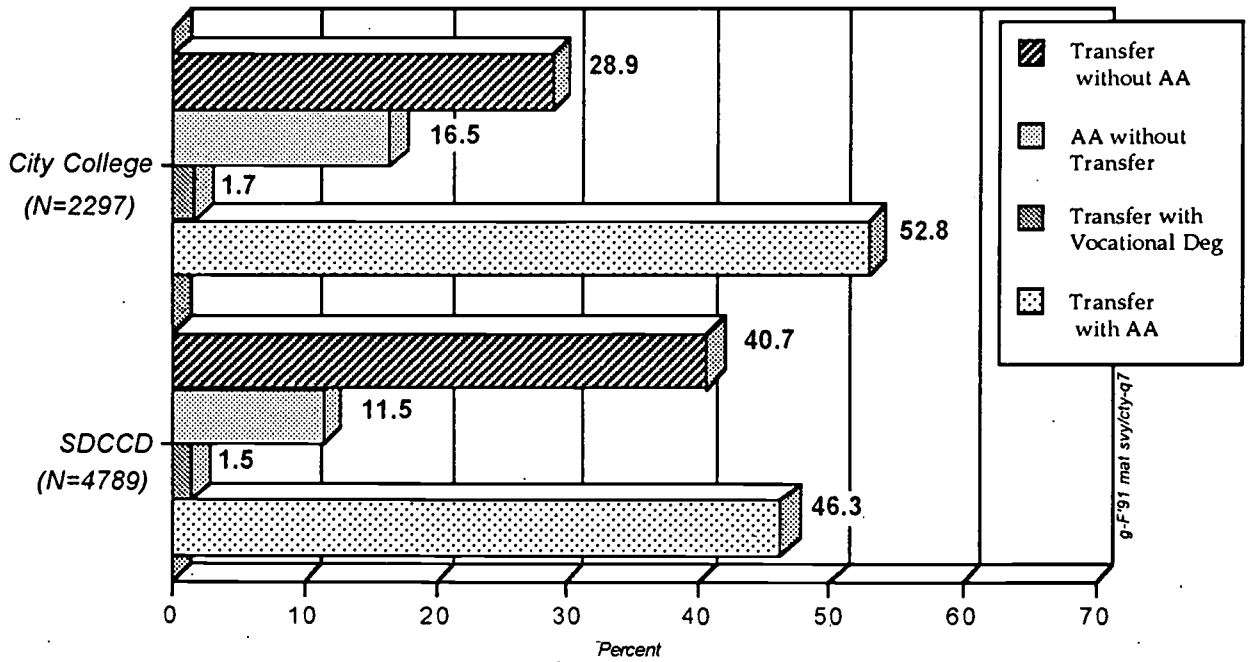

Q7: Please indicate your educational goal

A large proportion of students indicated transferring to a four-year university as one of their educational goals. This finding was not surprising given that intention to get a degree was one of the criteria used to select students for inclusion in the final sample. Compared to the average of other colleges (the SDCCD), more students at City College aimed to earn an associate degree with or without transferring to a four-year university.

Matriculation Services Survey

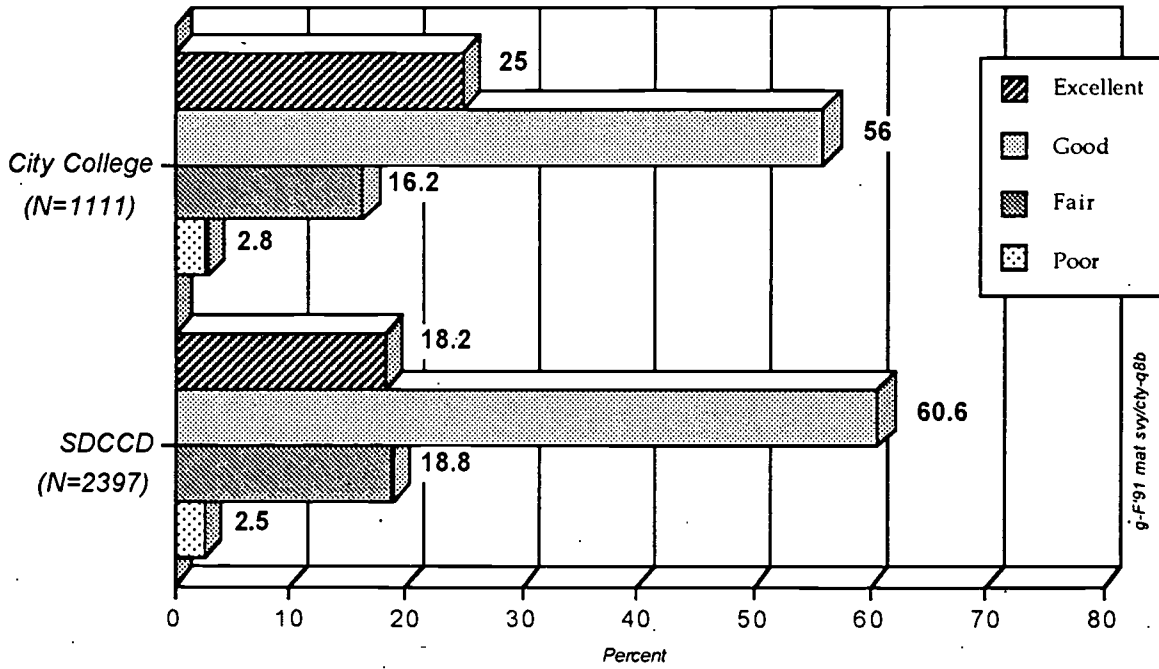

Q8a: Please indicate your satisfaction with Orientation

Approximately three quarters of students considered the orientation "excellent" or "good." The proportion of students who rated the orientation as "excellent" was slightly higher at City College than the SDCCD.

Matriculation Services Survey

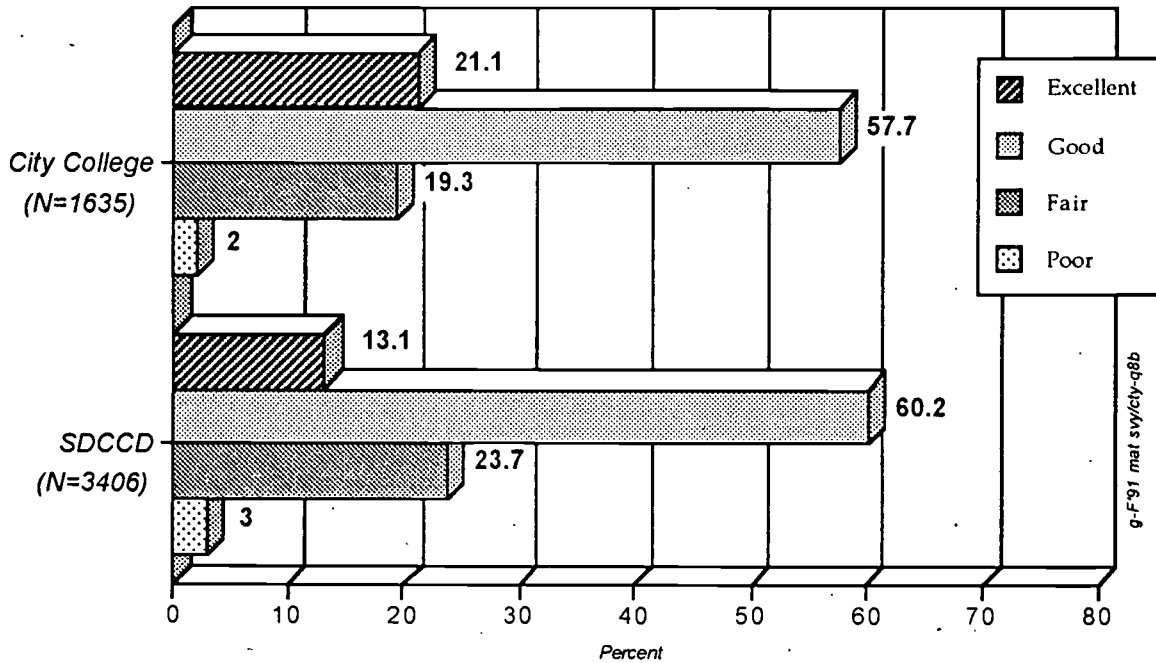

Q8b: Please indicate your satisfaction with Reading and Math Assessment

Most students at City College and the SDCCD rated the assessment process as "excellent" or "good." Approximately one-fifth of City College students indicated the assessment was "excellent." This ratio was slightly higher than the SDCCD.

Matriculation Services Survey

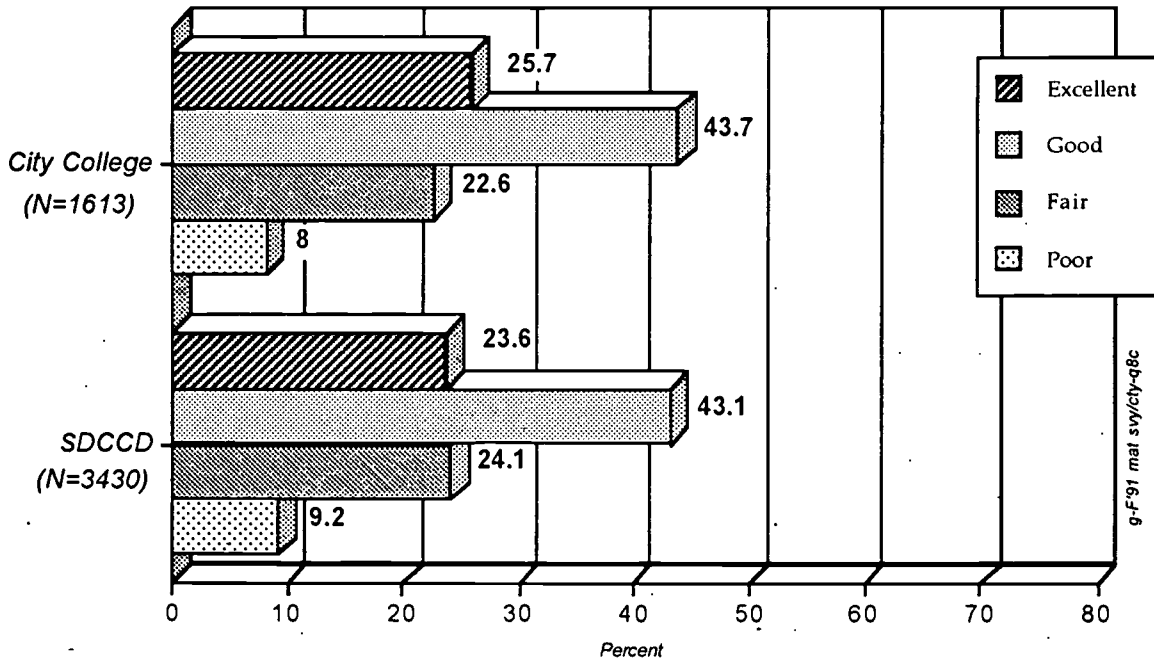

Q8c: Please indicate your satisfaction with Advisement/Counseling

Although most students indicated that counseling services were "excellent" or "good," approximately 1 out of 4 students found the services unsatisfactory ("fair" or "poor" rating). The responses to this question from City College students were similar to the rest of the SDCCD respondents.

Matriculation Services Survey

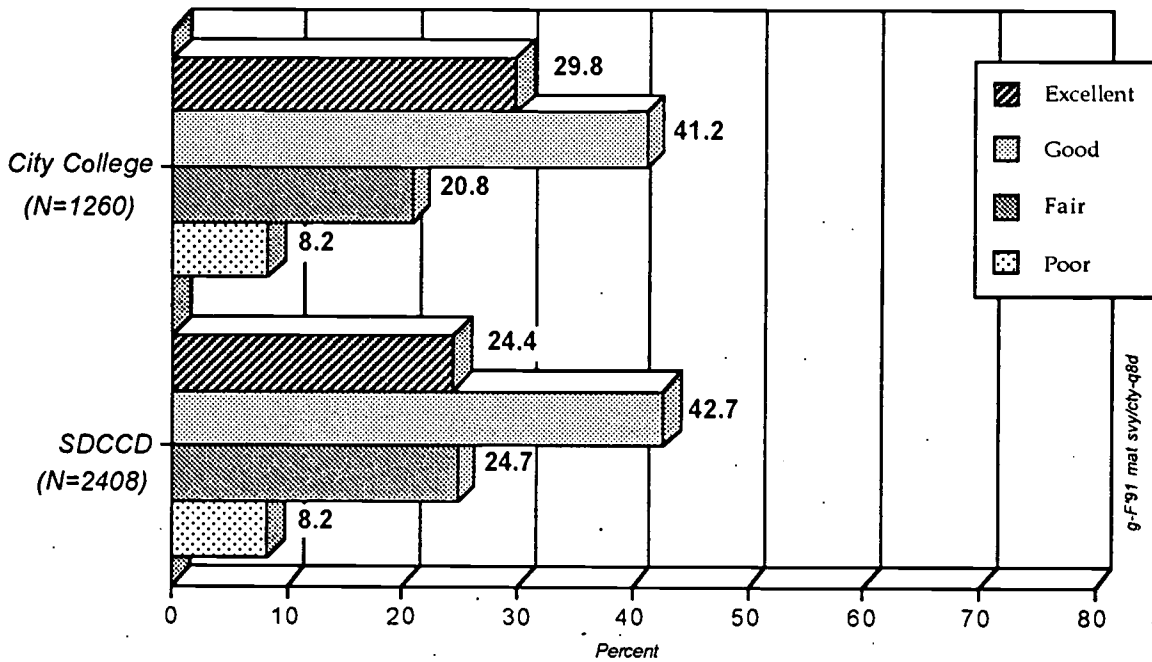

Q8d: Please indicate your satisfaction with Educational Plan development

Compared to the rest of the district, a higher proportion of students at City College regarded their educational plan development as excellent. Approximately 30% of students were not pleased (“fair” and “poor” rating) with their educational plan development. Since the time of this survey, the SDCCD has developed and implemented a comprehensive automated educational planning program for matriculating students. As this system has been implemented, many more students are developing and revising their individual educational plan. A recent survey conducted by the research and planning office in consultation with the SDCCD student service council found higher level of satisfaction with educational plan development districtwide. This report, Educational Plan Survey Report, 1995 is available from Research and Planning.

Matriculation Services Survey

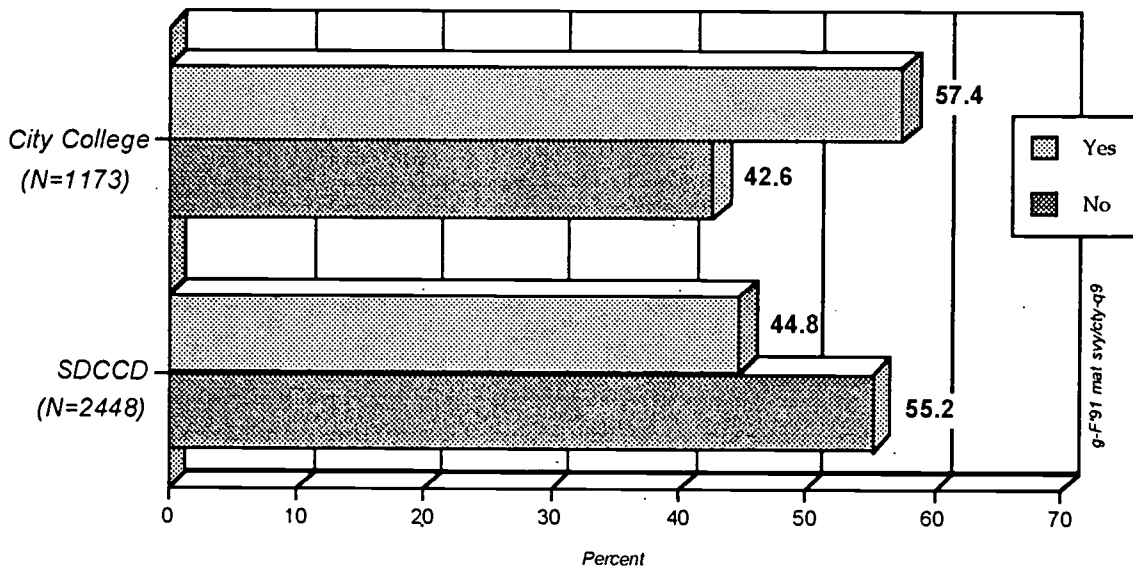

Q9: Did attending the orientation session influence you to visit or use other campus services?

More than half of the City College respondents indicated the orientation facilitated their visit or use of other campus services. The proportion of students who answered “yes” to this question was higher at City College than the SDCCD average.

Matriculation Services Survey

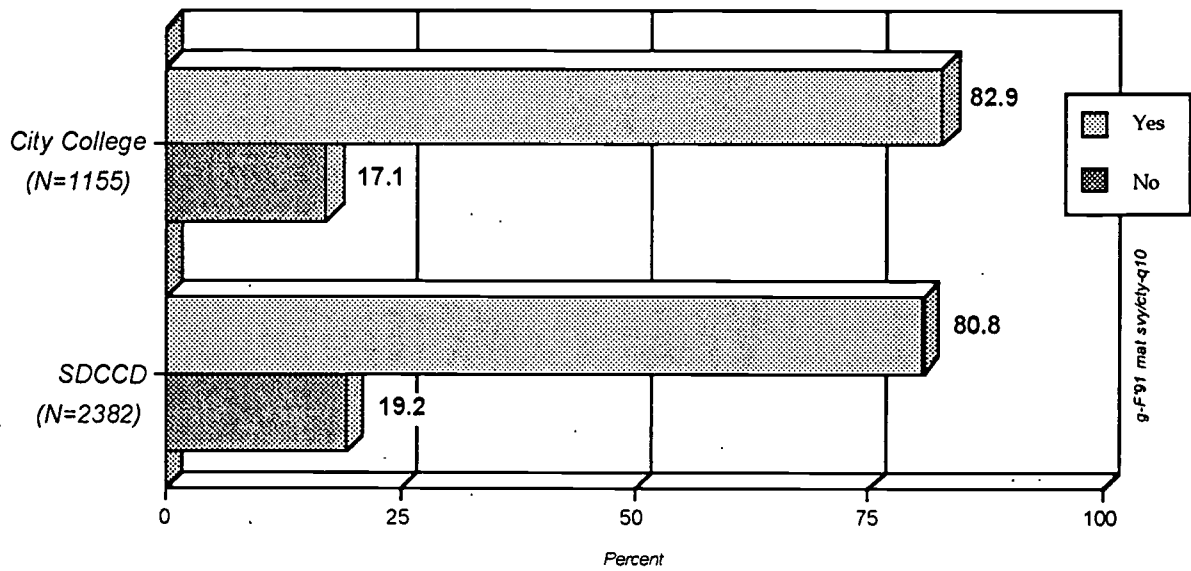

Q10: Were you informed about your rights and responsibilities as a student during your orientation?

The majority of students indicated that they were informed about their rights and responsibilities as a student during the orientation.

Matriculation Services Survey

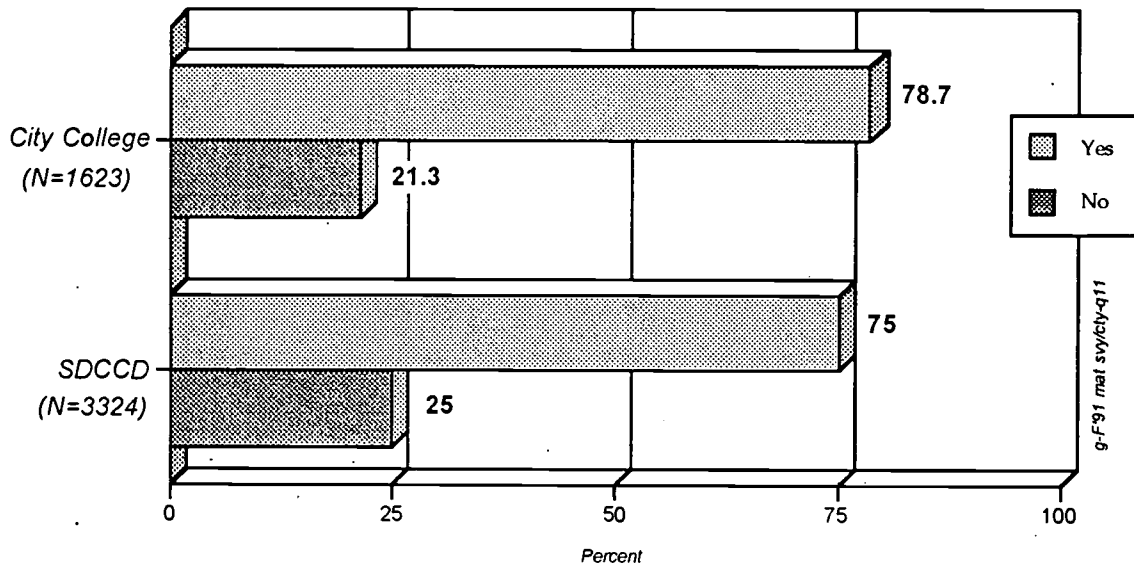

Q11: Have the services you have received help to clarify your educational goals and how to achieve them?

Slightly more than three quarters of students at City College said that the matriculation service helped them to clarify their goals. The proportion of students who found the matriculation service helpful was slightly higher at City College than the rest of the district.

Matriculation Services Survey

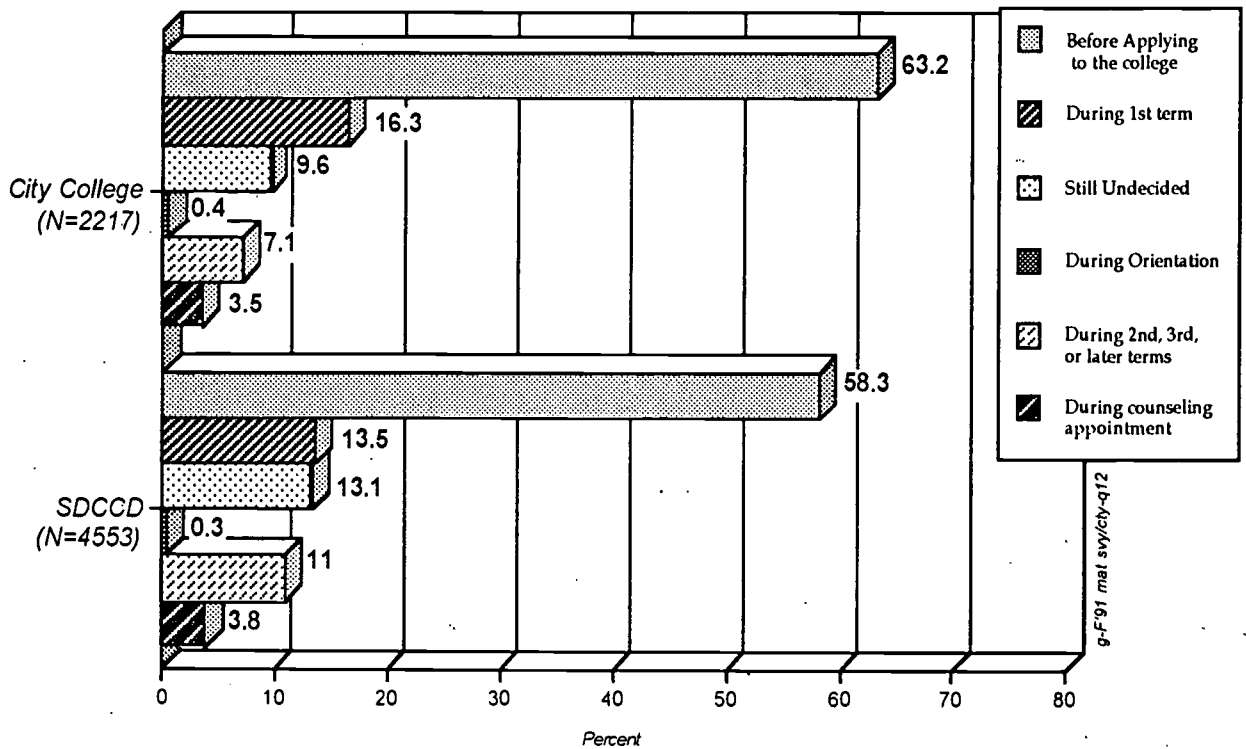

Q12: When did you first decide upon a specific educational goal to pursue at this college?

Very few respondents stated that they decided upon a specific educational goal during a counseling session, most decided prior to matriculating or during their first term of enrollment. At City College, 63.2% of students decided their specific educational goals before applying to the college, and this ratio is somewhat higher than the SDCCD average.

Matriculation Services Survey

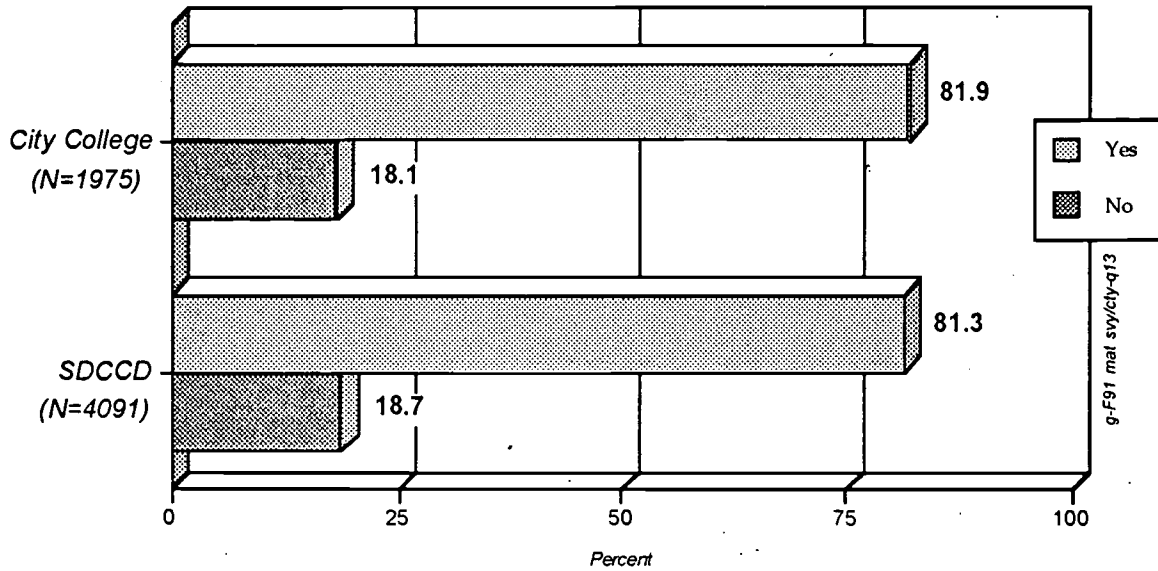

Q13: Have you been provided with information to help you understand course and basic skills prerequisites?

Over 80% of students said they were provided information to help them understand course prerequisites. This finding was consistent across the SDCCD.

Matriculation Services Survey

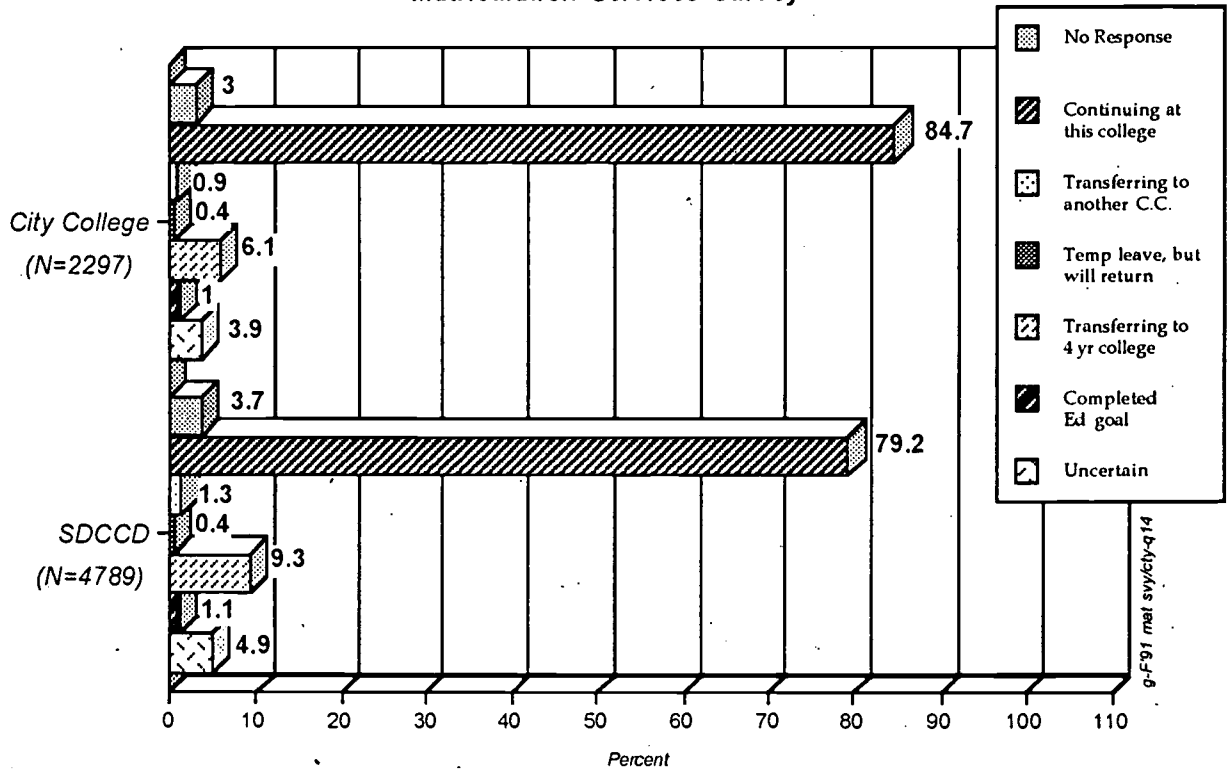

Q14: What will your student status be next term?

To address students follow-up questions, the respondents were asked about their short-term educational plan. The vast majority of students indicated they would continue at the same campus they were attending. Approximately 6% of City College students and 9% of the SDCCD students stated that they would be transferring to a four-year college or university next term.

Matriculation Services Survey

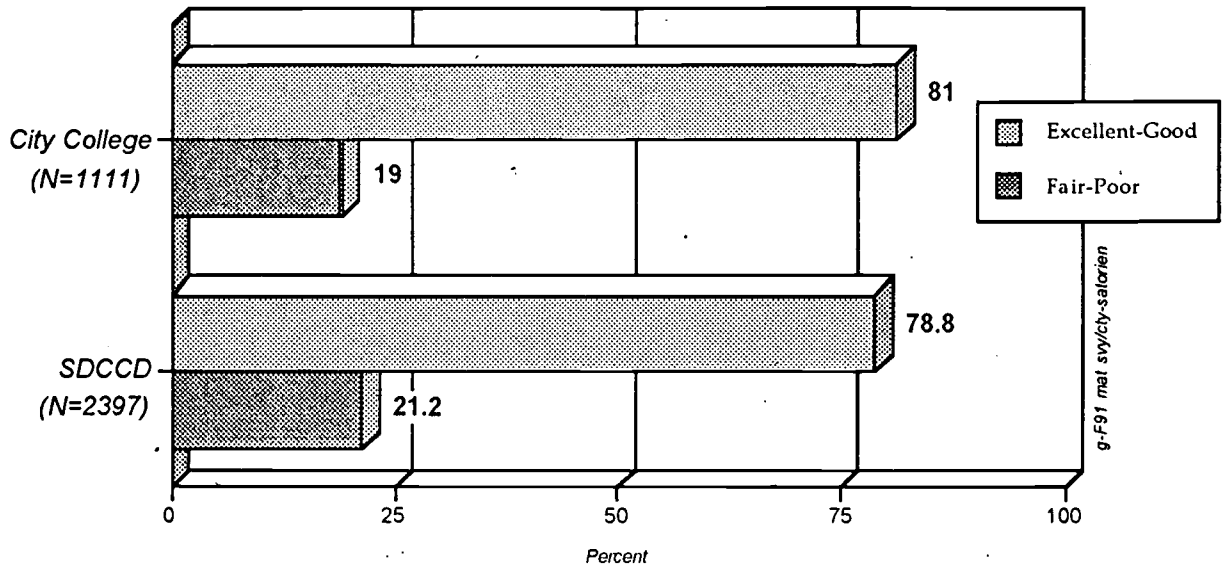

Satisfaction Ratio for Orientation

For ease of interpretation, responses to questions regarding satisfaction with various matriculation services were re-scaled into a satisfaction ratio. Included here are students who actually used a service and indicated their level of satisfaction with it. Approximately 80% of students found the orientation satisfactory.

Matriculation Services Survey

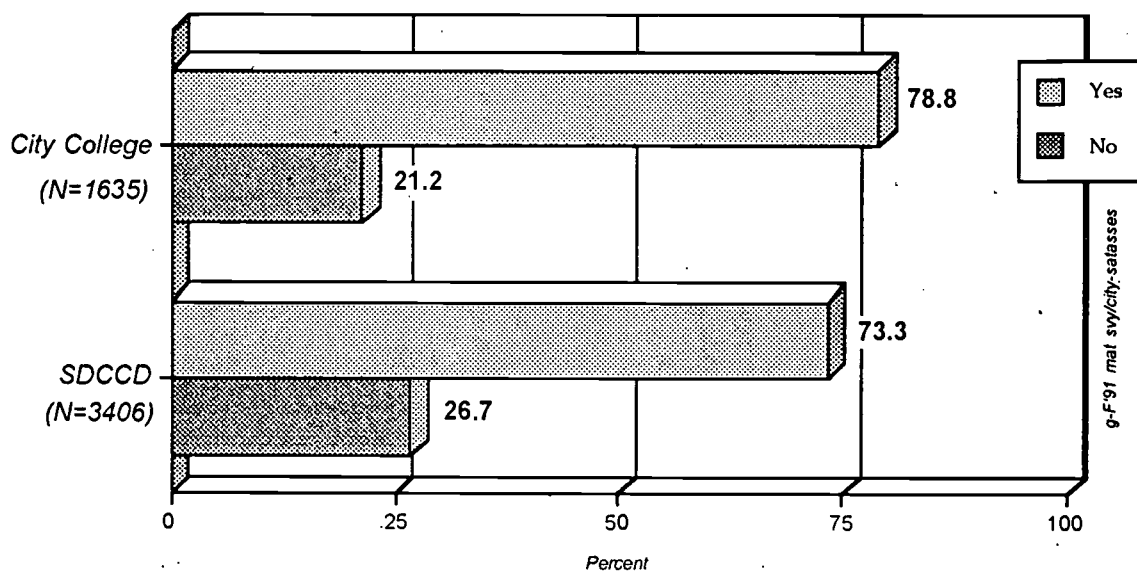

Satisfaction Ratio for Reading/Math Assessment

Most students were satisfied with the reading and math skill assessment. The proportion of students who found the assessment satisfactory was slightly higher at City College than the SDCCD.

Matriculation Services Survey

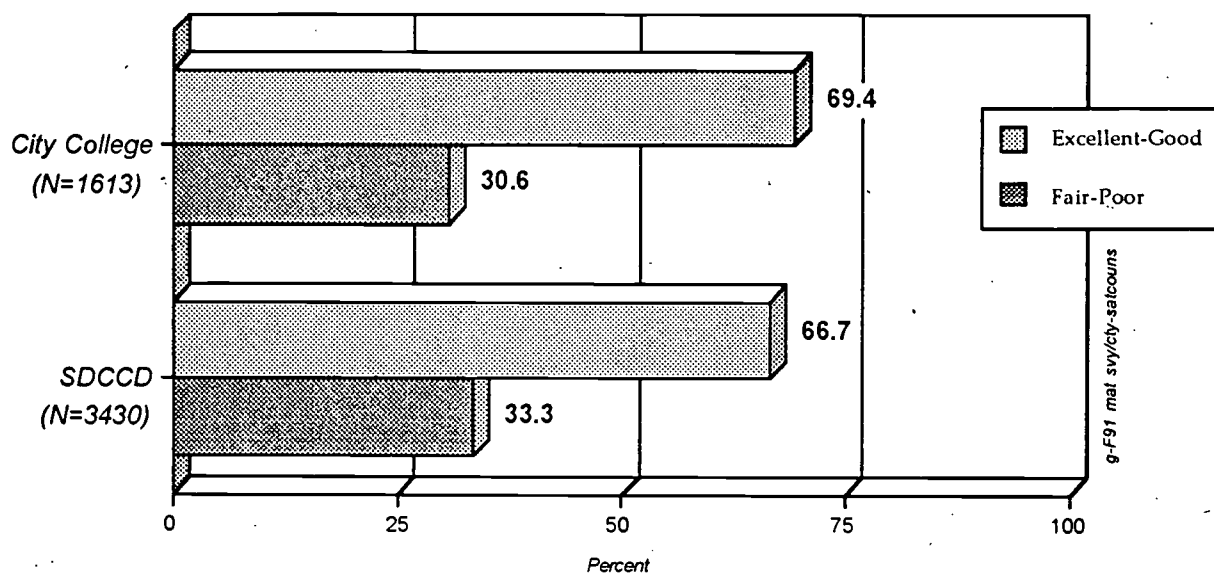

Satisfaction Ratio for Counseling

Satisfaction ratio for the counseling and advisement service was somewhat lower than other matriculation services at City College and the SDCCD. Approximately one-third of students found the counseling service not satisfactory.

Matriculation Services Survey

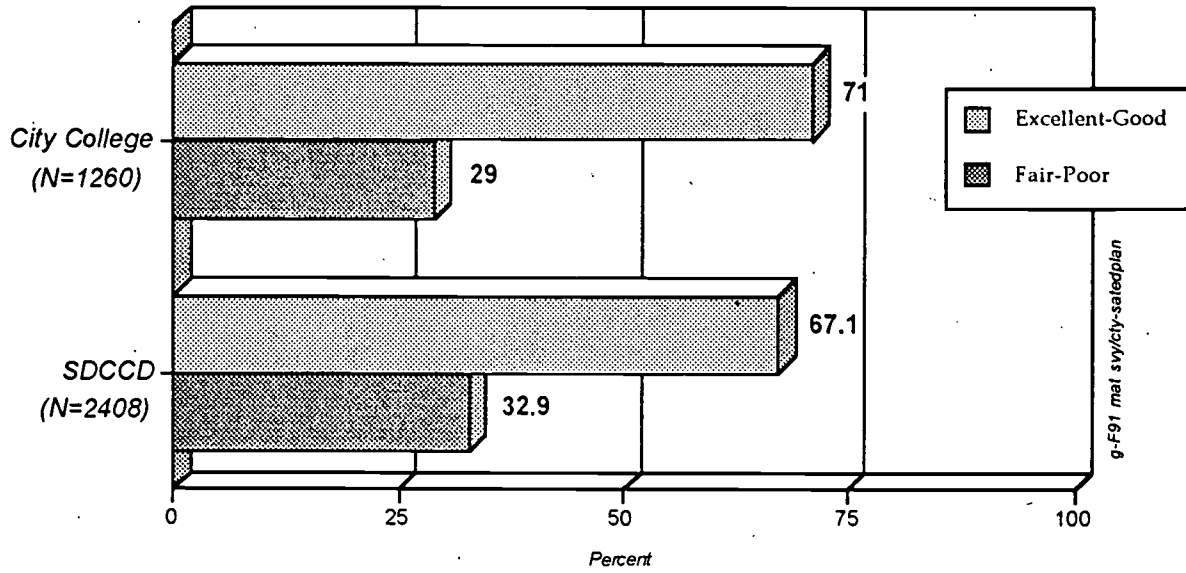

Satisfaction Ratio for Educational Plan Development

Approximately 7 out of 10 students were pleased with their educational plan development. At City College, somewhat larger proportion of students indicated their educational plan development was satisfactory compared to the rest of the district.

Matriculation Services Survey

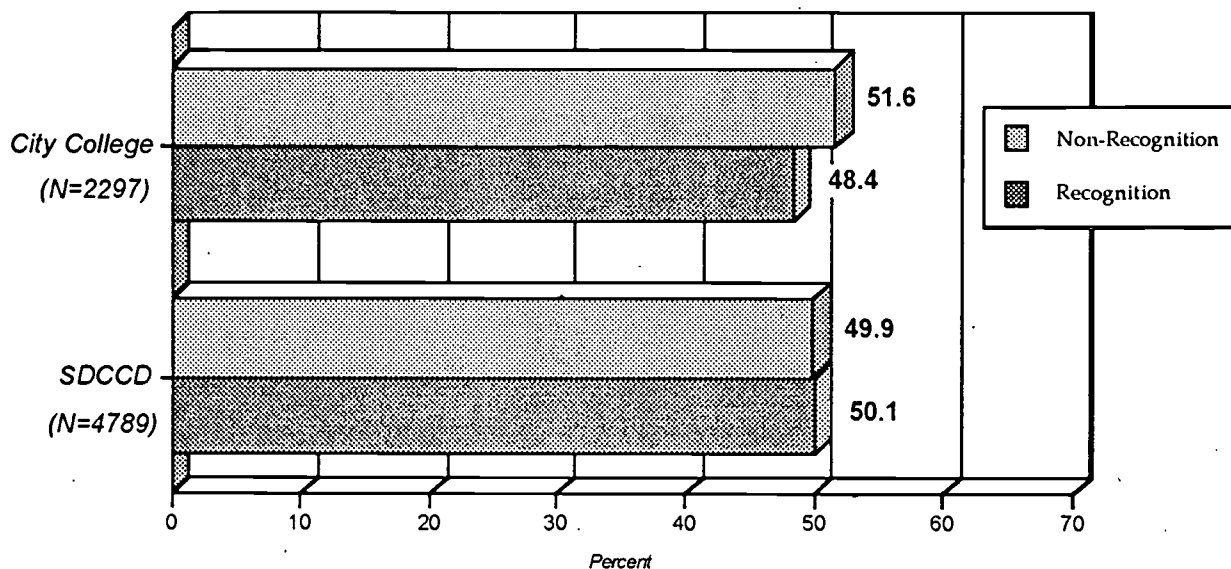

Students Responding to Orientation Question

Approximately half of the students were not aware of the orientation. Slightly less percentage of students recognized the orientation at City College. At the time of the survey, or at the time they matriculated, orientation sessions were changing in response to students needs and increased attendance. Since the time of this survey, campus leaders report that many more students are attending orientation and more sessions are scheduled than in the early years of matriculation implementation.

Matriculation Services Survey

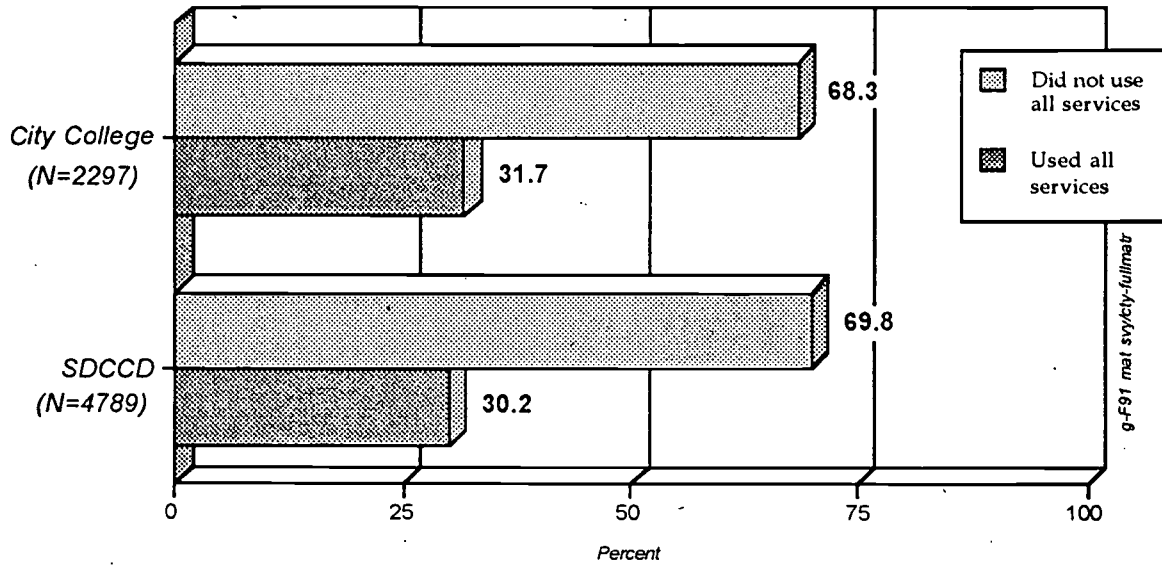

Student Use of Matriculation Services

About one third of students used all the matriculation services. The response to this question was almost identical at City College and the SDCCD.

Summary

Overall, the majority of respondents stated they were satisfied with the matriculation services they had used. Students gave high marks to orientation (at least for those who attended), English assessment and placement, math assessment and placement, and educational plan development. Moreover, the vast majority of respondents stated that they had been informed of their rights and responsibilities as students during orientation, and that overall, the service they had received had helped them to clarify their educational goals and how to achieve them.

Appendix A

Students Equity in Matriculation Services Satisfaction

In addition to the summary analyses provided in the body of this report, additional analysis were conducted to address students equity questions. Responses to Matriculation Services Satisfaction Survey were broken out by race, ethnicity, and sex of respondent to determine if any practical difference could be discerned between students groupings. This would be helpful in not only evaluating matriculation service staff and college faculty to more closely identify groups of students that indicated lower level of satisfaction with certain educational services. This information was also provided to determine if certain groups were using matriculation services at a higher or lower rate compared to the other groups. For example, this survey found that Asians tended to attend orientation session at higher rates than any other groups. The graphs that follow summarize responses to the matriculation survey districtwide by students grouping. Only districtwide data are presented because breaking these data by campus and also by group lowered sample sizes dramatically. This limited the reliability of the finding for certain groups.

San Diego Community College District Matriculation Services Survey Fall 1992

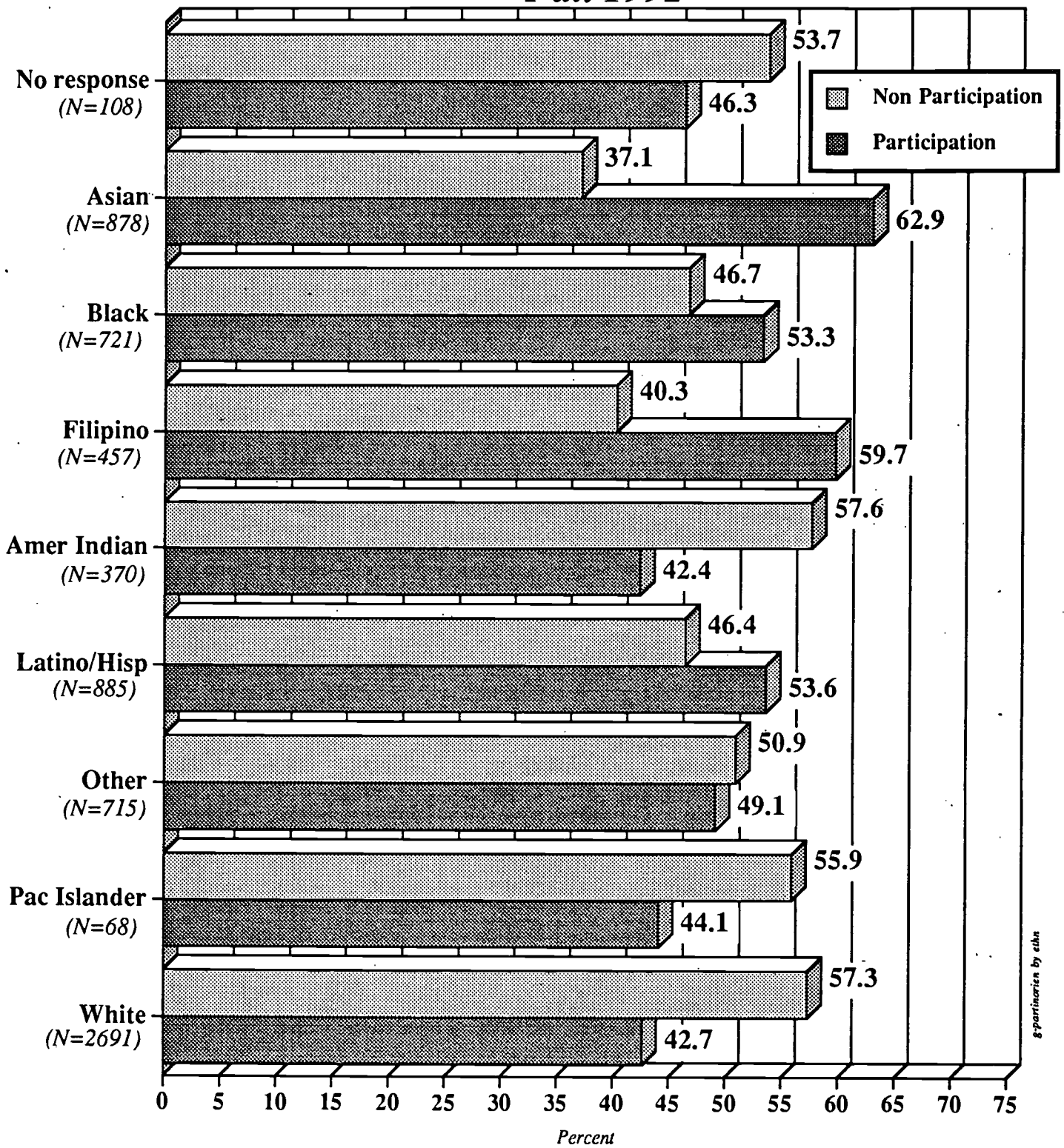

*Percentage of students who participated in orientation
by
Ethnicity*

San Diego Community College District Matriculation Services Survey Fall 1992

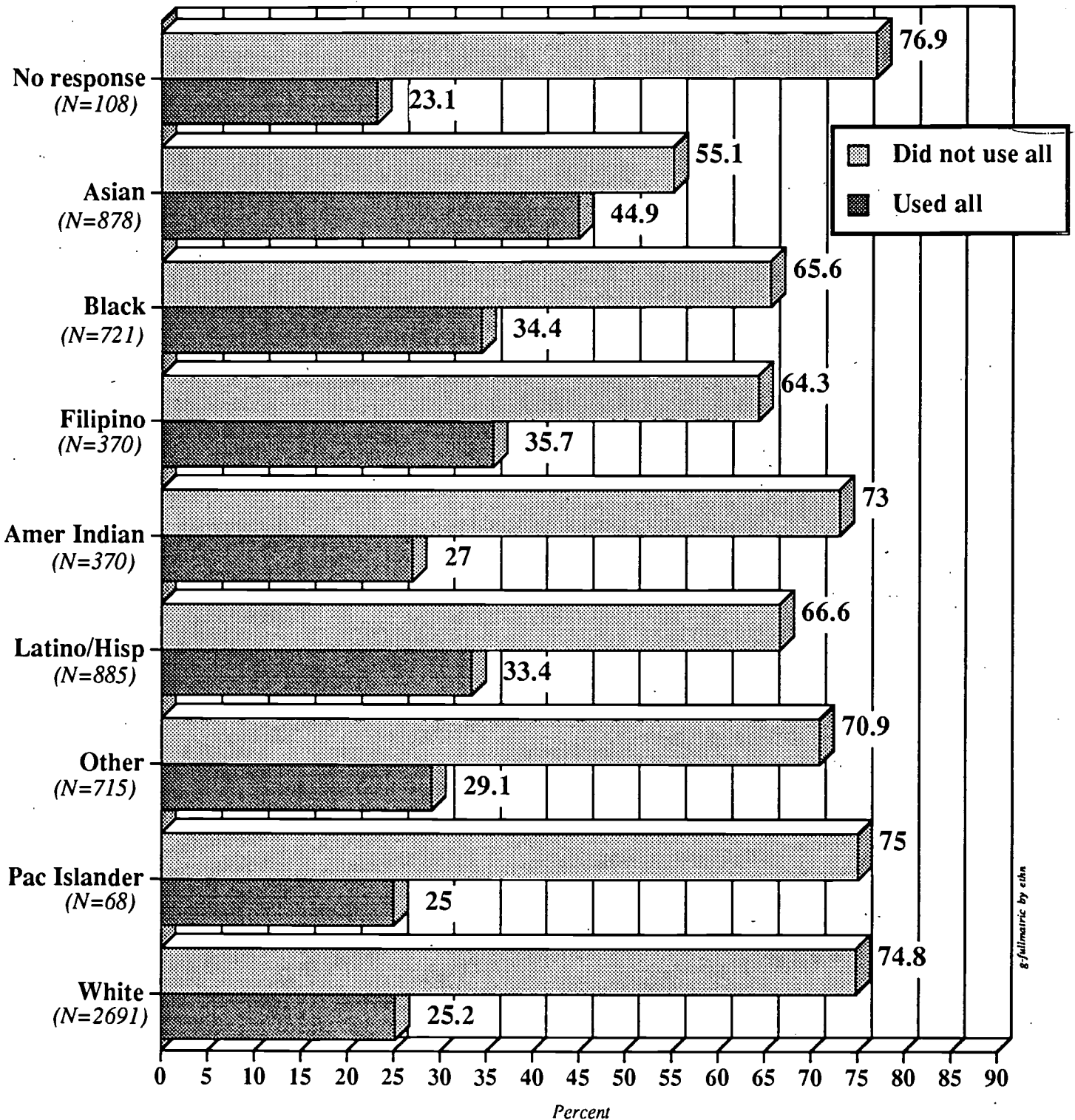

*Percentage of students who have used matriculation services
by
Ethnicity*

*San Diego Community College District
Matriculation Services Survey
Fall 1992*

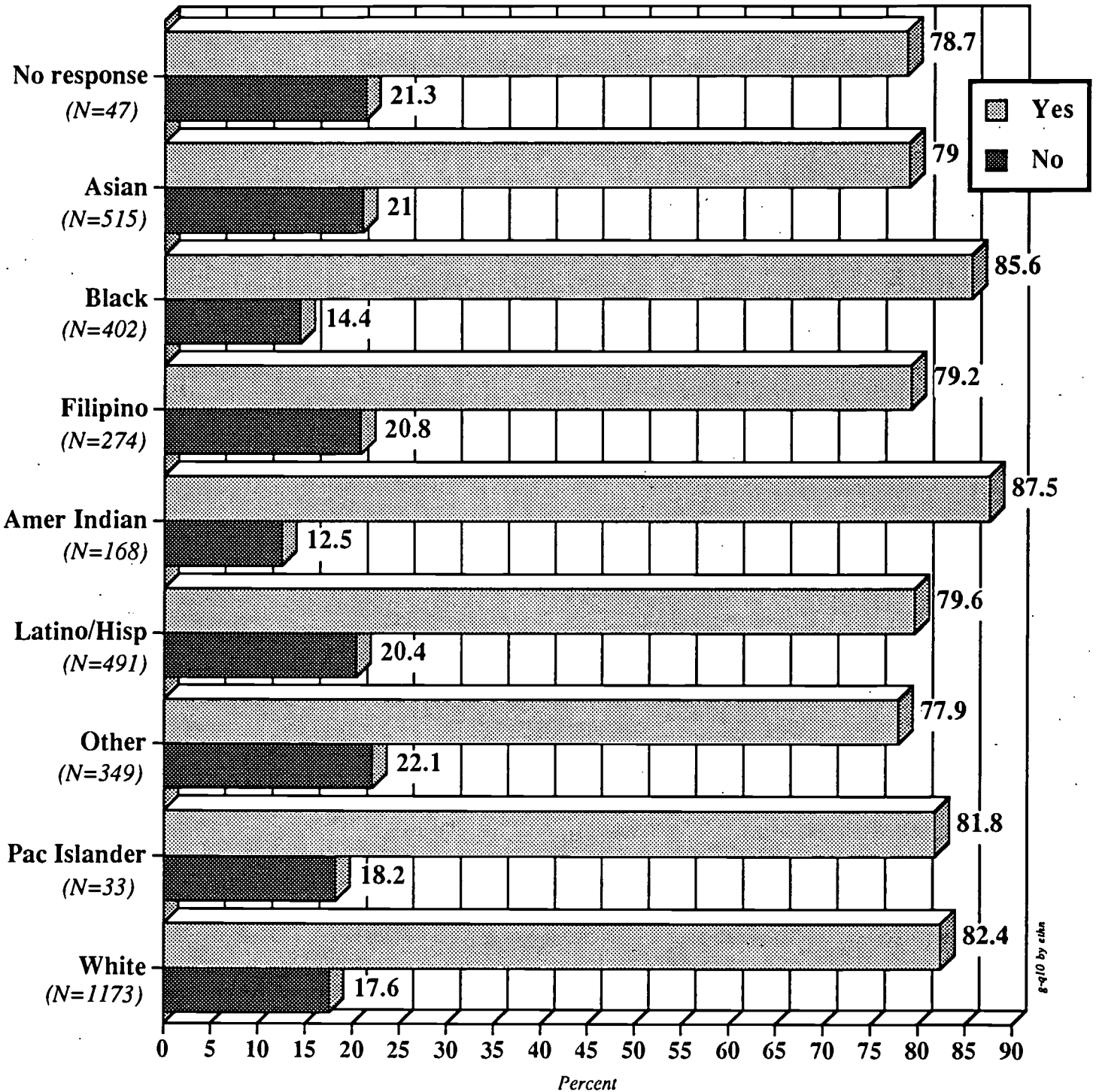

*Q10: Were you informed about your rights and responsibilities
as a student during your orientation?
by
Ethnicity*

*San Diego Community College District
Matriculation Services Survey
Fall 1992*

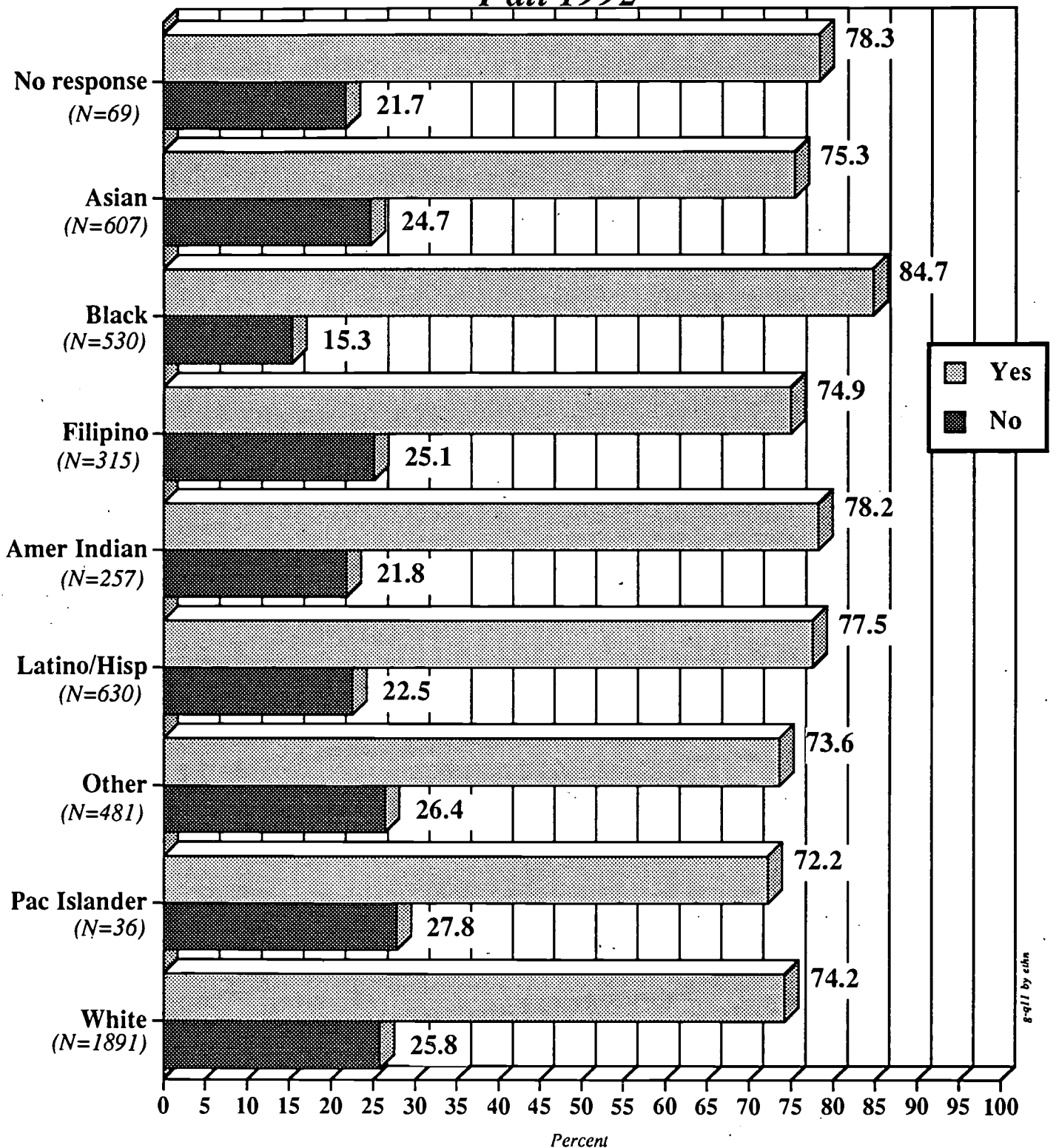

*Q11: Have the services you have received help to clarify your educational goals and how to achieve them?
by
Ethnicity*

San Diego Community College District Matriculation Services Survey Fall 1992

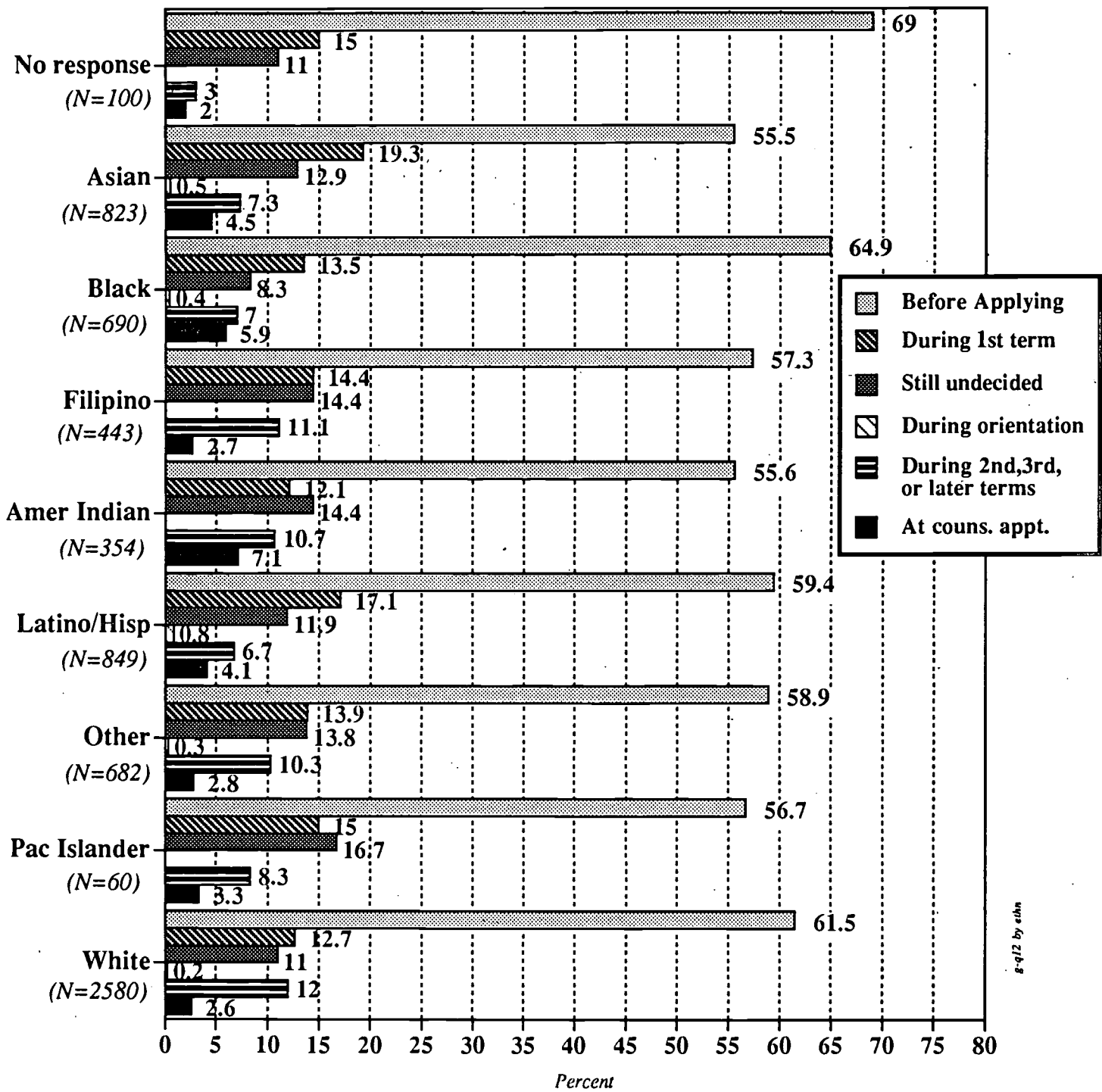

8-q12 by ethn

Q12: When did you first decide upon a specific educational goal to pursue at this college?
by
Ethnicity

*San Diego Community College District
Matriculation Services Survey
Fall 1992*

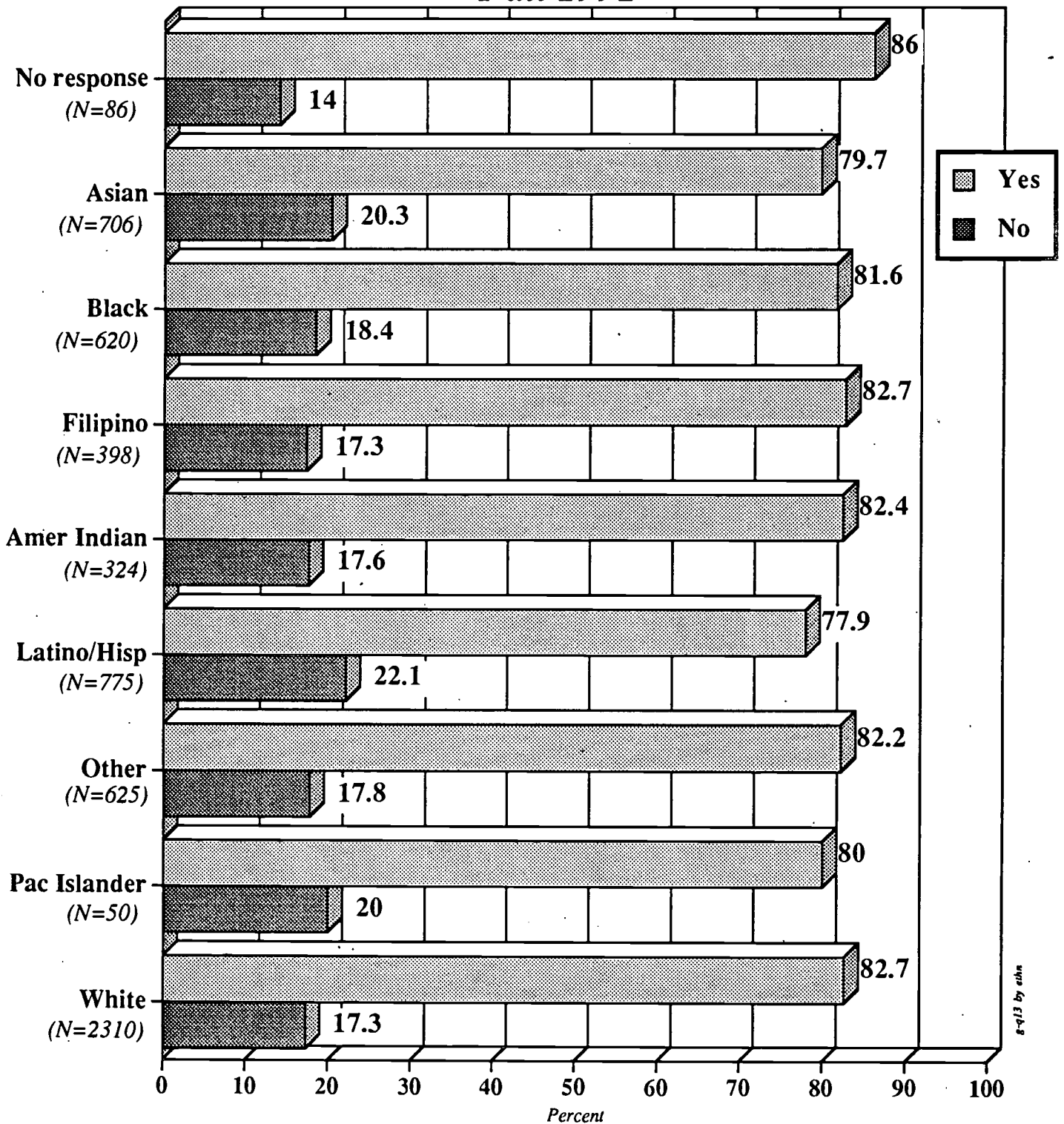

Q13: Have you been provided with information to help you understand course and basic skills prerequisites by Ethnicity

San Diego Community College District Matriculation Services Survey Fall 1992

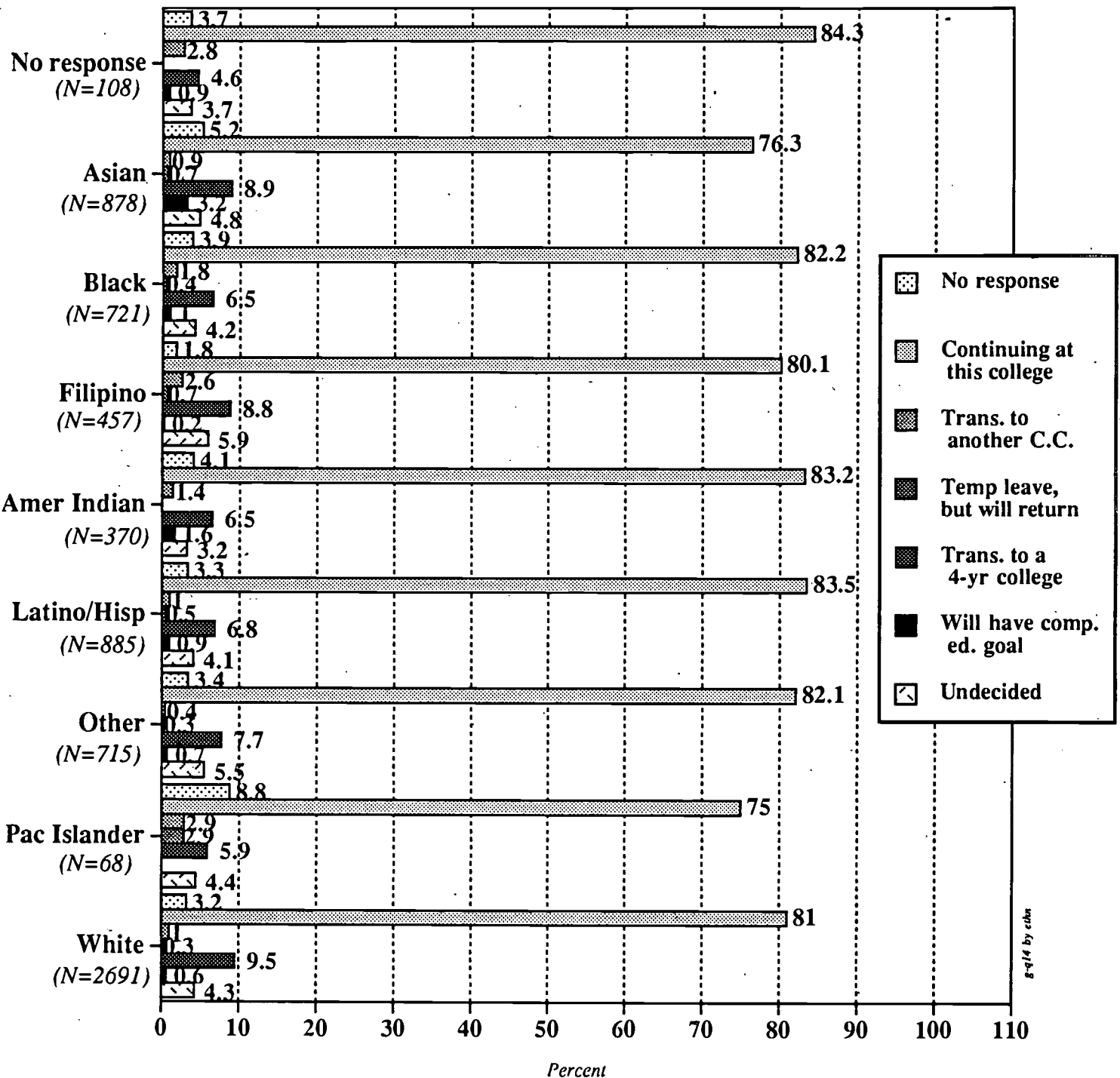

**Q14: What will your student status be next term?
by
Ethnicity**

8-914 by etha

San Diego Community College District Matriculation Services Survey Fall 1992

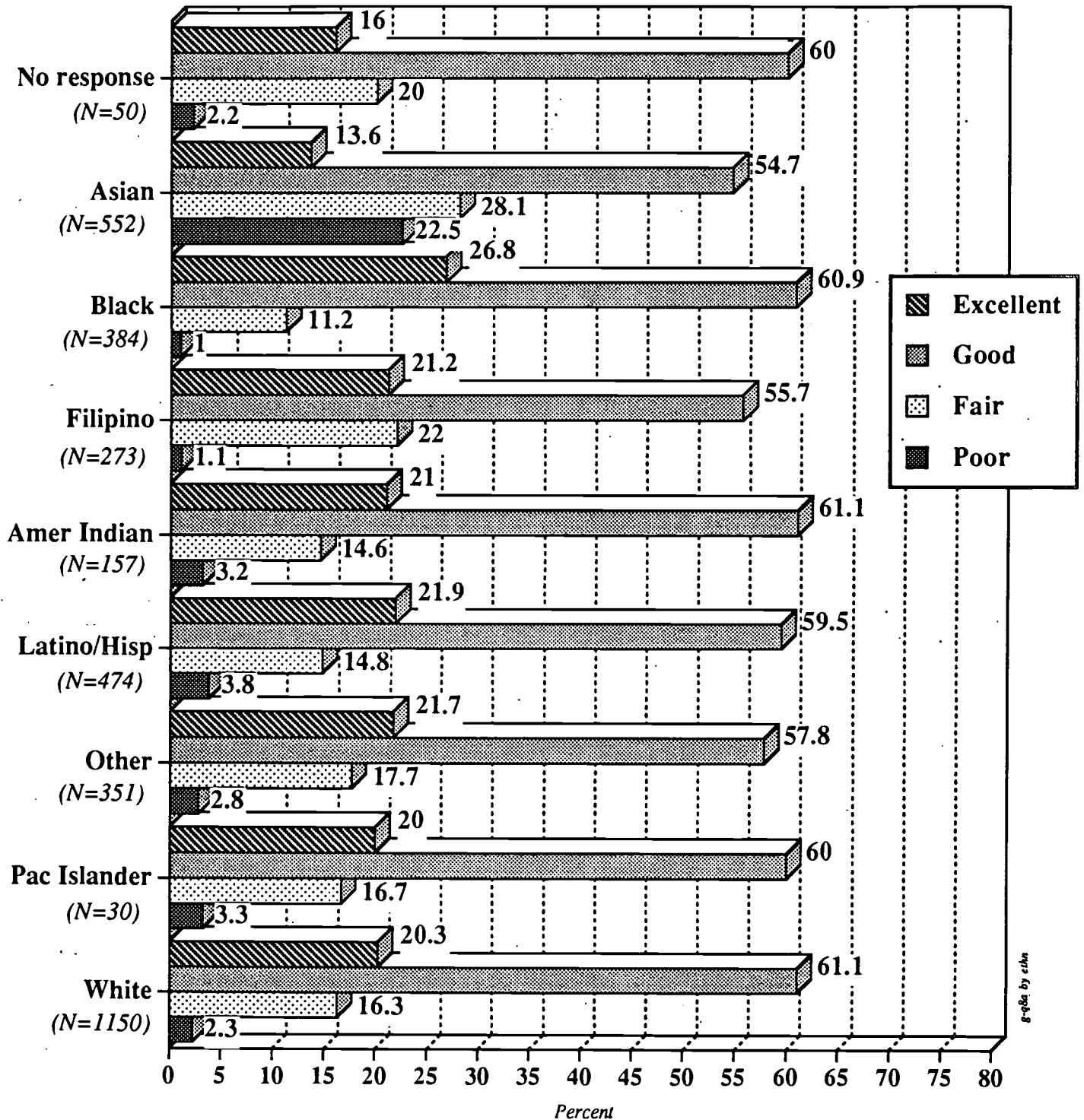

*Q8a: Please evaluate your orientation session
by
ethnicity*

San Diego Community College District Matriculation Services Survey Fall 1992

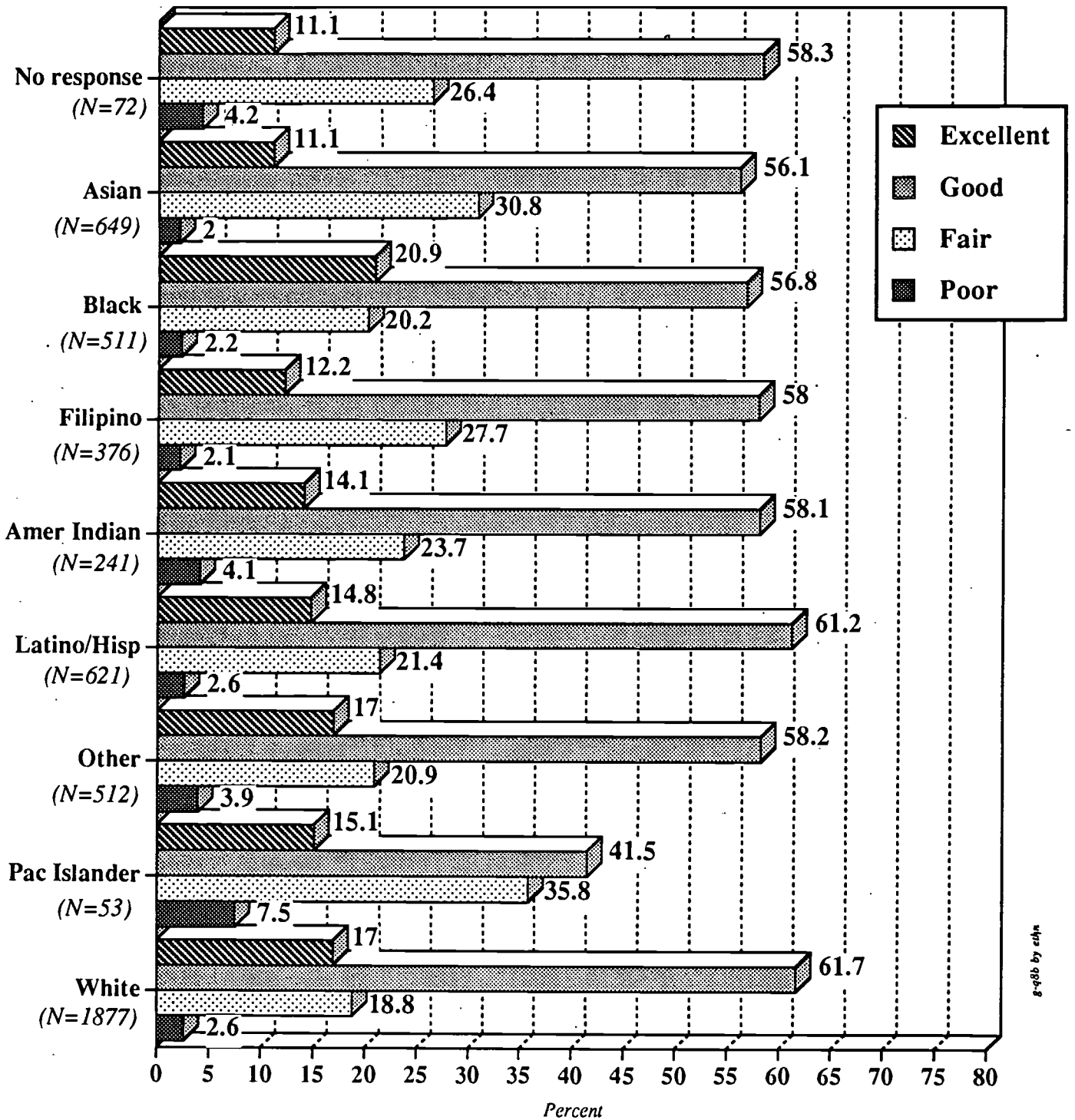

*Q8b: Please evaluate your Reading/Math Assessment
by
Ethnicity*

San Diego Community College District Matriculation Services Survey Fall 1992

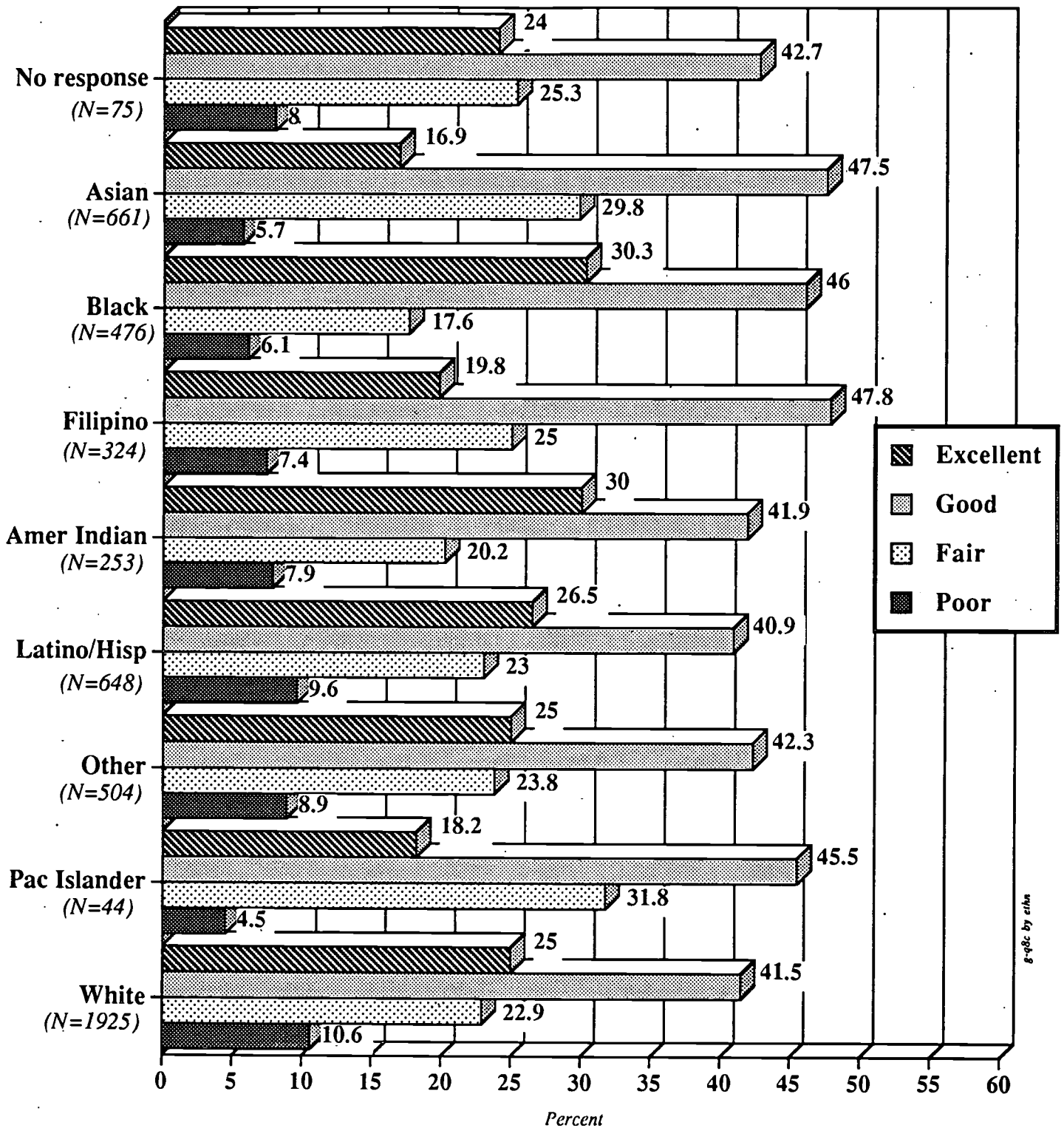

*Q8c: Please evaluate your Advisement/Counseling
by
Ethnicity*

San Diego Community College District Matriculation Services Survey Fall 1992

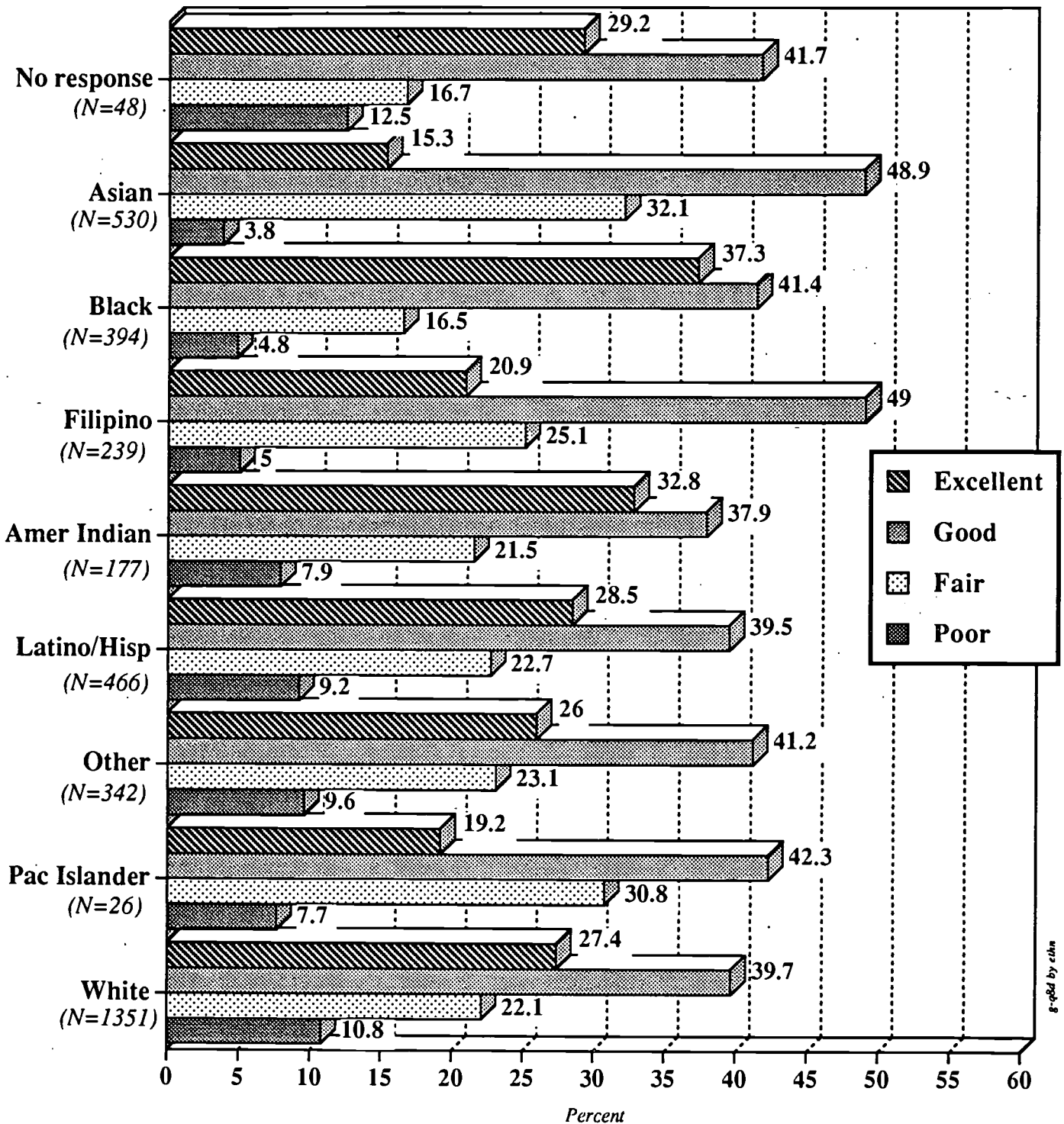

*Q8d: Please evaluate your Educational Plan development
by
Ethnicity*

San Diego Community College District Matriculation Services Survey Fall 1992

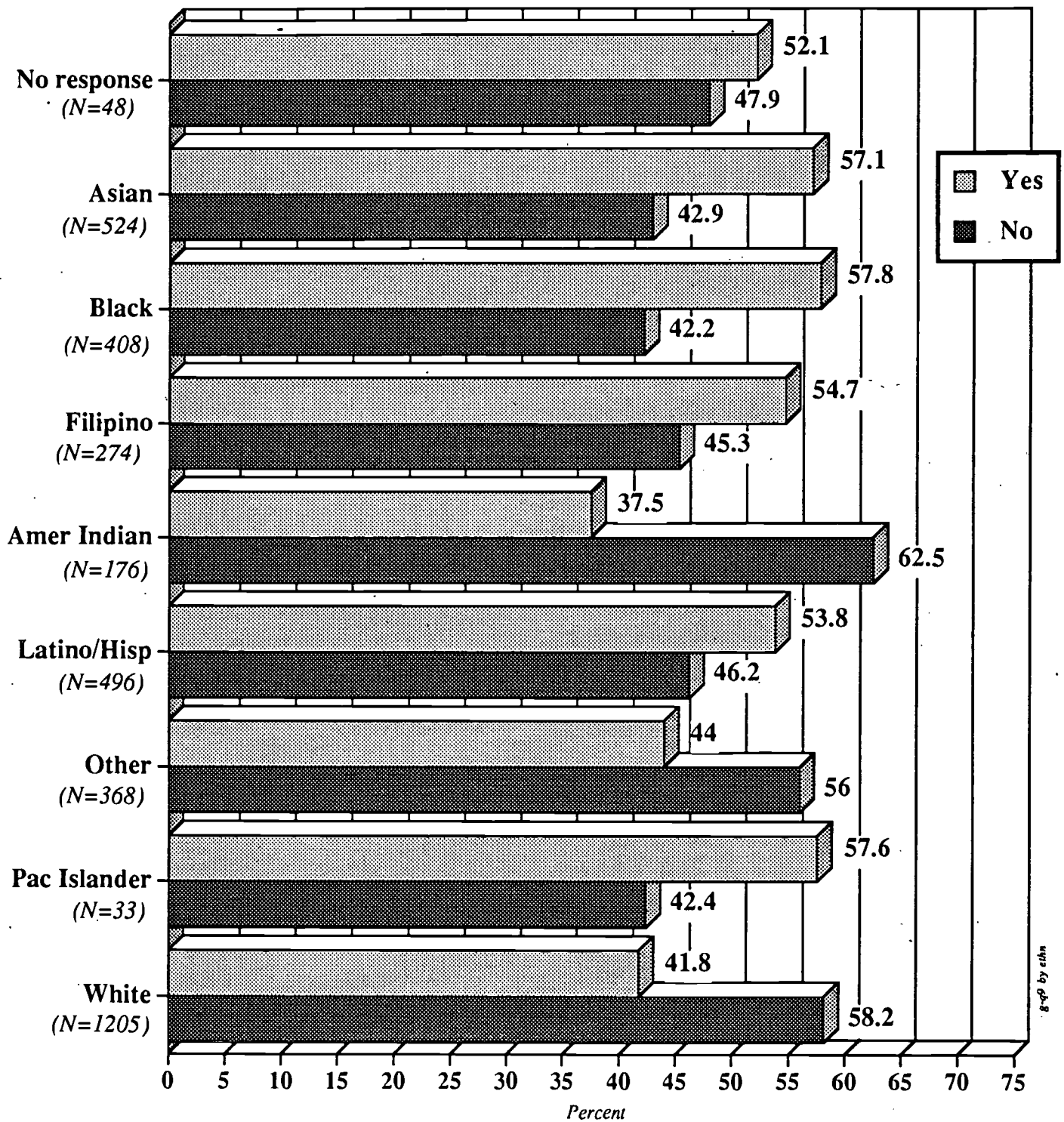

**Q9: Did attending the orientation session influence you to visit or use other campus services?
by
Ethnicity**

*San Diego Community College District
Matriculation Services Survey
Fall 1992*

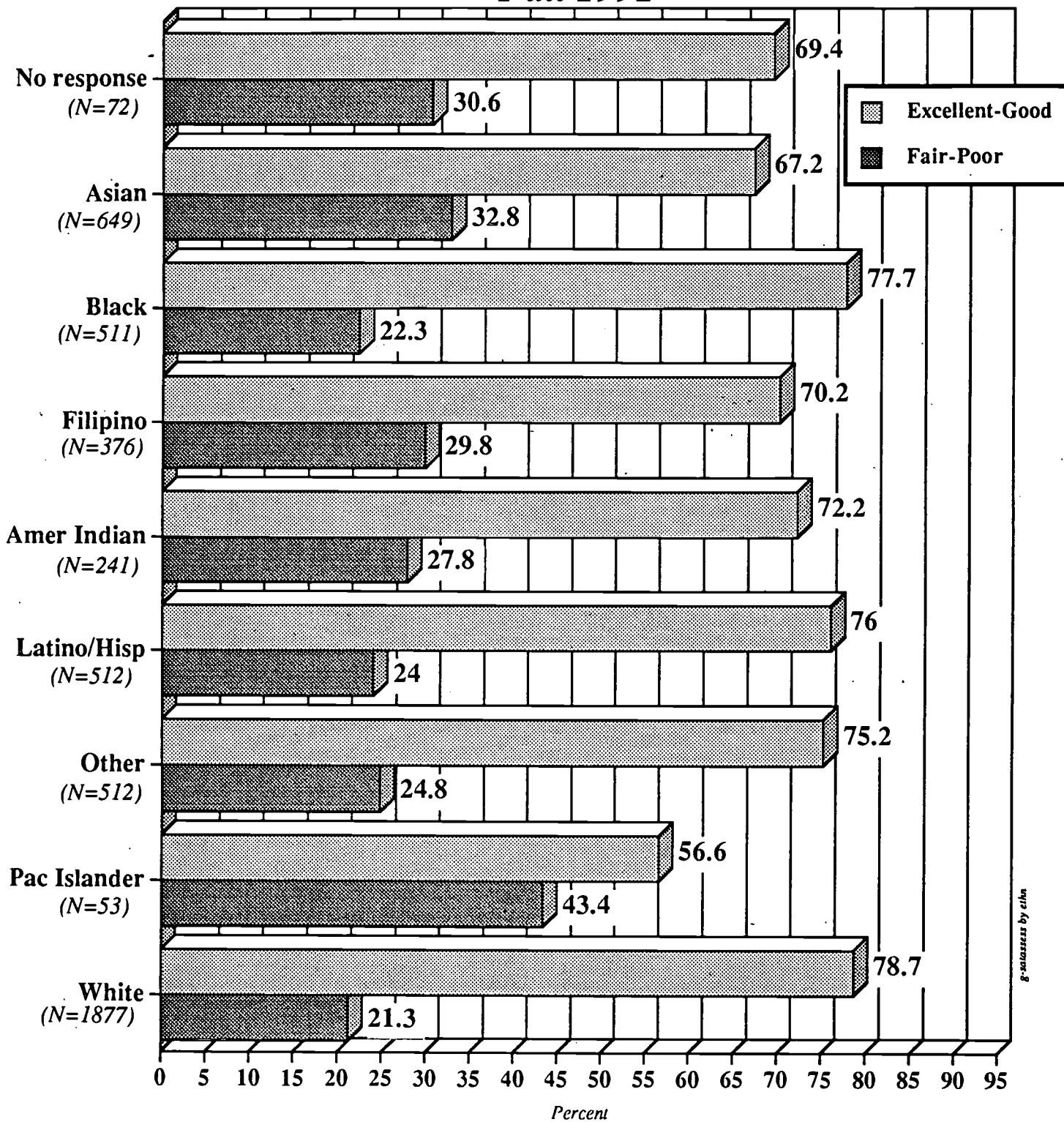

*Q8b: Satisfaction ratio for assessment
by
Ethnicity*

*San Diego Community College District
Matriculation Services Survey
Fall 1992*

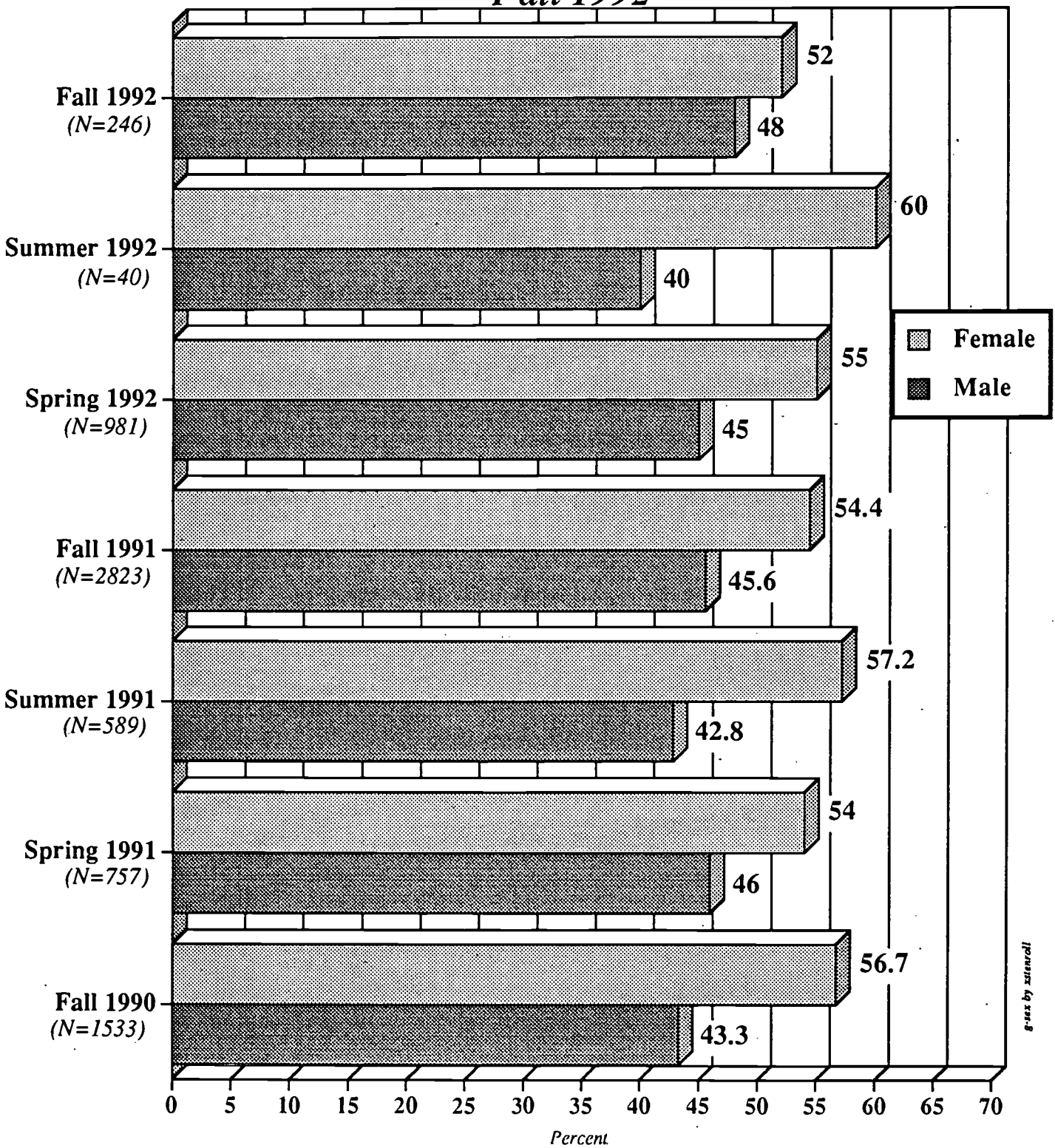

*Q4: When did you first enroll at this college?
by
Ethnicity*

San Diego Community College District Matriculation Services Survey Fall 1992

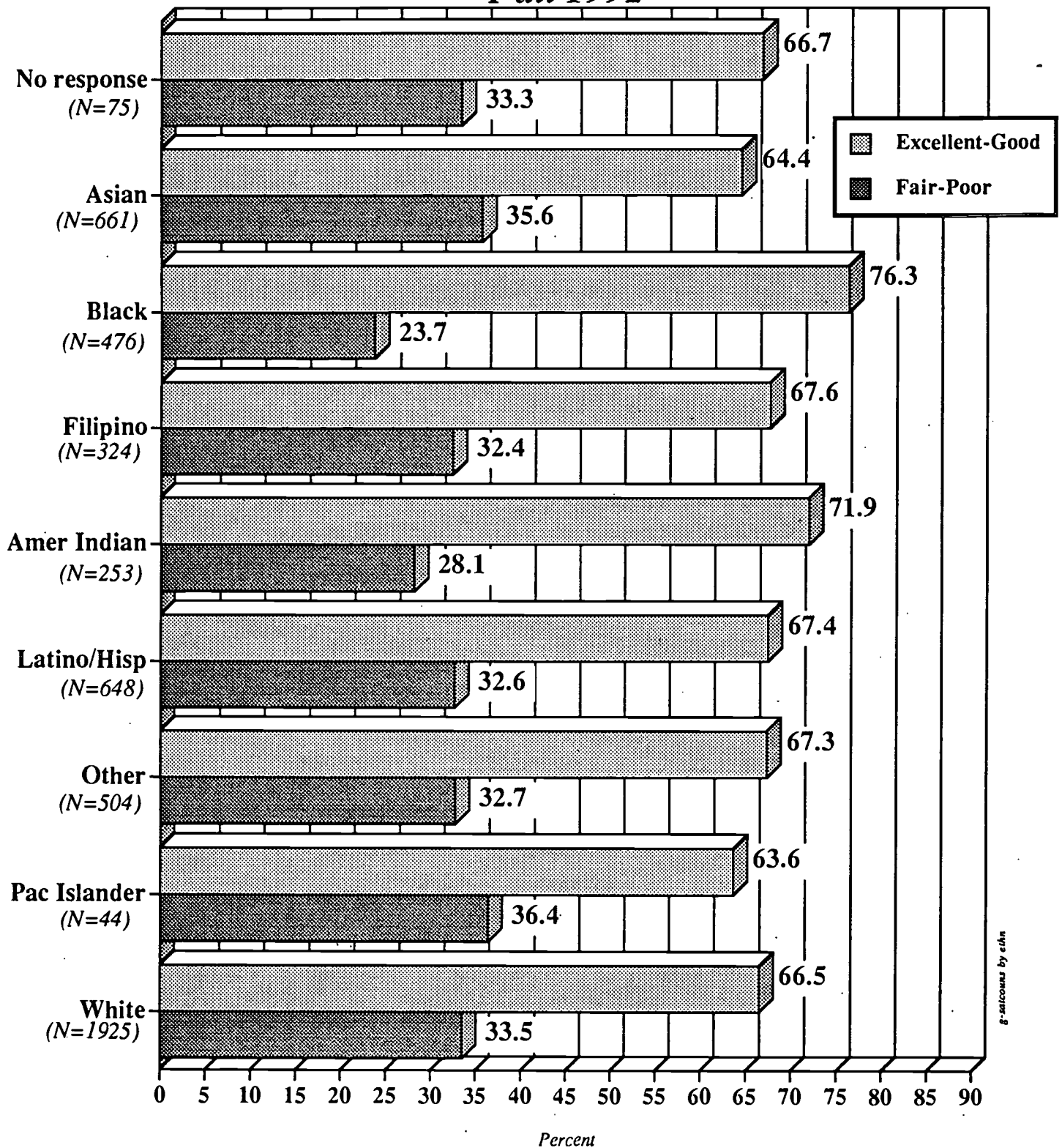

*Q8c: Satisfaction ratio for Advisement/Counseling
by
Ethnicity*

San Diego Community College District Matriculation Services Survey Fall 1992

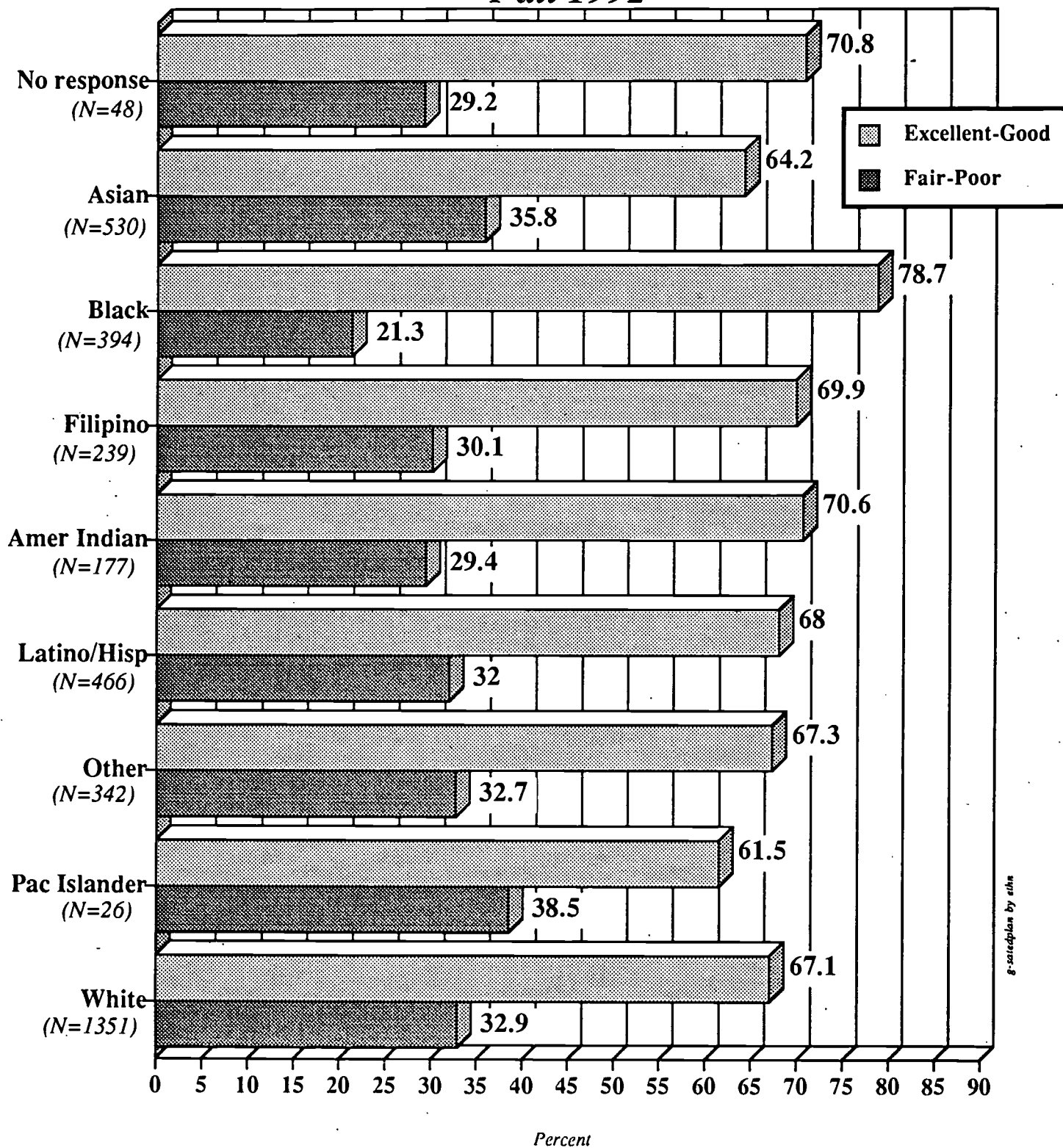

*Q8d: Satisfaction ratio for Educational Plan development
by
Ethnicity*

San Diego Community College District Matriculation Services Survey Fall 1992

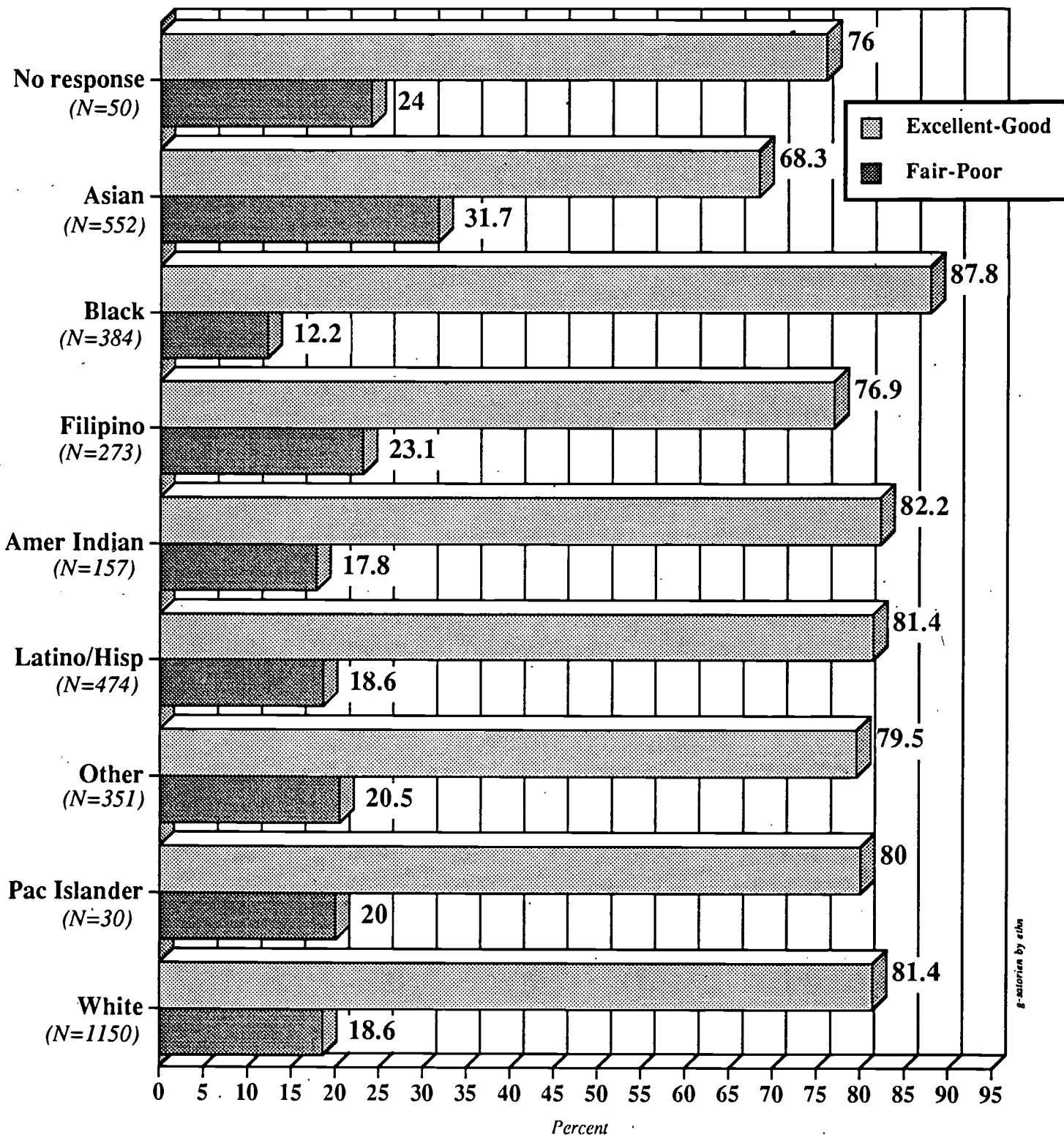

*Q8a: Satisfaction ratio for orientation
by
Ethnicity*

*San Diego Community College District
Matriculation Services Survey
Fall 1992*

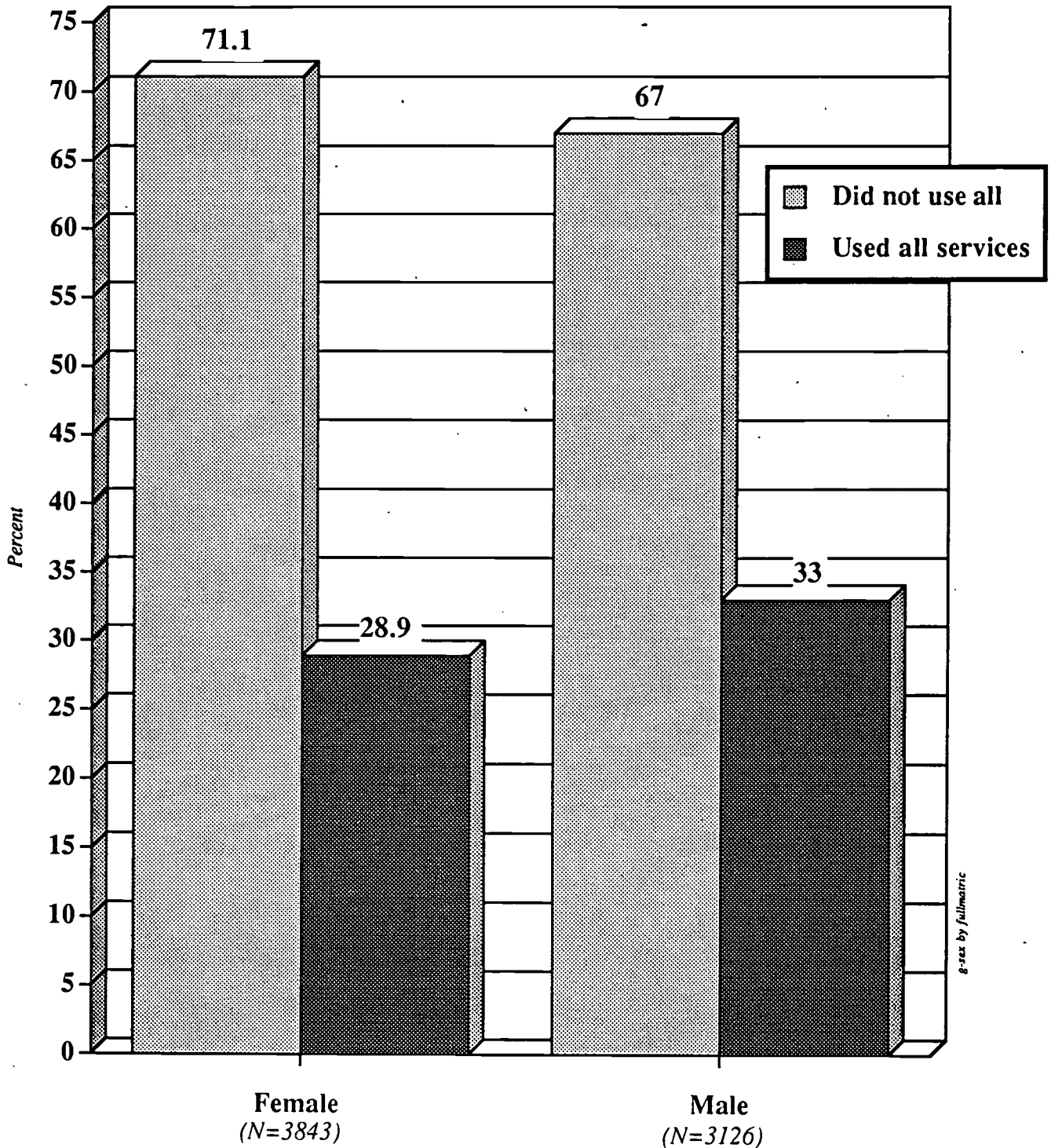

*Percentage of students who have used matriculation services
by
Gender*

*San Diego Community College District
Matriculation Services Survey
Fall 1992*

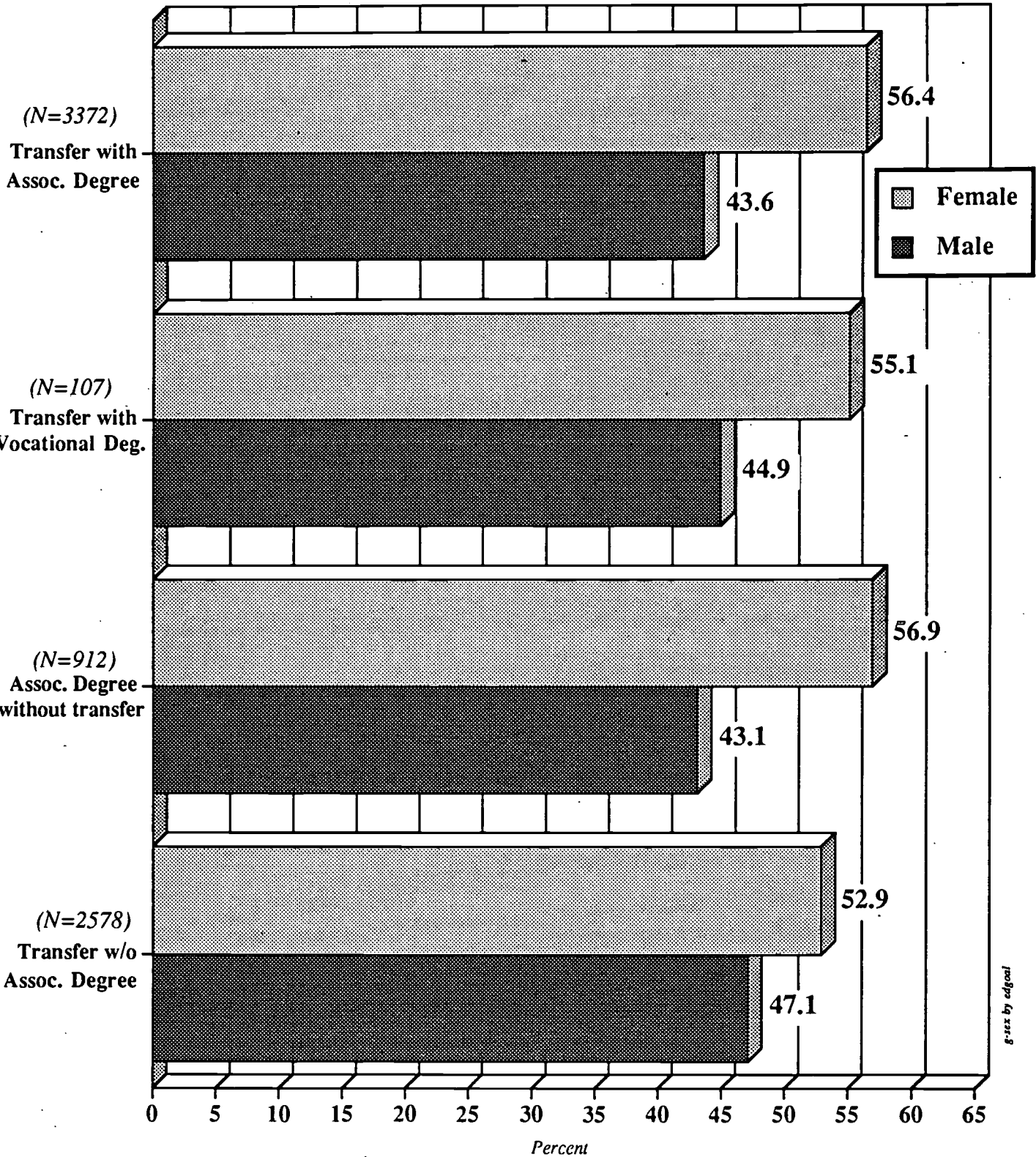

*Q7: Please indicate your educational goal
by
Gender*

*San Diego Community College District
Matriculation Services Survey
Fall 1992*

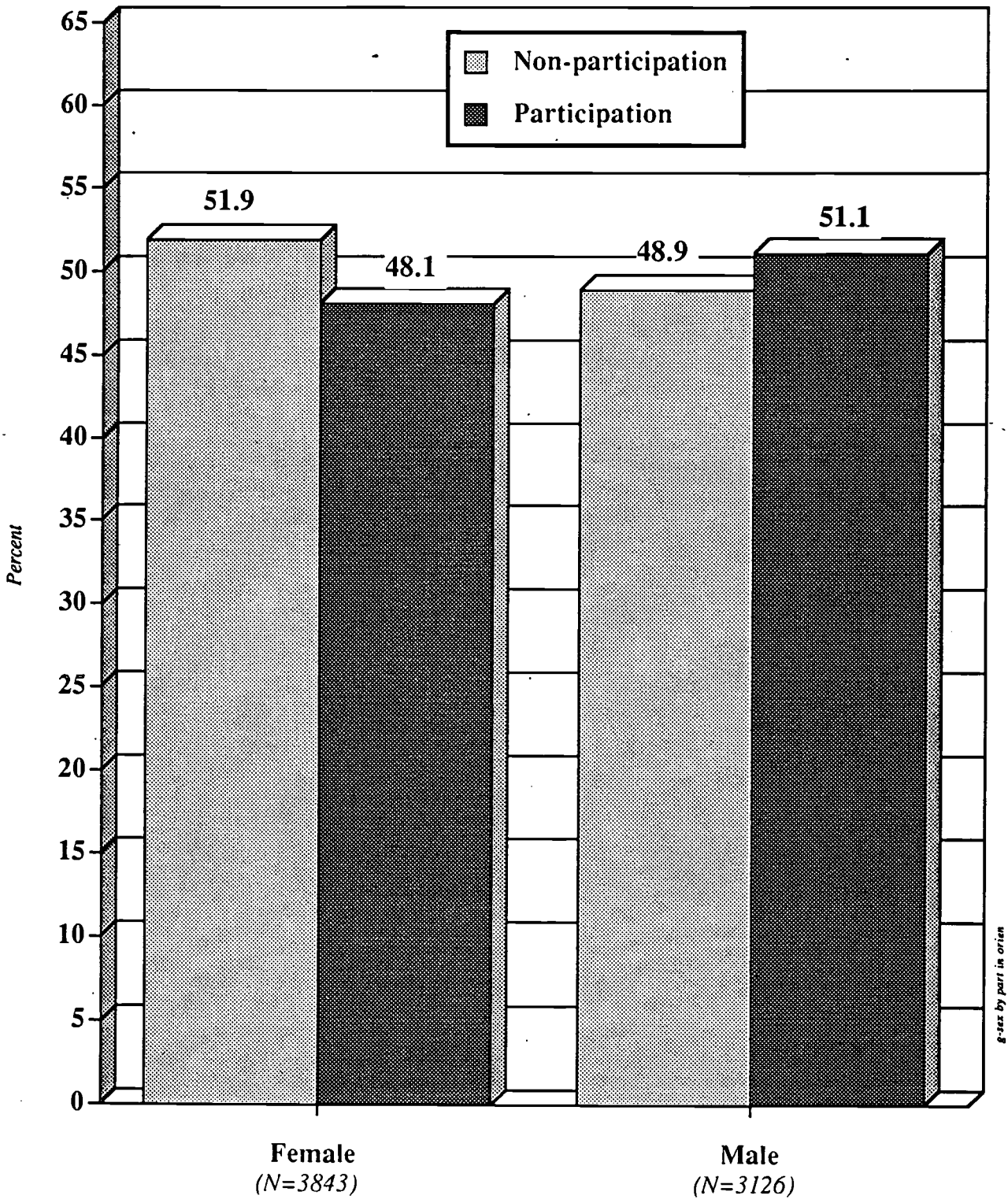

*Percentage of students who participated in orientation
by
Gender*

*San Diego Community College District
Matriculation Services Survey
Fall 1992*

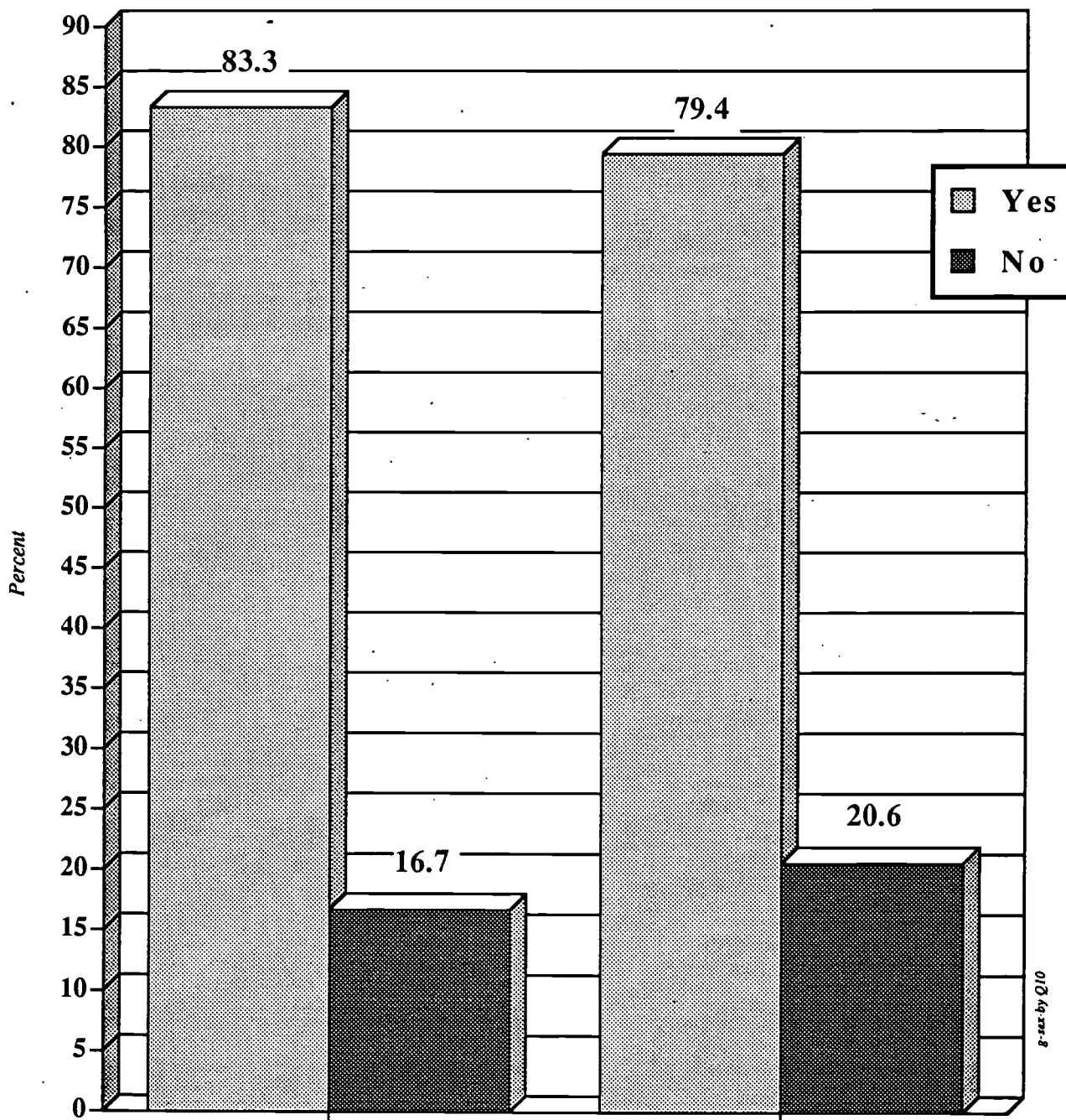

Female
(N=1867)

Male
(N=1603)

*Q10: Were you informed about your rights and responsibilities
as a student during your orientation?
by
Gender*

*San Diego Community College District
Matriculation Services Survey
Fall 1992*

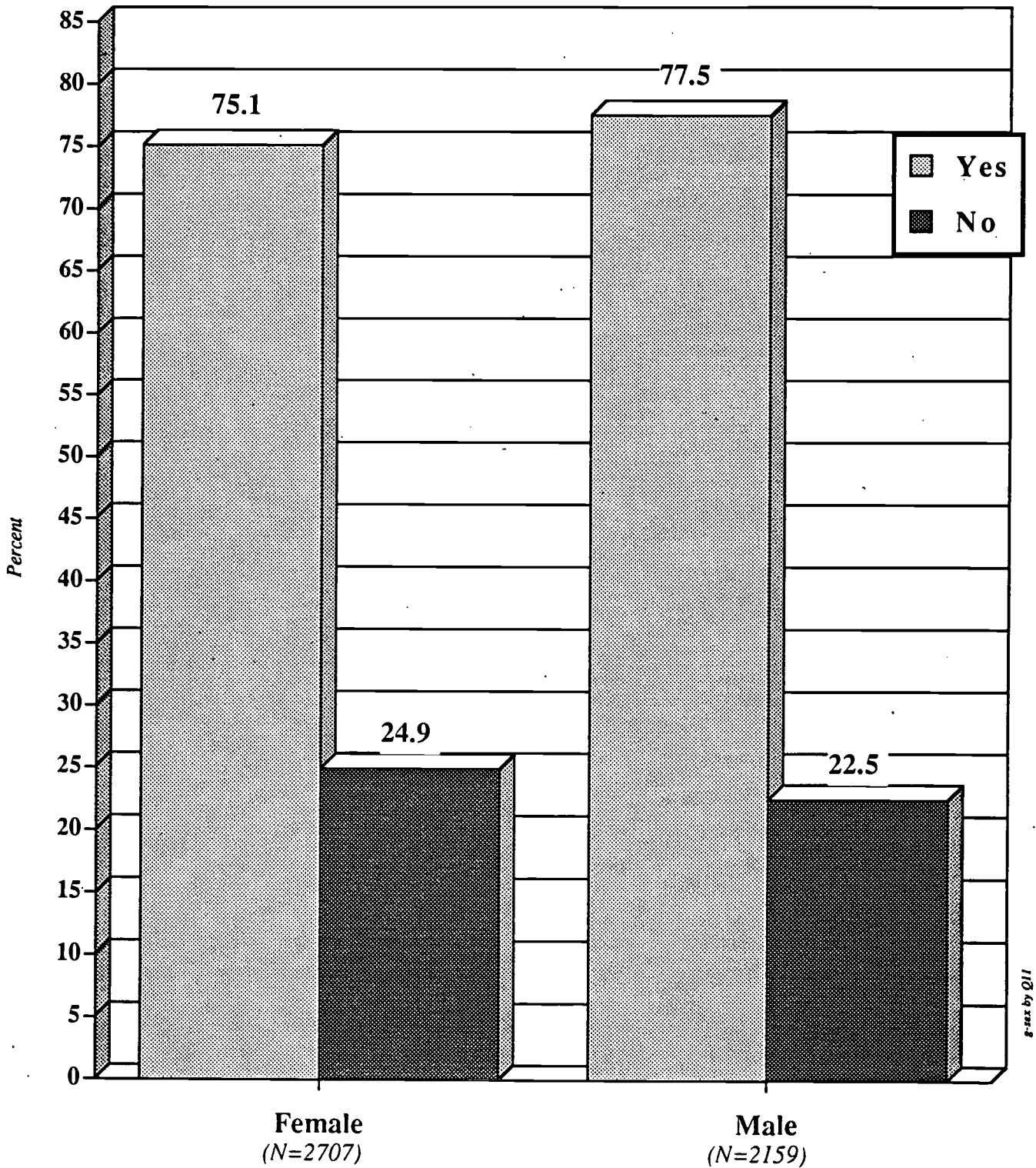

*Q11: Have the services you have received help to clarify your educational goals and how to achieve them?
by
Gender*

*San Diego Community College District
Matriculation Services Survey
Fall 1992*

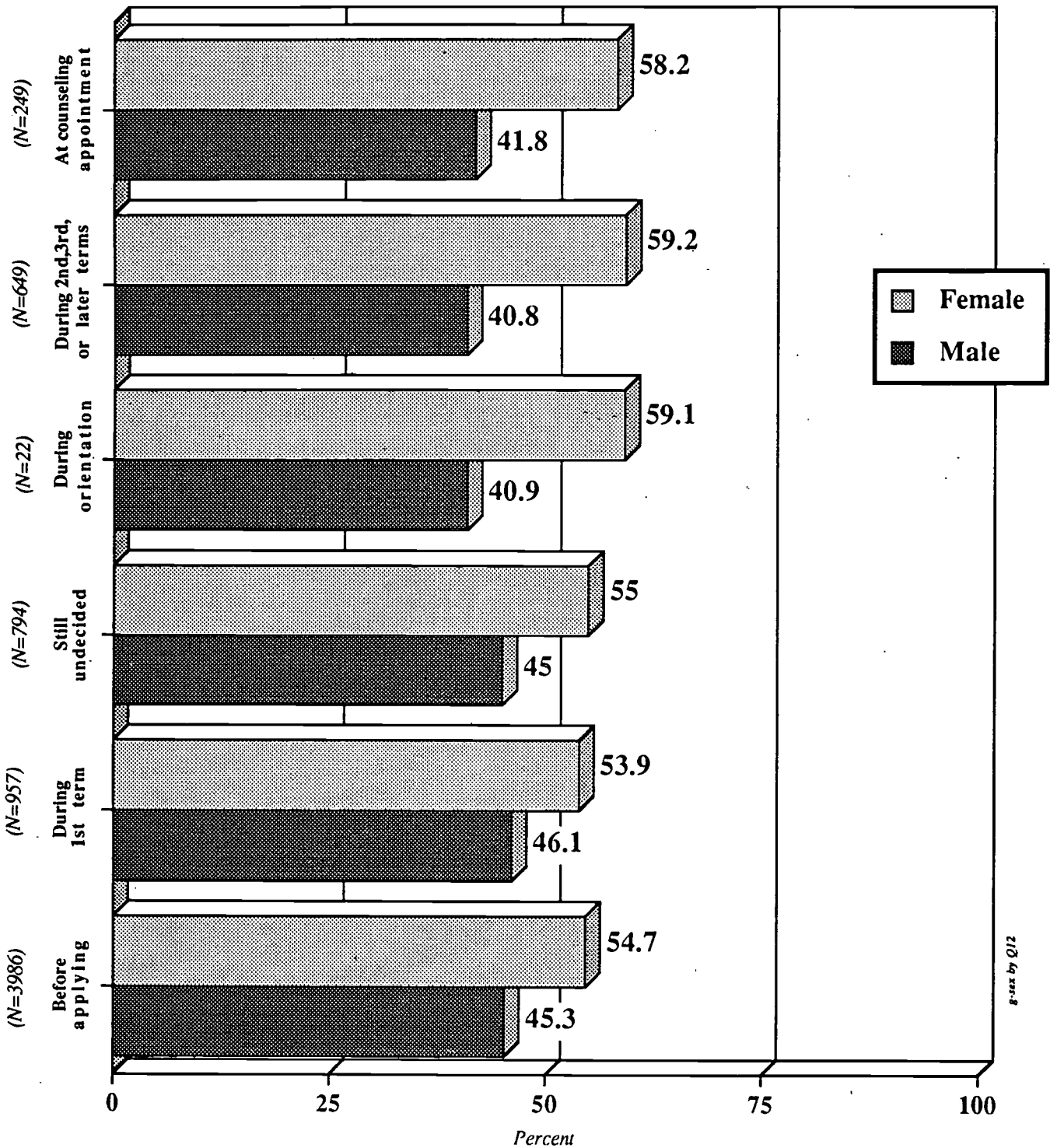

*Q12: When did you first decide upon a specific educational goal to pursue at this college?
by
Gender*

*San Diego Community College District
Matriculation Services Survey
Fall 1992*

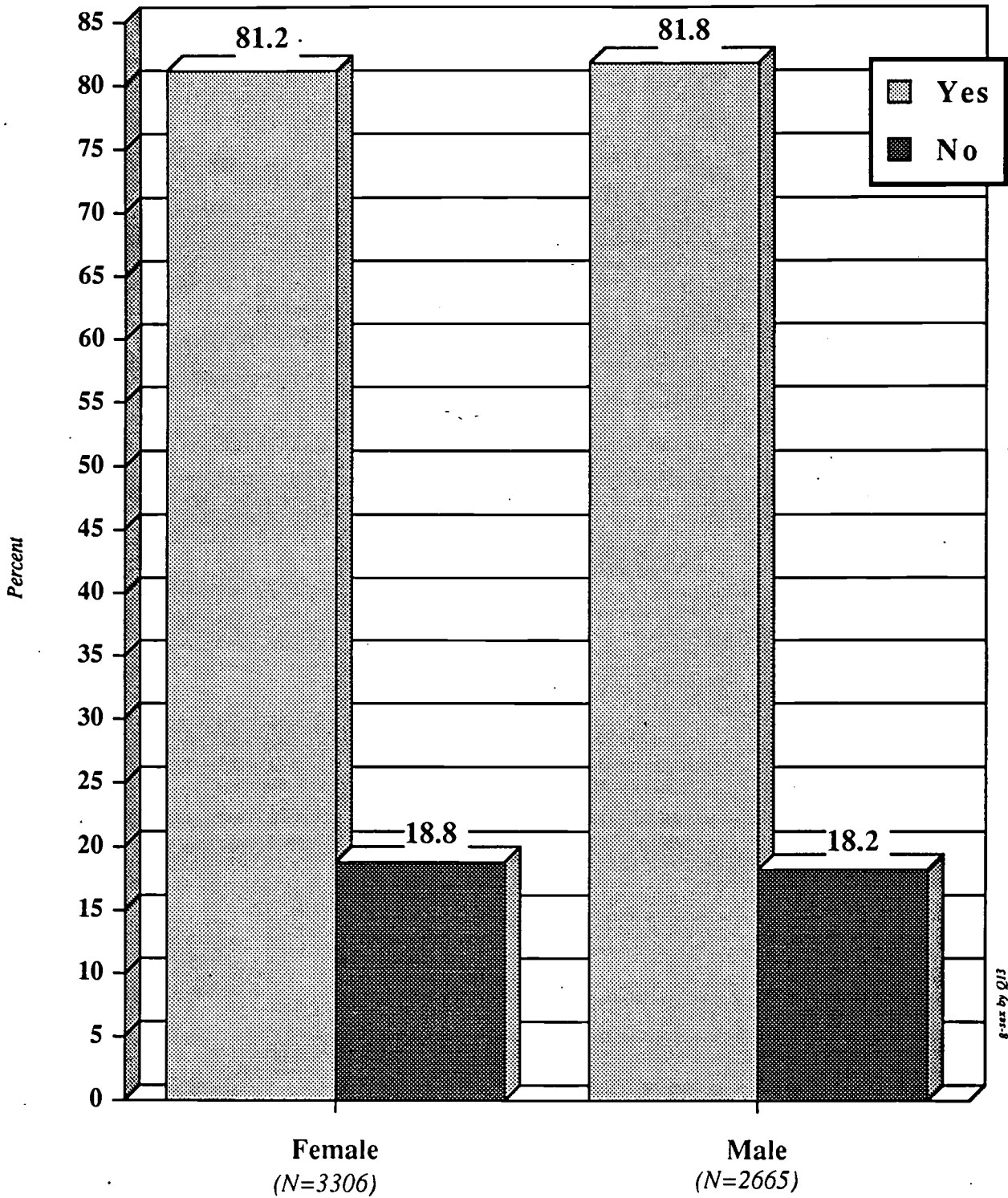

*Q13: Have you been provided with information to help you understand course and basic skills prerequisites?
by Gender*

San Diego Community College District Matriculation Services Survey Fall 1992

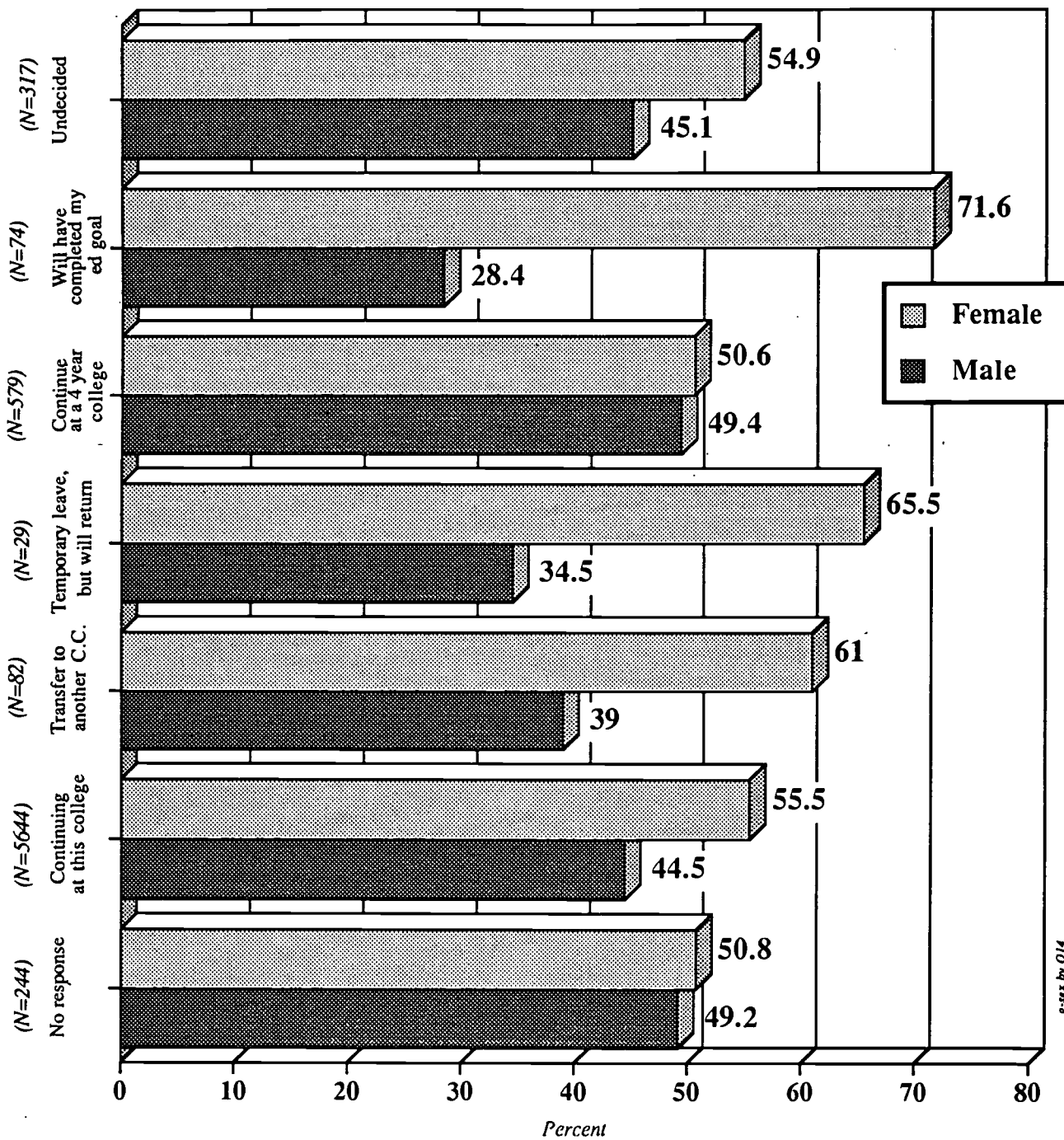

*Q14: What will your student status be next term?
by
Gender*

*San Diego Community College District
Matriculation Services Survey
Fall 1992*

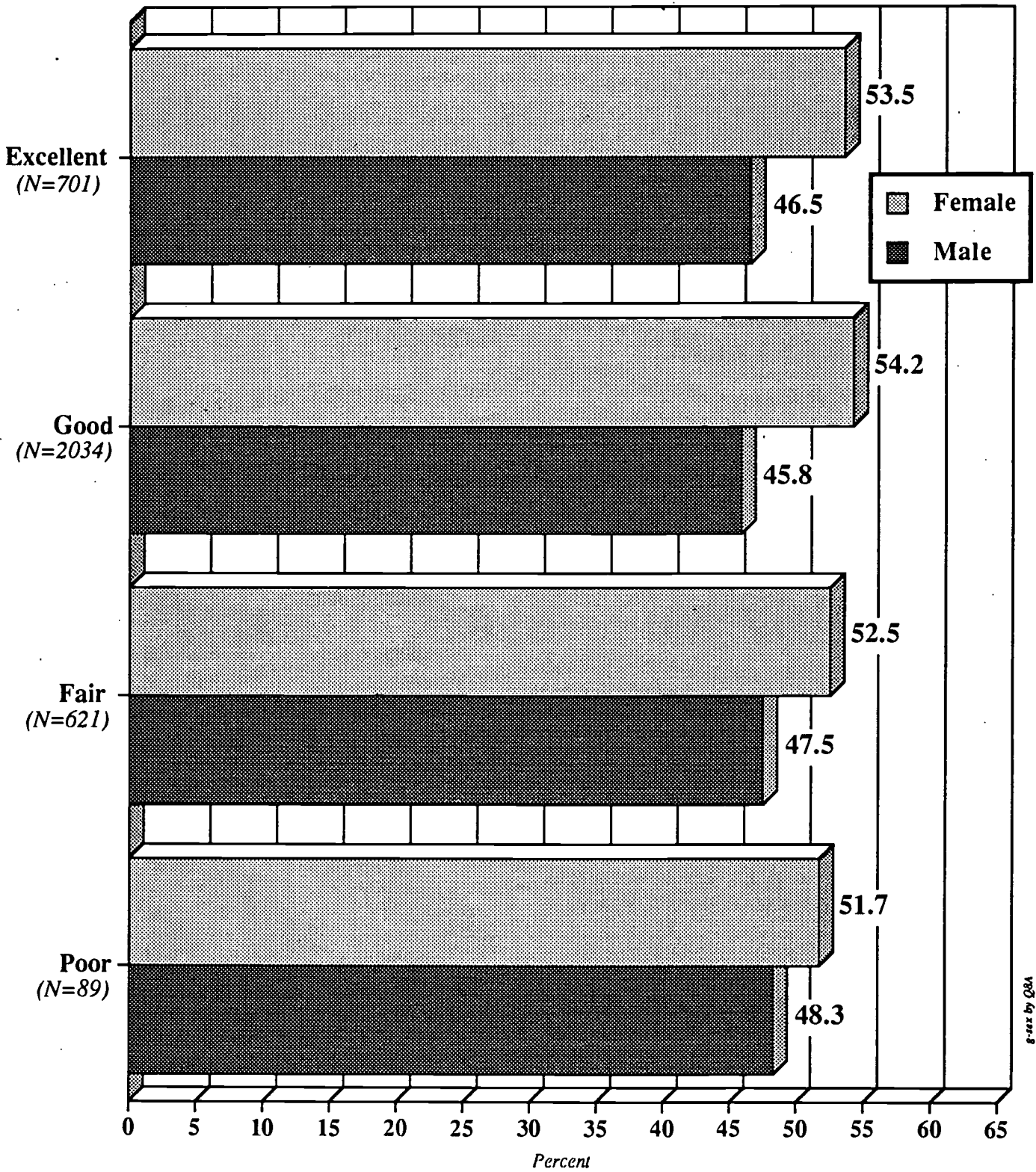

*Q8a: Please evaluate your orientation session?
by
Gender*

*San Diego Community College District
Matriculation Services Survey
Fall 1992*

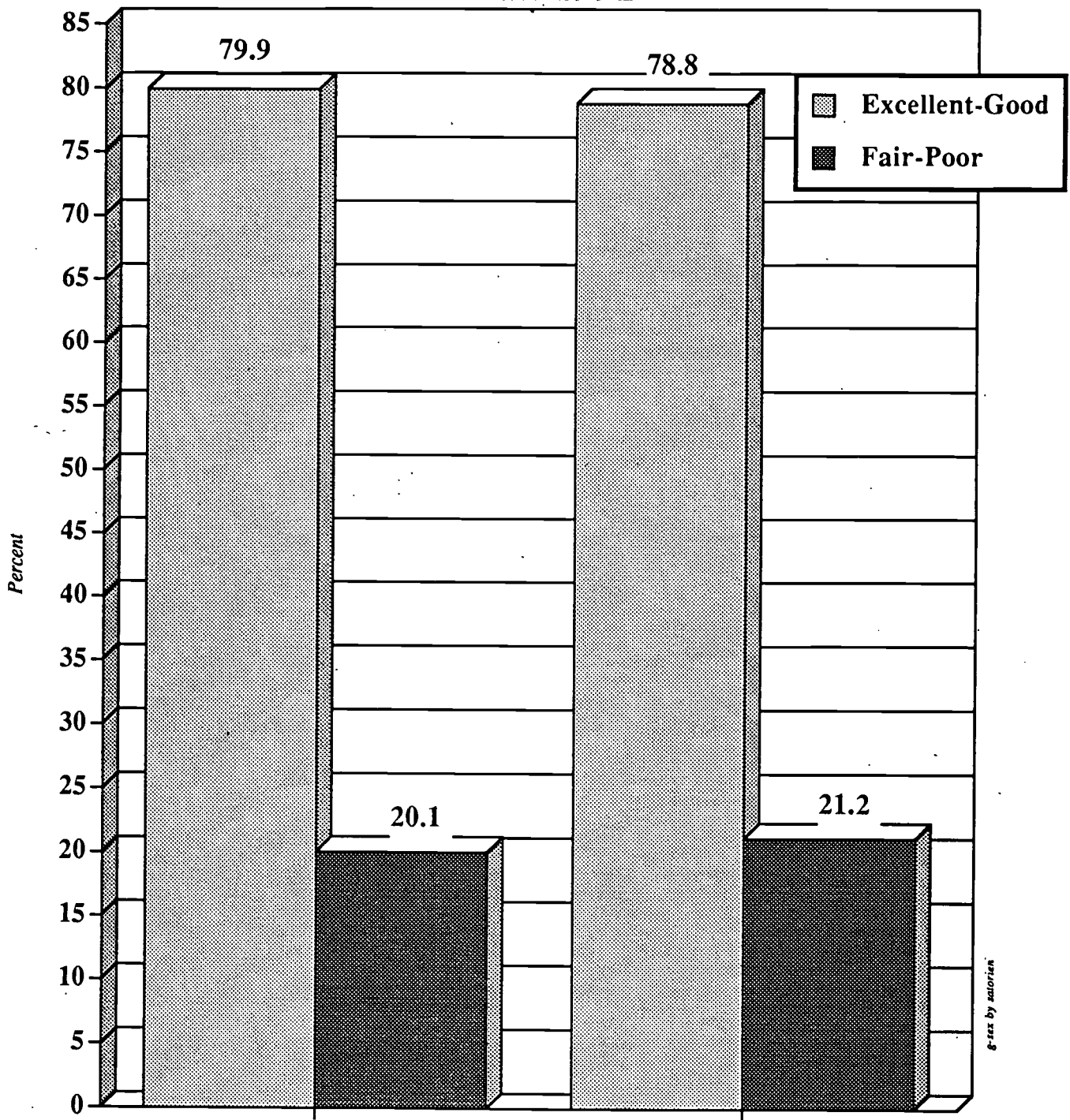

Female
(N=1849)

Male
(N=1596)

*Q8a: Satisfaction ratio for orientation
by
Gender*

*San Diego Community College District
Matriculation Services Survey
Fall 1992*

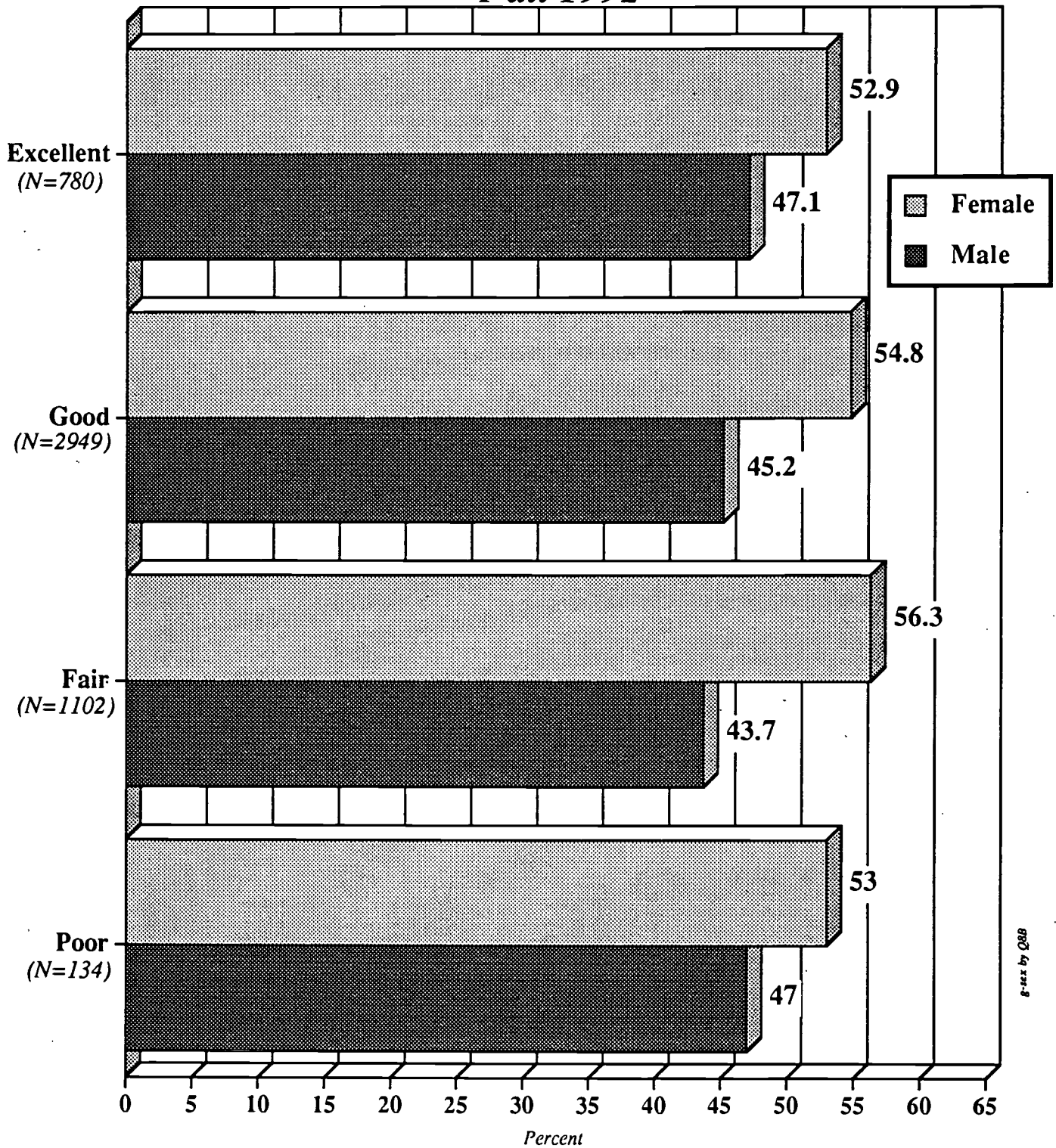

*Q8b: Please evaluate your Reading/Math assessment
by
Gender*

*San Diego Community College District
Matriculation Services Survey
Fall 1992*

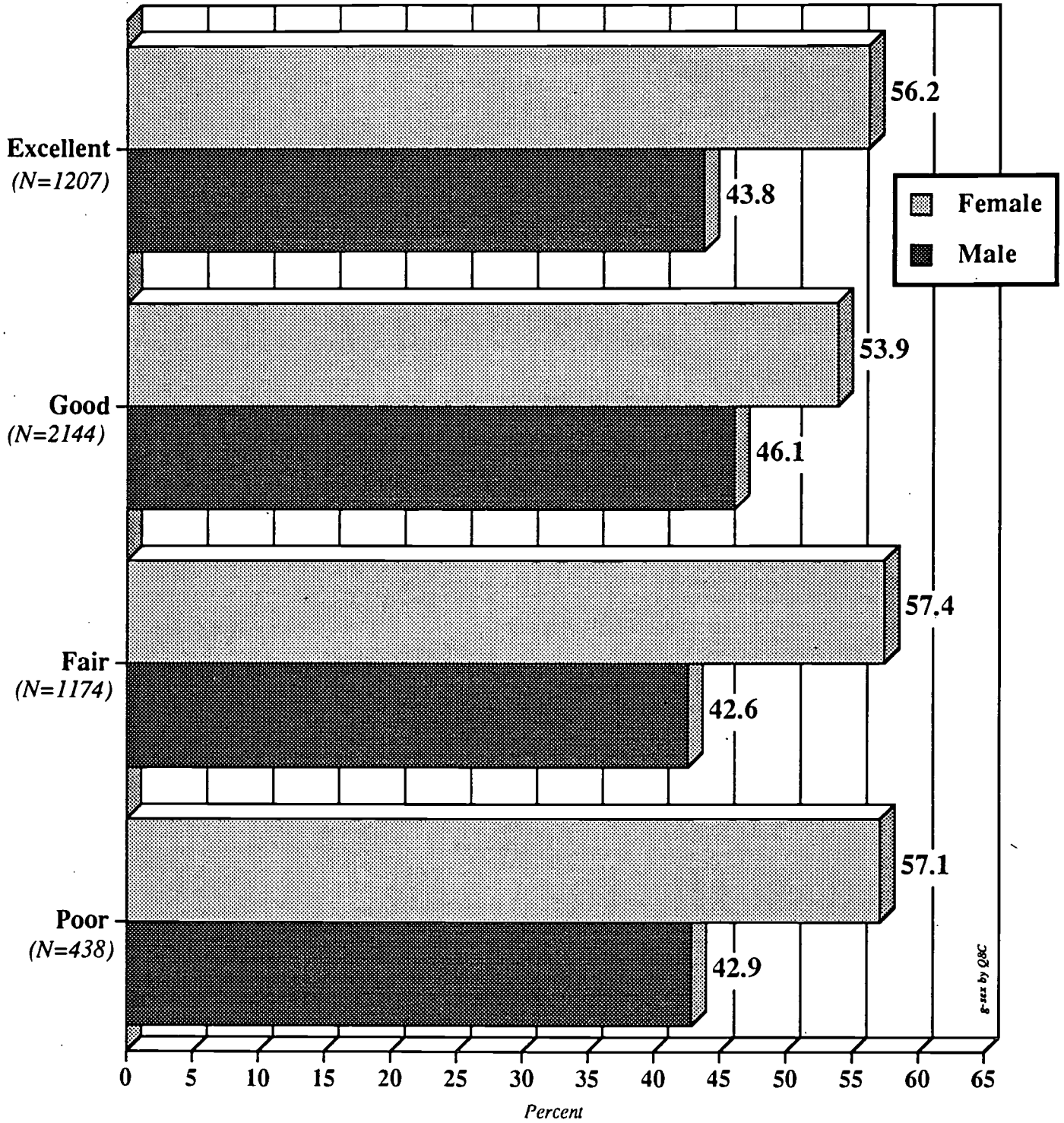

*Q8C: Please evaluate your Advisment/Counseling
by
Gender*

*San Diego Community College District
Matriculation Services Survey
Fall 1992*

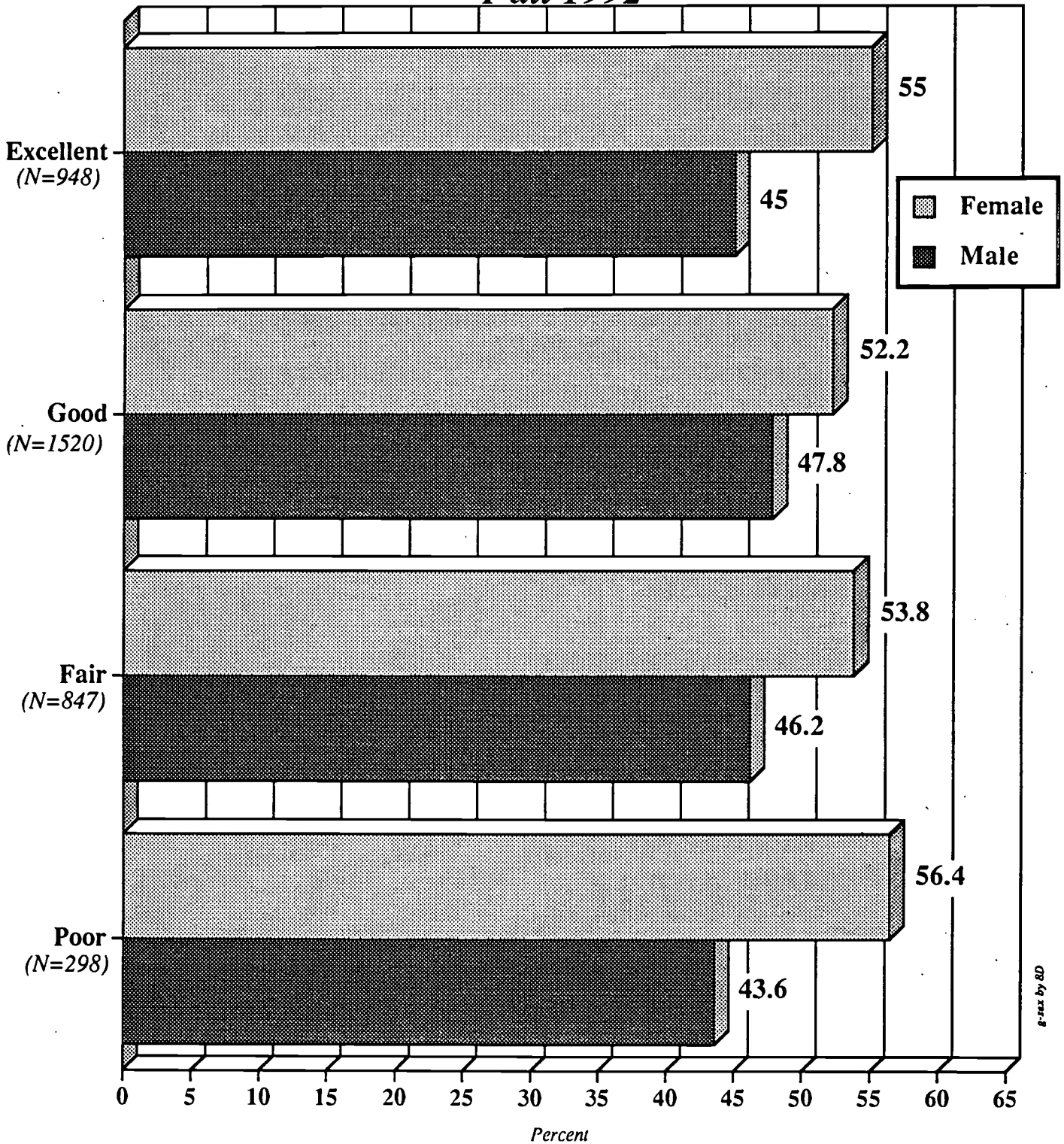

*Q8d: Please evaluate your Educational Plan Development
by
Gender*

*San Diego Community College District
Matriculation Services Survey
Fall 1992*

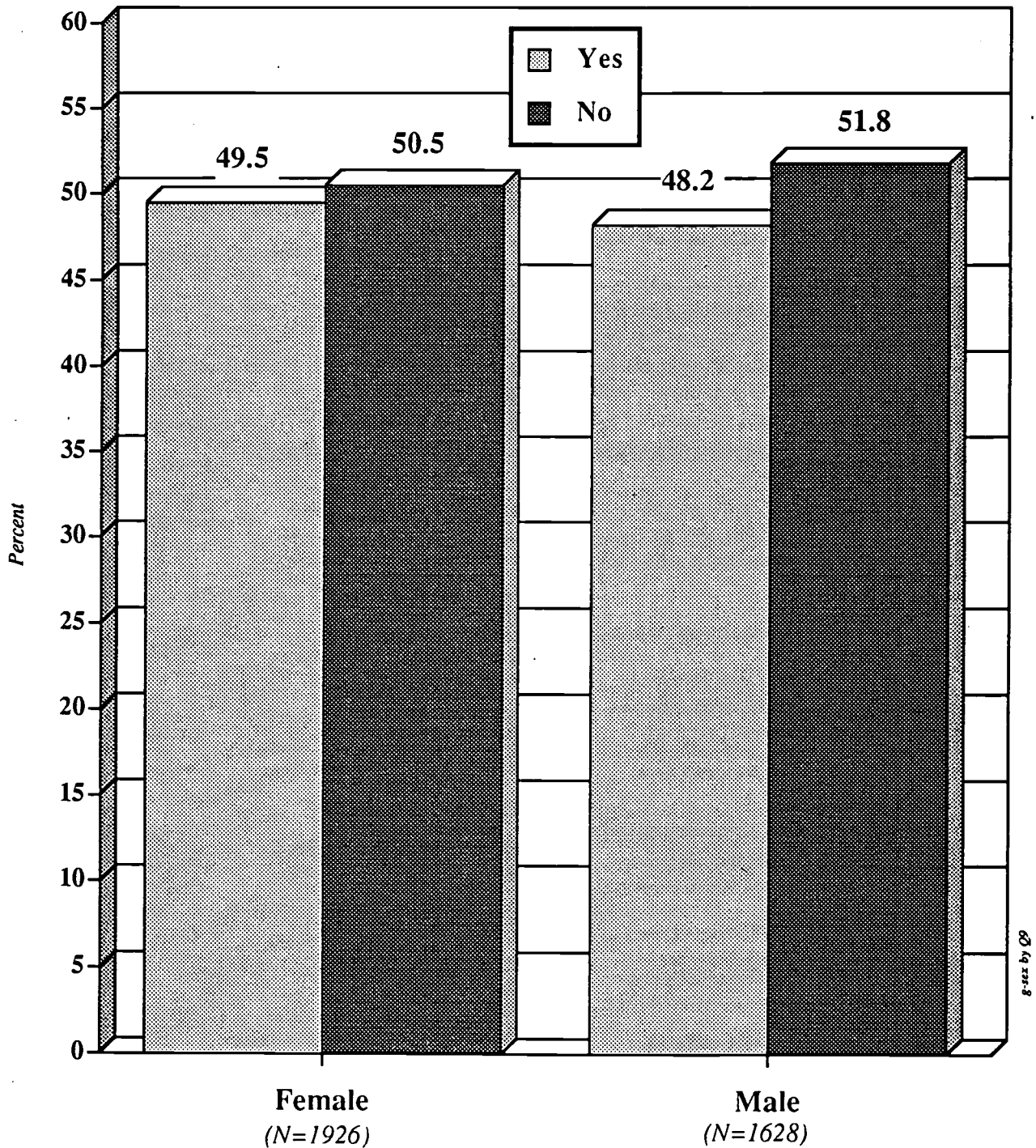

*Q9: Did attending the orientation session influence you to visit
or use other campus services?
by
Gender*

*San Diego Community College District
Matriculation Services Survey
Fall 1992*

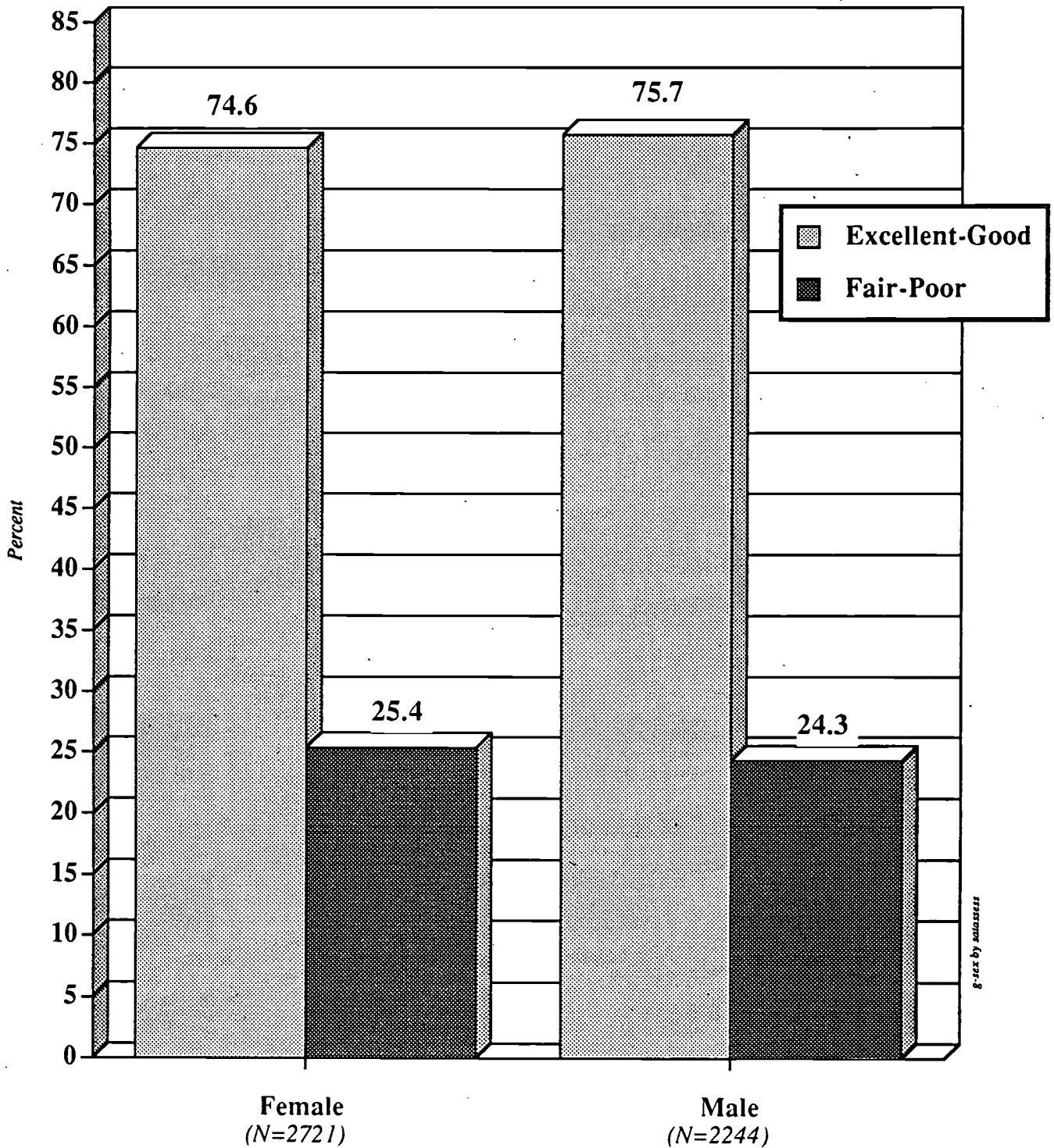

*Q8b: Satisfactio ratio for assessment
by
Gender*

*San Diego Community College District
Matriculation Services Survey
Fall 1992*

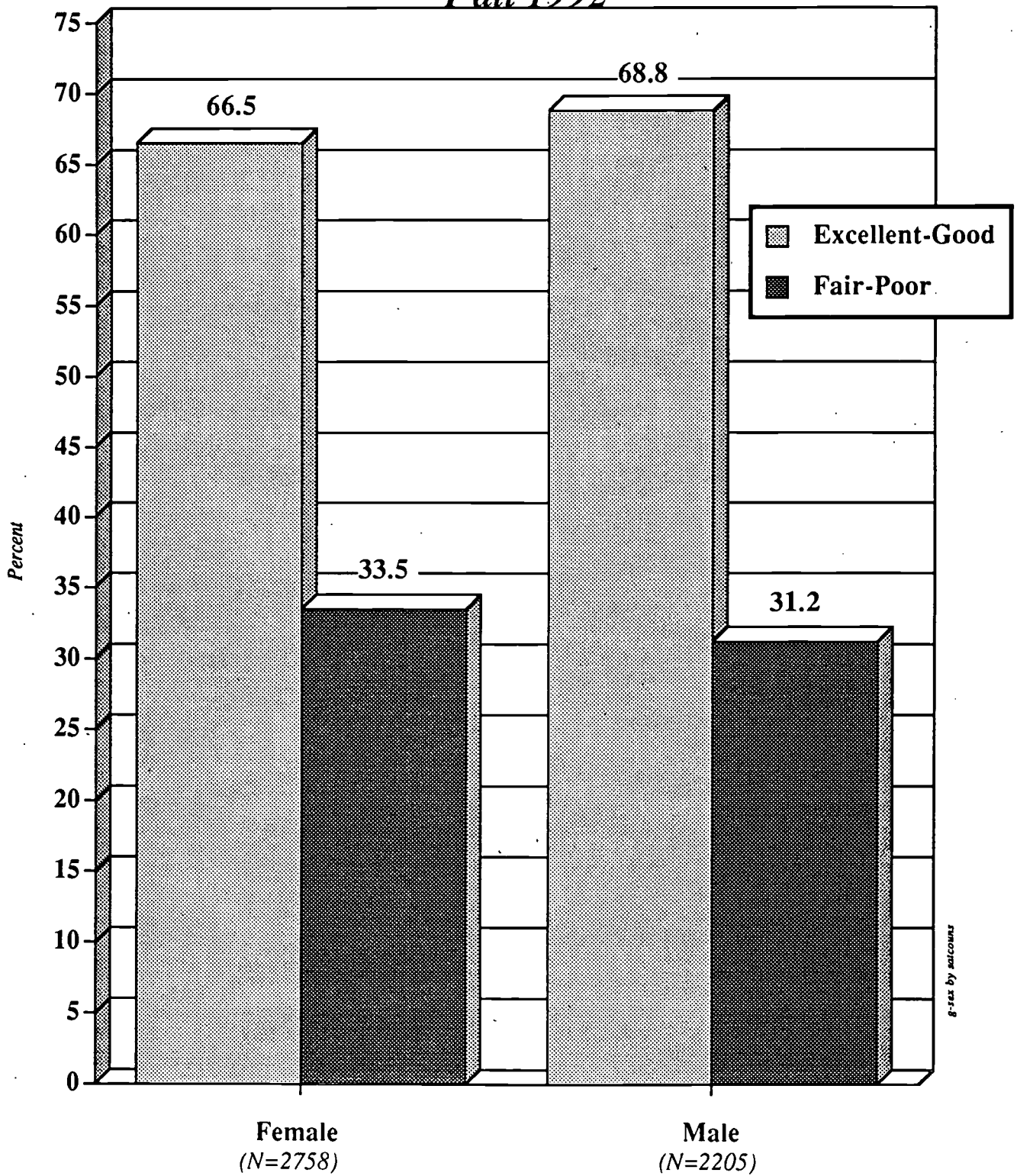

*Q8c: Satisfaction ratio for Advisement/Counseling
by
Gender*

*San Diego Community College District
Matriculation Services Survey
Fall 1992*

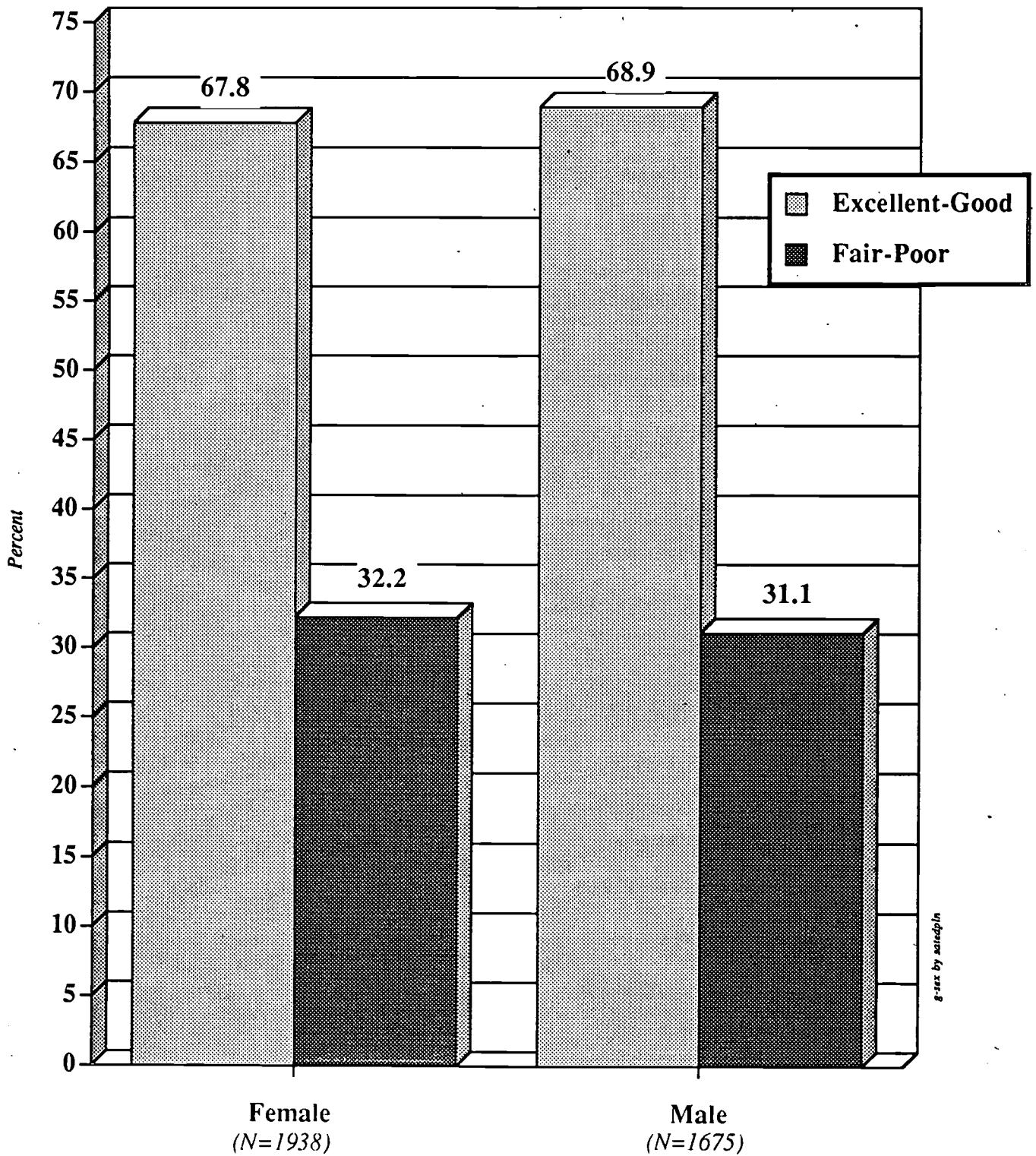

*Q8d: Satisfaction ratio for Educational Plan development
by
Gender*

Appendix B

Matriculation Services Satisfaction Survey Instrument

SURVEY INSTRUMENT

STUDENT SURVEY -PLEASE COMPLETE

We want your opinions about our educational services. Please take a minute to answer the following questions.

1. Which best describes your ethnicity?

Asian

African-American

Anglo-American

Pacific Islander

Latino/Hispanic

Filipino

Other

2. Gender

Male

Female

3. What is your residential zip code? _____

4. When did you first enroll at this college

Fall _____ 19____

Spring _____ 19____

Summer _____ 19____

5. How many units will you complete this term? _____

6. How many units have you completed at this college prior to this term? _____

7. Please indicate your educational goal

Transfer without Assoc. Deg.

Transfer with Assoc. Deg.

Assoc. Deg without transfer
 Transfer with Vocational Deg.
 Certificate
 Skill Development

Vocational Deg. without transfer
 Prepare/Advance in Career
 Discover interests
 Undecided

8. Please indicate which of the following activities you have participated in and your evaluation of these activities?

Participated	Excellent	Good	Fair	Poor	N/A
Orientation					
Reading/Math Assessment					
Advisement/Counseling					
Educational Plan development					
Not aware/have not used these services (if Yes, skip to last question)					

9. Did attending the orientation session influence you to visit or use other campus services?

Yes No Did not attend

10. Were you informed about your rights and responsibilities as a student during your orientation?

Yes

No

Did not attend

11. Have the services you have received help to clarify your educational goals and how to achieve them?

Yes

No

N/A

12. When did you first decide upon a specific educational goal to pursue at this college?

Before applying to the college

During orientation session

During my first term at the college

During my second, third, or later terms.

I'm still undecided

13. Have you been provided with information to help you understand course and basic skills prerequisites?

Yes

No

Not Applicable

14. What will your student status be next term?

Continuing at this college

Continuing at a 4 year college

Transferring to another community college

Will have completed my educational goal

Temporary leave, but will return

Uncertain at this time

15. Please indicate which college you are enrolled in:

City

Mesa

Miramar

ECC

References

State Chancellor's Office of the California Community Colleges (SCOCCC) (1989).
Matriculation Local Research Options Project. Sacramento, CA: Matriculation Unit.

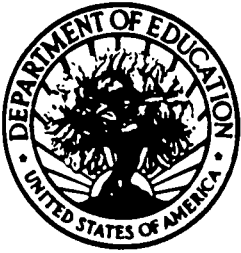

U.S. DEPARTMENT OF EDUCATION
Office of Educational Research and Improvement (OERI)
Educational Resources Information Center (ERIC)



REPRODUCTION RELEASE
(Specific Document)

JC 960-496

I. DOCUMENT IDENTIFICATION:

Title: <i>Matriculation in the SDCCD : Student satisfaction & Equity in Matriculation Services</i>	
Author(s): <i>William B. Armstrong</i>	
Corporate Source:	Publication Date: <i>March, 1996</i>

II. REPRODUCTION RELEASE:

In order to disseminate as widely as possible timely and significant materials of interest to the educational community, documents announced in the monthly abstract journal of the ERIC system, *Resources in Education* (RIE), are usually made available to users in microfiche, reproduced paper copy, and electronic/optical media, and sold through the ERIC Document Reproduction Service (EDRS) or other ERIC vendors. Credit is given to the source of each document, and, if reproduction release is granted, one of the following notices is affixed to the document.

If permission is granted to reproduce the identified document, please CHECK ONE of the following options and sign the release below.



Sample sticker to be affixed to document

Sample sticker to be affixed to document



Check here

Permitting microfiche (4"x 6" film), paper copy, electronic, and optical media reproduction

"PERMISSION TO REPRODUCE THIS MATERIAL HAS BEEN GRANTED BY _____ *Sample* _____ TO THE EDUCATIONAL RESOURCES INFORMATION CENTER (ERIC)."

Level 1

"PERMISSION TO REPRODUCE THIS MATERIAL IN OTHER THAN PAPER COPY HAS BEEN GRANTED BY _____ *Sample* _____ TO THE EDUCATIONAL RESOURCES INFORMATION CENTER (ERIC)."

Level 2

or here

Permitting reproduction in other than paper copy.

Sign Here, Please

Documents will be processed as indicated provided reproduction quality permits. If permission to reproduce is granted, but neither box is checked, documents will be processed at Level 1.

"I hereby grant to the Educational Resources Information Center (ERIC) nonexclusive permission to reproduce this document as indicated above. Reproduction from the ERIC microfiche or electronic/optical media by persons other than ERIC employees and its system contractors requires permission from the copyright holder. Exception is made for non-profit reproduction by libraries and other service agencies to satisfy information needs of educators in response to discrete inquiries."	
Signature: <i>William B. Armstrong</i>	Position: <i>Director, Institutional Research</i>
Printed Name: <i>William B. Armstrong</i>	Organization: <i>San Diego Community College District</i>
Address: <i>3375 Camino del Rio S. San Diego, CA 92108</i>	Telephone Number: <i>619 584-6941</i>
	Date: <i>8/22/96</i>

III. DOCUMENT AVAILABILITY INFORMATION (FROM NON-ERIC SOURCE):

If permission to reproduce is not granted to ERIC, or, if you wish ERIC to cite the availability of this document from another source, please provide the following information regarding the availability of the document. (ERIC will not announce a document unless it is publicly available, and a dependable source can be specified. Contributors should also be aware that ERIC selection criteria are significantly more stringent for documents which cannot be made available through EDRS).

Publisher/Distributor:	
Address:	
Price Per Copy:	Quantity Price:

IV. REFERRAL OF ERIC TO COPYRIGHT/REPRODUCTION RIGHTS HOLDER:

If the right to grant reproduction release is held by someone other than the addressee, please provide the appropriate name and address:

Name and address of current copyright/reproduction rights holder:
Name:
Address:

V. WHERE TO SEND THIS FORM:

Send this form to the following ERIC Clearinghouse:

If you are making an unsolicited contribution to ERIC, you may return this form (and the document being contributed) to:

ERIC Clearinghouse for Community Colleges
University of California, Los Angeles
3051 Moore Hall
405 Hilgard Avenue
Los Angeles, CA 90024-1521