

DOCUMENT RESUME

ED 384 507

SE 056 388

AUTHOR Sosa, Maria, Ed.; And Others
 TITLE Great Explorations: Discovering Science in the Library.
 INSTITUTION American Association for the Advancement of Science, Washington, D.C.
 SPONS AGENCY Department of Education, Washington, DC.
 REPORT NO AAAS-Pub-No-94-36S; ISBN-0-87168-537-X
 PUB DATE 94
 CONTRACT R036A30066-93
 NOTE 183p.
 AVAILABLE FROM American Association for the Advancement of Science (AAAS), 1333 H Street, N.W., Washington, DC 20005.
 PUB TYPE Guides - Classroom Use - Teaching Guides (For Teacher) (052) -- Guides - Non-Classroom Use (055)

EDRS PRICE MF01/PC08 Plus Postage.
 DESCRIPTORS Elementary Secondary Education; Learning Activities; *Librarian Teacher Cooperation; *Libraries; Mathematics Education; *Professional Development; *Science Activities; Science Education
 IDENTIFIERS *Hands on Science

ABSTRACT

The American Association for the Advancement of Science (AAAS) Library Institute was a project that brought together 28 school and public librarians from the Washington, D.C., metropolitan area to discuss science, mathematics, and technology education reform and what can be done to bring it about. This book discusses the project in 12 chapters: (1) "Implementing Reform of Science and Mathematics Education"; (2) "Dirigibles and Submarines: The Rise and Fall and Rise of Science Education Reform"; (3) "Selecting Excellent Science Resources"; (4) "The Perennial Joy of Dinosaurs"; (5) "'Sun/Shadows/Bears': Interdisciplinary Activities for the Library"; (6) "Teaching Science in a Multicultural Context"; (7) "Technology in the Library"; (8) "Libraries As Partners in Reforming Science, Mathematics, and Technology Education"; (9) "Fund-raising for the Media Center"; (10) "Hands-on Science in the Media Center"; (11) "Science Activities and Exhibits"; (12) "Replicating the AAAS Science Library Institute Experience." Appendices contain: list of 105 science resources, materials review form, AAAS Science Library Institute Evaluation form, 20-item list of selected science career brochures, and 7-item list of activity materials suppliers. (MKR)

 * Reproductions supplied by EDRS are the best that can be made *
 * from the original document. *

U. S. DEPARTMENT OF EDUCATION
Office of Educational Research and Improvement
EDUCATIONAL RESOURCES INFORMATION
CENTER (ERIC)

This document has been reproduced as
received from the person or organization
originating it.
Minor changes have been made to improve
reproduction quality.

Points of view or opinions stated in this docu-
ment do not necessarily represent official
OERI position or policy.

GREAT EXPLORATIONS. Discovering Science in the Library

Edited by

Maria Sosa, Estrella M. Triana
and Valerie L. Worthington

BEST COPY AVAILABLE

ED 384 507

SE 056 388

Great Explorations: Discovering Science in the Library

Compiled and edited by Maria Sosa
Estrella M. Triana
Valerie L. Worthington
Mary C. Chobot

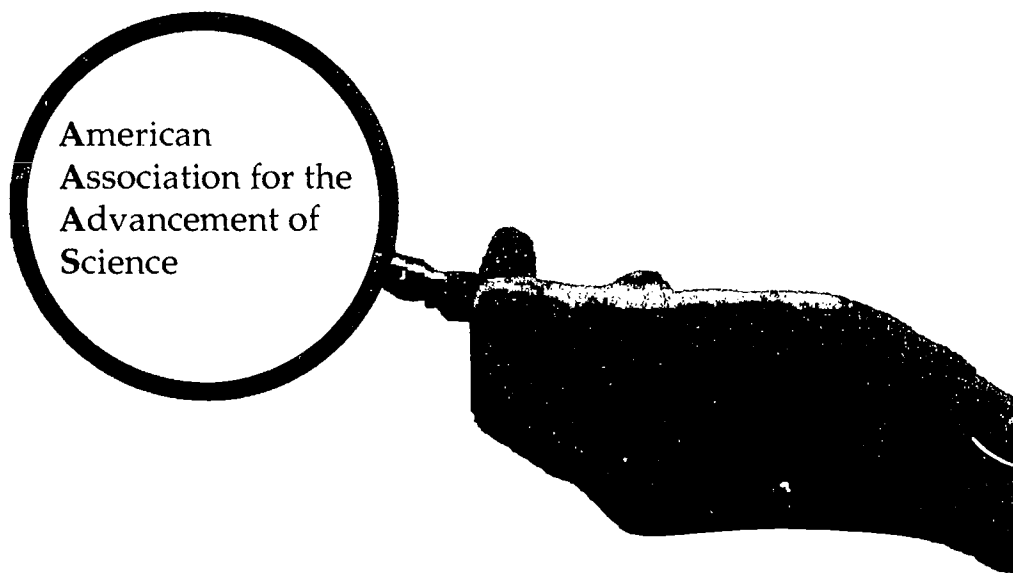

Funded by the U.S. Department of Education, Washington, DC

ABOUT AAAS

The American Association for the Advancement of Science (AAAS), founded in 1848, is the world's largest federation of scientific and engineering societies. It currently has some 139,000 individual members and nearly 300 affiliated societies and academies of science. AAAS publishes *Science*, the weekly professional journal, and *Science Books & Films*, a source of critical reviews for schools and libraries.

The programs and activities of AAAS respond to a broad spectrum of scientific opportunities. In addition to its activities to strengthen school science, mathematics, and technology education, AAAS programs focus on broadening the human resource pool of scientists and engineers, shaping science and technology policy, promoting the public understanding of science, expanding scientific cooperation in global issues, defending scientific freedom, and championing high professional standards.

The Directorate for Education and Human Resources Programs (EHR) seeks to improve the quality of science, mathematics, and technology (SMT) education for all students at all levels; to increase the participation of minorities, women, and people with disabilities in science and engineering; and to improve the public understanding of science and technology for all people. EHR programs focus on supporting systemic educational reform: developing models, materials, mechanisms, processes, and networks; supporting policies and conducting studies and analyses; and implementing findings as appropriate to accomplish the "overreaching" goal — that real education means connecting schooling and out-of-school experiences.

The Directorate moves to support comprehensive efforts that recognize the connectedness of the learning communities both in and out of school. To this end, efforts are coordinated through three distinct but collaborating program units: Science, Mathematics, and Technology Education Programs; Human Resources Programs; and Public Understanding of Science and Technology Programs.

This publication was supported by a grant from the U.S. Department of Education (grant number R036A30066-93). Any interpretations and conclusions in this publication are those of the authors and do not necessarily represent the views of the U.S. Department of Education or the American Association for the Advancement of Science.

Printed in the United States of America

ISBN: 0-87168-537-X

AAAS Publication Number: 94-36S

© 1994 by the American Association for the Advancement of Science (AAAS)
1333 H Street, NW, Washington, DC 20005

Contents

Acknowledgements	
Introduction: The AAAS Science Library Institute	vii
Chapter One: Implementing Reform of Science and Mathematics Education	1
Chapter Two: Dirigibles and Submarines: The Rise and Fall and Rise of Science Education Reform	5
Chapter Three: Selecting Excellent Science Resources	21
Chapter Four: The Perennial Joy of Dinosaurs	29
Chapter Five: "Sun/Shadows/Bears": Interdisciplinary Activities for the Library	35
Chapter Six: Teaching Science in a Multicultural Context	45
Chapter Seven: Technology in the Library	51
Chapter Eight: Libraries As Partners in Reforming Science, Mathematics, and Technology Education	71
Chapter Nine: Fund-raising for the Media Center	77
Chapter Ten: Hands-on Science in the Media Center	97
Chapter Eleven: Science Activities and Exhibits	127
Chapter Twelve: Replicating the AAAS Science Library Institute Experience	161
Appendices	165

ACKNOWLEDGEMENTS

We would like to express our appreciation to the AAAS Science Library Institute Advisory Board for suggestions and support. Members include:

- Ann Benbow, American Chemical Society
- Connie Carter, Library of Congress
- Carolyn Cousin, University of the District of Columbia
- Agnes Day, Howard University
- Kathleen Johnston, National Science Resources Center
- Hipolito Niño, Food and Drug Administration
- Phyllis Marcuccio, National Science Teachers Association
- T. Paul Torda, Senior Scientists and Engineers, AAAS

We are also grateful to the presenters at the AAAS Science Library Institute sessions for their insight and ideas. They include:

- Michael Alford, Sonic Images
- Linda Brannan, Mid-continent Regional Educational Laboratory
- Agnes Day, Howard University
- Jim Kessler, American Chemical Society
- Gayle Kirwan, American Institute of Physics
- Hipolito Niño, Food and Drug Administration
- Jim Oglesby, Project 2061, AAAS
- Bobbie Scull, Louisiana Energy and Environmental Resource and Information Center
- Patsy Wang-Iverson, Research for Better Schools

We would also like to thank the AAAS Science Library Institute participants, whose enthusiasm and spirit were truly inspirational. They are:

- Patricia Bonds, Duke Ellington School of the Arts
- Billie Branscomb, Hearst Elementary School
- Doris Broughton, Oakridge Elementary School
- Pauleze Bryant, Calvin Coolidge High School
- Judy Bullock, Turner Elementary School
- Jessie Campbell, McGogney Elementary School
- Geraldine Capehart, Thomson School
- Mary Jane Cox, Hardy Middle School
- Barbara Holton, University of Maryland
- Lydia Jenkins, Alice Deal Junior High School
- Rose Jones, Chillum Elementary School
- Violet Lentner, Calvary Lutheran School
- Marilyn Moser, Amidon Elementary School
- Patricia Munoz, Randolph Elementary School
- Clara Neal, Dunbar Senior High School
- Eleanor Organ, Anthony Bowen Elementary School
- Annette Ortiga, Jefferson Junior High School
- Ruby Osia, Lyles-Crouch Elementary School
- M. Catherine Pfeiffer, Capitol Hill Cluster School, Watkins Primary Campus
- Charles Phillips, Bancroft Elementary School
- Edna Becton Pittmon, Langley Junior High School
- Rose Pringle, Roper Middle School of Science, Mathematics, and Technology

- Barbara Roberts, District of Columbia Public Library
- Diane Schule, Paul VI High School
- Judith Scott, Stoddert Primary School
- Jannette Smithson, Mount Vernon Elementary
- Janice Spencer, Shepherd School
- Suzanne Willett, Francis Junior High School

We are grateful also to the scientist volunteers, who have agreed to help the Institute participants implement science-based activities in their libraries. They include:

- Irene Anne Eckstrand
- John Edwards
- Lester Hubert
- Kathleen Michels
- Denise Pettit
- Erik Scully
- Mary Tobin
- T. Paul Torda
- Leanne Wiberg

Thanks go also to Mary Chobot, the library consultant; Mary Johnson, who helped with recruitment for the Institute; and the book publishers who provided the Institute with materials.

We would also like to thank all the boys and girls, and teachers and administrators who participated in the Institute project at their schools and libraries. And thanks to the Department of Education program staff, Louise Sutherland and Frank Stephens, for their help in keeping the AAAS Science Library Institute on course. A special thank you goes to Jerry Bell, for his advice and sense of humor.

And finally, thanks to Pam Coblyn of Coblyn Design for her great work on the cover of this manual, and to Gloria Gilbert, AAAS, for production assistance.

For more information regarding the AAAS Science Library Institute or for information about technical assistance for libraries in science, mathematics, and technology education, please call Maria Sosa, Estrella Triana, or Valerie Worthington at (202) 326-6670, or send a fax to (202) 371-9849.



Introduction

The AAAS Science Library Institute

Introduction

Most people would agree that improving mathematics and science education is an urgent national goal. How to achieve that goal, however, is the subject of much debate. While no definitive consensus has been reached, curriculum reform is being implemented in schools and school districts across the country. Important steps in science and mathematics education reform include an increase in hands-on, inquiry-based classroom experiences and the use of technology, as well as a greater role of trade books and a decreased dependence on textbooks in science instruction. Though these and other approaches have proven effective, they have not been widely implemented, particularly in schools serving minority and disadvantaged youth. As evidence now points to the need for systemic reform and restructured schools rather than piecemeal improvements, it is clear that improving education in America will require the commitment of entire communities involved in collaborations or partnerships.

A critical step in forming these partnerships is identifying key players. Science and mathematics teachers are certainly central to any real reform, but they cannot accomplish the task by themselves. We believe that the public or school librarian is a vital partner in educational reform efforts. By virtue of academic training and on-the-job experience, the librarian is poised to take an active role in improving mathematics and science opportunities for children, both in and out of school. However, support and resources are needed to encourage this more active role.

The AAAS Science Library Institute was a project that brought together 28 school and public librarians from the Washington, DC, metropolitan area to discuss science, mathematics, and technology (SMT) education reform and what they can do to bring it about. During the project, participants shared their observations about what the project meant to their professional development and to their libraries in journal entries. Throughout this book, we will share these observations in the librarians' own words.

Implementing the AAAS Science Library Institute

With a one-year grant from the U.S. Department of Education, AAAS implemented a model Institute to make libraries a focal point of school science and mathematics reform. Twenty-eight public and school librarians were recruited to participate in five monthly Saturday sessions held at AAAS headquarters in Washington, DC, and conducted by AAAS staff.

The objectives of the Institute were:

- to enhance the skill of librarians in selecting accurate and effective science resources that support educational reform and reflect equity issues that address the needs of minority and disadvantaged youth;
- to train librarians to become disseminators, for science teachers, parents, and community members, of new science and mathematics education projects, products, techniques, and exemplary practices;
- to create partnerships between public and school librarians and members of the scientific community who will assist them in collections review and the incorporation of scientifically accurate materials, as well as in planning science opportunities for children in the library;
- to increase the number of librarians in the Washington, DC, metropolitan area who can play a key role in science and mathematics reform by providing them with access to a matrix of the concepts and topics recommended by current national "standards" projects, such as AAAS's Project 2061; NSTA's Scope, Sequence, and Coordination; and the emerging national standards being developed by the National Research Council; and
- to increase in-school and out-of-school science opportunities for children by providing hands-on science training and support to school and public librarians serving elementary and junior high school-aged children.

The participant selection process was based on letters of support from colleagues and administrators and statements summarizing the needs of the applicant's library for enhancing science resources. Seventy percent of the participants selected were minority group members who serve high

minority and limited English-proficient populations. All but two of the participants were librarians from K-9 schools. Each institute session focused on a theme or central activity. In addition, a portion of time at each session was devoted to hands-on training and planning sessions for implementing Institute objectives.

To ensure long-term impact, Institute participants received starting grants to conduct science programming in the library that focused on educational reform issues and/or hands-on science and mathematics. Additionally, Institute participants were introduced to scientists and engineers, who assisted the librarians in enhancing their science and mathematics programs.

A review of applications and evaluations of the Institute revealed that librarians want assistance both in identifying funds to supplement their inadequate budgets and in selecting quality science resources. Librarians also expressed an interest in becoming empowered with respect to science reform, in order to increase their opportunities to work closely with teachers in evaluating materials and curricula and to become more skilled at assisting students with their independent research assignments. Feedback also indicated that participants enjoyed the science and mathematics hands-on activities, and they generated ideas for using hands-on techniques in library exhibits and for helping science teachers implement the techniques in their curricula.

Disseminating Science Education Reform in the Library

Information Power, the ground-breaking report of the American Association of School Libraries (AASL), advocates that the school library media specialist should be a master teacher, able to work with classroom teachers to integrate information management skills into the school curriculum. Nowhere is this more important than in math and science education. Innovative materials and curricula appear on an almost daily basis. Science teachers, already overburdened with large classes and workloads, are often unable to keep abreast of new developments, even with the best of intentions. In addition, pressures to improve student performance in basic skills, as measured by scores on standardized tests, have often resulted in a decrease in the number of hours of instruction that elementary students receive in science as schools increase hours of instruction in other areas. The school librarian/media specialist can become a catalyst for

reform and exemplary teaching by providing teachers with reliable and well-researched information about new techniques and resources that will infuse science across the curriculum, thus increasing the amount of science instruction students receive.

We recognize that it is not possible to provide a science or mathematics background to every librarian. However, as trained information specialists, librarians can learn to access and use tools already at their disposal to help them make decisions about materials and programs for their libraries. They can also become a dissemination point for teachers and parents, providing them with information about innovations and effective strategies for improving students' math and science performance.

The Institute participants were pioneers—very little effort was expended in converting them to a vision of science, mathematics, and technology education reform or in persuading them to become leaders and role models for their peers. With such outstanding participants—natural leaders filled with enthusiasm, curiosity, and a willingness to learn—it really would have been impossible to fail. We are proud to have been associated with such fine individuals, and we share with them the credit for developing the Science Library Institute model that is outlined in this book. It is our fervent wish that other library media specialists throughout the country can learn from our experiences. If the projects conducted by Institute participants are any indication, the beneficiaries are likely to be the children served by all the library media specialists who choose to make supporting science, mathematics, and technology education reform a priority in the library.

— The Editors



Chapter One

Implementing Reform of Science and Mathematics Education

This summary is based on remarks made by Dr. Shirley M. Malcom, Head, Directorate for Education and Human Resources Programs, AAAS, at the Secretary's Conference on Improving Mathematics and Science Education.

I am probably in science today because of Sputnik. The launch of this satellite by the then Soviet Union sparked the reform of science and mathematics education of my childhood, beginning in the late 1950s. Curricula were updated and made more rigorous. Teachers were provided with extensive professional development opportunities. The goal was to produce more scientists and engineers, and the clarion call was heard across the U.S.—even in my segregated, resource-poor elementary school in Birmingham, Alabama.

But as times changed and the world and our economy became much more science and technology connected, we needed education in science and mathematics that could move beyond production of professionals to the creation of a science- and technology-literate citizenry.

The reform of science and mathematics education of my adulthood had this more extensive and more difficult goal to achieve. This reform began in the early 1980s and was given an additional impetus during the Education Summit convened by then President Bush in 1989. From it, reform of science and mathematics education emerged as a separate goal of the six National Education Goals, signalling the importance these fields have assumed in our lives and the dismal conditions that such education had reached. In 1990, the National Governors Association adopted these goals, and the states set about the task of developing policies or practices to achieve them. The immediate action translated into increased course requirements for mathematics and science for graduation.

Setting goals is one thing; implementing them is a much greater challenge. We have had to rethink the way that education might respond to the challenge of improved science and mathematics education for all.

Some five years after the Education Summit in Charlottesville, we have evolved a new language to discuss education reform. "Standards-based" and "systemic" are the adjectives that have invaded our conversations about how to improve science and mathematics achievement for all children. Perhaps use of these terms signals a new realization—that we are attempting to affect a very complex system and the way science and math education are delivered within it. It is doubtful that changes of the magnitude envisioned by the goals can even be approached outside of the larger restructuring (structural or systemic change) of the school system.

We have shown over and over that we know how to change schools. What we do not yet know how to do is to change school systems. Maybe we need to begin by showing due respect to "the system" and by remembering that we are in fact dealing with a system, with all the characteristics of systems, such as *synergy* (the whole is more than the sum of its parts), *homeostasis* (resistance to change), and *feedback* (the mutual interaction effects among system components).

What are the system elements that are essential for reform of science and mathematics education? I will begin a list of components that I believe to be essential. I still consider this set a work in progress. Additional recommendations of elements are appreciated.

There are many ways to achieve reform, but with them all we need at least to consider:

- (1) *Developing a common vision*: We need a very public discussion about what we want children to know and be able to do in science and mathematics. The dialogue needs to include not only businesses and policy makers, but also parents, teachers, other school personnel, senior citizens, etc.
- (2) *Agreement on content goals*: What specific content do we need for our children? We need to gather this information from multiple perspectives, including those of end-users (business, industry, colleges), the community of the disciplines (teachers, university staff, people who

apply science and mathematics in their jobs), people with current knowledge of teaching and learning, and those who promote the intersection and interaction of science and mathematics with other fields.

The goals must directly affect the structure of assessment. We must assess at world-class standards to send a "wake-up" call to complacent schools that believe everything is all right.

- (3) *Scope and sequence*: What is the ordering of content, taking into account standards, the cognitive development of students, the application of local resources and people, and considerations of context, such as the experiences students bring to the classroom?
- (4) *Policy climate*: This includes the regulatory environment that affects issues such as graduation requirements, testing requirements, certification, licensure, financing formulas, admissions standards of colleges and universities, federal regulations regarding programs such as Title I, bilingual and special education, and voluntary programs such as the New Standards Project and the National Board for Professional Teaching Standards. We must move from a waiver mentality, where changes are allowed by "exception," to a more positive and proactive policy climate that encourages and helps move change forward.
- (5) *Staff development*: How do we provide staff development, and what do we provide as part of staff development? We must connect staff development to vision, to content goals, to frameworks. We must move away from a "smorgasbord approach" of accumulated credits toward coherent efforts to provide staff development that is not for teachers only. We must help principals and other staff understand their roles in reform.
- (6) *Teacher preparation*: We must develop a connected and coherent way of educating new teachers and affecting college and university programs using the levers provided by licensure and certification. This means affecting the opportunities for interacting with children and for being exposed to quality teaching. This requires confronting issues related to the quality of instruction and courses in education, but also confronting problems of the quality and relevance of content courses offered by faculty in arts and sciences.

- (7) **School organization:** The way time, space, and people are used, and the move to site-based management are serious issues that affect reform in science and mathematics. We must address the question of the school calendar and how we respond to issues such as summer regression, which is seen in children from disadvantaged backgrounds who lose ground when not in school.
- (8) **Integration of school and community, relation to home and connection to social services:** We must integrate and reinforce the fulfillment of human needs for children so that hungry children can eat and children who need glasses are properly diagnosed and provided for, so that the other parts of the community, such as libraries and museums, as well as the home, connect with the schools to support and reinforce the goals and the vision. We must look explicitly at out-of-school programs and activities and at how these can connect to science reform.
- (9) **Resources:** We must make sure that the material and human resources needed to accomplish the reform are available, including equipment for math and science, technology, telephone lines, and paraprofessionals in the schools. We must confront the issue of resource alignment (school financing) so that schools receive equitable resources, as opposed to what they can raise, or even equal resources.
- (10) **Equity:** And over all of this we must use equity as the litmus test against which to measure the effectiveness of reform in science and mathematics education. We must embed equity concerns in all other elements as well. Are the elements likely to produce positive results for girls as well as boys, for minority as well as majority students, for students with disabilities as well as able-bodied students, for rural and inner-city systems as well as for suburban systems?

We must find the system's critical points and reach for levers that have broad impact across the elements of the systems. We need to keep the pot stirred for reform, for it is only by perturbing the system that structural change can be achieved that will allow us to affect significantly the quality of science and mathematics education.

— Shirley M. Malcom

Chapter Two

Dirigibles and Submarines: The Rise and Fall and Rise of Science Education Reform

Introduction

The partnership of a scientific society, the American Association for the Advancement of Science (AAAS), school and public librarians, and scientists to enhance and enrich the science, mathematics, and technology learning opportunities for K–12 students is a powerful model for science education reform. We did not start with any preconceived ideas about where this partnership might take us, but the library/laboratory combination that exists serendipitously in one school is a paradigm for the direction we would like to head, if not the specific destination that would make sense in all libraries. The emphasis on technology in many libraries is consistent with other technology-based projects that AAAS is developing or helping to develop. This is a great beginning.

During the oral presentation of this material, there were several planned periods of discussion and hands-on audience participation. These will be noted in this written version by text outlined by a black box.

The Ghost of Science Reform Past

Most of us have lived through one or more waves of educational reform and may be pretty jaded by now. It is important to look at how this wave differs from the past and perhaps builds on lessons from the past to be more effective. For example, reforms of a few years back emphasized that science and mathematics are everywhere and sought to make them “relevant” through problems such as this:

*In this article, we provide the framework of basic science education reform elements upon which the AAAS Science Library Institute was grounded. The article is based upon the comments of Dr. Jerry Bell, director, Science, Mathematics, and Technology Programs, AAAS, at the first Institute session. In his presentation: **Dirigibles and Submarines: The Rise and Fall and Rise of Science Education Reform, Bell and the Institute** participants considered several of the components of science education reform, elaborated on each a bit, illustrated them with activities as they went along, and suggested ways for libraries and librarians to play not only a role but a leading role in encouraging science education reform in their schools and communities.*

Activity 1

Suppose you are having a small party for two of your friends and you want to make pizza for the group. You have a recipe for an 8-inch pizza, but you don't think this will be big enough for three people, so you want to make a 10-inch pizza. This means increasing the amount of each ingredient. The 8-inch recipe calls for two cups of flour. How much flour will you need to make a 10-inch pizza?

Assuming that the larger pizza is made the same thickness as the smaller one, we need to know the relative areas of the circular pizzas in order to figure out how much more flour to use for the larger one. We remember that the area of a circle is given by the product of the square of its radius (r) times pi (π) — equal to about 3.1416. The radius of the 8-inch (diameter) pizza is 4 inches and the radius of the 10-inch pizza is 5 inches. Therefore, the areas are $4 \times 4 \times \pi = 16\pi$ sq. inch and $5 \times 5 \times \pi = 25\pi$ sq. inch, respectively, for the 8-inch and 10-inch pizzas. We can see that the relative size of the two pizzas is 25 to 16 (about 3 to 2), so it will take about one-and-one-half times as much flour (3 cups) to make the larger pizza.

*In this discussion, from which this article is derived, Bell reviewed five major components of science education reform: **constructivism**, in which science learning builds on meaning that children construct from all their experiences, **science for all**, which stresses the reform goal of science literacy for all students, **less is more**, de-emphasizing the use of technical jargon and content coverage and emphasizing deeper concept understanding, **assessment** in a manner that allows children to demonstrate their best work and chronicles their progress, and the concept of **systemic reform**, which states that no one component of science education can bring about the desired reform; instead, curricula, policy, and science education teaching delivery structures must all be involved.*

When we conducted this activity with Institute participants, we noted that everyone in the group did not feel equally comfortable with the "solution" to the problem. It had come by very quickly, pieces of information that may have been long dormant were suddenly called into play, the lecturer hurried the solution along by appealing to this information, and he used a "correct" chain of reasoning he had devised without reference to what the participants might have contributed.

Although it overstates the case somewhat, we might say that the curricula and activities from the past reforms were focused on processes that would lead to a predetermined result. There was an emphasis on students carrying out activities, but these were directed by teachers. The learners' roles were relatively circumscribed and their work was supposed to lead each of them to the same final, correct understanding, as in Activity 1 above.

Science Reform Present — Constructivism

One of the foundations of the present reforms is "constructivism," a concept that has grown out of the work of cognitive psychologists over the past few decades. In simplest terms, constructivism suggests that from each new experience or piece of information, a person constructs meaning for him- or herself based on his or her previous experiences; there are no blank slates. The educational conse-

quences have been to stress learning activities that are experiential, hands-on, and, to as large an extent as possible, devised by the learner. This provides experiences that are "personalized," because they are actually carried out by the individual who devised them and are therefore likely to overlap with other experiences to facilitate the construction of new meaning.

Activity 2

Another relative measurement problem was posed as an activity. The glasses on the tables were stylish cylinders—but bottles of almost any kind, such as soft drink containers, will work just as well—and the activity was to guess first whether the circumference (girth) of the glass was longer or shorter than the height of the glass and then to work in groups at the tables, to "prove" the guess. Participants used several different approaches, many of which amounted to comparing the length of paper required to go all the way around the glass to the height of the glass.

The surprising result of the above problem-solving activity was that the circumference was quite a bit larger than the height, although this was not obvious upon visual examination of the glass. Everyone seemed comfortable with this finding, even though it looked a bit counterintuitive, since each one had participated in an activity that involved deciding how to solve the problem and then actually carrying out the procedure. Hands-on "discovery" (based upon methods that come from experience) that the circumference of a cylinder is quite large (more than three times its diameter) has more impact than "learning" or being told that the circumference is the product of the diameter times pi.

Constructivism also leads us to consider whether a learning activity or concept is developmentally appropriate for the students with whom we want to use it. If there are no previous experiences upon which to connect and to build, the concept might be inappropriate. Or it might require an approach that allows students time to develop the necessary experiential base, rather than the efficient, but perhaps ineffective, "tell it like it is" method.

As an analogy, we might imagine that our minds are like forests with a lot of paths running through them that we have trampled down through a great deal of use and by means of which we can get from one place (piece of information, problem solving technique, etc.) to another. As we learn, we are continually increasing the number and extent of the paths and their crossing points (interconnections). If a new idea comes along that is easily accessible from one or

more of these paths, then we can easily incorporate it into our working knowledge and make connections to it.

However, the new idea might be one that fits best in a remote region of the forest where we have made few paths. If we are forced to use previous knowledge to construct our version of this new idea for ourselves, we have to start from a well-known path (perhaps more than one) to get where we need to go. We probably will have to retrace the new paths several times as we struggle with our construction, so the paths will begin to be pretty well worn and the new knowledge, once connected to the rest, will be more easily accessible, both now and later. By contrast, we could be given a map (simply told the idea) of how to get from some familiar path to where the new idea should be located. If we follow the map diligently, we will get where we need to be and will have trod the path once. However, this barely detectable path will provide only a tenuous connection to everything else and little ability to use the knowledge in a new context.

The role of communication is critical to "internalizing" learning and to discovering whether what has been constructed has enough connections to be accessible in many different contexts, so that it can be used in solving many different kinds of problems. Students need to "talk through" (and "write through") their understandings and their approaches to problems with peers, teachers, and others. This gives them a chance to find out how well they can use ideas and reinforces connections among them (widens and tramples the pathways even further). Libraries and librarians can provide books on hands-on activities that will intrigue students, space and materials for project work, time to tell about it, and resource books and materials for teachers who want to incorporate a constructivist approach in their teaching.

Science Reform Present — Science for All

Demographic data show that the cohort of 4,000,000 students who were high school sophomores in 1977 yielded about 340,000 college freshmen in 1980 who said they were interested in natural sciences, engineering, and mathematics. Of these, about 200,000 graduated with baccalaureate degrees in these fields by 1984, and fewer than 10,000 went on to get Ph.D. degrees in these fields by 1992. The attrition rate is large at each stage of education. This attrition has been called the "pipeline problem." Some believe that too few

scientists and engineers are being produced and that this will lead to large problems in the future. However, there is a good deal of controversy about whether, in fact, more scientists and engineers will be needed than are getting degrees.

Regardless of the controversy, the overall demographics obscure the fact that women, minorities, and the physically handicapped are underrepresented among those in the "pipeline," and this is a great waste of talent. The numbers, or their usual graphical presentation, that focus on the "pipeline" also divert our attention from the vast majority of students, the rest of the cohort of high school sophomores, who don't express an interest in careers in science, mathematics, and technology.

To address these problems, the present reform efforts, in one way or another, espouse the idea that science is for everyone; that is, that excellent science learning opportunities should be available to all, whether or not they have an interest in a science-based career. And these opportunities should be consciously structured to welcome those who have been underrepresented and to encourage them to consider that science is for them as well. Libraries should have science books that illustrate appropriate equity concerns and librarians should help teachers select and use them.

For example, AAAS's Project 2061 is a science literacy project designed to outline what all (12th grade) students should know and understand and to provide guidelines and resources to achieve these goals. Publications available from Project 2061 are the outcome goals, *Science for All Americans*, and intermediate goals for each grade level, *Benchmarks for Science Literacy*, both of which are based on science for all and equity. These resources, as well as the other print and computer-based resources that are being produced, should be available in every library for students, teachers, parents, and others to use.

Keep in mind, as you refer to the content in Project 2061 and help others to use it, that it represents the science that all students should know and understand, but not all the science that some students (those who really get "turned on" to science) should know and study. For Project 2061 and other science education reform efforts, there is probably no single piece of knowledge or understanding that is absolutely essential. What is essential is the constructivist approach to learning with its emphasis on the teacher as a facilitator rather than as an information provider.

Activity 3

A simple activity that catches students' attention is to investigate the floating and sinking behavior of unopened cans of soft drinks, for example, Coke. They (as we did) observe that almost all cans of "regular" Coke sink in water, while almost all cans of diet Coke float. Why? Essentially all students will, with judicious questioning and discussion, formulate the following logic for themselves: If two objects look identical, but one sinks and one floats in water, the sinker must be heavier than the floater. The regulars must be heavier than the diets. Since the cans are all exactly alike (except for the paint on the label), the difference must be that the content of the regulars is heavier than the content of the diets. The labels tell us that both kinds contain exactly the same volume of beverage, 355 mL, so it must be that the regular liquid is heavier than the diet liquid. This conclusion leads to many further questions and possible investigations, such as: What difference in composition of the beverage could cause the difference in masses?

Activity 4

Another kind of activity that all students can do successfully and that allows some degree of creativity extends observation (as in the Coke float) to classification. The goal is to classify a group of objects into categories (at least two and fewer than the number of objects) and specify the characteristics of each category carefully enough so that a new object added to the group can be put into an appropriate existing category. We tried the activity with small pieces of plastic cut from various household products and containers. Some of the characteristics used for the classification were color, texture, transparency, and size. No classification scheme is "wrong" (unless it doesn't uniquely classify each object in the set), so a wide variety is possible and none is "better" than any other.

Science Reform Present — Less Is More

One of the catch phrases associated with the present science education reform efforts is "less is more," an obvious oxymoron. What can this mean? Science is not a collection of facts or techniques, yet many textbooks are litanies of facts, new words, and definitions. The reform is to present many fewer facts and concepts and to take the requisite amount of time for students to explore them in some depth in a variety of contexts, so that they have a real working knowledge of several "big ideas," not simply a nodding acquaintance with a lot of words and definitions out of context.

Activity 5

In small groups, we revisited the pieces of plastic we had previously classified and observed their behavior (floating or sinking) in three liquids (salt water, water, and rubbing alcohol). Now, each piece could be classified according to its characteristic floating and sinking behaviors in the three liquids. The result was that some of the previous classifications were better than others at putting the plastics into groups with similar floating and sinking behaviors. The lesson is that some previous classifications are more useful than others when new criteria or properties are investigated. For students, this activity, building on the Coke float, provides further experience with the property and concept of density of matter. Density is a fundamental, but not easy, "big idea" in terms of explaining many natural phenomena, including the rise and fall of dirigibles and submarines. Building a solid understanding through multiple experiences of growing complexity replaces "learning" the definition that density is mass divided by volume, doing a few end-of-chapter problems, and going on to the next topic. Less is more.

Librarians can help teachers by being on the lookout for books and other materials that embody the "less is more" philosophy. These are materials that support depth of learning rather than shallow breadth and will often be characterized by the absence of long lists of technical terms (often found in some sort of glossary or end-of-chapter review of definitions) and the presence of multiple perspectives on each topic. In our analogy of the brain to a forest, following a typical textbook is rather like running hither and yon through the forest and leaving little trace of one's passage. Teachers can do better and librarians can support, reinforce, and extend their efforts with appropriate resources and library activities.

Science Reform Present — Assessment

None of the above works unless teachers keep in constant touch with what students are learning. End-of-unit paper-and-pencil tests don't do this very well. They are too late (the unit is over) to help adjust teaching to what is being learned and they are not usually designed to assess the higher-order thinking and problem-solving skills we want students to develop. Learning has to be assessed on a constant and ongoing basis. We need to assess what is being learned as it is being learned. Assessment should be built into the activities that students do, and teachers should use the results to determine whether different or additional learning opportunities are needed to be sure the students have appropriate opportunities to construct robust understandings of the topic under study.

Activity 6

An interesting possible assessment activity built around the concept of density involves a "Cartesian diver." The device is a capped 1-liter plastic soft drink bottle filled to the top with water and containing a glass medicine dropper with a rubber bulb. Holding the bottle in one hand, the presenter commanded the "diver" (medicine dropper and bulb) to descend from its starting point at the top of the bottle to the bottom, which it did. Upon the command to rise, the diver again obeyed. Cartesian diver devices were handed out to the group, and they were asked to figure out how to make the diver descend and rise on command. Within a few minutes, everyone had discovered that gently squeezing the plastic bottle caused the diver to dive and releasing the pressure allowed it to rise again. Close examination of the diver revealed that, when the bottle is squeezed, the increased pressure in the bottle forces water into the medicine dropper (by compressing the air trapped in it). The extra water in the dropper now is part of the diver and increases its density, so it sinks. When the squeezing stops, the pressure in the bottle decreases and the extra water in the dropper is forced out by the air trapped inside it as it expands to the lower pressure. Students who work through this logic for themselves have shown a high level of understanding of the concept of density by analyzing a device based upon it.

"Authentic assessment" is another of the many catch phrases that are used often in the present reform discussions. In general terms, an assessment is "authentic" if it is based on a real-life problem or situation of interest to the students, is related directly to the core of what is being learned (not some peripheral topic), and involves students in actually doing things that show their level of understanding. Coming up with activities that can be the basis for authentic assessment is an area where teachers can take advantage of the questions and problems that students raise and want to explore, since these are the ones that have already captured their interest.

The hard part is figuring out what to look for as indicators of what the students are learning and designing scoring systems that provide a succinct way to record achievement on these indicators that will be understandable to all stakeholders: teachers, students, administrators, parents, and so on. Libraries should contain resources (e.g. journals, books, and copies of articles) for teachers who are trying to develop authentic assessments. They can also contain activities and puzzles related to the science curriculum for students to try out to assess their own learning.

Ideally, assessment of all kinds should be self-assessment, and teachers' efforts with ongoing and embedded assessment activities should be aimed at getting students to be

self-assessors, as well as at providing information to the teachers. One of the more popular alternative forms of assessment nowadays is the use of portfolios. Portfolios, like artists' portfolios, are collections of "best work" that, in the case of students, demonstrate growth over time. They are not just a hodgepodge of papers and projects, but a thoughtful collection that demonstrates the student's awareness of his or her own progress and achievement. A librarian can be a resource to help students select their best work by, for example, acting as a sounding board for students to justify their choices and become clearer about their rationales.

Science Reform Present — Systemic

Almost always in the "real world," each part affects many others and is in turn affected by them. The parts are coupled and combined into networks of interactions. Thus, we talk about "systems," which are these networks of interacting parts. Although essentially everything is connected to everything else through these networks, we often restrict our attention to networks of relatively tightly connected parts that focus on some particular aspect of society, such as the education of the young.

Activity 7

As a simple example of a physical system, we considered a device that consists of a tall sealed cylinder of clear, colorless liquid in which are floating several sealed glass spheres, each about half full of a colored liquid. To each sphere is attached a small metal medallion that hangs below the sphere in the liquid. Several other spheres and medallions are at the bottom of the cylinder, not floating. Assuming that the device interacts with the rest of the world and has some use in the system, the problems are: What does this device do, and how does it do it? Using a twenty-questions format, we determined, among other things, that the spheres have different densities (same volumes but different masses, as do regular and diet Cokes) and that under different conditions different numbers of spheres are floating. A hypothesis was suggested that the device is a thermometer. This is correct; it is a Galileo thermometer. The medallions are labeled from 60° F to 80° F in increments of 2° F. Most liquids expand when their temperature increases, so we can predict whether more or fewer of the spheres will float as the temperature rises and hence, can predict whether the 60° F or 80° F sphere is the topmost one in the cylinder. Predictions are checked by closer observations of the thermometer. In this system, the behavior of the spheres is affected by the changing density of the colorless liquid which is, in turn, affected by the temperature of the surroundings.

Activity 8

A second physical system with more application to larger physical world systems is the sort of "carousel" decoration commonly seen around the Christmas season. These have a vertical rotating shaft with a propeller or series of propeller blades at the top and to which are attached one or more platforms with small figures depicting a scene. There are usually places around the stationary base of the carousel to place candles. Our carousel (without candles) sat on a box containing an electric hot plate and having holes near the bottom and holes on the top surface where the carousel sat. Soon after the hot plate was turned on, the shaft began to turn, and the scene rotated rapidly. When air is heated over the hot plate it expands (like the colorless liquid in the Galileo thermometer). The expanded air, occupying more volume, is less dense than the surrounding cooler air, so the cooler air pushes in at the bottom of the box below the warm air and the warm air is pushed up (rises) through the holes in the top of the box and continues to rise past the propeller blades. This wind of rising hot air causes the propeller (and thus the shaft) to turn. It is exactly this same interaction of a warm surface (the earth) and the air above it that causes the wind that gently brushes our cheek on a spring day and the hurricane that destroys ships, houses, and seacoasts.

An objective of the AAAS Science Library Institute is to increase the number of librarians in the Washington, D.C., metropolitan area who can play a key role in science and mathematics reform by providing them with access to a matrix of the concepts and topics recommended by current national "standards" projects such as AAAS's Project 2061, NSTA's Scope, Sequence, and Coordination, and the National Science Education Standards. We hope that the inclusion of the bibliography starting on the following page continues the work of the Institute in achieving this objective.

The physical systems we observed are very simple compared to the educational system whose reform we have been discussing. At a minimum, the parts of this system include: students, teachers, librarians, curriculum, assessment, school administrators, parents, the community (local, state, and national), and school governance. You are a part of the system and probably very much aware of the effects the various other parts have on you. The AAAS Science Library Institute is designed to help you expand and enhance the ways you can affect the other parts to bring about a system that provides the best opportunities for all students to learn.

Obviously, a brief overview like this can do no more than provide a glimpse of the richness of present-day science education reform. We hoped to whet your appetite so you would want to examine at least some of its aspects in depth (to create in your own brain forest well-trod pathways among these many ideas and practices). The following bibliography is provided to help you begin your own search and to suggest resources you might wish to make available to teachers, administrators, and parents in your library.

— Jerry Bell

Science Education Reform Resources

Adams, Steve and Gerald D. Bailey. "Education for the Information Age: Is It Time to Trade Vehicles?" *NASSP Bulletin*; v77 n553 p57-63 May 1993.

Aldridge, Bill G. "Project on Scope, Sequence, and Coordination: A New Synthesis for Improving Science Education." *Journal of Science Education and Technology*; v1 n1 p13-21 Mar 1992.

Armstrong, J., A. Davis, A. Odden, and J. Gallagher. *The Impact of State Policies on Improving Science Curriculum*. Education Commission of the States. Denver, CO, 1988.

Anderson, Ronald D. "Perspectives on Complexity: An Essay on Curricular Reform." *Journal of Research in Science Teaching*; v29 n8 p861-76 Oct 1992 Special Issue: Science Curriculum Reform.

Apple, Michael W. "Educational Reform and Educational Crisis." *Journal of Research in Science Teaching*; v29 n8 p779-89 Oct 1992 Special Issue: Science Curriculum Reform.

Atchley, Debra. "Curriculum Reform in California." *Science Teacher*; v60 n4 p37-39 Apr 1993.

Arbuckle, Susan H. and, Steven A. Schneider. "Coordinating Our Efforts." *Science Teacher*; v60 n4 p40 Apr 1993.

Atwater, Mary M. "Multicultural Science Education." *Science Teacher*; v60 n3 p32-37 Mar 1993.

Ball, Deborah Loewenberg. "Magical Hopes: Manipulatives and the Reform of Math Education." *American Educator: The Professional Journal of the American Federation of Teachers*; v16 n2 p14-18, 46-47 Sum 1992.

Bebout, Harriett C., and others. "Collaboration to Restructure Mathematics and Science Teacher Education." *Urban Education*; v27 n3 p248-62 Oct 1992.

Berlin, Donna F. and Arthur L. White. Report from the NSF/SSMA "Wingspread Conference: A Network for Integrated Science and Mathematics Teaching and Learning." *School Science and Mathematics*; v92 n6 p340-42 Oct 1992.

Blank, Rolf K., and Pamela Espenshade. *State Education: Education Policies Related to Science and Mathematics*. Science and Mathematics Indicators Project, Council of Chief State School Officers, Washington, DC.

Bruder, Isabelle, and others. "School Reform: Why You Need Technology to Get There." *Electronic Learning*; v11 n8 p22-28 May-Jun 1992.

Bybee, Rodger W. "Planet Earth in Crisis: How Should Science Educators Respond?" *American Biology Teacher*; v53 n3 p146-53 Mar 1991.

Byrd, Steven E., and Cindy L. Doherty. *Constraints to Teacher Change*. Apr 1993 16p.; Paper presented at the Annual Meeting of the National Association for Research in Science Teaching (Atlanta, GA, Apr 1993).

Campoy, Renee. "The Role of Technology in the School Reform Movement." *Educational Technology*; v32 n8 p17-22 Aug 1992.

Carnegie Commission on Science, Technology, and Government. *In the National Interest: The Federal Government in the Reform of K-12 Math and Science Education*. Carnegie Commission on Science, Technology, and Government, New York, NY. Sep 1991 80p. Sponsoring Agency: Carnegie Corp. of New York, N.Y.

Clune, William H., Paula White, and Janice Patterson. *The Implementation and Effects of High School Graduation Requirements: First Steps Toward Curricular Reform*. Rutgers, The State University of New Jersey, Center for Policy Research in Education, Feb 1989.

Council of Chief State School Officers. *Learning Technologies Essential for Education Change*. Council of Chief State School Officers, Washington, DC 1992 82p.

Donivan, Marilee. "A Dynamic Duo Takes on Science." *Science and Children*; v31 n2 p29-32 Oct 1993.

Donmoyer, Robert, and others. "The Knowledge and Pedagogical Base of Science Education: An Overview." *Teaching Education*; v3 n2 p11-16 Win-Spr 1991.

Education Commission of the States. *State Initiatives to Improve Science and Mathematics Education*. Denver, CO, 1987.

Gann, Jeanette H. "Implementing the Professional Standards for Teaching Mathematics: Making Change in Schools." *Arithmetic Teacher*; v40 n5 p286-89 Jan 1993.

Gardner, David P., chair. *A Nation At Risk: The Imperative for Educational Reform*. The National Commission on Excellence in Education, U.S. Department of Education, Washington, DC, Apr 1983.

Gifford, Bernard R. "Where Is the Knowledge? Knowledge Management, Research and Pedagogy in the Electronic Age." *Education Libraries*; v16 n3 p14-22 Fall-Win 1992.

Hirschbuhl, John J. "Multimedia: Why Invest?" *Interactive Learning International*; v8 n4 p321-23 Oct-Dec 1992.

Hunter, Beverly. "Linking for Learning: Computer-and-Communications Network Support for Nationwide Innovation." *Journal of Science Education and Technology*; v1 n1 p23-34 Mar 1992.

Hurd, Paul DeHart. "Issues in Linking Research to Science Teaching." *Science Education*; v75 n6 p723-32 Nov 1991.

Instructor Special Report. "A Teacher's Guide to Science Reform." *Instructor*; v102 n7 p23 Mar 1993.

Johnson, Judith, and Elizabeth Kean. "Improving Science Teaching in Multicultural Settings: A Qualitative Study." *Journal of Science Education and Technology*; v1 n4 p275-87 Dec 1992.

Johnson, Judith, and others *Multicultural Science Education Project: A Model of Reform*. Apr 1993 8p.; Paper presented at the Annual Meeting of the National Association for Research in Science Teaching (Atlanta, GA, Apr 15-19, 1993).

Koballa, Thomas R., Jr., and Frank E. Crawley. "Curriculum Reform in Texas." *Science Teacher*; v60 n4 p41-45 Apr 1993.

Kulm, Gerald, and Shirley M. Malcom, eds. *Science Assessment in the Service of Reform*. American Association for the Advancement of Science, Washington, DC 1991 410p.

Linn, Marcia C. "Science Education Reform: Building on the Research Base." *Journal of Research in Science Teaching*; v29 n8 p821-40 Oct 1992 Special Issue: Science Curriculum Reform.

McFadden, Charles P. "Author-Publisher-Educator Relationships and Curriculum Reform." *Journal of Curriculum Studies*; v24 n1 p71-87 Jan-Feb 1992.

Marker, Gerald W. "Integrating Science-Technology-Society into Social Studies Education." *Theory into Practice*; v31 n1 p20-26 Win 1992.

Martens, Mary Lee. Inhibitors to Implementing a Problem-Solving Approach to Teaching Elementary Science: Case Study of a Teacher in Change. *School Science and Mathematics*; v92 n3 p150-56 Mar 1992.

Mathematical Association of America. *A Call for Change: Recommendations for the Mathematical Preparation of Teachers of Mathematics*. Washington, DC 1991.

McColskey, Wendy, and others. *Matching Assessment to the Curriculum in a Systemic Science Reform Project*. Apr 1993 23p.; Paper presented at the Annual Meeting of the American Educational Research Association (Atlanta, GA, Apr 12-16, 1993).

Mullis, Ina V. and Lynn B. Jenkins. *The Science Report Card, Elements of Risk and Recovery*. Educational Testing Service, Princeton, NJ September, 1988.

Murnane, R. J. and S. A. Raizen. *Improving Indicators of the Quality of Science and Mathematics Education in Grades K-12*. National Academy Press, Washington, DC, 1988

Moore, G. Robert; and Peggy Moore. "Making Science Matter in Elementary School." *Here's How*, v11 n1 Sep 1992 5p.

National Council of Teachers of Mathematics. *Curriculum and Evaluation Standards for School Mathematics*. Reston, VA 1991.

National Research Council. *Everybody Counts: A Report to the Nation on the Future of Mathematics Education*. National Academy Press Washington, DC 1989.

National Research Council, Mathematical Sciences Education Board. *Reshaping School Mathematics: A Philosophy and Framework for Curriculum*. National Academy Press, Washington, DC, 1990.

Raizen, Senta A., and L. V. Jones. *Indicators of Pre-College Education in Science and Mathematics: A Preliminary Review*. National Academy Press, Washington, DC 1985.

Rakow, Steven J. Assessment: A Driving Force. *Science Scope*; v15 n6 p3 Mar 1992.

Resnick, L. B. *Educating and Learning to Think*. National Academy Press, Washington, DC, 1987.

Romberg, Thomas A. NCTM's Standards: A Rallying Flag for Mathematics Teachers. *Educational Leadership*; v50 n5 p36-41 Feb 1993.

Romberg, Thomas A., and Linda D. Wilson. Alignment of Test with the Standards. *Arithmetic Teacher*; v40 n1 p18-22 Sep 1992.

Schoen, Harold L. *The Mathematics Outlook: Assessment Issues from a Mathematics Education Perspective*. ERIC Clearinghouse for Science, Mathematics, and Environmental Education, Columbus, OH May 1993 11p.

Scully, John. Reforming Learning. *American School Board Journal*; v180 n3 p37-38 Mar 1993.

Shavelson, R. J., L. M. McDonnell & Oakes, Eds. *Indicators for Monitoring Mathematics and Science Education: A Sourcebook*. The RAND Corporation, Santa Monica, CA Jul 1989.

Shymansky, James A. Establishing a Research Agenda: Critical Issues of Science Curriculum Reform. *Journal of Research in Science Teaching*; v29 n8 p749-78 Oct 1992 Special Issue: Science Curriculum Reform.

Smith, Laura M., and others. *Assessment of Student Learning in Science*. South Carolina Univ., Columbia. South Carolina Center for Excellence in the Assessment of Student Learning. Mar 1993 21p. Paper presented at the Annual Meeting of the American Educational Research Association (Atlanta, GA, Apr 12-16 1993).

Staver, John R., and others. *A Summary of Research in Science Education - 1987*. SMEAC Information Reference Center, The Ohio State University, Columbus, OH, Mar 1989; ED 309 921.

Steen, L. A., Ed. *On the Shoulders of Giants: New Approaches to Numeracy*. National Academy Press, Washington, DC, 1990.

Steffe, Leslie P., and Heide G. Wiegel. On Reforming Practice in Mathematics Education. *Educational Studies in Mathematics*; v23 n5 p445-65 Oct 1992.

Sutman, Francis X., and Ana Guzman. *Teaching and Learning Science with Understanding to Limited English Proficient Students: Excellence through Reform*. ERIC Clearinghouse on Urban Education, New York, N.Y. Dec 1992 159p.

Taitt, Henry A. *Technology in the Classroom: Planning for Educational Change*. National Association of Secondary School Principals, Reston, VA. NASSP Curriculum Report; v22 n4 Mar 1993 7p.

Tobin, Kenneth, and George Dawson. Constraints to Curriculum Reform: Teachers and the Myths of Schooling. *Educational Technology, Research and Development*; v40 n1 p81-92 1992.

Tobin, Kenneth, and others. Enhancing Science and Mathematics Teaching. *Journal of Science Teacher Education*; v2 n4 p85-89 Fall 1991.

Triangle Coalition for Science and Technology Education. *A Guide for Building an Alliance for Science, Mathematics and Technology Education*. Triangle Coalition for Science and Technology Education, College Park, MD. Dec 1991 57p.; Revised edition.

Thurston, W. P. *Mathematical Education*. Notices of the American Mathematical Society. 37, 844-850 Sep 1990.

United States Department of Education. *The Nation Responds, Recent Efforts To Improve Education*. U.S. Government Printing Office, Washington, DC, May, 1984. ED 240 748.

Weiss, Iris R. *Report of the 1985-86 National Survey of Science and Mathematics Education*. Research Triangle Institute, Durham, NC, 1987. ED 292 620.

Weissglass, Julian. Changing the Culture of Mathematics Instruction. *Journal of Mathematical Behavior*; v11 n2 p195-203 Jun 1992.

Yager, Robert E. Science-Technology-Society as Reform. *School Science and Mathematics*; v93 n3 p145-51 Mar 1993.

Yager, Robert E., and John E. Penick. Using Science as a Connector for the Reformed School Curriculum. *NASSP Bulletin*; v76 n547 p56-68 Nov 1992.

Chapter Three

Selecting Excellent Science Resources

Are you confident of your ability to select the best science resources for your library? Like many librarians, you may be more comfortable selecting biographies, poetry, or fiction than science materials. Also, like most librarians, the amount of money you have to spend on resources of any kind is shrinking. So, how do you make sure your precious dollars are spent effectively, especially in a subject area in which you are not an expert?

Librarians are especially sensitive to the responsibility they have for assembling a collection of books that are appealing, useful, and free of obvious errors and distortions. While adults may possess prior knowledge or have a context from which to evaluate the information and perspective provided in a book, this is not likely to be the case with children, especially with technical materials. This article poses and attempts to answer some questions that are intended to help you to enhance your skills in selecting excellent science resources. Because most libraries are still book-centered, we will begin with children's science books.

What Makes a Good Children's Science Book?

Many of the same components that make a good children's book make a good children's science book: presentation, organization, language, and quality of illustrations, to name a few. But science books must do more than just tell a good story; they must also be accurate and present the processes of science in a way that can be understood by a child without misleading oversimplification. Besides this fundamental

One of the goals of the AAAS Science Library Institute is to empower librarians to make confident and effective choices when selecting science materials. This article summarizes the concepts covered in the workshops. Because the author, Maria Sosa, is also the editor-in-chief of Science Books & Films (SB&F), it is frequently cited as an example. This is not, however, intended to suggest that SB&F should be the only source consulted for reviews of science resources.

requirement of scientific accuracy, good children's science books should also encourage an interest in science by prompting young readers to want to know more.

Good science books should also have a well-defined scope and be free of jargon. Although gimmicks, characters, and other motivational features can often help make the subject matter more appealing to young readers, the very best children's science books allow the intrinsic appeal of the scientific subject to shine through. By fostering a genuine interest in a subject, good science books motivate children to want to know more.

Teachers, librarians, parents, grandparents, and, indeed, all adults who have experienced the joy of reading to and with children know the impact that a book can have on a child. It's a known fact that children are naturally curious. This makes them, as many have pointed out, natural scientists. For the very young, science begins by asking questions: Why does it rain? What is thunder? How do birds fly? Why can't I fly? As children grow and learn, the questions (if we're lucky) become more focused: Why are dinosaurs extinct? Where does acid rain come from? How do you get energy from the sun?

But not all children continue to ask these questions. What is it that turns some children off to science as they grow older? Do they lose their curiosity? Or do they simply cease to equate curiosity with science? These questions are not easily answered. However, one way to keep children curious about science is to convince them that science can be fun. Another way is to show young boys and girls that science is relevant by relating it to their lives in an active and direct manner. These are both strategies that successful children's science writers, such as Patricia Lauber and Seymour Simon, effectively employ.

The challenges we face in educating our nation's children are not limited to science and mathematics. Reading and literacy are also central concerns. The growth of whole language teaching methods and the call for integrating science, mathematics, and language arts instruction have enhanced the visibility of children's science trade books. More books are being published every year, and more teachers are using them to teach both science and reading. Indeed, reading specialists have long stressed the importance of reading in the content areas.

The current climate of education reform has created an increased demand for science books in schools, libraries, and bookstores. Concerned teachers and parents who strive to make the very best books available to young people have prompted this increased demand. In the future, we can measure success by the extent to which the demand for good science books is prompted by young readers' own intrinsic interests.

How Do I Assess My Collection?

First of all, don't be intimidated by the explosion of scientific information. Remember that you are an information specialist. Your role is to provide access to resources, not expertise on subject matter. Begin to assess your collection's strengths and deficiencies with regard to science materials by considering the following points:

1. What is the overall size of your collection? What is the ratio of science books to books in other subject areas? What is the average age of the materials in your science collection? Remember, in science, more than in any other subject area, there are few classics. Resources can become quickly outdated as new discoveries are made.
2. Which science topic is best represented in your collection? Which is least represented? Does this match your needs? In other words, if you have more books on rocks and minerals than on any other science topic, is there a valid reason for this?
3. Do you have quality materials for all ages and levels represented in your school? If not, which level seems to be the most deficient? Are there any valid reasons for this deficiency? A valid reason might be that there simply are not quality materials available on a particular subject for a particular age group.
4. What curriculum areas do you need to support with your collection? Are these well represented? Work with the science teachers or classroom teachers to consider not only what they are currently teaching, but what they might like to introduce into their classes if they had the appropriate resources.
5. Does your collection consist of a good mixture of different types of books, i.e., hands-on science books, science-related fiction, informational books on single topics, and reference books?

After answering these questions, you may well decide that your collection needs to be enhanced. This brings us back to the issue of how best to utilize your financial resources in order to achieve your goal of a balanced, accurate, and appropriate science collection. One thing is certain: To acquire anything short of the best resource available to you would be a disappointment. So you may wish to rely on expert reviews to point you towards the best materials.

Where Can I Find Expert Reviews?

There are many tools that provide expert reviews. Some are publications devoted entirely to reviewing, such as *Science Books & Films*. In addition to review journals look for expert reviews in specialized publications for educators, such as the journals published by the National Science Teachers Association, the National Association of Biology Teachers, and others. When turning to an expert review, the librarian needs to feel confident that the reviewer is indeed an expert. Therefore, look for reviews that publish the affiliations of the reviewers. Also, look for review sources that provide a detailed explanation of the criteria they provide to reviewers. Any good review source should explain the criteria by which materials are appraised. For example, *SB&F* book reviewers are given the following general instructions, which are summarized in each issue so that readers can refer to them.

Please write a critical evaluation of approximately 200 words (slightly more, if necessary), emphasizing the merits and/or demerits of the book (and accompanying supplements, if any). Describe and critique the content, technical quality, and instructional value. Take special note of the overall quality of the presentation of facts, theories, and processes of science and their interrelationships (for example, does the material accurately depict the uses and limitations of the scientific method?) Indicate for which audience(s) the material is most appropriate and why. Also mention how the material could be used (reference, classroom, general awareness, other).

The more expensive the product you are considering purchasing, the more you need to get a second or a third opinion. Remember that reviewers are only human and that in the vast majority of cases, the material is reviewed by just one person. Consider inviting an expert into your library to assist you in assessing your collection's strengths and deficiencies.

Don't forget to ask the experts in your own building. By this we mean: Work with your science teachers. But also, ask the children. Consider having focus groups in which you invite a group to the library and examine their attitudes about science books. Find out what works for them and what doesn't. An adult reviewer can praise a book, but if a child is turned off, the target is missed.

How Important Are Facts?

We want to avoid the impression that science is a collection of facts. However, some facts are more important than others. For example, a book may say that there are 10 billion nerve cells in the brain. Another may say there are 100 billion. One reason for the discrepancy is that neuroscience is an area of inquiry in which new discoveries are so abundant that it is difficult for books to be completely current. So, while you may not necessarily want to discard a book for citing the lower number of neurons, you may rightly be wary of a new book that is not aware of current developments.

Also, there are areas in which scientists legitimately disagree, global warming, for example. The best reason for rejecting a book with a very blatant error (for example, one that would say that Venus is the closest planet to the Sun) is that such carelessness with regard to readily available facts tends to make one suspicious about details that may be more obscure.

Can Science Books Be Dangerous?

While this question may be tongue-in-cheek, there are some scenarios in which inappropriate materials can actually be harmful. Among these are the following:

1. A boring science book can be dangerous, for such a book conveys to children the sense that science is uninteresting, tedious, or difficult. Books can be boring because they are poorly written or illustrated or, worse, because the author cannot convincingly convey the excitement of science.
2. Another dangerous type of science book is one that makes children feel that science is not for them because it excludes people of their gender, race, or socioeconomic status. Books that use settings or examples that are not relevant to all children can make some readers feel that science is not appropriate for them.

3. Books that portray science as a static collection of facts, rather than a process, endanger the innate sense of wonder and curiosity that children typically feel for the natural world.
4. Books that are inaccurate to the point of creating or fostering misconceptions are dangerous because such misconceptions can be stumbling blocks to children's understanding of science.
5. Hands-on science books that don't take safety into account can be dangerous for obvious reasons. Some safety issues to consider are detailed below.

What Are the Safety Considerations in Selecting Hands-on Science Resources?

In general, when evaluating hands-on science activities, consider whether children will have to handle any of the following: chemicals that are poisonous, harmful to their skin or eyes, or flammable; flames or electrical currents with enough power to shock or burn; or knives, razor blades, broken glass, or other objects that can cut. If an activity includes one or more of these things, it doesn't mean that you can't use it, but it does mean that you must consider the appropriate safety precautions needed, the age of the children who will do the activity, and whether the instructions indicate that the activity is to be done under adult supervision.

Isn't a Library More Than Books?

Videos and software should be an integral part of a good library collection. But when your total budget for new materials is \$500 per year, reluctance to enhance these parts of your collection are understandable. Those of you who can't identify with a \$500 budget can count your blessings. However, you still can't afford to throw away money on costly resources. For a child who lives hundreds of miles away from a zoo, videos can provide an introduction to wildlife. Similarly, videos and films can take children to places they can normally only imagine. But, like science books, they will not do the job if the children are not paying attention. The same is true with software.

Since distributors will allow you to preview most videos and software, consider setting up a preview committee in which children are invited to help you review materials for pur-

chase. One caveat: Don't make this just an opportunity to reward children who are most likely to participate. After all, they are already paying attention. You need to be sure that your acquisitions are working for all children, especially those who might believe that they would not like a science video or software package.

Also important for your science collections are hands-on science kits, games, toys, posters, and exhibits. These materials can be used by teachers in classroom instruction or they can be checked out by students for science explorations outside of school.

Who Can Help Me Build an Exemplary Science, Mathematics, and Technology Library?

Like Rome, a model science, mathematics, and technology library collection cannot be built in a day. Nor can it be built by just one person. The human resources required to build your collection are as important as the books, videos, and software that line your shelves. The following tips can help you get started.

1. Work with science teachers in your school or community to select and focus on an area that correlates with what they are teaching. After you have built up one area, it will be easier to convince administrators that other areas need to be enhanced as well.
2. Make an effort to involve parents in your library programs. If you don't already have one, consider an inexpensive newsletter that informs parents about the library and about what your needs are. Public librarians can enlist parental assistance in enhancing the science offerings in the children's section. School librarians can work with parents to devise fund-raising strategies and to come up with family programming that is centered in the library. Once parents understand how an exemplary collection can help their children achieve in science and mathematics, they will be your staunchest supporters.
3. Bring your science resources to the attention of library patrons via displays and special activities in the library. When something good happens in your library, spread the news. Many local newspapers will be happy to feature stories about your efforts to enhance science, mathematics, and technology programs in your library.

4. Start a science and mathematics reform collection in your library. Keep teachers informed of such materials and encourage them to share reform issues with parents. Teachers may not have time to stay abreast of current information about research and standards-based reform. You can be a resource for them on exemplary practices and new products for the classroom. Much information is available on-line via electronic bulletin boards.

5. Develop a resource list in conjunction with local companies, science organizations, university departments, and other community groups, and join them in devising fund-raising and program strategies. These might include lectures or readings, children's book clubs, and developing hands-on activity kits or materials to check out with the books. This can position libraries to support out-of-school learning in science, increase the interest and involvement of donors and organizations that have a special interest in the sciences, and support the National Education Goals in science and mathematics. A more comprehensive approach might include involving teachers and area scientists in a review of current titles and holdings with joint planning of a collection.

You can see how it could take some legwork to develop a collection of equitable, excellent materials that meets the needs of your entire school. But you can also probably imagine the possibilities that would open up for you, teachers, parents, and especially students, as you all use the quality resources you have selected to further your understanding of the world around you. And isn't that the main function of a library anyway?

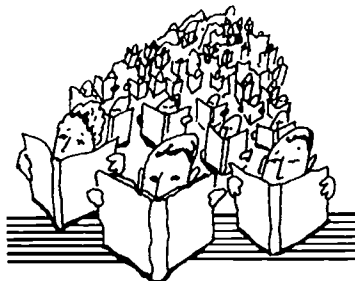

— Maria Sosa

Chapter Four

The Perennial Joy of Dinosaurs

If to everything there is a season, this is indeed the season of the dinosaur. However, it is by no means self-evident to me that the appeal of dinosaurs is limited to a single season. There has been a steady stream of printed and electronic material on dinosaurs in recent years, and I see no evidence that it is about to abate soon. It is merely that the usually high profile of dinosaurs has become even higher with the staggering success of Stephen Spielberg's vivid cinematic recreation of the Michael Crichton novel, *Jurassic Park*. Perceptive readers and viewers will realize that there is more to the subject of dinosaurs than greeted the theater-goer. There is an urgent need for the public to be able to recognize quality offerings on dinosaurs.

Recommended books need to meet certain minimal requirements of information content and accuracy. A definition of dinosaurs should be offered so that the reader has a basis for recognizing the difference between an animal that actually was a dinosaur versus one that merely lived at the same time or during some other remote geological time. A sense of time is needed so that it is clear that not all dinosaurs lived together in the same time and place. Illustrations should be esthetically appealing but also meet standards of accuracy.

There is a genuine surge in the scientific study of dinosaurs. So far this year, three notable new animals have entered our vocabulary: *Utahraptor* from the United States; *Eoraptor* from Argentina, one of the earliest and most primitive dinosaurs yet discovered; and *Mononykus* from Mongolia (but wait, is it a bird or a dinosaur?). We are anxiously awaiting descrip-

Originally published in the October, 1993 (vol. 29 no. 7), issue of SB&F, this section was written by Dr. Peter Dodson, an SB&F reviewer and an instructor of veterinary anatomy at the University of Pennsylvania. It can help you select accurate and engaging resources to create a library exhibit or activity based on a subject many students love to learn about: dinosaurs!

tions of new dinosaurs from Antarctica and China. But fueling public interest is the artwork by a young cohort of illustrators, including John Gurche, Doug Henderson, Mark Hallett, Bob Walters, Greg Paul, Wayne Bariowe, Brian Franczak, John Sibbick, and Donna Braginetz to name but a few among an ever-increasing group. Collectively, their imaginative works show accurate animals in convincing natural settings with a vitality and drama seldom seen before. Selections from this opus grace the jackets and pages of many of the offerings below.

Although flawed books continue to be produced and to enjoy commercial success, it seems that more and more publishers are taking the desirable extra step of obtaining a critical reading by a reputable dinosaur scientist in order to ensure that their publications meet reasonable standards. It is a pity when a lushly illustrated, beautifully produced book (for example, *Dinosaur for a Day*, by Jim Murphy, illustrated by Mark Alan Weatherby, Scholastic, 1992) fails to meet these standards for want of scientific supervision.

When I am recommending books to a general audience, the first book I mention is *The Illustrated Encyclopedia of Dinosaurs* by Dr. David B. Norman (Crescent). Although this book was published in 1985 and could profit from being updated, I believe that it is the best and most comprehensive book on dinosaurs for a general audience that has ever been written. The author is an excellent British dinosaur scientist. Although the text is written for a general audience (high school level or beyond), it is extensively and beautifully illustrated with anatomical drawings of skeletons, colorful life reconstructions by John Sibbick, and photographs as well, which will broaden its appeal. The extensive and accurate skeletal drawings make this an excellent reference work for artists. I use the book frequently myself.

There is now a fairly extensive literature on dinosaurs for general, and even juvenile, audiences written by scientists themselves. For years, the only dinosaur scientist writing for general audiences was Edwin H. Colbert, whose *The Dinosaur Book*, published by McGraw-Hill in 1951, was the book that inspired me when I was a kid and that remains one of my treasured possessions today. Colbert's books include *Dinosaurs, Their Discovery and Their World* (Dutton, 1961); *Men and Dinosaurs* (Dutton, 1968); and *Dinosaurs, An Illustrated History* (Hammond, 1983). Colbert made extensive use of the magnificent old paintings of Charles Knight and field

photos of the classic dinosaur expeditions of the American Museum of Natural History in the first three decades of this century.

Dr. Dale A. Russell is the first of the modern dinosaur scientists to write for general audiences. His two books (*A Vanished World—The Dinosaurs of Western Canada*, Ottawa: National Museum of Natural Sciences, 1977; and *An Odyssey in Time: The Dinosaurs of North America*, University of Toronto Press, 1989) each feature original art by Ely Kish and superb photography of the fossil beds and living plants that shared Mesozoic landscapes with the dinosaurs.

More recently, there has been a plethora of titles by scientists themselves. Most of these are aimed for mature readers, but are generally well illustrated, informative, and entertaining. Offerings include Robert T. Bakker's *The Dinosaur Heresies* (Morrow, 1986); Horner and Gorman's *Digging Dinosaurs* (Workman, 1988); Martin G. Lockley's *Tracking Dinosaurs* (Cambridge, 1991); Christopher McGowan's *Dinosaurs, Spitfires and Sea Dragons* (Harvard, 1991); John R. Horner and Don Lessem's *The Complete T. rex* (Simon & Schuster, 1993); and Louis Jacob's collecting memoir, *Quest for the African Dinosaurs* (Villard, 1993).

A slender, idiosyncratic, and stimulating little book that really stands by itself is by R. McNeill Alexander, *The Dynamics of Dinosaurs and Other Extinct Giants* (Columbia, 1989). Alexander is a biomechanicist who examines mechanical aspects of being a giant. He concludes, among other things, that he could have outrun *Tyrannosaurus rex*! David Norman also has written several other popular books of encyclopedic nature, most notable of which is the beautifully illustrated *Dinosaur* with Angela Milner (Eyewitness Books, Knopf, 1989).

Scientists also write for children. Michael Benton is another British dinosaur paleontologist who has been prolific with attractive books that appeal to younger readers. Among these are *Dinosaurs: An A-Z Guide* (1988) and *Dinosaurs and Other Prehistoric Animal Fact Finder* (1992), both published by Kingfisher. James O. Farlow has written *On the Tracks of Dinosaurs: A Study of Dinosaur Footprints* (Franklin Watts, 1991) and David B. Weishampel wrote *Plant Eating Dinosaurs* (1992) also for Franklin Watts; these attractive books are aimed at the fourth- to sixth-grade level.



The Horner and Lessem book, *Digging Up Tyrannosaurus rex* (Crown, 1992), presents the story of the 1990 excavation of a very complete skeleton of every child's favorite dinosaur. Horner and James Gorman teamed up with artist Doug Henderson to produce *Maia, A Dinosaur Grows Up* (Running Press, 1985), one of the most impressive juvenile dinosaur books ever written. This book presents visually the life cycle and habitats of the duckbill *Maiaasaura*, based on some of the most important dinosaur finds ever made.

Several science journalists have made significant contributions to the popular literature for adults. *New York Times* writer John Noble Wilford, in his *The Riddle of the Dinosaur* (Knopf, 1984), emphasizes the colorful history of paleontology, while Don Lessem, in *The Kings of Creation* (Simon & Schuster, 1992), highlights contemporary research and controversies. The Publications International *Encyclopedia of Dinosaurs* (1990) is an unusually attractive and generally thorough and well done effort. I find that one of the most useful general books is Helen Roney Sattler's *The New Illustrated Dinosaur Dictionary* (Lothrop, Lee & Shepard, 1990). The illustrations add little, but the text represents an attempt to list dinosaurs comprehensively and includes etymologies for all dinosaur names.

The children's literature on dinosaurs is too vast to review comprehensively. I will simply pick a few notables that I enjoy. David Peters' *A Gallery of Dinosaurs & Other Early Reptiles* (Knopf, 1989) includes some of the most imaginatively yet convincingly colored reconstructions I have ever seen, arrayed along a time line and drawn to the same scale. Thus, the portrait of *Seismosaurus* cleverly folds out to cover a span of seven pages. Patricia Lauber's *The News about Dinosaurs* (Bradbury, 1989) provides a beautiful sampler of recent dinosaur art with a very simple text for young children. *The Dinosaurium* by Barbara Brenner, illustrated by Donna Braginetz (Bantam, 1993), colorfully designs a modern very lively dinosaur museum for children. Dougal Dixon's *Dinosaurs* (Boyds Mill Press, 1993) is published by *Highlights for Children* at a level suitable for their target audience of elementary school children; some of the art and photographs here are stunning.

A lively Canadian book is *The Dinosaur Question and Answer Book*, written by Sylvia Funston (Little, Brown, 1992). It features some of the new work resulting from the Canada-China dinosaur project. An attractive series of four slender

oversized books, written by William Lindsay and published by Dorling Kindersley, has recently appeared. These highlight, respectively, four dinosaur treasures of the American Museum of Natural History, *Barosaurus*, *Tyrannosaurus* (1992), *Corythosaurus*, and *Triceratops* (1993). Each colorful book features historical and geographic material on the original discovery and discoverer, photos of the skeleton in the field and the museum, life reconstruction and discussion of habits and habitats, plus a series of soft sculptures in various poses. These informative books will appeal to a wide age range of young readers.

A book that stands apart from any other that I have seen is *Investigating Science with Dinosaurs* by Craig A. Munsart (Englewood, CO: Teacher Ideas Press, 1993). This book offers a science curriculum based on dinosaurs, adaptable for grades 4 through 12. It includes 40 lab exercises, reading assignments and homework, an extensive bibliography, black-and-white illustrations suitable for overheads, and much else besides. It really is a good place to start for educators who want to incorporate some paleontology into their curricula.

Beyond this eclectic list, which will become dated quickly as the deluge continues, a more general question is, How does the interested public become informed of new dinosaur science, short of delving into the primary scientific literature? High-quality monthly magazines, including *Natural History* (e.g., September 1993) and *Discover* (January 1993), cover dinosaur research with some regularity. The cover story of *National Geographic* (January 1993) is noteworthy.

The Dinosaur Society (200 Carleton Ave., East Islip, NY 11730) was recently established to create an interface between scientists and the public. It provides a mechanism for publishers and manufacturers catering to public interest in dinosaurs to obtain scientific evaluation of their products prior to release; books and products that are approved are eligible to bear the logo of the society. The society publishes a list of recommended books that meets reasonable standards of accuracy of text and art. The society publishes a monthly newspaper for children, *The Dino Times*, and a quarterly newsletter for adults, *The Dinosaur Report*. Both are excellent mechanisms for disseminating information about dinosaur studies around the world.

— Peter Dodson

Chapter Five

"Sun/Shadows/Bears": Interdisciplinary Activities for the Library

The activities in this chapter, written by Dr. Jerry Bell, director, Science, Mathematics, and Technology Programs, AAAS, combine reading, science, and mathematics to sharpen children's observation skills. The chapter was originally published in the November, 1993 (vol. 29, no. 8) issue of SB&F.

Introduction

"Sun/Shadows/Bears" combines several activities that involve reading, science, and mathematics. Although the activities were designed for classrooms, they can easily be used in library or child-oriented community service programs. One of the most important objectives of the activities is to help children become very good observers and to use observations made in one activity to help answer questions or analyze results from another activity. Some of the activities take place outside (on sunny days) and others inside. For most of the activities, students should work in small (three to five person) groups, because they will benefit from discussions with others about what to do and how to do it.

You will have to decide whether reading *Bear Shadow* or measuring sun shadows should be the first activity you do with your class. You can use either one to lead into the other. You'll want to measure the sun shadows at least twice and perhaps three or four times during the year to see how they vary with the time of year. It is best to couple the sun shadow activity with reading the book and making a map of Bear's neighborhood when the sun is relatively high in the sky, either near the beginning or the end of the school year. No separate directions for students are provided here. This is because the questions you will want to pose to children and the order of the activities will depend upon your circumstances: the age and background of the children, the time of the year you use the activities, and the depth to which you want to take each activity. Lots of questions and suggestions

for variants on the activities are presented for you to choose among to tailor "Sun/Shadows/Bears" to your particular needs.



Feading Bear Shadow by Frank Asch

Materials. *Bear Shadow* by Frank Asch is available in paperback and Big Book versions from Scholastic Inc., 730 Broadway, New York, NY 10003. You will probably need a Big Book when you work with an entire class and enough of the paperback version so that each group working on the activities will have it available as a reference. Ideally, each child should have a copy, but your budget may not allow this.

Activity. Either individually or as a participatory exercise, you and the children should read *Bear Shadow*. If this will be the introduction to a study of shadows, with particular emphasis on those caused by the sun, spend time finding out from the children what they already know about shadows.

- What things do the children know that make the book funny?
- Why did Bear's shadow disappear when he hid behind a tree?
- Why did the shadow disappear when he buried it?
- What makes a sun shadow fall one direction at one time and another direction earlier or later in the day?
- What would the children like to learn about sun shadows? about shadows in general?

Use the responses to help the children shape activities through which they will discover the answers to their questions.

If you have already begun the study of shadows and have measured sun shadows at least once, your discussion of *Bear Shadow* can be more pointed. In addition to the kinds of questions above, you can, for example, discuss the time of day when the various events occur and the direction Bear's shadow will fall at these times. This discussion can lead directly to the mapping activity below.

Measuring Sun Shadows

Materials. You will need a magnetic compass to determine which direction is north, a clock or watch, and a long straightedge, such as a meter stick to draw lines all the way

across pieces of poster board. In addition, *for each group*, you will need the things in this list:

- a reasonably level area on the school grounds that is in the sun all day,
- sheet of stiff poster board (any color),
- unsharpened pencil,
- small piece of modeling clay or similar substance,
- felt-tip marker (any color that will show up well on the poster board),
- sharpened pencil,
- ruler (combination metric/English is probably best), and
- whatever mathematics manipulatives the children use to figure out one half of a number.

Activity. Measure the length and width of the poster board and then figure out half of each of these distances. [It's probably easier to measure in inches, since standard poster board is 18 inches wide and 24 inches long and these are even numbers that give whole numbers as halves. Measurement in centimeters will give results that aren't whole numbers and be correspondingly harder to divide in two. You'll have to make the decision about units based on your knowledge of your group and what you want them to learn.]

Starting from the same end, measure halfway along each long side of the poster board and make a pencil mark at the halfway point on each side. Place one edge of a long straightedge against these marks and use the straightedge as a guide to draw a pencil line through the marks across the poster board. Repeat this process along the short sides of the poster board so that you end up with two lines that cross in the center of the poster board and are at right angles to one another. Label one end of the longer line "north" and its other end "south." Looking at the board with "north" at the top, label the right-hand end of the shorter line "east" and the left-hand end "west."

Hold an unsharpened pencil straight up from the poster board at the point where the two lines cross. Mold modeling clay around the pencil where it touches the poster board in order to hold the pencil in place straight up and down. Beginning as early in the morning as possible on a clear sunny day, place the poster board and pencil outdoors on a level surface in an area that will receive sunlight all day. Place a magnetic compass on the longer line and rotate the poster board until the needle exactly lines up with the line

and the north pole of the needle is pointing to the end of the line marked "north." (Positioning the poster board will probably require adult or advanced student guidance.) Use rocks or other weights to hold down the corners of the poster board so that it will remain pointed in this direction all day. Check to be sure the pencil is straight up and down and at the center of the board.

Every hour during the day use a felt tip marker to make a dot at the very end of the shadow that the pencil makes on the poster board surface. Next to the dot, use a pencil to write the time the dot is made. At the end of the day, bring the poster board indoors.

Remove the unsharpened pencil and modeling clay from the poster board. Measure the distance from the center of the board (where the lines cross) to each of the dots. Record the result in a table next to the time corresponding to when the dot was made. These distances are the length of the pencil's shadow at each of these times during the day.

Display the results on a graph. Put hours of the day along a horizontal line and draw or paste on vertical bars the length of the shadow corresponding to each time during the day.

- What does the graph look like?
- When is the shadow shortest?
- When is it longest?
- When does the sun appear lowest in the sky?
- When does it appear highest?
- Can you tell from the shadows how high the sun is in the sky? How?
- Could you use the lengths of the shadows to tell time? How? Look at where the points are on the poster board.
- What direction (in terms of east, west, north, and south) does the earliest shadow point?
- What direction does the latest shadow point?
- What direction does the shortest shadow point?
- In what direction do you have to look to see the sun in the early morning? in the late afternoon? at midday?
- Can you tell from the shadows where the sun is in the sky? How?
- Could you use the directions the shadows point to tell time? How?

Save the poster board and pencil to repeat this activity later in the year. You need to use the same pencil so that any changes in the shadows are caused by changes in the sun,

not changes in the apparatus. Remember to use the same time standard each time you do the activity, that is, always use either standard time or daylight savings time, so the times you compare from one season to another are the same. About two or three months between trials will yield interesting new results. Use a different color marker each time the activity is done so that all data can be collected on the same poster board, but are easy to distinguish from one another.

This activity can be part of a study of the solar system including: the rotation of the earth (although the sun looks like it moves across the sky and casts shadows accordingly, the earth's rotation is responsible), the motion of planets about the sun, and the tilt of the earth on its axis (which coupled with revolution about the sun explains long shadows in the winter and shorter ones in the summer at the same time of day).

Mapping/Modeling Bear's Neighborhood

Materials. What you need will depend upon how you intend to do this activity. Three options are suggested:

- a map drawn on a large sheet of paper or poster board for which you only need the appropriate paper/board and pencils, crayons, and markers,
- a three-dimensional map/model that children construct on some appropriate area in the classroom for which you need cardboard, scissors, glue, tape, pencils, crayons, markers, and a bright lamp, and
- a three-dimensional map/model someplace on the school grounds (perhaps the area used for the sun shadow activity) for which you will need the same sort of materials as for the indoor three-dimensional map (except the lamp), but perhaps larger pieces of cardboard or whatever material students will use to create landmarks like the tree, Bear's house, and so on.

Activity. Make a map/model of the neighborhood where Bear lives. The map/model made should show clearly which direction is north, either with an arrow on a map or by orienting a three-dimensional model correctly with respect to the actual directions. Be sure the map/model includes:

- Bear's house,
- the pond where he went fishing,
- the brook he jumped over,
- the tree he hid behind,
- the cliff he climbed,

- the place where he tried to nail shadow to the ground, and
- the place where he dug the hole to bury shadow.

When the map/model is finished you should be able to trace the story through the neighborhood and have Bear's shadow fall as the pictures in the book show it. In particular, on the map/model, children should show where Bear stood when he:

- left his fishing pole,
- was behind the tree,
- stood at the top of the cliff,
- nailed his shadow to the ground,
- buried his shadow,
- opened the door of his house after his nap, and
- caught the fish.

The simplest way for children to construct their maps/models is to draw them on paper, but this is also the most abstract and demands a great deal of transfer from the observational world of shadows cast by real objects on real surfaces to *imagining* an object drawn on paper casting a shadow. This approach should be used only with older children who have had some previous experience drawing maps of such places as their homes, their school, or a small neighborhood. The added difficulty of mapping an imaginary neighborhood where the only clues to the relative positions of things are the shadows that they cast or are cast upon them is substantial.

An easier approach is to construct the imaginary neighborhood in the classroom and to create a three-dimensional model by making a tree, a cliff, and a house that stand up and using a doll or other model for Bear. Now, by turning out the lights and using one bright lamp to represent the sun, the model can be checked to see how faithfully it represents the neighborhood shown in the book. The degree of abstraction is smaller, but the motion of the sun is only simulated, so some children, especially younger ones, might not really see the connection between this mapping activity and measuring sun shadows.

For young children, it's almost imperative to construct the neighborhood map/model out of doors where the position of the sun in the sky is determined by the rotation of the earth, its tilt, and its location in its yearly circuit of the sun, so it does not have to be simulated. Children will have to

check their map/model several times during the day to be sure it represents the neighborhood shown in the book. If a map is simply drawn on paper, each group should prepare its own map and then present it and argue in front of the whole group for the choices made. When there are differences between and among groups, discuss first whether each is a valid representation, that is, explains the pictures shown in the book. Any map that does this is "correct." The locations of most of the features relative to one another aren't determined by the pictures and students will have valid reasons for choosing quite different arrangements. This is a valuable lesson. There is not always one correct solution to a problem; several different ones may explain the data that are available.

For the three-dimensional models, one approach would be to assign each group a feature to place on the model (after the site for the pond is chosen). When all the features have been placed, each group can explain the reasoning that led them to their placement. Again, there may be disagreements and the criterion for "correctness" is whether the placement explains the pictures in the book.

As preparation for the mapping/modeling activity, there are several questions that might be posed to all the children or to the groups, either to answer "immediately" or to direct thinking during the map/model construction. Some of these might be used as part of your assessment of the children's understanding of what has been done and/or their attentiveness to the details of the book and their reasoning from it. In all cases, the response to a question should contain an *explanation* of how the answer was obtained, not just the answer itself.

- At what time of the year does the story happen?
- At what time of day did Bear go out to fish?
- At what time of day did Bear try to nail shadow to the ground?
- At what time of day did Bear try to bury shadow?
- How long did Bear nap?
- How many windows are there in Bear's house?
- Which direction does the door of Bear's house face?
- How are the pictures that show the passage of time while Bear naps like your measurements on sun shadows?
- How are the pictures that show the passage of time while Bear naps different from your measurements on sun shadows?
- What other questions can you answer?

Extensions

There are many possible extensions of these activities that can build upon and enrich what has been done. Two such extensions, depending upon the interests of the children, are to learn and write more about bears (the lives of real bears or more about Bear and other imaginary bears, such as Winnie the Pooh, the Berenstain Bears, or the Care Bears) and to learn and write more about shadows (and the solar system). Based on further reading or what they have learned in the above activities, children should use what they have learned as a basis for writing.

For example, as the children find out about bears, ask them to reread *Bear Shadow* and list ways that Bear behaves like a real bear and ways he acts like a person, a child. Examine other books in the same way to help children begin to make distinctions between "true" books and imaginative writing or fiction. Such examinations could be the basis for expository writing by the children, or they might write (and illustrate) their own story about bears or shadows (or both).

— Jerry Bell

Relevant Resources

Bears

Baker, Lucy. *Polar Bears*. (Illus.; from the Facts, Stories, Games Series.) NY: Puffin, 1990.

Greenaway, Theresa. *Amazing Bears* (Illus.; photographs by Dave King; an Eyewitness Juniors Bk.) NY: Knopf, 1992.

Greene, Carol. *Reading about the Grizzly Bear* (Illus.; from the Friends in Danger Series.) Hillside, NJ: Enslow, 1993.

Jeunesse, Gallimard, and Laura Bour, and translated by Karen Backstein. *Bears*. (Illus., a First Discovery Bk.) NY: Scholastic, 1992.

McIntyre, Rick. *Grizzly Cub: Five Years in the Life of a Bear*. (Illus.) Anchorage, AK: Alaska Northwest Publishing, 1990.

Petterson, Bertil, and translated by Steven T. Murray. *In the Bears' Forest*. (Illus.) NY: R&S Books, 1991.

Light and Shadows

Ardley, Neil. *Light*. (Illus.; from the Way It Works Series.) NY: New Discovery, 1992.

Color and Light, by the Smithsonian Institution. (Illus.) Milwaukee: Gareth Stevens, 1993. 4

Darling, David. *Making Light Work: The Science of Optics*. (Illus.; from the Experiment! Series.) NY: Dillon Press, 1991

Davies, Kay and Wendy Oldfield. *Light*. (Illus.; from the Starting Science Series.) Austin, TX: Steck-Vaughn, 1992.

Devonshire, Hilary. *Light*. (Illus.; from the Science Through Art Series.) NY: Watts, 1992.

Fowler, Allan. *The Sun Is Always Shining Somewhere*. (Illus.; from the Rookie Read-about Science Series.) Chicago: Childrens Press, 1991.

Friedhoffer, Robert. *Light*. (Illus.; from the Scientific Magic Series.) NY: Watts, 1993.

Gardner, Robert. *Experimenting with Light* (Illus. by Fine Line; a Venture Bk.) NY: Watts, 1991.

Gardner, Robert. *Investigate and Discover Light*. (Illus.; a Franklin Institute Science Museum Bk.) Englewood Cliffs, NJ: Messner, 1991.

Taylor, Barbara *Light*. (Illus.; from the Focus on Series.) NY: Gloucester Press, 1992.

Taylor, Barbara. *Seeing Is Not Believing! The Science of Shadow and Light*. (Illus. from the Step into Science Series.) NY: Random House, 1991.

Ward, Alan. *Experimenting with Light and Illusions* (Illus. by Zena Flax; from the Experimenting With Series.) NY: Chelsea House, 1990.

Ward, Alan. *Light and Color*. (Illus. by Ian Thompson; from the Project Science Series.) NY: Watts, 1992.

Chapter Six

Teaching Science in a Multicultural Context

Originally published in the April, 1994 (vol. 30, no. 3), issue of SB&F, this article was written by Mozell P. Lang, science education specialist in the School Quality Services program for the Michigan Department of Education. It provides an overview of a multicultural approach to science education, as well as a bibliography of resources.

Introduction

Multicultural science education provides an opportunity to enrich the curriculum with science-related experiences and perspectives of diverse groups. It affirms the value of different cultures, fosters appreciation of them, improves self-esteem and academic achievement, and is an important component in achieving the goal of literacy for all students.

This approach serves to reduce prejudice and enhance cultural appreciation in the service of improved academic achievement of minority students. Cultural perspectives should naturally permeate the curriculum in a variety of ways, including trade books, experiences, traditions, and characteristics related to scientific endeavors seen through the eyes of those who reflect the spirit of a particular culture.

Sensitivity Awareness

In designing curriculum and instruction, sensitivity awareness is encouraged regarding diversity in the science classroom. Recognizing the strengths and positive characteristics of each ethnic group and their importance to the scientific enterprise fosters mutual respect for all students and the culture they represent.

Sensitive educators assume that science literacy is within reach of all students and that the responsibility for getting students to that point is at the heart of his or her role. Each student's scientific performance is evaluated on the basis of



his or her opportunity to learn, prior knowledge, preparation, economic background, and individual needs.

Context

Throughout history, underrepresented groups have found solutions to problems related to medicine, the environment, agriculture, architecture, the arts, sports, music, and philosophy. Science curriculum and instruction can recognize these discoveries through the context of real-life experiences.

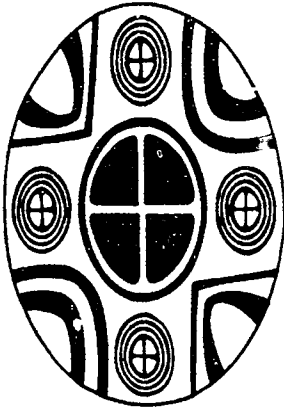

Instruction can include topics that have natural relevance to specific cultural mores. For example, Native Americans have a tradition of success in agriculture, stewardship to nature, astronomy, and food preservation. African Americans have a keen understanding of agriculture and have excelled in many areas of science through various contributions and inventions. Hispanics have a rich history, through storytelling, and the asset of bilingual learning.

Role Models

Students are influenced by cues and stereotypes they view in the media, textbooks, and other learning materials. Positive role models can openly affirm pride in one's own culture and convey images that counteract the historical omission and underrepresentation of various ethnic groups in science.

Students and teachers can use the accomplishments of role models as a basis and reference point to motivate successful performance. For example, tracing the history of African Americans in science or the role of Native American environmental stewardship provides a balanced perspective and dispels notions that these ethnic groups have not contributed to science. Integrating multicultural models into the curriculum helps all students to understand and appreciate various cultures and their accurate and appropriate representation in instructional materials.

Motivational Extensions

Because much learning occurs outside of the classroom, students can be encouraged to seek out information in their communities. Appropriate extension and application activities can support classroom multicultural instruction and take advantage of natural and cultural opportunities that are available in the students' environment. Students can gain

information from local experts and written material as well. Some examples include interviewing the elderly about their farming practices, medical treatment, storytelling, and weather predictions, as well as "shadowing" minority role models in scientific professions.

Another effective motivational tool is the use of interactive study groups and cultural support groups. The collaborative learning process can promote understanding and appreciation for individuals and their perspectives. The beneficial outcomes include working together cooperatively, sharing ideas, focusing on a goal, and improving achievement. Finally, and most importantly, motivational extensions help students develop decision-making and problem-solving skills in becoming effective agents of change in today's technological and multicultural society.

— Mozell P. Lang

Multicultural Science Resources

Multiculturalism in mathematics, science, and technology: Readings and activities. New York, Addison-Wesley, 1993.

Atwater, M.A. *Multicultural science education: Assumptions and alternative views.* Athens, GA, University of Georgia, 1993.

Aveni, A.F. *Empires of time: Calendars, clocks, and cultures.* New York, Basic Books, 1989.

Clewell, B.C., B.T. Anderson, and M.E. Thorpe. *Breaking the barriers: Helping female and minority students succeed in math and science.* San Francisco, Jossey-Bass, 1992.

Colorado, P., E. Landeo, and M. Jones. *Native science: Recording #2227.* San Francisco, New Dimensions Tapes, 1991.

Densmore, F. *How Indians use wild plants for food, medicine, and crafts.* New York, Dover, 1974.

Derman-Sparks, L. *Anti-bias curriculum: Tools for empowering young children.* Washington, DC, National Association for the Education of Young Children, 1989.

Dommen, A.J. *Innovation in African agriculture.* Boulder, CO, Westview, 1988.

Duschi, R.A. (1990). *Restructuring Science Education.* New York, Teacher's College Press, 1990.

Estes, J.W. *The medical skills of ancient Egypt.* Canton, MA, Science History, 1989.

- Ezeabasili, N. *African science: Myth or reality?* New York, Vantage, 1977.
- Froschl, M., and B. Sprung. *Hands on to science*. New York, Educational Equity Concepts, 1991.
- Goldstein, T. *Dawn of modern science*. Boston, Houghton Mifflin, 1988.
- Good, T.L., and J.E. Brophy. *Looking in classrooms*. New York, Harper and Row, 1987.
- Howard, J., et.al. *Efficacy: The elementary school curriculum*. Arlington, MA, The Efficacy Institute Incorporated, 1988.
- Jegede, O.J. Toward a philosophical basis for science education of the 1990s: An African view-point. In D.E. Herget (Ed.), *The History and Philosophy of Science in Science Teaching*. Tallahassee, FL, Science Education and Department of Philosophy, Florida State University, 1989.
- Jegede, O.J., and P.A. Okebukola. The effect of instruction on socio-cultural beliefs hindering the learning of science. *Journal of Research in Science Teaching*, 28(3), 1991.
- Kreinberg, N. The practice of equity. *Peabody Journal of Education*, 66(2), 1989.
- Lofquist, V. *Science lives: Women and minorities in science*. Minneapolis, University of Minnesota, Media Distribution, 1991.
- Nabhan, G.P. *Endung seeds: Native American and wild plant conservation*. San Francisco, North Point Press, 1989.
- Oakes, J., and Ormseth, T. *Multiplying inequalities: The effects of race, social class and tracking on opportunities to learn mathematics and science*. Santa Monica, CA, Rand Corporation, 1990.
- Oakes, J., A. Gamoran, and R.N. Page. Curriculum differentiation: Opportunities, outcomes and meanings. In P.W. Jackson (Ed.), *Handbook of research on curriculum*. New York, Macmillan, 1992.
- Ogbu, J.U. The individual in collective adaptation: A framework for focusing on academic underperformance and dropping out among involuntary minorities. In L. Weis, E. Farrar, and H.G. Petrie (Eds.), *Dropouts from schools: Issues, dilemmas and solutions* (pp. 181-204). Buffalo, State University of New York Press, 1989.
- Ogbu, J.U. Minority status and literacy in comparative perspective. *Daedalus*, 119(2), 141-168, 1990.
- Ogbu, J.U. Low school performance as an adaptation: The case of blacks in Stockton, California. In M.A. Gibson and J.U. Ogbu (Eds.), *Minority status and schooling: A comparative study of immigrants and involuntary minorities* (pp. 249-285). New York, Garland, 1991.

Solomon, R.P. *The creation of separation: Black culture and struggle in an American high school*. Albany, State University of New York Press, 1992.

Sprung, B., L. Colon, M. Froschl, and S. Jenoure. *Playtime in science: Implementing a parent/child activity program*. New York, Educational Equity Concepts, 1990.

Van Sertima, I. (1983). *Blacks in science: Ancient and modern*. New Brunswick, NJ, Transaction, 1983.

Weatherford, J.M. *Indian givers: How the Indians of Americas transformed the world*. New York, Crown, 1988.

Wong-Fillmore, L. *The curriculum and linguistic minorities: Handbook of research on curriculum*. New York, Macmillan, 1992.

Chapter Seven

Technology in the Library

The advent of the electronic age has begun to transform the nature of information exchange and retrieval; nowhere is this more apparent than in the library. What was once a storage and dissemination center for print resources is now more accurately called a media center, housing CD-ROM technology, videos, cassettes, laser disks, and computer terminals as well as print materials. As technological advances introduce new resources and information formats, these find their way almost immediately into the library. Given the increase in the number of users of and materials available via telecommunications technology, such as the Internet, in the recent past, it is evident that such resources will soon be consulted as commonly and regularly in library research as a call number.

However, librarians, teachers, students, and other library visitors must have access to the necessary equipment if they want to use these resources. Unfortunately, the new-found wealth of information that is available electronically is spawning a negative by-product: the widening gap between the "haves" and the "have-nots" in an information age. Some schools have sufficient funding for computer hardware and software that allows them to purchase up-to-date software and connect to the information superhighway. But others, like many of the schools whose librarians participated in the Institute, receive very little funding for such activities and subsequently cannot offer their students the opportunity to try these newer resources.

One of the AAAS Science Library Institute objectives is to train librarians to become disseminators, for science teachers, parents, and community members, of new science and mathematics education projects, products, techniques, and exemplary practices. In the interest of fulfilling this objective, one of the Institute sessions covered telecommunications technology and electronic dissemination of science and mathematics education reform information.

To address this imbalance, Institute participants engaged in a discussion of the place technology will have in their professional lives. Given that it is the professional responsibility of the librarian to remain abreast of alterations and advances in information dissemination in order to help library users access the most up-to-date information available, it follows logically that technology belongs first and foremost in the library. Several Institute participants attested to this when they used some of the \$500 they were awarded for completion of the Institute to enhance their multimedia collections by purchasing CD-ROM packages and computer software.

However, this does not mean that the current state of affairs in the library with respect to technology is desirable. For instance, in conducting the technology portion of the Institute, we found that:

- five participants had no computers in their libraries;
- only one participant used the Internet in the library;
- most participants indicated that they use their computers for collection management;
- only about one-third of the participants had modems in their libraries; and
- although participants indicated that they enjoyed learning about available technologies, such as the Eisenhower Clearinghouse and the Earth Explorer CD-ROM package, many expressed regret on the exit survey that they would not be able to use this information in their library settings.

It became apparent that at least among Institute participants, the library tends to be a low-tech place. It is more expedient for librarians to network on a personal level than electronically. According to participants, one of the main reasons for this is financial. Technology can get expensive; you need to have hardware and software, and there are also on-line charges to consider. Thus, funding has to be reallocated if the library is to be able to fulfill its role as an information center. Without access to the latest technologies, a library's resources will constantly run the risk of being outdated.

Libraries have a role to play in fulfilling the vision of an information superhighway that is accessible to all. To inform the discussion and help shape the dialogue on that role, we have excerpted information relevant to the discussion of libraries from *Putting the Information Infrastructure to Work*. On a practical note, we have also provided a list of on-line resources.

Excerpt From Putting the *Information Infrastructure to Work*

Description of Education and Lifelong Learning

Communications technology is transforming the way we live by connecting us with information and each other. The NII promises every business, government agency, hospital, home, library, and school in the nation access anywhere to voice, data, full-motion video, and multimedia applications. The impact of these capabilities on learning—for the children, for higher education students, and for lifelong learners—will be substantial.

The way Americans teach, learn, transmit and access information remains largely unchanged from a century ago. We find the following conditions in American education and training:

- The textbook remains the basic unit of instruction. Absorption of its contents tends to be the measure of educational success.
- Teachers and instructors use "chalk and talk" to convey information. Students are often recipients of instruction rather than active participants in learning.
- School teachers work largely in isolation from their peers. Teachers interact with their colleagues only for a few moments each day. Most other professionals collaborate, exchange information and develop new skills on a daily basis.
- Although half of the nation's school teachers use passive video materials for instruction, only a small fraction have access to interactive video, computer networks, or even telephones in the classroom.
- While computers are a frequent sight in America's classrooms and training sites, they are usually used simply as electronic workbooks. Interactive, high performance uses of technology, such as networked teams collaborating to solve real-world problems, retrieving information from electronic libraries, and performing scientific experiments in simulated environments, are all too uncommon.

The document Putting the Information Infrastructure to Work: Report of the Information Infrastructure Task Force Committee on Applications and Technology outlines the National Institute of Standards and Technology's (NIST) proposed plans for fulfilling the objectives of the Clinton Administration regarding the National Information Infrastructure (NII). These objectives are:

- *to develop, demonstrate and promote applications of information technology in manufacturing, electronic commerce, education, health care, government services, libraries, environmental monitoring, and other areas; and*
- *to develop and recommend technology strategies and policy to accelerate the implementation of the NII.*

- "U.S. schooling is a conservative institution, which adopts new practice and technology slowly. Highly regulated and financed from a limited revenue base, schools serve many educational and social purposes, subject to local consent. The use of computer technology, with its demands on teacher professional development, physical space, time in the instruction day, and budget...has found a place in classroom practice and school organization slowly and tentatively."¹

Events of the last two decades have proven that we can do better. We have found that most American children are capable of learning at dramatically higher levels—levels of performance we now expect only of our best students. We have learned this from research in cognitive science, from the educational achievements of other countries, and from pioneering efforts in our own schools. Moreover, after 35 years of research, we have found that technology can be the key to higher levels of achievement.²

Similarly, in the American workplace we have found that workers can achieve levels of productivity and quality equal to the best in the world.³ Well-educated, well-trained, motivated workers can produce high-quality goods and services at low cost, enhance industrial productivity and competitiveness, and sustain high living standards. High-quality education and training pay off for the individual whose skills are upgraded, for the company seeking a competitive edge, and for the nation in achieving overall productivity and competitiveness.

Our major foreign competitors place much greater emphasis on developing and maintaining workforce skills than we do. Experienced production workers at Japanese auto assembly plants, for example, receive three times as much training each year as their American counterparts. Research in our country has shown that workers who receive formal job training are 30 percent more productive than those who do not. Again, we have found that technology is the key to making training accessible and affordable—especially for small- to medium-sized firms with few resources of their own to devote to producing and implementing the training and lifelong learning their workers need and for workers who, on their own, are attempting to improve their skills or transfer them to new areas of endeavor.

Finally, in preparing students for the workplace, we have learned that interactive, high performance technology can

produce immersive, real world instructional environments. These environments can smooth long-term school-to-work transitions while helping to meet the immediate objectives of both schools and workplaces. Our efforts to develop this capability have been fragmentary and short-lived at best.

A Vision for the Use of the NII

The NII will be the vehicle for improving education and lifelong learning throughout America in ways we now know are critically important. Our nation will become a place where students of all ages and abilities reach the highest standards of academic achievement. Teachers, engineers, business managers, and all knowledge workers will constantly be exposed to new methods, and will collaborate and share ideas with one another.

Through the NII, students of all ages will use multimedia electronic libraries and museums containing text, images, video, music, simulations, and instructional software. The NII will give teachers, students, workers, and instructors access to a great variety of instructional resources and to each other. It will give educators and managers new tools for improving the operations and productivity of their institutions.

The NII will remove school walls as barriers to learning in several ways. It will provide access to the world beyond the classroom. It will also permit both teachers and students access to the tools of learning and their peers—outside the classroom and outside the typical nine-to-three school day. It will enable family members to stay in contact with their children's schools. The NII will permit students, workers, and instructors to converse with scientists, scholars, and experts around the globe.

Workplaces will become lifelong learning environments, supporting larger numbers of high-skill, high-wage jobs. Printed books made the content of great instruction widely and inexpensively available in the 18th century. The interactive capabilities of the NII will make both the content and interactions of great teaching universally and inexpensively available in the 21st century.

Education and Lifelong Learning Applications for the NII

The NII will provide the backbone for a lifelong-learning society. Education and training communities will better accommodate an enormous diversity of learners in an

equally diverse variety of settings. In addition to schools and workplaces, interconnected, high-performance applications will extend interactive learning to community centers, libraries, and homes. Education, training, and lifelong learning applications available from the NII may include:

- Multimedia interactive learning programs delivered to homes to immigrant children and their parents to collaborate on learning English as a second language.
- Troubleshooting and operating applications that access the computer-assisted-design (CAD) databases used to design workplace technology and to integrate the CAD data with instructional and job-aiding capabilities to provide just-in-time training and maintenance assistance.
- Comprehensive interconnectivity for students that allows them to receive and complete assignments, collaborate with students in distant locations on school projects, and interact with teachers and outside experts to receive help, hints, and critiques.
- Simulated learning activities such as laboratory experiments and archeological digs.
- Universal access interfaces for computers and telecommunications devices for students, workers, and others with disabilities to allow access to the NII.
- Affordable, portable personal learning assistance that taps into the NII from any location at any time and provides multimedia access to any NII information resource.
- Immersive, realistic interactive simulations that allow emergency teams made up of geographically dispersed members to practice together on infrequently used procedures that may be urgently needed to meet local exigencies.

Current Uses of Telecommunications for Education

The existing telecommunications infrastructure is composed of telephone, broadcast, cable, and electronic networks. It is used for education, training, and lifelong learning in five basic ways: 1) instructing with video; 2) gathering information from remote libraries and databases; 3) communicating using two-way asynchronous capabilities such as e-mail and information bulletin boards; 4) distance learning; and 5)

electronic transfer of instructional software and simulations.

- Instructional video. Seventy-five percent of America's schools have cable television, and half of its teachers use video material in their courses.¹⁰ The Stars Schools program is reaching 200,000 students in 48 states with advanced placement courses in mathematics, science, and foreign language instruction using fiber optics, computers, and satellites.¹¹ Cassette videotapes for instruction are widely used in schools and workplaces, and the development of these videotapes for both education and training has become a vigorous industry.
- Information collection. This activity includes location and retrieval of documents such as lesson plans and research reports, but it also includes newer data sources such as CAD databases for workplace technologies and equipment, and multimedia information retrieval from digital libraries that can be accessed by students, workers, or people in homes, libraries, and museums. Over 60,000 electronic bulletin boards are used by more than 12 million Americans every day.¹² The annual rate of Gopher traffic on the Internet, which directly represents an effort to use NII facilities to gather information is growing at an annual rate of approximately 1000%.¹³ The Department of Education has a Gopher server which points to or contains educational research information, such as the AskERIC service and information from sources such as CNN, Academy One, and the Educational Testing Service. NASA Spacelink makes lesson plans on space flight and related science topics available on the Internet.
- Two-way communication. This includes communication via electronic mail and conferencing among teachers, students, workers, mentors, technicians, and subject matter experts of every sort. Approximately one-quarter of the teachers in Texas regularly sign on to the Texas Education Network, or TENET, to share information, exchange mail, and find resources. A professor at Virginia Polytechnic Institute and State University teaches a writing course entirely on-line. Students swap writing projects and discuss their assignments on-line. In the workplace, electronic mail is used by more than 12 million workers, increasing to over 27 million workers by 1995. Just less than a sixth of U.S. homes now have at least one computer connected to a modem, and this

percentage is growing rapidly.¹⁴ As of July, 1993, there were four Internet hosts for every 1000 people in the United States. There are now 60 countries on the Internet. About 137 countries can now be reached by electronic mail.¹⁵

- Distance learning. Hundreds of thousands of students in schools, community colleges, and universities now take courses via one- and two-way video and two-way audio communication. In South Carolina, high school students across the state study with a teacher of Russian based in Columbia through South Carolina Educational Television. Boise State University offers a masters degree program conducted entirely over networked computers to students all over the country. The Department of Defense is investing well over \$1 billion in the development and implementation of networked distributed interactive simulation. This technology, which allows dispersed learners to engage in collaborative problem solving activities in real time, is now ready for transfer to schools and workplaces outside of the defense sector.
- Transfer of instructional software and simulations. Instructional programs, simulations, materials, and databases can all be accessed over the NII and delivered to schools, homes, libraries, and workplaces wherever and whenever it is desirable to do so. Currently, there are massive exchanges of software, databases, and files using the Internet, but relatively little of this activity occurs in the service of education, training and lifelong learning.

Nonetheless, compelling applications that will become indispensable to teachers, students, and workers are not yet available. All the capabilities of computer-based instruction and multimedia instruction can be distributed using NII facilities to schools, workplaces, homes, libraries, museums, community centers, store fronts—wherever and whenever people wish to learn. Yet the infrastructure and applications to support this level of accessibility for education, training, and lifelong learning uses have yet to be developed. Until compelling applications are available, educators will not realize the potential of the NII.

Immediate Objectives

NIST proposes the following objectives as goals for the near term:

- Schools, libraries, workplaces, and other learning sites will have high speed access to the NII, capable of supporting interactive, multimedia applications.
- Interactive, multimedia, high-quality educational applications for students in the basic learning areas and at different skills levels will be affordable and readily available in the marketplace.
- Schools will have internal networking capabilities and hardware capable of supporting high-quality applications.
- High-quality basic skills training that provides every motivated worker with the verbal and quantitative skills needed to learn and perform job-relevant tasks will be available in every workplace.

The following conditions should exist in support of these goals:

- Educators and the public will understand the potential of the NII to support high-performing learning environments, and they will be able to use NII resources effectively. Examples of the effective use of the NII for education, training, and lifelong learning, and evidence of concrete instructional benefits, will be widely available.
- All states, and a majority of school districts, will have comprehensive plans in place for the integration of technology into education and lifelong learning, that are linked to systemic education improvement plans, and will have begun implementation of these plans. At a minimum, these plans will address the challenges of diminished budgets while meeting requirements for increased investments in technology, professional development, maintenance, and technical support; provision for access by users with disabilities; provide broadband access to classrooms and other learning sites; and make changes in regulatory structures to facilitate infrastructure and applications investments.

- Investment by all levels of government in research, development, and evaluation, implementation, and technical support will increase dramatically. The investments will include professional development and technical assistance for teachers, school administrators, instructors, and managers in the use of information technologies. Providers of professional development and technical assistance will be encouraged to offer quality, easily accessible services in a variety of ways—including access through the NII. A majority of teachers will have access to personal telecommunications devices and networking services to support continuing professional growth and interchange of professional information.
- The demand for high-quality software packages and tools for education, training, and lifelong learning will grow rapidly and substantially such that the private sector will make massive new investments in the infrastructure and increase the quality and accessibility of the software packages and tools.
- Multimedia education and training packages will become portable so that they can be delivered across the NII and used when they reach their destination regardless of the hardware platform to be found there.
- Strategies and standards will be available for making at least the current generation applications accessible to users with disabilities or who are experiencing limitations due to aging.

Long Term Goals

To serve the needs of the educational community in the long term, an improved NII must have the following attributes:

- Convenient and equitable access. Connection to every American classroom, public library, and other learning locations will ensure that NII applications are available to all citizens as instructional tools and not available just as special, rationed services. Affordable workplace and home access will give all learners access to the NII resources whenever and wherever they are needed, will enable family members to be fully involved in the education of their children, and will allow workers to participate in a productive, lifelong learning society.

- High speed transmission capability. The NII will permit the interactive transmission of voice, videodata, multimedia applications, and other digitized information at the capacities needed to support education, training, and lifelong learning.
- Easy use. User interfaces will be simple and easy to use. Networks and applications will be interoperable, to permit easy access from all hardware platforms to the widest possible array of resources. The NII will have directories and other exploration tools that allow students, teachers, and workers to make their way conveniently through the massive amounts of available information. Tools to help users identify resources will be developed.
- Technological simplification. Telecommunications hardware and software will be simplified so that connecting a computer to the NII is no more complex than connecting to a telephone.
- Accessibility. User interfaces and information must accommodate users with a widespread range of abilities through built in interface options, flexibility, and compatibility with special access technologies.
- Security. The NII will accommodate security systems adequate to protect privacy, the confidentiality of sensitive information, and to safeguard intellectual property rights. The network must also accommodate varying levels of access to resources in education and training settings.
- Content. The NII must offer information, communication, and learning opportunities that meet high standards of quality and help America reach the National Education Goals.
- Portability. Interactive courseware will have the same operating interoperability—"plug and play"—now available in high fidelity audio systems. Investments in multimedia education and training programs will be preserved through NII delivery using interoperability standards in the development of software and hardware.
- Instructional delivery. Instructional delivery will provide workers with a "Ph.D. in a pocket." Instruction and

According to the eight National Education Goals, which are listed below, by the year 2000:

- *all children will start school ready to learn.*
- *at least 90 percent of students will finish high school.*
- *students will leave grades four, eight, and 12 with demonstrated competence in English, math, science, foreign languages, civics and government, economics, arts, history, and geography.*
- *teachers will have access to programs for the continued improvement of their skills.*
- *the United States will be first in the world in math and science achievement.*
- *every adult will be literate and possess the skills to compete in a global economy.*
- *every school will be free of drugs and violence.*
- *every school will promote involvement of parents in their childrens' education.*

job performance aiding will be delivered on a device that resembles a pocket calculator. Every complex device will include sufficient embedded training and user assistance to make it easily useable.

- Instructional intelligence. Instructional intelligence will support integrated, individualized tutoring that integrates goal setting, instruction, job performance aiding, and decision aiding into a single package. Natural language interaction will be an essential feature of this capability.
- Institutional integration. Institutional integration will be the most difficult challenge to meet. The new instructional capabilities will first have to be integrated into the routine, daily practice of our current instructional and workplace institutions. Just-in-time and just-enough training that is universally available will not only change the ways people are treated in the workplace but the workplace itself.

Notes

1. Melmed, Arthur (June 1993) *A Learning Infrastructure for All Americans*. Fairfax, VA: Institute of Public Policy, George Mason University.
2. For example, see U.S. Congress, Office of Technology Assessment (September 1988) *Power On! New Tools for Teaching and Learning*. OTA-SET-379 Washington, DC: U.S. Government Printing Office.
3. U.S. Congress, Office of Technology Assessment. (1990) *Worker Training: Competing in the New International Economy* (OTA-ITE-457). Washington, D.C.: U.S. Government Printing Office.
10. Corporation for Public Broadcasting Study of School Uses of Television and Video, Spring, 1991.
11. Withrow, F. *Personal Communication*, 2 March 1994.
12. *Investor's Business Daily*, 17 February 1994.
13. Treese, Win (December 1993) "Internet Index."
14. Melmed, Arthur, *op cit*.
15. Treese, Win., *op. cit*.
18. Melmed, Arthur, *op. cit*.
19. Princeton Survey Research Associates. NEA Communications Survey, Spring 1993. Weighted sample of 1,206 NEA member teachers.
20. Honey, M. and Henriquez, A. (1993) *Telecommunications and K-12 Educators: Findings from a National Survey*. New York, NY: Bank Street College of Education.
23. *Worker Training op.cit*.
24. The Fidler Report (January 1994).

BEST COPY AVAILABLE

Networks/Organizations and On-Line Resources

The following networks/organizations and on-line resources are printed in *Edutopia*, the newsletter of the George Lucas Educational Foundation. For further information about Edutopia or for a free subscription, contact The George Lucas Educational Foundation, P.O. Box 3494, San Rafael, CA 94912. Phone (415) 662-1600; fax (415) 662-1605.

Networks/Organizations

The Buddy System Project places technology in the homes and classrooms of Indiana students in grades 4–5 through a competitive grant process. Local coordinators are given training to facilitate Buddy's mission of extending learning through cooperative home–school activities.

Contact: Alan T. Hill, (317) 464-2074; fax (317) 464-2080.

The Iowa Communications Network (ICN) is a statewide fiber optic network with 125 endpoints serving a community of learners from preschool through adults. Full motion interactive video enhances learning opportunities for on-line users throughout the state.

Contact: Pamela Adams Johnson, (515) 242-4180, fax (515) 242-3155; pjohnson@po-1.star.k12.ia.us

The Center for Applied Special Technology (CAST) is a national organization designed to expand opportunities for all people, especially those with disabilities. Focusing on innovative uses of technologies, CAST pursues its mission through both direct services and research and development.

Contact: David Rose, (508) 531-8555; fax (508) 531-0192.

Hawaii FYI is an on-line service that puts K–12 schools, government offices, libraries, and homes in touch with information and resources unique to Hawaii and around the world. Resources for K–12 students include access to numerous discussion groups and databases.

Contact: Arthur F. Koga, (808) 586-4636; fax (808) 586-4625; akoga@hinc.hawaii.gov

The University of Washington's **Center for Educational Renewal** seeks the simultaneous renewal of Pre-School-12 schools and the education of its educators. It links universities and schools through its National Network and conducts research on the conceptual and practical aspects of simultaneous renewal.

Contact: Roger Soder, (206) 543-6230; fax (206) 543-8439;
rsoder@u.washington.edu

The Texas Education Network (TENET) is a statewide telecommunications network for K-12 educators. Serving more than 35,000 users, TENET provides electronic mail, databases, numerous Internet resources, and a comprehensive staff development program.

Contact: Connie Stout, (512) 471-2472; fax (512) 471-2445;
cstout@tenet.edu

The National Center to Improve Practice Network (NCIP^{NET}) is an electronic mail and conferencing system focused on helping students with disabilities. The system links administrators, practitioners, parents, and consumers and shares information on technology and media.

Contact: Denise Ethier, (617) 969-4529; fax (617) 969-3440;
DeniseE@edc.org

The National Center for Restructuring Education, Schools and Teaching (NCREST) is a networking and research organization. It offers services to inform and connect teachers, parents, and states through publications, conferences, and workshops.

Contact: Janine Ley-King, (212) 678-3432; fax (212) 678-4170.

The Coalition of Essential Schools (CES) supports secondary schools, districts, and states in improving student learning through research, professional development, and other cooperative activities. Their journal, *HORACE*, is published five times a year.

Contact: Lisa Lasky, (401) 863-2847; fax (401) 863-2045

Parents Let's Unite for Kids (PLUK) is a coalition that provides support to parents of children with all types of disabilities. PLUK offers a monthly newsletter, various support programs, and referrals to other support groups around the nation.

Contact: Kathy Kelker, (406) 657-2055; fax (406) 657-2061;
plukmt@aol.com

The California Middle Grades Reform Model is a state-wide network of 405 middle schools in 36 regional partnerships. The network is helping to improve education through various collaborative efforts including local and statewide professional development activities, and a bi-monthly faxline that shares information on such issues as flexible scheduling, advisory programs, and interdisciplinary team teaching.

Contact: Sandra Davis, (916) 322-2786; fax (916) 322-3390

The National Information Center for Children and Youth with Disabilities (NICHCY) is an information clearinghouse providing free information on disabilities and disability-related issues. Available to the general public, NICHCY also offers referrals to other organizations and a variety of publications in alternative formats (Braille, audio tapes) and in Spanish.

Contact: Information Specialist, (800) 695-0285; fax (202) 884-8441; nichcy@capcon.net

On-Line Resources

Global SchoolNet is a conference that serves as a centralized information source for on-line learning projects. Students and teachers can network with others around the world to share project ideas.

Contact: Al Rogers, (619) 475-4852; info@acme.fred.org

InterNIC Information Services is a clearinghouse, funded through the National Science Foundation, offering Internet support. Documentation, training materials, and on-line directories are available.

Contact: Reference Desk, (619) 455-4600; fax (619) 455-4640; Gopher: is.internic.net; URL: <http://www.internic.net>; refdesk@is.internic.net

NetTeach News is a newsletter that provides telecommunications resources for K-12 educators. Available in both paper and electronic forms, it documents resources, applications, and events on the Internet.

Contact: Kathy Rutkowski, (703) 471-0593; kmr@chaos.com

The Internet Services List is a bimonthly compilation of hundreds of public-access Internet resources. The list is available in a number of ways:

Gopher: <gopher.csd.uwm.edu> (select Remote Info Serv...);

URL: <http://www.uwm.edu/Mirror/inet.services.html>;

Email: inetlist@aug3.augsburg.edu (replies with lists)

Contact: Scott Yanoff; yanoff@csd4.csd.uwm.edu

The Usenet

The Usenet is an electronic network that facilitates the exchange of ideas among millions of people. All you have to do is read the electronic mail messages posted to a Usenet area, or newsgroup, of interest to you, and reply to any messages that catch your attention. You can get advice on many topics on the Usenet. The following is a list of newsgroups that may be of interest and relevance to K-12 school professionals interested in enhancing the science and mathematics content of their curricula.

k12.ed.comp.literacy K-12 computer literacy curriculum

k12.ed.life-skills K-12 career education, counseling

k12.ed.math K-12 mathematics curriculum

k12.ed.science K-12 science curriculum

k12.ed.tag gifted and talented K-12 students

k12.ed.tech K-12 industrial arts and vocational education

k12.library information technologies in K-12 libraries

k12.sys.projects on-line teaching projects

bionet.announce biology announcements

bionet.jobs scientific job opportunities

bionet.journals.contents biology journals

bionet.molbio.genome-program Human Genome Project

bionet.plants plant biology

bionet.sci-resources funding agencies

bionet.software.sources biology software
bionet.users.addresses who's who in biology
bionet.women-in-bio women in biology
sci.answers USENET science articles
sci.anthropology anthropology, study of humankind
sci.astro astronomy
sci.chem chemistry and related sciences
sci.edu the science of education
sci.environment environmental and ecological issues
sci.geo.meteorology meteorology
sci.math mathematics
sci.med medicine
sci.med.nursing nursing
sci.physics physics
sci.psychology psychology
sci.research.careers careers in scientific research
comp.ai.edu artificial intelligence for education
comp.arch computer architecture
comp.archives public access archives
comp.bbs.misc computer bulletin board systems
comp.benchmarks benchmarking techniques and results
comp.graphics computer graphics, art
comp.graphics.animation computer animation
comp.ivideodisc interactive videodiscs

comp.lang.misc miscellaneous computer languages

comp.publish.cdrom.software CD-ROM software

comp.society.development computer technology

comp.sources.games recreational software

comp.text.desktop desktop publishing

Chapter Eight

Libraries As Partners in Reforming Science, Mathematics, and Technology Education

Children are in school about six hours a day, five days a week, 36 weeks a year, but learning does not confine itself to this schedule. Children are learning all the time. Working as partners, families and other concerned adults in the community can play an important role in making sure that science and mathematics are part of what children learn every day. Libraries can help to initiate and nurture these partnerships.

Partnerships in the School

Teachers have primary responsibility for teaching science in the schools. Librarians can help teachers in a variety of ways. They can provide teachers with resources. They can also augment science instruction by providing informal science activities in the library. When librarians and teachers work toward a common goal, children will be the winners.

The role of the teacher in a reformed mathematics and science curriculum is not that of a dispenser of information; the science teacher must become a facilitator of learning. Information is provided to students in the context of a rich, learner-centered environment where active learning can occur. This means that the teacher must create an environment in which the student can be active in acquiring learning, primarily through the processes of inquiry, experimentation, and problem-solving.

To facilitate an environment conducive to active learning, teachers must become familiar with resources—curriculum materials and human resources, such as community members with special expertise—that support such learning.

To truly change science education, a widespread effort is required. Librarians, teachers, administrators, policymakers, parents, and community members must all contribute to the process of furthering reform. The AAAS Science Library Institute sought to build capacity for librarians to form partnerships with other stakeholders who share the vision of promoting excellent and effective education for all children. As the reports in Chapter 11 of this book indicate, many such partnerships were forged by Institute participants. This chapter, written by Maria Sosa, editor-in-chief of SB&F, focuses on three key areas of partnership: schools, home, and community.

Libraries can provide the professional support teachers need by disseminating information about recommended resources and research findings that can help teachers become more effective. Librarians can be particularly helpful in providing material resources that support students' exploration of scientific ideas, such as children's trade books and magazines, videos, films, and computer software.

AAAS Science Library Institute participants collaborated with teachers in many ways. At Paul VI High School in Fairfax, VA, school media specialist Diane Schule was able to demonstrate the value of the library to science teachers by making it a focal point for previewing science resources for classroom use. In the Duke Ellington School of the Arts in Washington, DC, librarian Pat Bonds engaged teacher participation by relating her Science Library Institute project to one of the objectives required for completion of senior high school biology. Similarly, Charles Phillips enhanced existing science curriculum at Bancroft Elementary School in Washington, DC, by purchasing materials that supported implementation of the Jason Project. Media specialist Pauleze Bryant supported an integrated science curriculum by coordinating a joint effort that linked the chemistry and social studies classes at Calvin Coolidge High School in Washington, DC.

For many librarians, the most difficult part of forging a partnership with teachers is taking the first step. In an already overcrowded day, media specialists may feel some reluctance to take on what might be perceived as additional responsibilities. The same is true of teachers. What Science Library Institute participants found, however, was that when both partners come together with a clear understanding of roles, the collaboration is productive and beneficial. The role of administrators is also critical. Science Library Institute participants actively enlisted support from school and library administrators. This support resulted in a deeper level of commitment.

Partnerships in the Home

If families view science as an important subject for all students, they will more likely promote science activities for their children. Libraries can help make parents more aware of the importance of science. They can also provide opportunities for families to participate in informal science experiences that provide a strong foundation for learning science.



Research tells us that parents play a vital role in the science and mathematics education of their children. Although most parents are willing to assume a more active role, many need to find an entry point. Libraries can help provide that entry point by sharing with parents a variety of strategies they can use to help children succeed in science and mathematics.

Librarians can help to encourage dialogue between parents and teachers. When parents and teachers communicate, children's classroom experiences can improve dramatically. Teachers can benefit from a parent's insight into a child's behavior and experiences. Parents can better understand the teacher's goals and help to support classroom learning. At Turner Elementary School in Washington, DC, Institute participant Judy Bullock organized a science media fair that brought together teachers, students, and parents to view new science resources and participate in hands-on science activities. At Calvary Lutheran School in Silver Spring, MD, library media specialist Violet Lentner spearheaded a sharing science activity during Spring Open House.

To encourage informal science experiences for children, libraries can provide parents with a list of community and science organizations that offer tutorial assistance and programs that provide science and mathematics enrichment for children of all ages. Libraries can also disseminate information about activities at zoos, museums, nature centers, parks, and community organizations such as 4-H clubs. They can encourage families to do science and mathematics activities at home by making science boxes that contain simple activities that children can check out and take home or by putting together simple monthly science activities that families can do. Encourage families to share their results with the library. These can be incorporated into displays that promote the family activities.

Many of these strategies can be inaugurated with a Family Night at the Library. Science Library Institute participant Rose Pringle, of Roper Middle School in Washington, DC, framed her project around a family event in order to gain parental support for Roper's new focus on mathematics, science and technology.

Partnerships in the Community



Every school or library is part of a larger community that has an important stake in making sure that the children in that community succeed in school. When educators reach out to the community, they often find that there are many individuals who will gladly volunteer time and resources to enhance educational opportunities for children. Scientists and science-based organizations often have a special interest in partnering with schools.

Classroom or library visits by scientists can stimulate young people's interest and curiosity about science and engineering. A perceptive scientist can convey the excitement of working in science. An engineer can provide insights on solving real-world problems. And a mathematician can present the role of mathematics as a way of describing and modeling the ideas in science and engineering. Scientists can bring librarians, teachers, and students up-to-date on the latest developments in their fields. They can describe career opportunities from their perspective of the workplace and demonstrate some of the livelier aspects of science.

Students and scientists alike can benefit from conversations in informal settings such as libraries. Informal conversations give students opportunities for greater insights into science and engineering. They can pursue their interests and questions about science with someone who really does it every day. These personal interactions can help students understand what makes scientists tick.

The benefits of such interactions flow both ways. The same informal conversations provide settings for scientists to gain better insights into the diversity of young people in our schools and their interests. Scientists can find out firsthand about students' concerns and thoughts on understanding and navigating the physical environment and social worlds of today and tomorrow. Conversations with students give scientists an opportunity to expand their appreciation and responsiveness to how young people learn science and mathematics.

When scientists visit classrooms or libraries, they should be encouraged to conduct simple hands-on science activities with students. In this way, students engage in the phenomena of science and encounter the products of engineering through activities and projects that interest them. Students

experience science as a way of knowing; they experience engineering as a way of designing. By working with scientists, students can more readily acquire the spirit and meaning of science.

Libraries can also play a part in encouraging teachers to take students to places of science by disseminating information about field trips and tours in the community that enable students to explore the science and engineering enterprises around them. Students can see firsthand where science and engineering is done and obtain glimpses of what kinds of work scientists do. Students can meet scientists, engineers, and mathematicians in the workplace. They can come away with some understanding of what a career in science and engineering could be like and some idea of the rewards and satisfactions of the work.

At the third Institute session, Program Evaluator Mary Chobot led a brainstorming session that yielded a list of suggestions for utilizing the skills of scientist partners in the library. These suggestions include having the scientists:

- assist in evaluating print and software collection for weeding and replacement;
- act as a resource person for simple hands-on experiments;
- attend brown-bag lunches with teachers;
- work with students as mentors;
- conduct seminars to generate ideas for science fair projects, etc.;
- provide information and assistance on-line;
- advise on stand-alone science activities;
- recommend media for circulation;
- provide assistance in setting up science projects in a public library setting;
- help librarians study the science of art and generate authentic murals (ocean or jungle scenes);
- discuss career possibilities for minority and women scientists;
- empower kids as scientists;
- help librarians learn more about a specific technology (CD-ROM, telecommunications, Internet);
- establish a resource database of skills;
- help librarians learn more about specific programs that use telecommunications technology;
- help students construct scale models; and
- help students plant a garden (for beautification as well as learning).



Partnerships are as varied as the individuals who form them. Sometimes partners are brought together by long-term goals, and sometimes the objectives are more immediate. The pieces may already be in place in some instances, and in others the groundwork must be laid. In any event, Institute participants demonstrated that librarians and media specialists are critical links in making such partnerships effective. At Chillum Elementary School in Hyattsville, MD, school media specialist Rose Jones tapped into an existing coalition of parents, teachers, community activists, and business leaders to promote the shared vision of making Chillum a county-designated science, mathematics, and technology school. Working toward a more immediate goal, Eleanor Organ led a group of students, teachers, and volunteers from the Environmental Protection Agency in a campaign to clean up the front lawn and playground of Bowen Elementary School in Washington, DC. Partnerships have played a key role in the success of all the projects conducted by Science Library Institute participants.

— Maria Sosa

Chapter Nine

Fund-raising for the Media Center

School personnel, particularly school media specialists, often find themselves in the position of wanting or needing resources and materials that don't fit their budgets. With the advent of technologies such as CD-ROM, video, and telecommunications, it has become increasingly expensive to maintain a well-stocked, up-to-date media center.

Although the ideal situation would be for school districts to have enough funding to give every school department and program every desirable resource, the reality can differ greatly from this ideal. This fact leaves a media specialist with a few options. The first option is to operate according to a very strict budget, selecting only the most necessary resources to augment the media collection and tracking down free resources whenever possible. Most media specialists become adept at this!

But what some of our Institute participants did not realize is that they have another option: fund-raising for the media center on their own. There are many resources and sources of funding that cater specifically to libraries and media specialists and their projects; for the Institute participants, the problem was one of access. How could they contact such places? What is the formal procedure for requesting funding? Did they really have a chance of receiving support from private organizations?

The following section shows how to raise funds. If you have a good project idea and the endorsement of your school administration, you may be able to win grant money for your project!

The materials budgets for Institute participants varied by school district, among other factors, but all Institute participants described library "wish lists" that exceeded their resources. The Institute serves to empower librarians to develop an awareness of, and an ability to capitalize on, fund-raising opportunities. This section was synthesized from the fund-raising suggestions of Roberta A. Scull, director, Louisiana Energy and Environmental Resource and Information Center (LEERIC) and Yolanda S. George, deputy director, Directorate for Education and Human Resources Programs, AAAS. Both Scull and George are veteran fund-raisers.

General Suggestions for Successful Fund-raising

The first hard and fast rule of fund-raising is: Remember that people give money to people. Try to adopt a positive, proactive attitude when planning your fund-raising strategy. If you believe your project should be supported and that it is within your power to obtain support, you will be better able to persuade others of that fact!

1. Make your case for support a compelling one. In letters, calls, and visits, emphasize in tangible terms why your activity is important to the local area and how it serves a critical need. Do **not** describe how it works. Focus on aspects of your situation that make it unique from other programs.
2. Know as much as you can learn about your prospective funder. Understand the funder's goals and objectives and demonstrate how support of the coalition will help to meet those goals.
3. Anticipate and overcome objections before they arise.
4. Identify how the funder's support will be recognized. This is particularly important with corporate support.
5. Be able to answer questions about how your activity or coalition will support itself over the long term.
6. When making calls, keep the "pitch" short, but don't forget to ask for the money.
7. Identify opportunities for non-monetary or in-kind support from corporations and others.
8. Follow-up is critical. Letters should indicate that follow-up will take place within a certain time frame. Be sure that it happens. After a call, send additional information or other materials that might help to increase the level of interest of the prospective funder. If a funder indicates "not now, but later," be sure to follow up at the appropriate time. If the prospective funder turns you down, find out why. Where did you "miss the boat?"

Elements of a Successful Fund-raising Plan

It is important to take a detail-oriented approach to seeking funding. Be as specific as you can when you are planning your project and writing your grant proposal; when funders are awarding grants, they want assurance that there is a comprehensive plan in place that is directed by competent individuals. Include consideration of the following elements in your project and your proposal.

1. **Program Goals:** Write these clearly and concisely for communicating them to a prospective funder.
2. **Financial Goals:** Determine "bottom-line" figures for the funding campaign and identify opportunities for in-kind support.
3. **Prospects and Approach Strategies:** Amass detailed information on all prospects and specific plans of approach for each.
4. **Board Members and Other Volunteers:** Brainstorm ways of using these individuals in the campaign's development/fund-raising committee.
5. **Follow-up Plan:** Make some personal contact either by phone or in person with every funder you approach. Make a concerted effort to identify what worked and what didn't. Modify your plan of approach accordingly.
6. **Acknowledgment and Recognition:** Determine the sort of recognition the funders can expect. Determine opportunities for future partnerships with them.

Submitting a Successful Grant Proposal

If you have never written a grant proposal before, the prospect can seem daunting. But lots of people write grants, and many of those people are financially rewarded for their efforts. Even if your first grant proposal doesn't get funded, the grant-writing process is a valuable learning experience, because there will always be other grants for you to apply for, which means other opportunities for you to amend your proposal's weaknesses. The following list of suggestions may help you improve your ability to identify the key elements of a successful grant proposal.

1. Read the proposal information several times and then outline which proposal elements **must** be included.
2. Include a table of contents of proposal elements; refer the reader to the page or paragraph that corresponds to the proposal elements.
3. Have an idea with a new twist. Many people will be submitting grant proposals, so if your idea is not fresh and does not suggest something that will spark interest, your proposal may not be selected.
4. Talk to teachers and administrators about your idea and enlist a support group of readers for your grant proposal. You will need **several** critical readers to edit for you.
5. Check your spelling, grammar, and punctuation.
6. Use a catchy title for your proposal.
7. Show how this proposal can be replicated and generalized to your entire school, county, and state.
8. Include a needs statement; this shows how your project will fill a need in your classes, school, county, and state.
9. Decide whether you will share materials with others after the project is completed.
10. Give an idea of how many students will be served by your proposal. The more, the better.
11. If you or your students will develop a product based on the project, describe it carefully.
12. State your budget in numbers and then support it with a very clearly written budget explanation that should include people, stores, vendors. List any free or donated materials that will reduce your budget as free items or as possible matching funds.
13. Assume the reader knows nothing about what you are describing. Never abbreviate or use acronyms without explaining their meaning. Never use colloquialisms.
14. Be brief and to the point. The readers do not want your life history.

Types of Support

There are countless foundations or branches of corporations whose main purpose is to engage in philanthropic activity. They have a certain amount of money each year to use for supporting grant proposals. Such places can be grouped into several categories; places in some categories will be more helpful to you than places in other categories. It all depends on your project and your own organization. The foundation categories and their characteristics are detailed below.

Corporate Foundations:

- Generally, grants are small in size; they average \$5,000–\$10,000. A grant of \$25,000 is considered most generous. Initial grants or contributions may be small; you will be judged on your stewardship of any gift, regardless of size.
- New groups/projects compete for a limited pool of discretionary funds.
- It is often best to solicit in late summer/early fall to coincide with corporate budgeting cycles.
- Projects must relate to corporate bottom-line interests and priorities to be successful; this must be clear.
- Internal contacts are the key to success; "cold" approaches are most often unsuccessful.
- There is a minimum 6 month turnaround in response to the request if it falls within the above time frame. This is true at the national level, but a local plant or division of a corporation may move more quickly.
- Historically, corporate funders have often awarded grants in fields of education, federated giving (United Way, etc.), minority enterprises, and local social services that demonstrate a benefit to the company employees as well as the community at large.

National Foundations

- They are not limited to a geographic area in their support.
- They are usually quite large, with assets of \$25 million or more.

- Programs or proposals with national or at least regional implications are very attractive.
- They have well-defined philanthropic goals.
- There is usually fierce competition for these grants.
- Examples include: Ford Foundation, Lilly Endowment

Special Interest Foundations

- They have a single field of interest.
- They are not limited to a geographic area in their support.
- They can be sources of special subject information as well as financial support. For example, the Joseph P. Kennedy Foundation provides information on mental retardation, the Robert Wood Johnson Foundation provides information on health, and DeWitt Wallace/Reader's Digest provides information on education and libraries.

Family Foundations

- The largest number of foundations are family foundations.
- The support pattern is often motivated by personal matters; there is no set special interest.
- Family members often control the foundation.
- Most of these are very small, with no staff and a very limited geographical pattern of giving.
- Examples include: Brown Foundation, McKnight Foundation, Evelyn J. Daniels Foundation

Community Foundations

- They are not grant foundations but public charities.
- They maintain their favored tax status by collecting money from the public and directing grants within the community for which they are named.
- Examples include: Baton Rouge Area Foundation, Cleveland Foundation.

Identifying a Prospective Funder

Once you have started your research, you will realize that there are thousands of potential funders for any given project. Obviously, it is impossible to appeal to every funder that might have resources for you. Below are lists of key questions and research parameters for you to consider that can help you narrow down your choices and pinpoint a handful of funders who would be favorably disposed toward your particular project.

Key Questions:

1. Which groups, companies, foundations, or individuals have a vested interest in your project or activity? What kind of assistance are they most likely to provide: funding, in-kind support, advice on whom to approach?
2. Are there board members or other volunteers who could be enlisted to assist in your fund-raising efforts by researching literature, identifying contacts, etc.?
3. Which local and national corporations/foundations are funding projects with objectives similar to yours?

Research Parameters:

1. Examine the funder's areas of interest; do not look at education or health donors only—be creative!
2. Note the type of support given; is it basically in-kind?
3. Find out grants and organizations the funder has funded.
4. Identify geographic and programmatic limitations associated with the funder. Pay particular attention to these limitations. Some foundations fund only programs located in certain areas of the country; corporations may only fund projects housed in the communities where they have facilities.
5. What is the range of the average gift from the funder?
6. Know and meet the funder's deadlines.
7. Identify contacts in prospective companies and foundations who are known to you or your board members.

Writing a Grant Proposal

Once you have identified a prospective funder, it is time to write a grant proposal to request funding. Many people have never written a grant proposal before and are reluctant to try, but in large part, a successful grant proposal is a matter of organization. Be sure to consult the proposal materials from each individual funder to determine the areas they emphasize; requirements differ with each funder.

To begin, you may want to develop an action plan that helps you give your project the proper focus and organization. Below are guidelines for writing an action plan as well as a sample action plan that gives you the general idea.

Action Plan Guidelines

Your action plan should contain the following information:

- **Who** is the **target audience** for your proposed effort? Provide a few details about your target audience. Who will be involved in **planning** the project? Try to involve as many key people as possible: principal(s), teachers, students, parents, volunteer scientist(s), as appropriate.
- **What**, specifically, do you intend to do for this audience? Describe in this section what **objective** you wish to accomplish. Briefly describe the need that you plan to address and how this relates to the science/math/technology strategies you have learned in the Institute.
- **Where** will this proposed activity occur? Will the activity take place in the library or at some other site?
- **How** will you accomplish your objective; that is, what is your **plan of action**? Describe the situations you will undertake to plan and carry out the project. Include activities, staff/volunteers who will be involved, materials to be purchased, etc.
- **When** will the proposed activity take place? Include the date(s) and time.
- **Expected Outcomes**: How will your project help to meet the need(s) you described? How will you determine what, if any, **effect** your program has had on the target audience?

- **Budget:** In addition to the grant, will you use any **supplemental funds** from other sources (e.g. PTA, friends of the library, etc.) for the proposed activity? If so, include these funds in your budget. How will the money be used?

Sample Action Plan: Science Olympics

This action plan describes how a \$500 mini-grant will be used at the McNamara Elementary School Library. The grant will be used to stage a **Science Olympics**.

WHO: The target audience for the grant are all third through sixth grade students in the school. There are approximately 300 students in 15 classrooms. Students at McNamara School represent a cross-section of the community. Approximately sixty-five percent of the student body is Black; twenty-five percent White, seven percent Hispanic; and the remainder Asian. The student body has performed above the average in district standardized testing in reading and math. The school has an active parent/teacher organization whose members will be asked to volunteer in staging the **Science Olympics**. This idea has been discussed with the teachers and principal. They have expressed their support, and the teachers are willing to integrate the **Science Olympics** into their classroom science and math activities.

WHAT: The objectives of this project are to raise the interest level of students and teachers in science; to develop teamwork and problem-solving skills; and to show the students that science can be fun. We hope to capitalize on the interest in the **Olympics** and to make this an annual event at the school. The **Science Olympics** will consist of four "events:"

- **Facts & Figures:** Teams of four students will attempt to solve a science puzzle using clues found in reference materials, books, periodicals, and other media in the library. The objective of this event is to get students to use a variety of science/math/technology materials.
- **Flights of Fancy:** Teams of students will build and fly paper airplanes. The planes will be judged on design and length of flight. The objective of this event is to introduce students to some basic principles of aerodynamics and design.

For proposal-writing practice, Institute participants submitted an action plan, a scaled-down grant proposal, describing how they planned to use a \$500 mini-grant they were awarded for completion of the Institute. The action plan reprinted here, developed by Mary C. Chobot, was distributed to the participants as a model for them to follow as they organized their ideas.

BEST COPY AVAILABLE

- **Bridges of Understanding:** Using straws, tongue depressors, balsa, or other available materials, teams of students will design and build bridges that will be tested during the **Olympics** for their load-bearing capability. The objective of this event is to introduce the students to some basic principles of engineering and the use of geometric shapes in design.
- **Great Eggspectations:** Using commonly available packaging material, teams of students will construct a container for an egg that will allow the egg to survive unbroken from a drop of ten feet. The objective of this event is to help students develop problem-solving skills.

There will be two levels of competition:

- **Junior Olympians:** Third and fourth graders
- **Senior Olympians:** Fifth and sixth graders

The 300 students will be divided into 75 teams, with each team containing an average of four students. Classroom teachers will assist in forming the teams for their classroom. Each team will enter only one event. This means that there will be approximately 18-20 teams per event. Each classroom will select a country of the world to represent. Part of the preparation for the **Science Olympics** will be for each class to identify and know something about a famous scientist/mathematician from that country, from an ethnic group represented in that country, or an American scientist whose ethnic origins relate to that country.

Medals or ribbons, depending on cost, will be awarded to each member of first through fifth place teams. The remainder of the students will get certificates of participation. Judges will include teachers, parents, and a volunteer scientist for each event.

WHERE: The **Science Olympics** activities will take place in the library, the cafeteria, and selected classrooms.

HOW: The following activities will be undertaken to plan and conduct the **Science Olympics**:

- Brief principal and teachers and secure commitment to participate.
- Publicize event to parents (letter home) and students (flyers/student-created posters).

- Develop guidelines for each event.
- Secure judges.
- Purchase and distribute materials needed for four events and order additional science/math/technology materials for the library.
- Set up event areas.
- Conduct **Olympics** and present awards.
- Conduct a brief survey of selected students and teachers to see how they liked the event and what they believe they learned from it.

WHEN: The **Science Olympics** will be held during National Science and Technology Week (April 24-30). The possibility of holding the actual event in the evening will be explored to allow parents the opportunity to assist/observe the event.

EVALUATION: A brief survey will be conducted of selected students and teachers to see how they liked the **Science Olympics** and what they believe they learned from it. Classroom teachers will give students a writing exercise the day after the event asking them to write about what they liked most, what they learned, and what suggestions they have for the **Science Olympics** for next year. They will be told that their essays will be given to the librarian to use in evaluating the project and to plan next year's **Science Olympics**.

BUDGET:

Funds:	Mini-Grant	\$500
	McNamara PTA	\$100
	Total:	\$600
Expenses:	Books and other science/math/technology materials to supplement collection and for use in Facts & Figures event:	\$350
	Materials for event kits:	\$150
	• 20 plane kits	
	• 20 bridge kits	
	• 20 egg drop kits	
	Awards/Certificates	\$100
	• 40 medals/ribbons	
	• certificates	
Total:		\$600



Fund-raising Resources

There are many publications you can read to find places that are interested in receiving grant proposals. Here are a few.

Corporate Publications

The Corporate 1000—Yellow Book
Corporate 500
Taft Corporate Giving Directory
Standard and Poor's (Corporate and Directors)
Corporate Annual Reports
Directory of Corporate Affiliations
National Directory of Corporate Giving
Directory of the International Corporate Giving in America

Foundation Publications

Foundation Directory
Foundation Annual Reports/Grant Guidelines
Source Book Profiles
Foundation Grants Index

Magazines and Newspapers

Foundation Giving Watch (newsletter)
Donor Briefing (newsletter)
Corporate Philanthropy Report (newsletter)
Philanthropic Digest (newsletter)
Chronicle of Philanthropy
Chronicle of Higher Education
Forbes
Fortune
Business Week
Local Business Publications

Other Publications

Federal Register
Membership Rosters of Local Business Organizations
Foundation Center Research Services
DIALOG Database Service

Possible Funding Sources

Listed below are some national offices and foundations that frequently award funding to schools and libraries. You can write or call them to receive guidelines for submitting proposals to them.

ACS Teacher Travel Grants

Office of High School Chemistry
American Chemical Society
1155 16th Street, NW
Washington, DC 20036
(202) 872-4590

Areas: Applicants (high school science teachers) must design presentations that focus on ACS programs. They may use grants to attend regional and national meetings of ACS and the National Science Teachers Association.

Annenberg/CPB Math and Science Project

Guidelines

901 East St., NW
Washington, DC 20004-2006
(202) 879-9658

Areas: Projects should create visual resources that will show how various teachers implement science instruction changes in kindergarten through eighth grade, or projects should link rural math and science teachers via computer, or projects should develop and implement new, cost-effective strategies for educating the public and parents, or projects should develop strategies for information and resource-sharing among teachers.

Bristol-Meyers Squibb Foundation

345 Park Avenue
New York, NY 10154
(212) 546-4566

Areas: Projects in K-12 public education in the areas of math, science, and health education and the shortage of qualified teachers in those areas.

Nathan Cummings Foundation

885 Third Avenue, Suite 3160
New York, NY 10022
(212) 230-3377

Areas: Projects in arts, environment, and health education.

DuPont Community Initiatives

DuPont de Nemours & Co., DuPont External Affairs, N-9541
Wilmington, DE 19898
(302) 774-6376

Areas: Elementary and secondary schools.

Hasbro Children's Foundation

32 W. 23rd Street
New York, NY 10010
(212) 645-2400

Areas: Preferably projects serving poor and at-risk children.

Edward G. Hazen Foundation

505 Eighth Avenue
New York, NY 10018
(212) 967-5920

Areas: Preferably programs involving disadvantaged and minority youth, partnerships, school reform.

**William Randolph Hearst Foundation and
the Hearst Foundation, Inc.**

888 Seventh Avenue
New York, NY 10106-0057
(212) 586-5404

Areas: Preferably disadvantaged and minority youth, private education, scholarships.

Hitachi Foundation

1509 22nd Street, NW
Washington, DC 20037-1073
(202) 457-0588

Areas: Particular interest in collaborative projects involving schools and higher education institutions, museums, arts agencies, or other organizations, and likes to see efforts that can be replicated in other communities. Hitachi is also interested in parent involvement projects.

Intel Foundation

5200 N.E. Elam Yound Parkway
Hillsboro, OR 97124-6497
(503) 696-2390

Areas: Projects enhancing math and science literacy.

International Paper Company Foundation

2 Manhattanville Road
Purchase, NY 10577
(914) 397-1500

Areas: Preferably advanced students, at-risk students, cur-

riculum development, disadvantaged and minority youth, educator training, partnerships, public education.

The J.M. Foundation

60 East 42nd Street, Room 1651
New York, NY 10165
(212) 687-7735

Areas: Preferably community programs, economics, public education, volunteers.

W. Alton Jones Foundation

232 East High Street
Charlottesville, VA 22901
(804) 295-2134

Areas: Preferably leadership development, partnerships, research, school reform.

W.K. Kellogg Foundation

1 Michigan Avenue, East
Battle Creek, MI 49017-4058
(616) 968-1611

Areas: Supports projects to develop new approaches in science education; to promote effectiveness and leadership in those who work with youths; and to provide child care services.

K-Mart Corporation

3100 W. Big Beaver Road
Troy, MI 48084
(313) 643-1000

Areas: Supports innovative elementary and secondary education programs, research and curriculum development related to business or marketing and programs dealing with child welfare and the family unit.

John D. and Catherine T. MacArthur Foundation

140 South Dearborn Street
Chicago, IL 60603
(312) 726-8000

Areas: Basic skills, curriculum development, educator training.

The Andrew W. Mellon Foundation

140 East Street
New York, NY 10021
(212) 838-8400

Areas: Preferably college preparation, educator training, literacy programs, partnerships, pregnancy prevention, private education, public education.

Meyer Memorial Trust

1515 SW Fifth Avenue, Suite 500

Portland, OR 97201

(503) 228-5512

Areas: Projects in parent education, early childhood development, improving early educational opportunities and new and effective ways to intervene with youth at risk.

General Mills Foundation

P.O. Box 1113

Minneapolis, MN 55440

(612) 540-4662

Areas: Curriculum improvement, inservice teacher training, arts education, dropout prevention, and multiculturalism.

Monsano Fund

800 North Lindberg Boulevard

St. Louis, MO 63167

(314) 694-4596

Areas: Capital projects, public education, science and math, start-up programs.

Charles Stewart Mott Foundation

1200 Mott Foundation Building

Flint, MI 48502-1851

(313) 238-5651

Areas: Curriculum development, disadvantaged and minority youth, family involvement, pregnancy prevention, pre-school programs, public education.

The David and Lucille Packard Foundation

300 Second Street, Suite 200

Los Altos, CA 94022

(415) 948-7658

Areas: Preferably at-risk students, basic skills, child care, disadvantaged and minority youth, family involvement, fine arts, job skills training, leadership development, partnerships, pregnancy prevention, scholarships.

The Pew Charitable Trusts

Suite 501, 3 Parkway

Philadelphia, PA 19102-1305

(215) 568-3330

Areas: Preferably community involvement, disadvantaged and minority youth, dropout prevention, employment programs, family involvement, pregnancy prevention, substance abuse prevention.

Public Welfare Foundation

2600 Virginia Avenue, NW
Washington, DC 20037
(202) 965-1800

Areas: supports public school districts, higher education institutions, and nonprofit organizations that provide direct services to low-income and disadvantaged populations.

The Rockefeller Foundation

1133 Avenue of the Americas
New York, NY 10036
(212) 869-8500

Areas: Preferably at-risk students, basic skills, arts and humanities, partnerships, cross-cultural activities

The Spencer Foundation

875 North Michigan Avenue
Chicago, IL 60611
(312) 337-7000

Areas: Preferably disadvantaged and minority youth, research, school reform.

Texaco Foundation

2000 Westchester Avenue
White Plains, NY 10650
(914) 253-4000

Areas: Supports initiatives to promote math and scientific literacy, as well as teacher and leadership training, in regions where Texaco has a significant presence.

These are just a few suggestions to get you started, but we hope they demonstrate that there are many places "out there" that take an active interest in learning and libraries. And that's where you come in! Your ideas for enhancing the learning experiences of your students coupled with the finances and backing of a grant foundation could make for a winning combination for your students, your school, and your community.

— Valerie Worthington, editor

After writing several letters of inquiry to the PTA president, school board members, and the Advisory Neighborhood Commission in her district, Clara Neal, the library media specialist at Dunbar Senior High School in Washington, DC, received an anonymous donation of \$1200 worth of periodicals for her library. Fund-raising can really work for you!

BEST COPY AVAILABLE

Funding References Especially for Librarians and Educators

General References

Annual Register of Grant Support. National Register Publishing Co., Wilmette, IL, 1991.

Bauer, David G. *The "How To" Grants Manual: Successful Grantseeking Techniques for Obtaining Public and Private Grants*, 2nd ed. American Council on Education, New York, NY, 1988.

Flanagan, John. *Successful Fund-raising: A Complete Handbook for Professionals and Volunteers*. Contemporary Books, Chicago, IL.

Greever, Jane C. and Liane Reif Lehrer. *Guide to Proposal Writing*. The Foundation Center, 1993.*

Lehrer, Liane Reif. *Writing a Successful Grant Application*, 2nd ed. Jones and Bartlett, Boston, MA, 1989.

Marjolin, Judith B. *The Foundation Center's User Friendly Guide: Grantseeker's Guide to Resources*, 2nd ed. The Foundation Center, 1992.*

Smith, Craig W. and Eric W. Skjei. *Getting Grants*. Harper and Row, New York, NY, 1980.

Foundation Sources

Foundation Directory, 15th ed. The Foundation Center, New York, 1993.*

Foundation Grants Index: A Cumulative Listing of Foundation Grants, 1990/1991. The Foundation Center, New York, 1990.*

Haile, Suzanne, ed. *Foundation Grants to Individuals*. The Foundation Center, New York, 1991.*

Jones, Francine, ed. *Source Book Profiles: An Information Service on the 1,000 Largest U.S. Foundations*. 2 vols. The Foundation Center, New York, 1991.*

National Data Book of Foundations. 2 vols. The Foundation Center, New York, 1990.*

Corporate Sources

Corporate 500: The Directory of Corporate Philanthropy. Public Management Institute, San Francisco, CA, 1990.

National Directory of Corporate Giving: A Guide to Corporate Giving Programs and Corporate Foundations. 3rd ed. The Foundation Center, New York, 1993.*

Renz, Lorens, ed. *Corporate Foundation Profiles*. 6th ed. The Foundation Center, New York, 1990.*

Government Sources

Catalog of Federal Domestic Assistance. Office of Management and Budget and U.S. General Services Administration, Washington, DC, 1993. (This is an annual publication.)

Federal Grants Management Handbook. Grants Management Advisory Service, Washington, DC, 1988.

Government Assistance Almanac, 1990-91: The Guide to All Federal Financial and Other Domestic Programs. Omnigraphics, Detroit, MI, 1990.

Guide to Federal Funding for Education. 2 vols. Education Funding Research Council, Washington, DC, 1991.

Specialized Sources

Blum, Laurie. *Free Money for Mathematics and Natural Sciences*, 2nd ed. Paragon House, New York, 1987.

Directory of Grants in the Physical Sciences. Oryx Press, Phoenix, AZ, 1988.

Grants for Libraries and Information Services. The Foundation Center, New York, 1993.*

Keats, Elizabeth. *Guide for the Preparation of Grants and Proposals for Starlab Portable Planetariums*. Learning Technologies, Inc, 59 Walden Street, Cambridge, MA 02140, 1992. 1-800-537-8703 (Free)

The National Guide to Funding for Elementary and Secondary Education, 2nd ed. The Foundation Center, New York, 1993.*

The National Guide to Funding for Libraries and Information Services, 2nd ed. The Foundation Center, New York, 1993.*

Periodicals

The Chronicle of Philanthropy: the Newspaper of the Non-Profit World. Biweekly. 1225 23rd Street, NW, Washington, DC.

The Foundation Grants Index Bimonthly. The Foundation Center, New York.

Grants for Schools. Bimonthly. 617 Wright Avenue, Terrytown, LA. (504) 362-9583.

Online Services

Dialog Information Services, Inc. supports three major files for locating foundation funding.

- *The Foundation Directory (File 26 on Dialog):* Covers over 5,000 independent, corporate, and community foundations with assets of \$1 million or annual grants totalling \$100,000 or more. Provides detailed information on the foundations, giving interests, and restrictions.
- *The Foundation Grants Index File (File 27 on Dialog):* Includes more than 300,000 actual grant descriptions for grants of \$5,000 or more which have been reported by approximately 500 foundations.
- *National Foundations (File 78 on Dialog):* Covers all 25,000 active U.S. foundations reporting to the IRS. Information is brief.

Dialcom, available to nonprofit organizations through the Telecommunication Cooperative Network (212) 714-9780. Gives access to The Foundation Grants Index Bimonthly and other Foundation Center services.

Video References

"Foundation Fundamentals for Nonprofit Organizations." The Foundation Center, New York.

"Introduction to Grant Funding." Nonprofit Resource Center, Sacramento Central Library, 828 I Street, Sacramento, CA 95814.

* You can contact The Foundation Center directly at 1-800-424-9836.

Chapter Ten ---

Hands-on Science in the Media Center

Introduction

Research indicates that students learn best by doing. They tend to internalize concepts better if they "get their hands dirty," trying things out and discovering the significance of concepts for themselves, rather than hearing a lecture and taking notes. Unfortunately, the length of class periods often limits the effectiveness and staying power of students' in-class science and mathematics experiences because there isn't always time for students to repeat an activity until they fully grasp the meaning, or to explore other ramifications of the subject matter. So how can schools cultivate children's natural curiosity about science within the constraints of the typical school day?

The library media center and the school media specialist can speak to this issue. The media center is the place to go if you have a question you want answered; hence, it is the ideal place to set up hands-on science activities. Students can complete activities at their own pace and then satisfy the curiosity that springs from such activities by exploring topics further using library resources. The library media specialist can set up simple science activities and related science books to provide students with easy access to an interesting activity as well as resources that can help them learn more.

This manual provides some hands-on science activities, adapted from trade books and AAAS activity manuals, that are suitable for children in elementary and grade school to complete in the library setting. They take into consideration

One of the goals of the AAAS Science Library Institute is to enhance participants' ability to provide engaging hands-on science and mathematics experiences for their students that promote critical thinking skills. To this end, participants spent an Institute session discussing hands-on science and its place in the media center. Feedback from participants who introduced hands-on science into the library curriculum indicates that the students were challenged and excited by hands-on science.

the special circumstances and limitations of the library; they use inexpensive, child-proof materials, and they require little supervision to complete. Although AAAS has used the activities provided here in a number of projects, you might want to try them yourself to make sure they work in your library's environment and to identify any precautions you may want students to take when conducting the activities.

Below is a list of suggestions for using hands-on science activities in the library:

- **Make activities the focus of a library exhibit.** Set up activity stations around the library that cover different science and mathematics topics. Include in your exhibit books that relate to the topic being emphasized so students can consult them as they conduct the activity.
- **Include activities in library lessons.** Read stories to the students that cover science concepts, and then conduct an activity based on the story.
- **Team up with a classroom teacher for science fairs.** Work with the teacher to come up with examples of science projects children can create based on certain activities.
- **Invite a scientist to discuss practical applications of science activities.** Contact professional science and pharmaceutical organizations to find scientists who can share with your students the relevance of specific activities to their everyday lives.

In many places and under almost any conditions, teachers and scientists have discovered—and rediscovered—that students can have tremendously positive experiences with hands-on science. Rather than sitting passively and trying to absorb information, students become active participants in their own learning. Hands-on science has helped many students develop determination, confidence, and a positive attitude toward science. If you try the activities on the following pages with your students, they will be poised to experience some of the same positive outcomes.

FINGERPRINTING DESIGN

WHAT'S THE POINT?

To observe your own fingerprint patterns.

MATERIALS NEEDED:

- inked stamp pad
- crayons
- white paper
- pencils
- rubbing alcohol
- magnifying glass (optional)



WHAT TO DO

Materials Preparation:

- Have paper towels on hand for cleanup.

To Prepare for Next Time:

- Make sure the alcohol bottle and the ink pad are closed tightly.

QUESTIONS TO ASK AS YOU DO THE ACTIVITY:

- How are the patterns of ridges on your fingertips different from someone else's? Write a description of each one that would enable someone else to tell which was which by comparing the description with the actual prints.
- Why do we have these ridges in our skin?
- How are prints made from these patterns of ridges used?

PROCEDURE:

- Press a thumb or other finger on the inked stamp pad.
- Press the inked finger onto a clean sheet of paper that has your name or picture on it. The resulting print will look something like the diagrams above.
- If you like, draw eyes, arms, and a nose on the print. Make a person or an animal.
- Clean your hands and fingers with the rubbing alcohol.
- Observe the prints through a magnifying glass.

WHAT IT MEANS:

There are several ways to copy the patterns of ridges from your finger to acquire what is called a *fingerprint*. Dusting for fingerprints, or powdering a glass that someone has touched, is one way. Another way is to press your fingertip onto an inked stamp pad and then onto a clean sheet of paper. No two people have the same patterns of ridges on their fingertips. In fact, no two of the patterns on any two of your fingertips are exactly the same, either. These patterns are called *ridge patterns*, and are unlike anybody else's in the world. They are clearly visible months before birth and never change throughout your lifetime. Since all of us are born with our very own ridge patterns, police are able to identify people who commit crimes by the prints they make of the patterns on people's fingertips. They match a set of the suspect's fingerprints to a set that they dusted from the scene of the crime. So remember that when you leave a room, you've left your ridge patterns behind! Interestingly, some people do not have ridge patterns. Why do you suppose that happens?

THE CARTESIAN DIVER

WHAT'S THE POINT?

To explore the concept of density by constructing a device called a Cartesian Diver that demonstrates its effects.

MATERIALS NEEDED:

- 1- or 2-liter plastic soft drink bottle with cap
- 14-cm length of a plastic drinking straw
- large (5 cm) paper clip
- water

WHAT TO DO

Materials Preparation:

- Fill bottles ahead of time.
- Have paper towels on hand for cleanup.

To Prepare for Next Time:

- Store unused straws and discard used straws.
- Make sure the paper clips are dry before you store them.

QUESTIONS TO ASK STUDENTS ABOUT THIS ACTIVITY:

- Why does the diver dive and resurface?
- Why do you always float right back to the surface when you dive?
- How do scuba divers manage to stay down instead of floating to the surface?
- How does a submarine dive and then return to the surface when it needs to?

PROCEDURE:

- Fold the straw in half. Insert the prongs of the paper clip into the open ends in order to hold the straw in the bent position and provide weight.

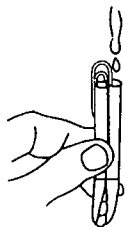
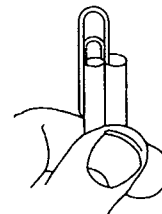

- Add water to the straw and shake the water to the bent end of the straw. Add enough water to fill each leg about half full. This is your Cartesian diver.

- Fill the soft drink bottle to the very top with water and place the diver in the bottle with the paper clip down. Cap the bottle tightly.

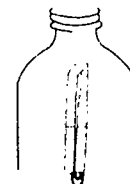

- Squeeze the bottle and observe what happens. If you use a clear plastic straw, you will be better able to see all that happens.

WHAT IT MEANS:

The Cartesian diver (the combination of the straw with its water and air and the paper clip) floats in water. This is because the diver displaces (pushes aside) a mass of water greater than its mass. Another way to express this is to say that the diver is less dense than water. If you completely fill up the straw with water, will the diver float? Why or why not? Check your hypothesis by trying it in a tall glass of water. (The use of a straw and paper clip as a diver originated at the Institute for Chemical Education, University of Wisconsin–Madison.)

When you squeeze the bottle filled with water, you increase the water pressure. Because the air is easy to compress, the higher pressure forces some water into the straw (compressing the air that is trapped in the straw). If you use a clear straw, you can easily see the water enter the straw and the volume of air get smaller. Now the diver is displacing less water. When the air volume in the straw has been decreased enough, the mass of water displaced is less than the mass of the diver (the diver is now denser than water). The diver sinks.

You can control the sinking by squeezing more or less gently. When you relax your pressure on the bottle, the compressed air in the straw can push the water back out and the diver rises (floats) again.

Note: This activity is featured in "Chapter Two: Dirigibles and Submarines: The Rise and Fall and Rise of Science Education Reform."

12 SPOT: A TEST OF HAND-EYE COORDINATION AND PERFORMANCE

WHAT'S THE POINT?

To explore the hypothesis that the proper function of the neuromuscular system and coordination depend on a healthy life-style, a positive attitude, total focus on a goal, and avoiding prolonged stress.

MATERIALS NEEDED:

- 12 disks on page 104, cut out.
- A timing device with a second hand plugged into an on-off switch

WHAT TO DO

Materials Preparation:

- Make copies of the page of disks.
- For repeated use, laminate the disks. This will keep them in good condition.
- Set disk sets out in envelopes.

To Prepare for Next Time:

- Have children count the disks and replace in envelopes.
- Replace incomplete or damaged sets.

QUESTIONS TO ASK STUDENTS ABOUT THIS ACTIVITY:

- Did you feel stress during the activity?
- Could you handle the comments? Is it important for a person to feel able to handle a situation?
- Does alertness matter? What affects alertness?
- Did putting one finger on your belly button cause you to lose focus? What else might?

PROCEDURE:

- Appoint a person as timer.
- Place the numbered disks on the table in random order in front of a volunteer.
- The object of 12 Spot is to touch each of the disks in order as fast as you can. The timer will begin timing at the word 'Go!' and stop when the volunteer touches the last disk.
- When both are ready, say, "Go!"
- Record the results.
- Try the same pattern three times, and record the best time. When students improve their times, say, "Does it feel good to beat yourself?"
- Ask the volunteers what they did to excel.
- Try a round in which you and some students agree to praise some of the remaining participants before they try 12 Spot. Choose a person who has tried but is not aware of the agreement. Smile at that person. Say, "You can do it. We know you are going to do really well this time."
- Try a negative approach as well. Say, "You can quit at any time." Then, as they get ready, say things like, "You might as well give up. This test is too difficult!" See how the times compare with those from the first round.

- Another variation is to test in the morning when people are rested. Compare these times with times late in the afternoon, or with the times of someone who has not had a good night's rest.
- Have volunteers try the test while placing a finger of their other hand on their belly button. This silly position may cause them to lose focus on the object of the test.

WHAT IT MEANS!

Performance of this task depends on *neurons* and *muscles*. Neurons carry signals in the *nerves, spinal cord, and brain*. Information goes to the brain, and signals are sent to prompt the muscles to touch the correct number. Many things can interfere with this process, such as *drugs* and *stress*.

1

2

3

4

5

6

7

8

9

10

11

12

110

104

CAN YOU PUSH AGAINST AIR AND WIN?

An Empty Container?

WHAT'S THE POINT?

To demonstrate that air takes up space and that air puts pressure, or pushes, on everything around it.

MATERIALS NEEDED

Per Group:

- wide-mouth plastic gallon jar (restaurants or hospital or nursing home cafeterias may have them) or small plastic bucket with opening small enough for plastic bag to cover
- sturdy plastic bag (not the zip-lock kind) without holes, that is large enough to cover mouth of container
- string or rubber band large enough to fit around mouth of container

WHAT TO DO

Materials Preparation:

- Remove the chairs from a table, and place the gallon jar on it so that everyone will be able to stand around the table and see and reach the container.
- Test the plastic bags for holes by filling them with water.
- Have extra bags handy since the first bag may develop holes as you do the activity.

To Prepare for Next Time:

- Replace any bags that have holes.

QUESTIONS TO ASK AS YOU DO THE ACTIVITY:

For the children:

- What other things can you think of, or see in the room, that are full of air?
- When have you felt the force or pressure of air? of strong wind?
- What experiences have you had filling a tire with air? Filling a balloon?

For you:

- Who seemed interested in this demonstration? Why do you think they were interested?
- Who seemed bored? What caught their attention?
- How did the children explain what they already know about air pressure?
- What do you think they learned about air pressure?

PROCEDURE:

- Put air into a plastic bag by blowing into it or waving it through the air.
- Clamp the opening of the bag around the mouth of a container, such as a jar or bucket, and fasten it tightly by either wrapping string around it two or three times and tying it or by putting a rubber band around it. The bag should be placed over the container.
- Now try to push the bag into the container. What do you feel as you push on the bag? Why do you think this happens?
- Let everyone try to push it in.
- Remove the bag and place it inside the container, like a liner.

- Drape the top of the bag over the lip of the container, just like the lining in a trash can, and tie string tightly around it two or three times, or fasten it tightly with a rubber band.
- Try to pull the bag up out of the container. What happens? How can you explain what happened?

WHY IT HAPPENS:

Inside the bucket and bag are a trillion trillion air particles called molecules bouncing around like ping-pong balls in a big box. As they strike the sides of the bucket and bag, they create pressure on the inside. The air on the outside of the bucket and bag are pushing on them as well. When you push down on the bag, the air pressure inside increases because you are forcing the same number of air molecules into a smaller space, and therefore, they hit the sides of the bag and bucket more often. What you feel, then, is this greater air pressure pushing up on the bag.

What about when you put the bag inside the bucket and then pulled up? By pulling up on the bag, you increased the amount of space inside the bucket and bag. This gives the air molecules inside more space to bounce around in so they hit the sides less often and produce less pressure. So why is it hard to pull the bag up? Because the air pressure *outside* the bag and bucket is now greater than the air pressure inside. What you feel is the outside air pushing the bag against the sides and bottom of the container.

AIR PRESSURE POWER

Book Lift

WHAT'S THE POINT?

To demonstrate that air has mass, and that it puts pressure, or pushes, on its surroundings.
To demonstrate that compressed air can do surprising work.

MATERIALS NEEDED

For the entire group:

- enough table space for everyone to have a flat area to work on

Per group

- plastic food storage bag (not zip-lock type)
- stack of 5-6 books

WHAT TO DO

Materials Preparation:

- Clear a large space on the tabletop.
- Move chairs away from the tables so that everyone will be able to stand close enough to see what's going on.
- Make sure plastic bags do not have holes in them by filling them with water. Have extra bags handy.

To Prepare for Next Time:

- Replace any plastic bags with holes.

QUESTIONS TO ASK AS YOU DO THE ACTIVITY:

- What happened that you expected to happen?
- What happened that you didn't expect to happen?
- When else have you felt the force or pressure of air?
- What experiences have you had with strong wind?
- Have you had any experiences with compressed air holding things up? How about the air in the tire of your bicycle or automobile?

PROCEDURE:

- Lay a plastic food storage bag flat on the surface of a table near the edge.
- Set a stack of books on top, leaving the open end of the bag sticking out over the edge of the table.
- Gather together the opening of the bag and blow into the bag like a balloon, keeping the opening as small as possible. What happens after a few blows? Did you topple the books?

WHY IT HAPPENS:

As you blow into the plastic bag, more and more air is forced into the same small space, the inside of the bag. The more air you blow into the bag, the more air particles (molecules) there are and the more collisions they make with the walls of the bag. More collisions mean higher pressure in the bag pushing the walls outward. At first, the pressure from the air outside plus all the books is larger than the pressure in the bag, and the books don't move. But, if you are able to blow enough air into the bag, the pressure will become large enough to push back on the books and move them off the surface of the table. The books are then being supported, held up, by compressed air. Many machines use compressed air and compressed liquid to do work in just this way. In fact, that is how the **brakes** in a car or truck work.

HOW STRONG IS YOUR MAGNET?

WHAT'S THE POINT?

To experimentally measure the strength of a magnet and graph how the strength changes as the distance from the magnet increases, and as a barrier (masking tape) is built between the magnet and an iron object.

MATERIALS NEEDED

(per group of 2 students):

- bar magnet
- clothespin
- masking tape (1 long strip and 21 one-inch [2.5-cm] pieces)
- 1 manila folder
- plastic or paper cup
- 20 paper clips
- data sheet
- pencil or pen

For leader:

- graph paper diagram

WHAT TO DO:

Materials Preparation:

- Make copies of the data sheet for each pair.
- Make a large graph on newsprint paper or the chalkboard. Average students' findings and graph the class findings. The x-axis (horizontal) is for the distance from the magnet (that is, the number of layers of tape beginning with zero); the y-axis (vertical) is for the strength of the magnet (number of paper clips it can hold). Refer to the sample below.

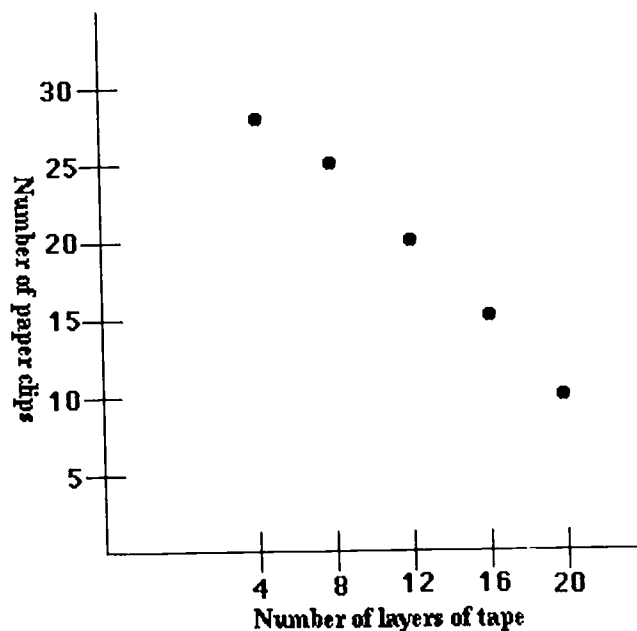

- Cut the tape for each pair. One long strip will be used to tape the clothespin to the cup. Then, cut 21 one-inch (2.5-cm) pieces (small enough to fit on the magnet). Stick them to a smooth manila folder and have students number them from 1 to 21.

To Prepare for Next Time:

- Dismantle the cup and clothespin apparatus.
- Discard tape.
- Store magnets separately from paper clips.

QUESTIONS TO ASK AS YOU DO THE ACTIVITY:

- How many paper clips can the magnet hold without any masking tape?
- As you begin adding layers of tape, what happens? Why?
- Is the masking tape a magnet? How do you know? If not, why are the paper clips attracted to it?
- What happens to the strength of the magnet as you add more layers of tape? Why?
- Is the magnetic attraction blocked by the tape, or is it just that the tape adds distance between the magnet and the paper clip? How could you test your answer?
- What does the graph tell us?

PROCEDURE:

Can your small magnet attract a paper clip from across the room? From across your desk? How can you find out how strong your magnet is? This experiment will help you find out!

- Work with a partner. Number your small pieces of tape from 1 to 21.
- Clamp your magnet in the clothespin. Tape it to the bottom of the cup as shown in the drawing.

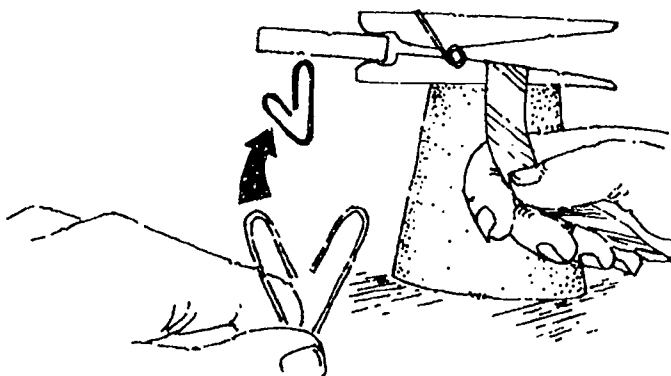

- Pull apart one end of a paper clip to form a hook. Touch the hook to the magnet. It should stick to one pole of your magnet.
- Take turns with your partner and carefully add paper clips to the hook, one by one. Count the total number of paper clips, including the hook, that you can hang onto the hook before the weight becomes too much for the magnet to hold and the paper clips fall.
- Write this number of paper clips on your data sheet on the line for zero pieces of tape.
- Next, stick three pieces of masking tape (labelled #1, #2, and #3) on the bottom of your magnet. See the picture below. Now repeat your experiment and see how many paper clips you can hang on the hook. Make sure the hook touches the tape, not the magnet itself. Write your findings on your data sheet.

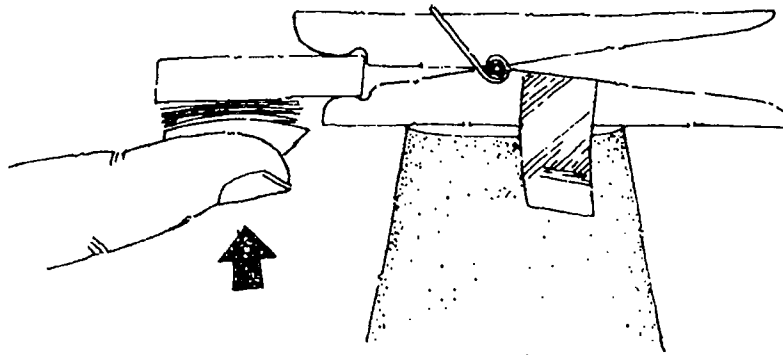

- Add three more pieces of tape and repeat your experiment. Mark your findings on your data sheet.
- Keep adding pieces of tape, three at a time, repeating the experiment, and writing down what you find. As you add more and more layers of tape, what do you notice about the number of paper clips you can add to the hook? Is the magnet able to hold more or fewer clips? Do you think the tape is causing this? Why?
- Use your findings to help your teacher and class complete a graph that describes the results of your experiment.

WHY IT HAPPENS:

A magnetic field (what causes the pull of the magnet) will pass through materials like tape with almost no effect. The tape does not block the attraction of the magnet for the paper clip. Rather, each piece of tape removes the paper clip from the surface of the magnet by one more small increment of distance, equal to the thickness of the tape. The tape is just a convenient way to move the clip and the magnet apart bit by bit. The distance between the magnet and the clips, not the tape itself, lessens the attraction of the magnet. We can also describe this in terms of the magnetic field: As you move farther from the magnet's pole, the field becomes weaker and weaker.

You can show that the strength of the magnetic field decreases the farther you move from the magnet by a simple demonstration. Tie one end of a thread to a paper clip and tape the other end to the surface of a table. Hold a magnet above the paper clip. You can hold the clip up in the air (and keep the string taut) as long as the magnet is fairly close to the paper clip. If you move the magnet too far away from the clip, the strength of the magnetic field decreases, and the paper clip falls.

HOW STRONG IS YOUR MAGNET? DATA SHEET

HOW MANY LAYERS OF TAPE?	HOW MANY PAPER CLIPS?
0	
3	
6	
9	
12	
15	
18	
21	

FLOATING GOLF BALLS

WHAT'S THE POINT?

To demonstrate that water density changes when substances are dissolved in it.

MATERIALS NEEDED

Per group:

- 2 tall, clear plastic or glass drinking glasses or similar containers (We like to use one-liter soda containers with the tops cut off and the labels removed.)
- approximately 1 cup salt (Kosher salt works best because it produces clear solutions.)
- 2 golf balls
- long-handled spoon for stirring solution and retrieving sunken golf balls
- paper or cloth towels for cleanup
- pitcher of water or sink for filling glasses
- sink for discarding salt and plain water

WHAT TO DO

Materials Preparation:

- Set up two glasses, water pitcher (if necessary), salt, spoon, and golf balls at a station for each group.
- Find a suitable place to empty the water when the activity is complete.

To Prepare for Next Time:

- All water can be rinsed safely down the drain.
- Empty, rinse, and dry all glasses, pitchers, and spoons.
- Save the golf balls for next time.

QUESTIONS TO ASK AS YOU DO THE ACTIVITY:

- What happened to the golf ball in plain water?
- What happened to the golf ball in salt water?
- What happened to the golf ball in the glass that contained both plain and salt water?

PROCEDURE:

- Fill one glass a little less than half-full with water. Add about 10 heaping teaspoons of salt, one at a time. Stir after you add each one until all, or almost all, of the salt dissolves.
- Fill another glass with plain water until it reaches the same level as the one with salt water.
- Using your spoon, lower a golf ball into each glass. What do you see? If the golf ball doesn't float in the salt water, remove it and stir more salt into the water. Then try again to float the ball.
- Use the spoon to remove the golf balls from the glasses of water.
- Carefully pour some of the plain water on top of the salt water by aiming it down along the inside wall of the glass and using a spoon to break the fall of the plain water. Pour enough of the plain water to fill the glass about three-quarters full, with salt water on the bottom and plain water on the top.
- Now use your spoon to add one of the golf balls to this glass again. What do you see now? Why do you think this happens?

WHAT IT MEANS:

Whether an object will sink or float in water depends mainly on two factors: density and buoyancy. Density describes how heavy something is compared to its size. A golf ball and a ping-pong ball are approximately the same size, but the golf ball is heavier than the ping-pong ball. Therefore, the golf ball is said to be denser. Also, a bowling ball and a soccer ball can be about the same size, but a bowling ball has a higher density, which makes it heavier than the soccer ball. For yet another example, think of a brick and a brick-sized piece of wood. A brick is denser than most kinds of wood, so the brick will be heavier. Liquids also have densities. If you have two measuring cups full of two liquids, the denser liquid will be heavier than the less dense liquid. For example, a cup of molasses is heavier than a cup of water, so we say that molasses is denser than water. In general, an object will float in a liquid if the object is less dense than the liquid, and the object will sink if it is denser than the liquid.

In the first three steps of Floating Golf Balls, the golf ball sinks in plain water because it is denser than water. There is not enough buoyancy to keep it afloat. The golf ball floats in the salt water, if it is salty enough, because the golf ball is less dense than the salt water and, therefore, there is a large enough buoyant force to hold it up. By adding salt to the plain water, you increased the amount of material taking up the same amount of space, so the density of the liquid has increased.

In the later steps of this activity, if the liquids are carefully poured so that they don't mix very much, then they will form layers with the denser salt water on the bottom and the less dense plain water on the top. The golf ball finds the place in the mixture where the salt water below it is denser than the golf ball and the plain water above it is less dense than the golf ball. And that's where it floats.

Volume is related to the density of a liquid. Volume measures how much space something takes up. For liquids, we commonly measure volume in teaspoons, cups, pints, quarts, or gallons. Volume can also be measured in cubic inches, cubic feet or cubic centimeters.

MAGNETIC PICKUPS

WHAT'S THE POINT?

To explore what types of things are and are not magnetic, that is, which things are and are not attracted to magnets. To make predictions, test those predictions, and discuss the results of the experiments.

MATERIALS NEEDED:

Samples of as many different objects as you can find (You may want to make a bag or box of these for each pair of children.):

- bar or horseshoe magnet or ceramic "refrigerator" magnet
- wooden toothpick
- penny
- jewelry
- cup
- paper clips
- needles
- thread
- rubber band
- "tin" can
- glass
- aluminum can (soft drink can) or foil
- crayon
- nail
- mitten
- paper

WHAT TO DO

Materials Preparation:

- Gather the materials needed for each pair of children and place them in a box or zip-lock plastic bag.
- Prepare the Predictions Sheet. Use the sample sheet on page ??? as a guide. You may also want to reproduce the Predictions Sheet on a large sheet of paper.
- Give the children time to fill in the ITEM column, listing all the objects to be tested for magnetic attraction, and also the PREDICTION column.
- Have the children carry out the activity.

To Prepare for Next Time:

- Ask each pair of children to replace their materials in their box or bag.
- Package and store the magnets separately. If using horseshoe magnets, replace the bar keeper across the ends.

QUESTIONS TO ASK STUDENTS ABOUT THIS ACTIVITY:

- What happens when you bring your magnet close to the wooden toothpick? What about when you bring it close to the paper clips?
- Why do different objects behave differently when they are near the magnet?

PROCEDURE:

A. Making Your Predictions

Scientists predict what they think will happen. They test their predictions by doing experiments to find out whether they were right or wrong. Then they talk about what they learned from their experiment. We can experiment with magnets!

1. Working with a partner, look at each of the things in the pile on your table. Which ones do you think will be attracted to the magnet? Place all of those items in one pile. Place all of the items you think will **not** be attracted to the magnet in another pile. How did you decide where to put each item?
2. On your data sheet, list each of the items in both piles in the spaces provided in the column marked ITEM. In the column marked PREDICTION, write "yes" next to each item you predict will be attracted to the magnet and "no" next to each item you predict will **not** be attracted to the magnet.

B. Testing Your Predictions:

1. Take turns with your partner. Bring your magnet close to one of the items. What happens? Is the item attracted to the magnet? How can you tell?
2. Test each item by bringing your magnet close to it. Remember to take turns with your partner!
3. After you test each item, write down whether or not the object was attracted to the magnet in the column marked RESULT.
4. Do you see something special about all of the items that are attracted to the magnet? How are they all the same? How are they different?

We call things that are attracted to the magnet *magnetic*. These items are always made of iron, nickel, or cobalt.

C. Talking about Your Results

Talk with your partner about the predictions you made at the start of the experiment.

1. Which predictions were correct? Which were incorrect?

It is all right if your predictions were incorrect. Scientists often make predictions that turn out to be incorrect. This is a part of learning!

2. Now how would you decide whether or not something is magnetic?

WHAT IT MEANS:

When an object is attracted to a magnet, you can feel the pull of the magnet toward the object. When you try to separate the two, it seems as though some invisible force is trying to hold the two objects together. It is indeed a force, just as gravity is a force.

After observing, sorting, and testing the different items in this experiment, children will find that only materials containing certain metals—iron, cobalt, or nickel—are attracted by the magnet. None of the other items will be attracted by the magnet. When an object is magnetic, it always contains one or more of the three metals listed above.

Why is a "tin" can magnetic? By itself, tin is not magnetic. A tin can is made by coating, or plating, an iron can with a very thin layer of tin so that it won't rust. A magnet is attracted not to the tin, but to the iron underneath the tin.

How is a ceramic magnet made? A ceramic magnet is made from a combination of clay, which is not magnetic, and oxides containing iron that have been magnetized by the magnetism from another magnet.

If nickel is magnetic, why isn't a magnet attracted to a nickel coin? The metal nickel is magnetic, but U.S. nickel coins don't really contain nickel anymore. They are made from a mixture of other nonmagnetic metals. If you have a Canadian nickel, try bringing it close to a magnet and see what happens!

MAGNETIC PICKUPS

Data Sheet

ITEM What material are we testing?	PREDICTION Do you think this item will be attracted to the magnet?	RESULT Was the object attracted to the magnet?

TANGRAMS

WHAT'S THE POINT?

To develop an understanding of spatial relationships using triangles, squares, and parallelograms.

MATERIALS NEEDED

Per group of two students:

- 1 tangram set (7 pieces); 2 sets for younger children
- pencil

WHAT TO DO

Materials Preparation:

- Take out tangrams. Be sure to keep individual sets of the same color together.
- Distribute or have students pass out tangram sets alternating colors in each group.

To Prepare for Next Time:

- Students should count the tangram pieces (7 per set) and return same color pieces to the pouches. Make sure the pouches are sealed.

QUESTIONS TO ASK STUDENTS ABOUT THIS ACTIVITY:

- How did you figure out how to make each shape using the required number of tangram pieces?
- What did you learn about the relationship of these shapes to one another?

PROCEDURE

Before the Activity:

- Identify all seven tangram shapes.
- Discuss all seven tangram shapes.
- Count the number of sides on each of your tangram pieces. Write down the number of sides below.

SHAPE	NUMBER OF SIDES
square	4
triangle	
parallelogram	

- Using 2 tangram pieces, make each of the shapes listed above (square, triangle, parallelogram). Is there more than one way to make any of the shapes? What's the largest number of ways you can find? Are there any of these shapes you can't make?
- Now make the same figures using 3 tangram pieces. Is there more than one way to make any of the shapes? What's the largest number of ways you can find? Are there any of these shapes you can't make?
- Now make the same figures using 4, 5, 6, and 7 tangram pieces. Is there more than one way to make any of the shapes? What's the largest number of ways you can find? Are there any of these shapes you can't make?

WHAT IT MEANS:

Experiences in exploring and understanding relationships of shapes to each other is an important prerequisite for advanced mathematics. The opportunity to explore shapes will introduce vocabulary and geometric concepts that are part of mathematics and everyday problem-solving.

Using the tangram shapes children learn, for instance, that two identical, isosceles right triangles fit together to form a square. Additionally, children learn that three basic shapes—triangles, squares, and parallelograms—fit together to form many other shapes and figures.

COLORFUL CHEMISTRY

WHAT'S THE POINT?

To determine what chemical indicators indicate.

MATERIALS NEEDED:

- piece of red cabbage
- knife
- bowl
- water
- lemon
- 2 glasses
- steel or glass pot
- drainer
- tablespoon
- baking soda

WHAT TO DO

Materials Preparation:

- Pour two cups of water into the pot.
- Chop or grate the cabbage.
- Cook the cabbage in the pot for 10 minutes until the water is deep purple. Let it cool.
- Strain the cabbage over a bowl. Save the "cabbage water."

To Prepare for Next Time:

- Clean up your area thoroughly

QUESTIONS TO ASK AS YOU DO THE ACTIVITY:

- What happens when you add cabbage water to the lemon juice?
- What happens when you add cabbage water to the baking soda?

PROCEDURE:

- Pour a tablespoon of lemon juice into a glass.
- Add a tablespoon of cabbage water. What happens?
- Place a tablespoon of baking soda into the other glass.
- Add a tablespoon of cabbage water. What happens?

WHAT IT MEANS:

Cabbage water is called an *indicator* because it turns color when it mixes with an acid or with a kind of chemical called a *base*. Many foods we eat contain weak acids. Lemon juice is an acid. Baking soda mixed with water is a base. Which color indicates an acid? Which indicates a base? Try your indicator on other foods, such as vinegar, soda pop, fruit juice, or egg white. Which are acids?

STRONG STRAWS

WHAT'S THE POINT?

To investigate the strength of a cylinder.

MATERIALS NEEDED:

- paper straws
- 16-oz (or larger) plastic cup
- string
- scissors
- 2 small rubber bands
- measuring cup
- large pan
- water

WHAT TO DO

Materials Preparation:

- Place two chairs or tables close together.

To Prepare for Next Time:

- Replace used straws and cups.

QUESTIONS TO ASK AS YOU DO THE ACTIVITY:

- How much water do you think you will be able to add to the cup before the straw breaks?
- How much water can you actually add?
- Does the number of straws you use at one time make a difference in the amount of water the cup can hold?

PROCEDURE:

- Poke three equally-spaced holes around the rim of a cup.
- Cut a piece of string long enough to reach all the way around the rim.
- Lace this string through two of the holes and tie the ends together to make a loop.
- Tie one end of a 45 cm length of string to the third hole. Tie this string to the loop so that the cup will hang level.
- Tie a loop in the free end of the string. Slip the loop over a straw, and let the cup hang from the very center of the straw.
- Lay the straw between two chairs or tables so the straw is just supported at its ends and the cup hangs from the center.

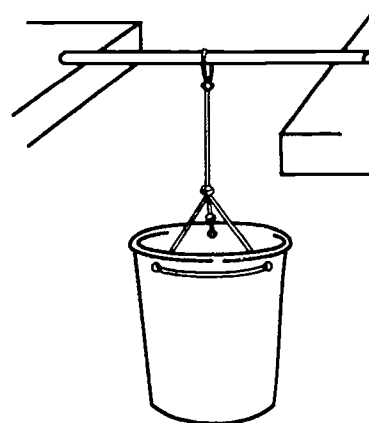

- Add water to the cup a little bit at a time. Protect the floor under the cup with a pan.
- Add water until the straw collapses. Catch the cup before any water spills.
- Measure the amount of water it took to break the straw.
- Repeat the test with more straws. For three or more, bundle them together. Use small rubber bands near each end to hold the bundle together.

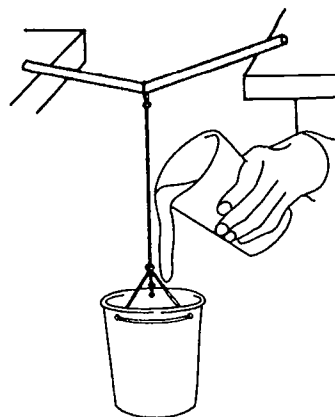

WHAT IT MEANS:

A strip of paper doesn't seem to have much strength. However, when it is rolled up to form a cylinder, the cylinder can withstand a great deal of force trying to break it. The "secret" to this strength is the arch shape of each half of the cylinder. The arch shape distributes the force pushing down (on the upper semicircular half of the straw) as well as the opposite force pushing up (on the bottom where the ends of the straw are supported). You probably observe that the collapse of the straw occurs when the straw folds, that is, the arch breaks.

When more than one straw is used, they reinforce one another and more force is required to break the combination because the force is distributed over more arches. Does it require twice as much force (water in the cup) to collapse two straws? three times as much for three straws?

BALLOON IN A BOTTLE

WHAT'S THE POINT?

To observe the effects of heat and cold on air contained in a balloon.

MATERIALS NEEDED:

- 12- or 16-ounce glass soft drink bottle
- 6–8 inch balloon
- deep pans of hot and cold water

WHAT TO DO

Materials Preparation:

- Collect all materials.

To Prepare for Next Time:

- Replace any torn balloons.

QUESTIONS TO ASK AS YOU DO THE ACTIVITY:

- What happens to the balloon when you place the bottle in hot water? in cold water?

PROCEDURE:

- Stretch the balloon and blow it up a few times to prepare it.

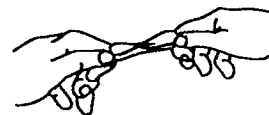

- Stretch the opening of the deflated balloon over the mouth of the bottle, so the balloon seals the bottle.

- Place the bottle in the hot water for 2–3 minutes. Observe what happens.

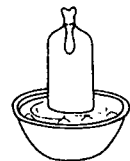

- Remove the bottle from the hot water.
- Place it in the ice water for a few minutes. Observe what happens.
- Try to explain what is going on as you heat and cool the bottle.

WHAT IT MEANS:

When the air inside the bottle sealed with the balloon is heated, the molecules move faster and the pressure increases if the air has no place to go. Since the balloon is flexible, some molecules leave the bottle and fill the balloon; the balloon will inflate a bit. Is this what you observe? The pressure inside the bottle and balloon only goes a little bit above the outside air pressure.

When you immerse the bottle in ice water, the temperature of the gas in the balloon falls, the molecules begin to move more slowly, and the pressure inside the bottle decreases. Now the air on the outside is at a higher pressure and tries to force its way into the bottle. The only way the atmosphere can do this is by pushing the air in the balloon back into the bottle, and that's what it does. If the air inside the bottle is cold enough, just pushing the air from the balloon back into the bottle won't raise the pressure in the bottle to atmospheric pressure. The outside air will still try to force its way into the bottle. The only way it can do this is by pushing the balloon into the bottle. Is this what you observe?

GLUEP POLYMER

WHAT'S THE POINT?

To make and observe the properties of a polymer.

MATERIALS NEEDED

Per Group of Two:

- Elmer's® white glue
- borax
- water
- 3-ounce cups
- plastic spoon
- 1-liter soft drink bottle
- measuring cups and spoons

WHAT TO DO

Materials Preparation:

- Mix $\frac{1}{4}$ cup borax with 1 liter of warm water in a soft drink bottle.
- Swirl and shake to dissolve the solid.
- Let any undissolved solid settle. Use the clear solution for the activity.

To Prepare for Next Time:

- Clean up the workspace.

QUESTIONS TO ASK AS YOU DO THE ACTIVITY:

- What is the consistency of the substance you are making?
- What properties do you observe of your creation?
- What uses can you think of for a substance like this?

PROCEDURE:

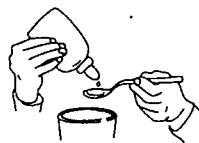

- Measure 1 tablespoon of glue into a cup. Add 1 tablespoon of water. Stir the mixture thoroughly.

- Measure 2 teaspoons of the borax solution into a clean cup. Stir the glue solution vigorously as your partner adds the borax solution. Keep stirring.



- Vary the ratio of the ingredients. Add more or less water. Add more or less borax solution. How does each change affect the properties of the polymer you make?

- When the Gluep has formed, take it out of the cup. Roll it between your hands for a few minutes. Investigate the properties of the polymer you have made. Be careful to keep it off furniture and carpets.



WHAT IT MEANS:

Some other white glues will also work to make Gluep. You should test them to be sure they work before using them for this activity with a class or group. The "active ingredient" in most white glues is polyvinyl acetate, PVA, dissolved in water. PVA is a *polymer*, its molecules are long chains of repeating small chemical units called *monomers*. Like strands of wet spaghetti, these long molecules can slide past one another pretty well. However, they do get sort of tangled together and impede one another's movement, so the glue is fairly thick and doesn't flow like water.

When borax is added, it forms weak attachments to the PVA. The borax is able to link two (or more) PVA chains together just like you can link two pieces of rope by holding one in each hand. Now the PVA chains are not free to slide past one another, because they are cross-linked. The cross links are rather easily broken, but there are so many of them that they have a large effect on the properties of the PVA.

If time is allowed for the cross links to break and reform, the PVA can still flow, although very slowly. If a sudden force is applied, the cross links break and can't reform fast enough to prevent the PVA chains from being pulled apart from one another. Are these the properties that you observe with your Gluep?

Chapter Eleven

Science Activities and Exhibits

Introduction

Each participant in the Science Library Institute (SLI) was given the opportunity to receive a \$500 mini-grant to be used to implement a project, activity or event to enhance science/math/technology (SMT) education and reform in their school.

At the third workshop session, participants learned about fund-raising and proposal writing from presenter Bobbie Scull. A brainstorming session was conducted by consultant Mary Chobot to generate a list of potential project ideas, and ways in which scientist volunteers might be utilized, both in conjunction with these projects and other activities in the participants' schools.

The participants were given an outline, and a completed example of an Action Plan for a project (refer to page 85), and asked to prepare a brief Action Plan for their project.

In order to receive their mini-grant, each participant was required to submit a written Action Plan. These plans were reviewed by the project staff, and feedback was provided to the SLI participants. Each participant was also asked to submit a final report, providing feedback on how the project went. Site visits were made to some of the schools and telephone interviews were conducted with some librarians.

An objective of the AAAS Science Library Institute is to increase in-school and out-of-school science opportunities for children by providing hands-on science training and support to school and public librarians serving elementary and junior high school-aged children so that they can act as inservice workshop leaders in their libraries and school systems.

To fulfill this objective, Institute participants conducted science activities and projects in the library with the help of a \$500 mini-grant they received for completion of the Institute. Dr. Mary C. Chobot of Chobot Associates, the Institute's project evaluator, summarized these activities and projects to facilitate their replication by other librarians in other library settings.

In the margins of this chapter, we share with you some of the participants' comments about their experiences in the AAAS Science Library Institute.

BEST COPY AVAILABLE

"I am very happy that I was chosen to participate in the Science Library Institute. It has been a refreshing but tiring time. I have learned much from the presenters and I am sure that the boys and the girls at Bowen School will benefit from the exposure that I have had with librarians from other areas. I don't think that my library will ever be without some science display."
— Eleanor H. Organ

The following section provides brief summaries for each of the 28 projects implemented by the SLI project participants in their schools. The 28 project summaries are arranged alphabetically by the title of the project.

Project Title: Bowen Improvement Project (BIP)

Library Media Specialist: Eleanor H. Organ

School / Address: Anthony Bowen Elementary School
Delaware Avenue & M Street, SW
Washington, DC 20024

The objectives of this project were to clean up the immediate environment near Bowen Elementary School, i.e., the playground and the front lawn of the school; to recycle the materials; and to raise the interest levels of the teachers and students in the quality of their environment. The appearance of the school has been an ongoing problem. Removal of broken glass and trash from the playground area requires approximately two hours of janitorial time each day. An average of three students have been injured by this debris during each recess period.

The target group involved in the project were a selected group of approximately 40 fourth grade students. The project was conducted in three stages. During Stage 1, students cleaned up the site by collecting the trash; sorted it into four groups: paper, glass, metal and other recyclable materials; and recorded the amount of material in each category. Stage 2 emphasized building students' pride and involvement in the project. A presentation was made to the student body about the amount and kind of trash found in the school's environment, and the dangers/effects experienced by living and playing in such a harmful environment. Students were urged to become involved in keeping their school environment safe and clean. Stage 3 consisted of a plan for continued upkeep. The process described in Stage 1 was repeated in two-week intervals; trash was sorted and the results compared.

The project, which took place between May 9-20, 1994, involved the students, teachers and others in the school community in several activities: a briefing on the BIP Project was held for the principal, science teacher, classroom teachers, and EPA volunteers; students and teachers viewed a video presentation on the value of a healthy environment; selected students attended a presentation by the Environ-

mental Protection Agency; classroom visits were made; the initial cleanup took place on May 9th; students sorted the trash, recorded and compared results, and graphed the results from each collection to show increases/decreases; follow-up visits were made to classrooms to show these results to students and ask for their continued support; a party was held on the last cleanup day; students were queried about their perception of the project, and because of their enthusiastic support, this will become an annual event at the school. As a result of the **BIP** Project, students are taking greater pride in their school environment and their ability to help make it a safer place.

A total of \$550 was expended on the project. Most of the money was used to purchase videos and books to supplement the science/math/technology collection in the library. Fifty dollars was used to purchase trash bags and cotton gloves to collect the trash; fifty dollars was used for student awards and certificates.

Project Title: **Butterfly Explosion**

Library Media Specialist: Jessie K. Campbell

School/Address: McGogney Elementary School
3400 Wheeler Road, SE
Washington, DC 20032

The **Butterfly Explosion** was the culmination of a science project which involved approximately 500 elementary school students, pre-K through sixth grade. Approximately 95% of the student population is Black; 3% white; 1% Hispanic; and the remainder Asian. Students observed the larval and pupal stages of the painted lady butterfly. During the time that these observations were taking place, students participated in multi-disciplinary activities to reinforce their interest in the project. Grades four through six used the library to conduct research throughout the entire project. After the students had studied the stages of butterfly development, and the butterflies were able to survive in the natural environment, a culminating outdoor assembly was held. During this assembly, all the butterflies were released, as the **Butterfly Explosion** was accompanied by music and festivity.

"The Institute has been a great experience for me. It has helped me get new ideas for my library because my science collection is a bit dated. The Institute was really helpful with ideas for my students' science experiments in the science fair. I have been sharing my experiences with my science teacher, and she plans to use some of them in her classes."

— Jessie K. Campbell

The objectives of this project were 1) to develop the concept that butterflies are a universal insect, but there are different species found in different countries/regions of the world; and 2) to improve the interest in science among students, with a special emphasis on the care of living things. During the project, students observed the butterfly life cycle; observed the maturation of the painted lady butterfly; charted/graphed the stages of maturation; identified butterflies as insects; drew butterflies representing various countries; read and wrote stories about butterflies; conducted library research on the international varieties of butterflies; prepared the soil and planted plants to attract a variety of butterflies; cultivated and cared for the plants; prepared displays for the **Butterfly Explosion**; developed observation skills; developed a concept of the interdependence of living things; and developed skills in caring for plants, butterflies and other living things.

Each of the 21 classes at the school was assigned a country; the class was responsible for nurturing the butterflies from that country. The larvae were purchased from a biological supply company. Each class prepared a glass-jar home for their butterfly, adding leaves and sticks to provide a natural environment. It took about three weeks for the butterflies to hatch. Once the butterflies had hatched, the students placed the glass-jar homes in a dark place or covered them with black construction paper, so that the butterflies would remain inactive until they could be released, thus preventing injury to the butterflies. The entire project took about four weeks during the month of May and involved all classrooms, the library, and the entire school community.

The total budget for this project was \$805, as the McGogney PTA contributed \$305. Expenditures were \$150 for fabric/decorations and artistic material; \$105 for painted lady butterflies for classrooms; \$100 for fabric for international costumes; \$75 for video and audio tapes; \$375 for books and other science/math/technology materials, especially materials to supplement the collection on butterflies.

Project Title: **Computer Simulation Course Development:
Sim Science**

Library Media Specialist: Diane Schule

School/Address: Paul VI High School
10675 Lee Highway
Fairfax, VA 22030

Paul VI is a private high school, offering a traditional, college preparatory curriculum. The librarian recognized the need to make science more appealing and useful to the school's students, especially those in what are referred to as the general courses; and to develop a closer working relationship between the library staff and the science faculty. The significance of the project lies in the collaboration it has engendered between the librarians and the faculty of the science department.

This project will operate over an extended period, culminating with the introduction of a new eleventh grade course in the fall of 1995. This new course will combine elements of chemistry, physics and environmental science. The course will utilize computer software games and simulations to involve students in problem solving and relate science applications to life-related situations.

During 1994, the librarian conducted extensive research on computer-based, science teaching applications, and identified specific software available. Materials were reviewed by the librarians and science teachers, and some preview materials were installed on library computers, for use by selected students. After this review process, seven pieces of computer software were procured with the \$500 Institute funds. Topics covered include air and water pollution, elementary chemistry, the laws of motion; Wood Car Rally, which takes a game-like approach to introductory physics; and the Great Chemistry Knowledge Race, which allows students to make decisions and compete with on topics such as atomic structure, chemical bonding and the periodic table.

The 1994-95 school year will be a period of planning during which the new course content will be specified and developed. The library will support this curriculum-development effort by conducting database research to identify literature and examples relating to computer-based, integrated science education. Software currently on hand will be installed on computers in the library and school computer lab for student

"I definitely feel that this was a worthwhile project. I'm delighted to have had the chance to be in on the planning of the new science course in our school. One of the biggest benefits which has come out of this project is that the library and the science department are talking so much more now. I think that we'll have them sending more kids down for projects and planning things together more."

— Diane Schule

and teacher familiarization and use. Teachers will also be able to borrow copies of the course software for use on personal computers. When the course is implemented in the fall of 1995, current plans call for the acquisition of at least one computer for use in the classroom.

The effect of the new course design and software will be assessed through pre/post knowledge and skill tests, as well as satisfaction surveys of students, parents, and participating teachers. While participation in the Institute has provided the Paul VI librarian with a better understanding of basic science concepts and SMT reform, this project will result in this information being shared with many others in the school. The project has and will continue to promote much greater cooperation between the science department and the library, and will also allow the staff to explore an alternative for delivery of science education.

"As a result of our involvement with AAAS, we hope to encourage other (students) to feel confident enough in science to participate in more science activities."

—Patricia Bonds

Project Title: DNA

Library Media Specialist: Patricia N. Bonds

School/Address: Duke Ellington School of the Arts
3500 R Street, NW
Washington, DC 20007

The Duke Ellington School of the Arts is a magnet program designed to develop the artistic skills of students while providing a strong academic program as well. The target audience for this project were the 258 tenth, eleventh and twelfth grade students studying biology, botany and anatomy.

The objective of the project was to demonstrate how DNA is separated for analysis. A related objective was to describe the basic structure and function of DNA and RNA molecules. DNA controls the production of protein in the cells, as well as genetic makeup. We hear and read about DNA in the news often, since the analysis of DNA has been used to identify criminals or determine biological parentage. This was, therefore, a topic of interest to students.

Two teachers, the librarian, and volunteer scientists were involved in the project, which took place during the month of April. The research began in the classroom. Students then researched DNA in the library and created charts and post-

ers on DNA. Experimentation with the actual separating of the DNA took place in the classroom. Follow-up included a video tape presentation on DNA in the classroom and in the library.

This project was directly related to one of the objectives required for the completion of senior high school biology. The hands on experience enhanced the students' knowledge of the subject of DNA, and made it more interesting and relevant.

The \$500 Institute funds were used to purchase a mini-gel electrophoresis system for use in the experimentation, and a videotape titled, *Bio-Chemical Basis of Biology: DNA and Protein Synthesis*; approximately \$210 was used to purchase high interest, low reading level print materials to supplement the science collection in the library.

Project Title: **Environments, Habitats and Ecology**

Library Media Specialist: Patricia Munoz

School/Address: Randolph Elementary School
306 S. Quincy Street
Arlington, VA 22204

"I would hope that other librarians would have the opportunity to participate in the future, perhaps in teams with science teachers. It has been a good experience and one worth expanding."

—Patricia Munoz

Randolph Elementary School has approximately 675 students. This project was designed to provide a variety of experiences related to environments and habitats for interested teachers and students in grades K-5. The objectives of the project were to support the school program by providing hands-on science experiences; to teach children to use elements of the scientific method; and to incorporate information retrieval skills into the science program.

The goal of school-wide participation was met, as many teachers elected to have their students participate, and a variety of activities were undertaken. The first grade classes each selected an environment: deserts, woods, oceans, rain forests and arctic environments. The library provided fiction/nonfiction "story hours" for these students, selecting one of the environments being studied for each week. One second grade class studied rain forests, another compared swamps from the time of the dinosaurs to modern swamps. Two third grade classes studied mammals, and used reference books in the library to graph the life spans of common

mammals. Some fourth grade students chose to do individual projects related to the overall theme. Two fifth grade classes did library research on rain forests; while another fifth grade class did reports on water in all its forms, and from many angles: sewers, viaducts, waterborne diseases, rivers, waterfalls, etc. The library assisted students with their research and the writing of reports, and provided appropriate materials to support the efforts of students and teachers. A practical note: books and materials on topics being studied were placed in bins, and a colored dot was placed on the circulation card. This worked well, enabling the library to keep the materials moving quickly between users studying the same topic.

Many of the student projects were displayed as murals throughout the building. Others created clay animals, constructions, and water drops containing reports, quizzes, graphs, as well as some science projects using the scientific method.

Displays were also available for parent viewing on the school's Starcase Night in April.

The Institute funds allowed for the purchase of books, science and art supplies to supplement the collection and support the project.

The project had several worthwhile outcomes: it was a unifying project for the school, encouraging interaction between teachers and the librarian; students enjoyed the variety of experiences and topics, improved their information-seeking skills and enhanced their appreciation of science.

"This is our first year as a Math, Science, and Technology school. We want our parents to see where we are headed in the library/media center with our new focus."

-—Rose Pringle

Project Title: **Family Science in the Library Night**

Library Media Specialist: Rose Pringle

School/Address: Roper Middle School of Mathematics,
Science & Technology
4800 Meade Street, NE
Washington, DC 20019

Roper Middle School was a math, science, technology school for the first time for the 1993-94 school year. The target audience for this project were the parents of students. The **Family Science in the Library Night** provided an opportu-

nity for parents to see how the library/media center was attempting to support the new focus of the school.

The objectives of the project were to give parents the opportunity to see firsthand the library materials available to their children; to see how students have utilized these materials in their learning activities; and to see and use the technology used by their children.

In order to ensure the success of the event, the principal and teachers were briefed and their commitment to participate was secured. The event was publicized to parents via a letter home and student-created posters and flyers. Guidelines were developed for each of the four components described here.

Family Science in the Library Night had four components:

- (1) **We're So Proud:** displays of the year's winning science fair projects and the library resources used to help pull the projects together;
- (2) **Slide tape presentation:** presenting views from the classroom, links to the library, and statements from students and faculty about the math/science/technology program;
- (3) **Resource and Technology Time:** descriptions of books and demonstrations of hardware and software available in the library;
- (4) **Hands-on!:** families had the opportunity to browse, and work with the same computers and software their children use.

Most of the Institute funds were used to purchase books, software, posters and other science/math/technology materials to supplement and update the collection and to use in the Resource and Technology Time component. Fifty dollars was budgeted for certificates and fifty dollars for slide film and processing for the slide/tape presentation.

The event was held the night of the last Parent, Teacher, Student Association (PTSA) meeting in May, and took place in the library and the cafeteria. Certificates were given to all participating families.

"Using science themes for library programs capitalizes on children's natural curiosity and fascination with the world and helps them make the connection between books and real life."

— Barbara Holton

Project Title: **Fascinatin' Physics**

Library Media Specialist: Barbara Holton, doctoral student,
University of Maryland

School/ Address: (Where materials were used:)
Capitol Hill Cluster School,
Watkins Primary Campus
12th & E Streets, SE
Washington, DC 20003

The four physics kits developed for this project provide an excellent means of introducing elementary students to some basic physics concepts in an interesting, hands-on approach, while providing motivation to read more about the science topic at the same time. The kits are intended to nurture the intrinsic motivation children have about science and the world around them, and to encourage them to learn more by using the library materials which supplement these kits.

Kits were developed on the following topics:

- (1) **Sound:** Several tuning forks, including an adjustable one, allow students the opportunity to experiment with sound waves.
- (2) **Mirrors:** Concave, convex, and flat mirrors are used to demonstrate the properties of mirrors.
- (3) **Magnetism:** Using magnets of different sizes and shapes, a dowel rod, and iron filings encased in plexiglass, students learn about the attracting and repelling power of magnets.
- (4) **Spectrums:** Prisms and diffraction gratings are used to examine the colors of natural and artificial light.

The booklet accompanying each kit contains the following elements: Problems - stated as questions to answer; a Hypothesis; Experiment - Materials contained in the kit; Procedure - suggestions and questions; Results; Conclusions; Further Investigations - ideas to try; and Read More About It, containing a listing, with call numbers, of books the library has on the topic. Lastly, students are given other subject headings to try if they wish to find more information on the topic. The booklets, which were produced using WordPerfect, were nicely formatted on four pages, and laminated for protection.

Each kit also contains a Log Book in which the student can record observations, charts, graphs, notes, etc. Each kit is packaged in a zip lock plastic bag, so that they can be stored and used in the library, or borrowed for use in classrooms or at home. Ensuring that all the components are returned in the plastic bags may present a challenge; however, this problem is not uncommon in libraries.

Approximately \$150 was spent to purchase the equipment for several kits on each of the topics. The remaining \$350 was used to purchase books on these topics to supplement the library collection, and include in the listing of materials in the booklets.

The kits were used at Watkins Elementary School with great success. Students worked in pairs, taking turns reading the directions and doing the experiments, and recording the results in the log book. Students enjoyed the experiments, and expressed enthusiasm for these hands-on experiences.

Project Title: **How Your Body Works**

Library Media Specialist: Judith Scott

School/Address: Stoddert Elementary School
40th and Calvert Streets, NW
Washington, DC 20007

Stoddert Elementary School is one of the smallest and most ethnically diverse public schools in Washington, DC. With 187 students from 28 countries, the school is an international microcosm. There are ten classes Pre-K through grade four, and three English as a Second Language (ESL) teachers serving eighty-three children whose native language is not English.

The librarian and full-time science teacher decided to use the Institute grant to strengthen the science unit, How the Body Works. Third and fourth grade students work on this unit for about 10 weeks. The objective is to give students hands-on, supervised experiences with the interdependent systems of the human body.

The funds were used to purchase a twelve-part human torso and basic supplies. In the past, the school had borrowed a three-dimensional model of the human body, which students

"I read and paraphrased (a book about whales and sharks to a second grade class). I asked questions during the reading, e.g., 'Do you have angry feelings toward the shark?' They said 'yes,' but I pointed out that for sharks, killing and eating is natural. That started a discussion and an acceptance of creatures doing what comes naturally."

— Judith Scott

had delighted in using. The new model is housed in the library. It serves as a research tool as well as a visual incentive to interest students in learning more about their own bodies and the functions of various organs. Students work in pairs, small groups, or individually, depending on the task assigned. Students have been delighted with the hands-on activities which the model has allowed them to experience. Working with the various body systems allows students to see a common denominator among their ethnically diverse student population — everyone has a respiratory system, digestive system, etc. The model has motivated students to pursue further study and self-exploration; and the primary teachers, Pre-K through grade two, have begun to develop projects and activities utilizing the model, so that even the youngest students can begin to learn about their bodies.

"This is definitely a worthy use of funds, to integrate the language arts with science. Having the books kept inside the kits makes them instantly accessible to a teacher, without her having to make a separate search for them. The benefit to the children is to further their immersion in language, specifically the printed word."

—Doris Broughton

Project Title: **Integrating Science and Language Arts**

Library Media Specialist: Doris Broughton

School/ Address: Oakridge Elementary School
1414 S. 24th Street
Arlington, VA 22202

Oakridge Elementary School has approximately 535 students in 27 classrooms. In an effort to provide more hands-on science experiences for these students, the school has been acquiring Full Option Science System (FOSS) and National Science Resources Center (NSRC) kits. The FOSS kits use an inquiry approach with hands-on science activities. Each module includes suggested student reading. The NSRC curriculum materials also include a bibliography of related trade books for each unit.

With the objective of integrating science and language arts, it was decided to use the Institute funds to purchase class sets of paperback copies of trade books to be used with these FOSS and NSRC kits. The school would eventually like to have a kit available for every science unit on every grade level, and to have sets of paperbacks for each kit.

The science lead teacher and librarian selected the titles that would be of use to the broadest audience. The librarian noted that there was not a wide selection of good, recent science books at the appropriate reading levels for the science topics desired available in paperback format. Fourteen

copies of each title were purchased, one title for each grade level, one through five. The books have been placed inside the kits, so they will be readily available to teachers preparing to make use of the kits.

The librarian hopes that having these reading materials readily available to the students will further their immersion in language, specifically the printed word, and help them to see that reading is another way to further their understanding of science topics.

Project Title: **Jack and the Beanstalk**

Library Media Specialist: Billie Branscomb

School/Address: Hearst Elementary School
36th and Tilden Streets, NW
Washington, DC 20008

The target audience for this project were a group of 17 English as a Second Language (ESL) students who come from several ethnic groups: Hispanic, Asian, African, Polish, Hungarian, and Italian. These students have limited English speaking and writing skills. Therefore, a project involving photography allowed them to express themselves in a new way, while learning some basic science concepts.

The objectives of the project were: to help students understand that plants are crucial to life on our planet; to observe the germination of a seed and its growth stages; to measure plant growth to the nearest centimeter; to plant the seedlings on Arbor Day, April 29, 1994.

Each student was provided with a set of hyacinth beans. They were also given soil, and paper cups in which to grow their beans. Students used the camera to photograph the beans before and after germination. When the beans became seedlings, the students photographed them every five days, and recorded their growth on charts. On Arbor Day, April 29, students photographed the planting of their seedlings on the school's campus.

The main expenditure for this project was for the camera (\$385); \$55 was allotted for film and developing; and \$60 was used for seeds, potting soil, fertilizer, and cups.

This project allowed these students with limited language skills to communicate via a new form of expression. The project increased their confidence and eagerness to learn.

"I was very excited to do the (Sink or Float) experiment with the pre-K class at my school...I went to the pre-K teacher's class. I told her about this wonderful experiment and how it was simple enough to capture the attention of her students and how it would deepen their understanding of these concepts. After listening to my story, the pre-K teacher became excited and informed me that she would be delighted if I performed the experiment with her class."

—Billie Branscomb

"The mini media fair was worthwhile. Our hands-on science activities created a sense of fun in learning science. The computer software and videos previewed and performed by students and parents benefited everyone and were well received.

"Our school community is aware of the ongoing science activities in the school library media center. The students, teachers, and parents will be able to perform science projects as well as research activities at the school.

"I plan to continue with science-related projects in the library media center. There will be continuing science and technological activities initiated by the AAAS Science Library Institute mini-grant."

— Judy Bullock

The camera is a welcome addition to the school media center, as it will be available for use in various projects in the future.

Project Title: **Mini Science Media Fair**

Library Media Specialist: Judy Bullock

School/ Address: Turner Elementary School
Stanton Rd. & Alabama Ave., SE
Washington, DC 20020

Turner Elementary School has approximately 600 students, most of whom reside in the adjacent low-income housing projects. Ninety-nine percent of the students are Afro-American; less than one percent are Hispanic. The concentration of students in poverty at Turner Elementary is greater than the city average of one in three; this is a rate that is forty percent higher than the national average, according to a 1991 report by the Children's Defense Fund. To counteract the stereotypes of inadequacy and self-fulfilling prophecies of failure that often result from such poverty, Turner Elementary School has the vision of becoming an exemplary elementary school with a math, science and technology focus, using an aerospace theme.

To support this goal, it was decided to use the Institute funds to purchase software on science topics for the library media center, and to have a day-long Mini Science Media Fair to allow parents and teachers to see and use the software, and to participate in hands-on science experiments.

The following software was acquired with Institute funds: *Mammals: A Multimedia Encyclopedia*; *Dinosaur Discovery*; *Amazing Universe*, which features full color photographs from earth-based observatories, orbiting space craft, and the Hubble telescope that allow students to explore the solar system; and *Galaxy Classroom K-5*, a satellite education network that integrates video with hands-on activities, books, science kits, and teacher/parent guides. Forty dollars was used for miscellaneous supplies to support the hands-on science activities.

The **Mini Science Media Fair** proved to be an excellent way to introduce teachers and students to this software and the exciting possibilities that exist when science, math and technology are successfully integrated into the curriculum. A dialogue was initiated among parents, teachers, and the

library media center, which should prove helpful in eventually making Turner Elementary School's vision a reality.

Project Title: **One Hundred Scientists of Color**

Library Media Specialist: Edna Becton Pittmon

School/Address: Langley Junior High School
101 T Street, NE
Washington, DC 20002

This project was a three-week experimental program of cooperative learning activities. Over 70 students in three ninth grade classes researched the contributions of outstanding scientists of color. The students who participated in the project were considered to be at-risk. Since a majority of the students were considered to have low self-esteem, an important goal of the project was to build self-worth and self-esteem. A team consisting of the teachers of the three ninth grade science classes, parents, an administrator and the librarian worked together to plan the project.

The objectives of the project were to provide activities to expose students to numerous examples of outstanding scientists of color, and to provide effective methods of cooperative learning which contributed positively to students' social skills and their overall ability to interact successfully with others, thereby increasing their feelings of self-worth and self-esteem.

The project was introduced in two segments held in the classroom and the library. An introduction was given to students on resources to use in this research, and on developing charts, posters, graphs and other ways to display or communicate the contributions of these scientists. Students were then organized into teams, and the advantages of cooperative learning were discussed. These student teams spent several sessions in the library media center using reference materials, books, videos, periodicals, and other media to conduct their research; they were exposed to a variety of science and technology materials.

Students demonstrated a great deal of creativity in the ways they chose to present their findings: they created bookmarks, posters, charts, graphs, biographical listings, even a book in the shape of a clock.

"A Science Awareness Day was held with two classes being assigned in the library. A visiting science teacher who also had experience in weather forecasting spent two class periods explaining scientific data in weather reports. The teacher brought several handouts for students to examine and compare with information on a video shown giving the weather report in the daily news. Both classes found this very fascinating!"

— Edna Becton Pittmon

BEST COPY AVAILABLE

To support this project, the library media center used Institute funds to purchase over twenty additional science resources: reference materials, books, three science periodicals, a video and supplies.

Several beneficial outcomes resulted from this project. The science teachers and librarian established strategies for exchanging ideas, communicating, and working effectively with students in hands-on science activities. The library media center acquired several needed science resources. Students expressed creativity, enthusiasm, a great sense of accomplishment, and a desire to continue more learning experiences in the area of science. Students increased their science awareness, as well as their own self-esteem.

"Unique features of Dunbar include the fact that its forerunner was the first high school for Blacks in the U.S.; consequently, Dunbar has produced many outstanding alumni, including doctor Charles Drew, mathematician Allison Davis, and engineer Lincoln Hawkins. The librarian serves as the archivist for all historical documents and realia."

— Clara Neal

Project Title: **Operation Library Lab (OLL)**

Library Media Specialist: Clara Neal

School / Address: Dunbar Senior High School
1301 New Jersey Avenue, NW
Washington, DC 20001

Dunbar Senior High School is a comprehensive high school with an enrollment of approximately 750 students in grades nine through twelve. The student population is almost all African-American (99.9%), with the overwhelming majority representing single parent or single guardian low income households. Approximately twenty-five percent of the student body participates in a pre-engineering program which draws students from throughout the District of Columbia.

The objective of **Operation Library Lab (OLL)** was to create an effective link between scientific learning and the library media center by building and/or replenishing current holdings of scientific software in the media center. The ninth grade biology students study anatomy and physiology. They dissect frogs, perch, crayfish, and earth worms. To enhance their learning, the media center decided to acquire a CD-ROM software package, *Dissection of the Frog, the Perch, the Earth worm, the Crayfish, and the Fetal Pig*, to bring technology into the classroom and stimulate student interest.

The biology teacher and library media specialist provided a staff development session for members of the science and math department during which the new software and additional library media center resources were displayed and

demonstrated. Each Tuesday during the months of April and May, the library aide brought the equipment and software to the fifth floor science lab and provided technical assistance for the biology teacher and students. Each Monday, the students reported to the media center to conduct research and document previous labs. On April 28, students conducted a demonstration for the PTA, discussing how the use of technology, hands-on science, and cooperative education had enhanced their learning experience. Two students designed and conducted a survey to determine how the biology students and teacher felt the use of this technology and software, and the cooperative learning experience had affected the overall learning environment and the learning process.

The Institute grant was used to purchase the CD-ROM software package (\$400); student notebooks and supplies (\$75) and certificates and pins for the students (\$25).

Project Title: **Passport to K-6 Student Success in Science**

Library Media Specialist: Rose Jones

School/Address: Chillum Elementary School
1420 Chillum Road
Hyattsville, MD 20782

Chillum Elementary School, which is a Milliken II school, is working toward becoming a Science, Math and Technology School. A team of parents, teachers, community activists, and merchants have been sharing ideas and working toward this goal. In March, a committee consisting of the library media specialist, principal, two teachers, and a community member documented how this effort might be supported, especially by the library media center.

It was decided that the Institute funds as well as those generated by a book fair would be used to purchase new science materials for the library media center, and that a Science Awareness Fair would showcase these new materials for parents, students and other interested members of the community. The event was held on Saturday, May 21, from 1-3 pm. Several mini-workshops and science stations were set up in the library and throughout the school building, and participants rotated among the various stations. One of these was a demonstration by a NASA aerospace education specialist about how astronauts live and work in space. Stu-

"Chillum Elementary School is a Milliken II school...The entire community is actively involved in the education of our students. Parents, teachers, community activists, and merchants meet and share ideas in an effort to promote academic growth. This teamwork will provide cohesion within the school and create better problem-solvers using hands-on science."

— Rose Jones

dents were able to see first hand what a space suit looks like, what space food is like, etc. Parents and students were able to ask questions, and one student got to try on the space suit. Another station was set up in the library where new science materials were on display; a video on various careers in science was playing; and students exhibits were on display. One of the teachers volunteered to be a "teacher in space", much to the students' delight. Another station allowed participants to explore magnetism, and another structures.

The Science Awareness Fair was well attended by both parents and students. So much enthusiasm was generated among teachers, students and parents that another event is already planned for early in the fall. This event will be an Invention-Convention.

Book fair funds of \$282 together with the \$500 grant enabled the library media center to purchase new science kits, videos, books and computer software, and to support the Science Awareness Day.

Outcomes of these activities have been more teacher and parent cooperation; more volunteering on the part of community leaders; the completion of a science laboratory in the building for grades K-6; and more enthusiasm and interest in science on the part of students, who are already eager to learn more about next year's project.

"This (mini-grant) activity will stimulate student interest in the physics kits that will be on loan in our library through Barbara Holton's Institute project."

—Cathy Pfeiffer

Project Title: **Physics Fair**

Library Media Specialist: Cathy Pfeiffer

School/Address: Capitol Hill Cluster School
Watkins Primary Campus
12th & E Streets, SE
Washington, DC 20003

One hundred fourth graders were involved in the week-long **Physics Fair** during National Science and Technology Week, April 25-29. The synergy created by this project resulted in several positive outcomes in the school. The project facilitated cooperation and collaboration between the library media specialist and the science resource teacher. Students used a new science laboratory for the first time during the **Physics Fair**. The science teacher set up experiments/activities on light and sound in the lab for primary students, and

laboratory experiments on magnetism and electricity in the Intermediate Laboratory.

In the library media center, the physics kits on sound, mirrors, magnetism, and spectrums that Barbara Holton created (see **Fascinatin' Physics**) were available for students to use during their regular library visit. The library had also purchased kits, books and other materials to support further study and investigation of these topics.

Students and teachers responded with much enthusiasm to the **Physics Fair**. After using one of the physics kits in the library, one student said, "I felt good that I could explain in my own words what had happened." The project has provided the impetus for greater interest and involvement in science on the part of both teachers and students; the enthusiasm generated by this project will be carried into the next school year.

The \$500 Institute funds were used to purchase materials for the **Physics Fair** (\$150); additional science kits (\$200); and science books on these physics topics (\$150).

Project Title: **Project Jason**

Library Media Specialist Charles Phillips

School/ Address: Bancroft Elementary School
1755 Newton Street, NW
Washington, DC 20010

At Bancroft Elementary School it was decided to use the grant to extend learning from the National Geographic Jason Project by allowing the staff and students to fully implement the Jason Project.

The Jason Project was founded by Dr. Robert Ballard, an oceanographer who was responsible for discovering the location of the Titanic and the Bismarck. National Geographic is a primary interactive site where students viewed Dr. Ballard's experiments live via satellite transmission during a two-week period in February/March. The program also provides teacher training and curriculum guides so that what is experienced and learned through the Jason Project can be integrated into the students' math/science/reading and geography classes.

"I noticed that during this month when I told folk tales something strange had taken place. It was actually very wonderful. In one of the book fair titles, The Three Little Pigs, I was retelling the story not as told but using scientific principles and terms. Roberto, the first pig, did no planning at all while his brother Jose did some thinking. However, the third brother went to the library/bookstore and got some books on how to build a house. Then he drew pictures, etc. Now the wolf had to plan to get into the house for pig snacks."

— Charles Phillips

The target group were the approximately one hundred and thirty fourth and fifth grade students in the school. There were three classes at each level. Many of these students were non-English speaking. Both levels were using the curriculum guides from the National Geographic Society.

Project Jason - Year 5 Belize was used as the nucleus for the project. A variety of learning activities, including hands-on activities, videos, field trips, guest speakers, displays and learning centers were used to reinforce learning from the Jason Project, and to interest as many students as possible in these science topics.

The library media center supported this effort with the \$500 Institute grant; plus \$250 in Reading Is Fundamental (RIF) materials and \$25 from the PTA. These funds were used to acquire books and other print materials on science topics (\$350); non-print materials (\$120); display materials/posters (\$55); RIF giveaway materials on science (\$250); and supplies for experiments (\$25).

"I met with librarians and computer staff of the National Library of Medicine. We discussed the offerings of the facility--(a) Medline database which contains seven million references. In addition to this, NLM has 40 other databases for cataloging and serials information on toxicological and chemical data, information on audiovisual materials, and data on cancer and other specialized areas of health and disease. We are ecstatic, to say the least, about this venture, for it will open the world of medicine and science to our students and staff."

— Pauleze Bryant

Project Title: **Quality of Drinking Water at Coolidge High School**

Library Media Specialist: Pauleze C. Bryant

School/Address: Calvin Coolidge High School
5th & Tuckerman Streets, NW
Washington, DC 20011

This project focused on the study of a potential environmental science problem that could exist at the school. Students studied the environmental and societal effects of lead as a pollutant and tested the drinking water in their school building.

Ten students from the chemistry and social studies classes were involved in this project. Students worked in teams, studying this issue from several aspects. The chemistry and social studies teachers, as well as the librarian worked with the students.

Guidelines for the project were developed. The chemistry teacher insured that proper procedures were followed. The Environmental Protection Agency (EPA) Standards for PPM lead concentration in water were used. Intermittent testing was done. The social studies teacher worked with the stu-

dents in exploring the societal implications of this environmental problem. The librarian coordinated the effort and insured that students had access to the research materials they needed to pursue their investigation of this problem. To support this project, grant funds were used to purchase a lead colorimeter (\$280); two refills for the colorimeter (\$175); and 22 reverse osmosis water bottles (\$45).

Exhibits from the project were displayed in the library as a culminating activity.

Project Title: **Science and Invention Fair**

Library Media Specialist: Janice Spencer

School/ Address: Shepherd Elementary School
14th & Kalmia Road, NW
Washington, DC 20012

Shepherd Elementary School used its grant funds to begin planning for a year long project culminating in a Science and Invention Fair in March of 1995.

A committee, chaired by the librarian, was formed to plan the project. Committee members are the principal, a teacher at each grade level, the counselor, the resource teacher, the mathematics teacher, two students, a parent, and the school supervisor.

Objectives of the project include raising the interest level of students and teachers in science; developing teamwork and problem solving skills; showing that science is fun; and developing student projects to enter in the city-wide Science Fair and the National Invent America competition.

Since the school does not have a science teacher, the librarian hopes that the year long effort will serve as a rallying point to establish a school wide discussion among students and teachers about hands-on science activities, and that teachers will incorporate more hands-on science activities into their classes.

Emphasis will first be placed on working with all third through fourth grade students in the school; this will include approximately 220 students in twelve classrooms. The following activities were planned to begin in March of 1994 and

"Today I tried (an) oil and water density activity. The classes were third and fourth grade. I mixed oil, water, and green food coloring in fruit juice bottles. I shook the bottles and placed one on each table. The students worked in groups. Each group had to make three observations about the bottles and their contents and report the observations back to the group. The students were very excited about the activity and did not want to stop. One group even guessed the contents without being prompted."

— Janice Spencer

continue through March of 1995. Students select and re-research a science/math subject in the library media center gathering information from at least four different sources in varied formats. As each class comes to the library, they participate in hands-on science activities. These activities are designed to stimulate student interest and discussion about the underlying principles explaining why the activities have the results they do. To encourage follow-up in the classroom, the librarian has developed a set of lesson sheets for the classroom teachers, with suggestions for follow-through hands-on science activities and discussion topics.

The culminating event for this year long effort will be a Science Invention Fair to be held in March of 1995. Students in grades three through six will participate within their grade level. The event will be held in the school auditorium, where students will demonstrate their inventions to other students and visitors. The Fair will be a week-long event, and include an evening for parent viewing, if possible. If successful, the event will be held again the following year.

To support this year long project, an additional \$400 from the DCPS Gifted and Talented Office will be used. The total budget of \$900 will be used as follows: Books and other science/math/technology materials to supplement the collection and for use in student research (\$550); materials for student team activity kits (\$150); awards and certificates (\$100); publicity (\$100).

"The objectives of (our mini-grant) project are to raise the interest level of students and teachers in science fair projects; to develop teamwork and problem-solving skills; and to show the students that science fair projects can be fun. We hope to have a wide variety of science resources in the school library to encourage all students and classes to participate in the project."
— Suzanne Willett

Project Title: Science Fair: Resource-Based Instruction

Library Media Specialist: Suzanne Willett

School/ Address: Francis Junior High School
24th & N Streets, NW
Washington, DC 20037

At Francis Junior High School the grant was used to coordinate science fair programs and to support resource-based instruction in science. The target audience were the 600 7th, 8th and 9th grade students at the school. The five science teachers were enthusiastic about the project, and worked with the librarian to implement it.

The objectives of the project were to raise the interest level of students and teachers in science fair projects; to develop

team work and problem solving skills; to show the students that science fair projects can be fun; to encourage student participation; and to update the science resources in the library to support this effort.

Preparation for the **Science Fair** began in early March. Students came to the library with their science classes to gather information and find science fair projects. Students could peruse several new resources such as, the Science Experiments on File Collection and books describing science fair projects. The library was also open before, during and after school for students wishing to do additional research.

The **Science Fair** was held on April 12. The **Science Fair** projects were arranged by grade level, and judging continued throughout the day. Medals, plaques, and ribbons were awarded to the first, second, and third place winners in each grade. All students received certificates of participation. Judges included volunteer scientists, parents and community leaders.

The \$500 grant enabled the library to replace outdated science materials and to add resources to help students with science fair projects. The new materials purchased included the *Science Experiments on File Collection* and *More Science Experiments on File Collection* (\$320); three books: *Learning on Your Own: Science Projects*, *Earth Science: 49 Science Fair Projects*, and *Environmental Science: 49 Science Fair Projects* (\$55); and a video, *Science Projects for Junior High* (\$125). Certificates, medals, plaques and ribbons were purchased with separate funds.

This project resulted in several positive outcomes. It generated interest in and enthusiasm for science fair projects. The librarian felt that because resources were readily available in the library, students and teachers were more interested in the science fair than in previous years. For the first time, there was 100% participation by students and teachers, with everyone contributing a project to the fair. There is a positive attitude among the science teachers regarding the science fair unit. They are pleased with the new library resources, and feel that students will select even more challenging projects because these resources are readily accessible. Science teachers have also begun to work as teams to develop units of study and inquiry using the new material.

"These Institute sessions have been very helpful in bolstering my argument that Calvary's library must be considered as a major part of the goal of quality education at Calvary. For too long, the library has been considered to be almost an 'afterthought' and not as an essential part of the education process.

At least one teacher is interested in doing an expanded version of the science fair with an all-day type experience. I think I can interest some of the others in this, also. Doing the mini-fair at open house was a productive idea with several parents talking to the principal about the science and math program at Calvary.

With this developing interest in increasing science and math projects at Calvary, my main objective for attending the Institute sessions has been met."

— Violet Lentner

Project Title: **Science Outreach Plan: Sharing Science**

Library Media Specialist: Violet Lentner

School/ Address: Calvary Lutheran School
9545 Georgia Avenue
Silver Spring, MD 20910

At Calvary Lutheran School the grant was used to provide additional up-to-date resources in several science study areas. Given special emphasis were space science, physical science and math concepts. By updating and augmenting the science and math collection, students were provided with more opportunities to learn about science and to share what they had learned with others.

The target audience included all the students in the school, grades kindergarten through sixth grade. The school houses 115 students in six classrooms.

The objective was to give students the opportunity to showcase their science and mathematics learning by sharing what they had learned with parents and students in other classes. To facilitate this, the second grade students prepared a mini-fair for Open House and the first grade students did some simple science experiments with their parents. Sharing science will continue next year at Back to School Night, and at other school events, where students' achievements in science will be showcased.

Grant funds enabled the library to acquire 50 up-to-date science and math books, and a few items such as tangram patterns for hands-on science activities. The addition of these new resources has greatly improved the science and math collections in the library, and there has been an increased demand for science and math materials in the school. This effort has resulted in an increased awareness of the importance of science among teachers, who are using the new library resources with their students and incorporating hands-on science activities into their classes. A Science Olympics is being considered for next year.

Project Title: **Science Software: Action/Motion Multimedia**

Library Media Specialist: Marilyn Moser

School/Address: Amidon Elementary School
4th & Eye Streets, SW
Washington, DC 20024

Amidon Elementary School has approximately 435 students in pre-kindergarten through grade six. The school had the hardware to use videotape and videodisc materials, but very little software, especially on science topics. The librarian decided to use the Institute grant to acquire up-to-date multimedia on science topics.

Many science topics that are especially interesting to students at this level involve motion and action. For example, the study of volcanoes, earthquakes, hurricanes, lightning, and wind would all lend themselves to media which can display motion and action. The librarian consulted with teachers as to which science topics they would most like to have initially, and selected eight titles. The library used the \$500 Institute grant plus \$200 from a book fair to purchase these eight titles in video and videodisc format.

The librarian showcased the new resources in the library with demonstrations for teachers, students, and parents during National Library Week. Teachers and students were enthusiastic about these new resources, and the librarian feels that these materials will continue to spark more interest in science, math and technology, among teachers and students. Because of the success of this initial effort, she plans to add more titles to this collection as resources permit.

Project Title: **Science Reading Room Update**

Library Media Specialist: Barbara Roberts

School/Address: Science & Technology Division
Martin Luther King Public Library
DC Public Library
901 G Street, NW
Washington, DC 20001

The Science and Technology Division is located in the Martin Luther King Memorial Library, the main branch of the DC

"I organized a display in our library on Black inventors to get ready for celebrating the annual Black History Month observance. A large poster shows pictures and illustrations of many inventions by Black Americans. Reference resources are included.

Students are requested to experiment by acquiring some of the inventions or constructing examples. One second grade class is growing peanuts and sweet potatoes to experiment with George Washington Carver's ideas. The class borrowed library resources on slavery and George Washington Carver."

—Marilyn Moser

"I checked with NSF (National Science Foundation) to get a copy of their grant proposal requirements. I am planning to try to promote science in the public library for patrons from preschool to high school...Thanks to the workshop at AAAS, I am beginning to think in terms of a chronology and what specific resources would be needed."

—Barbara Roberts

Public Library. Many students use this facility. The target audience for this project are the junior and senior high school students who use the library. The library receives many requests each year from these users for information on science fair topics. The objective is to provide updated resources to help these users in gathering information to select science fair projects, and to interest them in learning more about science, math and technology in general.

To pique user interest, the library purchased posters and charts on science topics, which are displayed in the reading room, along with some of the available books on topics such as astronomy, rocks and minerals, early man, dinosaurs, and meerkats. A transparent celestial globe was also acquired; it is on display for the public to view, and will also be used with programs sponsored by the library on astronomy. Branch libraries will also be able to borrow it.

To provide additional resources on science fair projects, the library acquired *Facts on File Historical Science Experiments*. Science experiments (non-copyrighted) are printed on card stock and housed in a loose-leaf format, so that users can photocopy those they select. The remainder of the grant funds were used to add books on science fair projects to the collection: for example, *Physics Projects for Young Scientists*, *Environmental Experiments About Air*, *Astronomy for Every Kid*, and *Science Projects About the Human Body*. Approximately \$60 was spent for posters; \$95 for the globe; \$150 for *Facts on File Historical Science Experiments*, and \$195 for books.

The posters and globe were featured in the Science Reading Room during the month of May. The new materials have been enthusiastically received by users, and should receive a great deal of use. These materials will also be available for use in the Children's Reading Room at the library, as well as other public library branches.

Project Title: **Seeing and Doing Science with Video**

Library Media Specialist: Geraldine Capehart

School/Address: Thomson Elementary School
12th & L Streets, NW
Washington, DC 20005

Thomson Elementary School has approximately 370 students in pre-kindergarten through grade six. The library had limited up-to-date science materials and no science videos in the collection. The librarian decided to use the Institute grant to acquire science videos for the library, and to begin video-taping science activities.

The \$500 was used as follows: Videos were purchased from the PBS Multi-Media Science Curriculum and Reading Rainbow series (\$400); and blank video tape was purchased to use in taping science activities at the school (\$100).

The response to this initiative was positive. Students and teachers were enthusiastic about the new science materials, which are being used both in classrooms and the library. Students enjoyed being videotaped, as they were able to see and hear themselves immediately after completing a science activity; this helped to reinforce their learning. The library is also building a collection of school-based science videos which other classes can use.

Given the success of this effort, the librarian plans to continue videotaping science activities both in classrooms and the library, and hopes to be able to add additional titles to the science video collection.

Project Title: **Senses Extravaganza**

Library Media Specialist: Jannette Smithson

School/Address: Mount Vernon Elementary School
2601 Commonwealth Avenue
Alexandria, VA 22305-2504

Mount Vernon Elementary School has approximately 655 students in pre-kindergarten through grade five. The objective of this project was to make students aware of happenings in their environment by having them participate in

"Thomson School is a multi-ethnic school which is comprised of students from Asia, Ethiopia, El Salvador...The students are in need of more up-to-date science materials, videos, equipment, and hands-on science-related activities and projects...By using instructional strategies such as videos, many students will be able to have...experiences right in the classroom, where they can fully explore the ideas in an ongoing course of study."

— Geraldine Capehart

"With the rapid changes in technology, it is my desire to become better acquainted with the wealth of materials that are available for minority and disadvantaged youth."

— Jannette Smithson

several hands-on science activities related to the five senses. The project was initiated with ten first and second grade students from a special education class. The librarian worked with the special education teacher to plan and execute the **Senses Extravaganza**. Up-to-date resources on the senses were purchased for the library to support this instruction.

Some of the activities were undertaken in the library, others in the special education classroom. To better understand the sense of taste, students sampled juices with four distinct flavors, from plain paper cups, while they held their noses closed, so they could not smell. Their teacher and an aide then helped record what they thought each flavor was. This helped them understand the relationship between the senses of smell and taste. This activity took place in the library. The librarian also shared a short book with the students about the sense of taste. Similar hands-on science activities were planned for the sense of touch (different textured materials); smell (create and compare fragrances); hearing (distinguish between loud and soft sounds); sight (blindfolded activities).

To support this effort, the library acquired \$475 in new science materials related to the senses, and other science topics, and used the remaining \$25 for hands-on science materials. The **Senses Extravaganza** took place the week of April 25th. The students liked these activities, and the special education teacher was enthusiastic. The project will be extended to other special education and primary classes, and all students will continue to benefit from the new science materials added to the library collection.

*"(O)ne of the good things about the Institute is the opportunity to 'network'...I learned of a very excellent geology professor at UDC (the University of the District of Columbia) from one of the Institute participants... Cathy (Pfeiffer) said he even took a bunch of kids to West Virginia on a fossil hunt field trip. True, it's not the 'wild west'...but it is west of D.C."
—Mary Jane Cox*

Project Title: **Student Reviews of New Science Materials**

Library Media Specialist: Mary Jane Cox

School / Address: Hardy Middle School
Foxhall & Q Streets, NW
Washington, DC 20007

Hardy Middle School has a student body of 225 middle school students in grades five through eight. The objectives of this project were to upgrade the science book and software collection and to use the new materials to improve students' critical thinking and writing skills. The latter objective was accomplished by having students read and then write student reviews of the new acquisitions.

Students helped inventory and weed the science collection, and had input, along with teachers, regarding areas of the collection where updated materials were needed. Final selections were based on teacher and student recommendations, published book reviews, and the librarian's research. Four hundred dollars of the grant was used to purchase new science book titles; \$100 will be used to purchase a new environmental CD-ROM as soon as it is released.

The new materials arrived fully processed, so they could be given to students immediately to review. The librarian and a science teacher developed guidelines for students to follow in writing their reviews of the new materials. In addition to the usual bibliographic information (title, author, publisher, copyright date), students were asked to: write a brief summary of the book; indicate the intended audience; describe how this book could be utilized in the classroom; comment on the book's illustrations, accuracy, organization; and explain five science facts that were new to them, with examples from the book.

Mr. Dunn's sixth grade science class was the first to participate in the project. Some of the topics included in the first shipment of new science books were: the human body, science experiments, compost critters, invertebrate animals and marine biology. These students read and reviewed the new titles and some of their reviews were published in the Hardy PTA Newsletter. This will be an ongoing activity in the fall. Students will continue to read and review the new science materials, and reviews will be published weekly in the school newsletter. Students will also have the opportunity to submit their reviews for possible publication in the Young Reviewer's Corner of AAAS' *Science Books and Films*.

This project has resulted in several positive outcomes. The science book collection in the library has been updated and improved. Teachers and students are excited about the new materials, and usage has increased. Teachers and students are more likely to find the information they need, and this means greater satisfaction for the users. For example, with more books on science experiments, next year's science fair will be less frustrating for everyone concerned. By reviewing the materials and writing book reviews, students are learning critical thinking skills and improving their writing skills; other students become interested in reading some of these titles; and teachers and parents learn about the new materials.

"I feel that partnering with a science teacher would be...helpful to me. I need to observe actual classes working with their science teachers. I want to see how lessons are presented and just what the students are asked to do. What types of assignments do they receive? What resources are in the classrooms, in the labs? What textbooks are they using? I need to see what is needed in the library to help the science teachers and their students."

—Annette Ortiga

Project Title: **Super Sleuths, Inc.**

Library Media Specialist: Annette Ortiga

School/Address: Jefferson Junior High School
8th & H Streets, SW
Washington, DC 20024

Jefferson Junior High School has 769 students in grades seven through nine. Approximately ninety-three percent of the students are African American; four percent Asian; two per cent Hispanic; and one percent white. The Institute grant was used to conduct a Super Sleuth, Inc. project and to provide the entire student body with the opportunity to participate in a Super Sleuths, Inc., training session.

The objectives of the program were to stimulate an interest in scientific investigation; to strengthen critical thinking/investigative skills; and to show students that science can be fun. In order to implement this project successfully, the librarian met with the Director of Science and the principal to get their input and support. All of the teachers in the science department expressed a willingness to support the project and to have their students participate.

Students were presented with the following scenario. Super Sleuths, Inc., employs a team of investigators whose job it is to seek answers to scientific questions. They use information gathered from various reference tools and the results from hands-on science experiments to help them formulate valid conclusions. You've just been hired by Super Sleuths, Inc., to solve one of their most baffling cases. After you check into your office, you will be handed an investigator's kit containing the following: a data sheet for the collection of information from selected science books; directions for the doing an experiment; materials for the experiment.

The training sessions and investigations took place in the library media center. The project was originally planned for School Library Media Week in April, but had to be postponed until May because of testing at the school. Students worked on their experiments in teams. To support the project, the library used the grant funds to purchase several new science reference books and other print materials to update the science collection (\$400); science magazine subscriptions (\$50); and the supplies for the experiments (\$50).

The project was well received by teachers and students, and the project's objectives appear to have been achieved. Students enjoyed doing the experiments and seeking out answers in this context. There is an increased awareness that science can be fun, and more interest in science on the part of many students.

Project Title: Supporting a New Curriculum in Environmental Science

Library Media Specialist: Lydia E. Jenkins

School/Address: Alice Deal Junior High School
Fort Drive & Nebraska Avenue, NW
Washington, DC 20016

"The opportunity to participate in the Science Library Institute falls in line with my personal goals of attempting to find the link to helping improve the science collection in the library and to provide resources to students which will enhance their classroom experiences."

— Lydia Jenkins

Alice Deal Junior High School used the Institute funds to purchase books and instructional media to support a new science curriculum component in environmental science that was being launched by three teachers at the school. The target audience were 125 students in five ninth grade science classes. The librarian worked with the three science teachers to plan and implement this project, which took place from April 18-May 20.

In this new curriculum component, the students studied biomes of the world; for example, the tundra, desert, and tropical rain forests. They studied the types of soil in each of the biomes and investigated how various elements affected the plant growth and animal survival in each of these areas. The interdependency of various components in each biome region were emphasized.

The librarian worked with students to conduct research in the library media center. Students had access to two periodical databases: *Newsbank* and *EMAS*, and an electronic encyclopedia, *Information Finder*. To supplement existing resources that supported this curriculum component, the library used the grant funds to acquire books and other media on these environmental science topics.

Based on the conclusions that students reached from their research, students created mini-environments that were displayed in the library media center and the classrooms. Students also described and discussed their projects, and the student projects were videotaped.

*"Thank you, thank you,
thank you for the information
on funding and grants.
Honestly, I never knew there
were so many agencies that
provided funding for schools."
— Ruby Osia*

Project Title: **Vegetable and Flower Gardening**

Library Media Specialist: Ruby Osia

School/Address: Lyles-Crouch Elementary School
530 S. St. Asaph Street
Alexandria, VA 22314

The objectives of the **Vegetable and Flower Gardening** project at Lyles-Crouch Elementary School were: to increase student interest in gardening; to beautify the school grounds; to raise the self-esteem of students and their pride in school property; and to share the responsibility and maintenance of the vegetable and flower garden.

The librarian planned and implemented the project with Andrea Courduvelis, the fifth grade teacher whose class of 21 students planted and cared for the garden; Donald Futrell, the physical education teacher; Robert Graham, the custodian; and the maintenance workers at the school.

Students began the study of gardening the week of March 21. The library media specialist and the classroom teacher introduced the unit, and various library resources which the students could use in their research and study about gardening. Students used these resources to conduct research on various gardening topics in the library media center. The maintenance workers, custodian, and students worked together to break ground and till the soil. The students researched and studied information on planting and maintaining a garden. They measured plots for the two gardens. Pansies were planted in early April, and tomato and cucumber plants were planted at the beginning of May. The students kept a journal of all the work they did, and observations about plant growth. The project was well-documented with photographs taken by the librarian.

Resource persons came to the school to share gardening techniques and information with students throughout the project. Students had the opportunity to interview a botanist, professional gardeners, and garden supply store owners.

Students were very enthusiastic about this project. They became more knowledgeable about gardening, and some of them expressed a desire to continue gardening at home. Students had the opportunity to harvest and eat the vegetables. They took pride in the fact that they had helped to

make the yard area more attractive, and proudly pointed out their garden to many visitors to the school. Since several math and science concepts were integral to the project (e.g., measuring the garden plots, learning how seeds develop into mature plants), the students gained an awareness that science can be both fun and useful.

To support this project, the library purchased science books and other materials on gardening and other related science topics (\$450), and spent \$50 for the tomato and cucumber plants, stakes, and cages. The PTA donated an additional \$50 to purchase the pansies.

— Mary C. Chobot

BEST COPY AVAILABLE

Chapter Twelve

Replicating the AAAS Science Library Institute Experience

Organizing a Science Library Institute

The AAAS Science Library Institute sought to develop a local capacity for conducting in-service workshops on equity and excellence in science and mathematics education. Librarians were able to make the transition from workshop participants to key players in educational reform in their schools. This result can be replicated in local communities either by in-service workshops or by less formal gatherings of librarians with similar goals.

An organizing committee can be formed to plan and conduct science and mathematics workshops for librarians that are activity-oriented and based on the recommendations from AASL's *Information Power* and AAAS's *Science for All Americans*. Such workshops can be organized and conducted using the resources provided in this book.

A Science Library Institute can become a team effort, organized and sponsored by the community in partnership with local science institutions and other community organizations. To help foster this partnership, an organizing committee could include representatives from all the stakeholders in improving science and mathematics opportunities for children, including parents, K-12 teachers, university or college faculty, school and library administrators, library volunteers, local clergy, science professionals, and science museums. We recognize that it is not possible to provide a science or mathematics background for every librarian. However, as

When planning the AAAS Science Library Institute, we considered the importance of making it a project that could be easily replicated in other settings. This chapter, written by Maria Sosa, provides suggestions on conducting an Institute in your own community. The suggestions are based on lessons learned in our project involving librarians in the greater metropolitan Washington, DC, area.

trained information specialists, librarians can learn to access and use tools already at their disposal to help them make decisions about materials and programs for their libraries. They can also become a dissemination point for teachers and parents, providing them with information about innovations and effective strategies for improving science and mathematics performance of students. Well-informed educators, parents, and community leaders increase the likelihood of meaningful and effective school reform.

Selecting Topics for Science Library Workshops

This book should give you some ideas about the major components of a science library institute in your community. In the AAAS Science Library Institute, a major focus of the five monthly workshops was hands-on science and mathematics techniques and strategies for engaging female, minority, and disadvantaged students. The sessions covered science and mathematics education participation issues as well as guidelines for developing media programs.

Although the AAAS Science Library Institute featured five monthly workshops and the topics mentioned above, you may wish to organize your institute in a way that better suits your needs. You may also wish to focus on all or only some of the objectives used in the AAAS Science Library Institute. Regardless of the topics selected for the institute training sessions, it is important in such sessions that librarians will not "sit and listen," but will be actively involved in doing specific hands-on science and mathematics activities that motivate all students, including limited English proficient students. Specific ties can also be made to books for different grade levels that relate to engaging female and/or minority students in science.

At the first AAAS workshop session, the curriculum focused on several major components of science education reform (see Chapter Two). The chapters on science, mathematics, and technology education reform in this book can help you devise topics for conducting a similar workshop. This session centered around methods for helping librarians act as catalysts in science and mathematics reform. The background portion of the sessions was based on the AAAS publication *Science for All Americans*, which outlines the science understandings and habits of mind that every student should possess at the end of high school, and AASL's *Information Power*, which sets forth guidelines for developing

the school library media programs needed to prepare students for success in the next century. Copies were provided to all participants.

In subsequent workshops issues discussed included:

- how to articulate and defend a budget on science/mathematics resources, including seeking outside funding through grants and business partnerships;
- how to develop research tools for compiling science and mathematics information;
- how to assist science and mathematics teachers in developing resource-based learning curricula.
- how to support hands-on activities in the existing school curriculum (that is, activities that will fit into the existing state/district objectives and standards);
- techniques that motivate and encourage male and female majority and minority students to participate in hands-on science and mathematics;
- resources that focus on "teaching" problem solving;
- relating science and mathematics studies to everyday life situations; and
- conducting science and mathematics activities to promote equity and excellence in education.

You may want to address some of these issues in your Institute, but there may also be topics that are relevant to your particular situation that are not listed here, such as science access for people with disabilities, family-oriented or intergenerational science opportunities, or "grazing" on the Internet. Feel free to explore such topics in your Institute sessions, and if you do, get in touch with us to let us know how it went!

Evaluation

Evaluation is one of the most important components of any program. An effective evaluation plan assesses the project goals, objectives, strategies, and timelines. Evaluation for a Science Library Institute should address these questions:

- What is the need for the project?
- Who participated in the project?
- What activities were conducted?
- Where were the activities conducted?
- How much time was involved?
- How much did the project cost? and
- How will the outcomes be measured?

The AAAS Science Library Institute utilized a variety of evaluation strategies. Participants kept journals throughout the project documenting their thoughts about the subject matter. Institute staff and consultants conducted site visits and prepared case studies of the programs developed by the participants at their own libraries.

To assess the effectiveness of the training workshops, entry and exit questionnaires were used (refer to Appendix C). This method of evaluation is advantageous because you can use the information collected from the questionnaires to modify and improve the format of the training sessions as well as to identify additional needs of participants. Another advantage to using pre- and post-questionnaires is that they provide immediate feedback about the effectiveness of the project components, e.g., because of initial feedback from the Institute participants, project staff began to budget more time during the sessions for participants to network and brainstorm. Generally, the AAAS self-report surveys were useful in the following ways:

- They provided general demographic information, including each participant's background and experience;
- They helped to identify participants' attitudes toward and perceptions of science and mathematics education;
- They helped to monitor participants' comfort level with the hands-on science and mathematics presented in the Institute sessions.

The questionnaires were distributed at the beginning and end of the first Institute session, and then at the end of each successive session. At the last session, participants filled out a questionnaire requesting their concerns and comments about the Institute as a whole. Each questionnaire was analyzed for changes in participants' attitudes, perceptions, comfort level, and comments on each workshop component. While more formal techniques can be used, self-reported information can help you gauge the effect of the content of your particular Institute on your particular audience.

We believe that any community, whether urban, suburban, or rural, can benefit from a Science Library Institute. We also believe that all librarians can be empowered to become leaders in efforts to enhance science and mathematics experiences for all children.

Appendices ---

Appendix A: Other Science Resources

This is a list of science and mathematics resources that were graciously donated to the AAAS Science Library Institute project by various publishers. Institute participants used these resources in the materials review exercises. Refer to Appendix B for the form participants used for reviewing resources.

Accorsi, William. *Rachel Carson*. New York, Holiday House, 1993.

Bash, Barbara. *Shadows of night: the hidden world of the little brown bat*. New York, Little, Brown and Co., 1993.

Bash, Barbara. *Urban roosts: where birds nest in the city*. New York, Little, Brown and Co., 1990.

Bellamy, David. *Tomorrow's earth: a squeaky-green guide*. Philadelphia, PA, Running Press, 1992.

Bernhard, Emery. *Dragonfly*. New York, Holiday House, 1993.

Bonnet, Robert L. and G. Daniel Keen. *Environmental science: 49 science fair projects*. Blue Ridge Summit, PA, TAB Books, 1990.

Bosak, Susan V. *Science is*. Richmond Hill, Ontario, Canada, Scholastic Canada, Ltd., 1991.

Brice, Raphaëlle. *Rice: the little grain that feeds the world*. Ossining, NY, Young Discovery Library, 1984.

Bright, Michael. *Scals*. New York, Aladdin Books, 1990.

- Brown, Ruth. *The world that Jack built*. New York, Dutton Children's Books, 1991.
- Cheney, Glenn Alan. *Chernobyl: the ongoing story of the world's deadliest nuclear disaster*. New York, Macmillan, 1993.
- Chinery, Michael. *Ant*. Mahwah, NJ, Troll Associates, 1991.
- Chinery, Michael. *Butterfly*. Mahwah, NJ, Troll Associates, 1991.
- Chinery, Michael. *Frog*. Mahwah, NJ, Troll Associates, 1991.
- Chinery, Michael. *Rainforest animals*. New York, Random House, Inc., 1992.
- Chinery, Michael. *Shark*. Mahwah, NJ, Troll Associates, 1991.
- Chinery, Michael. *Snake*. Mahwah, NJ, Troll Associates, 1991.
- Chinery, Michael. *Spider*. Mahwah, NJ, Troll Associates, 1991.
- Collard, Sneed B., III. *Do they scare you? Creepy creatures*. Watertown, MA: Charlesbridge Publishing, 1992.
- Cossi, Olga. *Water wars: the fight to control and conserve nature's most precious resource*. New York, New Discovery Books, 1993.
- Criswell, Susie Gwen. *Nature through science and art*. Blue Ridge Summit, PA, TAB Books, 1994.
- Davis, Kathleen. *Killer bees*. New York, Macmillan Publishing Company, 1993.
- Denis-Huot, Christine and Michel Denis-Huot. *The giraffe: a living tower*. Watertown MA, Charlesbridge Publishing, 1993.
- DeStefano, Susan. *Drugs and the family*. Frederick, MD Twenty-First Century Books, 1991.
- DeStefano, Susan. *Focus on medicines*. Frederick, MD, Twenty-First Century Books, 1991.
- DeStefano, Susan. *Focus on opiates*. Frederick, MD, Twenty-First Century Books, 1991.
- DeVito, Alfred and Gerald H. Crockover. *Creative sciencing: ideas and activities for teachers and children*. Glenview, IL, Scott, Foresman and Company, 1991.
- Dickinson, Terence. *Exploring the sky by day*. Camden East, Ontario, Canada, Camden House Publishing, 1988.
- Dickinson, Terence. *From the big bang to Planet X: the 50 most-asked questions about the universe—and their answers*. Camden East, Ontario, Canada, Camden House Publishing, 1993.

- Dickinson, Terence. *Night watch*. Camden East, Ontario, Canada, Camden House, 1983.
- Ellis, Richard. *Physty*. Philadelphia, PA, Running Press, 1993.
- Evans, Lisa Gollin. *An elephant never forgets its snorkel: how animals survive without tools and gadgets*. New York, Crown Publishers, Inc., 1992.
- Friedman, David. *Focus on drugs and the brain*. Frederick, MD, Twenty-First Century Books, 1990.
- Gibbons, Gail. *Frogs*. New York, Holiday House, 1993.
- Gibbons, Gail. *The planets*. New York, Holiday House, 1993.
- Gibbons, Gail. *Spiders*. New York, Holiday House, 1993.
- The great book of the sea: a complete guide to marine life*. Philadelphia, PA, Running Press, 1988.
- Harris, Jacqueline. *Communicable diseases*. New York, Twenty-First Century Books, 1993.
- Harris, Jacqueline. *Drugs and Disease*. New York, Twenty-First Century Books, 1993.
- Harris, Jacqueline. *Hereditary diseases*. New York, Twenty-First Century Books, 1993.
- Hayden, Robert C. *11 African-American doctors*. New York, Twenty-First Century Books, 1992.
- Hayden, Robert C. *9 African-American inventors*. Frederick, MD, Twenty-First Century Books, 1992.
- Hayden, Robert C. *7 African-American scientists*. Frederick, MD, Twenty-First Century Books, 1992.
- Isdell, Wendy. *A gebra named Al*. Minneapolis, MN, Free Spirit Publishing, Inc., 1993.
- Jordan, Helene. *How a seed grows*. New York, Harper Collins Children's Books, 1992.
- Kaye, Judith. *The life of Alexander Fleming*. New York, Twenty-First Century Books, 1993.
- Kaye, Judith. *The life of Benjamin Spock*. New York, Twenty-First Century Books, 1993.
- Kaye, Judith. *The life of Daniel Hale Williams*. New York, Twenty-First Century Books, 1993.
- Kaye, Judith. *The life of Florence Sabin*. New York, Twenty-First Century Books, 1993.
- Kim, Hy. *Showy science: exciting hands-on activities that explore the world around us*. Glenview, IL, GoodYearBooks, 1994.

- Kurjian, Judi. *In my own backyard*. Watertown, MA, Charlesbridge Publishing, 1993.
- Lafferty, Peter. *Albert Einstein*. New York, The Bookwright Press, 1991.
- Lafferty, Peter. *Marshall Cavendish more science projects electricity and magnetism*. Freeport, NY, Marshall Cavendish Limited, 1989.
- Lambert, David. *Forests*. Mahwah, NJ, Troll Associates, 1990.
- Lambert, David. *Weather*. Mahwah, NJ, Troll Associates, 1990.
- Leedy, Loreen. *Postcards from pluto: a tour of the solar system*. New York, Holiday House, 1993.
- Lerner, Carol. *Plants that make you sniffle and sneeze*. New York, William Morrow and Co., 1993.
- Loulan, JoAnn Gardner. *Period*. Volcano, CA, Volcano Press, 1979.
- Milton, Joyce. *Wild, wild wolves*. New York, Random House, 1992.
- Murphy, Bryan. *Experiment with air*. Minneapolis, MN, Lerner Publications Co., 1991.
- Murphy, Bryan. *Experiment with light*. Minneapolis, MN, Lerner Publications Co., 1991.
- Murphy, Bryan. *Experiment with movement*. Minneapolis, MN, Lerner Publications Co., 1991.
- Murphy, Bryan. *Experiment with water*. Minneapolis, MN, Lerner Publications Co., 1991.
- Newfield, Marcia. *The life of Louis Pasteur*. Frederick, MD, Twenty-First Century Books, 1992.
- O'Neill, Catherine. *Focus on Alcohol*. Frederick, MD, Twenty-First Century Books, 1990.
- Pallotta, Jerry. *The extinct alphabet book*. Watertown, MA, Charlesbridge Publishing, 1993.
- Pallotta, Jerry. *The icky bug alphabet book*. Watertown, MA, Charlesbridge Publishing, 1986.
- Patent, Dorothy Hinshaw. *Killer whales*. New York, Holiday House, 1993.
- Patent, Dorothy Hinshaw. *Looking at penguins*. New York, Holiday House, 1993.
- Perdue, Peggy K. *Schoolyard science*. Glenview, IL, Scott, Foresman and Co., 1991.
- Perdue, Peggy K. *Small wonders: hands-on science activities for young children*. Glenview, IL, Scott, Foresman and Co., 1989.
- Perham, Molly and Philip Steele. *The children's illustrated world atlas*. Philadelphia, PA, Running Press, 1992.

- Perry, Robert. *Focus on Nicotine and Caffeine*. Frederick, MD, Twenty-First Century Books, 1990.
- Prot, Viviane Abel and Philippe Delorme. *The story of birth*. Ossining, NY, Young Discovery Library, 1986.
- Reef, Catherine. *Eat the right stuff: food facts*. New York, Twenty-First Century Books, 1993.
- Reef, Catherine. *Stay fit: build a strong body*. New York, Twenty-First Century Books, 1993.
- Reef, Catherine. *Think positive: cope with stress*. New York, Twenty-First Century Books, 1993.
- Rozakis, Laurie. *Teen pregnancy: why are kids having babies?* New York, Twenty-First Century Books, 1993.
- Salak, John. *Drugs in society: are they our suicide pill?* New York, Twenty-First Century Books, 1993.
- Samuelson, Mary Lou. *The coyote*. New York, Macmillan Publishing Co., 1993.
- Schleichert, Elizabeth. *The Life of Dorothea Dix*. New York, Twenty-First Century Books, 1992.
- Schleichert, Elizabeth. *The life of Elizabeth Blackwell*. Frederick, MD, Twenty-First Century Books, 1992.
- Shulman, Jeffrey. *The drug-alert dictionary and resource guide*. Frederick, MD, Twenty-First Century Books, 1991.
- Shulman, Jeffrey. *Drugs and crime*. Frederick, MD, Twenty-First Century Books, 1991.
- Shulman, Jeffrey. *Focus on Cocaine and Crack*. Frederick, MD, Twenty-First Century Books, 1990.
- Shulman, Jeffrey. *Focus on Hallucinogens*. Frederick, MD, Twenty-First Century Books, 1991.
- Simon, Seymour. *Our solar system*. New York, William Morrow and Co., 1992.
- Simon, Seymour. *Weather*. New York, William Morrow and Co., 1993.
- Siy, Alexandra. *The Efe: people of the Ituri Forest*. New York, Macmillan Publishing Co., 1993.
- Siy, Alexandra. *The Penan: people of the Borneo jungle*. New York, Macmillan Publishing Co., 1993.
- Stangl, Jean. *The little scientist: an activity lab*. Blue Ridge Summit, PA: TAB Books, 1993.

- Staton, Hilarie N. and Tara McCarthy. *Science and stories: integrating science and literature*. Glenview, IL, GoodYearBooks, 1994.
- Stephen, Richard. *Deserts*. Mahwah, NJ, Troll Associates, 1990.
- Stephen, Richard. *Rivers*. Mahwah, NJ, Troll Associates, 1990.
- Super, Gretchen. *Drugs and our world*. New York, Twenty-First Century Books, 1990.
- Super, Gretchen. *You can say "no" to drugs!* New York, Twenty-First Century Books, 1990.
- Talmadge, Katherine S. *Drugs and sports*. Frederick, MD, Twenty-First Century Books, 1991.
- Talmadge, Katherine S. *Focus on steriods*. Frederick, MD, Twenty-First Century Books, 1991.
- Talmadge, Katherine S. *The life of Charles Drew*. Frederick, MD, Twenty-First Century Books, 1992.
- Taylor, Barbara. *Green thumbs up!: the science of growing plants*. New York, Random House, 1991.
- Vrobova, Zuza, *Mountains*. Mahwah, NJ, Troll Associates, 1990.
- Vrobova, Zuza. *Volcanoes & earthquakes*. Mahwah, NJ, Troll Associates, 1990.
- Ward, Lorraine. *A walk in the wild: exploring a wildlife refuge*. Watertown, MA, Charlesbridge Publishing, 1993.
- Willow, Diane. *At home in the rain forest*. Watertown, MA, Charlesbridge Publishing, 1991.
- Wood, A.J. *Egg! A dozen eggs, what will they be? Unfold each page and you will see!* Canada, Little, Brown and Co., 1993.
- Wright, Alexandra. *Will we miss them? Endangered species*. Watertown, MA, Charlesbridge Publishing, 1992.
- Zeller, Paula Klevan. *Focus on Marijuana*. Frederick, MD, Twenty-First Century Books, 1990.

Appendix B: Materials Review Form

INSTRUCTIONS FOR REVIEW:

Write a critical evaluation of approximately 200 words emphasizing the merits and/or demerits of the resource. Describe and critique the content, technical quality, and instructional value. Take special note of the overall quality of the presentation of facts, theories, and processes of science and their interrelationships (for example, does the book accurately depict the uses and limitations of the scientific method?). Indicate for which audience the book is most appropriate and why. Also mention how the book could be used (reference, classroom, general awareness, other).

Please answer *yes* or *no* to the following questions:

Is the information accurate? _____

Is the purpose clear? _____

Is the material well-organized? _____

Are the processes of science clearly and accurately presented? _____

For science and society books, are the issues involved well-presented and analyzed? _____

Are conclusions, if any, valid? _____

Please indicate whether the material is *excellent*, *good*, *fair*, *poor*, or *not applicable* regarding the following criteria:

Scope (completeness): _____

Quality of illustrations: _____

Value when compared with similar titles: _____

Do you need this book for your collection? _____

Write down a science fact that would need to be verified:

List three sources that could verify the fact:

List sources where you could find a review of the book:

Appendix C: AAAS Science Library Institute Evaluation Form

Below is the evaluation form we distributed to Institute participants. You might use something similar in an Institute session in your community, but you can modify it to suit your specific needs.

AAAS Science Library Institute

This questionnaire is part of a study for the American Association for the Advancement of Science (AAAS). The information we gather from this questionnaire will help us to evaluate and improve the AAAS Science Library Institute sessions.

1. My school/public library is _____

Directions: For items 2-4, please circle **one** number to the right of each question.

2. The last time I attended a national professional meeting, such as an ALA Conference, was:

- (1) within the last 1-5 months.
- (2) within the last 6-12 months.
- (3) at least 1-2 years ago.
- (4) at least 3-5 years ago.
- (5) more than 5 years ago.
- (6) Never attended 1 2 3 4 5 6

3. Besides the SLI Institute, have you ever participated in another mathematics or science workshop or inservice program?

- (1) yes (2) no 1 2

4. Do you, or does your library, subscribe to *Science Books & Films*?

- (1) yes (2) no 1 2

Directions: For items 5-9, please **circle one number** from 1-5 that best indicates where you feel you should place yourself on the following continuum:

Weak					Strong
1	2	3	4	5	

5. My background in the sciences 1 2 3 4 5

6. My background in mathematics 1 2 3 4 5

7. My background in engineering 1 2 3 4 5

8. My background in reading 1 2 3 4 5

9. My background in language arts 1 2 3 4 5

Directions: For items 10-17, please circle one number from 1-5 that best indicates where you feel you should place yourself on the following continuum:

- | | Very Uncomfortable | | | | | Very Comfortable |
|--|--------------------|---|---|---|---|------------------|
| | 1 | 2 | 3 | 4 | 5 | |
| 10. My comfort level working with the sciences | 1 | 2 | 3 | 4 | 5 | |
| 11. My comfort level working with mathematics | 1 | 2 | 3 | 4 | 5 | |
| 12. My comfort level in reading | 1 | 2 | 3 | 4 | 5 | |
| 13. My comfort level in language arts | 1 | 2 | 3 | 4 | 5 | |
| 14. My comfort level working with computers | 1 | 2 | 3 | 4 | 5 | |
| 15. How comfortable would you feel right now about
setting up science displays? | 1 | 2 | 3 | 4 | 5 | |
| 16. How comfortable would you feel right now about
setting up mathematics displays? | 1 | 2 | 3 | 4 | 5 | |
| 17. How comfortable would you feel right now about
contacting a scientist or engineer for assistance? | 1 | 2 | 3 | 4 | 5 | |

The AAAS Science Library Institute Workshop Sessions

Which of the five workshop sessions was **most helpful** to you?

Which session was of **least interest** to you?

Do you have **suggestions for other topics**?

Overall Evaluation

is there anything you would change if you could redesign the Institute?

What benefits do you feel have accrued to your school community as a result of your participation in the AAAS Science Library Institute? Please give examples, if possible.

Thank you!

Appendix D: Selected Science Career Brochures

The following is a list of brochures and places to contact for information on careers in a variety of careers related to the sciences. They are listed by organization, address, contact (if available), phone number, and title of brochure (if available).

American Society of Microbiology, 1325 Massachusetts Avenue, NW, Washington, DC 20005; Amy L. Chang, (202) 942-9264. Career information available.

American Society of Agronomy, 677 South Segoe Road, Madison, WI 53711-1048; Leanne J. Malison; (608) 273-8080; "Exploring Careers in Agronomy, Crops, and Soils."

American Association of Zoological Parks and Aquariums, 7970-D Old Georgetown Road, Bethesda, MD 20814; Nancy A. Hotchkiss; (301) 907-7777; "So You Want to Be a Zookeeper?"

American Society of Ichthyologists and Herpetologists, Dept. of Zoology, Southern Illinois University, Carbondale, IL 62901-6501; Brooks M. Burr; (618) 453-4112; "Careers in Ichthyology" and "Careers in Herpetology."

Soil and Water Conservation Society, 7515 North East Ankeny Road, Ankeny, IA 50021; Tim Kautza; (515) 289-2331; "Careers in Conservation." Monographs on careers also available.

North Carolina Science and Mathematics Alliance, 410 Oberlin Road, No. 306, Raleigh, NC 27605-1352; Dennis Dubay; (919) 733-9159; "Are You Ready for the Job Market?"

National Oceanic and Atmospheric Administration, Atmospheric Turbulence and Diffusion Division, P.O. Box 2456, Oak Ridge, TN 37831; Barbara Johnson, (615) 576-0061; various career brochures.

World Forestry Center, 4033 S.W. Canyon Road, Portland, OR 97221; Rick Zenn; (503) 228-1367; general career brochure.

National Association of Biology Teachers, 11250 Roger Bacon Drive, #19, Reston, VA 22090; Mary Lousie Bellamy; (703) 471-1134; "Careers in Biology: An Introduction."

American Physiology Society, 9650 Rockville Pike, Bethesda, MD 20814-3991; Marsha Lakes Matyas, (301) 530-7164; "Physiology Careers."

National Aquarium in Baltimore, Pier 3, 501 East Pratt Street, Baltimore, MD 21202; Sylvia James; (301) 576-3875; career packet available.

U.S. Department of Energy, Office of University and Science Education, 1000 Independence Avenue, SW, Washington, DC 20285; Richard Stephens, director, (202) 586-8949; offers career information about science and engineering topics.

National Marine Fisheries Service, Narragansett Lab, 28 Tarzwell Drive, Narragansett, RI

02882; Kenneth Sherman, (401) 782-3210; career information.

Ecological Society of America, 2010 Massachusetts Avenue, No. 420, Washington, DC 20036-1023; (202) 833-8773; "Careers in Biology."

American Physical Society, 1 Physics Ellipse, College Park, MD 20740-3844; Brian Schwartz, (301) 209-3200; "Physics Careers."

Geological Society of America, 3300 Penrose Place, PO Box 9140, Boulder, CO 80301; Edward Geary, (303) 447-2020; "Careers in the Geosciences."

American Geological Institute, 4220 King Street, Alexandria, VA 22303-1507; Andrew Verndon, (703) 379-2480; career information.

Student Conservation Association, PO Box 550, Charlestown, NH 03603-0550.

Junior Engineering and Technical Society (JETS), 1420 King Street, Alexandria, VA 22314-2715; Dan Kunz, (703) 548-JETS; career information.

American Academy of Optometry, Pennsylvania College of Optometry, 1200 West Godfrey Avenue, Philadelphia, PA 19141; Thomas Lewis, (215) 276-6210.

Appendix E: Where to Obtain Supplies

The following is a list of addresses and phone numbers of activity materials suppliers. Contact one or more of these places to obtain materials, such as tangrams, that aren't readily available in the grocery or hardware store.

Learning Things, Inc.
68A Broadway, P.O. Box 436
Arlington, MA 02175
(617) 646-0093

Charette Corporation
Order Dept.
31 Olympia Avenue
Woburn, MA 01888
(800) 242-7738

Edmund Scientific Co.
7789 Edscrop Building
Barrington, NJ 08007
(609) 547-3488

EDU-Mart Co., Inc.
154 E. Central Street
Natick, MA 01760
(617) 235-4567 or
(508) 651-3060

Chasselle, Inc.
9645 Gerwig Lane
Columbia, MD 21046
(800) 242-7355

or

P.O. Box 1581
Springfield, MA 01101
(800) 628-8608

Burt Harrison and Co., Inc.
P.O. Box 732
Weston, MA 02193-0732
(800) 628-4724

Directorate for Education and Human Resources
AMERICAN ASSOCIATION FOR THE ADVANCEMENT OF SCIENCE
1333 H Street, NW • Washington, DC 20005
202/326-6670

BEST COPY AVAILABLE

183

ERIC
Full Text Provided by ERIC