

DOCUMENT RESUME

ED 384 491

SE 055 074

AUTHOR Mickelson, Belle; Barr, Nancy
 TITLE Fish and Fisheries. Alaska Sea Week Curriculum Series VI. Alaska Sea Grant Report 83-7.
 INSTITUTION Alaska Univ., Fairbanks. Alaska Sea Grant Program.
 SPONS AGENCY National Oceanic and Atmospheric Administration (DOC), Rockville, Md. National Sea Grant Program.
 REPORT NO ISBN-0-912006-32-3
 PUB DATE [83]
 CONTRACT NOAA-NA82AA-D-00044
 NOTE 291p.; Volume IV was never produced. For related documents, see SE 055 070-075.
 AVAILABLE FROM Alaska Sea Grant College Program, University of Alaska, P.O. Box 755040, Fairbanks, AK 99775-5040 (\$11.50; quantity discounts).
 PUB TYPE Guides - Classroom Use - Teaching Guides (For Teacher) (052)

EDRS PRICE MF01/PC12 Plus Postage.
 DESCRIPTORS *Activities; Conservation (Environment); Curriculum Guides; Environmental Education; Field Studies; *Fisheries; Ichthyology; *Interdisciplinary Approach; Intermediate Grades; *Marine Education; Natural Sciences; *Resource Units; Water Resources; Worksheets

IDENTIFIERS Alaska; Aquatic Life; Aquatic Organisms; *Fishes

ABSTRACT

This curriculum guide is the fifth (Series VI) in a six-volume set that comprises the Sea Week Curriculum Series developed in Alaska. The book lends itself to the fifth-grade level but can be adapted to preschool, secondary, and adult education. Seven units contain 48 activities with worksheets that cover the following topics: (1) fish, their appearance, behavior, and classification; (2) fish species; (3) fish field studies; (4) fishing and fishing history; (5) human culture related to the seas and rivers; (6) fish as food; and (7) fisheries and the future. An introduction provides information designed to help teachers become familiar with the contents of the curriculum guide and to assist in planning. Each unit contains information on student objectives, and activity background, vocabulary, materials, and procedure. Activities engage students in interdisciplinary projects that involve the skills of classifying, identifying, comparing, computing, measuring, game playing, role playing, writing, observing, mapping, collecting data, recording data, and analyzing data. An annotated bibliography contains 168 resources. A packet of teacher reproducible worksheet masters accompanies the curriculum guide. (LZ)

 * Reproductions supplied by EDRS are the best that can be made *
 * from the original document. *

ED 384 491

"PERMISSION TO REPRODUCE THIS
MATERIAL HAS BEEN GRANTED BY
S. Keller

TO THE EDUCATIONAL RESOURCES
INFORMATION CENTER (ERIC)."

U.S. DEPARTMENT OF EDUCATION
Office of Educational Research and Improvement
EDUCATIONAL RESOURCES INFORMATION
CENTER (ERIC)

This document has been reproduced as
received from the person or organization
originating it
 Minor changes have been made to improve
reproduction quality

• Points of view or opinions stated in this docu-
ment do not necessarily represent official
OERI position or policy

BEST COPY AVAILABLE

**Alaska Sea Grant College Program
University of Alaska
Fairbanks, Alaska**

Alaska Sea Wee' Curriculum Series: V:

Fish and Fisheries

By:
Belle Mickelson
Nancy Barr

Editor:
Grant Sims

Illustrator:
Renee Patten

Graphics and Layout:
Ben Swan

Alaska Sea Grant Report 83-7

Originally printed by the
Alaska Sea Grant College Program
in 1983. Reprinted by the
University of Alaska Press
in 1988 and 1991.

Acknowledgments

The seven volumes comprising the new Sea Week Curriculum Guide Series are an expansion and revision of a curriculum project begun by Juneau parents 15 years ago. Publication of this volume is the result of work sponsored by the Alaska Sea Grant College Program, cooperatively sponsored by the National Oceanic and Atmospheric Administration's Office of Sea Grant and Extramural Programs under grant number NA82AA-D-00044, projects E-70-08 and A-75-01, and by the University of Alaska with funds appropriated by the State of Alaska; Alaska Department of Environmental Conservation, National Marine Fisheries Service, University of Alaska Cooperative Extension Service, Alaska Department of Fish and Game, and Alaska Department of Education.

Thanks for assisting in preparing these materials go to Sea Week Marine Education Specialist Peggy Cowan, and to Laurie Dumdie, Joan Bechtold, Don Bailey, Chris Rice, Mark Pope, Phyllis Wells, Greg Loughridge, Mary Lou King, Marianne Addington, Sue Baxter, Kay Pearson, Peggy Demmert, Larry Rockhill, Sandy Poor, Ann Schultz, Mary Couche, and Mike Stichick. Carol Coyle provided several illustrations. Sam Hammerick and Bud Root are the cartoon artists. Several activities were adapted from Alaska Tidelines edited by Virginia Sims. And the following people reviewed initial drafts of the guide (or portions thereof) for accuracy: Ken Holbrook, U.S. Forest Service fisheries biologist; Pete Islieb, commercial fisherman and past member of the Alaska Board of Fisheries; Bob Armstrong and Dr. Pete Mickelson, Wildlife and Fisheries Department, University of Alaska; Rick Steiner and Dr. Don Kramer, Alaska Sea Grant Marine Advisory Program; Suzanne Iudicello, Bob Clasby, and Fred Anderson, Alaska Department of Fish and Game; Chuck Parsons, commercial shrimp fisherman; Vince Addington, formerly with St. Elias Ocean Products; and Lori Svensson, Alaska Seafood Marketing Institute.

The 1988 reprinting of this volume was made possible by support from the State of Alaska Department of Education.

Table of Contents

Introduction.....	vii
Tips for Teachers.....	ix
Sea Week Planning Sheet.....	xii
Unit One: Fish: Their Appearance, Behavior and Classification	1
* Activity 1 - Fish Watching.....	3
Activity 2 - What is a Fish?.....	6
Activity 3 - Classifying Fish.....	7
Activity 4 - The Outside of a Fish.....	10
Activity 5 - What's Inside a Fish?.....	13
* Activity 6 - Fish Printing.....	17
Activity 7 - Fish Poetry.....	19
Unit Two: Fish Species	21
Activity 1 - Name that Salmon.....	23
* Activity 2 - The Salmon Life Cycle.....	25
* Activity 3 - Salmon Habitat.....	28
Activity 4 - Salmon Survival.....	34
* Activity 5 - Herring and the Food Web.....	35
Activity 6 - Hide a Halibut.....	38
Activity 7 - The Amazing Alaska Blackfish.....	39
Activity 8 - Freshwater Fish Card Game.....	43
* Activity 9 - Design a Fish.....	53
Unit Three: Fish in the Field	55
Activity 1 - Mapping Your Watershed.....	57
* Activity 2 - Stream Field Trip.....	60
Activity 3 - Lake Field Trip.....	63
Activity 4 - Data Analysis and Report Writing.....	67

Unit Four: Fishing Then and Now **71**

Activity 1 - Fishing Myths and Legends 75

Activity 2 - Traditional Fishing Methods 78

Activity 3 - Constructing a Fish Wheel 82

Activity 4 - Jigging Derby 84

* Activity 5 - Gillnetting 86

Activity 6 - Purse Seining 89

Activity 7 - Trolling 90

Activity 8 - Longlining 92

Activity 9 - Shrimping and Crabbing on the High Seas..... 94

Activity 10 - Who Gets the Fish? 99

Activity 11 - Harbor Field Trip 101

Unit Five: Life on the Seas and Rivers **105**

Activity 1 - Art, Music, Literature, and the Sea 108

Activity 2 - Boat and Nautical Language..... 110

Activity 3 - Navigation 111

Activity 4 - Knots..... 114

* Activity 5 - Tides 115

* Activity 6 - Boating Safety 116

Activity 7 - Sportfishing Trip 118

Unit Six: Fish as Food **121**

Activity 1 - Fish Quality 123

Activity 2 - Fish Processing..... 126

Activity 3 - Grocery Store Survey..... 127

* Activity 4 - Nutrition and a Fish Feast 128

Activity 5 - The Fish Business 130

Unit Seven: Fisheries and the Future **133**

- * Activity 1 - Fish for the World 136
- Activity 2 - Aquaculture 140
- Activity 3 - New Fisheries 143
- * Activity 4 - The Mighty Salmon Cannery Game..... 145
- Activity 5 - Cartooning Local Issues..... 150
- BIBLIOGRAPHY..... 153
- STUDENT ACTIVITY SHEETS 177

*If you're short on time, these activities will give you and your students an overview of Fish and Fisheries.

Introduction

Sea Week is a celebration. It's one of those rare school programs that can saturate a class with learning opportunities without intimidating a single child. The hundreds of teachers now participating in Sea Week throughout Alaska have found it to be a highlight of the year: a week of delight and awe, intrigue and excitement. It's a week that translates classroom science, mathematics, language, history, social studies, art and music into the crash of a wave, the scuttle of a crab, the drift of a kayak, the bark of a sea lion, the taste of smoked salmon, the scent of a pier. The only frustrations we've found are among teachers who discover that a week isn't enough. Many have expanded their programs to a month. Several have simply given up on trying to confine Sea Week to a time, and now make use of the curriculum throughout the year. However you design your own program, we're confident that its primary ingredients - Alaska's kids and coastlines - come to you satisfaction guaranteed!

Fish and Fisheries is the sixth of seven Sea Week curriculum guides. The book lends itself well to a fifth grade curriculum, but is not "locked" into that grade level. It has been adapted effectively to preschool, secondary and adult education. Several factors are responsible for the versatility. One is that while student activities in each book are at grade level, the teacher background materials are written at university level, and can be transferred to the classroom at any level the teacher desires. Another is that the curriculum encourages the use of community resource experts, who can gear their talks and tours to anyone from preschoolers to retirees. A third reason for the versatility is that many of the student activities have latitude. When in Volume VI the guide suggests building model boats, for instance, it includes the pattern for a paper cutout. But the same activity can be used by high schoolers constructing complicated models, or by adult students trying their hands at building an actual kayak!

The lives of all Alaskans are touched often by the sea: literally, aesthetically, productively. To begin with is the sheer immensity of the Alaska coastline. It stretches and twists, pounds and lies placid along two oceans and three seas for 6,640 miles - more than half that of all the contiguous United States. Islands, inlets, bays, fjords and delta regions add another 28,000 miles of saltwater shoreline for a total of 34,640 miles - a distance almost equal to twice the circumference of the earth. Alaska's continental shelf covers more than 830,000 square miles, more than 75 percent of the U.S. total. More than 90 percent of the fish caught in the U.S. come from Alaskan waters. And Alaska's coastal zones, both onshore and off shore, contain an estimated 75 billion barrels of petroleum and 380 trillion cubic feet of natural gas - amounts that would equal 50 percent of the nation's remaining petroleum reserves.

More than three-quarters of Alaska's almost half-million people live along its coastline. Their careers are generally sea-related. Grocers sell to the fishing fleet, lumbermen float their log rafts oversea to the mill, real estate salesmen get more money for property with an ocean view, and schoolteachers

find that one of the most effective ways to spark interest in a child's eyes is to turn those eyes seaward.

The bulk of Alaska's culture is so closely interlaced with the sea that in many cases the sea is Alaska culture. The seven volumes of the Sea Week Curriculum Guide series escort youngsters through the crafts, arts, music and oral and written literature of the coastal Haida, Tlingit, Koniag, Chugach, Aleut, Yupik and Inupiat to the poetry, literature and artwork of Alaska today.

And even the lives of that one quarter of Alaska's folk who don't live along the coastline are linked to the sea. They are consumers of sea products, of course; and beneficiaries of seacoast oil wealth, and even occasional visitors to the sea. But more importantly they are linked to the sea by Alaska's myriad rivers and wetlands: Alaska's vast interior, which its inhabitants call "The Golden Heart" of the state, includes hundreds of thousands of miles of rivers and streams, and 390,941 square miles of wetlands. That's two thirds of the state, all linked to the coastline by freshwater systems that serve as nurseries for Alaska's salmon and waterfowl, as transportation arteries to and from the coast, and as the nutrient-rich replenishers of the ocean currents.

It is because of such interconnections between wetlands and the sea that with this edition, the Sea Week Curriculum Guide series has been expanded to include units on Alaska's wetlands and the traditional Athabascan and contemporary peoples who inhabit them.

The resulting series is the foundation of the most comprehensive marine education program ever developed in the Northland. We hope that you will find it as valuable and motivating as it is intended. We hope, too, that through Sea Week, the youngsters of your classrooms will come to more deeply respect and appreciate the environments for which they will soon be responsible. The insights they gain in your classrooms will become the votes and legislation, the lifestyles and attitudes, the wisdom and understanding - the sea harvest - of tomorrow.

Tips for Teachers

Welcome to Sea Week! Here's a checklist of tips designed to help familiarize you with the contents of Fish and Fisheries, and to assist your Sea Week planning.

- If you haven't scanned the book already, we suggest you get a sense of its format by glancing through the Table of Contents, the different units containing teacher background and student activities, the student worksheets, and the bibliography.
- Note that each unit is headed by a list of objectives that specify which activities are designed to accomplish those objectives.
- Student worksheets have been placed together at the end of the book. But they are numbered to correlate to the units they complement. Thus Worksheet 1-A is the first worksheet (A) listed among the activities in Unit 1; Worksheet 2-C is the third worksheet (C) assigned in Unit 2, and so on. Some teachers like to copy the worksheets en masse and bind them into student activity books. Other prefer to insert the worksheets into the corresponding units of the text, then distribute them one by one as the appropriate topics are covered.
- Many more ideas are included than can be used in a week, but we wanted to give you a selection and so you can expand to Sea Weeks. But if you are short on time, we've starred a good selection of activities in the Table of Contents.
- Brainstorm Sea Week ideas with other teachers and parents. Use the Sea Week Planning Sheet beginning on Page x to list the names of parents and local resource people who can help make your Sea Week a success. You'll find most people are pleased to be asked, and more than happy to help.
- Involve your bilingual staff as you identify such community resources as speakers (fishermen or women, net menders, Coast Guardsmen, boat captains, village elders, artists, musicians) and field trip sites (beaches, harbors, canneries, seafood markets, salmon spawning streams, marshes, hatcheries, museums).
- Plan your school's Sea Week at a time best suiting your location. Teachers in southwestern, southcentral and southeastern Alaska are finding it best to consult tide tables and plan beach trips at low tide. In northern, central and western Alaska, Sea Week activities are proving most successful when there's open water, or when they are planned to coincide with a longstanding community fishing or whaling season.
- Order films early, and plan well in advance for school and community events.
- Make lesson plans. Preview the units more thoroughly, selecting those activities most appropriate for your students. You may want to juggle the order to suit your existing class format. Note that we've included

activities to sharpen skills in language arts, science, social studies, math, music, art and physical education so that all aspects of education during Sea Week can focus on Alaska's ocean, river and wetland environments.

- Plan your field trips. Decide on a place, time and means of transportation. Arrange to take parents, older students or resource people as helpers. The most successful trips usually have one adult per five or fewer students. If possible, visit the field trip site ahead of time with your helpers. If you're taking a bus, make up a game or checklist of things to watch for to develop a learning atmosphere for the trip.
- Develop an outline for your field trip. Suggested inclusions:
 - A. Discovery and exploration time.
 - B. Structured learning activities.
 - C. Snacktime.
 - D. Organized games, treasure hunts, litter pickup.
 - E. Review of the day's events (which can be as simple as having each student and parent telling what he or she enjoyed most).
- One or more parents or teachers can be appointed to coordinate in scheduling speakers, movies and field trip transportation, and in presenting your Sea Week plan to school district officials for approval.
- Talk to your librarian about books to back up your studies. Suggestions are included in the general bibliography at the end of this book.
- Field trips and other Sea Week activities make bright news features. Consider contacting your local newspaper, television or radio station. Teachers usually find that reporters generally enjoy going to the beach as much as do the students!
- Check through the "materials" list of each unit; then make, buy, scrounge or order any equipment you might need.
- Write a letter to parents. Include requests for field trip assistants, resources, ideas, and permission slips.
- Promote conservation - the protection and wise use of our natural resources. Ask children how they can help take care of animals and plants they encounter in their field and classroom studies. Through their concern for life and habitat, have students develop some rules: step softly and quietly while observing animals, replace rocks or logs after looking underneath (to keep the roofs on animal homes), handle animals gently, fill in holes after looking for clams (to prevent suffocation of the animals next door), and don't take live animals or plants away from their homes.

- So that future children can enjoy the area, too, it is a good idea to discourage personal collections of any natural items, living or nonliving. Limit collections to educational purposes such as art projects or aquarium study - and return any living animals to their natural habitats as soon as possible. Preserve for classroom specimens only those animals which are already dead.
- Encourage students to leave the beach, river or wetland cleaner than when they arrived.
- Remember safety. For field trips, have a plan for keeping students in groups through a buddy system or adult supervision. Take a first aid kit. Discuss hypothermia. Take matches and tinder for starting a warm-up fire if necessary. Make sure students dress warmly and take extra clothes and rain gear (plastic trash bags will do in a pinch). And wear life jackets on boat trips.
- If your school is inland, consider exchanges with coastal schools. Send them a selection of items found on your field trips, a class story, or perhaps photos. Maybe they can send you fish stories, pieces of net, floats, seaweed, beach sand. Most activities in this book can easily be adapted for in land schools. Try to get a saltwater aquarium for your school.
- Follow up your Sea Week with thank-you notes, student evaluations, and a brief report or copy of a news article for your administrators.
- Photocopy your lesson plans and stick them in this guide, so you'll be ready for next year!

Sea Week Planning Sheet

Resource People: Speakers, craftsmen, field trip leaders.

Name	Expertise	Phone
_____	_____	_____
_____	_____	_____
_____	_____	_____
_____	_____	_____
_____	_____	_____
_____	_____	_____
_____	_____	_____
_____	_____	_____
_____	_____	_____
_____	_____	_____
_____	_____	_____
_____	_____	_____
_____	_____	_____
_____	_____	_____
_____	_____	_____
_____	_____	_____

Field Trip Possibilities:

Location	Habitat (Beach, river, pond)	Transportation Arrangements
_____	_____	_____
_____	_____	_____
_____	_____	_____
_____	_____	_____
_____	_____	_____
_____	_____	_____
_____	_____	_____
_____	_____	_____
_____	_____	_____
_____	_____	_____
_____	_____	_____
_____	_____	_____
_____	_____	_____
_____	_____	_____
_____	_____	_____

Volunteers: To help with field trips, seafood meals, classroom activities.

Name	To Help With:	Phone
_____	_____	_____
_____	_____	_____
_____	_____	_____
_____	_____	_____
_____	_____	_____
_____	_____	_____
_____	_____	_____
_____	_____	_____
_____	_____	_____
_____	_____	_____
_____	_____	_____
_____	_____	_____
_____	_____	_____
_____	_____	_____
_____	_____	_____
_____	_____	_____
_____	_____	_____
_____	_____	_____
_____	_____	_____

Films:

Call Number	Title	Source	Rating
_____	_____	_____	_____
_____	_____	_____	_____
_____	_____	_____	_____
_____	_____	_____	_____
_____	_____	_____	_____
_____	_____	_____	_____
_____	_____	_____	_____
_____	_____	_____	_____
_____	_____	_____	_____
_____	_____	_____	_____
_____	_____	_____	_____
_____	_____	_____	_____
_____	_____	_____	_____
_____	_____	_____	_____
_____	_____	_____	_____
_____	_____	_____	_____
_____	_____	_____	_____
_____	_____	_____	_____
_____	_____	_____	_____



Books:

Call Number	Title	Source	Rating
_____	_____	_____	_____
_____	_____	_____	_____
_____	_____	_____	_____
_____	_____	_____	_____
_____	_____	_____	_____
_____	_____	_____	_____
_____	_____	_____	_____
_____	_____	_____	_____
_____	_____	_____	_____
_____	_____	_____	_____
_____	_____	_____	_____
_____	_____	_____	_____
_____	_____	_____	_____
_____	_____	_____	_____
_____	_____	_____	_____
_____	_____	_____	_____
_____	_____	_____	_____
_____	_____	_____	_____
_____	_____	_____	_____
_____	_____	_____	_____
_____	_____	_____	_____
_____	_____	_____	_____

Equipment:

Type	Purpose	Source
_____	_____	_____
_____	_____	_____
_____	_____	_____
_____	_____	_____
_____	_____	_____
_____	_____	_____
_____	_____	_____
_____	_____	_____
_____	_____	_____
_____	_____	_____
_____	_____	_____
_____	_____	_____
_____	_____	_____
_____	_____	_____
_____	_____	_____
_____	_____	_____
_____	_____	_____
_____	_____	_____
_____	_____	_____
_____	_____	_____
_____	_____	_____
_____	_____	_____

Unit One

Fish: Their Appearance, Behavior and Classification

Index

Activity 1: Fish Watching ... 3	Activity 4: The Outside of a Fish..... 10
Worksheet: Watch that Fish!1A	Worksheet: The Outside of a Fish..1E
Activity 2: What is a Fish? .. 6	Activity 5: What's Inside a Fish? 13
Worksheet: A Fish is a What?.....1B	Worksheets: The Inside of a Fish ...1F Body Parts and Their Functions1G
Activity 3: Classifying Fish..... 7	Activity 6: Fish Printing 17
Worksheets: Fish to Classify.....1C The Three Major Groups of Fish1D	Activity 7: Fish Poetry 19

Objectives:

To help students:

- Record the behavior of live fish (Activity 1).
- Observe functions of different fish fins (Activity 1).
- Design a simple experiment with live fish (Activity 1).
- Define what a fish is (Activity 2).
- Sort and classify the three main types of fish (Activity 3).
- Identify external fish features and explain their functions (Activity 4).
- Identify internal fish features and explain their functions (Activity 5).
- Compare the internal anatomy of a fish with that of the human body (Activity 5).
- Make fish prints (Activity 6).
- Share fish poetry (Activity 7).
- Write a fish poem (Activity 7).

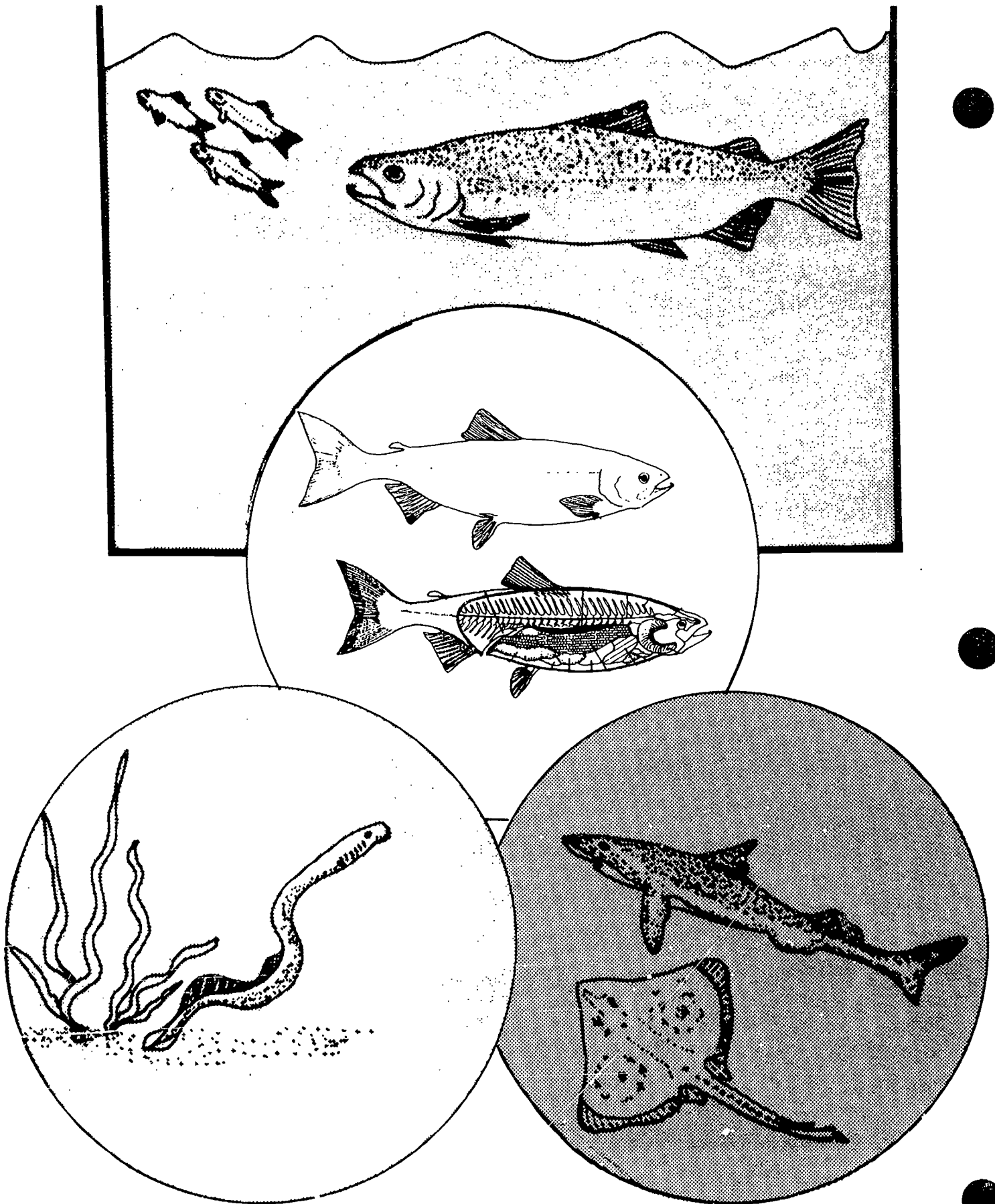

Unit One: The three major fish groups: bony fish (represented by salmon, top and center); hagfish and lampreys (represented by lamprey, lower left); and sharks, skates and rays.

Alaska's waters often teem with fish. Salmon can fill streams from bank to bank as they ascend to spawn. Herring sometimes school by the hundreds of millions, forming vast finny clouds just beneath the surface of coastal waters. And interior lakes and streams are an angler's paradise filled with grayling, char, pike, trout, burbot, and whitefish.

This unit covers the characteristics of these fish and their basic biology.

Activity 1 Fish Watching

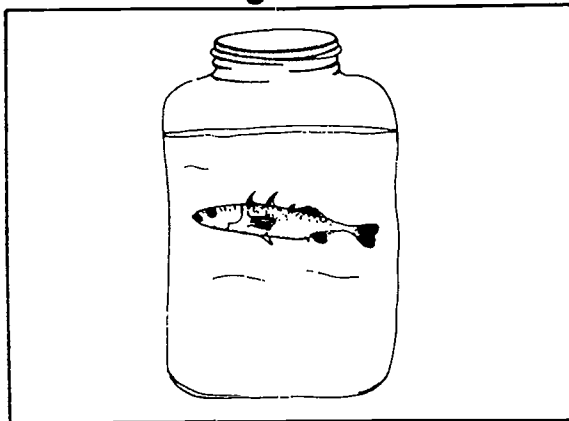

Vocabulary:

- habitat
- conservation
- renewable
- resource

Materials:

- live fish in a jar of water or an aquarium
- worksheet:
...Watch That Fish (1A)

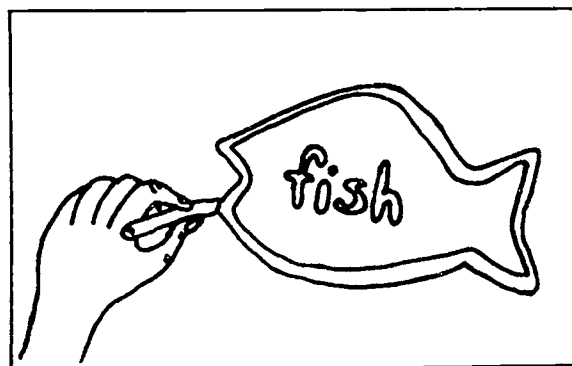

Procedure:

1. Write the word "fish" on the board. Ask students what they already know about fish. Write their answers in a circle around the fish. Then ask what they would like to know about fish. Write these

questions about the fish in a larger circle.

Discuss where to find the answers: from books, fishermen, elders, fisheries biologists, and field trips. You might want to record the questions in a notebook; and as you proceed through this book, add to the questions and use them to guide your study.

2. You will need live fish for this activity; one fish for each group of four to five students. (Parents, students, pet stores, fishermen, or biologists may be of help in obtaining specimens. Check with Alaska Department of Fish and Game officials in your area to obtain permits to hold native fish.) Fish need ample oxygen, so keep their numbers low and the water cold, as water of a lower temperature holds more oxygen. You'll probably need an aerator filter and pump. If you're using jars, one pump can supply the oxygen by hooking the jars in series. Alaska blackfish are ideal for this study because of their low oxygen requirements.

Encourage students to observe their fish carefully. Emphasize care for the fish. Discuss the term "habitat" as the natural home of an animal or plant. Mention the basic requirements for life: food, cover and water. In addition to water and food, fish like other animals need cover, or places to hide--either to protect them from bigger fish or so that smaller fish will not see them coming!

"Conservation" is the wise use of our resources. Fish are a "renewable resource" which means that if we are careful and protect their habitats and don't harvest too many, Alaska's fish will continue to provide food and enjoyment for generations to come.

3. Distribute the worksheet Watch That Fish. After students have had time to watch their fish, discuss how they think a fish swims. Have students use their fish drawing on the worksheet to point to the fin that the fish uses to:

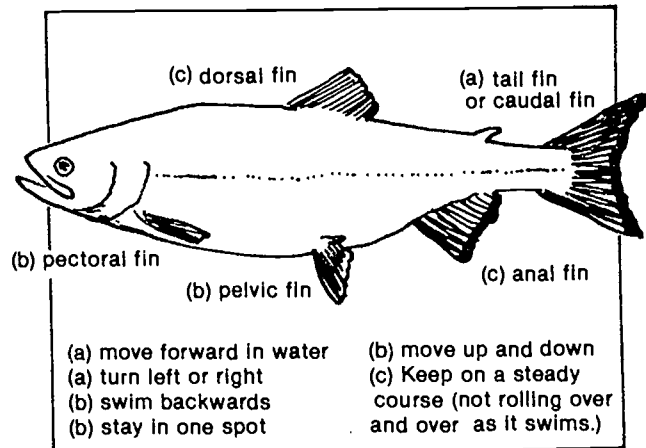

Discuss any differences of opinion. It may be necessary to watch the fish again to confirm specific functions. Have students concentrate on observations at this point. Names of the fins will be covered later in this unit.

4. Have each group of students design simple experiments with their fish. Students may want to feed their fish, be quiet or noisy, place a mirror in the jar, place one fish jar near another one, place paper of different colors behind the fish to note camouflage abilities, or place one

jar in the light and one in the dark. Remind them they will need a control fish or jar for comparison and they will need to run several trials to see if the fish behaves the same way every time. Ask students to record what happens and work up a brief report for the class.

Additional Activities:

1. Language Arts: Encourage students to read books about fish. Check the bibliography at the end of this volume for suggestions. Also, be sure students have a chance to read the fish descriptions in the Alaska Department of Fish and Game's Wildlife Notebook Series. Students can prepare oral or written book reviews for the class.
 2. Art: Decorate the classroom with fish nets and floats, fishing gear, paper fish, fish pictures, drawings and paintings to set the atmosphere for your studies.
 3. Science: Individual students may want to conduct long-term experiments with live fish, keeping records of temperature, behavior, and feeding patterns.
 4. Art: Make dough fish out of bakers clay (which doesn't require firing in a kiln). To make the clay, mix 1 cup flour, $\frac{1}{4}$ -cup salt, and a scant $\frac{1}{2}$ -cup water. Mix with your hands for 5 minutes. (A heavy duty mixer and bread hook will work for larger quantities.) Make only the amount you need; the dough does not store well.
- Have students sculpt the clay into fish shapes, and criss-cross them with designs. Bake in an oven at 250-275° for 10-15 hours. Then have students paint their creations with watercolors or brushes. When the fish are dry, dip them in varathane or spray them with varnish to prevent them from softening (bakers clay tends to absorb moisture from the atmosphere).

-suggested by Mazie Van Den Brock, art teacher, Cordova

4. Art, Science: Cut a large fish and several smaller fish out of construction paper. Staple the large fish to a bulletin board with its mouth open and body puffed, so small fish can be fed in. Have students write down things they learn on the smaller fish and feed them to the large fish. At the end of the study, the large fish can be opened up and the small fish can be used for review!
5. Language Arts: Have students write creative stories about what it feels like to be a fish in an aquarium or jar, looking out.

Activity 2

What is a Fish?

Fish (fish) *n., pl.* in referring to different species, **fishes**. 1. any of a large group of cold-blooded vertebrate animals living in water, having permanent gills for breathing, fins, and, usually, scales. 2. especially, any of the larger species, as a salmon. 3. a small fish, especially a trout, used as bait. 4. a fish lacking intelligence or emotion, etc. 5. *Naut.* a device for raising an anchor.

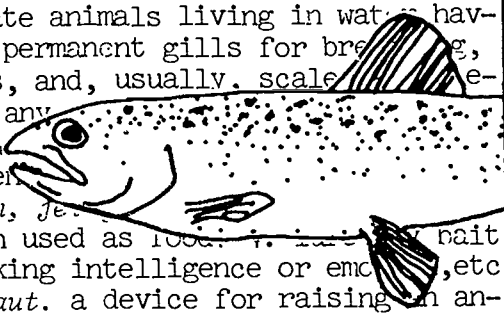

Background:

Scientists define fish as cold-blooded aquatic, gill-breathing vertebrates equipped with fins and usually scales. It's a definition that entails a lot of concepts, which we'll try to simplify in this activity.

Vocabulary:

- cold-blooded
- aquatic
- gill-breathing
- vertebrate
- gill filaments*
- gill rakers
- caudal fin
- pelvic fin
- pectoral fin
- dorsal fin
- anal fin

Materials:

- red and blue pencils or

* See page 14 for a labeled illustration of gill filaments and gill rakers which are described in the student worksheet. And see page 4 for an illustration of the fish fins which are on the worksheet.

- felt-tip markers
- dictionaries
- encyclopedia
- worksheet:
...A Fish Is A What? (1B)

Procedure:

1. Ask students to come up with a class definition of fish. Record this definition on the board for later reference.
2. Distribute the worksheet A Fish Is A What? Students will need dictionaries, an encyclopedia, and red and blue pencils or felt-tip markers to complete the worksheet.
3. Compare the class definition with the scientific definition of fish. Discuss the worksheet answers and what makes fish unique. There are other cold-blooded vertebrates (snakes, frogs) and other aquatic animals with fins (whales, dolphins). There are also other animals that breathe with gills (crab, shrimp). But only fish have all the characteristics included in the definition. Not all fish have scales as students will find out in the next activity. But the scale shown on the worksheet is from a four-year-old winter-caught fish. The slower winter growth results in the dark rings which the students should have colored blue.

Activity 3 Classifying Fish

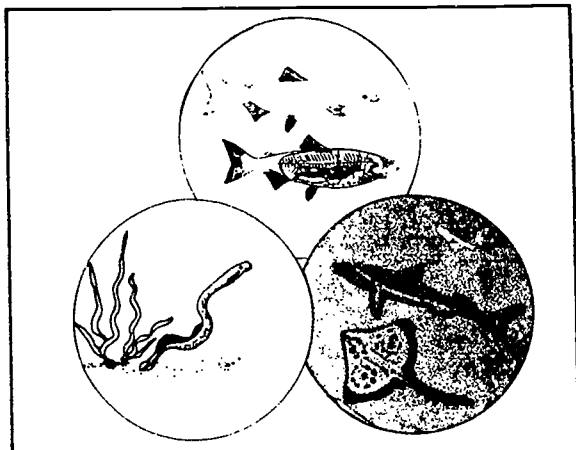

Background:

All fish belong to one of three major groups and all three of these groups are present in Alaskan waters:

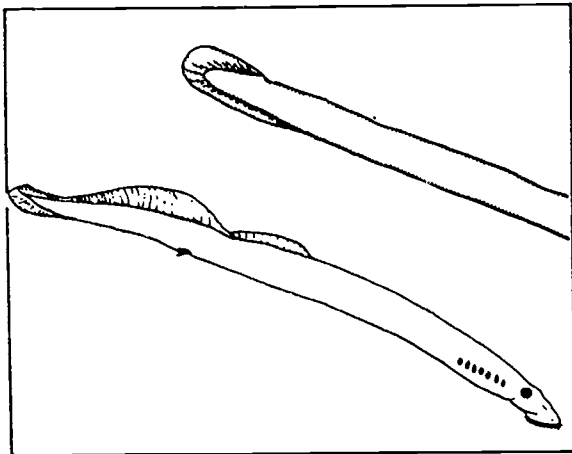

- I. Hagfish and lampreys: These fish have no jaws, no paired fins, and no scales. The opening to the gills is a round hole. The skeleton is entirely of cartilage, not bone. Two species of hagfish and four species of lampreys occur in Alaska. Arctic lampreys are locally abundant in northwest Alaska.

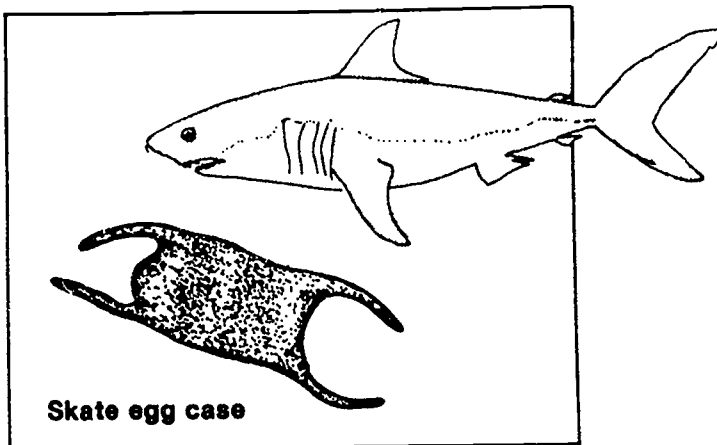

Skate egg case

- II. Sharks, skates and rays: Members of this group have jaws and some paired fins, but no scales. The openings to the gills are five to seven slits either on the sides of the body or on the underside of the fish. The skeletons of these fish are made of cartilage, not bone. Seven species of sharks and five species of skates occur in Alaska. There are no rays here. Skates leave their eggs in curious cases that are sometimes washed ashore.

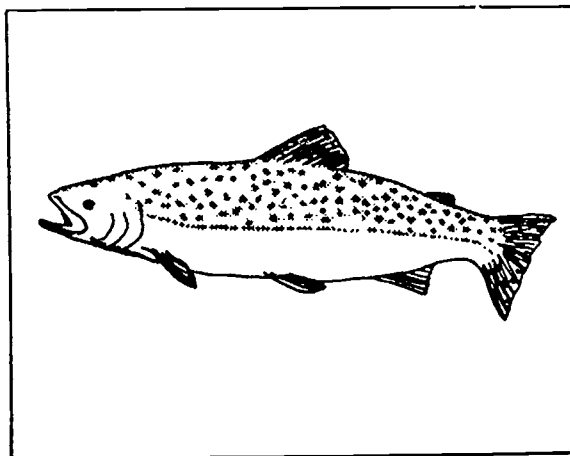

- III. Salmon, herring, blackfish and many others are called the "bony fish"

because their skeletons, unlike those of sharks and skates, are made of bone. Bony fish have jaws, some paired fins, and one gill slit on each side of the head. They are the only fish with scales, but most fish are bony fish. Alaska's fresh and marine waters include many species.

Vocabulary:

- genus
- species
- hagfish
- lamprey
- skate
- ray
- shark
- cartilage

Materials:

- scissors
- glue or tape
- worksheets:
 - ...Fish to Classify (1C)
 - ...The Three Major Groups of Fish (1D)

Procedure:

1. Explain that when scientists study plants and animals, they put them in groups based on their similarities. Pass out the Fish to Classify worksheet and have students cut out the fish and sort them into groups based on their observable characteristics. Have students discuss the group similarities. Then challenge students to sort their fish into just three groups.
2. Distribute The Three Major Groups of Fish worksheet. Explain to students that

scientists have classified fish into three major groups. The main characteristics of each group are listed at the bottom of each column. Have the students place the cutout fish from the previous worksheet into one of these three groups. Write on the board the names of the three groups: (1) hagfish and lampreys; (2) sharks, skates and rays; and (3) bony fishes.

Have the students label each column and figure out which names go with which column. Discuss their choices. Have them glue or tape the fish in the proper column. (Suggested by Laurie Dumdrie, Science Resource Teacher, Anchorage School District)

3. Introduce the term "species." Each of the fish is a different type or species. In addition to common names such as "king salmon," scientists have given each species a scientific name such as Oncorhynchus tshawytscha. The first term Oncorhynchus refers to the fish's family. All scientific salmon names begin with Oncorhynchus, or the fish's "genus." The "species" name, tshawytscha belongs only to that particular type of salmon. Students might run across some of these scientific names as they research reports. Scientific names are the same all over the world, generally derived from Latin or having Latin roots. Japanese and Russian fisheries biologists use the same scientific names as we do. Yet common names vary from place to place. Sometimes Oncorhynchus tshawytscha are

called "kings" and other times are "chinooks."

Additional Activities:

1. Science: Students might want to try to identify and find out more about the fish on the Fish to Classify worksheet by looking through various Freshwater Fishes of Alaska, Pacific Fishes of Canada, or other reference books listed in the bibliography. Here are the answers:

1. king salmon,
Oncorhynchus tshawytscha
2. sheefish,
Stenodus leucichthys
3. salmon shark,
Lamna ditropis
4. threespine stickleback,
Gasterosteus aculeatus
5. white sturgeon,
Acipenser transmontanus
6. Alaska blackfish,
Dallia pectoralis
7. arctic lamprey,
Lampetra japonica
8. humpback whitefish,
Coregonus pidschian

9. basking shark,
Cetorhinus maximus
10. big skate,
Raja binoculata
11. stingray, Dasyatis sp.
12. Pacific hagfish,
Eptatretus stouti
13. slimy sculpin,
Cottus cognatus
14. spiny dogfish,
Squalus acanthias
15. Pacific herring,
Clupea harengus pallasii

2. Science, Art: Have students research and draw fish oddities from around the world. How many are bony fish? How many are in the other two groups?
3. Science, Language Arts: Research the Lake Illiama monster story. See Tide-lines, Vol. 1, No. 2, Oct. 1978, "Does Alaska Have a Monster"; and Alaska magazine, Jan. and Feb. 1978, "A Monster Mystery;" and "The Lakes: Magnificent Gap on the Map." Then have students write their own creative monster stories.

Activity 4

The Outside of a Fish

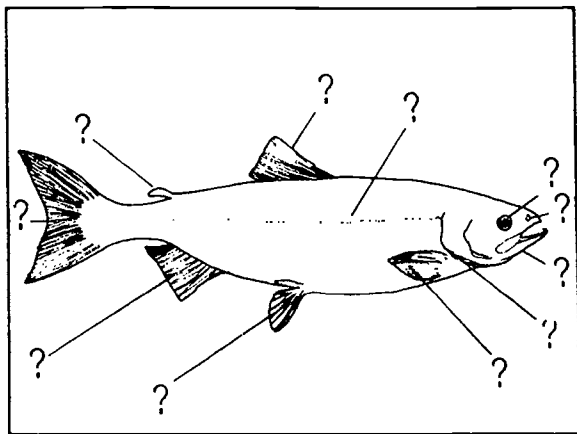

Background:

There are good reasons to learn the names of the external features of a fish. In order to talk to each other about fish, we need to know the words that describe them. As students begin to distinguish one kind of fish from another, they will need words to describe the shapes, colors, differences and similarities they find. In writing or reading descriptions of individual fish species, vocabulary is important; sometimes even small differences in external features mark the difference between one species and another.

Students who enjoy fishing will quickly notice abnormal external features on fish if they have learned how the fish usually looks. For example, one kind of abnormality may be a missing adipose fin on a salmon, a sign that biologists may have tagged that fish with a coded wire tag in its head which when recovered reveals from where the fish came. Return of such a fish aids scientific studies and may bring a reward to the captor.

For this activity, you will need a

whole fish. The best fish for the activity would be one caught locally. Ask a commercial or sport fisherman to save a scrap fish for you, or catch the fish yourself, or ask a student who enjoys fishing to bring one. Alternatively, the whole class could go on an expedition to secure a biological specimen. If you get a local fish ahead of time, it could be frozen whole and then thawed the day before you want to use it.

If you cannot get a fish locally, preserved specimens can be ordered from a biological supply house, but be sure to order well in advance of your planned activity.

Vocabulary:

- lateral line
- nostril
- gill cover
- adipose fin
- dorsal fin (review)
- pectoral fin (review)
- pelvic fin (review)
- caudal fin (review)
- anal fin (review)

Materials:

- a whole fish (ideally one for every 2-3 students)
- magnifying lenses or microscopes
- ruler
- scales to weigh the fish
- worksheet:
...Outside of a Fish (1E)

Procedure:

1. Distribute the fish to students, directing them to carefully look at and touch the fish. Distribute the worksheet Outside of a Fish.

Notice that this worksheet

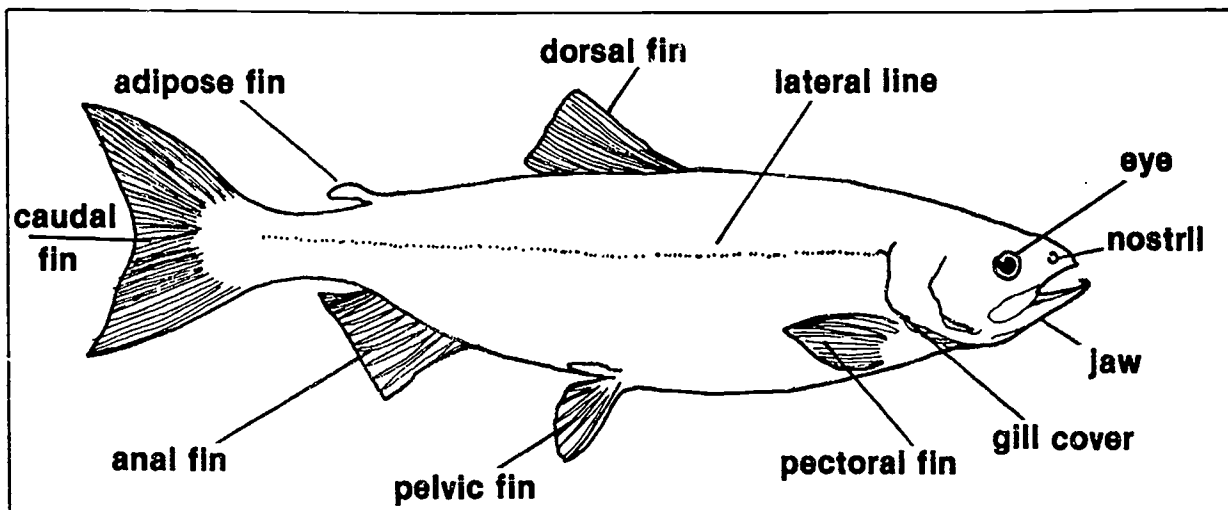

illustrates a salmon. If your fish is not a salmon, you or your students may want to make up a worksheet for it. Except for the adipose fin, fins found on a salmon also occur on all other bony fishes, but the shapes and numbers of fins may vary. Sculpins, for example, have two dorsal fins instead of one.

As you and the students describe and talk about the fish, have the students label each part on the worksheet.

FEEL THE SIDE OF THE FISH. If the specimen is fresh or frozen rather than preserved, it may feel slimy. The slime actually is mucus secreted by single-cell glands in the fish's skin. Mucus protects the underlying skin and may keep bacteria away from the living tissue. It also acts as a lubricant to help the fish slip through the water. Mucus protects fish from predators by making them more difficult to grasp. In some species, the mucus is a barrier between the fluids of the fish's body and the

surrounding water. (When two solutions of unequal strength are separated by a semipermeable membrane, the solutions tend to equalize by passage of the weaker solution to the stronger. The fluids of a fish are less salty than sea water but are saltier than fresh water. Thus, the fish may need a barrier to prevent it from losing fluid in salt water or gaining fluid in fresh water.)

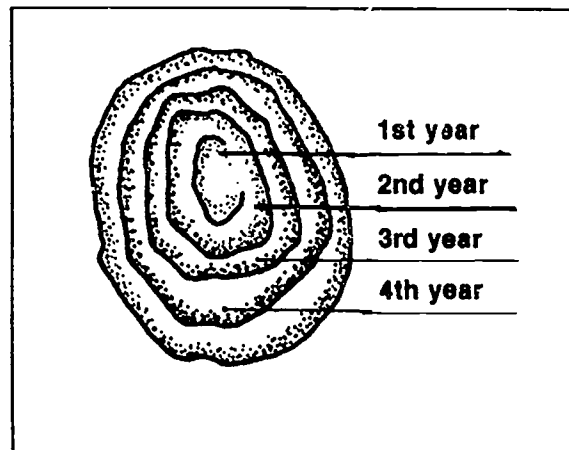

LOOK AT THE SCALES. They give the fish a form of exterior armor, but at the same time allow complete freedom of movement. Use a hand lens or microscope to look at individual scales.

Like the growth rings on a tree, the rings on a fish scale often can be used to read its age. A series of fine rings are formed on the scale each year. In summer, when growth is more rapid, the rings are further apart; in winter, when growth slows, the rings have only narrow separations. By counting the number of bands that represent winter growth, students can decipher the age of their fish.

NOTE THE EYE AND HOW SIMILAR IT IS TO OUR OWN. Like the human eye, the eye of a fish has a pupil and a cornea. See if students notice the fish's eye has no eyelid. Because the lens of the fish's eye bulges through the pupil opening, the eye can gather light from the eye's entire hemisphere, resulting in "wide angle" vision. If you have or can find a picture taken with a fish-eye lens, it will give students an idea of what a fish's vision might be like. Fish probably can see color, but because water filters out light of certain wave lengths, color that can be seen above water may not be visible under water.

LOOK IN THE MOUTH. Feel and describe the teeth. Ask students what they think the fish eats. Most species of fish have rather specific diets. Many feed on smaller fish, but they may eat plants, clams, worms, squid or other animals. Some fish, such as herring, feed mainly on zooplankton, tiny drifting or weakly swimming animals. If the fish you are examining

is a fresh local fish, you may want to take guesses about what it has eaten and later open its stomach to see what it contains.

EXTEND AND FEEL THE FINS OF THE FISH. Count the bony rays in each fin. Note the membrane connecting them. The supporting structures of the fins may be either rays, which are segmented and flexible, or spines, which are unsegmented and rigid. Ask students which fins are paired (pectoral, pelvic) and which are not (dorsal, caudal, anal). Review with students the function of each fin:

- Dorsal and anal fins help keep the fish upright and prevent it from rolling over.
- Pectoral fins may help the fish stop or may slow its forward motion. They are used for fine maneuvering, for resting or walking on bottom, and in some cases for slow propulsion.
- Pelvic fins help the fish control a tendency to veer upward as it slows down.
- The caudal fin moves from side to side to propel the fish.

LOCATE THE GILL COVER. If it is still flexible, bend it forward to reveal the gills. To breathe, the fish opens its mouth, takes in water, then closes its mouth. The water moves from the fish's mouth, past its gills, and out from beneath the gill cover. As the water moves over the gills, oxygen from the water is absorbed into blood vessels in the gills.

MANY FISH HAVE AN OBVIOUS LATERAL LINE THAT RUNS FROM THE GILL COVER TO THE CAUDAL FIN. The lateral line is a complex of sensory receptors. It enables the fish to detect changes in water pressure and thereby helps it detect the presence of predators or prey, orient to the current, keep its position in a school of fish and avoid obstacles.

SEE IF STUDENTS CAN FIND THE FISH'S NOSTRILS ON ITS HEAD. A sense of smell is important to fish. Many species rely heavily on this sense to find food. Biologists believe that a salmon's sense of smell is important to the fish's ability to return to the stream where its life began.

2. Have the students guess the weight and length of their fish. Then measure and weigh them. Fisheries biologists often collect data on sex, weight, length and age of fish to help decide on the number of fish that should be harvested. Age can be determined by counting the growth rings on scales. Sex (σ =male, ? =female) is difficult to discern from the outside of the fish, except in spawning salmon among which the males have hooked snouts.

Activity 5 What's Inside a Fish?

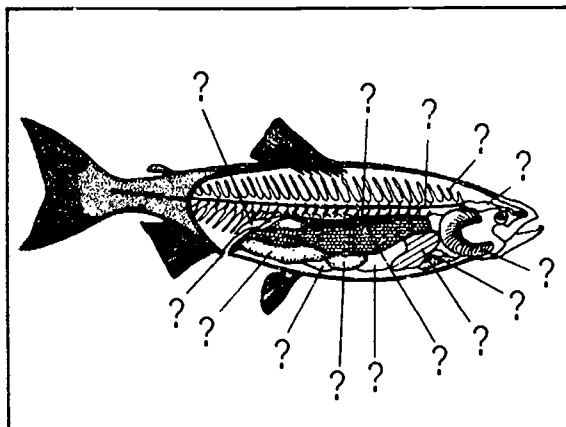

Background:

If students already have studied the human body, they will encounter many familiar organs in fish. They will be able to make comparisons and reinforce what they have already learned about anatomy.

If the fish you used to examine external structures was a whole, uncleaned fish, use it for this activity too. If you keep it from one day to the next, be sure to refrigerate it overnight. A preserved fish can be obtained from a biological supply house if you have no local specimens. Wash preserved specimens thoroughly with water to lessen the smell of the preservative (many of which are health hazards).

One fish will suffice to show the class what's inside, but it's better to have enough fish for students to work in small groups.

Vocabulary:

- gonads
- esophagus
- spinal cord
- gas bladder
- swim bladder

- vent
- spleen
- testes
- ovaries

Materials:

- a whole fish (ideally one for every 2-3 students)
- glue
- scissors
- colored pencils or felt-tip markers
- knife or scalpel
- dissecting needle or other pointed probe
- worksheets:
 - ...The Inside of a Fish (1F)
 - ...Body Parts and Their Functions (1G)

and cutting a straight line forward up the belly until you reach the point where the gill covers almost meet. This cut is the same one that anglers make as they begin to clean fish; it will enable you to lay open the body cavity and examine the organs inside.

THE HEART LIES NEAR THE FORWARD END OF YOUR INCISION. Pyramid, or fist-shaped, it serves, as does the human heart, to circulate blood through the body. Like people, fish have a system of veins and arteries to transport blood.

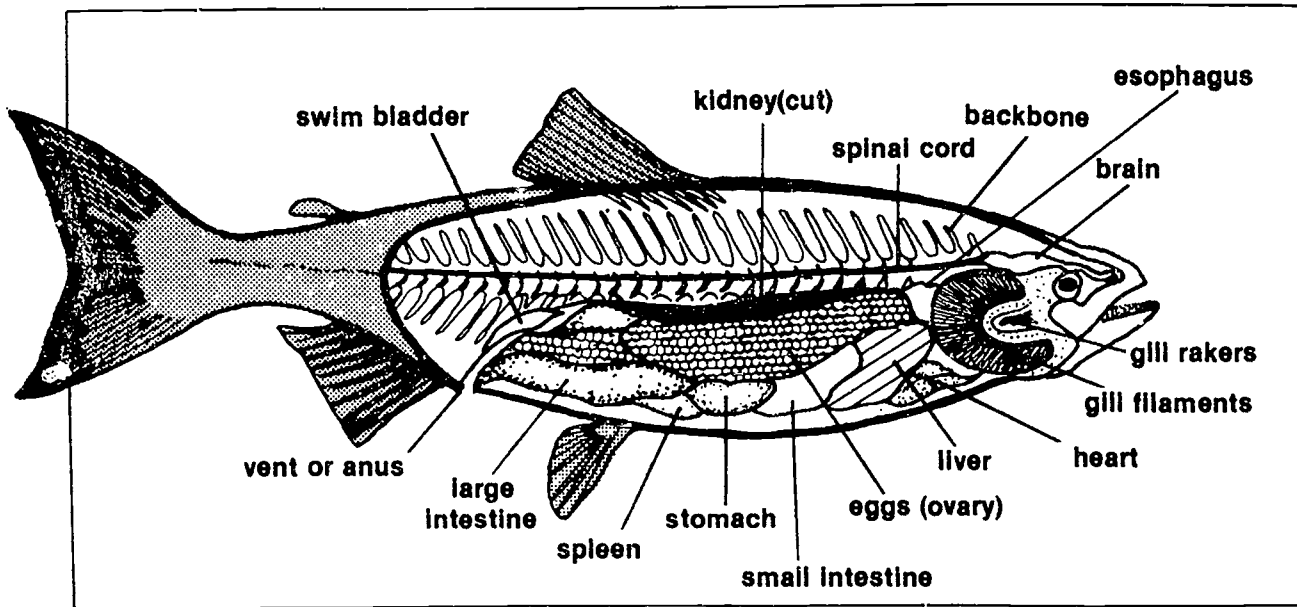

Procedure:

1. Distribute worksheet The Inside of a Fish. Have the student label and color the fish parts as they are identified and discussed.
2. Place the fish on a flat surface. Begin the dissection by inserting a knife or scalpel in the vent (anus) of the fish

JUST BEHIND THE HEART IS THE LIVER. The liver a blood storage organ and filters poisons from the blood. Students may have heard of cod liver oil, a codfish liver extract rich in vitamins A and D.

LIKE OUR DIGESTIVE SYSTEM, the digestive system of a fish consists of several

parts. The whole of this system can be removed from the fish and laid out in a pan for better examination. The digestive system begins with an ESOPHAGUS that carries food from the fish's mouth to its STOMACH. Behind the stomach are the PYLORIC CAECA (pronounced see'-ka), finger-like projections that secrete enzymes which help the fish digest its food. The pyloric caeca are attached to the intestines. The number of pyloric caeca varies with the kind of fish. Salmon may have as many as 200 but flatfish usually have fewer than five.

With your scalpel or knife, open the stomach of the fish. It may contain a sample of the food the fish ate. When cleaning fish, many fishermen routinely open the fish's stomach to help themselves learn more about the fish and its food, and to give themselves a better idea of what kind of bait might attract the fish.

THE GAS BLADDER, OR SWIM BLADDER, is a thin-walled sac that usually lies high in the body cavity. The gas bladder may be collapsed in your fish, but if students have ever cleaned a fresh fish, they may have seen a gas bladder when it is still expanded like a small, thin balloon or like a bubble blown from bubble gum. The bladder regulates pressure by releasing or reabsorbing gas. In this way it enables the fish to adjust to changing water pressure at varying depths and to maintain neutral buoyancy. It also func-

tions in respiration and helps the fish make and receive sounds.

THE GONADS are the structures that produce either eggs or sperm. In bony fishes, the sperm-producing gonads (testes) are white. The egg-producing gonads (ovaries) are usually yellow or red-orange. The gonads lie along the gas bladder. Fish are either male or female and thus have either white sperm-producing testes or egg-producing ovaries. The gonads may be quite large if spawning time is near and large eggs may easily be seen in the ovaries. The unspawned eggs of both herring and salmon are highly prized for food by Alaskan Natives, and by Japanese and other Asian peoples. Salmon roe (eggs) from commercially caught salmon are a valuable cash crop that is carefully boxed and exported to Asia.

THE FISH'S KIDNEYS are long, slender, dark organs that lie along the top of the body cavity just under the vertebrae and above the gas bladder. They can be easily seen when the other internal organs have been removed. There are two kidneys in each fish; like ours, they function in removal of waste products from the body.

THE BRAIN of the fish is located on the back of its head behind its eyes. By making several lengthwise, parallel cuts behind the eyes, you will be able to expose cross-sections of the brain for examination.

THE SPINAL CORD may be seen by cutting through the center of the column of vertebrae that are exposed in the central body cavity. The spinal cord is part of the nervous system through which messages travel from the brain to the other parts of the body. The BACKBONE protects the spinal cord and provides support for the fish.

GAIN ACCESS TO THE GILLS by raising the gill cover. You can remove the gills by making two cuts with a knife, severing the gills at their points of attachment. Bony fishes have four curved gill arches on either side of the head. On the insides of the gill arches are short projections called gill rakers. These help in gathering food. If the fish feeds on large prey, the gill rakers may be few in number and may have

rough structures that aid in holding their captives. Fish that feed on plankton usually have long slender gill rakers that help strain the plankton from the water. Herring, for example, have gill rakers of the second type, while the gill rakers on some salmon are less prominent. On the outside of the curve of the gill arch are the gill filaments which let the fish absorb oxygen from the water.

3. Distribute the worksheet Body Parts and Their Functions. Have students cut out the sections and glue or tape them to another paper so the correct functions are opposite the appropriate body parts. Compare fish organs to those of humans. (Most are similar, but humans lack swim bladders, and have lungs instead of gills.)

Activity 6 Fish Printing

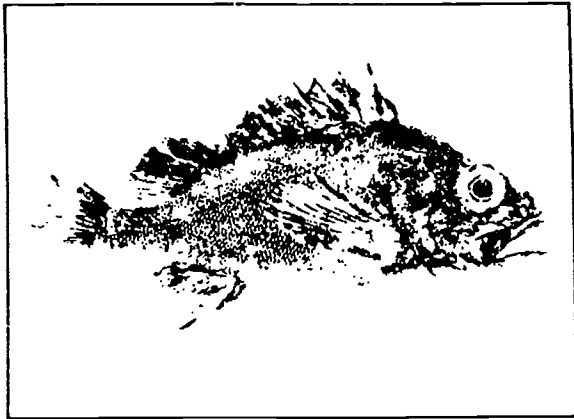

Background:

Down through the ages, fish have inspired artists and craftsmen. Museums throughout the world have fish art objects and paintings. Here in Alaska, Natives use fish designs in their art work.

Japanese fish printing (gyotaku) is a great way for every child to be a successful artist. In Japan, fisherman often do gyotaku (pronounced ghio-ta-koo) as a record of their catch. Fish printing began in Japan or China in the early 1800s, spreading to this country during the present century.

Vocabulary:

- gyotaku

Materials:

- a whole fish
- watercolor, oil paint, or ink (especially linoleum block printing ink)
- rice paper, construction paper, newsprint, or linen
- clay
- straight pins
- paper towels
- small paint brush

- 1/2-inch wide paint brush or small brayer (roller)

Procedure:

1. Obtain a whole fish (the one from the proceeding activities would work fine). Wash it thoroughly using detergent. Rinse and dry the fish to remove all cleanser and any blood or mucus. Place the fish on a good working surface. If your fish is gutted, stuff the body cavity with paper towels. You may want to fill a bag with wet sand and cradle the fish on top of it. Place clay under the fins to hold them out. A pin inserted in the muscular base of one of the first spines of each fin will help keep the fins erect. Stuff part of a paper towel under the gill to sop up excess water.
2. Use a large brush or brayer to apply paint or ink. Stroke consistently from front to back or vice versa so that scales are accentuated. Carefully place a piece of paper over the fish and with your fingers rub gently but firmly over the fish. Remove the paper and hang it up to dry. The eye of the fish can be painted on later with a small paint brush.
3. Then if the fish is fresh, you can eat it! Just clean and wash it thoroughly.

Additional Activities:

1. Art, Social Studies: Sign your fish prints with Japanese or Chinese characters. Make a small stamp out of a wood or a linoleum block and dip it in red ink. Use a



Gyo (fish)



Uotsuri (fishing)



Ryoshi (fisherman)

Japanese or Chinese dictionary to figure out which character to use. When you're carving the stamp, do not forget to carve it backwards so it will print the right way. Then add a cardboard or paper frame to your picture and some yarn on the back to hang it on the wall.

2. Art, Social Studies: Another famous Japanese art form is paper folding, origami (pronounced or-i-gah-mee). Make

fish by folding colorful square sheets of tissue paper. Then tie string or thread through the centers of their dorsal fins and hang them throughout the room.

3. Art, Social Studies: Have students look around their own homes or in local business for examples of fish art. Bring them to school and discuss their origins, histories, and the artists' techniques. Local artists might be willing to demonstrate their skills and assist the students in making similar art projects.
4. Art: Have students fill a bulletin board aquarium with thumbprint fish. To make the fish, have students stick their thumbs on an ink pad, and then press it on the aquarium paper. Add fins with magic markers. (Suggested by Nanette Thomas, Sunnyland School, Bellingham, Washington)

Activity 7 Fish Poetry

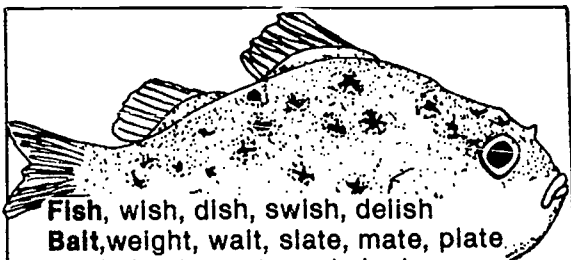

Fish, wish, dish, swish, delish
Bait, weight, wait, slate, mate, plate
Hook, book, nook, rook, look
Boat, mote, float, tote, dote, coat
Line, pine, mine, swine, dine, fine
Trout, pout, doubt, clout, without
Salmon, backgammon, famine, sun, fun

Materials:

- poems about fish or fishing
- pencils
- paper

Procedure:

1. Share some of your favorites and the following poems about fish. Talk about the students' feelings toward fish and some of their favorite fish stories.

FISHING

I'm wearing old clothes,
My favorite kind.
They're faded and tattered,
But fish never mind.

My line's in the water
With squirming live bait.
I like to go fishing
And dream while I wait.

--Vivian G. Gould

The Fish

I caught a tremendous fish
and held him beside the boat

half out of water, with my hook
fast in a corner of his mouth.

He didn't fight.

He hadn't fought at all.

He hung a grunting weight,
battered and venerable
and homely. Here and there
his brown skin hung in strips
like ancient wall-paper,
and its pattern of darker brown
was like wall-paper:

shaped like full-blown roses
stained and lost through age.

He was speckled with barnacles,
fine rosettes of lime
and infested

with tiny white sea-lice,
and underneath two or three
rags of green weed hung down.
While his gills were breathing in
the terrible oxygen

--and frightened gills
fresh and crisp with blood
that can cut so badly--

I thought of coarse white flesh
packed in like feathers,
the big bones and the little bones,
the dramatic reds and blacks
of his shiny entrails,
and the pink swim-bladder
like a big peony.

I looked into his eyes
which were far larger than mine
but shallower, and yellowed,
the irises backed and packed
with tarnished tinfoil
seen through the lenses
of old scratched isinglass.
They shifted a little, but not
to return my stare.

--It was more like the tipping
of an object toward the light.

I admired his sullen face,
the mechanism of his jaw,
and then I saw

that from his lower lip
-if you could call it a lip-
grim, wet, and weapon-like,
hung five old pieces of fish-line,
or four and a wire leader
with a swivel still attached,
with all their five big hooks
grown firmly in his mouth.

A green line, frayed at the end
 where he broke it, two heavier lines,
 and a fine black thread
 still crimped from the strain and snap
 when it broke and he got away.
 Like medals with their ribbons
 frayed and wavering,
 a five-haired beard of wisdom
 trailing from his aching jaw.
 I stared and stared
 and victory filled up
 the little rented boat,
 from the pool of bilge
 where oil spread a rainbow
 around the rusted engine
 to the bailer rusted orange,
 the sun-cracked thwarts,
 the oarlocks on their strings,
 the gunnels--until everything
 was rainbow, rainbow, rainbow!
 And I let the fish go.

-Elizabeth Bishop

2. Then let students try writing some of their own poetry. Here are some sample formats to follow and some sample poems contributed by Mary Couche's fifth and sixth grade class in Kivalina.

Haiku - This an unrhymed Japanese verse consisting of 3 lines containing 5, 7, and 5 syllables, respectively.

The fish go away
 And it take my hooks away
 Then I swim for it.

--Albert Norton

Limerick - These are light humorous poems consisting of five lines of verse. Lines 1, 2, and 5 consist of three anapestic feet (two short syllables followed by one long syllable) while lines 3 and 4 contain two feet. Lines 1, 2, and 5 rhyme with each other, and lines 3 and 4 rhyme together.

There is a big fish who eat pies,
 After he eats them he dies,
 Because inside the pies
 There are too many flies.
 And his mother gets sad and she
 cries.

--Mary Couche's whole class

Cinquain - These are five-line stanzas. The first line consists of one word, the second line two words, and so on until the 5th line which again contains one word. Have your students use the name of a fish for the first line. (Aqaluk means "fish" in Inupiaq.)

Aqaluk
 Big, strong
 Fast, fighting, jumping
 It's a big one
 Trout.

--Antonio Sage

Salmon
 Scaly, strong
 Leaping, making waves
 It's a very big
 fish.

--Harold Koenig

Unit Two

Fish Species

Index

Activity 1: Name that Salmon	23	Worksheet: The Pink Salmon Game..	2J
Worksheets:		Activity 4: Salmon Survival..	34
Ocean Salmon Cards....	2A	Worksheet: Only the Strong	
Spawning Salmon Cards.....	2B	Survive.....	2K
Ocean Salmon Identification Charts.....	2C	Activity 5: Herring and the Food Web.....	35
Spawning Salmon.....	2D	Worksheet: What's for Dinner	2L
Ocean and Spawning Salmon	2E	Activity 6: Hide a Halibut ...	38
Activity 2: The Salmon Life Cycle	25	Worksheet: Halibut, Halibut	2M
Worksheets:		Activity 7: The Amazing Alaska Blackfish	39
Salmon Life Cycle Stages	2F	Activity 8: Freshwater Fish Card Game	43
A Salmon's Life Cycle ..	2G	Activity 9: Design a Fish ...	53
Salmon Match Game.....	2H		
Salmon Word Search	2I		
Activity 3: Salmon Habitat... ..	28		

Objectives:

To help students:

- Identify the five species of salmon based on their observable characteristics (Activity 1).
- Compare the five species of salmon in the saltwater and freshwater phases of their life cycles (Activity 1).
- Read about salmon and their life cycle (Activity 2).
- Identify the sequence of salmon life cycle stages as egg, alevin, fry, smolt, and adult (Activity 2).
- Make a mural of local salmon habitat and hazards (Activity 3).
- Calculate salmon survival potential (Activity 4).
- Diagram the role of herring in the ocean's food web (Activity 5).
- Taste herring (Activity 5).
- Camouflage a halibut in a watercolor painting (Activity 6).
- Observe a blackfish's ability to survive low oxygen conditions (Activity 7).
- Become familiar with Alaska's freshwater fish species by making and playing a freshwater fish card game (Activity 8).
- Design and make a tissue paper fish adapted for a particular habitat (Activity 9).

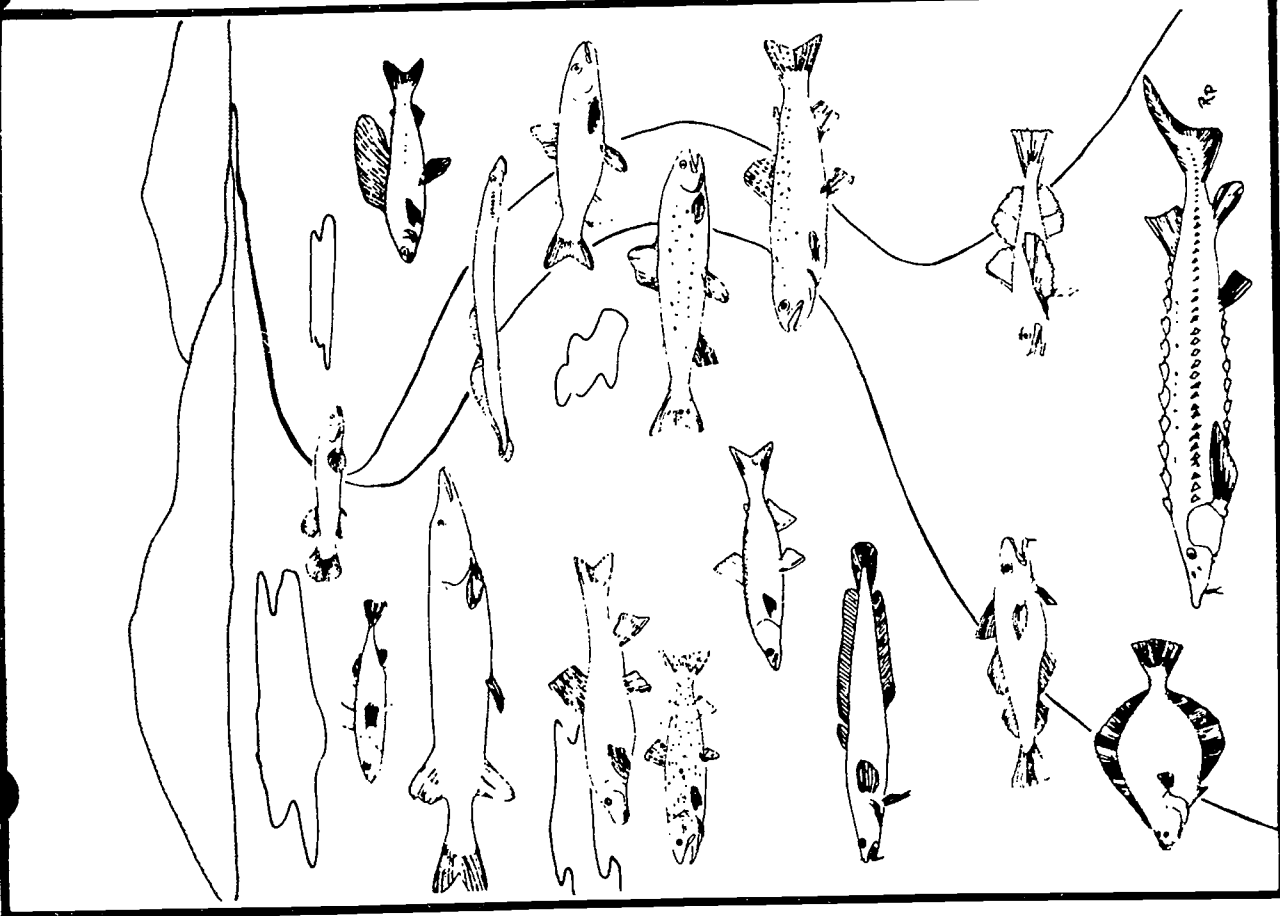

Unit Two: Fish species, left panel, clockwise from bottom: sturgeon, flounder, cod, burbot, sheefish, cutthroat trout, longnose sucker, pike, stickleback, blackfish, grayling, lampry.

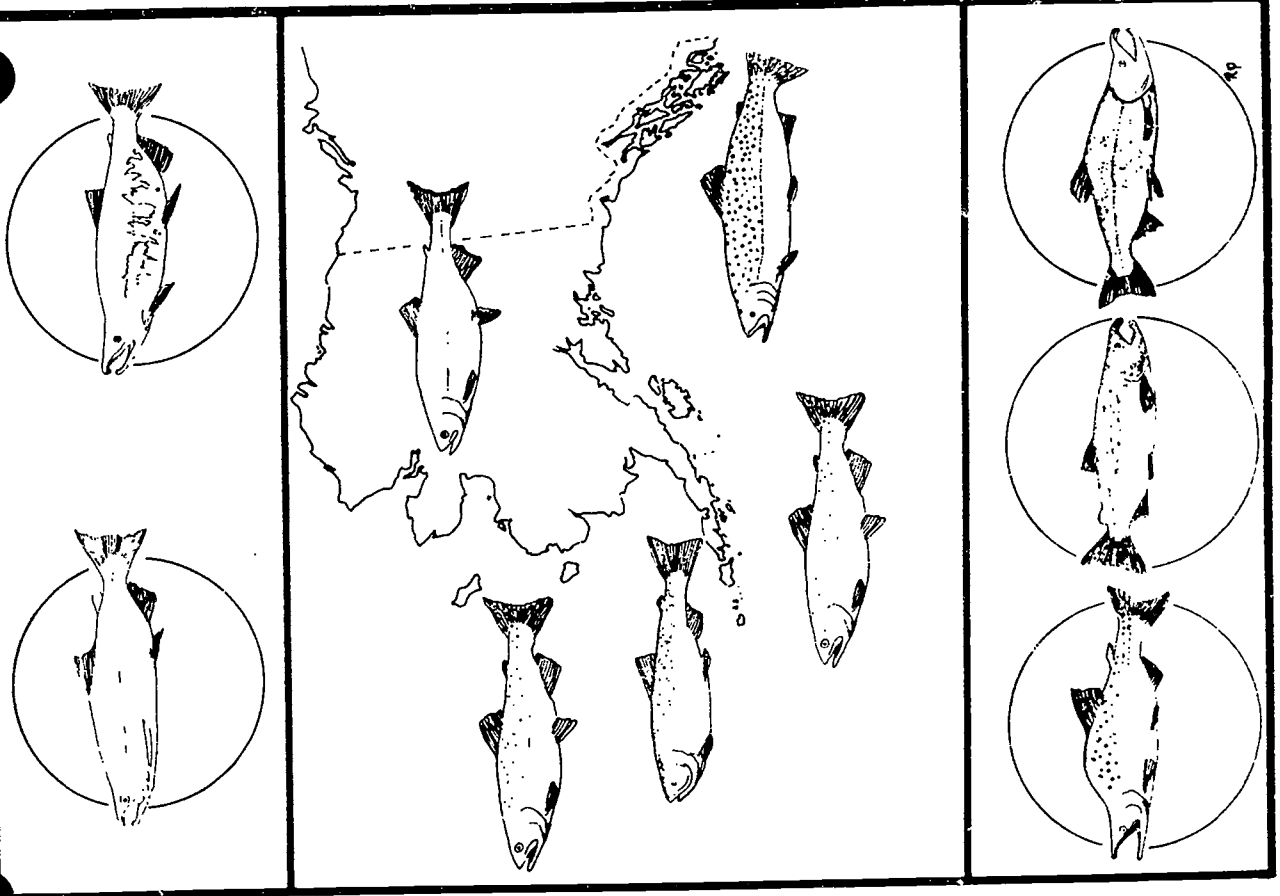

prey, lake char, Dolly Varden char, rainbow trout, sculpin. Right panel, salmon at sea (on map, clockwise from bottom): silver, red, pink, chum, king. Spawning salmon circled.

Activity 1 Name that Salmon

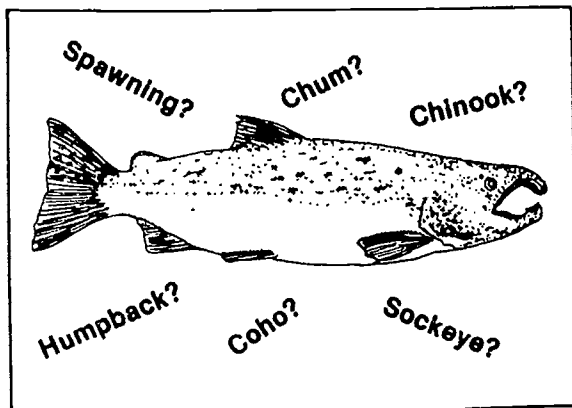

Background:

Salmon are the most important Alaskan fish for commercial, subsistence, and sport fishing. Alaska produces 85 to 95 percent of the entire U.S. salmon harvest and almost half of the world's catch.

All five species of Alaskan salmon are anadromous (pronounced a-nah-dra-mous), meaning that they hatch from eggs in fresh water, travel to salt water to grow and mature, and then return to fresh water to deposit their eggs. Ocean salmon are bright silver. As salmon travel up freshwater streams to spawn, their color turns from silver to shades of copper, brown, red, or green. The upper jaw of the male becomes hooked downward, and the shape of his body may also change.

(This activity was contributed by Laurie Dumdrie, Science Resource Teacher, Anchorage School District.)

Vocabulary:

- chinook
- sockeye
- humpback

- coho
- chum
- spawning
- anadromous
- protective coloration

Materials:

- scissors
- color pencils or small felt-tip markers
- ocean salmon cards (one per student)
- salmon identification chart (one per student)
- master card for each species of salmon
- worksheets:
 - ...Ocean Salmon Cards (2A)
 - ...Spawning Salmon Cards (2B)
 - ...Ocean Salmon Identification Chart (2C)
 - ...Spawning Salmon (2D)
 - ...Ocean and Spawning Salmon (2E)

Procedure:

1. Each student will need a salmon picture card (ocean phase) for this activity. First make a master set for yourself by duplicating the ocean and spawning salmon card worksheets accompanying this unit. Laminate the ocean and spawning phases back-to-back for handier identification. For student cards, block out the identifying names before copying.
2. Ask students to guess how many different kinds of salmon are in Alaska (five). Can they name some of the species? Record these names on the board. Tell students that each species has at least two names. Add any they omitted: king or chinook; coho or silver; pink or humpy

(humpback); sockeye or red; dog or chum.

3. Shuffle the ocean salmon picture cards and pass them out one per student. Ask students to find others with salmon cards exactly like their own. When several students have identified their salmon as the same, they should cluster as a group. There should be five groups.
4. Within each group, have students guess their species of salmon. Then give each group copies of the worksheet Ocean Salmon Identification Chart with which to compare their guesses. As each group is ready, ask them to tell you the name of their salmon. Compare their answer with your master set. If the answer is correct, give the group the master card to hold. Continue this procedure until all groups have the correct master card.
5. As a class, discuss the differences between the fish and the distinguishing physical characteristics of each species. Talk about how the coloration of ocean fish gives them protective coloring. The fish are darker above so that predators such as eagles, gulls, and people have trouble seeing them; and lighter underneath so preda-

tors from below can't readily pick them out. Ask students if salmon always look like the fish you have been discussing. Have each group turn over the master card and compare the spawning appearance of the species with its saltwater appearance. Salmon change rapidly during their spawning migrations.

6. Distribute the worksheet Spawning Salmon. Allow time for students to draw and color the different species. Check the bibliography for several sources of salmon species color charts.
7. Use the worksheet Ocean and Spawning Salmon to compare and review salmon changes.

Additional Activities:

1. Science: Make flashcards or a card game with picture sets of the ocean and spawning salmon. A card game suggestion: Students try for four of a kind by asking other students and drawing from the main deck.
2. Home Economics, Art: Make stuffed-animal salmon out of cloth, filling them with old hose, rice, or beans. Color them with permanent felt-tip markers to look like specific salmon species.

Salmon Card Key

2A Ocean Salmon Cards	Red	Red	Spawning Salmon Cards
Silver	Pink	Pink	Silver
Pink	Chum	Chum	Pink

Activity 2 The Salmon Life Cycle

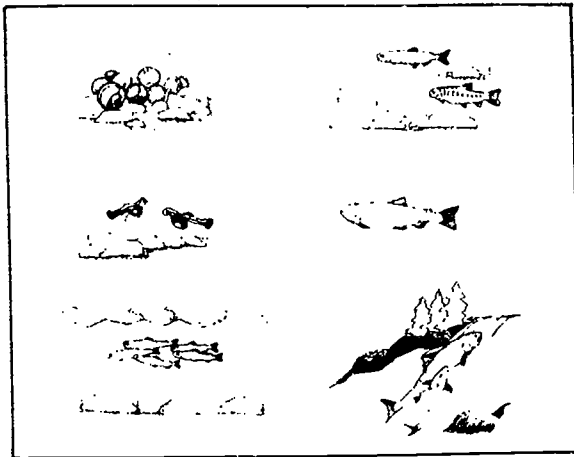

Background:

The stages of a salmon life cycle are summarized in the following paragraphs:

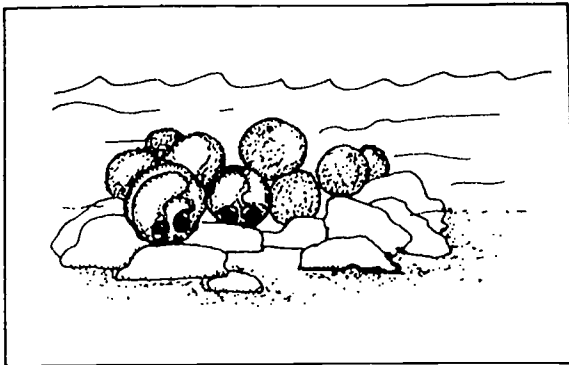

Egg

This is the first stage of the life cycle, in which a female salmon deposits as many as 10,000 eggs in the gravel of a stream. The bright pink eggs, about one-fourth inch in diameter, are covered to help protect them from predators and direct sunlight. After about a month, eyes become visible within the eggs. It is essential to the eggs' survival during this time that water flow and temperature are suitable. Salmonids are coldwater fish and normally cannot tolerate temperatures above 68°F. The

greatest mortality in the salmon life cycle is the egg-to-fry stage.

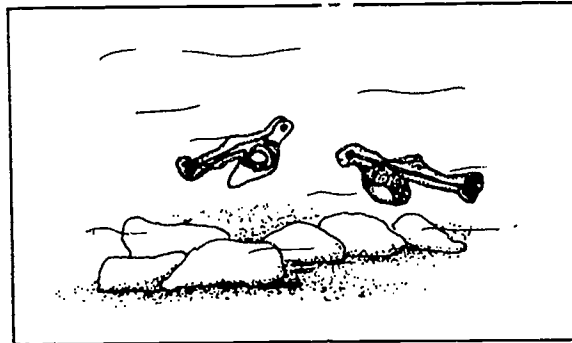

Alevin

In late winter and spring, salmon eggs hatch and become quarter-inch alevins (pronounced ay-luh-vins) which grow slowly under the gravel for three to four months. The alevin is a fragile creature with huge eyes and a large yolk sac protruding from its belly. The orange yolk sac contains a balanced diet of protein, carbohydrates, vitamins, and minerals. The vitelline vein, running through the center of the sac, extracts oxygen from the water. The fish at this stage remains under gravel, protected from predators and other hazards. A good flow of pure water is critical to alevin survival.

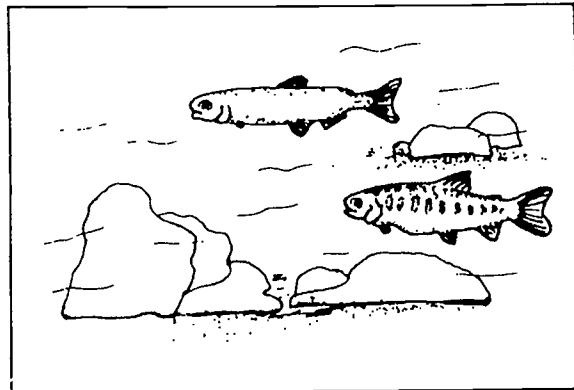

Fry

Alevins absorb their yolk sacs and emerge from the gravel as fry in late spring and summer. About an inch long, they are easy prey for larger fish. Sockeye, chinook and

coho spend at least one year in streams or lakes, unlike the pink and chum which usually head directly to sea. Fry feed on plankton and small insects. At this stage, important survival requirements include good stream-side cover and an ample food supply.

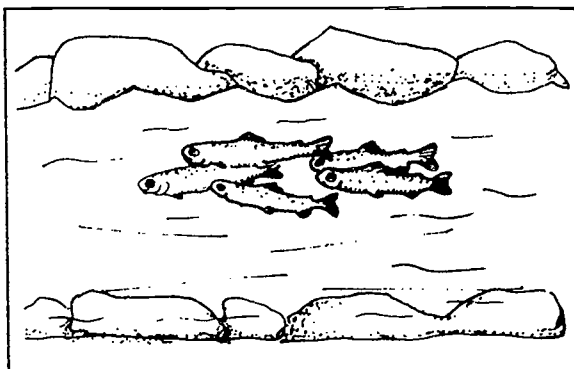

Smolt (or fingerlings)

Young salmon remain in fresh water for varying periods: chinook spend one year, coho one to four years, sockeye one or two years, and pinks and chum about six months. At the smolte stage, they head downstream. Four to six inches long, they swim seaward in late May during the spring freshet, and enter salt water where they grow to adulthood.

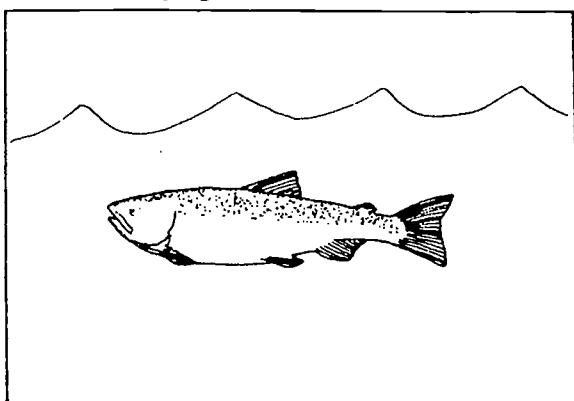

Ocean adult salmon spend varied amounts of time in the sea, ranging up to five years, eating greedily and growing rapidly in the ocean feeding grounds.

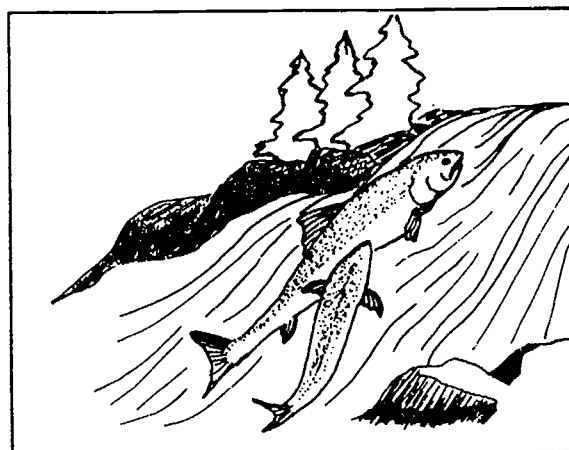

Spawning Adults

Usually in the early summer of their maturing year, salmon begin to head back to their home streams, navigating at least partially by their sense of smell. They stop feeding as they enter fresh water, living on stored body fats. They struggle sometimes for weeks against falls and obstructions to reach the same spawning beds in which they themselves were hatched. During the trip upstream, many are killed by natural predators or man. When a pair of salmon reaches its spawning ground, the female digs a nest, or redd, up to 16 inches deep in the gravel. When the nest is ready, which may be weeks after the pair reaches the gravel beds, the female lays her eggs. The male fertilizes them by covering them with a milky substance known as milt, which contains the sperm. The female then covers the eggs with gravel to complete the spawning process. The salmon's life is finished and within a short time it dies and the body drifts downstream, providing nutrients to the stream system as it decays.

Vocabulary:

- redd

- alevin
- yolk sac
- fry
- smolt
- fingerling
- plankton
- anadromous (review)

Materials:

- paper
- glue
- scissors
- worksheets:
 - ... Salmon Life Cycle Stages (2F)
 - ... A Salmon's Life Cycle (2G)
 - ... Salmon Match Game (2H)
 - ... Salmon Word Search (2I)

Procedure:

1. Ask students to tell you what is meant by a "life cycle." Discuss the idea that it is the chain of life from birth to death to birth again. Distribute the worksheet Salmon Life Cycle Stages. Have students cut out the pictures depicting the stages. Challenge students to place the pictures in their proper order. Suggest they look for the clues in the pictures, and not rely on the labels for each of the stages. Remind them that it's a life cycle, so the pictures should be placed in a circle. Have students leave these cards on their desk in their predicted order for later reference.
2. Distribute copies of the worksheet A Salmon's Life Cycle. Call attention to the questions at the beginning of the worksheet which are designed to guide student reading. Notice that there is a space for predicted answers to complete beforehand and

then the actual answers which they can complete as they read. (Answers: 1: six; 2: five; 3: born in fresh water, enter salt water, returns to fresh water; 4: in stream; 5: pea-sized; 6: alevin; 7: fry; 8: smolts or fingerlings; 9: silvery; 10: nose or sense of smell; 11: redd; 12: die; 13: by providing food for animals (including people), nutrients to streams, beauty, recreation.)

3. Have students re-examine the life cycle pictures on their desks and make any changes inspired by their reading. Then have them glue the pictures on another piece of paper and place arrows between them depicting the correct order. They might add where each stage occurs. For example, the egg stage occurs in fresh water in a gravel bed.
4. Have students complete the worksheet Salmon Match Game and Salmon Word Search to review terms covered in this and the preceding activity. (Salmon Match Game answers: 1: smolt; 2: redd; 3: spawn; 4: anadromous; 5: plankton; 6: fry; 7: alevin; 8: life cycle; 9: ♂; 10: ♀; 11: fingerling; 12: sockeye; 13: chinook; 14: chum; 15: coho; 16: humpy. Salmon Word Search answers: see page 151.)

Additional Activities:

1. Science: Play "only your nose knows for sure" to illustrate how salmon find their stream by smell. Place several different powerful odors (vanilla, garlic, onion, basil, spruce needles, orange

peel, molasses, tea, coffee) in little jars or cans. Be sure all the containers are the same size and with lids, if possible, to concentrate the smells. Give one container to each group of students. Tell them to close their eyes and sniff, but not discuss what they smell. Then place all the containers, which represent the smells of the different streams, at the front of the classroom. Tell the students that salmon can find their way back by smell. Let's see if the students can. Blindfold and lead them up by groups to see if they can find their "stream"! (Suggested by Bill Hastic, Oregon).

2. Science, Art and Language Arts: Construct a timeline for your area showing when salmon return to local streams. Students may need to question local biologists, fishermen, long-time residents.
3. Art: Make salmon egg paintings. Mix paint by blending fresh or frozen salmon eggs with a little water and crushed charcoal to color the paint. Red ochre also works well to color the paint. Paint designs on paper, rock, or driftwood pieces. (Suggested by Laurie Dumdie, Science Resource Teacher, Anchorage School District.)
4. Math, Science: Have students make bar graphs of local salmon seasons and runs.

Activity 3 Salmon Habitat

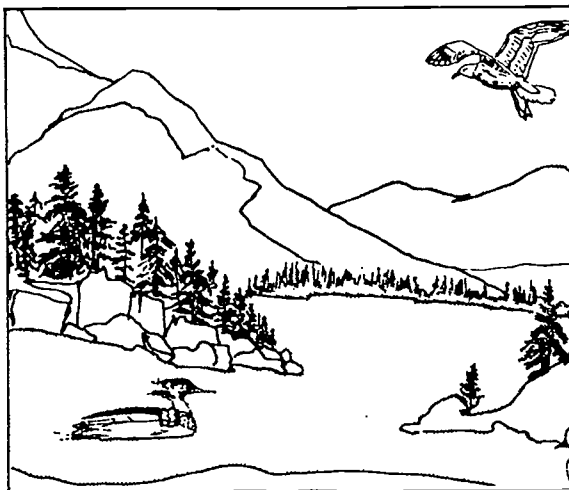

Background:

At each stage in their life cycles, salmon have different habitat needs and face different hazards. Habitat is a place that provides the basic needs of an animal or plant. It's an animal or plant's "home."

Wetlands with their accompanying streams, ponds, lakes, and rivers are important to the early and final stages of a salmon life cycle. In the period between the first and last stages, salmon need salt water and the abundance of smaller food fish found in Alaska's coastal waters. Quality water and habitat is critical to salmon survival.

Vocabulary:

- cover
- wetland
- water quality
- stream bed
- flow
- temperature
- volume
- velocity
- habitat (review)
- plankton (review)

Materials:

- large piece of butcher paper or newsprint
- felt-tip markers or tempera paint and brushes
- paper
- pencils
- map of Alaska
- Salmon Habitat Map (page 152)
- worksheet
...Pink Salmon Game (2J)

Procedure:

1. Divide students into small groups. Have them brainstorm and write down the habitat needs and hazards a salmon faces throughout its life. Have them look at a map of Alaska and sketch a map of the journey their local salmon travel. Students may want to question local residents or biologists to check their predictions of salmon routes.
2. As a class, draw a mural with markers or paints of one of your local salmon streams on a large piece of butcher paper or newsprint. Discuss each habitat need or hazard as it's brought up by your students or you. Mention some of the future hazards salmon in your area may face, as well as hazards and habitat losses in other places. Use the following map and notes to guide your discussion.

SALMON HABITAT NEEDS

- Stream: Eggs, alevin, fry, smolt, and spawning salmon need cool, high quality water with lots of oxygen, and adequate water flow. Bushes and trees along the stream help keep the water cool by

shading the stream and providing places to hide (cover) for fry, smolt, and spawning salmon. The bushes and trees also provide places for insects to live. Some of these fall in the water for fry and smolt to eat. However, most insects the salmon eat are aquatic insects that live in the stream itself. Gravel on the stream bottom provides a place for spawning salmon to lay their eggs. Different types of salmon like different sizes and types of gravel.

- Lake: Red salmon like to spawn in lakes. And the young of several salmon species often feed in shallow lakeshore waters.
- Rivers: Salmon require high quality water to survive. Often, Alaska's rivers are so silty that salmon wait to spawn until they reach the clearwater streams or lakes.
- Marsh and Tundra Wetlands: The soggy spongy grounds surrounding streams, lakes, and rivers help assure that there is enough water for salmon in the waterways because they soak up rain water and release it slowly. In this way, wetlands also help prevent floods, as they have the capability of soaking up water during storms. Wetlands also produce nutrients which they add to the waterways. The nutrients mean that there will be better plankton, plant, and in turn animal growth (like salmon) in the system.
- Estuary: Among wetlands, estuaries are the most pro-

ductive and richest! An estuary is created where a river meets the sea. There, the mixing of the fresh and salt water produces tremendous quantities of nutrients and food for young growing salmon, as well as for other plants and animals. Estuaries probably are our best food producers, yielding even more than the commercial agriculture. And they don't take any human effort, just habitat protection.

- Ocean: The main habitat requirement of ocean salmon is cool, high quality water with adequate oxygen and abundant food.

HABITAT HAZARDS

- Predators: Commercial fishers, subsistence fishermen, and sport fishermen all try to catch salmon. Ducks, seabirds, other fish, gulls and eagles eat some of the smolts. Sharks and toothed whales eat some adult salmon. And gulls and eagles eat the spawners. Gulls also eat salmon eggs. Foxes and bears eat spawning salmon.
 - Towns with their houses, airstrips and factories produce sewage and other pollution that reduce the amount of healthy wetland habitat that normally would contribute to stream flow. Oil and chemicals from garbage, trash and industrial dumps seep into the water. Roads can be especially hard on salmon because roadbanks often erode, sending silt into rivers and streams, covering salmon eggs, and reducing water quality. Also, oil and gasoline can wash from the road into the stream.
- Ocean pollution can affect salmon by poisoning smaller fish that the salmon eat. Also, scientists are concerned that even a tiny amount of oil in the water might impede a salmon's sense of smell, preventing it from finding its home stream.
 - Dams block salmon migration routes. They also change the water quality by raising its temperature (Sun rays heat the greater surface area of the lake impounded by the dam.), and reducing water flow and velocity.
 - Logging, especially if improperly done, can contribute to salmon losses by causing stream erosion. Skidding operations (bulldozers) and logging roads construction can add silt to the stream.
 - Culverts are difficult for salmon to negotiate because of the velocity of culvert water. Also, some culverts are placed too high for salmon to reach without repeated jumping attempts.
 - Float planes and boats with motors can add oil, gasoline, and noise pollution to lakes, rivers, and the sea.
3. Remind students that human communities require some development. However, most of that development--houses, stores, factories, airstrips, logging operations--can be located where they will least damage salmon habitat. Usually it's not one particular development that ruins a

salmon run, but the cumulative effect of many developments.

Ask students:

- How can we help local salmon runs? (By taking no more salmon than we need; by not disturbing salmon in their spawning grounds; by taking care that our motorboat engine is running efficiently so that less oil and gasoline gets into the water; by stepping very carefully when we cross streams.)
- What developments now underway in our area will affect salmon? (Discuss their positive and negative effects.)
- Is there any way these effects can be reduced?
- Is there any way our class can help?

Additional Activities:

1. Science, Language Arts: Have students play the Pink Salmon Game (Worksheet 2J). Students may want to color the game and cover it with clear contact paper, or laminate it. Explain to students that sac fry is another name for alevin and that fingerlings are the same as smolts.
2. Language Arts: Write a story from the viewpoint of a salmon about its journey down or upstream and the dangers it faces in its daily life.
3. Social Studies, Math: Make an overhead transparency of the Ocean Migration of Alaskan Salmon maps included

with this activity. Imagine where your local salmon are going. Discuss the idea that salmon are an international fish. Talk about the number of different nationalities that eat salmon, and some of the ways the United States has been trying to protect Alaskan Fisheries. (See Unit 7, Activity 3 for a description of the 200 mile limit and the Law of the Sea.)

4. Physical Education, Science: Make a salmon journey game in your gym or other large open area. Design a variety of hazards for an obstacle course:

- Erosion: Small piles of dirt or torn brown crepe paper plus four large jars filled one-fourth full with dirt and three-fourths full with water that students can shake and see how cloudy water can become with erosion and how long it takes to filter down.
- Humans obstacles: Fish net, fishing poles, model boats.
- Heat: Heat lamps, registers, yellow construction paper.
- Garbage and toxic wastes: Old tires, bottles, containers, plumbing fixtures, pictures of car batteries, gas, oil, anti-freeze, pesticides.
- Culverts: Chairs with blankets over them or cardboard boxes to crawl through.
- Good salmon habitat: Overhanging boughs, logs to hide behind, good stream water with lots of oxygen and flow made out of blue construction

paper, nearby wetlands made out of sponges, insects, good spawning gravel, pools in which to rest.

- Predators: Students dressed as bears, gulls, eagles.

Swimming is a good activity to include as part of the game. Older students might want to develop the obstacle course for younger students. (The idea for this game comes from the ORCA Curriculum Activity Guide, Life Cycle of the Salmon.)

Ocean Migration of Alaska Salmon Maps

The dashed line on the Red and Chum Ocean Migration Maps shows the ranges of Asian Salmon of those species. Note the overlap!

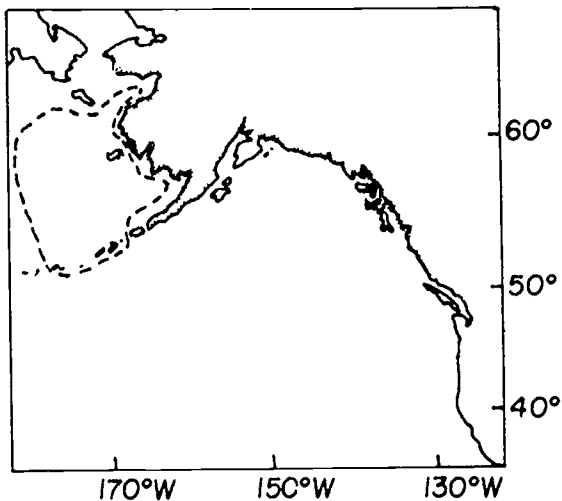

King

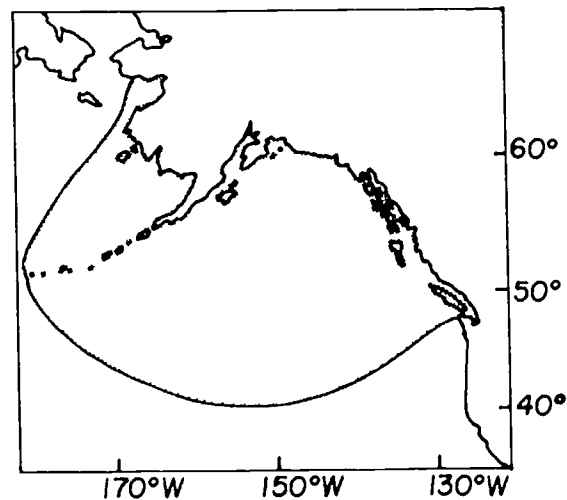

Coho

Red

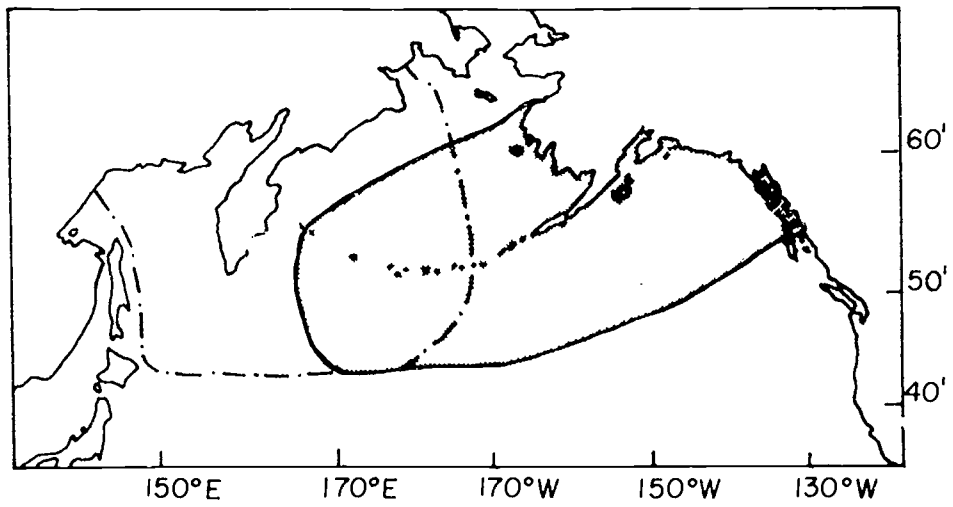

Pink

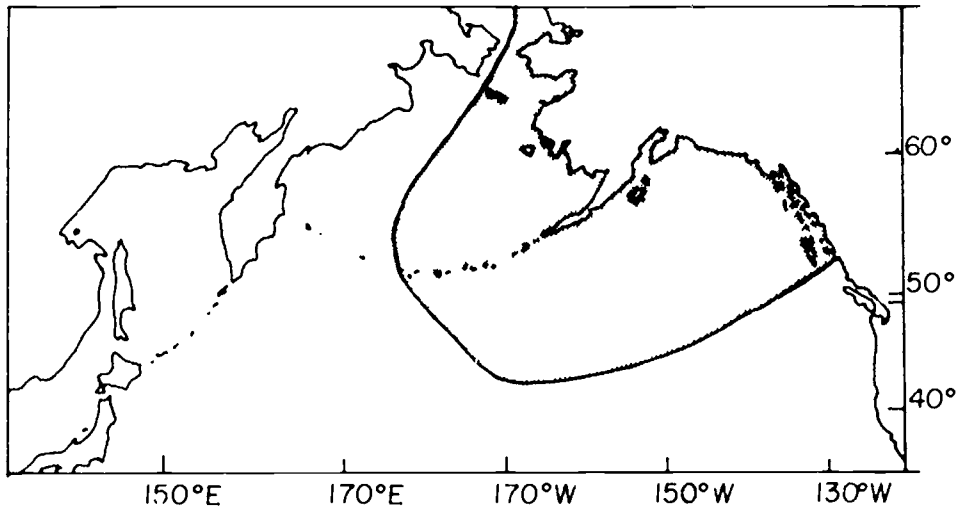

Chum

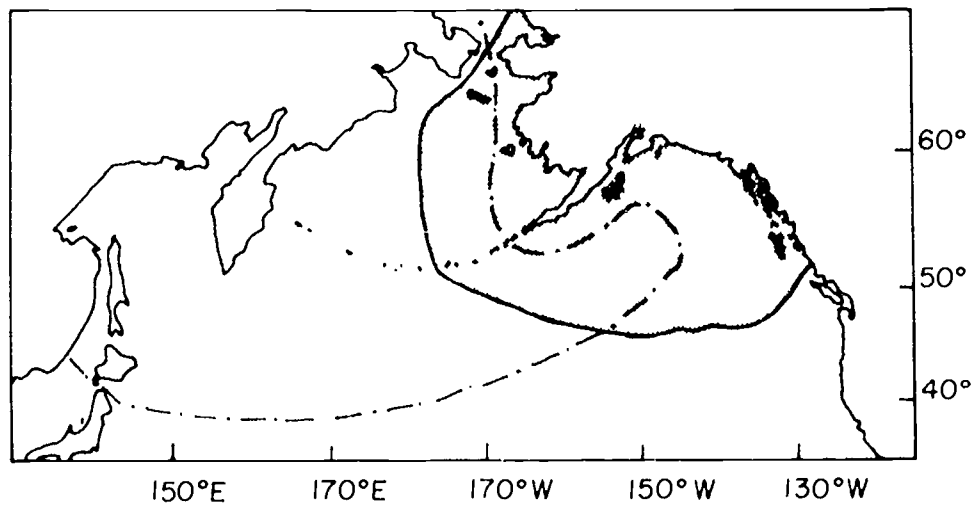

Activity 4 Salmon Survival

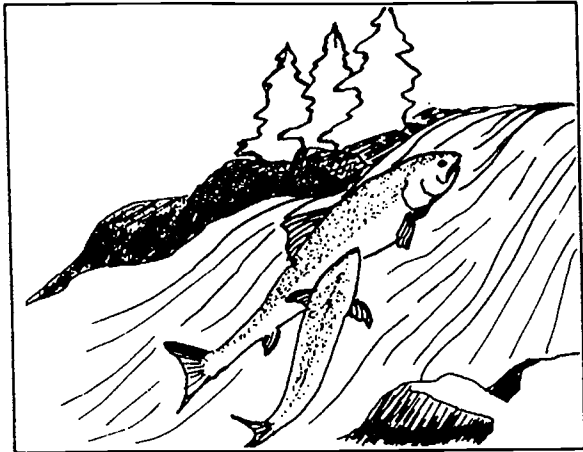

Background:

Biologists use mathematics to predict fish runs and to plan for a "sustained yield" of fish for future generations.

Materials:

- worksheet:
...Only the Strong Survive
(2K)

Procedure:

1. Discuss how biologists plan for the future so there will always be fish to catch and eat. The worksheet Only the Strong Survive illustrates

what happens in just one redd. (Answers: 1=5000; 2=4,500; 3=4,440; 4=3,440; 5=3,140; 6=2,640; 7=2,539; 8=2,339; 9=839; 10=744; 11=188; 12=8; 13=5; 14=5; 15=5.)

2. After your students complete the worksheet, have them figure the number of salmon redds for a whole stream, using a local stream as an example.
3. Discuss various other calamities that might occur in the stream, such as running a bulldozer through the stream right after the salmon spawn; an earthquake; or silt covering the eggs from mining, logging or road construction for a new subdivision. Ask students to list ways they can help care for salmon in nearby streams. By not disturbing salmon in their spawning grounds; by not taking more salmon than needed; by cleaning and taking care of fish right away so they don't spoil; by not wasting salmon served with meals; by not spilling oil or gas into the water; by walking carefully when crossing salmon streams.)

Activity 5 Herring and the Food Web

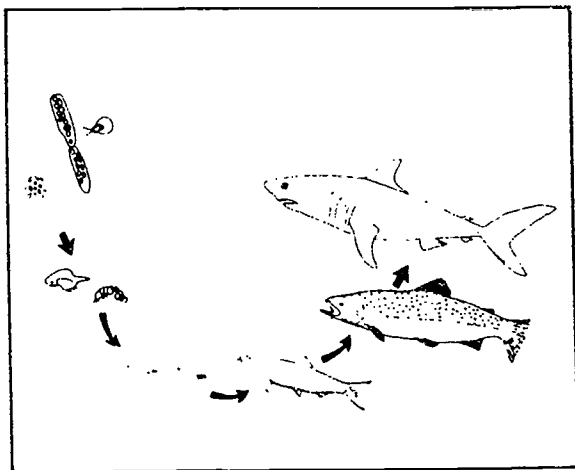

Background:

Every living organism must have food to survive. Large fish feed on smaller fish that feed on smaller fish that feed on smaller fish, and the smallest fish feed on plankton (tiny plants and animals). When animals eat more than one type of food, the food "chain" expands into a food "web."

Nutrients present in sea water are derived from decaying sea plants and animals, and from materials carried to the sea by rivers. The nutrients in the sea become food for seaweeds and for the one-celled, microscopic plants called phytoplankton. Phytoplankton, which often drift abundantly in ocean waters, are food for the microscopic animals called zooplankton, which include the larval forms of many sea animals. Seaweeds, at the same time, serve as food for grazing animals. Each feeding animal is in turn food for another animal. Any animal or plant that is not eaten directly, dies, decays, and becomes food for scavengers or is changed by microorganisms into the nutrients

that will feed succeeding generations of life in the sea.

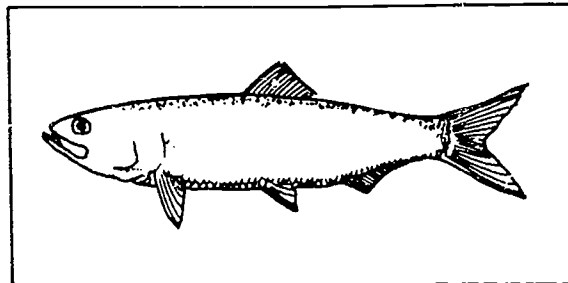

Herring, one of Alaska's important commercial and food fishes, plays an important role in the ocean's food web. In Alaska, hundreds of millions of herring spawn from mid-March to early July. They spawn in early spring in southeast and in June and July in Bristol Bay and Norton Sound. They may spawn as late as August in the Kotzebue area. Females lay from 10,000 to 60,000 eggs per year depending on their size and age. Unlike salmon, herring females spawn year after year and the older females produce more eggs. But 50 to 99 percent of the eggs may be lost because of wave action, exposure at high tide, and predation. Eggs are laid on seaweed, brush, pilings, or rocks in shallow water. The males fertilize them by releasing milt into the water. The eggs hatch after about 10 days into tiny yolk-sac larvae. About two weeks later, the young herring have absorbed their yolk sacs and begin feeding on plankton. At this stage, herring are eaten by jellyfish, amphipods, young salmon, and other small fish. Herring continue their growth in shallow bays and estuaries and by the end of the summer are five inches long. As the fish grow, they eat larger food items. Adults eat crustaceans and a wide variety of small fishes. Adult herring are preyed upon by virtually every animal large enough to eat them: dogfish and other

sharks, salmon, cod, mackeral, squid, seals, sea lions, birds, baleen whales, and man.

Many commercial fisheries have developed around herring. Herring are caught whole for bait, food, or eggs. Their eggs also are harvested after the fish deposit them on seaweed. Herring eggs (roe) in various forms are considered delicacies in Japan. Because herring spawn only over a period of one to two weeks, the harvest can be hectic. Herring are shipped whole to Japan, or the roe is harvested and sent while the carcass is processed into fish meal.

Alaska's Native peoples have harvested and eaten the Pacific herring for perhaps thousands of years.

Southeast Natives still eat herring roe; and villages in western Alaska on the Yukon-Kuskokwim Delta depend heavily on herring as a major subsistence food. About 200,000 pounds are harvested there annually. In northern Europe, the Atlantic herring has served as a basic food fish for people for centuries. In several ancient languages including Norse and Old English, the word "herring" meant "army." In Old English it referred particularly to hordes of Anglo-Saxon invaders. It might be interesting to point out the old definition to students and ask them to compare how vast schools of herring are like an army.

Vocabulary:

- food chain
- food web
- predator
- prey
- phytoplankton
- zooplankton
- herring

- roe
- fish meal

Materials:

- herring to taste
- worksheet:
...What's For Dinner (2L)

Procedure:

1. Introduce the terms "predator" (one who eats other animals) and "prey" (the one eaten). Give an example of a local food chain. Start with something students had for lunch, such as a fish sandwich.

Now have students make that into a food web.

2. Distribute the worksheet What's For Dinner? and have students try to figure out who's eating who. The sun is the powerhouse that runs the whole system.
3. Discuss the role of herring in commercial fisheries and in the food web.

Copy the following diagram on the blackboard:

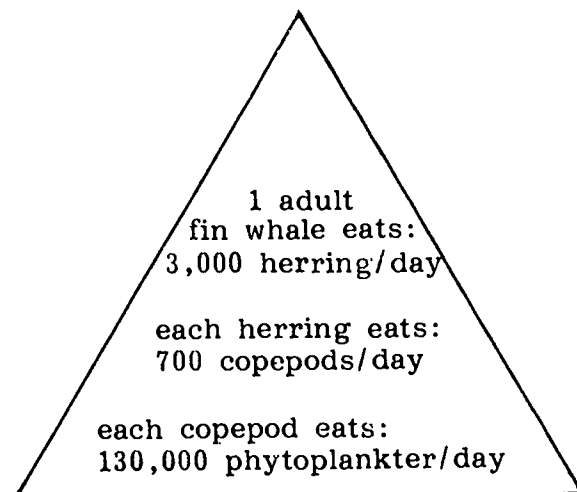

from Pacific Seashores by Thomas Carefoot, 1977, J.J. Douglas Ltd., North Vancouver, Canada.

Discuss the diagram. If students are unfamiliar with copepods, explain that they are tiny crustaceans (animals with jointed appendages and external skeletons like crabs' or shrimps').

Ask a student to consult an encyclopedia or science book for a description of copepods. Phytoplankton, too, can be the subject of student research. Take time to calculate the following:

How many copepods would it take to feed the herring that a fin whale eats in one day?
(2,100,000)

How many phytoplankters per day would be needed to feed those copepods?
(273,000,000,000)

How many herring would be needed to feed 2 fin whales for a week? (42,000)

Ask the students:

- What would happen if herring were overharvested? (Other animals such as whales would be short on food.)
- What would happen if herring were underharvested? (Other animals would have a lot to eat and their populations would increase.)
- Why do we have to be especially careful with overharvesting herring? (Because we're taking eggs which are the future fish.)
- Why might it be hard to know just the right amount of herring to harvest? (No one

knows exactly how many herring are in the ocean. Biologists have to estimate. Also, there are so many people fishing for herring in such a short period, that just one extra hour of fishing might result in too many herring being caught. In some small bays in Alaska the season has been closed after only five minutes of frantic fishing! See Tidelines, Volume III, Number 7, "The Herring Bonanza."

4. Bring smoked, kippered, pickled, dried, fresh or frozen herring for students to cook and taste. Look for herring as cans of kippered herring, or in a variety of styles in the oriental section, or pickled in little jars in the refrigerated meat and fish department. Parents or fishermen might be sources of fresh, smoked, dried, or frozen herring. Japanese restaurants usually will have a variety of herring roe dishes.

Additional Activities:

1. Science, Social Studies: Invite someone involved in the herring fishery to show your class some of his or her gear and talk about what happens in the harvesting process. Native elders might be able to tell the class about herring legends or history and subsistence harvest methods.
2. Art, Science: Make a mobile showing the herring's role in the food chain.

Activity 6 Hide a Halibut

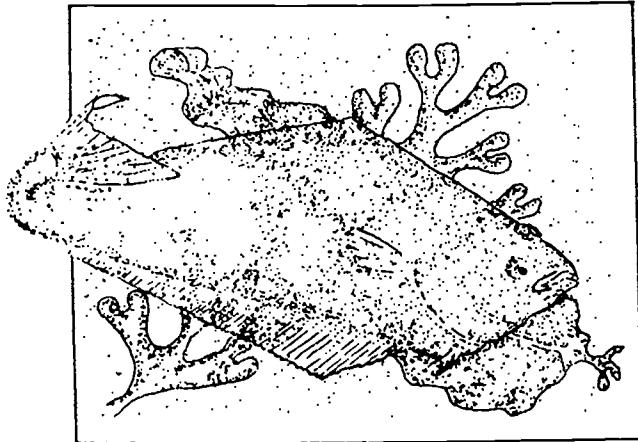

Background:

Students in coastal communities from Ketchikan to St. Lawrence Island may be familiar with halibut, the largest flatfish in the world and one of the best food fishes. The halibut also is a good example of camouflage or protective coloration. Many bottom-dwelling fish, including halibut, can change color patterns on their skins to match those of their surroundings. They also can flick their bodies to toss silt from the ocean floor over their backs to hide. Then they remain motionless, or "freeze," which is an important camouflage ploy. The halibut also has a dark, mottled upper surface to blend into the bottom of the ocean. Its undersurface is white, so that if it is swimming higher in the water column its light-colored belly will be difficult to see against the ocean's surface. A very young halibut is nearly transparent so that its surroundings show through and make it difficult to see.

Vocabulary:

- camouflage

- protective coloration

Materials:

- paper
- watercolors and brushes
- worksheet:
...Halibut, Halibut (2M)

Procedure:

1. Introduce "camouflage," a term meaning "whiff of smoke" and introduced in World War II to describe the technique of making soldiers, tanks, and all kinds of fighting equipment seem to disappear through the use of colors and patterns. Of course, animals have been using these techniques of protective coloration for millions of years!

Ask the students:

- What examples of camouflage can you think of? (Snowshoe hares and ptarmigan change to white in the winter to match the snow; sea anemones look like flowers until their tentacles close around a nearby fish to paralyze it; female ducks are the same colors as the marsh grasses; octopus release clouds of ink.)
 - Have you ever seen an animal "freeze" to blend with its background?
 - Why would an animal want to be a master of camouflage? (To hide from predators or to attract prey.)
2. Pass out the worksheet Halibut, Halibut. Explain that we will be studying a fish that is a master of camouflage. Have students

read and answer the questions. (1: It moves over to the right side; 2: In the ocean waters; 3: Shrimp, young crabs, and other bottom-dwelling animals; 4: false; 5a: almost 9 feet; 5b: 500 lbs; 6: 7-12 years old; 7: 50-100 fathoms; 8: Because many other animals eat them; 9: Other animals have trouble seeing them to eat; 10: Dark above and white below, change colors, motionless, hide in sand on ocean floor, transparent young; 11: \$89.25)

3. Have the students make watercolor paintings of halibut to illustrate some of their camouflage properties.

Display your paintings and invite younger students to see if they can "find the halibut!"

Activity 7 The Amazing Alaska Blackfish

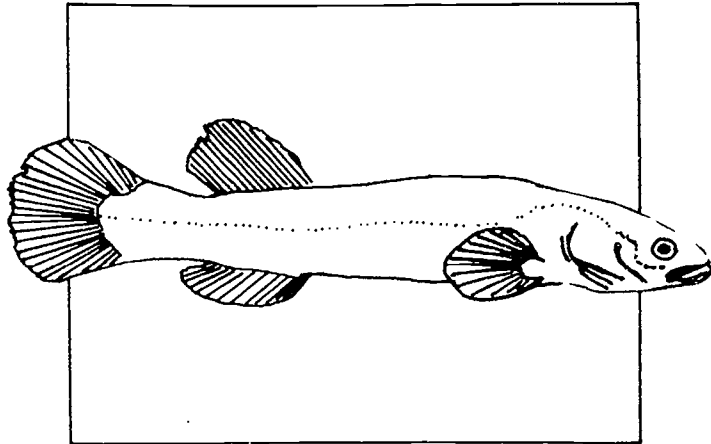

Background:

The Alaska blackfish is a small mud minnow that grows to eight inches. It is a rather sluggish, bottom-dwelling fish, which in winter tends to live in deeper portions of lakes where the oxygen is more abundant. In summer, it moves to heavily vegetated tundra, ponds, streams, rivers and lake edges. The blackfish uses its large pectoral fins to paddle slowly about the vegetation in search of aquatic insects and other small invertebrates. Once it spots something to eat, it captures it with a quick dart, much like the lightning dash of a northern pike.

The blackfish is a Native food in western Alaska. In the early spring, people set traps for these creatures in freshwater ponds, lakes, and sloughs.

The blackfish also is prized as a dog food with a high oil content. Many a musher has poured a gunny sack full of frozen blackfish into a dog pot only to be amazed as the creatures thaw and begin swimming. Children all over western Alaska take them out of

frozen gunny sacks and put them into a glass of water indoors to watch them "come alive." However, experiments have shown that even partial freezing of Alaska blackfish results in eventual death. Frozen tissue means dead tissue.

Alaska blackfish are unique because they have a modified esophagus capable of gas absorption. This means they can exist off atmospheric oxygen! Alaska blackfish thus can live in small stagnant tundra pools that are almost devoid of oxygen and they can survive in moist tundra mosses during extended dry periods while waiting for rain to fill the pools again.

Because of the blackfish's air breathing capabilities, handling and care of them in the classroom is relatively easy. But be sure you get a permit to hold blackfish, or any other native fish, from the Alaska Department of Fish and Game. (The idea for this activity came from Mark Pope, Ambler. Technical information was supplied by Bob Armstrong, associate professor of fisheries, University of Alaska, Fairbanks.)

Vocabulary:

- adaptation

Materials:

- thermometer
- 2 large jars (peanut butter)
- 2 or more live blackfish
- damp moss
- large deep container (dish pan)
- live bugs
- chunks of meat, fish, bread, etc.

Procedure:

1. Obtain at least two blackfish. A funnel-shaped trap can be made from strips of tamarack, spruce or small mesh galvanized hardware cloth. Local residents may be glad to give you a couple blackfish or show you how to make a trap. In early spring, the trap can be placed around holes in lake ice where blackfish come up to breath because oxygen often becomes depleted there in late winter. Blackfish can also be easily caught in spring and fall as they migrate to and from their summer habitats, by placing the traps in narrow sloughs or stream channels.
2. Place each blackfish in a wide-mouthed jar of cold water. Then prepare a tundra model by placing at least four inches of moist moss in a deep container such as a dish pan. Tell the students that the moss and the jars of water represent tundra habitat. Ask the students how they think blackfish have adapted to life on the tundra. Explain that blackfish can breathe atmospheric oxygen because they have a modified esophagus that can absorb oxygen! The blackfish's airbreathing ability can be demonstrated by taking the fish out of the water and placing it in the moist moss for an hour. Both the moss and the water in the jars should be kept cool, and approximately the same temperature. Cold water holds more oxygen and cool temperatures slow down respiration. Blackfish are air breathers

but there are limits to everything! (Be sure students wet their hands before touching the blackfish so they do not disturb its protective layer of mucus. Explain the importance of being quiet and making slow movements when working with animals so that they are not stressed unnecessarily. Since this is a scientific experiment, students should handle the fish in the jar (the control) an equal amount of time. Then leave both fish to rest quietly.)

3. At the end of the hour, put the fish on the moss back in the water. What differences do the students notice between the two fish? What survival advantages do the blackfish have because of this adaptation?
4. Later, after the excitement subsides, have students try feeding the blackfish with crumbs, bits of meat or any other food that doesn't squirm. The fish probably won't sample it.
5. Now have students offer the blackfish small live insects. If the fish are hungry, they'll eat; if they don't, try again later. When they eat the insects, ask students why they ate the live food instead of the "dead" food. (You may want to try feeding the "dead" food again at that point.)
6. Discuss the basic requirements of blackfish. Like any animal, they need food, water and cover. Keep daily records of blackfish observations by your students.

Change the water and feed them once a day. Drop ice chunks into the water to keep it cool, especially if your classroom temperature is in the 70-80° range. Cold water holds more oxygen. Alternatively, set up an aquarium and aerator. Release the blackfish when your observations are completed. Students may be interested in being able to tell males from females. Mature males can be distinguished from females by a reddish fringe along the dorsal, caudal, and anal fins. Also, in mature males, the tips of the pelvic fins extend well beyond the front of the anal fin, whereas in females, they do not.

Blackfish Experiment

Object:
To verify an investigation described by Belle Mickelson of the Alaska Sea Grant College Program, wherein a blackfish is kept in a damp moss environment instead of water.

Hypothesis:
A blackfish should be capable of surviving a damp moss environment without water by virtue of its esophagus being able to absorb atmospheric oxygen rather than being solely dependent upon its gills.

Method:
Moss was soaked in water and shaken dry and placed in coffee cans or 500-ml beakers. A live healthy blackfish was removed from water at room temperature (60-70 degrees F) and placed in the moss. A thermometer was inserted through a loose fitting cover and the arrangement was left in a quiet place for one hour. Afterwards the entire contents of the container were dumped into an aquarium and the condition of the blackfish was observed.

Conclusion:
The information is largely subjective as only temperature measurements were taken.
In six specific trials all blackfish survived regardless of temperature and no difference in the trials could be discerned in temperatures ranging from 40° to 70°.
It appears the behavior of the blackfish may be as significant as the physiology. In all cases the blackfish thrashed about periodically in convulsive type of activity until they reached the lowest layers of the moss, and in most cases worked their way completely below the moss to rest at the bottom of the container. After one hour all fish remained still with the mouth closed.
Recovery in some cases was very slow. A fish would remain motionless for some time when returned to the aquarium and not swim for several hours afterward. All fish were stable and did not belly-up.

Mike Stichick 4-14-83
Mike Stichick

Here's the blackfish experiment as

actually conducted by Bethel-Kilbuck science teacher Mike Stichick. You might want to use it as a model and have your own class record its observations and write a similar "scientific report" of the experiment.

Additional Activities:

1. History: Have a village elder show your class how to make a wooden blackfish trap. Then try making your own.
2. Language Arts, Home Economics: Collect and try some blackfish recipes.
3. Science: Weigh a dead blackfish, then cut it into pieces and boil them in water. Wait 10 minutes, then ask students

what they see floating on top of the water (Oil). Skim off the oil and weigh it. What percentage of the blackfish is oil? Might this be a key to their success in the cold?

4. Science: Conduct yarn tagging experiments with the assistance of the Alaska Department of Fish and Game. Insert different colored yarn in the dorsal fin, depending on which local body of water the blackfish were captured. Then release them in the same water and see if they are recaptured in any other places. Note time, date, size, place and when captured. (Activity suggested by Mike Stichick, Bethel-Kilbuck Elementary.)

Activity 8 Freshwater Fish Card Game

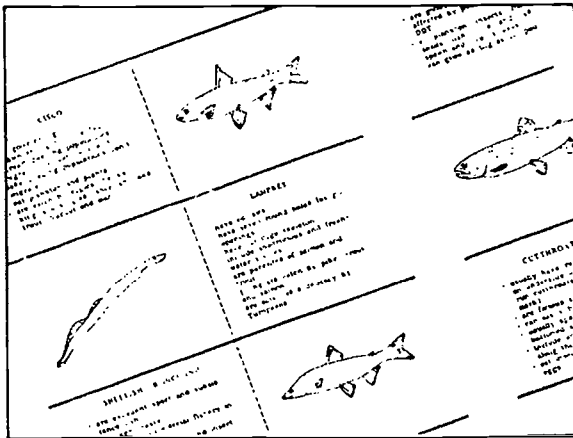

Background:

Alaska's uncounted lakes and ponds and thousands of miles of rivers and streams are home to incredible numbers of fish. Salmon are perhaps the most famous, but those species are covered in other activities in this unit. For this activity, we'll concentrate on the many other freshwater and estuarine varieties. A good reference for this activity is James Morrow's The Freshwater Fishes of Alaska.

Vocabulary:

- circumpolar
- lamprey
- sheefish
- inconnu
- cisco
- dolly varden
- grayling
- eulachon
- hooligan
- sucker
- pike
- burbot
- tomcod
- stickleback
- sculpin
- flounder
- sturgeon

Materials:

- copies of freshwater fish cards (4 per each group of 4-6 students)
- scissors
- glue
- contact paper or laminator
- person knowledgeable about local freshwater fish

Procedure:

1. Make up sets of freshwater fish cards before class time or have students help put them together. Copy four sets for each group of four to six students. Pick two of the species to color red. Each of those cards will be worth extra points. Cut and fold the cards so the fish appears on one side, its description on the other. Laminate or glue.
2. Shuffle the cards and you're ready to play the freshwater fish card game. Explain to students that this is a game to test their observational powers and memories, as well as a chance to learn about freshwater fish. Lay the deck fish-side up. Before the game starts, have individual students decide at which level they want to play the game.

Beginning fishermen can simply pick up the card, read aloud its name and one "fish fact," and keep the card.

Intermediate fishermen get to keep the card only if they can tell the name of the fish. If they miss, that card goes to the bottom of the deck. If they're right, they read aloud

one "fish fact" before the next player takes a turn.

Super fishermen get to keep the card only if they can name the fish plus tell three interesting facts about the fish. If they miss, that card goes to the bottom of the deck.

Students can advance to higher levels as they become more proficient. After all the cards are picked up, have each student count his number of cards. Beginning fishers get one point per card; intermediate fishers get two points per card; and super fishers get three points per card. Add two points for each red fish. Have students total their points to determine the winner, and try the game again.

3. Invite a person knowledgeable about local freshwater fish to come to your class and tell you more about the fish in your area. Check with village elders, the bilingual staff, biologists, local fishermen. Amaze them with what you know and ask any questions you've been saving.

Additional Activities:

1. Science, Language Arts: Have students research and report on local freshwater fish. These are the names, species and ranges of those found on the cards.
 - Arctic Lamprey, Lampetra japonica: Kenai Peninsula north along the western coast and all along the northern

coast and up to Yukon River into Canada.

- Sheefish, Inconnu, Stenodus leucichthys: Kuskokwim, Yukon, Selawik, Kobuk, and lower reaches of the Koyukuk and Tanana Rivers.
- Least Cisco, Coregonus sardinella: Streams and lakes north of the Alaska Range, and from Bristol Bay to the Arctic coast. Also in the Kuskokwim and Yukon drainages.
- Round Whitefish, Prosopium cylindraceum: Throughout mainland Alaska from the Taku River, near Juneau, to the arctic coast.
- Humpback Whitefish, Coregonus clupeaformis: Northern and western coastal Alaska and Yukon River drainages.
- Cutthroat Trout, Salmo clarki: From the northern parts of Prince William Sound down through Southeast Alaska.
- Rainbow Trout, Salmo gairdneri: Throughout Southeast Alaska north to the Kuskokwim River and West to Port Moeller on the Alaska Peninsula.
- Lake Char, Salvelinus namaycush: From the Alaska Peninsula north and east into Canada and down to northern Southeast Alaska.
- Arctic Grayling, Thymallus arcticus: Throughout Alaska except the Aleutians and southeast islands.
- Dolly Varden, Salvelinus malma: Throughout Alaska.

- Eulachon, Thaleichthys pacificus: From the Southeast coast north to Bristol Bay and west to the Pribilof Islands.
 - Alaska Blackfish, Dallia pectoralis: From the Colville River Delta on the arctic coast west and south to the central Alaska Peninsula near Chignik. In the Yukon-Tanana drainage to around Fairbanks and on Nunivak and St. Lawrence Islands.
 - Northern Pike, Esox lucius: Northern, western and interior Alaska.
 - Longnose Sucker, Catostomus catostomus: Throughout Alaska except southeast Alaska islands, Aleutian Islands, and islands in the Bering Sea.
 - Burbot, Lota lota: Throughout Alaska except Southeast, Aleutians and Bering Sea Islands.
 - Saffron Cod, Eleginus gracilis: North Pacific Ocean and Bering and Chukchi Seas, plus along coast down to Sitka and north to Kotzebue plus sometimes enters rivers.
 - Ninespine Stickleback, Panoptilus pungitius: Northern and western coastal Alaska (the three spine stickleback is found in southern and southeastern coastal Alaska, plus some western areas, and both types are found on St. Lawrence Island).
 - Slimy Sculpin, Cottus cognatus: Throughout Alaska except for the Aleutians and southern Southeast Alaska.
 - Starry Flounder, Platichthys stellatus: Throughout coastal Alaska except for the Aleutians.
 - White Sturgeon, Acipenser transmontanus: In rivers, estuaries, and the sea in Southeast Alaska north along the Gulf of Alaska.
2. Language Arts, Science: Encourage students to make up their own freshwater fish game, everything from tag, relays, and quizzes to board games.

Freshwater Fish Cards

CISCO

- are good eating.
- spawn at night in the fall.
- stream-dwelling populations migrate upstream to spawn.
- lake-dwelling populations don't migrate.
- eat plankton and plants.
- are eaten by eagles, hawks, kingfishers, pike, sheefish, lake trout, burbot and man.

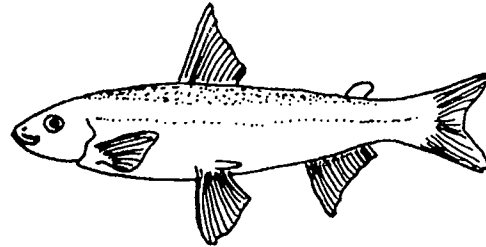

LAMPREY

- have no jaws.
- have seven round holes for gill openings.
- have cartilage skeleton.
- include anadromous and freshwater species.
- are parasites of salmon and trout.
- young are eaten by pike, trout, and salmon.
- are eaten as a delicacy by Europeans.

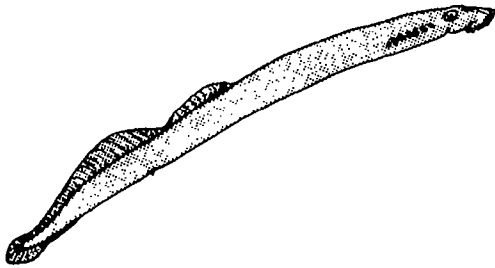

SHEEFISH OR INCONNU

- are excellent sport and subsistence fish.
- are very tasty.
- support a commercial fishery in Kotzebue.
- young eat plankton and insect larvae.
- adults eat other fish.
- usually winter in lower rivers and estuaries.
- slowly move upstream to clear waters beginning in the spring.
- spawn in the fall.

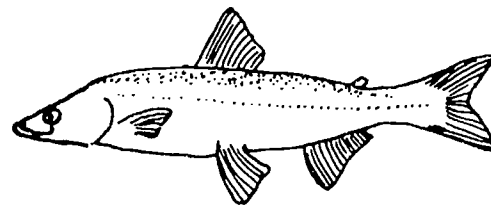

LAKE CHAR

- are good, but eating easily affected by pollution such as DDT.
- eat plankton, insects, clams, snails, fish, mice, and algae.
- spawn and live in lakes.
- can grow as big as 100 pounds!

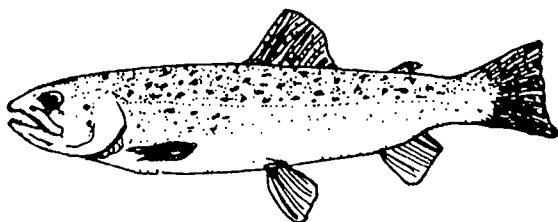
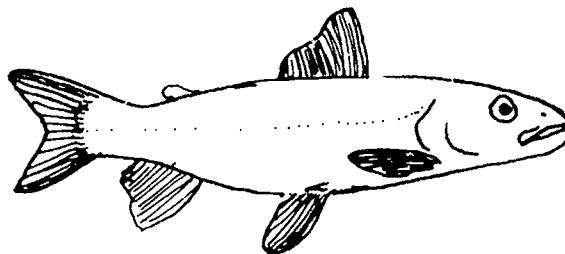

RAINBOW TROUT

- have a reddish band along each side.
- are called steelhead if they migrate to sea.
- are very important sport fish.
- like cold water.
- include stream-dwellers that do not migrate to sea.
- include lake-dwellers that migrate to streams to spawn.
- migrate at night.

CUTTHROAT TROUT

- usually have red or orange mark on underside of each jaw (sea-run cutthroats often lack this mark).
- are famous sport fish.
- can easily be overfished.
- usually spawn in small, gravel-bottomed streams.
- include anadromous populations along the coast.
- eat insects, young fish and eggs.

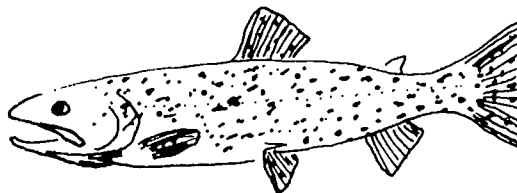

ALASKA BLACKFISH

- have rounded tails.
- live in small muddy ponds and quiet streams with lots of vegetation.
- are subsistence food for both people and dogs.
- can live off atmospheric oxygen.
- as adults eat insects, small fishes and invertebrates.

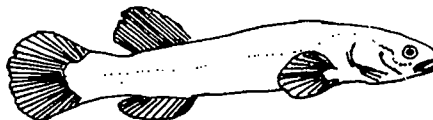

NORTHERN PIKE

- have sharp teeth and long, flat snout (nose).
- are delicious eating.
- have a circumpolar range.
- winter in deep water of lakes and rivers.
- spawn in marsh areas in the spring.
- as adults eat mostly fish, but also ducklings, frogs, mice, insects.



LONG NOSE SUCKERS

- feed by sucking up insect larvae and other invertebrates on stream or lake bottoms.
- are important as dog food in some areas.
- supposedly eat many eggs of other fish but damage is probably greatly exaggerated.
- most commonly eat whitefish eggs which are spread over the bottom (Whitefish do not build redds.).

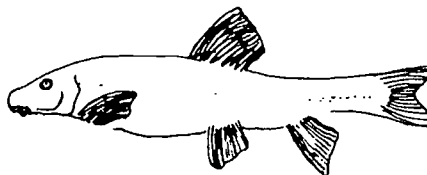

ARCTIC GRAYLING

- have huge dorsal fins.
- have small mouths.
- are famous sport fish.
- are subsistence fish in some areas.
- spawn in spring after breakup.
- eat insects.
- establish territories for feeding (biggest and strongest fish take the best feeding spots).

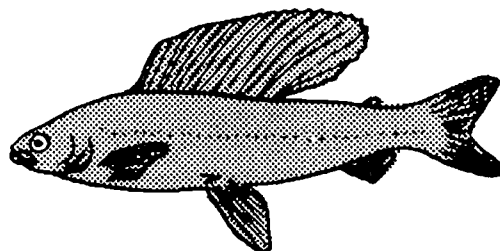

DOLLY VARDEN

- have light pink spots on a dark background.
- are a type of char (not trout) and are very similar to the arctic char found in northern and southwest Alaska.
- include some anadromous populations.
- are important sport fish.
- used to have a reputation for being serious predators on salmon eggs and young salmon. Now biologists are finding that's not so.

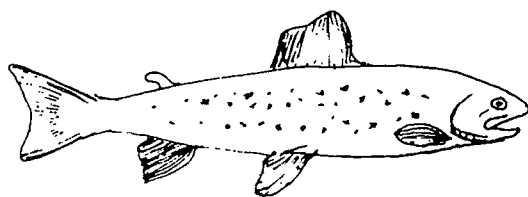

HUMPBACK WHITEFISH

- are important subsistence fish.
- usually are anadromous.
- move upstream to spawn.
- young eat plankton.
- adults eat clams, crabs, shrimp, and midge larvae.

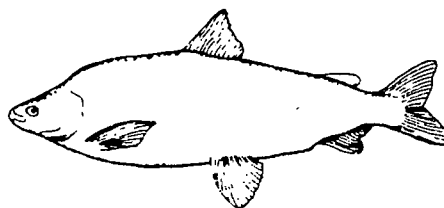

BURBOT

- also are called lush or fresh-water cod.
- are excellent food fish.
- liver is prized in Europe.
- liver contains lots of vitamins A and D.
- often are caught by ice fishing in the winter.
- range is circumpolar.
- have a large head.
- young eat mostly insect larvae.
- adults eat mostly fish.
- spawn in the winter at night under the ice.

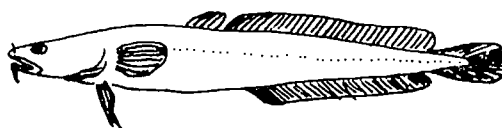

SAFFRON COD

- also are called tomcod.
- are mainly saltwater fish, but ranges upstream in coastal rivers.
- have large head, barbel hanging from chin.
- are important subsistence food fish for animals in arctic seas, as well as people.
- liver are very high in vitamins A and D.
- are caught commercially in Siberia.

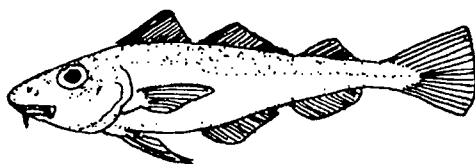

STARRY FLOUNDER

- are bottom-dwellers.
- have both eyes on same side of their heads.
- fins have dark and light bars.
- live in salt water as well as brackish water and may head upriver into fresh water.
- are excellent eating.
- may have color and eyes on either right or left side.
- can change color to match the ocean or river bottom.

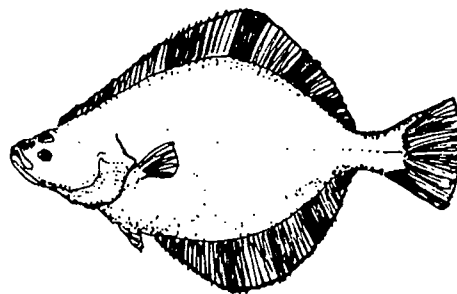

WHITE STURGEON

- bodies have five rows of large bony plates.
- are anadromous.
- begin upstream spawning migrations in the spring.
- favorite foods are culachon and lamprey.
- flesh is delicious fresh or smoked.
- eggs make excellent cavier.
- size includes one that weighed more than 1,300 pounds when caught.
- could be the Lake Iliamna monster.

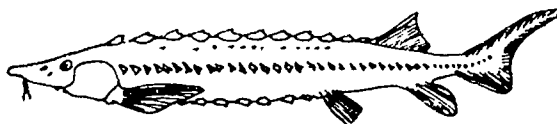

ROUND WHITEFISH

- are important subsistence fish.
- are very good smoked.
- are found throughout mainland Alaska and from Juneau north to the arctic coast.
- spawn in the fall, after migrating upstream or inshore in lakes.
- eat various insects and in some places, lake trout eggs.

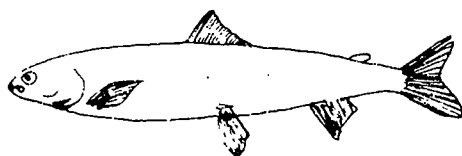

EULACHON

- also are called hooligan, ooligan, or candlefish.
- have a very high fat content, so that when dried they can be burned directly or with the addition of a wick.
- are very tasty.
- are anadromous.
- migrate into freshwater streams in the spring to spawn.
- sometimes migrate in such large numbers that they can be scooped out of rivers with hand nets. Gulls and eagles enjoy the feast too and congregate in great numbers to eat hooligan.

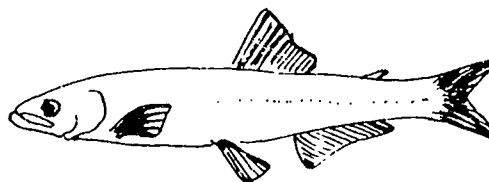

STICKLEBACK

- also are called needlefish or pinfish.
- include two species in Alaska: one species has three spines; the other has nine spines.
- are an important food of larger fishes and birds.
- sometimes compete with young salmon for food.
- can lock spines upright to prevent predators from swallowing them.
- males' breasts turn bright red orange when spawning.
- males build a nest, attract a female, and raise the young by themselves!

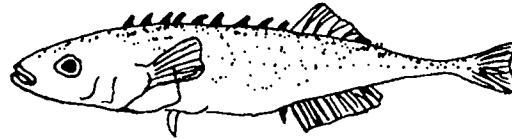

SLIMY SCULPIN

- are bottom-dwelling fish.
- have large head.
- have many spines.
- are mostly marine, but this is a freshwater species.
- include at least one sculpin species has a natural antifreeze in its blood to help survive life in cold waters.
- eat mainly insects.
- sometimes eat or compete with salmon fry.
- males "bark" at each other by rapidly opening and closing their mouths.
- males often fight to the finish in defense of their territories.
- males guard eggs and "fan" them with their large pectoral fins.

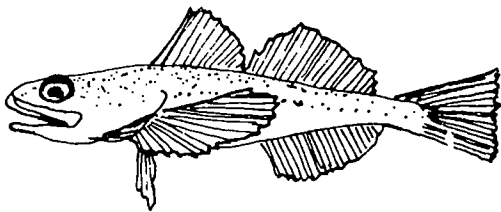

Activity 9 Design a Fish

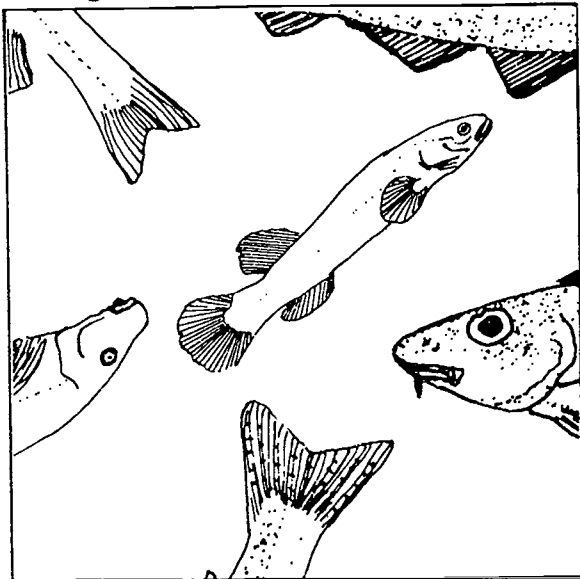

Vocabulary:

- adaptation (review)

Materials:

- paper
- pencil
- colored tissue paper
- old newspaper or scrap paper for stuffing
- glue
- scissors
- felt-tip markers
- yarn or string

Procedure:

1. Have students create their own fish, adapted to a real or imaginary habitat. Have them first sketch their fish on paper and tell:

- how it gets its food
- what it eats
- what eats it
- where it lives
- how it gets oxygen
- how it moves in the water
- where it hides
- what its purpose is in life

Encourage everyone to use imagination.

2. Have students make a tissue paper model of their fish by cutting the paper to the right size, then gluing three of the sides. After it dries, stuff the model with paper. Glue the last edge. Use felt-tip pens to add eyes and designs. Then tie yarn or string through the dorsal fins (or the tops of the fish) and hang them from the ceiling for a real fantasy fish world!
3. Have each student show his creation to the rest of the class, and tell about its wonderful adaptations.

Unit Three

Fish in the Field

Index

Activity 1: Mapping Your Watershed	57	Worksheets: Lake Checklist	3C
Activity 2: Stream Field Trip.....	60	Lake Transect	3D
Worksheets: Stream Checklist	3A	Activity 4: Data Analysis and Report Writing	67
Stream Transect.....	3B	Worksheets: Stream Data.....	3E
Activity 3: Lake Field Trip..	63	Lake Data.....	3F

Objectives:

To help students:

- Map their own watershed (Activity 1).
- Diagram the hydrologic cycle (what happens when it rains!) (Activity 1)
- Explore the fish, wildlife and vegetation of a local stream (Activity 2)
- Measure stream flow and temperatures (Activity 2).
- Observe aquatic insects (Activity 3).
- Describe a stream bottom (Activity 2).
- Map pools and riffles and stream direction (Activity 2).
- Explore the fish, wildlife, and vegetation of a local lake (Activity 3).
- Measure lake density and temperature (Activity 3).
- Describe a lake bottom (Activity 3).
- Sample a lake plankton (Activity 3).
- Map a lake's major features (Activity 3).
- Analyze data collected on field trips (Activity 4).
- Write a report on the stream or lake study (Activity 4).

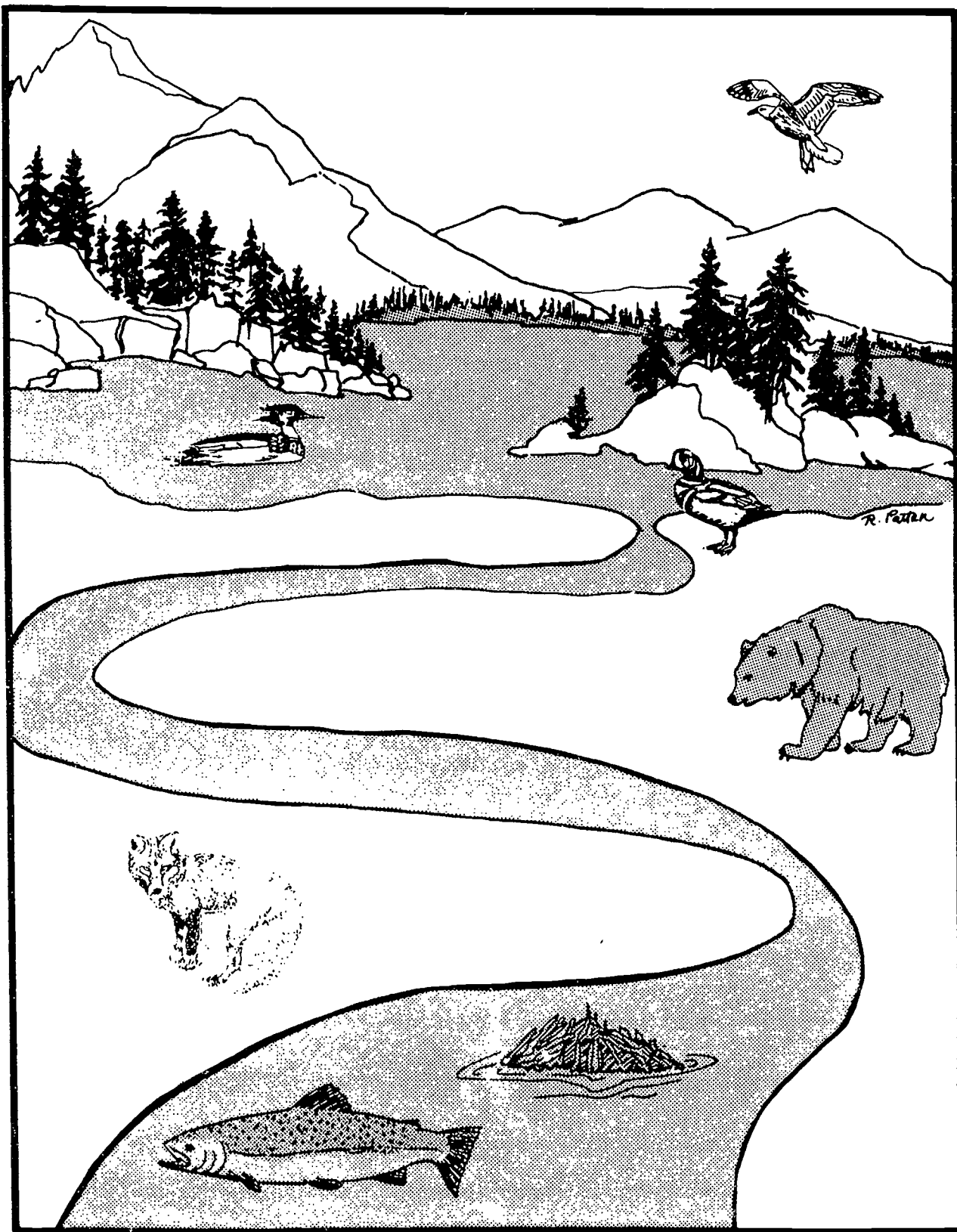

Unit Three: The spawning of salmon into freshwater streams sometimes involves a migration of hundreds of miles from the ocean.

Activity 1 Mapping Your Watershed

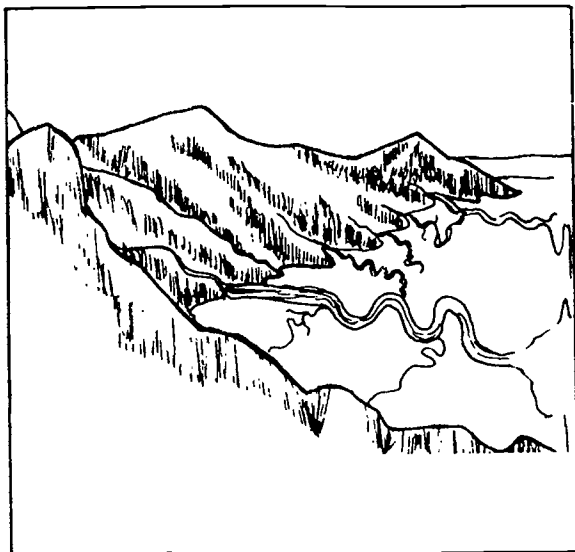

Background:

Fish live in watersheds. A watershed is the region from which a stream or lake receives its supply of water; all the land that carries rainfall to the same river system.

Biologists are beginning to realize that 95 percent of what happens to a stream occurs outside its banks. To study fish habitat, it's necessary to look at everything happening in the watershed. The concept of watershed is particularly hard to understand, because so much is underground and out-of-sight in a series of underground rivers, streams, and reservoirs.

Vocabulary:

- watershed
- evaporation
- contour
- saturation
- hydrologic water cycle
- topography
- headwaters
- drainage
- tributary

Materials:

- large sheet of butcher paper
- felt-tip markers
- sponges
- water
- measuring cups
- flat pans with edges to hold water
- small and large pieces of plastic or plastic bags
- heat lamp or hot room
- tape or string
- local topographic maps
- paper
- pencils

Procedure:

1. Introduce the term watershed as the area drained by a river or stream. Draw a picture on the board. Rain falling on the stream's side of the mountain goes down and is drained off by the stream. Drainage is a term used to describe the course the stream follows. The watersheds of several streams join to make up the watershed of a river.
2. Show students a topographic map that shows the area surrounding one of your local rivers or streams. Any large-scale map will suffice, but it's better to have one that shows the contours. Have students trace all the streams that go into the river. Each contour line is drawn at a specific elevation. For instance, the 100-foot contour line means that everywhere along that line the elevation is 100 feet. The area where the stream or river begins is called the headwaters. Streams that form the river are called tributaries.

3. Have students draw their local watershed on a large sheet of butcher paper with felt-tip markers. Add features such as the site of your town or village, cabins, fish camps, roads, dams.

4. Show students how a watershed works by pouring measured amounts of water (rain) on sponges (the land) in a pan (bedrock or permafrost). Tilt the pan on its side and poke a hole (the stream) in the bottom of the lower edge, so students will get an even more realistic picture of a watershed. Now try several experiments:

a. What happens if it rains

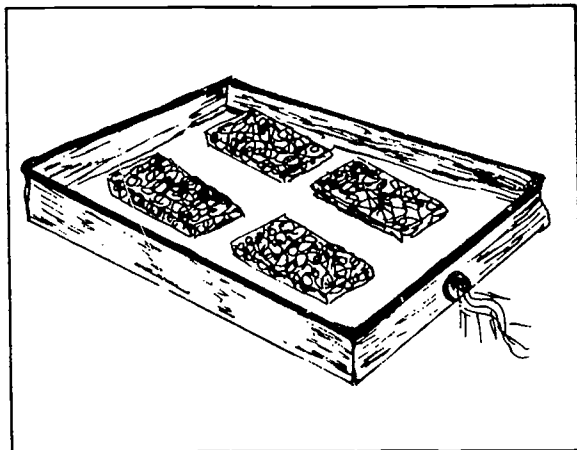

just a little? (Pour a little measured amount of water on the "land." The sponges soak it up. This is a very good analogy for Alaska--as most of Alaska is wetland--soggy, spongy ground that just soaks up the water when it rains or snows and slowly releases it later.)

b. What happens when it rains a little more? (The watershed continues

to soak up the water. Now cover your whole pan with a large piece of plastic bag. Tape or tie it strongly around the pan. The bag represents the earth's atmosphere.)

c. What happens when the sun comes out? (Use a heat lamp or leave the pan overnight in a hot room. You should see droplets of water forming on the underside of the plastic. The water slowly evaporates from the "land." Eventually the droplets form clouds and under the right conditions rain again. This is called the hydrologic cycle which means that water is never lost, but it just keeps changing form.

d. What happens when it rains a lot? (Better do this part over the sink! Take off the plastic bag and slowly pour a greater measured amount of water on the "land." At first the land soaks up the water but eventually it floods. Note the measurement at which it first starts to flood.)

e. What happens when people disturb the watershed by building on top of it? (Cover some of the sponges with a piece of plastic or plastic bag to illustrate that when you build a house or pave a parking lot, the water doesn't have a chance to soak in. Pour

water on the watershed and see how much water it takes to flood it this time.

5. Have students draw pictures of what's happening on the watershed. They should show the hydrologic cycle, plus local events that are affecting the watershed. What happens in the headwaters is important downstream. Undisturbed headwaters mean a steady, constant supply of water instead of floods and dry spells. Wetlands along the banks of

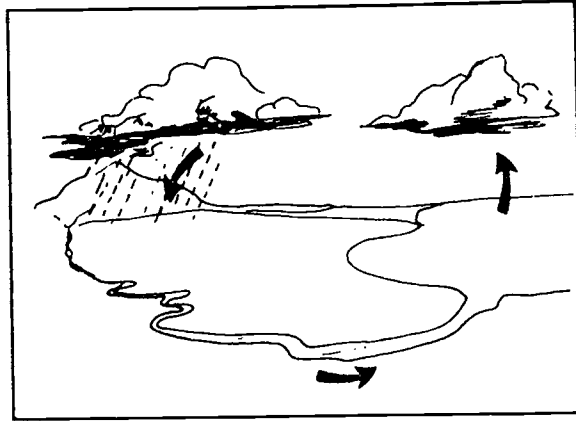

streams and rivers help assure this steady, constant supply of water for drinking, cooking, washing, transportation and fish habitat.

Activity 2 Stream Field Trip

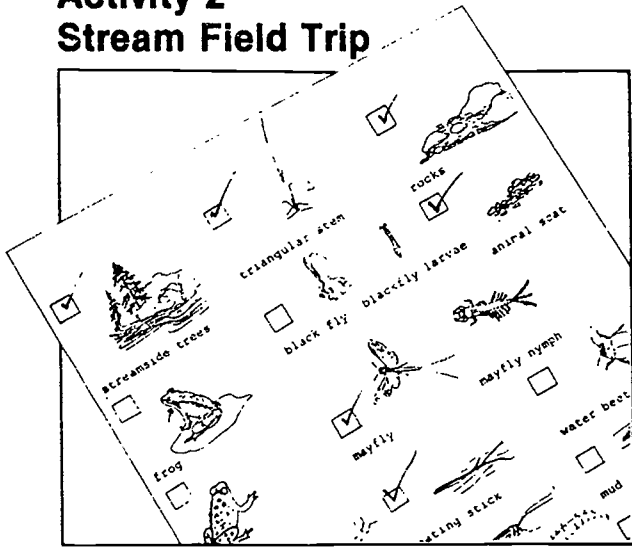

Background:

Streams and rivers are places to explore. The moving water and streamside vegetation provide habitat for an array of fish and wildlife.

Vocabulary:

- riffle
- pool
- current
- meander
- velocity
- flow
- aquatic
- transect

Materials:

- maps, charts, aerial photos of your area
- flagging tape or colored streamers
- pencils
- magnifying lenses
- binoculars
- stop watch or watch that marks seconds
- thermometers
- yardsticks
- 100-foot measuring tape

- sampling screens
- white enamel pan or pie pan painted white
- litterbag
- local resource person
- field guides
- snack or lunch
- worksheets:
 - ...Stream Checklist (3A)
 - ...Stream Transect (3B)

Procedure:

1. Select a local stream (or river) for your field trip. Look at maps, charts, and aerial photos of your area. Pick one that has fish plus easy access. Local resource people (fisheries biologists, village elders, fishermen) may be able to help, or even offer to go along.
2. Plan your stream visit to include:
 - a. structured learning
 - b. summary or review
 - c. litter pickup and snack or lunch

The Stream Checklist worksheet can be used initially or in conjunction with the Stream Transect worksheet. You may also want students to work on language arts or art projects. The summary can take the form of every student (and adult) telling what they liked or learned that day. Litter pickup can be slightly modified to take on a stream or fish theme, i.e., pile filled litter bags in fish shapes.

3. Send home transportation and permission slips and invite parents to participate as group leaders. High school students can be group leaders

if they are well prepared. If possible, meet in advance with your group leaders. Visit the site and designate 100-foot sections of stream for each group to investigate. Mark the sections with flagging tape or colored streamers.

4. Get equipment together for the trip. Each group should have a thermometer, watch, yardstick, litterbag, magnifying lenses, pencils and copies of the two worksheets. Students may also want to make sampling screens and paint pie pans white for aquatic insect investigations. Go over the checklist, eliminating or adding animals to typify your area.
5. Prepare your students. You might want to do a "dry run" in which students wear rubber boots and bring rain gear and warm clothes. Show students the aerial photos, maps and charts. Lay out a model stream on the classroom floor. Explain to students that they will be doing a scientific study of the stream and later writing a scientific report about their findings. Divide students into teams of four to six, and have each team survey a 10-foot section of the stream with the Stream Transect worksheet. Explain to students that is a transect a section of a particular habitat. They will be looking closely at one part of a stream; and by doing so, they will have a better idea of what the entire stream is like. Then preview the rest of the worksheet.

Location of transect: When biolo-

gists do studies like this one, it's very important that they know where they are so that they can go back another time to see if any changes have occurred.

Temperature: Have students practice using the thermometers. Can they predict the temperatures of their streambank, water, and air?

Stream bottom type: Ask students why the bottom is important. (Because that's where fish often feed and usually spawn. Some types of fish will spawn only where the gravel is a certain size. Other fish like a muddier bottom. Some aquatic insects will live only on certain types of stream bottoms. Students should write down what the bottom is like--sandy, muddy, small gravel, rock.)

Average stream depth and width: Students can use their yard sticks or meter sticks.

Fish species, size, and numbers: Because fish are under water, it's sometimes difficult to tell what kind they are; but students should do the best they can. Quietness at the bank of the stream is important to keep from frightening the fish. If a fisheries biologist or someone with a fish collecting permit is along, your class may be able to use seines, dipnets, or minnow traps to show the students what is in the stream. Students might also try dropping salmon eggs or bread crumbs quietly on the surface of a stream pool and see if any fish arrive to feed. Another possibility is sport fishing. How long does it take your students to catch a fish? What lures or baits work best? (Be sure to comply with sport fishing regulations.)

Aquatic insects: By drawing pictures of what they find, students may be able to identify the insects later. There is a good section on aquatic insects in Volume III of the Sea Week Curriculum Guide series. Look under rocks and sticks for the insects but be sure to put them back so their homes are disturbed as little as possible. Students may also want to make a sampling screen to check for aquatic insects. Have students kick up rocks and debris upstream from the screen so insects are dislodged onto the screen. Place the insects in water in a white enamel plan or pie pan painted white for observation and identification before releasing them.

Birds and mammals: List any birds and mammals that students find on their transects. Any observed elsewhere may be checked off on the checklist. Several bird identification guides are listed in the bibliography.

Animal tracks: Again, if students draw careful pictures they may be able to identify the tracks later. Local people who spend a lot of time outdoors plus Olaus Murie's A Field Guide to Animal Tracks should be very helpful. Have students be sure and measure not only the size of the tracks, but the distance between them. Another option is to give each group a package of plaster-of-Paris with which to make casts of bird and animal tracks.

Streamside vegetation is important to fish. It provides shade to keep the water cold, insects falling from the vegetation are eaten by fish. Leaves also fall into the water, providing food and nutrients for aquatic insects, which are in turn eaten by fish. Logs and branches

which naturally fall into the stream make good hiding places for fish.

Velocity is the speed of flow, measured in feet per second. To figure the average velocity of a stream, measure off a set length such as 20 feet. Then drop in a stick or an orange--anything that floats. Use the second hand on your watch to see how long it takes to go 20 feet. If it took 5 seconds, the velocity would be 4 feet per second. Experiment several times to check the accuracy of your measurement.

Pools and riffles: Pools are deep areas in streams or rivers where the current is slow. Riffles are shallow portions of streams or rivers where the current is fast. The ratio of pools and riffles in a stream helps determine how many fish can live there because fish need both types of habitats. Pools are good resting spots. Riffles add oxygen by mixing water with the air as little waves form. Also, different kinds of aquatic insects are found in each area. The more a stream or river meanders or curves back and forth, the less steep it is and the easier for fish to go up and down, and the more fish habitat is present because the distance covered is longer than would be covered by a straight line.

Additional observations: Sometimes it's the small things you notice that later turn out to be the most important, so encourage your students to take careful notes.

6. Ask students to make up some rules for the trip to protect the animals and plants of the stream (step softly and carefully, turn rocks or logs back over so the animals who like the moist environment

underneath can survive, leave everything just as found, pick up litter). Discourage collecting unless for a specific purpose such as an art project or freshwater aquarium.

7. Review safety procedures:
 - Stay together. Have a buddy. If you become lost, stay where you are and call out periodically.
 - Dress warmly and keep dry.
 - Stay a safe distance from the water (If you will be visiting a river, you may want to bring several life rings with lines attached and have the students practice throwing them).
 - Be careful of slippery mud, rocks, and logs.
 - Help each other.
 - Carry a first aid kit.
8. Plan follow-up activities. (See Activity 4 in this unit.)
9. Enjoy the trip!

Activity 3 Lake Field Trip

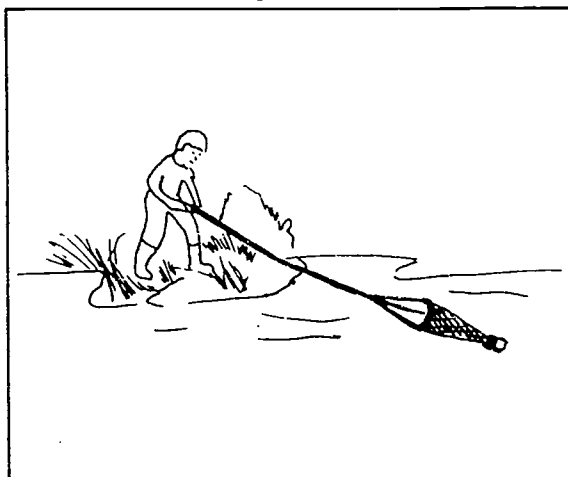

Background:

Lakes generally are large, deep bodies of water with rooted plants growing on their edges, in comparison to ponds which are small and usually shallow. Lake Illiamna is Alaska's largest, but other lakes of considerable size are located throughout the state. Most lakes were formed by the scouring and erosion of glaciers in the distant past. If large enough, lakes can alter local climate by moderating temperatures. They may also produce foggy conditions and cause snowfall on their lee sides. Lakes are constantly changing, and geologically are a comparatively short-lived phenomena. Lakes are continually filling in and have a life span of a few thousand to tens of thousands of years. Limnologists study lakes. Limnology is the formal, scientific study of lakes, ponds, rivers, and streams. The study also is called freshwater ecology or "inland oceanography."

Vocabulary:

- transparency

- secchi disk
- vegetation
- emergent
- plankton (review)
- aquatic (review)
- transect (review)

Materials:

- plankton nets
- secchi disk
- thermometers
- pencils
- magnifying lenses
- flagging tape or colored streamers
- 100-foot measuring tape
- rulers
- maps, charts aerial photos of the lake
- local resource persons
- binoculars/spotting scope
- litter bags
- large cans
- field guides
- white enamel pans or pie pans painted white
- life rings with ropes attached
- worksheets:
 - ...Lake Checklist (3C)
 - ...Lake Transect (3D)

Procedure:

1. Select a local lake (or pond) for your field trip. Look at maps, charts, and aerial photos of your lake. Pick a part of the lake to explore that has a variety of habitats (wetlands, river or stream inlet or outlet, heavy fish or bird concentrations, etc.). Local resource people (fisheries biologists, village elders, fishermen, birdwatchers) may be able to help.
2. Plan your lake visit to include:
 - a. structured learning
 - b. summary or review

- c. litter pickup, snack or lunch

The magnifying lenses and worksheet Lake Checklist can be used initially or in conjunction with the worksheet Lake Transect. You may also want students to work on language arts or art projects. The review can take the form of every student (and adult) telling what they liked best, or their favorite learning experience that day or each team can come up with a summary statement. Litter pickup can be a separate activity or just a continual part of the field study. If you have extra time at the end while waiting for transportation, play fish tag where a few "bears," "gulls," and "eagles" try to catch the "fish" (the rest of the students).

3. Arrange transportation and send home permission slips. Invite parents to participate as small group leaders. High school students can also be small group leaders if they are well-prepared ahead of time. If at all possible, meet with your group leaders ahead of time and go over what you'll be doing. Visit the site and lay out 100-foot sections along the lake shore for each team of four to six students to investigate. Mark the sections with flagging tape or colored streamers.
4. Gather equipment. Each team of four to six students should have a thermometer, plankton net, secchi disk, ruler, a large can, litterbag, magnifying lenses, white enamel pans or pans painted white, pencils

and copies of the two worksheets. Try to locate a spotting scope and tripod in case there are birds on the lake. Go over the checklist, eliminating or adding animal and plants typify your area. Have the students assist in making plankton nets and secchi disks if you don't have any on hand.

5. Prepare your students. Try a "dry run" several days before the field trip. Have students wear short rubber boots or hip boots and bring rain gear, binoculars, and warm clothes. Show students the aerial photos, maps, and charts. Lay out a model lake on the classroom floor. Divide the class into teams of four to six students, and have each team survey a 10-foot section of the lakeshore. The teams should be numbered consecutively along the shore. Remind the students that a transect means a section. By looking closely at one section of the lake, they'll have a better idea of what the whole lake is like. Then go through the different parts of the worksheet.

Location of transect: When biologists do studies like this one, it's very important that they know where they are so that they can go back another time to see if any changes have occurred.

Temperature: Have students practice using the thermometers. Can they predict the temperatures of their lakeshore, water, and air?

Lake bottom type: Ask students why the bottom is important. (Because that's the home of

aquatic insects on which the fish feed. Some types of insects will live only on a certain type of bottom. Red salmon and some other fish do spawn in lakes and they like bottoms of certain types. Students should write down what the bottom is like: sandy, muddy, gravelly, rocky.)

Estimated lake size: This information probably would be easiest to collect before the field trip from maps, charts, and aerial photos. Size can be estimated in acres or length and width in miles.

Fish species, size, and numbers: Because fish are under water, it's sometimes difficult to tell what kind they are; but students should do the best they can. Quietness at the lakeshore is important to keep from frightening the fish. On their transects, each team should count in the same direction so that fish aren't counted twice as they move around the lake. If a fisheries biologist or someone with a fish collecting permit is along, students may be able to use seines, dipnets, or minnow traps to see what's in the lake. Students also might try dropping salmon eggs or bread crumbs quietly on the surface and see if any fish arrive to feed. Another way to check for fish is by sport fishing! How long does it take your students to catch each fish and what type of baits or lures work best?

Aquatic insects: By drawing pictures of what they find, students may be able to identify the insects later. There is a good section on aquatic insects in Volume III of the Sea Week Curriculum Guide Series. Look under rocks and sticks for the insects, but be sure to put them back so their homes are disturbed as little

as possible. Also collect a sample of the lake bottom with your can. Dump the contents into the white pan and carefully sort through the mud or gravel looking for aquatic insects. Return the insects to the lake after each student has observed, drawn, and taken notes on the "finds."

Birds and mammals: List any that students find on their transects. Any observed elsewhere may be checked off on the checklist. Spotting scopes and binoculars could be helpful. Take along bird field guides to help with identification. Several suggested guides are listed in the bibliography.

Animal tracks: Again, if students draw careful pictures, they may be able to identify the tracks later. Local people who spend a lot of time outdoors plus Olaus Murie's A Field Guide to Animal Tracks should be very helpful. Have students be sure and measure not only the size of the tracks, but the distance between them. Another option is to give each group a package of plaster-of-Paris with which to make casts of bird and animal tracks.

Lakeshore vegetation is important to fish. They provide shade to keep the water cold, and insects falling from the vegetation are eaten by fish. Leaves also fall into the water, providing food and nutrients for aquatic insects, which are in turn eaten by fish. Logs and branches which naturally fall into the lake make good hiding places for fish.

Lakes may have pondweeds and water lilies growing in the water, shore vegetation on the land, and emergent vegetation (plants that grow half in and half out of the water). Emergent vegetation and

the deeper pondweeds are excellent hiding places and feeding places for young fish. Larger fish come into the shallows to try to find and feed on the little ones.

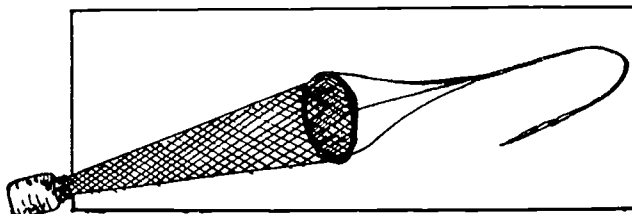

Plankton. Drag your plankton net under water for the length of your transect. Then put your lid on the sample. Hold the jar up to the light and see if you can see any tiny plants or animals. This plankton is what many of the smaller fish and some of the bigger fish eat. Directions for the plankton net are in Volume III of the Sea Week Curriculum Guide Series.

Secchi disk. Try to find a good spot to lower your secchi disk in the water to measure the clarity or transparency of the water. Lower the disk slowly until you can't see it anymore. Mark down at what

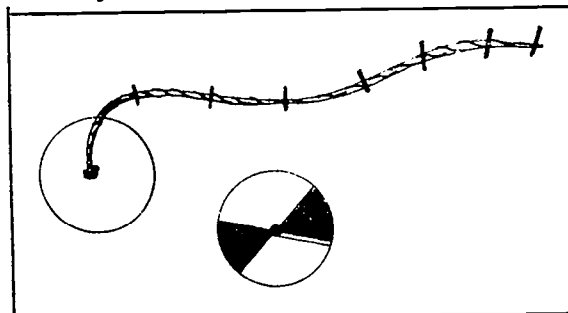

depth the disk disappeared. Then lower the disk even farther, and slowly bring it up. Mark down the depth at which the disk appeared. Now take the average of the two depths and that is the secchi disk reading.

Ask students: Do you think this reading would be the same year-round? (No, because plankton blooms in the spring and reduces

some of the clarity. Also, many Alaskan lakes are influenced by glaciers, so when the glaciers are melting in the summer, the lake transparency is reduced.)

Lake map. Students should draw a rough map of the lake and add features that they notice plus any additional observations.



If the class has access to a boat (and life jackets), additional measurements of plankton transparency, temperature, and depth can be recorded. Lake measurements also can be taken in the winter by drilling holes through the ice.

6. Ask students to make up some rules for the trip to protect the animals and plants of the lake. (Step softly and carefully, turn rocks or logs back over so the animals who like the moist environment underneath can survive, leave everything just as found, pick up litter.) Discourage collecting unless it's for a specific purpose such as an art project or freshwater aquarium.
7. Review safety procedures.
8. Plan follow-up activities. (See Activity 4 in this unit.)
9. Enjoy the trip!

Activity 4 Data Analysis and Report Writing

Class and School	_____							
Stream	_____		Date _____					
Topic and locations and lengths _____								

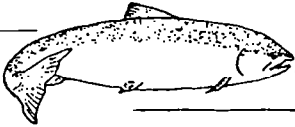
TABLE NUMBERS								
DATA	1	2	3	4	5	6	7	ADDITIONAL COMMENTS
Streambank Temperature								
Water Temperature								
Air Temperature								
Stream Bottom Type								
Ave. Stream Depth								
Ave. Stream Depth								
Fish Species, Size and Numbers								



Background:

Field studies are fun; but if the data is not carefully analyzed and written up, it is of little use. Students can contribute to scientific knowledge, especially in Alaska where, due to the state's vastness and small population, comparatively little is known biologically. Especially helpful are long-term studies (in your class's case, perhaps yearly studies of the same stream or lake).

Vocabulary:

- abstract
- goals
- introduction
- method

Materials:

- data from lake and/or stream field studies
- paper
- pencils
- large sheet of newsprint or butcher paper
- felt-tip markers
- field guides
- graph paper

- worksheets:
 - ...Stream Data (3F)
 - ...Lake Data (3F)

Procedure:

1. Have each team go over its data, perhaps copying the information onto another sheet if the writing is illegible. Use field guides and other reference books to identify unknowns. Post completed data sheets where they can be studied and compared.
2. Make a class mural of the lake or stream with large sheets of butcher paper and felt-tip markers. Transfer information and observations into pictures and notes on the mural.
3. Pass out the worksheets Stream Data and/or Lake Data. Have each team copy information from the other teams' investigations.

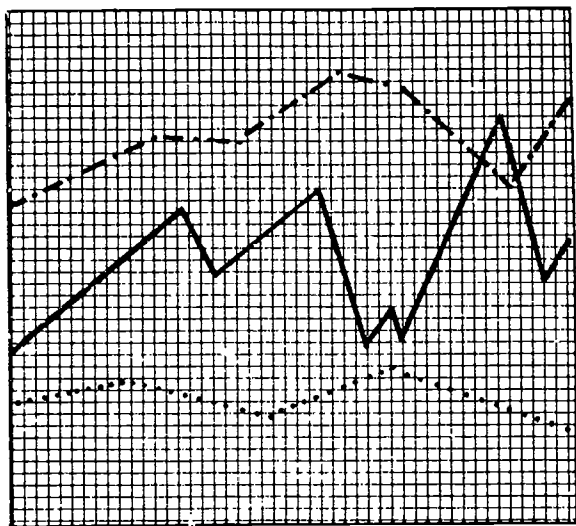

4. Pass out graph paper and have each student graph the air, water and land temperatures.
5. As a class discuss, the information. You may want to

ask a local biologist for help in the data analysis. Ask the students:

- Do you notice any trends as you move upstream or downstream, or from one part of the lake to another?
 - What additional things would you like to know about this stream or lake?
 - What types of fish is this stream or lake suitable for?
 - What would you do differently if you were doing this study again?
6. Have the students write reports of their findings. Include drawings and graphs. Begin with an abstract--a couple sentences about the purpose of your study and your findings. Next write an introduction (a few sentences introducing a stranger to your local stream or lake and to your class study including your goals (what you hoped to achieve by the study)); method (how you collected your data); results (what you found out, any trends you noticed, and your Stream Data or Lake Data worksheets) and finally, a summary of your study.
 7. Ask the students:
 - How would you rate this stream or lake as fish habitat?
 - Is there anyone who would be interested in our reports? (Newspaper, community groups, village or town government, local planners, parents.)

- Are any developments planned for this stream or lake or the surrounding watershed?
- How might our reports have an effect on the future uses and resources in this area?
- Is there anything further we should do? (Write a story or take photos to give to the local newspaper; write letters to the editor; make a slide show or videotape about our stream or lake; make a presentation with maps, charts, our mural and reports to a community group; etc.)

Additional Activities:

1. Art, Language Art, Science:
Have students fold an 11-inch

by 18-inch paper into eight equal parts. On the top four spaces have them drawn an event from the field trip. On the bottom four spaces have them write two facts related to each event. (Suggested by Ann Schultz, Mt. Eccles Elementary, Cordova)

2. Language Arts, Science:
Have students pick one aspect of their field study that interests them, and research and prepare an oral and/or written report on that topic.
3. Science: Have students figure out what types of fish their stream is suitable for, based on the data they collected.

Unit Four

Fishing Then and Now

Index

Activity 1: Fishing Myths and Legends..... 75	Activity 7: Trolling 90
Worksheet:	Worksheet:
How the Fish Came Into the Sea4A	Trolling.....4F
Activity 2: Traditional Fishing Methods 78	Activity 8: Longlining 92
Worksheet:	Worksheet:
Halibut Hooks.....4B	Longlining4G
Activity 3: Constructing a Fish Wheel..... 82	Activity 9: Shrimping and Crabbing on the High Seas . 94
Worksheet:	Worksheet:
Fish Wheels4C	Trawl and Pots4H
Activity 4: Jigging Derby ... 84	Shrimp and Crab matching4I
Activity 5: Gillnetting 86	Activity 10: Who Gets the Fish?..... 99
Worksheet:	Activity 11: Harbor Field Trip101
Gillnetting4D	Worksheets:
Activity 6: Purse Seining ... 89	Fishing4J
Worksheet:	Harbor Investigation ...4K
Purse Seining4E	

Objectives:

To help the student:

- Read and listen to fishing legends (Activity 1).
- Research local fishing legends (Activity 1).
- Make a spear, hook, line, float, sinker, net, and/or fish trap (Activity 2).
- Learn about halibut hooks (Activity 2).
- Construct a model fish wheel (Activity 3).
- Read about fish wheels (Activity 3).
- Participate in a jigging derby (Activity 4).
- Practice gillnetting (Activity 5).

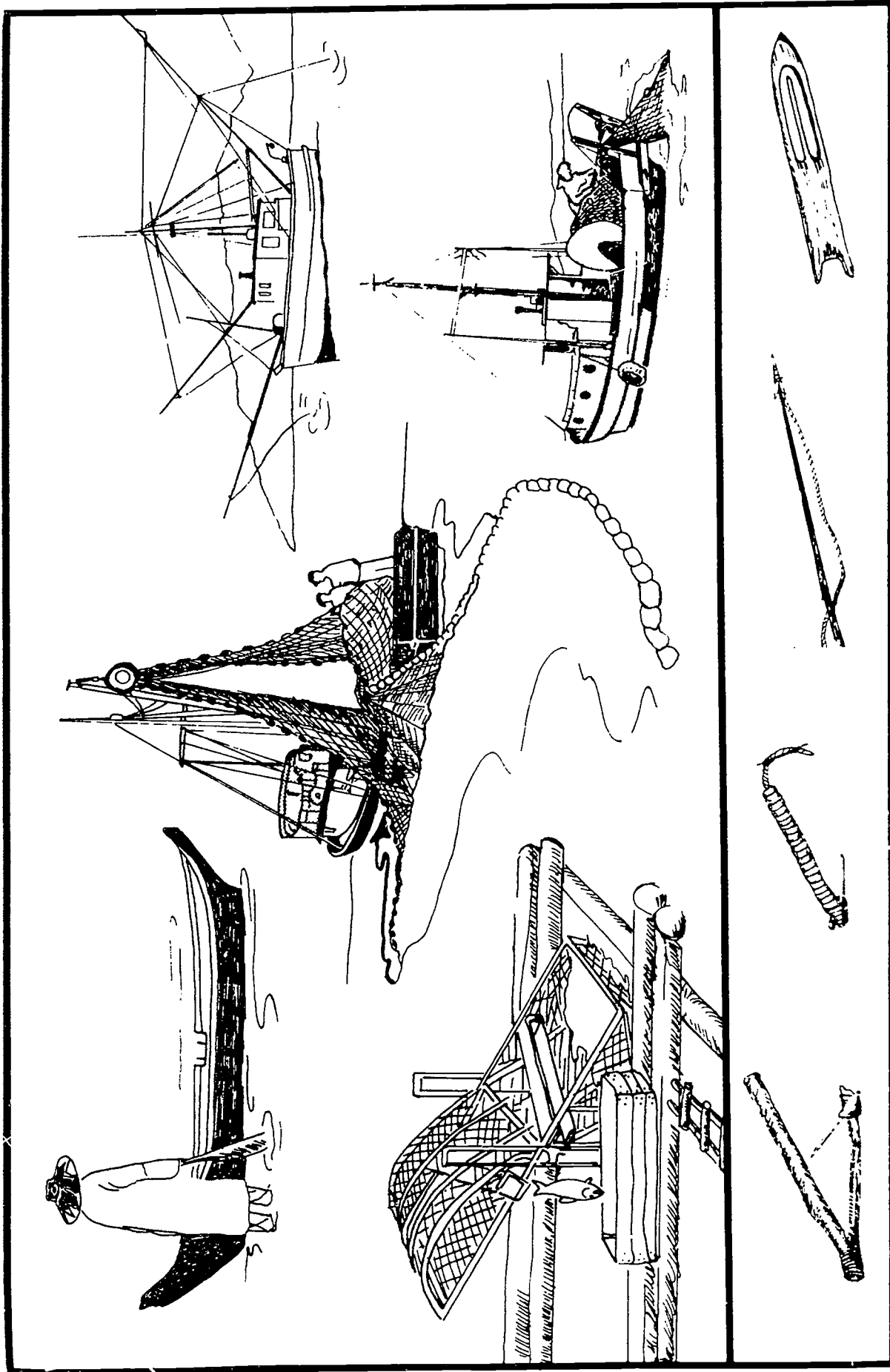

Unit Four: Fishing methods, clockwise from bottom left: fishwheel, baldarka, purse seiner, troller, gillnetter. Im-
 plements from left: native Alaskan halibut hook, fishhook,
 spear, and net needle.

- Explain why undersize fish and shellfish incidently caught in the net are the fishermen's future (Activity 5).
- Diagram purse seining techniques (Activity 6).
- Pantomime how a troller catches and takes care of his fish (Activity 7).
- Write a story or poem or draw cartoons about longlining for halibut (Activity 8).
- Read about gillnetting, seining, trolling, and longlining (Activity 5-9).
- Construct model shrimp trawls and crab pots (Activity 9).
- Match crab and shrimp descriptions with their pictures (Activity 9).
- Map a local harbor (Activity 10).
- Observe different types of fishing boats (Activity 10).
- Interview a local fishermen and harbor masters (Activity 10).
- Write a newspaper story about the local harbor or waterfront (Activity 10).

Rivers, lakes and the sea are traditional sources of food for Alaskans. Natives observed and studied the animals to learn where they lived and how their behaviors and appearances changed with the seasons. They knew when and how marine or freshwater animals were best to eat. They devised ways to catch fish and mammals with nets, hooks, harpoons and traps. They learned how to preserve their catch so there would be food throughout the year. Such ties to northern waters are reflected in the legends and traditional beliefs of Alaska's Native people.

As non-Native people began to settle in Alaska, they, too, turned to the waters for food. They learned from Alaska's Native people and brought and introduced new ideas and technologies.

With time, outside markets developed for Alaska's rich marine resources. With the markets came commercial fishing, whaling, canneries, salteries, imported labor and regulation and management of the resources.

The state of Alaska divides fishing into four categories: subsistence, personal use, commercial and sport. Subsistence fishing is for food on which one depends directly. Personal use is a category established recently by the Alaska Boards of Fisheries and Game. It is a non-priority designation,

usually established on a temporary basis to allow extra harvests whenever there is a surplus of fish in a particular area. Commercial fishing is a term used to cover all fishing done by fishermen licensed by the state to take and sell a particular species. Commercial fishing began in Alaska during the late 1800s. Sport fishing is primarily for pleasure, although sport-caught fish may form a considerable part of the food supply for those who catch them.

Regulations for these fisheries are set by the Alaska Board of Fisheries. Local advisory committees and individual Alaskans can and do propose changes in these regulations. The Alaska Department of Fish and Game supplies management data and information to the Board and the fish and wildlife protection officers in the Department of Public Safety enforce the regulations.

Today, Alaska's fisheries and the many people dependent upon them are a complex mosaic. To begin to understand it, students will have to learn about many lifestyles, past and present. This and following units present information about how the lives of Alaskans are linked to seas and rivers. The materials here, however, are only a beginning. Exploration of fisheries resources is best individualized for each community.

Activity 1 Fishing Myths and Legends



Background:

Myths serve to explain some phenomenon of nature, the origin of man, or the customs, institutions and religious rites of a people. They can be defined generally as "sacred" stories.

Legends usually ascribe fanciful or fantastic deeds to a particular place or person.

The two terms have been used with such latitude that it's often difficult to label a story "myth" or "legend." If the question should arise among students, one way to judge the difference is to ask whether the story has a moral. Does it explain why the sun sets, or why the tide moves in and out, or what happens to parents who treat their children cruelly? If so--if it explains a phenomenon or belief, it can be called a myth. If it simply ascribes fantastic deeds to a person or place, without any particular moral, it can be called a legend.

By such a "morality criterion," the stories Raven and the Fog Woman

and How the Fish Came Into the Sea in this activity are myths, while Raven Is Swallowed By Big Fish appears to be a legend.

Folklore is the whole body of oral tradition--myths, legends, music, games, dances, strengthening properties ascribed to certain foods and herbs--that is passed from generation to generation.

Vocabulary:

- myth
- legend
- folklore

Materials:

- paper
- pencils
- tape recorder
- village elder
- Raven and the Fog Woman Legend
- Raven Is Swallowed by Big Fish Legend
- worksheet:
...How the Fish Came to the Sea (4A)

Procedure:

1. Discuss how traditions are passed from generation to generation. In the old days, the abilities to listen and remember were vitally important because there was no written language. Explain that students long ago were very skilled at listening. Mention that you will be reading them a Tlingit myth and an Athabascan legend. Afterwards, see how well they do at telling the stories back to you!
2. Explain to students that Raven is an important figure in Alaskan Native traditions.

Raven, who created the world, is wise and cunning and full of trickery. To set the mood, have the students

sit around on the floor as if you were telling them the stories around the campfire on a summer evening.

RAVEN AND THE FOG WOMAN

Raven wanted to get married. He went to the chief called Fog-Over-the-Salmon, who had a daughter of marriageable age. The chief was glad that Raven wanted to marry his daughter but he said,

"You must promise to treat my daughter well. You must have respect for her, and look after her. If you behave badly, she will leave you and you won't get her back."

Raven agreed to what the chief demanded, and the couple were soon married. They lived contentedly in the village near the water all summer and fall. Then winter came and they were without food.

One bleak, rainy day, after they had been hungry for some time, Raven's wife started making a basket.

"What are you making a basket for?" asked Raven testily. "We have nothing to put in it."

His wife did not answer him, but continued making the basket until it was very big.

That night they went to sleep hungry again, and the next morning when the Raven woke up, he saw his wife sitting on the floor, washing her hands in the basket. He got up to look at what she was doing, and when she had finished, there were salmon in the basket! These were the first salmon ever created.

Raven and his wife were very glad, and they cooked and ate the salmon. Every day, she did the same thing: she washed her hands in the basket, and when she had finished, there were salmon in it. Soon, their house was full of drying salmon, and they had plenty to eat.

After awhile however, Raven forgot that he owed his good fortune to his wife. He quarreled with her. Every day they would exchange bad words with one another; and in the end, Raven got so angry he hit his wife on the shoulder with a piece of dried salmon! He had forgotten the words of his father-in-law, the chief.

Raven's wife ran away from him. He chased her, but when he tried to catch hold of her, his hands passed right through her as if through mist. She ran on, and every time Raven clutched her body, there was nothing to hold on to. He closed his hand on emptiness.

Then she ran into the water, and all the salmon she had dried followed her.

Her figure became dim and she slowly disappeared into the mist. Raven could not catch her, because she was the fog.

Raven went to his father-in-law, Chief Fog-Over-the-Salmon, and begged to have his wife returned. But his father-in-law looked at him sternly, and said,

"You promised me that you would have respect for my daughter and take care of her. You did not keep your promise. Therefore you cannot have her back."

From Booklet IV, Alaska Multimedia Education Program, Alaska State Museum. Adapted from John R. Swanton's Tlingit Myths and Texts (1909).

RAVEN IS SWALLOWED BY BIG FISH

Raven was by the seashore. Along came Big Fish. Raven said, "We are cousins."

Big fish was doubtful but Raven said, "yes, we are. My father and your mother were brother and sister. Look in my mouth and you will see."

Raven opened his mouth and Big Fish looked in. Then Raven said, "Open your mouth so I can see."

And Big Fish opened his mouth. Raven said, "Open wider."

Then Raven ran right down Big Fish's throat into his stomach. He made camp there. He cut out strips of fat and made a fire. Big Fish dove deep into the water and swam all through the seas, but he could not get rid of raven. Finally he swam near shore.

Raven started up Big Fish's gullet. When he got near the heart he stopped. He took his knife and cut into Big Fish's heart and cooked and ate all. Some Indians saw the dead creature stranded on the shore. They thought, "Good, here is lots of meat."

They went to the body and began to cut it open. When they slit open the belly, a burst of air shot out, followed by some smoke and a little black thing that went shooting off into the trees. This was Raven. He changed into a man and came back to the Indians. He said, "You better not eat that meat for it is poison. Don't you see it smoking?"

The Indians all went off, and Raven had the fish for himself.

-told by Chisana Joe and recorded in The Upper Tanana Indians, by Robert A. McKennan

3. Discuss how the seas and rivers and their creatures are important to Alaskan Natives. Ask the students:

- How are these stories similar to modern life?

- What lessons can you learn from these stories?

Then have the students try to repeat the stories in the proper sequence.

4. Allow students time to read the worksheet How the Fish Came Into the Sea. This is a Tlingit myth that accurately defines, with the sequence in which the doors are opened, the order of Alaskan annual fish migrations. The fish that "stop," or stay, are those that do not migrate. This myth was taken from Hilary Stewart's Indian Fishing: Early Methods on the Northwest Coast (University of Washington Press, Seattle and London, 1977) and was told by Billy Wilson, a fisherman and silversmith, when he was 84--just the year before he died.
5. Collect local folklore. Ask students about village elders in their community who might know some oral traditions about fishing, and would like to share them in their homes or in the classroom. Have students practice interviewing each other and using a tape recorder. Discuss interview techniques (how to make the person you're interviewing feel at ease; how to be at ease yourself; remembering everything said in case the tape recorder doesn't work; going over the tape right away so if there are blank spots you can fill them in, etc.). The school bilingual staff should be of great help in executing this activity.

Activity 2 Traditional Fishing Methods

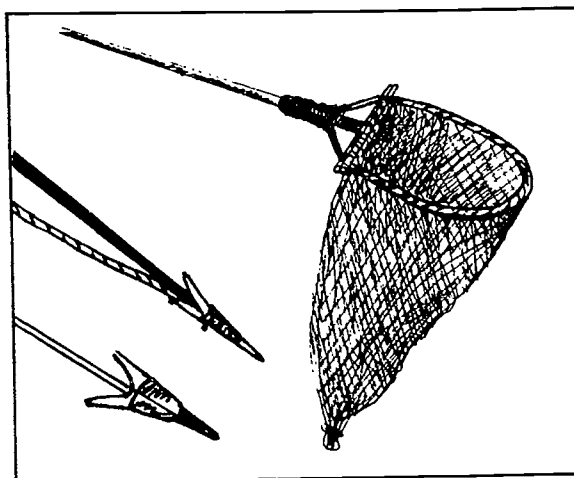

Background:

Successful sea and river harvests literally were matters of life or death to Alaskan Natives and early settlers. Fishing methods that evolved from long and careful observation, from trial and error, and from sudden inspirations have been perfected through long use by many generations. Today, some Eskimos and Indians still move to summer fish camps where salmon or other foods from the seas or rivers are gathered and preserved for winter use. In the wintertime, ice fishing remains a traditional harvest method.

Vocabulary:

- netting needle
- weir

Materials:

- stones
- twine
- string
- sticks
- chunks of wood
- sandstone or sandpaper
- bone

- netting needles
- knives
- traditional fisherman or woman
- worksheet:
...Halibut Hooks (4B)

Procedure:

1. Ask the students:

- If you were lost in the woods (or tundra), or went down in a plane next to a lake or stream, would you know how to make something with which to catch fish? (That's when some old-time fishing techniques would come in handy!)
- What do you know about these old-time fishing methods?
- Do you know someone who could come and show our class some of these fishing strategies? (Well, let's invite them!)

2. Ask an old-time fisherman or woman to come to the class and demonstrate how to make hooks, sinkers, floats, nets, line, spears and/or traps. Contact the guest ahead of time to offer to round up the required materials. Here are some ideas adapted from Hilary Stewart's Indian Fishing.

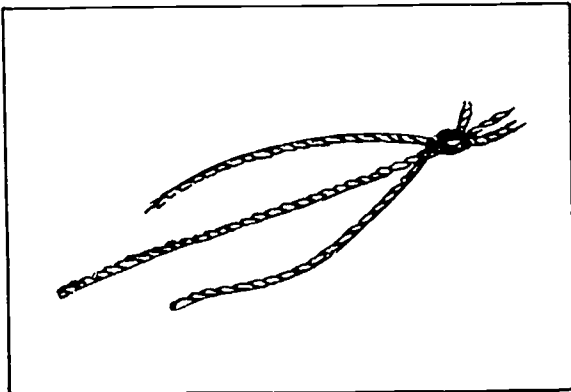

a. Fishing line initially was

made from cedar bark, nettle fibers, animal sinew, or bull kelp stems. Students can learn some of the principles of line (or rope) making by braiding twine. Tie an overhand knot at one end of three pieces of twine. Keep folding first the right, then the left piece over the centerpiece, in the same way as one braids hair.

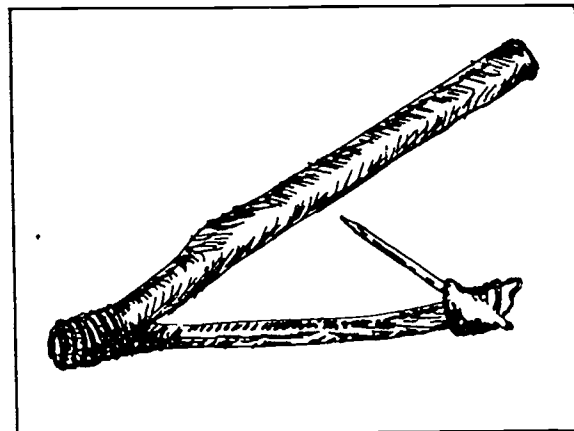

- b. Hooks can be made by lashing two sticks together, or a piece of bone and a stick. To use a bone, first splinter the bone by smashing it with a stone, then smooth one of the sharp shards with sandstone or sandpaper. Hooks also can be carved from wood. Students can make a variety of sizes and types to try out in one of the local fishing holes. For inspiration, read the worksheet Halibut Hooks. (Answers: 1: yew and yellow cedar; 2: bone or a nail; 3: cedar bark, nettle fibers, animal sinew, or bull kelp stems; 4: rock; 5: piece

of wood; 6: octopus, herring, etc.; 7: to encourage a spirit helper to aid in catching the halibut; 8: several hours or days)

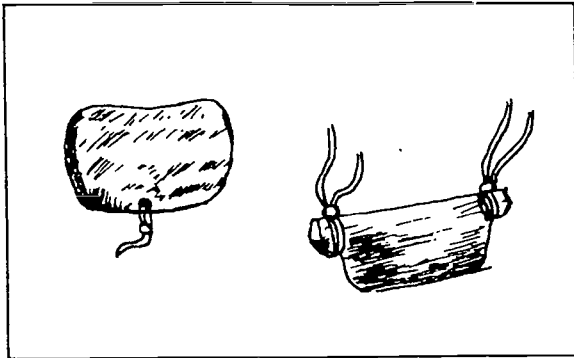

c. Floats can be carved out of chunks of wood. They can be fancy ones as were used for catching halibut or plainer ones for gill nets.

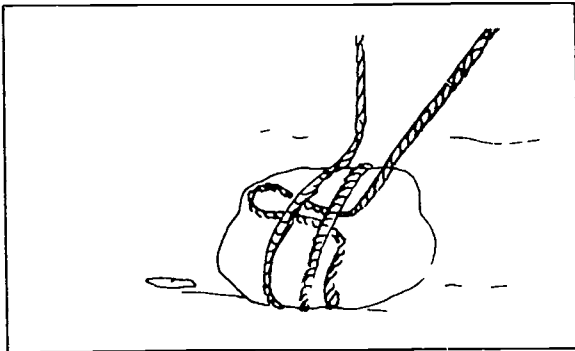

d. Sinkers can be made from stones or rocks for hook and line fishing, or for placement at the bottom of a gill net.

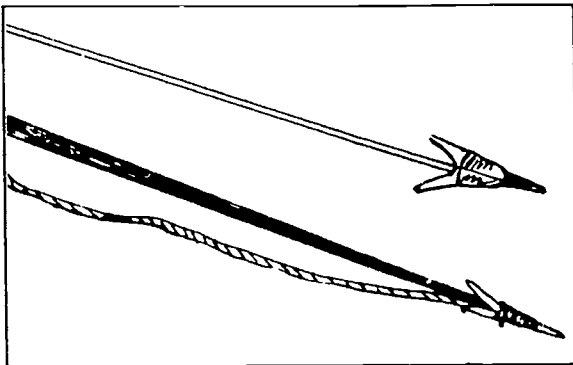

e. Spears or harpoons can

be made from pieces of bone, metal, carved wood or stone lashed to a long stick.

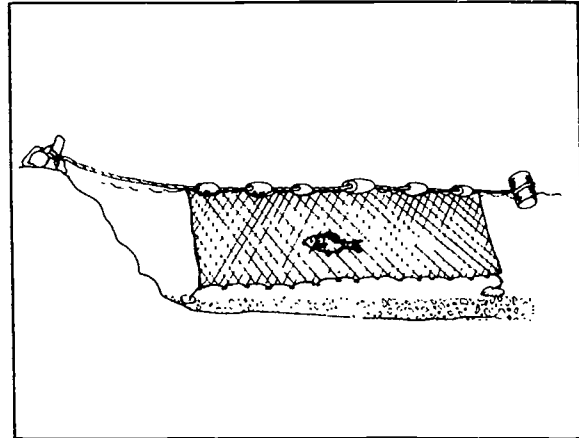

f. Netmaking is a real art. Students can carve or buy netting needles and use string or fishline to make small sample nets. Modern fishing nets differ only in material, not in form, so it should be possible to find someone to practice netmaking with your students. Run the

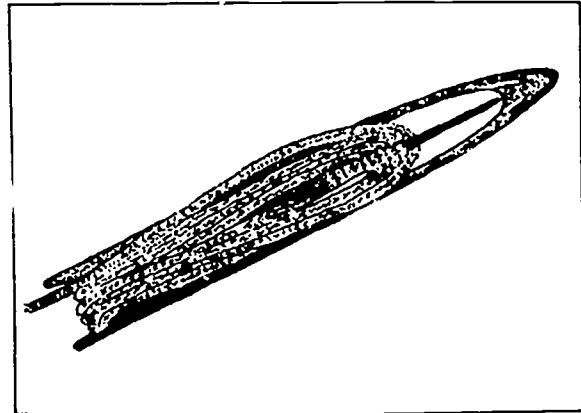

heavier cork line and heavier sinker line between two chairs then run a lighter weight line down the sides. Wrap your netting needle (not too full) with the fishing line. Begin in one of the upper corners with

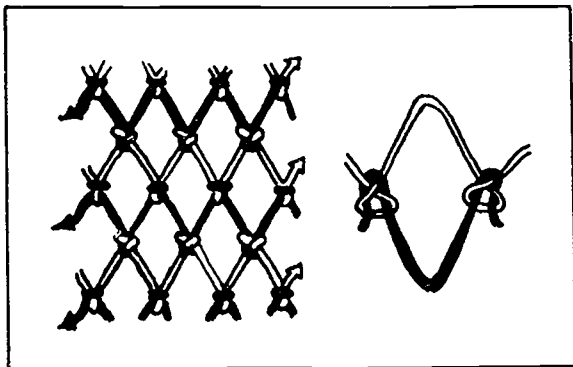

the knot illustrated here. Make a net size gauge out of a wood chunk to keep the mesh uniform. Nets with king salmon mesh should be 4

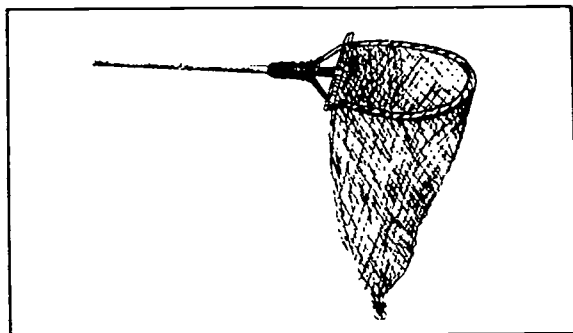

by 4 inches; other salmon nets about 2 3/4 inches by 2 3/4 inches; and herring nets 1 1/4 inch by 1 1/4 inches so that the fish will stick its head through and get stuck behind its gill. Add handmade floats and sinkers to complete your gill net. Or dip nets can be made with similar techniques.

- g. Students also can make belts, basketball goal nets, and other craft items. See teacher's reference bibliography entry for netmaking by Charles Holdgate. Traps and weirs probably are the most productive of any fishing devices, due

primarily to the salmon's urge to run upstream. Salmon traps were used first by Natives, and later by commercial canneries. These traps

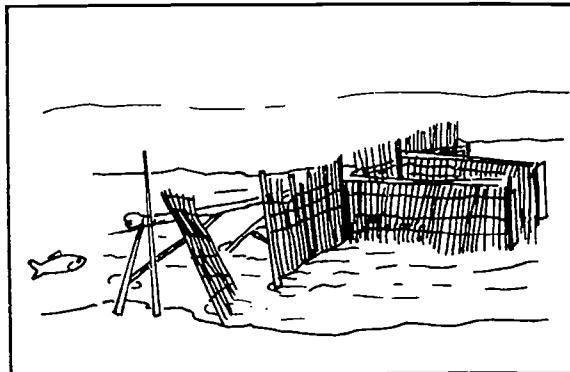

were the scenes of many bitter battles; and in some cases, whole runs of salmon were wiped out by overharvesting. Salmon traps are now illegal (except for use in one area of Southeast Alaska). Alaska Department of Fish and Game biologists do use weirs in their biological work, but the fish are merely counted, not harvested. Weirs and traps can be made of sticks lashed together with string.

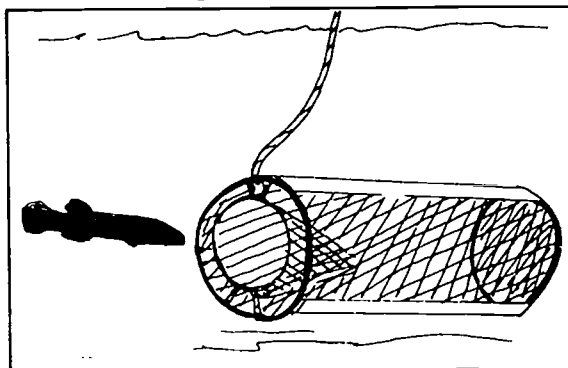

One trap that students might especially enjoy making is a blackfish trap, which is legal.

3. Now have students put their

fishing gear together and try it out as an after-school project. Be sure to familiarize the class with local fish and game regulations ahead of time. Pick up a copy of the regulations at any place in your community where licenses are sold or write to the Alaska Department of Fish and Game, Box 3-2000, Juneau, Alaska 99801.

Activity 3 Constructing a Fish Wheel

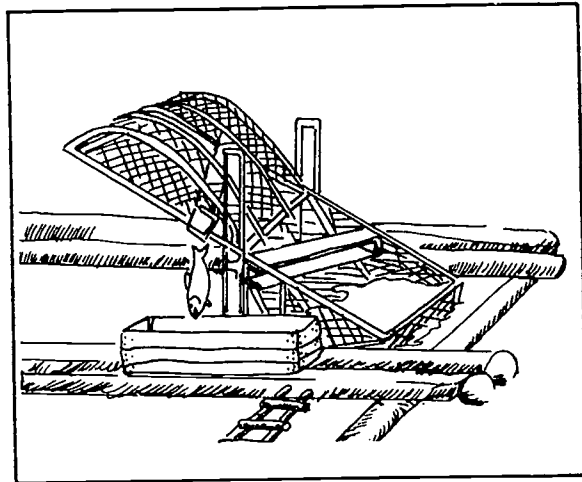

Background:

The fish wheel was introduced to Alaska by white settlers about 1900. Its coming revolutionized Interior Alaskan life because salmon for people and dogs could be caught more easily. People could afford to have enough dogs to run teams and hunt, trap, and travel much greater distances in wintertime.

Vocabulary:

- axle
- basket
- bearing block
- chute
- debris
- fish wheel
- stanchions
- spar

Materials:

- sticks
- string
- glue
- small pieces of wood
- nylon window screening
- scissors
- knife

- map of Alaska
- worksheet:
...Fish Wheels (4C)

Procedure:

1. Ask students to tell you what they already know about fish wheels. Then pass out the worksheet Fish Wheels and read it individually or as a class. You'll need a map of Alaska to answer the last question on the worksheet. A good reference for any additional questions is Kathleen Lynch's Fishwheels and How to Build Them (see Teacher's Reference bibliography) whence came the information for this activity. (Worksheet answers: 1: since 1900; 2: the river's current;

3: the fish are caught in the revolving baskets as they migrate upstream; 4: storage box; 5: commercial fish; 6: Yukon, Tanana, Kuskokwim, Copper)

2. Have the students make a model fish wheel from the drawing on the worksheet and a variety of materials (sticks, string, glue, small pieces of wood, nylon window screening, scissors, knives) stockpiled in the classroom. If there is anyone in the community familiar with fish wheels, ask them to help supervise the project. Visit any nearby fish wheels so students can see how closely their models match the real item.

Activity 4 Jigging Derby

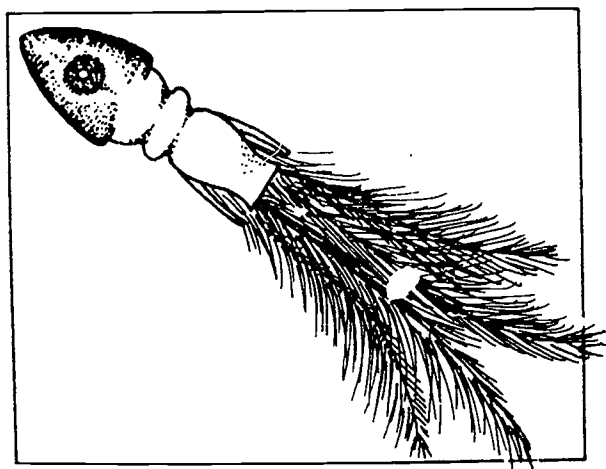

Background:

Jigging has been used as a fishing technique both winter and summer for centuries. Today jigging machines are being used to catch ocean whitefish.

The idea for this fun activity comes from Jim Gall at Kotzebue Elementary in Kotzebue. These procedures can be used in other areas of the state with other fish species and other types of fishing gear. But be careful not to decimate your local fish population. Check with a fisheries biologist before beginning the contest. You may need to strictly limit student fishing time or methods to save some fish for next year.

Vocabulary:

- jigging lure

Materials:

- ice chisel, ax or auger
- jigging sticks and helping sticks
- lines
- lures and bait if needed

- ice skimmers or old cups or strainers
- sled (on which to sit and carry gear and fish)
- knife
- pliers
- spare line and lures
- weighing scale
- measuring stick

Procedure:

1. Discuss local fishing techniques. Invite a village elder to your class and discuss jigging for fish and ice safety tips on weather, breakup, ice chisels, axes, ice augers, lures, knots, bait, barbed and barbless hooks, fish cleaning and preservation and use.
2. Plan a school-wide one- or two-week jigging derby in which students hook fish before and after school. Make up contest rules. Some suggestions:
 - a. Hook a tomcod between Monday _____ and Sunday _____.
 - b. Bring it into room _____ for weighing and fin clipping any school day from _____ to _____ a.m. or from _____ to _____ p.m.
 - c. Sign an "official on-my-honor" form that says you actually caught the tomcod and caught it during derby week.
 - d. Last day for entries is _____, so you can hook during the weekend.
 - e. Winners announced on _____.

- f. Prizes will be given to each boy and girl at each grade level who catches the most and largest tomcods.
3. Also plan a daylong derby day, in which each class spends an hour hooking fish as part of the physical education and science program. Send home permission slips and make sure each child dresses warmly, and has a hooking stick and bag with his or her name on it in which to carry the fish back to school. Plan hot drinks and snacks when each class returns to school. Invite parents to assist with the derby and alert them to alternative plans in case of bad weather. Arrange to donate leftover fish to a convalescence home or similar facility.
4. Discuss derby plans with other teachers and your principal.
5. Round up weighing scales, a measuring stick, sled, knife, pliers, spare lines and lures. Cut ice holes ahead of time and mark their locations.
6. Review ice safety procedures. Each student should have a buddy, dress warmly and return when the whistle blows. Head counts should be taken frequently.
7. Enjoy the day!
8. Follow up with demonstrations of fish cleaning, preservation, and tasting.

Activity 5 Gillnetting

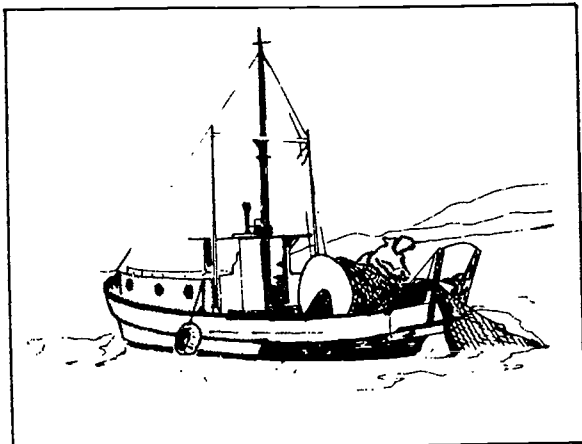

Background:

Gillnetting, as the word implies, means catching fish by their gills in a net. This is the principle behind both set and drift gillnetting.

Gill net fisheries concentrate primarily on returning runs of salmon and herring as they near their spawning grounds. Because of this, they are closely managed by the Alaska Department of Fish and Game. Regulations are set by the Board of Fisheries to govern when, where and what kind of gear can be used.

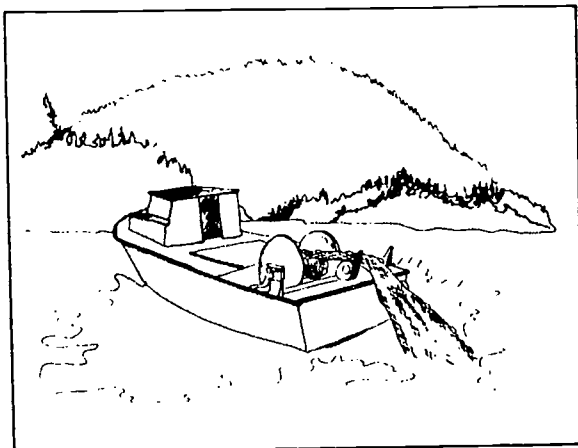

Drift gillnetting means setting the gill net from a boat, then tending

the net as it drifts and fishes. Boats used for gillnetting come in all sizes and shapes. Some are as short as 16 feet, others longer than 40 feet. The boats can be rigged to pick the net up over the bow or the stern and thus are termed bowpickers or sternpickers.

Gillnetting may be carried out as a one-person operation, but most often a gill-netter will have a partner. If a reel is used to pull the net, for example, it is efficient to have one person on each side of the net, using gloves or a short hooked tool to release salmon tangled in the net.

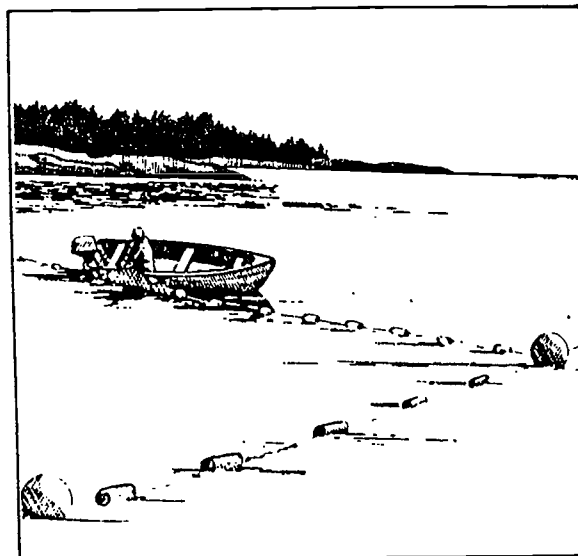

Setnetting operates on the same principles as drift gillnetting, except that the set net is stationary and set out from an anchor on shore rather than being left adrift. Set net sites are for the most part traditional, and many sites have been used by families for years.

In both kinds of gillnetting, a cork line keeps the upper edge of the net floating and a lead line keeps the net vertical by holding down the lower edge. How long a net is allowed to fish before it is checked and the catch removed

depends on the person fishing the net. One way of judging how well the net is fishing is by noting whether the individual corks along the top of the net are bobbing or being pulled under water. The more fish caught in the net, the more changes can be seen in the cork line. This gives the gill-netter a quick, visual check of whether fish are being caught.

In addition to salmon or herring, various incidental fish and crabs are pulled in with the gill net. These often are termed "trash," but actually these young fish and crabs are the fishermen's future. Many will return later as larger fish or shellfish to be caught by someone in the fishing community--or they will provide food for growing salmon, herring, halibut. Gillnetters should toss these incidental fish back as required by state law, being careful not to mangle them in the rush to clean the net and return to fishing.

Vocabulary:

NOTE: The spellings of set net and gill net vary with context. It's set net and gill net (the net itself); setnetting and gillnetting (activity); set-netter and gill-netter (the person); and gillnetter (the boat; setnetting is not a boating activity).

- reel
- drift gillnetting
- setnetting
- bowpicker
- sternpicker
- cork line
- lead line

Materials:

- old gill net or gill net drawn on butcher paper
- 2 floats

- 2 sets of rubber gloves, rain gear and hip boots
- rulers
- bucket or water basket
- reel or roller on which to wrap net
- magic markers
- local person who gillnets
- construction paper
- scissors
- current prices of salmon or herring on the dock
- worksheet:
...Gillnetting (4D)

Procedure:

1. Encourage students to relate their own gillnetting experiences. Pass out the worksheet Gillnetting and have students read and answer the questions. (1: set and drift; 2: 200 fathoms; 3: 6 fathoms; 4: fish are striking the net; 5: drift; 6: because the fish stick their heads through the net and get caught behind the gills; 7: a bowpicker has the reel or roller in front, sternpicker has the reel or roller in back and picks the fish off the stern.)
2. Bring in a manageable piece of an old gill net (or draw one on a long sheet of butcher paper or newsprint); two large floats for either end of the net; a reel or roller (map tube and broomstick); two sets of rain gear, rubber gloves and hip boots. All this should provide great room decorations in addition to the instructional potential!
3. Roll out the net on one side of the classroom. Hook up the floats at either end and you're fishing! Review the terms "cork line" and "lead line." Have students measure

the mesh size and see if they can tell you the species of fish they'll be catching. (Refer to the netmaking section of Activity 2 for information on mesh sizes.)

4. Pass out the construction paper and have students cut out a typical catch for your local area. Include salmon or herring and a variety of incidentals: jellyfish, crabs, young bottomfish, young halibut, shrimp, seaweed. Each salmon or herring should be labeled on the back with the amount it weighs.
5. Have the students stick the fish and shellfish in the net, gently bobbing the cork line as the fish strike.
6. Ask for volunteers: two to pick the net; two to manage the reel; two to pitch the fish; two to weigh the fish; one to run the tender; one to pump gas and sell groceries; one to pay the gillnetters.
7. Have the gillnetters put on the hip boots, rain gear, and rubber gloves and place the rest of the students appropriately around the room.
8. As the gillnetters pull the net, discuss what they will do with the fish as they pick them out of the net. (Ideally they should be placed carefully in a fish bin--an iced bin if they are a long way from the tender, especially if the weather is warm. Fish should always be grasped by

the head or body rather than the tail to retain their quality.)

- What should they do with the other incidental fish and shellfish? (State law requires that they be pitched overboard. These fish are the fishers future--the ones that will come back later as large fish and crabs, or the ones that will provide food for growing salmon, herring, and halibut. So students should carefully untangle them from the net and gently drop them overboard. They are an important part of the ocean's food web.)
9. After the gillnetters have picked the net, they may want to set the net again or head for the tender. There they can deliver the fish, buy groceries and gas (remember no smoking while the gas is being pumped!). As the fish are being weighed, have a student record their weights on the board. Students should multiply the total weight times the price per pound and then subtract the prices of groceries and gas to determine the amount the gillnetter will be paid. They can either be given a fish ticket or cash, depending on the type of tender.
 10. Invite a local gillnetter to visit the class, answer questions, and discuss gillnetting techniques and safety.

Activity 6 Purse Seining

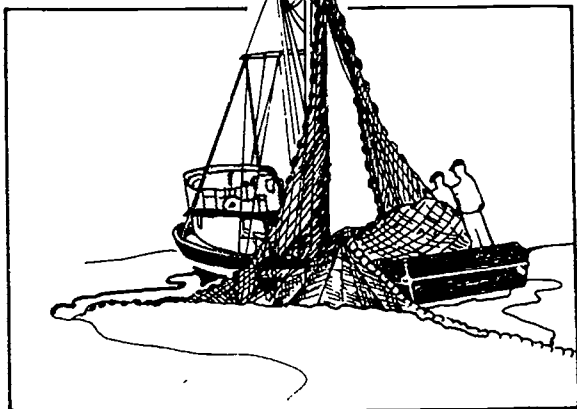

Background:

Purse seining was first tried in the United States on the East Coast in the early 19th century. It is a method that has been used in the Pacific salmon fishery since its beginning and has probably been more economically valuable to the salmon fishery than any other method. In purse seining, a large net is issued to encircle a whole school of fish at one time. After the school is surrounded, the bottom of the net is pursed, or drawn shut, preventing the fish from diving to escape.

On the first seine boats the nets were pulled by hand, an effort requiring many men and much muscle. By the mid-20th century, hydraulic systems were developed to do much of the work previously done with muscle power. In the early 1950s, the power drum and the power block were first used on seiners. Both the drum and the block are hydraulically run and both help bring the net onto the boat. The power drum was quickly outlawed in Alaska because it was so effective and because fewer crew are needed. Alaska has so many fishermen and women that with the power drum, the catch would be harvested too quickly (or

overharvested) and they would not be as many crew jobs. The power drum is still used in Washington, Oregon, and British Columbia--but Alaskans use the power block, a large unit that looks like a pulley and hangs from a boom angled upward above the boat's work deck.

As in all commercial fisheries, many state regulations apply to the seine fisheries. Seine boats operating in Alaska can be no more than 58 feet long, hence the term "limit seiners." The length of the seine net is also regulated, and the limit differs depending on the area to be fished. In Southeast Alaska, for example, the seine nets used for salmon must be between 150 and 250 fathoms long (six feet = one fathom). In Prince William Sound it must be between 125 and 150 fathoms long. The net depth and mesh size also are regulated. Where and when seining may occur is determined by the Alaska Board of Fisheries, and is based on a combination of two factors: the number of fish needed to enter the river system to reproduce, and the number of fish from the "run" already caught that year.

Vocabulary:

- seiner
- power block
- boom
- seine skiff
- jitney
- fathometer
- diagram

Materials:

- paper
- pencils
- seine captain or crew member
- worksheet:
...Purse Seining (4E).

Procedure:

1. Discuss information that students have heard about purse seining. Pass out the worksheet Purse Seining and have students answer the questions. (1: to pull the seine around a school of fish; 2: by relying on past knowledge of where the fish have been, plus currents and tides and a recording fathometer; 3: the top of the net where the floats are; 4: the bottom of the net where the lead weights are; 5: pull in the net; 6: scoop them out with the brailer; 7: 4-6; 8a: \$180.30; 8b: \$19.83; 8c: \$260.80; 8d: \$29.24; 8e: \$49.07.)
2. Have students get out papers and pencils. Ask the students how they explain something complicated to other people. (One of the best ways of passing on information is by pictures--by drawing a diagram.) Have the students individually diagram how a purse seiner works. They can draw everything on one picture or they might try a series of pictures or cartoons.
3. Have students exchange diagrams and see if the explanations and labels are clear.
4. Invite a seine captain or crew member to show slides or pictures and tell of some of their adventures and critique your diagrams.

Activity 7 Trolling

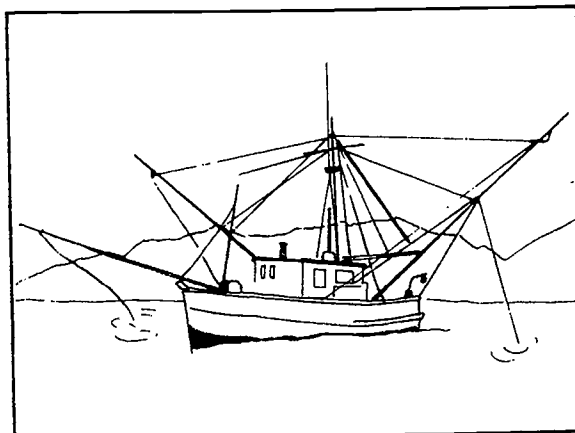

Background:

Trolling is a line fishery, which means fish are caught one by one, or a few at a time.

Because a troller catches just a few fish at a time, the fish are landed more carefully. After a fish is swung aboard with the gaff (a wooden club with a steel hook at the end), it is cleaned and rinsed. Then it is carefully bedded in ice, or placed in a slush tank filled with ice and sea water, or frozen. Troll-caught fish have a higher market value because of their quick, immediate and careful handling.

Trollers traditionally have been the most independent and the least restricted of salmon fishermen. Restrictions on them, however, are increasing annually. Until recently, both power and hand trollers could fish year-round anywhere from Ketchikan to Yakutat. Unlike gillnetters and seiners, they were not limited to brief "open" fishing periods.

Vocabulary:

- troller
- gurdies

- gaff
- pantomime

Materials:

- map of Alaska
- person who works on a troller
- worksheet:
...Trolling (4F)

Procedure:

1. Ask students what they know about trolling. Ask if anyone can imitate a troller. Explain that silent imitation is a form of acting called mime or pantomime. Mime players often paint their faces so that the audience can see their expressions more clearly. Charades is a common party game that similiarly relies on silent imitation. To imitate trollers, so that anyone can tell what's happening, students will have to find out everything they can about trolling.
2. Distribute the worksheet Trolling and have students read and complete the questions. You'll need to have an Alaska map handy for question 6. (Answers: 1: by the two or more long poles sticking up in the air or out to the sides; 2: fish are individually caught, carefully cleaned and chilled; 3: kings and cohos; 4: gurdies; 5: Southeast Alaska from Ketchi-

kan to Yakutat; 6: 430 miles; 7: to refer to the boat or to the person who fishes it; 8a: \$698.20; 8b: \$454; 8c: \$506.10)

3. Have the students practice their pantomiming skills as a class. Perhaps start by having them silently bait hooks. Other suggestions:

Ohh--did somebody hook their finger? Indicate that the boat is rolling a bit with the swells. Drop the baited hooks overboard and watch them slowly go out behind the boat. Ding, the bell on one of the poles rang indicating a hit. Better get busy pulling it in. Boy it's a big one--a 60 lb king! Use a gaff to haul it on board. Then bait the hook, drop it in again. Clean your fish and hold it up to admire! Isn't trolling great?

4. Divide the class into small groups and have each group invent a trolling adventure and practice pantomiming.
5. Have each group perform, and let the other guess what they were doing. Invite a troller to come and critique the mime performance and to tell stories, answer questions and demonstrate gear.

Activity 8 Longlining

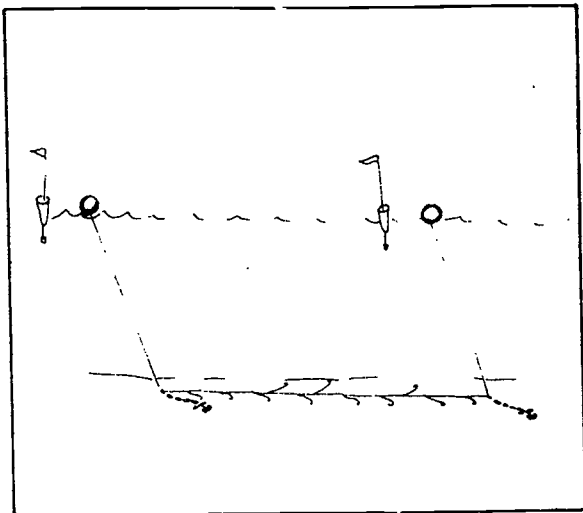

Background:

Longlining is the primary method used in Alaska to catch halibut commercially. Incidentally caught halibut picked up by trollers also can be sold, if caught when halibut season is open.

Halibut fishing in the northeastern Pacific is regulated by a joint U.S.-Canadian Commission called the International Pacific Halibut Commission (IPHC). The commission watches over the fishery, and decides when and where fishing can occur. Before the beginning of the fishing season, the IPHC announces the times and places halibut fishing will be allowed in the waters of the two countries. As the season goes on, the halibut catch is monitored. If it is high, some of the scheduled fishing times, or openings, are canceled or shortened.

The size of halibut that may be kept is regulated for commercial fishing. Fish shorter than 32 inches must be released and returned live to the sea.

Vocabulary:

- longlining
- skates
- gangions

Materials:

- paper
- pencils
- person who fishes halibut commercially
- worksheet:
...Longlining (4G)

Procedure:

1. Ask students if they have ever gone halibut fishing. Introduce longlining as the way halibut are caught commercially. Pass out the worksheet Longlining and have students read and answer the questions. (Answers: 1: halibut; 2: tuna, swordfish, and sharks; 3: a skate; 4: gangions; 5: anchor, buoy line, buoy, and 17-foot pole; 6: so the groundline and gangions will be held on the bottom and so the gear won't drift away; 7: they're so big; 8: by the bundles of tall poles with flags and lights on them and by the longline gear with hundreds of hooks.)
2. Discuss halibut life cycles and the halibut's need for shallow nearshore waters and estuaries for rapid juveniles growth. Order the Sea Grant Life Cycle Poster (see bibliography) and read Alaska Tidelines "The Old Woman," Vol. IV, No. 6, March 1982.

THE LONGLINERS

Yes, give me a packet that's sound and tight.
And a skipper with guts to boom her
Up under the heel of the northern lights
Where the grey seas strive to doom her.
Through the grinding ice where the ground lines freeze,
Through the howling gale and the pounding seas--
Into such tranquil spots as these
You must drive with a halibut schooner.

--from "The Doryman" (author unknown)

3. Have students write stories and poems, or draw cartoons about halibut longlining. Invite someone who fishes halibut to tell some of their adventures as an incentive for accurate, creative big fish stories. Ask them to describe some of the current issues in the halibut fisheries.

Activity 9

Shrimping and Crabbing on the High Seas

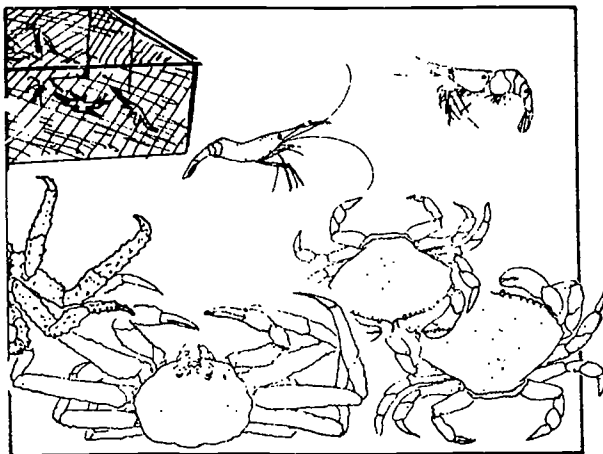

Background:

Five types of shrimp are caught in Alaskan waters. Their names and maximum sizes are: the northern pink, 6 1/2"; humpie, 4 3/4"; sidestripe, 8 1/2"; coonstripe, 8"; and spot, 11". All five species may be found in the same areas, but at varying depths and over different bottom types.

Shrimp can be caught with pots but most commercial operations use huge otter trawls anywhere from 70 to 130 feet long. The net is held open by two huge doors. The Bureau of Commercial Fisheries is developing a trawl which separates bottom-dwelling creatures from shrimp while fishing. Otherwise, tremendous numbers of fish, invertebrates and debris are mixed with the shrimp. This not only costs the shrimp fishermen and women sorting time, but also disrupts the ocean food web as many of these small creatures are food for--or the young of--fish caught in other fisheries.

In Alaska, a large boat (70-80 feet

long) may catch as much as 30-40,000 pounds of shrimp a day. They are rinsed and then shoveled into the hold where they are mixed with crushed ice. Because of the perishability of their catch, shrimp fishermen and women usually fish within 12 hours of their home port. Kodiak is the center of shrimp fishing on the Pacific coast, though the bulk of U.S.-caught shrimp comes from the Gulf of Mexico and the waters off the south Atlantic states.

Three types of crab are caught in Alaska: king, Dungeness and tanner or snow crab. Both shrimp and crab depend on shallow near-shore waters and estuaries for mating and rearing of their young. (See the Sea Week Curriculum Series Volume II for descriptions and further information on both crabs and shrimp and Tidelines "Wanted: Information on the whereabouts of Pandalis borealis, alias Pink Shrimp," Vol. 1, #5, Feb. 1979, for information on shrimp or get a set of the Sea Grant life cycle posters listed in the bibliography.)

Dungeness are fished in small round pots approximately 30 inches in diameter, 12 inches high, and covered with stainless steel mesh. The pots weigh about 80 pounds each. King and tanner crab are fished with rectangular seven-by-seven-by-four-foot steel pots with nylon or steel webbing. These pots weigh 500 to 700 pounds and more when they're filled with crab. In both types of pots, crabs enter through a webbed tunnel to get at such bait as dead herring, squid, or fish heads. The pots are attached by a line (rope) to a float at the water's surface. The lines may be 600 to 1,000 feet long for the king crab fishery.

Fishermen use large, stable boats for crabbing because of often foul weather and because they need storage room for all the pots and the huge seawater tanks used to keep the crabs alive. The profits in crab fishing can be tremendous but so can the risks. Alaska's crab seasons are open in the winter when ocean storms are at their worst. Boats can ice up, or go down and crew members can be washed overboard in heavy seas or hit by the heavy crab pots as they are swung aboard. King crab are caught in the eastern Bering Sea and in the waters around Kodiak, Adak, Dutch Harbor, Sand Point, Cook Inlet, Prince William Sound and Southeast Alaska. (See Tidelines "Alaska's Scariest Fishery," Vol. II, No. 5, February 1980 for more information on the crab fishery.)

Basic shrimp and crab biology are known but there are many gaps in this knowledge. Populations seem to rise and plummet mysteriously. Such unpredictability has both biologists and members of the fishing industry worried. Overfishing and poor handling methods may be reasons for recent major declines in both shrimp and crab populations. For instance, while undersized and female crabs are supposed to be released to help keep the crab populations up, often they are frozen, stepped on or otherwise injured before being returned to the sea.

Yet, while it is true that crab and shrimp populations have declined in heavily fished areas, the populations also are down in areas where there has been no fishing at all.

Weather may be one factor. Changes of only a few degrees in water temperature can affect the

movements and developments of marine life. Shrimp, for instance, spawn earlier and carry their eggs longer when the water is cold. And if it's too cold, they have trouble keeping their eggs.

On the other hand, when the water is warm, shrimp grow faster and mature earlier. Speeding up the growth rate like this might throw off the balance of males and



females needed for a healthy population, because most shrimp species begin life as males and then transform into females when they are three or four years old.

Water temperatures have been warmer lately in both the Bering Sea and the Gulf of Alaska. The increases might have resulted not only in changes in shellfish reproduction, but also the movements of pollock, cod, halibut and salmon, all of which eat young shellfish. Supporting this theory is the fact that the numbers of such fish have been much higher lately in traditional shellfish waters.

(Background information for this activity is from Alaska Tidelines, The North Pacific Deckhand's and

Alaska Cannery Worker's Handbook
by John Higgins, and from Chuck
Parsons, Homer.)

Vocabulary:

NOTE: The plural of crab is "crab" when referring to marine animals of the same species, but "crabs" when referring to more than one species.

- shrimper
- crabber
- trawler
- king
- tanner
- Dungeness
- coonstripe
- sidestripe
- humpie
- spot
- northern pink

Materials:

- scissors
- tape
- thin felt-tip markers
- small balloons
- small dowling
- knife
- thread
- needles
- copy of the WANTED poster (see background)
- person who fishes crab or shrimp
- worksheet:
 - ... Trawl and Pots (4H)
 - ... Shrimp and Crab Matching (4I)

Procedure:

1. Ask students what they know about shrimp and crab fishing. Mention that even though shrimp and crabs are not fish, they are part of the fishery. Familiarize students with the workings of a shrimp trawler (which hauls a big

net through the water) and a crabber (which drops pots at set intervals). Small shrimp boats haul the net in over the side, while large boats bring it in over the stern. Crabbers have to be careful not to lose their pots in strong tides and currents. Distribute the worksheet Trawl and Pots. Explain that the trawl is 70 to 130 feet long; the king crab pot is seven-by-seven-by-four feet, and the Dungeness pot, one-by-two-and-a-half feet.

2. Have students sketch netting for the trawl and the two pots with dark felt tip markers. The doors of the otter trawl should be a solid dark color. The frames (all the edges and fold lines) of the crab pots should be a solid dark color.

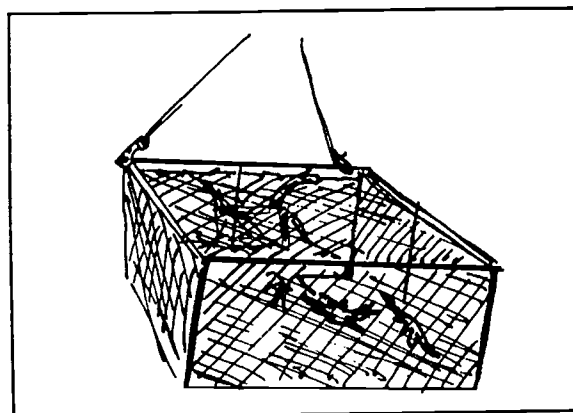
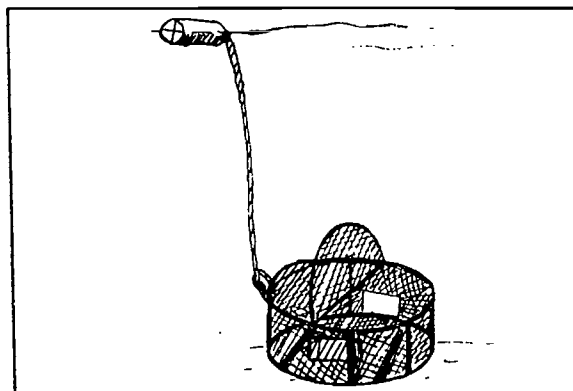

3. Then have the students cut and tape their pots and tie on

lines (thread) and attach floats (small balloons for the king crab pots and short pieces of colored sticks for the Dungeness pots) to the crab pots. The students should write their initials on the crab pot floats to mark them as required by law. Plus, students need to punch holes in the bait cans so the crabs can smell what's in there.

4. Pass out the worksheet Shrimp and Crab Matching so the students can catch something to put in their traps! Have them match the pictures with the descriptions. They may need the WANTED poster on the next page to locate the parts of the shrimp that are mentioned. (Answers: 1: king crab; 2: northern pink shrimp; 3: spot shrimp; 4: Dungeness crab; 5: humpie shrimp; 6: tanner or snow crab; 7: coonstripe shrimp; 8: sidestripe shrimp.)

5. Have students color the shrimp and crab, cut them out, and write their names on the back. Then they can put them in the proper traps: shrimp in the otter trawl; tanner and king in the king crab pot; and Dungeness in the Dungeness pot. Explain that some commercial fishers use special tanner crab pots

with openings just the right size for this smaller species to get into the pots. Others use king pots and put a board partially across the opening to keep kings out when king season is closed.

6. Discuss the difficulties that the shrimp and crab industry has had because of the mysteries of weather and biology. Show students the WANTED poster on the next page and explain some of the puzzles about crabs and shrimp mentioned in the teacher background. Students can do their part to help Alaska's future fisheries by always tossing back the young, females, and incidently caught fish when they are out fishing. Invite a local shrimp or crab fisherman or woman to discuss these and other aspects of the fishery and to answer questions.
7. Be sure students know the sportfishing regulations on these species. Shrimp are often sport-fished in pots. Small crabs and females should be tossed back to provide for the next generation of fishing and eating!! (The female crab has a wide tail under which she broods her eggs.)

WANTED

first posted in *Tidelines*

Information on the whereabouts of *Pandalus Borealis*,
alias pink shrimp

DESCRIPTION

Size: About 3-5 inches

Color: Pale Pink

Weight: 60-160 per pound

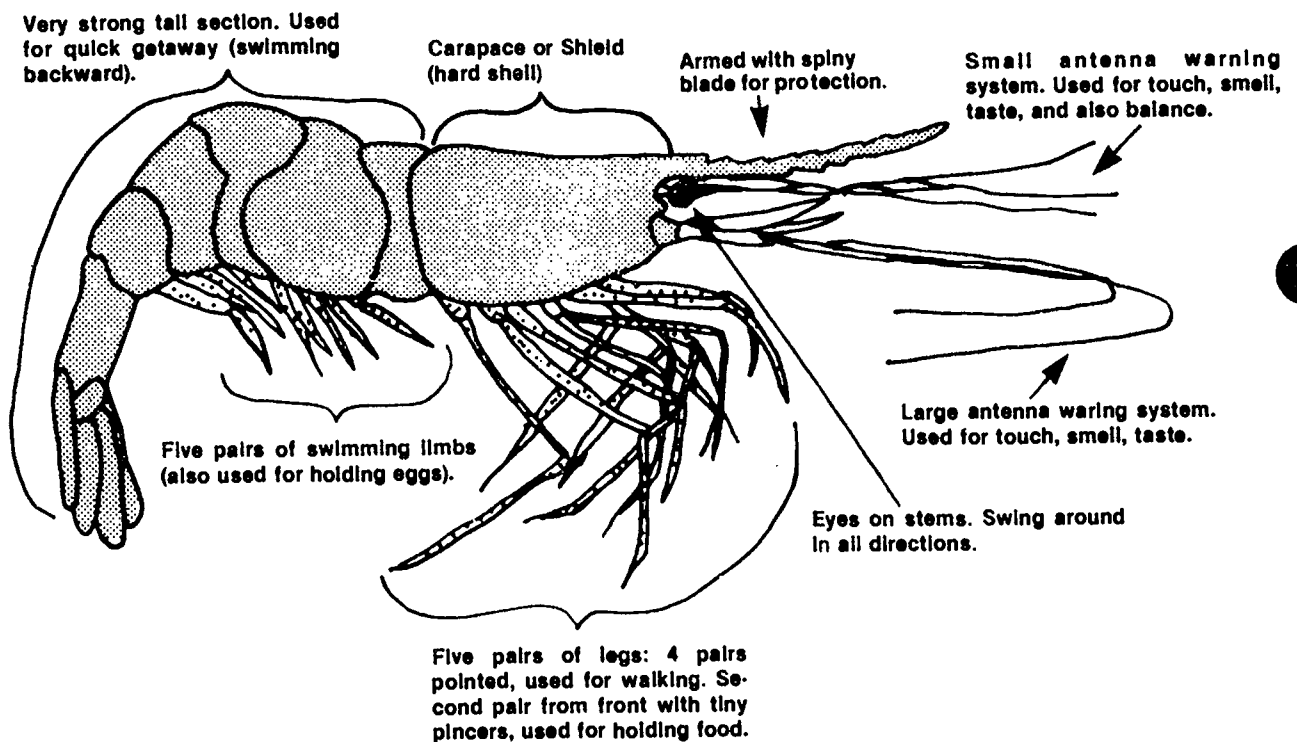

REWARD

ABOUT \$12 MILLION A YEAR FOR ALASKA FISHERMEN . . . MILLIONS MORE FOR ALASKA'S ECONOMY . . . AND MOUNTAINS OF FRESH SHRIMP SALAD FOR EVERYBODY.

Activity 10 Who Gets the Fish ?



Background:

Sometimes there is complaint about fishing regulations without recognition of the background issues behind them, and without realization that regulations can be changed if they really aren't for the best. The Alaska Board of Fisheries makes the regulations, but there are opportunities for public input.

Regulations are, in effect, allocation decisions governing the private uses of common property resources. In other words, the Board of Fisheries makes decisions about who gets the fish. Subsistence fishermen need fish for survival. Sport fishermen support many businesses by purchasing gear for recreational fishing; and commercial fishermen need fish in order to make a living, to keep canneries open, and to provide fish for people to eat. The issue of who gets the fish can become extremely complex.

To make those decisions, the seven-member Alaska Board of Fisheries is appointed by the governor and confirmed by the

legislature. In addition to the Board of Fisheries, there are local fisheries advisory boards (currently 68 of them), overlaid by six regional fishery councils. The Alaska Department of Fish and Game is charged with providing management data and information to the board. The Fish and Wildlife Protection Division of the Alaska Department of Public Safety (which also includes the State Troopers) enforces the regulations.

The increasing competition for limited fishery resources has resulted in frequent litigation, which also affects regulations. The Board of Fisheries also works with the North Pacific Fisheries Management Council which is a federally mandated advisory group responsible for fisheries between three and 200 miles offshore (outside state waters).

Individual citizens can make recommendations to the various boards and agencies, either privately or during regularly scheduled meetings and hearings.

The strength of the Alaska Board of Fisheries is in its being a public forum through which diverse input and scrutiny serve as crosschecks between competing viewpoints. The board is accessible to your students, along with all other Alaska residents. Many of the board's decisions rest not only on management data, but also on the quality of public participation.

Vocabulary:

- regulations
- Board of Fisheries
- advisory council
- litigation
- common property resource

Materials:

- copies of fishing regulations
- member of local Fish and Game Advisory Committee
- Fish and Wildlife Protection Officer

Procedure:

1. Ask students to name as many local fish regulations as they can. Then pass out copies of the fishing regulations (commercial, sport and/or subsistence). Add to the class list.
2. Invite a fish and wildlife protection officer to come to your class and talk about the challenges and rewards of enforcing regulations.
3. Invite a member of the local fish and game advisory committee to show to your class and share experiences or have students interview the committee member at home. Outline the procedure for changing a regulation.
 - a. A proposal is submitted to the local fish and game advisory committee (Committee members or fish and game employees can assist with proper wording.)
 - b. The advisory committee makes a recommendation on the proposal.
 - c. The regional council makes a recommendation on the proposal.
 - d. The Board of Fisheries acts on the proposal with input from the Alaska Department of Fish and Game, the Fish and

Wildlife Protection Division, and other agencies.

- e. A regulation adopted by the board is drafted into the proper format for publication and, after lengthy legal review, goes to the lieutenant governor for signing into law. The regulations become effective 30 days after the signing.

Remind students that they are welcome to go to any of these meetings and add their verbal input before a decision is made. Students also can go directly to the Board of Fisheries with their proposals.

4. Ask the students if they can think of any regulations they would like to see changed. How would their proposal most likely be approved? The proposal should:
 - a. be well researched (The students might want to do their own scientific study to be sure the fish would benefit too!). Discuss the proposal with a fish and game biologist and a protection officer as well as other fishers. (Is the proposal biologically sound, reasonable, and enforceable?)
 - b. have local support (Generally but not always students should at least talk to someone with an opposing viewpoint to be sure they can respond to all the objections.).

- c. be well-worded.
- d. Have the support of the local advisory committee (generally but not always). Students should talk to each advisory committee member and attend a meeting ready to speak up in support of their proposal.
- e. Write letters about their proposal to the regional advisory committee and the Board of Fisheries.

Now come up with a proposal and give it a try. Good luck!

Activity 11 Harbor Field Trip

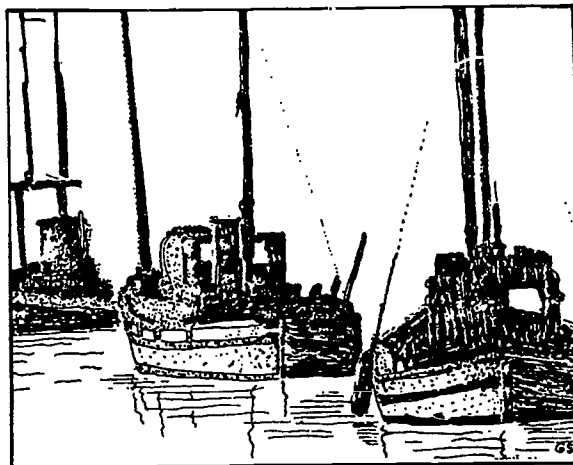

Background:

The harbor is the focal point of just about every coastal community. Good harbor sites are extremely valuable, and are usually the first coastal sites to be inhabited. The comings and goings of local boats as well as those from other states and nations add excitement and color. In fishing communities, the boats in the harbor often are worth more than the houses in town. Harbors offer tremendous learning opportunities and are often within walking distance from local schools.

Even for interior communities, local waterfronts bustle with boats and motors, and serve as sources of hunting and fishing stories and outdoor adventures. This activity focuses on harbors, but easily can be adapted to general waterfront studies along Interior rivers.

Materials:

- notepads
- pencils
- binoculars
- life rings and ropes

- fisherman or woman
- harbor master or mistress
- worksheets:
 - ...Fishing (4J)
 - ...Harbor Investigation (4K)

Procedure:

1. Plan a field trip (preferably more than one) to your local harbor or waterfront.
2. Send home permission slips. Invite parents and local resource people to go with you or meet you at the harbor for a tour of their boat. Plan to divide your class into small groups, if possible, for part of the field trip. High school students involved in local fisheries could be good group leaders. All your assistants, in fact, will perform better with pre-trip preparation. Visit the harbor with your assistants ahead of time, if possible. Go over the two worksheets with them, reviewing the different types of fishing boats and ways to find invertebrates, birds, fish, mammals, and signs of environmental impact.
3. Pass out the worksheet Fishing Boats and have students label the pictures.

(1. purse seining; 2. salmon (mainly pinks) or herring; 3. drift gillnetting; 4. salmon or herring; 5. trolling; 6. salmon (kings and cohos); 7. crabbing; 8. crab (dungeness); 9. longlining; 10. halibut; 11. set gillnetting; 12. salmon.) Then go over the worksheet Harbor Investigation and talk about the answers you might expect. Binoculars might help in identifying birds and

mammals. Tell students to look carefully for seaweeds and invertebrates under the dock, on the sides of pilings, inside old tires hanging down for bumpers, and on lines (ropes) hanging down in the water. For a sure way to find invertebrates, several days (or the day before) your field trip--put aged meat, entrails, or a baited crab pot (in season) into the water.

Typical environmental problems include oil and gas spills, litter, dog droppings, sewage, garbage seepage from a landfill, and fish gurry or crab wastes from a cannery. The class might want to interview a fisherman or woman and the harbor master or mistress as a group. Go over the questions students might ask about the harbor's past, present and future; fishing techniques; fishing boats and gear; problems of harbor management; fishing and harbor adventures. Have the students take notepads and pencils so they can jot down quick notes for writing a story later. Students may want to take cameras, plankton nets, and secchi disks, as well. (For more information on plankton nets and secchi disks, see Unit 3, Activity 3.)

4. Go over safety procedures and take a life ring and rope with you. Have each student practice throwing it beforehand.
 - Use the buddy system.
 - Stay together.

- If someone falls in, yell for help, toss a life ring or oar, launch a rowboat but don't go in the water yourself.
5. Plan follow-up activities. If you have only one chance to go to the harbor, you may want to do some of the activities in the next unit, Life on the Seas and Rivers, before you go.
 6. Enjoy your trip to the harbor!
 7. Follow up by having students write stories from their interviews for the school or community paper. Go over pointers for newspaper journalism:
 - Have a strong lead-in (interesting but true statement).
 - Tell what's happening (the "five Ws" are Who, What, When, Why, Where) in the first paragraph.
 - Go over other story events in succeeding paragraphs.
 - Remember, quotes make your story lively and interesting.

Additional Activities:

1. Art, Science: Have students make model fishing boats out of paper. Assemble soda straws, spools of thread (for reels), needles, old nylon stockings (for nets), felt-tip markers, scissors, construction paper. A sample hull cutout is enclosed. As the hull is folded down and the bow and stern are taped to the sides, the boat assumes an arched deck. (There is no bottom to the hull!) Students can create paper boxes for pilot houses and use the soda straws for masts, outriggers, cross-ties, stove pipes, or the center of reels and winches. Anything added to the pilot house should be done before the pilot house is taped to the deck. Felt-tip markers can be used to show port holes, scuppers, and other detail, plus to add the boat's name. (Activity developed by Bill Hastie, Marine Education Consultant, Oregon Department of Education)
2. Art, Science, Language Arts: Have students make charts comparing different types of sport, commercial and subsistence fishing boats. They can either draw the boats or cut pictures out of fishing magazines or catalogs.

Boat Hull

Directions: Cut on the solid lines, fold on the dotted lines.

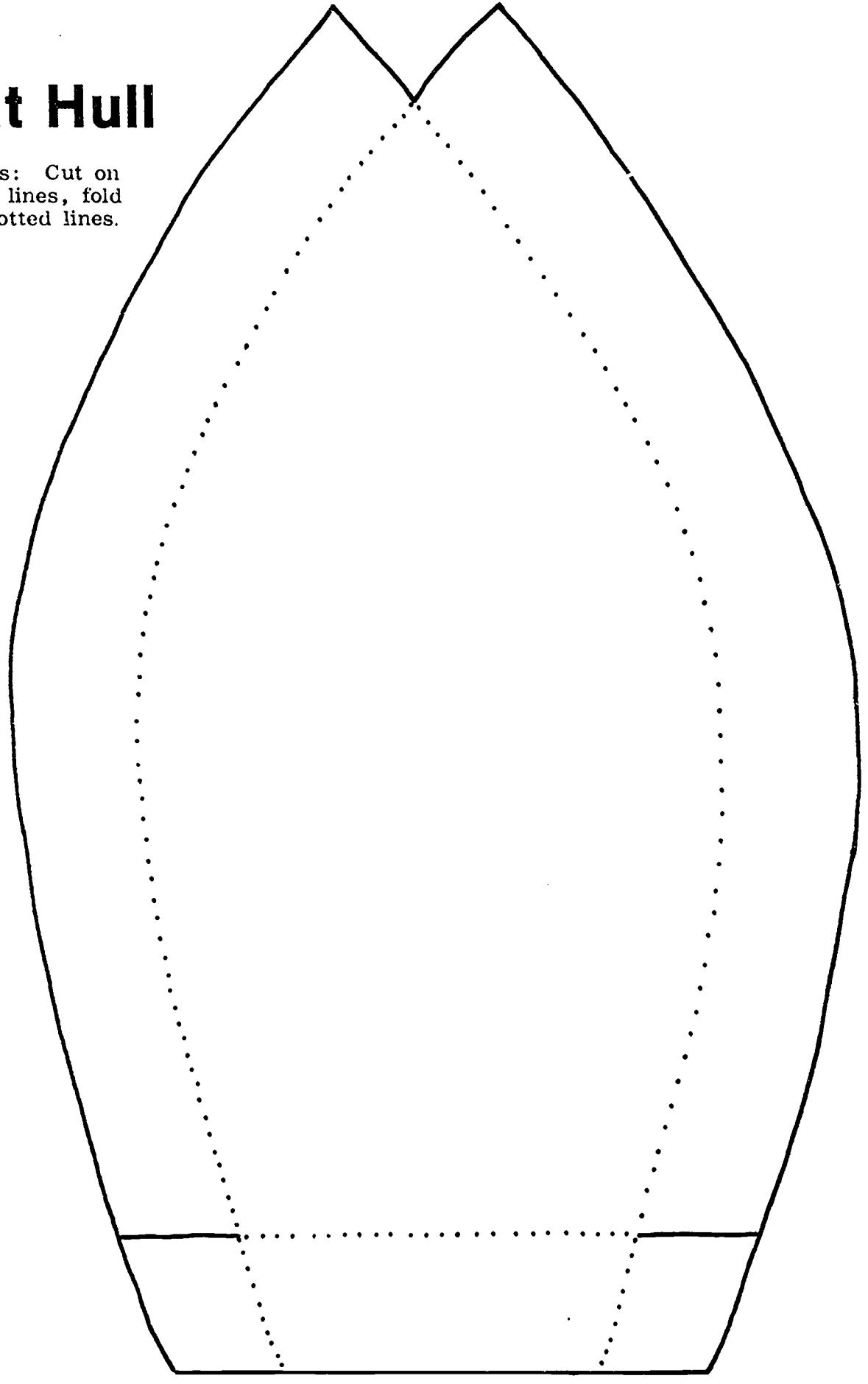

Unit Five

Life on the Seas and Rivers

Index

Activity 1: Art, Music, Literature, and the Sea.....108	Activity 4: Knots.....114 Worksheet: Eight Knots5E
Activity 2: Boat and Nautical Language110 Worksheets: Captains Know Their Boats5A Ship Ahoy!.....5B	Activity 5: Tides.....115 Worksheet: Tides5F
Activity 3: Navigation111 Worksheets: Port of Anchorage Chart.....5C Nautical Knots5D	Activity 6: Boating Safety ..116 Worksheets: Putting Out to Sea.....5G Safety Afloat.....5H
	Activity 7: Sportfishing Trip.....118

Objectives:

To help students:

- Explore the influence of the sea on art, music and literature (Activity 1).
- Express their feelings about the sea through poems, stories, watercolor paints, music and wood or soap carvings (Activity 1).
- Label the parts of a boat (Activity 2).
- Use nautical phrases (Activity 2).
- Read a nautical chart (Activity 3).
- Compute a variety of knotty problems (Activity 3).
- Tie eight different knots (Activity 4).
- Read a tide table (Activity 5).
- Graph local tides for a week or more (Activity 5).
- Plan necessary boat safety practices and equipment for their own boat (Activity 6).
- Wear life jackets and survival suits (Activity 6).
- Play a Safety Afloat Game (Activity 6).
- Survey local sportfish and their habits (Activity 7).
- Read sportfishing regulations (Activity 7).
- Practice sportfishing skills (Activity 7).

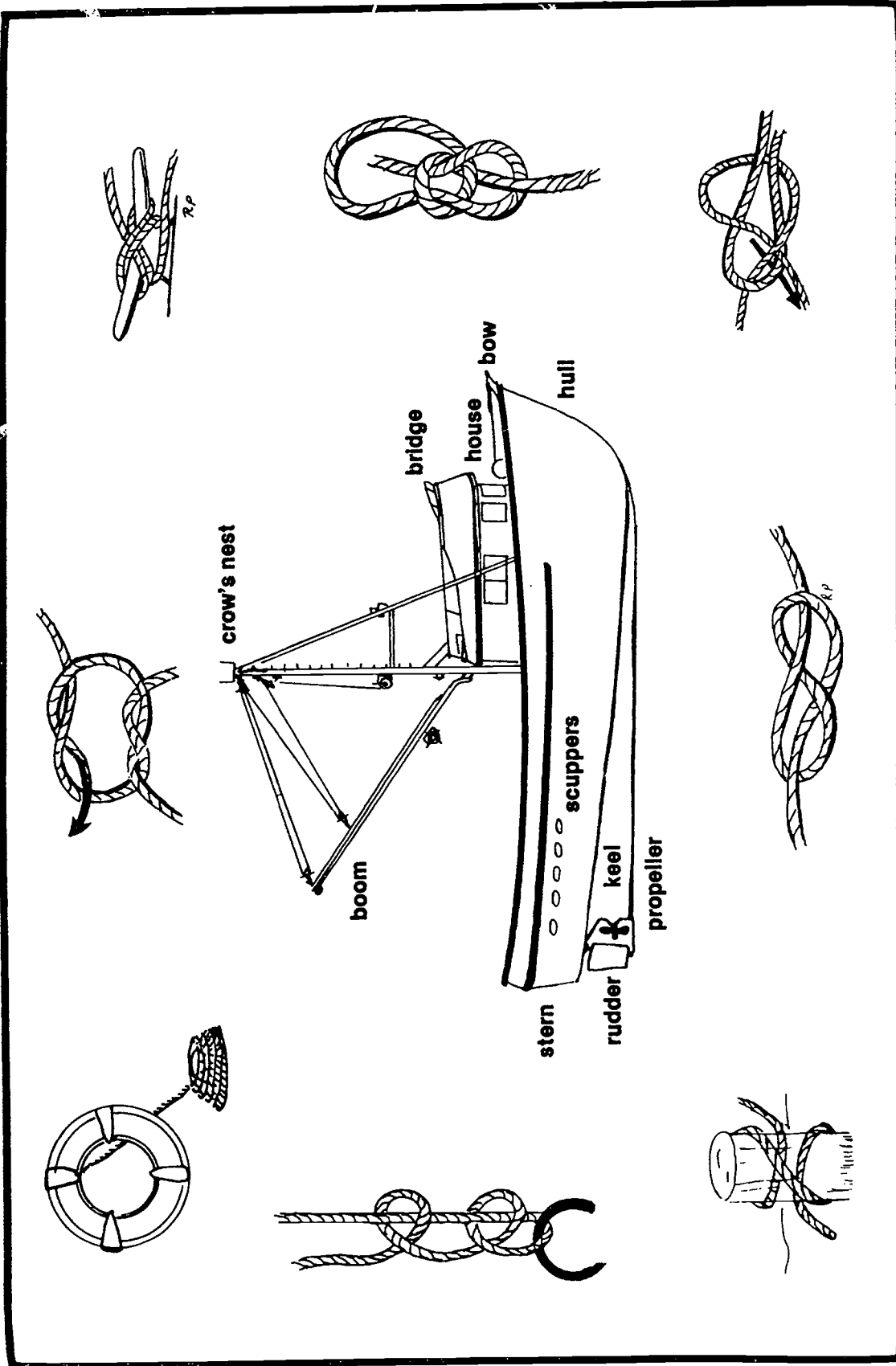

Unit Five: Sea ropes, clockwise from top left: life ring, square knot, figure eight on a cleat, bowline, sheet bend, figure eight, clove hitch, two half hitches.

1.5.1

Fishing is an old, old way of life. At its most basic, it is a way of getting food - a means of survival. Before people had supermarkets, even before fields were cultivated and seeds planted, people hunted and fished to obtain their food.

From earliest times, those people who set out in boats to fish have been aware of the risks involved. Fishing peoples past and present have pitted themselves and their frail vessels against the unpredictable, often violent, forces of wind and waves. Anyone who has ever fished or known people who fish can give accounts of vessels and people lost without a trace in stormy weather, of ships driven onto rocky shores, of crew members lost overboard. The sea and rivers can be hard masters that do not compromise or forgive mistakes.

Knowing the risks they take, many men and women still choose to make fishing their way of life. The reasons for such a choice are

many but high on the list would be a desire for independence, a desire to live close to the elements of nature, and a need to face challenge.

Risks and rewards of fishing have changed little over thousands of years. Modern technology has, of course, made some aspects of life at sea easier, but it has not yet tamed the elemental forces nor substantially reduced the risks. Modern fishermen and women draw upon knowledge and skills from generations before them. To these are added the latest electronic or mechanical products of our time. Survival and success at sea depend on knowledge drawn from many sources over many years.

Fishing consists of more than understanding and being able to operate a boat and its gear. For students to understand fishing as a way of life, they will need to explore some of the many areas of knowledge and skill fishing requires.

Activity 1 Art, Music, Literature and the Sea

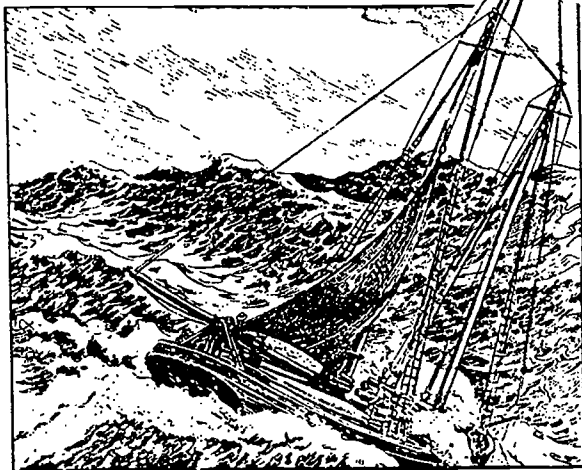

Background:

The seas and rivers have powerful influences on most Alaskans, who receive most of their food and supplies from over the sea, if not from the sea itself. Many jobs are sea-related: The grocer stocks seafood products and sea-transported products; and dockhands, captains, boat builders and manufacturers of a multitude of boat and fishing equipment for the commercial, sport, and subsistence fisheries are all involved directly with the sea. In addition to supplying bodily needs, the sea has had a tremendous effect on the art, music, and literature, of our history and culture. This activity just barely opens the door (or the porthole) to a vast array of exciting reading, writing, painting and carving.

Materials:

- sea and river poems and stories, paintings and carvings
- paper
- pencil
- watercolors

- brushes
- bar of soap or block of wood for each student
- knife for each student
- local artist

Procedure:

1. To capture the spirit of "putting out to sea," share these poems and others with your class; or sing a few sea chanties, read some of the stories listed in the bibliography, and bring carvings and paintings (such as those of Winslow Homer). Try to capture the mood of the sea. Imagine the ocean both in calm and stormy days, rain and sun. Mention the long hours at sea and that some sailors and fishermen filled by carving exquisite scrimshaw into ivory, keeping journals, or making sketches of sea life.

Sea-Fever

I must go down to the seas again,
to the lonely sea and the
sky,
And all I ask is a tall ship and a
star to steer her by,
And the wheel's kick and the
wind's song and the white
sail's shaking,
And a grey mist on the sea's face
and a grey dawn breaking.

I must go down to the seas again,
for the call of the running
tide
Is a wild call and a clear call that
may not be denied;
And all I ask is a windy day with
the white clouds flying,
And the flung spray and the blown
spume, and the sea-gulls
crying.

I must go down to the seas again

to the vagrant gypsy life,
To the gull's way and the whale's
way where the wind's like a
whetted knife;
And all I ask is a merry yarn from
a laughing fellow-rover,
And quiet sleep and a sweet dream
when the long trick's over.

by John Masefield

The Sea to a Sailor

Blue green water
stretching forever
ebbing gently
whispering
slipping by
broken only by the distant
white
of seagulls.

Then suddenly
the fish jumps
the solemnity is shattered
the ripples laugh
silver bubbles burst
then slowly
silently
the calm returns
to reign
once more.

by John Hannah,
a British Columbia student

Poem of the Wintery Fisherman

At the foot of October
where the current narrows,
the salmon wait,
Burning in the shallows -

blood-red, green and orange,
in the ice-blue glacier water.

Listen! you can hear
the long, slow pull of slush

against the banks,
deep rumble of stones.

I stand alone in the smoking
frost, a long hook poised,
and fling the bright fish up
the pebbled, icy bar
to quiver and lie still,
a sinking fire.

Sometimes the cold eggs spill
in the snow, glowing
like the eyes of foxes who wait
at sundown, when I shoulder
my catch and mount
the frozen twilight homeward.

Along the darkening river,
ravens grip their iron twigs,
shadows of
the hungry, shuddering night.

by John Haines, Alaskan poet
from Winter News, p. 61

2. Then have students try to express their own feelings with watercolors; soap or wood carvings; poems; stories; music. Invite local artists, musicians, poets, and authors to share their experiences with your class and assist the students in their projects.

Fish
Gold red
It eats animals
Lives in the sea
Diving and swimming
Salmon, halibut, fish.

by Cherish Carroll, (Gerry Young,
teacher) University Park Elementa-
ry, Fairbanks)

Activity 2

Boat and Nautical Language

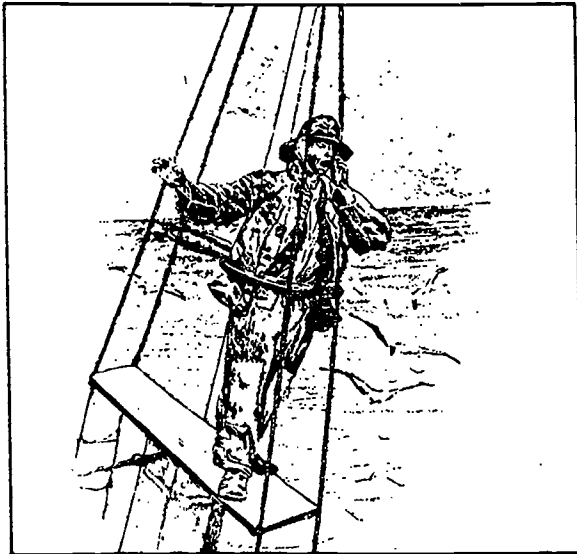

Background:

Boat terminology and language have developed over the centuries. In times of emergency, many seconds of valuable time can be saved by using correct and precise terms.

Vocabulary:

- keel
- hull
- house
- mast
- boom
- bow
- stern
- port
- flying bridge
- crow's nest
- starboard
- rudder
- propeller
- aft
- aboard
- aloft
- below
- deck
- hatch
- scuppers

- galley
- head
- batten
- shipshape
- bilge
- stow
- list
- bunk
- helm
- line
- cast off
- belay
- P.F.D.

Materials:

- model boat
- paper
- pencils
- worksheets:
 - ...Captains Know Their Boats (5A)
 - ...Ship Ahoy (5B)

Procedure:

1. Ask students to think of nautical terms and share them with the class. Pass out the worksheet Captains Know Their Boats and have students label the parts. (Answers: a: bow; b: starboard; c: port; d: stern; e: bridge; f: house; g: hull; h: crow's nest; i: boom; j: scuppers; k: keel; l: rudder; m: propeller.) Use a model boat in the discussion afterwards to assist students in visualizing all the features.
2. Share this boat poem with students as a sample of what happens when a part is forgotten!

Homemade Boat

This boat that we just built is just fine -
And Don't try to tell us it's not.

The sides and the back are divine
It's the bottom I guess we forgot....

by Shel Silverstein

3. Then try out nautical phrases with the students. Pass out the worksheet Ship Ahoy. (Answers: 1: e; 2: i; 3: d; 4: j; 5: l; 6: g; 7: f; 8: k; 9: m; 10: b; 11: a; 12: p; 13: n; 14: h; 15: o; 16: c.)
4. Begin a class collection of nautical terms and phrases. Have students write short humorous paragraphs or poems using as many nautical terms as possible.

Activity 3 Navigation

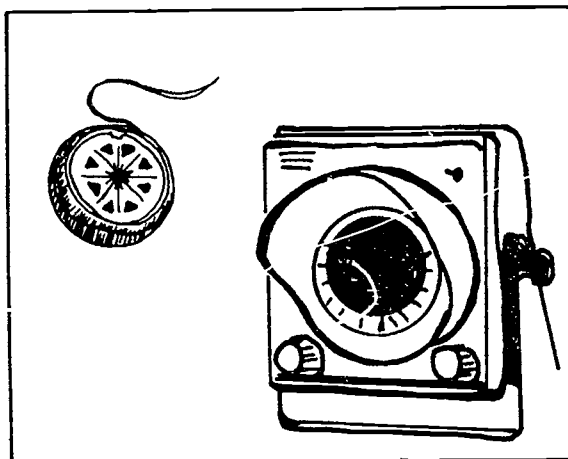

Background:

Navigation is a complex science, but its basic concept can be conveyed through the relatively easy skill of reading a chart. Landlubbers have maps which delineate roads, cities, and political boundaries. Charts emphasize natural and man-made features of interest to a navigator. To travel anywhere safely, a skipper must have knowledge of water depths, shoals, channels, and where ports and harbors are located. This information can be gained only from other local residents, or through long experience in an area, or by reading a chart. For details in navigation or chart reading, use Chapman's Piloting, Seamanship and Small Boat Handling.

Vocabulary:

- chart
- scale
- compass rose
- declination
- latitude
- longitude
- navigational aids

Materials:

- local charts
- compasses
- pieces of string
- pencils
- copies of local charts
- electronic navigational equipment
- worksheets:
 - ...Port of Anchorage Chart
(5C)
 - ...Nautical Knots (5D)

Procedure:

1. Obtain a nautical chart of your area from a government agency, store, local resident, or order one from National Ocean Survey Chart Sales and Geodetic Control, Federal Building and U.S. Court House, 701 C Street, Box 38, Anchorage, Alaska 99513. Make copies of portions of the chart and develop questions for the students to answer. Use the worksheet Port of Anchorage Chart as an introduction. You'll need to tape the two sheets of the chart together. (Answers: 1: starboard, port; 2: hard, rock; 3: 66 feet; 4: port; 5: 140 feet, equal intervals 6 seconds light; 6: port; 7: draw a line so that the boat has more than 6 fathoms of water.) For more information, check Tidelines, "The Port That Grew in the Wrong Place," Vol. III, No. 3, November 1980.
2. Go over the following terms and information about navigational aids:
 - Scale indicates distances. A chart is a representation in miniature of a certain area. Actual distances must be

"scaled down." Have students calculate distances between different points on their charts by using a piece of string to measure the distance, and then comparing it to the equivalency scale. Note that from the scale on your chart that distances are given in nautical miles as well as statute (or land) miles. 1 nautical mile = 1.5 statute miles, so nautical miles are a little longer. The worksheet Knotty Problems contains a few computations for your students using nautical miles and boat speeds. (Answers: 1: 5 hours; 2: 70 nautical miles; 3: 6 knots; 4: \$15.)

- A Compass Rose is the star shape printed on maps to indicate the 64 compass points (Some compass roses contain only 32 points, some 16, and some eight: North, Northeast, East, Southeast, South, Southwest, West, and Northwest). A student using a map and compass should spread the map on a flat surface, then rotate it so that its compass rose point indicating magnetic north is pointing the same direction as the compass needle.
- Latitude and longitude are indicators of exact location on the earth's surface. The whole world is divided like graph paper with longitude lines running north and south, and latitude lines running east and west. Have students find the latitude and longitude lines on their charts. Ask the students:
 - Where are the 0° latitude

and longitude located? (They should be able to tell by looking at their charts that the 0° longitude is east and the 0° latitude is south. Latitude starts at the equator and longitude starts on a line that runs through Greenwich, England.)

- Depths on the Pacific Coast are listed in fathoms (1 fathom = 6 feet) at the "mean lower low water." The definition of mean lower low water is the average of all the lowest water levels for tidal days over a period of time. Have students find the deepest spots on their charts. Then have them change those readings to feet. For example, if the depth is 6 fathoms, it would translate to 36 feet.
- Natural and man-made features are marked throughout the chart. Have students look for uncovered rocks; bottom types (Knowing whether a bottom is sandy, rocky or muddy is important to

know for anchoring), wrecks, snags or stumps. Note the land contours which show heights of mountains and other landmarks that a person might be able to see briefly through the fog! Have students make a class list of all the different markings.

- Navigational aids are a variety of markers that help people traveling in seas and large rivers. Buoys are used to indicate channels. There is a little phrase students should know: "Red right returning." When anyone's coming into the harbor, all the red buoys should be on their right.
3. Research old and news ways of navigation. Invite village elders, a long-time fisherman or woman, someone from the Coast Guard, a Sea Grant Marine Advisory agent or a marine supply owner to go over old-time and the latest electronic navigational equipment. Your class may want to visit a boat or marine supply store, or look at marine catalogs.

Activity 4 Knots

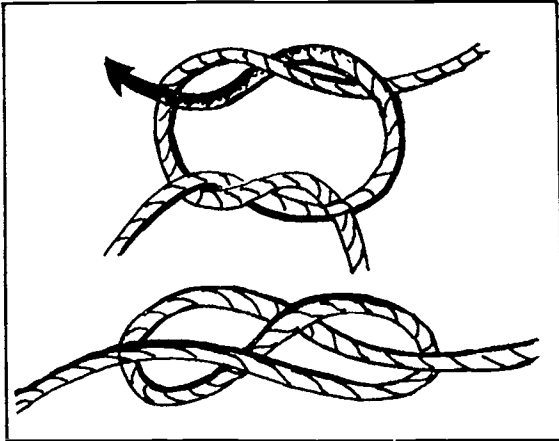

Background:

Knowing knots is critical to anyone who spends any time around water. Fishermen and other boat handlers should know knots so well that they can tie them in the dark and blindfolded! Knots often must be able to hold under adverse weather conditions, yet untie easily. And that's sometimes tough when they are wet and frozen. Every smart fisherman or woman always carries a knife to cut the lines quickly in an emergency.

Materials:

- 2 pieces of string or line per student
- several cleats mounted on wooden boards
- small log or chair leg
- ring or coat hanger
- scissors
- colored pencils
- worksheet:
...Eight Knots (5E)

Procedure:

1. Collect two pieces of string or line for each student, several small logs or chair legs, rings or coat hangers pulled out of shape, and colored pencils. Attach several cleats to boards (devise imitation cleats out of pieces of wood if you don't have the real thing).
2. Explain to students that they'll need to know these knots for their next ocean or river voyage! Then pass out copies of the worksheet Eight Knots and two pieces of string per student. Remind students that on a boat, ropes are called "lines." The students may want to shade each line a different color on the drawings of the square knot and sheet bend so that they can tell where each line goes. Have students cut out the pictures of the different knots to make little cards, then practice tying.
3. After the students practice, call out the different knots and see how fast their hands can move. Check for knot accuracy throughout the session. Discuss situations in which each knot would be needed, such as "The line was rapidly slipping through my partner's hands as he tried to hold our skiff, which was being pulled away by a fierce rip tide (strong current). I quickly grabbed the end of the line and wrapped it in a figure eight around a cleat."

Activity 5 Tides

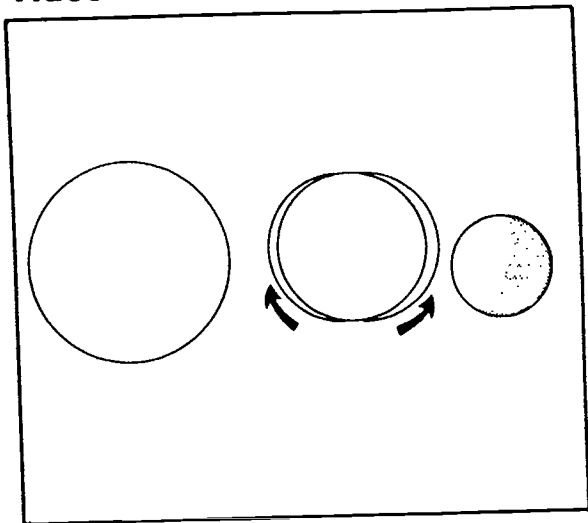

Background:

Tides are important to fishermen. Some places may be better to fish at a particular stage of the tide and may even be impossible to fish if the tide is ebbing or flooding too strongly. When fishing, a boat operator must always be aware of whether the tide is flooding or ebbing and must operate the boat and the fishing gear accordingly. Everybody fishing carries one or more tide books and often a book showing tidal currents as well.

Tides are caused by the gravitational pull of the moon and the sun on the earth's surface. The moon, because it's closer to the earth, exerts the strongest pull. As a result, the side of the earth (a) closest to the moon will have higher tides than the side closer to the sun (b). Water is pulled from the intermediate areas (c and d) to form the high tides, so these areas will have low tides. The earth is continually spinning so that areas c, d, e and f alternate between low and high tides.

The average highs and lows vary in different areas because of land formations and ocean currents. Cook Inlet has the greatest tidal range in Alaska and the second highest worldwide. Sometimes the Cook Inlet tide varies 40 feet from low to high tide. Yet the tides are almost nonexistent along the shores of the Bering Sea and other northern coast areas of Alaska.

Materials:

- tide tables, one per student if possible
- worksheet:
...Tides (5F)

Procedure:

1. Obtain tide tables for each student or at least enough so that every two or three students will have one to share. Banks, marine supply, and sporting goods stores often distribute tide tables free or at a nominal cost.
2. As a class, review the causes of tides and then spend time looking through the tide books and discussing the kinds of information they contain. If possible, look at tidal information for a location near your community. Ask the students:
 - When is there a low tide today?
 - When is there a high tide?
 - When is the highest tide of the month?

If the tide book contains information on the combined effect of wind and temperature, discuss the importance

wind chill tables. If you live near a marked channel, and channel marker information is included in your tide books, review the colors and markings of navigational aids.

- Distribute the worksheet Tides and allow time for students to complete the answers to the questions. (Answers: 1: 12.7; 2: .09; 3: 8:59 a.m. and 9:06 p.m.; 4: 6:53 a.m. and 7:39 p.m.; 5: Nov. 5; 6: Nov. 5; 7: 9.4 feet.)

HIGH Tides CORDOVA District NOVEMBER 1983					LOW Tides CORDOVA District NOVEMBER 1983				
DAY	DOT	TIME	FT.	TIME	FT.	DAY	DOT	TIME	FT.
1	Tues	9:36	12.7	9:49	12.2	1	Tues	3:06	0.9
2	Wed	10:16	13.6	10:42	12.6	2	Wed	3:54	0.5
3	Thur	10:56	14.4	11:33	12.9	3	Thur	4:40	0.4
4	Fri	11:32	14.8			4	Fri	5:19	0.6
5	Sat	0:19	12.9	12:07	15.0	5	Sat	5:59	1.1
6	SUN	1:03	12.7	12:42	14.8	6	SUN	6:36	1.9
7	Mon	1:45	12.2	1:15	14.3	7	Mon	7:15	2.8
8	Tues	2:31	11.6	1:49	13.5	8	Tues	7:54	3.8
9	Wed	3:13	10.9	2:26	12.5	9	Wed	8:39	4.8
10	Thur	4:09	10.2	3:08	11.4	10	Thur	9:24	5.6
11	Fri	5:18	9.7	4:04	10.3	11	Fri	10:20	6.2
12	Sat	6:32	9.6	5:34	9.5	12	Sat	11:28	6.5
13	SUN	7:34	9.8	7:03	9.3	13	SUN	0:09	3.1
14	Mon	8:21	10.4	8:13	9.6	14	Mon	1:23	3.2
15	Tues	8:59	11.0	9:06	10.0	15	Tues	2:24	3.0
16	Wed	9:33	11.7	9:54	10.5	16	Wed	3:14	2.7
17	Thur	10:07	12.5	10:42	10.9	17	Thur	3:54	2.4
18	Fri	10:39	13.2	11:24	11.4	18	Fri	4:31	2.2
19	Sat	11:09	13.8			19	Sat	5:03	2.1
20	SUN	0:07	11.7	11:44:	14.3	20	SUN	5:39	2.3
21	Mon	0:47	11.8	12:17	14.5	21	Mon	6:17	2.6
22	Tues	1:30	11.8	12:53	14.5	22	Tues	6:53	3.1
23	Wed	2:13	11.6	1:30	14.2	23	Wed	7:38	3.6
24	Thur	3:03	11.2	2:15	13.6	24	Thur	8:26	4.2
25	Fri	4:00	10.8	3:07	12.6	25	Fri	9:21	4.7
26	Sat	5:12	10.7	4:21	11.5	26	Sat	10:27	4.9
27	SUN	6:21	10.9	5:56	10.7	27	SUN	11:41	4.8
28	Mon	7:23	11.5	7:22	10.5	28	Mon	0:15	1.3
29	Tues	8:14	12.3	8:35	10.6	29	Tues	1:23	1.7
30	Wed	9:02	13.1	9:38	10.9	30	Wed	2:29	1.9

CO II
BIGGER THE DOT-BETTER THE FISHING
STANDARD TIME
CO II

- Using the tide tables obtained for the class, have students graph the tides for your area for one or more months. Label the vertical scale in feet and the horizontal scale in days of the month. Have each student plot one week or one month of tidal activity. Then the charts of all students can be combined, if the same scale is used, to show tidal changes over a longer period.

Activity 6 Boating Safety

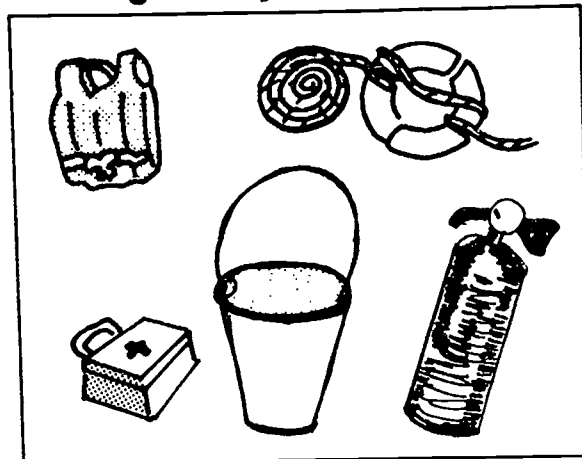

Background:

The risks of fishing, being aboard a vessel at sea, or running a skiff up a river can be reduced by boating safety practices. Many students already are involved in commercial, subsistence and sport-fishing or in recreational boating, so knowing about safety precautions can be of real practical importance.

Vocabulary:

- radar
- fathometer
- VHF
- bilge pump
- bailer

Materials:

- paper
- pencils
- life jackets (P.F.D.s) and survival suits
- safety afloat net, safety afloat equipment, safety afloat playing cards
- fishermen's newspapers and magazines and marine supply catalogs
- Coast Guard representative or

Sea Grant Marine Advisory Agent

• worksheets:

- ...Putting Out to Sea (5G)
- ...Safety Afloat (5H)

1. Ask students what safety equipment they take with them on boat trips. Ask them about other safety equipment with which they're familiar. Then distribute the worksheet Putting Out To Sea and any fishing newspapers, magazines, marine supply catalogs that you have available. Look in the bibliography for suggestions. The worksheet asks students to draw a picture of a large or small boat they'd like to own and add and label all the necessary safety equipment. If there are enough catalogs, they can figure safety equipment costs.
2. Go over each item on the worksheet and discuss safety needs in terms of local conditions. You might want to add extra rain gear and warm clothes to the list of safety needs. Have the students try on life jackets and survival suits. Invite someone from the Coast Guard or a Sea Grant Marine Advisory Agent to demonstrate equipment and mention stories of people who had to use some of these safety items.
3. As a review, make up sets of the Safety Afloat card game worksheet for students to

play. It is similar to "pick-up sticks"--only students pick up safety equipment, naming each item before picking it up with their boat hooks.

Additional Activities:

1. Physical Education: Have life jacket relays in the gym or swimming pool. Stress the need to take special care of jackets because they may be needed to save lives. Never sit on a jacket; sew up rips immediately; and replace jackets when they show signs of wear. Have students practice putting them on in and out of the water. Remind students that life jackets are made to be worn. They won't do any good sitting in a locker.
2. Art: Have students make a safety collage with pictures of safety equipment from magazines and newspapers.
3. Language Arts: Encourage students to interview people who have had close calls, asking what happened and what they would have done differently. Then have students write stories and read them to the rest of the class.
4. Language Arts, Science, Art: Arrange for students to tour a boat and make a drawing of where all its safety equipment is located.

Activity 7 Sportfishing Trip

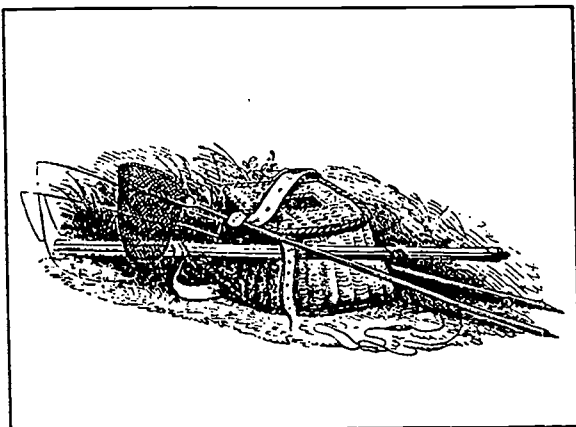

Background:

A fishing trip may be just the thing needed to spark your students' interest in fisheries. It can be a good review of what a fish is, how it lives, what it looks like and how it behaves, plus a chance to practice the nautical skills covered in this unit.

More than 200,000 anglers fish Alaska annually, harvesting about 2½ million fish. Sportfishing is important to Alaska's economy, and is one of the state's main tourist attractions. About 25 percent of the total number of anglers are non-residents. The Kenai River is one of the most heavily fished rivers in the United States. And fish caught sportfishing form an important food base for many Alaskan households.

Materials:

- pencils
- chalkboard
- chalk
- art supplies
- poles, lines, hooks and dip nets (if applicable) for students to use or share in pairs

- bait or lures
- knife
- pliers
- stringer or sack to hold the fish
- warm clothing and rain gear
- sportfishing regulations
- sport fisherman or woman
- Fish and Wildlife protection officer
- small group leaders

Procedure:

1. Make a chart to survey local fish and fish habitats. Give students individual copies of the chart and have them talk to biologists, their parents and other local resource people about fish. Then compile a big class chart on the board of everyone's

Name of Fish	How It's Identified	How It's Caught	Where It's Caught	Time of Year Caught
1.				
2.				
3.				
4.				
5.				

answers. (This chart was suggested by Mary Couche, Kivalina)

2. Invite sport fishermen or women to explain and demonstrate their techniques. Also check Volume III of the Sea Week Curriculum Series for information on sportfishing lures and how they are developed to look like aquatic insects.
3. Involve students in planning the trip. Have them help get the equipment together (or make it), develop safety rules, read the tide tables and nautical charts, plan a

nutritious snack or lunch, invite parents, resource people, or older students to come along as small group leaders, send home permission slips. You might want to consider taking part of the class at a time, or fishing on a well-lighted dock at night (as lights often attract fish so that they can more easily be seen and caught).

4. Discuss conservation of fish and the need for fishing regulations. Read some of the local sport fishing regulations. Write to the Sport Fish Division, Alaska Department of Fish and Game, Box 3-2000, Juneau, Alaska 99802 for a copy of the regulations, or pick them up at wherever fishing licenses are sold in your community. Invite a local fish and wildlife protection officer to talk with the class.

Why is fish habitat important? What has happened to sport fishing opportunities in the Lower 48? What has happened to fish habitats there? (Mention filling and dredging, channelization, housing, roads, logging, dams.) Ask students what they can do to be sure there will be plenty of fishing for their children and grandchildren. This might be a good time to remind students that fish are a renewable resource. (Used wisely, fish will be here for generations to come.)

5. Study the fish you catch. If the fish are common in your area, be sure all students can name them and understand how to identify them. If you catch fish that they can't

identify, take them back to school and key them out, thumb through reference books until you identify them, or ask a local person familiar with fish. If you catch several different fish, compare their external features. What about color patterns? Are there any apparent differences in scales? What about placement of the fish's eye on the body? How do body shapes differ?

Stress to students the importance of not wasting a natural resource. If youngsters want to see a fish and study it, but have no further use for it, be sure it is carefully unhooked and returned alive to the stream. Keep only the fish you can use in further studies or for food. And remember, any time fish are handled, your hands should be wet to help prevent stripping the protective outer mucus layer of the fish.

If you plan to keep any of the fish, clean them right after they are caught. Have students identify internal structures as a review of what they have already learned. Be sure to open the stomach to see what the fish has been eating.

6. As a follow-up, have the students write stories, poems or music, and use a variety of art supplies to draw, paint or carve reminders of their fishing trip. Compare these projects to the ones developed at the unit's beginning. Was the actual fishing a real inspiration?

Additional Activities:

1. Art, Language Arts: Have students make up and draw cartoon stories about "the fish that got away." (Suggested by Tuck Mallory, Turnagain Elementary, Anchorage)
2. Language Arts: Have students prepare oral or written reports on big fish they have caught or want to catch. Write to the Alaska Department of Fish and Game,

Division of Sport Fish, P.O. Box 3-200, Juneau, Alaska 99802 for information about trophy fish award rules. The department awards 8"x10" parchment certificates to all contestants that win one of these awards. Certificates are given for fish of trophy weight, for the largest weight for the year; and for any new state records. The fish must be weighed, photographed, and an affidavit signed in the presence of a trophy fish official.

Unit Six

Fish as Food

Index

Activity 1: Fish Quality123	Activity 3: Grocery Store
Worksheet:	Survey.....127
Taking Care of Your	Worksheet:
Catch.....6A	Grocery Store Survey
	Form.....6C
Activity 2: Fish	Activity 4: Nutrition and a
Processing126	Fish Feast.....128
Worksheet:	
Salting, Canning,	Activity 5: The Fish
Freezing and	Business130
Smoking.....6B	

Objectives:

To help the student:

- Compute how quickly bacteria multiply (Activity 1).
- Properly handle and clean a freshly caught fish (Activity 1).
- Read about processing fish (Activity 2).
- Diagram the workings of a cannery (Activity 2).
- Design a label for canned salmon (Activity 2).
- Survey a local grocery store for seafood products (Activity 3).
- Plot the origins of the local store's seafood on a world map (Activity 3).
- Figure the distance traveled by each of the locally stocked products (Activity 3).
- Make a fish-shaped recipe book (Activity 4).
- Describe the nutritional values of fish (Activity 4).
- Prepare and taste fish (Activity 4).
- Design a fish business (Activity 5).
- Advertise and sell a fish product (Activity 5).
- Develop a profit and loss statement and investment analysis for stockholders (Activity 5).

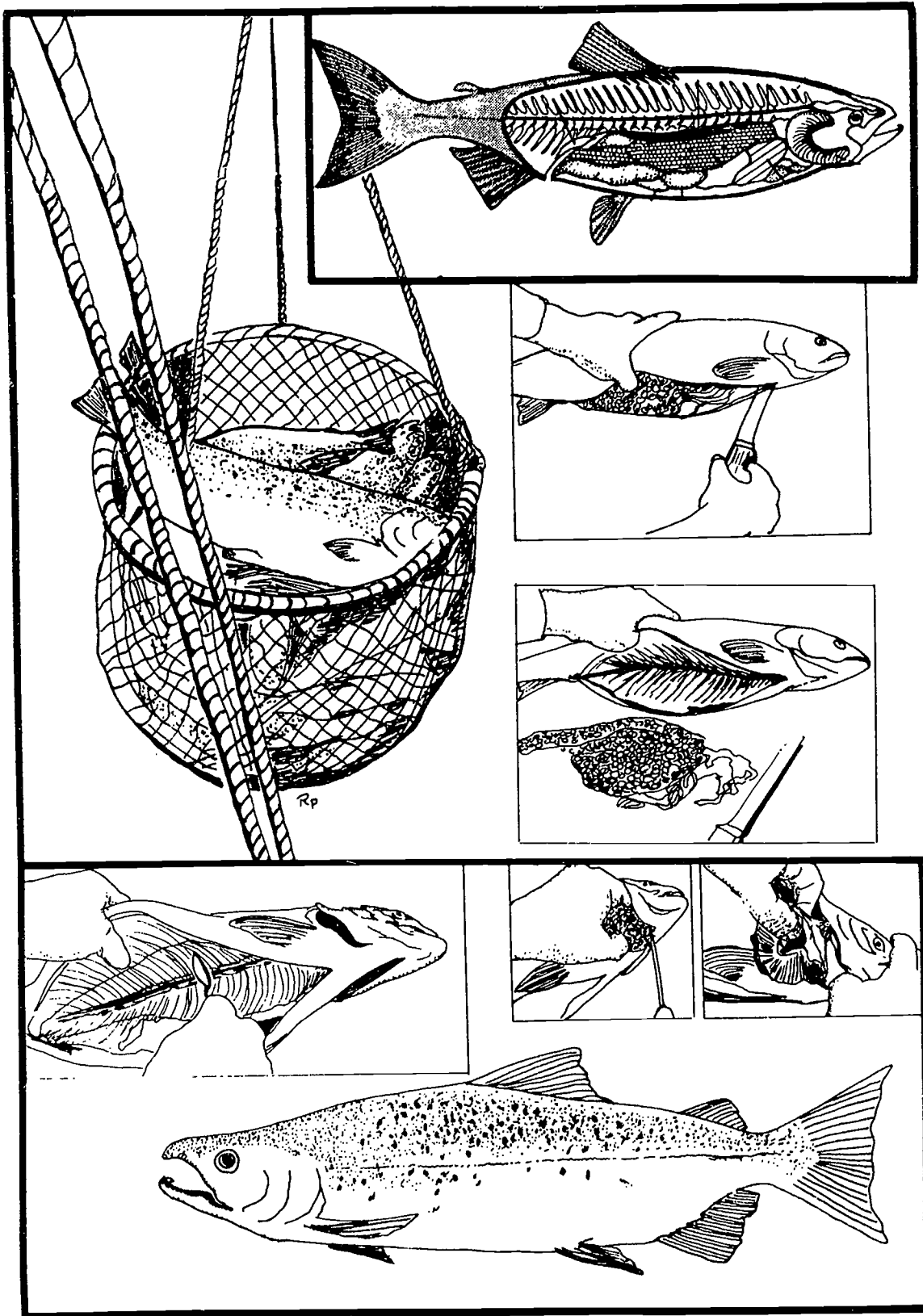

Unit Six: Fish as food: Salmon are cleaned as soon as possible after being caught. The fish are gutted, top right; and the kidney and gills removed before the salmon is stored on ice for shipment to a processor.

Alaskan waters produce a great abundance and variety of seafoods. Historically, people who lived along the coasts and rivers were sustained by fish, shellfish, sea vegetables and other aquatic foods. Today, many Alaskans still depend on fish, for their tables, their livelihoods or both. Commercial seafood processing is an important enterprise in Alaska, and its products are shipped around the world.

The processing industry changes continually, with new technology and new consumer demands. Consumer preference has shifted, for instance, from canned salmon to fresh or frozen salmon; but the shift came so suddenly it caught both fishermen and processors unprepared. In less than 10 years Alaska's fresh and frozen salmon production soared from around 30 million pounds to 195 million pounds in 1980. That increase amounted to more than one-third of the state's total salmon catch.

Activity 1 Fish Quality



Background:

To compete in the world market, Alaskan processors and fishermen are beginning to concentrate more on fish quality than quantity. With refrigerated cargo planes, ships, barges, trucks and trains, people can have their Alaskan fish any way they want it, no matter where they live.

Materials:

- several whole fish
- sharp knives with 5- to 6-inch blades
- cutting boards
- teaspoons
- copies of Cleaning a Fish
- worksheet:
...Taking Care of Your Catch
(6A)

Procedure:

1. Use the worksheet Taking Care of Your Catch (adapted from "How to Take Care of Your Catch," Tidelines, Vol. IV, No. 1, Sept. 1981) to start your discussion. (Answers to questions 1 and 2

are 1,073,741,824 and 2,147,483,648,000,000,000. Remaining answers will vary among individuals.)

2. Invite parents or others to bring in several whole fish or go on a fishing expedition to catch your own. (See Unit 5, Activity 7.)
3. Have students clean the fish. Round up teaspoons and some sharp knives with 5- to 6-inch blades. Plastic or some other hard material is better than wood because knife handles is easier to clean. You'll also need cutting boards. Again, a plexiglass or steel surface is better than wood for the same reason. If you do use wood, rub the board with salt to help sanitize and cut the slime and to make the job less slippery. Pass out copies of *Cleaning a Fish*. Remind students to be careful of the knives and to always cut away from themselves.
4. Review external and internal fish features (Unit 1, Activities 4 and 5) and get ready to taste the fish (Unit 6, Activity 4). This cleaning technique is the one recommended by Dr. Don Kramer, seafood technologist and quality control specialist with the Alaska Marine Advisory Program. It was first printed in *Tidelines*, "How to Take Care of Your Catch," Vol. IV., No. 1, Sept. 1981.

CLEANING A FISH

1. Insert the point of your knife into the vent opening, just deep enough to cut through the skin. Then run the cut

smoothly the length of the belly to a point just below where the pectoral fins join the body. Keep the cut shallow to keep from damaging the internal flesh or the egg cases.

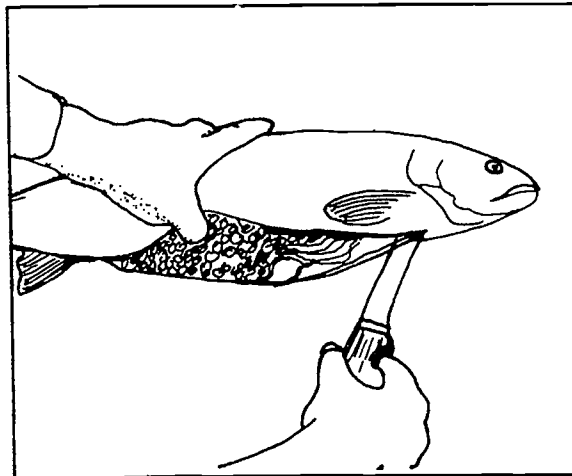

2. Carefully cut the connecting tissues at both ends of the digestive tract (throat and anal vent) and the viscera will fall right out. Wash the eggs and put them in a clean plastic bag. If you don't eat them (many people do), save them for bait--either fresh or dusted well with Borax.

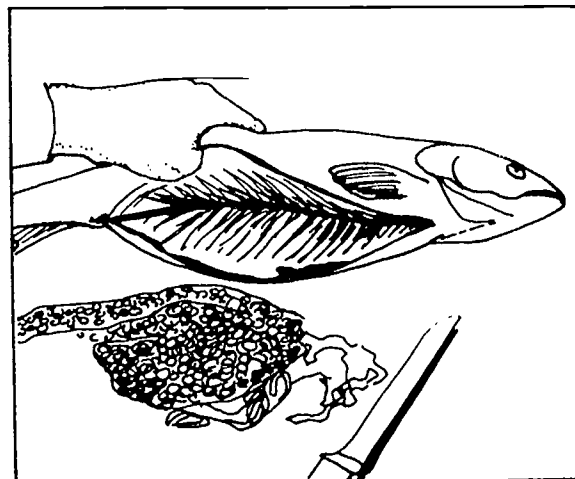

3. Next the gills. Go in under the gill cover. Cut through the connecting tissue at the top and run the knife around

the jaws to the bottom. Then twist the gills out.

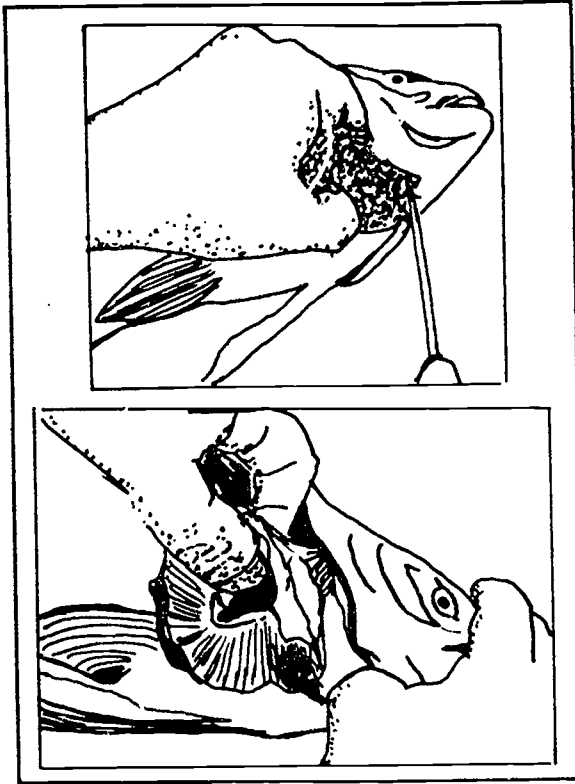

4. Now all that is left is the kidney. This looks like a line of clotted blood running along the spine from the head to the vent. Some fishermen simply slit the kidney down the middle and then scrape out the dark material. But a better way is to make two long slits through the membrane down either side of the kidney. The double cut makes the kidney easier to remove and also does away with the "ribbons" of membrane (which many processors

object to) that are left behind by the center cut.



5. Scrape out the kidney with a spoon. Get every trace of it. The hardest to reach is the kidney tissue in the small bones near the vent, called the "knuckles." Use the knife tip carefully, trying not to puncture the flesh. Now wash the fish inside and out with clean cold water and it's ready to be iced or refrigerated.

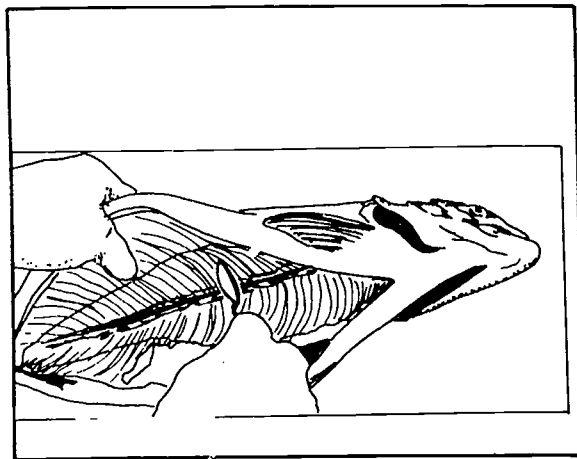

Activity 2 Fish Processing

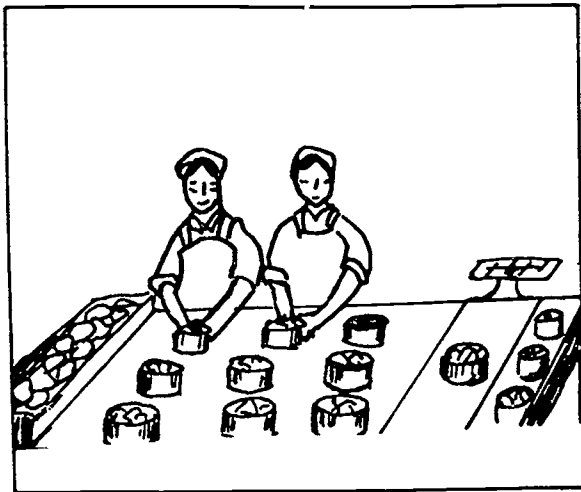

Background:

Processing Alaskan salmon, halibut, king crab and other seafoods is a major industry in Alaska. Processing probably began with early settlers who shipped a few salted salmon back to their native lands.

In 1878, the North Pacific Trading and Packing Company built the first Alaskan cannery at Klawock on Prince of Wales Island. Later the same year, a cannery opened in Sitka. Within 10 years there were many canneries along the coast from Southeast Alaska to the Bering Sea.

The cannery business was a tough, a boom or bust operation. If fishing in nearby waters was good, the cannery might thrive; but no fish meant failure for the operation. In addition, there was cutthroat competition between canneries and their wealthy backers. Sometimes price wars erupted, with the one packing company undercutting others in an attempt to bankrupt the competition.

Today, cannery operations still involve risk. Fishing from year to year can be good or bad. Markets fluctuate, and prices and profits go with them. Abandoned canneries dot the Alaskan coast, many of them old and long-deserted; and each year more canneries consolidate or close.

Materials:

- colored pencils or felt-tip markers
- paper
- a variety of salmon cans
- What Happens in an Alaskan Salmon Cannery (page 153)
- the manager of a fish processing plant or a cannery worker
- worksheet:
...Salting, Canning, Freezing, and Smoking (6B)

Procedure:

1. Ask students how they preserve fish. Then pass out the worksheet Salting, Canning, Freezing, and Smoking. (Answers: 1: freezing, smoking, or drying; 2: salting; 3: king (also red and silver) salmon; 4: canned or frozen; 5: glaze it with a thin covering of ice; 6: false.)
2. Have the students diagram what happens in an Alaskan salmon cannery. Use the "What Happens in an Alaskan Salmon Cannery" illustration for reference. Go through the steps one by one on the board and let students make their own drawings with colored pencils or thin felt-tip markers as the class talks about them. Have the students predict what happens from one step to another.
3. Invite a local cannery man-

ager or worker to talk about the fish processing business and critique your class's drawings. Better yet, take a trip through a cannery and have the students check the accuracy of their own drawings. In the Interior, you should be able to find a parent or brother or sister of one of your students who has worked in a cannery.

4. Have the students look over different canned salmon labels and then design their own.
5. Discuss home canning and the need to use clean and sterile utensils and containers to prevent botulism. This type of bacteria can appear in many foods besides fish. Botulism cannot be smelled or tasted, so students should watch for damaged cans or canned lids that are puffed outward.
6. List the benefits of canning, freezing, smoking, drying, salting, pickling, and eating fish fresh.

Activity 3 Grocery Store Survey

Name		Date		Town/Village	
Grocery	Product	Packaging	Country of Origin	Size & Price	Additional Comments
1.					
2.					
3.					
4.					
5.					

Background:

Grocery stores are the consumer's main contact with the fishing industry. Fresh, frozen, canned, pickled, smoked and dried fish as well as other seafood products from all over the world line the shelves, refrigerator, and freezer compartments.

Materials:

- sample of seafood products
- grocery store
- pencils
- world map
- colored yarn
- tacks
- small slips of paper
- worksheet:
...Grocery Store Survey Form
(6C)

Procedure:

1. Ask students what seafood products they eat. Ask about others that they know about. Then plan a field trip to a grocery store or assign students to fill out the survey form as an assignment.

Pass out copies of the Grocery Survey Form. Have students complete the first few items with samples that you've bought. Encourage students to look in the ethnic sections of the store and to read labels closely. (Ice cream for instance, has seaweed extract--algin--in it to make it extra smooth.) Then see how well your super sleuths do at finding the amazing number of products from the sea.

2. Make a class list of all the products and mark each on the world map with a tack and a small slip of paper listing the product by name. Tuck pieces of yarn from the tacks to your town or village.
3. Figure the distance traveled by each product and the cost per pound of each product. (Save these figures for Activity 5 in this unit.)
4. Follow-up this activity by discussing the role of Alaska in feeding the world (Unit 7, Activity 1) and by trying the next activity - fish nutrition and a fish feast. Students may want to purchase some of the products they discovered at the store for their feast. Mention that what everyone likes to eat is a result of where they grow up and of what their parents and friends eat. Encourage your class to try foods new to them--some of which they'll find wonderfully delicious.

Activity 4 Nutrition and a Fish Feast

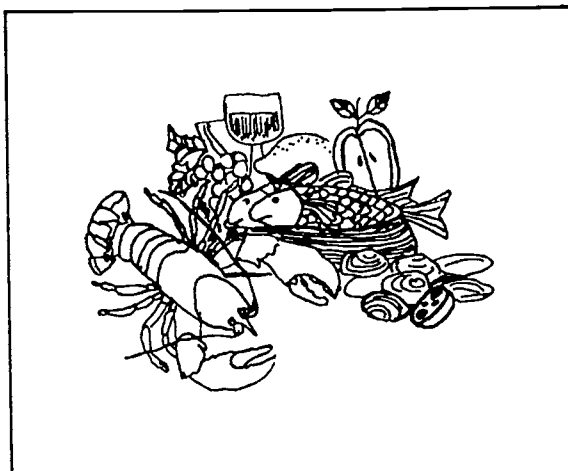

Background:

Fish is rich in vitamins and minerals and is a delicious source of protein. Fish and shellfish can provide in generous amounts most of the nutrients the body requires. High quality amino acids in fish are readily digested; and fish products are rich in B complex vitamins such as thiamine, riboflavin, niacin, vitamin B₆, vitamin B₁₂, and pantothenic acid. Fish is also a good source of calcium, iron, potassium, phosphorous, copper, iodine, manganese, and cobalt. Fish is especially good for heart patients because it is low in sodium and the great majority of species are low in fat. Fish is low in calories, too!

Seafood meals are time and money savers. Preparation is simple with little waste. No special equipment is required. Seafood can be mixed with soups, chowders, and casseroles and goes well with almost any spice. It can be baked, broiled, grilled, poached, steamed, or fried. Many ethnic groups have settled in Alaska and their recipes have been passed from generation

to generation providing a great variety of culinary delights.

Materials:

- seafood
- spices
- cooking utensils
- heat source
- plates and silverware
- paper
- pencils
- crayons, colored pencils or narrow felt-tip markers
- construction paper
- scissors
- stapler

Procedure:

1. Discuss with students how fish are prepared in their homes. Ask them to bring several of their favorite seafood recipes from home for a class cookbook. Mimeograph copies and have the students place them in fish-shaped booklets with construction paper covers for family presents and student mementos. Alternatively, copy your recipes on fish shapes and place them in a bulletin board of pots--ready to be cooked! (Suggested by Sandy Poor

and Ann Schultz, Mt. Eccles Elementary, Cordova)

2. Discuss seafood nutrition and cooking. Important to remember about seafood is that it should not be overcooked. Crabs and shrimps should be steamed about 10 minutes. Clams need only a few minutes of steaming or frying. Fish requires less cooking time than "red" meats. Fillets and steaks should be tested often with a fork while cooking to avoid overcooking. When fish flakes, it's done.
3. Have the students assist you in planning a seafood snack or feast. Invite parents to bring favorite seafood dishes. Have students prepare some of the simpler recipes, measuring ingredients and computing quantities. You might want to purchase a variety of seafoods from the store or the whole feast could originate there. Or you might want to try making some special local recipes such as cooking in a fire pit, smoking or pickling fish. For additional suggestions, write to the Alaska Seafood Marketing Institute, 526 Main Street, Juneau, Alaska 99801.

Activity 5 The Fish Business

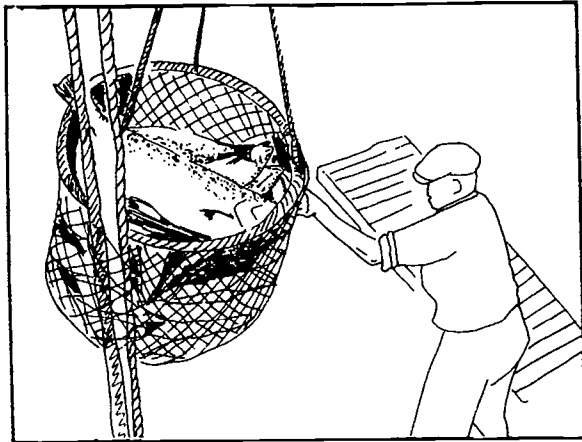

Background:

The fishing industry is vital to Alaskan economy. Twenty-five percent of Alaska's jobs are connected directly with fishing and many more depend upon it indirectly. There are many costs involved in getting fish from water to mouth. Perhaps the best way for students to understand the fish business is to try it themselves.

Vocabulary:

- product
- consumer
- perishable
- capitol loan
- market value
- profit
- loss
- labor
- wholesale
- retail
- advertising
- sales
- competition
- investment
- stocks
- stockholders

Materials:

- prices of fish at various

- stages of processing
- seafood product to sell
- poster paper
- felt-tip markers

Procedure:

1. Approach students with the idea that now that they know something about fisheries, maybe they would like to get into the fish business. The business can be real or imaginary. Ask them what local seafood products would make a good investment. Go over the price figures from Activity 3 in this unit and see what looks like the best bet to make a profit and what they think people would like to buy, such as specially prepared fish (smoked or pickled); fresh fish delivered to their door; canned salmon with a delicious recipe attached; sometimes hard to obtain seafood (clams, crabs); or a local tradition (hot fish and chips).
2. Have students check out the market (by asking their parents or friends if they would like to buy a particular item and at what price). Who will be the competition? Students may even do some preliminary figuring such as checking:
 - costs of boat and gear
 - cost of fuel
 - boat maintenance and repairs
 - time spent fishing
 - amount of fuel used
 - captain wages
 - crew wages
 - price paid to the fisherman by the processor
 - electricity and water
 - costs of can or other packaging

- wages paid to cannery workers
- salary paid to cannery supervisors
- price of fish sold to wholesaler
- transportation costs (shipping)
- retail price on the shelf

To have much meaning, the figures will need to be standardized with such a standard of comparison, to cost-per-pound. Students then can relate such items as cost of fuel per pound to the price paid per pound to the fisherman, the retail price per pound, and so on.

3. One of the biggest considerations with seafood is perishability. Have the students decide how to get their product from the water to the consumer as quickly as possible, using a good method of preservation.
4. Have the students decide on one product to sell and a name for their business. If students need money (capital)

to start their business, check with a local banker. Students may prepare a mock presentation and go in and ask for a loan. Or they might want to sell stock.

5. Develop an advertising campaign. Have the students make posters about their product and plan business details such as advance orders, who's going to get the product, who will transport, who will sell it, who will take the money and keep track of profits and losses.
6. Then the students should be ready for business. They might even want to have a grand opening!
7. After the product is "sold," have the students figure profits and losses, analyze their strengths and weaknesses as a business, and write a stockholders' report. Discuss such correlation between the student business and the fishing industry as transportation, preservation, weather problems and fish product availability.

Unit Seven

Fisheries and the Future

Index

Activity 1: Fish for the World.....136	Worksheets: What Are Those Funny- Looking Fish?.....7C Gearing Up for Whitefish7D
Activity 2: Aquaculture140 Worksheets: You've Just Got a Job in the Hatchery.....7A Hatchery Basics7B	Activity 4: The Mighty Salmon Cannery Game.....145
Activity 3: New Fisheries ...143	Activity 5: Cartooning Local Issues.....150

Objectives:

To help the student:

- Explore the needs of other countries for fish resources (Activity 1).
- Define and use terms common to hatchery operations (Activity 2).
- Sequence the yearly events in a salmon hatchery (Activity 2).
- Identify ocean whitefish by use of a taxonomic key (Activity 3).
- Read about the difficulties of entering the whitefish industry (Activity 3).
- List solutions to problems involved in development of the Alaska ocean whitefish industry (Activity 3).
- Role-play development and habitat issues in the Mighty Salmon Cannery Game (Activity 4).
- Draw cartoons to influence local issues (Activity 5).

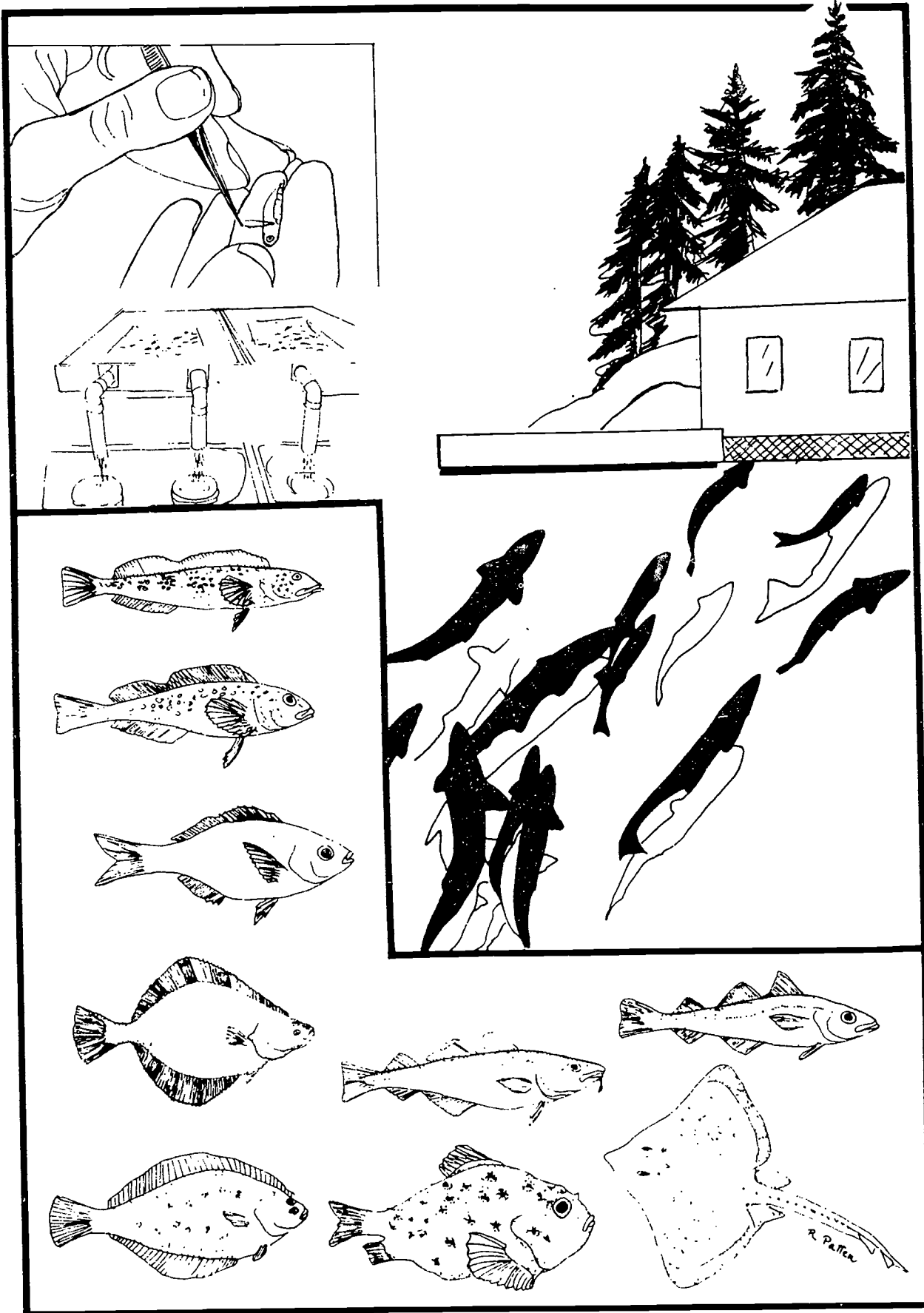

Unit Seven: Fisheries and the future: top left, tagging salmon fry; top right, salmon returning to hatchery. At bottom, some of the white fish involved in Alaskas' fishery plants.

When few people were living in Alaska, everyone could take fish needed for food and have little worry about depleting the resource. Now, however, there are more people to feed, more people fishing, more sophisticated fishing gear, and fisheries habitat losses. Each season, management biologists with state or federal agencies must reevaluate the status of marine resources and determine how much fishing pressure they can bear. These decisions affect all who depend on the resources for food or livelihood.

As pressure increases on fishery resources, four means of keeping them healthy are used.

First, managers try to regulate existing fisheries to achieve the maximum sustainable yield. That is, they allow the most possible fish of any one species or run to be taken without decreasing the numbers of fish that will be available in the years to come.

Second, the fishing industry has turned its attention to unfished resources. Here, Alaska's developing ocean industry is an example. Relatively few marine species have been the object of intensive fisheries, and many others may yet become commercially important as public demands make them profitable.

Third, state and private organizations are turning toward aquaculture, the controlled rearing of various aquatic species, usually with the intention of making them available as food.

And fourth, development projects are carefully reviewed for their impact on fish habitat. Subdivisions, shopping centers, logging, oil and gas explorations and drilling, mining, dams, roads, airports and agriculture all can affect rivers, streams, and the fragile coastal environment which is so important for fisheries.

Activity 1

Fish for the World

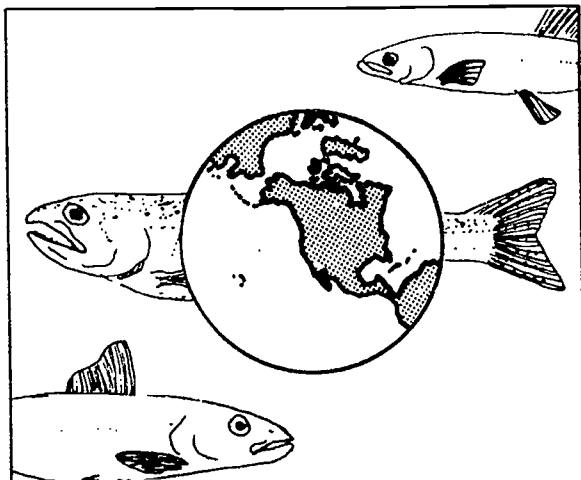

Background:

The ocean has been proposed as a food source for hungry peoples around the world. Sometimes forgotten is the fact that the ocean is most productive along its coasts, over the outer continental shelf, and in bays and estuaries. Nutrients are flushed down rivers to shallow coastal waters or are trapped in bays and estuaries by the mixing of salt and fresh waters. These nutrients insure luxuriant phytoplankton (plant) growth which in turn produces food for fish. In the depths of the ocean, where light penetrates only so far and not all below 1,700 feet, phytoplankton (plant) growth which fuels the ocean's food web is very low, and hence there are not many fish. The most prolific fishing grounds are already being fished. The ocean can be an important solution to world food problems but we need to:

- Increase the efficiency of fish transportation and fish processing so that fish are kept fresh and all parts are utilized.

- Increase our knowledge of fish biology and ecology and develop workable international agreements so that fish are not overharvested.
- Investigate new fisheries, new fishing gear, and fish farming.
- Decrease ocean pollution from both land and sea sources.
- Protect fragile coastal and riverine habitats where the majority of fish spawn and raise their young.
- Change our eating habits so we eat less and eat lower on the food chain--more seaweed and less tuna; more grains and less beef.

Vocabulary:

- import
- export
- per capita

Materials:

- fish-shaped crackers or cookies
- paper bag
- slips of paper with names of countries written on them
- Ocean Fish Consumption Chart
- Major Ocean Fishing Grounds map
- world map

Make a photocopy of the Ocean Fish Consumption Chart contained in this unit. Cut out the names of the countries and place them in a container.

Procedure:

1. Place slips of paper with names of countries for each class member in a paper bag.

(Cut up a copy of the Ocean Consumption Chart for as many countries as you have students. Pick a variety from the different continents.) Tell students to pretend that instead of being born in the United States, they have been born in a foreign country. As students draw slips of paper from the container, tell them that for today they are residents of that country. Ask them to imagine what it would be like to live there. Have students find their countries on the world map.

2. Hand out the fish-shaped crackers or cookies to students based on the percentage of their countries' fish consumption. Some countries will have many and others will have none. Explain "per capita" consumption. Ask the students:
 - Should you share? (Most countries do not!)
 - Can you see why countries have wars sometimes?
 - What could be done to make everyone feel better? (When students talk about giving everyone the same number of crackers, write the words "import" and "export" on the board. Explain the difference. If the class is going to "even up" the crackers, how many of them think they will be exporting? How many will be importing? As a class

exercise, total on the blackboard the number of crackers in the class and divide by the number of class members. Have the exporters reduce their supplies to the average, then have the importers increase their supplies to the average.

3. For additional discussion, show students the map of the major ocean fishing grounds, plus the list of the 10 largest marine fishing nations.

Additional Activities:

1. Math, Social Studies: Have students figure the effects of population or fish consumption. How many pounds of fish does each country consume?
2. Social Studies. Have each student write a paragraph about his or her country's fishing industry, including an answer to the question of whether most of the fish eaten in that country are imported or exported.
3. Art, Science, Speech: Have students draw a picture of the fish most eaten in their countries, and give a one-minute oral report on the fish, covering such points as its size and color, whether it lives on the bottom or travels in schools, what it eats, whether it is found in shallow or deep water, how it is caught and how it is most often eaten.

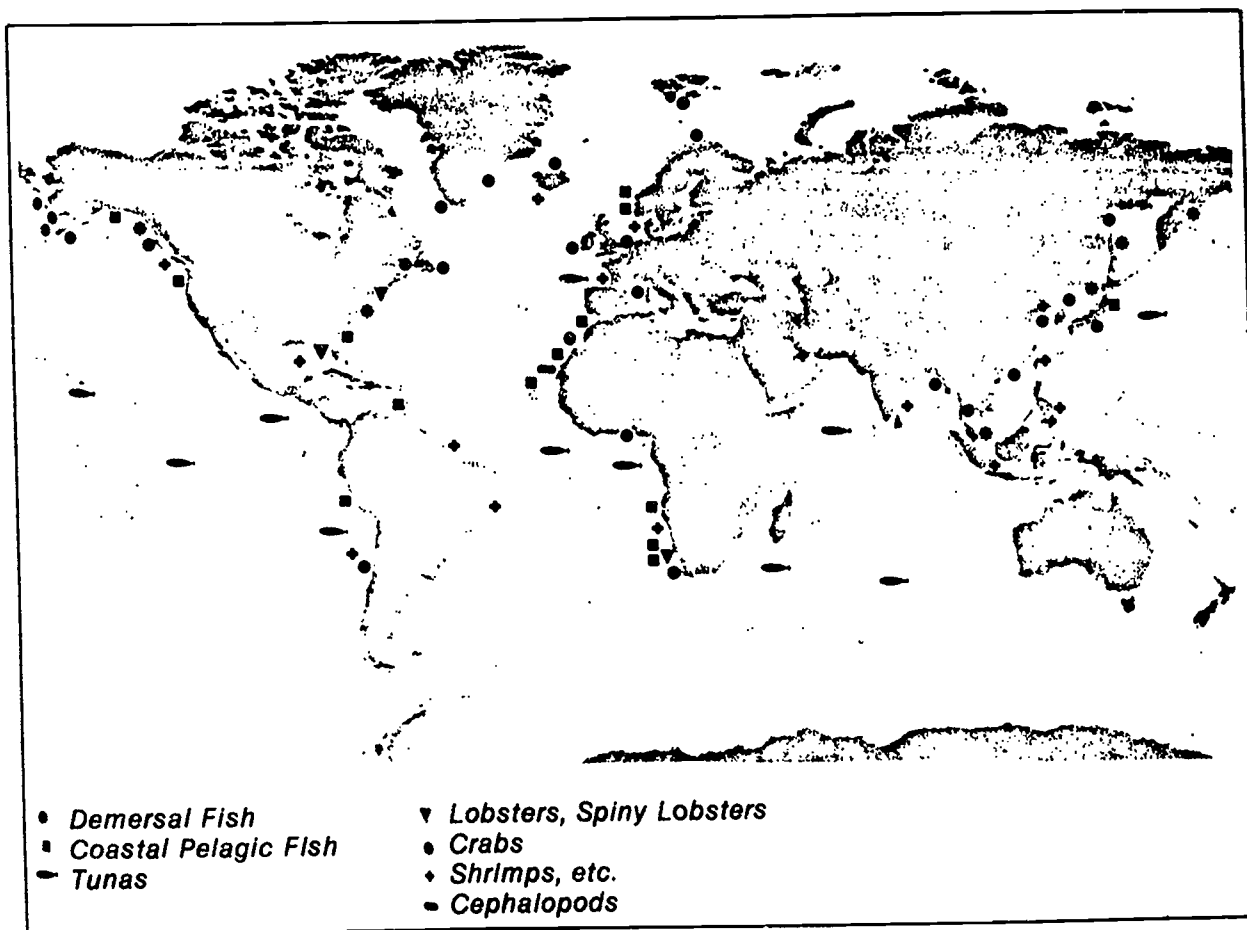

The world's major fisheries. Demersal fish are bottom fish, Coastal pelagic fish are open-sea fish caught offshore, and Cephalopods are members of the squid and octopus family.

From *The Cousteau Almanac* by Jacques-Yves Cousteau and the staff of the Cousteau Society, Doubleday & Company, Inc., Garden City, New York, 1981. 838 p.

THE TEN LARGEST MARINE FISHING NATIONS		
Rank	Country	Catch in Metric Tons
1.	Japan	10,508,451
2.	USSR	9,876,173
3.	China	6,880,000
4.	Peru	3,447,485
5.	United States	2,798,703
6.	Norway	2,550,438
7.	India	2,328,000
8.	South Korea	2,133,371
9.	Denmark	1,767,039
10.	Spain	1,532,878

SOURCE: *Fisheries Yearbook*, U.N. Food and Agriculture Organization, 1977.

Ocean Fish Consumption Chart

<u>Country</u>	<u>(Millions) Population</u>	<u>(lbs) Per Capita</u>	<u>Crackers</u>
United States	216.8	35.1	5
Canada	23.3	40.1	6
Peru	16.6	37.9	5
Chile	10.7	34.8	5
Guatemala	6.4	1.5	0
Columbia	25.1	7.5	1
Venezuela	12.7	22.5	3
Cuba	9.5	46.1	7
Argentina	26.1	9.0	1
Costa Rica	2.1	9.9	1
Panama	1.8	21.4	3
Italy	56.5	27.3	4
France	53.1	48.9	7
Portugal	9.7	85.1	12
Sweden	8.3	71.6	10
USSR	240.0	63.3	9
Austria	7.5	17.2	2
West Germany	61.4	41.0	6
Ireland	3.2	31.3	4
Norway	4.0	103.6	15
Burma	31.5	28.7	4
China	865.7	13.0	2
Hong Kong	4.5	111.3	16
Malaysia	12.6	76.5	11
Nepal	13.1	.4	0
Vietnam	47.9	48.1	7
Indonesia	143.3	23.6	3
India	625.8	7.0	1
Japan	113.9	148.6	21
Philippines	45.0	73.	10
Afghanistan	20.3	.2	0
Iran	33.6	1.1	0
Iraq	11.9	6.2	1
Israel	3.6	24.5	4
Libya	2.4	16.1	2
Saudi Arabia	9.5	11.5	2
Turkey	42.1	9.7	1
Egypt	38.7	9.3	1
Algeria	17.9	4.8	1
Kenya	14.3	5.7	1
Senegal	4.2	89.3	13
Togo	2.3	25.4	4
Nigeria	66.6	23.4	3
South Africa	26.1	15.4	2
Ghana	10.4	60.8	9
Ethiopia	28.9	1.3	0
Morocco	18.2	9.7	1
Uganda	12.3	32.6	5
Australia	12.4	32.2	5
New Zealand	2.7	37.3	5

Activity 2 Aquaculture

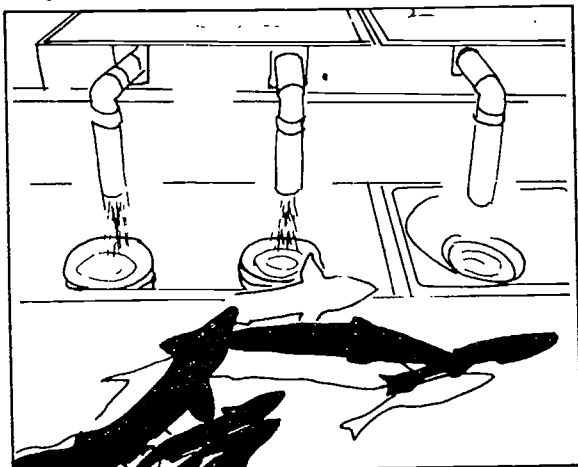

Background:

"...Down through the centuries, people have tried their luck at cultivating- or farming-aquatic plants and animals. As early as 475 B.C., a gentlemen named Fan Li raised carp in a small fresh-water pond in China. Trout farming began in Europe in the 15th Century; and today, aquaculture is practiced all over the world.

"Shrimp are penned and raised in the backwaters and estuaries of such far distant places as the South China Sea and the Mediterranean Sea. Salmon, trout and even catfish are cultivated in the U.S., Canada, Russia, Spain, and many other countries.

"In the island nation of Japan, everything from eels to seaweed to salmon to shellfish is farmed. Oysters, scallops, clams, and mussels are cultivated on neat hanging underwater racks and lines, well out of reach of sea bottom predators. And the network of salmon hatcheries which Japan has developed over the past 100 years recently yielded a har-

vest of chums that was greater than the natural chum runs of Alaska.

"In aquaculture, the "farmer" controls the elements that are vital to the growth of marine life: light, shelter, weather, oxygen, water flow, and food. The "crop" is protected from disease and from other animals that might prey upon it. Under ideal circumstances, the survival rate increases, the growth cycle is speeded up, and healthy fish are produced.

"It takes solid scientific knowledge, however, to determine just these ideal circumstances might be. Care must be taken not to tip the delicate balance of food and life support systems in the sea by building up one species at the expense of others. Inferior stock should not be turned loose to interbreed with, and weaken or disease natural runs of fish."

-from "Aqua (water) + Culture (cultivate)," Tidelines, Vol. 1, No. 1, September 1978

In Alaska, salmon hatcheries are the most prevalent form of aquaculture. Some are government operated and involved in researching aquaculture techniques. Others are run by aquaculture associations, private individuals, schools, or Native associations.

Establishing and operating a hatchery is a demanding task. Water circulation, temperature, food and disease control are all factors that can decide the success or failure of fish rearing.

Hatchery schedules and activities vary with the species being reared. The general sequence of activities

in a salmon hatchery goes something like this:

Mature fish are taken in the fall when they are ready to spawn. Eggs are stripped from females and milt, or sperm, from mature males are added. Immediately after this procedure, fertilized eggs are placed in incubators and bathed with a continuous flow of fresh water. Eggs are tended until they hatch into alevins with a large yolk sac that will supply them with all the food they need for two to four months. In many hatcheries, fry (young fish that have now absorbed the yolk) emerge and voluntarily leave the incubation boxes on their way to holding pens where they will be fed until the time is right to release them. Upon release, the fish make their way downstream and out to the open ocean to feed and mature.

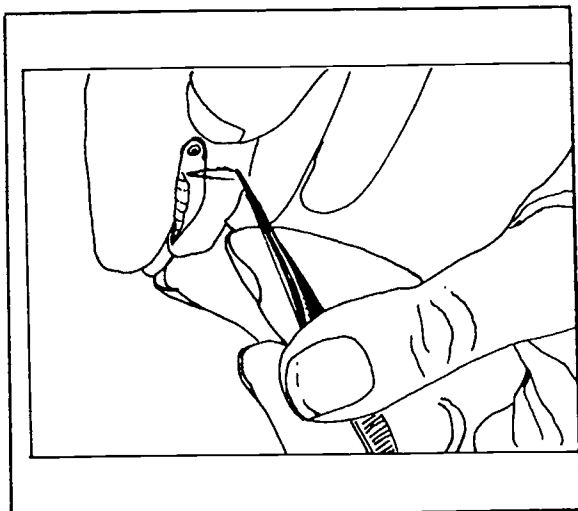

Fish tagging is one way fish managers gauge the success of their operation. Any types of visible markings can also be seen by predators, so the numbers of returning fish are naturally reduced when outside markers are

used. Fin clipping has also been used but fish need all their fins except the adipose fin for swimming or resting.

So, lately, hatchery managers and fish biologists involved in other studies have begun placing magnetized stainless steel wire bearing a code number into the nose cartilage of the fish. To indicate the presence of this tag, the adipose fin is clipped.

Advise your students to save the head of any salmon they catch that has the adipose fin missing and turn the head of the fish over to the Alaska Department of Fish and Game. Tagged salmon are a real prize for hatchery managers and biologists, especially if the fish is ocean caught, because comparatively little is known about the ocean migration of salmon.

Vocabulary:

- egg
- sperm
- fertilization
- spawn (review)
- alevin (review)
- hatchery
- aquaculture
- mature
- incubator
- egg box
- fry (review)

Materials:

- hatchery manager or fish biologist
- worksheets:
 - ...You've Just Got a Job in the Hatchery (7A)
 - ...Hatchery Basics (7B)

Procedure:

1. Use the worksheets You've Just Got a Job in the

Hatchery and Hatchery Basics.
Explain tagging and go over the dictionary definition of each word. Students may need fishery books or an encyclopedia for some terms. Go over what happens in a hatchery. Then ask the students:

- What are some ways we can help fish production without hatcheries? (Protect fish habitat and natural fish production.)
- Why is aquaculture important to us? (As a source of food, a way to replenish fish stocks, a source of employment.)
- What are some of the reasons we have to be careful with aquaculture? (To not tip the balance of food webs of the sea by building up one species at the expense of others. Also, if hatchery fish are inferior for any reason, they should not be turned loose to interbreed and weaken or disease natural fish runs.)
- What promise does aquaculture offer? (Increased fish runs by increased survival of

young, and return of salmon to formerly empty streams or streams where salmon numbers are few.)

2. Invite a hatchery manager or fisheries biologist to visit your class and discuss hatchery management and their fish tagging procedures. If a hatchery is located in your community, try to visit the facility. As an alternative, have students research hatcheries and fish tagging in your local library or write letters to the Alaska Department of Fish and Game or private aquaculture associations asking for additional information.
3. Although the life cycle phases of pink salmon occur in different months depending upon the area, the following are generally true and apply to worksheet (7B) - Hatchery Basics: spawning salmon (June-Sept); eggs (June-Feb); alevin (late Feb-April); fry and smolt (in pinks, they go immediately from one to the other in April-May); ocean salmon (June-Sept one year later).

Activity 3 New Fisheries

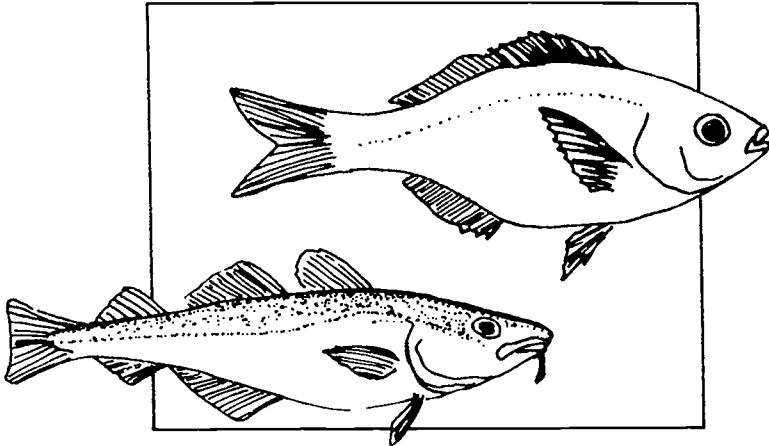

Background:

As more fishing pressure is exerted in existing fisheries and as regulation of these fisheries stiffens, many fishermen are beginning to explore alternatives. Some are gearing up to harvest "whitefish"--the great bulk of finfishes of the sea--and the main food fish of the world. Sometimes they are called "bottomfish" or "groundfish"--which they really aren't, since only a few spend their lives on the bottom.

There are billions and billions of commercially important whitefish in the Bering Sea and Gulf of Alaska. So far, these stocks have been harvested almost entirely by foreign fishermen. But now that the United States has extended its fisheries management zone to 200 miles off our shores, Alaskans and other U.S. fishermen are getting more interested in what could be a multi-million dollar year-round industry.

The 200-mile zone was established in 1976 with the passage of the Fisheries Management and Conservation Act. Until that time,

except for a few international treaties, high seas fishing was a wide open affair. Fishermen could go after anything they wanted and take as much as they pleased. And the whitefish stocks off Alaska were being harvested so heavily by foreign fleets that some species had dropped to dangerously low levels. The goals of the act were (1) to bring foreign fishing under control and set up management plans so the stocks could build back, and (2) give Americans a reasonable chance to develop fisheries off their own coasts.

The law did not say that foreign fishermen would have to stay out of the 200-mile zone. But it did say that foreign harvests would be limited to those fish that Americans are unable to catch. In other words, if we don't take them, they will.

The tricky task of setting up management plans, including quotas for foreign and domestic (U.S.) fishermen, belongs to regional councils - whose actions must be approved by the U.S. Secretary of Commerce. In Alaska, this council is the North Pacific Fisheries Management Council.

The Fisheries and Management and Conservation Act is designed to fill a gap until the nations of the world can agree on a Law of the Sea treaty to cover the ocean's resources. (Information for this activity was taken from "What's That Funny-Looking Fish?," Tidelines, Vol. III, No. 5, Feb. 1981.)

Materials:

- library books, encyclopaedias
- map of Alaska

- person involved in a new fishery
- worksheets:
- ...What are Those Funny-looking Fish? (7C)
- ...Gearing Up for Whitefish (7D)

Procedure:

1. Have students try the worksheet What are those Funny-looking Fish?. (Answers: 1: Pacific (true) cod; 2: Alaska (walleye) pollock; 3: sablefish; 4: rattail; 5: smooth lump sucker; 6: Pacific Ocean perch; 7: ling cod; 8: greenling; 9: skate; 10: yellowfin sole; 11: starry flounder)
2. Follow-up with class mini-research on the kinds of whitefish found in local waters. How many can students name without doing research? How many additional names of fish can they list by consulting books, encyclopaedias, local fishermen, their parents or friends? Students might want to learn something about some of these fish (where they are found, what they look like, what they eat, how they might be used).
3. Then have students read the worksheet Gearing Up for Whitefish. You will need a map of Alaska for the last question. (Answers: 1: pollock, cod, ocean perch, etc.; 2: salmon, shark; 3: human food, fertilizers, pet food; 4: fishermen would rather fish salmon, crab, shrimp, halibut, processing plants and fishing boats would have to change gear, bigger boats required for many tons of fish, some Alaskan ports would have to

be enlarged for these deep water ships, a fish must be processed immediately, high labor costs, gutting machines don't fit fish, little is known about whitefish biology, developing a market; 5: individual answers to above solutions; 6: The Pribilofs are in the Bering Sea north of the Aleutian Islands and west of Bristol Bay. In the discussion of predicted changes, one of the main ones would be the increased numbers of people coming to the islands, plus increased noise activity, jobs, stores, along with social problems such as alcoholism and crime. The Aleut young people would probably tend to stay on the islands because they could get jobs. There would be some loss in wildlife habitat and disruption of some birds and animals used for subsistence lifestyle. One of the few alternative vocations would be to build up the tourism industry to get people to come to watch birds and marine mammals and buy Native crafts. These similar options for development are being faced by many other rural Alaskan communities.

4. If a new fishery has recently started in your community, find someone who is involved in it and arrange for them to address the class. Before the speaker comes, prepare students by having them think about the kinds of things they would like to learn from the speaker. For example:

- What kind of gear is used?
- Is it hard to change over

from some other kind of fishery?

- What time of year must the fishing be done?
- Is it expensive to prepare for fishing?
- What will be the market for the fish?
- Do the fish require any special handling?
- What are sources of information about the new fisheries?
- Is a state or federal agency helping fishermen get started in it?

If possible, arrange for students to visit a vessel engaged in the fishery in question. Be sure the vessel captain or a crew member is present to answer questions and explain the gear to students.

Activity 4 The Mighty Salmon Cannery Game

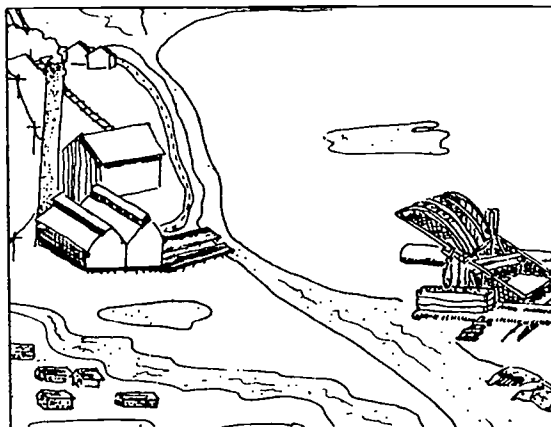

Background:

Throughout Alaska, every community is facing development issues. Sometimes there are possibilities for compromise. Other times inhabitants have to decide on development or the status quo. In any case, residents have to decide on their own priorities and live with the consequences.

Many times, decisions are made in Juneau or Washington, D.C.--or Tokyo or Cairo. But Alaska is famous for the "coffee cup decision"--whether made over coffee at a hotel in Anchorage or someone's kitchen table in a village.

Hopefully, as Alaskans become more cognizant of all the results of decisions, and more astute politically, Alaskan resources and Alaskans will benefit. Our young people need to learn at an early age what's going on in their community and the world in general, and that they can have an effect on their own lifestyles and surroundings. One fun way to get started is to role play

different points of view in a simulation game.

Materials:

- butcher paper
- felt-tip markers
- sets of role cards
- copies of Mighty Salmon Cannery Map

Procedure:

1. Ask students to name planned local development projects. Pass out copies of the Mighty Salmon Cannery Map and go over the proposal. Ask them how they would imagine people in Eekoute Village feel. Tell them that there will be a public hearing on this issue soon.
2. Divide the class in seven groups and hand out the role cards. Each group represents the point of view typified by the role on the card. Have each group tell the rest of the class its name and title. Then tell them to read over the card and elect one of their group to the village council and elect one person spokesperson. The village council should meet up front while the rest of the group helps the spokesperson put together a two minute speech for the public hearing which will be occurring in 15 minutes (or so). Go over techniques for making a presentation (outline the points you want to make, develop charts and graphs, speak clearly and convincingly, etc.)
3. Have the village council elect a mayor (who will chair the

hearing), recording secretary, and timekeeper; and arrange the room for the hearing. Brief the village council on its role. The council members need to listen to all sides and ask questions that might give them better information to make the decision. After the public hearing, they will go outside the room briefly to make their decision. Then they'll come back and announce their decision and reasons.

4. During the hearing, allow each speaker two minutes, followed by questions from the council and audience.
5. After the hearing is over and the council has made its decision, debrief the group by talking about the way decisions are made. Ask the students:

- What would have happened if everyone had tried to influence everyone else?
- Does everyone have equal influence?
- Who else might have affected the decision? (The governor, legislature, Congress.)
- What are important things to know before a decision is made? (Affects on natural resources, the economy, people's feelings, traditional ways, new opportunities.)

Mention several local examples of past development decisions, the roles of community residents, and decision results. Compare these with current local issues.

The Mighty Salmon Cannery Game Role Cards

FRED FRIDAY - manager of the Native Company Store and Corporation Board member.

Fred is excited about the idea of the Mighty Salmon Cannery Corporation locating a cannery at Eekoute. There should be jobs for corporation members in the cannery plus the local fishermen and women could sell their catch locally instead of having to take it down the coast. He likes the idea of the dam, because the excess electricity could be used for other corporation development projects. Plus electricity would be a lot cheaper for everyone in Eekoute, and they wouldn't have to worry about breakdowns all the time on the village's diesel generators. He doesn't care where the cannery is located, just so it comes!

CATHY COHO - fisheries biologist with the Alaska Department of Fish and Game

Cathy would like to see the cannery located over by the airstrip instead of by the Big Riley River. A lot of good wetland habitat would be lost at the river site. The Eekoute Village area is famous for its duck and goose production as well as salmon runs. Oil and gas from the road might seep into the river and, also, there could be erosion that would cover up the salmon eggs. Though the dam would be located above the place where salmon are spawning, nutrients that the fish need would be trapped up above the dam and the water below the dam would be much warmer than it should be for good salmon runs.

THORNE THURBER - cannery owner

Thorne has just come to Alaska from Seattle. He's anxious that everything will go well. His company has put a lot of money into planning the cannery already and this is definitely the cheapest and best design. The cannery will boost the local economy and he's promised to hire local people as much as possible. The barge can bring all the materials right to the cannery site. Once the fish are processed, the majority will be flown out fresh to the Lower 48. The rest will be canned and barged to Seattle at the end of the summer.

NELLIE NIKOLAI - postmistress

Nellie is quite concerned about the situation. She thinks it should be studied a lot more. She likes the idea of the wind generator. As a government employee, she's sure that the village can get money from the government to build it and maybe that would be a source of cheap electricity. The wind's always blowing! She doesn't really like the idea of the dam but the road sounds great. She'd just like to be able to drive, drive, drive!

RIP RYEBACK - old timer hunter and trapper

Rip likes it just like it is. He doesn't want to see any development around Eekoute. Any development will hurt the hunting, fishing, and trapping. And development would bring more people which he dreads. He's comfortable in his cabin in Eekoute, just like he's comfortable in his long underwear which he wears all winter.

PAUL PANNIYAK - local conservationist

Paul grew up in Eekoute and just graduated from the University of Alaska. He's not sure what he's going to do back in the village, but he'd sure like to see a wind generator go in. He sees this as the perfect opportunity to get a wind generator. The dam sounds like a poor idea to him and he agrees with the new fish biologist, Cathy Coho, that the site by the airport would be much better. With the wind generator, they wouldn't need a road--which would save a lot of fish and wildlife habitat.

WILLIE WEBER - long-time fisherman, head of the fisherman's co-op

Willie is really happy to hear about the cannery as that will save local fisherman a long trip down the coast to deliver fish. He is concerned about anything that would damage fish habitat and is especially concerned about the dam. He would also hate to see the loss of wetland habitat, so favors the airstrip site for the cannery. The little Riley River is big enough to handle the fish wastes and all the fishermen could run the materials from the barge up to the airstrip site on a high tide. Also, the cases of canned salmon could be boated down to the barge after the cannery is built.

from some other kind of fishery?

- What time of year must the fishing be done?
- Is it expensive to prepare for fishing?
- What will be the market for the fish?
- Do the fish require any special handling?
- What are sources of information about the new fisheries?
- Is a state or federal agency helping fishermen get started in it?

If possible, arrange for students to visit a vessel engaged in the fishery in question. Be sure the vessel captain or a crew member is present to answer questions and explain the gear to students.

Activity 4 The Mighty Salmon Cannery Game

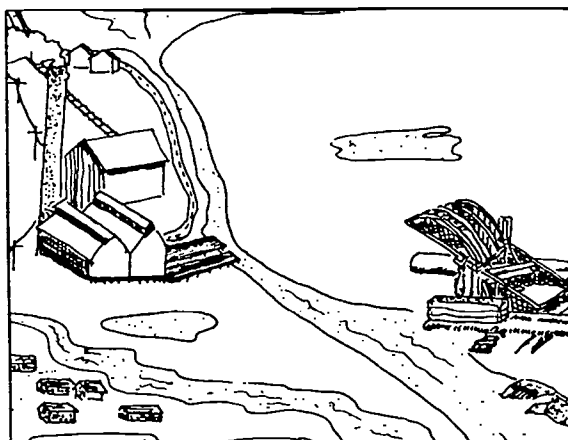

Background:

Throughout Alaska, every community is facing development issues. Sometimes there are possibilities for compromise. Other times inhabitants have to decide on development or the status quo. In any case, residents have to decide on their own priorities and live with the consequences.

Many times, decisions are made in Juneau or Washington, D.C.--or Tokyo or Cairo. But Alaska is famous for the "coffee cup decision"--whether made over coffee at a hotel in Anchorage or someone's kitchen table in a village.

Hopefully, as Alaskans become more cognizant of all the results of decisions, and more astute politically, Alaskan resources and Alaskans will benefit. Our young people need to learn at an early age what's going on in their community and the world in general, and that they can have an effect on their own lifestyles and surroundings. One fun way to get started is to role play

different points of view in a simulation game.

Materials:

- butcher paper
- felt-tip markers
- sets of role cards
- copies of Mighty Salmon Cannery Map

Procedure:

1. Ask students to name planned local development projects. Pass out copies of the Mighty Salmon Cannery Map and go over the proposal. Ask them how they would imagine people in Eekoute Village feel. Tell them that there will be a public hearing on this issue soon.
2. Divide the class in seven groups and hand out the role cards. Each group represents the point of view typified by the role on the card. Have each group tell the rest of the class its name and title. Then tell them to read over the card and elect one of their group to the village council and elect one person spokesperson. The village council should meet up front while the rest of the group helps the spokesperson put together a two minute speech for the public hearing which will be occurring in 15 minutes (or so). Go over techniques for making a presentation (outline the points you want to make, develop charts and graphs, speak clearly and convincingly, etc.)
3. Have the village council elect a mayor (who will chair the hearing), recording secretary, and timekeeper; and arrange the room for the hearing. Brief the village council on its role. The council members need to listen to all sides and ask questions that might give them better information to make the decision. After the public hearing, they will go outside the room briefly to make their decision. Then they'll come back and announce their decision and reasons.
4. During the hearing, allow each speaker two minutes, followed by questions from the council and audience.
5. After the hearing is over and the council has made its decision, debrief the group by talking about the way decisions are made. Ask the students:
 - What would have happened if everyone had tried to influence everyone else?
 - Does everyone have equal influence?
 - Who else might have affected the decision? (The governor, legislature, Congress.)
 - What are important things to know before a decision is made? (Affects on natural resources, the economy, people's feelings, traditional ways, new opportunities.)Mention several local examples of past development decisions, the roles of community residents, and decision results. Compare these with current local issues.

The Mighty Salmon Cannery Game Role Cards

FRED FRIDAY - manager of the Native Company Store and Corporation Board member.

Fred is excited about the idea of the Mighty Salmon Cannery Corporation locating a cannery at Eekoute. There should be jobs for corporation members in the cannery plus the local fishermen and women could sell their catch locally instead of having to take it down the coast. He likes the idea of the dam, because the excess electricity could be used for other corporation development projects. Plus electricity would be a lot cheaper for everyone in Eekoute, and they wouldn't have to worry about breakdowns all the time on the village's diesel generators. He doesn't care where the cannery is located, just so it comes!

CATHY COHO - fisheries biologist with the Alaska Department of Fish and Game

Cathy would like to see the cannery located over by the airstrip instead of by the Big Riley River. A lot of good wetland habitat would be lost at the river site. The Eekoute Village area is famous for its duck and goose production as well as salmon runs. Oil and gas from the road might seep into the river and, also, there could be erosion that would cover up the salmon eggs. Though the dam would be located above the place where salmon are spawning, nutrients that the fish need would be trapped up above the dam and the water below the dam would be much warmer than it should be for good salmon runs.

THORNE THURBER - cannery owner

Thorne has just come to Alaska from Seattle. He's anxious that everything will go well. His company has put a lot of money into planning the cannery already and this is definitely the cheapest and best design. The cannery will boost the local economy and he's promised to hire local people as much as possible. The barge can bring all the materials right to the cannery site. Once the fish are processed, the majority will be flown out fresh to the Lower 48. The rest will be canned and barged to Seattle at the end of the summer.

NELLIE NIKOLAI - postmistress

Nellie is quite concerned about the situation. She thinks it should be studied a lot more. She likes the idea of the wind generator. As a government employee, she's sure that the village can get money from the government to build it and maybe that would be a source of cheap electricity. The wind's always blowing! She doesn't really like the idea of the dam but the road sounds great. She'd just like to be able to drive, drive, drive!

RIP RYEBACK - old timer hunter and trapper

Rip likes it just like it is. He doesn't want to see any development around Eekoute. Any development will hurt the hunting, fishing, and trapping. And development would bring more people which he dreads. He's comfortable in his cabin in Eekoute, just like he's comfortable in his long underwear which he wears all winter.

PAUL PANNIYAK - local conservationist

Paul grew up in Eekoute and just graduated from the University of Alaska. He's not sure what he's going to do back in the village, but he'd sure like to see a wind generator go in. He sees this as the perfect opportunity to get a wind generator. The dam sounds like a poor idea to him and he agrees with the new fish biologist, Cathy Coho, that the site by the airport would be much better. With the wind generator, they wouldn't need a road--which would save a lot of fish and wildlife habitat.

WILLIE WEBER - long-time fisherman, head of the fisherman's co-op

Willie is really happy to hear about the cannery as that will save local fisherman a long trip down the coast to deliver fish. He is concerned about anything that would damage fish habitat and is especially concerned about the dam. He would also hate to see the loss of wetland habitat, so favors the airstrip site for the cannery. The little Riley River is big enough to handle the fish wastes and all the fishermen could run the materials from the barge up to the airstrip site on a high tide. Also, the cases of canned salmon could be boated down to the barge after the cannery is built.

The Mighty Salmon Cannery Map

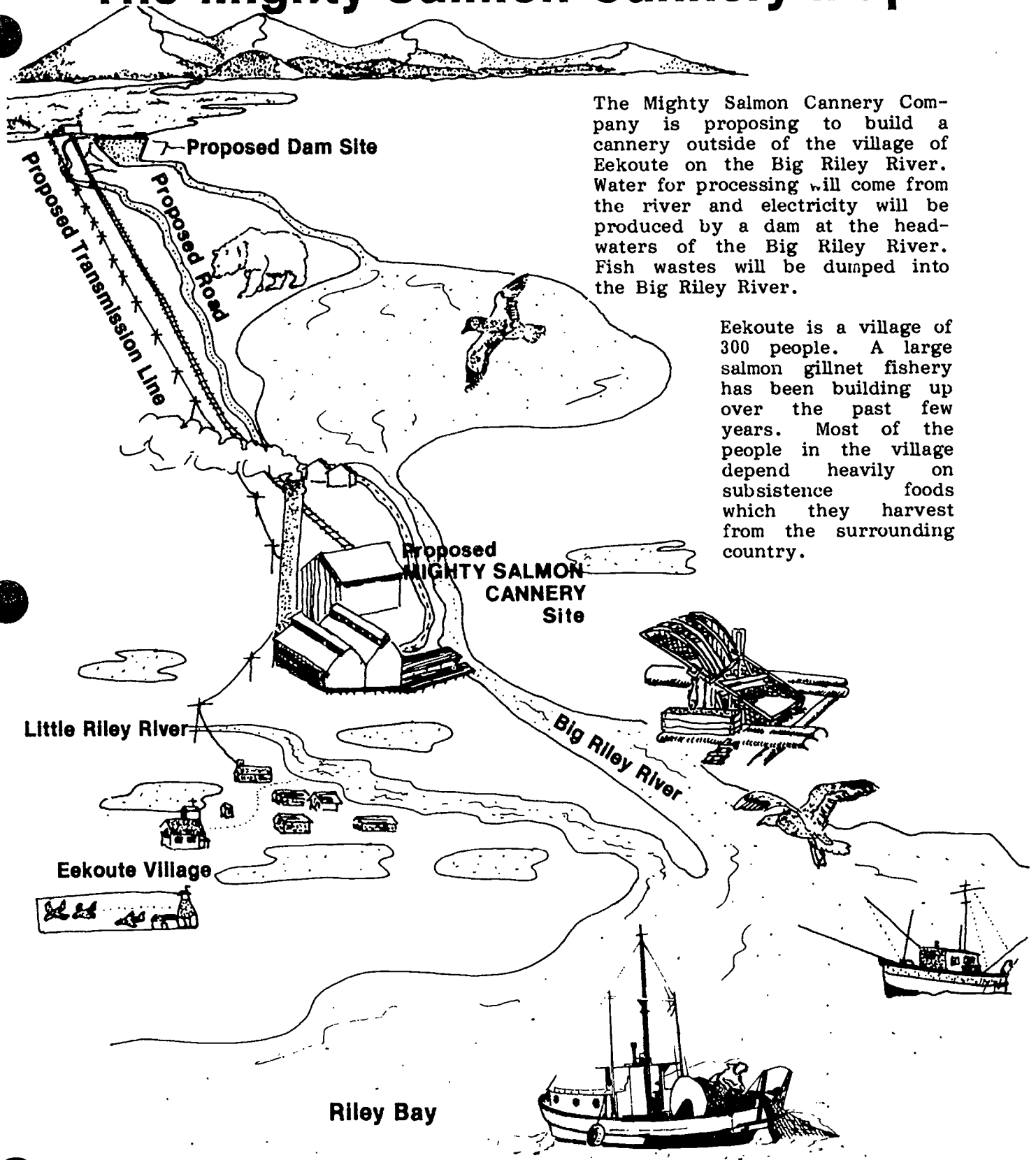

The Mighty Salmon Cannery Company is proposing to build a cannery outside of the village of Eekoute on the Big Riley River. Water for processing will come from the river and electricity will be produced by a dam at the headwaters of the Big Riley River. Fish wastes will be dumped into the Big Riley River.

Eekoute is a village of 300 people. A large salmon gillnet fishery has been building up over the past few years. Most of the people in the village depend heavily on subsistence foods which they harvest from the surrounding country.

Activity 5

Cartooning Local Issues

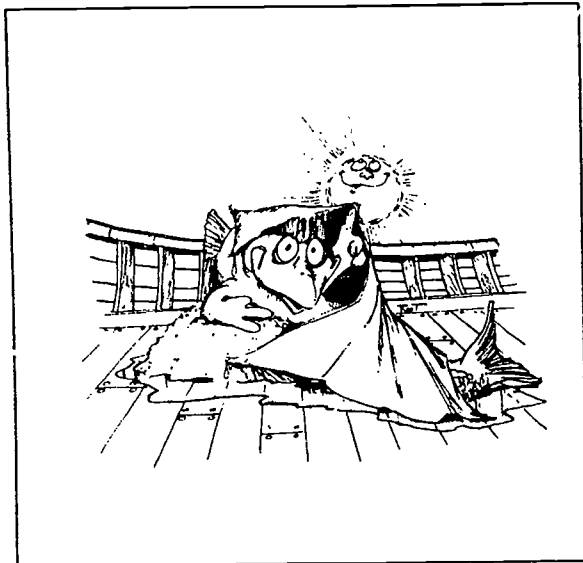

Background:

Oftentimes a cartoon or a sense of humor can be very effective politically. Plus, humor makes life more bearable and enjoyable for all of us.

Materials:

- paper
- pencil
- sample cartoons

Procedure:

1. Brainstorm with your class a list of local fisheries issues. These might include disregard of a fisheries regulation, potential losses in fisheries habitat by proposed developments, lack of knowledge of

how to hold a fish, the importance of fish spawning habitat, or the need to be careful with incidental fish and crabs caught in gill nets, seines, or trawls. The class might be interested in helping the community obtain an aquarium, hatchery, or education program.

2. Select and research one issue. Students may interview or invite speakers.
3. Decide on a point of view or proposed solution. Then draw cartoons to illustrate your point.
4. Show your results to the decision makers or people involved in the issue. Offer your help in resolution of the issue. Students can make a difference!

Additional Activities:

1. Art, Social Studies: Have students make T-shirts with a fish cartoon or saying on the front. They can silkscreen the shirts themselves or order them from a specialty company. The students might want to make enough to sell and to spread their points of view to the community!
2. Art, Social Studies: Have students design postage stamp posters as another way of conveying their ideas to the community.

Salmon Word Search

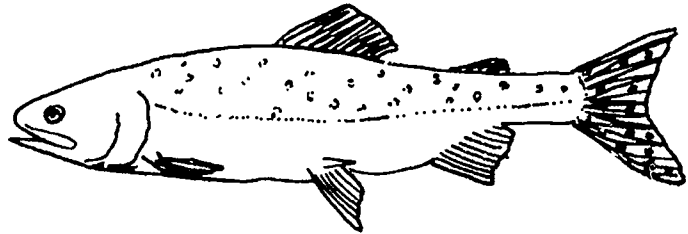
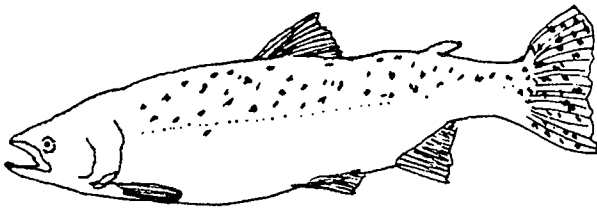

Can you find the 13 "salmon words" in the square below?
Some words may be diagonal or even backwards!

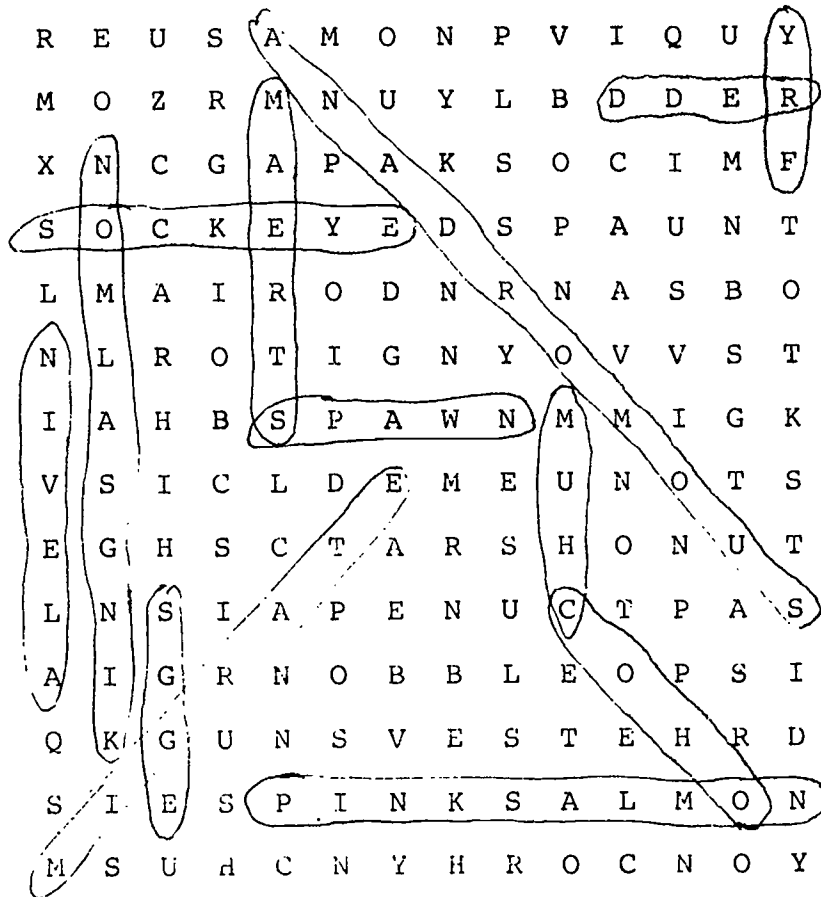

1. ALEVIN
2. ANADROMOUS
3. CHUM
4. COHO
5. EGGS
6. FRY
7. KING SALMON

8. MIGRATE
9. PINK SALMON
10. REDD
11. SOCKEYE
12. SPAWN
13. STREAM

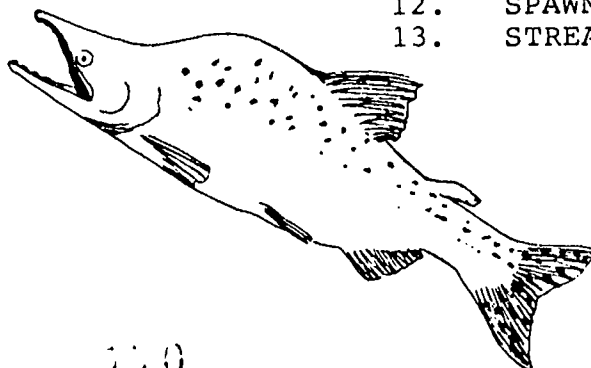

SALMON HABITAT MAP

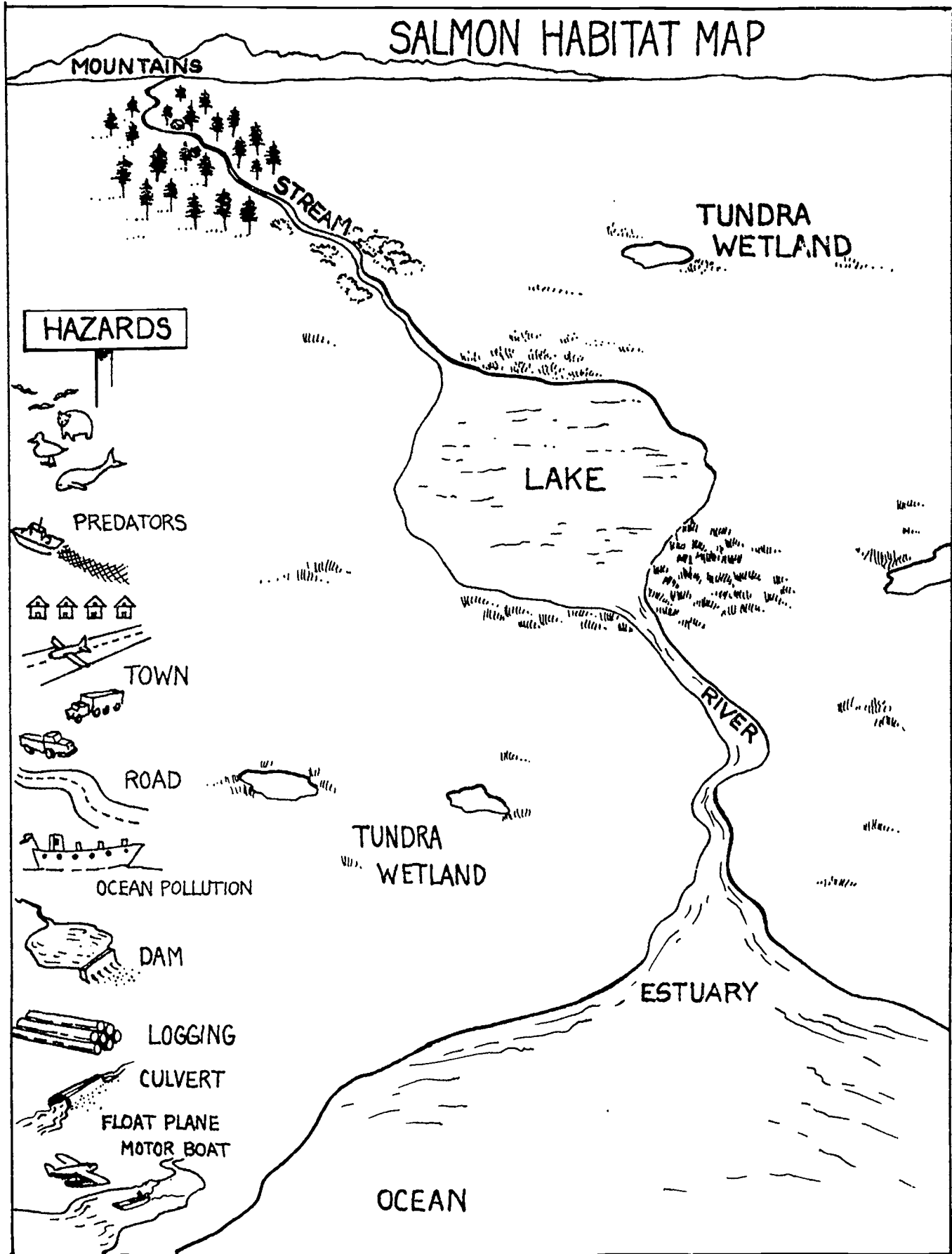

What Happens in an Alaskan Salmon Cannery

BEGIN

Fish unloaded at dock suckers used in some canneries

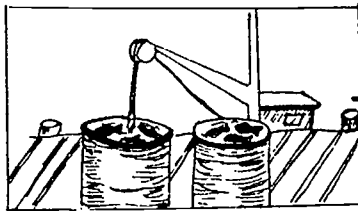

Go into chilled seawater tanks according to species

To revolving knife for beheading

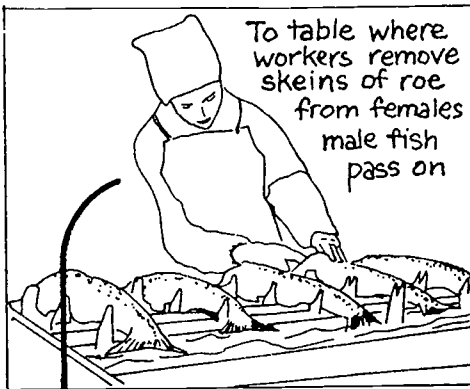
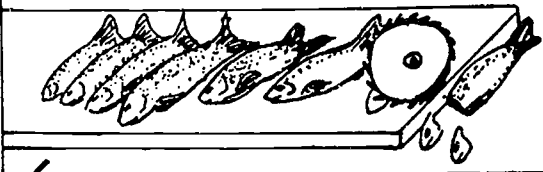

To table where workers remove skeins of roe from females male fish pass on

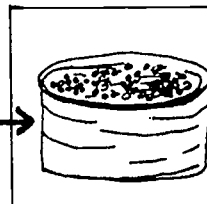

Roe washed in salt brine and sorted

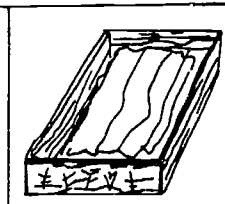

Roe packed in small wooden boxes with lots of salt

Sent to Japan

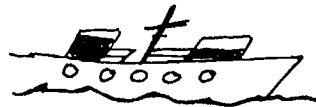

Fish to iron chink where tails, fins + guts are removed

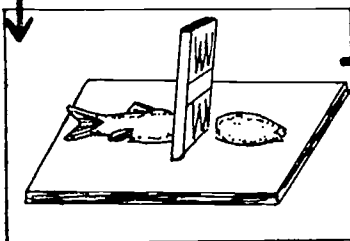

To slime table for final cleaning

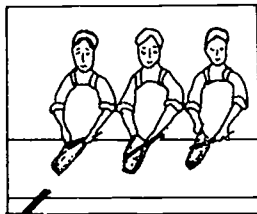

Shipped under bond to where shipment is passed by FDA — Then shipped all over world



To filler where fish are chopped into chunks + put in cans

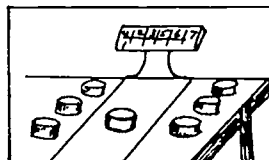

Weighing machine sidetracks light cans

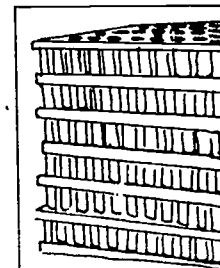

To britestack or caseup room for palletizing with shrink wrap or put in cases

Air cooled in warehouse or water cooled in retort

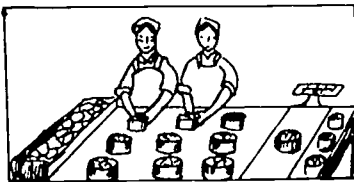

Patch table where small chunks added to light cans

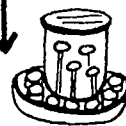

To seamer and vacuum chamber where air is drawn out and lid put on



Racked, stacked and rolled into retorts where cooked at 250° at 15 lbs. pressure for 1 1/2 hours

Bibliography

Compiled by Nancy Barr, Belle Mickelson, and Dr. Earl Clark, Associate Professor, University of Alaska, Juneau, and his students Patricia Muchnick and Chris Winter.

For additional suggestions of books on fish and fisheries and other Sea-Week related stories, consult these two excellent annotated bibliographies:

Bagnall, Norma. Sea Sources. Texas A&M Sea Grant College Program, Texas A&M University, College Station, Texas 77843, 1981. 187 p.

A List of Books on the Marine Environment for Children and for Young People. Project Coast, 310 Willard Hall Education Building, University of Delaware, Newark, Delaware, 1971.

We have included several selections from these two sources plus from the following two out-of-print bibliographies.

Lee, Richard S. and F.F. Wright. Bibliography of Marine Teaching Materials. Marine Advisory Program - Cooperative Extension Service, University of Alaska, Anchorage, Alaska 99504, 1976. 40 p.

Currier, Janice A. Skiff and Shore: A Teachers' Guide to Fisheries Education Materials. Alaska Native Foundation, Fisheries Program, 411 West Fourth Avenue, Anchorage, Alaska 99501.

Children's Literature:

Additional easy reading fish books are found in Volume II of the Sea Week Curriculum Series.

Adkins, Jan. The Craft of Sail. Illustrated by author, Walker & Co., NY., 1973. 64 p.

Aesthetically pleasing, carefully detailed study of sailing vessels that includes charts that show various kinds of sails, knots, chart symbols, as well as engineering principles written and illustrated so even the youngest reader can understand.

Altman, Margery. Jaws 2 Sharks: Everything That's Good and Bad About Them. Illustrated by Tony Tallarico, Grossett & Dunlap, NY, 1978. 62 p.

Questions asked by some Connecticut high school students together with answers and line drawings to color.

Angel, Heather. The World of a Stream. Illustrated with photographs and line drawings. Faber and Faber, Salem, NH, 1976. 128 p.

An information book about the plants and animals which live in streams.

Boudreau, Norman (ed.). Old Fourlegs, a 'Living Fossil'. National Museums of Canada, Ottawa, Canada K1A 0M8, 1976. 8 p.

Background information and directions for making a paper sculpture of an ancient fish, the coelacanth. Text and directions are in both English and French.

Buehr, Walter. Sea Monsters. Illustrated by the author. Archway Paperbacks, Simon & Schuster, NY, 1970. 113 p.

An information book written as literature which serves as a good starting point for children interested in studying sea creatures. Gives the history of "monster" sightings from the middle ages through the Loch Ness Monster. An honest interpretation of monsters as they have been perceived by people since earliest times.

Bernard, Christine. The Book of Fantastic Boats. Illustrated by Roy Coombs. Golden Press, 1974. 30 p.

Magnificent color plates dominate each page. The brief text contains facts and trivia to intrigue students. The picture of each boat is captioned with date, country of origin, size and prominent feature or use.

Burton, Maurice. The Life of Fishes. Golden Press, NY, 1974. 62 p.

Discusses fishes from the earliest known and illustrates them with full color drawings. Includes interesting descriptions of how a paleontologist works, the results of pollution, and how to set up and maintain an aquarium. Discusses evolution, life cycles, anatomy, food chains and pyramids.

Bleeker, Sonia. The Sea Hunters - Indians of the Northwest Coast. Illustrated by Althea Karr. William Morrow & Company, NY, 1951. 159 p.

Effectively portrays the life of the Northwest Coast Indians before the coming of the white man. Subjects range from salmon fishing to food preservation and sea otter, sea lion, seal, deer and bear hunting. Illustrations are numerous and depict the regional area and customs.

Blumberg, Roda. Sharks. Franklin Watts, Inc., N.Y., 1976.

Tells about sharks and rays and how they hear, see, mate, and eat. Scary photographs, exciting text.

Brindze, Ruth. The Rise and Fall of the Seas: The Story of Tides. Illustrated by Felix Cooper. Harcourt, Brace & World, Inc., 1964. 91 p.

Good introduction to causes, effects, dangers, and uses of tides. Illustrated with black-and-white photographs and diagrams.

Buck, Margaret Waring. In Ponds and Streams. Abingdon Press, 1955. 77 p.

A specialized reference book giving an overview of many facets of pond and stream life. Different types of plants, worms, snails, insects, fishes, mammals, etc., are illustrated and discussed. Specifically deals with the northeastern part of the U.S., but is still useful for Alaskans.

Burger, Carl. All About Fish. Random House, N.Y., 1960. 139 p.

Very interesting and well written text which begins by comparing fish with other living creatures. Discusses fish origins; serpents and monsters; and fish oddities. Includes both salt and fresh water fish. Describes commercial and sport fishing.

Clemons, Elizabeth. Waves, Tides and Currents. Illustrated with maps, diagrams and photographs. Alfred A. Knopf, NY, 1967. 112 p.

Explains what a tide is and accurately describes the difference between an ebb tide and flood tides; what causes the tides; and the effect of currents in the oceans.

Cole, Joanna and Jerome Wexler. A Fish Hatches. Wm. Morrow & Co., N.Y., 1978. 39 p.

Photographically illustrated description of life of a hatchery trout from egg onward. Discusses importance of scales, gills, sensory organs and explains in detail how a fish swims.

Cole, William. The Sea, Ships and Sailors. Illustrated by Robin Jacques. Viking, NY, 1967. 236 p.

A Grant collection of marine poetry and songs with the rhythm of the men working on the ships, the intrigue of the strange lands they visit and the exciting adventures they have.

Cousteau, Jacques. A Sea of Legends: Inspiration From the Sea. World Publishing, NY, 1973. 144 p.

A collection of sea legends from our earliest history in a lovely, oversized book. Part of "The Ocean World of Jacques Cousteau." Beautifully illustrated with prints, full-color photographs, and drawings.

Cousteau, J-Y. and P. Cousteau. The Shark: Splendid Savage of the Sea. Doubleday, 1970.

Another entertaining book by the French team that originated and has so effectively publicized SCUBA. Consists primarily of anecdotes, but has the excellent photos and poetic prose typical of the Cousteau clan.

Figdor, George and B. Figdor. Salmon Fishing. George Figdor, Box 612, Haines, Alaska 99827. 48 p.

Excellent photographic illustrations and creative text which explains what is involved in commercial salmon fishing.

Fletcher, Alan Mark. Fishes and Their Young. Illustrated by Allan Eitzen. Addison-Wesley, 1974. 46 p.

Tells how fish vary enormously in the amount of care they give to their young - from none at all to a considerable degree of protection. Covers many kinds of fish with good illustrations.

Fletcher, Alan Mark. Fishes Dangerous to Man. Illustrated by Jane Teiko Oka and Willi Baum. Addison-Wesley, 1969.

Categorizes fishes dangerous to man into those which shock, bite, sting, or are poisonous to eat. Short descriptive stories of persons who have had close calls with these frightening animals are followed by informational passages. Black-and-white illustrations are dramatic and well designed.

Fletcher, Alan Mark. Fishes that Hide. Illustrated by Jean Day Zallinger. Addison-Wesley, 1973.

Explains how fish are camouflaged to obtain food or escape enemies by various shapes and markings and by coloring, transparency, counter-shading, or changing colors.

Fletcher, Alan Mark. Fishes that Travel. Illustrated by Michael Eagle. Addison-Wesley, 1971. 48 p.

Describes the migration of some species of fish and unusual methods of locomotion of others, including flying fish and fish which travel on land.

Garret, Maxwell R. The Science-Hobby Book of Boating. Lerner Publications, 1974. 55 p.

Gives basic instructions for canoeing, rowing, sailing and power boating in this clearly-written and profusely-illustrated book. Emphasizes safety and techniques. Includes information on navigational aids, buoys, running lights, signaling and nautical "rules of the road."

Goetz, Delia. Lakes. William Morrow and Co., N.Y., 1973. 66 p.

Focuses on various aspects of lakes: their origins, life cycles, and plants and animals associated with them. Mentions people's use of lakes thousands of years ago and today, including pollution. Soft greenish and charcoal colored illustrations heighten the attraction of the text.

Goetz, Delia. Rivers. Illustrated by John Kaufmann. Wm. Morrow & Co., 1969. 63 p.

An exploratory book about the rivers of the world. Discusses history as well as how they are formed. Mentions some famous rivers and points out the need for river conservation and water pollution controls. Illustrated with black-and-white drawings.

Gracza, Margaret. The Ship and the Sea in Art. Designed by Robert Clark Nelson. Lerner Publications Co., 1969. 64 p.

Covers ships and the sea in art through the ages, from Egyptian bas-relief of boats on the Nile to Jacques Lipschitz' cubist Sailor with Guitar. Combines art appreciation with an introduction to nautical terminology and history.

Harris, Christie. Once Upon a Totem. Atheneum, New York, 1973. 195 p.

Includes the story "The Prince who was Taken Away by the Salmon," a tale about the disappearance and return of salmon to rivers of the Northwest.

Hausamn, Leon A. Beginners' Guide to Fresh-Water Life. G.P. Putnam's Sons, 1950. 128 p.

Brief descriptions of freshwater critters accompanied by black-and-white line drawings.

Higgins, Art. Inside an Alaskan Cannery. Art Higgins, Juneau, Alaska (printed by Alaska Litho), 1972. Approximately 50 p.

Describes salmon and crab cannery processing in Alaska with a series of pen and ink drawings and brief text.

Holling, Holling Clancy. Paddle-to-the-Sea. Houghton Mifflin Co., 1941.

An excellent book about the flow of water from the snow on a mountain-top to salt water in the ocean. Traces the voyage of a canoe carved by a young Indian boy from the Great Lakes to the Atlantic Ocean. Wonderful text and illustrations.

Jacobsen, Daniel. The Fishermen. Franklin Watts, N.Y., 1975. 87 p.

Describes life, customs, history of Indians of America's Northwest coast with emphasis on the Tlingit. Includes information on land claims and Tlingit life today.

Kipling, Rudyard. Captains Courageous. Doubleday, NY, 1897. 322 p.

Classic sea adventure filled with sea imagery. Written when Kipling was living in the United States.

Latham, Jean Lee. Carry On, Mr. Bowditch. Illustrated by John O'Hara Cosgrave II. Houghton Mifflin, Boston, 1955. 251 p.

In a true sea adventure describes Nathaniel Bowditch life in Salem in the 1700s. Through hard work and much study, he gets to sail with a crew. He discovers new ways of navigation, and he is, in all ways, a model to emulate.

Liss, Howard. Fishing Talk for Beginners. Illustrated by Leonard Cole. Julian Messner, New York. 1978. 96 p.

Detailed information in dictionary form about various aspects of sport fishing. Includes drawings showing spinning, surf casting and fly fishing and their associated lures. Explains types of fish and how to measure them.

Matteson, George. Draggermen: Fishing on Georges Bank. Four Winds Press, NY, 1979. 138 p.

Describes a stern trawler and the men who fish from her on Georges Bank off the New England coast. Matteson accompanied the crew on an actual voyage and tells of their work with care, craft and compassion. The four man crew works as a team; each knows exactly what his task is, and the captain works as hard as the men; profits are shared identically. Tells how they find where the fish are, how they make the catch, what things can go wrong when the net is dragging the bottom, how the fish are separated and the deck cleaned.

MacGregor, Ellen. Miss Pickerell Goes Undersea. Illustrated by Paul Galdone. McGraw-Hill Book Co., N.Y., 1953. 125 p.

Describes sonar, atomic-powered submarines, and under-the-sea salvaging in a fun way. The unpredictable Miss Pickerell uses these things in the recovery of her priceless Mars rocks that were being transported on a ship that sank.

MacGregor, Ellen and Dora Pantell. Miss Pickerell Harvests the Sea. Illustrated by Charles Geer. McGraw-Hill, NY, 1968. 144 p.

Tells about how Miss Pickerell's friend opens a sea diner and his menu depends on seaweed, algae and other things from his ocean farm. When it stops producing, Miss Pickerell helps solve the mystery.

McGovern, Ann. Sharks. Illustrated by Murray Tinkelman. Four Winds Press, N.Y., 1976. 47 p.

Presents a great deal of information with question-answer format and attractive black and white illustrations.

Mundie, Rosemary and Colin. The Story of the Sailing Ship. Exeter Books, New York, 1975. 152 p.

Exquisitely illustrated large format book which details sailing ships round the world from the past and present.

Nordhoff, Charles and James Normal Hall. Mutiny on the Bounty. Little, Brown, Boston, 1960 (reprint 1932 ed.). 384 p.

Details the famous late 18th Century mutiny.

Onmanney, F.D. The Fishes. Time-Life Books, NY, 1967. 128 p.

A marvelous, descriptive text with pictures of fish, their life habits and how food is harvested from the oceans. Illustrated with full color photographs, maps and drawings.

Oxford Scientific Films. The Stickleback Cycle. Photographs by David Thompson. G.P. Putnam's Sons, N.Y., 1979. 27 p.

Explains the life cycle of the stickleback with a short introductory text and clear, outstanding close-up photos.

Parnall, Peter. The Great Fish. Illustrated by the author. Doubleday, NY, 1973, n. pag.

Charlie is an Indian boy who listens to his grandfather's stories about how their land developed. One of the best is about the salmon that always returns to the land of the Indians to spawn. Has a strong ecology statement. Beautifully illustrated in black and white.

Paul, Frances Lackey. Kahtahah. Illustrated by Rie Munoz. Alaska Northwest Publishing Co., Anchorage, Alaska, 1976. 109 p.

Originally written in 1938 for a fourth-grade class. Based on the real life of a 19th century Tlingit girl. Includes several sea-related legends, as well as information on traditional fishing. Wonderful illustrations.

Peck, Christopher. The Scholastic Fun Fact Book of Underwater Worlds. Scholastic Book Services, N.Y., 1977. 32 p.

Packed with facts, full-color illustrations, and diagrams of sea creatures and underwater exploration voyages.

Pedersen, Elsa. Alaska Harvest. Illustrated by Kurt Werth. Abington Press, N.Y., 1960. 192 p. Out of print (check your library).

Story of a family's life on a crab boat in Kachemak Bay. High catches cause many others to accuse them of pirating. The resulting bravery and determination prove their honesty, gain their respect in Seldovia, and earn them a house for their mom's return from the hospital.

_____. Cook Inlet Decision. Illustrated by Walter Ferro, Atheneum, N.Y., 1963. 203 p. Out of print (check your library).

Story of Gregor, an orphaned half Norwegian, half Aleut teenager who tries his luck as an independent fisherman in Cook Inlet. Action packed events give birth to thoughtful reflections by Gregory, who changes considerably through his experiences.

_____. Fisherman's Choice. Illustrated by Alvin Smith. Atheneum, N.Y., 1964. 182 p. Out of print (check your library).

Story of Dave Moffitt's job on a crab boat. Mystery, intrigue, and constant adventure that lead to Dave growing from a boy to a man.

_____. Petticoat Fisherman. Atheneum, N.Y., 1969. 231 p. Out of print (check your library).

Alaskan fishing out of Seldovia forms part of a girl's growing from teenager to adult.

Phleger, Fred. Red Tag Comes Back. Illustrated by Arnold Lobel. Harper & Row, N.Y., 1961. 64 p.

Teaches the life cycle of a salmon with a simple story line.

Pringle Lawrence. This is a River: Exploring an Ecosystem. Macmillan Pub. Co., Inc., 1972. 55 p.

Presents the river as a flowing-water ecosystem. Of note are drawings of stream animals found under a stone, a diagram showing a food web, and another drawing illustrating types of life present in the water in relation to the amount and location of industrial pollution.

Reekie, Isabel M. Red Paddle. Illustrated by Dennis Hutchins. Mitchell Press, Vancouver, 1968. 99 p.

Partially fiction, set among real people in a real setting, this tells of Dave's building a dugout canoe on Burrard Inlet in British Columbia before Vancouver became incorporated as a city.

Reid, George K. Pond Life. Golden Press, N.Y., 1967. 150 p.

The best simplified guide to life in and around ponds and lakes. Packed with color drawings. One of the Golden Nature Series.

Selsam, Millicent E. and Joyce Hunt. A First Look at Fish. Walker Publishing Co., N.Y., 1972. 32 p.

A simple look at what a fish is. Discusses unique structures and the diversity of shapes and sizes among fishes.

_____. A First Look at Sharks. Illustrated by Harriett Springer. Scholastic Book Services, N.Y., 1979. 32 p.

Compares sharks with fish and with each other. Makes the subject of shark identification clear and comprehensible for the novice of any age.

Soule, Gardner. Remarkable Creatures of the Sea. G.P. Putnam's Sons, N.Y., 1975. 96 p.

Deals with true stories of the odd, the enormous, and the mysterious. Leaves the reader disbelieving, yet wanting to hear from "fish stories." Presents the fish of the very deep, the largest invertebrates, fish that fish, tracks on the bottom, and over half a dozen others. Few black and white photographs, but fortunately, the writing is so descriptive that it allows the reader to visualize what is not pictured.

Stevenson, Robert L. Treasure Island. Dutton, NY, 1977. 161 p.

A classic written about 100 years ago. Still lures readers with its tale of intrigue, hidden treasure and brave and honest young men. Continues to entrance readers as they, like Jim Hawkins, are lured to the sea and to adventure.

Straker, Joan Ann. Animals that Live in the Sea. National Geographic Society, 1978. 32 p.

Designed to impress and awe the reader with vivid pictures and information. Pictures common fish and colorful tropical beauties, including a humorous clownfish and various anemones. A small amount of interesting factual information accompanies each full-color photograph.

Thompson, Donnis Stark. Mystery of the Alaska Fish Site. Illustrated by Jack Gaughan, Criterion Books, N.Y., 1966. 143 p. Out of print (check your libraries).

Todd, a Chicago boy, has traveled to Alaska to fish with his cousin Buff for the summer. Todd is exhausted by all the preparatory work for setting nets and is baffled by the special vocabulary that goes with it. The two boys work as men and can't understand the rude, unfriendly behavior of their neighbor, Vimri. The two unravel an international gun smuggling ring that Vimri is involved with. Gives valuable background information about salmon fishing in an adventure and mystery that appeals to even a reluctant reader.

Todd, Joan Marlow and Robert Sietsema (editors). I Must Go Down to the Seas Again. Hart Publishing Company, Inc., N.Y., 1978. 63 p.

Passages of nautical poetry and prose are matched with fine engravings to catalog mankind's fascination with the sea.

Tunis, Edwin. Oars, Sails and Steam. Illustrated by author. Thos. Crowell, NY, 1952. 79 p.

A meticulously crafted book with detailed line drawings of ships of the past 10,000 years. Includes a history of ships that combines facts with humor and charm. A book to read slowly and return to again for reference and for pure pleasure.

Turner, Philip. Sea Peril. Illustrated by W.T. Mars. Cleveland World, 1968. 224 p.

David, Arthur and Peter discover an old punt (a long, narrow, flat-bottom boat) in the town junkyard and restore it so they can put out to sea.

Van Doren, Charles. Growing Up on a Clipper Ship. Illustrated by Robert Patterson. Hill & Wang, NY, 1964. 127 p.

One of Van Doren's "Growing Up" series about 16-year-old Nat Dawson in the 1850s when he was the youngest sailor on the Rebecca.

Ware, Kay. Let's Read About Fishes. Webster Publishing Co., 1957. 32 p.

Introduces fish in general and a wide variety of unusual fish species with color and black and white stylized illustrations.

Wei, Tu. Landing the Giant Sturgeon. Illustrated by the author. Foreign Language Press, Peking, 1976. n. pages.

Beautiful Chinese watercolor illustrations of a big fish story. Simply story line intertwined with a few quotes from Chairman Mao and other communists.

Wheeler, Alwyne. Fishes. Usborne Publishing Ltd., London, 1982. 24 p.

Superb descriptions of fish and their adaptations in gorgeous color drawings. Heavily illustrated with a simple story line.

Wise, William. Monsters of the Deep. Illustrated by Ben F. Stahl. G.P. Putnam's Sons, 1975. 63 p.

Introduces some of the "most dangerous and mysterious monsters" of the deep to the young reader. Includes different kinds of sharks, octopus, squid, whale, sawfish, moray eel, and stingray. Discusses the development of diving equipment. Exceptional illustrations are the strength of this book.

Woods, Loren P. Fishes. Illustrated by Tom Dolan. Follett Publishing Co., Chicago, 1969. 32 p.

A simple overview of fish that discusses evolution, distribution and ecology. Covers anatomy and information about tropical and cold water fishes with brilliant colored illustrations.

Wyss, Max Albert. Magic of the Sea. Viking Press, 1968. 86 p.

Combines superb photographs of the sea and its inhabitants with prose and poetry to make a moving essay about people and the sea. Influence of the oceans on human cultures is impressively developed in this handsome book.

Zim, Herbert. The Waves. Illustrated by Rene Martin. Wm. Morrow & Co., 1967. 63 p.

Explains water in motion, better known as waves. Discusses technical studies of waves and their significance. Also mentions tidal waves, their past destructiveness, and current warning devices used by the Coast and Geodetic Survey. Illustrated with pencil drawings.

Zim, Herbert S. and Lucretia Krantz. Commercial Fishing. Illustrated by Lee J. Ames. Wm. Morrow, NY, 1973. 64 p.

Zim, Herbert S. and Hurst H. Shoemaker. Fishes. Illustrated by James Gordon Irving. Golden Press, NY, 1955, 160 p.

A guide to the more common of the world's fishes, both salt water and fresh with full color illustrations and classifications listed for easy identification.

Herbert S. Zim. Sharks. Illustrated by Stephen Howe. Wm. Morrow, NY, 1966. 64 p.

Describes different kinds of sharks, their importance, and the danger they present to people.

Teacher's Reference:

Alaska Geographic Society, Box 4-EEE, Anchorage, Alaska 99509.

- Vol. 1, No. 1 - The North Slope (out of print)
- No. 3 - Admiralty: Island in Contention
- No. 4 - Excerpt from Fisheries of the North Pacific: History, Species, Gear & Processes (out of print)
- Vol. 2, No. 3 - Prince William Sound (out of print)
- No. 4 - Yakutat: The Turbulent Crescent (out of print)
- Vol. 3, No. 4 - The Silver Years of the Alaska Canned Salmon Industry: An Album of Historical Photos (out of print)
- Vol. 4, No. 3 - Kodiak: Island of Change (out of print)
- Vol. 5, No. 1 - Cook Inlet Country
- No. 2 - Southeast: Alaska's Panhandle
- No. 3 - Bristol Bay Basin
- Vol. 6, No. 1 - Yukon-Kuskokwim Delta (out of print)
- No. 3 - Alaska's Native People
- No. 4 - Stikine River
- Vol. 7, No. 1 - Alaska's Great Interior
- No. 3 - The Aleutians
- Vol. 9, No. 2 - Sitka and It's Ocean Island World
- No. 3 - Islands of the Seals: The Pribilofs

Regional picture books that contain some information on fish and fishing techniques for each area of the state.

Alaska Sport Fish Identification Handbook. Alaska Department of Fish and Game, P.O. Box 3-2000, Juneau, Alaska 99801. (free)

Explains basic fish anatomy and how to identify common fresh and salt-water sport fish. Includes line drawings and weight information.

Alaska Wildlife Notebook Series. Public Communications Section, Alaska Department of Fish and Game, P.O. Box 3-2000, Juneau, Alaska 99801. (free)

Series of one-page sheets on fish and other animal species. Excellent line drawings and range maps.

Armstrong, R.H. A Guide to the Birds of Alaska. Alaska Northwest Publishing, Anchorage, 1980. 309 p.

Species descriptions and range information on Alaskan birds. Very good color photographs that students will enjoy. Good reference for identifying birds on stream and lake studies.

Bailey, Jack E. Alaska's Fishery Resources - The Pink Salmon. United States Department of the Interior, Fish and Wildlife Service, Bureau of Commercial Fisheries, Fishery Leaflet 619, 1969. 8 p. Out of print (check your libraries or ask a fisheries biologist).

Browning, R.J. Fisheries of the North Pacific: History, Species, Gear and Processes. Alaska Northwest Publishing Company, Anchorage, 1974. 408 p.

Good overview of all aspects of commercial fishing in the North Pacific. Covers the species of fish found in Alaskan waters, vessels, and gear used in each fishery, fishery management, processing and marketing.

Chapman, C.F., et al. Piloting, Seamanship, and Small Boat Handling--Motor Boating. Hearst Books, NY, 1981 (5th edition). 640 p.

Comprehensive, well-written and illustrated review of everything you want to know about small boat handling.

Childerhose, R.J. and M. Trim. Pacific Salmon. University of Washington Press, Seattle, 1979. 158 p.

Large picture book format which details salmon species, life cycles, hatchery techniques, and pollution problems with extensive text and color photos.

Cole, Gerald A. Textbook of Limnology. C.V. Mosby Co., St. Louis, Missouri, 1979.

Introduces biological, chemical, and physical processes of lakes, ponds, and streams.

Commercial Fish Species of the Pacific West Coast and Alaska. National Marine Fisheries Service (& others), P.O. Box 1668, Juneau, Alaska 99802.

Booklet with beautiful water colors of fish species plus line drawings of fishing gear, range maps, and other miscellaneous facts in English, French, German, Spanish and Japanese.

Cooperative Extension Service, University of Alaska, Fairbanks, Alaska 99701.

P-468 Easy Steps for Canning Salmon (12 p.)
P-24 Pickling Fish (4 p.)
P-25 Smelt (4 p.)
P-26 To Salt Fish (2 p.)

- P-27 The Fisherman Returns (67 p.) (cookbook)
 P-128 Pressure Canning Alaska Fish at Home
 P-229 All About Alaskan Clams (2 p.)
 P-040 Hypothermia-Cold Blooded Killer (2^d p.)
 P-036 Some ABC's of Fo'c'sle Living (52 p.)
 P-1-031 Utilization and Disposal of Crab and Shrimp Wastes (45 p.)
 P-1-032 Safety Notes for the North Pacific (126 p.)

Publish a variety of pamphlets and booklets on fish and fishing.

Davis, J.C. Fish Cookery. A.S. Barnes and Co., 1967.

A surprising collection which, in addition to good advice on standard fish cooking, gives many interesting and exotic recipes. If you bring anything from an octopus to a whale home from fishing, this will tell you how to prepare it.

Dennon, Jerry. The Salmon Cookbook. Pacific Search Press, Seattle, 1978. 127 p.

Many delicious recipes together with salmon history, spawning and migration patterns, aquaculture, species descriptions, and cooking and cleaning techniques highlighted with pen and ink drawings.

Hart, J.L. Pacific Fishes of Canada. Bulletin 180, Fisheries Research Board of Canada, 1973. 740 p.

Best reference available for Alaskan saltwater fish. Detailed species descriptions and illustrations.

Hartman, Wilbur L. Alaska's Fishery Resources - The Sockeye Salmon. United States Department of Commerce, National Oceanic and Atmospheric Administration, National Marine Fisheries Service, Fishery Leaflet 636, Seattle, Washington, 1971. 8 p.

Presents information on the life history and management of the sockeye salmon. Contains a good graphic of the life cycle of the salmon.

Higgins, John. The North Pacific Deckhand's and Alaska Cannery Worker's Handbook. Albacore Press, P.O. Box 335, Eastsound, Washington 98245, 1978. 81 p. (LC 78-53530) (ISBN 0-9601716-1-4)

Details information, advice, stories and anecdotes on entering the fishing industry. Explains major methods used in fisheries (trolling, gill netting, purse seining, dragging, tuna and halibut fishing, shrimping, and crabbing). Includes a section on what to expect in jobs in the cannery, on floaters, or in cold storage plants.

Holdgate, Charles. Netmaking. Emerson Books, Inc., Reynolds Lane, Buchanan, New York 10511, 1972.

Excellent details and directions for making all kinds of netcraft from bags to crab pots and basketball goal nets. Written specifically for students, includes a chapter on "netting as a group activity."

Lynch, Kathleen. Fishwheels and How to Build Them. Illustrated by the author. Adult Literacy Lab, Anchorage Community College, 2533 Providence Avenue, Anchorage, Alaska 99504, 1979. 45 p.

Excellent description of fish wheels in large print with ample illustrations.

MaCafferty, W. Patrick. Aquatic Entomology. Science Books International, Inc., Boston, 1981. 488 p.

Beautifully illustrated text on aquatic insects written for both the biologist and the sport fly fisher.

Meltzer, Michael. The World of the Small Commercial Fishermen: Their Lives and Their Boats. Dover Publications, New York, 1980. 88 p.

Describes the life histories and methods of harvest of Pacific salmon, New England lobster, cod, halibut, whitefish, tuna, menhaden, mollusks and crustaceans. Includes some first-person narratives. Chapters on fishing vessels, fishing gear, and ethnic fishing communities. Many good photographs, engravings, and drawings.

McNeil, William J., and Jack E. Bailey. Salmon Ranchers' Manual. Northwest Fisheries Center, National Marine Fisheries Service, 2725 Montlake Boulevard East, Seattle, Washington 98112, July 1975. 95 p.

Prepared to assist groups or individuals with ocean ranching of Pacific salmon. Contains excellent information on special characteristics of species; biology of salmon; hatchery and water supplies; incubation systems; selection of stock; care of brood fish; eggs; alevins and fry; genetic problems; economic and legal perspectives.

Morgan, Ann Haven. Field Book of Ponds and Streams. G.P. Putnam's Sons, NY, 1930. 448 p. Out of print (check your libraries).

A classic field guide to freshwater life. Includes background information plus many fine line drawings.

Morrow, James E. Freshwater Fishes of Alaska. Alaska Northwest Publishing Company, Anchorage, Alaska, 1980. 248 p.

Lists distinctive characteristics, description, range, abundance, and habits of freshwater species and their importance to man. Includes line drawings and maps of the Alaskan range of each species plus a selection of color photographs.

Morrow, James E. Illustrated Keys to the Fresh Water Fishes of Alaska. Alaska Northwest Publishing Co., Anchorage, 1974. 78 p.

Handy field guide with line drawings and brief descriptions.

Murie, Olaus J. A Field Guide to Animal Tracks. Houghton Mifflin Co., Boston, 1975. 375 p.

Describes tracks and other animal signs. Many of the fascinating stories happen in Alaska. Illustrated by line drawings. One of the Peterson Field Guide Series. Excellent reference for lake, stream, and pond studies.

Murray, C. and D. Somerton. Field Guide to the Fish of Puget Sound and the Northwest Coast. University of Washington Press, Seattle, Washington, 1976. 70 p.

Excellent field identification guide for saltwater fishes. Printed on waterproof paper.

Needham, James G. and Paul R. Needham. A Guide to the Study of Freshwater Biology. Holden-Day, Inc., San Francisco, 1962. 108 p.

Pictures and brief descriptions of freshwater animals. Includes chapter on making and using sampling equipment.

Pennak, Robert W. Fresh-water Invertebrates of the United States. The Ronald Press Company, New York, 1953. 769 p.

Excellent text on freshwater invertebrates. Line drawings and extensive descriptions of each group of animals.

Peterson, Roger Tony. Field Guide to Western Birds. Houghton Mifflin Company, Boston, 1961. 366 p.

Descriptions of birds, their habits, habitats, and field marks. Illustrated by color and black and white plates. One of the Peterson Field Guide Series. Good to have along on lake and stream studies for bird identification.

Reid, Gerald M. Alaska's Fishery Resources - The Pacific Herring. United States Department of Commerce, National Oceanic and Atmospheric Administration, National Marine Fisheries Service, Seattle (For sale by the Superintendent of Documents, U.S. Government Printing Office, Washington, DC 20402).

Good source of information on the life cycle, biological characteristics, and population dynamics of herring and on the commercial herring industry. Lacks information on the Bering Sea herring fisheries.

Robbins, C.S., B. Bruun, and M.S. Zim. Birds of North America. Golden Press, New York, 1966. 340 p.

Descriptions of birds and their habits, songs, and ranges. Illustrated by color drawings. Easy to use in the field, but not as much background information as the Peterson Field Guide. Handy to have along on stream and lake field studies.

Scott, W.B. and E.J. Crossman. Freshwater Fishes of Canada. Bulletin 184, Fisheries Research Board of Canada, Ottawa, Canada, 1973. 977 p.

Detailed descriptions and line drawings of fish and their ranges (including Alaska).

Smith, D.L. A Guide to Marine Coastal Plankton and Marine Invertebrate Larvae. Kendall/Hunt Publishing Co., Dubuque, Iowa, 1977. 161 p.

Useful key to common inshore plankton. Includes good line drawings of these plants and animals.

Stewart, Hilary. Indian Fishing: Early Methods on the Northwest Coast. University of Washington Press, Seattle, 1977. 188 p.

Contains numerous superb line drawings and photographs which accompany text on the life of the people of the Northwest coast. Describes the use of hooks, lures, and floats; spears and harpoons; nets, traps and weirs; cooking and preserving fish; and songs, customs, and ceremonies.

Newspapers, periodicals, directories and catalogs

Alaskan Publications:

Alaska Currently, State of Alaska, Office of Coastal Management, Planning Section, Pouch AP, Juneau, Alaska 99811

Alaska Earthlines Tidelines, Alaska Geographic Society, Box 4-EEE, Anchorage, Alaska 99509

Excellent monthly student newspaper. Back issues that are especially relevant include:

- Vol. 1, No. 1 - Aqua (water) + culture (cultivate)
- No. 2 - Does Alaska Have a Monster?
- No. 3 - Alaska Tides - and the Tricks They Play
- No. 5 - Wanted: Information on the Whereabouts of Pandalus borealis, Alias Pink Shrimp
- Vol. 2, No. 1 - To Catch a Salmon
- No. 5 - Alaska's Scariest Fishery (crabbing)
- Vol. 3, No. 3 - The Port That Grew in the Wrong Place
- No. 5 - What's That Funny-Looking Fish?
- No. 7 - The Herring Bonanza
- Vol. 4, No. 1 - How to Take Care of Your Catch
- No. 6 - The Old Woman (Halibut)

Alaska Fish Tales and Game Trails, Alaska Department of Fish and Game, Public Communications, P.O. Box 3-2000, Juneau, Alaska 99801 (quarterly) (free upon request)

Alaska Fisherman, 197 South Franklin St., Juneau, Alaska 99801 (monthly)

(free to all households of commercial fisheries permit holders for salmon, herring, halibut, shellfish and bottomfish)

Alaska Fisherman's Journal, 1115 NW 46th, Seattle, Washington 98107

Alaska Marine Educators Newsletter, Alaska Sea Grant Program, University of Alaska, Fairbanks, Alaska 99701 (free upon request)

Alaska Seafood Report, 130 Seward Street, Suite 501, Juneau, Alaska 99801 (quarterly)

Alaska Seas and Coasts, Alaska Sea Grant Program, University of Alaska, Fairbanks, Alaska 99701

Aquaculture News, Prince William Sound Aquaculture Corporation, P.O. Box 1110, Cordova, Alaska 99574 (monthly) (free)

Bering Sea Fisherman, 805 West Third Avenue, Anchorage, Alaska 99501 (monthly) (free)

Fish and Game Bulletin, Alaska Department of Fish and Game, Public Communication, Support Building, Juneau, Alaska 99801 (monthly) (free upon request)

The Network, Alaska Seafood Marketing Institute, 526 Main St., Juneau 99801.

Northwest and Alaska Fisheries Center Monthly Report, U.S. Department of Commerce, National Marine Fisheries Service, Seattle, Washington 98112 (monthly)

National and Regional Publications:

Aquaculture Magazine, 610 E. Sixth St., Little Rock, AR 72202 (bimonthly)

Fishermen's News, C-3 Building, Room 110, Fishermen's Terminal, Seattle, Washington 98119

Fishing Gazette, 461 Eighth Ave., New York, New York 10001 (monthly)

Marine Digest, Room 218, National Bldg., 1008 Western Ave., Seattle, WA 98104 (weekly)

Marine Fish Management, Nautilus Press, 1056 National Press Bldg., Washington, DC (monthly)

Marine Fisheries Review, NMFS Scientific Publications Staff, Room 450, 1107 N.E. 45th Street, Seattle, WA 98105 (monthly)

National Fisherman, Pacific Office, 4215 21st Avenue West, Seattle, WA 98199 (monthly)

Ocean Leader Seafood Quarterly, Waterfront Press, 1115 N.W. 46th St., Seattle, WA 98107 (quarterly)

Oceans, Oceanic Society, P.O. Box 10167, Des Moines, Iowa 50340 (bimonthly)

Oceanus, Woods Hole Oceanographic Institution, Woods Hole, MA 02543
(quarterly)

Pacific Fishing, Circulation Department, 2208 N.W. Market Street, Seattle, WA
98107 (monthly)

Progressive Fish-Culturist, Supt. of Documents, U.S. Fish and Wildlife Service,
Washington, DC 20240 (quarterly)

Sea Frontiers, International Oceanographic Foundation, 3979 Rickenbacker
Causeway, Virginia Key, Miami, Florida 33149 (bimonthly)

Seafood America, P.O. Box 656, Harbor Square, Camden, Maine 04843 (monthly)
(free to seafood processors, brokers, wholesalers, exporters and
importers; seafood buyers for restaurant and grocery store chains;
shipyard owners and operators of processing vessels; processors and
wholesalers of fish meal, oil, and seaweed; foreign seafood buyers and
processors; fishermen's marketing cooperatives, and cold storage operators)

International Publications:

Canadian Fisherman and Ocean Science, Sentinale Publishing Company, 27
Centrale St., LaSalle, PQ, Canada H8R 2J1 (bimonthly)

Facts on Fish, Fisheries Association of British Columbia, Room 400, 100 W.
Pender Street, Vancouver, BC, Canada V6B 1R8

Fisheries World, Japan Fisheries Association, Dainihon Suisankai a-9-13
Akasaka, Minato-ku, Tokyo 107, Japan (monthly)

The Fisherman, 138 East Cordova Street, Vancouver, BC, Canada V6A 1K9
(semimonthly)

Fishing News International, Arthur J. Heighway Publication, Ltd., 110 Fleet
Street, London EC4A 2JL, England (weekly)

Pacific Packers Report, 21 Elm Street, Camden, Maine 04843 (quarterly) (free
to seafood processing management, purchasing, sales, buyers, wholesalers,
brokers, fishing company management, vessel owner or operators,
fishermen, government, and others)

Salmonid, Department of Fisheries and Oceans, 1090 West Pender Street,
Vancouver, BC, Canada V6E 2P1 (free)

Western Fisheries, Interpress Publications, Ltd., 202, 1132 Hamilton Street,
Vancouver, BC, Canada V6B 2S2 (monthly)

World Fishing, IPC Industrial Press, Ltd. Dorset House, Stamford St.,
London SE1, England (monthly)

Curriculums:

Alaska Wildlife Notebook Series Teacher Activity Guide, Alaska Department of Fish and Game, Public Communications Sections, P.O. Box 3-200, Juneau, Alaska 99801.

Includes the Wildlife Notebook Series with numerous fresh and saltwater fishes. Activities are primarily for junior high and high students but they can be adapted for elementary children.

Alaska Wildlife Week Education Packet, Nongame Wildlife Program, Alaska Department of Fish and Game, 1300 College Road, Fairbanks, Alaska 99701.

Contains excellent activity guide, materials source booklet, poster, coupon book, and additional wildlife notebook series and animal descriptions.

Borton, Wendy, Lavonne Bucher, Claire Dyckman, Art Johnson, and Bill Way. Clean Water, Streams and Fish. Washington State Office of Environmental Education, c/o Shoreline District Office, NE 195th and 20th Avenue NE, Seattle, WA 98115, 1982. 327 p.

Characters on salmonids, habitat, threats, solutions, roles and issues. Well designed interdisciplinary activities for upper elementary and middle school students. A similar curriculum for secondary students is also available.

Davidson, Nancy. A Programmed Learning Unit on Fishes. Alaska Multi-Media Education Program, Alaska State Museum, Pouch FM, Juneau, Alaska 99811.

Illustrated booklet designed to allow students to check their own answers as they proceed through the unit. Covers internal and external fish features and characteristics.

Minnesota Environmental Sciences Foundation, Inc. Fish and Water Temperature. National Wildlife Federation, 1412 Sixteenth Street, N.W., Washington, DC 20036, 1971. 19 p.

Describes an extensive experiment to investigate the response of goldfish to various water temperatures. Includes lots of practice in graphing and an additional experiment on crickets.

Salmonids in the Classroom. BCTF Lesson Aids, B.C. Teachers Federation, 105-2235 Burrard Street, Vancouver, BC V6J 3Np, 1982 (revised).

Extensive curriculum on salmonids that includes lesson plans, activity sheets, reference material, film, "hands-on" project suggestions, catalogue, evaluation activities, teacher answers, and bibliography. Separate packets for upper elementary and secondary school students.

Tanabochia, Kathy. Life Cycle of the Salmon. Pacific Science Center/Sea Grant, 200 Second Avenue North, Seattle, Washington 98109, 1980. 125 P.

Presents eight activities on salmon and their life cycles, habitats and journeys. Includes slide show script.

University of British Columbia, Vancouver, Canada V6T 1W5. The Greek Book, The Pond Book, The Lake Book, Estuary Studies, The Rain Book, The Snow Book, The Beach Book, and more.

Excellent books on a variety of topics. Include a multitude of activities and suggestions for sampling equipment to buy or make.

Charts, Posters, Games and Kits:

Game Fishes of Alaska. Division of Sport Fish, P.O. Box 3-2000, Juneau, Alaska 99801.

Colorful poster of many of the freshwater fishes of Alaska (including salmon).

Marine Fishes of the North Pacific (stock no. 003-020-00051-7) and Mollusks and Crustaceans of the Coastal U.S. (stock no. 003-020-00087-8). U.S. Government Printing Office, Washington, DC 20402.

Large, beautiful color posters depicting these animals in their habitats.

Marine Life Posters. Alaska Sea Grant, University of Alaska, Fairbanks, Alaska 99701.

Blue and white line drawings of king crab, ocean perch, Pacific halibut, pink shrimp, and scallop life cycles.

National Bilingual Materials Development Center, University of Alaska, 2223 Spenard Road, Anchorage, Alaska 99503.

Sets of 11"x17" posters on fish and crustaceans, plus bilingual books on a variety of topics.

Oregon State University, Extension Communications - Marine Advisory Program, OSU ADS422, Corvallis, Oregon 97331.

Posters on beach safety and pamphlets on tides, crabs, and other marine topics.

Nautical Charts. National Ocean Survey, Chart Sales & Geodetic Control, Federal Building and U.S. Court House, 701 C Street, Box 38, Anchorage, Alaska 99513.

Source of nautical charts, tide tables, coast pilots, current tables, and tidal current charts.

Salmon Kit, Alaska State Museum, Pouch FM, Juneau, Alaska 99811.

Salmon Game. Western Education Development Group, University of British Columbia, Vancouver, Canada V6T 1W5.

Regular board game which follows the salmon life cycle.

Salmon Legends. Alaska State Museum, Pouch FM, Juneau, Alaska 99811.

Legends include "Nakani Stealing Fish" from Ingalik Mental Culture by Cornelius Osgood; "Red Stone Shaman Brings Back the Salmon" from Ingalik Social Culture by Cornelius Osgood; "Moldy End," and Haida legend adapted from The Wolf and Raven: Totem Poles of Southeastern Alaska, by Viola Garfield and Linn Forrest; "The Prince Who Was Taken Away by the Salmon People," from Once Upon a Totem by Christie Harris; and "Coyote Helped the People" from Indian Legends of the Pacific Northwest by Ella E. Clark.

Salmon Posters. B.C. Wildlife Federation, 5659 176th St., Surrey, BC V3S 4C5.

Full color 18"x21" posters of the five Pacific salmon species and steel-head.

Sharks of the World. National Geographic Society, 17th and M Streets NW, Washington, DC 20036.

Source of shark chart plus also a shark filmstrip.

Splash! National Park Service, 709 W. 9th Street, Juneau, Alaska 99801.

Game on folding sheet of heavy 17"x22" paper that focuses on the hazards to migrating salmon. (Also available is a coloring book Life of the Salmon on the same topic.)

Student Activity Sheets

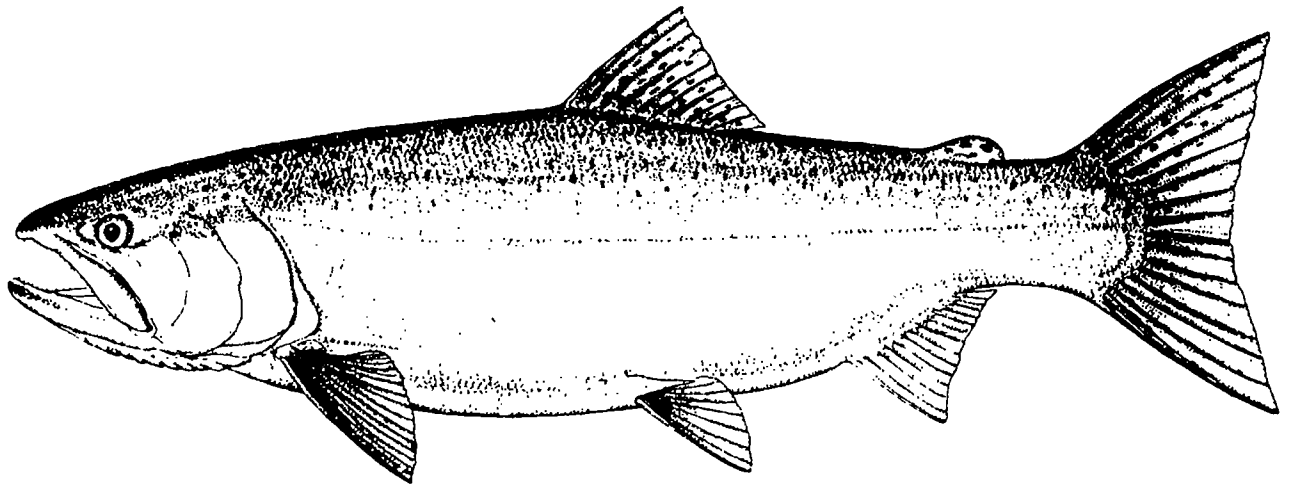

Watch that Fish!

1. Draw a picture of your fish. Include as much detail as possible.

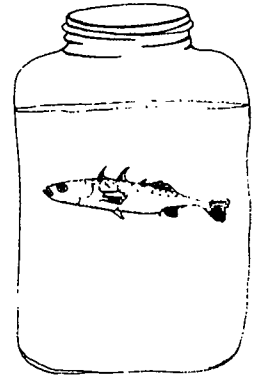

2. Describe how the fish moves forward.
3. Describe how it turns.
4. Can the fish swim backwards? Which fin does it use?
5. Can the fish swim in one spot? Which fins does it use?
6. Which fins does it use to move up and down?
7. Which fin does the fish use to keep on a steady course?
8. As the fish swims, does it keep its mouth open or closed?
9. What else do you notice about your fish?

A Fish is What?

Fish are defined by scientists as cold-blooded, aquatic, gill breathing vertebrates equipped with fins and usually scales. That is a mouthful! Let's explore what this definition means.

A. Cold blooded

Some animals are cold-blooded. That means the temperature of their bodies is the same as the temperature of the air or water in which they live. Some animals are warm-blooded. That means that the temperature of their bodies is always the same warm temperature, and does not change with the temperature of the air or water around them. Try naming...

Three cold-blooded animals

Three warm-blooded animals

1. _____

1. _____

2. _____

2. _____

3. _____

3. _____

Check your guesses with an encyclopedia.

Is a fish warm-blooded or cold-blooded? _____

B. Aquatic

What does "aquatic" mean? _____
(Hint: Where do fish live?)

List three other aquatic animals:

1. _____

2. _____

3. _____

C. Gills

Fish, like people, need oxygen to live. They take their oxygen from the water around them. Oxygen is taken from the water through fine filaments on the fish's gills. Gills are located at the back of the fish's mouth cavity and are under a gill cover that protects them. The fish make water pass over its gills by opening its mouth to take in water, then closing its mouth and forcing the water over the gills and out from beneath the gill cover.

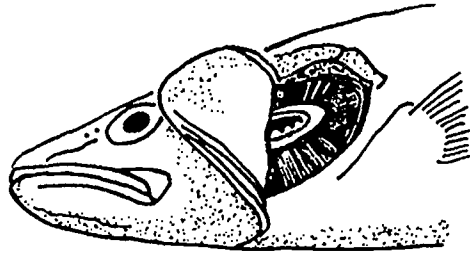

Locate the gill filaments in the picture. As water passes over the gill filaments, which are long and slender, oxygen is taken from the water for the fish to use.

Locate the gill rakers in the picture. The gill rakers, fewer and shorter than the filaments, strain food out of the water for the fish to use. Color the part of the gill used to breathe blue. Color the part of the gill used to strain the food from the water red.

D. Vertebrates

A fish is a vertebrate. Look up the word "vertebrate" in the dictionary. Name three other animals that are vertebrates.

1. _____
2. _____
3. _____

E. Fins

The fins on a fish all work together. Remember your observations of a live fish in the last investigation? Color the fin the fish uses to move forward in the water blue. This fin is called the caudal or tail fin. Label the caudal fin in the drawing below.

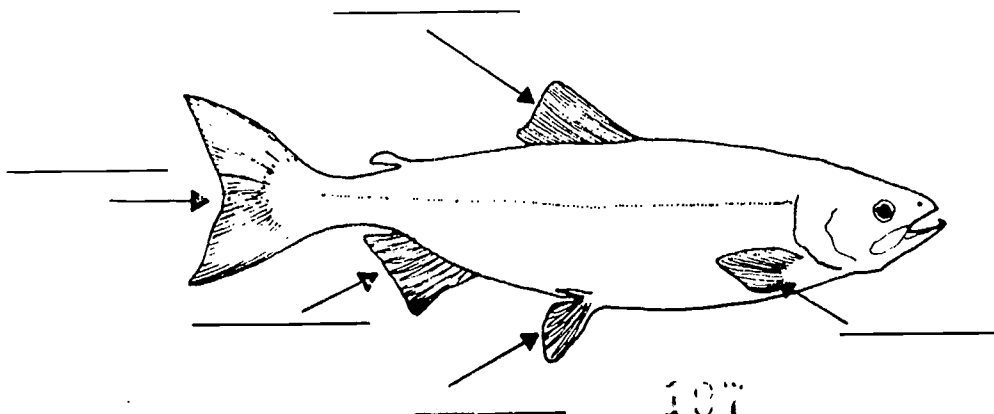

Color the fins the fish uses to go up and down red. These are the pelvic and pectoral fins. They also act as brakes for the fish.

The fin on the back is called the dorsal fin. Label the dorsal fin in the drawing below. Locate the anal fin. The dorsal and anal fins help to balance the fish in the water. These fins keep the fish from rolling over and over as it moves.

F. Scales

A fish is usually covered from head to tail by a coat of scales. These scales are a type of bone. Scales increase in size as the fish grows. Rings, like the ones that form in tree trunks, also form on growing scales. Each ring represents one year of the fish's life. The tiny scale in the center is just the start of the growth. How old was this fish? _____



Fish to Classify

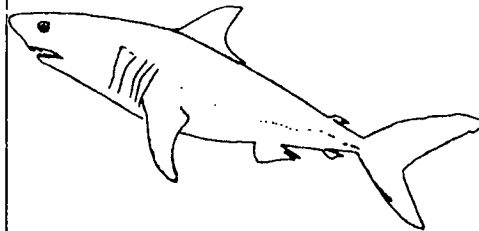
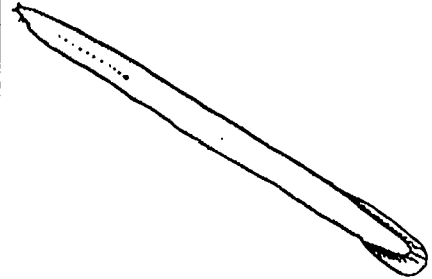
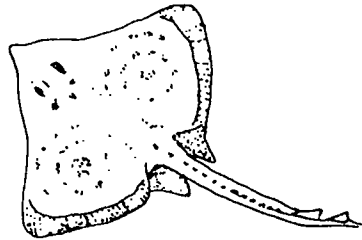
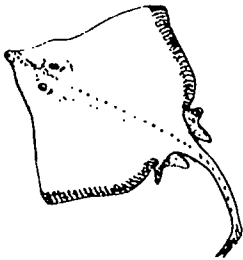
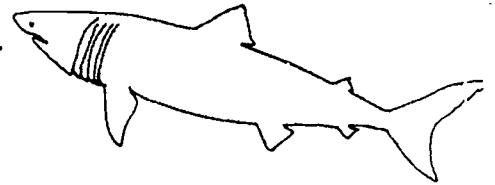
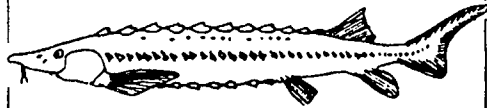
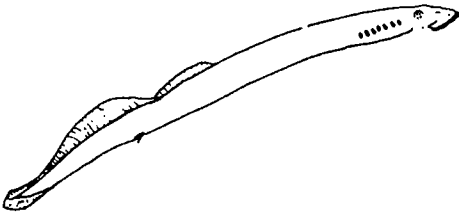
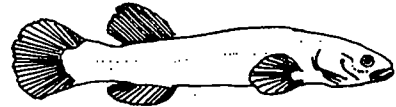
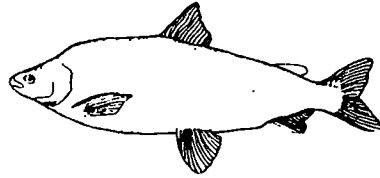
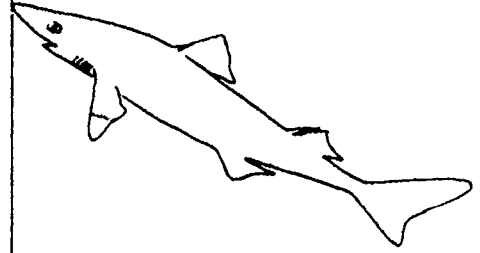
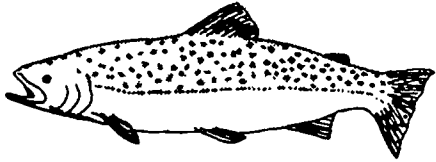

The Three Major Groups of Fish

- no jaws
- no paired fins
- gill opening is a round hole
- skeleton of cartilage, not bone
- no scales

- jaws
- some paired fins
- gill openings are 5-7 slits on either side of the body
- skeleton of cartilage, not bone
- no scales

- jaws
- some paired fins
- single gill opening on either side of the body
- skeleton of bone
- scales

The Outside of a Fish

Label the parts of this fish.

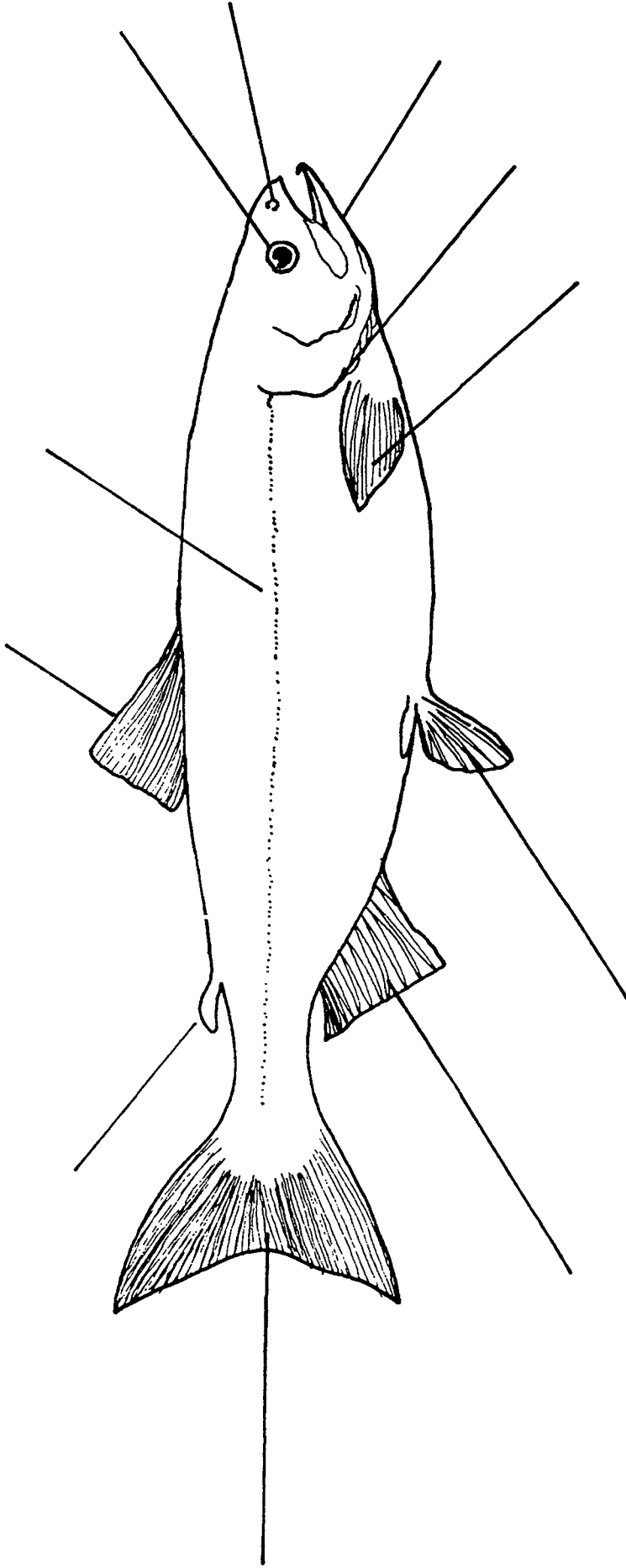

Your labels will include:

- eye
- nostril
- jaw
- gill cover
- lateral line
- pectoral fin
- dorsal fin
- pelvic fin
- anal fin
- caudal fin
- adipose fin

Record the length _____ and weight _____ of your fish.

How old is your fish? _____ years. Is it ♂ or ♀ _____?



The Inside of a Fish

Label the internal parts of this fish.

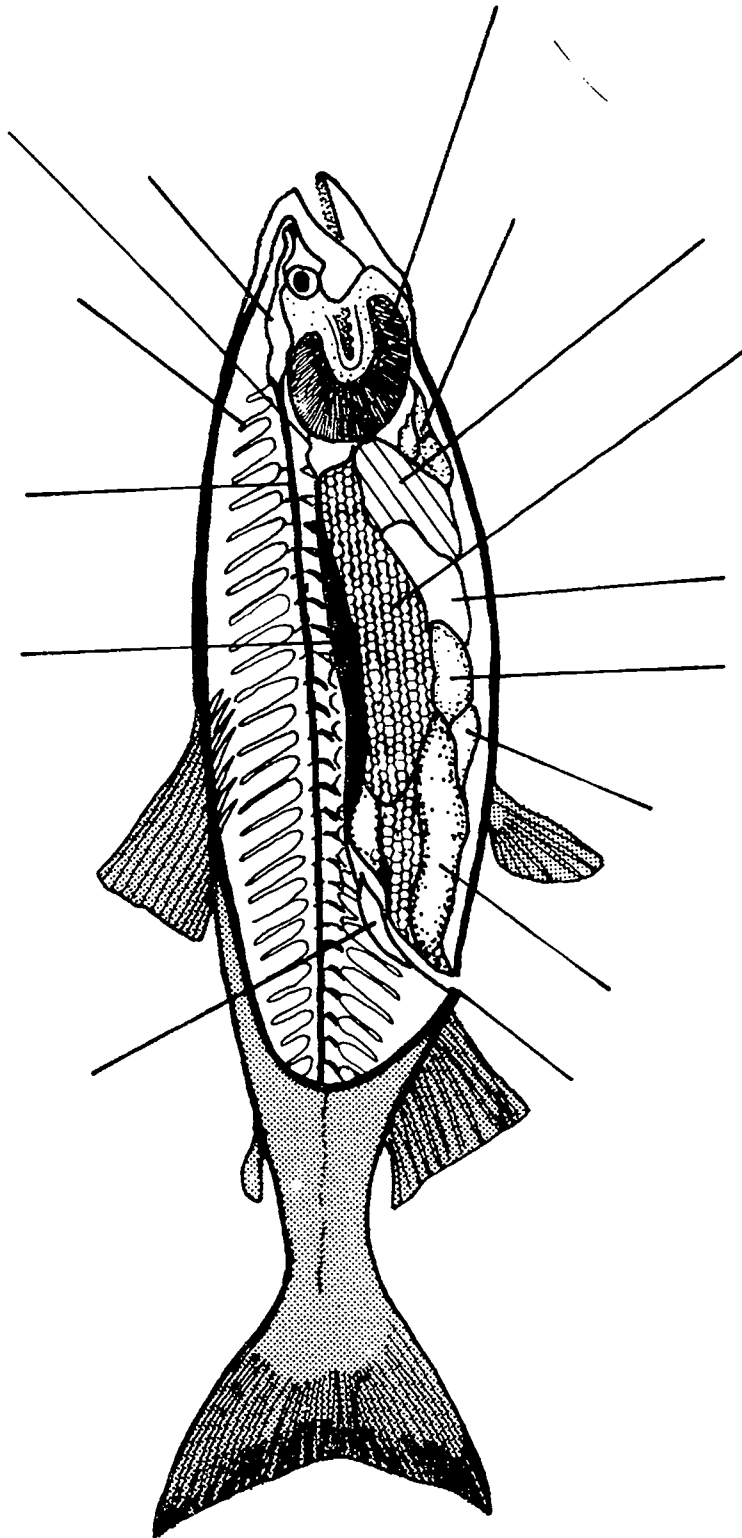

Your labels will include:

- | | | | |
|-----------|-------------|--------------|-----------------------------|
| brain | liver | kidney | backbone |
| heart | stomach | vent or anus | small intestine |
| eggs | spinal cord | spleen | gas bladder or swim bladder |
| esophagus | gills | | |

(If your fish is a ♂, instead of eggs, you'll see white milky testes.)

Body Parts and Their Functions

Directions: Cut apart these body parts and their functions. Correctly match them and glue or tape them to another sheet of paper.

Body Parts	Functions
gills	pumps blood through the body
gonad	digests food
swim or gas bladder	stores blood and filters out poisons from the blood
kidney	produces eggs or sperm
heart	carries food from mouth to stomach
liver	remove waste from the body
spleen	provides body support and protects the spinal cord
stomach	carries messages from the brain to other parts of the body
esophagus	controls the fish's activities
spinal cord	absorbs oxygen from the water, gathers food from the water
brain	maintains buoyancy, regulates pressure by releasing or absorbing gas
backbone	breaks down red blood cells

Ocean Salmon Cards

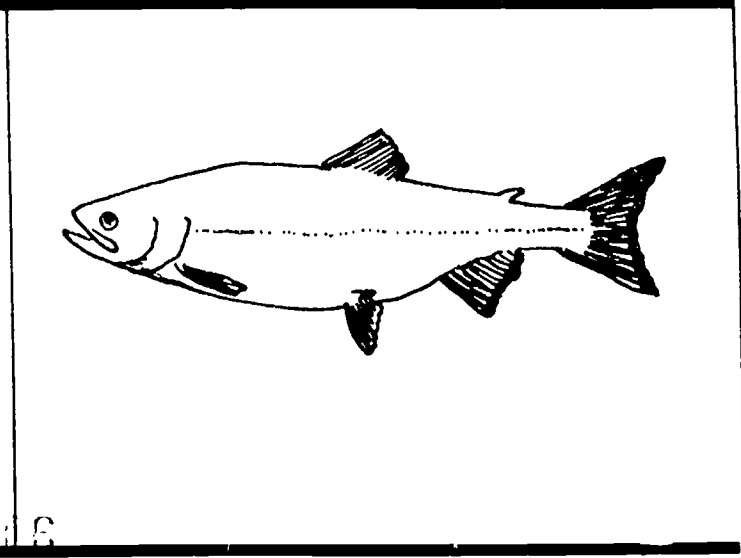
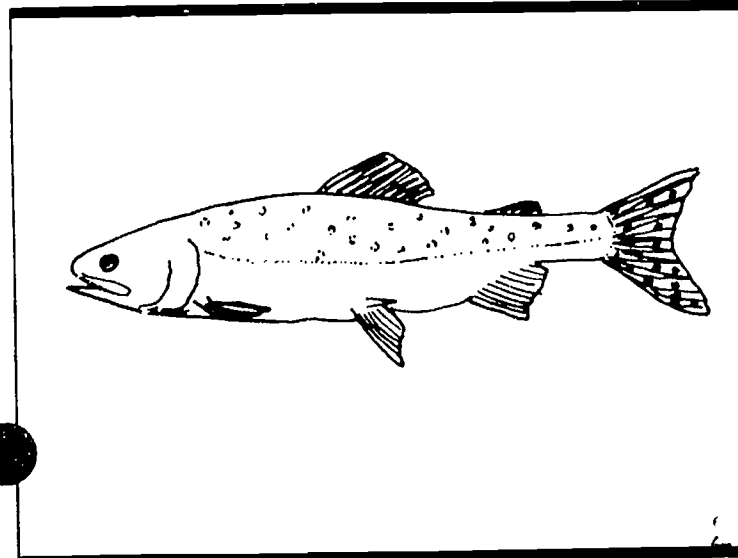
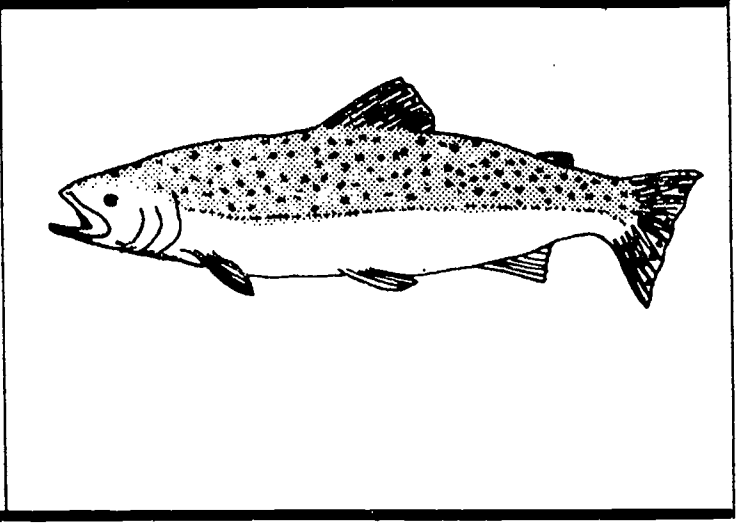
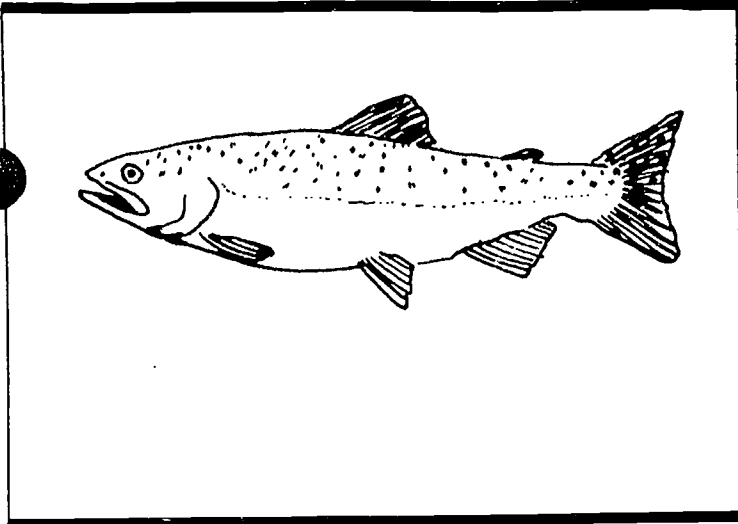
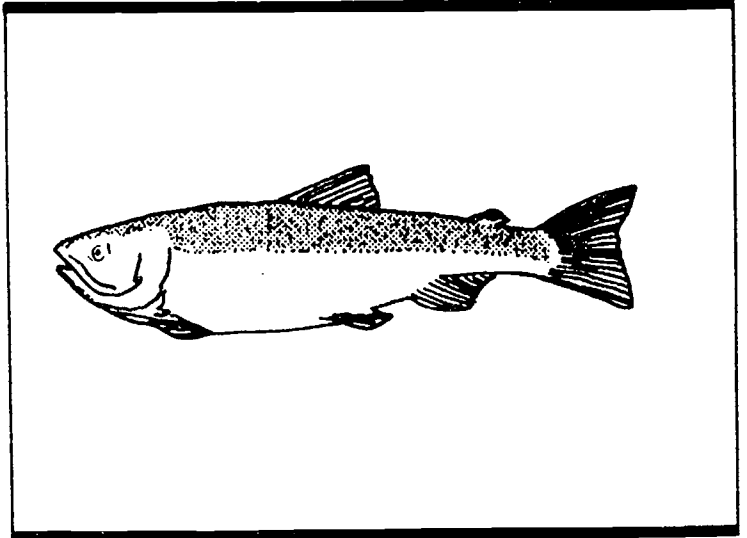

2/6

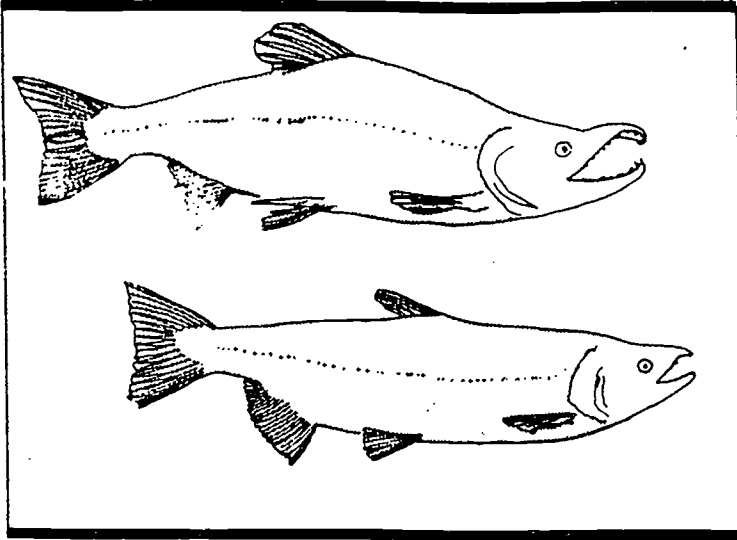

Spawning Salmon Cards

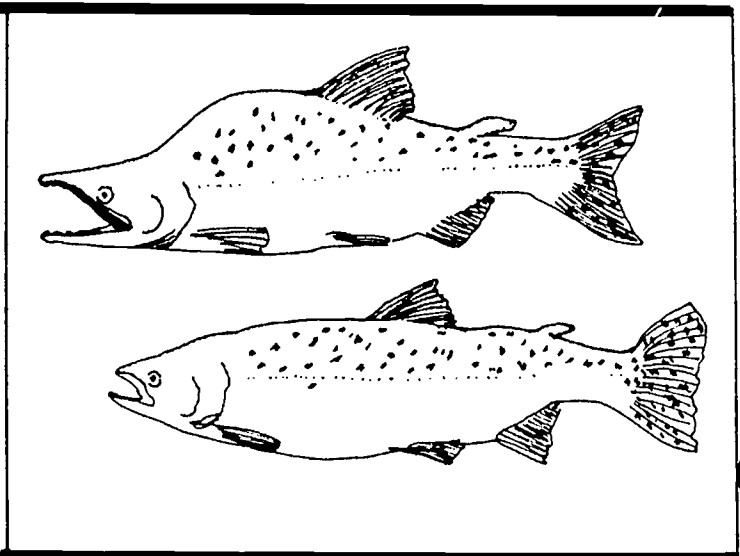
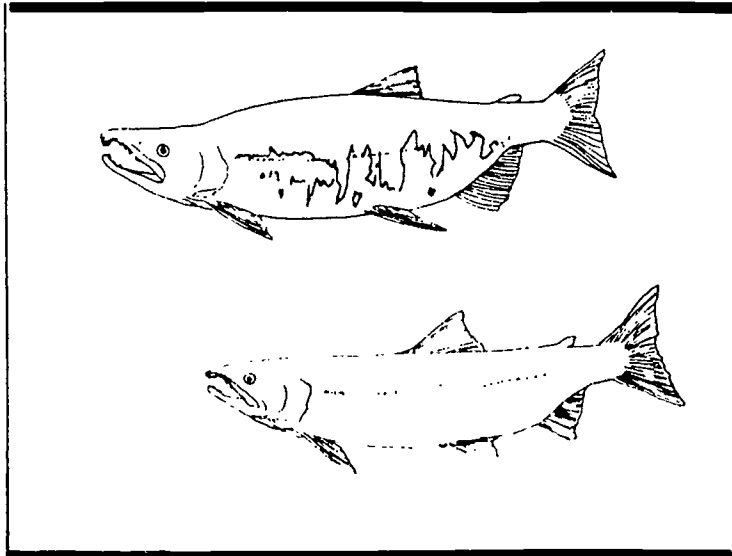
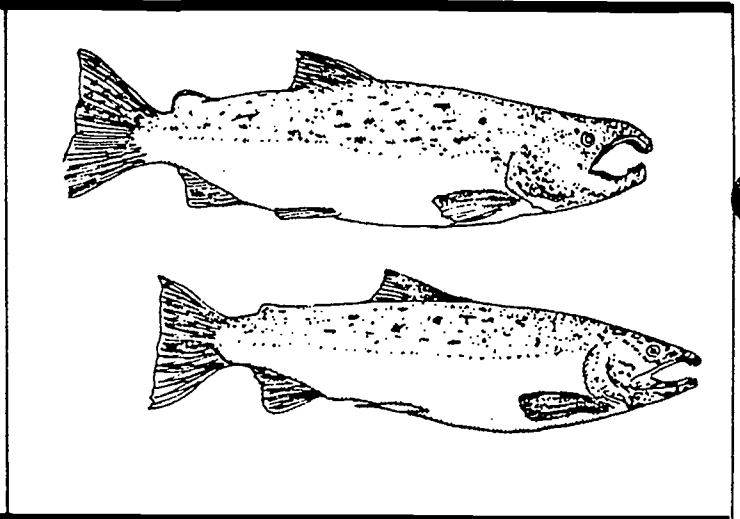
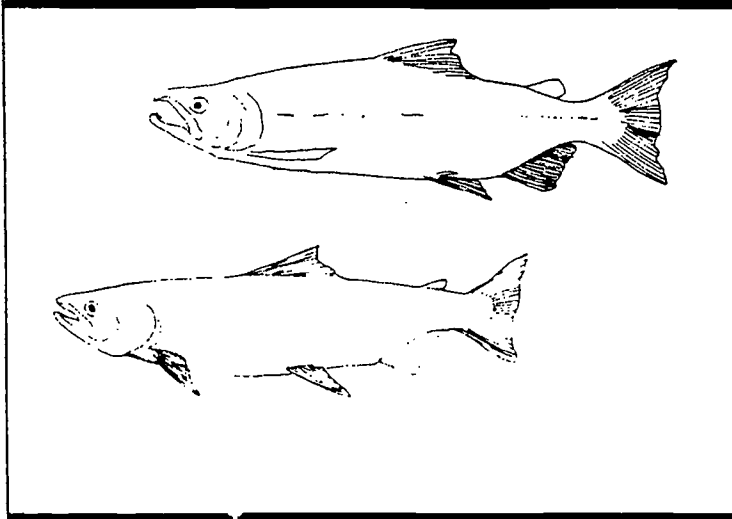

Ocean Salmon Identification Charts

from ALASKA Tidelines

Black gums

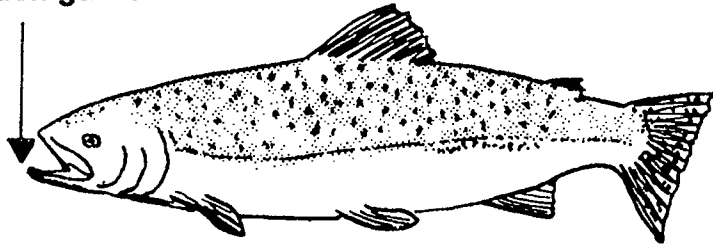

King or Chinook

Spots may not be clear

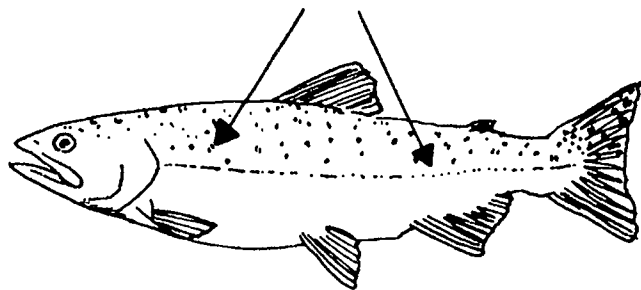

Silver or Coho

Tiny scales

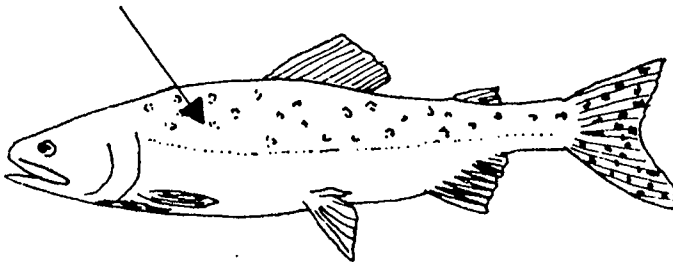

Pink or Humpback

Very narrow

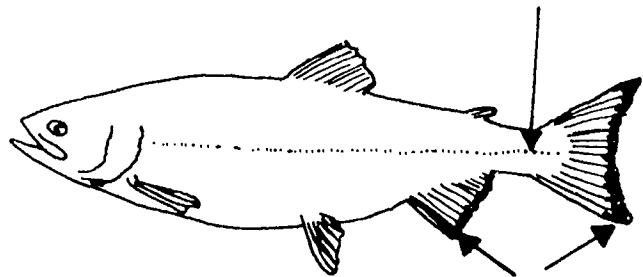

Dark fin edges

Chum or Dog

Fine black speckling

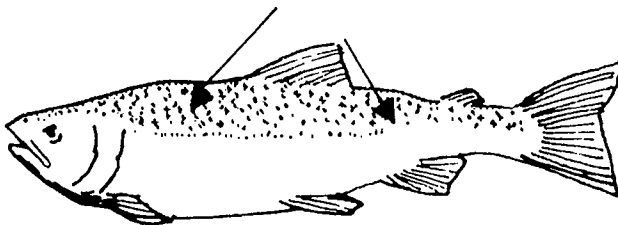

Red or Sockeye

Spawing Salmon

As salmon move into freshwater and start their journey upstream to the place where they will spawn, they stop feeding. They begin to "grow old." If their journey is a long, one, the changes happen more slowly than they do if the journey is short. But by the time any Pacific salmon is ready to spawn, the silver of its ocean coat is gone. The fish may begin to look tattered and torn. Its body has changed both in shape and color.

Below is a chart that will help you tell one kind of spawning salmon from another. Draw and color a picture of each type of salmon in its spawning colors in the blank spaces below.

KING COHO SOCKEYE CHUM PINK

Dull red to copper or black Males - darker than females	Maroon-red sides	Female - dark red, often with yellow green blotches Male - bright red back darker red sides Head of both sexes - olive green Lower jaw - white	Male - up & down bars of green & purple on sides Female - a dark band along each side	Male - brown to black white underside. Female - Olive-green with tan bars of patches. white underside	
Male - Hooked upper jaw	Male - teeth large Male - upper jaw very hooked Lower jaw - slightly hooked	Male - Hooked upper jaw	Male - Hooked upper jaw, very large teeth	Male - hooked	
Male - Somewhat ridged instead of rounded	Little change	Male - Large hump	Little change	Male - Very large hump	

ILLUSTRATION

COLOR

JAW

BACK

Ocean and Spawning Salmon

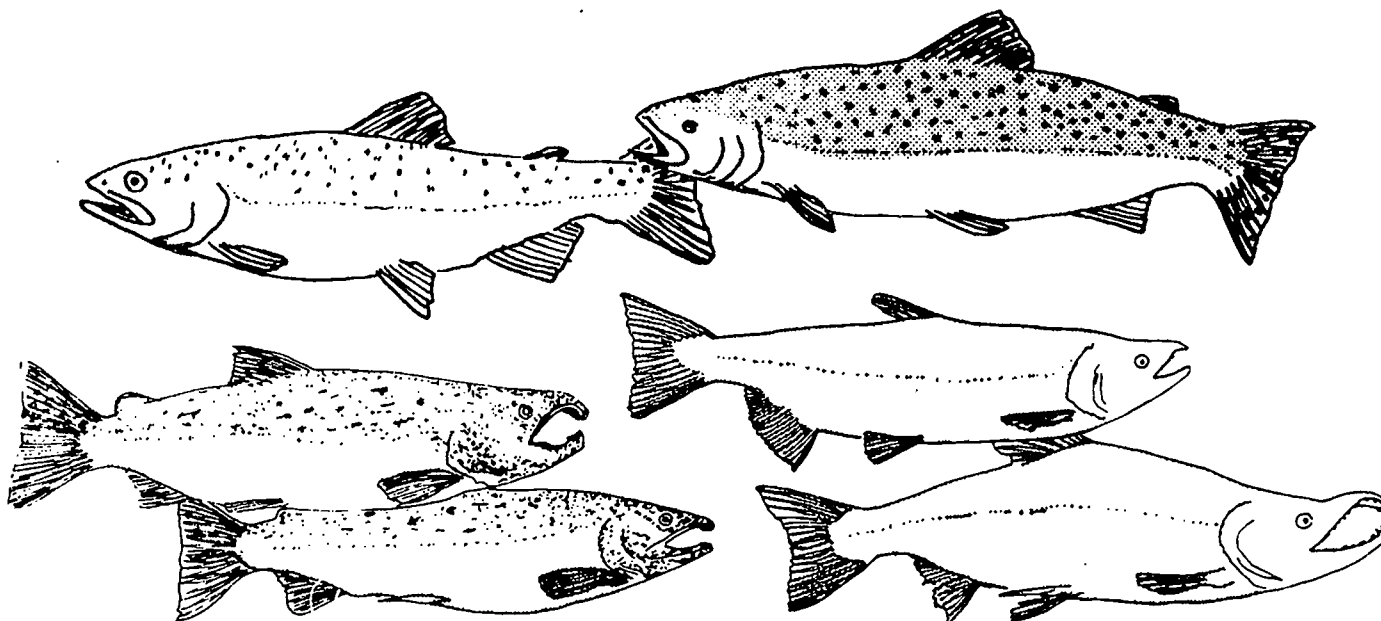

Using your ocean salmon identification chart and your Spawning Salmon worksheet, answer the following questions about the five species of salmon found in Alaskan waters.

1. Which ocean salmon can be identified by large black spots on the dorsal and caudal fins?

2. Which ocean salmon has black spots ONLY on the upper half of the caudal fin?

3. Which ocean salmon has black gums?

4. Which spawning male salmon turns bright red?

5. In which two salmon does the spawning male salmon develop a humped back?

6. Which spawning male salmon develops very large teeth?

Salmon Life Cycle Stages

Directions: Cut apart and place in the proper order.



Spawning salmon

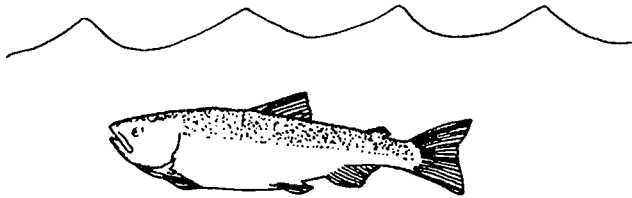

Ocean salmon

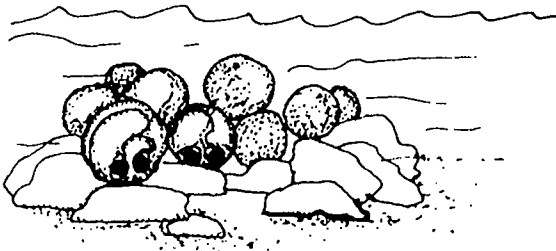

Eggs

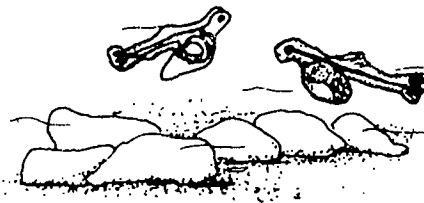

Alevins

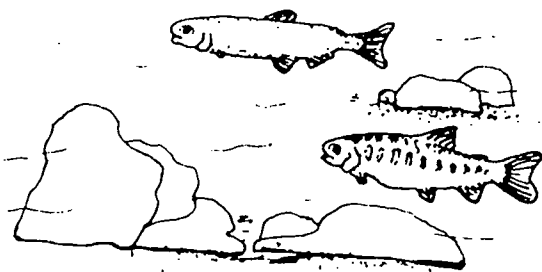

Fry

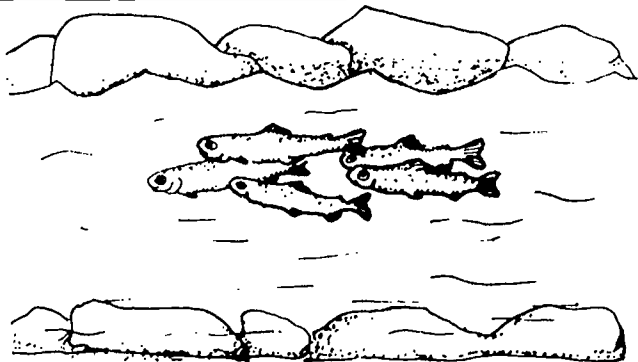

Smolt

A Salmon's Life Cycle

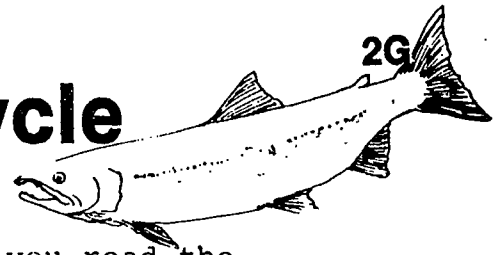

Predict the answers to these questions before you read the following paragraphs. Then put down the correct answer as you read. How well did you predict? (super, great, O.K., or better next time!)

My Prediction	Correct Answer
	1. How many kinds, or species, of Pacific salmon are there?
	2. How many kinds of Pacific salmon are found in Alaskan waters?
	3. What does <u>anadromous</u> mean?
	4. Where do salmon lay their eggs?
	5. How big are salmon eggs?
	6. What are salmon called when they have a yolk sac?
	7. Salmon an inch long are called _____.
	8. Salmon 3-4 inches long are called _____.
	9. What color are ocean salmon?
	10. What helps a salmon return to the stream where it was hatched?

	11. What is a salmon "nest" called?
	12. What happens to Pacific salmon after they have spawned and covered their eggs?
	13. How do salmon help our world?

Pacific salmon are found along the North American coast from California to Alaska and in Asia from Japan to the Soviet Union. In Alaska, we have five of the six species of Pacific salmon. The Japanese cherry salmon is found only around the Japanese Islands and the nearby Asian mainland. The one species of Atlantic salmon lives in the waters of New England, Canada's eastern provinces, and across the Atlantic Ocean in Iceland, the British Isles, Norway and as far south as Spain.

Pacific salmon are all anadromous. That means they hatch from eggs in fresh water, travel to salt water to grow and mature, and then return to fresh water to deposit their own eggs, or spawn in gravel. The eggs are bright pink, about the size of a pea. In late fall or winter, the eggs hatch and become alevins (pronounced al'-luh-vins). These little baby salmon, or larvae, have huge yolk sacs attached to their bodies. The yolk sac provides all the food each fish needs. By late spring or summer, these alevins have consumed their yolk sac and are ready to emerge from the gravel as fry. By this time, the baby salmon are an inch long. They eat small insects and plankton (tiny floating plants and animals). After one or more winters in lakes or streams, the salmon are 3-4 inches long and are called smolts or fingerlings. They are ready to begin their journey downstream to the ocean. When they reach the ocean, salmon begin to eat greedily. They grow rapidly. They are bright and silvery. After 1 to 5 years in the ocean, they travel up freshwater streams to reach their spawning place. The salmon stop feeding and their bodies change rapidly. Their color turns from silver to shades of copper, brown, red or green. The upper jaw of the male becomes hooked downward, and the shape of his body may change as well.

Salmon almost always spawn in the same stream in which they were hatched. Biologists think a salmon's sense of smell is important in helping it return home. When the salmon reach

their spawning spot, the female digs a nest, or redd, with her tail. As she deposits eggs in the redd, they are fertilized by a male of the same species. Using her tail, the female salmon then covers her eggs with material from the stream bed. Soon after they have spawned, the salmon die. Their bodies become food for bears, birds and other animals of the stream and bays into which the water flows. And the nutrients from their bodies help make these waters more productive. Thus, the adult salmon help to insure that there will be food for their young.

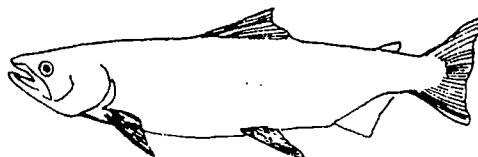
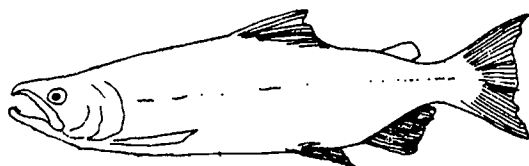

Salmon Match Game

Directions: Write the word from the column on the left in front of the correct meaning.

- | | | |
|------------|-------|--------------------------------------------------------------------------------------|
| Humpy | _____ | 1. A young salmon ready to go to sea. |
| Chum | _____ | 2. A round hole in a gravel bed where salmon eggs are laid. |
| Fry | _____ | 3. To lay and fertilize eggs. |
| Alevin | _____ | 4. Any fish that is hatched in fresh water but lives most of its life in salt water. |
| Spawn | _____ | 5. Very tiny plants and animals that live in the sea. |
| Chinook | _____ | 6. Salmon young that have used up their yolk sac. |
| Redd | _____ | 7. Newly hatched salmon with its yolk sac still attached to its body. |
| Sockeye | _____ | 8. A kind of circle of life. The chain of life from birth to death, to birth again. |
| Life cycle | _____ | 9. The symbol of male animals. |
| ♀ | _____ | 10. The symbol for female animals. |
| Plankton | _____ | 11. Another name for a smolt. |
| Fingerling | _____ | 12. Red salmon. |
| Anadromous | _____ | 13. King salmon. |
| Coho | _____ | 14. Dog salmon. |
| Smolt | _____ | 15. Silver salmon. |
| ♂ | _____ | 16. Pink salmon. |

How well did you do?

- 16 right - Biologist
 13-15 right - Better luck next time
 10-12 right - Just getting started
 Under 10 right - Well, I like to eat fish!



Salmon Word Search

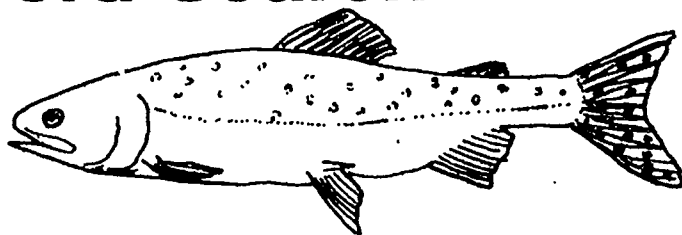
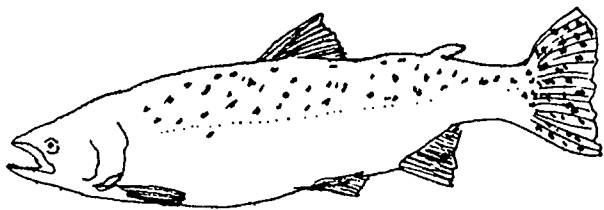

Can you find the 13 "salmon words" in the square below?
Some words may be diagonal or even backwards!

```

R E U S A M O N P V I Q U Y
M O Z R M N U Y L B D D E R
X N C G A P A K S O C I M F
S O C K E Y E D S P A U N T
L M A I R O D N R N A S B O
N L R O T I G N Y O V V S T
I A H B S P A W N M M I G K
V S I C L D E M E U N O T S
E G H S C T A R S H O N U T
L N S I A P E N U C T P A S
A I G R N O B B L E O P S I
Q K G U N S V E S T E H R D
S I E S P I N K S A L M O N
M S U H C N Y H R O C N O Y
  
```

1. ALEVIN
2. ANADROMOUS
3. CHUM
4. COHO
5. EGGS
6. FRY
7. KING SALMON

8. MIGRATE
9. PINK SALMON
10. REDD
11. SOCKEYE
12. SPAWN
13. STREAM

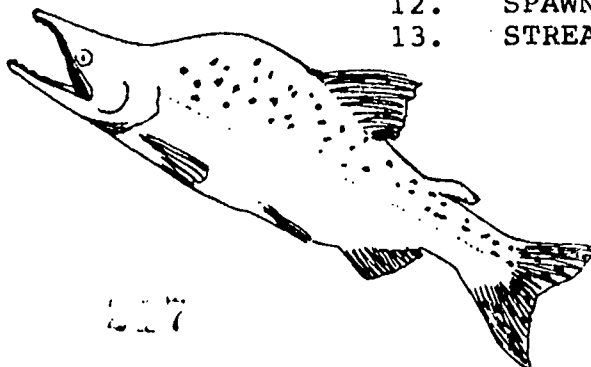

Only the Strong Survive

(Adapted from the Alaska State Museum's Salmon Kit)

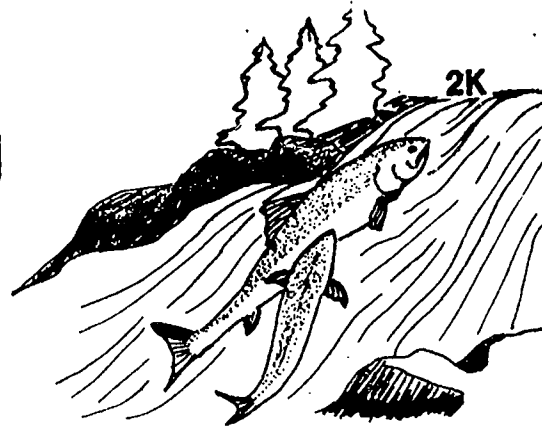

Use the numbers below to find out how many salmon are left.
Use this page for your work.

1. A salmon deposited 5,000 eggs in a redd. _____
2. Five hundred (500) eggs were not fertilized. _____
3. Sixty (60) were washed out of the gravel when a 3-wheeler crossed the stream. _____
4. Mud from building a new subdivision eroded into the stream and suffocated one thousand (1,000). _____
5. Three hundred (300) alevins died because they were very weak. _____
6. After the alevins developed into fry, five hundred (500) were eaten by other fish in the stream. _____
7. Forty-one (41) were eaten by birds. _____
8. As they neared the ocean, 260 salmon were caught in a pool where they got too hot because of thermal pollution from a coal-fired power plant. _____
9. In the ocean, 1,500 were eaten by bigger fish. _____
10. Seals ate 95. _____
11. Fisherman caught 556. _____
12. As the salmon returned to their spawning stream, bears ate 180 of them. _____
13. Three (3) were dashed against the rocks trying to jump a waterfall. _____
14. The rest of the salmon spawned. _____
15. HOW MANY SALMON WERE LEFT TO SPAWN? _____

What's for Dinner?

All animals and plants must have food to survive. Our coastal waters are particularly rich in food resources. See if you can figure out who eats who in this picture. Draw arrows from the predators to the prey. What runs this whole system?

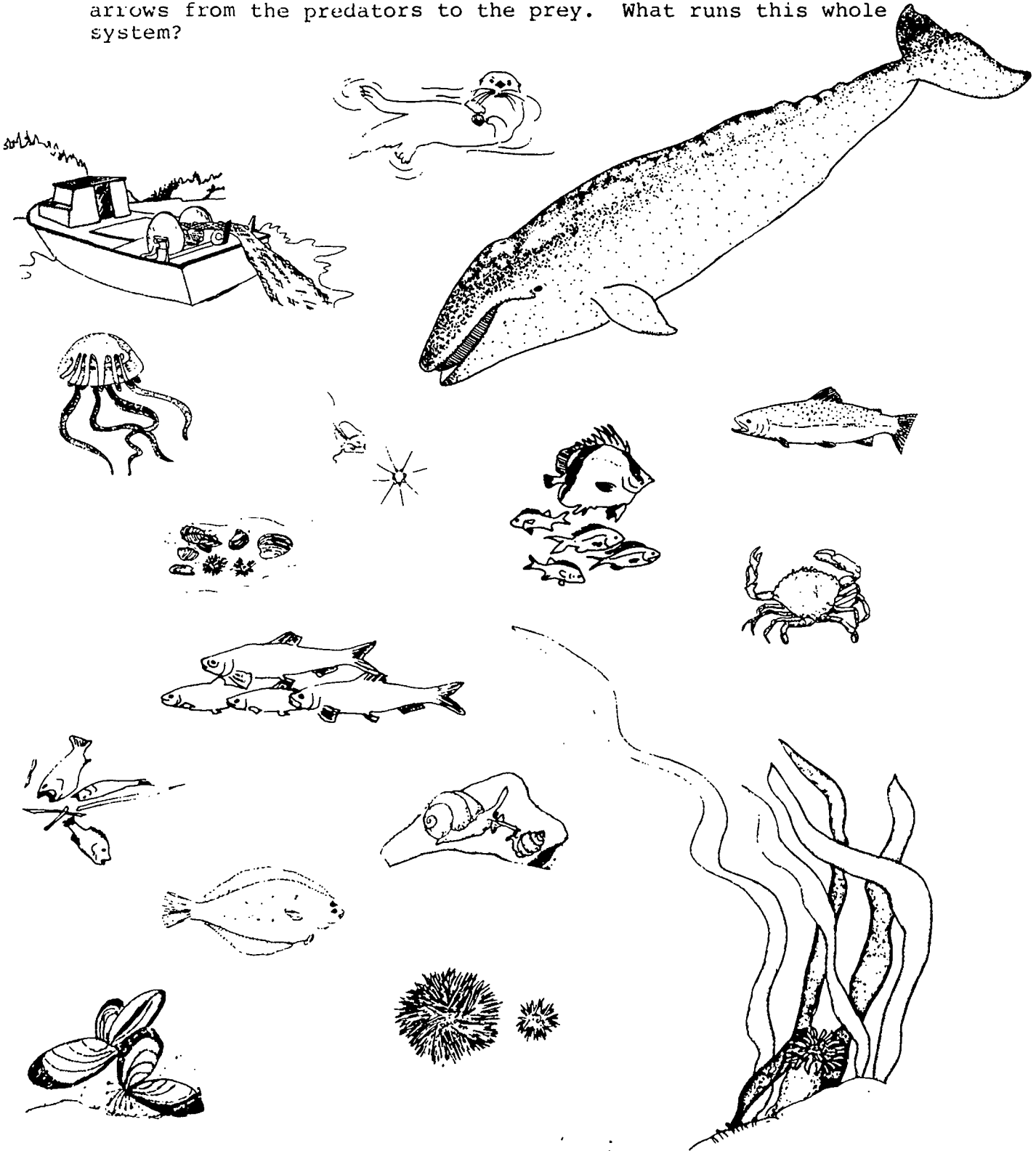

Halibut, Halibut

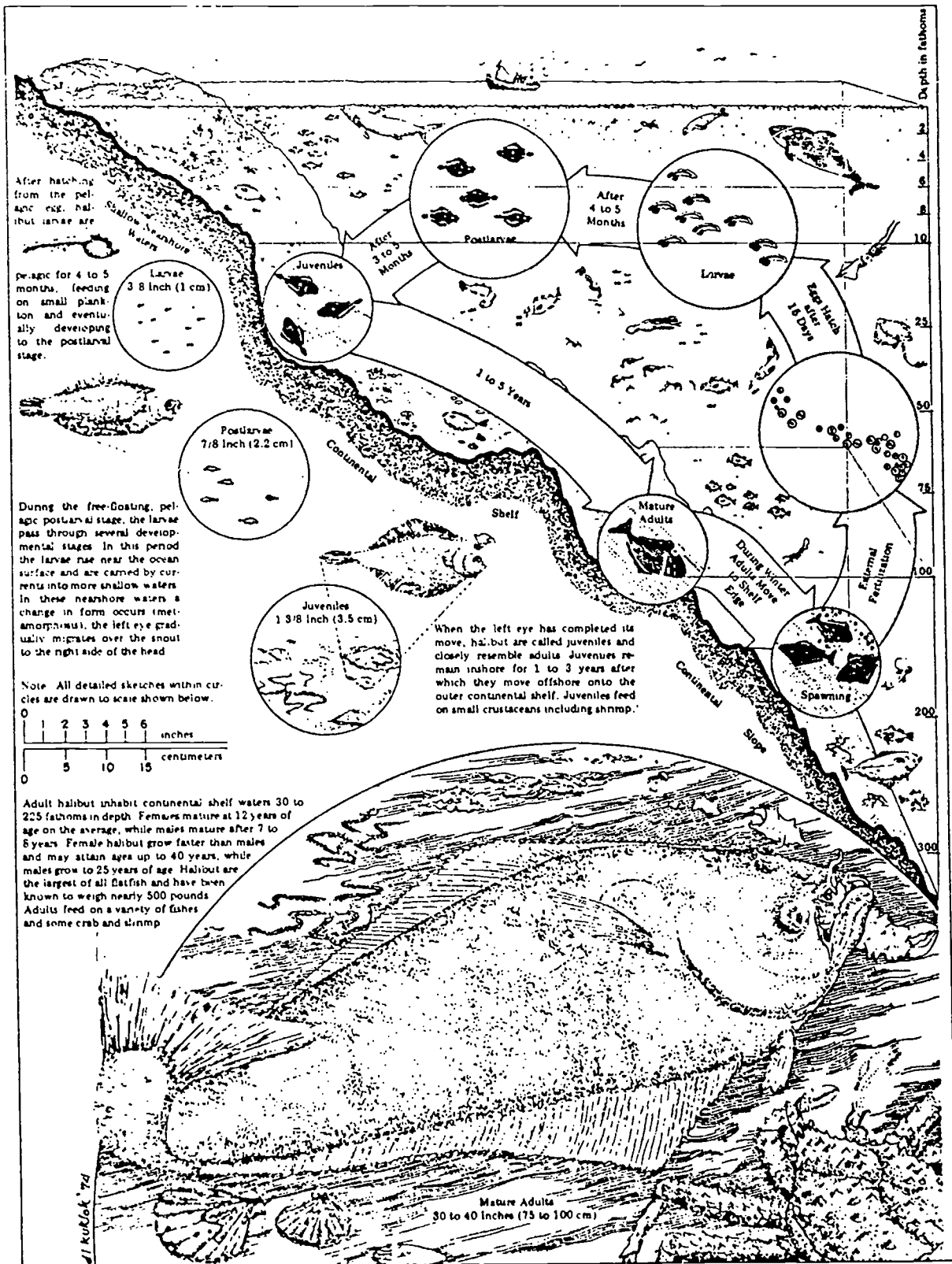

Halibut are the biggest flatfish in the world. The largest one caught in Alaska weighed about 500 pounds and came from near Petersburg. Females grow faster than males and get bigger. One record-sized female was 8 feet, 9 inches long. Females live longer, too. The oldest recorded female was 42 years old, but the oldest recorded male was only 27 years old.

Halibut, and about 20 other species of fish found in Alaska's waters, are called flatfish. They are flat and built to spend much of their lives lying quietly on the ocean floor, motionless, but alert for any smaller fish that might make a good meal.

Halibut spawn in the winter in deep ocean waters. Each spawning female may produce as many as 3 million eggs. Instead of depositing her eggs on the ocean floor, she releases them into the ocean. The eggs are just heavy enough to stay adrift about 300 to 600 feet below the surface. The young fish that develop from the eggs are transparent except for their eyes, and like salmon, they have a large yolk sac for food. Until they are about one-half inch long, halibut look like normal, upright fish. But then, the eye on the left side of the head starts to move around to the right. By the time the fish is a little over an inch long, the left eye has stopped moving and the young fish looks like its parents. Now it is a fish that can lie on its side on the ocean bottom and still be able to see with two eyes because both are on the top side of its head. Underneath, the halibut is white to match the ocean's surface, while its top side is dark and mottled to match the ocean bottom. It can even change colors to match the different colored ocean floor.

Now flat, the young fish rise and are carried toward shore by ocean currents. By the time they are 6 or 7 months old, halibut settle to the bottom of the sea where they feed on shrimp, young crabs, and other bottom-dwelling animals. When the fish are older, they move farther from shore. When they are 7 to 12 years old, they begin to spawn once a year. Soon, they are big enough to be caught by fishermen and women, like you and me!

Now answer these questions:

1. What is curious about the left eye of the halibut?

-
2. Where do female halibut leave their eggs when they spawn?
-

3. When young halibut settle to the ocean floor, what do they eat?

4. Male halibut grow faster and live longer than female halibut. (True or false?) _____
5. a. How long might a very large halibut be? _____
b. How much might a very large halibut weigh?

6. How old are halibut before they begin to reproduce?

7. Halibut eggs drift 300 to 600 feet below the ocean surface. There are 6 feet in a fathom. How many fathoms below the surface are the eggs?

8. If each mature female halibut releases as many as 3 million eggs a year, why isn't the ocean clogged with halibut?

9. Halibut eggs are transparent. How is that important to their survival?

10. List four different ways that halibut camouflage themselves.
a. _____
b. _____
c. _____
d. _____
11. If you caught a 105 pound halibut and decided to sell it to the cannery at 85¢ per pound, how much would your fish be worth? _____

Stream Checklist



dipper or water ouzel



mink



salmon adult



gull



muskrat



salmon fly



kingfisher



muskrat pushup



salmon smolt



harrlequin duck



beaver lodge



salmon eggs



bear



tracks

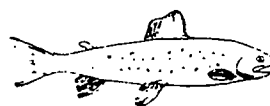

dolly varden



fox



trout

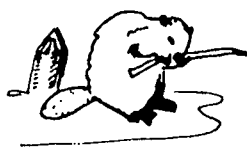

beaver



river otter



grayling

otter slide



streamside trees



triangular stem, sedge



rocks



frog



black fly blackfly larvae



animal scat



toad

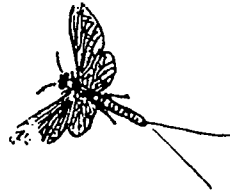

mayfly



mayfly nymph



stonefly stonefly nymph



floating stick



water beetle

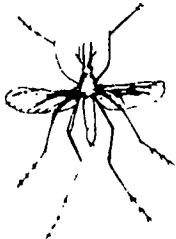

mosquito

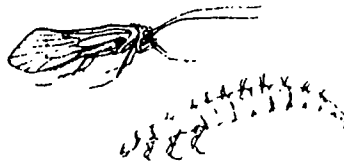

caddis fly caddis fly larvae

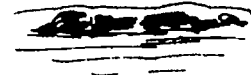

mud

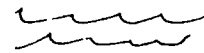

riffle



mosquito larvae



gravel

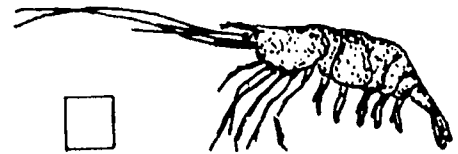

fairy shrimp



streamside bushes



round stem, grass



pool

Stream Transect

STREAM TRANSECT-TEAM # _____

Team Members _____ Date _____

Name of Stream _____

Location of transect _____

Transect length _____

Streambank temperature _____ Water temperature _____

Air temperature _____

Stream bottom type _____

Average stream depth _____ Average stream width _____

Fish Species	Size	Numbers
--------------	------	---------

Draw pictures of the aquatic insects found in your transect.

List birds or mammals observed in your transect

Draw pictures of animal tracks or signs found in your transect.

Describe the streamside vegetation along your transect.

Make a map of pools and riffles on the back of this sheet and add any other observations.

Lake Checklist

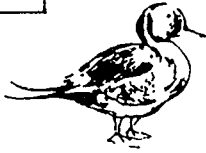

pintail



mallard



gull

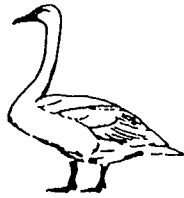

trumpeter swan



Bald eagle

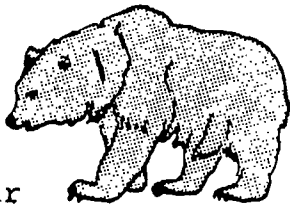

bear



sheefish



muskrat



muskrat pushup



beaver



beaver lodge



animal tracks



frog



toad

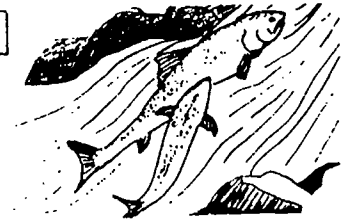

salmon adult



Salmon eggs



Salmon fry

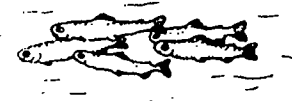

salmon smolt



dolly varden



trout



burbot



water lilies



lakeside trees



dragonfly adult



Lakeside grasses



water flea



dragonfly nymph

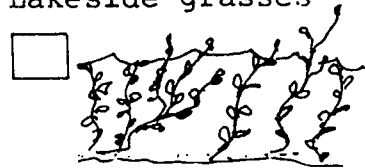

pondweeds



caddis fly adult



water boatman



log in water

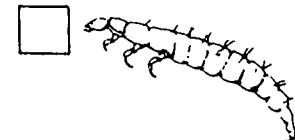

caddis fly larvae

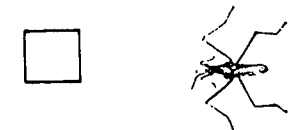

water strider



rocks

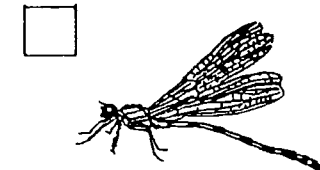

damselfly adult

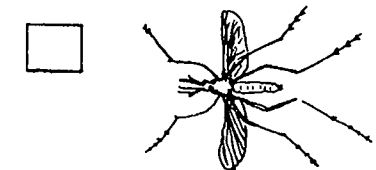

mosquito



floating stick



predacious diving beetle adult

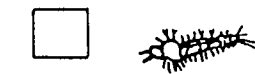

mosquito larvae



animal scat



gravel



lakeside bushes



mud

Lake Transect

Transect Team # _____

Date _____

1. Team Members _____

2. Name of Lake _____

3. Transect Location _____

Transect Length _____

4. Lake shore temperature _____

Water temperature _____

Air temperature _____

5. Lake bottom type _____

6. Estimated lake size _____

7. Fish Species	Size	Numbers
_____	_____	_____
_____	_____	_____
_____	_____	_____
_____	_____	_____

8. Draw pictures of the aquatic insects found in your transect.

9. List birds and mammals observed in your transect.

10. Draw pictures of animal tracks or signs found in your transect.

11. Describe and draw the lakeside vegetation along your transect.

12. Collect a plankton sample.

13. Take a secchi disk reading. At what depth does the disk disappear?

14. Make a rough map of the lake on the back of this sheet and add any additional observations.

Stream Data

Class and School _____

Stream _____ Date _____

Transect Locations and Lengths _____

DATA	TEAM NUMBERS							ADDITIONAL COMMENTS
	1	2	3	4	5	6	7	

Streambank
Temperature _____

Water
Temperature _____

Air
Temperature _____

Stream Bottom Type _____

Ave. Stream Width _____

Ave. Stream Depth _____

Fish Species, Size
and Numbers _____

Aquatic Insects _____

Birds and Mammals _____

Animal Tracks _____

Streamside
Vegetation _____

Velocity _____

102

Lake Data

Class and School _____

Lake _____ Date _____

Transect Locations _____

DATA	TEAM NUMBERS							ADDITIONAL COMMENTS
	1	2	3	4	5	6	7	

Lake Shore
Temperature _____

Water
Temperature _____

Air
Temperature _____

Lake Bottom Type _____

Estimated Lake
Size _____

Fish Species, Size
and Numbers _____

Aquatic Insects _____

Birds and Mammals _____

Animal Tracks _____

Lakeside
Vegetation _____

Plankton _____

Secchi Disk
Reading _____

403

How the Fish Came Into the Sea

A Tlingit Myth

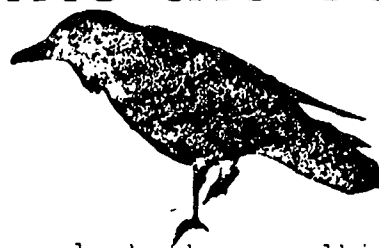
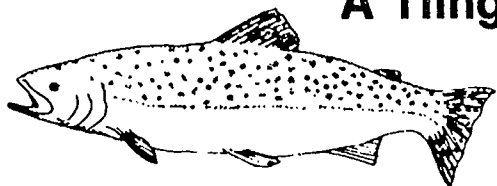

After Raven bring daylight to all the people he keep walkin' north, lookin' around, he keep going up, up north. And he see something big, big just like a scow way out on the sea, like a floating box, and he ask:

"What is it out there?"

"That's a tank. All different kinds of fish in there. They try to keep them in there so there's no fish going around this ocean."

Well, he's thinkin' about it, how he's gonna get it. Raven send that black and white bird with the long tail - the magpie - to go up and cut a cane for him, and he fix it like octopus finger, he carve it like two tentacles of the octopus. He's gonna try to drag in that big scow with it, no matter how far off a thing is, that octopus finger cane will always reach it.

In the evening Raven got all the peoples together and they beat drums. He hold the cane in his hands and move it around, going up, going down, going around, testing it. All right. That woman said she's satisfied with it. Then he get all the peoples down on the beach and they begin to sing, and he start to hook it, he tried to pull that thing ashore. And he tried again.

"OOH, OOH, OOH, OH, OH!"

Saying to the people "Sing stronger all the time" and he tried again.

And he begin to draw it in to shore little by little. Finally, he pull it onto the beach and he jump inside, and he open each door. He open the doors for smelts (fish, small fish) and the smelts comes out from that tank. After that herrings, and oolichons, and out of the other sides, king salmon first, and humpies, and coho, and later on the one they call the fall fish, dog salmon, and last comes the ones that stop, the halibut and flounders and cod, and he pushed them out.

See, just the way he opened the doors, is just the way they come every year. No mistake on it. And Raven was satisfied, he released all that fish to go around the world.

Told by Billy Wilson, Sr., of Hoonah, Alaska.

Halibut Hooks

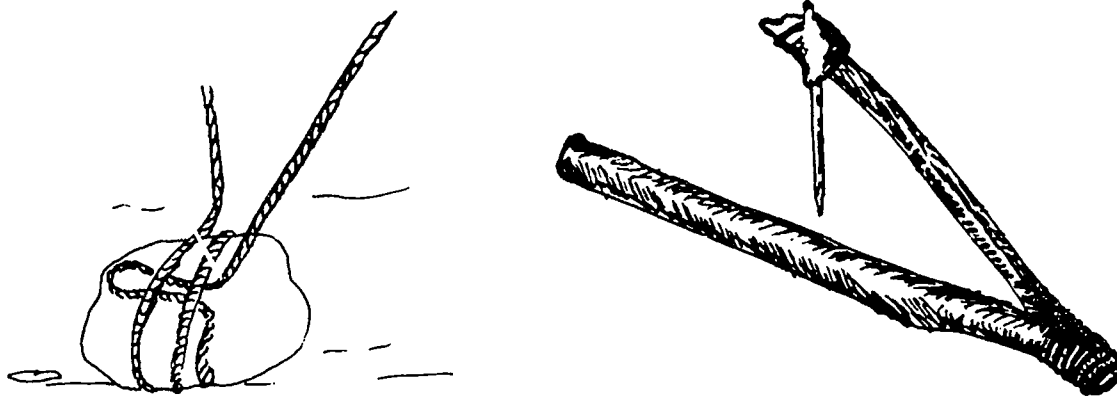

Long before they knew about steel, from which modern fish-hooks are made, Indians of the Pacific Northwest coast made hooks out of wood and bone. One of the special hooks was, and still is, the halibut hook. It often includes a carefully carved design that encourages a spirit helper to aid in catching the halibut.

The halibut hook is made of two pieces of wood. The lower part of the hook with the design, is often made of yew, a wood that gets harder as it ages. The top piece of the hook is usually made of yellow cedar. The cedar must not have knots in it and should be aged as much as a year before it is used.

A halibut hook may take several hours or days to make. Much of the time goes into carefully carving the piece of yew. When the cedar piece of the hook has been shaped, it is fitted with a hook, which traditionally was a piece of sharpened bone lashed to the cedar with strips of rawhide or split roots. Today a nail may be used instead of bone. The hook parts should be shaped so that when they are placed together three fingers will fit between the widest part of the opening between the two parts. There should be a thumb-width between the tip of the bone or nail and the piece of yew. By drawing an imaginary line along the bone or nail and extending it to the piece of yew, the maker knows where to drill the hole through which he will put the line. The finished halibut hook is usually about 8 inches long. Before the invention of nylon and other modern fishing lines, the hook was attached to lines made of natural materials such as strips of cedar bark, kelp stems and rawhide.

To use a halibut hook, the hook must first be baited with octopus, herring or some other meat. The bait should be wrapped over the top of the hook and around the bone or nail point so it doesn't show.

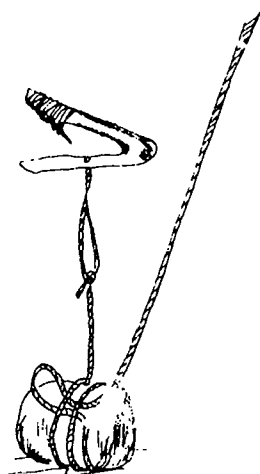

The fisherman wants the hook to float just off bottom, so a weight is attached to the line a short distance from the hook. Sometimes fishermen use rocks for weights. The rocks are tied in such a way that they will hold the hook near the bottom, but can be released by a tug on the line. In that way the fisherman does not have to pull up the rock as well as the fish. From the weight, the line goes up to a float. After the hook and weight are dropped down, the float attached to the line stays on the surface so the hook can always be located.

The fisherman chooses a favorite spot in which to set his hook. Knowing where halibut may be found takes years of fishing experience.

Halibut swim along the bottom, and they are not very fussy about what they eat. When a fish sees the baited halibut hook, it opens its mouth wide. The lower sides of the mouth slide between the two pieces of the hook and when the fish tries to spit out the hook because it cannot be swallowed, the bone or nail point catches onto the fish and it is hooked!

Questions:

1. What kinds of wood are preferred for making halibut hooks?

2. What is used for the point that will actually catch the fish?

3. Before the use of nylon or other line, what natural materials might have been used to make the line for the halibut hook?

4. What was used as a weight or sinker? _____
5. What do you think might have been used for a float?

6. What is used for bait on the halibut hook?

7. Why was one side of the halibut hook often carved?

8. How long does it take to make a halibut hook?

9. Now, try to make your own halibut hook!

Fish Wheels

Fish wheels are an old, old idea that didn't originate in Alaska. No one knows for sure where the first fish wheels were used but it may have been in China several hundred years ago. Fish wheels were first used in the United States in the 1800s. After being introduced in the Eastern states, they were tried in other parts of the country. Around 1900, a fish wheel was used for the first time in Alaska, on the Tanana River.

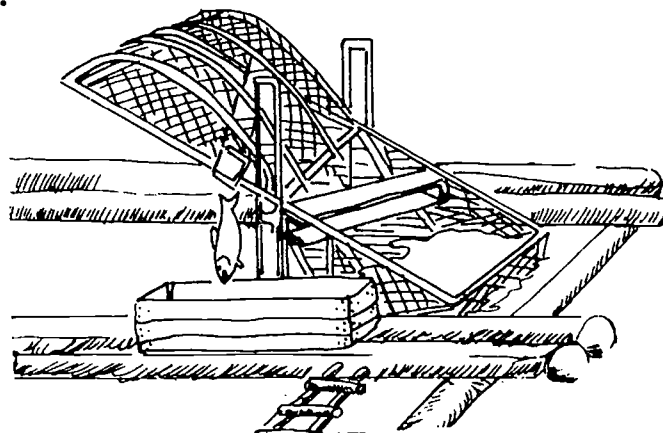

Fish wheels have various shapes and sizes, but the typical Alaskan fish wheel is a large structure mounted between log rafts. It usually has two baskets, but sometimes may have three. A board chute is on the side of the basket nearest the axle of the fish wheel. On the side of the log raft is a storage box for fish.

The fish wheel is powered by the river's current. The force of the current against the paddles of the fish wheel causes the wheel to turn slowly. Fish moving upstream are caught in the scoop-like baskets as they swim upstream. Then, the fish are carried upward, out of the water, by the basket. As the wheel once again starts downward toward the water, the fish slides out of the slanted chute at the bottom of the basket and falls into the storage box. The fish wheel is so cleverly constructed that it can catch fish and place them in storage without using any energy except that of the passing water. The wheel doesn't need anyone to run it, except for occasional checking to remove fish from the storage box.

The fish wheel is anchored to the bank of the river with cables. Sometimes a boardwalk is built from the fish wheel to shore so the owner can walk to the wheel, but other times a skiff is used to get from shore to the wheel.

Fish wheels in Alaska are used both by people who catch fish to use themselves and by people who want to sell them.

Fish wheels are used today on the Yukon, Tanana, Kuskokwim and Copper Rivers.

Answer these questions:

1. How long have fish wheels been used in Alaska?

2. What turns the fish wheel?

3. How does the fish wheel catch a fish?

4. Where are the fish kept after they are caught?

5. Fish wheels may be used for subsistence fishing. How else may they be used?

6. In Alaska, fish wheels are only used today on four large rivers. Which rivers are these?

7. Draw a map of Alaska showing these rivers and your hometown.

Gillnetting

Gillnetting is carried out in just about every coastal area of the state where there are salmon. Gillnets are also used to catch herring.

The gill net is composed of mesh large enough for a fish to poke its head through but small enough to catch the fish behind its gill covers. Different size meshes are used for different fish species. Mesh size plus the length and width of the gill net are regulated by laws which vary in different areas. The gill net has a line with cork floats at its top edge (to make the top of the net float) and a line with a lead core or lead weights on the bottom edge (to make the bottom of the net sink).

Gill nets are used in two ways in Alaska. Setnetting, or set gillnetting as it is also called, means anchoring a gill net to shore at one end and anchoring it out in the water at its other end. The set net is fixed, or set, in its location for as long as its owners want or are allowed to leave it to catch fish.

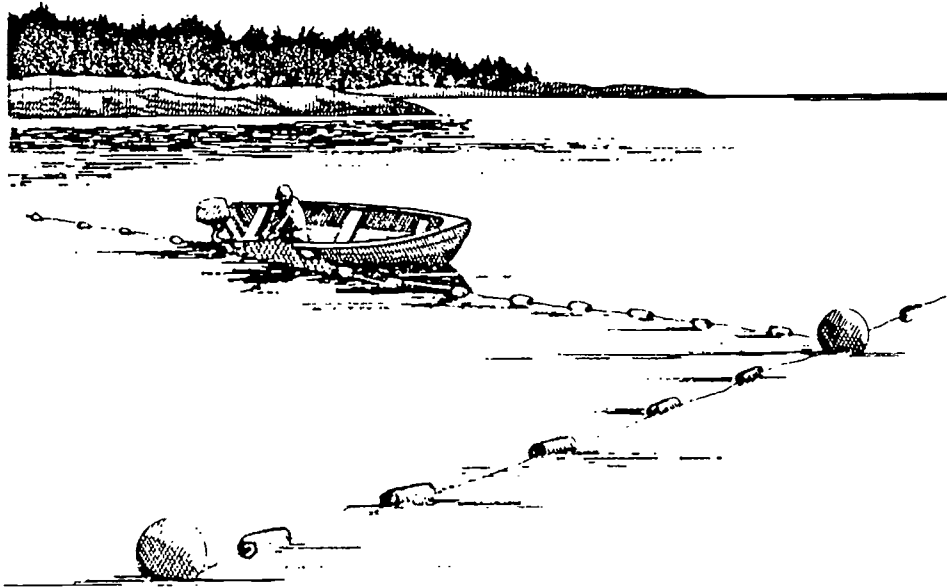

Set nets are used in many coastal areas of Alaska. Set net sites are valued family possessions. Sometimes a site has been used by one family for several generations. Today, each set net must show the official registration number assigned to it. Set nets are often tended by families who move to summer camps or cabins near their net sites and spend the summer season tending one or more set nets. Some set net fishermen or women pick fish out of the nets only when the tide is at its lowest, but others use skiffs to check their nets often.

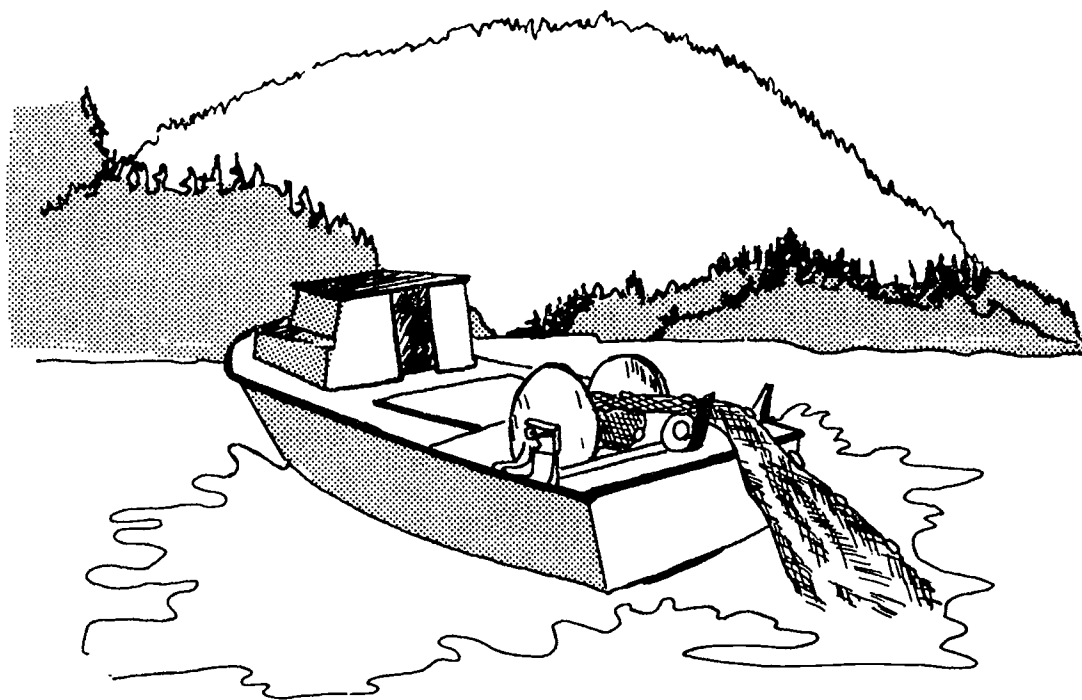

Drift gillnetting, in contrast, means using a fishing boat, called a gillnetter, and letting the net drift free while the boat's crew keeps constant watch.

Like setnetting, the drift gillnetter sets his nets as close to shore as possible because when salmon are migrating toward their spawning grounds, they usually move along the beach. The gillnetter usually tries to move the boat close to shore before dropping the large float that is attached to one end of the net overboard. As the boat moves away from shore, the gill net is carefully let out behind the boat. When the whole length of the net has been released into the water, another buoy is attached to the other end of the net and the boat pulls free. The gillnetter lets the net drift and fish for several hours, trying to keep the net in a straight line. To do this, the fishermen sometimes attaches the end of the net to the boat which then pulls against the net to straighten it.

When it is time to pull the net aboard, the buoy and one net end are picked up and the net is hauled. In many areas of the state, the typical gillnet boat has a power operated reel on its deck to pull in the net. Boats are called bowpickers or sternpickers depending on whether the net is picked up at the bow or the stern of the boat. Fishermen stand between the reel and the end of the boat and pull fish out of the net as it comes on board. In Bristol Bay, however, a gill-netter may catch a great many fish in a short time. So Bristol Bay drift gillnetters often use power rollers to bring portions of the whole net aboard to take fish from the nets.

Questions to answer about gillnetting:

1. What are the two kinds of gillnetting found in Alaska?

_____ and _____

2. Gill nets may be as much as 1,200 feet long. They are often measured in fathoms. A fathom is equal to 6 feet. How many fathoms long is a gill net that is 1,200 feet long?

3. If the gill net is 36 feet deep, how many fathoms deep is it? _____

4. What do bobbing corks mean? _____

5. Which kind of gillnetting requires a larger boat?

6. Why are the nets used in this kind of fishing called gill nets?

7. What's the difference between a bowpicker and a stern-picker?

Purse Seining

Many kinds and sizes of boats are used to fish for salmon and herring in Alaska. Among the largest boats are the purse seiners, which can measure up to 58 feet long.

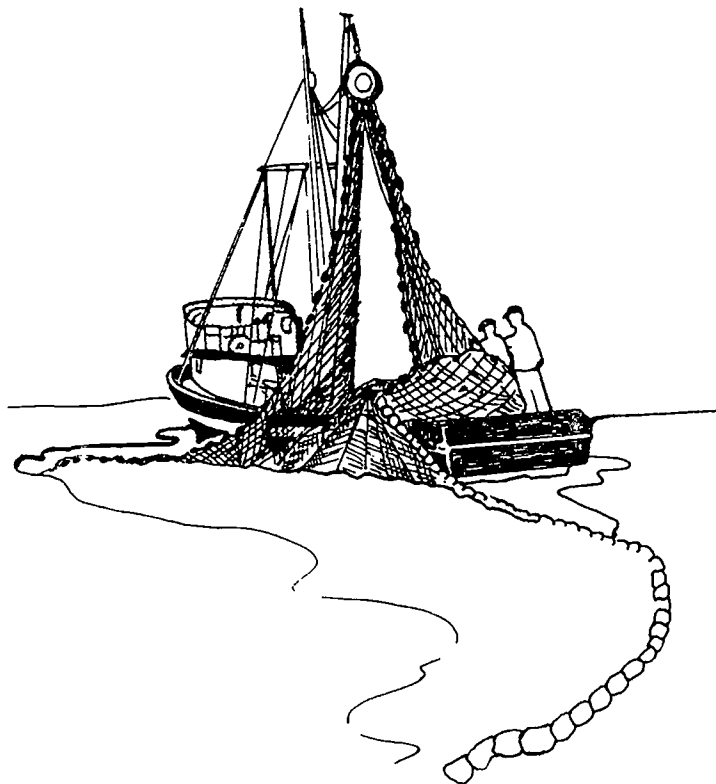

The seiner can be recognized by certain special features. Alaska seiners have a long boom that forms a "v" with the mast of the boat. Hanging from the tip of the boom is a power block that looks like a large pulley. If the seiner is not fishing when you see it, it may have a huge pile of net called a purse seine on the deck. Resting on the deck or being pulled behind the seiner will be a small boat called a seine skiff or jitney.

Seiners usually catch pink salmon, but they may catch other kinds of salmon or herring. The seiner's captain has the responsibility of deciding where the nets will be put out, or set. In making this decision, the captain relies on his knowledge of where the fish have been in the past, as well as currents and tides. Now days, the captain also depends on a recording fathometer, an instrument that makes small black marks on paper if fish are in the water beneath his boat.

When a fishing location has been selected, the boat lays the net while the jitney holds the end of the net. The purse seine may be held out for a time in a huge "u" shape. Then the jitney and the seiner head toward each other until they meet, and the seine net is pulled into a big circle. Deckhands use power equipment to pull lines that close off,

or purse, the net at the bottom. Thus, all the fish surrounded by the net are trapped and can be hauled onboard.

If the catch is small enough to handle, the crew members haul the net on deck using the power block. As they do so, one person stacks the cork line (the top line of the net which has floats to hold it at the surface of the water while it is fishing). One or more people pile up the purse seine webbing, and another person stacks up the lead line (the bottom line of the purse seine containing weights, or lead, to help stretch the fishing net tight from top to bottom).

If the catch is large, a big power-operated dip net, called a brailer, is used to scoop the load out of the closed net.

Purse seine crews usually include three to five people, plus the captain.

Answer these questions:

1. In purse seining, what is the job of the jitneyman and jitney?

2. How does a seiner captain decide where to set the net?

3. What is a cork line?

4. What is a lead line?

5. What does the power block help fishermen do?

6. What do fishermen do if there are too many fish in the net for them to haul it up?

7. How many people are usually used to run a seine boat?

8. a. If you were a purse seiner and you caught 172 pinks and 5 reds in your first set. Assume each pink weights 3 pounds and each red weighs 6 pounds and that you would get \$.30 per pound for pinks and \$.85 per pound for reds. How much would they be worth? _____

b. Now figure how much you as a crew member would make for that set, or haul, assuming your crew share is 11 percent. _____

c. In your second set, you caught 250 pinks and 8 red. How much would they be worth? _____

d. What is your crew share (11%) for this set?

e. What is your total crew share for those two sets?

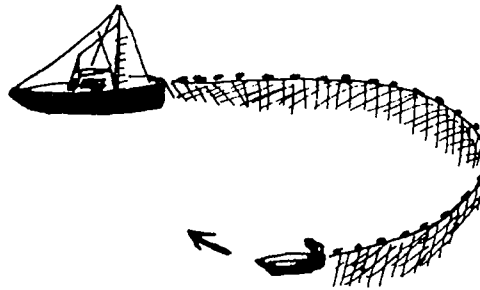

Trolling

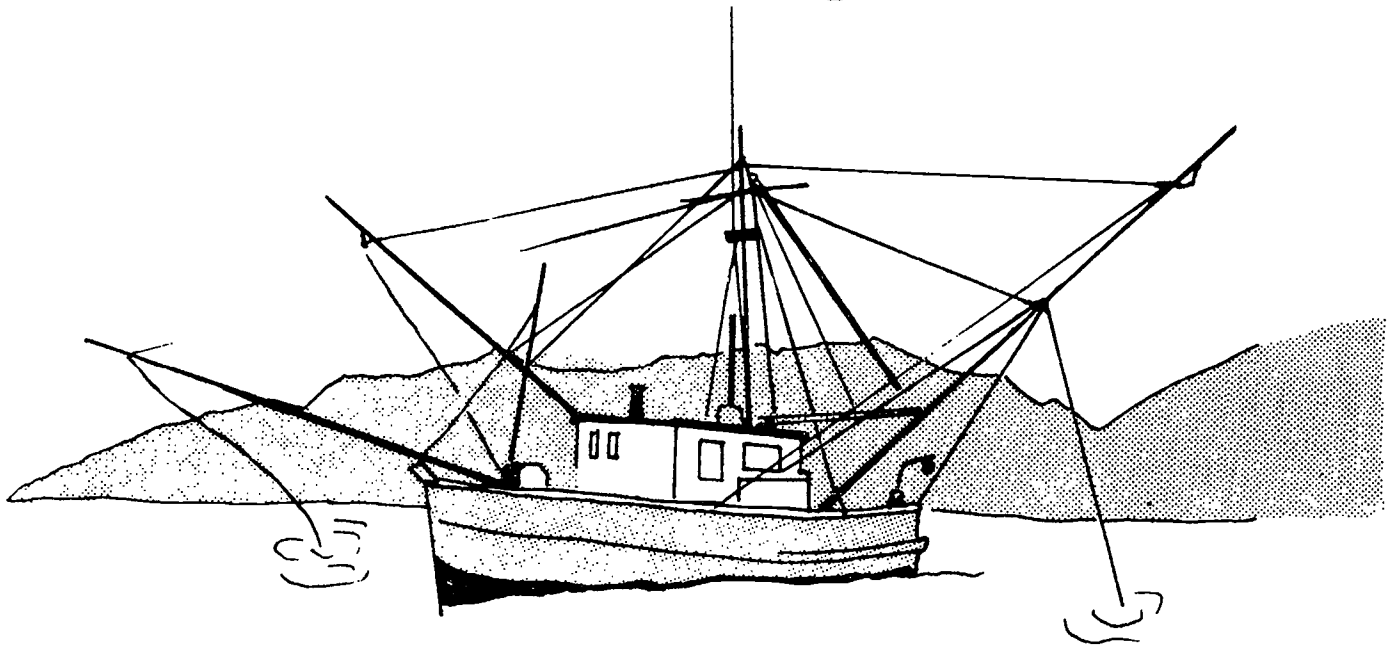

Trollers are the only commercial salmon fishermen and women who do not use nets. Their fishing is done with poles, lines and hooks. In many ways, the troller's fishing gear is like the fishing poles, hooks and lines used by sport fishermen. But trolling gear is larger, stouter and more complicated.

Boats used by trollers may be any size, shape or color and may range from less than 20 feet long to more than 60 feet long. Many of the boats look as if they were built for fishing but other trollers may be converted pleasure cruisers. Whatever they look like, though, all trollers, as the boats are called, have one or two pairs of long, tall poles.

Every troller has one set of main poles that are as tall as the boat is long. The main poles often are attached to either side of the boat, just behind the cabin by a hinge, so when they are not needed, they can be pulled up until they stick straight up into the air. When they are needed for fishing, the main poles are lowered to form about a 45 degree angle with the mast. In Alaska if the troller has a second set of poles, they are usually "bow" poles, attached to the boat ahead of the cabin.

When fishing, the troller usually stands in a large pit at the stern of the fishing boat. Steel fishing lines run off of large brass reels called gurdies. Short nylon line is used to attach the hook or bait to the steel line. For bait the troller may use herring or artificial bait such as flashers (shiny pieces of metal that look like small fish to salmon). The troller checks often for damaged or missing bait and to see if any fish have been caught.

Compared to the numbers of fish caught by gill-netters or purse seiners, the troller's catch is small, but the value and quality of the fish is high. Trollers usually catch kings and cohos, the two species of salmon most highly regarded for fresh eating. That, and the fact that the troller carefully handles, cleans and chills each fish as it is caught, gives the troller's catch a higher value, fish for fish.

Trollers are allowed to fish in Alaska from Ketchikan to Yakutat. Like the other fisheries, trolling is controlled by regulations that come mainly from the Alaska Board of Fisheries. Two federal agencies, the North Pacific Fisheries Management Council and the National Marine Fisheries Service, regulate trolling that is done more than three miles off Alaska's coast.

Now answer these questions:

1. How would you recognize a troller (the boat) if you saw it?

2. How is the method of catching salmon used by trollers different from that used by gill-netters and purse seiners?

3. What are the two kinds of salmon that trollers usually catch?

4. What are the brass fishing reels called?

5. Where in Alaska might you see a trolling boat?

6. Locate Ketchikan and Yakutat on a map of Alaska. How many miles (as the crow flies) can be fished between these two towns? _____

7. In what two ways is the word "troller" used?

8. a. If you were trolling and caught 5 king salmon (averaging 20 lbs @ \$2.25 per lb) and 52 coho (averaging 7 lbs @ \$1.30 per lb), how much would your day's catch be worth?

b. If you caught 2 kings and 40 coho, how much would your catch be worth? _____

c. If you caught 7 kings and 21 coho, how much would your catch be worth? _____

Longlining

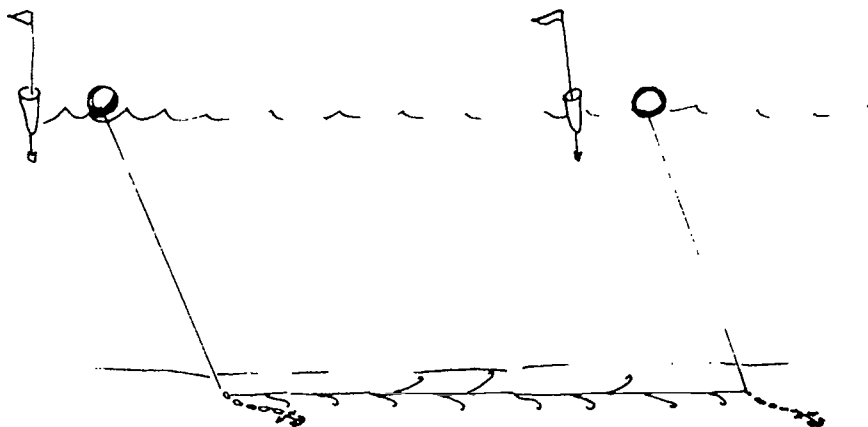

Longlining is a fishing method used in Alaska to catch halibut and other fish that live on the ocean floor. The Japanese longline for tuna, swordfish and sharks.

Longlining means using a long line with hooks on it and dropping one end of the line down to the ocean floor so it will catch fish. Longline gear used to catch halibut is made up of lengths called skates, which usually are 300 fathoms (1,800 feet) long. The main part of the skate is the strong nylon groundline. At regular intervals along the groundline, often every 26 feet, longliners attach a short line and a hook. These short lines and their hooks are called gangions (pronounced gan-yons).

When the crew members on a longliner are getting ready to set out their gear, they first bait the many hooks of the gangions. Sometimes machines are used to do the baiting but more often it must be done by hand. Herring, codfish or sablefish may be used as bait, but octopus is the favorite since it is tougher and lasts longer than the others.

When a halibut boat is setting gear, it must be moving steadily through the water. First a 17-foot long pole, with a flag and a flashing light at the upper end and a combination of weights and buoys at the other, goes overboard. The pole will stand upright in the water and will mark the location of the longline gear so the crew can find it later. Attached to the pole is a large float, or buoy, which will support one end of the longline. Overboard with the buoy goes the first of the buoy line that connects the buoy to the baited skate, or skates. When the buoy line is clear, an anchor is pushed overboard. The anchor quickly sinks to the bottom and will hold the groundline and the gangions along the bottom. As the boat moves along, groundline and gangions go overboard until the whole length of line is out. A boat may put out just one skate at a time or several

skates may be strung end to end to form one line that is as much as two or three miles long. At the end of the string of gear, another anchor, buoy line, buoy and pole are put overboard.

After one string of longline gear has been set out, the crew on the halibut boat put out another string, and another. Often it is not long after the last string is set that the crew must go back to the first string and pull it aboard. Usually the gear is left to fish for about 24 hours, then poles, buoys, anchors, lines and fish must be hauled aboard the fishing boat.

When the gear is pulled, a reel like a gill net reel may be used to wind the groundline. On some boats, however, the line is pulled without using a reel. As the fish start to come aboard, caution must be used. Halibut are often larger than 100 pounds and may weigh more than 400 pounds. They are very strong, and just a tail flick from a large fish can break bones. Fish are brought aboard with gaffs and then must be cleaned and carefully packed in ice in the hold.

A boat rigged for longlining is distinctive and can be spotted by its bundle of tall poles with flags and lights on them. Long-lining can be done from boats of any size. Some longliners have reels for winding the groundline while other don't. Many large longliners have a "shed" at the stern in which to store all the lines, hooks and other gear, and to shelter crew members as they bait and rebait hundreds of hooks each day.

Questions to answer about long-lining:

1. In Alaska, what is the main kind of fish caught by longlining?

2. What other kinds of fish are also caught by longlining?

3. What is a length of longline gear called?

4. Along the groundline of the halibut gear, crew members attach leaders and the hooks that will catch the fish. What is the name that longliners use for the leaders and hooks?

5. Longline crew set out their strings of fishing gear. Then they leave them and go off to set out more gear. What do they put at each end of a string of gear so they can come back and find it later?

6. Why do you think longliners put an anchor at each end of the string of fishing gear?

7. Why are halibut dangerous fish to bring aboard a boat?

8. How might you recognize a boat that is outfitted for longlining?

Trawl and Pots

Directions: Cut out these paper models on the heavy black lines and tape them together.

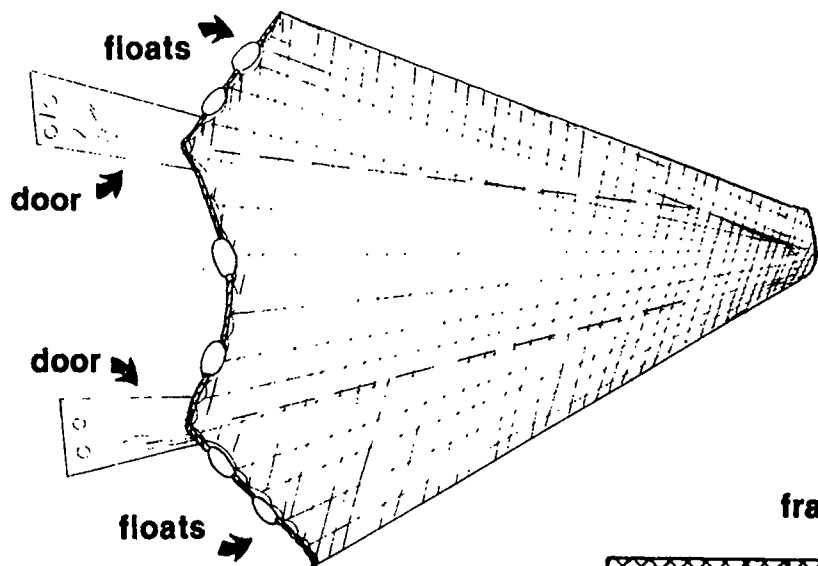

Otter Trawl

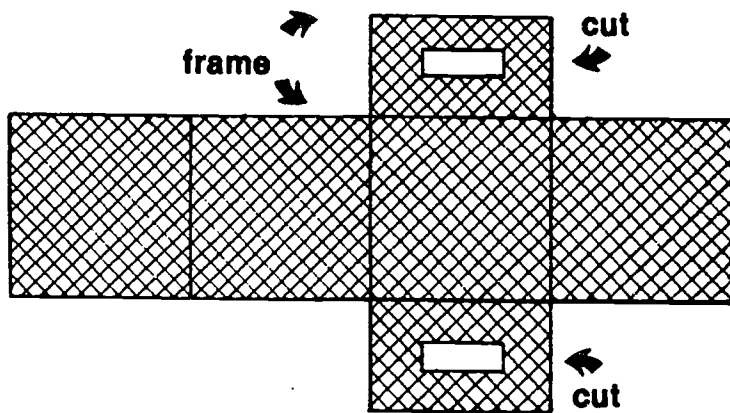

King Crab Pot

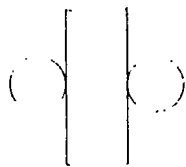

bait can

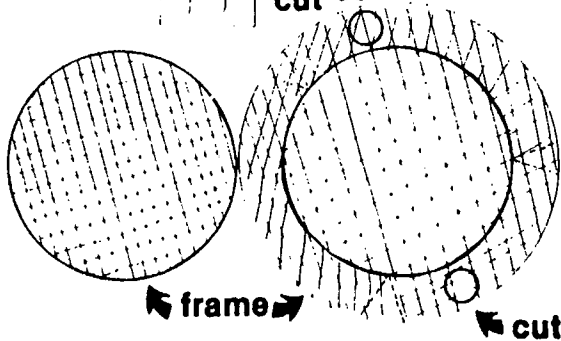
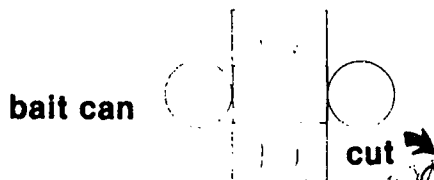

Dungeness Pot

Shrimp and Crab Matching

Directions: Write the name of the crab or shrimp next to the description.

tanner or snow _____

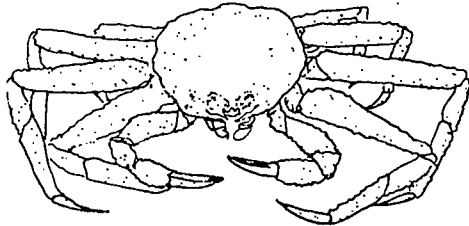

1. Thick shell with large round sharp spines; right claw larger than left claw; three pairs of walking legs jointed to bend towards the back of the body.

sidestripe _____



2. Third segment of tail section is partially ridged and has two spines one in front of the other on the back of that segment; pale pink color; maximum size 6½ inches.

king _____

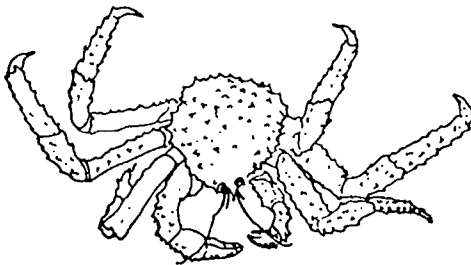

3. Third segment of tail section not ridged and no lobes or spines on the back of that segment; dorsal spines only on the front half of the carapace or shield; maximum size 11 inches.

humpy _____



4. Shell fairly smooth; walking legs (stretched out) short when compared to width of body shell; claws both the same size and short and heavy.

Dungeness

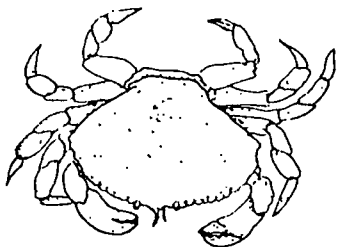

- _____ 5. Third segment of tail section is partially ridged and has just one lobe or spine just in front of the back of that segment; maximum size 4 and 3/4 inches.

spot



- _____ 6. Shell fairly smooth; walking legs (stretched out) much longer than width of body shell; 4 pairs of walking legs jointed to bend towards the front of the body; claws slim and sharply pointed.

northern pink



- _____ 7. Third segment of tail section not ridged and no lobes or spines on the back of that segment, dorsal spines on carapace (or shield) extend down the back past the halfway point; maximum size 8 inches.

coon stripe

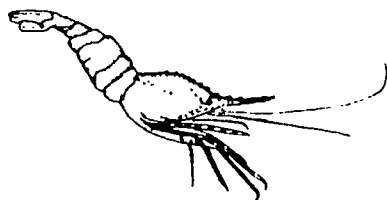

- _____ 8. Only commercially important shrimp with top pair of antenna as long as lower pair; stripe running down side of tail section; maximum size 8 1/2 inches.

Fishing

Directions: Under each picture write the name of the kind of fishing it shows. Then write the name of the kind of fish usually caught by that fishing method.

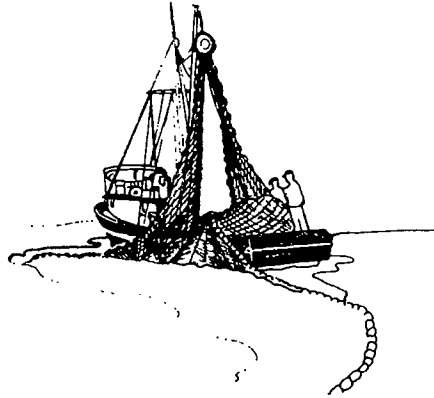

1. Kind of fishing _____
2. Kind of fish caught _____

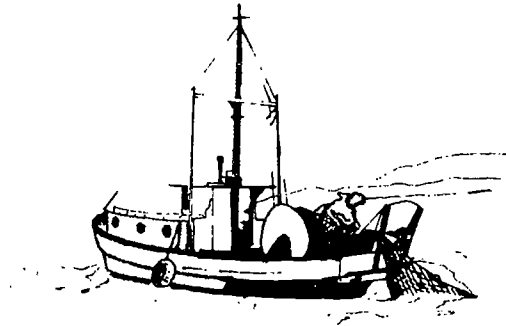

3. Kind of fishing _____
4. Kind of fish caught _____

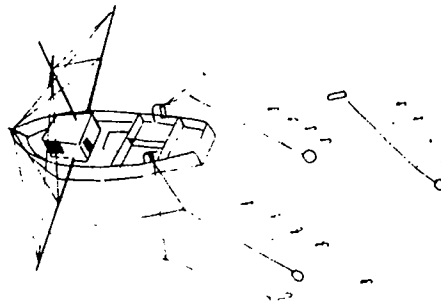

5. Kind of fishing _____
6. Kind of fish caught _____

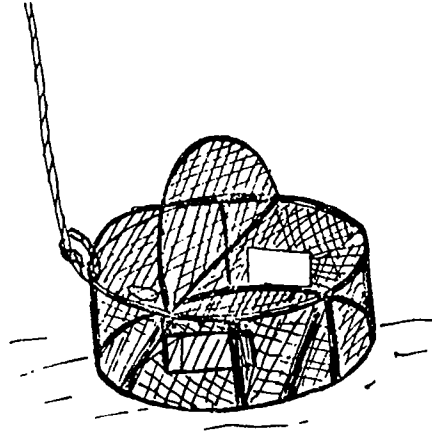

7. Kind of fishing _____

8. Kind of fish caught _____

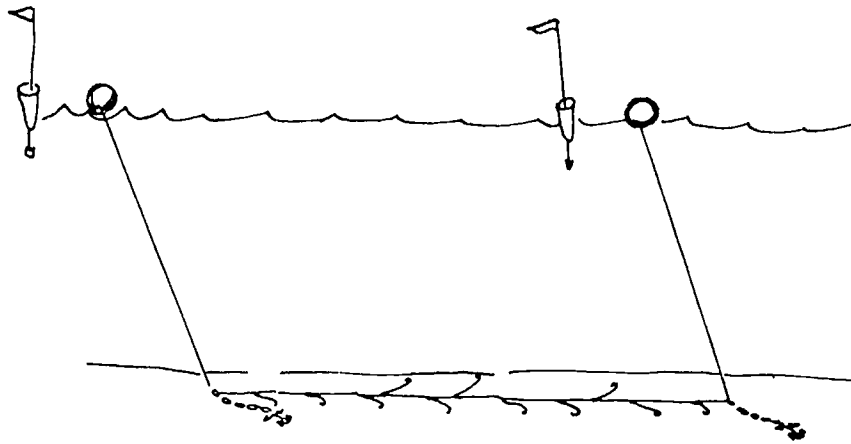

9. Kind of fishing _____

10. Kind of fish caught _____

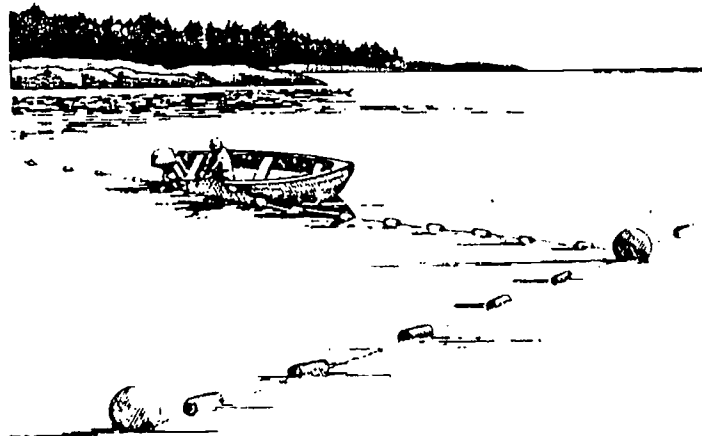

11. Kind of fishing _____

12. Kind of fish caught _____

Name _____
Date _____

Harbor Investigation

1. Draw a quick map of the harbor on the back of this sheet. Label floats, docks, breakwater, buildings, restrooms, oil dump, garbage dumpsters, electrical outlets, water lines or spigots, gasoline pumps.
2. Find examples of each type of boat and explain how you know it's that kind of boat.

NAME OF BOAT	TYPE	HOW CAN YOU TELL?
_____	gillnetter	_____
_____	seiner	_____
_____	troller (power)	_____
_____	troller (hand)	_____

_____	longliner	_____
_____	trawler	_____
_____	tender	_____
_____	sport boat	_____
_____	sailboat	_____
_____	patrol boat	_____
_____	ferry	_____
_____	freighter	_____

3. List any birds, fish, mammals that you see.

4. List invertebrates that you can find.

5. Find and describe three types of seaweed.

6. Find an example of three environmental problems.

7. Interview a fisherman or woman and the harbor master or mistress.

Captains Know Their Boats

To fish, a person must know many things and have many skills. Among the most basic is how to talk about a boat.

Each part of a boat has a special name. Knowing these names makes it easier to talk about the boat. Here is a diagram of a boat and a list of terms and definitions used to describe its parts. See if you can label the parts correctly.

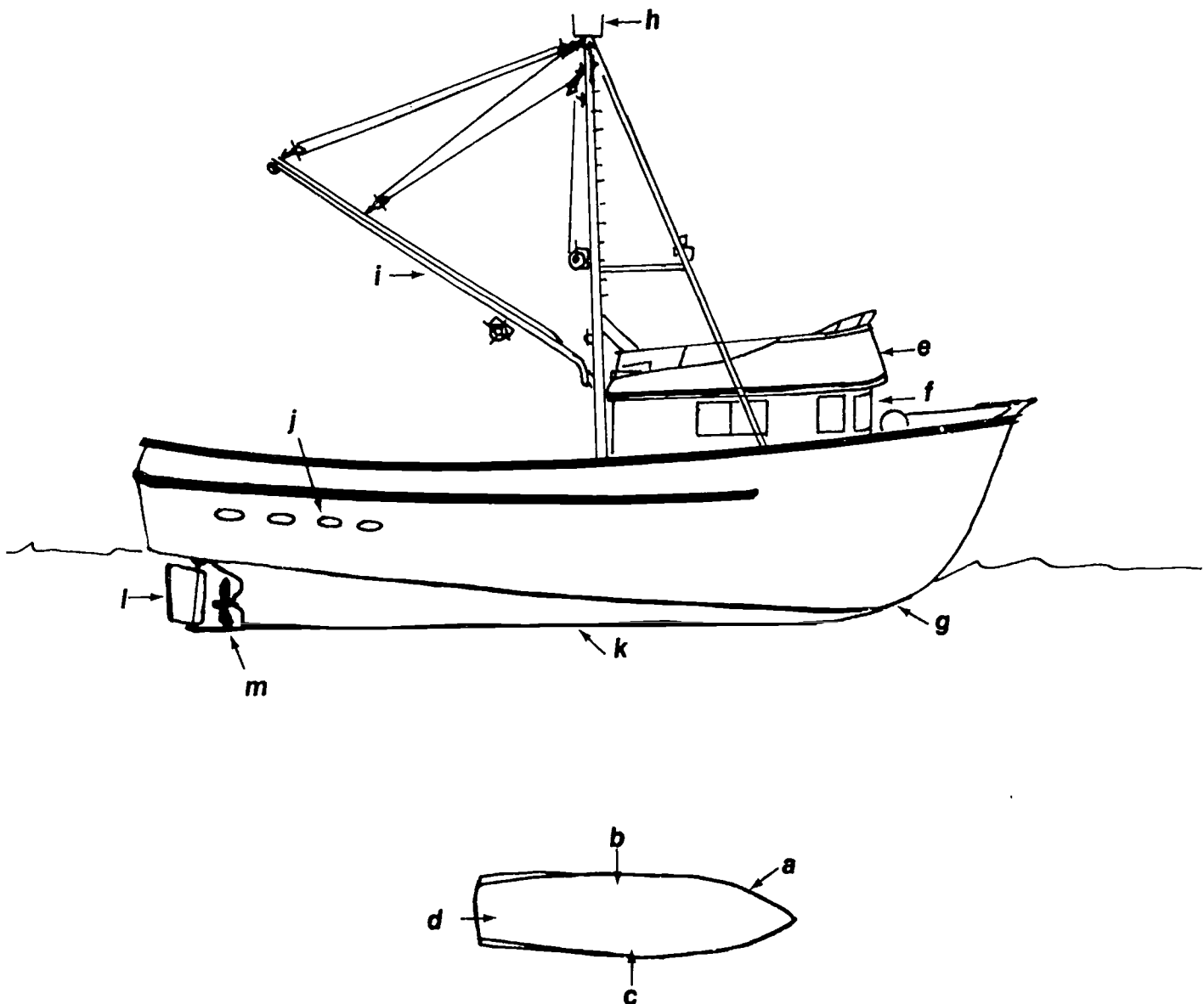

(Note: you are looking at the bottom of the hull.)

- Keel - a timber or plate running lengthwise along the center bottom of a boat.
- Hull - the outer covering of the main part of a boat.
- House - the cabin or living space built above the deck and hull.
- Mast - a long pole rising from the deck of a boat and used to support various rigging.
- Boom - a long pole that extends horizontally from the mast. It may be used to hold the bottom of a sail or to support gear or rigging.
- Bow - the forward part of the boat.
- Stern - the aft, or rear, part of the boat.
- Port - the left hand side of the boat if you are facing toward the bow.
- Starboard - the right hand side of the boat if you are facing toward the bow.
- Rudder - a "board" below water level at the stern of the boat. Changing its position mechanically makes the boat turn or change direction.
- Propeller - a blade-bearing device which under power turns and by its motion, moves the boat.
- Crow's Nest - lookout point at the top of the mast.
- Scuppers - holes that allow water to drain off the deck.
- Flying Bridge - the location from which a boat is steered and its speed controlled.

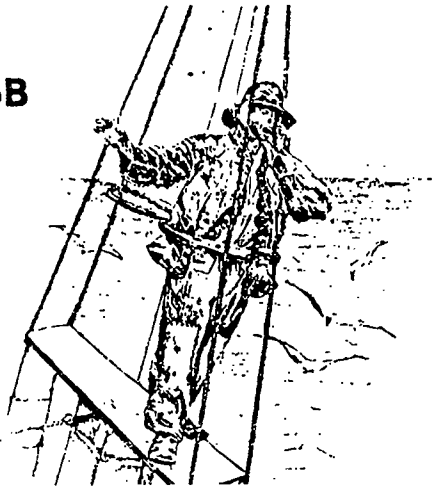

Ship Ahoy!

Stow that landlubber chatter and try your hand at becoming an old salt!

Put the letter of the landlubber meanings in front of the old salt sayings.

LANDLUBBER	_____	OLD SALT
a. Park the boat.	_____	1. Cast off, matey.
b. Come on in.	_____	2. Haul on that line.
c. Secure the doors.	_____	3. Get below.
d. Go downstairs	_____	4. Swab the deck.
e. Untie the ropes and let's go.	_____	5. Use the head.
f. Go to bed.	_____	6. Pump the bilges.
g. Drain the basement.	_____	7. Roll into your bunk.
h. Life preservers are in the back.	_____	8. Man the helm.
i. Pull that rope.	_____	9. Stow your gear.
j. Wash the floor.	_____	10. Welcome aboard.
k. Drive the boat.	_____	11. Make fast to the dock.
l. Go to the bathroom.	_____	12. She's listing to the starboard.
m. Put your clothes away.	_____	13. Go aloft.
n. Get up above.	_____	14. P.F.D.'s are aft.
o. Put everything in good order.	_____	15. Make everything shipshape.
p. The boat's leaning to the right.	_____	16. Batten down the hatches.

Port of Anchorage Chart

from ALASKA Tidelines

Nautical charts are the road maps of the sea. They tell you how deep the water is and what the bottom is like. They warn you of rocks, reefs, mud flats and other hidden hazards. And they show the signposts you need, such as lights, bells, buoys, and landmarks on shore.

The waters of Cook Inlet are so tricky that a special pilot is required on all large vessels traveling north of Homer. But there's no law against a little desktop navigation. So study the legend in the lower right-hand corner and steer yourself safely into port.

1. In the lingo of the sea, starboard is to your right as you face the front of your boat, and port is to your left. (An easy way to remember: "port" and "left" have the same number of letters.) So from your boat's position shown on the chart, Moose Point is on your _____ side and the lighted (oil) platform is on your _____ side.
2. The Inlet bottom right about there is generally _____ and _____.
3. Moving right along, you have reached the buoy in the middle of the Inlet north of Point Possession. Water depth is usually measured by the fathom, which is equal to six feet. The chart shows the water depth here is 11 fathoms. How many feet is that? _____
4. When heading in from the sea, the general rule is to keep red buoys and even numbers on your starboard side, and green lights or black buoys with odd numbers on your port side. (Remember: "red-right-returning.") So you want to keep that buoy on your _____ side.
5. Now you're off Fire Island and lined up with the beacon lights on Point MacKenzie. (Note the solid and dotted lines on the chart which show the recommended route into port.) How high is the top light? _____
What does "E Int 6sec" mean? _____
6. Getting close! Keep that N "2" buoy to your _____ side.
7. The Port of Anchorage is in sight and you're on your own. Your vessel draws (needs) 36 feet of water. So check the fathom markings (this chart shows depths at average low low tide) and draw a line to plot your course to the dock.

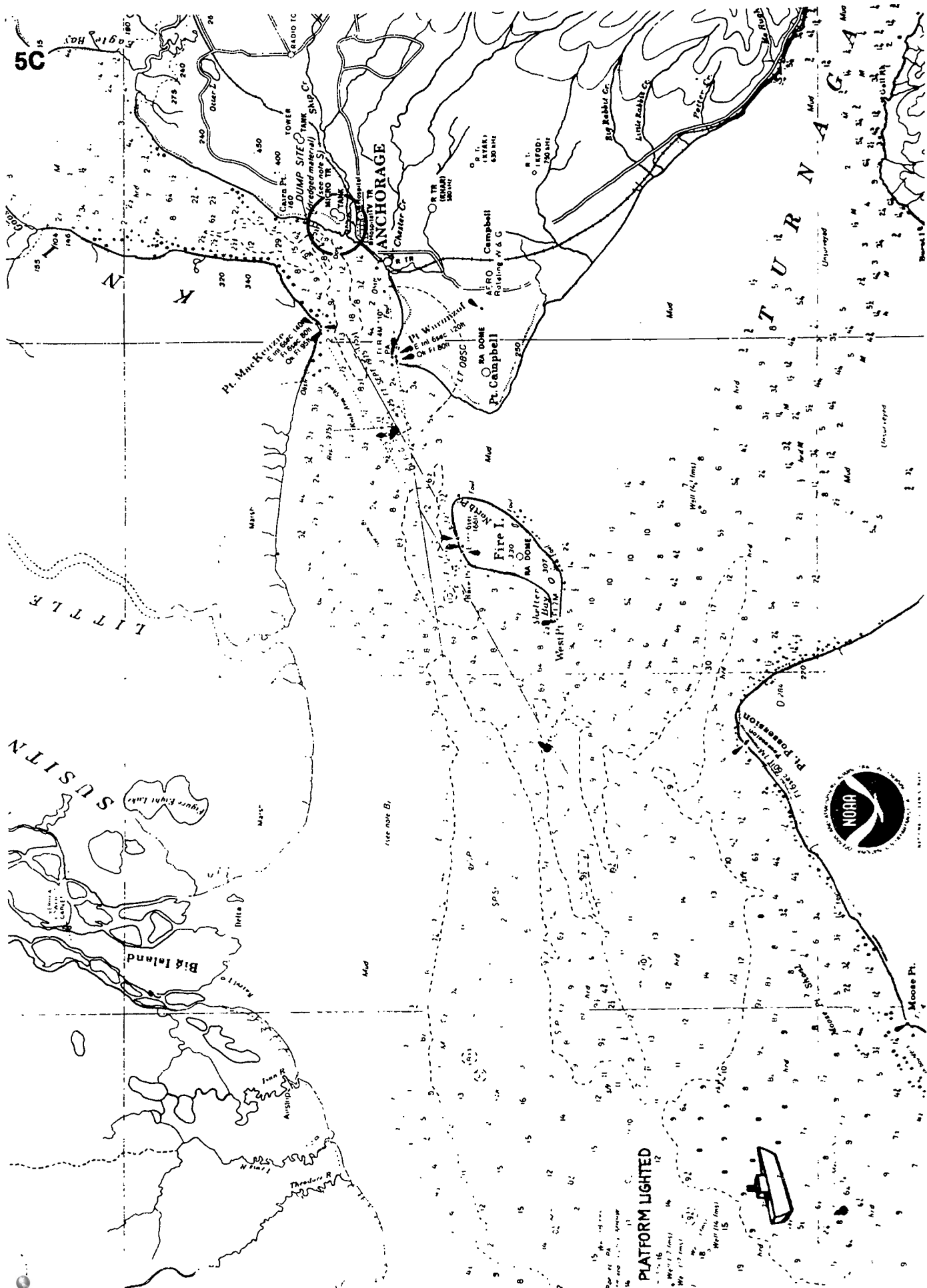

Chart No. 16660, Cook Inlet, Northern Part, National Ocean Survey, September, 1979.

603

BEST COPY AVAILABLE

604

LEGEND

All soundings (depths) are in fathoms (6 feet) at mean (average) lower low tide.

.....	less than 10 fathoms
-----	10 fathoms or more
MHHW	mean higher high water
MLLW	mean lower low water

Bottom

hrd	hard
rky	rocky
stk	sticky
sft	soft
SPSt	sand, pebbles, stones
gySP	gray sand, pebbles

Hazards

+	sunken rock
*	rocks that cover & uncover with tides

Buoys & Beacons

◇	buoy (lighted)
○	buoy (unlighted)
▲	beacon (land)
⊙	RA (radar dome)
⊙	R TR (radio tower)
N	"nun" (black buoy)
C	can buoy
"2"	number on buoy
R	red
G	green
F1	flashing
Qk	quick
E	equal
Int	intervals
sec	seconds
ft	feet above water at high tide
M	nautical mile (distance can be seen)
PA	position approximate
obst	obstruction
LTOBSC	light obscured

Nautical Knots

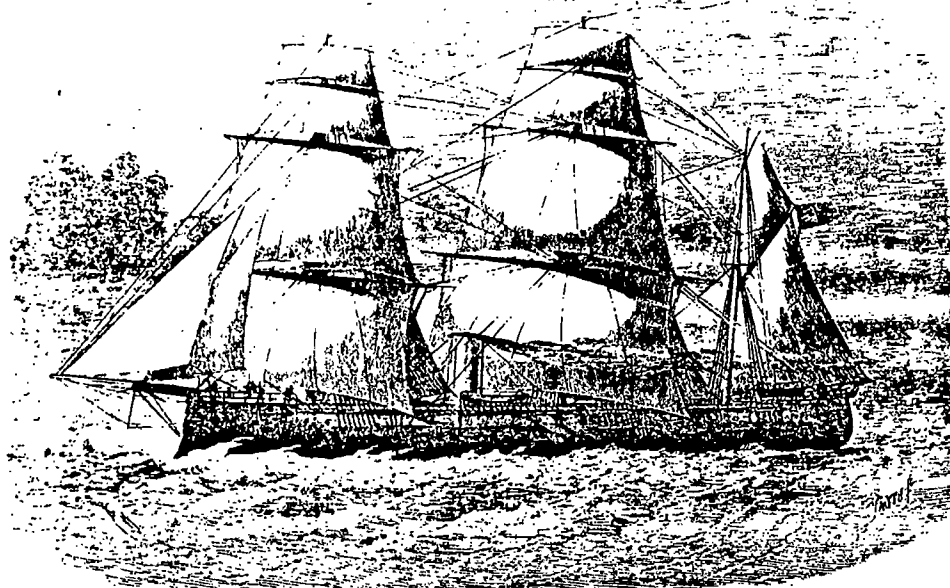

A knot is something you tie, but also a way of measuring how fast a boat travels! On land we talk about how many miles per hour a car or snowmobile can go. On water, if a boat is moving at one knot, it is traveling one nautical mile per hour. A nautical mile is a little longer than a land mile. So if a boat goes at a speed of 8 or 9 knots, it is traveling at about the same speed as 8 or 9 miles per hour. Not very fast on land but a good speed for a boat!

1 knot - 1 nautical mile per hour

Try these knotty problems.

1. If your boat travels 45 nautical miles to get to the fishing grounds at a speed of 9 knots, how long will it take to get there? _____
2. To travel from one fishing spot to another, your boat travels for 10 hours at a speed of 7 knots. How many nautical miles did your boat travel?

3. Coming back to port, your fishing boat traveled five hours and went a total distance of 30 nautical miles. At what speed (how many knots) was it traveling?

4. If fuel costs \$1.50/gal. and your engine averages 3 knots/gallon, how much did your 30 nautical-mile trip back to port cost? _____
5. Now make up your own knotty problem and exchange it with your neighbor to see if he or she can do it!

Eight Knots

Directions: Practice typing these knots until you can tie them blindfolded. Sometime you may need to tie them fast, at night, in cold weather.



FIGURE EIGHT
Use to keep the end of a line from unraveling or as something to hold onto.

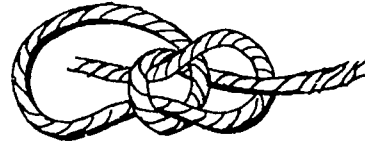

BOWLINE (pronounced bōlyn)
Use to tie a non-slip loop at the end of a line. The bowline does not jam and can be untied.

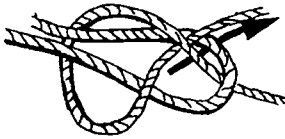

SHEET BEND
Use to tie two uneven lines together.

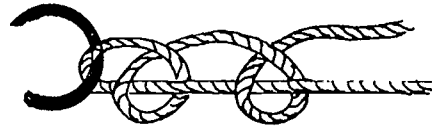

TWO HALF HITCHES
Use to make a line fast to a piling or a ring.

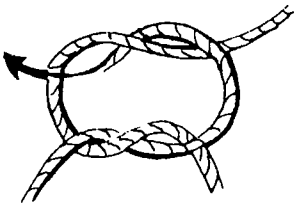

SQUARE KNOT
Use to tie two light lines of the same size together. (Be sure that the line going into one side on top is going out on top as it comes back through--otherwise it's a granny knot and won't hold!)

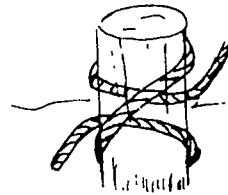

CLOVE HITCH
Use to make a line fast temporarily to a piling. (Be sure you push the top and bottom together, or it won't hold!)

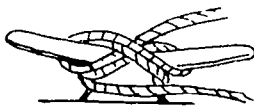
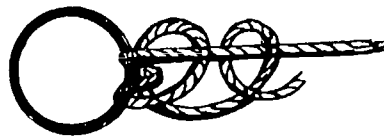

FIGURE EIGHT ON A CLEAT
Use to tie to a cleat. (Make sure the line is wrapped around the base of the cleat first.)



FISHERMEN'S BEND
Use to make fast to a buoy or the ring of an anchor. This knot is also called the anchor bend.

Tides

Tides involve the rising, and lowering and movement of great masses of water. People fishing watch the tides almost as closely as people living on land might watch a clock. Boats can go dry or float away, depending on the tides. Channels can be too shallow to get through on a low tide. Fishing is often best on a rising tide.

If water is moved through a narrow opening by the tides, a tidal current may be very evident. In fact, it may be so strong that a boat cannot move against it even at full power. Even on the coast of the open ocean, tidal currents are sometimes very strong. People traveling from one place to another by boat, they try to time their travels in such a way as to be going in the same direction as the tidal current. That gives them a faster trip and saves on fuel. A great deal of where and when and how a person fishes depends on the strength and direction of the tidal currents.

Knowing how to read a tide book is important. The main part of a tide book gives the time and height of the tides for every day of the year for several main locations. Additional pages of corrections enable the reader to figure out the same kinds of information for other nearby places.

On the following page are two pages from a tide table. Look at them, and notice there are two low tides and two high tides on most days. Then answer the following questions.

1. On November 1, how high is the highest tide in Cordova?

2. On November 1, how low is the lowest tide in Cordova?

3. What time are the high tides in Cordova on November 15?
_____ and _____
4. What time are the low tides in Cordova on November 22?
_____ and _____
5. On what day in November is the lowest tide of the month in Cordova? _____
6. On what day in November is the highest tide of the month in Cordova? _____
7. On November 16, what is the difference in the height of the water when the tide is at its lowest and when it is at its highest? _____

Tide Tables

HIGH Tides CORDOVA District NOVEMBER 1983

DATE	DOT'S	A. M.		P. M.	
DAY	GUIDE	TIME	FT.	TIME	FT.
1	Tues ●	9:36	12.7	9:49	12.2
2	Wed ●	10:16	13.6	10:42	12.6
3	Thur ●	10:56	14.4	11:33	12.9
4	Fri ●	11:32	14.8	-----	-----
5	Sat ●	0:19	12.9	12:07	15.0
6	SUN ●	1:03	12.7	12:42	14.8
7	Mon ●	1:45	12.2	1:15	14.3
8	Tues ●	2:31	11.6	1:49	13.5
9	Wed ●	3:13	10.9	2:26	12.5
10	Thur ●	4:09	10.2	3:08	11.4
11	Fri ●	5:18	9.7	4:04	10.3
12	Sat ●	6:32	9.6	5:34	9.5
13	SUN ●	7:34	9.8	7:03	9.3
14	Mon ●	8:21	10.4	8:13	9.6
15	Tues ●	8:59	11.0	9:06	10.0
16	Wed ●	9:33	11.7	9:54	10.5
17	Thur ●	10:07	12.5	10:42	10.9
18	Fri ●	10:39	13.2	11:24	11.4
19	Sat ●	11:09	13.8	-----	-----
20	SUN ●	0:07	11.7	11:44 ^A	14.3
21	Mon ●	0:47	11.8	12:17	14.5
22	Tues ●	1:30	11.8	12:53	14.5
23	Wed ●	2:13	11.6	1:30	14.2
24	Thur ●	3:03	11.2	2:15	13.6
25	Fri ●	4:00	10.8	3:07	12.6
26	Sat ●	5:12	10.7	4:21	11.5
27	SUN ●	6:21	10.9	5:56	10.7
28	Mon ●	7:23	11.5	7:22	10.5
29	Tues ●	8:14	12.3	8:35	10.6
30	Wed ●	9:02	13.1	9:38	10.9

● BIGGER THE DOT—BETTER THE FISHING

LOW Tides CORDOVA District NOVEMBER 1983

DATE	DOT'S	A. M.		P. M.	
DAY	GUIDE	TIME	FT.	TIME	FT.
1	Tues ●	3:06	0.9	3:43	1.7
2	Wed ●	3:54	0.5	4:31	0.0
3	Thur ●	4:40	0.4	5:14	-1.3
4	Fri ●	5:19	0.6	5:56	-2.1
5	Sat ●	5:59	1.1	6:36	-2.4
6	SUN ●	6:36	1.9	7:16	-2.1
7	Mon ●	7:15	2.8	7:55	-1.5
8	Tues ●	7:54	3.8	8:37	-0.5
9	Wed ●	8:39	4.8	9:21	0.5
10	Thur ●	9:24	5.6	10:09	1.6
11	Fri ●	10:20	6.2	11:05	2.5
12	Sat ●	11:28	6.5	-----	-----
13	SUN ●	0:09	3.1	12:56	6.1
14	Mon ●	1:23	3.2	2:23	5.1
15	Tues ●	2:24	3.0	3:16	3.7
16	Wed ●	3:14	2.7	3:57	2.3
17	Thur ●	3:54	2.4	4:31	0.9
18	Fri ●	4:31	2.2	5:08	-0.3
19	Sat ●	5:03	2.1	5:40	-1.3
20	SUN ●	5:39	2.3	6:19	-1.9
21	Mon ●	6:17	2.6	6:57	-2.1
22	Tues ●	6:53	3.1	7:39	-2.0
23	Wed ●	7:38	3.6	8:25	-1.6
24	Thur ●	8:26	4.2	9:16	-0.9
25	Fri ●	9:21	4.7	10:09	-0.2
26	Sat ●	10:27	4.9	11:09	0.6
27	SUN ●	11:41	4.8	-----	-----
28	Mon ●	0:15	1.3	1:05	4.0
29	Tues ●	1:23	1.7	2:25	2.6
30	Wed ●	2:29	1.9	3:27	1.0

STANDARD TIME

Putting Out to Sea

Working at sea is tough and dangerous, and much of the hazard comes from the sea itself. Alaskan waters, for example, are so cold that, unprotected, a person can survive no longer than 30 minutes before becoming unconscious. In addition to the cold water, sudden storms and winds can whip seas into huge waves capable of endangering even the largest and strongest of vessels.

Modern equipment has helped make boating and fishing safer, but the most important part of being safe is still to be very cautious and to know and understand as much as possible about winds, weather and the ways of the sea. Eskimo hunters sometimes travel far from land in small boats, but they carefully watch changes in the sky, the wind and the sea and know what even the slightest changes mean to them and their safety. People traveling the rivers of Interior Alaska must know the swift parts of the river where currents or eddies are dangerous and the shallow places. People fishing salmon or halibut on the open sea must always carefully calculate how long they dare stay out and fish if the weather is deteriorating. They must know when to run for shelter of safe bays or other anchorages along the coast.

Here is a list of equipment needed for a safe voyage. Draw a picture of a boat that you would like to own and show and LABEL the safety equipment you'll need.

670

1. A stout boat. Any boat that goes to sea should be strong, in good shape, and free of leaks or rot that will make it weak.
2. A radio. Many boats have two kinds of radios. A citizens band radio, or CB, can be used for talking over short distances, such as to a boat fishing nearby. A very high frequency radio, or VHF, is used for talking over longer distances. With a VHF radio, a person can make ship-to-shore, long-distance phone calls; can get up-to-date weather forecasts; or can call the U.S. Coast Guard if there is an emergency and help is needed. On a small boat, a regular transistor radio can be used to listen to periodic weather forecasts. Be sure and check the weather forecast before even starting your trip!

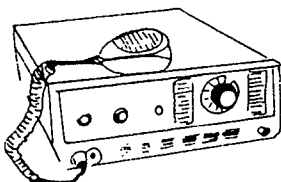

3. Life preservers and/or survival suit. By law every boat is required to have one approved life preserver or P.F.D. (personal floatation device) for each person on the boat. Many fishing boats carry survival suits as well. Survival suits are like loose fitting diving suits. They are made out of neoprene rubber and insulate a person's body from icy waters. With a survival suit, a person can stay alive in the open sea for several days awaiting rescue.



4. Life ring and line. These should always be handy to throw to anyone who falls overboard because sometimes it takes awhile to turn the boat around.

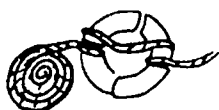

5. Survival gear. If you're tossed on shore in an open life boat, survival gear can be most helpful! Wrap a spare sleeping bag in a waterproof bag or plastic bags together with a survival kit containing food, matches, flares, propane lighters, signal mirror, fishing line and hooks, tarp or pieces of plastic, water, etc.

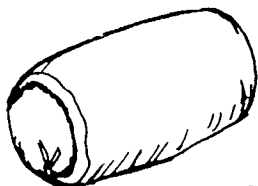

6. Life raft. Some life rafts store in small containers and automatically inflate and release if the vessel sinks. The life raft will give shelter and help conserve the body heat of people who have abandoned their boats at sea. Be sure to store emergency food and water with the raft and have the raft checked every so often to make sure it will still inflate!

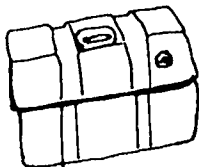

7. Fire extinguishers. Surrounded by water on a boat, there may be no way to put out a fire unless there is an extinguisher that will put out electrical or chemical fires.



8. Bilge pump or bailer. Water does sometimes come inside boats, and it's very important to be able to get rid of it quickly! Larger boats require bilge pumps. Always have a spare handy too! Smaller boats can use a bucket or can for bailing.
9. Radar. Having radar is like having eyes that can see in the fog or the dark. With radar, a person on a boat can watch at night for other nearby boats, can see icebergs ahead or large floating logs that might damage the vessel. The operator can also see the shape of a river, the outline of a coast and can measure the distance from the boat to any of these. Many fishermen these days are buying Loran systems as an alternative radar. Courses can be programmed so boats can get through channels in the dark. Loran utilizes the differences in two radio pulses to determine position.
10. Fathometer. This instrument shows the depth of the water. Water depth changes with the tide and fishermen must often be careful of where and when they cross shallow areas. No one wants to end up high and dry on a mud flat or a reef. People fishing often use a recording fathometer that provides depths on a long sheet of paper. This kind of fathometer will tell how deep the water is under the boat and will record small black marks for every fish passing beneath the boat.
11. Horn, whistle and/or bell. In times of poor visibility, some sort of warning is needed to keep vessels from running into each other. The Coast Guard has outlined rules of the road for different situations. The danger signal is four short blasts.
12. Charts. No one should set out in a boat without having a good chart of the area--either inside his head or on paper. Charts for all coastal areas are put out by the United States government. They show depths, hazards, harbors--everything that is known about a particular piece of coast line. The government also puts out a book called The Coast Pilot that describes coastal features shown on the charts.
13. Compass. Under conditions of poor visibility, there may be no other way to keep track of where you are.
14. Anchor. If any vessel is in distress, it may drift into shallow water where an anchor can hold it securely and prevent it from being tossed on a rocky shore. And when you anchor, be sure you attach even line to allow for a rising tide!

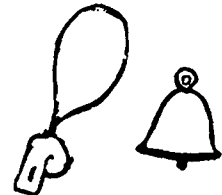
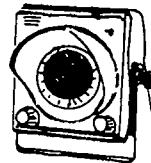
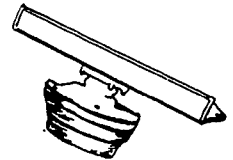

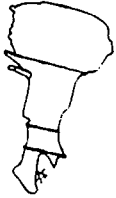

15. Tools, spare parts, and a spare motor. Many times whether you get back before dark will depend on your mechanical ability, tools, parts, and a spare motor!

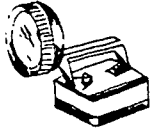

16. Lights and spare batteries. If you need to attract attention, work on your motor in the dark, anchor your boat at night, or find the channel, lights are very necessary. When running at night, boats should show a red light on the port side and a green light on the starboard, plus white lights on the bow and/or stern depending on the size of vessel.

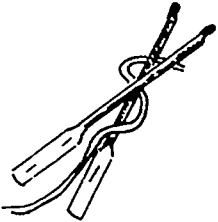

17. Oars. Every motorboat should have oars and spare oars aboard. A motor can always quit or run out of gas. Then oars and muscle power become important.



18. First aid kit. Basic supplies include bandages, antiseptic and burn ointments, lotions, aspirin, bandaids, tape, scissors, tweezers, thermometer, safety pins, cotton, and a first aid book!

19. Sailing plan. Always leave word of where you're going and your planned date and time of return with your family, friends or the harbor master, so they'll know where to look if you fail to return.

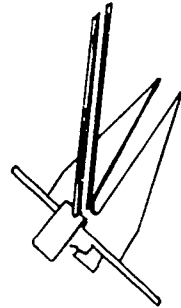
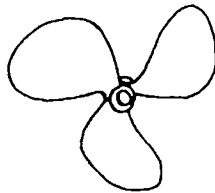
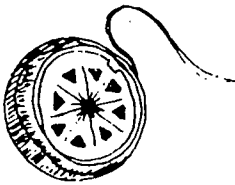

The Safety Afloat Game

To the Teacher:

Make four copies of this sheet. Back sheets with tagboard. Carefully cut out each Safety Device and glue to end of a cocktail swizzle or similar small stick. Back playing board on tagboard, cover with clear laminate if possible. Store Safety Devices in an envelope.

Objective of the game is to enable students to identify by sight and name the Safety Devices needed aboard boats.



Approved
Fuel Tanks



Sailing
direction and
Return time
left with
harbor master



Bouyant
materials to
throw over board
for rescue.



Lights and
extra batteries

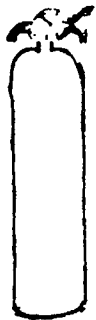

Fire Extinguisher(s)



P.F.D.
Personal Floatation
Device



Mooring Lines
for mooring
for Rescue
Retrieval.



Bailing Bucket



Radar Finder



First Aid Kit and Manual
(Marine type)

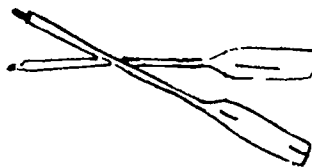

Extra Oars
or
Paddles

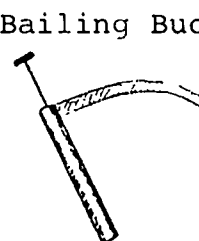

Bilge Pump

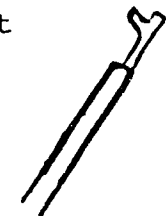

Boat Hook*

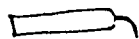

Flares or other
distress signals.

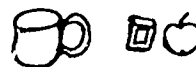

Food and Water
Rations



Transister
Radio



Anchor



Bell

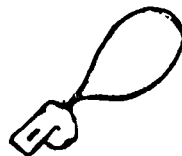

Horn or Whistle



Tool Kit



Spare Parts

*Playing Piece for each player to use.

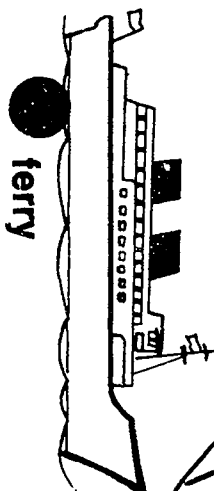

ferry

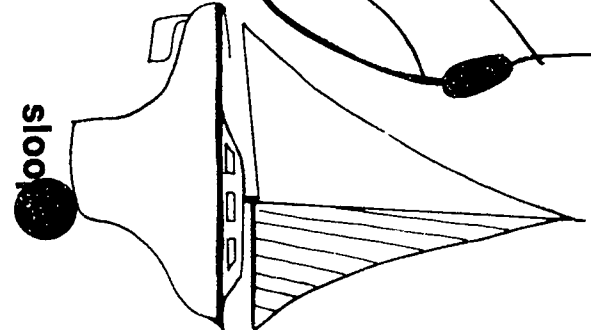

sloop

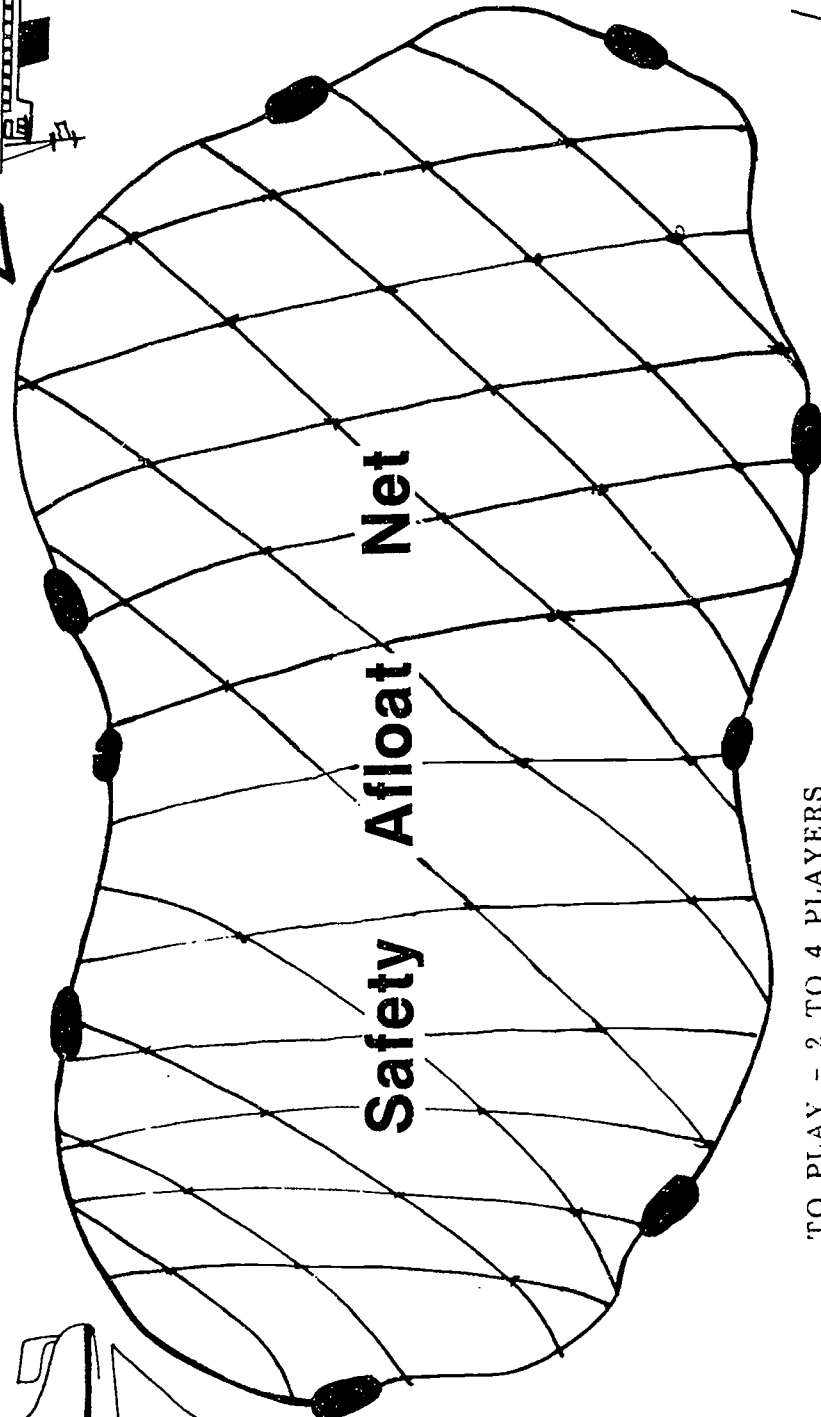

Safety Afloat Net

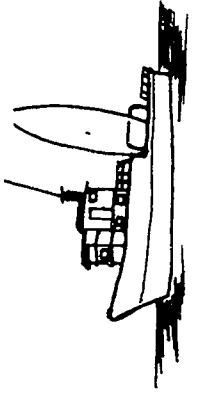

trawler



runabout

TO PLAY - 2 TO 4 PLAYERS

1. Place Safety Devices in hand and release in pile in the Safety Afloat Net.
2. Each player in turn removes as many Safety Devices as possible without moving any but the intended one.
3. Each time a player must name the Safety Device before attempting to remove it. A single plain "boat hook" is used for each player who places all "caught" safety devices on his "ship."
4. Play is terminated when any Safety Device other than the one intended moves. At the end of each turn, one Safety Device must be returned to the net.
5. Play ends when one player has one of each device aboard.

Taking Care of Your Catch

by Virginia Sims, editor of ALASKA Tidelines

Think back to all those great fishing trips you've been on (or are planning). What happens after you land a big one? Do you clean and gut it right away or do you throw it in the bottom of the boat or on the riverbank? Does it matter? Read on.

WHO CARES ABOUT A TEENSY BACTERIUM?

Take a tiny one-celled creature called a bacterium. (The "um" ending is singular; the "a" is plural.) It is one of the teensiest life forms on the face of the earth. They are all over the place and you can't even see them. It would take about 400,000,000 bacteria just to form a clump the size of a grain of sugar.

Nothing to worry about, right? Well, take a look at how they grow.

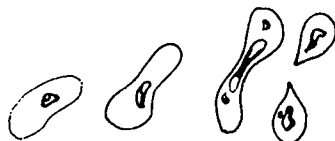

Bacteria don't grow by getting bigger and older. Instead, they divide themselves by splitting in two. As you see here, the cell stretches out, then squeezes in the middle and finally breaks apart, forming two cells.

Under ideal conditions, one bacterium can divide every 20 minutes. And those ideal conditions might well be met by a dead fish (right food) in a warm sloppy fish box (right temperature/right humidity).

So it's a beautiful day and you've gone fishing. You catch your first salmon at 7 a.m., put it in the fish box and figure you'll clean it when you get home. You arrive back at the dock at 5 p.m. What has one bacterium done in those 10 hours? Figure it out for yourself:

+ 20 mins. 40 mins.

7 a.m.

8 a.m.

(Keep multiplying by 2)

9 a.m.

10 a.m.

6.77

11 a.m.

12 noon

1 p.m.

2 p.m.

3 p.m.

4 p.m.

1. So at 5 p.m., that 1 teensy bacterium has multiplied into _____.
 2. Now figure out how many bacteria those 400,000,000 in that clump the size of a grain of sugar could have multiplied themselves into:
-

So, when you go fishing, KEEP IT COOL! The flesh of most fish is free from bacteria. But the gills and guts are loaded with them. They do little harm while the fish is alive. But after the fish dies, they begin to multiply like mad and the warmer the fish, the faster they spread. When this happens, we say the fish is spoiling. What is really happening is that bacteria are "eating up" the warm, dead fish.

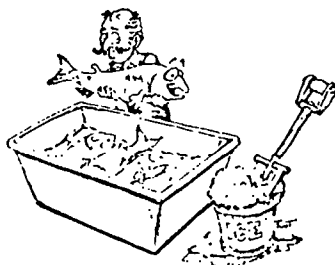

The best way to slow down bacterial growth is to keep the fish cold. And the best way to do that is with ice - lots and lots of clean crushed ice that will hold the fish just about at the freezing point. There are times, of course, when you can't pack a supply of ice along on your fish trips. But you should still keep your catch as cool as possible. Even putting the fish in the shade or covering it with a wet gunny sacks helps a lot.

AND KEEP IT CLEAN! All fish should be gilled, gutted, bled and washed just as quickly as possible after they are caught. This helps get rid of the worst of the bacteria. And it also does away with the No. 2 among the big spoilers, which are called enzymes (EN-zymes - rhymes with, well, rhymes).

Enzymes are the juices we all have that help digest the food we eat. After the fish dies, these juices keep right on working and can eat their way through the stomach wall and into the flesh. This makes the flesh turn brown and soft, a condition fishers call "belly burn."



Keeping the fish cold slows down this action, too. And when fish are caught in great quantities, as in nets or trawls, chilling is often the only practical way to go.

All this gilling, gutting and cleaning isn't going to do much good if you then throw your fish into a slimy bloody fish box or on the bottom of the boat. (It's surprising how fast a fish can pick up the smell and taste of gas and oil in the bilge water.)

Everything a fish touches - holds, fish boxes, decks - should be cleaned after each fish trip. Look at it this way. Fish is food, and you should try to keep your boat as clean and bacteria-free as a kitchen. That also includes clean knives, tools, gaff hooks and cutting boards.



So be sure you **HANDLE WITH CARE!** The best way to pick up a fish - especially a big fish - is through the gills behind its head, never by its tail. Alive or dead, fish bruise very easily. Bruises release blood into the flesh and show up as black or brown spots. Often these spots don't appear until after the fish is frozen. But when they do, forget about trying to sell it.

The most common ways of bruising a fish are:

- Picking up or pulling a heavy fish by its tail.
- Stepping on it.
- Throwing it roughly into the fish box or hold.
- Letting it flop around on the deck or in the fish box.

Be careful, too, in boating your fish. Most sports fishermen use a net to haul a big fish aboard. But if you must use a gaff, hook it in the head, not in the side.

3. Now, plan your next fishing trip to

_____.

4. How will you keep your fish cool?

5. Keep it cleaned?

6. Handle with care?

By now you should be ready for a super taste treat of fresh fish!



Salting, Canning, Freezing, and Smoking

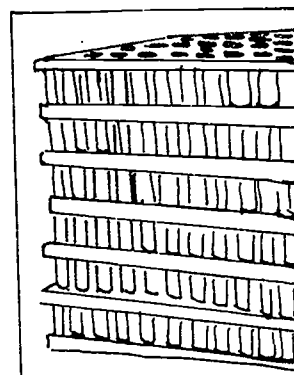
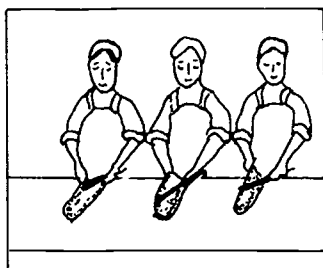
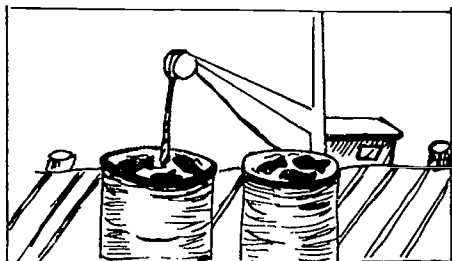

Long before anyone thought of selling Alaska's seafoods, Native people had solved the problem of keeping these perishable foods for future use by drying, smoking or freezing.

During the days of Russian activity in Alaska, salmon began to be salted as a way of preserving it, and for awhile, several salteries operated on Alaska's coast. Salted salmon was packed in barrels and sent across the ocean to Russia.

Canneries for salmon began to appear along the Alaskan coast in the late 1800s. The first cannery was built at Klawock on Prince of Wales Island in Southeast Alaska in 1878. By 1929, 156 canneries were operating in Alaska. Some canneries did well, but others operated for a few years and then closed. Today, salmon canning is still a big business, but Alaska's coast is dotted with the rotting remains of canneries that failed.

Although freezing is the most common commercial treatment of seafood for market, today Alaska's seafoods are processed in several ways. Some fish, especially the highly valued king salmon, may be quickly handled and flown out of Alaska still fresh and ready for fish markets or restaurant use. Many people pickle some of their fish. In 1982, Alaska's Seafood Marketing Institute reported that 75% of Alaska's salmon was frozen and then sold fresh and that under 10% of other fish and shellfish were canned.

If fish are frozen, they must be carefully cleaned in a cold storage plant. Fish can be frozen whole or in serving pieces. In most Alaskan plants, fish are placed on racks and wheeled into freezer rooms where the temperature is many degrees below zero. Freezing preserves fish, but if they are to be kept frozen for a long time, they must be glazed using a special brine mixture, usually containing some kind of syrup as well as salt.

Canning is an important way of preserving salmon. The types

of salmon most often canned are sockeye and pink. Many canneries are open only during the summer months when salmon are being caught. When the canneries are busy, many people are needed for the work and they put in long days cleaning, cutting and canning salmon.

Answer these questions:

1. Fish such as salmon are often preserved by Alaskan Natives by _____, _____ or _____.
2. Early Russians could send salmon back to Russia by first _____ it, then putting it in barrels to ship.
3. What kind of salmon is often flown out of Alaska fresh for use in restaurants and fresh fish markets?

4. Today, salmon that will be shipped to other states or countries for food is either shipped fresh or it is _____ or _____.
5. A good way to freeze salmon is to _____.
6. Canneries usually operate all year-round (true or false). _____

Name _____

Date _____

Grocery Store Survey Form

Grocery _____ Town/Village _____

PRODUCT	PACKAGING	COUNTRY OF ORIGIN	SIZE & PRICE	ADDITIONAL COMMENTS
1.				
2.				
3.				
4.				
5.				
6.				
7.				
8.				
9.				
10.				
11.				
12.				
13.				
14.				
15.				
16.				
17.				
18.				

You've Just Got a Job in the Hatchery



You must use special words to describe what happens in a salmon's life cycle and to talk about your work. Here are some of those words. Use your dictionary to look up a definition for each one. Write down the definition, then write a sentence for each word, using that word to describe something that might happen in the hatchery.

egg _____

sperm _____

fertilization _____

spawn _____

alevin _____

fry _____

mature _____

incubator _____

Hatchery workers often talk about "tagging" fish. Tagging fish helps them learn where fish from their hatchery travel and where they are caught by fishermen. Look up the word "tag" in the dictionary. Now think about how you might be able to tag a fish. Write down your ideas!

Hatchery Basics

You've just been promoted to hatchery manager and you need to explain how a hatchery works to some new employees. Here is a diagram of the natural life cycle of pink salmon.

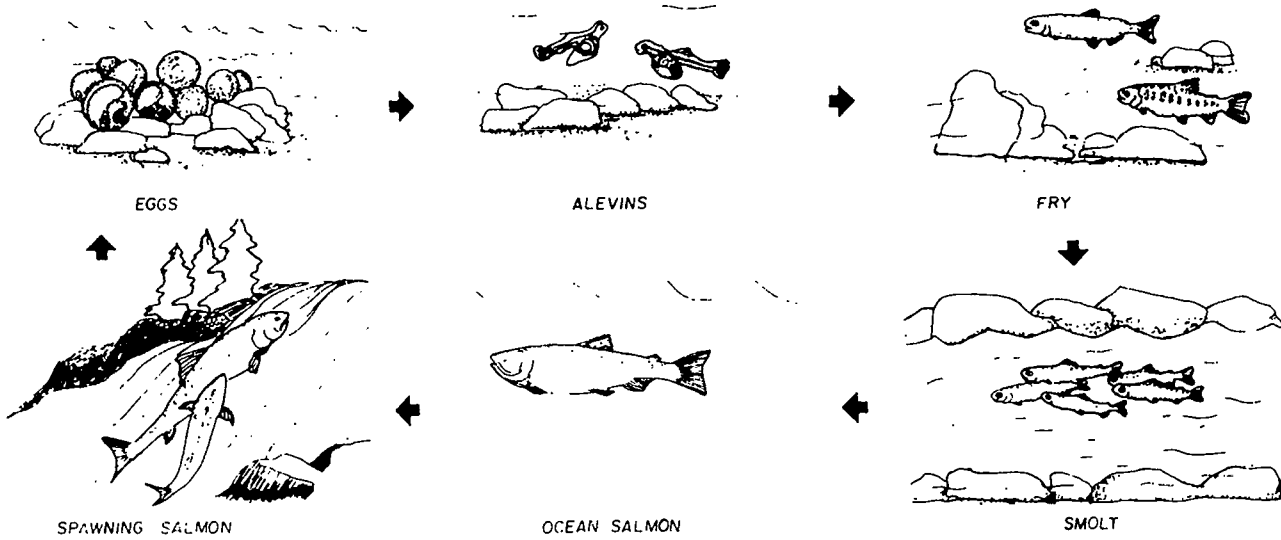

Then cut out the seven squares below. On another sheet of paper paste them in a circle that show the order of events in your hatchery during one year. Under each event write the name of the month or months in which the event described in the square might take place.

<p>fry are counted, tagged and released to swim to the ocean month(s) _____</p>	<p>2-year-old fish return to hatchery, are captured and spawned. Fertilized eggs are put in trays with circulating fresh water. month(s) _____</p>
<p>fish leave incubators as fry and to holding pens where they are fed month(s) _____</p>	<p>incubators cleaned and readied for return of mature fish in fall month(s) _____</p>
<p>eggs begin to hatch to alevins month(s) _____</p>	<p>eggs mature enough to be handled, eggs sorted and put in large incubators month(s) _____</p>
<p>eggs and alevins held in incubators month(s) _____</p>	

What are those Funny-Looking Fish?

The easiest way to identify fish and other living things is with a kind of yes/no system called a "key." The idea is to compare your fish with the two-part descriptions--body shape, number of dorsal fins, etc.---choose the one that fits best and follow the directions until you get the answer.

Study the parts of a fish in the drawing above. Then pick out a fish to identify. Start with 1a and 1b. Does the fish look round like a salmon? (Go to 2 and repeat the process.) Does it look flat like a halibut? (Go to 11, etc.) When you find its name, write it on the line. Continue until all are identified.

1. a) Body round.....Go to 2
b) Body flat.....Go to 9
2. a) 3 separate dorsal fins.....Go to 3
b) Less than 3 dorsal fins.....Go to 4
3. a) Barbel (whisker) on chin.....Pacific (true) cod
b) No barbel on chin.....Alaska pollock
4. a) 2 dorsal fins.....Go to 5
b) Less than 2 dorsal fins.....Go to 6
5. a) 2 separate dorsal fins that
lock alike.....sablefish
b) Front dorsal fin high and narrow;
rear fin long like a pointed ball.....rattail
6. a) One small dorsal fin set far
to rear.....smooth lumpsucker
b) One long dorsal fin, but
different front and back.....Go to 7
7. a) Front part of dorsal fin wi
sharp spiney spikes; back part
smooth.....Pacific Ocean perch
b) One long dorsal fin, notched
(like a "V") in the middle.....Go to 8
8. a) One lateral line and large mouth
with big sharp teeth.....lingcod
b) Several lateral lines; small teeth.....greenling
9. a) Flat fish with one eye on either
side of head; winglike pectoral fins.....skate
b) Flat fish with both eyes on one side
of head.....Go to 10
10. a) Eyes on right side of head only....yellowfin sole
b) Eyes may be on either right
or left side of head.....starry flounder

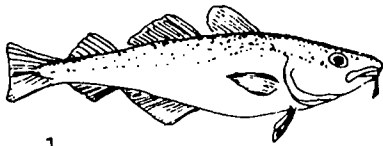

1.

Godus = codfish macrocephalus = large head. Gray-brown with spots. To 3 feet 3 inches. Fine food fish; big commercial fishery.

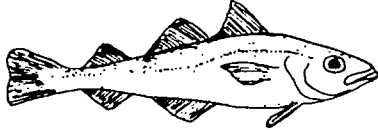

2.

Theragra = beast food (for fur seal) chalcogrammu = brass mark. Brown back with silvery sides. To 3 feet. Now most heavily harvested white fish in Alaska waters.

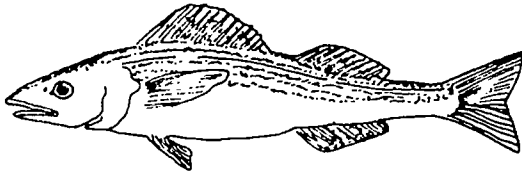

3.

Anoplopoma = unarmed gills fimbria = fringe. Grayish black or green. To 3 feet 4 inches. Next to halibut, most highly prized white fish; especially good smoked. (Also called black cod.)

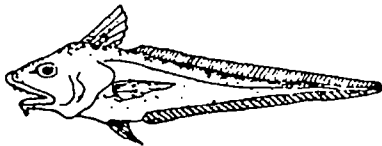

4.

Coryphaenoides = dolphin-like. Gray-brown with black-edged scales. To 3 feet 3 inches. Good eating (like cod) but found only in very deep waters.

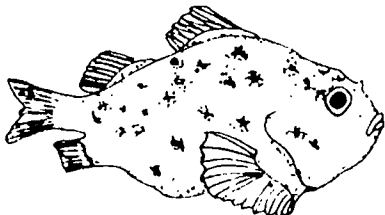

5.

Aptocyclus = touching circles ventricosus = large bellied. Brown with big spots. To 11 inches. Flesh and eggs prized by Japanese who harvest them with gill nets.

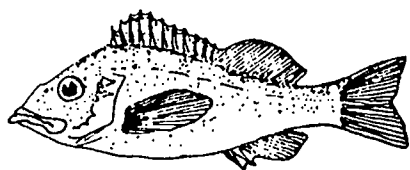

6.

Sebastes = magnificent alutus = speckled. Light red with speckles near tail. To 18 inches. Most sought-after rockfish for fillets (boneless steaks).

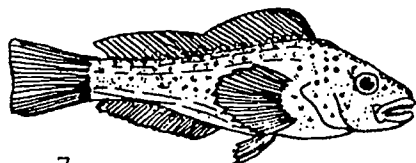

7.

Hexagrammos = six line (lateral lines). Green, brown, blue with spots. To 21 inches. Good food fish; found around rocks and reefs.



8.

Ophiodon = snake tooth elongatus = long. Splotchy gray-brown and green. To 5 feet. Large size and fine flesh make this a prized sport and commercial fish.

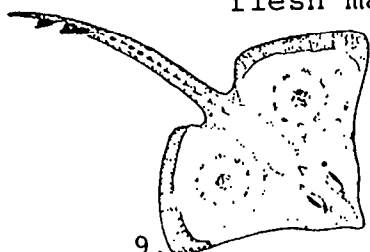

9.

Raja = skates binoculata = two-eyed. Dark brown-gray to black. To 8 feet. Flesh in the "wings" delicious; tastes like scallops or crab.

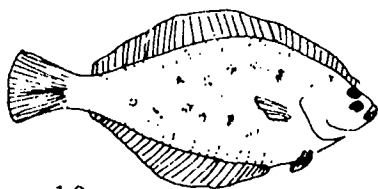

10.

Limanda = old man aspera = rough. Light brown with yellow fins. To 18 inches. Stocks building back after heavy over-fishing by foreign fleets. (Called "long-nosed flounder" in Chukchi Sea.)

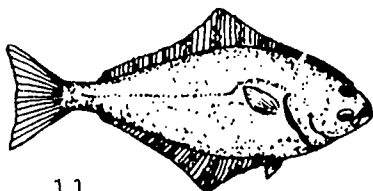

11.

Platichthys = flatfish stellatus = starry. Dark brown with spots on fins. To 3 feet. Good flavor; firm texture. Most important flounder being caught in Alaska.

Gearing Up for Whitefish

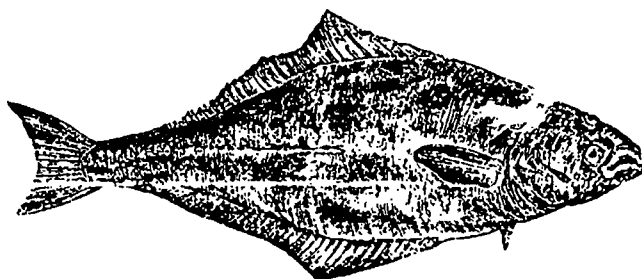

What are whitefish?

Defining whitefish isn't easy, but one definition that can be used is...."all the white-fleshed finfish except the small bait fish, like herring or smelt, and perhaps excluding halibut." Because the definition says "finfish," that leaves out sharks, and because it says "white-fleshed," that leaves out salmon. Some people call whitefish "bottomfish" or "groundfish" which they really aren't, since only a few species spend their lives on the ocean floor.

What whitefish does include are all the flatfishes, and rockfishes, pollock, cod, black cod and lots of others. Instead of catching a few high value fish such as salmon, the whitefisherman must catch many tons of cod or flatfish, knowing that the price received for each fish will be low.

Whitefish have as many uses as there are different kinds of fish. In England and Northern Europe, these tasty fish are favorites on seafood menus. And they are beginning to catch on in this country, too. Some, like rockfish, red snapper and Pacific Ocean perch are sold in fish markets or grocery stores. Some, like cod, are cut up into small pieces and are covered with a coating or breading, and then used for fish sticks, fish and chips or fish sandwiches. Some are used for bait, and some find their way into fish fertilizers or pet food.

Government people involved in fisheries in Alaska hope more and more people and vessels will become involved in whitefish harvesting, but this may come about slowly. For one thing, many Alaskan fishermen would rather fish for salmon or halibut when the seasons are open. If these fishermen only fish for whitefish in the winter, when they can't fish for salmon or halibut, then the processing plants don't find it worthwhile to change all their equipment and people over to take care of these bottomfish for only a few

months out of the year. Another problem is that operating a fishing boat large enough to handle the many tons of whitefish a fisherman has to catch is expensive. Some Alaskan ports would have to be enlarged for deepwater ships. And whitefish have to be gutted immediately because otherwise, they spoil rapidly. Labor costs in America are much higher than in foreign countries. Gutting machines are available, but it's difficult to get them to fit the many sizes and shapes of whitefish. Many fishermen are not sure it makes financial sense for them to fish for whitefish. And not too much is known about whitefish ecology and biology, so it is easy to overharvest them. Plus, people across the United States need to learn about these fish so they will know how good they are to eat and will buy them. Then, if there are more people eager to buy these fish, fishermen will be able to sell more of their catch for a better price.

Don't be too surprised, however, when sooner or later Alaskan fishermen come up with solutions to these problems. In recent years, Alaska's old standby fisheries have become increasingly crowded. Limited entry laws have cut down on the number of salmon fishermen, and shortened seasons for crab and shrimp have left many boats idle for much of the year. Already, there are many different ways in which whitefishing is now being tried in Alaska, including some cooperative fishing with vessels from other nations.

1. Name three kinds of fish that might be called whitefish.

2. Name two kinds of fish that are NOT whitefish.

3. List the uses for whiterish.

4. List at least four problems in the development of the whitefish industry.

5. How would you solve these problems in the development of the whitefish industry?

6. The Pribilof Islands may be one site of future whitefish development. Can you find them on a map of Alaska? Where are they?

Until recently, the Aleut people on the islands have lived a subsistence lifestyle, depending primarily on a federal government-supported fur seal harvest for their yearly income. Those funds are being cut off and islanders are looking for new sources of income. One possibility is the development of a deepwater port and fish processing plants for whitefish. Some local people are worried about the changes in their lifestyle and the effects on the huge colonies of seabirds and marine mammals that live on and around the islands.

What changes do you predict will happen on the islands if the whitefish industry is developed?

How do you suggest the local people handle this development?
