

DOCUMENT RESUME

ED 383 880

CE 069 243

AUTHOR Bliss, Clifford; Giles, Bob  
 TITLE Fourth Grade Factory--An Integrated, Collaborative Unit in Manufacturing and Economics--Make It, Take It.  
 PUB DATE Feb 95  
 NOTE 36p.  
 PUB TYPE Guides - Classroom Use - Teaching Guides (For Teacher) (052)

EDRS PRICE MF01/PC02 Plus Postage.  
 DESCRIPTORS \*Career Exploration; \*Design; Economics; Grade 4; High Schools; Integrated Curriculum; Intermediate Grades; \*Manufacturing; Problem Solving; \*Technology Education; Units of Study; Vocational Education

ABSTRACT

This unit for fourth grade and high school includes elements of careers, economics and free enterprise for fourth graders and elements of problem solving and design, manufacturing, drafting, and woodworking for high school students. The unit is taught in both the fourth grade and the high school classrooms. The unit involves planning, designing, and producing a small product in an actual factory run, with the high school students planning the run and the fourth graders acting as factory workers. The fourth-grade students study the following subjects: capital financing, free enterprise, stocks, corporations, raw materials, labor, training, expenses, profits, and other such topics. The high school students go through the design from brainstorming through sketching, sampling, making prototypes, working drawings, and problem solving. After the factory production run, the process is evaluated by students to determine how it could have been done better, and the younger students are encouraged to enroll in technology classes when they get older. The unit includes behavioral objectives and plans for the following: an abacus, a frog, a tic-tac-toe game, a bird feeder, an airplane whistle, a clothes peg plaque-mirror, a gum ball machine, a jelly bean machine, a gum ball bank, a race car, a kaleidoscope, a top, a basketball flipper game, and a notepad holder. (KC)

\*\*\*\*\*  
 \* Reproductions supplied by EDRS are the best that can be made \*  
 \* from the original document. \*  
 \*\*\*\*\*

**Fourth Grade Factory  
An Integrated, Collaborative Unit in  
Manufacturing and Economics  
Make It, Take It**

Clifford Bliss  
Bob Giles

Tallmadge High School  
Tallmadge, Ohio

February 1995

U.S. DEPARTMENT OF EDUCATION  
Office of Educational Research and Improvement  
EDUCATIONAL RESOURCES INFORMATION  
CENTER (ERIC)

- This document has been reproduced as received from the person or organization originating it.
- Minor changes have been made to improve reproduction quality.
- Points of view or opinions stated in this document do not necessarily represent official OERI position or policy.

"PERMISSION TO REPRODUCE THIS MATERIAL HAS BEEN GRANTED BY

C Bliss  
B Giles

TO THE EDUCATIONAL RESOURCES INFORMATION CENTER (ERIC)."

## ABSTRACT

### Fourth Grade Factory - An Integrated, Collaborative Unit in Manufacturing and Economics - Make It, Take It

#### OVERVIEW

This is a unit for fourth grade and high school that includes elements of careers, economics and free enterprise for fourth graders, and elements of problem solving and design, manufacturing, drafting and woodworking for high school students. These elements are taught at respective buildings.

The culminating activity for both sets of students is the actual factory run. The fourth grade students are invited to the high school for a morning and become factory workers. They start out with a stack of lumber and parts. They do the sawing, drilling, sanding, finishing, assembly, inspection, and packaging. In two hours they have produced 50 products; enough that each student may have one for themselves and enough extra for principals, board members, etc. The high school students do the instructing and supervision of the fourth graders at the individual work stations. The operations are kept very simple. The work stations are engineered specifically for safe use by a ten year old, although we've done it with second grade students and fifth grade students. Any operations that are too difficult or dangerous are simplified, eliminated or done before hand by high school students.

The project is different each year. We have done an abacus, toy frog, tic tac toe box, bird feeder, whistle, coat rack-mirror, gumball machine, jelly bean machine, gumball bank, race car, kaleidoscope, top, basketball flipper, and labyrinth.

#### ELEMENTARY SCHOOL

The students at the fourth grade study topics and terms: capital, financing, free enterprise, stocks, corporation, raw materials, scrap,

waste, energy, prototype, manufacturing, management, labor, training, expenses, sales and marketing, competition, mass production, liability, consumerism, division of labor, profit, loss, and dividends, etc.

We hope that the students will begin to understand themselves in relationship to careers - to understand what they like or don't like; that both boys and girls can do the same jobs; that it takes lots of cooperation to make a product and that by dividing up the work they can be more productive than individuals working alone. Safety is important. We hope they will also begin to understand why their parents are tired at the end of their day.

The unit may be integrated with other fourth grade units easily. Music classes can focus on work songs; math skills are sharpened by figuring costs or amount of materials needed; the health and hygiene of workers can be studied, sequencing the operations and thank-you notes are used as activities in language arts, the ecology of the product or manufacturing process relate to science and social studies.

#### HIGH SCHOOL

At the high school level, the design process begins in September by learning to brainstorm. Project ideas are sketched, considered and condensed from hundreds to a score. Sample projects are brought in by the students to study and they begin to problem solve for production. Crude prototypes are made. The best ideas are kept and project selection is further condensed to two or three ideas. A second generation prototype is made. Problem solving is done to simplify design and operation, safety and low cost. Final project selec-

tion is made and a good working model is fabricated.

A complete set of drawings for the product is made, including renderings and assembly drawings. The drawings must show all the information necessary to make the project. The tooling (jigs and fixtures) must then be designed and drawn. Safety and ease of operation are prime considerations. Computer Assisted Drafting (CAD) is used for some of the simple parts. A flow process chart showing how the different operations are sequenced is drawn. Cost analysis is determined after vendors are found. When this is completed in December, the drawings are sent to the wood-working students who fabricate the tooling.

Once the tooling is done, a pilot (test) run is made. Adjustments are made and safety is checked. Two weeks before the production in the spring, invitations generated on the computer are sent to each fourth grade room to invite the classes to participate.

### **FACTORY PRODUCTION**

About a week before the production run, there is an assembly of the fourth grade students. At the assembly, the high school teacher(s) involved are introduced, the project, sample tooling, drawings are displayed and there is a discussion of what to expect in the way of noise and activity when the students arrive at the high school.

On the day of production, the high school students are assigned a work station to supervise. They are already partly familiar with the work station because they helped design or build the tooling. They are given last minute instruction and practice at the work station. Computers have been used to generate technical drawings, name tags, banners, lists, work station signs, decorations, instructions, etc. When the fourth graders arrive, there is a demonstration of how the materials flow through the work stations showing various

operations being performed to complete the projects. Next, the students are assigned to a work station and produce enough parts for the day's quota. As jobs are completed, students are reassigned to new work and/or clean up. Inspection occurs at every work station. Protective and safety gear are used. There are always tooling and production problems that occur during the production run. These are dealt with as they occur by the high school students and/or teachers.

At the end of the production, the fourth grade students are de-briefed. We talk about what was fun, difficult, dirty, dangerous, etc. What jobs might be better handled by a robot? Would it have been better to have each student make their own instead of having a division of labor? Why? What happened when a mistake was made?

The elementary school students are encouraged to continue this activity by enrolling in technology classes five years from now when they enroll at the high school.

February 1995

**Clifford Bliss, Bob Giles**  
**Tallmadge High School**  
**484 East Avenue**  
**Tallmadge, Oh.o 44278**  
**(216) 633-5505**  
**fax (216) 633-5331**  
**tallmadh@phoenix.kent.edu**  
**crbliss@aol.com**

# FOURTH GRADE FACTORY IMPACT

These are some of the objectives we intend to accomplish in the Fourth Grade Factory.

Items marked with "\*" indicate that that objectives has impact for both levels of students.

## Intended impact for high school students:

- \*Define and use terms related to the drafting, manufacturing and economic industry

- \*Demonstrate drafting as a communication skill

Translate a product idea into a technical drawing and parts list

- \*Understand the technical process of manufacturing and production

- \*Understand how manufacturing reflects societal needs and wants

- \*Develop an awareness of skills needed to read prints and make drawings to acquire a job

- \*To be aware of the students own talents, and tastes as they relate to work both positively and negatively

- \*To be aware of how manufacturing in a technological society influences their own lives and the community in which they live

- \*To develop skills toward building working relationships with those he/she works with

To develop drafting skills as related to equipment, materials, tools, and practices

To develop skills in making working drawings, parts lists and cost estimates

To develop skills at making reproductions of drawings

- \*To represent and interpret various data into charts, graphs, and diagrams

To express tolerances and precision on drawings

- \*Understand principles of jig and fixture design

Knowledge of various methods of manufacture using the best suited materials for the job

Formulate and appreciation for new, unique, and innovative design and materials

Develop an attitude of respect, care, and professionalism toward drafting tools and equipment and processes

Use and appreciate the differences among paper, vellum and mylar

Appreciate differences among the various drafting methods

Value the variety of methods in the reproduction of drawings

Appreciate how improved drafting techniques have improved lifestyles

Students do comparative shopping to determine best buys for materials and tools

Appreciate the difficulty and rewards of being a teacher as they supervise and teach the younger students

- \*Safety in the work place

**Intended impact for elementary school students**

Develop an appreciation for work with their hands

Appreciate how much more productive people can be done by organizing their efforts

Understand how shortages and surpluses of raw materials can cause big problems in the production

Understand how their labor adds value to raw materials

Understand that all work or jobs have value

Appreciate that hygiene (personal and work place) is important

Experience the excitement of using an item they made themselves

No jobs are "boy" jobs or "girl" jobs-sex plays no roles these days

People with handicaps can be just as valuable workers as non-handicapped people

Ability to read simple assembly drawings

Appreciate quality workmanship by keeping rejects to a minimum

Appreciate advantages and disadvantages of power equipment as opposed to manual tools

Exposes the elementary student to the high school setting

Appreciate the large volume of work necessary in advance to make mass produced products

Production line work is often tedious

Robotics can do work that is dangerous or boring

Absenteeism costs production and profit

February, 1995

Clifford Bliss, Bob Giles  
Tallmadge High School  
484 East Avenue  
Tallmadge, Ohio 44278  
(216) 633-5505  
fax (216) 633-5331  
tallmadh@phoenix.kent.edu  
crbliss@aol.com

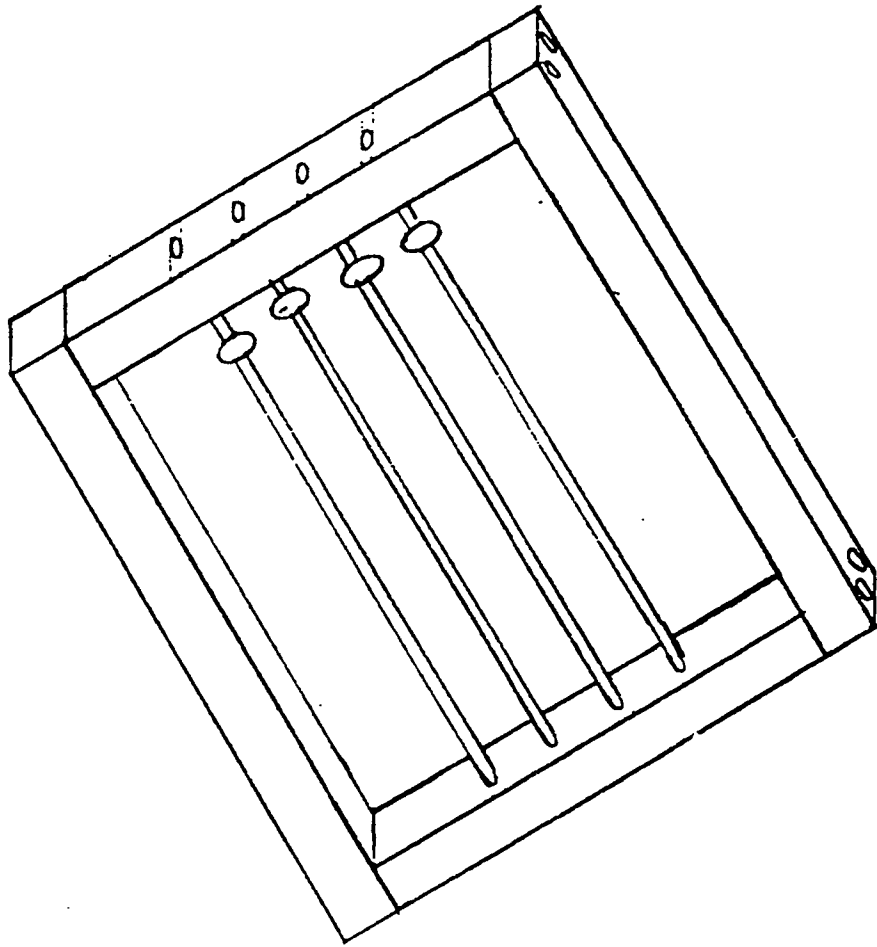

T H S

E-16-51

SCALE: 1/2" = 1" ABACUS

7





- NOTE:
- 1 2 X BRAD AND  $\frac{1}{4}$  WASHER
  - 2  $\frac{1}{2}$  PINE
  - 3 2 -  $\frac{3}{4}$  NO. 6 SCREW
  - 4 2 -  $\frac{1}{2}$  X  $\frac{5}{8}$  DOWELL.
  - 5 SPRING
  - 6 2 X  $\frac{3}{8}$  VINYL STRIPS
  - 7  $\frac{1}{2}$  PINE
  - 8  $\frac{1}{2}$  PINE

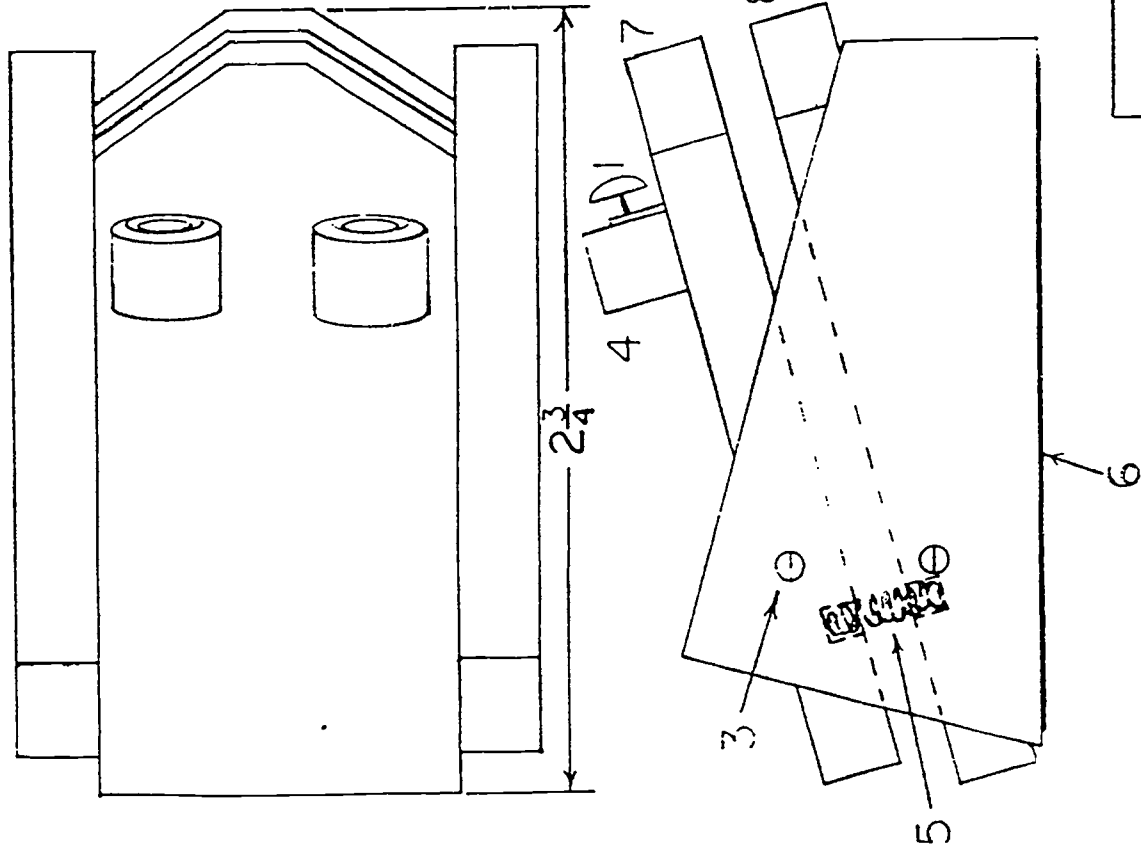

TALLMADGE HIGH SCHOOL

SCALE 1:1 FROG

1-16-91

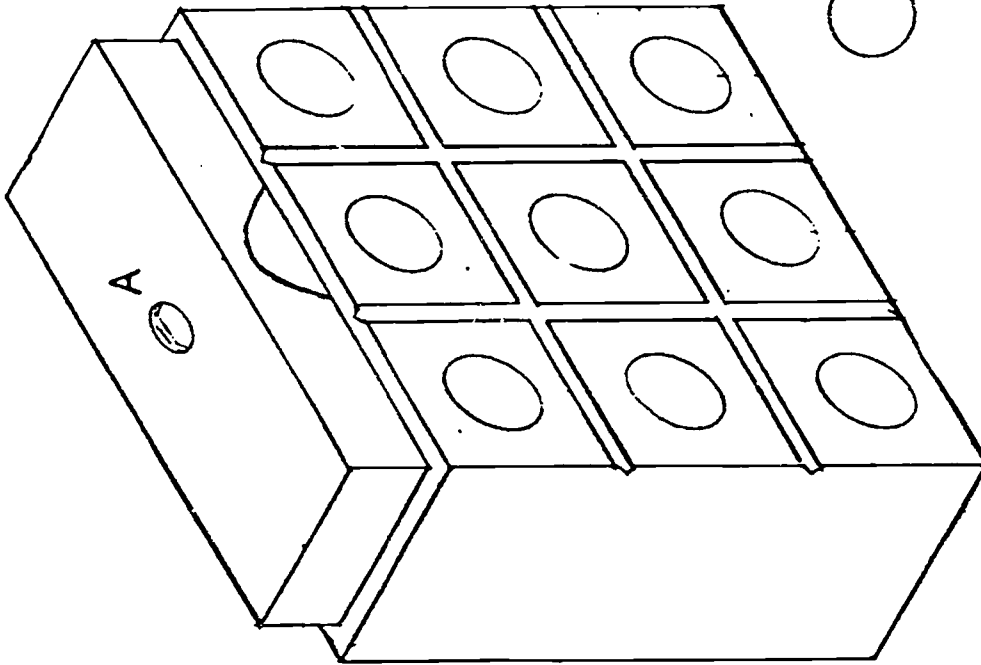

NOTES

A 1 NO. 8 ROUND HEAD  
SCREW - 1"

B 2 ROUND HEAD  
BRASS BRADS

C 10 MARBLES  
2 COLORS  
Ø  $\frac{2}{16}$

MAT'L PINE

TALLMADGE HIGH SCHOOL

1-16-91

TIC-TAC-TOE

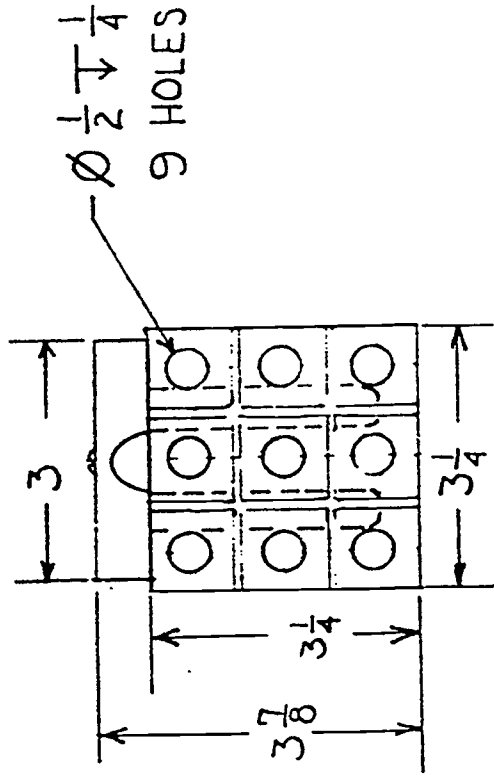
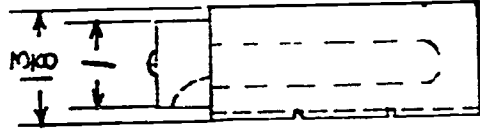
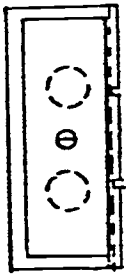

TALLMAGE HIGH SCHOOL		TIG-TAC-70E
$\frac{1}{2}$ SCALE	1-16-91	

NOTE:

FINISH : NONE

4 : 1" NO. 6 FLATHEAD WOOD  
SCREW

WOOD : PINE

SCALE :  $\frac{1}{2}$

Ⓐ HANGER :  $\frac{1}{16}$  WELDING ROD

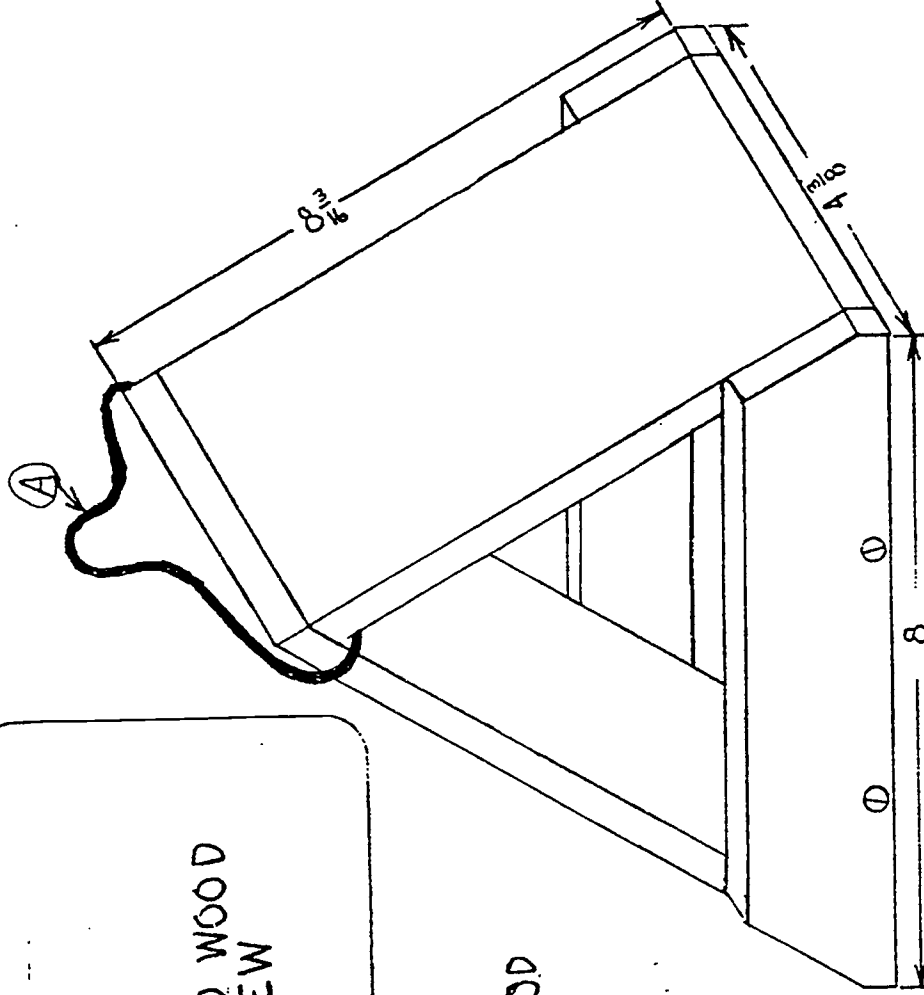

TALLMADGE HIGH SCHOOL

BIRD FEEDER

16 JAN 91

PARTS SEE OBLIQUE  
SCALE: 1/2

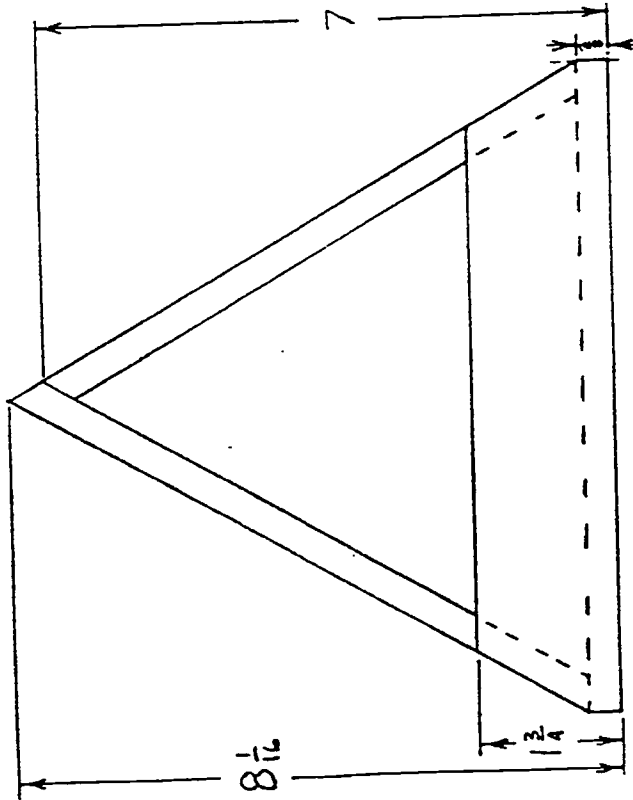
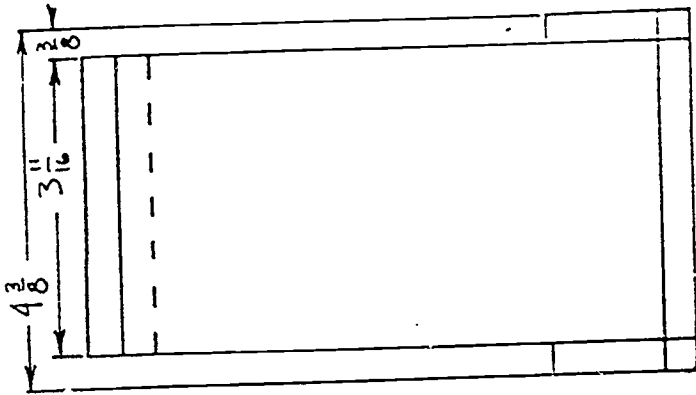
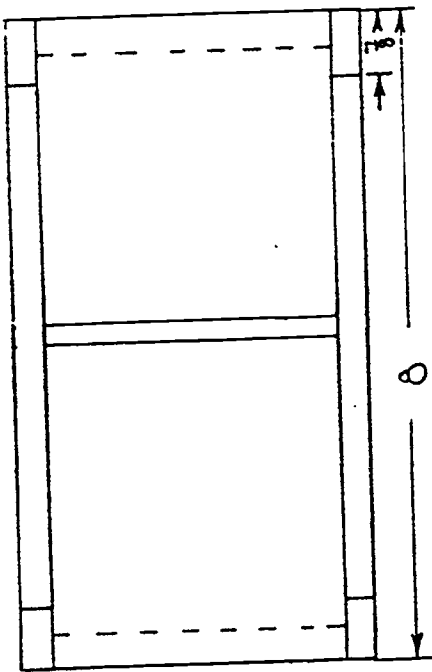

TALLMADGE HIGH SCHOOL

BIRD FEEDER

16 JAN 91

PARTS LIST

<u>QUANTITY</u>	<u>DESCRIPTION</u>	<u>PART #</u>
1	FUSELAGE	1
2	WINGS	2
2	DOWEL ( STRUTS)	3
1	DOWEL ( WHISTLE +WHEELS)	4
1	TWINE	5

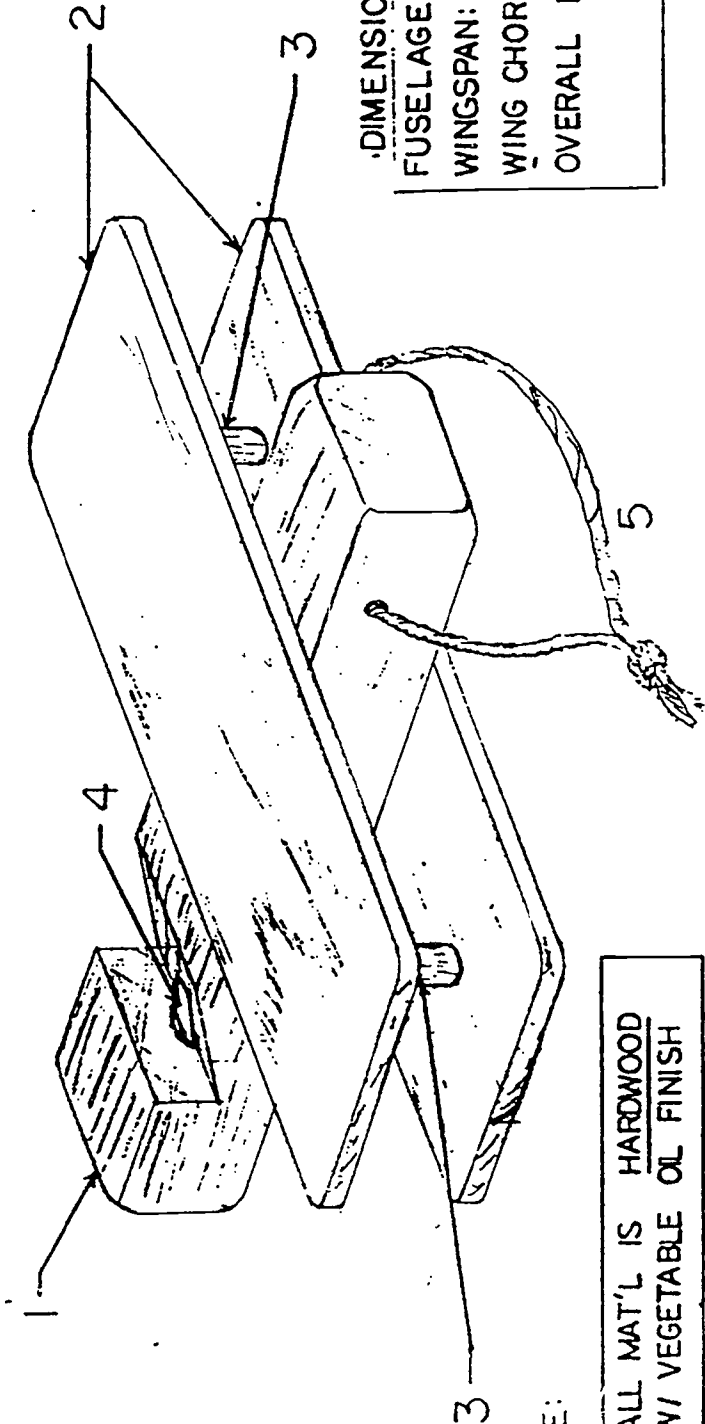

DIMENSIONS  
 FUSELAGE: 4 1/2 X 1 X 3/4  
 WINGSPAN: 5"  
 WING CHORD: 1 5/8"  
 OVERALL HEIGHT:  
 1 1/2"

NOTE:  
 ALL MAT'L IS HARDWOOD  
 W/ VEGETABLE OIL FINISH

<u>TALLMADGE</u>	<u>HIGH</u>	<u>SCHOOL</u>
1-16-91		AIRPLANE WHISTLE

NOTE:

PART	QUANTITY	SIZE	MATERIAL
A	1	2 1/8 x 1/2 x 1/4	HARDWOOD
B	1	1 3/4 OVAL	GLASS
C	1	7-4 x 7/8	HARDWOOD
D	1	1 x 1 x 1/2	METAL

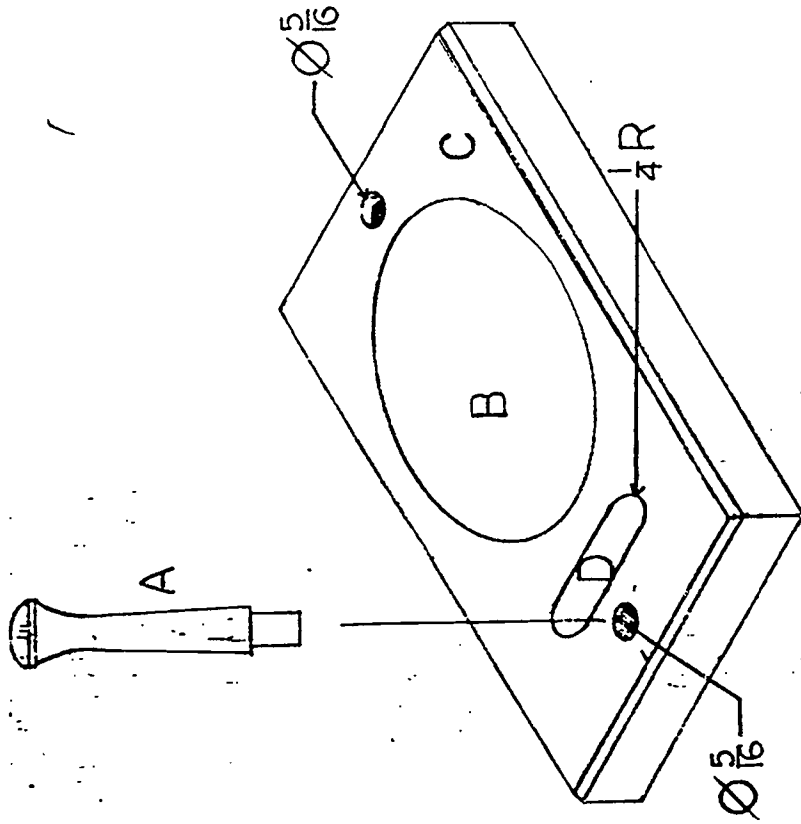

CLOTHES PEG PLAQUE - MIRROR

THS

1/2 SCALE

1-16-91

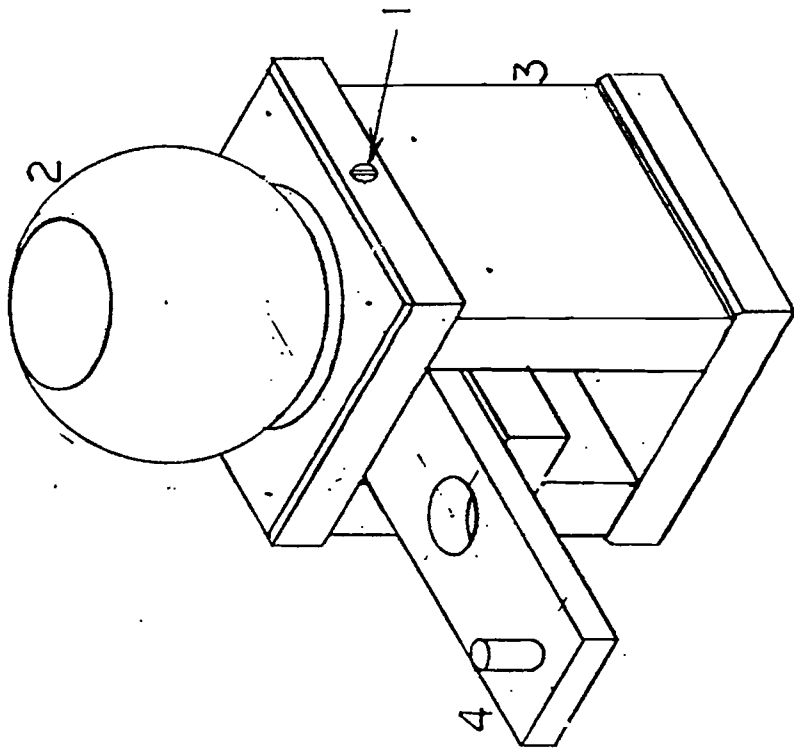

NOTE:

- 1-1 IN., NUMBER 8  
PAN HEAD SCREW
- 2-4 IN. FISH BOWL
- 3-MAIN BODY  $3\frac{3}{8}$  SQ. x 5
- 4-SLIDE  $\frac{1}{2}$  x  $\frac{7}{16}$  x 8
- OVERALL HEIGHT 8 $\frac{1}{2}$

TALLMADGE HIGH SCHOOL

SCALE:  $\frac{1}{2}$  1-16-90

GUM B. M.



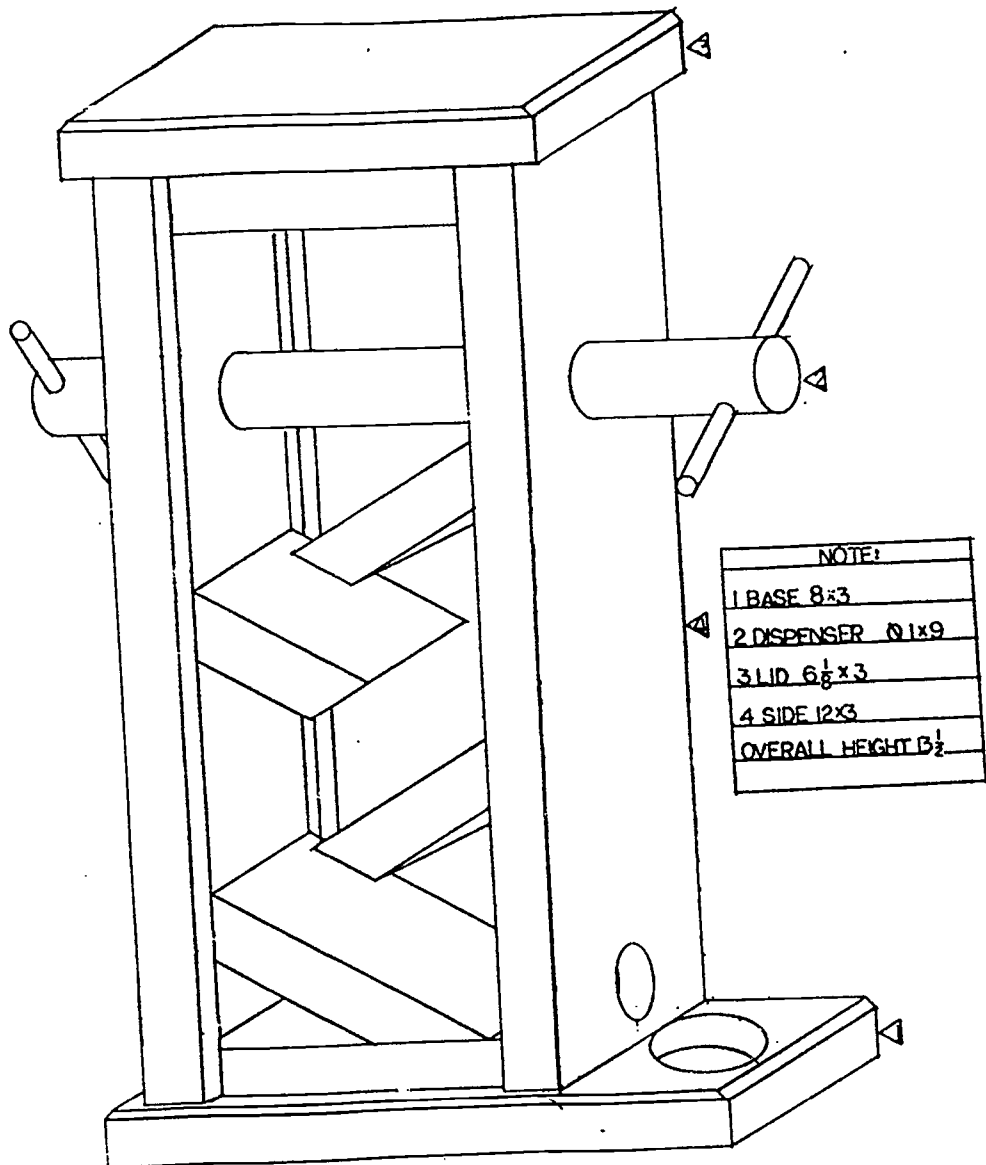

JELLY BEAN MACHINE

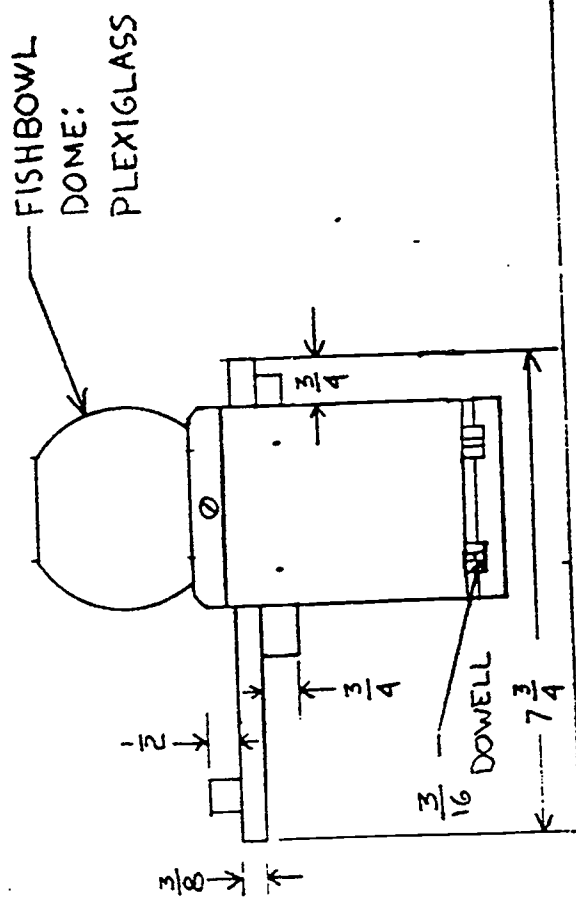
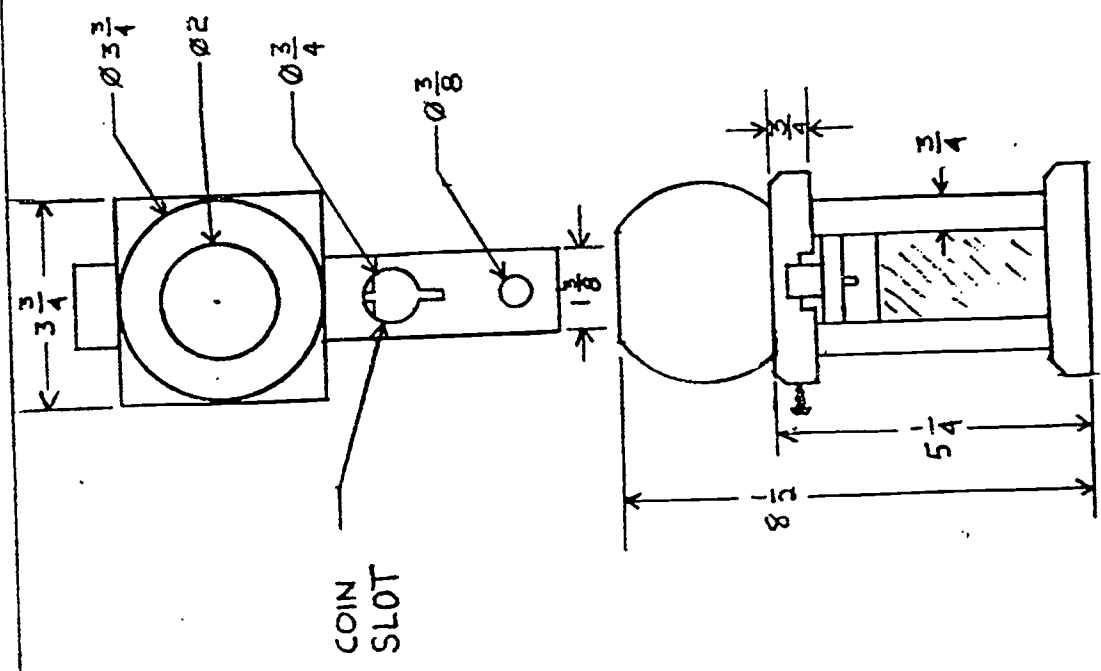

TALLMADGE HIGH SCHOOL

JAN. 16, '91

SCALE 1/3 GUM BANK

1. RUBBER BAND NO. 18
2. POWER BLOCK  $\frac{5}{16} \times \frac{3}{8}$
3. RUBBER BAND NO. 64(2)
4. TACK  $\frac{1}{2}$
5. TACK  $\frac{1}{4}$
6. REAR WHEEL (2)  $\frac{1}{2} \times \frac{3}{8} \times \frac{1}{4}$
7. FRONT WHEEL  $\frac{1}{4} \times \frac{3}{8} \times \frac{1}{4}$   
HOLE
8. AXLE FASTNER EYELET  
 $\frac{1}{16} \times \frac{1}{4} \times \frac{5}{8}$ (4)

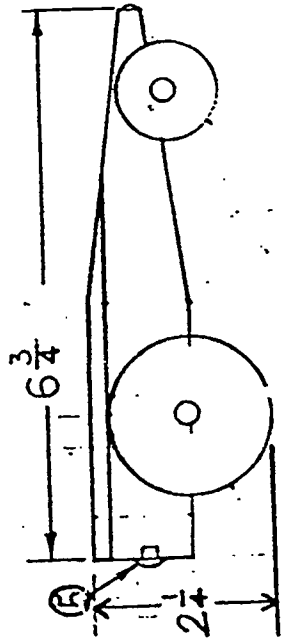
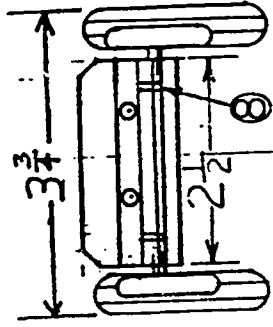
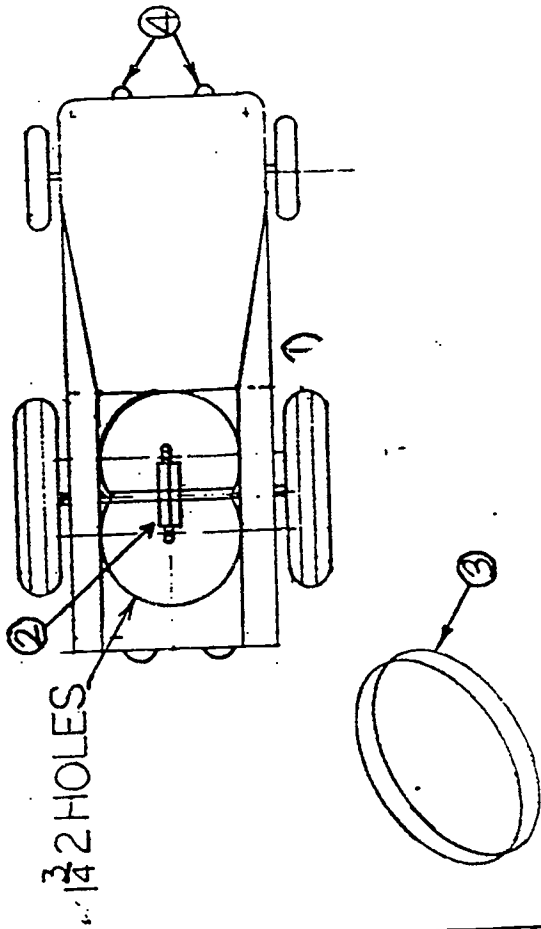

TALLMADGE HIGH SCHOOL

CAR

SCALE 1:2

I-16-91

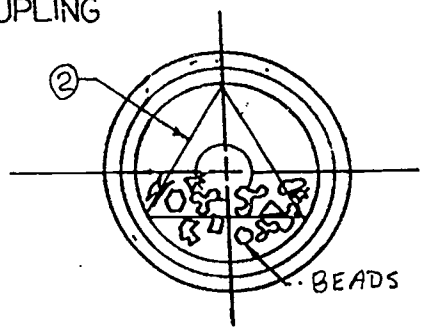
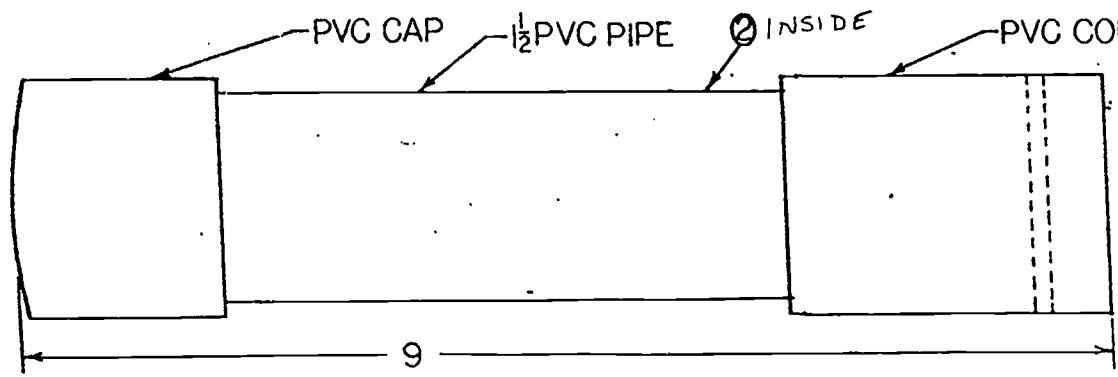
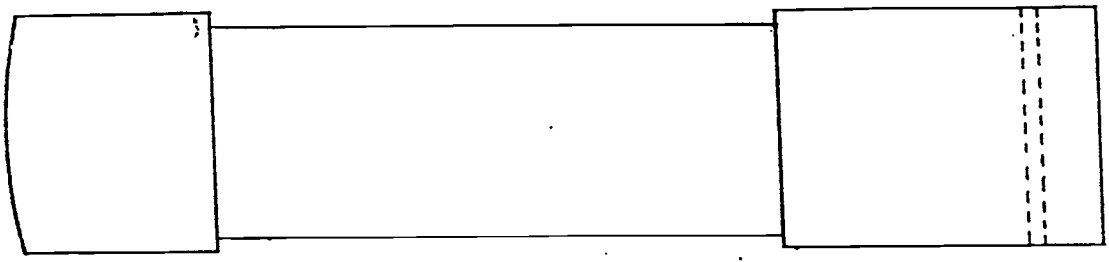
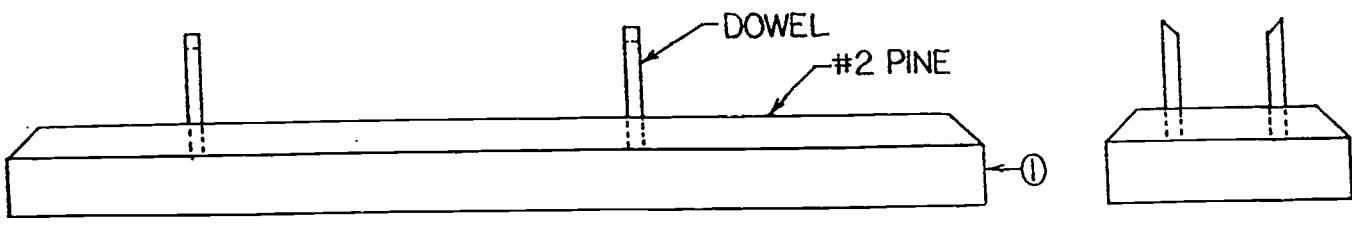
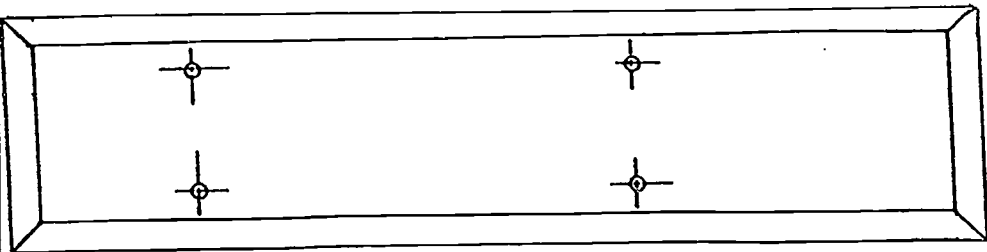

KALEIDOSCOPE

NOTE  
 1 BASE STAND 1 3/4 x 2 x 8  
 2 EQUAL TRIANGULAR MYLAR COATED CARDBOARD 8' LONG

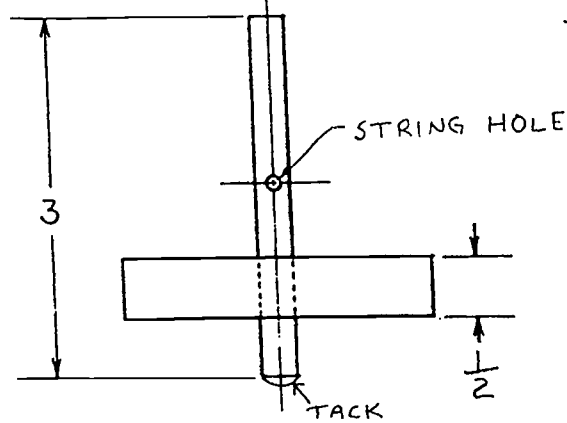
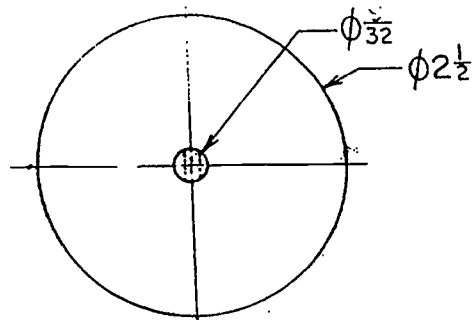
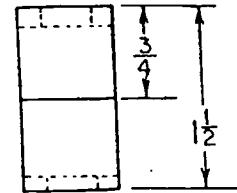
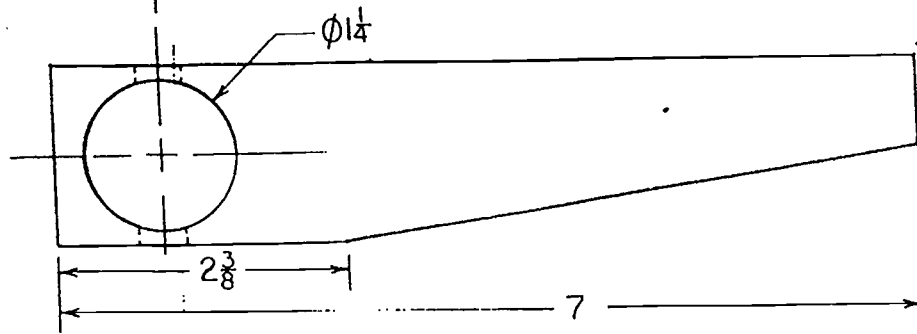
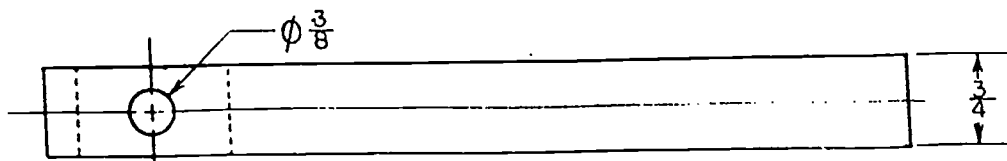

TOP

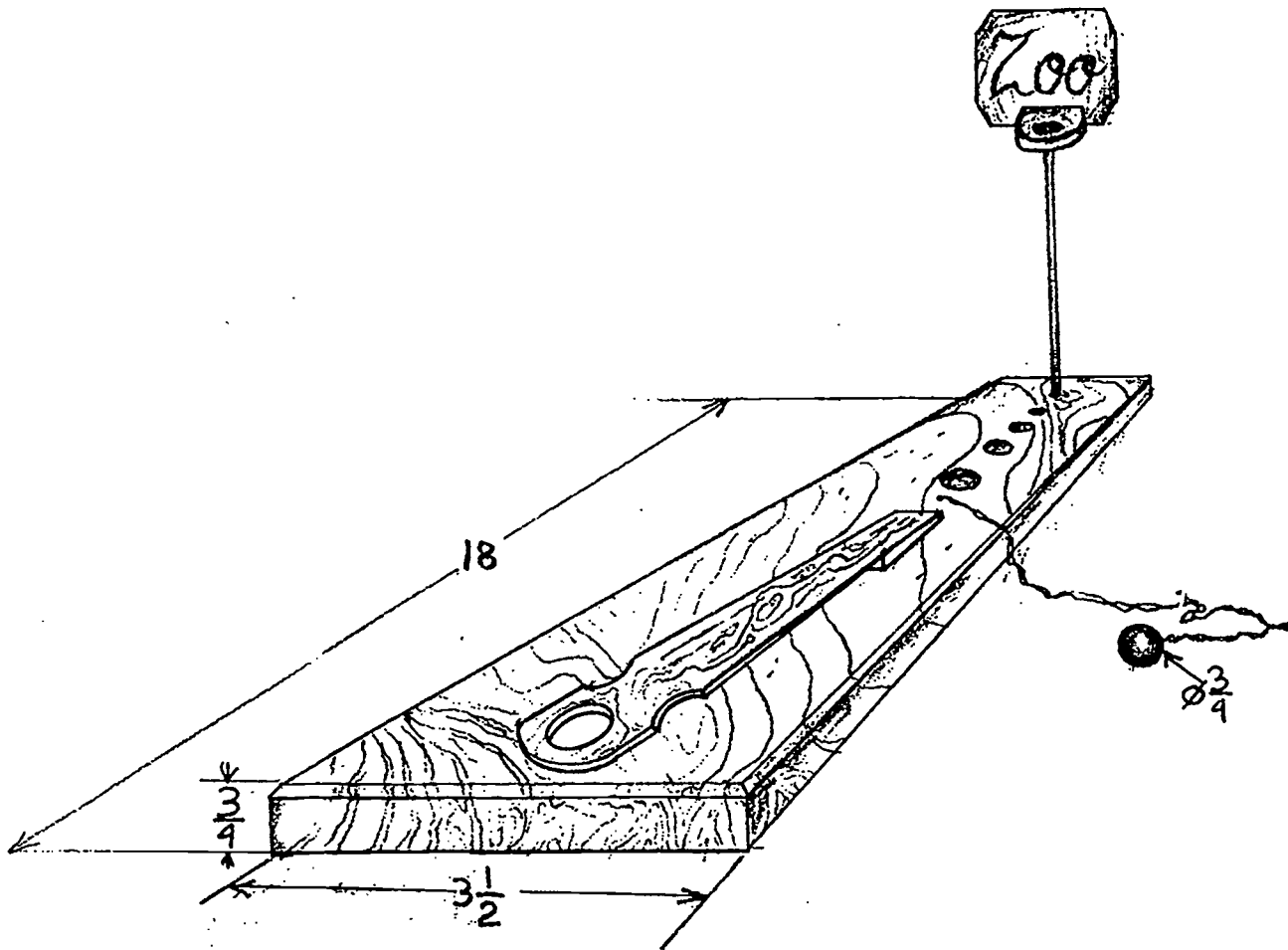

BASKETBALL FLIPPER GAME

QTY	ITEM
A 2	1/4 X 1 1/2 WOOD SCREW
B 1	3/8 X 12 1/8 X 3 1/8 OAK
C 1	9 X 2 NOTE PAPER
D 1	1/4 X 2 X 1 1/2 MAPLE
E 1	3/8 X 1 X 3 1/8 OAK

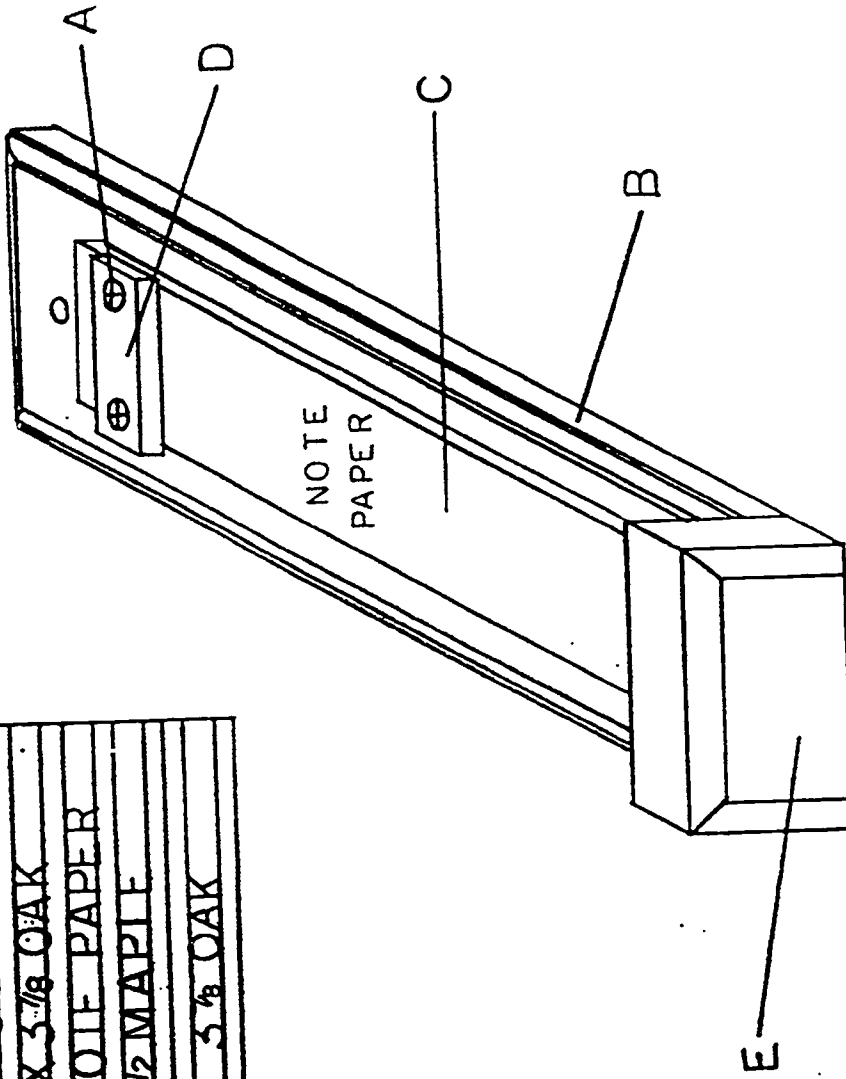

NOTE: GLUE WHERE NEEDED, OAK STAIN.

T.H.S.

NOTE PAD

1/2 SCALE

1/16/91