

DOCUMENT RESUME

ED 383 547

SE 056 251

TITLE The Universal House: Energy, Shelter & The California Indian. Activity Guide, 4th/5th Grade.

INSTITUTION California Energy Extension Service, Sacramento.

PUB DATE 92

NOTE 38p.; Photographs may not reproduce well.

PUB TYPE Guides - Classroom Use - Teaching Guides (For Teacher) (052)

EDRS PRICE MF01/PC02 Plus Postage.

DESCRIPTORS \*American Indian Culture; Cooperative Learning; Energy Conservation; \*Energy Education; Environmental Education; Grade 5; Grade 6; \*Housing; Interdisciplinary Approach; Intermediate Grades; Lesson Plans; \*Natural Resources; Sustainable Development; Units of Study

IDENTIFIERS \*California; Hands On Experience

ABSTRACT

This activity guide links energy awareness with resource management and traditional California Indian cultures for the 3rd-6th grade span. The materials combine cooperative, hands-on activities with background information and learning extensions. The interdisciplinary lessons are built upon themes, concepts, and learning processes outlined in California science frameworks. The use of a student journal, folder, or folio is recommended as a method for authentic assessment. The guide contains six major sections: (1) an introduction; (2) an examination of student's preconceptions; (3) an overview of energy and energy use; (3) explorations of shelter (focusing on earthen, plank, sapling and thatch, and conical bark slab structures); (4) energy activities (focusing on insulation, thermal mass, shade, and orientation); and (5) resources. The resources section contains a list of 15 lessons and activity guides from which this unit was adapted; a selection of 14 reference materials that could be utilized in the classroom for research and implementation; and a list of 18 sites at which traditional California Indian architecture can be viewed. The guide is accompanied by four oversize posters (not included here) that discuss California Indian use of thermal mass, shade, insulation, and orientation in the construction of housing. (LZ)

\*\*\*\*\*

\* Reproductions supplied by EDRS are the best that can be made \*  
 \* from the original document. \*

\*\*\*\*\*

**U.S. DEPARTMENT OF EDUCATION**  
Office of Educational Research and Improvement  
**EDUCATIONAL RESOURCES INFORMATION**  
**CENTER (ERIC)**

- This document has been reproduced as received from the person or organization originating it
- Minor changes have been made to improve reproduction quality
- 
- Points of view or opinions stated in this document do not necessarily represent official OERI position or policy

**"PERMISSION TO REPRODUCE THIS  
MATERIAL HAS BEEN GRANTED BY**

BONNIE J. CORNWALL

**TO THE EDUCATIONAL RESOURCES  
INFORMATION CENTER (ERIC)."**

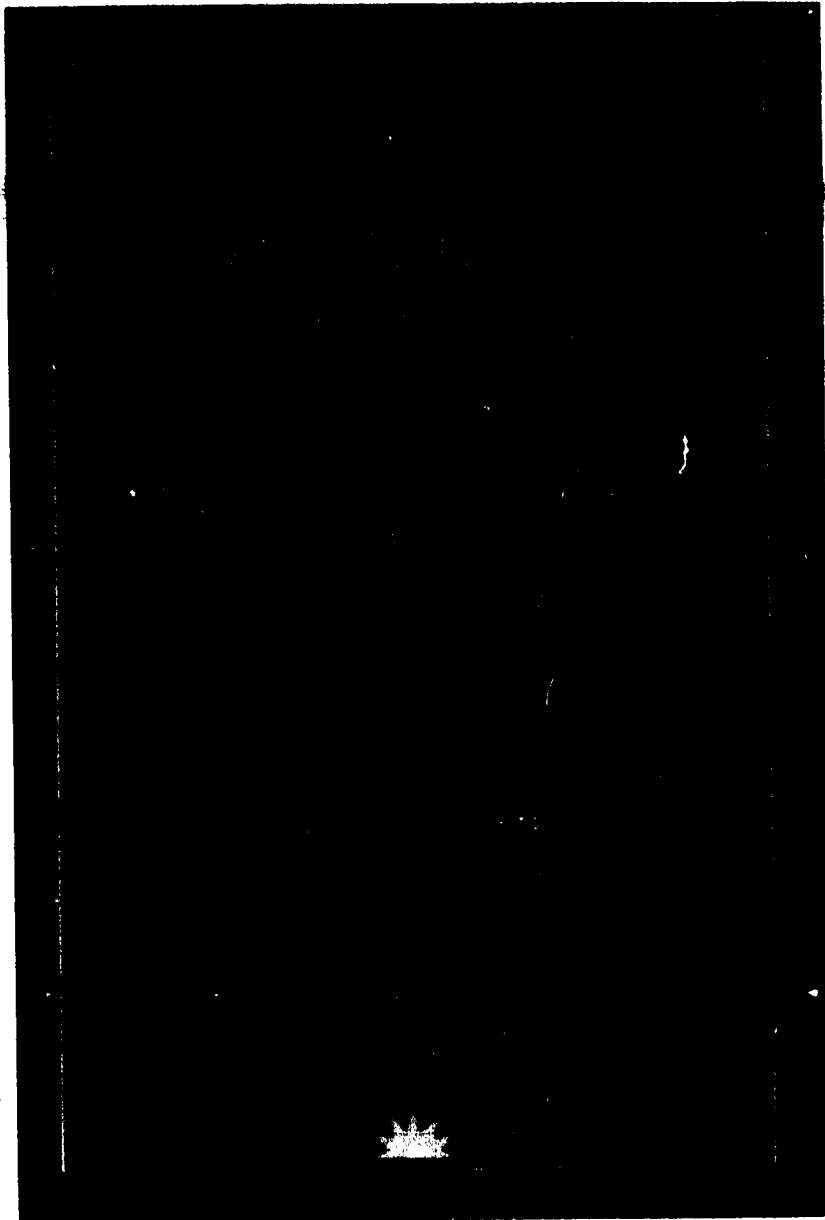

**CALIFORNIA ENERGY EXTENSION SERVICE**

**GOVERNOR'S OFFICE OF PLANNING & RESEARCH  
PETE WILSON, GOVERNOR**



**FALL 1992**

UNIVERSAL HOUSE

ACKNOWLEDGMENTS

Concept, research  
and development,  
writing,  
graphic design,  
photography:

**CAITLIN RIVERS**

Assistance in  
curriculum development  
and editing:

**BONNIE CORNWALL**

Production assistance:  
**BILL MCGUIRE**



State of California  
Pete Wilson, Governor

California Energy  
Extension Service  
Governor's Office of  
Planning and Research  
1400 Tenth Street  
Sacramento,  
California 95814  
916.323.4388

U  
N  
I  
V  
E  
R  
S  
A  
L  
  
H  
O  
U  
S  
E



The following individuals made valuable contributions to the development of this document:

**BILL ANDREWS, Consultant**  
Science and Environmental Education Unit,  
California Department of Education

**KAY ANTUNEZ, Coordinator**  
Project Learning Tree

**MELISSA M. READING, Ph.D.**  
Pacific Gas & Electric, R & D

In addition, the following individuals reviewed and/or assisted in the preparation of material for this guide :

**ANNETTE DIETZ, Education Consultant**  
San Diego

**RICHARD FARNSWORTH, Lesson Program Manager**  
Lawrence Livermore National Laboratory

**INGRID N. KELLEY, Chief**  
Energy Information Services  
Energy Conservation & Management Division,  
State of New Mexico

**SANDRA LOWRY, Executive Director**  
Lassen Indian Education Center

**RITA NUNES, Historical Guide 1**  
Chaw'se Regional Indian Museum

**SARAH SUPAHAN, Title V Coordinator**  
Klamath-Trinity Joint Unified School District

The preparation of this document was financed through an Energy Extension Service grant from the U.S. Department of Energy. The views & opinions of the author expressed herein do not necessarily state or reflect those of the State of California or the United States government. These parties & their employees make no warranty, expressed or implied, or assume any legal liability or responsibility for the accuracy, completeness, or usefulness of any information, apparatus, product or process disclosed.

In hope of sharing lessons learned by our programs, material contained in this guide may be reproduced freely, so long as proper credit is given.

TABLE OF

CONTENTS

**INTRODUCTION 5**

**UNIVERSAL HOUSE**

*Students' Preconception 6*

**WHAT IS ENERGY? Overview 8**

*Activity 11*

**SHELTER**

**EARTHEN Overview 14**

**PLANK Overview 16**

**SAPLING & THATCH Overview 18**

**CONICAL BARK SLAB Overview 20**

*Students Exploration 22*

**ENERGY**

**INSULATION Overview 24**

*Activity 25*

**THERMAL MASS Overview 26**

*Activity 27*

**SHADE Overview 28**

*Activity 29*

**ORIENTATION Overview 30**

*Activity 1 31*

*Activity 2 32*

**RESOURCES**

*Do For Yourself 34*

*Read For Yourself 34*

*See For Yourself 35*



***Their villages will be good.  
They will plan many things.  
They will be full of knowledge  
... and their intentions will be good.***

POMO CREATION MYTH



U  
N  
I  
V  
E  
R  
S  
A  
L  
  
H  
O  
U  
S  
E



***Humans are part of the biosphere  
and are dependent on it . . .  
They need to exercise judgement,  
care, and planning, in their use  
of natural resources.***

SCIENCE FRAMEWORK FOR  
CALIFORNIA PUBLIC SCHOOLS



C E E S

6

# Introduction

It is not incidental that this activity guide *The Universal House: Energy, Shelter, and the California Indian* is being issued this fall. October has been designated "Energy Awareness Month" while November is "Native American Heritage Month." More than simply being apropos to each occasion, this guide links energy awareness with resource management and traditional California Indian cultures for the 3rd–6th grade span. The synthesis of these topics offers students and teachers a unique opportunity to examine cultural and scientific information as well as contemporary issues with respect to shelter, community, and energy efficiency. *The Universal House* combines cooperative, hands-on activities with background information and learning extensions.

We've brought a spectrum of skills to bear on the subject, incorporating science, social studies, art, math, and language arts. We encourage you to be flexible and creative with this activity guide. In designing and constructing it, we built upon themes, concepts, and learning processes outlined in *Science Framework for California Public Schools (1990)* and the *History-Social Science Framework*. From the *Science Framework*, lessons have been built around the themes of Energy and Systems and Interactions with organizing questions from Physical, Earth, and Life Sciences keyed to each activity. While not specifying *History-Social Science Framework* concepts, 4th/5th grade students study California from pre-Columbian times to the present with particular emphasis on how early people of California used natural settings without significantly modifying the environment.

We urge students keep a journal, folder, or folio (a Home Work Book) over the course of this unit. Doing so will help them focus, track, interpret, and evaluate both the subject and their own comprehension. In addition, it will provide teachers a means for "authentic assessment" of progress and performance. Another option is to introduce additional variables into the activities. For example, extending the "shoe box house" from the *Orientation* activity to test other factors in shelter design that affect energy efficiency: color of walls, and roof, window overhangs, vegetation, thermal mass, window size, insulation, scale of house, etc., either as hands-on experiments or in their journals, provides another means of assessment. Student performance may also be assessed on individual tasks assigned throughout the activities.

Above all, be creative—stay the course but take the initiative, and encourage your students to do the same. In the process, we hope that *The Universal House* will engender an awareness, understanding, and appreciation of not only the subjects at hand, but of the role that traditional wisdom and the students themselves play in shaping their communities, the environment, and the future.

This publication is intended to supplement the quartet of color posters (each 17" x 22") on energy efficiency and traditional California Indian architecture, available from the California Energy Extension Service in the Governor's Office of Planning and Research, 1400 Tenth Street, Sacramento, CA, 95814, (916) 323-4388.



---

STUDENTS' PRECONCEPTION

UNIVERSAL HOUSE

Guide students in a comparison of the meaning of house/home, neighborhood/community, and environment/habitat.

⊕ Have students describe in writing and in pictures their idea of a UNIVERSAL HOUSE as though it were an actual building. Ask them to consider:

- What "neighborhood" is it in?
- What is the view from the Universal House?
- What is its "roof" made of? Its "floor"?
- Name the materials it is made from. Are they renewable or non-renewable resources? Why?
- How is it insulated from the outer environment?
- How is the Universal House lit?
- How is it warmed? Cooled?
- Who lives there?

Share some examples of California Indian creation myths. Good sources for these are *Whispers from the First Californians* and *The Way We Lived* (see Resources, pages 34 and 35).





WHAT IS

# Energy?

California Indians accepted that many different forces, spiritual to physical, were at work in the world. But rather than deny or attempt to resist these forces, they acknowledged them, learned from actual experience, and then applied the lessons to their lives in practical and graceful ways.

Today, we often fail to notice whether or how something is working, until it's not. So too, we tend to take energy for granted. We use all we want whenever we want—until we can't. When it ceases or runs out, when we can't afford it, when something breaks or isn't working, only then do we recognize its importance.

In essence, energy is the capacity to do work—the passage of energy from one body to another enables all things to move, grow, or otherwise interact.

All life requires energy. And yet, it is a difficult concept to explain, for while it has practical, predictable, daily applications in our lives, it is also an inconstant and abstract quantity—constantly changing form.

Whether as uncontrollably extraordinary as hurricanes and earthquakes, or as habitually commonplace as light and locomotion, it is a critically important part of our world—causing, affecting, and enabling every aspect of our lives.

Energy makes the universe go and grow. It's sunlight—the difference between day and night. It's the electric light. It's factories, and fruit trees. It's thunder and lightning, and it's MTV. It's planes, trains, and freeways, and it's the whole world, spinning in space. You know energy exists because you can see it, hear it, and feel it—for light, heat, sound, and motion are all forms of energy.

Some sources of energy are naturally renewable and virtually inexhaustible (such as solar and wind power) while other sources are non-renewable (such as fossil fuels like oil, coal, and natural gas) and cannot be replaced.



Traditionally, California Indians understood both the benefits and the responsibilities that arise from our relationship with the ecosystem and its resources. They also understood the fundamental role that sun, wind, and renewable resources play in heating, cooling, and lighting our homes.

In their houses and communities, they took advantage of the very same energy principles that are available to us today: ORIENTATION, SHADING, INSULATION, AND THERMAL MASS. By applying these principles to the design or retrofit of our buildings, we can reduce energy demand, cut energy costs, and create comfortable places in which to live and work.

Growth is the fuel that drives the economic engine of the United States. Since the Industrial Revolution, our population has continued to explode, as has the demand for energy. Our modern society indulges in a reckless appetite for expensive and limited fossil fuels, and yet our choice of energy sources largely based on political and economic factors, rather than scientific ones. As consumption of these fuels increases—every turn of a thermostat, every flip of a switch, supplies are running out.

The impact of fossil fuel use on the environment has many people concerned. But if we want to move from non-renewable fossil fuels to renewable alternatives, we must understand how and why we decide to use what we do—as a society and as individuals. We should more closely match the characteristics of the energy source we choose to its eventual use. ORIENTATION, SHADING, INSULATION, and THERMAL MASS are all practical, efficient means of conserving energy and are better methods of heating and cooling our homes.

#### SCIENCE FRAMEWORK CONCEPTS

**Physical Science** D. Energy: Sources and Transformations

D1. What is energy and what are its characteristics? (page 61)

D2. What do we do with energy? What changes occur as we use it? (page 63)

**Earth Science** B. Geology

B3. What are the responsibilities of humans toward natural resources? (page 97)

**Life Sciences** A. Living Things

A4. How do humans interact with other living things? (page 125)



## DEFINITION

### energy

The capacity for doing work and for overcoming inertia.

Greek derivation: *Energia* coined by Aristotle from *energos* meaning active, at work: *en-*, at + *ergon*, work.

*Excerpt from the 1990 Science Framework for California Public Schools, page 28, "Some Major Themes of Science"*

Energy is a central concept of the physical sciences, and it pervades biological and geological sciences because it underlies any system of interactions. Energy can be taught as a bond linking various scientific disciplines. Defined in physical terms, energy is the capacity to do work or the ability to make things move. In chemical terms, it provides the basis for reactions between compounds. In biological terms, it provides living systems with the ability to maintain their systems, to grow, and to reproduce.

In the physical sciences, energy can be explored in its many manifestations (heat, light, sound, electricity, etc.), in conversions from one form to another. Energy is perhaps the most important theme to the physical sciences because all physical phenomena and interactions involve energy. Whether one discusses the energy of heat, light, sounds, magnetism, electricity, or the conversions of energy from kinetic to potential, electrical to heat or sound, or even the products formed by the combination of an acid and base, energy is involved.

In the biological sciences, the flow of energy through individuals is what drives metabolism, growth, and development. The flow of energy through ecosystems is how organisms interact through the trophic levels of

communities. Because all life requires energy, biochemistry is really the study of how energy facilitates biochemical reactions that allow the body to synthesize biochemical molecules—the basis of growth.

In the earth sciences, the flow of Earth's energy comes from two sources. First, there are forces within the Earth, fueled by nuclear reactions within the mantle and core, that translate through the crust and are responsible for the processes that drive mountain-building, continental drift, volcanic eruptions, and earthquakes. Second, there are the forces on the surface of the Earth, such as wind, precipitation, physical and chemical reactions, and the activities of living organisms (mostly driven by the Sun's energy), that alter the face of the Earth and are responsible for many geological processes.

The theme of Energy is important to considerations of ethical behavior and the relationships of science and technology to society. Sources of energy on Earth include solar, wind, and water power, geothermal energy, nuclear energy, and fossil fuels. Some sources of energy are virtually inexhaustible, such as solar, wind, water, and nuclear. Renewable sources are those that can be recycled and replaced, such as water power. Non-renewable sources are those that cannot be replaced, such as fossil fuels. Students should appreciate these distinctions, the limitations of some sources of energy, and the need to conserve them or avoid their use.



### SCIENCE FRAMEWORK CONNECTION

Physical Science D. Energy: Sources and Transformations (page 61)

D-1 What is energy? What are its characteristics?

D-2 What do we do with energy?

## ACTIVITY

### WHAT IS ENERGY?

#### OBJECTIVE

To demonstrate that energy is required when work is done or when matter changes its form.

#### MATERIALS

Heavy textbooks, desks

#### STUDENTS' PRECONCEPTION

Ask them what they have to do or change about the book to have it perform "work." Is energy required? Where will it come from? What "kind" of energy will it be?

#### PROCEDURE

- Have students select their heaviest textbooks and hold them horizontally over the floor.
- Have them drop the books in unison for best effect, and observe what happened.
- What is different about the book now? (It changed position.)
- What happened when it was dropped? (It fell/ motion, it made a loud noise/sound, it moved the air, it hit the floor, etc.)

*Each form of energy has its own characteristics. A given material will transmit some forms of energy and absorb or reflect others. The book transmits sound energy, but not light or heat.*

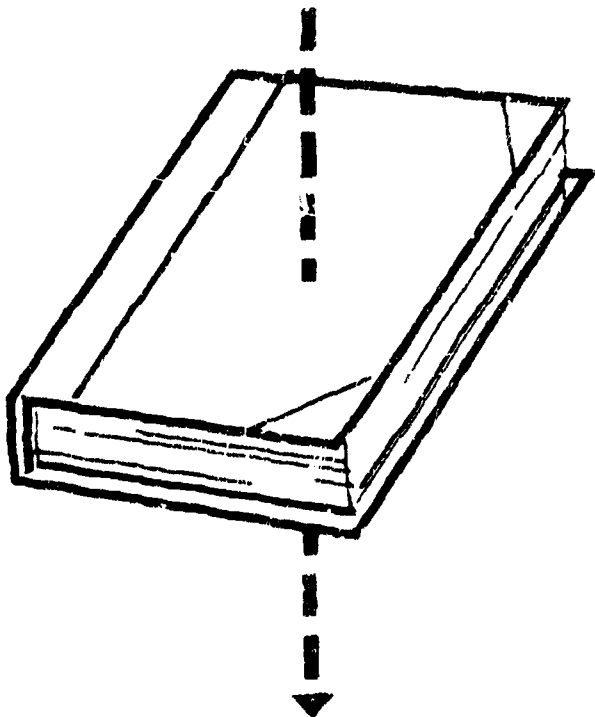

#### CONCEPTUAL CHALLENGE

Did the book "work"?

Can the book do other kinds of work?

Organize the students into groups and ask them to come up with as many kinds of work that they can for the books to perform (flatten things, ring bells, pull things, crack nuts, break eggs, etc.)

Where did the energy come from that caused the work? (From the potential energy of the book converted to kinetic energy which caused the ringing, cracking, etc.)

Explain that the activity demonstrated the difference between the potential energy of the book in the air (energy that is possible due to its position relative to another body) and the kinetic energy of the falling book (energy produced or caused by motion).

#### APPLICATION

☼ Heat is a form of energy often produced by conversion from other forms. Ask students to cite examples of heat energy moving from one body to another? (students standing in the sun—from the sun to the student, from the flame of a gas stove to the pan of hot chocolate, etc.)

☼ Re-focus your discussion on the student as the source of energy that caused the book to fall. Explain to the students that the egg they ate for breakfast or the sandwich they ate for lunch is now being changed into energy to "fuel" their activities. (Food contains stored chemical energy that passes through ecosystems in food chains.)

☼ What is their home's "diet"? What kinds of fuel does it "eat" for breakfast, lunch, and dinner? What "work" does their home do with these different kinds of energy? Choosing a "fuel" from each of these two "diets," have the students identify the energy conversions and construct energy or food chains. For example, the students can choose milk as their fuel: sun provides energy for grass to grow, grass provides energy for the cow to grow and produce milk, MILK gives the student energy to push the book. For their homes, they might choose wood: sun provides energy for the tree to grow, tree (WOOD) provides fuel for the fire in the woodstove, fire provides light and heat. Who can make the longest chain? Is the longest chain necessarily the "best" or most efficient if energy is lost during each conversion?



**When Indians came to live on earth,  
the first people were changed  
into animals bearing their names.**

**Seal, sea lion, and grizzly bear built a dance house.**

**God of the north, Nagaicho, made redwood trees  
grow on the tail of the earth dragon to the north.**

**He carved streams with his foot,  
so that people had good fresh water to drink.  
In the waters of the ocean, he grew sea food  
for the people to eat.**

**Then Nagaicho travelled all over the earth,  
making earth a comfortable place  
for human beings to live.**

**NORTH COAST**



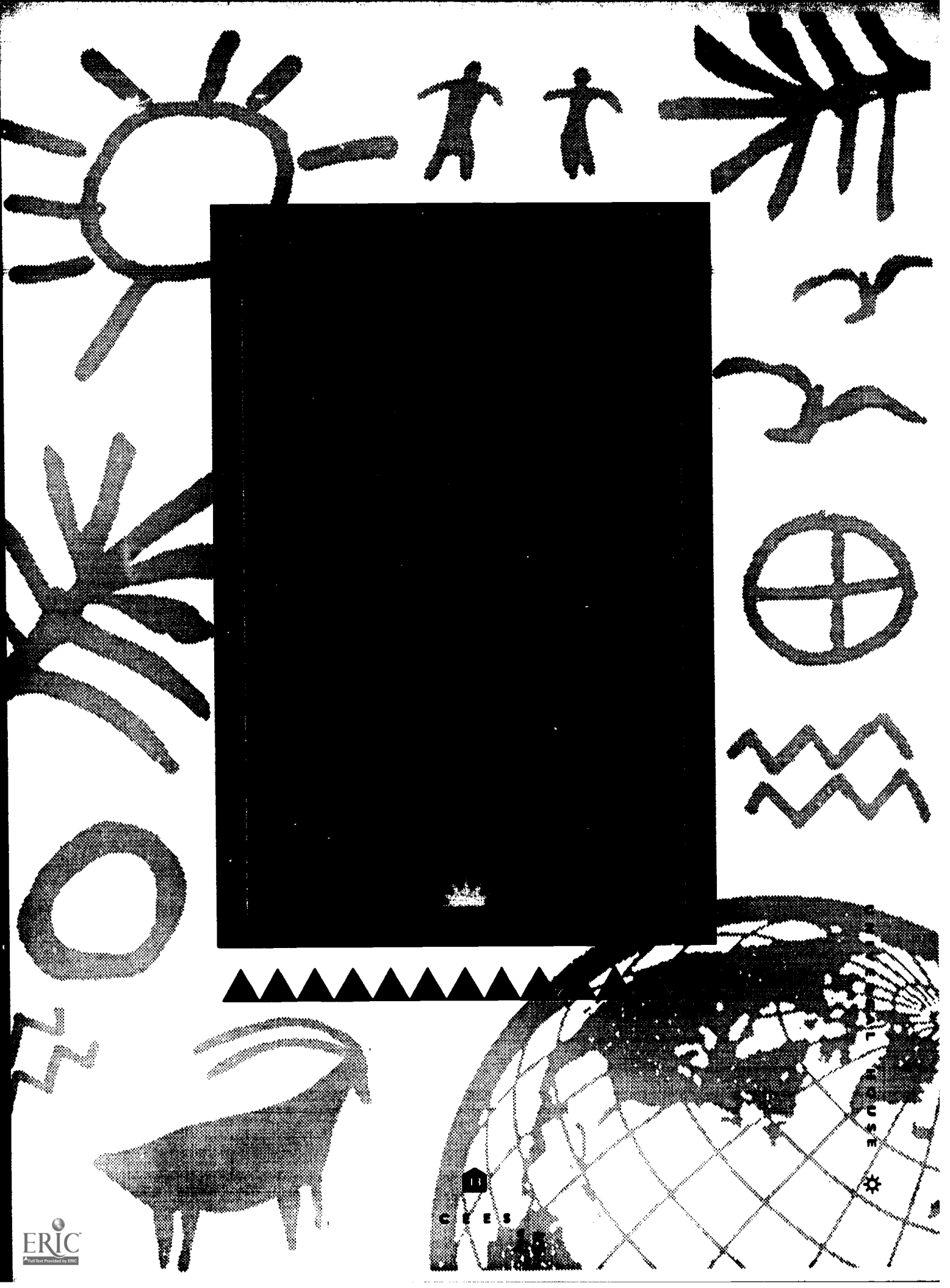

# *Earthen*

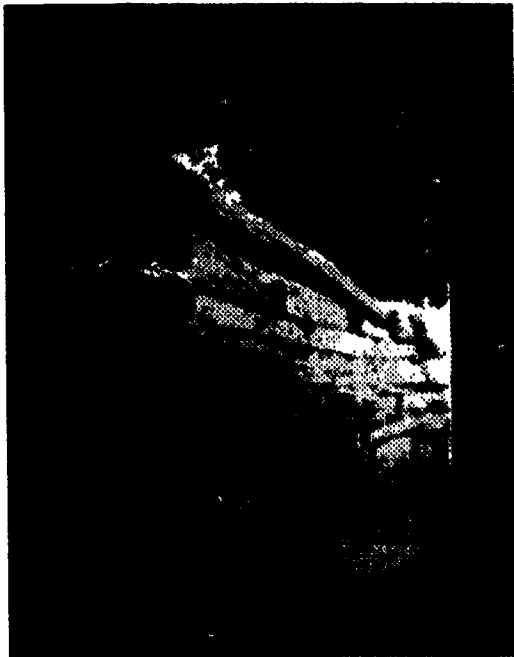

Traditional Indian builders, in what is now called California, made the earth itself their home, using it to build and enclose various house forms. Ground, the land surface of the earth, maintains a relatively constant temperature barrier between outside temperatures and inside conditions, thus regulating the temperature of interior spaces.

✦ The Luiseno constructed mud-covered sweathouses or temescals which heat from a central fire, effectively trapping the heat.

The Mohave oriented their winter houses with their backs blocking fierce north winds. Earth shelters remain warm in winter and cool in summer, whether covered with soil or built either wholly or partially below ground. ✦ A common substance with an uncommon capacity to shelter, earth was a practical and invaluable material in every region of California—from low sand-covered shelters of the Colorado River tribes; to stone-capped redwood sweathouses of the northwest; to pit houses of the Central Valley and foothills; to cavernous dance houses and ceremonial chambers, fifty feet across, with fires as their centers and large holes overhead “for the smoke and sparks to fly out.” ✦



OVERVIEW

SHELTER

*In all regions of California, the earth was excavated by tribal builders and used in combination with local materials (wood, stone, fiber) to create various kinds of shelter—round, rectangular, and subterranean or semi-subterranean (partially below ground).*

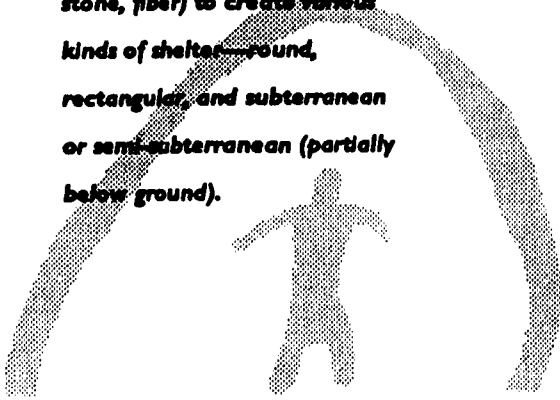

UNIVERSAL HOUSE



CEES

# Plank

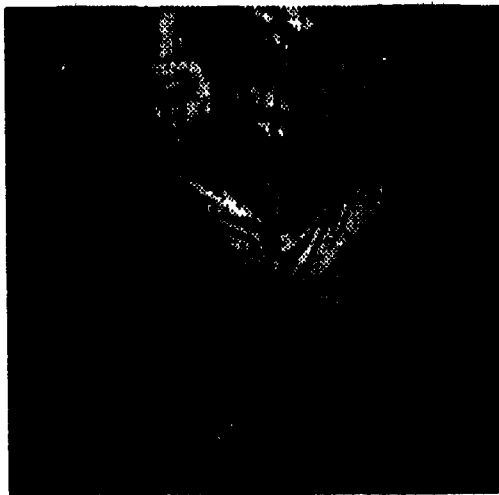
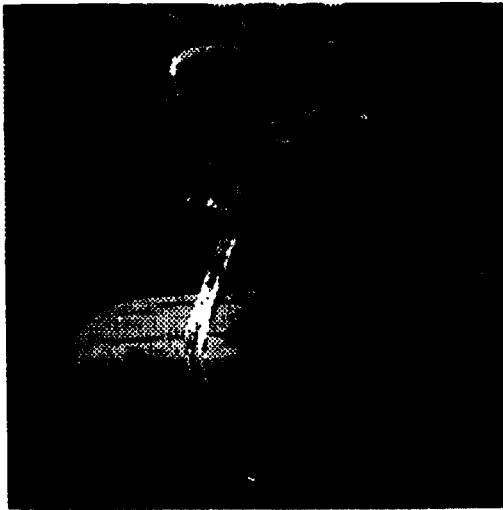

When native people first appeared on the whale gray coast of what is now Northwest California, the world floated on water, grizzly bears danced beneath redwood trees, and the rivers ran thick with salmon. ■ Distinctive gabled plank houses were constructed by local tribes, using redwood, cedar, hazel, earth, and river rock. Rocks were used to edge the rectangular buildings, to pave adjoining outdoor areas, and to cap the subterranean (underground) sweathouses.

■ More than formal ornament, however, the thermal mass of the rocks, and of the earth itself, acted as solar collectors. By day, they absorbed the heat of the sun. When the sun had passed and the air had cooled, this heat was transferred to the house.

Skillfully adapting local materials and solar energy to their needs, the Yurok, Karuk, Hupa, and others crafted elegant, energy-efficient shelter—comfortable places for human beings to live. ■



OVERVIEW

SHELTER

*In Northwestern California, low gabled houses were built over rectangular earthen pits. Thick broad planks of redwood or cedar*



*were set on end to line firepits and form house walls. Wooden rafters supported pitched, plank roofs. River rocks and grapevines secured the structures. House walls were often set back from the edge of the pit, leaving an earthen "shelf" on which people were warmed by the rising heat from the firepit.*



UNIVERSAL HOUSE

# Sapling & Thatch



Many native tribes in California's valley, desert, and coastal regions erected domed houses of bent sapling or tule framework. Natural fiber shelters, covered with brush or thatch (grass or tule reed) and curved like the vault of the sky, shielded their builders from cold, wet, wind, and sun. \* In summer, the same materials were used to create shade with a

sun shelter. These open-air arbors and lean-to shelters furnished shade and comfort during the hottest hours of the day and year, blocking the light and heat of the "traveling fire in the sky." \* Traditional Indian builders adapted resourcefully to California's warm and arid regions, making and remaking households defined by religion and traditions, wood and grass, earth and sky. The Paiutes' brush-covered shelters made efficient use of the scarce resources on the high desert. Both the Yokuts and Pomo erected covered arbors and oblong houses large and long enough to shelter whole villages. The Maidu built summer shelters facing east to temper the intense heat of the late afternoon sun. The Chumash placed the entrance to their sapling and sea-grass houses on the south side for solar gain. \*

OVERVIEW

SHELTER

*Traditional Indian builders in California's valleys, marshes, deserts, and coastal areas made fiber shelters of sapling or tule frames covered with brush or thatch (reeds, grasses). Built above ground or over earthen pits, sapling frames were often bent into domical or oval shapes and secured with fiber. In summer, the same materials were used to build flat-topped arbors or lean-to shelters.*

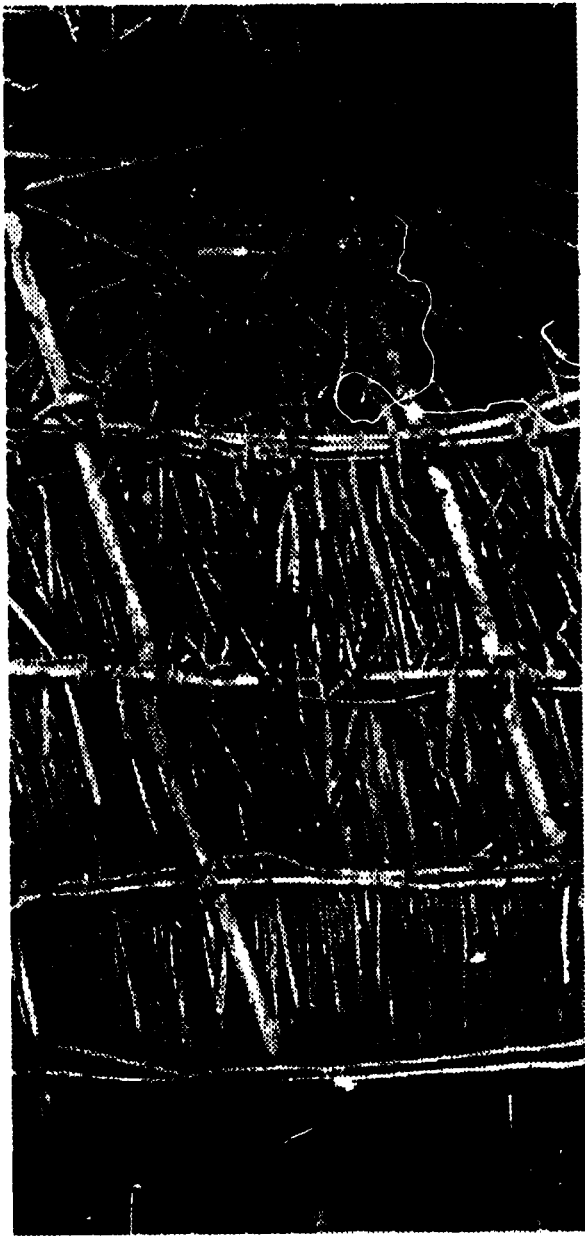

# Conical Bark Slab



California Indians oriented, or positioned, their traditional houses in relation to the sun. They understood the sun's movement through a day and a year—its cyclical, seasonal passage across the sky. They made its constancy and energy work for them. Houses were placed to admit the welcome warmth of the low winter sun as well as to block chill winds. In summer, orientation was reversed, limiting exposure to hot afternoon sun and admitting fresh air.

▲ The Sierra Miwok sited bark slab houses on sunlit leeward slopes, above cold ravines but below windswept ridges. In the mountains, the eastern side of the cone for both the Maidu and the Miwok houses is angled sharply to prevent snow accumulation. ▲ The placement of buildings in relation to the sun, wind, and landscape, affects daily and seasonal heat gain and loss. A house that is properly oriented and insulated can be heated or cooled by natural, sustainable means. Orientation is common sense. It's a lesson as old as the sun and coyote, but as new and as certain as tomorrow's sunrise. ▲

---

OVERVIEW

SHELTER

*Conical bark houses were built by California's coastal and mountain Indian tribes. In cold, damp, or foggy areas, large slabs of redwood and cedar (or other conifers) were arranged on end in a conical shape. The thick bark slabs were either freestanding or supported by a cone-shaped sapling frame. Earth was banked against the base. The Miwok referred to their conical bark houses as kotca, "a place where real people live."*

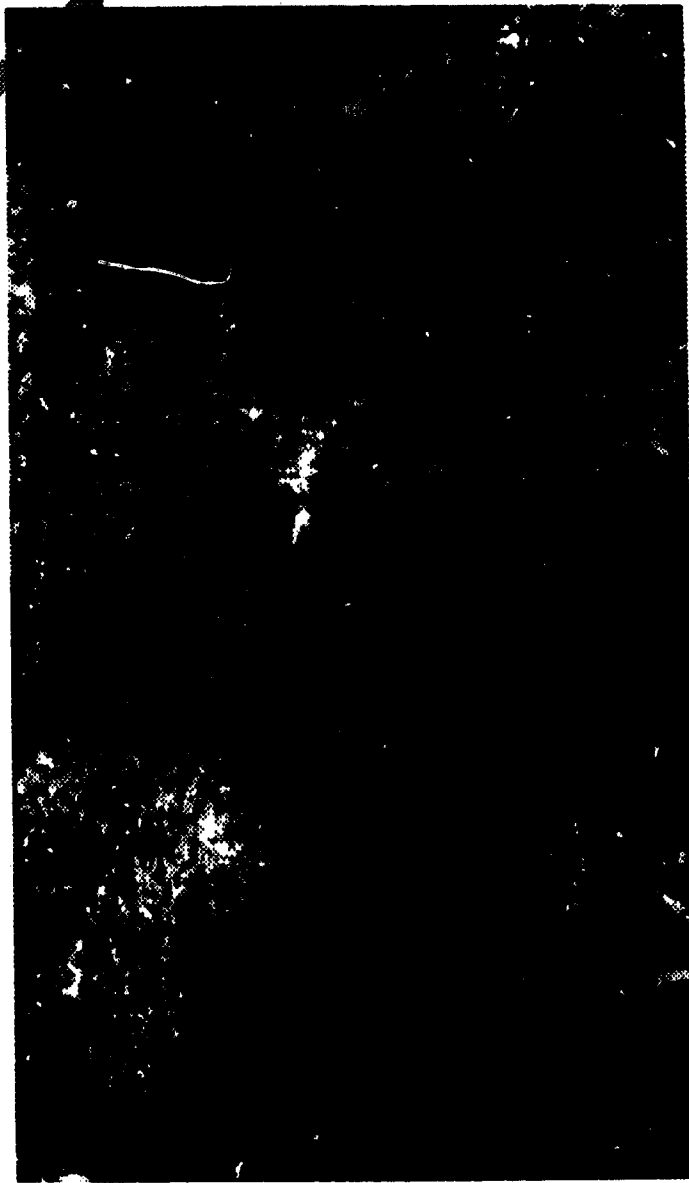

STUDENT  
EXPLORATION

SHELTER

● Houses are but one kind of shelter, or home, in which to live. People live in houses, pent-houses, trailers, apartments, cars, rooms, boats, etc. Ask students to name as many different kinds of shelter as they can. Have them create a collage of homes from magazines different kinds, different times, different cultures. Select several of these and ask students to suggest what materials they are made of, what forms of energy are required to construct and "operate" them. Ask them to imagine what it might be like to live in them.

● Ask students to imagine what it might be like to live in different types of traditional California Indian houses: a redwood/cedar plank house in the forests of the northwest; an earthen house in the central foothills or deserts; a conical bark slab house in a mountain meadow; and a sapling frame house with a grass/thatch cover in treeless grasslands on the coast.

● Organize students into groups. Have each group research one type of traditional California Indian house (see above). Ask them to describe the housing type and identify the tribes that erected this form of shelter and what they called it. Have them describe the habitat in which it would most likely be found. How did the habitat affect the design of the house and the selection of materials used in construction? What materials were used and how were they obtained?

● Energy is required to build, heat, cool, and light a home. But energy is also needed to produce and transport the building materials. California Indians reduced the need to transport

or produce materials by using locally available, renewable resources in their natural state. Materials available on or near the building site might include, for example, reeds and grasses in marshy areas, or tree bark in forested areas. Ask students to cite other examples. Have them consider the kinds of energy required to produce the materials, to transport them, and to construct each type of traditional house.

● Ask students to decide what type of traditional California Indian house would be best to build in their neighborhood, considering locally available natural materials and climatic conditions.

● Compare this to the construction of a contemporary house. Which house, traditional or contemporary, uses the greatest amount of energy in the production and transportation of materials, in construction, and in "operation." Why? Which house uses the greatest amount of non-renewable resources? Why?

● Ask students to think of their neighborhood (or the neighborhood outside the classroom) as a source of "local" materials. Challenge them to design a small house using any locally available materials, renewable or not, attractive or not, conventional or not (encourage them to try an unconventional approach). Ask them to consider energy conservation in their design.

● How do houses let us live comfortably in many different environments? How do houses reflect the values of a community or culture? How does energy use reflect the values of a community or culture?





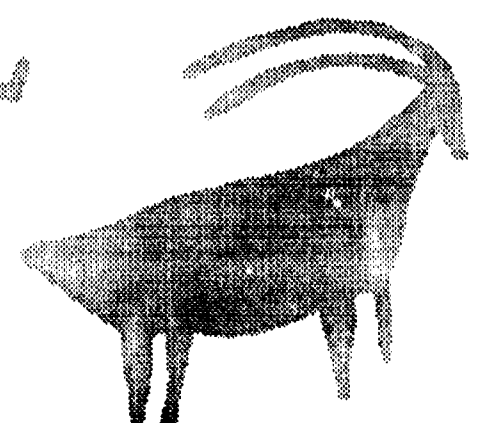
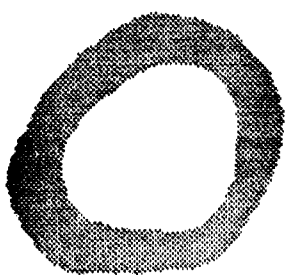
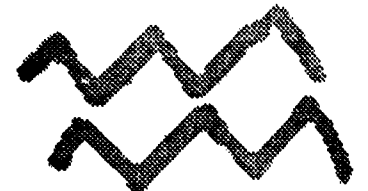
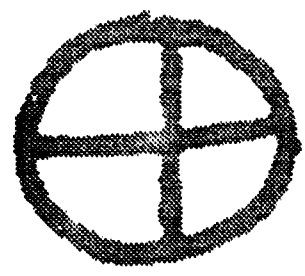
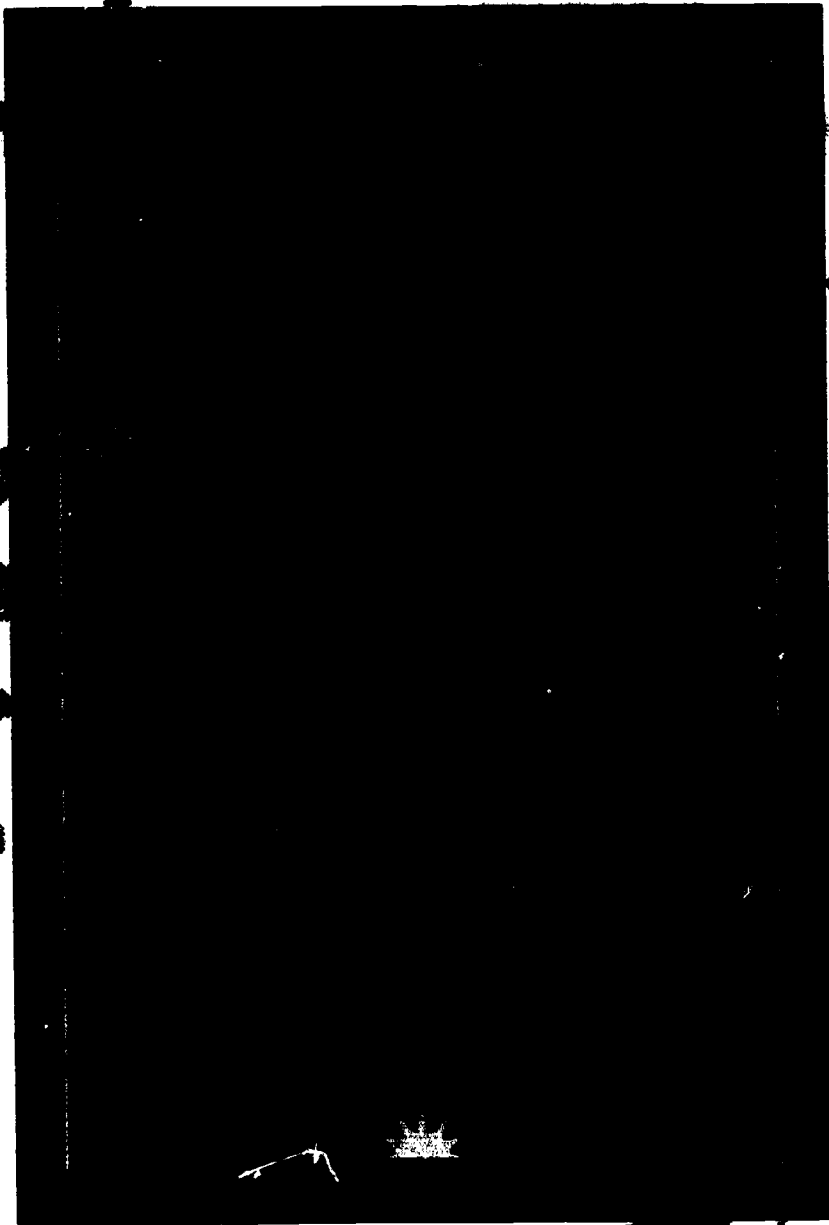

## I N S U L A T I O N

## D E F I N I T I O N

*in·su·la·tion*

To prevent the passage of heat into or out of a body or region. From the Latin—*insula* meaning island.

When heat is lost, energy is lost, and additional energy must be spent to replace it. An alternative means of preventing heat loss or heat gain is "insulation." Materials that insulate well do so because they are poor conductors of heat. Instead of passing heat, they form barriers between interior and exterior spaces—between warmed interiors and cold weather, or cool interiors and hot weather. Insulation is as effective in hot conditions as in cold conditions. As a result, less energy is required to cool homes in hot weather or heat homes in cold climates. Well insulated, energy-efficient houses maintain an even temperature year-round.

Insulation actually begins with the structural material itself, and ends with the outer "skin" of a building. Between, layers of non-conducting materials reinforce the effect. Although we don't usually think of it in this way, air itself is an insulating material. Spaces of air trapped by these materials slow the transfer of heat (conduction). California Indians used many indigenous materials as insulation—grasses, reeds, brush, boughs, wood, sand, mud, and earth. While many materials can be used as insulation, some possess other characteristics that make them more desirable as building materials. For example, earth is not the most efficient insulating material, but it is usually more abundant, close to the building site, and fire resistant. Some materials insulate better than others, but all insulation saves energy and money, for heat contained is energy conserved.

S C I E N C E  
F R A M E W O R K  
C O N N E C T I O N

## Physical Science

E. Energy: Heat

E1. What is heat energy?

Where does it come from and what are its properties? (page 64)

E2. How do we use heat energy?

G. Energy: Light

G1. What is light? (page 72)

G2. What are the



## ACTIVITY

# INSULATION

### OBJECTIVE

To demonstrate the role of insulation in the prevention of heat loss and gain.

### MATERIALS

3 glass jars, 2 boxes or milk cartons, dirt, grass clippings, piece of cardboard (same size as bottom of carton), 3 thermometers, 3 rubber bands and 3 pieces of plastic wrap (to cover jars), hot water.

### TIME

2 sessions, 50 minutes each.

### STUDENTS' PRECONCEPTION

Ask students to discuss ways in which they use different kinds of insulation to keep themselves and their homes warm. Have them predict which jar will retain the most heat, and which will lose the most. Why?

### PROCEDURE

Place a glass jar in an upright box or truncated milk carton. Surround jar with dirt. Place identical second jar in similar box or carton. Surround second jar with grass clippings. Place identical third jar on a flat piece of cardboard. Pour the same amount of very hot water into each jar. (Instructor should pour.) Cover the jars with plastic wrap "lids" and secure the "lids" with rubber bands. Poke a hole in the "lids" large enough for the thermometer to fit through. Cover the hole until you take temperature readings. Use a thermometer to record the temperature in each jar every 5 minutes for 30-40 minutes. (Cover the hole whenever you remove the thermometer.) Have groups of students create graphs from the data (one group per jar). Compare the results and share conclusions.

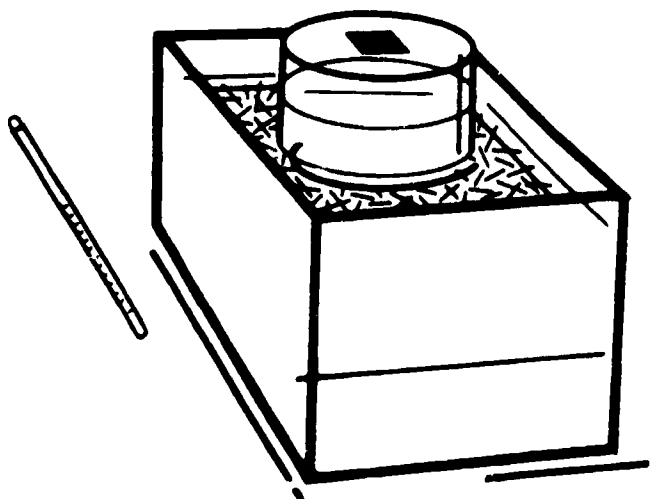

### CONCEPTUAL CHALLENGE

Which jar of water remained hottest the longest? Did the insulation make a difference? If so, which insulation was the most effective?

### APPLICATION

■ Repeat activity using "insulation" that students contribute from home (cereal, gravel, cotton, bread, paper, etc.). Ask them to predict the effectiveness of each material.

▲ † Have students put on their sweaters, coats, boots, hats, etc. and take them outside on a cold day. Discuss (and demonstrate) how these items of clothing insulate them from the cold. Explain that 80 percent of their body's heat is lost through an uncovered head. Ask students to draw parallels between themselves and their houses (wearing hat/insulating roof; leaving front of coat open/opening window; wearing sweater and coat/insulating walls; raising their body temperature through activity/using energy to heat the interior of their house).

▲ California Indians traditionally built houses in several different shapes: rectangular, circular, domical and conical. Explain to students that when air (a gas) is heated, it expands and rises (convection). Ask them which kind of house would be more efficient to heat (all else being equal)—one with a conical-shaped interior space or one with a rectangular-shaped space?

† Redwood/cedar plank houses of northwestern California were not conical in shape, but with pitched roofs on very low rectangular walls over sunken firepits. The shape of their interior space was also efficient to heat.

\* Ask students to imagine that snow has blanketed their neighborhood. Later that day, they discover that while many homes still have snow covering their roofs, others have none. The sky is overcast. It has been cold all day. The homes all face the same direction. There are no overhanging trees. Ask the students to suggest reasons for the difference. (Hint: it relates to insulation.)

Can snow and ice insulate and prevent heat loss? Ask students to identify a traditional form of American Indian architecture that illustrates this concept. Why would this material have been used in that environment and not in others?



THERMAL MASS

DEFINITION

*thermal mass*

The relative capacity of solid materials to gain and hold heat (thermal energy). From the Greek—*therme* meaning heat, and *mass* meaning barley cake, lump, or mass.

The sun's rays, wherever they fall, convert to heat. Some objects are composed of material that can conduct this "thermal energy" better than others—transmitting it to cooler surroundings. Materials that are capable of absorbing and holding thermal energy have "thermal mass." Structural materials with thermal mass (walls, roofs, paving, earth, stones, etc.) become solar collectors when exposed to the sun. The greater the area of thermal mass, the greater its ability to store heat and maintain a uniform temperature. Dark objects absorb heat better than light-colored ones—the darker the thermal mass, the more heat it will hold. The sun is an unlimited source of renewable energy, and thermal mass is a clean, direct means of collecting and distributing it to our homes and communities.

SCIENCE  
FRAMEWORK  
CONNECTION

Physical Science

- E. Energy: Heat
  - E1. What is heat energy? Where does it come from and what are its properties? (page 64)
  - E2. How do we use heat energy?
- G. Energy: Light
  - G2. What are the properties of light? 3. How do we use light? (page 73)

Life Sciences

- A. Living Things
  - A3. What are the relationships of organisms and how are living things classified? (page 121)



## ACTIVITY

### THERMAL MASS

#### OBJECTIVE

To compare the ability of potential building materials to absorb and hold heat from the sun (thermal energy).

#### MATERIALS

4 identical containers with lids, 4 thermometers, water to fill containers (room temperature), material samples (similar in size): brick, block of wood, 2 ziplock bags—one holding dirt and one holding grass clippings or styrofoam beads (compress air out of bags before sealing), 4 blankets.

#### TIME

2 hours, 3 sessions: 1. Discuss principle, students' preconception, and activity. Prepare samples (20 min.). 2. Move objects from sun to containers. Record results (1 hr.) 3. Conceptual challenge and application (40 min.).

#### STUDENTS' PRECONCEPTION

Have students cite examples of material surfaces that radiate heat after the air temperature (inside or outside) has cooled. Why? Ask them to predict which material samples used in the activity will absorb and hold the most heat. The least?

#### PROCEDURE

Place material samples in direct sunlight for one hour or more. Fill each container with the same volume (2/3 full) and temperature of water. Record water temperature in each. Remove samples from sun and place each one in a container. Cover with lids and blankets. After 45 minutes, uncover containers and record water temperature in each. Subtract original from final water temperatures. Record results for each container.

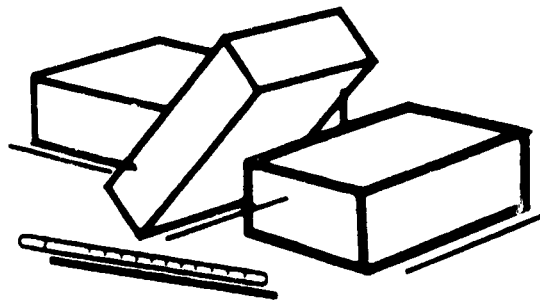
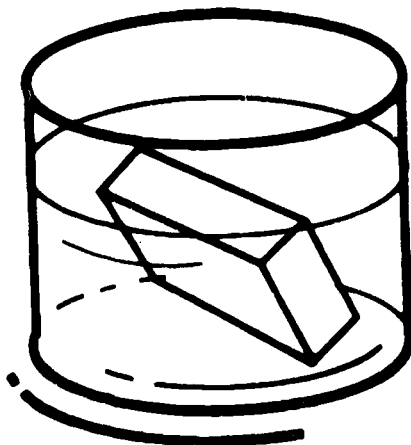

27

C E E S

29

#### CONCEPTUAL CHALLENGE

The water in which container gained the most heat? The least heat? The warmest water held which material? The coolest held which material? To what do you attribute this variance in temperature? Which material gained and held heat the best (has the greater heat capacity/thermal mass)?

#### APPLICATION

☞ Demonstrate the transference (conduction) of heat from one thermal mass to another. Fill a hot water bottle with water that is very warm (but not uncomfortable to touch). Lay it on the desk of a student volunteer. Have students test the normal temperature of their palms by placing them against their cheeks. Ask them to place their hands, palms down, on the hot water bottle for a least 2 minutes. Have them test the temperature of their palms against their cheeks again. What has happened? Why? Let other students repeat the activity, and guide students in a discussion of the transference (conduction) of heat—in this case from water to rubber to hand to cheek. Lift hot water bottle from desk to reveal heat conducted to desk.

■ Ask students to select materials for a house to be built in a cold climate. What type and color of materials would they choose for the exterior of the house to take advantage of thermal mass? What if they wanted to melt snow on a roof or walkway? What type and color of material would they use on the floor of a sunny room? Why?

▲ California Indians cooked food with hot stones. Clean cooking stones were heated in a fire and then, using a wooden utensil, placed in beautiful baskets filled with acorn mush. As stones cooled, they were removed and new stones added to further cook the mush. Where did the heat from the stones go? Why don't we cook this way today?

## S H A D E

## D E F I N I T I O N

*shād*

Shade results when sunlight, solar energy, is blocked or inhibited. From the Greek—*Skotis* meaning darkness.

In summer, California Indians not only took advantage of natural shade, they made their own shade with open-air shelters. The sun's energy heats everything in its path, even air. Interrupting or blocking this energy creates shade (diminished light and heat). To cover a space without enclosing it provides shade, circulation of fresh air (ventilation), and protection from solar radiation. Thermal energy is most intense on a structure's south and west faces, and when the sun is directly overhead. The angle and intensity of its rays vary from hour to hour, season to season, but as this variation is cyclical, shelters can be planned and managed to benefit both human comfort and the environment. Relative size and position of structural openings (windows and doors) and sun blocks (roofs, overhangs, window coverings, awnings, walls, trees, etc.) affect the absorption and retention of thermal energy. When it comes to energy efficiency and cost effectiveness, sometimes the best relationship with the sun is a cautious one—little or no sun at all.

S C I E N C E  
F R A M E W O R K  
C O N N E C T I O N

## Physical Science

## E. Energy: Heat

E1. What is heat energy? (page 64)

E2. How do we use heat energy? (page 64)

## G. Energy: Light

G1. What is light energy? (page 72)

G2. What are the properties of light? (page 73)

## Earth Science

## A. Astronomy

A1. How do the objects of the universe relate to one another? (page 79)

## B. Geology

B1. What are the responsibilities of humans toward natural resources? (page 97)

## Life Science

## A. Living Things

A4. How do humans interact with other living things? (page 125)



## ACTIVITY

### SHADE

#### OBJECTIVE

To demonstrate the role that shade plays in the prevention of heat gain.

#### MATERIALS

Cardboard, scissors or utility knife, ice cubes, ziplock plastic bags, sun.

#### TIME

50 minutes (near midday).

#### STUDENTS' PRECONCEPTION

Guide students in visualizing and describing the conditions, cause and effect of a shaded environment in a warm climate. Have them describe the same environment without protection from the sun (especially at midday). Ask the students to predict in which environment (sun or shade) the ice cube will melt more quickly. Why?

#### PROCEDURE

Cut a rectangle of cardboard measuring 11" x 14", plus 2 squares measuring 6" x 6". Fold the rectangle in half at a 90 (degree) angle to form a cardboard "roof" or sunscreen. Place both squares of cardboard in a sunny location and put an ice cube (in a plastic bag) on each. Immediately place the cardboard roof over one of the ice cubes. Be sure not to shade the other ice cube with your body! After 30 minutes, measure the amount of water that has collected in each bag.

#### CONCEPTUAL CHALLENGE

Which ice cube melted more quickly—the one in the shade, or the one without protection? Which ice cube absorbed the most thermal energy? Why? What was the source of this energy? What is shade a result of?

#### APPLICATION

☼ Ask students to illustrate shade with drawings showing a "sunscreen" of their choice blocking the sun and creating shade.

■ Ask students to break into groups and compose lists of as many sources of shade as they can think of that block the sun's heat from their homes, thereby reducing the need for cooling their homes in the summer. Compare lists.

○ Is the moon ever a source of shade? (Diagram a solar eclipse on the blackboard to demonstrate how sunlight is dimmed or eliminated by the moon.)

☼ Discuss where the energy needed to cool a home without sufficient shade comes from.

Can shade be grown? What kinds?

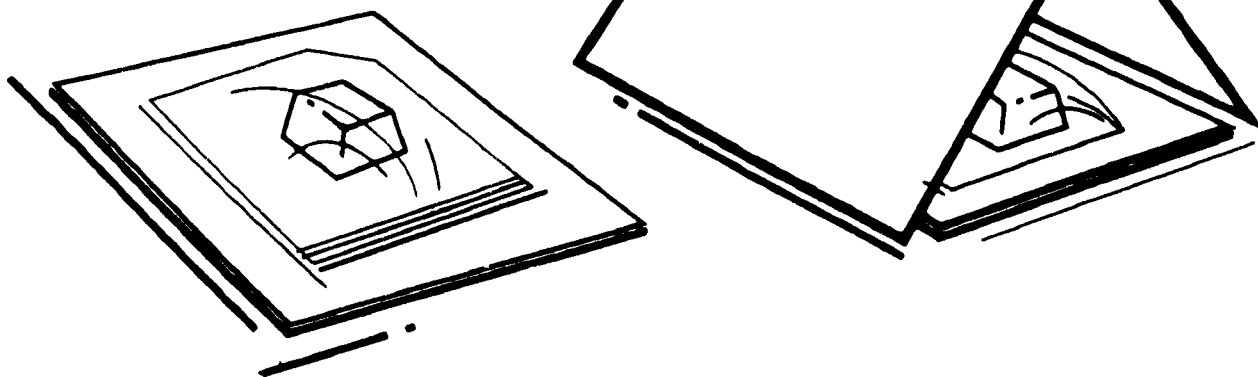



ORIENTATION

DEFINITION

**o·ri·en·ta·tion**  
 To place or adjust in relation to the points of a compass. To adjust in relation to a situation. From the Latin—*Oriens* meaning rising, rising sun, east.

What is a house without windows or doors? Windows and doors enable us to enter and exit a building, but they also allow sunlight, air, heat, and cold to enter and exit. How we position windows, doors, and the house itself, in relation to the wind, the landscape, and the movement of the sun, can increase its comfort and energy efficiency. The sun rises in the east and sets in the west, and when its light falls on or in a house it is converted to heat. The summer sun arcs high overhead, while the winter sun passes low across the southern sky. The most critical period for solar heat gain is late afternoon during the summer, when the sun is low to the northwest and protection is important. Because surface area affects heat gain and loss, the short side of a house should face west and be used for storage, etc., forming a thermal buffer. Rooms with large windows should face south for winter solar heat gain. The next time you routinely reach for a thermostat, open or close a window instead. Save money and energy. Don't flip switches. Open the drapes, close a door, use the sun! Orientation is as practical and convenient as windows and doors.

SCIENCE FRAMEWORK CONNECTION

- Physical Science  
 E. Energy: Heat  
 E1. What is heat energy? (page 64)  
 E2. How do we use heat energy? (page 64)  
 G. Energy: Light  
 G1. What is light energy? (page 72)  
 G2. What are the properties of light? (page 73)
- Earth Science  
 A. Astronomy  
 A1. How do the objects of the universe relate to one another? (page 79)  
 B. Geology  
 B1. What are the responsibilities of human toward natural resources? (page 97)
- Life Science  
 A. Living Things  
 A4. How do humans interact with other living things? (page 125)

UNIVERSAL HOUSE





## ACTIVITY

# ORIENTATION I

### OBJECTIVE

To understand the importance of the placement, or orientation, of your house in relation to the sun's position in the sky.

### MATERIALS

2 shoe boxes, plastic wrap, tape, scissors or utility knife, thermometers, construction paper (optional for roof).

### TIME

1 hour on a sunny afternoon.

### STUDENTS' PRECONCEPTION

Ask students to name the four directions or cardinal points of the compass. Diagram them on the chalkboard. Review them, and the sun's passage through the sky as it relates to the directions of the compass during the course of the day and in different seasons. (An optional procedure to make this concept visible is noted below.) Guide students in assigning climatic characteristics to each direction (e.g., cold, windy, hot, dry, snow, warm, wet, etc.). Ask students to predict the characteristics of the shoe box "house" that will be warmest in the winter (will collect the most thermal energy). Why?

### PROCEDURE

Make 2 "houses" from similar shoe boxes. Cut a 2 3/4" x 6" window on one side of each box. Cover windows with clear plastic wrap and tape edges. Lay a thermometer in each house (so temperature may be read through window). Make a roof (optional) and tape it to the top of the "house." Put both houses in a sunny afternoon location, with the window of one facing south and the other facing north. Record the temperature of both every 10 minutes for 30 minutes.

### OPTIONAL PROCEDURE

Place a paper-tape X on a sunny window and let students track the shadow as it moves around the classroom. By marking and recording the shadow Xs at different times of the day, month, or year, students can track the sun's movement overhead plus the corresponding angle and depth of penetration of its rays into the room. Let students draw conclusions from this activity regarding solar energy and orientation and the effect both can have on heating and cooling a house. Can shading be factored into the exercise?

### CONCEPTUAL CHALLENGE

The warmest house faced which direction? Why? The coolest house faced which direction? Why?

### APPLICATION

Which direction(s) should the windows of a house face in the winter to take advantage of the sun's thermal energy? Why?

Which direction should they NOT face. Why?

How should windows be oriented and/or treated in the summer to minimize the sun's thermal energy? Why?

The Yurok and their neighbors, in what is now northwestern California, had no cardinal directions. Instead, they thought in terms of water and the directions in which it moved: *pul* refers to the downstream direction, *wolpe* refers to the direction across the ocean; *hiko* is across the stream; *won* is uphill, or away from the stream on one's own side; etc. You could say that the Yurok based their directions on the flow of energy.

It is likely that the direction(s) used by other northern California Indians were based on the prevailing direction of their streams and watershed as much as on celestial occurrences. Would tribes in southern California have been as likely to use streams for their directions? According to anthropologists, southern tribes were influenced far more by solar orientation in determining their directions. (Water was scarce, its flow was inconstant and irregular while celestial phenomena were constant.)

Ask students to research and demonstrate the significance of our contemporary cardinal directions. What do we base them on physically and historically? What one direction reveals itself most easily and thus reveals the placement of the others? How do you know that direction? (east is where the sun rises.)

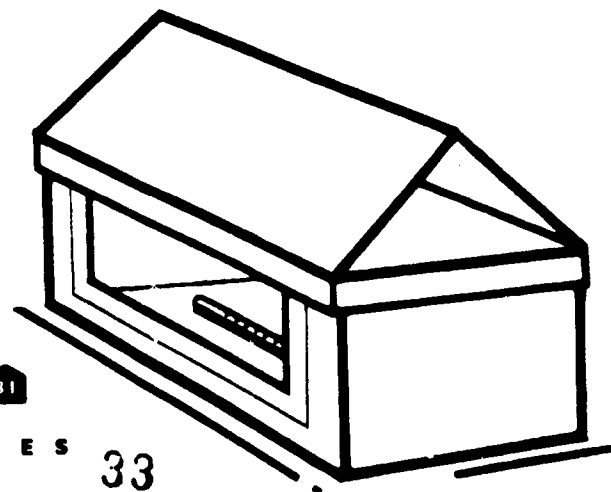

UNIVERSAL HOUSE

ACTIVITY

ORIENTATION

2

**OBJECTIVE**

To examine the forces, directions, and uses of the wind.

**MATERIALS**

Masking tape, new pencil, rubber band, long plastic bag (bread or newspaper wrapper), plastic or cardboard cup with bottom cut out, strong T-shaped straight pin, wind, compass.

**TIME**

2 hours initially. Can be repeated for 30 minutes over the course of several days to gather more data.

**STUDENTS' PRECONCEPTION**

Ask students to describe their experiences with the wind. Take them outside on a windy day—ask them what they think the direction of the strongest wind will be. We know that winds come from different directions, but what is the wind and what is its cause? Explain to them that winds are named for the direction from which they come.

**PROCEDURE**

Using a compass, use masking tape to mark north, south, east and west on the playground. Have students construct wind socks. (Cut open bottom of plastic bag. Attach one end of bag around edge of cup, top of cup outside bag, with rubber band. Push T-pin through edge of cup and into end of eraser so that cup rotates freely.) Have students test their wind socks outside, away from buildings. The cup will face the direction from which the wind is coming. Ask students to record their observations on the force and direction of the wind, as indicated by the wind socks. Repeat over a period of several days to a week. Compare results.

**SCIENCE FRAMEWORK CONNECTION**

- Earth Science A. Astronomy
  - A1. How do the objects of the universe relate to one another? (page 79)
- B. Geology
  - B4. What are the responsibilities of humans toward natural resources? (page 97)
- D. Meteorology
  - D2. What are the physical bases of earth's climate and weather? (page 106)
- Physical Science D. Energy: Sources and Transformation
  - D2. What do we do with energy? (page 63)

**CONCEPTUAL CHALLENGE**

Were forces and directions constant? Why or why not?

**APPLICATION**

➔ Why is it important to know the direction of the wind?

■ How can the position of a house in relation to the direction of the wind affect the heating or cooling of that house? For better? For worse?

✎ Describe ways in which wind energy can perform "work" (moving boats, drying clothes, "playing" wind chimes, cooling people and surroundings, etc.). Draw pictures of some examples.

✎ How is wind energy converted to electricity? Why should we consider using it as an energy source? Compare wind energy to energy obtained from fossil fuels — which is safer, cheaper, more plentiful? Why?

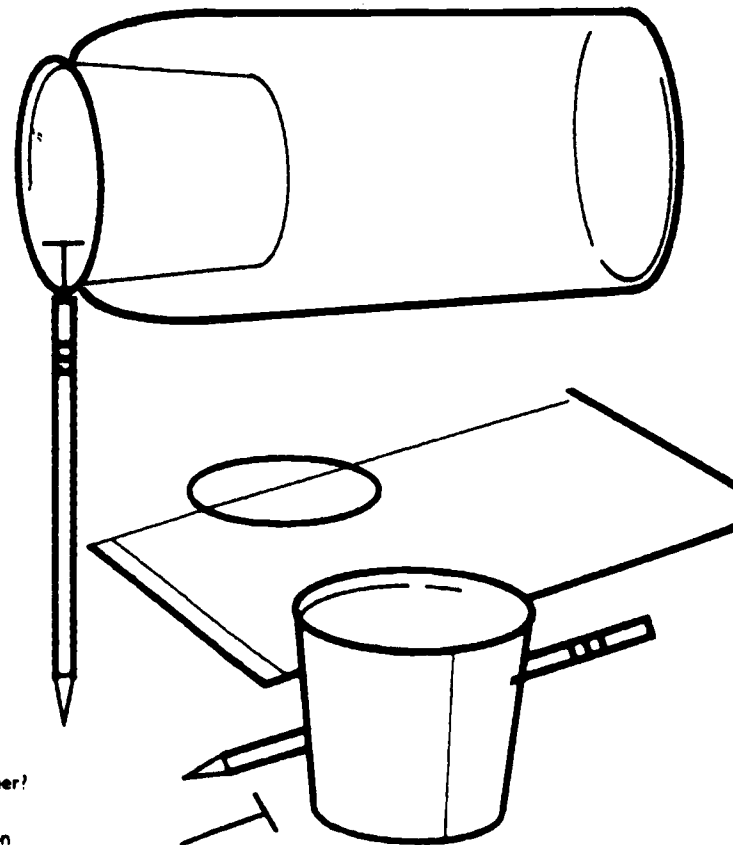

UNIVERSAL HOUSE



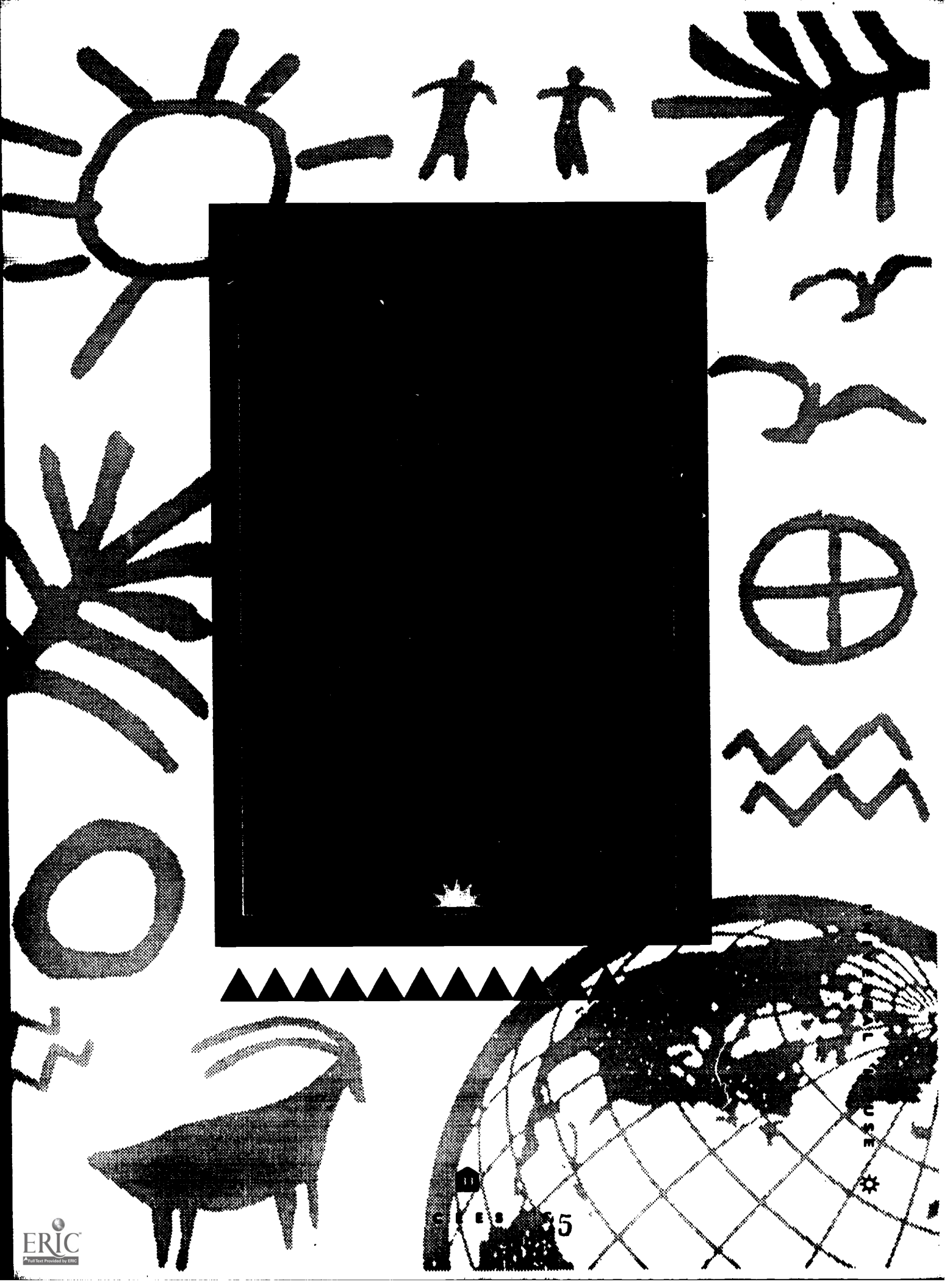

## RESOURCES

## DO FOR YOURSELF

The *Universal House* activities were adapted from the lessons and activity guides below. Many variations of these lessons appear in other guides. The materials are described more completely in the *Environmental Education, Compendium for Energy Resources*. California Department of Education, California Energy Extension Service, Sonoma State University, 1992. (Available from CEES, 1400 Tenth St., Sacramento, CA, 95814).

## WHAT IS ENERGY?

**Lesson Program.** Science Education Center, Lawrence Livermore National Laboratory.

**Energy Activities for the Primary Grades.** El Dorado County Office of Education and California Energy Extension Service, 1985.

Tourillot, Lecann. *Conserve and Renew*. Sonoma State Energy Center and California Energy Extension Service, 1990.

## SHELTER

**Indians of Northwest California.** "Our Ancestors and Our Community" and "Home for Diné." Indian Education Program, Klamath-Trinity Joint Unified School Districts, 1992.

**California State Environmental Education Guide, "Communities and Cultures Unit."** Alameda County Office of Education, 1988.

Clymire, Olga. ***A Child's Place in the Environment, "Conceiving Natural Resources Unit."*** Konocti Unified School District and California Dept. of Education, 1993.

**Project Learning Tree, "Second Little Pig," "Another Way of Seeing" and "Start A City."** The American Forest Council, 1977.

## INSULATION

**Energy Activities for the Primary Grades.** El Dorado County Office of Education and California Energy Extension Service, 1985.

**Conservation: Science Activities in Energy.** U.S. Department of Energy, 1978.

## THERMAL MASS

With assistance from Melissa Reading, Pacific Gas & Electric, 1992.

## SHADE

**Conservation: Science Activities in Energy, "Ice Race."** U.S. Department of Energy, 1978.

## ORIENTATION 1

**Hot Water and Warm Homes, Great Explorations in Math and Science (GEMS) series.** Lawrence Hall of Science, University of California, 1986.

**California State Environmental Education Guide, "Energy Unit."**

## ORIENTATION 2

**Can We Plug Into Windmills? Breakthroughs-Strategies for Thinking.** Zaner-Bloser, Inc., 1992.

**Energy Activities for the Primary Grades, "Wind Experiments."**

## READ FOR YOURSELF

The examples offered here represent a selection of reference materials that could be utilized in the classroom for research, and to assist in the implementation of activities and concepts presented in this guide.

Caduto, Michael J., & Bruchac, Joseph. ***Keepers of The Earth: Native American Stories and Environmental Activities for Children.*** Fulcrum, Inc., 1988.

**News From Native California.** Quarterly periodical. Heyday Books, 2054 University Ave., #403, Berkeley, CA 94704. 415/549-3564.

**The Way We Lived: California Indian Reminiscences, Stories and Songs.** Edited by Malcolm Margolin. Heyday Books, 1981.

Margolin, Malcolm. ***The Ohlone Way.*** Heyday Books. Berkeley, 1978.

**American Indian Myths and Legends.** Edited by Richard Erdoes & Alfonso Ortiz. Pantheon Books, 1984.

**The California Indians: A Source Book.** Edited by R. F. Heizer & M. A. Whipple. 2nd edition. University of California Press, 1971. 2120 Berkeley Way, Berkeley, CA, 94720.

Eargle, Dolan H. ***The Earth Is Our Mother: A Guide to the Indians of California, Their Locales and Historic Sites.*** Trees Company Press, 1986. 49 Van Buren Way, San Francisco, CA, 94131.

**California Indian Nights.** Compiled by E.W. Gifford & G.H. Block. University of Nebraska Press, 1990.

Kroeber, A.L. ***Handbook of The Indians of California.*** Dover Publications, Inc., 1976.



## RESOURCES

Faber, G., & Lasagna, M. *Whispers From the First Californians: A Story of California's First People*. Maggie Publications, 1984.

*The American Indian: Yesterday, Today, & Tomorrow - A Handbook For Educators*. California Department of Education, 1991.

Nabokov, Peter, & Easton, Robert. *Native American Architecture*. Oxford University Press, 1989.

Rudofsky, Bernard. *Architecture Without Architects: A Short Introduction to Non-Pedigreed Architecture*. University of New Mexico Press, 1988.

*The Trees Stand Shining: Poetry of The North American Indians*. Selected by Hettie Jones. Illustrated by Robert Andrew Parker. Dial Press, 1971.

*The Whispering Wind: Poetry by Young American Indians*. Compiled by Terry Allen. Doubleday, 1972.

## SEE FOR YOURSELF

Examples of traditional California Indian architecture (reconstructions, with the exception of Hupa where original structures still exist), and/or cultural museums, may be seen at the following sites (please call ahead). A more complete list may be found in *The Earth Is Our Mother*, Appendix D.

**ANDERSON MARSH STATE PARK**  
Lower Lake, CA  
707/279-4293

**CALIFORNIA ACADEMY OF SCIENCES**  
Hall of Human Cultures  
Golden Gate Park, San Francisco, CA  
415/221-5100

**CALIFORNIA STATE INDIAN MUSEUM**  
2618 K St., Sacramento, CA  
916/324-0971

**CHAWSE**  
Indian Grinding Rock State  
Historic Park, Pine Grove, CA  
209/296-7488

**CHUMASH TRIBE**  
P.O. Box 517, Santa Ynez, CA  
805/686-1455

**COYOTE HILLS REGIONAL PARK  
VISITOR CENTER**  
8000 Patterson Rd., Fremont, CA  
510/795-9385

**FT. YUMA RESERVATION MUSEUM**  
Quechan Tribal Council  
P.O. Box 11352, Yuma, AZ  
619/572-0661

**HUPA TRIBAL MUSEUM**  
P.O. Box 1348, Hucopa, CA  
916/625-4110

**KULE LOKLO**  
Point Reyes National Seashore  
Visitors Center, Olema, CA  
415/663-1092

**LANDO HALL OF CALIFORNIA HISTORY**  
L.A. Museum of Natural History  
900 Exposition Blvd., Los Angeles, CA  
213/744-3466

**THE MARIN MUSEUM OF  
THE AMERICAN INDIAN**  
2200 Novato Blvd., Novato, CA  
415/897-4064

**OAKLAND MUSEUM**  
1000 Oak St., Oakland, CA  
510/834-2413

**PHOEBE HEARST MUSEUM  
OF ANTHROPOLOGY**  
University of California  
Berkeley, CA  
510/642-3681

**SAN DIEGO MUSEUM OF MAN**  
Balboa Park, San Diego, CA  
619/239-2001

**SIERRA MONO MUSEUM**  
State Hiway 225 at 228  
North Fork, CA  
209/877-2115

**SATWIWA**  
Rancho Sierra Vista  
Santa Monica Mountains N.R.A.  
Woodland Hills, CA  
213/888-3770

**SUMEG VILLAGE**  
Patrick's Point State Park  
Trinidad, CA  
707/677-3570

**YOSEMITE MIWOK VILLAGE**  
Yosemite National Park, CA  
Park Info : 209/372-0200

**COYOTE SLEPT FOUR  
TIMES. AT FIRST, HE  
SLEPT WITH HIS  
HEAD TOWARD THE  
WEST. HE SLEPT  
WITH IT TOWARD  
THE NORTH,  
AND THE  
SOUTH,  
AND THE FOURTH TIME  
COYOTE SLEPT WITH HIS HEAD TO  
THE EAST. WHILE HE SLEPT, HIS  
FOREHEAD GREW VERY WARM. THEN HE  
AWOKE AND SAID, "I DREAMED OF THE SUN."  
SO, COYOTE DECIDED TO GET THE SUN, AND BRING IT  
BACK FOR THE PEOPLE.**

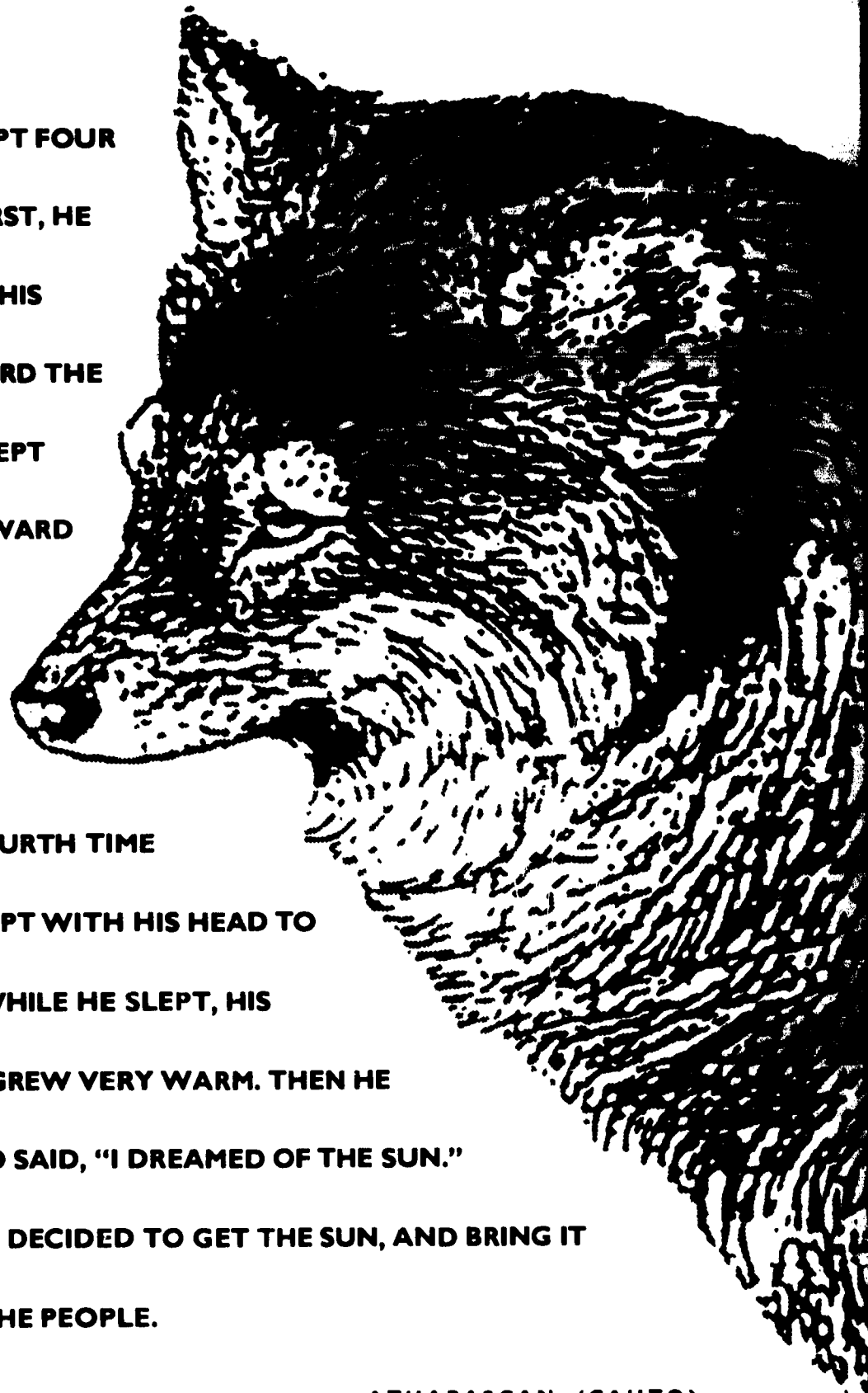

U  
N  
I  
V  
E  
R  
S  
A  
L  
H  
O  
U  
S  
E



ATHABASCAN (CAHTO)

36

C E E S

38